

# Connecting Pedestrians with Disabilities to Adaptive Signal Control for Safe Intersection Crossing and Enhanced Mobility

## System Design Document (SDD)

Final – August, 2018

Publication Number: FHWA-JPO-18-685



U.S. Department of Transportation

Produced by Carnegie Mellon University with support from Booz Allen Hamilton.  
(Cover page figure source: US Department of Transportation)

U.S. Department of Transportation  
Intelligent Transportation Systems (ITS) Joint Program Office

## **Notice**

This document is disseminated under the sponsorship of the Department of Transportation in the interest of information exchange. The United States Government assumes no liability for its contents or use thereof. The U.S. Government is not endorsing any manufacturers, products, or services cited herein and any trade name that may appear in the work has been included only because it is essential to the contents of the work.

---

**Technical Report Documentation Page**

<b>1. Report No.</b> FHWA-JPO-18-685		<b>2. Government Accession No.</b>		<b>3. Recipient's Catalog No.</b>	
<b>4. Title and Subtitle</b> Connecting Pedestrians with Disabilities to Adaptive Signal Control for Safe Intersection Crossing and Enhanced Mobility – System Design Document				<b>5. Report Date</b> August 2018	
				<b>6. Performing Organization Code</b>	
<b>7. Author(s)</b> Stephen F. Smith, Zachary B. Rubinstein, Raj Kamalanathsharma (BAH) Sara Sarkhili (BAH), Bernardine Dias (Diyunu), Sina Bahram (Prime Access Consulting)				<b>8. Performing Organization Report No.</b> Task 1.1.3 Report	
<b>9. Performing Organization Name And Address</b> Carnegie Mellon University 5000 Forbes Avenue Pittsburgh PA, 15213-3890				<b>10. Work Unit No. (TRAIS)</b>	
				<b>11. Contract or Grant No.</b> DTFH6117C00014	
<b>12. Sponsoring Agency Name and Address</b> U.S. Department of Transportation ITS Joint Program Office 1200 New Jersey Avenue, SE Washington, DC 20590				<b>13. Type of Report and Period Covered</b> Year 1 Report	
				<b>14. Sponsoring Agency Code</b>	
<b>15. Supplementary Notes</b>					
<b>16. Abstract</b>  This document presents the system design of a mobile application for use by pedestrians with disabilities to facilitate safe and efficient intersection crossing. The mobile application is designed to allow the pedestrian to communicate directly to the intersection and to actively influence traffic control decisions. Most basically, the mobile application enables the pedestrian to communicate personalized crossing duration requirements to the infrastructure. However, the mobile app is also capable of monitoring pedestrian progress, and by utilizing the SURTRAC real-time adaptive traffic signal control system, it is capable of triggering dynamic extension of the green phase if necessary. Various aspects of the design are specified, including the physical architecture, the DSRC-based pedestrian-to-infrastructure communication framework, the mobile application's user interface, and necessary extensions to the SURTRAC adaptive signal control system.					
<b>17. Key Words</b>  pedestrians with disabilities, safe intersection crossing, smartphone app			<b>18. Distribution Statement</b>		
<b>19. Security Classif. (of this report)</b> Unclassified		<b>20. Security Classif. (of this page)</b> Unclassified		<b>21. No. of Pages</b> 61	<b>22. Price</b>

# Table of Contents

<b>1</b>	<b>Introduction .....</b>	<b>5</b>
	1.1 PURPOSE OF THE SYSTEM DESIGN DOCUMENT .....	5
	1.2 DOCUMENT OVERVIEW.....	6
	1.3 ASSUMPTIONS .....	6
	1.4 CONSTRAINTS .....	7
	1.5 RISKS .....	8
<b>2</b>	<b>System Description.....</b>	<b>10</b>
	2.1 PHYSICAL SYSTEM OVERVIEW.....	10
	2.1.1 SURTRAC .....	10
	2.1.2 Safe Intersection Crossing .....	11
	2.1.3 More Efficient Intersection Crossing .....	13
	2.2 LIST OF SUBSYSTEMS AND COMPONENTS .....	14
<b>3</b>	<b>Subsystems and Components .....</b>	<b>15</b>
	3.1 PEDESTRIAN DEVICE COMPONENTS.....	15
	3.2 INTERSECTION INFRASTRUCTURE COMPONENTS.....	17
	3.3 DSRC COMMUNICATION .....	19
	<b>3.3.1</b> MapData Message .....	<b>20</b>
	<b>3.3.2</b> Signal Phase and Timing Message.....	<b>23</b>
	<b>3.3.3</b> Signal Request Message .....	<b>25</b>
	<b>3.3.4</b> Signal Status Message.....	<b>26</b>
	3.4 INTERFACING WITH THE PEDESTRIAN.....	26
	3.4.1 Visual Interface .....	27
	3.4.2 Audible Interface.....	30
	3.4.3 Haptic Interface.....	31
	3.4.4 Current UI-Prototype Design .....	31
	3.5 INTERFACING WITH SURTRAC .....	34
	3.6 MONITORING CROSSING PROGRESS .....	35
	3.7 USING INFORMATION ABOUT PEDESTRIAN ROUTES, REAL-TIME BUS ARRIVAL TIMES AND THE BUILT INFRASTRUCTURE .....	37
<b>4</b>	<b>Acronyms.....</b>	<b>39</b>
<b>5</b>	<b>References .....</b>	<b>41</b>
<b>6</b>	<b>Requirements Traceability Matrix .....</b>	<b>42</b>

## List of Tables

Table 3-1. Defined Audible Functions of the Safe Intersection Crossing Application.....31

## List of Figures

Figure 2-1: SURTRAC System Architecture ..... 11

Figure 2-3: Overall Physical Architecture of the Safe Intersection Crossing System..... 14

Figure 3-1: Overall Physical Architecture of the Safe Intersection Crossing System..... 15

Figure 3-2: Physical Architecture of the Pedestrian Device Components..... 16

Figure 3-7: Schema of MapData Message Set .....21

Figure 3-8: Visual and XML Representations of the Center Avenue / Melwood Avenue  
MapData Message .....22

Figure 3-9: Finding the Signal Group ID for A Given Crossing Direction .....23

Figure 3-10: Schema of Signal Phase and Timing Message Dataset.....24

Figure 3-11: Retrieving Countdown Information from the SPaT Message.....25

Figure 3-12: SRM and SSM – Message Types .....26

Figure 3-13: Simple Illustration of the Main Application Interface.....28

Figure 3-14: Selection of Intersections for Crossing .....29

Figure 3-15: User Interface for Pedestrian Crossing Count-down .....30

Figure 3-16: Initial UI Prototype Crossing Process .....32

Figure 3-17: Mobile App State Transition Graph .....34

Figure 3-18: Current Mobile App Settings Screen.....35

Figure 3-19: Algorithm for SURTRAC Response to an SRM – General Case of Multiple  
Simultaneous Requests.....37

# 1 Introduction

Transportation and mobility are crucial for living today. However, for people with disabilities (mobility, vision, hearing, and cognitive), inadequate transportation can prevent them from living a full life. The Accessible Transportation Technology Research Initiative (ATTRI) of the U.S Department of Transportation's (USDOT) Intelligent Transportation Systems Joint Program Office (ITS-JPO) aims at improving the mobility of travelers with disabilities through research, development, and implementation of transformative technologies, applications, or systems for people of all abilities to effectively plan their personal and independent travel. ATTRI research focuses on the needs of three stakeholder groups: persons with disabilities, older adults, and veterans with disabilities.

The ATTRI Broad Agency Announcement aims at leading transformational changes and revolutionary advances in accessible transportation, personal mobility, and independent travel for all travelers, and lead to offering a totally new travel experience in intermodal surface transportation in the United States. This involves research and development in three key application areas:

1. Smart Wayfinding and Navigation Systems.
2. Pre-trip Concierge and Virtualization, and
3. Safe Intersection Crossing.

This document is developed as a part of the Safe Intersection Crossing application area.

## 1.1 Purpose of the System Design Document

This project will develop and demonstrate assistive services that (1) promote safe passage of veterans with disabilities, older adults, and other persons with blindness, low vision, cognitive, or mobility related disabilities when crossing signalized intersections, and (2) exploit smart traffic signal infrastructure to further provide these persons with significant mobility enhancements.

These services will be accessible to users via smartphones that are equipped with Dedicated Short-Range Communication (DSRC) capability, allowing them (1) access to real-time information from traffic signal infrastructure and nearby vehicles, and (2) the ability to actively influence traffic signal control decisions and vehicle movements at the intersection. The smartphone app will provide accessible interfaces that allow pedestrians to communicate personalized intersection crossing constraints (e.g., required duration, crossing direction) to the signal system to ensure that the signal system allocates sufficient crossing time, and to be alerted when a crossing movement indicates safety concerns (e.g., moving outside of the crosswalk). Real-time monitoring of crossing performance will also be used to automatically extend the green time in real-time when appropriate.

The app will also enable users to provide pre-planned pedestrian route and destination information (e.g., walking path and target bus stop and route) to the traffic signal infrastructure, which can be used in conjunction with other real-time information (e.g., bus locations and routes) to adapt signal phase

timings preemptively as the pedestrian approaches the intersection, leading to shorter and more reliable pedestrian travel times, and more efficient travel connections. Moreover, since the real-time traffic signal control system is optimizing all detected traffic flows at a given intersection, the approach will yield compound benefits in areas with large concentrations of disadvantaged pedestrians (e.g., near elder care facilities, retirement homes, schools for persons with disabilities, etc.).

The purpose of this document is to specify the system design of a mobile app and smartphone device that will provide this set of intersection crossing services. Since the development of capabilities for using pedestrian routes and synchronizing with buses is planned for the second year of the project, this Year 1 edition of the System Design Document will focus on the design of basic capabilities for communicating and using personalized crossing constraints to provide sufficient green time for crossing, for monitoring the user's crossing progress and for dynamically extending the green and/or alerting the user if the situation warrants. In the design phase at the beginning of Year 2, this system design document will be updated to incorporate more advanced mobility enhancement capabilities. In both years, technical design and development will build on the existing real-time adaptive traffic control system developed at the Carnegie Mellon University, known as Scalable Urban Traffic Control (SURTRAC).

## 1.2 Document Overview

This document presents the system design of a mobile application for use by pedestrians with disabilities to facilitate safe and efficient intersection crossing. The mobile application is designed to allow the pedestrian to communicate directly to the intersection and to actively influence traffic control decisions. As indicated above, this edition of the document will concentrate on the design of the Year 1 prototype, which will provide basic capabilities that promote safe intersection crossing. Most basically, this version of the mobile application will enable the pedestrian to communicate personalized crossing duration requirements to the infrastructure and have these constraints reflected in the green time that is allocated for crossing. However, the mobile app will also be capable of monitoring pedestrian progress, and by utilizing the SURTRAC real-time adaptive traffic signal control system, it will be capable of triggering dynamic extension of the green phase if necessary. Various aspects of the design are specified, including the physical architecture, the DSRC-based pedestrian-to-infrastructure communication framework, the mobile application's user interface, and necessary extensions to the SURTRAC adaptive signal control system.

This system design is intended to enable Year 1 prototype, development, demonstration and evaluation of the proposed safe intersection crossing application, and will be extended to include capabilities planned for the second year of the project during the Year 2 design phase.

## 1.3 Assumptions

The system architecture design specified in this report makes the following assumptions:

1. *Positioning and directional accuracy:* The architecture design specified assumes sufficient positioning and directional accuracy from a cell phone Global Positioning System (GPS) to allow for precise curbside navigation of users. Supplementary technology might be required if the accuracy turns out to be less than ideal during our implementation phase. (See Section for our latest thinking on providing this localization capability.)

2. *DSRC message sets beyond standardized messages*: It was originally assumed that our system architecture design would require some extension of the standardized Society of Automotive Engineers (SAE) J2735 message sets. However, as the design has developed it has been possible to use the Signal Request Message (SRM) and Signal Status Message (SSM) types without change to support communication of pedestrian requests to the infrastructure. The only potential deviation from the J2735 2016 message standard might be in our interpretation of the minimum time remaining values of the Signal Phase and Timing (SPaT) message, which is ill-defined in the context of real-time adaptive signal control systems. But we believe that ultimately innovation may be required here to define the semantics of this case.
3. *Phase 1 Prototype*: The version of system architecture represented in this report focuses on safety aspects of the mobile application (i.e., the Year 1 objective) and does not include mobility components such as use of pre-planned pedestrian routes and bus-stop synchronization. These features will be specified as part of a revised architecture document that will be developed during Phase 2 of this project. The current document contains placeholder sections for these Phase 2 capabilities.
4. *User interface design*: This project includes human-machine interactions, which require further evaluation and studies in the area of human-factors. This is beyond the scope of this project, and the architecture and interface designs specified in this document are based on principles that have proven to be most effective in previous research. We expect the Phase 1 field test to provide feedback into the utility of the mobile application's user interface and lead to its refinement in phase 2.

## 1.4 Constraints

Safe navigation of crosswalks can be a key challenge for people who need more time to traverse an intersection. If there is no safe island zone mid-intersection then signal light duration becomes very important, for example. Within this application area, providing safe intersection crossing assistance for all unique travelers as they interface with existing traffic, signals, all types of vehicles and assistive devices is a key focus area. It is therefore imperative that the design of technological solutions focuses on assistive tools for people with blindness, low vision, cognitive and mobility issues. Assistive tools may be in the form of personal nomadic devices, wearable technologies and kiosks on streets corners to allow for ubiquitous access to connected services.

Applications in this area should, for example, provide guidance, notifications and alerts in various communication formats that assist pedestrians and all users of the transportation system as they navigate safely through intersections. They should also focus on providing precise and concise information when it is needed and at the right moment to promote decision-making and actions. These applications should address and could include but are not limited to the following components: the pedestrian's interface with traffic signals, vehicles, nomadic devices, and automated intersection crossing assistance, beacons or electronic tags to interact with the built and pedestrian environment including support for multiple languages and the sharing of real-time information. It should provide contextual information including Geographical Information Systems (GIS) and crowd sourced information on curb cuts, bus stop locations, side walk grade and slope, and any disruption of the built environment (damaged infrastructure, dead ends, potholed) to aid all travelers. Additional examples could include; futuristic and innovate approaches to solving this issue with automated intersection crossing assistance, technical design solutions for people with blindness, low vision, cognitive and mobility issues, or integrated beacons or electronic tags to interact with the built environment.



## 1.5 Risks

Several assumptions presented in section 1.3 are also risks associated with this project, and additional risks will be documented as we proceed through design and implementation stages in future deliverables. Some of the identified risks and mitigation strategies based on current design are presented below:

No.	Risk	Mitigation Strategy
1	Without positional systems such as differential GPS, the architecture design presented here runs the risk of degraded positional and directional accuracy.	The team plans to investigate alternate approaches such as DSRC signal-strength estimation, introduction of external Bluetooth beacons at the intersection, and localization based on multiple GPS devices to improve accuracy of GPS-based location services.
2	The current architecture utilizes SRM and SSM, which are currently only standardized for Transit Signal Priority (TSP) and Emergency Vehicle Preemption (EVP).	Pedestrian calls and phases work similar to TSP and EVP, and we expect minimal modifications to SRM and SSM to allow SURTRAC to utilize pedestrian calls to adjust the green time.
3	DSRC message-set latency or errors could cause Signal Phasing and Timing information to switch back and forth and confuse users.	The software design will utilize smoothing methods to avoid unknown variations in Time to Red by utilizing an internal timer.
4	We have found the mobile DSRC technology to be somewhat unstable and the learning curve for getting it to work to be rather steep. More generally, the documentation is sparse for all DSRC devices, which has further complicated development.	At this point we have worked through most issues and have the ability for all of the bi-directional communication we need. However, we have had to make undesirable compromises to achieve this. Specifically, it was necessary to upgrade the firmware of the mobile DSRC sleeve to enable communication with the intersection road-side unit (RSU). But the firmware upgrade has broken the ability to use Bluetooth to communicate with the smartphone (which worked on the older firmware).
5	Unless and until we are able to get this firmware bug corrected, we are stuck using a wired connection between the phone and the sleeve. While functional, this is not particularly attractive from a usability perspective.	We have investigated the use of either (1) a larger plastic case to encapsulate the mobile device and the exposed wiring, or (2) the use of a fanny pack to hold all equipment at the waist and allow the user to handle just the tethered phone or use a runner's sleeve to attach it to the user's arm. Our current plan is to adopt (2) for the Year 1 field test, and we believe that with appropriate discussion with field test participants during training the negative impact of no Bluetooth communication should be minimized. In a way, it results in an easier device package for the user to interact with.

No.	Risk	Mitigation Strategy
6	Lear has informed us that it plans to discontinue the Arada Systems Locomate ME sleeve device, and no longer support it.	To address this longer-term issue, we have spent some time examining other vendor's DSRC hardware solutions. We have not yet found another sleeve device, but Codha makes a compact OBU that could be adaptable for this purpose. Codha has provided us with a sample unit to experiment with, and we have also recommended this OBU to the Port Authority as the device to use onboard its buses.

# 2 System Description

In this chapter, we describe the application view of the Safe Intersection Crossing technology we intend to build, and the associated mobility enhancements that will be added in the optional task award.

## 2.1 Physical System Overview

### 2.1.1 SURTRAC

As mentioned in the previous chapter, the “Safe Intersection Crossing” application will be built on the existing adaptive traffic signal system developed by Carnegie Mellon University (CMU) and currently marketed by Rapid Flow Technologies, known as SURTRAC (Scalable Urban Traffic Control).

SURTRAC is a real-time adaptive traffic signal system designed specifically for optimization of traffic flows in complex urban road networks, where there are competing dominant flows that change significantly through the day. SURTRAC takes a totally decentralized approach to traffic control. Each intersection allocates its green time independently in real-time based on actual incoming vehicle flows, as seen through video or radar detection, and projected outflows are then communicated to neighboring intersections to increase their visibility of future incoming traffic. Reliance on decentralized intersection control ensures maximum real-time responsiveness to actual traffic conditions, while communication of projected outflows to downstream neighbors enables coordinated activity and creation of green corridors. The system is inherently scalable to road networks of arbitrary size, since there is no centralized computational bottleneck.

SURTRAC implements schedule-driven traffic control as part of a flexible signal control system that is modularly designed for integration with any commercially available controller and sensor hardware. True to the schedule-driven traffic control model, SURTRAC is organized as a completely decentralized multi-agent system. Each intersection is controlled by an agent running on an embedded computer located in the traffic cabinet for the intersection. The agent for each intersection manages the control of the traffic signal and all the vehicle detectors located at that intersection.

The embedded computer running the SURTRAC system interfaces directly with the hardware controller at the intersection, utilizing either the National Transportation Communications for Intelligent Transportation Systems Protocol (NTCIP) 1202 standard for North Electrical Manufacturers Association (NEMA) controllers, or more controller-specific protocols in the case of non-NEMA controllers such as the 170 Controllers used by the City of Pittsburgh. At the beginning of every planning cycle (which is invoked every second), the SURTRAC system accepts standardized traffic detection inputs representing traffic counts, location and heading information that are produced by commercially available vehicle detection technology (e.g., video cameras, radar, induction loops). Using this information, SURTRAC generates a prediction of stop-line arrivals in all directions. This predictive model is then used to generate, in real-time, a timing plan for moving the traffic that has been sensed through the intersection in an optimized fashion (currently minimizing cumulative wait time). Commands (calls) corresponding to the first step of the plan are then communicated to the

---

U.S. Department of Transportation  
Intelligent Transportation System Joint Program Office

signal controller for implementation. The SURTRAC intersection scheduler also communicates projected vehicle outflows to its downstream neighbors. The SURTRAC agent resident at each downstream intersection integrates this expected traffic with the traffic it is sensing through its local detectors to generate its own local timing plan, which allows plans to be developed over a longer future horizon.

Architecturally, the SURTRAC system is organized internally and interacts with intersection infrastructure and neighboring intersections as depicted in Figure 2-1. Detector inputs are received by the Communicator module and forwarded to the Scheduler module for construction of the predictive model. The scheduler then generates a timing plan to optimize movement of these predicted traffic flows through the intersection and forwards this plan to the Communication module. The Communication module (1) sends the plan to the Executor module, which begins to issue commands to the traffic controller, and (2) sends the projected traffic outflows implied by the plan to the intersection's downstream neighbors.

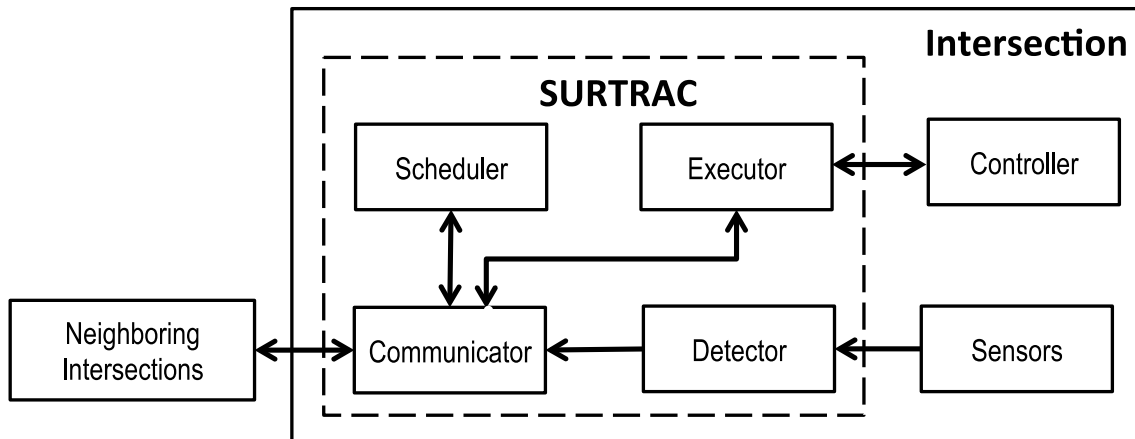

**Figure 2-1: SURTRAC System Architecture**  
(source: [Smith2013])

Further details on the SURTRAC system can be found in [Xie, 2012a, b, Smith2013]

### 2.1.2 Safe Intersection Crossing

The safe-intersection crossing application is envisioned to be an add-on module (or extension) to the SURTRAC system. The core of the safe-intersection crossing will be a hand-held device, consisting of a cell-phone that has been integrated with a DSRC sleeve. This coupled mobile device will be either held by or on the person of the pedestrian and will be used by the pedestrian to communicate with the intersection. This device will interact with a DSRC Roadside Equipment (RSE) unit mounted at the intersection, and the DSRC RSE will be connected to the SURTRAC processor residing in the controller cabinet (via an extended Detector module interface). Through SURTRAC's normal interaction with the intersection's hardware controller (also resident in the cabinet), both traffic and pedestrian signals are

adjusted to fit the pedestrians crossing constraints. Figure 2-2 shows the schematic of different elements of the safe intersection crossing application.<sup>1</sup>

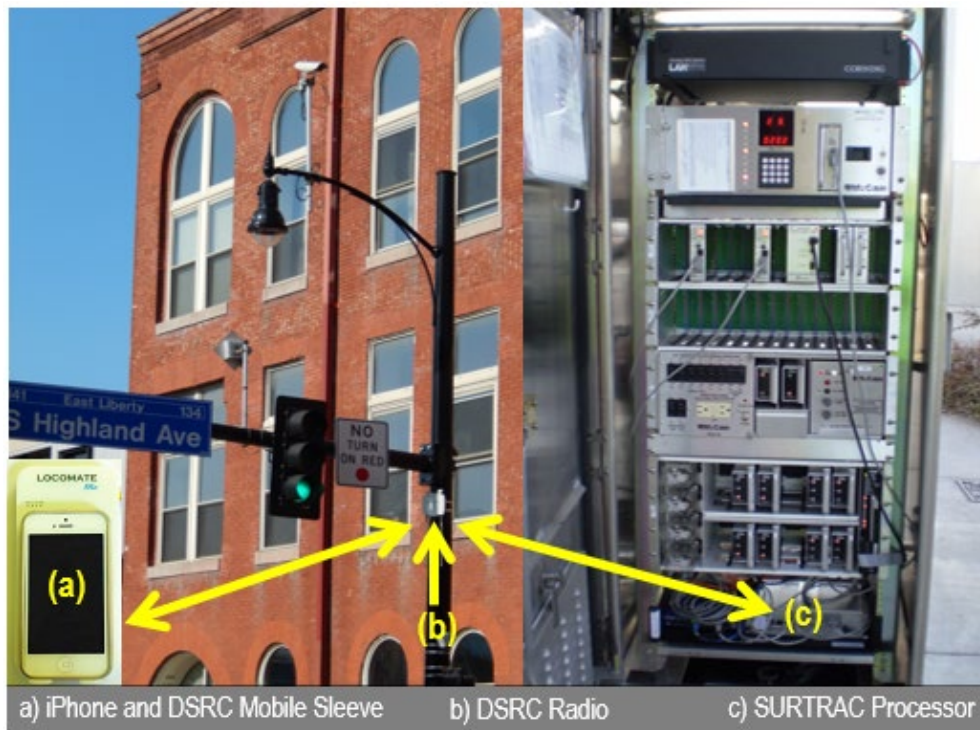

**Figure 2-2: Schematic of Different Elements of the Safe Intersection Crossing Application**

In operation, as the pedestrian approaches the intersection, both MapData (MAP) and Signal Phase and Timing (SPaT) messages will be detected by the mobile application. This message content will be used by the mobile application to present the pedestrian with different crossing options. Based on the content of the SPaT and MAP messages that are being received, the application will inform the pedestrian of which crossing phase is green and what time remains until the beginning of future crossing phases. When the pedestrian arrives at the intersection and is ready to cross, s/he will use the smartphone application to select a crossing option and trigger a crossing request. This request will indicate the pedestrian's crossing direction and required crossing duration (based on the mobile application's knowledge of the pedestrian's speed).

If the cross-walk is active (i.e., the corresponding signal phase is green) and the "time remaining" is deemed sufficient, then the pedestrian can begin to cross the street; the application will monitor

<sup>1</sup> Although many of the application's capabilities rely fundamentally on a real-time, adaptive signal control system such as SURTRAC, it is possible to provide the simple, basic capability to substitute a longer, personalized crossing duration that could be used with a conventional signal timing plan. We intend to design the mobile app in such a way that this basic capability can be utilized at non- SURTRAC controlled intersections with DSRC communication capability.

progress, generate alerts as necessary, and potentially extend the green time to help the pedestrian safely cross.

If the cross-walk is inactive (i.e., the corresponding signal phase is red), or if the “time remaining” in the current green crossing phase is less than that required for the pedestrian to cross the street, then the pedestrian will be alerted to wait for the next cycle. In this case, the previously communicated crossing duration will be used by the signal control system to ensure that sufficient green time is allocated when the crossing direction does eventually become green. Once the pedestrian signals that s/he is starting to cross, the application will monitor progress, generate alerts and potentially extend the green time as before.

The safe intersection crossing application will be tailored in different ways to the disability of the pedestrian using the application. The User Interface (UI) of the application will be tailored to the type of disability, so that it can provide visual, audible or haptic feedback. In addition, the pedestrian request will be based on the average moving speed of the pedestrian so that the walk-phase is long enough for his/her safe passage.

### **2.1.3 More Efficient Intersection Crossing**

This section will be added during the Year 2 design phase, where capabilities will be expanded to incorporate (1) use of pre-planned pedestrian routes to anticipate arrival at the intersection and streamline crossing, and (2) use of traffic signals in conjunction with real-time bus information and knowledge of target pedestrian bus routes to synchronize respective arrivals at near-side bus stops and streamline bus connections.

## 2.2 List of Subsystems and Components

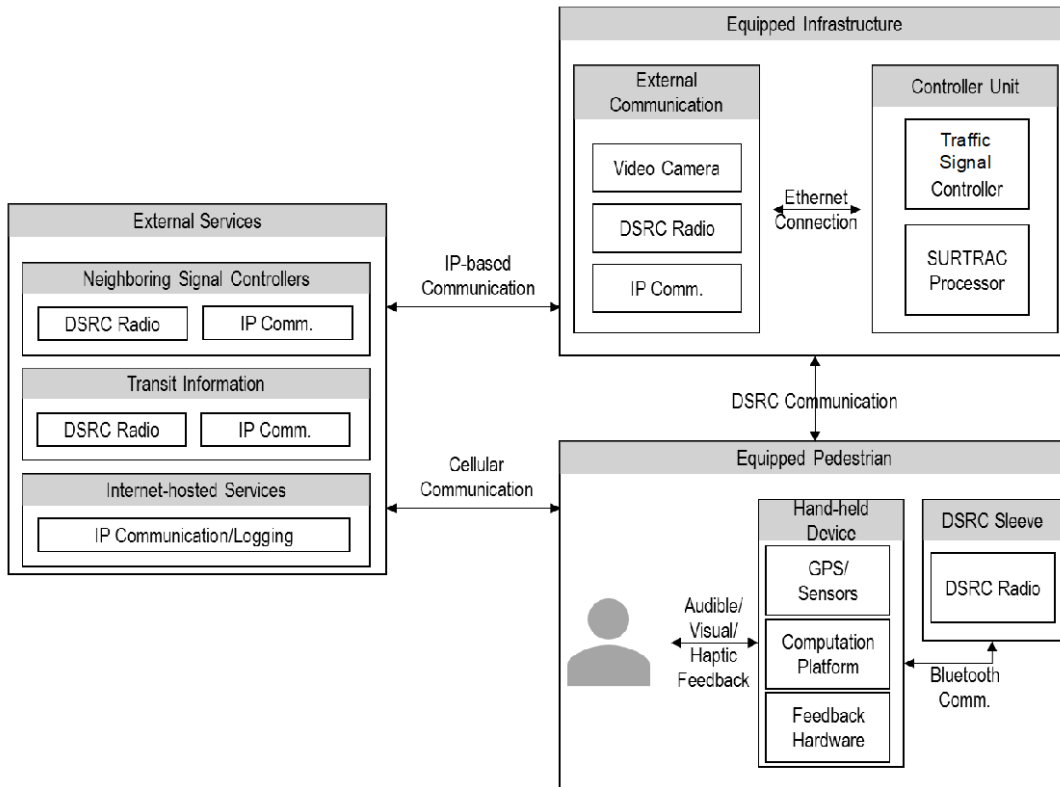

**Figure 2-3: Overall Physical Architecture of the Safe Intersection Crossing System**

Given that the intersection crossing application is built on the existing SURTRAC adaptive signal control system, the design is proposed to work coherently with the SURTRAC architecture. The overall physical architecture of the safe intersection crossing system is depicted in Figure 2-3.

As shown in the figure, the overall system architecture consists of three independent systems that interact with each other to enable safe crossing and other mobility enhancements for equipped pedestrians. These three independent systems include:

1. The Hand-held Pedestrian Device
2. The Infrastructure Equipment at the Intersection (including the real-time adaptive traffic signal control system) and
3. External Services.

These systems use a combination of DSRC, cellular/wired/wireless IP-based communication and wired ethernet communication for inter-system and sub-system level communications. More details on the first two of these subsystems, which constitute the core of the proposed mobile application, are provided in the next chapter.

# 3 Subsystems and Components

In the subsections below we provide a detailed design for each of the subsystems and components that are part of the overall system shown in figure below. A given subsystem/component can be primarily hardware, primarily software or have both hardware and software components. For subsystems/components where there is a mix of legacy design and new hardware/software to enable the proposed mobile application, we focus principally on the new elements and reference the legacy design with existing documentation where appropriate.

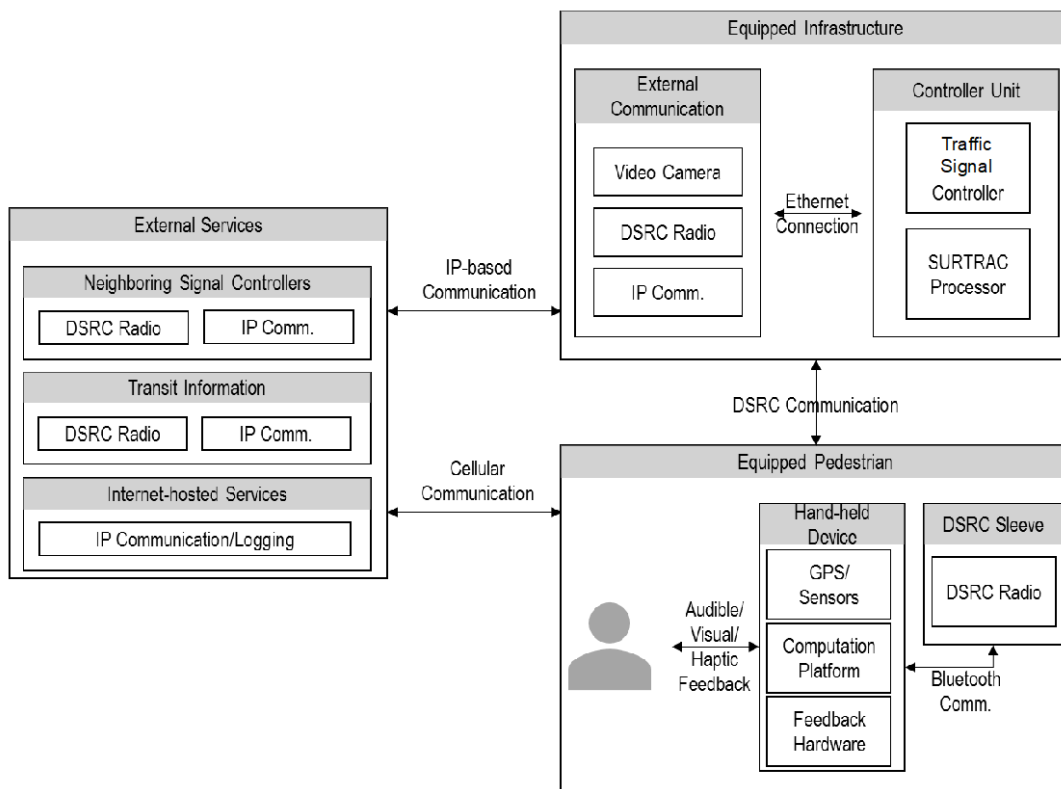

**Figure 3-1: Overall Physical Architecture of the Safe Intersection Crossing System**

## 3.1 Pedestrian Device Components

As described before, the core of the safe pedestrian crossing application is the hand-held device that is carried and accessed by the pedestrian. The physical architecture of this device is presented in Figure 3-1 and an example hardware unit is shown in Figure 3-2. The physical hardware consists of a cell-phone and a DSRC device connected via Bluetooth. At a high-level, the pedestrian crossing application works as follows:



1. Equipped pedestrian configures the device with the type of feedback (audible, visual or tactile) and the average crossing speed at intersections. Speed is adjustable to fit current conditions (e.g., high heels versus running shoes, inclement weather), and in the future, the app could include learning processes that refine crossing speed through accumulated crossing experience.
2. Pedestrian device consists of a computation platform for running the mobile app (i.e. a smartphone) and a mobile sleeve to which the smartphone attaches with a DSRC radio (for communication to the infrastructure).
3. As the pedestrian approaches the intersection, the mobile application receives both MAP and SPaT messages that are being broadcast by the infrastructure.
4. This information is used by the mobile app to provide the pedestrian with street crossing options.
5. Upon selection of a street to cross by the pedestrian, the mobile application issues a System Request Message (SRM) to the infrastructure, requesting a crossing duration that is consistent with the pedestrian's speed.
6. The application will use incoming SPAT messages to convey remaining crossing time to the pedestrian.

Readers are encouraged to refer to the Concept of Operations (ConOps) document for detailed steps on 16 use-cases identified for this application.

Figure 3-2 below depicts the physical architecture of the mobile device. MAP and SPaT messages are both received by the DSRC radio in the sleeve, and then communicated to the smartphone via Bluetooth. SRMs are sent from the Safe Crossing Application to the DSRC sleeve via Bluetooth, and then communicated via DSRC radio to the intersection. The phone's GPS sensors and the DSRC device's GPS sensor, used in combination with landmark beacons installed at the intersection if necessary, will provide a basis for tracking the progress of the user during crossing, and for issuing a request to dynamically extend the green if the user has encountered some difficulty and is moving slower than expected.

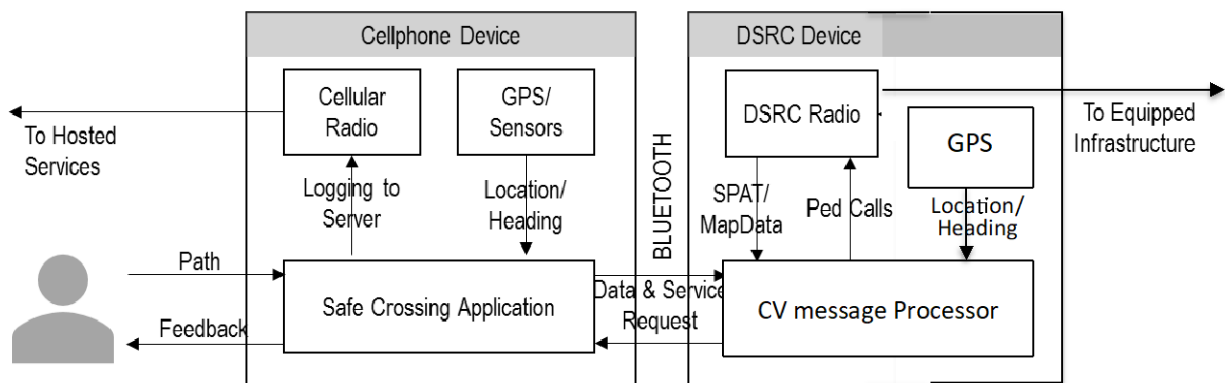

**Figure 3-2: Physical Architecture of the Pedestrian Device Components**

Figure 3-3 shows an example of a cell-phone that can be used as the computation platform and a DSRC-enabled sleeve to allow the device to send System Request Message and receive Signal Phasing and Timing message and MAP. For the purpose of this project and prototype demonstration, an iPhone running the iPhone Operating System (iOS) will be utilized. The DSRC device will be a Leer Locomate ME sleeve, which will communicate with the smartphone via a Bluetooth server.



**Figure 3-3: Proposed Mobile Device**  
(source: www.aradasystems.com)

### 3.2 Intersection Infrastructure Components

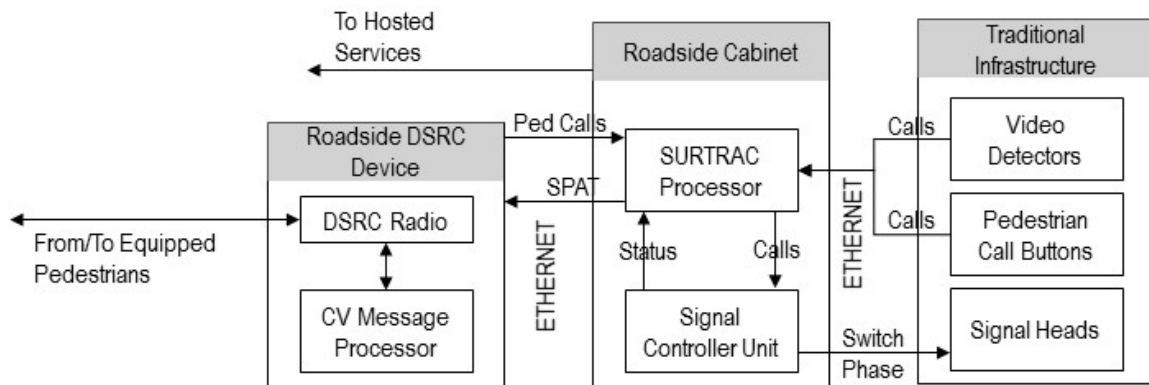

**Figure 3-4: Physical Architecture of the Infrastructure Components**

The pedestrian device will communicate to a suite of infrastructure-based components via Dedicated Short-Range Communication. The physical architecture of the infrastructure system is shown in Figure 3-4. As

shown, the infrastructure components consist of three systems - (a) A DSRC Roadside Equipment (RSE) unit, (b) the Roadside Cabinet containing the SURTRAC processor and (c) the traditional Infrastructure (hardware controller and traffic signals). Communication between the three systems is based on wired Ethernet.

The DSRC-based RSE has several functions – (a) to receive Basic Safety Messages (BSM) from Connected Vehicles and SRMs from pedestrians for integration into SURTRAC’s predictive models of approaching traffic, (b) to broadcast SPaT and MAP messages continuously, and optionally (c) to send an SSM to acknowledge receipt of SRM and whether the request was granted or denied.

Within the Roadside Cabinet, the SURTRAC processor realizes an iterative planning cycle wherein it (1) accepts detector data (from cameras, pedestrian call buttons, and other sensors at the intersection), (2) generates (in real-time) a timing plan for moving currently sensed traffic through the intersection efficiently, (3) issues commands to the Signal Controller (the device that actually drives the signal heads), and (4) communicates predicted outflows to downstream intersections. SURTRAC uses the current timing plan at any point to generate SPaT messages.

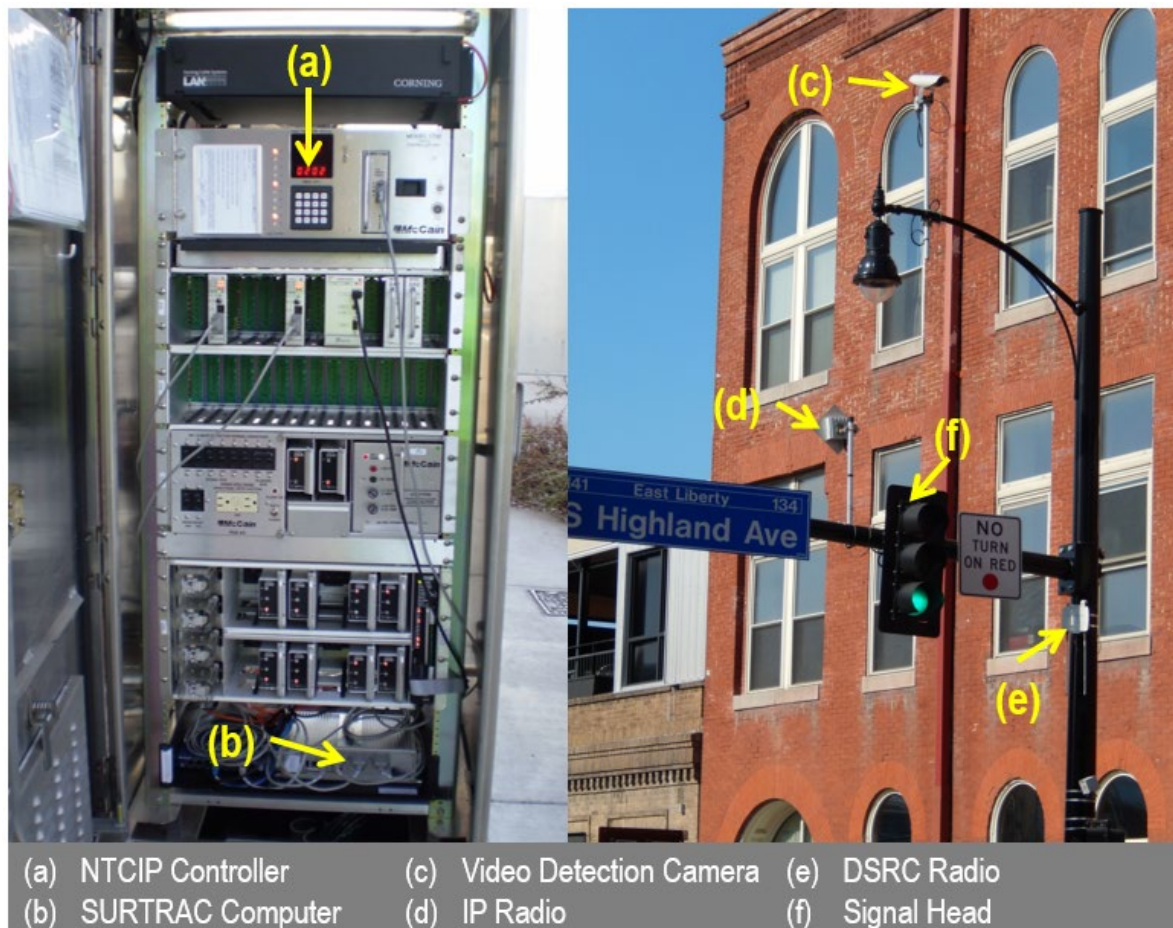

**Figure 3-5: Schematic of Physical Hardware at Equipped Intersection**

Figure 3-5 shows a schematic of the physical hardware at an equipped intersection. The six components shown are: (a) signal controller, (b) SURTRAC computer, (c) Video Detection Camera, (d) IP radio for

communicating with other signal controllers if fiber optic cable connections do not exist, (e) DSRC RSE radio and (f) Signal Head.

### 3.3 DSRC Communication

Communication between the intersection and pedestrian components of the proposed system is achieved using DSRC radios. As indicated above, this communication involves the use of five standard message types:

1. MAP message - The MAP message provides a physical description of the intersection including the number of approach lanes in each direction, the number of left and right turning lanes, the pedestrian sidewalk and crosswalk locations, and their geometric attributes. The MAP message is broadcast once every second and is used in conjunction with the SPaT Data.
2. SPaT – The SPaT message communicates the current active green phase at the intersection, the time remaining in this active phase and the upcoming next active phase. This message is broadcasted every 0.1s.
3. SRM – The SRM is sent by an equipped pedestrian's device to request a right-of-way access through the intersection. In the case of this project, the message will specify the pedestrian's desired crossing direction (or directions if the intent is to get to the diagonal side of the intersection) and the requested crossing duration (which is computed as the pedestrian's travel speed x the width of the road being crossed).
4. SSM – The SSM is emitted by the intersection to acknowledge the receipt of an SRM, and indicate whether the request was granted or denied. In the case that the request has been granted, the SSM also specifies the actual duration that was allocated, given that the signal system may not be able to grant the full requested duration.
5. BSM – Finally, the BSM is emitted every 0.1s by Connected Vehicles to inform the road-side equipment (RSE) and other CVs about the location, speed, and heading of each approaching vehicle. A fourth payload field will be used to additionally specify the vehicle mode (e.g., a bus).

DSRC Messages are assumed to use the current SAE J2735 2016 Standard. Message encoding and decoding takes place at both endpoints of the transmission (i.e., within the SURTRAC Communication module on the infrastructure side and within the smartphone app on the pedestrian side), and the DSRC devices (RSU and Sleeve). DSRC devices generally serve to transport encoded messages between these two software processes.<sup>2</sup> The one exception to this communication scheme is the SPaT message. In this case, the Traffic Signal Controller Broadcast Message (TSCBM) is generated by the Executor module within SURTRAC (with input from the hardware controller) and communicated to the DSRC RSE, which in turn transforms the message content into a well formed, encoded SPaT message and forwards to the DSRC Sleeve. This extended communication framework is depicted in Figure 3-6. (Requirements SR-31, SR-32, SR-33, SR-34, SR-35, SR-36, SR-37

---

<sup>2</sup> Intuitively, it would seem that encoding//decoding would be performed on the DSRC devices themselves. However, after considerable effort, we were unable to find a way to accomplish this on either DSRC device (RSE or Sleeve), When we were finally pointed to open source C code to do the encoding /decoding by Chris Stanley of Leidos , a design decision was made to adapt this code for both the iPhone and Linux programming environments and to put this functionality at the message transmission end points. This open source code is available at (ASN1C: <https://github.com/vlm/asn1c>).

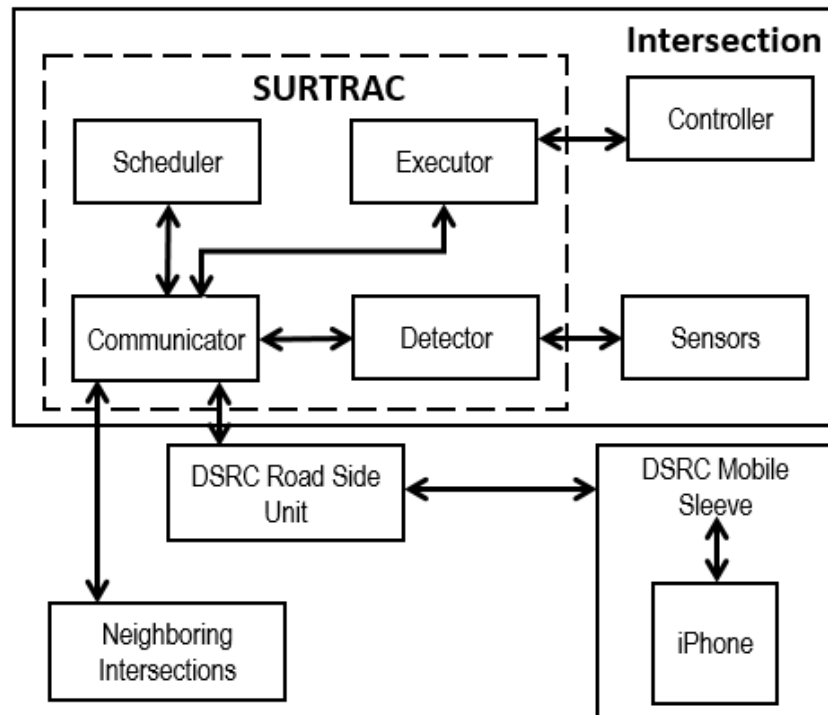
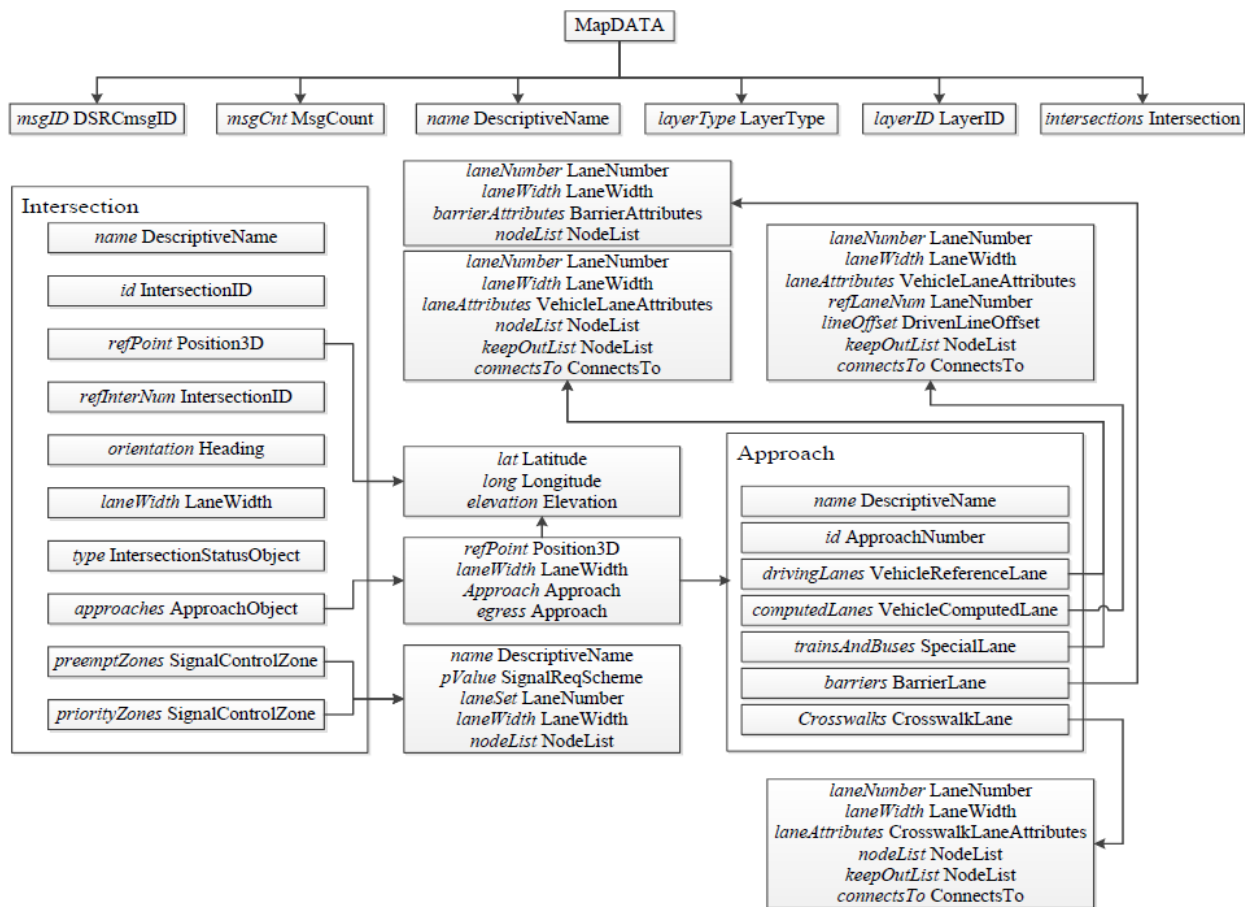

**Figure 3-6: Extended SURTRAC Communication Framework**

In the following sections, we provide more detailed specification of each of these message types.

### 3.3.1 MapData Message

The MapData (or MAP) message is used to provide intersection and roadway lane geometry data for one or more locations (e.g. intersections and fragments of maps). Almost all roadway geometry information as well as roadway attributes (such as where a do not block region exists, or what maneuvers are legally allowed at a given point) are contained in the “generic lane” details of this message. MAP messages are used in intersections to number and describe lane level details of each lane. Figure 3-7 summarizes the overall structure and content of the MAP message schema.



**Figure 3-7: Schema of MapData Message Set**

For our safe intersection crossing application, the MAP message provides the following specific types of information:

- Lane width information for different intersection approaches to enable computation of requested crossing duration in a given direction (see Section 3.3.3 below)
- Street information to enable identification of intersection corners for assistance in orienting the user at the intersection
- Street information to enable user selection of crossing direction
- Signal group IDs for mapping crossing direction to relevant timing information in the SPaT message (see Section 3.3.2 below)

To discuss this information in more detail, consider the example MAP message depicted in Figure 3-8, which gives visual and xml representations of a MAP message that describes the intersection of Melwood Avenue and Centre Avenue in the Pittsburgh East End. A designated reference point (shown as the blue pin at the NE corner) is used to ground the message; all other locations in this MAP messages are aligned to this known <lat, long> location and specified as offsets. Three types of lanes (shown in orange) are specified in the message: vehicle (e.g., 2,3), crosswalk (e.g. 11), and sidewalk (which are labeled in yellow). Sidewalk lanes, as one might expect, designate the pedestrian approaches to the intersection.



```

<MessageFrame e>
  <messageid>18</messageid>
  <value>
    <MapData>
      <messageRevision>1</messageRevision>
      <layerType>IntersectionData/</layerType>
      <layerID>1</layerID>
      <intersections>
        <IntersectionGeometry>
          <name>Centre Ave. | Melwood Ave.</name>
          <id>
            <id>2812</id>
          </id>
          <revision>1</revision>
          <refPoint>
            <lat>404522524</lat>
            <long>799508479</long>
            <elevation>2460</elevation>
          </refPoint>
          <laneWidth>366</laneWidth>
          <laneSet>
            ... A list of lanes, each described as a <Generic Lane>
          </laneSet>
        </IntersectionGeometry>
      </intersections>
    </MapData>
  </value>
</MessageFrame>

```

**Figure 3-8: Visual and XML Representations of the Center Avenue / Melwood Avenue MapData Message<sup>3</sup>**

In the context of use by connected or autonomous vehicles, the names given to various approaches to the intersections are of no particular significance. <lat, long> information and other encoded geometric information are all that is needed to navigate. However, in the safe intersection crossing application, understandable street names are essential for communication with the user and determination of crossing intentions, and hence must be extractable in meaningful form from the MAP message. For this purpose, we adopt the following naming conventions for lanes of type sidewalk:

- A sidewalk's name is a string that consists of sequential components:
  1. the name of the street to the left or right of the sidewalk (the primary name)
  2. vertical bar ("|")
  3. the name of the preceding (or next) cross street (the secondary name). For example, the western sidewalk approaches to Melwood Avenue from Craig Street on Centre Avenue are given the name "Centre Ave. | Craig St".
- The 2 sidewalks that form a given corner of the intersection have start nodes with the same <lat, long>

Using these conventions, the four corners of the intersection can be identified via the following simple 3-step procedure:

1. Collect all lanes of type "sidewalk"

<sup>3</sup> Visualization produced using Leidos ISD Message Creator software: <https://webapp2.connectedvcs.com>

2. Identify sidewalk pairs with the same starting location.
3. Extract the primary names of each sidewalk pair to get the street names for each of these corners

For example, if this procedure is applied to find the lower left intersection corner in the MAP message of Figure 3-8, the following two descriptions can be generated to assist in orienting the user:

- “Centre Ave. is in front, Melwood Ave. is on the right, and Bayard St. is behind”
- “Melwood Ave. is in front, Centre Ave. is on the left, and Craig St. is behind”

From the selected corner, the primary street component of the constituent sidewalk lane names identifies the desired crossing direction, e.g., Centre Ave. and Melwood Ave. respectively in the two choices just given). Once the crossing direction is known, the associated Signal Group ID needed to obtain relevant data from the SPaT message can be found via the algorithm specified in Figure 3-9.

#### To determine the signal group ID:

1. Find the <GenericLane> description for the sidewalk lane whose primary street designates the crossing direction (e.g., “Centre Ave.|Craig St.” for crossing along Centre Ave.)
2. The <connectsTo> subfield will contain a single Connection, which has both the connecting lane ID (e.g., 19) and the Signal Group ID (e.g., 8)

```

<IntersectionGeometry>
  <name>Centre Ave. |Melwood Ave.</name>
  ...
  <laneSet>
    <GenericLane>
      <laneID>12</laneID>
      <name>Centre Ave. |Craig St.</name>
      <ingressApproach>8</ingressApproach>
      <laneAttributes>
        <directionalUse>1</directionalUse>
        <sharedWith/>
        <laneType>
          <sidewalk/>
        </laneType>
      </laneAttributes>
      <nodeList>
        <nodes>
          ... list of <nodes>, whose coordinates delineate the center line of the lane
        </nodes>
      </nodeList>
      <connectsTo>
        <Connection>
          <connectingLane>
            <lane>19</lane>
          </connectingLane>
          <signalGroup>8</signalGroup>
        </Connection>
      </connectsTo>
    </GenericLane>
    ...
  </laneSet>
</IntersectionGeometry>

```

Figure 3-9: Finding the Signal Group ID for A Given Crossing Direction

### 3.3.2 Signal Phase and Timing Message

The SPaT message is used to provide the current SPaT data (i.e., times at which the signal phases are expected to change) for one or more signalized intersections, as well as other time of day status details. All SPaT messages link to MAP messages to convey the roadway details and to link the signal controller phases to the correct set of lanes.. The SPaT message schema is provided below in Figure 3-10.



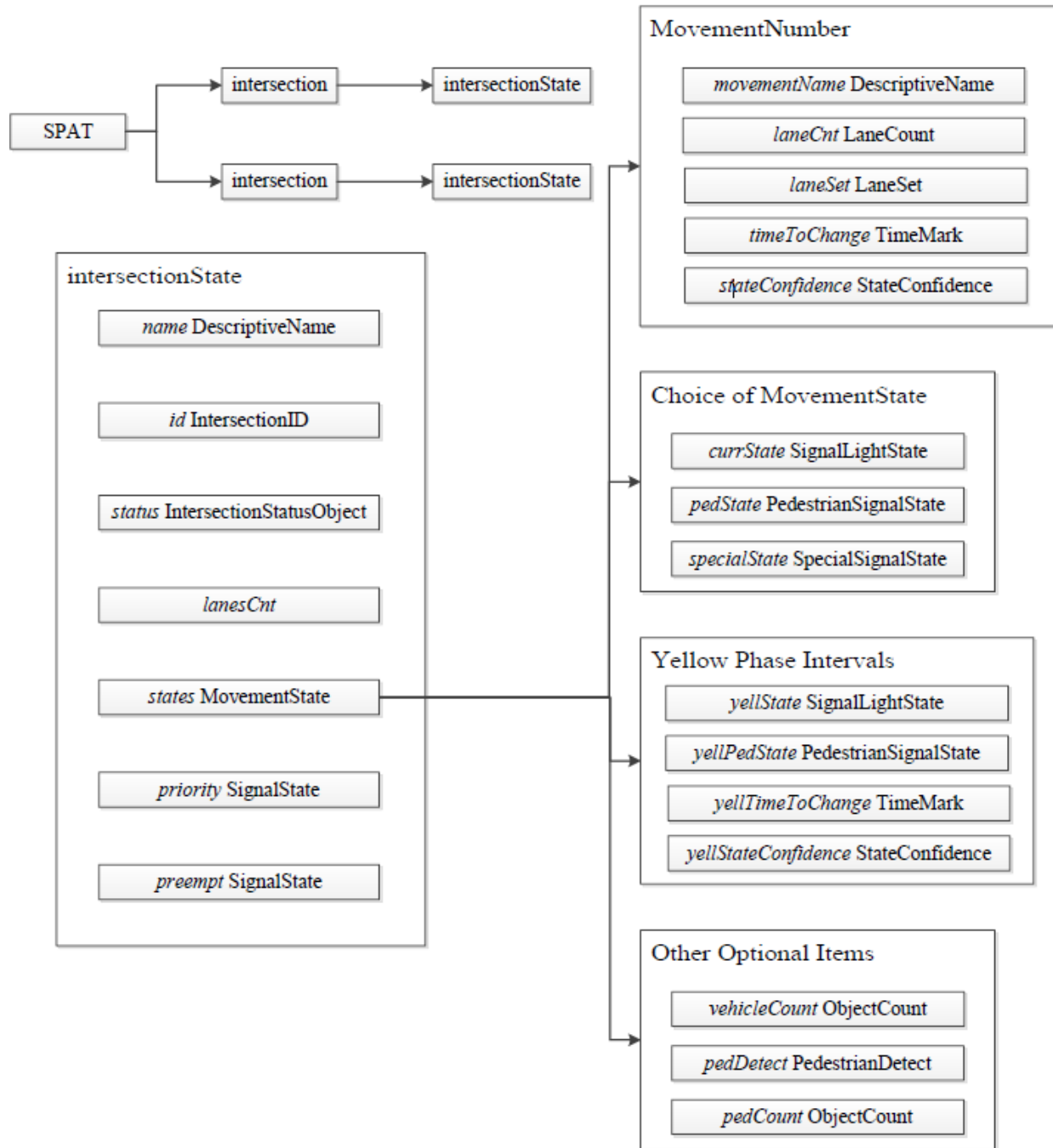

**Figure 3-10: Schema of Signal Phase and Timing Message Dataset**

For purposes of the Safe Intersection Crossing application, we are interested in conveying the time remaining for the crossing direction that is currently green. Continuing to use the example started during the MAP message discussion, the procedure for extracting time remaining from the SPaT message is given in Figure 3-11.

To find the countdown on the SPaT message:

1. In the <states> section of the message, find the <MovementState> entry whose signal group matches the requested signal group ID (e.g., 8)
2. Check that the value of the <eventState> of the entry is **permissive-Movement-Allowed** (i.e., green)
3. The countdown is the value of the <minEndTime> of the entry (e.g., **15000** msec)

```

<SPAT>
  <intersections>
    <IntersectionState>
      <id>
        <id>0</id>
      </id>
      <revision>1</revision>
      <status/>
      <states>
        <MovementState>
          <signalGroup>8</signalGroup>
          <state-time-speed>
            <MovementEvent>
              <eventState><permissive-Movement-Allowed/></eventState>
              <timing>
                <minEndTime>15000</minEndTime>
              </timing>
            </MovementEvent>
          </state-time-speed>
        </MovementState>
        ...
      </states>
    </IntersectionState>
  </intersections>
</SPAT>

```

**Figure 3-11: Retrieving Countdown Information from the SPaT Message**

### 3.3.3 Signal Request Message

The SRM is used by authorized parties (e.g., emergency vehicles) to request services from an intersection signal controller. Vehicles approaching an intersection use this message to affect the signal operation. This is how traditional preemption and priority requests are handled for intersection safety in DSRC. For our Safe Intersection Crossing application, the SRM will be used to request a personalized crossing duration in the specified crossing direction.

To illustrate the relevant information, Figure 3-12(a) provides an example of an SRM in xml format. The request is issued by mobile application (the “requestor”) to the intersection (the “id”), and it specifies both a crossing phase (encoded as a Signal Group ID in the “connection” field of the “in-bound-lane”) and a requested crossing duration in milliseconds (the “duration”). To compute the duration, geometric information from the MAP message is used to determine the crossing distance, and then this is multiplied by personalized rate of speed specified in the mobile application.

```

<MessageFrame>
  <messageId>29</messageId>
  <value>
    <SignalRequestMessage>
      <timeStamp>146256</timeStamp>
      <second>24909</second>
      <requests>
        <SignalRequestPackage>
          <request>
            <id>
              <id>5119</id>
            </id>
            <requestID>90</requestID>
            <requestType><priorityRequest/></requestType>
            <inBoundLane>
              <connection>8</connection>
            </inBoundLane>
          </request>
          <duration>25000</duration>
        </SignalRequestPackage>
      </requests>
      <requestor>
        <id>
          <stationID>45</stationID>
        </id>
      </requestor>
    </SignalRequestMessage>
  </value>
</MessageFrame>

```

(a) SRM Message

```

<MessageFrame>
  <messageId>30</messageId>
  <value>
    <SignalStatusMessage>
      <timeStamp>153459</timeStamp>
      <second>17876</second>
      <status>
        <SignalStatus>
          <sequenceNumber>0</sequenceNumber>
          <id>
            <id>5119</id>
          </id>
          <sigStatus>
            <SignalStatusPackage>
              <requester>
                <id>
                  <stationID>45</stationID>
                </id>
              </requester>
              <request>90</request>
              <sequenceNumber>0</sequenceNumber>
            </SignalStatusPackage>
            <inboundOn>
              <connection>9</connection>
            </inboundOn>
          <status><granted/></status>
        </SignalStatus>
      </SignalStatus>
    </SignalStatusMessage>
  </value>
</MessageFrame>

```

(b) SSM Message

Figure 3-12: SRM and SSM – Message Types

### 3.3.4 Signal Status Message

An SSM sent by the SURTRAC system is used to reflect the outcome of prior requests for service (SRM). This message therefore serves to acknowledge signal requests. Figure 3-12(b) shows the basic structure of the message. The “status” field indicates the outcome of the associated SRM and can take on one of two possible values: granted or rejected. If an SRM is received too late in the current green phase, or the requested extension would violate intersection maximum time constraints, then it may be necessary for the intersection to reject the request.

## 3.4 Interfacing with the Pedestrian

Fundamental to the viability of the proposed safe intersection crossing application is an effective user interface. The user interface must make it easy for the pedestrian to utilize the handheld device to orient herself/himself at the intersection, to communicate the crossing direction without having to manually push the traditional infrastructure pedestrian call button, and to know when it is safe and appropriate to cross. The interface will be developed according to the guidance provided in Section 4E.11 of the Manual of Uniform Traffic Control Devices (2009) and the Institute of Transportation Engineer’s (ITE) Electronic Toolbox for Making Intersections More Accessible for Pedestrians Who are Blind or Visually Impaired, as well as Web Content Accessibility Guidelines (WCAG) and BBC standards and guidelines for mobile accessibility (Requirements SR-2 and SR-

3)The smartphone application, which is the core interface between the pedestrian and the signal control system, will follow universal design principles and be designed for different types of disabilities (Requirement SR-1).<sup>4</sup> It will provide multiple modalities for communicating information, specifically incorporating three types of interfaces: (a) a Visual Interface, (b) an Audible Interface and (c) a Tactile/Haptic Interface. The design of each of these interfaces is defined below.

### 3.4.1 Visual Interface

For pedestrians without a visual disability, a visual interface provides the most straightforward basis for utilizing the mobile app, and the design specified in this section reflects this basic requirement. This interface will be organized into two components:

1. *On-boarding*: This component of the app will be used to gather initial information about the user and to set initial configurations for the mobile app accordingly.
2. *General Use*: This component will comprise the interface required to use the pedestrian crossing capabilities that the mobile app provides. It will provide a basic process for crossing to the user, encompassing steps of orienting and specifying the crossing direction, and indicating when it is time to cross, and also issuing visual alerts and notifications when exceptional conditions such as moving too slow or moving outside of the crosswalk occur. (Requirement SR-8)

In both components, the visual interface will facilitate use in visually difficult lighting situations. (Requirement SR-12).

#### ***On-Boarding Interface:***

The on-boarding interface will let the user input his/her information and preferences regarding types of alerts to issue, types of feedback to provide, and other application settings. In addition, the user will be asked to choose options to designate their crossing speed based on their disabilities. For example, the user can specify the traveler/pedestrian type (e.g. cane traveler, guide dog traveler, wheelchair user, walker user, etc.), which associates a default travel speed, as well as further tune the travel speed that is set in the app. The on-boarding interface will also request user approval of services to be utilized by the app, such as Bluetooth, GPS, RSSI etc.

---

<sup>4</sup> For the current project we intend to de-emphasize cognitive disabilities, since they are particularly unique and challenging. However, our goal is to eventually extend the design to address this segment of individuals.

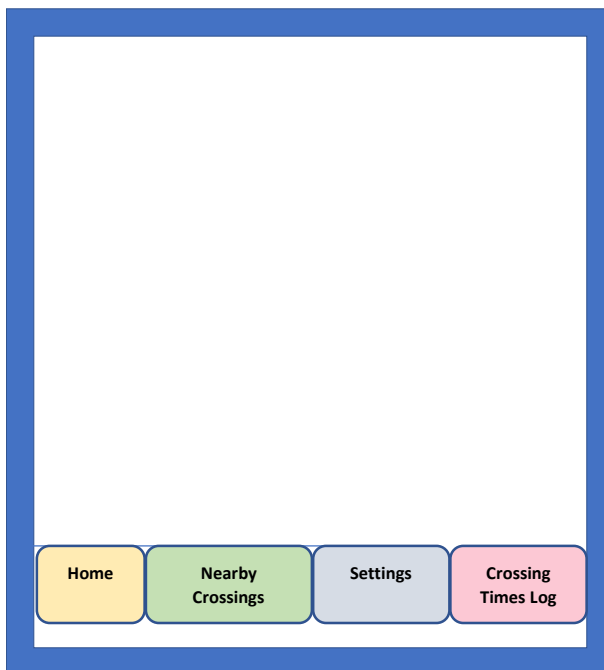

**Figure 3-13: Simple Illustration of the Main Application Interface**

#### ***General Use Interface:***

The general user interface will provide the capabilities necessary to successfully navigate across intersections while promoting safety. The general use interface design assumes a base display with four tabs: (a) Home Tab, (b) Nearby Crossings, (c) Settings and (d) Crossing Times Log, as shown in the Mock-Up display in Figure 3-13. The capabilities provided by each of these tabs (and consequently what visual content appears in the blank space on the mock screen in Figure 3-13) are described in more detail below.

#### **1. Home Tab**

This tab will have basic information about the app and any priority information (e.g. liability, Institutional Review Board (IRB), etc.) that we need to provide to the user each time they use the app. We may also provide a list of instrumented intersections here.

#### **2. Nearby Crossings**

This tab will provide an enumerated list of corners in the nearest intersection being approached by the user. Each corner will be labeled relative to the user. The user will be prompted to choose one of the corners as illustrated below in Figure 3-14(a). Once the user chooses a corner, we prompt the user to choose a street to cross. The choices for the streets to cross will be labeled with both the street name and an updating timer indicating time remaining in the green phase to cross that street Figure 3-14(b).

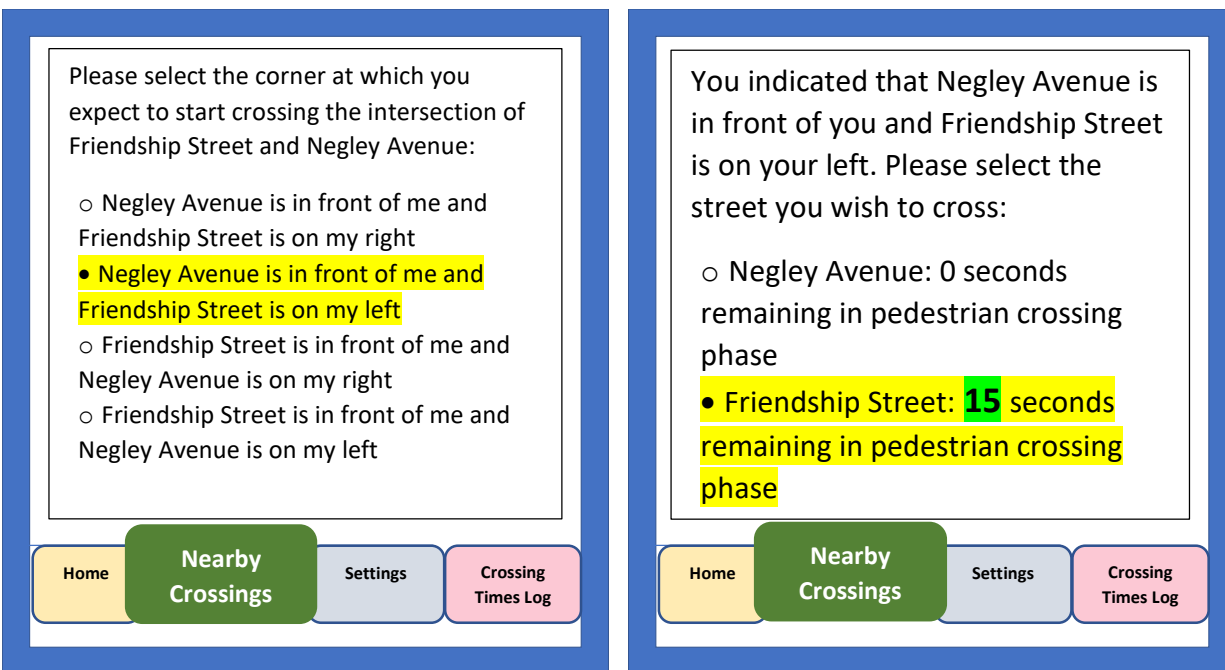

(a) Listing of all Nearby Intersection

(b) Active Pedestrian Phase of Selected Intersection

**Figure 3-14: Selection of Intersections for Crossing**

Once the user has selected both the corner and street, if the geometry and traffic signal phases allow for it, the user will be given a further option to choose to cross straight ahead or diagonally. The diagonal option can be suppressed by the user in the settings based on preference since most blind travelers will not cross an intersection diagonally. Once the user has chosen the corner, street, and direction of crossing, the relevant green phase countdown will be expressed both visually and aurally via the app as shown in Figure 3-15(a). The user will also be presented with two buttons to indicate if they want to start crossing or to cancel that crossing.

Once the user indicates that he or she has begun crossing, the interface presents two buttons to indicate that they either completed that crossing or wish to cancel that crossing for whatever reason as shown in Figure 3-15(b).

Once the user indicates that the crossing is complete, the list of corners will once again be displayed, but will be re-sorted to move previous corner down to the bottom. It also bubbles up the 3 or fewer remaining corners, with the corner that the user is known to be at, as the first.

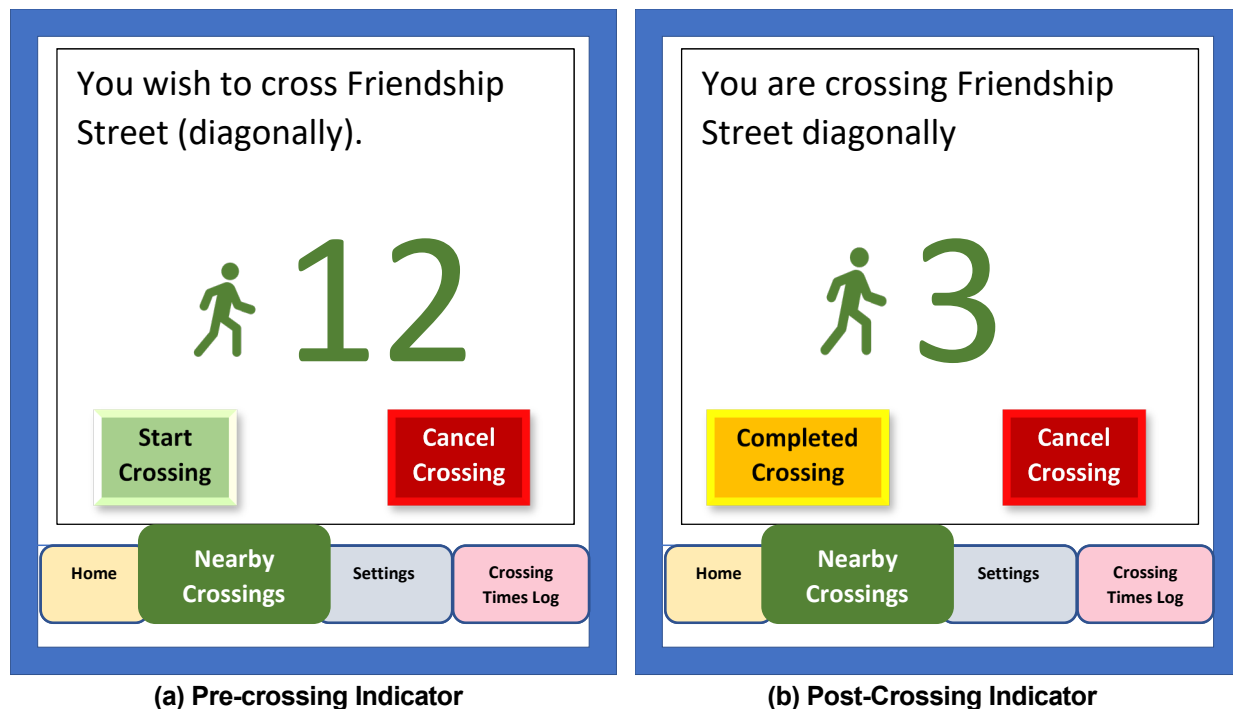

Figure 3-15: User Interface for Pedestrian Crossing Count-down

### 3. Settings Tab:

This tab will provide users with options to change settings relevant to the app. At least three setting options would be provided to users:

1. Re-sort corners list upon successful completion of crossing, on/off (People with some cognitive challenges will prefer to keep the list in a fixed order)
2. Pedestrian speed: low, medium, high, - an initial baseline approach to specifying crossing speed until dynamic tracking (and learning based on this data) is available.
3. Display diagonal crossings, on/off

These options are defined in Section 3.4.4 below.

### 4. Crossing Times Log:

This tab will provide users to see a log of crossings that are done using the app, along with an option to send CSV file of crossings to the application deployment team.

## 3.4.2 Audible Interface

For pedestrians who are blind or visually impaired, the application will also feature an audible interface. To avoid any ambiguity and confusion, the audible interface will be designed based on relevant standards pertaining to pedestrians with disabilities (Requirements SR-2, SR-3, and SR-4). Table 3-1 shows the different speech and tones that the application will produce to interface with the user based on the Manual on Uniform Traffic Control Devices (MUTCD) standards. As shown in the table, audible speech is utilized when there are

multiple crosswalks in the vicinity to avoid ambiguity around which crosswalk sign is on active and inactive sessions.

**Table 3-1. Defined Audible Functions of the Safe Intersection Crossing Application**

	WHEN TO USE?	IT IS UNSAFE TO CROSS THE INTERSECTION	IT IS SAFE TO CROSS THE INTERSECTION
<b>SPEECH</b>	When the crosswalk is less than 10 feet from another crosswalk.	“Wait to cross <street name>” <i>{Volume should automatically adjust to ambient volume; 5 dBA louder than ambient volume, up to 100 dBA.}</i>	“<Street Name>. Walk sign is on to cross <Street Name>”
<b>TONES</b>	When the crosswalk is more than 10 feet from another cross-walk	“Tick-tones at 1/second interval”	“Rapid tick tones with a very brief burst of high-frequency sound at the beginning of walk indication that rapidly decays to 8-10 ticks/second.

Note: dBA= A-weighted decibels

The project team is also considering other open standards such as WayFindr Open Standards etc., to tailor the application response.

### 3.4.3 Haptic Interface

For pedestrians who are blind and deaf as well as for other disabled pedestrians under noisy situations, haptic feedback is a good way to indicate “walk” and “non-walk” signs. The handheld device vibration motors are used for such vibrotactile Walk/Don’t Walk indication. The vibration-based alerts will also be coded into the application interface to replicate the audible tone functionality for such purposes. Hence, the rapid tick-tones and slow tick-tones will indicate walk and don’t-walk signs, respectively. (Requirement SR-9)

### 3.4.4 Current UI-Prototype Design

An initial safe intersection crossing UI-Prototype, which refines the visual mock-up designs summarized in Section 3.4.1 and incorporates standard IOS voice-over libraries to convey information audibly (Requirement SR-4), is shown in Figure 3-16. The “Nearby” tab is visible in these screenshots and the figure conveys the basic intersection crossing process. In brief:

1. As the pedestrian approaches the intersection, the mobile app is suspended, waiting for data. This state generally indicates that the device is currently “off-line” (Requirements SR-26, SR-28, and SR-29)
2. When MAP and SPaT being broadcast from the intersection are first received by the mobile app, the app uses this information to convey crossing choices to the user (in this case, the app takes advantage of the fact that the pedestrian has approached a simple 2-phase intersection, and hence it is not necessary to go through an orienting and corner identification step as in the mock-up presented in Figure 3-15– the mobile app knows this from information contained in the MAP message). The display of crossing options also indicates the current green phase and the time remaining before phase change. (Requirements SR-17, SR-18, SR-38, SR-39, SR-40, SR-46, SR-47, SR-61, SR-63, SR-66, SR-67, SR-68, SR-70, SR-71, SR-92, SR-108, SR-109)
3. When the pedestrian selects crossing direction, the mobile app automatically issues an SRM to the intersection and begins to display time remaining in the crossing direction. If the request were for a



future phase, then the mobile app displays and /or announces “DON’T CROSS” indicating that the pedestrian should wait. When the crossing direction eventually gets the green, the mobile app alerts the user that it is “OK TO CROSS”.(Requirements SR-57, SR-59, SR-60, SR-62, SR-63, SR-70, SR-71, SR-76)

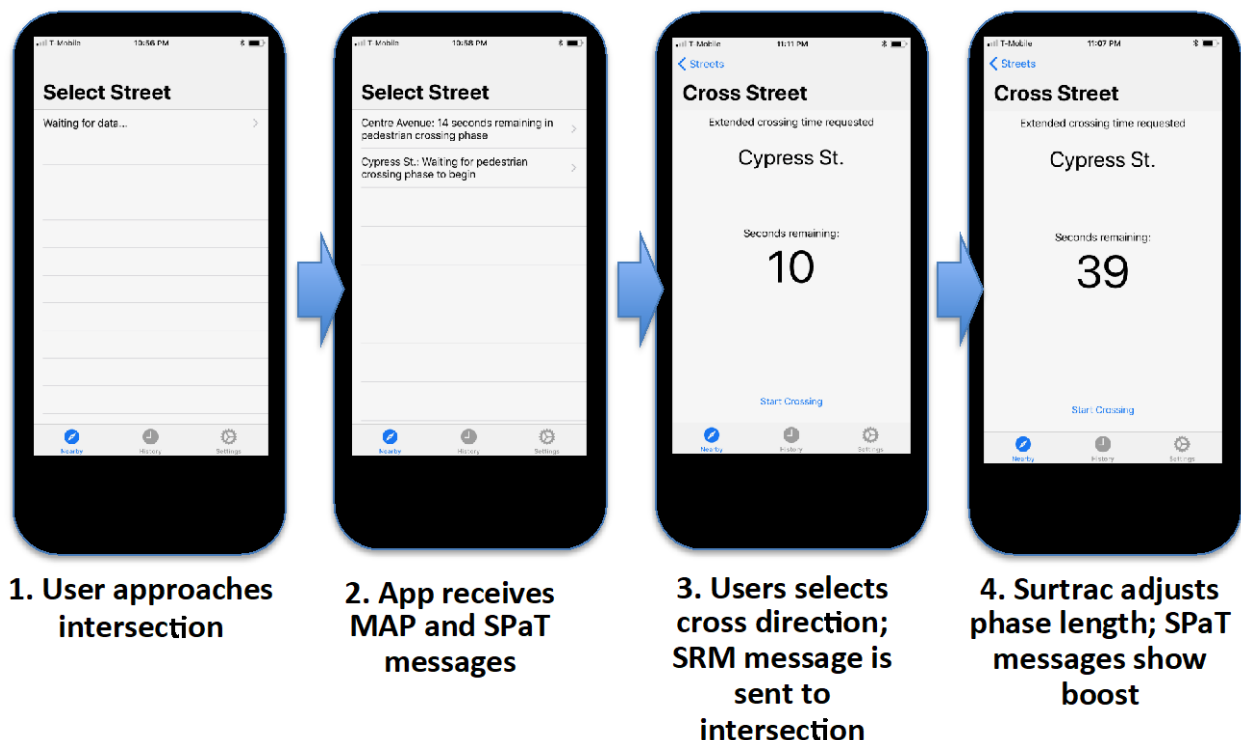

**Figure 3-16: Initial UI Prototype Crossing Process**

4. After Surtrac processes the request and adjusts the phase length, this boost in crossing time is reflected in subsequent SPaT messages and the time remaining is increased. (Requirements SR-72, SR-73,
5. When ready, the pedestrian clicks “Start Crossing” and begins to cross. When the pedestrian is across, “Crossing Completed” is clicked and the history is updated.<sup>5</sup> (Requirement SR-30)

The full intersection-crossing process implemented in the mobile app follows the design specified in the state transition graph depicted in Figure 3-17. One option specified in this transition graph is to navigate back to the “Select Street to Cross” screen, effectively canceling the prior request (Requirement SR-21), and of course it is possible to turn the app completely off (Requirement SR-22).

<sup>5</sup> Once we incorporate the ability to dynamically detect location information, we anticipate that there will no longer be a need for the user to input “Start Crossing” and “Crossing Completed” information and that these buttons will be removed from the interface.

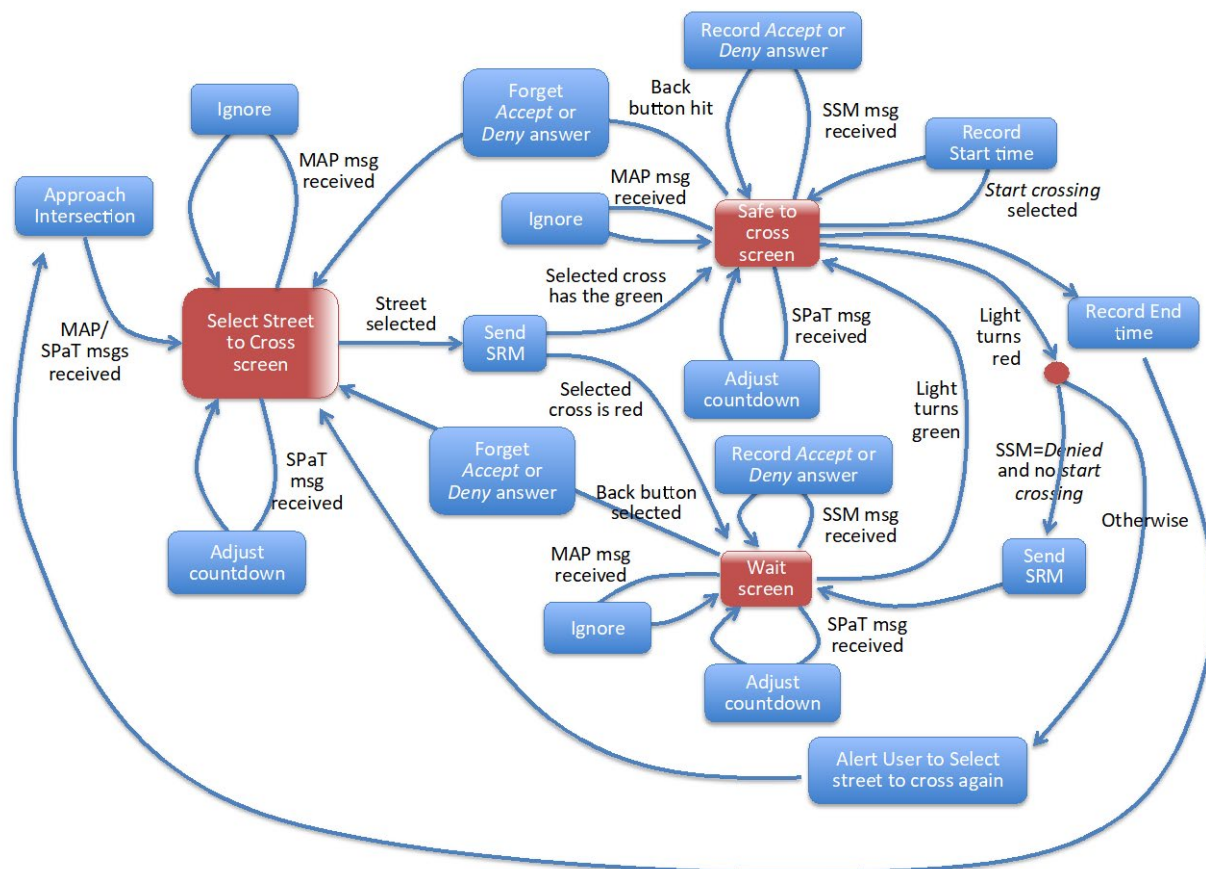

Figure 3-17: Mobile App state transition graph

The mobile app also provides a number of user configuration options designed to personalize the app to the pedestrian user. Figure 3-18 displays the app's current "Settings" screen, which illustrates a number of customization options:

- **Travel speed** – As a baseline, the app allows you (as the user) to adopt one of several personas (e.g., walk with cane, guide dog, wheelchair (motorized or not), deaf, etc.). Each of these personas has an associated nominal speed that can be combined with the crossing distance obtained from the MAP message to compute a requested duration. This baseline can be further tuned to fit current circumstances (e.g., weather, type of shoes, etc.) by adjusting the "crossing speed". (Requirement SR-113)
- **Diagonal Crossing** – For intersections that exhibit an "all-ped" phase, there is an option of whether the user would like to consider diagonal crossings or have those options filtered out. A second related option specifies whether the user would like options resorted upon completion of a cross to push the option in the direction of an original diagonal crossing to the top (and making it easier for a user with visual impairment).

- Device orientation – Some users will prefer the orientation of the display to adjust (from vertical to horizontal and vice versa) as the mobile device is manipulated, whereas others will prefer that the orientation be fixed.
- Voiceover (VO) – Through the iPhone’s native “settings” interface, the user can enable voiceover and set the voice speed to match their preference (Requirements SR-5, SR-7)
- Font sizing – The iPhones native “settings” interface can also be used to adjust the font sizes used within the mobile app.
- Verbosity – Although not shown in the version of the settings screen in Figure 3-18, the frequency at which the countdown of the time remaining within the “Cross Street” screen is announced if VO is enabled can be adjusted. By default, the count is announced in VO mode every 5 seconds, to be compatible with slow speed VO settings (Requirements SR-6, SR-14, SR-19). The system will also have the ability to vary the amount of information provided based on the user’s familiarity with the area (Requirement SR-20).

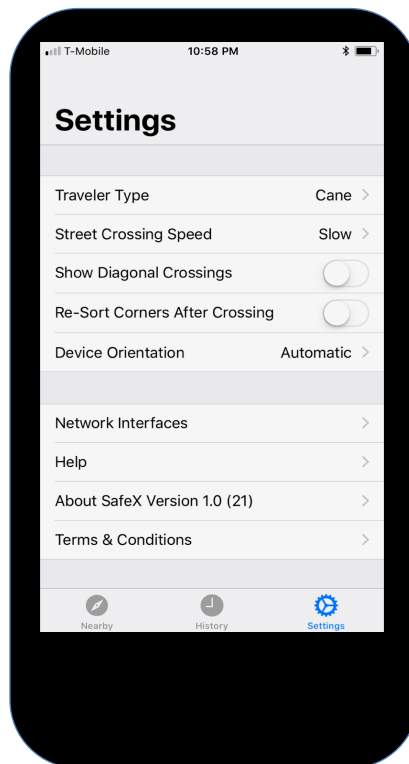

Figure 3-18: Current Mobile App Settings Screen.

## 3.5 Interfacing with SURTRAC

On the intersection side, the safe intersection crossing application also requires extension to the SURTRAC traffic signal control system. The most important consideration is how to handle generation of SPaT messages. Since SURTRAC is a real-time adaptive traffic signal system, it acts to extend or terminate the current green phase on a second by second basis, based on continual re-generation of timing plans that reflect current sensed traffic. Hence, unlike the case of a conventional traffic signal control system, the definition of remaining

time in the current green phase (for inclusion in SPaT messages) is generally not well-defined and must instead be estimated (or predicted).

In general, this is a hard problem, but in the current context we can take advantage of the fact that the pedestrian is requesting a minimum crossing time to simplify the solution. In particular, the SPaT message requires specification of minimum and maximum phase ending times, and we can use the fact that the crossing duration requested by the pedestrian is to be treated as a new phase minimum constraint to ensure that the remaining time will never be less than required. It is of course possible that the actual phase end will be greater than this minimum. Consequently, the countdown of remaining time conveyed by SPaT messages over time can increase (as SURTRAC determines that due to the current sensed traffic it should further extend the current phase), but it will never decrease.

Currently, to better synchronize with the Pedestrian walk signals, SURTRAC uses its generated plans to predict when the phase is likely to end. Specifically, when the generated timing plan during any planning cycle predicts a phase change that is sooner than the fixed time required for the “flashing don’t walk” signal, SURTRAC will trigger the “flashing don’t walk” on assumption that the phase end is near.

A second complication with regard to the extensions required to the SURTRAC system stem from the fact that the City of Pittsburgh (our field test site) is currently standardized on McCain 170 controllers, which do not follow NTCIP protocols and have a non-standard interface. Whereas SURTRAC interfaces with NTCIP controllers and issues SPaT messages via the standard Traffic Signal Controller Broadcast Message (TSCBM) provided by the controller, this approach must be implemented in a customized manner in the case of the 170s. We are taking this approach and extending the Executor module of the SURTRAC system to provide the necessary interface to the Wapiti firmware that is used by the McCain170 Controllers currently in service.

Finally, it is necessary to define the semantics for responding to a given SRM. If the request is for a future phase, then the minimum green time for that phase needs to be overridden with the request on the next green cycle. If the request is for the current green phase the situation is more complex. In this case SURTRAC must determine whether enough green time exists to reasonably extend this cycle, or whether the pedestrian should be asked to wait until the next green cycle. The behavior to be implemented in the Year 1 prototype is specified in Figure 3.18.

In Figure 3-18, we make the following assumptions:

- *cutoff* represents some rule for deciding when it is too late in the phase to grant an accept. It could be the beginning of the flashing don’t walk period, or the time at which Surtrac’s prediction of end of phase kicks in and starts the transition to the next phase.
- SRM priority indicates whether the user has already started crossing (high) or has not yet started (low)
- We assume that the user is not alerted if the duration granted < requested duration; the user will see the change in the SPaT countdown.
- PhaseMin(*p,t*) is reset to the system default at the end of each green phase *p*
- *t* is used to index the current cycle - future phases are designated as occurring on cycle *t+1*; when a phase turns green the cycle = *t*

## 3.6 Monitoring Crossing Progress

The second basic capability proposed for year one of the project involves monitoring of the user’s progress as s/he moves across the intersection. Given knowledge of the requested crossing duration of the user and some

ability to determine the location of the device, the app should be able to infer whether the user has encountered an unexpected obstacle or otherwise is crossing at a pace slower than expected. If the app detects this situation, then the desired reaction is to send an SRM requesting that the intersection dynamically extend the green for some period to allow the user to safely complete the crossing. Secondly, the app should be capable of alerting the user if s/he moves out side of the crosswalk.

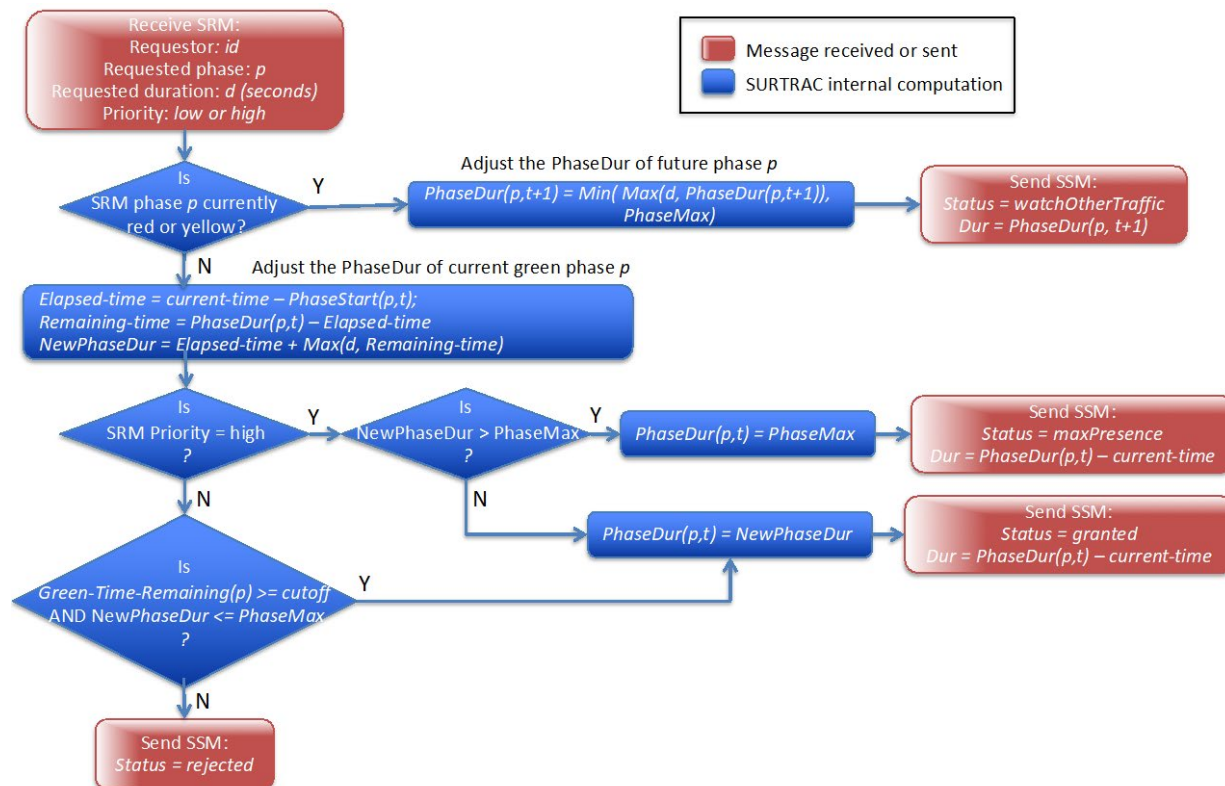

Figure 3-18: Algorithm for SURTRAC response to an SRM – General case of multiple simultaneous requests

The principal challenge to providing this capability is localization accuracy. Whereas both the iPhone8 and the Arada Locmate ME sleeve have independent GPS-based localization capabilities, it is well known that GPS accuracy can be less than satisfactory and is generally rated at no better than +/-1 meter accuracy. Although initial tests of the iPhone8 localization accuracy at the intersection currently planned for the Year 1 evaluation have actually yielded satisfactory results and may be sufficient for demonstration of the year 1 prototype, a better solution is required to make the app generally applicable in practice.

To boost localization accuracy of the smartphone, we have considered the following possibilities:

- Use of Bluetooth beacons – In [Lao 2013], the use of two or more Bluetooth beacons were used to boost the accuracy of a mobile phone and enable some amount of tracking of pedestrians through the intersection. Under this approach, the known fixed locations of the beacons provide some error correcting capability. However, although the results were effective at the time the work was done, it turns out that the resulting accuracy obtained was about +/- 1 meter accuracy, which is basically equivalent to the accuracy of current day smartphones. Hence, it is not clear how much additional improvement will be possible through addition of beacons. As a second more general argument against this approach, Bluetooth technology is nearing the end of its lifetime and it perhaps it makes sense to find a more forward-looking approach.

- DSRC-based correction – A second possible approach is provided by the RTCM Corrections DSRC message, which is designed to take an OBU GPS reading that has been communicated to the RSU and provide location correction information back to the OBU based on the RSU connectivity to an absolute satellite location. There is a grouping network of access points nationwide, and several in the Pittsburgh area. Although the approach has been rejected by some urban areas (e.g., New York City) it is still under consideration in other areas of the country (e.g., California). Unfortunately for our purposes here, this approach requires the mobile device to utilize a particular, large antenna, which does not fit well with the profile of the Mobile App device...
- Utilization of multiple GPS readings – A third recent branch of research (e.g., [Hedgecock et. al 2013, Schrader et. al 2012]) has considered the potential of combining multiple independent GPS readings to improve location accuracy. This approach seems particularly relevant given that both the DSRC sleeve and the iPhone have GPS sensors and hence two simultaneous independent readings should be easily obtainable. In [Hedgecock et. al 2013] it is demonstrated (using raw GPS readings) that integration of two sensors can yield cm-level accuracy, although the conditions under which these results were obtained are not exactly the same as the current context. Nonetheless, this option is currently deemed as the best possibility and is the approach that we are currently pursuing.

Incorporation of pedestrian progress monitoring also requires extension to the mobile app design. Suppose that a sufficiently accurate localization capability has been established and validated (using one of the approaches outlined above). This capability will then be incorporated into the app to enable the following:

- Start and stop times of pedestrian crossings – Most basically, localization will be used to detect when a pedestrian starts to cross and completes a crossing, eliminating the need for the user to tap this information into the app as in the initial prototype. These “Start Crossing” and “Crossing Completed” times, together with the pedestrian’s specified speed and the width of the crossing, provides the basic information required for monitoring. (Requirements SR-42, SR-47, SR-90, SR-91, SR-93)
- Detecting slow progress – Given the pedestrian’s expected speed, the width of the crossing and crossing start time, the app can determine whether the pedestrian is moving faster or slower than expected at any intermediate location. Accordingly, the app will periodically query the pedestrian’s current location, and if the progress being made falls below a specified threshold, an SRM will be issued to dynamically extend the green for an additional amount of time equivalent the time that would be required to cross if the pedestrian continues at his/her current crossing speed. (Requirements SR-13, SR-77, SR-78, SR-79, SR-80, SR-82, SR-84, SR-85, SR-94)
- Detecting movement outside of the crosswalk – A third capability that is made possible by a sufficiently accurate localization capability is that of detecting movement outside of the crosswalk. To provide this capability, it will be necessary to extend the intersection MAP message to include crosswalk width information. Once this is done, localization can be used to detect this condition. If detected, the app will issue an alert to the user (both visually and audibly) that indicates the appropriate recovery action. (Requirements SR-43, SR-44, SR-53, SR-54, SR-65, SR-81, SR-86, SR-87, SR-95)

## 3.7 Using Information about Pedestrian Routes, Real-Time Bus Arrival Times and the Built Infrastructure

The design of capabilities to anticipate pedestrian arrival at intersections using route information (Requirements SR-58, SR-64, SR-65, SR-69, SR-74 SR-104), to synchronize getting pedestrians to desired bus routes with real-time bus arrival information, and to support navigation of the user to and through the crosswalk at an intersection based on information about the built environment (Requirements SR-48, SR-49, SR-50, SR-51, SR-52, SR-55, SR-56, SR-89), will be elaborated in the Phase 2 version of this document. The

design of additional advanced user interface capabilities will also be specified at this time. (Requirements SR-20, SR-23, SR-24, SR-25)

## 4 Acronyms

<b>Acronym</b>	<b>Description</b>
ATTRI	Accessible Transportation Technology Research Initiative
BSM	Basic Safety Message
CMU	Carnegie Melon University
ConOps	Concept of Operations
CSV	Comma Separated Values
CV	Connected Vehicles
dBA	A-weighted decibels
DSRC	Dedicated Short Range Communication
EVP	Emergency Vehicle Preemption
GIS	Geospatial Information System
GPS	Global Positioning Systems)
iOS	iPhone Operating System
IRB	Institutional Review Board
ITE	Institute of Transportation Engineers
ITS-JPO	Intelligent Transportation Systems - Joint Program Office
JSON	JavaScript Object Notation
MAP	Map Data
MUTCD	Manual of Uniform Traffic Control Devices
NEMA	North Electrical Manufacturers Association
NTCIP	National Transportation Communications for Intelligent Transportation Systems (ITS) Protocol
RSE	Road-Side Equipment
RSSI	Relative Signal Strength Indicator
RSU	Roadside Unit
SAE	Society of Automotive Engineers
SPaT	Signal Phase and Timing
SRM	Signal Request Message
SSM	Signal Status Message
SURTRAC	Scalable Urban Traffic Control
TSCBM	Traffic Signal Controller Broadcast Message
TSP	Transit Signal Priority
UI	User Interface

U.S. Department of Transportation  
Intelligent Transportation System Joint Program Office



#### 4. Acronyms

<b>Acronym</b>	<b>Description</b>
USDOT	United States Department of Transportation
WAS	WAVE Service Announcement
WAVE	Wireless Access in Vehicular Environments

# 5 References

1. Connecting Pedestrians with Disabilities to Adaptive Signal Control for Safe Intersection Crossing and Enhanced Mobility: Concept of Operations (ConOps)
2. IEEE Std. 1233 – IEEE Guide for Developing System Requirements Specifications
3. INCOSE Systems Engineering Handbook version
4. Real-Time Adaptive Traffic Signal Control for Urban Road Networks: The East Liberty Pilot Test, Stephen F. Smith, Gregory J. Barlow, Xiao-Feng, Zachary B. Rubinstein, Technical Report, July 2013
5. Smart Urban Signal Networks: Initial Application of the SURTRAC Adaptive Traffic Signal Control System, Stephen F. Smith, Gregory J. Barlow, Xiao-Feng Xie, Zachary B. Rubinstein, *Proceedings 23rd International Conference on Automated Planning and Scheduling*, Rome, Italy, June 2013.
6. Schedule-Driven Coordination for Real-Time Traffic Network Control, , Xiao-Feng Xie, Stephen F. Smith, and Gregory J. Barlow, *Proceedings 22nd International Conference on Automated Planning and Scheduling*, Atibaia, Sao Paulo, Brazil, June 2012.
7. Schedule-Driven Intersection Control, Xiao-Feng Xie, Stephen F. Smith, Liang Lu and Gregory J. Barlow, *Transportation Research Part C: Emerging Technologies*, 24: 168-189, October 2012.
8. IEEE 1609.2 Standard for Wireless Access in Vehicular Environments (WAVE) - Security Services for Applications and Management Messages. Note: This standard defines three types of end entities, or potential certificate holders: Identified, Identified Not Localized, and WAVE Service Announcement (WSA) Signer. It says that future versions of this standard will also define end entities of type Anonymous.
9. IEEE 1609.4 Standard for Wireless Access in Vehicular Environments (WAVE) - MultiChannel Operations
10. SAE J2735 Standard specifying Dedicated Short Range Communications (DSRC) message set dictionary
11. IEEE 802.11p Standard to add wireless access in vehicular environments (WAVE), adding enhancement required to support Intelligent Transportation Systems (ITS) applications.
12. Web Content Accessibility Guidelines (WCAG): <https://www.w3.org/WAI/intro/wcag>
13. BBC Standards and Guidelines for Mobile Accessibility: <http://www.bbc.co.uk/guidelines/futuremedia/accessibility/mobile>
14. Using a Smartphone Application to Support Visually Impaired Pedestrians at Signalized Intersection Crossings, Chen-Fu Laio, *Transportation Research Record*, No. 2393, 2013.
15. High-Accuracy Differential Tracking of Low-Cost GPS Receivers, Will Hedgecock, Miklos Maroti, Janos Sallai, Peter Volgyesi, and Akos, Ledecz, *Mobi Sys '13*, Taipei Taiwan, June 2013.
16. Combining Multiple, Inexpensive GPS Receivers to Improve Accuracy and Reliability, Daniel K. Schrader, Byung-Cheol Min, Eric T. Matson, and J. Eric Dietz *IEEE Conference*, 2012.

# 6 Requirements Traceability Matrix

Note: The system here is referred to the overall system developed by the team that will make the safe intersection crossing possible. This system consists of two major subsystems: the Mobile Subsystem and the SURTRAC2 Subsystem.

- The **Mobile Subsystem** includes the mobile app and DSRC extension attached to the smartphone that the pedestrian will hold and utilize for assistance. That is the subsystem that the user directly interfaces with.
- The **SURTRAC2 Subsystem** includes all the hardware and software that interacts with the intersection signal system and will be installed at or near the signal system at the intersection. That is the unit that interacts with both the intersection signal system and the Mobile Subsystem. The SURTRAC2 Subsystem will be a revised version of the SURTRAC system that CMU previously developed.

Req. ID	Requirement Description	Source of the Requirement	Requirement Category	Verification Method	System Architecture Subsystem	Current Status
SR-1	The mobile system shall provide accessible interfaces and content that follows universal design standards.	ConOps/ Chapter 5/ Operational Policies and Constraints	Interface Requirement	Demonstration	Mobile Subsystem	SATISFIED
SR-2	The mobile system shall provide accessible interfaces and content that follows Web Content Accessibility Guidelines (WCAG)	System Requirements Analysis Discussions	Interface Requirement	Demonstration	Mobile Subsystem	SATISFIED
SR-3	The mobile system shall provide accessible interfaces and content that follows BBC Standards and Guidelines for Mobile Accessibility.	System Requirements Analysis Discussions	Interface Requirement	Demonstration	Mobile Subsystem	SATISFIED

6. Requirements Traceability Matrix

Req. ID	Requirement Description	Source of the Requirement	Requirement Category	Verification Method	System Architecture Subsystem	Current Status
SR-4	The mobile system should follow Apple's recommended advice on accessible app.	System Requirements Analysis Discussions	Interface Requirement	Demonstration	Mobile Subsystem	SATISFIED
SR-5	The mobile system shall have audio components to provide audible notifications and alerts.	ConOps / Operational Scenarios/ Desired Design Features/ Table 1	Interface Requirement	Inspection	Mobile Subsystem	In progress – Voice over is operational and some alerting is in place
SR-6	The mobile system shall have the option of reducing the narration speed when delivering aural (ear or hearing) information.	ConOps / Operational Scenarios/ Desired Design Features/ Table 1	Interface Requirement	Inspection	Mobile Subsystem	SATISFIED
SR-7	The mobile system shall be capable of providing mono aural information.	ConOps / Operational Scenarios/ Desired Design Features/ Table 1	Interface Requirement	Demonstration	Mobile Subsystem	SATISFIED
SR-8	The mobile system shall be capable of flashing visual alerts and notifications.	ConOps / Operational Scenarios/ Desired Design Features/ Table 1	Interface Requirement	Demonstration	Mobile Subsystem	NOT DONE YET
SR-9	The mobile system shall be capable of providing tactile (vibration) alerts and notifications.	ConOps / Operational Scenarios/ Desired Design Features/ Table 1	Interface Requirement	Demonstration	Mobile Subsystem	NOT DONE YET
SR-10	The mobile system shall have the option of delivering visual information slowly.	ConOps / Operational Scenarios/ Desired Design Features/ Table 1	Interface Requirement	Inspection	Mobile Subsystem	SATISFIED by default – This capability has been designed out

6. Requirements Traceability Matrix

Req. ID	Requirement Description	Source of the Requirement	Requirement Category	Verification Method	System Architecture Subsystem	Current Status
SR-11	The mobile system shall have the option of repeating visual information when needed (i.e. requested by user).	ConOps / Operational Scenarios/ Use Case 13	Interface Requirement	Inspection	Mobile Subsystem	SATISFIED by default – This capability has been designed out.
SR-12	The mobile system shall facilitate visual interface (reading of the instructions, etc.) in visually difficult situations (e.g. bright light, dark, etc.)	ConOps / Operational Scenarios/ Desired Design Features/ Table 1	Interface Requirement	Inspection	Mobile Subsystem	SATISFIED
SR-13	The mobile system should be capable of providing the user with confirmation throughout tasks.	ConOps / Operational Scenarios/ Desired Design Features/ Table 1	Interface Requirement	Demonstration	Mobile Subsystem	In Progress
SR-14	The mobile system shall provide the option to the user for adjusting (i.e. reducing or increasing) the amount of notifications user receives.	ConOps / Operational Scenarios/ Desired Design Features/ Table 1	Interface Requirement	Demonstration	Mobile Subsystem	NOT DONE YET
SR-15	The mobile system shall be able to receive commands (e.g., crossing direction) from a user through text input.	ConOps/ Operational Scenarios/ Use Case 1	Interface Requirement	Demonstration	Mobile Subsystem	SATISFIED by default – This capability has been designed out
SR-16	The mobile system shall be able to receive commands from the user through voice communication	ConOps / Operational Scenarios/ Desired Design Features/ Table 1	Interface Requirement	Demonstration	Mobile Subsystem	Limited – Siri can be used to start up the app but that's it wrt voice commands.

6. Requirements Traceability Matrix

Req. ID	Requirement Description	Source of the Requirement	Requirement Category	Verification Method	System Architecture Subsystem	Current Status
SR-17	The mobile system shall be capable of announcing upcoming task or step.	ConOps / Operational Scenarios/ Desired Design Features/ Table 1	Interface Requirement	Demonstration	Mobile Subsystem	SATISFIED
SR-18	The mobile system should be capable of displaying upcoming task or step with text descriptions.	ConOps / Operational Scenarios/ Desired Design Features/ Table 1	Interface Requirement	Demonstration	Mobile Subsystem	SATISFIED
SR-19	The mobile system shall be able to adjust level of assistance based on user profile (e.g., disability type).	ConOps / Chapter 4/ Description of Desired Changes	Interface Requirement	Demonstration	Mobile Subsystem	SATISFIED
SR-20	The mobile system shall have the option of choosing the level of assistance (e.g., verbosity) based on familiarity of the user with the area.	ConOps / Chapter 4/ Description of Desired Changes	Interface Requirement	Demonstration	Mobile Subsystem	NOT DONE YET – Deferred to Year 2
SR-21	The mobile system shall provide the user with an option to cancel receiving directions and alerts.	ConOps / Operational Scenarios/ Use Case 14	Functional Requirement	Demonstration	Mobile Subsystem	SATISFIED – User can hit the back button for this effect the (actually called “streets”)
SR-22	The mobile system shall have the option to be completely turned off.	ConOps / Operational Scenarios/ Use Case 14	Functional Requirement	Demonstration	Mobile Subsystem	SATISFIED
SR-23	The mobile system shall have the option of providing direction using clock position.	ConOps / Chapter 4/ Description of Desired Changes	Functional Requirement	Demonstration	Mobile Subsystem	NOT DONE YET – Year 2 capability

6. Requirements Traceability Matrix

Req. ID	Requirement Description	Source of the Requirement	Requirement Category	Verification Method	System Architecture Subsystem	Current Status
SR-24	The mobile system shall have the option of providing cardinal directions.	ConOps / Operational Scenarios/ Desired Design Features/Table 1	Interface Requirement	Demonstration	Mobile Subsystem	NOT DONE YET – Year 2 capability
SR-25	The mobile system should have the option of providing relative directions (e.g. left, right, behind, in front of).	ConOps / Operational Scenarios/ Desired Design Features/ Table 1	Interface Requirement	Demonstration	Mobile Subsystem	NOT DONE YET – Year 2 capability
SR-26	The mobile system shall be capable of recognizing when there is no connectivity with the intersection (e.g., traffic signal mobile system).	ConOps / Operational Scenarios/ Use Case 5	Functional Requirement	Formal Test	Mobile Subsystem	SATISFIED -
SR-27	The SURTRAC2 system shall be capable of recognizing when there is no connectivity with the traffic signal system.	ConOps / Operational Scenarios/ Use Case 5	Functional Requirement	Formal Test	SURTRAC2 Subsystem	SATISFIED by default – this capability has been designed out
SR-28	The mobile system shall be capable of communicating "no connectivity with the intersection", with the user.	ConOps / Operational Scenarios/ Use Case 5	Functional Requirement	Formal Test	Mobile Subsystem	SATISFIED
SR-29	The SURTRAC2 system shall be capable of communicating "no connectivity with the signal system", with the mobile system.	ConOps / Operational Scenarios/ Use Case 5	Functional Requirement	Formal Test	SURTRAC2 Subsystem	NOT DONE YET

6. Requirements Traceability Matrix

Req. ID	Requirement Description	Source of the Requirement	Requirement Category	Verification Method	System Architecture Subsystem	Current Status
SR-30	The mobile system shall have an option for the user to communicate his progress in case of unreliable or unavailable GPS.	ConOps /Chapter 8/ Acquisition and incorporation of personalized crossing constraints	Functional Requirement	Demonstration	Mobile Subsystem	SATISFIED minimally - the pedestrian can push crossing complete button when he finishes his crossing.
SR-31	The mobile system shall be capable of communicating with the SURTRAC2 system.	ConOps / Operational Scenarios/ Use Case 1	Interface Requirement	Formal Test	Mobile Subsystem	SATISFIED
SR-32	The SURTRAC2 system shall be capable of communicating with a traffic signal system.	ConOps / Operational Scenarios/ Use Case 1	Interface Requirement	Formal Test	SURTRAC2 Subsystem	SATISFIED
SR-33	The mobile system shall be able to collect the signal phase and timing data from the SURTRAC2 system	ConOps / Operational Scenarios/ Use Case 1	Interface Requirement	Formal Test	Mobile Subsystem	SATISFIED
SR-34	The SURTRAC2 system shall be able to collect the signal phase and timing data from the intersection signal system.	ConOps / Operational Scenarios/ Use Case 1	Interface Requirement	Formal Test	SURTRAC2 Subsystem	SATISFIED
SR-35	The SURTRAC2 system shall be able to interact with the traffic signal system to influence signal timing and duration.	ConOps / Operational Scenarios/ Use Case 1	Interface Requirement	Formal Test	SURTRAC2 Subsystem	SATISFIED
SR-36	The mobile system shall integrate a Smart Phone with a DSRC sleeve to enable communication with the signal system.	ConOps /Chapter 5/ Mobile app – RSE Connectivity	Interface Requirement	Formal Test	Mobile Subsystem	SATISFIED
SR-37	The SURTRAC2 system should be able to influence adjustment of signal timing plan based on the pedestrian speed.	ConOps /Chapter 8/ Active monitoring and attention to crossing progress	Functional Requirement	Formal Test	SURTRAC2 Subsystem	SATISFIED



6. Requirements Traceability Matrix

Req. ID	Requirement Description	Source of the Requirement	Requirement Category	Verification Method	System Architecture Subsystem	Current Status
SR-38	The SURTRAC2 system should be able to communicate with the mobile system any change to signal phase and timing.	ConOps /Chapter3/ Existing SURTRAC System	Functional Requirement	Formal Test	SURTRAC2 Subsystem	SATISFIED
SR-39	The mobile system should be capable of providing the user with information about the upcoming intersection (If it's signalized, walk/no-walk signal, how many streets crossing, etc.)	ConOps / Operational Scenarios/ Use Case 9	Interface Requirement	Formal Test	Mobile Subsystem	SATISFIED - Does not provide all of this information listed in the requirement but it's not clear that it can
SR-40	The mobile system shall be able to recognize the intersection (e.g., intersection of Maine and 3rd).	ConOps / Operational Scenarios/ Use Case 10-12	Functional Requirement	Formal Test	Mobile Subsystem	SATISFIED
SR-41	The mobile system should be able to locate the intersection at which the user is positioned (e.g., southwest corner of Maine and 3rd).	ConOps / Operational Scenarios/ Use Case 10-12	Functional Requirement	Formal Test	Mobile Subsystem	SATISFIED - for simple 2 phase intersections; more complex types of intersections will be addressed in Year 2
SR-42	The mobile system should be able to identify where the user is standing (side walk or street).	ConOps / Operational Scenarios/ Use Case 15	Functional Requirement	Formal Test	Mobile Subsystem	NOT DONE YET

6. Requirements Traceability Matrix

Req. ID	Requirement Description	Source of the Requirement	Requirement Category	Verification Method	System Architecture Subsystem	Current Status
SR-43	The mobile system should be able to determine location of crosswalk corridor.	ConOps / Operational Scenarios/ Use Case 10-12	Functional Requirement	Formal Test	Mobile Subsystem	NOT DONE YET - needs an update to the MAP message and localization
SR-44	The mobile system should be able to determine location of crosswalk corridor relative to the user.	ConOps / Operational Scenarios/ Use Case 10-12	Functional Requirement	Formal Test	Mobile Subsystem	NOT DONE YET - needs an update to the MAP message and localization
SR-45	The mobile system shall be able to collect personalized intersection crossing constraints from the user.	ConOps / Chapter 5 Operational Concept/ Use Cases	Interface Requirement	Formal Test	Mobile Subsystem	SATISFIED
SR-46	The mobile system should be able to communicate to the user which intersection the user is at.	ConOps / Operational Scenarios/ Use Case 12	Interface Requirement	Demonstration	Mobile Subsystem	SATISFIED
SR-47	The mobile system should be able to communicate with the user the exact corner of the intersection he is standing at.	ConOps / Operational Scenarios/ Use Case 12	Interface Requirement	Demonstration	Mobile Subsystem	NOT DONE YET - we have an algorithm for doing this, but it is not implemented yet

6. Requirements Traceability Matrix

Req. ID	Requirement Description	Source of the Requirement	Requirement Category	Verification Method	System Architecture Subsystem	Current Status
SR-48	The mobile system should be able to communicate with the user contextual information on the built environment around an intersection.	ConOps / Operational Scenarios/ Use Case 10-12	Functional Requirement	Demonstration	Mobile Subsystem	NOT DONE YET - This capability could involve a 3rd party like PathVu. Might lead to a synergistic ATTRI demo in Year 2
SR-49	The mobile system should be able to provide guidance to the user in locating the crosswalk corridor (the rectangular path defined by the crosswalk pattern borders, extended onto the sidewalk it adjoins).	ConOps / Operational Scenarios/ Use Case 10-12	Functional Requirement	Demonstration	Mobile Subsystem	NOT DONE YET
SR-50	The mobile system should be able to provide a notification when the user locates crosswalk corridor.	ConOps / Operational Scenarios/ Use Case 10-12	Functional Requirement	Demonstration	Mobile Subsystem	NOT DONE YET
SR-51	The mobile system should have the capability to provide information on crosswalk entrance points, such as cut-outs, grade, and geometry, facilitating entry into the crosswalk for those with visual impairments.	ConOps / Chapter 7/ Operational Impacts/Locating the start of the crosswalk	Functional Requirement	Formal Test	Mobile Subsystem	NOT DONE YET
SR-52	The mobile system should have the capability to guide the user to the starting location of the crosswalk.	ConOps / Chapter 7/ Operational Impacts/Locating the start of the crosswalk	Functional Requirement	Formal Test	Mobile Subsystem	NOT DONE YET

6. Requirements Traceability Matrix

Req. ID	Requirement Description	Source of the Requirement	Requirement Category	Verification Method	System Architecture Subsystem	Current Status
SR-53	The mobile system should be able to provide an alert when the user is not inside of crosswalk corridor.	ConOps / Chapter 7/ Operational Impacts/Locating the start of the crosswalk	Functional Requirement	Formal Test	Mobile Subsystem	NOT DONE YET
SR-54	The mobile system should provide confirmation when the user is inside of crosswalk corridor.	ConOps / Chapter 7/ Operational Impacts/Locating the start of the crosswalk	Functional Requirement	Formal Test	Mobile Subsystem	NOT DONE YET
SR-55	The mobile system should inform the user with intersection geometric information (e.g., curb cut locations).	ConOps /Chapter 7/ Operational Impacts/Traversing a crosswalk	Interface Requirement	Formal Test	Mobile Subsystem	NOT DONE YET – Year 2 Requirement
SR-56	The mobile system should inform the user with obstacle information (e.g., pothole or construction) about the intersection	ConOps /Chapter 7/ Operational Impacts/Traversing a crosswalk	Interface Requirement	Formal Test	Mobile Subsystem	NOT DONE YET - also requires synergy with PathVu
SR-57	The mobile system shall be capable of alerting the user to wait when the signal indicates No Walk.	ConOps / Operational Scenarios/ Use Case 8	Interface Requirement	Formal Test	Mobile Subsystem	SATISFIED
SR-58	The mobile system should provide users with pre-planned route and destination information (e.g., walking path).	ConOps / Chapter 5/ Mobile App User Interfaces (UI)	Interface Requirement	Formal Test	Mobile Subsystem	NOT DONE YET – Year 2 requirement
SR-59	The mobile system shall communicate with the SURTRAC2 system that the user intends to cross the intersection.	ConOps / Chapter 6/ Use case 14	Interface Requirement	Formal Test	SURTRAC2 Subsystem	SATISFIED
SR-60	The SURTRAC2 system shall communicate with the intersection signal system that the user intends to cross the intersection.	ConOps / Chapter 6/ Use case 14	Interface Requirement	Formal Test	SURTRAC2 Subsystem	SATISFIED

6. Requirements Traceability Matrix

Req. ID	Requirement Description	Source of the Requirement	Requirement Category	Verification Method	System Architecture Subsystem	Current Status
SR-61	The SURTRAC2 system shall communicate with the mobile system the phase and time remaining of that phase of the signal system.	ConOps / Operational Scenarios/ Use Case 3	Interface Requirement	Formal Test	SURTRAC2 Subsystem	SATISFIED
SR-62	The mobile system shall be capable of alerting the user to wait when the signal indicates Walk, but there is not enough time remaining for the user to cross.	ConOps / Operational Scenarios/ Use Case 3	Interface Requirement	Formal Test	Mobile Subsystem	SATISFIED
SR-63	The mobile system shall be capable of notifying the user of how much time is remained of a specific signal phase (walk or no-walk)	ConOps / Chapter 5/ Modes of Operation	Interface Requirement	Formal Test	Mobile Subsystem	SATISFIED
SR-64	The mobile system shall communicate with the user whether an intersection has a traffic island. If the information is not available, the notification shall say so.	ConOps / Operational Scenarios/ Use Case 15	Interface Requirement	Formal Test	Mobile Subsystem	NOT DONE YET – Year 2 Requirement
SR-65	The mobile system shall be able to provide guidance, notifications, and alerts in order to assist the users in crossing the intersection.	ConOps / Chapter 6/ Description of Desired Changes/ Table 1	Functional Requirement	Demonstration	Mobile Subsystem	NOT DONE YET
SR-66	The mobile system shall provide the option for the user so he can enter his crossing direction.	ConOps / Operational Scenarios/ Use Case 1	Interface Requirement	Demonstration	Mobile Subsystem	SATISFIED
SR-67	The mobile system shall provide the option for the user so he can indicate his intent to cross.	ConOps / Operational Scenarios/ Use Case 1	Interface Requirement	Demonstration	Mobile Subsystem	SATISFIED

6. Requirements Traceability Matrix

Req. ID	Requirement Description	Source of the Requirement	Requirement Category	Verification Method	System Architecture Subsystem	Current Status
SR-68	The mobile system should be able to determine direction of the user relative to crossing direction.	ConOps / Operational Scenarios/ Use Case 10	Functional Requirement	Formal Test	Mobile Subsystem	PARTIALLY SATISFIED - Functionality works for simple 2-phase intersections; extend to complex intersection in year 2
SR-69	If the user intends to make two consequent crosses at an intersection, the SURTRAC2 system shall be capable of determining which cross should occur first.	ConOps / Operational Scenarios/ Use Case 8	Functional Requirement	Formal Test	SURTRAC2 Subsystem	NOT DONE YET – Year 2 requirement
SR-70	The SURTRAC2 system shall be able to provide the mobile system with real time information (signal phase, timing, etc.) about the traffic signal system.	ConOps / Chapter 6/ Use cases 1-15	Functional Requirement	Formal Test	SURTRAC2 Subsystem	SATISFIED
SR-71	The mobile system shall be able to provide the user with real time information (signal phase, timing, etc.) about the traffic signal system.	ConOps / Chapter 6/ Use cases 1-15	Functional Requirement	Formal Test	Mobile Subsystem	SATISFIED
SR-72	The mobile system shall be able to notify the user when Walk time is extended.	ConOps / Chapter 6/ Use case 2	Functional Requirement	Formal Test	Mobile Subsystem	SATISFIED
SR-73	The mobile system shall be capable of informing the user to cross when the signal indicates Walk and there is enough time left for the user to cross.	ConOps / Operational Scenarios/ Use Case 2	Interface Requirement	Formal Test	Mobile Subsystem	SATISFIED

6. Requirements Traceability Matrix

Req. ID	Requirement Description	Source of the Requirement	Requirement Category	Verification Method	System Architecture Subsystem	Current Status
SR-74	The SURTRAC2 system should have the capability of coordinating the signal timing plans with anticipated user arrivals.	Conops/ Chapter 5/ SURTRAC Adaptive Traffic Signal Control	Functional Requirement	Formal Test	SURTRAC2 Subsystem	NOT DONE YET - This is a Year 2 requirement
SR-75	<del>The mobile system shall notify the SURTRAC2 system of the intersection crossing intention of the user.</del>	<del>Conops: Chapter 5 SURTRAC Adaptive Traffic Signal Control</del>	<del>Functional Requirement</del>	<del>Formal Test</del>	<del>Mobile Subsystem</del>	<del>Deleted – Redundant</del>
SR-76	The SURTRAC2 system shall have the capability to notify the traffic signal system of the intersection crossing intention of the user.	ConOps: Chapter 7/ Operational Impacts	Functional Requirement	Formal Test	SURTRAC2 Subsystem	SATISFIED
SR-77	The mobile system should be able to determine the user speed crossing an intersection.	ConOps / Operational Scenarios/ Use Case 7	Functional Requirement	Analysis	Mobile Subsystem	NOT DONE YET - In Progress and depending on localization accuracy
SR-78	The mobile system should be capable of computing time required for a user to cross a specific intersection.	ConOps / Operational Scenarios/ Use Case 1	Functional Requirement	Analysis	Mobile Subsystem	NOT DONE YET - In Progress and depending on localization accuracy
SR-79	The mobile system should have the capability to track the user's progress through the crosswalk (from one corner to the other).	ConOps / Chapter 7 / Operational Impacts	Functional Requirement	Formal Test	Mobile Subsystem	NOT DONE YET - In Progress and depending on localization accuracy
SR-80	The mobile system should be capable of identifying the user's delays in crossing an intersection.	ConOps / Operational Scenarios/ Use Case 7	Functional Requirement	Formal Test	Mobile Subsystem	NOT DONE YET - In Progress and depending on localization accuracy

6. Requirements Traceability Matrix

Req. ID	Requirement Description	Source of the Requirement	Requirement Category	Verification Method	System Architecture Subsystem	Current Status
SR-81	The mobile system should be capable of identifying the users' drift from a safe zone when crossing an intersection.	ConOps / Operational Scenarios/ Use Case 6	Functional Requirement	Formal Test	Mobile Subsystem	NOT DONE YET - In Progress and depending on localization accuracy
SR-82	The mobile system should be capable of communicating with the user of his progress crossing an intersection.	ConOps / Chapter 5 Mobile App User Interface (UI) for Use of Pre-Planned Routes	Functional Requirement	Formal Test	Mobile Subsystem	NOT DONE YET - In Progress and depending on localization accuracy
SR-83	<del>The mobile system shall enable the user to notify the mobile system of his/her delay crossing an intersection.</del>	<del>ConOps / Operational Scenarios/ Use Case 7</del>	Interface Requirement	Demonstration	Mobile Subsystem	This requirement should be removed. We don't want to encourage pedestrian to be communicating with phone while crossing.
SR-84	The mobile system should be capable of communicating the user's delay to the SURTRAC2 system in real time.	ConOps / Operational Scenarios/ Use Case 7	Interface Requirement	Formal Test	Mobile Subsystem	NOT DONE YET - In Progress and depending on localization accuracy.
SR-85	The SURTRAC2 system shall have the capability to allow for dynamic extension of minimum crossing time constraint if an unexpected delay is detected	ConOps / Chapter 5/ SURTRAC Adaptive Traffic Signal Control	Functional Requirement	Formal Test	SURTRAC2 Subsystem	NOT DONE YET
SR-86	The mobile system should notify the user of his drift from the crosswalk.	ConOps / Operational Scenarios/ Use Case 6	Interface Requirement	Formal Test	Mobile Subsystem	NOT DONE YET - Same as SR-81 ???



6. Requirements Traceability Matrix

Req. ID	Requirement Description	Source of the Requirement	Requirement Category	Verification Method	System Architecture Subsystem	Current Status
SR-87	The mobile system should provide directional guidance to help the user get back in the safe zone path in case of a drift.	ConOps / Operational Scenarios/ Use Case 10	Interface Requirement	Formal Test	Mobile Subsystem	NOT DONE YET
SR-88	<del>The mobile system should notify the user of his delay crossing an intersection.</del>	<del>ConOps / Operational Scenarios/ Use Case 7</del>	<del>Interface Requirement</del>	<del>Formal Test</del>	<del>Mobile Subsystem</del>	Remove – Redundant requirement
SR-89	The mobile system should have the capability to advise users on how to exit the crosswalk by providing guidance to the exit point (whether there is a curb or a cut-out, grade, etc.)	ConOps / Chapter 7 /Operational Impacts	Functional Requirement	Formal Test	Mobile Subsystem	NOT DONE YET – Year 2 requirement
SR-90	The mobile system shall be able to provide a notification when the user successfully crosses an intersection.	ConOps / Chapter 4 /Description of Desired Changes	Functional Requirement	Formal Test	Mobile Subsystem	NOT DONE YET - In Progress and depending on localization accuracy.
SR-91	The mobile system shall be capable of identifying a location (i.e. coordinates).	ConOps / Operational Scenarios/ Use Case 6	Performance Requirement	Analysis	Mobile Subsystem	NOT DONE YET - In Progress and depending on localization accuracy.
SR-92	The system shall correctly identify the intersection the user is at.	ConOps / Chapter 8/ Performance Measures	Performance Requirement	Analysis	Mobile Subsystem	NOT DONE YET - In Progress and depending on localization accuracy.

6. Requirements Traceability Matrix

Req. ID	Requirement Description	Source of the Requirement	Requirement Category	Verification Method	System Architecture Subsystem	Current Status
SR-93	The system shall correctly identify the intersection corner the user is at.	ConOps / Chapter 8/ Performance Measures	Performance Requirement	Analysis	Mobile Subsystem	NOT DONE YET - In Progress and depending on localization accuracy.
SR-94	The system shall correctly identify that a user is delayed crossing an intersection.	ConOps / Chapter 8/ Performance Measures	Performance Requirement	Analysis	Mobile Subsystem	NOT DONE YET - In Progress and depending on localization accuracy.
SR-95	The system shall correctly detect the users' deviation from the path.	ConOps / Chapter 8/ Performance Measures	Performance Requirement	Analysis	Mobile Subsystem	NOT DONE YET - In Progress and depending on localization accuracy.
SR-96	The system shall increase the users' perceived safety crossing an intersection.	ConOps / Chapter 8/ Performance Measures	Performance Requirement	Analysis	Mobile Subsystem	Pending Field Test Evaluation
SR-97	The system shall reduce the number of cycles the user waits to feel safe crossing the intersection to 0.	ConOps / Chapter 8/ Performance Measures	Performance Requirement	Analysis	Mobile Subsystem	Pending Field Test Evaluation
SR-98	The system shall increase the percentage of new intersections crossed by a user.	ConOps / Chapter 8/ Performance Measures	Performance Requirement	Analysis	Mobile Subsystem	Pending Field Test Evaluation
SR-99	The system shall decrease percentage of total duration of the time from start-finish crossing an intersection.	ConOps / Chapter 8/ Performance Measures	Performance Requirement	Analysis	Mobile Subsystem	Pending Field Test Evaluation
SR-100	The system shall improve the user travel time (rush hour, mid-day).	ConOps / Chapter 8/ Performance Measures	Performance Requirement	Analysis	Mobile Subsystem	Pending Field Test Evaluation

6. Requirements Traceability Matrix

Req. ID	Requirement Description	Source of the Requirement	Requirement Category	Verification Method	System Architecture Subsystem	Current Status
SR-101	The mobile system shall communicate intersection crossing information (alerts, coordinates, etc.) with the user in a timely manner.	ConOps / Chapter 8/ Performance Measures	Performance Requirement	Analysis	Mobile Subsystem	Pending Field Test Evaluation
SR-102	The SURTRAC2 system shall communicate intersection crossing information (alerts, coordinates, etc.) with the Mobile system in a timely manner.	ConOps / Chapter 8/ Performance Measures	Performance Requirement	Analysis	Mobile Subsystem	Pending Field Test Evaluation
SR-103	The SURTRAC2 system shall communicate user information (arrival; time, speed, etc.) with the intersection signal system in a timely manner.	ConOps / Chapter 8/ Performance Measures	Performance Requirement	Analysis	Mobile Subsystem	Pending Field Test Evaluation
SR-104	The mobile system should have the data if an intersection has a traffic island.	ConOps / Operational Scenarios/ Use Case 15	Data Requirement	Inspection	Mobile Subsystem	NOT DONE YET – Year 2 requirement
SR-105	The mobile system should have the data if an intersection is signalized.	ConOps / Operational Scenarios/Use Case 1	Data Requirement	Inspection	Mobile Subsystem	SATISFIED
SR-106	The mobile system should have the data if an intersection signal system is operational.	ConOps / Operational Scenarios/ Use Case 5	Data Requirement	Inspection	Mobile Subsystem	SATISFIED
SR-107	The mobile system should have the data if an intersection signal system is DSRC equipped.	ConOps / Operational Scenarios/Use Case 1	Data Requirement	Inspection	Mobile Subsystem	SATISFIED
SR-108	The system shall be able to ingest MAP message data.	System Requirements Analysis Discussions	Data Requirement	Demonstration	Mobile Subsystem	SATISFIED

6. Requirements Traceability Matrix

Req. ID	Requirement Description	Source of the Requirement	Requirement Category	Verification Method	System Architecture Subsystem	Current Status
SR-109	The system shall be able to ingest SPaT message data.	System Requirements Analysis Discussions	Data Requirement	Demonstration	Mobile Subsystem	SATISFIED
SR-110	The system should have a data validation process.	System Requirements Analysis Discussions	Data Requirement	Inspection	Mobile Subsystem	In Progress
SR-111	The system should be able to ingest external data format (e.g., by applying appropriate APIs)	System Requirements Analysis Discussions	Data Requirement	Demonstration	Mobile Subsystem	NOT DONE YET - Not relevant for Year 1 field test
SR-112	The system shall not store any PII data.	System Requirements Analysis Discussions	Data Requirement	Inspection	Mobile Subsystem	SATISFIED
SR-113	The mobile system shall collect data about the type of assistive tools (e.g. wheelchair, cane, dog, etc.) that the user is using.	System Requirements Analysis Discussions	Data Requirement	Inspection	Mobile Subsystem	SATISFIED
SR-114	The system shall track the performance of the system by recording anonymized data of pedestrians (who use the intersection crossing mobile system) crossing the intersections.	System Requirements Analysis Discussions	Data Requirement	Formal Test	Mobile Subsystem	Pending Field Test Evaluation

U.S. Department of Transportation  
ITS Joint Program Office-HOIT  
1200 New Jersey Avenue, SE  
Washington, DC 20590

Toll-Free "Help Line" 866-367-7487  
[www.its.dot.gov](http://www.its.dot.gov)

FHWA-JPO-18-685



U.S. Department of Transportation