

# **Final Report**

**2009-SGP-1042**

Effective Decision Making Starts with an Effective  
Curriculum

David Blehman  
California State University, Los Angeles

# **Effective Decision Making Starts with an Effective Curriculum**

## **PROJECT REPORT**

**To: Leonard Transportation Center  
California State University San Bernardino  
(230678—GT10120)**

**David Blekhman, PhD  
Associate Professor  
Power, Energy and Transportation Program  
California State University Los Angeles**

**July 2009—September 2010**



## Contents

Executive Summary .....	3
Project Outcomes .....	3
Laboratory 1 Summary .....	4
Laboratory 2 Summary .....	4
Conclusions .....	5

## Appendix A

- Laboratory 1 Instructor manual
- Laboratory 1 Solution manual
- Laboratory 1 Student manual

## Appendix B

- Laboratory 2 Instructor manual
- Laboratory 2 Solution manual
- Laboratory 2 Student manual

## Executive Summary

The effectiveness of Decision Making and Management of Transportation Systems is based on well-prepared decision makers and managers, who possess knowledge and experiences related to the technologies that are the subject of their decision making. With the advent of new electric, hybrid and fuel cell vehicles, the need for engineers and technology managers with related knowledge will grow. CSULA is extending its curriculum to meet those needs. A brand new Electric, Hybrid and Alternatively Fueled Vehicles course seeks to introduce students to all major technologies implemented in those vehicles. Among them are electric motors and generators. This project resulted in the development of two laboratory experiences with the Hampden electric motor test station available in the Department of Technology. The findings of the project were presented at the 2010 Jack R. Widmeyer Transportation Research Conference at CSU San Bernardino.

## Project Outcomes

The PI worked with two students, Pavlo Andoni and Amanda Turk. Pavlo Andoni conducted the initial research and prepared first drafts of the two laboratories on the topics he had identified to benefit the Electric, Hybrid and Alternatively Fueled Vehicles course. He worked for ten weeks in summer 2009. His work was supported by NSF Research Experience for Undergraduates funding. Pavlo Andoni was a visiting researcher from Grand Valley State University, MI. Amanda Turk joined the project in winter 2010 and provided a major evaluation and rewriting of the draft versions of laboratories. Also funded by the NSF, she was a visiting researcher from MIT, MA.

The Department of Technology owns the Hampden Series 100 motor experimentation station, not currently utilized for any of the courses, see Figure 1. The test bench is specifically designed for students to perform experiments with motors and generators. The test bench is also equipped with a set of modules serving as a versatile power and instrument facility for a wide range of other laboratory experiments in power technologies. As the outcome of this project two laboratories were created to support the course in Electric, Hybrid and Alternatively Fueled Vehicles. The two labs addressed: “*DC Motors and Generators: Efficiency and Losses*” and “*AC Motors: Efficiency and Losses*”.

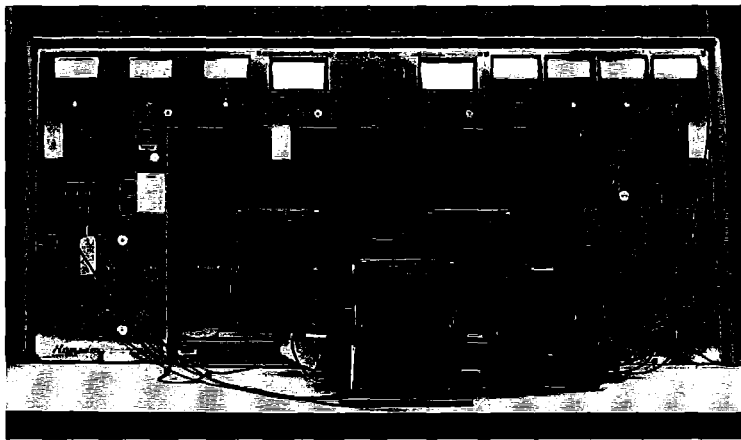

Figure 1. Hampden Electric Motor Testing Station.

## Laboratory 1 Summary

*DC Motors and Generators: Efficiency and Losses* sets the following outcomes for student learning for cases when the DC motors are used.

1. To gain hands-on experience with the circuitry layout of DC motors and generators.
2. To calculate the efficiency of a self-excited motor and of a separately-excited generator.
3. To determine where losses occur in DC electric machines and discuss methods for reducing losses and increasing efficiency.
4. To identify the ideal operating range for electric motors and for electric generators.

For example, students obtain the DC motor efficiency as a function of RPM utilizing the current and voltage data collected in the laboratory, see Figure 2.

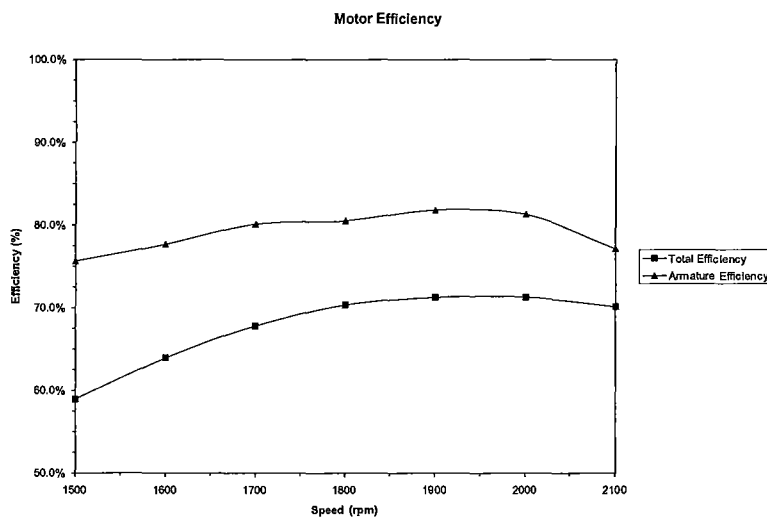

Figure 2. The relationship of a DC motor efficiency and shaft speed.

The laboratory contains theoretical section addressing DC motor operating principles, clear instructions on experiment set up and procedures, connection diagrams, formulas for calculations and the assignment of specific observations and determinations.

Three documents are prepared: Instructor's manual, Student's manual and Solution manual.

## Laboratory 2 Summary

*AC Motors: Efficiency and Losses* sets the following outcomes for student learning for cases when the AC motors are used.

1. To gain hands-on experience with the circuitry layout of AC induction motors.
2. To calculate the efficiency of an induction motor.
3. To determine where losses occur in AC machines and discuss methods for reducing losses and increasing efficiency.
4. To identify the ideal operating range for AC induction motors.

For example, students obtain the DC motor efficiency as a function of RPM utilizing the current and voltage data collected in the laboratory, see Figure 3.

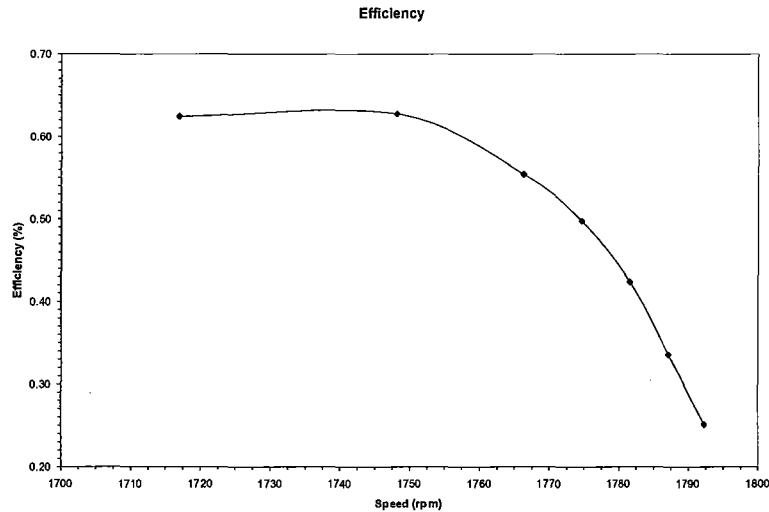

**Figure 3. The relationship of an AC motor efficiency and shaft speed.**

The laboratory contains theoretical section addressing DC motor operating principles, clear instructions on experiment set up and procedures, connection diagrams, formulas for calculations and the assignment of specific observations and determinations.

Three documents are prepared: Instructor's manual, Student's manual and Solution manual.

## **Conclusions**

Two laboratory manuals and accompanying instructor's manuals to support the introduction of the topic of electric motors in the Electric, Hybrid and Alternatively Fueled Vehicles course were created. During the project, two students were mentored and prepared educational materials to be used at the college level. Previously underutilized equipment was brought back into the instruction. The next offering of the course where the new laboratories will be tested is Winter 2011.

# Lab 1

## *DC Motors and Generators: Efficiency and Losses*

### Instructor Manual

Background Information.....	2
Concept Check (Solutions) .....	3
Objectives .....	6
Equipment.....	7
Procedure .....	7
Data Collection (Solutions).....	9
Table 1: Collected Data.....	9
Data Analysis (Solutions) .....	10
Table 2: Motor Calculations.....	10
Table 3: Generator Calculations.....	11
Discussion (Solutions) .....	12
Appendix A: Motor Connections.....	17
Appendix B: Generator Connections.....	18

## Background Information

An **electric motor** is a device that transforms *electrical* energy into *mechanical* energy through electromagnetic induction. An electromagnet is rotated in the presence of a second, stationary electromagnet; the interaction of the two magnetic fields results in a torque that drives a shaft. In a sense, a **generator** is simply an electric motor working backwards, transforming *mechanical* energy into *electrical* energy. The source of the mechanical energy can be anything that turns a shaft- from a simple hand crank to a steam engine, wheels turned by road friction to an electric motor- but the principle remains the same. The mechanical force moves a magnet near a wire in order to induce a magnetic flux which, in turn, creates a steady flow of electrons in the wire.

Hybrid and electric vehicles (HEVs) contain both motors and generators. HEVs are powered by a combination of a gasoline-powered engine and a battery-powered electric motor. These two power sources can be combined either in **parallel** (in which both the engine and the electric motor are directly connected to the transmission) or in **series** (in which only the electric motor is directly connected to the transmission; the gasoline engine turns a generator that either charges the batteries or directly powers the electric motor.)

You will most frequently encounter two types of generators in HEVs. The type of generator discussed above, that appears in series hybrid systems, is called a **gasoline generator**. The second type, common to both hybrid and electric vehicles, is the **regenerative braking system**. Such a system runs the electric motor backwards as a vehicle brakes, using the motor as a generator that is turned by the transaxle as the vehicle slows. The mechanical energy of the spinning axles, instead of being completely dissipated by traditional brakes, is partially converted into electrical energy that recharges the car batteries.

Both motors and generators contain an **alternator**, which converts the mechanical input into an electrical output or vice versa. An alternator contains a **rotor** (the rotating component) and a **stator** (the stationary component).

In electrical terms, the stator is called the **field coil**: it contains either a permanent magnet or, more commonly, an electromagnet (current-carrying wire wound in coils around an iron core). The field coil creates a magnetic field through which the rotor will turn.

The rotor can also be called the **armature coil**. In a motor, the armature coil acts as an electromagnet; a power source directly *supplies* current through the armature coil. The interaction between the two magnetic fields (of the field coil and the armature coil) results in a torque that drives a shaft. In a generator, the armature is not connected to an external power source. Instead, as the armature rotates through the magnetic field created by the field coil, the resulting magnetic flux *induces* a current in the armature. This current flows through a load (like the motor of a car) or back to a battery, recharging it for future use.

Not all of the input energy to a motor or generator is transformed into output energy; some energy is lost during the process due to friction between parts, inappropriate



operating conditions, necessary internal power draws, and dozens of other factors. The ratio of input energy to output energy is called **efficiency**, and one of the most important challenges for modern technicians is to develop vehicles with the highest efficiency. In this laboratory exercise, you will be working with a self-excited<sup>1</sup> shunt motor, commonly used to power vehicles, and a separately-excited shunt generator, much like those used in regenerative braking and series hybrid systems. You will calculate the power inputs, outputs, and efficiencies of both machines and determine the operating range for which each machine has the highest efficiency.

## Concept Check (Solutions)

1. . An electric motor:

- (a) converts mechanical energy into electrical energy

*Incorrect; a motor converts electrical energy into mechanical energy.*

- (b) does not convert all input power into output power.

*Correct; there are always power losses in a motor due to internal mechanical and electrical resistances.*

- (c) contains an alternator coil and a rotor coil.

*Incorrect; a motor contains an alternator which, in turn, contains an armature coil (the rotor) and a field coil (the stator)*

- (d) can also be called a regenerative braking system.

*Incorrect; a regenerative braking system is a type of generator.*

2. The armature carries current that is:

- (a) drawn directly from a battery or generator.

*Partially correct; this is true in a motor.*

- (b) induced as the armature rotates through a magnetic field.

*Partially correct; this is true in a generator.*

---

<sup>1</sup> A generator may be **self-excited** (the field coil is powered by some of the current produced in the armature) or **separately-excited** (the field coil is powered by an independent outside power source.) The advantages of self-excitation include high starting torque and rapid acceleration, but separately-excited generators are more often used in electric vehicles, as they offer excellent control flexibility and potential for optimization.

→(c) either (a) or (b), depending on whether it is part of a generator or a motor.

*Correct; see (a) and (b) for explanation.*

(d) An armature does not carry current.

*Incorrect; the armature coil becomes an electromagnet by carrying current.*

### 3. Generators:

→(a) are used in regenerative braking systems.

*Correct; generators play a key role in regenerative braking systems.*

(b) do not appear in modern electric vehicles.

*Incorrect; gasoline generators appear in hybrid vehicles and electric generators play a key role in regenerative braking systems.*

(c) convert electrical energy into mechanical energy.

*Incorrect; generators convert mechanical energy into electrical energy.*

(d) all of the above.

*Incorrect; see (b) and (c) for explanation.*

### 4. The efficiency of an electric vehicle:

(a) is not an overwhelming concern in vehicle design.

*Incorrect; increasing vehicle efficiency is a main focus for modern technicians.*

(b) is the ratio of input power to output power.

*Correct; efficiency is the ratio of input power to output power and is most often expressed as a percentage. However, (d) is a better answer.*

(c) is reduced when motor parts are poorly machined.

*Correct; poorly machined parts increase power loss due to friction, thereby reducing vehicle efficiency. However, (d) is a better answer.*

→(d) b and c

*Correct; see (b) and (c) for explanation.*

5. A regenerative braking system:

(a) creates electrical energy by regenerating the motor.

*Incorrect; a regenerative braking systems converts mechanical energy into electrical energy by running the motor backwards as a generator. One cannot create energy.*

(b) lets no rotational energy be dissipated as heat.

*Incorrect; a regenerative braking system relies on a generator, and is therefore not 100% efficient. Some rotational energy is dissipated as heat due to internal resistances.*

→(c) is an electric generator that converts rotational energy into electrical energy.

*Correct; a regenerative braking system converts rotational energy into electrical energy as a vehicle slows.*

(d) is powered by gasoline.

*Incorrect; a regenerative braking system is a generator powered by the rotational energy of vehicle tires. See answer (c).*

6. Power losses in a motor or generator occur:

(a) in the armature coil only.

*Incorrect; power losses do occur in the armature coil, but they also occur elsewhere.*

(b) in the armature and field coils only.

*Incorrect; power losses do occur in the armature and field coils, but they also occur elsewhere.*

(c) in the rotating shaft only.

*Incorrect; power losses do occur in the rotating shaft, but they also occur elsewhere.*

→(d) in every part of the machine.

*Correct; power losses occur in every part of the machine, though some parts have higher losses than others.*

7. In this lab, the motor is a(n) \_\_\_\_ machine and the generator is a(n) \_\_\_\_ machine.

(a) AC, AC

*Incorrect; see (a) for explanation.*

(b) AC, DC

*Incorrect; see (a) for explanation.*

(c) DC, AC

*Incorrect; see (a) for explanation.*

→(d) DC, DC

*Correct; this lab uses the DC Machine and the Dynamometer, both of which are DC machines.*

**8. Big Picture:** In Lab 1, your overall aim is to:

(a) measure shaft speed, torque, armature current, and field voltage.

*Incorrect; while you will measure these quantities in Lab 1, your overall aim is to use them for calculating efficiency (see (b)).*

→(b) find the efficiency of a motor and a generator and identify the source of power losses.

*Correct; the objective of Lab 1 is to calculate motor/generator efficiency and to identify power losses.*

(c) observe the effect of a changing load on motor and generator efficiency.

*Incorrect; the load is held constant in Lab 1, at  $68.18\Omega$ .*

(d) find the output power of a motor and a generator.

*Incorrect; while you will calculate these quantities in Lab 1, your overall aim is to use them for calculating efficiency (see (b)).*

## Objectives

1. To gain hands-on experience with the circuitry layout of DC motors and generators.
2. To calculate the efficiency of a self-excited motor and of a separately-excited generator.
3. To determine where losses occur in DC electric machines and discuss methods for reducing losses and increasing efficiency.
4. To identify the ideal operating range for electric motors and for electric generators.

## Equipment

### Console Instruments:

1. 0-150 volt Variable DC supply, 1 amp
2. (2) 0-150 volt DC voltmeter
3. (2) 0-5.0amp DC ammeter

### Additional Equipment:

1. DM-100A DC Machine
2. DYN-100-DM Dynamometer
3. RL-100A Resistance Load Bank
4. HT-100 Series Tachometer
5. (2) Auxiliary ammeter

## Procedure

1. Place the two machines on the bedplate with the motor (DYN-100-DM Dynamometer) on the left and the generator (DM-100A DC Machine) on the right.
2. Couple the machines and clamp both tightly to the bedplate.
3. Turn the knob of the 0-125 volt and the 0-150 volt DC supplies fully counterclockwise to the zero output position. Power should remain off.
4. Connect the motor as shown in Figure 1. Refer to Appendix A for schematic of motor. Turn the motor's field rheostat knob (black dial located on top of the dynamometer) fully counterclockwise to its minimum resistance position.

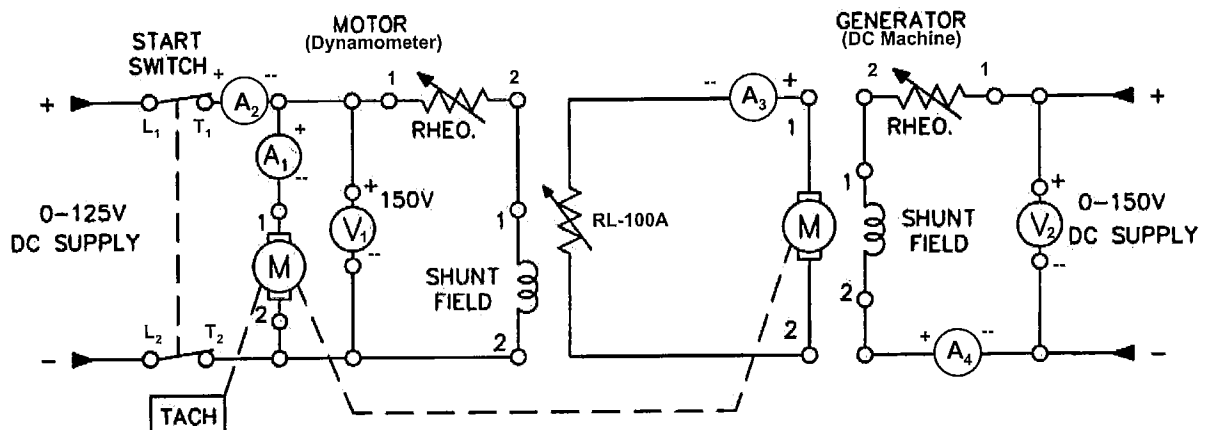

Figure 1: Motor and generator connections

5. Connect the generator as shown in Figure 1. Refer to Appendix B for schematic of generator. Note that this is a separately excited generator connection. Turn the generator's field rheostat knob (black dial located on top of the DC machine) fully counterclockwise to its minimum resistance position.
6. Ground both machines. (Connect the green terminal on each machine to the green terminal on the console.)
7. Have someone check your connections to be sure they are correct. Be certain that your auxiliary ammeter is ON and set to handle at least 2.5A of current. Then turn ON only the main AC and the 0-150V DC supply circuit breakers.
8. Turn ON the 0-150 volt supply and the circuit breaker switch.
9. Locate the voltmeter connected across the 0-150 volt supply ( $V_2$ ) and adjust the knob until voltmeter 2 reads 124 volts. (If you followed the setup in Appendix B,  $V_2$  is the voltmeter on the left of the console.)
10. Turn the generator's field rheostat knob (located on top of DC Machine) clockwise until voltmeter 2 reads 130V.
11. Calibrate the dynamometer. (Turn the silver knob, located on top of the scale, until the scale reads zero.)
12. Turn ON the 0-125 volt supply and the circuit breaker switches on the motor.
13. Locate the voltmeter connected across the 0-125 volt supply ( $V_1$ ) and start the motor by adjusting the knob until  $V_1$  reads 124 volts. (If you followed the setup in Appendix A,  $V_1$  is the voltmeter on the left of the console.)
14. Now locate the RL-100A Resistance Load Bank. Switch on resistance legs 1-10. This will produce a load of 68.18 $\Omega$ .
15. Adjust the knob on the tachometer to read 1500 RPM.
16. Point the tachometer against the motor shaft and turn the motor's field rheostat knob clockwise until the motor shaft appears to stop moving.
17. Recheck voltmeter 1 to verify that the output of the 0-125 volt supply is still 124 volts. If it is not, adjust 0-125 volt supply until voltmeter 1 reads 125V and then repeat step 16.
18. Record the following values in Table 1:
  - a. *Shaft speed*: Adjust the field rheostat knob until the motor shaft appears to stop moving under the light of the tachometer. Record the value displayed on the tachometer screen in column 1.
  - b. *Torque*: Record the value displayed by the dynamometer scale in column 2. Use the outer scale and record all results in N·m.

- c. *Motor armature current:* Verify that  $A_1$  (the leftmost ammeter) is set to read on a 0-2.5A scale. Record the value displayed by ammeter 1 in column 3. (Note: If the needle points at or past the 2.5A mark for later measurements, you will need to adjust  $A_1$  to read on a 0-5.0A scale.)
  - d. *Motor input current:* Verify that  $A_2$  (the rightmost ammeter) is set to read on a 0-5.0A scale. Record the value displayed by ammeter 2 in column 4.
  - e. *Load current:* Record the value displayed by  $A_3$ , an auxiliary ammeter, in column 5.
  - f. *Generator input current:* Record the value displayed by  $A_4$ , an auxiliary ammeter, in column 6.
  - g. *Motor and generator voltages:* Record the values displayed by voltmeters 1 and 2 in columns 7 and 8. (Since you are constantly monitoring the power into the motor in step 17, these values should remain fixed at 124 and 130 volts, respectively.)
19. Adjust the speed on the tachometer to 1600 RPM
  20. Repeat steps 16-18.
  21. Repeat, increasing tachometer speed by intervals of 100 RPM, until the tachometer reads 2100 RPM.
  22. Adjust all voltage supplies to zero and turn OFF all circuit breaker switches.

## Data Collection (Solutions)

Table 1: Collected Data

1	2	3	4	5	6	7	8	9
$\omega_{\text{shaft}}$ (RPM)	$\tau_{\text{shaft}}$ (N·m)	$I_1$ (Amps)	$I_2$ (Amps)	$I_3$ (Amps)	$I_4$ (Amps)	$V_1$ (Volts)	$V_2$ (Volts)	$R_{\text{Load}}$ ( $\Omega$ )
1500	1.105	1.85	2.38	1.41	0.38	124	130	68.18
1600	1.15	2.00	2.43	1.49	0.38	124	130	68.18
1700	1.2	2.15	2.54	1.56	0.38	124	130	68.18
1800	1.25	2.35	2.69	1.65	0.38	124	130	68.18
1900	1.275	2.50	2.87	1.73	0.38	124	130	68.18
2000	1.3	2.70	3.08	1.81	0.38	124	130	68.18
2100	1.305	3.00	3.30	1.89	0.38	124	130	68.18

## Data Analysis (Solutions)

Table 2: Motor Calculations

1	2	3	4	5	6	7
$I_{\text{Field}}$ (Amps)	$P_{\text{In}}$ (Watts)	$P_{\text{Arm}}$ (Watts)	$P_{\text{Field}}$ (Watts)	$P_{\text{Out}}$ (Watts)	$\eta_{\text{Motor}}$ (%)	$\eta_{\text{Arm}}$ (%)
0.53	294.50	229.40	68.25	173.57	58.94	75.66
0.43	301.32	248.00	55.90	192.68	63.95	77.70
0.39	314.96	266.60	50.70	213.63	67.83	80.13
0.34	333.56	291.40	44.20	234.68	70.36	80.53
0.37	355.88	310.00	48.10	253.68	71.28	81.83
0.38	381.92	334.80	49.40	272.27	71.29	81.32
0.30	409.20	372.00	39.00	286.98	70.13	77.15

- Using equation 1, find the current through the motor rheostat and field coil. Record the result in column 1 of Table 2.

$$(1) I_{\text{Field}} = I_2 - I_1$$

- Calculate the power input to the motor armature, the power input to the motor field coil and rheostat, and the total power supplied to the motor. Record the results in columns 2-4 of Table 2.

$$(2) P_{\text{Arm}} = V_1 \cdot I_1$$

$$(3) P_{\text{Field}} = V_1 \cdot I_{\text{Field}}$$

$$(4) P_{\text{In}} = V_1 \cdot I_2$$

- Use equation 5 to calculate the power output of the motor. Record the results in column 5 of Table 2.

**Note:** Because the motor shaft and the generator shaft are mechanically linked, the power *output* of the motor is equal to the power *input* to the generator armature. Therefore, you may also record these results in column 1 of Table 3.



$$(5) P_{Out}[Motor] = P_{Arm}[Generator] = \frac{\tau_{shaft} \cdot 2\pi \cdot \omega_{shaft}}{60}$$

4. Use equation 6 to calculate the % efficiency of the motor and record the results in column 6 of Table 2.

$$(6) \eta_{Motor} = \frac{P_{Out}}{P_{In}} \cdot 100$$

5. Find the % efficiency of the motor armature using equation 7. Record the results in column 7 of Table 2.

$$(7) \eta_{Arm} = \frac{P_{Out}}{P_{Arm}} \cdot 100$$

**Table 3: Generator Calculations**

1	2	3	4	5	6
$P_{Arm}$ (Watts)	$P_{Field}$ (Watts)	$P_{In}$ (Watts)	$P_{Out}$ (Watts)	$\eta_{Generator}$ (%)	$\eta_{Arm}$ (%)
173.57	49.40	222.97	135.55	60.73	78.09
192.68	49.40	242.08	151.37	62.53	78.56
213.63	49.40	263.03	165.92	63.08	77.67
234.68	49.40	284.08	185.62	65.34	79.10
253.68	49.40	303.08	204.06	67.33	80.44
272.27	49.40	321.67	223.36	69.44	82.04
286.98	49.40	336.38	243.55	72.40	84.86

6. Using equation 8, find the power supplied to the generator field coil. Record the results in column 2 of Table 3. Then, use equation 9 to compute the input power to the generator. Record the results in column 3 of Table 3.

$$(8) P_{Field} = V_2 \cdot I_A$$

$$(9) P_{In} = P_{Arm} + P_{Field}$$

7. Use equation 10 to find the power output of the generator (the power supplied to the load.) Record the results in column 4 of Table 3.

$$(10) P_{Out} = I_3^2 \cdot R_{Load}$$

8. Using equation 11, calculate the % efficiency of the generator. Record the results in column 5 of Table 2.

$$(11) \eta_{Generator} = \frac{P_{Out}}{P_{In}} \cdot 100$$

9. Find the % efficiency of the generator armature using equation 12. Record the results in column 6 of Table 2.

$$(12) \eta_{Arm} = \frac{P_{Out}}{P_{Arm}} \cdot 100$$

## Discussion (Solutions)

1. Where do the most significant energy losses occur in the motor? What could be responsible for these losses?

**Hint:** Compare the input power to the armature input power. Then, compare the armature input power to the armature output power (the total output). Which efficiency is higher, the total efficiency or the armature efficiency? What accounts for the difference?

*The most significant energy losses occur in (1) the field/rheostat circuit branch and (2) the armature.*

- (1) The field/rheostat branch: In the range of shaft speeds tested, 75-90% of the input power reaches the armature; as the shaft speed increases, more current (and therefore a higher portion of the input power) is drawn through the armature. The remaining power (10-25% of the input) flows through the field coil and the rheostat, where most of it is either dissipated by the rheostat (which is an electrical resistor) or is used to power the field coil. Other minor losses in this branch include dissipation by resistance in the motor wires and connections.*

(2) *The armature branch: In the range of shaft speeds tested, 75-80% of the electrical power drawn into the armature circuit branch is converted into a mechanical output. The remaining power (20-25% of the armature input) is dissipated as heat due to the internal friction between the motor's moving parts. Other minor losses in this branch include dissipation by resistance in the motor wires and connections.*

2. Where do the most significant energy losses occur in the generator? What could be responsible for these losses?

*The most significant energy losses occur in (1) the field/rheostat circuit and (2) the armature.*

(1) *The field/rheostat circuit: In the range of shaft speeds tested, only 77-85% of the total input power is a direct input to the armature. As the speed of the armature shaft increases, the mechanical power input to the system increases; however, a constant amount of electrical power must be separately supplied to the field coil. As the mechanical input changes, this electrical input comprises 15-23% of the total power input. This electrical power input flows through the field coil and the rheostat, where most of it is either dissipated by the rheostat (which is an electrical resistor) or is used to power the field coil. Other minor losses in this branch include dissipation by resistance in the motor wires and connections.*

(2) *The armature branch: In the range of shaft speeds tested, 78-85% of the mechanical power input to the armature is converted into an electrical power output. The remaining power (15-22% of the armature input) is dissipated as heat due to the internal friction between the motor's moving parts. Other minor losses in this branch include dissipation by resistance in the motor wires and connections.*

3. How would the efficiency of each machine change if the field coils were replaced by permanent magnets?

*The efficiency of each machine would simply become the armature efficiency. Permanent magnets, unlike field coils, do not require an electrical input in order to generate a magnetic field. Thus, replacing the field coil with a permanent magnet eliminates one of the main power losses (the field/rheostat branch, see questions 1 and 2) from the machine and increases efficiency by 15-20%.*

- Plot a curve showing the relationship of motor efficiency and shaft speed. Plot speed along the x-axis and efficiency along the y-axis. Title the graph "Motor Efficiency." On the same graph, also plot the motor armature efficiency.

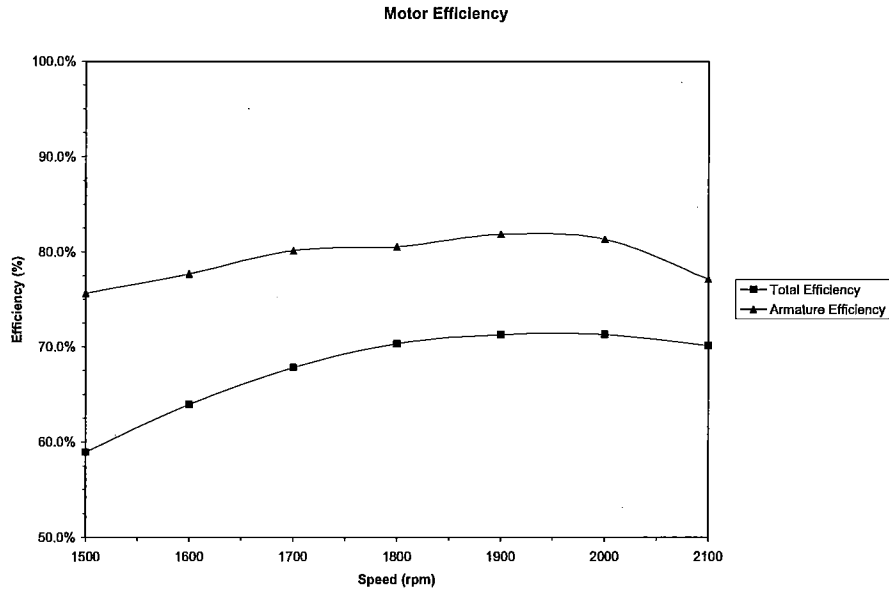

- On a separate graph, plot the relationship between generator efficiency and shaft speed. Title the graph "Generator Efficiency." On the same graph, also plot the generator armature efficiency.

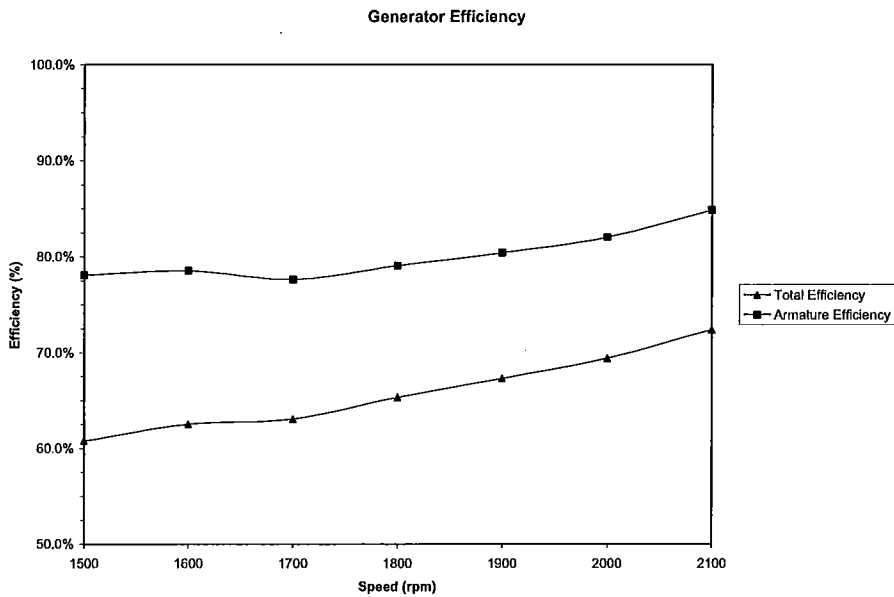

- Plot a curve showing the relationship of shaft speed and motor output torque. Plot speed along the x-axis scale and torque along the y-axis. Title the graph "Torque and Power."

See question 7.

- On the same graph, plot a curve showing the relationship between shaft speed and output power (use the same x-axis scale for speed, make a second scale along the y-axis for power.)

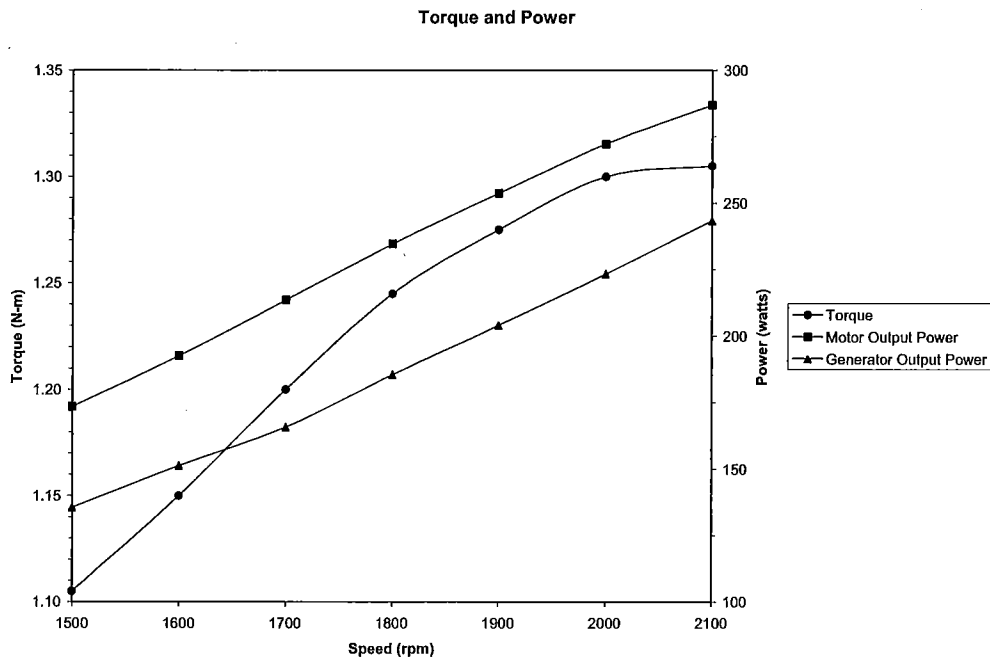

- For which shaft speeds are the efficiencies highest? For which shaft speeds does the motor produce the highest output torque?

*Motor efficiency is highest (around 80%) when the shaft speed is greater than approximately 1900rpm. Until 1900rpm, motor efficiency increases as shaft speed increases. Above 1900rpm, the efficiency remains at approximately 80%.*

*Generator efficiency is highest (around 80%) when the shaft speed is 2100rpm. Generator efficiency increases as shaft speed increases.*

*Output torque is highest when the shaft speed is greater than approximately 2000rpm. Until 2000rpm, torque increases linearly in the region of shaft speeds that we tested; above 2000rpm, the torque remains at approximately 1.3 N·m.*

9. What is the relationship between power and torque?

*When the shaft speed is less than 2000rpm, both torque and output power increase linearly. The output power is directly related to the shaft speed in this region. When the shaft speed is greater than 2000rpm, the torque remains the same, while the power continues to increase. The torque and output power are independent of each other in this region.*

10. How would you define an optimal operating range? Based on your graphs and your answers in question 1, what can you conclude about the optimal operating range (i.e. range of optimal shaft speeds) of the motor?

*The optimal operating range is the range of speeds within which torque, output power, and efficiency are at a maximum.*

*One can make several key observations from question 1 and the graphs:*

- 1. Efficiency is highest when the shaft speed is above 1900rpm.*
- 2. Torque is highest when the shaft speed is above 2000rpm.*
- 3. Armature loss increases slightly (but stays relatively constant) as shaft speed increases.*
- 4. Field coil loss increases as shaft speed increases and increases sharply when the shaft speed is greater than 1900rpm.*

*From these observations, one can conclude that the motor is in its optimal operating range when the shaft speed is between 2000rpm and 2100rpm. Above 1900rpm, the field coil loss increases more quickly than the total power output, resulting in a decreasing efficiency above 1900rpm.*

## Appendix A: Motor Connections

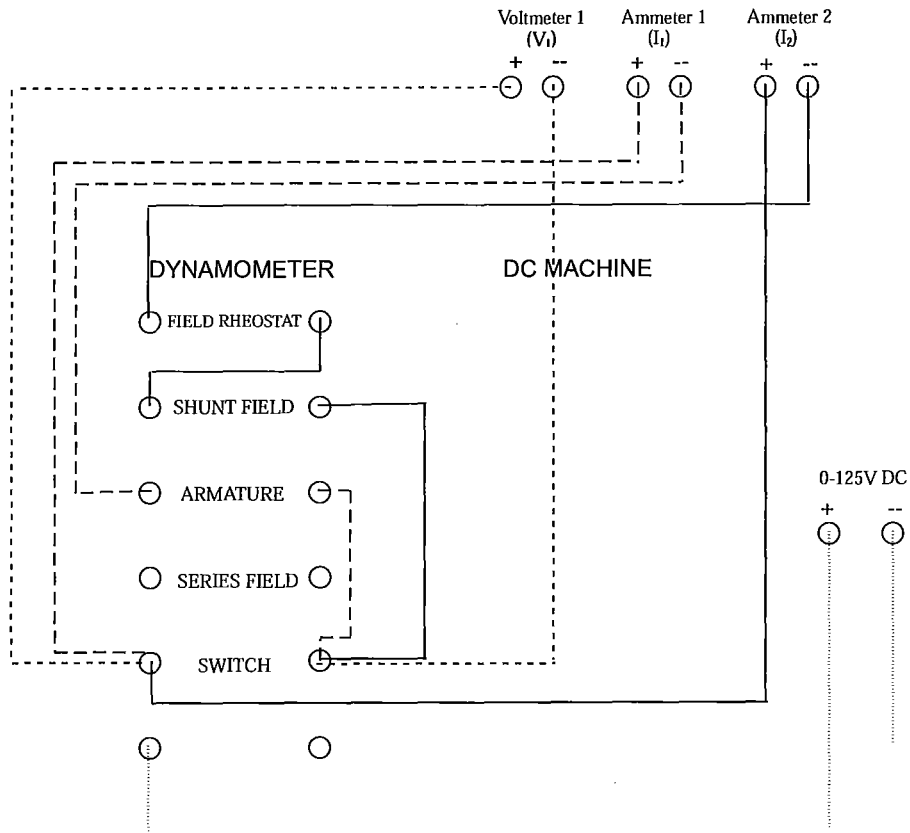

## Appendix B: Generator Connections

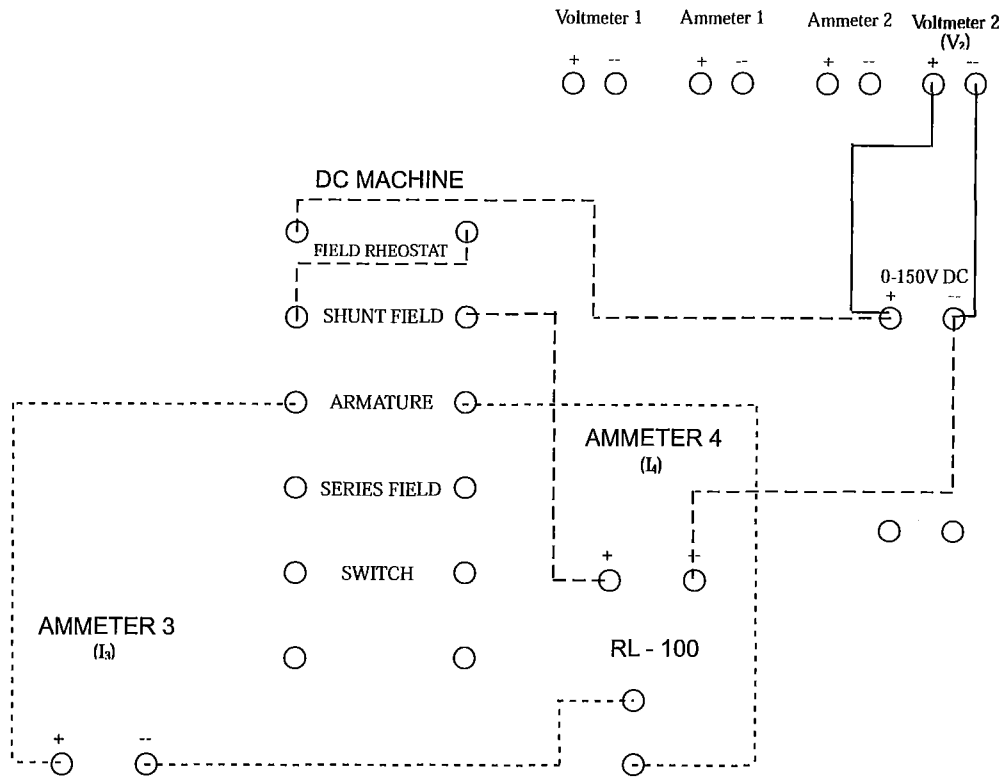



# Lab 1

## *DC Motors and Generators: Efficiency and Losses*

### Solutions Manual

Concept Check (Solutions) .....	2
Data Collection (Solutions).....	5
Table 1: Collected Data.....	5
Data Analysis (Solutions) .....	6
Table 2: Motor Calculations.....	6
Table 3: Generator Calculations.....	7
Discussion (Solutions) .....	8

## Concept Check (Solutions)

1. . An electric motor:

- (a) converts mechanical energy into electrical energy

*Incorrect; a motor converts electrical energy into mechanical energy.*

→(b) does not convert all input power into output power.

*Correct; there are always power losses in a motor due to internal mechanical and electrical resistances.*

- (c) contains an alternator coil and a rotor coil.

*Incorrect; a motor contains an alternator which, in turn, contains an armature coil (the rotor) and a field coil (the stator)*

- (d) can also be called a regenerative braking system.

*Incorrect; a regenerative braking system is a type of generator.*

2. The armature carries current that is:

- (a) drawn directly from a battery or generator.

*Partially correct; this is true in a motor.*

- (b) induced as the armature rotates through a magnetic field.

*Partially correct; this is true in a generator.*

→(c) either (a) or (b), depending on whether it is part of a generator or a motor.

*Correct; see (a) and (b) for explanation.*

- (d) An armature does not carry current.

*Incorrect; the armature coil becomes an electromagnet by carrying current.*

3. Generators:

→(a) are used in regenerative braking systems.

*Correct; generators play a key role in regenerative braking systems.*

- (b) do not appear in modern electric vehicles.

*Incorrect; gasoline generators appear in hybrid vehicles and electric generators play a key role in regenerative braking systems.*

- (c) convert electrical energy into mechanical energy.

*Incorrect; generators convert mechanical energy into electrical energy.*

- (d) all of the above.

*Incorrect; see (b) and (c) for explanation.*

4. The efficiency of an electric vehicle:

- (a) is not an overwhelming concern in vehicle design.

*Incorrect; increasing vehicle efficiency is a main focus for modern technicians.*

- (b) is the ratio of input power to output power.

*Correct; efficiency is the ratio of input power to output power and is most often expressed as a percentage. However, (d) is a better answer.*

- (c) is reduced when motor parts are poorly machined.

*Correct; poorly machined parts increase power loss due to friction, thereby reducing vehicle efficiency. However, (d) is a better answer.*

→(d) b and c

*Correct; see (b) and (c) for explanation.*

5. A regenerative braking system:

- (a) creates electrical energy by regenerating the motor.

*Incorrect; a regenerative braking system converts mechanical energy into electrical energy by running the motor backwards as a generator. One cannot create energy.*

- (b) lets no rotational energy be dissipated as heat.

*Incorrect; a regenerative braking system relies on a generator, and is therefore not 100% efficient. Some rotational energy is dissipated as heat due to internal resistances.*

→(c) is an electric generator that converts rotational energy into electrical energy.

*Correct; a regenerative braking system converts rotational energy into electrical energy as a vehicle slows.*

- (d) is powered by gasoline.

*Incorrect; a regenerative braking system is a generator powered by the rotational energy of vehicle tires. See answer (c).*

6. Power losses in a motor or generator occur:

(a) in the armature coil only.

*Incorrect; power losses do occur in the armature coil, but they also occur elsewhere.*

(b) in the armature and field coils only.

*Incorrect; power losses do occur in the armature and field coils, but they also occur elsewhere.*

(c) in the rotating shaft only.

*Incorrect; power losses do occur in the rotating shaft, but they also occur elsewhere.*

→(d) in every part of the machine.

*Correct; power losses occur in every part of the machine, though some parts have higher losses than others.*

7. In this lab, the motor is a(n) \_\_\_\_ machine and the generator is a(n) \_\_\_\_ machine.

(a) AC, AC

*Incorrect; see (a) for explanation.*

(b) AC, DC

*Incorrect; see (a) for explanation.*

(c) DC, AC

*Incorrect; see (a) for explanation.*

→(d) DC, DC

*Correct; this lab uses the DC Machine and the Dynamometer, both of which are DC machines.*

8. **Big Picture:** In Lab 1, your overall aim is to:

(a) measure shaft speed, torque, armature current, and field voltage.

*Incorrect; while you will measure these quantities in Lab 1, your overall aim is to use them for calculating efficiency (see (b)).*

- (b) find the efficiency of a motor and a generator and identify the source of power losses.

*Correct; the objective of Lab 1 is to calculate motor/generator efficiency and to identify power losses.*

- (c) observe the effect of a changing load on motor and generator efficiency.

*Incorrect; the load is held constant in Lab 1, at 68.18Ω.*

- (d) find the output power of a motor and a generator.

*Incorrect; while you will calculate these quantities in Lab 1, your overall aim is to use them for calculating efficiency (see (b)).*

## Data Collection (Solutions)

Table 1: Collected Data

1	2	3	4	5	6	7	8	9
$\omega_{\text{shaft}}$ (RPM)	$\tau_{\text{shaft}}$ (N·m)	$I_1$ (Amps)	$I_2$ (Amps)	$I_3$ (Amps)	$I_4$ (Amps)	$V_1$ (Volts)	$V_2$ (Volts)	$R_{\text{Load}}$ (Ω)
1500	1.105	1.85	2.38	1.41	0.38	124	130	68.18
1600	1.15	2.00	2.43	1.49	0.38	124	130	68.18
1700	1.2	2.15	2.54	1.56	0.38	124	130	68.18
1800	1.25	2.35	2.69	1.65	0.38	124	130	68.18
1900	1.275	2.50	2.87	1.73	0.38	124	130	68.18
2000	1.3	2.70	3.08	1.81	0.38	124	130	68.18
2100	1.305	3.00	3.30	1.89	0.38	124	130	68.18

## Data Analysis (Solutions)

Table 2: Motor Calculations

1	2	3	4	5	6	7
$I_{Field}$ (Amps)	$P_{In}$ (Watts)	$P_{Arm}$ (Watts)	$P_{Field}$ (Watts)	$P_{Out}$ (Watts)	$\eta_{Motor}$ (%)	$\eta_{Arm}$ (%)
0.53	294.50	229.40	68.25	173.57	58.94	75.66
0.43	301.32	248.00	55.90	192.68	63.95	77.70
0.39	314.96	266.60	50.70	213.63	67.83	80.13
0.34	333.56	291.40	44.20	234.68	70.36	80.53
0.37	355.88	310.00	48.10	253.68	71.28	81.83
0.38	381.92	334.80	49.40	272.27	71.29	81.32
0.30	409.20	372.00	39.00	286.98	70.13	77.15

- Using equation 1, find the current through the motor rheostat and field coil. Record the result in column 1 of Table 2.

$$(1) I_{Field} = I_2 - I_1$$

- Calculate the power input to the motor armature, the power input to the motor field coil and rheostat, and the total power supplied to the motor. Record the results in columns 2-4 of Table 2.

$$(2) P_{Arm} = V_1 \cdot I_1$$

$$(3) P_{Field} = V_1 \cdot I_{Field}$$

$$(4) P_{In} = V_1 \cdot I_2$$

- Use equation 5 to calculate the power output of the motor. Record the results in column 5 of Table 2.

**Note:** Because the motor shaft and the generator shaft are mechanically linked, the power *output* of the motor is equal to the power *input* to the generator armature. Therefore, you may also record these results in column 1 of Table 3.

$$(5) P_{Out}[Motor] = P_{Arm}[Generator] = \frac{\tau_{shaft} \cdot 2\pi \cdot \omega_{shaft}}{60}$$

4. Use equation 6 to calculate the % efficiency of the motor and record the results in column 6 of Table 2.

$$(6) \eta_{Motor} = \frac{P_{Out}}{P_{In}} \cdot 100$$

5. Find the % efficiency of the motor armature using equation 7. Record the results in column 7 of Table 2.

$$(7) \eta_{Arm} = \frac{P_{Out}}{P_{Arm}} \cdot 100$$

**Table 3: Generator Calculations**

1	2	3	4	5	6
$P_{Arm}$ (Watts)	$P_{Field}$ (Watts)	$P_{In}$ (Watts)	$P_{Out}$ (Watts)	$\eta_{Generator}$ (%)	$\eta_{Arm}$ (%)
173.57	49.40	222.97	135.55	60.73	78.09
192.68	49.40	242.08	151.37	62.53	78.56
213.63	49.40	263.03	165.92	63.08	77.67
234.68	49.40	284.08	185.62	65.34	79.10
253.68	49.40	303.08	204.06	67.33	80.44
272.27	49.40	321.67	223.36	69.44	82.04
286.98	49.40	336.38	243.55	72.40	84.86

6. Using equation 8, find the power supplied to the generator field coil. Record the results in column 2 of Table 3. Then, use equation 9 to compute the input power to the generator. Record the results in column 3 of Table 3.

$$(8) P_{Field} = V_2 \cdot I_A$$

$$(9) P_{In} = P_{Arm} + P_{Field}$$

7. Use equation 10 to find the power output of the generator (the power supplied to the load.) Record the results in column 4 of Table 3.

$$(10) P_{Out} = I_3^2 \cdot R_{Load}$$

8. Using equation 11, calculate the % efficiency of the generator. Record the results in column 5 of Table 2.

$$(11) \eta_{Generator} = \frac{P_{Out}}{P_{In}} \cdot 100$$

9. Find the % efficiency of the generator armature using equation 12. Record the results in column 6 of Table 2.

$$(12) \eta_{Arm} = \frac{P_{Out}}{P_{Arm}} \cdot 100$$

## Discussion (Solutions)

1. Where do the most significant energy losses occur in the motor? What could be responsible for these losses?

**Hint:** Compare the input power to the armature input power. Then, compare the armature input power to the armature output power (the total output). Which efficiency is higher, the total efficiency or the armature efficiency? What accounts for the difference?

*The most significant energy losses occur in (1) the field/rheostat circuit branch and (2) the armature.*

*(1) The field/rheostat branch: In the range of shaft speeds tested, 75-90% of the input power reaches the armature; as the shaft speed increases, more current (and therefore a higher portion of the input power) is drawn through the armature. The remaining power (10-25% of the input) flows through the field coil and the rheostat, where most of it is either dissipated by the rheostat (which is an electrical resistor) or is used to power the field coil. Other minor losses in this branch include dissipation by resistance in the motor wires and connections.*

*(2) The armature branch: In the range of shaft speeds tested, 75-80% of the electrical power drawn into the armature circuit branch is converted into a mechanical output. The remaining power (20-25% of the armature input) is dissipated as heat due to the internal friction between the motor's moving parts. Other minor losses in this branch include dissipation by resistance in the motor wires and connections.*



2. Where do the most significant energy losses occur in the generator? What could be responsible for these losses?

*The most significant energy losses occur in (1) the field/rheostat circuit and (2) the armature.*

*(1) The field/rheostat circuit: In the range of shaft speeds tested, only 77-85% of the total input power is a direct input to the armature. As the speed of the armature shaft increases, the mechanical power input to the system increases; however, a constant amount of electrical power must be separately supplied to the field coil. As the mechanical input changes, this electrical input comprises 15-23% of the total power input. This electrical power input flows through the field coil and the rheostat, where most of it is either dissipated by the rheostat (which is an electrical resistor) or is used to power the field coil. Other minor losses in this branch include dissipation by resistance in the motor wires and connections.*

*(2) The armature branch: In the range of shaft speeds tested, 78-85% of the mechanical power input to the armature is converted into an electrical power output. The remaining power (15-22% of the armature input) is dissipated as heat due to the internal friction between the motor's moving parts. Other minor losses in this branch include dissipation by resistance in the motor wires and connections.*

3. How would the efficiency of each machine change if the field coils were replaced by permanent magnets?

*The efficiency of each machine would simply become the armature efficiency. Permanent magnets, unlike field coils, do not require an electrical input in order to generate a magnetic field. Thus, replacing the field coil with a permanent magnet eliminates one of the main power losses (the field/rheostat branch, see questions 1 and 2) from the machine and increases efficiency by 15-20%.*

4. Plot a curve showing the relationship of motor efficiency and shaft speed. Plot speed along the x-axis and efficiency along the y-axis. Title the graph "Motor Efficiency." On the same graph, also plot the motor armature efficiency.

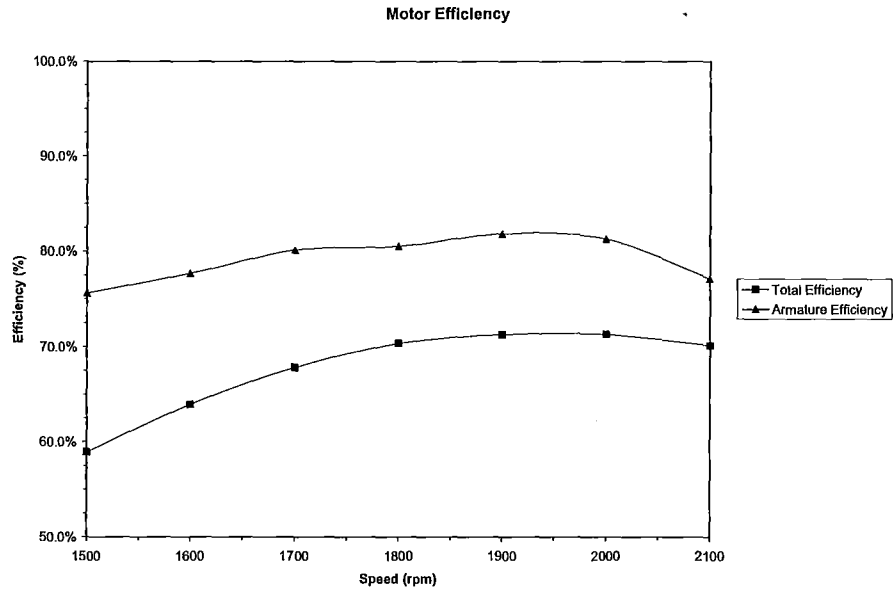

5. On a separate graph, plot the relationship between generator efficiency and shaft speed. Title the graph "Generator Efficiency." On the same graph, also plot the generator armature efficiency.

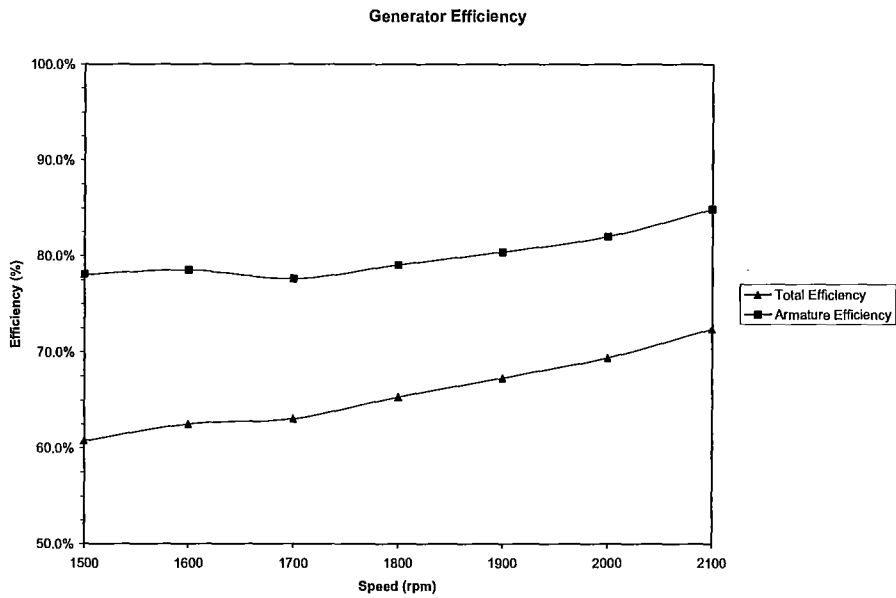

- Plot a curve showing the relationship of shaft speed and motor output torque. Plot speed along the x-axis scale and torque along the y-axis. Title the graph "Torque and Power."

See question 7.

- On the same graph, plot a curve showing the relationship between shaft speed and output power (use the same x-axis scale for speed, make a second scale along the y-axis for power.)

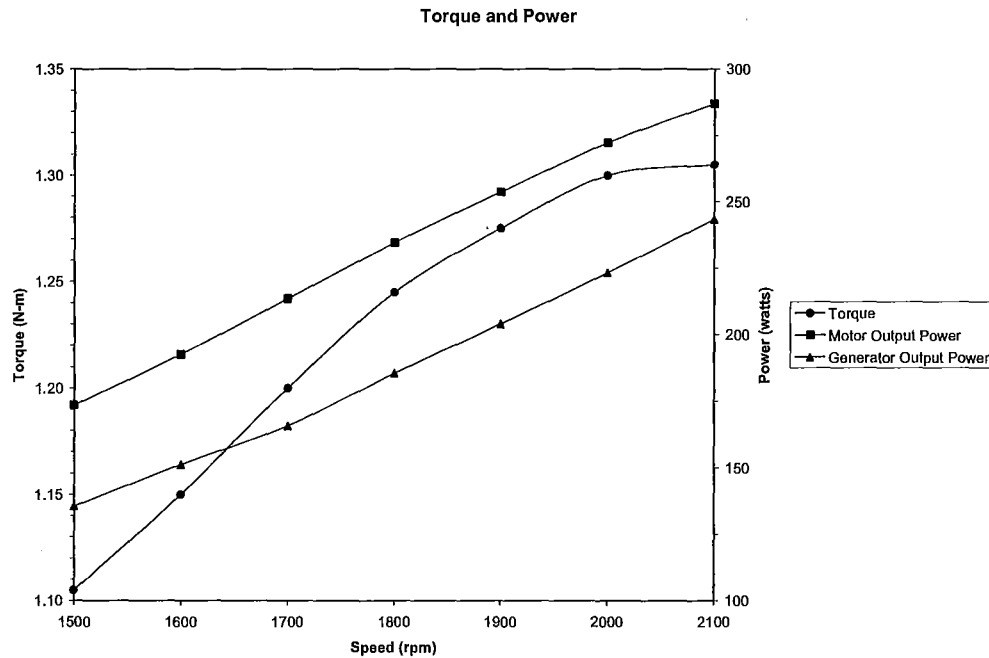

- For which shaft speeds are the efficiencies highest? For which shaft speeds does the motor produce the highest output torque?

*Motor efficiency is highest (around 80%) when the shaft speed is greater than approximately 1900rpm. Until 1900rpm, motor efficiency increases as shaft speed increases. Above 1900rpm, the efficiency remains at approximately 80%.*

*Generator efficiency is highest (around 80%) when the shaft speed is 2100rpm. Generator efficiency increases as shaft speed increases.*

*Output torque is highest when the shaft speed is greater than approximately 2000rpm. Until 2000rpm, torque increases linearly in the region of shaft speeds that we tested; above 2000rpm, the torque remains at approximately 1.3 N-m.*

9. What is the relationship between power and torque?

*When the shaft speed is less than 2000rpm, both torque and output power increase linearly. The output power is directly related to the shaft speed in this region. When the shaft speed is greater than 2000rpm, the torque remains the same, while the power continues to increase. The torque and output power are independent of each other in this region.*

10. How would you define an optimal operating range? Based on your graphs and your answers in question 1, what can you conclude about the optimal operating range (i.e. range of optimal shaft speeds) of the motor?

*The optimal operating range is the range of speeds within which torque, output power, and efficiency are at a maximum.*

*One can make several key observations from question 1 and the graphs:*

- 1. Efficiency is highest when the shaft speed is above 1900rpm.*
- 2. Torque is highest when the shaft speed is above 2000rpm.*
- 3. Armature loss increases slightly (but stays relatively constant) as shaft speed increases.*
- 4. Field coil loss increases as shaft speed increases and increases sharply when the shaft speed is greater than 1900rpm.*

*From these observations, one can conclude that the motor is in its optimal operating range when the shaft speed is between 2000rpm and 2100rpm.*

*Above 1900rpm, the field coil loss increases more quickly than the total power output, resulting in a decreasing efficiency above 1900rpm.*

# Lab 1

## *DC Motors and Generators: Efficiency and Losses*

Student Manual

Background Information.....	2
Concept Check.....	3
Objectives .....	5
Equipment.....	5
Procedure .....	5
Data Collection .....	8
Table 1: Collected Data.....	8
Data Analysis .....	8
Table 2: Motor Calculations.....	8
Table 3: Generator Calculations.....	10
Discussion.....	11
Appendix A: Motor Connections.....	12
Appendix B: Generator Connections .....	13

## Background Information

An **electric motor** is a device that transforms *electrical* energy into *mechanical* energy through electromagnetic induction. An electromagnet is rotated in the presence of a second, stationary electromagnet; the interaction of the two magnetic fields results in a torque that drives a shaft. In a sense, a **generator** is simply an electric motor working backwards, transforming *mechanical* energy into *electrical* energy. The source of the mechanical energy can be anything that turns a shaft- from a simple hand crank to a steam engine, wheels turned by road friction to an electric motor- but the principle remains the same. The mechanical force moves a magnet near a wire in order to induce a magnetic flux which, in turn, creates a steady flow of electrons in the wire.

Hybrid and electric vehicles (HEVs) contain both motors and generators. HEVs are powered by a combination of a gasoline-powered engine and a battery-powered electric motor. These two power sources can be combined either in **parallel** (in which both the engine and the electric motor are directly connected to the transmission) or in **series** (in which only the electric motor is directly connected to the transmission; the gasoline engine turns a generator that either charges the batteries or directly powers the electric motor.)

You will most frequently encounter two types of generators in HEVs. The type of generator discussed above, that appears in series hybrid systems, is called a **gasoline generator**. The second type, common to both hybrid and electric vehicles, is the **regenerative braking system**. Such a system runs the electric motor backwards as a vehicle brakes, using the motor as a generator that is turned by the transaxle as the vehicle slows. The mechanical energy of the spinning axles, instead of being completely dissipated by traditional brakes, is partially converted into electrical energy that recharges the car batteries.

Both motors and generators contain an **alternator**, which converts the mechanical input into an electrical output or vice versa. An alternator contains a **rotor** (the rotating component) and a **stator** (the stationary component).

In electrical terms, the stator is called the **field coil**: it contains either a permanent magnet or, more commonly, an electromagnet (current-carrying wire wound in coils around an iron core). The field coil creates a magnetic field through which the rotor will turn.

The rotor can also be called the **armature coil**. In a motor, the armature coil acts as an electromagnet; a power source directly *supplies* current through the armature coil. The interaction between the two magnetic fields (of the field coil and the armature coil) results in a torque that drives a shaft. In a generator, the armature is not connected to an external power source. Instead, as the armature rotates through the magnetic field created by the field coil, the resulting magnetic flux *induces* a current in the armature. This current flows through a load (like the motor of a car) or back to a battery, recharging it for future use.

Not all of the input energy to a motor or generator is transformed into output energy; some energy is lost during the process due to friction between parts, inappropriate operating conditions, necessary internal power draws, and dozens of other factors. The ratio of input energy to output energy is called **efficiency**, and one of the most important challenges for modern technicians is to develop vehicles with the highest efficiency. In this laboratory exercise,

you will be working with a self-excited<sup>1</sup> shunt motor, commonly used to power vehicles, and a separately-excited shunt generator, much like those used in regenerative braking and series hybrid systems. You will calculate the power inputs, outputs, and efficiencies of both machines and determine the operating range for which each machine has the highest efficiency.

## Concept Check

1. An electric motor:

- (a) converts mechanical energy into electrical energy.
- (b) does not convert all input power into output power.
- (c) contains an alternator coil and a rotor coil.
- (d) can also be called a regenerative braking system.

2. The armature carries current that is:

- (a) drawn directly from a battery or generator.
- (b) induced as the armature rotates through a magnetic field.
- (c) either (a) or (b), depending on whether it is part of a generator or a motor.
- (d) An armature does not carry current.

3. Generators:

- (a) are used in regenerative braking systems.
- (b) do not appear in modern electric vehicles.
- (c) convert electrical energy into mechanical energy.
- (d) all of the above.

---

<sup>1</sup> A generator may be **self-excited** (the field coil is powered by some of the current produced in the armature) or **separately-excited** (the field coil is powered by an independent outside power source.) The advantages of self-excitation include high starting torque and rapid acceleration, but separately-excited generators are more often used in electric vehicles, as they offer excellent control flexibility and potential for optimization.

4. The efficiency of an electric vehicle:

- (a) is not an overwhelming concern in vehicle design.
- (b) is the ratio of input power to output power.
- (c) is reduced when motor parts are poorly machined.
- (d) b and c

5. A regenerative braking system:

- (a) creates electrical energy by regenerating the motor.
- (b) lets no rotational energy be dissipated as heat.
- (c) is an electric generator that converts rotational energy into electrical energy.
- (d) is powered by gasoline.

6. Power losses in a motor or generator occur:

- (a) in the armature coil only.
- (b) in the armature and field coils only.
- (c) in the rotating shaft only.
- (d) in every part of the machine.

7. In this lab, the motor is a(n) \_\_\_\_ machine and the generator is a(n) \_\_\_\_ machine.

- (a) AC, AC
- (b) AC, DC
- (c) DC, AC
- (d) DC, DC

8. **Big Picture:** In Lab 1, your overall aim is to:

- (a) measure shaft speed, torque, armature current, and field voltage.
- (b) find the efficiency of a motor and a generator and identify the source of power losses.
- (c) observe the effect of a changing load on motor and generator efficiency.
- (d) find the output power of a motor and a generator.



## Objectives

1. To gain hands-on experience with the circuitry layout of DC motors and generators.
2. To calculate the efficiency of a self-excited motor and of a separately-excited generator.
3. To determine where losses occur in DC electric machines and discuss methods for reducing losses and increasing efficiency.
4. To identify the ideal operating range for electric motors and for electric generators.

## Equipment

### Console Instruments:

1. 0-150 volt Variable DC supply, 1 amp
2. (2) 0-150 volt DC voltmeter
3. (2) 0-5.0amp DC ammeter

### Additional Equipment:

1. DM-100A DC Machine
2. DYN-100-DM Dynamometer
3. RL-100A Resistance Load Bank
4. HT-100 Series Tachometer
5. (2) Auxiliary ammeter

## Procedure

1. Place the two machines on the bedplate with the motor (DYN-100-DM Dynamometer) on the left and the generator (DM-100A DC Machine) on the right.
2. Couple the machines and clamp both tightly to the bedplate.
3. Turn the knob of the 0-125 volt and the 0-150 volt DC supplies fully counterclockwise to the zero output position. Power should remain off.

4. Connect the motor as shown in Figure 1. Refer to Appendix A for schematic of motor. Turn the motor's field rheostat knob (black dial located on top of the dynamometer) fully counterclockwise to its minimum resistance position.

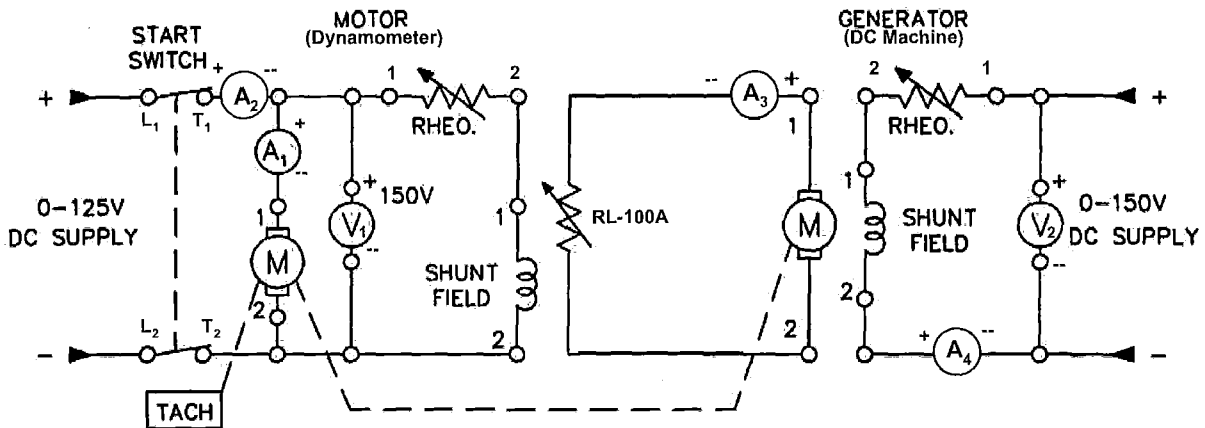

Figure 1: Motor and generator connections

5. Connect the generator as shown in Figure 1. Refer to Appendix B for schematic of generator. Note that this is a separately excited generator connection. Turn the generator's field rheostat knob (black dial located on top of the DC machine) fully counterclockwise to its minimum resistance position.
6. Ground both machines. (Connect the green terminal on each machine to the green terminal on the console.)
7. Have someone check your connections to be sure they are correct. Be certain that your auxiliary ammeter is ON and set to handle at least 2.5A of current. Then turn ON only the main AC and the 0-150V DC supply circuit breakers.
8. Turn ON the 0-150 volt supply and the circuit breaker switch.
9. Locate the voltmeter connected across the 0-150 volt supply ( $V_2$ ) and adjust the knob until voltmeter 2 reads 124 volts. (If you followed the setup in Appendix B,  $V_2$  is the voltmeter on the left of the console.)
10. Turn the generator's field rheostat knob (located on top of DC Machine) clockwise until voltmeter 2 reads 130V.
11. Calibrate the dynamometer. (Turn the silver knob, located on top of the scale, until the scale reads zero.)
12. Turn ON the 0-125 volt supply and the circuit breaker switches on the motor.
13. Locate the voltmeter connected across the 0-125 volt supply ( $V_1$ ) and start the motor by adjusting the knob until  $V_1$  reads 124 volts. (If you followed the setup in Appendix A,  $V_1$  is the voltmeter on the left of the console.)

14. Now locate the RL-100A Resistance Load Bank. Switch on resistance legs 1-10. This will produce a load of  $68.18\Omega$ .
15. Adjust the knob on the tachometer to read 1500 RPM.
16. Point the tachometer against the motor shaft and turn the motor's field rheostat knob clockwise until the motor shaft appears to stop moving.
17. Recheck voltmeter 1 to verify that the output of the 0-125 volt supply is still 124 volts. If it is not, adjust 0-125 volt supply until voltmeter 1 reads 125V and then repeat step 16.
18. Record the following values in Table 1:
  - a. *Shaft speed*: Adjust the field rheostat knob until the motor shaft appears to stop moving under the light of the tachometer. Record the value displayed on the tachometer screen in column 1.
  - b. *Torque*: Record the value displayed by the dynamometer scale in column 2. Use the outer scale and record all results in N·m.
  - c. *Motor armature current*: Verify that  $A_1$  (the leftmost ammeter) is set to read on a 0-2.5A scale. Record the value displayed by ammeter 1 in column 3. (Note: If the needle points at or past the 2.5A mark for later measurements, you will need to adjust  $A_1$  to read on a 0-5.0A scale.)
  - d. *Motor input current*: Verify that  $A_2$  (the rightmost ammeter) is set to read on a 0-5.0A scale. Record the value displayed by ammeter 2 in column 4.
  - e. *Load current*: Record the value displayed by  $A_3$ , an auxiliary ammeter, in column 5.
  - f. *Generator input current*: Record the value displayed by  $A_4$ , an auxiliary ammeter, in column 6.
  - g. *Motor and generator voltages*: Record the values displayed by voltmeters 1 and 2 in columns 7 and 8. (Since you are constantly monitoring the power into the motor in step 17, these values should remain fixed at 124 and 130 volts, respectively.)
19. Adjust the speed on the tachometer to 1600 RPM
20. Repeat steps 16-18.
21. Repeat, increasing tachometer speed by intervals of 100 RPM, until the tachometer reads 2100 RPM.
22. Adjust all voltage supplies to zero and turn OFF all circuit breaker switches.

### Data Collection

Table 1: Collected Data

1	2	3	4	5	6	7	8	9
$\omega_{\text{shaft}}$ (RPM)	$\tau_{\text{shaft}}$ (N·m)	$I_1$ (Amps)	$I_2$ (Amps)	$I_3$ (Amps)	$I_4$ (Amps)	$V_1$ (Volts)	$V_2$ (Volts)	$R_{\text{Load}}$ ( $\Omega$ )
						124	130	68.18
						124	130	68.18
						124	130	68.18
						124	130	68.18
						124	130	68.18
						124	130	68.18
						124	130	68.18

### Data Analysis

Table 2: Motor Calculations

1	2	3	4	5	6	7
$I_{\text{Field}}$ (Amps)	$P_{\text{In}}$ (Watts)	$P_{\text{Arm}}$ (Watts)	$P_{\text{Field}}$ (Watts)	$P_{\text{Out}}$ (Watts)	$\eta_{\text{Motor}}$ (%)	$\eta_{\text{Arm}}$ (%)

- Using equation 1, find the current through the motor rheostat and field coil. Record the result in column 1 of Table 2.

$$(1) I_{Field} = I_2 - I_1$$

- Calculate the power input to the motor armature, the power input to the motor field coil and rheostat, and the total power supplied to the motor. Record the results in columns 2-4 of Table 2.

$$(2) P_{Arm} = V_1 \cdot I_1$$

$$(3) P_{Field} = V_1 \cdot I_{Field}$$

$$(4) P_{In} = V_1 \cdot I_2$$

- Use equation 5 to calculate the power output of the motor. Record the results in column 5 of Table 2.

**Note:** Because the motor shaft and the generator shaft are mechanically linked, the power *output* of the motor is equal to the power *input* to the generator armature. Therefore, you may also record these results in column 1 of Table 3.

$$(5) P_{Out}[Motor] = P_{Arm}[Generator] = \frac{\tau_{shaft} \cdot 2\pi \cdot \omega_{shaft}}{60}$$

- Use equation 6 to calculate the % efficiency of the motor and record the results in column 6 of Table 2.

$$(6) \eta_{Motor} = \frac{P_{Out}}{P_{In}} \cdot 100$$

- Find the % efficiency of the motor armature using equation 7. Record the results in column 7 of Table 2.

$$(7) \eta_{Arm} = \frac{P_{Out}}{P_{Arm}} \cdot 100$$

Table 3: Generator Calculations

1	2	3	4	5	6
$P_{Arm}$ (Watts)	$P_{Field}$ (Watts)	$P_{In}$ (Watts)	$P_{Out}$ (Watts)	$\eta_{Generator}$ (%)	$\eta_{Arm}$ (%)

6. Using equation 8, find the power supplied to the generator field coil. Record the results in column 2 of Table 3. Then, use equation 9 to compute the input power to the generator. Record the results in column 3 of Table 3.

$$(8) P_{Field} = V_2 \cdot I_4$$

$$(9) P_{In} = P_{Arm} + P_{Field}$$

7. Use equation 10 to find the power output of the generator (the power supplied to the load.) Record the results in column 4 of Table 3.

$$(10) P_{Out} = I_3^2 \cdot R_{Load}$$

8. Using equation 11, calculate the % efficiency of the generator. Record the results in column 5 of Table 2.

$$(11) \eta_{Generator} = \frac{P_{Out}}{P_{In}} \cdot 100$$

9. Find the % efficiency of the generator armature using equation 12. Record the results in column 6 of Table 2.

$$(12) \eta_{Arm} = \frac{P_{Out}}{P_{Arm}} \cdot 100$$

## Discussion

1. Where do the most significant energy losses occur in the motor? What could be responsible for these losses?

**Hint:** Compare the input power to the armature input power. Then, compare the armature input power to the armature output power (the total output). Which efficiency is higher, the total efficiency or the armature efficiency? What accounts for the difference?

2. Where do the most significant energy losses occur in the generator? What could be responsible for these losses?
3. How would the efficiency of each machine change if the field coils were replaced by permanent magnets?
4. Plot a curve showing the relationship of motor efficiency and shaft speed. Plot speed along the x-axis and efficiency along the y-axis. Title the graph "Motor Efficiency." On the same graph, also plot the motor armature efficiency.
5. On a separate graph, plot the relationship between generator efficiency and shaft speed. Title the graph "Generator Efficiency." On the same graph, also plot the generator armature efficiency.
6. Plot a curve showing the relationship of shaft speed and motor output torque. Plot speed along the x-axis scale and torque along the y-axis. Title the graph "Torque and Power."
7. On the same graph, plot a curve showing the relationship between shaft speed and output power (use the same x-axis scale for speed, make a second scale along the y-axis for power.)
8. For which shaft speeds are the efficiencies highest? For which shaft speeds does the motor produce the highest output torque?
9. What is the relationship between power and torque?
10. How would you define an optimal operating range? Based on your graphs and your answers in question 1, what can you conclude about the optimal operating range (i.e. range of optimal shaft speeds) of the motor?

## Appendix A: Motor Connections

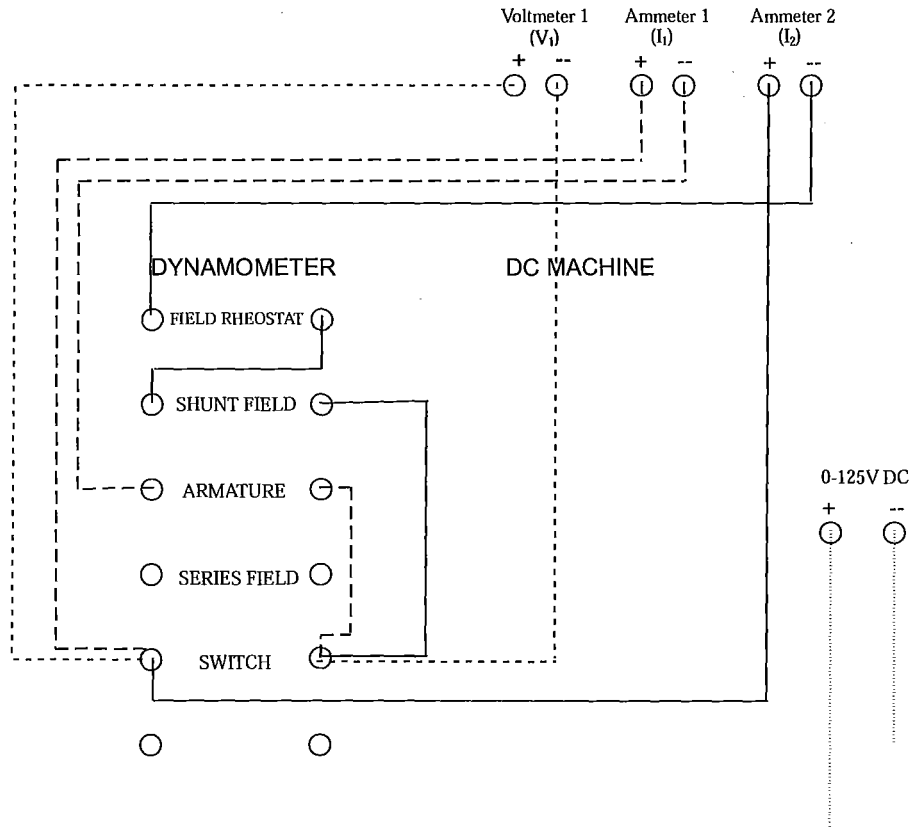



## Appendix B: Generator Connections

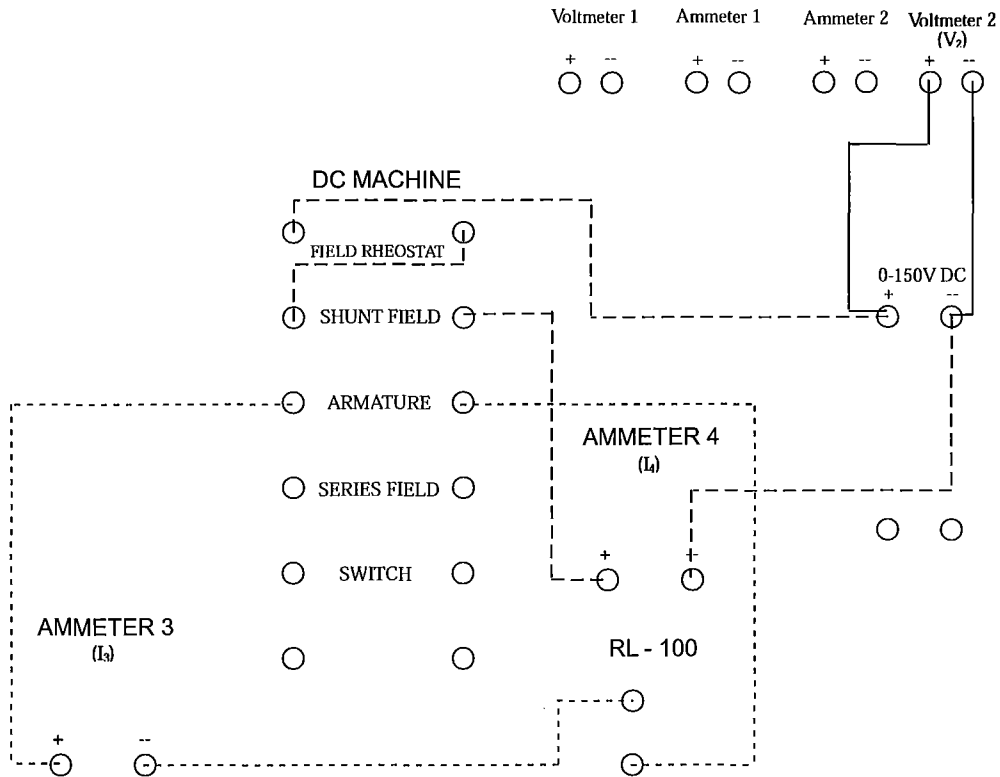

# Lab 2

## *AC Motors: Efficiency and Losses*

Instructor Manual

Background Information.....	2
Concept Check (Solutions) .....	3
Objectives .....	6
Equipment .....	7
Procedure .....	7
Part I: No Load Test.....	7
Part II: Locked Rotor Test.....	9
Part III: Load Test .....	9
Data Collection (Solutions).....	11
Data Analysis (Solutions) .....	12
Discussion .....	15
Appendix A: Installing the Rotor Locking Device .....	19
Appendix B: Motor Connections .....	19
Appendix C: Generator Connections .....	20

## Background Information

An alternating-current (AC) motor, like a DC motor, converts electrical energy into mechanical energy by means of electromagnetic induction. However, while a DC motor has a *rotating* armature coil and a stationary field coil, an AC motor uses a *stationary* armature coil and a rotating field coil (or permanent magnet). This eliminates the need for the commutator and brushes of a DC machine. This, along with their superior speed control, ability to deliver high initial torque, and overall high efficiency have contributed to the increasing popularity of AC motors in hybrid and electric vehicle (HEV) applications.

There are two main types of AC motors, both of which run using 3-phase<sup>1</sup> AC power: **synchronous** and **asynchronous**. The main difference is simple: synchronous rotors rotate at the same rate as the changing magnetic fields in the motor (the “synchronous speed”) and asynchronous rotors rotate at a rate slightly off from the synchronous speed. Though permanent magnet (PM) synchronous machines are sometimes used in HEVs, this lab will focus on the asynchronous AC machine, more commonly called an **induction motor**.

Within the category of induction motors, there are also two main types: squirrel-cage and wound rotor. The difference lies in the rotor structure, as all induction motors (and, indeed, all AC motors) use the same type of stator. **Wound-rotors** are exactly that; a set of “windings” (wire wrapped around a solid core) that are connected by slip-rings to form a cylinder. The **squirrel-cage rotor** is the most common in automotive applications. It consists of two conductive rings connected by a set of copper or aluminum bars to form a cylinder (see Figure A).

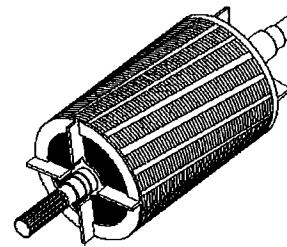

Figure A: Squirrel-cage rotor

This lab examines the squirrel-cage induction motor, the type of AC motor used most often in the automotive industry. It has a squirrel-cage rotor, as described above, and a typical AC motor stator. This stator consists of three electromagnets (conducting wire wound several times around a core) that are evenly spaced around the cylindrical interior of the motor.

In this lab, you will measure the power input, output, and efficiency of an AC induction motor, both while unloaded and driving a DC generator (a configuration often seen in HEVs<sup>2</sup>). You will then use these results to determine optimal operating range for the AC induction motor.

---

<sup>1</sup> In a 3-phase system, three different conductors carry sinusoidal currents (of the same frequency). Taking one conductor as the reference, the other two currents are delayed in time by one-third and two-thirds of one cycle of the electrical current. In this way, one of the conductors is carrying the maximum level of current at any given point.

<sup>2</sup> See Lab 1 Background for a discussion on series and parallel power source configurations in HEVs.

## Concept Check (Solutions)

1. AC motors are often used to power HEVs because:

- (a) it is easy to control AC motor speed.

*Partially correct; one can easily control the shaft speed of an AC motor by varying the frequency of the input current.*

- (b) AC motors deliver high initial torque.

*Partially correct; AC motors can almost instantly deliver their rated torque upon starting.*

- (c) AC motors require less maintenance than DC motors.

*Partially correct; because AC motors are brushless, they require less maintenance than the brushed DC motors usually used in automotive applications.*

→(d) all of the above.

*Correct; see (a), (b), and (c) for explanation.*

2. The main difference between AC and DC machines is:

- (a) AC machines use alternating current, while DC machines use direct current.

*Partially correct; AC and DC machines use alternating current (AC) and direct current (DC) respectively.*

- (b) AC machines are brushed while DC machines are brushless.

*Incorrect; many DC machines used in automotive applications are brushed (they use a commutator and brush to create a magnetomotive force), while AC machines are brushless (they use alternating current to create a magnetomotive force.)*

- (c) the armature is on the rotor in DC machines and on the stator in AC machines.

*Partially correct; in DC machines, the armature coil is the rotor and the field coil is the stator. The opposite is true in AC machines.*

→(d) Both a and c are major differences.

*Correct; see (a) and (c) for explanation.*

3. An induction motor is a:

- (a) permanent magnet (PM) motor.

*Incorrect; permanent magnet (PM) motors are a type of synchronous AC machine. An induction motor is a type of asynchronous AC machine.*

- (b) asynchronous motor.

*Correct; "induction motor" is another term for "asynchronous motor."*

- (c) squirrel-cage motor.

*Incorrect; a squirrel-cage motor is only one type of induction motor.*

- (d) all of the above.

*Incorrect; see (a) and (c) for explanation.*

4. An asynchronous motor:

- (a) most often uses 2-phase power.

*Incorrect; an asynchronous motor most often uses 3-phase power.*

- (b) is an induction motor.

*Correct; "induction motor" is another term for "asynchronous motor."*

- (c) has a rotor that spins in synch with the changing magnetic fields.

*Incorrect; an asynchronous motor has a rotor that spins slightly out of synch with the changing magnetic fields.*

- (d) Both a and b are correct.

*Incorrect; see (a) for explanation.*

5. An AC motor has two main parts. One part is the stator, which:

- (a) can be constructed in three distinct ways.

*Incorrect; the stator is constructed the same way in all AC machines.*

- (b) contains the three field coils.

*Incorrect; while the stator does contain three electromagnets, these are not the field coils. The field coil is located on the rotor in an AC machine.*

→(c) can also be called the armature coil.

*Correct; the stator can also be called the armature coil in an AC motor, as the stator is the part of the motor in which a current is induced by magnetomotive forces.*

(d) Both a and c are correct.

*Incorrect; see (a) for explanation.*

6. The other part of an AC motor is the rotor. The rotor:

→(a) often used in HEVs is the squirrel-cage rotor.

*Correct; the squirrel-cage rotor is often used in HEVs.*

(b) is the same in every AC motor.

*Incorrect; there are many different types of AC rotors, including squirrel-cage, permanent magnet (PM), and wound rotors.*

(c) is most often made of copper and steel.

*Incorrect; squirrel-cage rotors are made of highly conductive metals, such as copper and aluminum. Other types of rotors can be made of wires, magnets, or other metals.*

(d) can also be called the armature coil.

*Incorrect; the rotor can also be called the field coil in AC machines.*

7. If a wattmeter needle moves to the left of the zero on the wattmeter scale, you should:

(a) Record the negative number to which the needle points.

*Incorrect; the wattmeter scale does not include negative values.*

(b) Turn the wattmeter off and switch the leads. Then, record all future readings as positive.

*Incorrect; all readings should be recorded as negative once the leads are switched.*

→(c) Turn the wattmeter off and switch the leads. Then, record all future readings as negative.

*Correct; proceed as in step 10b in Part I.*

(d) It is impossible for the wattmeter needle to move to the left of the zero.

*Incorrect; when the power factor is negative, the wattmeter needle will point to the left of the zero on the wattmeter scale.*

8. **Big Picture:** The purpose of Part I is to \_\_\_\_\_, while Part II focuses on \_\_\_\_\_.

(a) study only the motor; both the motor and the generator

*Incorrect; Both Part I and Part II focus on taking measurements and making calculations for only the motor. The generator functions only to load the motor.*

→ (b) gather data for calculating copper and frictional losses; gathering data to calculate motor efficiency

*Correct; In Part I, you gather data that allows you to calculate copper and frictional losses. In Part II, you gather data that allows you to calculate motor efficiency.*

(c) study power only; studying power and torque

*Incorrect; Both Part I and Part II study power, but in different contexts (see (b) for explanation). Torque is measured in Part II, but with the purpose of using it to study power.*

(d) study AC machines only; both AC and DC machines

*Incorrect; Both Part I and Part II focus on taking measurements and making calculations for only the motor, which is an AC machine. The DC generator functions only to load the motor.*

## Objectives

1. To gain hands-on experience with the circuitry layout of AC induction motors.
2. To calculate the efficiency of an induction motor.
3. To determine where losses occur in AC machines and discuss methods for reducing losses and increasing efficiency.
4. To identify the ideal operating range for AC induction motors.

## Equipment

### Console Instruments:

1. Variable 3 $\phi$  AC supply
2. 0-300 volt AC Voltmeter
3. 0-4 amp AC Ammeter
4. (2) AC Wattmeter
5. 0-150 volt Variable DC Supply, 1 amp
6. 0-150 volt DC Voltmeter
7. 0-2.4 amp DC Ammeter

### Additional Equipment:

1. IM-100 Induction Motor
2. DYN-100-DM Dynamometer
3. RL-100A Resistance Load Bank
4. HT-100 Series Tachometer

## Procedure

### Part I: No Load Test

1. Place the IM-100 induction motor on the left side of the bedplate. Clamp it tightly.
2. Connect the motor to the variable 240V AC supply as shown in Figure 2. (Refer to Appendix B for schematic of motor.) Ground the motor by connecting the green terminal on the motor to the green terminal on the console.

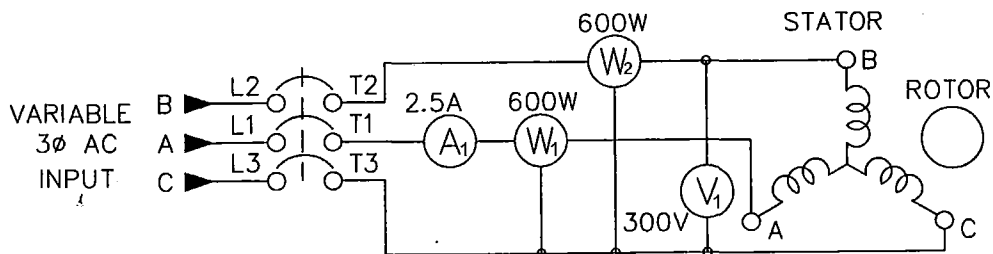

*Figure 2: Motor (no load)*

3. Have someone check your connections to be sure they are correct.
4. Turn the knob of the 0-240V AC power supply fully counterclockwise to the zero output position. Power should remain off. Verify that the circuit breaker switch on the motor is off.



5. Turn ON the main AC and the 0-240V AC power supply.
6. Locate the voltmeter connected across the 0-240V supply ( $V_1$ ) and adjust the power supply knob until there is an output of 210 volts. (Note: If you followed the setup in Appendix A,  $V_1$  is the only voltmeter on the left side of the console.)
7. Locate  $A_1$ , an AC ammeter on the left side of the console. Turn the current reading knob fully clockwise to 8 amps. (This sets the ammeter to read a current from 0-8.0A and is to protect against an inrush of current when the motor is turned on.)
8. Locate the two wattmeters in the center of the console. Verify that both wattmeters are turned off.
9. Turn ON the motor.
10. Turn on each wattmeter in turn and observe which way the needle moves.
  - a. If the needle moves to the right side of the zero on the wattmeter scale (a positive number), leave the wattmeter on.
  - b. If the needle moves to the left side of the zero on the wattmeter scale (a negative number), turn the wattmeter off. Reverse the leads of the voltage terminals, keeping all current connections the same, and turn on the wattmeter again. It should now read a positive number, though the readings from this wattmeter should be recorded as negative.

**Note:** The power factor on an unloaded induction motor is likely to be negative, but the wattmeter cannot display negative values. For this reason, we proceed as in step 9b in the case that the wattmeter reads a negative value.

11. Record the following values in Table 2:
  - a. *Motor current:* Set ammeter 1 to read on a 0-2.0A scale. Record the displayed value in column 1.
  - b. *Input power:* Turn wattmeter 1 fully clockwise to read on a 0-300W scale. Record the displayed value in column 2, referring to the conversion table directly beneath the wattmeters for proper scaling. Turn wattmeter 2 fully counterclockwise to read on a 0-150W scale. Record the displayed value in column 3. If necessary, remember to record readings as negative (see step 9)!
12. Turn OFF the motor. Turn the 0-240V AC supply knob fully clockwise to the zero output position. Turn OFF the wattmeters. Turn OFF all circuit breaker switches.
13. If necessary, readjust the leads of the wattmeters so that they are once again wired according to the schematic in Appendix A.

## Part II: Locked Rotor Test

1. Locate the dynamometer. Install the rotor locking device, referring to Appendix A for directions.
2. Place the dynamometer on the right side of the bedplate. Couple it to the induction motor and clamp both machines securely in place. Install all the safety guards.
3. Verify that the 0-240V AC supply knob is turned to the zero output position. Turn the current reading knob on ammeter 1 fully clockwise to 8 amps.
4. Turn ON the main circuit breaker switch. Turn ON the 0-240V AC circuit breaker switch. Turn ON the motor.
5. Slowly increase the output of the 0-240V AC supply until ammeter 1 reads 2.4A.
6. Turn on both wattmeters and record the following values in Table 1:
  - a. *Motor current:* Set ammeter 1 to read on a 0-4.0A scale. Record the displayed value in column 1.
  - b. *Input power:* Turn wattmeter 1 fully clockwise to read on a 0-300W scale. Record the displayed value in column 2, referring to the conversion table directly beneath the wattmeters for proper scaling. Turn wattmeter 2 fully counterclockwise to read on a 0-150W scale. Record the displayed value in column 3.
7. Turn OFF the motor. Adjust the knob of the 0-240V AC supply back to zero. Turn OFF the wattmeters. Turn OFF all circuit breaker switches.
8. Remove the rotor locking device.

## Part III: Load Test

1. Connect the dynamometer as shown in Figure 3. (Refer to Appendix C for schematic of generator.) Ground the dynamometer by connecting the green terminal on the machine to the green terminal on the console.

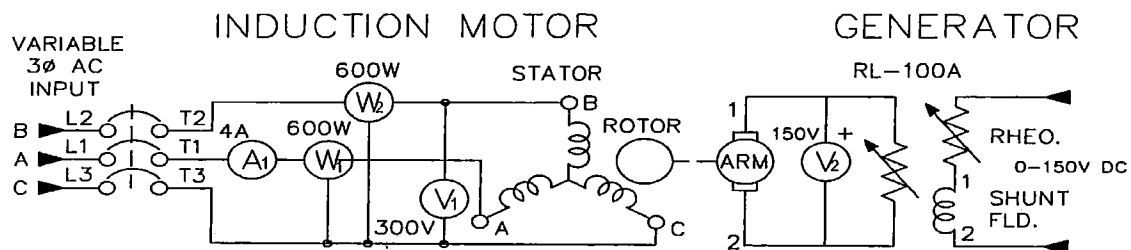

Figure 3: Motor and generator (with load)

2. Have someone check your connections to be sure they are correct.
  3. Calibrate the dynamometer. (Turn the silver knob, located on top of the scale, until the scale reads zero.)
  4. Adjust the dynamometer field rheostat knob (black dial located on top of the dynamometer) fully clockwise to its maximum resistance position. Verify that both power supply knobs are turned fully counterclockwise to the zero output position.
  5. With the motor switch OFF, turn on the main AC, the 0-240V AC, and the 0-150V DC supplies.
  6. Using the reading from  $V_1$ , adjust the AC supply to 210 volts.
  7. Slowly turn the 0-150V DC supply knob fully clockwise.
  8. Make sure all switches on the RL-100A resistance load bank are off, in the downward position. Turn the current reading knob on ammeter 1 fully clockwise to 8 amps.
  9. Turn the motor ON.
  10. Adjust ammeter 1 to read on a 0-2.0A scale. Repeat step 10 of Part 1.
  11. Locate the DC voltmeter across the generator armature,  $V_2$ . Adjust the dynamometer field rheostat knob (the black dial located on top of the dynamometer) until voltmeter 2 reads 120V DC.
  12. Read and record the following values in Table 3:
    - a. *Motor current*: Set ammeter 1 to read on a 0-2.0A scale. Record the displayed value in column 2.
    - b. *Input power*: Turn wattmeter 1 fully clockwise to read on a 0-300W scale. Record the displayed value in column 3, referring to the conversion table directly beneath the wattmeters for proper scaling. Turn wattmeter 2 fully counterclockwise to read on a 0-150W scale. Record the displayed value in column 4. If necessary, remember to record readings as negative (see step 9)!
    - c. *Torque*: Record the value displayed by the dynamometer scale in column 5. Use the outer scale and record all results in N·m.
    - d. *Shaft speed*: Turn on the tachometer and set it to read 1500rpm. Then, keeping the tachometer pointed at the shaft, turn the black dial on the tachometer *away* from you (so that the displayed value increases) until the shaft appears to stop moving. Record the value displayed by the tachometer in column 6.
- Note:** If it becomes necessary to switch wattmeter leads at any time during the experiment, switch off the relevant wattmeter before removing the leads.
13. Turn ON load steps 1 and 2 on the RL-100A load bank.

14. Adjust the dynamometer's field rheostat knob as required to maintain a reading of 120V on voltmeter 2.
15. Repeat steps 12-14, switching on two additional load steps each time, until load steps 1-12 are switched on.
16. Turn OFF the motor. Adjust all voltage supplies to zero. Turn OFF the wattmeters. Turn OFF all circuit breaker switches.

### Data Collection (Solutions)

**Table 1: Locked Rotor Test**

1	2	3
$I_{LR}$ (Amps)	$P_1$ (Watts)	$P_2$ (Watts)
2.40	156.00	48.00

**Table 2: No Load Test**

1	2	3
$I_{NL}$ (Amps)	$P_3$ (Watts)	$P_4$ (Watts)
1.20	184.0	-101.0

Table 3: Load Test

1	2	3	4	5	6
Load	$I_L$ (Amps)	$P_5$ (Watts)	$P_6$ (Watts)	$\tau_{\text{shaft}}$ (N·m)	$\omega_{\text{shaft}}$ (rpm)
None	1.250	204.0	-92.0	0.150	1792.3
1-2	1.250	214.0	-72.0	0.255	1787.1
1-4	1.255	230.0	-54.0	0.400	1781.6
1-6	1.355	250.0	-26.0	0.600	1774.6
1-8	1.400	268.0	-1.0	0.800	1766.3
1-10	1.505	316.0	50.0	1.255	1748.1
1-12	1.950	400.0	134.0	1.855	1716.9

### Data Analysis (Solutions)

Table 4: Locked Rotor Calculations

1	2	3
$P_{\text{In}}$ (Watts)	$R_{\text{Internal}}$ ( $\Omega$ )	$P_{\text{CL}}$ (Watts)
204.0	11.81	204.0

- Using the results of the locked rotor test, you can calculate the internal resistance of the induction motor. First, find the total input power during the locked rotor test,  $P_{\text{InLR}}$ , using equation 1. Record the result in column 1 of Table 4.

$$(1) P_{\text{InLR}} = P_1 + P_2$$

2. Because the rotor is locked, all parts inside of the motor are stationary. Thus, all of the input power must be dissipated *inside* of the motor due to internal electrical resistance. We can find this internal resistance,  $R_{Internal}$ , using formula 2. Record the result in column 2 of Table 4.

$$(2) R_{Internal} = \frac{P_{InLR}}{3 \cdot I_{LR}^2}$$

3. Internal electrical losses are also called **copper losses**. During the locked rotor test, all of the input power is dissipated internally so that the copper loss during the locked rotor test,  $P_{CL1}$ , is given by equation 3. Record the result column 3 of Table 4.

$$(3) P_{CL1} = P_{InLR}$$

**Table 5: No Load Calculations**

1	2	3
$P_{In}$ (Watts)	$P_{CL}$ (Watts)	$P_{FL}$ (Watts)
83.0	51.0	32.0

4. Using the results of the no load test, you can calculate the power loss due to rotational friction. First, calculate the total input power during the no load test,  $P_{InNL}$ , using equation 4. Record the result in column 1 of Table 5.

$$(4) P_{InNL} = P_3 + P_4$$

5. Because the motor shaft is allowed to spin freely under no load, all of the input power is dissipated *inside* of the motor due either to electrical resistance (copper loss) or mechanical resistance (friction loss.) Use equation 5 to find the copper loss during the no load test,  $P_{CL2}$ . Record the result in column 2 of Table 5.

$$(5) P_{CL2} = 3 \cdot I_{NL}^2 \cdot R_{Internal}$$

6. As stated above, the no load input power is the sum of the no load copper loss and the friction loss. Use this relationship (found in equation 6) to calculate the friction loss. Record this result in column 3 of Table 5.

$$(6) P_{FL} = P_{InNL} - P_{CL2}$$

**Note:** The friction loss,  $P_{FL}$ , is a mechanical loss; it is independent of the current through the motor and therefore has a *constant* value, regardless of loading conditions. Therefore, you may copy your calculated value for  $P_{FL}$  (in column 3 of Table 5) into column 4 of Table 6.

**Table 6: Load Calculations**

1	2	3	4	5	6	7
Load	$P_{In}$ (Watts)	$P_{CL}$ (Watts)	$P_{FL}$ (Watts)	$P_{Loss}$ (Watts)	$P_{Out}$ (Watts)	$\eta_{Motor}$ (%)
No Load	112.0	55.34	32.0	87.34	28.15	0.2514
1-2	142.0	55.34	32.0	87.34	47.72	0.3361
1-4	176.0	55.78	32.0	87.78	74.63	0.4240
1-6	224.0	65.03	32.0	97.03	111.50	0.4978
1-8	267.0	69.42	32.0	101.42	147.97	0.5542
1-10	366.0	80.22	32.0	112.22	229.74	0.6277
1-12	534.0	134.67	32.0	166.67	333.52	0.6246

7. Using equation 7, find the total power input to the motor for each loading condition. Record the results in column 2 of Table 6.

$$(7) P_{InL} = P_5 + P_6$$

8. Use equation 8 to calculate the copper loss at each loading condition. Record the results in column 3 of Table 6.

$$(8) P_{CL3} = 3 \cdot I_L^2 \cdot R_{Internal}$$

9. Use equation 9 to find the total power loss for each loading condition. Record result in column 5 of Table 6.

$$(9) P_{Loss} = P_{FL} + P_{CL3}$$

10. Using equation 10, calculate the output power,  $P_{Out}$ , for each loading condition. Record the result in column 6 of Table 6.

$$(10) P_{Out} = \frac{\tau_{shaft} \cdot 2\pi \cdot \omega_{shaft}}{60}$$

11. Use equation 11 to find the efficiency of the motor for each loading condition. Record the result in column 7 of Table 6.

$$(11) \eta_{Motor} = \frac{P_{Out}}{P_{In}} \cdot 100$$

## Discussion

1. In Analysis 9, you found the power loss,  $P_{Loss}$ , by adding the copper loss and the frictional loss. Another way to find the  $P_{Loss}$  is to subtract the output power from the input power. Calculate  $P_{Loss}$  this way (using  $P_{Loss} = P_{In} - P_{Out}$ ) and make a table comparing your newly calculated values for  $P_{Loss}$  to the values of  $P_{Loss}$  in column 5 of Table 5. Do your results suggest that copper and frictional losses are the only losses?

1	2	3
Load	$P_{Loss} (P_{FL} + P_{CL})$ (Watts)	$P_{Loss} (P_{In} - P_{Out})$ (Watts)
No Load	87.34	83.85
1-2	87.34	94.28
1-4	87.78	101.37
1-6	97.03	112.50
1-8	101.42	119.03
1-10	112.22	136.26
1-12	166.67	200.48



*These results suggest the copper and frictional losses are not the only losses; in all but the unloaded case, the actual power loss (found using  $P_{Loss} = P_{In} - P_{Out}$ ) is greater than just the sum of the copper and frictional losses.*

2. Based on your results in Table 6 and your answer to question 1, where do the most significant energy losses occur in the motor? What is responsible for these losses? What might be responsible for any additional losses?

*The most significant energy losses are (1) the copper loss and (2) the frictional (mechanical) loss.*

*(1) The copper loss: Copper loss is a variable loss; the amount of energy lost due to copper loss increases as the load increases. However, the percentage of energy lost due to copper loss decreases as load increases. For the loading conditions tested, copper loss accounts for 20-50% of input power, with the largest copper losses occurring when there is no load. Copper losses occur due to electrical resistances inside of the motor and are dependent on the amount of current flowing through the motor.*

*(2) The frictional (mechanical) loss in the motor: Frictional losses are fixed; the amount of energy lost due to friction remains constant, regardless of load. As such, frictional losses account for anywhere from 6% to 30% of input power. It occurs due to the internal friction between the motor's moving parts, which dissipates energy as heat.*

*Other, minor power losses account for 5-8% of the input energy. Mechanical friction in the generator or in the axle coupling, electrical resistance in the generator, and assorted electrical losses in the wires connecting the motor may be responsible for additional losses. There may have been an unavoidable experimental error in the calculation of motor internal resistance and/or mechanical friction; it is also possible that internal resistance and/or mechanical friction vary slightly with increased load, a factor that has been neglected in this lab*

- Plot a curve showing the relationship between motor efficiency and shaft speed. Plot speed along the x-axis and efficiency along the y-axis. Label the graph "Efficiency."

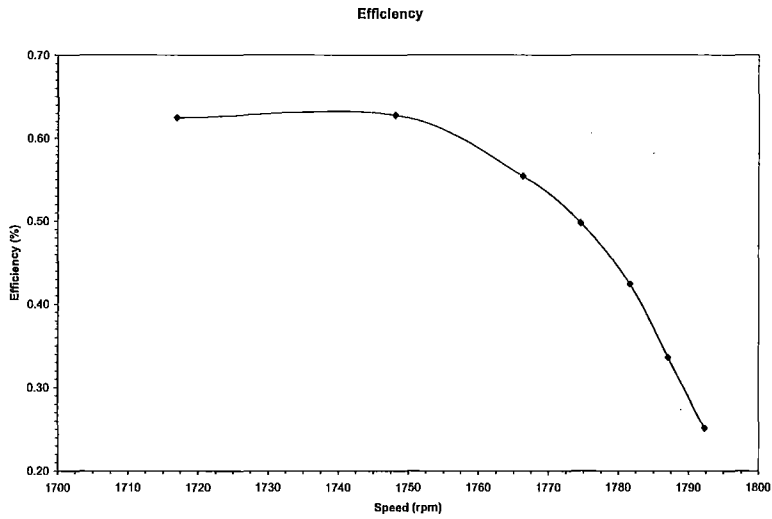

- Plot a curve showing the relationship between shaft speed and output torque. Plot speed along the x-axis and efficiency along the y-axis. Label the graph "Torque and Power."

See question 5.

- On the same graph, plot a curve showing the relationship between shaft speed and output power (use the same x-axis scale for speed, make a second scale along the y-axis for power.)

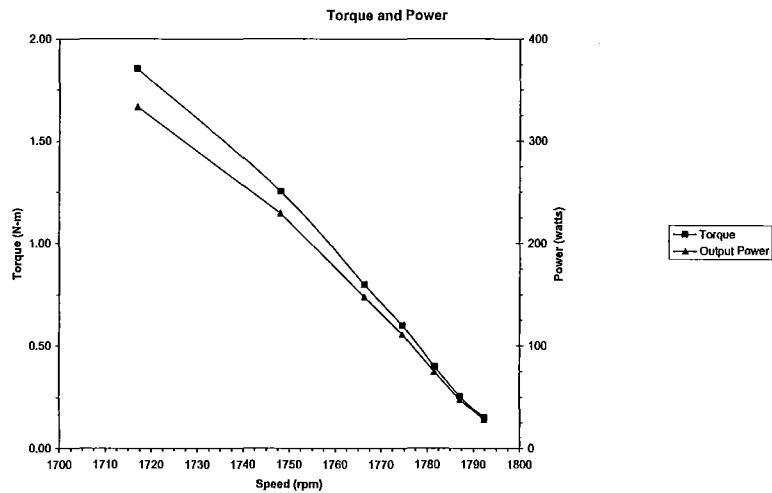

6. For which shaft speeds is the motor efficiency highest? For which shaft speeds does the motor produce the highest output torque?

*Efficiency is highest (around 60%) when the shaft speed is less than 1750rpm. Above 1750rpm, efficiency begins to decrease approximately linearly. Output torque decreases linearly in the region of shaft speeds that we tested; therefore, the highest output torque occurs at lower shaft speeds.*

7. What is the relationship between output power and torque?

*Power and torque both decrease (in an approximately linear manner) as shaft speed increases. Thus, output power and torque are directly related (as power changes linearly with torque).*

8. How would you define an optimal operating range? Based on your graphs and your answers in question 2, what can you conclude about the optimal operating range (i.e. range of optimal shaft speeds) of the motor?

*The optimal operating range is the range of speeds within which torque, output power, and efficiency are at a maximum.*

*One can make several key observations from question 2 and the graphs:*

- 1. Efficiency is highest when the shaft speed is below 1750rpm*
- 2. Torque and output power decrease linearly as shaft speed increases*
- 3. Copper loss and stray power loss increase as current (input power) increases. Both decrease as shaft speed increases.*
- 4. Copper loss decreases more slowly than output power above a shaft speed of 1750rpm.*
- 5. Frictional loss is independent of shaft speed.*

*From these observations, one can conclude that the motor is in its optimal operating range when the shaft speed is between 1710rpm and 1750rpm. Above 1750rpm, the copper loss decreases more slowly than the total power output, resulting in a decreasing efficiency above 1750rpm.*

## Appendix A: Installing the Rotor Locking Device

1. Check that there are NO leads connected to the dynamometer. If possible, the machine should be oriented so that the right side is facing you.
2. Locate the rotor locking device. Notice that the front face has a pin protruding from the center while the back face has two thumbscrews, one in each corner.
3. Locate the circular indentation in the rotor on the dynamometer's right side. The pin will fit into this indentation. Then, locate the two threaded holes through the righthand coupling disk of the dynamometer. The thumbscrews will fit into these holes.
4. Align the coupling disk with the thumbscrews and fit the pin into the indentation.
5. Tightly screw the thumbscrews into the threaded holes in the coupling disk.
6. Carefully test your installation by manually turning the left side of the dynamometer axle. The finished locking device should keep the dynamometer axle from rotating more than a few degrees in any direction.

## Appendix B: Motor Connections

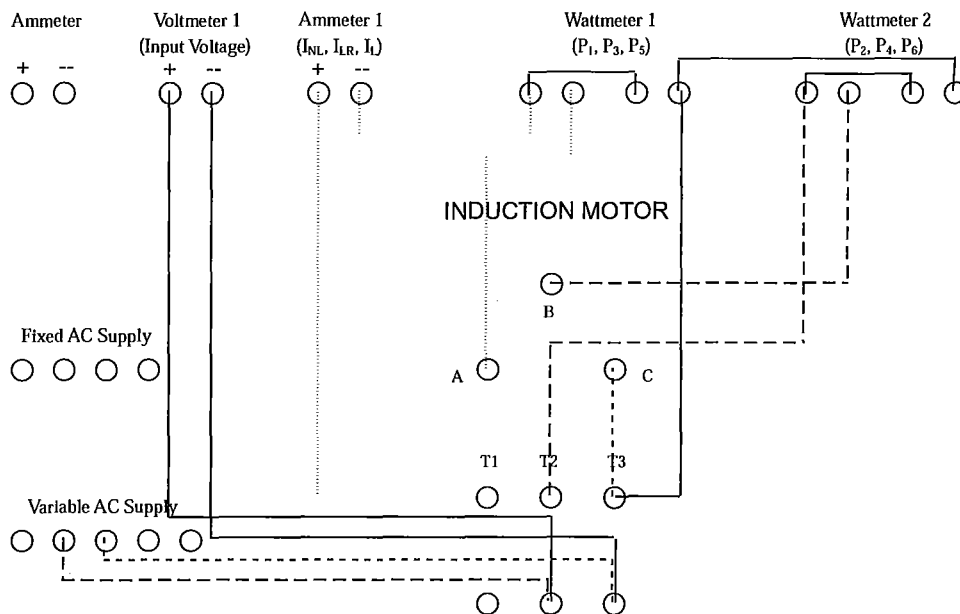

### Appendix C: Generator Connections

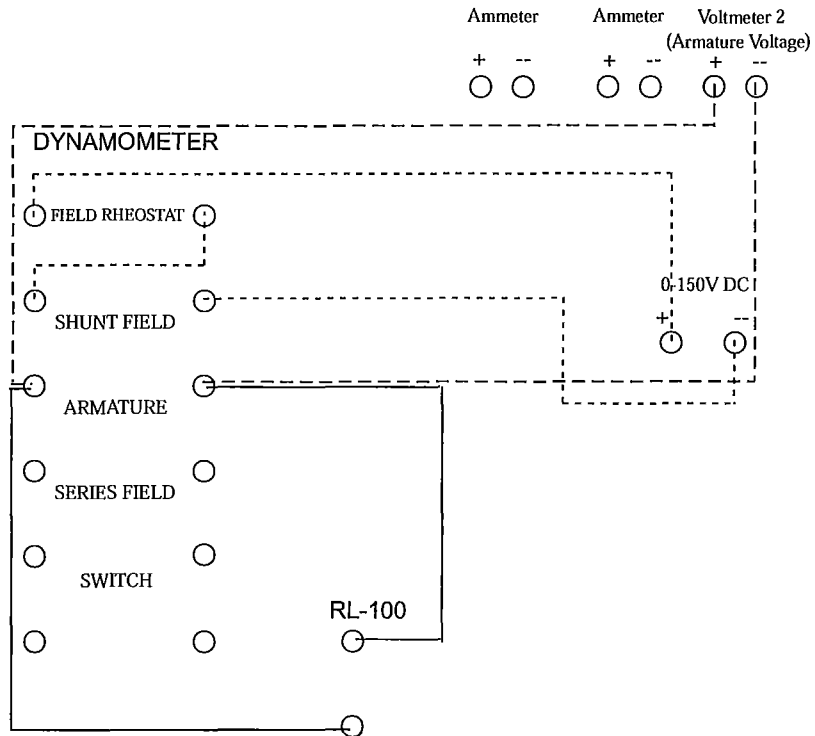

**Lab 2**  
*AC Motors: Efficiency and Losses*  
Solution Manual

Concept Check (Solutions) ..... 2  
Data Collection (Solutions)..... 5  
Data Analysis (Solutions) ..... 6  
Discussion..... 9

## Concept Check (Solutions)

1. AC motors are often used to power HEVs because:

- (a) it is easy to control AC motor speed.

*Partially correct; one can easily control the shaft speed of an AC motor by varying the frequency of the input current.*

- (b) AC motors deliver high initial torque.

*Partially correct; AC motors can almost instantly deliver their rated torque upon starting.*

- (c) AC motors require less maintenance than DC motors.

*Partially correct; because AC motors are brushless, they require less maintenance than the brushed DC motors usually used in automotive applications.*

→(d) all of the above.

*Correct; see (a), (b), and (c) for explanation.*

2. The main difference between AC and DC machines is:

- (a) AC machines use alternating current, while DC machines use direct current.

*Partially correct; AC and DC machines use alternating current (AC) and direct current (DC) respectively.*

- (b) AC machines are brushed while DC machines are brushless.

*Incorrect; many DC machines used in automotive applications are brushed (they use a commutator and brush to create a magnetomotive force), while AC machines are brushless (they use alternating current to create a magnetomotive force.)*

- (c) the armature is on the rotor in DC machines and on the stator in AC machines.

*Partially correct; in DC machines, the armature coil is the rotor and the field coil is the stator. The opposite is true in AC machines.*

→(d) Both a and c are major differences.

*Correct; see (a) and (c) for explanation.*

3. An induction motor is a:

- (a) permanent magnet (PM) motor.

*Incorrect; permanent magnet (PM) motors are a type of synchronous AC machine. An induction motor is a type of asynchronous AC machine.*

→(b) asynchronous motor.

*Correct; "induction motor" is another term for "asynchronous motor."*

- (c) squirrel-cage motor.

*Incorrect; a squirrel-cage motor is only one type of induction motor.*

- (d) all of the above.

*Incorrect; see (a) and (c) for explanation.*

4. An asynchronous motor:

- (a) most often uses 2-phase power.

*Incorrect; an asynchronous motor most often uses 3-phase power.*

→(b) is an induction motor.

*Correct; "induction motor" is another term for "asynchronous motor."*

- (c) has a rotor that spins in synch with the changing magnetic fields.

*Incorrect; an asynchronous motor has a rotor that spins slightly out of synch with the changing magnetic fields.*

- (d) Both a and b are correct.

*Incorrect; see (a) for explanation.*

5. An AC motor has two main parts. One part is the stator, which:

- (a) can be constructed in three distinct ways.

*Incorrect; the stator is constructed the same way in all AC machines.*

- (b) contains the three field coils.

*Incorrect; while the stator does contain three electromagnets, these are not the field coils. The field coil is located on the rotor in an AC machine.*

→(c) can also be called the armature coil.



*Correct; the stator can also be called the armature coil in an AC motor, as the stator is the part of the motor in which a current is induced by magnetomotive forces.*

- (d) Both a and c are correct.

*Incorrect; see (a) for explanation.*

6. The other part of an AC motor is the rotor. The rotor:

- (a) often used in HEVs is the squirrel-cage rotor.

*Correct; the squirrel-cage rotor is often used in HEVs.*

- (b) is the same in every AC motor.

*Incorrect; there are many different types of AC rotors, including squirrel-cage, permanent magnet (PM), and wound rotors.*

- (c) is most often made of copper and steel.

*Incorrect; squirrel-cage rotors are made of highly conductive metals, such as copper and aluminum. Other types of rotors can be made of wires, magnets, or other metals.*

- (d) can also be called the armature coil.

*Incorrect; the rotor can also be called the field coil in AC machines.*

7. If a wattmeter needle moves to the left of the zero on the wattmeter scale, you should:

- (a) Record the negative number to which the needle points.

*Incorrect; the wattmeter scale does not include negative values.*

- (b) Turn the wattmeter off and switch the leads. Then, record all future readings as positive.

*Incorrect; all readings should be recorded as negative once the leads are switched.*

- (c) Turn the wattmeter off and switch the leads. Then, record all future readings as negative.

*Correct; proceed as in step 10b in Part I.*

- (d) It is impossible for the wattmeter needle to move to the left of the zero.

*Incorrect; when the power factor is negative, the wattmeter needle will point to the left of the zero on the wattmeter scale.*

8. **Big Picture:** The purpose of Part I is to \_\_\_\_\_, while Part II focuses on \_\_\_\_\_.

(a) study only the motor; both the motor and the generator

*Incorrect; Both Part I and Part II focus on taking measurements and making calculations for only the motor. The generator functions only to load the motor.*

→ (b) gather data for calculating copper and frictional losses; gathering data to calculate motor efficiency

*Correct; In Part I, you gather data that allows you to calculate copper and frictional losses. In Part II, you gather data that allows you to calculate motor efficiency.*

(c) study power only; studying power and torque

*Incorrect; Both Part I and Part II study power, but in different contexts (see (b) for explanation). Torque is measured in Part II, but with the purpose of using it to study power.*

(d) study AC machines only; both AC and DC machines

*Incorrect; Both Part I and Part II focus on taking measurements and making calculations for only the motor, which is an AC machine. The DC generator functions only to load the motor.*

### Data Collection (Solutions)

**Table 1: Locked Rotor Test**

1	2	3
$I_{LR}$ (Amps)	$P_1$ (Watts)	$P_2$ (Watts)
2.40	156.00	48.00

**Table 2: No Load Test**

1	2	3
---	---	---

$I_{NL}$ (Amps)	$P_3$ (Watts)	$P_4$ (Watts)
1.20	184.0	-101.0

Table 3: Load Test

1	2	3	4	5	6
Load	$I_L$ (Amps)	$P_5$ (Watts)	$P_6$ (Watts)	$\tau_{shaft}$ (N·m)	$\omega_{shaft}$ (rpm)
None	1.250	204.0	-92.0	0.150	1792.3
1-2	1.250	214.0	-72.0	0.255	1787.1
1-4	1.255	230.0	-54.0	0.400	1781.6
1-6	1.355	250.0	-26.0	0.600	1774.6
1-8	1.400	268.0	-1.0	0.800	1766.3
1-10	1.505	316.0	50.0	1.255	1748.1
1-12	1.950	400.0	134.0	1.855	1716.9

## Data Analysis (Solutions)

Table 4: Locked Rotor Calculations

1	2	3
$P_{In}$ (Watts)	$R_{Internal}$ ( $\Omega$ )	$P_{CL}$ (Watts)
204.0	11.81	204.0

- Using the results of the locked rotor test, you can calculate the internal resistance of the induction motor. First, find the total input power during the locked rotor test,  $P_{InLR}$ , using equation 1. Record the result in column 1 of Table 4.

$$(1) P_{InLR} = P_1 + P_2$$

2. Because the rotor is locked, all parts inside of the motor are stationary. Thus, all of the input power must be dissipated *inside* of the motor due to internal electrical resistance. We can find this internal resistance,  $R_{Internal}$ , using formula 2. Record the result in column 2 of Table 4.

$$(2) R_{Internal} = \frac{P_{InLR}}{3 \cdot I_{LR}^2}$$

3. Internal electrical losses are also called **copper losses**. During the locked rotor test, all of the input power is dissipated internally so that the copper loss during the locked rotor test,  $P_{CL1}$ , is given by equation 3. Record the result column 3 of Table 4.

$$(3) P_{CL1} = P_{InLR}$$

**Table 5: No Load Calculations**

1	2	3
$P_{In}$ (Watts)	$P_{CL}$ (Watts)	$P_{FL}$ (Watts)
83.0	51.0	32.0

4. Using the results of the no load test, you can calculate the power loss due to rotational friction. First, calculate the total input power during the no load test,  $P_{InNL}$ , using equation 4. Record the result in column 1 of Table 5.

$$(4) P_{InNL} = P_3 + P_4$$

5. Because the motor shaft is allowed to spin freely under no load, all of the input power is dissipated *inside* of the motor due either to electrical resistance (copper loss) or mechanical resistance (friction loss.) Use equation 5 to find the copper loss during the no load test,  $P_{CL2}$ . Record the result in column 2 of Table 5.

$$(5) P_{CL2} = 3 \cdot I_{NL}^2 \cdot R_{Internal}$$

6. As stated above, the no load input power is the sum of the no load copper loss and the friction loss. Use this relationship (found in equation 6) to calculate the friction loss. Record this result in column 3 of Table 5.

$$(6) P_{FL} = P_{InL} - P_{CL2}$$

**Note:** The friction loss,  $P_{FL}$ , is a mechanical loss; it is independent of the current through the motor and therefore has a *constant* value, regardless of loading conditions. Therefore, you may copy your calculated value for  $P_{FL}$  (in column 3 of Table 5) into column 4 of Table 6.

**Table 6: Load Calculations**

1	2	3	4	5	6	7
Load	$P_{In}$ (Watts)	$P_{CL}$ (Watts)	$P_{FL}$ (Watts)	$P_{Loss}$ (Watts)	$P_{Out}$ (Watts)	$\eta_{Motor}$ (%)
No Load	112.0	55.34	32.0	87.34	28.15	0.2514
1-2	142.0	55.34	32.0	87.34	47.72	0.3361
1-4	176.0	55.78	32.0	87.78	74.63	0.4240
1-6	224.0	65.03	32.0	97.03	111.50	0.4978
1-8	267.0	69.42	32.0	101.42	147.97	0.5542
1-10	366.0	80.22	32.0	112.22	229.74	0.6277
1-12	534.0	134.67	32.0	166.67	333.52	0.6246

7. Using equation 7, find the total power input to the motor for each loading condition. Record the results in column 2 of Table 6.

$$(7) P_{InL} = P_5 + P_6$$

8. Use equation 8 to calculate the copper loss at each loading condition. Record the results in column 3 of Table 6.

$$(8) P_{CL3} = 3 \cdot I_L^2 \cdot R_{Internal}$$

9. Use equation 9 to find the total power loss for each loading condition. Record result in column 5 of Table 6.

$$(9) P_{Loss} = P_{FL} + P_{CL3}$$

10. Using equation 10, calculate the output power,  $P_{Out}$ , for each loading condition. Record the result in column 6 of Table 6.

$$(10) P_{Out} = \frac{\tau_{shaft} \cdot 2\pi \cdot \omega_{shaft}}{60}$$

11. Use equation 11 to find the efficiency of the motor for each loading condition. Record the result in column 7 of Table 6.

$$(11) \eta_{Motor} = \frac{P_{Out}}{P_{In}} \cdot 100$$

## Discussion

1. In Analysis 9, you found the power loss,  $P_{Loss}$ , by adding the copper loss and the frictional loss. Another way to find the  $P_{Loss}$  is to subtract the output power from the input power. Calculate  $P_{Loss}$  this way (using  $P_{Loss} = P_{In} - P_{Out}$ ) and make a table comparing your newly calculated values for  $P_{Loss}$  to the values of  $P_{Loss}$  in column 5 of Table 5. Do your results suggest that copper and frictional losses are the only losses?

1	2	3
Load	$P_{Loss} (P_{FL} + P_{CL})$ (Watts)	$P_{Loss} (P_{In} - P_{Out})$ (Watts)
No Load	87.34	83.85
1-2	87.34	94.28
1-4	87.78	101.37
1-6	97.03	112.50
1-8	101.42	119.03
1-10	112.22	136.26
1-12	166.67	200.48

*These results suggest the copper and frictional losses are not the only losses; in all but the unloaded case, the actual power loss (found using  $P_{Loss} = P_{In} - P_{Out}$ ) is greater than just the sum of the copper and frictional losses.*

2. Based on your results in Table 6 and your answer to question 1, where do the most significant energy losses occur in the motor? What is responsible for these losses? What might be responsible for any additional losses?

*The most significant energy losses are (1) the copper loss and (2) the frictional (mechanical) loss.*

*(1) The copper loss: Copper loss is a variable loss; the amount of energy lost due to copper loss increases as the load increases. However, the percentage of energy lost due to copper loss decreases as load increases. For the loading conditions tested, copper loss accounts for 20-50% of input power, with the largest copper losses occurring when there is no load. Copper losses occur due to electrical resistances inside of the motor and are dependent on the amount of current flowing through the motor.*

*(2) The frictional (mechanical) loss in the motor: Frictional losses are fixed; the amount of energy lost due to friction remains constant, regardless of load. As such, frictional losses account for anywhere from 6% to 30% of input power. It occurs due to the internal friction between the motor's moving parts, which dissipates energy as heat.*

*Other, minor power losses account for 5-8% of the input energy. Mechanical friction in the generator or in the axle coupling, electrical resistance in the generator, and assorted electrical losses in the wires connecting the motor may be responsible for additional losses. There may have been an unavoidable experimental error in the calculation of motor internal resistance and/or mechanical friction; it is also possible that internal resistance and/or mechanical friction vary slightly with increased load, a factor that has been neglected in this lab*

- Plot a curve showing the relationship between motor efficiency and shaft speed. Plot speed along the x-axis and efficiency along the y-axis. Label the graph "Efficiency."

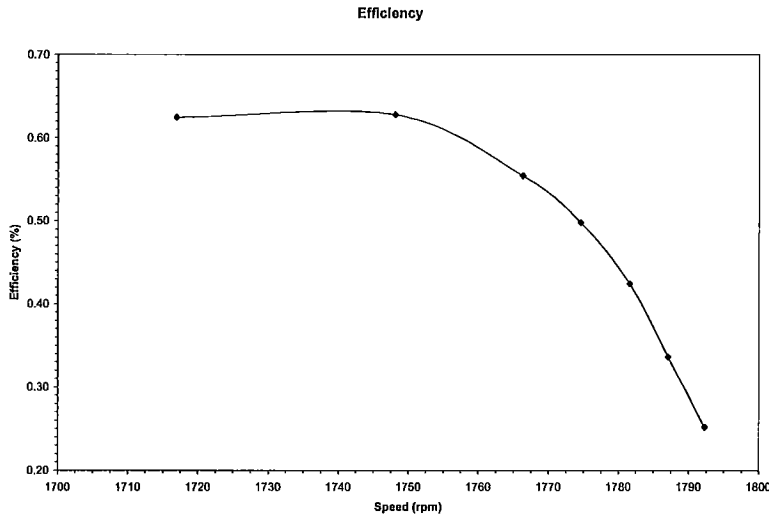

- Plot a curve showing the relationship between shaft speed and output torque. Plot speed along the x-axis and efficiency along the y-axis. Label the graph "Torque and Power."

See question 5.

- On the same graph, plot a curve showing the relationship between shaft speed and output power (use the same x-axis scale for speed, make a second scale along the y-axis for power.)

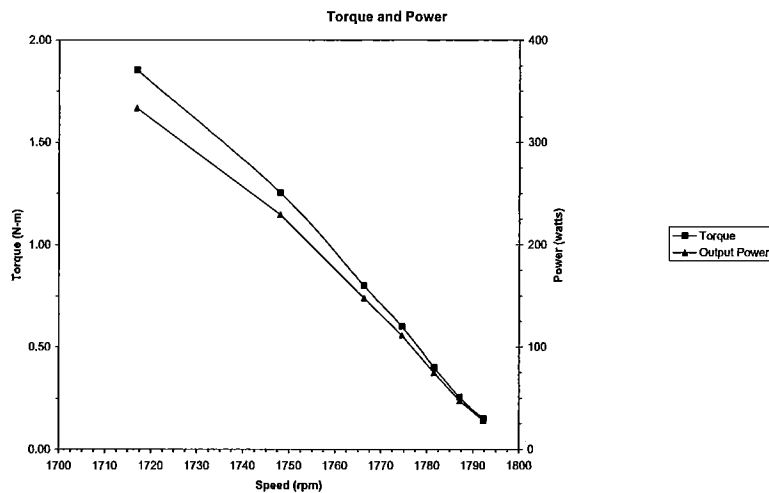



6. For which shaft speeds is the motor efficiency highest? For which shaft speeds does the motor produce the highest output torque?

*Efficiency is highest (around 60%) when the shaft speed is less than 1750rpm. Above 1750rpm, efficiency begins to decrease approximately linearly. Output torque decreases linearly in the region of shaft speeds that we tested; therefore, the highest output torque occurs at lower shaft speeds.*

7. What is the relationship between output power and torque?

*Power and torque both decrease (in an approximately linear manner) as shaft speed increases. Thus, output power and torque are directly related (as power changes linearly with torque).*

8. How would you define an optimal operating range? Based on your graphs and your answers in question 2, what can you conclude about the optimal operating range (i.e. range of optimal shaft speeds) of the motor?

*The optimal operating range is the range of speeds within which torque, output power, and efficiency are at a maximum.*

*One can make several key observations from question 2 and the graphs:*

- 1. Efficiency is highest when the shaft speed is below 1750rpm*
- 2. Torque and output power decrease linearly as shaft speed increases*
- 3. Copper loss and stray power loss increase as current (input power) increases. Both decrease as shaft speed increases.*
- 4. Copper loss decreases more slowly than output power above a shaft speed of 1750rpm.*
- 5. Frictional loss is independent of shaft speed.*

*From these observations, one can conclude that the motor is in its optimal operating range when the shaft speed is between 1710rpm and 1750rpm. Above 1750rpm, the copper loss decreases more slowly than the total power output, resulting in a decreasing efficiency above 1750rpm.*

## Lab 2

### *AC Motors: Efficiency and Losses*

Student Manual

Background Information .....	2
Concept Check .....	3
Objectives .....	4
Equipment: .....	5
Procedure .....	5
Part I: No Load Test .....	5
Part II: Locked Rotor Test .....	7
Part III: Load Test .....	7
Data Collection .....	9
Table 1: Locked Rotor Test .....	9
Table 2: No Load Test .....	9
Table 3: Load Test .....	10
Data Analysis .....	10
Table 4: Locked Rotor Calculations .....	10
Table 5: No Load Calculations .....	11
Table 6: Load Calculations .....	12
Discussion .....	13
Appendix A: Installing the Rotor Locking Device .....	14
Appendix B: Motor Connections .....	15
Appendix C: Generator Connections .....	16

## Background Information

An alternating-current (AC) motor, like a DC motor, converts electrical energy into mechanical energy by means of electromagnetic induction. However, while a DC motor has a *rotating* armature coil and a stationary field coil, an AC motor uses a *stationary* armature coil and a rotating field coil (or permanent magnet). This eliminates the need for the commutator and brushes of a DC machine. This, along with their superior speed control, ability to deliver high initial torque, and overall high efficiency have contributed to the increasing popularity of AC motors in hybrid and electric vehicle (HEV) applications.

There are two main types of AC motors, both of which run using 3-phase<sup>1</sup> AC power: **synchronous** and **asynchronous**. The main difference is simple: synchronous rotors rotate at the same rate as the changing magnetic fields in the motor (the "synchronous speed") and asynchronous rotors rotate at a rate slightly off from the synchronous speed. Though permanent magnet (PM) synchronous machines are sometimes used in HEVs, this lab will focus on the asynchronous AC machine, more commonly called an **induction motor**.

Within the category of induction motors, there are also two main types: squirrel-cage and wound rotor. The difference lies in the rotor structure, as all induction motors (and, indeed, all AC motors) use the same type of stator. **Wound-rotors** are exactly that; a set of "windings" (wire wrapped around a solid core) that are connected by slip-rings to form a cylinder. The **squirrel-cage rotor** is the most common in automotive applications. It consists of two conductive rings connected by a set of copper or aluminum bars to form a cylinder (see Figure A).

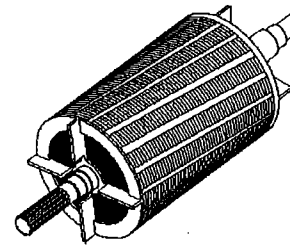

Figure A: Squirrel-cage rotor

This lab examines the squirrel-cage induction motor, the type of AC motor used most often in the automotive industry. It has a squirrel-cage rotor, as described above, and a typical AC motor stator. This stator consists of three electromagnets (conducting wire wound several times around a core) that are evenly spaced around the cylindrical interior of the motor.

In this lab, you will measure the power input, output, and efficiency of an AC induction motor, both while unloaded and driving a DC generator (a configuration often seen in HEVs<sup>2</sup>). You will then use these results to determine optimal operating range for the AC induction motor.

<sup>1</sup> In a 3-phase system, three different conductors carry sinusoidal currents (of the same frequency). Taking one conductor as the reference, the other two currents are delayed in time by one-third and two-thirds of one cycle of the electrical current. In this way, one of the conductors is carrying the maximum level of current at any given point.

<sup>2</sup> See Lab 1 Background for a discussion on series and parallel power source configurations in HEVs.

## Concept Check

1. AC motors are often used to power HEVs because:

- (a) it is easy to control their speed.
- (b) they deliver high initial torque.
- (c) they require less maintenance.
- (d) all of the above.

2. The main difference between AC and DC machines is:

- (a) AC machines use alternating current, while DC machines use direct current.
- (b) AC machines are brushed while DC machines are brushless.
- (c) the armature is on the rotor in DC machines and on the stator in AC machines.
- (d) Both a and c are major differences.

3. An induction motor is a:

- (a) permanent magnet (PM) motor.
- (b) asynchronous motor.
- (c) squirrel-cage motor.
- (d) all of the above.

4. An asynchronous motor:

- (a) most often uses 2-phase power.
- (b) is an induction motor.
- (c) has a rotor that spins in synch with the changing magnetic fields.
- (d) Both a and b are correct.

5. An AC motor has two main parts. One part is the stator, which:

- (a) can be constructed in three distinct ways.
- (b) contains the three field coils.
- (c) can also be called the armature coil.
- (d) Both a and c are correct.

6. The other part of an AC motor is the rotor. The rotor:
- (a) usually used in HEVs is the squirrel-cage rotor.
  - (b) is the same in every AC motor.
  - (c) is most often made of copper and steel.
  - (d) can also be called the armature coil.
7. When a wattmeter reads a negative number, you should:
- (a) Record the negative number to which the needle points.
  - (b) Turn the wattmeter off and switch the leads. Then, record all future readings as positive.
  - (c) Turn the wattmeter off and switch the leads. Then, record all future readings as negative.
  - (d) It is impossible for a wattmeter to read a negative number.
8. The purpose of Part I is to \_\_\_\_\_, while Part II focuses on \_\_\_\_\_.
- (a) study only the motor; both the motor and the generator
  - (b) gather data for calculating copper and frictional losses; gathering data to calculate motor efficiency
  - (c) focus on power only; both power and torque
  - (d) study AC machines only; both AC and DC machines

## Objectives

1. To gain hands-on experience with the circuitry layout of AC induction motors.
2. To calculate the efficiency of an induction motor.
3. To determine where losses occur in AC machines and discuss methods for reducing losses and increasing efficiency.
4. To identify the ideal operating range for AC induction motors.

## Equipment:

### Console Instruments:

1. Variable 3 $\phi$  AC supply
2. 0-300 volt AC Voltmeter
3. 0-4 amp AC Ammeter
4. (2) AC Wattmeter
5. 0-150 volt Variable DC Supply, 1 amp
6. 0-150 volt DC Voltmeter
7. 0-2.4 amp DC Ammeter

### Additional Equipment:

1. IM-100 Induction Motor
2. DYN-100-DM Dynamometer
3. RL-100A Resistance Load Bank
4. HT-100 Series Tachometer

## Procedure

### Part I: No Load Test

1. Place the IM-100 induction motor on the left side of the bedplate. Clamp it tightly.
2. Connect the motor to the variable 240V AC supply as shown in Figure 2. (Refer to Appendix B for schematic of motor.) Ground the motor by connecting the green terminal on the motor to the green terminal on the console.

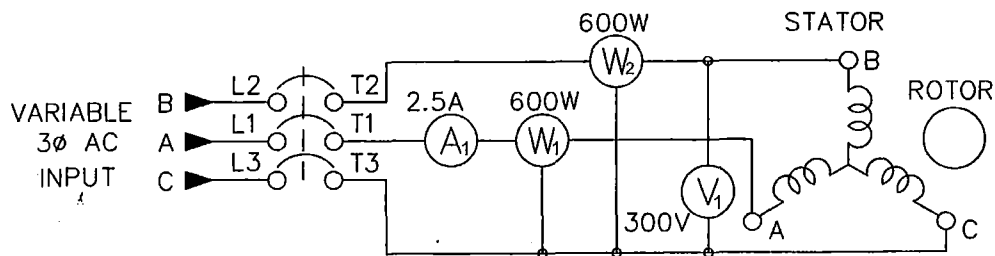

*Figure 2: Motor (no load)*

3. Have someone check your connections to be sure they are correct.
4. Turn the knob of the 0-240V AC power supply fully counterclockwise to the zero output position. Power should remain off. Verify that the circuit breaker switch on the motor is off.

5. Turn ON the main AC and the 0-240V AC power supply.
  6. Locate the voltmeter connected across the 0-240V supply ( $V_1$ ) and adjust the power supply knob until there is an output of 210 volts. (Note: If you followed the setup in Appendix A,  $V_1$  is the only voltmeter on the left side of the console.)
  7. Locate  $A_1$ , an AC ammeter on the left side of the console. Turn the current reading knob fully clockwise to 8 amps. (This sets the ammeter to read a current from 0-8.0A and is to protect against an inrush of current when the motor is turned on.)
  8. Locate the two wattmeters in the center of the console. Verify that both wattmeters are turned off.
  9. Turn ON the motor.
  10. Turn on each wattmeter in turn and observe which way the needle moves.
    - a. If the needle moves to the right side of the zero on the wattmeter scale (a positive number), leave the wattmeter on.
    - b. If the needle moves to the left side of the zero on the wattmeter scale (a negative number), turn the wattmeter off. Reverse the leads of the voltage terminals, keeping all current connections the same, and turn on the wattmeter again. It should now read a positive number, though the readings from this wattmeter should be recorded as negative.
- Note:** The power factor on an unloaded induction motor is likely to be negative, but the wattmeter cannot display negative values. For this reason, we proceed as in step 9b in the case that the wattmeter reads a negative value.
11. Record the following values in Table 2:
    - a. *Motor current:* Set ammeter 1 to read on a 0-2.0A scale. Record the displayed value in column 1.
    - b. *Input power:* Turn wattmeter 1 fully clockwise to read on a 0-300W scale. Record the displayed value in column 2, referring to the conversion table directly beneath the wattmeters for proper scaling. Turn wattmeter 2 fully counterclockwise to read on a 0-150W scale. Record the displayed value in column 3. If necessary, remember to record readings as negative (see step 9)!
  12. Turn OFF the motor. Turn the 0-240V AC supply knob fully clockwise to the zero output position. Turn OFF the wattmeters. Turn OFF all circuit breaker switches.
  13. If necessary, readjust the leads of the wattmeters so that they are once again wired according to the schematic in Appendix A.

## Part II: Locked Rotor Test

1. Locate the dynamometer. Install the rotor locking device, referring to Appendix A for directions.
2. Place the dynamometer on the right side of the bedplate. Couple it to the induction motor and clamp both machines securely in place. Install all the safety guards.
3. Verify that the 0-240V AC supply knob is turned to the zero output position. Turn the current reading knob on ammeter 1 fully clockwise to 8 amps.
4. Turn ON the main circuit breaker switch. Turn ON the 0-240V AC circuit breaker switch. Turn ON the motor.
5. Slowly increase the output of the 0-240V AC supply until ammeter 1 reads 2.4A.
6. Turn on both wattmeters and record the following values in Table 1:
  - a. *Motor current:* Set ammeter 1 to read on a 0-4.0A scale. Record the displayed value in column 1.
  - b. *Input power:* Turn wattmeter 1 fully clockwise to read on a 0-300W scale. Record the displayed value in column 2, referring to the conversion table directly beneath the wattmeters for proper scaling. Turn wattmeter 2 fully counterclockwise to read on a 0-150W scale. Record the displayed value in column 3.
7. Turn OFF the motor. Adjust the knob of the 0-240V AC supply back to zero. Turn OFF the wattmeters. Turn OFF all circuit breaker switches.
8. Remove the rotor locking device.

## Part III: Load Test

1. Connect the dynamometer as shown in Figure 3. (Refer to Appendix C for schematic of generator.) Ground the dynamometer by connecting the green terminal on the machine to the green terminal on the console.

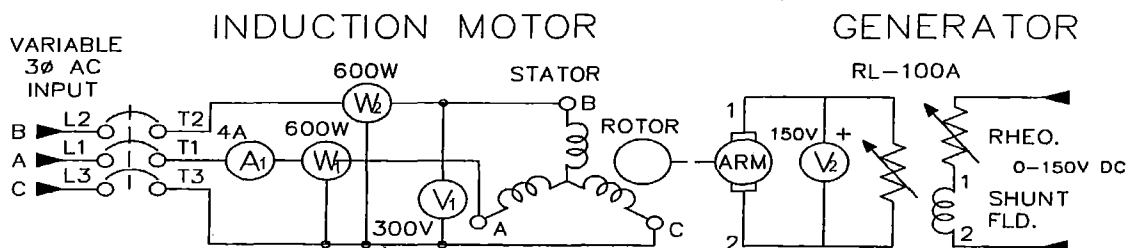

Figure 3: Motor and generator (with load)



2. Have someone check your connections to be sure they are correct.
  3. Calibrate the dynamometer. (Turn the silver knob, located on top of the scale, until the scale reads zero.)
  4. Adjust the dynamometer field rheostat knob (black dial located on top of the dynamometer) fully clockwise to its maximum resistance position. Verify that both power supply knobs are turned fully counterclockwise to the zero output position.
  5. With the motor switch OFF, turn on the main AC, the 0-240V AC, and the 0-150V DC supplies.
  6. Using the reading from  $V_1$ , adjust the AC supply to 210 volts.
  7. Slowly turn the 0-150V DC supply knob fully clockwise.
  8. Make sure all switches on the RL-100A resistance load bank are off, in the downward position. Turn the current reading knob on ammeter 1 fully clockwise to 8 amps.
  9. Turn the motor ON.
  10. Adjust ammeter 1 to read on a 0-2.0A scale. Repeat step 10 of Part 1.
  11. Locate the DC voltmeter across the generator armature,  $V_2$ . Adjust the dynamometer field rheostat knob (the black dial located on top of the dynamometer) until voltmeter 2 reads 120V DC.
  12. Read and record the following values in Table 3:
    - a. *Motor current:* Set ammeter 1 to read on a 0-2.0A scale. Record the displayed value in column 2.
    - b. *Input power:* Turn wattmeter 1 fully clockwise to read on a 0-300W scale. Record the displayed value in column 3, referring to the conversion table directly beneath the wattmeters for proper scaling. Turn wattmeter 2 fully counterclockwise to read on a 0-150W scale. Record the displayed value in column 4. If necessary, remember to record readings as negative (see step 9)!
    - c. *Torque:* Record the value displayed by the dynamometer scale in column 5. Use the outer scale and record all results in N·m.
    - d. *Shaft speed:* Turn on the tachometer and set it to read 1500rpm. Then, keeping the tachometer pointed at the shaft, turn the black dial on the tachometer *away* from you (so that the displayed value increases) until the shaft appears to stop moving. Record the value displayed by the tachometer in column 6.
- Note:** If it becomes necessary to switch wattmeter leads at any time during the experiment, switch off the relevant wattmeter before removing the leads.
13. Turn ON load steps 1 and 2 on the RL-100A load bank.

14. Adjust the dynamometer's field rheostat knob as required to maintain a reading of 120V on voltmeter 2.
15. Repeat steps 12-14, switching on two additional load steps each time, until load steps 1-12 are switched on.
16. Turn OFF the motor. Adjust all voltage supplies to zero. Turn OFF the wattmeters. Turn OFF all circuit breaker switches.

### Data Collection

**Table 1: Locked Rotor Test**

1	2	3
$I_{LR}$ (Amps)	$P_1$ (Watts)	$P_2$ (Watts)

**Table 2: No Load Test**

1	2	3
$I_{NL}$ (Amps)	$P_3$ (Watts)	$P_4$ (Watts)

**Table 3: Load Test**

1	2	3	4	5	6
Load	$I_L$ (Amps)	$P_5$ (Watts)	$P_6$ (Watts)	$\tau_{\text{shaft}}$ (N·m)	$\omega_{\text{shaft}}$ (rpm)
None					
1-2					
1-4					
1-6					
1-8					
1-10					
1-12					

## Data Analysis

**Table 4: Locked Rotor Calculations**

1	2	3
$P_{In}$ (Watts)	$R_{\text{Internal}}$ ( $\Omega$ )	$P_{CL}$ (Watts)

- Using the results of the locked rotor test, you can calculate the internal resistance of the induction motor. First, find the total input power during the locked rotor test,  $P_{InLR}$ , using equation 1. Record the result in column 1 of Table 4.

$$(1) P_{InLR} = P_1 + P_2$$

- Because the rotor is locked, all parts inside of the motor are stationary. Thus, all of the input power must be dissipated *inside* of the motor due to internal electrical resistance. We can find this internal resistance,  $R_{Internal}$ , using formula 2. Record the result in column 2 of Table 4.

$$(2) R_{Internal} = \frac{P_{InLR}}{3 \cdot I_{LR}^2}$$

- Internal electrical losses are also called **copper losses**. During the locked rotor test, all of the input power is dissipated internally so that the copper loss during the locked rotor test,  $P_{CL1}$ , is given by equation 3. Record the result column 3 of Table 4.

$$(3) P_{CL1} = P_{InLR}$$

**Table 5: No Load Calculations**

1	2	3
$P_{In}$ (Watts)	$P_{CL}$ (Watts)	$P_{FL}$ (Watts)

- Using the results of the no load test, you can calculate the power loss due to rotational friction. First, calculate the total input power during the no load test,  $P_{InNL}$ , using equation 4. Record the result in column 1 of Table 5.

$$(4) P_{InNL} = P_3 + P_4$$

- Because the motor shaft is allowed to spin freely under no load, all of the input power is dissipated *inside* of the motor due either to electrical resistance (copper loss) or mechanical resistance (friction loss.) Use equation 5 to find the copper loss during the no load test,  $P_{CL2}$ . Record the result in column 2 of Table 5.

$$(5) P_{CL2} = 3 \cdot I_{NL}^2 \cdot R_{Internal}$$

- As stated above, the no load input power is the sum of the no load copper loss and the friction loss. Use this relationship (found in equation 6) to calculate the friction loss. Record this result in column 3 of Table 5.

$$(6) P_{FL} = P_{InNL} - P_{CL2}$$

**Note:** The friction loss,  $P_{FL}$ , is a mechanical loss; it is independent of the current through the motor and therefore has a *constant* value, regardless of loading conditions. Therefore, you may copy your calculated value for  $P_{FL}$  (in column 3 of Table 5) into column 4 of Table 6.

**Table 6: Load Calculations**

1	2	3	4	5	6	7
Load	$P_{In}$ (Watts)	$P_{CL}$ (Watts)	$P_{FL}$ (Watts)	$P_{Loss}$ (Watts)	$P_{Out}$ (Watts)	$\eta_{Motor}$ (%)
No Load						
1-2						
1-4						
1-6						
1-8						
1-10						
1-12						

7. Using equation 7, find the total power input to the motor for each loading condition. Record the results in column 2 of Table 6.

$$(7) P_{InL} = P_5 + P_6$$

8. Use equation 8 to calculate the copper loss at each loading condition. Record the results in column 3 of Table 6.

$$(8) P_{CL3} = 3 \cdot I_L^2 \cdot R_{Internal}$$

9. Use equation 9 to find the total power loss for each loading condition. Record result in column 5 of Table 6.

$$(9) P_{Loss} = P_{FL} + P_{CL3}$$

10. Using equation 10, calculate the output power,  $P_{Out}$ , for each loading condition. Record the result in column 6 of Table 6.

$$(10) P_{Out} = \frac{\tau_{shaft} \cdot 2\pi \cdot \omega_{shaft}}{60}$$

11. Use equation 11 to find the efficiency of the motor for each loading condition. Record the result in column 7 of Table 6.

$$(11) \eta_{Motor} = \frac{P_{Out}}{P_{In}} \cdot 100$$

### Discussion

1. In Analysis 9, you found the power loss,  $P_{Loss}$ , by adding the copper loss and the frictional loss. Another way to find the  $P_{Loss}$  is to subtract the output power from the input power. Calculate  $P_{Loss}$  this way (using  $P_{Loss} = P_{In} - P_{Out}$ ). Create a table like the one started below and use it to compare your newly calculated values for  $P_{Loss}$  to the values of  $P_{Loss}$  in column 5 of Table 5. Do your results suggest that copper and frictional losses are the only losses?

1	2	3	4
Load	$P_{Loss} (P_{FL} + P_{CL})$ (Watts)	$P_{Loss2} (P_{In} - P_{Out})$ (Watts)	$P_{Difference} (P_{Loss2} - P_{Loss})$ (Watts)
No Load			

2. Based on your results in Table 6 and your answer to question 1, where do the most *significant* energy losses occur in the motor? What is responsible for these losses? What might be responsible for any additional losses?
3. Plot a curve showing the relationship between motor efficiency and shaft speed. Plot speed along the x-axis and efficiency along the y-axis. Label the graph "Efficiency."
4. Plot a curve showing the relationship between shaft speed and output torque. Plot speed along the x-axis and efficiency along the y-axis. Label the graph "Torque and Power."
5. On the same graph, plot a curve showing the relationship between shaft speed and output power (use the same x-axis scale for speed, make a second scale along the y-axis for power.)

6. For which shaft speeds is the motor efficiency highest? For which shaft speeds does the motor produce the highest output torque?
7. What is the relationship between power and torque?
8. How would you define an optimal operating range? Based on your graphs and your answers in question 2, what can you conclude about the optimal operating range (i.e. range of optimal shaft speeds) of the motor?

### **Appendix A: Installing the Rotor Locking Device**

1. Check that there are NO leads connected to the dynamometer. If possible, the machine should be oriented so that the right side is facing you.
2. Locate the rotor locking device. Notice that the front face has a pin protruding from the center while the back face has two thumbscrews, one in each corner.
3. Locate the circular indentation in the rotor on the dynamometer's right side. The pin will fit into this indentation. Then, locate the two threaded holes through the righthand coupling disk of the dynamometer. The thumbscrews will fit into these holes.
4. Align the coupling disk with the thumbscrews and fit the pin into the indentation.
5. Tightly screw the thumbscrews into the threaded holes in the coupling disk.
6. Carefully test your installation by manually turning the left side of the dynamometer axle. The finished locking device should keep the dynamometer axle from rotating more than a few degrees in any direction.

## Appendix B: Motor Connections

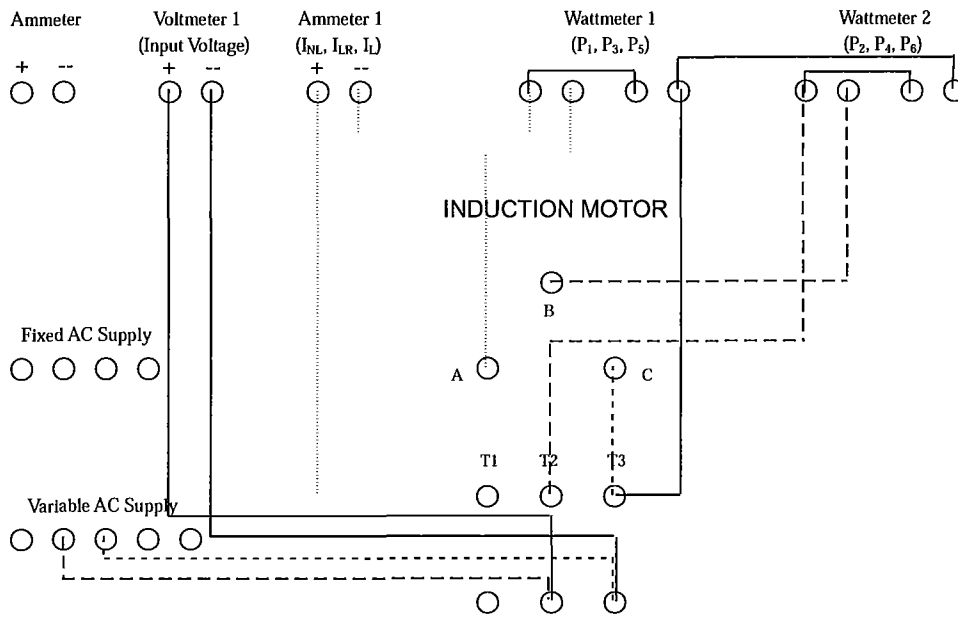



### Appendix C: Generator Connections

