

U.S. DEPARTMENT OF COMMERCE  
National Technical Information Service

PB-282 394

Freeway Data for Incident and Nonincident  
Conditions. Volume 1: Traffic Data  
Sets from Widely Spaced Detectors

California State Dept of Transportation, Los Angeles

Prepared for

Federal Highway Administration, Washington, D C

Sep 76

Report No. FHWA-RD-76-175

PB 282 394

✓  
**FREEWAY DATA FOR INCIDENT  
AND NONINCIDENT CONDITIONS**

**Vol. 1 Traffic Data Sets from Widely Spaced Detectors**



**September 1976  
Final Report**

Document is available to the public through  
the National Technical Information Service,  
Springfield, Virginia 22161

**Prepared for  
FEDERAL HIGHWAY ADMINISTRATION  
Offices of Research & Development  
Washington, D. C. 20590**

REPRODUCED BY  
**NATIONAL TECHNICAL  
INFORMATION SERVICE**  
U. S. DEPARTMENT OF COMMERCE  
SPRINGFIELD, VA. 22161

## FOREWORD

This report describes real-time freeway incident and non-incident data collected from the San Diego Freeway in Los Angeles, California. The data was used in the development of freeway incident detection algorithms and a microscopic freeway simulation model. The data has been collected from freeway loop detectors every 20 seconds. In that the data may be of use in many other applications, it has been retained on magnetic data tapes. If a user wishes to use any of the available magnetic data tapes, they should contact the Federal Highway Administration, Traffic Systems Division, HRS-33, Washington, D. C. 20590..

This report is being distributed on a limited basis to selected researchers, a few Washington Headquarters specialists, and NTIS.



Charles F. Scheffey

Director, Office of Research

## NOTICE

This document is disseminated under the sponsorship of the Department of Transportation in the interest of information exchange. The United States Government assumes no liability for its contents or use thereof.

The contents of this report reflect the view of the California Department of Transportation which is responsible for the facts and the accuracy of the data presented herein. The contents do not necessarily reflect the official views or policy of the Department of Transportation.

This report does not constitute a standard, specification, or regulation.

The United States Government does not endorse products or manufacturers. Trademarks or manufacturers' names appear herein only because they are considered essential to the object of this document.

1. Report No. FHWA-RD-76-175		2. Government Accession No.		3. Recipient's Catalog No. <b>PB282394</b>										
4. Title and Subtitle FREEWAY DATA FOR INCIDENT AND NONINCIDENT CONDITIONS--VOL. 1.-Traffic Data Sets from Widely Spaced Detectors				5. Report Date September, 1976										
Author(s) Richard H. Green, Walter L. McKinnon				6. Performing Organization Contract										
7. Performing Organization Name and Address California Department of Transportation District 07 Freeway Operation Branch 120 S. Spring St., Los Angeles, CA 90012				8. Performing Organization Report No.										
9. Sponsoring Agency Name and Address Offices of Research and Development Federal Highway Administration U.S. Department of Transportation Washington, D.C. 20590				10. Work Unit No. 31C3-512										
				11. Contract or Grant No. DOT-FH-11-8293										
				13. Type of Report and Period Covered Final										
				14. Sponsoring Agency Code <b>T-0274</b>										
15. Supplementary Notes FHWA Contract Manager for this project: S. C. Tignor (HRS-33)														
16. Abstract The results of the project to collect freeway traffic data for use in developing and verifying incident detection algorithms are presented in three volumes. This volume gives a description of the first 200 data sets collected from a 42-mile freeway loop that had magnetic detectors at approximately one-half mile intervals. Included are a description of the freeway system used, classification of the data sets, description of 200 data sets, an overview of an analysis program that will process the data sets, weather conditions and a description of the incident. Other volumes in this report include:														
<table border="1"> <thead> <tr> <th>Vol. No.</th> <th>FHWA No.</th> <th>Title</th> </tr> </thead> <tbody> <tr> <td>2</td> <td>RD-76-176</td> <td>Traffic Data Sets from Closely Spaced Detectors</td> </tr> <tr> <td>3</td> <td>RD-76-177</td> <td>FORTTRAN Program Documentation for Analyzing Individual Data Sets</td> </tr> </tbody> </table>						Vol. No.	FHWA No.	Title	2	RD-76-176	Traffic Data Sets from Closely Spaced Detectors	3	RD-76-177	FORTTRAN Program Documentation for Analyzing Individual Data Sets
Vol. No.	FHWA No.	Title												
2	RD-76-176	Traffic Data Sets from Closely Spaced Detectors												
3	RD-76-177	FORTTRAN Program Documentation for Analyzing Individual Data Sets												
17. Key Words Freeway, traffic data, data records, peak hour traffic, daily traffic, data reduction, surveys/data/collection			18. Distribution Statement No restrictions. This document is available to the public through the National Technical Information Service, Springfield, Virginia 22161											
19. Security Classif. (of this report) Unclassified		20. Security Classif. (of this page) Unclassified		21. No. of Pages 262	22. Price A12									

## TABLE OF CONTENTS

<u>SECTION</u>	<u>PAGE</u>
LIST OF FIGURES .....	iii
LIST OF TABLES .....	iii
1. PROJECT LOCATION .....	1
2. DETECTOR STATION LOCATIONS .....	1
3. DATA CLASSIFICATION .....	6
4. DATA SET FORMAT .....	7
5. RAMP METERING .....	7
6. FORTRAN ANALYSIS PROGRAM .....	8
7. RUNNING THE ANALYSIS PROGRAM .....	8
8. ANALYSIS PROGRAM OUTPUT FORMAT .....	10
 <u>APPENDIXES</u>	
A. LOOP LOCATION MAPS .....	24
B. NARRATIVE DESCRIPTION OF DATA SETS .....	41
C. POST MILE, CALL BOX, DETECTOR STATIONS AND CHANGEABLE MESSAGE SIGN LOCATIONS .....	242
D. GLOSSARY OF TERMS .....	251
E. NUMERICAL DATA SET INDEXES .....	252

## LIST OF FIGURES

<u>FIGURE</u>		<u>PAGE</u>
1	FREEWAY SURVEILLANCE PROJECT LOCATION	2
2	ILLUSTRATION OF DOCUMENTATION INFORMATION	11-12
3	ILLUSTRATION OF SENSOR INDEX TABLE	16-17
4	ILLUSTRATION OF TRAFFIC DATA SUMMARY	20-23

## LIST OF TABLES

<u>TABLE</u>		<u>PAGE</u>
1.	LANE MILE TABLE - SANTA MONICA FREEWAY	3
2.	LANE MILE TABLE - SAN DIEGO FREEWAY	4
3.	LANE MILE TABLE - HARBOR FREEWAY	5

# METRIC CONVERSION FACTORS

Approximate Conversions to Metric Measures		Approximate Conversions from Metric Measures		
Symbol	When You Know	Multiply by	To Find	Symbol
<b>LENGTH</b>				
in	inches	2.5	centimeters	cm
ft	feet	30	meters	m
yd	yards	0.9	kilometers	km
mi	miles	1.6		
<b>AREA</b>				
sq in	square inches	6.5	square centimeters	cm <sup>2</sup>
sq ft	square feet	0.09	square meters	m <sup>2</sup>
sq yd	square yards	0.8	square meters	m <sup>2</sup>
sq mi	square miles	2.6	square kilometers	km <sup>2</sup>
acres	acres	0.4	hectares	ha
<b>MASS (weight)</b>				
oz	ounces	28	grams	g
lb	pounds	0.45	kilograms	kg
	short tons (2000 lb)	0.9	tonnes	t
<b>VOLUME</b>				
teaspoon	teaspoons	5	milliliters	ml
tablespoon	tablespoons	15	milliliters	ml
fluid ounce	fluid ounces	30	milliliters	ml
cup	cups	0.24	liters	l
quart	quarts	0.95	liters	l
gallon	gallons	3.8	liters	l
cu ft	cubic feet	0.03	cubic meters	m <sup>3</sup>
yd <sup>3</sup>	cubic yards	0.76	cubic meters	m <sup>3</sup>
<b>TEMPERATURE (exact)</b>				
°F	Fahrenheit temperature	5/9 (after subtracting 32)	Celsius temperature	°C

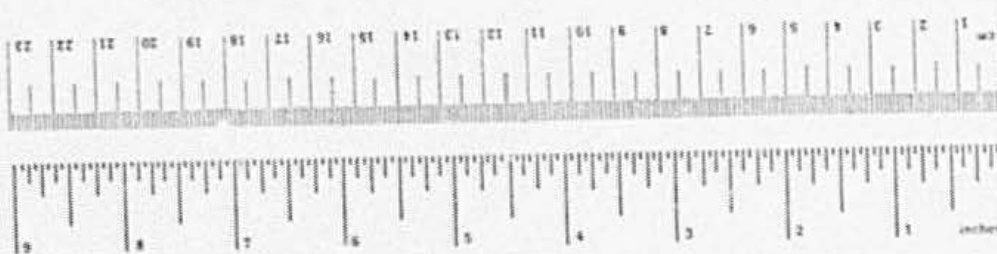

Approximate Conversions from Metric Measures		Approximate Conversions to Metric Measures	
When You Know	Multiply by	To Find	Symbol
<b>LENGTH</b>			
centimeters	0.04	inches	in
meters	0.4	feet	ft
kilometers	0.6	miles	mi
<b>AREA</b>			
square centimeters	0.16	square inches	in <sup>2</sup>
square meters	1.2	square yards	yd <sup>2</sup>
square kilometers	0.8	square miles	mi <sup>2</sup>
hectares (10,000 m <sup>2</sup> )	2.5	acres	acres
<b>MASS (weight)</b>			
grams	0.05	ounces	oz
kilograms	2.2	pounds	lb
tonnes (1000 kg)	1.1	short tons	
<b>VOLUME</b>			
milliliters	0.03	fluid ounces	fl oz
liters	2.1	pints	pt
liters	1.06	quarts	qt
liters	0.26	gallons	gal
cubic meters	35	cubic feet	ft <sup>3</sup>
cubic meters	1.3	cubic yards	yd <sup>3</sup>
<b>TEMPERATURE (exact)</b>			
Celsius temperature	9/5 (then add 32)	Fahrenheit temperature	°F

Fig. 1-2-54 (revised). For other exact conversions and more details on tables, see AGS Manual, Publ. 210, Guide to Weights and Measures, Price \$2.25, 320 Celsius No. C13-10750.

## 1. PROJECT LOCATION

The Los Angeles Area Freeway Surveillance and Control Project (LAAFSCP) provided the basis for this data collection study. The California Department of Transportation had already installed loop detectors in the freeway lanes at about  $\frac{1}{2}$  mile spacing on 42 miles of urban freeway. These detectors were connected, over phone lines, to a central computer which polls each loop 15 times a second in order to build summaries of vehicle counts and occupancy to be used in ramp metering control and incident detection.

Figure 1 shows the freeways that are under LAAFSCP's control. The Harbor Freeway is an eight lane north-south route that runs from the San Pedro Harbor area to the Los Angeles Central Business District where it becomes the Pasadena Freeway. Average daily traffic on this freeway runs from 110,000 in the south to 210,000 in the north end. Interchanges on the Harbor Freeway are generally either diamond or cloverleaf. The Santa Monica Freeway is another eight lane freeway, which runs from the beach area in Santa Monica to the Central Business District and then feeds into two other freeways. Interchanges on the Santa Monica are diamond, cloverleaf and collector/distributor road. Average daily traffic on the Santa Monica is 124,000 on the west end and 230,000 on the east end. Both the Santa Monica and Harbor Freeways carry heavy directional peak hour flows with traffic coming into the CBD in the morning and going out in the evening.

The San Diego Freeway is an eight lane freeway that runs along the western portion of the Los Angeles area. The portion under LAAFSCP control runs from the southern end of the Harbor Freeway to the western end of the Santa Monica Freeway and carries an ADT of from 170,000 to 210,000. Interchanges on the San Diego vary from diamond to cloverleaf to collector/distributor road.

## 2. DETECTOR STATION LOCATIONS

Loop detector stations are spaced at about one-half mile intervals over the 42 miles of freeway. Tables 1, 2 and 3 give a listing of the number of lanes at each station, the actual distance between stations and the total lane miles between stations.

While all lanes at each station have detector loops installed, not all loops are connected to the computer. Partial count stations, with only one or two loops being used, are intermixed with the full count stations. Generally, every other to every third station is a full count station. A 4-mile section at the northern end of the San Diego Freeway has all stations connected as full count and was used to collect 25% of the data sets.

Appendix A is a set of maps showing the general freeway layout, number of lanes, ramp and connector locations, and which lanes are actually connected to the computer.



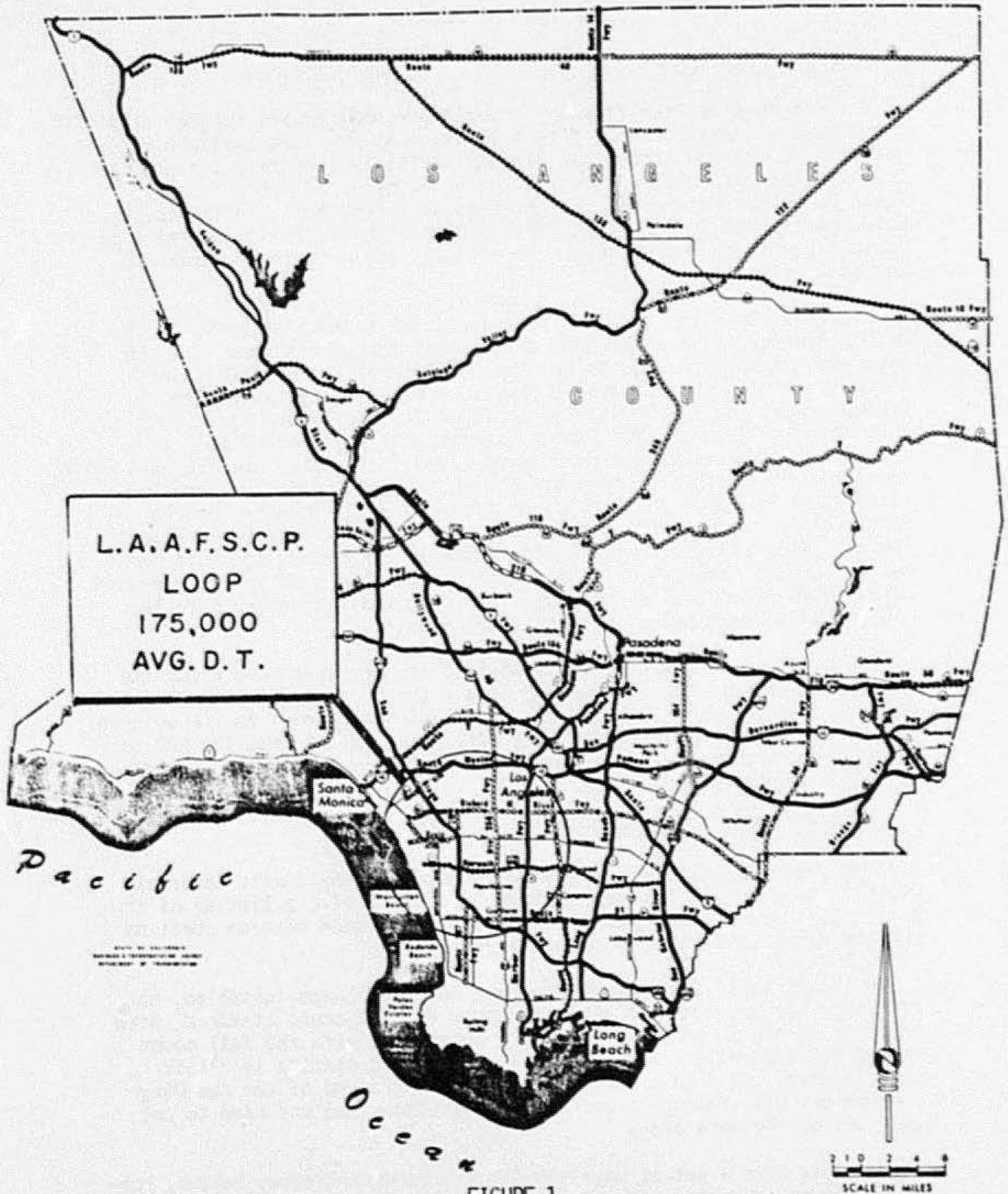

FIGURE 1  
L.A.A.F.S.C.P. LOCATION

TABLE 1. LANE MILE TABLE  
SANTA MONICA FREEWAY

Station	WESTBOUND			EASTBOUND		
	Distance Between Stations	Number of Lanes	Lane Miles	Distance Between Stations	Number of Lanes	Lane Miles
SM01-SM02	0.57	2	1.14	0.57	2	1.14
SM02-SM03	0.46	2&4	1.44	0.46	2&3	1.11
SM03-SM04	0.46	4&3	1.64	0.46	3	1.38
SM04-SM05	0.35	3	1.05	0.35	4	1.40
SM05-SM06	0.50	4	2.00	0.50	4	2.00
SM06-SM07	0.43	4	1.72	0.43	4	1.72
SM07-SM08	0.41	4&5	1.64	0.41	4	1.64
SM08-SM09	0.42	5	2.10	0.42	4&5	1.87
SM09-SM10	0.43	3	1.29	0.43	3	1.29
SM10-SM11	0.54	5	2.70	0.54	3&5	2.16
SM11-SM12	0.58	4	2.32	0.58	5&4	2.45
SM12-SM13	0.46	4	1.84	0.46	4	1.84
SM13-SM14	0.63	4	2.52	0.63	4	2.52
SM14-SM15	0.55	4	2.20	0.55	4	2.20
SM15-SM16	0.38	4	1.52	0.38	4	1.52
SM16-SM17	0.47	4	1.88	0.47	4	1.88
SM17-SM18	0.60	4	2.40	0.60	4&5	2.64
SM18-SM19	0.44	5	2.20	0.44	5&4	2.04
SM19-SM20	0.47	4	1.88	0.47	4	1.88
SM20-SM21	0.36	5	1.80	0.36	4&5	1.74
SM21-SM22	0.48	5	2.40	0.48	5	2.40
SM22-SM23	0.70	5	3.50	0.70	5&6	4.01
SM23-SM24	0.36	4	1.44	0.36	4&5	1.53
SM24-SM25	0.38	4	1.52	0.38	4	1.52
SM25-SM26	0.56	4	2.24	0.56	4	2.24
SM26-SM27	0.60	4&5	2.80	0.60	4&5	2.90
SM27-SM28	0.61	4&3	2.10	No loops on E/B freeway at Station 28		
TOTALS	13.20		53.28	12.59		51.02

TABLE 2. LANE MILE TABLE  
SAN DIEGO FREEWAY

Station	NORTHBOUND			SOUTHBOUND		
	Distance Between Stations	Number of Lanes	Lane Miles	Distance Between Stations	Number of Lanes	Lane Miles
SD01-SD02	0.64	4	2.56	0.64	3&4	2.54
SD02-SD03	0.54	4	2.16	0.54	4	2.16
SD03-SD04	0.62	4	2.48	0.62	4	2.48
SD04-SD05	0.66	4	2.64	0.66	4	2.64
SD05-SD06	0.53	4	2.12	0.53	4	2.13
SD06-SD07	0.53	4	2.12	0.53	4	2.13
SD07-SD08	0.33	4	1.32	0.33	4	1.32
SD08-SD09	0.34	4	1.36	0.34	4	1.36
SD09-SD10	0.49	4	1.96	0.49	4	1.96
SD10-SD11	0.37	4	1.48	0.37	4	1.48
SD11-SD12	0.42	4	1.68	0.42	4	1.68
SD12-SD13	0.56	4	2.24	0.56	4	2.24
SD13-SD14	0.42	4	1.68	0.42	4	1.68
SD14-SD15	0.57	4	2.28	0.57	4	2.28
SD15-SD16	0.47	4&5	2.34	0.47	4	1.88
SD16-SD17	0.49	5&4	2.11	0.49	4	1.96
SD17-SD18	0.64	4	2.56	0.64	4	2.56
SD18-SD19	0.49	4	1.96	0.49	4	1.96
SD19-SD20	0.43	4	1.92	0.48	4	1.92
SD20-SD21	0.44	4	1.76	0.44	4&5	2.14
SD21-SD22	0.49	4	1.96	0.49	5&4	2.36
SD22-SD23	0.66	4&5	2.94	0.66	4	2.64
SD23-SD24	0.40	4	1.60	0.40	4	1.60
SD24-SD25	0.50	4	2.00	0.50	4	2.00
SD25-SD26	0.68	4	2.72	0.68	4	2.72
SD26-SD27	0.33	4	1.42	0.33	4	1.32
SD27-SD28	0.70	4	2.80	0.70	4	2.80
SD28-SD29	0.51	4	2.04	0.51	4	2.04
SD29-SD30	0.47	4	1.88	0.47	4	1.88
SD30-SD31	0.58	4	2.32	0.58	4	2.32
SD31-SD32	0.77	4&3	3.05	0.77	4	3.08
TOTALS	16.12		65.46	16.12		65.26

TABLE 3. LANE MILE TABLE  
HARBOR FREEWAY

Station	NORTHBOUND			SOUTHBOUND		
	Distance Between Stations	Number of Lanes	Lane Miles	Distance Between Stations	Number of Lanes	Lane Miles
H01-H02	0.64	4	2.56	0.64	3&4	2.53
H02-H03	0.70	4	2.80	0.70	4	2.80
H03-H04	0.47	4	1.88	0.47	4	1.88
H04-H05	0.45	4	1.80	0.45	4	1.80
H05-H06	0.55	4	2.20	0.55	4	2.20
H06-H07	0.41	4	1.64	0.41	4	1.64
H07-H08	0.52	4	2.08	0.52	4	2.08
H08-H09	0.38	4	1.52	0.38	4	1.52
H09-H10	0.69	4	2.76	0.69	4	2.76
H10-H11	0.49	4	1.96	0.49	4	1.96
H11-H12	0.52	4	2.08	0.52	4	2.08
H12-H13	0.56	4	2.24	0.56	4	2.30
H13-H14	0.53	4	2.12	0.53	4	2.12
H14-H15	0.71	4	2.84	0.71	4	2.84
H15-H16	0.52	4	2.08	0.52	4	2.08
H16-H17	0.29	4	1.16	0.29	4	1.16
H17-H18	0.47	4	1.88	0.47	4	1.88
H18-H19	0.45	4	1.80	0.45	4	1.80
H19-H20	0.57	4	2.28	0.57	4	2.28
H20-H21	0.47	4	1.88	0.47	4	1.88
H21-H22	0.29	4	1.16	0.29	4	1.16
H22-H23	0.46	4	1.84	0.46	4	1.84
H23-H24	0.43	4	1.72	0.43	4	1.72
H24-H25	0.61	4	2.44	0.61	3&4	2.44
TOTALS	12.18		48.72	12.18		48.75

### 3. DATA CLASSIFICATION

Of the 200 data sets collected for this project, 150 were to contain an incident of some kind, where an incident may be defined as something abnormal that occurred within the roadway or something unusual outside the roadway that affected traffic. The remaining 50 sets were to be non-incident in that nothing unusual happened during that period. Normal heavy traffic that causes stop-and-go conditions would not be considered an incident, while a car stalled in a lane or on a shoulder creating the same type of condition would be.

Within each incident and non-incident category there were four sub-categories according to the traffic level at the time of the incident. Category 1 was an incident that occurred when freeway occupancy was over 24% occupancy, categories 2, 3 and 4 were for occupancies less than 24% and lane volume levels of over 1400 vph for category 2; 700 vph to 1400 vph for type 3; and less than 700 vph for type 4. Twenty-five percent of the data sets in each subcategory was to be obtained from the fully instrumented section on the San Diego Freeway. Categories 5, 6, 7 and 8 are the corresponding non-incident divisions.

The number of data sets that were originally scheduled to be collected were:

	Incident			Non-Incident		
Type	1	2	3&4	5	6	7&8
Total	60	45	45	20	15	15
Full Instrumented	15	12	12	5	4	4

The numbers actually collected vary slightly due to lack of detectable incidents in some of the categories. The number of sets actually collected were:

	Incident			Non-Incident		
Type	1	2	3&4	5	6	7&8
Total	54	57	42	21	15	11
Full Instrumented	14	16	16	9	6	4

Appendix B gives a narrative description of each data set giving the type of incident and general traffic and weather condition.

#### 4. DATA SET FORMAT

Each data set is recorded on a separate 800 bpi 9-track magnetic tape with fixed length logical records. The format used for all tapes is identical except that the number of data blocks will vary according to the length of the incident involved. This section will provide only a general description of the information on the tape; to get a detailed listing refer to the analysis program documentation.

There are three types of records contained on each data set. The first record is a header block that contains all the documentation information. This gives incident location, affected freeways, weather conditions and any other information.

The second record is a lane sensor table that relates the logical sensor number used in the continuous time series data records to physical sensor location on the freeway.

The remaining records on the tape are continuous time series data blocks that contain the actual detector data.

Time series data contain an entry for each sensor every time it changes state. The entries are very general in nature giving only the logical sensor number, the time and whether the sensor is turning on or off. All entries are in chronological order.

The time given in the entries is accurate to 1/15 of a second since this is the sweep time the computer uses. The time entry will never be earlier than the change of state and at most 1/15 of a second late. Since this error occurs in the same direction for both the on and off times at a loop, the maximum error for vehicle duration over a loop is also 1/15 of a second.

#### 5. RAMP METERING

The California Department of Transportation is using ramp metering to help relieve congestion during urban peak traffic periods. Some of the sections of freeway used to collect data for this project are under either real-time or fixed-time traffic control during portions of the day.

Real-time control is when ramp metering rates are set by the computer that is being used to do the data collection. Within set limits, the computer can select the most appropriate metering rates for the current traffic conditions. This can have effect on traffic flow around an incident by allowing more cars on downstream from the incident.

Fixed-time control makes use of a historical table of metering rates run off a time of day clock. The rates are set by trial and error over a period of time and reflect the best average metering rate for any particular time period. This control is not traffic responsive and consequently cannot try to correct for an incident.

Sections of freeway under ramp control are:

Freeway Section	Time of Day	Date Began	Method
San Diego Fwy-Nbnd Marina Fwy to SM Fwy	0630 to 0930	Dec 75	Fixed-time
San Diego Fwy-Nbnd Harbor Fwy to 120th St	0600 to 0900	Dec 72	Real-time
Harbor Fwy-Sbnd SM Fwy to Century	1500 to 1830	Oct 71	Real-time
Harbor Fwy-Sbnd Century to SD Fwy	1500 to 1800	Oct 73	Fixed-time
Santa Monica Fwy-Wbnd Harbor Fwy to Overland	1545 to 1615	July 74	Fixed-time
Santa Monica Fwy-Ebnd National to Harbor Fwy	0630 to 0930	May 75	Fixed-time

## 6. FORTRAN ANALYSIS PROGRAM

In order to make the data sets more usable, an analysis program is being provided. This program is capable of generating summary data in either hard copy report format or as a condensed data set to be used in testing algorithms.

The analysis program is written in ANSI FORTRAN IV with no extensions. It should be usable, with only minor modifications to the I/O routines, on any machine with a FORTRAN IV compiler, a tape drive and 80K bytes of available memory.

The complete program documentation and instruction are included in Volume 3, "FORTRAN Program Documentation for Analyzing Individual Data Sets".

## 7. RUNNING THE ANALYSIS PROGRAM

When the analysis program starts, it gives the user the capability of specifying nine parameters that control what processing is to be done. The nine parameters are:

- OUTPUT - An integer value code specifying the form of program output. The default value is zero ( $\emptyset$ ).
- $\emptyset$  - List documentation information and stop.
  - 1 - List documentation information and computed statistics.
  - 2 - Write documentation information and computed statistics to tape.
  - 3 - Both 1 and 2.
- LIMITS - An integer value specifying whether or not changes are to be made to the stations limits of the freeway segments. Default is no change (zero).
- $\emptyset$  - Use existing station limits.
  - 1 - Changes are to be made to the station limits.
- UPDINT\* - An integer value designating the updating time interval in seconds. Default value is 20 seconds.
- AVGINT\* - An integer value designating the averaging time interval in seconds. Default value is 60 seconds. AVGINT must be equal to or multiple of UPDINT.
- LSTINT - An integer value designating the listing time interval in seconds. Default value is 20 seconds. Minimum value is UPDINT and maximum value is AVGINT. Valid parameter only when output is one (1) or three (3).
- ISTART - A maximum of six (6) digit integer value designating the first averaging time for which statistics are to be averaged. Default value is the starting time of the input data tape (STIME). The program may adjust ISTART if it is less than (STIME + AVGINT) to the greater of (STIME + AVGINT) or (ISTART - AVGINT). The time is in the format HHMMSS where HHMM is the hour and minutes in military and SS is in seconds. Leading zeroes are optional and imbedded blanks are not allowed.
- IFINAL - A maximum of six (6) digit integer value designating the last averaging time for which statistics are to be averaged. Default value is the input data tape ending time (ETIME). The format is the same as ISTART.
- SMPLRT - An integer value designating the number of sensor samples per second for which the Continuous Time Series Data Records were collected. Default value of 15 times per second.
- GFACTR - A real value designating a factor used in estimating density and speed. Default value of 2.8.

\*NOTE: (AVGINT/UPDINT) must be a value of 1 through 15.



## 8. ANALYSIS PROGRAM OUTPUT FORMAT

Hardcopy generated by the analysis program includes the documentation information and summarized traffic statistics as shown in Figures 2 through 4. The documentation information is fixed for each data set but the traffic data summaries can be varied by the user to get the time intervals or locations that he wishes.

Figure 2 illustrates the documentation information that is contained on the tape. The entries on this printout will be:

Tape No. - This is the identification number assigned to each tape and is in the format YYMMDDNN, where:

YY - refers to the year  
MM - is the month  
DD - is the day  
NN - is a number used to differentiate between data sets collected on the same day

Traffic Code - The traffic density level as explained in the Data Classification section of this volume.

Time Limits - These are the time limits for which data was collected for this data set. Time is based on a 24 hour clock.

Incident Location - Used only on incident data sets to indicate the two freeway stations between which the incident occurred. Format is FFSSD, where:

FF - indicates the freeway involved  
SM - Santa Monica Freeway  
SD - San Diego Freeway  
HA - Harbor Freeway  
SS - gives the freeway station  
D - gives the direction of travel  
N - North  
S - South  
E - East  
W - West

Affected Segments - This entry gives the number of and locations of the freeway segments from which data was collected. Freeway segments are in the same format as for the incident location.

Incident Type - Used only for incident data sets to indicate what occurred to affect traffic. Possible entries are:

TCOL - Traffic collision  
DISL - Disabled vehicle

TAPE NO. 74061033      TRAFFIC CODE - 3      FROM 07:01:00 TO 08:30:00

INCIDENT LOCATION: SM19E TO SM20E

AFFECTED SEGMENTS: 2

SEGMENT(1) FROM SM16E TO SM20E  
SEGMENT(2) FROM SM20W TO SM16W

INCIDENT TYPE: TCOL

VEHICLES INVOLVED: 3

LIGHT DUTY VEHICLES - 1  
LIGHT TRUCKS - 1  
HEAVY TRUCKS - 1

WEATHER AND ROAD CODES:      WEATHER - C  
VISIBILITY - O  
PAVEMENT - D

DETECTION AND VERIFICATION: DETECTED AT 07:36:40 BY CODE C  
VERIFIED AT 07:39:00 BY CODE V

LAND MARKS:      SIGN - E 1  
CALL BOX - SM182  
LOOP STATION - SM19E  
POST MILE - 10.24

INCIDENT FREEWAY GEOMETRY

	M	1	2	3	4	5	6	S	R	S	C	C	S	COMMENTS
GEOMETRY	1	1	1	1	1	1	1	1	1	1	1	1	1	CONSTRUCTION LN. 2

INCIDENT SENARIO EVENT TIMES

TIME	M	1	2	3	4	5	6	S	R	S	C	C	S	COMMENTS
07:36:00	1	1	1	0	0	0	0	0	0	0	0	0	0	PU TK HIT CEMENT TK
07:37:00	0	0	0	0	0	0	0	0	0	0	0	0	0	VEH HIT PU TK
07:40:00	1	1	1	0	0	0	0	0	0	0	0	0	0	CHP & TOW TK 1097
07:47:00	1	1	0	0	0	0	0	0	0	0	0	0	0	AMB 1097
07:55:00	0	0	0	0	0	0	0	0	0	0	0	0	0	LANES CLEAR

FIGURE 2

ILLUSTRATION OF DOCUMENTATION INFORMATION

TRAFFIC VOLUME COUNTS:

START TIME	STOP TIME	DURATION	COUNT
07:40:00	07:41:00	60	51
07:44:00	07:45:00	60	42

ADDITIONAL COMMENT LINES:

MAJOR ACCIDENT, MINOR INJURIES TO PU TK DRIVER

FIGURE 2 (CONTINUED)

ILLUSTRATION OF DOCUMENTATION INFORMATION

SPIL - Spilled load  
GAWK - Gawking where people are looking at something either on or off the freeway.  
NOTH - No apparent reason for the incident.

Vehicles Involved - Indicates the total number of vehicles actively involved in the incident. The total is then broken down into three classes:

LIGHT DUTY VEHICLES - Cars, motorcycles and pickups.  
LIGHT TRUCKS - Vans and delivery trucks.  
HEAVY TRUCKS - Trucks larger than delivery van size.

Weather and Road Codes - Weather codes can be:

C - Clear  
L - Light rain  
H - Heavy rain

Visibility can be:

S - Sunny  
H - Hazy  
O - Overcast  
F - Foggy  
D - Dark

Pavement can be:

D - Dry  
P - Damp  
W - Wet

Detection and Verification - Detection is an indication if the incident was detected by the existing LAAFSCP incident detection logic. A code of "C" indicates that the computer detected the incident at the time indicated.

Verification is the method used to certify that there actually was an incident and not just a false alarm. The time indicates when verification was made and the code indicates the manner:

H - Helicopter  
C - California Highway Patrol  
V - Verification driver

Land Marks - This section gives physical reference points to where the incident occurred. The post mile locations of the changeable message signs, the call boxes and the loop stations are given in Appendix C.

SIGN - If the incident occurred on the Santa Monica Freeway this will indicate the nearest changeable message sign in the format DNN, where 'D' is the direction either east or west and 'NN' is the sign number from 1 to 35.

CALL BOX - Indicates the nearest freeway trouble phone and is the format FFNN, where 'FF' indicates the freeway, the same as under incident location, and 'NNN' indicates the call box number.

LOOP STATION - Shows the closest loop station in the same format as used under incident location.

POST MILE - Indicates the actual position according to post mile measurements.

Incident Freeway Geometry - This section gives the lane configuration at the incident site. The heading M123456SRSCCS is broken up into three sections, M123456S, R and SCCS, where the first is the freeway proper, the next is used to indicate a ramp and the last a collector-distributor road.

In the freeway section, the M refers to a median shoulder and the 1 through 6 indicate freeway lanes with the lanes numbered from left to right when facing in the direction of travel. The S refers to an outside shoulder.

The R in the ramp section indicates the presence or absence of either an on or off-ramp.

The collector-distributor road can show an S for the left hand shoulder, two traffic lanes and a right hand shoulder.

A one placed under the letter or number indicates that the item is present while a zero indicates that it is not.

For example:

M123456SRSCCS  
111110010000

This is a four-lane freeway with a median shoulder and right hand shoulder, no ramps and no collector-distributor.

M123456SRSCCS  
1111110110000

This five-lane section has both a median and right hand shoulder and there is either an on or off-ramp

M123456SRSCCS  
1111100101101

This four-lane freeway with both shoulders also has a one lane collector-distributor with shoulders on both sides.

Incident Scenario Event Times - The meaning of the geometry heading is the same for this section as for the Incident Freeway Geometry.

Entries are arranged chronologically with a 1 in the columns that the comments refer to.

As an example, in Figure 2, the first entry there has 1's in the M, 1 and 2 columns. This would indicate that when the two trucks collided they blocked the median shoulder and two inside lanes. When the vehicle hit the trucks at 07:37:00, there was some question as to what lane he was traveling in so no entry is shown. The CHP and tow truck that arrived at 07:40:00 also worked on the shoulder and the two inside lanes, while the ambulance that arrived at 07:45:00 needed only the shoulder and one inside lane. (Abbreviations and codes used in the comments are explained in Appendix D.)

Traffic Volume Counts - If manual traffic counts were taken within the incident location, they will be recorded in this section. The duration is time in seconds and the count is for all freeway lanes.

Additional Comment Lines - Any comments that could not be fit into the Incident Scenario section will be placed here using the same abbreviations and codes.

Figure 3 is an example of the sensor index table. This figure gives a listing of all the active loops from which data was collected. The table is broken up into separate sections for each of the segments and for the environmental sensors.

The entries in the table are:

Sensor Index Number - This is the logical index number used to identify this sensor on this particular data set. This is the number used to select records from the data set and will not be needed by a user, unless he writes his own programs to access data on the tapes.

Freeway Station, Direction, Lane Type and Number - This section identifies the physical location of the loop on the freeway. The FWY STA DIR part follows the same format as used for the affected segment.

SEGMENT(1) FROM SM16E TO SM20E SENSORS 1 TO 20

SENSOR INDEX NO.	FWY	STA	DIR	LANE		MBAI CODE	STATION INDEX NO.
				TYPE	NO.		
1	SM	16	E	LANE	1	1	1
2	SM	16	E	LANE	3	1	
3	SM	16	E	OFFA	1	1	
4	SM	16	E	ONA	1	1	
5	SM	17	E	LANE	1	1	2
6	SM	17	E	LANE	3	1	
7	SM	17	E	OFFA	1	1	
8	SM	17	E	OFFA	2	1	
9	SM	17	E	ONA	1	1	
10	SM	18	E	LANE	1	1	3
11	SM	18	E	LANE	2	1	
12	SM	18	E	LANE	3	1	
13	SM	18	E	LANE	4	1	
14	SM	18	E	LANE	5	1	
15	SM	19	E	LANE	1	1	4
16	SM	19	E	LANE	3	1	
17	SM	19	E	OFFA	1	1	
18	SM	20	E	LANE	1	1	5
19	SM	20	E	LANE	3	1	
20	SM	20	E	ONA	1	1	

SEGMENT(2) FROM SM20W TO SM16W SENSORS 21 TO 40

SENSOR INDEX NO.	FWY	STA	DIR	LANE		MBAI CODE	STATION INDEX NO.
				TYPE	NO.		
21	SM	20	W	LANE	1	1	6
22	SM	20	W	LANE	3	1	
23	SM	20	W	OFFA	1	1	
24	SM	19	W	LANE	1	1	7
25	SM	19	W	LANE	3	1	
26	SM	19	W	ONA	1	1	

FIGURE 3

ILLUSTRATION OF SENSOR INDEX TABLE

27	SM	18	W	LANE	1	1	8
28	SM	18	W	LANE	2	1	
29	SM	18	W	LANE	3	1	
30	SM	18	W	LANE	4	4	
31	SM	17	W	LANE	1	1	9
32	SM	17	W	LANE	3	1	
33	SM	17	W	OFFA	1	1	
34	SM	17	W	OFFB	1	1	
35	SM	17	W	OFFB	2	1	
36	SM	17	W	ONA	1	1	
37	SM	17	W	ONA	2	1	
38	SM	16	W	LANE	1	1	10
39	SM	16	W	LANE	3	1	
40	SM	16	W	ONA	1	1	

ENVIRONMENTAL SENSORS 41 TO 49

SENSOR INDEX NO.	FWY	STA	DIR	LANE		MBAI CODE	STATION INDEX
				TYPE	NO.		
41	SM	18	E	ENVT	1	1	
42	SM	18	E	ENVL	1	1	
43	SM	18	E	ENWV	1	1	
44	SD	4	N	ENVT	1	1	
45	SD	4	N	ENVL	1	1	
46	SD	4	N	ENWV	1	1	
47	HA	20	N	ENVT	1	1	
48	HA	20	N	ENVL	1	1	
49	HA	20	N	ENWV	1	1	

FIGURE 3 (CONTINUED)

ILLUSTRATION OF SENSOR INDEX TABLE



Within the lane type codes, the on-ramps, off-ramps, connectors and collector-distributor codes use suffixes of "A" and "B." The suffixes are needed to establish a unique identification because occasionally two separate on-ramps, etc., are associated with the same freeway station.

Possible lane type codes are:

LANE - Mainline freeway  
ONA, ONB - Freeway on-ramp  
OFFA, OFFB - Freeway off-ramp  
CONA, CONB - Freeway-to-freeway connector  
CDA, CDB - Collector-distributor road  
ENVT - Environmental sensor for temperature  
ENVL - Environmental sensor for light  
ENWV - Environmental sensor for moisture

Lane number indicates the lane position within the station and is numbered from left to right when facing in the direction of travel.

MBAI Code - Modified, bad, active and inactive state code for the sensor.

Modified - The sensor was recently changed from the inactive state to the active state, or vice versa.

Bad - A malfunction was detected for this sensor.

Active - The sensor was collecting data at this time.

Inactive - The sensor was not collecting data at this time.

Code Number	Meaning
Ø	Inactive
1	Active
2	Bad, inactive
3	Bad, active
4	Modified, inactive
5	Modified, active
6	Modified, bad, inactive
7	Modified, bad, active

Station Index No. - These are the index numbers that the user must input, when starting the program, if he wishes to get a summary of only some of the stations.

For example, if only SM16E to SM17E is desired, then

1 2 00 00 00 00 would be used in the input parameters.<sup>1</sup>

However, if station SM17E and SM19W to SM17W were desired, then

2 2 7 9 00 00 would be input.

Figure 4 is an example of the 20-second traffic data summaries that will be printed out. The heading for each segment gives the time interval and the station limits of the subtotal.

The vertical format of the data entries is:

```

_____ HEADING _____
                Mainline lane
                :
                :
                Mainline station summary
Ramp, collector and connector individual lane data
                :
Ramp, collector and connector individual lane data
_____ HEADING _____
                :
                :
```

The mainline station summary gives an average of the individual lane values for occupancy, VOL/LN/HR, DENSITY and SPEED and a total of the individual lane values for volume.

The data entries used are:

OCCUPANCY - This represents the percent of time that a vehicle was actually within the influence area of the loop.

VOLUME - The count of vehicles that pass over the loop.

VOL/LN/HR - Hourly volume per lane.

DENSITY - Vehicles per lane per mile. This value is calculated by using occupancy and an assumed average vehicle length.

SPEED - A calculated speed (MPH) from hourly lane volume, occupancy and an assumed average vehicle length, e.g.,  $Speed = Volume / (2.8 \times occupancy)$ .

<sup>1</sup> For a full discussion of the input parameters, see Volume 3.

TIME IS 07:01:00 FROM STATION SM16E TO STATION SM20E

	OCCUPANCY	VOLUME	VOL/LN/HR	DENSITY	SPEED
SM16ELANE1	13.00	34.00	2040.00	36.40	56.48
SM16ELANE3	11.22	26.00	1560.00	31.42	49.86
SM16E	12.11	60.00	1800.00	33.91	53.17
SM16EOFFA1	.00	.00	.00	.00	.00
SM16EONA 1	15.22	23.00	1380.00	42.62	37.15
	OCCUPANCY	VOLUME	VOL/LN/HR	DENSITY	SPEED
SM17ELANE1	13.56	33.00	1980.00	37.96	52.46
SM17ELANE3	11.78	28.00	1680.00	32.98	51.74
SM17E	12.67	61.00	1830.00	35.47	52.10
SM17EOFFA1	2.11	4.00	240.00	5.91	25.55
SM17EOFFA2	.00	.00	.00	.00	.00
SM17EONA 1	18.56	29.00	1740.00	51.96	33.49
	OCCUPANCY	VOLUME	VOL/LN/HR	DENSITY	SPEED
SM18ELANE1	15.56	34.00	2040.00	43.56	46.87
SM18ELANE2	13.78	33.00	1980.00	38.58	51.58
SM18ELANE3	16.78	36.00	2160.00	46.98	46.08
SM18ELANE4	12.56	25.00	1500.00	35.16	43.48
SM18ELANE5	8.67	16.00	960.00	24.27	39.09
SM18E	13.47	144.00	1728.00	37.71	45.42
	OCCUPANCY	VOLUME	VOL/LN/HR	DENSITY	SPEED
SM19ELANE1	14.89	33.00	1980.00	41.69	48.20
SM19ELANE3	12.33	25.00	1500.00	34.53	43.95
SM19E	13.61	58.00	1740.00	38.11	46.08
SM19EOFFA1	4.89	9.00	540.00	13.69	43.50
	OCCUPANCY	VOLUME	VOL/LN/HR	DENSITY	SPEED
SM20ELANE1	14.11	33.00	1980.00	39.51	49.97
SM20ELANE3	16.33	31.00	1860.00	45.73	41.74
SM20E	15.22	64.00	1920.00	42.62	45.85
SM20EONA 1	15.89	29.00	1740.00	44.49	30.03

FIGURE 4

ILLUSTRATION OF TRAFFIC DATA SUMMARY

TIME IS 07:01:00 FROM STATION SM20W TO STATION SM16W					
	OCCUPANCY	VOLUME	VOL/LN/HR	DENSITY	SPEED
SM20WLANE1	7.89	18.00	1080.00	22.09	49.36
SM20WLANE3	13.56	25.00	1500.00	37.96	40.32
SM20W	10.72	43.00	1290.00	30.02	44.84
SM20WOFFA1	9.33	19.00	1140.00	26.13	44.21
	OCCUPANCY	VOLUME	VOL/LN/HR	DENSITY	SPEED
SM19WLANE1	4.44	11.00	660.00	12.44	52.30
SM19WLANE3	9.22	20.00	1200.00	25.82	46.03
SM19W	6.83	31.00	930.00	19.13	49.16
SM19WONA 1	4.67	10.00	600.00	13.07	45.70
	OCCUPANCY	VOLUME	VOL/LN/HR	DENSITY	SPEED
SM18WLANE1	8.89	19.00	1140.00	24.89	45.32
SM18WLANE2	9.33	21.00	1260.00	26.13	48.21
SM18WLANE3	11.22	24.00	1440.00	31.42	45.95
SM18WLANE4	12.33	21.00	1260.00	34.53	36.69
SM18W	10.44	85.00	1275.00	29.24	44.04
	OCCUPANCY	VOLUME	VOL/LN/HR	DENSITY	SPEED
SM17WLANE1	9.22	22.00	1320.00	25.82	55.58
SM17WLANE3	8.44	18.00	1080.00	23.64	46.43
SM17W	8.83	40.00	1200.00	24.73	51.00
SM17WOFFA1	15.89	22.00	1320.00	44.49	31.85
SM17WOFFB1	.89	2.00	120.00	2.49	16.07
SM17WOFFB2	3.33	6.00	360.00	9.33	37.35
SM17WONA 1	2.78	5.00	300.00	7.78	24.25
SM17WONA 2	.56	1.00	60.00	1.56	12.86
	OCCUPANCY	VOLUME	VOL/LN/HR	DENSITY	SPEED
SM16WLANE1	4.78	11.00	660.00	13.38	48.91
SM16W	5.89	27.00	810.00	16.49	49.14
SM16WONA 1	3.89	5.00	300.00	10.89	16.54

FIGURE 4 (CONTINUED)

ILLUSTRATION OF TRAFFIC DATA SUMMARY

TIME IS 07:01:20 FROM STATION SM16E TO STATION SM20E						
	OCCUPANCY	VOLUME	VOL/LN/HR	DENSITY	SPEED	
SM16ELANE1	14.22	37.00	2220.00	39.82	55.83	
SM16ELANE3	9.56	22.00	1320.00	26.76	49.10	
SM16E	11.89	59.00	1770.00	33.29	52.46	
SM16EOFFA1	.56	1.00	60.00	1.56	12.86	
SM16EONA 1	9.33	18.00	1080.00	26.13	42.08	
	OCCUPANCY	VOLUME	VOL/LN/HR	DENSITY	SPEED	
SM17ELANE1	14.33	34.00	2040.00	40.13	51.19	
SM17ELANE3	11.11	26.00	1560.00	31.11	50.66	
SM17E	12.72	60.00	1800.00	35.62	50.93	
SM17EOFFA1	2.00	4.00	240.00	5.60	27.69	
SM17EOFFA2	.00	.00	.00	.00	.00	
SM17EONA 1	14.33	21.00	1260.00	40.13	30.71	
	OCCUPANCY	VOLUME	VOL/LN/HR	DENSITY	SPEED	
SM18ELANE1	15.00	33.00	1980.00	42.00	47.26	
SM18ELANE2	14.11	34.00	2040.00	39.51	51.91	
SM18ELANE3	18.11	37.00	2220.00	50.71	43.74	
SM18ELANE4	16.00	27.00	1620.00	44.80	37.00	
SM18ELANE5	9.89	19.00	1140.00	27.69	41.14	
SM18E	14.62	150.00	1800.00	40.94	44.21	
	OCCUPANCY	VOLUME	VOL/LN/HR	DENSITY	SPEED	
SM19ELANE1	15.44	34.00	2040.00	43.24	47.42	
SM19ELANE3	12.22	27.00	1620.00	34.22	47.39	
SM19E	13.83	61.00	1830.00	38.73	47.41	
SM19EOFFA1	6.11	12.00	720.00	17.11	44.57	
	OCCUPANCY	VOLUME	VOL/LN/HR	DENSITY	SPEED	
SM20ELANE1	13.67	30.00	1800.00	38.27	47.37	
SM20ELANE3	15.67	31.00	1860.00	43.87	43.44	
SM20E	14.67	61.00	1830.00	41.07	45.41	
SM20EONA 1	14.11	25.00	1500.00	39.51	37.69	

FIGURE 4 (CONTINUED)

ILLUSTRATION OF TRAFFIC DATA SUMMARY

TIME IS 07:01:20 FROM STATION SM20W TO STATION SM16W

	OCCUPANCY	VOLUME	VOL/LN/HR	DENSITY	SPEED
SM20WLANE1	7.22	17.00	1020.00	20.22	50.82
SM20WLANE3	13.22	25.00	1500.00	37.02	41.37
SM20W	10.22	42.00	1260.00	28.62	46.09
SM20WOFFA1	9.44	19.00	1140.00	26.44	43.26
	OCCUPANCY	VOLUME	VOL/LN/HR	DENSITY	SPEED
SM19WLANE1	7.67	18.00	1080.00	21.47	51.86
SM19WLANE3	11.78	24.00	1440.00	32.98	44.11
SM19W	9.72	42.00	1260.00	27.22	47.99
SM19WONA 1	5.56	11.00	660.00	15.56	43.69
	OCCUPANCY	VOLUME	VOL LN/HR	DENSITY	SPEED
SM18WLANE1	6.89	15.00	900.00	19.29	45.92
SM18WLANE2	8.00	18.00	1080.00	22.40	48.21
SM18WLANE3	9.33	21.00	1260.00	26.13	42.12
SM18WLANE4	10.11	19.00	1140.00	28.31	40.58
SM18W	8.58	73.00	1095.00	24.03	45.71
	OCCUPANCY	VOLUME	VOL/LN/HR	DENSITY	SPEED
SM17WLANE1	9.78	23.00	1380.00	27.38	50.22
SM17WLANE3	8.56	18.00	1080.00	23.96	45.66
SM17W	9.17	41.00	1230.00	25.67	47.94
SM17WOFFA1	22.56	29.00	1740.00	63.16	28.79
SM17WOFFB1	.89	2.00	120.00	2.49	16.07
SM17WOFFB2	3.44	5.00	300.00	9.64	32.14
SM17WONA 1	2.11	4.00	240.00	5.91	13.53
SM17WONA 2	.56	1.00	60.00	1.56	12.86
	OCCUPANCY	VOLUME	VOL/LN/HR	DENSITY	SPEED
SM16WLANE1	5.56	13.00	780.00	15.56	49.29
SM16WLANE3	7.67	17.00	1020.00	21.47	48.44
SM16W	6.61	30.00	900.00	18.51	48.87
SM16WONA 1	4.67	6.00	360.00	13.07	25.72

FIGURE 4 (CONTINUED)

ILLUSTRATION OF TRAFFIC DATA SUMMARY

## APPENDIX A

### Loop Location Maps

This set of maps gives a schematic view of the freeways used for the data collection. They illustrate the number of lanes at each location, the loops that were connected to the computer and the location of ramps and collector roads. Active and inactive loops are designated by the following symbols:

- - Active Loop
- - Inactive Loop

<u>TABLE OF CONTENTS</u>	<u>PAGE</u>
HARBOR FREEWAY STATIONS (H-1 through H-25)	25-29
SANTA MONICA FREEWAY STATIONS (SM-1 through SM-28)	30-34
SAN DIEGO FREEWAY STATIONS (SD-1 through SD-32)	31-40

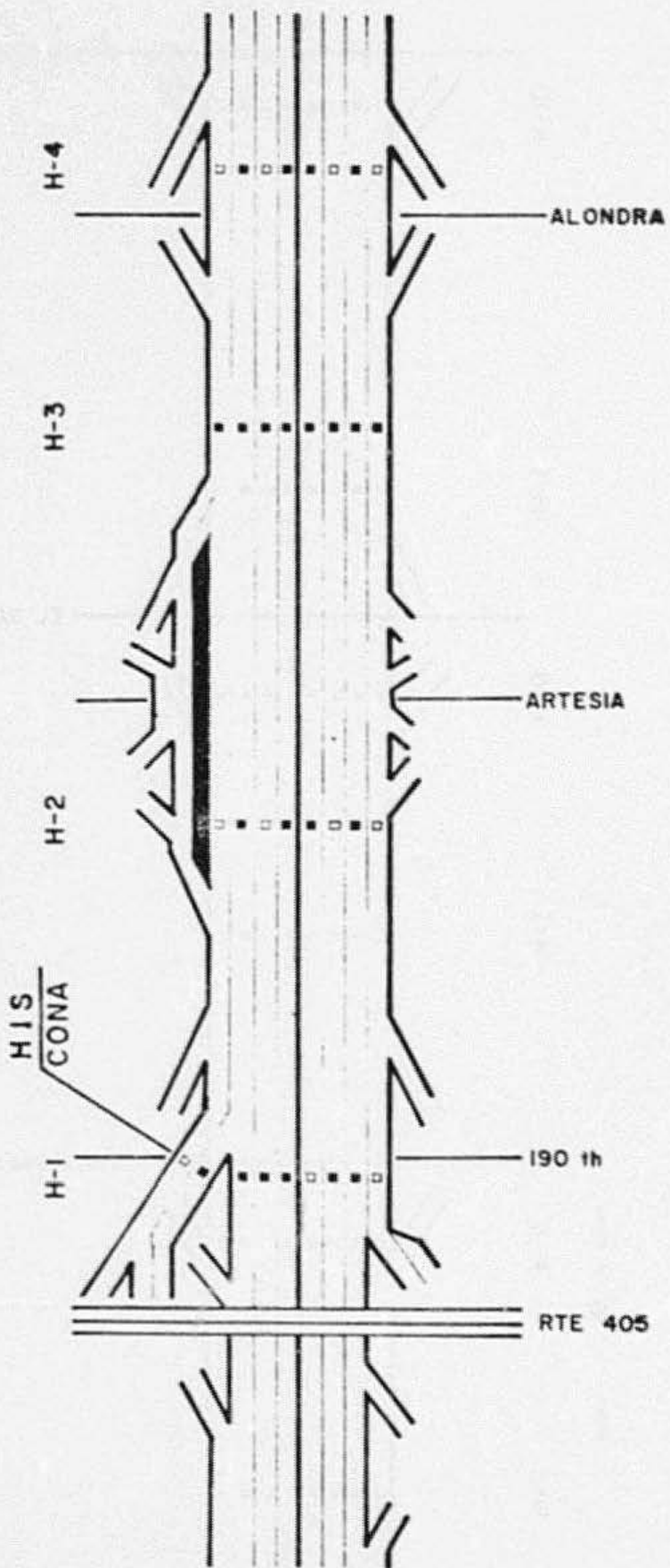



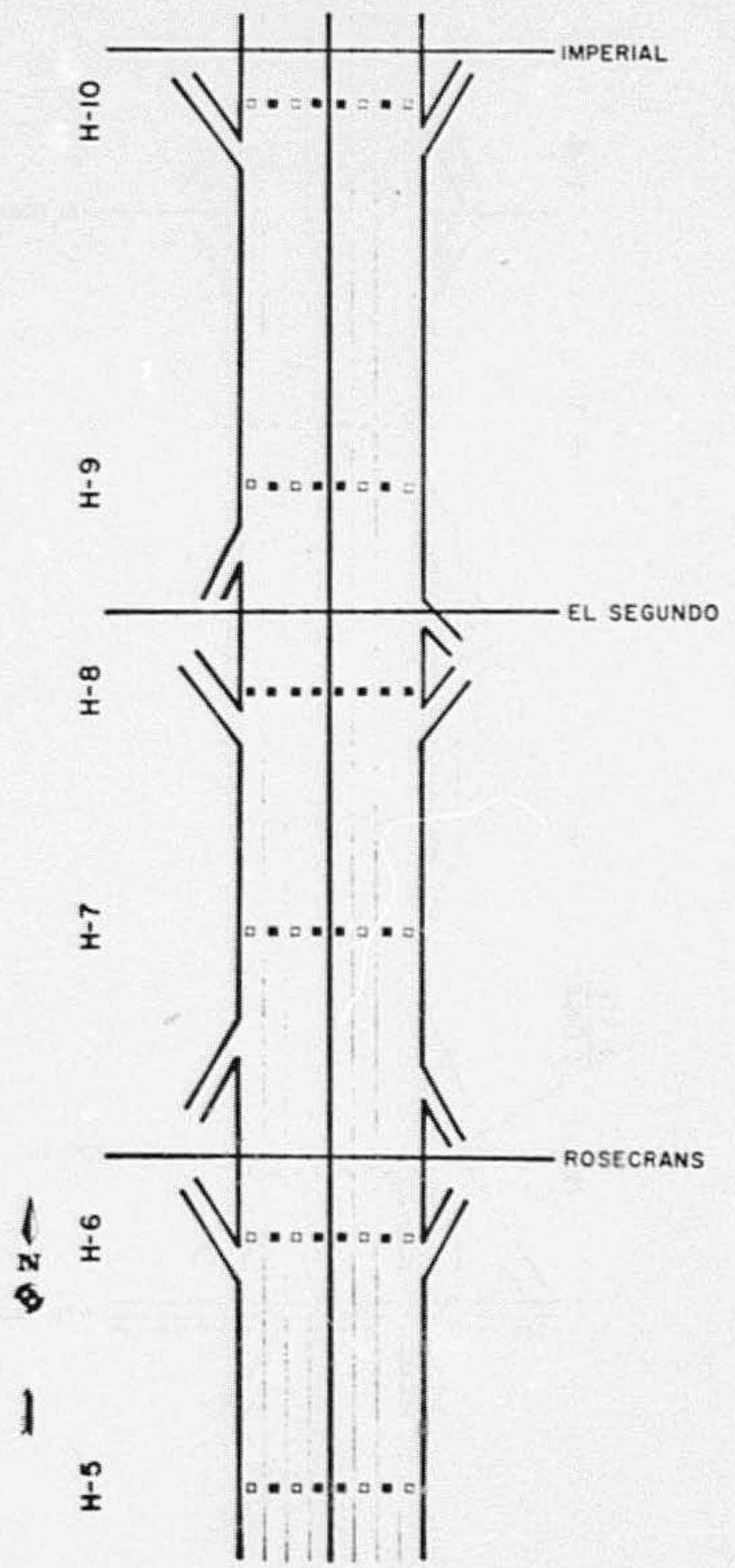

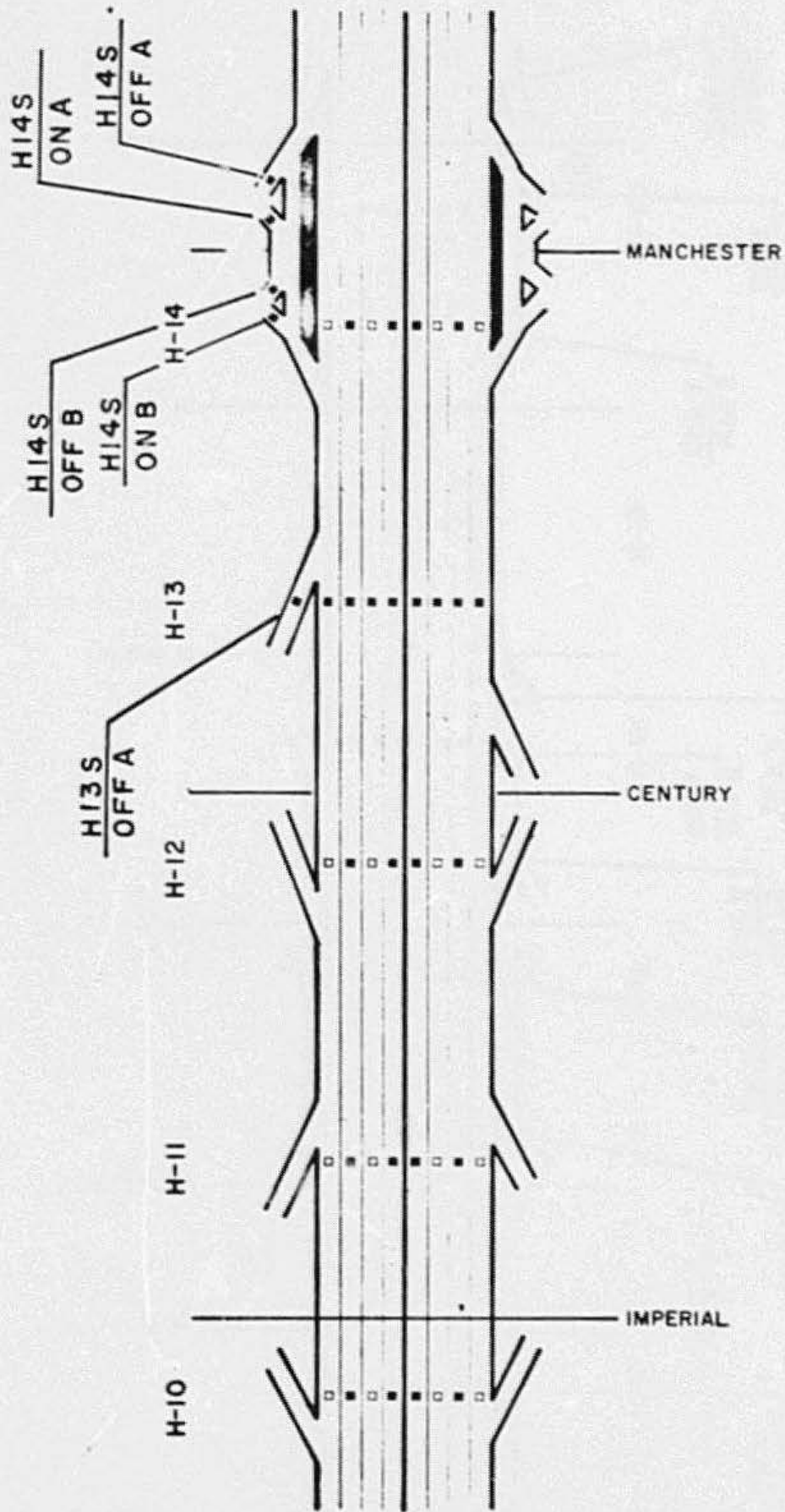

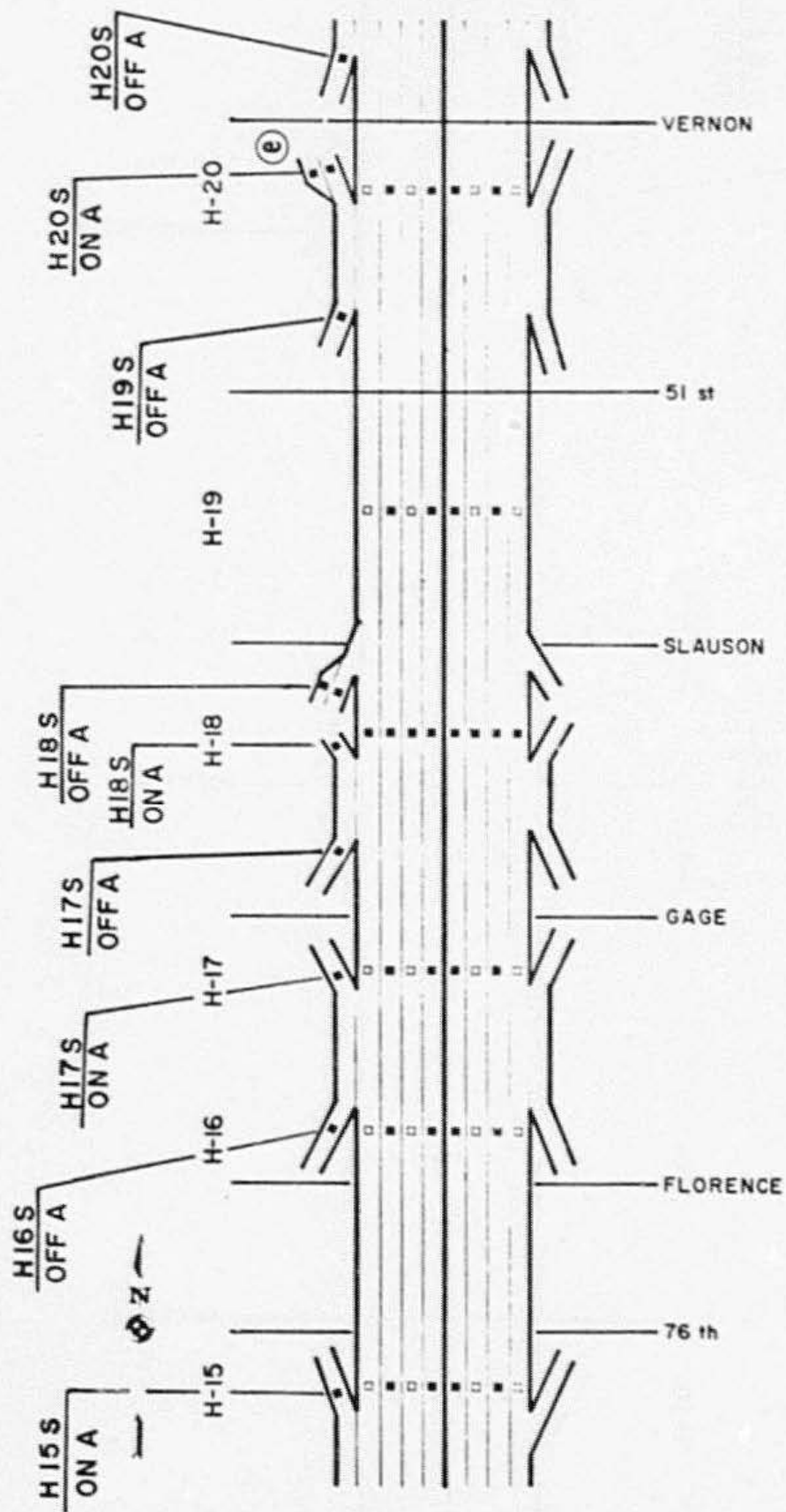

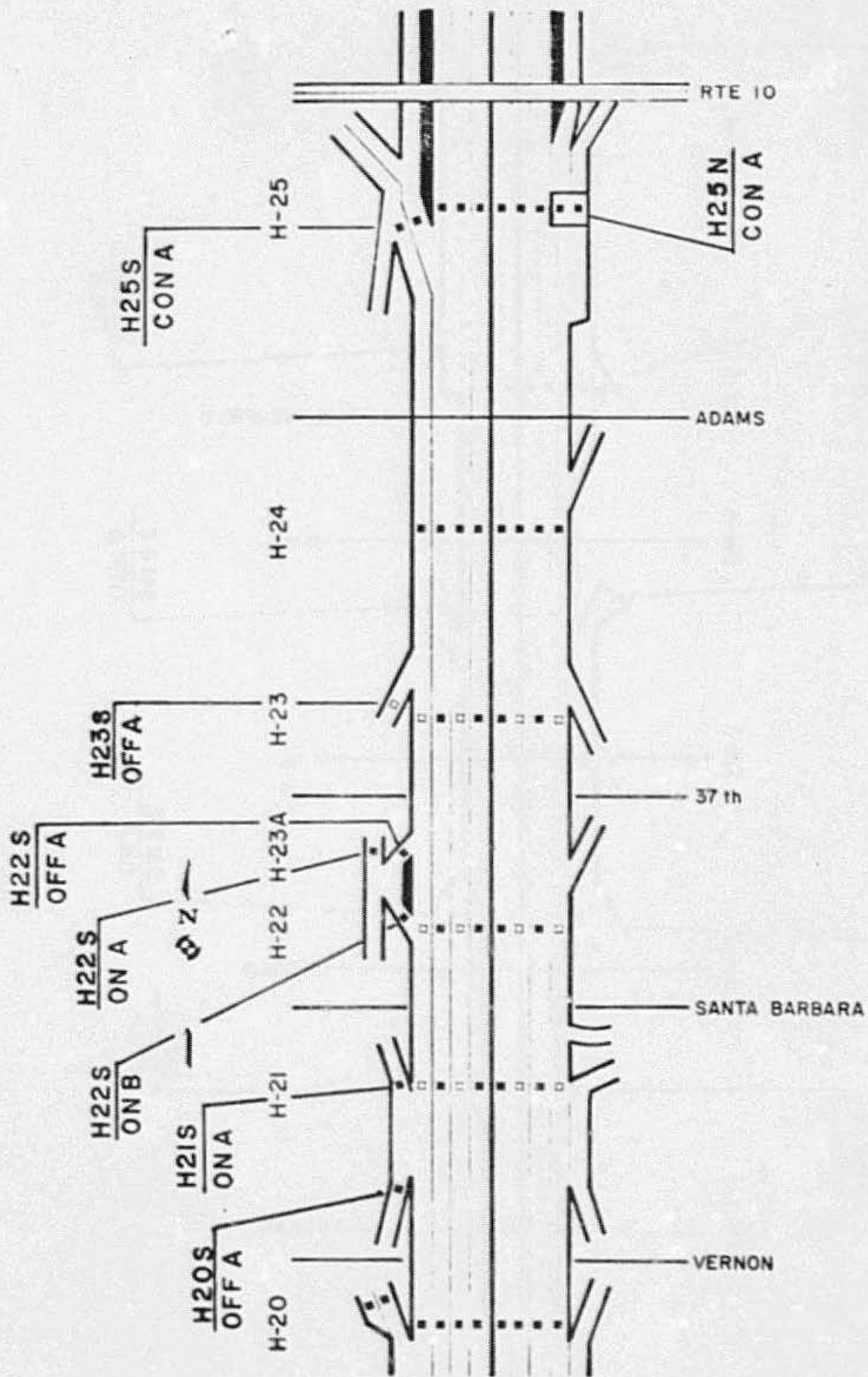

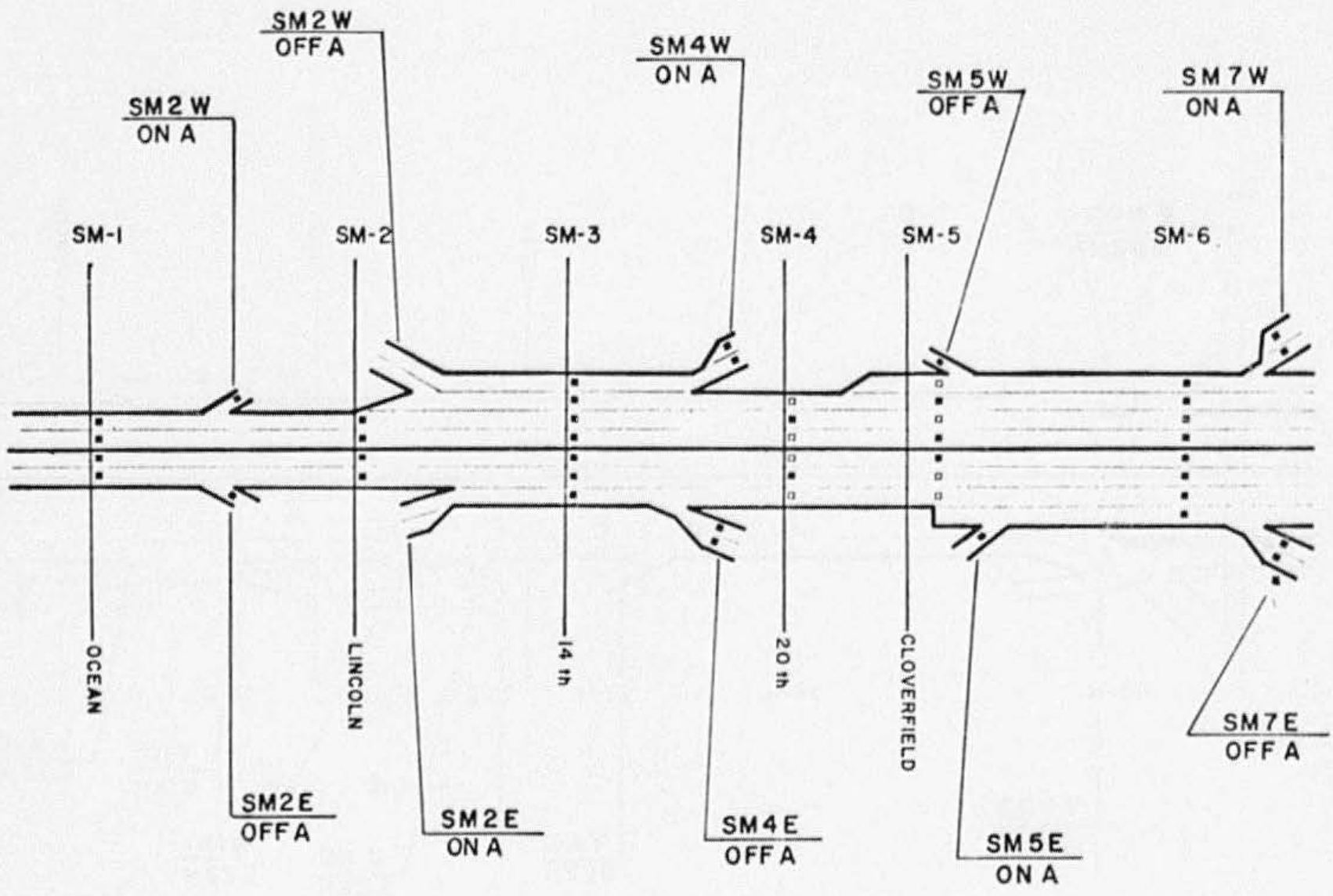

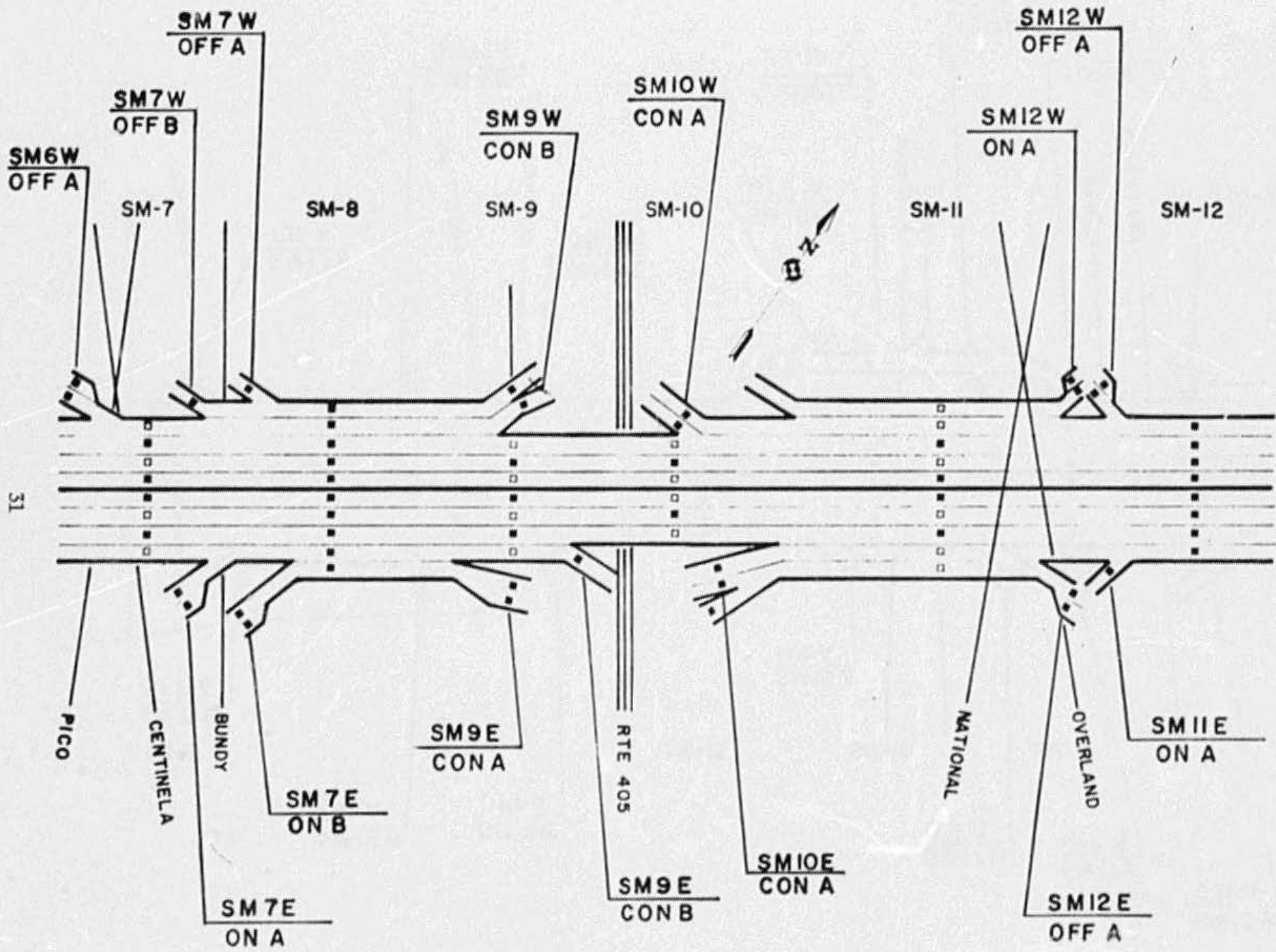

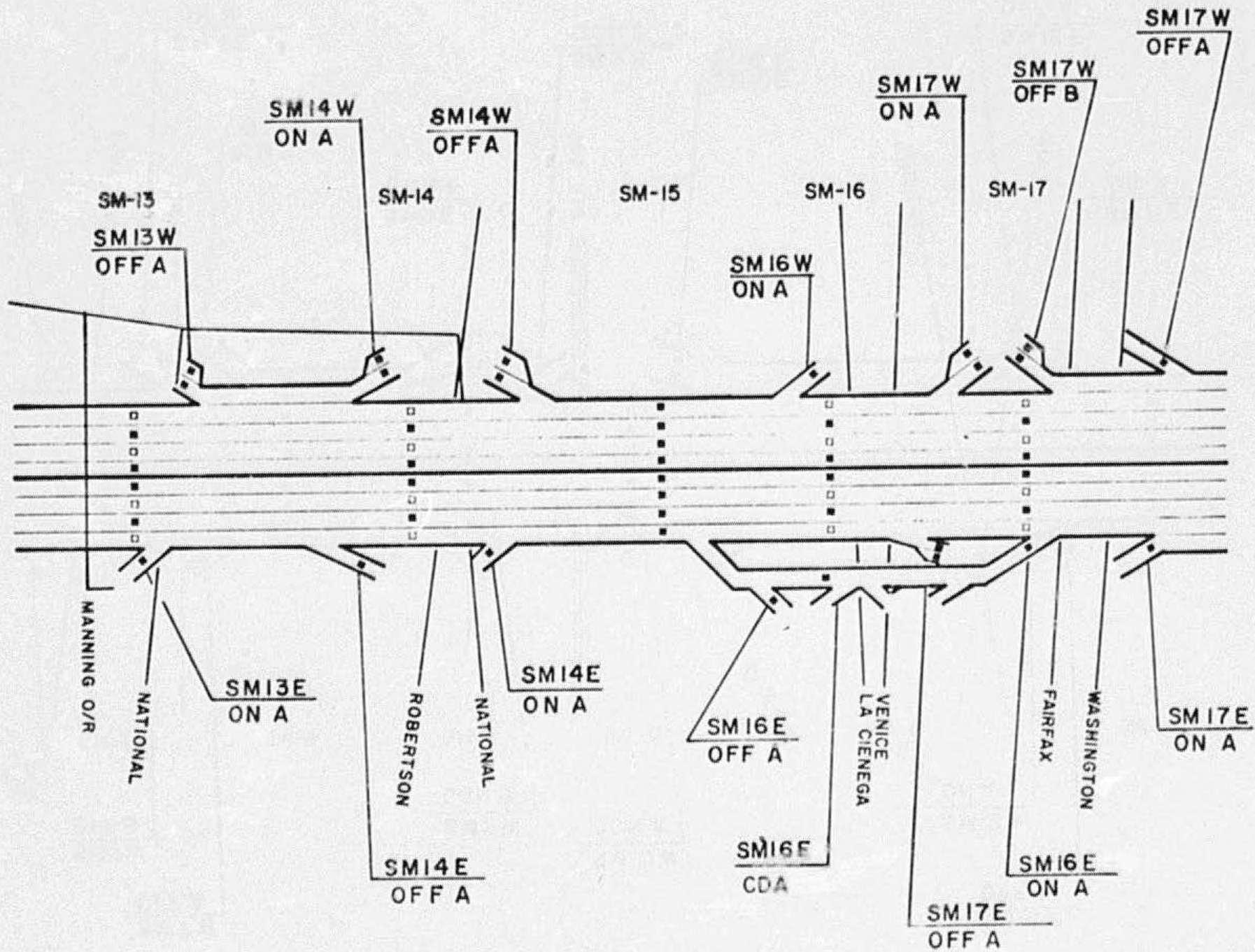

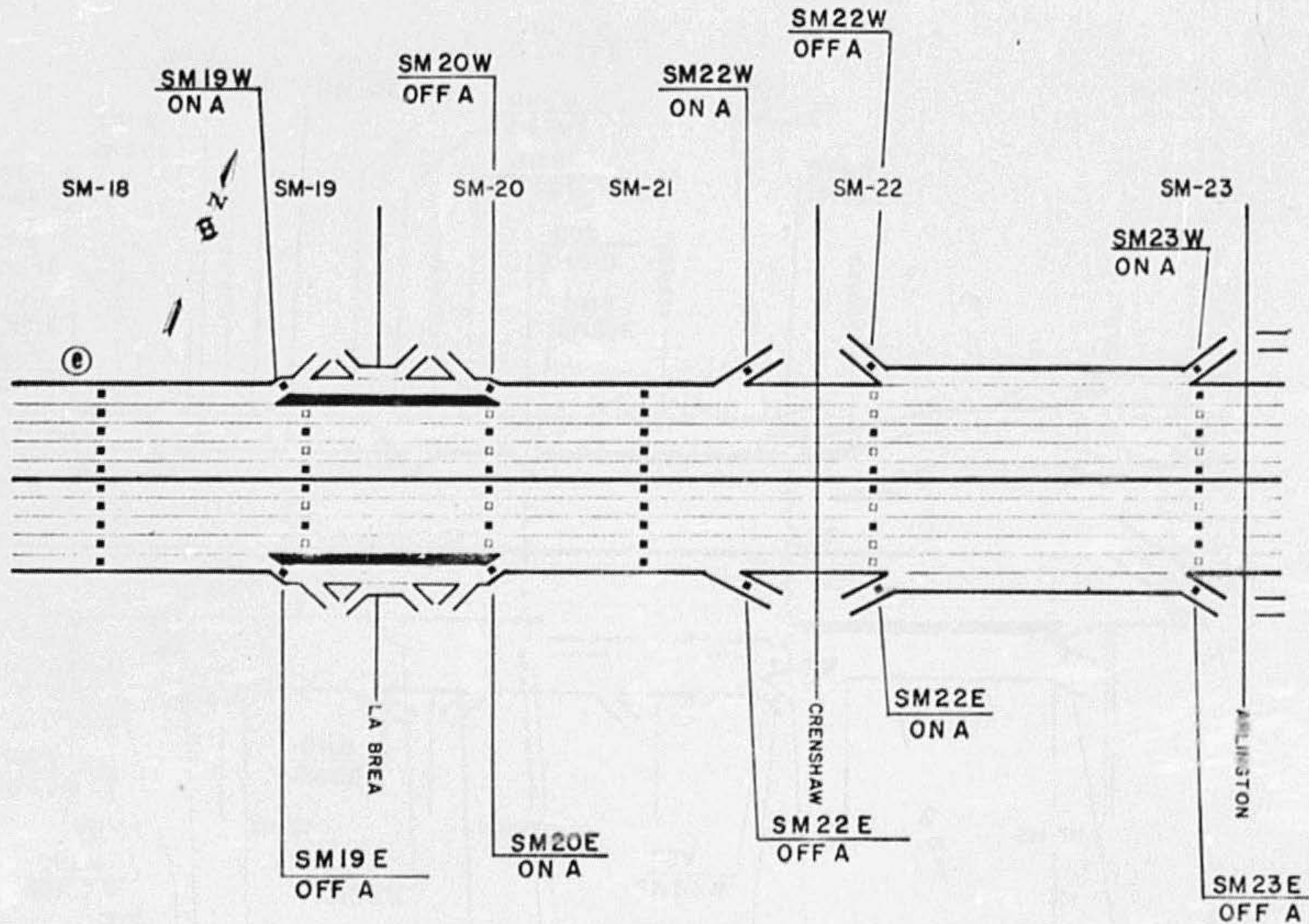



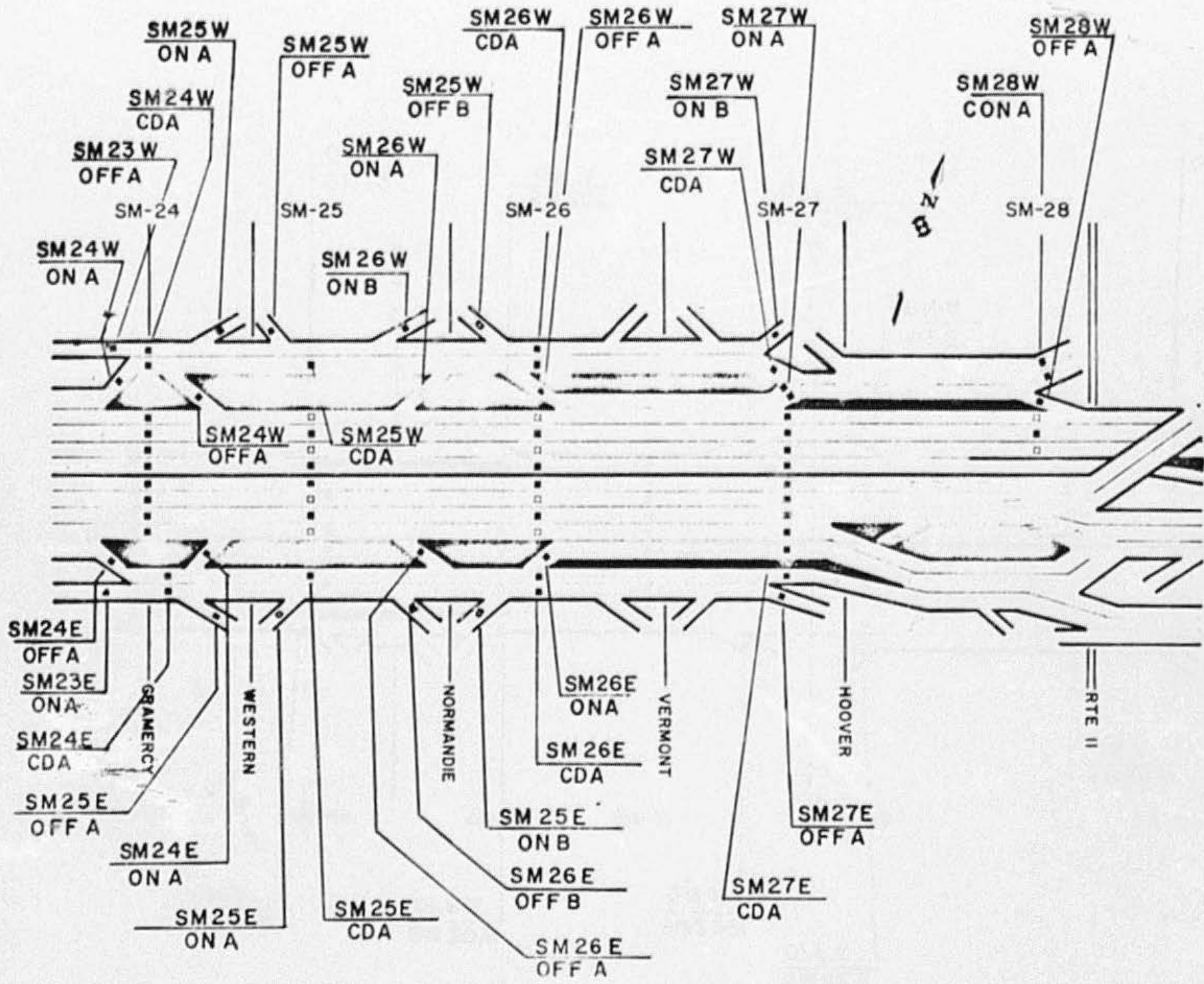

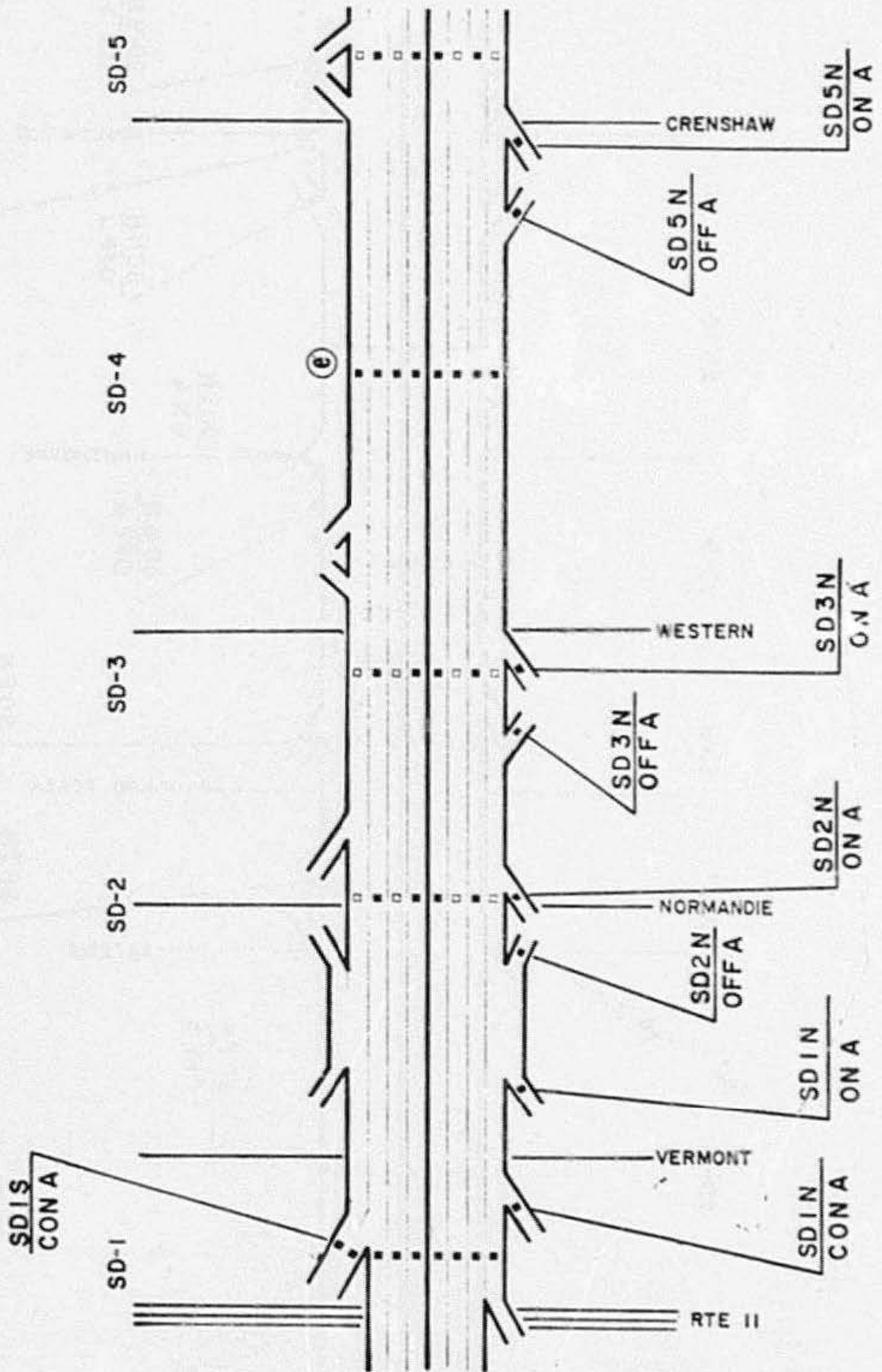

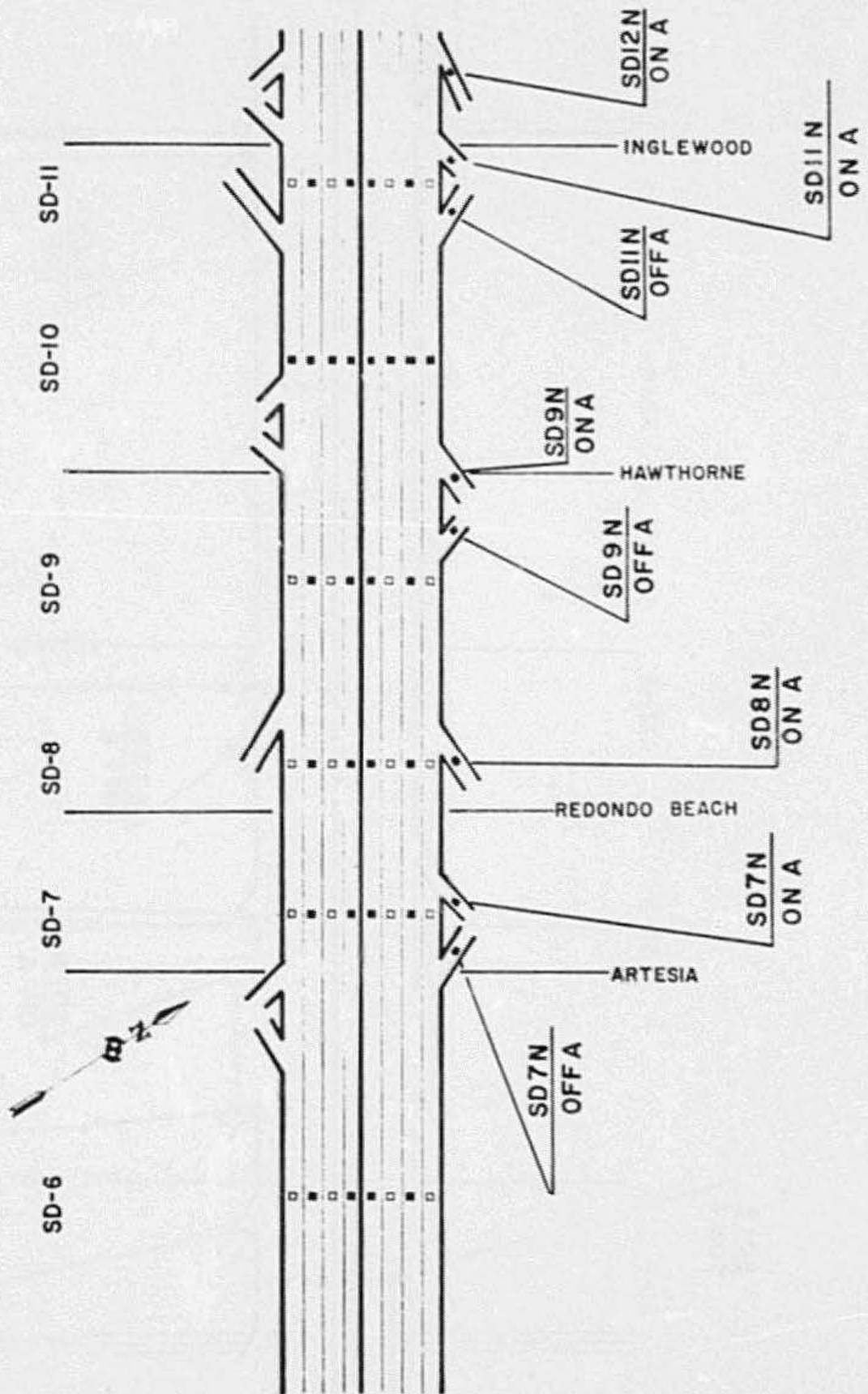

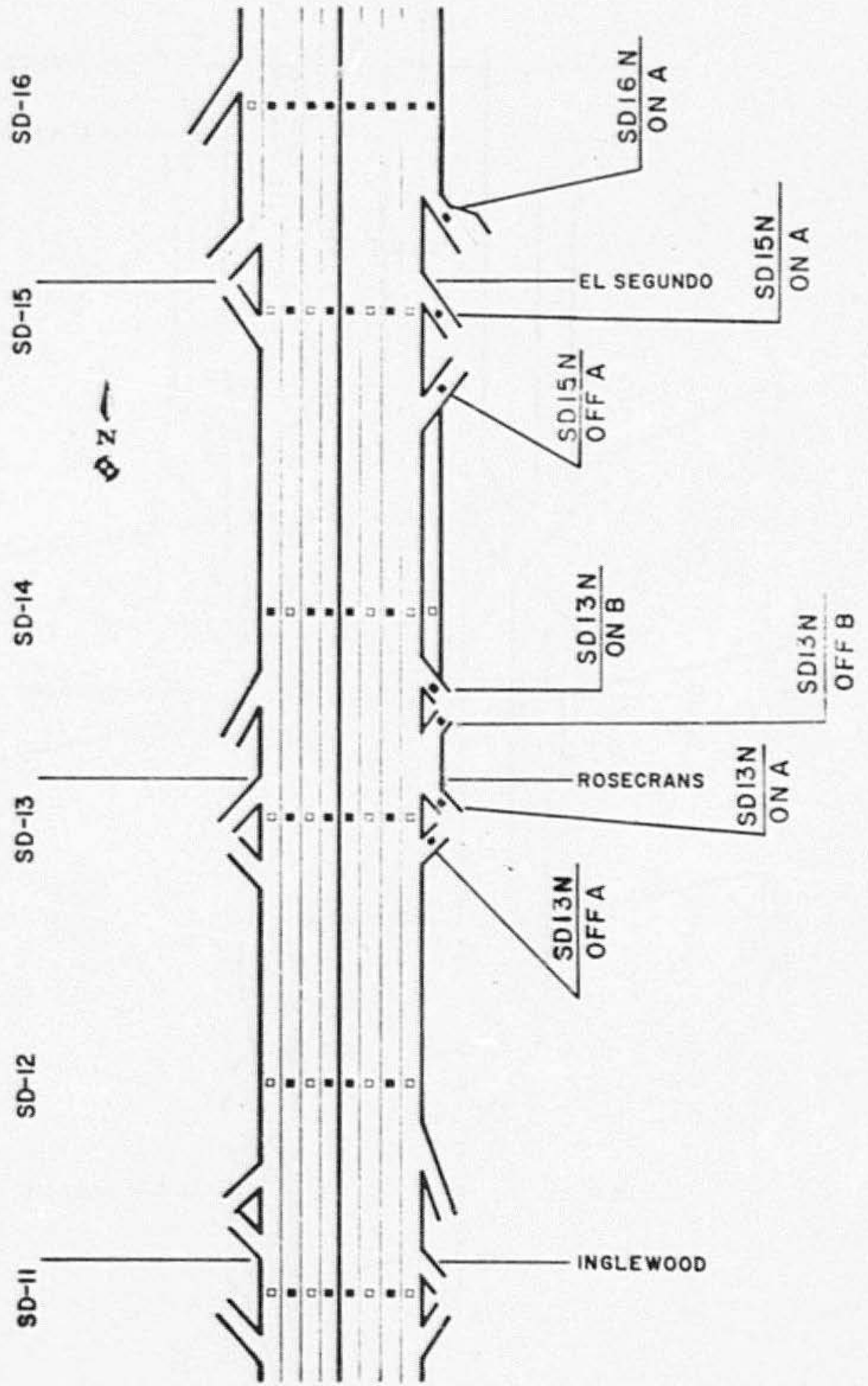

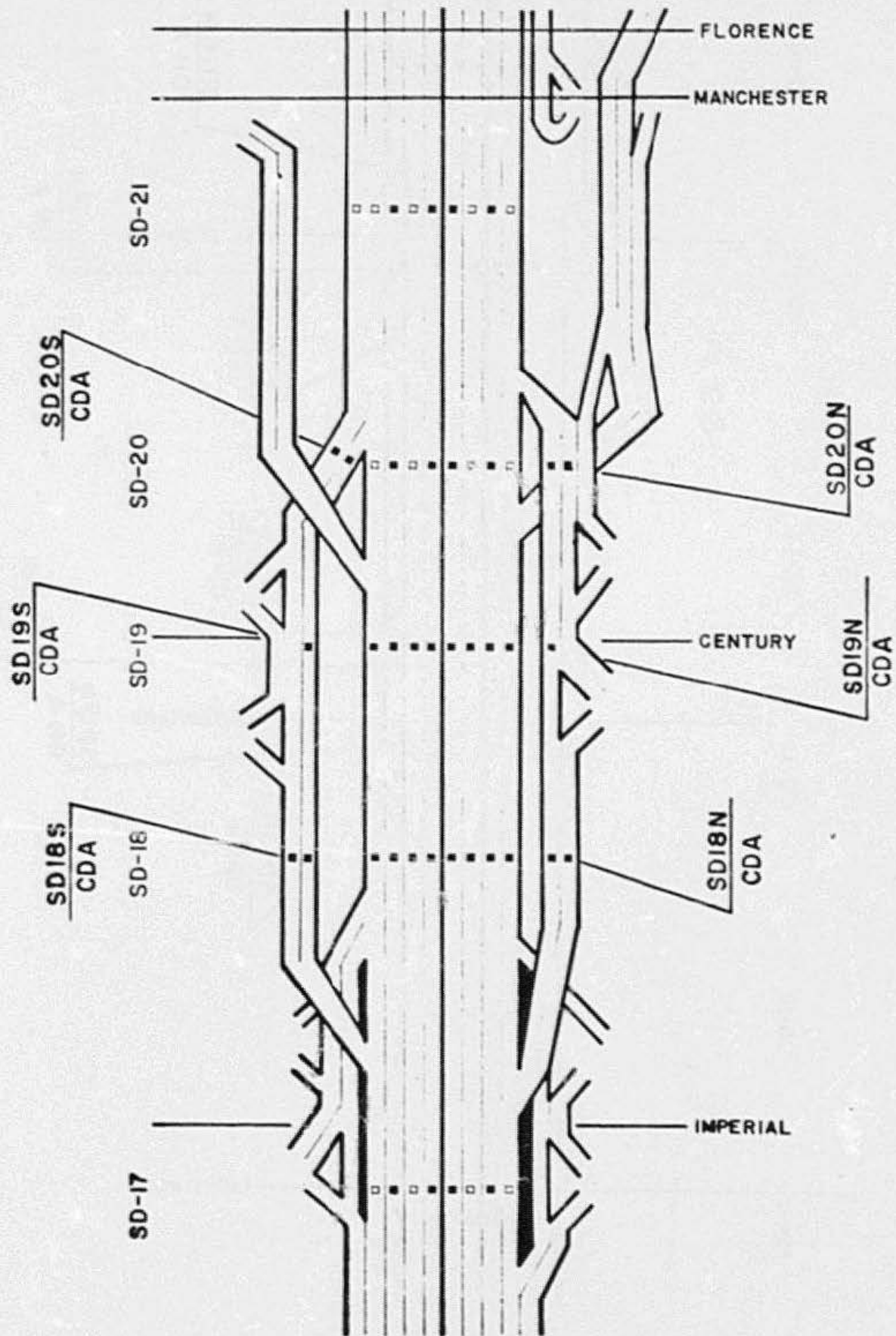

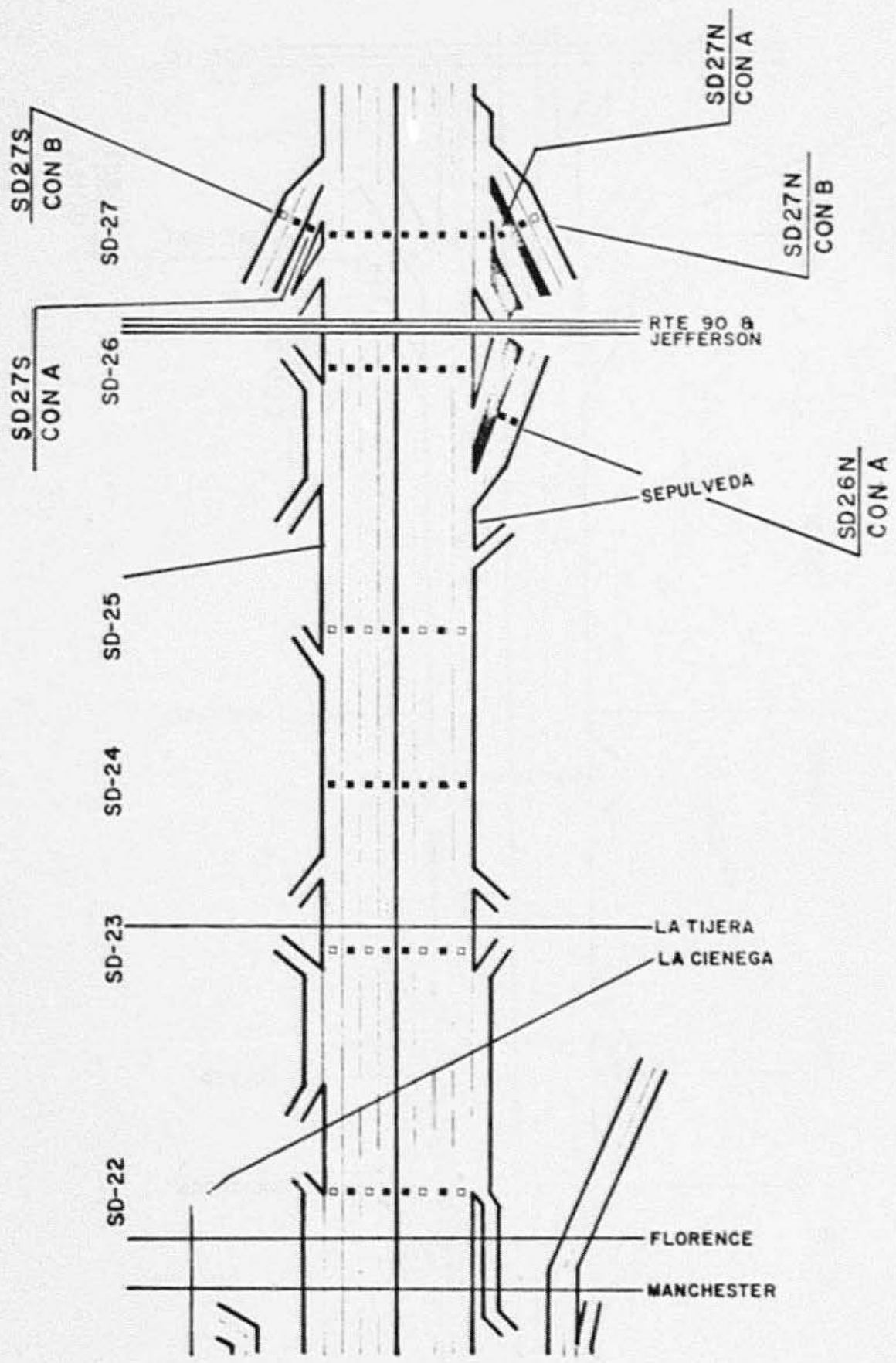

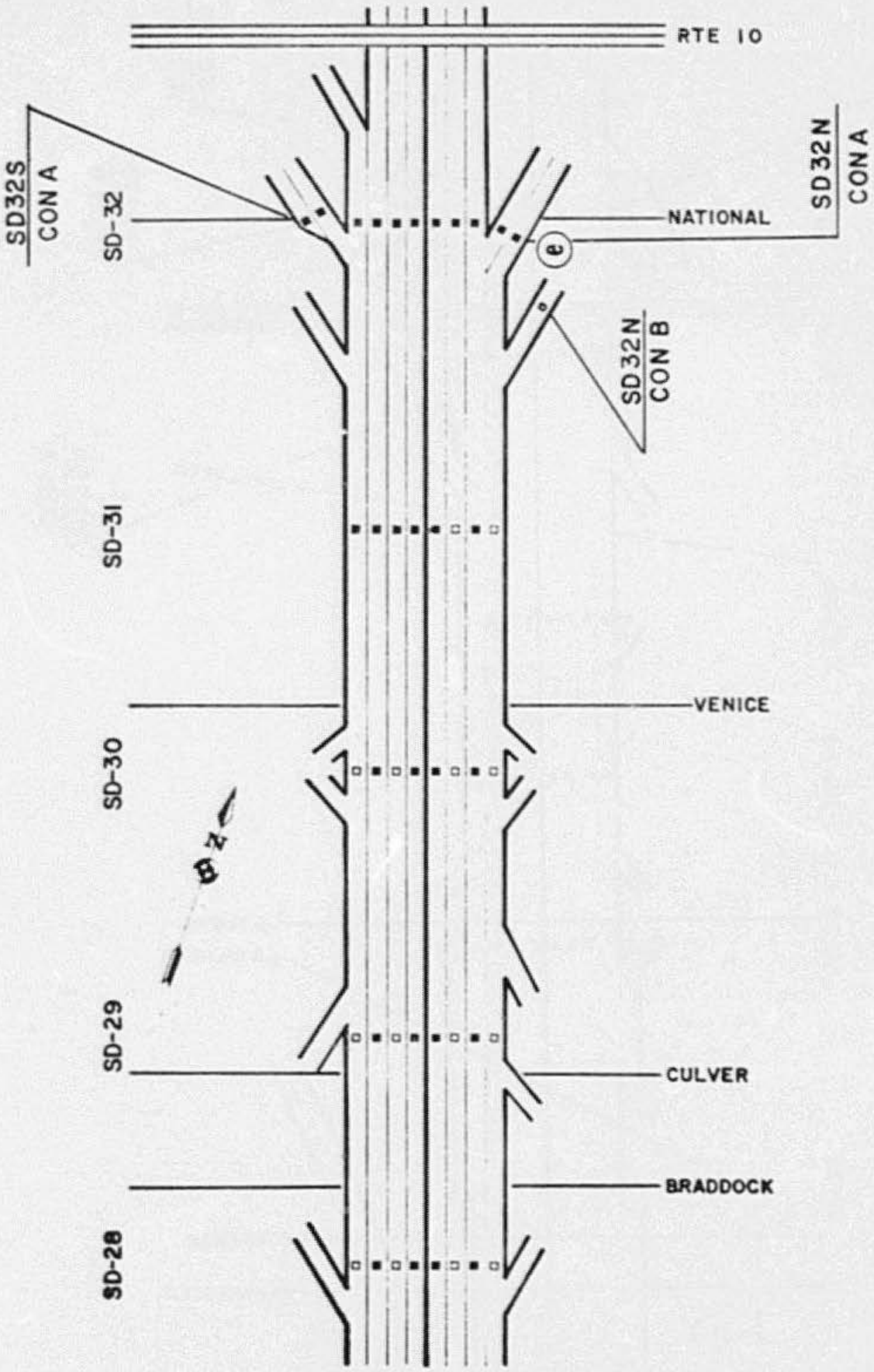

## APPENDIX B

### Narrative Description of Data Sets

This appendix provides short description of the data contained on each of the data sets.

A certain amount of information can be obtained from the data set number, i.e.:

74062802-2

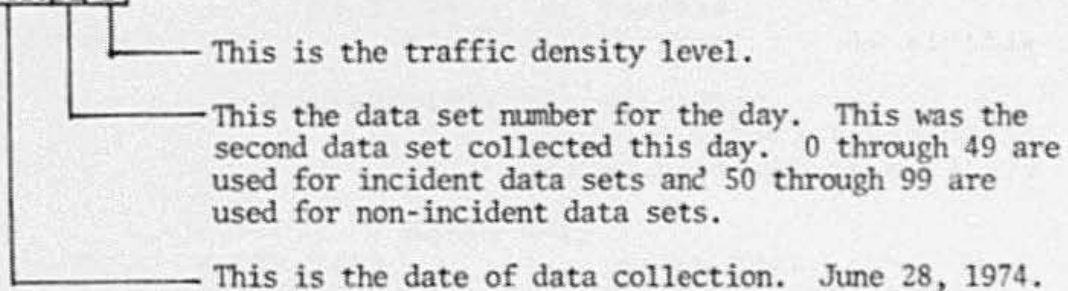

Abbreviations used in referring to incident location and data collection segments are:

- SM - Santa Monica Freeway
- SD - San Diego Freeway
- HA - Harbor Freeway
- N - North
- S - South
- W - West
- E - East

For user convenience, a numerical listing of both incident and non-incident data sets are given in Appendix E.



TAPE NO. 74031201      TRAFFIC CODE = 2      FROM 15:35: 0  
TO 16: 0: 0

INCIDENT LOCATION: HA14N TO HA23N

AFFECTED SEGMENTS: 1

SEGMENT(1) HA14N TO HA23N

INCIDENT TYPE: DISL

VEHICLES INVOLVED: 1

LIGHT DUTY VEHICLES = 1    LIGHT TRUCKS = 0    HEAVY TRUCKS = 0

WEATHER AND ROAD CODES

WEATHER =C      VISIBILITY =S      PAVEMENT =0

DETECTION AND VERIFICATION

DETECTED AT 16:34: 0 BY CODE S

VERIFIED AT 16:41: 0 BY CODE C

LAND MARKS

SIGN = 0      CALL BOX = 0  
LOOP STATION = HA21N      POST MILE = 0. 0

INCIDENT FREEWAY GEOMETRY

	M	1	2	3	4	5	6	S	R	S	C	C	S	COMMENTS
GEOMETRY	1	1	1	1	1	0	0	1	1	0	0	0	0	

ADDITIONAL COMMENT LINES

DISABLED VEHICLE AT VERNON

TAPE NO. 74031301      TRAFFIC CODE = 2      FROM 15:10: 0  
TO 16:40: 0

INCIDENT LOCATION: SM19E TO SM25E

AFFECTED SEGMENTS: 1

SEGMENT(1) SM19E TO SM25E

INCIDENT TYPE: TCOL

VEHICLES INVOLVED: 0

LIGHT DUTY VEHICLES = 0    LIGHT TRUCKS = 0    HEAVY TRUCKS = 0

WEATHER = C      WEATHER AND ROAD CODES  
VISIBILITY = H      PAVEMENT = D

DETECTION AND VERIFICATION

DETECTED AT 15:50:20 BY CODE S

VERIFIED AT 15:57: 0 BY CODE V

LAND MARKS

SIGN = 0      CALL BOX = 0  
LOOP STATION = SM23E      POST MILE = 0. 0

INCIDENT FREEWAY GEOMETRY

	M	1	2	3	4	5	6	S	R	S	C	C	S	COMMENTS
GEOMETRY	1	1	1	1	1	1	0	1	0	0	1	0	1	

ADDITIONAL COMMENT LINES

COLLISION IN LANE FIVE. NO DETAILS

TAPE NO. 74031302      TRAFFIC CODE = 3      FROM 13:20: 0  
TO      15: 5: 0

INCIDENT LOCATION: HA25S TO HA22S

AFFECTED SEGMENTS: 1

SEGMENT(1) HA25S TO HA22S

INCIDENT TYPE: DISL

VEHICLES INVOLVED: 1

LIGHT DUTY VEHICLES = 1    LIGHT TRUCKS = 0    HEAVY TRUCKS = 0

WEATHER AND ROAD CODES  
WEATHER =C      VISIBILITY =H      PAVEMENT =0

DETECTION AND VERIFICATION

DETECTED AT 13:53:20 BY CODE S

VERIFIED AT 13:59: 0 BY CODE V

LAND MARKS

SIGN = 0      CALL BOX = 0  
LOOP STATION = 0      POST MILE = 20+76

INCIDENT FREEWAY GEOMETRY

	M	1	2	3	4	5	6	S	R	S	C	C	S	COMMENTS
GEOMETRY	1	1	1	1	1	0	0	1	0	0	0	0	0	

INCIDENT SCENARIO EVENT TIMES

TIME	M	1	2	3	4	5	6	S	R	S	C	C	S	COMMENTS
13:59: 0	0	1	0	0	0	0	0	0	0	0	0	0	0	CAR ON FIRE, LANE ONE

TAPE NO. 74031303 TRAFFIC CODE = 2 FROM 16:41: 0  
TO 18:55: 0

INCIDENT LOCATION: HA25S TO HA 1S

AFFECTED SEGMENTS: 1

SEGMENT(1) HA10N TO HA25N

INCIDENT TYPE: TCHL

VEHICLES INVOLVED: 0  
LIGHT DUTY VEHICLES = 0 LIGHT TRUCKS = 0 HEAVY TRUCKS = 0

WEATHER AND ROAD CODES  
WEATHER = C VISIBILITY = H PAVEMENT = 0

DETECTION AND VERIFICATION  
DETECTED AT 17:11: 0 BY CODE S  
VERIFIED AT 17:14: 0 BY CODE C

LAND MARKS  
SIGN = 0 CALL BOX = 0  
LOOP STATION = HA12S POST MILE = 0.4

INCIDENT FREEWAY GEOMETRY

	M	1	2	3	4	5	6	S	R	S	C	C	S	COMMENTS
GEOMETRY	1	1	1	1	1	0	0	1	1	0	0	0	0	

TAPE NO: 74031401 TRAFFIC CODE = 3 FROM 13:45: 0

TO 17: 5: 0

INCIDENT LOCATION: SM28W TO SM17W

AFFECTED SEGMENTS: 1

SEGMENT(1) SM19E TO SM27E.

INCIDENT TYPE: TCCL

VEHICLES INVOLVED: 1

LIGHT DUTY VEHICLES = 1 LIGHT TRUCKS = 0 HEAVY TRUCKS = 0

WEATHER = C WEATHER AND ROAD CODES  
VISIBILITY = S PAVEMENT = D

DETECTION AND VERIFICATION

DETECTED AT 14:22: 0 BY CODE C

VERIFIED AT 14:22:49 BY CODE S

LAND MARKS

SIGN = 0 CALL BOX = 0  
LOOP STATION = SM22W POST MILE = 0. 0

INCIDENT FREEWAY GEOMETRY

	M	1	2	3	4	5	6	S	R	S	C	C	S	COMMENTS
GEOMETRY	1	1	1	1	1	1	0	1	1	1	0	0	0	

INCIDENT SCENARIO EVENT TIMES

TIME	M	1	2	3	4	5	6	S	R	S	C	C	S	COMMENTS
14:31: 0	0	0	0	0	0	1	0	0	0	0	0	0	0	OVERTURNED P.O. TRUK
14:45: 0	0	0	0	0	0	1	0	0	0	0	0	0	0	FIRE DPT, CHP, TOW TRK
15: 1: 0	0	0	0	0	0	1	0	0	0	0	0	0	0	VEH REMVD, LANE CLSD
15: 6: 0	0	0	0	0	0	0	0	0	0	0	0	0	0	ALL LANES OPEN

TAPE No. 74031402 TRAFFIC CODE = 2 FROM 14:10: 0

TO 15:45: 0

INCIDENT LOCATION: SM21E TO SM22E

AFFECTED SEGMENTS: 1

SEGMENT(1) SM19E TO SM27E

INCIDENT TYPE: GAWK

VEHICLES INVOLVED: 0

LIGHT DUTY VEHICLES = 0 LIGHT TRUCKS = 0 HEAVY TRUCKS = 0

WEATHER AND ROAD CODES

WEATHER = C

VISIBILITY = S

PAVEMENT = D

DETECTION AND VERIFICATION

DETECTED AT 14:46: 0 BY CODE S

VERIFIED AT 14:48: 0 BY CODE H.

LAND MARKS

SIGN = 0

CALL BOX = 0

LOOP STATION = SM21E

POST MILE = 0.0

INCIDENT FREEWAY GEOMETRY

	M	1	2	3	4	5	6	S	R	S	C	C	S	COMMENTS
GEOMETRY	1	1	1	1	1	1	0	1	0	0	0	0	0	

TAPE NO. 74032102      TRAFFIC CODE = 1      FROM 18: 1: 0  
TO 19:50: 0

INCIDENT LOCATION: HA24S TO HA23S

AFFECTED SEGMENTS: 2

SEGMENT(1) HA25S TO HA 1S      SEGMENT(2) HA22N TO HA25N

INCIDENT TYPE: DISL

VEHICLES INVOLVED: 1  
LIGHT DUTY VEHICLES = 0    LIGHT TRUCKS = 0    HEAVY TRUCKS = 1

WEATHER = C      WEATHER AND ROAD CODES  
VISIBILITY = S      PAVEMENT = 0

DETECTION AND VERIFICATION  
DETECTED AT 18:36:40 BY CODE S  
VERIFIED AT 18:42: 0 BY CODE V

LAND MARKS  
SIGN = 0      CALL BOX = 0  
LOOP STATION = 0      POST MILE = 20.23

INCIDENT FREEWAY GEOMETRY

	M	1	2	3	4	5	6	S	R	S	C	C	S	COMMENTS
GEOMETRY	1	1	1	1	1	0	0	1	0	0	0	0	0	

INCIDENT SCENARIO EVENT TIMES

TIME	M	1	2	3	4	5	6	S	R	S	C	C	S	COMMENTS
18:42: 0	0	0	1	0	0	0	0	0	0	0	0	0	0	DISABLED SET OF DBLS

TAPE NO. 74032201 TRAFFIC CODE = 3 FROM 12:45:0  
TO 14:20:0  
INCIDENT LOCATION: HA19S TO HA14S

AFFECTED SEGMENTS: 2

SEGMENT(1) HA 15 TO HA22S SEGMENT(2) HA15N TO HA12N

INCIDENT TYPE: VCOL

VEHICLES INVOLVED: 2  
LIGHT DUTY VEHICLES = 2 LIGHT TRUCKS = 0 HEAVY TRUCKS = 0

WEATHER = C WEATHER AND ROAD CODES  
VISIBILITY = H PAVEMENT = D

DETECTION AND VERIFICATION  
DETECTED AT 13: 8:20 BY CODE S  
VERIFIED AT 13:12: 0 BY CODE C

LAND MARKS  
SIGN = 0 CALL BOX = 0  
LAMP STATION = 0 POST MILE = 10.78

INCIDENT FREEWAY GEOMETRY

	M	1	2	3	4	5	6	S	R	S	C	C	S	COMMENTS
GEOMETRY	1	1	1	1	1	0	0	1	0	0	1	1	1	

ADDITIONAL COMMENT LINES

TWO CAR T.C. S/B S/O MANCHESTER H16STA185 FLASHED DUE TO C.H.P.  
BREAK TO REMOVE VEHICLES TO RIGHT SHOULDER

Reproduced from  
best available copy.



TAPE NO. 74032202      TRAFFIC CODE = 1      FROM 17:10: 0  
TO 19:30: 0

INCIDENT LOCATION: SM22W TO SM20W

AFFECTED SEGMENTS: 2

SEGMENT(1) SM28W TO SM11W      SEGMENT(2) SM21E TO SM27E

INCIDENT TYPE: TCBL

VEHICLES INVOLVED: 1  
LIGHT DUTY VEHICLES = 1    LIGHT TRUCKS = 0    HEAVY TRUCKS = 0

WEATHER = C      WEATHER AND ROAD CODES  
VISIBILITY = H      PAVEMENT = D

DETECTION AND VERIFICATION

DETECTED AT 17:46: 0 BY CODE C  
VERIFIED AT 18: 1:40 BY CODE S

LAND MARKS

SIGN = 0      CALL BOX = 0  
LOOP STATION = SM21W      POST MILE = 0. 0

INCIDENT FREEWAY GEOMETRY

	M	1	2	3	4	5	6	S	R	S	C	C	S	COMMENTS
GEOMETRY	1	1	1	1	1	1	0	1	0	0	0	0	0	

INCIDENT SCENARIO EVENT TIMES

TIME	M	1	2	3	4	5	6	S	R	S	C	C	S	COMMENTS
17:46: 0	0	0	0	0	1	0	0	0	0	0	0	0	0	T.C. LANE 4

TAPE NO. 74032203 TRAFFIC CODE = 3 FROM 17:45:20  
TO 19:25:20

INCIDENT LOCATION: SM22E TO SM24E

AFFECTED SEGMENTS: 2

SEGMENT(1) SM18E TO SM27E SEGMENT(2) SM26W TO SM12W

INCIDENT TYPE: GAWK

VEHICLES INVOLVED: 1  
LIGHT DUTY VEHICLES = 1 LIGHT TRUCKS = 0 HEAVY TRUCKS = 0

WEATHER AND ROAD CODES  
WEATHER = C VISIBILITY = H PAVEMENT = D

DETECTION AND VERIFICATION  
DETECTED AT 18:23:20 BY CODE S  
VERIFIED AT 18:31:0 BY CODE C

LAND MARKS  
SIGN = 0 CALL BOX = 0  
LOOP STATION = SM23E POST MILE = 0

INCIDENT FREEWAY GEOMETRY

	M	1	2	3	4	5	6	S	R	S	C	C	S	COMMENTS
GEOMETRY	1	1	1	1	1	0	0	1	1	1	0	0	0	

INCIDENT SCENARIO EVENT TIMES

TIME	M	1	2	3	4	5	6	S	R	S	C	C	S	COMMENTS
18:31:0	0	0	0	0	0	0	0	0	0	0	0	0	0	CAR ON FIRE

TAPE NO. 74032209 TRAFFIC CODE = 2 FROM 17:55:20  
TO 19:30:0

INCIDENT LOCATION: SM22W TO SM24W

AFFECTED SEGMENTS: 1

SEGMENT(1) SM12W TO SM28W

INCIDENT TYPE: GAWK

VEHICLES INVOLVED: 0

LIGHT DUTY VEHICLES = 0 LIGHT TRUCKS = 0 HEAVY TRUCKS = 0

WEATHER AND ROAD CODES

WEATHER =

VISIBILITY =

PAVEMENT =

DETECTION AND VERIFICATION

DETECTED AT 18:30:20 BY CODE S

VERIFIED AT 18:36:00 BY CODE H

LAND MARKS

SIGN = 0

CALL BOX = 0

LOOP STATION = SM23E

POST MILE = 0.4

INCIDENT FREEWAY GEOMETRY

	M	1	2	3	4	5	6	S	R	S	C	C	S	COMMENTS
GEOMETRY	1	1	1	1	1	1	0	1	1	1	0	0	0	

TAPE NO. 74032502 TRAFFIC CODE = 1 FROM 14:55:0  
TO 16:44:0

INCIDENT LOCATION: HAZOS TO HAIKS

AFFECTED SEGMENTS: 1

SEGMENT(1) HAZOS TO HAIKS

INCIDENT TYPE: DISL

VEHICLES INVOLVED: 1

LIGHT DUTY VEHICLES = 1 LIGHT TRUCKS = 0 HEAVY TRUCKS = 0

WEATHER AND ROAD CODES

WEATHER = C

VISIBILITY = 0

PAVEMENT = 0

DETECTION AND VERIFICATION

DETECTED AT 15:30:0 BY CODE C

VERIFIED AT 15:32:40 BY CODE S

LAND MARKS

SIGN = 0

CALL BOX = 0

LOOP STATION = HAZOS

POST MILE = 0\*

INCIDENT FREEWAY GEOMETRY

	M	1	2	3	4	5	6	S	R	S	C	C	S	COMMENTS
GEOMETRY	1	1	1	1	1	0	0	1	1	1	0	0	0	

INCIDENT SCENARIO EVENT TIMES

TIME	M	1	2	3	4	5	6	S	R	S	C	C	S	COMMENTS
15:30:0	1	0	0	0	0	0	0	0	0	0	0	0	0	DISABLED VEH & MEDIA

ADDITIONAL COMMENT LINES

DISABLED VEHICLE IN CENTER DIVIDER S/R HARBOR AT VERNON. SLOWDOWN &  
TRAFFIC POSSIBLY DUE TO GAWKING AT CHP AND TOWTRUCK.

TAPE NO. 74032603 TRAFFIC CODE = 1 FROM 15:30: 0  
TO 17:30: 0

INCIDENT LOCATION: HA22N TO HA24N

AFFECTED SEGMENTS: 2

SEGMENT(1) HA15N TO HA25N SEGMENT(2) HA25S TO HA19S

INCIDENT TYPE: GAWK

VEHICLES INVOLVED: 0

LIGHT DUTY VEHICLES = 0 LIGHT TRUCKS = 0 HEAVY TRUCKS = 0

WEATHER = L WEATHER AND ROAD CODES  
VISIBILITY = 0 PAVEMENT = W

DETECTION AND VERIFICATION

DETECTED AT 16: 5: 0 BY CODE S

VERIFIED AT 16: 6: 0 BY CODE C

LAND MARKS

SIGN = 0 CALL BOX = 0  
LOOP STATION = 0 POST MILE = 27.13

INCIDENT FREEWAY GEOMETRY

	M	1	2	3	4	5	6	S	R	S	C	C	S	COMMENTS
GEOMETRY	1	1	1	1	1	0	0	0	1	0	0	0	0	

INCIDENT SCENARIO EVENT TIMES

TIME	M	1	2	3	4	5	6	S	R	S	C	C	S	COMMENTS
16: 6: 0	0	1	0	0	0	0	0	0	0	0	0	0	0	N/R DUG LANE 1

TAPE NO. 74632901 TRAFFIC CODE = 1 FROM 16:55: 0  
TO 18:40: 0

INCIDENT LOCATION: SM28W TO SM26W

AFFECTED SEGMENTS: 1

SEGMENT(1) SM28W TO SM16W

INCIDENT TYPE: TCBL

VEHICLES INVOLVED: 1  
LIGHT DUTY VEHICLES = 1 LIGHT TRUCKS = 0 HEAVY TRUCKS = 0

WEATHER AND ROAD CODES  
WEATHER = C VISIBILITY = S PAVEMENT = D

DETECTION AND VERIFICATION  
DETECTED AT 17:30: 0 BY CODE S  
VERIFIED AT 17:37: 0 BY CODE C

LAND MARKS  
SIGN = 0 CALL BOX = 0  
LOOP STATION = SM27W POST MILE = 0.0

INCIDENT FREEWAY GEOMETRY

	M	1	2	3	4	5	6	S	R	S	C	C	S	COMMENTS
GEOMETRY	1	1	1	1	1	0	0	1	1	1	1	1	1	

TAPE NO. 74032902 TRAFFIC CODE = 1 FROM 17:10: 0  
TO 19:20: 0

INCIDENT LOCATION: SD15S TO SD13S

AFFECTED SEGMENTS: 1

SEGMENT(1) SD23S TO SD 2S

INCIDENT TYPE: TCOL

VEHICLES INVOLVED: 1

LIGHT DUTY VEHICLES = 1 LIGHT TRUCKS = 0 HEAVY TRUCKS = 0

WEATHER = C WEATHER AND ROAD CODES  
VISIBILITY = 0 PAVEMENT = 0

DETECTION AND VERIFICATION

DETECTED AT 17:48:40 BY CODE S

VERIFIED AT 17:51: 0 BY CODE C

LAND MARKS

SIGN = 0 CALL BOX = 0  
LOOP STATION = 0 POST MILE = 19.38

INCIDENT FREEWAY GEOMETRY

	M	1	2	3	4	5	6	S	R	5	C	C	S	COMMENTS
GEOMETRY	1	1	1	1	1	0	0	0	1	1	0	0	0	

INCIDENT SCENARIO EVENT TIMES

TIME	M	1	2	3	4	5	6	S	R	5	C	C	S	COMMENTS
17:51: 0	1	0	0	0	0	0	0	0	0	0	0	0	0	T.C. C/O

TAPE NO. 74040101      TRAFFIC CODE = 2      FROM 14:50: 0  
TO 17:20: 0

INCIDENT LOCATION: HA18N TO HA20N

AFFECTED SEGMENTS: 2

SEGMENT(1) HA11N TO HA22N      SEGMENT(2) HA19S TO HA21S

INCIDENT TYPE: GAWK

VEHICLES INVOLVED: 0  
LIGHT DUTY VEHICLES = 0    LIGHT TRUCKS = 0    HEAVY TRUCKS = 0

WEATHER = C      WEATHER AND ROAD CODES  
VISIBILITY = 0      PAVEMENT = 0

DETECTION AND VERIFICATION  
DETECTED AT 0: 0: 0 BY CODE  
VERIFIED AT 15:58: 0 BY CODE C

LAND MARKS  
SIGN = 0      CALL BOX = 0  
LOOP STATION = 0      POST MILE = 17.98

INCIDENT FREEWAY GEOMETRY

	M	1	2	3	4	5	6	S	R	S	C	C	S	COMMENTS
GEOMETRY	1	1	1	1	1	0	0	1	1	1	0	0	0	

ADDITIONAL COMMENT LINES

DOG LOOSE ON FREEWAY



TAPE NO. 74040102      TRAFFIC CODE = 2      FROM 16:15: 0  
TO 16: 5: 0

INCIDENT LOCATION: HA19N TO HA21N

AFFECTED SEGMENTS: 1

SEGMENT(1) HA12N TO HA25N

INCIDENT TYPE: TCBL

VEHICLES INVOLVED: 3  
LIGHT DUTY VEHICLES = 3    LIGHT TRUCKS = 0    HEAVY TRUCKS = 0

WEATHER AND ROAD CODES  
WEATHER = C      VISIBILITY = 0      PAVEMENT = D

DETECTION AND VERIFICATION  
DETECTED AT 16:46: 0 BY CODE S  
VERIFIED AT 16:46: 0 BY CODE C

LAND MARKS  
SIGN = 0      CALL BOX = 0  
LOOP STATION = 0      POST MILE = 19. 0

INCIDENT FREEWAY GEOMETRY

	M	1	2	3	4	5	6	S	R	S	C	C	S	COMMENTS
GEOMETRY	1	1	1	1	1	0	0	1	1	1	0	0	0	

INCIDENT SCENARIO EVENT TIMES

TIME	M	1	2	3	4	5	6	S	R	S	C	C	S	COMMENTS
16:45: 0	0	1	0	0	0	0	0	0	0	0	0	0	0	THREE CAR T.C.
16:49: 0	0	0	0	0	0	0	0	0	0	1	0	0	0	LANES CLEARED

TAPE NO. 74040103      TRAFFIC CODE = 2      FROM 17:20: 0  
TO 19:10: 0

INCIDENT LOCATION: SM21W TO SM19W

AFFECTED SEGMENTS: 1

SEGMENT(1) SM27W TO SM11W

INCIDENT TYPE: DISL

VEHICLES INVOLVED: 1

LIGHT DUTY VEHICLES = 1    LIGHT TRUCKS = 0    HEAVY TRUCKS = 0

WEATHER = C      WEATHER AND ROAD CODES  
VISIBILITY = 0      PAVEMENT = 0

DETECTION AND VERIFICATION

DETECTED AT 17:50:20 BY CODE S

VERIFIED AT 17:53: 0 BY CODE C

LAND MARKS

SIGN = 0      CALL BOX = 0  
LOOP STATION = SM20W      POST MILE = 0+ 0

INCIDENT FREEWAY GEOMETRY

	M	1	2	3	4	5	6	S	R	S	C	C	S	COMMENTS
GEOMETRY	1	1	1	1	1	0	0	0	1	1	1	1	1	

INCIDENT SCENARIO EVENT TIMES

TIME	M	1	2	3	4	5	6	S	R	S	C	C	S	COMMENTS
17:50: 0	0	0	0	0	0	0	0	0	0	0	0	0	0	DISABLED VEH. LANE 1
17:58: 0	0	0	0	0	0	0	0	0	0	0	0	0	0	R/W CLEAR

TAPE NO. 74040301      TRAFFIC CODE = 3      FROM 14: 5: 0  
TO 15:50: 0

INCIDENT LOCATION: HA12S TO HA10S

AFFECTED SEGMENTS: 2

SEGMENT(1) HA17S TO HA 1S      SEGMENT(2) HA10N TO HA12N

INCIDENT TYPE: TCBL

VEHICLES INVOLVED: 2

LIGHT DUTY VEHICLES = 2    LIGHT TRUCKS = 0    HEAVY TRUCKS = 0

WEATHER = C      WEATHER AND ROAD CODES  
VISIBILITY = 5      PAVEMENT = D

DETECTION AND VERIFICATION

DETECTED AT 14:35:20 BY CODE 5

VERIFIED AT 14:10: 0 BY CODE 1

LAND MARKS

SIGN = 0      CALL BOX = 0  
LOOP STATION = 0      POST MILE = 14.32

INCIDENT FREEWAY GEOMETRY

	M	1	2	3	4	5	6	S	R	S	C	C	S	COMMENTS
GEOMETRY	1	1	1	1	1	0	0	1	1	0	0	0	0	

INCIDENT SCENARIO EVENT TIMES

TIME	M	1	2	3	4	5	6	S	R	S	C	C	S	COMMENTS
14:47: 0	2	0	0	0	0	0	0	0	0	0	0	0	0	CALLING FOR BREAK

TAPE NO. 74040302      TRAFFIC CODE - 2      FROM 15: 1: 0  
TO 16:25: 0

INCIDENT LOCATION: HA235 TO HA255

AFFECTED SEGMENTS: 1

SEGMENT(1) HA255 TO HA195

INCIDENT TYPE: DISL

VEHICLES INVOLVED: 1

LIGHT DUTY VEHICLES = 1    LIGHT TRUCKS = 0    HEAVY TRUCKS = 0

WEATHER AND ROAD CONDITIONS

WEATHER = C      VISIBILITY = 5      PAVEMENT = 0

DETECTION AND VERIFICATION

DETECTED AT 15:33: 0 BY CLDE S

VERIFIED AT 15:32: 0 BY CLDE C

LAND MARKS

SIGN = 0      CALL BOX = 0  
LOOP STATION = 0      POST MILE = 20.21

INCIDENT FREEWAY GEOMETRY

	M	1	2	3	4	5	6	5	R	5	C	C	5	COMMENTS
GEOMETRY	1	1	1	1	1	0	0	1	0	0	0	0	0	

INCIDENT SCENARIO EVENT TIMES

TIME	M	1	2	3	4	5	6	5	R	5	C	C	5	COMMENTS
15:33: 0	0	0	1	0	0	0	0	0	0	0	0	0	0	DISABLED VEH,LANE 2

TAPE NO. 74040401      TRAFFIC CODE = 2      FROM 14:20:0  
TO 17:15:0

INCIDENT LOCATION: SM14W TO SM12W

AFFECTED SEGMENTS: 1

SEGMENT(1) SM26W TO SM 1W

INCIDENT TYPE: TCOL

VEHICLES INVOLVED: 2

LIGHT DUTY VEHICLES = 2    LIGHT TRUCKS = 0    HEAVY TRUCKS = 0

WEATHER AND ROAD CODES

WEATHER = C

VISIBILITY = S

PAVEMENT = D

DETECTION AND VERIFICATION

DETECTED AT 15:07:40 BY CODE S

VERIFIED AT 14:58:00 BY CODE V

LAND MARKS

SIGN = 0

CALL BOX = 0

LOOP STATION = SM13+

POST MILE = 0+

INCIDENT FREEWAY GEOMETRY

	M	1	2	3	4	5	6	S	R	S	C	C	S	COMMENTS
GEOMETRY	1	1	1	1	1	0	0	1	0	0	0	0	0	

INCIDENT SCENARIO EVENT TIMES

TIME	M	1	2	3	4	5	6	S	R	S	C	C	S	COMMENTS
14:58:00	1	0	0	0	0	0	0	0	0	0	0	0	0	2 VEH. 15 MEDIAN
15:07:00	0	0	0	0	0	0	0	0	0	0	0	0	0	LANES OPEN

TAPE NO. 74041603 TRAFFIC CODE = 1 FROM 9:45: 0

TO 11:15: 0

INCIDENT LOCATION: SM22E TO SM23E

AFFECTED SEGMENTS: 1

SEGMENT(1) SM15E TO SM26E

INCIDENT TYPE: DISL

VEHICLES INVOLVED: 1

LIGHT DUTY VEHICLES = 1 LIGHT TRUCKS = 0 HEAVY TRUCKS = 0

WEATHER AND ROAD CODES

WEATHER = C

VISIBILITY = S

PAVEMENT = D

DETECTION AND VERIFICATION

DETECTED AT 10:20: 0 BY CODE V

VERIFIED AT 10:20: 0 BY CODE H

LAND MARKS

SIGN = 0

CALL BOX = 0

LOOP STATION = SM22E

POST MILE = 0. 0

INCIDENT FREEWAY GEOMETRY

	M	1	2	3	4	5	6	S	R	S	C	C	S	COMMENTS
GEOMETRY	1	1	1	1	1	1	0	0	0	0	0	0	0	

INCIDENT SCENARIO EVENT TIMES

TIME	M	1	2	3	4	5	6	S	R	S	C	C	S	COMMENTS
10:20: 0	0	0	0	1	0	0	0	0	0	0	0	0	0	DISABLED CAR #3 LANE
10:28: 0	0	0	0	0	0	0	0	0	0	0	0	0	0	LANES CLEAR

TAPE NO. 74041901 TRAFFIC CODE = 3 FROM 15:20:0  
TO 17:45:0

INCIDENT LOCATION: HA10N TO HA 8N

AFFECTED SEGMENTS: 2

SEGMENT(1) HA 1N TO HA23N SEGMENT(2) HA25S TO HA 3S

INCIDENT TYPE: TCOL

VEHICLES INVOLVED: 1

LIGHT DUTY VEHICLES = 1 LIGHT TRUCKS = 0 HEAVY TRUCKS = 0

WEATHER AND ROAD CODES

WEATHER = C

VISIBILITY = S

PAVEMENT = D

DETECTION AND VERIFICATION

DETECTED AT 15:51:20 BY CODE S

VERIFIED AT 15:55:0 BY CODE C

LAND MARKS

SIGN = 0

CALL BOX = 0

LOOP STATION = 0

POST MILE = 13.2

INCIDENT FREEWAY GEOMETRY

	M	1	2	3	4	5	6	S	R	S	C	C	S	COMMENTS
GEOMETRY	1	1	1	1	1	0	0	1	0	0	0	0	0	

INCIDENT SCENARIO EVENT TIMES

TIME	M	1	2	3	4	5	6	S	R	S	C	C	S	COMMENTS
15:55:0	0	0	0	0	0	0	0	0	0	0	0	0	0	1182,N/B,N/S EL SEG.
16:3:0	0	1	0	0	0	0	0	0	0	0	0	0	0	#1 LANE BLOCKED
16:5:0	0	0	0	0	0	0	0	0	0	0	0	0	0	START TRAFFIC BREAK

ADDITIONAL COMMENT LINES

UNIDENTIFIED INCIDENT AT HA18S APPROX. 1730

TAPE NO. 74042201      TRAFFIC CODE = 1      FROM 8:50: 0  
 TH 10:30: 0

INCIDENT LOCATION: SM21E TO SM22E

AFFECTED SEGMENTS: 2

SEGMENT(1) SM14E TO SM24E      SEGMENT(2) SM24W TO SM21W

INCIDENT TYPE: DISL

VEHICLES INVOLVED: 1

LIGHT DUTY VEHICLES = 1    LIGHT TRUCKS = 0    HEAVY TRUCKS = 0

WEATHER AND ROAD CODES  
 WEATHER = C      VISIBILITY = S      PAVEMENT = D

DETECTION AND VERIFICATION

DETECTED AT 9:22: 0 BY CODE C  
 VERIFIED AT 9:22: 0 BY CODE C

LAND MARKS

SIGN = 0      CALL BOX = 0  
 LOOP STATION = SM22E      POST MILE = 34.0

INCIDENT FREEWAY GEOMETRY

	M	1	2	3	4	5	6	S	R	S	C	C	S	COMMENTS
GEOMETRY	1	1	1	1	1	1	0	1	1	1	0	0	0	

INCIDENT SCENARIO EVENT TIMES

TIME	M	1	2	3	4	5	6	S	R	S	C	C	S	COMMENTS
9:22: 0	0	0	0	0	0	1	0	0	0	0	0	0	0	DISABLED VEH, CHP ARR
9:29: 0	0	0	0	0	0	0	0	0	0	0	0	0	0	CHP 97
9:37: 0	0	0	0	0	0	0	0	0	0	0	0	0	0	TRAFFIC BREAK
9:39: 0	0	0	0	0	0	0	0	0	0	0	0	0	0	CHP REMOVING VEH.
9:40: 0	0	0	0	0	0	0	0	0	0	0	0	0	0	FREEWAY CLEAR



TAPE NO. 74042401      TRAFFIC CODE = 2      FROM 6:00:0  
TO 7:30:0

INCIDENT LOCATION: SM22E TO SM23E

AFFECTED SEGMENTS: 2

SEGMENT(1) SM14E TO SM24E      SEGMENT(2) SM21E TO SM24W

INCIDENT TYPE: DISL

VEHICLES INVOLVED: 1

LIGHT DUTY VEHICLES = 1    LIGHT TRUCKS = 0    HEAVY TRUCKS = 0

WEATHER AND ROAD CODES

WEATHER = C      VISIBILITY = 0      PAVEMENT = 0

DETECTION AND VERIFICATION

DETECTED AT 6:40:0 BY CODE V

VERIFIED AT 6:40:0 BY CODE V

LAND MARKS

SIGN = 0      CALL BOX = 0  
LOOP STATION = 0      POST MILE = 11.5

INCIDENT FREEWAY GEOMETRY

	M	1	2	3	4	5	6	S	R	S	C	C	S	COMMENTS
GEOMETRY	1	1	1	1	1	1	0	0	0	0	1	0	1	

INCIDENT SCENARIO EVENT TIMES

TIME	M	1	2	3	4	5	6	S	R	S	C	C	S	COMMENTS
6:40:0	0	0	0	0	0	0	0	0	0	0	1	0	0	DISABLED VEH.
6:46:0	0	0	0	0	0	0	0	0	0	0	0	0	0	VEH 1098

TAPE NO: 74042402      TRAFFIC CODE = 2      FROM 6:35: 0  
 TO 8: 5: 0

INCIDENT LOCATION: SM22E TO SM23E

AFFECTED SEGMENTS: 2

SEGMENT(1) SM14E TO SM26E      SEGMENT(2) SM24\* TO SM21\*

INCIDENT TYPE: TCCL

VEHICLES INVOLVED: 2  
 LIGHT DUTY VEHICLES = 2    LIGHT TRUCKS = 0    HEAVY TRUCKS = 0

WEATHER = C      WEATHER AND ROAD CODES  
 VISIBILITY = 0      PAVEMENT = D

DETECTION AND VERIFICATION  
 DETECTED AT 7: 6: 0 BY CODE V  
 VERIFIED AT 7: 6: 0 BY CODE V

LAND MARKS  
 SIGN = 0      CALL BOX = 0  
 LOOP STATION = 0      PMST MILE = 11.53

INCIDENT FREEWAY GEOMETRY

	M	1	2	3	4	5	6	S	R	S	C	C	S	COMMENTS
GEOMETRY	1	1	1	1	1	1	0	0	0	0	1	0	1	

INCIDENT SCENARIO EVENT TIMES

TIME	M	1	2	3	4	5	6	S	R	S	C	C	S	COMMENTS
7: 6: 0	0	0	0	0	0	0	0	0	0	0	1	0	0	TWO VEH.
7:16: 0	0	0	0	0	0	0	0	0	0	0	0	0	0	VEH. 109X

TAPE NO. 74042403 TRAFFIC CODE = 1 FROM 6:55:0  
TO 8:45:0

INCIDENT LOCATION: SM16E TO SM17E

AFFECTED SEGMENTS: 2

SEGMENT(1) SM12E TO SM23E SEGMENT(2) SM16E TO SM18E

INCIDENT TYPE: TCBL

VEHICLES INVOLVED: 3  
LIGHT DUTY VEHICLES = 3 LIGHT TRUCKS = 0 HEAVY TRUCKS = 0

WEATHER AND ROAD CODES  
WEATHER = C VISIBILITY = 0 PAVEMENT = 0

DETECTION AND VERIFICATION  
DETECTED AT 7:31:0 BY CODE V  
VERIFIED AT 7:31:0 BY CODE V

LAND MARKS  
SIGN = 0 CALL BOX = 0  
LOOP STATION = 0 POST MILE = 9.22

INCIDENT FREEWAY GEOMETRY

	M	1	2	3	4	5	6	S	R	S	C	C	S	COMMENTS
GEOMETRY	1	1	1	1	1	0	0	0	0	1	1	0	1	

INCIDENT SCENARIO EVENT TIMES

TIME	M	1	2	3	4	5	6	S	R	S	C	C	S	COMMENTS
7:31:0	1	0	0	0	0	0	0	0	0	0	0	0	0	3 VEH. IN MEDIAN
7:37:0	0	0	0	0	0	0	0	0	0	0	0	0	0	VEH. 109K

TAPE NO. 74042601 TRAFFIC CODE = 3 FROM 6:45: 0

TO 8:15: 0

INCIDENT LOCATION: SM22W TO SM21W

AFFECTED SEGMENTS: 2

SEGMENT(1) SM26W TO SM11W SEGMENT(2) SM20E TO SM23E

INCIDENT TYPE: TCBL

VEHICLES INVOLVED: 11

LIGHT DUTY VEHICLES =11 LIGHT TRUCKS =10 HEAVY TRUCKS = 0

WEATHER = WEATHER AND ROAD CODES  
VISIBILITY =

PAVEMENT =

DETECTION AND VERIFICATION

DETECTED AT 7:14: 0 BY CODE S

VERIFIED AT 7:11: 0 BY CODE V

LAND MARKS

SIGN = 0  
LOOP STATION = 0

CALL BOX = 0  
POST MILE = 11.53

INCIDENT FREEWAY GEOMETRY

	M	1	2	3	4	5	6	S	R	S	C	C	S	COMMENTS
GEOMETRY	1	1	1	1	1	1	0	0	0	0	1	0	1	

INCIDENT SCENARIO EVENT TIMES

TIME	H	1	2	3	4	5	6	S	R	S	C	C	S	COMMENTS
7:11: 0	1	0	0	0	0	0	0	0	0	0	0	0	0	3 VEH. IN MEDIAN
7:24: 0	0	0	0	0	0	0	0	0	0	0	0	0	0	VEH. REMOVED

TAPE NO. 74042602 TRAFFIC CODE = 1 FROM 7:20:0  
TO 10:30:0

INCIDENT LOCATION: SM22E TO SM23E

AFFECTED SEGMENTS: 2

SEGMENT(1) SM 7E TO SM27E SEGMENT(2) SM26W TO SM18W

INCIDENT TYPE: DISL

VEHICLES INVOLVED: 1

LIGHT DUTY VEHICLES = 0 LIGHT TRUCKS = 0 HEAVY TRUCKS = 1

WEATHER = C WEATHER AND ROAD CODES  
VISIBILITY = S PAVEMENT = 0

DETECTION AND VERIFICATION

DETECTED AT 7:53:40 BY CODE S

VERIFIED AT 7:54:0 BY CODE C

LAND MARKS

SIGN = 0 CALL BOX = 0  
LOOP STATION = 0 POST MILE = 11+53

INCIDENT FREEWAY GEOMETRY

	M	1	2	3	4	5	6	S	R	S	C	C	S	COMMENTS
GEOMETRY	1	1	1	1	1	1	0	0	0	1	0	1	0	1

INCIDENT SCENARIO EVENT TIMES

TIME	H	1	2	3	4	5	6	S	R	S	C	C	S	COMMENTS
7:54:0	0	0	0	0	0	1	0	0	0	0	1	0	0	SEMI BLOCKG. LN 5&C1
8:21:0	0	0	0	0	0	0	0	0	0	0	0	0	0	CLEAR

TAPE NO. 74042605 TRAFFIC CODE = 2 FROM 14:01:0  
TO 16:15:0

INCIDENT LOCATION: HA205 TO HA195

AFFECTED SEGMENTS: 2

SEGMENT(1) HA255 TO HA 15 SEGMENT(2) HA185 TO HA225

INCIDENT TYPE: TCBL

VEHICLES INVOLVED: 1

LIGHT DUTY VEHICLES = 1 LIGHT TRUCKS = 0 HEAVY TRUCKS = 0

WEATHER = C WEATHER AND ROAD CODES  
VISIBILITY = 5 PAVEMENT = D

DETECTION AND VERIFICATION

DETECTED AT 14:35:40 BY CODE S

VERIFIED AT 14:37:0 BY CODE C

LAND MARKS

SIGN = 0 CALL BOX = 0  
LOOP STATION = 0 POST MILE = 18.66

INCIDENT FREEWAY GEOMETRY

	M	1	2	3	4	5	6	S	F	S	C	C	S	COMMENTS
GEOMETRY	1	1	1	1	1	0	0	0	0	0	1	0	1	

INCIDENT SCENARIO EVENT TIMES

TIME	M	1	2	3	4	5	6	S	F	S	C	C	S	COMMENTS
14:37:0	0	0	0	0	0	0	0	0	0	0	0	0	0	1183 UNKNOWN LN.
14:45:0	0	0	0	0	0	0	0	0	0	0	0	0	0	1185 NO REPORTS TAKE

TAPE NO. 74042606      TRAFFIC CODE = 1      FROM 16:40: 0  
TO 17:40: 0

INCIDENT LOCATION: SD16S TO SD15S

AFFECTED SEGMENTS: 2

SEGMENT(1) SD22S TO SD13S      SEGMENT(2) SD14N TO SD18N

INCIDENT TYPE: TCBL

VEHICLES INVOLVED: 1

LIGHT DUTY VEHICLES = 1    LIGHT TRUCKS = 0    HEAVY TRUCKS = 0

WEATHER = C      WEATHER AND ROAD CODES  
VISIBILITY = S      PAVEMENT = 0

DETECTION AND VERIFICATION

DETECTED AT 16: 9:20 BY CODE S

VERIFIED AT 16:11: 0 BY CODE C

LAND MARKS

SIGN = 0      CALL BOX = 0  
LOOP STATION = 0      POST MILE = 20.76

INCIDENT FREEWAY GEOMETRY

	M	1	2	3	4	5	6	S	R	S	C	C	S	COMMENTS
GEOMETRY	1	1	1	1	1	0	0	0	0	0	1	0	1	

INCIDENT SCENARIO EVENT TIMES

TIME	M	1	2	3	4	5	6	S	R	S	C	C	S	COMMENTS
16:12: 0	0	0	0	0	0	0	0	0	0	0	0	0	0	ROADWAY CLEAR

TAPE No. 74051501 TRAFFIC CODE = 2 FROM 6:45:0  
10 8:40:0

INCIDENT LOCATION: SM25E TO SM26E

AFFECTED SEGMENTS: 2

SEGMENT(1) SM 9E TO SM27E SEGMENT(2) SM27A TO SM22A

INCIDENT TYPE: DISL

VEHICLES INVOLVED: 0  
LIGHT DUTY VEHICLES = 0 LIGHT TRUCKS = 0 HEAVY TRUCKS = 0

WEATHER AND ROAD CODES  
WEATHER = C VISIBILITY = 0 PAVEMENT = 0

DETECTION AND VERIFICATION  
DETECTED AT 7:17:20 BY CODE S  
VERIFIED AT 7:18:0 BY CODE V

LAND MARKS  
SIGN = 0 CALL BOX = 0  
LOOP STATION = SM26E POST MILE = 13+30

INCIDENT FREEWAY GEOMETRY

	M	1	2	3	4	5	6	S	R	S	C	C	S	COMMENTS
GEOMETRY	1	1	1	1	1	0	0	0	0	1	1	1	1	

INCIDENT SCENARIO EVENT TIMES

TIME	M	1	2	3	4	5	6	S	R	S	C	C	S	COMMENTS
7:17:20	0	0	0	0	0	0	0	0	0	1	0	0	0	DISL w/6 CHP UNITS
7:44:0	0	0	0	0	0	0	0	0	0	0	0	0	0	ALL CLEAR



TAPE NO. 74091502      TRAFFIC CODE = 2      FROM 7:10:0  
TO 9:00:0

INCIDENT LOCATION: SD 9N TO SD10N

AFFECTED SEGMENTS: 2

SEGMENT(1) SD 1N TO SD13N      SEGMENT(2) SD 8S TO SD12S

INCIDENT TYPE: DISL

VEHICLES INVOLVED: 1  
LIGHT DUTY VEHICLES = 1    LIGHT TRUCKS = 0    HEAVY TRUCKS = 0

WEATHER = C      WEATHER AND ROAD CODES  
VISIBILITY = 0      PAVEMENT = D

DETECTION AND VERIFICATION  
DETECTED AT 7:51:20 BY CODE S  
VERIFIED AT 8:2:0 BY CODE C

LAND MARKS  
SIGN = 0      CALL BOX = 0  
LOOP STATION = SD 9N      POST MILE = 17.56

INCIDENT FREEWAY GEOMETRY

	M	1	2	3	4	5	6	S	R	S	C	C	S	COMMENTS
GEOMETRY	1	1	1	1	1	0	0	0	0	1	0	0	0	

INCIDENT SCENARIO EVENT TIMES

TIME	M	1	2	3	4	5	6	S	R	S	C	C	S	COMMENTS
7:51:20	0	1	0	0	0	0	0	0	0	0	0	0	0	
8:3:0	1	0	0	0	0	0	0	0	0	0	0	0	0	

TAPE No. 74051503 TRAFFIC CODE = 1 FROM 8:00:0  
TO 9:30:0

INCIDENT LOCATION: SM19E TO SM20E

AFFECTED SEGMENTS: 2

SEGMENT(1) SM 9E TO SM25E SEGMENT(2) SM21W TO SM19W

INCIDENT TYPE: DISL

VEHICLES INVOLVED: 1

LIGHT DUTY VEHICLES = 1 LIGHT TRUCKS = 0 HEAVY TRUCKS = 0

WEATHER = C WEATHER AND ROAD CODES  
VISIBILITY = 0 PAVEMENT = D

DETECTION AND VERIFICATION

DETECTED AT 8:48:0 BY CODE S

VERIFIED AT 8:38:0 BY CODE V

LAND MARKS

SIGN = 0 CALL BOX = 0  
LOOP STATION = SM19E POST MILE = 10+43

INCIDENT FREEWAY GEOMETRY

	M	1	2	3	4	5	6	S	R	S	C	C	S	COMMENTS
GEOMETRY	1	1	1	1	1	1	0	1	1	0	1	0	1	

INCIDENT SCENARIO EVENT TIMES

TIME	M	1	2	3	4	5	6	S	R	S	C	C	S	COMMENTS
8:38:0	0	0	0	1	0	0	0	0	0	0	0	0	0	AT LA BREA
8:48:0	1	0	0	0	0	0	0	0	0	0	0	0	0	LNS CLEAR

TAPE NO. 74052101 TRAFFIC CODE = 1 FROM 7:30:0  
TO 10:00:0

INCIDENT LOCATION: SM19E TO SM20E

AFFECTED SEGMENTS: 2

SEGMENT(1) SM 9E TO SM24E SEGMENT(2) SM21W TO SM17W

INCIDENT TYPE: TCBL

VEHICLES INVOLVED: 2  
LIGHT DUTY VEHICLES = 2 LIGHT TRUCKS = 0 HEAVY TRUCKS = 0

WEATHER AND ROAD CODES  
WEATHER = C VISIBILITY = 5 PAVEMENT = D

DETECTION AND VERIFICATION  
DETECTED AT 0:00:0 BY CODE  
VERIFIED AT 8:54:0 BY CODE W

LAND MARKS  
SIGN = 0 CALL BOX = 0  
LOOP STATION = SM19E POST MILE = 10+24

INCIDENT FREEWAY GEOMETRY

	M	1	2	3	4	5	6	S	R	S	C	C	S	COMMENTS
GEOMETRY	1	1	1	1	1	0	0	1	1	0	1	0	1	

INCIDENT SCENARIO EVENT TIMES

TIME	M	1	2	3	4	5	6	S	R	S	C	C	S	COMMENTS
8:54:0	0	0	0	0	0	0	0	1	0	0	0	0	0	

TAPE No. 74052102      TRAFFIC CODE = 2      FROM 8:35: 0  
TO 9:50: 0

INCIDENT LOCATION: HA19N TO HA20N

AFFECTED SEGMENTS: 2

SEGMENT(1) HA15N TO HA25N      SEGMENT(2) HA15S TO HA17S

INCIDENT TYPE: TCBL

VEHICLES INVOLVED: 1  
LIGHT DUTY VEHICLES = 1    LIGHT TRUCKS = 1    HEAVY TRUCKS = 0

WEATHER AND ROAD CODES  
WEATHER =C      VISIBILITY =S      PAVEMENT =D

DETECTION AND VERIFICATION  
DETECTED AT 0: 0: 0 BY CODE  
VERIFIED AT 9: 6: 0 BY CODE H

LAND MARKS  
SIGN = 0      CALL BOX = 0  
LOOP STATION = HA19N      POST MILE = 18.3

INCIDENT FREEWAY GEOMETRY

	M	1	2	3	4	5	6	5	R	5	C	C	S	COMMENTS
GEOMETRY	1	1	1	1	1	0	0	1	0	0	0	0	0	

INCIDENT SCENARIO EVENT TIMES

TIME	M	1	2	3	4	5	6	S	R	S	C	C	S	COMMENTS
9: 6: 0	0	0	0	0	0	0	0	0	0	1	0	0	0	

TAPE NO. 74052201 TRAFFIC CODE = 2 FROM 7:50:0  
TO 9:30:0

INCIDENT LOCATION: HA10N TO HA11N

AFFECTED SEGMENTS: 2

SEGMENT(1) HA 2N TO HA15N SEGMENT(2) HA125 TO HA 85

INCIDENT TYPE: TCBL

VEHICLES INVOLVED: 2

LIGHT DUTY VEHICLES = 2 LIGHT TRUCKS = 0 HEAVY TRUCKS = 0

WEATHER AND ROAD CODES  
WEATHER = C VISIBILITY = S PAVEMENT = D

DETECTION AND VERIFICATION

DETECTED AT 8:35:20 BY CODE S

VERIFIED AT 8:40:0 BY CODE H

LAND MARKS

SIGN = 0 CALL BOX = 0  
LOOP STATION = HA10N POST MILE = 13.97

INCIDENT FREEWAY GEOMETRY

	M	1	2	3	4	5	6	8	9	C	C	S	COMMENTS
GEOMETRY	1	1	1	1	1	0	0	1	1	0	0	1	

INCIDENT SCENARIO EVENT TIMES

TIME	M	1	2	3	4	5	6	8	9	C	C	S	COMMENTS
8:35:20	0	0	0	0	0	0	0	0	0	0	0	0	UNK LNS
8:40:0	0	0	0	0	0	0	0	0	0	0	0	0	PHONED CHP FOR VAR.
8:48:0	0	0	0	0	0	0	0	0	0	0	0	1	LNS CLEAR

ADDITIONAL COMMENT LINES

AT BEGINING OF INC. IT WAS UNK. W/TH LANE, CHP IND. RT. LNS.

TAPE NO. 74052202      TRAFFIC CODE = 3      FROM 13:30: 0  
TO 15:30: 0

INCIDENT LOCATION: SM22W TO SM21W

AFFECTED SEGMENTS: 2

SEGMENT(1) SM26W TO SM21W      SEGMENT(2) SM21E TO SM23E

INCIDENT TYPE: DISL

VEHICLES INVOLVED: 0  
LIGHT DUTY VEHICLES = 0    LIGHT TRUCKS = 1    HEAVY TRUCKS = 0

WEATHER AND ROAD CODES  
WEATHER = C      VISIBILITY = S      PAVEMENT = 0

DETECTION AND VERIFICATION  
DETECTED AT 14: 3: 40 BY CODE S  
VERIFIED AT 14: 6: 0 BY CODE V

LAND MARKS  
SIGN = 0      CALL BOX = 0  
LOOP STATION = SM22W      POST MILE = 11.39

INCIDENT FREEWAY GEOMETRY

	M	1	2	3	4	5	6	S	R	S	C	C	S	COMMENTS
GEOMETRY	1	1	1	1	1	1	0	0	0	0	0	0	1	

INCIDENT SCENARIO EVENT TIMES

TIME	M	1	2	3	4	5	6	S	R	S	C	C	S	COMMENTS
14: 6: 0	0	0	0	0	0	1	0	0	0	0	0	0	0	STALLED TRUCK

TAPE NO. 74052203 TRAFFIC CODE = 2 FROM 15:35: 0  
TO 17:35: 0  
INCIDENT LOCATION: SM26W TO SM25W

AFFECTED SEGMENTS: 2

SEGMENT(1) SM28W TO SM 3W SEGMENT(2) SM24E TO SM27E

INCIDENT TYPE: TCOL

VEHICLES INVOLVED: 1  
LIGHT DUTY VEHICLES = 1 LIGHT TRUCKS = 0 HEAVY TRUCKS = 0

WEATHER AND ROAD CODES  
WEATHER = C VISIBILITY = 5 PAVEMENT = D

DETECTION AND VERIFICATION  
DETECTED AT 0: 0: 0 BY CODE  
VERIFIED AT 16: 9: 0 BY CODE V

LAND MARKS  
SIGN = 0 CALL BOX = 0  
LOOP STATION = 0 POST MILE = 13.3

INCIDENT FREEWAY GEOMETRY

	M	1	2	3	4	5	6	S	R	S	C	C	S	COMMENTS
GEOMETRY	1	1	1	1	1	0	0	1	0	0	1	1	1	

INCIDENT SCENARIO EVENT TIMES

TIME	M	1	2	3	4	5	6	S	R	S	C	C	S	COMMENTS
16: 9: 0	0	0	0	0	1	0	0	0	0	0	0	0	0	

TAPE NO. 74052204 TRAFFIC CODE = 2 FROM 15:45: 0  
TO 16: 0: 0

INCIDENT LOCATION: HA20N TO HA21N

AFFECTED SEGMENTS: 2

SEGMENT(1) HA 6N TO HA25N SEGMENT(2) HA23S TO HA17S

INCIDENT TYPE: TCML

VEHICLES INVOLVED: 2  
LIGHT DUTY VEHICLES = 2 LIGHT TRUCKS = 0 HEAVY TRUCKS = 0

WEATHER AND ROAD CONDES  
WEATHER = C VISIBILITY = 5 PAVEMENT = 0

DETECTION AND VERIFICATION  
DETECTED AT 16:27: 0 BY CODE S  
VERIFIED AT 16:32: 0 BY CODE V

LAND MARKS  
SIGN = 0 CALL BOX = 0  
LOOP STATION = H2 0 POST MILE = 19\*

INCIDENT FREEWAY GEOMETRY

	M	1	2	3	4	5	6	S	R	S	C	C	S	COMMENTS
GEOMETRY	1	1	1	1	1	0	0	0	1	0	0	0	1	

INCIDENT SCENARIO EVENT TIMES

TIME	M	1	2	3	4	5	6	S	R	S	C	C	S	COMMENTS
16:32: 0	0	0	0	1	1	0	0	0	0	0	0	0	0	LNS BLOCKED

ADDITIONAL COMMENT LINES

TC AT VERNON



TAPE NO. 74052301 TRAFFIC CODE = 4 FROM 15:30: 0

TO 17: 0: 0

INCIDENT LOCATION: SM 4W TO SM 3W

AFFECTED SEGMENTS: 2

SEGMENT(1) SM 6W TO SM 1W SEGMENT(2) SM 1E TO SM 5E

INCIDENT TYPE: TCBL

VEHICLES INVOLVED: 2

LIGHT DUTY VEHICLES = 2 LIGHT TRUCKS = 0 HEAVY TRUCKS = 0

WEATHER AND ROAD CODES

WEATHER =C

VISIBILITY =5

PAVEMENT =D

DETECTION AND VERIFICATION

DETECTED AT 0: 0: 0 BY CODE

VERIFIED AT 16:50: 0 BY CODE V

LAND MARKS

SIGN = 0

CALL BOX = 0

LOOP STATION = 0

POST MILE = 2.84

INCIDENT FREEWAY GEOMETRY

	M	1	2	3	4	5	6	S	R	S	C	C	S	COMMENTS
GEOMETRY	1	1	1	1	0	0	0	0	0	0	1	0	1	

INCIDENT SCENARIO EVENT TIMES

TIME	M	1	2	3	4	5	6	S	R	S	C	C	S	COMMENTS
16:15: 0	0	0	0	0	0	0	0	0	0	0	0	0	1	

ADDITIONAL COMMENT LINES

LOCATION, 200 FT. W/R 17 TH ST.

TAPE NO. 74052302      TRAFFIC CODE = 3      FROM 16: 0: 0

TO 18:30: 0

INCIDENT LOCATION: SM27W TO SM26W

AFFECTED SEGMENTS: 2

SEGMENT(1) SM28W TO SM22W      SEGMENT(2) SM24E TO SM28E

INCIDENT TYPE: TC0L

VEHICLES INVOLVED: 1

LIGHT DUTY VEHICLES = 1    LIGHT TRUCKS = 0    HEAVY TRUCKS = 0

WEATHER = C      WEATHER AND ROAD CODES  
VISIBILITY = S      PAVEMENT = D

DETECTION AND VERIFICATION

DETECTED AT 0: 0: 0 BY CODE

VERIFIED AT 16:38: 0 BY CODE C

LAND MARKS

SIGN = 0      CALL BOX = 0  
LOOP STATION = 0      POST MILE = 13.80

INCIDENT FREEWAY GEOMETRY

	M	1	2	3	4	5	6	S	R	S	C	C	S	COMMENTS
GEOMETRY	1	1	1	1	0	0	0	0	1	1	1	1	1	

INCIDENT SCENARIO EVENT TIMES

TIME	M	1	2	3	4	5	6	S	R	S	C	C	S	COMMENTS
16:48: 0	0	0	0	0	0	0	0	0	0	0	0	0	0	LNS CLEAR G.O.A.

TAPE NO. 74052303 TRAFFIC CODE = 2 FROM 16:00:0  
TO 18:30:0

INCIDENT LOCATION: SM13W TO SM12W

AFFECTED SEGMENTS: 2

SEGMENT(1) SM28W TO SM 3W SEGMENT(2) SM11E TO SM15E

INCIDENT TYPE: TCOL

VEHICLES INVOLVED: 2

LIGHT DUTY VEHICLES = 2 LIGHT TRUCKS = 0 HEAVY TRUCKS = 0

WEATHER = C WEATHER AND ROAD CODES  
VISIBILITY = S PAVEMENT = D

DETECTION AND VERIFICATION

DETECTED AT 16:37:40 BY CODE S

VERIFIED AT 16:45:0 BY CODE V

LAND MARKS

SIGN = 0 CALL BOX = 0  
LOOP STATION = SM14W POST MILE = 7.9

INCIDENT FREEWAY GEOMETRY

	M	1	2	3	4	5	6	S	R	S	C	C	S	COMMENTS
GEOMETRY	1	1	1	1	1	0	0	0	0	1	0	0	0	

INCIDENT SCENARIO EVENT TIMES

TIME	M	1	2	3	4	5	6	S	R	S	C	C	S	COMMENTS
16:45:0	0	0	0	0	0	0	0	0	0	0	0	0	1	BIKE AND VEH.

TAPE NO. 74052304 TRAFFIC CODE = 3 FROM 16:15: 0  
TO 16:30: 0

INCIDENT LOCATION: SM12W TO SM11W

AFFECTED SEGMENTS: 2

SEGMENT(1) SM14W TO SM13W SEGMENT(2) SM 1E TO SM14E

INCIDENT TYPE: DISL

VEHICLES INVOLVED: 1  
LIGHT DUTY VEHICLES = 1 LIGHT TRUCKS = 0 HEAVY TRUCKS = 0

WEATHER = C WEATHER AND ROAD CODES  
VISIBILITY = S PAVEMENT = 0

DETECTION AND VERIFICATION  
DETECTED AT 0: 0: 0 BY CODE  
VERIFIED AT 16:47: 0 BY CODE C

LAND MARKS  
SIGN = 0 CALL BOX = 0  
LOOP STATION = 0 POST MILE = 0+31

INCIDENT FREEWAY GEOMETRY

	M	1	2	3	4	5	6	S	R	S	C	C	S	COMMENTS
GEOMETRY	1	1	1	1	1	0	0	0	0	0	1	0	1	

INCIDENT SCENARIO EVENT TIMES

TIME	M	1	2	3	4	5	6	S	R	S	C	C	S	COMMENTS
16:47: 0	0	0	1	0	0	0	0	0	0	0	0	0	0	

TAPE NO. 74052305 TRAFFIC CODE = 1 FROM 16:30: 0  
TO 18:30: 0

INCIDENT LOCATION: SM14W TO SM13W

AFFECTED SEGMENTS: 2

SEGMENT(1) SM28W TO SM 3W SEGMENT(2) SM12E TO SM16E

INCIDENT TYPE: TCBL

VEHICLES INVOLVED: 2

LIGHT DUTY VEHICLES = 2 LIGHT TRUCKS = 0 HEAVY TRUCKS = 0

WEATHER AND ROAD CODES

WEATHER = C

VISIBILITY = S

PAVEMENT = D

DETECTION AND VERIFICATION

DETECTED AT 0: 0: 0 BY CODE

VERIFIED AT 17:45: 0 BY CODE V

LAND MARKS

SIGN = 0

CALL BOX = 0

LOOP STATION = 0

POST MILE = 7.36

INCIDENT FREEWAY GEOMETRY

	M	1	2	3	4	5	6	S	R	S	C	C	S	COMMENTS
GEOMETRY	1	1	1	1	1	0	0	1	1	0	0	0	1	

INCIDENT SCENARIO EVENT TIMES

TIME	M	1	2	3	4	5	6	S	R	S	C	C	S	COMMENTS
17: 9: 0	0	0	0	0	0	0	0	0	0	1	0	0	0	IN GORE @ NAT. OFF
17:11: 0	0	0	0	0	0	0	0	0	0	0	0	0	0	C.H.P. 1097

ADDITIONAL COMMENT LINES

LOCATION, 600 FT. E/O NATIONAL

TAPE NO. 74052306 TRAFFIC CODE = 1 FROM 17: 0: 0  
TO 18:30: 0

INCIDENT LOCATION: SM27W TO SM26W

AFFECTED SEGMENTS: 2

SEGMENT(1) SM28W TO SM14W SEGMENT(2) SM15E TO SM27E

INCIDENT TYPE: DISL

VEHICLES INVOLVED: 1

LIGHT DUTY VEHICLES = 1 LIGHT TRUCKS = 0 HEAVY TRUCKS = 0

WEATHER = C WEATHER AND ROAD CODES  
VISIBILITY = S PAVEMENT = D

DETECTION AND VERIFICATION

DETECTED AT 17:44:40 BY CODE S

VERIFIED AT 17:50: 0 BY CODE V

LAND MARKS

SIGN = 0 CALL BOX = 0  
LOOP STATION = SM27W POST MILE = 13.80

INCIDENT FREEWAY GEOMETRY

	M	1	2	3	4	5	6	S	R	S	C	C	S	COMMENTS
GEOMETRY	1	1	1	1	1	0	0	0	1	1	1	1	1	

INCIDENT SCENARIO EVENT TIMES

TIME	M	1	2	3	4	5	6	S	R	S	C	C	S	COMMENTS
17:50: 0	1	0	0	0	0	0	0	0	0	0	0	0	0	

TAPE NO. 74052401      TRAFFIC CODE = 2      FROM 7: 0: 0  
TO 8:45: 0

INCIDENT LOCATION: SM17E TO SM18E

AFFECTED SEGMENTS: 2

SEGMENT(1) SM 7E TO SM27E      SEGMENT(2) SM19W TO SM15W

INCIDENT TYPE: TCHL

VEHICLES INVOLVED: 2

LIGHT DUTY VEHICLES = 2    LIGHT TRUCKS = 0    HEAVY TRUCKS = 0

WEATHER = C      WEATHER AND ROAD CODES  
VISIBILITY = 0      PAVEMENT = 0

DETECTION AND VERIFICATION

DETECTED AT 7:37: 0 BY CODE S  
VERIFIED AT 7:43: 0 BY CODE V

LAND MARKS

SIGN = 0      CALL BOX = 0  
LOOP STATION = SM17E      POST MILE = 96.30

INCIDENT FREEWAY GEOMETRY

	M	1	2	3	4	5	6	S	R	S	C	C	S	COMMENTS
GEOMETRY	1	1	1	1	1	1	0	1	0	0	0	0	0	

TAPE NO. 74052402 TRAFFIC CODE = 3 FROM 8:30: 0

TO 10:30: 0

INCIDENT LOCATION: SD24N TO SD25N

AFFECTED SEGMENTS: 2

SEGMENT(1) SD20N TO SD31N SEGMENT(2) SD26S TO SD22S

INCIDENT TYPE: TCBL

VEHICLES INVOLVED: 1

LIGHT DUTY VEHICLES = 1 LIGHT TRUCKS = 0 HEAVY TRUCKS = 0

WEATHER = C WEATHER AND ROAD CODES  
VISIBILITY = 0

PAVEMENT = 0

DETECTION AND VERIFICATION

DETECTED AT 9:23: 0 BY CODE S

VERIFIED AT 9:15: 0 BY CODE C

LAND MARKS

SIGN = 0

CALL BOX = SD343

LOOP STATION = SD24N

POST MILE = 0.0

INCIDENT FREEWAY GEOMETRY

	M	1	2	3	4	5	6	S	R	S	C	C	S	COMMENTS
GEOMETRY	1	1	1	1	1	0	0	1	0	0	0	0	0	

ADDITIONAL COMMENT LINES

LOCATION, 1/2 MILE N/O LA TIJERA

FULL COUNT STATION



TAPE NO. 74052403      TRAFFIC CODE = 2      FROM 14:10: 0  
TO 18:25: 0

INCIDENT LOCATION: SD31N TO SD32N

AFFECTED SEGMENTS: 2

SEGMENT(1) SD 1N TO SD32N      SEGMENT(2) SD32S TO SD29S

INCIDENT TYPE: TC0L

VEHICLES INVOLVED: 2  
LIGHT DUTY VEHICLES = 2    LIGHT TRUCKS = 0    HEAVY TRUCKS = 0

WEATHER = C      WEATHER AND ROAD CODES  
VISIBILITY = 0      PAVEMENT = 0

DETECTION AND VERIFICATION  
DETECTED AT 0: 0: 0 BY CODE  
VERIFIED AT 14:41: 0 BY CODE C

LAND MARKS  
SIGN = 0      CALL BOX = 0  
LOOP STATION = 0      POST MILE = 29+16

INCIDENT FREEWAY GEOMETRY

	M	1	2	3	4	5	6	S	R	B	C	C	S	COMMENTS
GEOMETRY	1	1	1	1	0	0	0	1	1	0	0	0	1	

ADDITIONAL COMMENT LINES

LOCATION, 2 FT. S/D NATIONAL  
FULL COUNTY STATION

TAPE NO. 74052404 TRAFFIC CODE = 1 FROM 15:40: 0

TO 17: 0: 0

INCIDENT LOCATION: SM22W TO SM21W

AFFECTED SEGMENTS: 2

SEGMENT(1) SM23W TO SM18W SEGMENT(2) SM20E TO SM24E

INCIDENT TYPE: NBTH

VEHICLES INVOLVED: 0

LIGHT DUTY VEHICLES = 0 LIGHT TRUCKS = 0 HEAVY TRUCKS = 0

WEATHER AND ROAD CODES

WEATHER = C

VISIBILITY = 0

PAVEMENT = 0

DETECTION AND VERIFICATION

DETECTED AT 16:14:40 BY CODE S

VERIFIED AT 16:20: 0 BY CODE V

LAND MARKS

SIGN = 0

CALL BOX = 0

LOOP STATION = SM22W

POST MILE = 0. 0

INCIDENT FREEWAY GEOMETRY

	M	1	2	3	4	5	6	S	R	S	C	C	S	COMMENTS
GEOMETRY	1	1	1	1	1	1	0	1	1	0	0	0	0	

ADDITIONAL COMMENT LINES

POSS. INCIDENT, GONE ON ARRIVAL OF V.P.U.

FULL COUNT STATION

TAPE NO. 74052802      TRAFFIC CODE = 1      FROM 7: 0: 0  
TO 8:30: 0

INCIDENT LOCATION: SM13E TO SM14E

AFFECTED SEGMENTS: 2

SEGMENT(1) SM10E TO SM16E      SEGMENT(2) SM16W TO SM12W

INCIDENT TYPE: DISL

VEHICLES INVOLVED: 1

LIGHT DUTY VEHICLES = 1    LIGHT TRUCKS = 0    HEAVY TRUCKS = 0

WEATHER = C      WEATHER AND ROAD CODES  
VISIBILITY = 0      PAVEMENT = 0

DETECTION AND VERIFICATION

DETECTED AT 7:45:40 BY CODE S

VERIFIED AT 7:51: 0 BY CODE V

LAND MARKS

SIGN = 0      CALL BOX = 0  
LOOP STATION = SM13E      POST MILE = 0+ 0

INCIDENT FREEWAY GEOMETRY

	M	1	2	3	4	5	6	S	R	S	C	C	S	COMMENTS
GEOMETRY	1	1	1	1	1	0	0	1	1	0	0	0	1	

INCIDENT SCENARIO EVENT TIMES

TIME	M	1	2	3	4	5	6	S	R	S	C	C	S	COMMENTS
7:45: 0	0	0	1	0	0	0	0	0	0	0	0	0	0	
7:51: 0	1	0	0	0	0	0	0	0	0	0	0	0	0	

TAPE NO. 7405280\* TRAFFIC CODE = 1 FROM 8:40:0

TO 10:40:0

INCIDENT LOCATION: SD285 TO SD275

AFFECTED SEGMENTS: 2

SEGMENT(1) SD325 TO SD185 SEGMENT(2) SD214 TO SD264

INCIDENT TYPE: TC0L

VEHICLES INVOLVED: 2

LIGHT DUTY VEHICLES = 2 LIGHT TRUCKS = 0 HEAVY TRUCKS = 0

WEATHER AND ROAD CODES

WEATHER = C

VISIBILITY = 0

PAVEMENT = D

DETECTION AND VERIFICATION

DETECTED AT 9: 7:20 BY CODE S

VERIFIED AT 9:38: 0 BY CODE C

LAND MARKS

SIGN = 0

CALL BOX = 0

LOOP STATION = SD275

POST MILE = 24+49

INCIDENT FREEWAY GEOMETRY

	M	1	2	3	4	5	6	S	R	S	C	C	S	COMMENTS
GEOMETRY	1	1	1	1	1	0	0	0	1	1	1	1	1	

INCIDENT SCENARIO EVENT TIMES

TIME	M	1	2	3	4	5	6	S	R	S	C	C	S	COMMENTS
9:35: 0	0	0	1	0	0	0	0	0	0	0	0	0	0	

ADDITIONAL COMMENT LINES

FULL COUNT INCIDENT

TAPE NO. 74052902

TRAFFIC CODE = 3

FROM 7:20: 0  
TO 8:50: 0

INCIDENT LOCATION: SM27W TO SM26W

AFFECTED SEGMENTS: 2

SEGMENT(1) SM28W TO SM25W

SEGMENT(2) SM25E TO SM27E

INCIDENT TYPE: DISL

VEHICLES INVOLVED: 1

LIGHT DUTY VEHICLES = 1 LIGHT TRUCKS = 0 HEAVY TRUCKS = 0

WEATHER = L WEATHER AND ROAD CODES  
VISIBILITY = 0

PAVEMENT = P

DETECTION AND VERIFICATION

DETECTED AT 0: 0: 0 BY CODE

VERIFIED AT 7:57: 0 BY CODE V

LAND MARKS

SIGN = 0

CALL BOX = 0

LOOP STATION = SM27W

POST MILE = 0. 0

INCIDENT FREEWAY GEOMETRY

	M	1	2	3	4	5	6	S	R	S	C	C	S	COMMENTS
GEOMETRY	1	1	1	1	1	0	0	1	1	1	1	1	1	

INCIDENT SCENARIO EVENT TIMES

TIME	M	1	2	3	4	5	6	S	R	S	C	C	S	COMMENTS
7:57: 0	0	0	0	0	1	0	0	0	0	0	0	0	0	

ADDITIONAL COMMENT LINES

LOCATION OF INC. HARD TO DEFINE, LIMITS ESTIMATED

TAPE NO. 74053001 TRAFFIC CODE = 3 FROM 6: 5: 0  
 TO 9:30: 0  
 INCIDENT LOCATION: SM14E TO SM15F

AFFECTED SEGMENTS: 2

SEGMENT(1) SM 8E TO SM24E SEGMENT(2) SM16W TO SM12W

INCIDENT TYPE: TCBL

VEHICLES INVOLVED: 2  
 LIGHT DUTY VEHICLES = 2 LIGHT TRUCKS = 0 HEAVY TRUCKS = 0

WEATHER AND ROAD CODES  
 WEATHER = C VISIBILITY = 0 PAVEMENT = P

DETECTION AND VERIFICATION  
 DETECTED AT 6:46: 0 BY CODE S  
 VERIFIED AT 6:40: 0 BY CODE V

LAND MARKS  
 SIGN = 0 CALL BOX = 0  
 LOOP STATION = SM14E POST MILE = 8.15

INCIDENT FREEWAY GEOMETRY

	M	1	2	3	4	5	6	S	R	S	C	C	S	COMMENTS
GEOMETRY	1	1	1	1	1	0	0	1	0	0	0	0	0	

INCIDENT SCENARIO EVENT TIMES

TIME	M	1	2	3	4	5	6	S	R	S	C	C	S	COMMENTS
6:40: 0	0	1	0	0	0	0	0	0	0	0	0	0	0	PARTIALLY BLOCKED
6:43: 0	1	0	0	0	0	0	0	0	0	0	0	0	0	LANES CLEAR
6:51: 0	0	0	0	0	0	0	0	0	0	0	0	0	0	AMB. 1097
6:54: 0	0	0	0	0	0	0	0	0	0	0	0	0	0	AMB. 1098

ADDITIONAL COMMENT LINES

LOCATION, HALF MILE W/O CORNING

TAPE NO. 74053003 TRAFFIC CODE = 1 FROM 7:10:0  
 TO 9:45:0  
 INCIDENT LOCATION: SD29N TO SD30N

AFFECTED SEGMENTS: 2

SEGMENT(1) SD22N TO SD32N SEGMENT(2) SD32S TO SD27S

INCIDENT TYPE: TCOL

VEHICLES INVOLVED: 5  
 LIGHT DUTY VEHICLES = 5 LIGHT TRUCKS = 0 HEAVY TRUCKS = 0

WEATHER AND ROAD CODES  
 WEATHER = C VISIBILITY = 5 PAVEMENT = P

DETECTION AND VERIFICATION  
 DETECTED AT 7:45:40 BY CODE S  
 VERIFIED AT 7:58:0 BY CODE H

LAND MARKS  
 SIGN = 0 CALL BOX = 0  
 LOOP STATION = SD29N POST MILE = 27.65

INCIDENT FREEWAY GEOMETRY

	M	1	2	3	4	5	6	S	R	S	C	C	S	COMMENTS
GEOMETRY	1	1	1	1	1	0	0	0	0	1	0	0	0	

INCIDENT SCENARIO EVENT TIMES

TIME	M	1	2	3	4	5	6	S	R	S	C	C	S	COMMENTS
7:58:0	0	0	0	0	0	0	0	1	0	0	0	0	0	5 VEHICLES
8:5:0	0	0	0	0	0	0	0	0	0	0	0	0	0	CHP 1097

ADDITIONAL COMMENT LINES

FULL COUNT INCIDENT.  
 LOCATION, 200 FEET N/O WASHINGTON PLACE.

TAPE NO. 74053004 TRAFFIC CODE = 1 FROM 7:10:0  
TO 8:50:0

INCIDENT LOCATION: HA18N TO HA19N

AFFECTED SEGMENTS: 2

SEGMENT(1) HA 5N TO HA25N SEGMENT(2) HA21S TO HA27S

INCIDENT TYPE: DISL

VEHICLES INVOLVED: 1  
LIGHT DUTY VEHICLES = 1 LIGHT TRUCKS = 0 HEAVY TRUCKS = 0

WEATHER = C WEATHER AND ROAD CODES  
VISIBILITY = 0 PAVEMENT = 0

DETECTION AND VERIFICATION  
DETECTED AT 7:51:40 BY CODE S  
VERIFIED AT 8: 8: 0 BY CODE M

LAND MARKS  
SIGN = 0 CALL BOX = 0  
LOOP STATION = HA18N POST MILE = 17.98

INCIDENT FREEWAY GEOMETRY

	M	1	2	3	4	5	6	S	R	S	C	C	S	COMMENTS
GEOMETRY	1	1	1	1	1	0	0	1	1	1	0	0	0	

INCIDENT SCENARIO EVENT TIMES

TIME	M	1	2	3	4	5	6	S	R	S	C	C	S	COMMENTS
8: 8: 0	0	0	0	0	0	0	0	1	0	0	0	0	0	UNDER SLAUSON BRIDGE

ADDITIONAL COMMENT LINES

CHP ALSO MN STOP, 500 FEET S/O SLAUSON BRIDGE



TAPE No. 74060301      TRAFFIC CODE = 3      FROM 7:20: 0  
TO 9:30: 0

INCIDENT LOCATION: SM 6W TO SM 5W

AFFECTED SEGMENTS: 2

SEGMENT(1) SM12W TO SM 3W      SEGMENT(2) SM 1E TO SM 5E

INCIDENT TYPE: TCOL

VEHICLES INVOLVED: 0

LIGHT DUTY VEHICLES = 0    LIGHT TRUCKS = 0    HEAVY TRUCKS = 0

WEATHER AND ROAD CODES

WEATHER = C

VISIBILITY = 0

PAVEMENT = D

DETECTION AND VERIFICATION

DETECTED AT 0: 0: 0 BY CODE

VERIFIED AT 8:10: 0 BY CODE V

LAND MARKS

SIGN = 0

CALL BOX = 0

LOOP STATION = 0

POST MILE = 3.71

INCIDENT FREEWAY GEOMETRY

	M	1	2	3	4	5	6	S	R	S	C	C	S	COMMENTS
GEOMETRY	1	1	1	1	1	0	0	1	0	0	0	0	0	

INCIDENT SCENARIO EVENT TIMES

TIME	M	1	2	3	4	5	6	S	R	S	C	C	S	COMMENTS
8:10: 0	0	0	0	0	0	0	0	1	0	0	0	0	0	TOW TRUCK & VEHICLE

ADDITIONAL COMMENT LINES

LOCATION, AT STEWART STREET

TAPE NO. 7\*060501 TRAFFIC CODE = 1 FROM 7:30:0  
 TO 9:55:0  
 INCIDENT LOCATION: HA16N TO HA17N

AFFECTED SEGMENTS: 2

SEGMENT(1) HA 1N TO HA25N SEGMENT(2) HA19S TO HA14S

INCIDENT TYPE: TCBL

VEHICLES INVOLVED: 1  
 LIGHT DUTY VEHICLES = 1 LIGHT TRUCKS = 0 HEAVY TRUCKS = 0

WEATHER = C WEATHER AND ROAD CODES  
 VISIBILITY = 0 PAVEMENT = 0

DETECTION AND VERIFICATION  
 DETECTED AT 8: 3: 0 BY CODE S  
 VERIFIED AT 8: 8: 0 BY CODE C

LAND MARKS  
 SIGN = 0 CALL BOX = 0  
 LOOP STATION = HA16N POST MILE = 17.23

INCIDENT FREEWAY GEOMETRY

	M	1	2	3	4	5	6	S	R	S	C	C	S	COMMENTS
GEOMETRY	1	1	1	1	1	0	0	0	1	0	0	0	1	

INCIDENT SCENARIO EVENT TIMES

TIME	M	1	2	3	4	5	6	S	R	S	C	C	S	COMMENTS
8:30:0	0	1	0	0	0	0	0	0	0	0	0	0	0	CIVILIAN CYCLIST
8:26:0	0	0	0	0	0	0	0	0	0	0	0	0	0	ROADWAY CLEAR

TAPE NR. 74060601      TRAFFIC CODE = 2      FROM 13:56: 0  
TO 15:35: 0

INCIDENT LOCATION: SM25W TO SM24W

AFFECTED SEGMENTS: 2

SEGMENT(1) SM27W TO SM23W      SEGMENT(2) SM23E TO SM26E

INCIDENT TYPE: GAWK

VEHICLES INVOLVED: 2

LIGHT DUTY VEHICLES = 2    LIGHT TRUCKS = 0    HEAVY TRUCKS = 0

WEATHER = C      WEATHER AND ROAD CODES  
VISIBILITY = S      PAVEMENT = 0

DETECTION AND VERIFICATION

DETECTED AT 0: 0: 0 BY CODE  
VERIFIED AT 14:32: 0 BY CODE V

LAND MARKS

SIGN = 0      CALL BOX = 0  
LOOP STATION = 0      POST MILE = 12.90

INCIDENT FREEWAY GEOMETRY

	M	1	2	3	4	5	6	S	R	S	C	C	S	COMMENTS
GEOMETRY	1	1	1	1	1	0	0	1	0	0	1	1	0	

INCIDENT SCENARIO EVENT TIMES

TIME	M	1	2	3	4	5	6	S	R	S	C	C	S	COMMENTS
14:32: 0	0	0	0	0	0	0	0	1	0	0	0	0	0	CHP CITING MOTORIST
14:46: 0	0	0	0	0	0	0	0	0	0	0	0	0	0	CLEAR

ADDITIONAL COMMENT LINES

JUST WEST OF SM25W

TAPE NR. 74060701      TRAFFIC CODE = 1      FROM 7:31: 0  
TO 8:55: 0

INCIDENT LOCATION: SM21E TO SM22E

AFFECTED SEGMENTS: 2

SEGMENT(1) SM10E TO SM27E      SEGMENT(2) SM23W TO SM20W

INCIDENT TYPE: TCOL

VEHICLES INVOLVED: 3  
LIGHT DUTY VEHICLES = 3    LIGHT TRUCKS = 0    HEAVY TRUCKS = 0

WEATHER = C      WEATHER AND ROAD CODES  
VISIBILITY = 0      PAVEMENT = 0

DETECTION AND VERIFICATION  
DETECTED AT 8: 3: 0 BY CODE C  
VERIFIED AT 8:10: 0 BY CODE V

LAND MARKS  
SIGN = 0      CALL BOX = 0  
LHP STATION = SM21E      POST MILE = 11.20

INCIDENT FREEWAY GEOMETRY

	M	1	2	3	4	5	6	S	R	S	C	C	S	COMMENTS
GEOMETRY	1	1	1	1	1	1	0	1	0	0	0	0	0	

INCIDENT SCENARIO EVENT TIMES

TIME	M	1	2	3	4	5	6	S	R	S	C	C	S	COMMENTS
8:10: 0	0	0	0	0	0	0	0	1	0	0	0	0	0	VPU 1097, CHP 1097

TAPE NO. 74061301 TRAFFIC CODE = 1 FROM 18:45: 0  
TO 19:30: 0

INCIDENT LOCATION: SD16S TO SD15S

AFFECTED SEGMENTS: 2

SEGMENT(1) SD24S TO SD12S SEGMENT(2) SD14N TO SD17N

INCIDENT TYPE: DISL

VEHICLES INVOLVED: 1  
LIGHT DUTY VEHICLES = 1 LIGHT TRUCKS = 0 HEAVY TRUCKS = 0

WEATHER = C WEATHER AND ROAD CODES  
VISIBILITY = H PAVEMENT = 0

DETECTION AND VERIFICATION  
DETECTED AT 16:18: 0 BY CODE S  
VERIFIED AT 16:31: 0 BY CODE C

LAND MARKS  
SIGN = 0 CALL BOX = . . 0  
LOOP STATION = SD16S POST MILE = 20#50

INCIDENT FREEWAY GEOMETRY

	M	1	2	3	4	5	6	S	R	S	C	C	S	COMMENTS
GEOMETRY	1	1	1	1	1	0	0	0	0	0	1	0	1	

INCIDENT SCENARIO EVENT TIMES

TIME	M	1	2	3	4	5	6	S	R	S	C	C	S	COMMENTS
16:31: 0	0	0	0	0	0	0	0	0	0	0	0	0	0	ROADWAY CLEAR

TAPE NO. 74061302 TRAFFIC CODE = 2 FROM 14:45: 0  
TO 19:15: 0

INCIDENT LOCATION: SD30S TO SD29S

AFFECTED SEGMENTS: 2

SEGMENT(1) SD32S TO SD16S SEGMENT(2) SD22N TO SD32N

INCIDENT TYPE: TCOL

VEHICLES INVOLVED: 2  
LIGHT DUTY VEHICLES = 2 LIGHT TRUCKS = 0 HEAVY TRUCKS = 0

WEATHER AND ROAD CODES  
WEATHER = C VISIBILITY = H PAVEMENT = D

DETECTION AND VERIFICATION  
DETECTED AT 15:17:20 BY CODE S  
VERIFIED AT 15:19: 0 BY CODE C

LAND MARKS  
SIGN = 0 CALL BOX = 0  
LOOP STATION = SD30S POST MILE = 27.43

INCIDENT FREEWAY GEOMETRY

	M	1	2	3	4	5	6	S	R	S	C	C	S	COMMENTS
GEOMETRY	1	1	1	1	1	0	0	1	1	1	0	0	0	

INCIDENT SCENARIO EVENT TIMES

TIME	M	1	2	3	4	5	6	S	R	S	C	C	S	COMMENTS
15:20: 0	0	0	0	0	0	0	0	0	0	0	0	0	0	CHPM1097

ADDITIONAL COMMENT LINES

FULL COUNT STATION  
LOCATION, 100 FT. S/D WASHINGTON BL.

TAPE NO. 74061701      TRAFFIC CODE = 1      FROM 8:00:0  
TO 10:15:0

INCIDENT LOCATION: SM13E TO SM14E

AFFECTED SEGMENTS: 2

SEGMENT(1) SM 8E TO SM17E      SEGMENT(2) SM12E TO SM15W

INCIDENT TYPE: TCBL

VEHICLES INVOLVED: 2

LIGHT DUTY VEHICLES = 2    LIGHT TRUCKS = 0    HEAVY TRUCKS = 0

WEATHER AND ROAD CODES

WEATHER = C      VISIBILITY = S      PAVEMENT = 0

DETECTION AND VERIFICATION

DETECTED AT 8:29:0 BY CODE S

VERIFIED AT 8:28:0 BY CODE V

LAND MARKS

SIGN = E 8      CALL BOX = 0  
LOOP STATION = SM13E      POST MILE = 7.63

INCIDENT FREEWAY GEOMETRY

	M	1	2	3	4	5	6	S	R	S	C	C	S	COMMENTS
GEOMETRY	1	1	1	1	1	0	0	1	0	0	0	0	0	

INCIDENT SCENARIO EVENT TIMES

TIME	M	1	2	3	4	5	6	S	R	S	C	C	S	COMMENTS
8:28:0	0	0	0	0	0	0	0	1	0	0	0	0	0	

ADDITIONAL COMMENT LINES

LOCATION, ADJACENT TO SIGN E08

TAPE NO. 74061901 TRAFFIC CODE = 2 FROM 16:30:0  
TO 19:0:0

INCIDENT LOCATION: SM22W TO SM21-

AFFECTED SEGMENTS: 2

SEGMENT(1) SM28W TO SM10W SEGMENT(2) SM19E TO SM23E

INCIDENT TYPE: TCBL

VEHICLES INVOLVED: 2  
LIGHT DUTY VEHICLES = 2 LIGHT TRUCKS = 0 HEAVY TRUCKS = 0

WEATHER = C WEATHER AND ROAD CODES  
VISIBILITY = 5 PAVEMENT = 0

DETECTION AND VERIFICATION

DETECTED AT 17:4:40 BY CODE S  
VERIFIED AT 17:16:0 BY CODE C

LAND MARKS

SIGN = 0 CALL BOX = 0  
LOOP STATION = 0 POST MILE = 11.39

INCIDENT FREEWAY GEOMETRY

	M	1	2	3	4	5	6	S	R	S	C	C	S	COMMENTS
GEOMETRY	1	1	1	1	1	1	0	1	0	0	0	0	0	

INCIDENT SCENARIO EVENT TIMES

TIME	M	1	2	3	4	5	6	S	R	S	C	C	S	COMMENTS
17:16:0	0	0	1	0	0	0	0	0	0	0	0	0	0	AT CRENSHAW
17:21:0	0	0	0	0	0	0	0	0	0	0	0	0	0	CLEAR



TAPE NO. 74062401      TRAFFIC CODE = 1      FROM 8:35: 0  
TO 9:55: 0

INCIDENT LOCATION: SM25E TO SM26E

AFFECTED SEGMENTS: 2

SEGMENT(1) SM20E TO SM27E      SEGMENT(2) SM28W TO SM23W

INCIDENT TYPE: DISL

VEHICLES INVOLVED: 1

LIGHT DUTY VEHICLES = 1    LIGHT TRUCKS = 0    HEAVY TRUCKS = 0

WEATHER = C      WEATHER AND ROAD CODES  
VISIBILITY = S      PAVEMENT = 0

DETECTION AND VERIFICATION

DETECTED AT 9: 7:20 BY CODE S  
VERIFIED AT 9: 9: 0 BY CODE V

LAND MARKS

SIGN = 0      CALL BOX = 0  
LOOP STATION = SM25E      POST MILE = 13.5

INCIDENT FREEWAY GEOMETRY

	M	1	2	3	4	5	6	S	R	S	C	C	S	COMMENTS
GEOMETRY	1	1	1	1	1	0	0	0	0	1	1	1	1	

INCIDENT SCENARIO EVENT TIMES

TIME	M	1	2	3	4	5	6	S	R	S	C	C	S	COMMENTS
9: 9: 0	1	0	0	0	0	0	0	0	0	0	0	0	0	POSTY IN LN EARLIER

TAPE NO. 74062402      TRAFFIC CODE = 1      FROM 8:20:0  
TO 10:30:0

INCIDENT LOCATION: HA20N TO HA21N

AFFECTED SEGMENTS: 2

SEGMENT(1) HA12N TO HA25N      SEGMENT(2) HA23S TO HA18S

INCIDENT TYPE: SPIL

VEHICLES INVOLVED: 1  
LIGHT DUTY VEHICLES = 1    LIGHT TRUCKS = 0    HEAVY TRUCKS = 0

WEATHER = C      WEATHER AND ROAD CODES  
VISIBILITY = S      PAVEMENT = 0

DETECTION AND VERIFICATION  
DETECTED AT 8:50:20 BY CODE S  
VERIFIED AT 8:51:0 BY CODE C

LAND MARKS  
SIGN = 0      CALL BOX = 0  
LOOP STATION = 0      POST MILE = 19.0

INCIDENT FREEWAY GEOMETRY

	M	1	2	3	4	5	6	S	R	S	C	C	S	COMMENTS
GEOMETRY	1	1	1	1	1	0	0	0	0	0	0	0	0	

INCIDENT SCENARIO EVENT TIMES

TIME	M	1	2	3	4	5	6	S	R	S	C	C	S	COMMENTS
8:51:0	0	0	0	1	1	0	0	0	0	0	0	0	0	SPILED LOAD, DOOR
8:51:0	0	0	0	1	1	0	0	0	0	0	0	0	0	HINGES BETWEEN #35#4

ADDITIONAL COMMENT LINES

LOCATED AT VERNON BRIDGE

TAPE NO. 74062501      TRAFFIC CODE = 1      FROM 7: 0: 0  
TO 10:30: 0

INCIDENT LOCATION: SM21E TO SM22E

AFFECTED SEGMENTS: 2

SEGMENT(1) SM 21E TO SM22E      SEGMENT(2) SM22W TO SM20W

INCIDENT TYPE: DISL

VEHICLES INVOLVED: 2

LIGHT DUTY VEHICLES = 2    LIGHT TRUCKS = 0    HEAVY TRUCKS = 0

WEATHER = C      WEATHER AND ROAD CONDS  
VISIBILITY = S      PAVEMENT = D

DETECTION AND VERIFICATION

DETECTED AT 8: 6:40 BY CODE S  
VERIFIED AT 7:55: 0 BY CODE V

LAND MARKS

SIGN = E14      CALL BOX = 0  
LOOP STATION = SM21E      POST MILE = 11.22

INCIDENT FREEWAY GEOMETRY

	M	1	2	3	4	5	6	S	R	S	C	C	S	COMMENTS
GEOMETRY	1	1	1	1	1	1	0	1	0	0	0	0	0	

INCIDENT SCENARIO EVENT TIMES

TIME	M	1	2	3	4	5	6	S	R	S	C	C	S	COMMENTS
7:55: 0	1	0	0	0	0	0	0	0	0	0	0	0	0	

ADDITIONAL COMMENT LINES

VEH IN MEDIAN, E/B, UNDER SIGN E14  
CHP IN MEDIAN W/B

TAPE NO. 74062502 TRAFFIC CODE = 1 FROM 7:15: 0

TO 10:30: 0

INCIDENT LOCATION: HA19N TO HA20N

AFFECTED SEGMENTS: 2

SEGMENT(1) HA 1N TO HA25N SEGMENT(2) HA25S TO HA 1S

INCIDENT TYPE: TC0L

VEHICLES INVOLVED: 2

LIGHT DUTY VEHICLES = 2 LIGHT TRUCKS = 0 HEAVY TRUCKS = 0

WEATHER AND ROAD CODES

WEATHER = C

VISIBILITY = 5

PAVEMENT = 0

DETECTION AND VERIFICATION

DETECTED AT 0: 0: 0 BY CODE

VERIFIED AT 8:19: 0 BY CODE V

LAND MARKS

SIGN = 0

CALL BOX = 0

LOOP STATION = 0

POST MILE = 18.45

INCIDENT FREEWAY GEOMETRY

	M	1	2	3	4	5	6	S	R	S	C	C	S	COMMENTS
GEOMETRY	1	1	1	1	1	0	0	1	0	0	0	0	0	

INCIDENT SCENARIO EVENT TIMES

TIME	M	1	2	3	4	5	6	S	R	S	C	C	S	COMMENTS
8:19: 0	0	0	0	0	0	0	0	1	0	0	0	0	0	CHP 1097

ADDITIONAL COMMENT LINES

MAP DISPLAY DID NOT FLASH  
LIMITS ESTIMATED

TAPE NO. 74062503 TRAFFIC CODE = 1 FROM 8:50:0  
TO 10:25:0

INCIDENT LOCATION: HA18N TO HA19N

AFFECTED SEGMENTS: 2

SEGMENT(1) HA 1N TO HA25N SEGMENT(2) HA25S TO HA 1S

INCIDENT TYPE: TCBL

VEHICLES INVOLVED: 2  
LIGHT DUTY VEHICLES = 2 LIGHT TRUCKS = 0 HEAVY TRUCKS = 0

WEATHER AND ROAD CODES  
WEATHER = C VISIBILITY = S PAVEMENT = 0

DETECTION AND VERIFICATION  
DETECTED AT 9:22:40 BY CODE S  
VERIFIED AT 9:30:0 BY CODE C

LAND MARKS  
SIGN = 0 CALL BOX = 0  
LOOP STATION = HA18N POST MILE = 0+

INCIDENT FREEWAY GEOMETRY

	M	1	2	3	4	5	6	5	R	S	C	C	S	COMMENTS
GEOMETRY	1	1	1	1	1	0	0	1	1	1	0	0	0	

INCIDENT SCENARIO EVENT TIMES

TIME	M	1	2	3	4	5	6	5	R	S	C	C	S	COMMENTS
9:30:0	0	0	0	0	1	0	0	0	0	0	0	0	0	CHP 1097
9:38:0	0	0	0	0	0	0	0	1	0	0	0	0	0	

ADDITIONAL COMMENT LINES

LOCATION , HALF MILE N/B GAGE

TAPE NO. 74062505 TRAFFIC CODE = 2 FROM 8:20: 0  
TO 9:50: 0

INCIDENT LOCATION: SM21E TO SM22E

AFFECTED SEGMENTS: 2

SEGMENT(1) SM10E TO SM27E SEGMENT(2) SM23W TO SM19W

INCIDENT TYPE: DISL

VEHICLES INVOLVED: 1  
LIGHT DUTY VEHICLES = 1 LIGHT TRUCKS = 0 HEAVY TRUCKS = 0

WEATHER = C WEATHER AND ROAD CODES  
VISIBILITY = S PAVEMENT = D

DETECTION AND VERIFICATION  
DETECTED AT 0: 0: 0 BY CODE  
VERIFIED AT 9:20: 0 BY CODE V

LAND MARKS  
SIGN = 0 CALL BOX = 0  
LOOP STATION = 0 POST MILE = 11.44

INCIDENT FREEWAY GEOMETRY

	M	1	2	3	4	5	6	S	R	S	C	C	S	COMMENTS
GEOMETRY	1	1	1	1	1	1	0	0	0	0	0	0	0	

INCIDENT SCENARIO EVENT TIMES

TIME	M	1	2	3	4	5	6	S	R	S	C	C	S	COMMENTS
9:20: 0	0	0	0	0	1	0	0	0	0	0	0	0	0	DISL #4 LANE
9:10: 0	0	0	0	0	0	0	0	1	0	0	0	0	0	TH R/S

TAPE NO. 74062802 TRAFFIC CODE = 2 FROM 9: 0: 0  
TO 11:15: 0

INCIDENT LOCATION: SM25W TO SM24W

AFFECTED SEGMENTS: 2

SEGMENT(1) SM28W TO SM11W SEGMENT(2) SM19E TO SM27E

INCIDENT TYPE: SPIL

VEHICLES INVOLVED: 0  
LIGHT DUTY VEHICLES = 0 LIGHT TRUCKS = 0 HEAVY TRUCKS = 0

WEATHER = C WEATHER AND ROAD CODES  
VISIBILITY = S PAVEMENT = D

DETECTION AND VERIFICATION  
DETECTED AT 9:31:40 BY CODE S  
VERIFIED AT 9:36: 0 BY CODE V

LAND MARKS  
SIGN = 0 CALL BOX = 0  
LOOP STATION = 0 POST MILE = 12.90

INCIDENT FREEWAY GEOMETRY

	M	1	2	3	4	5	6	5	R	5	C	C	S	COMMENTS
GEOMETRY	1	1	1	1	1	0	0	1	0	0	1	1	1	

INCIDENT SCENARIO EVENT TIMES

TIME	M	1	2	3	4	5	6	5	R	5	C	C	S	COMMENTS
9:31:40	0	1	1	0	0	0	0	0	0	0	0	0	0	SYSTEM FLASH, HEAVY
9:31:40	0	1	1	0	0	0	0	0	0	0	0	0	0	OCCUPANCIES, *1&2 LNS
9:36: 0	0	1	1	0	0	0	0	0	0	0	0	0	0	VPU VERIFIED
9:40: 0	0	1	1	0	0	0	0	0	0	0	0	0	0	DOT MAINTNCE 10-97
10:10: 0	0	0	0	0	0	0	0	0	0	0	0	0	0	LANES CLEAR
10:12: 0	0	0	0	0	0	0	0	0	0	0	0	0	0	DOT CREW 10-98

ADDITIONAL COMMENT LINES

HEAVY GARKING E/B, SYSTEM FLASH E/B AT 0954, SM24E

TAPE NO. 74062803      TRAFFIC CODE = 3      FROM 15:45: 0  
 TO 17:30: 0

INCIDENT LOCATION: SD225 TO SD215

AFFECTED SEGMENTS: 2

SEGMENT(1) SD285 TO SD 15      SEGMENT(2) SD20N TO SD24N

INCIDENT TYPE: TCML

VEHICLES INVOLVED: 2  
 LIGHT DUTY VEHICLES = 2    LIGHT TRUCKS = 0    HEAVY TRUCKS = 0

WEATHER = C      WEATHER AND ROAD CODES  
 VISIBILITY = S      PAVEMENT = D

DETECTION AND VERIFICATION  
 DETECTED AT 16:20:20 BY CODE S  
 VERIFIED AT 16:18: 0 BY CODE C

LAND MARKS  
 SIGN = 0      CALL BOX = 0  
 LOOP STATION = SD225      POST MILE = 25.36

INCIDENT FREEWAY GEOMETRY

	M	1	2	3	4	5	6	S	R	S	C	C	S	COMMENTS
GEOMETRY	1	1	1	1	1	0	0	1	0	1	1	0	1	

INCIDENT SCENARIO EVENT TIMES

TIME	M	1	2	3	4	5	6	S	R	S	C	C	S	COMMENTS
16:18: 0	0	0	0	0	0	0	0	0	0	0	0	0	0	CHP REPTS. TC AT
16:18: 0	0	0	0	0	0	0	0	0	0	0	0	0	0	MANCHESTER
16:34: 0	0	0	0	0	0	0	0	1	0	0	0	0	0	TR R/S
16:57: 0	0	0	0	0	0	0	0	0	0	0	0	0	0	CLEAR

FULL COUNT STATION  
 INCIDENT



TAPE NO. 74070102 TRAFFIC CODE = 2 FROM 6:50:0  
TO 9:0:0

INCIDENT LOCATION: SM21E TO SM22E

AFFECTED SEGMENTS: 2

SEGMENT(1) SM10E TO SM27E SEGMENT(2) SM23W TO SM20W

INCIDENT TYPE: DISL

VEHICLES INVOLVED: 1  
LIGHT DUTY VEHICLES = 1 LIGHT TRUCKS = 0 HEAVY TRUCKS = 0

WEATHER AND ROAD CODES  
WEATHER = C VISIBILITY = 0 PAVEMENT = 0

DETECTION AND VERIFICATION  
DETECTED AT 7:25:40 BY CODE S  
VERIFIED AT 7:26:10 BY CODE V

LAND MARKS  
SIGN = 0 CALL BOX = 0  
LOOP STATION = 0 POST MILE = 11.41

INCIDENT FREEWAY GEOMETRY

	M	1	2	3	4	5	6	S	R	S	C	C	S	COMMENTS
GEOMETRY	1	1	1	1	1	0	0	1	0	0	1	1	1	

INCIDENT SCENARIO EVENT TIMES

TIME	M	1	2	3	4	5	6	S	R	S	C	C	S	COMMENTS
7:26:0	0	0	0	0	1	0	0	0	0	0	0	0	0	DISL, LANE 4
7:29:0	0	0	0	0	0	0	0	0	0	0	0	0	0	LANES CLEAR

TAPE NO. 74070201 TRAFFIC CODE = 2 FROM 8:15: 0  
TO 9:40: 0

INCIDENT LOCATION: SM17E TO SM18E

AFFECTED SEGMENTS: 2

SEGMENT(1) SM14E TO SM24E SEGMENT(2) SM19W TO SM16W

INCIDENT TYPE: GAWK

VEHICLES INVOLVED: 2  
LIGHT DUTY VEHICLES = 2 LIGHT TRUCKS = 0 HEAVY TRUCKS = 0

WEATHER = C WEATHER AND ROAD CODES  
VISIBILITY = H PAVEMENT = D

DETECTION AND VERIFICATION  
DETECTED AT 8:50:20 BY CODE S  
VERIFIED AT 8:55: 0 BY CODE V

LAND MARKS  
SIGN = 0 CALL BOX = 0  
LOOP STATION = 0 POST MILE = 95+20

INCIDENT FREEWAY GEOMETRY

	M	1	2	3	4	5	6	S	R	S	C	C	S	COMMENTS
GEOMETRY	1	1	1	1	1	0	0	1	1	1	0	0	0	

INCIDENT SCENARIO EVENT TIMES

TIME	M	1	2	3	4	5	6	S	R	S	C	C	S	COMMENTS
8:55: 0	0	0	0	0	0	0	0	1	0	0	0	0	0	CHP ON A STOP
9: 2: 0	0	0	0	0	0	0	0	0	0	0	0	0	0	CLEAR

TAPE NO. 74070202      TRAFFIC CODE = 2      FROM 8:30: 0  
 TO 10:20: 0

INCIDENT LOCATION: SM22E TO SM23E

AFFECTED SEGMENTS: 2

SEGMENT(1) SM20E TO SM25E      SEGMENT(2) SM24W TO SM21W

INCIDENT TYPE: DISL

VEHICLES INVOLVED: 2  
 LIGHT DUTY VEHICLES = 2    LIGHT TRUCKS = 0    HEAVY TRUCKS = 0

WEATHER = C      WEATHER AND ROAD CODES  
 VISIBILITY = M      PAVEMENT = D

DETECTION AND VERIFICATION  
 DETECTED AT 0: 0: 0 BY CODE  
 VERIFIED AT 9:37: 0 BY CODE V

LAND MARKS  
 SIGN = 0      CALL BOX = 0  
 LOOP STATION = 0      POST MILE = 11.69

INCIDENT FREEWAY GEOMETRY

	M	1	2	3	4	5	6	S	R	S	C	C	S	COMMENTS
GEOMETRY	1	1	1	1	1	1	1	0	0	0	0	0	0	

INCIDENT SCENARIO EVENT TIMES

TIME	M	1	2	3	4	5	6	S	R	S	C	C	S	COMMENTS
9:37: 0	0	0	0	0	0	0	0	1	0	0	0	0	0	2 DISL #6 LANE
9:40: 0	0	0	0	0	0	0	0	0	1	0	0	0	0	TO ARLINGTON OFF

TAPE NO. 74070302      TRAFFIC CODE = 4      FROM 8:15: 0  
TO 9:40: 0

INCIDENT LOCATION: SM 2W TO SM 3W

AFFECTED SEGMENTS: 2

SEGMENT(1) SM 1W TO SM 3W      SEGMENT(2) SM 1E TO SM 4E

INCIDENT TYPE: TCBL

VEHICLES INVOLVED: 3  
LIGHT DUTY VEHICLES = 3    LIGHT TRUCKS = 0    HEAVY TRUCKS = 0

WEATHER AND ROAD CODES  
WEATHER = C      VISIBILITY = S      PAVEMENT = 0

DETECTION AND VERIFICATION  
DETECTED AT 8:51:20 BY CODE S  
VERIFIED AT 8:55: 0 BY CODE V

LAND MARKS  
SIGN = 0      CALL BOX = 0  
LOOP STATION = SM 3W      POST MILE = 2.18

INCIDENT FREEWAY GEOMETRY

	M	1	2	3	4	5	6	S	R	S	C	C	S	COMMENTS
GEOMETRY	1	1	1	0	0	0	0	1	1	1	0	0	0	

INCIDENT SCENARIO EVENT TIMES

TIME	M	1	2	3	4	5	6	S	R	S	C	C	S	COMMENTS
8:55: 0	0	0	0	0	0	0	0	0	1	0	0	0	0	3 VEH'S ON LINCOLN

ADDITIONAL COMMENT LINES

LOCATION, AT BOTTOM OF LINCOLN OFF/RMP

TAPE NO. 74070304      TRAFFIC CODE = 2      FROM 7: 0: 0  
 TO 8:55: 0  
 INCIDENT LOCATION: HA12N TO HA13N

AFFECTED SEGMENTS: 2

SEGMENT(1) HA 1N TO HA20N      SEGMENT(2) HA14S TO HA11S

INCIDENT TYPE: DISL

VEHICLES INVOLVED: 1  
 LIGHT DUTY VEHICLES = 1    LIGHT TRUCKS = 0    HEAVY TRUCKS = 0

WEATHER AND ROAD CODES  
 WEATHER = C      VISIBILITY = S      PAVEMENT = D

DETECTION AND VERIFICATION  
 DETECTED AT 7:35:20 BY CODE S  
 VERIFIED AT 7:34: 0 BY CODE M

LAND MARKS  
 SIGN = 0      CALL BOX = 0  
 LOOP STATION = 0      POST MILE = 14+9

INCIDENT FREEWAY GEOMETRY

	M	1	2	3	4	5	6	S	R	S	C	C	S	COMMENTS
GEOMETRY	1	1	1	1	1	0	0	1	0	0	0	0	0	

INCIDENT SCENARIO EVENT TIMES

TIME	M	1	2	3	4	5	6	S	R	S	C	C	S	COMMENTS
7:34: 0	1	1	0	0	0	0	0	0	0	0	0	0	0	DISL PARTIALLY IN #1
8: 3: 0	0	0	0	0	0	0	0	0	0	0	0	0	0	CLEAR

TAPE NO. 74071101 TRAFFIC CODE = 3 FROM 12:20: 0  
TO 15: 0: 0

INCIDENT LOCATION: SD28N TO SD29N

AFFECTED SEGMENTS: 2

SEGMENT(1) SD24N TO SD32N SEGMENT(2) SD32S TO SD24S

INCIDENT TYPE: DISL

VEHICLES INVOLVED: 1

LIGHT DUTY VEHICLES = 1 LIGHT TRUCKS = 0 HEAVY TRUCKS = 0

WEATHER = C WEATHER AND ROAD CODES  
VISIBILITY = S PAVEMENT = D

DETECTION AND VERIFICATION

DETECTED AT 13: 2:20 BY CODE S

VERIFIED AT 13:16: 0 BY CODE C

LAND MARKS

SIGN = 0 CALL BOX = 0  
LOOP STATION = 0 POST MILE = 27.20

INCIDENT FREEWAY GEOMETRY

	M	1	2	3	4	5	6	S	R	S	C	C	S	COMMENTS
GEOMETRY	1	1	1	1	1	0	0	0	1	1	0	0	0	

INCIDENT SCENARIO EVENT TIMES

TIME	M	1	2	3	4	5	6	S	R	S	C	C	S	COMMENTS
13:16: 0	0	1	0	0	0	0	0	0	0	0	0	0	0	VEH. BRAKES LOCKED
13:48: 0	1	1	0	0	0	0	0	0	0	0	0	0	0	TOW 1097
13:53: 0	0	0	0	0	0	0	0	0	0	0	0	0	0	ROADWAY CLEAR

ADDITIONAL COMMENT LINES

LOCATION, AT CULVER  
FULL COUNT INCIDENT

TAPE NO. 74071201 TRAFFIC CODE = 4 FROM 5:45: 0  
TO 7:20: 0

INCIDENT LOCATION: SM 5W TO SM 4W

AFFECTED SEGMENTS: 2

SEGMENT(1) SM11W TO SM 1W SEGMENT(2) SM 3E TO SM 7E

INCIDENT TYPE: GAWK

VEHICLES INVOLVED: 1

LIGHT DUTY VEHICLES = 1 LIGHT TRUCKS = 0 HEAVY TRUCKS = 0

WEATHER = C WEATHER AND ROAD CMDES  
VISIBILITY = S PAVEMENT = 0

DETECTION AND VERIFICATION

DETECTED AT 0: 0: 0 BY CODE  
VERIFIED AT 6:25: 0 BY CODE V

LAND MARKS

SIGN = 0 CALL BOX = 0  
LOOP STATION = 0 POST MILE = 3+34

INCIDENT FREEWAY GEOMETRY

	M	1	2	3	4	5	6	S	R	S	C	C	S	COMMENTS
GEOMETRY	1	1	1	1	1	0	0	0	1	0	0	0	0	

INCIDENT SCENARIO EVENT TIMES

TIME	M	1	2	3	4	5	6	S	R	S	C	C	S	COMMENTS
6:25: 0	0	0	0	0	0	0	0	0	0	0	0	0	0	VEH ON O/C
6:40: 0	0	0	0	0	0	0	0	0	1	0	0	0	0	VEH
6:45: 0	0	0	0	0	0	0	0	0	1	0	0	0	0	CHP 1097
6:46: 0	0	0	0	0	0	0	0	0	0	0	0	0	0	ROADWAY CLEAR

ADDITIONAL COMMENT LINES

VEH ON O/C TETERING OVER RAMP  
LOCATION, AT CLOVERFIELD OFF/RMP

TAPE NO. 74072501 TRAFFIC CODE = 1 FROM 7:25:0  
TO 9:30:0

INCIDENT LOCATION: SD285 TO SD275

AFFECTED SEGMENTS: 2

SEGMENT(1) SD325 TO SD145 SEGMENT(2) SD244 TO SD324

INCIDENT TYPE: TCBL

VEHICLES INVOLVED: 2

LIGHT DUTY VEHICLES = 2 LIGHT TRUCKS = 0 HEAVY TRUCKS = 0

WEATHER = C WEATHER AND ROAD CODES  
VISIBILITY = S PAVEMENT = D

DETECTION AND VERIFICATION

DETECTED AT 7:57:40 BY CODE S

VERIFIED AT 8:0:0 BY CODE C

LAND MARKS

SIGN = 0 CALL BOX = 0  
LOOP STATION = SD285 POST MILE = 26.50

INCIDENT FREEWAY GEOMETRY

	M	1	2	3	4	5	6	S	R	S	C	C	S	COMMENTS
GEOMETRY	1	1	1	1	1	0	0	1	0	0	0	0	0	

ADDITIONAL COMMENT LINES

FULL COUNT INCIDENT



TAPE NO: 74073001      TRAFFIC CODE = 3      FROM 5:40: 0  
TO 8:30: 0

INCIDENT LOCATION: SD27S TO SD26S

AFFECTED SEGMENTS: 2

SEGMENT(1) SD32S TO SD24S      SEGMENT(2) SD24N TO SD32N

INCIDENT TYPE: DISL

VEHICLES INVOLVED: 0  
LIGHT DUTY VEHICLES = 0    LIGHT TRUCKS = 1    HEAVY TRUCKS = 0

WEATHER = C      WEATHER AND ROAD CODES  
VISIBILITY = 0      PAVEMENT = 0

DETECTION AND VERIFICATION  
DETECTED AT 6:13: 0 BY CODE S  
VERIFIED AT 6:30: 0 BY CODE C

LAND MARKS  
SIGN = 0      CALL BOX = 0  
LOOP STATION = SD27S      POST MILE = 25.93

INCIDENT FREEWAY GEOMETRY

	M	1	2	3	4	5	6	S	R	S	C	C	S	COMMENTS
GEOMETRY	1	1	1	1	1	0	0	1	1	1	1	1	1	

INCIDENT SCENARIO EVENT TIMES

TIME	M	1	2	3	4	5	6	S	R	S	C	C	S	COMMENTS
6:30: 0	0	0	0	0	1	0	0	0	0	0	0	0	0	
6:46: 0	0	0	0	0	0	0	0	1	0	0	0	0	0	CHP 1097

ADDITIONAL COMMENT LINES

LOCATION, AT JEFFERSON  
FULL COUNT INCIDENT

TAPE NO. 74081201      TRAFFIC CODE = 2      FROM 14:30: 0  
 TO 17:30: 0

INCIDENT LOCATION: SM22E TO SM23E

AFFECTED SEGMENTS: 2

SEGMENT(1) SM10E TO SM27E      SEGMENT(2) SM28W TO SM16W

INCIDENT TYPE: SPIL

VEHICLES INVOLVED: 0  
 LIGHT DUTY VEHICLES = 0    LIGHT TRUCKS = 0    HEAVY TRUCKS = 0

WEATHER AND ROAD CODES  
 WEATHER = C      VISIBILITY = 5      PAVEMENT = D

DETECTION AND VERIFICATION  
 DETECTED AT 15:10:20 BY CODE S  
 VERIFIED AT 15: 4: 0 BY CODE V

LAND MARKS  
 SIGN = 0      CALL BOX = 0  
 LOOP STATION = 0      POST MILE = 12. 6

INCIDENT FREEWAY GEOMETRY

	M	1	2	3	4	5	6	S	R	S	C	C	S	COMMENTS
GEOMETRY	1	1	1	1	1	1	1	0	0	0	0	0	0	

INCIDENT SCENARIO EVENT TIMES

TIME	M	1	2	3	4	5	6	S	R	S	C	C	S	COMMENTS
15: 4: 0	0	0	0	0	1	1	0	0	0	0	0	0	0	FIBERGLASS MATERIAL,
15: 4: 0	0	0	0	0	0	0	0	0	0	0	0	0	0	LANES 4 & 5
15:19: 0	0	0	0	0	1	1	1	0	0	0	0	0	0	LANE #6 BLOCKED
16:19: 0	0	0	0	0	0	0	0	0	0	0	0	0	0	ROADWAY CLEAR

TAPE NO. 74083001 TRAFFIC CODE = 1 FROM 13:45: 0  
TO 16:45: 0

INCIDENT LOCATION: SD29N TO SD30N

AFFECTED SEGMENTS: 2

SEGMENT(1) SD24N TO SD32N SEGMENT(2) SD32S TO SD24S

INCIDENT TYPE: DISL

VEHICLES INVOLVED: 2  
LIGHT DUTY VEHICLES = 2 LIGHT TRUCKS = 0 HEAVY TRUCKS = 0

WEATHER AND ROAD CODES  
WEATHER = C VISIBILITY = S PAVEMENT = D

DETECTION AND VERIFICATION  
DETECTED AT 14:20:20 BY CODE S  
VERIFIED AT 14:42: 0 BY CODE C

LAND MARKS  
SIGN = 0 CALL BOX = 0  
LBBP STATION = 0 POST MILE = 27.45

INCIDENT FREEWAY GEOMETRY

	M	1	2	3	4	5	6	S	R	S	C	C	S	COMMENTS
GEOMETRY	1	1	1	1	1	0	0	1	0	0	0	0	0	

INCIDENT SCENARIO EVENT TIMES

TIME	M	1	2	3	4	5	6	S	R	S	C	C	S	COMMENTS
14:42: 0	0	0	0	0	0	0	0	1	0	0	0	0	0	2 VEH'S

ADDITIONAL COMMENT LINES

FLASH AT SD30N PROBABLY UNRELATED  
LOCATION, AT WASHINGTON  
FULL COUNT INCIDENT

TAPE NO. 74100201 TRAFFIC CODE = 3 FROM 10:40:0  
TO 14:10:0

INCIDENT LOCATION: SD30N TO SD31N

AFFECTED SEGMENTS: 2

SEGMENT(1) SD26N TO SD32N SEGMENT(2) SD32S TO SD23S

INCIDENT TYPE:

VEHICLES INVOLVED: 2

LIGHT DUTY VEHICLES = 2 LIGHT TRUCKS = 0 HEAVY TRUCKS = 0

WEATHER = C WEATHER AND ROAD CODES VISIBILITY = S PAVEMENT = 0

DETECTION AND VERIFICATION

DETECTED AT 11:10:20 BY CODE S

VERIFIED AT 11:30:0 BY CODE C

LAND MARKS

SIGN = 0 CALL BOX = 0  
LOOP STATION = SD29S POST MILE = 28.35

INCIDENT FREEWAY GEOMETRY

	M	1	2	3	4	5	6	S	R	S	C	C	S	COMMENTS
GEOMETRY	1	1	1	1	1	0	0	1	0	0	0	0	0	

INCIDENT SCENARIO&EVENT TIMES

TIME	M	1	2	3	4	5	6	S	R	S	C	C	S	COMMENTS
11:30:0	1	0	0	0	0	0	0	0	0	0	0	0	0	CALL FOR MAINT-

ADDITIONAL COMMENT LINES

LOCATION, S/B PALMS B/C  
FULL COUNT INCIDENT

TAPE NO. 74100701 TRAFFIC CODE = 1 FROM 6:30:0  
TO 9:30:0

INCIDENT LOCATION: SD28N TO SD30N

AFFECTED SEGMENTS: 2

SEGMENT(1) SD24N TO SD32N SEGMENT(2) SD32S TO SD24S

INCIDENT TYPE: GAWK

VEHICLES INVOLVED: 2  
LIGHT DUTY VEHICLES = 2 LIGHT TRUCKS = 0 HEAVY TRUCKS = 0

WEATHER AND ROAD CODES  
WEATHER = C VISIBILITY = 0 PAVEMENT = 0

DETECTION AND VERIFICATION  
DETECTED AT 0:0:0 BY CODE  
VERIFIED AT 7:47:0 BY CODE V

LAND MARKS  
SIGN = 0 CALL BOX = 0  
LOOP STATION = SD29N POST MILE = 27.36

INCIDENT FREEWAY GEOMETRY

	M	1	2	3	4	5	6	S	R	S	C	L	S	COMMENTS
GEOMETRY	1	1	1	1	1	0	0	0	1	1	0	0	0	

INCIDENT SCENARIO/EVENT TIMES

TIME	M	1	2	3	4	5	6	S	R	S	C	L	S	COMMENTS
7:47:0	1	0	0	0	0	0	0	0	0	0	0	0	0	CHP & MOTORCYCLE
8:18:0	0	0	0	0	0	0	0	0	0	0	0	0	0	ROADWAY CLEAR

ADDITIONAL COMMENT LINES

FULL COUNT INCIDENT

TAPE NO. 74100702 TRAFFIC CODE = 1 FROM 6:30:0  
TO 9:30:0

INCIDENT LOCATION: SD31N TO SD324

AFFECTED SEGMENTS: 2

SEGMENT(1) SD22N TO SD32N SEGMENT(2) SD32S TO SD24S

INCIDENT TYPE: TCOL

VEHICLES INVOLVED: 2

LIGHT DUTY VEHICLES = 2 LIGHT TRUCKS = 0 HEAVY TRUCKS = 0

WEATHER = C WEATHER AND ROAD CODES  
VISIBILITY = 5 PAVEMENT = 0

DETECTION AND VERIFICATION

DETECTED AT 0:0:0 BY CODE

VERIFIED AT 7:58:0 BY CODE V

LAND MARKS

SIGN = 0 CALL BOX = 0  
LOOP STATION = 0 POST MILE = 28.57

INCIDENT FREEWAY GEOMETRY

	M	1	2	3	4	5	6	S	R	S	C	C	S	COMMENTS
GEOMETRY	1	1	1	1	1	0	0	1	0	0	0	0	0	

INCIDENT SCENARIO & EVENT TIMES

TIME	M	1	2	3	4	5	6	S	R	S	C	C	S	COMMENTS
7:58:0	1	0	0	0	0	0	0	0	0	0	0	0	0	2 VEHICLES
8:11:0	1	0	0	0	0	0	0	0	0	0	0	0	0	TSC VPU, VERIFIES
8:10:0	0	0	0	0	0	0	0	0	0	0	0	0	0	ROADWAY CLEAR

ADDITIONAL COMMENT LINES

LOCATION, PER DOT, .02 MILES N/O PALMS  
LOCATION, PER TSC, AT WESTWOOD  
DIFFERENCE OF .08 MILES  
ESTIMATED TIME OF INCIDENT, BTWN. 07:30 & 07:40  
FULL COUNT INCIDENT

TAPE NO. 74100703 TRAFFIC CODE = 2 FROM 15: 0: 0  
TO 16: 0: 0

INCIDENT LOCATION: SD30N TO SD31N

AFFECTED SEGMENTS: 2

SEGMENT(1) SD24N TO SD32N SEGMENT(2) SD32S TO SD24S

INCIDENT TYPE: DISL

VEHICLES INVOLVED: 0  
LIGHT DUTY VEHICLES = 0 LIGHT TRUCKS = 1 HEAVY TRUCKS = 0

WEATHER AND ROAD CODES  
WEATHER = C VISIBILITY = 0 PAVEMENT = 0

DETECTION AND VERIFICATION  
DETECTED AT 0: 0: 0 BY CODE  
VERIFIED AT 15:41: 0 BY CODE V

LAND MARKS  
SIGN = 0 CALL BOX = SD367  
LOOP STATION = 0 POST MILE = 0\*

INCIDENT FREEWAY GEOMETRY

	M	1	2	3	4	5	6	5	R	S	C	C	S	COMMENTS
GEOMETRY	1	1	1	1	1	0	0	1	0	0	0	0	0	

INCIDENT SCENARIO&EVENT TIMES

TIME	M	1	2	3	4	5	6	5	R	S	C	C	S	COMMENTS
15:41: 0	0	0	0	0	0	0	0	1	0	0	0	0	0	GARBAGE TRUCK
15:41: 0	0	0	0	0	0	0	0	1	0	0	0	0	0	P.U. TRUCK ASSTING
15:58: 0	0	0	0	0	0	0	0	1	0	0	0	0	0	VEH'S LEAVING
16: 0: 0	0	0	0	0	0	0	0	0	0	0	0	0	0	ROADWAY CLEAR

ADDITIONAL COMMENT LINES

P.U. TRUCK USED FLASHING RED LIGHT WHEN LEAVING  
FULL COUNT INCIDENT

TAPE NO. 74100704 TRAFFIC CODE = 2 FROM 15: 0: 0  
15: 16: 0: 0

INCIDENT LOCATION: SD295 TO SD285

AFFECTED SEGMENTS: 2

SEGMENT(1) SD325 TO SD245 SEGMENT(2) SD245 TO SD325

INCIDENT TYPE: DISL

VEHICLES INVOLVED: 1

LIGHT DUTY VEHICLES = 1 LIGHT TRUCKS = 0 HEAVY TRUCKS = 0

WEATHER = C WEATHER AND ROAD CODES  
VISIBILITY = 0 PAVEMENT = 0

DETECTION AND VERIFICATION

DETECTED AT 15:41:00 BY CODE S

VERIFIED AT 15:43:00 BY CODE V

LAND MARKS

SIGN = 0 CALL BOX = 0  
LOOP STATION = 0 POST MILE = 27.53

INCIDENT FREEWAY GEOMETRY

	M	1	2	3	4	5	6	S	R	S	C	C	S	COMMENTS
GEOMETRY	1	1	1	1	1	0	0	1	0	0	0	0	0	

INCIDENT SCENARIO/EVENT TIMES

TIME	M	1	2	3	4	5	6	S	R	S	C	C	S	COMMENTS
15:43:00	1	0	0	0	0	0	0	0	0	0	0	0	0	
15:51:00	1	0	0	0	0	0	0	0	0	0	0	0	0	1124 TAGGED BY CHP
15:51:00	1	0	0	0	0	0	0	0	0	0	0	0	0	FLAT TIRE
16:05:00	1	0	0	0	0	0	0	0	0	0	0	0	0	CITED BY CHP
16:16:00	0	0	0	0	0	0	0	0	0	0	0	0	0	TIRE CHANGED, 109R

ADDITIONAL COMMENT LINES

LOCATION, 0.13 MILES N/O CULVER OFF/RMP  
FULL COUNT INCIDENT



TAPE NO. 74100706 TRAFFIC CODE = 2 FROM 15: 0: 0  
TO 16: 0: 0

INCIDENT LOCATION: SD29S TO SD28S

AFFECTED SEGMENTS: 2

SEGMENT(1) SD32S TO SD24S SEGMENT(2) SD24N TO SD32N

INCIDENT TYPE: DISL

VEHICLES INVOLVED: 1

LIGHT DUTY VEHICLES = 1 LIGHT TRUCKS = 0 HEAVY TRUCKS = 0

WEATHER = C WEATHER AND ROAD CODES  
VISIBILITY = 0 PAVEMENT = 0

DETECTION AND VERIFICATION

DETECTED AT 0: 0: 0 BY CODE

VERIFIED AT 16:36: 0 BY CODE V

LAND MARKS

SIGN = 0 CALL BOX = 0  
LOOP STATION = 0 POST MILE = 27.20

INCIDENT FREEWAY GEOMETRY

	N	1	2	3	4	5	6	S	R	S	C	C	S	COMMENTS
GEOMETRY	1	1	1	1	1	0	0	1	1	1	0	0	0	

INCIDENT SCENARIO&EVENT TIMES

TIME	N	1	2	3	4	5	6	S	R	S	C	C	S	COMMENTS
16:36: 0	0	1	0	0	0	0	0	0	0	0	0	0	0	SPINOUT
16:42: 0	0	0	0	0	0	0	0	0	0	0	0	0	0	ROADWAY CLEAR

ADDITIONAL COMMENT LINES

VEH. SPUNOUT IN FRONT OF VPU, NO TC, VEH. LEFT ON OWN POWER  
LOCATION, AT CULVER  
FULL COUNT INCIDENT

TAPE NO. 74100707 TRAFFIC CODE = 3 FROM 15: 0: 0  
TO 16: 0: 0

INCIDENT LOCATION: SD26S TO SD25S

AFFECTED SEGMENTS: 2

SEGMENT(1) SD32S TO SD24S SEGMENT(2) SD24S TO SD32N

INCIDENT TYPE: DISL

VEHICLES INVOLVED: 1  
LIGHT DUTY VEHICLES = 0 LIGHT TRUCKS = 0 HEAVY TRUCKS = 1

WEATHER = C WEATHER AND ROAD CONDS  
VISIBILITY = 0 PAVEMENT = 0

DETECTION AND VERIFICATION  
DETECTED AT 0: 0: 0 BY CODE  
VERIFIED AT 16:38: 0 BY CODE V

LAND MARKS  
SIGN = 0 CALL BOX = 0  
LOOP STATION = 0 POST MILE = 25+61

INCIDENT FREEWAY GEOMETRY

	M	1	2	3	4	5	6	S	R	S	C	C	S	COMMENTS
GEOMETRY	1	1	1	1	1	0	0	0	1	0	0	0	1	

INCIDENT SCENARIO&EVENT TIMES

TIME	M	1	2	3	4	5	6	S	R	S	C	C	S	COMMENTS
16:38: 0	0	0	0	0	0	0	0	0	0	1	0	0	0	FLATBED
16:47: 0	0	0	0	0	0	0	0	0	0	0	0	0	0	ROADWAY CLEAR

ADDITIONAL COMMENT LINES

LOCATION, AT CENTILLA OFF/RMP  
FULL COUNT INCIDENT

TAPE NO. 74100708 TRAFFIC CODE = 2 FROM 15: 0: 0  
TO 18: 0: 0

INCIDENT LOCATION: SD25N TO SD26N

AFFECTED SEGMENTS: 2

SEGMENT(1) SD24N TO SD32N SEGMENT(2) SD32S TO SD24S

INCIDENT TYPE: DISL

VEHICLES INVOLVED: 0  
LIGHT DUTY VEHICLES = 0 LIGHT TRUCKS = 0 HEAVY TRUCKS = 0

WEATHER AND ROAD CODES  
WEATHER = C VISIBILITY = 0 PAVEMENT = 0

DETECTION AND VERIFICATION  
DETECTED AT 0: 0: 0 BY CODE  
VERIFIED AT 17: 9: 0 BY CODE V

LAND MARKS  
SIGN = 0 CALL BOX = 0  
LOOP STATION = 0 POST MILE = 25.37

INCIDENT FREEWAY GEOMETRY

	M	1	2	3	4	5	6	S	R	S	C	C	S	COMMENTS
GEOMETRY	1	1	1	1	1	0	0	1	0	0	0	0	0	

INCIDENT SCENARIO & EVENT TIMES

TIME	M	1	2	3	4	5	6	S	R	S	C	C	S	COMMENTS
17: 9: 0	0	0	0	0	0	0	0	1	0	0	0	0	0	
17:23: 0	0	0	0	0	0	0	0	0	0	0	0	0	0	ROADWAY CLEAR

ADDITIONAL COMMENT LINES

LOCATION, 500 FT. N/B CENTINELLA  
NO NOTICABLE EFFECT ON TRAFFIC  
FULL COUNT INCIDENT

TAPE NO. 74100710 TRAFFIC CODE = 3 FROM 15: 0: 0  
TO 16: 0: 0

INCIDENT LOCATION: S0255 TO S0245

AFFECTED SEGMENTS: 2

SEGMENT(1) S0325 TO S0245 SEGMENT(2) S0245 TO S0324

INCIDENT TYPE: DISL

VEHICLES INVOLVED: 1

LIGHT DUTY VEHICLES = 1 LIGHT TRUCKS = 1 HEAVY TRUCKS = 0

WEATHER AND ROAD CODES

WEATHER = C

VISIBILITY = 0

PAVEMENT = 0

DETECTION AND VERIFICATION

DETECTED AT 0: 0: 0 BY CODE

VERIFIED AT 15:29: 0 BY CODE C

LAND MARKS

SIGN = 0

CALL BOX = 0

LOOP STATION = 0

POST MILE = 24.76

INCIDENT FREEWAY GEOMETRY

	M	1	2	3	4	5	6	S	R	S	C	C	S	COMMENTS
GEOMETRY	1	1	1	1	1	0	0	1	0	0	0	0	0	

INCIDENT SCENARIO&EVENT TIMES

TIME	M	1	2	3	4	5	6	S	R	S	C	C	S	COMMENTS
16:29: 0	0	0	0	0	0	0	0	1	0	0	0	0	0	TOW AND VER
16:32: 0	0	0	0	0	0	0	0	0	0	0	0	0	0	ROADWAY CLEAR

ADDITIONAL COMMENT LINES

LOCATION, 1/2 MILE N/B LA TIJERA  
FULL COUNT INCIDENT

TAPE NO. 74100711 TRAFFIC CODE = 3 FROM 6:30:0  
TO 9:30:0

INCIDENT LOCATION: SM 3E TO SM 4E

AFFECTED SEGMENTS: 2

SEGMENT(1) SM 1E TO SM 2E SEGMENT(2) SM 5A TO SM 2W

INCIDENT TYPE: DISL

VEHICLES INVOLVED: 1  
LIGHT DUTY VEHICLES = 1 LIGHT TRUCKS = 0 HEAVY TRUCKS = 0

WEATHER = C WEATHER AND ROAD CODES  
VISIBILITY = 0 PAVEMENT = P

DETECTION AND VERIFICATION  
DETECTED AT 0: 0: 0 BY CODE  
VERIFIED AT 7: 2: 0 BY CODE V

LAND MARKS  
SIGN = 0 CALL BOX = 0  
LOOP STATION = 0 POST MILE = 2.87

INCIDENT FREEWAY GEOMETRY

	M	1	2	3	4	5	6	S	R	S	C	C	S	COMMENTS
GEOMETRY	1	1	1	1	0	0	0	1	1	0	0	0	0	

INCIDENT SCENARIO/EVENT TIMES

TIME	M	1	2	3	4	5	6	S	R	S	C	C	S	COMMENTS
7: 2: 0	0	0	0	0	0	0	0	0	1	0	0	0	0	TAGGED BY CHP
8:16: 0	0	0	0	0	0	0	0	0	1	0	0	0	0	

ADDITIONAL COMMENT LINES

LOCATION: 20TH ST OFF/RMP

TAPE NO. 74100712 TRAFFIC CODE = 3 FROM 6:30:0

TO 9:30:0

INCIDENT LOCATION: SM 6E TO SM 7E

AFFLICTED SEGMENTS: 2

SEGMENT(1) SM 4E TO SM 10F SEGMENT(2) SM 8W TO SM 5W

INCIDENT TYPE: GAWK

VEHICLES INVOLVED: 2

LIGHT DUTY VEHICLES = 2 LIGHT TRUCKS = 0 HEAVY TRUCKS = 0

WEATHER AND ROAD CODES

WEATHER = C

VISIBILITY = 0

PAVEMENT = 0

DETECTION AND VERIFICATION

DETECTED AT 0: 0: 0 BY CODE

VERIFIED AT 7: 2: 0 BY CODE V

LAND MARKS

SIGN = 0

CALL BOX = 0

LOOP STATION = 0

POST MILE = 4.27

INCIDENT FREEWAY GEOMETRY

	M	1	2	3	4	5	6	5	R	5	C	C	S	COMMENTS
GEOMETRY	1	1	1	1	1	0	0	1	0	0	0	0	0	

INCIDENT SCENARIO&EVENT TIMES

TIME	M	1	2	3	4	5	6	5	R	5	C	C	S	COMMENTS
7: 2: 0	0	0	0	0	0	0	0	1	0	0	0	0	0	CHP ON STOP

ADDITIONAL COMMENT LINES

LOCATION, AT PICCO/CENTINELLA BRIDGE

TAPE NO. 74100713 TRAFFIC CODE = 4 FROM 6:30: 0  
TH 9:30: 0

INCIDENT LOCATION: SM 2W TO SM 1W

AFFECTED SEGMENTS: 2

SEGMENT(1) SM 4W TO SM 1W SEGMENT(2) SM 1E TO SM 3E

INCIDENT TYPE: DISL

VEHICLES INVOLVED: 1  
LIGHT DUTY VEHICLES = 1 LIGHT TRUCKS = 0 HEAVY TRUCKS = 0

WEATHER AND ROAD CODES  
WEATHER = C VISIBILITY = 0 PAVEMENT = 0

DETECTION AND VERIFICATION  
DETECTED AT 0: 0: 0 BY CODE  
VERIFIED AT 7:13: 0 BY CODE V

LAND MARKS  
SIGN = 0 CALL BOX = 0  
LOOP STATION = 0 POST MILE = 2.25

INCIDENT FREEWAY GEOMETRY

	M	1	2	3	4	5	6	S	R	S	C	C	S	COMMENTS
GEOMETRY	1	1	1	1	0	0	0	1	1	0	0	0	0	

INCIDENT SCENARIO/EVENT TIMES

TIME	M	1	2	3	4	5	6	S	R	S	C	C	S	COMMENTS
7:13: 0	0	0	0	0	0	0	0	1	0	0	0	0	0	

TAPE NO. 74100714 / TRAFFIC CODE = 4 FROM 6:30:0  
TO 9:30:0

INCIDENT LOCATION: SM 7W TO SM 6W

AFFECTED SEGMENTS: 2

SEGMENT(1) SM 9W TO SM 3W SEGMENT(2) SM 5E TO SM 8E

INCIDENT TYPE: GAWK

VEHICLES INVOLVED: 0

LIGHT DUTY VEHICLES = 0 LIGHT TRUCKS = 0 HEAVY TRUCKS = 0

WEATHER AND ROAD CODES  
WEATHER = L VISIBILITY = 0 PAVEMENT = W

DETECTION AND VERIFICATION

DETECTED AT 0:0:0 BY CODE

VERIFIED AT 7:34:0 BY CODE V

LAND MARKS

SIGN = 0 CALL BOX = 0  
LOOP STATION = 0 POST MILE = 4.13

INCIDENT FREEWAY GEOMETRY

	M	1	2	3	4	5	6	S	R	S	C	C	S	COMMENTS
GEOMETRY	1	1	1	1	1	0	0	1	1	1	0	0	0	

INCIDENT SCENARIO/EVENT TIMES

TIME	M	1	2	3	4	5	6	S	R	S	C	C	S	COMMENTS
7:34:0	0	0	0	0	0	0	0	1	0	0	0	0	0	MAINTENANCE CREW
7:55:0	0	0	0	0	0	0	0	0	0	0	0	0	0	NOW AT DORCHESTER
8:14:0	0	0	0	0	0	0	0	0	0	0	0	0	0	EXP DORCHESTER
8:56:0	0	0	0	0	0	0	0	0	0	0	0	0	0	EXP DORCHESTER



TAPE NO. 74100715 TRAFFIC CODE = 1 FROM 6:30:0  
 TO 9:30:0

INCIDENT LOCATION: SM11E TO SM12E

AFFECTED SEGMENTS: 2

SEGMENT(1) SM 8E TO SM14E SEGMENT(2) SM13E TO SM10W

INCIDENT TYPE: DISL

VEHICLES INVOLVED: 1  
 LIGHT DUTY VEHICLES = 1 LIGHT TRUCKS = 0 HEAVY TRUCKS = 0

WEATHER AND ROAD CODES  
 WEATHER = L VISIBILITY = 0 PAVEMENT = W

DETECTION AND VERIFICATION  
 DETECTED AT 0: 0: 0 BY CODE  
 VERIFIED AT 8: 8: 0 BY CODE V

LAND MARKS  
 SIGN = 0 CALL BOX = 0  
 LOOP STATION = 0 POST MILE = 5+38

INCIDENT FREEWAY GEOMETRY

	M	1	2	3	4	5	6	S	R	S	C	C	S	COMMENTS
GEOMETRY	1	1	1	1	1	0	0	0	0	0	1	0	1	

INCIDENT SCENARIO EVENT TIMES

TIME	M	1	2	3	4	5	6	S	R	S	C	C	S	COMMENTS
8: 8: 0	0	0	0	0	0	0	0	0	0	0	0	0	1	
8:17: 0	0	0	0	0	0	0	0	0	0	0	0	0	1	

TAPE NO. 74100716 TRAFFIC CODE = 3 FROM 8:30: 0  
TO 9:30: 0

INCIDENT LOCATION: SM10W TO SM 9W

AFFECTED SEGMENTS: 2

SEGMENT(1) SM13W TO SM 6W SEGMENT(2) SM 8E TO SM11E

INCIDENT TYPE: DISL

VEHICLES INVOLVED: 1

LIGHT DUTY VEHICLES = 1 LIGHT TRUCKS = 0 HEAVY TRUCKS = 0

WEATHER AND ROAD CODES

WEATHER = L

VISIBILITY = 0

PAVEMENT = W

DETECTION AND VERIFICATION

DETECTED AT 0: 0: 0 BY CODE

VERIFIED AT 8:24: 0 BY CODE V

LAND MARKS

SIGN = 0

CALL BOX = 0

LOOP STATION = 0

POST MILE = 5.53

INCIDENT FREEWAY GEOMETRY

	M	1	2	3	4	5	6	S	R	S	C	C	S	COMMENTS
GEOMETRY	1	1	1	1	0	0	0	1	1	1	0	0	1	SHO RMP SHO, SRMP SHO

INCIDENT SCENARIO & EVENT TIMES

TIME	M	1	2	3	4	5	6	S	R	S	C	C	S	COMMENTS
8:24: 0	0	0	0	0	0	0	0	1	0	0	0	0	0	
8:56: 0	0	0	0	0	0	0	0	1	0	0	0	0	0	

TAPE NO. 74100717 TRAFFIC CODE = 1 FROM 6:30: 0  
TO 9:30: 0

INCIDENT LOCATION: SM10E TO SM11E

AFFECTED SEGMENTS: 2

SEGMENT(1) SM 7E TO SM13E SEGMENT(2) SM12W TO SM 9W

INCIDENT TYPE: DISL

VEHICLES INVOLVED: 1

LIGHT DUTY VEHICLES = 1 LIGHT TRUCKS = 0 HEAVY TRUCKS = 0

WEATHER = L WEATHER AND ROAD CODES VISIBILITY = 0 PAVEMENT = W

DETECTION AND VERIFICATION

DETECTED AT 0: 0: 0 BY CODE  
VERIFIED AT 8:21: 0 BY CODE V

LAND MARKS

SIGN = 0 CALL BOX = SM148  
LOOP STATION = 0 POST MILE = 5.94

INCIDENT FREEWAY GEOMETRY

	M	1	2	3	4	5	6	S	R	S	C	C	S	COMMENTS
GEOMETRY	1	1	1	1	0	0	0	0	0	0	1	1	1	

INCIDENT SCENARIO EVENT TIMES

TIME	M	1	2	3	4	5	6	S	R	S	C	C	S	COMMENTS
8:29: 0	0	0	0	0	0	0	0	0	0	0	0	0	1	DRIVER USING CALLBOX
8:45: 0	0	0	0	0	0	0	0	0	0	0	0	0	1	

TAPE NO. 74100716 TRAFFIC CODE = 2 FROM 15:15:0  
TO 17:30:0

INCIDENT LOCATION: SM21E TO SM22E

AFFECTED SEGMENTS: 2

SEGMENT(1) SM11E TO SM27E SEGMENT(2) SM25W TO SM18W

INCIDENT TYPE: DISL

VEHICLES INVOLVED: 1

LIGHT DUTY VEHICLES = 1 LIGHT TRUCKS = 0 HEAVY TRUCKS = 0

WEATHER AND ROAD CODES  
WEATHER = C VISIBILITY = 0 PAVEMENT = 0

DETECTION AND VERIFICATION  
DETECTED AT 15:51:40 BY CODE S  
VERIFIED AT 15:52:0 BY CODE C

LAND MARKS  
SIGN = 0 CALL BOX = 0  
LOOP STATION = 0 POST MILE = 11.39

INCIDENT FREEWAY GEOMETRY

	M	1	2	3	4	5	6	S	R	S	C	C	S	COMMENTS
GEOMETRY	1	1	1	1	1	1	0	1	0	0	0	0	0	

INCIDENT SCENARIO/EVENT TIMES

TIME	M	1	2	3	4	5	6	S	R	S	C	C	S	COMMENTS
15:52:0	0	0	0	0	0	0	0	0	0	0	0	0	0	CHP REPTS # 1125
15:54:0	0	0	0	0	0	1	0	1	0	0	0	0	0	VPU CONFIRMS DISL #5

TAPE NO. 74100719      TRAFFIC CODE = 1      FROM 15:30: 0  
 TO      17:10: 0

INCIDENT LOCATION: SM22W TO SM21W

AFFECTED SEGMENTS: 2

SEGMENT(1) SM22W TO SM16W      SEGMENT(2) SM19E TO SM24E

INCIDENT TYPE: 100L

VEHICLES INVOLVED: 2  
 LIGHT DUTY VEHICLES = 2    LIGHT TRUCKS = 0    HEAVY TRUCKS = 0

WEATHER AND ROAD CODES  
 WEATHER = C      VISIBILITY = 0      PAVEMENT = 0

DETECTION AND VERIFICATION  
 DETECTED AT 0: 0: 0 BY CODE  
 VERIFIED AT 16: 5: 0 BY CODE V

LAND MARKS  
 SIGN = 0      CALL BOX = 0  
 LOOP STATION = 0      POST MILE = 11.8

INCIDENT FREEWAY GEOMETRY

	M	1	2	3	4	5	6	S	R	S	C	C	S	COMMENTS
GEOMETRY	1	1	1	1	1	1	0	1	0	0	0	0	0	

INCIDENT SCENARIO/AE EVENT TIMES

TIME	M	1	2	3	4	5	6	S	R	S	C	C	S	COMMENTS
16: 5: 0	0	0	0	0	0	0	1	0	0	0	0	0	0	2VPHS/35 LANE
16:14: 0	0	0	0	0	0	0	0	0	0	0	0	0	0	CHP UNABLE TO LOCATE
16:15: 0	0	0	0	0	0	0	0	0	0	0	0	0	0	VPO CONFIRM UTL/TRAF
16:15: 0	0	0	0	0	0	0	0	0	0	0	0	0	0	FREE FLOWING

TAPE NO. 74100720 TRAFFIC CODE = 2 FROM 16: 0: 0

TO 16: 0: 0

INCIDENT LOCATION: SM22E TO SM23E

AFFECTED SEGMENTS: 2

SEGMENT(1) SM18E TO SM27E SEGMENT(2) SM24W TO SM21W

INCIDENT TYPE: DISL

VEHICLES INVOLVED: 1

LIGHT DUTY VEHICLES = 1 LIGHT TRUCKS = 0 HEAVY TRUCKS = 0

WEATHER AND ROAD CODES

WEATHER = C

VISIBILITY = 0

PAVEMENT = 0

DETECTION AND VERIFICATION

DETECTED AT 0: 0: 0 BY CODE

VERIFIED AT 16:58: 0 BY CODE V

LAND MARKS

SIGN = 0

CALL BOX = 0

LUMP STATION = 0

POST MILE = 11.86

INCIDENT FREEWAY GEOMETRY

	M	1	2	3	4	5	6	S	R	S	C	C	S	COMMENTS
GEOMETRY	1	1	1	1	1	1	1	0	0	0	0	0	0	

INCIDENT SCENARIO/EVENT TIMES

TIME	M	1	2	3	4	5	6	S	R	S	C	C	S	COMMENTS
16:58: 0	0	0	0	0	0	0	0	1	0	0	0	0	0	DISL #6LANE
16:59: 0	0	0	0	0	0	0	0	1	0	0	0	0	0	CHP PUSHING OFF FWY
17: 1: 0	0	0	0	0	0	0	0	0	0	0	0	0	0	CLEAR

TAPE NO. 74100801 TRAFFIC CODE = 2 FROM 8:30:0  
TO 10:40:0

INCIDENT LOCATION: SD31N TO SD32N

AFFECTED SEGMENTS: 2

SEGMENT(1) SD24N TO SD32N SEGMENT(2) SD32S TO SD24S

INCIDENT TYPE: OISL

VEHICLES INVOLVED: 1

LIGHT DUTY VEHICLES = 1 LIGHT TRUCKS = 0 HEAVY TRUCKS = 0

WEATHER AND ROAD CODES

WEATHER = C

VISIBILITY = 0

PAVEMENT = 0

DETECTION AND VERIFICATION

DETECTED AT 0:00:0 BY CODE

VERIFIED AT 8:27:0 BY CODE V

LAND MARKS

SIGN = 0

CALL BOX = SD374

LOOP STATION = 0

POST MILE = 28.67

INCIDENT FREEWAY GEOMETRY

	M	1	2	3	4	5	6	S	R	S	C	C	S	COMMENTS
GEOMETRY	1	1	1	1	1	0	0	1	0	0	0	0	0	

INCIDENT SCENARIO/EVENT TIMES

TIME	M	1	2	3	4	5	6	S	R	S	C	C	S	COMMENTS
8:27:0	0	0	0	0	0	0	0	1	0	0	0	0	0	2 VEH'S, 1 ASST'ING
8:34:0	0	0	0	0	0	0	0	1	0	0	0	0	0	ASST'ING VEH 1098
8:40:0	0	0	0	0	0	0	0	1	0	0	0	0	0	DRIVER BACK w/GAS
8:52:0	0	0	0	0	0	0	0	0	0	0	0	0	0	ROADWAY CLEAR

ADDITIONAL COMMENT LINES

FULL COUNT INCIDENT

TAPE NO. 74100802      TRAFFIC CODE = 3      FROM 6:30: 0  
TO 10:40: 0

INCIDENT LOCATION: SD30S TO SD29S

AFFECTED SEGMENTS: 2

SEGMENT(1) SD32S TO SD24S      SEGMENT(2) SD24W TO SD32W

INCIDENT TYPE: DISL

VEHICLES INVOLVED: 1  
LIGHT DUTY VEHICLES = 1    LIGHT TRUCKS = 0    HEAVY TRUCKS = 0

WEATHER = C      WEATHER AND ROAD CODES  
VISIBILITY = 0      PAVEMENT = 0

DETECTION AND VERIFICATION  
DETECTED AT 0: 0: 0 BY CODE  
VERIFIED AT 9:22: 0 BY CODE V

LAND MARKS  
SIGN = 0      CALL BOX = 0  
LOOP STATION = 0      POST MILE = 27.41

INCIDENT FREEWAY GEOMETRY

	M	1	2	3	4	5	6	S	R	S	C	C	S	COMMENTS
GEOMETRY	1	1	1	1	1	0	0	1	0	0	0	0	0	

INCIDENT SCENARIO&EVENT TIMES

TIME	M	1	2	3	4	5	6	S	R	S	C	C	S	COMMENTS
9:22: 0	0	0	0	0	0	0	0	1	0	0	0	0	0	
9:33: 0	0	0	0	0	0	0	0	0	0	0	0	0	0	ROADWAY CLEAR

ADDITIONAL COMMENT LINES

FULL COUNT INCIDENT



TAPE NO. 74100809 TRAFFIC CODE = 3 FROM 6:30: 0  
TO 10:40: 0

INCIDENT LOCATION: SD26N TO SD27N

AFFECTED SEGMENTS: 2

SEGMENT(1) SD24N TO SD32N SEGMENT(2) SD32S TO SD24S

INCIDENT TYPE: DISL

VEHICLES INVOLVED: 2  
LIGHT DUTY VEHICLES = 2 LIGHT TRUCKS = 0 HEAVY TRUCKS = 0

WEATHER = C WEATHER AND ROAD CODES  
VISIBILITY = 0 PAVEMENT = 0

DETECTION AND VERIFICATION  
DETECTED AT 0: 0: 0 BY CODE  
VERIFIED AT 9:22: 0 BY CODE V

LAND MARKS  
SIGN = 0 CALL BOX = 0  
LOOP STATION = 0 POST MILE = 25+95

INCIDENT FREEWAY GEOMETRY

	M	1	2	3	4	5	6	S	R	S	C	C	S	COMMENTS
GEOMETRY	1	1	1	1	1	0	0	1	1	0	1	1	1	

INCIDENT SCENARIO/EVENT TIMES

TIME	M	1	2	3	4	5	6	S	R	S	C	C	S	COMMENTS
9:22: 0	0	0	0	0	0	0	0	1	0	0	0	0	0	VEH & CHP
9:25: 0	0	0	0	0	0	0	0	0	0	0	0	0	0	ROADWAY CLEAR

ADDITIONAL COMMENT LINES

LOCATION, AT MARINA FREEWAY  
FULL COUNT INCIDENT

TAPE NO. 74100804 TRAFFIC CODE = 3 FROM 6:30: 0  
TO 10:40: 0

INCIDENT LOCATION: SD32S TO SD22S

AFFECTED SEGMENTS: 2

SEGMENT(1) SD32S TO SD 1S SEGMENT(2) SD24N TO SD32N

INCIDENT TYPE: GAWK

VEHICLES INVOLVED: 0

LIGHT DUTY VEHICLES = 0 LIGHT TRUCKS = 0 HEAVY TRUCKS = 0

WEATHER AND ROAD CODES  
WEATHER = C VISIBILITY = 0 PAVEMENT = D

DETECTION AND VERIFICATION

DETECTED AT 9:44: 0 BY CODE S

VERIFIED AT 9:45: 0 BY CODE V

LAND MARKS

SIGN = 0 CALL BOX = 0  
LOOP STATION = SD32S POST MILE = 0. 0

INCIDENT FREEWAY GEOMETRY

	M	1	2	3	4	5	6	S	R	S	C	C	S	COMMENTS
GEOMETRY	1	1	1	1	1	0	0	1	0	0	0	0	0	

INCIDENT SCENARIO EVENT TIMES

TIME	M	1	2	3	4	5	6	S	R	S	C	C	S	COMMENTS
9:45: 0	0	0	1	1	0	0	0	0	0	0	0	0	0	FUNERAL PROCESSION
10: 0: 0	0	0	0	0	0	0	0	0	0	0	0	0	0	EXIT AT MANCHESTER

ADDITIONAL COMMENT LINES

FULL COUNT INCIDENT

TAPE NO. 74100809 TRAFFIC CODE = 2 FROM 15:15: 0  
TO 18:15: 0

INCIDENT LOCATION: SD29N TO SD30N

AFFECTED SEGMENTS: 2

SEGMENT(1) SD24N TO SD32N SEGMENT(2) SD32S TO SD24S

INCIDENT TYPE: DISL

VEHICLES INVOLVED: 1

LIGHT DUTY VEHICLES = 0 LIGHT TRUCKS = 0 HEAVY TRUCKS = 1

WEATHER = C WEATHER AND ROAD CODES  
VISIBILITY = H PAVEMENT = D

DETECTION AND VERIFICATION

DETECTED AT 0: 0: 0 BY CODE  
VERIFIED AT 17:13: 0 BY CODE V

LAND MARKS

SIGN = 0 CALL BOX = 0  
LOOP STATION = 0 POST MILE = 27.51

INCIDENT FREEWAY GEOMETRY

	M	1	2	3	4	5	6	S	R	S	C	C	S	COMMENTS
GEOMETRY	1	1	1	1	1	1	0	1	0	0	0	0	0	

INCIDENT SCENARIO/EVENT TIMES

TIME	M	1	2	3	4	5	6	S	R	S	C	C	S	COMMENTS
17:13: 0	0	0	0	0	0	0	0	1	0	0	0	0	0	
17:20: 0	0	0	0	0	0	0	0	0	0	0	0	0	0	ROADWAY CLEAR

ADDITIONAL COMMENT LINES

LOCATION, POST MILE, 02750, PER DBT  
LOCATION, CALL BOX 364, PER TSC  
FULL COUNT INCIDENT

T&PE NR. 74100805 TRAFFIC CODE = 2 FROM 15:16: 0  
TO 18:15: 0

INCIDENT LOCATION: SD29N TO SD30N

AFFECTED SEGMENTS: 2

SEGMENT(1) SD24N TH SD32N SEGMENT(2) SD32S TH SD24S

INCIDENT TYPE: DISL

VEHICLES INVOLVED: 1  
LIGHT DUTY VEHICLES = 1 LIGHT TRUCKS = 0 HEAVY TRUCKS = 0

WEATHER AND ROAD CODES  
WEATHER = C VISIBILITY = H PAVEMENT = D

DETECTION AND VERIFICATION  
DETECTED AT 0: 0: 0 BY CODE  
VERIFIED AT 17:13: 0 BY CODE V

LAND MARKS  
SIGN = 0 CALL BOX = 0  
LOOP STATION = 0 POST MILE = 27.50

INCIDENT FREEWAY GEOMETRY

	M	1	2	3	4	5	6	S	R	S	C	C	S	COMMENTS
GEOMETRY	1	1	1	1	1	0	0	1	0	0	0	0	0	

INCIDENT SCENARIO EVENT TIMES

TIME	M	1	2	3	4	5	6	S	R	S	C	C	S	COMMENTS
17:13: 0	0	0	0	0	0	0	0	1	0	0	0	0	0	
17:20: 0	0	0	0	0	0	0	0	0	0	0	0	0	0	ROADWAY CLEAR

ADDITIONAL COMMENT LINES

LOCATION, POST MILE 27.50/DUT  
LOCATION, CALL BOX 364/TSC  
FULL COUNT INCIDENT

TAPE NO. 74100806 TRAFFIC CODE = 3 FROM 18:15: 0  
TO 19:10: 0

INCIDENT LOCATION: SD32S TO SD2+S

AFFECTED SEGMENTS: 2

SEGMENT(1) SD32S TO SD2+S SEGMENT(2) SD24N TO SD32N

INCIDENT TYPE: SPIL

VEHICLES INVOLVED: 0  
LIGHT DUTY VEHICLES = 0 LIGHT TRUCKS = 0 HEAVY TRUCKS = 0

WEATHER = C WEATHER AND ROAD CODES  
VISIBILITY = H PAVEMENT = 0

DETECTION AND VERIFICATION  
DETECTED AT 0: 0: 0 BY CODE  
VERIFIED AT 18: 9: 0 BY CODE V

SIGN = 0 LAND MARKS  
LOOP STATION = 0 CALL BOX = 0  
POST MILE = 28.7

INCIDENT FREEWAY GEOMETRY

	M	1	2	3	4	5	6	S	R	S	C	C	S	COMMENTS
GEOMETRY	1	1	1	1	1	0	0	1	0	0	0	0	0	

INCIDENT SCENARIO/EVENT TIMES

TIME	M	1	2	3	4	5	6	S	R	S	C	C	S	COMMENTS
18: 9: 0	0	0	0	1	1	0	0	0	0	0	0	0	0	SCRAP METAL
18:29: 0	0	0	0	0	0	0	0	0	0	0	0	0	0	METAL REMOVED
18:30: 0	0	0	0	0	0	0	0	0	0	0	0	0	0	ROADWAY CLEAR

ADDITIONAL COMMENT LINES

FULL COUNT INCIDENT

TAPE NO. 7410080/ TRAFFIC CODE = 3 FROM 6:30: 0  
TO 9:30: 0

INCIDENT LOCATION: SM 9W TO SM 8W

AFFECTED SEGMENTS: 2

SEGMENT(1) SM15W TO SM 5W SEGMENT(2) SM 7E TO SM10E

INCIDENT TYPE: DISL

VEHICLES INVOLVED: 1  
LIGHT DUTY VEHICLES = 1 LIGHT TRUCKS = 0 HEAVY TRUCKS = 0

WEATHER = C WEATHER AND ROAD CODES  
VISIBILITY = 0 PAVEMENT = 0

DETECTION AND VERIFICATION  
DETECTED AT 0: 0: 0 BY CODE  
VERIFIED AT 8:16: 0 BY CODE V

LAND MARKS  
SIGN = 0 CALL BOX = 0  
LOOP STATION = 0 POST MILE = 5.7

INCIDENT FREEWAY GEOMETRY

	M	1	2	3	4	5	6	S	R	S	C	C	S	COMMENTS
GEOMETRY	1	1	1	1	1	0	0	0	0	0	1	0	1	

INCIDENT SCENARIO & EVENT TIMES

TIME	M	1	2	3	4	5	6	S	R	S	C	C	S	COMMENTS
8:16: 0	1	0	0	0	0	0	0	0	0	0	0	0	0	DISL/MED. LADY DRIVER
8:16: 0	0	0	0	0	0	0	0	0	0	0	0	0	0	OUTSIDE CAR, HOOD UP

TAPE NO. 74100808      TRAFFIC CODE = 2      FROM 6:30: 0  
 TO 9:30: 0

INCIDENT LOCATION: SD23N TO SD244

AFFECTED SEGMENTS: 2

SEGMENT(1) SD20N TO SD28N      SEGMENT(2) SD25S TO SD22S

INCIDENT TYPE: GAWK

VEHICLES INVOLVED: 2

LIGHT DUTY VEHICLES = 2    LIGHT TRUCKS = 0    HEAVY TRUCKS = 0

WEATHER = C      WEATHER AND ROAD CODES  
 VISIBILITY = 0      PAVEMENT = 0

DETECTION AND VERIFICATION

DETECTED AT 0: 0: 0 BY CODE  
 VERIFIED AT 8:45: 0 BY CODE V

LAND MARKS

SIGN = 0      CALL BOX = 0  
 LOOP STATION = 0      POST MILE = 24.53

INCIDENT FREEWAY GEOMETRY

	M	1	2	3	4	5	6	S	H	S	C	C	S	COMMENTS
GEOMETRY	1	1	1	1	1	0	0	1	0	0	0	0	0	

INCIDENT SCENARIO/AEVENT TIMES

TIME	M	1	2	3	4	5	6	S	H	S	C	C	S	COMMENTS
8:45: 0	0	0	0	0	0	0	0	1	0	0	0	0	0	CHP & VEH R/S
8:51: 0	0	0	0	0	0	0	0	0	0	0	0	0	0	VEH GONE, CHP STILL

TAPE NO. 74100809 TRAFFIC CODE = 2 FROM 8:45: 0  
TO 10:40: 0

INCIDENT LOCATION: SD27N TO SD28N

AFFECTED SEGMENTS: 2

SEGMENT(1) SD24N TO SD32N SEGMENT(2) SD32S TO SD24S

INCIDENT TYPE: DISL

VEHICLES INVOLVED: 1

LIGHT DUTY VEHICLES = 1 LIGHT TRUCKS = 0 HEAVY TRUCKS = 0

WEATHER AND ROAD CODES

WEATHER = C

VISIBILITY = 0

PAVEMENT = 0

DETECTION AND VERIFICATION

DETECTED AT 0: 0: 0 BY CODE

VERIFIED AT 9:30: 0 BY CODE Y

LAND MARKS

SIGN = 0

CALL BOX = 0

LOOP STATION = 0

POST MILE = 26.6

INCIDENT FREEWAY GEOMETRY

	M	1	2	3	4	5	6	S	R	S	C	C	S	COMMENTS
GEOMETRY	1	1	1	1	1	0	0	0	0	0	0	0	0	

INCIDENT SCENARIO EVENT TIMES

TIME	M	1	2	3	4	5	6	S	R	S	C	C	S	COMMENTS
9:30: 0	0	0	0	0	0	0	0	1	0	0	0	0	0	DISL R/S
9:32: 0	0	0	0	0	0	0	0	0	0	0	0	0	0	CLEAR

FULL COUNT STATION  
INCIDENT



TAPE NO. 74100810

TRAFFIC CODE = 3

FROM 16:15: 0  
TO 18:15: 0

INCIDENT LOCATION: SM 3W TO SM 2W

AFFECTED SEGMENTS: 2

SEGMENT(1) SM 6W TO SM 1W      SEGMENT(2) SM 1E TO SM 4E

INCIDENT TYPE: DISL

VEHICLES INVOLVED: 1

LIGHT DUTY VEHICLES = 1    LIGHT TRUCKS = 0    HEAVY TRUCKS = 0

WEATHER = C      WEATHER AND ROAD CODES  
VISIBILITY = H      PAVEMENT = 0

DETECTION AND VERIFICATION

DETECTED AT 0: 0: 0 BY CODE  
VERIFIED AT 16:55: 0 BY CODE V

SIGN = 0      LAND MARKS  
LOOP STATION = 0      CALL BOX = 0  
POST MILE = 2+35

INCIDENT FREEWAY GEOMETRY

	M	1	2	3	4	5	6	S	R	S	C	C	S	COMMENTS
GEOMETRY	1	1	1	1	0	0	0	1	1	0	0	0	0	

INCIDENT SCENARIO/EVENT TIMES

TIME	M	1	2	3	4	5	6	S	R	S	C	C	S	COMMENTS
16:55: 0	0	0	0	0	0	0	0	0	1	0	0	0	0	DISL, LINCOLN OFF
16:56: 0	0	0	0	0	0	0	0	0	1	0	0	0	0	CHP 10-97
17:13: 0	0	0	0	0	0	0	0	0	0	0	0	0	0	CLEAR

TAPE NO. 74100901 TRAFFIC CODE = 1 FROM 6:30:0  
TO 9:30:0

INCIDENT LOCATION: SD29N TO SD30N

AFFECTED SEGMENTS: 2

SEGMENT(1) SD24N TO SD32N SEGMENT(2) SD32S TO SD24S

INCIDENT TYPE: DISL

VEHICLES INVOLVED: 1

LIGHT DUTY VEHICLES = 1 LIGHT TRUCKS = 0 HEAVY TRUCKS = 0

WEATHER AND ROAD CODES  
WEATHER = C VISIBILITY = 0 PAVEMENT = 0

DETECTION AND VERIFICATION

DETECTED AT 0:0:0 BY CODE

VERIFIED AT 7:54:0 BY CODE V

LAND MARKS

SIGN = 0 CALL BOX = SD364  
LOOP STATION = 0 POST MILE = 0.0

INCIDENT FREEWAY GEOMETRY

	H	1	2	3	4	5	6	S	R	S	C	C	S	COMMENTS
GEOMETRY	1	1	1	1	1	0	0	1	0	0	0	0	0	

INCIDENT SCENARIO & EVENT TIMES

TIME	H	1	2	3	4	5	6	S	R	S	C	C	S	COMMENTS
7:54:0	0	0	0	0	0	0	0	1	0	0	0	0	0	
8:00:0	0	0	0	0	0	0	0	0	0	0	0	0	0	ROADWAY CLEAR

ADDITIONAL COMMENT LINES

INCIDENT OCCURED AT APPROXIMATELY 07:40  
FULL COUNT INCIDENT

TAPE NO. 74100902 TRAFFIC CODE = 1 FROM 6:30: 0  
TO 9:30: 0

INCIDENT LOCATION: SD27N TO SD28N

AFFECTED SEGMENTS: 2

SEGMENT(1) SD24N TO SD32N SEGMENT(2) SD32S TO SD24S

INCIDENT TYPE: DISL

VEHICLES INVOLVED: 1

LIGHT DUTY VEHICLES = 1 LIGHT TRUCKS = 0 HEAVY TRUCKS = 0

WEATHER = C WEATHER AND ROAD CODES  
VISIBILITY = 0 PAVEMENT = 0

DETECTION AND VERIFICATION

DETECTED AT 0: 0: 0 BY CODE

VERIFIED AT 7:59: 0 BY CODE V

LAND MARKS

SIGN = 0 CALL BOX = 0  
LOOP STATION = SD27N POST MILE = 26.27

INCIDENT FREEWAY GEOMETRY

	M	1	2	3	4	5	6	S	R	S	C	C	S	COMMENTS
GEOMETRY	1	1	1	1	1	0	0	0	1	1	0	0	0	

INCIDENT SCENARIO&EVENT TIMES

TIME	M	1	2	3	4	5	6	S	R	S	C	C	S	COMMENTS
7:59: 0	0	0	0	0	0	0	0	0	0	1	0	0	0	FLAT TIRE
8: 1: 0	0	0	0	0	0	0	0	0	0	1	0	0	0	DRIVER CHANGING TIRE
8: 8: 0	0	0	0	0	0	0	0	0	0	0	0	0	0	ROADWAY CLEAR

ADDITIONAL COMMENT LINES

LOCATION, AT END OF E/B RMP FROM ROUTE 90  
FULL COUNT INCIDENT

TAPE NO. 74100903 TRAFFIC CODE = 1 FROM 6:30: 0  
TO 9:55: 0

INCIDENT LOCATION: SD325 TO SD245

AFFECTED SEGMENTS: 2

SEGMENT(1) SD325 TO SD245 SEGMENT(2) SD245 TO SD325

INCIDENT TYPE: TCBL

VEHICLES INVOLVED: 3  
LIGHT DUTY VEHICLES = 3 LIGHT TRUCKS = 0 HEAVY TRUCKS = 0

WEATHER AND ROAD CODES  
WEATHER = C VISIBILITY = 0 PAVEMENT = 0

DETECTION AND VERIFICATION  
DETECTED AT 8:19: 0 BY CODE S  
VERIFIED AT 8:21: 0 BY CODE V

LAND MARKS  
SIGN = 0 CALL BOX = 0  
LOOP STATION = SD305 ; POST MILE = 25+00

INCIDENT FREEWAY GEOMETRY

	M	1	2	3	4	5	6	S	R	S	C	C	S	COMMENTS
GEOMETRY	1	1	1	1	1	0	0	1	0	0	0	0	0	

INCIDENT SCENARIO/EVENT TIMES

TIME	M	1	2	3	4	5	6	S	R	S	C	C	S	COMMENTS
8:21: 0	0	0	0	0	0	0	0	1	0	0	0	0	0	3 VEH'S
8:29: 0	0	0	0	0	0	0	0	1	0	0	0	0	0	CHP 1097
8:52: 0	0	0	0	0	0	0	0	1	0	0	0	0	0	TBW 1097
9: 2: 0	0	0	0	0	0	0	0	0	0	0	0	0	0	ROADWAY CLEAR

ADDITIONAL COMMENT LINES

LOCATION, AT WESTWOOD CHANNEL  
COMPUTER FLASH AT SD305 NOT BE UNRELATED  
FULL COUNT INCIDENT

TAPE NO. 7410090\* TRAFFIC CODE = 1 FROM 16:15: 0  
 To 18: 0: 0

INCIDENT LOCATION: SM25W TO SM26W

AFFECTED SEGMENTS: 2

SEGMENT(1) SM28W TO SM14W SEGMENT(2) SM24E TO SM27E

INCIDENT TYPE: TCCL

VEHICLES INVOLVED: 2

LIGHT DUTY VEHICLES = 2 LIGHT TRUCKS = 0 HEAVY TRUCKS = 0

WEATHER = C WEATHER AND ROAD CODES  
 VISIBILITY = 5 PAVEMENT = 0

DETECTION AND VERIFICATION

DETECTED AT 16:48:40 BY CODE S  
 VERIFIED AT 16:54: 0 BY CODE V

LAND MARKS

SIGN = 0 CALL BOX = 0  
 LOOP STATION = SM26W POST MILE = 13+28

INCIDENT FREEWAY GEOMETRY

	M	1	2	3	4	5	6	S	R	S	C	C	S	COMMENTS
GEOMETRY	1	1	1	1	1	0	0	0	0	0	0	0	0	

INCIDENT SCENARIO/EVENT TIMES

TIME	M	1	2	3	4	5	6	S	R	S	C	C	S	COMMENTS
16:54: 0	1	1	0	0	0	0	0	0	0	0	0	0	0	
16:56: 0	1	0	0	0	0	0	0	0	0	0	0	0	0	
16:58: 0	0	0	0	0	0	0	0	0	0	0	0	0	0	ROADWAY CLEAR

TAPE NO. 74100906 TRAFFIC CODE = 2 FROM 15:30: 0  
TO 16:30: 0

INCIDENT LOCATION: SD30N TO SD31N

AFFECTED SEGMENTS: 2

SEGMENT(1) SD24N TO SD32N SEGMENT(2) SD32S TO SD24S

INCIDENT TYPE: GAWK

VEHICLES INVOLVED: 0  
LIGHT DUTY VEHICLES = 0 LIGHT TRUCKS = 0 HEAVY TRUCKS = 0

WEATHER AND ROAD CODES  
WEATHER = C VISIBILITY = 5 PAVEMENT = 0

DETECTION AND VERIFICATION  
DETECTED AT 0: 0: 0 BY CODE  
VERIFIED AT 17:23: 0 BY CODE Y

LAND MARKS  
SIGN = 0 CALL BOX = 0  
LOOP STATION = 0 POST MILE = 27.95

INCIDENT FREEWAY GEOMETRY

	M	1	2	3	4	5	6	5	R	5	C	C	S	COMMENTS
GEOMETRY	1	1	1	1	1	0	0	0	0	1	0	0	0	

INCIDENT SCENARIO/EVENT TIMES

TIME	M	1	2	3	4	5	6	5	R	5	C	C	S	COMMENTS
17:23: 0	0	0	0	0	0	0	0	1	0	0	0	0	0	PEDESTRIAN
17:30: 0	0	0	0	0	0	0	0	0	0	0	0	0	0	CLEAR

ADDITIONAL COMMENT LINES

PEDESTRIAN WALKING ON R/S, NO VEHICLE SEEN.

FULL COUNT STATION  
INCIDENT

TAPE NO. 74101002 TRAFFIC CODE = 3 FROM 8:15: 0  
TO 9:25: 0

INCIDENT LOCATION: SD325 TO SD315

AFFECTED SEGMENTS: 2

SEGMENT(1) SD325 TO SD245 SEGMENT(2) SD245 TO SD325

INCIDENT TYPE: DISL

VEHICLES INVOLVED: 1  
LIGHT DUTY VEHICLES = 0 LIGHT TRUCKS = 0 HEAVY TRUCKS = 1

WEATHER AND ROAD CODES  
WEATHER = C VISIBILITY = 0 PAVEMENT = 0

DETECTION AND VERIFICATION  
DETECTED AT 0: 0: 0 BY CODE  
VERIFIED AT 8:56: 0 BY CODE V

LAND MARKS  
SIGN = 0 CALL BOX = 0  
LOMP STATION = 0 POST MILE = 26.69

INCIDENT FREEWAY GEOMETRY

	M	1	2	3	4	5	6	S	R	S	C	C	S	COMMENTS
GEOMETRY	1	1	1	1	1	0	0	1	0	0	0	0	0	

INCIDENT SCENARIO & EVENT TIMES

TIME	M	1	2	3	4	5	6	S	R	S	C	C	S	COMMENTS
8:56: 0	0	0	0	0	0	0	0	1	0	0	0	0	0	SEMI
9: 3: 0	0	0	0	0	0	0	0	0	0	0	0	0	0	ROADWAY CLEAR

ADDITIONAL COMMENT LINES

LOCATION, .3 MILES N/M SD315  
FULL COUNT INCIDENT

TAPE NO. 74101003 TRAFFIC CODE = 1 FROM 15:35: 0  
TO 16:30: 0

INCIDENT LOCATION: SD30N TO SD31N

AFFECTED SEGMENTS: 2

SEGMENT(1) SD24N TO SD32N SEGMENT(2) SD32S TO SD24S

INCIDENT TYPE: DISL

VEHICLES INVOLVED: 1

LIGHT DUTY VEHICLES = 1 LIGHT TRUCKS = 0 HEAVY TRUCKS = 0

WEATHER = C WEATHER AND ROAD CODES  
VISIBILITY = S PAVEMENT = 0

DETECTION AND VERIFICATION

DETECTED AT 0: 0: 0 BY CODE

VERIFIED AT 16: 8: 0 BY CODE V

LAND MARKS

SIGN = 0 CALL BOX = 0  
LOOP STATION = 0 POST MILE = 28+35

INCIDENT FREEWAY GEOMETRY

	M	1	2	3	4	5	6	S	R	S	C	C	S	COMMENTS
GEOMETRY	1	1	1	1	1	0	0	1	0	0	0	0	0	

INCIDENT SCENARIO&EVENT TIMES

TIME	M	1	2	3	4	5	6	S	R	S	C	C	S	COMMENTS
16: 8: 0	0	0	0	0	0	0	0	1	0	0	0	0	0	
16:29: 0	0	0	0	0	0	0	0	1	0	0	0	0	0	TOW 1097
16:37: 0	0	0	0	0	0	0	0	0	0	0	0	0	0	ROADWAY CLEAR

ADDITIONAL COMMENT LINES

LOCATION, +04 MILES N/O VENICE  
FULL COUNT INCIDENT



TAPE NO. 74101004 TRAFFIC CODE = 2 FROM 15:59: 0  
TO 18:30: 0

INCIDENT LOCATION: SD30S TO SD29S

AFFECTED SEGMENTS: 2

SEGMENT(1) SD32S TO SD24S SEGMENT(2) SD24N TO SD32N

INCIDENT TYPE: DISL

VEHICLES INVOLVED: 1

LIGHT DUTY VEHICLES = 1 LIGHT TRUCKS = 0 HEAVY TRUCKS = 0

WEATHER = C WEATHER AND ROAD CODES  
VISIBILITY = S PAVEMENT = D

DETECTION AND VERIFICATION

DETECTED AT 0: 0: 0 BY CODE  
VERIFIED AT 16:11: 0 BY CODE V

LAND MARKS

SIGN = 0 CALL BOX = 0  
LOOP STATION = 0 POST MILE = 27.61

INCIDENT FREEWAY GEOMETRY

	M	1	2	3	4	5	6	S	R	S	C	C	S	COMMENTS
GEOMETRY	1	1	1	1	1	0	0	1	0	0	0	0	0	

INCIDENT SCENARIO & EVENT TIMES

TIME	M	1	2	3	4	5	6	S	R	S	C	C	S	COMMENTS
16:11: 0	0	0	0	0	0	0	0	1	0	0	0	0	0	
16:34: 0	0	0	0	0	0	0	0	1	0	0	0	0	0	TRK 1097
16:37: 0	0	0	0	0	0	0	0	0	0	0	0	0	0	ROADWAY CLEAR

ADDITIONAL COMMENT LINES

LOCATION, AT WASHINGTON PLACE  
FULL COUNT INCIDENT

TAPE NO. 74101005 TRAFFIC CODE = 2 FROM 15:35: 0  
TO 18:20: 0

INCIDENT LOCATION: SD25N TO SD26N

AFFECTED SEGMENTS: 2

SEGMENT(1) SD24N TO SD32N SEGMENT(2) SD32S TO SD24S

INCIDENT TYPE: DISL

VEHICLES INVOLVED: 1

LIGHT DUTY VEHICLES = 1 LIGHT TRUCKS = 0 HEAVY TRUCKS = 0

WEATHER AND ROAD CODES  
WEATHER = C VISIBILITY = 5 PAVEMENT = 0

DETECTION AND VERIFICATION

DETECTED AT 0: 0: 0 BY CODE  
VERIFIED AT 16:15: 0 BY CODE V

LAND MARKS

SIGN = 0 CALL BOX = 0  
LOOP STATION = 0 POST MILE = 25+27

INCIDENT FREEWAY GEOMETRY

	M	1	2	3	4	5	6	S	R	S	C	C	S	COMMENTS
GEOMETRY	1	1	1	1	1	0	0	1	0	0	0	0	0	

INCIDENT SCENARIO&EVENT TIMES

TIME	M	1	2	3	4	5	6	S	R	S	C	C	S	COMMENTS
16:15: 0	0	0	0	0	0	0	0	1	0	0	0	0	0	TAGGED BY CHP
16:25: 0	0	0	0	0	0	0	0	1	0	0	0	0	0	TRW 1097
16:30: 0	0	0	0	0	0	0	0	1	0	0	0	0	0	VEH 109K
16:34: 0	0	0	0	0	0	0	0	0	0	0	0	0	0	ROADWAY CLEAR

ADDITIONAL COMMENT LINES

LOCATION, AT CENTURY BRIDGE  
FULL COUNT INCIDENT

TAPE NO. 74101006 TRAFFIC CODE = 3 FROM 16:35: 0  
TO 16:30: 0

INCIDENT LOCATION: SD26N TO SD27N

AFFECTED SEGMENTS: 2

SEGMENT(1) SD24N TO SD32N SEGMENT(2) SD32S TO SD24S

INCIDENT TYPE: DISL

VEHICLES INVOLVED: 1  
LIGHT DUTY VEHICLES = 0 LIGHT TRUCKS = 0 HEAVY TRUCKS = 1

WEATHER AND ROAD CODES  
WEATHER = C VISIBILITY = S PAVEMENT = D

DETECTION AND VERIFICATION  
DETECTED AT 0: 0: 0 BY CODE  
VERIFIED AT 16:29: 0 BY CODE V

LAND MARKS  
SIGN = 0 CALL BOX = 0  
LOOP STATION = 0 POST MILE = 25.95

INCIDENT FREEWAY GEOMETRY

	M	1	2	3	4	5	6	S	R	S	C	C	S	COMMENTS
GEOMETRY	1	1	1	1	1	0	0	1	0	0	0	0	0	

INCIDENT SCENARIO&EVENT TIMES

TIME	M	1	2	3	4	5	6	S	R	S	C	C	S	COMMENTS
16:29: 0	0	0	0	0	0	0	0	1	0	0	0	0	0	TRUCK-TRAILER
16:34: 0	0	0	0	0	0	0	0	0	0	0	0	0	0	ROADWAY CLEAR

ADDITIONAL COMMENT LINES

LOCATION UNDER MARINA FREEWAY  
FULL COUNT INCIDENT

TAPE NO. 74101007 TRAFFIC CODE = 1 FROM 15:35: 0  
TO 16:30: 0

INCIDENT LOCATION: SD31N TO SD32N

AFFECTED SEGMENTS: 2

SEGMENT(1) SD24N TO SD32N SEGMENT(2) SD32S TO SD24S

INCIDENT TYPE: DISL

VEHICLES INVOLVED: 1

LIGHT DUTY VEHICLES = 1 LIGHT TRUCKS = 0 HEAVY TRUCKS = 0

WEATHER AND ROAD CODES

WEATHER = C VISIBILITY = S PAVEMENT = D

DETECTION AND VERIFICATION

DETECTED AT 0: 0: 0 BY CODE

VERIFIED AT 17:31: 0 BY CODE V

LAND MARKS

SIGN = 0 CALL BOX = 0  
LOOP STATION = 0 POST MILE = 28.96

INCIDENT FREEWAY GEOMETRY

	M	1	2	3	4	5	6	S	R	S	C	C	S	COMMENTS
GEOMETRY	1	1	1	1	1	0	0	1	0	1	0	0	0	

INCIDENT SCENARIO&EVENT TIMES

TIME	M	1	2	3	4	5	6	S	R	S	C	C	S	COMMENTS
17:33: 0	0	0	0	0	0	0	0	1	0	0	0	0	0	
17:41: 0	0	0	0	0	0	0	0	0	0	0	0	0	0	ROADWAY CLEAR

ADDITIONAL COMMENT LINES

LOCATION, +2 MILES S/W NATIONAL BL.  
FULL COUNT INCIDENT

TAPE NO. 74101008 TRAFFIC CODE = 3 FROM 15:35: 0  
TO 16:30: 0

INCIDENT LOCATION: SD32S TO SD31S

AFFECTED SEGMENTS: 2

SEGMENT(1) SD32S TO SD24S SEGMENT(2) SD24N TO SD32N

INCIDENT TYPE: DISL

VEHICLES INVOLVED: 1  
LIGHT DUTY VEHICLES = 1 LIGHT TRUCKS = 0 HEAVY TRUCKS = 0

WEATHER AND ROAD CODES  
WEATHER = C VISIBILITY = S PAVEMENT = D

DETECTION AND VERIFICATION  
DETECTED AT 0: 0: 0 BY CODE  
VERIFIED AT 17:50: 0 BY CODE V

LAND MARKS  
SIGN = 0 CALL BOX = 0  
LOOP STATION = 0 POST MILE = 28.46

INCIDENT FREEWAY GEOMETRY

	M	1	2	3	4	5	6	S	R	S	C	C	S	COMMENTS
GEOMETRY	1	1	1	1	1	0	0	1	0	0	0	0	0	

INCIDENT SCENARIO/EVENT TIMES

TIME	M	1	2	3	4	5	6	S	R	S	C	C	S	COMMENTS
17:50: 0	0	0	0	0	0	0	0	1	0	0	0	0	0	
17:57: 0	0	0	0	0	0	0	0	0	0	0	0	0	0	ROADWAY CLEAR

ADDITIONAL COMMENT LINES

LOCATION, .05 MILES N/B PALMS  
FULL COUNT INCIDENT

TAPE NO. 74101009 TRAFFIC CODE = 1 FROM 16: 0: 0  
TO 18: 0: 0

INCIDENT LOCATION: SM22W TO SM21W

AFFECTED SEGMENTS: 2

SEGMENT(1) SM28W TO SM17W SEGMENT(2) SM20E TO SM23E

INCIDENT TYPE: TCBL

VEHICLES INVOLVED: 2

LIGHT DUTY VEHICLES = 2 LIGHT TRUCKS = 0 HEAVY TRUCKS = 0

WEATHER AND ROAD CODES

WEATHER = C

VISIBILITY = S

PAVEMENT = D

DETECTION AND VERIFICATION

DETECTED AT 16:35:20 BY CODE S

VERIFIED AT 16:31: 0 BY CODE V

LAND MARKS

SIGN = 0

CALL BOX = 0

LBBP STATION = SM22W

POST MILE = 11.39

INCIDENT FREEWAY GEOMETRY

	M	1	2	3	4	5	6	5	R	S	C	C	S	COMMENTS
GEOMETRY	1	1	1	1	1	1	0	1	0	0	0	0	0	

INCIDENT SCENARIO&EVENT TIMES

TIME	M	1	2	3	4	5	6	5	R	S	C	C	S	COMMENTS
16:31: 0	0	0	0	0	0	0	0	1	0	0	0	0	0	
16:37: 0	0	0	0	0	0	0	0	0	0	0	0	0	0	ROADWAY CLEAR

ADDITIONAL COMMENT LINES

LOCATION, AT CRENSHAW

TAPE NO. 74101011 TRAFFIC CODE = 3 FROM 6:30: 0  
TO 9:30: 0

INCIDENT LOCATION: SM 9E TO SM10E

AFFECTED SEGMENTS: 2

SEGMENT(1) SM 4E TO SM14E SEGMENT(2) SM11E TO SM 8W

INCIDENT TYPE: DISL

VEHICLES INVOLVED: 1

LIGHT DUTY VEHICLES = 1 LIGHT TRUCKS = 0 HEAVY TRUCKS = 0

WEATHER AND ROAD CODES

WEATHER = C

VISIBILITY = S

PAVEMENT = 0

DETECTION AND VERIFICATION

DETECTED AT 0: 0: 0 BY CODE

VERIFIED AT 8:45: 0 BY CODE V

LAND MARKS

SIGN = 0

CALL BOX = 0

LOOP STATION = 0

POST MILE = 5.56

INCIDENT FREEWAY GEOMETRY

	M	1	2	3	4	5	6	S	R	S	C	C	S	COMMENTS
GEOMETRY	1	1	1	1	0	0	0	1	0	0	0	0	0	

INCIDENT SCENARIO&EVENT TIMES

TIME	M	1	2	3	4	5	6	S	R	S	C	C	S	COMMENTS
8:45: 0	0	0	0	0	0	0	0	1	0	0	0	0	0	DISL N/S EMERGENCY

ADDITIONAL COMMENT LINES

AT SEPULVEDA UC

TAPE NO. 74101101 TRAFFIC CODE = 2 FROM 6:00:0  
TO 9:30:0

INCIDENT LOCATION: SD27S TO SD26S

AFFECTED SEGMENTS: 2

SEGMENT (1) SD32S TO SD24S SEGMENT (2) SD24N TO SD32N

INCIDENT TYPE: GAWK

VEHICLES INVOLVED: 2

LIGHT DUTY VEHICLES = 2 LIGHT TRUCKS = 0 HEAVY TRUCKS = 0

WEATHER = C WEATHER AND ROAD CODES  
VISIBILITY = 0 PAVEMENT = D

DETECTION AND VERIFICATION

DETECTED AT 0:0:0 BY CODE  
VERIFIED AT 7:10:0 BY CODE V

LAND MARKS

SIGN = 0 CALL BOX = 0  
LOOP STATION = 0 POST MILE = 3+51

INCIDENT FREEWAY GEOMETRY

	M	1	2	3	4	5	6	S	R	S	C	C	S	COMMENTS
GEOMETRY	1	1	1	1	1	0	0	1	1	1	0	0	0	

INCIDENT SCENARIO&EVENT TIMES

TIME	M	1	2	3	4	5	6	S	R	S	C	C	S	COMMENTS
7:10:0	0	0	0	0	0	0	0	1	0	0	0	0	0	CHP ON STOP
7:15:0	0	0	0	0	0	0	0	1	0	0	0	0	0	CHP 1097
7:18:0	0	0	0	0	0	0	0	1	0	0	0	0	0	VEH POSSIBLY DISL
7:27:0	0	0	0	0	0	0	0	1	0	0	0	0	0	TRW 1097
7:31:0	0	0	0	0	0	0	0	0	0	0	0	0	0	ROADWAY CLEAR

ADDITIONAL COMMENT LINES

LOCATION: S/O MARINA FREEWAY  
FULL COUNT INCIDENT



TAPE NO. 74101102 TRAFFIC CODE = 3 FROM 6:30: 0  
TO 9:30: 0

INCIDENT LOCATION: SD27N TO SD29N

AFFECTED SEGMENTS: 2

SEGMENT(1) SD24N TO SD32N SEGMENT(2) SD32S TO SD24S

INCIDENT TYPE: DISL

VEHICLES INVOLVED: 1

LIGHT DUTY VEHICLES = 1 LIGHT TRUCKS = 0 HEAVY TRUCKS = 0

WEATHER AND ROAD CODES  
WEATHER = C VISIBILITY = 0 PAVEMENT = 0

DETECTION AND VERIFICATION

DETECTED AT 0: 0: 0 BY CODE  
VERIFIED AT 7:53: 0 BY CODE V

LAND MARKS

SIGN = 0 CALL BOX = 0  
LOOP STATION = 0 POST MILE = 25.78

INCIDENT FREEWAY GEOMETRY

	M	1	2	3	4	5	6	S	R	S	C	C	S	COMMENTS
GEOMETRY	1	1	1	1	1	0	0	1	1	0	0	0	0	

INCIDENT SCENARIO/EVENT TIMES

TIME	N	1	2	3	4	5	6	S	R	S	C	C	S	COMMENTS
7:53: 0	1	0	0	0	0	0	0	0	0	0	0	0	0	VEH IN N/B MED
8: 0: 0	1	0	0	0	0	0	0	0	0	0	0	0	0	CHP IN S/B MED
8: 8: 0	1	0	0	0	0	0	0	0	0	0	0	0	0	CHP 1098
8:47: 0	1	0	0	0	0	0	0	0	0	0	0	0	0	CHP 1097 N/B MED
8:55: 0	1	0	0	0	0	0	0	0	0	0	0	0	0	CHP 1098
9: 7: 0	0	0	0	0	0	0	0	0	0	0	0	0	0	ROADWAY CLEAR

ADDITIONAL COMMENT LINES

LOCATION, ACROSS FROM NOSE OF CULVER OFF/RMP  
FULL COUNT INCIDENT

TAPE NO. 74101103 TRAFFIC CODE = 1 FROM 6:35: 0

TO 9:30: 0

INCIDENT LOCATION: SD29S TO SD27S

AFFECTED SEGMENTS: 2

SEGMENT(1) SD32S TO SD24S SEGMENT(2) SD24N TO SD32N

INCIDENT TYPE: GAWK

VEHICLES INVOLVED: 3

LIGHT DUTY VEHICLES = 3 LIGHT TRUCKS = 0 HEAVY TRUCKS = 0

WEATHER AND ROAD CODES

WEATHER = C

VISIBILITY = 0

PAVEMENT = 0

DETECTION AND VERIFICATION

DETECTED AT 8: 5:20 BY CODE S

VERIFIED AT 7:53: 0 BY CODE V

LAND MARKS

SIGN = 0

CALL BOX = 0

LOOP STATION = 0

POST MILE = 26.78

INCIDENT FREEWAY GEOMETRY

	M	1	2	3	4	5	6	S	R	S	C	C	S	COMMENTS
GEOMETRY	1	1	1	1	1	0	0	1	1	0	0	0	0	

INCIDENT SCENARIO EVENT TIMES

TIME	M	1	2	3	4	5	6	S	R	S	C	C	S	COMMENTS
7:53: 0	1	0	0	0	0	0	0	0	0	0	0	0	0	VEH IN N/B MED
8: 0: 0	1	0	0	0	0	0	0	0	0	0	0	0	0	CHP IN S/B MED
8: 8: 0	1	0	0	0	0	0	0	0	0	0	0	0	0	CHP 1096
8:47: 0	1	0	0	0	0	0	0	0	0	0	0	0	0	CHP 1097 N/B MED
8:55: 0	1	0	0	0	0	0	0	0	0	0	0	0	0	CHP 1096
9: 7: 0	0	0	0	0	0	0	0	0	0	0	0	0	0	ROADWAY CLEAR

ADDITIONAL COMMENT LINES

LOCATION, ACROSS FROM NOSE OF CULVER OFF/RMP  
FLASH AT SD30S MAY BE UNRELATED  
FULL COUNT INCIDENT

TAPE NO. 74101109 TRAFFIC CODE = 2 FROM 6:30: 0  
TO 9:35: 0

INCIDENT LOCATION: SD26S TO SD24S

AFFECTED SEGMENTS: 2

SEGMENT(1) SD32S TO SD24S SEGMENT(2) SD24N TO SD32N

INCIDENT TYPE: DISL

VEHICLES INVOLVED: 3

LIGHT DUTY VEHICLES = 3 LIGHT TRUCKS = 0 HEAVY TRUCKS = 0

WEATHER = C WEATHER AND ROAD CODES  
VISIBILITY = 0 PAVEMENT = D

DETECTION AND VERIFICATION

DETECTED AT 0: 0: 0 BY CODE

VERIFIED AT 7:55: 0 BY CODE V

LAND MARKS

SIGN = 0 CALL BOX = 0  
LOOP STATION = 02527 POST MILE = 0.

INCIDENT FREEWAY GEOMETRY

GEOMETRY M 1 2 3 4 5 6 5 R S C C S COMMENTS  
1 1 1 1 1 0 0 1 0 0 0 0 0

INCIDENT SCENARIO&EVENT TIMES

TIME	M	1	2	3	4	5	6	5	R	S	C	C	S	COMMENTS
7:55: 0	1	0	0	0	0	0	0	0	0	0	0	0	0	2 VEH'S IN AED
8: 0: 0	1	0	0	0	0	0	0	0	0	0	0	0	0	1 VEH 1098
8: 8: 0	1	0	0	0	0	0	0	0	0	0	0	0	0	VEH ABANDONED
8:14: 0	1	0	0	0	0	0	0	0	0	0	0	0	0	VEH HAS FLAT
8:33: 0	1	0	0	0	0	0	0	0	0	0	0	0	0	3RD VEH IN C/D
8:37: 0	1	0	0	0	0	0	0	0	0	0	0	0	0	TRK 1097 N/E C/D
8:42: 0	1	0	0	0	0	0	0	0	0	0	0	0	0	3RD VEH 1098
8:50: 0	0	0	0	0	0	0	0	0	0	0	0	0	0	ROADWAY CLEAR

ADDITIONAL COMMENT LINES

LOCATION, ON CENTINELLA BRIDGE  
VERY CLOSE TO LOOP STATION 25  
FULL COUNT INCIDENT

TAPE NO. 74101105 TRAFFIC CODE = 3 FROM 8:30: 0  
TO 8:30: 0

INCIDENT LOCATION: SD28N TO SD29N

AFFECTED SEGMENTS: 2

SEGMENT(1) SD24N TO SD32N SEGMENT(2) SD32S TO SD24S

INCIDENT TYPE: DISL

VEHICLES INVOLVED: 1

LIGHT DUTY VEHICLES = 1 LIGHT TRUCKS = 0 HEAVY TRUCKS = 0

WEATHER = C WEATHER AND ROAD CODES  
VISIBILITY = 0 PAVEMENT = L

DETECTION AND VERIFICATION

DETECTED AT 0: 0: 0 BY CODE

VERIFIED AT 8:10: 0 BY CODE Y

LAND MARKS

SIGN = 0 CALL BOX = 0  
LOOP STATION = 0 POST MILE = 27.20

INCIDENT FREEWAY GEOMETRY

	M	1	2	3	4	5	6	S	R	S	C	C	S	COMMENTS
GEOMETRY	1	1	1	1	1	0	0	0	1	1	0	0	0	

INCIDENT SCENARIO/EVENT TIMES

TIME	M	1	2	3	4	5	6	S	R	S	C	C	S	COMMENTS
8:11: 0	1	0	0	0	0	0	0	0	0	0	0	0	0	TAGGED BY DHP
8:29: 0	0	0	0	0	0	0	0	0	0	0	0	0	0	ROADWAY CLEAR

ADDITIONAL COMMENT LINES

LOCATION, AT CULVER  
FULL COUNT INCIDENT

TAPE NO. 74101106 TRAFFIC CODE = 2 FROM 6:30: 0  
TO 9:30: 0

INCIDENT LOCATION: SD27S TO SD26S

AFFECTED SEGMENTS: 2

SEGMENT(1) SD32S TO SD24S SEGMENT(2) SD24N TO SD32N

INCIDENT TYPE: DISL

VEHICLES INVOLVED: 1  
LIGHT DUTY VEHICLES = 1 LIGHT TRUCKS = 0 HEAVY TRUCKS = 0

WEATHER = C WEATHER AND ROAD CODES  
VISIBILITY = 0 PAVEMENT = 0

DETECTION AND VERIFICATION  
DETECTED AT 0: 0: 0 BY CODE  
VERIFIED AT 8:21: 0 BY CODE V

LAND MARKS  
SIGN = 0 CALL BOX = 0  
LOHP STATION = 0 POST MILE = 26+27

INCIDENT FREEWAY GEOMETRY

	M	1	2	3	4	5	6	5	R	S	C	C	S	COMMENTS
GEOMETRY	1	1	1	1	1	0	0	1	1	1	0	0	0	

INCIDENT SCENARIO/EVENT TIMES

TIME	M	1	2	3	4	5	6	5	R	S	C	C	S	COMMENTS
8:21: 0	0	0	0	0	0	0	0	1	0	0	0	0	0	
8:42: 0	0	0	0	0	0	0	0	1	0	0	0	0	0	ABANDONED VEH
8:46: 0	0	0	0	0	0	0	0	1	0	0	0	0	0	PUTTING GAS IN TANK
8:49: 0	0	0	0	0	0	0	0	0	0	0	0	0	0	ROADWAY CLEAR

ADDITIONAL COMMENT LINES

LOCATION, IN CORE AT JEFFERSON OFF/RMP  
FULL COUNT INCIDENT

TAPE NO. 74101107 TRAFFIC CODE = 1 FROM 16:40: 0  
TO 18:30: 0

INCIDENT LOCATION: SD28N TO SD30N

AFFECTED SEGMENTS: 2

SEGMENT(1) SD24N TO SD32N SEGMENT(2) SD32S TO SD24S

INCIDENT TYPE: GAWK

VEHICLES INVOLVED: 0  
LIGHT DUTY VEHICLES = 0 LIGHT TRUCKS = 0 HEAVY TRUCKS = 0

WEATHER AND ROAD CODES  
WEATHER = C VISIBILITY = S PAVEMENT = D

DETECTION AND VERIFICATION  
DETECTED AT 17: 4:20 BY CODE S  
VERIFIED AT 17:14: 0 BY CODE V

LAND MARKS  
SIGN = 0 CALL BOX = 0  
LOOP STATION = 0 POST MILE = 27.38

INCIDENT FREEWAY GEOMETRY

	M	1	2	3	4	5	6	S	R	S	C	C	S	COMMENTS
GEOMETRY	1	1	1	1	1	1	0	1	1	1	0	0	0	

INCIDENT SCENARIO/EVENT TIMES

TIME	M	1	2	3	4	5	6	S	R	S	C	C	S	COMMENTS
17:14: 0	0	0	0	0	0	0	0	1	0	0	0	0	0	DRUNK PED ON RDWAY
17:24: 0	0	0	0	0	0	0	0	0	0	0	0	0	0	ROADWAY CLEAR

ADDITIONAL COMMENT LINES

DRUNK PED WALKING S/B OR N/B SHOULDER  
N/O LOOP STATION 29  
SHAKING FIST AT PASSING MOTORIST  
COMPUTER FLASHED AT 170420 SD29N  
COMPUTER FLASHED AT 171920 SD28N  
FULL COUNT INCIDENT

TAPE NO. 74111402 TRAFFIC CODE = 1 FROM 7:01:0  
 TO 9:15:0

INCIDENT LOCATION: HA18N TO HA20N

AFFECTED SEGMENTS: 2

SEGMENT(1) HA13N TO HA21N SEGMENT(2) HA21S TO HA18S

INCIDENT TYPE: GAWK

VEHICLES INVOLVED: 0  
 LIGHT DUTY VEHICLES = 0 LIGHT TRUCKS = 0 HEAVY TRUCKS = 0

WEATHER AND ROAD CODES  
 WEATHER = C VISIBILITY = 5 PAVEMENT = D

DETECTION AND VERIFICATION  
 DETECTED AT 7:53:20 BY CODE S  
 VERIFIED AT 7:47:0 BY CODE V

LAND MARKS  
 SIGN = 0 CALL BOX = 0  
 LOOP STATION = 0 POST MILE = 18.30

INCIDENT FREEWAY GEOMETRY

	M	1	2	3	4	5	6	S	R	S	C	C	S	COMMENTS
GEOMETRY	1	1	1	1	1	0	0	1	0	0	0	0	0	

INCIDENT SCENARIO EVENT TIMES

TIME	M	1	2	3	4	5	6	S	R	S	C	C	S	COMMENTS
7:47:0	0	0	0	0	0	0	0	1	0	0	0	0	0	DOG
8:10:0	0	0	0	0	0	0	0	0	0	0	0	0	0	N/B RWY CLEAR
8:24:0	0	0	0	0	0	0	0	0	0	0	0	0	0	DOG SEEN ON S/B SIDE
8:34:0	0	0	0	0	0	0	0	0	0	0	0	0	0	DOGGONE

ADDITIONAL COMMENT LINES

DOG APPARENTLY S/B COMPUTER FLASH AT HA18N AT 075320

TAPE NO. 74120502 TRAFFIC CODE = 3 FROM 6:20:0  
TO 8:00:0

INCIDENT LOCATION: SM23W TO SM22W

AFFECTED SEGMENTS: 2

SEGMENT(1) SM28W TO SM19W SEGMENT(2) SM21E TO SM24E

INCIDENT TYPE: DISL

VEHICLES INVOLVED: 1

LIGHT DUTY VEHICLES = 1 LIGHT TRUCKS = 0 HEAVY TRUCKS = 0

WEATHER = C WEATHER AND ROAD CODES  
VISIBILITY = 0 PAVEMENT = P

DETECTION AND VERIFICATION

DETECTED AT 0:00:0 BY CODE

VERIFIED AT 6:57:0 BY CODE V

LAND MARKS

SIGN = 0 CALL BOX = 0  
LOOP STATION = 0 POST MILE = 12.5

INCIDENT FREEWAY GEOMETRY

	M	1	2	3	4	5	6	S	R	S	C	C	S	COMMENTS
GEOMETRY	1	1	1	1	1	1	1	1	0	0	0	0	0	

INCIDENT SCENARIO EVENT TIMES

TIME	M	1	2	3	4	5	6	S	R	S	C	C	S	COMMENTS
6:57:0	0	0	0	0	0	0	1	0	0	0	0	0	0	DISL #6 LANE
7:17:0	0	0	0	0	0	0	0	0	0	0	0	0	0	10=98



TAPE NO. 74120503      TRAFFIC CODE = 2      FROM 7: 0: 0  
 TO 8:45: 0

INCIDENT LOCATION: SM26E TO SM27E

AFFECTED SEGMENTS: 2

SEGMENT(1) SM17E TO SM27E      SEGMENT(2) SM24W TO SM24W

INCIDENT TYPE: DISL

VEHICLES INVOLVED: 0

LIGHT DUTY VEHICLES = 0    LIGHT TRUCKS = 1    HEAVY TRUCKS = 0

WEATHER AND ROAD CODES

WEATHER = C

VISIBILITY = 0

PAVEMENT = F

DETECTION AND VERIFICATION

DETECTED AT 0: 0: 0 BY CODE

VERIFIED AT 7:38: 0 BY CODE V

LAND MARKS

SIGN = 0

CALL BOX = 0

LOOP STATION = 0

POST MILE = 13+8

INCIDENT FREEWAY GEOMETRY

	M	1	2	3	4	5	6	S	R	S	C	C	S	COMMENTS
GEOMETRY	1	1	1	1	1	0	0	1	0	0	0	0	0	

INCIDENT SCENARIO EVENT TIMES

TIME	M	1	2	3	4	5	6	S	R	S	C	C	S	COMMENTS
7:38: 0	1	0	0	0	0	0	0	0	0	0	0	0	0	DISL IN MED.
7:44: 0	1	0	0	0	0	0	0	1	0	0	0	0	0	CHP ON STOP R/S
7:50: 0	0	0	0	0	0	0	0	0	0	0	0	0	0	TRUCK 10-96

TAPE NO. 74120505 TRAFFIC CODE = 1 FROM 7:15: 0  
TO 9:15: 0

INCIDENT LOCATION: SM25E TO SM26F

AFFECTED SEGMENTS: 2

SEGMENT(1) SM20E TO SM27E SEGMENT(2) SM274 TO SM24W

INCIDENT TYPE: DISL

VEHICLES INVOLVED: 1  
LIGHT DUTY VEHICLES = 1 LIGHT TRUCKS = 0 HEAVY TRUCKS = 0

WEATHER AND ROAD CODES  
WEATHER = C VISIBILITY = 0 PAVEMENT = 0

DETECTION AND VERIFICATION  
DETECTED AT 0: 0: 0 BY CODE  
VERIFIED AT 7:56: 0 BY CODE V

LAND MARKS  
SIGN = 0 CALL BOX = 0  
LOOP STATION = 0 POST MILE = 13.23

INCIDENT FREEWAY GEOMETRY

	M	1	2	3	4	5	6	S	R	S	C	C	S	COMMENTS
GEOMETRY	1	1	1	1	1	0	0	1	0	0	1	1	1	

INCIDENT SCENARIO EVENT TIMES

TIME	M	1	2	3	4	5	6	S	R	S	C	C	S	COMMENTS
7:56: 0	0	0	0	0	0	0	0	1	0	0	0	0	0	DISL R/S
8:16: 0	0	0	0	0	0	0	0	0	0	0	0	0	0	TOW 10-97
8:35: 0	0	0	0	0	0	0	0	0	0	0	0	0	0	CLEAR

TAPE NO. 7-120507 TRAFFIC CODE = 1 FROM 7:30:0  
TO 9:55:0

INCIDENT LOCATION: SM25E TO SM26E

AFFECTED SEGMENTS: 2

SEGMENT(1) SM 8E TO SM27E SEGMENT(2) SM27W TO SM24W

INCIDENT TYPE: TCOL

VEHICLES INVOLVED: 2  
LIGHT DUTY VEHICLES = 2 LIGHT TRUCKS = 0 HEAVY TRUCKS = 0

WEATHER AND ROAD CODES  
WEATHER = C VISIBILITY = 0 PAVEMENT = D

DETECTION AND VERIFICATION  
DETECTED AT 8:18:0 BY CODE S  
VERIFIED AT 8:0:0 BY CODE V

LAND MARKS  
SIGN = 0 CALL BOX = 0  
LOOP STATION = 0 POST MILE = 12.98

INCIDENT FREEWAY GEOMETRY

	M	1	2	3	4	5	6	S	R	S	C	C	S	COMMENTS
GEOMETRY	1	1	1	1	1	0	0	1	0	0	1	0	0	

INCIDENT SCENARIO EVENT TIMES

TIME	M	1	2	3	4	5	6	S	R	S	C	C	S	COMMENTS
8:0:0	0	0	0	0	0	0	0	0	0	0	1	0	0	11-82 IN COLLECTOR
8:16:0	0	0	0	0	0	0	0	0	0	0	1	0	1	TOW 10-97, VEH TO R/S
8:33:0	0	0	0	0	0	0	0	0	0	0	0	0	0	CLEAR

TAPE NO. 74120508      TRAFFIC CODE = 1      FROM 7:55: 0  
 TO 9:33: 0

INCIDENT LOCATION: SM16E TO SM18E

AFFECTED SEGMENTS: 2

SEGMENT(1) SM12E TO SM20E      SEGMENT(2) SM18E TO SM15W

INCIDENT TYPE: DISL

VEHICLES INVOLVED: 1  
 LIGHT DUTY VEHICLES = 1    LIGHT TRUCKS = 0    HEAVY TRUCKS = 0

WEATHER = C      WEATHER AND ROAD CODES  
 VISIBILITY = H      PAVEMENT = 0

DETECTION AND VERIFICATION  
 DETECTED AT 0: 0: 0 BY CODE  
 VERIFIED AT 8:30: 0 BY CODE V

LAND MARKS  
 SIGN = 0      CALL BOX = 0  
 LOOP STATION = 0      POST MILE = 9.22

INCIDENT FREEWAY GEOMETRY

	M	1	2	3	4	5	6	5	R	S	C	C	S	COMMENTS
GEOMETRY	1	1	1	1	1	0	0	1	1	0	0	0	0	

INCIDENT SCENARIO EVENT TIMES

TIME	M	1	2	3	4	5	6	5	R	S	C	C	S	COMMENTS
8:30: 0	0	0	0	1	0	0	0	0	0	0	0	0	0	DISL IN *3 LANE
8:32: 0	0	0	0	0	0	0	0	1	0	0	0	0	0	TO R/S
8:42: 0	0	0	0	0	0	0	0	0	0	0	0	0	0	10-98

TAPE NO. 75012301      TRAFFIC CODE = 2      FROM 16:25: 0  
 TO 16:45: 0

INCIDENT LOCATION: SM22W TO SM21W

AFFECTED SEGMENTS: 2

SEGMENT(1) SM28W TO SM19W      SEGMENT(2) SM23E TO SM20E

INCIDENT TYPE: DISL

VEHICLES INVOLVED: 1

LIGHT DUTY VEHICLES = 1    LIGHT TRUCKS = 0    HEAVY TRUCKS = 0

WEATHER = C      WEATHER AND ROAD CODES  
 VISIBILITY = 0      PAVEMENT = 0

DETECTION AND VERIFICATION

DETECTED AT 0: 0: 0 BY CODE  
 VERIFIED AT 16:57: 0 BY CODE V

LAND MARKS

SIGN = 0      CALL BOX = 0  
 LOOP STATION = 0      POST MILE = 10.42

INCIDENT FREEWAY GEOMETRY

	N	1	2	3	4	5	6	S	R	S	C	C	S	COMMENTS
GEOMETRY	1	1	1	1	1	0	0	1	0	0	1	1	0	

INCIDENT SCENARIO EVENT TIMES

TIME	M	1	2	3	4	5	6	S	R	S	C	C	S	COMMENTS
16:57: 0	0	0	0	0	1	0	0	1	0	0	0	0	0	DISL BETWEEN R/SK#4
17: 6: 0	0	0	0	0	1	0	0	1	0	0	0	0	0	PEO. APPROACHING 1125
17:13: 0	0	0	0	0	1	0	0	1	0	0	0	0	0	MTRST HAS FLARES AND
17:13: 0	0	0	0	0	1	0	0	1	0	0	0	0	0	IS FLAGGING TRAFFIC
17:13: 0	0	0	0	0	1	0	0	1	0	0	0	0	0	AROUND
17:18: 0	0	0	0	1	1	0	0	1	0	0	0	0	0	TOW 10-9752 IN CAR
17:18: 0	0	0	0	1	1	0	0	1	0	0	0	0	0	NEXT TO TOW
17:20: 0	0	0	0	0	1	0	0	1	0	0	0	0	0	2ND CAR GONE
17:20: 0	0	0	0	0	0	0	0	0	0	0	0	0	0	TOW LEAVING WITH VEH

TAPE NO. 75012302

TRAFFIC CODE = 2

FROM 16:50:0  
TO 17:45:0

INCIDENT LOCATION: SM23E TO SM24E

AFFECTED SEGMENTS: 2

SEGMENT(1) SM20F TO SM27E      SEGMENT(2) SM25W TO SM22W

INCIDENT TYPE: DISL

VEHICLES INVOLVED: 1  
LIGHT DUTY VEHICLES = 1    LIGHT TRUCKS = 0    HEAVY TRUCKS = 0

WEATHER = C      WEATHER AND ROAD CODES  
                  VISIBILITY = S      PAVEMENT = 0

DETECTION AND VERIFICATION  
DETECTED AT 0: 0: 0 BY CODE  
VERIFIED AT 17: 3: 0 BY CODE V

LAND MARKS  
SIGN = 0      CALL BOX = 0  
LOOP STATION = 0      POST MILE = 12.32

INCIDENT FREEWAY GEOMETRY

	M	1	2	3	4	5	6	S	R	S	C	C	S	COMMENTS
GEOMETRY	1	1	1	1	1	1	0	1	0	0	0	0	0	

INCIDENT SCENARIO EVENT TIMES

TIME	M	1	2	3	4	5	6	S	R	S	C	C	S	COMMENTS
17: 3: 0	0	0	0	0	0	1	0	1	0	0	0	0	0	CHPAVEN, PARTIALLY IN
17: 3: 0	0	0	0	0	0	0	0	0	0	0	0	0	0	#5 LANE
17:10: 0	0	0	0	0	0	0	0	0	0	0	0	0	0	CLEAR

TAPE No. 75012303 TRAFFIC CODE = 1 FROM 16:55: 0

TO 18:40: 0

INCIDENT LOCATION: SM25W TO SM24W

AFFECTED SEGMENTS: 2

SEGMENT(1) SM28W TO SM18W SEGMENT(2) SM23E TO SM26E

INCIDENT TYPE: GAWK

VEHICLES INVOLVED: 2

LIGHT DUTY VEHICLES = 2 LIGHT TRUCKS = 0 HEAVY TRUCKS = 0

WEATHER = C WEATHER AND ROAD CODES  
VISIBILITY = 0 PAVEMENT = D

DETECTION AND VERIFICATION

DETECTED AT 17:27: 0 BY CODE S

VERIFIED AT 17:29: 0 BY CODE V

LAND MARKS

SIGN = 0 CALL BOX = 0  
LOOP STATION = 0 POST MILE = 12.80

INCIDENT FREEWAY GEOMETRY

	M	1	2	3	4	5	6	S	R	S	C	C	S	COMMENTS
GEOMETRY	1	1	1	1	1	0	0	1	0	0	0	0	0	

INCIDENT SCENARIO EVENT TIMES

TIME	H	1	2	3	4	5	6	S	R	S	C	C	S	COMMENTS
17:29: 0	0	0	0	0	0	0	0	1	0	0	0	0	0	CHP&VEH,R/S
17:40: 0	0	0	0	0	0	0	0	0	0	0	0	0	0	CLEAR

TAPE NO. 75012305      TRAFFIC CODE = 1      FROM 17:15: 0  
 TO 19:15: 0

INCIDENT LOCATION: SM23W TO SM22W

AFFECTED SEGMENTS: 2

SEGMENT(1) SM28W TO SM 5W      SEGMENT(2) SM21E TO SM24E

INCIDENT TYPE: DISL

VEHICLES INVOLVED: 1  
 LIGHT DUTY VEHICLES = 1    LIGHT TRUCKS = 0    HEAVY TRUCKS = 0

WEATHER = C      WEATHER AND ROAD CODES  
 VISIBILITY = 0      PAVEMENT = 0

DETECTION AND VERIFICATION  
 DETECTED AT 17:59:20 BY CMDE 5  
 VERIFIED AT 18: 0: 0 BY CODE V

LAND MARKS  
 SIGN = 0      CALL BOX = 0  
 LOOP STATION = 0      POST MILE = 11.97

INCIDENT FREEWAY GEOMETRY

	M	1	2	3	4	5	6	S	R	S	C	C	S	COMMENTS
GEOMETRY	1	1	1	1	1	1	1	1	0	0	0	0	0	

INCIDENT SCENARIO EVENT TIMES

TIME	M	1	2	3	4	5	6	S	R	S	C	C	S	COMMENTS
18: 0: 0	0	0	0	1	0	0	0	0	0	0	0	0	0	DISL SMALL BUS #31NE
18:11: 0	0	0	0	1	0	0	0	0	0	0	0	0	0	WOMAN OUTSIDE BUS
18:15: 0	0	0	0	0	0	0	0	0	0	0	0	0	0	CHP PUSHING TR R/S
18:18: 0	0	0	0	0	0	0	0	0	0	0	0	0	0	BUS PUSHED OFF TR
18:18: 0	0	0	0	0	0	0	0	0	0	0	0	0	0	CRENSHAW OFF/RAMP



TAPE NO. 75012401      TRAFFIC CODE = 2      FROM 7: 0: 0  
 TO 8:30: 0

INCIDENT LOCATION: SM21W TO SM22E

AFFECTED SEGMENTS: 2

SEGMENT(1) SM27W TO SM18W      SEGMENT(2) SM19E TO SM22E

INCIDENT TYPE: GAWK

VEHICLES INVOLVED: 2  
 LIGHT DUTY VEHICLES = 2    LIGHT TRUCKS = 0    HEAVY TRUCKS = 0

WEATHER AND ROAD CODES  
 WEATHER = C      VISIBILITY = S      PAVEMENT = D

DETECTION AND VERIFICATION  
 DETECTED AT 0: 0: 0 BY CODE  
 VERIFIED AT 7:35: 0 BY CODE V

LAND MARKS  
 SIGN = 0      CALL BOX = J  
 LOOP STATION = 0      POST MILE = 11.3

INCIDENT FREEWAY GEOMETRY

	M	1	2	3	4	5	6	S	R	S	C	C	S	COMMENTS
GEOMETRY	1	1	1	1	1	1	0	1	0	0	0	0	0	

INCIDENT SCENARIO EVENT TIMES

TIME	M	1	2	3	4	5	6	S	R	S	C	C	S	COMMENTS
7:35: 0	0	0	0	0	0	0	0	1	0	0	0	0	0	CHP ON A STOP
7:49: 0	0	0	0	0	0	0	0	0	0	0	0	0	0	CLEAR

TAPE NO. 75022701 TRAFFIC CODE = 1 FROM 7:30:0

TO 9:30:0

INCIDENT LOCATION: SM13E TO SM14E

AFFECTED SEGMENTS: 2

SEGMENT(1) SM 7E TO SM18E SEGMENT(2) SM15W TO SM12W

INCIDENT TYPE: DISL

VEHICLES INVOLVED: 1

LIGHT DUTY VEHICLES = 1 LIGHT TRUCKS = 0 HEAVY TRUCKS = 0

WEATHER AND ROAD CODES

WEATHER = C

VISIBILITY = F

PAVEMENT = D

DETECTION AND VERIFICATION

DETECTED AT 8:22:20 BY CODE S

VERIFIED AT 8:15:0 BY CODE V

LAND MARKS

SIGN = 0

CALL BOX = 0

LOOP STATION = 0

POST MILE = 7.55

INCIDENT FREEWAY GEOMETRY

	M	1	2	3	4	5	6	S	R	S	C	C	S	COMMENTS
GEOMETRY	1	1	1	1	1	0	0	0	1	0	0	0	0	

INCIDENT SCENARIO EVENT TIMES

TIME	M	1	2	3	4	5	6	S	R	S	C	C	S	COMMENTS
8:15:0	0	0	0	1	0	0	0	0	0	0	0	0	0	DISL #2 LANE
8:27:0	1	0	0	0	0	0	0	0	0	0	0	0	0	VEH IN REQ WITH TOW
8:28:0	0	0	0	0	0	0	0	0	0	0	0	0	0	TOW & VEH 10-98

ADDITIONAL COMMENT LINES

FLASH UPSTREAM AT SM11E

TAPE NO. 75022801 TRAFFIC CODE = 3 FROM 12:55: 0  
TO 14:30: 0

INCIDENT LOCATION: HA24N TO HA25N

AFFECTED SEGMENTS: 2

SEGMENT(1) HA11N TO HA25N SEGMENT(2) HA25S TO HA19S

INCIDENT TYPE: DISL

VEHICLES INVOLVED: 1  
LIGHT DUTY VEHICLES = 1 LIGHT TRUCKS = 0 HEAVY TRUCKS = 0

WEATHER AND ROAD CODES  
WEATHER = C VISIBILITY = H PAVEMENT = 0

DETECTION AND VERIFICATION  
DETECTED AT 13:29:40 BY CODE S  
VERIFIED AT 13:40: 0 BY CODE V

LAND MARKS  
SIGN = 0 CALL BOX = 0  
LOOP STATION = 0 POST MILE = 21.3

INCIDENT FREEWAY GEOMETRY

	M	1	2	3	4	5	6	S	R	S	C	C	S	COMMENTS
GEOMETRY	1	1	1	1	1	1	0	1	0	0	0	0	0	

INCIDENT SCENARIO EVENT TIMES

TIME	M	1	2	3	4	5	6	S	R	S	C	C	S	COMMENTS
13:40: 0	0	0	0	0	1	0	0	0	0	0	0	0	0	DISL, #4 LANE
13:42: 0	0	0	0	0	0	0	0	0	0	0	0	0	0	CLEAR

TAPE NO. 75032401 TRAFFIC CODE = 2 FROM 15:45: 0  
TO 17:20: 0

INCIDENT LOCATION: SM15W TO SM13W

AFFECTED SEGMENTS: 2

SEGMENT(1) SM19W TO SM 8W SEGMENT(2) SM14E TO SM16E

INCIDENT TYPE: DISL

VEHICLES INVOLVED: 1  
LIGHT DUTY VEHICLES = 1 LIGHT TRUCKS = 0 HEAVY TRUCKS = 0

WEATHER = C WEATHER AND ROAD CODES  
VISIBILITY = 5 PAVEMENT = 0

DETECTION AND VERIFICATION  
DETECTED AT 16:17:40 BY CODE S  
VERIFIED AT 16:21: 0 BY CODE V

LAND MARKS  
SIGN = 0 CALL BOX = 0  
LOOP STATION = 0 POST MILE = 7+01

INCIDENT FREEWAY GEOMETRY

	M	1	2	3	4	5	6	5	R	S	C	C	S	COMMENTS
GEOMETRY	1	1	1	1	1	0	0	1	0	0	0	0	0	

INCIDENT SCENARIO EVENT TIMES

TIME	M	1	2	3	4	5	6	5	R	S	C	C	S	COMMENTS
16:21: 0	0	0	0	0	0	0	0	1	0	0	0	0	0	DISLATION ON R/S
16:31: 0	0	0	0	0	0	0	0	0	0	0	0	0	0	CLEAR

ADDITIONAL COMMENT LINES

RIGHT AT LOOP STATION SM14W

TAPE NO. 75032402 TRAFFIC CODE = 1 FROM 16:50: 0  
TO 17:50: 0

INCIDENT LOCATION: SM25W TO SM24W

AFFECTED SEGMENTS: 2

SEGMENT(1) SM28W TO SM22W SEGMENT(2) SM23E TO SM26E

INCIDENT TYPE: GAWK

VEHICLES INVOLVED: 3  
LIGHT DUTY VEHICLES = 3 LIGHT TRUCKS = 0 HEAVY TRUCKS = 0

WEATHER AND ROAD CODES  
WEATHER = C VISIBILITY = 5 PAVEMENT = 0

DETECTION AND VERIFICATION  
DETECTED AT 0: 0: 0 BY CODE  
VERIFIED AT 16:45: 0 BY CODE V

LAND MARKS  
SIGN = 0 CALL BOX = 0  
LOOP STATION = 0 POST MILE = 12+72

INCIDENT FREEWAY GEOMETRY

	M	1	2	3	4	5	6	S	R	S	C	C	S	COMMENTS
GEOMETRY	1	1	1	1	1	0	0	1	0	0	1	1	1	

INCIDENT SCENARIO EVENT TIMES

TIME	M	1	2	3	4	5	6	S	R	S	C	C	S	COMMENTS
16:45: 0	0	0	0	0	0	0	0	0	0	0	0	0	1	3CHPS ON SHOULDER
16:50: 0	0	0	0	0	0	0	0	0	0	0	0	0	1	CHPS APPEAR TO BE
16:50: C	0	0	0	0	0	0	0	0	0	0	0	0	1	TICKETING RAMP VIA-
16:50: 0	0	0	0	0	0	0	0	0	0	0	0	0	1	LATERS
17:15: 0	0	0	0	0	0	0	0	0	0	0	0	0	0	GONE

ADDITIONAL COMMENT LINES

CHPS IN GORE AT WESTERN ON TO COLLECTOR

TAPE NO. 75032403 TRAFFIC CODE = 2 FROM 16:30:0  
TO 18:00:0

INCIDENT LOCATION: SM20W TO SM19W

AFFECTED SEGMENTS: 2

SEGMENT(1) SM25W TO SM17W SEGMENT(2) SM18E TO SM21E

INCIDENT TYPE: GAWK

VEHICLES INVOLVED: 2

LIGHT DUTY VEHICLES = 2 LIGHT TRUCKS = 0 HEAVY TRUCKS = 0

WEATHER AND ROAD CODES  
WEATHER = C VISIBILITY = S PAVEMENT = D

DETECTION AND VERIFICATION

DETECTED AT 0:0:0 BY CODE

VERIFIED AT 17:6:0 BY CODE V

LAND MARKS

SIGN = 0 CALL BOX = 0  
LBBP STATION = 0 POST MILE = 10.43

INCIDENT FREEWAY GEOMETRY

	M	1	2	3	4	5	6	S	H	5	C	C	S	COMMENTS
GEOMETRY	1	1	1	1	1	0	0	0	0	1	1	1	1	

INCIDENT SCENARIO EVENT TIMES

TIME	M	1	2	3	4	5	6	S	H	5	C	C	S	COMMENTS
17:6:0	0	0	0	0	0	0	0	0	0	1	0	0	0	CHP ON A STOP
17:16:0	0	0	0	0	0	0	0	0	0	0	0	0	0	CLEAR

TAPE NO. 75032404 TRAFFIC CODE = 1 FROM 16:50: 0  
TO 16:25: 0

INCIDENT LOCATION: SM26W TO SM25W

AFFECTED SEGMENTS: 2

SEGMENT(1) SM28W TO SM20W SEGMENT(2) SM24E TO SM27E

INCIDENT TYPE: DISL

VEHICLES INVOLVED: 1

LIGHT DUTY VEHICLES = 1 LIGHT TRUCKS = 0 HEAVY TRUCKS = 0

WEATHER AND ROAD CONDS  
WEATHER = C VISIBILITY = 5 PAVEMENT = D

DETECTION AND VERIFICATION

DETECTED AT 0: 0: 0 BY CODE  
VERIFIED AT 17:21: 0 BY CODE V

LAND MARKS

SIGN = 0 CALL BOX = 0  
LOOP STATION = 0 POST MILE = 13+22

INCIDENT FREEWAY GEOMETRY

	M	1	2	3	4	5	6	S	R	S	C	C	S	COMMENTS
GEOMETRY	1	1	1	1	1	0	0	1	1	0	1	1	1	

INCIDENT SCENARIO EVENT TIMES

TIME	M	1	2	3	4	5	6	S	R	S	C	C	S	COMMENTS
17:21: 0	1	0	0	0	0	0	0	0	0	0	0	0	0	DISL, C/D
17:23: 0	0	0	0	0	0	0	0	0	0	0	0	0	0	CHP NOTIFIED
17:38: 0	0	0	0	0	0	0	0	0	0	0	0	0	0	CLEAR

TAPE NO. 75032601 TRAFFIC CODE = 2 FROM 14:50: 0  
TO 16:30: 0

INCIDENT LOCATION: SM25W TO SM24W

AFFECTED SEGMENTS: 2

SEGMENT(1) SM28W TO SM22W SEGMENT(2) SM23E TO SM26E

INCIDENT TYPE: CAWK

VEHICLES INVOLVED: 2  
LIGHT DUTY VEHICLES = 2 LIGHT TRUCKS = 0 HEAVY TRUCKS = 0

WEATHER = C WEATHER AND ROAD CODES  
VISIBILITY = 5 PAVEMENT = 0

DETECTION AND VERIFICATION  
DETECTED AT 01:07:0 BY CODE  
VERIFIED AT 15:31:0 BY CODE V

SIGN = 0 LAND MARKS  
LOOP STATION = 0 CALL BOX = 0  
POST MILE = 12.82

INCIDENT FREEWAY GEOMETRY

	M	1	2	3	4	5	6	S	R	S	C	C	S	COMMENTS
GEOMETRY	1	1	1	1	1	0	0	0	0	1	1	1	1	

INCIDENT SCENARIO EVENT TIMES

TIME	M	1	2	3	4	5	6	S	R	S	C	C	S	COMMENTS
15:31:0	0	0	0	0	0	0	0	0	0	1	0	0	0	CHP ON STOP
15:35:0	0	0	0	0	0	0	0	0	0	0	0	0	0	ONE

ADDITIONAL COMMENT LINES

RIGHT AT SM19W



TAPE NO. 75032602 TRAFFIC CODE = 2 FROM 15: 5: 0  
TO 16:35: 0

INCIDENT LOCATION: SM20W TO SM18W

AFFECTED SEGMENTS: 2

SEGMENT(1) SM23W TO SM16W SEGMENT(2) SM21E TO SM17E

INCIDENT TYPE: GAWK

VEHICLES INVOLVED: 2  
LIGHT DUTY VEHICLES = 2 LIGHT TRUCKS = 0 HEAVY TRUCKS = 0

WEATHER AND ROAD CONDES  
WEATHER = C VISIBILITY = S PAVEMENT = U

DETECTION AND VERIFICATION  
DETECTED AT 0: 0: 0 BY CODE  
VERIFIED AT 15:42: 0 BY CODE V

LAND MARKS  
SIGN = 0 CALL BOX = 01 24  
LOOP STATION = 0 POST MILE = 0. 0

INCIDENT FREEWAY GEOMETRY

	M	1	2	3	4	5	6	S	R	S	C	C	S	COMMENTS
GEOMETRY	1	1	1	1	1	0	0	0	0	1	1	1	1	

INCIDENT SCENARIO EVENT TIMES

TIME	M	1	2	3	4	5	6	S	R	S	C	C	S	COMMENTS
15:42: 0	0	0	0	0	0	0	0	0	0	1	0	0	0	CHP ON STOP
16: 0: 0	0	0	0	0	0	0	0	0	0	0	0	0	0	CLEAR

TAPE NO. 74042350

TRAFFIC CODE = 5

FROM 6:30: 0  
TO 9:25: 0

INCIDENT LOCATION: HA IN TO HA25N

AFFECTED SEGMENTS: 1

SEGMENT (1) HA IN TO HA25N

INCIDENT TYPE:

VEHICLES INVOLVED: 0  
LIGHT DUTY VEHICLES = 0 LIGHT TRUCKS = 0 HEAVY TRUCKS = 0

WEATHER = L WEATHER AND ROAD CODES  
VISIBILITY = 0

PAVEMENT = P

DETECTION AND VERIFICATION  
DETECTED AT 0: 0: 0 BY CODE  
VERIFIED AT 0: 0: 0 BY CODE

SIGN = 0 LAND MARKS  
LOOP STATION = 0

CALL BOX = 0  
POST MILE = 0. 0

INCIDENT FREEWAY GEOMETRY

GEOMETRY	M	1	2	3	4	5	6	S	R	S	C	C	S	COMMENTS
	1	1	1	1	1	0	0	1	1	1	1	1	1	

TAPE NO. 74042351 TRAFFIC CODE = 5 FROM 6:30: 0

TO 9:25: 0

INCIDENT LOCATION: SD32S TO SD 1S

AFFECTED SEGMENTS: 1

SEGMENT(1) SD32S TO SD 1S

INCIDENT TYPE:

VEHICLES INVOLVED: 0

LIGHT DUTY VEHICLES = 0 LIGHT TRUCKS = 0 HEAVY TRUCKS = 0

WEATHER AND ROAD CODES

WEATHER =L

VISIBILITY =0

PAVEMENT =P

DETECTION AND VERIFICATION

DETECTED AT 0: 0: 0 BY CODE

VERIFIED AT 0: 0: 0 BY CODE

LAND MARKS

SIGN = 0

CALL BOX = 0

LOOP STATION = 0

POST MILE = 0. 0

INCIDENT FREEWAY GEOMETRY

	M	1	2	3	4	5	6	S	R	S	C	C	S	COMMENTS
GEOMETRY	1	1	1	1	1	1	0	1	1	1	1	1	1	

TAPE NO. 74042352      TRAFFIC CODE = 5      FROM 6:30: 0  
TO 9:25: 0

INCIDENT LOCATION: SD 1N TO SD32N

AFFECTED SEGMENTS: 1

SEGMENT(1) SD 1N TO SD32N

INCIDENT TYPE:

VEHICLES INVOLVED: 0  
LIGHT DUTY VEHICLES = 0    LIGHT TRUCKS = 0    HEAVY TRUCKS = 0

WEATHER = L      WEATHER AND ROAD CODES      PAVEMENT = P  
VISIBILITY = 0

DETECTION AND VERIFICATION  
DETECTED AT 0: 0: 0 BY CODE  
VERIFIED AT 0: 0: 0 BY CODE

LAND MARKS  
SIGN = 0      CALL BOX = 0  
LOOP STATION = 0      POST MILE = 0. 0

INCIDENT FREEWAY GEOMETRY

	M	1	2	3	4	5	6	S	R	S	C	C	S	COMMENTS
GEOMETRY	1	1	1	1	1	1	0	1	1	1	1	1	1	

TAPE NO. 74042353      TRAFFIC CODE - 5      FROM 6:31: 0  
TO 9:25: 0

INCIDENT LOCATION: SM 1E TO SM27E

AFFECTED SEGMENTS: 1

SEGMENT(1) SM 1E TO SM27E      SEGMENT(1)

INCIDENT TYPE:

VEHICLES INVOLVED: NONE

WEATHER AND ROAD CONDITIONS

WEATHER = L

VISIBILITY = 0

PAVEMENT = P

DETECTION AND VERIFICATION

DETECTED AT 0: 0: 0 BY CLDE

VERIFIED AT 0: 0: 0 BY CLDE

LAND MARKS: NONE

INCIDENT FREEWAY GEOMETRY

	M	1	2	3	4	5	6	S	R	S	C	C	S	COMMENTS
GEOMETRY	1	1	1	1	1	1	1	1	1	1	1	1	1	

INCIDENT SCENARIO EVENT TIMES: NONE

TRAFFIC VOLUME COUNTS: NONE

ADDITIONAL COMMENTS LINES:

#1 CONN. CLOSED, SMC TO HAS, 0900 TO 1300 UNSPECIFIED ROADWORK

TAPE NO. 7404235\* TRAFFIC CODE = 6 FROM 6:30: 0  
TO 9:25: 0

INCIDENT LOCATION: SM28W TO SM 1W

AFFECTED SEGMENTS: 1

SEGMENT(1) SM28W TO SM 1W

INCIDENT TYPE:

VEHICLES INVOLVED: 0  
LIGHT DUTY VEHICLES = 0 LIGHT TRUCKS = 0 HEAVY TRUCKS = 0

WEATHER AND ROAD CODES  
WEATHER =L VISIBILITY =0 PAVEMENT =P

DETECTION AND VERIFICATION  
DETECTED AT 0: 0: 0 BY CODE  
VERIFIED AT 0: 0: 0 BY CODE

LAND MARKS  
SIGN = 0 CALL BOX = 0  
LOOP STATION = 0 POST MILE = 0. 0

INCIDENT FREEWAY GEOMETRY

	M	1	2	3	4	5	6	S	R	S	C	C	S	COMMENTS
GEOMETRY	1	1	1	1	1	1	1	1	1	1	1	1	1	

TAPE NO. 74042355

TRAFFIC CODE = 5

FROM 11: 0: 0  
TO 13:55: 0

INCIDENT LOCATION: SM 1E TO SM27E

AFFECTED SEGMENTS: 1

SEGMENT(1) SM 1E TO SM27E

INCIDENT TYPE:

VEHICLES INVOLVED: 0

LIGHT DUTY VEHICLES = 0 LIGHT TRUCKS = 0 HEAVY TRUCKS = 0

WEATHER = L WEATHER AND ROAD CODES  
VISIBILITY = 0

PAVEMENT = P

DETECTION AND VERIFICATION

DETECTED AT 0: 0: 0 BY CODE

VERIFIED AT 0: 0: 0 BY CODE

LAND MARKS

SIGN = 0

CALL BOX = 0

LOOP STATION = 0

POST MILE = 0+ 0

INCIDENT FREEWAY GEOMETRY

	M	1	2	3	4	5	6	S	R	S	C	C	S	COMMENTS
GEOMETRY	1	1	1	1	1	1	1	1	1	1	1	1	1	

TAPE NO. 74042356 TRAFFIC CODE = 6 FROM 16: 0: 0  
TO 18:55: 0

INCIDENT LOCATION: SM 1E TO SM27E

AFFECTED SEGMENTS: 1

SEGMENT(1) SM 1E TO SM27E

INCIDENT TYPE:

VEHICLES INVOLVED: 0  
LIGHT DUTY VEHICLES = 0 LIGHT TRUCKS = 0 HEAVY TRUCKS = 0

WEATHER = C WEATHER AND ROAD CODES  
VISIBILITY = 0 PAVEMENT = D

DETECTION AND VERIFICATION  
DETECTED AT 0: 0: 0 BY CODE  
VERIFIED AT 0: 0: 0 BY CODE

LAND MARKS  
SIGN = 0 CALL BOX = 0  
LOOP STATION = 0 POST MILE = 0. 0

INCIDENT FREEWAY GEOMETRY

	M	1	2	3	4	5	6	S	R	S	C	C	S	COMMENTS
GEOMETRY	1	1	1	1	1	1	1	1	1	0	1	1	1	



TAPE NO. 74042357      TRAFFIC CODE = 7      FROM 21: 0: 0  
TO      23:55: 0

INCIDENT LOCATION: SM 1E TO SM27E

AFFECTED SEGMENTS: 1

SEGMENT(1) SM 1E TO SM27E

INCIDENT TYPE:

VEHICLES INVOLVED: 0  
LIGHT DUTY VEHICLES = 0    LIGHT TRUCKS = 0    HEAVY TRUCKS = 0

WEATHER AND ROAD CODES  
WEATHER = C      VISIBILITY = 0      PAVEMENT = 0

DETECTION AND VERIFICATION  
DETECTED AT 0: 0: 0 BY CODE  
VERIFIED AT 0: 0: 0 BY CODE

LAND MARKS  
SIGN = 0      CALL BOX = 0  
LOOP STATION = 0      POST MILE = 0. 0

INCIDENT FREEWAY GEOMETRY

	M	1	2	3	4	5	6	S	R	S	C	C	S	COMMENTS
GEOMETRY	1	1	1	1	1	1	1	1	1	1	1	1	1	

TAPE NO. 74042358 TRAFFIC CODE = 6 FROM 11: 0: 0  
TO 13:55: 0

INCIDENT LOCATION: SM28W TO SM 1W

AFFECTED SEGMENTS: 1

SEGMENT(1) SM28W TO SM 1W

INCIDENT TYPE:

VEHICLES INVOLVED: 0  
LIGHT DUTY VEHICLES = 0 LIGHT TRUCKS = 0 HEAVY TRUCKS = 0

WEATHER = C WEATHER AND ROAD CODES  
VISIBILITY = 0 PAVEMENT = P

DETECTION AND VERIFICATION  
DETECTED AT 0: 0: 0 BY CODE  
VERIFIED AT 0: 0: 0 BY CODE

LAND MARKS  
SIGN = 0 CALL BOX = 0  
LOOP STATION = 0 POST MILE = 0. 0

INCIDENT FREEWAY GEOMETRY

	M	1	2	3	4	5	6	S	R	S	C	C	S	COMMENTS
GEOMETRY	1	1	1	1	1	1	1	1	1	1	1	1	1	

TAPE NO. 74042359

TRAFFIC CODE = 5

FROM 16: 0: 0

TO 18:55: 0

INCIDENT LOCATION: SM28W TO SM 1W

AFFECTED SEGMENTS: 1

SEGMENT(1) SM28W TO SM 1W

INCIDENT TYPE:

VEHICLES INVOLVED: 0

LIGHT DUTY VEHICLES = 0 LIGHT TRUCKS = 0 HEAVY TRUCKS = 0

WEATHER AND ROAD CODES

WEATHER =C

VISIBILITY =0

PAVEMENT =D

DETECTION AND VERIFICATION

DETECTED AT 0: 0: 0 BY CODE

VERIFIED AT 0: 0: 0 BY CODE

LAND MARKS

SIGN = 0

CALL BOX = 0

LOOP STATION = 0

POST MILE = 0. 0

INCIDENT FREEWAY GEOMETRY

	M	1	2	3	4	5	6	S	R	S	C	C	S	COMMENTS
GEOMETRY	1	1	1	1	1	1	1	1	1	1	1	1	1	

TAPE NO. 74042360      TRAFFIC CODE = 8      FROM 21: 0: 0  
TO 23:55: 0

INCIDENT LOCATION: SM28W TO SM 1W

AFFECTED SEGMENTS: 1

SEGMENT(1) SM28W TO SM 1W

INCIDENT TYPE:

VEHICLES INVOLVED: 0  
LIGHT DUTY VEHICLES = 0    LIGHT TRUCKS = 0    HEAVY TRUCKS = 0

WEATHER = C      WEATHER AND ROAD CODES  
VISIBILITY = 0      PAVEMENT = D

DETECTION AND VERIFICATION  
DETECTED AT 0: 0: 0 BY CODE  
VERIFIED AT 0: 0: 0 BY CODE

LAND MARKS  
SIGN = 0      CALL BOX = 0  
LOOP STATION = 0      POST MILE = 0. 0

INCIDENT FREEWAY GEOMETRY

	M	1	2	3	4	5	6	S	R	S	C	C	S	COMMENTS
GEOMETRY	1	1	1	1	1	1	1	1	1	1	1	1	1	

TAPE NO. 74042361      TRAFFIC CODE = 6      FROM 11: 0: 0  
TO 13:55: 0

INCIDENT LOCATION: SD32S TO SD 1S

AFFECTED SEGMENTS: 1

SEGMENT(1) SD32S TO SD 1S

INCIDENT TYPE:

VEHICLES INVOLVED: 0  
LIGHT DUTY VEHICLES = 0    LIGHT TRUCKS = 0    HEAVY TRUCKS = 0

WEATHER AND ROAD CODES  
WEATHER = C      VISIBILITY = 0      PAVEMENT = 0

DETECTION AND VERIFICATION  
DETECTED AT 0: 0: 0 BY CODE  
VERIFIED AT 0: 0: 0 BY CODE

LAND MARKS  
SIGN = 0      CALL BOX = 0  
LOOP STATION = 0      POST MILE = 0. 0

INCIDENT FREEWAY GEOMETRY

	M	1	2	3	4	5	6	S	K	S	C	C	S	COMMENTS
GEOMETRY	1	1	1	1	1	1	0	1	1	1	1	1	1	

TAPE NO. 74042362      TRAFFIC CODE = 5      FROM 16: 0: 0  
TO 18:55: 0

INCIDENT LOCATION: SD32S TO SD 1S

AFFECTED SEGMENTS: 1

SEGMENT(1) SD32S TO SD 1S

INCIDENT TYPE:

VEHICLES INVOLVED: 0  
LIGHT DUTY VEHICLES = 0    LIGHT TRUCKS = 0    HEAVY TRUCKS = 0

WEATHER AND ROAD CODES  
WEATHER = C      VISIBILITY = 0      PAVEMENT = D

DETECTION AND VERIFICATION  
DETECTED AT 0: 0: 0 BY CODE  
VERIFIED AT 0: 0: 0 BY CODE

LAND MARKS  
SIGN = 0      CALL BOX = 0  
LOOP STATION = 0      POST MILE = 0+ 0

INCIDENT FREEWAY GEOMETRY

	M	1	2	3	4	5	6	S	R	S	C	C	S	COMMENTS
GEOMETRY	1	1	1	1	1	1	0	1	1	1	1	1	1	

TAPE NO. 74042363      TRAFFIC CODE = 8      FROM 21: 0: 0

TO 23:55: 0

INCIDENT LOCATION: SD325 TO SD 15

AFFECTED SEGMENTS: 1

SEGMENT(1) SD325 TO SD 15

INCIDENT TYPE:

VEHICLES INVOLVED: 0

LIGHT DUTY VEHICLES = 0    LIGHT TRUCKS = 0    HEAVY TRUCKS = 0

WEATHER AND ROAD CODES

WEATHER = C

VISIBILITY = 0

PAVEMENT = 0

DETECTION AND VERIFICATION

DETECTED AT 0: 0: 0 BY CODE

VERIFIED AT 0: 0: 0 BY CODE

LAND MARKS

SIGN = 0

CALL BOX = 0

LOOP STATION = 0

POST MILE = 0. 0

INCIDENT FREEWAY GEOMETRY

	M	1	2	3	+	5	6	S	R	S	C	C	S	COMMENTS
GEOMETRY	1	1	1	1	1	1	0	1	1	1	1	1	1	

TAPE NO. 740+2364 TRAFFIC CODE = 6 FROM 11: 0: 0  
TO 13:55: 0

INCIDENT LOCATION: HA 1N TO HA25N

AFFECTED SEGMENTS: 1

SEGMENT(1) HA 1N TO HA25N

INCIDENT TYPE:

VEHICLES INVOLVED: 0

LIGHT DUTY VEHICLES = 0 LIGHT TRUCKS = 0 HEAVY TRUCKS = 0

WEATHER AND ROAD CODES

WEATHER =C

VISIBILITY =0

PAVEMENT =D

DETECTION AND VERIFICATION

DETECTED AT 0: 0: 0 BY CODE

VERIFIED AT 0: 0: 0 BY CODE

LAND MARKS

SIGN = 0

CALL BOX = 0

LOOP STATION = 0

POST MILE = 0. 0

INCIDENT FREEWAY GEOMETRY

	M	1	2	3	4	5	6	S	R	S	C	C	S	COMMENTS
GEOMETRY	1	1	1	1	1	0	0	1	1	1	1	1	1	



TAPE NO. 74042365

TRAFFIC CODE = 5

FROM 16: 0: 0

TO 16:55: 0

INCIDENT LOCATION: HA IN TO HA25N

AFFECTED SEGMENTS: 1

SEGMENT(1) HA IN TO HA25N

INCIDENT TYPE:

VEHICLES INVOLVED: 0

LIGHT DUTY VEHICLES = 0 LIGHT TRUCKS = 0 HEAVY TRUCKS = 0

WEATHER = C WEATHER AND ROAD CODES  
VISIBILITY = 0

PAVEMENT = 0

DETECTION AND VERIFICATION

DETECTED AT 0: 0: 0 BY CODE

VERIFIED AT 0: 0: 0 BY CODE

LAND MARKS

SIGN = 0

CALL BOX = 0

LOOP STATION = 0

POST MILE = 0. 0

INCIDENT FREEWAY GEOMETRY

	M	1	2	3	4	5	6	S	R	S	C	C	S	COMMENTS
GEOMETRY	1	1	1	1	1	0	0	1	1	1	1	1	1	

TAPE NO. 74042366      TRAFFIC CODE = 7      FROM 21: 0: 0  
TO 23:55: 0

INCIDENT LOCATION: HA 1N TO HA25N

AFFECTED SEGMENTS: 1

SEGMENT(1) HA 1N TO HA25N

INCIDENT TYPE:

VEHICLES INVOLVED: 0  
LIGHT DUTY VEHICLES = 0    LIGHT TRUCKS = 0    HEAVY TRUCKS = 0

WEATHER = C      WEATHER AND ROAD CODES  
VISIBILITY = 0      PAVEMENT = D

DETECTION AND VERIFICATION  
DETECTED AT 0: 0: 0 BY CODE  
VERIFIED AT 0: 0: 0 BY CODE

LAND MARKS  
SIGN = 0      CALL BOX = 0  
LOOP STATION = 0      POST MILE = 0. 0

INCIDENT FREEWAY GEOMETRY

	M	1	2	3	4	5	6	S	R	S	C	C	S	COMMENTS
GEOMETRY	1	1	1	1	1	0	0	1	1	1	1	1	1	

TAPE NO. 74042367 TRAFFIC CODE = 6 FROM 11: 0: 0

TO 13:55: 0

INCIDENT LOCATION: SD 1N TO SD32N

AFFECTED SEGMENTS: 1

SEGMENT(1) SD 1N TO SD32N

INCIDENT TYPE:

VEHICLES INVOLVED: 0

LIGHT DUTY VEHICLES = 0 LIGHT TRUCKS = 0 HEAVY TRUCKS = 0

WEATHER AND ROAD CODES

WEATHER = C

VISIBILITY = 0

PAVEMENT = D

DETECTION AND VERIFICATION

DETECTED AT 0: 0: 0 BY CODE

VERIFIED AT 0: 0: 0 BY CODE

LAND MARKS

SIGN = 0

CALL BOX = 0

LOOP STATION = 0

POST MILE = 0. 0

INCIDENT FREEWAY GEOMETRY

	M	1	2	3	4	5	6	S	R	S	C	C	S	COMMENTS
GEOMETRY	1	1	1	1	1	1	0	1	1	1	1	1	1	

TAPE NO. 74042368      TRAFFIC CODE = 5      FROM 16: 0: 0  
TO 18:55: 0

INCIDENT LOCATION: SD 1N TO SD32N

AFFECTED SEGMENTS: 1

SEGMENT(1) SD 1N TO SD32N

INCIDENT TYPE:

VEHICLES INVOLVED: 0  
LIGHT DUTY VEHICLES = 0    LIGHT TRUCKS = 0    HEAVY TRUCKS = 0

WEATHER AND ROAD CODES  
WEATHER = C      VISIBILITY = 0      PAVEMENT = D

DETECTION AND VERIFICATION  
DETECTED AT 0: 0: 0 BY CODE  
VERIFIED AT 0: 0: 0 BY CODE

LAND MARKS  
SIGN = 0      CALL BOX = 0  
LOOP STATION = 0      POST MILE = 0. 0

INCIDENT FREEWAY GEOMETRY

	M	1	2	3	4	5	6	S	R	S	C	C	S	COMMENTS
GEOMETRY	1	1	1	1	1	0	1	1	1	1	1	1	1	

TAPE NO. 74042369

TRAFFIC CODE = 7

FROM 21: 0: 0

TO 23: 0: 0

INCIDENT LOCATION: SD 1N TO SD32N

AFFECTED SEGMENTS: 1

SEGMENT(1) SD 1N TO SD32N

INCIDENT TYPE:

VEHICLES INVOLVED: 0

LIGHT DUTY VEHICLES = 0 LIGHT TRUCKS = 0 HEAVY TRUCKS = 0

WEATHER AND ROAD CODES

WEATHER = C

VISIBILITY = 0

PAVEMENT = 0

DETECTION AND VERIFICATION

DETECTED AT 0: 0: 0 BY CODE

VERIFIED AT 0: 0: 0 BY CODE

LAND MARKS

SIGN = 0

CALL BOX = 0

LOOP STATION = 0

POST MILE = 0. 0

INCIDENT FREEWAY GEOMETRY

	M	1	2	3	4	5	6	S	R	S	C	C	S	COMMENTS
GEOMETRY	1	1	1	1	1	1	0	1	1	1	1	1	1	

TAPE NO. 74042370      TRAFFIC CODE = 6      FROM 6:30: 0  
TO 9:25: 0

INCIDENT LOCATION: HA25S TO HA 1S

AFFECTED SEGMENTS: 1

SEGMENT(1) HA25S TO HA 1S

INCIDENT TYPE:

VEHICLES INVOLVED: 0  
LIGHT DUTY VEHICLES = 0    LIGHT TRUCKS = 0    HEAVY TRUCKS = 0

WEATHER = L      WEATHER AND ROAD CODES  
VISIBILITY = 0      PAVEMENT = P

DETECTION AND VERIFICATION  
DETECTED AT 0: 0: 0 BY CODE  
VERIFIED AT 0: 0: 0 BY CODE

SIGN = 0      LAND MARKS  
LOOP STATION = 0      CALL BOX = 0  
POST MILE = 0: 0

INCIDENT FREEWAY GEOMETRY

	M	1	2	3	4	5	6	S	R	S	C	C	S	COMMENTS
GEOMETRY	1	1	1	1	1	0	0	1	1	1	1	1	1	

TAPE NO. 74042371      TRAFFIC CODE = 6      FROM 11: 0: 0  
TO 13:55: 0

INCIDENT LOCATION: HA25S TO HA 1S

AFFECTED SEGMENTS: 1

SEGMENT(1) HA25S TO HA 1S

INCIDENT TYPE:

VEHICLES INVOLVED: 0  
LIGHT DUTY VEHICLES = 0    LIGHT TRUCKS = 0    HEAVY TRUCKS = 0

WEATHER = C      WEATHER AND ROAD CODES  
VISIBILITY = 0      PAVEMENT = P

DETECTION AND VERIFICATION  
DETECTED AT 0: 0: 0 BY CODE  
VERIFIED AT 0: 0: 0 BY CODE

LAND MARKS  
SIGN = 0      CALL BOX = 0  
LOOP STATION = 0      POST MILE = 0. 0

INCIDENT FREEWAY GEOMETRY

	M	1	2	3	4	5	6	S	R	S	C	C	S	COMMENTS
GEOMETRY	1	1	1	1	1	0	0	1	1	1	1	1	1	

TAPE NO. 74042372      TRAFFIC CODE = 5      FROM 16: 0: 0  
TO 18:55: 0

INCIDENT LOCATION: HA255 TO HA 15

AFFECTED SEGMENTS: 1

SEGMENT(1) HA255 TO HA 15

INCIDENT TYPE:

VEHICLES INVOLVED: 0  
LIGHT DUTY VEHICLES = 0    LIGHT TRUCKS = 0    HEAVY TRUCKS = 0

WEATHER AND ROAD CODES  
WEATHER = C      VISIBILITY = 0      PAVEMENT = D

DETECTION AND VERIFICATION  
DETECTED AT 0: 0: 0 BY CODE  
VERIFIED AT 0: 0: 0 BY CODE

LAND MARKS  
SIGN = 0      CALL BOX = 0  
LOOP STATION = 0      POST MILE = 0. J

INCIDENT FREEWAY GEOMETRY

	M	1	2	3	4	5	6	5	R	5	C	C	S	COMMENTS
GEOMETRY	1	1	1	1	1	1	1	1	1	1	1	1	1	



TAPE NO. 74061051      TRAFFIC CODE = 6      FROM 11: 0: 0  
TO      14: 0: 0

INCIDENT LOCATION: SM 1E TO SM27E

AFFECTED SEGMENTS: 1

SEGMENT(1) SM 1E TO SM27E

INCIDENT TYPE:

VEHICLES INVOLVED: 0

LIGHT DUTY VEHICLES = 0    LIGHT TRUCKS = 0    HEAVY TRUCKS = 0

WEATHER AND ROAD CODES

WEATHER =C      VISIBILITY =S      PAVEMENT =D

DETECTION AND VERIFICATION

DETECTED AT 0: 0: 0 BY CODE

VERIFIED AT 0: 0: 0 BY CODE

LAND MARKS

SIGN = 0      CALL BOX = 0  
LOOP STATION = 0      POST MILE = 0. 0

INCIDENT FREEWAY GEOMETRY

	M	1	2	3	4	5	6	S	R	S	C	C	S	COMMENTS
GEOMETRY	1	1	1	1	1	1	1	1	1	1	1	1	1	

TAPE NO. 7\*061052      TRAFFIC CODE = 5      FROM 16: 0: 0  
TO 19: 0: 0

INCIDENT LOCATION: SM 1E TO SM27E

AFFECTED SEGMENTS: 1

SEGMENT(1) SM 1E TO SM27E

INCIDENT TYPE:

VEHICLES INVOLVED: 0  
LIGHT DUTY VEHICLES = 0    LIGHT TRUCKS = 0    HEAVY TRUCKS = 0

WEATHER = C      WEATHER AND ROAD CODES  
VISIBILITY = S      PAVEMENT = 0

DETECTION AND VERIFICATION  
DETECTED AT 0: 0: 0 BY CODE  
VERIFIED AT 0: 0: 0 BY CODE

LAND MARKS  
SIGN = 0      CALL BOX = 0  
LOOP STATION = 0      POST MILE = 0. 0

INCIDENT FREEWAY GEOMETRY

	M	1	2	3	4	5	6	S	R	S	C	C	S	COMMENTS
GEOMETRY	1	1	1	1	1	1	1	1	1	1	1	1	1	

TAPE NO. 74061053      TRAFFIC CODE = 6      FROM 6:30: 0  
TO 9:30: 0

INCIDENT LOCATION: SM28W TO SM 14

AFFECTED SEGMENTS: 1

SEGMENT(1) SM28W TO SM 14

INCIDENT TYPE:

VEHICLES INVOLVED: 0

LIGHT DUTY VEHICLES = 0    LIGHT TRUCKS = 0    HEAVY TRUCKS = 0

WEATHER = C      WEATHER AND ROAD CODES  
VISIBILITY = S      PAVEMENT = P

DETECTION AND VERIFICATION

DETECTED AT 0: 0: 0 BY CODE

VERIFIED AT 0: 0: 0 BY CODE

LAND MARKS

SIGN = 0      CALL BOX = 0  
LBBP STATION = 0      POST MILE = 0. 0

INCIDENT FREEWAY GEOMETRY

	M	1	2	3	4	5	6	S	R	S	C	C	S	COMMENTS
GEOMETRY	1	1	1	1	1	1	1	1	1	1	1	1	1	

TAPE NO. 7406105\*      TRAFFIC CODE = 6      FROM 11: 0: 0  
TO 14: 0: 0

INCIDENT LOCATION: SM28W TO SM 1W

AFFECTED SEGMENTS: 1

SEGMENT(1) SM28W TO SM 1W

INCIDENT TYPE:

VEHICLES INVOLVED: 0  
LIGHT DUTY VEHICLES = 0    LIGHT TRUCKS = 0    HEAVY TRUCKS = 0

WEATHER AND ROAD CODES  
WEATHER = C      VISIBILITY = S      PAVEMENT = D

DETECTION AND VERIFICATION  
DETECTED AT 0: 0: 0 BY CODE  
VERIFIED AT 0: 0: 0 BY CODE

LAND MARKS  
SIGN = 0      CALL BOX = 0  
LOOP STATION = 0      POST MILE = 0.1

INCIDENT FREEWAY GEOMETRY

	M	1	2	3	4	5	6	S	R	S	C	C	S	COMMENTS
GEOMETRY	1	1	1	1	1	1	1	1	1	1	1	1	1	

TAPE NO. 74061055      TRAFFIC CODE = 5      FROM 16: 0: 0  
TO 19: 0: 0

INCIDENT LOCATION: SM28W TO SM 1W

AFFECTED SEGMENTS: 1

SEGMENT(1) SM28W TO SM 1W

INCIDENT TYPE:

VEHICLES INVOLVED: 0  
LIGHT DUTY VEHICLES = 0    LIGHT TRUCKS = 0    HEAVY TRUCKS = 0

WEATHER = C      WEATHER AND ROAD CODES  
VISIBILITY = S      PAVEMENT = D

DETECTION AND VERIFICATION  
DETECTED AT 0: 0: 0 BY CODE  
VERIFIED AT 0: 0: 0 BY CODE

SIGN = 0      LAND MARKS  
LOOP STATION = 0      CALL BOX = 0  
POST MILE = 0. 0

INCIDENT FREEWAY GEOMETRY

	M	1	2	3	4	5	6	S	R	S	C	C	S	COMMENTS
GEOMETRY	1	1	1	1	1	1	1	1	1	1	1	1	1	

TAPE NO. 74061056      TRAFFIC CODE = 5      FROM 6:30: 0  
TO 9:30: 0

INCIDENT LOCATION: SD 1N TO SD32N

AFFECTED SEGMENTS: 1

SEGMENT(1) SD 1N TO SD32N

INCIDENT TYPE:

VEHICLES INVOLVED: 0

LIGHT DUTY VEHICLES = 0    LIGHT TRUCKS = 0    HEAVY TRUCKS = 0

WEATHER = C      WEATHER AND ROAD CODES  
VISIBILITY = 0      PAVEMENT = D

DETECTION AND VERIFICATION

DETECTED AT 0: 0: 0 BY CODE

VERIFIED AT 0: 0: 0 BY CODE

LAND MARKS

SIGN = 0      CALL BOX = 0  
LOOP STATION = 0      POST MILE = 0. 0

INCIDENT FREEWAY GEOMETRY

	M	1	2	3	4	5	6	S	R	S	C	C	S	COMMENTS
GEOMETRY	1	1	1	1	1	1	0	1	1	1	1	1	1	

TAPE NO. 74061057

TRAFFIC CODE = 6

FROM 11: 0: 0

TO 14: 0: 0

INCIDENT LOCATION: SD 1N TO SD32N

AFFECTED SEGMENTS: 1

SEGMENT(1) SD 1N TO SD32N

INCIDENT TYPE:

VEHICLES INVOLVED: 0

LIGHT DUTY VEHICLES = 0 LIGHT TRUCKS = 0 HEAVY TRUCKS = 0

WEATHER AND ROAD CODES

WEATHER = C

VISIBILITY = S

PAVEMENT = D

DETECTION AND VERIFICATION

DETECTED AT 0: 0: 0 BY CODE

VERIFIED AT 0: 0: 0 BY CODE

LAND MARKS

SIGN = 0

CALL BOX = 0

LOOP STATION = 0

POST MILE = 0+ 0

INCIDENT FREEWAY GEOMETRY

	M	1	2	3	4	5	6	S	R	S	C	C	S	COMMENTS
GEOMETRY	1	1	1	1	1	1	0	1	1	1	1	1	1	

TAPE No. 74061059      TRAFFIC CODE = 5      FROM 6:30: 0  
TO 9:30: 0

INCIDENT LOCATION: SD32S TO SD 1S

AFFECTED SEGMENTS: 1

SEGMENT(1) SD32S TO SD 1S

INCIDENT TYPE:

VEHICLES INVOLVED: 0  
LIGHT DUTY VEHICLES = 0    LIGHT TRUCKS = 0    HEAVY TRUCKS = 0

WEATHER = C      WEATHER AND ROAD CODES  
                    VISIBILITY = 5      PAVEMENT = P

DETECTION AND VERIFICATION  
DETECTED AT 0: 0: 0 BY CODE  
VERIFIED AT 0: 0: 0 BY CODE

                    LAND MARKS  
SIGN = 0      CALL BOX = 0  
LOOP STATION = 0      POST MILE = 0+ 0

INCIDENT FREEWAY GEOMETRY

	M	1	2	3	4	5	6	S	R	S	C	C	S	COMMENTS
GEOMETRY	1	1	1	1	1	1	0	1	1	1	1	1	1	



TAPE NO. 74061060 TRAFFIC CODE = 6 FROM 11: 0: 0  
TO 14: 0: 0

INCIDENT LOCATION: SD32S TO SD 1S

AFFECTED SEGMENTS: 1

SEGMENT(1) SD32S TO SD 1S

INCIDENT TYPE:

VEHICLES INVOLVED: 0  
LIGHT DUTY VEHICLES = 0 LIGHT TRUCKS = 0 HEAVY TRUCKS = 0

WEATHER AND ROAD CODES  
WEATHER = C VISIBILITY = S PAVEMENT = D

DETECTION AND VERIFICATION  
DETECTED AT 0: 0: 0 BY CODE  
VERIFIED AT 0: 0: 0 BY CODE

LAND MARKS  
SIGN = 0 CALL BOX = 0  
LOOP STATION = 0 POST MILE = 0. 0

INCIDENT FREEWAY GEOMETRY

	M	1	2	3	4	5	6	S	R	S	C	C	S	COMMENTS
GEOMETRY	1	1	1	1	1	1	0	1	1	1	1	1	1	

TAPE NO. 74090450      TRAFFIC CODE = 6      FROM 6:30: 0  
TO 8:30: 0

INCIDENT LOCATION: SD 1N TO SD32N

AFFECTED SEGMENTS: 1

SEGMENT(1) SD 1N TO SD32N

INCIDENT TYPE:

VEHICLES INVOLVED: 0

LIGHT DUTY VEHICLES = 0    LIGHT TRUCKS = 0    HEAVY TRUCKS = 0

WEATHER = C      WEATHER AND ROAD CODES      PAVEMENT = D  
VISIBILITY = 0

DETECTION AND VERIFICATION

DETECTED AT 0: 0: 0 BY CODE

VERIFIED AT 0: 0: 0 BY CODE

LAND MARKS

SIGN = 0      CALL BOX = 0  
LOOP STATION = 0      POST MILE = 0. 0

INCIDENT FREEWAY GEOMETRY

	M	1	2	3	4	5	6	S	R	S	C	C	S	COMMENTS
GEOMETRY	1	1	1	1	1	1	0	1	1	1	1	1	1	

ADDITIONAL COMMENT LINES

BUS DRIVERS ON STRIKE, POSSIBLE HEAVY TRAFFIC

TAPE NO. 74090451 TRAFFIC CODE = 7 FROM 11: 0: 0  
TO 13:55: 0

INCIDENT LOCATION: SD 1N TO SD32N

AFFECTED SEGMENTS: 1

SEGMENT(1) SD 1N TO SD32N

INCIDENT TYPE:

VEHICLES INVOLVED: 0

LIGHT DUTY VEHICLES = 0 LIGHT TRUCKS = 0 HEAVY TRUCKS = 0

WEATHER AND ROAD CODES  
WEATHER = C VISIBILITY = S PAVEMENT = D

DETECTION AND VERIFICATION

DETECTED AT 0: 0: 0 BY CODE

VERIFIED AT 0: 0: 0 BY CODE

LAND MARKS

SIGN = 0 CALL BOX = 0  
LOOP STATION = 0 POST MILE = 0. 0

INCIDENT FREEWAY GEOMETRY

	M	1	2	3	4	5	6	S	R	S	C	C	S	COMMENTS
GEOMETRY	1	1	1	1	1	1	0	1	1	1	1	1	1	

ADDITIONAL COMMENT LINES

BUS DRIVERS ON STRIKE, POSSIBLE HEAVY TRAFFIC

TAPE NO. 74090452

TRAFFIC CODE = 5

FROM 16: 0: 0  
TO 18:55: 0

INCIDENT LOCATION: SD 1N TO SD32N

AFFECTED SEGMENTS: 1

SEGMENT(1) SD 1N TO SD32N

INCIDENT TYPE:

VEHICLES INVOLVED: 0

LIGHT DUTY VEHICLES = 0 LIGHT TRUCKS = 0 HEAVY TRUCKS = 0

WEATHER = C WEATHER AND ROAD CODES  
VISIBILITY = S PAVEMENT = D

DETECTION AND VERIFICATION

DETECTED AT 0: 0: 0 BY CODE

VERIFIED AT 0: 0: 0 BY CODE

SIGN = 0 LAND MARKS  
LOOP STATION = 0 CALL BOX = 0  
POST MILE = 0. 0

INCIDENT FREEWAY GEOMETRY

GEOMETRY M 1 2 3 4 5 6 S R S C C S COMMENTS  
1 1 1 1 1 1 0 1 1 1 1 1

ADDITIONAL COMMENT LINES

BUS DRIVERS ON STRIKE, POSSIBLE HEAVY TRAFFIC

TAPE NO. 74090453      TRAFFIC CODE = 6      FROM 21: 0: 0  
TO 23:55: 0

INCIDENT LOCATION: SD 1N TO SD32N

AFFECTED SEGMENTS: 1

SEGMENT(1) SD 1N TO SD32N

INCIDENT TYPE:

VEHICLES INVOLVED: 0  
LIGHT DUTY VEHICLES = 0    LIGHT TRUCKS = 0    HEAVY TRUCKS = 0

WEATHER = C      WEATHER AND ROAD CODES  
VISIBILITY = D      PAVEMENT = D

DETECTION AND VERIFICATION  
DETECTED AT 0: 0: 0 BY CODE  
VERIFIED AT 0: 0: 0 BY CODE

LAND MARKS  
SIGN = 0      CALL BOX = 0  
LOOP STATION = 0      POST MILE = 0. 0

INCIDENT FREEWAY GEOMETRY

	M	1	2	3	4	5	6	S	R	S	C	C	S	COMMENTS
GEOMETRY	1	1	1	1	1	1	0	1	1	1	1	1	1	

ADDITIONAL COMMENT LINES

BUS DRIVERS ON STRIKE, POSSIBLE HEAVY TRAFFIC

TAPE NO. 7+09045+ TRAFFIC CODE = 5 FROM 6:30: 0  
TO 9:25: 0

INCIDENT LOCATION: SD32S TO SD 1S

AFFECTED SEGMENTS: 1

SEGMENT(1) SD32S TO SD 1S

INCIDENT TYPE:

VEHICLES INVOLVED: 0  
LIGHT DUTY VEHICLES = 0 LIGHT TRUCKS = 0 HEAVY TRUCKS = 0

WEATHER = C WEATHER AND ROAD CODES  
VISIBILITY = 0 PAVEMENT = 0

DETECTION AND VERIFICATION  
DETECTED AT 0: 0: 0 BY CODE  
VERIFIED AT 0: 0: 0 BY CODE

LAND MARKS  
SIGN = 0 CALL BOX = 0  
LBBP STATION = 0 POST MILE = 0. 0

INCIDENT FREEWAY GEOMETRY

	M	1	2	3	4	5	6	S	R	S	C	C	S	COMMENTS
GEOMETRY	1	1	1	1	1	1	0	1	1	1	1	1	1	

ADDITIONAL COMMENT LINES

BUS DRIVERS ON STRIKE, POSSIBLE HEAVY TRAFFIC

TAPE NO. 74090455      TRAFFIC CODE = 5      FROM 11: 0: 0  
TO 13:55: 0

INCIDENT LOCATION: SD32S TO SD 1S

AFFECTED SEGMENTS: 1

SEGMENT(1) SD32S TO SD 1S

INCIDENT TYPE:

VEHICLES INVOLVED: 0  
LIGHT DUTY VEHICLES = 0    LIGHT TRUCKS = 0    HEAVY TRUCKS = 0

WEATHER AND ROAD CODES  
WEATHER = C      VISIBILITY = S      PAVEMENT = 0

DETECTION AND VERIFICATION  
DETECTED AT 0: 0: 0 BY CODE  
VERIFIED AT 0: 0: 0 BY CODE

LAND MARKS  
SIGN = 0      CALL BOX = 0  
LOOP STATION = 0      POST MILE = 0. 0

INCIDENT FREEWAY GEOMETRY

	M	1	2	3	4	5	6	S	R	S	C	C	S	COMMENTS
GEOMETRY	1	1	1	1	1	1	0	1	1	1	1	1	1	

ADDITIONAL COMMENT LINES

BUS DRIVERS ON STRIKE, POSSIBLE HEAVY TRAFFIC

TAPE NO. 7409045b      TRAFFIC CODE = 5      FROM 16: 0: 0  
TO      18:55: 0

INCIDENT LOCATION: SD32S TO SD 1S

AFFECTED SEGMENTS: 1

SEGMENT(1) SD32S TO SD 1S

INCIDENT TYPE:

VEHICLES INVOLVED: 0

LIGHT DUTY VEHICLES = 0    LIGHT TRUCKS = 0    HEAVY TRUCKS = 0

WEATHER AND ROAD CODES

WEATHER = C

VISIBILITY = S

PAVEMENT = D

DETECTION AND VERIFICATION

DETECTED AT 0: 0: 0 BY CODE

VERIFIED AT 0: 0: 0 BY CODE

LAND MARKS

SIGN = 0

CALL BOX = 0

LOOP STATION = 0

POST MILE = 0. 0

INCIDENT FREEWAY GEOMETRY

	M	1	2	3	4	5	6	S	R	S	C	C	S	COMMENTS
GEOMETRY	1	1	1	1	1	1	0	1	1	1	1	1	1	

ADDITIONAL COMMENT LINES

BUS DRIVERS ON STRIKE, POSSIBLE HEAVY TRAFFIC



TAPE NO. 74090457      TRAFFIC CODE = 7      FROM 21: 0: 0  
TO 23:55: 0

INCIDENT LOCATION: SD32S TO SD 1S

AFFECTED SEGMENTS: 1

SEGMENT(1) SD32S TO SD 1S

INCIDENT TYPE:

VEHICLES INVOLVED: 0  
LIGHT DUTY VEHICLES = 0    LIGHT TRUCKS = 0    HEAVY TRUCKS = 0

WEATHER AND ROAD CODES  
WEATHER = C      VISIBILITY = 0      PAVEMENT = 0

DETECTION AND VERIFICATION  
DETECTED AT 0: 0: 0 BY CODE  
VERIFIED AT 0: 0: 0 BY CODE

LAND MARKS  
SIGN = 0      CALL BOX = 0  
LOOP STATION = 0      POST MILE = 0. 0

INCIDENT FREEWAY GEOMETRY

	M	1	2	3	4	5	6	S	R	S	C	C	S	COMMENTS
GEOMETRY	1	1	1	1	1	1	0	1	1	1	1	1	1	

ADDITIONAL COMMENT LINES

BUS DRIVERS ON STRIKE, POSSIBLE HEAVY TRAFFIC

TAPE NO. 74090458      TRAFFIC CODE = 5      FROM 6:30: 0  
TH 9:25: 0

INCIDENT LOCATION: HA 1N TO HA25N

AFFECTED SEGMENTS: 1

SEGMENT(1) HA 1N TO HA25N

INCIDENT TYPE:

VEHICLES INVOLVED: 0

LIGHT DUTY VEHICLES = 0    LIGHT TRUCKS = 0    HEAVY TRUCKS = 0

WEATHER AND ROAD CODES

WEATHER = C

VISIBILITY = 0

PAVEMENT = D

DETECTION AND VERIFICATION

DETECTED AT 0: 0: 0 BY CODE

VERIFIED AT 0: 0: 0 BY CODE

LAND MARKS

SIGN = 0

CALL BOX = 0

LOOP STATION = 0

POST MILE = 0. 0

INCIDENT FREEWAY GEOMETRY

	M	1	2	3	4	5	6	S	R	S	C	C	S	COMMENTS
GEOMETRY	1	1	1	1	1	0	0	1	1	1	1	1	1	

ADDITIONAL COMMENT LINES

BUS DRIVERS ON STRIKE, POSSIBLE HEAVY TRAFFIC

TAPE NO. 74090459      TRAFFIC CODE = 7      FROM 21: 0: 0  
TO      23:55: 0

INCIDENT LOCATION: HA 1N TO HA25N

AFFECTED SEGMENTS: 1

SEGMENT(1) HA 1N TO HA25N

INCIDENT TYPE:

VEHICLES INVOLVED: 0  
LIGHT DUTY VEHICLES = 0    LIGHT TRUCKS = 0    HEAVY TRUCKS = 0

WEATHER AND ROAD CODES  
WEATHER = C      VISIBILITY = D      PAVEMENT = D

DETECTION AND VERIFICATION  
DETECTED AT 0: 0: 0 BY CODE  
VERIFIED AT 0: 0: 0 BY CODE

LAND MARKS  
SIGN = 0      CALL BOX = 0  
LOOP STATION = 0      POST MILE = 0. 0

INCIDENT FREEWAY GEOMETRY

	M	1	2	3	4	5	6	S	R	S	C	C	S	COMMENTS
GEOMETRY	1	1	1	1	1	0	0	1	1	1	1	1	1	

ADDITIONAL COMMENT LINES

BUS DRIVERS ON STRIKE, POSSIBLE HEAVY TRAFFIC

TAPE NB. 74090460      TRAFFIC CODE = 5      FROM 16: 0: 0  
TO 18:55: 0

INCIDENT LOCATION: HA25S TO HA 1S

AFFECTED SEGMENTS: 1

SEGMENT(1) HA25S TO HA 1S

INCIDENT TYPE:

VEHICLES INVOLVED: 0  
LIGHT DUTY VEHICLES = 0    LIGHT TRUCKS = 0    HEAVY TRUCKS = 0

WEATHER AND ROAD CODES  
WEATHER = C      VISIBILITY = S      PAVEMENT = D

DETECTION AND VERIFICATION  
DETECTED AT 0: 0: 0 BY CODE  
VERIFIED AT 0: 0: 0 BY CODE

LAND MARKS  
SIGN = 0      CALL BOX = 0  
LOOP STATION = 0      POST MILE = 0. 0

INCIDENT FREEWAY GEOMETRY

	M	1	2	3	4	5	6	S	R	S	C	C	S	COMMENTS
GEOMETRY	1	1	1	1	1	0	0	1	1	1	1	1	1	

ADDITIONAL COMMENT LINES

BUS DRIVERS ON STRIKE, POSSIBLE HEAVY TRAFFIC

TAPE NO. 74090462      TRAFFIC CODE = 5      FROM 6:30: 0  
TO 9:25: 0

INCIDENT LOCATION: SM 1E TO SM27E

AFFECTED SEGMENTS: 1

SEGMENT(1) SM 1E TO SM27E

INCIDENT TYPE:

VEHICLES INVOLVED: 0  
LIGHT DUTY VEHICLES = 0    LIGHT TRUCKS = 0    HEAVY TRUCKS = 0

WEATHER AND ROAD CODES  
WEATHER = C    VISIBILITY = 0    PAVEMENT = 0

DETECTION AND VERIFICATION  
DETECTED AT 0: 0: 0 BY CODE  
VERIFIED AT 0: 0: 0 BY CODE

LAND MARKS  
SIGN = 0    CALL BOX = 0  
LOOP STATION = 0    POST MILE = 0. 0

INCIDENT FREEWAY GEOMETRY

	M	1	2	3	4	5	6	S	R	S	C	C	S	COMMENTS
GEOMETRY	1	1	1	1	1	1	1	1	1	1	1	1	1	

ADDITIONAL COMMENT LINES

BUS DRIVERS ON STRIKE, POSSIBLE HEAVY TRAFFIC  
AT 08:23, TC ON R/S AT SM13E  
AT 08:59, TC IN C/D AT SM19E

TAPE NO. 74090463      TRAFFIC CODE = 7      FROM 21: 0: 0  
TO 23:55: 0

INCIDENT LOCATION: SM 1E TO SM27E

AFFECTED SEGMENTS: 1

SEGMENT(1) SM 1E TO SM27E

INCIDENT TYPE:

VEHICLES INVOLVED: 0  
LIGHT DUTY VEHICLES = 0    LIGHT TRUCKS = 0    HEAVY TRUCKS = 0

WEATHER AND ROAD CODES  
WEATHER = C      VISIBILITY = 0      PAVEMENT = D

DETECTION AND VERIFICATION  
DETECTED AT 0: 0: 0 BY CODE  
VERIFIED AT 0: 0: 0 BY CODE

LAND MARKS  
SIGN = 0      CALL BOX = 0  
LOOP STATION = 0      POST MILE = 0. 0

INCIDENT FREEWAY GEOMETRY

	M	1	2	3	4	5	6	S	R	S	C	C	S	COMMENTS
GEOMETRY	1	1	1	1	1	1	1	1	1	1	1	1	1	

ADDITIONAL COMMENT LINES

BUS DRIVERS ON STRIKE, POSSIBLE HEAVY TRAFFIC

TAPE NO: 74090464 TRAFFIC CODE = 7 FROM 16: 0: 0  
TO 16:55: 0

INCIDENT LOCATION: SM28W TO SM 1W

AFFECTED SEGMENTS: 1

SEGMENT(1) SM28W TO SM 1W

INCIDENT TYPE:

VEHICLES INVOLVED: 0  
LIGHT DUTY VEHICLES = 0 LIGHT TRUCKS = 0 HEAVY TRUCKS = 0

WEATHER = C WEATHER AND ROAD CODES  
VISIBILITY = S PAVEMENT = D

DETECTION AND VERIFICATION  
DETECTED AT 0: 0: 0 BY CODE  
VERIFIED AT 0: 0: 0 BY CODE

LAND MARKS  
SIGN = 0 CALL BOX = 0  
LOOP STATION = 0 POST MILE = 0. 0

INCIDENT FREEWAY GEOMETRY

	M	1	2	3	4	5	6	S	R	S	C	C	S	COMMENTS
GEOMETRY	1	1	1	1	1	1	1	1	1	1	1	1	1	

ADDITIONAL COMMENT LINES

BUS DRIVERS ON STRIKE, POSSIBLE HEAVY TRAFFIC  
AT 17:06, DISL VEH AT SM27W

TAPE NO. 74090465

TRAFFIC CODE = 7

FROM 21: 0: 0

TO 23:55: 0

INCIDENT LOCATION: SM28W TO SM 1W

AFFECTED SEGMENTS: 1

SEGMENT(1) SM28W TO SM 1W

INCIDENT TYPE:

VEHICLES INVOLVED: 0

LIGHT DUTY VEHICLES = 0 LIGHT TRUCKS = 0 HEAVY TRUCKS = 0

WEATHER AND ROAD CODES

WEATHER =C

VISIBILITY =D

PAVEMENT =D

DETECTION AND VERIFICATION

DETECTED AT 0: 0: 0 BY CODE

VERIFIED AT 0: 0: 0 BY CODE

LAND MARKS

SIGN = 0

CALL BOX = 0

LOOP STATION = 0

POST MILE = 0: 0

INCIDENT FREEWAY GEOMETRY

	M	1	2	3	4	5	6	S	R	S	C	C	S	COMMENTS
GEOMETRY	1	1	1	1	1	1	1	1	1	1	1	1	1	

ADDITIONAL COMMENT LINES

BUS DRIVERS ON STRIKE, POSSIBLE HEAVY TRAFFIC



## APPENDIX C

This set of tables gives the post mile locations of freeway call boxes and loop stations on the Santa Monica, San Diego and Harbor Freeways. Also included is a table which gives the locations of the changeable message signs on the Santa Monica Freeway.

<u>TABLE OF CONTENTS</u>	<u>PAGE</u>
1. CALL BOX LOCATIONS	43-46
A. SANTA MONICA FREEWAY	43
B. SAN DIEGO FREEWAY	44-45
C. HARBOR FREEWAY	46
2. LOOP STATIONS	47-49
A. SANTA MONICA FREEWAY	47
B. SAN DIEGO FREEWAY	48
C. HARBOR FREEWAY	49
3. CHANGEABLE MESSAGE SIGNS - SANTA MONICA FREEWAY	50

# 1. CALL BOX

## A. SANTA MONICA FREEWAY

Call Box Number	Post Mile	Call Box Number	Post Mile	Call Box Number	Post Mile
101	35.12	151	6.46	210	12.90
102	35.12	152	6.44	211	13.09
103	2.24	153	6.69	212	13.23
104	2.24	154	6.71	215	13.43
105	2.57	155	6.97	216	13.43
106	2.50	156	6.97	217	13.78
107	2.73	157	7.27	218	13.68
108	2.73	158	7.32	221	14.06
109	3.03	159	7.52	222	14.14
110	3.03	160	7.52	223	14.07
111	3.29	161	7.77	224	14.16
112	3.29	162	7.77	225	14.33
113	3.67	163	7.99	226	14.34
114	3.65	164	7.97	227	14.34
115	3.86	165	8.29	228	14.34
116	3.86	166	8.29	229	14.58
117	4.18	167	8.53	230	14.57
118	4.13	168	8.51	231	14.59
121	4.39	169	8.83	232	14.59
122	4.39	170	8.82	233	14.59
123	4.71	171	9.07	234	14.60
124	4.65	172	9.07	235	14.86
125	4.96	173	9.31	236	14.89
126	4.96	174	9.28	237	14.90
127	5.24	176	9.49	238	14.91
128	5.21	179	10.08	239	14.93
129	5.24	182	10.29	240	14.87
131	5.24	183	10.40	241	14.90
134	5.40	184	10.48	242	15.20
136	?	187	10.68	243	15.23
137	5.53	188	10.69	244	15.25
139	5.53	189	11.02	245	15.23
142	5.65	190	11.00	246	15.49
143	5.82	201	12.37	247	15.33
145	5.82	202	12.47		
148	5.94	205	12.63		
149	6.19	206	12.67		
150	6.19	209	12.85		

# 1. CALL BOX

## B. SAN DIEGO FREEWAY

Call Box Number	Post Mile	Call Box Number	Post Mile	Call Box Number	Post Mile
207	12.52	261	17.47	318	22.53
208	12.53	262	17.47	319	22.66
209	12.66	263	17.66	320	22.66
211	12.67	264	17.71	321	22.89
214	12.79	265	17.86	322	22.66
216	12.79	266	17.89	323	22.89
218	12.95	267	18.14	324	22.89
220	12.93	268	18.14	325	23.11
222	12.93	269	18.38	326	22.89
223	13.01	270	18.38	328	23.12
225	13.05	271	18.62	329	23.37
227	13.10	272	18.61	330	23.12
229	13.40	273	18.90	331	23.62
230	13.37	274	18.93	332	23.37
231	13.48	275	19.11	334	23.62
232	13.58	276	19.11	335	23.94
233	13.73	279	19.36	336	23.93
234	13.80	280	19.33	337	24.18
235	13.99	281	19.68	338	24.17
236	14.05	282	19.68	339	24.35
237	14.35	283	19.90	340	24.35
238	14.35	284	19.88	341	24.63
239	14.58	286	20.01	342	24.63
240	14.57	287	20.21	343	24.83
241	14.87	288	20.32	344	24.83
242	14.87	289	20.53	346	25.09
243	15.09	290	20.53	347	25.41
244	15.10	291	20.82	348	25.43
245	15.33	292	20.94	349	25.64
246	15.39	297	21.21	350	25.66
247	15.61	298	21.17	351	25.89
248	15.63	300	21.17	352	25.89
249	15.91	301	21.54	353	26.15
250	15.92	302	21.35	354	26.14
251	16.19	303	21.54	355	26.43
252	16.19	304	21.72	356	26.43
253	16.48	305	21.54	357	26.71
254	16.48	306	21.72	358	26.71
255	16.67	309	21.95	359	27.05
256	16.67	310	21.95	360	27.05
257	16.92	311	22.21	361	27.29
258	16.92	312	22.20	362	27.35
259	17.20	315	22.41	363	27.58
260	17.20	317	22.44	364	27.58

# 1. CALL BOX

## B. SAN DIEGO FREEWAY (Continued)

Call Box Number	Post Mile	Call Box Number	Post Mile	Call Box Number	Post Mile
367	27.94	377	29.22	389	29.89
368	28.02	378	29.22	391	30.05
369	28.14	379	29.45	392	30.05
370	28.14	381	29.48	393	30.73
371	28.40	382	29.49	394	30.36
372	28.40	383	29.59	395	30.62
373	28.67	384	29.60	396	30.61
374	28.67	386	29.60	397	30.89
375	28.92	388	29.81	398	30.86
376	28.91				

# 1. CALL BOX

## C. HARBOR FREEWAY

Call Box Number	Post Mile	Call Box Number	Post Mile	Call Box Number	Post Mile
163	7.90	200	11.93	235	16.49
164	7.90	201	12.21	236	16.47
165	8.22	202	12.21	237	16.75
166	8.22	203	12.42	238	16.76
167	8.40	204	12.43	239	17.02
168	8.39	205	12.60	240	17.02
169	8.68	206	12.60	241	17.26
170	8.63	207	12.95	242	17.26
171	8.90	208	12.98	243	17.49
172	8.90	209	13.13	244	17.49
173	9.10	210	13.09	245	17.82
174	9.10	211	13.41	246	17.73
175	9.32	212	13.42	247	18.14
176	9.32	213	13.67	248	18.14
177	9.44	214	13.66	249	18.34
178	9.44	215	13.94	250	18.34
179	9.76	216	13.94	251	18.58
180	9.76	217	14.14	252	18.56
183	10.01	218	14.14	253	18.79
184	10.00	219	14.45	254	18.80
185	10.36	220	14.45	255	19.03
186	10.36	221	14.70	256	19.04
187	10.54	222	14.72	257	19.28
188	10.54	223	15.04	258	19.28
189	10.78	224	15.04	259	19.60
190	10.78	225	15.26	260	19.58
191	10.97	226	15.26	261	19.80
192	10.97	227	15.52	262	19.83
193	11.17	228	15.51	263	20.09
194	11.17	229	15.73	264	20.12
195	11.44	230	15.72	265	20.28
196	11.44	231	16.02	266	20.30
197	11.65	232	16.06	267	20.56
198	11.65	233	16.29	268	20.62
199	11.93	234	16.30	269	20.80
				270	20.82
				271	21.01
				272	21.03
				273	21.31
				274	21.34
				275	21.55
				276	21.55
				280	21.80
				279	21.75

## 2. LOOP STATION

### A. SANTA MONICA FREEWAY

Station Loop	Station Number	Post Mile
SM-1	86+20	1.60
2	32+73	2.17
3	56+65	2.62
4	81+07	3.09
5	99+20	3.43
6	125+70	3.93
7	148+40	4.36
8	182+04	4.77
9	204+60	5.20
10	226+23	5.61
11	255+12	6.15
12	285+59	6.73
13	342+05	7.20
14	374+15	7.81
15	402+65	8.33
16	423+10	8.72
17	448+05	9.22
18	450+00	9.80
19	473+55	10.24
20	497+65	10.70
21	516+34	11.05
22	541+38	11.53
23	578+78	12.24
24	596+88	12.58
25	616+90	12.96
26	647+15	13.53
27	678+09	14.12
28	709+80	14.72

## 2. LOOP STATION

### B. SAN DIEGO FREEWAY

Station Loop	Station Number	Post Mile
SD-2	718+80	13.76
3	745+80	14.27
4	778+90	14.90
5	813+80	15.62
6	844+05	16.19
7	868+65	16.65
8	886+00	16.98
9	904+15	17.32
10	930+20	17.82
11	949+50	18.19
12	971+65	18.61
13	1000+70	19.16
14	1022+95	19.58
15		
16	1077+00	20.60
17	1102+30	21.08
18	1136+50	21.73
19	594+07	22.21
20	620+11	22.70
21	642+25	23.12
22	666+63	23.58
23	702+13	24.25
24	723+35	24.65
25	754+32	25.22
26	786+28	25.83
27	803+80	26.15
28	840+17	26.84
29	867+60	27.36
31	21+92	28.39
32	62+40	29.15

## 2. LOOP STATIONS

### C. HARBOR FREEWAY

Station Loop	Station Number	Post Mile
H-1/SD-1	686+05	9.49
H-1/SD-1	662+40	9.04
H-2	696+02	9.68
3	732+80	10.38
4	756+30	10.82
5	780+80	11.29
6	809+33	11.83
7	831+20	12.25
8	859+60	12.79
9	877+73	13.13
10	913+70	13.81
11	940+40	14.32
12	968+65	14.85
13	1120+80	15.36
14	1149+30	15.90
15	1187+80	16.62
16	1214+20	17.12
17	1228+58	17.40
18	1254+30	17.88
19	1276+05	18.30
20	1306+87	18.88
21	1331+20	19.34
22	1347+30	19.66
23A	1336+49	19.45
23	1371+20	20.11
24	1393+20	20.53
25	1425+37	21.12



### 3. MESSAGE SIGN - SANTA MONICA FREEWAY

Sign	Station Number	Post Mile
E-1	55+85	2.61
2	104+70	3.53
3	126+35	3.94
4	181+79	4.77
5	215+73	5.41
6	255+12	6.15
7	288+89	6.79
8	361+65	7.57
9	402+45	8.33
10	437+05	8.99
11	442+00	9.08
12	473+55	10.24
13	497+65	10.70
14	525+24	11.22
15	549+88	11.69
16	577+48	12.21
17	616+90	12.96
18	654+65	13.67
W-19	676+09	14.08
20	647+15	13.53
21	605+48	12.74
22	557+58	11.84
23	525+24	11.22
24	497+65	10.70
25	455+00	9.36
26	437+05	8.99
27	402+45	8.33
28	351+55	7.38
29	288+89	6.79
30	255+12	6.15
31	208+90	5.28
32	181+79	4.77
33	140+40	4.21
34	104+70	3.53
35	56+45	2.62

## APPENDIX D

This appendix gives a glossary of the abbreviations and codes that are used in the documentation information for the individual data sets.

### GLOSSARY OF TERMS

- (1) VPH - Vehicles per hour
- (2) LAAFSCP - Los Angeles Area Freeway Surveillance and Control Project
- (3) T.C. - Traffic collision (T/C)
- (4) CHP - California Highway Patrol
- (5) C/D - Center divider or center median
- (6) Break (traffic) - Highway Patrol escorting a queue of vehicles to enable removal of a traffic hazard
- (7) Veh - Vehicle
- (8) Arr - Arrived
- (9) 1098 - California Highway Patrol code for assignment completed or leaving the scene
- (10) 1097 - California Highway Patrol code for arriving at the scene
- (11) LN - Lane
- (12) G.O.A. - Gone on arrival
- (13) Amb - Ambulance
- (14) CHPM - California Highway Patrol Motorcycle unit
- (15) DOT - California Department of Transportation (Caltrans)
- (16) Repts - Reports
- (17) O/C - Overcrossing
- (18) Maint - Caltrans Maintenance
- (19) P.U. - Public Utility
- (20) UTL - Unable to locate
- (21) R/S - Right shoulder
- (22) Ped - Pedestrian
- (23) Collector - Collector-distributor road
- (24) Mtrst - Motorist
- (25) Flatbed - Flatbed truck
- (26) M/C - Motorcycle
- (27) N/B - Northbound
- (28) S/B - Southbound
- (29) SDF - San Diego Freeway
- (30) PU TK - Pick Up Truck
- (31) CMS - Changeable Message Sign

APPENDIX E  
 NUMERICAL DATA SET INDEXES  
 INCIDENT DATA

<u>Data Set</u>	<u>Loop Station Limits</u>	<u>Time</u>
74031201-2	HA14N to HA23N	1535 to 1800
74031301-2	SM19E to SM25E	1510 to 1640
74031302-3	HA25S to HA22S	1320 to 1505
74031303-2	HA25S to HA01S	1641 to 1855
74031401-3	SM28W to SM17W	1345 to 1705
74031402-2	SM21E to SM22E	1410 to 1545
74032102-1	HA24S to HA23S	1801 to 1950
74032201-3	HA13S to HA14S	1235 to 1420
74032202-1	SM22W to SM20W	1710 to 1930
74032203-3	SM22E to SM24E	1745 to 1925
74032204-2	SM22W to SM24W	1755 to 1930
74032502-1	HA20S to HA18S	1455 to 1644
74032603-1	HA22N to HA24N	1530 to 1730
74032901-1	SM28W to SM26W	1655 to 1845
74032902-1	SD15S to SD13S	1710 to 1920
74040101-2	HA18N to HA20N	1450 to 1720
74040102-2	HA19N to HA21N	1615 to 1805
74040103-2	SM21W to SM19W	1720 to 1910
74040301-3	HA12S to HA10S	1405 to 1550
74040302-2	HA23S to HA25S	1500 to 1625
74040401-2	SM14W to SM12W	1420 to 1715
74041603-1	SM22E to SM23E	0945 to 1115
74041901-3	HA10N to HA08N	1520 to 1745
74042201-1	SM21E to SM22E	0850 to 1030
74042401-2	SM22E to SM23E	0600 to 0730
74042402-2	SM22E to SM23E	0635 to 0805
74042403-1	SM16E to SM17E	0655 to 0845
74042601-3	SM22W to SM21W	0645 to 0815
74042602-1	SM22E to SM23E	0720 to 1030
74042605-2	HA20S to HA19S	1400 to 1615
74042606-1	SD16S to SD15S	1540 to 1740
74051501-2	SM25E to SM26E	0645 to 0840
74051502-2	SD09N to SD10N	0710 to 0900
74051503-1	SM19E to SM20E	0800 to 0930
74052101-1	SM19E to SM20E	0730 to 1000
74052102-2	HA19N to HA20N	0835 to 0950
74052201-2	HA10N to HA11N	0750 to 0930
74052202-3	SM22W to SM21W	1330 to 1530
74052203-2	SM26W to SM25W	1535 to 1735
74052204-2	HA20N to HA21N	1545 to 1800
74052301-4	SM04W to SM03W	1530 to 1700
74052302-3	SM27W to SM26W	1600 to 1830
74052303-2	SM13W to SM12W	1600 to 1830
74052304-3	SM12W to SM11W	1615 to 1830

### INCIDENT DATA (CONTINUED)

<u>Data Set</u>	<u>Loop Station Limits</u>	<u>Time</u>
74052305-1	SM14W to SM13W	1630 to 1830
74052306-1	SM27W to SM26W	1700 to 1830
74052401-2	SM17E to SM18E	0700 to 0845
74052402-3	SD24N to SD25N	0830 to 1030
74052403-2	SD31N to SD32N	1410 to 1825
74052404-1	SM22W to SM21W	1540 to 1700
74052802-1	SM13E to SM14E	0700 to 0830
74052804-1	SD28S to SD27S	0840 to 1040
74052902-3	SM27W to SM26W	0720 to 0850
74053001-3	SM14E to SM15E	0605 to 0930
74053003-1	SD29N to SD30N	0710 to 0945
74053004-1	HA18N to HA19N	0710 to 0850
74060301-3	SM06W to SM05W	0720 to 0930
74060601-2	SM25W to SM24W	1355 to 1535
74060501-1	HA16N to HA17N	0730 to 0955
74060701-1	SM21E to SM22E	0731 to 0855
74061301-1	SD16S to SD15S	1545 to 1930
74061302-2	SD30S to SD29S	1445 to 1915
74061701-1	SM13E to SM14E	0800 to 1015
74061901-2	SM22W to SM21W	1630 to 1900
74062401-1	SM25E to SM26E	0835 to 0955
74062402-1	HA20N to HA21N	0820 to 1030
74062501-1	SM21E to SM22E	0700 to 1030
74062502-1	HA19N to HA20N	0715 to 1030
74062503-1	HA18N to HA19N	0850 to 1025
74062505-2	SM21E to SM22E	0820 to 0950
74062502-2	SM25W to SM24W	0900 to 1115
74062503-3	SD22S to SD21S	1545 to 1730
74070102-2	SM21E to SM22E	0650 to 0900
74070201-2	SM17E to SM18E	0815 to 0940
74070202-2	SM22E to SM23E	0830 to 1020
74070302-4	SM02W to SM03W	0815 to 0940
74070304-2	HA12N to HA13N	0700 to 0855
74071101-3	SD28N to SD29N	1220 to 1500
74071201-4	SM05W to SM04W	0545 to 0720
74072501-1	SD28S to SD27S	0725 to 0930
74073001-3	SD27S to SD26S	0540 to 0830
74081201-2	SM22E to SM23E	1430 to 1730
74083001-1	SD29N to SD30N	1345 to 1645
74100201-3	SD30N to SD31N	1040 to 1410
74100701-1	SD28N to SD30N	0630 to 0930
74100702-1	SD31N to SD32N	0630 to 0930

## INCIDENT DATA (CONTINUED)

<u>Data Set</u>	<u>Loop Station Limits</u>	<u>Time</u>
74100703-2	SD30N to SD31N	1500 to 1800
74100704-2	SD29S to SD28S	1500 to 1800
74100706-2	SD29S to SD28S	1500 to 1800
74100707-3	SD26S to SD25S	1500 to 1800
74100708-2	SD25N to SD26N	1500 to 1800
74100710-3	SD25S to SD24S	1500 to 1800
76100711-3	SM03E to SM04E	0630 to 0930
74100712-3	SM06E to SM07E	0630 to 0930
74100713-4	SM02W to SM01W	0630 to 0930
74100714-4	SM07W to SM06W	0630 to 0930
74100715-1	SM11E to SM12E	0630 to 0930
74100716-3	SM10W to SM09W	0630 to 0930
74100717-1	SM10E to SM11E	0630 to 0930
74100718-2	SM21E to SM22E	1515 to 1730
74100719-1	SM22W to SM21W	1530 to 1710
74100720-2	SM22E to SM23E	1600 to 1800
74100801-2	SD31N to SD32N	0630 to 1040
74100802-3	SD30S to SD29S	0630 to 1040
74100803-3	SD26N to SD27N	0630 to 1040
74100804-3	SD32S to SD22S	0630 to 1040
74100805-2	SD29N to SD30N	1515 to 1815
74100806-3	SD32S to SD24S	1515 to 1910
74100807-3	SM09W to SM08W	0630 to 0930
74100808-2	SD23N to SD24N	0630 to 0930
74100809-2	SD27N to SD28N	0845 to 1040
74100810-3	SD03N to SD02N	1515 to 1815
74100901-1	SD29N to SD30N	0630 to 0930
74100902-1	SD27N to SD28N	0630 to 0930
74100903-1	SD32S to SD24S	0630 to 0955
74100904-1	SM25W to SM26W	1615 to 1800
74100906-2	SD30N to SD31N	1530 to 1830
74101002-3	SD32S to SD31S	0815 to 0925
74101003-1	SD30N to SD31N	1535 to 1830
74101004-2	SD30S to SD29S	1535 to 1830
74101005-2	SD25N to SD29N	1535 to 1830
74101006-3	SD26N to SD27N	1535 to 1830
74101007-1	SD31N to SD32N	1535 to 1830
74101008-3	SD32S to SD31S	1535 to 1830
74101009-1	SM22W to SM21W	1600 to 1800
74101011-3	SM09E to SM10E	0630 to 0930
74101101-2	SD27S to SD26S	0630 to 0930
74101102-3	SD27N to SD29N	0630 to 0930

## INCIDENT DATA (CONTINUED)

<u>Data Set</u>	<u>Loop Station Limits</u>	<u>Time</u>
74101103-1	SD29S to SD27S	0635 to 0930
74101104-2	SD26S to SD24S	0635 to 0935
74101105-3	SD28N to SD29N	0630 to 0930
74101106-2	SD27S to SD26S	0630 to 0930
74101107-1	SD28N to SD30N	1630 to 1830
74111402-1	HA18N to HA20N	0700 to 0915
74120502-3	SM23W to SM22W	0620 to 0800
74120503-2	SM26E to SM27E	0700 to 0845
74120505-1	SM25E to SM26E	0715 to 0915
74120507-1	SM25E to SM26E	0730 to 0955
74120508-1	SM16E to SM18E	0755 to 0930
75012301-2	SM22W to SM21W	1625 to 1845
75012302-2	SM23E to SM24E	1630 to 1745
75012303-1	SM25W to SM24W	1655 to 1840
75012305-1	SM23W to SM22W	1715 to 1915
75012401-2	SM21W to SM22W	0700 to 0830
75022701-1	SM13E to SM14E	0730 to 0930
75022801-3	HA24N to HA25N	1255 to 1430
75032401-2	SM15W to SM13W	1545 to 1720
75032402-1	SM25W to SM24W	1550 to 1750
75032403-2	SM20W to SM19W	1630 to 1800
75032404-1	SM26W to SM25W	1650 to 1825
75032601-2	SM25W to SM24W	1450 to 1630
75032602-2	SM20W to SM18W	1505 to 1635

## NON-INCIDENT DATA

<u>Data Set</u>	<u>Loop Station Limits</u>	<u>Time</u>
74042350-5	HA01N to HA25N	0630 to 0925
74042351-5	SD32S to SD01S	0630 to 0925
74042352-5	SD01N to SD32N	0630 to 0925
74042354-6	SM28W to SM01W	0630 to 0925
74042355-5	SM01E to SM27E	1100 to 1355
74042356-6	SM01E to SM27E	1600 to 1855
74042357-7	SM01E to SM27E	2100 to 2355
74042358-6	SM28W to SM01W	1100 to 1355
74042359-5	SM28W to SM01W	1600 to 1855
74042360-8	SM28W to SM01W	2100 to 2355
74042361-6	SD32S to SD01S	1100 to 1355
74042362-5	SD32S to SD01S	1600 to 1855

## NON-INCIDENT DATA (CONTINUED)

<u>Data Set</u>	<u>Loop Station Limits</u>	<u>Time</u>
74042363-8	SD32S to SD01S	2100 to 2355
74042364-6	HA01N to HA25N	1100 to 1355
74042365-5	HA01N to HA25N	1600 to 1855
74042366-7	HA01N to HA25N	2100 to 2355
74042367-6	SD01N to SD32N	1100 to 1355
74042368-5	SD01N to SD32N	1600 to 1855
74042369-7	SD01N to SD32N	2100 to 2300
74042370-6	HA25S to HA01S	0630 to 0925
74042371-6	HA25S to HA01S	1100 to 1355
74042372-5	HA25S to HA01S	1600 to 1855
74061051-6	SM01E to SM27E	1100 to 1400
74061052-5	SM01E to SM27E	1600 to 1900
74061053-6	SM28W to SM01W	0630 to 0930
74061054-6	SM28W to SM01W	1100 to 1400
74061055-5	SM28W to SM01W	1600 to 1900
74061056-	SD01N to SD32N	0630 to 0930
74061057-6	SD01N to SD32N	1100 to 1400
74061059-5	SD32S to SD01S	0630 to 0930
74061060-6	SD32S to SD01S	1100 to 1400
74090450-6	SD01N to SD32N	0630 to 0830
74090451-7	SD01N to SD32N	1100 to 1355
74090452-5	SD01N to SD32N	1600 to 1855
74090453-6	SD01N to SD32N	1100 to 2355
74090454-5	SD32S to SD01S	0630 to 0925
74090455-5	SD32S to SD01S	1100 to 1355
74090456-5	SD32S to SD01S	1600 to 1855
74090457-7	SD32S to SD01S	2100 to 2355
74090458-5	HA01N to HA25N	0630 to 0925
74090459-7	HA01N to HA25N	2100 to 2355
74090460-5	HA25S to HA01S	1600 to 1855
74090462-5	SM01E to SM27E	0630 to 0925
74090463-7	SM01E to SM27E	2100 to 2355
74090464-7	SM28W to SM01W	1600 to 1855