

# VARIABLE MESSAGE SIGN OPERATIONS MANUAL

## FINAL REPORT

Submitted by  
Conrad L. Dudek, Ph.D., P.E.  
Professor of Civil Engineering  
Texas A&M University  
and  
Associate Director, SWUTC

With Contributions by  
Gerald L. Ullman, Ph.D., P.E.  
Program Manager

Texas Transportation Institute  
Texas A&M University System  
College Station, Texas 77843-3135

In Cooperation with  
New Jersey Department of Transportation  
Division of Research and Technology

and

U.S. Department of Transportation  
Federal Highway Administration

December 2001



1. Report No. FHWA-NJ-2001-10		2. Government Accession No.		3. Recipient's Catalog No.	
4. Title and Subtitle VARIABLE MESSAGE SIGN OPERATIONS MANUAL				5. Report Date December 2001	
				6. Performing Organization Code	
7. Author(s) Conrad L. Dudek  With Contributions By: Gerald L. Ullman				8. Performing Organization Report No.	
9. Performing Organization Name and Address Texas Transportation Institute The Texas A&M University System College Station, Texas 77843-3135				10. Work Unit No. (TRAIS)	
				11. Contract or Grant No. Contract No. 71401-092496	
12. Sponsoring Agency Name and Address New Jersey Department of Transportation Division of Research and Technology P. O. Box 600 Trenton, New Jersey 08625-0600				13. Type of Report and Period Covered Research: November 1996 – December 2001	
				14. Sponsoring Agency Code	
15. Supplementary Notes Research performed in cooperation with the New Jersey Department of Transportation and the U.S. Department of Transportation, Federal Highway Administration. Research Project Title: VMS and HAR Message Research Project					
16. Abstract Project  This <i>Variable Message Sign Operations Manual</i> was written for use by New Jersey Department of Transportation (NJDOT) personnel who have responsibility for the operation of and/or message design for large permanent variable message signs (VMSs) or portable VMSs. The Manual, which contains the latest and best information and practices, is designed to help both new and experienced users of VMSs at various levels of the agency including 1) entry level personnel, 2) personnel very experienced with traffic operations, and 3) managers. It provides very specific information for entry-level personnel, reminders for experienced personnel and higher-level information for managers regardless whether or not they work in one of the Traffic Operations Centers (TOCs) in the state.  The <i>Variable Message Sign Operations Manual</i> contains the following sixteen modules: 1) Introduction; 2) Principles of Variable Message Sign Operations; 3) VMS Operating Policy for New Jersey Department of Transportation; 4) VMS Operating Fundamentals; 5) Principles of VMS Message Design; 6) Designing the Basic VMS Message for Incidents; 7) Designing the Basic VMS Message for Roadwork; 8) Establishing the Maximum Message Length; 9) Dealing with Long Messages; 10) Designing VMS Messages for Incidents; 11) Designing VMS Messages for Roadwork; 12) Quick Reference Guide for Designing VMS Messages; 13) Modifying Messages to Improve Effectiveness; 14) Priorities When Competing Message Needs Arise; 15) Message Design Examples for Incidents: Large VMS; and 16) Message Design Example for Incidents: Portable VMS.					
17. Key Words Variable Message Signs, Variable Message Sign Operations, Variable Message Sign Operations Policy, Variable Message Sign Message Design, Abbreviations; Highway Incidents; Highway Construction and Maintenance			18. Distribution Statement No restrictions. This document is available to the public through NTIS: National Technical Information Service 5285 Port Royal Road Springfield, Virginia 22161		
19. Security Classif.(of this report) Unclassified		20. Security Classif.(of this page) Unclassified		21. No. of Pages 654	22. Price

**THIS PAGE LEFT BLANK**

## ACKNOWLEDGMENTS

This Manual was prepared as part of a research project sponsored by the New Jersey Department of Transportation in cooperation with the New Jersey Turnpike Authority, New Jersey Highway Authority, South Jersey Transportation Authority, TRANSCOM, and the United States Department of Transportation, Federal Highway Administration.

The author acknowledges the contributions of Dr. Gerald Ullman, Program Manager, Texas Transportation Institute. Dr. Ullman prepared Appendices A through D and was the principal author of Modules 4 and 8.

The author is grateful to the members of the Project Advisory Committee for their guidance during the conduct of this work. Members of the Committee were:

- Karl Brodtman, Project Manager, Research and Technology (NJDOT),
- James Paral, Director of Traffic Operations (NJDOT),
- Kurt Aufschneider, Manager, Traffic Operations South (NJDOT)
- Patricia Ott, Manager, Traffic Engineering (NJDOT),
- Mark Smith, Principal Engineer, Traffic Operations North (NJDOT),
- William Kingsland, Principal Engineer, Traffic Operations South (NJDOT),
- Spencer Purdum, Traffic Engineer, Operations (NJTA),
- Jude Depko, Principal Traffic Engineer (NJHA),
- Anthony Marino, Traffic Engineer (SJTA), and
- Tom Batz, Manager, Technology Development, TRANSCOM.

Two test training programs were administered in New Jersey in late April 2001—one in north New Jersey and the other in South New Jersey. The author is grateful for the individuals who participated in the test training sessions and offered constructive comments to the author for improving the Manual and the training course. A special thank you is extended to:

- Karl Brodtman, Project Manager, Research and Technology (NJDOT),
- Kurt Aufschneider, Manager, Traffic Operations South (NJDOT),
- Jim Hogan, Acting Manager, Traffic Operations North (NJDOT),
- Mark Smith, Principal Engineer, Traffic Operations North (NJDOT),
- Richard Eng, Project Engineer, Traffic Operations South, (NJDOT),
- Leo Jackson, Manager, Traffic Operations Center (NJTA),
- Laurie Matkowski, Transportation Engineer, Delaware Valley Region Planning Commission,
- John Friel, Engineer Technician IV, Traffic Operations North (NJDOT), and
- Kevin Hall, Engineer Technician, Traffic Operations South (NJDOT).

The contents of this report reflect the views of the author who is responsible for the facts and the accuracy of the data presented herein. The contents do not necessarily reflect the official views or policies of the New Jersey Department of Transportation or the United States Department of Transportation, Federal Highway Administration. The report does not constitute a standard, specification or regulation.

## GLOSSARY

**Backlight** – Daytime viewing condition where the sun is positioned in front of the driver behind (just above, below or next to) the variable message sign

**Blocked Lane** – When an incident occurs on a freeway that physically obstructs lanes on the facility but police or traffic control personnel have not arrived at the scene to direct traffic, the affected lanes are *blocked*.

**Closed Lane** – When an incident occurs on a freeway that physically obstructs lanes on the facility and police or traffic control personnel have arrived at the scene to direct traffic, the affected lanes are *closed*.

**Downstream** – Similar to water flowing downstream in a river, traffic is considered to be flowing downstream on a freeway. Therefore, an incident that occurs beyond the location of a variable message sign is said to be *downstream* from the sign.

**Upstream** – Similar to water flowing downstream in a river, traffic is considered to be flowing downstream on a freeway. Therefore, an incident that occurs ahead of the location of a variable message sign is said to be *upstream* from the sign.

**Washout** – Daytime viewing condition where the sun is positioned behind the driver (just above the horizon) and shining directly on the variable message sign face.

**Note:** The word “freeway” is used as the primary highway throughout this Manual. This word was adopted because the primary use of this Manual will be by personnel in the New Jersey Department of Transportation Traffic Operations Centers who have the responsibility for designing variable message sign messages and for operating the signs on the freeways in New Jersey. The user of the Manual can substitute the terms “turnpike,” “parkway,” “toll road,” “highway,” etc. whenever “freeway” is found in the Manual.

## MAIN TABLE OF CONTENTS

<b>MODULE 1. INTRODUCTION</b> .....	1-1
<b>1.1 BACKGROUND AND SIGNIFICANCE OF THE VARIABLE MESSAGE SIGN OPERATIONS MANUAL</b> .....	1-1
<b>1.2 VMS MESSAGE DESIGN PROCESS</b> .....	1-2
<b>1.3 OVERVIEW OF MANUAL MODULES</b> .....	1-3
MODULE 1. INTRODUCTION .....	1-3
MODULE 2. PRINCIPLES OF VMS OPERATIONS .....	1-3
MODULE 3. VMS OPERATING POLICY FOR NEW JERSEY DEPARTMENT OF TRANSPORTATION .....	1-4
MODULE 4. VMS OPERATING FUNDAMENTALS .....	1-4
MODULE 5. PRINCIPLES OF VMS MESSAGE DESIGN.....	1-4
MODULE 6. DESIGNING THE BASIC VMS MESSAGE FOR INCIDENTS.....	1-4
MODULE 7. DESIGNING THE BASIC VMS MESSAGE FOR ROADWORK .....	1-4
MODULE 8. ESTABLISHING THE MAXIMUM MESSAGE LENGTH .....	1-5
MODULE 9. DEALING WITH LONG MESSAGES .....	1-5
MODULE 10. DESIGNING VMS MESSAGES FOR INCIDENTS .....	1-5
MODULE 11. DESIGNING VMS MESSAGES FOR ROADWORK .....	1-5
MODULE 12. QUICK REFERENCE GUIDE FOR DESIGNING VMS MESSAGES .....	1-5
MODULE 13. MODIFYING MESSAGES TO IMPROVE EFFECTIVENESS .....	1-5
MODULE 14. PRIORITIES WHEN COMPETING MESSAGE NEEDS ARISE .....	1-6
MODULE 15. MESSAGE DESIGN EXAMPLES FOR INCIDENTS: LARGE VMS .....	1-6
MODULE 16. MESSAGE DESIGN EXAMPLE FOR INCIDENTS: PORTABLE VMS .....	1-6
APPENDIX A. MESSAGE LENGTH REDUCTIONS FOR VERTICAL CURVES ...	1-6
APPENDIX B. MESSAGE LENGTH REDUCTIONS FOR HORIZONTAL CURVES .....	1-6
APPENDIX C. MESSAGE LENGTH REDUCTIONS FOR RAIN AND FOG.....	1-6
APPENDIX D. EFFECTS OF LARGE TRUCKS ON VMS LEGIBILITY .....	1-6
 <b>MODULE 2. PRINCIPLES OF VMS OPERATIONS</b> .....	 2-1
<b>2.1 INTRODUCTION</b> .....	2-1
EARLY WARNING MESSAGES.....	2-1
ADVISORY MESSAGES.....	2-1
ALTERNATIVE ROUTE MESSAGES .....	2-1

**2.2 IMPORTANCE OF MAINTAINING VMS CREDIBILITY .....2-2**

**MODULE 3. VMS OPERATING POLICY FOR NEW JERSEY DEPARTMENT OF TRANSPORTATION .....3-1**

**3.1 RESPONSIBILITY FOR OPERATION OF VMSs.....3-1**

**3.2 GENERAL OPERATIONS .....3-1**

**3.3 PERMANENT VARIABLE MESSAGE SIGNS .....3-7**

**3.4 PORTABLE VARIABLE MESSAGE SIGNS .....3-8**

**MODULE 4. VMS OPERATING FUNDAMENTALS .....4-1**

**4.1 BASIC CONSIDERATIONS FOR OPERATING VMSs .....4-1**

DETERMINE THE PURPOSE FOR USING A VMS .....4-2

What Is the Problem I Am Trying to Address? .....4-2

What Verified Information Do I Have?.....4-2

Who is the Audience for the VMS Message?.....4-3

What Type of Motorist Response Is Required?.....4-3

Where Should the Response Take Place?.....4-3

What Degree of Motorist Response Is Required? .....4-4

DETERMINE THE APPROPRIATE VMS TO USE.....4-4

Proximity of VMSs to Problem .....4-4

Characteristics of the VMS Hardware.....4-4

Roadway, Traffic, and Environmental Characteristics in the Vicinity of the VMS...4-5

DETERMINE WHAT TO DISPLAY ON THE VMS.....4-5

Basic Information Needs and VMS Message.....4-5

Diversion Routes .....4-6

VMS Operator Message Options.....4-6

*Selecting a Message from a Message Library.....4-6*

*Modifying a Message from a Message Library .....4-6*

*Creating a New Message .....4-7*

DETERMINE HOW LONG TO DISPLAY THE MESSAGE.....4-7

RESOLVE ANY MESSAGE SIGNING CONFLICTS THAT EXIST.....4-7

**MODULE 5. PRINCIPLES OF VMS MESSAGE**

**DESIGN** .....5-1

**5.1 OVERVIEW OF ISSUES** .....5-1

**5.2 SELECTING AN AUDIENCE FOR THE VMS MESSAGE** .....5-3

**5.3 DEFINITIONS AND MESSAGE DESIGN**

**CONSIDERATIONS** .....5-4

DEVELOPING EFFECTIVE VMS MESSAGES .....5-4

MESSAGE CONTENT .....5-4

MESSAGE LENGTH.....5-4

MESSAGE LOAD AND UNIT OF INFORMATION .....5-6

MESSAGE FORMAT .....5-7

**5.4 BASIC VMS MESSAGE TO SATISFY MOTORIST**

**INFORMATION NEEDS** .....5-8

GENERAL CONCEPT OF BASIC VMS MESSAGE .....5-8

INCIDENT/ROADWORK DESCRIPTOR .....5-8

INCIDENT/ROADWORK LOCATION .....5-8

LANES CLOSED/BLOCKED.....5-10

CLOSURE DESCRIPTOR.....5-10

CLOSURE LOCATION.....5-10

EFFECT ON TRAVEL .....5-10

    Delay.....5-10

    Travel Time .....5-11

AUDIENCE FOR ACTION .....5-12

ACTION .....5-13

GOOD REASON FOR FOLLOWING THE ACTION .....5-13

**5.5 WORD AND PHRASE MEANINGS AND CRITERIA** .....5-14

SELECTING FROM ALTERNATIVE WORDS AND PHRASES.....5-14

    Use, Take and Follow .....5-14

    Construction vs. Roadwork .....5-14

    Exit vs. Ramp .....5-15

    A Dash vs. Thru.....5-15

    Nite vs. Night.....5-15

    For 1 Week .....5-15

    Weekend .....5-15

WORDS AND TERMS WITH LOW MOTORIST UNDERSTANDING.....5-16

    Local Lanes.....5-16

    Express Lanes .....5-16

    Outer Roadway .....5-16



Lane Shift, Traffic Shifts, Lanes Change and New Traffic Pattern .....	5-16
Calendar Dates.....	5-17
<b>5.6 DIVERSION/DETOUR ROUTE DESCRIPTIONS FOR INCIDENT AND ROADWORK SITUATIONS.....</b>	<b>5-18</b>
INTRODUCTION .....	5-18
DIVERSION/DETOUR ROUTE TYPES.....	5-18
Type 1 Diversion Route.....	5-18
Type 2 Diversion Route.....	5-18
Type 3 Diversion Route.....	5-19
Type 4 Diversion Route.....	5-19
Type 5 Diversion Route: Incident Emergency Route Plan.....	5-19
Type 6 Detour Route: Traffic Control Plan for Roadwork Closure .....	5-20
Summary of Diversion/Detour Route Types .....	5-20
<b>5.7 DYNAMIC FEATURES ON VMSs .....</b>	<b>5-22</b>
INTRODUCTION .....	5-22
FLASHING AN ENTIRE ONE-FRAME MESSAGE .....	5-22
FLASHING ONE LINE OF A ONE-FRAME MESSAGE .....	5-23
ALTERNATING TEXT ON ONE LINE OF A THREE LINE VMS WHILE KEEPING THE OTHER TWO LINES OF TEXT THE SAME .....	5-23
 <b>MODULE 6. DESIGNING THE BASIC VMS MESSAGE FOR INCIDENTS.....</b>	 <b>6-1</b>
<b>6.1 BASIC VMS MESSAGE FOR LANE-CLOSURE (BLOCKAGE) INCIDENTS.....</b>	<b>6-1</b>
BASIC VMS MESSAGE ELEMENTS .....	6-1
VMS ON SAME FREEWAY AND RELATIVELY CLOSE TO THE INCIDENT .....	6-2
Incident Descriptor .....	6-2
Incident Location.....	6-3
Lanes Closed/Blocked .....	6-4
Effect on Travel .....	6-5
Action .....	6-6
<i>Motorists Are <u>Not</u> Advised to Take an Alternative Route – No Diversion</i> <i>Action Message.....</i>	6-6
<i>Motorists Are Advised to Take Other Routes but the Specific Route Is Not</i> <i>Specified in the VMS Message (Soft Diversion) .....</i>	6-7
<i>Motorists Are Advised to Take a Specific Type 1 or Type 2 Diversion</i> <i>Route.....</i>	6-8
Audience for Action .....	6-9
Good Reason for Following the Action.....	6-10

VMS ON SAME FREEWAY BUT RELATIVELY FAR FROM INCIDENT .....6-11

- Incident Descriptor .....6-11
- Incident Location .....6-12
- Lanes Closed/Blocked .....6-13
- Effect on Travel .....6-14
- Action .....6-15
  - Motorists Are Not Advised to Take an Alternative Route – No Diversion*  
*Action Message* .....6-15
  - Motorists Are Advised to Take Other Routes but the Specific Route Is Not*  
*Specified in the VMS Message (Soft Diversion)* .....6-16
  - Motorists Are Advised to Take a Specific Type 1 or Type 2 Diversion*  
*Route* .....6-17
- Audience for Action .....6-18
- Good Reason for Following the Action.....6-19

VMS ON DIFFERENT FREEWAY THAN INCIDENT .....6-20

- Incident Descriptor .....6-21
- Incident Location .....6-22
- Lanes Closed/Blocked .....6-23
- Effect on Travel .....6-24
- Action .....6-25
  - Motorists Are Not Advised to Take an Alternative Route – No Diversion*  
*Action Message* .....6-25
  - Motorists Are Advised to Take Other Routes but the Specific Route Is Not*  
*Specified in the VMS Message (Soft Diversion)* .....6-26
  - Motorists Are Advised to Take A Specific Type 1 or Type 2 Diversion*  
*Route* .....6-27
- Audience for Action .....6-28
- Good Reason for Following the Action.....6-29

**6.2 BASIC MESSAGE FOR INCIDENTS THAT BLOCK ALL THE LANES** .....6-30

BASIC VMS MESSAGE ELEMENTS .....6-30

VMS ON SAME FREEWAY AND RELATIVELY CLOSE TO THE INCIDENT ...6-31

- Incident Descriptor .....6-31
- Incident (Blockage) Location .....6-32
- Lanes Blocked .....6-33
- Effect on Travel .....6-34
- Action .....6-35
  - Motorists Are Not Advised to Take an Alternative Route – No Diversion*  
*Action Message* .....6-35
  - Motorists Are Advised to Take Other Routes but the Specific Route Is*  
*Not Specified in the VMS Message (Soft Diversion)* .....6-36
  - Motorists Are Advised to Take a Specific Type 1 or Type 2 Diversion*  
*Route* .....6-37

Audience for Action .....6-38  
 Good Reason for Following the Action.....6-39

VMS ON SAME FREEWAY BUT RELATIVELY FAR FROM INCIDENT .....6-40  
 Incident Descriptor .....6-40  
 Incident Location .....6-41  
 Lanes Blocked .....6-42  
 Effect on Travel .....6-43  
 Action .....6-44  
     *Motorists Are Not Advised to Take an Alternative Route – No Diversion  
         Action Message*.....6-44  
     *Motorists Are Advised to Take Other Routes but the Specific Route Is  
         Not Specified in the VMS Message (Soft Diversion)* .....6-45  
     *Motorists Are Advised to Take a Specific Type 1 or Type 2 Diversion  
         Route* .....6-46  
 Audience for Action .....6-47  
 Good Reason for Following the Action.....6-48

VMS ON DIFFERENT FREEWAY THAN INCIDENT .....6-49  
 Incident Descriptor .....6-50  
 Incident Location .....6-51  
 Lanes Blocked .....6-52  
 Effect on Travel .....6-53  
 Action .....6-54  
     *Motorists Are Not Advised to Take an Alternative Route – No Diversion  
         Action Message*.....6-54  
     *Motorists Are Advised to Take Other Routes but the Specific Route Is  
         Not Specified in the VMS Message (Soft Diversion)* .....6-55  
     *Motorists Are Advised to Take a Specific Type 1 or Type 2 Diversion  
         Route* .....6-56  
 Audience for Action .....6-57  
 Good Reason for Following the Action.....6-58

**6.3 BASIC VMS MESSAGE FOR INCIDENTS THAT REQUIRE CLOSING THE FREEWAY.....6-59**

BASIC VMS MESSAGE ELEMENTS .....6-59

VMS ON SAME FREEWAY AND RELATIVELY CLOSE TO THE CLOSURE.....6-60  
 Incident Location .....6-61  
 Lanes Closed.....6-62  
 Closure Location.....6-63  
 Effect on Travel .....6-64  
 Action .....6-65  
     *Motorists Are Advised to Take a Specific Type 1, Type 2, Type 3 or  
         Type 4 Diversion Route* .....6-66  
     *Motorists Are Advised to Take a Specific Type 5 Diversion Route* .....6-67

Audience for Action .....	6-68
Good Reason for Following the Action.....	6-69
<b>VMS ON SAME FREEWAY BUT RELATIVELY FAR FROM THE CLOSURE ....</b>	<b>6-70</b>
Incident Descriptor .....	6-70
Incident Location.....	6-71
Lanes Closed.....	6-72
Closure Location.....	6-73
Effect on Travel .....	6-74
Action .....	6-75
<i>Motorists Are <u>Not</u> Advised to Take an Alternative Route – No Diversion</i>	
Action Message.....	6-75
<i>Motorists Are Advised to Take Other Routes but the Specific Route Is</i>	
<i>Not Specified in the VMS Message (Soft Diversion) .....</i>	<i>6-76</i>
<i>Motorists Are Advised to Take a Specific Type 1, Type 2, Type 3 or</i>	
<i>Type 4 Diversion Route .....</i>	<i>6-77</i>
<i>Motorists Are Advised to Take a Specific Type 5 Diversion Route .....</i>	<i>6-78</i>
Audience for Action .....	6-79
Good Reason for Following the Action.....	6-80
<b>VMS ON DIFFERENT FREEWAY THAN CLOSURE.....</b>	<b>6-81</b>
Incident Descriptor .....	6-82
Incident Location.....	6-83
Lanes Closed.....	6-84
Closure Location.....	6-85
Effect on Travel .....	6-86
Action .....	6-87
<i>Motorists Are <u>Not</u> Advised to Take an Alternative Route – No Diversion</i>	
Action Message.....	6-87
<i>Motorists Are Advised to Take Other Routes but The Specific Route Is</i>	
<i>Not Specified in the VMS Message (Soft Diversion) .....</i>	<i>6-88</i>
<i>Motorists Are Advised to Take a Specific Type 1 or Type 2 Diversion</i>	
<i>Route .....</i>	<i>6-89</i>
Audience for Action .....	6-90
Good Reason for Following the Action.....	6-91
<b>6.4 BASIC VMS MESSAGE FOR INCIDENTS ON AN</b>	
<b>INTERSECTING FREEWAY THAT REQUIRE CLOSING</b>	
<b>THE CONNECTOR RAMP.....</b>	<b>6-92</b>
<b>BASIC VMS MESSAGE ELEMENTS .....</b>	<b>6-92</b>
<b>VMS UPSTREAM OF CONNECTOR RAMP CLOSURE .....</b>	<b>6-93</b>
Incident Descriptor .....	6-93
Incident Location.....	6-94
Lanes Closed.....	6-95
Ramp Closure Descriptor .....	6-96

Action .....6-97

*Motorists Are Not Advised to Take an Alternative Route – No Diversion*

*Action Message*.....6-97

*Motorists Are Advised to Take Other Routes but the Specific Route Is*

*Not Specified in the VMS Message (Soft Diversion)* .....6-98

*Motorists Are Advised to Take a Specific Type 1 or Type 2 Diversion*

*Route*.....6-99

*Motorists Are Advised to Take a Specific Type 5 Diversion Route* .....6-100

Audience for Action .....6-101

Good Reason for Following Action.....6-102

**MODULE 7. DESIGNING THE BASIC VMS MESSAGE FOR ROADWORK.....7-1**

**7.1 BASIC VMS MESSAGE FOR LANE CLOSURES DURING ROADWORK.....7-1**

BASIC VMS MESSAGE ELEMENTS .....7-1

VMS ON SAME FREEWAY AND RELATIVELY CLOSE TO THE ROADWORK.....7-2

Roadwork Descriptor.....7-2

Roadwork (Lane Closure) Location .....7-3

Lanes Closed.....7-5

Effect on Travel .....7-6

Action .....7-7

*Motorists Are Not Advised to Take an Alternative Route – No Diversion*

*Action Message*.....7-7

*Motorists Are Advised to Take Other Routes but the Specific Route Is*

*Not Specified in the VMS Message (Soft Diversion)* .....7-8

*Motorists Are Advised to Take a Specific Type 1 or Type 2 Diversion*

*Route*.....7-9

Audience for Action .....7-10

Good Reason for Following the Action.....7-11

VMS ON SAME FREEWAY BUT RELATIVELY FAR FROM THE ROADWORK.....7-12

Roadwork Descriptor.....7-12

Roadwork (Lane Closure) Location .....7-13

Lanes Closed.....7-14

Effect on Travel .....7-15

Action .....7-16

*Motorists Are Not Advised to Take an Alternative Route – No Diversion*

*Action Message*.....7-16

*Motorists Are Advised to Take Other Routes but the Specific Route Is*

*Not Specified in the VMS Message (Soft Diversion)* .....7-17

*Motorists Are Advised to Take a Specific Type 1 or Type 2 Diversion*

Route .....7-18

Audience for Action .....7-19

Good Reason for Following the Action.....7-20

VMS ON DIFFERENT FREEWAY THAN THE ROADWORK .....7-21

Roadwork Descriptor.....7-21

Roadwork (Lane Closure) Location .....7-22

Lanes Closed.....7-23

Effect on Travel .....7-24

Action .....7-25

*Motorists Are Not Advised to Take an Alternative Route – No Diversion*

Action Message.....7-25

*Motorists Are Advised to Take Other Routes but the Specific Route Is Not Specified in the VMS Message (Soft Diversion) .....7-26*

*Motorists Are Advised to Take a Specific Type 1 or Type 2 Diversion*

Route .....7-27

Audience for Action .....7-28

Good Reason for Following the Action.....7-29

**7.2 BASIC VMS MESSAGE FOR ROADWORK THAT REQUIRES CLOSING THE FREEWAY** .....7-30

BASIC VMS MESSAGE ELEMENTS .....7-30

VMS ON SAME FREEWAY AND RELATIVELY CLOSE TO THE CLOSURE.....7-31

Basic VMS Message Elements.....7-31

Roadwork Descriptor.....7-32

Closure Location.....7-33

Lanes Closed.....7-34

Effect on Travel .....7-35

Action .....7-36

Audience for Action .....7-37

Good Reason for Following the Action.....7-38

VMS ON SAME FREEWAY BUT RELATIVELY FAR FROM THE CLOSURE ...7-39

Roadwork Descriptor.....7-39

Closure Location.....7-40

Lanes Closed.....7-41

Effect on Travel .....7-42

Action .....7-43

*Motorists Are Not Advised to Take an Alternative Route – No Diversion*

Action Message.....7-43

*Motorists Are Advised to Take Other Routes but the Specific Route Is Not Specified in the VMS Message (Soft Diversion) .....7-44*

*Motorists Are Advised to Take a Specific Type 1 or Type 2 Diversion*

Route .....7-45

*Motorists Are Advised to Take a Specific Type 6 Diversion Route .....7-46*

Audience for Action .....7-47  
 Good Reason for Following the Action.....7-48

VMS ON DIFFERENT FREEWAY THAN THE ROADWORK AND CLOSURE....7-49  
 Roadwork Descriptor.....7-50  
 Closure Location.....7-51  
 Lanes Closed.....7-52  
 Effect on Travel .....7-53  
 Action .....7-54  
     *Motorists Are Not Advised to Take an Alternative Route – No Diversion  
         Action Message*.....7-54  
     *Motorists Are Advised to Take Other Routes but the Specific Route Is  
         Not Specified in the VMS Message (Soft Diversion)* .....7-55  
     *Motorists Are Advised to Take a Specific Type 1 or Type 2 Diversion  
         Route* .....7-56  
 Audience for Action .....7-57  
 Good Reason for Following the Action.....7-58

**7.3 BASIC VMS MESSAGE FOR ROADWORK ON AN INTERSECTING FREEWAY THAT REQUIRES CLOSING THE CONNECTOR RAMP** .....7-59

BASIC VMS MESSAGE ELEMENTS .....7-59

VMS UPSTREAM OF THE RAMP CLOSURE.....7-60  
 Roadwork Descriptor.....7-60  
 Closure Location.....7-61  
 Ramp Closure Descriptor .....7-62  
 Action .....7-63  
     *Motorists Are Advised to Take Other Routes but the Specific Route Is  
         Not Specified in the VMS Message (Soft Diversion)* .....7-63  
     *Motorists Are Advised to Take a Specific Type 1 or Type 2 Diversion  
         Route* .....7-64  
     *Motorists Are Advised to Take a Specific Type 6 Diversion Route* .....7-65  
 Audience for Action .....7-66  
 Good Reason for Following the Action.....7-67

**MODULE 8. ESTABLISHING THE MAXIMUM MESSAGE LENGTH**.....8-1

**8.1 MESSAGE LENGTH AND VMS VIEWING DISTANCE REQUIREMENTS** .....8-1

**8.2 MAXIMUM VMS LEGIBILITY DISTANCES FOR DAY AND NIGHT OPERATIONS.....8-4**

**8.3 UNITS OF INFORMATION REDUCTIONS FOR VERTICAL CURVES – LED VMSs .....8-6**  
INTRODUCTION .....8-6  
REDUCTIONS FOR VERTICAL CURVE DESIGN SPEEDS 45 MPH AND ABOVE .....8-6  
REDUCTIONS FOR VERTICAL CURVE DESIGN SPEEDS BELOW 45 MPH.....8-6  
EXAMPLES .....8-6  
    Example 1 .....8-6  
    Example 2 .....8-7

**8.4 UNITS OF INFORMATION REDUCTIONS FOR HORIZONTAL CURVES – LED VMSs .....8-10**  
INTRODUCTION .....8-10  
REDUCTIONS FOR HORIZONTAL CURVES FOR PERMANENT VMSs .....8-10  
REDUCTIONS FOR HORIZONTAL CURVES FOR PORTABLE VMSs.....8-10  
EXAMPLES .....8-10  
    Example 1 .....8-10  
    Example 2 .....8-11

**8.5 UNITS OF INFORMATION REDUCTIONS FOR RAIN AND FOG .....8-18**  
REDUCTIONS FOR RAIN .....8-18  
REDUCTIONS FOR FOG .....8-18  
EXAMPLE .....8-19

**8.6 UNITS OF INFORMATION REDUCTIONS WHEN LARGE TRUCKS ARE PRESENT .....8-20**  
INTRODUCTION .....8-20  
EFFECT OF LARGE TRUCKS ON VMS VIEWING.....8-20

**MODULE 9. DEALING WITH LONG MESSAGES .....9-1**

**9.1 SPLITTING MESSAGES .....9-1**  
NO MORE THAN TWO FRAMES SHOULD BE USED .....9-1  
EACH FRAME MUST BE UNDERSTOOD BY ITSELF .....9-1  
COMPATIBLE UNITS OF INFORMATION SHOULD BE DISPLAYED ON THE SAME FRAME .....9-2  
A MESSAGE LINE SHOULD NOT CONTAIN PORTIONS OF TWO DIFFERENT UNITS OF INFORMATION .....9-3



NO MORE THAN THREE UNITS OF INFORMATION SHOULD BE DISPLAYED  
ON A SINGLE FRAME AT HIGH FREEWAY SPEEDS .....9-3

**9.2 APPROACHES TO REDUCING MESSAGE LENGTH .....9-5**

DELETING “DEAD” WORDS .....9-5

    Street, Avenue or Boulevard .....9-5

    Ahead.....9-5

FORMATTING MESSAGES .....9-6

    Messages WITH Incident Descriptor Message Element .....9-6

    Messages WITH Roadwork Descriptor Message Element .....9-7

    Messages WITHOUT Incident Descriptor Message Element.....9-8

    Messages WITHOUT Roadwork Descriptor Message Element .....9-9

USING ABBREVIATIONS .....9-10

    Acceptable Abbreviations.....9-10

    Acceptable Abbreviation in North New Jersey, But Not South New Jersey .....9-11

    Acceptable Abbreviations For Some Major Destinations in New Jersey .....9-11

    Acceptable Abbreviations For Major Destinations by Region: North and South  
        New Jersey.....9-11

    Unacceptable Abbreviations.....9-12

**9.3 REDUCING MESSAGE UNITS OF INFORMATION .....9-13**

REFORMATTING THE MESSAGE .....9-13

**9.4 REDUCING UNITS OF INFORMATION FROM THE BASIC  
VMS MESSAGE .....9-14**

INITIAL REDUCTION APPROACHES .....9-14

    Reducing Redundancy in Incident and Roadwork Messages.....9-14

*Omitting Reference to Same Freeway as Incident/Roadwork and VMS* .....9-14

    Combining Message Elements for Incident Messages .....9-15

*Combining Incident Descriptor, Location and Lanes Closed/Blocked Message  
        Elements*.....9-15

*Combining Location of Closure Message Element and Action Message  
        Element* .....9-16

    Combining Message Elements for Roadwork Messages .....9-17

*Combining Roadwork Descriptor Message Elements with Lanes Closed  
        Message Element* .....9-17

*Combining Roadwork Descriptor, Location and Lanes Closed Message  
        Elements*.....9-18

*Combining Location of Closure Message Element and Action Message  
        Element* .....9-18

SECONDARY REDUCTION APPROACH .....9-19

    Reducing the Number of Definitions in the Action Message Element .....9-19

PRIORITY REDUCTION PRINCIPLES .....9-20

**MODULE 10. DESIGNING VMS MESSAGES FOR INCIDENTS** .....10-1

**10.1 LANE CLOSURE (BLOCKAGE) INCIDENTS** .....10-1

VMS ON SAME FREEWAY AND RELATIVELY CLOSE TO THE INCIDENT ....10-1

Establish Initial Maximum Allowable Number of Units of Information in the Message Based on VMS Type and Freeway Operating Speeds.....10-1

Assess Whether the Message Must Be Reduced Because of Local Geometric Sight Distance Restrictions to the VMS .....10-2

Assess Whether the Message Must Be Reduced Because of Local Environmental Sight Distance Restrictions to the VMS Due to Rain or Fog .....10-2

Finalize the Maximum Allowable Units of Information in the Message .....10-3

Define the Basic VMS Message to Satisfy Motorist Information Needs .....10-3

Reduce the Number of Message Units if Necessary .....10-4

Format the Message.....10-5

Adjust Message to Fit on Existing VMS .....10-5

Adjust Message to Fit on 3 Lines or Less .....10-6

Finalize VMS Message.....10-7

Assess Effects of Large Trucks on the Ability of Motorists to View the VMS Message .....10-7

VMS ON SAME FREEWAY BUT RELATIVELY FAR FROM THE INCIDENT ....10-8

Establish Initial Maximum Allowable Number of Units of Information in the Message Based on VMS Type and Freeway Operating Speeds.....10-8

Assess Whether the Message Must Be Reduced Because of Local Geometric Sight Distance Restrictions to the VMS .....10-8

Assess Whether the Message Must Be Reduced Because of Local Environmental Sight Distance Restrictions to the VMS Due to Rain or Fog .....10-9

Finalize the Maximum Allowable Units of Information in the Message .....10-9

Define the Basic VMS Message to Satisfy Motorist Information Needs .....10-9

Reduce the Number of Message Units if Necessary .....10-11

Format the Message.....10-12

Adjust Message to Fit on Existing VMS .....10-12

Adjust Message to Fit on 3 Lines or Less .....10-12

Finalize VMS Message.....10-13

Assess Effects of Large Trucks on the Ability of Motorists to View the VMS Message .....10-13

VMS ON DIFFERENT FREEWAY THAN THE INCIDENT .....10-14

Establish Initial Maximum Allowable Number of Units of Information in the Message Based on VMS Type and Freeway Operating Speeds.....10-14

Assess Whether the Message Must Be Reduced Because of Local Geometric Sight Distance Restrictions to the VMS .....10-14

Assess Whether the Message Must Be Reduced Because of Local Environmental Sight Distance Restrictions to the VMS Due to Rain or Fog .....10-15

Finalize the Maximum Allowable Units of Information in the Message .....10-15

- Define the Basic VMS Message to Satisfy Motorist Information Needs .....10-15
- Reduce the Number of Message Units if Necessary .....10-17
- Format the Message.....10-18
- Adjust Message to Fit on Existing VMS .....10-18
- Adjust Message to Fit on 3 Lines or Less .....10-18
- Finalize VMS Message.....10-19
- Assess Effects of Large Trucks on the Ability of Motorists to View the VMS  
Message .....10-19
- 10.2 INCIDENTS THAT BLOCK ALL THE LANES .....10-20**
  - VMS ON SAME FREEWAY AND RELATIVELY CLOSE TO THE INCIDENT ..10-20**
    - Establish Initial Maximum Allowable Number of Units of Information in the  
Message Based on VMS Type and Freeway Operating Speeds.....10-20
    - Assess Whether the Message Must Be Reduced Because of Local Geometric  
Sight Distance Restrictions to the VMS .....10-20
    - Assess Whether the Message Must Be Reduced Because of Local Environmental  
Sight Distance Restrictions to the VMS Due to Rain or Fog .....10-21
    - Finalize the Maximum Allowable Units of Information in the Message .....10-21
    - Define the Basic VMS Message to Satisfy Motorist Information Needs .....10-21
    - Reduce the Number of Message Units if Necessary .....10-23
    - Format the Message.....10-23
    - Adjust Message to Fit on Existing VMS .....10-23
    - Adjust Message to Fit on 3 Lines or Less .....10-24
    - Finalize VMS Message.....10-25
    - Assess Effects of Large Trucks on the Ability of Motorists to View the VMS  
Message .....10-25
  - VMS ON SAME FREEWAY BUT RELATIVELY FAR FROM THE INCIDENT ..10-26**
    - Establish Initial Maximum Allowable Number of Units of Information in the  
Message Based on VMS Type and Freeway Operating Speeds.....10-26
    - Assess Whether the Message Must Be Reduced Because of Local Geometric  
Sight Distance Restrictions to the VMS .....10-26
    - Assess Whether the Message Must Be Reduced Because of Local Environmental  
Sight Distance Restrictions to the VMS Due to Rain or Fog .....10-27
    - Finalize the Maximum Allowable Units of Information in the Message .....10-27
    - Define the Basic VMS Message to Satisfy Motorist Information Needs .....10-27
    - Reduce the Number of Message Units if Necessary .....10-28
    - Format the Message.....10-29
    - Adjust Message to Fit on Existing VMS .....10-29
    - Adjust Message to Fit on 3 Lines or Less .....10-30
    - Finalize VMS Message.....10-31
    - Assess Effects of Large Trucks on the Ability of Motorists to View the VMS  
Message .....10-31
  - VMS ON DIFFERENT FREEWAY THAN THE INCIDENT .....10-32**
    - Establish Initial Maximum Allowable Number of Units of Information in the  
Message Based on VMS Type and Freeway Operating Speeds.....10-32

Assess Whether the Message Must Be Reduced Because of Local Geometric Sight Distance Restrictions to the VMS .....	10-32
Assess Whether the Message Must Be Reduced Because of Local Environmental Sight Distance Restrictions to the VMS Due to Rain or Fog .....	10-33
Finalize the Maximum Allowable Units of Information in the Message .....	10-33
Define the Basic VMS Message to Satisfy Motorist Information Needs .....	10-33
Reduce the Number of Message Units if Necessary .....	10-34
Format the Message .....	10-35
Adjust Message to Fit on Existing VMS .....	10-35
Adjust Message to Fit on 3 Lines or Less .....	10-36
Finalize VMS Message.....	10-37
Assess Effects of Large Trucks on the Ability of Motorists to View the VMS Message .....	10-37
<b>10.3 INCIDENTS THAT REQUIRE CLOSING THE FREEWAY ...</b>	<b>10-38</b>
<b>VMS ON SAME FREEWAY AND RELATIVELY CLOSE TO THE CLOSURE...</b>	<b>10-38</b>
Establish Initial Maximum Allowable Number of Units of Information in the Message Based on VMS Type and Freeway Operating Speeds.....	10-38
Assess Whether the Message Must Be Reduced Because of Local Geometric Sight Distance Restrictions to the VMS .....	10-38
Assess Whether the Message Must Be Reduced Because of Local Environmental Sight Distance Restrictions to the VMS Due to Rain or Fog .....	10-39
Finalize the Maximum Allowable Units of Information in the Message .....	10-39
Define the Basic VMS Message to Satisfy Motorist Information Needs .....	10-39
Reduce the Number of Message Units if Necessary .....	10-40
Format the Message .....	10-41
Adjust Message to Fit on Existing VMS .....	10-41
Adjust Message to Fit on 3 Lines or Less .....	10-41
Finalize VMS Message.....	10-42
Assess Effects of Large Trucks on the Ability of Motorists to View the VMS Message .....	10-43
<b>VMS ON SAME FREEWAY BUT RELATIVELY FAR FROM THE CLOSURE ..</b>	<b>10-44</b>
Establish Initial Maximum Allowable Number of Units of Information in the Message Based on VMS Type and Freeway Operating Speeds.....	10-44
Assess Whether the Message Must Be Reduced Because of Local Geometric Sight Distance Restrictions to the VMS .....	10-44
Assess Whether the Message Must Be Reduced Because of Local Environmental Sight Distance Restrictions to the VMS Due to Rain or Fog .....	10-45
Finalize the Maximum Allowable Units of Information in the Message .....	10-45
Define the Basic VMS Message to Satisfy Motorist Information Needs .....	10-45
Reduce the Number of Message Units if Necessary .....	10-47
Format the Message .....	10-47
Adjust Message to Fit on Existing VMS .....	10-47
Adjust Message to Fit on 3 Lines or Less .....	10-48
Finalize VMS Message.....	10-49

Assess Effects of Large Trucks on the Ability of Motorists to View the VMS  
 Message .....10-49

VMS ON DIFFERENT FREEWAY THAN THE CLOSURE.....10-50

  Establish Initial Maximum Allowable Number of Units of Information in the  
 Message Based on VMS Type and Freeway Operating Speeds.....10-50

  Assess Whether the Message Must Be Reduced Because of Local Geometric  
 Sight Distance Restrictions to the VMS .....10-50

  Assess Whether the Message Must Be Reduced Because of Local Environmental  
 Sight Distance Restrictions to the VMS Due to Rain or Fog .....10-51

  Finalize the Maximum Allowable Units of Information in the Message .....10-51

  Define the Basic VMS Message to Satisfy Motorist Information Needs .....10-51

  Reduce the Number of Message Units if Necessary .....10-52

  Format the Message.....10-53

  Adjust Message to Fit on Existing VMS .....10-53

  Adjust Message to Fit on 3 Lines or Less .....10-54

  Finalize VMS Message.....10-55

  Assess Effects of Large Trucks on the Ability of Motorists to View the VMS  
 Message .....10-55

**10.4 INCIDENTS ON INTERSECTING FREEWAY THAT  
 REQUIRE CLOSING THE CONNECTOR RAMP .....10-56**

VMS UPSTREAM OF CONNECTOR RAMP CLOSURE .....10-56

  Establish Initial Maximum Allowable Number of Units of Information in the  
 Message Based on VMS Type and Freeway Operating Speeds.....10-56

  Assess Whether the Message Must Be Reduced Because of Local Geometric  
 Sight Distance Restrictions to the VMS .....10-56

  Assess Whether the Message Must Be Reduced Because of Local Environmental  
 Sight Distance Restrictions to the VMS Due to Rain or Fog .....10-57

  Finalize the Maximum Allowable Units of Information in the Message .....10-57

  Define the Basic VMS Message to Satisfy Motorist Information Needs .....10-57

  Reduce the Number of Message Units if Necessary .....10-59

  Format the Message.....10-59

  Adjust Message to Fit on Existing VMS .....10-59

  Adjust Message to Fit on 3 Lines or Less .....10-60

  Finalize VMS Message.....10-61

  Assess Effects of Large Trucks on the Ability of Motorists to View the VMS  
 Message .....10-61

**MODULE 11. DESIGNING VMS MESSAGES FOR  
 ROADWORK.....11-1**

**11.1 LANE CLOSURE DURING ROADWORK .....11-1**

VMS ON THE SAME FREEWAY AND RELATIVELY CLOSE TO THE ROADWORK.....11-1

- Establish Initial Maximum Allowable Number of Units of Information in the Message Based on VMS Type and Freeway Operating Speeds.....11-1
- Assess Whether the Message Must Be Reduced Because of Local Geometric Sight Distance Restrictions to the VMS .....11-1
- Assess Whether the Message Must Be Reduced Because of Local Environmental Sight Distance Restrictions to the VMS Due to Rain or Fog .....11-2
- Finalize the Maximum Allowable Units of Information in the Message .....11-2
- Define the Basic VMS Message to Satisfy Motorist Information Needs .....11-2
- Reduce the Number of Message Units if Necessary .....11-4
- Format the Message.....11-5
- Adjust Message to Fit on Existing VMS .....11-5
- Adjust Message to Fit on 3 Lines or Less .....11-5
- Finalize VMS Message.....11-6
- Assess Effects of Large Trucks on the Ability of Motorists to View the VMS Message .....11-6

VMS ON SAME FREEWAY BUT RELATIVELY FAR FROM THE ROADWORK.....11-7

- Establish Initial Maximum Allowable Number of Units of Information in the Message Based on VMS Type and Freeway Operating Speeds.....11-7
- Assess Whether the Message Must Be Reduced Because of Local Geometric Sight Distance Restrictions to the VMS .....11-7
- Assess Whether the Message Must Be Reduced Because of Local Environmental Sight Distance Restrictions to the VMS Due to Rain or Fog .....11-8
- Finalize the Maximum Allowable Units of Information in the Message .....11-8
- Define the Basic VMS Message to Satisfy Motorist Information Needs .....11-8
- Reduce the Number of Message Units if Necessary .....11-10
- Format the Message.....11-10
- Adjust Message to Fit on Existing VMS .....11-10
- Adjust Message to Fit on 3 Lines or Less .....11-11
- Finalize VMS Message.....11-12
- Assess Effects of Large Trucks on the Ability of Motorists to View the VMS Message .....11-12

VMS ON DIFFERENT FREEWAY THAN THE ROADWORK .....11-13

- Establish Initial Maximum Allowable Number of Units of Information in the Message Based on VMS Type and Freeway Operating Speeds.....11-13
- Assess Whether the Message Must Be Reduced Because of Local Geometric Sight Distance Restrictions to the VMS .....11-13
- Assess Whether the Message Must Be Reduced Because of Local Environmental Sight Distance Restrictions to the VMS Due to Rain or Fog .....11-14
- Finalize the Maximum Allowable Units of Information in the Message .....11-14
- Define the Basic VMS Message to Satisfy Motorist Information Needs .....11-14
- Reduce the Number of Message Units if Necessary .....11-16
- Format the Message.....11-16
- Adjust Message to Fit on Existing VMS .....11-16

Adjust Message to Fit on 3 Lines or Less .....	11-17
Finalize VMS Message.....	11-18
Assess Effects of Large Trucks on the Ability of Motorists to View the VMS Message .....	11-18
<b>11.2 ROADWORK THAT REQUIRES CLOSING THE FREEWAY .....</b>	<b>11-19</b>
<b>VMS ON THE SAME FREEWAY AND RELATIVELY CLOSE TO THE CLOSURE .....</b>	<b>11-19</b>
Establish Initial Maximum Allowable Number of Units of Information in the Message Based on VMS Type and Freeway Operating Speeds.....	11-19
Assess Whether the Message Must Be Reduced Because of Local Geometric Sight Distance Restrictions to the VMS .....	11-19
Assess Whether the Message Must Be Reduced Because of Local Environmental Sight Distance Restrictions to the VMS Due to Rain or Fog .....	11-20
Finalize the Maximum Allowable Units of Information in the Message .....	11-20
Define the Basic VMS Message to Satisfy Motorist Information Needs .....	11-20
Reduce the Number of Message Units if Necessary .....	11-21
Format the Message.....	11-21
Adjust Message to Fit on Existing VMS .....	11-21
Adjust Message to Fit on 3 Lines or Less .....	11-22
Finalize VMS Message.....	11-23
Assess Effects of Large Trucks on the Ability of Motorists to View the VMS Message .....	11-23
<b>VMS ON SAME FREEWAY BUT RELATIVELY FAR FROM THE CLOSURE ..</b>	<b>11-24</b>
Establish Initial Maximum Allowable Number of Units of Information in the Message Based on VMS Type and Freeway Operating Speeds.....	11-24
Assess Whether the Message Must Be Reduced Because of Local Geometric Sight Distance Restrictions to the VMS .....	11-24
Assess Whether the Message Must Be Reduced Because of Local Environmental Sight Distance Restrictions to the VMS Due to Rain or Fog .....	11-25
Finalize the Maximum Allowable Units of Information in the Message .....	11-25
Define the Basic VMS Message to Satisfy Motorist Information Needs .....	11-25
Reduce the Number of Message Units if Necessary .....	11-26
Format the Message.....	11-27
Adjust Message to Fit on Existing VMS .....	11-27
Adjust Message to Fit on 3 Lines or Less .....	11-28
Finalize VMS Message.....	11-29
Assess Effects of Large Trucks on the Ability of Motorists to View the VMS Message .....	11-29
<b>VMS ON DIFFERENT FREEWAY THAN THE ROADWORK AND CLOSURE..</b>	<b>11-30</b>
Establish Initial Maximum Allowable Number of Units of Information in the Message Based on VMS Type and Freeway Operating Speeds.....	11-30
Assess Whether the Message Must Be Reduced Because of Local Geometric Sight Distance Restrictions to the VMS .....	11-30

Assess Whether the Message Must Be Reduced Because of Local Environmental Sight Distance Restrictions to the VMS Due to Rain or Fog .....	11-31
Finalize the Maximum Allowable Units of Information in the Message .....	11-31
Define the Basic VMS Message to Satisfy Motorist Information Needs .....	11-31
Reduce the Number of Message Units if Necessary .....	11-32
Format the Message .....	11-33
Adjust Message to Fit on Existing VMS .....	11-33
Adjust Message to Fit on 3 Lines or Less .....	11-33
Finalize VMS Message .....	11-34
Assess Effects of Large Trucks on the Ability of Motorists to View the VMS Message .....	11-35
<b>11.3 ROADWORK ON INTERSECTING FREEWAY THAT REQUIRES CLOSING THE CONNECTOR RAMP .....</b>	<b>11-36</b>
VMS UPSTREAM OF THE CONNECTOR RAMP CLOSURE .....	11-36
Establish Initial Maximum Allowable Number of Units of Information in the Message Based on VMS Type and Freeway Operating Speeds.....	11-36
Assess Whether the Message Must Be Reduced Because of Local Geometric Sight Distance Restrictions to the VMS .....	11-36
Assess Whether the Message Must Be Reduced Because of Local Environmental Sight Distance Restrictions to the VMS Due to Rain or Fog .....	11-37
Finalize the Maximum Allowable Units of Information in the Message .....	11-37
Define the Basic VMS Message to Satisfy Motorist Information Needs .....	11-37
Reduce the Number of Message Units if Necessary .....	11-39
Format the Message .....	11-39
Adjust Message to Fit on Existing VMS .....	11-39
Adjust Message to Fit on 3 Lines or Less .....	11-40
Finalize VMS Message .....	11-41
Assess Effects of Large Trucks on the Ability of Motorists to View the VMS Message .....	11-41
<b>MODULE 12. QUICK REFERENCE GUIDE FOR DESIGNING VMS MESSAGES .....</b>	<b>12-1</b>
<b>12.1 INTRODUCTION .....</b>	<b>12-1</b>
<b>12.2 LANE BLOCKAGE INCIDENTS .....</b>	<b>12-2</b>
VMS ON SAME FREEWAY UPSTREAM AND RELATIVELY CLOSE TO THE INCIDENT .....	12-2
VMS ON SAME FREEWAY BUT RELATIVELY FAR FROM INCIDENT .....	12-4
VMS ON DIFFERENT FREEWAY THAN INCIDENT .....	12-6



**12.3 LANE CLOSURE INCIDENTS** .....12-8  
VMS ON SAME FREEWAY AND RELATIVELY CLOSE TO THE INCIDENT ....12-8  
VMS ON SAME FREEWAY BUT RELATIVELY FAR FROM INCIDENT .....12-10  
VMS ON DIFFERENT FREEWAY THAN INCIDENT .....12-12

**12.4 INCIDENTS THAT BLOCK ALL LANES** .....12-14  
VMS ON SAME FREEWAY AND RELATIVELY CLOSE TO THE INCIDENT ..12-14  
VMS ON SAME FREEWAY BUT RELATIVELY FAR FROM INCIDENT .....12-16  
VMS ON DIFFERENT FREEWAY THAN INCIDENT .....12-18

**12.5 INCIDENTS THAT REQUIRE CLOSING THE FREEWAY** ...12-20  
VMS ON SAME FREEWAY AND RELATIVELY CLOSE TO THE CLOSURE...12-20  
VMS ON SAME FREEWAY BUT RELATIVELY FAR FROM CLOSURE .....12-25  
VMS ON DIFFERENT FREEWAY THAN CLOSURE.....12-30

**12.6 LANE CLOSURES DURING ROADWORK** .....12-33  
VMS ON SAME FREEWAY AND RELATIVELY CLOSE TO THE  
ROADWORK.....12-33  
VMS ON SAME FREEWAY BUT RELATIVELY FAR FROM THE  
ROADWORK.....12-35  
VMS ON DIFFERENT FREEWAY THAN THE ROADWORK .....12-37

**12.7 ROADWORK REQUIRING TOTAL FREEWAY CLOSURE** .12-39  
VMS ON SAME FREEWAY AND RELATIVELY CLOSE TO THE CLOSURE...12-39  
VMS ON SAME FREEWAY BUT RELATIVELY FAR FROM THE CLOSURE ..12-41  
VMS ON DIFFERENT FREEWAY THAN THE ROADWORK AND CLOSURE..12-43

**MODULE 13. MODIFYING MESSAGES TO IMPROVE EFFECTIVENESS** .....13-1

**13.1 INTRODUCTION** .....13-1  
EXAMPLES OF IMPROVED MESSAGES FOR INCIDENTS .....13-2  
EXAMPLES OF IMPROVED MESSAGES FOR ROADWORK.....13-7

**MODULE 14. PRIORITIES WHEN COMPETING MESSAGE NEEDS ARISE**.....14-1

**14.1 INTRODUCTION** .....14-1

**14.2 BASIC MESSAGE PRIORITIES**.....14-1

**14.3 COMMON TYPES OF COMPETING MESSAGE NEEDS.....14-1**

**14.4 RESOLUTION OF COMMON TYPES OF COMPETING MESSAGE NEEDS.....14-2**

**TWO EVENTS OCCUR CONCURRENTLY ON THE SAME FREEWAY.....14-3**

- Major Accident with Another Event .....14-3
- Minor Accident with Another Event .....14-4
- Construction with Another Event .....14-5
- Construction with Temporary Lane Closure(s) with Another Event .....14-6
- Disabled Vehicle with Another Event .....14-7
- Incident (Load Spill, Debris, etc.) Requiring a Lane Closure with Another Event .....14-8
- Incidents (Load Spill, Debris, etc.) Requiring Total Freeway Closures with Another Event .....14-9
- Maintenance Operations with Lane Closure(s) with Another Event.....14-10
- Maintenance Operations Requiring Total Freeway Closures with Another Event .....14-11
- Special Event Exit with Another Event.....14-12

**ONE EVENT OCCURS ON THE PRIMARY FREEWAY AND THE SECOND OCCURS CONCURRENTLY ON AN INTERSECTING FREEWAY .....14-13**

- Major Accident on the Primary Freeway with Another Event on an Intersecting Freeway.....14-14
- Minor Accident on the Primary Freeway with Another Event on an Intersecting Freeway.....14-15
- Construction on the Primary Freeway with Another Event on an Intersecting Freeway .....14-16
- Construction with Temporary Lane Closure(s) on the Primary Freeway with Another Event on an Intersecting Freeway .....14-17
- Disabled Vehicle on the Primary Freeway with Another Event on an Intersecting Freeway.....14-18
- Incident (Load Spill, Debris, etc.) Requiring a Lane Closure on the Primary Freeway with Another Event on an Intersecting Freeway .....14-19
- Incident (Load Spill, Debris, etc.) Requiring Total Closure of the Primary Freeway with Another Event on the Intersecting Freeway .....14-20
- Maintenance Operations Requiring a Lane Closure on the Primary Freeway with Another Event on an Intersecting Freeway .....14-21
- Maintenance Operations Requiring Total Closure of the Primary Freeway with Another Event on an Intersecting Freeway .....14-22
- Special Event Exit on the Primary Freeway with Another Event on an Intersecting Freeway.....14-23

**ONE EVENT OCCURS ON THE PRIMARY FREEWAY AND THE SECOND OCCURS CONCURRENTLY ON A CONNECTING FREEWAY IN AN I-95 CORRIDOR COALITION STATE.....14-24**

TWO EVENTS OCCUR CONCURRENTLY ON AN INTERSECTING  
 FREEWAY .....14-25  
 Major Accident with Another Event .....14-25  
 Minor Accident with Another Event .....14-26  
 Construction with Another Event .....14-27  
 Construction with Temporary Lane Closure(s) with Another Event .....14-28  
 Disabled Vehicle with Another Event .....14-29  
 Incident (Load Spill, Debris, etc.) Requiring a Lane Closure with Another  
 Event .....14-30  
 Incidents (Load Spill, Debris, etc.) Requiring Total Freeway Closure with  
 Another Event .....14-31  
 Maintenance Operations with Lane Closure(s) with Another Event .....14-32  
 Maintenance Operations Requiring Total Freeway Closure with Another  
 Event .....14-33  
 Special Event Exit with Another Event .....14-34

ONE EVENT OCCURS ON AN INTERSECTING FREEWAY AND THE SECOND  
 OCCURS CONCURRENTLY ON A CONNECTING FREEWAY IN AN  
 I-95 CORRIDOR COALITION STATE .....14-35

**MODULE 15. MESSAGE DESIGN EXAMPLES FOR  
 INCIDENTS: LARGE VMSs .....15-1**

**15.1 OBJECTIVES AND SUMMARY ..... 15-1**

**15A. INCIDENT EXAMPLE #1 ALL LANES ARE (BLOCKED)  
 CLOSED ..... 15-2**

**15A.1 BEFORE POLICE ARRIVE ..... 15-2**

DEFINE SITUATION .....15-3

Analyze Incident and Incident Scene Characteristics .....15-3

DESIGN MESSAGE FOR VMS ON SAME FREEWAY AND RELATIVELY

CLOSE TO THE INCIDENT (VMS #1) .....15-4

Identify VMS Characteristics .....15-4

Review Conditions at the VMS Location .....15-4

Identify Diversion Route Characteristics .....15-4

Set Objectives .....15-5

Establish Initial Maximum Allowable Number of Units of Information in the  
 Message Based on VMS Type and Freeway Operating Speeds .....15-5

Assess Whether the Message Must Be Reduced Because of Local Geometric  
 Sight Distance Restrictions to the VMS .....15-6

Assess Whether the Message Must Be Reduced Because of Local  
 Environmental Sight Distance Restrictions to the VMS Due to Rain or  
 Fog .....15-6

Finalize the Maximum Allowable Units of Information in the Message .....15-6  
Define Basic VMS Message to Satisfy Motorist Information Needs.....15-6  
Reduce the Number of Message Units if Necessary .....15-8  
Format the Message.....15-8  
Adjust Message to Fit on Existing VMS .....15-8  
Adjust Message to Fit on 3 Lines or Less .....15-8  
Finalize VMS Message.....15-9  
Assess Effects of Large Trucks on the Ability of Motorists to View the VMS  
Message .....15-10

DESIGN MESSAGE FOR VMS ON SAME FREEWAY BUT RELATIVELY

FAR FROM THE INCIDENT (VMS #2) .....15-11  
Identify VMS Characteristics .....15-11  
Review Conditions at the VMS Location.....15-11  
Identify Diversion Route Characteristics .....15-11  
Set Objectives .....15-12  
Establish Initial Maximum Allowable Number of Units of Information in the  
Message Based on VMS Type and Freeway Operating Speeds.....15-12  
Assess Whether the Message Must Be Reduced Because of Local Geometric  
Sight Distance Restrictions to the VMS .....15-12  
Assess Whether the Message Must Be Reduced Because of Local  
Environmental Sight Distance Restrictions to the VMS Due to Rain or  
Fog.....15-13  
Finalize the Maximum Allowable Units of Information in the Message .....15-13  
Define Basic VMS Message to Satisfy Motorist Information Needs.....15-13  
Reduce the Number of Message Units if Necessary .....15-15  
Format the Message.....15-15  
Adjust Message to Fit on Existing VMS .....15-15  
Adjust Message to Fit on 3 Lines or Less .....15-15  
Finalize VMS Message.....15-16  
Assess Effects of Large Trucks on the Ability of Motorists to View the VMS  
Message .....15-17

**15A.2 AFTER POLICE ARRIVE** ..... 15-18

DEFINE SITUATION.....15-19  
Analyze Incident and Incident Scene Characteristics.....15-19

DEFINE MESSAGE FOR VMS ON SAME FREEWAY AND RELATIVELY

CLOSE TO THE INCIDENT (VMS #1) .....15-20  
Identify VMS Characteristics .....15-20  
Review Conditions at the VMS Location.....15-20  
Identify Diversion Route Characteristics .....15-20  
Set Objectives .....15-21  
Establish Initial Maximum Allowable Number of Units of Information in the  
Message Based on VMS Type and Freeway Operating Speeds.....15-21  
Assess Whether the Message Must Be Reduced Because of Local Geometric  
Sight Distance Restrictions to the VMS .....15-22

Assess Whether the Message Must Be Reduced Because of Local Environmental Sight Distance Restrictions to the VMS Due to Rain or Fog.....15-22

Finalize the Maximum Allowable Units of Information in the Message .....15-22

Define Basic VMS Message to Satisfy Motorist Information Needs.....15-22

Reduce the Number of Message Units if Necessary .....15-24

Format the Message.....15-24

Adjust Message to Fit on Existing VMS .....15-24

Adjust Message to Fit on 3 Lines or Less .....15-24

Finalize VMS Message.....15-25

Assess Effect of Large Trucks on the Ability of Motorists to View the VMS Message .....15-26

DESIGN MESSAGE FOR VMS ON SAME FREEWAY BUT RELATIVELY FAR FROM THE INCIDENT (VMS #2) .....15-27

Identify VMS Characteristics .....15-27

Review Conditions at the VMS Location.....15-27

Identify Diversion Route Characteristics .....15-27

Set Objectives .....15-28

Establish Initial Maximum Allowable Number of Units of Information in the Message Based on VMS Type and Freeway Operating Speeds.....15-28

Assess Whether the Message Must Be Reduced Because of Local Geometric Sight Distance Restrictions to the VMS .....15-28

Assess Whether the Message Must Be Reduced Because of Local Environmental Sight Distance Restrictions to the VMS Due to Rain or Fog.....15-29

Finalize the Maximum Allowable Units of Information in the Message .....15-29

Define Basic VMS Message to Satisfy Motorist Information Needs.....15-29

Reduce the Number of Message Units if Necessary .....15-30

Format the Message.....15-31

Adjust Message to Fit on Existing VMS .....15-31

Adjust Message to Fit on 3 Lines or Less .....15-31

Finalize VMS Message.....15-32

Assess Effects of Large Trucks on the Ability of Motorists to View the VMS Message .....15-32

**15B. INCIDENT EXAMPLE #2 ALL LANES ARE (BLOCKED) CLOSED..... 15-33**

**15B.1 BEFORE POLICE ARRIVE ..... 15-33**

DEFINE SITUATION DETAILS .....15-34

Analyze Incident and Incident Scene Characteristics.....15-34

DESIGN MESSAGE FOR VMS ON DIFFERENT FREEWAY THAN THE INCIDENT (VMS #1) .....15-35

Identify VMS Characteristics .....15-35

Review Conditions at the VMS Location.....15-35

Identify Diversion Route Characteristics .....15-35  
Set Objectives .....15-36  
Establish Initial Maximum Allowable Number of Units of Information in the  
Message Based on VMS Type and Freeway Operating Speeds.....15-36  
Assess Whether the Message Must Be Reduced Because of Local Geometric  
Sight Distance Restrictions to the VMS .....15-37  
Assess Whether the Message Must Be Reduced Because of Local  
Environmental Sight Distance Restrictions to the VMS Due to Rain or  
Fog .....15-37  
Finalize the Maximum Allowable Units of Information in the Message .....15-37  
Define Basic VMS Message to Satisfy Motorist Information Needs.....15-37  
Reduce the Number of Message Units if Necessary .....15-39  
Format the Message.....15-40  
Adjust Message to Fit on Existing VMS .....15-40  
Adjust Message to Fit on 3 Lines or Less .....15-40  
Finalize VMS Message.....15-41  
Assess Effects of Large Trucks on the Ability of Motorists to View the VMS  
Message .....15-42

**DESIGN MESSAGE FOR VMS ON DIFFERENT FREEWAY THAN THE**

**INCIDENT (VMS #2) .....15-43**  
Identify VMS Characteristics .....15-43  
Review Conditions at the VMS Location.....15-43  
Identify Diversion Route Characteristics .....15-43  
Set Objectives .....15-44  
Establish Initial Maximum Allowable Number of Units of Information in the  
Message Based on VMS Type and Freeway Operating Speeds.....15-44  
Assess Whether the Message Must Be Reduced Because of Local Geometric  
Sight Distance Restrictions to the VMS .....15-45  
Assess Whether the Message Must Be Reduced Because of Local  
Environmental Sight Distance Restrictions to the VMS Due to Rain or  
Fog .....15-45  
Finalize the Maximum Allowable Units of Information in the Message .....15-45  
Define Basic VMS Message to Satisfy Motorist Information Needs.....15-45  
Reduce the Number of Message Units if Necessary .....15-47  
Format the Message.....15-48  
Adjust Message to Fit on Existing VMS .....15-48  
Adjust Message to Fit on 3 Lines or Less .....15-48  
Finalize VMS Message.....15-49  
Assess Effects of Large Trucks on the Ability of Motorists to View the VMS  
Message .....15-50

**15B.2 AFTER POLICE ARRIVE..... 15-51**  
**DEFINE SITUATION DETAILS .....15-52**  
Analyze Incident and Incident Scene Characteristics.....15-52

DESIGN MESSAGE FOR VMS ON DIFFERENT FREEWAY THAN THE  
INCIDENT (VMS #1) .....15-53

- Identify VMS Characteristics .....15-53
- Review Conditions at the VMS Location.....15-53
- Identify Diversion Route Characteristics .....15-53
- Set Objectives .....15-54
- Establish Initial Maximum Allowable Number of Units of Information in the  
Message Based on VMS Type and Freeway Operating Speeds.....15-54
- Assess Whether the Message Must Be Reduced Because of Local Geometric  
Sight Distance Restrictions to the VMS .....15-55
- Assess Whether the Message Must Be Reduced Because of Local  
Environmental Sight Distance Restrictions to the VMS Due to Rain or  
Fog.....15-55
- Finalize the Maximum Allowable Units of Information in the Message .....15-55
- Define Basic VMS Message to Satisfy Motorist Information Needs.....15-55
- Reduce the Number of Message Units if Necessary .....15-57
- Format the Message.....15-58
- Adjust Message to Fit on Existing VMS .....15-58
- Adjust Message to Fit on 3 Lines or Less .....15-58
- Finalize VMS Message.....15-59
- Assess Effects of Large Trucks on the Ability of Motorists to View the VMS  
Message .....15-59

DESIGN MESSAGE FOR VMS ON DIFFERENT FREEWAY THAN THE  
INCIDENT (VMS #2) .....15-60

- Identify VMS Characteristics .....15-60
- Review Conditions at the VMS Location.....15-60
- Identify Diversion Route Characteristics .....15-60
- Set Objectives .....15-61
- Establish Initial Maximum Allowable Number of Units of Information in the  
Message Based on VMS Type and Freeway Operating Speeds.....15-61
- Assess Whether the Message Must Be Reduced Because of Local Geometric  
Sight Distance Restrictions to the VMS .....15-62
- Assess Whether the Message Must Be Reduced Because of Local  
Environmental Sight Distance Restrictions to the VMS Due to Rain or  
Fog.....15-62
- Finalize the Maximum Allowable Units of Information in the Message .....15-62
- Define Basic VMS Message to Satisfy Motorist Information Needs.....15-62
- Reduce the Number of Message Units if Necessary .....15-64
- Format the Message.....15-65
- Adjust Message to Fit on Existing VMS .....15-65
- Adjust Message to Fit on 3 Lines or Less .....15-65
- Finalize VMS Message.....15-66
- Assess Effects of Large Trucks on the Ability of Motorists to View the VMS  
Message .....15-66

**MODULE 16. MESSAGE DESIGN EXAMPLE FOR INCIDENTS: PORTABLE VMSs** .....16-1

**16.1 OBJECTIVES AND SUMMARY**.....16-1

**16A. INCIDENT EXAMPLE #3 LANES ARE (BLOCKED)**

**CLOSED** ..... 16-2

**16A.1 AFTER POLICE ARRIVE** .....16-2

DEFINE SITUATION DETAILS .....16-3

Analyze Incident and Incident Scene Characteristics.....16-3

DESIGN MESSAGE FOR VMS ON SAME HIGHWAY AND RELATIVELY

CLOSE TO THE INCIDENT (PORTABLE VMS #1).....16-4

Identify VMS Characteristics .....16-4

Review Conditions at the VMS Location.....16-4

Identify Diversion Route Characteristics .....16-4

Set Objectives .....16-5

Establish Initial Maximum Allowable Number of Units of Information in the Message Based on VMS Type and Freeway Operating Speeds.....16-5

Assess Whether the Message Must Be Reduced Because of Local Geometric Sight Distance Restrictions to the VMS .....16-6

Assess Whether the Message Must Be Reduced Because of Local Environmental Sight Distance Restrictions to the VMS Due to Rain or Fog.....16-6

Finalize the Maximum Allowable Units of Information in the Message .....16-6

Define Basic VMS Message to Satisfy Motorist Information Needs.....16-6

Reduce the Number of Message Units if Necessary .....16-8

Format the Message.....16-9

Adjust Message to Fit on Existing VMS .....16-9

Adjust Message to Fit on 3 Lines or Less .....16-10

Finalize VMS Message.....16-11

Assess Effects of Large Trucks on the Ability of Motorists to View the VMS Message .....16-12

DESIGN MESSAGE FOR VMS ON DIFFERENT HIGHWAY THAN THE

INCIDENT (PORTABLE VMS #2) .....16-13

Identify VMS Characteristics .....16-13

Review Conditions at the VMS Location.....16-13

Identify Diversion Route Characteristics .....16-13

Set Objectives .....16-14

Establish Initial Maximum Allowable Number of Units of Information in the Message Based on VMS Type and Freeway Operating Speeds.....16-14

Assess Whether the Message Must Be Reduced Because of Local Geometric Sight Distance Restrictions to the VMS .....16-15



Assess Whether the Message Must Be Reduced Because of Local  
Environmental Sight Distance Restrictions to the VMS Due to Rain or  
Fog.....16-15  
Finalize the Maximum Allowable Units of Information in the Message .....16-15  
Define Basic VMS Message to Satisfy Motorist Information Needs.....16-15  
Reduce the Number of Message Units if Necessary .....16-17  
Format the Message.....16-19  
Adjust Message to Fit on Existing VMS .....16-19  
Adjust Message to Fit on 3 Lines or Less .....16-19  
Finalize VMS Message.....16-21  
Assess Effects of Large Trucks on the Ability of Motorists to View the VMS  
Message .....16-22

**APPENDICES**

**A. MESSAGE LENGTH REDUCTIONS FOR VERTICAL  
CURVES .....A-1**

**B. MESSAGE LENGTH REDUCTIONS FOR HORIZONTAL  
CURVES.....B-1**

**C. MESSAGE LENGTH REDUCTIONS FOR RAIN AND FOG .....C-1**

**D. EFFECTS OF LARGE TRUCKS ON VMS LEGIBILITY.....D-1**

# MODULE 1. INTRODUCTION

## TABLE OF CONTENTS

<b>1.1 BACKGROUND AND SIGNIFICANCE OF THE VARIABLE MESSAGE SIGN OPERATIONS MANUAL.....</b>	<b>1-1</b>
<b>1.2 VMS MESSAGE DESIGN PROCESS .....</b>	<b>1-2</b>
<b>1.3 OVERVIEW OF MANUAL MODULES .....</b>	<b>1-3</b>
MODULE 1. INTRODUCTION .....	1-3
MODULE 2. PRINCIPLES OF VMS OPERATIONS .....	1-3
MODULE 3. VMS OPERATING POLICY FOR NEW JERSEY DEPARTMENT OF TRANSPORTATION.....	1-4
MODULE 4. VMS OPERATING FUNDAMENTALS.....	1-4
MODULE 5. PRINCIPLES OF VMS MESSAGE DESIGN .....	1-4
MODULE 6. DESIGNING THE BASIC VMS MESSAGE FOR INCIDENTS .....	1-4
MODULE 7. DESIGNING THE BASIC VMS MESSAGE FOR ROADWORK .....	1-4
MODULE 8. ESTABLISHING THE MAXIMUM MESSAGE LENGTH.....	1-5
MODULE 9. DEALING WITH LONG MESSAGES .....	1-5
MODULE 10. DESIGNING VMS MESSAGES FOR INCIDENTS .....	1-5
MODULE 11. DESIGNING VMS MESSAGES FOR ROADWORK.....	1-5
MODULE 12. QUICK REFERENCE GUIDE FOR DESIGNING VMS MESSAGES .....	1-5
MODULE 13. MODIFYING MESSAGES TO IMPROVE EFFECTIVENESS .....	1-5
MODULE 14. PRIORITIES WHEN COMPETING MESSAGE NEEDS ARISE.....	1-6
MODULE 15. MESSAGE DESIGN EXAMPLES FOR INCIDENTS: LARGE VMS.....	1-6
MODULE 16. MESSAGE DESIGN EXAMPLE FOR INCIDENTS: PORTABLE VMS .....	1-6
APPENDIX A. MESSAGE LENGTH REDUCTIONS FOR VERTICAL CURVES.....	1-6
APPENDIX B. MESSAGE LENGTH REDUCTIONS FOR HORIZONTAL CURVES.....	1-6
APPENDIX C. MESSAGE LENGTH REDUCTIONS FOR RAIN AND FOG .....	1-6
APPENDIX D. EFFECTS OF LARGE TRUCKS ON VMS LEGIBILITY .....	1-6

**THIS PAGE LEFT BLANK**

# MODULE 1. INTRODUCTION

## 1.1 BACKGROUND AND SIGNIFICANCE OF THE VARIABLE MESSAGE SIGN OPERATIONS MANUAL

This *Variable Message Sign Operations Manual* is designed for use by personnel in the New Jersey Department of Transportation (NJDOT) and their partner agencies who have responsibility for the operation of and/or message design for large permanent variable message signs (VMSs) or portable VMSs. The Manual is written to help both new and experienced users of VMSs at various levels of the agency including 1) entry level personnel, 2) personnel very experienced with traffic operations, and 3) managers. It provides very specific information for entry level personnel, reminders for experienced personnel and higher level information for managers regardless whether or not they work in one of the Traffic Operations Centers (TOCs) in the state.

The design and display of messages on VMSs introduce many challenges to transportation agencies. The following paragraphs briefly summarize some of the relevant issues involved.

Variable message signs (VMSs), previously termed changeable message signs (CMSs) and sometimes referred to as dynamic message signs (DMSs), are one of the primary links a transportation agency has to the motoring public it serves. Although they have been in existence for more than 40 years in some parts of the U.S., only the recent emphasis and financial support of the Intelligent Transportation System (ITS) legacy has allowed most state transportation departments to purchase them and build the electronic monitoring systems necessary to operate them as a key component in an Advanced Transportation Management System (ATMS).

Since they represent many motorists' primary concept of ITS, improperly designed or operated VMSs will have a negative impact on the public's perception of ITS in general. It is imperative that state DOTs take steps to ensure that the content, format, and application of information on the VMSs under their jurisdictions are of the highest possible quality and consistency statewide. The fact that VMS are operated by different TOCs in different cities should be transparent to the motorist as they travel from one region of the state to the other.

The design and display of messages on VMSs introduce many challenges to transportation agencies. Recommendations to meet these challenges are presented in this Manual.

## 1.2 VMS MESSAGE DESIGN PROCESS

The *Variable Message Sign Operations Manual* is written with a focus on 1) the design of effective VMS messages for incident conditions and roadwork and 2) when and where to display messages. This emphasis is intentional for the following reason. VMS operations require the user to have a good understanding of not only traffic operations but also a working knowledge of how messages are designed. The latter is important because the VMS message design procedure in this Manual helps the VMS operator to learn more about traffic operations and to understand the strengths, limitations and possible consequences of the messages the operator displays.

Emphasis is given throughout the Manual for effective message designs for VMSs located:

- On the same freeway and relatively close to the incident or roadwork;
- On the same freeway but relatively far from the incident or roadwork; and
- On a different freeway than the incident or roadwork.

The VMS message design process begins with the development of a Basic VMS Message using guidelines of acceptable words and message terms for either incident or roadwork events. The Basic VMS Message is the sum total of all the information that motorists need in order to make rational driving decisions (e.g., whether to take an alternative route). In most cases, the Basic VMS Message must be shortened because it will exceed the amount of information that motorists can read and comprehend in the short time they have available to read the message, or will exceed the amount of information that can physically fit on the VMS.

The maximum length of message that can be displayed on a VMS depends on how far away motorists can adequately view the message and on their perception and information processing capabilities. Viewing distance will be affected by the type of sign used (light-emitting diode [LED], fiberoptic, etc.), the sun position, geometric design, and environmental conditions at the VMS location. Travel speed will affect the amount of information that motorists can read and comprehend.

Guidance is given in the Manual in tables on the maximum number of units of information that can be displayed on a VMS based on type of VMS, travel speed, and sun position. In some cases when portable VMSs are used, it may be necessary to reduce the maximum number of units of information (using tables in the Manual) because of sight distance restrictions to the VMS due to vertical grades or horizontal curves. Additional guidelines are given for sight distance restrictions to the VMS because of heavy rain or fog.

After the maximum number of units of information that can be displayed on a VMS is determined, detailed guidance is provided to shorten the Basic VMS Message so that the maximum is not exceeded while keeping the most important information in the message. The process provides for consistency of information and format. Furthermore, the process assures that motorists will be able to read and understand the messages. The underlying objective is to keep messages as complete and concise as possible.

## 1.3 OVERVIEW OF MANUAL MODULES

The *Variable Message Sign Operations Manual* contains the following sixteen modules and four appendices:

- Module 1. Introduction;
- Module 2. Principles of VMS Operations;
- Module 3. VMS Operating Policy for New Jersey Department of Transportation;
- Module 4. VMS Operating Fundamentals;
- Module 5. Principles of VMS Message Design;
- Module 6. Designing the Basic VMS Message for Incidents;
- Module 7. Designing the Basic VMS Message for Roadwork;
- Module 8. Establishing the Maximum Message Length;
- Module 9. Dealing with Long Messages;
- Module 10. Designing VMS Messages for Incidents;
- Module 11. Designing VMS Messages for Roadwork;
- Module 12. Quick Reference Guide for Designing VMS Messages;
- Module 13. Modifying Messages to Improve Effectiveness;
- Module 14. Priorities When Competing Message Needs Arise;
- Module 15. Message Design Examples for Incidents: Large VMS;
- Module 16. Message Design Example for Incidents: Portable VMS;
  
- Appendix A. Message Length Reductions for Vertical Curves;
- Appendix B. Message Length Reductions for Horizontal Curves;
- Appendix C. Message Length Reductions for Rain and Fog; and
- Appendix D. Effects of Large Trucks on VMS Legibility.

As discussed below, Modules 6, 7, 10 and 11 address details of the VMS message design processes for incidents and roadwork. These modules were written in a style to simplify the message design process for the VMS message designer. In addition, the intent was to reduce the amount of information the user has to search within the Manual when messages are designed. As such, the user will find a degree of repetition if Modules 6, 7, 10 and 11 are read from the beginning to the end. The Manual user will recognize the value of these modules with repetition when messages are actually designed. A summary of the type of material covered in each module is provided below.

### MODULE 1. INTRODUCTION

The first module includes a discussion of the background and significance of the *Variable Message Sign Operations Manual*. The importance of the design of effective VMS messages is discussed and the message design process is summarized.

### MODULE 2. PRINCIPLES OF VMS OPERATIONS

Basic principles of VMS operations including the use of VMSs and the importance of maintaining VMS credibility are presented in the second module.

### **MODULE 3. VMS OPERATING POLICY FOR NEW JERSEY DEPARTMENT OF TRANSPORTATION**

Module 3 contains the current New Jersey Department of Transportation VMS Operating Policy.

### **MODULE 4. VMS OPERATING FUNDAMENTALS**

Module 4 contains a discussion of the five basic considerations when operating VMSs. These are: 1) Determine the purpose for using a VMS; 2) Determine which VMS is (are) appropriate to use; 3) Determine what to display on the VMS; 4) Determine how long to display the message; and 5) Resolve any message signing conflicts that exist.

### **MODULE 5. PRINCIPLES OF VMS MESSAGE DESIGN**

Basic principles for designing VMS messages are presented in Module 5. It contains an overview of issues for message design, discussion of selecting the audience for the message and definitions and message design considerations. Details are given for the first step in the VMS message design process, and that is the design of the Basic VMS Message needed to satisfy motorist information needs when the VMS is used to advise motorists of an accident or roadwork. Meanings of words and phrases based on human factors research are also given. The module also includes classification, definition, and discussion of six types of diversion routes that might apply in a diversion situation.

### **MODULE 6. DESIGNING THE BASIC VMS MESSAGE FOR INCIDENTS**

Module 6 is devoted to presentation of the details, including message elements and words or terms, for designing the Basic VMS Message when the sign is used to advise motorists of incidents. It includes detailed guidelines for 1) lane-closure (blockage) incidents, 2) incidents that block all the lanes, and 3) incidents that require closing the freeway. The guidelines are addressed for VMSs located on 1) the same freeway and relatively close to the incident or closure, 2) the same freeway but relatively far from the incident or closure, and 3) a different freeway than the incident or closure.

The user of the Manual will find a degree of repetition in this module. The repetition is necessary in order to allow the user to reference successive pages when designing a message for the specific VMS location relative to the incident (i.e., relatively near, relatively far, on a different freeway) rather than shuffling through several sections of the Manual. In addition, it will more easily accommodate the user who uses the CD ROM version of the Manual.

### **MODULE 7. DESIGNING THE BASIC VMS MESSAGE FOR ROADWORK**

Module 7 is similar to Module 6 with the exception it addresses designing the Basic VMS Message when the sign is used to advise motorists of roadwork.

Also, similar to Module 6, the user of the Manual will find a degree of repetition in this module. The repetition is necessary in order to allow the user to reference successive pages when designing a message for the specific VMS location relative to the roadwork (i.e., relatively near, relatively far, on a different freeway) rather than shuffling through several sections of the

Manual. In addition, it will more easily accommodate the user who uses the CD ROM version of the Manual.

## **MODULE 8. ESTABLISHING THE MAXIMUM MESSAGE LENGTH**

Guidelines for the maximum VMS message length in terms of the maximum number of units of information that can be displayed are given in Module 8 based on VMS type, travel speed and sun position. Guidelines for reducing this maximum on LED VMSs due to adverse vertical grades, horizontal curves, rain or fog are also presented. A discussion and data concerning the number of motorists who may fail to read the VMS message because of the presence of trucks in the traffic stream are also given.

## **MODULE 9. DEALING WITH LONG MESSAGES**

In most cases, the Basic VMS Message designed in Modules 6 and 7 and reduced in length based on data in Module 8 will exceed the amount of information that motorists can read and comprehend in the short time they have available to read the message, or will exceed the amount of information that can physically fit on the VMS. Module 9 contains guidelines for several ways to reduce the message length and units of information. It includes guidelines on using abbreviations, deleting “dead” words, reformatting the message and combining message elements. Guidelines for splitting a message onto two frames when the message is too long to fit on one frame are also presented.

## **MODULE 10. DESIGNING VMS MESSAGES FOR INCIDENTS**

A detailed step-by-step procedure for designing VMS messages for incidents is provided in Module 10. It includes detailed procedures for 1) lane-closure (blockage) incidents, 2) incidents that block all the lanes, and 3) incidents that require closing the freeway. The procedures are given for VMSs located on 1) the same freeway and relatively close to the incident or closure, 2) the same freeway but relatively far from the incident or closure, and 3) a different freeway than the incident or closure.

## **MODULE 11. DESIGNING VMS MESSAGES FOR ROADWORK**

Module 11 is similar to Module 10, with the exception that it addresses designing VMS messages when the sign is used to advise motorists of roadwork.

## **MODULE 12. QUICK REFERENCE GUIDE FOR DESIGNING VMS MESSAGES**

The objective of Module 12 is to provide a quick reference guide for designing and selecting VMS messages. It is intended for TOC supervisory personnel and for VMS operators who have considerable experience with using the guidelines in Modules 10 and 11.

## **MODULE 13. MODIFYING MESSAGES TO IMPROVE EFFECTIVENESS**

Module 13 is a quick reference guide illustrating how messages that violate good and sound principles for effective design can be improved. The Module includes examples of both incident and roadwork messages.



**MODULE 14. PRIORITIES WHEN COMPETING MESSAGE NEEDS ARISE**

Occasionally, two or more simultaneous events occur that require a decision as to which event should be displayed on the VMS. Module 14 contains a set of tables to help the VMS operator establish signing priority.

**MODULE 15. MESSAGE DESIGN EXAMPLES FOR INCIDENTS: LARGE VMS**

Two examples are given that illustrate how Module 10 is used to design VMS messages for large VMSs when incidents occur that block all the lanes of a freeway. The two examples address messages required before and after the police arrive.

**MODULE 16. MESSAGE DESIGN EXAMPLE FOR INCIDENTS: PORTABLE VMS**

Module 16 is similar to Module 15 with the exception that Module 10 is used to design messages for portable VMSs when incidents occur that block all the lanes of a freeway. The example addresses messages required before and after the police arrive.

**APPENDIX A. MESSAGE LENGTH REDUCTIONS FOR VERTICAL CURVES**

The theory and procedure for determining the sight distance to a VMS when there are restrictions because of a vertical curve are presented in Appendix A. Four examples using the procedure in Appendix A are also included.

**APPENDIX B. MESSAGE LENGTH REDUCTIONS FOR HORIZONTAL CURVES**

The theory and procedure for determining the sight distance to a VMS when there are restrictions because of a horizontal curve are presented in Appendix B. Two examples using the procedure in Appendix B are also included.

**APPENDIX C. MESSAGE LENGTH REDUCTIONS FOR RAIN AND FOG**

The theory and procedure for determining the sight distance to a VMS when there are visual restrictions because of a heavy rain or fog are presented in Appendix C. An example illustrating the procedure is included.

**APPENDIX D. EFFECTS OF LARGE TRUCKS ON VMS LEGIBILITY**

The theory and procedure for determining the effects of large trucks on VMS legibility are presented in Appendix D. Two examples illustrating the procedure are included.

# MODULE 2. PRINCIPLES OF VMS OPERATIONS

## TABLE OF CONTENTS

<b>2.1 INTRODUCTION</b> .....	2-1
EARLY WARNING MESSAGES.....	2-1
ADVISORY MESSAGES.....	2-1
ALTERNATIVE ROUTE MESSAGES .....	2-1
<b>2.2 IMPORTANCE OF MAINTAINING VMS CREDIBILITY</b> .....	2-2

**THIS PAGE LEFT BLANK**

## MODULE 2. PRINCIPLES OF VMS OPERATIONS

### 2.1 INTRODUCTION

Road signs exist to communicate information to motorists. Static guide signs are permanent and are limited to presenting information that is largely "geographically linked." Variable message signs (VMSs) can present up-to-the-moment traffic information.

Variable message signs (VMSs), sometimes referred to as changeable message signs (CMSs), are programmable traffic control devices that can usually display any combination of characters to present messages to motorists. These signs are either permanent in which case they are usually installed above or on the side of the roadway, or transportable, in which case they are attached to a trailer or mounted directly on a truck and driven to a desired location. Portable VMSs are much smaller than permanent VMSs and are oftentimes used in highway work zones, when major accidents or natural disasters occur, or for special events (e.g., sport events).

Variable message signs perform a critical role on freeways by furnishing motorists with real-time information that advises them of a problem and in some cases, a suggested course of action. Variable message signs improve motorist safety and reduce traffic congestion and delay. They are used to manage traffic by displaying early warning, advisory and alternative route messages.

**VMSs are used to manage traffic by displaying:**

- Early warning messages
- Advisory messages
- Alternative route messages

#### EARLY WARNING MESSAGES

Early warning messages give motorists advance notice of slow traffic and queuing ahead and are effective in reducing secondary accidents. When used in freeway work zones, early warning messages also give notice of new detours, changes in detour route, changes in lane patterns, special speed control measures, etc.

#### ADVISORY MESSAGES

Advisory messages provide motorists with useful information about a specific problem along their route. This information allows motorists to change their speed or path, as the situation dictates, in advance of the problem area, or motorists may elect to voluntarily take an alternative route to their destination.

#### ALTERNATIVE ROUTE MESSAGES

Alternative route messages influence motorists to travel to their chosen destination by using different routes than originally intended. The alternative route is one designated by the transportation agency. In cases when the freeway is physically closed as a result of construction, accident, or natural disaster, the motorists are notified that an alternative route must be used.

## 2.2 IMPORTANCE OF MAINTAINING VMS CREDIBILITY

To be effective, VMSs must provide timely, reliable, accurate and relevant information and they must be operated properly. An important consideration in properly operating a VMS system is to **maintain credibility**. Regardless of how well a message is designed, there is a risk of motorists distrusting the signing system if the messages are not changed at the correct times and updated to reflect current traffic conditions. Each time the information displayed is disproved, the credibility of the system decreases. Eventually the messages are ignored and the VMS system is in jeopardy.

### WHAT MOTORISTS EXPECT FROM VMSs:

- Up-to-the-minute information
- Reliable information
- Accurate information
- Relevant information

The first rule of good VMS operation is that specific traffic information (e.g., accident) should not be displayed before it has been verified. For example, does the VMS operator know there was an accident? Does he/she know where it occurred? Does he/she know how many lanes are closed? Does he/she know if a specific route for diversion can handle the capacity?

**RULE 1 - Never display specific traffic information before it has been verified.**

It is the responsibility of the VMS operator to ensure that the motorists respect the VMSs and continue to have confidence in them. There are at least six ways to reduce message credibility:

**RULE 2 - There are at least six ways to lose the motorists' confidence in the VMS:**  
*Display information that is*

- Inaccurate
  - Not current
  - Irrelevant
  - Obvious
  - Trivial
- and/or display*
- Erroneous numbers (e.g., incorrect speeds, travel times, etc.)

- **Inaccurate** information (e.g., no accident is observed when traffic passes by the location where an incident was displayed on a VMS).
- Information is **not current** (e.g., the message is the same each morning when motorists pass the sign).
- Information is **irrelevant** to essentially all motorists using that facility.
- Information is **obvious** by inspection, hence, is redundant (e.g., displaying "HEAVY CONGESTION" when motorists are driving bumper to bumper in peak traffic).
- Information is **trivial** (e.g., "DRIVE CAREFULLY", "SUPPORT YOUR LOCAL RED CROSS", time and temperature). Displaying trivial information can result in many motorists, particularly commuters, ignoring the messages that have no direct impact on their trips and consequently will begin ignoring the VMS. When an important message is displayed that will impact their trip, the motorists may not read the message.

- Displaying **erroneous numbers** such as traffic speeds and time to reach a destination can be easily checked and disproved. Never display these values unless they can be accurately predicted. However, delay time is more difficult to disprove by motorists.

**THIS PAGE LEFT BLANK**

**MODULE 3. VMS OPERATING POLICY FOR  
NEW JERSEY DEPARTMENT OF TRANSPORTATION**

**TABLE OF CONTENTS**

**3.1 RESPONSIBILITY FOR OPERATION OF VMSs.....3-1**

**3.2 GENERAL OPERATIONS .....3-1**

**3.3 PERMANENT VARIABLE MESSAGE SIGNS .....3-7**

**3.4 PORTABLE VARIABLE MESSAGE SIGNS .....3-8**



**THIS PAGE LEFT BLANK**

## **MODULE 3. VMS OPERATING POLICY FOR NEW JERSEY DEPARTMENT OF TRANSPORTATION**

### **3.1 RESPONSIBILITY FOR OPERATION OF VMSs**

The Director of Traffic Operations has final responsibility for the operation of VMSs on roadways under the jurisdiction of the NJDOT. NJDOT Traffic Operations North and NJDOT Traffic Operations South have the responsibility for the daily operations of the VMSs in north and south New Jersey, respectively. General questions about the VMSs and the overall responsibility should be addressed to either the Manager of Traffic Operations North or the Manager of Traffic Operations South.

### **3.2 GENERAL OPERATIONS**

- 1. Only real-time information that conveys current traffic safety and congestion information shall be displayed. Traffic-related information that applies to the future (e.g., future lane closures) may at times be displayed, but should be replaced by current incident information whenever applicable. The signs shall remain blank at other times. Public service announcements are not permitted.**

**DISPLAY:**

- Current traffic safety and congestion information

**MAY DISPLAY:**

- Existing and planned roadwork-related information that could have an affect on travel

**DO NOT DISPLAY:**

- Public service announcements

**VMSs ARE TO REMAIN BLANK AT OTHER  
TIMES**

Public service messages (air quality/ozone alerts, ridesharing, safety advice/tips, enforcement actions, telephone hotlines, potential transit strike notices, etc.) are not permitted because motorists who continually travel a specific route will become accustomed to the public service sign message and then began to ignore messages on the VMSs. Subsequent messages indicating lane closures, detours, etc., that directly affect the motorists' travels may tend to be unnoticed due to the display of routine messages during other times. Since variable message signs are provided for the purpose of informing the motorist of unexpected conditions, the signs should be left blank and not be used until such conditions warrant their use. When the use of the signs for real-time information is infrequent, it may be desirable to display existing or planned roadwork-related information that could have an affect on their travel on the specific facility or on other intersecting freeways, expressways or toll roads. However, this information should be replaced by relevant information about major incidents downstream or on intersecting freeways, should they occur.

Public service announcements provide motorists with information that can be more effectively given through other methods such as media campaigns or pamphlets. These and other methods

would benefit a greater majority of the motoring public since it would not be limited to only those that travel roadways that include VMSs.

- 2. During daily peak traffic periods, messages shall be used to advise motorists of unusual conditions (e.g., accidents, lane blockages, etc.) and shall not be used to advise motorists of normal daily peak period traffic congestion conditions. However, travel time information should be displayed when it can be accurately measured. When the travel times of vehicles that have previously traveled the section of freeway are displayed, the time of day that the travel time was measured must also appear in the VMS message.**

**DURING PEAK PERIODS, DISPLAY:**

- **Unusual** conditions
- Travel times

**DO NOT DISPLAY:**

- Normal peak period congestion conditions

The display of the same information daily which can be redundant and therefore trivial will result in many commuters eventually ignoring the messages on the VMS. Thus, they may not read the VMS messages when important information is given. VMSs are more effective when they are used only when some response by motorists is required (e.g., become alert; change of speed, path or route).

Travel time information is among the most useful information to motorists. The major problem is the inability to accurately measure travel times with the more common types of detectors. Automated Vehicle Identification (AVI) technology, now being installed at selected traffic management sites in the United States, has made measurement of travel times a reality. However, the process of accurately predicting future travel times is not currently available. The data that are available are the travel times of the vehicles that just traveled between two AVI sensor stations. In essence it is historical travel time. Therefore, to maintain credibility, motorists must have knowledge that the travel time displayed on the VMS is not what is predicted for his/her trip, but what was measured at a specific time of day.

- 3. When a VMS is in the “blank” mode for extensive time periods, traffic- and freeway-related information about upcoming roadwork on the facility or current or upcoming roadwork on an intersecting freeway may be displayed on the signs for short periods of time.**

**TO REDUCE THE AMOUNT OF BLANK TIME:**

- Display traffic- and freeway-related information about upcoming roadwork

Displaying relevant information that may impact most of the motorists is consistent with providing useful traffic-related information to motorists. This process will help circumvent possible adverse public reaction to seeing blank signs for prolonged periods of time.

4. It is sometimes necessary to display test messages on a VMS to assure correct operations, to “burn-in” a new sign, or for special studies. Acceptable test messages should either state “TEST MESSAGE”, display a portion of the alphabet or a sequence of numbers, or a non-message test pattern such as moving columns or rows, etc. Other test messages shall be reviewed by Manager or Duty Officer of the Traffic Operations Center before they are displayed.

**ACCEPTABLE TEST MESSAGES:**

- “TEST MESSAGE”,
- Portion of alphabet,
- Sequence of numbers, or
- Non-message test pattern.

**OTHER TEST MESSAGES SHALL BE REVIEWED BY THE MANAGER OR DUTY OFFICER OF THE TRAFFIC OPERATIONS CENTER.**

It is vital that test messages do not misdirect motorists; therefore, non-message formats should be used.

5. When incidents occur which do not require the full closure of the roadway, VMS messages shall not divert motorists to specific alternative routes unless 1) positive guidance is available along the alternative route in the form of either guide signs or 2) trailblazers to the major destination, or else police officers or traffic control personnel control and guide traffic along the alternative route. Furthermore, both of the following conditions should exist:

**WHEN ROADWAY IS NOT TOTALLY CLOSED, DIVERSION MESSAGES SHALL NOT BE DISPLAYED UNLESS:**

- Positive guidance is available on the alternative route, or police officers or traffic control personnel guide traffic along the alternative route;
- Information is available of conditions on alternative route; and
- Using the alternative route results in a time saving to motorists.

- The VMS operator has knowledge of the conditions on the alternative route; and
- The alternative route should result in a time saving to motorists.

Motorists are more willing to divert to an alternative route before they enter the freeway. They are less willing to divert after they are on the freeway because the average motorist is reluctant to drive unfamiliar routes. Studies have shown that the average motorist would be willing to divert when the time saving is 20 minutes or more. Further studies showed that the average motorist in New Jersey believes that HEAVY DELAY implies a delay of about 25 minutes or more and MAJOR DELAY implies a delay of about 45 minutes or more.

6. Messages recommending that motorists divert to specific roadways and/or local streets that are not within the jurisdiction of NJDOT are not advised unless severe conditions exist and the appropriate agencies are involved. Messages supporting preplanned diversion routes are permitted at all times.

The diversion of traffic from roadways under the jurisdiction of NJDOT to roadways under the jurisdiction of other agencies in the State must be coordinated with those agencies.

7. **Displaying advance notice of roadwork or other potential impacts to a roadway is acceptable. However, the advance notice should *not* be displayed more than six days before the roadwork or other event. The advance notice shall be displayed in terms of days of the week. Calendar dates shall not be displayed. Messages that impact the safety and operations of the roadway shall have priority over advance notice messages.**

**ADVANCE NOTICE OF ROADWORK OR OTHER POTENTIAL ROADWAY IMPACTS:**

- Should not be displayed more than six days before the event;
- Shall be displayed in terms of days of the week (calendar dates shall not be displayed); and
- Shall yield to messages that impact safety and operations of roadway.

Giving advance notice of roadway activities that may impact motorists' travel helps them in planning future trips and travel paths. Research conducted in New Jersey has shown that motorists cannot translate calendar dates to specific days of the week; thus, calendar dates should not be displayed. To adequately sign using the days of the week, it is important that the motorists are not confused as to whether the message applies to the current week or the following week. Thus, the message should not be displayed more than six days before the event takes place.

Advance notice messages have much lower priority to messages that impact the safety and operations of the roadway.

8. **VMS messages may be displayed to accommodate motorists traveling to special events (e.g., sporting event) when the anticipated traffic flow rates to the event is 5,000 vehicles per hour or greater, or when an engineering assessment indicates that the added special event traffic will result in congestion on the primary facility. The engineering assessment should consider the capacity of the primary facility, day of the week, time of day, parking**

**MESSAGES FOR SPECIAL EVENTS:**

- May be displayed when anticipated traffic flow is 5,000 vph or greater, or when an engineering assessment indicates that the added event traffic will result in congestion on the primary facility.

**MESSAGES MAY BE USED TO DIRECT MOTORISTS TO AN ALTERNATIVE ROUTE TO SPECIAL EVENT PARKING IF:**

- Trailblazers to parking facilities are on the route,
- Traffic conditions on the alternative route are monitored, and
- There is a significant saving in travel time.

**capacity at the special event site, and whether the event has a fixed (e.g., football game) or variable starting time (e.g., state fair). The messages may be used to direct motorists from the primary route to an alternative route that will eventually lead to a parking area. Trailblazers shall be used on the alternative route to direct motorists to the special event parking areas. Traffic conditions on the primary route and alternative route must be monitored. Messages intended to elicit diversion shall only be displayed when there is a significant savings in travel time for the motorists destined to the event. The message shall be blanked alternately whenever the alternative route does not provide a significant travel time saving. Another application of VMSs during special events is to inform motorists which parking lot has available spaces (or is full) so that motorists can make informed decisions about which parking lots to use.**

Research has shown that one of the most effective uses of VMSs is for special events. A very large majority of motorists will respond to VMS messages when the information directs them to a faster route to the special event. The alternative route must provide a significant travel time saving. Also, motorists are concerned with specific directions to parking areas.

One advantage of VMSs is that the message can be displayed when it is desirable to divert motorists to the alternative route and can be turned off whenever it no longer applies. It is essential that NJDOT personnel monitor the traffic conditions on both the primary and secondary routes to ensure that the motorists are not being diverted to an alternative route that does not provide significant time saving.

9. **Regulatory Speed Limit messages may be displayed when the new speed limit is temporarily below the normal speed limit posted for the roadway. The VMS message can be displayed to supplement existing static speed limit signs. The VMS message is not enforceable and shall not be used in place of a static sign. However, the VMS can be used to display advisory speed limits without static advisory speed limit signs.**

**REGULATORY SPEED LIMIT MESSAGES MAY BE USED UNDER CERTAIN CONDITIONS**

For certain conditions such as in freeway work zones there is a need to lower the speed limit below the normal posted speed limit. VMSs may be used to emphasize this temporary change.

10. **VMSs may be used to display severe weather or driving conditions (e.g., major snow storms, icy roadway, etc.).**

**SEVERE WEATHER OR DRIVING CONDITIONS MAY BE DISPLAYED**

11. **Messages should be displayed to advise motorists of verified incidents (e.g., accidents, stalled vehicles, etc.) that occur downstream on the freeway, and when warranted, suggest alternative routes under the following conditions:**

**DISPLAY INFORMATION ABOUT LANE CLOSURES AND VERIFIED:**

- Minor incidents occurring up to 10 miles downstream from the VMS;
- Major incidents occurring downstream of the VMS;
- Lane-blocking incidents on downstream intersecting freeways depending on location, severity and duration; and
- Major incidents on connecting freeways within states in the I-95 Corridor Coalition depending on the location, severity and duration.

- **Information concerning verified minor incidents and lane closures should be displayed for incidents occurring up to 10 miles from the VMS, provided that information about the location, and effects to the motorist (e.g., amount of delay, number of lanes closed, etc.) can also be given.**
- **Messages should be displayed for all verified major incidents (e.g., all lanes blocked or closed, truck overturn, etc.) that occur on the freeway downstream of the VMS regardless of the distance between the VMS and incident. The message should include the location of the incident and the effects to the motorist (e.g., amount of delay, number of lanes closed, etc.).**

- **Information concerning lane-blocking incidents that occur on an intersecting freeway should be displayed on VMSs that are located upstream of the interchange with that freeway depending on the location, severity and duration of the incident. The message should include the location of the incident and the effects to the motorist (e.g., amount of delay, number of lanes closed, etc.).**
- **VMSs located on freeways leading to other states may display messages concerning verified major incidents (e.g., all lanes blocked or closed, truck overturn, etc.) on connecting freeways within states in the I-95 Corridor Coalition depending on the location, severity and duration of the incident.**

**It is not practical or advisable to display information on a VMS for more than one incident at a time. When more than one of the above situation occurs, the VMS operator shall follow the VMS message display priority that is documented in the NJDOT VMS Operations Manual.**

- 12. Advertising should not be used in messages when VMS messages are used for special events.**

**NO ADVERTISING IN VMS MESSAGES**

Oftentimes, special events will have a significant impact on motorists--those attending the special event and those using the same primary freeway to pass by the special event location. Messages for special events can be well designed without including the private company or person sponsoring or performing at the event. For example, if Garth Brooks was performing at the Meadowlands, rather than displaying "GARTH BROOKS CONCERT", the facility at which the concert will be performed "MEADOWLANDS" can be used.

- 13. Only light-emitting technology or a combination of light-emitting and light-reflecting technologies shall be used. When light-emitting diode lamps are used, they shall be amber in color.**

**USE ONLY LIGHT-EMITTING OR  
LIGHT-EMITTING/LIGHT  
REFLECTING TECHNOLOGIES**

**DIODE LAMPS SHALL BE AMBER**

Research has demonstrated that VMSs with light-emitting technologies have greater message legibility. Colors such as red or green should not be used for freeway VMSs.

- 14. All VMSs used on freeways, expressways or toll roads shall have a minimum character height of 18 inches.**

**CHARACTER HEIGHT SHALL BE 18 INCHES**

Research has shown that for the typical VMS legibility distances, freeway operating speeds, and message requirements, an 18-inch character minimum is required. In practice, the character height on light-emitting VMSs is generally indicated by manufacturers in terms of the nominal character height of the sign, rather than the actual physical height. For example, the physical character height of a VMS may be 17.5 inches, but the VMS is referred to as an 18-inch character sign. This is due to the halo effect of the lighted pixels on the sign.



- 15. Messages displayed on VMSs must use words and names that are compatible with the existing static signs.**

**WORDS AND NAMES MUST BE COMPATIBLE WITH EXISTING STATIC SIGNS**

VMS become part of an existing highway signing system; therefore, the text must be compatible with the static signs in at least the following ways:

- Proper names and abbreviations must match those on static guide signs;
- Incident location should be consistent with signed cross-streets and ramps;
- Exit numbers (or names) must be consistent; and
- The names of alternative routes displayed should be consistent with existing signing

- 16. NJDOT VMSs may be used to display messages relating to major incidents and major construction for other agencies. The priority for displaying messages shall remain in the control of NJDOT. If another agency's message is preempted by NJDOT for higher priority needs, NJDOT shall notify the other agency.**

**NJDOT VMSs MAY BE USED TO DISPLAY MESSAGES ABOUT MAJOR ACCIDENTS AND MAJOR CONSTRUCTION FOR OTHER AGENCIES**

**PRIORITY OF MESSAGES IS IN CONTROL OF NJDOT**

**NOTIFY OTHER AGENCY WHEN THE AGENCY'S MESSAGE IS PREEMPTED FOR HIGHER PRIORITY NEEDS**

- 17. VMSs may be used to display messages to inform motorists of intermodal travel situations. For example, VMSs may display messages to inform motorists of the availability of parking at Park-and-Ride facilities and the Newark Airport. Information concerning whether AMTRAK trains are running on schedule may also be displayed. This information is of a lower priority than information concerning roadway incidents. The priority for displaying messages shall remain in the control of NJDOT.**

**VMSs MAY BE USED TO DISPLAY MESSAGES TO INFORM MOTORISTS OF INTERMODAL TRAVEL SITUATIONS**

### **3.3 PERMANENT VARIABLE MESSAGE SIGNS**

Permanent VMSs are normally controlled remotely from traffic control centers that have the capability of monitoring conditions on the roadway. Permanent VMSs come in a wide variety of sizes. The number of lines can range from one to four. The number of characters per line can also vary and in typical use can range up to 25 characters per line. In 1997, the most common sign in the United States had three lines with 18 to 21 characters per line.



### 3.4 PORTABLE VARIABLE MESSAGE SIGNS

Most portable VMSs commonly used have a fixed number of lines ranging from one line to three lines. Normally the signs have the capability of displaying up to eight characters per line. Full matrix signs are more flexible, but in normal usage will display up to three eight-character lines.

- 1. When all three lines are used for message display, no more than two frames of message shall be displayed.**

Research has shown that for three-line portable VMSs no more than two frames should be used when a message must be divided into parts. The 2000 Edition of the Manual on Uniform Traffic Control Devices requires that messages should not be more than two frames.

- 2. In areas where portable VMSs are used with permanent VMSs, no conflicting messages shall be displayed.**

VMSs are part of a total highway system and their message must be consistent with other signs.

# MODULE 4. VMS OPERATING FUNDAMENTALS

## TABLE OF CONTENTS

<b>4.1 BASIC CONSIDERATIONS FOR OPERATING VMSs</b> .....	4-1
DETERMINE THE PURPOSE FOR USING A VMS .....	4-2
What Is the Problem I Am Trying to Address? .....	4-2
What Verified Information Do I Have? .....	4-2
Who is the Audience for the VMS Message? .....	4-3
What Type of Motorist Response Is Required? .....	4-3
Where Should the Response Take Place? .....	4-3
What Degree of Motorist Response Is Required? .....	4-4
DETERMINE THE APPROPRIATE VMS TO USE .....	4-4
Proximity of VMSs to Problem .....	4-4
Characteristics of the VMS Hardware .....	4-4
Roadway, Traffic, and Environmental Characteristics in the Vicinity of the VMS .....	4-5
DETERMINE WHAT TO DISPLAY ON THE VMS .....	4-5
Basic Information Needs and VMS Message .....	4-5
Diversion Routes .....	4-6
VMS Operator Message Options .....	4-6
<i>Selecting a Message from a Message Library</i> .....	4-6
<i>Modifying a Message from a Message Library</i> .....	4-6
<i>Creating a New Message</i> .....	4-7
DETERMINE HOW LONG TO DISPLAY THE MESSAGE .....	4-7
RESOLVE ANY MESSAGE SIGNING CONFLICTS THAT EXIST .....	4-7

**THIS PAGE LEFT BLANK**

## MODULE 4. VMS OPERATING FUNDAMENTALS

### 4.1 BASIC CONSIDERATIONS FOR OPERATING VMSs

It is important to remember that VMSs are tools to help manage traffic on a roadway system. Just as a carpenter carefully selects a tool and then uses that tool to accomplish a particular construction task, one must determine when and how to use VMSs to best accomplish traffic management tasks.

The operation of VMSs involves five basic considerations presented in logical order:

1. Determine the purpose for using a VMS;
2. Determine the appropriate VMS to use;
3. Determine what to display on the VMS;
4. Determine how long to display the message; and
5. Resolve any message signing conflicts that exist.

Within each of these, several factors and issues need to be addressed. It is important to realize that these factors often change over the duration of an incident or other event. These changes require the operator to revisit the situation and possibly modify how the VMS is being used. This process can be illustrated as shown in Figure 4.1.

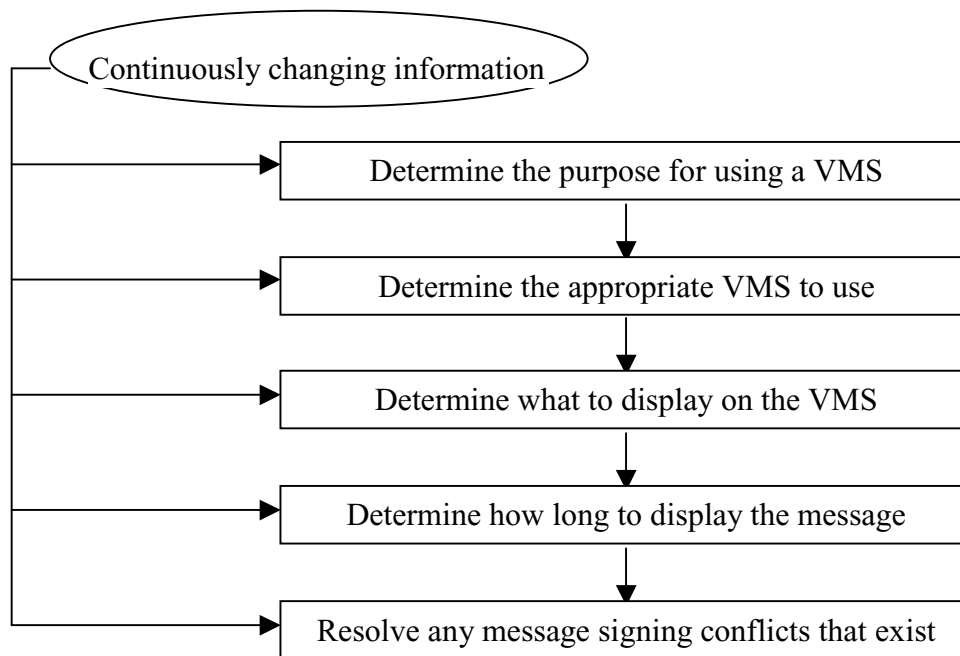

**Figure 4.1 VMS Operating Process**

## DETERMINE THE PURPOSE FOR USING A VMS

VMSs should always be used with a specific purpose or objective in mind. To determine this purpose, the VMS operator must fully understand six things:

1. What is the problem I am trying to address?
2. What verified information do I have?
3. Who is the audience that I am trying to reach with the VMS message?
4. What type of motorist response is required?
5. Where should the response take place?
6. What degree of response is required?

### What Is the Problem I Am Trying to Address?

The VMS operator must consider not only the basic type of problem (i.e., accident, work zone lane closure, etc.) that exists, but also the following:

- Location of problem (position within the roadway right-of-way as well as its relation to other freeways and major traffic generators);
- Scope (number and types of agencies that will likely need to be involved, whether police officers will be required to direct traffic at the scene or on a detour, whether a major incident response team will be activated);
- Potential duration of the situation; and
- Extent of impacts (number of lanes affected, location where lanes are affected, nearby ramps that are blocked or constrained by the traffic queue, etc.);

### What Verified Information Do I Have?

Credibility is very important in VMS operations. Although it is desirable to select and design messages based on complete and perfect information, situations often occur where an operator receives only limited information about a problem (particularly early in the timeline of an event). Furthermore, the information may be from an unknown or untrained source (i.e., a motorist) or may conflict with other information the operator has received. As a result, a VMS operator must decide what information can be used, and how it can be best used to operate the VMS.

**Verified** information is that which is obtained directly by the VMS operator via closed circuit television or other visual means, or is provided by approved personnel of selected agencies. Law enforcement officers, emergency response personnel, or transportation agency courtesy patrol personnel are examples of individuals who can generally provide verified information. **Unverified** information, on the other hand, is not obtained directly by the VMS operator or received from the sources above. Most common examples of unverified information are calls received from motorists about incidents that they have encountered. Unconfirmed commercial radio reports are another source of unverified information.

VMS operators should only use verified information to operate VMSs. Motorists and other sources of unverified information will often provide inaccuracies about locations and effects that, if presented to the public and found to be false, degrade the credibility of the VMS system and the operating agency. *However, unverified information can be useful to the operator in identifying information items that may need to be explored further.* For example, calls from one or more motorists that an incident has cleared may prompt the VMS operator to check a closed circuit television camera or contact the appropriate enforcement agency to verify that the incident has indeed cleared.

If recommendations are to be made about a specific diversion route to use around a problem, the VMS operator must also have information about current conditions on that route. If the operator can not obtain such information, the VMS should not recommend a specific route. The only exception to this is when the freeway has been completely closed and police officers are directing traffic along a designated detour route.

### **Who Is the Audience for the VMS Message?**

A component of establishing an objective for a VMS message is to decide who the audience will be for the message. The audience is the group of motorists that the VMS operator wants to respond to the message in some manner. In some cases, this may be all of the motorists who pass the VMS. In other cases, the message is intended for only some of the motorists (e.g., those who are traveling all the way downtown). Depending on the situation, it may be necessary to identify the intended audience as part of the VMS message itself. In other situations, the intended audience is implied.

### **What Type of Motorist Response Is Required?**

The operator of a VMS must first decide what he or she wants motorists to do in response to the message placed on a sign or group of signs. Messages will be most effective when they encourage some type of response from the motorist, such as to:

- Reduce speed,
- Move out of a blocked or closed lane, and/or
- Take an alternative route.

### **Where Should the Response Take Place?**

The location where responses are desired will depend on 1) type of response desired, 2) the layout of the roadway system, 3) the type and severity of problem being addressed, and 4) the availability of existing guide signs or those installed by the Department in response to a major incident. It is important to realize that the desired motorist response to a particular problem may differ depending on where in the roadway system the motorists are at that particular time. For example, the desired response for a motorist traveling immediately upstream of a full freeway closure might be to follow the designated traffic control devices off of the freeway, along the designated alternative route, and back to the freeway. For motorists approaching on an intersecting freeway farther upstream of the closure, however, the desired response might simply be to not exit onto the closed freeway, and find their own alternative route to their ultimate destination. In general, the

more severe the problem and the longer it is expected to last, the farther upstream messages can be displayed on VMSs.

### **What Degree of Motorist Response Is Required?**

The VMS operator must continuously monitor traffic conditions and motorist response to the VMS messages. Suggested alternative routes must provide improved travel to motorists compared to remaining on the freeway. Remember, the messages on the VMSs can be changed when conditions on the alternative route(s) no longer are better than the freeway.

## **DETERMINE THE APPROPRIATE VMS TO USE**

### **Proximity of VMSs to Problem**

Next, the operator must determine which VMS or VMS group within the overall VMS system should be used to address a particular situation or problem. VMS operators should have a fairly good idea of current locations of permanent VMSs or be able to quickly determine their location from maps or computerized databases. These signs should be located where it is most advantageous to provide information to motorists. For advance warning of future lane closures and special events, the messages displayed are typically of a general warning nature and so can be displayed on VMSs over a fairly wide area. When signing for a current incident or work zone lane closure, however, the VMS operator must be careful to make sure that the VMSs selected will reach the appropriate audience for the message to be displayed. Two simple questions should be asked when determining which VMS should be activated:

- Is the expected duration of the incident or lane closure longer than the expected travel time from that VMS to the incident or lane closure?
- Are there a significant number of motorists traveling past the VMS who are destined for the incident or lane closure location?

If the answer to either of these questions is “no,” the VMS is probably not appropriate to activate for that situation.

### **Characteristics of the VMS Hardware**

Once appropriate VMSs are located, the operator must determine the characteristics of the VMSs. These include the type of sign (LED, fiberoptic, etc.), the number of lines available, and the number of characters on each line. If the characters are less than 18 inches in height, the operator should know this as well. Each of these characteristics can have an effect on how far away the VMS can be read and, consequently, how much information can be presented to motorists.

In locations where permanent VMSs have not been installed or in situations where the amount of information that needs to be presented exceeds the motorists’ processing capabilities from a single sign, it may be necessary to deploy portable VMSs to provide the necessary information to motorists. The operator must consider the time needed to deploy these devices in determining whether they are appropriate for a given situation. These VMSs should also be deployed far enough away from other VMS, existing static signing, and complex roadway geometrics such as

weaving areas. The VMS operator must ensure that motorists are not overloaded with information when choosing where to place the portable VMS.

### **Roadway, Traffic, and Environmental Characteristics in the Vicinity of the VMS**

The VMS operator needs to also know about the actual site characteristics in the vicinity of the VMS. These characteristics dictate the amount of information that can be displayed. Among the items of interest are the following:

- The operating speed of traffic on the roadway;
- The presence and design characteristics of any vertical curves affecting sight distance;
- The presence of horizontal curves and obstructions such as trees, bridge abutments, or construction vehicles that constrain sight distance to the VMS around the curve;
- The location of the VMS relative to the position of the sun (for daytime conditions);
- The presence, number, and information on static guide signs in the vicinity; and
- Whether or not rain or fog is present to degrade visibility to the sign.

### **DETERMINE WHAT TO DISPLAY ON THE VMS**

#### **Basic Information Needs and VMS Message**

VMSs are a transportation agency's direct link to the motoring public. Displaying well-designed messages on VMSs is key to effectively managing traffic and to maintaining credibility with motorists. The vast majority of this Manual is devoted to proper design of VMS messages.

Proper design begins with understanding the basic information needs of motorists. Motorists need several different types of information in order to make their driving decisions. These elements include the following:

- The type of problem (incident or road work descriptor);
- Location of the problem;
- The lanes that are affected (closure description);
- Location of the lane closure;
- The effect on travel;
- The audience for the message;
- Proper response or driving action by motorists; and
- A reason to follow the recommended driving action.

Unfortunately, motorists are not equipped to perceive, process, and remember a large amount of information at one time. Consequently, the job of the VMS operator is to decide what information is most important and how to present that information on a VMS in a way that maximizes motorist understanding and encourages them to take appropriate actions.



## **Diversion Routes**

Motorists must not be diverted to arbitrary routes. It is important that the suggested diversion route result in a significant time savings in comparison to remaining on the primary freeway. In addition, it must be a route that motorists can travel on without getting lost. Therefore, before recommended diversion routes are displayed on a VMS, the VMS operator must know the following about the route:

- Current traffic conditions;
- Current traffic capacity constraints; and
- Guide sign information.

When motorists are advised by the VMS message to divert and take a specific highway or route, it is essential that the destination names and routes used in the message are the same as those displayed on the existing guide signs. Inconsistency between the VMS message and the existing guide signs will lead to motorist confusion and cause some to take incorrect routes. Therefore, the VMS operator must have full knowledge of the wording and route markers on the existing guide signs before diversion messages directing motorists to a specific highway or route are used in a VMS message.

## **VMS Operator Message Options**

The design of a safe, effective VMS message requires consideration of a number of different factors and interactions between factors. This design process is complex, as is shown in the following modules, and can take a significant amount of time to utilize properly. Fortunately, many situations require a message or group of messages that are identical to those used in other past situations or that have been developed in advance for a particular event. In other situations, a VMS message or message group can utilize a general template and modify an item or two prior to display on the VMS(s). Finally, an extremely complicated or unusual situation may necessitate following the complete design process in order to determine the best VMS message to display. Basic considerations under each of these approaches are discussed below.

### ***Selecting a Message from a Message Library***

In the simplest case, a VMS operator may be able to select a proper message from an existing message library on the VMS operating system. The agency would have a predefined scenario prepared (following the proper message design process) for a given type of problem, location, severity (such as how many and which lanes are blocked or closed), and time of day. If a problem develops that fits the scenario, the VMS operator can simply call up a message from the library and display it on the appropriate sign(s). This approach only requires that the VMS operator be able to verify that all of the information to be displayed on the VMS is correct (which lane or lanes are blocked, the location of the problem, etc.).

### ***Modifying a Message from a Message Library***

Another type of VMS message that may be included in message libraries is one that requires some modification by the operator prior to displaying it on a sign. The modification may be needed to

display the correct location of a problem to motorists, the lane(s) that are affected, the action that should be taken, etc.

Modified messages present special challenges in VMS operations. They require VMS operators to make sometimes complex decisions about message elements that need to be changed, whether a change in overall message format is required (e.g., if the location name is fairly long), the proper term to use for a location, etc. Consequently, the potential for errors to creep into modified messages can increase during periods of high operator workload. VMS operators need to pay special attention to ensure that they review such messages prior to posting on a VMS.

### ***Creating a New Message***

If a message in the library does not properly address the particular situation of interest or cannot be modified to address the situation, a new message must be created. Principles and procedures illustrated elsewhere in this Manual should be followed to formulate the message. This requires the highest level of reasoning and decision making from the VMS operator. Those operators who have responsibility for creating new messages must have adequate training in the message design process.

## **DETERMINE HOW LONG TO DISPLAY THE MESSAGE**

After messages have been selected and conflicts resolved, the VMS operator must decide how long to display the message on the sign. For advance warning of upcoming work activity or special events, the message can be shown for several hours or even days prior to the event. However, it is more difficult to determine an appropriate duration for incidents. If the VMS operator has responsibility for only a limited number of VMSs and the incident occurs during off-peak periods when demand for attention is lower, it may be acceptable to set an extremely long duration on the message and simply turn the message off when the incident clears. This means that the operator must constantly monitor the incident and then remember to deactivate the signs at its conclusion.

During periods of high operator workload or if the operator has a large number of VMS to operate, it may be necessary to estimate the expected duration of the incident and set the message display time to that duration. This may require the operator to periodically adjust the time setting if the expected duration changes as more information about the incident is obtained. The advantage of such a procedure is that it ensures against an operator forgetting that a message is being displayed long after an incident is cleared. Failure to deactivate messages that are no longer relevant can degrade the agency's credibility with the motoring public.

## **RESOLVE ANY MESSAGE SIGNING CONFLICTS THAT EXIST**

After determining which message or messages are appropriate for the situation, the fourth step in the process is to resolve any conflicts that may exist within the VMS system. For example, it is possible, that two incidents may occur in adjacent sections of roadway. These incidents may each warrant several VMS messages in the vicinity, some on the same signs. In these cases, the operator must prioritize messages at each VMS and display the message that is most appropriate. Details on how to make these prioritization decisions are provided in [MODULE 14 PRIORITIES WHEN COMPETING MESSAGE NEEDS ARISE](#).

The most common types of possible message conflicts are as follows:

- Two events (incidents and/or road work) occur concurrently on the same freeway as the VMS;
- One event (incident or roadwork) occurs on the same freeway as the VMS and a second event occurs concurrently on an intersecting freeway;
- One event (incident or roadwork) occurs on the same freeway as the VMS and a second event occurs concurrently on a connecting freeway in an I-95 Corridor Coalition State; and;
- One event (incident or roadwork) occurs on an intersecting freeway to the VMS and a second event occurs concurrently on a connecting freeway in an I-95 Corridor Coalition State

Generally speaking, events on New Jersey freeways that are more current, more severe, and impact a greater number of motorists passing the VMS will have higher priority.

# MODULE 5. PRINCIPLES OF VMS MESSAGE DESIGN

## TABLE OF CONTENTS

<b>5.1 OVERVIEW OF ISSUES</b> .....	5-1
<b>5.2 SELECTING AN AUDIENCE FOR THE VMS MESSAGE</b> .....	5-3
<b>5.3 DEFINITIONS AND MESSAGE DESIGN</b>	
<b>CONSIDERATIONS</b> .....	5-4
DEVELOPING EFFECTIVE VMS MESSAGES .....	5-4
MESSAGE CONTENT .....	5-4
MESSAGE LENGTH.....	5-4
MESSAGE LOAD AND UNIT OF INFORMATION .....	5-6
MESSAGE FORMAT .....	5-7
<b>5.4 BASIC VMS MESSAGE TO SATISFY MOTORIST</b>	
<b>INFORMATION NEEDS</b> .....	5-8
GENERAL CONCEPT OF BASIC VMS MESSAGE .....	5-8
INCIDENT/ROADWORK DESCRIPTOR .....	5-8
INCIDENT/ROADWORK LOCATION .....	5-8
LANES CLOSED/BLOCKED.....	5-10
CLOSURE DESCRIPTOR.....	5-10
CLOSURE LOCATION.....	5-10
EFFECT ON TRAVEL .....	5-10
Delay.....	5-10
Travel Time .....	5-11
AUDIENCE FOR ACTION .....	5-12
ACTION .....	5-13
GOOD REASON FOR FOLLOWING THE ACTION .....	5-13
<b>5.5 WORD AND PHRASE MEANINGS AND CRITERIA</b> .....	5-14
SELECTING FROM ALTERNATIVE WORDS AND PHRASES.....	5-14
Use, Take and Follow .....	5-14
Construction vs. Roadwork .....	5-14
Exit vs. Ramp .....	5-15
A Dash vs. Thru.....	5-15
Nite vs. Night.....	5-15
For 1 Week .....	5-15
Weekend .....	5-15
WORDS AND TERMS WITH LOW MOTORIST UNDERSTANDING.....	5-16
Local Lanes.....	5-16
Express Lanes .....	5-16

Outer Roadway .....5-16  
Lane Shift, Traffic Shifts, Lanes Change and New Traffic Pattern .....5-16  
Calendar Dates.....5-17

**5.6 DIVERSION/DETOUR ROUTE DESCRIPTIONS FOR INCIDENT AND ROADWORK SITUATIONS.....5-18**

INTRODUCTION .....5-18  
DIVERSION/DETOUR ROUTE TYPES.....5-18  
    Type 1 Diversion Route.....5-18  
    Type 2 Diversion Route.....5-18  
    Type 3 Diversion Route.....5-19  
    Type 4 Diversion Route.....5-19  
    Type 5 Diversion Route: Incident Emergency Route Plan.....5-19  
    Type 6 Detour Route: Traffic Control Plan for Roadwork Closure .....5-20  
    Summary of Diversion/Detour Route Types .....5-20

**5.7 DYNAMIC FEATURES ON VMSs .....5-22**

INTRODUCTION .....5-22  
FLASHING AN ENTIRE ONE-FRAME MESSAGE .....5-22  
FLASHING ONE LINE OF A ONE-FRAME MESSAGE .....5-23  
ALTERNATING TEXT ON ONE LINE OF A THREE LINE VMS WHILE  
    KEEPING THE OTHER TWO LINES OF TEXT THE SAME .....5-23

## MODULE 5. PRINCIPLES OF VMS MESSAGE DESIGN

### 5.1 OVERVIEW OF ISSUES

Variable message signs (VMSs) are one of the primary links a transportation agency has to the motoring public it serves. Since the signs represent the primary concept of ITS to motorists, improperly designed or operated VMS messages will have a negative impact on the perception of the public about ITS in general. The design and display of messages on VMSs introduce many challenges to transportation agencies. The following paragraphs briefly summarize some of the relevant issues involved.

***VMSs are the direct link with the motoring public***--VMSs can be an effective tool for communicating with motorists. However, displaying messages that are too long for motorists to read at prevailing highway speeds or that are too complex or inappropriately designed leading to motorist confusion, can adversely affect both traffic flow and the transportation agency's credibility.

***Efforts must be made to ensure that VMS messages are standardized and consistently applied throughout the state or region***--The messages displayed must be "transparent" to travelers in the state or region. Therefore, messages need to be presented in a consistent manner and order based on motorists' expectancies.

***Only a few seconds are available to communicate a message***--At prevailing highway speeds, the VMS message must be presented to motorists in about eight seconds or less. This translates to a message with a maximum of eight words. Uninformed transportation personnel sometimes display messages that are too long for motorists, particularly slower readers such as the elderly, to read while driving at prevailing speeds.

***Available exposure time controls the maximum length of message that should be displayed***--Research indicates that reading times for VMSs are higher than for static guide signs. The distinguishing factor is that motorists can scan guide signs for relevant information, whereas they must read the entire message displayed on VMSs in order to understand the message. Exposure time is directly related to message legibility distance and driving speed. For a specific type and design of VMS, the available message exposure time dictates the maximum length of message that can be displayed for a given highway operating speed.

***In many signing situations, some of the basic information needed by motorists must be omitted from the VMS message***--Key VMS objectives include maximizing information transfer to motorists; providing explicit advice, eliciting specific motorist response and inducing motorist confidence. One major challenge is that this must be accomplished within a short time frame. VMS operators must strive to satisfy basic motorist information needs that allow more informed driving decisions to be made during incidents and roadwork. However, in most cases these basic needs exceed the number of units of information that a motorist can read and comprehend at prevailing driving speeds. Therefore, some of the information in the basic message must be omitted in order to meet the maximum number of units of information that can be processed by motorists. Tradeoffs must be made as to what elements of the message should be omitted.

In many signing situations VMS legibility distance constraints dictate the need to reduce the amount of information that is needed to fully communicate with motorists—The length of message that can be displayed on a VMS at a location also depends on how far away the motorists can adequately view the message and the prevailing speed of vehicles. At some locations, geometric features can obscure visibility of the VMS. At times, trucks in the traffic stream may obscure the motorist's view of the VMS. Environmental conditions such as rain and fog deteriorate the amount of light that is coming from the VMS, thus reducing the distance at which motorists can read the message. The VMS message length must be reduced to compensate for the reduced legibility distance.

***Measures must be taken when developing VMS messages to enhance motorist understanding of messages***--Research and experience have allowed the author of this Manual to determine which words and word combinations are understood by most motorists. In developing messages, factors that enhance understanding of messages include the following:

1. Simplicity of words,
2. Brevity,
3. Standardized order of words,
4. Standardized order of message lines, and
5. Using understood abbreviations when abbreviations are needed.

## 5.2 SELECTING AN AUDIENCE FOR THE VMS MESSAGE

The VMS message designer must know the intended audience for the message that will be displayed. Research has found that in some cases commuters and visitors have different informational needs. The visitor has very limited information about a city other than interstate route numbers, whereas, commuters understand most of the intersecting and parallel streets. Thus, messages that incorporate local street or highway names that would be understood by commuters may not be understood by unfamiliar motorists. Also, abbreviations used for landmarks, bridges, and entertainment and recreational facilities may not be well-understood by an unfamiliar motorist even though they may be understood by local motorists.

**UNFAMILIAR MOTORISTS WILL HAVE DIFFICULTY IN UNDERSTANDING:**

- Local street and highway names; and
- Abbreviations for local landmarks, bridges, and entertainment and recreational facilities.

Research has also found differences in understanding of terms and abbreviations that would ordinarily be displayed on VMSs between motorists in north and south New Jersey. For example, motorists in north New Jersey would be more familiar with the term *EXPRESS LANES* than motorists in south New Jersey

**Certain local names of facilities, landmarks, bridges, and entertainment and recreational facilities in north New Jersey are not well-understood by motorists from south New Jersey, and vice-versa.**

because freeways in the north have express lanes. Likewise, motorists in south New Jersey understand the abbreviation *W WHITMN BRDG* for “Walt Whitman Bridge”, while many motorists in north New Jersey do not understand the abbreviation.



## 5.3 DEFINITIONS AND MESSAGE DESIGN CONSIDERATIONS

### DEVELOPING EFFECTIVE VMS MESSAGES

To be effective, a VMS must communicate a meaningful message that can be read and comprehended by motorists within a very short time period (constrained by the sight distance characteristics of the location and design features of the VMS). Extensive human factors and traffic operations research has been previously conducted, most of it by the author of this Manual and his colleagues, to develop fundamental principles and guidelines for VMS message design. The principles and guidelines are based on a solid understanding of motorist physical and information-processing capabilities and are valid *as long as they are consistently and properly applied*.

### MESSAGE CONTENT

Message *content* refers to specific information displayed on a VMS, essentially, what is wrong ahead and what the motorist should do about it are the key elements.

If VMSs are to be read and believed by motorists, the content of the message must provide information relative to their needs. Above all, they want to know if something “ahead” has occurred on the roadway which would change their plans.

#### DEFINITIONS FOR MESSAGE “\_\_\_\_\_”

**CONTENT:** specific information displayed.  
**LENGTH:** number of words or number of characters and spaces.

**LOAD:** number of units of information in message.  
**INFORMATIONAL UNIT:** the answer to a question a motorist might ask.

**FORMAT:** order of the units of information.

A VMS message must present “advice.” This appears at the end of the brief message. It may be *REDUCE SPEED, EXIT AND TAKE OTHER ROUTES* or some other advice.

Motorists will ignore advice unless a reason is offered for taking it. The “reason” in most cases is the problem (*ACCIDENT, 2 LEFT LANES CLOSED*, etc.). Motorists expect this information to appear first in a VMS message. Motorists also would like to know where the problem has occurred. This is given on the second line. If the incident occurs far away, it may not affect them because they planned to exit long before then.

### MESSAGE LENGTH

*Length* refers to either the number of words or the number of characters and spaces in a VMS message. With VMS line capacity less than optimal, it becomes necessary to count the characters in a message to determine if the message will fit. If the message does not fit, look for abbreviations to use and/or eliminate redundant words. It may at times be necessary to display the message in two frames.

The maximum length of a VMS message is controlled in part by *reading time*--the time the motorist has available to read the message. Reading time is affected by 1) the time that the motorist is within the legibility zone of the VMS message, and 2) by the amount of activity in the

traffic stream which the motorist must attend to (e.g., reading signs, adjusting vehicle speed, lane positioning, etc.). The entire message must be short enough to allow motorists to glance at the sign and read and comprehend the message while attending to the complex driving situation.

Message familiarity enhances motorist reading time. When information displayed on a VMS applies to unfamiliar drivers or when the information being presented to commuters is unusual, longer reading times will be required than for information posted frequently and seen repeatedly by commuting traffic. Obviously, site-specific characteristics and normal VMS operating procedures dictate what information is usual and what is not, and so this factor varies from location to location.

**It takes unfamiliar motorists longer to read a VMS message than familiar motorists who see the sign regularly.**

**Familiar motorists need more time to read unusual messages.**

Another important consideration in designing VMS messages is the need for motorists to time-share their attention to the roadway, to traffic, and to reading signs. Adults can read quite fast while sitting at home reading a newspaper or novel or while in stopped traffic reading a sign or billboard. However, motorists cannot always devote full attention to sign reading. They must share their attention between information necessary for the task of driving and the information on signs. Because of this time-sharing, it will take longer to read a sign than if the motorists could devote all of their attention to the sign.

Another important consideration is that motorists must read the entire message on a VMS. In contrast, they do not have to read the entire guide sign to obtain relevant information about guidance. Therefore, it takes a motorist longer to read a VMS message than to read the message on a guide sign.

In a driving situation, the motorist has a limited amount of time to read a message on a sign. He/she can start reading a sign when the words become legible at the *legibility distance* of the sign. About 85 percent of motorists in New Jersey can begin reading a message on LED VMSs-- commonly used in New Jersey--at about 650 feet in front of the sign. At 55 miles per hour, this means that the motorist has about 8 seconds to read the message. Research strongly suggests that motorists can read an 8-word message (excluding prepositions such as *TO* and *AT*) in 8 seconds. Longer messages should be avoided because motorists will often reduce their speeds in order to read the message.

**There is evidence that an 8-word message (excluding prepositions such as *TO* and *AT*) is approaching the processing limits of motorists traveling at speeds of 55 miles per hour or more.**

**AVOID messages longer than 8 words.**

**VMS messages that are too long for motorists to read while traveling at normal speeds will result in some motorists slowing to read the message.**

When the complexity of the driving situation increases due to extremes in geometrics, heavier traffic volumes, increased traffic conflicts (e.g., merging, lane changing), or climatological conditions, motorists will attend to those information needs they feel are most important to them and to their safety.

**REDUCE MESSAGE LENGTH WHEN:**

- Motorist work load is increased due to extreme geometrics, very heavy traffic, merging, heavy lane changing, or adverse climatological conditions.
- Conditions change during the day that affects motorist visibility to the VMS (e.g., sun in eyes).

These demands on the motorist will result in less time available to read the VMS message.

In addition, lighting and environmental conditions change. For example, during part of the day the sun may not affect the legibility of the VMS. However, if the sun shines directly in the eyes of the motorist, then the legibility of the distance at which the motorist can read the sign message can be greatly reduced. It may be necessary to reduce the length of the message to account for the reduced visibility.

The VMS message designer should always look for ways to reduce the message length without losing the intent of the message. Reducing message length can sometimes be accomplished by using alternative phrases that are understandable by motorists and have the same meaning as the original. Also, there may be redundancy or unimportant information in the message which can be omitted. For situations such as these refer to *MODULE 9 DEALING WITH LONG MESSAGES*.

**Always look for ways to reduce message length without losing the intent of the message.**

**See Module 9 - DEALING WITH LONG MESSAGES**

**MESSAGE LOAD AND UNIT OF INFORMATION**

The term *load* refers to the units of information in the total message. A *unit of information (informational unit)* refers to the answer to a question a motorist might ask. Stated another way, a unit of information is each data item in a message that a motorist could use to make a decision. Each answer is one unit of information. The message in the following table has five (5) units of information and serves to illustrate the concept of units of information.

<u>UNIT OF INFORMATION</u>		
<u>Question</u>	<u>Answer</u>	<u>Unit of Info</u>
1. What happened?	⇒ ACCIDENT	⇒ 1 unit
2. Where?	⇒ AT EXIT 12	⇒ 1 unit
3. What effect on traffic?	⇒ MAJOR DELAY	⇒ 1 unit
4. Who is advisory for?	⇒ NEW YORK	⇒ 1 unit
5. What is advised?	⇒ USE ROUTE 46	⇒ 1 unit

A unit of information typically is one to three words, but at times can be up to four words.

Since motorists can process a limited amount of information, the amount of information that should be displayed on a VMS is also limited. Research and operational experience indicate that no more than four units of information should be in a message when the traffic operating speeds are 35 mph or more. No more than five units of information should be displayed when the operating speeds are less than 35 mph.

In addition, no more than three units of information should be displayed on one frame.

**ENTIRE MESSAGE:**

- No more than 4 units of information for operating speeds of 35 mph or more.
- No more than 5 units of information for operating speeds less than 35 mph

**LENGTH OF MESSAGE FRAME:**

- No more than 3 units of information.

**LENGTH OF MESSAGE LINE:**

- No more than 2 units of information.

Normally, only one unit of information appears on each line of the VMS. However, a unit of information may be displayed on more than one line. A sign line, however, should not contain more than two units of information.

When a VMS message meeting all informational requirements of the motorist exceeds the maximum number of units of information that should be displayed on a single sign, tradeoffs must be made to determine what elements of the messages should be omitted. If it is deemed necessary by the agency to display all of the required information, two VMSs will be needed. Guidelines to reduce the number of units of information are given in [Section 9.2 APPROACHES TO REDUCING MESSAGE LENGTH](#), on page 9-5.

**MESSAGE FORMAT**

Message *formatting* refers to the order and arrangement of the units of information on a VMS. The VMS message must contain the proper information in the expected order to allow motorists to easily read and interpret the information and make rational decisions based on that information.

Placement of message elements on the wrong line or in the wrong sequence will result in driver confusion and will increase message reading times. Conversely, consistent formatting of information enhances motorist expectations and reduces the time required to read and understand messages. Examples of acceptable and unacceptable format approaches are shown below.

**ROADWORK  
ON I-85 EAST  
AT PATERSON**

*Acceptable*

**~~I-85 EAST~~  
~~AT PATERSON~~  
ROADWORK**

*Not Acceptable*

## 5.4 BASIC VMS MESSAGE TO SATISFY MOTORIST INFORMATION NEEDS

### GENERAL CONCEPT OF BASIC VMS MESSAGE

The *Basic VMS Message* is the sum total of all the information that motorists need on the VMS in order to make a fully informed driving decision (e.g., whether to take an alternative route). In most cases, the Basic VMS Message will exceed the maximum amount of informational units that should be displayed on a VMS. Therefore, the Basic VMS Message must be reduced in length and content to allow motorists to read, understand and react to the message.

#### THE BASIC VMS MESSAGE:

- Is the sum total of all the information that motorists need to make a fully informed driving decision;
- Will normally exceed the maximum amount of informational units that should be displayed; and
- Must normally be reduced in length and content.

The message elements that make up the Basic VMS Message include: 1) *Incident/ Roadwork Descriptor* (situation description); 2) *Incident/Roadwork Location*; 3) *Lanes Closed/Blocked*; 4) *Closure Descriptor*; 5) *Closure Location*; 6) *Effect on Travel* (e.g., major delay); 7) *Audience for Action*; 8) *Action*; and 9) *Good Reason for Following the Action*.

#### BASIC VMS MESSAGE ELEMENTS:

- Incident/Roadwork Descriptor (situation description);
- Incident/Roadwork Location;
- Lanes Closed/Blocked;
- Closure Descriptor;
- Closure Location;
- Effect on Travel (e.g., major delay);
- Audience for Action (when the action is for a specific group of motorists);
- Action (tells motorists what to do); and
- One Good Reason for Following Action (usually implied by other message elements).

### INCIDENT/ROADWORK DESCRIPTOR

The *Incident/Roadwork Descriptor* informs the motorist of the unusual situation. When an accident or roadwork blocks part of the roadway, motorists want advance knowledge.

### INCIDENT/ROADWORK LOCATION

The *Incident/Roadwork Location* informs the motorist about the location of the unusual situation and thus must directly follow the Incident/Roadwork Descriptor. Knowing the location helps the motorist in making judgements as to the distance he/she could be affected. In addition, it also provides basic information as to the location downstream where the motorist can return to the freeway.

If the incident or roadwork is on the same freeway as the VMS, there is no need to display the freeway route number or name; this is understood by motorists. However, when displaying information about an incident that has occurred on an intersecting freeway, the route number or name must be displayed.

#### WHEN INCIDENT/ROADWORK IS ON SAME FREEWAY AS THE VMS:

- No need to display route number or name

When a majority of motorists are commuters, the incident/roadwork location should be referenced to the nearest cross-street or exit ramp. Commuters are highly familiar with cross-street names and exit ramp names (or numbers). When there are no cross-streets or exit ramps in the vicinity of the incident, a prominent landmark (airport, factory, etc.) may be substituted.

When a majority of motorists would be unfamiliar with the names of local cross-streets, the incident/roadwork location should be described in distances to the nearest half-mile. Where numbers are used for exit ramps, the incident location can be referenced by the exit ramp number.

**FOR COMMUTERS:**  
Reference location of problem to street names, exit names, exit numbers, or landmarks.

**FOR UNFAMILIAR MOTORISTS:**  
Reference location of problem by distance or exit numbers.

**ACCIDENT  
AT ROWLAND**

*For familiar motorists*

**ACCIDENT  
AT EXIT 12**

*For familiar and  
unfamiliar motorists*

**ACCIDENT  
1 MILE**

*For unfamiliar motorists*

When a lane is closed, it is advisable to display the location where the lane closure begins and where it ends. This information is useful to the motorist in assessing where to return to the freeway if he/she decides to avoid the congestion. An example follows.

**Displaying the location where a lane closure begins and where it ends helps motorists.**

**LEFT LANE CLOSED  
FROM EXIT 12  
TO EXIT 14**

*Showing limits of lane  
closure*

The terms *ST*, *RD* and *AVE* are used with the names of streets, roads and avenues, respectively. These terms are not required and could be omitted. However, these terms must be used for streets and avenues with the same numeric names in the region (e.g., *7TH ST* vs. *7TH AVE*). An example follows.

***ST*, *RD* and *AVE* are not required and could be omitted.**

**They must be used for streets and avenues with the same numeric names (e.g., *7TH ST*, *7TH AVE*).**

**ACCIDENT  
AT ROWLAND**

*AVE not required*

**ACCIDENT  
AT 7TH AVE**

*AVE required*

## LANES CLOSED/BLOCKED

The *Lanes Closed/Blocked* message element gives specific information about which lanes or exit ramps are closed or blocked. It helps the motorist prepare to change into the open lanes or to prepare to use another exit ramp.

## CLOSURE DESCRIPTOR

The *Closure Descriptor* message element is used in place of the *Incident/Roadwork Descriptor* when all lanes on the facility or exit ramp are closed.

## CLOSURE LOCATION

The location of a freeway closure will be at an exit ramp that will normally be different than the actual incident location. The *Closure Location* message element specifically states the location where the freeway is closed and would be used in place of the *Incident/Roadwork Location*.

## EFFECT ON TRAVEL

The *Effect on Travel* message element informs the motorist of the severity of the situation (i.e., delay or travel time) and helps the motorist make informed decisions about whether diversion is appropriate. In addition, it can imply the expected arrival time (in general terms) to the motorist's destination.

### Delay

Motorists interpret *DELAY* (shown in minutes) as being relative to their normal expected travel time to traverse the freeway and arrive at their destination. *DELAY* implies that it will take that much longer than usual. *DELAY* does not mean that the motorist will be held up in traffic at one location for that long or that it will take that long to remove an incident.

**(number) MIN DELAY means that the motorist can expect his/her trip to be that much longer than usual.**

**AVOID (number) MIN DELAY gives the advantage of the stated diversion route over the existing route.**

**SAVE (number) MIN also gives the advantage of the stated diversion route over the primary route.**

Delay information can be displayed in terms of “X Minutes Delay”, “Avoid X Minutes Delay”, or “Save X Minutes.” If the delay is expressed in the first form, it refers to travel time on the primary route and should appear in the VMS message immediately after the *Incident/Roadwork Descriptor* and the *Incident/Roadwork Location* (if displayed). If delay is expressed in terms of “Avoid X Minutes Delay” or “Save X Minutes”, the reference is to an advantage of using the alternative route and should appear after the *Action* message element that mentions the alternative route. The following examples illustrate the different ways that delay information could be displayed.



**ACCIDENT  
AT EXIT 12  
20 MIN DELAY  
USE ROUTE 46**

*Example of  
"X MIN DELAY"*

**ACCIDENT  
AT EXIT 12  
USE ROUTE 46  
AVOID 20 MIN DELAY**

*Example of  
"AVOID X MIN DELAY"*

**ACCIDENT  
AT EXIT 12  
USE ROUTE 46  
SAVE 20 MIN**

*Example of  
"SAVE X MIN"*

To be useful to the motorist, it is best to display specific delay times. However, when displaying a value (number) the VMS operator must have full confidence in the delay values selected. This is a number that motorists can sometimes check. Confidence in the VMS system can be adversely affected if the numbers are incorrect.

As an alternative to displaying a specific delay value, it is safer to display generic information such as *MAJOR DELAY* or *MINOR DELAY*.

**THE GENERIC TERMS:**

***MAJOR DELAY* means to the average motorist in New Jersey a delay of 45 minutes or more.**

***HEAVY DELAY* means to the average motorist in New Jersey a delay of 25 to 45 minutes.**

Results of studies conducted showed that the average New Jersey motorist interprets *MAJOR DELAY* as implying the delay is at least 45 minutes. *HEAVY DELAY* was interpreted to mean that the delay is at least 25 minutes. A majority of motorists understood *MAJOR DELAY* to be more severe than *HEAVY DELAY*.

Sometimes the *Effect on Travel* element can be combined with the *Incident/Roadwork Descriptor*. In the case of delay, the message *MAJOR ACCIDENT* has specific meaning to motorists. Motorists in New Jersey would interpret *MAJOR ACCIDENT* to mean that they can expect delays of 45 minutes or more.

## Travel Time

Another form of an *Effect on Travel* element is travel time. Travel time is very useful to motorists because it gives them some indication as to the potential arrival time to their destination.

Current technology does not allow the NJDOT to accurately predict travel times. In contrast, motorists can easily measure their own travel times and dispute incorrectly posted travel times. If the VMS says "10 minutes" and it takes motorists 15 minutes, credibility is weakened. Delay information is more difficult for motorists to refute.

**Travel time is very difficult to predict and has been difficult to estimate. Since motorists can measure and refute travel time information, it has not normally been displayed on VMSs.**

New automated vehicle identification (AVI) equipment is providing transportation agencies with the capability of identifying specific vehicles equipped with electronic

**AVI equipment is providing more current and accurate travel times and allowing agencies to post "historical" travel times on VMSs.**



transponders (tags) as they pass roadside antennae. Roadside “readers” then transmit the information to a computer in the traffic control center. Travel times over a section of freeway are computed as each vehicle passes successive reading stations. Some agencies using this type equipment are beginning to display “historic” travel times during the peak period in the absence of vehicle incidents. This is accomplished by displaying the travel time of the most recent vehicle. Although this information is historical in nature, it is fairly recent. It is important that the VMS message specifically state the time at which the travel time was determined. A typical VMS message is as follows:

**TRAVEL TIME  
TO DOWNTOWN  
AT 8:20 AM:  
20 MIN**

Another approach is to display a range of the estimated travel time. The VMS operator gives motorists the important information they need about potential arrival times while maintaining motorist credibility and support of the VMS system. An example of a message showing a range of travel time is shown below.

**Travel time RANGE is a good alternative.**

**TRAVEL TIME  
TO DOWNTOWN  
8-12 MINUTES**

## AUDIENCE FOR ACTION

The *Audience for Action* message element is used when the *Action* message element applies to a specific group of motorists rather than all of the motorists traveling past the VMS. It alerts a specific group of motorists that the action part of the message applies to them. When the *Audience for Action* applies to all motorists on the highway at the location of the VMS, then the statement is not displayed. When the *Action* applies to only a segment of the motorists, then the *Audience for Action* message element should be used to avoid confusion as to whom the *Action* applies.

### WHEN THE ACTION APPLIES TO:

- ALL MOTORISTS – *Audience for Action* message element is NOT used.
- A SEGMENT OF MOTORISTS – *Audience for Action* message element is used.

Motorists expect when they see an *Audience for Action* message element on the VMS, they will also see an *Action* message element. An *Audience for Action* message element must always be accompanied by an *Action* statement.

**An *Audience for Action* message element must always be accompanied by an *Action* message element.**

Generally, the word *TRAFFIC* after a destination is not necessary. The reader of a sign can only be a motorist who is a part of the traffic stream, so *NEW YORK, TAKE NEXT EXIT* can only mean *NEW YORK TRAFFIC, TAKE NEXT EXIT*.

**Generally, the word *TRAFFIC* after a destination name is not necessary.**

The primary exception to this message design principle is when the location of the incident--either in terms of the cross street, miles ahead, or simply *AHEAD*--is not displayed, it is frequently necessary to display *TRAFFIC* after the destination. The following examples are presented:

ACCIDENT  
AT EXIT 14  
MEADOWLANDS  
USE ROUTE 46

*“TRAFFIC” not required*

ACCIDENT  
MEADOWLANDS TRAFFIC  
USE ROUTE 46

*“TRAFFIC” required*

If *TRAFFIC* were omitted from the second message, motorists could interpret the message to mean that an accident occurred near the Meadowlands.

City destinations appearing on a VMS must be consistent with existing signing practices. Nicknames should be avoided. For example, *PHILADELPHIA* rather than the abbreviated term *PHILLY*.

Names used for cities must be identical to those appearing on existing static signs.

Many cities have large areas known locally by a single name, but which house smaller areas of wider general knowledge. Caution should be used when signing for these areas so that the name displayed is consistent with the name used by motorists. If the audience includes non-local, unfamiliar motorists, the more general, lesser known destination would be confusing if the activity was being held at a specific, more widely known destination.

Names used for major generators must be specific and address the exact place where the activity takes place.

## ACTION

The *Action* message element is necessary because it tells the motorist what to do. It is best that every incident management VMS message have an action statement. Omitting the *Action* leaves the motorist with a great deal of uncertainty as to the best course of action.

## GOOD REASON FOR FOLLOWING THE ACTION

When a motorist is advised to take an alternative route, he/she must be confident that it is the correct decision and that doing so will result in significant time savings. Therefore, the motorist should be given a *Good Reason for Following the Action*. In most cases, the good reason is implied through the *Incident* or *Roadwork Descriptor*, *Lanes Affected* and *Effect on Travel* elements of the message and need not be displayed separately. However, in other situations, a specific *Good Reason for Following the Action* message element is needed.

## 5.5 WORD AND PHRASE MEANINGS AND CRITERIA

### SELECTING FROM ALTERNATIVE WORDS AND PHRASES

#### Use, Take and Follow

The *Action* message element requires an action verb. In general, the three verbs *USE*, *TAKE* and *FOLLOW* are synonymous and no strong preference has been found. The verb *USE* has been employed more often because it is slightly shorter. There are, however, small differences in meaning which make one verb preferable to another when used in a particular VMS message.

The verb *USE* should be selected whenever the advisory in the VMS message is to employ a route that will carry the motorist to his/her destination. The destination could be a major generator or a point of return to the freeway.

***USE***: a route that will carry motorists to the destination.  
***TAKE***: directive to begin the first “leg” of route.  
***FOLLOW***: motorist will be guided by other signs along the route.  
***EXIT***: sometimes used as a verb.  
***GO***: not used.

The verb *TAKE* should be selected whenever the advisory is a directive to begin taking the first highway or “leg” of a route.

The verb *FOLLOW* carries the additional connotation that the motorist will be guided by other signs along the route. *FOLLOW* should never be used when guidance is not available.

The verb *EXIT* may also be used as a verb in action message statements that are displayed on a freeway. When *EXIT* is employed as a verb, it should usually be followed by the name of the cross-street or highway associated with the exit ramp.

The verb *GO* is not used in VMS messages for route guidance, but may be used in highway advisory radio messages. It connotes initiation of action, but would be out of place in situations where *USE* or *TAKE* is appropriate.

**MAJOR ACCIDENT  
AT EXIT 12  
USE ROUTE 46**

*Example of “USE”*

**BEST ROUTE  
TO NEW YORK  
TAKE NEXT EXIT**

*Example of “TAKE”*

**MAJOR ACCIDENT  
AT ROWLAND  
EXIT AT BASEL  
FOLLOW DETOUR**

*Example of “FOLLOW”*

#### Construction vs. Roadwork

The word *ROADWORK* may be substituted for the longer word *CONSTRUCTION*. Human factors studies indicated that 59 percent of the motorists surveyed in New Jersey interpret the words *CONSTRUCTION* and *ROADWORK* to have the same meanings. The other 41 percent stated that the meanings differ. To these 41 percent, *CONSTRUCTION* implied larger scale,

longer-term work such as building bridges. The results were consistent among motorists in both north New Jersey and south New Jersey.

There are two disadvantages to displaying the word *CONSTRUCTION*. First of all, it is a longer and more complex word than *ROADWORK* and, therefore, will take longer for motorists to read. Secondly, the word *CONSTRUCTION* will not fit on an eight-character line of a portable sign and, therefore, must either be abbreviated with *CONST* or replaced with the word *ROADWORK*.

***ROADWORK* may be substituted for the longer word *CONSTRUCTION*.**

Results of human factors studies showed that approximately 95 percent of New Jersey motorists surveyed understood the abbreviation *CONST* to mean *CONSTRUCTION*.

### **Exit vs. Ramp**

When referring to an off ramp on VMSs located on a freeway, the word *EXIT* should be used. The word *RAMP* should not be used because it has different shades of meaning for some motorists.

Results of human factors studies indicated that 26 percent of the New Jersey motorists surveyed believed that the two terms have different meanings. Interpretations included: 1) the term *EXIT* is for when the motorist gets off the freeway, and *RAMP* is for when the motorist gets on; and 2) the term *EXIT* means a motorist can leave the freeway, and *RAMP* means the motorist will go to a rest stop.

### **A Dash vs. Thru**

The dash may be substituted for the term *THRU* to indicate a set of inclusive days (e.g., TUE – THURS to indicate Tuesday thru Thursday). Ninety-two percent of motorists surveyed in New Jersey correctly stated the days of the week when the dash was used.

### **Nite vs. Night**

The term *NITE* may be used in place of *NIGHT*. Human factors studies resulted in data that showed most New Jersey motorists understand the term *NITE* as a substitute for *NIGHT*.

### **For 1 Week**

Frequently roadwork is performed over a one-week period (i.e., 7 consecutive days). Although the term *FOR 1 WEEK* takes less VMS space, it should not be used to indicate the 7-day work period. The results of human factor studies in New Jersey revealed that the term *FOR 1 WEEK* was ambiguous as to whether the roadwork begins the date the message was viewed, the next day, or from the beginning of the current or next week.

### **Weekend**

Oftentimes, major lane or roadway closures are necessary on the weekend. Although it is desirable to present the inclusive days and hours (e.g., *FRI 6 PM – MON 5 AM*), the portable

VMS is limited to eight characters per line. If a term such as *NEXT WEEKEND* can be used rather than days and hours, then the message can be made much shorter in length.

The message term *WEEKEND* should not be used in New Jersey if either the roadwork begins on Friday evening or ends on Monday morning. However, it may be satisfactory to use the term if the work begins on Saturday morning and ends on Sunday evening. The results of human factors studies in New Jersey indicated that 60 percent of the motorists would believe the work would begin on Saturday morning and 79 percent would believe the work would end on Sunday evening.

## **WORDS AND TERMS WITH LOW MOTORIST UNDERSTANDING**

The recommendations that follow are based on results of human factors studies conducted in New Jersey.

### **Local Lanes**

For dual-dual facilities with both local and express lanes such as portions of I-80, the term *LOCAL LANES* can be used when communicating with motorists in north New Jersey. However, motorists from the southern part of New Jersey and motorists from other states traveling through the area in the north would most likely not understand the message. Therefore, the term *LOCAL LANES* should not be displayed in south New Jersey and should only be used in north New Jersey during the peak weekday traffic periods.

### **Express Lanes**

The term *EXPRESS LANES* can be used when communicating with motorists in north New Jersey. However, motorists from the southern part of New Jersey and motorists from other states traveling through the area in the north would most likely not understand the message. Therefore, the term *EXPRESS LANES* should not be displayed in south New Jersey and should only be used in north New Jersey during the peak weekday traffic periods.

### **Outer Roadway**

The term *OUTER ROADWAY* should not be displayed because there is significant confusion on the part of motorists from both north and south New Jersey about the meaning of the term.

### **Lane Shift, Traffic Shifts, Lanes Change and New Traffic Pattern**

There are several terms that have sometimes been used in work zones to indicate a temporary alignment change (i.e., all lanes shift left or right). The following terms should not be used:

- *LANES SHIFT*;
- *TRAFFIC SHIFTS*;
- *LANES CHANGE*; and
- *NEW TRAFFIC PATTERN*.

Instead, the following term should be used:

- *LANES SHIFT/STAY IN LANE.*

The results of human factors studies revealed that a large majority of the motorists surveyed in New Jersey believed that they would have to merge with traffic in another lane when the terms *LANE SHIFT*, *TRAFFIC SHIFTS*, *LANE CHANGES* or *NEW TRAFFIC PATTERN* was displayed. Therefore, these terms would encourage undesirable lane changing. Most of the motorists surveyed understood that they would not have to merge to another lane when the term *LANES SHIFT/STAY IN LANE* was used.

### **Calendar Dates**

It is desirable to notify motorists of upcoming roadwork or of a special event that will impact traffic. In the past, calendar dates have been used (e.g., OCT 10 – OCT 12) to indicate when the roadwork or special event activity begins and/or ends. However, results of human factors studies showed that New Jersey motorists have difficulty in corresponding calendar dates with specific days of the week.

Therefore, use days of the week (e.g., TUE – THUR) rather than calendar dates (OCT 10 – OCT 12). The use of days of the week is preferred over calendar dates.

## 5.6 DIVERSION/DETOUR ROUTE DESCRIPTIONS FOR INCIDENT AND ROADWORK SITUATIONS

### INTRODUCTION

The *Action* message element that involves traffic diversion is influenced by the type of diversion route that will be used by motorists to travel around the incident. Six diversion route types have been identified for use in this Manual. These are described and summarized in the next section.

### DIVERSION/DETOUR ROUTE TYPES

#### Type 1 Diversion Route

Type 1 is the simplest form of diversion route. The diversion route has a major road (e.g., frontage road, arterial, etc.) that is basically parallel and close to the primary freeway and offers opportunities for motorists to either turn toward the freeway and reenter downstream of the incident; or head directly to the major destination.

Some form of surveillance (electronic or human) exists on the diversion route and sends information about traffic conditions to the TOC. Therefore, the VMS operator has knowledge of the traffic conditions on both the primary freeway and the diversion route.

Guide signs and/or trailblazers to the freeway or major destination **may not be** present. However, commuters most likely know the crossroads that will allow them to drive back to the freeway once they pass the incident or know the route to the major destination. Police and/or traffic control personnel are not guiding traffic along the diversion route.

The Type 1 diversion route is generally applicable when:

- Lanes are blocked due to an incident;
- Lanes are closed due to an incident;
- Freeway is totally blocked due to an incident;
- Freeway is closed due to an incident;
- Lanes are closed due to roadwork; or
- Freeway is closed due to roadwork.

#### Type 2 Diversion Route

The Type 2 diversion route has one or more primary major roads (e.g., arterials, other freeways, etc.) that offer opportunities for motorists to either turn toward the freeway and reenter downstream of the incident or head directly to the major destination.

Some form of surveillance (electronic or human) exists on the diversion route and sends information about traffic conditions to the TOC. Therefore, the VMS operator has knowledge of the traffic conditions on both the primary freeway and the diversion route.

Existing static guide signs and/or trailblazers to the freeway or to the major destination **are** present. Police and/or traffic control personnel are not guiding traffic along the diversion route.

The Type 2 diversion route is generally applicable when:

- Lanes are blocked due to an incident;
- Lanes are closed due to an incident;
- Freeway is totally blocked due to an incident;
- Freeway is closed due to an incident;
- Lanes are closed due to roadwork; or
- Freeway is closed due to roadwork.

### **Type 3 Diversion Route**

The Type 3 diversion route has one or more primary major roads (e.g., arterials, other freeways, etc.) that offer opportunities for motorists to either turn toward the freeway and reenter downstream of the incident or head directly to the major destination.

Some form of surveillance (electronic or human) exists on the diversion route and sends information about traffic conditions to the TOC. Therefore, the VMS operator has knowledge of the traffic conditions on both the primary freeway and the diversion route.

Static guide signs and/or trailblazers to the freeway or to the major destination **are not** present. Police and/or traffic control personnel are guiding traffic along the diversion route.

The Type 3 diversion route is generally applicable when:

- Freeway is closed due to an incident.

### **Type 4 Diversion Route**

The Type 4 diversion route has one or more primary major roads (e.g., arterials, other freeways, etc.) that offer opportunities for motorists to either turn toward the freeway and reenter downstream of the incident or head directly to the major destination.

Some form of surveillance (electronic or human) exists on the diversion route and sends information about traffic conditions to the TOC. Therefore, the VMS operator has knowledge of the traffic conditions on both the primary freeway and the diversion route.

Existing static guide signs and/or trailblazers to the freeway or to the major destination **are** present. In addition, police and/or traffic control personnel are guiding traffic along the diversion route.

The Type 4 diversion route is generally applicable when:

- Freeway is closed due to an incident.

### **Type 5 Diversion Route: Incident Emergency Route Plan**

The Type 5 diversion route has one or more primary major roads (e.g., arterials, other freeways, etc.) that offer opportunities for motorists to either turn toward the freeway and reenter downstream of the incident; or head directly to the major destination.



Existing static guide signs and/or trailblazers to the freeway or to the major destination may not be present. Diversion/detour signs are installed after the incident occurs. In addition, police and/or traffic control personnel are guiding traffic along the diversion route.

The Type 5 Diversion Route is applicable when:

- Freeway is closed due to an incident.

#### **Type 6 Detour Route: Traffic Control Plan for Roadwork Closure**

The Type 6 detour route is a route that has been established and contains the full complement of traffic control devices specified in the traffic control plan for the major roadwork project.

The Type 6 detour route is applicable when:

- Freeway is closed due to roadwork.

#### **Summary of Diversion/Detour Route Types**

A summary of the characteristics for diversion/detour route types is shown in [Table 5.1](#). The applicable incident or roadwork situation for the various diversion/detour route types based on the location of the VMS relative to the incident/roadwork location is given in [Table 5.2](#).

Table 5.1 Characteristics of Diversion/Detour Routes						
Characteristics	Diversion/Detour Route					
	Type 1	Type 2	Type 3	Type 4	Type 5	Type 6
Electronic and/or human surveillance are required on diversion route	X	X	X	X		
Existing guide signs and/or trailblazers to freeway or destination on diversion route		X		X		
Police and/or traffic control personnel at critical decision points on diversion route			X	X	X	
Incident Emergency Route Plan signing					X	
Roadwork Traffic Control Plan traffic control devices						X

Table 5.2 Incident/Roadwork Situation, VMS Location and Diversion/Detour Route Type							
Incident/Roadwork	VMS Location	Diversion/Detour Route					
		Type 1	Type 2	Type 3	Type 4	Type 5	Type 6
Incident Lane Blockage	Same freeway & near incident	X	X				
	Same freeway & far upstream of incident	X	X				
	Different freeway	X	X				
Incident Lane Closure	Same freeway & near incident	X	X				
	Same freeway & far upstream of incident	X	X				
	Different freeway	X	X				
Incident Total Freeway Blockage	Same freeway & near incident	X	X				
	Same freeway & far upstream of incident	X	X				
	Different freeway	X	X				
Incident Total Freeway Closure	Same freeway & near incident	X	X	X	X	X	
	Same freeway & far upstream of incident	X	X	X	X	X	
	Different freeway	X	X				
Roadwork Lane Closure	Same freeway & near incident	X	X				
	Same freeway & far upstream of incident	X	X				
	Different freeway	X	X				
Roadwork Total Freeway Closure	Same freeway & near incident						X
	Same freeway & far upstream of incident						X
	Different freeway	X	X				
Connector Ramp Closure: Incident on Intersecting Freeway	Upstream of connector ramp	X	X			X	
Connector Ramp Closure: Roadwork on Intersecting Freeway	Upstream of connector ramp	X	X				X

## 5.7 DYNAMIC FEATURES ON VMSs

### INTRODUCTION

VMSs are capable of using dynamic features to display messages. Results of research indicate that the use of the following dynamic features should be avoided:

**AVOID:**

- Flashing an entire one-frame message;
- Flashing one line of a one-frame message; and
- Alternating text on one line of a three-line VMS while keeping the other two lines of text the same.

- Flashing an entire one-frame message;



- Flashing one line of a one-frame message;



- Alternating text on one line of a three-line VMS while keeping the other two lines of text the same.



### FLASHING AN ENTIRE ONE-FRAME MESSAGE

Results of research indicate that flashing a one-frame 3-unit message on a VMS has no significant effect upon motorist comprehension of the information being presented. Furthermore, driver preferences are fairly evenly split between flashing the message or not (i.e., a static message). However, the data show that flashing the message increases the amount of time required to read and comprehend the message. In this particular study, the fact that the message contained only 3 units of information allowed most subject drivers to correctly comprehend the message. However, this would not be expected to be the case if more information were presented.

Given that there does not appear to be strong driver preference for flashing one-frame messages and that such a practice does increase reading times, it is recommended that flashing messages not be used as part of VMS operations. However, if personnel in a TOC choose to use flashing one-frame messages, it is strongly recommended that the message themselves be limited to 3 units of information or less to account for the increased reading and comprehension times.

**FLASHING ONE LINE OF A ONE-FRAME MESSAGE**

Research results indicate that flashing one line of a one-frame, 3-unit message on a VMS does reduce the ability of motorists to remember parts of the message that are not flashing. The data further indicate that reading times are significantly increased when a line is flashed. Driver preferences are fairly evenly split between flashing the message line or not (i.e., a static message). In this particular study, the fact that the message contained only 3 units of information allowed most subject drivers to correctly comprehend the message. However, this would not be expected to be the case if more information were presented.

Given that there does not appear to be strong driver preference for flashing one line of a one-frame message and that such a practice reduces overall motorist comprehension and increases reading time, it is recommended that this technique not be used as part of VMS operations either.

**ALTERNATING TEXT ON ONE LINE OF A THREE-LINE VMS WHILE KEEPING THE OTHER TWO LINES OF TEXT THE SAME**

Research results indicate that on three-line VMSs including redundant information by repeating the top two lines on both frames of a two-frame message while changing the bottom line does not reduce the ability of motorists to remember parts of the message. However, total message reading times are significantly increased when redundant information is included. Driver preferences are fairly evenly split between having and not having redundant information in both frames.

Given these findings, it is recommended that redundant information on a two-frame, four-unit VMS message should not be displayed such that two lines are kept the same and a third line is changed.

**THIS PAGE LEFT BLANK**

# MODULE 6. DESIGNING THE BASIC VMS MESSAGE FOR INCIDENTS

## TABLE OF CONTENTS

<b>6.1 BASIC VMS MESSAGE FOR LANE-CLOSURE (BLOCKAGE) INCIDENTS</b> .....	6-1
BASIC VMS MESSAGE ELEMENTS .....	6-1
VMS ON SAME FREEWAY AND RELATIVELY CLOSE TO THE INCIDENT .....	6-2
Incident Descriptor .....	6-2
Incident Location .....	6-3
Lanes Closed/Blocked .....	6-4
Effect on Travel .....	6-5
Action .....	6-6
<i>Motorists Are <u>Not</u> Advised to Take an Alternative Route – No Diversion</i>	
Action Message .....	6-6
<i>Motorists Are Advised to Take Other Routes but the Specific Route Is Not Specified in the VMS Message (Soft Diversion)</i> .....	6-7
<i>Motorists Are Advised to Take a Specific Type 1 or Type 2 Diversion Route</i> .....	6-8
Audience for Action .....	6-9
Good Reason for Following the Action.....	6-10
VMS ON SAME FREEWAY BUT RELATIVELY FAR FROM THE INCIDENT ....	6-11
Incident Descriptor .....	6-11
Incident Location .....	6-12
Lanes Closed/Blocked .....	6-13
Effect on Travel .....	6-14
Action .....	6-15
<i>Motorists Are <u>Not</u> Advised to Take an Alternative Route – No Diversion</i>	
Action Message .....	6-15
<i>Motorists Are Advised to Take Other Routes but the Specific Route Is Not Specified in the VMS Message (Soft Diversion)</i> .....	6-16
<i>Motorists Are Advised to Take a Specific Type 1 or Type 2 Diversion Route</i> .....	6-17
Audience for Action .....	6-18
Good Reason for Following the Action.....	6-19

VMS ON DIFFERENT FREEWAY THAN THE INCIDENT.....6-20

- Incident Descriptor .....6-21
- Incident Location .....6-22
- Lanes Closed/Blocked .....6-23
- Effect on Travel .....6-24
- Action .....6-25
  - Motorists Are Not Advised to Take an Alternative Route – No Diversion*
  - Action Message*.....6-25
  - Motorists Are Advised to Take Other Routes but the Specific Route Is Not Specified in the VMS Message (Soft Diversion)* .....6-26
  - Motorists Are Advised to Take a Specific Type 1 or Type 2 Diversion Route*.....6-27
- Audience for Action .....6-28
- Good Reason for Following the Action.....6-29

**6.2 BASIC MESSAGE FOR INCIDENTS THAT BLOCK ALL THE LANES**.....6-30

BASIC VMS MESSAGE ELEMENTS .....6-30

VMS ON SAME FREEWAY AND RELATIVELY CLOSE TO THE INCIDENT....6-31

- Incident Descriptor .....6-31
- Incident (Blockage) Location .....6-32
- Lanes Blocked .....6-33
- Effect on Travel .....6-34
- Action .....6-35
  - Motorists Are Not Advised to Take an Alternative Route – No Diversion*
  - Action Message*.....6-35
  - Motorists Are Advised to Take Other Routes but the Specific Route Is Not Specified in the VMS Message (Soft Diversion)* .....6-36
  - Motorists Are Advised to Take a Specific Type 1 or Type 2 Diversion Route*.....6-37
- Audience for Action .....6-38
- Good Reason for Following the Action.....6-39

VMS ON SAME FREEWAY BUT RELATIVELY FAR FROM THE INCIDENT ...6-40

- Incident Descriptor .....6-40
- Incident Location .....6-41
- Lanes Blocked .....6-42
- Effect on Travel .....6-43
- Action .....6-44
  - Motorists Are Not Advised to Take an Alternative Route – No Diversion*
  - Action Message*.....6-44
  - Motorists Are Advised to Take Other Routes but the Specific Route Is Not Specified in the VMS Message (Soft Diversion)* .....6-45
  - Motorists Are Advised to Take a Specific Type 1 or Type 2 Diversion Route*.....6-46

Audience for Action .....6-47  
 Good Reason for Following the Action.....6-48

VMS ON DIFFERENT FREEWAY THAN THE INCIDENT.....6-49  
 Incident Descriptor .....6-50  
 Incident Location .....6-51  
 Lanes Blocked .....6-52  
 Effect on Travel .....6-53  
 Action .....6-54  
     *Motorists Are Not Advised to Take an Alternative Route – No Diversion  
         Action Message*.....6-54  
     *Motorists Are Advised to Take Other Routes but the Specific Route Is  
         Not Specified in the VMS Message (Soft Diversion)* .....6-55  
     *Motorists Are Advised to Take a Specific Type 1 or Type 2 Diversion  
         Route*.....6-56  
 Audience for Action .....6-57  
 Good Reason for Following the Action.....6-58

**6.3 BASIC VMS MESSAGE FOR INCIDENTS THAT REQUIRE  
 CLOSING THE FREEWAY**.....6-59

BASIC VMS MESSAGE ELEMENTS .....6-59

VMS ON SAME FREEWAY AND RELATIVELY CLOSE TO THE CLOSURE ....6-60  
 Incident Location .....6-61  
 Lanes Closed.....6-62  
 Closure Location.....6-63  
 Effect on Travel .....6-64  
 Action .....6-65  
     *Motorists Are Advised to Take a Specific Type 1, Type 2, Type 3 or  
         Type 4 Diversion Route* .....6-66  
     *Motorists Are Advised to Take a Specific Type 5 Diversion Route* .....6-67  
 Audience for Action .....6-68  
 Good Reason for Following the Action.....6-69

VMS ON SAME FREEWAY BUT RELATIVELY FAR FROM THE CLOSURE.....6-70  
 Incident Descriptor .....6-70  
 Incident Location .....6-71  
 Lanes Closed.....6-72  
 Closure Location.....6-73  
 Effect on Travel .....6-74  
 Action .....6-75  
     *Motorists Are Not Advised to Take an Alternative Route – No Diversion  
         Action Message*.....6-75  
     *Motorists Are Advised to Take Other Routes but the Specific Route Is  
         Not Specified in the VMS Message (Soft Diversion)* .....6-76



*Motorists Are Advised to Take a Specific Type 1, Type 2, Type 3 or Type 4 Diversion Route* .....6-77

*Motorists Are Advised to Take a Specific Type 5 Diversion Route* .....6-78

Audience for Action .....6-79

Good Reason for Following the Action.....6-80

VMS ON DIFFERENT FREEWAY THAN THE CLOSURE .....6-81

    Incident Descriptor .....6-82

    Incident Location .....6-83

    Lanes Closed.....6-84

    Closure Location.....6-85

    Effect on Travel .....6-86

    Action .....6-87

*Motorists Are Not Advised to Take an Alternative Route – No Diversion Action Message*.....6-87

*Motorists Are Advised to Take Other Routes but the Specific Route Is Not Specified in the VMS Message (Soft Diversion)* .....6-88

*Motorists Are Advised to Take a Specific Type 1 or Type 2 Diversion Route* .....6-89

    Audience for Action .....6-90

    Good Reason for Following the Action.....6-91

**6.4 BASIC VMS MESSAGE FOR INCIDENTS ON AN INTERSECTING FREEWAY THAT REQUIRE CLOSING THE CONNECTOR RAMP**.....6-92

BASIC VMS MESSAGE ELEMENTS .....6-92

VMS UPSTREAM OF THE CONNECTOR RAMP CLOSURE .....6-93

    Incident Descriptor .....6-93

    Incident Location .....6-94

    Lanes Closed.....6-95

    Ramp Closure Descriptor .....6-96

    Action .....6-97

*Motorists Are Not Advised to Take an Alternative Route – No Diversion Action Message*.....6-97

*Motorists Are Advised to Take Other Routes but the Specific Route Is Not Specified in the VMS Message (Soft Diversion)* .....6-98

*Motorists Are Advised to Take a Specific Type 1 or Type 2 Diversion Route* .....6-99

*Motorists Are Advised to Take a Specific Type 5 Diversion Route* .....6-100

    Audience for Action .....6-101

    Good Reason for Following Action.....6-102

## MODULE 6. DESIGNING THE BASIC VMS MESSAGE FOR INCIDENTS

### 6.1 BASIC VMS MESSAGE FOR LANE-CLOSURE (BLOCKAGE) INCIDENTS

#### BASIC VMS MESSAGE ELEMENTS

The Basic VMS Message for lane-closure (blockage) incidents includes the following elements: 1) *Incident Descriptor* (situation description); 2) *Incident Location*; 3) *Lanes Closed/Blocked*; 4) *Effect on Travel* (e.g., major delay); 5) *Audience for Action*; 6) *Action*; and 7) *Good Reason for Following the Action*.

#### BASIC VMS MESSAGE ELEMENTS

- Incident Descriptor (situation description);
- Incident Location;
- Lanes Closed/Blocked;
- Effect on Travel (e.g., major delay);
- Audience for Action (when the action is for a specific group of motorists);
- Action (tells motorists what to do); and
- Good Reason for Following the Action statement (usually implied by other message elements).

## VMS ON SAME FREEWAY AND RELATIVELY CLOSE TO THE INCIDENT

### Incident Descriptor

Warnings of hazardous incidents should be displayed under all traffic conditions in peak or off-peak periods. Minor off-the-roadway incidents such as grass cutting, stalled vehicles on the shoulder, etc. should not be displayed.

Acceptable terms for the *Incident Descriptor* message element are shown in Table 6.1

<b>Table 6.1 ACCEPTABLE INCIDENT DESCRIPTORS VMS ON SAME FREEWAY AND RELATIVELY CLOSE TO INCIDENT</b>	
<b><u>Large Signs</u></b>	<b><u>Portable Signs</u></b>
ACCIDENT	ACCIDENT
MAJOR ACCIDENT	MAJOR   ACCIDENT
MINOR ACCIDENT	MINOR   ACCIDENT
TRUCK ACCIDENT	TRUCK   ACCIDENT
<p>“ ” Indicates that the next portion of the message will be displayed on the next line(s) of VMS.</p>	

A general message phrase, such as *ACCIDENT*, is preferred and reduces the need for a large library of messages for every conceivable incident. Also, credibility is weakened when overly precise messages are not verified. For example, the terms *MAJOR ACCIDENT* or *TRUCK ACCIDENT* is preferred to more exact descriptions such as *VEHICLE OVERTURNED*. Some motorists will voluntarily divert in response to either of the terms.

The message phrase *MAJOR ACCIDENT* implies to motorists a more serious accident that may block more than one lane and will result in extensive delay. To the average New Jersey motorist, it implies a delay of more than 45 minutes.

***MAJOR ACCIDENT* means delays of 45 minutes or more to the average New Jersey motorist.**

## Incident Location

General principles for the message element *Incident Location* can be found beginning on [page 5-8](#).

Acceptable terms for the *Incident Location* message element are shown in Table 6.2.

<b>Table 6.2 ACCEPTABLE TERMS FOR INCIDENT LOCATION VMS ON SAME FREEWAY AND RELATIVELY CLOSE TO INCIDENT</b>	
<b>Large Signs</b>	<b>Portable Signs</b>
1 MILE (AHEAD)	1 MILE (AHEAD)
[number] MILES (AHEAD)	[number] MILES (AHEAD)
AT [highway, street name]	AT   [highway, street name]
AT EXIT [exit ramp number]	AT EXIT [exit ramp number]
AT [exit ramp name] EXIT	AT   [exit ramp name]   EXIT
AT [landmark]	AT   [landmark]
BEFORE [highway, street name]	BEFORE   [highway, street name]
BEFORE EXIT [exit ramp number]	BEFORE   EXIT [exit ramp number]
BEFORE [exit ramp name] EXIT	BEFORE   [exit ramp name]   EXIT
BEFORE [landmark]	BEFORE   [landmark]
NEAR [highway, street name]	NEAR   [highway, street name]
NEAR EXIT [exit ramp number]	NEAR   EXIT [exit ramp number]
NEAR [exit ramp name] EXIT	NEAR   [exit ramp name]   EXIT
NEAR [landmark]	NEAR   [landmark]
PAST [highway, street name]	PAST   [highway, street name]
PAST EXIT [exit ramp number]	PAST   EXIT [exit ramp number]
PAST [exit ramp name] EXIT	PAST   [exit ramp name]   EXIT
PAST [landmark]	PAST   [landmark]

“|” Indicates that the next portion of the message will be displayed on the next line(s) of VMS.

## Lanes Closed/Blocked

General principles for the message element *Lanes Closed/Blocked* can be found beginning on [page 5-10](#).

When the VMS is located on the same freeway as the incident and relatively close to and upstream of the incident, the VMS message can encourage motorists to leave the closed/blocked lane(s) and move into the open lanes by informing them which specific lanes are closed/blocked. This helps the movement of vehicles through the restricted area.

Acceptable terms for the *Lanes Affected* message element for these cases are shown in Table 6.3.

<b>Table 6.3 ACCEPTABLE TERMS FOR LANES CLOSED/BLOCKED VMS ON SAME FREEWAY AND RELATIVELY CLOSE TO INCIDENT</b>	
<b><u>Large Signs</u></b>	<b><u>Portable Signs</u></b>
CENTER LANE BLOCKED	CENTER   LANE   BLOCKED
CENTER LANES BLOCKED	CENTER   LANES   BLOCKED
LEFT LANE BLOCKED	LEFT   LANE   BLOCKED
[number] LEFT LANES BLOCKED	[number] LEFT   LANES   BLOCKED
RIGHT LANE BLOCKED	RIGHT   LANE   BLOCKED
[number] RIGHT LANES BLOCKED	[number] RIGHT   LANES   BLOCKED
CENTER LANE CLOSED	CENTER   LANE   CLOSED
CENTER LANES CLOSED	CENTER   LANES   CLOSED
LEFT LANE CLOSED	LEFT   LANE   CLOSED
[number] LEFT LANES CLOSED	[number] LEFT   LANES   CLOSED
RIGHT LANE CLOSED	RIGHT   LANE   CLOSED
[number] RIGHT LANES CLOSED	[number] RIGHT   LANES   CLOSED

“|” Indicates that the next portion of the message will be displayed on the next line(s) of VMS.

## Effect on Travel

General principles for the message element *Effect on Travel* can be found beginning on [page 5-10](#).

Acceptable terms for the *Effect on Travel* message element when lane-blocking incidents occur are shown in Table 6.4.

**Table 6.4 ACCEPTABLE TERMS FOR *EFFECT ON TRAVEL*  
VMS ON SAME FREEWAY AND RELATIVELY CLOSE TO INCIDENT**

**Large Signs**

DELAY

MAJOR DELAY

[*number*] MINUTES DELAY

**Portable Signs**

DELAY

MAJOR | DELAY

[*number*] MIN | DELAY

“|” Indicates that the next portion of the message will be displayed on the next line(s) of VMS.

**Action**

General principles for the message element *Action* statements can be found beginning on [page 5-13](#).

The *Action* message element displayed to motorists will be dictated by whether:

- Motorists are not advised to take an alternative route;
- Motorists are advised to take other routes but the specific route is not specified in the VMS message (sometimes referred to as “soft” diversion); or
- Motorists are advised by the VMS message to take a specific [Type 1 or Type 2](#) diversion route. *(Note: [Type 3](#), [Type 4](#), [Type 5](#) and [Type 6](#) diversion routes are not applicable.)*

NJDOT has an established policy that defines when motorists can be advised to take a specific alternative route. This policy should be reviewed before diversion messages are displayed.

***Motorists Are Not Advised to Take an Alternative Route – No Diversion Action Message***

In some cases, motorists should not be encouraged to divert to another route because it would result in greater travel time than if the motorists were to remain on the primary freeway. However, it is still important to tell motorists what they need to do.

Acceptable terms for the *Action* message element when lane-blocking incidents occur under this situation are shown in Table 6.5.

<b>Table 6.5 ACCEPTABLE TERMS FOR ACTION                      VMS ON SAME FREEWAY AND RELATIVELY CLOSE TO INCIDENT                      MOTORISTS ARE NOT ADVISED TO TAKE AN ALTERNATIVE ROUTE-                      NO DIVERSION ACTION</b>	
<p><b>Large Signs</b>                      PREPARE TO STOP                      REDUCE SPEED                      STAY ON [route number][cardinal direction]                      STAY ON [highway, street name][cardinal direction]</p>	<p><b>Portable Signs</b>                      PREPARE   TO   STOP                      REDUCE   SPEED                      STAY ON   [route number][cardinal direction]                      STAY ON   [highway, street name][cardinal direction]</p>
<p>“ ” Indicates that the next portion of the message will be displayed on the next line(s) of VMS.</p>	

***Motorists Are Advised to Take Other Routes but the Specific Route Is Not Specified in the VMS Message (Soft Diversion)***

A “Soft” Diversion *Action* message element might be displayed for a variety of reasons including:

- There are no suitable alternative routes that can be recommended because traffic conditions on the most logical routes would not result in travel time savings to motorists if they diverted from the primary freeway;
- The VMS operator is unaware of the traffic conditions on the most logical alternative routes because surveillance does not exist on these routes;
- It is important to display an *Action* before the VMS operator has had a chance to assess the full impact of the incident; and/or
- It is important to display an *Action* before the police have arrived and establish positive diversion routes.

Acceptable terms for the *Action* message element when lane-blocking incidents occur under this situation are shown in Table 6.6.

<p><b>Table 6.6 ACCEPTABLE TERMS FOR <i>ACTION</i></b>  <b>VMS ON SAME FREEWAY AND RELATIVELY CLOSE TO INCIDENT</b>  <b><i>MOTORISTS ARE ADVISED TO TAKE AN ALTERNATIVE ROUTE-</i></b>  <b><i>SOFT DIVERSION</i></b></p>	
<p><b><u>Large Signs</u></b>  EXIT AND USE OTHER ROUTES  USE OTHER ROUTES</p>	<p><b><u>Portable Signs</u></b>  USE   OTHER   ROUTES</p>
<p>“ ” Indicates that the next portion of the message will be displayed on the next line(s) of VMS.</p>	



**Motorists Are Advised to Take a Specific Type 1 or Type 2 Diversion Route**

There are times when the VMS operator is aware of an acceptable alternative route and has real-time information about the conditions on the alternative route. Guide signs or trailblazers may or may not be present. Police or traffic control personnel are not positioned at critical decision points along the diversion route.

Acceptable terms for the *Action* message element when these conditions exist are shown in Table 6.7.

<b>Table 6.7 ACCEPTABLE TERMS FOR ACTION</b> <b>VMS ON SAME FREEWAY AND RELATIVELY CLOSE TO INCIDENT</b> <b>MOTORISTS ARE ADVISED TO TAKE A TYPE 1 OR TYPE 2 DIVERSION ROUTE</b>	
<p><b>Large Signs</b></p> <p>EXIT AND USE [highway, street name] [cardinal direction]                      EXIT AND USE [route number] [cardinal direction]                      EXIT AT [highway, street name] [cardinal direction] /                          USE [highway, street name] [cardinal direction]                      EXIT AT [highway, street name] [cardinal direction] /                          USE [route number] [cardinal direction]                      EXIT AT [route number] [cardinal direction] /                          USE [highway, street name] [cardinal direction]                      EXIT AT [route number] [cardinal direction] /                          USE [route number] [cardinal direction]                      TAKE [exit ramp name] EXIT                      TAKE [exit ramp name] EXIT /                          USE [highway, street name] [cardinal direction]                      TAKE [exit ramp name] EXIT /                          USE [route number] [cardinal direction]                      TAKE EXIT [exit ramp number]                      TAKE EXIT [exit ramp number] /                          USE [highway, street name] [cardinal direction]                      TAKE EXIT [exit ramp number] /                          USE [route number] [cardinal direction]                      TAKE [highway, street name] [cardinal direction]                      TAKE [highway, street name] [cardinal direction] /                          USE [highway, street name] [cardinal direction]                      TAKE [highway, street name] [cardinal direction] /                          USE [route number] [cardinal direction]                      TAKE [route number] [cardinal direction]                      TAKE [route number] [cardinal direction] /                          USE [highway, street name] [cardinal direction]                      TAKE [route number] [cardinal direction] /                          USE [route number] [cardinal direction]                      TAKE NEXT EXIT                      TAKE NEXT [number] EXITS                      TUNE RADIO TO [number] AM                      USE [highway, street name] [cardinal direction]                      USE [route number] [cardinal direction]</p>	<p><b>Portable Signs</b></p> <p>EXIT   AND USE   [highway, street name] [cardinal direction]                      EXIT AND   USE [route number] [cardinal direction]                      EXIT   AT   [highway, street name] [cardinal direction] /                          USE   [highway, street name] [cardinal direction]                      EXIT   AT   [highway, street name] [cardinal direction] /                          USE [route number] [cardinal direction]                      EXIT   AT [route number] [cardinal direction] /                          USE   [highway, street name] [cardinal direction]                      EXIT   AT [route number] [cardinal direction]                            USE [route number] [cardinal direction]                      TAKE   [exit ramp name]   EXIT                      TAKE   [exit ramp name]   EXIT /                          USE   [highway, street name] [cardinal direction]                      TAKE   [exit ramp name]   EXIT                            USE [route number] [cardinal direction]                      TAKE   EXIT [exit ramp number]                      TAKE   EXIT [exit ramp number] /                          USE   [highway, street name] [cardinal direction]                      TAKE   EXIT [exit ramp number]                            USE [route number] [cardinal direction]                      TAKE   [highway, street name] [cardinal direction]                      TAKE   [highway, street name] [cardinal direction] /                          USE   [highway, street name] [cardinal direction]                      TAKE   [highway, street name] [cardinal direction] /                          USE [route number] [cardinal direction]                      TAKE [route number] [cardinal direction]                      TAKE [route number] [cardinal direction] /                          USE   [highway, street name] [cardinal direction]                      TAKE [route number] [cardinal direction] /                          USE [route number] [cardinal direction]                      TAKE   NEXT   EXIT                      TAKE   NEXT   [number] EXITS                      TUNE   RADIO   TO [number] AM                      USE   [highway, street name] [cardinal direction]                      USE [route number] [cardinal direction]</p>
<p>“ ” Indicates that the next portion of the message will be displayed on the next line(s) of VMS.</p>	

**Audience for Action**

General principles for the message element *Audience for Action* can be found beginning on [page 5-12](#).

Acceptable terms for the *Audience for Action* message element are shown in Table 6.8.

<b>Table 6.8 ACCEPTABLE TERMS FOR AUDIENCE FOR ACTION VMS ON SAME FREEWAY AND RELATIVELY CLOSE TO INCIDENT</b>	
<b><u>Large Signs</u></b>	<b><u>Portable Signs</u></b>
<i>[highway, street name] [cardinal direction]</i>	<i>[highway, street name] [cardinal direction]</i>
<i>[route number] [cardinal direction]</i>	<i>[route number] [cardinal direction]</i>
<i>[name of city or state]</i>	<i>[name of city or state]</i>
<i>[name of event, tourist attraction]</i>	<i>[name of event, tourist attraction]</i>
<i>[name of stadium, park, etc.]</i>	<i>[name of stadium, park, etc.]</i>
TO <i>[highway, street name] [cardinal direction]</i>	TO <i>[highway, street name] [cardinal direction]</i>
TO <i>[route number] [cardinal direction]</i>	TO <i>[route number] [cardinal direction]</i>
TO <i>[name of city or state]</i>	TO <i>[name of city or state]</i>
TO <i>[name of event, tourist attraction]</i>	TO <i>[name of event, tourist attraction]</i>
TO <i>[name of stadium, park, etc.]</i>	TO <i>[name of stadium, park, etc.]</i>
<p>“ ” Indicates that the next portion of the message will be displayed on the next line(s) of VMS.</p>	

### Good Reason for Following the Action

General guidelines for displaying to motorists the message element *Good Reason for Following the Action* are given on [page 5-13](#).

When *MAJOR ACCIDENT* or *TRUCK ACCIDENT* are displayed, the reason for following the suggested action is implied, and there is no need to display the reason. However, when the incident descriptors *ACCIDENT* or *MINOR ACCIDENT* are displayed, then a reason needs to be displayed. Also, when it is important to convince motorists to use an alternative route, it is oftentimes advantageous to display *BEST ROUTE TO [destination]*.

The terms shown in Table 6.9 are acceptable to display.

<b>Table 6.9 ACCEPTABLE TERMS FOR <i>GOOD REASON FOR FOLLOWING THE ACTION</i> VMS ON SAME FREEWAY AND RELATIVELY CLOSE TO INCIDENT</b>	
<b><u>Large Signs</u></b>	<b><u>Portable Signs</u></b>
AVOID DELAY	AVOID   DELAY
AVOID MAJOR DELAY	AVOID   MAJOR   DELAY
SAVE [number] MINUTES	SAVE   [number] MIN
BEST ROUTE TO [destination]	BEST   ROUTE TO   [destination]
<p>“ ” Indicates that the next portion of the message will be displayed on the next line(s) of VMS.</p>	

## VMS ON SAME FREEWAY BUT RELATIVELY FAR FROM THE INCIDENT

### Incident Descriptor

Warnings of hazardous incidents should be displayed under all traffic conditions in peak or off-peak periods. Minor off-the-roadway incidents such as grass cutting, stalled vehicles on the shoulder, etc., should not be displayed.

Acceptable terms for the *Incident Descriptor* message element are shown in Table 6.10.

<b>Table 6.10 ACCEPTABLE INCIDENT DESCRIPTORS</b>	
<b>VMS ON SAME FREEWAY BUT RELATIVELY FAR FROM INCIDENT</b>	
<b><u>Large Signs</u></b>	<b><u>Portable Signs</u></b>
ACCIDENT	ACCIDENT
MAJOR ACCIDENT	MAJOR   ACCIDENT
MINOR ACCIDENT	MINOR   ACCIDENT
TRUCK ACCIDENT	TRUCK   ACCIDENT
<p>“ ” Indicates that the next portion of the message will be displayed on the next line(s) of VMS.</p>	

A general message phrase, such as *ACCIDENT*, is preferred and reduces the need for a large library of messages for every conceivable incident. Also, credibility is weakened when overly precise messages are not verified. For example, the terms *MAJOR ACCIDENT* or *TRUCK ACCIDENT* is preferred to more exact descriptions such as *VEHICLE OVERTURNED*. Some motorists will voluntarily divert in response to either of the terms.

The message phrase *MAJOR ACCIDENT* implies to motorists a more serious accident that may block more than one lane and will result in extensive delay. To the average New Jersey motorist, it implies a delay of more than 45 minutes.

***MAJOR ACCIDENT* means delays of 45 minutes or more to the average New Jersey motorist.**

## Incident Location

General principles for the message element *Incident Location* can be found beginning on [page 5-8](#).

Acceptable terms for the *Incident Location* message element are shown in Table 6.11.

<b>Table 6.11 ACCEPTABLE TERMS FOR INCIDENT LOCATION VMS ON SAME FREEWAY BUT RELATIVELY FAR FROM INCIDENT</b>	
<b>Large Signs</b>	<b>Portable Signs</b>
1 MILE (AHEAD)	1 MILE   (AHEAD)
[number] MILES (AHEAD)	[number] MILES   (AHEAD)
AT [highway, street name]	AT   [highway, street name]
AT EXIT [exit ramp number]	AT EXIT [exit ramp number]
AT [exit ramp name] EXIT	AT   [exit ramp name]   EXIT
AT [landmark]	AT   [landmark]
BEFORE [highway, street name]	BEFORE   [highway, street name]
BEFORE EXIT [exit ramp number]	BEFORE   EXIT [exit ramp number]
BEFORE [exit ramp name] EXIT	BEFORE   [exit ramp name]   EXIT
BEFORE [landmark]	BEFORE   [landmark]
NEAR [highway, street name]	NEAR   [highway, street name]
NEAR EXIT [exit ramp number]	NEAR   EXIT [exit ramp number]
NEAR [exit ramp name] EXIT	NEAR   [exit ramp name]   EXIT
NEAR [landmark]	NEAR   [landmark]
PAST [highway, street name]	PAST   [highway, street name]
PAST EXIT [exit ramp number]	PAST   EXIT [exit ramp number]
PAST [exit ramp name] EXIT	PAST   [exit ramp name]   EXIT
PAST [landmark]	PAST   [landmark]

“|” Indicates that the next portion of the message will be displayed on the next line(s) of VMS.

## Lanes Closed/Blocked

General principles for the message element *Lanes Closed/Blocked* can be found beginning on [page 5-10](#).

Situations arise when the VMS is on the same freeway and upstream of the incident but at a location far enough upstream of the incident where it is not advisable to encourage lane changing. It is best to move traffic in all the lanes. Therefore, there is no traffic flow advantage to inform motorists the specific lanes that are closed. However, it is important to notify motorists the number of lanes closed/blocked so that they can make earlier decisions about whether to take alternative routes.

Acceptable terms for *Lanes Closed/Blocked* message element for these cases are shown in Table 6.12.

<b>Table 6.12 ACCEPTABLE TERMS FOR LANES CLOSED/BLOCKED VMS ON SAME FREEWAY BUT RELATIVELY FAR FROM INCIDENT</b>	
<b><u>Large Signs</u></b>	<b><u>Portable Signs</u></b>
1 LANE BLOCKED	1 LANE   BLOCKED
[number] LANES BLOCKED	[number] LANES   BLOCKED
1 LANE CLOSED	1 LANE   CLOSED
[number] LANES CLOSED	[number] LANES   CLOSED
1 LANE OPEN	1 LANE   OPEN
[number] LANES OPEN	[number] LANES   OPEN
“ ” Indicates that the next portion of the message will be displayed on the next line(s) of VMS	

## Effect on Travel

General principles for the message element *Effect on Travel* can be found beginning on [page 5-10](#).

Acceptable terms for the *Effect on Travel* message element when lane-blocking incidents occur are shown in Table 6.13.

**Table 6.13 ACCEPTABLE TERMS FOR *EFFECT ON TRAVEL*  
VMS ON SAME FREEWAY BUT RELATIVELY FAR FROM INCIDENT**

**Large Signs**

DELAY

MAJOR DELAY

[number] MINUTES DELAY

**Portable Signs**

DELAY

MAJOR | DELAY

[number] MIN | DELAY

“|” Indicates that the next portion of the message will be displayed on the next line(s) of VMS

**Action**

General principles for the message element *Action* can be found beginning on [page 5-13](#).

The *Action* message element displayed to motorists will be dictated by whether:

- Motorists are not advised to take an alternative route;
- Motorists are advised to take other routes but the specific route is not specified in the VMS message (sometimes referred to as “soft” diversion); or
- Motorists are advised by the VMS message to take a specific [Type 1](#) or [Type 2](#) diversion route. *(Note: [Type 3](#), [Type 4](#), [Type 5](#) and [Type 6](#) diversion routes are not applicable.)*

NJDOT has an established policy that defines when motorists can be advised to take a specific alternative route. This policy should be reviewed before diversion messages are displayed.

***Motorists Are Not Advised to Take an Alternative Route – No Diversion Action Message***

In some cases, motorists should not be encouraged to divert to another route because it would result in greater travel time than if the motorists were to remain on the primary freeway. However, it is still important to tell motorists what they need to do.

Acceptable terms for the *Action* message element when lane-blocking incidents occur under this situation are shown in Table 6.14.

<b>Table 6.14 ACCEPTABLE TERMS FOR ACTION</b>	
<b>VMS ON SAME FREEWAY BUT RELATIVELY FAR FROM INCIDENT</b>	
<b>MOTORISTS ARE NOT ADVISED TO TAKE AN ALTERNATIVE ROUTE- NO DIVERSION ACTION</b>	
<b>Large Signs</b>	<b>Portable Signs</b>
PREPARE TO STOP	PREPARE   TO   STOP
REDUCE SPEED	REDUCE   SPEED
STAY ON [route number][cardinal direction]	STAY ON   [route number][cardinal direction]
STAY ON [highway, street name][cardinal direction]	STAY ON   [highway, street name][cardinal direction]
“ ” Indicates that the next portion of the message will be displayed on the next line(s) of VMS.	



***Motorists Are Advised to Take Other Routes but the Specific Route Is Not Specified in the VMS Message (Soft Diversion)***

A “Soft” Diversion *Action* message element might be displayed for a variety of reasons including:

- There are no suitable alternative routes that can be recommended because traffic conditions on the most logical routes would not result in travel time savings to motorists if they diverted from the primary freeway;
- The VMS operator is unaware of the traffic conditions on the most logical alternative routes because surveillance does not exist on these routes;
- It is important to display an *Action* before the VMS operator has had a chance to assess the full impact of the incident; and/or
- It is important to display an *Action* before the police have arrived and establish positive diversion routes.

Acceptable terms for the *Action* message element when lane-blocking incidents occur under this situation are shown in Table 6.15.

<b>Table 6.15 ACCEPTABLE TERMS FOR <i>ACTION</i></b> <b>VMS ON SAME FREEWAY BUT RELATIVELY FAR FROM INCIDENT</b> <b><i>MOTORISTS ARE ADVISED TO TAKE AN ALTERNATIVE ROUTE-</i></b> <b><i>SOFT DIVERSION</i></b>	
<p><b><u>Large Signs</u></b>                      EXIT AND USE OTHER ROUTES                      USE OTHER ROUTES</p>	<p><b><u>Portable Signs</u></b>                      USE   OTHER   ROUTES</p>
<p>“ ” Indicates that the next portion of the message will be displayed on the next line(s) of VMS.</p>	

**Motorists Are Advised to Take a Specific Type 1 or Type 2 Diversion Route**

There are times when the VMS operator is aware of an acceptable alternative route and has real-time information about the conditions on the alternative route. Guide signs or trailblazers may or may not be present. Police or traffic control personnel are not positioned at critical decision points along the diversion route.

Acceptable terms for the *Action* message element when these conditions exist are shown in Table 6.16.

<b>Table 6.16 ACCEPTABLE TERMS FOR ACTION</b> <b>VMS ON SAME FREEWAY BUT RELATIVELY FAR FROM INCIDENT</b> <b>MOTORISTS ARE ADVISED TO TAKE A TYPE 1 OR TYPE 2 DIVERSION ROUTE</b>	
<p><b>Large Signs</b></p> <p>EXIT AND USE [highway, street name] [cardinal direction]                      EXIT AND USE [route number] [cardinal direction]                      EXIT AT [highway, street name] [cardinal direction] /                          USE [highway, street name] [cardinal direction]                      EXIT AT [highway, street name] [cardinal direction] /                          USE [route number] [cardinal direction]                      EXIT AT [route number] [cardinal direction] /                          USE [highway, street name] [cardinal direction]                      EXIT AT [route number] [cardinal direction] /                          USE [route number] [cardinal direction]                      TAKE [exit ramp name] EXIT                      TAKE [exit ramp name] EXIT /                          USE [highway, street name] [cardinal direction]                      TAKE [exit ramp name] EXIT /                          USE [route number] [cardinal direction]                      TAKE EXIT [exit ramp number]                      TAKE EXIT [exit ramp number] /                          USE [highway, street name] [cardinal direction]                      TAKE EXIT [exit ramp number] /                          USE [route number] [cardinal direction]                      TAKE [highway, street name] [cardinal direction]                      TAKE [highway, street name] [cardinal direction] /                          USE [highway, street name] [cardinal direction]                      TAKE [highway, street name] [cardinal direction] /                          USE [route number] [cardinal direction]                      TAKE [route number] [cardinal direction]                      TAKE [route number] [cardinal direction] /                          USE [highway, street name] [cardinal direction]                      TAKE [route number] [cardinal direction] /                          USE [route number] [cardinal direction]                      TAKE NEXT EXIT                      TAKE NEXT [number] EXITS                      TUNE RADIO TO [number] AM                      USE [highway, street name] [cardinal direction]                      USE [route number] [cardinal direction]</p>	<p><b>Portable Signs</b></p> <p>EXIT   AND USE   [highway, street name] [cardinal direction]                      EXIT AND   USE [route number] [cardinal direction]                      EXIT   AT   [highway, street name] [cardinal direction] /                          USE   [highway, street name] [cardinal direction]                      EXIT   AT   [highway, street name] [cardinal direction] /                          USE [route number] [cardinal direction]                      EXIT   AT [route number] [cardinal direction] /                          USE   [highway, street name] [cardinal direction]                      EXIT   AT [route number] [cardinal direction]                            USE [route number] [cardinal direction]                      TAKE   [exit ramp name]   EXIT                      TAKE   [exit ramp name]   EXIT /                          USE   [highway, street name] [cardinal direction]                      TAKE   [exit ramp name]   EXIT                            USE [route number] [cardinal direction]                      TAKE   EXIT [exit ramp number]                          TAKE   EXIT [exit ramp number] /                          USE   [highway, street name] [cardinal direction]                      TAKE   EXIT [exit ramp number]                            USE [route number] [cardinal direction]                      TAKE   [highway, street name] [cardinal direction]                      TAKE   [highway, street name] [cardinal direction] /                          USE   [highway, street name] [cardinal direction]                      TAKE   [highway, street name] [cardinal direction] /                          USE [route number] [cardinal direction]                      TAKE [route number] [cardinal direction]                      TAKE [route number] [cardinal direction] /                          USE   [highway, street name] [cardinal direction]                      TAKE [route number] [cardinal direction] /                          USE [route number] [cardinal direction]                      TAKE   NEXT   EXIT                      TAKE   NEXT   [number] EXITS                      TUNE   RADIO   TO [number] AM                      USE   [highway, street name] [cardinal direction]                      USE [route number] [cardinal direction]</p>
<p>" " Indicates that the next portion of the message will be displayed on the next line(s) of VMS.</p>	

**Audience for Action**

General principles for the message element *Audience for Action* can be found beginning on [page 5-12](#).

Acceptable terms for *Audience for Action* message element are shown in Table 6.17.

<b>Table 6.17 ACCEPTABLE TERMS FOR AUDIENCE FOR ACTION VMS ON SAME FREEWAY BUT RELATIVELY FAR FROM INCIDENT</b>	
<b><u>Large Signs</u></b>	<b><u>Portable Signs</u></b>
<i>[highway, street name] [cardinal direction]</i>	<i>[highway, street name] [cardinal direction]</i>
<i>[route number] [cardinal direction]</i>	<i>[route number] [cardinal direction]</i>
<i>[name of city or state]</i>	<i>[name of city or state]</i>
<i>[name of event, tourist attraction]</i>	<i>[name of event, tourist attraction]</i>
<i>[name of stadium, park, etc.]</i>	<i>[name of stadium, park, etc.]</i>
TO <i>[highway, street name] [cardinal direction]</i>	TO <i>[highway, street name] [cardinal direction]</i>
TO <i>[route number] [cardinal direction]</i>	TO <i>[route number] [cardinal direction]</i>
TO <i>[name of city or state]</i>	TO <i>[name of city or state]</i>
TO <i>[name of event, tourist attraction]</i>	TO <i>[name of event, tourist attraction]</i>
TO <i>[name of stadium, park, etc.]</i>	TO <i>[name of stadium, park, etc.]</i>

“;” Indicates that the next portion of the message will be displayed on the next line(s) of VMS.

### Good Reason for Following the Action

General guidelines for displaying the message element *Good Reason for Following the Action* are given on [page 5-13](#).

When *MAJOR ACCIDENT* or *TRUCK ACCIDENT* are displayed, the reason for following the suggested action is implied, and there is no need to display the reason. However, when the incident descriptors *ACCIDENT* or *MINOR ACCIDENT* are displayed, then a reason needs to be displayed. Also, when it is important to convince motorists to use an alternative route, it is oftentimes advantageous to display *BEST ROUTE TO [destination]*.

The terms shown in Table 6.18 are acceptable to display.

Table 6.18 ACCEPTABLE TERMS FOR <i>GOOD REASON FOR FOLLOWING THE ACTION</i> VMS ON SAME FREEWAY BUT RELATIVELY FAR FROM INCIDENT	
<b><u>Large Signs</u></b>	<b><u>Portable Signs</u></b>
AVOID DELAY	AVOID   DELAY
AVOID MAJOR DELAY	AVOID   MAJOR   DELAY
SAVE [number] MINUTES	SAVE   [number] MIN
BEST ROUTE TO [destination]	BEST   ROUTE TO   [destination]
“ ” Indicates that the next portion of the message will be displayed on the next line(s) of VMS.	

## **VMS ON DIFFERENT FREEWAY THAN THE INCIDENT**

The VMS operational guidelines in this section of the Manual apply when the VMS is on a different freeway than the incident, but the incident still can have an affect on motorists who are passing the VMS. For example, westbound I-195 motorists who intend to exit I-195 and enter northbound I-295 to travel to the city of Princeton could be affected by incidents that occur on northbound I-295 north of the I-195/I-295 interchange. Messages displayed on VMSs on westbound I-195 concerning incidents on northbound I-295 can be helpful to those motorists heading to Princeton.

The major difference between the messages displayed on VMSs located on a different freeway than the incident in comparison to the messages on VMSs located on the same freeway as the incident but far upstream of the incident is in the diversion information provided.

## Incident Descriptor

Warnings of hazardous incidents should be displayed under all traffic conditions in peak or off-peak periods. Minor off-the-roadway incidents such as grass cutting, stalled vehicles on the shoulder, etc. should not be displayed.

Acceptable terms for the *Incident Descriptor* message element are shown in Table 6.19

<b>Table 6.19 ACCEPTABLE INCIDENT DESCRIPTORS VMS ON DIFFERENT FREEWAY THAN INCIDENT</b>	
<u><b>Large Signs</b></u> ACCIDENT MAJOR ACCIDENT MINOR ACCIDENT TRUCK ACCIDENT	<u><b>Portable Signs</b></u> ACCIDENT MAJOR   ACCIDENT MINOR   ACCIDENT TRUCK   ACCIDENT
<p>“ ” Indicates that the next portion of the message will be displayed on the next line(s) of VMS.</p>	

A general message phrase, such as *ACCIDENT*, is preferred and reduces the need for a large library of messages for every conceivable incident. Also, credibility is weakened when overly precise messages are not verified. For example, the terms *MAJOR ACCIDENT* or *TRUCK ACCIDENT* is preferred to more exact descriptions such as *VEHICLE OVERTURNED*. Some motorists will voluntarily divert in response to either of the terms.

The message phrase *MAJOR ACCIDENT* implies to motorists a more serious accident that may block more than one lane and will result in extensive delay. To the average New Jersey motorist, it implies a delay of more than 45 minutes.

***MAJOR ACCIDENT* means delays of 45 minutes or more to the average New Jersey motorist.**

## Incident Location

General principles for the message element *Incident Location* can be found beginning on [page 5-8](#).

Acceptable terms for the *Incident Location* message element are shown in Table 6.20.

<b>Table 6.20 ACCEPTABLE TERMS FOR <i>INCIDENT LOCATION</i> VMS ON DIFFERENT FREEWAY THAN INCIDENT</b>	
<b><u>Large Signs</u></b>	<b><u>Portable Signs</u></b>
AT <i>[highway, street name]</i> *	AT   <i>[highway, street name]</i> *
AT EXIT <i>[exit ramp number]</i> *	AT EXIT <i>[exit ramp number]</i> *
AT <i>[exit ramp name]</i> EXIT*	AT   <i>[exit ramp name]</i>   EXIT*
AT <i>[landmark]</i> *	AT   <i>[landmark]</i> *
BEFORE <i>[highway, street name]</i> *	BEFORE   <i>[highway, street name]</i> *
BEFORE EXIT <i>[exit ramp number]</i> *	BEFORE   EXIT <i>[exit ramp number]</i> *
BEFORE <i>[exit ramp name]</i> EXIT*	BEFORE   <i>[exit ramp name]</i>   EXIT*
BEFORE <i>[landmark]</i> *	BEFORE   <i>[landmark]</i> *
NEAR <i>[highway, street name]</i> *	NEAR   <i>[highway, street name]</i> *
NEAR EXIT <i>[exit ramp number]</i> *	NEAR   EXIT <i>[exit ramp number]</i> *
NEAR <i>[exit ramp name]</i> EXIT*	NEAR   <i>[exit ramp name]</i>   EXIT*
NEAR <i>[landmark]</i> *	NEAR   <i>[landmark]</i> *
PAST <i>[highway, street name]</i> *	PAST   <i>[highway, street name]</i> *
PAST EXIT <i>[exit ramp number]</i> *	PAST   EXIT <i>[exit ramp number]</i> *
PAST <i>[exit ramp name]</i> EXIT*	PAST   <i>[exit ramp name]</i>   EXIT*
PAST <i>[landmark]</i> *	PAST   <i>[landmark]</i> *
* Insert “ON <i>[route number, highway name or street name]</i> <i>[cardinal direction]</i> ” in front of the Incident Location.	
“ ” Indicates that the next portion of the message will be displayed on the next line(s) of VMS.	

## Lanes Closed/Blocked

General principles for the message element *Lanes Closed/Blocked* can be found beginning on [page 5-10](#).

When the incident occurs downstream of the VMS but on a different highway, it is not necessary to inform motorists the specific lanes that are closed/blocked. What is important to the motorist is knowledge of the number of lanes that are closed/blocked.

The acceptable terms for the *Lanes Closed/Blocked* message element are shown in Table 6.21.

<b>Table 6.21 ACCEPTABLE TERMS FOR LANES CLOSED/BLOCKED VMS ON DIFFERENT FREEWAY THAN INCIDENT</b>	
<b><u>Large Signs</u></b>	<b><u>Portable Signs</u></b>
1 LANE BLOCKED	1 LANE   BLOCKED
[number] LANES BLOCKED	[number] LANES   BLOCKED
1 LANE CLOSED	1 LANE   CLOSED
[number] LANES CLOSED	[number] LANES   CLOSED
1 LANE OPEN	1 LANE   OPEN
[number] LANES OPEN	[number] LANES   OPEN
“[ ]” Indicates that the next portion of the message will be displayed on the next line(s) of VMS	



## Effect on Travel

General principles for the message element *Effect on Travel* can be found beginning on [page 5-10](#).

Acceptable terms for the *Effect on Travel* message element when lane-blocking incidents occur are shown in Table 6.22.

**Table 6.22 ACCEPTABLE TERMS FOR *EFFECT ON TRAVEL*  
VMS ON DIFFERENT FREEWAY THAN INCIDENT**

<b><u>Large Signs</u></b>	<b><u>Portable Signs</u></b>
DELAY	DELAY
MAJOR DELAY	MAJOR   DELAY
<i>[number]</i> MINUTES DELAY	<i>[number]</i> MIN   DELAY

“|” Indicates that the next portion of the message will be displayed on the next line(s) of VMS.

**Action**

General principles for the message element *Action* can be found beginning on [page 5-13](#).

The *Action* message element displayed to motorists will be dictated by whether:

- Motorists who will turn onto the affected freeway are not advised to take an alternative route;
- Motorists who will turn onto the affected freeway are advised to take other routes but the specific route is not specified in the VMS message (sometimes referred to as “soft” diversion); or
- Motorists who will turn onto the affected freeway are advised by the VMS message to take a specific [Type 1](#) or [Type 2](#) diversion route. (*Note: [Type 3](#), [Type 4](#), [Type 5](#) and [Type 6](#) diversion routes are not applicable.*)

NJDOT has an established policy that defines when motorists can be advised to take a specific alternative route. This policy should be reviewed before diversion messages are displayed.

***Motorists Are Not Advised to Take an Alternative Route – No Diversion Action Message***

In some cases, motorists should not be encouraged to divert to another route because it would result in greater travel time than if the motorists were to remain on the primary freeway. However, it is still important to tell motorists what they need to do.

Acceptable terms for the *Action* message element when lane-blocking incidents occur under this situation are shown in Table 6.23.

<b>Table 6.23 ACCEPTABLE TERMS FOR ACTION                      VMS ON DIFFERENT FREEWAY THAN INCIDENT                      MOTORISTS ARE NOT ADVISED TO TAKE AN ALTERNATIVE ROUTE-                      NO DIVERSION ACTION</b>	
<b><u>Large Signs</u></b> PREPARE TO STOP REDUCE SPEED STAY ON [route number][cardinal direction] STAY ON [highway, street name][cardinal direction]	<b><u>Portable Signs</u></b> PREPARE   TO   STOP REDUCE SPEED STAY ON   [route number][cardinal direction] STAY ON   [highway, street name][cardinal direction]
“ ” Indicates that the next portion of the message will be displayed on the next line(s) of VMS.	

***Motorists Are Advised to Take Other Routes but the Specific Route Is Not Specified in the VMS Message (Soft Diversion)***

A “Soft” Diversion *Action* message element might be displayed for a variety of reasons including:

- There are no suitable alternative routes that can be recommended because traffic conditions on the most logical routes would not result in travel time savings to motorists if they diverted from the primary freeway;
- The VMS operator is unaware of the traffic conditions on the most logical alternative routes because surveillance does not exist on these routes;
- It is important to display an *Action* before the VMS operator has had a chance to assess the full impact of the incident; and/or
- It is important to display an *Action* before the police have arrived and establish positive diversion routes.

Acceptable terms for the *Action* message element when lane-blocking incidents occur under this situation are shown in Table 6.24.

<b>Table 6.24 ACCEPTABLE TERMS FOR <i>ACTION</i>  VMS ON DIFFERENT FREEWAY THAN INCIDENT  MOTORISTS ARE ADVISED TO TAKE AN ALTERNATIVE ROUTE-  SOFT DIVERSION</b>	
<p><b><u>Large Signs</u></b>  USE OTHER ROUTES</p>	<p><b><u>Portable Signs</u></b>  USE   OTHER   ROUTES</p>
<p>“ ” Indicates that the next portion of the message will be displayed on the next line(s) of VMS.</p>	

***Motorists Are Advised to Take a Specific Type 1 or Type 2 Diversion Route***

There are times when the VMS operator is aware of an acceptable alternative route and has real-time information about the conditions on the alternative route. Guide signs or trailblazers may or may not be present. Police or traffic control personnel are not positioned at critical decision points along the diversion route.

Acceptable terms for the *Action* message element when these conditions exist are shown in Table 6.25.

**Table 6.25 ACCEPTABLE TERMS FOR ACTION  
VMS ON DIFFERENT FREEWAY THAN INCIDENT  
MOTORISTS ARE ADVISED TO TAKE A TYPE 1 OR TYPE 2 DIVERSION ROUTE**

**Large Signs**

USE [highway, street name] [cardinal direction]

USE [route number] [cardinal direction]

**Portable Signs**

USE | [highway, street name] [cardinal direction]

USE [route number] [cardinal direction]

“|” Indicates that the next portion of the message will be displayed on the next line(s) of VMS.

**Audience for Action**

General principles for the message element *Audience for Action* can be found beginning on [page 5-12](#).

Acceptable terms for the *Audience for Action* message element are shown in Table 6.26.

<b>Table 6.26 ACCEPTABLE TERMS FOR AUDIENCE FOR ACTION VMS ON DIFFERENT FREEWAY THAN INCIDENT</b>	
<b><u>Large Signs</u></b>	<b><u>Portable Signs</u></b>
<i>[highway, street name] [cardinal direction]</i>	<i>[highway, street name] [cardinal direction]</i>
<i>[route number] [cardinal direction]</i>	<i>[route number] [cardinal direction]</i>
<i>[name of city or state]</i>	<i>[name of city or state]</i>
<i>[name of event, tourist attraction]</i>	<i>[name of event, tourist attraction]</i>
<i>[name of stadium, park, etc.]</i>	<i>[name of stadium, park, etc.]</i>
TO <i>[highway, street name] [cardinal direction]</i>	TO <i>[highway, street name] [cardinal direction]</i>
TO <i>[route number] [cardinal direction]</i>	TO <i>[route number] [cardinal direction]</i>
TO <i>[name of city or state]</i>	TO <i>[name of city or state]</i>
TO <i>[name of event, tourist attraction]</i>	TO <i>[name of event, tourist attraction]</i>
TO <i>[name of stadium, park, etc.]</i>	TO <i>[name of stadium, park, etc.]</i>

“|” Indicates that the next portion of the message will be displayed on the next line(s) of VMS.

### Good Reason for Following the Action

General guidelines for displaying the message element *Good Reason for Following the Action* are given on [page 5-13](#).

When *MAJOR ACCIDENT* or *TRUCK ACCIDENT* are displayed, the reason for following the suggested action is implied, and there is no need to display the reason. However, when the incident descriptors *ACCIDENT* or *MINOR ACCIDENT* are displayed, then a reason needs to be displayed. Also, when it is important to convince motorists to use an alternative route, it is oftentimes advantageous to display *BEST ROUTE TO [destination]*.

The terms shown in Table 6.27 below are acceptable to display.

<b>Table 6.27 ACCEPTABLE TERMS FOR <i>GOOD REASON FOR FOLLOWING THE ACTION</i> VMS ON DIFFERENT FREEWAY THAN INCIDENT</b>	
<b><u>Large Signs</u></b> AVOID DELAY AVOID MAJOR DELAY SAVE [number] MINUTES BEST ROUTE TO [destination]	<b><u>Portable Signs</u></b> AVOID   DELAY AVOID   MAJOR   DELAY SAVE   [number] MIN BEST   ROUTE TO   [destination]
<p>“ ” Indicates that the next portion of the message will be displayed on the next line(s) of VMS.</p>	

## 6.2 BASIC MESSAGE FOR INCIDENTS THAT BLOCK ALL THE LANES

When an incident occurs that affects all lanes of the freeway, there is a period of time until the police and/or traffic control personnel arrive that it can be said that the incident is *blocking* the freeway. No traffic control is in place to *close* the lanes and to divert traffic to alternative routes. Under these conditions, the guidelines in this section of the Manual should be used to develop the Basic VMS Message.

When the police and/or traffic control personnel arrive, the freeway is *closed* and traffic is diverted to an alternative route. The freeway closure, the location where traffic is diverted from the freeway, is in most cases at different location than the incident. Under these conditions, [Section 6.3 BASIC VMS MESSAGE FOR INCIDENTS THAT REQUIRE CLOSING THE FREEWAY](#) should be used to develop the Basic VMS Message.

### BASIC VMS MESSAGE ELEMENTS

The Basic VMS Message for incidents that block all lanes of the freeway includes the following elements: 1) *Incident Descriptor* (situation description); 2) *Incident (Blockage) Location*; 3) *Lanes Blocked*; 4) *Effect on Travel* (implied); 5) *Audience for Action* (implied); 6) *Action*; and 7) *Good Reason for Following the Action* (implied).

#### BASIC VMS MESSAGE ELEMENTS: BLOCKAGE

- Incident Descriptor (situation description);
- Incident (Blockage) Location;
- Lanes Blocked;
- Effect on Travel (implied by other message elements);
- Audience for Action (implied by other message elements);
- Action (tells motorists what to do); and
- Good Reason for Following the Action statement (implied by other message elements).

**VMS ON SAME FREEWAY AND RELATIVELY CLOSE TO THE INCIDENT****Incident Descriptor**

Warnings of road-blocking incidents should be displayed under all traffic conditions in peak or off-peak periods.

Acceptable terms for the *Incident Descriptor* message element are shown in Table 6.28.

<b>Table 6.28 ACCEPTABLE INCIDENT DESCRIPTORS VMS ON SAME FREEWAY AND RELATIVELY CLOSE TO INCIDENT</b>	
<b><u>Large Signs</u></b>	<b><u>Portable Signs</u></b>
ACCIDENT	ACCIDENT
MAJOR ACCIDENT	MAJOR   ACCIDENT
TRUCK ACCIDENT	TRUCK   ACCIDENT
<p>“ ” Indicates that the next portion of the message will be displayed on the next line(s) of VMS.</p>	

A general message phrase, such as *ACCIDENT*, is preferred and reduces the need for a large library of messages for every conceivable incident. Also, credibility is weakened when overly precise messages are not verified. For example, the terms *MAJOR ACCIDENT* or *TRUCK ACCIDENT* is preferred to more exact descriptions such as *VEHICLE OVERTURNED*. Some motorists will voluntarily divert in response to either of the terms.

The message phrase *MAJOR ACCIDENT* implies to motorists a more serious accident that may block more than one lane and will result in extensive delay. To the average New Jersey motorist, it implies a delay of more than 45 minutes.

***MAJOR ACCIDENT* means delays of 45 minutes or more to the average New Jersey motorist.**



## Incident (Blockage) Location

General principles for the message element *Incident (Blockage) Location* can be found beginning on [page 5-8](#).

Acceptable terms for the *Incident Location* message element are shown in Table 6.29.

<b>Table 6.29 ACCEPTABLE TERMS FOR INCIDENT LOCATION VMS ON SAME FREEWAY AND RELATIVELY CLOSE TO INCIDENT</b>	
<b><u>Large Signs</u></b>	<b><u>Portable Signs</u></b>
1 MILE (AHEAD)	1 MILE (AHEAD)
[number] MILES (AHEAD)	[number] MILES (AHEAD)
AT [highway, street name]	AT   [highway, street name]
AT EXIT [exit ramp number]	AT EXIT [exit ramp number]
AT [exit ramp name] EXIT	AT   [exit ramp name]   EXIT
AT [landmark]	AT   [landmark]
BEFORE [highway, street name]	BEFORE   [highway, street name]
BEFORE EXIT [exit ramp number]	BEFORE   EXIT [exit ramp number]
BEFORE [exit ramp name] EXIT	BEFORE   [exit ramp name]   EXIT
BEFORE [landmark]	BEFORE   [landmark]
NEAR [highway, street name]	NEAR   [highway, street name]
NEAR EXIT [exit ramp number]	NEAR   EXIT [exit ramp number]
NEAR [exit ramp name] EXIT	NEAR   [exit ramp name]   EXIT
NEAR [landmark]	NEAR   [landmark]
PAST [highway, street name]	PAST   [highway, street name]
PAST EXIT [exit ramp number]	PAST   EXIT [exit ramp number]
PAST [exit ramp name] EXIT	PAST   [exit ramp name]   EXIT
PAST [landmark]	PAST   [landmark]
“ ” Indicates that the next portion of the message will be displayed on the next line(s) of VMS.	

## Lanes Blocked

General principles for the message element *Lanes Blocked* can be found beginning on [page 5-10](#).

When the VMS is located on the same freeway as the incident and relatively close to the incident, the VMS message should be used to encourage motorists to leave the freeway and find alternative routes.

Acceptable terms for the *Lanes Blocked* message elements are shown in Table 6.30.

<b>Table 6.30 ACCEPTABLE TERMS FOR <i>LANES BLOCKED</i> VMS ON SAME FREEWAY AND RELATIVELY CLOSE TO INCIDENT</b>	
<b><u>Large Signs</u></b>	<b><u>Portable Signs</u></b>
ALL LANES BLOCKED	ALL   LANES   BLOCKED
“ ” Indicates that the next portion of the message will be displayed on the next line(s) of VMS.	

## Effect on Travel

General principles for the message element *Effect on Travel* can be found beginning on [page 5-10](#).

There is no need to include the *Effect on Travel* message element because the effects are implied from other message elements such as the *Lanes Blocked* message element (i.e., *ALL LANES BLOCKED*).

<p><b>Table 6.31 ACCEPTABLE TERMS FOR <i>EFFECT ON TRAVEL</i> VMS ON SAME FREEWAY AND RELATIVELY CLOSE TO INCIDENT</b></p>
--

<p>(Not necessary to display because it is implied by other message elements)</p>
---

**Action**

General principles for the message element *Action* can be found beginning on [page 5-13](#).

The *Action* message element displayed to motorists will be dictated by whether:

- Motorists are not advised to take an alternative route;
- Motorists are advised to take other routes but the specific route is not specified in the VMS message (sometimes referred to as “soft” diversion); or
- Motorists are advised by the VMS message to take a specific [Type 1](#) or [Type 2](#) diversion route. *(Note: [Type 3](#), [Type 4](#), [Type 5](#) and [Type 6](#) diversion routes are not applicable.)*

NJDOT has an established policy that defines when motorists can be advised to take a specific alternative route. This policy should be reviewed before diversion messages are displayed.

***Motorists Are Not Advised to Take an Alternative Route – No Diversion Action Message***

In some cases, motorists should not be encouraged to divert to another route because it would result in greater travel time than if the motorists were to remain on the primary freeway. However, it is still important to tell motorists what they need to do.

Acceptable terms for the *Action* when lane-blocking incidents occur under this situation are shown in Table 6.32.

<p><b>Table 6.32 ACCEPTABLE TERMS FOR ACTION VMS ON SAME FREEWAY AND RELATIVELY CLOSE TO INCIDENT MOTORISTS ARE NOT ADVISED TO TAKE AN ALTERNATIVE ROUTE- NO DIVERSION ACTION</b></p>	
<p><b><u>Large Signs</u></b> PREPARE TO STOP REDUCE SPEED</p>	<p><b><u>Portable Signs</u></b> PREPARE   TO   STOP REDUCE   SPEED</p>
<p>“ ” Indicates that the next portion of the message will be displayed on the next line(s) of VMS.</p>	

***Motorists Are Advised to Take Other Routes but the Specific Route Is Not Specified in the VMS Message (Soft Diversion)***

A “Soft” Diversion *Action* message element might be displayed for a variety of reasons including:

- The VMS operator is unaware of the traffic conditions on the most logical alternative routes because surveillance does not exist on these routes;
- It is important to display an *Action* before the VMS operator has had a chance to assess the full impact of the incident; and/or
- It is important to display an *Action* before the police have arrived and establish positive diversion routes.

Acceptable terms for the *Action* message element are shown in Table 6.33.

<b>Table 6.33 ACCEPTABLE TERMS FOR ACTION</b> <b>VMS ON SAME FREEWAY AND RELATIVELY CLOSE TO INCIDENT</b> <b>MOTORISTS ARE ADVISED TO TAKE AN ALTERNATIVE ROUTE-</b> <b>SOFT DIVERSION</b>	
<p><b><u>Large Signs</u></b>                      EXIT AND USE OTHER ROUTES                      USE OTHER ROUTES</p>	<p><b><u>Portable Signs</u></b>                      USE   OTHER   ROUTES</p>
<p>“ ” Indicates that the next portion of the message will be displayed on the next line(s) of VMS.</p>	

**Motorists Are Advised to Take a Specific Type 1 or Type 2 Diversion Route**

There are times when the VMS operator is aware of an acceptable alternative route and has real-time information about the conditions on the alternative route. Guide signs or trailblazers may or may not be present. Police or traffic control personnel are not positioned at critical decision points along the diversion route.

Acceptable terms for the *Action* message element when these conditions exist are shown in Table 6.34.

<b>Table 6.34 ACCEPTABLE TERMS FOR ACTION                      VMS ON SAME FREEWAY AND RELATIVELY CLOSE TO INCIDENT                      MOTORISTS ARE ADVISED TO TAKE A TYPE 1 OR TYPE 2 DIVERSION ROUTE</b>	
<p><b>Large Signs</b></p> <p>EXIT AND USE [highway, street name] [cardinal direction]                      EXIT AND USE [route number] [cardinal direction]                      EXIT AT [highway, street name] [cardinal direction] /                          USE [highway, street name] [cardinal direction]                      EXIT AT [highway, street name] [cardinal direction] /                          USE [route number] [cardinal direction]                      EXIT AT [route number] [cardinal direction] /                          USE [highway, street name] [cardinal direction]                      EXIT AT [route number] [cardinal direction] /                          USE [route number] [cardinal direction]                      TAKE [exit ramp name] EXIT                      TAKE [exit ramp name] EXIT /                          USE [highway, street name] [cardinal direction]                      TAKE [exit ramp name] EXIT /                          USE [route number] [cardinal direction]                      TAKE EXIT [exit ramp number]                      TAKE EXIT [exit ramp number] /                          USE [highway, street name] [cardinal direction]                      TAKE EXIT [exit ramp number] /                          USE [route number] [cardinal direction]                      TAKE [highway, street name] [cardinal direction]                      TAKE [highway, street name] [cardinal direction] /                          USE [highway, street name] [cardinal direction]                      TAKE [highway, street name] [cardinal direction] /                          USE [route number] [cardinal direction]                      TAKE [route number] [cardinal direction]                      TAKE [route number] [cardinal direction] /                          USE [highway, street name] [cardinal direction]                      TAKE [route number] [cardinal direction] /                          USE [route number] [cardinal direction]                      TAKE NEXT EXIT                      TAKE NEXT [number] EXITS                      TUNE RADIO TO [number] AM                      USE [highway, street name] [cardinal direction]                      USE [route number] [cardinal direction]</p>	<p><b>Portable Signs</b></p> <p>EXIT   AND USE   [highway, street name] [cardinal direction]                      EXIT AND   USE [route number] [cardinal direction]                      EXIT   AT   [highway, street name] [cardinal direction] /                          USE   [highway, street name] [cardinal direction]                      EXIT   AT   [highway, street name] [cardinal direction] /                          USE [route number] [cardinal direction]                      EXIT   AT [route number] [cardinal direction] /                          USE   [highway, street name] [cardinal direction]                      EXIT   AT [route number] [cardinal direction]                            USE [route number] [cardinal direction]                      TAKE   [exit ramp name]   EXIT                      TAKE   [exit ramp name]   EXIT /                          USE   [highway, street name] [cardinal direction]                      TAKE   [exit ramp name]   EXIT                            USE [route number] [cardinal direction]                      TAKE   EXIT [exit ramp number]                      TAKE   EXIT [exit ramp number] /                          USE   [highway, street name] [cardinal direction]                      TAKE   EXIT [exit ramp number]                            USE [route number] [cardinal direction]                      TAKE   [highway, street name] [cardinal direction]                      TAKE   [highway, street name] [cardinal direction] /                          USE   [highway, street name] [cardinal direction]                      TAKE   [highway, street name] [cardinal direction] /                          USE [route number] [cardinal direction]                      TAKE [route number] [cardinal direction]                      TAKE [route number] [cardinal direction] /                          USE   [highway, street name] [cardinal direction]                      TAKE [route number] [cardinal direction] /                          USE [route number] [cardinal direction]                      TAKE   NEXT   EXIT                      TAKE   NEXT   [number] EXITS                      TUNE   RADIO   TO [number] AM                      USE   [highway, street name] [cardinal direction]                      USE [route number] [cardinal direction]</p>
<p>" " Indicates that the next portion of the message will be displayed on the next line(s) of VMS.</p>	

**Audience for Action**

General principles for the message element *Audience for Action* can be found beginning on [page 5-12](#).

Acceptable terms for the *Audience for Action* message element are shown in Table 6.35.

<b>Table 6.35 ACCEPTABLE TERMS FOR AUDIENCE FOR ACTION VMS ON SAME FREEWAY AND RELATIVELY CLOSE TO INCIDENT</b>	
<b><u>Large Signs</u></b>	<b><u>Portable Signs</u></b>
[highway, street name] [cardinal direction]	[highway, street name] [cardinal direction]
[route number] [cardinal direction]	[route number] [cardinal direction]
[name of city or state]	[name of city or state]
[name of event, tourist attraction]	[name of event, tourist attraction]
[name of stadium, park, etc.]	[name of stadium, park, etc.]
TO [highway, street name] [cardinal direction]	TO [highway, street name] [cardinal direction]
TO [route number] [cardinal direction]	TO [route number] [cardinal direction]
TO [name of city or state]	TO [name of city or state]
TO [name of event, tourist attraction]	TO [name of event, tourist attraction]
TO [name of stadium, park, etc.]	TO [name of stadium, park, etc.]

“;” Indicates that the next portion of the message will be displayed on the next line(s) of VMS.

### Good Reason for Following the Action

General guidelines for displaying the message element *Good Reason for Following the Action* are given on [page 5-13](#).

As a rule, when the freeway is blocked and *ALL LANES BLOCKED* or *FREEWAY BLOCKED* is displayed, the reason for following the suggested action is implied, and there is no need to display the reason. However, when a recommended diversion route may be perceived by motorists as not being the most logical route, then a *Good Reason for Following the Action* should be displayed.

The terms shown in Table 6.36 below are acceptable to display.

<b>Table 6.36 ACCEPTABLE TERMS FOR GOOD REASON FOR FOLLOWING THE ACTION VMS ON SAME FREEWAY AND RELATIVELY CLOSE TO INCIDENT</b>	
<b><u>Large Signs</u></b>	<b><u>Portable Signs</u></b>
AVOID DELAY	AVOID   DELAY
AVOID MAJOR DELAY	AVOID   MAJOR   DELAY
SAVE [number] MINUTES	SAVE   [number] MIN
BEST ROUTE TO [destination]	BEST   ROUTE TO   [destination]
<p>“ ” Indicates that the next portion of the message will be displayed on the next line(s) of VMS.</p>	



## VMS ON SAME FREEWAY BUT RELATIVELY FAR FROM THE INCIDENT

### Incident Descriptor

Warnings of road-blocking incidents should be displayed under all traffic conditions in peak or off-peak periods.

Acceptable terms for the *Incident Descriptor* message element are shown in Table 6.37.

<b>Table 6.37 ACCEPTABLE INCIDENT DESCRIPTORS</b>	
<b>VMS ON SAME FREEWAY BUT RELATIVELY FAR FROM INCIDENT</b>	
<b><u>Large Signs</u></b>	<b><u>Portable Signs</u></b>
ACCIDENT	ACCIDENT
MAJOR ACCIDENT	MAJOR   ACCIDENT
TRUCK ACCIDENT	TRUCK   ACCIDENT
“ ” Indicates that the next portion of the message will be displayed on the next line(s) of VMS.	

A general message phrase, such as *ACCIDENT*, is preferred and reduces the need for a large library of messages for every conceivable incident. Also, credibility is weakened when overly precise messages are not verified. For example, the terms *MAJOR ACCIDENT* or *TRUCK ACCIDENT* is preferred to more exact descriptions such as *VEHICLE OVERTURNED*. Some motorists will voluntarily divert in response to either of the terms.

The message phrase *MAJOR ACCIDENT* implies to motorists a more serious accident that may block more than one lane and will result in extensive delay. To the average New Jersey motorist, it implies a delay of more than 45 minutes.

***MAJOR ACCIDENT* means delays of 45 minutes or more to the average New Jersey motorist.**

## Incident Location

General principles for the message element *Incident Location* can be found beginning on [page 5-8](#).

Acceptable terms for the *Incident Location* message element are shown in Table 6.38.

<b>Table 6.38 ACCEPTABLE TERMS FOR <i>INCIDENT LOCATION</i> VMS ON SAME FREEWAY BUT RELATIVELY FAR FROM INCIDENT</b>	
<b>Large Signs</b>	<b>Portable Signs</b>
<i>[number]</i> MILES (AHEAD)	<i>[number]</i> MILES   (AHEAD)
AT <i>[highway, street name]</i>	AT   <i>[highway, street name]</i>
AT EXIT <i>[exit ramp number]</i>	AT EXIT <i>[exit ramp number]</i>
AT <i>[exit ramp name]</i> EXIT	AT   <i>[exit ramp name]</i>   EXIT
AT <i>[landmark]</i>	AT   <i>[landmark]</i>
BEFORE <i>[highway, street name]</i>	BEFORE   <i>[highway, street name]</i>
BEFORE EXIT <i>[exit ramp number]</i>	BEFORE   EXIT <i>[exit ramp number]</i>
BEFORE <i>[exit ramp name]</i> EXIT	BEFORE   <i>[exit ramp name]</i>   EXIT
BEFORE <i>[landmark]</i>	BEFORE   <i>[landmark]</i>
NEAR <i>[highway, street name]</i>	NEAR   <i>[highway, street name]</i>
NEAR EXIT <i>[exit ramp number]</i>	NEAR   EXIT <i>[exit ramp number]</i>
NEAR <i>[exit ramp name]</i> EXIT	NEAR   <i>[exit ramp name]</i>   EXIT
NEAR <i>[landmark]</i>	NEAR   <i>[landmark]</i>
PAST <i>[highway, street name]</i>	PAST   <i>[highway, street name]</i>
PAST EXIT <i>[exit ramp number]</i>	PAST   EXIT <i>[exit ramp number]</i>
PAST <i>[exit ramp name]</i> EXIT	PAST   <i>[exit ramp name]</i>   EXIT
PAST <i>[landmark]</i>	PAST   <i>[landmark]</i>

“|” Indicates that the next portion of the message will be displayed on the next line(s) of VMS.

## Lanes Blocked

General principles for the message element *Lanes Blocked* can be found beginning on [page 5-10](#).

When the VMS is located on the same freeway as the incident even though it may be located some distance upstream of the incident, it is oftentimes advantageous to advise motorists of the freeway closure.

Acceptable terms for *Lanes Blocked* message element are shown in Table 6.39.

**Table 6.39 ACCEPTABLE TERMS FOR *LANES BLOCKED*  
VMS ON SAME FREEWAY BUT RELATIVELY FAR FROM INCIDENT**

**Large Signs**

ALL LANES BLOCKED

**Portable Signs**

ALL | LANES | BLOCKED

“|” Indicates that the next portion of the message will be displayed on the next line(s) of VMS.

## Effect on Travel

General principles for the message element *Effect on Travel* can be found beginning on [page 5-10](#).

There is no need to include the *Effect on Travel* message element because the effects are implied from other message elements such as Lanes Blocked (i.e., ALL LANES BLOCKED).

<p><b>Table 6.40 ACCEPTABLE TERMS FOR <i>EFFE</i>CT ON TRAVEL VMS ON SAME FREEWAY BUT RELATIVELY FAR FROM INCIDENT</b></p>
--

<p>(Not necessary to display because it is implied by other message elements)</p>
---

**Action**

General principles for the message element *Action* can be found beginning on [page 5-13](#).

The *Action* message element displayed to motorists will be dictated by whether:

- Motorists are not advised to take an alternative route;
- Motorists are advised to take other routes but the specific route is not specified in the VMS message (sometimes referred to as “soft” diversion); or
- Motorists are advised by the VMS message to take a specific [Type 1](#) or [Type 2](#) diversion route. *(Note: [Type 3](#), [Type 4](#), [Type 5](#) and [Type 6](#) diversion routes are not applicable.)*

NJDOT has an established policy that defines when motorists can be advised to take a specific alternative route. This policy should be reviewed before diversion messages are displayed.

***Motorists Are Not Advised to Take an Alternative Route – No Diversion Action Message***

In some cases, motorists should not be encouraged to divert to another route because it would result in greater travel time than if the motorists were to remain on the primary freeway. However, it is still important to tell motorists what they need to do.

Acceptable terms for the *Action* message element in this situation are shown in Table 6.41.

<p><b>Table 6.41 ACCEPTABLE TERMS FOR ACTION</b>  <b>VMS ON SAME FREEWAY BUT RELATIVELY FAR FROM INCIDENT</b>  <b>MOTORISTS ARE NOT ADVISED TO TAKE AN ALTERNATIVE ROUTE-</b>  <b>NO DIVERSION ACTION</b></p>	
<p><b><u>Large Signs</u></b>                  PREPARE TO STOP                  REDUCE SPEED</p>	<p><b><u>Portable Signs</u></b>                  PREPARE   TO   STOP                  REDUCE   SPEED</p>
<p>“ ” Indicates that the next portion of the message will be displayed on the next line(s) of VMS.</p>	

***Motorists Are Advised to Take Other Routes but the Specific Route Is Not Specified in the VMS Message (Soft Diversion)***

A “Soft” Diversion *Action* message element might be displayed for a variety of reasons including:

- The VMS operator is unaware of the traffic conditions on the most logical alternative routes because surveillance does not exist on these routes;
- It is important to display an *Action* before the VMS operator has had a chance to assess the full impact of the incident; and/or
- It is important to display an *Action* before the police have arrived and establish positive diversion routes.

Acceptable terms for the *Action* message element are shown in Table 6.42.

<p><b>Table 6.42 ACCEPTABLE TERMS FOR <i>ACTION</i></b>  <b>VMS ON SAME FREEWAY BUT RELATIVELY FAR FROM INCIDENT</b>  <b><i>MOTORISTS ARE ADVISED TO TAKE AN ALTERNATIVE ROUTE-</i></b>  <b><i>SOFT DIVERSION</i></b></p>	
<p><b><u>Large Signs</u></b>  EXIT AND USE OTHER ROUTES  USE OTHER ROUTES</p>	<p><b><u>Portable Signs</u></b>  USE   OTHER   ROUTES</p>
<p>“ ” Indicates that the next portion of the message will be displayed on the next line(s) of VMS.</p>	

**Motorists Are Advised to Take a Specific Type 1 or Type 2 Diversion Route**

There are times when the VMS operator is aware of an acceptable alternative route and has real-time information about the conditions on the alternative route. Guide signs or trailblazers may or may not be present. Police or traffic control personnel are not positioned at critical decision points along the diversion route.

Acceptable terms for the *Action* message element when these conditions exist are shown in Table 6.43.

<b>Table 6.43 ACCEPTABLE TERMS FOR ACTION                      VMS ON SAME FREEWAY BUT RELATIVELY FAR FROM INCIDENT                      MOTORISTS ARE ADVISED TO TAKE A TYPE 1 OR TYPE 2 DIVERSION ROUTE</b>	
<p><b>Large Signs</b></p> <p>EXIT AND USE [highway, street name] [cardinal direction]                      EXIT AND USE [route number] [cardinal direction]                      EXIT AT [highway, street name] [cardinal direction] /                          USE [highway, street name] [cardinal direction]                      EXIT AT [highway, street name] [cardinal direction] /                          USE [route number] [cardinal direction]                      EXIT AT [route number] [cardinal direction] /                          USE [highway, street name] [cardinal direction]                      EXIT AT [route number] [cardinal direction] /                          USE [route number] [cardinal direction]                      TAKE [exit ramp name] EXIT                      TAKE [exit ramp name] EXIT /                          USE [highway, street name] [cardinal direction]                      TAKE [exit ramp name] EXIT /                          USE [route number] [cardinal direction]                      TAKE EXIT [exit ramp number]                      TAKE EXIT [exit ramp number] /                          USE [highway, street name] [cardinal direction]                      TAKE EXIT [exit ramp number] /                          USE [route number] [cardinal direction]                      TAKE [highway, street name] [cardinal direction]                      TAKE [highway, street name] [cardinal direction] /                          USE [highway, street name] [cardinal direction]                      TAKE [highway, street name] [cardinal direction] /                          USE [route number] [cardinal direction]                      TAKE [route number] [cardinal direction]                      TAKE [route number] [cardinal direction] /                          USE [highway, street name] [cardinal direction]                      TAKE [route number] [cardinal direction] /                          USE [route number] [cardinal direction]                      TAKE NEXT EXIT                      TAKE NEXT [number] EXITS                      TUNE RADIO TO [number] AM                      USE [highway, street name] [cardinal direction]                      USE [route number] [cardinal direction]</p>	<p><b>Portable Signs</b></p> <p>EXIT   AND USE   [highway, street name] [cardinal direction]                      EXIT AND   USE [route number] [cardinal direction]                      EXIT   AT   [highway, street name] [cardinal direction]                            USE   [highway, street name] [cardinal direction]                      EXIT   AT   [highway, street name] [cardinal direction]                            USE [route number] [cardinal direction]                      EXIT   AT [route number] [cardinal direction]                            USE   [highway, street name] [cardinal direction]                      EXIT   AT [route number] [cardinal direction]                            USE [route number] [cardinal direction]                      TAKE   [exit ramp name]   EXIT                      TAKE   [exit ramp name]   EXIT /                          USE   [highway, street name] [cardinal direction]                      TAKE   [exit ramp name]   EXIT                            USE [route number] [cardinal direction]                      TAKE   EXIT [exit ramp number]                      TAKE   EXIT [exit ramp number] /                          USE   [highway, street name] [cardinal direction]                      TAKE   EXIT [exit ramp number]                            USE [route number] [cardinal direction]                      TAKE   [highway, street name] [cardinal direction]                      TAKE   [highway, street name] [cardinal direction]                            USE   [highway, street name] [cardinal direction]                      TAKE   [highway, street name] [cardinal direction]                            USE [route number] [cardinal direction]                      TAKE [route number] [cardinal direction]                      TAKE [route number] [cardinal direction] /                          USE   [highway, street name] [cardinal direction]                      TAKE [route number] [cardinal direction] /                          USE [route number] [cardinal direction]                      TAKE   NEXT   EXIT                      TAKE   NEXT   [number] EXITS                      TUNE   RADIO   TO [number] AM                      USE   [highway, street name] [cardinal direction]                      USE [route number] [cardinal direction]</p>
<p>“ ” Indicates that the next portion of the message will be displayed on the next line(s) of VMS.</p>	

**Audience for Action**

General principles for the message element *Audience for Action* can be found beginning on [page 5-12](#).

Acceptable terms for the *Audience for Action* message element are shown in Table 6.44.

<b>Table 6.44 ACCEPTABLE TERMS FOR AUDIENCE FOR ACTION VMS ON SAME FREEWAY BUT RELATIVELY FAR FROM INCIDENT</b>	
<b><u>Large Signs</u></b>	<b><u>Portable Signs</u></b>
[highway, street name] [cardinal direction]	[highway, street name] [cardinal direction]
[route number] [cardinal direction]	[route number] [cardinal direction]
[name of city or state]	[name of city or state]
[name of event, tourist attraction]	[name of event, tourist attraction]
[name of stadium, park, etc.]	[name of stadium, park, etc.]
TO [highway, street name] [cardinal direction]	TO [highway, street name] [cardinal direction]
TO [route number] [cardinal direction]	TO [route number] [cardinal direction]
TO [name of city or state]	TO [name of city or state]
TO [name of event, tourist attraction]	TO [name of event, tourist attraction]
TO [name of stadium, park, etc.]	TO [name of stadium, park, etc.]

“;” Indicates that the next portion of the message will be displayed on the next line(s) of VMS.



## Good Reason for Following the Action

General guidelines for displaying the message element *Good Reason for Following the Action* are given on [page 5-13](#).

As a rule, when the freeway is blocked and *ALL LANES BLOCKED* or *FREEWAY BLOCKED* is displayed, the reason for following the suggested action is implied, and there is no need to display the reason. However, when a recommended diversion route may be perceived by motorists as not being the most logical route, then a *Good Reason for Following the Action* should be displayed.

The terms shown in Table 6.45 below are acceptable to display.

**Table 6.45 ACCEPTABLE TERMS FOR GOOD REASON FOR FOLLOWING THE ACTION  
VMS ON SAME FREEWAY BUT RELATIVELY FAR FROM INCIDENT**

**Large Signs**

AVOID DELAY

AVOID MAJOR DELAY

SAVE [number] MINUTES

BEST ROUTE TO [destination]

**Portable Signs**

AVOID | DELAY

AVOID | MAJOR | DELAY

SAVE | [number] MIN

BEST | ROUTE TO | [destination]

“|” Indicates that the next portion of the message will be displayed on the next line(s) of VMS.

## **VMS ON DIFFERENT FREEWAY THAN THE INCIDENT**

The VMS operational guidelines in this section of the Manual apply when the VMS is on a different freeway than the incident, but the incident still can have an effect on motorists who are passing the VMS. For example, westbound I-195 motorists who intend to exit I-195 and enter northbound I-295 to travel to the city of Princeton, could be affected by incidents that occur on northbound I-295 north of the I-195/I-295 interchange. Messages displayed on VMSs on westbound I-195 concerning incidents on northbound I-295 can be helpful to those motorists heading to Princeton.

The major difference between the messages displayed on VMSs located on a different freeway than the incident in comparison to the messages on VMSs located on the same freeway as the incident but far upstream of the incident is in the diversion information provided.

## Incident Descriptor

Warnings of road-blocking incidents should be displayed under all traffic conditions in peak or off-peak periods.

Acceptable terms for the *Incident Descriptor* message element are shown in Table 6.46.

<b>Table 6.46 ACCEPTABLE INCIDENT DESCRIPTORS VMS ON DIFFERENT FREEWAY THAN INCIDENT</b>	
<b><u>Large Signs</u></b>	<b><u>Portable Signs</u></b>
ACCIDENT	ACCIDENT
MAJOR ACCIDENT	MAJOR   ACCIDENT
TRUCK ACCIDENT	TRUCK   ACCIDENT
<p>“ ” Indicates that the next portion of the message will be displayed on the next line(s) of VMS.</p>	

A general message phrase, such as *ACCIDENT*, is preferred and reduces the need for a large library of messages for every conceivable incident. Also, credibility is weakened when overly precise messages are not verified. For example, the terms *MAJOR ACCIDENT* or *TRUCK ACCIDENT* is preferred to more exact descriptions such as *VEHICLE OVERTURNED*. Some motorists will voluntarily divert in response to either of the terms.

The message phrase *MAJOR ACCIDENT* implies to motorists a more serious accident that may block more than one lane and will result in extensive delay. To the average New Jersey motorist, it implies a delay of more than 45 minutes.

***MAJOR ACCIDENT* means delays of 45 minutes or more to the average New Jersey motorist.**

## Incident Location

General principles for the message element *Incident Location* can be found beginning on [page 5-8](#).

Acceptable terms to use for the *Incident Location* are shown in Table 6.47.

<b>Table 6.47 ACCEPTABLE TERMS FOR INCIDENT LOCATION VMS ON DIFFERENT FREEWAY THAN INCIDENT</b>	
<b>Large Signs</b>	<b>Portable Signs</b>
AT [highway, street name]*	AT   [highway, street name]*
AT EXIT [exit ramp number]*	AT EXIT [exit ramp number]*
AT [exit ramp name] EXIT*	AT   [exit ramp name]   EXIT*
AT [landmark]*	AT   [landmark]*
BEFORE [highway, street name]*	BEFORE   [highway, street name]*
BEFORE EXIT [exit ramp number]*	BEFORE   EXIT [exit ramp number]*
BEFORE [exit ramp name] EXIT*	BEFORE   [exit ramp name]   EXIT*
BEFORE [landmark]*	BEFORE   [landmark]*
NEAR [highway, street name]*	NEAR   [highway, street name]*
NEAR EXIT [exit ramp number]*	NEAR   EXIT [exit ramp number]*
NEAR [exit ramp name] EXIT*	NEAR   [exit ramp name]   EXIT*
NEAR [landmark]*	NEAR   [landmark]*
PAST [highway, street name]*	PAST   [highway, street name]*
PAST EXIT [exit ramp number]*	PAST   EXIT [exit ramp number]*
PAST [exit ramp name] EXIT*	PAST   [exit ramp name]   EXIT*
PAST [landmark]*	PAST   [landmark]*
* Insert “ON [route number, highway name or street name][cardinal direction]” in front of the Incident Location.	
“ ” Indicates that the next portion of the message will be displayed on the next line(s) of VMS.	

## Lanes Blocked

General principles for the message element *Lanes Blocked* can be found beginning on [page 5-10](#).

When the VMS is located on a different freeway as the lane blockage, it is oftentimes advantageous to advise motorists of that blockage. Acceptable terms for the *Lanes Blocked* message element are shown in Table 6.48.

**Table 6.48 ACCEPTABLE TERMS FOR *LANES BLOCKED*  
VMS ON DIFFERENT FREEWAY THAN INCIDENT**

**Large Signs**

ALL LANES BLOCKED

**Portable Signs**

ALL | LANES | BLOCKED

“|” Indicates that the next portion of the message will be displayed on the next line(s) of VMS.

**Effect on Travel**

General principles for the message element *Effect on Travel* can be found beginning on [page 5-10](#).

There is no need to include the *Effect on Travel* message element because the effects are implied from other message elements such as Lanes Blocked (i.e., ALL LANES BLOCKED).

**Table 6.49 ACCEPTABLE TERMS FOR *EFFECT ON TRAVEL*  
VMS ON DIFFERENT FREEWAY THAN INCIDENT**

(Not necessary to display because it is implied by other message elements)

**Action**

General principles for the message element *Action* can be found beginning on [page 5-13](#).

The *Action* message element displayed to motorists will be dictated by whether:

- Motorists who will turn onto the affected freeway are not advised to take an alternative route;
- Motorists who will turn onto the affected freeway are advised to take other routes but the specific route is not specified in the VMS message (sometimes referred to as “soft” diversion); or
- Motorists who will turn onto the affected freeway are advised by the VMS message to take a specific [Type 1](#) or [Type 2](#) diversion route. (Note: [Type 3](#), [Type 4](#), [Type 5](#) and [Type 6](#) diversion routes are not applicable.)

NJDOT has an established policy that defines when motorists can be advised to take a specific alternative route. This policy should be reviewed before diversion messages are displayed.

***Motorists Are Not Advised to Take an Alternative Route – No Diversion Action Message***

In some cases, motorists should not be encouraged to divert to another route because it would result in greater travel time than if the motorists were to remain on the primary freeway. However, it is still important to tell motorists what they need to do.

Acceptable terms for the *Action* message element in this situation are shown in Table 6.50.

<b>Table 6.50 ACCEPTABLE TERMS FOR ACTION                      VMS ON DIFFERENT FREEWAY THAN INCIDENT                      MOTORISTS ARE NOT ADVISED TO TAKE AN ALTERNATIVE ROUTE-                      NO DIVERSION ACTION</b>	
<b>Large Signs</b> PREPARE TO STOP REDUCE SPEED STAY ON [highway, street name] [cardinal direction] STAY ON [route number] [cardinal direction]	<b>Portable Signs</b> PREPARE   TO   STOP REDUCE SPEED STAY ON   [highway, street name] [cardinal direction] STAY   ON [route number] [cardinal direction]
“ ” Indicates that the next portion of the message will be displayed on the next line(s) of VMS.	

***Motorists Are Advised to Take Other Routes but the Specific Route Is Not Specified in the VMS Message (Soft Diversion)***

A “Soft” Diversion *Action* message element might be displayed for a variety of reasons including:

- The VMS operator is unaware of the traffic conditions on the most logical alternative routes because surveillance does not exist on these routes;
- It is important to display an *Action* before the VMS operator has had a chance to assess the full impact of the incident; and/or
- It is important to display an *Action* before the police have arrived and establish positive diversion routes.

Acceptable terms for the *Action* message element when lane-blocking incidents occur under this situation are shown in Table 6.51.

<p><b>Table 6.51 ACCEPTABLE TERMS FOR ACTION VMS ON DIFFERENT FREEWAY THAN INCIDENT MOTORISTS ARE ADVISED TO TAKE AN ALTERNATIVE ROUTE- SOFT DIVERSION</b></p>	
<p><b><u>Large Signs</u></b> USE OTHER ROUTES</p>	<p><b><u>Portable Signs</u></b> USE   OTHER   ROUTES</p>
<p>“ ” Indicates that the next portion of the message will be displayed on the next line(s) of VMS.</p>	



***Motorists Are Advised to Take a Specific Type 1 or Type 2 Diversion Route***

There are times when the VMS operator is aware of an acceptable alternative route and has real-time information about the conditions on the alternative route. Guide signs or trailblazers may or may not be present. Police or traffic control personnel are not positioned at critical decision points along the diversion route.

Acceptable terms for the *Action* message element when these conditions exist are shown in Table 6.52.

**Table 6.52 ACCEPTABLE TERMS FOR ACTION  
VMS ON DIFFERENT FREEWAY THAN INCIDENT  
MOTORISTS ARE ADVISED TO TAKE A TYPE 1 OR TYPE 2 DIVERSION ROUTE**

**Large Signs**

USE [highway, street name] [cardinal direction]

USE [route number] [cardinal direction]

**Portable Signs**

USE | [highway, street name] [cardinal direction]

USE [route number] [cardinal direction]

“|” Indicates that the next portion of the message will be displayed on the next line(s) of VMS.

**Audience for Action**

General principles for the message element *Audience for Action* can be found beginning on [page 5-12](#).

Acceptable terms for the *Audience for Action* message element are shown in Table 6.53.

<b>Table 6.53 ACCEPTABLE TERMS FOR AUDIENCE FOR ACTION VMS ON DIFFERENT FREEWAY THAN INCIDENT</b>	
<b><u>Large Signs</u></b>	<b><u>Portable Signs</u></b>
[highway, street name] [cardinal direction]	[highway, street name] [cardinal direction]
[route number] [cardinal direction]	[route number] [cardinal direction]
[name of city or state]	[name of city or state]
[name of event, tourist attraction]	[name of event, tourist attraction]
[name of stadium, park, etc.]	[name of stadium, park, etc.]
TO [highway, street name] [cardinal direction]	TO [highway, street name] [cardinal direction]
TO [route number] [cardinal direction]	TO [route number] [cardinal direction]
TO [name of city or state]	TO [name of city or state]
TO [name of event, tourist attraction]	TO [name of event, tourist attraction]
TO [name of stadium, park, etc.]	TO [name of stadium, park, etc.]

“|” Indicates that the next portion of the message will be displayed on the next line(s) of VMS.

### Good Reason for Following the Action

General guidelines for displaying the message element *Good Reason for Following the Action* are given on [page 5-13](#).

As a rule, when the freeway is blocked and *ALL LANES BLOCKED* or *FREEWAY BLOCKED* is displayed, the reason for following the suggested action is implied, and there is no need to display the reason. However, when a recommended diversion route may be perceived by motorists as not being the most logical route, then a *Good Reason for Following the Action* should be displayed.

The terms shown in Table 6.54 below are acceptable to display.

<b>Table 6.54 ACCEPTABLE TERMS FOR GOOD REASON FOR FOLLOWING THE ACTION VMS ON DIFFERENT FREEWAY THAN INCIDENT</b>	
<p><b><u>Large Signs</u></b>                      AVOID DELAY                      AVOID MAJOR DELAY                      SAVE [number] MINUTES                      BEST ROUTE TO [destination]</p>	<p><b><u>Portable Signs</u></b>                      AVOID   DELAY                      AVOID   MAJOR   DELAY                      SAVE   [number] MIN                      BEST   ROUTE TO   [destination]</p>
<p>“ ” Indicates that the next portion of the message will be displayed on the next line(s) of VMS.</p>	

## 6.3 BASIC VMS MESSAGE FOR INCIDENTS THAT REQUIRE CLOSING THE FREEWAY

When an incident occurs that affects all lanes of the freeway, there is a period of time until the police and/or traffic control personnel arrive that it can be said the incident is *blocking* the freeway. No traffic control is in place to *close* the lanes and to divert traffic to alternative routes. Under these conditions, [Section 6.2 BASIC VMS MESSAGE FOR INCIDENTS THAT BLOCK ALL THE LANES](#) should be used to develop the Basic VMS Message.

When the police and/or traffic control personnel arrive, the freeway is *closed* and traffic is diverted to an alternative route. The freeway closure (the location where traffic is diverted from the freeway) is in most cases at different location than the incident. Under these conditions, the guidelines in this section of the Manual should be used.

### BASIC VMS MESSAGE ELEMENTS

The Basic VMS Message for incidents that block all lanes of the freeway includes the following elements: 1) *Incident Descriptor* (situation description); 2) *Incident Location*; 3) *Lanes Closed*; 4) *Closure Location*; 5) *Effect on Travel* (implied); 6) *Audience for Action* (implied); 7) *Action*; and 8) *Good Reason for Following the Action* (implied).

#### BASIC VMS MESSAGE ELEMENTS: CLOSURE

- **Incident Descriptor (situation description);**
- **Incident Location;**
- **Lanes Closed;**
- **Closure Location;**
- **Effect on Travel (implied by other message elements)**
- **Audience for Action (implied by other message elements);**
- **Action (tells motorists what to do); and**
- **Good Reason for Following the Action statement (implied by other message elements.**

**VMS ON SAME FREEWAY AND RELATIVELY CLOSE TO THE CLOSURE**

Warnings of road closures due to incidents should be displayed under all traffic conditions in peak or off-peak periods.

Acceptable terms for the *Incident Descriptor* message element are shown in Table 6.55.

<b>Table 6.55 ACCEPTABLE INCIDENT DESCRIPTORS VMS ON SAME FREEWAY AND RELATIVELY CLOSE TO CLOSURE</b>	
<b><u>Large Signs</u></b>	<b><u>Portable Signs</u></b>
ACCIDENT	ACCIDENT
MAJOR ACCIDENT	MAJOR   ACCIDENT
TRUCK ACCIDENT	TRUCK   ACCIDENT
<p>“ ” Indicates that the next portion of the message will be displayed on the next line(s) of VMS.</p>	

A general message phrase, such as *ACCIDENT*, is preferred and reduces the need for a large library of messages for every conceivable incident. Also, credibility is weakened when overly precise messages are not verified. For example, the terms *MAJOR ACCIDENT* or *TRUCK ACCIDENT* is preferred to more exact descriptions such as *VEHICLE OVERTURNED*. Some motorists will voluntarily divert in response to either of the terms.

The message phrase *MAJOR ACCIDENT* implies to motorists a more serious accident that may block more than one lane and will result in extensive delay. To the average New Jersey motorist, it implies a delay of more than 45 minutes.

***MAJOR ACCIDENT* means delays of 45 minutes or more to the average New Jersey motorist.**

## Incident Location

General principles for the message element *Incident Location* can be found beginning on [page 5-8](#).

Acceptable terms for the *Incident Location* message element are shown in Table 6.56.

<b>Table 6.56 ACCEPTABLE TERMS FOR INCIDENT LOCATION VMS ON SAME FREEWAY AND RELATIVELY CLOSE TO CLOSURE</b>	
<b>Large Signs</b>	<b>Portable Signs</b>
1 MILE (AHEAD)	1 MILE (AHEAD)
[number] MILES (AHEAD)	[number] MILES (AHEAD)
AT [highway, street name]	AT   [highway, street name]
AT EXIT [exit ramp number]	AT EXIT [exit ramp number]
AT [exit ramp name] EXIT	AT   [exit ramp name]   EXIT
AT [landmark]	AT   [landmark]
BEFORE [highway, street name]	BEFORE   [highway, street name]
BEFORE EXIT [exit ramp number]	BEFORE   EXIT [exit ramp number]
BEFORE [exit ramp name] EXIT	BEFORE   [exit ramp name]   EXIT
BEFORE [landmark]	BEFORE   [landmark]
NEAR [highway, street name]	NEAR   [highway, street name]
NEAR EXIT [exit ramp number]	NEAR   EXIT [exit ramp number]
NEAR [exit ramp name] EXIT	NEAR   [exit ramp name]   EXIT
NEAR [landmark]	NEAR   [landmark]
PAST [highway, street name]	PAST   [highway, street name]
PAST EXIT [exit ramp number]	PAST   EXIT [exit ramp number]
PAST [exit ramp name] EXIT	PAST   [exit ramp name]   EXIT
PAST [landmark]	PAST   [landmark]

“|” Indicates that the next portion of the message will be displayed on the next line(s) of VMS.

## Lanes Closed

General principles for the message element *Lanes Closed* can be found beginning on [page 5-10](#).

When the VMS is located on the same freeway as the incident and relatively close to and upstream of the incident, the VMS message should be used to encourage motorists to leave the freeway and find alternative routes.

Acceptable terms for the *Lanes Closed* message element are shown in Table 6.57.

**Table 6.57 ACCEPTABLE TERMS FOR LANES CLOSED  
VMS ON SAME FREEWAY AND RELATIVELY CLOSE TO CLOSURE**

**Large Signs**

ALL LANES CLOSED

**Portable Signs**

ALL | LANES | CLOSED

“|” Indicates that the next portion of the message will be displayed on the next line(s) of VMS.

## Closure Location

General principles for the message element *Closure Location* can be found beginning on [page 5-10](#).

Acceptable terms for the *Closure Location* message element are shown in Table 6.58.

**Table 6.58 ACCEPTABLE TERMS FOR CLOSURE LOCATION  
VMS ON SAME FREEWAY AND RELATIVELY CLOSE TO CLOSURE**

**Large Signs**

1 MILE (AHEAD)  
[number] MILES (AHEAD)  
AT [highway, street name]  
AT EXIT [exit ramp number]  
AT [exit ramp name] EXIT

**Portable Signs**

1 MILE (AHEAD)  
[number] MILES (AHEAD)  
AT | [highway, street name]  
AT EXIT [exit ramp number]  
AT | [exit ramp name] | EXIT

“|” Indicates that the next portion of the message will be displayed on the next line(s) of VMS.



## Effect on Travel

General principles for the message element *Effect on Travel* can be found beginning on [page 5-10](#).

There is no need to include the *Effect on Travel* message element because the effects are implied from other message elements such as the *Lanes Closed* (i.e., *ALL LANES CLOSED*) message element.

<p><b>Table 6.59 ACCEPTABLE TERMS FOR <i>EFFECT ON TRAVEL</i> VMS ON SAME FREEWAY AND RELATIVELY CLOSE TO CLOSURE</b></p>
---

<p>(Not necessary to display because it is implied by other message elements)</p>
---

**Action**

General principles for the message element *Action* can be found beginning on [page 5-13](#).

The *Action* message element displayed to motorists will be dictated by whether:

- Motorists are advised by the VMS message to take a specific [Type 1](#), [Type 2](#), [Type 3](#) or [Type 4](#) diversion route; or
- Motorists are advised by the VMS message to take a specific [Type 5](#) diversion route. (*Note: Type 6 diversion route is not applicable.*)

NJDOT has an established policy that defines when motorists can be advised to take a specific alternative route. This policy should be reviewed before diversion messages are displayed.

**Motorists Are Advised to Take a Specific Type 1, Type 2, Type 3 or Type 4 Diversion Route**

After the arrival of the police, diversion routes are set up. The VMS operator is aware of the established diversion route on which the police or traffic control personnel are controlling traffic at critical points. In addition, existing guide signs or trailblazers may also be available along the route to direct motorists back to the freeway or to the major destination.

Acceptable terms for the *Action* message element for this situation is given in Table 6.60.

<b>Table 6.60 ACCEPTABLE TERMS FOR ACTION</b> <b>VMS ON SAME FREEWAY AND RELATIVELY CLOSE TO CLOSURE</b> <b>MOTORISTS ARE ADVISED TO TAKE A TYPE 1, TYPE 2, TYPE 3, OR TYPE 4 DIVERSION ROUTE</b>	
<p><b>Large Signs</b></p> <p>EXIT AND USE [highway, street name] [cardinal direction]                      EXIT AND USE [route number] [cardinal direction]                      EXIT AT [highway, street name] [cardinal direction] /                          USE [highway, street name] [cardinal direction]                      EXIT AT [highway, street name] [cardinal direction] /                          USE [route number] [cardinal direction]                      EXIT AT [route number] [cardinal direction] /                          USE [highway, street name] [cardinal direction]                      EXIT AT [route number] [cardinal direction] /                          USE [route number] [cardinal direction]                      TAKE [exit ramp name] EXIT                      TAKE [exit ramp name] EXIT /                          USE [highway, street name] [cardinal direction]                      TAKE [exit ramp name] EXIT /                          USE [route number] [cardinal direction]                      TAKE EXIT [exit ramp number]                      TAKE EXIT [exit ramp number] /                          USE [highway, street name] [cardinal direction]                      TAKE EXIT [exit ramp number] /                          USE [route number] [cardinal direction]                      TAKE [highway, street name] [cardinal direction]                      TAKE [highway, street name] [cardinal direction] /                          USE [highway, street name] [cardinal direction]                      TAKE [highway, street name] [cardinal direction] /                          USE [route number] [cardinal direction]                      TAKE [route number] [cardinal direction]                      TAKE [route number] [cardinal direction] /                          USE [highway, street name] [cardinal direction]                      TAKE [route number] [cardinal direction] /                          USE [route number] [cardinal direction]                      TAKE NEXT EXIT                      TAKE NEXT [number] EXITS                      TUNE RADIO TO [number] AM                      USE [highway, street name] [cardinal direction]                      USE [route number] [cardinal direction]</p>	<p><b>Portable Signs</b></p> <p>EXIT   AND USE   [highway, street name] [cardinal direction]                      EXIT AND   USE [route number] [cardinal direction]                      EXIT   AT   [highway, street name] [cardinal direction]                            USE   [highway, street name] [cardinal direction]                      EXIT   AT   [highway, street name] [cardinal direction]                            USE [route number] [cardinal direction]                      EXIT   AT [route number] [cardinal direction]                            USE   [highway, street name] [cardinal direction]                      EXIT   AT [route number] [cardinal direction]                            USE [route number] [cardinal direction]                      TAKE   [exit ramp name]   EXIT                      TAKE   [exit ramp name]   EXIT /                          USE   [highway, street name] [cardinal direction]                      TAKE   [exit ramp name]   EXIT                            USE [route number] [cardinal direction]                      TAKE   EXIT [exit ramp number]                      TAKE   EXIT [exit ramp number] /                          USE   [highway, street name] [cardinal direction]                      TAKE   EXIT [exit ramp number]                            USE [route number] [cardinal direction]                      TAKE   [highway, street name] [cardinal direction]                      TAKE   [highway, street name] [cardinal direction]                            USE   [highway, street name] [cardinal direction]                      TAKE   [highway, street name] [cardinal direction]                            USE [route number] [cardinal direction]                      TAKE [route number] [cardinal direction]                      TAKE [route number] [cardinal direction] /                          USE   [highway, street name] [cardinal direction]                      TAKE [route number] [cardinal direction] /                          USE [route number] [cardinal direction]                      TAKE   NEXT   EXIT                      TAKE   NEXT   [number] EXITS                      TUNE   RADIO   TO [number] AM                      USE   [highway, street name] [cardinal direction]                      USE [route number] [cardinal direction]</p>
<p>“ ” Indicates that the next portion of the message will be displayed on the next line(s) of VMS.</p>	

**Motorists Are Advised to Take a Specific Type 5 Diversion Route**

After the arrival of the police and the NJDOT Incident Response Team, traffic control devices are placed along the route in accordance with the Incident Emergency Route Plan. The Plan may also include positioning of police or traffic control personnel at critical points. The VMS operator is aware of the established diversion route(s).

Acceptable terms for the *Action* message element for this situation is given in Table 6.61.

<b>Table 6.61 ACCEPTABLE TERMS FOR ACTION</b> <b>VMS ON SAME FREEWAY AND RELATIVELY CLOSE TO CLOSURE</b> <b>MOTORISTS ARE ADVISED TO TAKE A SPECIFIC TYPE 5 DIVERSION ROUTE</b>	
<p><b>Large Signs</b></p> <p>EXIT AND FOLLOW DETOUR</p> <p>EXIT AND FOLLOW SIGNS</p> <p>EXIT AT [highway, street name] [cardinal direction] / FOLLOW DETOUR</p> <p>EXIT AT [highway, street name] [cardinal direction] / FOLLOW SIGNS</p> <p>EXIT AT [route number] [cardinal direction] / FOLLOW DETOUR</p> <p>EXIT AT [route number] [cardinal direction] / FOLLOW SIGNS</p> <p>TAKE [exit ramp name] EXIT / FOLLOW DETOUR</p> <p>TAKE [exit ramp name] EXIT / FOLLOW SIGNS</p> <p>TAKE EXIT [exit ramp number] / FOLLOW DETOUR</p> <p>TAKE EXIT [exit ramp number] / FOLLOW SIGNS</p> <p>TAKE [highway, street name] [cardinal direction] / FOLLOW DETOUR</p> <p>TAKE [highway, street name] [cardinal direction] / FOLLOW SIGNS</p> <p>TAKE [route number] [cardinal direction] / FOLLOW DETOUR</p> <p>TAKE [route number] [cardinal direction] / FOLLOW SIGNS</p>	<p><b>Portable Signs</b></p> <p>EXIT AND   FOLLOW   DETOUR</p> <p>EXIT AND   FOLLOW   SIGNS</p> <p>EXIT   AT   [highway, street name] [cardinal direction] / FOLLOW   DETOUR</p> <p>EXIT   AT   [highway, street name] [cardinal direction] / FOLLOW   SIGNS</p> <p>EXIT   AT [route number] [cardinal direction] / FOLLOW   DETOUR</p> <p>EXIT   AT [route number] [cardinal direction] / FOLLOW   SIGNS</p> <p>TAKE   [exit ramp name]   EXIT / FOLLOW   DETOUR</p> <p>TAKE   [exit ramp name]   EXIT / FOLLOW   SIGNS</p> <p>TAKE   EXIT [exit ramp number] / FOLLOW   DETOUR</p> <p>TAKE   EXIT [exit ramp number] / FOLLOW   SIGNS</p> <p>TAKE   [highway, street name] [cardinal direction] / FOLLOW   DETOUR</p> <p>TAKE   [highway, street name] [cardinal direction] / FOLLOW   SIGNS</p> <p>TAKE [route number] [cardinal direction] / FOLLOW   DETOUR</p> <p>TAKE [route number] [cardinal direction] / FOLLOW   SIGNS</p>
<p>“ ” Indicates that the next portion of the message will be displayed on the next line(s) of VMS.</p>	

**Audience for Action**

General principles for the message element *Audience for Action* can be found beginning on [page 5-12](#).

Acceptable terms for the *Audience for Action* message element are shown in Table 6.62.

<b>Table 6.62 ACCEPTABLE TERMS FOR AUDIENCE FOR ACTION VMS ON SAME FREEWAY AND RELATIVELY CLOSE TO CLOSURE</b>	
<b><u>Large Signs</u></b>	<b><u>Portable Signs</u></b>
[highway, street name] [cardinal direction]	[highway, street name] [cardinal direction]
[route number] [cardinal direction]	[route number] [cardinal direction]
[name of city or state]	[name of city or state]
[name of event, tourist attraction]	[name of event, tourist attraction]
[name of stadium, park, etc.]	[name of stadium, park, etc.]
TO [highway, street name] [cardinal direction]	TO [highway, street name] [cardinal direction]
TO [route number] [cardinal direction]	TO [route number] [cardinal direction]
TO [name of city or state]	TO [name of city or state]
TO [name of event, tourist attraction]	TO [name of event, tourist attraction]
TO [name of stadium, park, etc.]	TO [name of stadium, park, etc.]

“;” Indicates that the next portion of the message will be displayed on the next line(s) of VMS.

### Good Reason for Following the Action

General guidelines for displaying the message element *Good Reason for Following the Action* are given on [page 5-13](#).

As a rule, when the freeway is closed and *ALL LANES CLOSED* or *FREEWAY CLOSED* is displayed, the reason for following the suggested action is implied, and there is no need to display the reason. However, when a recommended diversion route may be perceived by motorists as not being the most logical route, then a *Good Reason for Following the Action* should be displayed.

The terms shown in Table 6.63 below are acceptable to display.

<b>Table 6.63 ACCEPTABLE TERMS FOR GOOD REASON FOR FOLLOWING THE ACTION VMS ON SAME FREEWAY AND RELATIVELY CLOSE TO CLOSURE</b>	
<b><u>Large Signs</u></b>	<b><u>Portable Signs</u></b>
AVOID DELAY	AVOID   DELAY
AVOID MAJOR DELAY	AVOID   MAJOR   DELAY
SAVE [number] MINUTES	SAVE   [number] MIN
BEST ROUTE TO [destination]	BEST   ROUTE TO   [destination]
<p>“ ” Indicates that the next portion of the message will be displayed on the next line(s) of VMS.</p>	

## VMS ON SAME FREEWAY BUT RELATIVELY FAR FROM THE CLOSURE

### Incident Descriptor

Warnings of road closures due to incidents should be displayed under all traffic conditions in peak or off-peak periods.

Acceptable terms for the *Incident Descriptor* message element are shown in Table 6.64.

<b>Table 6.64 ACCEPTABLE INCIDENT DESCRIPTORS</b>	
<b>VMS ON SAME FREEWAY BUT RELATIVELY FAR FROM CLOSURE</b>	
<b><u>Large Signs</u></b>	<b><u>Portable Signs</u></b>
ACCIDENT	ACCIDENT
MAJOR ACCIDENT	MAJOR   ACCIDENT
TRUCK ACCIDENT	TRUCK   ACCIDENT
<p>“ ” Indicates that the next portion of the message will be displayed on the next line(s) of VMS.</p>	

A general message phrase, such as *ACCIDENT*, is preferred and reduces the need for a large library of messages for every conceivable incident. Also, credibility is weakened when overly precise messages are not verified. For example, the terms *MAJOR ACCIDENT* or *TRUCK ACCIDENT* is preferred to more exact descriptions such as *VEHICLE OVERTURNED*. Some motorists will voluntarily divert in response to either of the terms.

The message phrase *MAJOR ACCIDENT* implies to motorists a more serious accident that may block more than one lane and will result in extensive delay. To the average New Jersey motorist, it implies a delay of more than 45 minutes.

***MAJOR ACCIDENT* means delays of 45 minutes or more to the average New Jersey motorist.**

## Incident Location

General principles for the message element *Incident Location* can be found beginning on [page 5-8](#).

Acceptable terms to use for the *Incident Location* are shown in Table 6.65.

<b>Table 6.65 ACCEPTABLE TERMS FOR INCIDENT LOCATION VMS ON SAME FREEWAY BUT RELATIVELY FAR FROM CLOSURE</b>	
<b>Large Signs</b>	<b>Portable Signs</b>
1 MILE (AHEAD)	1 MILE (AHEAD)
[number] MILES (AHEAD)	[number] MILES (AHEAD)
AT [highway, street name]	AT   [highway, street name]
AT EXIT [exit ramp number]	AT EXIT [exit ramp number]
AT [exit ramp name] EXIT*	AT   [exit ramp name]   EXIT
AT [landmark]	AT   [landmark]
BEFORE [highway, street name]	BEFORE   [highway, street name]
BEFORE EXIT [exit ramp number]	BEFORE   EXIT [exit ramp number]
BEFORE [exit ramp name] EXIT	BEFORE   [exit ramp name]   EXIT
BEFORE [landmark]	BEFORE   [landmark]
NEAR [highway, street name]	NEAR   [highway, street name]
NEAR EXIT [exit ramp number]	NEAR   EXIT [exit ramp number]
NEAR [exit ramp name] EXIT	NEAR   [exit ramp name]   EXIT
NEAR [landmark]	NEAR   [landmark]
PAST [highway, street name]	PAST   [highway, street name]
PAST EXIT [exit ramp number]	PAST   EXIT [exit ramp number]
PAST [exit ramp name] EXIT	PAST   [exit ramp name]   EXIT
PAST [landmark]	PAST   [landmark]

“|” Indicates that the next portion of the message will be displayed on the next line(s) of VMS.



## Lanes Closed

General principles for the message element *Lanes Closed* can be found beginning on [page 5-10](#).

When the VMS is located on the same freeway as the incident and relatively close to and upstream of the incident, the VMS message should be used to encourage motorists to leave the freeway and find alternative routes.

Acceptable terms for the *Lanes Closed* message element are shown in Table 6.66.

**Table 6.66 ACCEPTABLE TERMS FOR LANES CLOSED  
VMS ON SAME FREEWAY BUT RELATIVELY FAR FROM CLOSURE**

**Large Signs**

ALL LANES CLOSED

**Portable Signs**

ALL | LANES | CLOSED

“|” Indicates that the next portion of the message will be displayed on the next line(s) of VMS.

## Closure Location

General principles for the message element *Closure Location* can be found beginning on [page 5-10](#).

Acceptable terms for the *Closure Location* message element are shown in Table 6.67.

**Table 6.67 ACCEPTABLE TERMS FOR CLOSURE LOCATION  
VMS ON SAME FREEWAY BUT RELATIVELY FAR FROM CLOSURE**

**Large Signs**

1 MILE (AHEAD)  
[number] MILES (AHEAD)  
AT [highway, street name]  
AT EXIT [exit ramp number]  
AT [exit ramp name] EXIT

**Portable Signs**

1 MILE (AHEAD)  
[number] MILES (AHEAD)  
AT | [highway, street name]  
AT EXIT [exit ramp number]  
AT | [exit ramp name] | EXIT

“|” Indicates that the next portion of the message will be displayed on the next line(s) of VMS.

## Effect on Travel

General principles for the message element *Effect on Travel* can be found beginning on [page 5-10](#).

There is no need to include the *Effect on Travel* message element because the effects are implied from other message elements such as the *Lanes Closed* (i.e., *ALL LANES CLOSED*) message element.

<p><b>Table 6.68 ACCEPTABLE TERMS FOR <i>EFFECT ON TRAVEL</i> VMS ON SAME FREEWAY BUT RELATIVELY FAR FROM CLOSURE</b></p>
---

<p>(Not necessary to display because it is implied by other message elements)</p>
---

**Action**

General principles for the message element *Action* can be found beginning on [page 5-13](#).

The *Action* message element displayed to motorists will be dictated by whether:

- Motorists are not advised to take an alternative route;
- Motorists are advised to take other routes but the specific route is not specified in the VMS message (sometimes referred to as “soft” diversion);
- Motorists are advised by the VMS message to take a specific [Type 1](#), [Type 2](#), [Type 3](#) or [Type 4](#) diversion route; or
- Motorists are advised by the VMS message to take a specific [Type 5](#) diversion route. (*Note: Type 6 diversion route is not applicable.*)

NJDOT has an established policy that defines when motorists can be advised to take a specific alternative route. This policy should be reviewed before diversion messages are displayed.

***Motorists Are Not Advised to Take an Alternative Route – No Diversion Action Message***

In some cases, motorists should not be encouraged to divert to another route because it would result in greater travel time than if the motorists were to remain on the primary freeway. However, it is still important to tell motorists what they need to do.

Acceptable terms for the *Action* message element in this situation are shown in Table 6.69.

<p><b>Table 6.69 ACCEPTABLE TERMS FOR ACTION</b>  <b>VMS ON SAME FREEWAY BUT RELATIVELY FAR FROM INCIDENT</b>  <b>MOTORISTS ARE NOT ADVISED TO TAKE AN ALTERNATIVE ROUTE-</b>  <b>NO DIVERSION ACTION</b></p>	
<p><b><u>Large Signs</u></b>                  PREPARE TO STOP                  REDUCE SPEED</p>	<p><b><u>Portable Signs</u></b>                  PREPARE   TO  STOP                  REDUCE SPEED</p>
<p>“ ” Indicates that the next portion of the message will be displayed on the next line(s) of VMS.</p>	

***Motorists Are Advised to Take Other Routes but the Specific Route Is Not Specified in the VMS Message (Soft Diversion)***

A “Soft” Diversion *Action* message element might be displayed for a variety of reasons including:

- There are no suitable alternative routes that can be recommended because traffic conditions on the most logical routes would not result in travel time savings to motorists if they diverted from the primary freeway;
- The VMS operator is unaware of the traffic conditions on the most logical alternative routes because surveillance does not exist on these routes;
- It is important to display an *Action* before the VMS operator has had a chance to assess the full impact of the incident; and/or
- It is important to display an *Action* before the police have arrived and establish positive diversion routes.

Acceptable terms for the *Action* message element in this situation are shown in Table 6.70.

<p><b>Table 6.70 ACCEPTABLE TERMS FOR ACTION</b>  <b>VMS ON SAME FREEWAY BUT RELATIVELY FAR FROM CLOSURE</b>  <b>MOTORISTS ARE ADVISED TO TAKE AN ALTERNATIVE ROUTE-</b>  <b>SOFT DIVERSION</b></p>	
<p><b><u>Large Signs</u></b>                  EXIT AND USE OTHER ROUTES                  USE OTHER ROUTES</p>	<p><b><u>Portable Signs</u></b>                  USE   OTHER   ROUTES</p>
<p>“ ” Indicates that the next portion of the message will be displayed on the next line(s) of VMS.</p>	

**Motorists Are Advised to Take a Specific Type 1, Type 2, Type 3 or Type 4 Diversion Route**

After the arrival of the police, diversion routes are set up. The VMS operator is aware of the established diversion route on which the police or traffic control personnel are controlling traffic at critical points. In addition, existing guide signs or trailblazers may also be available along the route to direct motorists back to the freeway or to the major destination.

Acceptable terms for the *Action* message element for this situation is given in Table 6.71.

**Table 6.71 ACCEPTABLE TERMS FOR ACTION  
VMS ON SAME FREEWAY BUT RELATIVELY FAR FROM CLOSURE  
MOTORISTS ARE ADVISED TO TAKE A SPECIFIC TYPE 1, TYPE 2, TYPE 3, OR TYPE 4 DIVERSION ROUTE**

**Large Signs**

EXIT AND USE [highway, street name] [cardinal direction]  
 EXIT AND USE [route number] [cardinal direction]  
 EXIT AT [highway, street name] [cardinal direction] /  
     USE [highway, street name] [cardinal direction]  
 EXIT AT [highway, street name] [cardinal direction] /  
     USE [route number] [cardinal direction]  
 EXIT AT [route number] [cardinal direction] /  
     USE [highway, street name] [cardinal direction]  
 EXIT AT [route number] [cardinal direction] /  
     USE [route number] [cardinal direction]  
 TAKE [exit ramp name] EXIT  
 TAKE [exit ramp name] EXIT /  
     USE [highway, street name] [cardinal direction]  
 TAKE [exit ramp name] EXIT /  
     USE [route number] [cardinal direction]  
 TAKE EXIT [exit ramp number]  
 TAKE EXIT [exit ramp number] /  
     USE [highway, street name] [cardinal direction]  
 TAKE EXIT [exit ramp number] /  
     USE [route number] [cardinal direction]  
 TAKE [highway, street name] [cardinal direction]  
 TAKE [highway, street name] [cardinal direction] /  
     USE [highway, street name] [cardinal direction]  
 TAKE [highway, street name] [cardinal direction] /  
     USE [route number] [cardinal direction]  
 TAKE [route number] [cardinal direction]  
 TAKE [route number] [cardinal direction] /  
     USE [highway, street name] [cardinal direction]  
 TAKE [route number] [cardinal direction] /  
     USE [route number] [cardinal direction]  
 TAKE NEXT EXIT  
 TAKE NEXT [number] EXITS  
 TUNE RADIO TO [number] AM  
 USE [highway, street name] [cardinal direction]  
 USE [route number] [cardinal direction]

**Portable Signs**

EXIT | AND USE | [highway, street name] [cardinal direction]  
 EXIT AND | USE [route number] [cardinal direction]  
 EXIT | AT | [highway, street name] [cardinal direction] /  
     USE | [highway, street name] [cardinal direction]  
 EXIT | AT | [highway, street name] [cardinal direction] /  
     USE [route number] [cardinal direction]  
 EXIT | AT [route number] [cardinal direction] /  
     USE | [highway, street name] [cardinal direction]  
 EXIT | AT [route number] [cardinal direction] |  
     USE [route number] [cardinal direction]  
 TAKE | [exit ramp name] | EXIT  
 TAKE | [exit ramp name] | EXIT /  
     USE | [highway, street name] [cardinal direction]  
 TAKE | [exit ramp name] | EXIT |  
     USE [route number] [cardinal direction]  
 TAKE | EXIT [exit ramp number]  
 TAKE | EXIT [exit ramp number] /  
     USE | [highway, street name] [cardinal direction]  
 TAKE | EXIT [exit ramp number] |  
     USE [route number] [cardinal direction]  
 TAKE | [highway, street name] [cardinal direction]  
 TAKE | [highway, street name] [cardinal direction] /  
     USE | [highway, street name] [cardinal direction]  
 TAKE | [highway, street name] [cardinal direction] /  
     USE [route number] [cardinal direction]  
 TAKE [route number] [cardinal direction]  
 TAKE [route number] [cardinal direction] /  
     USE | [highway, street name] [cardinal direction]  
 TAKE [route number] [cardinal direction] /  
     USE [route number] [cardinal direction]  
 TAKE | NEXT | EXIT  
 TAKE | NEXT | [number] EXITS  
 TUNE | RADIO | TO [number] AM  
 USE | [highway, street name] [cardinal direction]  
 USE [route number] [cardinal direction]

“|” Indicates that the next portion of the message will be displayed on the next line(s) of VMS.

**Motorists Are Advised to Take a Specific Type 5 Diversion Route**

After the arrival of the police and the NJDOT Incident Response Team, traffic control devices are placed along the route in accordance with the Incident Emergency Route Plan. The Plan may also include positioning of police or traffic control personnel at critical points. The VMS operator is aware of the established diversion route(s).

Acceptable terms for the *Action* message element for this situation is given in Table 6.72.

<b>Table 6.72 ACCEPTABLE TERMS FOR ACTION</b> <b>VMS ON SAME FREEWAY BUT RELATIVELY FAR FROM CLOSURE</b> <b>MOTORISTS ARE ADVISED TO TAKE A SPECIFIC TYPE 5 DIVERSION ROUTE</b>	
<p><b>Large Signs</b></p> <p>EXIT AT [highway, street name] [cardinal direction] / FOLLOW DETOUR</p> <p>EXIT AT [highway, street name] [cardinal direction] / FOLLOW SIGNS</p> <p>EXIT AT [route number] [cardinal direction] / FOLLOW DETOUR</p> <p>EXIT AT [route number] [cardinal direction] / FOLLOW SIGNS</p> <p>TAKE [exit ramp name] EXIT / FOLLOW DETOUR</p> <p>TAKE [exit ramp name] EXIT / FOLLOW SIGNS</p> <p>TAKE EXIT [exit ramp number] / FOLLOW DETOUR</p> <p>TAKE EXIT [exit ramp number] / FOLLOW SIGNS</p> <p>TAKE [highway, street name] [cardinal direction] / FOLLOW DETOUR</p> <p>TAKE [highway, street name] [cardinal direction] / FOLLOW SIGNS</p> <p>TAKE [route number] [cardinal direction] / FOLLOW DETOUR</p> <p>TAKE [route number] [cardinal direction] / FOLLOW SIGNS</p>	<p><b>Portable Signs</b></p> <p>EXIT   AT   [highway, street name] [cardinal direction] / FOLLOW   DETOUR</p> <p>EXIT   AT   [highway, street name] [cardinal direction] / FOLLOW   SIGNS</p> <p>EXIT   AT [route number] [cardinal direction] / FOLLOW   DETOUR</p> <p>EXIT   AT [route number] [cardinal direction]   FOLLOW   SIGNS</p> <p>TAKE   [exit ramp name]   EXIT / FOLLOW   DETOUR</p> <p>TAKE   [exit ramp name]   EXIT   FOLLOW   SIGNS</p> <p>TAKE   EXIT [exit ramp number] / FOLLOW   DETOUR</p> <p>TAKE   EXIT [exit ramp number]   FOLLOW   SIGNS</p> <p>TAKE   [highway, street name] [cardinal direction] / FOLLOW   DETOUR</p> <p>TAKE   [highway, street name] [cardinal direction] / FOLLOW   SIGNS</p> <p>TAKE [route number] [cardinal direction] / FOLLOW   DETOUR</p> <p>TAKE [route number] [cardinal direction] / FOLLOW   SIGNS</p>
<p>“ ” Indicates that the next portion of the message will be displayed on the next line(s) of VMS.</p>	

**Audience for Action**

General principles for the message element *Audience for Action* can be found beginning on [page 5-12](#).

Acceptable terms for the *Audience for Action* message element are shown in Table 6.73.

<b>Table 6.73 ACCEPTABLE TERMS FOR AUDIENCE FOR ACTION VMS ON SAME FREEWAY BUT RELATIVELY FAR FROM CLOSURE</b>	
<b><u>Large Signs</u></b>	<b><u>Portable Signs</u></b>
[highway, street name] [cardinal direction]	[highway, street name] [cardinal direction]
[route number] [cardinal direction]	[route number] [cardinal direction]
[name of city or state]	[name of city or state]
[name of event, tourist attraction]	[name of event, tourist attraction]
[name of stadium, park, etc.]	[name of stadium, park, etc.]
TO [highway, street name] [cardinal direction]	TO [highway, street name] [cardinal direction]
TO [route number] [cardinal direction]	TO [route number] [cardinal direction]
TO [name of city or state]	TO [name of city or state]
TO [name of event, tourist attraction]	TO [name of event, tourist attraction]
TO [name of stadium, park, etc.]	TO [name of stadium, park, etc.]

“;” Indicates that the next portion of the message will be displayed on the next line(s) of VMS.



## Good Reason for Following the Action

General guidelines for displaying the message element *Good Reason for Following the Action* are given on [page 5-13](#).

As a rule, when the freeway is closed and *ALL LANES CLOSED* or *FREEWAY CLOSED* is displayed, the reason for following the suggested action is implied, and there is no need to display the reason. However, when a recommended diversion route may be perceived by motorists as not being the most logical route, then a *Good Reason for Following the Action* should be displayed.

The terms shown in Table 6.74 below are acceptable to display.

**Table 6.74 ACCEPTABLE TERMS FOR GOOD REASON FOR FOLLOWING THE ACTION  
VMS ON SAME FREEWAY BUT RELATIVELY FAR FROM CLOSURE**

**Large Signs**

AVOID DELAY

AVOID MAJOR DELAY

SAVE [number] MINUTES

BEST ROUTE TO [destination]

**Portable Signs**

AVOID | DELAY

AVOID | MAJOR | DELAY

SAVE | [number] MIN

BEST | ROUTE TO | [destination]

“|” Indicates that the next portion of the message will be displayed on the next line(s) of VMS.

**VMS ON DIFFERENT FREEWAY THAN THE CLOSURE**

The VMS operational guidelines in this section of the Manual apply when the VMS is on a different freeway than the closure, but the closure still can have an effect on motorists who are passing the VMS. For example, westbound I-195 motorists who intend to exit I-195 and enter northbound I-295 to travel to the city of Princeton could be affected by freeway closures that occur on northbound I-295 north of the I-195/I-295 interchange. Messages displayed on VMSs on westbound I-195 concerning closures on northbound I-295 can be helpful to those motorists heading to Princeton.

The major difference between the messages displayed on VMSs located on a different freeway than the closure in comparison to the messages on VMSs located on the same freeway as the closure but far upstream of the closure is in the diversion information provided.

## Incident Descriptor

Warnings of road closures due to incidents should be displayed under all traffic conditions in peak or off-peak periods.

Acceptable terms for the *Incident Descriptor* message element are shown in Table 6.75.

<b>Table 6.75 ACCEPTABLE INCIDENT DESCRIPTORS VMS ON DIFFERENT FREEWAY THAN CLOSURE</b>	
<b><u>Large Signs</u></b>	<b><u>Portable Signs</u></b>
ACCIDENT	ACCIDENT
MAJOR ACCIDENT	MAJOR   ACCIDENT
TRUCK ACCIDENT	TRUCK   ACCIDENT
<p>“ ” Indicates that the next portion of the message will be displayed on the next line(s) of VMS.</p>	

A general message phrase, such as *ACCIDENT*, is preferred and reduces the need for a large library of messages for every conceivable incident. Also, credibility is weakened when overly precise messages are not verified. For example, the terms *MAJOR ACCIDENT* or *TRUCK ACCIDENT* is preferred to more exact descriptions such as *VEHICLE OVERTURNED*. Some motorists will voluntarily divert in response to either of the terms.

The message phrase *MAJOR ACCIDENT* implies to motorists a more serious accident that may block more than one lane and will result in extensive delay. To the average New Jersey motorist, it implies a delay of more than 45 minutes..

***MAJOR ACCIDENT* means delays of 45 minutes or more to the average New Jersey motorist.**

## Incident Location

General principles for the message element *Incident Location* can be found beginning on [page 5-8](#).

Acceptable terms for the *Incident Location* message element are shown in Table 6.76.

**Table 6.76 ACCEPTABLE TERMS FOR *INCIDENT LOCATION*  
VMS ON DIFFERENT FREEWAY THAN CLOSURE**

**Large Signs**

AT *[highway, street name]*\*  
 AT EXIT *[exit ramp number]*\*  
 AT *[exit ramp name]* EXIT\*  
 AT *[landmark]*\*  
 BEFORE *[highway, street name]*\*  
 BEFORE EXIT *[exit ramp number]*\*  
 BEFORE *[exit ramp name]* EXIT\*  
 BEFORE *[landmark]*\*  
 NEAR *[highway, street name]*\*  
 NEAR EXIT *[exit ramp number]*\*  
 NEAR *[exit ramp name]* EXIT\*  
 NEAR *[landmark]*\*  
 PAST *[highway, street name]*\*  
 PAST EXIT *[exit ramp number]*\*  
 PAST *[exit ramp name]* EXIT\*  
 PAST *[landmark]*\*

**Portable Signs**

AT | *[highway, street name]*\*  
 AT EXIT *[exit ramp number]*\*  
 AT | *[exit ramp name]* | EXIT\*  
 AT | *[landmark]*\*  
 BEFORE | *[highway, street name]*\*  
 BEFORE | EXIT *[exit ramp number]*\*  
 BEFORE | *[exit ramp name]* | EXIT\*  
 BEFORE | *[landmark]*\*  
 NEAR | *[highway, street name]*\*  
 NEAR | EXIT *[exit ramp number]*\*  
 NEAR | *[exit ramp name]* | EXIT\*  
 NEAR | *[landmark]*\*  
 PAST | *[highway, street name]*\*  
 PAST | EXIT *[exit ramp number]*\*  
 PAST | *[exit ramp name]* | EXIT\*  
 PAST | *[landmark]*\*

\* Insert “ON *[route number, highway name or street name]**[cardinal direction]*” in front of the Incident Location.

“|” Indicates that the next portion of the message will be displayed on the next line(s) of VMS.

## Lanes Closed

General principles for the message element *Lanes Closed* can be found beginning on [page 5-10](#).

When the VMS is located on a different freeway than the incident, it is oftentimes advantageous to advise motorists of the freeway closure. Acceptable terms for the *Lanes Closed* message element are shown in Table 6.77.

**Table 6.77 ACCEPTABLE TERMS FOR LANES CLOSED  
VMS ON DIFFERENT FREEWAY THAN CLOSURE**

**Large Signs**

ALL LANES CLOSED

**Portable Signs**

ALL | LANES | CLOSED

“|” Indicates that the next portion of the message will be displayed on the next line(s) of VMS.

## Closure Location

General principles for the message element *Closure Location* can be found beginning on [page 5-10](#).

Acceptable terms for the *Closure Location* message element are shown in Table 6.78.

**Table 6.78 ACCEPTABLE TERMS FOR CLOSURE LOCATION  
VMS ON DIFFERENT FREEWAY THAN CLOSURE**

**Large Signs**

AT [*highway, street name*]\*  
AT EXIT [*exit ramp number*]\*  
AT [*exit ramp name*] EXIT\*

**Portable Signs**

AT | [*highway, street name*]\*  
AT EXIT [*exit ramp number*]\*  
AT | [*exit ramp name*] | EXIT\*

\* Insert “ON [*route number, highway name or street name*][*cardinal direction*]” in front of the Incident Location.

“|” Indicates that the next portion of the message will be displayed on the next line(s) of VMS.

**Effect on Travel**

General principles for the message element *Effect on Travel* can be found beginning on [page 5-10](#).

There is no need to include the *Effect on Travel* message element because the effects are implied from other message elements such as *Lanes Closed* (i.e., *ALL LANES CLOSED*) message element.

<p><b>Table 6.79 ACCEPTABLE TERMS FOR <i>EFFECT ON TRAVEL</i> VMS ON DIFFERENT FREEWAY THAN CLOSURE</b></p>
---

<p>(Not necessary to display because it is implied by other message elements)</p>
---

**Action**

General principles for *Action* message element can be found beginning on [page 5-13](#).

The *Action* message element displayed to motorists will be dictated by whether:

- Motorists who will turn onto the affected freeway are not advised to take an alternative route;
- Motorists who will turn onto the affected freeway are advised to take other routes but the specific route is not specified in the VMS message (sometimes referred to as “soft” diversion); or
- Motorists who will turn onto the affected freeway are advised by the VMS message to take a specific [Type 1](#) or [Type 2](#) diversion route. (*Note: [Type 3](#), [Type 4](#), [Type 5](#) and [Type 6](#) diversion routes are not applicable.*)

NJDOT has an established policy that defines when motorists can be advised to take a specific alternative route. This policy should be reviewed before diversion messages are displayed.

***Motorists Are Not Advised to Take an Alternative Route – No Diversion Action Message***

In some cases, it may be best for the motorists to stay on the current freeway rather than turning onto the freeway that is affected by the closure.

Acceptable terms for the *Action* message element in this situation are shown in Table 6.80.

<b>Table 6.80 ACCEPTABLE TERMS FOR ACTION                      VMS ON DIFFERENT FREEWAY THAN CLOSURE                      MOTORISTS ARE NOT ADVISED TO TAKE AN ALTERNATIVE ROUTE-                      NO DIVERSION ACTION</b>	
<p><b><u>Large Signs</u></b>                      PREPARE TO STOP                      REDUCE SPEED                      STAY ON [highway, street name] [cardinal direction]                      STAY ON [route number] [cardinal direction]</p>	<p><b><u>Portable Signs</u></b>                      PREPARE   TO   STOP                      REDUCE   SPEED                      STAY ON   [highway, street name] [cardinal direction]                      STAY   ON [route number] [cardinal direction]</p>
<p>“ ” Indicates that the next portion of the message will be displayed on the next line(s) of VMS.</p>	



***Motorists Are Advised to Take Other Routes but the Specific Route Is Not Specified in the VMS Message (Soft Diversion)***

A “Soft” Diversion *Action* message element might be displayed for a variety of reasons including:

- The VMS operator is unaware of the traffic conditions on the most logical alternative routes because surveillance does not exist on these routes;
- It is important to display an *Action* before the VMS operator has had a chance to assess the full impact of the incident; and/or
- It is important to display an *Action* before the police have arrived and establish positive diversion routes.

Acceptable terms for the *Action* message element in this situation are shown in Table 6.81.

<p><b>Table 6.81 ACCEPTABLE TERMS FOR <i>ACTION</i> VMS ON DIFFERENT FREEWAY THAN CLOSURE <i>MOTORISTS ARE ADVISED TO TAKE AN ALTERNATIVE ROUTE- SOFT DIVERSION</i></b></p>	
<p><b><u>Large Signs</u></b> USE OTHER ROUTES</p>	<p><b><u>Portable Signs</u></b> USE   OTHER   ROUTES</p>
<p>“ ” Indicates that the next portion of the message will be displayed on the next line(s) of VMS.</p>	

***Motorists Are Advised to Take a Specific Type 1 or Type 2 Diversion Route***

There are times when the VMS operator is aware of an acceptable alternative route and has real-time information about the conditions on the alternative route. Guide signs or trailblazers may or may not be present. Police or traffic control personnel are not positioned at critical decision points along the diversion route.

Acceptable terms for the *Action* message element when these conditions exist are shown in Table 6.82.

**Table 6.82 ACCEPTABLE TERMS FOR ACTION  
VMS ON DIFFERENT FREEWAY THAN CLOSURE  
MOTORISTS ARE ADVISED TO TAKE A SPECIFIC TYPE 1 OR TYPE 2 DIVERSION ROUTE**

**Large Signs**

USE [highway, street name] [cardinal direction]

USE [route number] [cardinal direction]

**Portable Signs**

USE | [highway, street name] [cardinal direction]

USE [route number] [cardinal direction]

“|” Indicates that the next portion of the message will be displayed on the next line(s) of VMS.

**Audience for Action**

General principles for the message element *Audience for Action* can be found beginning on [page 5-12](#).

Acceptable terms for the *Audience for Action* message element are shown in Table 6.83.

<b>Table 6.83 ACCEPTABLE TERMS FOR AUDIENCE FOR ACTION VMS ON DIFFERENT FREEWAY THAN CLOSURE</b>	
<b><u>Large Signs</u></b>	<b><u>Portable Signs</u></b>
<i>[highway, street name] [cardinal direction]</i>	<i>[highway, street name] [cardinal direction]</i>
<i>[route number] [cardinal direction]</i>	<i>[route number] [cardinal direction]</i>
<i>[name of city or state]</i>	<i>[name of city or state]</i>
<i>[name of event, tourist attraction]</i>	<i>[name of event, tourist attraction]</i>
<i>[name of stadium, park, etc.]</i>	<i>[name of stadium, park, etc.]</i>
TO <i>[highway, street name] [cardinal direction]</i>	TO <i>[highway, street name] [cardinal direction]</i>
TO <i>[route number] [cardinal direction]</i>	TO <i>[route number] [cardinal direction]</i>
TO <i>[name of city or state]</i>	TO <i>[name of city or state]</i>
TO <i>[name of event, tourist attraction]</i>	TO <i>[name of event, tourist attraction]</i>
TO <i>[name of stadium, park, etc.]</i>	TO <i>[name of stadium, park, etc.]</i>

“*]*” Indicates that the next portion of the message will be displayed on the next line(s) of VMS.

## Good Reason for Following the Action

General guidelines for displaying the message element *Good Reason for Following the Action* are given on [page 5-13](#).

As a rule, when the freeway is closed and *ALL LANES CLOSED* or *FREEWAY CLOSED* is displayed, the reason for following the suggested action is implied, and there is no need to display the reason. However, when a recommended diversion route may be perceived by motorists as not being the most logical route, then a *Good Reason for Following the Action* should be displayed.

The terms shown in Table 6.84 below are acceptable to display.

**Table 6.84 ACCEPTABLE TERMS FOR GOOD REASON FOR FOLLOWING THE ACTION  
VMS ON DIFFERENT FREEWAY THAN CLOSURE**

**Large Signs**

AVOID DELAY

AVOID MAJOR DELAY

SAVE [number] MINUTES

BEST ROUTE TO [destination]

**Portable Signs**

AVOID | DELAY

AVOID | MAJOR | DELAY

SAVE | [number] MIN

BEST | ROUTE TO | [destination]

“|” Indicates that the next portion of the message will be displayed on the next line(s) of VMS.

## 6.4 BASIC VMS MESSAGE FOR INCIDENTS ON AN INTERSECTING FREEWAY THAT REQUIRE CLOSING THE CONNECTOR RAMP

### BASIC VMS MESSAGE ELEMENTS

The Basic VMS Message for closure of a freeway-to-freeway connector during incidents includes the following: 1) *Incident Descriptor*; 2) *Incident Location*; 3) *Lanes Closed*; 4) *Ramp Closure Descriptor*; 5) *Audience for Action*; 6) *Action*; and 7) *Good Reason for Following the Action*.

#### BASIC VMS MESSAGE ELEMENTS

- **Incident Descriptor (situation description);**
- **Incident Location;**
- **Lanes Closed;**
- **Ramp Closure Descriptor;**
- **Audience for Action (when the action is for a specific group of motorists);**
- **Action (tells motorists what to do); and**
- **Good Reason for Following the Action statement (usually implied by other message elements)**

**VMS UPSTREAM OF THE CONNECTOR RAMP CLOSURE****Incident Descriptor**

Acceptable terms for the *Incident Descriptor* message element are given in Table 6.85.

<b>Table 6.85 ACCEPTABLE INCIDENT DESCRIPTORS VMS UPSTREAM OF CONNECTOR RAMP CLOSURE</b>	
<b><u>Large Signs</u></b>	<b><u>Portable Signs</u></b>
MAJOR ACCIDENT	MAJOR   ACCIDENT
TRUCK ACCIDENT	TRUCK   ACCIDENT
“ ” Indicates that the next portion of the message will be displayed on the next line(s) of VMS.	

A general message phrase, such as *ACCIDENT*, is preferred and reduces the need for a large library of messages for every conceivable incident. Also, credibility is weakened when overly precise messages are not verified. For example, the terms *MAJOR ACCIDENT* or *TRUCK ACCIDENT* is preferred to more exact descriptions such as *VEHICLE OVERTURNED*. Some motorists will voluntarily divert in response to either of the terms.

The message phrase *MAJOR ACCIDENT* implies to motorists a more serious accident that may block more than one lane and will result in extensive delay. To the average New Jersey motorist, it implies a delay of more than 45 minutes.

***MAJOR ACCIDENT* means delays of 45 minutes or more to the average New Jersey motorist.**

## Incident Location

General principles for the message element *Incident Location* can be found beginning on [page 5-8](#).

Acceptable terms for the *Incident Location* message element are shown in Table 6.86.

**Table 6.86 ACCEPTABLE TERMS FOR *INCIDENT LOCATION*  
VMS UPSTREAM OF CONNECTOR RAMP CLOSURE**

### **Large Signs**

AT [*highway, street name*]\*  
 AT EXIT [*exit ramp number*]\*  
 AT [*exit ramp name*] EXIT\*  
 AT [*landmark*]\*  
 BEFORE [*highway, street name*]\*  
 BEFORE EXIT [*exit ramp number*]\*  
 BEFORE [*exit ramp name*] EXIT\*  
 BEFORE [*landmark*]\*  
 NEAR [*highway, street name*]\*  
 NEAR EXIT [*exit ramp number*]\*  
 NEAR [*exit ramp name*] EXIT\*  
 NEAR [*landmark*]\*  
 PAST [*highway, street name*]\*  
 PAST EXIT [*exit ramp number*]\*  
 PAST [*exit ramp name*] EXIT\*  
 PAST [*landmark*]\*

### **Portable Signs**

AT | [*highway, street name*]\*  
 AT EXIT [*exit ramp number*]\*  
 AT | [*exit ramp name*] | EXIT\*  
 AT | [*landmark*]\*  
 BEFORE | [*highway, street name*]\*  
 BEFORE | EXIT [*exit ramp number*]\*  
 BEFORE | [*exit ramp name*] | EXIT\*  
 BEFORE | [*landmark*]\*  
 NEAR | [*highway, street name*]\*  
 NEAR | EXIT [*exit ramp number*]\*  
 NEAR | [*exit ramp name*] | EXIT\*  
 NEAR | [*landmark*]\*  
 PAST | [*highway, street name*]\*  
 PAST | EXIT [*exit ramp number*]\*  
 PAST | [*exit ramp name*] | EXIT\*  
 PAST | [*landmark*]\*

\* Insert “ON [*route number, highway name or street name*][*cardinal direction*]” in front of the Incident Location.

“|” Indicates that the next portion of the message will be displayed on the next line(s) of VMS.

## Lanes Closed

General principles for the message element *Lanes Closed* can be found beginning on [page 5-10](#).

Acceptable terms for the *Lanes Closed* message element are shown in Table 6.87.

<b>Table 6.87 ACCEPTABLE TERMS FOR LANES CLOSED VMS UPSTREAM OF CONNECTOR RAMP CLOSURE</b>	
<b><u>Large Signs</u></b>	<b><u>Portable Signs</u></b>
ALL LANES CLOSED	ALL   LANES   CLOSED
“ ” Indicates that the next portion of the message will be displayed on the next line(s) of VMS.	



## Ramp Closure Descriptor

Acceptable terms for the *Ramp Closure Descriptor* message element are shown in Table 6.88.

<b>Table 6.88 ACCEPTABLE TERMS FOR RAMP CLOSURE DESCRIPTORS VMS UPSTREAM OF CONNECTOR RAMP CLOSURE</b>	
<p><b><u>Large Signs</u></b>                      RAMP CLOSED                            TO [intersecting fwy number] [card. direction]                      RAMP CLOSED                            TO [intersecting freeway name] FREEWAY                      [intersecting fwy number] CLOSED                      [intersecting fwy number] [card. direction] CLOSED</p>	<p><b><u>Portable Signs</u></b>                      RAMP   CLOSED                            TO [intersecting fwy number] [card. direction]                        [intersecting fwy number] / CLOSED                      [intersecting fwy number] [card. direction] CLOSED</p>
<p>“ ” Indicates that the next portion of the message will be displayed on the next line(s).</p>	

**Action**

General principles for the message element *Action* can be found beginning on [page 5-13](#).

The *Action* message element displayed to motorists will be dictated by whether:

- Motorists who will turn onto the affected freeway are not advised to take an alternative route;
- Motorists are advised to take other routes but the specific route is not specified in the VMS message (sometimes referred to as “soft” diversion);
- Motorists who will turn onto the affected ramp are advised by the VMS message to take a specific [Type 1](#) or [Type 2](#) diversion route (*Note: [Type 3](#), [Type 4](#) and [Type 6](#) diversion routes are not applicable.*); or
- Motorists who will turn onto the affected ramp are advised by the VMS message to take the [Type 5](#) diversion (detour) route.

NJDOT has an established policy that defines when motorists can be advised to take a specific alternative route. This policy should be reviewed before diversion messages are displayed.

***Motorists Are Not Advised to Take an Alternative Route – No Diversion Action Message***

In some cases, it may be best for the motorists to stay on the current freeway rather than turning onto the freeway that is affected by the closure.

Acceptable terms for the *Action* message element in this situation are shown in Table 6.89.

<b>Table 6.89 ACCEPTABLE TERMS FOR ACTION</b> <b>VMS UPSTREAM OF CONNECTOR RAMP CLOSURE</b> <b>MOTORISTS ARE NOT ADVISED TO TAKE AN ALTERNATIVE ROUTE-</b> <b>NO DIVERSION ACTION</b>	
<p><b><u>Large Signs</u></b>                      PREPARE TO STOP                      REDUCE SPEED                      STAY ON [highway, street name] [cardinal direction]                      STAY ON [route number] [cardinal direction]</p>	<p><b><u>Portable Signs</u></b>                      PREPARE   TO   STOP                      REDUCE   SPEED                      STAY ON   [highway, street name] [cardinal direction]                      STAY   ON [route number] [cardinal direction]</p>
<p>“ ” Indicates that the next portion of the message will be displayed on the next line(s) of VMS.</p>	

***Motorists Are Advised to Take Other Routes but the Specific Route Is Not Specified in the VMS Message (Soft Diversion)***

A “Soft” Diversion *Action* message element might be displayed when it is not possible for the VMS operator to specify a specific route the motorist should use.

Acceptable terms for the *Action* message element in this situation are shown in Table 6.90.

<p><b>Table 6.90 ACCEPTABLE TERMS FOR ACTION VMS UPSTREAM OF CONNECTOR RAMP CLOSURE MOTORISTS ARE ADVISED TO TAKE AN ALTERNATIVE ROUTE- SOFT DIVERSION</b></p>	
<p><b><u>Large Signs</u></b> EXIT AND USE OTHER ROUTES USE OTHER ROUTES</p>	<p><b><u>Portable Signs</u></b> USE   OTHER   ROUTE</p>
<p>“ ” Indicates that the next portion of the message will be displayed on the next line(s) of VMS.</p>	

**Motorists Are Advised to Take a Specific Type 1 or Type 2 Diversion Route**

There are times when the VMS operator is aware of an acceptable alternative route and has real-time information about the conditions on the alternative route. Guide signs or trailblazers may or may not be present. Police or traffic control personnel are not positioned at critical decision points along the diversion route.

Acceptable terms for the *Action* message element when these conditions exist are shown in Table 6.91.

<b>Table 6.91 ACCEPTABLE TERMS FOR ACTION                      VMS UPSTREAM OF CONNECTOR RAMP CLOSURE                      MOTORISTS ARE ADVISED TO TAKE A TYPE 1 OR TYPE 2 DIVERSION ROUTE</b>	
<p><b>Large Signs</b></p> <p>EXIT AND USE [highway, street name] [cardinal direction]                      EXIT AND USE [route number] [cardinal direction]                      EXIT AT [highway, street name] [cardinal direction] /                          USE [highway, street name] [cardinal direction]                      EXIT AT [highway, street name] [cardinal direction] /                          USE [route number] [cardinal direction]                      EXIT AT [route number] [cardinal direction] /                          USE [highway, street name] [cardinal direction]                      EXIT AT [route number] [cardinal direction] /                          USE [route number] [cardinal direction]                      TAKE [exit ramp name] EXIT                      TAKE [exit ramp name] EXIT /                          USE [highway, street name] [cardinal direction]                      TAKE [exit ramp name] EXIT /                          USE [route number] [cardinal direction]                      TAKE EXIT [exit ramp number]                      TAKE EXIT [exit ramp number] /                          USE [highway, street name] [cardinal direction]                      TAKE EXIT [exit ramp number] /                          USE [route number] [cardinal direction]                      TAKE [highway, street name] [cardinal direction]                      TAKE [highway, street name] [cardinal direction] /                          USE [highway, street name] [cardinal direction]                      TAKE [highway, street name] [cardinal direction] /                          USE [route number] [cardinal direction]                      TAKE [route number] [cardinal direction]                      TAKE [route number] [cardinal direction] /                          USE [highway, street name] [cardinal direction]                      TAKE [route number] [cardinal direction] /                          USE [route number] [cardinal direction]                      TAKE NEXT EXIT                      TAKE NEXT [number] EXITS                      TUNE RADIO TO [number] AM                      USE [highway, street name] [cardinal direction]                      USE [route number] [cardinal direction]</p>	<p><b>Portable Signs</b></p> <p>EXIT   AND USE   [highway, street name] [cardinal direction]                      EXIT AND   USE [route number] [cardinal direction]                      EXIT   AT   [highway, street name] [cardinal direction]                            USE   [highway, street name] [cardinal direction]                      EXIT   AT   [highway, street name] [cardinal direction]                            USE [route number] [cardinal direction]                      EXIT   AT [route number] [cardinal direction]                            USE   [highway, street name] [cardinal direction]                      EXIT   AT [route number] [cardinal direction]                            USE [route number] [cardinal direction]                      TAKE   [exit ramp name]   EXIT                      TAKE   [exit ramp name]   EXIT /                          USE   [highway, street name] [cardinal direction]                      TAKE   [exit ramp name]   EXIT                            USE [route number] [cardinal direction]                      TAKE   EXIT [exit ramp number]                      TAKE   EXIT [exit ramp number] /                          USE   [highway, street name] [cardinal direction]                      TAKE   EXIT [exit ramp number]                            USE [route number] [cardinal direction]                      TAKE   [highway, street name] [cardinal direction]                      TAKE   [highway, street name] [cardinal direction]                            USE   [highway, street name] [cardinal direction]                      TAKE   [highway, street name] [cardinal direction]                            USE [route number] [cardinal direction]                      TAKE [route number] [cardinal direction]                      TAKE [route number] [cardinal direction] /                          USE   [highway, street name] [cardinal direction]                      TAKE [route number] [cardinal direction] /                          USE [route number] [cardinal direction]                      TAKE   NEXT   EXIT                      TAKE   NEXT   [number] EXITS                      TUNE   RADIO   TO [number] AM                      USE   [highway, street name] [cardinal direction]                      USE [route number] [cardinal direction]</p>
<p>“ ” Indicates that the next portion of the message will be displayed on the next line(s) of VMS.</p>	

**Motorists Are Advised to Take a Specific Type 5 Diversion Route**

There are times when the Incident Emergency Route Plan has been implemented. Guide signs, trailblazers, and police and/or traffic control personnel are guiding motorists at critical locations along the route.

Acceptable terms for the *Action* message element when this condition exists are shown in Table 6.92.

<b>Table 6.92 ACCEPTABLE TERMS FOR ACTION                      VMS UPSTREAM OF CONNECTOR RAMP CLOSURE                      MOTORISTS ARE ADVISED TO TAKE THE TYPE 5 DIVERSION (DETOUR) ROUTE</b>	
<p><b>Large Signs</b></p> <p>EXIT AT [highway, street name] [cardinal direction] / FOLLOW DETOUR</p> <p>EXIT AT [highway, street name] [cardinal direction] / FOLLOW SIGNS</p> <p>EXIT AT [route number] [cardinal direction] / FOLLOW DETOUR</p> <p>EXIT AT [route number] [cardinal direction] / FOLLOW SIGNS</p> <p>TAKE [exit ramp name] EXIT   FOLLOW DETOUR</p> <p>TAKE [exit ramp name] EXIT   FOLLOW SIGNS</p> <p>TAKE EXIT [exit ramp number] / FOLLOW DETOUR</p> <p>TAKE EXIT [exit ramp number] / FOLLOW SIGNS</p> <p>TAKE [highway, street name] [cardinal direction] / FOLLOW DETOUR</p> <p>TAKE [highway, street name] [cardinal direction] / FOLLOW SIGNS</p> <p>TAKE [route number] [cardinal direction] / FOLLOW DETOUR</p> <p>TAKE [route number] [cardinal direction] / FOLLOW SIGNS</p>	<p><b>Portable Signs</b></p> <p>EXIT   AT   [highway, street name] [cardinal direction] / FOLLOW DETOUR</p> <p>EXIT   AT   [highway, street name] [cardinal direction] / FOLLOW   SIGNS</p> <p>EXIT   AT [route number] [cardinal direction] / FOLLOW   DETOUR</p> <p>EXIT   AT [route number] [cardinal direction]   FOLLOW   SIGNS</p> <p>TAKE   [exit ramp name]   EXIT FOLLOW DETOUR</p> <p>TAKE   [exit ramp name]   EXIT FOLLOW SIGNS</p> <p>TAKE   EXIT [exit ramp number] / FOLLOW   DETOUR</p> <p>TAKE   EXIT [exit ramp number] / FOLLOW   SIGNS</p> <p>TAKE   [highway, street name] [cardinal direction] / FOLLOW   DETOUR</p> <p>TAKE   [highway, street name] [cardinal direction] / FOLLOW SIGNS</p> <p>TAKE [route number] [cardinal direction] / FOLLOW   DETOUR</p> <p>TAKE [route number] [cardinal direction] / FOLLOW   SIGNS</p>
<p>“ ” Indicates that the next portion of the message will be displayed on the next line(s) of VMS.</p>	

**Audience for Action**

General principles for the message element *Audience for Action* can be found beginning on [page 5-12](#).

Acceptable terms for the *Audience for Action* message element are shown in Table 6.93.

<b>Table 6.93 ACCEPTABLE TERMS FOR AUDIENCE FOR ACTION VMS UPSTREAM OF CONNECTOR RAMP CLOSURE</b>	
<b><u>Large Signs</u></b>	<b><u>Portable Signs</u></b>
[highway, street name] [cardinal direction]	[highway, street name] [cardinal direction]
[route number] [cardinal direction]	[route number] [cardinal direction]
[name of city or state]	[name of city or state]
[name of event, tourist attraction]	[name of event, tourist attraction]
[name of stadium, park, etc.]	[name of stadium, park, etc.]
TO [highway, street name][cardinal direction]	TO [highway, street name][cardinal direction]
TO [route number] [cardinal direction]	TO [route number] [cardinal direction]
TO [name of city or state]	TO [name of city or state]
TO [name of event, tourist attraction]	TO [name of event, tourist attraction]
TO [name of stadium, park, etc.]	TO [name of stadium, park, etc.]
<p>“ ” Indicates that the next portion of the message will be displayed on the next line(s) of VMS.</p>	

## Good Reason for Following Action

General guidelines for displaying the message element *Good Reason for Following the Action* are given on [page 5-13](#).

The terms shown in Table 6.94 are acceptable to display.

**Table 6.94 ACCEPTABLE TERMS FOR *GOOD REASON FOR FOLLOWING THE ACTION*  
CLOSURE VMS UPSTREAM OF CONNECTOR RAMP CLOSURE**

**Large Signs**

AVOID DELAY

AVOID MAJOR DELAY

SAVE *[number]* MINUTES

BEST ROUTE TO *[destination]*

**Portable Signs**

AVOID | DELAY

AVOID | MAJOR | DELAY

SAVE | *[number]* MIN

BEST | ROUTE TO | *[destination]*

“|” Indicates that the next portion of the message will be displayed on the next line(s) of VMS.

# MODULE 7. DESIGNING THE BASIC VMS MESSAGE FOR ROADWORK

## TABLE OF CONTENTS

**7.1 BASIC VMS MESSAGE FOR LANE CLOSURES DURING ROADWORK**.....7-1

BASIC VMS MESSAGE ELEMENTS .....7-1

VMS ON SAME FREEWAY AND RELATIVELY CLOSE TO THE ROADWORK..7-2

Roadwork Descriptor.....7-2

Roadwork (Lane Closure) Location .....7-3

Lanes Closed.....7-5

Effect on Travel .....7-6

Action .....7-7

*Motorists Are Not Advised to Take an Alternative Route – No Diversion*

*Action Message*.....7-7

*Motorists Are Advised to Take Other Routes but the Specific Route Is Not Specified in the VMS Message (Soft Diversion)* .....7-8

*Motorists Are Advised to Take q Specific Type 1 or Type 2 Diversion Route*.....7-9

Audience for Action .....7-10

Good Reason for Following the Action.....7-11

VMS ON SAME FREEWAY BUT RELATIVELY FAR FROM THE ROADWORK.....7-12

Roadwork Descriptor.....7-12

Roadwork (Lane Closure) Location .....7-13

Lanes Closed.....7-14

Effect on Travel .....7-15

Action .....7-16

*Motorists Are Not Advised to Take an Alternative Route – No Diversion*

*Action Message*.....7-16

*Motorists Are Advised to Take Other Routes but the Specific Route Is Not Specified in the VMS Message (Soft Diversion)* .....7-17

*Motorists Are Advised to Take a Specific Type 1 or Type 2 Diversion Route*.....7-18

Audience for Action .....7-19

Good Reason for Following the Action.....7-20

VMS ON DIFFERENT FREEWAY THAN THE ROADWORK.....7-21

Roadwork Descriptor.....7-21

Roadwork (Lane Closure) Location .....7-22



Lanes Closed.....7-23  
 Effect on Travel .....7-24  
 Action .....7-25  
     *Motorists Are Not Advised to Take an Alternative Route – No Diversion*  
         *Action Message*.....7-25  
     *Motorists Are Advised to Take Other Routes but the Specific Route Is*  
         *Not Specified in the VMS Message (Soft Diversion)* .....7-26  
     *Motorists Are Advised to Take a Specific Type 1 or Type 2 Diversion*  
         *Route*.....7-27  
 Audience for Action .....7-28  
 Good Reason for Following the Action.....7-29

**7.2 BASIC VMS MESSAGE FOR ROADWORK THAT REQUIRES CLOSING THE FREEWAY** .....7-30

BASIC VMS MESSAGE ELEMENTS .....7-30

VMS ON SAME FREEWAY AND RELATIVELY CLOSE TO THE CLOSURE .....7-31  
     Basic VMS Message Elements .....7-31  
     Roadwork Descriptor.....7-32  
     Closure Location.....7-33  
     Lanes Closed.....7-34  
     Effect on Travel .....7-35  
     Action .....7-36  
     Audience for Action .....7-37  
     Good Reason for Following the Action.....7-38

VMS ON SAME FREEWAY BUT RELATIVELY FAR FROM THE CLOSURE.....7-39  
     Roadwork Descriptor.....7-39  
     Closure Location.....7-40  
     Lanes Closed.....7-41  
     Effect on Travel .....7-42  
     Action .....7-43  
         *Motorists Are Not Advised to Take an Alternative Route – No Diversion*  
             *Action Message*.....7-43  
         *Motorists Are Advised to Take Other Routes but the Specific Route Is*  
             *Not Specified in the VMS Message (Soft Diversion)* .....7-44  
         *Motorists Are Advised to Take a Specific Type 1 or Type 2 Diversion*  
             *Route*.....7-45  
             *Motorists Are Advised to Take a Specific Type 6 Diversion Route* .....7-46  
     Audience for Action .....7-47  
     Good Reason for Following the Action.....7-48

VMS ON DIFFERENT FREEWAY THAN THE ROADWORK AND CLOSURE.....7-49  
     Roadwork Descriptor.....7-50  
     Closure Location.....7-51

Lanes Closed.....7-52  
 Effect on Travel .....7-53  
 Action .....7-54  
     *Motorists Are Not Advised to Take an Alternative Route – No Diversion*  
         *Action Message*.....7-54  
     *Motorists Are Advised to Take Other Routes but the Specific Route Is*  
         *Not Specified in the VMS Message (Soft Diversion)* .....7-55  
     *Motorists Are Advised to Take a Specific Type 1 or Type 2 Diversion*  
         *Route*.....7-56  
 Audience for Action .....7-57  
 Good Reason for Following the Action.....7-58

**7.3 BASIC VMS MESSAGE FOR ROADWORK ON AN INTERSECTING FREEWAY THAT REQUIRES CLOSING THE CONNECTOR RAMP**.....7-59

BASIC VMS MESSAGE ELEMENTS .....7-59  
 VMS UPSTREAM OF THE RAMP CLOSURE .....7-60  
     Roadwork Descriptor.....7-60  
     Closure Location.....7-61  
     Ramp Closure Descriptor .....7-62  
     Action .....7-63  
         *Motorists Are Advised to Take Other Routes but the Specific Route Is*  
             *Not Specified in the VMS Message (Soft Diversion)* .....7-63  
         *Motorists Are Advised To Take a Specific Type 1 or Type 2 Diversion*  
             *Route*.....7-64  
         *Motorists Are Advised to Take a Specific Type 6 Diversion Route* .....7-65  
     Audience for Action .....7-66  
     Good Reason for Following the Action.....7-67

**THIS PAGE LEFT BLANK**

# MODULE 7. DESIGNING THE BASIC VMS MESSAGE FOR ROADWORK

## 7.1 BASIC VMS MESSAGE FOR LANE CLOSURES DURING ROADWORK

This section of the Manual applies to roadwork that requires closure of some of the lanes of the freeway while other lanes are open to traffic. When the roadwork requires closure of all the lanes on the freeway, [Section 7.2 BASIC VMS MESSAGE FOR ROADWORK THAT REQUIRES CLOSING THE FREEWAY](#) should be used to develop the Basic VMS Message.

### BASIC VMS MESSAGE ELEMENTS

The Basic VMS Message for roadwork lane-closures includes the following: 1) ***Roadwork Descriptor*** (situation description); 2) ***Roadwork (Lane Closure) Location***; 3) ***Lanes Closed***; 4) ***Effect on Travel*** (e.g., major delay); 5) ***Audience for Action***; 6) ***Action***; and 7) ***Good Reason for Following the Action***.

#### BASIC VMS MESSAGE ELEMENTS

- **Roadwork Descriptor (situation description);**
- **Roadwork (Lane Closure) Location;**
- **Lanes Closed;**
- **Effect on Travel (e.g., major delay);**
- **Audience for Action (when the action is for a specific group of motorists);**
- **Action (tells motorists what to do); and**
- **Good Reason for Following the Action statement (usually implied by other message elements).**

**VMS ON SAME FREEWAY AND RELATIVELY CLOSE TO THE ROADWORK****Roadwork Descriptor**

Warnings of lane closures due to roadwork should be displayed under all traffic conditions in peak or off-peak periods. Minor off-the-roadway work such as grass mowing should not be displayed.

Acceptable terms for the *Roadwork Descriptor* message element are given in Table 7.1.

<b>Table 7.1 ACCEPTABLE <i>ROADWORK DESCRIPTORS</i> VMS ON SAME FREEWAY AND RELATIVELY CLOSE TO ROADWORK</b>	
<b><u>Large Signs</u></b> CONSTRUCTION* ROADWORK	<b><u>Portable Signs</u></b> CONST <u>or</u> ROADWORK* ROADWORK
* The word <i>CONSTRUCTION</i> will not fit on an eight-character line of a portable VMS. Therefore, the word must either be abbreviated or replaced with the word <i>ROADWORK</i> .	

The word *ROADWORK* may be substituted for the longer word *CONSTRUCTION*. Motorist interpretations of both words are described on [page 5-14](#). In addition, *CONST* is an acceptable abbreviation for *CONSTRUCTION*.

**Roadwork (Lane Closure) Location**

General principles for the message element *Roadwork (Lane Closure) Location* can be found on [page 5-8](#).

Acceptable terms to use for the *Roadwork (Lane Closure) Location* message element are shown in [Table 7.2](#). Note that portable VMSs cannot be used when it is desirable to inform motorists about the length of the closure for the roadwork (e.g., *2 LANES CLOSED FROM EXIT 42 TO EXIT 43*).

**Table 7.2 ACCEPTABLE TERMS FOR ROADWORK (LANE CLOSURE) LOCATION VMS ON SAME FREEWAY AND RELATIVELY CLOSE TO ROADWORK**

**Large Signs**

[number] MILES (AHEAD)  
 AT [highway, street name]  
 AT EXIT [exit ramp number]  
 AT [exit ramp name] EXIT  
 AT [landmark]  
 BEFORE [highway, street name]  
 BEFORE EXIT [exit ramp number]  
 BEFORE [exit ramp name] EXIT  
 BEFORE [landmark]  
 NEAR [highway, street name]  
 NEAR EXIT [exit ramp number]  
 NEAR [exit ramp name] EXIT  
 NEAR [landmark]  
 PAST [highway, street name]  
 PAST EXIT [exit ramp number]  
 PAST [exit ramp name] EXIT  
 PAST [landmark]  
 FROM [highway, street name] /  
     TO [highway, street name]  
 FROM [highway, street name] /  
     TO EXIT [exit ramp number]  
 FROM [highway, street name] /  
     TO [exit ramp name] EXIT  
 FROM [highway, street name] /  
     TO [landmark]  
 FROM EXIT [exit ramp number] /  
     TO [highway, street name]  
 FROM EXIT [exit ramp number] /  
     TO EXIT [exit ramp number]  
 FROM EXIT [exit ramp number] /  
     TO [exit ramp name] EXIT  
 FROM EXIT [exit ramp number] /  
     TO [landmark]  
 FROM [exit ramp name] EXIT  
     TO [highway, street name]  
 FROM [exit ramp name] EXIT /  
     TO EXIT [exit ramp number]  
 FROM [exit ramp name] EXIT /  
     TO [exit ramp name] EXIT  
 FROM [exit ramp name] EXIT /  
     TO [landmark]  
 FROM [landmark] /  
     TO [highway, street name]  
 FROM [landmark] /  
     TO EXIT [exit ramp number]  
 FROM [landmark] /  
     TO [exit ramp name] EXIT  
 FROM [landmark] /  
     TO [landmark]

**Portable Signs**

[number] MILES (AHEAD)  
 AT | [highway, street name]  
 AT EXIT [exit ramp number]  
 AT | [exit ramp name] | EXIT  
 AT | [landmark]  
 BEFORE | [highway, street name]  
 BEFORE | EXIT [exit ramp number]  
 BEFORE | [exit ramp name] | EXIT  
 BEFORE | [landmark]  
 NEAR | [highway, street name]  
 NEAR | EXIT [exit ramp number]  
 NEAR | [exit ramp name] | EXIT  
 NEAR | [landmark]  
 PAST | [highway, street name]  
 PAST | EXIT [exit ramp number]  
 PAST | [exit ramp name] | EXIT  
 PAST | [landmark]

“|” Indicates that the next portion of the message will be displayed on the next line(s) of VMS.

## Lanes Closed

General principles for the message element *Lanes Closed* can be found beginning on [page 5-10](#).

When the VMS is located on the same freeway as the roadwork and relatively close to and upstream of the lane closure, the VMS message can encourage motorists to leave the closed lane(s) and move into the open lanes by informing them of which specific lanes are closed. This helps the movement of vehicles through the restricted lane closure area.

Acceptable terms for the *Lanes Closed* message element for these cases are shown in Table 7.3.

<b>Table 7.3 ACCEPTABLE TERMS FOR LANES CLOSED VMS ON SAME FREEWAY AND RELATIVELY CLOSE TO ROADWORK</b>	
<b><u>Large Signs</u></b>	<b><u>Portable Signs</u></b>
CENTER LANE CLOSED	CENTER   LANE   CLOSED
CENTER LANES CLOSED	CENTER   LANES   CLOSED
LEFT LANE CLOSED	LEFT   LANE   CLOSED
[number] LEFT LANES CLOSED	[number] LEFT   LANES   CLOSED
RIGHT LANE CLOSED	RIGHT   LANE   CLOSED
[number] RIGHT LANES CLOSED	[number] RIGHT   LANES   CLOSED
<p>“ ” Indicates that the next portion of the message will be displayed on the next line(s) of VMS.</p>	



**Effect on Travel**

General principles for the message element *Effect on Travel* can be found beginning on [page 5-10](#).

Acceptable terms for the *Effect on Travel* message element are shown in Table 7.4.

<b>Table 7.4 ACCEPTABLE TERMS FOR <i>EFFECT ON TRAVEL</i> VMS ON SAME FREEWAY AND RELATIVELY CLOSE TO ROADWORK</b>	
<b><u>Large Signs</u></b>	<b><u>Portable Signs</u></b>
DELAY	DELAY
MAJOR DELAY	MAJOR   DELAY
[number] MINUTES DELAY	[number] MIN   DELAY
“ ” Indicates that the next portion of the message will be displayed on the next line(s) of VMS.	

**Action**

General principles for the message element *Action* can be found beginning on [page 5-13](#).

The *Action* message element displayed to motorists will be dictated by whether:

- Motorists are not advised to take an alternative route;
- Motorists are advised to take other routes but the specific route is not specified in the VMS message (sometimes referred to as “soft” diversion); or
- Motorists are advised by the VMS message to take a specific [Type 1](#) or [Type 2](#) diversion route. *(Note: [Type 3](#), [Type 4](#), [Type 5](#) and [Type 6](#) diversion routes are not applicable.)*

NJDOT has an established policy that defines when motorists can be advised to take a specific alternative route. This policy should be reviewed before diversion messages are displayed.

***Motorists Are Not Advised to Take an Alternative Route – No Diversion Action Message***

In some cases, motorists should not be encouraged to divert to another route because it would result in greater travel time than if the motorists were to remain on the primary freeway. However, it is still important to tell motorists what they need to do.

Acceptable terms for the *Action* when lane-blocking incidents occur under this situation are shown in Table 7.5.

<b>Table 7.5 ACCEPTABLE TERMS FOR ACTION</b> <b>VMS ON SAME FREEWAY AND RELATIVELY CLOSE TO ROADWORK</b> <b>MOTORISTS ARE NOT ADVISED TO TAKE AN ALTERNATIVE ROUTE-</b> <b>NO DIVERSION ACTION</b>	
<p><b>Large Signs</b>                      PREPARE TO STOP                      REDUCE SPEED                      STAY ON [route number][cardinal direction]                      STAY ON [highway, street name][cardinal direction]</p>	<p><b>Portable Signs</b>                      PREPARE   TO   STOP                      REDUCE   SPEED                      STAY ON   [route number][cardinal direction]                      STAY ON   [highway, street name][cardinal direction]</p>
<p>“ ” Indicates that the next portion of the message will be displayed on the next line(s) of VMS.</p>	

***Motorists Are Advised to Take Other Routes but the Specific Route Is Not Specified in the VMS Message (Soft Diversion)***

A “Soft” Diversion *Action* message element might be displayed for a variety of reasons including:

- There are no suitable alternative routes that can be recommended because traffic conditions on the most logical routes would not result in travel time savings to motorists if they diverted from the primary freeway;
- The VMS operator is unaware of the traffic conditions on the most logical alternative routes because surveillance does not exist on these routes; and/or
- No specific alternative route has been selected by the work crew where police, traffic control personnel and/or traffic control devices are available to provide positive guidance to motorists.

Acceptable terms for the *Action* when lane-blocking incidents occur under these situations are shown in Table 7.6.

<p><b>Table 7.6 ACCEPTABLE TERMS FOR <i>ACTION</i></b>  <b>VMS ON SAME FREEWAY AND RELATIVELY CLOSE TO ROADWORK</b>  <b><i>MOTORISTS ARE ADVISED TO TAKE AN ALTERNATIVE ROUTE-</i></b>  <b><i>SOFT DIVERSION</i></b></p>	
<p><b><u>Large Signs</u></b>                  EXIT AND USE OTHER ROUTES                  USE OTHER ROUTES</p>	<p><b><u>Portable Signs</u></b>                  USE   OTHER   ROUTES</p>
<p>“ ” Indicates that the next portion of the message will be displayed on the next line(s) of VMS.</p>	

**Motorists Are Advised to Take a Specific Type 1 or Type 2 Diversion Route**

There are times when the VMS operator is aware of an acceptable alternative route and has real-time information about the conditions on the alternative route. Guide signs or trailblazers may or may not be present. Police or traffic control personnel are not positioned at critical decision points along the diversion route.

Acceptable terms for the *Action* message element when these conditions exist are shown in Table 7.7.

<b>Table 7.7 ACCEPTABLE TERMS FOR ACTION</b> <b>VMS ON SAME FREEWAY AND RELATIVELY CLOSE TO ROADWORK</b> <b>MOTORISTS ARE ADVISED TO TAKE A TYPE 1 OR TYPE 2 DIVERSION ROUTE</b>	
<p><b>Large Signs</b></p> <p>EXIT AND USE [highway, street name] [cardinal direction]                      EXIT AND USE [route number] [cardinal direction]                      EXIT AT [highway, street name] [cardinal direction] /                          USE [highway, street name] [cardinal direction]                      EXIT AT [highway, street name] [cardinal direction] /                          USE [route number] [cardinal direction]                      EXIT AT [route number] [cardinal direction] /                          USE [highway, street name] [cardinal direction]                      EXIT AT [route number] [cardinal direction] /                          USE [route number] [cardinal direction]                      TAKE [exit ramp name] EXIT                      TAKE [exit ramp name] EXIT /                          USE [highway, street name] [cardinal direction]                      TAKE [exit ramp name] EXIT /                          USE [route number] [cardinal direction]                      TAKE EXIT [exit ramp number]                      TAKE EXIT [exit ramp number] /                          USE [highway, street name] [cardinal direction]                      TAKE EXIT [exit ramp number] /                          USE [route number] [cardinal direction]                      TAKE [highway, street name] [cardinal direction]                      TAKE [highway, street name] [cardinal direction] /                          USE [highway, street name] [cardinal direction]                      TAKE [highway, street name] [cardinal direction] /                          USE [route number] [cardinal direction]                      TAKE [route number] [cardinal direction]                      TAKE [route number] [cardinal direction] /                          USE [highway, street name] [cardinal direction]                      TAKE [route number] [cardinal direction] /                          USE [route number] [cardinal direction]                      TAKE NEXT EXIT                      TAKE NEXT [number] EXITS                      TUNE RADIO TO [number] AM                      USE [highway, street name] [cardinal direction]                      USE [route number] [cardinal direction]</p>	<p><b>Portable Signs</b></p> <p>EXIT   AND USE   [highway, street name] [cardinal direction]                      EXIT AND   USE [route number] [cardinal direction]                      EXIT   AT   [highway, street name] [cardinal direction] /                          USE   [highway, street name] [cardinal direction]                      EXIT   AT   [highway, street name] [cardinal direction] /                          USE [route number] [cardinal direction]                      EXIT   AT [route number] [cardinal direction] /                          USE   [highway, street name] [cardinal direction]                      EXIT   AT [route number] [cardinal direction]                            USE [route number] [cardinal direction]                      TAKE   [exit ramp name]   EXIT                      TAKE   [exit ramp name]   EXIT /                          USE   [highway, street name] [cardinal direction]                      TAKE   [exit ramp name]   EXIT                            USE [route number] [cardinal direction]                      TAKE   EXIT [exit ramp number]                      TAKE   EXIT [exit ramp number] /                          USE   [highway, street name] [cardinal direction]                      TAKE   EXIT [exit ramp number]                            USE [route number] [cardinal direction]                      TAKE   [highway, street name] [cardinal direction]                      TAKE   [highway, street name] [cardinal direction] /                          USE   [highway, street name] [cardinal direction]                      TAKE   [highway, street name] [cardinal direction] /                          USE [route number] [cardinal direction]                      TAKE [route number] [cardinal direction]                      TAKE [route number] [cardinal direction] /                          USE   [highway, street name] [cardinal direction]                      TAKE [route number] [cardinal direction] /                          USE [route number] [cardinal direction]                      TAKE   NEXT   EXIT                      TAKE   NEXT   [number] EXITS                      TUNE   RADIO   TO [number] AM                      USE   [highway, street name] [cardinal direction]                      USE [route number] [cardinal direction]</p>
<p>" " Indicates that the next portion of the message will be displayed on the next line(s) of VMS.</p>	

**Audience for Action**

General principles for the message element *Audience for Action* can be found beginning on [page 5-12](#).

Acceptable terms for the *Audience for Action* message element are shown in Table 7.7.

<b>Table 7.8 ACCEPTABLE TERMS FOR <i>AUDIENCE FOR ACTION</i> VMS ON SAME FREEWAY AND RELATIVELY CLOSE TO ROADWORK</b>	
<b><u>Large Signs</u></b>	<b><u>Portable Signs</u></b>
<i>[highway, street name] [cardinal direction]</i>	<i>[highway, street name] [cardinal direction]</i>
<i>[route number] [cardinal direction]</i>	<i>[route number] [cardinal direction]</i>
<i>[name of city or state]</i>	<i>[name of city or state]</i>
<i>[name of event, tourist attraction]</i>	<i>[name of event, tourist attraction]</i>
<i>[name of stadium, park, etc.]</i>	<i>[name of stadium, park, etc.]</i>
TO <i>[highway, street name] [cardinal direction]</i>	TO <i>[highway, street name] [cardinal direction]</i>
TO <i>[route number] [cardinal direction]</i>	TO <i>[route number] [cardinal direction]</i>
TO <i>[name of city or state]</i>	TO <i>[name of city or state]</i>
TO <i>[name of event, tourist attraction]</i>	TO <i>[name of event, tourist attraction]</i>
TO <i>[name of stadium, park, etc.]</i>	TO <i>[name of stadium, park, etc.]</i>

“*]*” Indicates that the next portion of the message will be displayed on the next line(s) of VMS.

## Good Reason for Following the Action

General guidelines for displaying the message element *Good Reason for Following the Action* are given on [page 5-13](#).

The terms shown in Table 7.9 are acceptable to display.

<b>Table 7.9 ACCEPTABLE TERMS FOR <i>GOOD REASON FOR FOLLOWING THE ACTION</i> VMS ON SAME FREEWAY AND RELATIVELY CLOSE TO ROADWORK</b>	
<b><u>Large Signs</u></b>	<b><u>Portable Signs</u></b>
AVOID DELAY	AVOID   DELAY
AVOID MAJOR DELAY	AVOID   MAJOR   DELAY
SAVE [number] MINUTES	SAVE   [number] MIN
BEST ROUTE TO [destination]	BEST   ROUTE TO   [destination]
“ ” Indicates that the next portion of the message will be displayed on the next line(s) of VMS.	

**VMS ON SAME FREEWAY BUT RELATIVELY FAR FROM THE ROADWORK****Roadwork Descriptor**

Warnings of lane closures due to roadwork should be displayed under all traffic conditions in peak or off-peak periods. Minor off-the-roadway work such as grass mowing should not be displayed.

Acceptable terms for the *Roadwork Descriptor* message element are given in Table 7.10.

<b>Table 7.10 ACCEPTABLE ROADWORK DESCRIPTORS</b>	
<b>VMS ON SAME FREEWAY BUT RELATIVELY FAR FROM ROADWORK</b>	
<b><u>Large Signs</u></b>	<b><u>Portable Signs</u></b>
CONSTRUCTION*	CONST <u>or</u> ROADWORK*
ROADWORK	ROADWORK
* The word <i>CONSTRUCTION</i> will not fit on an eight-character line of a portable VMS. Therefore, the word must either be abbreviated or replaced with the word <i>ROADWORK</i> .	

The word *ROADWORK* may be substituted for the longer word *CONSTRUCTION*. Motorist interpretations of both words are described on [page 5-14](#). In addition, *CONST* is an acceptable abbreviation for *CONSTRUCTION*.

## Roadwork (Lane Closure) Location

General principles for the message element *Roadwork (Lane Closure) Location* can be found on [page 5-8](#).

Terms for the *Roadwork (Lane Closure) Location* message element are shown in Table 7.11.

<b>Table 7.11 ACCEPTABLE TERMS FOR ROADWORK (LANE CLOSURE) LOCATION VMS ON SAME FREEWAY BUT RELATIVELY FAR FROM ROADWORK</b>	
<b>Large Signs</b>	<b>Portable Signs</b>
[number] MILES (AHEAD)	[number] MILES (AHEAD)
AT [highway, street name]	AT   [highway, street name]
AT EXIT [exit ramp number]	AT EXIT [exit ramp number]
AT [exit ramp name] EXIT	AT   [exit ramp name]   EXIT
AT [landmark]	AT   [landmark]
BEFORE [highway, street name]	BEFORE   [highway, street name]
BEFORE EXIT [exit ramp number]	BEFORE   EXIT [exit ramp number]
BEFORE [exit ramp name] EXIT	BEFORE   [exit ramp name]   EXIT
BEFORE [landmark]	BEFORE   [landmark]
NEAR [highway, street name]	NEAR   [highway, street name]
NEAR EXIT [exit ramp number]	NEAR   EXIT [exit ramp number]
NEAR [exit ramp name] EXIT	NEAR   [exit ramp name]   EXIT
NEAR [landmark]	NEAR   [landmark]
PAST [highway, street name]	PAST   [highway, street name]
PAST EXIT [exit ramp number]	PAST   EXIT [exit ramp number]
PAST [exit ramp name] EXIT	PAST   [exit ramp name]   EXIT
PAST [landmark]	PAST   [landmark]
FROM [highway, street name]   TO [highway, street name]	
FROM [highway, street name]   TO EXIT [exit ramp number]	
FROM [highway, street name]   TO [exit ramp name] EXIT	
FROM [highway, street name]   TO [landmark]	
FROM EXIT [exit ramp number]   TO [highway, street name]	
FROM EXIT [exit ramp number]   TO EXIT [exit ramp number]	
FROM EXIT [exit ramp number]   TO [exit ramp name] EXIT	
FROM EXIT [exit ramp number]   TO [landmark]	
FROM [exit ramp name] EXIT TO [highway, street name]	
FROM [exit ramp name] EXIT   TO EXIT [exit ramp number]	
FROM [exit ramp name] EXIT   TO [exit ramp name] EXIT	
FROM [exit ramp name] EXIT   TO [landmark]	
FROM [landmark]   TO [highway, street name]	
FROM [landmark]   TO EXIT [exit ramp number]	
FROM [landmark]   TO [exit ramp name] EXIT	
FROM [landmark]   TO [landmark]	
“ ” Indicates that the next portion of the message will be displayed on the next line(s) of VMS.	



## Lanes Closed

General principles for the message element *Lanes Closed* can be found beginning on [page 5-10](#).

Situations arise when the VMS is on the same freeway and upstream of the roadwork but at a location far enough upstream of the lane closure where it is not advisable to encourage lane changing. It is best to move traffic in all the lanes. Therefore, there is no traffic flow advantage to inform motorists the specific lanes that are closed. However, it is important to notify motorists the number of lanes closed so that they can make earlier decisions about whether to take alternative routes.

Acceptable terms for the *Lanes Closed* message element for these cases are shown in Table 7.12.

<b>Table 7.12 ACCEPTABLE TERMS FOR LANES CLOSED VMS ON SAME FREEWAY BUT RELATIVELY FAR FROM ROADWORK</b>	
<b><u>Large Signs</u></b>	<b><u>Portable Signs</u></b>
1 LANE CLOSED	1 LANE   CLOSED
[number] LANES CLOSED	[number] LANES   CLOSED
1 LANE OPEN	1 LANE   OPEN
[number] LANES OPEN	[number] LANES   OPEN
“ ” Indicates that the next portion of the message will be displayed on the next line(s) of VMS.	

**Effect on Travel**

General principles for the message element *Effect on Travel* can be found beginning on [page 5-10](#).

Acceptable terms for the *Effect on Travel* message element are shown in Table 7.13.

<b>Table 7.13 ACCEPTABLE TERMS FOR <i>EFFECT ON TRAVEL</i> VMS ON SAME FREEWAY BUT RELATIVELY FAR FROM ROADWORK</b>	
<b><u>Large Signs</u></b>	<b><u>Portable Signs</u></b>
DELAY	DELAY
MAJOR DELAY	MAJOR   DELAY
[number] MINUTES DELAY	[number] MIN   DELAY
“ ” Indicates that the next portion of the message will be displayed on the next line(s) of VMS.	

**Action**

General principles for the message element *Action* can be found beginning on [page 5-13](#).

The *Action* message element displayed to motorists will be dictated by whether:

- Motorists are not advised to take an alternative route;
- Motorists are advised to take other routes but the specific route is not specified in the VMS message (sometimes referred to as “soft” diversion); or
- Motorists are advised by the VMS message to take a specific [Type 1](#) or [Type 2](#) diversion route. *(Note: [Type 3](#), [Type 4](#), [Type 5](#) and [Type 6](#) diversion routes are not applicable.)*

NJDOT has an established policy that defines when motorists can be advised to take a specific alternative route. This policy should be reviewed before diversion messages are displayed.

***Motorists Are Not Advised to Take an Alternative Route – No Diversion Action Message***

In some cases, motorists should not be encouraged to divert to another route because it would result in greater travel time than if the motorists were to remain on the primary freeway. However, it is still important to tell motorists what they need to do.

Acceptable terms for the *Action* message element in this situation are shown in Table 7.14.

<b>Table 7.14 ACCEPTABLE TERMS FOR ACTION</b> <b>VMS ON SAME FREEWAY BUT RELATIVELY FAR FROM ROADWORK</b> <b>MOTORISTS ARE NOT ADVISED TO TAKE AN ALTERNATIVE ROUTE-</b> <b>NO DIVERSION ACTION</b>	
<p><b><u>Large Signs</u></b>                      PREPARE TO STOP                      REDUCE SPEED                      STAY ON [route number][cardinal direction]                      STAY ON [highway, street name][cardinal direction]</p>	<p><b><u>Portable Signs</u></b>                      PREPARE   TO   STOP                      REDUCE   SPEED                      STAY ON   [route number][cardinal direction]                      STAY ON   [highway, street name][cardinal direction]</p>
<p>“ ” Indicates that the next portion of the message will be displayed on the next line(s) of VMS.</p>	

***Motorists Are Advised to Take Other Routes but the Specific Route Is Not Specified in the VMS Message (Soft Diversion)***

A “Soft” Diversion *Action* message element might be displayed for a variety of reasons including:

- There are no suitable alternative routes that can be recommended because traffic conditions on the most logical routes would not result in travel time savings to motorists if they diverted from the primary freeway;
- The VMS operator is unaware of the traffic conditions on the most logical alternative routes because surveillance does not exist on these routes; and/or
- No specific alternative route has been selected by the work crew where police, traffic control personnel and/or traffic control devices are available to provide positive guidance to motorists.

Acceptable terms for the *Action* message element in these situations are shown in Table 7.15.

<p><b>Table 7.15 ACCEPTABLE TERMS FOR <i>ACTION</i></b>  <b>VMS ON SAME FREEWAY BUT RELATIVELY FAR FROM ROADWORK</b>  <b><i>MOTORISTS ARE ADVISED TO TAKE AN ALTERNATIVE ROUTE-</i></b>  <b><i>SOFT DIVERSION</i></b></p>	
<p><b><u>Large Signs</u></b>                  EXIT AND USE OTHER ROUTES                  USE OTHER ROUTES</p>	<p><b><u>Portable Signs</u></b>                  USE   OTHER   ROUTES</p>
<p>“ ” Indicates that the next portion of the message will be displayed on the next line(s) of VMS.</p>	

**Motorists Are Advised to Take a Specific Type 1 or Type 2 Diversion Route**

There are times when the VMS operator is aware of an acceptable alternative route and has real-time information about the conditions on the alternative route. Guide signs or trailblazers may or may not be present. Police or traffic control personnel are not positioned at critical decision points along the diversion route.

Acceptable terms for the *Action* message element when these conditions exist are shown in Table 7.16.

<b>Table 7.16 ACCEPTABLE TERMS FOR ACTION                      VMS ON SAME FREEWAY BUT RELATIVELY FAR FROM ROADWORK                      MOTORISTS ARE ADVISED TO TAKE A TYPE 1 OR TYPE 2 DIVERSION ROUTE</b>	
<p><b>Large Signs</b></p> <p>EXIT AND USE [highway, street name] [cardinal direction]                      EXIT AND USE [route number] [cardinal direction]                      EXIT AT [highway, street name] [cardinal direction] /                          USE [highway, street name] [cardinal direction]                      EXIT AT [highway, street name] [cardinal direction] /                          USE [route number] [cardinal direction]                      EXIT AT [route number] [cardinal direction] /                          USE [highway, street name] [cardinal direction]                      EXIT AT [route number] [cardinal direction] /                          USE [route number] [cardinal direction]                      TAKE [exit ramp name] EXIT                      TAKE [exit ramp name] EXIT /                          USE [highway, street name] [cardinal direction]                      TAKE [exit ramp name] EXIT /                          USE [route number] [cardinal direction]                      TAKE EXIT [exit ramp number]                      TAKE EXIT [exit ramp number] /                          USE [highway, street name] [cardinal direction]                      TAKE EXIT [exit ramp number] /                          USE [route number] [cardinal direction]                      TAKE [highway, street name] [cardinal direction]                      TAKE [highway, street name] [cardinal direction] /                          USE [highway, street name] [cardinal direction]                      TAKE [highway, street name] [cardinal direction] /                          USE [route number] [cardinal direction]                      TAKE [route number] [cardinal direction]                      TAKE [route number] [cardinal direction] /                          USE [highway, street name] [cardinal direction]                      TAKE [route number] [cardinal direction] /                          USE [route number] [cardinal direction]                      TAKE NEXT EXIT                      TAKE NEXT [number] EXITS                      TUNE RADIO TO [number] AM                      USE [highway, street name] [cardinal direction]                      USE [route number] [cardinal direction]</p>	<p><b>Portable Signs</b></p> <p>EXIT   AND USE   [highway, street name] [cardinal direction]                      EXIT AND   USE [route number] [cardinal direction]                      EXIT   AT   [highway, street name] [cardinal direction]                            USE   [highway, street name] [cardinal direction]                      EXIT   AT   [highway, street name] [cardinal direction]                            USE [route number] [cardinal direction]                      EXIT   AT [route number] [cardinal direction]                            USE   [highway, street name] [cardinal direction]                      EXIT   AT [route number] [cardinal direction]                            USE [route number] [cardinal direction]                      TAKE   [exit ramp name]   EXIT                      TAKE   [exit ramp name]   EXIT /                          USE   [highway, street name] [cardinal direction]                      TAKE   [exit ramp name]   EXIT                            USE [route number] [cardinal direction]                      TAKE   EXIT [exit ramp number]                      TAKE   EXIT [exit ramp number] /                          USE   [highway, street name] [cardinal direction]                      TAKE   EXIT [exit ramp number]                            USE [route number] [cardinal direction]                      TAKE   [highway, street name] [cardinal direction]                      TAKE   [highway, street name] [cardinal direction]                            USE   [highway, street name] [cardinal direction]                      TAKE   [highway, street name] [cardinal direction]                            USE [route number] [cardinal direction]                      TAKE [route number] [cardinal direction]                      TAKE [route number] [cardinal direction] /                          USE   [highway, street name] [cardinal direction]                      TAKE [route number] [cardinal direction] /                          USE [route number] [cardinal direction]                      TAKE   NEXT   EXIT                      TAKE   NEXT   [number] EXITS                      TUNE   RADIO   TO [number] AM                      USE   [highway, street name] [cardinal direction]                      USE [route number] [cardinal direction]</p>
<p>" " Indicates that the next portion of the message will be displayed on the next line(s) of VMS.</p>	

**Audience for Action**

General principles for the message element *Audience for Action* can be found beginning on [page 5-12](#).

Acceptable terms for the *Audience for Action* message element are shown in Table 7.17.

<b>Table 7.17 ACCEPTABLE TERMS FOR AUDIENCE FOR ACTION VMS ON SAME FREEWAY BUT RELATIVELY FAR FROM ROADWORK</b>	
<b><u>Large Signs</u></b>	<b><u>Portable Signs</u></b>
[highway, street name] [cardinal direction]	[highway, street name] [cardinal direction]
[route number] [cardinal direction]	[route number] [cardinal direction]
[name of city or state]	[name of city or state]
[name of event, tourist attraction]	[name of event, tourist attraction]
[name of stadium, park, etc.]	[name of stadium, park, etc.]
TO [highway, street name] [cardinal direction]	TO [highway, street name] [cardinal direction]
TO [route number] [cardinal direction]	TO [route number] [cardinal direction]
TO [name of city or state]	TO [name of city or state]
TO [name of event, tourist attraction]	TO [name of event, tourist attraction]
TO [name of stadium, park, etc.]	TO [name of stadium, park, etc.]

“;” Indicates that the next portion of the message will be displayed on the next line(s) of VMS.

## Good Reason for Following the Action

General guidelines for displaying the message element *Good Reason for Following the Action* are given on [page 5-13](#).

The terms shown in Table 7.18 are acceptable to display.

**Table 7.18 ACCEPTABLE TERMS FOR *GOOD REASON FOR FOLLOWING THE ACTION*  
VMS ON SAME FREEWAY BUT RELATIVELY FAR FROM ROADWORK**

**Large Signs**

AVOID DELAY

AVOID MAJOR DELAY

SAVE *[number]* MINUTES

BEST ROUTE TO *[destination]*

**Portable Signs**

AVOID | DELAY

AVOID | MAJOR | DELAY

SAVE | *[number]* MIN

BEST | ROUTE TO | *[destination]*

“|” Indicates that the next portion of the message will be displayed on the next line(s) of VMS.

**VMS ON DIFFERENT FREEWAY THAN THE ROADWORK**

The VMS operational guidelines in this section of the Manual apply when the VMS is on a different freeway than the roadwork, but the lane closures still can have an effect on motorists who are passing the VMS. For example, westbound I-195 motorists who intend to exit I-195 and enter northbound I-295 to travel to the city of Princeton could be affected by roadwork on northbound I-295 north of the I-195/I-295 interchange. Messages displayed on VMSs on westbound I-195 concerning the lane closures on northbound I-295 can be helpful to those motorists heading to Princeton.

The major difference between the messages displayed on VMSs located on a different freeway than the roadwork in comparison to the messages on VMSs located on the same freeway as the work but far upstream of the work is in the diversion information provided.

**Roadwork Descriptor**

Warnings of lane closures due to roadwork should be displayed under all traffic conditions in peak or off-peak periods. Minor off-the-roadway work such as grass mowing should not be displayed.

Acceptable terms for the *Roadwork Descriptor* message elements are given in Table 7.19.

<b>Table 7.19 ACCEPTABLE ROADWORK DESCRIPTORS VMS ON DIFFERENT FREEWAY THAN ROADWORK</b>	
<u><b>Large Signs</b></u> CONSTRUCTION* ROADWORK	<u><b>Portable Signs</b></u> CONST <u>or</u> ROADWORK* ROADWORK
* The word <i>CONSTRUCTION</i> will not fit on an eight-character line of a portable VMS. Therefore, the word must either be abbreviated or replaced with the word <i>ROADWORK</i> .	

The word *ROADWORK* may be substituted for the longer word *CONSTRUCTION*. Motorist interpretations of both words are described on [page 5-14](#). In addition, *CONST* is an acceptable abbreviation for *CONSTRUCTION*.



## Roadwork (Lane Closure) Location

General principles for the message element *Roadwork (Lane Closure) Location* can be found on [page 5-8](#).

Acceptable terms for the *Roadwork (Lane Closure) Location* message element are shown in Table 7.20.

<b>Table 7.20 ACCEPTABLE TERMS FOR ROADWORK (LANE CLOSURE) LOCATION VMS ON DIFFERENT FREEWAY THAN ROADWORK</b>	
<b><u>Large Signs</u></b>	<b><u>Portable Signs</u></b>
AT [highway, street name]*	AT   [highway, street name]*
AT EXIT [exit ramp number]*	AT EXIT [exit ramp number]*
AT [exit ramp name] EXIT*	AT   [exit ramp name]   EXIT*
AT [landmark]*	AT   [landmark]*
BEFORE [highway, street name]*	BEFORE   [highway, street name]*
BEFORE EXIT [exit ramp number]*	BEFORE   EXIT [exit ramp number]*
BEFORE [exit ramp name] EXIT*	BEFORE   [exit ramp name]   EXIT*
BEFORE [landmark]*	BEFORE   [landmark]*
NEAR [highway, street name]*	NEAR   [highway, street name]*
NEAR EXIT [exit ramp number]*	NEAR   EXIT [exit ramp number]*
NEAR [exit ramp name] EXIT*	NEAR   [exit ramp name]   EXIT*
NEAR [landmark]*	NEAR   [landmark]*
PAST [highway, street name]*	PAST   [highway, street name]*
PAST EXIT [exit ramp number]*	PAST   EXIT [exit ramp number]*
PAST [exit ramp name] EXIT*	PAST   [exit ramp name]   EXIT*
PAST [landmark]*	PAST   [landmark]*
* Insert <b>"ON [route number, highway name or street name][cardinal direction]"</b> in front of the Roadwork Location.	
" " Indicates that the next portion of the message will be displayed on the next line(s) of VMS.	

## Lanes Closed

General principles for the message element *Lanes Closed* can be found beginning on [page 5-10](#).

It is not important to inform motorists on another freeway about the specific lanes that are closed. However, it is important to notify motorists about the number of lanes closed so that they can make earlier decisions about whether to take alternative routes.

Acceptable terms for the *Lanes Closed* message element are shown in Table 7.21.

<b>Table 7.21 ACCEPTABLE TERMS FOR LANES CLOSED VMS ON DIFFERENT FREEWAY THAN ROADWORK</b>	
<b><u>Large Signs</u></b>	<b><u>Portable Signs</u></b>
1 LANE CLOSED	1 LANE   CLOSED
[number] LANES CLOSED	[number] LANES   CLOSED
1 LANE OPEN	1 LANE   OPEN
[number] LANES OPEN	[number] LANES   OPEN
<p>“ ” Indicates that the next portion of the message will be displayed on the next line(s) of VMS.</p>	

**Effect on Travel**

General principles for the message element *Effect on Travel* can be found beginning on [page 5-10](#).

Acceptable terms for the *Effect on Travel* message element are shown in Table 7.22

**Table 7.22 ACCEPTABLE TERMS FOR *EFFECT ON TRAVEL*  
VMS ON DIFFERENT FREEWAY THAN ROADWORK**

**Large Signs**

DELAY  
MAJOR DELAY  
[number] MINUTES DELAY

**Portable Signs**

DELAY  
MAJOR | DELAY  
[number] MIN | DELAY

“|” Indicates that the next portion of the message will be displayed on the next line(s) of VMS.

**Action**

General principles for the message element *Action* can be found beginning on [page 5-13](#).

The *Action* message element displayed to motorists will be dictated by whether:

- Motorists who will turn onto the affected freeway are not advised to take an alternative route;
- Motorists who will turn onto the affected freeway are advised to take other routes but the specific route is not specified in the VMS message (sometimes referred to as “soft” diversion); or
- Motorists who will turn onto the affected freeway are advised by the VMS message to take a specific [Type 1](#) or [Type 2](#) diversion route. (*Note: [Type 3](#), [Type 4](#), [Type 5](#) and [Type 6](#) diversion routes are not applicable.*)

NJDOT has an established policy that defines when motorists can be advised to take a specific alternative route. This policy should be reviewed before diversion messages are displayed.

***Motorists Are Not Advised to Take an Alternative Route – No Diversion Action Message***

In some cases, it may be best for the motorists to stay on the current freeway rather than turning onto the freeway that is affected by the roadwork.

Acceptable terms for the *Action* when lane closures are on another freeway under this situation are shown in Table 7.23.

<b>Table 7.23 ACCEPTABLE TERMS FOR ACTION                      VMS ON DIFFERENT FREEWAY THAN ROADWORK                      MOTORISTS ARE NOT ADVISED TO TAKE AN ALTERNATIVE ROUTE-                      NO DIVERSION ACTION</b>	
<p><b><u>Large Signs</u></b>                      PREPARE TO STOP                      REDUCE SPEED                      STAY ON [highway, street name] [cardinal direction]                      STAY ON [route number] [cardinal direction]</p>	<p><b><u>Portable Signs</u></b>                      PREPARE   TO   STOP                      REDUCE   SPEED                      STAY ON   [highway, street name] [cardinal direction]                      STAY   ON [route number] [cardinal direction]</p>
<p>“ ” Indicates that the next portion of the message will be displayed on the next line(s) of VMS.</p>	

***Motorists Are Advised to Take Other Routes but the Specific Route Is Not Specified in the VMS Message (Soft Diversion)***

A “Soft” Diversion *Action* message element might be displayed for a variety of reasons including:

- There are no suitable alternative routes that can be recommended because traffic conditions on the most logical routes would not result in travel time savings to motorists if they diverted from the primary freeway;
- The VMS operator is unaware of the traffic conditions on the most logical alternative routes because surveillance does not exist on these routes; and/or
- No specific alternative route has been selected by the work crew where police, traffic control personnel and/or traffic control devices are available to provide positive guidance to motorists.

Acceptable terms for the *Action* message element in this situation are shown in Table 7.24.

<b>Table 7.24 ACCEPTABLE TERMS FOR ACTION            VMS ON DIFFERENT FREEWAY THAN ROADWORK            MOTORISTS ARE ADVISED TO TAKE AN ALTERNATIVE ROUTE-            SOFT DIVERSION</b>	
<p><b><u>Large Signs</u></b>            USE OTHER ROUTES</p>	<p><b><u>Portable Signs</u></b>            USE   OTHER   ROUTES</p>
<p>“ ” Indicates that the next portion of the message will be displayed on the next line(s) of VMS.</p>	

***Motorists Are Advised to Take a Specific Type 1 or Type 2 Diversion Route***

There are times when the VMS operator is aware of an acceptable alternative route and has real-time information about the conditions on the alternative route. Guide signs or trailblazers may or may not be present. Police or traffic control personnel are not positioned at critical decision points along the diversion route.

Acceptable terms for the *Action* message element when these conditions exist are shown in Table 7.25.

<b>Table 7.25 ACCEPTABLE TERMS FOR ACTION                      VMS ON DIFFERENT FREEWAY THAN ROADWORK                      MOTORISTS ARE ADVISED TO TAKE A TYPE 1 OR TYPE 2 DIVERSION ROUTE</b>	
<p><b><u>Large Signs</u></b>                      USE [highway, street name] [cardinal direction]                      USE [route number] [cardinal direction]</p>	<p><b><u>Portable Signs</u></b>                      USE   [highway, street name] [cardinal direction]                      USE [route number] [cardinal direction]</p>
<p>" " Indicates that the next portion of the message will be displayed on the next line(s) of VMS.</p>	

**Audience for Action**

General principles for the message element *Audience for Action* can be found beginning on [page 5-12](#).

Acceptable terms for the *Audience for Action* message element are shown in Table 7.26.

<b>Table 7.26 ACCEPTABLE TERMS FOR AUDIENCE FOR ACTION VMS ON DIFFERENT FREEWAY THAN ROADWORK</b>	
<b><u>Large Signs</u></b>	<b><u>Portable Signs</u></b>
[highway, street name] [cardinal direction]	[highway, street name] [cardinal direction]
[route number] [cardinal direction]	[route number] [cardinal direction]
[name of city or state]	[name of city or state]
[name of event, tourist attraction]	[name of event, tourist attraction]
[name of stadium, park, etc.]	[name of stadium, park, etc.]
TO [highway, street name] [cardinal direction]	TO [highway, street name] [cardinal direction]
TO [route number] [cardinal direction]	TO [route number] [cardinal direction]
TO [name of city or state]	TO [name of city or state]
TO [name of event, tourist attraction]	TO [name of event, tourist attraction]
TO [name of stadium, park, etc.]	TO [name of stadium, park, etc.]

“” Indicates that the next portion of the message will be displayed on the next line(s) of VMS.

## Good Reason for Following the Action

General guidelines for displaying the message element *Good Reason for Following the Action* are given on [page 5-13](#).

The terms shown in Table 7.27 are acceptable to display.

**Table 7.27 ACCEPTABLE TERMS FOR *GOOD REASON FOR FOLLOWING THE ACTION*  
VMS ON DIFFERENT FREEWAY THAN ROADWORK**

**Large Signs**

AVOID DELAY

AVOID MAJOR DELAY

SAVE *[number]* MINUTES

BEST ROUTE TO *[destination]*

**Portable Signs**

AVOID | DELAY

AVOID | MAJOR | DELAY

SAVE | *[number]* MIN

BEST | ROUTE TO | *[destination]*

“|” Indicates that the next portion of the message will be displayed on the next line(s) of VMS.



## 7.2 BASIC VMS MESSAGE FOR ROADWORK THAT REQUIRES CLOSING THE FREEWAY

When construction or maintenance roadwork requires closure of the entire freeway, a traffic control plan is implemented. The traffic control plan includes installation of traffic control devices to divert traffic off the primary freeway and to give positive guidance to the motorists along the diversion route and then back to the primary freeway. The closure of the primary freeway will take place at an exit ramp upstream of the roadwork.

### BASIC VMS MESSAGE ELEMENTS

The Basic VMS Message for roadwork that requires a total freeway closure usually includes the following: 1) *Roadwork Descriptor* (situation description); 2) *Closure Location*; 3) *Lanes Closed*; 4) *Effect on Travel* (e.g., major delay); 5) *Audience for Action*; 6) *Action*; and 4) *Good Reason for Following the Action*.

#### BASIC VMS MESSAGE ELEMENTS:

- **Roadwork Descriptor (situation description);**
- **Closure Location;**
- **Lanes Closed;**
- **Effect on Travel (e.g., major delay);**
- **Audience for Action (when the action is for a specified group of motorists);**
- **Action (tells motorists what to do); and**
- **Good Reason for Following the Action statement (usually implied by other message elements.**

## VMS ON SAME FREEWAY AND RELATIVELY CLOSE TO THE CLOSURE

### Basic VMS Message Elements

In contrast to other situations, the Basic Message when the VMS is located upstream on the same freeway and near the freeway closure will only include the following four elements: 1) ***Roadwork Descriptor***; 2) ***Closure Location***; 3) ***Lanes Closed***; and 4) ***Action***.

#### BASIC VMS MESSAGE ELEMENTS FOR VMS NEAR CLOSURE:

- **Roadwork Descriptor;**
- **Closure Location;**
- **Lanes Closed; and**
- **Action.**

The *Effect on Travel*, *Audience for Action* and *Good Reason for Following the Action* are implied by the *Lanes Closed* and diversion *Action* message elements and are not displayed on the VMS that is near the freeway closure location.

## Roadwork Descriptor

Warnings of freeway closures due to roadwork should be displayed under all traffic conditions in peak or off-peak periods.

Acceptable terms for the *Roadwork Descriptor* message element are given in Table 7.28.

<b>Table 7.28 ACCEPTABLE ROADWORK DESCRIPTORS VMS ON SAME FREEWAY AND RELATIVELY CLOSE TO CLOSURE</b>	
<b><u>Large Signs</u></b>	<b><u>Portable Signs</u></b>
CONSTRUCTION*	CONST or ROADWORK*
ROADWORK	ROADWORK
* The word <i>CONSTRUCTION</i> will not fit on an eight-character line of a portable VMS. Therefore, the word must either be abbreviated or replaced with the word <i>ROADWORK</i> .	

The word *ROADWORK* may be substituted for the longer word *CONSTRUCTION*. Motorist interpretations of both words are described on [page 5-14](#). In addition, *CONST* is an acceptable abbreviation for *CONSTRUCTION*.

**Closure Location**

General principles for the message element *Closure Location* can be found beginning on [page 5-10](#).

Acceptable terms to use for the *Closure Location* message element are shown in Table 7.29. Note that portable VMSs cannot be used when it is desirable to inform motorists the length of the closure for the roadwork (e.g., *I-80 EAST CLOSED FROM EXIT 42 TO EXIT 43*).

<b>Table 7.29 ACCEPTABLE TERMS FOR CLOSURE LOCATION VMS ON SAME FREEWAY AND RELATIVELY CLOSE TO CLOSURE</b>	
<b><u>Large Signs</u></b>	<b><u>Portable Signs</u></b>
1 MILE (AHEAD)	1 MILE (AHEAD)
[number] MILES (AHEAD)	[number] MILES (AHEAD)
AT [highway, street name]	AT   [highway, street name]
AT EXIT [exit ramp number]	AT EXIT [exit ramp number]
AT [exit ramp name] EXIT	AT   [exit ramp name]   EXIT
FROM [highway, street name] /	
TO [highway, street name]	
FROM [highway, street name] /	
TO EXIT [exit ramp number]	
FROM [highway, street name] /	
TO [exit ramp name] EXIT	
FROM [highway, street name] /	
TO [landmark]	
FROM EXIT [exit ramp number] /	
TO [highway, street name]	
FROM EXIT [exit ramp number] /	
TO EXIT [exit ramp number]	
FROM EXIT [exit ramp number] /	
TO [exit ramp name] EXIT	
FROM EXIT [exit ramp number] /	
TO [landmark]	
FROM [exit ramp name] EXIT	
TO [highway, street name]	
FROM [exit ramp name] EXIT /	
TO EXIT [exit ramp number]	
FROM [exit ramp name] EXIT /	
TO [exit ramp name] EXIT	
FROM [exit ramp name] EXIT /	
TO [landmark]	
FROM [landmark] /	
TO [highway, street name]	
FROM [landmark] /	
TO EXIT [exit ramp number]	
FROM [landmark] /	
TO [exit ramp name] EXIT	
FROM [landmark] /	
TO [landmark]	

“|” Indicates that the next portion of the message will be displayed on the next line(s) of VMS.

## Lanes Closed

General principles for the message element *Lanes Closed* can be found beginning on [page 5-10](#).

Acceptable terms for the *Lanes Closed* message element are shown in Table 7.30.

<b>Table 7.30 ACCEPTABLE TERMS FOR LANES CLOSED VMS ON SAME FREEWAY AND RELATIVELY CLOSE TO CLOSURE</b>	
<b><u>Large Signs</u></b>	<b><u>Portable Signs</u></b>
ALL LANES CLOSED	ALL   LANES   CLOSED
“ ” Indicates that the next portion of the message will be displayed on the next line(s) of VMS.	

**Effect on Travel**

General principles for the message element *Effect on Travel* can be found beginning on [page 5-10](#).

The *Effect on Travel* is implied to motorists by the *Lanes Closed* and *Action* message elements and is not required in the message.

<p><b>Table 7.31 ACCEPTABLE TERMS FOR <i>EFFECT ON TRAVEL</i> VMS ON SAME FREEWAY AND RELATIVELY CLOSE TO CLOSURE</b></p>
---

<p>(Not necessary to display because it is implied by other message elements)</p>
---

**Action**

General principles for the message element *Action* can be found beginning on [page 5-13](#).

Because a [Type 6](#) diversion (detour) route has been set up, acceptable terms for the *Action* message element are shown in Table 7.32.

<b>Table 7.32 ACCEPTABLE TERMS FOR ACTION</b> <b>VMS ON SAME FREEWAY AND RELATIVELY CLOSE TO CLOSURE</b> <b>MOTORISTS ARE ADVISED TO TAKE A SPECIFIC TYPE 6 DIVERSION (DETOUR) ROUTE</b>	
<b>Large Signs</b>	<b>Portable Signs</b>
EXIT AND FOLLOW DETOUR	EXIT AND   FOLLOW   DETOUR
EXIT AND FOLLOW SIGNS	EXIT AND   FOLLOW   SIGNS
EXIT AT [highway, street name] [cardinal direction] / FOLLOW DETOUR	EXIT   AT   [highway, street name] [cardinal direction] / FOLLOW   DETOUR
EXIT AT [highway, street name] [cardinal direction] / FOLLOW SIGNS	EXIT   AT   [highway, street name] [cardinal direction] / FOLLOW   SIGNS
EXIT AT [route number] [cardinal direction] / FOLLOW DETOUR	EXIT   AT [route number] [cardinal direction] / FOLLOW   DETOUR
EXIT AT [route number] [cardinal direction] / FOLLOW SIGNS	EXIT   AT [route number] [cardinal direction] / FOLLOW   SIGNS
TAKE [exit ramp name] EXIT   FOLLOW DETOUR	TAKE   [exit ramp name]   EXIT   FOLLOW   DETOUR
TAKE [exit ramp name] EXIT   FOLLOW SIGNS	TAKE   [exit ramp name]   EXIT   FOLLOW   SIGNS
TAKE EXIT [exit ramp number] / FOLLOW DETOUR	TAKE   EXIT [exit ramp number] / FOLLOW   DETOUR
TAKE EXIT [exit ramp number] / FOLLOW SIGNS	TAKE   EXIT [exit ramp number] / FOLLOW   SIGNS
TAKE [highway, street name] [cardinal direction] / FOLLOW DETOUR	TAKE   [highway, street name] [cardinal direction] / FOLLOW   DETOUR
TAKE [highway, street name] [cardinal direction] / FOLLOW SIGNS	TAKE   [highway, street name] [cardinal direction] / FOLLOW   SIGNS
TAKE [route number] [cardinal direction] / FOLLOW DETOUR	TAKE [route number] [cardinal direction] / FOLLOW   DETOUR
TAKE [route number] [cardinal direction] / FOLLOW SIGNS	TAKE [route number] [cardinal direction] / FOLLOW   SIGNS
TAKE NEXT EXIT	TAKE   NEXT   EXIT

“|” Indicates that the next portion of the message will be displayed on the next line(s) of VMS.

## **Audience for Action**

General principles for the message element *Audience for Action* can be found beginning on [page 5-12](#).

The *Audience for Action* is implied to motorists by the *Lanes Closed* and *Action* message elements to mean all traffic passing the VMS and is not required in the message.

<p><b>Table 7.33 ACCEPTABLE TERMS FOR <i>AUDIENCE FOR ACTION</i> VMS ON SAME FREEWAY AND RELATIVELY CLOSE TO CLOSURE</b></p>
--

<p>(Not necessary to display because it is implied by other message elements)</p>
---



## Good Reason for Following the Action

General guidelines for displaying the message element *Good Reason for Following the Action* are given on [page 5-13](#).

The *Good Reason for Following the Action* is implied to motorists by the *Lanes Closed* and *Action* message elements and is not required in the message.

<p><b>Table 7.34 ACCEPTABLE TERMS FOR <i>GOOD REASON FOR FOLLOWING THE ACTION</i> VMS ON SAME FREEWAY AND RELATIVELY CLOSE TO CLOSURE</b></p>
---

<p>(Not necessary to display because it is implied by other message elements)</p>
---

**VMS ON SAME FREEWAY BUT RELATIVELY FAR FROM THE CLOSURE****Roadwork Descriptor**

Warnings of freeway closures due to roadwork should be displayed under all traffic conditions in peak or off-peak periods.

Acceptable terms for the *Roadwork Descriptor* message element are given in Table 7.35.

<b>Table 7.35 ACCEPTABLE ROADWORK DESCRIPTORS</b>	
<b>VMS ON SAME FREEWAY BUT RELATIVELY FAR FROM CLOSURE</b>	
<b><u>Large Signs</u></b>	<b><u>Portable Signs</u></b>
CONSTRUCTION*	CONST <u>or</u> ROADWORK*
ROADWORK	ROADWORK
* The word <i>CONSTRUCTION</i> will not fit on an eight-character line of a portable VMS. Therefore, the word must either be abbreviated or replaced with the word <i>ROADWORK</i> .	

The word *ROADWORK* may be substituted for the longer word *CONSTRUCTION*. Motorist interpretations of both words are described on [page 5-14](#). In addition, *CONST* is an acceptable abbreviation for *CONSTRUCTION*.

**Closure Location**

General principles for the message element *Closure Location* can be found beginning on [page 5-10](#).

Acceptable terms for the *Closure Location* message element are shown in Table 7.36. . Note that portable VMSs cannot be used when it is desirable to inform motorists the length of the closure for the roadwork (e.g., *I-80 EAST CLOSED FROM EXIT 42 TO EXIT 43*).

<b>Table 7.36 ACCEPTABLE TERMS FOR CLOSURE LOCATION VMS ON SAME FREEWAY BUT RELATIVELY FAR FROM CLOSURE</b>	
<b><u>Large Signs</u></b>	<b><u>Portable Signs</u></b>
<i>[number]</i> MILES (AHEAD)	<i>[number]</i> MILES (AHEAD)
AT <i>[highway, street name]</i>	AT   <i>[highway, street name]</i>
AT EXIT <i>[exit ramp number]</i>	AT EXIT <i>[exit ramp number]</i>
AT <i>[exit ramp name]</i> EXIT	AT   <i>[exit ramp name]</i>   EXIT
AT <i>[landmark]</i>	AT   <i>[landmark]</i>
FROM <i>[highway, street name]</i> / TO <i>[highway, street name]</i>	
FROM <i>[highway, street name]</i> / TO EXIT <i>[exit ramp number]</i>	
FROM <i>[highway, street name]</i> / TO <i>[exit ramp name]</i> EXIT	
FROM <i>[highway, street name]</i> / TO <i>[landmark]</i>	
FROM EXIT <i>[exit ramp number]</i> / TO <i>[highway, street name]</i>	
FROM EXIT <i>[exit ramp number]</i> / TO EXIT <i>[exit ramp number]</i>	
FROM EXIT <i>[exit ramp number]</i> / TO <i>[exit ramp name]</i> EXIT	
FROM EXIT <i>[exit ramp number]</i> / TO <i>[landmark]</i>	
FROM <i>[exit ramp name]</i> EXIT TO <i>[highway, street name]</i>	
FROM <i>[exit ramp name]</i> EXIT / TO EXIT <i>[exit ramp number]</i>	
FROM <i>[exit ramp name]</i> EXIT / TO <i>[exit ramp name]</i> EXIT	
FROM <i>[exit ramp name]</i> EXIT / TO <i>[landmark]</i>	
FROM <i>[landmark]</i> / TO <i>[highway, street name]</i>	
FROM <i>[landmark]</i> / TO EXIT <i>[exit ramp number]</i>	
FROM <i>[landmark]</i> / TO <i>[exit ramp name]</i> EXIT	
FROM <i>[landmark]</i> / TO <i>[landmark]</i>	

“|” Indicates that the next portion of the message will be displayed on the next line(s) of VMS.

## Lanes Closed

General principles for the message element *Lanes Closed* can be found beginning on [page 5-10](#).

Acceptable terms for the *Lanes Closed* message element are shown in Table 7.37.

<b>Table 7.37 ACCEPTABLE TERMS FOR LANES CLOSED VMS ON SAME FREEWAY BUT RELATIVELY FAR FROM CLOSURE</b>	
<b><u>Large Signs</u></b> ALL LANES CLOSED	<b><u>Portable Signs</u></b> ALL   LANES   CLOSED
“ ” Indicates that the next portion of the message will be displayed on the next line(s) of VMS.	

## Effect on Travel

General principles for the message element *Effect on Travel* can be found beginning on [page 5-10](#).

The *Effect on Travel* is implied to motorists by the *Lanes Closed* and *Action* message elements and is not required in the message.

<p><b>Table 7.38 ACCEPTABLE TERMS FOR <i>EFFECT ON TRAVEL</i> VMS ON SAME FREEWAY BUT RELATIVELY FAR FROM CLOSURE</b></p>
---

<p>(Not necessary to display because it is implied by other message elements)</p>
---

**Action**

General principles for the message element *Action* can be found beginning on [page 5-13](#).

The *Action* message element displayed to motorists will be dictated by whether:

- Motorists are not advised to take an alternative route;
- Motorists are advised to take other routes but the specific route is not specified in the VMS message (sometimes referred to as “soft” diversion);
- Motorists are advised by the VMS message to take a specific [Type 1 or Type 2](#) diversion route (*Note: [Type 3](#), [Type 4](#) and [Type 5](#) diversion routes are not applicable.*); or
- Motorists are advised by the VMS to take the specific [Type 6](#) diversion (detour) route.

NJDOT has an established policy that defines when motorists can be advised to take a specific alternative route. This policy should be reviewed before diversion messages are displayed.

***Motorists Are Not Advised to Take an Alternative Route – No Diversion Action Message***

In some cases, it may be best for the motorists to stay on the current freeway rather than turning onto the freeway that is affected by the roadwork.

Acceptable terms for the *Action* message element when lane closures are on another freeway under this situation are shown in Table 7.39.

<b>Table 7.39 ACCEPTABLE TERMS FOR ACTION</b> <b>VMS ON SAME FREEWAY BUT RELATIVELY FAR FROM CLOSURE</b> <b>MOTORISTS ARE NOT ADVISED TO TAKE AN ALTERNATIVE ROUTE-</b> <b>NO DIVERSION ACTION</b>	
<p><b><u>Large Signs</u></b>                      PREPARE TO STOP                      REDUCE SPEED</p>	<p><b><u>Portable Signs</u></b>                      PREPARE   TO   STOP                      REDUCE   SPEED</p>
<p>“ ” Indicates that the next portion of the message will be displayed on the next line(s) of VMS.</p>	

***Motorists Are Advised to Take Other Routes but the Specific Route Is Not Specified in the VMS Message (Soft Diversion)***

A “Soft” Diversion *Action* message element might be displayed when it is advantageous for motorists to leave the freeway far upstream of the closure rather than exiting at the detour location where severe congestion may be present.

Acceptable terms for the *Action* message element in this situation are shown in Table 7.40.

<p><b>Table 7.40 ACCEPTABLE TERMS FOR ACTION</b>  <b>VMS ON SAME FREEWAY BUT RELATIVELY FAR FROM CLOSURE</b>  <b>MOTORISTS ARE ADVISED TO TAKE AN ALTERNATIVE ROUTE-</b>  <b>SOFT DIVERSION</b></p>	
<p><b><u>Large Signs</u></b>  EXIT AND USE OTHER ROUTES  USE OTHER ROUTES</p>	<p><b><u>Portable Signs</u></b>  USE   OTHER   ROUTES</p>
<p>“ ” Indicates that the next portion of the message will be displayed on the next line(s) of VMS.</p>	

**Motorists Are Advised to Take a Specific Type 1 or Type 2 Diversion Route**

There are times when the VMS operator is aware of an acceptable alternative route and has real-time information about the conditions on the alternative route. Guide signs or trailblazers may or may not be present. Police or traffic control personnel are not positioned at critical decision points along the diversion route.

Acceptable terms for the *Action* message element when these conditions exist are shown in Table 7.41.

<b>Table 7.41 ACCEPTABLE TERMS FOR ACTION                      VMS ON SAME FREEWAY BUT RELATIVELY FAR FROM CLOSURE                      MOTORISTS ARE ADVISED TO TAKE A TYPE 1 OR TYPE 2 DIVERSION ROUTE</b>	
<p><b>Large Signs</b></p> <p>EXIT AND USE [highway, street name] [cardinal direction]                      EXIT AND USE [route number] [cardinal direction]                      EXIT AT [highway, street name] [cardinal direction] /                          USE [highway, street name] [cardinal direction]                      EXIT AT [highway, street name] [cardinal direction] /                          USE [route number] [cardinal direction]                      EXIT AT [route number] [cardinal direction] /                          USE [highway, street name] [cardinal direction]                      EXIT AT [route number] [cardinal direction] /                          USE [route number] [cardinal direction]                      TAKE [exit ramp name] EXIT                      TAKE [exit ramp name] EXIT /                          USE [highway, street name] [cardinal direction]                      TAKE [exit ramp name] EXIT /                          USE [route number] [cardinal direction]                      TAKE EXIT [exit ramp number]                      TAKE EXIT [exit ramp number] /                          USE [highway, street name] [cardinal direction]                      TAKE EXIT [exit ramp number] /                          USE [route number] [cardinal direction]                      TAKE [highway, street name] [cardinal direction]                      TAKE [highway, street name] [cardinal direction] /                          USE [highway, street name] [cardinal direction]                      TAKE [highway, street name] [cardinal direction] /                          USE [route number] [cardinal direction]                      TAKE [route number] [cardinal direction]                      TAKE [route number] [cardinal direction] /                          USE [highway, street name] [cardinal direction]                      TAKE [route number] [cardinal direction] /                          USE [route number] [cardinal direction]                      TAKE NEXT EXIT                      TAKE NEXT [number] EXITS                      TUNE RADIO TO [number] AM                      USE [highway, street name] [cardinal direction]                      USE [route number] [cardinal direction]</p>	<p><b>Portable Signs</b></p> <p>EXIT   AND USE   [highway, street name] [cardinal direction]                      EXIT AND   USE [route number] [cardinal direction]                      EXIT   AT   [highway, street name] [cardinal direction] /                          USE   [highway, street name] [cardinal direction]                      EXIT   AT   [highway, street name] [cardinal direction] /                          USE [route number] [cardinal direction]                      EXIT   AT [route number] [cardinal direction] /                          USE   [highway, street name] [cardinal direction]                      EXIT   AT [route number] [cardinal direction]                            USE [route number] [cardinal direction]                      TAKE   [exit ramp name]   EXIT                      TAKE   [exit ramp name]   EXIT /                          USE   [highway, street name] [cardinal direction]                      TAKE   [exit ramp name]   EXIT                            USE [route number] [cardinal direction]                      TAKE   EXIT [exit ramp number]                      TAKE   EXIT [exit ramp number] /                          USE   [highway, street name] [cardinal direction]                      TAKE   EXIT [exit ramp number]                            USE [route number] [cardinal direction]                      TAKE   [highway, street name] [cardinal direction]                      TAKE   [highway, street name] [cardinal direction] /                          USE   [highway, street name] [cardinal direction]                      TAKE   [highway, street name] [cardinal direction] /                          USE [route number] [cardinal direction]                      TAKE [route number] [cardinal direction]                      TAKE [route number] [cardinal direction] /                          USE   [highway, street name] [cardinal direction]                      TAKE [route number] [cardinal direction] /                          USE [route number] [cardinal direction]                      TAKE   NEXT   EXIT                      TAKE   NEXT   [number] EXITS                      TUNE   RADIO   TO [number] AM                      USE   [highway, street name] [cardinal direction]                      USE [route number] [cardinal direction]</p>
<p>" " Indicates that the next portion of the message will be displayed on the next line(s) of VMS.</p>	



**Motorists Are Advised to Take a Specific Type 6 Diversion Route.**

There are times when it is best to send the motorists at the VMS location to the diversion (detour) route that has been set up downstream.

Acceptable terms for the *Action* message element when this condition exists are shown in Table 7.42.

<b>Table 7.42 ACCEPTABLE TERMS FOR ACTION</b> <b>VMS ON SAME FREEWAY BUT RELATIVELY FAR FROM CLOSURE</b> <b>MOTORISTS ARE ADVISED TO TAKE THE TYPE 6 DIVERSION (DETOUR) ROUTE</b>	
<p><b>Large Signs</b></p> <p>EXIT AT [highway, street name] [cardinal direction] / FOLLOW DETOUR</p> <p>EXIT AT [highway, street name] [cardinal direction] / FOLLOW SIGNS</p> <p>EXIT AT [route number] [cardinal direction] / FOLLOW DETOUR</p> <p>EXIT AT [route number] [cardinal direction] / FOLLOW SIGNS</p> <p>TAKE [exit ramp name] EXIT   FOLLOW DETOUR</p> <p>TAKE [exit ramp name] EXIT   FOLLOW SIGNS</p> <p>TAKE EXIT [exit ramp number] / FOLLOW DETOUR</p> <p>TAKE EXIT [exit ramp number] / FOLLOW SIGNS</p> <p>TAKE [highway, street name] [cardinal direction] / FOLLOW DETOUR</p> <p>TAKE [highway, street name] [cardinal direction] / FOLLOW SIGNS</p> <p>TAKE [route number] [cardinal direction] / FOLLOW DETOUR</p> <p>TAKE [route number] [cardinal direction] / FOLLOW SIGNS</p>	<p><b>Portable Signs</b></p> <p>EXIT   AT   [highway, street name] [cardinal direction] / FOLLOW   DETOUR</p> <p>EXIT   AT   [highway, street name] [cardinal direction] / FOLLOW   SIGNS</p> <p>EXIT   AT [route number] [cardinal direction] / FOLLOW   DETOUR</p> <p>EXIT   AT [route number] [cardinal direction] / FOLLOW   SIGNS</p> <p>TAKE   [exit ramp name]   EXIT   FOLLOW   DETOUR</p> <p>TAKE   [exit ramp name]   EXIT   FOLLOW   SIGNS</p> <p>TAKE   EXIT [exit ramp number] / FOLLOW   DETOUR</p> <p>TAKE   EXIT [exit ramp number] / FOLLOW   SIGNS</p> <p>TAKE   [highway, street name] [cardinal direction] / FOLLOW   DETOUR</p> <p>TAKE   [highway, street name] [cardinal direction] / FOLLOW   SIGNS</p> <p>TAKE [route number] [cardinal direction] / FOLLOW   DETOUR</p> <p>TAKE [route number] [cardinal direction] / FOLLOW   SIGNS</p>
<p>“ ” Indicates that the next portion of the message will be displayed on the next line(s) of VMS.</p>	

**Audience for Action**

General principles for the message element *Audience for Action* can be found beginning on [page 5-12](#).

Acceptable terms for the *Audience for Action* message element are shown in Table 7.43.

<b>Table 7.43 ACCEPTABLE TERMS FOR AUDIENCE FOR ACTION VMS ON SAME FREEWAY BUT RELATIVELY FAR FROM CLOSURE</b>	
<b><u>Large Signs</u></b>	<b><u>Portable Signs</u></b>
<i>[highway, street name] [cardinal direction]</i>	<i>[highway, street name] [cardinal direction]</i>
<i>[route number] [cardinal direction]</i>	<i>[route number] [cardinal direction]</i>
<i>[name of city or state]</i>	<i>[name of city or state]</i>
<i>[name of event, tourist attraction]</i>	<i>[name of event, tourist attraction]</i>
<i>[name of stadium, park, etc.]</i>	<i>[name of stadium, park, etc.]</i>
TO <i>[highway, street name][cardinal direction]</i>	TO <i>[highway, street name][cardinal direction]</i>
TO <i>[route number] [cardinal direction]</i>	TO <i>[route number] [cardinal direction]</i>
TO <i>[name of city or state]</i>	TO <i>[name of city or state]</i>
TO <i>[name of event, tourist attraction]</i>	TO <i>[name of event, tourist attraction]</i>
TO <i>[name of stadium, park, etc.]</i>	TO <i>[name of stadium, park, etc.]</i>
<p>“ ” Indicates that the next portion of the message will be displayed on the next line(s) of VMS.</p>	

## Good Reason for Following the Action

General guidelines for displaying the message element *Good Reason for Following the Action* are given on [page 5-13](#).

As a rule, when the freeway is closed and *ALL LANES CLOSED* or *FREEWAY CLOSED* is displayed, the reason for following the suggested action is implied, and there is no need to display the reason. However, when a recommended diversion route may be perceived by motorists as not being the most logical route, then a *Good Reason for Following the Action* should be displayed.

The terms shown in Table 7.44 below are acceptable to display.

<b>Table 7.44 ACCEPTABLE TERMS FOR <i>GOOD REASON FOR FOLLOWING THE ACTION</i> VMS ON SAME FREEWAY BUT RELATIVELY FAR FROM CLOSURE</b>	
<b><u>Large Signs</u></b>	<b><u>Portable Signs</u></b>
AVOID DELAY	AVOID   DELAY
AVOID MAJOR DELAY	AVOID   MAJOR   DELAY
SAVE [number] MINUTES	SAVE   [number] MIN
BEST ROUTE TO [destination]	BEST   ROUTE TO   [destination]
<p>“ ” Indicates that the next portion of the message will be displayed on the next line(s) of VMS.</p>	

**VMS ON DIFFERENT FREEWAY THAN THE ROADWORK AND CLOSURE**

The VMS operational guidelines in this section of the Manual apply when the VMS is on a different freeway than the freeway closure, but the closure still can have an effect on motorists who are passing the VMS. For example, westbound I-195 motorists who intend to exit I-195 and enter northbound I-295 to travel to the city of Princeton could be affected by the closure of northbound I-295. Messages displayed on VMSs on westbound I-195 concerning the closure on northbound I-295 can be helpful to those motorists heading to Princeton.

The major difference between the messages displayed on VMSs located on a different freeway than the closure in comparison to the messages on VMSs located on the same freeway as the closure but far upstream of the work is in the diversion information provided.

## Roadwork Descriptor

Warnings of freeway closures due to roadwork should be displayed under all traffic conditions in peak or off-peak periods.

Acceptable terms for the *Roadwork Descriptor* message element are given in Table 7.45.

<b>Table 7.45 ACCEPTABLE <i>ROADWORK DESCRIPTORS</i> VMS ON DIFFERENT FREEWAY THAN CLOSURE</b>	
<b><u>Large Signs</u></b> CONSTRUCTION* ROADWORK	<b><u>Portable Signs</u></b> CONST or ROADWORK* ROADWORK
* The word <i>CONSTRUCTION</i> will not fit on an eight-character line of a portable VMS. Therefore, the word must either be abbreviated or replaced with the word <i>ROADWORK</i> .	

The word *ROADWORK* may be substituted for the longer word *CONSTRUCTION*. Motorist interpretations of both words are described on [page 5-14](#). In addition, *CONST* is an acceptable abbreviation for *CONSTRUCTION*.

**Closure Location**

General principles for the message element *Closure Location* can be found beginning on [page 5-10](#).

Acceptable terms for the *Closure Location* message element are shown in Table 7.46. Note that portable VMSs cannot be used when it is desirable to inform motorists the length of the closure for the roadwork (e.g., *I-80 EAST CLOSED FROM EXIT 42 TO EXIT 43*).

<b>Table 7.46 ACCEPTABLE TERMS FOR CLOSURE LOCATION VMS ON DIFFERENT FREEWAY THAN CLOSURE</b>	
<b><u>Large Signs</u></b>	<b><u>Portable Signs</u></b>
AT [highway, street name]*	AT   [highway, street name]*
AT EXIT [exit ramp number]*	AT EXIT [exit ramp number]*
AT [exit ramp name] EXIT*	AT   [exit ramp name]   EXIT*
AT [landmark]*	AT   [landmark]*
FROM [highway, street name] / TO [highway, street name]*	
FROM [highway, street name] / TO EXIT [exit ramp number]*	
FROM [highway, street name] / TO [exit ramp name] EXIT*	
FROM [highway, street name] / TO [landmark]*	
FROM EXIT [exit ramp number] / TO [highway, street name]*	
FROM EXIT [exit ramp number] / TO EXIT [exit ramp number]*	
FROM EXIT [exit ramp number] / TO [exit ramp name] EXIT*	
FROM EXIT [exit ramp number] / TO [landmark]*	
FROM [exit ramp name] EXIT TO [highway, street name]*	
FROM [exit ramp name] EXIT / TO EXIT [exit ramp number]*	
FROM [exit ramp name] EXIT / TO [exit ramp name] EXIT*	
FROM [exit ramp name] EXIT / TO [landmark]*	
FROM [landmark] / TO [highway, street name]*	
FROM [landmark] / TO EXIT [exit ramp number]*	
FROM [landmark] / TO [exit ramp name] EXIT*	
FROM [landmark] / TO [landmark]*	
* Insert "ON [route number, highway or street name] [cardinal direction]" in front of <b>Closure Location</b> .	
" " Indicates that the next portion of the message will be displayed on the next line(s) of VMS.	

## Lanes Closed

General principles for the message element *Lanes Closed* can be found beginning on [page 5-10](#).

Acceptable terms for the *Lanes Closed* message element are shown in Table 7.47.

**Table 7.47 ACCEPTABLE TERMS FOR LANES CLOSED  
VMS ON DIFFERENT FREEWAY THAN CLOSURE**

**Large Signs**

ALL LANES CLOSED

**Portable Signs**

ALL | LANES | CLOSED

“|” Indicates that the next portion of the message will be displayed on the next line(s) of VMS.

**Effect on Travel**

General principles for the message element *Effect on Travel* can be found beginning on [page 5-10](#).

The *Effect on Travel* is implied to motorists by the *Lanes Closed* and *Action* message elements and is not required in the message.

<p><b>Table 7.48 ACCEPTABLE TERMS FOR <i>EFFECT ON TRAVEL</i> VMS ON DIFFERENT FREEWAY THAN CLOSURE</b></p>
---

<p>(Not necessary to display because it is implied by other message elements)</p>
---



**Action**

General principles for the message element *Action* can be found beginning on [page 5-13](#).

The *Action* message element displayed to motorists will be dictated by whether:

- Motorists who will turn onto the affected freeway are not advised to take an alternative route;
- Motorists who will turn onto the affected freeway are advised to take other routes but the specific route is not specified in the VMS message (sometimes referred to as “soft” diversion); or
- Motorists who will turn onto the affected freeway are advised by the VMS message to take a specific [Type 1](#) or [Type 2](#) diversion route. (*Note: [Type 3](#), [Type 4](#), [Type 5](#) and [Type 6](#) diversion routes are not applicable.*)

NJDOT has an established policy that defines when motorists can be advised to take a specific alternative route. This policy should be reviewed before diversion messages are displayed.

***Motorists Are Not Advised to Take an Alternative Route – No Diversion Message***

There may be situations when it is better for the motorists intending to turn onto the freeway with the closure to stay on the existing freeway.

Acceptable terms for the *Action* message element when closures occur under this situation are shown in Table 7.49.

<b>Table 7.49 ACCEPTABLE TERMS FOR ACTION                      VMS ON DIFFERENT FREEWAY THAN CLOSURE                      MOTORISTS ARE NOT ADVISED TO TAKE AN ALTERNATIVE ROUTE-                      NO DIVERSION ACTION</b>	
<p><b><u>Large Signs</u></b>                      PREPARE TO STOP                      REDUCE SPEED                      STAY ON [route number] [cardinal direction]                      STAY ON [highway, street name] [cardinal direction]</p>	<p><b><u>Portable Signs</u></b>                      PREPARE   TO   STOP                      REDUCE   SPEED                      STAY   ON [route number] [cardinal direction]                      STAY   ON   [highway, street name] [cardinal direction]</p>
<p>“ ” Indicates that the next portion of the message will be displayed on the next line(s) of VMS.</p>	

***Motorists Are Advised to Take Other Routes but the Specific Route Is Not Specified in the VMS Message (Soft Diversion)***

A “Soft” Diversion *Action* message element might be displayed when it is advantageous for motorists to leave the existing freeway rather than turning onto the freeway with the closure and exiting at the detour location where severe congestion may be present.

Acceptable terms for the *Action* message element in this situation are shown in Table 7.50.

<p><b>Table 7.50 ACCEPTABLE TERMS FOR ACTION VMS ON DIFFERENT FREEWAY THAN CLOSURE MOTORISTS ARE ADVISED TO TAKE AN ALTERNATIVE ROUTE- SOFT DIVERSION</b></p>	
<p><b><u>Large Signs</u></b> EXIT AND USE OTHER ROUTES USE OTHER ROUTES</p>	<p><b><u>Portable Signs</u></b> USE   OTHER   ROUTE</p>
<p>“ ” Indicates that the next portion of the message will be displayed on the next line(s) of VMS.</p>	

**Motorists Are Advised to Take a Specific Type 1 or Type 2 Diversion Route.**

There are times when the VMS operator is aware of an acceptable alternative route and has real-time information about the conditions on the alternative route. Guide signs or trailblazers may or may not be present. Police or traffic control personnel are not positioned at critical decision points along the diversion route.

Acceptable terms for the *Action* message element when these conditions exist are shown in Table 7.51.

**Table 7.51 ACCEPTABLE TERMS FOR ACTION  
VMS ON DIFFERENT FREEWAY THAN CLOSURE  
MOTORISTS ARE ADVISED TO TAKE A TYPE 1 OR TYPE 2 DIVERSION ROUTE**

**Large Signs**

EXIT AND USE [highway, street name] [cardinal direction]  
 EXIT AND USE [route number] [cardinal direction]  
 EXIT AT [highway, street name] [cardinal direction] /  
     USE [highway, street name] [cardinal direction]  
 EXIT AT [highway, street name] [cardinal direction] /  
     USE [route number] [cardinal direction]  
 EXIT AT [route number] [cardinal direction] /  
     USE [highway, street name] [cardinal direction]  
 EXIT AT [route number] [cardinal direction] /  
     USE [route number] [cardinal direction]  
 TAKE [exit ramp name] EXIT  
 TAKE [exit ramp name] EXIT /  
     USE [highway, street name] [cardinal direction]  
 TAKE [exit ramp name] EXIT /  
     USE [route number] [cardinal direction]  
 TAKE EXIT [exit ramp number]  
 TAKE EXIT [exit ramp number] /  
     USE [highway, street name] [cardinal direction]  
 TAKE EXIT [exit ramp number] /  
     USE [route number] [cardinal direction]  
 TAKE [highway, street name] [cardinal direction]  
 TAKE [highway, street name] [cardinal direction] /  
     USE [highway, street name] [cardinal direction]  
 TAKE [highway, street name] [cardinal direction] /  
     USE [route number] [cardinal direction]  
 TAKE [route number] [cardinal direction]  
 TAKE [route number] [cardinal direction] /  
     USE [highway, street name] [cardinal direction]  
 TAKE [route number] [cardinal direction] /  
     USE [route number] [cardinal direction]  
 TAKE NEXT EXIT  
 TAKE NEXT [number] EXITS  
 TUNE RADIO TO [number] AM  
 USE [highway, street name] [cardinal direction]  
 USE [route number] [cardinal direction]

**Portable Signs**

EXIT | AND USE | [highway, street name] [cardinal direction]  
 EXIT AND | USE [route number] [cardinal direction]  
 EXIT | AT | [highway, street name] [cardinal direction] /  
     USE | [highway, street name] [cardinal direction]  
 EXIT | AT | [highway, street name] [cardinal direction] /  
     USE [route number] [cardinal direction]  
 EXIT | AT [route number] [cardinal direction] /  
     USE | [highway, street name] [cardinal direction]  
 EXIT | AT [route number] [cardinal direction] |  
     USE [route number] [cardinal direction]  
 TAKE | [exit ramp name] | EXIT  
 TAKE | [exit ramp name] | EXIT /  
     USE | [highway, street name] [cardinal direction]  
 TAKE | [exit ramp name] | EXIT |  
     USE [route number] [cardinal direction]  
 TAKE | EXIT [exit ramp number]  
 TAKE | EXIT [exit ramp number] /  
     USE | [highway, street name] [cardinal direction]  
 TAKE | EXIT [exit ramp number] |  
     USE [route number] [cardinal direction]  
 TAKE | [highway, street name] [cardinal direction]  
 TAKE | [highway, street name] [cardinal direction] /  
     USE | [highway, street name] [cardinal direction]  
 TAKE | [highway, street name] [cardinal direction] /  
     USE [route number] [cardinal direction]  
 TAKE [route number] [cardinal direction]  
 TAKE [route number] [cardinal direction] /  
     USE | [highway, street name] [cardinal direction]  
 TAKE [route number] [cardinal direction] /  
     USE [route number] [cardinal direction]  
 TAKE | NEXT | EXIT  
 TAKE | NEXT | [number] EXITS  
 TUNE | RADIO | TO [number] AM  
 USE | [highway, street name] [cardinal direction]  
 USE [route number] [cardinal direction]

"|" Indicates that the next portion of the message will be displayed on the next line(s) of VMS.

**Audience for Action**

General principles for the message element *Audience for Action* can be found beginning on [page 5-12](#).

Acceptable terms for the *Audience for Action* message element are shown in Table 7.52.

<b>Table 7.52 ACCEPTABLE TERMS FOR AUDIENCE FOR ACTION VMS ON DIFFERENT FREEWAY THAN CLOSURE</b>	
<b><u>Large Signs</u></b>	<b><u>Portable Signs</u></b>
<i>[highway, street name] [cardinal direction]</i>	<i>[highway, street name] [cardinal direction]</i>
<i>[route number] [cardinal direction]</i>	<i>[route number] [cardinal direction]</i>
<i>[name of city or state]</i>	<i>[name of city or state]</i>
<i>[name of event, tourist attraction]</i>	<i>[name of event, tourist attraction]</i>
<i>[name of stadium, park, etc.]</i>	<i>[name of stadium, park, etc.]</i>
TO <i>[highway, street name][cardinal direction]</i>	TO <i>[highway, street name][cardinal direction]</i>
TO <i>[route number] [cardinal direction]</i>	TO <i>[route number] [cardinal direction]</i>
TO <i>[name of city or state]</i>	TO <i>[name of city or state]</i>
TO <i>[name of event, tourist attraction]</i>	TO <i>[name of event, tourist attraction]</i>
TO <i>[name of stadium, park, etc.]</i>	TO <i>[name of stadium, park, etc.]</i>

“|” Indicates that the next portion of the message will be displayed on the next line(s) of VMS.

### Good Reason for Following the Action

General guidelines for a displaying the message element *Good Reason for Following the Action* are given on [page 5-13](#).

As a rule, when the freeway is closed and *ALL LANES CLOSED* or *FREEWAY CLOSED* is displayed, the reason for following the suggested action is implied, and there is no need to display the reason. However, when a recommended diversion route may be perceived by motorists as not being the most logical route, then a *Good Reason for Following the Action* should be displayed.

The terms shown in Table 7.53 below are acceptable to display.

<b>Table 7.53 ACCEPTABLE TERMS FOR GOOD REASON FOR FOLLOWING THE ACTION VMS ON DIFFERENT FREEWAY THAN CLOSURE</b>	
<p><b><u>Large Signs</u></b>                      AVOID DELAY                      AVOID MAJOR DELAY                      SAVE [number] MINUTES                      BEST ROUTE TO [destination]</p>	<p><b><u>Portable Signs</u></b>                      AVOID   DELAY                      AVOID   MAJOR   DELAY                      SAVE   [number] MIN                      BEST   ROUTE TO   [destination]</p>
<p>“ ” Indicates that the next portion of the message will be displayed on the next line(s) of VMS.</p>	

## 7.3 BASIC VMS MESSAGE FOR ROADWORK ON AN INTERSECTING FREEWAY THAT REQUIRES CLOSING THE CONNECTOR RAMP

### BASIC VMS MESSAGE ELEMENTS

The Basic VMS Message for closure of a freeway-to-freeway connector during roadwork includes the following: 1) *Roadwork Descriptor (situation description)*; 2) *Closure Location*; 3) *Lanes Closed*; 4) *Ramp Closure Descriptor*; 5) *Audience for Action*; 6) *Action*; and 7) *Good Reason for Following the Action*.

#### BASIC VMS MESSAGE ELEMENTS

- **Roadwork Descriptor (situation description);**
- **Closure Location;**
- **Lanes Closed;**
- **Ramp Closure Descriptor;**
- **Audience for Action (when the action is for a specific group of motorists);**
- **Action (tells motorists what to do); and**
- **Good Reason for Following the Action statement (usually implied by other message elements).**

**VMS UPSTREAM OF THE CONNECTOR RAMP CLOSURE****Roadwork Descriptor**

Acceptable terms for the *Roadwork Descriptor* message element are given in Table 7.54.

<b>Table 7.54 ACCEPTABLE ROADWORK DESCRIPTORS VMS UPSTREAM OF CONNECTOR RAMP CLOSURE</b>	
<b><u>Large Signs</u></b>	<b><u>Portable Signs</u></b>
CONSTRUCTION*	CONST <u>or</u> ROADWORK*
ROADWORK	ROADWORK
* The word <i>CONSTRUCTION</i> will not fit on an eight-character line of a portable VMS. Therefore, the word must either be abbreviated or replaced with the word <i>ROADWORK</i> .	

The word *ROADWORK* may be substituted for the longer word *CONSTRUCTION*. Motorist interpretations of both words are described on [page 5-14](#). In addition, *CONST* is an acceptable abbreviation for *CONSTRUCTION*.

## Closure Location

General principles for the message element *Closure Location* can be found beginning on [page 5-10](#).

Acceptable terms for the *Closure Location* message element are shown in Table 7.55. Note that portable VMSs cannot be used when it is desirable to inform motorists the length of the closure for the roadwork (e.g., *I-80 EAST CLOSED FROM EXIT 42 TO EXIT 43*).

<b>Table 7.55 ACCEPTABLE TERMS FOR <i>CLOSURE LOCATION</i> VMS UPSTREAM OF CONNECTOR RAMP CLOSURE</b>	
<b><u>Large Signs</u></b>	<b><u>Portable Signs</u></b>
AT [ <i>highway, street name</i> ]*	AT   [ <i>highway, street name</i> ]*
AT EXIT [ <i>exit ramp number</i> ]*	AT EXIT [ <i>exit ramp number</i> ]*
AT [ <i>exit ramp name</i> ] EXIT*	AT   [ <i>exit ramp name</i> ]   EXIT*
AT [ <i>landmark</i> ]*	AT   [ <i>landmark</i> ]*
FROM [ <i>highway, street name</i> ]   TO [ <i>highway, street name</i> ]*	
FROM [ <i>highway, street name</i> ]   TO EXIT [ <i>exit ramp number</i> ]*	
FROM [ <i>highway, street name</i> ]   TO [ <i>exit ramp name</i> ] EXIT*	
FROM [ <i>highway, street name</i> ]   TO [ <i>landmark</i> ]*	
FROM EXIT [ <i>exit ramp number</i> ]   TO [ <i>highway, street name</i> ]*	
FROM EXIT [ <i>exit ramp number</i> ]   TO EXIT [ <i>exit ramp number</i> ]*	
FROM EXIT [ <i>exit ramp number</i> ]   TO [ <i>exit ramp name</i> ] EXIT*	
FROM EXIT [ <i>exit ramp number</i> ]   TO [ <i>landmark</i> ]*	
FROM [ <i>exit ramp name</i> ] EXIT TO [ <i>highway, street name</i> ]*	
FROM [ <i>exit ramp name</i> ] EXIT   TO EXIT [ <i>exit ramp number</i> ]*	
FROM [ <i>exit ramp name</i> ] EXIT   TO [ <i>exit ramp name</i> ] EXIT*	
FROM [ <i>exit ramp name</i> ] EXIT   TO [ <i>landmark</i> ]*	
FROM [ <i>landmark</i> ]   TO [ <i>highway, street name</i> ]*	
FROM [ <i>landmark</i> ]   TO EXIT [ <i>exit ramp number</i> ]*	
FROM [ <i>landmark</i> ]   TO [ <i>exit ramp name</i> ] EXIT*	
FROM [ <i>landmark</i> ]   TO [ <i>landmark</i> ]*	
* Insert “ON [ <i>route number, highway or street name</i> ] [ <i>cardinal direction</i> ]” in front of <b>Closure Location</b> .	
“ ” Indicates that the next portion of the message will be displayed on the next line(s) of VMS.	



## Ramp Closure Descriptor

Acceptable terms for the *Ramp Closure Descriptor* Message Element are shown in Table 7.56.

**Table 7.56 ACCEPTABLE TERMS FOR RAMP CLOSURE DESCRIPTORS  
VMS UPSTREAM OF CONNECTOR RAMP CLOSURE**

**Large Signs**

RAMP CLOSED |  
 TO [intersecting fwy number] [card. direction])  
 RAMP CLOSED |  
 TO [intersecting freeway name] FREEWAY  
 [intersecting fwy number] CLOSED  
 [intersecting fwy number] [card. direction]) CLOSED

**Portable Signs**

RAMP | CLOSED |  
 TO [intersecting fwy number] [card. direction]  
 [intersecting fwy number] | CLOSED  
 [intersecting fwy number] [card. direction])  
 CLOSED

“|” Indicates that the next portion of the message will be displayed on the next line(s).

**Action**

General principles for the message element *Action* can be found beginning on [page 5-13](#).

The *Action* message element displayed to motorists will be dictated by whether:

- Motorists are advised to take other routes but the specific route is not specified in the VMS message (sometimes referred to as “soft” diversion);
- Motorists who will turn onto the affected ramp are advised by the VMS message to take a specific [Type 1 or Type 2](#) diversion route (*Note: Type 3, Type 4 and Type 6 diversion routes are not applicable.*); or
- Motorists who will turn onto the affected ramp are advised by the VMS message to take the [Type 5](#) diversion (detour) route.

NJDOT has an established policy that defines when motorists can be advised to take a specific alternative route. This policy should be reviewed before diversion messages are displayed.

***Motorists Are Advised to Take Other Routes but the Specific Route Is Not Specified in the VMS Message (Soft Diversion)***

A “Soft” Diversion *Action* message element might be displayed when it is not possible for the VMS operator to specify a specific route the motorist should use.

Acceptable terms for the *Action* message element in this situation are shown in Table 7.57.

<p><b>Table 7.57 ACCEPTABLE TERMS FOR ACTION VMS UPSTREAM OF CONNECTOR RAMP CLOSURE MOTORISTS ARE ADVISED TO TAKE AN ALTERNATIVE ROUTE- SOFT DIVERSION</b></p>	
<p><b><u>Large Signs</u></b> EXIT AND USE OTHER ROUTES USE OTHER ROUTES</p>	<p><b><u>Portable Signs</u></b> USE   OTHER   ROUTES</p>
<p>“ ” Indicates that the next portion of the message will be displayed on the next line(s) of VMS.</p>	

**Motorists Are Advised to Take a Specific Type 1 or Type 2 Diversion Route**

There are times when the VMS operator is aware of an acceptable alternative route and has real-time information about the conditions on the alternative route. Guide signs or trailblazers may or may not be present. Police or traffic control personnel are not positioned at critical decision points along the diversion route.

Acceptable terms for the *Action* message element when these conditions exist are shown in Table 7.58.

<b>Table 7.58 ACCEPTABLE TERMS FOR ACTION                      VMS UPSTREAM OF CONNECTOR RAMP CLOSURE                      MOTORISTS ARE ADVISED TO TAKE A TYPE 1 OR TYPE 2 DIVERSION ROUTE</b>	
<p><b>Large Signs</b></p> <p>EXIT AND USE [highway, street name] [cardinal direction]                      EXIT AND USE [route number] [cardinal direction]                      EXIT AT [highway, street name] [cardinal direction] /                          USE [highway, street name] [cardinal direction]                      EXIT AT [highway, street name] [cardinal direction] /                          USE [route number] [cardinal direction]                      EXIT AT [route number] [cardinal direction] /                          USE [highway, street name] [cardinal direction]                      EXIT AT [route number] [cardinal direction] /                          USE [route number] [cardinal direction]                      TAKE [exit ramp name] EXIT                      TAKE [exit ramp name] EXIT /                          USE [highway, street name] [cardinal direction]                      TAKE [exit ramp name] EXIT /                          USE [route number] [cardinal direction]                      TAKE EXIT [exit ramp number]                      TAKE EXIT [exit ramp number] /                          USE [highway, street name] [cardinal direction]                      TAKE EXIT [exit ramp number] /                          USE [route number] [cardinal direction]                      TAKE [highway, street name] [cardinal direction]                      TAKE [highway, street name] [cardinal direction] /                          USE [highway, street name] [cardinal direction]                      TAKE [highway, street name] [cardinal direction] /                          USE [route number] [cardinal direction]                      TAKE [route number] [cardinal direction]                      TAKE [route number] [cardinal direction] /                          USE [highway, street name] [cardinal direction]                      TAKE [route number] [cardinal direction] /                          USE [route number] [cardinal direction]                      TAKE NEXT EXIT                      TAKE NEXT [number] EXITS                      TUNE RADIO TO [number] AM                      USE [highway, street name] [cardinal direction]                      USE [route number] [cardinal direction]</p>	<p><b>Portable Signs</b></p> <p>EXIT   AND USE   [highway, street name] [cardinal direction]                      EXIT AND   USE [route number] [cardinal direction]                      EXIT   AT   [highway, street name] [cardinal direction] /                          USE   [highway, street name] [cardinal direction]                      EXIT   AT   [highway, street name] [cardinal direction] /                          USE [route number] [cardinal direction]                      EXIT   AT [route number] [cardinal direction] /                          USE   [highway, street name] [cardinal direction]                      EXIT   AT [route number] [cardinal direction]                            USE [route number] [cardinal direction]                      TAKE   [exit ramp name]   EXIT                      TAKE   [exit ramp name]   EXIT /                          USE   [highway, street name] [cardinal direction]                      TAKE   [exit ramp name]   EXIT                            USE [route number] [cardinal direction]                      TAKE   EXIT [exit ramp number]                      TAKE   EXIT [exit ramp number] /                          USE   [highway, street name] [cardinal direction]                      TAKE   EXIT [exit ramp number]                            USE [route number] [cardinal direction]                      TAKE   [highway, street name] [cardinal direction]                      TAKE   [highway, street name] [cardinal direction] /                          USE   [highway, street name] [cardinal direction]                      TAKE   [highway, street name] [cardinal direction] /                          USE [route number] [cardinal direction]                      TAKE [route number] [cardinal direction]                      TAKE [route number] [cardinal direction] /                          USE   [highway, street name] [cardinal direction]                      TAKE [route number] [cardinal direction] /                          USE [route number] [cardinal direction]                      TAKE   NEXT   EXIT                      TAKE   NEXT   [number] EXITS                      TUNE   RADIO   TO [number] AM                      USE   [highway, street name] [cardinal direction]                      USE [route number] [cardinal direction]</p>
<p>" " Indicates that the next portion of the message will be displayed on the next line(s) of VMS.</p>	

**Motorists Are Advised to Take a Specific Type 6 Diversion Route**

There are times when the Incident Emergency Route Plan has been implemented. Thus guide signs, trailblazers and police and/or traffic control personnel are guiding motorists at critical locations along the route.

Acceptable terms for the *Action* message element when this condition exists are shown in Table 7.59.

<b>Table 7.59 ACCEPTABLE TERMS FOR ACTION                      VMS UPSTREAM OF CONNECTOR RAMP CLOSURE                      MOTORISTS ARE ADVISED TO TAKE THE TYPE 5 DIVERSION (DETOUR) ROUTE</b>	
<b>Large Signs</b>	<b>Portable Signs</b>
EXIT AT [highway, street name] [cardinal direction] / FOLLOW DETOUR	EXIT   AT   [highway, street name] [cardinal direction] / FOLLOW   DETOUR
EXIT AT [highway, street name] [cardinal direction] / FOLLOW SIGNS	EXIT   AT   [highway, street name] [cardinal direction] / FOLLOW   SIGNS
EXIT AT [route number] [cardinal direction] / FOLLOW DETOUR	EXIT   AT [route number] [cardinal direction] / FOLLOW   DETOUR
EXIT AT [route number] [cardinal direction] / FOLLOW SIGNS	EXIT   AT [route number] [cardinal direction]   FOLLOW   SIGNS
TAKE [exit ramp name] EXIT   FOLLOW DETOUR	TAKE   [exit ramp name]   EXIT   FOLLOW   DETOUR
TAKE [exit ramp name] EXIT   FOLLOW SIGNS	TAKE   [exit ramp name]   EXIT   FOLLOW   SIGNS
TAKE EXIT [exit ramp number] / FOLLOW DETOUR	TAKE   EXIT [exit ramp number] / FOLLOW   DETOUR
TAKE EXIT [exit ramp number] / FOLLOW SIGNS	TAKE   EXIT [exit ramp number]   FOLLOW   SIGNS
TAKE [highway, street name] [cardinal direction] / FOLLOW DETOUR	TAKE   [highway, street name] [cardinal direction] / FOLLOW   DETOUR
TAKE [highway, street name] [cardinal direction] / FOLLOW SIGNS	TAKE   [highway, street name] [cardinal direction] / FOLLOW   SIGNS
TAKE [route number] [cardinal direction] / FOLLOW DETOUR	TAKE [route number] [cardinal direction] / FOLLOW   DETOUR
TAKE [route number] [cardinal direction] / FOLLOW SIGNS	TAKE [route number] [cardinal direction] / FOLLOW   SIGNS

“|” Indicates that the next portion of the message will be displayed on the next line(s) of VMS.

**Audience for Action**

General principles for the message element *Audience for Action* can be found beginning on [page 5-12](#).

Acceptable terms for the *Audience for Action* message element are shown in Table 7.60.

<b>Table 7.60 ACCEPTABLE TERMS FOR AUDIENCE FOR ACTION VMS UPSTREAM OF CONNECTOR RAMP CLOSURE</b>	
<b><u>Large Signs</u></b>	<b><u>Portable Signs</u></b>
<i>[highway, street name] [cardinal direction]</i>	<i>[highway, street name] [cardinal direction]</i>
<i>[route number] [cardinal direction]</i>	<i>[route number] [cardinal direction]</i>
<i>[name of city or state]</i>	<i>[name of city or state]</i>
<i>[name of event, tourist attraction]</i>	<i>[name of event, tourist attraction]</i>
<i>[name of stadium, park, etc.]</i>	<i>[name of stadium, park, etc.]</i>
TO <i>[highway, street name][cardinal direction]</i>	TO <i>[highway, street name][cardinal direction]</i>
TO <i>[route number] [cardinal direction]</i>	TO <i>[route number] [cardinal direction]</i>
TO <i>[name of city or state]</i>	TO <i>[name of city or state]</i>
TO <i>[name of event, tourist attraction]</i>	TO <i>[name of event, tourist attraction]</i>
TO <i>[name of stadium, park, etc.]</i>	TO <i>[name of stadium, park, etc.]</i>
<p>“ ” Indicates that the next portion of the message will be displayed on the next line(s) of VMS.</p>	

## Good Reason for Following the Action

General guidelines for displaying the message element *Good Reason for Following the Action* are given on [page 5-13](#).

The terms shown in Table 7.61 are acceptable to display.

<b>Table 7.61 ACCEPTABLE TERMS FOR <i>GOOD REASON FOR FOLLOWING THE ACTION</i> VMS UPSTREAM OF CONNECTOR RAMP CLOSURE</b>	
<p><b><u>Large Signs</u></b>                      AVOID DELAY                      AVOID MAJOR DELAY                      SAVE [number] MINUTES                      BEST ROUTE TO [destination]</p>	<p><b><u>Portable Signs</u></b>                      AVOID   DELAY                      AVOID   MAJOR   DELAY                      SAVE   [number] MIN                      BEST   ROUTE TO   [destination]</p>
<p>“ ” Indicates that the next portion of the message will be displayed on the next line(s) of VMS.</p>	

**THIS PAGE LEFT BLANK**

# MODULE 8. ESTABLISHING THE MAXIMUM MESSAGE LENGTH

## TABLE OF CONTENTS

<b>8.1 MESSAGE LENGTH AND VMS VIEWING DISTANCE REQUIREMENTS</b>	8-1
<b>8.2 MAXIMUM VMS LEGIBILITY DISTANCES FOR DAY AND NIGHT OPERATIONS</b>	8-4
<b>8.3 UNITS OF INFORMATION REDUCTIONS FOR VERTICAL CURVES – LED VMSs</b>	8-6
INTRODUCTION	8-6
REDUCTIONS FOR VERTICAL CURVE DESIGN SPEEDS 45 MPH AND ABOVE	8-6
REDUCTIONS FOR VERTICAL CURVE DESIGN SPEEDS BELOW 45 MPH	8-6
EXAMPLES	8-6
Example 1	8-6
Example 2	8-7
<b>8.4 UNITS OF INFORMATION REDUCTIONS FOR HORIZONTAL CURVES – LED VMSs</b>	8-10
INTRODUCTION	8-10
REDUCTIONS FOR HORIZONTAL CURVES FOR PERMANENT VMSs	8-10
REDUCTIONS FOR HORIZONTAL CURVES FOR PORTABLE VMSs	8-10
EXAMPLES	8-10
Example 1	8-10
Example 2	8-11
<b>8.5 UNITS OF INFORMATION REDUCTIONS FOR RAIN AND FOG</b>	8-18
REDUCTIONS FOR RAIN	8-18
REDUCTIONS FOR FOG	8-18
EXAMPLE	8-19
<b>8.6 UNITS OF INFORMATION REDUCTIONS WHEN LARGE TRUCKS ARE PRESENT</b>	8-20
INTRODUCTION	8-20
EFFECT OF LARGE TRUCKS ON VMS VIEWING	8-20



**THIS PAGE LEFT BLANK**

## MODULE 8. ESTABLISHING THE MAXIMUM MESSAGE LENGTH

### 8.1 MESSAGE LENGTH AND VMS VIEWING DISTANCE REQUIREMENTS

The maximum length of message that can be displayed on a VMS at a location depends not only on the perception and information processing capabilities of motorists, but also on how far away they can adequately view the message. Stated another way, available viewing distance (coupled with the speed that the motorist is traveling) dictates the amount of time that the motorist has available to read a VMS. The viewing distance from a motorist to a VMS viewed straight on that is necessary to read a message of a given length (in terms of units of information presented) is illustrated in Figure 8.1. Any obstruction that comes between the motorist and the sign within this viewing distance will hinder the motorist from reading the entire message. At higher speeds, distances as great as 800 feet are needed for messages that contain 4 units of information.

**Available viewing distance to the VMS (coupled with traveling speed) dictates the amount of time the motorist has to read the sign.**

**Any obstruction that comes between the motorist and the VMS within this viewing distance will hinder the motorist from reading the entire message.**

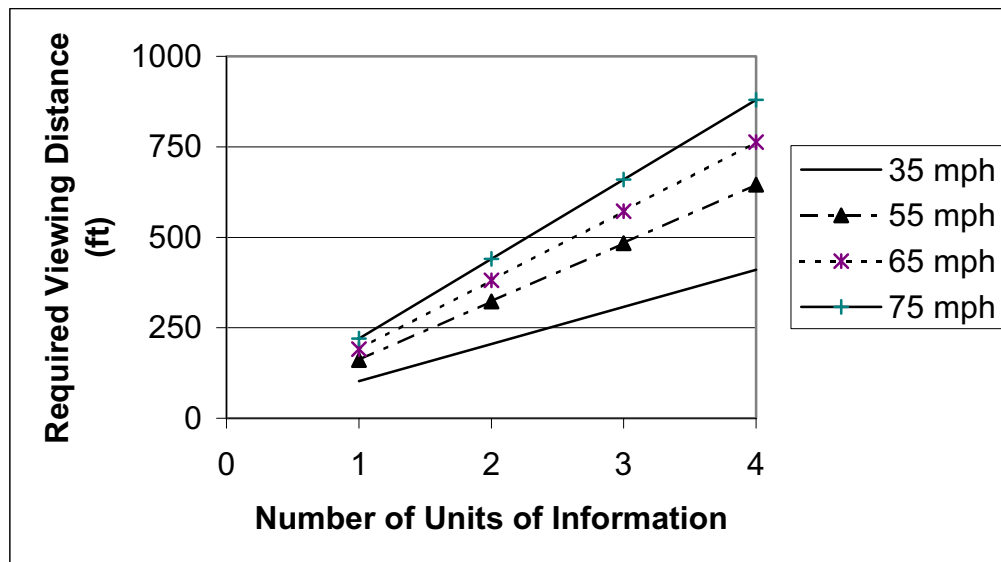

**Figure 8.1 Required Viewing Distances to a VMS**

The values in Figure 8.1 are for VMSs mounted directly over the travel lanes. However, for VMSs positioned off to the side of the roadway (either permanent-mounted or portable), additional sight distance is required to ensure that the message is read entirely while still within

the driver's field of vision (assumed to be 10° right or left of head-on viewing). The distances that should be added to the values in Figure 8.1 for a given lateral offset between the motorist and the center of the VMS are shown in Figure 8.2. Note that the additional sight distance required can be quite significant for larger offsets, adding 300 feet or more to the necessary sight distance between the motorist and the VMS.

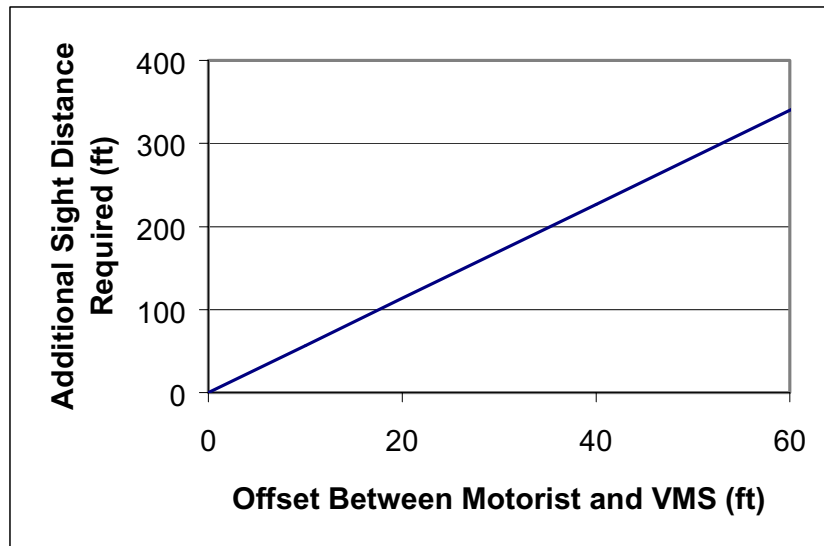

**Figure 8.2 Additional Sight Distance Required For Lateral VMS Offset**

The maximum distance at which a motorist can first correctly identify letters and words on a VMS is termed the legibility distance of the sign. In some situations, a motorist may not be able to utilize the maximum possible legibility distance (and thus, viewing time) from a VMS. Lighting conditions (day vs. night and position of the sun) can reduce the legibility distance to the VMS. Roadway geometric features such as vertical or horizontal curvature (around sight obstructions) can restrict a motorist's sight distance to a VMS. Spot obstructions such as overpasses and sign bridges can also restrict VMS viewing distances, particularly for signs mounted over the travel lanes. A number of environmental factors or conditions also impact VMS visibility. Rain and fog (and even snow) all scatter and block light rays from a VMS as that light travels through the atmosphere. Finally, the presence of a significant number of trucks on the roadway will likewise limit the ability of motorists to adequately view a VMS positioned on the side of the roadway.

**THE LEGIBILITY DISTANCE TO A VMS MAY BE LESS THAN EXPECTED BECAUSE OF:**

- Lighting conditions,
- Sun position,
- Vertical curvature,
- Horizontal curvature,
- Spot obstructions,
- Rain or fog, and
- Trucks in the traffic stream.

**THEREFORE, THE MAXIMUM ALLOWABLE NUMBER OF UNITS OF INFORMATION MAY HAVE TO BE REDUCED.**

Just as factors such as reduced lane widths and sharp grades reduce the ideal traffic-carrying capacity of a roadway, one or more of these conditions can constrain the available VMS viewing

distances to values lower than what are ideal. This means that there may not always be enough viewing time for a motorist to read a VMS message providing four units of information (5 units on lower speed roadways), and so shorter messages may have to be used.

Adjustments that may need to be made to the Base Maximum Message Length assumed to be available for a particular type of VMS are described in the following sections for five major conditions:

- Day and night operations,
- Vertical curves,
- Horizontal curves,
- Presence of a large proportion of trucks, and
- Presence of rain or fog.

## 8.2 MAXIMUM VMS LEGIBILITY DISTANCES FOR DAY AND NIGHT OPERATIONS

The maximum distance at which a motorist can first correctly identify letters and words on a VMS is termed the legibility distance of the sign. This distance depends on the design characteristics of the sign. Key design parameters are the type of display technology (light-emitting, light-reflecting, etc.), height and width of the characters, the stroke width of the characters, and the type of font displayed. Legibility distances proposed for use in VMS message design (based on results of several studies) are presented in Table 8.1. These distances represent standard font (all uppercase), 18-inch character heights, 13-inch (approximate) character widths, and about 2.5-inch stroke (pixel) widths. Smaller characters would yield shorter distances.

The legibility distances shown in Table 8.1 affect the maximum number of units of information that should be displayed on a VMS which will allow motorists to read and comprehend the message at prevailing highway operating speeds. Based on these distances, the maximum number of informational units that motorists can actually read and comprehend in a VMS message is summarized in Table 8.2. These numbers establish the Base Maximum Message Length.

<b>Condition</b>	<b>Light-Emitting Diode<sup>A</sup></b>	<b>Fiberoptic</b>	<b>Incandescent Bulb</b>	<b>Reflective Disk</b>
Mid-Day	800	700	700	700
Washout	800	700	700	400
Backlight	600	400	400	200
Nighttime	600	600	600	350

<sup>A</sup> Valid only for the newer aluminum indium gallium phosphide (or equivalent) LEDs

**Table 8.2 Maximum Number of Units of Information in VMS Message  
(Base Maximum Message Length)**

Condition	Light-Emitting Diode <sup>A</sup>			Fiberoptic			Incandescent Bulb			Reflective Disk		
	0-35 mph	36-55 mph	56-70 mph	0-35 mph	36-55 mph	56-70 mph	0-35 mph	36-55 mph	56-70 mph	0-35 mph	36-55 mph	56-70 mph
Mid-Day	5 units	4 units	4 units	5 units	4 units	3 units	5 units	4 units	3 units	5 units	4 units	3 units
Washout	5 units	4 units	4 units	5 units	4 units	3 units	5 units	4 units	3 units	4 units	3 units	2 units
Backlight	4 units	4 units	3 units	4 units	3 units	2 units	4 units	3 units	2 units	2 units	1 unit	1 unit
Nighttime	4 units	4 units	3 units	4 units	3 units	3 units	4 units	3 units	3 units	3 units	2 units	1 unit

<sup>A</sup> Valid only for the newer aluminum indium gallium phosphide (or equivalent) LEDs

## 8.3 UNITS OF INFORMATION REDUCTIONS FOR VERTICAL CURVES - LED VMSs

### INTRODUCTION

Generally speaking, permanent VMSs mounted above the travel lanes are not affected by the presence of crest vertical curves. Vertical curvature is established based on safe stopping sight distances to a rather small (i.e., 6-inch) object located on the roadway, based on the design speed of the roadway. The high (20 to 25 ft) typical mounting heights of permanent VMSs provide viewing distances over the curve which usually exceed the visual capabilities of the signs themselves. However, this is often not the case for portable VMS positioned on the shoulder of the roadway. Furthermore, conditions where actual operating speeds are higher than the design speed of the vertical curve can sometimes provide less viewing time than is normally assumed to exist.

A procedure for determining the potential influence of the vertical curve on the maximum number of information units that should be displayed on a VMS is given in [Appendix A](#).

### REDUCTIONS FOR VERTICAL CURVE DESIGN SPEEDS 45 MPH AND ABOVE

No reductions in the number of units of information are required for LED VMSs. Therefore, use the Base Maximum Message Length shown in [Table 8.2](#) for the traffic operating speed on the highway.

### REDUCTIONS FOR VERTICAL CURVE DESIGN SPEEDS BELOW 45 MPH

Vertical curve design speeds lower than 45 mph require that the number of informational units be reduced to account for the lower legibility. The number of units that must be subtracted from the Base Maximum Message Length shown in [Table 8.2](#) when LED signs are used are given in [Tables 8.3 and 8.4](#) for PERMANENT VMSs with mounting heights of 20 and 25 feet and offsets of 0, 20 and 60 feet. The number of units that must be subtracted from the Base Maximum Message Length shown in [Table 8.2](#) when LED signs are used are given in [Tables 8.5 and 8.6](#) for PORTABLE VMSs with mounting heights of 7 and 10 feet and offsets of 20 and 60 feet.

### EXAMPLES

#### Example 1

##### *Question*

A permanent LED VMS mounted 20 feet above the roadway is located to the right of a six-lane urban arterial. The sign is positioned such that the offset from the VMS to the motorist in the left lane is approximately 60 ft. It is located at the downstream end of a 600-foot crest vertical curve that is designed for 35 mph. Does the Base Maximum Message Length have to be reduced in this situation?

***Answer***

Yes. Using [Table 8.3](#) for a 60-ft offset and 35 mph operating speed, the Base Maximum Message Length must be reduced by 3 units in all viewing conditions (mid-day, washout, backlight, and nighttime).

**Example 2*****Question***

A portable LED VMS that is 7 ft high is located in the middle of a 20-foot median on a four-lane freeway with a 6-foot inside paved shoulder. The sign is placed on the downstream end of a 1200-foot crest vertical curve. The design speed of the curve is 60 mph. Does the curve constrain the amount of information that can be presented on the VMS?

***Answer***

Since the design speed of the curve is greater than 45 mph, a sight distance restriction is not expected for the portable VMS. No reduction in Base Maximum Message Length is necessary.



<b>Table 8.3 Number of Units of Information that Must Be <u>Subtracted</u> from                      Number Given in <a href="#">Table 8.2</a> Due to Vertical Curve                      PERMANENT LED VMS<sup>A</sup>                      Mounting Height: 20 feet</b>									
Condition	Vertical Curve Design Speed								
	Overhead			20-foot Offset			60-foot Offset		
	30 mph	35 mph	40 mph	30 mph	35 mph	40 mph	30 mph	35 mph	40 mph
Mid-Day	1 unit	0 unit	0 unit	2 units	0 unit	0 unit	5 units	3 units	1 unit
Washout	1 unit	0 unit	0 unit	2 units	0 unit	0 unit	5 units	3 units	1 unit
Backlight	0 unit	0 unit	0 unit	1 unit	0 unit	0 unit	4 units	3 units	1 unit
Nighttime	0 unit	0 unit	0 unit	1 unit	0 unit	0 unit	4 units	3 units	1 unit

<sup>A</sup> Valid only for the newer aluminum indium gallium phosphide (or equivalent) LEDs.

<b>Table 8.4 Number of Units of Information that Must Be <u>Subtracted</u> from                      Number Given in <a href="#">Table 8.2</a> Due to Vertical Curve                      PERMANENT LED VMS<sup>A</sup>                      Mounting Height: 25 feet</b>									
Condition	Vertical Curve Design Speed								
	Overhead			20-foot Offset			60-foot Offset		
	30 mph	35 mph	40 mph	30 mph	35 mph	40 mph	30 mph	35 mph	40 mph
Mid-Day	0 unit	0 unit	0 unit	2 units	1 unit	0 unit	5 units	4 units	1 unit
Washout	0 unit	0 unit	0 unit	2 units	1 unit	0 unit	5 units	4 units	1 unit
Backlight	0 unit	0 unit	0 unit	1 unit	0 unit	0 unit	4 units	3 units	1 unit
Nighttime	0 unit	0 unit	0 unit	1 unit	0 unit	0 unit	4 units	3 units	1 unit

<sup>A</sup> Valid only for the newer aluminum indium gallium phosphide (or equivalent) LEDs.

<b>Table 8.5 Number of Units of Information that Must Be <u>Subtracted</u>                      from Number Given in <a href="#">Table 8.2</a> Due to Vertical Curve                      PORTABLE LED VMS<sup>A</sup>                      Mounting Height: 7 feet</b>						
Condition	Vertical Curve Design Speed					
	20-foot Offset			60-foot Offset		
	30 mph	35 mph	40 mph	30 mph	35 mph	40 mph
Mid-Day	3 units	2 units	1 unit	5 units	5 units	3 units
Washout	3 units	2 units	1 unit	5 units	5 units	3 units
Backlight	2 units	1 unit	1 unit	4 units	4 units	2 units
Nighttime	2 units	1 unit	1 unit	4 units	4 units	2 units

<sup>A</sup> Valid only for the newer aluminum indium gallium phosphide (or equivalent) LEDs.

<b>Table 8.6 Number of Units of Information that Must Be <u>Subtracted</u>                      from Number Given in <a href="#">Table 8.2</a> Due to Vertical Curve                      PORTABLE LED VMS<sup>A</sup>                      Mounting Height: 10 feet</b>						
Condition	Vertical Curve Design Speed					
	20-foot Offset			60-foot Offset		
	30 mph	35 mph	40 mph	30 mph	35 mph	40 mph
Mid-Day	2 units	2 units	1 unit	5 units	4 units	3 units
Washout	2 units	2 units	1 unit	5 units	4 units	3 units
Backlight	1 unit	1 unit	0 unit	4 units	3 units	2 units
Nighttime	1 unit	1 unit	0 unit	4 units	3 units	2 units

<sup>A</sup> Valid only for the newer aluminum indium gallium phosphide (or equivalent) LEDs.

## 8.4 UNITS OF INFORMATION REDUCTIONS FOR HORIZONTAL CURVES – LED VMSs

### INTRODUCTION

Whereas vertical curvature design is based on stopping sight distance, design criteria for horizontal curvature are based on driver comfort and the friction between the tires and the roadway. With respect to VMS visibility and viewing time, horizontal curvature generally does not impact permanent VMSs mounted over travel lanes. Likewise, permanent VMS mounted adjacent to the travel lanes (in the median or off to the right) will extend above most obstructions that may exist on the roadside and so are not affected by any horizontal curvature (although certain spot obstructions such as overhead signs or luminaires may be more problematic to VMS viewing on horizontal curves).

However, the situation is different for portable VMSs placed on the side of the road within the curve (on the right side of a right-hand curve, on the left side of a left-hand curve). If an object (construction vehicle, tree, etc.) is located close to the edge of a roadway on the same side as the VMS, a driver in the closest lane may not be able to see around the object and fully read and comprehend the message. The detailed process to assess whether an obstruction may constrain the reading time of a portable VMS around a horizontal curve is described in [Appendix B](#).

### REDUCTIONS FOR HORIZONTAL CURVES FOR PERMANENT VMSs

No reduction is necessary for permanent VMSs.

### REDUCTIONS FOR HORIZONTAL CURVES FOR PORTABLE VMSs

[Tables 8.7 through 8.9](#) give the number of units of information that must be subtracted from the Basic Maximum Message Length when LED signs are used and the portable VMS is offset 2 feet. Similar numbers to subtract when the portable VMS is offset 10 feet are given in [Tables 8.10 through 8.12](#).

### EXAMPLES

#### Example 1

##### *Question*

A portable LED VMS is to be placed two feet from the edge of travel lanes on a rural highway upstream of a work zone towards the end of a long (2500 ft) horizontal curve. Traffic speeds on the roadway average 65 mph. A bridge overpass abutment is located upstream of the VMS along the curve as well. The abutment is 50 feet from the edge of the travel lane. The curve radius is 1500 feet. The VMS will not be in washout or backlighted conditions during the day, and will not have overhead lighting present at night. Does the Base Maximum Message Length have to be reduced in this situation?

***Answer***

For the characteristics identified, go to [Table 8.9](#). A curve radius of 1500 ft and obstruction offset of 50 ft does not require a reduction in Base Maximum Message Length for either the backlight overhead or nighttime viewing conditions. However, it does require a 1 unit reduction for mid-day and washout.

**Example 2*****Question***

A portable VMS is to be used to assist in providing trailblazer information along a detour route for a section of freeway. The sign will be placed 10 feet from the travel lanes. The diversion route is an urban arterial with vehicle operating speeds about 40 mph. The operating agency is contemplating the location of the sign towards the end of the 750-foot horizontal curve with curve radius of 500 feet. A brick wall located 20 feet from the roadway is used to separate the roadway from the adjacent neighborhood. Does the curve constrain the amount of information that can be presented on the VMS?

***Answer***

For the characteristics identified, go to [Table 8.11](#). A curve radius of 500 ft and obstruction offset of 20 ft does require the Base Maximum Message Length to be reduced by 4 units in the mid-day and washout viewing conditions, and reduced by 3 units under backlight and nighttime viewing conditions. In effect, not enough sight distance is available at this location to provide any information on a portable VMS. An alternative location for the VMS should be found.

**Table 8.7 Number of Units of Information that Must Be Subtracted from  
Number Given in [Table 8.2](#) Due to Horizontal Curve  
PORTABLE LED VMS<sup>A</sup>  
Offset: 2 feet**

**Traffic Operating Speeds: 0-35 mph**

Curve Radii (ft)	Mid-Day and Washout							Backlight and Nighttime						
	Offset of Sight Obstruction from Edge of Travel Lanes (feet)							Offset of Sight Obstruction from Edge of Travel Lanes (feet)						
	10	20	50	100	150	200	250	10	20	50	100	150	200	250
250	4 units	4 units	2 units	1 unit	1 unit	1 unit		3 units	3 units	1 unit				
500	4 units	3 units	1 unit	1 unit				3 units	2 units					
750	4 units	2 units	1 unit	1 unit				3 units	2 units					
1000	3 units	2 units	1 unit					2 units	1 unit					
1250	3 units	2 units	1 unit					2 units	1 unit					
1500	3 units	1 unit	1 unit					2 units	1 unit					
1750	3 units	1 unit						2 units	1 unit					
2000	3 units	1 unit						2 units	1 unit					
2250	2 units	1 unit						1 unit						
2500	2 units	1 unit						1 unit						
2750	2 units	1 unit						1 unit						
3000	2 units	1 unit						1 unit						
4000	1 unit	1 unit												
5000	1 unit													
7500	1 unit													
10000	1 unit													

<sup>A</sup> Valid only for the newer aluminum indium gallium phosphide (or equivalent) LEDs.

**Table 8.8 Number of Units of Information that Must Be Subtracted from  
Number Given in Table 8.2 Due to Horizontal Curve  
PORTABLE LED VMS<sup>A</sup>  
Offset: 2 feet**

**Traffic Operating Speeds: 36-55 mph**

Curve Radii (ft)	Mid-Day and Washout							Backlight and Nighttime						
	Offset of Sight Obstruction from Edge of Travel Lanes (feet)							Offset of Sight Obstruction from Edge of Travel Lanes (feet)						
	10	20	50	100	150	200	250	10	20	50	100	150	200	250
250	N/A	N/A	N/A	N/A	N/A	N/A	N/A	N/A	N/A	N/A	N/A	N/A	N/A	N/A
500	3 units	3 units	2 units	1 unit				3 units	3 units	2 units	1 unit			
750	3 units	3 units	1 unit					3 units	3 units	1 unit				
1000	3 units	2 units	1 unit					3 units	2 units	1 unit				
1250	3 units	2 units						3 units	2 units					
1500	3 units	2 units						3 units	2 units					
1750	3 units	2 units						3 units	2 units					
2000	3 units	1 unit						3 units	1 unit					
2250	3 units	1 unit						3 units	1 unit					
2500	2 units	1 unit						2 units	1 unit					
2750	2 units	1 unit						2 units	1 unit					
3000	2 units	1 unit						2units	1 unit					
4000	2 units							2 units						
5000	2 units							2 units						
7500	1 unit							1 unit						
10000	1 unit													

<sup>A</sup> Valid only for the newer aluminum indium gallium phosphide (or equivalent) LEDs.

N/A Adequate sight distance not available for any message.

**Table 8.9 Number of Units of Information that Must Be Subtracted from  
Number Given in [Table 8.2](#) Due to Horizontal Curve  
PORTABLE LED VMS<sup>A</sup>  
Offset: 2 feet**

**Traffic Operating Speeds: 56-70 mph**

Curve Radii (ft)	Mid-Day and Washout							Backlight and Nighttime						
	Offset of Sight Obstruction from Edge of Travel Lanes (feet)							Offset of Sight Obstruction from Edge of Travel Lanes (feet)						
	10	20	50	100	150	200	250	10	20	50	100	150	200	250
250	N/A	N/A	N/A	N/A	N/A	N/A	N/A	N/A	N/A	N/A	N/A	N/A	N/A	N/A
500	N/A	N/A	N/A	N/A	N/A	N/A		N/A	N/A	N/A	N/A	N/A	N/A	N/A
750	3 units	3 units	2 units	1 unit				2 units	1 unit					
1000	3 units	3 units	2 units					1 unit	1 unit					
1250	3 units	3 units	1 unit					1 unit	1 unit					
1500	3 units	2 units	1 unit					1 unit						
1750	3 units	2 units	1 unit					1 unit						
2000	3 units	2 units						1 unit						
2250	3 units	2 units						1 unit						
2500	3 units	2 units						1 unit						
2750	3 units	2 units						1 unit						
3000	3 units	2 units						1 unit						
4000	2 units	1 unit												
5000	2 units													
7500	2 units													
10000	2 units													

<sup>A</sup> Valid only for the newer aluminum indium gallium phosphide (or equivalent) LEDs.

N/A Adequate sight distance not available for any message.

**Table 8.10 Number of Units of Information that Must Be Subtracted from  
Number Given in [Table 8.2](#) Due to Horizontal Curve  
PORTABLE LED VMS<sup>A</sup>  
Offset: 10 feet**

**Traffic Operating Speeds: 0-35 mph**

Curve Radii (ft)	Mid-Day and Washout							Backlight and Nighttime						
	Offset of Sight Obstruction from Edge of Travel Lanes (feet)							Offset of Sight Obstruction from Edge of Travel Lanes (feet)						
	10	20	50	100	150	200	250	10	20	50	100	150	200	250
250	5 units	4 units	2 units	1 unit	1 unit			4 units	3 units	1 unit				
500	5 units	3 units	1 unit					4 units	2 units					
750	5 units	3 units	1 unit					4 units	2 units					
1000	5 units	3 units	1 unit					4 units	2 units					
1250	5 units	2 units						4 units	1 unit					
1500	5 units	2 units						4 units	1 unit					
1750	5 units	2 units						4 units	1 unit					
2000	5 units	1 unit						4 units						
2250	5 units	1 unit						4 units						
2500	5 units	1 unit						4 units						
2750	5 units	1 unit						4 units						
3000	5 units	1 unit						4 units						
4000	5 units	1 unit						4 units						
5000	5 units							4 units						
7500	5 units							4 units						
10000	5 units							4 units						

<sup>A</sup> Valid only for the newer aluminum indium gallium phosphide (or equivalent) LEDs.



**Table 8.11 Number of Units of Information that Must Be Subtracted from  
Number Given in [Table 8.2](#) Due to Horizontal Curve  
PORTABLE LED VMS<sup>A</sup>  
Offset: 10 feet**

**Traffic Operating Speeds: 36-55 mph**

Curve Radii (ft)	Mid-Day and Washout							Backlight and Nighttime						
	Offset of Sight Obstruction from Edge of Travel Lanes (feet)							Offset of Sight Obstruction from Edge of Travel Lanes (feet)						
	10	20	50	100	150	200	250	10	20	50	100	150	200	250
250	N/A	N/A	N/A	N/A	N/A	N/A	N/A	N/A	N/A	N/A	N/A	N/A	N/A	N/A
500	5 units	4 units	3 units	2 units	1 unit	1 unit		5 units	3 units	2 units	1 unit			
750	5 units	4 units	2 units	1 unit	1 unit			5 units	3 units					
1000	5 units	4 units	2 units	1 unit				5 units	3 units					
1250	5 units	3 units	1 unit					5 units	2 units					
1500	5 units	3 units	1 unit					5 units	2 units					
1750	5 units	3 units	1 unit					5 units	2 units					
2000	5 units	3 units	1 unit					5 units	2 units					
2250	5 units	3 units	1 unit					5 units	2 units					
2500	5 units	3 units	1 unit					5 units	2 units					
2750	5 units	2 units						5 units	1 unit					
3000	5 units	2 units						5 units	1 unit					
4000	5 units	2 units						5 units						
5000	5 units	1 unit						5 units						
7500	5 units	1 unit						5 units						
10000	5 units	1 unit						5 units						

<sup>A</sup> Valid only for the newer aluminum indium gallium phosphide (or equivalent) LEDs.

N/A Adequate sight distance not available for any message.

**Table 8.12 Number of Units of Information that Must Be Subtracted from  
Number Given in [Table 8.2](#) Due to Horizontal Curve  
PORTABLE LED VMS<sup>A</sup>  
Offset: 10 feet**

**Traffic Operating Speeds: 56-70 mph**

Curve Radii (ft)	Mid-Day and Washout							Backlight and Nighttime						
	Offset of Sight Obstruction from Edge of Travel Lanes (feet)							Offset of Sight Obstruction from Edge of Travel Lanes (feet)						
	10	20	50	100	150	200	250	10	20	50	100	150	200	250
250	N/A	N/A	N/A	N/A	N/A	N/A	N/A	N/A	N/A	N/A	N/A	N/A	N/A	N/A
500	N/A	N/A	N/A	N/A	N/A	1 unit		N/A	N/A	N/A	N/A	N/A	N/A	N/A
750	5 units	4 units	3 units	2 units	1 unit			4 units	3 units	2 units	1 unit			
1000	5 units	4 units	3 units	1 unit	1 unit			4 units	3 units	2 units				
1250	5 units	4 units	2 units	1 unit	1 unit			4 units	3 units	1 unit				
1500	5 units	4 units	2 units	1 unit				4 units	3 units	1 unit				
1750	5 units	4 units	2 units	1 unit				4 units	3 units	1 unit				
2000	5 units	3 units	1 unit	1 unit				4 units	2 units					
2250	5 units	3 units	1 unit					4 units	2 units					
2500	5 units	3 units	1 unit					4 units	2 units					
2750	5 units	3 units	1 unit					4 units	2 units					
3000	5 units	3 units	1 unit					4 units	2 units					
4000	5 units	3 units	1 unit					4 units	2 units					
5000	5 units	2 units						4 units	1 unit					
7500	5 units	2 units						4 units	1 unit					
10000	5 units	1 unit						4 units						

<sup>A</sup> Valid only for the newer aluminum indium gallium phosphide (or equivalent) LEDs.

N/A Adequate sight distance not available for any message.

## 8.5 UNITS OF INFORMATION REDUCTIONS FOR RAIN AND FOG

Rain and fog are additional factors that can influence the amount of information that can be presented on a VMS. Both conditions deteriorate the amount of light that is coming from the VMS (either direct illumination from the light pixels on the VMS or reflected by the VMS from other light sources such as the sun, overhead lighting, or automobile headlights). This reduces the contrast between the sign legend and its background. If the contrast becomes too low, motorists cannot read the VMS message.

For light-emitting VMSs, contrast ratios are at their minimums on bright, sunny days because the sun increases the background luminance of the signs. Under cloudy conditions, the luminance of the legend will be much greater than the background and can create very large contrast ratios. Unfortunately, data on typical VMS background luminance or contrast ratios on cloudy, rainy, or foggy days are not available (in actuality, there may not be a true “typical” cloudy day anyway). Conversely, contrast ratios for light-reflecting VMSs decrease as external lighting levels decrease, becoming zero (or nearly so) as the amount of light falling on the sign reaches zero. A procedure for determining the effects of rain and fog on the number of units of information that can be displayed is given in [Appendix C](#).

Because the majority of VMSs are light-emitting technologies, the following section is provided for those signs. The VMS operator should apply the detailed procedure in [Appendix C](#) for consideration of light-reflecting VMS.

### REDUCTIONS FOR RAIN

The effect of rainfall on desired VMS message lengths is believed to be relatively insignificant under most operating conditions. The exception to this situation is when rainfall intensities exceed 2 inches per hour. Under these conditions, the VMS operator should reduce the units of information on a portable LED VMS by one if the operating speed on the roadway exceeds 55 mph. Portable LED VMS generally utilize fewer numbers of LEDs per pixel and so typically generate lower character luminance levels than permanent VMS. The higher character luminance levels of permanent LED VMS now in use is believed to provide significant contrast even under heavy rain.

### REDUCTIONS FOR FOG

The effect of fog is more significant. The reductions in the base number of information units that can be displayed on a portable LED VMS under daytime conditions under various operating speed and VMS offset scenarios are presented in [Table 8.13](#). As noted previously, reductions for permanent LED VMS are not suggested due to their much higher character luminance values (and thus much higher contrast ratios).

**EXAMPLE**

**Question**

A portable LED VMS is being used in the median of a divided rural highway (offset between VMS and right lane motorist is 60 feet). A heavy fog is present that limits visibility to approximately 1/2 mile. Does this condition require a reduction in the Base Maximum Message Length?

**Answer**

Using Table 8.13 for a 60-ft offset and an assumed traffic speed of greater than 56 mph (since it is a rural highway) and a 1/2-mi visibility, no reduction is necessary. If the fog had been thicker and reduced visibility to 1/4 mile, then the Base Maximum Message Length would have to be reduced by 2 units.

Table 8.13 Number of Units of Information that Must Be <u>Subtracted</u> from Number Given in <b>Table 8.2</b> Due to Effects of Fog in Daytime Conditions PORTABLE LED <sup>A</sup> VMS									
Visibility Range in Fog	No Offset			20-ft Offset			60-ft Offset		
	0-35 mph	36-55 mph	56-70 mph	0-35 mph	36-55 mph	56-70 mph	0-35 mph	36-55 mph	56-70 mph
1/2 mi	0	0	0	0	0	0	0	0	0
1/4 mi	0	0	1 unit	0	1 unit	1 unit	2 units	2 units	2 units
1/10 mi	2 units	2 units	2 units	3 units	3 units	3 units	5 units <sup>B</sup>	4 units <sup>B</sup>	4 units <sup>B</sup>

<sup>A</sup> Valid only for the newer aluminum indium gallium phosphide (or equivalent) LEDs.

<sup>B</sup> Adequate sight distance not available for any message under this viewing condition.

## 8.6 UNITS OF INFORMATION REDUCTIONS WHEN LARGE TRUCKS ARE PRESENT

### INTRODUCTION

Large trucks can be a major cause of sight obstructions to VMSs. Motorists in vehicles travelling closely behind or adjacent to a truck may be limited in the amount of time they have to read a VMS. If they follow too closely, they may not be able to see the VMS at all. This can occur in some instances for permanent overhead VMSs as well. However, the majority of concerns relating to trucks pertain to the portable VMSs located off to the side of the travel lanes.

Evaluating truck obstructions of VMSs requires a slightly different analysis approach than that used for horizontal and vertical curvature. This is because a motorist has the ability to adjust his or her speed slightly relative to that of a truck and find a travel position that allows for adequate viewing. However, as the number of trucks on the roadway increases, the amount of roadway space that a motorist can travel in with an unobstructed view decreases. If the number of vehicles traveling on the facility approaches or exceeds the number that can “fit” into the unobstructed viewing spaces, then some motorists will not be able to read all of a VMS message. Depending on the specific message being presented, this can begin to create operational problems on the facility.

### EFFECT OF LARGE TRUCKS ON VMS VIEWING

A detailed procedure to assess the impact of large trucks on VMS viewing time is given in [Appendix D](#). This procedure computes the amount of roadway space available for adequate VMS viewing and compares it to the amount of traffic on the roadway that needs to use that space. In this section, this analysis is simplified to a series of tables designed to assist the operator in determining the influence of large trucks on the ability of motorists in the overall traffic stream to adequately read a VMS message containing the maximum base number of information units.

[Tables 8.14 through 8.17](#) present the estimated percentage of motorists on the roadway who would likely be able to read an entire VMS message that consists of the maximum base number of units of information. Separate tables are provided for four major roadway cross-sections (two-lane, two-way highway; four-lane roadway; six-lane roadway; and eight-lane roadway). The numbers represent average conditions for messages on high-quality LED VMSs. Assumptions have been made regarding the distribution of large trucks across the various travel lanes in a given direction. These assumptions are noted at the bottom of the tables. The percentages also assume that all truck drivers will be able to adequately see the VMS (since they sit higher than a typical automobile).

The tables illustrate how quickly viewing conditions can degrade as truck volumes increase. The point of the tables is not to define a specific threshold between acceptable and unacceptable viewing conditions for VMSs. Rather, the information contained in the tables should be used in deciding when less information should be presented on a VMS, or where a redundant VMS may be needed. If redundant VMS are used, consideration should also be given to placing them on

the left side of the roadway (the percentages in the tables assume the VMS is placed on the right side of the roadway 10 feet from the travel lanes).

<b>Table 8.14 Percent of Motorists Able to Fully Read a VMS Message with Maximum Base Number of Units (Two-Lane, Two-Way Highway)</b>									
<b>Percent Trucks</b>	<b>Operating Speed Range</b>								
	<b>0-35 mph</b>			<b>36-55 mph</b>			<b>56-70 mph</b>		
	<b>500 vph</b>	<b>1000 vph</b>	<b>1500 vph</b>	<b>500 vph</b>	<b>1000 vph</b>	<b>1500 vph</b>	<b>500 vph</b>	<b>1000 vph</b>	<b>1500 vph</b>
5	95	95	90	100	95	95	100	95	90
10	95	90	85	95	90	85	95	90	80
20	90	80	70	90	85	75	90	85	70
30	90	75	65	90	80	65	90	80	60
50	85	70	55	85	75	60	90	75	50*

\* Under these conditions, only truck drivers are assumed to be able to see the VMS.

<b>Table 8.15 Percent of Motorists Able to Fully Read a VMS Message with Maximum Base Number of Units (Four-Lane Roadway: Two Lanes in Each Direction)</b>									
<b>Percent Trucks</b>	<b>Operating Speed Range</b>								
	<b>0-35 mph</b>			<b>36-55 mph</b>			<b>56-70 mph</b>		
	<b>1000 vph</b>	<b>2000 vph</b>	<b>3000 vph</b>	<b>1000 vph</b>	<b>2000 vph</b>	<b>3000 vph</b>	<b>1000 vph</b>	<b>2000 vph</b>	<b>3000 vph</b>
5	95	90	85	95	90	85	95	90	80
10	90	80	70	90	80	70	90	80	65
20	80	65	45	80	65	45	85	65	40
30	75	50	30*	75	55	30	75	55	30*
50	70	50*	50*	70	50*	50*	75	50*	50*

Note: Assumes an 85%/15% split of truck traffic in shoulder and median travel lanes.

\* Under these conditions, only truck drivers are assumed to be able to see the VMS.

<b>Table 8.16 Percent of Motorists Able to Fully Read a VMS Message with Maximum Base Number of Units (Six-Lane Roadway: Three Lanes in Each Direction)</b>									
<b>Percent Trucks</b>	<b>Operating Speed Range</b>								
	<b>0-35 mph</b>			<b>36-55 mph</b>			<b>56-70 mph</b>		
	<b>2000 vph</b>	<b>4000 vph</b>	<b>6000 vph</b>	<b>2000 vph</b>	<b>4000 vph</b>	<b>6000 vph</b>	<b>2000 vph</b>	<b>4000 vph</b>	<b>6000 vph</b>
5	90	75	65	90	80	65	90	80	65
10	80	55	35	80	60	35	80	60	40
20	60	25	20*	65	25	20*	65	25	20*
30	50	30*	30*	50	30*	30*	50	30*	30*
50	50*	50*	50*	50*	50*	50*	50*	50*	50*

Note: Assumes an 85%/15%/0% split of truck traffic in shoulder, center, and median travel lanes, respectively.

\* Under these conditions, only truck drivers are assumed to be able to see the VMS.

<b>Table 8.17 Percent of Motorists Able to Fully Read a VMS Message with Maximum Base Number of Units (Eight-Lane Roadway: Four Lanes in Each Direction)</b>									
<b>Percent Trucks</b>	<b>Operating Speed Range</b>								
	<b>0-35 mph</b>			<b>36-55 mph</b>			<b>56-70 mph</b>		
	<b>2000 vph</b>	<b>4000 vph</b>	<b>6000 vph</b>	<b>2000 vph</b>	<b>4000 vph</b>	<b>6000 vph</b>	<b>2000 vph</b>	<b>4000 vph</b>	<b>6000 vph</b>
5	90	80	70	90	80	70	90	80	70
10	80	60	45	80	65	45	80	65	45
20	65	35	20*	70	35	20*	65	35	20*
30	60	30*	30*	60	30*	30*	55	30*	30*
50	50*	50*	50*	50*	50*	50*	50*	50*	50*

Note: Assumes an 70%/20%/10%/0% split of truck traffic in shoulder, right center, left center, and median travel lanes, respectively.

\* Under these conditions, only truck drivers are assumed to be able to see the VMS.

# MODULE 9. DEALING WITH LONG MESSAGES

## TABLE OF CONTENTS

<b>9.1 SPLITTING MESSAGES</b> .....	9-1
NO MORE THAN TWO FRAMES SHOULD BE USED .....	9-1
EACH FRAME MUST BE UNDERSTOOD BY ITSELF .....	9-1
COMPATIBLE UNITS OF INFORMATION SHOULD BE DISPLAYED ON THE SAME FRAME.....	9-2
A MESSAGE LINE SHOULD <u>NOT</u> CONTAIN PORTIONS OF TWO DIFFERENT UNITS OF INFORMATION .....	9-3
NO MORE THAN THREE UNITS OF INFORMATION SHOULD BE DISPLAYED ON A SINGLE FRAME AT HIGH FREEWAY SPEEDS .....	9-3
<b>9.2 APPROACHES TO REDUCING MESSAGE LENGTH</b> .....	9-5
DELETING “DEAD” WORDS .....	9-5
Street, Avenue or Boulevard.....	9-5
Ahead .....	9-5
FORMATTING MESSAGES.....	9-6
Messages WITH Incident Descriptor Message Element.....	9-6
Messages WITH Roadwork Descriptor Message Element .....	9-7
Messages WITHOUT Incident Descriptor Message Element.....	9-8
Messages WITHOUT Roadwork Descriptor Message Element.....	9-9
USING ABBREVIATIONS.....	9-10
Acceptable Abbreviations .....	9-10
Acceptable Abbreviation in North New Jersey, But Not South New Jersey .....	9-11
Acceptable Abbreviations For Some Major Destinations in New Jersey .....	9-11
Acceptable Abbreviations For Major Destinations by Region: North and South New Jersey .....	9-11
Unacceptable Abbreviations .....	9-12
<b>9.3 REDUCING MESSAGE UNITS OF INFORMATION</b> .....	9-13
REFORMATTING THE MESSAGE .....	9-13
<b>9.4 REDUCING UNITS OF INFORMATION FROM THE BASIC VMS MESSAGE</b> .....	9-14
INITIAL REDUCTION APPROACHES .....	9-14
Reducing Redundancy in Incident and Roadwork Messages.....	9-14
Omitting Reference to Same Freeway as Incident/Roadwork and VMS.....	9-14



---

Combining Message Elements for Incident Messages.....	9-15
<i>Combining Incident Descriptor, Location, and Lanes Closed/Blocked Message Elements</i> .....	9-15
<i>Combining Location of Closure Message Element and Action Message Element</i> .....	9-16
Combining Message Elements for Roadwork Messages .....	9-17
<i>Combining Roadwork Descriptor Message Elements with Lanes Closed Message Element</i> .....	9-17
<i>Combining Roadwork Descriptor, Location and Lanes Closed Message Elements</i> .....	9-18
<i>Combining Location of Closure Message Element and Action Message Element</i> .....	9-18
SECONDARY REDUCTION APPROACH .....	9-19
Reducing the Number of Definitions in the Action Message Element.....	9-19
PRIORITY REDUCTION PRINCIPLES .....	9-20

## MODULE 9. DEALING WITH LONG MESSAGES

After the VMS message designer selects the necessary elements of the Basic VMS Message, in many cases the message will be too long. That is, it may exceed the number of message units that motorists can read and understand while traveling at the prevailing freeway speeds, or it may exceed the physical limitations of the VMS itself. Guidelines and helpful hints for reducing the length of messages are presented in this section of the Manual.

### 9.1 SPLITTING MESSAGES

When a VMS message is too long to fit on one frame, it can be split and displayed on multiple frames that are shown sequentially. The VMS is best formatted into a horizontal rectangular space consisting of two lines on one message frame and two lines on the second frame. On large overhead signs, each line typically has two words (or three if within line capacity). On portable VMSs, each line typically has one word when abbreviations are not used.

When it is necessary to divide a message and display it on multiple frames, the five principles below must be used.

#### MESSAGE SPLITTING PRINCIPLES:

- No more than two frames should be used;
- Each frame must be understood by itself;
- Compatible units of information should be displayed on the same frame;
- A message line should not contain portions of two different units of information; and
- No more than three units of information should be displayed on a single frame at high freeway speeds.

#### 1. NO MORE THAN TWO FRAMES SHOULD BE USED

Research has shown that for the typical three- or four-line VMSs, motorists have difficulty in reading messages displayed on more than two frames.

#### 2. EACH FRAME MUST BE UNDERSTOOD BY ITSELF

Each message frame must be understood by itself because either frame may be read first by the passing motorist. Typically, the problem and location appear on the first frame and the advisory and attention statement (if needed) on the second frame. The following two examples help illustrate Principle 2.

**Example of an UNACCEPTABLE MESSAGE SPLIT with a frame that is not understood by itself**

**MAJOR ACCIDENT  
AT RT 23  
NEW YORK TRAFFIC**

*Frame 1*

**USE  
I-280 EAST**

*Frame 2*

In Frame 1, the message *MAJOR ACCIDENT/ AT I-80 EAST/ NEW YORK TRAFFIC* is not understood by itself. This is because the *Audience (NEW YORK TRAFFIC)* is not compatible with the *Incident Descriptor* and *Incident Location* message elements. The *Audience* message element should be combined with the *Action (USE I-280 EAST)* so that the two terms *NEW YORK* and *USE I-280 EAST* are on the same message frame as shown below.

**Example of an ACCEPTABLE MESSAGE SPLIT with each frame understood by itself**

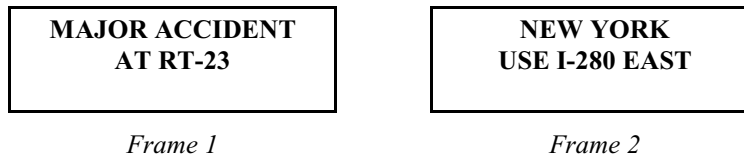

**3. COMPATIBLE UNITS OF INFORMATION SHOULD BE DISPLAYED ON THE SAME FRAME**

Compatible units of information should be displayed on the same frame. The previous examples shown for Principle 2 also help to illustrate Principle 3. The *Incident Descriptor (MAJOR ACCIDENT)* and the *Incident Location (AT ROUTE 23)* message elements are compatible and can be displayed on the same frame. Also, the *Audience (NEW YORK)* and *Action (USE I-280 EAST)* message elements are compatible and can be displayed on the same frame. In contrast, the *Audience (NEW YORK)* message element is not compatible with the *Incident Descriptor (MAJOR ACCIDENT)* and the *Incident Location (USE I-280 EAST)*.

Another illustration of the violation of Principle 3 and the corrected message are shown in the examples below. The first example (UNACCEPTABLE MESSAGE SPLIT) shows two *Action* message elements that are split. One action is on the first frame and the second action on the second frame. The two *Action* message elements should be displayed on the same message frame as shown in the second example (ACCEPTABLE MESSAGE SPLIT).

**Example of an UNACCEPTABLE MESSAGE SPLIT with frame that is not compatible**

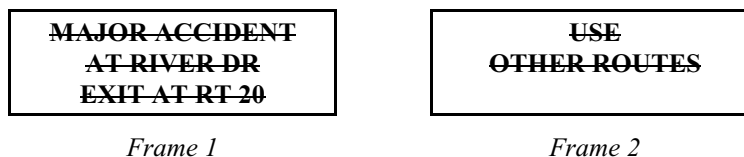

**Example of an ACCEPTABLE MESSAGE SPLIT with each frame compatible**

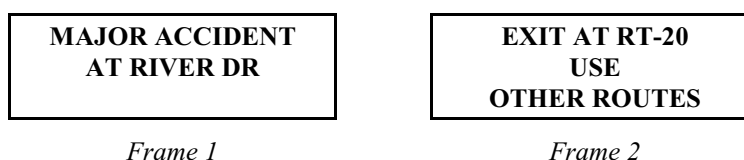

#### 4. A MESSAGE LINE SHOULD NOT CONTAIN PORTIONS OF TWO DIFFERENT UNITS OF INFORMATION

Sometimes, two interrelated units of information are too long for each to fit on one line when it is desirable to display both in the same message frame. The temptation, at times, is to “squeeze” both units of information on the same frame by splitting each unit and displaying portions of each unit on the same line. This should be avoided because it confuses motorists and increases reading time. An example of an unacceptable message split is shown below. Note the unacceptable splitting and combining of portions of the two message units of information in Frame 2 (i.e., combining *DRIVE* and *USE* on the second line of Frame 2 from the two units of information *EXIT AT RIVER DRIVE* and *USE OTHER ROUTES*).

#### Example of an UNACCEPTABLE SPLITTING AND COMBINING PORTIONS OF TWO MESSAGE UNITS

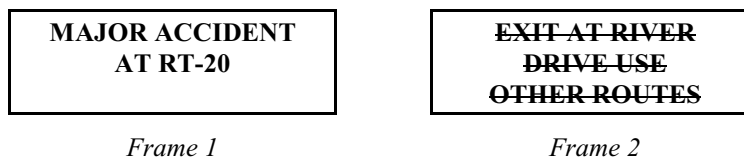

In most cases, the unacceptable message can be corrected by using better terms in the message frame or by using abbreviations. In the example above, the unacceptable message can be corrected by using abbreviations as shown in the acceptable message below.

#### Example of an ACCEPTABLE MESSAGE SPLIT

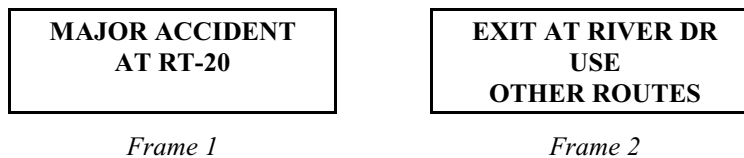

#### 5. NO MORE THAN THREE UNITS OF INFORMATION SHOULD BE DISPLAYED ON A SINGLE FRAME AT HIGH FREEWAY SPEEDS

Research has shown that, at typical freeway speeds, no more than three units of information should be displayed on a single message frame when all three units must be recalled by motorists to make a driving decision. Frame 2 in the example below has the following four units of information that motorists destined to Philadelphia and to I-95 (two *Audiences*) must read in order to make a diversion decision:

- Unit 1 – *BEST ROUTE TO*;
- Unit 2 – *PHILADELPHIA*;
- Unit 3 – *I-95*; and
- Unit 4 – *USE RT-322*.

The four-unit message frame is too complex for motorists to read and understand while traveling at

high freeway speeds.

**Example of an UNACCEPTABLE MESSAGE FRAME with four units of information (Frame 2)**

**3 LANES CLOSED  
AT I-295**

*Frame 1*

**BEST ROUTE TO  
PHILADELPHIA/ I-95  
USE RT-322**

*Frame 2*

One alternative solution is to direct the *Action* message element to only one of the two *Audiences*. The decision would need to be made whether it is best to advise motorists destined to Philadelphia or destined to I-95. In the acceptable message below, the *Action* is directed to the Philadelphia-bound motorists.

**Example of an ACCEPTABLE MESSAGE FRAME with three units of information (Frame 2)**

**3 LANES CLOSED  
AT I-295**

*Frame 1*

**BEST ROUTE TO  
PHILADELPHIA  
USE RT-322**

*Frame 2*

## 9.2 APPROACHES TO REDUCING MESSAGE LENGTH

Always look for ways to reduce the message length without losing the intent of the message by:

- Deleting “dead” words, and/or
- Reformatting the message.

### DELETING “DEAD” WORDS

“Dead” words should be deleted whenever possible. “Dead” words are ones that 99 percent of local motorists would assume without being told.

#### Street, Avenue or Boulevard

One example of a “dead” word is the use of "street", "avenue", or "boulevard" following a familiar arterial name. These words are not required and could be omitted. There are exceptions to this principle that are discussed on [page 5-9](#).

#### Ahead

Another “dead” word is “ahead.” It is not necessary to tell motorists that an incident or road work is “ahead” when the VMS is on the same freeway as the event because it will be understood by motorists that the event is ahead.

**MESSAGE LENGTH CAN BE REDUCED BY:**

- Omitting “dead” words; and/or
- Reformatting the message.

**MESSAGE LENGTH CAN ALSO BE REDUCED BY**

- Using abbreviations.

## FORMATTING MESSAGES

The order of information is dependent upon whether

- An *Incident Descriptor* or *Roadwork Descriptor* message element is part of the message; or
- The *Incident Descriptor* or *Roadwork Descriptor* message element is replaced by or combined with a *Lanes Closed* message element.

(See [MODULE 13 MODIFYING MESSAGES TO IMPROVE EFFECTIVENESS](#) for reformatting examples.)

### Messages WITH Incident Descriptor Message Element

The format order for messages that contain an *Incident Descriptor* message element (e.g., *ACCIDENT*) is summarized in Table 9.1 for the cases when lane-closure (blockage) incidents occur or when incidents occur that require closing the freeway.

Table 9.1 Format Order When <i>Incident Descriptor</i> Message Element is Used for Incidents	
Message Elements for Lane Closure Incidents	Message Elements for Freeway Closure Incidents
1. Incident Descriptor 2. Incident Location 3. Lanes Closed (Blocked) 4. Audience for Action (if needed) 5. Action 6. Good Reason for Following Action <sup>A</sup>	1. Incident Descriptor 2. Incident Location 3. Lanes Closed (Blocked) 4. Audience for Action (if needed) 5. Action

<sup>A</sup> When *BEST ROUTE TO* is used as the Good Reason, then *the Good Reason for Following Action* message element is placed before the *Action* message element.

When the message is split into two frames, then the combinations of formatting shown in Table 9.2 should be used:

Table 9.2 Format Order for Two-Frame Messages When <i>Incident Descriptor</i> Message Element is Used for Incidents	
Message Frame 1	Message Frame 2
1. Incident Descriptor 2. Incident Location	3. Lanes Closed (Blocked) 4. Action
1. Incident Descriptor 2. Incident Location	3. Audience for Action 4. Action
1. Incident Descriptor 2. Incident Location 3. Lanes Closed (Blocked)	4. Audience for Action 5. Action
1. Incident Descriptor 2. Incident Location	3. Audience for Action 4. Action 5. Good Reason for Following Action <sup>A</sup>

<sup>A</sup> When *BEST ROUTE TO* is used as the Good Reason, then *the Good Reason for Following Action* message element is placed before the *Action* message element.

**Messages WITH Roadwork Descriptor Message Element**

The format order for messages that contain a *Roadwork Descriptor* message element (e.g., *ROADWORK*) is summarized in Table 9.3 for the cases when lane closures occur due to roadwork and when the road work requires closing the freeway.

<b>Table 9.3 Format Order When <i>Roadwork Descriptor</i> Message Element is Used for Roadwork</b>	
<b>Message Elements for Lane Closures</b>	<b>Message Elements for Freeway Closures</b>
1. Roadwork Descriptor 2. Lane Closure Location 3. Lanes Closed 4. Audience for Action (if needed) 5. Action 6. Good Reason for Following Action <sup>A</sup>	1. Roadwork Descriptor 2. Closure Location 3. Lanes Closed 4. Audience for Action (if needed) 5. Action

<sup>A</sup> When *BEST ROUTE TO* is used as the Good Reason, then *the Good Reason for Following Action* message element is placed before the *Action* message element.

When the message is split into two frames, then the combinations of formatting shown in Table 9.4 should be used.

<b>Table 9.4 Format Order for Two-Frame Messages When <i>Roadwork Descriptor</i> Message Element is Used for Roadwork</b>	
<b>Message Frame 1</b>	<b>Message Frame 2</b>
1. Roadwork Descriptor 2. Lane Closure Location	3. Lanes Closed 4. Action
1. Roadwork Descriptor 2. Lane Closure Location	3. Audience for Action 4. Action
1. Roadwork Descriptor 2. Lane Closure Location 3. Lanes Closed	4. Audience for Action 5. Action
1. Roadwork Descriptor 2. Lane Closure Location	3. Audience for Action 4. Action 5. Good Reason for Following Action <sup>A</sup>

<sup>A</sup> When *BEST ROUTE TO* is used as the Good Reason, then *the Good Reason for Following Action* message element is placed before the *Action* message element.



**Messages WITHOUT Incident Descriptor Message Element**

The format order for messages in which the *Incident Descriptor* message element is replaced by or combined with a *Lanes Closed* message element is shown in Table 9.5.

<b>Table 9.5 Format Order When <i>Incident Descriptor</i> Message Element is Replaced By or Combined With the <i>Lanes Closed</i> Message Element for Incidents</b>	
<b>Message Elements for Lane Closure Incidents</b>	<b>Message Elements for Freeway Closure Incidents</b>
1. Lanes Closed (Blocked) 2. Lane Closure (Blockage) Location 3. Audience for Action (if needed) 4. Action 5. Good Reason for Following Action <sup>A</sup>	1. Freeway Closure (Blocked) 2. Location of Closure 3. Audience for Action (if needed) 4. Action 5. Good Reason for Following Action <sup>A</sup>

<sup>A</sup>When *BEST ROUTE TO* is used as the Good Reason, then *the Good Reason for Following Action* message element is placed before the *Action* message element.

When the message is split into two frames, then the combinations of formatting shown in Table 9.6 should be used:

<b>Table 9.6 Format Order for Two-Frame Messages When <i>Incident Descriptor</i> Message Element is Replaced By or Combined With the <i>Lanes Closed</i> Message Element for Incidents</b>	
<b>Message Frame 1</b>	<b>Message Frame 2</b>
1. Lanes Closed (Blocked) 2. Lane Closure (Blockage) Location	3. Audience for Action 4. Action
1. Lanes Closed (Blocked) 2. Lane Closure (Blockage) Location	3. Audience for Action 4. Action 5. Good Reason for Following Action <sup>A</sup>
1. Freeway Closed (Blocked) 2. Location of Closure	3. Audience for Action 4. Action

<sup>A</sup>When *BEST ROUTE TO* is used as the Good Reason, then *the Good Reason for Following Action* message element is placed before the *Action* message element.

**Messages WITHOUT Roadwork Descriptor Message Element**

The format order for messages in which the *Roadwork Descriptor* message element is replaced by or combined with a *Lanes Closed* message element is shown in Table 9.7.

Table 9.7 Format Order When <i>Roadwork Descriptor</i> Message Element is Replaced By or Combined With the <i>Lanes Closed</i> Message Element for Roadwork	
Message Elements for Lane Closures	Message Elements for Freeway Closures
1. Lanes Closed 2. Lane Closure Location 3. Audience for Action (if needed) 4. Action 5. Good Reason for Following Action <sup>A</sup>	1. Freeway Closed 2. Closure Location 3. Audience for Action (if needed) 4. Action

<sup>A</sup> When *BEST ROUTE TO* is used as the Good Reason, then *the Good Reason for Following Action* message element is placed before the *Action* message element.

When the message is split into two frames, then the combinations of formatting shown in Table 9.8 should be used.

Table 9.8 Format Order For Two-Frame Messages When <i>Roadwork Descriptor</i> Message Element is Replaced By or Combined With the <i>Lanes Closed</i> Message Element for Roadwork	
Message Frame 1	Message Frame 2
1. Lanes Closed 2. Lane Closure Location	3. Audience for Action 4. Action
1. Lanes Closed 2. Lane Closure Location	3. Audience for Action 4. Action 5. Good Reason for Following Action <sup>A</sup>
1. Freeway Closed 2. Closure Location	3. Audience for Action 4. Action

<sup>A</sup> When *BEST ROUTE TO* is used as the Good Reason, then *the Good Reason for Following Action* message element is placed before the *Action* message element.

## USING ABBREVIATIONS

### Acceptable Abbreviations

Table 9.9 shows the message words and terms with abbreviations that were understood by 85 percent or more of either New Jersey drivers tested in 1997 or drivers in a study conducted in 1981 by Dudek and his colleagues. These abbreviations are acceptable for use on VMSs for New Jersey drivers.

Table 9.9 ACCEPTABLE Abbreviation Terms For New Jersey Drivers			
Word or Phrase	ACCEPTABLE Abbreviation Term	Word or Phrase	ACCEPTABLE Abbreviation Term
Access	NO ACCS	Minute(s)	[number] MIN
Accident	ACCDT AT	National Park	[name] NATL PRK
Ahead	[incident, distance, etc.] AHD	Normal	NORM TRAFFIC
Alternate Routes	ALT RTS	Oversized	OVRSZ LOAD
Blocked	BLKD LANE	Parking	PRK LOT
Boulevard	[name] BLVD	Prepare	PREP TO STOP
Bridge	[name] BRDG	Pavement	WET PVMT
Center Lane	CTR LANE or CTR LN	Quality	AIR QLTY
Center	ARTS CTR	Right	KEEP RGT
Chemical	CHEM SPILL	Right Lane	RGT LANE or RGT LN
Construction	CONST	Road	[name] RD
Emergency	EMER VEHICLE	Route	BEST RTE
Entrance	FREEWAY ENT	Route	TO RT [number]
Exit	EX [number]	Service	SERV ROAD
Exit	NEXT EX	Shoulder	ON SHLDR
Express Lanes	EXP LANES or EXP LNS	Slippery	SLIP PAVEMENT
Expressway	[name] EXPWY	Speed	SPD LIMIT
Freeway	[name] FWY or [name] FRW	Traffic	TRAF ADVISORY
Hazardous	HAZ DRIVING	Travelers	TRVLRS WARNING
Highway	HWY [number]	Turnpike	TO TNPK
Information	TRAFFIC INFO	Vehicle	STALLED VEH
Interstate	I-[number]	Cardinal	[name] N, S, E, or W
Left	LFT LANE or LFT LN	Directions	
Left	MERGE LFT	Upper	UPR LEVEL
Maintenance	MAINT WORK	Warning	BLIZZARD WARN
Major	MAJ ACCIDENT	Weight	WT LIMIT
Mile(s)	[number] MI		
Minor	MNR ACCIDENT		

**Acceptable Abbreviations In North New Jersey, But Not South New Jersey**

Table 9.10 shows abbreviations that would be acceptable for drivers in north New Jersey but would not be unacceptable for drivers in south New Jersey. The table reflects regional differences in understanding between drivers in north and south New Jersey.

<b>Table 9.10 ACCEPTABLE Abbreviations in NORTH New Jersey, But Unacceptable in South New Jersey</b>	
<b>Word or Phrase</b>	<b>ACCEPTABLE Abbreviation Term In NORTH New Jersey Only</b>
Express Closed Local Lanes	EXP CLSD LOCL LNS

**Acceptable Abbreviations For Some Major Destinations In New Jersey**

Personal nouns are used frequently to direct drivers to specific entertainment or recreational facilities. Recent human factors studies revealed that there are some personal noun abbreviations that were understood by most drivers tested in New Jersey. These abbreviations are shown in Table 9.11. It should be recognized by the VMS message designer or VMS operator that the personal noun abbreviations may not be understood by unfamiliar drivers from other states.

<b>Table 9.11 ACCEPTABLE Abbreviation Noun Message Terms For New Jersey Drivers</b>			
<b>Word or Phrase</b>	<b>ACCEPTABLE Abbreviation Term</b>	<b>Word or Phrase</b>	<b>ACCEPTABLE Abbreviation Term</b>
[name] Aquarium Atlantic City Expressway	[name] AQRM ATL CTY EXPWY	Arts Center Garden State Parkway	ARTS CTR GRDN ST PKWY

**Acceptable Abbreviations For Major Destinations By Region: North And South New Jersey**

Because of regional familiarity, there were some personal noun abbreviations of facilities located in north New Jersey that were understood by drivers in north New Jersey, but not understood by a high majority of drivers in south New Jersey, and vice-versa. The abbreviations that were found to be acceptable in one region but not the other are shown in [Table 9.12](#).

<b>Table 9.12 ACCEPTABLE Abbreviation Noun Message Terms For New Jersey Drivers— North and South Regions</b>		
<b>Word or Phrase</b>	<b>ACCEPTABLE Abbreviation Term Only For NORTH New Jersey Drivers</b>	<b>ACCEPTABLE Abbreviation Term Only For SOUTH New Jersey Drivers</b>
Mount Tabor Sandy Hook National Park Walt Whitman Bridge	MT TABOR SANDY HK NATL PRK	W WHITMN BRDG

**Unacceptable Abbreviations**

Results of human factors studies revealed a group of abbreviations that were not understood by 85 percent or more of the drivers tested in New Jersey, and are therefore unacceptable for use on VMSs in New Jersey. A list of these abbreviations is shown in Table 9.13.

<b>Table 9.13 UNACCEPTABLE Abbreviation Terms</b>		
<b>Word or Phrase</b>	<b>UNACCEPTABLE Abbreviation</b>	<b>Recommended Abbreviation for 8-Character VMS Line</b>
County Road [number] Interchange [number] Left Lane	CR [number] or C RD [number] INTCH [number] or INT [number] LT LN	CO RD [number] EX [number] LFT LANE or LFT LN
Left Local Lane Local Lanes Truck Plaza	LFT LOC or LFT LCL LOC LNS or LCL LNS TRK PLAZ or TRK PLZ	(none) LOCL LNS TRK STOP
Vicinity of Route [number]	VIC OF RT [number]	NEAR RT [number]

Personal noun abbreviations that were found to be unacceptable for use in both north and south New Jersey are given in Table 9.14.

<b>Table 9.14 UNACCEPTABLE Abbreviation Noun Message Terms</b>	
<b>Word or Phrase</b>	<b>UNACCEPTABLE Abbreviation Term For New Jersey Drivers</b>
Great Adventure Island Beach State Park	GRT ADV ISL BECH ST PRK

## 9.3 REDUCING MESSAGE UNITS OF INFORMATION

VMS messages should be as short as possible. Therefore, the message designer should look for ways to reduce long messages or Basic VMS Messages that exceed the maximum number of information units that can be displayed for the given situation. Units of information can be reduced without losing information content or the important information required by motorists to make decision by:

**UNITS OF INFORMATION CAN BE REDUCED BY:**

- Omitting unimportant information;
- Omitting redundant information; and/or
- Combining Basic VMS Message elements.

- Omitting unimportant information;
- Omitting redundant information; and/or
- Combining Basic VMS Message elements.

### REFORMATTING THE MESSAGE

The units of information in a message can sometimes be reduced by reformatting the message. At times it is possible to use alternative phrases that are understandable by motorists and have the same meaning as the original. The following example illustrates how message length can be reduced by reformatting.

#### **The Original Message:**

ROAD CLOSED AHEAD  
DUE TO CONSTRUCTION  
FOLLOW DETOUR ROUTE

#### **Can Be Shortened To:**

ROAD CLOSED  
1 MILE  
FOLLOW DETOUR

#### **With Better Results.**

In the above, the most important message elements are the road is closed and the location of the closure. The reason *DUE TO CONSTRUCTION* is not necessary to display and can be omitted. In addition, the word *AHEAD* can be omitted because it is obvious to motorists by simply stating *ROAD CLOSED*.

## 9.4 REDUCING UNITS OF INFORMATION FROM THE BASIC VMS MESSAGE

In most cases a Basic VMS Message required for the incident or roadwork situation will contain more units of information than is acceptable to display for the prevailing freeway speed. Therefore, the number of units of information must be

**THE NUMBER OF UNITS OF INFORMATION CONTAINED IN A BASIC VMS MESSAGE CAN BE REDUCED BY:**

- **First applying the Initial Reduction Approaches;**
- **Then applying the Priority Reduction Principles.**

reduced. The VMS message designer should first use the *Initial Reduction Approaches* that are discussed in the section that follows. After these approaches are applied, then the message designer should follow the principles set discussed in *Priority Reduction Principles* on [page 9-20](#).

### INITIAL REDUCTION APPROACHES

The first step that should be taken to reduce the units of information of the Basic VMS Message to an acceptable level is to apply the approaches discussed in this section. Approaches to reducing the number of units of information for both incidents and roadwork are presented in the sections that follow.

#### Reducing Redundancy in Incident and Roadwork Messages

##### *Omitting Reference to Same Freeway as Incident/Roadwork and VMS*

It is not necessary nor is it desirable to make reference to the freeway if the VMS is on the same freeway as the incident/roadwork. For example, if a major accident occurs on northbound I-276 just past I-80 that blocks all the lanes, reference to *ON I-276 NORTH* should be omitted since this information is evident to motorists and increases the units of information and the length of the message.

**INCIDENT AND ROADWORK MESSAGES CAN BE REDUCED BY:**

- **Omitting reference to same freeway as incident/roadwork and VMS.**

Message Element and Message	Revised Message
<p><u>Incident on Same Freeway as VMS</u></p> <p><i>Incident Descriptor</i>    <b>MAJOR ACCIDENT</b></p> <p><i>Location</i>                <b>ON I-276 NORTH</b></p> <p>                                  <b>PAST I-80</b></p> <p><i>Lanes Blocked</i>         <b>ALL LANES BLOCKED</b></p>	<p><b>MAJOR ACCIDENT</b></p> <p><b>PAST I-80</b></p> <p><b>ALL LANES BLOCKED</b></p>

## Combining Message Elements for Incident Messages

### Combining Incident Descriptor, Location and Lanes Closed/Blocked Message Elements

In an effort to reduce the length of VMS messages, it is sometimes necessary and, in most cases, useful to combine the *Incident Descriptor*, *Incident Location* and *Lanes Affected* message elements. For example, when a major accident occurs that blocks all of the lanes, the term *FREEWAY BLOCKED* can be used in place of the longer combination of *MAJOR ACCIDENT* and *ALL LANES BLOCKED*. Examples of combining *Incident Descriptor*, *Incident Location* and *Lanes Affected* message elements are shown in Table 9.16.

**INCIDENT MESSAGES CAN BE REDUCED BY:**  
 ● Combining *Incident Descriptor*, *Incident Location* and *Lanes Closed/Blocked* message elements.

Table 9.16 Examples of Combining <i>Incident Descriptor</i> , <i>Incident Location</i> and <i>Lanes Closed/Blocked</i> Message Elements	
Message Element and Message	Revised Message
<u>Incident on Same Freeway as VMS</u>	
<i>Incident Descriptor</i> <b>MAJOR ACCIDENT</b>	<b>FREEWAY BLOCKED</b> <b>PAST I-80</b>
<i>Location</i> <b>PAST I-80</b>	
<i>Lanes Blocked</i> <b>ALL LANES BLOCKED</b>	
<u>Incident on Another Freeway than VMS</u>	
<i>Incident Descriptor</i> <b>MAJOR ACCIDENT</b>	<b>I-76 WEST BLOCKED</b> <b>AT WALT WHITMAN BRIDGE</b>
<i>Location</i> <b>ON I-76 WEST</b> <b>AT WALT WHITMAN BRIDGE</b>	
<i>Lanes Blocked</i> <b>ALL LANES BLOCKED</b>	
<u>Closed Roadway Due to Incident on Same Freeway as VMS</u>	
<i>Incident Descriptor</i> <b>TRUCK ACCIDENT</b>	<b>FREEWAY CLOSED</b>
<i>Location</i> <b>PAST I-80</b>	
<i>Lanes Affected</i> <b>ALL LANES CLOSED</b>	<b>EXIT AT I-80</b> <b>FOLLOW DETOUR</b>
<i>Location of Closure</i> <b>AT I-80</b>	
<i>Audience for Action</i> <b>I-287 NORTH TRAFFIC</b>	
<i>Action</i> <b>EXIT AT I-80</b> <b>FOLLOW DETOUR</b>	
<u>Closed Exit Ramp at Major Interchange on Same Freeway as VMS</u>	
<i>Incident Descriptor</i> <b>MAJOR ACCIDENT</b>	<b>RAMP CLOSED</b>
<i>Location</i> <b>ON I-80 EAST RAMP</b>	
<i>Lanes Closed</i> <b>RAMP CLOSED</b>	<b>TO I-80 EAST</b>
<i>Location of Closure</i> <b>TO I-80 EAST</b>	
<i>Audience for Action</i> <b>I-287 NORTH TRAFFIC</b>	
<i>Action</i> <b>EXIT AT RT-10</b> <b>FOLLOW DETOUR</b>	<b>EXIT AT RT-10</b> <b>FOLLOW DETOUR</b>





## Combining Message Elements for Roadwork Messages

### Combining Roadwork Descriptor Message Element with Lanes Closed Message Element

When motorists are about to encounter roadwork on the freeway, it is more important for them to know that lanes are closed and, more specifically, which lanes are closed rather than be given information on a VMS that roadwork is taking place on the freeway. The information about the roadwork will ordinarily be displayed on static signs as part of the work zone traffic control plan, and displaying the information on a VMS is redundant and takes up space for more relevant information. For example, if roadwork requires closure of the two left freeway lanes, the *Roadwork Descriptor (ROADWORK)* can be omitted on the first line of the VMS and replaced with the *Lanes Closed* message element **2 LEFT LANES CLOSED**.

**ROADWORK MESSAGES CAN BE REDUCED BY:**

- Combining *Roadwork Descriptor* message element with *Lanes Closed* message element; or
- Combining *Roadwork Descriptor, Closure Location, and Lanes Closed* message elements.

Examples of how the *Roadwork Descriptor* message element can be replaced with the *Lanes Closed* message element are shown in Table 9.18.

Table 9.18 Examples of Combining <i>Roadwork Descriptor</i> Message Element with <i>Lanes Closed</i> Message Element	
Message Element and Message	Revised Message
<u>Roadwork on Same Freeway as VMS</u>	
<i>Roadwork Descriptor</i> <b>ROADWORK</b> <i>Lane Closure Location</i> <b>PAST I-80</b> <i>Lanes Closed</i> <b>2 LEFT LANES CLOSED</b>	<b>2 LEFT LANES CLOSED</b> <b>PAST I-80</b>
<u>Roadwork on Same Freeway as VMS</u>	
<i>Roadwork Descriptor</i> <b>ROADWORK</b> <i>Lane Closure Location</i> <b>AT EXIT 42</b> <i>Lanes Closed</i> <b>2 LEFT LANES CLOSED</b>	<b>2 LEFT LANES CLOSED</b> <b>AT EXIT 42</b>
<u>Closed Roadway Due to Roadwork on Same Freeway as VMS</u>	
<i>Roadwork Descriptor</i> <b>ROADWORK</b> <i>Lane Closure Location</i> <b>AT ROUTE 46</b> <i>Lanes Closed</i> <b>ALL LANES CLOSED</b> <i>Location of Closure</i> <b>I-80</b> <i>Audience for Action</i> <b>I-287 NORTH TRAFFIC</b> <i>Action</i> <b>EXIT AT I-80</b> <b>FOLLOW DETOUR</b>	<b>FREEWAY CLOSED</b>  <b>EXIT AT I-80</b> <b>FOLLOW DETOUR</b>

**Combining Roadwork Descriptor, Closure Location, and Lanes Closed Message Elements**

When the VMS gives information about roadwork closures on an intersecting freeway that many motorists will use to get to their destinations, it is oftentimes desirable and necessary to combine the *Roadwork Descriptor*, *Closure Location*, and *Lanes Closed* message elements. An example is shown in Table 9.19.

Table 9.19 Example of Combining <i>Roadwork Descriptor</i> , <i>Closure Location</i> and <i>Lanes Closed</i> Message Elements	
Message Element and Message	Revised Message
<u>Roadwork on Different Highway than VMS</u>	
<i>Roadwork Descriptor</i> <b>ROADWORK</b>	<b>I-80 EAST CLOSED FROM EXIT 52 TO EXIT 53</b>
<i>Closure Location</i> <b>ON I-80 EAST FROM EXIT 52 TO EXIT 53</b>	
<i>Lanes Closed</i> <b>ALL LANES CLOSED</b>	

**Combining Location of Closure Message Element and Action Message Element**

When the freeway is closed and a detour route set in place with signs, police and/or traffic control personnel, and the VMS is on the same freeway and near the closure, then the *Location of Closure* message element becomes unnecessary to display because it will be contained in the *Action* message element. One of the examples in Table 9.16 is repeated here to illustrate the concept. In the table below, the *Location of Closure* (*AT I-80*) is combined with the *Action* (*EXIT AT I-80/ FOLLOW DETOUR*) and should be omitted because it is redundant.

**WHEN THE FREEWAY IS CLOSED, ROADWORK MESSAGES CAN BE REDUCED FURTHER BY:**

- Combining *Location of Closure* message element and *Action* message element.

Table 9.20 Example of Combining <i>Location of Closure</i> Message Element and <i>Action</i> Message Element	
Message Element and Message	Revised Message
<u>Closed Roadway Due to Roadwork on Same Freeway as VMS</u>	
<i>Roadwork Descriptor</i> <b>ROADWORK</b>	<b>FREEWAY CLOSED</b>
<i>Lane Closure Location</i> <b>AT ROUTE 46</b>	
<i>Lanes Closed</i> <b>ALL LANES CLOSED</b>	<b>EXIT AT I-80 FOLLOW DETOUR</b>
<i>Location of Closure</i> <b>AT I-80</b>	
<i>Audience for Action</i> <b>I-287 NORTH TRAFFIC</b>	
<i>Action</i> <b>EXIT AT I-80 FOLLOW DETOUR</b>	

## SECONDARY REDUCTION APPROACH

### Reducing the Number of Destinations in the Action Message Element

After the Initial Reduction Approaches have been applied to the Basic VMS Message, it may still be possible to reduce the number of informational units, if required, when the *Action* message element contains more than two *Audiences*. A decision will have to be made by the message designer concerning which of the two *Audiences* should be addressed in the message. The second *Audience* must then be omitted from the *Action* message element. In the example shown in Table 9.21, a Basic VMS Message with eight units of information was reduced to the message shown on the left side.

Table 9.21 Example of Reducing Number of Destinations in the <i>Action</i> Message Element			
Reduced Message After Applying Initial Reduction Approaches		Revised Message	
<u>Roadwork on Different Highway than VMS</u>			
<b>I-76 CLOSED</b>	<b>BEST ROUTE TO PHILADELPHIA/ I-95 USE RT-73 NORTH</b>	<b>I-76 CLOSED</b>	<b>BEST ROUTE TO PHILADELPHIA USE RT-73 NORTH</b>
<i>Frame 1</i>	<i>Frame 2</i>	<i>Frame 1</i>	<i>Frame 2</i>

The reduced message has the following five units of information:

- *I-76 CLOSED* - 1 unit
- *BEST ROUTE TO* - 1 unit
- *PHILADELPHIA/ I-95* - 2 units
- *USE RT-73 NORTH* - 1 unit

Five units of information exceed the maximum number of units that motorists can read and comprehend while traveling at high freeway speeds. The message must therefore be reduced to four units of information. In the revised message, the destination *I-95* is omitted in preference to *PHILADELPHIA*, resulting in an acceptable four-unit message.

**PRIORITY REDUCTION PRINCIPLES**

After the Initial Reduction Approaches and the Secondary Reduction Approach are applied and the Basic VMS Message still has more units of information than should be displayed to motorists at the prevailing freeway speed, then the Priority Reduction Principles discussed in this section should be applied.

There is a priority of information that motorists need in order to make driving decisions when incidents occur or lanes are closed due to roadwork. The information needed by motorists in order of priority for incidents and roadwork are shown in Tables 9.22 and 9.23.

<b>Table 9.22 Information Order of Priority for Incidents</b>	
<b>Message Elements for Lane Closure Incidents</b>	<b>Message Elements for Freeway Closure Incidents</b>
1. Incident Descriptor 2. Incident Location 3. Lanes Closed (Blocked) 4. Diversion Action 5. Audience for Action (if needed)	1. Freeway Closure (Blocked) 2. Location of Closure 3. Diversion Action 4. Audience for Action (if needed)

<b>Table 9.23 Information Order of Priority for Roadwork</b>	
<b>Message Elements for Lane Closure for Roadwork</b>	<b>Message Elements for Freeway Closure for Roadwork</b>
1. Roadwork Descriptor 2. Roadwork (Lane Closure) Location 3. Action Concerning Speed Reductions 4. Diversion Action 5. Audience for Action (if needed)	1. Freeway Closure (Blocked) 2. Location of Closure 3. Action Concerning Speed Reductions 4. Diversion Action 5. Audience for Action (if needed)

Although *the Incident Descriptor* and the *Roadwork Descriptor* are useful to motorists these message elements can be replaced with the *Lanes Closed* message element.

When the number of information units exceeds the maximum that should be displayed under prevailing speeds and the Initial Reduction Approaches and the Secondary Reduction Approach have been applied, then the message designer must begin eliminating informational units. **This is done by eliminating units of information starting with the lowest priority.**

# MODULE 10. DESIGNING VMS MESSAGES FOR INCIDENTS

## TABLE OF CONTENTS

**10.1 LANE CLOSURE (BLOCKAGE) INCIDENTS**.....10-1

**VMS ON SAME FREEWAY AND RELATIVELY CLOSE TO THE INCIDENT**.....10-1

        Establish Initial Maximum Allowable Number of Units of Information in the Message Based on VMS Type and Freeway Operating Speeds .....10-1

        Assess Whether the Message Must Be Reduced Because of Local Geometric Sight Distance Restrictions to the VMS .....10-2

        Assess Whether the Message Must Be Reduced Because of Local Environmental Sight Distance Restrictions to the VMS Due to Rain or Fog.....10-2

        Finalize the Maximum Allowable Units of Information in the Message .....10-3

        Define the Basic VMS Message to Satisfy Motorist Information Needs .....10-3

        Reduce the Number of Message Units if Necessary.....10-4

        Format the Message .....10-5

        Adjust Message to Fit on Existing VMS .....10-5

        Adjust Message to Fit on 3 Lines or Less.....10-6

        Finalize VMS Message .....10-7

        Assess Effects of Large Trucks on the Ability of Motorists to View the VMS Message.....10-7

**VMS ON SAME FREEWAY BUT RELATIVELY FAR FROM THE INCIDENT** .....10-8

        Establish Initial Maximum Allowable Number of Units of Information in the Message Based on VMS Type and Freeway Operating Speeds .....10-8

        Assess Whether the Message Must Be Reduced Because of Local Geometric Sight Distance Restrictions to the VMS .....10-8

        Assess Whether the Message Must Be Reduced Because of Local Environmental Sight Distance Restrictions to the VMS Due to Rain or Fog.....10-9

        Finalize the Maximum Allowable Units of Information in the Message .....10-9

        Define the Basic VMS Message to Satisfy Motorist Information Needs .....10-9

        Reduce the Number of Message Units if Necessary.....10-11

        Format the Message .....10-12

        Adjust Message to Fit on Existing VMS .....10-12

        Adjust Message to Fit on 3 Lines or Less.....10-12

        Finalize VMS Message .....10-13

        Assess Effects of Large Trucks on the Ability of Motorists to View the VMS Message.....10-13

**VMS ON DIFFERENT FREEWAY THAN THE INCIDENT**.....10-14

        Establish Initial Maximum Allowable Number of Units of Information in the Message Based on VMS Type and Freeway Operating Speeds .....10-14

        Assess Whether the Message Must Be Reduced Because of Local Geometric Sight Distance Restrictions to the VMS .....10-14

Assess Whether the Message Must Be Reduced Because of Local Environmental  
Sight Distance Restrictions to the VMS Due to Rain or Fog.....10-15

Finalize the Maximum Allowable Units of Information in the Message .....10-15

Define the Basic VMS Message to Satisfy Motorist Information Needs .....10-15

Reduce the Number of Message Units if Necessary.....10-17

Format the Message .....10-18

Adjust Message to Fit on Existing VMS .....10-18

Adjust Message to Fit on 3 Lines or Less.....10-18

Finalize VMS Message .....10-19

Assess Effects of Large Trucks on the Ability of Motorists to View the VMS  
Message.....10-19

**10.2 INCIDENTS THAT BLOCK ALL THE LANES.....10-20**

**VMS ON SAME FREEWAY AND RELATIVELY CLOSE TO THE INCIDENT....10-20**

Establish Initial Maximum Allowable Number of Units of Information in the  
Message Based on VMS Type and Freeway Operating Speeds .....10-20

Assess Whether the Message Must Be Reduced Because of Local Geometric  
Sight Distance Restrictions to the VMS .....10-20

Assess Whether the Message Must Be Reduced Because of Local Environmental  
Sight Distance Restrictions to the VMS Due to Rain or Fog.....10-21

Finalize the Maximum Allowable Units of Information in the Message .....10-21

Define the Basic VMS Message to Satisfy Motorist Information Needs .....10-21

Reduce the Number of Message Units if Necessary.....10-23

Format the Message .....10-23

Adjust Message to Fit on Existing VMS .....10-23

Adjust Message to Fit on 3 Lines or Less.....10-24

Finalize VMS Message .....10-25

Assess Effects of Large Trucks on the Ability of Motorists to View the VMS  
Message.....10-25

**VMS ON SAME FREEWAY BUT RELATIVELY FAR FROM THE INCIDENT ...10-26**

Establish Initial Maximum Allowable Number of Units of Information in the  
Message Based on VMS Type and Freeway Operating Speeds .....10-26

Assess Whether the Message Must Be Reduced Because of Local Geometric  
Sight Distance Restrictions to the VMS .....10-26

Assess Whether the Message Must Be Reduced Because of Local Environmental  
Sight Distance Restrictions to the VMS Due to Rain or Fog.....10-27

Finalize the Maximum Allowable Units of Information in the Message .....10-27

Define the Basic VMS Message to Satisfy Motorist Information Needs .....10-27

Reduce the Number of Message Units if Necessary.....10-28

Format the Message .....10-29

Adjust Message to Fit on Existing VMS .....10-29

Adjust Message to Fit on 3 Lines or Less.....10-30

Finalize VMS Message .....10-31

Assess Effects of Large Trucks on the Ability of Motorists to View the VMS  
Message.....10-31

VMS ON DIFFERENT FREEWAY THAN THE INCIDENT.....10-32

- Establish Initial Maximum Allowable Number of Units of Information in the Message Based on VMS Type and Freeway Operating Speeds .....10-32
- Assess Whether the Message Must Be Reduced Because of Local Geometric Sight Distance Restrictions to the VMS .....10-32
- Assess Whether the Message Must Be Reduced Because of Local Environmental Sight Distance Restrictions to the VMS Due to Rain or Fog.....10-33
- Finalize the Maximum Allowable Units of Information in the Message .....10-33
- Define the Basic VMS Message to Satisfy Motorist Information Needs .....10-33
- Reduce the Number of Message Units if Necessary .....10-34
- Format the Message .....10-35
- Adjust Message to Fit on Existing VMS .....10-35
- Adjust Message to Fit on 3 Lines or Less .....10-36
- Finalize VMS Message .....10-37
- Assess Effects of Large Trucks on the Ability of Motorists to View the VMS Message.....10-37

**10.3 INCIDENTS THAT REQUIRE CLOSING THE FREEWAY .....10-38**

VMS ON SAME FREEWAY AND RELATIVELY CLOSE TO THE CLOSURE ....10-38

- Establish Initial Maximum Allowable Number of Units of Information in the Message Based on VMS Type and Freeway Operating Speeds .....10-38
- Assess Whether the Message Must Be Reduced Because of Local Geometric Sight Distance Restrictions to the VMS .....10-38
- Assess Whether the Message Must Be Reduced Because of Local Environmental Sight Distance Restrictions to the VMS Due to Rain or Fog.....10-39
- Finalize the Maximum Allowable Units of Information in the Message .....10-39
- Define the Basic VMS Message to Satisfy Motorist Information Needs .....10-39
- Reduce the Number of Message Units if Necessary .....10-40
- Format the Message .....10-41
- Adjust Message to Fit on Existing VMS .....10-41
- Adjust Message to Fit on 3 Lines or Less .....10-41
- Finalize VMS Message .....10-42
- Assess Effects of Large Trucks on the Ability of Motorists to View the VMS Message.....10-43

VMS ON SAME FREEWAY BUT RELATIVELY FAR FROM THE CLOSURE....10-44

- Establish Initial Maximum Allowable Number of Units of Information in the Message Based on VMS Type and Freeway Operating Speeds .....10-44
- Assess Whether the Message Must Be Reduced Because of Local Geometric Sight Distance Restrictions to the VMS .....10-44
- Assess Whether the Message Must Be Reduced Because of Local Environmental Sight Distance Restrictions to the VMS Due to Rain or Fog.....10-45
- Finalize the Maximum Allowable Units of Information in the Message .....10-45
- Define the Basic VMS Message to Satisfy Motorist Information Needs .....10-45
- Reduce the Number of Message Units if Necessary .....10-47
- Format the Message .....10-47
- Adjust Message to Fit on Existing VMS .....10-47



Adjust Message to Fit on 3 Lines or Less .....10-48

Finalize VMS Message .....10-49

Assess Effects of Large Trucks on the Ability of Motorists to View the VMS  
Message.....10-49

VMS ON DIFFERENT FREEWAY THAN THE CLOSURE .....10-50

Establish Initial Maximum Allowable Number of Units of Information in the  
Message Based on VMS Type and Freeway Operating Speeds .....10-50

Assess Whether the Message Must Be Reduced Because of Local Geometric  
Sight Distance Restrictions to the VMS .....10-50

Assess Whether the Message Must Be Reduced Because of Local Environmental  
Sight Distance Restrictions to the VMS Due to Rain or Fog.....10-51

Finalize the Maximum Allowable Units of Information in the Message .....10-51

Define the Basic VMS Message to Satisfy Motorist Information Needs .....10-51

Reduce the Number of Message Units if Necessary .....10-52

Format the Message .....10-53

Adjust Message to Fit on Existing VMS .....10-53

Adjust Message to Fit on 3 Lines or Less .....10-54

Finalize VMS Message .....10-55

Assess Effects of Large Trucks on the Ability of Motorists to View the VMS  
Message.....10-55

**10.4 INCIDENTS ON AN INTERSECTING FREEWAY THAT  
REQUIRE CLOSING THE CONNECTOR RAMP .....10-56**

VMS UPSTREAM OF THE CONNECTOR RAMP CLOSURE.....10-56

Establish Initial Maximum Allowable Number of Units of Information in the  
Message Based on VMS Type and Freeway Operating Speeds .....10-56

Assess Whether the Message Must Be Reduced Because of Local Geometric  
Sight Distance Restrictions to the VMS .....10-56

Assess Whether the Message Must Be Reduced Because of Local Environmental  
Sight Distance Restrictions to the VMS Due to Rain or Fog.....10-57

Finalize the Maximum Allowable Units of Information in the Message .....10-57

Define the Basic VMS Message to Satisfy Motorist Information Needs .....10-57

Reduce the Number of Message Units if Necessary .....10-59

Format the Message .....10-59

Adjust Message to Fit on Existing VMS .....10-59

Adjust Message to Fit on 3 Lines or Less .....10-60

Finalize VMS Message .....10-61

Assess Effects of Large Trucks on the Ability of Motorists to View the VMS  
Message.....10-61

# MODULE 10. DESIGNING VMS MESSAGES FOR INCIDENTS

## 10.1 LANE CLOSURE (BLOCKAGE) INCIDENTS

### VMS ON SAME FREEWAY AND RELATIVELY CLOSE TO THE INCIDENT

Use the procedure outlined in this section of the Manual when an incident occurs that blocks one or more lanes of traffic and the VMS is located on the same freeway and relatively close to the incident. When a major incident occurs that blocks all of the lanes:

- Before the police arrive at the scene, use [Section 10.2 INCIDENTS THAT BLOCK ALL LANES](#), page 10-20, for VMS; and
- After the police arrive at the scene and begin to control traffic, use [Section 10.3 INCIDENTS THAT REQUIRE CLOSING THE FREEWAY](#), page 10-38.

### Establish Initial Maximum Allowable Number of Units of Information in the Message Based on VMS Type and Freeway Operating Speeds.

Step 1 – Determine Freeway Operating Speeds.

Step 2 – Determine the Initial Maximum Allowable Number of Units of Information in the Message from [Table 8.2](#), page 8-5. For LED VMSs, these maximum values are as follows:

<b>Maximum Number of Units of Information Allowed in VMS Message</b>			
<b>Condition</b>	<b>Light-Emitting Diode VMS</b>		
	<b>0-35 mph</b>	<b>36-55 mph</b>	<b>56-70 mph</b>
Mid-Day	5 units	4 units	4 units
Sun Washout	5 units	4 units	4 units
Sun Backlight	4 units	4 units	3 units
Nighttime	4 units	4 units	3 units

---

**Assess Whether the Message Must Be Reduced Because of Local Geometric Sight Distance Restrictions to the VMS**

Step 3 – Determine Whether There Are Sight Distance Restrictions to the VMS Because of a Vertical Curve Using the Guidelines in [Section 8.3 UNITS OF INFORMATION REDUCTIONS FOR VERTICAL CURVES – LED VMSs](#) on page 8-6.

If “no” Go Directly to Step 5.

If “yes” Continue to Step 4.

Step 4 – Identify the Reduction in the Number of Message Units of Information to Compensate for Lower Legibility to the VMS because of the Vertical Curve Using [Tables 8.3 through 8.6](#) on pages 8-8 and 8-9.

Step 5 – Determine Whether There Are Sight Distance Restrictions to the VMS Because of a Horizontal Curve Using the Guidelines in [Section 8.4 UNITS OF INFORMATION REDUCTIONS FOR HORIZONTAL CURVES – LED VMSs](#) on page 8-10.

If “no” Go Directly to Step 7.

If “yes” Continue to Step 6.

Step 6 – Identify the Reduction in the Number of Units of Information to Compensate for Lower Legibility to the VMS Because of the Horizontal Curve Using [Tables 8.7 through 8.12](#) on pages 8-12 through 8-17.

---

**Assess Whether the Message Must Be Reduced Because of Local Environmental Sight Distance Restrictions to the VMS Due to Rain or Fog**

Step 7 – Determine Whether Rainfall Near the VMS Exceeds 2 Inches per Hour.

If “no” Go Directly to Step 9.

If “yes” Continue to Step 8.

Step 8 – The Reduction in the Number of Units of Information to Compensate for Rain Is 1.

Step 9 – Determine Whether Fog Exists Near the VMS.

If “no” Go Directly to Step 11.

If “yes” Continue to Step 10.

Step 10 – Identify the Reduction in the Number of Units of Information to Compensate for Fog Using [Table 8.13](#) on page 8-19.

---

**Finalize the Maximum Allowable Units of Information in the Message**

Step 11 – Select the Largest Reduction in the Number of Units of Information from Among the Effects of a Vertical Curve (Step 4), a Horizontal Curve (Step 6), Rain (Step 8), or Fog (Step 10), and Use this Number to Subtract from the Maximum Allowable Number of Units of Information in the Message shown in [Table 8.2](#) on page 8-5. The new number after the subtraction represents the final Maximum Allowable Units of Information in the message.

---

**Define the Basic VMS Message to Satisfy Motorist Information Needs**

Step 12– Select *Incident Descriptor* Message Element from [Table 6.1](#), page 6-2.

Step 13 – Select *Incident Location* Message Element from [Table 6.2](#), page 6-3.

Step 14 – Determine Whether the Police or Traffic Control Personnel Arrived to Control Traffic at Incident Site.

If “no” Select *Lanes Blocked* Message Element from [Table 6.3](#), page 6-4.  
Go Directly to Step 16.

If “yes” Continue to Step 15.

Step 15 – Select *Lanes Closed* Message Element from [Table 6.3](#), page 6-4.

Step 16 – Establish Whether the *Effect on Travel* Message Element Is Implied by the *Lanes Closed (Blocked)* Message Element.

If “no” Continue to Step 17.  
If “yes” Go Directly to Step 18.

Note: Statements in the *Lanes Closed (Blocked)* message element such as *3 RIGHT LANES CLOSED* imply to motorists that, depending upon the time of day, they will experience delay or major delay. Thus, an *Effect on Travel* message element does not have to be included in the Basic VMS Message.

Step 17 – Select *Effect on Travel* Message Element from [Table 6.4](#), page 6-5.

Step 18 – Establish Whether Diversion Action Should be Recommended.

If “no” Continue to Step 19.  
If “yes” Go Directly to Step 20.

Step 19 – Select No Diversion *Action* Message Element from [Table 6.5](#), page 6-6 or Omit *Action* Message Element.

GO TO Step 28.

Step 20 – Establish Whether “Soft” Diversion Should be Recommended.

If “no” Go Directly to Step 22.

If “yes” Continue to Step 21.

Step 21 – Select “Soft” Diversion *Action* Message Element from [Table 6.6](#), page 6-7.

GO TO Step 23.

Step 22 – Select Type 1 or Type 2 Diversion Route *Action* Message Element from [Table 6.7](#), page 6-8.

Step 23 – Establish Whether *Action* Message Is for a Select Group of Motorists.

If “no” Go Directly to Step 25.

If “yes” Continue to Step 24.

Step 24 – Select *Audience for Action* Message Element from [Table 6.8](#), page 6-9.

Step 25 – Establish Whether a *Good Reason for Motorists to Follow Action* Is Implied in *Lanes Closed (Blocked)* and *Incident Location* Message Elements.

If “no” Go Directly to Step 27.

If “yes” Continue to Step 26.

Step 26 – Examine Whether the Diversion Route Will Be Perceived By Motorists as Being a Most Logical Route.

If “no” Continue to Step 27.

If “yes” Go Directly to Step 28.

Step 27 – Select a *Good Reason for Following the Action* Statement Message Element from [Table 6.9](#), page 6-10.

---

### **Reduce the Number of Message Units if Necessary**

Step 28 – Examine Whether the Number of Units of Information in the Basic Message Is Greater than the Maximum Allowable from Step 11.

If “no” Go Directly to Step 35.

If “yes” Continue to Step 29.

Step 29 – Omit *Incident Descriptor* Message Element According to Guidelines in the Section on *Combining Message Elements for Incident Messages* Beginning on [page 9-15](#).

Step 30 – Examine Whether the Number of Units of Information in the Basic Message Is Greater than the Maximum Allowable from Step 11.

If “no” Go Directly to Step 35.

If “yes” Continue to Step 31.

Step 31 – Examine Whether The Message Contains More Than One *Audience for Action* (Destination) Message Element.

If “no” Go Directly to Step 34.

If “yes” Continue to Step 32.

Step 32 – Omit All but One *Audience for Action*

Step 33 – Examine Whether the Number of Units of Information in the Basic Message Is Greater than the Maximum Allowable from Step 11.

If “no” Continue to Step 34.

If “yes” Go Directly to Step 35.

Step 34 – Omit Other Information According to Guidelines in the Section on *PRIORITY REDUCTION PRINCIPLES* on [page 9-20](#).

---

### **Format the Message**

Step 35 – Format the Message According to Guidelines in the Section on *FORMATTING MESSAGES* on [page 9-6](#).

---

### **Adjust Message to Fit on Existing VMS**

Step 36 – Determine Whether the VMS Has 4 Lines.

If “no” Continue to Step 37.

If “yes” Go Directly to Step 38.

Step 37 – Determine Whether the VMS Has 3 Lines.

If “no” MESSAGE CANNOT BE DESIGNED USING THIS PROCEDURE.

If “yes” Continue to Step 38.

---

### **Adjust Message to Fit on 3 Lines or Less**

Step 38 – Determine Whether the Message Can Be Displayed on 3 Lines or less.

If “no” Continue to Step 39.

If “yes” Go Directly to Step 40.

Step 39 – Split Message Into 2 Frames According to Guidelines in [Section 9.1 SPLITTING MESSAGES](#) on page 9-1.

Step 40 – Examine Whether There Are 3 or Fewer Decision-Relevant Units of Information Displayed on Each of the Frames.

If “no” Continue to Step 41.

If “yes” Go Directly to Step 42.

Step 41 – Omit Information to Reduce Frame to 3 Decision-Relevant Units According to Guidelines in Item 5. *NO MORE THAN THREE UNITS OF INFORMATION SHOULD BE DISPLAYED ON A SINGLE FRAME AT HIGH FREEWAY SPEEDS* on [page 9-3](#).

Step 42 – Examine Whether Message Elements Are Split in Such a Way That a Part of One Message Element Is on the Same Line as a Part of a Second Message Element.

If “no” Go Directly to Step 44.

If “yes” Continue to Step 43.

Step 43 – Separate Message Elements According to Guidelines in Item 4. *A MESSAGE LINE SHOULD NOT CONTAIN PORTIONS OF TWO DIFFERENT UNITS OF INFORMATION* on [page 9-3](#).

Step 44 – Examine Whether the Message or Any of the Message Lines Are Too Long to Fit in the Available VMS Space.

If “no” Go Directly to Step 48.

If “yes” Continue to Step 45.

Step 45 – Apply Abbreviations to Selected Words According to Guidelines in the Section on *USING ABBREVIATIONS*, [page 9-10](#).

Step 46 – Examine Whether the Application of Abbreviation Guidelines Adequately Reduced the Length of the Message Lines and the Entire Message Can Fit in the Available VMS Space.

If “no” Continue to Step 47.

If “yes” Go Directly to Step 48.

Step 47 – Omit Information According to Guidelines in the Sections on *PRIORITY REDUCTION PRINCIPLES* on [page 9-20](#) and *FORMATTING MESSAGES* on [page 9-6](#).

**Finalize VMS Message**

Step 48 – Review Message for Inconsistencies and Incompatibility.

Step 49 – Make Additional Adjustments if Necessary.

*You now should have an acceptable message ready to display or to store in the VMS message library.*

---

**Assess Effects of Large Trucks on the Ability of Motorists to View the VMS Message**

The final step in the process is to assess the effects of large trucks in the traffic stream on the ability of motorists to see the VMS and read the message. [Tables 8.14 through 8.17](#) on pages 8-21 and 8-22 should be studied to determine the percentage of motorists who will be able to see the VMS message (or consequently, the percentage who will not be able to see the VMS message because their visibility to the sign is blocked by large trucks). This information will help the VMS operator and the TOC manager to determine the potential effectiveness in communicating the message to the motorists in the traffic stream.



**VMS ON SAME FREEWAY BUT RELATIVELY FAR FROM THE INCIDENT**

Use the procedure outlined in this section of the Manual when an incident occurs that blocks one or more lanes of traffic and the VMS is on the same freeway but relatively far from the incident. When a major incident occurs that blocks all of the lanes:

- Before the police arrive at the scene, use [Section 10.2 INCIDENTS THAT BLOCK ALL LANES](#), page 10-20, and
- After the police arrive at the scene and begin to control traffic, use [Section 10.3 INCIDENTS THAT REQUIRE CLOSING THE FREEWAY](#), page 10-38.

**Establish Initial Maximum Allowable Number of Units of Information in the Message Based on VMS Type and Freeway Operating Speeds.**

Step 1 – Determine Freeway Operating Speeds.

Step 2 – Determine the Initial Maximum Allowable Number of Units of Information in the Message from [Table 8.2](#), page 8-5. For LED VMSs, these maximum values are as follows:

<b>Maximum Number of Units of Information Allowed in VMS Message</b>			
<b>Condition</b>	<b>Light-Emitting Diode VMS</b>		
	<b>0-35 mph</b>	<b>36-55 mph</b>	<b>56-70 mph</b>
Mid-Day	5 units	4 units	4 units
Sun Washout	5 units	4 units	4 units
Sun Backlight	4 units	4 units	3 units
Nighttime	4 units	4 units	3 units

**Assess Whether the Message Must Be Reduced Because of Local Geometric Sight Distance Restrictions to the VMS**

Step 3 – Determine Whether There Are Sight Distance Restrictions to the VMS Because of a Vertical Curve Using the Guidelines in [Section 8.3 UNITS OF INFORMATION REDUCTIONS FOR VERTICAL CURVES – LED VMSs](#) on page 8-6.

- If “no” Go Directly to Step 5.
- If “yes” Continue to Step 4.

Step 4 – Identify the Reduction in the Number of Message Units of Information to Compensate for Lower Legibility to the VMS because of the Vertical Curve Using [Tables 8.3 through 8.6](#) on pages 8-8 and 8-9.

Step 5 – Determine Whether There Are Sight Distance Restrictions to the VMS Because of a Horizontal Curve Using the Guidelines in [Section 8.4 UNITS OF INFORMATION REDUCTIONS FOR HORIZONTAL CURVES – LED VMSs](#) on page 8-10.

If “no” Go Directly to Step 7.  
If “yes” Continue to Step 6.

Step 6 – Identify the Reduction in the Number of Units of Information to Compensate for Lower Legibility to the VMS Because of the Horizontal Curve Using [Tables 8.7 through 8.12](#) on pages 8-12 through 8-17.

---

**Assess Whether the Message Must Be Reduced Because of Local Environmental Sight Distance Restrictions to the VMS Due to Rain or Fog**

Step 7 – Determine Whether Rainfall Near the VMS Exceeds 2 Inches per Hour.

If “no” Go Directly to Step 9.  
If “yes” Continue to Step 8.

Step 8 – The Reduction in the Number of Units of Information to Compensate for Rain Is 1.

Step 9 – Determine Whether Fog Exists Near the VMS.

If “no” Go Directly to Step 11.  
If “yes” Continue to Step 10.

Step 10 – Identify the Reduction in the Number of Units of Information to Compensate for Fog Using [Table 8.13](#) on page 8-19.

---

**Finalize the Maximum Allowable Units of Information in the Message**

Step 11 – Select the Largest Reduction in the Number of Units of Information from Among the Effects of a Vertical Curve (Step 4), a Horizontal Curve (Step 6), Rain (Step 8), or Fog (Step 10), and Use this Number to Subtract from the Maximum Allowable Number of Units of Information in the Message shown in [Table 8.2](#) on page 8-5. The new number after the subtraction represents the final Maximum Allowable Units of Information in the message.

---

**Define the Basic VMS Message to Satisfy Motorist Information Needs**

Step 12– Select *Incident Descriptor* Message Element from [Table 6.10](#), page 6-11.

Step 13 – Select *Incident Location* Message Element from [Table 6.11](#), page 6-12.

Step 14 – Determine Whether the Police or Traffic Control Personnel Arrived to Control Traffic at Incident Site.

If “no” Select *Lanes Blocked* Message Element from [Table 6.12](#), page 6-13.  
Go Directly to Step 16.

If “yes” Continue to Step 15.

Step 15 – Select *Lanes Closed* Message Element from [Table 6.12](#), page 6-13.

Step 16 – Establish Whether the *Effect on Travel* Message Element Is Implied by the *Lanes Closed (Blocked)* Message Element.

If “no” Continue to Step 17.  
If “yes” Go Directly to Step 18.

Note: Statements in the *Lanes Closed (Blocked)* message element such as *3 RIGHT LANES CLOSED* imply to motorists that, depending upon the time of day, they will experience delay or major delay. Thus, an *Effect on Travel* message element does not have to be included in the Basic VMS Message.

Step 17 – Select *Effect on Travel* Message Element from [Table 6.13](#), page 6-14.

Step 18 – Establish Whether Diversion Action Should be Recommended.

If “no” Continue to Step 19.  
If “yes” Go Directly to Step 20.

Step 19 – Select No Diversion *Action* Message Element from [Table 6.14](#), page 6-15 or Omit *Action* Message Element.

GO TO Step 28.

Step 20 – Establish Whether “Soft” Diversion Should be Recommended.

If “no” Go Directly to Step 22.  
If “yes” Continue to Step 21.

Step 21 – Select “Soft” Diversion *Action* Message Element from [Table 6.15](#), page 6-16.

GO TO Step 23.

Step 22 – Select Type 1 or Type 2 Diversion Route *Action* Message Element from [Table 6.16](#), page 6-17.

Step 23 – Establish Whether *Action* Message Is for a Select Group of Motorists.

If “no” Go Directly to Step 25.

If “yes” Continue to Step 24.

Step 24 – Select *Audience for Action* Message Element from [Table 6.17](#), page 6-18.

Step 25 – Establish Whether a *Good Reason for Motorists to Follow Action* Is Implied in *Lanes Closed (Blocked)* and *Lane Closure (Blockage) Location* Message Elements.

If “no” Go Directly to Step 27.

If “yes” Continue to Step 26.

Step 26 – Examine Whether the Diversion Route Will Be Perceived By Motorists as Being a Most Logical Route.

If “no” Continue to Step 27.

If “yes” Go Directly to Step 28.

Step 27 – Select a *Good Reason for Following the Action* Statement Message Element from [Table 6.18](#), page 6-19.

---

### **Reduce the Number of Message Units if Necessary**

Step 28 – Examine Whether the Number of Units of Information in the Basic Message Is Greater than the Maximum Allowable from Step 11.

If “no” Go Directly to Step 35.

If “yes” Continue to Step 29.

Step 29 – Omit *Incident Descriptor* Message Element According to Guidelines in the Section on *Combining Message Elements for Incident Messages* Beginning on [page 9-15](#).

Step 30 – Examine Whether the Number of Units of Information in the Basic Message Is Greater than the Maximum Allowable from Step 11.

If “no” Go Directly to Step 35.

If “yes” Continue to Step 31.

Step 31 – Examine Whether The Message Contains More Than One *Audience for Action* (Destination) Message Element.

If “no” Go Directly to Step 34.

If “yes” Continue to Step 32.

Step 32 – Omit All but One *Audience for Action*.

Step 33 – Examine Whether the Number of Units of Information in the Basic Message Is Greater than the Maximum Allowable from Step 11.

If “no” Continue to Step 34.

If “yes” Go Directly to Step 35.

Step 34 – Omit Other Information According to Guidelines in the Section on *PRIORITY REDUCTION PRINCIPLES* on [page 9-20](#).

---

### **Format the Message**

Step 35 – Format the Message According to Guidelines in the Section on *FORMATTING MESSAGES* on [page 9-6](#).

---

### **Adjust Message to Fit on Existing VMS**

Step 36 – Determine Whether the VMS Has 4 Lines.

If “no” Continue to Step 37.

If “yes” Go Directly to Step 38.

Step 37 – Determine Whether the VMS Has 3 Lines.

If “no” MESSAGE CANNOT BE DESIGNED USING THIS PROCEDURE.

If “yes” Continue to Step 38.

---

### **Adjust Message to Fit on 3 Lines or Less**

Step 38 – Determine Whether the Message Can Be Displayed on 3 Lines or less.

If “no” Continue to Step 39.

If “yes” Go Directly to Step 40.

Step 39 – Split Message Into 2 Frames According to Guidelines in [Section 9.1 SPLITTING MESSAGES](#) on page 9-1.

Step 40 – Examine Whether There Are 3 or Fewer Decision-Relevant Units of Information Displayed on Each of the Frames.

If “no” Continue to Step 41.

If “yes” Go Directly to Step 42.

Step 41 – Omit Information to Reduce Frame to 3 Decision-Relevant Units According to Guidelines in Item 5. *NO MORE THAN THREE UNITS OF INFORMATION SHOULD BE DISPLAYED ON A SINGLE FRAME AT HIGH FREEWAY SPEEDS* on [page 9-3](#).

Step 42 – Examine Whether Message Elements Are Split in Such a Way That a Part of One Message Element Is on the Same Line as a Part of a Second Message Element.

If “no” Go Directly to Step 44.

If “yes” Continue to Step 43.

Step 43 – Separate Message Elements According to Guidelines in Item 4. *A MESSAGE LINE SHOULD NOT CONTAIN PORTIONS OF TWO DIFFERENT UNITS OF INFORMATION* on [page 9-3](#).

Step 44 – Examine Whether the Message or Any of the Message Lines Are Too Long to Fit in the Available VMS Space.

If “no” Go Directly to Step 48.

If “yes” Continue to Step 45.

Step 45 – Apply Abbreviations to Selected Words According to Guidelines in the Section on *USING ABBREVIATIONS*, [page 9-10](#).

Step 46 – Examine Whether the Application of Abbreviation Guidelines Adequately Reduced the Length of the Message Lines and the Entire Message Can Fit in the Available VMS Space.

If “no” Continue to Step 47.

If “yes” Go Directly to Step 48.

Step 47 – Omit Information According to Guidelines in the Sections on *PRIORITY REDUCTION PRINCIPLES* on [page 9-20](#) and *FORMATTING MESSAGES* on [page 9-6](#).

---

### **Finalize VMS Message**

Step 48 – Review Message for Inconsistencies and Incompatibility.

Step 49 – Make Additional Adjustments if Necessary.

*You now should have an acceptable message ready to display or to store in the VMS message library.*

---

### **Assess Effects of Large Trucks on the Ability of Motorists to View the VMS Message**

The final step in the process is to assess the effects of large trucks in the traffic stream on the ability of motorists to see the VMS and read the message. [Tables 8.14 through 8.17](#) on pages 8-21 and 8-22 should be studied to determine the percentage of motorists who will be able to see the VMS message (or consequently, the percentage who will not be able to see the VMS message because their visibility to the sign is blocked by large trucks). This information will help the VMS operator and the TOC manager to determine the potential effectiveness in communicating the message to the motorists in the traffic stream.

**VMS ON DIFFERENT FREEWAY THAN THE INCIDENT**

Use the procedure outlined in this section of the Manual when an incident occurs that blocks one or more lanes of traffic and the VMS is located on a different freeway than the incident. When a major incident occurs that blocks all of the lanes:

- Before the police arrive at the scene, use [Section 10.2 INCIDENTS THAT BLOCK ALL LANES](#), page 10-20, and
- After the police arrive at the scene and begin to control traffic, use [Section 10.3 INCIDENTS THAT REQUIRE CLOSING THE FREEWAY](#), page 10-38.

**Establish Initial Maximum Allowable Number of Units of Information in the Message Based on VMS Type and Freeway Operating Speeds**

Step 1 – Determine Freeway Operating Speeds.

Step 2 – Determine the Initial Maximum Allowable Number of Units of Information in the Message from [Table 8.2](#), page 8-5. For LED VMSs, these maximum values are as follows:

<b>Maximum Number of Units of Information Allowed in VMS Message</b>			
<b>Condition</b>	<b>Light-Emitting Diode VMS</b>		
	<b>0-35 mph</b>	<b>36-55 mph</b>	<b>56-70 mph</b>
Mid-Day	5 units	4 units	4 units
Sun Washout	5 units	4 units	4 units
Sun Backlight	4 units	4 units	3 units
Nighttime	4 units	4 units	3 units

**Assess Whether the Message Must Be Reduced Because of Local Geometric Sight Distance Restrictions to the VMS**

Step 3 – Determine Whether There Are Sight Distance Restrictions to the VMS Because of a Vertical Curve Using the Guidelines in [Section 8.3 UNITS OF INFORMATION REDUCTIONS FOR VERTICAL CURVES – LED VMSs](#) on page 8-6.

- If “no” Go Directly to Step 5.
- If “yes” Continue to Step 4.

Step 4 – Identify the Reduction in the Number of Message Units of Information to Compensate for Lower Legibility to the VMS because of the Vertical Curve Using [Tables 8.3 through 8.6](#) on pages 8-8 and 8-9.

Step 5 – Determine Whether There Are Sight Distance Restrictions to the VMS Because of a Horizontal Curve Using the Guidelines in [Section 8.4 UNITS OF INFORMATION REDUCTIONS FOR HORIZONTAL CURVES – LED VMSs](#) on page 8-10.

If “no” Go Directly to Step 7.

If “yes” Continue to Step 6.

Step 6 – Identify the Reduction in the Number of Units of Information to Compensate for Lower Legibility to the VMS Because of the Horizontal Curve Using [Tables 8.7 through 8.12](#) on pages 8-12 through 8-17.

---

### **Assess Whether the Message Must Be Reduced Because of Local Environmental Sight Distance Restrictions to the VMS Due to Rain or Fog**

Step 7 – Determine Whether Rainfall Near the VMS Exceeds 2 Inches per Hour.

If “no” Go Directly to Step 9.

If “yes” Continue to Step 8.

Step 8 – The Reduction in the Number of Units of Information to Compensate for Rain Is 1.

Step 9 – Determine Whether Fog Exists Near the VMS.

If “no” Go Directly to Step 11.

If “yes” Continue to Step 10.

Step 10 – Identify the Reduction in the Number of Units of Information to Compensate for Fog Using [Table 8.13](#) on page 8-19.

---

### **Finalize the Maximum Allowable Units of Information in the Message**

Step 11 – Select the Largest Reduction in the Number of Units of Information from Among the Effects of a Vertical Curve (Step 4), a Horizontal Curve (Step 6), Rain (Step 8), or Fog (Step 10), and Use this Number to Subtract from the Maximum Allowable Number of Units of Information in the Message shown in [Table 8.2](#) on page 8-5. The new number after the subtraction represents the final Maximum Allowable Units of Information in the message.

---

### **Define the Basic VMS Message to Satisfy Motorist Information Needs**

Step 12– Select *Incident Descriptor* Message Element from [Table 6.19](#), page 6-21.

Step 13 – Select *Incident Location* Message Element from [Table 6.20](#), page 6-22.



Step 14 – Determine Whether the Police or Traffic Control Personnel Arrived to Control Traffic at Incident Site.

If “no” Select *Lanes Blocked* Message Element from [Table 6.21](#), page 6-23.  
Go Directly to Step 16.

If “yes” Continue to Step 15.

Step 15 – Select *Lanes Closed* Message Element from [Table 6.21](#), page 6-23.

Step 16 – Establish Whether the *Effect on Travel* Message Element Is Implied by the *Lanes Closed (Blocked)* Message Element.

If “no” Continue to Step 17.  
If “yes” Go Directly to Step 18.

Note: Statements in the *Lanes Closed (Blocked)* message element such as *3 RIGHT LANES CLOSED* imply to motorists that, depending upon the time of day, they will experience delay or major delay. Thus, an *Effect on Travel* message element does not have to be included in the Basic VMS Message.

Step 17 – Select *Effect on Travel* Message Element from [Table 6.22](#), page 6-24.

Step 18 – Establish Whether Diversion Action Should be Recommended.

If “no” Continue to Step 19.  
If “yes” Go Directly to Step 20.

Step 19 – Select No Diversion *Action* Message Element from [Table 6.23](#), page 6-25 or Omit *Action* Message Element.

GO TO Step 28.

Step 20 – Establish Whether “Soft” Diversion Should be Recommended.

If “no” Go Directly to Step 22.  
If “yes” Continue to Step 21.

Step 21 – Select “Soft” Diversion *Action* Message Element from [Table 6.24](#), page 6-26.

GO TO Step 23.

Step 22 – Select Type 1 or Type 2 Diversion Route *Action* Message Element from [Table 6.25](#), page 6-27.

Step 23 – Establish Whether *Action* Message Is for a Select Group of Motorists.

If “no” Go Directly to Step 25.

If “yes” Continue to Step 24.

Step 24 – Select *Audience for Action* Message Element from [Table 6.26](#), page 6-28.

Step 25 – Establish Whether a *Good Reason for Motorists to Follow Action* Is Implied in *Lanes Closed (Blocked)* and *Lane Closure (Blockage) Location* Message Elements.

If “no” Go Directly to Step 27.

If “yes” Continue to Step 26.

Step 26 – Examine Whether the Diversion Route Will Be Perceived By Motorists as Being a Most Logical Route.

If “no” Continue to Step 27.

If “yes” Go Directly to Step 28.

Step 27 – Select a *Good Reason for Following the Action* Statement Message Element from [Table 6.27](#), page 6-29.

---

### **Reduce the Number of Message Units if Necessary**

Step 28 – Examine Whether the Number of Units of Information in the Basic Message Is Greater than the Maximum Allowable from Step 11.

If “no” Go Directly to Step 35.

If “yes” Continue to Step 29.

Step 29 – Omit *Incident Descriptor* Message Element According to Guidelines in the Section on *Combining Message Elements for Incident Messages* Beginning on [page 9-15](#).

Step 30 – Examine Whether the Number of Units of Information in the Basic Message Is Greater than the Maximum Allowable from Step 11.

If “no” Go Directly to Step 35.

If “yes” Continue to Step 31.

Step 31 – Examine Whether The Message Contains More Than One *Audience for Action* (Destination) Message Element.

If “no” Go Directly to Step 34.

If “yes” Continue to Step 32.

Step 32 – Omit All but One *Audience for Action*.

Step 33 – Examine Whether the Number of Units of Information in the Basic Message Is Greater than the Maximum Allowable from Step 11.

If “no” Continue to Step 34.

If “yes” Go Directly to Step 35.

Step 34 – Omit Other Information According to Guidelines in the Section on *PRIORITY REDUCTION PRINCIPLES* on [page 9-20](#).

---

### **Format the Message**

Step 35 – Format the Message According to Guidelines in the Section on *FORMATTING MESSAGES* on [page 9-6](#).

---

### **Adjust Message to Fit on Existing VMS**

Step 36 – Determine Whether the VMS Has 4 Lines.

If “no” Continue to Step 37.

If “yes” Go Directly to Step 38.

Step 37 – Determine Whether the VMS Has 3 Lines.

If “no” MESSAGE CANNOT BE DESIGNED USING THIS PROCEDURE.

If “yes” Continue to Step 38.

---

### **Adjust Message to Fit on 3 Lines or Less**

Step 38 – Determine Whether the Message Can Be Displayed on 3 Lines or less.

If “no” Continue to Step 39.

If “yes” Go Directly to Step 40.

Step 39 – Split Message Into 2 Frames According to Guidelines in [Section 9.1 SPLITTING MESSAGES](#) on page 9-1.

Step 40 – Examine Whether There Are 3 or Fewer Decision-Relevant Units of Information Displayed on Each of the Frames.

If “no” Continue to Step 41.

If “yes” Go Directly to Step 42.

Step 41 – Omit Information to Reduce Frame to 3 Decision-Relevant Units According to Guidelines in Item 5. *NO MORE THAN THREE UNITS OF INFORMATION SHOULD BE DISPLAYED ON A SINGLE FRAME AT HIGH FREEWAY SPEEDS* on [page 9-3](#).

Step 42 – Examine Whether Message Elements Are Split in Such a Way That a Part of One Message Element Is on the Same Line as a Part of a Second Message Element.

If “no” Go Directly to Step 44.

If “yes” Continue to Step 43.

Step 43 – Separate Message Elements According to Guidelines in Item 4. *A MESSAGE LINE SHOULD NOT CONTAIN PORTIONS OF TWO DIFFERENT UNITS OF INFORMATION* on [page 9-3](#).

Step 44 – Examine Whether the Message or Any of the Message Lines Are Too Long to Fit in the Available VMS Space.

If “no” Go Directly to Step 48.

If “yes” Continue to Step 45.

Step 45 – Apply Abbreviations to Selected Words According to Guidelines in the Section on *USING ABBREVIATIONS*, [page 9-10](#).

Step 46 – Examine Whether the Application of Abbreviation Guidelines Adequately Reduced the Length of the Message Lines and the Entire Message Can Fit in the Available VMS Space.

If “no” Continue to Step 47.

If “yes” Go Directly to Step 48.

Step 47 – Omit Information According to Guidelines in the Sections on *PRIORITY REDUCTION PRINCIPLES* on [page 9-20](#) and *FORMATTING MESSAGES* on [page 9-6](#).

---

### **Finalize VMS Message**

Step 48 – Review Message for Inconsistencies and Incompatibility.

Step 49 – Make Additional Adjustments if Necessary.

*You now should have an acceptable message ready to display or to store in the VMS message library.*

---

### **Assess Effects of Large Trucks on the Ability of Motorists to View the VMS Message**

The final step in the process is to assess the effects of large trucks in the traffic stream on the ability of motorists to see the VMS and read the message. [Tables 8.14 through 8.17](#) on pages 8-21 and 8-22 should be studied to determine the percentage of motorists who will be able to see the VMS message (or consequently, the percentage who will not be able to see the VMS message because their visibility to the sign is blocked by large trucks). This information will help the VMS operator and the TOC manager to determine the potential effectiveness in communicating the message to the motorists in the traffic stream.

## 10.2 INCIDENTS THAT BLOCK ALL THE LANES

When an incident occurs that affects all lanes of the freeway, there is a period of time until the police and/or traffic control personnel arrive that it can be said that the incident is *blocking* the freeway. No traffic control is in place to *close* the lanes and to divert traffic to alternative routes. Under these conditions, the guidelines presented in this section of the Manual should be used to develop VMS messages.

When the police and/or traffic control personnel arrive, the freeway is *closed* and traffic is diverted to an alternative route. The freeway closure, the location where traffic is diverted from the freeway, is in most cases at different location than the incident. Under these conditions, use [Section 10.3 INCIDENTS THAT REQUIRE CLOSING THE FREEWAY](#) on page 10-38 to design messages.

### VMS ON SAME FREEWAY AND RELATIVELY CLOSE TO THE INCIDENT

Use the procedure outlined in this section of the Manual when an incident occurs that blocks all of the lanes of traffic and the VMS is on the same freeway and relatively close to the incident.

---

#### Establish Initial Maximum Allowable Number of Units of Information in the Message Based on VMS Type and Freeway Operating Speeds

Step 1 – Determine Freeway Operating Speeds.

Step 2 – Determine the Initial Maximum Allowable Number of Units of Information in the Message from [Table 8.2](#), page 8-5. For LED VMSs, these maximum values are as follows:

Maximum Number of Units of Information Allowed in VMS Message			
Condition	Light-Emitting Diode VMS		
	0-35 mph	36-55 mph	56-70 mph
Mid-Day	5 units	4 units	4 units
Sun Washout	5 units	4 units	4 units
Sun Backlight	4 units	4 units	3 units
Nighttime	4 units	4 units	3 units

---

#### Assess Whether the Message Must Be Reduced Because of Local Geometric Sight Distance Restrictions to the VMS

Step 3 – Determine Whether There Are Sight Distance Restrictions to the VMS Because of a Vertical Curve Using the Guidelines in [Section 8.3 UNITS OF INFORMATION REDUCTIONS FOR VERTICAL CURVES – LED VMSs](#) on page 8-6.

If “no” Go Directly to Step 5.

If “yes” Continue to Step 4.

Step 4 – Identify the Reduction in the Number of Message Units of Information to Compensate for Lower Legibility to the VMS because of the Vertical Curve Using [Tables 8.3 through 8.6](#) on pages 8-8 and 8-9.

Step 5 – Determine Whether There Are Sight Distance Restrictions to the VMS Because of a Horizontal Curve Using the Guidelines in [Section 8.4 UNITS OF INFORMATION REDUCTIONS FOR HORIZONTAL CURVES – LED VMSs](#) on page 8-10.

If “no” Go Directly to Step 7.

If “yes” Continue to Step 6.

Step 6 – Identify the Reduction in the Number of Units of Information to Compensate for Lower Legibility to the VMS Because of the Horizontal Curve Using [Tables 8.7 through 8.12](#) on pages 8-12 through 8-17.

---

### **Assess Whether the Message Must Be Reduced Because of Local Environmental Sight Distance Restrictions to the VMS Due to Rain or Fog**

Step 7 – Determine Whether Rainfall Near the VMS Exceeds 2 Inches per Hour.

If “no” Go Directly to Step 9.

If “yes” Continue to Step 8.

Step 8 – The Reduction in the Number of Units of Information to Compensate for Rain Is 1.

Step 9 – Determine Whether Fog Exists Near the VMS.

If “no” Go Directly to Step 11.

If “yes” Continue to Step 10.

Step 10 – Identify the Reduction in the Number of Units of Information to Compensate for Fog Using [Table 8.13](#) on page 8-19.

---

### **Finalize the Maximum Allowable Units of Information in the Message**

Step 11 – Select the Largest Reduction in the Number of Units of Information from Among the Effects of a Vertical Curve (Step 4), a Horizontal Curve (Step 6), Rain (Step 8), or Fog (Step 10), and Use this Number to Subtract from the Maximum Allowable Number of Units of Information in the Message shown in [Table 8.2](#) on page 8-5. The new number after the subtraction represents the final Maximum Allowable Units of Information in the message.

---

### **Define the Basic VMS Message to Satisfy Motorist Information Needs**

Step 12 – Select *Incident Descriptor* Message Element from [Table 6.28](#), page 6-31.

Step 13 – Determine Whether the Police or Traffic Control Personnel Arrived to Close the Freeway:

If “no” Continue to Step 14.

If “yes” Go Directly to [Section 10.3 INCIDENTS THAT REQUIRE CLOSING THE FREEWAY](#) on page 10-38.

Step 14 – Select *Incident (Blockage) Location* Message Element from [Table 6.29](#), page 6-32.

Step 15 – Select *Lanes Blocked* Message Element from [Table 6.30](#), page 6-33.

Step 16 – Establish Whether Diversion Action Should be Recommended.

If “no” Continue to Step 17.

If “yes” Go Directly to Step 18.

Step 17 – Select No Diversion *Action* Message Element from [Table 6.32](#), page 6-35 or Omit *Action* Message Element.

GO TO Step 21.

Step 18 – Establish Whether “Soft” Diversion Should be Recommended.

If “no” Go Directly to Step 20.

If “yes” Continue to Step 19.

Step 19 – Select “Soft” Diversion *Action* Message Element from [Table 6.33](#), page 6-36.

GO TO Step 21.

Step 20 – Select Type 1 or Type 2 Diversion Route *Action* Message Element from [Table 6.34](#), page 6-37.

Step 21 – Establish Whether *Action* Message Element Is for a Select Group of Motorists.

If “no” Go Directly to Step 23.

If “yes” Continue to Step 22.

Step 22 – Select *Audience for Action* Message Element from [Table 6.35](#), page 6-38.

Step 23 – Examine Whether the Diversion Route Will Be Perceived By Motorists as Being a Most Logical Route.

If “no” Continue to Step 24.

If “yes” Go Directly to Step 25.

Step 24 – Select a *Good Reason for Following the Action* Statement Message Element from [Table 6.36](#), page 6-39.

---

**Reduce the Number of Message Units if Necessary**

Step 25 – Examine Whether the Number of Units of Information in the Basic Message Is Greater than the Maximum Allowable from Step 11.

If “no” Go Directly to Step 32.

If “yes” Continue to Step 26.

Step 26 – Omit *Incident Descriptor* Message Element According to Guidelines in the Section on *Combining Message Elements for Incident Messages* Beginning on [page 9-15](#).

Step 27 – Examine Whether the Number of Units of Information in the Basic Message Is Greater than the Maximum Allowable from Step 11.

If “no” Go Directly to Step 32.

If “yes” Continue to Step 28.

Step 28 – Examine Whether The Message Contains More Than One *Audience for Action* (Destination) Message Element.

If “no” Go Directly to Step 31.

If “yes” Continue to Step 29.

Step 29 – Omit All but One *Audience for Action*

Step 30 – Examine Whether the Number of Units of Information in the Basic Message Is Greater than the Maximum Allowable from Step 11.

If “no” Continue to Step 31.

If “yes” Go Directly to Step 32.

Step 31 – Omit Other Information According to Guidelines in the Section on *PRIORITY REDUCTION PRINCIPLES* on [page 9-20](#).

---

**Format the Message**

Step 32 – Format the Message According to Guidelines in the Section on *FORMATTING MESSAGES* on [page 9-6](#).

---

**Adjust Message to Fit on Existing VMS**

Step 33 – Determine Whether the VMS Has 4 Lines.

If “no” Continue to Step 34.

If “yes” Go Directly to Step 35.



Step 34 – Determine Whether the VMS Has 3 Lines.

If “no” MESSAGE CANNOT BE DESIGNED USING THIS PROCEDURE.

If “yes” Continue to Step 35.

---

### **Adjust Message to Fit on 3 Lines or Less**

Step 35 – Determine Whether the Message Can Be Displayed on 3 Lines or less.

If “no” Continue to Step 36.

If “yes” Go Directly to Step 37.

Step 36 – Split Message Into 2 Frames According to Guidelines in [Section 9.1 SPLITTING MESSAGES](#) on page 9-1.

Step 37 – Examine Whether There Are 3 or Fewer Decision-Relevant Units of Information Displayed on Each of the Frames.

If “no” Continue to Step 38.

If “yes” Go Directly to Step 39.

Step 38 – Omit Information to Reduce Frame to 3 Decision-Relevant Units According to Guidelines in Item 5. *NO MORE THAN THREE UNITS OF INFORMATION SHOULD BE DISPLAYED ON A SINGLE FRAME AT HIGH FREEWAY SPEEDS* on [page 9-3](#).

Step 39 – Examine Whether Message Elements Are Split in Such a Way That a Part of One Message Element Is on the Same Line as a Part of a Second Message Element.

If “no” Go Directly to Step 41.

If “yes” Continue to Step 40.

Step 40 – Separate Message Elements According to Guidelines in Item 4. *A MESSAGE LINE SHOULD NOT CONTAIN PORTIONS OF TWO DIFFERENT UNITS OF INFORMATION* on [page 9-3](#).

Step 41 – Examine Whether the Message or Any of the Message Lines Are Too Long to Fit in the Available VMS Space.

If “no” Go Directly to Step 45.

If “yes” Continue to Step 42.

Step 42 – Apply Abbreviations to Selected Words According to Guidelines in the Section on *USING ABBREVIATIONS*, [page 9-10](#).

Step 43 – Examine Whether the Application of Abbreviation Guidelines Adequately Reduced the Length of the Message Lines and the Entire Message Can Fit in the Available VMS Space.

If “no” Continue to Step 44.

If “yes” Go Directly to Step 45.

Step 44 – Omit Information According to Guidelines in the Sections on *PRIORITY REDUCTION PRINCIPLES* on [page 9-20](#) and *FORMATTING MESSAGES* on [page 9-6](#).

---

### **Finalize VMS Message**

Step 45 – Review Message for Inconsistencies and Incompatibility.

Step 46 – Make Additional Adjustments if Necessary.

*You now should have an acceptable message ready to display or to store in the VMS message library.*

---

### **Assess Effects of Large Trucks on the Ability of Motorists to View the VMS Message**

The final step in the process is to assess the effects of large trucks in the traffic stream on the ability of motorists to see the VMS and read the message. [Tables 8.14 through 8.17](#) on pages 8-21 and 8-22 should be studied to determine the percentage of motorists who will be able to see the VMS message (or consequently, the percentage who will not be able to see the VMS message because their visibility to the sign is blocked by large trucks). This information will help the VMS operator and the TOC manager to determine the potential effectiveness in communicating the message to the motorists in the traffic stream.

**VMS ON SAME FREEWAY BUT RELATIVELY FAR FROM THE INCIDENT**

Use the procedure outlined in this section of the Manual when an incident occurs that blocks all of the lanes of traffic and the VMS is on the same freeway but relatively far from the incident.

**Establish Initial Maximum Allowable Number of Units of Information in the Message Based on VMS Type and Freeway Operating Speeds.**

Step 1 – Determine Freeway Operating Speeds.

Step 2 – Determine the Initial Maximum Allowable Number of Units of Information in the Message from [Table 8.2](#), page 8-5. For LED VMSs, these maximum values are as follows:

<b>Maximum Number of Units of Information Allowed in VMS Message</b>			
<b>Condition</b>	<b>Light-Emitting Diode VMS</b>		
	<b>0-35 mph</b>	<b>36-55 mph</b>	<b>56-70 mph</b>
Mid-Day	5 units	4 units	4 units
Sun Washout	5 units	4 units	4 units
Sun Backlight	4 units	4 units	3 units
Nighttime	4 units	4 units	3 units

**Assess Whether the Message Must Be Reduced Because of Local Geometric Sight Distance Restrictions to the VMS**

Step 3 – Determine Whether There Are Sight Distance Restrictions to the VMS Because of a Vertical Curve Using the Guidelines in [Section 8.3 UNITS OF INFORMATION REDUCTIONS FOR VERTICAL CURVES – LED VMSs](#) on page 8-6.

If “no” Go Directly to Step 5.  
 If “yes” Continue to Step 4.

Step 4 – Identify the Reduction in the Number of Message Units of Information to Compensate for Lower Legibility to the VMS because of the Vertical Curve Using [Tables 8.3 through 8.6](#) on pages 8-8 and 8-9.

Step 5 – Determine Whether There Are Sight Distance Restrictions to the VMS Because of a Horizontal Curve Using the Guidelines in [Section 8.4 UNITS OF INFORMATION REDUCTIONS FOR HORIZONTAL CURVES – LED VMSs](#) on page 8-10.

If “no” Go Directly to Step 7.  
 If “yes” Continue to Step 6.

Step 6 – Identify the Reduction in the Number of Units of Information to Compensate for Lower Legibility to the VMS Because of the Horizontal Curve Using [Tables 8.7 through 8.12](#) on pages 8-12 through 8-17.

---

**Assess Whether the Message Must Be Reduced Because of Local Environmental Sight Distance Restrictions to the VMS Due to Rain or Fog**

Step 7 – Determine Whether Rainfall Near the VMS Exceeds 2 Inches per Hour.

If “no” Go Directly to Step 9.

If “yes” Continue to Step 8.

Step 8 – The Reduction in the Number of Units of Information to Compensate for Rain Is 1.

Step 9 – Determine Whether Fog Exists Near the VMS.

If “no” Go Directly to Step 11.

If “yes” Continue to Step 10.

Step 10 – Identify the Reduction in the Number of Units of Information to Compensate for Fog Using [Table 8.13](#) on page 8-19.

---

**Finalize the Maximum Allowable Units of Information in the Message**

Step 11 – Select the Largest Reduction in the Number of Units of Information from Among the Effects of a Vertical Curve (Step 4), a Horizontal Curve (Step 6), Rain (Step 8), or Fog (Step 10), and Use this Number to Subtract from the Maximum Allowable Number of Units of Information in the Message shown in [Table 8.2](#) on page 8-5. The new number after the subtraction represents the final Maximum Allowable Units of Information in the message.

---

**Define the Basic VMS Message to Satisfy Motorist Information Needs**

Step 12 – Select *Incident Descriptor* Message Element from [Table 6.37](#), page 6-40.

Step 13 – Determine Whether the Police or Traffic Control Personnel Arrived to Close the Freeway:

If “no” Continue to Step 14.

If “yes” Go Directly to [Section 10.3 INCIDENTS THAT REQUIRE CLOSING THE FREEWAY](#) on page 10-38.

Step 14 – Select *Incident (Blockage) Location* Message Element from [Table 6.38](#), page 6-41.

Step 15 – Select *Lanes Blocked* Message Element from [Table 6.39](#), page 6-42.

Step 16 – Establish Whether Diversion Action Should be Recommended.

If “no” Continue to Step 17.  
If “yes” Go Directly to Step 18.

Step 17 – Select No Diversion *Action* Message Element from [Table 6.41](#), page 6-44 or Omit *Action* Message Element.

GO TO Step 21.

Step 18 – Establish Whether “Soft” Diversion Should be Recommended.

If “no” Go Directly to Step 20.  
If “yes” Continue to Step 19.

Step 19 – Select “Soft” Diversion *Action* Message Element from [Table 6.42](#), page 6-45.

GO TO Step 21.

Step 20 – Select Type 1 or Type 2 Diversion Route *Action* Message Element from [Table 6.43](#), page 6-46.

Step 21 – Establish Whether *Action* Message Element Is for a Select Group of Motorists.

If “no” Go Directly to Step 23.  
If “yes” Continue to Step 22.

Step 22 – Select *Audience for Action* Message Element from [Table 6.44](#), page 6-47.

Step 23 – Examine Whether the Diversion Route Will Be Perceived By Motorists as Being a Most Logical Route.

If “no” Continue to Step 24.  
If “yes” Go Directly to Step 25.

Step 24 – Select a *Good Reason for Following the Action* Statement Message Element from [Table 6.45](#), page 6-48.

---

### **Reduce the Number of Message Units if Necessary**

Step 25 – Examine Whether the Number of Units of Information in the Basic Message Is Greater than the Maximum Allowable from Step 11.

If “no” Go Directly to Step 32.  
If “yes” Continue to Step 26.

Step 26 – Omit *Incident Descriptor* Message Element According to Guidelines in the Section on *Combining Message Elements for Incident Messages* Beginning on [page 9-15](#).

Step 27 – Examine Whether the Number of Units of Information in the Basic Message Is Greater than the Maximum Allowable from Step 11.

If “no” Go Directly to Step 32.

If “yes” Continue to Step 28.

Step 28 – Examine Whether The Message Contains More Than One *Audience for Action* (Destination) Message Element.

If “no” Go Directly to Step 31.

If “yes” Continue to Step 29.

Step 29 – Omit All but One *Audience for Action*

Step 30 – Examine Whether the Number of Units of Information in the Basic Message Is Greater than the Maximum Allowable from Step 11.

If “no” Continue to Step 31.

If “yes” Go Directly to Step 32.

Step 31 – Omit Other Information According to Guidelines in the Section on *PRIORITY REDUCTION PRINCIPLES* on [page 9-20](#).

---

### **Format the Message**

Step 32 – Format the Message According to Guidelines in the Section on *FORMATTING MESSAGES* on [page 9-6](#).

---

### **Adjust Message to Fit on Existing VMS**

Step 33 – Determine Whether the VMS Has 4 Lines.

If “no” Continue to Step 34.

If “yes” Go Directly to Step 35.

Step 34 – Determine Whether the VMS Has 3 Lines.

If “no” MESSAGE CANNOT BE DESIGNED USING THIS PROCEDURE.

If “yes” Continue to Step 35.

---

**Adjust Message to Fit on 3 Lines or Less**

Step 35 – Determine Whether the Message Can Be Displayed on 3 Lines or less.

If “no” Continue to Step 36.

If “yes” Go Directly to Step 37.

Step 36 – Split Message Into 2 Frames According to Guidelines in [Section 9.1 SPLITTING MESSAGES](#) on page 9-1.

Step 37 – Examine Whether There Are 3 or Fewer Decision-Relevant Units of Information Displayed on Each of the Frames.

If “no” Continue to Step 38.

If “yes” Go Directly to Step 39.

Step 38 – Omit Information to Reduce Frame to 3 Decision-Relevant Units According to Guidelines in Item 5. *NO MORE THAN THREE UNITS OF INFORMATION SHOULD BE DISPLAYED ON A SINGLE FRAME AT HIGH FREEWAY SPEEDS* on [page 9-3](#).

Step 39 – Examine Whether Message Elements Are Split in Such a Way That a Part of One Message Element Is on the Same Line as a Part of a Second Message Element.

If “no” Go Directly to Step 41.

If “yes” Continue to Step 40.

Step 40 – Separate Message Elements According to Guidelines in Item 4. *A MESSAGE LINE SHOULD NOT CONTAIN PORTIONS OF TWO DIFFERENT UNITS OF INFORMATION* on [page 9-3](#).

Step 41 – Examine Whether the Message or Any of the Message Lines Are Too Long to Fit in the Available VMS Space.

If “no” Go Directly to Step 45.

If “yes” Continue to Step 42.

Step 42 – Apply Abbreviations to Selected Words According to Guidelines in the Section on *USING ABBREVIATIONS*, [page 9-10](#).

Step 43 – Examine Whether the Application of Abbreviation Guidelines Adequately Reduced the Length of the Message Lines and the Entire Message Can Fit in the Available VMS Space.

If “no” Continue to Step 44.

If “yes” Go Directly to Step 45.

Step 44 – Omit Information According to Guidelines in the Sections on *PRIORITY REDUCTION PRINCIPLES* on [page 9-20](#) and *FORMATTING MESSAGES* on [page 9-6](#).

---

**Finalize VMS Message**

Step 45 – Review Message for Inconsistencies and Incompatibility.

Step 46 – Make Additional Adjustments if Necessary.

*You now should have an acceptable message ready to display or to store in the VMS message library.*

---

**Assess Effects of Large Trucks on the Ability of Motorists to View the VMS Message**

The final step in the process is to assess the effects of large trucks in the traffic stream on the ability of motorists to see the VMS and read the message. [Tables 8.14 through 8.17](#) on pages 8-21 and 8-22 should be studied to determine the percentage of motorists who will be able to see the VMS message (or consequently, the percentage who will not be able to see the VMS message because their visibility to the sign is blocked by large trucks). This information will help the VMS operator and the TOC manager to determine the potential effectiveness in communicating the message to the motorists in the traffic stream.



**VMS ON DIFFERENT FREEWAY THAN THE INCIDENT**

Use the procedure outlined in this section of the Manual when an incident occurs that blocks all of the lanes of traffic on a cross freeway and the VMS is on a different freeway than the incident.

**Establish Initial Maximum Allowable Number of Units of Information in the Message Based on VMS Type and Freeway Operating Speeds**

Step 1 – Determine Freeway Operating Speeds.

Step 2 – Determine the Initial Maximum Allowable Number of Units of Information in the Message from [Table 8.2](#), page 8-5. For LED VMSs, these maximum values are as follows:

<b>Maximum Number of Units of Information Allowed in VMS Message</b>			
<b>Condition</b>	<b>Light-Emitting Diode VMS</b>		
	<b>0-35 mph</b>	<b>36-55 mph</b>	<b>56-70 mph</b>
Mid-Day	5 units	4 units	4 units
Sun Washout	5 units	4 units	4 units
Sun Backlight	4 units	4 units	3 units
Nighttime	4 units	4 units	3 units

**Assess Whether the Message Must Be Reduced Because of Local Geometric Sight Distance Restrictions to the VMS**

Step 3 – Determine Whether There Are Sight Distance Restrictions to the VMS Because of a Vertical Curve Using the Guidelines in [Section 8.3 UNITS OF INFORMATION REDUCTIONS FOR VERTICAL CURVES – LED VMSs](#) on page 8-6.

If “no” Go Directly to Step 5.  
 If “yes” Continue to Step 4.

Step 4 – Identify the Reduction in the Number of Message Units of Information to Compensate for Lower Legibility to the VMS because of the Vertical Curve Using [Tables 8.3 through 8.6](#) on pages 8-8 and 8-9.

Step 5 – Determine Whether There Are Sight Distance Restrictions to the VMS Because of a Horizontal Curve Using the Guidelines in [Section 8.4 UNITS OF INFORMATION REDUCTIONS FOR HORIZONTAL CURVES – LED VMSs](#) on page 8-10.

If “no” Go Directly to Step 7.  
 If “yes” Continue to Step 6.

Step 6 – Identify the Reduction in the Number of Units of Information to Compensate for Lower Legibility to the VMS Because of the Horizontal Curve Using [Tables 8.7 through 8.12](#) on pages 8-12 through 8-17.

---

**Assess Whether the Message Must Be Reduced Because of Local Environmental Sight Distance Restrictions to the VMS Due to Rain or Fog**

Step 7 – Determine Whether Rainfall Near the VMS Exceeds 2 Inches per Hour.

If “no” Go Directly to Step 9.

If “yes” Continue to Step 8.

Step 8 – The Reduction in the Number of Units of Information to Compensate for Rain Is 1.

Step 9 – Determine Whether Fog Exists Near the VMS.

If “no” Go Directly to Step 11.

If “yes” Continue to Step 10.

Step 10 – Identify the Reduction in the Number of Units of Information to Compensate for Fog Using [Table 8.13](#) on page 8-19.

---

**Finalize the Maximum Allowable Units of Information in the Message**

Step 11 – Select the Largest Reduction in the Number of Units of Information from Among the Effects of a Vertical Curve (Step 4), a Horizontal Curve (Step 6), Rain (Step 8), or Fog (Step 10), and Use this Number to Subtract from the Maximum Allowable Number of Units of Information in the Message shown in [Table 8.2](#) on page 8-5. The new number after the subtraction represents the final Maximum Allowable Units of Information in the message.

---

**Define the Basic VMS Message to Satisfy Motorist Information Needs**

Step 12 – Select *Incident Descriptor* Message Element from [Table 6.46](#), page 6-50.

Step 13 – Determine Whether the Police or Traffic Control Personnel Arrived to Close the Freeway:

If “no” Continue to Step 14.

If “yes” Go Directly to [Section 10.3 INCIDENTS THAT REQUIRE CLOSING THE FREEWAY](#) on page 10-38.

Step 14 – Select *Incident (Blockage) Location* Message Element from [Table 6.47](#), page 6-51.

Step 15 – Select *Lanes Blocked* Message Element from [Table 6.48](#), page 6-52.

Step 16 – Establish Whether Diversion Action Should be Recommended.

If “no” Continue to Step 17.  
If “yes” Go Directly to Step 18.

Step 17 – Select No Diversion *Action* Message Element from [Table 6.50](#), page 6-54 or Omit *Action* Message Element.

GO TO Step 21.

Step 18 – Establish Whether “Soft” Diversion Should be Recommended.

If “no” Go Directly to Step 20.  
If “yes” Continue to Step 19.

Step 19 – Select “Soft” Diversion *Action* Message Element from [Table 6.51](#), page 6-55.

GO TO Step 21.

Step 20 – Select Type 1 or Type 2 Diversion Route *Action* Message Element from [Table 6.52](#), page 6-56.

Step 21 – Establish Whether *Action* Message Element Is for a Select Group of Motorists.

If “no” Go Directly to Step 23.  
If “yes” Continue to Step 22.

Step 22 – Select *Audience for Action* Message Element from [Table 6.53](#), page 6-57.

Step 23 – Examine Whether the Diversion Route Will Be Perceived By Motorists as Being a Most Logical Route.

If “no” Continue to Step 24.  
If “yes” Go Directly to Step 25.

Step 24 – Select a *Good Reason for Following the Action* Statement Message Element from [Table 6.54](#), page 6-58.

---

### **Reduce the Number of Message Units if Necessary**

Step 25 – Examine Whether the Number of Units of Information in the Basic Message Is Greater than the Maximum Allowable from Step 11.

If “no” Go Directly to Step 32.  
If “yes” Continue to Step 26.

Step 26 – Omit *Incident Descriptor* Message Element According to Guidelines in the Section on *Combining Message Elements for Incident Messages* Beginning on [page 9-15](#).

Step 27 – Examine Whether the Number of Units of Information in the Basic Message Is Greater than the Maximum Allowable from Step 11.

If “no” Go Directly to Step 32.

If “yes” Continue to Step 28.

Step 28 – Examine Whether The Message Contains More Than One *Audience for Action* (Destination) Message Element.

If “no” Go Directly to Step 31.

If “yes” Continue to Step 29.

Step 29 – Omit All but One *Audience for Action*

Step 30 – Examine Whether the Number of Units of Information in the Basic Message Is Greater than the Maximum Allowable from Step 11.

If “no” Continue to Step 31.

If “yes” Go Directly to Step 32.

Step 31 – Omit Other Information According to Guidelines in the Section on *PRIORITY REDUCTION PRINCIPLES* on [page 9-20](#).

---

### **Format the Message**

Step 32 – Format the Message According to Guidelines in the Section on *FORMATTING MESSAGES* on [page 9-6](#).

---

### **Adjust Message to Fit on Existing VMS**

Step 33 – Determine Whether the VMS Has 4 Lines.

If “no” Continue to Step 34.

If “yes” Go Directly to Step 35.

Step 34 – Determine Whether the VMS Has 3 Lines.

If “no” MESSAGE CANNOT BE DESIGNED USING THIS PROCEDURE.

If “yes” Continue to Step 35.

---

## Adjust Message to Fit on 3 Lines or Less

Step 35 – Determine Whether the Message Can Be Displayed on 3 Lines or less.

If “no” Continue to Step 36.

If “yes” Go Directly to Step 37.

Step 36 – Split Message Into 2 Frames According to Guidelines in [Section 9.1 SPLITTING MESSAGES](#) on page 9-1.

Step 37 – Examine Whether There Are 3 or Fewer Decision-Relevant Units of Information Displayed on Each of the Frames.

If “no” Continue to Step 38.

If “yes” Go Directly to Step 39.

Step 38 – Omit Information to Reduce Frame to 3 Decision-Relevant Units According to Guidelines in Item 5. *NO MORE THAN THREE UNITS OF INFORMATION SHOULD BE DISPLAYED ON A SINGLE FRAME AT HIGH FREEWAY SPEEDS* on [page 9-3](#).

Step 39 – Examine Whether Message Elements Are Split in Such a Way That a Part of One Message Element Is on the Same Line as a Part of a Second Message Element.

If “no” Go Directly to Step 41.

If “yes” Continue to Step 40.

Step 40 – Separate Message Elements According to Guidelines in Item 4. *A MESSAGE LINE SHOULD NOT CONTAIN PORTIONS OF TWO DIFFERENT UNITS OF INFORMATION* on [page 9-3](#).

Step 41 – Examine Whether the Message or Any of the Message Lines Are Too Long to Fit in the Available VMS Space.

If “no” Go Directly to Step 45.

If “yes” Continue to Step 42.

Step 42 – Apply Abbreviations to Selected Words According to Guidelines in the Section on *USING ABBREVIATIONS*, [page 9-10](#).

Step 43 – Examine Whether the Application of Abbreviation Guidelines Adequately Reduced the Length of the Message Lines and the Entire Message Can Fit in the Available VMS Space.

If “no” Continue to Step 44.

If “yes” Go Directly to Step 45.

Step 44 – Omit Information According to Guidelines in the Sections on *PRIORITY REDUCTION PRINCIPLES* on [page 9-20](#) and *FORMATTING MESSAGES* on [page 9-6](#).

**Finalize VMS Message**

Step 45 – Review Message for Inconsistencies and Incompatibility.

Step 46 – Make Additional Adjustments if Necessary.

*You now should have an acceptable message ready to display or to store in the VMS message library.*

---

**Assess Effects of Large Trucks on the Ability of Motorists to View the VMS Message**

The final step in the process is to assess the effects of large trucks in the traffic stream on the ability of motorists to see the VMS and read the message. [Tables 8.14 through 8.17](#) on pages 8-21 and 8-22 should be studied to determine the percentage of motorists who will be able to see the VMS message (or consequently, the percentage who will not be able to see the VMS message because their visibility to the sign is blocked by large trucks). This information will help the VMS operator and the TOC manager to determine the potential effectiveness in communicating the message to the motorists in the traffic stream.

## 10.3 INCIDENTS THAT REQUIRE CLOSING THE FREEWAY

### VMS ON THE SAME FREEWAY AND RELATIVELY CLOSE TO THE CLOSURE

Use the procedure outlined in this section of the Manual when an incident occurs that blocks all lanes of traffic and requires closing the freeway using signs, police or traffic control personnel. The procedure is for situations when the VMS is on the same freeway and relatively close to the closure.

---

#### Establish Initial Maximum Allowable Number of Units of Information in the Message Based on VMS Type and Freeway Operating Speeds

Step 1 – Determine Freeway Operating Speeds.

Step 2 – Determine the Initial Maximum Allowable Number of Units of Information in the Message from [Table 8.2](#), page 8-5. For LED VMSs, these maximum values are as follows:

<b>Maximum Number of Units of Information Allowed in VMS Message</b>			
<b>Condition</b>	<b>Light-Emitting Diode VMS</b>		
	<b>0-35 mph</b>	<b>36-55 mph</b>	<b>56-70 mph</b>
Mid-Day	5 units	4 units	4 units
Sun Washout	5 units	4 units	4 units
Sun Backlight	4 units	4 units	3 units
Nighttime	4 units	4 units	3 units

---

#### Assess Whether the Message Must Be Reduced Because of Local Geometric Sight Distance Restrictions to the VMS

Step 3 – Determine Whether There Are Sight Distance Restrictions to the VMS Because of a Vertical Curve Using the Guidelines in [Section 8.3 UNITS OF INFORMATION REDUCTIONS FOR VERTICAL CURVES – LED VMSs](#) on page 8-6.

If “no” Go Directly to Step 5.

If “yes” Continue to Step 4.

Step 4 – Identify the Reduction in the Number of Message Units of Information to Compensate for Lower Legibility to the VMS because of the Vertical Curve Using [Tables 8.3 through 8.6](#) on pages 8-8 and 8-9.

Step 5 – Determine Whether There Are Sight Distance Restrictions to the VMS Because of a Horizontal Curve Using the Guidelines in [Section 8.4 UNITS OF INFORMATION REDUCTIONS FOR HORIZONTAL CURVES – LED VMSs](#) on page 8-10.

If “no” Go Directly to Step 7.

If “yes” Continue to Step 6.

Step 6 – Identify the Reduction in the Number of Units of Information to Compensate for Lower Legibility to the VMS Because of the Horizontal Curve Using [Tables 8.7 through 8.12](#) on pages 8-12 through 8-17.

---

### **Assess Whether the Message Must Be Reduced Because of Local Environmental Sight Distance Restrictions to the VMS Due to Rain or Fog**

Step 7 – Determine Whether Rainfall Near the VMS Exceeds 2 Inches per Hour.

If “no” Go Directly to Step 9.

If “yes” Continue to Step 8.

Step 8 – The Reduction in the Number of Units of Information to Compensate for Rain Is 1.

Step 9 – Determine Whether Fog Exists Near the VMS.

If “no” Go Directly to Step 11.

If “yes” Continue to Step 10.

Step 10 – Identify the Reduction in the Number of Units of Information to Compensate for Fog Using [Table 8.13](#) on page 8-19.

---

### **Finalize the Maximum Allowable Units of Information in the Message**

Step 11 – Select the Largest Reduction in the Number of Units of Information from Among the Effects of a Vertical Curve (Step 4), a Horizontal Curve (Step 6), Rain (Step 8), or Fog (Step 10), and Use this Number to Subtract from the Maximum Allowable Number of Units of Information in the Message shown in [Table 8.2](#) on page 8-5. The new number after the subtraction represents the final Maximum Allowable Units of Information in the message.

---

### **Define the Basic VMS Message to Satisfy Motorist Information Needs**

Step 12 – Select *Incident Descriptor* Message Element from [Table 6.55](#), page 6-60.

Step 13 – Select *Incident Location* Message Element from [Table 6.56](#), page 6-61.

Step 14 – Select *Lanes Closed* Message Element from [Table 6.57](#), page 6-62.

Step 15 – Select *Closure Location* Message Element from [Table 6.58](#), page 6-63.



Step 16 – Determine Whether Diversion Traffic Control Is in Place on the Selected Diversion Route (i.e., police, traffic control personnel and/or guide signs/trailblazers providing positive guidance).

If “no” Continue to Step 17.

If “yes” Go Directly to Step 18.

Step 17. – Select Type 1, Type 2, Type 3 or Type 4 Diversion Route *Action* Message Element from [Table 6.60](#), page 6-66.

GO TO Step 19.

Step 18 – Select Type 5 Diversion Route *Action* Message Element from [Table 6.61](#), page 6-67.

Step 19 – Establish Whether *Action* Message Element If for a Select Group of Motorists.

If “no” Go Directly to Step 21.

If “yes” Continue to Step 20.

Step 20 – Select *Audience for Action* Message Element from [Table 6.62](#), page 6-68.

Step 21 – Examine Whether the Diversion Route Will Be Perceived By Motorists as Being a Most Logical Route.

If “no” Continue to Step 22.

If “yes” Go Directly to Step 23.

Step 22 – Select a *Good Reason for Following the Action* Statement Message Element from [Table 6.63](#), page 6-69.

---

### **Reduce the Number of Message Units if Necessary**

Step 23 – Examine Whether the Number of Units of Information in the Basic Message Is Greater than the Maximum Allowable from Step 11.

If “no” Go Directly to Step 30.

If “yes” Continue to Step 24.

Step 24 – Omit *Incident Descriptor* Message Element According to Guidelines in the Section on *Combining Message Elements for Incident Messages* Beginning on [page 9-15](#).

Step 25 – Examine Whether the Number of Units of Information in the Basic Message Is Greater than the Maximum Allowable from Step 11.

If “no” Go Directly to Step 30.

If “yes” Continue to Step 26.

Step 26 – Examine Whether The Message Contains More Than One *Audience for Action* (Destination) Message Element.

If “no” Go Directly to Step 29.

If “yes” Continue to Step 27.

Step 27 – Omit All but One *Audience for Action*

Step 28 – Examine Whether the Number of Units of Information in the Basic Message Is Greater than the Maximum Allowable from Step 11.

If “no” Continue to Step 29.

If “yes” Go Directly to Step 30.

Step 29 – Omit Other Information According to Guidelines in the Section on *PRIORITY REDUCTION PRINCIPLES* on [page 9-20](#).

---

### **Format the Message**

Step 30 – Format the Message According to Guidelines in the Section on *FORMATTING MESSAGES* on [page 9-6](#).

---

### **Adjust Message to Fit on Existing VMS**

Step 31 – Determine Whether the VMS Has 4 Lines.

If “no” Continue to Step 32.

If “yes” Go Directly to Step 33.

Step 32 – Determine Whether the VMS Has 3 Lines.

If “no” MESSAGE CANNOT BE DESIGNED USING THIS PROCEDURE.

If “yes” Continue to Step 33.

---

### **Adjust Message to Fit on 3 Lines or Less**

Step 33 – Determine Whether the Message Can Be Displayed on 3 Lines or less.

If “no” Continue to Step 34.

If “yes” Go Directly to Step 35.

Step 34 – Split Message Into 2 Frames According to Guidelines in [Section 9.1 SPLITTING MESSAGES](#) on page 9-1.

Step 35 – Examine Whether There Are 3 or Fewer Decision-Relevant Units of Information Displayed on Each of the Frames.

If “no” Continue to Step 36.

If “yes” Go Directly to Step 37.

Step 36 – Omit Information to Reduce Frame to 3 Decision-Relevant Units According to Guidelines in Item 5. *NO MORE THAN THREE UNITS OF INFORMATION SHOULD BE DISPLAYED ON A SINGLE FRAME AT HIGH FREEWAY SPEEDS* on [page 9-3](#).

Step 37 – Examine Whether Message Elements Are Split in Such a Way That a Part of One Message Element Is on the Same Line as a Part of a Second Message Element.

If “no” Go Directly to Step 39.

If “yes” Continue to Step 38.

Step 38 – Separate Message Elements According to Guidelines in Item 4. *A MESSAGE LINE SHOULD NOT CONTAIN PORTIONS OF TWO DIFFERENT UNITS OF INFORMATION* on [page 9-3](#).

Step 39 – Examine Whether the Message or Any of the Message Lines Are Too Long to Fit in the Available VMS Space.

If “no” Go Directly to Step 43.

If “yes” Continue to Step 40.

Step 40 – Apply Abbreviations to Selected Words According to Guidelines in the Section on *USING ABBREVIATIONS*, [page 9-10](#).

Step 41 – Examine Whether the Application of Abbreviation Guidelines Adequately Reduced the Length of the Message Lines and the Entire Message Can Fit in the Available VMS Space.

If “no” Continue to Step 42.

If “yes” Go Directly to Step 43.

Step 42 – Omit Information According to Guidelines in the Sections on *PRIORITY REDUCTION PRINCIPLES* on [page 9-20](#) and *FORMATTING MESSAGES* on [page 9-6](#).

---

### **Finalize VMS Message**

Step 43 – Review Message for Inconsistencies and Incompatibility.

Step 44 – Make Additional Adjustments if Necessary.

*You now should have an acceptable message ready to display or to store in the VMS message library.*

---

**Assess Effects of Large Trucks on the Ability of Motorists to View the VMS Message**

The final step in the process is to assess the effects of large trucks in the traffic stream on the ability of motorists to see the VMS and read the message. [Tables 8.14 through 8.17](#) on pages 8-21 and 8-22 should be studied to determine the percentage of motorists who will be able to see the VMS message (or consequently, the percentage who will not be able to see the VMS message because their visibility to the sign is blocked by large trucks). This information will help the VMS operator and the TOC manager to determine the potential effectiveness in communicating the message to the motorists in the traffic stream.

**VMS ON SAME FREEWAY BUT RELATIVELY FAR FROM THE CLOSURE**

The steps discussed below should be used to create a new VMS message when an incident occurs that blocks all lanes and requires closing the freeway using static signs, police or traffic control personnel. The procedure is for situations when the VMS is on the same freeway but relatively far from the closure.

**Establish Initial Maximum Allowable Number of Units of Information in the Message Based on VMS Type and Freeway Operating Speeds**

Step 1 – Determine Freeway Operating Speeds.

Step 2 – Determine the Initial Maximum Allowable Number of Units of Information in the Message from [Table 8.2](#), page 8-5. For LED VMSs, these maximum values are as follows:

<b>Maximum Number of Units of Information Allowed in VMS Message</b>			
<b>Condition</b>	<b>Light-Emitting Diode VMS</b>		
	<b>0-35 mph</b>	<b>36-55 mph</b>	<b>56-70 mph</b>
Mid-Day	5 units	4 units	4 units
Sun Washout	5 units	4 units	4 units
Sun Backlight	4 units	4 units	3 units
Nighttime	4 units	4 units	3 units

**Assess Whether the Message Must Be Reduced Because of Local Geometric Sight Distance Restrictions to the VMS**

Step 3 – Determine Whether There Are Sight Distance Restrictions to the VMS Because of a Vertical Curve Using the Guidelines in [Section 8.3 UNITS OF INFORMATION REDUCTIONS FOR VERTICAL CURVES – LED VMSs](#) on page 8-6.

- If “no” Go Directly to Step 5.
- If “yes” Continue to Step 4.

Step 4 – Identify the Reduction in the Number of Message Units of Information to Compensate for Lower Legibility to the VMS because of the Vertical Curve Using [Tables 8.3 through 8.6](#) on pages 8-8 and 8-9.

Step 5 – Determine Whether There Are Sight Distance Restrictions to the VMS Because of a Horizontal Curve Using the Guidelines in [Section 8.4 UNITS OF INFORMATION REDUCTIONS FOR HORIZONTAL CURVES – LED VMSs](#) on page 8-10.

- If “no” Go Directly to Step 7.
- If “yes” Continue to Step 6.

Step 6 – Identify the Reduction in the Number of Units of Information to Compensate for Lower Legibility to the VMS Because of the Horizontal Curve Using [Tables 8.7 through 8.12](#) on pages 8-12 through 8-17.

---

**Assess Whether the Message Must Be Reduced Because of Local Environmental Sight Distance Restrictions to the VMS Due to Rain or Fog**

Step 7 – Determine Whether Rainfall Near the VMS Exceeds 2 Inches per Hour.

If “no” Go Directly to Step 9.

If “yes” Continue to Step 8.

Step 8 – The Reduction in the Number of Units of Information to Compensate for Rain Is 1.

Step 9 – Determine Whether Fog Exists Near the VMS.

If “no” Go Directly to Step 11.

If “yes” Continue to Step 10.

Step 10 – Identify the Reduction in the Number of Units of Information to Compensate for Fog Using [Table 8.13](#) on page 8-19.

---

**Finalize the Maximum Allowable Units of Information in the Message**

Step 11 – Select the Largest Reduction in the Number of Units of Information from Among the Effects of a Vertical Curve (Step 4), a Horizontal Curve (Step 6), Rain (Step 8), or Fog (Step 10), and Use this Number to Subtract from the Maximum Allowable Number of Units of Information in the Message shown in [Table 8.2](#) on page 8-5. The new number after the subtraction represents the final Maximum Allowable Units of Information in the message.

---

**Define the Basic VMS Message to Satisfy Motorist Information Needs**

Step 12 – Select *Incident Descriptor* Message Element from [Table 6.64](#), page 6-70.

Step 13 – Select *Incident Location* Message Element from [Table 6.65](#), page 6-71.

Step 14 – Select *Lanes Closed* Message Element from [Table 6.66](#), page 6-72.

Step 15 – Select *Closure Location* Element from [Table 6.67](#), page 6-73.

Step 16 – Establish Whether Diversion Action Should be Recommended.

If “no” Continue to Step 17.

If “yes” Go Directly to Step 18.

Step 17 – Select No Diversion *Action* Message Element from [Table 6.69](#), page 6-75, or Omit *Action* Message Element

GO TO Step 27.

Step 18 – Establish Whether “Soft” Diversion Should be Recommended.

If “no” Go Directly to Step 20.

If “yes” Continue to Step 19.

Step 19 – Select “Soft” Diversion *Action* Message Element from [Table 6.70](#), page 6-76.

GO TO Step 23.

Step 20 – Determine Whether Diversion Traffic Control Is in Place on the Selected Alternative Route (i.e., police, traffic control personnel and/or guide signs/trailblazers providing positive guidance).

If “no” Continue to Step 21.

If “yes” Go Directly to Step 22.

Step 21 – Select Type 1, Type 2, Type 3 or Type 4 Diversion Route *Action* Message Element from [Table 6.71](#), page 6-77.

GO TO Step 23.

Step 22 – Select Type 5 Diversion Route *Action* Message Element from [Table 6.72](#), page 6-78.

Step 23 – Establish Whether *Action* Message Element Is for a Select Group of Motorists.

If “no” Go Directly to Step 25.

If “yes” Continue to Step 24.

Step 24 – Select *Audience for Action* Message Element from [Table 6.73](#), page 6-79.

Step 25 – Examine Whether the Diversion Route Will Be Perceived By Motorists as Being a Most Logical Route.

If “no” Continue to Step 26.

If “yes” Go Directly to Step 27.

Step 26 – Select a *Good Reason for Following the Action* Statement Message Element from [Table 6.74](#), page 6-80.

**Reduce the Number of Message Units if Necessary**

Step 27 – Examine Whether the Number of Units of Information in the Basic Message Is Greater than the Maximum Allowable from Step 11.

If “no” Go Directly to Step 34.

If “yes” Continue to Step 28.

Step 28 – Omit *Incident Descriptor* Message Element According to Guidelines in the Section on *Combining Message Elements for Incident Messages* Beginning on [page 9-15](#).

Step 29 – Examine Whether the Number of Units of Information in the Basic Message Is Greater than the Maximum Allowable from Step 11.

If “no” Go Directly to Step 34.

If “yes” Continue to Step 30.

Step 30 – Examine Whether The Message Contains More Than One *Audience for Action* (Destination) Message Element.

If “no” Go Directly to Step 33.

If “yes” Continue to Step 31.

Step 31 – Omit All but One *Audience for Action*

Step 32 – Examine Whether the Number of Units of Information in the Basic Message Is Greater than the Maximum Allowable from Step 11.

If “no” Continue to Step 33.

If “yes” Go Directly to Step 34.

Step 33 – Omit Other Information According to Guidelines in the Section on *PRIORITY REDUCTION PRINCIPLES* on [page 9-20](#).

---

**Format the Message**

Step 34 – Format the Message According to Guidelines in the Section on *FORMATTING MESSAGES* on [page 9-6](#).

---

**Adjust Message to Fit on Existing VMS**

Step 35 – Determine Whether the VMS Has 4 Lines.

If “no” Continue to Step 36.

If “yes” Go Directly to Step 37.



Step 36 – Determine Whether the VMS Has 3 Lines.

If “no” MESSAGE CANNOT BE DESIGNED USING THIS PROCEDURE.

If “yes” Continue to Step 37.

---

### **Adjust Message to Fit on 3 Lines or Less**

Step 37 – Determine Whether the Message Can Be Displayed on 3 Lines or less.

If “no” Continue to Step 38.

If “yes” Go Directly to Step 39.

Step 38 – Split Message Into 2 Frames According to Guidelines in [Section 9.1 SPLITTING MESSAGES](#) on page 9-1.

Step 39 – Examine Whether There Are 3 or Fewer Decision-Relevant Units of Information Displayed on Each of the Frames.

If “no” Continue to Step 40.

If “yes” Go Directly to Step 41.

Step 40 – Omit Information to Reduce Frame to 3 Decision-Relevant Units According to Guidelines in Item 5. *NO MORE THAN THREE UNITS OF INFORMATION SHOULD BE DISPLAYED ON A SINGLE FRAME AT HIGH FREEWAY SPEEDS* on [page 9-3](#).

Step 41 – Examine Whether Message Elements Are Split in Such a Way That a Part of One Message Element Is on the Same Line as a Part of a Second Message Element.

If “no” Go Directly to Step 43.

If “yes” Continue to Step 42.

Step 42 – Separate Message Elements According to Guidelines in Item 4. *A MESSAGE LINE SHOULD NOT CONTAIN PORTIONS OF TWO DIFFERENT UNITS OF INFORMATION* on [page 9-3](#).

Step 43 – Examine Whether the Message or Any of the Message Lines Are Too Long to Fit in the Available VMS Space.

If “no” Go Directly to Step 47.

If “yes” Continue to Step 44.

Step 44 – Apply Abbreviations to Selected Words According to Guidelines in the Section on *USING ABBREVIATIONS*, [page 9-10](#).

Step 45 – Examine Whether the Application of Abbreviation Guidelines Adequately Reduced the Length of the Message Lines and the Entire Message Can Fit in the Available VMS Space.

If “no” Continue to Step 46.

If “yes” Go Directly to Step 47.

Step 46 – Omit Information According to Guidelines in the Sections on *PRIORITY REDUCTION PRINCIPLES* on [page 9-20](#) and *FORMATTING MESSAGES* on [page 9-6](#).

---

### **Finalize VMS Message**

Step 47 – Review Message for Inconsistencies and Incompatibility.

Step 48 – Make Additional Adjustments if Necessary.

*You now should have an acceptable message ready to display or to store in the VMS message library.*

---

### **Assess Effects of Large Trucks on the Ability of Motorists to View the VMS Message**

The final step in the process is to assess the effects of large trucks in the traffic stream on the ability of motorists to see the VMS and read the message. [Tables 8.14 through 8.17](#) on pages 8-21 and 8-22 should be studied to determine the percentage of motorists who will be able to see the VMS message (or consequently, the percentage who will not be able to see the VMS message because their visibility to the sign is blocked by large trucks). This information will help the VMS operator and the TOC manager to determine the potential effectiveness in communicating the message to the motorists in the traffic stream.

**VMS ON DIFFERENT FREEWAY THAN THE CLOSURE**

The steps discussed below should be used to create a new VMS message when an incident occurs that blocks all lanes and requires closing the freeway using static signs, police or traffic control personnel. The procedure is for situations when the VMS is on a different freeway than the closure.

---

**Establish Initial Maximum Allowable Number of Units of Information in the Message Based on VMS Type and Freeway Operating Speeds**

Step 1 – Determine Freeway Operating Speeds.

Step 2 – Determine the Initial Maximum Allowable Number of Units of Information in the Message from [Table 8.2](#), page 8-5. For LED VMSs, these maximum values are as follows:

<b>Maximum Number of Units of Information Allowed in VMS Message</b>			
<b>Condition</b>	<b>Light-Emitting Diode VMS</b>		
	<b>0-35 mph</b>	<b>36-55 mph</b>	<b>56-70 mph</b>
Mid-Day	5 units	4 units	4 units
Sun Washout	5 units	4 units	4 units
Sun Backlight	4 units	4 units	3 units
Nighttime	4 units	4 units	3 units

---

**Assess Whether the Message Must Be Reduced Because of Local Geometric Sight Distance Restrictions to the VMS**

Step 3 – Determine Whether There Are Sight Distance Restrictions to the VMS Because of a Vertical Curve Using the Guidelines in [Section 8.3 UNITS OF INFORMATION REDUCTIONS FOR VERTICAL CURVES – LED VMSs](#) on page 8-6.

- If “no” Go Directly to Step 5.
- If “yes” Continue to Step 4.

Step 4 – Identify the Reduction in the Number of Message Units of Information to Compensate for Lower Legibility to the VMS because of the Vertical Curve Using [Tables 8.3 through 8.6](#) on pages 8-8 and 8-9.

Step 5 – Determine Whether There Are Sight Distance Restrictions to the VMS Because of a Horizontal Curve Using the Guidelines in [Section 8.4 UNITS OF INFORMATION REDUCTIONS FOR HORIZONTAL CURVES – LED VMSs](#) on page 8-10.

- If “no” Go Directly to Step 7.
- If “yes” Continue to Step 6.

Step 6 – Identify the Reduction in the Number of Units of Information to Compensate for Lower Legibility to the VMS Because of the Horizontal Curve Using [Tables 8.7 through 8.12](#) on pages 8-12 through 8-17.

---

**Assess Whether the Message Must Be Reduced Because of Local Environmental Sight Distance Restrictions to the VMS Due to Rain or Fog**

Step 7 – Determine Whether Rainfall Near the VMS Exceeds 2 Inches per Hour.

If “no” Go Directly to Step 9.

If “yes” Continue to Step 8.

Step 8 – The Reduction in the Number of Units of Information to Compensate for Rain Is 1.

Step 9 – Determine Whether Fog Exists Near the VMS.

If “no” Go Directly to Step 11.

If “yes” Continue to Step 10.

Step 10 – Identify the Reduction in the Number of Units of Information to Compensate for Fog Using [Table 8.13](#) on page 8-19.

---

**Finalize the Maximum Allowable Units of Information in the Message**

Step 11 – Select the Largest Reduction in the Number of Units of Information from Among the Effects of a Vertical Curve (Step 4), a Horizontal Curve (Step 6), Rain (Step 8), or Fog (Step 10), and Use this Number to Subtract from the Maximum Allowable Number of Units of Information in the Message shown in [Table 8.2](#) on page 8-5. The new number after the subtraction represents the final Maximum Allowable Units of Information in the message.

---

**Define the Basic VMS Message to Satisfy Motorist Information Needs**

Step 12 – Select *Incident Descriptor* Message Element from [Table 6.75](#), page 6-82.

Step 13 – Select *Incident Location* Message Element from [Table 6.76](#), page 6-83.

Step 14 – Select *Lanes Closed* Message Element from [Table 6.77](#), page 6-84.

Step 15 – Select *Closure Location* Element from [Table 6.78](#), page 6-85.

Step 16 – Determine Whether Diversion Action should be Recommended.

If “no” Continue to Step 17.

If “yes” Go Directly to Step 18.

Step 17 – Select No Diversion *Action* Message Element from [Table 6.80](#), page 6-87 or Omit *Action* Message Element.

GO TO Step 25.

Step 18 – Establish Whether “Soft” Diversion should be Recommended.

If “no” Go Directly to Step 20.

If “yes” Continue to Step 19.

Step 19 – Select “Soft” Diversion *Action* Message Element from [Table 6.81](#), page 6-88.

GO TO Step 21.

Step 20 – Select Type 1 or Type 2 Diversion Route *Action* Message Element from [Table 6.82](#), page 6-89.

Step 21 – Establish Whether *Action* Message Is for a Select Group of Motorists.

If “no” Go Directly to Step 23.

If “yes” Continue to Step 22.

Step 22 – Select *Audience for Action* Message Element from [Table 6.83](#), page 6-90.

Step 23 – Examine Whether the Diversion Route May Be Perceived by Motorists as Being a Most Logical Route.

If “no” Continue to Step 24.

If “yes” Go Directly to Step 25.

Step 24 – Select a *Good Reason for Following the Action* Message Element from [Table 6.84](#), page 6-91.

---

### **Reduce the Number of Message Units if Necessary**

Step 25 – Examine Whether the Number of Units of Information in the Basic Message Is Greater than the Maximum Allowable from Step 11.

If “no” Go Directly to Step 32.

If “yes” Continue to Step 26.

Step 26 – Omit *Incident Descriptor* Message Element According to Guidelines in the Section on *Combining Message Elements for Incident Messages* Beginning on [page 9-15](#).

Step 27 – Examine Whether the Number of Units of Information in the Basic Message Is Greater than the Maximum Allowable from Step 11.

If “no” Go Directly to Step 32.

If “yes” Continue to Step 28.

Step 28 – Examine Whether The Message Contains More Than One *Audience for Action* (Destination) Message Element.

If “no” Go Directly to Step 31.

If “yes” Continue to Step 29.

Step 29 – Omit All but One *Audience for Action*

Step 30 – Examine Whether the Number of Units of Information in the Basic Message Is Greater than the Maximum Allowable from Step 11.

If “no” Continue to Step 31.

If “yes” Go Directly to Step 32.

Step 31 – Omit Other Information According to Guidelines in the Section on *PRIORITY REDUCTION PRINCIPLES* on [page 9-20](#).

---

### **Format the Message**

Step 32 – Format the Message According to Guidelines in the Section on *FORMATTING MESSAGES* on [page 9-6](#).

---

### **Adjust Message to Fit on Existing VMS**

Step 33 – Determine Whether the VMS Has 4 Lines.

If “no” Continue to Step 34.

If “yes” Go Directly to Step 35.

Step 34 – Determine Whether the VMS Has 3 Lines.

If “no” MESSAGE CANNOT BE DESIGNED USING THIS PROCEDURE.

If “yes” Continue to Step 35.

---

## Adjust Message to Fit on 3 Lines or Less

Step 35 – Determine Whether the Message Can Be Displayed on 3 Lines or less.

If “no” Continue to Step 36.

If “yes” Go Directly to Step 39.

Step 36 – Split Message Into 2 Frames According to Guidelines in [Section 9.1 SPLITTING MESSAGES](#) on page 9-1.

Step 37 – Examine Whether There Are 3 or Fewer Decision-Relevant Units of Information Displayed on Each of the Frames.

If “no” Continue to Step 38.

If “yes” Go Directly to Step 39.

Step 38 – Omit Information to Reduce Frame to 3 Decision-Relevant Units According to Guidelines in Item 5. *NO MORE THAN THREE UNITS OF INFORMATION SHOULD BE DISPLAYED ON A SINGLE FRAME AT HIGH FREEWAY SPEEDS* on [page 9-3](#).

Step 39 – Examine Whether Message Elements Are Split in Such a Way That a Part of One Message Element Is on the Same Line as a Part of a Second Message Element.

If “no” Go Directly to Step 41.

If “yes” Continue to Step 40.

Step 40 – Separate Message Elements According to Guidelines in Item 4. *A MESSAGE LINE SHOULD NOT CONTAIN PORTIONS OF TWO DIFFERENT UNITS OF INFORMATION* on [page 9-3](#).

Step 41 – Examine Whether the Message or Any of the Message Lines Are Too Long to Fit in the Available VMS Space.

If “no” Go Directly to Step 45.

If “yes” Continue to Step 42.

Step 42 – Apply Abbreviations to Selected Words According to Guidelines in the Section on *USING ABBREVIATIONS*, [page 9-10](#).

Step 43 – Examine Whether the Application of Abbreviation Guidelines Adequately Reduced the Length of the Message Lines and the Entire Message Can Fit in the Available VMS Space.

If “no” Continue to Step 44.

If “yes” Go Directly to Step 45.

Step 44 – Omit Information According to Guidelines in the Sections on *PRIORITY REDUCTION PRINCIPLES* on [page 9-20](#) and *FORMATTING MESSAGES* on [page 9-6](#).

## **Finalize VMS Message**

Step 45 – Review Message for Inconsistencies and Incompatibility.

Step 46 – Make Additional Adjustments if Necessary.

*You now should have an acceptable message ready to display or to store in the VMS message library.*

---

## **Assess Effects of Large Trucks on the Ability of Motorists to View the VMS Message**

The final step in the process is to assess the effects of large trucks in the traffic stream on the ability of motorists to see the VMS and read the message. [Tables 8.14 through 8.17](#) on pages 8-21 and 8-22 should be studied to determine the percentage of motorists who will be able to see the VMS message (or consequently, the percentage who will not be able to see the VMS message because their visibility to the sign is blocked by large trucks). This information will help the VMS operator and the TOC manager to determine the potential effectiveness in communicating the message to the motorists in the traffic stream.



## 10.4 INCIDENTS ON AN INTERSECTING FREEWAY THAT REQUIRE CLOSING THE CONNECTOR RAMP

### VMS UPSTREAM OF THE CONNECTOR RAMP CLOSURE

Use the procedure outlined in this section of the Manual when an incident occurs on an intersecting freeway and the connector ramp from the VMS freeway to the intersecting freeway is closed.

---

#### Establish Initial Maximum Allowable Number of Units of Information in the Message Based on VMS Type and Freeway Operating Speeds

Step 1 – Determine Freeway Operating Speeds.

Step 2 – Determine the Initial Maximum Allowable Number of Units of Information in the Message from [Table 8.2](#), page 8-5. For LED VMSs, these maximum values are as follows:

Maximum Number of Units of Information Allowed in VMS Message			
Condition	Light-Emitting Diode VMS		
	0-35 mph	36-55 mph	56-70 mph
Mid-Day	5 units	4 units	4 units
Sun Washout	5 units	4 units	4 units
Sun Backlight	4 units	4 units	3 units
Nighttime	4 units	4 units	3 units

---

#### Assess Whether the Message Must Be Reduced Because of Local Geometric Sight Distance Restrictions to the VMS

Step 3 – Determine Whether There Are Sight Distance Restrictions to the VMS Because of a Vertical Curve Using the Guidelines in [Section 8.3 UNITS OF INFORMATION REDUCTIONS FOR VERTICAL CURVES – LED VMSs](#) on page 8-6.

If “no” Go Directly to Step 5.

If “yes” Continue to Step 4.

Step 4 – Identify the Reduction in the Number of Message Units of Information to Compensate for Lower Legibility to the VMS because of the Vertical Curve Using [Tables 8.3 through 8.6](#) on pages 8-8 and 8-9.

Step 5 – Determine Whether There Are Sight Distance Restrictions to the VMS Because of a Horizontal Curve Using the Guidelines in [Section 8.4 UNITS OF INFORMATION REDUCTIONS FOR HORIZONTAL CURVES – LED VMSs](#) on page 8-10.

If “no” Go Directly to Step 7.

If “yes” Continue to Step 6.

Step 6 – Identify the Reduction in the Number of Units of Information to Compensate for Lower Legibility to the VMS Because of the Horizontal Curve Using [Tables 8.7 through 8.12](#) on pages 8-12 through 8-17.

---

### **Assess Whether the Message Must Be Reduced Because of Local Environmental Sight Distance Restrictions to the VMS Due to Rain or Fog**

Step 7 – Determine Whether Rainfall Near the VMS Exceeds 2 Inches per Hour.

If “no” Go Directly to Step 9.

If “yes” Continue to Step 8.

Step 8 – The Reduction in the Number of Units of Information to Compensate for Rain Is 1.

Step 9 – Determine Whether Fog Exists Near the VMS.

If “no” Go Directly to Step 11.

If “yes” Continue to Step 10.

Step 10 – Identify the Reduction in the Number of Units of Information to Compensate for Fog Using [Table 8.13](#) on page 8-19.

---

### **Finalize the Maximum Allowable Units of Information in the Message**

Step 11 – Select the Largest Reduction in the Number of Units of Information from Among the Effects of a Vertical Curve (Step 4), a Horizontal Curve (Step 6), Rain (Step 8), or Fog (Step 10), and Use this Number to Subtract from the Maximum Allowable Number of Units of Information in the Message shown in [Table 8.2](#) on page 8-5. The new number after the subtraction represents the final Maximum Allowable Units of Information in the message.

---

### **Define the Basic VMS Message to Satisfy Motorist Information Needs**

Step 12 – Select *Incident Descriptor* Message Element from [Table 6.85](#), page 6-93.

Step 13 – Select *Incident Location* Message Element from [Table 6.86](#), page 6-94.

Step 14 – Select *Lanes Closed* Message Element from [Table 6.87](#), page 6-95.

Step 15 – Select *Ramp Closure Descriptor* Message Element from [Table 6.88](#), page 6-96.

Step 16 – Determine Whether Diversion Action should be Recommended.

- If “no” Continue to Step 17.
- If “yes” Go Directly to Step 18.

Step 17 – Select No Diversion *Action* Message Element from [Table 6.89](#), page 6-97 or Omit *Action* Message Element.

GO TO Step 27.

Step 18 – Establish Whether “Soft” Diversion should be Recommended.

- If “no” Go Directly to Step 20.
- If “yes” Continue to Step 19.

Step 19 – Select “Soft” Diversion *Action* Message Element from [Table 6.90](#), page 6-98.

GO TO Step 23.

Step 20 – Determine Whether Diversion Traffic Control Is in Place on the Selected Alternative Route (i.e., police, traffic control personnel and/or guide signs/trailblazers providing guidance).

- If “no” Continue to Step 21.
- If “yes” Go directly to Step 22.

Step 21 – Select Type 1 or Type 2 Diversion Route *Action* Message Element from [Table 6.91](#), page 6-99.

GO TO Step 23.

Step 22 – Select Type 5 Diversion Route *Action* Message Element from [Table 6.92](#), page 6-100.

Step 23 – Establish Whether *Action* Message Is for a Select Group of Motorists.

- If “no” Go Directly to Step 25.
- If “yes” Continue to Step 24.

Step 24 – Select *Audience for Action* Message Element from [Table 6.93](#), page 6-101.

Step 25 – Examine Whether the Diversion Route May Be Perceived by Motorists as Being a Most Logical Route.

- If “no” Continue to Step 26.
- If “yes” Go Directly to Step 27.

Step 26 – Select a *Good Reason for Following the Action* Message Element from [Table 6.94](#), page 6-102.

**Reduce the Number of Message Units if Necessary**

Step 27 – Examine Whether the Number of Units of Information in the Basic Message Is Greater than the Maximum Allowable from Step 11.

If “no” Go Directly to Step 34.

If “yes” Continue to Step 28.

Step 28 – Omit *Incident Descriptor* Message Element According to Guidelines in the Section on *Combining Message Elements for Incident Messages* Beginning on [page 9-15](#).

Step 29 – Examine Whether the Number of Units of Information in the Basic Message Is Greater than the Maximum Allowable from Step 11.

If “no” Go Directly to Step 34.

If “yes” Continue to Step 30.

Step 30 – Examine Whether The Message Contains More Than One *Audience for Action* (Destination) Message Element.

If “no” Go Directly to Step 33.

If “yes” Continue to Step 31.

Step 31 – Omit All but One *Audience for Action*

Step 32 – Examine Whether the Number of Units of Information in the Basic Message Is Greater than the Maximum Allowable from Step 11.

If “no” Continue to Step 33.

If “yes” Go Directly to Step 34.

Step 33 – Omit Other Information According to Guidelines in the Section on *PRIORITY REDUCTION PRINCIPLES* on [page 9-20](#).

---

**Format the Message**

Step 34 – Format the Message According to Guidelines in the Section on *FORMATTING MESSAGES* on [page 9-6](#).

---

**Adjust Message to Fit on Existing VMS**

Step 35 – Determine Whether the VMS Has 4 Lines.

If “no” Continue to Step 36.

If “yes” Go Directly to Step 37.

Step 36 – Determine Whether the VMS Has 3 Lines.

If “no” MESSAGE CANNOT BE DESIGNED USING THIS PROCEDURE.

If “yes” Continue to Step 37.

---

### **Adjust Message to Fit on 3 Lines or Less**

Step 37 – Determine Whether the Message Can Be Displayed on 3 Lines or less.

If “no” Continue to Step 38.

If “yes” Go Directly to Step 41.

Step 38 – Split Message Into 2 Frames According to Guidelines in [Section 9.1 SPLITTING MESSAGES](#) on page 9-1.

Step 39 – Examine Whether There Are 3 or Fewer Decision-Relevant Units of Information Displayed on Each of the Frames.

If “no” Continue to Step 40.

If “yes” Go Directly to Step 41.

Step 40 – Omit Information to Reduce Frame to 3 Decision-Relevant Units According to Guidelines in Item 5. *NO MORE THAN THREE UNITS OF INFORMATION SHOULD BE DISPLAYED ON A SINGLE FRAME AT HIGH FREEWAY SPEEDS* on [page 9-3](#).

Step 41 – Examine Whether Message Elements Are Split in Such a Way That a Part of One Message Element Is on the Same Line as a Part of a Second Message Element.

If “no” Go Directly to Step 43.

If “yes” Continue to Step 42.

Step 42 – Separate Message Elements According to Guidelines in Item 4. *A MESSAGE LINE SHOULD NOT CONTAIN PORTIONS OF TWO DIFFERENT UNITS OF INFORMATION* on [page 9-3](#).

Step 43 – Examine Whether the Message or Any of the Message Lines Are Too Long to Fit in the Available VMS Space.

If “no” Go Directly to Step 47.

If “yes” Continue to Step 44.

Step 44 – Apply Abbreviations to Selected Words According to Guidelines in the Section on *USING ABBREVIATIONS*, [page 9-10](#).

Step 45 – Examine Whether the Application of Abbreviation Guidelines Adequately Reduced the Length of the Message Lines and the Entire Message Can Fit in the Available VMS Space.

If “no” Continue to Step 46.

If “yes” Go Directly to Step 47.

Step 46 – Omit Information According to Guidelines in the Sections on *PRIORITY REDUCTION PRINCIPLES* on [page 9-20](#) and *FORMATTING MESSAGES* on [page 9-6](#).

---

### **Finalize VMS Message**

Step 47 – Review Message for Inconsistencies and Incompatibility.

Step 48 – Make Additional Adjustments if Necessary.

*You now should have an acceptable message ready to display or to store in the VMS message library.*

---

### **Assess Effects of Large Trucks on the Ability of Motorists to View the VMS Message**

The final step in the process is to assess the effects of large trucks in the traffic stream on the ability of motorists to see the VMS and read the message. [Tables 8.14 through 8.17](#) pages 8-21 and 8-22 should be studied to determine the percentage of motorists who will be able to see the VMS message (or consequently, the percentage who will not be able to see the VMS message because their visibility to the sign is blocked by large trucks). This information will help the VMS operator and the TOC manager to determine the potential effectiveness in communicating the message to the motorists in the traffic stream.

**THIS PAGE LEFT BLANK**

# MODULE 11. DESIGNING VMS MESSAGES FOR ROADWORK

## TABLE OF CONTENTS

<b>11.1 LANE CLOSURE DURING ROADWORK .....</b>	<b>11-1</b>
VMS ON THE SAME FREEWAY AND RELATIVELY CLOSE TO THE ROADWORK .....	11-1
Establish Initial Maximum Allowable Number of Units of Information in the Message Based on VMS Type and Freeway Operating Speeds .....	11-1
Assess Whether the Message Must Be Reduced Because of Local Geometric Sight Distance Restrictions to the VMS .....	11-1
Assess Whether the Message Must Be Reduced Because of Local Environmental Sight Distance Restrictions to the VMS Due to Rain or Fog.....	11-2
Finalize the Maximum Allowable Units of Information in the Message .....	11-2
Define the Basic VMS Message to Satisfy Motorist Information Needs .....	11-2
Reduce the Number of Message Units if Necessary .....	11-4
Format the Message .....	11-5
Adjust Message to Fit on Existing VMS .....	11-5
Adjust Message to Fit on 3 Lines or Less .....	11-5
Finalize VMS Message .....	11-6
Assess Effects of Large Trucks on the Ability of Motorists to View the VMS Message.....	11-6
VMS ON SAME FREEWAY BUT RELATIVELY FAR FROM THE ROADWORK .....	11-7
Establish Initial Maximum Allowable Number of Units of Information in the Message Based on VMS Type and Freeway Operating Speeds .....	11-7
Assess Whether the Message Must Be Reduced Because of Local Geometric Sight Distance Restrictions to the VMS .....	11-7
Assess Whether the Message Must Be Reduced Because of Local Environmental Sight Distance Restrictions to the VMS Due to Rain or Fog.....	11-8
Finalize the Maximum Allowable Units of Information in the Message .....	11-8
Define the Basic VMS Message to Satisfy Motorist Information Needs .....	11-8
Reduce the Number of Message Units if Necessary .....	11-10
Format the Message .....	11-10
Adjust Message to Fit on Existing VMS .....	11-10
Adjust Message to Fit on 3 Lines or Less .....	11-11
Finalize VMS Message .....	11-12
Assess Effects of Large Trucks on the Ability of Motorists to View the VMS Message.....	11-12
VMS ON DIFFERENT FREEWAY THAN THE ROADWORK .....	11-13
Establish Initial Maximum Allowable Number of Units of Information in the Message Based on VMS Type and Freeway Operating Speeds .....	11-13



Assess Whether the Message Must Be Reduced Because of Local Geometric  
 Sight Distance Restrictions to the VMS .....11-13

Assess Whether the Message Must Be Reduced Because of Local Environmental  
 Sight Distance Restrictions to the VMS Due to Rain or Fog.....11-14

Finalize the Maximum Allowable Units of Information in the Message .....11-14

Define the Basic VMS Message to Satisfy Motorist Information Needs .....11-14

Reduce the Number of Message Units if Necessary .....11-16

Format the Message .....11-16

Adjust Message to Fit on Existing VMS .....11-16

Adjust Message to Fit on 3 Lines or Less .....11-17

Finalize VMS Message .....11-18

Assess Effects of Large Trucks on the Ability of Motorists to View the VMS  
 Message.....11-18

**11.2 ROADWORK THAT REQUIRES CLOSING THE**

**FREEWAY** .....11-19

VMS ON THE SAME FREEWAY AND RELATIVELY CLOSE TO THE  
 CLOSURE .....11-19

Establish Initial Maximum Allowable Number of Units of Information in the  
 Message Based on VMS Type and Freeway Operating Speeds .....11-19

Assess Whether the Message Must Be Reduced Because of Local Geometric  
 Sight Distance Restrictions to the VMS .....11-19

Assess Whether the Message Must Be Reduced Because of Local Environmental  
 Sight Distance Restrictions to the VMS Due to Rain or Fog.....11-20

Finalize the Maximum Allowable Units of Information in the Message .....11-20

Define the Basic VMS Message to Satisfy Motorist Information Needs .....11-20

Reduce the Number of Message Units if Necessary .....11-21

Format the Message .....11-21

Adjust Message to Fit on Existing VMS .....11-21

Adjust Message to Fit on 3 Lines or Less .....11-22

Finalize VMS Message .....11-23

Assess Effects of Large Trucks on the Ability of Motorists to View the VMS  
 Message.....11-23

VMS ON SAME FREEWAY BUT RELATIVELY FAR FROM THE CLOSURE....11-24

Establish Initial Maximum Allowable Number of Units of Information in the  
 Message Based on VMS Type and Freeway Operating Speeds .....11-24

Assess Whether the Message Must Be Reduced Because of Local Geometric  
 Sight Distance Restrictions to the VMS .....11-24

Assess Whether the Message Must Be Reduced Because of Local Environmental  
 Sight Distance Restrictions to the VMS Due to Rain or Fog.....11-25

Finalize the Maximum Allowable Units of Information in the Message .....11-25

Define the Basic VMS Message to Satisfy Motorist Information Needs .....11-25

Reduce the Number of Message Units if Necessary .....11-26

Format the Message .....11-27

Adjust Message to Fit on Existing VMS .....11-27

Adjust Message to Fit on 3 Lines or Less .....11-28

Finalize VMS Message 11-29

Assess Effects of Large Trucks on the Ability of Motorists to View the VMS Message.....11-29

VMS ON DIFFERENT FREEWAY THAN THE ROADWORK AND CLOSURE ...11-30

Establish Initial Maximum Allowable Number of Units of Information in the Message Based on VMS Type and Freeway Operating Speeds .....11-30

Assess Whether the Message Must Be Reduced Because of Local Geometric Sight Distance Restrictions to the VMS .....11-30

Assess Whether the Message Must Be Reduced Because of Local Environmental Sight Distance Restrictions to the VMS Due to Rain or Fog.....11-31

Finalize the Maximum Allowable Units of Information in the Message .....11-31

Define the Basic VMS Message to Satisfy Motorist Information Needs .....11-31

Reduce the Number of Message Units if Necessary .....11-32

Format the Message .....11-33

Adjust Message to Fit on Existing VMS .....11-33

Adjust Message to Fit on 3 Lines or Less .....11-33

Finalize VMS Message .....11-34

Assess Effects of Large Trucks on the Ability of Motorists to View the VMS Message.....11-35

**11.3 ROADWORK ON AN INTERSECTING FREEWAY THAT REQUIRES CLOSING THE CONNECTOR RAMP** .....11-36

VMS UPSTREAM OF THE CONNECTOR RAMP CLOSURE.....11-36

Establish Initial Maximum Allowable Number of Units of Information in the Message Based on VMS Type and Freeway Operating Speeds .....11-36

Assess Whether the Message Must Be Reduced Because of Local Geometric Sight Distance Restrictions to the VMS .....11-36

Assess Whether the Message Must Be Reduced Because of Local Environmental Sight Distance Restrictions to the VMS Due to Rain or Fog.....11-37

Finalize the Maximum Allowable Units of Information in the Message .....11-37

Define the Basic VMS Message to Satisfy Motorist Information Needs .....11-37

Reduce the Number of Message Units if Necessary .....11-39

Format the Message .....11-39

Adjust Message to Fit on Existing VMS .....11-39

Adjust Message to Fit on 3 Lines or Less .....11-40

Finalize VMS Message .....11-41

Assess Effects of Large Trucks on the Ability of Motorists to View the VMS Message.....11-41

**THIS PAGE BLANK**

# MODULE 11. DESIGNING VMS MESSAGES FOR ROADWORK

## 11.1 LANE CLOSURE DURING ROADWORK

The VMS message design process described in this section of the Manual applies to roadwork that requires closure of some of the lanes of the freeway while other lanes are open to traffic. When the roadwork requires closure of all the lanes on the freeway, [Section 11.2 ROADWORK REQUIRING CLOSURE OF THE FREEWAY](#) on page 11-19 should be used.

### VMS ON THE SAME FREEWAY AND RELATIVELY CLOSE TO THE ROADWORK

The steps discussed below should be used to create a new VMS message when it is necessary to close one or more lanes while other lanes are open to traffic and the VMS is located on the same freeway and relatively close to the roadwork.

---

#### Establish Initial Maximum Allowable Number of Units of Information in the Message Based on VMS Type and Freeway Operating Speeds

Step 1 – Determine Freeway Operating Speeds.

Step 2 – Determine the Initial Maximum Allowable Number of Units of Information in the Message from [Table 8.2](#), page 8-5. For LED VMSs, these maximum values are as follows:

<b>Maximum Number of Units of Information Allowed in VMS Message</b>			
<b>Condition</b>	<b>Light-Emitting Diode VMS</b>		
	<b>0-35 mph</b>	<b>36-55 mph</b>	<b>56-70 mph</b>
Mid-Day	5 units	4 units	4 units
Sun Washout	5 units	4 units	4 units
Sun Backlight	4 units	4 units	3 units
Nighttime	4 units	4 units	3 units

---

#### Assess Whether the Message Must Be Reduced Because of Local Geometric Sight Distance Restrictions to the VMS

Step 3 – Determine Whether There Are Sight Distance Restrictions to the VMS Because of a Vertical Curve Using the Guidelines in [Section 8.3 UNITS OF INFORMATION REDUCTIONS FOR VERTICAL CURVES – LED VMSs](#) on page 8-6.

If “no” Go Directly to Step 5.

If “yes” Continue to Step 4.

Step 4 – Identify the Reduction in the Number of Message Units of Information to Compensate for Lower Legibility to the VMS Because of the Vertical Curve Using [Tables 8.3 through 8.6](#) on pages 8-8 and 8-9.

Step 5 – Determine Whether There Are Sight Distance Restrictions to the VMS Because of a Horizontal Curve Using the Guidelines in [Section 8.4 UNITS OF INFORMATION REDUCTIONS FOR HORIZONTAL CURVES – LED VMSs](#) on page 8-10.

If “no” Go Directly to Step 7.

If “yes” Continue to Step 6.

Step 6 – Identify the Reduction in the Number of Units of Information to Compensate for Lower Legibility to the VMS Because of the Horizontal Curve Using [Tables 8.7 through 8.12](#) on pages 8-12 through 8-17.

---

### **Assess Whether the Message Must Be Reduced Because of Local Environmental Sight Distance Restrictions to the VMS Due to Rain or Fog**

Step 7 – Determine Whether Rainfall Near the VMS Exceeds 2 Inches per Hour.

If “no” Go Directly to Step 9.

If “yes” Continue to Step 8.

Step 8 – The Reduction in the Number of Units of Information to Compensate for Rain Is 1.

Step 9 – Determine Whether Fog Exists Near the VMS.

If “no” Go Directly to Step 11.

If “yes” Continue to Step 10.

Step 10 – Identify the Reduction in the Number of Units of Information to Compensate for Fog Using [Table 8.13](#) on page 8-19.

---

### **Finalize the Maximum Allowable Units of Information in the Message**

Step 11 – Select the Largest Reduction in the Number of Units of Information from Among the Effects of a Vertical Curve (Step 4), a Horizontal Curve (Step 6), Rain (Step 8), or Fog (Step 10), and Use this Number to Subtract from the Maximum Allowable Number of Units of Information in the Message shown in [Table 8.2](#) on page 8-5. The new number after the subtraction represents the final Maximum Allowable Units of Information in the message.

---

### **Define the Basic VMS Message to Satisfy Motorist Information Needs**

Step 12 – Select *Roadwork Descriptor* Message Element from [Table 7.1](#), page 7-2.

Step 13 – Select *Roadwork (Lane Closure) Location* Message Element from [Table 7.2](#), page 7-4.

Step 14 – Select *Lanes Closed* Message Element from [Table 7.3](#), page 7-5.

Step 15 – Establish Whether *Effect on Travel* Message Element Is Implied by the *Lanes Closed* Message Element.

If “no” Continue to Step 16.

If “yes” Go Directly to Step 17.

Note: Statements in the *Lanes Closed* message element such as *3 RIGHT LANES CLOSED* imply to motorists that, depending upon the time of day, they will experience delay or major delay. Thus, an *Effect on Travel* message element does not have to be included in the Basic VMS Message.

Step 16 – Select *Effect on Travel* Message Element from [Table 7.4](#), page 7-6.

Step 17 – Establish Whether Diversion Action Should Be Recommended.

If “no” Continue to Step 18.

If “yes” Go Directly to Step 19.

Step 18 – Select No Diversion *Action* Message Element from [Table 7.5](#), page 7-7 or omit *Action* Message Element.

GO TO Step 27.

Step 19 – Establish Whether “Soft” Diversion Should Be Recommended.

If “no” Go Directly to Step 21.

If “yes” Continue to Step 20.

Step 20 – Select “Soft” Diversion *Action* Message Element from [Table 7.6](#), page 7-8.

GO TO Step 22.

Step 21 – Select Type 1 or Type 2 Diversion Route *Action* Message Element from [Table 7.7](#), page 7-9.

Step 22 – Establish Whether *Action* Message Is for a Select Group of Motorists.

If “no” Go Directly to Step 24.

If “yes” Continue to Step 23.

Step 23 – Select *Audience for Action* Message Element from [Table 7.8](#), page 7-10.

Step 24 – Establish Whether a *Good Reason for Following the Action* Is Implied in *Lanes Closed and Roadwork (Lane Closure) Location* Message Elements.

If “no” Go Directly to Step 26.

If “yes” Continue to Step 25.

Step 25 – Determine Whether Motorists Will Be Advised to Take a Route That May Be Perceived by Them as Not Being Logical.

If “no” Go Directly to Step 27.

If “yes” Continue to Step 26.

Step 26 – Select a *Good Reason for Following the Action* Message Element from [Table 7.9](#), page 7-11.

---

### **Reduce the Number of Message Units if Necessary**

Step 27 – Examine Whether the Number of Units of Information in the Basic Message Is Greater than the Maximum Allowable from Step 11.

If “no” Go Directly to Step 34.

If “yes” Continue to Step 28.

Step 28 – Omit *Incident Descriptor* Message Element According to Guidelines in the Section on *Combining Message Elements for Incident Messages* Beginning on [page 9-15](#).

Step 29 – Examine Whether the Number of Units of Information in the Basic Message Is Greater than the Maximum Allowable from Step 11.

If “no” Continue to Step 30.

If “yes” Go Directly to Step 34.

Step 30 – Examine Whether The Message Contains More Than One *Audience for Action* (Destination) Message Element.

If “no” Go Directly to Step 32.

If “yes” Continue to Step 31.

Step 31 – Omit All but One *Audience for Action*.

Step 32 – Examine Whether the Number of Units of Information in the Basic Message Is Greater than the Maximum Allowable from Step 11.

If “no” Continue to Step 33.

If “yes” Go Directly to Step 34.

Step 33 – Omit Other Information According to Guidelines in the Section on *PRIORITY REDUCTION PRINCIPLES* on [page 9-20](#).

---

### **Format the Message**

Step 34 – Format the Message According to Guidelines in the Section on *FORMATTING MESSAGES* on [page 9-6](#).

---

### **Adjust Message to Fit on Existing VMS**

Step 35 – Determine Whether the VMS Has 4 Lines.

If “no” Continue to Step 36.

If “yes” Go Directly to Step 37.

Step 36 – Determine Whether the VMS Has 3 Lines.

If “no” MESSAGE CANNOT BE DESIGNED USING THIS PROCEDURE.

If “yes” Continue to Step 37.

---

### **Adjust Message to Fit on 3 Lines or Less**

Step 37 – Determine Whether the Message can Be Displayed on 3 Lines or less.

If “no” Continue to Step 38.

If “yes” Go Directly to Step 39.

Step 38 – Split Message Into 2 Frames According to Guidelines in [Section 9.1 SPLITTING MESSAGES](#) on page 9-1.

Step 39 – Examine Whether There Are 3 or Fewer Decision-Relevant Units of Information Displayed on Each of the Frames.

If “no” Continue to Step 40.

If “yes” Go Directly to Step 41.

Step 40 – Omit Information to Reduce Frame to 3 Decision-Relevant Units According to Guidelines in Item 5. *NO MORE THAN THREE UNITS OF INFORMATION SHOULD BE DISPLAYED ON A SINGLE FRAME AT HIGH FREEWAY SPEEDS* on [page 9-3](#).

Step 41 – Examine Whether Message Elements Are Split in Such a Way That a Part of One Message Element Is on the Same Line as a Part of a Second Message Element.

If “no” Go Directly to Step 43.

If “yes” Continue to Step 42.



Step 42 – Separate Message Elements According to Guidelines in *Item 4. A MESSAGE LINE SHOULD NOT CONTAIN PORTIONS OF TWO DIFFERENT UNITS OF INFORMATION* on [page 9-3](#).

Step 43 – Examine Whether the Message or Any of the Message Lines Are Too Long to Fit in the Available VMS Space.

If “no” Go Directly to Step 47.

If “yes” Continue to Step 44.

Step 44 – Apply Abbreviations to Selected Words According to Guidelines in the Section on *USING ABBREVIATIONS*, [page 9-10](#).

Step 45 – Examine Whether the Application of Abbreviation Guidelines Adequately Reduced the Length of the Message Lines and the Entire Message Can Fit in the Available VMS Space.

If “no” Continue to Step 46.

If “yes” Go Directly to Step 47.

Step 46 – Omit Information According to Guidelines in the Sections on *PRIORITY REDUCTION PRINCIPLES* on [page 9-20](#) and *FORMATTING MESSAGES* on [page 9-6](#).

---

### **Finalize VMS Message**

Step 47 – Review Message for Inconsistencies and Incompatibility.

Step 48 – Make Additional Adjustments if Necessary.

*You now should have an acceptable message ready to display or to store in the VMS message library.*

---

### **Assess Effects of Large Trucks on the Ability of Motorists to View the VMS Message**

The final step in the process is to assess the effects of large trucks in the traffic stream on the ability of motorists to see the VMS and read the message. [Tables 8.14 through 8.17](#) on pages 8-21 and 8-22 should be studied to determine the percentage of motorists who will be able to see the VMS message (or consequently, the percentage who will not be able to see the VMS message because their visibility to the sign is blocked by large trucks). This information will help the VMS operator and the TOC manager to determine the potential effectiveness in communicating the message to the motorists in the traffic stream.

**VMS ON SAME FREEWAY BUT RELATIVELY FAR FROM THE ROADWORK**

The steps discussed below should be used to create a new VMS message when it is necessary to close one or more lanes while other lanes are open to traffic and the VMS is on the same freeway but relatively far from the roadwork.

---

**Establish Initial Maximum Allowable Number of Units of Information in the Message Based on VMS Type and Freeway Operating Speeds**

Step 1 – Determine Freeway Operating Speeds.

Step 2 – Determine the Initial Maximum Allowable Number of Units of Information in the Message from [Table 8.2](#), page 8-5. For LED VMSs, these maximum values are as follows:

<b>Maximum Number of Units of Information Allowed in VMS Message</b>			
<b>Condition</b>	<b>Light-Emitting Diode VMS</b>		
	<b>0-35 mph</b>	<b>36-55 mph</b>	<b>56-70 mph</b>
Mid-Day	5 units	4 units	4 units
Sun Washout	5 units	4 units	4 units
Sun Backlight	4 units	4 units	3 units
Nighttime	4 units	4 units	3 units

---

**Assess Whether the Message Must Be Reduced Because of Local Geometric Sight Distance Restrictions to the VMS**

Step 3 – Determine Whether There Are Sight Distance Restrictions to the VMS Because of a Vertical Curve Using the Guidelines [Section 8.3 UNITS OF INFORMATION REDUCTIONS FOR VERTICAL CURVES – LED VMSs](#) on page 8-6.

- If “no” Go Directly to Step 5.
- If “yes” Continue to Step 4.

Step 4 – Identify the Reduction in the Number of Message Units of Information to Compensate for Lower Legibility to the VMS Because of the Vertical Curve Using [Tables 8.3 through 8.6](#) on pages 8-8 and 8-9.

Step 5 – Determine Whether There Are Sight Distance Restrictions to the VMS Because of a Horizontal Curve Using the Guidelines [Section 8.4 UNITS OF INFORMATION REDUCTIONS FOR HORIZONTAL CURVES – LED VMSs](#) on page 8-10.

- If “no” Go Directly to Step 7.
- If “yes” Continue to Step 6.

Step 6 – Identify the Reduction in the Number of Units of Information to Compensate for Lower Legibility to the VMS Because of the Horizontal Curve Using [Tables 8.7 through 8.12](#) on pages 8-12 through 8-17.

---

**Assess Whether the Message Must Be Reduced Because of Local Environmental Sight Distance Restrictions to the VMS Due to Rain or Fog**

Step 7 – Determine Whether Rainfall Near the VMS Exceeds 2 Inches per Hour.

If “no” Go Directly to Step 9.

If “yes” Continue to Step 8.

Step 8 – The Reduction in the Number of Units of Information to Compensate for Rain Is 1.

Step 9 – Determine Whether Fog Exists Near the VMS.

If “no” Go Directly to Step 11.

If “yes” Continue to Step 10.

Step 10 – Identify the Reduction in the Number of Units of Information to Compensate for Fog Using [Table 8.13](#) on page 8-19.

---

**Finalize the Maximum Allowable Units of Information in the Message**

Step 11 – Select the Largest Reduction in the Number of Units of Information from Among the Effects of a Vertical Curve (Step 4), a Horizontal Curve (Step 6), Rain (Step 8), or Fog (Step 10), and Use this Number to Subtract from the Maximum Allowable Number of Units of Information in the Message shown in [Table 8.2](#) on page 8-5. The new number after the subtraction represents the final Maximum Allowable Units of Information in the message.

---

**Define the Basic VMS Message to Satisfy Motorist Information Needs**

Step 12 – Select *Roadwork Descriptor* Message Element from [Table 7.10](#), page 7-12.

Step 13 – Select *Roadwork (Lane Closure) Location* Message Element from [Table 7.11](#), page 7-13.

Step 14 – Select *Lanes Closed* Message Element from [Table 7.12](#), page 7-14.

Step 15 – Establish Whether *Effect on Travel* Message Element Is Implied by the *Lanes Closed* Message Element.

If “no” Continue to Step 16.

If “yes” Go Directly to Step 17.

Note: Statements in the *Lanes Closed* message element such as *3 RIGHT LANES CLOSED* imply to motorists that, depending upon the time of day, they will experience delay or major delay. Thus, an *Effect on Travel* message element does not have to be included in the Basic VMS Message.

Step 16 – Select *Effect on Travel* Message Element from [Table 7.13](#), page 7-15.

Step 17 – Establish Whether Diversion Action Should Be Recommended.

If “no” Continue to Step 18.

If “yes” Go Directly to Step 19.

Step 18 – Select No Diversion *Action* Message Element from [Table 7.14](#), page 7-16 or omit *Action* Message Element.

GO TO Step 27.

Step 19 – Establish Whether “Soft” Diversion Should Be Recommended.

If “no” Go Directly to Step 21.

If “yes” Continue to Step 9.

Step 20 – Select “Soft” Diversion *Action* Message Element from [Table 7.15](#), page 7-17.

GO TO Step 22.

Step 21 – Select Type 1 or Type 2 Diversion Route *Action* Message Element from [Table 7.16](#), page 7-18.

Step 22 – Establish Whether *Action* Message Is for a Select Group of Motorists.

If “no” Go Directly to Step 24.

If “yes” Continue to Step 23.

Step 23 – Select *Audience for Action* Message Element from [Table 7.17](#), page 7-19.

Step 24 – Establish Whether a *Good Reason for Following the Action* Is Implied in *Lanes Closed and Roadwork (Lane Closure) Location* Message Elements.

If “no” Go Directly to Step 26.

If “yes” Continue to Step 25.

Step 25 – Determine Whether Motorists Will Be Advised to Take a Route That May Be Perceived by Them as Not Being Logical.

If “no” Go Directly to Step 27.

If “yes” Continue to Step 26.

Step 26 – Select a *Good Reason for Following the Action* Message Element from [Table 7.18](#), page 7-20.

---

### **Reduce the Number of Message Units if Necessary**

Step 27 – Examine Whether the Number of Units of Information in the Basic Message Is Greater than the Maximum Allowable from Step 11.

If “no” Go Directly to Step 34.

If “yes” Continue to Step 28.

Step 28 – Omit *Incident Descriptor* Message Element According to Guidelines in the Section on *Combining Message Elements for Incident Messages* Beginning on [page 9-15](#).

Step 29 – Examine Whether the Number of Units of Information in the Basic Message Is Greater than the Maximum Allowable from Step 11.

If “no” Continue to Step 30.

If “yes” Go Directly to Step 34.

Step 30 – Examine Whether The Message Contains More Than One *Audience for Action* (Destination) Message Element.

If “no” Go Directly to Step 32.

If “yes” Continue to Step 31.

Step 31 – Omit All but One *Audience for Action*.

Step 32 – Examine Whether the Number of Units of Information in the Basic Message Is Greater than the Maximum Allowable from Step 11.

If “no” Continue to Step 33.

If “yes” Go Directly to Step 34.

Step 33 – Omit Other Information According to Guidelines in the Section on *PRIORITY REDUCTION PRINCIPLES* on [page 9-20](#).

---

### **Format the Message**

Step 34 – Format the Message According to Guidelines in the Section on *FORMATTING MESSAGES* on [page 9-6](#).

---

## **Adjust Message to Fit on Existing VMS**

Step 35 – Determine Whether the VMS Has 4 Lines.

- If “no” Continue to Step 36
- If “yes” Go Directly to Step 37.

Step 36 – Determine Whether the VMS Has 3 Lines.

- If “no” MESSAGE CANNOT BE DESIGNED USING THIS PROCEDURE.
- If “yes” Continue to Step 37.

---

## **Adjust Message to Fit on 3 Lines or Less**

Step 37 – Determine Whether the Message can Be Displayed on 3 Lines or less.

- If “no” Continue to Step 38.
- If “yes” Go Directly to Step 39.

Step 38 – Split Message Into 2 Frames According to Guidelines in [Section 9.1 SPLITTING MESSAGES](#) on page 9-1.

Step 39 – Examine Whether There Are 3 or Fewer Decision-Relevant Units of Information Displayed on Each of the Frames.

- If “no” Continue to Step 40.
- If “yes” Go Directly to Step 41.

Step 40 – Omit Information to Reduce Frame to 3 Decision-Relevant Units According to Guidelines in Item 5. *NO MORE THAN THREE UNITS OF INFORMATION SHOULD BE DISPLAYED ON A SINGLE FRAME AT HIGH FREEWAY SPEEDS* on [page 9-3](#).

Step 41 – Examine Whether Message Elements Are Split in Such a Way That a Part of One Message Element Is on the Same Line as a Part of a Second Message Element.

- If “no” Go Directly to Step 43.
- If “yes” Continue to Step 42.

Step 42 – Separate Message Elements According to Guidelines in *Item 4. A MESSAGE LINE SHOULD NOT CONTAIN PORTIONS OF TWO DIFFERENT UNITS OF INFORMATION* on [page 9-3](#).

Step 43 – Examine Whether the Message or Any of the Message Lines Are Too Long to Fit in the Available VMS Space.

- If “no” Go Directly to Step 47.
- If “yes” Continue to Step 44.

Step 44 – Apply Abbreviations to Selected Words According to Guidelines in the Section on *USING ABBREVIATIONS*, [page 9-10](#).

Step 45 – Examine Whether the Application of Abbreviation Guidelines Adequately Reduced the Length of the Message Lines and the Entire Message Can Fit in the Available VMS Space.

If “no” Continue to Step 46.

If “yes” Go Directly to Step 47.

Step 46 – Omit Information According to Guidelines in the Sections on *PRIORITY REDUCTION PRINCIPLES* on [page 9-20](#) and *FORMATTING MESSAGES* on [page 9-6](#).

---

### **Finalize VMS Message**

Step 47 – Review Message for Inconsistencies and Incompatibility.

Step 48 – Make Additional Adjustments if Necessary.

*You now should have an acceptable message ready to display or to store in the VMS message library.*

---

### **Assess Effects of Large Trucks on the Ability of Motorists to View the VMS Message**

The final step in the process is to assess the effects of large trucks in the traffic stream on the ability of motorists to see the VMS and read the message. [Tables 8.14 through 8.17](#) on pages 8-21 and 8-22 should be studied to determine the percentage of motorists who will be able to see the VMS message (or consequently, the percentage who will not be able to see the VMS message because their visibility to the sign is blocked by large trucks). This information will help the VMS operator and the TOC manager to determine the potential effectiveness in communicating the message to the motorists in the traffic stream.

**VMS ON DIFFERENT FREEWAY THAN THE ROADWORK**

The steps discussed below should be used to create a new VMS message when it is necessary to close one or more lanes while other lanes are open to traffic and the VMS is located on a different freeway than the roadwork.

---

**Establish Initial Maximum Allowable Number of Units of Information in the Message Based on VMS Type and Freeway Operating Speeds**

Step 1 – Determine Freeway Operating Speeds.

Step 2 – Determine the Initial Maximum Allowable Number of Units of Information in the Message from [Table 8.2](#), page 8-5. For LED VMSs, these maximum values are as follows:

<b>Maximum Number of Units of Information Allowed in VMS Message</b>			
<b>Condition</b>	<b>Light-Emitting Diode VMS</b>		
	<b>0-35 mph</b>	<b>36-55 mph</b>	<b>56-70 mph</b>
Mid-Day	5 units	4 units	4 units
Sun Washout	5 units	4 units	4 units
Sun Backlight	4 units	4 units	3 units
Nighttime	4 units	4 units	3 units

---

**Assess Whether the Message Must Be Reduced Because of Local Geometric Sight Distance Restrictions to the VMS**

Step 3 – Determine Whether There Are Sight Distance Restrictions to the VMS Because of a Vertical Curve Using the Guidelines [Section 8.3 UNITS OF INFORMATION REDUCTIONS FOR VERTICAL CURVES – LED VMSs](#) on page 8-6.

- If “no” Go Directly to Step 5.
- If “yes” Continue to Step 4.

Step 4 – Identify the Reduction in the Number of Message Units of Information to Compensate for Lower Legibility to the VMS Because of the Vertical Curve Using [Tables 8.3 through 8.6](#) on pages 8-8 and 8-9.

Step 5 – Determine Whether There Are Sight Distance Restrictions to the VMS Because of a Horizontal Curve Using the Guidelines in [Section 8.4 UNITS OF INFORMATION REDUCTIONS FOR HORIZONTAL CURVES – LED VMSs](#) on page 8-10.

- If “no” Go Directly to Step 7.
- If “yes” Continue to Step 6.



Step 6 – Identify the Reduction in the Number of Units of Information to Compensate for Lower Legibility to the VMS Because of the Horizontal Curve Using [Tables 8.7 through 8.12](#) on pages 8-12 through 8-17.

---

**Assess Whether the Message Must Be Reduced Because of Local Environmental Sight Distance Restrictions to the VMS Due to Rain or Fog**

Step 7 – Determine Whether Rainfall Near the VMS Exceeds 2 Inches per Hour.

If “no” Go Directly to Step 9.

If “yes” Continue to Step 8.

Step 8 – The Reduction in the Number of Units of Information to Compensate for Rain Is 1.

Step 9 – Determine Whether Fog Exists Near the VMS.

If “no” Go Directly to Step 11.

If “yes” Continue to Step 10.

Step 10 – Identify the Reduction in the Number of Units of Information to Compensate for Fog Using [Table 8.13](#) on page 8-19.

---

**Finalize the Maximum Allowable Units of Information in the Message**

Step 11 – Select the Largest Reduction in the Number of Units of Information from Among the Effects of a Vertical Curve (Step 4), a Horizontal Curve (Step 6), Rain (Step 8), or Fog (Step 10), and Use this Number to Subtract from the Maximum Allowable Number of Units of Information in the Message shown in [Table 8.2](#) on page 8-5. The new number after the subtraction represents the final Maximum Allowable Units of Information in the message.

---

**Define the Basic VMS Message to Satisfy Motorist Information Needs**

Step 12 – Select *Roadwork Descriptor* Message Element from [Table 7.19](#), page 7-21.

Step 13 – Select *Roadwork (Lane Closure) Location* Message Element from [Table 7.20](#), page 7-22.

Step 14 – Select *Lanes Closed* Message Element from [Table 7.21](#), page 7-23.

Step 15 – Establish Whether *Effect on Travel* Message Element Is Implied by the *Lanes Closed* Message Element.

If “no” Continue to Step 16.

If “yes” Go Directly to Step 17.

Note: Statements in the *Lanes Closed* message element such as *3 RIGHT LANES CLOSED* imply to motorists that, depending upon the time of day, they will experience delay or major delay. Thus, an *Effect on Travel* message element does not have to be included in the Basic VMS Message.

Step 16 – Select *Effect on Travel* Message Element from [Table 7.22](#), page 7-24.

Step 17 – Establish Whether Diversion Action Should Be Recommended.

If “no” Continue to Step 18.

If “yes” Go Directly to Step 19.

Step 18 – Select No Diversion *Action* Message Element from [Table 7.23](#), page 7-25 or omit *Action* Message Element.

GO TO Step 27.

Step 19 – Establish Whether “Soft” Diversion Should Be Recommended.

If “no” Go Directly to Step 21.

If “yes” Continue to Step 9.

Step 20 – Select “Soft” Diversion *Action* Message Element from [Table 7.24](#), page 7-26.

GO TO Step 22.

Step 21 – Select Type 1 or Type 2 Diversion Route *Action* Message Element from [Table 7.25](#), page 7-27.

Step 22 – Establish Whether *Action* Message Is for a Select Group of Motorists.

If “no” Go Directly to Step 24.

If “yes” Continue to Step 23.

Step 23 – Select *Audience for Action* Message Element from [Table 7.26](#), page 7-28.

Step 24 – Establish Whether a *Good Reason for Following the Action* Is Implied in *Lanes Closed and Roadwork (Lane Closure) Location* Message Elements.

If “no” Go Directly to Step 26.

If “yes” Continue to Step 25.

Step 25 – Determine Whether Motorists Will Be Advised to Take a Route That May Be Perceived by Them as Not Being Logical.

If “no” Go Directly to Step 27.

If “yes” Continue to Step 26.

Step 26 – Select a *Good Reason for Following the Action* Message Element from [Table 7.27](#), page 7-29.

---

### **Reduce the Number of Message Units if Necessary**

Step 27 – Examine Whether the Number of Units of Information in the Basic Message Is Greater than the Maximum Allowable from Step 11.

If “no” Go Directly to Step 34.

If “yes” Continue to Step 28.

Step 28 – Omit *Incident Descriptor* Message Element According to Guidelines in the Section on *Combining Message Elements for Incident Messages* Beginning on [page 9-15](#).

Step 29 – Examine Whether the Number of Units of Information in the Basic Message Is Greater than the Maximum Allowable from Step 11.

If “no” Continue to Step 30.

If “yes” Go Directly to Step 34.

Step 30 – Examine Whether The Message Contains More Than One *Audience for Action* (Destination) Message Element.

If “no” Go Directly to Step 32.

If “yes” Continue to Step 31.

Step 31 – Omit All but One *Audience for Action*.

Step 32 – Examine Whether the Number of Units of Information in the Basic Message Is Greater than the Maximum Allowable from Step 11.

If “no” Continue to Step 33.

If “yes” Go Directly to Step 34.

Step 33 – Omit Other Information According to Guidelines in the Section on *PRIORITY REDUCTION PRINCIPLES* on [page 9-20](#).

---

### **Format the Message**

Step 34 – Format the Message According to Guidelines in the Section on *FORMATTING MESSAGES* on [page 9-6](#).

---

## Adjust Message to Fit on Existing VMS

Step 35 – Determine Whether the VMS Has 4 Lines.

- If “no” Continue to Step 36
- If “yes” Go Directly to Step 37.

Step 36 – Determine Whether the VMS Has 3 Lines.

- If “no” MESSAGE CANNOT BE DESIGNED USING THIS PROCEDURE.
- If “yes” Continue to Step 37.

---

## Adjust Message to Fit on 3 Lines or Less

Step 37 – Determine Whether the Message can Be Displayed on 3 Lines or less.

- If “no” Continue to Step 38.
- If “yes” Go Directly to Step 39.

Step 38 – Split Message Into 2 Frames According to Guidelines in [Section 9.1 SPLITTING MESSAGES](#) on page 9-1.

Step 39 – Examine Whether There Are 3 or Fewer Decision-Relevant Units of Information Displayed on Each of the Frames.

- If “no” Continue to Step 40.
- If “yes” Go Directly to Step 41.

Step 40 – Omit Information to Reduce Frame to 3 Decision-Relevant Units According to Guidelines in Item 5. *NO MORE THAN THREE UNITS OF INFORMATION SHOULD BE DISPLAYED ON A SINGLE FRAME AT HIGH FREEWAY SPEEDS* on [page 9-3](#).

Step 41 – Examine Whether Message Elements Are Split in Such a Way That a Part of One Message Element Is on the Same Line as a Part of a Second Message Element.

- If “no” Go Directly to Step 43.
- If “yes” Continue to Step 42.

Step 42 – Separate Message Elements According to Guidelines in *Item 4. A MESSAGE LINE SHOULD NOT CONTAIN PORTIONS OF TWO DIFFERENT UNITS OF INFORMATION* on [page 9-3](#).

Step 43 – Examine Whether the Message or Any of the Message Lines Are Too Long to Fit in the Available VMS Space.

- If “no” Go Directly to Step 47.
- If “yes” Continue to Step 44.

Step 44 – Apply Abbreviations to Selected Words According to Guidelines in the Section on *USING ABBREVIATIONS*, [page 9-10](#).

Step 45 – Examine Whether the Application of Abbreviation Guidelines Adequately Reduced the Length of the Message Lines and the Entire Message Can Fit in the Available VMS Space.

If “no” Continue to Step 46.

If “yes” Go Directly to Step 47.

Step 46 – Omit Information According to Guidelines in the Sections on *PRIORITY REDUCTION PRINCIPLES* on [page 9-20](#) and *FORMATTING MESSAGES* on [page 9-6](#).

---

### **Finalize VMS Message**

Step 47 – Review Message for Inconsistencies and Incompatibility.

Step 48 – Make Additional Adjustments if Necessary.

*You now should have an acceptable message ready to display or to store in the VMS message library.*

---

### **Assess Effects of Large Trucks on the Ability of Motorists to View the VMS Message**

The final step in the process is to assess the effects of large trucks in the traffic stream on the ability of motorists to see the VMS and read the message. [Tables 8.14 through 8.17](#) on pages 8-21 and 8-22 should be studied to determine the percentage of motorists who will be able to see the VMS message (or consequently, the percentage who will not be able to see the VMS message because their visibility to the sign is blocked by large trucks). This information will help the VMS operator and the TOC manager to determine the potential effectiveness in communicating the message to the motorists in the traffic stream.

## 11.2 ROADWORK THAT REQUIRES CLOSING THE FREEWAY

When construction or maintenance roadwork requires closure of the entire freeway, a traffic control plan is implemented. The traffic control plan includes installation of traffic control devices to divert traffic off the primary freeway and to give positive guidance to the motorists along the diversion route and then back to the primary freeway. The closure of the primary freeway will take place at an exit ramp upstream of the roadwork.

### VMS ON THE SAME FREEWAY AND RELATIVELY CLOSE TO THE CLOSURE

Use the procedure outlined in this section of the Manual when roadwork requires closure of all the traffic lanes and the VMS is located on the same freeway and relatively close to the closure.

---

#### Establish Initial Maximum Allowable Number of Units of Information in the Message Based on VMS Type and Freeway Operating Speeds

Step 1 – Determine Freeway Operating Speeds.

Step 2 – Determine the Initial Maximum Allowable Number of Units of Information in the Message from [Table 8.2](#), page 8-5. For LED VMSs, these maximum values are as follows:

Maximum Number of Units of Information Allowed in VMS Message			
Condition	Light-Emitting Diode VMS		
	0-35 mph	36-55 mph	56-70 mph
Mid-Day	5 units	4 units	4 units
Sun Washout	5 units	4 units	4 units
Sun Backlight	4 units	4 units	3 units
Nighttime	4 units	4 units	3 units

---

#### Assess Whether the Message Must Be Reduced Because of Local Geometric Sight Distance Restrictions to the VMS

Step 3 – Determine Whether There Are Sight Distance Restrictions to the VMS Because of a Vertical Curve Using the Guidelines in [Section 8.3 UNITS OF INFORMATION REDUCTIONS FOR VERTICAL CURVES – LED VMSs](#) on page 8-6.

If “no” Go Directly to Step 5.

If “yes” Continue to Step 4.

Step 4 – Identify the Reduction in the Number of Message Units of Information to Compensate for Lower Legibility to the VMS Because of the Vertical Curve Using [Tables 8.3 through 8.6](#) on pages 8-8 and 8-9.

Step 5 – Determine Whether There Are Sight Distance Restrictions to the VMS Because of a Horizontal Curve Using the Guidelines [Section 8.4 UNITS OF INFORMATION REDUCTIONS FOR HORIZONTAL CURVES – LED VMSs](#) on page 8-10.

If “no” Go Directly to Step 7.

If “yes” Continue to Step 6.

Step 6 – Identify the Reduction in the Number of Units of Information to Compensate for Lower Legibility to the VMS Because of the Horizontal Curve Using [Tables 8.7 through 8.12](#) on pages 8-12 through 8-17.

---

### **Assess Whether the Message Must Be Reduced Because of Local Environmental Sight Distance Restrictions to the VMS Due to Rain or Fog**

Step 7 – Determine Whether Rainfall Near the VMS Exceeds 2 Inches per Hour.

If “no” Go Directly to Step 9.

If “yes” Continue to Step 8.

Step 8 – The Reduction in the Number of Units of Information to Compensate for Rain Is 1.

Step 9 – Determine Whether Fog Exists Near the VMS.

If “no” Go Directly to Step 11.

If “yes” Continue to Step 10.

Step 10 – Identify the Reduction in the Number of Units of Information to Compensate for Fog Using [Table 8.13](#) on page 8-19.

---

### **Finalize the Maximum Allowable Units of Information in the Message**

Step 11 – Select the Largest Reduction in the Number of Units of Information from Among the Effects of a Vertical Curve (Step 4), a Horizontal Curve (Step 6), Rain (Step 8), or Fog (Step 10), and Use this Number to Subtract from the Maximum Allowable Number of Units of Information in the Message shown in [Table 8.2](#) on page 8-5. The new number after the subtraction represents the final Maximum Allowable Units of Information in the message.

---

### **Define the Basic VMS Message to Satisfy Motorist Information Needs**

Step 12 – Select *Roadwork Descriptor* Message Element from [Table 7.28](#), page 7-32.

Step 13 – Select *Closure Location* Message Element from [Table 7.29](#), page 7-33.

Step 14 – Select *Lanes Closed* Message Element from [Table 7.30](#), page 7-34.

Step 15 – Select Type 6 Diversion (Detour) Route *Action* Message Element from [Table 7.32](#), page 7-36.

---

### **Reduce the Number of Message Units if Necessary**

Step 16 – Examine Whether the Number of Units of Information in the Basic Message Is Greater than the Maximum Allowable from Step 11.

If “no” Go Directly to Step 20.

If “yes” Continue to Step 17.

Step 17 – Omit *Incident Descriptor* Message Element According to Guidelines in the Section on *Combining Message Elements for Incident Messages* Beginning on [page 9-15](#).

Step 18 – Examine Whether the Number of Units of Information in the Basic Message Is Greater than the Maximum Allowable from Step 11.

If “no” Continue to Step 19.

If “yes” Go Directly to Step 20.

Step 19 – Omit Other Information According to Guidelines in the Section on *PRIORITY REDUCTION PRINCIPLES* on [page 9-20](#).

---

### **Format the Message**

Step 20 – Format the Message According to Guidelines in the Section on *FORMATTING MESSAGES* on [page 9-6](#).

---

### **Adjust Message to Fit on Existing VMS**

Step 21 – Determine Whether the VMS Has 4 Lines.

If “no” Continue to Step 22.

If “yes” Go Directly to Step 23.

Step 22 – Determine Whether the VMS Has 3 Lines.

If “no” MESSAGE CANNOT BE DESIGNED USING THIS PROCEDURE.

If “yes” Continue to Step 23.



---

## Adjust Message to Fit on 3 Lines or Less

Step 23 – Determine Whether the Message Can Be Displayed on 3 Lines or less.

If “no” Continue to Step 24.

If “yes” Go Directly to Step 25.

Step 24 – Split Message Into 2 Frames According to Guidelines in [Section 9.1 SPLITTING MESSAGES](#) on page 9-1.

Step 25 – Examine Whether There Are 3 or Fewer Decision-Relevant Units of Information Displayed on Each of the Frames.

If “no” Continue to Step 26.

If “yes” Go Directly to Step 27.

Step 26 – Omit Information to Reduce Frame to 3 Decision-Relevant Units According to Guidelines in Item 5. *NO MORE THAN THREE UNITS OF INFORMATION SHOULD BE DISPLAYED ON A SINGLE FRAME AT HIGH FREEWAY SPEEDS* on [page 9-3](#).

Step 27 – Examine Whether Message Elements Are Split in Such a Way That a Part of One Message Element Is on the Same Line as a Part of a Second Message Element.

If “no” Go Directly to Step 29.

If “yes” Continue to Step 28.

Step 28 – Separate Message Elements According to Guidelines in *Item 4. A MESSAGE LINE SHOULD NOT CONTAIN PORTIONS OF TWO DIFFERENT UNITS OF INFORMATION* on [page 9-3](#).

Step 29 – Examine Whether the Message or Any of the Message Lines Are Too Long to Fit in the Available VMS Space.

If “no” Go Directly to Step 33.

If “yes” Continue to Step 30.

Step 30 – Apply Abbreviations to Selected Words According to Guidelines in the Section on *USING ABBREVIATIONS*, [page 9-10](#).

Step 31 – Examine Whether the Application of Abbreviation Guidelines Adequately Reduced the Length of the Message Lines and the Entire Message Can Fit in the Available VMS Space.

If “no” Continue to Step 32.

If “yes” Go Directly to Step 33.

Step 32 – Omit Information According to Guidelines in the Sections on *PRIORITY REDUCTION PRINCIPLES* on [page 9-20](#) and *FORMATTING MESSAGES* on [page 9-6](#).

## **Finalize VMS Message**

Step 33 – Review Message for Inconsistencies and Incompatibility.

Step 34 – Make Additional Adjustments if Necessary.

*You now should have an acceptable message ready to display or to store in the VMS message library.*

---

## **Assess Effects of Large Trucks on the Ability of Motorists to View the VMS Message**

The final step in the process is to assess the effects of large trucks in the traffic stream on the ability of motorists to see the VMS and read the message. [Tables 8.14 through 8.17](#) on pages 8-21 and 8-22 should be studied to determine the percentage of motorists who will be able to see the VMS message (or consequently, the percentage who will not be able to see the VMS message because their visibility to the sign is blocked by large trucks). This information will help the VMS operator and the TOC manager to determine the potential effectiveness in communicating the message to the motorists in the traffic stream.

**VMS ON SAME FREEWAY BUT RELATIVELY FAR FROM THE CLOSURE**

Use the procedure outlined in this section of the Manual when roadwork requires closure of all the traffic lanes and the VMS is located on the same freeway but relatively far from the closure.

**Establish Initial Maximum Allowable Number of Units of Information in the Message Based on VMS Type and Freeway Operating Speeds**

Step 1 – Determine Freeway Operating Speeds.

Step 2 – Determine the Initial Maximum Allowable Number of Units of Information in the Message from [Table 8.2](#), page 8-5. For LED VMSs, these maximum values are as follows:

<b>Maximum Number of Units of Information Allowed in VMS Message</b>			
<b>Condition</b>	<b>Light-Emitting Diode VMS</b>		
	<b>0-35 mph</b>	<b>36-55 mph</b>	<b>56-70 mph</b>
Mid-Day	5 units	4 units	4 units
Sun Washout	5 units	4 units	4 units
Sun Backlight	4 units	4 units	3 units
Nighttime	4 units	4 units	3 units

**Assess Whether the Message Must Be Reduced Because of Local Geometric Sight Distance Restrictions to the VMS**

Step 3 – Determine Whether There Are Sight Distance Restrictions to the VMS Because of a Vertical Curve Using the Guidelines in [Section 8.3 UNITS OF INFORMATION REDUCTIONS FOR VERTICAL CURVES – LED VMSs](#) on page 8-6.

If “no” Go Directly to Step 5.  
 If “yes” Continue to Step 4.

Step 4 – Identify the Reduction in the Number of Message Units of Information to Compensate for Lower Legibility to the VMS Because of the Vertical Curve Using [Tables 8.3 through 8.6](#) on pages 8-8 and 8-9.

Step 5 – Determine Whether There Are Sight Distance Restrictions to the VMS Because of a Horizontal Curve Using the Guidelines in [Section 8.4 UNITS OF INFORMATION REDUCTIONS FOR HORIZONTAL CURVES – LED VMSs](#) on page 8-10.

If “no” Go Directly to Step 7.  
 If “yes” Continue to Step 6.

Step 6 – Identify the Reduction in the Number of Units of Information to Compensate for Lower Legibility to the VMS Because of the Horizontal Curve Using [Tables 8.7 through 8.12](#) on pages 8-12 through 8-17.

---

**Assess Whether the Message Must Be Reduced Because of Local Environmental Sight Distance Restrictions to the VMS Due to Rain or Fog**

Step 7 – Determine Whether Rainfall Near the VMS Exceeds 2 Inches per Hour.

If “no” Go Directly to Step 9.

If “yes” Continue to Step 8.

Step 8 – The Reduction in the Number of Units of Information to Compensate for Rain Is 1.

Step 9 – Determine Whether Fog Exists Near the VMS.

If “no” Go Directly to Step 11.

If “yes” Continue to Step 10.

Step 10 – Identify the Reduction in the Number of Units of Information to Compensate for Fog Using [Table 8.13](#) on page 8-19.

---

**Finalize the Maximum Allowable Units of Information in the Message**

Step 11 – Select the Largest Reduction in the Number of Units of Information from Among the Effects of a Vertical Curve (Step 4), a Horizontal Curve (Step 6), Rain (Step 8), or Fog (Step 10), and Use this Number to Subtract from the Maximum Allowable Number of Units of Information in the Message shown in [Table 8.2](#) on page 8-5. The new number after the subtraction represents the final Maximum Allowable Units of Information in the message.

---

**Define the Basic VMS Message to Satisfy Motorist Information Needs**

Step 12 – Select *Roadwork Descriptor* Message Element from [Table 7.35](#), page 7-39.

Step 13 – Select *Closure Location* Message Element from [Table 7.36](#), page 7-40.

Step 14 – Select *Lanes Closed* Message Element from [Table 7.37](#), page 7-41.

Step 15 – Establish Whether Diversion Action Should Be Recommended.

If “no” Continue to Step 16.

If “yes” Go Directly to Step 17.

Step 16 – Select No Diversion *Action* Message Element from [Table 7.39](#), page 7-43.

GO TO Step 26.

Step 17 – Establish Whether “Soft” Diversion *Action* Should Be Recommended.

If “no” Go Directly to Step 19.

If “yes” Continue to Step 18.

Step 18 – Select “Soft” Diversion *Action* Message Element from [Table 7.40](#), page 7-44.

GO TO Step 22.

Step 19 – Establish Whether Type 6 Diversion (Detour) Route *Action* Should Be Recommended.

If “no” Continue to Step 20.

If “yes” Go Directly to Step 21.

Step 20 – Select Type 1 or Type 2 Diversion Route *Action* Message Element from [Table 7.41](#), page 7-45.

GO TO Step 22.

Step 21 – Select Type 6 Diversion (Detour) Route *Action* Message Element from [Table 7.42](#), page 7-46.

Step 22 – Establish Whether *Action* Message Is for a Select Group of Motorists.

If “no” Go Directly to Step 24.

If “yes” Continue to Step 23.

Step 23 – Select *Audience for Action* Message Element from [Table 7.43](#), page 7-47.

Step 24 – Determine Whether Motorists Will Be Advised to Take a Route That May Be Perceived by Them as Not Being Logical.

If “no” Go Directly to Step 26.

If “yes” Continue to Step 25.

Step 25 – Select a *Good Reason for Following the Action* Message Element from [Table 7.44](#) page 7-48.

---

### **Reduce the Number of Message Units if Necessary**

Step 26 – Examine Whether the Number of Units of Information in the Basic Message Is Greater than the Maximum Allowable from Step 11.

If “no” Go Directly to Step 33.

If “yes” Continue to Step 27.

Step 27 – Omit *Incident Descriptor* Message Element According to Guidelines in the Section on *Combining Message Elements for Incident Messages* Beginning on [page 9-15](#).

Step 28 – Examine Whether the Number of Units of Information in the Basic Message Is Greater than the Maximum Allowable from Step 11.

If “no” Continue to Step 29.

If “yes” Go Directly to Step 33.

Step 29 – Examine Whether The Message Contains More Than One *Audience for Action* (Destination) Message Element.

If “no” Go Directly to Step 31.

If “yes” Continue to Step 30.

Step 30 – Omit All but One *Audience for Action*

Step 32 – Examine Whether the Number of Units of Information in the Basic Message Is Greater than the Maximum Allowable from Step 11.

If “no” Continue to Step 32.

If “yes” Go Directly to Step 33

Step 32 – Omit Other Information According to Guidelines in the Section on *PRIORITY REDUCTION PRINCIPLES* on [page 9-20](#).

---

### **Format the Message**

Step 33 – Format the Message According to Guidelines in the Section on *FORMATTING MESSAGES* on [page 9-6](#).

---

### **Adjust Message to Fit on Existing VMS**

Step 34 – Determine Whether the VMS Has 4 Lines.

If “no” Continue to Step 35.

If “yes” Go Directly to Step 36.

Step 35 – Determine Whether the VMS Has 3 Lines.

If “no” MESSAGE CANNOT BE DESIGNED USING THIS PROCEDURE.

If “yes” Continue to Step 36.

---

## Adjust Message to Fit on 3 Lines or Less

Step 36 – Determine Whether the Message Can Be Displayed on 3 Lines or less.

If “no” Continue to Step 37.

If “yes” Go Directly to Step 38.

Step 37 – Split Message Into 2 Frames According to Guidelines in [Section 9.1 SPLITTING MESSAGES](#) on page 9-1.

Step 38 – Examine Whether There Are 3 or Fewer Decision-Relevant Units of Information Displayed on Each of the Frames.

If “no” Continue to Step 39.

If “yes” Go Directly to Step 40.

Step 39 – Omit Information to Reduce Frame to 3 Decision-Relevant Units According to Guidelines in Item 5. *NO MORE THAN THREE UNITS OF INFORMATION SHOULD BE DISPLAYED ON A SINGLE FRAME AT HIGH FREEWAY SPEEDS* on [page 9-3](#).

Step 40 – Examine Whether Message Elements Are Split in Such a Way That a Part of One Message Element Is on the Same Line as a Part of a Second Message Element.

If “no” Go Directly to Step 42.

If “yes” Continue to Step 41.

Step 41 – Separate Message Elements According to Guidelines in *Item 4. A MESSAGE LINE SHOULD NOT CONTAIN PORTIONS OF TWO DIFFERENT UNITS OF INFORMATION* on [page 9-3](#).

Step 42 – Examine Whether the Message or Any of the Message Lines Are Too Long to Fit in the Available VMS Space.

If “no” Go Directly to Step 46.

If “yes” Continue to Step 43.

Step 43 – Apply Abbreviations to Selected Words According to Guidelines in the Section on *USING ABBREVIATIONS*, [page 9-10](#).

Step 44 – Examine Whether the Application of Abbreviation Guidelines Adequately Reduced the Length of the Message Lines and the Entire Message Can Fit in the Available VMS Space.

If “no” Continue to Step 45.

If “yes” Go Directly to Step 46.

Step 45 – Omit Information According to Guidelines in the Sections on *PRIORITY REDUCTION PRINCIPLES* on [page 9-20](#) and *FORMATTING MESSAGES* on [page 9-6](#).

## **Finalize VMS Message**

Step 46 – Review Message for Inconsistencies and Incompatibility.

Step 47 – Make Additional Adjustments if Necessary.

*You now should have an acceptable message ready to display or to store in the VMS message library.*

---

## **Assess Effects of Large Trucks on the Ability of Motorists to View the VMS Message**

The final step in the process is to assess the effects of large trucks in the traffic stream on the ability of motorists to see the VMS and read the message. [Tables 8.14 through 8.17](#) on pages 8-21 and 8-22 should be studied to determine the percentage of motorists who will be able to see the VMS message (or consequently, the percentage who will not be able to see the VMS message because their visibility to the sign is blocked by large trucks). This information will help the VMS operator and the TOC manager to determine the potential effectiveness in communicating the message to the motorists in the traffic stream.



**VMS ON DIFFERENT FREEWAY THAN THE ROADWORK AND CLOSURE**

Use the procedure outlined in this section of the Manual when roadwork requires closure of all the traffic lanes and the VMS is located on a different freeway than the closure.

**Establish Initial Maximum Allowable Number of Units of Information in the Message Based on VMS Type and Freeway Operating Speeds**

Step 1 – Determine Freeway Operating Speeds.

Step 2 – Determine the Initial Maximum Allowable Number of Units of Information in the Message from [Table 8.2](#), page 8-5. For LED VMSs, these maximum values are as follows:

<b>Maximum Number of Units of Information Allowed in VMS Message</b>			
<b>Condition</b>	<b>Light-Emitting Diode VMS</b>		
	<b>0-35 mph</b>	<b>36-55 mph</b>	<b>56-70 mph</b>
Mid-Day	5 units	4 units	4 units
Sun Washout	5 units	4 units	4 units
Sun Backlight	4 units	4 units	3 units
Nighttime	4 units	4 units	3 units

**Assess Whether the Message Must Be Reduced Because of Local Geometric Sight Distance Restrictions to the VMS**

Step 3 – Determine Whether There Are Sight Distance Restrictions to the VMS Because of a Vertical Curve Using the Guidelines in [Section 8.3 UNITS OF INFORMATION REDUCTIONS FOR VERTICAL CURVES – LED VMSs](#) on page 8-6.

If “no” Go Directly to Step 5.  
 If “yes” Continue to Step 4.

Step 4 – Identify the Reduction in the Number of Message Units of Information to Compensate for Lower Legibility to the VMS Because of the Vertical Curve Using [Tables 8.3 through 8.6](#) on pages 8-8 and 8-9.

Step 5 – Determine Whether There Are Sight Distance Restrictions to the VMS Because of a Horizontal Curve Using the Guidelines in [Section 8.4 UNITS OF INFORMATION REDUCTIONS FOR HORIZONTAL CURVES – LED VMSs](#) on page 8-10.

If “no” Go Directly to Step 7.  
 If “yes” Continue to Step 6.

Step 6 – Identify the Reduction in the Number of Units of Information to Compensate for Lower Legibility to the VMS Because of the Horizontal Curve Using [Tables 8.7 through 8.12](#) on pages 8-12 through 8-17.

---

**Assess Whether the Message Must Be Reduced Because of Local Environmental Sight Distance Restrictions to the VMS Due to Rain or Fog**

Step 7 – Determine Whether Rainfall Near the VMS Exceeds 2 Inches per Hour.

If “no” Go Directly to Step 9.

If “yes” Continue to Step 8.

Step 8 – The Reduction in the Number of Units of Information to Compensate for Rain Is 1.

Step 9 – Determine Whether Fog Exists Near the VMS.

If “no” Go Directly to Step 11.

If “yes” Continue to Step 10.

Step 10 – Identify the Reduction in the Number of Units of Information to Compensate for Fog Using [Table 8.13](#) on page 8-19.

---

**Finalize the Maximum Allowable Units of Information in the Message**

Step 11 – Select the Largest Reduction in the Number of Units of Information from Among the Effects of a Vertical Curve (Step 4), a Horizontal Curve (Step 6), Rain (Step 8), or Fog (Step 10), and Use this Number to Subtract from the Maximum Allowable Number of Units of Information in the Message shown in [Table 8.2](#) on page 8-5. The new number after the subtraction represents the final Maximum Allowable Units of Information in the message.

---

**Define the Basic VMS Message to Satisfy Motorist Information Needs**

Step 12 – Select *Roadwork Descriptor* Message Element from [Table 7.45](#), page 7-50.

Step 13 – Select *Closure Location* Message Element from [Table 7.46](#), page 7-51.

Step 14 – Select *Lanes Closed* Message Element from [Table 7.47](#), page 7-52.

Step 15 – Establish Whether Diversion Action Should Be Recommended.

If “no” Continue to Step 16.

If “yes” Go Directly to Step 17.

Step 16 – Select No Diversion *Action* Message Element from [Table 7.49](#), page 7-54.

GO TO Step 24.

Step 17 – Establish Whether “Soft” Diversion *Action* Should Be Recommended.

If “no” Go Directly to Step 19.

If “yes” Continue to Step 18.

Step 18 – Select “Soft” Diversion *Action* Message Element from [Table 7.50](#), page 7-55.

GO TO Step 20.

Step 19 – Select Type 1 or Type 2 Diversion Route *Action* Message Element from [Table 7.51](#), page 7-56.

Step 20 – Establish Whether *Action* Message Is for a Select Group of Motorists.

If “no” Go Directly to Step 23.

If “yes” Continue to Step 21.

Step 21 – Select *Audience for Action* Message Element from [Table 7.52](#), page 7-57.

Step 22 – Determine Whether Motorists Will Be Advised to Take a Route That May Be Perceived by Them as Not Being Logical.

If “no” Go Directly to Step 13.

If “yes” Continue to Step 12.

Step 23 – Select a *Good Reason for Following the Action* Message Element from [Table 7.53](#) page 7-58.

---

### **Reduce the Number of Message Units if Necessary**

Step 24 – Examine Whether the Number of Units of Information in the Basic Message Is Greater than the Maximum Allowable from Step 11.

If “no” Go Directly to Step 31.

If “yes” Continue to Step 25.

Step 25 – Omit *Incident Descriptor* Message Element According to Guidelines in the Section on *Combining Message Elements for Incident Messages* Beginning on [page 9-15](#).

Step 26 – Examine Whether the Number of Units of Information in the Basic Message Is Greater than the Maximum Allowable from Step 11.

If “no” Continue to Step 27.

If “yes” Go Directly to Step 31.

Step 27 – Examine Whether The Message Contains More Than One *Audience for Action* (Destination) Message Element.

If “no” Go Directly to Step 29.

If “yes” Continue to Step 28.

Step 28 – Omit All but One *Audience for Action*.

Step 29 – Examine Whether the Number of Units of Information in the Basic Message Is Greater than the Maximum Allowable from Step 11.

If “no” Continue to Step 30.

If “yes” Go Directly to Step 31

Step 30 – Omit Other Information According to Guidelines in the Section on *PRIORITY REDUCTION PRINCIPLES* on [page 9-20](#).

---

### **Format the Message**

Step 31 – Format the Message According to Guidelines in the Section on *FORMATTING MESSAGES* on [page 9-6](#).

---

### **Adjust Message to Fit on Existing VMS**

Step 32 – Determine Whether the VMS Has 4 Lines.

If “no” Continue to Step 33.

If “yes” Go Directly to Step 34.

Step 33 – Determine Whether the VMS Has 3 Lines.

If “no” MESSAGE CANNOT BE DESIGNED USING THIS PROCEDURE.

If “yes” Continue to Step 34.

---

## Adjust Message to Fit on 3 Lines or Less

Step 34 – Determine Whether the Message Can Be Displayed on 3 Lines or less.

If “no” Continue to Step 35.

If “yes” Go Directly to Step 36.

Step 35 – Split Message Into 2 Frames According to Guidelines in [Section 9.1 SPLITTING MESSAGES](#) on page 9-1.

Step 36 – Examine Whether There Are 3 or Fewer Decision-Relevant Units of Information Displayed on Each of the Frames.

If “no” Continue to Step 37.

If “yes” Go Directly to Step 38.

Step 37 – Omit Information to Reduce Frame to 3 Decision-Relevant Units According to Guidelines in Item 5. *NO MORE THAN THREE UNITS OF INFORMATION SHOULD BE DISPLAYED ON A SINGLE FRAME AT HIGH FREEWAY SPEEDS* on [page 9-3](#).

Step 38 – Examine Whether Message Elements Are Split in Such a Way That a Part of One Message Element Is on the Same Line as a Part of a Second Message Element.

If “no” Go Directly to Step 40.

If “yes” Continue to Step 39.

Step 39 – Separate Message Elements According to Guidelines in *Item 4. A MESSAGE LINE SHOULD NOT CONTAIN PORTIONS OF TWO DIFFERENT UNITS OF INFORMATION* on [page 9-3](#).

Step 40 – Examine Whether the Message or Any of the Message Lines Are Too Long to Fit in the Available VMS Space.

If “no” Go Directly to Step 44.

If “yes” Continue to Step 41.

Step 41 – Apply Abbreviations to Selected Words According to Guidelines in the Section on *USING ABBREVIATIONS*, [page 9-10](#).

Step 42 – Examine Whether the Application of Abbreviation Guidelines Adequately Reduced the Length of the Message Lines and the Entire Message Can Fit in the Available VMS Space.

If “no” Continue to Step 43.

If “yes” Go Directly to Step 44.

Step 43 – Omit Information According to Guidelines in the Sections on *PRIORITY REDUCTION PRINCIPLES* on [page 9-20](#) and *FORMATTING MESSAGES* on [page 9-6](#).

**Finalize VMS Message**

Step 44 – Review Message for Inconsistencies and Incompatibility.

Step 45 – Make Additional Adjustments if Necessary.

*You now should have an acceptable message ready to display or to store in the VMS message library.*

---

**Assess Effects of Large Trucks on the Ability of Motorists to View the VMS Message**

The final step in the process is to assess the effects of large trucks in the traffic stream on the ability of motorists to see the VMS and read the message. [Tables 8.14 through 8.17](#) on pages 8-21 and 8-22 should be studied to determine the percentage of motorists who will be able to see the VMS message (or consequently, the percentage who will not be able to see the VMS message because their visibility to the sign is blocked by large trucks). This information will help the VMS operator and the TOC manager to determine the potential effectiveness in communicating the message to the motorists in the traffic stream.

## 11.3 ROADWORK ON AN INTERSECTING FREEWAY THAT REQUIRES CLOSING THE CONNECTOR RAMP

### VMS UPSTREAM OF THE CONNECTOR RAMP CLOSURE

Use the procedure outlined in this section of the Manual when roadwork occurs on an intersecting freeway and the connector ramp from the VMS freeway to the intersecting freeway is closed.

---

#### Establish Initial Maximum Allowable Number of Units of Information in the Message Based on VMS Type and Freeway Operating Speeds

Step 1 – Determine Freeway Operating Speeds.

Step 2 – Determine the Initial Maximum Allowable Number of Units of Information in the Message from [Table 8.2](#), page 8-5. For LED VMSs, these maximum values are as follows:

Maximum Number of Units of Information Allowed in VMS Message			
Condition	Light-Emitting Diode VMS		
	0-35 mph	36-55 mph	56-70 mph
Mid-Day	5 units	4 units	4 units
Sun Washout	5 units	4 units	4 units
Sun Backlight	4 units	4 units	3 units
Nighttime	4 units	4 units	3 units

---

#### Assess Whether the Message Must Be Reduced Because of Local Geometric Sight Distance Restrictions to the VMS

Step 3 – Determine Whether There Are Sight Distance Restrictions to the VMS Because of a Vertical Curve Using the Guidelines in [Section 8.3 UNITS OF INFORMATION REDUCTIONS FOR VERTICAL CURVES – LED VMSs](#) on page 8-6.

If “no” Go Directly to Step 5.

If “yes” Continue to Step 4.

Step 4 – Identify the Reduction in the Number of Message Units of Information to Compensate for Lower Legibility to the VMS Because of the Vertical Curve Using [Tables 8.3 through 8.6](#) on pages 8-8 and 8-9.

Step 5 – Determine Whether There Are Sight Distance Restrictions to the VMS Because of a Horizontal Curve Using the Guidelines in [Section 8.4 UNITS OF INFORMATION REDUCTIONS FOR HORIZONTAL CURVES – LED VMSs](#) on page 8-10.

If “no” Go Directly to Step 7.

If “yes” Continue to Step 6.

Step 6 – Identify the Reduction in the Number of Units of Information to Compensate for Lower Legibility to the VMS Because of the Horizontal Curve Using [Tables 8.7 through 8.12](#) on pages 8-12 through 8-17.

---

### **Assess Whether the Message Must Be Reduced Because of Local Environmental Sight Distance Restrictions to the VMS Due to Rain or Fog**

Step 7 – Determine Whether Rainfall Near the VMS Exceeds 2 Inches per Hour.

If “no” Go Directly to Step 9.

If “yes” Continue to Step 8.

Step 8 – The Reduction in the Number of Units of Information to Compensate for Rain Is 1.

Step 9 – Determine Whether Fog Exists Near the VMS.

If “no” Go Directly to Step 11.

If “yes” Continue to Step 10.

Step 10 – Identify the Reduction in the Number of Units of Information to Compensate for Fog Using [Table 8.13](#) on page 8-19.

---

### **Finalize the Maximum Allowable Units of Information in the Message**

Step 11 – Select the Largest Reduction in the Number of Units of Information from Among the Effects of a Vertical Curve (Step 4), a Horizontal Curve (Step 6), Rain (Step 8), or Fog (Step 10), and Use this Number to Subtract from the Maximum Allowable Number of Units of Information in the Message shown in [Table 8.2](#) on page 8-5. The new number after the subtraction represents the final Maximum Allowable Units of Information in the message.

---

### **Define the Basic VMS Message to Satisfy Motorist Information Needs**

Step 12 – Select *Roadwork Descriptor* Message Element from [Table 7.54](#), page 7-60.

Step 13 – Select *Closure Location* Message Element from [Table 7.55](#), page 7-61.

Step 14 – Select *Ramp Closure Descriptor* Message Element from [Table 7.56](#), page 7-62.



Step 15 – Determine Whether Diversion Action Should Be Recommended.

- If “no” Continue to Step 16.
- If “yes” Go Directly to Step 18.

Step 16 – Establish Whether “Soft” Diversion Should Be Recommended.

- If “no” Go Directly to Step 18.
- If “yes” Continue to Step 17.

Step 17 – Select “Soft” Diversion *Action* Message Element from [Table 7.57](#), page 7-63.

GO TO Step 21.

Step 18 – Establish Whether Detour Route has been established as part of Traffic Control Plan.

- If “no” Continue to Step 19.
- If “yes” Go Directly to Step 20.

Step 19 – Select Type 1 or Type 2 Diversion Route *Action* Message Element from [Table 7.58](#), page 7-64.

GO TO Step 21.

Step 20 – Select Type 6 Diversion Route *Action* Message Element from [Table 7.59](#), page 7-65.

Step 21 – Establish Whether *Action* Message Is for a Select Group of Motorists.

- If “no” Go Directly to Step 25.
- If “yes” Continue to Step 24.

Step 22 – Select *Audience for Action* Message Element from [Table 7.60](#), page 7-66.

Step 23 – Examine Whether the Diversion Route May Be Perceived by Motorists as Being a Most Logical Route.

- If “no” Continue to Step 24.
- If “yes” Go Directly to Step 25.

Step 24 – Select a *Good Reason for Following the Action* Message Element from [Table 7.61](#), page 7-67.

---

**Reduce the Number of Message Units if Necessary**

Step 25 – Examine Whether the Number of Units of Information in the Basic Message Is Greater than the Maximum Allowable from Step 11.

If “no” Go Directly to Step 32.

If “yes” Continue to Step 26.

Step 26 – Omit *Incident Descriptor* Message Element According to Guidelines in the Section on *Combining Message Elements for Incident Messages* Beginning on [page 9-15](#).

Step 27 – Examine Whether the Number of Units of Information in the Basic Message Is Greater than the Maximum Allowable from Step 11.

If “no” Go Directly to Step 32.

If “yes” Continue to Step 28.

Step 28 – Examine Whether The Message Contains More Than One *Audience for Action* (Destination) Message Element.

If “no” Go Directly to Step 31.

If “yes” Continue to Step 29.

Step 29 – Omit All but One *Audience for Action*

Step 30 – Examine Whether the Number of Units of Information in the Basic Message Is Greater than the Maximum Allowable from Step 11.

If “no” Continue to Step 31.

If “yes” Go Directly to Step 32.

Step 31 – Omit Other Information According to Guidelines in the Section on *PRIORITY REDUCTION PRINCIPLES* on [page 9-20](#).

---

**Format the Message**

Step 32 – Format the Message According to Guidelines in the Section on *FORMATTING MESSAGES* on [page 9-6](#).

---

**Adjust Message to Fit on Existing VMS**

Step 33 – Determine Whether the VMS Has 4 Lines.

If “no” Continue to Step 34.

If “yes” Go Directly to Step 35.

Step 34 – Determine Whether the VMS Has 3 Lines.

If “no” MESSAGE CANNOT BE DESIGNED USING THIS PROCEDURE.

If “yes” Continue to Step 35.

---

### **Adjust Message to Fit on 3 Lines or Less**

Step 35 – Determine Whether the Message Can Be Displayed on 3 Lines or less.

If “no” Continue to Step 36.

If “yes” Go Directly to Step 39.

Step 36 – Split Message Into 2 Frames According to Guidelines in [Section 9.1 SPLITTING MESSAGES](#) on page 9-1.

Step 37 – Examine Whether There Are 3 or Fewer Decision-Relevant Units of Information Displayed on Each of the Frames.

If “no” Continue to Step 38.

If “yes” Go Directly to Step 39.

Step 38 – Omit Information to Reduce Frame to 3 Decision-Relevant Units According to Guidelines in Item 5. *NO MORE THAN THREE UNITS OF INFORMATION SHOULD BE DISPLAYED ON A SINGLE FRAME AT HIGH FREEWAY SPEEDS* on [page 9-3](#).

Step 39 – Examine Whether Message Elements Are Split in Such a Way That a Part of One Message Element Is on the Same Line as a Part of a Second Message Element.

If “no” Go Directly to Step 41.

If “yes” Continue to Step 40.

Step 40 – Separate Message Elements According to Guidelines in Item 4. *A MESSAGE LINE SHOULD NOT CONTAIN PORTIONS OF TWO DIFFERENT UNITS OF INFORMATION* on [page 9-3](#).

Step 41 – Examine Whether the Message or Any of the Message Lines Are Too Long to Fit in the Available VMS Space.

If “no” Go Directly to Step 45.

If “yes” Continue to Step 42.

Step 42 – Apply Abbreviations to Selected Words According to Guidelines in the Section on *USING ABBREVIATIONS*, [page 9-10](#).

Step 43 – Examine Whether the Application of Abbreviation Guidelines Adequately Reduced the Length of the Message Lines and the Entire Message Can Fit in the Available VMS Space.

If “no” Continue to Step 44.

If “yes” Go Directly to Step 45.

Step 44 – Omit Information According to Guidelines in the Sections on *PRIORITY REDUCTION PRINCIPLES* on [page 9-20](#) and *FORMATTING MESSAGES* on [page 9-6](#).

---

### **Finalize VMS Message**

Step 45 – Review Message for Inconsistencies and Incompatibility.

Step 46 – Make Additional Adjustments if Necessary.

*You now should have an acceptable message ready to display or to store in the VMS message library.*

---

### **Assess Effects of Large Trucks on the Ability of Motorists to View the VMS Message**

The final step in the process is to assess the effects of large trucks in the traffic stream on the ability of motorists to see the VMS and read the message. [Tables 8.14 through 8.17](#) pages 8-21 and 8-22 should be studied to determine the percentage of motorists who will be able to see the VMS message (or consequently, the percentage who will not be able to see the VMS message because their visibility to the sign is blocked by large trucks). This information will help the VMS operator and the TOC manager to determine the potential effectiveness in communicating the message to the motorists in the traffic stream.

**THIS PAGE LEFT BLANK**

# MODULE 12. QUICK REFERENCE GUIDE FOR DESIGNING VMS MESSAGES

## TABLE OF CONTENTS

<b>12.1 INTRODUCTION</b> .....	12-1
<b>12.2 LANE BLOCKAGE INCIDENTS</b> .....	12-2
VMS ON SAME FREEWAY UPSTREAM AND RELATIVELY CLOSE TO THE INCIDENT .....	12-2
VMS ON SAME FREEWAY BUT RELATIVELY FAR FROM INCIDENT .....	12-4
VMS ON DIFFERENT FREEWAY THAN INCIDENT .....	12-6
<b>12.3 LANE CLOSURE INCIDENTS</b> .....	12-8
VMS ON SAME FREEWAY AND RELATIVELY CLOSE TO THE INCIDENT.....	12-8
VMS ON SAME FREEWAY BUT RELATIVELY FAR FROM INCIDENT .....	12-10
VMS ON DIFFERENT FREEWAY THAN INCIDENT .....	12-12
<b>12.4 INCIDENTS THAT BLOCK ALL LANES</b> .....	12-14
VMS ON SAME FREEWAY AND RELATIVELY CLOSE TO THE INCIDENT....	12-14
VMS ON SAME FREEWAY BUT RELATIVELY FAR FROM INCIDENT .....	12-16
VMS ON DIFFERENT FREEWAY THAN INCIDENT .....	12-18
<b>12.5 INCIDENTS THAT REQUIRE CLOSING THE FREEWAY</b> ....	12-20
VMS ON SAME FREEWAY AND RELATIVELY CLOSE TO THE CLOSURE ....	12-20
VMS ON SAME FREEWAY BUT RELATIVELY FAR FROM CLOSURE .....	12-25
VMS ON DIFFERENT FREEWAY THAN CLOSURE .....	12-30
<b>12.6 LANE CLOSURES DURING ROADWORK</b> .....	12-33
VMS ON SAME FREEWAY AND RELATIVELY CLOSE TO THE ROADWORK .....	12-33
VMS ON SAME FREEWAY BUT RELATIVELY FAR FROM THE ROADWORK .....	12-35
VMS ON DIFFERENT FREEWAY THAN THE ROADWORK.....	12-37
<b>12.7 ROADWORK REQUIRING TOTAL FREEWAY CLOSURE</b> ...	12-39
VMS ON SAME FREEWAY AND RELATIVELY CLOSE TO THE CLOSURE ....	12-39
VMS ON SAME FREEWAY BUT RELATIVELY FAR FROM THE CLOSURE....	12-41
VMS ON DIFFERENT FREEWAY THAN THE ROADWORK AND CLOSURE ...	12-43

**THIS PAGE LEFT BLANK**

## **MODULE 12. QUICK REFERENCE GUIDE FOR DESIGNING VMS MESSAGES**

### **12.1 INTRODUCTION**

Details of the VMS message design process for incidents and roadwork were presented in Modules 10 and 11. The objective of Module 12 is to provide a quick reference guide for designing messages. It is intended for supervisory personnel and for VMS operators who have considerable experience with using the guidelines in Modules 10 and 11.

As one examines the large number of alternative terms that are available for each of the VMS message elements in Modules 6 and 7, it becomes apparent that there are numerous combinations of messages that can be used—too numerous to list each combination. Therefore, only typical example messages are shown in Module 12 to illustrate specific principles of message design.

The VMS messages apply only to situations where a maximum of 4 units of information can be displayed.



## 12.2 LANE BLOCKAGE INCIDENTS

### VMS ON SAME FREEWAY UPSTREAM AND RELATIVELY CLOSE TO THE INCIDENT

Table 12.1 VMS Message Examples for Lane Blockage Incidents VMS Close to Incident <sup>A</sup>				
Message Characteristics Highlights	Large VMS		Portable VMS <sup>B</sup>	
	Frame 1	Frame 2	Frame 1	Frame 2
<ul style="list-style-type: none"> <li>● “ACCIDENT” for Incident Descriptor message element.</li> <li>● Incident (Blockage) Location message element.</li> <li>● Lanes Blocked message element.</li> <li>● No Action message element.</li> </ul>	ACCIDENT AT ROWLAND DR RIGHT LANE BLOCKED		ACCIDENT AT ROWLAND	RIGHT LANE BLOCKED
<ul style="list-style-type: none"> <li>● “MAJOR ACCIDENT” for Incident Descriptor message element.</li> </ul>	MAJOR ACCIDENT AT ROWLAND 3 RIGHT LANES BLOCKD			
<ul style="list-style-type: none"> <li>● “TRUCK ACCIDENT” for Incident Descriptor message element.</li> </ul>	TRUCK ACCIDENT AT ROWLAND 3 RIGHT LANES BLOCKD			
<ul style="list-style-type: none"> <li>● Highway name (number) for Incident (Blockage) Location message element.</li> <li>● No Action message element.</li> </ul>	ACCIDENT NEAR I-287 2 RIGHT LANES BLOCKD		ACCIDENT NEAR I-287	2 RIGHT LANES BLOCKED
<ul style="list-style-type: none"> <li>● Replacing Incident Descriptor message element with Lanes Blocked message element.</li> </ul>	2 RIGHT LANES BLOCKD NEAR I-287			
<ul style="list-style-type: none"> <li>● Action message element.</li> <li>● No diversion.</li> </ul>	ACCIDENT PAST ROWLAND	2 RIGHT LANES BLOCKD PREPARE TO STOP		
<ul style="list-style-type: none"> <li>● Action message element.</li> <li>● No diversion.</li> <li>● Replacing Incident Descriptor message element with Lanes Blocked message element.</li> </ul>	2 RIGHT LANES BLOCKD PAST ROWLAND ----- 2 RIGHT LANES BLOCKD PAST ROWLAND PREPARE TO STOP	PREPARE TO STOP		

<sup>A</sup> Large VMS: 3 lines, 20 characters per line; Portable VMS: 3 lines, 8 characters per line. All messages are for operating speeds above 35 mph and thus are limited to 4 units of information.

<sup>B</sup> Blank cells indicate that the message cannot be displayed on a portable VMS.

Message Characteristics Highlights	Large VMS		Portable VMS <sup>B</sup>	
	Frame 1	Frame 2	Frame 1	Frame 2
<ul style="list-style-type: none"> <li>• “Soft” diversion.</li> </ul>	ACCIDENT BEFORE ROWLAND	2 RIGHT LANES BLOCKD USE OTHER ROUTES		
<ul style="list-style-type: none"> <li>• “Soft” diversion.</li> <li>• Replacing Incident Descriptor message element with Lanes Blocked message element.</li> </ul>	2 RIGHT LANES BLOCKD BEFORE ROWLAND	USE OTHER ROUTES		
	2 RIGHT LANES BLOCKD BEFORE ROWLAND USE OTHER ROUTES			
<ul style="list-style-type: none"> <li>• Diversion to Type 1 or Type 2 Diversion Route.</li> </ul>	ACCIDENT AT ROWLAND	2 RIGHT LANES BLOCKD USE MONROE BLVD		
<ul style="list-style-type: none"> <li>• Diversion to Type 1 or Type 2 Diversion Route.</li> <li>• Replacing Incident Descriptor message element with Lanes Blocked message element.</li> </ul>	2 RIGHT LANES BLOCKD AT ROWLAND	USE MONROE BLVD		
	2 RIGHT LANES BLOCKD AT ROWLAND USE MONROE BLVD			
<ul style="list-style-type: none"> <li>• Diversion to Type 1 or Type 2 Diversion Route.</li> <li>• Good reason for following Action message element.</li> <li>• Replacing Incident Descriptor message element with Lanes Blocked message element.</li> </ul>	2 RIGHT LANES BLOCKD AT ROWLAND	USE MONROE BLVD AVOID DELAY		
<ul style="list-style-type: none"> <li>• Diversion to Type 1 or Type 2 Diversion Route.</li> <li>• Implied good reason for following Action message element (MAJOR ACCIDENT).</li> <li>• No Lanes Blocked message element.</li> </ul>	MAJOR ACCIDENT AT ROWLAND	USE RT-42 SOUTH		
	MAJOR ACCIDENT AT ROWLAND USE RT-42 SOUTH			
<ul style="list-style-type: none"> <li>• Diversion to Type 1 or Type 2 Diversion Route.</li> <li>• Diversion message for specific audience.</li> <li>• Implied good reason for following Action message element (TRUCK ACCIDENT).</li> <li>• No Lanes Blocked message element.</li> </ul>	TRUCK ACCIDENT AT ROWLAND	PHILADELPHIA USE I-676 NORTH		

<sup>A</sup> Large VMS: 3 lines, 20 characters per line; Portable VMS: 3 lines, 8 characters per line. All messages are for operating speeds above 35 mph and thus are limited to 4 units of information.

<sup>B</sup> Blank cells indicate that the message cannot be displayed on a portable VMS.

## VMS ON SAME FREEWAY BUT RELATIVELY FAR FROM INCIDENT

Table 12.2 VMS Message Examples for Lane Blockage Incidents VMS Relatively Far from Incident <sup>A</sup>				
Message Characteristics Highlights	Large VMS		Portable VMS	
	Frame 1	Frame 2	Frame 1	Frame 2
<ul style="list-style-type: none"> <li>● "ACCIDENT" for Incident Descriptor message element.</li> <li>● Incident (Blockage) Location message element.</li> <li>● Lanes Blocked message element.</li> <li>● No Action message element.</li> </ul>	ACCIDENT AT ROWLAND DR 1 LANE BLOCKED		ACCIDENT AT ROWLAND	1 LANE BLOCKED
<ul style="list-style-type: none"> <li>● "MAJOR ACCIDENT" for Incident Descriptor message element.</li> </ul>	MAJOR ACCIDENT AT ROWLAND 3 LANES BLOCKED			
<ul style="list-style-type: none"> <li>● "TRUCK ACCIDENT" for Incident Descriptor message element.</li> </ul>	TRUCK ACCIDENT AT ROWLAND 3 LANES BLOCKED			
<ul style="list-style-type: none"> <li>● Distance for Incident (Blockage) Location message element.</li> <li>● No Action message element.</li> </ul>	ACCIDENT 1 MILE 2 LANES BLOCKED		ACCIDENT 1 MILE	2 LANES BLOCKED
<ul style="list-style-type: none"> <li>● Highway name (number) for Incident (Blockage) Location message element.</li> <li>● No Action message element.</li> </ul>	ACCIDENT NEAR I-287 2 LANES BLOCKED		ACCIDENT NEAR I-287	2 LANES BLOCKED
<ul style="list-style-type: none"> <li>● Replacing Incident Descriptor message element with Lanes Blocked message element.</li> </ul>	2 LANES BLOCKED NEAR I-287			
<ul style="list-style-type: none"> <li>● Action message element.</li> <li>● No diversion.</li> </ul>	ACCIDENT PAST ROWLAND	2 LANES BLOCKED PREPARE TO STOP		
<ul style="list-style-type: none"> <li>● Action message element.</li> <li>● No diversion.</li> <li>● Replacing Incident Descriptor message element with Lanes Blocked message element.</li> </ul>	2 LANES BLOCKED PAST ROWLAND ----- 2 LANES BLOCKED PAST ROWLAND PREPARE TO STOP	PREPARE TO STOP		

<sup>A</sup> Large VMS: 3 lines, 20 characters per line; Portable VMS: 3 lines, 8 characters per line. All messages are for operating speeds above 35 mph and thus are limited to 4 units of information.

<sup>B</sup> Blank cells indicate that the message cannot be displayed on a portable VMS.

Message Characteristics Highlights	Large VMS		Portable VMS	
	Frame 1	Frame 2	Frame 1	Frame 2
<ul style="list-style-type: none"> <li>• “Soft” diversion.</li> </ul>	ACCIDENT BEFORE ROWLAND	2 LANES BLOCKED USE OTHER ROUTES		
<ul style="list-style-type: none"> <li>• “Soft” diversion.</li> <li>• Replacing Incident Descriptor message element with Lanes Blocked message element.</li> </ul>	2 LANES BLOCKED BEFORE ROWLAND	USE OTHER ROUTES		
	2 LANES BLOCKED BEFORE ROWLAND USE OTHER ROUTES			
<ul style="list-style-type: none"> <li>• Diversion to Type 1 or Type 2 Diversion Route.</li> </ul>	MAJOR ACCIDENT AT ROWLAND	2 LANES BLOCKED USE MONROE BLVD		
<ul style="list-style-type: none"> <li>• Diversion to Type 1 or Type 2 Diversion Route.</li> <li>• Replacing Incident Descriptor message element with Lanes Blocked message element.</li> </ul>	2 LANES BLOCKED AT ROWLAND	USE MONROE BLVD		
	2 LANES BLOCKED AT ROWLAND USE MONROE BLVD			
<ul style="list-style-type: none"> <li>• Diversion to Type 1 or Type 2 Diversion Route.</li> <li>• Good reason for following Action message element.</li> <li>• Replacing Incident Descriptor message element with Lanes Blocked message element.</li> </ul>	2 LANES BLOCKED AT ROWLAND	USE MONROE BLVD AVOID DELAY		
<ul style="list-style-type: none"> <li>• Diversion to Type 1 or Type 2 Diversion Route.</li> <li>• Implied good reason for following Action message element (MAJOR ACCIDENT).</li> <li>• No Lanes Blocked message element.</li> </ul>	MAJOR ACCIDENT AT ROWLAND	USE RT-42 SOUTH		
	MAJOR ACCIDENT AT ROWLAND USE RT-42 SOUTH			
<ul style="list-style-type: none"> <li>• Diversion to Type 1 or Type 2 Diversion Route.</li> <li>• Diversion message for specific audience.</li> <li>• Implied good reason for following Action message element (TRUCK ACCIDENT).</li> <li>• No Lanes Blocked message element.</li> </ul>	TRUCK ACCIDENT AT ROWLAND	PHILADELPHIA USE I-676 NORTH		

<sup>A</sup> Large VMS: 3 lines, 20 characters per line; Portable VMS: 3 lines, 8 characters per line. All messages are for operating speeds above 35 mph and thus are limited to 4 units of information.

<sup>B</sup> Blank cells indicate that the message cannot be displayed on a portable VMS.

## VMS ON DIFFERENT FREEWAY THAN INCIDENT

Table 12.3 VMS Message Examples for Lane Blockage Incidents VMS on Different Freeway than Incident <sup>A</sup>				
Message Characteristics Highlights	Large VMS		Portable VMS <sup>B</sup>	
	Frame 1	Frame 2	Frame 1	Frame 2
<ul style="list-style-type: none"> <li>● “ACCIDENT” for Incident Descriptor message element.</li> <li>● Incident (Blockage) Location message element.</li> <li>● No Lanes Blocked message element.</li> <li>● No Action message element.</li> </ul>	ACCIDENT ON I-80 WEST AT ROWLAND DR			
<ul style="list-style-type: none"> <li>● “MAJOR ACCIDENT for Incident Descriptor message element.</li> </ul>	MAJOR ACCIDENT ON I-80 WEST AT ROWLAND			
<ul style="list-style-type: none"> <li>● “TRUCK ACCIDENT for Incident Descriptor message element.</li> </ul>	TRUCK ACCIDENT ON I-80 WEST AT ROWLAND			
<ul style="list-style-type: none"> <li>● Highway name (number) for Incident (Blockage) Location message element.</li> <li>● No Action message element.</li> </ul>	ACCIDENT ON I-80 WEST NEAR I-287			
<ul style="list-style-type: none"> <li>● Replacing Incident Descriptor message element with Lanes Blocked message element.</li> </ul>	2 LANES BLOCKED ON I-80 WEST NEAR I-287			
<ul style="list-style-type: none"> <li>● Action message element.</li> <li>● No diversion.</li> </ul>	(Does not apply in this case.)			
<ul style="list-style-type: none"> <li>● Action message element.</li> <li>● No diversion.</li> <li>● Replacing Incident Descriptor message element with Lanes Blocked message element.</li> </ul>	(Does not apply in this case.)			

<sup>A</sup> Large VMS: 3 lines, 20 characters per line; Portable VMS: 3 lines, 8 characters per line. All messages are for operating speeds above 35 mph and thus are limited to 4 units of information.

<sup>B</sup> Blank cells indicate that the message cannot be displayed on a portable VMS.

Message Characteristics Highlights	Large VMS		Portable VMS <sup>B</sup>	
	Frame 1	Frame 2	Frame 1	Frame 2
<ul style="list-style-type: none"> <li>● “Soft” diversion.</li> </ul>	ACCIDENT ON I-80 WEST BEFORE ROWLAND	USE OTHER ROUTES		
<ul style="list-style-type: none"> <li>● “Soft” diversion.</li> <li>● Replacing Incident Descriptor message element with Lanes Blocked message element.</li> </ul>	2 LANES BLOCKED ON I-80 WEST BEFORE ROWLAND	USE OTHER ROUTES		
<ul style="list-style-type: none"> <li>● Diversion to Type 1 or Type 2 Diversion Route.</li> </ul>	ACCIDENT ON I-80 WEST AT ROWLAND	USE TILLMAN DR		
<ul style="list-style-type: none"> <li>● Diversion to Type 1 or Type 2 Diversion Route.</li> <li>● Replacing Incident Descriptor message element with Lanes Blocked message element.</li> </ul>	2 LANES BLOCKED ON I-80 WEST AT ROWLAND	USE TILLMAN DR		
<ul style="list-style-type: none"> <li>● Diversion to Type 1 or Type 2 Diversion Route.</li> <li>● Good reason for following Action message element.</li> <li>● Replacing Incident Descriptor message element with Lanes Blocked message element.</li> </ul>	(Requires a five-unit message.)			
<ul style="list-style-type: none"> <li>● Diversion to Type 1 or Type 2 Diversion Route.</li> <li>● Implied good reason for following Action message element (MAJOR ACCIDENT).</li> <li>● No Lanes Blocked message element.</li> </ul>	MAJOR ACCIDENT ON I-80 WEST AT ROWLAND	USE RT-42 SOUTH		
<ul style="list-style-type: none"> <li>● Diversion to Type 1 or Type 2 Diversion Route.</li> <li>● Diversion message for specific audience.</li> <li>● Implied good reason for following Action message element (MAJOR ACCIDENT).</li> <li>● No Lanes Blocked message element.</li> </ul>	(Requires a five-unit message.)			

<sup>A</sup> Large VMS: 3 lines, 20 characters per line; Portable VMS: 3 lines, 8 characters per line. All messages are for operating speeds above 35 mph and thus are limited to 4 units of information.

<sup>B</sup> Blank cells indicate that the message cannot be displayed on a portable VMS.

## 12.3 LANE CLOSURE INCIDENTS

### VMS ON SAME FREEWAY AND RELATIVELY CLOSE TO THE INCIDENT

Table 12.4 VMS Message Examples for Lane Closure Incidents VMS Close to Incident <sup>A</sup>				
Message Characteristics Highlights	Large VMS		Portable VMS <sup>B</sup>	
	Frame 1	Frame 2	Frame 1	Frame 2
<ul style="list-style-type: none"> <li>● "ACCIDENT" for Incident Descriptor message element.</li> <li>● Incident (Blockage) Location message element.</li> <li>● Lanes Closed message element.</li> <li>● No Action message element.</li> </ul>	ACCIDENT AT ROWLAND DR RIGHT LANE CLOSED		ACCIDENT AT ROWLAND	RIGHT LANE CLOSED
<ul style="list-style-type: none"> <li>● "MAJOR ACCIDENT" for Incident Descriptor message element.</li> </ul>	MAJOR ACCIDENT AT ROWLAND 3 RIGHT LANES CLOSED			
<ul style="list-style-type: none"> <li>● "TRUCK ACCIDENT" for Incident Descriptor message element.</li> </ul>	TRUCK ACCIDENT AT ROWLAND 3 RIGHT LANES CLOSED			
<ul style="list-style-type: none"> <li>● Highway name (number) for Incident (Blockage) Location message element.</li> <li>● No Action message element.</li> </ul>	ACCIDENT NEAR I-287 2 RIGHT LANES CLOSED		ACCIDENT NEAR I-287	2 RIGHT LANES CLOSED
<ul style="list-style-type: none"> <li>● Replacing Incident Descriptor message element with Lanes Closed message element.</li> </ul>	2 RIGHT LANES CLOSED NEAR I-287			
<ul style="list-style-type: none"> <li>● Action message element.</li> <li>● No diversion.</li> </ul>	ACCIDENT PAST ROWLAND	2 RIGHT LANES CLOSED PREPARE TO STOP		
<ul style="list-style-type: none"> <li>● Action message element.</li> <li>● No diversion.</li> <li>● Replacing Incident Descriptor message element with Lanes Closed message element.</li> </ul>	2 RIGHT LANES CLOSED PAST ROWLAND ----- 2 RIGHT LANES CLOSED PAST ROWLAND PREPARE TO STOP	PREPARE TO STOP		

<sup>A</sup> Large VMS: 3 lines, 20 characters per line; Portable VMS: 3 lines, 8 characters per line. All messages are for operating speeds above 35 mph and thus are limited to 4 units of information.

<sup>B</sup> Blank cells indicate that the message cannot be displayed on a portable VMS.

Message Characteristics Highlights	Large VMS		Portable VMS <sup>B</sup>	
	Frame 1	Frame 2	Frame 1	Frame 2
<ul style="list-style-type: none"> <li>• “Soft” diversion.</li> </ul>	ACCIDENT BEFORE ROWLAND	2 RIGHT LANES CLOSED USE OTHER ROUTES		
<ul style="list-style-type: none"> <li>• “Soft” diversion.</li> <li>• Replacing Incident Descriptor message element with Lanes Closed message element.</li> </ul>	2 RIGHT LANES CLOSED BEFORE ROWLAND	USE OTHER ROUTES		
	2 RIGHT LANES CLOSED BEFORE ROWLAND USE OTHER ROUTES			
<ul style="list-style-type: none"> <li>• Diversion to Type 1 or Type 2 Diversion Route.</li> </ul>	ACCIDENT AT ROWLAND	2 RIGHT LANES CLOSED USE MONROE BLVD		
<ul style="list-style-type: none"> <li>• Diversion to Type 1 or Type 2 Diversion Route.</li> <li>• Replacing Incident Descriptor message element with Lanes Closed message element.</li> </ul>	2 RIGHT LANES CLOSED AT ROWLAND	USE MONROE BLVD		
	2 RIGHT LANES CLOSED AT ROWLAND USE MONROE BLVD			
<ul style="list-style-type: none"> <li>• Diversion to Type 1 or Type 2 Diversion Route.</li> <li>• Good reason for following Action message element.</li> <li>• Replacing Incident Descriptor message element with Lanes Closed message element.</li> </ul>	2 RIGHT LANES CLOSED AT ROWLAND	USE MONROE BLVD AVOID DELAY		
<ul style="list-style-type: none"> <li>• Diversion to Type 1 or Type 2 Diversion Route.</li> <li>• Implied good reason for following Action message element (MAJOR ACCIDENT).</li> <li>• No Lanes Closed message element.</li> </ul>	MAJOR ACCIDENT AT ROWLAND	USE RT-42 SOUTH		
	MAJOR ACCIDENT AT ROWLAND USE RT-42 SOUTH			
<ul style="list-style-type: none"> <li>• Diversion to Type 1 or Type 2 Diversion Route.</li> <li>• Diversion message for specific audience.</li> <li>• Implied good reason for following Action message element (TRUCK ACCIDENT).</li> <li>• No Lanes Closed message element.</li> </ul>	TRUCK ACCIDENT AT ROWLAND	PHILADELPHIA USE I-676 NORTH		

<sup>A</sup> Large VMS: 3 lines, 20 characters per line; Portable VMS: 3 lines, 8 characters per line. All messages are for operating speeds above 35 mph and thus are limited to 4 units of information.

<sup>B</sup> Blank cells indicate that the message cannot be displayed on a portable VMS.



## VMS ON SAME FREEWAY BUT RELATIVELY FAR FROM INCIDENT

Table 12.5 VMS Message Examples for Lane Closure Incidents VMS Relatively Far from Incident <sup>A</sup>				
Message Characteristics Highlights	Large VMS		Portable VMS	
	Frame 1	Frame 2	Frame 1	Frame 2
<ul style="list-style-type: none"> <li>● “ACCIDENT” for Incident Descriptor message element.</li> <li>● Incident (Blockage) Location message element.</li> <li>● Lanes Closed message element.</li> <li>● No Action message element.</li> </ul>	ACCIDENT AT ROWLAND DR 1 LANE CLOSED		ACCIDENT AT ROWLAND	1 LANE CLOSED
<ul style="list-style-type: none"> <li>● “MAJOR ACCIDENT” for Incident Descriptor message element.</li> </ul>	MAJOR ACCIDENT AT ROWLAND 3 LANES CLOSED			
<ul style="list-style-type: none"> <li>● “TRUCK ACCIDENT” for Incident Descriptor message element.</li> </ul>	TRUCK ACCIDENT AT ROWLAND 3 LANES CLOSED			
<ul style="list-style-type: none"> <li>● Distance for Incident (Blockage) Location message element.</li> <li>● No Action message element.</li> </ul>	ACCIDENT 1 MILE 2 LANES CLOSED		ACCIDENT 1 MILE	2 LANES CLOSED
<ul style="list-style-type: none"> <li>● Highway name (number) for Incident (Blockage) Location message element.</li> <li>● No Action message element.</li> </ul>	ACCIDENT NEAR I-287 2 LANES CLOSED		ACCIDENT NEAR I-287	2 LANES CLOSED
<ul style="list-style-type: none"> <li>● Replacing Incident Descriptor message element with Lanes Closed message element.</li> </ul>	2 LANES CLOSED NEAR I-287			
<ul style="list-style-type: none"> <li>● Action message element.</li> <li>● No diversion.</li> </ul>	ACCIDENT PAST ROWLAND	2 LANES CLOSED PREPARE TO STOP		
<ul style="list-style-type: none"> <li>● Action message element.</li> <li>● No diversion.</li> <li>● Replacing Incident Descriptor message element with Lanes Closed message element.</li> </ul>	2 LANES CLOSED PAST ROWLAND ----- 2 LANES CLOSED PAST ROWLAND PREPARE TO STOP	PREPARE TO STOP		

<sup>A</sup> Large VMS: 3 lines, 20 characters per line; Portable VMS: 3 lines, 8 characters per line. All messages are for operating speeds above 35 mph and thus are limited to 4 units of information.

<sup>B</sup> Blank cells indicate that the message cannot be displayed on a portable VMS.

Message Characteristics Highlights	Large VMS		Portable VMS	
	Frame 1	Frame 2	Frame 1	Frame 2
<ul style="list-style-type: none"> <li>• “Soft” diversion.</li> </ul>	ACCIDENT BEFORE ROWLAND	2 LANES CLOSED USE OTHER ROUTES		
<ul style="list-style-type: none"> <li>• “Soft” diversion.</li> <li>• Replacing Incident Descriptor message element with Lanes Closed message element.</li> </ul>	2 LANES CLOSED BEFORE ROWLAND	USE OTHER ROUTES		
	2 LANES CLOSED BEFORE ROWLAND USE OTHER ROUTES			
<ul style="list-style-type: none"> <li>• Diversion to Type 1 or Type 2 Diversion Route.</li> </ul>	MAJOR ACCIDENT AT ROWLAND	2 LANES CLOSED USE MONROE BLVD		
<ul style="list-style-type: none"> <li>• Diversion to Type 1 or Type 2 Diversion Route.</li> <li>• Replacing Incident Descriptor message element with Lanes Closed message element.</li> </ul>	2 LANES CLOSED AT ROWLAND	USE MONROE BLVD		
	2 LANES CLOSED AT ROWLAND USE MONROE BLVD			
<ul style="list-style-type: none"> <li>• Diversion to Type 1 or Type 2 Diversion Route.</li> <li>• Good reason for following Action message element.</li> <li>• Replacing Incident Descriptor message element with Lanes Closed message element.</li> </ul>	2 LANES CLOSED AT ROWLAND	USE MONROE BLVD AVOID DELAY		
<ul style="list-style-type: none"> <li>• Diversion to Type 1 or Type 2 Diversion Route.</li> <li>• Implied good reason for following Action message element (MAJOR ACCIDENT).</li> <li>• No Lanes Closed message element.</li> </ul>	MAJOR ACCIDENT AT ROWLAND	USE RT-42 SOUTH		
	MAJOR ACCIDENT AT ROWLAND USE RT-42 SOUTH			
<ul style="list-style-type: none"> <li>• Diversion to Type 1 or Type 2 Diversion Route.</li> <li>• Diversion message for specific audience.</li> <li>• Implied good reason for following Action message element (TRUCK ACCIDENT).</li> <li>• No Lanes Closed message element.</li> </ul>	TRUCK ACCIDENT AT ROWLAND	PHILADELPHIA USE I-676 NORTH		

<sup>A</sup> Large VMS: 3 lines, 20 characters per line; Portable VMS: 3 lines, 8 characters per line. All messages are for operating speeds above 35 mph and thus are limited to 4 units of information.

<sup>B</sup> Blank cells indicate that the message cannot be displayed on a portable VMS.

## VMS ON DIFFERENT FREEWAY THAN INCIDENT

Table 12.6 VMS Message Examples for Lane Closure Incidents VMS on Different Freeway than Incident <sup>A</sup>				
Message Characteristics Highlights	Large VMS		Portable VMS <sup>B</sup>	
	Frame 1	Frame 2	Frame 1	Frame 2
<ul style="list-style-type: none"> <li>● “ACCIDENT” for Incident Descriptor message element.</li> <li>● Incident (Blockage) Location message element.</li> <li>● No Lanes Closed message element.</li> <li>● No Action message element.</li> </ul>	ACCIDENT ON I-80 WEST AT ROWLAND DR			
<ul style="list-style-type: none"> <li>● “MAJOR ACCIDENT for Incident Descriptor message element.</li> </ul>	MAJOR ACCIDENT ON I-80 WEST AT ROWLAND			
<ul style="list-style-type: none"> <li>● “TRUCK ACCIDENT for Incident Descriptor message element.</li> </ul>	TRUCK ACCIDENT ON I-80 WEST AT ROWLAND			
<ul style="list-style-type: none"> <li>● Highway name (number) for Incident (Blockage) Location message element.</li> <li>● No Action message element.</li> </ul>	ACCIDENT ON I-80 WEST NEAR I-287			
<ul style="list-style-type: none"> <li>● Replacing Incident Descriptor message element with Lanes Closed message element.</li> </ul>	2 LANES CLOSED ON I-80 WEST NEAR I-287			
<ul style="list-style-type: none"> <li>● Action message element.</li> <li>● No diversion.</li> </ul>	(Does not apply in this case.)			
<ul style="list-style-type: none"> <li>● Action message element.</li> <li>● No diversion.</li> <li>● Replacing Incident Descriptor message element with Lanes Closed message element.</li> </ul>	(Does not apply in this case.)			

<sup>A</sup> Large VMS: 3 lines, 20 characters per line; Portable VMS: 3 lines, 8 characters per line. All messages are for operating speeds above 35 mph and thus are limited to 4 units of information.

<sup>B</sup> Blank cells indicate that the message cannot be displayed on a portable VMS.

Message Characteristics Highlights	Large VMS		Portable VMS <sup>B</sup>	
	Frame 1	Frame 2	Frame 1	Frame 2
<ul style="list-style-type: none"> <li>● “Soft” diversion.</li> </ul>	ACCIDENT ON I-80 WEST BEFORE ROWLAND	USE OTHER ROUTES		
<ul style="list-style-type: none"> <li>● “Soft” diversion.</li> <li>● Replacing Incident Descriptor message element with Lanes Closed message element.</li> </ul>	2 LANES CLOSED ON I-80 WEST BEFORE ROWLAND	USE OTHER ROUTES		
<ul style="list-style-type: none"> <li>● Diversion to Type 1 or Type 2 Diversion Route.</li> </ul>	ACCIDENT ON I-80 WEST AT ROWLAND	USE TILLMAN DR		
<ul style="list-style-type: none"> <li>● Diversion to Type 1 or Type 2 Diversion Route.</li> <li>● Replacing Incident Descriptor message element with Lanes Closed message element.</li> </ul>	2 LANES CLOSED ON I-80 WEST AT ROWLAND	USE TILLMAN DR		
<ul style="list-style-type: none"> <li>● Diversion to Type 1 or Type 2 Diversion Route.</li> <li>● Good reason for following Action message element.</li> <li>● Replacing Incident Descriptor message element with Lanes Closed message element.</li> </ul>	(Requires a five-unit message.)			
<ul style="list-style-type: none"> <li>● Diversion to Type 1 or Type 2 Diversion Route.</li> <li>● Implied good reason for following Action message element (MAJOR ACCIDENT).</li> <li>● No Lanes Closed message element.</li> </ul>	MAJOR ACCIDENT ON I-80 WEST AT ROWLAND	USE RT-42 SOUTH		
<ul style="list-style-type: none"> <li>● Diversion to Type 1 or Type 2 Diversion Route.</li> <li>● Diversion message for specific audience.</li> <li>● Implied good reason for following Action message element (TRUCK ACCIDENT).</li> <li>● No Lanes Closed message element.</li> </ul>	(Requires a five-unit message.)			

<sup>A</sup> Large VMS: 3 lines, 20 characters per line; Portable VMS: 3 lines, 8 characters per line. All messages are for operating speeds above 35 mph and thus are limited to 4 units of information.

<sup>B</sup> Blank cells indicate that the message cannot be displayed on a portable VMS.

## 12.4 INCIDENTS THAT BLOCK ALL LANES

### VMS ON SAME FREEWAY AND RELATIVELY CLOSE TO THE INCIDENT

Table 12.7 VMS Message Examples for Incidents that Block All Lanes VMS Close to Incident <sup>A</sup>				
Message Characteristics Highlights	Large VMS		Portable VMS <sup>B</sup>	
	Frame 1	Frame 2	Frame 1	Frame 2
<ul style="list-style-type: none"> <li>● “ACCIDENT” for Incident Descriptor message element.</li> <li>● Incident (Blockage) Location message element.</li> <li>● Lanes Blocked message element.</li> <li>● No Action message element.</li> </ul>	(Does not apply in this case.)			
<ul style="list-style-type: none"> <li>● “MAJOR ACCIDENT” for Incident Descriptor message element.</li> </ul>	MAJOR ACCIDENT AT ROWLAND DR ALL LANES BLOCKED			
<ul style="list-style-type: none"> <li>● “TRUCK ACCIDENT” for Incident Descriptor message element.</li> </ul>	TRUCK ACCIDENT AT ROWLAND ALL LANES BLOCKED			
<ul style="list-style-type: none"> <li>● Highway name (number) for Incident (Blockage) Location message element.</li> <li>● No Action message element.</li> </ul>	MAJOR ACCIDENT NEAR I-287 ALL LANES BLOCKED		ACCIDENT NEAR I-287	ALL LANES BLOCKED
<ul style="list-style-type: none"> <li>● Combining Incident Descriptor and Lanes Closed message elements.</li> </ul>	FREEWAY BLOCKED NEAR I-287			
<ul style="list-style-type: none"> <li>● Action message element.</li> <li>● No diversion.</li> </ul>	MAJOR ACCIDENT PAST ROWLAND		ALL LANES BLOCKED PREPARE TO STOP	
<ul style="list-style-type: none"> <li>● Action message element.</li> <li>● No diversion.</li> <li>● Combining Incident Descriptor and Lanes Closed message elements.</li> </ul>	FREEWAY BLOCKED PAST ROWLAND		PREPARE TO STOP	
	FREEWAY BLOCKED PAST ROWLAND PREPARE TO STOP			

<sup>A</sup> Large VMS: 3 lines, 20 characters per line; Portable VMS: 3 lines, 8 characters per line. All messages are for operating speeds above 35 mph and thus are limited to 4 units of information.

<sup>B</sup> Blank cells indicate that the message cannot be displayed on a portable VMS.

Message Characteristics Highlights	Large VMS		Portable VMS <sup>B</sup>	
	Frame 1	Frame 2	Frame 1	Frame 2
<ul style="list-style-type: none"> <li>• “Soft” diversion.</li> </ul>	MAJOR ACCIDENT BEFORE ROWLAND	ALL LANES BLOCKED USE OTHER ROUTES		
<ul style="list-style-type: none"> <li>• “Soft” diversion.</li> <li>• Combining Incident Descriptor and Lanes Closed message elements.</li> </ul>	FREEWAY BLOCKED BEFORE ROWLAND	USE OTHER ROUTES		
	----- FREEWAY BLOCKED BEFORE ROWLAND USE OTHER ROUTES			
<ul style="list-style-type: none"> <li>• Diversion to Type 1 or Type 2 Diversion Route.</li> </ul>	MAJOR ACCIDENT AT ROWLAND	ALL LANES BLOCKED USE MONROE BLVD		
<ul style="list-style-type: none"> <li>• Diversion to Type 1 or Type 2 Diversion Route.</li> <li>• Combining Incident Descriptor and Lanes Closed message elements.</li> </ul>	FREEWAY BLOCKED AT ROWLAND	USE MONROE BLVD		
	----- FREEWAY BLOCKED AT ROWLAND USE MONROE BLVD			
<ul style="list-style-type: none"> <li>• Diversion to Type 1 or Type 2 Diversion Route.</li> <li>• Good reason for following Action message element.</li> <li>• Combining Incident Descriptor and Lanes Closed message elements.</li> </ul>	FREEWAY BLOCKED AT ROWLAND	USE MONROE BLVD AVOID DELAY		
<ul style="list-style-type: none"> <li>• Diversion to Type 1 or Type 2 Diversion Route.</li> <li>• Implied good reason for following Action message element (MAJOR ACCIDENT).</li> <li>• No Lanes Blocked message element.</li> </ul>	MAJOR ACCIDENT AT ROWLAND	USE RT-42 SOUTH		
	----- MAJOR ACCIDENT AT ROWLAND USE RT-42 SOUTH			
<ul style="list-style-type: none"> <li>• Diversion to Type 1 or Type 2 Diversion Route.</li> <li>• Diversion message for specific audience.</li> <li>• Implied good reason for following Action message element (TRUCK ACCIDENT).</li> <li>• No Lanes Blocked message element.</li> </ul>	TRUCK ACCIDENT AT ROWLAND	PHILADELPHIA USE I-676 NORTH		

<sup>A</sup> Large VMS: 3 lines, 20 characters per line; Portable VMS: 3 lines, 8 characters per line. All messages are for operating speeds above 35 mph and thus are limited to 4 units of information.

<sup>B</sup> Blank cells indicate that the message cannot be displayed on a portable VMS.

## VMS ON SAME FREEWAY BUT RELATIVELY FAR FROM INCIDENT

Table 12.8 VMS Message Examples for Incidents that Block All Lanes VMS Relatively Far from Incident <sup>A</sup>				
Message Characteristics Highlights	Large VMS		Portable VMS	
	Frame 1	Frame 2	Frame 1	Frame 2
<ul style="list-style-type: none"> <li>● "ACCIDENT" for Incident Descriptor message element.</li> <li>● Incident (Blockage) Location message element.</li> <li>● Lanes Blocked message element.</li> <li>● No Action message element.</li> </ul>	(Does not apply in this case.)			
<ul style="list-style-type: none"> <li>● "MAJOR ACCIDENT" for Incident Descriptor message element.</li> </ul>	MAJOR ACCIDENT AT ROWLAND DR ALL LANES BLOCKED			
<ul style="list-style-type: none"> <li>● "TRUCK ACCIDENT" for Incident Descriptor message element.</li> </ul>	TRUCK ACCIDENT AT ROWLAND ALL LANES BLOCKED			
<ul style="list-style-type: none"> <li>● Distance for Incident (Blockage) Location message element.</li> <li>● No Action message element.</li> </ul>	MAJOR ACCIDENT 1 MILE ALL LANES BLOCKED		MAJOR ACCIDENT 1 MILE	ALL LANES BLOCKED
<ul style="list-style-type: none"> <li>● Highway name (number) for Incident (Blockage) Location message element.</li> <li>● No Action message element.</li> </ul>	MAJOR ACCIDENT NEAR I-287 ALL LANES BLOCKED			
<ul style="list-style-type: none"> <li>● Combining Incident Descriptor and Lanes Closed message elements.</li> </ul>	FREEWAY BLOCKED NEAR I-287			
<ul style="list-style-type: none"> <li>● Action message element.</li> <li>● No diversion.</li> </ul>	MAJOR ACCIDENT PAST ROWLAND	ALL LANES BLOCKED PREPARE TO STOP		
<ul style="list-style-type: none"> <li>● Action message element.</li> <li>● No diversion.</li> <li>● Combining Incident Descriptor and Lanes Closed message elements.</li> </ul>	FREEWAY BLOCKED PAST ROWLAND	PREPARE TO STOP		
	FREEWAY BLOCKED PAST ROWLAND PREPARE TO STOP			

<sup>A</sup> Large VMS: 3 lines, 20 characters per line; Portable VMS: 3 lines, 8 characters per line. All messages are for operating speeds above 35 mph and thus are limited to 4 units of information.

<sup>B</sup> Blank cells indicate that the message cannot be displayed on a portable VMS.

Message Characteristics Highlights	Large VMS		Portable VMS	
	Frame 1	Frame 2	Frame 1	Frame 2
<ul style="list-style-type: none"> <li>● “Soft” diversion.</li> </ul>	MAJOR ACCIDENT BEFORE ROWLAND	ALL LANES BLOCKED USE OTHER ROUTES		
<ul style="list-style-type: none"> <li>● “Soft” diversion.</li> <li>● Combining Incident Descriptor and Lanes Closed message elements.</li> </ul>	FREEWAY BLOCKED BEFORE ROWLAND	USE OTHER ROUTES		
	FREEWAY BLOCKED BEFORE ROWLAND USE OTHER ROUTES			
<ul style="list-style-type: none"> <li>● Diversion to Type 1 or Type 2 Diversion Route.</li> </ul>	MAJOR ACCIDENT AT ROWLAND	ALL LANES BLOCKED USE MONROE BLVD		
<ul style="list-style-type: none"> <li>● Diversion to Type 1 or Type 2 Diversion Route.</li> <li>● Combining Incident Descriptor and Lanes Closed message elements.</li> </ul>	FREEWAY BLOCKED AT ROWLAND	USE MONROE BLVD		
	FREEWAY BLOCKED AT ROWLAND USE MONROE BLVD			
<ul style="list-style-type: none"> <li>● Diversion to Type 1 or Type 2 Diversion Route.</li> <li>● Good reason for following Action message element.</li> <li>● Combining Incident Descriptor and Lanes Closed message elements.</li> </ul>	FREEWAY BLOCKED AT ROWLAND	USE MONROE BLVD AVOID DELAY		
<ul style="list-style-type: none"> <li>● Diversion to Type 1 or Type 2 Diversion Route.</li> <li>● Implied good reason for following Action message element (MAJOR ACCIDENT).</li> <li>● No Lanes Blocked message element.</li> </ul>	MAJOR ACCIDENT AT ROWLAND	USE RT-42 SOUTH		
	MAJOR ACCIDENT AT ROWLAND USE RT-42 SOUTH			
<ul style="list-style-type: none"> <li>● Diversion to Type 1 or Type 2 Diversion Route.</li> <li>● Diversion message for specific audience.</li> <li>● Implied good reason for following Action message element (TRUCK ACCIDENT).</li> <li>● No Lanes Blocked message element.</li> </ul>	TRUCK ACCIDENT AT ROWLAND	PHILADELPHIA USE I-676 NORTH		

<sup>A</sup> Large VMS: 3 lines, 20 characters per line; Portable VMS: 3 lines, 8 characters per line. All messages are for operating speeds above 35 mph and thus are limited to 4 units of information.

<sup>B</sup> Blank cells indicate that the message cannot be displayed on a portable VMS.



## VMS ON DIFFERENT FREEWAY THAN INCIDENT

Table 12.9 VMS Message Examples for Incidents that Block All Lanes VMS on Different Freeway than Incident <sup>A</sup>				
Message Characteristics Highlights	Large VMS		Portable VMS <sup>B</sup>	
	Frame 1	Frame 2	Frame 1	Frame 2
<ul style="list-style-type: none"> <li>● <i>“ACCIDENT” for Incident Descriptor message element.</i></li> <li>● <i>Incident (Blockage) Location message element.</i></li> <li>● <i>No Lanes Blocked message element.</i></li> <li>● <i>No Action message element.</i></li> </ul>	(Does not apply in this case.)			
<ul style="list-style-type: none"> <li>● <i>“MAJOR ACCIDENT for Incident Descriptor message element.</i></li> </ul>	MAJOR ACCIDENT ON I-80 WEST AT ROWLAND DR			
<ul style="list-style-type: none"> <li>● <i>“TRUCK ACCIDENT for Incident Descriptor message element.</i></li> </ul>	TRUCK ACCIDENT ON I-80 WEST AT ROWLAND			
<ul style="list-style-type: none"> <li>● <i>Highway name (number) for Incident (Blockage) Location message element.</i></li> <li>● <i>No Action message element.</i></li> </ul>	MAJOR ACCIDENT ON I-80 WEST NEAR I-287			
<ul style="list-style-type: none"> <li>● <i>Combining Incident Descriptor and Incident (Blockage) Location message elements.</i></li> </ul>	I-80 WEST BLOCKED NEAR I-287			
<ul style="list-style-type: none"> <li>● <i>Action message element.</i></li> <li>● <i>No diversion.</i></li> </ul>	(Does not apply in this case.)			
<ul style="list-style-type: none"> <li>● <i>Action message element.</i></li> <li>● <i>No diversion.</i></li> <li>● <i>Combining Incident Descriptor and Incident (Blockage) Location message elements.</i></li> </ul>	(Does not apply in this case.)			

<sup>A</sup> Large VMS: 3 lines, 20 characters per line; Portable VMS: 3 lines, 8 characters per line. All messages are for operating speeds above 35 mph and thus are limited to 4 units of information.

<sup>B</sup> Blank cells indicate that the message cannot be displayed on a portable VMS.

Message Characteristics Highlights	Large VMS		Portable VMS <sup>B</sup>	
	Frame 1	Frame 2	Frame 1	Frame 2
<ul style="list-style-type: none"> <li>● “Soft” diversion.</li> </ul>	MAJOR ACCIDENT ON I-80 WEST BEFORE ROWLAND	USE OTHER ROUTES		
<ul style="list-style-type: none"> <li>● “Soft” diversion.</li> <li>● Combining Incident Descriptor and Incident (Blockage) Location message elements.</li> </ul>	I-80 WEST BLOCKED BEFORE ROWLAND	USE OTHER ROUTES		
	I-80 WEST BLOCKED BEFORE ROWLAND USE OTHER ROUTES			
<ul style="list-style-type: none"> <li>● Diversion to Type 1 or Type 2 Diversion Route.</li> </ul>	MAJOR ACCIDENT ON I-80 WEST AT ROWLAND	USE TILLMAN DR		
<ul style="list-style-type: none"> <li>● Diversion to Type 1 or Type 2 Diversion Route.</li> <li>● Combining Incident Descriptor and Incident (Blockage) Location message elements.</li> </ul>	I-80 WEST BLOCKED AT ROWLAND	USE TILLMAN DR		
	I-80 WEST BLOCKED AT ROWLAND USE TILLMAN DR			
<ul style="list-style-type: none"> <li>● Diversion to Type 1 or Type 2 Diversion Route.</li> <li>● Good reason for following Action message element.</li> <li>● Combining Incident Descriptor and Incident (Blockage) Location message elements.</li> </ul>	(Requires a five-unit message.)			
<ul style="list-style-type: none"> <li>● Diversion to Type 1 or Type 2 Diversion Route.</li> <li>● Implied good reason for following Action message element (MAJOR ACCIDENT).</li> <li>● No Lanes Blocked message element.</li> </ul>	MAJOR ACCIDENT ON I-80 WEST AT ROWLAND	USE RT-42 SOUTH		
<ul style="list-style-type: none"> <li>● Diversion to Type 1 or Type 2 Diversion Route.</li> <li>● Diversion message for specific audience.</li> <li>● Implied good reason for following Action message element (MAJOR ACCIDENT).</li> <li>● No Lanes Blocked message element.</li> </ul>	(Requires a five-unit message.)			

<sup>A</sup> Large VMS: 3 lines, 20 characters per line; Portable VMS: 3 lines, 8 characters per line. All messages are for operating speeds above 35 mph and thus are limited to 4 units of information.

<sup>B</sup> Blank cells indicate that the message cannot be displayed on a portable VMS.

## 12.5 INCIDENTS THAT REQUIRE CLOSING THE FREEWAY

### VMS ON SAME FREEWAY AND RELATIVELY CLOSE TO THE CLOSURE

Table 12.10 VMS Message Examples for Incidents that Require Closing the Freeway VMS Close to Incident <sup>A</sup>				
Message Characteristics Highlights	Large VMS		Portable VMS <sup>B</sup>	
	Frame 1	Frame 2	Frame 1	Frame 2
<ul style="list-style-type: none"> <li>● <i>“ACCIDENT” for Incident Descriptor message element.</i></li> <li>● <i>Incident (Blockage) Location message element.</i></li> <li>● <i>Lanes Closed message element.</i></li> <li>● <i>No Action message element.</i></li> </ul>	(Does not apply in this case.)			
<ul style="list-style-type: none"> <li>● <i>“MAJOR ACCIDENT” for Incident Descriptor message element.</i></li> <li>● <i>Lanes Closed message element.</i></li> <li>● <i>Closure Location message element.</i></li> <li>● <i>No Action message element.</i></li> </ul>	MAJOR ACCIDENT AT RIVER RD ALL LANES CLOSED			
<ul style="list-style-type: none"> <li>● <i>“TRUCK ACCIDENT” for Incident Descriptor message element.</i></li> </ul>	TRUCK ACCIDENT AT RIVER RD ALL LANES CLOSED			
<ul style="list-style-type: none"> <li>● <i>Highway name (number) for Closure Location message element.</i></li> <li>● <i>No Action message element.</i></li> </ul>	MAJOR ACCIDENT AT I-287 ALL LANES CLOSED			
<ul style="list-style-type: none"> <li>● <i>Combining Incident Descriptor and Lanes Closed message elements.</i></li> </ul>	FREEWAY CLOSED AT I-287			
<ul style="list-style-type: none"> <li>● <i>Action message element.</i></li> <li>● <i>No diversion.</i></li> </ul>	MAJOR ACCIDENT AT RIVER RD ALL LANES CLOSED		PREPARE TO STOP	

<sup>A</sup> Large VMS: 3 lines, 20 characters per line; Portable VMS: 3 lines, 8 characters per line. All messages are for operating speeds above 35 mph and thus are limited to 4 units of information.

<sup>B</sup> Blank cells indicate that the message cannot be displayed on a portable VMS.

Message Characteristics Highlights	Large VMS		Portable VMS <sup>B</sup>	
	Frame 1	Frame 2	Frame 1	Frame 2
<ul style="list-style-type: none"> <li>Action message element.</li> <li>No diversion.</li> <li>Combining Incident Descriptor and Lanes Closed message elements.</li> </ul>	FREEWAY CLOSED AT RIVER RD	PREPARE TO STOP		
	FREEWAY CLOSED AT RIVER RD PREPARE TO STOP			
<ul style="list-style-type: none"> <li>“Soft” diversion.</li> <li>Combining Incident Descriptor and Lanes Closed message elements.</li> </ul>	FREEWAY CLOSED AT RIVER RD	USE OTHER ROUTES		
	FREEWAY CLOSED AT RIVER RD USE OTHER ROUTES			
<ul style="list-style-type: none"> <li>Diversion to Type 1 or Type 2 Diversion Route.</li> </ul>	MAJOR ACCIDENT AT RIVER RD ALL LANES CLOSED	USE MONROE BLVD		
<ul style="list-style-type: none"> <li>Diversion to Type 1 or Type 2 Diversion Route.</li> <li>Combining Incident Descriptor and Lanes Closed message elements.</li> </ul>	FREEWAY CLOSED AT RIVER RD	USE MONROE BLVD		
	FREEWAY CLOSED AT RIVER RD USE MONROE BLVD			
<ul style="list-style-type: none"> <li>Diversion to Type 1 or Type 2 Diversion Route.</li> <li>Good reason for following Action message element</li> <li>Replacing Incident Descriptor message element with Lanes Closed message element.</li> </ul>	(Good reason is implied by ALL LANES CLOSED in above message.)			
<ul style="list-style-type: none"> <li>Diversion to Type 1 or Type 2 Diversion Route.</li> <li>Implied good reason for following Action message element (MAJOR ACCIDENT).</li> <li>No Lanes Closed message element.</li> </ul>	MAJOR ACCIDENT AT ROWLAND	USE RT-42 SOUTH		
	MAJOR ACCIDENT AT ROWLAND USE RT-42 SOUTH			

<sup>A</sup> Large VMS: 3 lines, 20 characters per line; Portable VMS: 3 lines, 8 characters per line. All messages are for operating speeds above 35 mph and thus are limited to 4 units of information.

<sup>B</sup> Blank cells indicate that the message cannot be displayed on a portable VMS.

Message Characteristics Highlights	Large VMS		Portable VMS <sup>B</sup>	
	Frame 1	Frame 2	Frame 1	Frame 2
<ul style="list-style-type: none"> <li>• Diversion to Type 1 or Type 2 Diversion Route.</li> <li>• Diversion message for specific audience.</li> <li>• Implied good reason for following Action message element (TRUCK ACCIDENT).</li> <li>• No Lanes Closed message element.</li> </ul>	TRUCK ACCIDENT AT ROWLAND	PHILADELPHIA USE I-676 NORTH		
<ul style="list-style-type: none"> <li>• Diversion to Type 1 or Type 2 Diversion Route.</li> <li>• Combining Incident Descriptor and Lanes Closed message elements.</li> <li>• Implied good reason for following Action message element (ALL LANES CLOSED).</li> </ul>	FREEWAY CLOSED AT RIVER RD	USE RT-42 SOUTH		
	FREEWAY CLOSED AT RIVER RD USE RT-42 SOUTH			
<ul style="list-style-type: none"> <li>• Diversion to Type 1 or Type 2 Diversion Route.</li> <li>• Diversion message for specific audience.</li> <li>• Combining Incident Descriptor and Lanes Closed message elements.</li> <li>• Implied good reason for following Action message element (ALL LANES CLOSED).</li> </ul>	FREEWAY CLOSED AT RIVER RD	PHILADELPHIA USE I-676 NORTH		
<ul style="list-style-type: none"> <li>• Diversion to Type 3 or Type 4 Diversion Route.</li> </ul>	MAJOR ACCIDENT EXIT AT RIVER RD ALL LANES CLOSED			
<ul style="list-style-type: none"> <li>• Diversion to Type 3 or Type 4 Diversion Route.</li> <li>• Combining Incident Descriptor and Lanes Closed message elements.</li> </ul>	FREEWAY CLOSED EXIT AT RIVER RD			
<ul style="list-style-type: none"> <li>• Diversion to Type 3 or Type 4 Diversion Route.</li> <li>• Good reason for following Action message element.</li> <li>• Replacing Incident Descriptor message element with Lanes Closed message element.</li> </ul>	(Good reason is implied by ALL LANES CLOSED in above message.)			

<sup>A</sup> Large VMS: 3 lines, 20 characters per line; Portable VMS: 3 lines, 8 characters per line. All messages are for operating speeds above 35 mph and thus are limited to 4 units of information.

<sup>B</sup> Blank cells indicate that the message cannot be displayed on a portable VMS.

Message Characteristics Highlights	Large VMS		Portable VMS <sup>B</sup>	
	Frame 1	Frame 2	Frame 1	Frame 2
<ul style="list-style-type: none"> <li>• Diversion to Type 3 or Type 4 Diversion Route.</li> <li>• Implied good reason for following Action message element (MAJOR ACCIDENT).</li> <li>• No Lanes Closed message element.</li> </ul>	MAJOR ACCIDENT AT ROWLAND	USE RIVER RD		
	MAJOR ACCIDENT AT ROWLAND USE RIVER RD			
<ul style="list-style-type: none"> <li>• Diversion to Type 3 or Type 4 Diversion Route.</li> <li>• Combining Incident Descriptor and Lanes Closed message elements.</li> <li>• Implied good reason for following Action message element (ALL LANES CLOSED).</li> </ul>	FREEWAY CLOSED EXIT AT RIVER RD			
	FREEWAY CLOSED PHILADELPHIA USE RIVER RD			
<ul style="list-style-type: none"> <li>• Diversion to Type 3 or Type 4 Diversion Route.</li> <li>• Diversion message for specific audience.</li> <li>• Combining Incident Descriptor and Lanes Closed message elements.</li> <li>• Implied good reason for following Action message element (ALL LANES CLOSED).</li> </ul>	FREEWAY CLOSED	PHILADELPHIA USE RIVER RD		
	FREEWAY CLOSED PHILADELPHIA USE RIVER RD			
<ul style="list-style-type: none"> <li>• Diversion to Type 5 Diversion Route.</li> </ul>	MAJOR ACCIDENT ALL LANES CLOSED	EXIT AT RIVER RD FOLLOW DETOUR		
	FREEWAY CLOSED	EXIT AT RIVER RD FOLLOW DETOUR		
<ul style="list-style-type: none"> <li>• Diversion to Type 5 Diversion Route.</li> <li>• Combining Incident Descriptor and Lanes Closed message elements.</li> </ul>	FREEWAY CLOSED EXIT AT RIVER RD FOLLOW DETOUR			
	(Good reason is implied by FREEWAY CLOSED in above message.)			

<sup>A</sup> Large VMS: 3 lines, 20 characters per line; Portable VMS: 3 lines, 8 characters per line. All messages are for operating speeds above 35 mph and thus are limited to 4 units of information.

<sup>B</sup> Blank cells indicate that the message cannot be displayed on a portable VMS.

Message Characteristics Highlights	Large VMS		Portable VMS <sup>B</sup>	
	Frame 1	Frame 2	Frame 1	Frame 2
<ul style="list-style-type: none"> <li>• Diversion to Type 5 Diversion Route.</li> <li>• Implied good reason for following Action message element (MAJOR ACCIDENT).</li> <li>• No Lanes Closed message element.</li> </ul>	MAJOR ACCIDENT AT ROWLAND	EXIT AT RIVER RD FOLLOW DETOUR		
<ul style="list-style-type: none"> <li>• Diversion to Type 5 Diversion Route.</li> <li>• Diversion message for specific audience.</li> <li>• Implied good reason for following Action message element (TRUCK ACCIDENT).</li> <li>• No Lanes Closed message element.</li> </ul>	TRUCK ACCIDENT AT ROWLAND	PHILADELPHIA EXIT AT RIVER RD		
<ul style="list-style-type: none"> <li>• Diversion to Type 5 Diversion Route.</li> <li>• Combining Incident Descriptor and Lanes Closed message elements.</li> <li>• Implied good reason for following Action message element (ALL LANES CLOSED).</li> </ul>	FREEWAY CLOSED	EXIT AT RIVER RD FOLLOW DETOUR		
	FREEWAY CLOSED EXIT AT RIVER RD FOLLOW DETOUR			
<ul style="list-style-type: none"> <li>• Diversion to Type 3 or Type 4 Diversion Route.</li> <li>• Diversion message for specific audience.</li> <li>• Combining Incident Descriptor and Lanes Closed message elements.</li> <li>• Implied good reason for following Action message element (ALL LANES CLOSED).</li> </ul>	FREEWAY CLOSED	PHILADELPHIA EXIT AT RIVER RD		
	FREEWAY CLOSED PHILADELPHIA EXIT AT RIVER RD			

<sup>A</sup> Large VMS: 3 lines, 20 characters per line; Portable VMS: 3 lines, 8 characters per line. All messages are for operating speeds above 35 mph and thus are limited to 4 units of information.

<sup>B</sup> Blank cells indicate that the message cannot be displayed on a portable VMS.

## VMS ON SAME FREEWAY BUT RELATIVELY FAR FROM CLOSURE

Table 12.11 VMS Message Examples for Incidents that Require Closing the Freeway VMS Relatively Far from Incident <sup>A</sup>				
Message Characteristics Highlights	Large VMS		Portable VMS <sup>B</sup>	
	Frame 1	Frame 2	Frame 1	Frame 2
<ul style="list-style-type: none"> <li>● <i>“ACCIDENT” for Incident Descriptor message element.</i></li> <li>● <i>Incident (Blockage) Location message element.</i></li> <li>● <i>Lanes Closed message element.</i></li> <li>● <i>No Action message element.</i></li> </ul>	(Does not apply in this case.)			
<ul style="list-style-type: none"> <li>● <i>“MAJOR ACCIDENT” for Incident Descriptor message element.</i></li> <li>● <i>Lanes Closed message element.</i></li> <li>● <i>Closure Location message element.</i></li> <li>● <i>No Action message element.</i></li> </ul>	MAJOR ACCIDENT AT RIVER RD ALL LANES CLOSED			
<ul style="list-style-type: none"> <li>● <i>“TRUCK ACCIDENT” for Incident Descriptor message element.</i></li> </ul>	TRUCK ACCIDENT AT RIVER RD ALL LANES CLOSED			
<ul style="list-style-type: none"> <li>● <i>Highway name (number) for Closure Location message element.</i></li> <li>● <i>No Action message element.</i></li> </ul>	MAJOR ACCIDENT AT I-287 ALL LANES CLOSED			
<ul style="list-style-type: none"> <li>● <i>Combining Incident Descriptor and Lanes Closed message elements.</i></li> </ul>	FREEWAY CLOSED AT I-287			
<ul style="list-style-type: none"> <li>● <i>Action message element.</i></li> <li>● <i>No diversion.</i></li> </ul>	MAJOR ACCIDENT AT RIVER RD ALL LANES CLOSED	PREPARE TO STOP		
<ul style="list-style-type: none"> <li>● <i>Action message element.</i></li> <li>● <i>No diversion.</i></li> <li>● <i>Combining Incident Descriptor and Lanes Closed message elements.</i></li> </ul>	FREEWAY CLOSED AT RIVER RD ----- FREEWAY CLOSED AT RIVER RD PREPARE TO STOP	PREPARE TO STOP		

<sup>A</sup> Large VMS: 3 lines, 20 characters per line; Portable VMS: 3 lines, 8 characters per line. All messages are for operating speeds above 35 mph and thus are limited to 4 units of information.

<sup>B</sup> Blank cells indicate that the message cannot be displayed on a portable VMS.



Message Characteristics Highlights	Large VMS		Portable VMS <sup>B</sup>	
	Frame 1	Frame 2	Frame 1	Frame 2
<ul style="list-style-type: none"> <li>• “Soft” diversion.</li> </ul>	MAJOR ACCIDENT AT RIVER RD ALL LANES CLOSED	USE OTHER ROUTES		
<ul style="list-style-type: none"> <li>• “Soft” diversion.</li> <li>• Combining Incident Descriptor and Lanes Closed message elements.</li> </ul>	FREEWAY CLOSED AT RIVER RD	USE OTHER ROUTES		
	----- FREEWAY CLOSED AT RIVER RD USE OTHER ROUTES			
<ul style="list-style-type: none"> <li>• Diversion to Type 1 or Type 2 Diversion Route.</li> </ul>	MAJOR ACCIDENT AT RIVER RD ALL LANES CLOSED	USE MONROE BLVD		
<ul style="list-style-type: none"> <li>• Diversion to Type 1 or Type 2 Diversion Route.</li> <li>• Combining Incident Descriptor and Lanes Closed message elements.</li> </ul>	FREEWAY CLOSED AT RIVER RD	USE MONROE BLVD		
	----- FREEWAY CLOSED AT RIVER RD USE MONROE BLVD			
<ul style="list-style-type: none"> <li>• Diversion to Type 1 or Type 2 Diversion Route.</li> <li>• Good reason for following Action message element.</li> <li>• Combining Incident Descriptor and Lanes Closed message elements.</li> </ul>	(Good reason is implied by FREEWAY CLOSED in above message.)			
<ul style="list-style-type: none"> <li>• Diversion to Type 1 or Type 2 Diversion Route.</li> <li>• Implied good reason for following Action message element (MAJOR ACCIDENT).</li> <li>• No Lanes Closed message element.</li> </ul>	MAJOR ACCIDENT AT ROWLAND	USE RT-42 SOUTH		
	----- MAJOR ACCIDENT AT ROWLAND USE RT-42 SOUTH			
<ul style="list-style-type: none"> <li>• Diversion to Type 1 or Type 2 Diversion Route.</li> <li>• Diversion message for specific audience.</li> <li>• Implied good reason for following Action message element (TRUCK ACCIDENT).</li> <li>• No Lanes Closed message element.</li> </ul>	TRUCK ACCIDENT AT ROWLAND	PHILADELPHIA USE I-676 NORTH		

<sup>A</sup> Large VMS: 3 lines, 20 characters per line; Portable VMS: 3 lines, 8 characters per line. All messages are for operating speeds above 35 mph and thus are limited to 4 units of information.

<sup>B</sup> Blank cells indicate that the message cannot be displayed on a portable VMS.

Message Characteristics Highlights	Large VMS		Portable VMS <sup>B</sup>	
	Frame 1	Frame 2	Frame 1	Frame 2
<ul style="list-style-type: none"> <li>• Diversion to Type 1 or Type 2 Diversion Route.</li> <li>• Combining Incident Descriptor and Lanes Closed message elements.</li> <li>• Implied good reason for following Action message element (ALL LANES CLOSED).</li> </ul>	FREEWAY CLOSED AT RIVER RD	USE RT-42 SOUTH		
	----- FREEWAY CLOSED AT RIVER RD USE RT-42 SOUTH			
<ul style="list-style-type: none"> <li>• Diversion to Type 1 or Type 2 Diversion Route.</li> <li>• Diversion message for specific audience.</li> <li>• Combining Incident Descriptor and Lanes Closed message elements.</li> <li>• Implied good reason for following Action message element (ALL LANES CLOSED).</li> </ul>	FREEWAY CLOSED AT RIVER RD	PHILADELPHIA USE I-676 NORTH		
<ul style="list-style-type: none"> <li>• Diversion to Type 3 or Type 4 Diversion Route.</li> </ul>	MAJOR ACCIDENT EXIT AT RIVER RD ALL LANES CLOSED			
<ul style="list-style-type: none"> <li>• Diversion to Type 3 or Type 4 Diversion Route.</li> <li>• Combining Incident Descriptor and Lanes Closed message elements.</li> </ul>	FREEWAY CLOSED EXIT AT RIVER RD			
<ul style="list-style-type: none"> <li>• Diversion to Type 3 or Type 4 Diversion Route.</li> <li>• Good reason for following Action message element.</li> <li>• Combining Incident Descriptor and Lanes Closed message elements.</li> </ul>	(Good reason is implied by FREEWAY CLOSED in above message.)			
<ul style="list-style-type: none"> <li>• Diversion to Type 3 or Type 4 Diversion Route.</li> <li>• Implied good reason for following Action message element (MAJOR ACCIDENT).</li> <li>• No Lanes Closed message element.</li> </ul>	MAJOR ACCIDENT AT ROWLAND	USE RIVER RD		
	----- MAJOR ACCIDENT AT ROWLAND USE RIVER RD			
<ul style="list-style-type: none"> <li>• Diversion to Type 3 or Type 4 Diversion Route.</li> <li>• Diversion message for specific audience.</li> <li>• Implied good reason for following Action message element (TRUCK ACCIDENT).</li> <li>• No Lanes Closed message element.</li> </ul>	TRUCK ACCIDENT AT ROWLAND	PHILADELPHIA USE RIVER RD		

<sup>A</sup> Large VMS: 3 lines, 20 characters per line; Portable VMS: 3 lines, 8 characters per line. All messages are for operating speeds above 35 mph and thus are limited to 4 units of information.

<sup>B</sup> Blank cells indicate that the message cannot be displayed on a portable VMS.

Message Characteristics Highlights	Large VMS		Portable VMS <sup>B</sup>	
	Frame 1	Frame 2	Frame 1	Frame 2
<ul style="list-style-type: none"> <li>• Diversion to Type 3 or Type 4 Diversion Route.</li> <li>• Combining Incident Descriptor and Lanes Closed message elements.</li> <li>• Implied good reason for following Action message element (ALL LANES CLOSED).</li> </ul>	FREEWAY CLOSED EXIT AT RIVER RD			
<ul style="list-style-type: none"> <li>• Diversion to Type 3 or Type 4 Diversion Route.</li> <li>• Diversion message for specific audience.</li> <li>• Combining Incident Descriptor and Lanes Closed message elements.</li> <li>• Implied good reason for following Action message element (ALL LANES CLOSED).</li> </ul>	FREEWAY CLOSED	PHILADELPHIA USE RIVER RD		
	----- FREEWAY CLOSED PHILADELPHIA USE RIVER RD			
<ul style="list-style-type: none"> <li>• Diversion to Type 5 Diversion Route.</li> </ul>	MAJOR ACCIDENT ALL LANES CLOSED	EXIT AT RIVER RD FOLLOW DETOUR		
<ul style="list-style-type: none"> <li>• Diversion to Type 5 Diversion Route.</li> <li>• Combining Incident Descriptor and Lanes Closed message elements.</li> </ul>	FREEWAY CLOSED	EXIT AT RIVER RD FOLLOW DETOUR		
	----- FREEWAY CLOSED EXIT AT RIVER RD FOLLOW DETOUR			
<ul style="list-style-type: none"> <li>• Diversion to Type 5 Diversion Route.</li> <li>• Good reason for following Action message element.</li> <li>• Combining Incident Descriptor and Lanes Closed message elements.</li> </ul>	(Good reason is implied by FREEWAY CLOSED in above message.)			
<ul style="list-style-type: none"> <li>• Diversion to Type 5 Diversion Route.</li> <li>• Implied good reason for following Action message element (MAJOR ACCIDENT).</li> <li>• No Lanes Closed message element.</li> </ul>	MAJOR ACCIDENT AT ROWLAND	EXIT AT RIVER RD FOLLOW DETOUR		

<sup>A</sup> Large VMS: 3 lines, 20 characters per line; Portable VMS: 3 lines, 8 characters per line. All messages are for operating speeds above 35 mph and thus are limited to 4 units of information.

<sup>B</sup> Blank cells indicate that the message cannot be displayed on a portable VMS.

Message Characteristics Highlights	Large VMS		Portable VMS <sup>B</sup>	
	Frame 1	Frame 2	Frame 1	Frame 2
<ul style="list-style-type: none"> <li>• Diversion to Type 5 Diversion Route.</li> <li>• Diversion message for specific audience.</li> <li>• Implied good reason for following Action message element (TRUCK ACCIDENT).</li> <li>• No Lanes Closed message element.</li> </ul>	TRUCK ACCIDENT AT ROWLAND	PHILADELPHIA EXIT AT RIVER RD		
<ul style="list-style-type: none"> <li>• Diversion to Type 5 Diversion Route.</li> <li>• Combining Incident Descriptor and Lanes Closed message elements.</li> <li>• Implied good reason for following Action message element (ALL LANES CLOSED).</li> </ul>	FREEWAY CLOSED	EXIT AT RIVER RD FOLLOW DETOUR		
	FREEWAY CLOSED EXIT AT RIVER RD FOLLOW DETOUR			
<ul style="list-style-type: none"> <li>• Diversion to Type 3 or Type 4 Diversion Route.</li> <li>• Diversion message for specific audience.</li> <li>• Combining Incident Descriptor and Lanes Closed message elements.</li> <li>• Implied good reason for following Action message element (ALL LANES CLOSED).</li> </ul>	FREEWAY CLOSED	PHILADELPHIA EXIT AT RIVER RD		
	FREEWAY CLOSED PHILADELPHIA EXIT AT RIVER RD			

<sup>A</sup> Large VMS: 3 lines, 20 characters per line; Portable VMS: 3 lines, 8 characters per line. All messages are for operating speeds above 35 mph and thus are limited to 4 units of information.

<sup>B</sup> Blank cells indicate that the message cannot be displayed on a portable VMS.

## VMS ON DIFFERENT FREEWAY THAN CLOSURE

Table 12.12 VMS Message Examples for Incidents that Require Closing the Freeway VMS on Different Freeway than Incident <sup>A</sup>				
Message Characteristics Highlights	Large VMS		Portable VMS <sup>B</sup>	
	Frame 1	Frame 2	Frame 1	Frame 2
<ul style="list-style-type: none"> <li>● “ACCIDENT” for Incident Descriptor message element.</li> <li>● Incident (Blockage) Location message element.</li> <li>● Lanes Closed message element.</li> <li>● No Action message element.</li> </ul>	(Does not apply in this case.)			
<ul style="list-style-type: none"> <li>● “MAJOR ACCIDENT” for Incident Descriptor message element.</li> <li>● Incident (Blockage) Location message element.</li> <li>● No Lanes Closed message element.</li> <li>● No Action message element.</li> </ul>	MAJOR ACCIDENT ON I-80 WEST AT RIVER RD			
<ul style="list-style-type: none"> <li>● “TRUCK ACCIDENT” for Incident Descriptor message element.</li> </ul>	TRUCK ACCIDENT ON I-80 WEST AT RIVER RD			
<ul style="list-style-type: none"> <li>● Highway name (number) for Closure Location message element.</li> <li>● No Action message element.</li> </ul>	MAJOR ACCIDENT ON I-80 WEST AT I-287			
<ul style="list-style-type: none"> <li>● Combining Incident Descriptor and Closure Location message elements.</li> </ul>	I-80 WEST CLOSED AT I-287			
<ul style="list-style-type: none"> <li>● Action message element.</li> <li>● No diversion.</li> </ul>	(Does not apply in this case.)			
<ul style="list-style-type: none"> <li>● Action message element.</li> <li>● No diversion</li> <li>● Combining Incident Descriptor and Closure Location message elements.</li> </ul>	(Does not apply in this case.)			

<sup>A</sup> Large VMS: 3 lines, 20 characters per line; Portable VMS: 3 lines, 8 characters per line. All messages are for operating speeds above 35 mph and thus are limited to 4 units of information.

<sup>B</sup> Blank cells indicate that the message cannot be displayed on a portable VMS.

Message Characteristics Highlights	Large VMS		Portable VMS <sup>B</sup>	
	Frame 1	Frame 2	Frame 1	Frame 2
<ul style="list-style-type: none"> <li>• “Soft” diversion.</li> </ul>	MAJOR ACCIDENT ON I-80 WEST AT RIVER RD	USE OTHER ROUTES		
<ul style="list-style-type: none"> <li>• “Soft” diversion.</li> <li>• Combining Incident Descriptor and Closure Location message elements.</li> </ul>	I-80 WEST CLOSED AT RIVER RD USE OTHER ROUTES			
<ul style="list-style-type: none"> <li>• Diversion to Type 1 or Type 2 Diversion Route.</li> </ul>	MAJOR ACCIDENT ON I-80 WEST AT RIVER RD	USE MONROE BLVD		
<ul style="list-style-type: none"> <li>• Diversion to Type 1 or Type 2 Diversion Route.</li> <li>• Combining Incident Descriptor and Closure Location message elements.</li> </ul>	I-80 WEST CLOSED AT RIVER RD USE MONROE BLVD			
<ul style="list-style-type: none"> <li>• Diversion to Type 1 or Type 2 Diversion Route.</li> <li>• Good reason for following Action message element.</li> <li>• Combining Incident Descriptor and Closure Location message elements.</li> </ul>	(Good reason is implied by FREEWAY CLOSED in above message.)			
<ul style="list-style-type: none"> <li>• Diversion to Type 1 or Type 2 Diversion Route.</li> <li>• Implied good reason for following Action message element (MAJOR ACCIDENT).</li> <li>• No Lanes Closed message element.</li> </ul>	MAJOR ACCIDENT ON I-80 WEST AT ROWLAND	USE RT-42 SOUTH		
<ul style="list-style-type: none"> <li>• Diversion to Type 1 or Type 2 Diversion Route.</li> <li>• Diversion message for specific audience.</li> <li>• Implied good reason for following Action message element (TRUCK ACCIDENT).</li> <li>• No Lanes Closed message element.</li> </ul>	(Requires a five-unit message.)			

<sup>A</sup> Large VMS: 3 lines, 20 characters per line; Portable VMS: 3 lines, 8 characters per line. All messages are for operating speeds above 35 mph and thus are limited to 4 units of information.

<sup>B</sup> Blank cells indicate that the message cannot be displayed on a portable VMS.

Message Characteristics Highlights	Large VMS		Portable VMS <sup>B</sup>	
	Frame 1	Frame 2	Frame 1	Frame 2
<ul style="list-style-type: none"> <li>• <i>Diversion to Type 1 or Type 2 Diversion Route.</i></li> <li>• <i>Combining Incident Descriptor and Closure Location message elements.</i></li> <li>• <i>Implied good reason for following Action message element (ALL LANES CLOSED).</i></li> </ul>	I-80 WEST CLOSED AT RIVER RD USE RT-42 SOUTH			
<ul style="list-style-type: none"> <li>• <i>Diversion to Type 1 or Type 2 Diversion Route.</i></li> <li>• <i>Diversion message for specific audience.</i></li> <li>• <i>Combining Incident Descriptor and Closure Location message elements.</i></li> <li>• <i>Implied good reason for following Action message element (ALL LANES CLOSED).</i></li> </ul>	I-80 WEST CLOSED AT RIVER RD	PHILADELPHIA USE I-676 NORTH		

<sup>A</sup> Large VMS: 3 lines, 20 characters per line; Portable VMS: 3 lines, 8 characters per line. All messages are for operating speeds above 35 mph and thus are limited to 4 units of information.

<sup>B</sup> Blank cells indicate that the message cannot be displayed on a portable VMS.

## 12.6 LANE CLOSURES DURING ROADWORK

### VMS ON SAME FREEWAY AND RELATIVELY CLOSE TO THE ROADWORK

Table 12.13 VMS Message Examples for Lane Closures During Roadwork VMS Close to Lane Closure <sup>A</sup>				
Message Characteristics Highlights	Large VMS		Portable VMS	
	Frame 1	Frame 2	Frame 1	Frame 2
<ul style="list-style-type: none"> <li>• “ROADWORK” for Roadwork Descriptor message element.</li> <li>• Lane Closure Location message element.</li> <li>• Lanes Closed message element.</li> <li>• No Action message element.</li> </ul>	ROADWORK AT ROWLAND DR RIGHT LANE CLOSED		ROADWORK AT ROWLAND	RIGHT LANE CLOSED
<ul style="list-style-type: none"> <li>• Highway name (number) for Lane Closure Location message element.</li> <li>• No Action message element.</li> </ul>	ROADWORK NEAR I-287 2 RIGHT LANES CLOSED		ROADWORK NEAR I-287	2 RIGHT LANES CLOSED
<ul style="list-style-type: none"> <li>• Replacing Roadwork Descriptor message element with Lanes Closed message element.</li> </ul>	2 RIGHT LANES CLOSED NEAR I-287			
<ul style="list-style-type: none"> <li>• Displaying the limits of the Lane Closure Location message element.</li> <li>• Replacing Roadwork Descriptor message element with Lanes Closed message element.</li> </ul>	2 RIGHT LANES CLOSED FROM I-287 TO ROWLAND			
<ul style="list-style-type: none"> <li>• Action message element.</li> <li>• No diversion.</li> </ul>	ROADWORK PAST ROWLAND	2 RIGHT LANES CLOSED PREPARE TO STOP		
<ul style="list-style-type: none"> <li>• Action message element.</li> <li>• No diversion.</li> <li>• Replacing Lane Closure Descriptor message element with Lanes Closed message element.</li> </ul>	2 RIGHT LANES CLOSED PAST ROWLAND  2 RIGHT LANES CLOSED PAST ROWLAND PREPARE TO STOP	PREPARE TO STOP		

<sup>A</sup> Large VMS: 3 lines, 20 characters per line; Portable VMS: 3 lines, 8 characters per line. All messages are for operating speeds above 35 mph and thus are limited to 4 units of information.

<sup>B</sup> Blank cells indicate that the message cannot be displayed on a portable VMS.



Message Characteristics Highlights	Large VMS		Portable VMS <sup>B</sup>	
	Frame 1	Frame 2	Frame 1	Frame 2
<ul style="list-style-type: none"> <li>● “Soft” diversion.</li> </ul>	ROADWORK BEFORE ROWLAND	2 RIGHT LANES CLOSED USE OTHER ROUTES		
<ul style="list-style-type: none"> <li>● “Soft” diversion.</li> <li>● Replacing Lane Closure Descriptor message element with Lanes Closed message element.</li> </ul>	2 RIGHT LANES CLOSED BEFORE ROWLAND	USE OTHER ROUTES		
	----- 2 RIGHT LANES CLOSED BEFORE ROWLAND USE OTHER ROUTES			
<ul style="list-style-type: none"> <li>● Diversion to Type 1 or Type 2 Diversion Route.</li> <li>● Replacing Incident Descriptor message element with Lanes Closed message element.</li> </ul>	2 RIGHT LANES CLOSED AT ROWLAND	USE MONROE BLVD		
	----- 2 RIGHT LANES CLOSED AT ROWLAND USE MONROE BLVD			
<ul style="list-style-type: none"> <li>● Diversion to Type 1 or Type 2 Diversion Route.</li> <li>● Good reason for following Action message element.</li> <li>● Replacing Incident Descriptor message element with Lanes Closed message element.</li> </ul>	2 RIGHT LANES CLOSED AT ROWLAND	USE MONROE BLVD AVOID DELAY		
<ul style="list-style-type: none"> <li>● Diversion to Type 1 or Type 2 Diversion Route.</li> <li>● Diversion message for specific audience.</li> <li>● Implied good reason for following Action message element (2 lanes closed).</li> <li>● Replacing Incident Descriptor message element with Lanes Closed message element.</li> </ul>	2 RIGHT LANES CLOSED AT ROWLAND	PHILADELPHIA USE I-676 NORTH		

<sup>A</sup> Large VMS: 3 lines, 20 characters per line; Portable VMS: 3 lines, 8 characters per line. All messages are for operating speeds above 35 mph and thus are limited to 4 units of information.

<sup>B</sup> Blank cells indicate that the message cannot be displayed on a portable VMS.

## VMS ON SAME FREEWAY BUT RELATIVELY FAR FROM THE ROADWORK

Table 12.14 VMS Message Examples for Lane Closures During Roadwork VMS Far Upstream of Lane Closure <sup>A</sup>				
Message Characteristics Highlights	Large VMS		Portable VMS	
	Frame 1	Frame 2	Frame 1	Frame 2
<ul style="list-style-type: none"> <li>● <i>“ROADWORK” for Roadwork Descriptor message element.</i></li> <li>● <i>Lane Closure Location message element.</i></li> <li>● <i>Lanes Closed message element.</i></li> <li>● <i>No Action message element.</i></li> </ul>	ROADWORK AT ROWLAND DR 1 LANE CLOSED		ROADWORK AT ROWLAND	1 LANE CLOSED
<ul style="list-style-type: none"> <li>● <i>Highway name (number) for Lane Closure Location message element.</i></li> <li>● <i>No Action message element.</i></li> </ul>	ROADWORK NEAR I-287 2 LANES CLOSED		ACCIDENT NEAR I-287	2 LANES CLOSED
<ul style="list-style-type: none"> <li>● <i>Replacing Roadwork Descriptor message element with Lanes Closed message element.</i></li> </ul>	2 LANES CLOSED NEAR I-287			
<ul style="list-style-type: none"> <li>● <i>Displaying the limits of the Lane Closure Location message element.</i></li> <li>● <i>Replacing Roadwork Descriptor message element with Lanes Closed message element.</i></li> </ul>	2 LANES CLOSED FROM I-287 TO ROWLAND			
<ul style="list-style-type: none"> <li>● <i>Action message element.</i></li> <li>● <i>No diversion.</i></li> </ul>	ROADWORK PAST ROWLAND	2 LANES CLOSED PREPARE TO STOP		
<ul style="list-style-type: none"> <li>● <i>Action message element.</i></li> <li>● <i>No diversion.</i></li> <li>● <i>Replacing Lane Closure Descriptor message element with Lanes Closed message element.</i></li> </ul>	2 LANES CLOSED PAST ROWLAND	PREPARE TO STOP		
	2 LANES CLOSED PAST ROWLAND PREPARE TO STOP			

<sup>A</sup> Large VMS: 3 lines, 20 characters per line; Portable VMS: 3 lines, 8 characters per line. All messages are for operating speeds above 35 mph and thus are limited to 4 units of information.

<sup>B</sup> Blank cells indicate that the message cannot be displayed on a portable VMS.

Message Characteristics Highlights	Large VMS		Portable VMS <sup>B</sup>	
	Frame 1	Frame 2	Frame 1	Frame 2
<ul style="list-style-type: none"> <li>• “Soft” diversion.</li> </ul>	ROADWORK BEFORE ROWLAND	2 LANES CLOSED USE OTHER ROUTES		
<ul style="list-style-type: none"> <li>• “Soft” diversion.</li> <li>• Replacing Lane Closure Descriptor message element with Lanes Closed message element.</li> </ul>	2 LANES CLOSED BEFORE ROWLAND	USE OTHER ROUTES		
	----- 2 LANES CLOSED BEFORE ROWLAND USE OTHER ROUTES			
<ul style="list-style-type: none"> <li>• Diversion to Type 1 or Type 2 Diversion Route.</li> <li>• Replacing Incident Descriptor message element with Lanes Closed message element.</li> </ul>	2 LANES CLOSED AT ROWLAND	USE MONROE BLVD		
	----- 2 LANES CLOSED AT ROWLAND USE MONROE BLVD			
<ul style="list-style-type: none"> <li>• Diversion to Type 1 or Type 2 Diversion Route.</li> <li>• Good reason for following Action message element.</li> <li>• Replacing Incident Descriptor message element with Lanes Closed message element.</li> </ul>	2 LANES CLOSED AT ROWLAND	USE MONROE BLVD AVOID DELAY		
<ul style="list-style-type: none"> <li>• Diversion to Type 1 or Type 2 Diversion Route.</li> <li>• Diversion message for specific audience.</li> <li>• Implied good reason for following Action message element (2 lanes closed).</li> <li>• Replacing Incident Descriptor message element with Lanes Closed message element.</li> </ul>	2 LANES CLOSED AT ROWLAND	PHILADELPHIA USE I-676 NORTH		

<sup>A</sup> Large VMS: 3 lines, 20 characters per line; Portable VMS: 3 lines, 8 characters per line. All messages are for operating speeds above 35 mph and thus are limited to 4 units of information.

<sup>B</sup> Blank cells indicate that the message cannot be displayed on a portable VMS.

## VMS ON DIFFERENT FREEWAY THAN THE ROADWORK

Table 12.15 VMS Message Examples for Lane Closures During Roadwork VMS on Different Freeway Than Lane Closure <sup>A</sup>				
Message Characteristics Highlights	Large VMS		Portable VMS <sup>B</sup>	
	Frame 1	Frame 2	Frame 1	Frame 2
<ul style="list-style-type: none"> <li>● “ROADWORK” for Roadwork Descriptor message element.</li> <li>● Lane Closure Location message element.</li> <li>● Lanes Closed message element.</li> <li>● No Action message element.</li> </ul>	(Requires a four-line VMS.)			
<ul style="list-style-type: none"> <li>● “ROADWORK” for Roadwork Descriptor message element.</li> <li>● Lane Closure Location message element.</li> <li>● No Action message element.</li> </ul>	ROADWORK ON I-80 WEST AT ROWLAND DR			
<ul style="list-style-type: none"> <li>● Highway name (number) for Lane Closure Location message element.</li> <li>● No Action message element.</li> </ul>	ROADWORK ON I-80 WEST NEAR I-287			
<ul style="list-style-type: none"> <li>● Replacing Roadwork Descriptor message element with Lanes Closed message element.</li> </ul>	2 LANES CLOSED ON I-80 WEST NEAR I-287			
<ul style="list-style-type: none"> <li>● Displaying the limits of the Lane Closure Location message element.</li> <li>● Replacing Roadwork Descriptor message element with Lanes Closed message element.</li> </ul>	(Requires a four-line VMS.)			
<ul style="list-style-type: none"> <li>● Action message element.</li> <li>● No diversion.</li> </ul>	(Does not apply in this case.)			
<ul style="list-style-type: none"> <li>● Action message element.</li> <li>● No diversion.</li> <li>● Replacing Lane Closure Descriptor message element with Lanes Closed message element.</li> </ul>	(Does not apply in this case.)			

<sup>A</sup> Large VMS: 3 lines, 20 characters per line; Portable VMS: 3 lines, 8 characters per line. All messages are for operating speeds above 35 mph and thus are limited to 4 units of information.

<sup>B</sup> Blank cells indicate that the message cannot be displayed on a portable VMS.

Message Characteristics Highlights	Large VMS		Portable VMS <sup>B</sup>	
	Frame 1	Frame 2	Frame 1	Frame 2
<ul style="list-style-type: none"> <li>• “Soft” diversion.</li> </ul>	(Requires a five-unit message.)			
<ul style="list-style-type: none"> <li>• “Soft” diversion.</li> <li>• Replacing Lane Closure Descriptor message element with Lanes Closed message element.</li> </ul>	(Requires a four-line VMS.)			
<ul style="list-style-type: none"> <li>• Diversion to Type 1 or Type 2 Diversion Route.</li> <li>• Replacing Incident Descriptor message element with Lanes Closed message element.</li> </ul>	(Requires a four-line VMS.)			
<ul style="list-style-type: none"> <li>• Diversion to Type 1 or Type 2 Diversion Route.</li> <li>• Good reason for following Action message element.</li> <li>• Replacing Incident Descriptor message element with Lanes Closed message element.</li> </ul>	(Requires a five-unit message.)			
<ul style="list-style-type: none"> <li>• Diversion to Type 1 or Type 2 Diversion Route.</li> <li>• Diversion message for specific audience.</li> <li>• Implied good reason for following Action message element (2 lanes closed).</li> <li>• Replacing Incident Descriptor message element with Lanes Closed message element.</li> </ul>	(Requires a five-unit message.)			

<sup>A</sup> Large VMS: 3 lines, 20 characters per line; Portable VMS: 3 lines, 8 characters per line. All messages are for operating speeds above 35 mph and thus are limited to 4 units of information.

<sup>B</sup> Blank cells indicate that the message cannot be displayed on a portable VMS.

## 12.7 ROADWORK REQUIRING TOTAL FREEWAY CLOSURE

### VMS ON SAME FREEWAY AND RELATIVELY CLOSE TO THE CLOSURE

Table 12.16 VMS Message Examples for Roadwork Requiring Total Freeway Closure VMS Close to Closure <sup>A</sup>				
Message Characteristics Highlights	Large VMS		Portable VMS	
	Frame 1	Frame 2	Frame 1	Frame 2
<ul style="list-style-type: none"> <li>• “ROADWORK” for Roadwork Descriptor message element.</li> <li>• Lane Closure Location message element.</li> <li>• Lanes Closed message element.</li> <li>• No Action message element.</li> </ul>	ROADWORK AT ROWLAND ALL LANES CLOSED		ROADWORK AT ROWLAND	ALL LANES CLOSED
<ul style="list-style-type: none"> <li>• Highway name (number) for Lane Closure Location message element.</li> <li>• No Action message element.</li> </ul>	ROADWORK NEAR I-287 ALL LANES CLOSED		ROADWORK NEAR I-287	ALL LANES CLOSED
<ul style="list-style-type: none"> <li>• Combining Roadwork Descriptor and Lanes Closed message elements.</li> </ul>	FREEWAY CLOSED NEAR I-287			
<ul style="list-style-type: none"> <li>• Combining Roadwork Descriptor and Lanes Closed message elements.</li> <li>• Replacing Roadwork Descriptor message element with Lanes Closed message element.</li> </ul>	FREEWAY CLOSED FROM I-287 TO ROWLAND			
<ul style="list-style-type: none"> <li>• Action message element.</li> </ul>	ROADWORK ALL LANES CLOSED	EXIT AT RIVER RD FOLLOW DETOUR		
<ul style="list-style-type: none"> <li>• Action message element.</li> <li>• Combining Roadwork Descriptor and Lanes Closed message elements.</li> </ul>	FREEWAY CLOSED EXIT AT RIVER RD FOLLOW DETOUR			
<ul style="list-style-type: none"> <li>• Action message element.</li> <li>• No diversion.</li> </ul>	(Does not apply in this case.)			

<sup>A</sup> Large VMS: 3 lines, 20 characters per line; Portable VMS: 3 lines, 8 characters per line. All messages are for operating speeds above 35 mph and thus are limited to 4 units of information.

<sup>B</sup> Blank cells indicate that the message cannot be displayed on a portable VMS.

Message Characteristics Highlights	Large VMS		Portable VMS <sup>B</sup>	
	Frame 1	Frame 2	Frame 1	Frame 2
<ul style="list-style-type: none"> <li>• “Soft” diversion.</li> </ul>	(Does not apply in this case.)			
<ul style="list-style-type: none"> <li>• “Soft” diversion.</li> <li>• Combining Roadwork Descriptor and Lanes Closed message elements.</li> </ul>	(Does not apply in this case.)			
<ul style="list-style-type: none"> <li>• Diversion to Type 1 or Type 2 Diversion Route.</li> <li>• Combining Roadwork Descriptor and Lanes Closed message elements.</li> </ul>	(Does not apply in this case.)			
<ul style="list-style-type: none"> <li>• Diversion to Type 1 or Type 2 Diversion Route.</li> <li>• Good reason for following Action message element.</li> <li>• Combining Roadwork Descriptor and Lanes Closed message elements.</li> </ul>	(Does not apply in this case.)			
<ul style="list-style-type: none"> <li>• Diversion to Type 1 or Type 2 Diversion Route.</li> <li>• Diversion message for specific audience.</li> <li>• Implied good reason for following Action message element (2 lanes closed).</li> <li>• Combining Roadwork Descriptor and Lanes Closed message elements.</li> </ul>	(Does not apply in this case.)			
<ul style="list-style-type: none"> <li>• Diversion to Type 6 Detour Route.</li> <li>• Combining Roadwork Descriptor and Lanes Closed message elements.</li> </ul>	FREEWAY CLOSED EXIT AT RIVER RD FOLLOW DETOUR			

<sup>A</sup> Large VMS: 3 lines, 20 characters per line; Portable VMS: 3 lines, 8 characters per line. All messages are for operating speeds above 35 mph and thus are limited to 4 units of information.

<sup>B</sup> Blank cells indicate that the message cannot be displayed on a portable VMS.

## VMS ON SAME FREEWAY BUT RELATIVELY FAR FROM THE CLOSURE

Table 12.17 VMS Message Examples for Roadwork Requiring Total Freeway Closure VMS Far from Closure <sup>A</sup>				
Message Characteristics Highlights	Large VMS		Portable VMS	
	Frame 1	Frame 2	Frame 1	Frame 2
<ul style="list-style-type: none"> <li>● “ROADWORK” for Roadwork Descriptor message element.</li> <li>● Lane Closure Location message element.</li> <li>● Lanes Closed message element.</li> <li>● No Action message element.</li> </ul>	ROADWORK AT ROWLAND DR ALL LANES CLOSED		ROADWORK AT ROWLAND	ALL LANES CLOSED
<ul style="list-style-type: none"> <li>● Highway name (number) for Lane Closure Location message element.</li> <li>● No Action message element.</li> </ul>	ROADWORK NEAR I-287 ALL LANES CLOSED		ROADWORK NEAR I-287	ALL LANES CLOSED
<ul style="list-style-type: none"> <li>● Combining Roadwork Descriptor and Lanes Closed message elements.</li> </ul>	FREEWAY CLOSED NEAR I-287			
<ul style="list-style-type: none"> <li>● Combining Roadwork Descriptor and Lanes Closed message elements.</li> <li>● Replacing Roadwork Descriptor message element with Lanes Closed message element.</li> </ul>	FREEWAY CLOSED FROM I-287 TO ROWLAND			
<ul style="list-style-type: none"> <li>● Action message element.</li> </ul>	ROADWORK ALL LANES CLOSED	EXIT AT RIVER RD FOLLOW DETOUR		
<ul style="list-style-type: none"> <li>● Action message element.</li> <li>● Combining Roadwork Descriptor and Lanes Closed message elements.</li> </ul>	FREEWAY CLOSED EXIT AT RIVER RD FOLLOW DETOUR			
<ul style="list-style-type: none"> <li>● Action message element.</li> <li>● No diversion.</li> </ul>	(Does not apply in this case.)			
<ul style="list-style-type: none"> <li>● Action message element.</li> <li>● No diversion.</li> <li>● Combining Roadwork Descriptor and Lanes Closed message elements.</li> </ul>	(Does not apply in this case.)			

<sup>A</sup> Large VMS: 3 lines, 20 characters per line; Portable VMS: 3 lines, 8 characters per line. All messages are for operating speeds above 35 mph and thus are limited to 4 units of information.

<sup>B</sup> Blank cells indicate that the message cannot be displayed on a portable VMS.



Message Characteristics Highlights	Large VMS		Portable VMS <sup>B</sup>	
	Frame 1	Frame 2	Frame 1	Frame 2
<ul style="list-style-type: none"> <li>● “Soft” diversion.</li> </ul>	ROADWORK BEFORE ROWLAND	ALL LANES CLOSED USE OTHER ROUTES		
<ul style="list-style-type: none"> <li>● “Soft” diversion.</li> <li>● Combining Roadwork Descriptor and Lanes Closed message elements.</li> </ul>	FREEWAY CLOSED BEFORE ROWLAND	USE OTHER ROUTES		
	----- FREEWAY CLOSED BEFORE ROWLAND USE OTHER ROUTES			
<ul style="list-style-type: none"> <li>● Diversion to Type 1 or Type 2 Diversion Route.</li> <li>● Combining Roadwork Descriptor and Lanes Closed message elements.</li> </ul>	FREEWAY CLOSED AT ROWLAND	USE MONROE BLVD		
	----- FREEWAY CLOSED AT ROWLAND USE MONROE BLVD			
<ul style="list-style-type: none"> <li>● Diversion to Type 1 or Type 2 Diversion Route.</li> <li>● Good reason for following Action message element.</li> <li>● Combining Roadwork Descriptor and Lanes Closed message elements.</li> </ul>	FREEWAY CLOSED AT ROWLAND	USE MONROE BLVD AVOID MAJOR DELAY		
<ul style="list-style-type: none"> <li>● Diversion to Type 1 or Type 2 Diversion Route.</li> <li>● Diversion message for specific audience.</li> <li>● Implied good reason for following Action message element (FREEWAY CLOSED).</li> <li>● Combining Roadwork Descriptor and Lanes Closed message elements.</li> </ul>	FREEWAY CLOSED AT ROWLAND	PHILADELPHIA USE I-676 NORTH		
<ul style="list-style-type: none"> <li>● Diversion to Type 6 Detour Route.</li> <li>● Combining Roadwork Descriptor and Lanes Closed message elements.</li> </ul>	FREEWAY CLOSED EXIT AT RIVER RD FOLLOW DETOUR			

<sup>A</sup> Large VMS: 3 lines, 20 characters per line; Portable VMS: 3 lines, 8 characters per line. All messages are for operating speeds above 35 mph and thus are limited to 4 units of information.

<sup>B</sup> Blank cells indicate that the message cannot be displayed on a portable VMS.

## VMS ON DIFFERENT FREEWAY THAN THE ROADWORK AND CLOSURE

Table 12.18 VMS Message Examples for Roadwork Requiring Total Freeway Closure VMS on Different Highway <sup>A</sup>				
Message Characteristics Highlights	Large VMS		Portable VMS <sup>B</sup>	
	Frame 1	Frame 2	Frame 1	Frame 2
<ul style="list-style-type: none"> <li>● <i>“ROADWORK” for Roadwork Descriptor message element.</i></li> <li>● <i>Lane Closure Location message element.</i></li> <li>● <i>Lanes Closed message element.</i></li> <li>● <i>No Action message element.</i></li> </ul>	(Requires four-line sign.)			
<ul style="list-style-type: none"> <li>● <i>Highway name (number) for Lane Closure Location message element.</i></li> <li>● <i>No Action message element.</i></li> </ul>	(Requires four-line sign.)			
<ul style="list-style-type: none"> <li>● <i>Combining Roadwork Descriptor and Lanes Closed message elements.</i></li> </ul>	I-80 WEST CLOSED NEAR I-287			
<ul style="list-style-type: none"> <li>● <i>Combining Roadwork Descriptor and Lanes Closed message elements.</i></li> <li>● <i>Replacing Roadwork Descriptor message element with Lanes Closed message element.</i></li> </ul>	I-80 WEST CLOSED FROM I-287 TO ROWLAND			
<ul style="list-style-type: none"> <li>● <i>Action message element.</i></li> </ul>	(Requires a five-unit message.)			
<ul style="list-style-type: none"> <li>● <i>Action message element.</i></li> <li>● <i>Combining Roadwork Descriptor and Lanes Closed message elements.</i></li> </ul>	(Does not apply in this case.)			
<ul style="list-style-type: none"> <li>● <i>Action message element.</i></li> <li>● <i>No diversion.</i></li> </ul>	(Does not apply in this case.)			
<ul style="list-style-type: none"> <li>● <i>Action message element.</i></li> <li>● <i>No diversion.</i></li> <li>● <i>Combining Roadwork Descriptor and Lanes Closed message elements.</i></li> </ul>	(Does not apply in this case.)			

<sup>A</sup> Large VMS: 3 lines, 20 characters per line; Portable VMS: 3 lines, 8 characters per line. All messages are for operating speeds above 35 mph and thus are limited to 4 units of information.

<sup>B</sup> Blank cells indicate that the message cannot be displayed on a portable VMS.

Message Characteristics Highlights	Large VMS		Portable VMS <sup>B</sup>	
	Frame 1	Frame 2	Frame 1	Frame 2
<ul style="list-style-type: none"> <li>● “Soft” diversion.</li> </ul>	(Requires a five-unit message.)			
<ul style="list-style-type: none"> <li>● “Soft” diversion.</li> <li>● Combining Roadwork Descriptor and Lanes Closed message elements.</li> </ul>	I-80 WEST CLOSED BEFORE ROWLAND USE OTHER ROUTES			
<ul style="list-style-type: none"> <li>● Diversion to Type 1 or Type 2 Diversion Route.</li> <li>● Combining Roadwork Descriptor and Lanes Closed message elements.</li> </ul>	I-80 WEST CLOSED AT ROWLAND USE MONROE BLVD			
<ul style="list-style-type: none"> <li>● Diversion to Type 1 or Type 2 Diversion Route.</li> <li>● Good reason for following Action message element.</li> <li>● Combining Roadwork Descriptor and Lanes Closed message elements.</li> </ul>	(Requires a four-line sign.)			
<ul style="list-style-type: none"> <li>● Diversion to Type 1 or Type 2 Diversion Route.</li> <li>● Diversion message for specific audience.</li> <li>● Implied good reason for following Action message element (FREEWAY CLOSED).</li> <li>● Combining Roadwork Descriptor and Lanes Closed message elements.</li> </ul>	I-80 WEST CLOSED AT ROWLAND	PHILADELPHIA USE I-676 NORTH		
<ul style="list-style-type: none"> <li>● Diversion to Type 6 Detour Route.</li> <li>● Combining Roadwork Descriptor and Lanes Closed message elements.</li> </ul>	(Does not apply in this case.)			

<sup>A</sup> Large VMS: 3 lines, 20 characters per line; Portable VMS: 3 lines, 8 characters per line. All messages are for operating speeds above 35 mph and thus are limited to 4 units of information.

<sup>B</sup> Blank cells indicate that the message cannot be displayed on a portable VMS.

# MODULE 13. MODIFYING MESSAGES TO IMPROVE EFFECTIVENESS

## TABLE OF CONTENTS

<b>13.1 INTRODUCTION</b> .....	13-1
EXAMPLES OF IMPROVED MESSAGES FOR INCIDENTS.....	13-2
EXAMPLES OF IMPROVED MESSAGES FOR ROADWORK .....	13-7

**THIS PAGE LEFT BLANK**

## **MODULE 13. MODIFYING MESSAGES TO IMPROVE EFFECTIVENESS**

### **13.1 INTRODUCTION**

Module 13 contains recommended improvements to several poorly designed VMS messages that have been observed by the author in different parts of the United States. They do not represent messages observed in New Jersey. Notes that highlight the reasons for the recommended changes to the observed messages are also provided.

It should be noted that in the examples given the freeway and highway numbers and names have been changed from the original.

## EXAMPLES OF IMPROVED MESSAGES FOR INCIDENTS

Table 13.1 Incident Messages

Old Message		Recommended Message*		Notes
First Frame	Second Frame	First Frame	Second Frame	
ACCIDENT AHEAD USE CAUTION		ACCIDENT AT [location]		<ul style="list-style-type: none"> <li>● It is best to give the location of the incident. Knowledge of the incident location is useful to motorists to make diversion and other driving decisions.</li> <li>● <i>AHEAD</i> is redundant and need not be displayed because it is understood by motorists that the accident is ahead on the freeway.</li> </ul>
ACCIDENT AHEAD 21ST STREET USE CAUTION		ACCIDENT AT 21ST STREET 2 LEFT LANES CLOSED		<ul style="list-style-type: none"> <li>● <i>AT</i> should be displayed before the location of the incident.</li> <li>● Knowledge of the number of lanes closed is useful to motorists to evaluate the potential amount of delay.</li> <li>● Knowledge of which lanes are closed is useful to motorists to determine which lanes they should use to travel past the incident.</li> <li>● <i>AHEAD</i> is redundant and need not be displayed because it is understood by motorists that the accident is ahead on the freeway.</li> </ul>
ACCIDENT AHEAD I-84 EXPECT DELAYS		ACCIDENT AT [location] 2 LEFT LANES CLOSED		<ul style="list-style-type: none"> <li>● It is best to give the location of the incident rather than the information that the accident is on I-84. If the VMS is on I-84, it will be understood by motorists that the accident is on I-84 and it need not be displayed.</li> <li>● Knowledge of the incident location is useful to motorists to make diversion and other driving decisions.</li> <li>● Knowledge of the number of lanes closed is useful to motorists to evaluate the potential amount of delay.</li> <li>● Knowledge of which lanes are closed is useful to motorists to determine which lanes they should use to travel past the incident.</li> <li>● <i>AHEAD</i> is redundant and need not be displayed because it is understood by motorists that the accident is ahead on I-84.</li> </ul>

\* Assumes 3- or 4-line, 20 character per line VMS.

Old Message		Recommended Message*		Notes
First Frame	Second Frame	First Frame	Second Frame	
ACCIDENT AHEAD RIGHT LANES USE CAUTION		ACCIDENT AT [location] 2 RIGHT LANES CLOSED		<ul style="list-style-type: none"> <li>● It is best to give the location of the incident rather than the information that the accident is ahead. Knowledge of the incident location is useful to motorists to make diversion and other driving decisions.</li> <li>● Knowledge of the number of lanes closed is useful to motorists to evaluate the potential amount of delay.</li> <li>● <b>AHEAD</b> is redundant and need not be displayed because it is understood by motorists that the accident is ahead.</li> </ul>
ACCIDENT AHEAD ONE RIGHT LANE OPEN	ACCIDENT AHEAD BROOK BRIDGE EXPECT DELAYS	ACCIDENT AT BROOK BRIDGE 2 LEFT LANES CLOSED		<ul style="list-style-type: none"> <li>● The current message has five units of information and can be reduced to three units.</li> <li>● Knowledge of the number of lanes closed is useful to motorists to evaluate the potential amount of delay.</li> <li>● Knowledge of which lanes are closed is useful to motorists to determine which lanes they should use to travel past the incident.</li> <li>● <b>AHEAD</b> is redundant and need not be displayed because it is understood by motorists that the accident is ahead on the freeway.</li> </ul>
ACCIDENT AHEAD REDUCE SPEED MERGE LEFT	RIGHT LANE CLOSED AHEAD DRIVE CAREFULLY	ACCIDENT AT [location] RIGHT LANE CLOSED		<ul style="list-style-type: none"> <li>● The current message has five units of information and can be reduced to three units.</li> <li>● It is best to give the location of the accident. Knowledge of the accident location is useful to motorists to make diversion and other driving decisions.</li> <li>● Knowledge of the number of lanes closed is useful to motorists to evaluate the potential amount of delay.</li> <li>● <b>AHEAD</b> is redundant and need not be displayed because it is understood by motorists that the accident is ahead on the freeway.</li> <li>● <b>MERGE LEFT</b> is redundant to <b>RIGHT LANE CLOSED</b> and can be omitted.</li> </ul>



Old Message		Recommended Message*		Notes
First Frame	Second Frame	First Frame	Second Frame	
ALL LANES CLOSED AHEAD KEEP RIGHT		FREEWAY CLOSED	EXIT AT [location] FOLLOW DETOUR	<ul style="list-style-type: none"> <li>● <b>FREEWAY CLOSED</b> is used rather than <b>ALL LANES CLOSED</b> because it is shorter and means the same thing to motorists.</li> <li>● Telling motorists where to exit is useful.</li> <li>● Telling motorists to follow a detour that is set up because of the closure gives motorists the assurance that they will have positive guidance along the alternative route.</li> <li>● The recommended message is placed on two frames because research has shown that no more than three units of information should be displayed on a message frame. The second frame in the recommended message has three units of information.</li> </ul>
ACCIDENT IH-84 EAST AT ROWLAND	USE ALTERNATE ROUTES	ACCIDENT AT ROWLAND	USE OTHER ROUTES	<ul style="list-style-type: none"> <li>● If the VMS is located on I-84 East, the accident is understood to be on I-84 East and it need not be displayed.</li> <li>● <b>OTHER</b> is used rather than <b>ALTERNATE</b> because it is shorter and easier to read and will be understood by motorists.</li> </ul>
		ACCIDENT ON I-84 EAST AT ROWLAND	USE OTHER ROUTES	<ul style="list-style-type: none"> <li>● If the VMS is located on a cross freeway to I-84 East, then <b>ON I-84 EAST</b> must be displayed.</li> <li>● <b>I-84</b> should be used rather than <b>IH-84</b>. Human factors research by TTI revealed that motorists do not understand "IH."</li> </ul>
IH-84 EAST ACCIDENT AT ROWLAND	USE ALTERNATE ROUTES	ACCIDENT AT ROWLAND USE OTHER ROUTES		<ul style="list-style-type: none"> <li>● If the VMS is located on I-84 EAST, the accident is understood to be on I-84 EAST and it need not be displayed.</li> <li>● The problem <b>ACCIDENT</b> should always be on the top line.</li> <li>● <b>OTHER</b> is used rather than <b>ALTERNATE</b> because it is shorter and easier to read and will be understood by motorists.</li> </ul>
IH-84 EAST ACCIDENT DOWNTOWN	TWO RIGHT LANES CLOSED	ACCIDENT NEAR DOWNTOWN 2 RIGHT LANES CLOSED		<ul style="list-style-type: none"> <li>● If the VMS is located on I-84 East, the accident is understood to be on I-84 East and it need not be displayed.</li> <li>● The problem <b>ACCIDENT</b> should always be on the top line.</li> <li>● <b>2</b> should be used rather than <b>TWO</b> because it is shorter and more easily read by motorists.</li> <li>● <b>NEAR</b> is displayed in front of <b>DOWNTOWN</b> to reduce possibility of confusion as to the location of the accident.</li> </ul>

Old Message		Recommended Message*		Notes
First Frame	Second Frame	First Frame	Second Frame	
IH-84 EB AT ROWLAND MAJOR ACCIDENT		MAJOR ACCIDENT AT ROWLAND 2 LANES CLOSED		<ul style="list-style-type: none"> <li>● The incident should be displayed on the top line followed by the location.</li> <li>● The word <b>AT</b> should be separated from the first unit of information and be placed with the location of the incident (second unit of information). A message line should not contain portions of two different units of information.</li> <li>● Knowledge of the number of lanes closed is useful to motorists to evaluate the potential amount of delay.</li> <li>● Human factors research conducted by TTI revealed that a large majority of motorists do not understand the meaning of the abbreviation <b>EB</b>.</li> </ul>
IH-84 EAST CLOSED AT ROWLAND	USE ALTERNATE ROUTES	FREEWAY CLOSED AT ROWLAND USE OTHER ROUTES		<ul style="list-style-type: none"> <li>● <b>FREEWAY</b> is used rather than <b>I-84 EAST</b> because it is shorter and easier to read and is well understood to mean the freeway on which the motorist is traveling.</li> <li>● The word <b>CLOSED</b> from the first unit of information should be separated from the word <b>AT</b> from the second unit of information. A message line should not contain portions of two different units of information.</li> <li>● <b>OTHER</b> is used rather than <b>ALTERNATE</b> because it is shorter and easier to read.</li> </ul>
IH-84 EB AT ROWLAND ACCIDENT	2 LEFT LANES CLOSED EXPECT DELAY	ACCIDENT AT ROWLAND 2 LEFT LANES CLOSED		<ul style="list-style-type: none"> <li>● If the VMS is located on I-84 EAST, the accident is understood to be on I-84 EAST and it need not be displayed.</li> <li>● The word <b>AT</b> should be separated from the first unit of information and be placed with the location of the incident (second unit of information). A message line should not contain portions of two different units of information.</li> <li>● Knowledge of the number of lanes closed is useful to motorists to evaluate the potential amount of delay.</li> <li>● <b>AHEAD</b> is redundant and need not be displayed because it is understood by motorists that the accident is ahead on I-84.</li> <li>● The abbreviation <b>EB</b> should not be used. Recent human factors studies conducted by TTI indicated that a large percentage of motorists would not understand the abbreviation <b>EB</b>.</li> <li>● When two lanes are closed due to an accident, most motorists will <b>EXPECT DELAYS</b>. Thus, it can be omitted.</li> </ul>

Old Message		Recommended Message*		Notes
First Frame	Second Frame	First Frame	Second Frame	
IH-84 EB AT ROWLAND FREEWAY CLOSED	AVOID DELAY USE ALTERNATE ROUTES	FREEWAY CLOSED AT ROWLAND USE OTHER ROUTES		<ul style="list-style-type: none"> <li>● The current message has five units of information and can be reduced to three units.</li> <li>● The incident should be displayed on the top line followed by the incident location.</li> <li>● Human factors research conducted by TTI revealed that a large majority of motorists do not understand the meaning of the abbreviation <b>EB</b>.</li> <li>● <b>OTHER</b> is used rather than <b>ALTERNATE</b> because it is shorter and easier to read and will be understood by motorists</li> </ul>
FREEWAY CLOSED AT ROWLAND MAJOR ACCIDENT	ALL TRAFFIC EXIT ROWLAND	FREEWAY CLOSED	EXIT AT ROWLAND USE SERVICE RD	<ul style="list-style-type: none"> <li>● The current message has five units of information and can be reduced to four units.</li> <li>● <b>FREEWAY CLOSED</b> is used rather than <b>MAJOR ACCIDENT</b> because it represents the immediate problem the motorists will face.</li> <li>● If the freeway is closed, the motorists will understand that <b>ALL TRAFFIC</b> must exit. The recommendation is to tell the motorists that they should <b>EXIT AT WASHINGTON</b> and then <b>USE SERVICE ROAD</b> to bypass the incident.</li> </ul>
MAJOR ACCIDENT AT ROWLAND ON MAIN LANES	AVOID DELAY USE ALTERNATE ROUTE	MAJOR ACCIDENT AT ROWLAND USE OTHER ROUTES		<ul style="list-style-type: none"> <li>● Information that the accident is <b>ON MAIN LANES</b> will be understood by motorists and it need not be displayed.</li> <li>● <b>OTHER</b> is used rather than <b>ALTERNATE</b> because it is shorter and easier to read.</li> <li>● The motorist would assume that if told to use other routes the motorist would avoid delay. Thus <b>AVOID DELAY</b> need not be displayed.</li> </ul>
MAJOR ACCIDENT AT ROWLAND CLEARED AT 5:10	2 LEFT LANES CLOSED EXPECT DELAY	MAJOR ACCIDENT AT ROWLAND CLEARED AT 5:10		<ul style="list-style-type: none"> <li>● Conflicting information is given in the current message. The first message frame states that the accident was cleared at 5:10; the second frame states that two lanes are closed. The recommended message is based on the assumption that the former is true.</li> </ul>

## EXAMPLES OF IMPROVED MESSAGES FOR ROADWORK

Table 13.2 Roadwork Messages

Old Message		Recommended Message*		Notes
First Frame	Second Frame	First Frame	Second Frame	
LEFT LANE CLOSED AHEAD EXPECT DELAY		LFT LANE CLOSED AT [location] EXPECT DELAY		<ul style="list-style-type: none"> <li>● It is best to give the location of the lane closure. Knowledge of the lane closure location is useful to motorists to make diversion and other driving decisions.</li> <li>● <b>AHEAD</b> is redundant and need not be displayed because it is understood by motorists that the lane closure is ahead on the freeway.</li> </ul>
RIGHT TWO LANES CLOSED KEEP LEFT		2 RIGHT LANES CLOSED AT [location]		<ul style="list-style-type: none"> <li>● It is best to give the location of the lane closure. Knowledge of the lane closure location is useful to motorists to make diversion and other driving decisions.</li> <li>● 2 should be used rather than <b>TWO</b> because it is shorter and more easily read by motorists.</li> <li>● <b>KEEP LEFT</b> is redundant and need not be displayed.</li> </ul>
IH 84 REDUCED TO ONE LANE AHEAD	ROWLAND TO WOODWARD EXPECT DELAY	2 LANES CLOSED FROM ROWLAND TO WOODWARD		<ul style="list-style-type: none"> <li>● The current message has five units of information and can be reduced to three units.</li> <li>● If the VMS is located on I-84, the lanes closures are understood to be on I-84 and it need not be displayed.</li> <li>● Giving the limits of the lane closures as was done in the current message is an excellent means of informing motorists the extent of the closure and where they may return to the freeway should they decide to divert.</li> </ul>
		1 LANE OPEN FROM ROWLAND TO WOODWARD		
LANE CLOSURES BEGIN TUESDAY 8 P.M. - 6 A.M.	LANE CLOSURES TUES - THURS 8 P.M. - 6 A.M.	1 LANE CLOSED TUES - THURS 8 PM - 6 AM		<ul style="list-style-type: none"> <li>● The current message has two frames with only the middle line changing information between frames. Motorists may not notice the subtle change of only the middle line. The message can be reduced to a simple one-frame, three-unit message.</li> <li>● <b>TUES - THURS</b> is more descriptive than <b>BEGIN TUESDAY</b>. However, including it in the message would result in a five-unit message.</li> </ul>

\* Assumes 3- or 4-line, 20 character per line VMS.

Current Message		Recommended Message*		Notes
First Frame	Second Frame	First Frame	Second Frame	
LEFT TWO LANES CLOSED AT ROWLAND CONSIDER DETOUR		2 LEFT LANES CLOSED AT ROWLAND USE OTHER ROUTES		<ul style="list-style-type: none"> <li>● The word <b>CLOSED</b> in the first unit of information should be separated from the second unit of information and be placed with the problem (first unit of information). A message line should not contain portions of two different units of information.</li> <li>● 2 should be used rather than <b>TWO</b> because it is shorter and more easily read by motorists.</li> <li>● <b>USE OTHER ROUTES</b> is used rather than <b>CONSIDER DETOUR</b>. DETOUR implies to motorists that positive guidance will be provided along a route in the form of trailblazers for motorists to follow around the incident and/or police control.</li> </ul>
RIGHT TWO LANES CLOSED DOWNTOWN		2 RIGHT LANES CLOSED NEAR DOWNTOWN		<ul style="list-style-type: none"> <li>● 2 should be used rather than <b>TWO</b> because it is shorter and more easily read by motorists.</li> <li>● <b>NEAR</b> is displayed in front of <b>DOWNTOWN</b> to reduce possibility of confusion as to the location of the lane closure.</li> </ul>
CAUTION INTERSTATE 84 EASTBOUND	RIGHT THREE LANES CLOSED AHEAD	3 RIGHT LANES CLOSED AT [location]		<ul style="list-style-type: none"> <li>● This current message has five units of information that can be reduced to three units.</li> <li>● If the VMS is located on I-84 East, the lane closures are understood to be on I-84 East and it need not be displayed.</li> <li>● 3 should be used rather than <b>THREE</b> because it is shorter and more easily read by motorists.</li> <li>● It is best to give the location of the lane closure. Knowledge of the lane closure location is useful to motorists to make diversion and other driving decisions.</li> <li>● The long word <b>INTERSTATE</b> should not be used; instead, use <b>I-</b>.</li> </ul>
IH-84 EASTBOUND	RIGHT THREE LANES CLOSED	3 RIGHT LANES CLOSED AT [location]		<ul style="list-style-type: none"> <li>● If the VMS is located on I-84 EAST, the lane closures are understood to be on I-84 EAST and it need not be displayed.</li> <li>● 3 should be used rather than <b>THREE</b> because it is shorter and more easily read by motorists.</li> <li>● It is best to give the location of the lane closure. Knowledge of the lane closure location is useful to motorists to make diversion and other driving decisions.</li> </ul>

Current Message		Recommended Message*		Notes
First Frame	Second Frame	First Frame	Second Frame	
IH-84 EAST DOWNTOWN ROAD WORK	THRU TRAFFIC USE LEFT TWO LANES	ROADWORK NEAR DOWNTOWN	THRU TRAFFIC USE LEFT 2 LANES	<ul style="list-style-type: none"> <li>● The problem, <b>ROADWORK</b> should be displayed on the first line.</li> <li>● If the VMS is located on I-84 East, the roadwork is understood to be on I-84 East and it need not be displayed.</li> <li>● 2 should be used rather than <b>TWO</b> because it is shorter and more easily read by motorists.</li> <li>● The second message frame is reformatted slightly to enhance readability.</li> </ul>
IH-84 EAST ROAD WORK	AT ROWLAND ON RAMP	ROADWORK AT ROWLAND 2 LANES CLOSED		<ul style="list-style-type: none"> <li>● The problem, <b>ROADWORK</b> should be displayed on the first line.</li> <li>● Since the VMS is located on I-84 East, the roadwork is understood to be on I-84 East and it need not be displayed.</li> <li>● 2 should be used rather than <b>TWO</b> because it is shorter and more easily read by motorists.</li> <li>● The message should include the number of lanes that are closed.</li> </ul>
US-59 SB EXIT RAMP CLOSED UNTIL DEC 1998	DETOUR US-59 NORTH TO MUNSONS	RAMP TO US-59 S CLOSED	USE US-59 NORTH TO MUNSON	<ul style="list-style-type: none"> <li>● The current message has six units of information and must be reduced to a maximum of four units. This is accomplished by omitting the least relevant unit of information, namely, <b>UNTIL DEC 1998</b>. About six days prior to the opening of the ramp, the VMS can display the day of the week when the ramp will be open, if the agency desires.</li> <li>● The abbreviation <b>SB</b> should not be used. Recent human factors studies conducted by TTI indicated that a large majority of motorists do not understand the meaning of the abbreviation <b>SB</b>.</li> </ul>

**THIS PAGE LEFT BLANK**

# MODULE 14. PRIORITIES WHEN COMPETING MESSAGE NEEDS ARISE

## TABLE OF CONTENTS

**14.1 INTRODUCTION**.....14-1

**14.2 BASIC MESSAGE PRIORITIES** .....14-1

**14.3 COMMON TYPES OF COMPETING MESSAGE NEEDS** .....14-1

**14.4 RESOLUTION OF COMMON TYPES OF COMPETING MESSAGE NEEDS** .....14-2

**TWO EVENTS OCCUR CONCURRENTLY ON THE SAME FREEWAY** .....14-3

        Major Accident with Another Event.....14-3

        Minor Accident with Another Event.....14-4

        Construction with Another Event .....14-5

        Construction with Temporary Lane Closure(s) with Another Event.....14-6

        Disabled Vehicle with Another Event .....14-7

        Incident (Load Spill, Debris, etc.) Requiring a Lane Closure with Another Event .....14-8

        Incidents (Load Spill, Debris, etc.) Requiring Total Freeway Closures with Another Event .....14-9

        Maintenance Operations with Lane Closure(s) with Another Event .....14-10

        Maintenance Operations Requiring Total Freeway Closures with Another Event .....14-11

        Special Event Exit with Another Event .....14-12

**ONE EVENT OCCURS ON THE PRIMARY FREEWAY AND THE SECOND OCCURS CONCURRENTLY ON AN INTERSECTING FREEWAY** .....14-13

        Major Accident on the Primary Freeway with Another Event on an Intersecting Freeway.....14-14

        Minor Accident on the Primary Freeway with Another Event on an Intersecting Freeway.....14-15

        Construction on the Primary Freeway with Another Event on an Intersecting Freeway.....14-16

        Construction with Temporary Lane Closure(s) on the Primary Freeway with Another Event on an Intersecting Freeway.....14-17

        Disabled Vehicle on the Primary Freeway with Another Event on an Intersecting Freeway.....14-18

        Incident (Load Spill, Debris, etc.) Requiring a Lane Closure on the Primary Freeway with Another Event on an Intersecting Freeway.....14-19

        Incident (Load Spill, Debris, etc.) Requiring Total Closure of the Primary Freeway with Another Event on the Intersecting Freeway.....14-20



Maintenance Operations Requiring a Lane Closure on the Primary Freeway with Another Event on an Intersecting Freeway.....	14-21
Maintenance Operations Requiring Total Closure of the Primary Freeway with Another Event on an Intersecting Freeway.....	14-22
Special Event Exit on the Primary Freeway with Another Event on an Intersecting Freeway.....	14-23
ONE EVENT OCCURS ON THE PRIMARY FREEWAY AND THE SECOND OCCURS CONCURRENTLY ON A CONNECTING FREEWAY IN AN I-95 CORRIDOR COALITION STATE.....	14-24
TWO EVENTS OCCUR CONCURRENTLY ON AN INTERSECTING FREEWAY .....	14-25
Major Accident with Another Event.....	14-25
Minor Accident with Another Event.....	14-26
Construction with Another Event .....	14-27
Construction with Temporary Lane Closure(s) with Another Event.....	14-28
Disabled Vehicle with Another Event .....	14-29
Incident (Load Spill, Debris, etc.) Requiring a Lane Closure with Another Event .....	14-30
Incidents (Load Spill, Debris, etc.) Requiring Total Freeway Closure with Another Event .....	14-31
Maintenance Operations with Lane Closure(s) with Another Event .....	14-32
Maintenance Operations Requiring Total Freeway Closure with Another Event .....	14-33
Special Event Exit with Another Event .....	14-34
ONE EVENT OCCURS ON AN INTERSECTING FREEWAY AND THE SECOND OCCURS CONCURRENTLY ON A CONNECTING FREEWAY IN AN I-95 CORRIDOR COALITION STATE.....	14-35

## **MODULE 14. PRIORITIES WHEN COMPETING MESSAGE NEEDS ARISE**

### **14.1 INTRODUCTION**

Sometimes the VMS operator is faced with competing message needs when two or more events take place at the same time. For example, the VMS may contain a message about a downstream accident when a second accident occurs on the freeway. The VMS operator must decide which of the two accidents should be presented on the VMS because it is neither possible nor advisable to display information about two accidents. This Module is intended to provide information to help the VMS operator resolve the most common types of competing message needs that might arise.

### **14.2 BASIC MESSAGE PRIORITIES**

There are a number of different combinations of events that can take place on the primary freeway, on intersecting freeways and on freeways in an adjoining state. In general the following priority principles shall apply:

- Messages about downstream lane closures (blockages) or full closures (blockages) on the primary freeway shall receive priority over events on downstream intersecting freeways or on freeways in other states; and
- Messages about lane closures (blockages) or full closures (blockages) on downstream intersecting freeways shall receive priority over events on freeways in other states.

### **14.3 COMMON TYPES OF COMPETING MESSAGE NEEDS**

Competing VMS message needs for incidents that occur downstream of the VMS can be classified according to whether:

- Two events occur concurrently on the same freeway;
- One event occurs on the primary freeway and the second occurs concurrently on an intersecting freeway;
- One event occurs on the primary freeway and the second occurs concurrently on a connecting freeway in an I-95 Corridor Coalition state;
- Two events occur concurrently on an intersecting freeway; or
- One event occurs on an intersecting freeway and the second occurs concurrently on a connecting freeway in an I-95 Corridor Coalition state.

## 14.4 RESOLUTION OF COMMON TYPES OF COMPETING MESSAGE NEEDS

This section provides guidance to the VMS operator about the priority of information display when two concurrent events occur on the freeway(s) for each of the classifications given in [Section 14.3](#).

[Article 11](#) in the VMS Operating Policy for New Jersey Department of Transportation (Module 3) specifies the circumstances for which VMS messages should be displayed for major and minor incidents. These are events that occur on 1) the primary freeway, 2) intersecting freeways and 3) connecting freeways in states within the I-95 Corridor Coalition.

In establishing the priorities in this section, it is assumed that incidents that occur on the freeways have a good chance of adversely affecting a large percentage of motorists on the freeways. For example, a major incident on an intersecting freeway may possibly have an adverse affect on motorists who will turn off the primary freeway onto the intersecting freeway. However, if the major incident is downstream (e.g., 10 miles) of the interchange, then the likelihood that the incident would affect motorists turning onto the intersecting freeway would greatly diminish. The VMS operator should consult with the TOC manager when the operator is uncertain about possible adverse affects to motorists on the primary freeway.

**THE VMS MESSAGE PRIORITIES ASSUME:**

- **Motorists who travel past the VMS will be adversely affected by the incidents; and**
- **A high majority of motorists normally remain on the primary freeway rather than turning onto an intersecting freeway.**

**TWO EVENTS OCCUR CONCURRENTLY ON THE SAME FREEWAY**

**Major Accident with Another Event**

The priorities of messages when a major accident occurs on the same freeway concurrently with another event are summarized in Tables 14.1 and 14.2.

<b>Table 14.1 Message Priority for Major Accidents that Occur UPSTREAM of Another Event</b>	
<b>Major Accident Occurs Upstream of:</b>	<b>Give Message Priority to:</b>
● Accident (Major)	Upstream major accident
● Accident (Minor)	Upstream major accident
● Construction project	Upstream major accident
● Construction project with temporary lane closure(s)	Upstream major accident
● Disabled vehicle blocking a lane	Upstream major accident
● Incident (Load spill, debris, etc.) requiring lane closure	Upstream major accident
● Incident (Load spill, debris, etc.) requiring total freeway closure	Upstream major accident
● Maintenance operations with lane closure(s)	Upstream major accident
● Maintenance operations requiring total freeway closure	Upstream major accident
● Special event exit	Upstream major accident
● Adjoining state accident (Major)	Upstream major accident
● Adjoining state maintenance operations requiring total freeway closure	Upstream major accident
● Adjoining state incident (Load spill, debris, etc.) requiring total freeway closure	Upstream major accident

<b>Table 14.2 Message Priority for Major Accidents that Occur DOWNSTREAM of Another Event</b>	
<b>Major Accident Occurs Downstream of:</b>	<b>Give Message Priority to:</b>
● Accident (Major)	Upstream major accident
● Accident (Minor)	Upstream minor accident
● Construction project	Downstream major accident
● Construction project with temporary lane closure(s)	Downstream major accident
● Disabled vehicle blocking a lane	Downstream major accident
● Incident (Load spill, debris, etc.) requiring lane closure	Downstream major accident
● Incident (Load spill, debris, etc.) requiring total freeway closure	Upstream incident
● Maintenance operations with lane closure(s)	Downstream major accident
● Maintenance operations requiring total freeway closure	Upstream maintenance
● Special event exit	Downstream major accident

**Minor Accident with Another Event**

The priorities of messages when a minor accident occurs on the same freeway concurrently with another event are summarized in Tables 14.3 and 14.4.

<b>Table 14.3 Message Priority for Minor Accidents that Occur UPSTREAM of Another Event</b>	
<b>Minor Accident Occurs Upstream of:</b>	<b>Give Message Priority to:</b>
● Accident (Major)	Upstream minor accident
● Accident (Minor)	Upstream minor accident
● Construction project	Upstream minor accident
● Construction project with temporary lane closure(s)	Upstream minor accident
● Disabled vehicle blocking a lane	Upstream minor accident
● Incident (Load spill, debris, etc.) requiring lane closure	Upstream minor accident
● Incident (Load spill, debris, etc.) requiring total freeway closure	Downstream incident
● Maintenance operations with lane closure(s)	Upstream minor accident
● Maintenance operations requiring total freeway closure	Downstream maintenance
● Special event exit	Upstream minor accident
● Adjoining state: Accident (Major)	Upstream minor accident
● Adjoining state: Maintenance operations requiring total freeway closure	Upstream minor accident
● Adjoining state incident (Load spill, debris, etc.) requiring total freeway closure	Upstream minor accident

<b>Table 14.4 Message Priority for Minor Accidents that Occur DOWNSTREAM of Another Event</b>	
<b>Minor Accident Occurs Downstream of:</b>	<b>Give Message Priority to:</b>
● Accident (Major)	Upstream major accident
● Accident (Minor)	Upstream minor accident
● Construction project	Downstream minor accident
● Construction project with temporary lane closure(s)	Downstream minor accident
● Disabled vehicle blocking a lane	Upstream disabled vehicle
● Incident (Load spill, debris, etc.) requiring lane closure	Upstream incident
● Incident (Load spill, debris, etc.) requiring total freeway closure	Upstream incident
● Maintenance operations with lane closure(s)	Downstream minor accident
● Maintenance operations requiring total freeway closure	Upstream maintenance
● Special event exit	Downstream minor accident

**Construction with Another Event**

The priorities of messages when construction is on the same freeway concurrently with another event are summarized in Tables 14.5 and 14.6.

<b>Table 14.5 Message Priority for Construction UPSTREAM of Another Event</b>	
<b>Construction Upstream of:</b>	<b>Give Message Priority to:</b>
● Accident (Major)	Downstream major accident
● Accident (Minor)	Downstream minor accident
● Construction project	Upstream construction
● Construction project with temporary lane closure(s)	Downstream construction
● Disabled vehicle blocking a lane	Downstream disabled vehicle
● Incident (Load spill, debris, etc.) requiring lane closure	Downstream incident
● Incident (Load spill, debris, etc.) requiring total freeway closure	Downstream incident
● Maintenance operations with lane closure(s)	Downstream maintenance
● Maintenance operations requiring total freeway closure	Downstream maintenance
● Special event exit	Downstream special event exit
● Adjoining state: Accident (Major)	Adjoining state major accident
● Adjoining state: Maintenance operations requiring total freeway closure	Adjoining state maintenance
● Adjoining state incident (Load spill, debris, etc.) requiring total freeway closure	Adjoining state incident

<b>Table 14.6 Message Priority for Construction DOWNSTREAM of Another Event</b>	
<b>Construction Downstream of:</b>	<b>Give Message Priority to:</b>
● Accident (Major)	Upstream major accident
● Accident (Minor)	Upstream minor accident
● Construction project	Upstream construction
● Construction project with temporary lane closure(s)	Upstream construction
● Disabled vehicle blocking a lane	Upstream disabled vehicle
● Incident (Load spill, debris, etc.) requiring lane closure	Upstream incident
● Incident (Load spill, debris, etc.) requiring total freeway closure	Upstream incident
● Maintenance operations with lane closure(s)	Upstream maintenance
● Maintenance operations requiring total freeway closure	Upstream maintenance
● Special event exit	Upstream special event exit

**Construction with Temporary Lane Closure(s) with Another Event**

The priorities of messages when a temporary lane closure in a construction project occurs on the same freeway concurrently with another event are summarized in Tables 14.7 and 14.8.

<b>Table 14.7 Message Priority for Construction with Temporary Lane Closure(s) UPSTREAM of Another Event</b>	
<b>Construction with Temporary Lane Closure(s) Upstream of</b>	<b>Give Message Priority to:</b>
● Accident (Major)	Downstream major accident
● Accident (Minor)	Downstream minor accident
● Construction project	Upstream construction
● Construction project with temporary lane closure(s)	Upstream construction
● Disabled vehicle blocking a lane	Downstream disabled vehicle
● Incident (Load spill, debris, etc.) requiring lane closure	Downstream incident
● Incident (Load spill, debris, etc.) requiring total freeway closure	Downstream incident
● Maintenance operations with lane closure(s)	Upstream construction
● Maintenance operations requiring total freeway closure	Downstream maintenance
● Special event exit	Upstream construction
● Adjoining state: Accident (Major)	Upstream construction
● Adjoining state: Maintenance operations requiring total freeway closure	Upstream construction
● Adjoining state incident (Load spill, debris, etc.) requiring total freeway closure	Upstream construction

<b>Table 14.8 Message Priority for Construction with Temporary Lane Closure(s) DOWNSTREAM of Another Event</b>	
<b>Construction with Temporary Lane Closure(s) Downstream of:</b>	<b>Give Message Priority to:</b>
● Accident (Major)	Upstream major accident
● Accident (Minor)	Upstream minor accident
● Construction project	Downstream construction
● Construction project with temporary lane closure(s)	Upstream construction
● Disabled vehicle blocking a lane	Upstream disabled vehicle
● Incident (Load spill, debris, etc.) requiring lane closure	Upstream incident
● Incident (Load spill, debris, etc.) requiring total freeway closure	Upstream incident
● Maintenance operations with lane closure(s)	Upstream maintenance
● Maintenance operations requiring total freeway closure	Upstream maintenance
● Special event exit	Upstream special event exit

**Disabled Vehicle with Another Event**

The priorities of messages when a lane-blocking disabled vehicle is on the same freeway concurrently with another event are summarized in Tables 14.9 and 14.10.

<b>Table 14.9 Message Priority for Disabled Vehicles that Occur UPSTREAM of Another Event</b>	
<b>Disabled Vehicle Occurs Upstream of:</b>	<b>Give Message Priority to:</b>
● Accident (Major)	Downstream major accident
● Accident (Minor)	Upstream disabled vehicle
● Construction project	Upstream disabled vehicle
● Construction project with temporary lane closure(s)	Upstream disabled vehicle
● Disabled vehicle blocking a lane	Upstream disabled vehicle
● Incident (Load spill, debris, etc.) requiring lane closure	Upstream disabled vehicle
● Incident (Load spill, debris, etc.) requiring total freeway closure	Downstream incident
● Maintenance operations with lane closure(s)	Upstream disabled vehicle
● Maintenance operations requiring total freeway closure	Downstream maintenance
● Special event exit	Upstream disabled vehicle
● Adjoining state: Accident (Major)	Upstream disabled vehicle
● Adjoining state: Maintenance operations requiring total freeway closure	Upstream disabled vehicle
● Adjoining state incident (Load spill, debris, etc.) requiring total freeway closure	Upstream disabled vehicle

<b>Table 14.10 Message Priority for Disabled Vehicles that Occur DOWNSTREAM of Another Event</b>	
<b>Disabled Vehicle Occurs Downstream of:</b>	<b>Give Message Priority to:</b>
● Accident (Major)	Upstream major accident
● Accident (Minor)	Upstream minor accident
● Construction project	Downstream disabled vehicle
● Construction project with temporary lane closure(s)	Downstream disabled vehicle
● Disabled vehicle blocking a lane	Upstream disabled vehicle
● Incident (Load spill, debris, etc.) requiring lane closure	Upstream incident
● Incident (Load spill, debris, etc.) requiring total freeway closure	Upstream incident
● Maintenance operations with lane closure(s)	Upstream maintenance
● Maintenance operations requiring total freeway closure	Upstream maintenance
● Special event exit	Downstream disabled vehicle



**Incident (Load Spill, Debris, etc.) Requiring a Lane Closure with Another Event**

The priorities of messages when an incident (load spill, debris, etc.) requiring a lane closure occurs on the same freeway concurrently with another event are summarized in Tables 14.11 and 14.12.

<b>Table 14.11 Message Priority for Incidents Requiring Lane Closures that Occur UPSTREAM of Another Event</b>	
<b>Incident Requiring Lane Closure Occurs Upstream of:</b>	<b>Give Message Priority to:</b>
● Accident (Major)	Downstream major accident
● Accident (Minor)	Upstream incident
● Construction project	Upstream incident
● Construction project with temporary lane closure(s)	Upstream incident
● Disabled vehicle blocking a lane	Upstream incident
● Incident (Load spill, debris, etc.) requiring lane closure	Upstream incident
● Incident (Load spill, debris, etc.) requiring total freeway closure	Downstream incident
● Maintenance operations with lane closure(s)	Upstream incident
● Maintenance operations requiring total freeway closure	Downstream maintenance
● Special event exit	Upstream incident
● Adjoining state: Accident (Major)	Upstream incident
● Adjoining state: Maintenance operations requiring total freeway closure	Upstream incident
● Adjoining state incident (Load spill, debris, etc.) requiring total freeway closure	Upstream incident

<b>Table 14.12 Message Priority for Incidents Requiring Lane Closures that Occur DOWNSTREAM of Another Event</b>	
<b>Incident Requiring Lane Closure Occurs Downstream of:</b>	<b>Give Message Priority to:</b>
● Accident (Major)	Upstream major accident
● Accident (Minor)	Upstream minor accident
● Construction project	Downstream incident
● Construction project with temporary lane closure(s)	Downstream incident
● Disabled vehicle blocking a lane	Upstream disabled vehicle
● Incident (Load spill, debris, etc.) requiring lane closure	Upstream incident
● Incident (Load spill, debris, etc.) requiring total freeway closure	Upstream incident
● Maintenance operations with lane closure(s)	Upstream maintenance
● Maintenance operations requiring total freeway closure	Upstream maintenance
● Special event exit	Downstream incident

**Incidents (Load Spill, Debris, etc.) Requiring Total Freeway Closures with Another Event**

The priorities of messages when an incident (load spill, debris, etc.) requiring total freeway closure occurs on the same freeway concurrently with another event are summarized in Tables 14.13 and 14.14.

<b>Table 14.13 Message Priority for Incidents Requiring Total Freeway Closures that Occur UPSTREAM of Another Event</b>	
<b>Incident Requiring Total Freeway Closure Occurs Upstream of:</b>	<b>Give Message Priority to:</b>
● Accident (Major)	Upstream incident
● Accident (Minor)	Upstream incident
● Construction project	Upstream incident
● Construction project with temporary lane closure(s)	Upstream incident
● Disabled vehicle blocking a lane	Upstream incident
● Incident (Load spill, debris, etc.) requiring lane closure	Upstream incident
● Incident (Load spill, debris, etc.) requiring total freeway closure	Upstream incident
● Maintenance operations with lane closure(s)	Upstream incident
● Maintenance operations requiring total freeway closure	Upstream incident
● Special event exit	Upstream incident
● Adjoining state accident (Major)	Upstream incident
● Adjoining state maintenance operations requiring total freeway closure	Upstream incident
● Adjoining state incident (Load spill, debris, etc.) requiring total freeway closure	Upstream incident

<b>Table 14.14 Message Priority for Incidents Requiring Total Freeway Closures that Occur DOWNSTREAM of Another Event</b>	
<b>Incident Requiring Total Freeway Closure Occurs Downstream of:</b>	<b>Give Message Priority to:</b>
● Accident (Major)	Upstream major accident
● Accident (Minor)	Downstream incident
● Construction project	Downstream incident
● Construction project with temporary lane closure(s)	Downstream incident
● Disabled vehicle blocking a lane	Downstream incident
● Incident (Load spill, debris, etc.) requiring lane closure	Downstream incident
● Incident (Load spill, debris, etc.) requiring total freeway closure	Upstream incident
● Maintenance operations with lane closure(s)	Downstream incident
● Maintenance operations requiring total freeway closure	Upstream maintenance
● Special event exit	Downstream incident

**Maintenance Operations with Lane Closure(s) with Another Event**

The priorities of messages when maintenance operations with lane closure(s) take place on the same freeway concurrently with another event are summarized in Tables 14.15 and 14.16.

<b>Table 14.15 Message Priority for Maintenance Operations with Lane Closure(s) UPSTREAM of Another Event</b>	
<b>Maintenance Operations with Lane Closure(s) Upstream of:</b>	<b>Give Message Priority to:</b>
● Accident (Major)	Downstream major accident
● Accident (Minor)	Downstream minor accident
● Construction project	Upstream maintenance
● Construction project with temporary lane closure(s)	Upstream maintenance
● Disabled vehicle blocking a lane	Upstream maintenance
● Incident (Load spill, debris, etc.) requiring lane closure	Upstream maintenance
● Incident (Load spill, debris, etc.) requiring total freeway closure	Downstream incident
● Maintenance operations with lane closure(s)	Upstream maintenance
● Maintenance operations requiring total freeway closure	Downstream maintenance
● Special event exit	Upstream maintenance
● Adjoining state: Accident (Major)	Upstream maintenance
● Adjoining state: Maintenance operations requiring total freeway closure	Upstream maintenance
● Adjoining state incident (Load spill, debris, etc.) requiring total freeway closure	Upstream maintenance

<b>Table 14.16 Message Priority for Maintenance Operations with Lane Closure(s) DOWNSTREAM of Another Event</b>	
<b>Maintenance Operations with Lane Closure(s) Downstream of:</b>	<b>Give Message Priority to:</b>
● Accident (Major)	Upstream major accident
● Accident (Minor)	Upstream minor accident
● Construction project	Downstream maintenance
● Construction project with temporary lane closure(s)	Upstream construction
● Disabled vehicle blocking a lane	Upstream disabled vehicle
● Incident (Load spill, debris, etc.) requiring lane closure	Upstream incident
● Incident (Load spill, debris, etc.) requiring total freeway closure	Upstream incident
● Maintenance operations with lane closure(s)	Upstream maintenance
● Maintenance operations requiring total freeway closure	Upstream maintenance
● Special event exit	Upstream special event exit

**Maintenance Operations Requiring Total Freeway Closures with Another Event**

The priorities of messages when maintenance operations requiring total freeway closure take place on the same freeway concurrently with another event are summarized in Tables 14.17 and 14.18.

<b>Table 14.17 Message Priority for Maintenance Operations Requiring Total Freeway Closures that Occur UPSTREAM of Another Event</b>	
<b>Maintenance Operations Requiring Total Freeway Closure Occurs Upstream of:</b>	<b>Give Message Priority to:</b>
● Accident (Major)	Upstream maintenance
● Accident (Minor)	Upstream maintenance
● Construction project	Upstream maintenance
● Construction project with temporary lane closure(s)	Upstream maintenance
● Disabled vehicle blocking a lane	Upstream maintenance
● Incident (Load spill, debris, etc.) requiring lane closure	Upstream maintenance
● Incident (Load spill, debris, etc.) requiring total freeway closure	Upstream maintenance
● Maintenance operations with lane closure(s)	Upstream maintenance
● Maintenance operations requiring total freeway closure	Upstream maintenance
● Special event exit	Upstream maintenance
● Adjoining state accident (Major)	Upstream maintenance
● Adjoining state maintenance operations requiring total freeway closure	Upstream maintenance
● Adjoining state incident (Load spill, debris, etc.) requiring total freeway closure	Upstream maintenance

<b>Table 14.18 Message Priority for Maintenance Operations Requiring Total Freeway Closures that Occur DOWNSTREAM of Another Event</b>	
<b>Maintenance Operations Requiring Total Freeway Closure Occurs Downstream of:</b>	<b>Give Message Priority to:</b>
● Accident (Major)	Upstream major accident
● Accident (Minor)	Downstream maintenance
● Construction project	Downstream maintenance
● Construction project with temporary lane closure(s)	Downstream maintenance
● Disabled vehicle blocking a lane	Downstream maintenance
● Incident (Load spill, debris, etc.) requiring lane closure	Downstream maintenance
● Incident (Load spill, debris, etc.) requiring total freeway closure	Upstream incident
● Maintenance operations with lane closure(s)	Downstream maintenance
● Maintenance operations requiring total freeway closure	Upstream maintenance
● Special event exit	Downstream maintenance

**Special Event Exit with Another Event**

The priorities of messages when special event traffic uses the same freeway concurrently with another event are summarized in Tables 14.19 and 14.20.

<b>Table 14.19 Message Priority for Special Event Exit UPSTREAM of Another Event</b>	
<b>Special Event Exit Upstream of:</b>	<b>Give Message Priority to:</b>
● Accident (Major)	Downstream major accident
● Accident (Minor)	Downstream minor accident
● Construction project	Upstream special event exit
● Construction project with temporary lane closure(s)	Upstream special event exit
● Disabled vehicle blocking a lane	Downstream disabled vehicle
● Incident (Load spill, debris, etc.) requiring lane closure	Downstream incident
● Incident (Load spill, debris, etc.) requiring total freeway closure	Downstream incident
● Maintenance operations with lane closure(s)	Upstream special event exit
● Maintenance operations requiring total freeway closure	Downstream maintenance
● Special event exit	Upstream special event exit
● Adjoining state: Accident (Major)	Upstream special event exit
● Adjoining state: Maintenance operations requiring total freeway closure	Upstream special event exit
● Adjoining state incident (Load spill, debris, etc.) requiring total freeway closure	Upstream special event exit

<b>Table 14.20 Message Priority for Special Event Exit DOWNSTREAM of Another Event</b>	
<b>Special Event Exit) Downstream of:</b>	<b>Give Message Priority to:</b>
● Accident (Major)	Upstream major accident
● Accident (Minor)	Upstream minor accident
● Construction project	Downstream special event exit
● Construction project with temporary lane closure(s)	Upstream construction
● Disabled vehicle blocking a lane	Upstream disabled vehicle
● Incident (Load spill, debris, etc.) requiring lane closure	Upstream incident
● Incident (Load spill, debris, etc.) requiring total freeway closure	Upstream incident
● Maintenance operations with lane closure(s)	Upstream maintenance
● Maintenance operations requiring total freeway closure	Upstream maintenance
● Special event exit	Upstream special event exit

**ONE EVENT OCCURS ON THE PRIMARY FREEWAY AND THE SECOND OCCURS CONCURRENTLY ON AN INTERSECTING FREEWAY**

The VMS message priorities when an event occurs on the primary freeway and a second event occurs concurrently on an intersecting freeway will be dictated by the following:

- Whether the intersecting freeway is upstream or downstream of the event that occurs on the primary freeway;
- The distances the events on the primary freeway and the intersecting freeway are from the VMS.

Message priorities for incidents that occur on the primary freeway upstream of an intersecting freeway that also experiences an incident have been established and are summarized in the tables that follow.

Because of the wide variety of issues involved, it is not possible to write only one set priorities for incidents that occur on the primary freeway which are downstream of an intersecting freeway that concurrently experiences an incident. Message priority in these latter cases will be dictated by the relative location that the incidents are from the VMS and the likelihood that the incidents will affect motorists who read the VMS message. Priority will be set separately for each case. The VMS operator should consult the TOC operator whenever concurrent events occur on both the primary freeway and on an upstream intersecting freeway.

**USE THE TABLES BELOW:**

- **When an incident occurs concurrently on the primary freeway and on an intersecting freeway that is downstream of the primary freeway incident.**

**CONSULT THE TOC MANAGER:**

- **When an incident occurs concurrently on the primary freeway and on an intersecting freeway that is upstream of the primary freeway incident.**

**Major Accident on the Primary Freeway with Another Event on an Intersecting Freeway**

The priorities of messages when a major accident occurs on the primary freeway concurrently with another event on an intersecting freeway that is UPSTREAM of the primary freeway incident are summarized in Table 14.21.

<b>Table 14.21 Message Priority for Major Accidents that Occur on the Primary Freeway UPSTREAM of an Intersecting Freeway Experiencing Another Event</b>	
<b>Major Accident Occurs on Primary Freeway Upstream of an Intersecting Freeway Experiencing the Following Event:</b>	<b>Give Message Priority to:<sup>A</sup></b>
● Accident (Major)	PF major accident
● Accident (Minor)	PF major accident
● Construction project	PF major accident
● Construction project with temporary lane closure(s)	PF major accident
● Disabled vehicle blocking a lane	PF major accident
● Incident (Load spill, debris, etc.) requiring lane closure	PF major accident
● Incident (Load spill, debris, etc.) requiring total freeway closure	PF major accident
● Maintenance operations with lane closure(s)	PF major accident
● Maintenance operations requiring total freeway closure	PF major accident
● Special event exit	PF major accident
● Adjoining state accident (Major)	PF major accident
● Adjoining state maintenance operations requiring total freeway closure	PF major accident
● Adjoining state incident (Load spill, debris, etc.) requiring total freeway closure	PF major accident

<sup>A</sup> PF = Primary Freeway; IF = Intersecting Freeway; AS = Adjoining State

**Minor Accident on the Primary Freeway with Another Event on an Intersecting Freeway**

The priorities of messages when a minor accident occurs on the primary freeway concurrently with another event on an intersecting freeway that is UPSTREAM of the primary freeway incident are summarized in Table 14.22.

<b>Table 14.22 Message Priority for Minor Accidents that Occur on the Primary Freeway UPSTREAM of an Intersecting Freeway Experiencing Another Event</b>	
<b>Minor Accident Occurs on Primary Freeway Upstream of an Intersecting Freeway Experiencing the Following Event:</b>	<b>Give Message Priority to:<sup>A</sup></b>
● Accident (Major)	PF minor accident
● Accident (Minor)	PF minor accident
● Construction project	PF minor accident
● Construction project with temporary lane closure(s)	PF minor accident
● Disabled vehicle blocking a lane	PF minor accident
● Incident (Load spill, debris, etc.) requiring lane closure	PF minor accident
● Incident (Load spill, debris, etc.) requiring total freeway closure	PF minor accident
● Maintenance operations with lane closure(s)	PF minor accident
● Maintenance operations requiring total freeway closure	PF minor accident
● Special event exit	PF minor accident
● Adjoining state accident (Major)	PF minor accident
● Adjoining state maintenance operations requiring total freeway closure	PF minor accident
● Adjoining state incident (Load spill, debris, etc.) requiring total freeway closure	PF minor accident

<sup>A</sup> PF = Primary Freeway; IF = Intersecting Freeway; AS = Adjoining State



**Construction on the Primary Freeway with Another Event on the Intersecting Freeway**

The priorities of messages when construction occurs on the primary freeway concurrently with another event on an intersecting freeway that is UPSTREAM of the primary freeway incident are summarized in Table 14.23.

<b>Table 14.23 Message Priority for Construction on the Primary Freeway UPSTREAM of an Intersecting Freeway Experiencing Another Event</b>	
<b>Construction on Primary Freeway Upstream of an Intersecting Freeway Experiencing the Following Event:</b>	<b>Give Message Priority to:<sup>A</sup></b>
● Accident (Major)	<i>Check with TOC manager</i>
● Accident (Minor)	<i>Check with TOC manager</i>
● Construction project	PF construction
● Construction project with temporary lane closure(s)	<i>Check with TOC manager</i>
● Disabled vehicle blocking a lane	<i>Check with TOC manager</i>
● Incident (Load spill, debris, etc.) requiring lane closure	<i>Check with TOC manager</i>
● Incident (Load spill, debris, etc.) requiring total freeway closure	<i>Check with TOC manager</i>
● Maintenance operations with lane closure(s)	<i>Check with TOC manager</i>
● Maintenance operations requiring total freeway closure	<i>Check with TOC manager</i>
● Special event exit	<i>Check with TOC manager</i>
● Adjoining state accident (Major)	AS major accident
● Adjoining state maintenance operations requiring total freeway closure	AS maintenance
● Adjoining state load spill requiring total freeway closure	AS incident

<sup>A</sup> PF = Primary Freeway; IF = Intersecting Freeway; AS = Adjoining State

**Construction with Temporary Lane Closure(s) on the Primary Freeway with Another Event on an Intersecting Freeway**

The priorities of messages when construction with a temporary lane closure occurs on the primary freeway concurrently with another event on an intersecting freeway that is UPSTREAM of the primary freeway incident are summarized in Table 14.24.

<b>Table 14.24 Message Priority for Construction with Temporary Lane Closure(s) on the Primary Freeway UPSTREAM of an Intersecting Freeway Experiencing Another Event</b>	
<b>Construction with a Temporary Lane Closure on the Primary Freeway Upstream of an Intersecting Freeway Experiencing the Following Event:</b>	<b>Give Message Priority to:<sup>A</sup></b>
● Accident (Major)	PF construction
● Accident (Minor)	PF construction
● Construction project	PF construction
● Construction project with temporary lane closure(s)	PF construction
● Disabled vehicle blocking a lane	PF construction
● Incident (Load spill, debris, etc.) requiring lane closure	PF construction
● Incident (Load spill, debris, etc.) requiring total freeway closure	PF construction
● Maintenance operations with lane closure(s)	PF construction
● Maintenance operations requiring total freeway closure	PF construction
● Special event exit	PF construction
● Adjoining state accident (Major)	PF construction
● Adjoining state maintenance operations requiring total freeway closure	PF construction
● Adjoining state incident (Load spill, debris, etc.) requiring total freeway closure	PF construction

<sup>A</sup> PF = Primary Freeway; IF = Intersecting Freeway; AS = Adjoining State

**Disabled Vehicle on the Primary Freeway with Another Event on an Intersecting Freeway**

The priorities of messages when a lane-blocking incident occurs on the primary freeway concurrently with another event on an intersecting freeway that is UPSTREAM of the primary freeway incident are summarized in Table 14.25.

<b>Table 14.25 Message Priority for Disabled Vehicles on the Primary Freeway UPSTREAM of an Intersecting Freeway Experiencing Another Event</b>	
<b>Disabled Vehicle on the Primary Freeway Upstream of an Intersecting Freeway Experiencing the Following Event:</b>	<b>Give Message Priority to:<sup>A</sup></b>
● Accident (Major)	PF disabled vehicle
● Accident (Minor)	PF disabled vehicle
● Construction project	PF disabled vehicle
● Construction project with temporary lane closure(s)	PF disabled vehicle
● Disabled vehicle blocking a lane	PF disabled vehicle
● Incident (Load spill, debris, etc.) requiring lane closure	PF disabled vehicle
● Incident (Load spill, debris, etc.) requiring total freeway closure	PF disabled vehicle
● Maintenance operations with lane closure(s)	PF disabled vehicle
● Maintenance operations requiring total freeway closure	PF disabled vehicle
● Special event exit	PF disabled vehicle
● Adjoining state accident (Major)	PF disabled vehicle
● Adjoining state maintenance operations requiring total freeway closure	PF disabled vehicle
● Adjoining state incident (Load spill, debris, etc.) requiring total freeway closure	PF disabled vehicle

<sup>A</sup> PF = Primary Freeway; IF = Intersecting Freeway; AS = Adjoining State

**Incident (Load Spill, Debris, etc.) Requiring a Lane Closure on the Primary Freeway with Another Event on an Intersecting Freeway**

The priorities of messages when an incident (load spill, debris, etc.) requiring a lane occurs on the primary freeway concurrently with another event on an intersecting freeway that is UPSTREAM of the primary freeway incident are summarized in Table 14.26.

<b>Table 14.26 Message Priority for Incidents Requiring Lane Closures on Primary Freeway UPSTREAM of an Intersecting Freeway Experiencing Another Event</b>	
<b>Incidents Requiring Lane Closure on Primary Freeway Upstream of an Intersecting Freeway Experiencing the Following Event:</b>	<b>Give Message Priority to:<sup>A</sup></b>
● Accident (Major)	PF incident
● Accident (Minor)	PF incident
● Construction project	PF incident
● Construction project with temporary lane closure(s)	PF incident
● Disabled vehicle blocking a lane	PF incident
● Incident (Load spill, debris, etc.) requiring lane closure	PF incident
● Incident (Load spill, debris, etc.) requiring total freeway closure	PF incident
● Maintenance operations with lane closure(s)	PF incident
● Maintenance operations requiring total freeway closure	PF incident
● Special event exit	PF incident
● Adjoining state accident (Major)	PF incident
● Adjoining state maintenance operations requiring total freeway closure	PF incident
● Adjoining state incident (Load spill, debris, etc.) requiring total freeway closure	PF incident

<sup>A</sup> PF = Primary Freeway; IF = Intersecting Freeway; AS = Adjoining State

**Incident (Load Spill, Debris, etc.) Requiring Total Closure of the Primary Freeway with Another Event on an Intersecting Freeway**

The priorities of messages when an incident (load spill, debris, etc.) occurs requiring total closure of the primary freeway concurrently with another event on an intersecting freeway that is UPSTREAM of the primary freeway incident are summarized in Table 14.27.

<b>Table 14.27 Message Priority for Incidents Requiring Total Closure of Primary Freeway UPSTREAM of an Intersecting Freeway Experiencing Another Event</b>	
<b>Incidents Requiring Total Closure of Primary Freeway Upstream of an Intersecting Freeway Experiencing the Following Event:</b>	<b>Give Message Priority to:<sup>A</sup></b>
● Accident (Major)	PF incident
● Accident (Minor)	PF incident
● Construction project	PF incident
● Construction project with temporary lane closure(s)	PF incident
● Disabled vehicle blocking a lane	PF incident
● Incident (Load spill, debris, etc.) requiring lane closure	PF incident
● Incident (Load spill, debris, etc.) requiring total freeway closure	PF incident
● Maintenance operations with lane closure(s)	PF incident
● Maintenance operations requiring total freeway closure	PF incident
● Special event exit	PF incident
● Adjoining state accident (Major)	PF incident
● Adjoining state maintenance operations requiring total freeway closure	PF incident
● Adjoining state incident (Load spill, debris, etc.) requiring total freeway closure	PF incident

<sup>A</sup> PF = Primary Freeway; IF = Intersecting Freeway; AS = Adjoining State

**Maintenance Operations Requiring a Lane Closure on the Primary Freeway with Another Event on an Intersecting Freeway**

The priorities of messages when an maintenance operations requiring a lane closure take place on the primary freeway concurrently with another event on an intersecting freeway that is UPSTREAM of the primary freeway incident are summarized in Table 14.28.

<b>Table 14.28 Message Priority for Maintenance Operations Requiring Lane Closures on Primary Freeway UPSTREAM of an Intersecting Freeway Experiencing Another Event</b>	
<b>Maintenance Operations Requiring Lane Closure on Primary Freeway Upstream of an Intersecting Freeway Experiencing the Following Event:</b>	<b>Give Message Priority to:<sup>A</sup></b>
● Accident (Major)	PF maintenance
● Accident (Minor)	PF maintenance
● Construction project	PF maintenance
● Construction project with temporary lane closure(s)	PF maintenance
● Disabled vehicle blocking a lane	PF maintenance
● Incident (Load spill, debris, etc.) requiring lane closure	PF maintenance
● Incident (Load spill, debris, etc.) requiring total freeway closure	PF maintenance
● Maintenance operations with lane closure(s)	PF maintenance
● Maintenance operations requiring total freeway closure	PF maintenance
● Special event exit	PF maintenance
● Adjoining state accident (Major)	PF maintenance
● Adjoining state maintenance operations requiring total freeway closure	PF maintenance
● Adjoining state incident (Load spill, debris, etc.) requiring total freeway closure	PF maintenance

<sup>A</sup> PF = Primary Freeway; IF = Intersecting Freeway; AS = Adjoining State

**Maintenance Operations Requiring Total Closure of the Primary Freeway with Another Event on an Intersecting Freeway**

The priorities of messages when maintenance operations requiring total closure take place on the primary freeway concurrently with another event on an intersecting freeway that is UPSTREAM of the primary freeway incident are summarized in Table 14.29.

<b>Table 14.29 Message Priority for Maintenance Operations Requiring Total Closure of Primary Freeway UPSTREAM of an Intersecting Freeway Experiencing Another Event</b>	
<b>Maintenance Operations Requiring Total Closure of Primary Freeway Upstream of an Intersecting Freeway Experiencing the Following Event:</b>	<b>Give Message Priority to:<sup>A</sup></b>
● Accident (Major)	PF maintenance
● Accident (Minor)	PF maintenance
● Construction project	PF maintenance
● Construction project with temporary lane closure(s)	PF maintenance
● Disabled vehicle blocking a lane	PF maintenance
● Incident (Load spill, debris, etc.) requiring lane closure	PF maintenance
● Incident (Load spill, debris, etc.) requiring total freeway closure	PF maintenance
● Maintenance operations with lane closure(s)	PF maintenance
● Maintenance operations requiring total freeway closure	PF maintenance
● Special event exit	PF maintenance
● Adjoining state accident (Major)	PF maintenance
● Adjoining state maintenance operations requiring total freeway closure	PF maintenance
● Adjoining state incident (Load spill, debris, etc.) requiring total freeway closure	PF maintenance

<sup>A</sup> PF = Primary Freeway; IF = Intersecting Freeway; AS = Adjoining State

**Special Event Exit on the Primary Freeway with Another Event on an Intersecting Freeway**

The priorities of messages when maintenance operations requiring total closure take place on the primary freeway concurrently with another event on an intersecting freeway that is UPSTREAM of the primary freeway incident are summarized in Table 14.30.

<b>Table 14.30 Message Priority for Special Event Exit on the Primary Freeway UPSTREAM of an Intersecting Freeway Experiencing Another Event</b>	
<b>Special Event Exit on Primary Freeway Upstream of an Intersecting Freeway Experiencing the Following Event:</b>	<b>Give Message Priority to:<sup>A</sup></b>
● Accident (Major)	PF special event exit
● Accident (Minor)	PF special event exit
● Construction project	PF special event exit
● Construction project with temporary lane closure(s)	PF special event exit
● Disabled vehicle blocking a lane	PF special event exit
● Incident (Load spill, debris, etc.) requiring lane closure	PF special event exit
● Incident (Load spill, debris, etc.) requiring total freeway closure	PF special event exit
● Maintenance operations with lane closure(s)	PF special event exit
● Maintenance operations requiring total freeway closure	PF special event exit
● Special event exit	PF special event exit
● Adjoining state accident (Major)	PF special event exit
● Adjoining state maintenance operations requiring total freeway closure	PF special event exit
● Adjoining state incident (Load spill, debris, etc.) requiring total freeway closure	PF special event exit

<sup>A</sup> PF = Primary Freeway; IF = Intersecting Freeway; AS = Adjoining State



**ONE EVENT OCCURS ON THE PRIMARY FREEWAY AND THE SECOND OCCURS CONCURRENTLY ON A CONNECTING FREEWAY IN AN I-95 CORRIDOR COALITION STATE**

Whenever there is a need to display a message for an event on the primary freeway in New Jersey, it should receive priority over any request for messages to inform motorists of major incidents on a connecting freeway in an I-95 Corridor Coalition State.

**TWO EVENTS OCCUR CONCURRENTLY ON AN INTERSECTING FREEWAY**

**Major Accident with Another Event**

The priorities of messages when a major accident occurs on the same intersecting freeway concurrently with another event are summarized in Tables 14.31 and 14.32.

<b>Table 14.31 Message Priority for Major Accidents that Occur UPSTREAM of Another Event</b>	
<b>Major Accident Occurs Upstream of:</b>	<b>Give Message Priority to:</b>
● Accident (Major)	Upstream major accident
● Accident (Minor)	Upstream major accident
● Construction project	Upstream major accident
● Construction project with temporary lane closure(s)	Upstream major accident
● Disabled vehicle blocking a lane	Upstream major accident
● Incident (Load spill, debris, etc.) requiring lane closure	Upstream major accident
● Incident (Load spill, debris, etc.) requiring total freeway closure	Upstream major accident
● Maintenance operations with lane closure(s)	Upstream major accident
● Maintenance operations requiring total freeway closure	Upstream major accident
● Special event exit	Upstream major accident
● Adjoining state accident (Major)	Upstream major accident
● Adjoining state maintenance operations requiring total freeway closure	Upstream major accident
● Adjoining state incident (Load spill, debris, etc.) requiring total freeway closure	Upstream major accident

<b>Table 14.32 Message Priority for Major Accidents that Occur DOWNSTREAM of Another Event</b>	
<b>Major Accident Occurs Downstream of:</b>	<b>Give Message Priority to:</b>
● Accident (Major)	Upstream major accident
● Accident (Minor)	Upstream minor accident
● Construction project	Downstream major accident
● Construction project with temporary lane closure(s)	Downstream major accident
● Disabled vehicle blocking a lane	Downstream major accident
● Incident (Load spill, debris, etc.) requiring lane closure	Downstream major accident
● Incident (Load spill, debris, etc.) requiring total freeway closure	Upstream incident
● Maintenance operations with lane closure(s)	Downstream major accident
● Maintenance operations requiring total freeway closure	Upstream maintenance
● Special event exit	Downstream major accident

**Minor Accident with Another Event**

The priorities of messages when a minor accident occurs on the same intersecting freeway concurrently with another event are summarized in Tables 14.33 and 14.34.

<b>Table 14.33 Message Priority for Minor Accidents that Occur UPSTREAM of Another Event</b>	
<b>Minor Accident Occurs Upstream of:</b>	<b>Give Message Priority to:</b>
● Accident (Major)	Upstream minor accident
● Accident (Minor)	Upstream minor accident
● Construction project	Upstream minor accident
● Construction project with temporary lane closure(s)	Upstream minor accident
● Disabled vehicle blocking a lane	Upstream minor accident
● Incident (Load spill, debris, etc.) requiring lane closure	Upstream minor accident
● Incident (Load spill, debris, etc.) requiring total freeway closure	Downstream incident
● Maintenance operations with lane closure(s)	Upstream minor accident
● Maintenance operations requiring total freeway closure	Downstream maintenance
● Special event exit	Upstream minor accident
● Adjoining state: Accident (Major)	Upstream minor accident
● Adjoining state: Maintenance operations requiring total freeway closure	Upstream minor accident
● Adjoining state incident (Load spill, debris, etc.) requiring total freeway closure	Upstream minor accident

<b>Table 14.34 Message Priority for Minor Accidents that Occur DOWNSTREAM of Another Event</b>	
<b>Minor Accident Occurs Downstream of:</b>	<b>Give Message Priority to:</b>
● Accident (Major)	Upstream major accident
● Accident (Minor)	Upstream minor accident
● Construction project	Downstream minor accident
● Construction project with temporary lane closure(s)	Downstream minor accident
● Disabled vehicle blocking a lane	Upstream disabled vehicle
● Incident (Load spill, debris, etc.) requiring lane closure	Upstream incident
● Incident (Load spill, debris, etc.) requiring total freeway closure	Upstream incident
● Maintenance operations with lane closure(s)	Downstream minor accident
● Maintenance operations requiring total freeway closure	Upstream maintenance
● Special event exit	Downstream minor accident

**Construction with Another Event**

The priorities of messages when construction is on the same intersecting freeway concurrently with another event are summarized in Tables 14.35 and 14.36.

<b>Table 14.35 Message Priority for Construction UPSTREAM of Another Event</b>	
<b>Construction Upstream of:</b>	<b>Give Message Priority to:</b>
● Accident (Major)	Downstream major accident
● Accident (Minor)	Downstream minor accident
● Construction project	Upstream construction
● Construction project with temporary lane closure(s)	Downstream construction
● Disabled vehicle blocking a lane	Downstream disabled vehicle
● Incident (Load spill, debris, etc.) requiring lane closure	Downstream incident
● Incident (Load spill, debris, etc.) requiring total freeway closure	Downstream incident
● Maintenance operations with lane closure(s)	Downstream maintenance
● Maintenance operations requiring total freeway closure	Downstream maintenance
● Special event exit	Downstream special event exit
● Adjoining state: Accident (Major)	Adjoining state major accident
● Adjoining state: Maintenance operations requiring total freeway closure	Adjoining state maintenance
● Adjoining state incident (Load spill, debris, etc.) requiring total freeway closure	Adjoining state incident

<b>Table 14.36 Message Priority for Construction DOWNSTREAM of Another Event</b>	
<b>Construction Downstream of:</b>	<b>Give Message Priority to:</b>
● Accident (Major)	Upstream major accident
● Accident (Minor)	Upstream minor accident
● Construction project	Upstream construction
● Construction project with temporary lane closure(s)	Upstream construction
● Disabled vehicle blocking a lane	Upstream disabled vehicle
● Incident (Load spill, debris, etc.) requiring lane closure	Upstream incident
● Incident (Load spill, debris, etc.) requiring total freeway closure	Upstream incident
● Maintenance operations with lane closure(s)	Upstream maintenance
● Maintenance operations requiring total freeway closure	Upstream maintenance
● Special event exit	Upstream special event exit

**Construction with Temporary Lane Closure(s) with Another Event**

The priorities of messages when a temporary lane closure in a construction project occurs on the same intersecting freeway concurrently with another event are summarized in Tables 14.37 and 14.38.

<b>Table 14.37 Message Priority for Construction with Temporary Lane Closure(s) UPSTREAM of Another Event</b>	
<b>Construction with Temporary Lane Closure(s) Upstream of</b>	<b>Give Message Priority to:</b>
● Accident (Major)	Downstream major accident
● Accident (Minor)	Downstream minor accident
● Construction project	Upstream construction
● Construction project with temporary lane closure(s)	Upstream construction
● Disabled vehicle blocking a lane	Downstream disabled vehicle
● Incident (Load spill, debris, etc.) requiring lane closure	Downstream incident
● Incident (Load spill, debris, etc.) requiring total freeway closure	Downstream incident
● Maintenance operations with lane closure(s)	Upstream construction
● Maintenance operations requiring total freeway closure	Downstream maintenance
● Special event exit	Upstream construction
● Adjoining state: Accident (Major)	Upstream construction
● Adjoining state: Maintenance operations requiring total freeway closure	Upstream construction
● Adjoining state incident (Load spill, debris, etc.) requiring total freeway closure	Upstream construction

<b>Table 14.38 Message Priority for Construction with Temporary Lane Closure(s) DOWNSTREAM of Another Event</b>	
<b>Construction with Temporary Lane Closure(s) Downstream of:</b>	<b>Give Message Priority to:</b>
● Accident (Major)	Upstream major accident
● Accident (Minor)	Upstream minor accident
● Construction project	Downstream construction
● Construction project with temporary lane closure(s)	Upstream construction
● Disabled vehicle blocking a lane	Upstream disabled vehicle
● Incident (Load spill, debris, etc.) requiring lane closure	Upstream incident
● Incident (Load spill, debris, etc.) requiring total freeway closure	Upstream incident
● Maintenance operations with lane closure(s)	Upstream maintenance
● Maintenance operations requiring total freeway closure	Upstream maintenance
● Special event exit	Upstream special event exit

**Disabled Vehicle with Another Event**

The priorities of messages when a lane-blocking disabled vehicle is on the same intersecting freeway concurrently with another event are summarized in Tables 14.39 and 14.40.

<b>Table 14.39 Message Priority for Disabled Vehicles that Occur UPSTREAM of Another Event</b>	
<b>Disabled Vehicle Occurs Upstream of:</b>	<b>Give Message Priority to:</b>
● Accident (Major)	Downstream major accident
● Accident (Minor)	Upstream disabled vehicle
● Construction project	Upstream disabled vehicle
● Construction project with temporary lane closure(s)	Upstream disabled vehicle
● Disabled vehicle blocking a lane	Upstream disabled vehicle
● Incident (Load spill, debris, etc.) requiring lane closure	Upstream disabled vehicle
● Incident (Load spill, debris, etc.) requiring total freeway closure	Downstream incident
● Maintenance operations with lane closure(s)	Upstream disabled vehicle
● Maintenance operations requiring total freeway closure	Downstream maintenance
● Special event exit	Upstream disabled vehicle
● Adjoining state: Accident (Major)	Upstream disabled vehicle
● Adjoining state: Maintenance operations requiring total freeway closure	Upstream disabled vehicle
● Adjoining state incident (Load spill, debris, etc.) requiring total freeway closure	Upstream disabled vehicle

<b>Table 14.40 Message Priority for Disabled Vehicles that Occur DOWNSTREAM of Another Event</b>	
<b>Disabled Vehicle Occurs Downstream of:</b>	<b>Give Message Priority to:</b>
● Accident (Major)	Upstream major accident
● Accident (Minor)	Upstream minor accident
● Construction project	Downstream disabled vehicle
● Construction project with temporary lane closure(s)	Downstream disabled vehicle
● Disabled vehicle blocking a lane	Upstream disabled vehicle
● Incident (Load spill, debris, etc.) requiring lane closure	Upstream incident
● Incident (Load spill, debris, etc.) requiring total freeway closure	Upstream incident
● Maintenance operations with lane closure(s)	Upstream maintenance
● Maintenance operations requiring total freeway closure	Upstream maintenance
● Special event exit	Downstream disabled vehicle

**Incident (Load Spill, Debris, etc.) Requiring a Lane Closure with Another Event**

The priorities of messages when an incident (load spill, debris, etc.) requiring a lane closure occurs on the same intersecting freeway concurrently with another event are summarized in Tables 14.41 and 14.42.

<b>Table 14.41 Message Priority for Incidents Requiring Lane Closures that Occur UPSTREAM of Another Event</b>	
<b>Incident Requiring Lane Closure Occurs Upstream of:</b>	<b>Give Message Priority to:</b>
● Accident (Major)	Downstream major accident
● Accident (Minor)	Upstream incident
● Construction project	Upstream incident
● Construction project with temporary lane closure(s)	Upstream incident
● Disabled vehicle blocking a lane	Upstream incident
● Incident (Load spill, debris, etc.) requiring lane closure	Upstream incident
● Incident (Load spill, debris, etc.) requiring total freeway closure	Downstream incident
● Maintenance operations with lane closure(s)	Upstream disabled vehicle
● Maintenance operations requiring total freeway closure	Upstream incident
● Special event exit	Upstream incident
● Adjoining state: Accident (Major)	Upstream incident
● Adjoining state: Maintenance operations requiring total freeway closure	Upstream incident
● Adjoining state incident (Load spill, debris, etc.) requiring total freeway closure	Upstream incident

<b>Table 14.42 Message Priority for Incidents Requiring Lane Closures that Occur DOWNSTREAM of Another Event</b>	
<b>Incident Requiring Lane Closure Occurs Downstream of:</b>	<b>Give Message Priority to:</b>
● Accident (Major)	Upstream major accident
● Accident (Minor)	Upstream minor accident
● Construction project	Downstream incident
● Construction project with temporary lane closure(s)	Downstream incident
● Disabled vehicle blocking a lane	Upstream disabled vehicle
● Incident (Load spill, debris, etc.) requiring lane closure	Upstream incident
● Incident (Load spill, debris, etc.) requiring total freeway closure	Upstream incident
● Maintenance operations with lane closure(s)	Upstream maintenance
● Maintenance operations requiring total freeway closure	Upstream maintenance
● Special event exit	Downstream incident

**Incidents (Load Spill, Debris, etc.) Requiring Total Freeway Closures with Another Event**

The priorities of messages when an incident (load spill, debris, etc.) requiring total freeway closure occurs on the same intersecting freeway concurrently with another event are summarized in Tables 14.43 and 14.44.

<b>Table 14.43 Message Priority for Incidents Requiring Total Freeway Closures that Occur UPSTREAM of Another Event</b>	
<b>Incident Requiring Total Freeway Closure Occurs Upstream of:</b>	<b>Give Message Priority to:</b>
● Accident (Major)	Upstream incident
● Accident (Minor)	Upstream incident
● Construction project	Upstream incident
● Construction project with temporary lane closure(s)	Upstream incident
● Disabled vehicle blocking a lane	Upstream incident
● Incident (Load spill, debris, etc.) requiring lane closure	Upstream incident
● Incident (Load spill, debris, etc.) requiring total freeway closure	Upstream incident
● Maintenance operations with lane closure(s)	Upstream incident
● Maintenance operations requiring total freeway closure	Upstream incident
● Special event exit	Upstream incident
● Adjoining state accident (Major)	Upstream incident
● Adjoining state maintenance operations requiring total freeway closure	Upstream incident
● Adjoining state incident (Load spill, debris, etc.) requiring total freeway closure	Upstream incident

<b>Table 14.44 Message Priority for Incidents Requiring Total Freeway Closures that Occur DOWNSTREAM of Another Event</b>	
<b>Incident Requiring Total Freeway Closure Occurs Downstream of:</b>	<b>Give Message Priority to:</b>
● Accident (Major)	Upstream major accident
● Accident (Minor)	Downstream incident
● Construction project	Downstream incident
● Construction project with temporary lane closure(s)	Downstream incident
● Disabled vehicle blocking a lane	Downstream incident
● Incident (Load spill, debris, etc.) requiring lane closure	Downstream incident
● Incident (Load spill, debris, etc.) requiring total freeway closure	Upstream incident
● Maintenance operations with lane closure(s)	Downstream incident
● Maintenance operations requiring total freeway closure	Upstream maintenance
● Special event exit	Downstream incident



**Maintenance Operations with Lane Closure(s) with Another Event**

The priorities of messages when maintenance operations with lane closure(s) take place on the same intersecting freeway concurrently with another event are summarized in Tables 14.45 and 14.46.

<b>Table 14.45 Message Priority for Maintenance Operations with Lane Closure(s) UPSTREAM of Another Event</b>	
<b>Maintenance Operations with Lane Closure(s) Upstream of:</b>	<b>Give Message Priority to:</b>
● Accident (Major)	Downstream major accident
● Accident (Minor)	Downstream minor accident
● Construction project	Upstream maintenance
● Construction project with temporary lane closure(s)	Upstream maintenance
● Disabled vehicle blocking a lane	Upstream maintenance
● Incident (Load spill, debris, etc.) requiring lane closure	Downstream incident
● Incident (Load spill, debris, etc.) requiring total freeway closure	Downstream incident
● Maintenance operations with lane closure(s)	Upstream maintenance
● Maintenance operations requiring total freeway closure	Downstream maintenance
● Special event exit	Upstream maintenance
● Adjoining state: Accident (Major)	Upstream maintenance
● Adjoining state: Maintenance operations requiring total freeway closure	Upstream maintenance
● Adjoining state incident (Load spill, debris, etc.) requiring total freeway closure	Upstream maintenance

<b>Table 14.46 Message Priority for Maintenance Operations with Lane Closure(s) DOWNSTREAM of Another Event</b>	
<b>Maintenance Operations with Lane Closure(s) Downstream of:</b>	<b>Give Message Priority to:</b>
● Accident (Major)	Upstream major accident
● Accident (Minor)	Upstream minor accident
● Construction project	Downstream maintenance
● Construction project with temporary lane closure(s)	Upstream construction
● Disabled vehicle blocking a lane	Upstream disabled vehicle
● Incident (Load spill, debris, etc.) requiring lane closure	Upstream incident
● Incident (Load spill, debris, etc.) requiring total freeway closure	Upstream incident
● Maintenance operations with lane closure(s)	Upstream maintenance
● Maintenance operations requiring total freeway closure	Upstream maintenance
● Special event exit	Upstream special event exit

**Maintenance Operations Requiring Total Freeway Closures with Another Event**

The priorities of messages when maintenance operations requiring total freeway closure take place on the same intersecting freeway concurrently with another event are summarized in Tables 14.47 and 14.48.

<b>Table 14.47 Message Priority for Maintenance Operations Requiring Total Freeway Closures that Occur UPSTREAM of Another Event</b>	
<b>Maintenance Operations Requiring Total Freeway Closure Occurs Upstream of:</b>	<b>Give Message Priority to:</b>
● Accident (Major)	Upstream maintenance
● Accident (Minor)	Upstream maintenance
● Construction project	Upstream maintenance
● Construction project with temporary lane closure(s)	Upstream maintenance
● Disabled vehicle blocking a lane	Upstream maintenance
● Incident (Load spill, debris, etc.) requiring lane closure	Upstream maintenance
● Incident (Load spill, debris, etc.) requiring total freeway closure	Upstream maintenance
● Maintenance operations with lane closure(s)	Upstream maintenance
● Maintenance operations requiring total freeway closure	Upstream maintenance
● Special event exit	Upstream maintenance
● Adjoining state accident (Major)	Upstream maintenance
● Adjoining state maintenance operations requiring total freeway closure	Upstream maintenance
● Adjoining state incident (Load spill, debris, etc.) requiring total freeway closure	Upstream maintenance

<b>Table 14.48 Message Priority for Maintenance Operations Requiring Total Freeway Closures that Occur DOWNSTREAM of Another Event</b>	
<b>Maintenance Operations Requiring Total Freeway Closure Occurs Downstream of:</b>	<b>Give Message Priority to:</b>
● Accident (Major)	Upstream major accident
● Accident (Minor)	Downstream maintenance
● Construction project	Downstream maintenance
● Construction project with temporary lane closure(s)	Downstream maintenance
● Disabled vehicle blocking a lane	Downstream maintenance
● Incident (Load spill, debris, etc.) requiring lane closure	Downstream maintenance
● Incident (Load spill, debris, etc.) requiring total freeway closure	Upstream incident
● Maintenance operations with lane closure(s)	Downstream maintenance
● Maintenance operations requiring total freeway closure	Upstream maintenance
● Special event exit	Downstream maintenance

**Special Event Exit with Another Event**

The priorities of messages when special event traffic uses the same intersecting freeway concurrently with another event are summarized in Tables 14.49 and 14.50.

<b>Table 14.49 Message Priority for Special Event Exit UPSTREAM of Another Event</b>	
<b>Special Event Exit Upstream of:</b>	<b>Give Message Priority to:</b>
● Accident (Major)	Downstream major accident
● Accident (Minor)	Downstream minor accident
● Construction project	Upstream special event exit
● Construction project with temporary lane closure(s)	Upstream special event exit
● Disabled vehicle blocking a lane	Downstream disabled vehicle
● Incident (Load spill, debris, etc.) requiring lane closure	Downstream incident
● Incident (Load spill, debris, etc.) requiring total freeway closure	Downstream incident
● Maintenance operations with lane closure(s)	Upstream special event exit
● Maintenance operations requiring total freeway closure	Downstream maintenance
● Special event exit	Upstream special event exit
● Adjoining state: Accident (Major)	Upstream special event exit
● Adjoining state: Maintenance operations requiring total freeway closure	Upstream special event exit
● Adjoining state incident (Load spill, debris, etc.) requiring total freeway closure	Upstream special event exit

<b>Table 14.50 Message Priority for Special Event Exit DOWNSTREAM of Another Event</b>	
<b>Special Event Exit) Downstream of:</b>	<b>Give Message Priority to:</b>
● Accident (Major)	Upstream major accident
● Accident (Minor)	Upstream minor accident
● Construction project	Downstream special event exit
● Construction project with temporary lane closure(s)	Upstream construction
● Disabled vehicle blocking a lane	Upstream disabled vehicle
● Incident (Load spill, debris, etc.) requiring lane closure	Upstream incident
● Incident (Load spill, debris, etc.) requiring total freeway closure	Upstream incident
● Maintenance operations with lane closure(s)	Upstream maintenance
● Maintenance operations requiring total freeway closure	Upstream maintenance
● Special event exit	Upstream special event exit

**ONE EVENT OCCURS ON AN INTERSECTING FREEWAY AND THE SECOND OCCURS CONCURRENTLY ON A CONNECTING FREEWAY IN AN I-95 CORRIDOR COALITION STATE.**

Whenever there is a need to display a message for an event on an intersecting freeway in New Jersey, it should receive priority over any request for messages to inform motorists of major incidents on a connecting freeway in an I-95 Corridor Coalition State.

**THIS PAGE LEFT BLANK**

# MODULE 15. MESSAGE DESIGN EXAMPLES FOR INCIDENTS: LARGE VMSs

## TABLE OF CONTENTS

<b>15.1 OBJECTIVES AND SUMMARY .....</b>	<b>15-1</b>
<b>15A. INCIDENT EXAMPLE #1 ALL LANES ARE (BLOCKED) CLOSED .....</b>	<b>15-2</b>
<b>15A.1 BEFORE POLICE ARRIVE .....</b>	<b>15-2</b>
<b>DEFINE SITUATION .....</b>	<b>15-3</b>
Analyze Incident and Incident Scene Characteristics .....	15-3
<b>DESIGN MESSAGE FOR VMS ON SAME FREEWAY AND RELATIVELY     CLOSE TO THE INCIDENT (VMS #1).....</b>	<b>15-4</b>
Identify VMS Characteristics.....	15-4
Review Conditions at the VMS Location .....	15-4
Identify Diversion Route Characteristics .....	15-4
Set Objectives .....	15-5
Establish Initial Maximum Allowable Number of Units of Information in the Message Based on VMS Type and Freeway Operating Speeds.....	15-5
Assess Whether the Message Must Be Reduced Because of Local Geometric Sight Distance Restrictions to the VMS .....	15-6
Assess Whether the Message Must Be Reduced Because of Local Environmental Sight Distance Restrictions to the VMS Due to Rain or Fog .....	15-6
Finalize the Maximum Allowable Units of Information in the Message .....	15-6
Define Basic VMS Message to Satisfy Motorist Information Needs .....	15-6
Reduce the Number of Message Units if Necessary .....	15-8
Format the Message .....	15-8
Adjust Message to Fit on Existing VMS .....	15-8
Adjust Message to Fit on 3 Lines or Less .....	15-8
Finalize VMS Message .....	15-9
Assess Effects of Large Trucks on the Ability of Motorist to View the VMS Message .....	15-10
<b>DESIGN MESSAGE FOR VMS ON SAME FREEWAY BUT RELATIVELY     FAR FROM THE INCIDENT (VMS #2).....</b>	<b>15-11</b>
Identify VMS Characteristics.....	15-11
Review Conditions at the VMS Location .....	15-11
Identify Diversion Route Characteristics .....	15-11
Set Objectives .....	15-12
Establish Initial Maximum Allowable Number of Units of Information in the Message Based on VMS Type and Freeway Operating Speeds.....	15-12

Assess Whether the Message Must Be Reduced Because of Local Geometric Sight Distance Restrictions to the VMS .....	15-12
Assess Whether the Message Must Be Reduced Because of Local Environmental Sight Distance Restrictions to the VMS Due to Rain or Fog .....	15-13
Finalize the Maximum Allowable Units of Information in the Message .....	15-13
Define Basic VMS Message to Satisfy Motorist Information Needs .....	15-13
Reduce the Number of Message Units if Necessary .....	15-15
Format the Message .....	15-15
Adjust Message to Fit on Existing VMS .....	15-15
Adjust Message to Fit on 3 Lines or Less .....	15-15
Finalize VMS Message .....	15-16
Assess Effects of Large Trucks on the Ability of Motorist to View the VMS Message .....	15-17
<b>15A.2 AFTER POLICE ARRIVE .....</b>	<b>15-18</b>
<b>DEFINE SITUATION .....</b>	<b>15-19</b>
Analyze Incident and Incident Scene Characteristics .....	15-19
<b>DEFINE MESSAGE FOR VMS ON SAME FREEWAY AND RELATIVELY CLOSE TO THE INCIDENT (VMS #1).....</b>	<b>15-20</b>
Identify VMS Characteristics.....	15-20
Review Conditions at the VMS Location .....	15-20
Identify Diversion Route Characteristics .....	15-20
Set Objectives .....	15-21
Establish Initial Maximum Allowable Number of Units of Information in the Message Based on VMS Type and Freeway Operating Speeds.....	15-21
Assess Whether the Message Must Be Reduced Because of Local Geometric Sight Distance Restrictions to the VMS .....	15-22
Assess Whether the Message Must Be Reduced Because of Local Environmental Sight Distance Restrictions to the VMS Due to Rain or Fog .....	15-22
Finalize the Maximum Allowable Units of Information in the Message .....	15-22
Define Basic VMS Message to Satisfy Motorist Information Needs .....	15-22
Reduce the Number of Message Units if Necessary .....	15-24
Format the Message .....	15-24
Adjust Message to Fit on Existing VMS .....	15-24
Adjust Message to Fit on 3 Lines or Less .....	15-24
Finalize VMS Message .....	15-25
Assess Effects of Large Trucks on the Ability of Motorist to View the VMS Message .....	15-26
<b>DESIGN MESSAGE FOR VMS ON SAME FREEWAY BUT RELATIVELY FAR FROM THE INCIDENT (VMS #2).....</b>	<b>15-27</b>
Identify VMS Characteristics.....	15-27
Review Conditions at the VMS Location .....	15-27
Identify Diversion Route Characteristics .....	15-27

- Set Objectives .....15-28
- Establish Initial Maximum Allowable Number of Units of Information in the  
Message Based on VMS Type and Freeway Operating Speeds.....15-28
- Assess Whether the Message Must Be Reduced Because of Local Geometric  
Sight Distance Restrictions to the VMS.....15-28
- Assess Whether the Message Must Be Reduced Because of Local  
Environmental Sight Distance Restrictions to the VMS Due to Rain or  
Fog.....15-29
- Finalize the Maximum Allowable Units of Information in the Message .....15-29
- Define Basic VMS Message to Satisfy Motorist Information Needs .....15-29
- Reduce the Number of Message Units if Necessary.....15-30
- Format the Message .....15-31
- Adjust Message to Fit on Existing VMS .....15-31
- Adjust Message to Fit on 3 Lines or Less.....15-31
- Finalize VMS Message .....15-32
- Assess Effects of Large Trucks on the Ability of Motorist to View the  
VMS Message .....15-32

**15B. INCIDENT EXAMPLE #2 ALL LANES ARE (BLOCKED)  
CLOSED .....15-33**

- 15B.1 BEFORE POLICE ARRIVE .....15-33**
- DEFINE SITUATION DETAILS .....15-34
- Analyze Incident and Incident Scene Characteristics .....15-34

**DESIGN MESSAGE FOR VMS ON DIFFERENT FREEWAY THAN THE**

- INCIDENT (VMS #1) .....15-35**
- Identify VMS Characteristics.....15-35
- Review Conditions at the VMS Location .....15-35
- Identify Diversion Route Characteristics.....15-35
- Set Objectives .....15-36
- Establish Initial Maximum Allowable Number of Units of Information in the  
Message Based on VMS Type and Freeway Operating Speeds.....15-36
- Assess Whether the Message Must Be Reduced Because of Local Geometric  
Sight Distance Restrictions to the VMS.....15-37
- Assess Whether the Message Must Be Reduced Because of Local  
Environmental Sight Distance Restrictions to the VMS Due to Rain or  
Fog.....15-37
- Finalize the Maximum Allowable Units of Information in the Message .....15-37
- Define Basic VMS Message to Satisfy Motorist Information Needs .....15-37
- Reduce the Number of Message Units if Necessary.....15-39
- Format the Message .....15-40
- Adjust Message to Fit on Existing VMS .....15-40
- Adjust Message to Fit on 3 Lines or Less.....15-40
- Finalize VMS Message .....15-41
- Assess Effects of Large Trucks on the Ability of Motorist to View the  
VMS Message .....15-42



DESIGN MESSAGE FOR VMS ON DIFFERENT FREEWAY THAN THE  
 INCIDENT (VMS #2) .....15-43  
 Identify VMS Characteristics.....15-43  
 Review Conditions at the VMS Location .....15-43  
 Identify Diversion Route Characteristics .....15-43  
 Set Objectives .....15-44  
 Establish Initial Maximum Allowable Number of Units of Information in the  
 Message Based on VMS Type and Freeway Operating Speeds.....15-44  
 Assess Whether the Message Must Be Reduced Because of Local Geometric  
 Sight Distance Restrictions to the VMS .....15-45  
 Assess Whether the Message Must Be Reduced Because of Local  
 Environmental Sight Distance Restrictions to the VMS Due to Rain or  
 Fog .....15-45  
 Finalize the Maximum Allowable Units of Information in the Message .....15-45  
 Define Basic VMS Message to Satisfy Motorist Information Needs .....15-45  
 Reduce the Number of Message Units if Necessary .....15-47  
 Format the Message .....15-48  
 Adjust Message to Fit on Existing VMS .....15-48  
 Adjust Message to Fit on 3 Lines or Less .....15-48  
 Finalize VMS Message .....15-49  
 Assess Effects of Large Trucks on the Ability of Motorist to View the  
 VMS Message.....15-50

**15B.2 AFTER POLICE ARRIVE**.....15-51  
 DEFINE SITUATION DETAILS .....15-52  
 Analyze Incident and Incident Scene Characteristics .....15-52

DESIGN MESSAGE FOR VMS ON DIFFERENT FREEWAY THAN THE  
 INCIDENT (VMS #1) .....15-53  
 Identify VMS Characteristics.....15-53  
 Review Conditions at the VMS Location .....15-53  
 Identify Diversion Route Characteristics .....15-53  
 Set Objectives .....15-54  
 Establish Initial Maximum Allowable Number of Units of Information in the  
 Message Based on VMS Type and Freeway Operating Speeds.....15-54  
 Assess Whether the Message Must Be Reduced Because of Local Geometric  
 Sight Distance Restrictions to the VMS .....15-55  
 Assess Whether the Message Must Be Reduced Because of Local  
 Environmental Sight Distance Restrictions to the VMS Due to Rain or  
 Fog .....15-55  
 Finalize the Maximum Allowable Units of Information in the Message .....15-55  
 Define Basic VMS Message to Satisfy Motorist Information Needs .....15-55  
 Reduce the Number of Message Units if Necessary .....15-57  
 Format the Message .....15-58  
 Adjust Message to Fit on Existing VMS .....15-58  
 Adjust Message to Fit on 3 Lines or Less .....15-58  
 Finalize VMS Message .....15-59

Assess Effects of Large Trucks on the Ability of Motorist to View the  
VMS Message.....15-59

DESIGN MESSAGE FOR VMS ON DIFFERENT FREEWAY THAN THE

INCIDENT (VMS #2) .....15-60

Identify VMS Characteristics.....15-60

Review Conditions at the VMS Location .....15-60

Identify Diversion Route Characteristics .....15-60

Set Objectives .....15-61

Establish Initial Maximum Allowable Number of Units of Information in the  
Message Based on VMS Type and Freeway Operating Speeds.....15-61

Assess Whether the Message Must Be Reduced Because of Local Geometric  
Sight Distance Restrictions to the VMS .....15-62

Assess Whether the Message Must Be Reduced Because of Local  
Environmental Sight Distance Restrictions to the VMS Due to Rain or  
Fog .....15-62

Finalize the Maximum Allowable Units of Information in the Message .....15-62

Define Basic VMS Message to Satisfy Motorist Information Needs .....15-62

Reduce the Number of Message Units if Necessary.....15-64

Format the Message .....15-65

Adjust Message to Fit on Existing VMS .....15-65

Adjust Message to Fit on 3 Lines or Less.....15-65

Finalize VMS Message .....15-66

Assess Effects of Large Trucks on the Ability of Motorist to View the  
VMS Message.....15-66

**THIS PAGE LEFT BLANK**

# MODULE 15. VMS MESSAGE DESIGN EXAMPLES FOR INCIDENTS: LARGE VMSs

## 15.1 OBJECTIVES AND SUMMARY

The objectives of Module 15 are to illustrate the:

- VMS message design process that is detailed in [Module 10](#) for incidents;
- Application of several design principles for messages displayed on large VMSs; and
- Differences in the messages before and after the police arrive to close the lanes of the freeway.

Table 15.1 is a summary of the incident and diversion characteristics message design principles illustrated in the examples in this Module.

<b>Table 15.1 Summary of Incident Characteristics and VMS Message Design Principles Illustrated in Module 15</b>						
<b>Incident Characteristics and VMS Message Design Principles</b>	<b>Example 1 (Page 15-2)</b>			<b>Example 2 (Page 15-33)</b>		
	<b>Large VMS</b>			<b>Large VMS</b>		
	<b>Near Incident</b>	<b>Far From Incident</b>	<b>On Other Freeway</b>	<b>Near Incident</b>	<b>Far From Incident</b>	<b>On Other Freeway</b>
Police have not arrived	X	X				X
Police arrived	X	X				X
Lanes blocked						
Freeway blocked	X	X				X
Lanes closed						
Freeway closed	X	X				X
No diversion						
Soft diversion	X	X				
Diversion to Type 1 or Type 2 diversion route						X
Diversion to Type 3 or Type 4 diversion route						
Diversion to Type 5 diversion route	X					
Diversion to Type 6 diversion route						
Reducing units of information by omitting incident descriptor	X	X				X
Reducing units of information by omitting audience						X
Splitting a message into two frames	X	X				X
Use of abbreviations						

## 15A. INCIDENT EXAMPLE #1 ALL LANES ARE (BLOCKED) CLOSED

### 15A.1 BEFORE POLICE ARRIVE

The location of the accident and VMSs are shown in Figure 15.1. Since the police have not yet arrived, no diversion route has been set. Two large overhead VMSs will be used to display a message:

- VMS #1 is located on I-287 North upstream of I-80; and
- VMS #2 is located on I-287 North but far upstream from I-80.

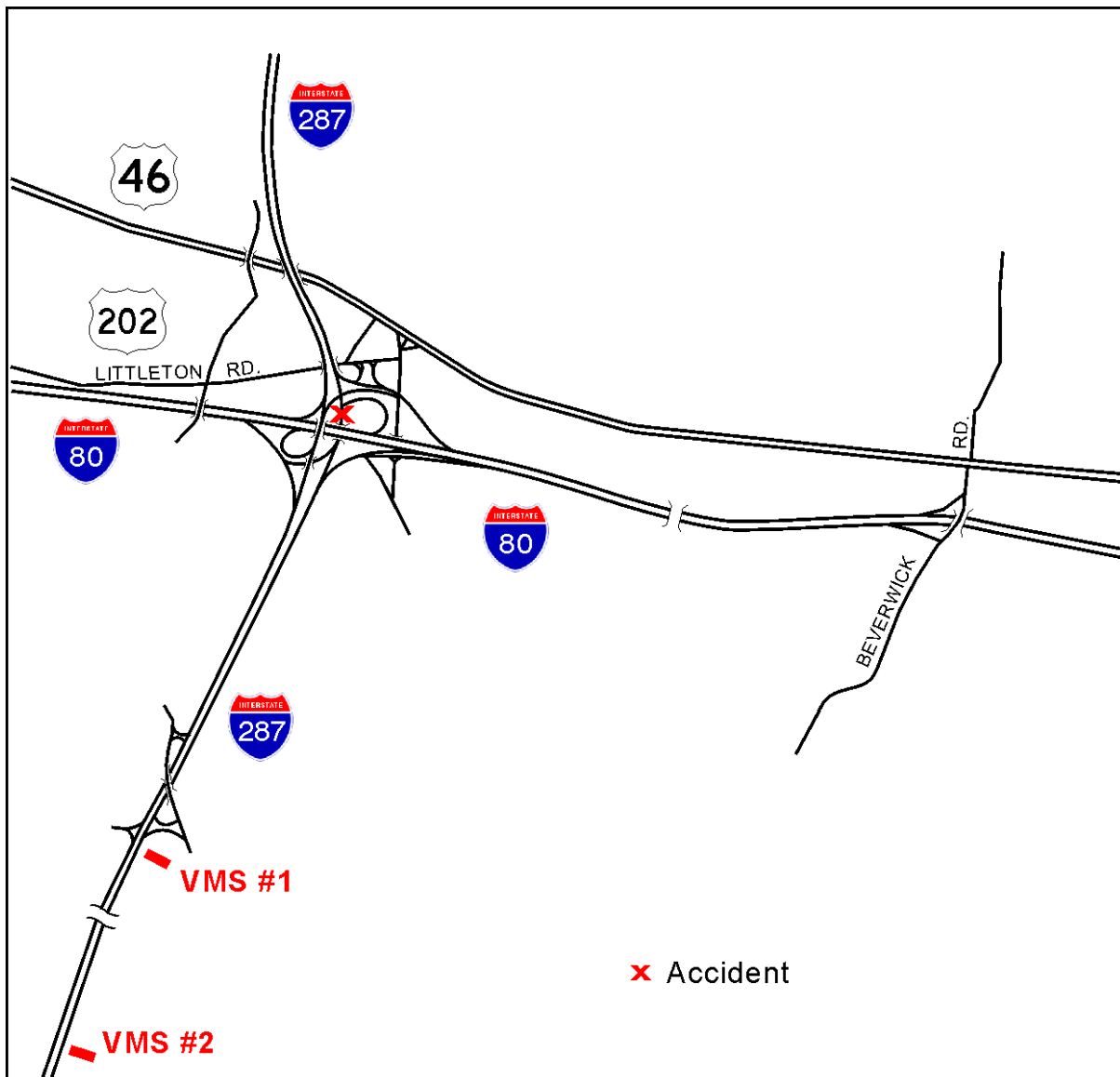

Figure 15.1 Locations of Accident and Variable Message Signs for Example 1

## DEFINE SITUATION

### Analyze Incident and Incident Scene Characteristics

**1. What happened?**

The Traffic Operations Center (TOC) personnel confirm that a major three-vehicle accident occurred. There appears to be a fatality.

The VMS operator in the TOC pans the closed circuit television cameras to view the accident scene.

**2. Where?**

On I-287 northbound just past I-80.

**3. What lanes (how many) lanes are affected?**

All lanes are blocked.

**4. What is the current time?**

It is now 10:00 a.m.

**5. How long do you expect the incident to block the lanes?**

The nature of the accident with a fatality indicates that the accident will block all the lanes for three hours until 1:00 p.m.

**6. What is the effect on traffic?**

Even though the incident will not block lanes during a peak traffic period, congestion will be severe because the northbound freeway will be closed for three hours.

**7. Are the police on the scene to direct traffic or close the freeway?**

No, the police have not arrived.

**8. Did the Emergency Incident Response Team arrive at the scene and implement the preplanned traffic control plan including detour signs and trailblazers along the preplanned diversion (detour) route?**

No, the Team has not arrived.

## DESIGN MESSAGE FOR VMS ON SAME FREEWAY AND RELATIVELY CLOSE TO THE INCIDENT (VMS #1)

### Identify VMS Characteristics

**1. Where is the VMS located in relation to the incident/closure?**

On the same freeway as the incident and upstream and relatively close to the incident. In addition, the VMS is located upstream of the exit to the primary diversion route.

**2. What type of VMS is being used?**

The sign is a light emitting diode (LED) VMS.

**3. How many lines and characters per line on the VMS?**

The overhead VMS has four lines, 20 characters per line.

### Review Conditions at the VMS Location

**1. What is the traffic operating speed at the VMS location?**

Speeds are about 60 miles per hour at the VMS location.

**2. Are there any geometric features (vertical or horizontal curves) which will adversely affect the motorists' sight distance to the VMS?**

Previous field inspections revealed that there are no geometric features that will adversely affect the motorists' sight distance to the VMS.

**3. What are the current natural lighting conditions?**

It is a bright sunlit day.

**4. Is there rain or fog at the VMS location? If so, what are the degrees of each?**

There is no rain or fog.

### Identify Diversion Route Characteristics

**1. Is a primary diversion route available?**

Although the VMS operator has determined that a primary diversion route was previously identified and documented by NJDOT, the Emergency Incident Response Team has not yet arrived to implement the diversion plan. In addition, the primary VMS operator is not aware of traffic conditions on the primary diversion route.

The established primary diversion route for I-287 North is as follows:

- I-80 East ramp (Exit 41A);
- Cross Smith Road exit ramp to Route 46 & Smith Road onto I-80 East;
- Exit right for Beverwyck Road;
- Turn left onto South Beverwyck Road;
- Cross over I-80;
- Turn left onto entrance ramp to I-80 West;
- Continue straight for I-287;

- Bear right for I-287 North;
- Cross ramp leading to Route 46/ Smith Road;
- Use entrance ramp to I-287 North.

**2. Is the primary diversion route complex for motorists?**

The primary diversion route is very complex.

**3. Are police or traffic control personnel directing traffic at critical locations along the diversion route, or are guide signs available along the route to provide positive guidance to motorists.**

No, the police are not at the scene.

**4. Will a diversion message be displayed? If so, what type?**

Because of the nature, severity and potential duration of the incident, it is desirable to display a “soft” diversion message to encourage motorists to leave the freeway as soon as possible.

### Set Objectives

Based on the information in the previous sections, the VMS operator establishes the following objectives to achieve with the VMS:

- Inform northbound I-287 motorists of freeway blockage and location of blockage; and
- Recommend that northbound I-287 motorists located south of I-80 interchange use alternative routes.

Because the incident is blocking all the lanes of the freeway, and the VMS is on the same freeway and relatively close to the incident, the steps given in [Section 10.2 INCIDENTS THAT BLOCK ALL THE LANES](#) on page 10-20 will be used to define the Basic VMS Message.

Since the incident blocks all of the lanes at a location just past I-80, the connector ramp to I-80 is available. Therefore, the message must give some clue to the motorists that the I-80 connector ramp is still open to traffic.

---

### Establish Initial Maximum Allowable Number of Units of Information in the Message Based on VMS Type and Freeway Operating Speeds.

**Step 1 – Determine Freeway Operating Speed at the VMS Location.**

The freeway operating speed at the VMS location was determined to be 60 miles per hour.

**Step 2 – Determine the Initial Maximum Allowable Number of Units of Information in the Message from [Table 8.2, page 8-5](#).**

Based on the sun position it is initially determined from [Table 8.2](#) that a maximum allowable of four units of information can be displayed on the VMS.



---

## Assess Whether the Message Must Be Reduced Because of Local Geometric Sight Distance Restrictions to the VMS

### Step 3 – Determine Whether There are Sight Distance Restrictions to the VMS Because of a Vertical Curve Using the Guidelines in Section 8.3 UNITS OF INFORMATION REDUCTIONS FOR VERTICAL CURVES – LED VMSs on page 8-6.

An examination of the data in Section 8.3 indicates that no reductions from the initial maximum allowable four units of information need to be made because no vertical curve geometric sight distance restriction exists. Therefore, go directly to Step 5.

### Step 5 – Determine Whether There are Sight Distance Restrictions to the VMS Because of a Horizontal Curve Using the Guidelines in Section 8.4 UNITS OF INFORMATION REDUCTIONS FOR HORIZONTAL CURVES – LED VMSs on page 8-10.

An examination of the data in Section 8.4 indicates that no reductions from the initial maximum allowable four units of information need to be made because of no horizontal curve geometric sight distance restriction exists. Therefore, go directly to Step 7.

---

## Assess Whether the Message Must Be Reduced Because of Local Environmental Sight Distance Restrictions to the VMS Due to Rain or Fog

### Step 7 – Determine Whether Rainfall Near the VMS Exceeds 2 Inches per Hour.

There is no rainfall. Therefore, go directly to Step 9.

### Step 9 – Determine Whether Fog Exists Near the VMS.

No fog. Therefore, go directly to Step 11.

---

## Finalize the Maximum Allowable Units of Information in the Message

### Step 11 – Based on Steps 1 through 10, Finalize the Maximum Allowable Number of Units of Information in the Message.

There are no reductions to the maximum allowable units of information found in Table 8.2. Therefore, it is allowable to use up to four units of information on the VMS.

---

## Define Basic VMS Message to Satisfy Motorist Information Needs

### Step 12 - Select Incident Descriptor Message Element from Table 6.28, page 6-31.

Incident Descriptor: MAJOR ACCIDENT

### Step 13 - Determine Whether the Police or Traffic Control Personnel Arrived to Close the Freeway

Since “no” Continue to Step 14.

### Step 14 - Select Incident (Blockage) Location Message Element from Table 6.29, page 6-32.

The incident is just beyond the I-80 interchange and cannot be referenced to any other cross street/road other than I-80. It is important to give motorists information that indicates the

exit ramp to I-80 is open. Selection of *PAST I-80* satisfies this requirement. The message *AT I-80* might indicate that the incident is upstream of the I-80 exit ramp and that it may not be possible to exit at this location. In addition, *PAST I-80* minimizes the possibility that some motorists might believe that the incident is on I-80.

*Location:*                   **PAST I-80**

**Step 15 - Select *Lanes Blocked* Message Element from Table 6.30, page 6-33.**

*Lanes Blocked:*           **ALL LANES BLOCKED**

**Step 16 - Establish Whether Diversion Action Should Be Recommended.**

“Yes”, diversion action should be recommended. Therefore, go to Step 18.

**Step 18 - Establish Whether “Soft” Diversion Should Be Recommended.**

The primary alternative route that loops around the incident is very complex and requires installation of direction arrow signs at the major intersections or the use of police officers or traffic control personnel to control traffic at selected interchanges. Soft diversion must be recommended because the police officers and traffic control personnel have not yet arrived to provide positive guidance along a specific alternative route. Until this occurs, the VMS operator can only suggest diversion in general terms. Therefore, continue to Step 19.

**Step 19 - Select “Soft” Diversion *Action* Message Element from Table 6.33, page 6-36.**

*Action:*                   **USE OTHER ROUTES**

Go to Step 21.

**Step 21 – Establish Whether *Action* Message Element Is for a Select Group of Motorists.**

“No”, the *Action* message element applies to all motorists passing the VMS. Therefore, go directly to Step 23.

**Step 23 – Examine Whether the Diversion Route Will Be Perceived By Motorists as Being a Most Logical Route.**

No specific route will be given since a “soft” diversion will be displayed. This step does not apply in this case. Therefore, go directly to Step 25.

**Summary**

In summary, the following Basic VMS Message is suggested:

*Incident Descriptor:*   **MAJOR ACCIDENT (1 unit)**  
*Location*               **PAST I-80 (1 unit)**  
*Lanes Blocked*       **ALL LANES BLOCKED (1 unit)**  
*Action*                 **USE OTHER ROUTES (1 unit)**

The Basic VMS Message contains four units of information.

**Note:**

- An *Audience for Action* message element **I-287 NORTH TRAFFIC** is not needed because it is understood that the *Action* applies to all northbound I-287 traffic.
- A *Good Reason for Following the Action* message element is not needed because the motorists should know that when all freeway lanes are blocked major delay will be experienced if the motorist elects to follow the intended primary freeway route.

---

**Reduce the Number of Message Units if Necessary****Step 26 – Examine Whether the Number of Units of Information in the Basic Message is Greater than the Maximum Allowable from Step 11.**

The Basic Message requires four units of information which does not exceed the maximum of four units identified in Step 11. Therefore, go directly to Step 32.

---

**Format the Message****Step 32 - Format the Message According to Guidelines in the Section on *FORMATTING MESSAGES* on page 9-6.**

The message format is consistent with the guidelines in the Section on *FORMATTING MESSAGES*. Therefore, continue to Step 33.

---

**Adjust Message to Fit on Existing VMS****Step 33 - Determine Whether the VMS Has 4 Lines.**

“Yes”, the VMS that will be used to display the message has four lines. Therefore, go directly to Step 35.

---

**Adjust Message to Fit on 3 Lines or Less****Step 35 - Determine Whether the Message Can Be Displayed on 3 Lines or Less.**

“No”, the message has four lines. Therefore, continue to Step 36.

**Step 36 - Split the Message Into 2 Frames According to Guidelines in Section 9.1 *SPLITTING MESSAGES* on page 9-1.**

Using the guidelines on page 9-1, the message was divided into two compatible frames as follows:

**MAJOR ACCIDENT  
PAST I-80**

*Frame 1*

**ALL LANES BLOCKED  
USE OTHER ROUTES**

*Frame 2*

**Step 37 – Examine Whether There Are 3 or Fewer Decision-Relevant Units of Information Displayed on Each of the Frames.**

There are only two units of information on each message frame. Therefore, go directly to Step 39.

**Step 39 - Examine Whether Message Elements are Split in Such a Way That a Part of One Message Element is on the Same Line as a Part of a Second Message Element.**

“No.” A review of the VMS message reveals that the message elements are separated such that part of one message element is not on the same line as part of a second message element. Therefore, go directly to Step 41.

**Step 41 - Examine Whether the Message or Any of the Message Lines Are Too Long to Fit in the Available VMS Space.**

“No”, since the VMS has space for 20 characters on each line, no message line exceeds the space on the sign. Therefore, go directly to Step 45.

---

**Finalize VMS Message****Step 45 - Review Message for Inconsistencies and Incompatibility.**

An examination of the VMS message indicates that there are no inconsistencies in the message. The motorist should understand the entire message. Therefore the message can be accepted as final and can be displayed or stored in a message file.

**Step 46 - Make Additional Adjustments if Necessary.**

An alternative to the message design shown in Step 36 is to omit the *Incident Descriptor* message element according to guidelines in the Section on *Combining Message Elements for Incident Messages* beginning on [page 9-15](#). The resulting message, which can then be displayed on one frame, is as follows:

**FREEWAY BLOCKED  
PAST I-80  
USE OTHER ROUTES**

**Summary**

<b>Table 15.2 Comparison of VMS #1 Basic VMS Message to Satisfy Motorist Information Needs And Final Message For Incident #1 Before Police Arrive</b>		
<b>Basic VMS Message Elements</b>	<b>Basic VMS Message to Satisfy Motorist Information Needs</b>	<b>Final Message</b>
<i>Incident Descriptor</i> <i>Incident Location</i> <i>Lanes Closed</i> <i>Closure Location</i> <i>Action</i>	MAJOR ACCIDENT PAST I-80 ALL LANES BLOCKED  USE OTHER ROUTES	FREEWAY BLOCKED PAST I-80  USE OTHER ROUTES
	<i>(4 Units of Information)</i>	<i>(3 Units of Information)</i>

*You now have an acceptable message ready to display or to store in the VMS message library.*

---

**Assess Effects of Large Trucks on the Ability of Motorists to View the VMS Message**

The final step in the process is to assess the effects of large trucks in the traffic stream on the ability of motorists to see the VMS and read the message. [Tables 8.14 through 8.17](#) on pages 8-21 and 8-22 should be studied to determine the percentage of motorists who will be able to see the VMS message (or consequently, the percentage who will not be able to see the VMS message because their visibility to the sign is blocked by large trucks). This information will help the VMS operator and the TOC manager to determine the potential effectiveness in communicating the message to the motorists in the traffic stream.

## **DESIGN MESSAGE FOR VMS ON SAME FREEWAY BUT RELATIVELY FAR FROM THE INCIDENT (VMS #2)**

### **Identify VMS Characteristics**

**1. Where is the VMS located in relation to the incident/closure?**

On the same freeway as the incident and upstream and relatively far from the incident. In addition, the VMS is located upstream of the exit to the primary diversion route.

**2. What type of VMS is being used?**

The sign is a light emitting diode (LED) VMS.

**3. How many lines and characters per line on the VMS?**

The overhead VMS has four lines, 20 characters per line.

### **Review Conditions at the VMS Location**

**1. What is the traffic operating speed at the VMS location?**

The operating speed at the VMS is about 60 miles per hour at the VMS location.

**2. Are there any geometric features (vertical or horizontal curves) which will adversely affect the motorists' sight distance to the VMS?**

Previous field inspections revealed that there are no geometric features that will adversely affect the motorists' sight distance to the VMS.

**3. What are the current natural lighting conditions?**

It is a bright sunlit day.

**4. Is there rain or fog at the VMS location? If so, what are the degrees of each?**

There is no rain or fog.

### **Identify Diversion Route Characteristics**

**1. Is a primary diversion route available?**

Although a primary diversion route has been identified for motorists viewing VMS #1, VMS #2 is very far upstream from the freeway blockage. It is desirable that motorists began to exit from the freeway as soon as possible upstream of the blockage in order to minimize the congestion and delays on the freeway. However, no suitable single diversion route is available for motorists viewing VMS #2.

**2. Is the primary diversion route complex for motorists?**

(Not Applicable)

**3. Are police or traffic control personnel directing traffic at critical locations along the diversion route, or are guide signs available along the route to provide positive guidance to motorists.**

(Not Applicable)

#### 4. Will a diversion message be displayed? If so, what type?

Because of the nature, severity and potential duration of the incident, it is desirable to display a diversion message. The situation dictates that a “soft” diversion message can be displayed. The VMS operator decides to display a message with “soft” diversion.

#### Set Objectives

Based on the information in the previous sections, the VMS operator establishes the following objectives to achieve with the VMS:

- Inform northbound I-287 motorists of the freeway closure and location of closure; and
- Recommend that northbound I-287 motorists located south of I-80 interchange to use alternative routes.

Because the incident is blocking all the lanes of the freeway and the VMS is on the same freeway but relatively far from the incident, the steps given in Section 10.2 *INCIDENTS THAT BLOCK ALL THE LANES* on page 10-26 will be used to define the Basic VMS Message.

Even though the incident blocks all of the lanes at a location just past I-80, the primary situation that confronts northbound I-287 motorists is that the normal route is closed at I-80.

---

#### Establish Initial Maximum Allowable Number of Units of Information in the Message Based on VMS Type and Freeway Operating Speeds

##### Step 1 – Determine Freeway Operating Speed at the VMS Location.

The freeway operating speed at the VMS location was determined to be 60 miles per hour.

##### Step 2 – Determine the Initial Maximum Allowable Number of Units of Information in the Message from Table 8.2, page 8-5.

Based on the sun position it is initially determined from Table 8.2 that a maximum allowable of four units of information can be displayed on the VMS.

---

#### Assess Whether the Message Must Be Reduced Because of Local Geometric Sight Distance Restrictions to the VMS

##### Step 3 – Determine Whether There are Sight Distance Restrictions to the VMS Because of a Vertical Curve Using the Guidelines in Section 8.3 *UNITS OF INFORMATION REDUCTIONS FOR VERTICAL CURVES – LED VMSs* on page 8-6.

An examination of the data in Section 8.3 indicates that no reductions from the initial maximum allowable four units of information need to be made because no vertical curve geometric sight distance restriction exists. Therefore, go directly to Step 5.

**Step 5 – Determine Whether There are Sight Distance Restrictions to the VMS Because of a Horizontal Curve Using the Guidelines in Section 8.4 UNITS OF INFORMATION REDUCTIONS FOR HORIZONTAL CURVES – LED VMSs on page 8-10.**

An examination of the data in Section 8.4 indicates that no reductions from the initial maximum allowable four units of information need to be made because of no horizontal curve geometric sight distance restriction exists. Therefore, go directly to Step 7.

---

**Assess Whether the Message Must be Reduced Because of Local Environmental Sight Distance Restrictions to the VMS Due to Rain or Fog**

**Step 7 – Determine Whether Rainfall Near the VMS Exceeds 2 Inches per Hour.**

There is no rainfall. Therefore, go directly to Step 9.

**Step 9 – Determine Whether Fog Exists Near the VMS.**

No fog. Therefore, go directly to Step 11.

---

**Finalize the Maximum Allowable Units of Information in the Message**

**Step 11 – Based on Steps 1 through 10, Finalize the Maximum Allowable Number of Units of Information in the Message.**

There are no reductions to the maximum allowable units of information found in Table 8.2. Therefore, it is allowable to use up to four units of information on the VMS.

---

**Define Basic VMS Message to Satisfy Motorist Information Needs**

**Step 12 - Select Incident Descriptor Message Element from Table 6.37, page 6-40.**

*Incident Descriptor:*           **MAJOR ACCIDENT**

**Step 13 - Determine Whether the Police or Traffic Control Personnel Arrived to Close the Freeway.**

Since “no” Continue to Step 14.

**Step 14 - Select Incident (Blockage) Location Message Element from Table 6.38, page 6-41.**

The incident is just beyond the I-80 interchange and cannot be referenced to any other cross street/road other than I-80. It is important to give motorists information that indicates the exit ramp to I-80 is open. Selection of *PAST I-80* satisfies this requirement. The message *AT I-80* might indicate that the incident is upstream of the I-80 exit ramp and that it may not be possible to exit at this location. In addition, *PAST I-80* minimizes the possibility that some motorists might believe that the incident is on I-80.

*Location:*                           **PAST I-80**

**Step 15 - Select Lanes Blocked Message Element from Table 6.39, page 6-42.**

*Lanes Blocked:*                   **ALL LANES BLOCKED**



**Step 16 - Establish Whether Diversion Action Should Be Recommended.**

“Yes”, diversion action should be recommended. Therefore, go to Step 18.

**Step 18 - Establish Whether “Soft” Diversion Should Be Recommended.**

The primary alternative route that loops around the incident is very complex and requires installation of direction arrow signs at the major intersections or the use of police officers or traffic control personnel to control traffic at selected interchanges. Soft diversion must be recommended because the police officers and traffic control personnel have not yet arrived to provide positive guidance along a specific alternative route. Until this occurs, the VMS operator can only suggest diversion in general terms. Therefore, continue to Step 19.

**Step 19 - Select “Soft” Diversion Action Message Element from Table 6.42, page 6-45.**

*Action:* **USE OTHER ROUTES**

Go to Step 21.

**Step 21 – Establish Whether Action Message Element Is for a Select Group of Motorists.**

“No”, the *Action* message element applies to all motorists passing the VMS. Therefore, go directly to Step 23.

**Step 23 – Examine Whether the Diversion Route Will Be Perceived By Motorists as Being a Most Logical Route.**

No specific route will be given since a “soft” diversion will be displayed. This step does not apply in this case. Therefore, go directly to Step 25.

**Summary**

In summary, the following Basic VMS Message is suggested:

<i>Incident Descriptor:</i>	<b>MAJOR ACCIDENT (1 unit)</b>
<i>Location</i>	<b>PAST I-80 (1 unit)</b>
<i>Lanes Blocked</i>	<b>ALL LANES BLOCKED (1 unit)</b>
<i>Action</i>	<b>USE OTHER ROUTES (1 unit)</b>

The Basic VMS Message contains four units of information.

**Notes:**

- An *Audience for Action* message element **I-287 NORTH TRAFFIC** is not needed because it is understood that the *Action* applies to all northbound I-287 traffic.
- A *Good Reason for Following the Action* message element is not needed because the motorists should know that when all freeway lanes are blocked major delay will be experienced if the motorist elects to follow the intended primary freeway route.

---

## Reduce the Number of Message Units if Necessary

### Step 25 – Examine Whether the Number of Units of Information in the Basic Message is Greater than the Maximum Allowable from Step 11.

The Basic Message requires four units of information which does not exceed the maximum of four units identified in Step 11. Therefore, go directly to Step 32.

---

## Format the Message

### Step 32 – Format the Message According to Guidelines in the Section on *FORMATTING MESSAGES* on page 9-6.

The message format is consistent with the guidelines in the Section on *FORMATTING MESSAGES*. Therefore, continue to Step 33.

---

## Adjust Message to Fit on Existing VMS

### Step 33 – Determine Whether the VMS Has 4 Lines.

“Yes”, the VMS that will be used to display the message has four lines. Therefore, go directly to Step 35.

---

## Adjust Message to Fit on 3 Lines or Less

### Step 35 – Determine Whether the Message Can Be Displayed on 3 Lines or Less.

“No”, the message has four lines. Therefore, continue to Step 36.

### Step 36 – Split the Message Into 2 Frames According Guidelines in Section 9.1 *SPLITTING MESSAGES* on page 9-1.

Using the guidelines on Page 9-1, the message was divided into two compatible frames as follows:

**MAJOR ACCIDENT  
PAST I-80**

*Frame 1*

**ALL LANES BLOCKED  
USE OTHER ROUTES**

*Frame 2*

### Step 37 – Examine Whether There Are 3 or Fewer Decision-Relevant Units of Information Displayed on Each of the Frames.

There are only two units of information on each message frame. Therefore, go directly to Step 39.

### Step 39 – Examine Whether Message Elements are Split in Such a Way That a Part of One Message Element is on the Same Line as a Part of a Second Message Element.

“No.” A review of the VMS message reveals that the message elements are separated such that part of one message element is not on the same line as part of a second message element. Therefore, go directly to Step 41.

**Step 41 - Examine Whether the Message or Any of the Message Lines Are Too Long to Fit in the Available VMS Space.**

“No”, since the VMS has space for 20 characters on each line, no message line exceeds the space on the sign. Therefore, go directly to Step 45.

**Finalize VMS Message**

**Step 45 - Review Message for Inconsistencies and Incompatibility.**

An examination of the VMS message indicates that there are no inconsistencies in the message. The motorist should understand the entire message. Therefore the message can be accepted as final and can be displayed or stored in a message file.

**Step 46 - Make Additional Adjustments if Necessary.**

An alternative to the message design shown in Step 36 is to omit the *Incident Descriptor* message element according to guidelines in the Section on *Combining Message Elements for Incident Messages* beginning on [page 9-15](#). The resulting message, which can then be displayed on one frame, is as follows:

**FREEWAY BLOCKED  
PAST I-80  
USE OTHER ROUTES**

**Summary**

<b>Table 15.3 Comparison of VMS #2 Basic VMS Message to Satisfy Motorist Information Needs And Final Message For Incident #1 Before Police Arrive</b>		
<b>Basic VMS Message Elements</b>	<b>Basic VMS Message to Satisfy Motorist Information Needs</b>	<b>Final Message</b>
<i>Incident Descriptor</i> <i>Incident Location</i> <i>Lanes Closed</i> <i>Closure Location</i> <i>Action</i>	MAJOR ACCIDENT PAST I-80 ALL LANES BLOCKED  USE OTHER ROUTES	FREEWAY BLOCKED PAST I-80  USE OTHER ROUTES
	<i>(4 Units of Information)</i>	<i>(3 Units of Information)</i>

*You now have an acceptable message ready to display or to store in the VMS message library.*

**Assess Effects of Large Trucks on the Ability of Motorists to View the VMS Message**

The final step in the process is to assess the effects of large trucks in the traffic stream on the ability of motorists to see the VMS and read the message. [Tables 8.14 through 8.17](#) on pages 8-21 and 8-22 should be studied to determine the percentage of motorists who will be able to see the VMS message (or consequently, the percentage who will not be able to see the VMS message because their visibility to the sign is blocked by large trucks). This information will help the VMS operator and the TOC manager to determine the potential effectiveness in communicating the message to the motorists in the traffic stream.

## 15A.2 AFTER POLICE ARRIVE

After their arrival, the police will close the freeway and in cooperation with the Emergency Incident Response Team will set up a diversion (detour) route. The location of the accident, VMSs and diversion (detour) route are shown in Figure 15.2.

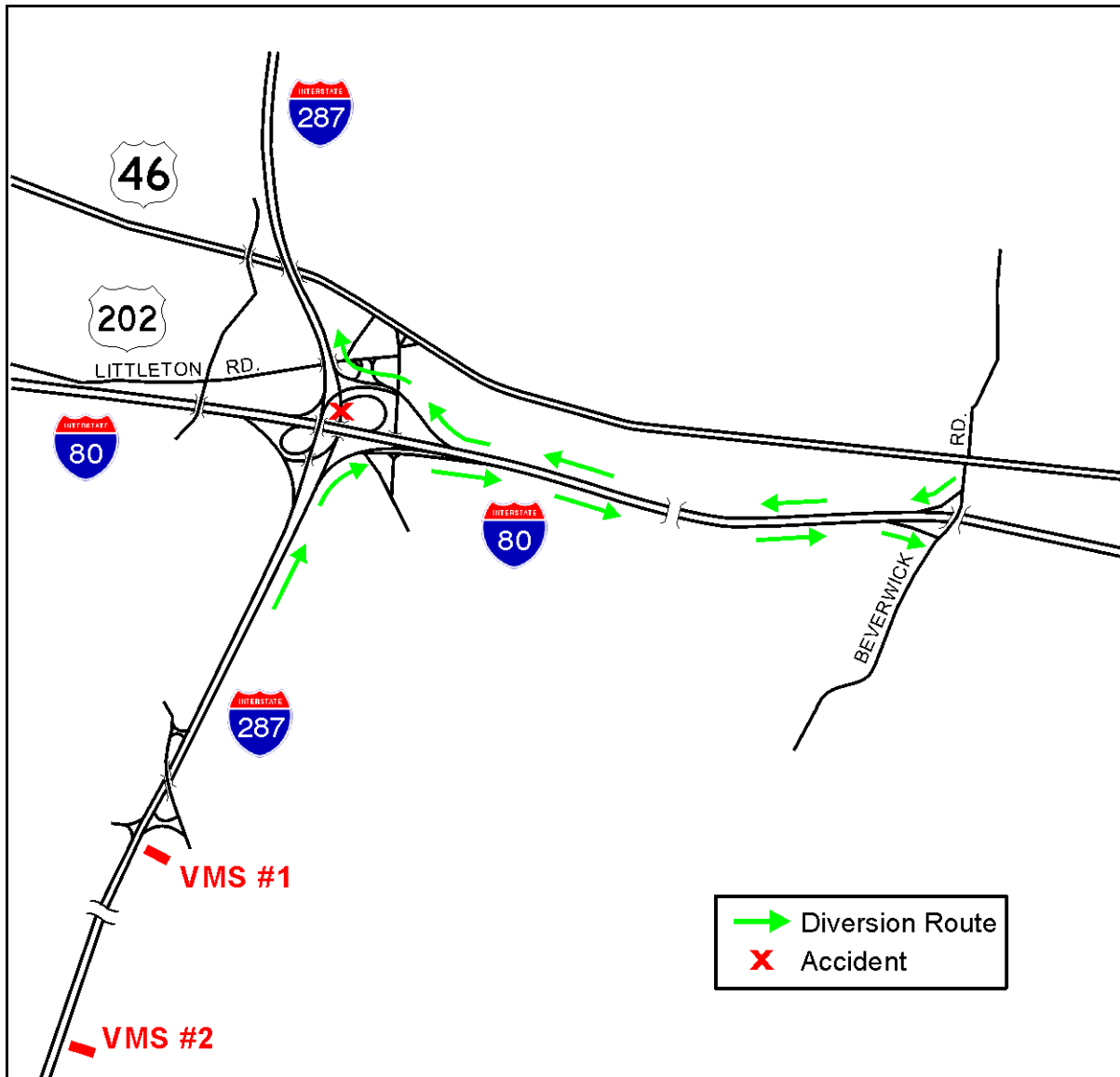

Figure 15.2 Locations of Accident, VMSs and Diversion (Detour) Route

## DEFINE SITUATION

### Analyze Incident and Incident Scene Characteristics

**1. What happened?**

The Traffic Operations Center (TOC) personnel confirm that a major three-vehicle accident occurred. There appears to be a fatality.

The VMS operator in the TOC pans the closed circuit television cameras to view the accident scene.

**2. Where?**

On I-287 northbound just past I-80.

**3. What lanes (how many) lanes are affected?**

All lanes are closed.

**4. What is the current time?**

It is now 10:15 a.m.

**5. How long do you expect the incident to block the lanes?**

The nature of the accident with a fatality indicates that the accident will block all the lanes for three hours until 1:00 p.m.

**6. What is the effect on traffic?**

Even though the incident will not block lanes during an off-peak traffic period, congestion will be severe because the northbound freeway will be closed for three hours.

**7. Are the police on the scene to direct traffic or close the freeway?**

Yes, the police have arrived and are directing traffic off the freeway at I-80.

**8. Did the Emergency Incident Response Team arrive at the scene and implement the preplanned traffic control plan including detour signs and trailblazers along the preplanned diversion (detour) route?**

Yes, the Team arrived and implemented the preplanned traffic control plan.

## DESIGN MESSAGE FOR VMS ON SAME FREEWAY AND RELATIVELY CLOSE TO THE INCIDENT (VMS #1)

### Identify VMS Characteristics

**1. Where is the VMS located in relation to the incident/closure?**

On the same freeway as the incident and upstream and relatively close to the incident. In addition, the VMS is located upstream of the exit to the primary diversion route.

**2. What type of VMS is being used?**

The sign is a light emitting diode (LED) VMS.

**3. How many lines and characters per line on the VMS?**

The overhead VMS has four lines, 20 characters per line.

### Review Conditions at the VMS Location

**1. What is the traffic operating speed at the VMS location?**

Speeds have reduced down to about 30 miles per hour at the VMS location.

**2. Are there any geometric features (vertical or horizontal curves) which will adversely affect the motorists' sight distance to the VMS?**

Previous field inspections revealed that there are no geometric features that will adversely affect the motorists' sight distance to the VMS.

**3. What are the current natural lighting conditions?**

It is a bright sunlit day.

**4. Is there rain or fog at the VMS location? If so, what are the degrees of each?**

There is no rain or fog.

### Identify Diversion Route Characteristics

**1. Is a primary diversion route available?**

The VMS operator has determined that a primary diversion route was previously identified and documented by NJDOT. Agreements are in place between NJDOT and the local agencies. Predetermined action plans have been published for diversion, including types and locations of signs (both static and VMSs) and locations of police officers to facilitate traffic movement during the freeway closure.

The established primary diversion route for I-287 North is as follows:

- I-80 East ramp (Exit 41A);
- Cross Smith Road exit ramp to Route 46 & Smith Road onto I-80 East;
- Exit right for Beverwyck Road;
- Turn left onto South Beverwyck Road;
- Cross over I-80;
- Turn left onto entrance ramp to I-80 West;

- Continue straight for I-287;
- Bear right for I-287 North;
- Cross ramp leading to Route 46/ Smith Road;
- Use entrance ramp to I-287 North.

## **2. Is the primary diversion route complex for motorists?**

The VMS operator concludes that the primary diversion route is complex. Therefore, it is necessary for police or traffic control personnel to direct traffic at critical locations along the diversion route, or that guide signs be available along the route to provide positive guidance to motorists before the primary diversion route is given in the VMS message.

## **3. Are police or traffic control personnel directing traffic at critical locations along the diversion route, or are guide signs available along the route to provide positive guidance to motorists?**

Yes.

## **4. Will a diversion message be displayed? If so, what type?**

Because of the nature, severity and potential duration of the incident, the Emergency Incident Management Team installed detour signing along the designated route. In addition, police are stationed at the established traffic control locations. A Type 5 diversion (detour) route is in place.

### **Set Objectives**

Based on the information in the previous sections, the VMS operator establishes the following objectives to achieve with the VMS:

- Inform northbound I-287 motorists of freeway closure and location of closure; and
- Inform northbound I-287 motorists that they will detour at I-80 around the incident.

Because the incident is blocking all the lanes of the freeway, the freeway is closed, and the VMS is on the same freeway and relatively close to the incident, the steps given in [Section 10.3 INCIDENTS THAT REQUIRE CLOSING THE FREEWAY](#) on page 10-38 will be used to define the Basic VMS Message.

Even though the incident blocks all of the lanes at a location just past I-80, the primary situation that confronts northbound I-287 motorists is that the normal route is closed at I-80. Therefore, motorists must exit at I-80 and they can follow the detour to return to I-287 North.

---

### **Establish Initial Maximum Allowable Number of Units of Information in the Message Based on VMS Type and Freeway Operating Speeds.**

#### **Step 1 – Determine Freeway Operating Speed at the VMS Location.**

The freeway operating speed at the VMS location was determined to be 30 miles per hour.



---

**Step 2 – Determine the Initial Maximum Allowable Number of Units of Information in the Message from Table 8.2, page 8-5.**

Based on the sun position it is initially determined from Table 8.2 that a maximum allowable of five units of information can be displayed on the VMS.

---

**Assess Whether the Message Must Be Reduced Because of Local Geometric Sight Distance Restrictions to the VMS****Step 3 – Determine Whether There are Sight Distance Restrictions to the VMS Because of a Vertical Curve Using the Guidelines in Section 8.3 UNITS OF INFORMATION REDUCTIONS FOR VERTICAL CURVES – LED VMSs on page 8-6.**

An examination of the data in Section 8.3 indicates that no reductions from the initial maximum allowable five units of information need to be made because no vertical curve geometric sight distance restriction exists. Therefore, go directly to Step 5.

**Step 5 – Determine Whether There are Sight Distance Restrictions to the VMS Because of a Horizontal Curve Using the Guidelines in Section 8.4 UNITS OF INFORMATION REDUCTIONS FOR HORIZONTAL CURVES – LED VMSs on page 8-10.**

An examination of the data in Section 8.4 indicates that no reductions from the initial maximum allowable five units of information need to be made because of no horizontal curve geometric sight distance restriction exists. Therefore, go directly to Step 7.

---

**Assess Whether the Message Must Be Reduced Because of Local Environmental Sight Distance Restrictions to the VMS Due to Rain or Fog****Step 7 – Determine Whether Rainfall Near the VMS Exceeds 2 Inches per Hour.**

There is no rainfall. Therefore, go directly to Step 9.

**Step 9 – Determine Whether Fog Exists Near the VMS.**

No fog. Therefore, go directly to Step 11.

---

**Finalize the Maximum Allowable Units of Information in the Message****Step 11 – Based on Steps 1 through 10, Finalize the Maximum Allowable Number of Units of Information in the Message.**

There are no reductions to the maximum allowable units of information found in Table 8.2. Therefore, it is allowable to use up to five units of information on the VMS.

---

**Define Basic VMS Message to Satisfy Motorist Information Needs****Step 12 - Select Incident Descriptor Message Element from Table 6.55, page 6-60.**

*Incident Descriptor:*       **MAJOR ACCIDENT**

**Step 13 - Select Incident Location Message Element from Table 6.56, page 6-61.**

*Incident Location:*           **PAST I-80**

**Step 14 -Select Lanes Closed Message Element from Table 6.57, page 6-62.**

*Lanes Closed:*               **ALL LANES CLOSED**

**Step 15 – Select Closure Location Message Element from Table 6.58, page 6-63.**

*Closure Location:*       **AT I-80**

**Step 16 -Determine Whether Diversion Traffic Control is in Place.**

“Yes.” Therefore, go directly to Step 18.

**Step 18 – Select Type 5 Diversion (Detour) Route Action Message Element from Table 6.61, page 6-67.**

*Action:*                       **EXIT AT I-80**  
**FOLLOW DETOUR**

**Step 19 – Establish Whether Action Message Element Is for a Select Group of Motorists.**

“No”, the *Action* message element applies to all motorists passing the VMS. Therefore, go directly to Step 21.

**Step 21 – Examine Whether the Diversion Route Will Be Perceived By Motorists as Being a Most Logical Route.**

“Yes”, the detour route set up with signs and trailblazers is expected by motorists and will provide positive guidance throughout. Therefore, go directly to Step 23.

**Summary**

In summary, the following Basic VMS Message is suggested:

*Incident Descriptor:*       **MAJOR ACCIDENT (1 unit)**  
*Incident Location:*       **PAST I-80 (1 unit)**  
*Lanes Closed:*             **ALL LANES CLOSED (1 unit)**  
*Closure Location:*       **AT I-80 (1 unit)**  
*Action:*                   **EXIT AT I-80 (1 unit)**  
**FOLLOW DETOUR (1 unit)**

The Basic VMS Message contains six units of information.

**Notes:**

- An *Audience for Action* message element **I-287 NORTH TRAFFIC** is not needed because it is understood that the *Action* applies to all northbound I-287 traffic.
- A *Good Reason for Following the Action* message element is not needed because the motorists should know that motorists must leave the freeway when it is closed.

---

## Reduce the Number of Message Units if Necessary

### Step 23 – Examine Whether the Number of Units of Information in the Basic Message is Greater than the Maximum Allowable from Step 11.

The Basic Message requires six units of information, one more than the maximum of five units identified in Step 11. Therefore, continue to Step 24.

### Step 24 – Omit Incident Descriptor Message Element According to Guidelines in the Section on *Combining Message Elements for Incident Messages* Beginning on page 9-15.

Using the guidelines beginning on page 9-15, the Basic VMS Message is revised to read:

**FREEWAY CLOSED** (1 unit)  
**EXIT AT I-80** (1 unit)  
**FOLLOW DETOUR** (1 unit)

The term *FREEWAY CLOSED* is used rather than *ALL LANES CLOSED* because it is shorter and means the same thing to motorists.

### Step 25 – Examine Whether the Number of Units of Information in the Basic Message is Greater than the Allowable from Step 11.

“No”, the message has been reduced to three units of information; the maximum allowable is five units. Therefore, go directly to Step 30.

---

## Format the Message

### Step 30 – Format the Message According to Guidelines in the Section on *FORMATTING MESSAGES* on page 9-6.

The message format is consistent with the guidelines on page 9-6. Therefore, continue to Step 31.

---

## Adjust Message to Fit on Existing VMS

### Step 31 – Determine Whether the VMS Has 4 Lines.

“Yes”, the VMS that will be used to display the message has four lines. Therefore, go directly to Step 33.

---

## Adjust Message to Fit on 3 Lines or Less

### Step 33 – Determine Whether the Current VMS Message Can Be Displayed on 3 Lines or Less.

“Yes”, the current message can be displayed on three lines. Therefore, go directly to Step 35.

**Step 35 – Examine Whether There Are 3 or Fewer Decision-Relevant Units of Information Displayed on Each of the Frames.**

“Yes”, the message contains only three units of information. Therefore, go directly to Step 37.

**Step 37 – Examine Whether Message Elements are Split in Such a Way That a Part of One Message Element is on the Same Line as a Part of a Second Message Element.**

“No”, the message elements are not split. Therefore, go directly to Step 39.

**Step 39 – Examine Whether the Message or Any of the Message Lines Are Too Long to Fit in the Available VMS Space.**

“No”, the message is small enough to fit on the available VMS space. Therefore, go directly to Step 43.

**Finalize VMS Message**

**Step 43 – Review Message for Inconsistencies and Incompatibility.**

An examination of the VMS message indicates that there are no inconsistencies in the message. The motorist should understand the entire message. Therefore the message can be accepted as final and can be displayed or stored in a message file.

**Step 44 – Make Additional Adjustments if Necessary.**

No adjustments are necessary. The following represents the final message:

**FREEWAY CLOSED  
EXIT AT I-80  
FOLLOW DETOUR**

**Summary**

<b>Table 15.4 Comparison of VMS #1 Basic VMS Message to Satisfy Motorist Information Needs and Final Message For Incident #1 After Police Arrive</b>		
<b>Basic VMS Message Elements</b>	<b>Basic VMS Message to Satisfy Motorist Information Needs</b>	<b>Final Message</b>
<i>Incident Descriptor</i> <i>Incident Location</i> <i>Lanes Closed</i> <i>Closure Location</i> <i>Action</i>	MAJOR ACCIDENT PAST I-80 ALL LANES CLOSED AT I-80 EXIT AT I-80 FOLLOW DETOUR	FREEWAY CLOSED  EXIT AT I-80 FOLLOW DETOUR
	<i>(6 Units of Information)</i>	<i>(3 Units of Information)</i>

*You now have an acceptable message ready to display or to store in the VMS message library.*

---

### **Assess Effects of Large Trucks on the Ability of Motorists to View the VMS Message**

The final step in the process is to assess the effects of large trucks in the traffic stream on the ability of motorists to see the VMS and read the message. [Tables 8.14 through 8.17](#) on pages 8-21 and 8-22 should be studied to determine the percentage of motorists who will be able to see the VMS message (or consequently, the percentage who will not be able to see the VMS message because their visibility to the sign is blocked by large trucks). This information will help the VMS operator and the TOC manager to determine the potential effectiveness in communicating the message to the motorists in the traffic stream.

## **DESIGN MESSAGE FOR VMS ON SAME FREEWAY BUT RELATIVELY FAR FROM THE INCIDENT (VMS #2)**

### **Identify VMS Characteristics**

**1. Where is the VMS located in relation to the incident/closure?**

On the same freeway as the incident and upstream and relatively far from the incident. In addition, the VMS is located upstream of the exit to the primary diversion route.

**2. What type of VMS is being used?**

The sign is a light emitting diode (LED) VMS.

**3. How many lines and characters per line on the VMS?**

The overhead VMS has four lines, 20 characters per line.

### **Review Conditions at the VMS Location**

**1. What is the traffic operating speed at the VMS location?**

The operating speed at the VMS is about 60 miles per hour at the VMS location.

**2. Are there any geometric features (vertical or horizontal curves) which will adversely affect the motorists' sight distance to the VMS?**

Previous field inspections revealed that there are no geometric features that will adversely affect the motorists' sight distance to the VMS.

**3. What are the current natural lighting conditions?**

It is a bright sunlit day.

**4. Is there rain or fog at the VMS location? If so, what are the degrees of each?**

There is no rain or fog.

### **Identify Diversion Route Characteristics**

**1. Is a primary diversion route available?**

Although a primary diversion route has been identified for motorists viewing VMS #1, VMS #2 is very far upstream of the freeway closure. It is desirable that motorists began to exit from the freeway as soon as possible upstream of the closure in order to minimize the congestion and delays on the freeway. However, no suitable single diversion route is available for motorists viewing VMS #2.

**2. Is the primary diversion route complex for motorists?**

(Not Applicable)

**3. Are police or traffic control personnel directing traffic at critical locations along the diversion route, or are guide signs available along the route to provide positive guidance to motorists.**

(Not Applicable)

#### 4. Will a diversion message be displayed? If so, what type?

Because of the nature, severity and potential duration of the incident, it is desirable to display a diversion message. The situation dictates that a “soft” diversion message can be displayed. The VMS operator decides to display a message with “soft” diversion.

#### Set Objectives

Based on the information in the previous sections, the VMS operator establishes the following objectives to achieve with the VMS:

- Inform northbound I-287 motorists of freeway closure and location of closure; and
- Recommend that northbound I-287 motorists located south of I-80 interchange to use alternative routes.

Because the incident is blocking all the lanes of the freeway, the freeway is closed and the VMS is on the same freeway but relatively far from the incident, the steps given in Section 10.3 *INCIDENTS THAT REQUIRE CLOSING THE FREEWAY* on [page 10-44](#) will be used to define the Basic VMS Message.

Even though the incident blocks all of the lanes at a location just past I-80, the primary situation that confronts northbound I-287 motorists is that the normal route is closed at I-80.

---

#### Establish Initial Maximum Allowable Number of Units of Information in the Message Based on VMS Type and Freeway Operating Speeds.

##### Step 1 – Determine Freeway Operating Speed at the VMS Location.

The freeway operating speed at the VMS location was determined to be 60 miles per hour.

##### Step 2 – Determine the Initial Maximum Allowable Number of Units of Information in the Message from [Table 8.2, page 8-5](#).

Based on the sun position it is initially determined from Table 8.2 that a maximum allowable of four units of information can be displayed on the VMS.

---

#### Assess Whether the Message Must be Reduced Because of Local Geometric Sight Distance Restrictions to the VMS

##### Step 3 – Determine Whether There are Sight Distance Restrictions to the VMS Because of a Vertical Curve Using the Guidelines in [Section 8.3 UNITS OF INFORMATION REDUCTIONS FOR VERTICAL CURVES – LED VMSs](#) on [page 8-6](#).

An examination of the data in Section 8.3 indicates that no reductions from the initial maximum allowable four units of information need to be made because no vertical curve geometric sight distance restriction exists. Therefore, go directly to Step 5.

**Step 5 – Determine Whether There are Sight Distance Restrictions to the VMS Because of a Horizontal Curve Using the Guidelines in Section 8.4 UNITS OF INFORMATION REDUCTIONS FOR HORIZONTAL CURVES – LED VMSs on page 8-10.**

An examination of the data in Section 8.4 indicates that no reductions from the initial maximum allowable four units of information need to be made because of no horizontal curve geometric sight distance restriction exists. Therefore, go directly to Step 7.

---

**Assess Whether the Message Must be Reduced Because of Local Environmental Sight Distance Restrictions to the VMS Due to Rain or Fog**

**Step 7 – Determine Whether Rainfall Near the VMS Exceeds 2 Inches per Hour.**

There is no rainfall. Therefore, go directly to Step 9.

**Step 9. Determine Whether Fog Exists Near the VMS.**

No fog. Therefore, go directly to Step 11.

---

**Finalize the Maximum Allowable Units of Information in the Message**

**Step 11 – Based on Steps 1 through 10, Finalize the Maximum Allowable Number of Units of Information in the Message.**

There are no reductions to the maximum allowable units of information found in Table 8.2. Therefore, it is allowable to use up to four units of information on the VMS.

---

**Define Basic VMS Message to Satisfy Motorist Information Needs**

**Step 12 - Select Incident Descriptor Message Element from Table 6.64, page 6-70.**

*Incident Descriptor:* MAJOR ACCIDENT

**Step 13 - Select Incident Location Message Element from Table 6.65, page 6-71.**

*Closure Location:* PAST I-80

**Step 14 - Select Lanes Closed Message Element from Table 6.66, page 6-72.**

*Lanes Closed:* ALL LANES CLOSED

**Step 15 - Select Closure Location Message Element from Table 6.67, page 6-73.**

*Closure Location:* AT I-80

**Step 16 – Establish Whether Diversion Action Should Be Recommended.**

“Yes.” The anticipated very congested traffic downstream justifies advising motorists at this VMS location to divert. Therefore, continue to Step 18.

**Step 18 – Establish Whether “Soft” Diversion Should Be Recommended.**

“Yes.” There are no suitable alternative routes that can be specified for the motorists at the VMS location. However, it is appropriate (and desirable) to use a “soft” diversion message element. Therefore, continue to Step 19.



**Step 19 - Select “Soft” Diversion Action Message Element from Table 6.70, page 6-76.**

*Action:* **USE OTHER ROUTES**

Go to Step 23.

**Step 23 – Establish Whether Action Message Element Is for a Select Group of Motorists.**

“No”, the *Action* message element applies to all motorists passing the VMS. Therefore, go directly to Step 25.

**Step 25 – Examine Whether the Diversion Route Will Be Perceived By Motorists as Being a Most Logical Route.**

No specific route will be given since a “soft” diversion will be displayed. This step does not apply in this case. Therefore, go directly to Step 27.

**Summary**

In summary, the following Basic VMS Message is suggested:

<i>Incident Descriptor:</i>	<b>MAJOR ACCIDENT (1 unit)</b>
<i>Incident Location</i>	<b>PAST I-80 (1 unit)</b>
<i>Lanes Closed</i>	<b>ALL LANES CLOSED (1 unit)</b>
<i>Closure Location</i>	<b>AT I-80 (1 unit)</b>
<i>Action</i>	<b>USE OTHER ROUTES (1 unit)</b>

The Basic VMS Message contains five units of information.

**Notes:**

- An *Audience for Action* message element **I-287 NORTH TRAFFIC** is not needed because it is understood that the *Action* applies to all northbound I-287 traffic.
- A *One Good Reason for Following the Action Statement* message element is not needed because the motorists should know that motorists must leave the freeway when it is closed.

---

**Reduce the Number of Message Units if Necessary****Step 27 – Examine Whether the Number of Units of Information in the Basic Message is Greater than the Maximum Allowable from Step 11.**

The Basic Message requires five units of information, one more than the maximum of four units identified in Step 11. Therefore, continue to Step 28.

**Step 28 – Omit Incident Descriptor Message Element According to Guidelines in the Section on Combining Message Elements for Incident Messages Beginning on page 9-15.**

Using the guidelines beginning on page 9-15, the Basic VMS Message is revised to read:

**FREEWAY CLOSED (1 unit)**  
**AT I-80 (1 unit)**  
**USE OTHER ROUTES (1 unit)**

The term ***FREEWAY CLOSED*** is used rather than ***ALL LANES CLOSED*** because it is shorter and means the same thing to motorists.

**Step 29 – Examine Whether the Number of Units of Information in the Basic Message is Greater than the Allowable from Step 11.**

“No”, the message has been reduced to three units of information; the maximum allowable is four units. Therefore, go directly to Step 34.

---

**Format the Message**

**Step 34 - Format the Message According to Guidelines in the Section on *FORMATTING MESSAGES* on page 9-6.**

The message format is consistent with the guidelines on page 9-6. Therefore, continue to Step 35.

---

**Adjust Message to Fit on Existing VMS**

**Step 35 - Determine Whether the VMS Has 4 Lines.**

“Yes”, the VMS that will be used to display the message has four lines. Therefore, go directly to Step 37.

---

**Adjust Message to Fit on 3 Lines or Less**

**Step 37 - Determine Whether the Message Can Be Displayed on 3 Lines or Less.**

“Yes”, the message has 3 lines. Therefore, go directly to Step 39.

**Step 39 - Examine Whether 3 or Fewer Decision-Relevant Units of Information Are Displayed on Each of the Frames.**

“Yes”, the one-frame message has three units of information. Therefore, go directly to Step 41.

**Step 41 - Examine Whether Message Elements are Split in Such a Way That a Part of One Message Element is on the Same Line as a Part of a Second Message Element.**

“No.” A review of the VMS message reveals that the message elements are separated such that part of one message element is not on the same line as part of a second message element. Therefore, go directly to Step 43.

**Step 43 - Examine Whether the Message or Any of the Message Lines Are Too Long to Fit in the Available VMS Space.**

“No”, since the VMS has space for 20 characters on each line, no message line exceeds the space on the sign. Therefore, go directly to Step 47.

**Finalize VMS Message**

**Step 47 - Review Message for Inconsistencies and Incompatibility.**

An examination of the VMS message indicates that there are no inconsistencies in the message. The motorist should understand the entire message. Therefore the message can be accepted as final and can be displayed or stored in a message file.

**Step 48 - Make Additional Adjustments if Necessary.**

No adjustments are necessary. The following represents the final message:

**FREEWAY CLOSED  
AT I-80  
USE OTHER ROUTES**

**Summary**

<b>Table 15.5 Comparison of VMS #2 Basic VMS Message to Satisfy Motorist Information Needs and Final Message For Incident #1 After Police Arrive</b>		
<b>Basic VMS Message Elements</b>	<b>Basic VMS Message to Satisfy Motorist Information Needs</b>	<b>Final Message</b>
<i>Incident Descriptor</i> <i>Incident Location</i> <i>Lanes Closed</i> <i>Closure Location</i> <i>Action</i>	MAJOR ACCIDENT PAST I-80 ALL LANES CLOSED AT I-80 USE OTHER ROUTES	FREEWAY CLOSED  AT I-80 USE OTHER ROUTES
	<i>(5 Units of Information)</i>	<i>(3 Units of Information)</i>

*You now have an acceptable message ready to display or to store in the VMS message library.*

**Assess Effects of Large Trucks on the Ability of Motorists to View the VMS Message**

The final step in the process is to assess the effects of large trucks in the traffic stream on the ability of motorists to see the VMS and read the message. [Tables 8.14 through 8.17](#) on pages 8-21 and 8-22 should be studied to determine the percentage of motorists who will be able to see the VMS message (or consequently, the percentage who will not be able to see the VMS message because their visibility to the sign is blocked by large trucks). This information will help the VMS operator and the TOC manager to determine the potential effectiveness in communicating the message to the motorists in the traffic stream.

## 15B. INCIDENT EXAMPLE #2 ALL LANES ARE (BLOCKED) CLOSED

### 15B.1 BEFORE POLICE ARRIVE

The location of the accident and VMSs are shown in Figure 15.3. Since the police have not yet arrived, no diversion route has been set. Two large overhead VMSs will be used:

- VMS #1 is located on Route 42 North, upstream of I-295 and just north of the New Jersey Turnpike (note that Route 42 North connects directly into I-76); and
- VMS #2 is located on I-295 North, upstream of I-76.

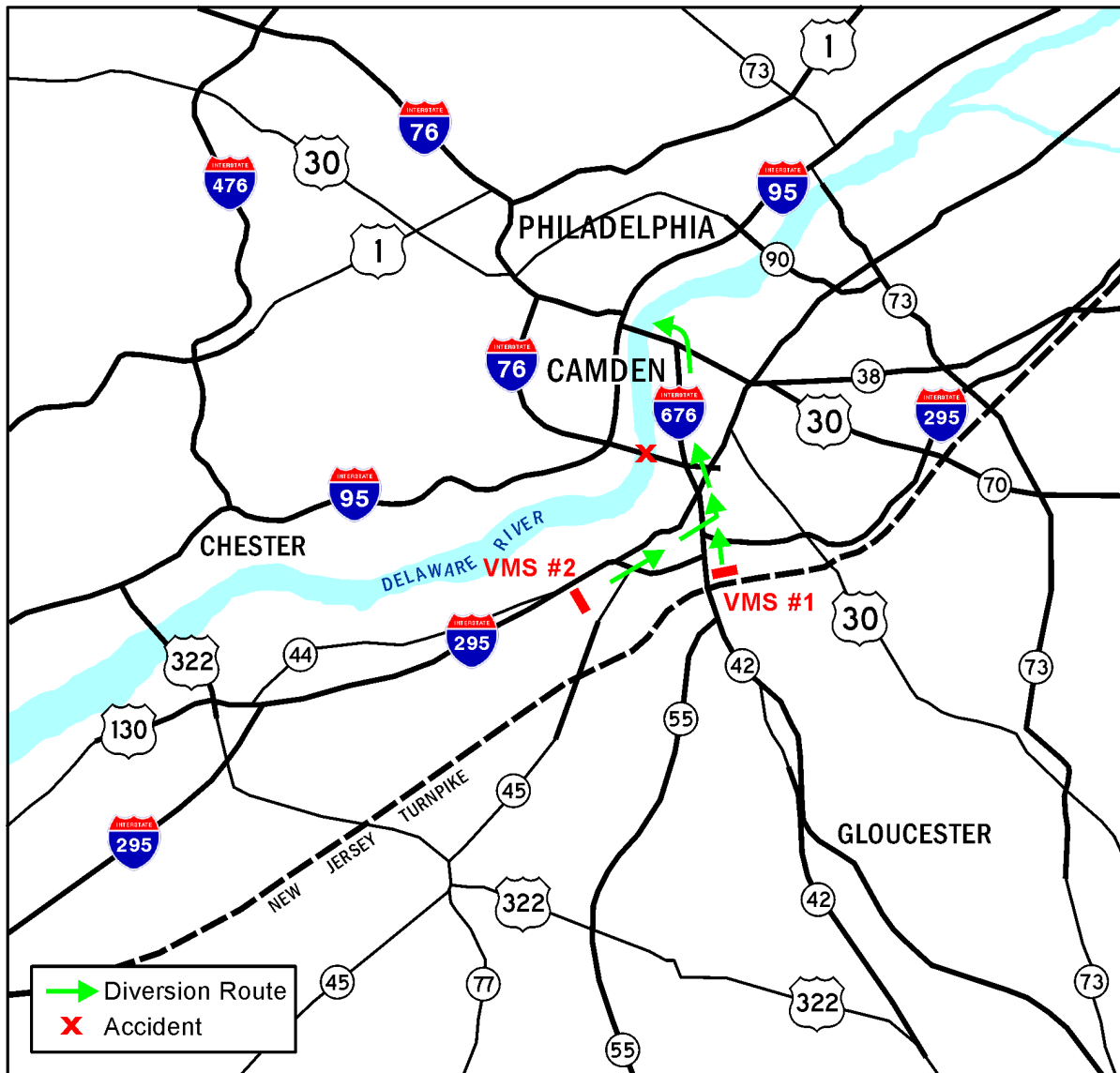

Figure 15.3 Locations of Accident, VMSs and Diversion (Detour) Route

## DEFINE SITUATION DETAILS

### Analyze Incident and Incident Scene Characteristics

#### 1. What happened?

The Traffic Operations Center (TOC) personnel confirm that a major three-vehicle accident occurred. There appears to be a fatality.

The VMS operator in the TOC pans the closed circuit television cameras to view the accident scene.

#### 2. Where?

On westbound I-76 on the Walt Whitman Bridge.

#### 3. What lanes (how many) lanes are affected?

All lanes are blocked.

#### 4. What is the current time?

It is now 12:00 noon.

#### 5. How long do you expect the incident to block the lanes?

The nature of the accident with a fatality indicates that the accident will block all the lanes from four to six hours.

#### 6. What is the effect on traffic?

Congestion will be severe. The Walt Whitman Bridge is a major structure over the Delaware River, and is one of a three routes which can handle substantial traffic from New Jersey across the river to Philadelphia and to I-95. In addition, the accident will most likely affect traffic during the afternoon peak traffic period.

#### 7. Are the police on the scene to direct traffic or close the freeway?

The police have not yet arrived.

#### 8. Did the Emergency Incident Response Team arrive at the scene and implement a preplanned traffic control plan including detour signing and trailblazers along the preplanned diversion (detour) route?

No, the Team has not arrived.

## DESIGN MESSAGE FOR VMS ON DIFFERENT FREEWAY THAN THE INCIDENT (VMS #1)

### Identify VMS Characteristics

#### 1. Where is the VMS located in relation to the incident/closure?

VMS #1 is located on Route 42 North, upstream of I-295 and just north of the New Jersey Turnpike. This is relatively close to the incident.

Although the incident is on a different numbered freeway (I-76), Route 42 connects directly into I-76 West.

#### 2. What type of VMS is being used?

The sign is a light emitting diode (LED) VMS.

#### 3. How many lines and characters per line on the VMS?

The overhead VMS has three lines, 20 characters per line.

### Review Conditions at the VMS Location

#### 1. What is the traffic operating speed at the VMS location?

Speeds are about 60 miles per hour at the VMS location.

#### 2. Are there any geometric features (vertical or horizontal curves) which will adversely affect the motorists' sight distance to the VMS?

Previous field inspections revealed that there are no geometric features that will adversely affect the motorists' sight distance to the VMS.

#### 3. What are the current natural lighting conditions?

It is a bright sunlit day.

#### 4. Is there rain or fog at the VMS location? If so, what are the degrees of each?

There is no rain or fog.

### Identify Diversion Route Characteristics

#### 1. Is a primary diversion route available?

Previous evaluations of candidate routes and information on guide signs along these routes led to the determination that an alternative route is available for motorists who are traveling on Route 42 North and who intend to connect with I-76 West and cross the Walt Whitman Bridge to Philadelphia and/or I-95.

The previous review of the guide signs showed that the I-676 North shield appears on overhead signs on Route 42 North starting at station 13.965 and continues to the I-76/I-676 fork which is at station 1.83 of I-76. Thus positive guidance is available to motorists on Route 42 North (that transitions into I-76 West) who want to take I-676 North. B.

*FRANKLIN BR.* appears on overhead signs on I-76 West which are associated with I-676 starting at station 1.380.

The primary alternative route for motorists is as follows:

- RT-42 North to I-76 West Local;
- I-76 West Local to I-676 North; then
- I-676 North across Ben Franklin Bridge to Philadelphia & I-95.

**2. Is the primary diversion route complex for motorists?**

The VMS operator has determined that the diversion route for Route 42 is complex. Therefore it is necessary that trailblazing information (i.e., Ben Franklin Bridge) be available on guide signs along the alternative route.

**3. Are police or traffic control personnel directing traffic at critical locations along the diversion route, or are guide signs available along the route to provide positive guidance to motorists.**

No, the police are not at the scene.

**4. Will a diversion message be displayed? If so, what type?**

Because of the nature, severity and potential duration of the incident, it is desirable to display a diversion message with specific information where to exit to get to an alternative river crossing (i.e., Ben Franklin Bridge).

## Set Objectives

Based on the information in the previous sections, the VMS operator establishes the following objectives to achieve with the VMS:

- Inform motorists of the blockage and location of blockage; and
- Recommend that Route 42 North motorists located south of the I-295 interchange and who are destined to Philadelphia or I-95 use I-676 North (Ben Franklin Bridge).

Because the incident is blocking all the lanes of the freeway and the VMS is on a different freeway than the incident, the steps given in Section 10.2 *INCIDENTS THAT BLOCK ALL THE LANES* on [page 10-32](#) will be used to define the Basic VMS Message.

---

## Establish Initial Maximum Allowable Number of Units of Information in the Message Based on VMS Type and Freeway Operating Speeds.

### Step 1 – Determine Freeway Operating Speed at the VMS Location.

The freeway operating speed at the VMS location was determined to be 60 miles per hour.

---

**Step 2 – Determine the Initial Maximum Allowable Number of Units of Information in the Message from Table 8.2, page 8-5.**

Based on the sun position it is initially determined from Table 8.2 that a maximum allowable of four units of information can be displayed on the VMS.

---

**Assess Whether the Message Must Be Reduced Because of Local Geometric Sight Distance Restrictions to the VMS****Step 3 – Determine Whether There are Sight Distance Restrictions to the VMS Because of a Vertical Curve Using the Guidelines in Section 8.3 UNITS OF INFORMATION REDUCTIONS FOR VERTICAL CURVES – LED VMSs on page 8-6.**

An examination of the data in Section 8.3 indicates that no reductions from the initial maximum allowable four units of information need to be made because no vertical curve geometric sight distance restriction exists. Therefore, go directly to Step 5.

**Step 5 - Determine Whether There are Sight Distance Restrictions to the VMS Because of a Horizontal Curve Using the Guidelines in Section 8.4 UNITS OF INFORMATION REDUCTIONS FOR HORIZONTAL CURVES – LED VMSs on page 8-10.**

An examination of the data in Section 8.4 indicates that no reductions from the initial maximum allowable four units of information need to be made because of no horizontal curve geometric sight distance restriction exists. Therefore, go directly to Step 7.

---

**Assess Whether the Message Must Be Reduced Because of Local Environmental Sight Distance Restrictions to the VMS Due to Rain or Fog****Step 7 – Determine Whether Rainfall Near the VMS Exceeds 2 Inches per Hour.**

There is no rainfall. Therefore, go directly to Step 9.

**Step 9 – Determine Whether Fog Exists Near the VMS.**

No fog. Therefore, go directly to Step 11.

---

**Finalize the Maximum Allowable Units of Information in the Message****Step 11 – Based on Steps 1 through 10, Finalize the Maximum Allowable Number of Units of Information in the Message.**

There are no reductions to the maximum allowable units of information found in Table 8.2. Therefore, it is allowable to use up to four units of information on the VMS.

---

**Define Basic VMS Message to Satisfy Motorist Information Needs****Step 12 - Select Incident Descriptor Message Element from Table 6.46, page 6-50.**

*Incident Descriptor:* MAJOR ACCIDENT



**Step 13 - Determine Whether the Police or Traffic Control Personnel Arrived to Close the Freeway.**

“No.” Therefore, continue to Step 14.

**Step 14 - Select Incident (Blockage) Location Message Element from Table 6.47, page 6-51.**

*Incident Location:*           **ON I-76 (WEST) EXPRESS  
AT WALT WHITMAN BRIDGE**

**Note:**

- Since the cardinal direction for I-76 does not appear on the guide signs on I-295 North, the cardinal direction is omitted from the message element. The terms *EXPRESS* and *LOCAL* are used to describe the lanes that lead to the Walt Whitman Bridge (EXPRESS) and the lanes that interconnect with other freeways (LOCAL). The VMS message terms must be compatible with the terms displayed on the static guide signs.

**Step 15 - Select Lanes Blocked Message Element from Table 6.48, page 6-52.**

*Lanes Blocked:*                   **ALL LANES BLOCKED**

**Step 16 - Establish Whether Diversion Action Should Be Recommended.**

“Yes.” Therefore, go directly to Step 18.

**Step 18 - Establish Whether “Soft” Diversion Should Be Recommended.**

“No.” Therefore, go directly to Step 20.

**Step 20 – Select Type 1 or Type 2 Diversion Route Action Message Element from Table 6.52, page 6-56.**

*Action:*                                   **USE I-676 NORTH**

**Step 21 – Establish Whether Action Message Is for a Select Group of Motorists**

“Yes.” Therefore, continue to Step 22.

**Step 22 – Select Audience for Action Message Element from Table 6.53, page 6-57.**

In this case, it is important to communicate the action to motorists heading to Philadelphia and to motorists heading to I-95 located on the west side of Philadelphia.

*Audience for Action:*               **PHILADELPHIA  
I-95**

**Step 23 – Examine Whether the Diversion Route May Be Perceived by Motorists as Being a Most Logical Route.**

“Yes.” Therefore go directly to Step 25.

## Summary

In summary, the following Basic VMS Message is suggested:

<i>Incident Descriptor:</i>	<b>MAJOR ACCIDENT</b> (1 unit)
<i>Incident Location:</i>	<b>ON I-76 (WEST) EXPRESS</b> (1 unit) <b>AT WALT WHITMAN BRIDGE</b> (1 unit)
<i>Lanes Blocked:</i>	<b>ALL LANES BLOCKED</b> (1 unit)
<i>Audience for Action:</i>	<b>PHILADELPHIA</b> (1 unit) <b>I-95</b> (1 unit)
<i>Action:</i>	<b>USE I-676 NORTH</b> (1 unit)

**The Basic VMS Message contains seven units of information.**

### Note:

- A *Good Reason for Following the Action* message element is not needed because the motorists should know that when all lanes are blocked, major delay will be experienced if the motorists elect to follow the intended primary freeway route.

---

## Reduce the Number of Message Units if Necessary

### Step 25 – Examine Whether the Number of Units of Information Units in the Basic VMS Message Is Greater than the Maximum Allowable from Step 11.

An examination of the Basic VMS Message reveals that the message contains seven units of information which is greater than the allowable four units. Therefore, continue to Step 26.

### Step 26 - Omit *Incident Descriptor* Message Element According Guidelines in the Section on *Combining Message Elements for Incident Messages Beginning on page 9-15*.

Using the guidelines beginning on page 9-15 the Basic VMS Message is revised to read:

**I-76 EXPRESS BLOCKED** (1 unit)  
**AT WALT WHITMAN BRIDGE** (1 unit)  
**PHILADELPHIA** (1 unit)  
**I-95** (1 unit)  
**USE I-676 NORTH** (1 unit)

### Step 27 – Examine Whether the Number of Units of Information Units in the Basic VMS Message Is Greater than the Maximum Allowable from Step 11.

“Yes.” An examination of the revised Basic VMS Message reveals that the message contains five units of information which is still greater than the allowable four units. Therefore, continue to Step 28.

### Step 28 - Examine Whether the Message Contains More Than One *Audience for Action* (Destination) Message Element.

“Yes.” The revised Basic VMS Message contains two *Audiences for Action* (Destinations), namely, Philadelphia and I-95. Therefore, continue to Step 29.

**Step 29 – Omit All but One Audience for Action.**

It was established that it is more important to sign for Philadelphia than for I-95. Therefore, I-95 is omitted from the message.

**Step 30 – Examine Whether the Number of Units of Information Units in the Basic VMS Message Is Greater than the Maximum Allowable from Step 11.**

The current message is as follows:

**I-76 EXPRESS BLOCKED** (1 unit)  
**AT WALT WHITMAN BRIDGE** (1 unit)  
**PHILADELPHIA** (1 unit)  
**USE I-676 NORTH** (1 unit)

The message has been reduced to four units of information. Therefore, go directly to Step 32.

**Format the Message****Step 32 – Format the Message According to Guidelines in the Section on *FORMATTING MESSAGES* on page 9-6.**

The message format is consistent with the guidelines in the Section on *FORMATTING MESSAGES*. Therefore, continue to Step 33.

**Adjust Message to Fit on Existing VMS****Step 33 – Determine Whether the VMS has 4 Lines.**

“No”, the VMS has three lines. Therefore, continue to Step 34.

**Step 34 – Determine Whether the VMS has 3 Lines.**

“Yes”, the VMS has three lines. Therefore, continue to Step 35.

**Adjust Message to Fit on 3 Lines or Less****Step 35 – Determine Whether the Message Can Be Displayed on 3 Lines or Less.**

“No”, the message cannot be displayed on three lines or less. Therefore, continue to Step 36.

**Step 36 – Split Message Into 2 Frames According to Guidelines in Section 9.1 *SPLITTING MESSAGES* on page 9-1.**

Using the guidelines found in the section on *SPLITTING MESSAGES*, the message is split into the following two frames:

<b>I-76 EXPRESS BLOCKED</b> (1 unit)	<b>PHILADELPHIA</b> (1 unit)
<b>AT WALT WHITMAN BRIDGE</b> (1 unit)	<b>USE I-676 NORTH</b> (1 unit)
(frame 1)	(frame 2)

**Step 37 – Examine Whether 3 or Fewer Decision-Relevant Units of Information are Displayed on Each of the Frames.**

“Yes”, each frame has only two units of information. Therefore, go directly to Step 39.

**Step 39 – Examine Whether the Message Elements are Split in Such a Way That a Part of One Message Element is on the Same Line as Part of a Second Message Element.**

“No.” Therefore, go directly to Step 41.

**Step 41 – Examine Whether the Message or Any of the Message Lines are Too Long to Fit in the Available VMS Space.**

“Yes”, the second line of frame 1 requires 22 spaces (including spaces between words). Therefore, continue to Step 42.

**Step 42 – Apply Abbreviations to Selected Words According to Guidelines in the Section on USING ABBREVIATIONS, page 9-10.**

“WALT WHITMAN BRIDGE” can be abbreviated as “WALT WHITMAN BRDG” which reduces the line to 20 characters. For commuter motorists, the abbreviation can be shortened even more to “W WHITMAN BRDG.” Continue to Step 43.

**Step 43 – Examine Whether the Application of Abbreviation Guidelines Adequately Reduced the Length of the Message Lines and the Entire Message Can Fit in the Available VMS Space.**

The message has been shortened to fit in the available VMS space:

<b>I-76 EXPRESS BLOCKED</b> (20 spaces)	<b>PHILADELPHIA</b> (12 spaces)
<b>AT WALT WHITMAN BRDG</b> (20 spaces)	<b>USE I-676 NORTH</b> (15 spaces)
(frame 1)	(frame 2)

Go directly to Step 45.

---

**Finalize VMS Message****Step 45 - Review Message for Inconsistencies and Incompatibility.**

An examination of the VMS message indicates that there are no inconsistencies in the message. Each frame can stand on its own merits. And it does not matter which of the two frames is read first by a motorist. The motorist should understand the entire message. Therefore the message can be accepted as final and can be displayed or stored in a message file. The following represents the final message:

<b>I-76 EXPRESS BLOCKED</b>	<b>PHILADELPHIA</b>
<b>AT WALT WHITMAN BRDG</b>	<b>USE I-676 NORTH</b>
(frame 1)	(frame 2)

For commuter traffic, the message can be shortened to read:

**I-76 EXPRESS BLOCKED  
AT W WHITMAN BRDG**  
*(frame 1)*

**PHILADELPHIA  
USE I-676 NORTH**  
*(frame 2)*

**Summary**

<b>Table 15.6 Comparison of VMS #1 Basic VMS Message to Satisfy Motorist Information Needs and Final Message For Incident #2 Before Police Arrive</b>		
<b>Basic VMS Message Elements</b>	<b>Basic VMS Message to Satisfy Motorist Information Needs</b>	<b>Final Message</b>
<i>Incident Descriptor</i>	MAJOR ACCIDENT	I-76 EXPRESS BLOCKED
<i>Incident Location</i>	ON I-76 ( <i>WEST</i> ) EXPRESS	AT WALT WHITMAN BRDG
<i>Lanes Blocked</i>	AT WALT WHITMAN BRIDGE	
<i>Audience for Action</i>	ALL LANES BLOCKED	PHILADELPHIA
	PHILADELPHIA	
<i>Action</i>	I-95	USE I-676 NORTH
	USE I-676 NORTH	
	<i>(7 Units of Information)</i>	<i>(4 Units of Information)</i>

**Assess Effects of Large Trucks on the Ability of Motorists to View the VMS Message**

The final step in the process is to assess the effects of large trucks in the traffic stream on the ability of motorists to see the VMS and read the message. [Tables 8.14 through 8.17](#) on pages 8-21 and 8-22 should be studied to determine the percentage of motorists who will be able to see the VMS message (or consequently, the percentage who will not be able to see the VMS message because their visibility to the sign is blocked by large trucks). This information will help the VMS operator and the TOC manager to determine the potential effectiveness in communicating the message to the motorists in the traffic stream.

## DESIGN MESSAGE FOR VMS ON DIFFERENT FREEWAY THAN THE INCIDENT (VMS #2)

### Identify VMS Characteristics

**1. Where is the VMS located in relation to the incident/closure?**

VMS #2 is located on I-295 North, upstream of I-76.

**2. What type of VMS is being used?**

The sign is a light emitting diode (LED) VMS.

**3. How many lines and characters per line on the VMS?**

The overhead VMS has three lines, 20 characters per line.

### Review Conditions at the VMS Location

**1. What is the traffic operating speed at the VMS location?**

Speeds are about 60 miles per hour at the VMS location.

**2. Are there any geometric features (vertical or horizontal curves) which will adversely affect the motorists' sight distance to the VMS?**

Previous field inspections revealed that there are no geometric features that will adversely affect the motorists' sight distance to the VMS.

**3. What are the current natural lighting conditions?**

It is a bright sunlit day.

**4. Is there rain or fog at the VMS location? If so, what are the degrees of each?**

There is no rain or fog.

### Identify Diversion Route Characteristics

**1. Is a primary diversion route available?**

Previous evaluations of candidate routes and information on guide signs along these routes led to the determination that a primary alternative route is available for motorists who are traveling on I-295 North and who intend to connect with I-76 West and cross the Walt Whitman Bridge to Philadelphia and/or I-95.

The previous review of the guide signs showed that the I-676 North shield and *B FRANKLIN BR* (for Ben Franklin Bridge) appear on overhead signs on I-295 North just past the I-76 Exit. Thus positive guidance is available to motorists on I-295 who want to take I-676 North and the Ben Franklin Bridge to Philadelphia and/or I-95.

The primary alternative route for motorists is as follows:

- I-295 North to I-76 West Local;
- I-76 West Local to I-676 North; then
- I-676 North across Ben Franklin Bridge to Philadelphia & I-95.

**2. Is the primary diversion route complex for motorists?**

The VMS operator has determined that the diversion route for I-295 is complex. Therefore it is necessary that trailblazing information (i.e., Ben Franklin Bridge) be available on guide signs along the alternative route.

**3. Are police or traffic control personnel directing traffic at critical locations along the diversion route, or are guide signs available along the route to provide positive guidance to motorists.**

No.

**4. Will a diversion message be displayed? If so, what type?**

Because of the nature, severity and potential duration of the incident, it is desirable to display a diversion message with specific information where to exit to get to an alternative river crossing (i.e., Ben Franklin Bridge).

**Set Objectives**

Based on the information in the previous sections, the VMS operator establishes the following objectives to achieve with the VMS:

- Inform motorists of the blockage and location of blockage; and
- Recommend that I-295 North motorists located south of the I-76 interchange and who are destined to Philadelphia or I-95 use I-676 North (Ben Franklin Bridge).

Because the incident is blocking all the lanes of the freeway and the VMS is on a different highway than the incident, the steps given in Section 10.2 *INCIDENTS THAT BLOCK ALL LANES* on [page 10-32](#) will be used to define the Basic VMS Message.

---

**Establish Initial Maximum Allowable Number of Units of Information in the Message Based on VMS Type and Freeway Operating Speeds.****Step 1 – Determine Freeway Operating Speed at the VMS Location.**

The freeway operating speed at the VMS location was determined to be 60 miles per hour.

**Step 2 – Determine the Initial Maximum Allowable Number of Units of Information in the Message from Table 8.2, page 8-5.**

Based on the sun position it is initially determined from Table 8.2 that a maximum allowable of four units of information can be displayed on the VMS.

---

## Assess Whether the Message Must Be Reduced Because of Local Geometric Sight Distance Restrictions to the VMS

### Step 3 – Determine Whether There are Sight Distance Restrictions to the VMS Because of a Vertical Curve Using the Guidelines in Section 8.3 UNITS OF INFORMATION REDUCTIONS FOR VERTICAL CURVES – LED VMSs on page 8-6.

An examination of the data in Section 8.3 indicates that no reductions from the initial maximum allowable four units of information need to be made because no vertical curve geometric sight distance restriction exists. Therefore, go directly to Step 5.

### Step 5 - Determine Whether There are Sight Distance Restrictions to the VMS Because of a Horizontal Curve Using the Guidelines in Section 8.4 UNITS OF INFORMATION REDUCTIONS FOR HORIZONTAL CURVES – LED VMSs on page 8-10.

An examination of the data in Section 8.4 indicates that no reductions from the initial maximum allowable four units of information need to be made because of no horizontal curve geometric sight distance restriction exists. Therefore, go directly to Step 7.

---

## Assess Whether the Message Must Be Reduced Because of Local Environmental Sight Distance Restrictions to the VMS Due to Rain or Fog

### Step 7 – Determine Whether Rainfall Near the VMS Exceeds 2 Inches per Hour.

There is no rainfall. Therefore, go directly to Step 9.

### Step 9 – Determine Whether Fog Exists Near the VMS.

No fog. Therefore, go directly to Step 11.

---

## Finalize the Maximum Allowable Units of Information in the Message

### Step 11 – Based on Steps 1 through 10, Finalize the Maximum Allowable Number of Units of Information in the Message.

There are no reductions to the maximum allowable units of information found in Table 8.2. Therefore, it is allowable to use up to four units of information on the VMS.

---

## Define Basic VMS Message to Satisfy Motorist Information Needs

### Step 12 - Select Incident Descriptor Message Element from Table 6.46, page 6-50.

*Incident Descriptor:* MAJOR ACCIDENT

### Step 13 - Determine Whether the Police or Traffic Control Personnel Arrived to Close the Freeway

“No.” Therefore, continue to Step 14.

### Step 14 - Select Incident (Blockage) Location Message Element from Table 6.47, page 6-51.

*Incident Location:* ON I-76 (WEST) EXPRESS  
AT WALT WHITMAN BRIDGE



**Note:**

- Since the cardinal direction for I-76 does not appear on the guide signs on I-295 North, the cardinal direction is omitted from the message element. The terms *EXPRESS* and *LOCAL* are used to describe the lanes that lead to the Walt Whitman Bridge (*EXPRESS*) and the lanes that interconnect with other freeways (*LOCAL*). The VMS message terms must be compatible with the terms displayed on the static guide signs.

**Step 15 - Select Lanes Blocked Message Element from Table 6.48, page 6-52.**

*Lanes Blocked:* **ALL LANES BLOCKED**

**Step 16 - Establish Whether Diversion Action Should Be Recommended.**

“Yes.” Therefore, go directly to Step 18.

**Step 18 - Establish Whether “Soft” Diversion Should Be Recommended.**

“No.” Therefore, go directly to Step 20.

**Step 20 - Select Type 1 or Type 2 Action Message Element from Table 6.52, page 6-56.**

*Action:* **USE I-676 NORTH**

**Step 21 – Establish Whether Action Message Is for a Select Group of Motorists**

“Yes.” Therefore, continue to Step 22.

**Step 22 – Select Audience for Action Message Element from Table 6.53, page 6-57.**

In this case, it is important to communicate the action to motorists heading to Philadelphia and to motorists heading to I-95 located on the west side of Philadelphia.

*Audience for Action:* **PHILADELPHIA  
I-95**

**Step 23 – Examine Whether the Diversion Route May Be Perceived by Motorists as Being a Most Logical Route.**

“Yes.” Therefore go directly to Step 25.

**Summary**

In summary, the following Basic VMS Message is suggested:

*Incident Descriptor:* **MAJOR ACCIDENT (1 unit)**  
*Incident Location:* **ON I-76 (WEST) EXPRESS (1 unit)**  
**AT WALT WHITMAN BRIDGE (1 unit)**  
*Lanes Blocked:* **ALL LANES BLOCKED (1 unit)**  
*Audience for Action:* **PHILADELPHIA (1 unit)**  
**I-95 (1 unit)**  
*Action:* **USE I-676 NORTH (1 unit)**

The Basic VMS Message has seven units of information.

**Note:**

- A *Good Reason for Following the Action* message element is not needed because the motorists should know that when all lanes are blocked, major delay will be experienced if the motorists elect to follow the intended primary freeway route.

---

**Reduce the Number of Message Units if Necessary****Step 25 – Examine Whether the Number of Informational Units in the Basic VMS Message is Greater than the Maximum Allowable from Step 11.**

An examination of the Basic VMS Message reveals that the message contains seven units of information which is greater than the maximum allowable of four units. Therefore, continue to Step 26.

**Step 26 - Omit Incident Descriptor Message Element According to Guidelines in the Section on *Combining Message Elements for Incident Messages Beginning on page 9-15*.**

Using the guidelines beginning on page 9-15, the Basic VMS Message is revised to read:

**I-76 EXPRESS BLOCKED** (1 unit)  
**AT WALT WHITMAN BRIDGE** (1 unit)  
**PHILADELPHIA** (1 unit)  
**I-95** (1 unit)  
**USE I-676 NORTH** (1 unit)

**Step 27 – Examine Whether the Number of Informational Units in the Basic VMS Message is Greater than the Maximum Allowable from Step 11.**

“Yes.” An examination of the Basic VMS Message reveals that the message contains five units of information which is greater than the maximum allowable of four units. Therefore, continue to Step 28.

**Step 28 - Examine Whether the Message Contains More Than One *Audience for Action* (Destination) Message Element.**

“Yes.” The revised Basic VMS Message contains two *Audiences for Action* (Destinations), namely, Philadelphia and I-95. Therefore, continue to Step 29.

**Step 29 – Reduce the Number of *Audience for Action* (Destination) Message Elements.**

It was established that it is more important to sign for Philadelphia than for I-95. Therefore, *I-95* is omitted from the message.

**Step 27 – Examine Whether the Number of Informational Units in the Basic VMS Message is Greater than the Maximum Allowable from Step 11.**

The current message is as follows:

**I-76 EXPRESS BLOCKED** (1 unit)  
**AT WALT WHITMAN BRIDGE** (1 unit)  
**PHILADELPHIA** (1 unit)  
**USE I-676 NORTH** (1 unit)

The message has been reduced to four units of information. Therefore, go directly to Step 32.

---

### Format the Message

#### **Step 32 – Format the Message According to Guidelines in the Section on *FORMATTING MESSAGES* on page 9-6.**

The message format is consistent with the guidelines in the Section on *FORMATTING MESSAGES*. Therefore, continue to Step 33.

---

### Adjust Message to Fit on Existing VMS

#### **Step 33 – Determine Whether the VMS has 4 Lines.**

“No”, the VMS has three lines. Therefore, continue to Step 34.

#### **Step 34 – Determine Whether the VMS has 3 Lines.**

“Yes”, the VMS has three lines. Therefore, continue to Step 35.

---

### Adjust Message to Fit on 3 Lines or Less

#### **Step 35 – Determine Whether the Message Can Be Displayed on 3 Lines or Less.**

No”, the message cannot be displayed on three lines or less. Therefore, continue to Step 36.

#### **Step 36 – Split Message Into 2 Frames According to Guidelines in Guidelines in Section 9.1 *SPLITTING MESSAGES* on page 9-1.**

Using the guidelines found in the section on *SPLITTING MESSAGES*, the message is split into the following two frames:

<b>I-76 EXPRESS BLOCKED</b> (1 unit)	<b>PHILADELPHIA</b> (1 unit)
<b>AT WALT WHITMAN BRIDGE</b> (1 unit)	<b>USE I-676 NORTH</b> (1 unit)
(frame 1)	(frame 2)

#### **Step 37 – Examine Whether 3 or Fewer Decision-Relevant Units of Information are Displayed on Each of the Frames.**

“Yes”, each frame has only two units of information. Therefore, go directly to Step 39.

#### **Step 39 – Examine Whether the Message Elements are Split in Such a Way That a Part of One Message Element is on the Same Line as Part of a Second Message Element.**

“No.” Therefore, go directly to Step 41.

#### **Step 41 – Examine Whether Any of the Message Lines are Too Long to Fit on the VMS.**

“Yes”, the second line of Frame 1 requires 22 spaces (including spaces between words). Therefore, continue to Step 42.

**Step 42 – Apply Abbreviations to Selected Words According to Guidelines in the Section on USING ABBREVIATIONS, page 9-10.**

“WALT WHITMAN BRIDGE” can be abbreviated as “WALT WHITMAN BRDG” which reduces the line to 20 characters. For commuter motorists, the abbreviation can be shortened even more to “W WHITMAN BRDG.” Continue to Step 43.

**Step 43 – Examine Whether the Application of Abbreviation Guidelines Adequately Reduced the Length of the Message Lines and the Entire Message Can Fit in the Available VMS Space.**

The message has been shortened to fit in the available VMS space:

<b>I-76 EXPRESS BLOCKED</b> (20 spaces)	<b>PHILADELPHIA</b> (12 spaces)
<b>AT WALT WHITMAN BRDG</b> (20 spaces)	<b>USE I-676 NORTH</b> (15 spaces)
(frame 1)	(frame 2)

Go directly to Step 45.

---

**Finalize VMS Message**

**Step 45 - Review Message for Inconsistencies and Incompatibility.**

An examination of the VMS message indicates that there are no inconsistencies in the message. Each frame can stand on its own merits. And it does not matter which of the two frames is read first by a motorist. The motorist should understand the entire message. Therefore the message can be accepted as final and can be displayed or stored in a message file. The following represents the final message:

<b>I-76 EXPRESS BLOCKED</b>	<b>PHILADELPHIA</b>
<b>AT WALT WHITMAN BRDG</b>	<b>USE I-676 NORTH</b>
(frame 1)	(frame 2)

For commuter traffic, the message can be shortened to read:

<b>I-76 EXPRESS BLOCKED</b>	<b>PHILADELPHIA</b>
<b>AT W WHITMAN BRDG</b>	<b>USE I-676 NORTH</b>
(frame 1)	(frame 2)

**Summary**

<b>Table 15.7 Comparison of VMS #2 Basic VMS Message to Satisfy Motorist Information Needs and Final Message For Incident #2 Before Police Arrive</b>		
<b>Basic VMS Message Elements</b>	<b>Basic VMS Message to Satisfy Motorist Information Needs</b>	<b>Final Message</b>
<i>Incident Descriptor</i>	MAJOR ACCIDENT	I-76 EXPRESS BLOCKED
<i>Incident Location</i>	ON I-76 ( <i>WEST</i> ) EXPRESS	AT WALT WHITMAN BRDG
<i>Lanes Blocked</i>	AT WALT WHITMAN BRIDGE	
<i>Audience for Action</i>	ALL LANES BLOCKED	
	PHILADELPHIA	PHILADELPHIA
<i>Action</i>	I-95	
	USE I-676 NORTH	USE I-676 NORTH
	<i>(7 Units of Information)</i>	<i>(4 Units of Information)</i>

---

**Assess Effects of Large Trucks on the Ability of Motorists to View the VMS Message**

The final step in the process is to assess the effects of large trucks in the traffic stream on the ability of motorists to see the VMS and read the message. [Tables 8.14 through 8.17](#) on pages 8-21 and 8-22 should be studied to determine the percentage of motorists who will be able to see the VMS message (or consequently, the percentage who will not be able to see the VMS message because their visibility to the sign is blocked by large trucks). This information will help the VMS operator and the TOC manager to determine the potential effectiveness in communicating the message to the motorists in the traffic stream.

## 15B.2 AFTER POLICE ARRIVE

After the their arrival, the police will close I-76 West. However no special signing will be installed for motorists on Route 42 North or I-295 North motorists. The locations of the accident, VMSs and the suggested diversion (detour) route are shown below.

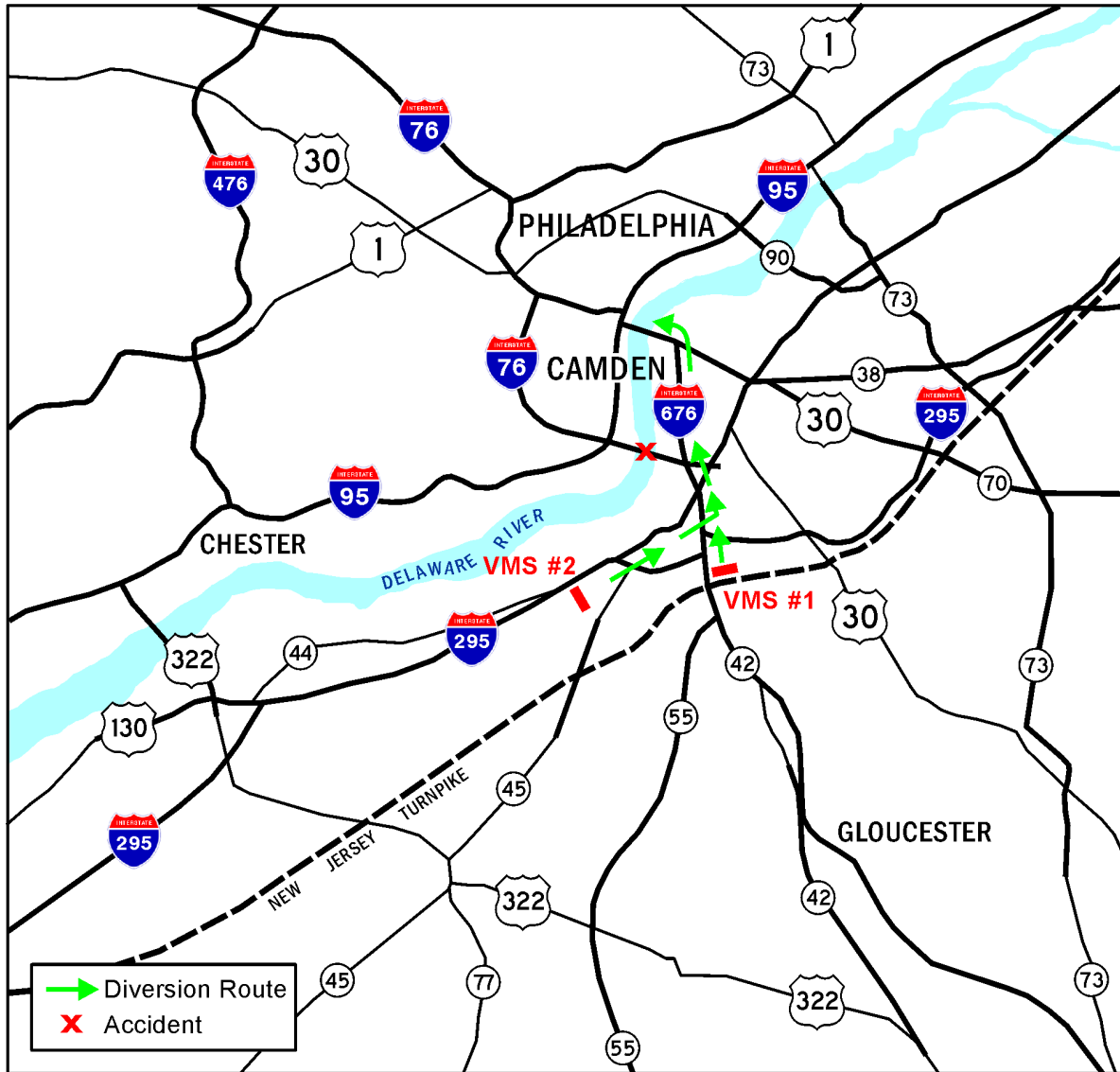

Figure 15.4 Locations of Accident, VMSs and Diversion (Detour) Route

## DEFINE SITUATION DETAILS

### Analyze Incident and Incident Scene Characteristics

#### 1. What happened?

The Traffic Operations Center (TOC) personnel confirm that a major three-vehicle accident occurred. There appears to be a fatality.

The VMS operator in the TOC pans the closed circuit television cameras to view the accident scene.

#### 2. Where?

On westbound I-76 on the Walt Whitman Bridge.

#### 3. What lanes (how many) lanes are affected?

All lanes are blocked.

#### 4. What is the current time?

It is now 12:00 noon.

#### 5. How long do you expect the incident to block the lanes?

The nature of the accident with a fatality indicates that the accident will block all the lanes from four to six hours.

#### 6. What is the effect on traffic?

Congestion will be severe. The Walt Whitman Bridge is a major structure over the Delaware River, and is one of a three routes which can handle substantial traffic from New Jersey across the river to Philadelphia and to I-95. In addition, the accident will most likely affect traffic during the afternoon peak traffic period.

#### 7. Are the police on the scene to direct traffic or close the freeway?

Yes, the police have arrived and are directing traffic on I-76.

#### 8. Did the Emergency Incident Response Team arrive at the scene and implement a preplanned traffic control plan including detour signing and trailblazers along the preplanned diversion (detour) route?

Yes, the Team has arrived and implemented the preplanned traffic control plan. The plan includes the following:

- Close the Walt Whitman Bridge (I-76 West at I-676);
- Close the ramp from RT-42 North to I-76 Express;
- Close the ramp from I-295 North to I-76;
- Close the ramp from I-76 Local to I-76 Express; and
- Close the ramp from I-76 Local to I-76 Express toward Walt Whitman Bridge.

However, the plan does not include additional signs on RT-46 North or I-295 North.

## DESIGN MESSAGE FOR VMS ON DIFFERENT FREEWAY THAN THE INCIDENT (VMS #1)

### Identify VMS Characteristics

#### 1. Where is the VMS located in relation to the incident/closure?

VMS #1 is located on Route 42 North, upstream of I-295 and just north of the New Jersey Turnpike. This is relatively close to the incident.

Although the incident is on a different numbered freeway (I-76), Route 42 connects directly into I-76 West.

#### 2. What type of VMS is being used?

The sign is a light emitting diode (LED) VMS.

#### 3. How many lines and characters per line on the VMS?

The overhead VMS has three lines, 20 characters per line.

### Review Conditions at the VMS Location

#### 1. What is the traffic operating speed at the VMS location?

Speeds are about 60 miles per hour at the VMS location.

#### 2. Are there any geometric features (vertical or horizontal curves) which will adversely affect the motorists' sight distance to the VMS?

Previous field inspections revealed that there are no geometric features that will adversely affect the motorists' sight distance to the VMS.

#### 3. What are the current natural lighting conditions?

It is a bright sunlit day.

#### 4. Is there rain or fog at the VMS location? If so, what are the degrees of each?

There is no rain or fog.

### Identify Diversion Route Characteristics

#### 1. Is a primary diversion route available?

Previous evaluations of candidate routes and information on guide signs along these routes led to the determination that an alternative route is available for motorists who are traveling on Route 42 North and who intend to connect with I-76 West and cross the Walt Whitman Bridge to Philadelphia and/or I-95.

The previous review of the guide signs showed that the I-676 North shield appears on overhead signs on Route 42 North starting at station 13.965 and continues to the I-76/I-676 fork which is at station 1.83 of I-76. Thus, positive guidance is available to motorists on Route 42 North (that transitions into I-76 West) who want to take I-676 North. *B. FRANKLIN BR.* appears on overhead signs on I-76 West which are associated with I-676 starting at station 1.380.



The primary alternative route for motorists is as follows:

- RT-42 North to I-76 West Local;
- I-76 West Local to I-676 North; then
- I-676 North across Ben Franklin Bridge to Philadelphia & I-95.

**2. Is the primary diversion route complex for motorists?**

The VMS operator has determined that the diversion route for Route 42 is complex. Therefore it is necessary that trailblazing information (i.e., Ben Franklin Bridge) be available on guide signs along the alternative route.

**3. Are police or traffic control personnel directing traffic at critical locations along the diversion route, or are guide signs available along the route to provide positive guidance to motorists.**

The police are directing traffic according to the Emergency Incident Response Plan. However, no additional signs were installed along the diversion route as part of the Plan.

**4. Will a diversion message be displayed? If so, what type?**

Because of the nature, severity and potential duration of the incident, it is desirable to display a diversion message with specific information about where to exit to get to an alternative river crossing (i.e., Ben Franklin Bridge).

### Set Objectives

Based on the information in the previous sections, the VMS operator establishes the following objectives to achieve with the VMS:

- Inform motorists of the blockage and location of blockage; and
- Recommend that Route 42 North motorists located south of the I-295 interchange and who are destined to Philadelphia or I-95 use I-676 North (Ben Franklin Bridge).

Because the incident is blocking all the lanes of the interconnecting I-76 freeway, the police are controlling traffic on I-76, the connector ramp to I-76 is closed, and the VMS is on a different freeway than the incident, the steps given in [Section 10.4 INCIDENTS ON INTERSECTING FREEWAY THAT REQUIRE CLOSING THE CONNECTOR RAMP](#) on Page 10-56 will be used to define the Basic VMS Message.

---

### Establish Initial Maximum Allowable Number of Units of Information in the Message Based on VMS Type and Freeway Operating Speeds

**Step 1 – Determine Freeway Operating Speed at the VMS Location.**

The freeway operating speed at the VMS location was determined to be 60 miles per hour.

---

**Step 2 – Determine the Initial Maximum Allowable Number of Units of Information in the Message from Table 8.2, page 8-5.**

Based on the sun position it is initially determined from Table 8.2 that a maximum allowable of four units of information can be displayed on the VMS.

---

**Assess Whether the Message Must Be Reduced Because of Local Geometric Sight Distance Restrictions to the VMS****Step 3 – Determine Whether There are Sight Distance Restrictions to the VMS Because of a Vertical Curve Using the Guidelines in Section 8.3 UNITS OF INFORMATION REDUCTIONS FOR VERTICAL CURVES – LED VMSs on page 8-6**

An examination of the data in Section 8.3 indicates that no reductions from the initial maximum allowable four units of information need to be made because no vertical curve geometric sight distance restriction exists. Therefore, go directly to Step 5.

**Step 5 - Determine Whether There are Sight Distance Restrictions to the VMS Because of a Horizontal Curve Using the Guidelines in Section 8.4 UNITS OF INFORMATION REDUCTIONS FOR HORIZONTAL CURVES – LED VMSs on page 8-10.**

An examination of the data in Section 8.4 indicates that no reductions from the initial maximum allowable four units of information need to be made because of no horizontal curve geometric sight distance restriction exists. Therefore, go directly to Step 7.

---

**Assess Whether the Message Must Be Reduced Because of Local Environmental Sight Distance Restrictions to the VMS Due to Rain or Fog****Step 7 – Determine Whether Rainfall Near the VMS Exceeds 2 Inches per Hour.**

There is no rainfall. Therefore, go directly to Step 9.

**Step 9 – Determine Whether Fog Exists Near the VMS.**

No fog. Therefore, go directly to Step 11.

---

**Finalize the Maximum Allowable Units of Information in the Message****Step 11 – Based on Steps 1 through 10, Finalize the Maximum Allowable Number of Units of Information in the Message.**

There are no reductions to the maximum allowable units of information found in Table 8.2. Therefore, it is allowable to use up to four units of information on the VMS.

---

**Define Basic VMS Message to Satisfy Motorist Information Needs****Step 12 - Select Incident Descriptor Message Element from Table 6.85, page 6-93.**

*Incident Descriptor:* MAJOR ACCIDENT

**Step 13 - Select Incident Location Message Element from Table 6.86, page 6-94.**

*Incident Location:* ON I-76 (WEST) EXPRESS  
AT WALT WHITMAN BRIDGE

**Note:**

- Since the cardinal direction for I-76 does not appear on the guide signs on I-295 North, the cardinal direction is omitted from the message element. The terms *EXPRESS* and *LOCAL* are used to describe the lanes that lead to the Walt Whitman Bridge (*EXPRESS*) and the lanes that interconnect with other freeways (*LOCAL*). The VMS message terms must be compatible with the terms displayed on the static guide signs.

**Step 14 - Select *Lanes Closed* Message Element from Table 6.87, page 6-95.**

*Lanes Blocked*                      **ALL LANES CLOSED**

**Step 15 – Select *Ramp Closure Descriptor* Message Element from Table 6.88, page 6-96.**

*Closure Location*                      **I-76 EXPRESS CLOSED**

**Step 16 - Determine Whether Diversion Action Should Be Recommended.**

“Yes.” Therefore, go directly to Step 18.

**Step 18 - Establish Whether “Soft” Diversion Should Be Recommended.**

“No.” Therefore, go directly to Step 20.

**Step 20 – Determine Whether Diversion Traffic Control is in Place on the Selected Alternative Route.**

“No.” No specific diversion signing will be installed on the route. However, previous inspection of the diversion route revealed that information on existing static guide signs give positive guidance to Philadelphia. Therefore, continue to Step 21.

**Step 21 – Select Type 1 or Type 2 *Action* Message Element from Table 6.91, page 6-99.**

*Action*                                      **USE I-676 NORTH**

GO TO Step 23.

**Step 23 – Establish Whether *Action* Message Is for a Select Group of Motorists**

“Yes.” Therefore, continue to Step 24.

**Step 24 – Select *Audience for Action* Message Element from Table 6.93, page 101.**

In this case, it is important to communicate the action to motorists heading to Philadelphia and to motorists heading to I-95 located on the west side of Philadelphia.

*Audience for Action:*                      **PHILADELPHIA  
I-95**

**Step 25 – Examine Whether the Diversion Route May Be Perceived by Motorists as Being a Most Logical Route.**

“Yes.” Therefore go directly to Step 27.

## Summary

In summary, the following Basic VMS Message is suggested:

<i>Incident Descriptor:</i>	<b>MAJOR ACCIDENT (1 unit)</b>
<i>Incident Location:</i>	<b>ON I-76 (WEST) EXPRESS (1 unit)</b> <b>AT WALT WHITMAN BRIDGE (1 unit)</b>
<i>Lanes Closed:</i>	<b>ALL LANES CLOSED (1 unit)</b>
<i>Ramp Closure Descriptor:</i>	<b>I-76 WEST EXPRESS CLOSED (1 unit)</b>
<i>Audience for Action:</i>	<b>PHILADELPHIA (1 unit)</b> <b>I-95 (1 unit)</b>
<i>Action:</i>	<b>USE I-676 NORTH (1 unit)</b>

The Basic VMS Message contains eight units of information.

### Note:

- A *Good Reason for Following the Action* message element is not needed because the motorists should know that when all lanes are blocked, major delay will be experienced if the motorists elect to follow the intended primary freeway route.

## Reduce the Number of Message Units if Necessary

### Step 27 – Examine Whether the Number of Informational Units in the Basic VMS Message is Greater than the Maximum Allowable from Step 11.

“Yes.” An examination of the Basic VMS Message reveals that the message contains eight units of information which is greater than the maximum allowable of four units. Therefore, continue to Step 28.

### Step 28 - Omit Incident Descriptor Message Element According Guidelines in the Section on *Combining Message Elements for Incident Messages Beginning on page 9-15*.

Using the guidelines beginning on page 9-15, the Basic VMS Message is revised to read:

**I-76 EXPRESS CLOSED (1 unit)**  
**PHILADELPHIA (1 unit)**  
**I-95 (1 unit)**  
**USE I-676 NORTH (1 unit)**

### Step 29 – Examine Whether the Number of Informational Units in the Basic VMS Message is Greater than the Maximum Allowable from Step 11.

“No.” An examination of the Basic VMS Message reveals that the message contains four units of information which does not exceed the maximum allowable of four units. Therefore, go directly to Step 34.

---

## Format the Message

### Step 34 – Format the Message According to Guidelines in the Section on *FORMATTING MESSAGES* on page 9-6.

The message is formatted according to the guidelines on page 9-6. Therefore, continue to Step 35.

---

## Adjust Message to Fit on Existing VMS

### Step 35 – Determine Whether the VMS has 4 Lines.

“No”, the VMS has three lines. Therefore, continue to Step 36.

### Step 36 – Determine Whether the VMS has 3 Lines.

“Yes”, the VMS has three lines. Therefore, continue to Step 37.

---

## Adjust Message to Fit on 3 Lines or Less

### Step 37 – Determine Whether the Message Can Be Displayed on 3 Lines or Less.

“No”, the message cannot be displayed on three lines or less. Therefore, continue to Step 38.

### Step 38 – Split Message Into 2 Frames According to Guidelines in Guidelines in Section 9.1 *SPLITTING MESSAGES* on page 9-1.

Using the guidelines found in the section on *SPLITTING MESSAGES*, the message is split into the following two frames:

**I-76 EXPRESS** (1 unit)  
**CLOSED**

(frame 1)

**PHILADELPHIA** (1 unit)

**I-95** (1 unit)

**USE I-676 NORTH** (1 unit)

(frame 2)

### Step 39 – Examine Whether 3 or Fewer Decision-Relevant Units of Information are Displayed on Each of the Frames.

“Yes.” Each frame has three or fewer units of information. Therefore, go directly to Step 41.

### Step 41 – Examine Whether the Message Elements are Split in Such a Way That a Part of One Message Element is on the Same Line as Part of a Second Message Element.

“No.” Therefore, go directly to Step 43.

### Step 43 – Examine Whether the Message or Any of the Message Lines are Too Long to Fit in the Available VMS Space.

“No.” Therefore, go directly to Step 47.

**Finalize VMS Message**

**Step 47 - Review Message for Inconsistencies and Incompatibility.**

An examination of the VMS message indicates that there are no inconsistencies in the message. Each frame can stand on its own merits. And it does not matter which of the two frames is read first by a motorist. The motorist should understand the entire message. Therefore the message can be accepted as final and can be displayed or stored in a message file. The following represents the final message:

**I-76 EXPRESS  
CLOSED**

*(frame 1)*

**PHILADELPHIA  
I-95  
USE I-676 NORTH**

*(frame 2)*

**Summary**

<b>Table 15.8 Comparison of VMS #1 Basic VMS Message to Satisfy Motorist Information Needs and Final Message For Incident #2 After Police Arrive</b>		
<b>Basic VMS Message Elements</b>	<b>Basic VMS Message to Satisfy Motorist Information Needs</b>	<b>Final Message</b>
<i>Incident Descriptor</i>	MAJOR ACCIDENT	I-76 EXPRESS CLOSED
<i>Incident Location</i>	ON I-76 (WEST) EXPRESS	
<i>Lanes Closed</i>	AT WALT WHITMAN BRDG	
<i>Ramp Closure Descr.</i>	ALL LANES CLOSED	
<i>Audience for Action</i>	I-76 WEST EXPRESS CLOSED	PHILADELPHIA
	PHILADELPHIA	I-95
<i>Action</i>	I-95	USE I-676 NORTH
	USE I-676 NORTH	
	<i>(8 Units of Information)</i>	<i>(4 Units of Information)</i>

**Assess Effects of Large Trucks on the Ability of Motorists to View the VMS Message**

The final step in the process is to assess the effects of large trucks in the traffic stream on the ability of motorists to see the VMS and read the message. Tables 8.14 through 8.17 on pages 8-21 and 8-22 should be studied to determine the percentage of motorists who will be able to see the VMS message (or consequently, the percentage who will not be able to see the VMS message because their visibility to the sign is blocked by large trucks). This information will help the VMS operator and the TOC manager to determine the potential effectiveness in communicating the message to the motorists in the traffic stream.

## DESIGN MESSAGE FOR VMS ON DIFFERENT FREEWAY THAN THE INCIDENT (VMS #2)

### Identify VMS Characteristics

**1. Where is the VMS located in relation to the incident/closure?**

VMS #2 is located on I-295 North, upstream of I-76.

**2. What type of VMS is being used?**

The sign is a light emitting diode (LED) VMS.

**3. How many lines and characters per line on the VMS?**

The overhead VMS has three lines, 20 characters per line.

### Review Conditions at the VMS Location

**1. What is the traffic operating speed at the VMS location?**

Speeds are about 60 miles per hour at the VMS location.

**2. Are there any geometric features (vertical or horizontal curves) which will adversely affect the motorists' sight distance to the VMS?**

Previous field inspections revealed that there are no geometric features that will adversely affect the motorists' sight distance to the VMS.

**3. What are the current natural lighting conditions?**

It is a bright sunlit day.

**4. Is there rain or fog at the VMS location? If so, what are the degrees of each?**

There is no rain or fog.

### Identify Diversion Route Characteristics

**1. Is a primary diversion route available?**

Previous evaluations of candidate routes and information on guide signs along these routes led to the determination that a primary alternative route is available for motorists who are traveling on I-295 North and who intend to connect with I-76 West and cross the Walt Whitman Bridge to Philadelphia and/or I-95.

The previous review of the guide signs showed that the I-676 North shield and *B FRANKLIN BR* (for Ben Franklin Bridge) appear on overhead signs on I-295 North just past the I-76 Exit. Thus, positive guidance is available to motorists on I-295 who want to take I-676 North and the Ben Franklin Bridge to Philadelphia and/or I-95.

The primary alternative route for motorists is as follows:

- I-295 North to I-76 West Local;
- I-76 West Local to I-676 North; then
- I-676 North across Ben Franklin Bridge to Philadelphia & I-95.

**2. Is the primary diversion route complex for motorists?**

The VMS operator has determined that the diversion route for I-295 is complex. Therefore it is necessary that trailblazing information (i.e., Ben Franklin Bridge) be available on guide signs along the alternative route.

**3. Are police or traffic control personnel directing traffic at critical locations along the diversion route, or are guide signs available along the route to provide positive guidance to motorists.**

The police are directing traffic according to the Emergency Incident Response Plan. However, no additional signs were installed along the diversion route as part of the Plan.

**4. Will a diversion message be displayed? If so, what type?**

Because of the nature, severity and potential duration of the incident, it is desirable to display a diversion message with specific information where to exit to get to an alternative river crossing (i.e., Ben Franklin Bridge).

**Set Objectives**

Based on the information in the previous sections, the VMS operator establishes the following objectives to achieve with the VMS:

- Inform motorists of the blockage and location of blockage; and
- Recommend that I-295 North motorists located south of the I-76 interchange and who are destined to Philadelphia or I-95 use I-676 North (Ben Franklin Bridge).

Because the incident is blocking all the lanes of the freeway and the VMS is on a different highway than the incident, the steps given in [Section 10.4 INCIDENTS ON INTERSECTING FREEWAY WHICH REQUIRE CLOSING THE CONNECTOR RAMP](#) on page 10-56 will be used to define the Basic VMS Message.

---

**Establish Initial Maximum Allowable Number of Units of Information in the Message Based on VMS Type and Freeway Operating Speeds****Step 1 – Determine Freeway Operating Speed at the VMS Location.**

The freeway operating speed at the VMS location was determined to be 60 miles per hour.

**Step 2 – Determine the Initial Maximum Allowable Number of Units of Information in the Message from [Table 8.2, page 8-5](#).**

Based on the sun position it is initially determined from Table 8.2 that a maximum allowable of four units of information can be displayed on the VMS.



---

### Assess Whether the Message Must Be Reduced Because of Local Geometric Sight Distance Restrictions to the VMS

#### Step 3 – Determine Whether There are Sight Distance Restrictions to the VMS Because of a Vertical Curve Using the Guidelines in Section 8.3 UNITS OF INFORMATION REDUCTIONS FOR VERTICAL CURVES – LED VMSs on page 8-6.

An examination of the data in Section 8.3 indicates that no reductions from the initial maximum allowable four units of information need to be made because no vertical curve geometric sight distance restriction exists. Therefore, go directly to Step 5.

#### Step 5 - Determine Whether There are Sight Distance Restrictions to the VMS Because of a Horizontal Curve Using the Guidelines in Section 8.4 UNITS OF INFORMATION REDUCTIONS FOR HORIZONTAL CURVES – LED VMSs on page 8-10.

An examination of the data in Section 8.4 indicates that no reductions from the initial maximum allowable four units of information need to be made because of no horizontal curve geometric sight distance restriction exists. Therefore, go directly to Step 7.

---

### Assess Whether the Message Must Be Reduced Because of Local Environmental Sight Distance Restrictions to the VMS Due to Rain or Fog

#### Step 7 – Determine Whether Rainfall Near the VMS Exceeds 2 Inches per Hour.

There is no rainfall. Therefore, go directly to Step 9.

#### Step 9 – Determine Whether Fog Exists Near the VMS.

No fog. Therefore, go directly to Step 11.

---

### Finalize the Maximum Allowable Units of Information in the Message

#### Step 11 – Based on Steps 1 through 10, Finalize the Maximum Allowable Number of Units of Information in the Message.

There are no reductions to the maximum allowable units of information found in Table 8.2. Therefore, it is allowable to use up to four units of information on the VMS.

---

### Define Basic VMS Message to Satisfy Motorist Information Needs

#### Step 12 - Select Incident Descriptor Message Element from Table 6.85, page 6-93.

*Incident Descriptor:* MAJOR ACCIDENT

#### Step 13 - Select Incident Location Message Element from Table 6.86, page 6-94.

*Incident Location:* ON I-76 (WEST) EXPRESS  
AT WALT WHITMAN BRIDGE

**Note:**

- Since the cardinal direction for I-76 does not appear on the guide signs on I-295 North, the cardinal direction is omitted from the message element. The terms *EXPRESS* and *LOCAL* are used to describe the lanes that lead to the Walt Whitman Bridge (*EXPRESS*) and the lanes that interconnect with other freeways (*LOCAL*). The VMS message terms must be compatible with the terms displayed on the static guide signs.

**Step 14 - Select Lanes Closed Message Element from Table 6.87, page 6-95.**

*Lanes Blocked*                      **ALL LANES CLOSED**

**Step 15 – Select Ramp Closure Descriptor Message Element from Table 6.88, page 6-96.**

*Closure Location*                      **I-76 EXPRESS CLOSED**

**Step 16 - Determine Whether Diversion Action Should Be Recommended.**

“Yes.” Therefore, go directly to Step 18.

**Step 18 - Establish Whether “Soft” Diversion Should Be Recommended.**

“No.” Therefore, go directly to Step 20.

**Step 20 – Determine Whether Diversion Traffic Control is in Place on the Selected Alternative Route.**

“No.” No specific diversion signing will be installed on the route. However, previous inspection of the diversion route revealed that information on existing static guide signs give positive guidance to Philadelphia. Therefore, continue to Step 21.

**Step 21 – Select Type 1 or Type 2 Action Message Element from Table 6.91, page 6-99.**

*Action*                                      **USE I-676 NORTH**

Go to Step 23.

**Step 23 – Establish Whether Action Message Is for a Select Group of Motorists**

“Yes.” Therefore, continue to Step 24.

**Step 24 – Select Audience for Action Message Element from Table 6.93, page 6-101.**

In this case, it is important to communicate the action to motorists heading to Philadelphia and to motorists heading to I-95 located on the west side of Philadelphia.

*Audience for Action:*                      **PHILADELPHIA  
I-95**

**Step 25 – Examine Whether the Diversion Route May Be Perceived by Motorists as Being a Most Logical Route.**

“Yes.” Therefore go directly to Step 27.

## Summary

In summary, the following Basic VMS Message is suggested:

<i>Incident Descriptor:</i>	<b>MAJOR ACCIDENT (1 unit)</b>
<i>Incident Location:</i>	<b>ON I-76 (WEST) EXPRESS (1 unit)</b> <b>AT WALT WHITMAN BRIDGE (1 unit)</b>
<i>Lanes Closed:</i>	<b>ALL LANES CLOSED (1 unit)</b>
<i>Ramp Closure Descriptor:</i>	<b>I-76 WEST EXPRESS CLOSED (1 unit)</b>
<i>Audience for Action:</i>	<b>PHILADELPHIA (1 unit)</b> <b>I-95 (1 unit)</b>
<i>Action:</i>	<b>USE I-676 NORTH (1 unit)</b>

The Basic VMS Message contains eight units of information.

### Note:

- A *Good Reason for Following the Action* message element is not needed because the motorists should know that when all lanes are blocked, major delay will be experienced if the motorists elect to follow the intended primary freeway route.

---

## Reduce the Number of Message Units if Necessary

### Step 27 – Examine Whether the Number of Informational Units in the Basic VMS Message is Greater than the Maximum Allowable from Step 11.

An examination of the Basic VMS Message reveals that the message contains eight units of information which is greater than the maximum allowable of four units. Therefore, continue to Step 28.

### Step 28 - Omit Incident Descriptor Message Element According Guidelines in the Section on *Combining Message Elements for Incident Messages Beginning on page 9-15.*

Using the guidelines beginning on page 9-15, the Basic VMS Message is revised to read:

**I-76 EXPRESS CLOSED (1 unit)**  
**PHILADELPHIA (1 unit)**  
**I-95 (1 unit)**  
**USE I-676 NORTH (1 unit)**

### Step 29 – Examine Whether the Number of Informational Units in the Basic VMS Message is Greater than the Maximum Allowable from Step 11.

“No.” An examination of the Basic VMS Message reveals that the message contains four units of information which does not exceed the maximum allowable of four units. Therefore, go directly to Step 34.

---

## Format the Message

### Step 34 – Format the Message According to Guidelines in the Section on *FORMATTING MESSAGES* on page 9-6.

The message is formatted according to the guidelines on page 9-6. Therefore, continue to Step 35.

---

## Adjust Message to Fit on Existing VMS

### Step 35 – Determine Whether the VMS has 4 Lines.

“No”, the VMS has three lines. Therefore, continue to Step 36.

### Step 36 – Determine Whether the VMS has 3 Lines.

“Yes”, the VMS has three lines. Therefore, continue to Step 37.

---

## Adjust Message to Fit on 3 Lines or Less

### Step 37 – Determine Whether the Message Can Be Displayed on 3 Lines or Less.

“No”, the message cannot be displayed on three lines or less. Therefore, continue to Step 38.

### Step 38 – Split Message Into 2 Frames According to Guidelines in Section 9.1 *SPLITTING MESSAGES* on page 9-1.

Using the guidelines found in the section on *SPLITTING MESSAGES*, the message is split into the following two frames:

**I-76 EXPRESS** (1 unit)  
**CLOSED**  
 (frame 1)

**PHILADELPHIA** (1 unit)  
**I-95** (1 unit)  
**USE I-676 NORTH** (1 unit)  
 (frame 2)

### Step 39 – Examine Whether 3 or Fewer Decision-Relevant Units of Information are Displayed on Each of the Frames.

“Yes.” Each frame has three or fewer units of information. Therefore, go directly to Step 41.

### Step 41 – Examine Whether the Message Elements are Split in Such a Way That a Part of One Message Element is on the Same Line as Part of a Second Message Element.

“No.” Therefore, go directly to Step 43.

### Step 43 – Examine Whether the Message or Any of the Message Lines are Too Long to Fit in the Available VMS Space.

“No.” Therefore, go directly to Step 47.

**Finalize VMS Message**

**Step 47 - Review Message for Inconsistencies and Incompatibility**

An examination of the VMS message indicates that there are no inconsistencies in the message. Each frame can stand on its own merits. And it does not matter which of the two frames is read first by a motorist. The motorist should understand the entire message. Therefore the message can be accepted as final and can be displayed or stored in a message file. The following represents the final message:

**I-76 EXPRESS  
CLOSED**

*(frame 1)*

**PHILADELPHIA  
I-95  
USE I-676 NORTH**

*(frame 2)*

**Summary**

<b>Table 15.9 Comparison of VMS #2 Basic VMS Message to Satisfy Motorist Information Needs and Final Message For Incident #2 After Police Arrive</b>		
<b>Basic VMS Message Elements</b>	<b>Basic VMS Message to Satisfy Motorist Information Needs</b>	<b>Final Message</b>
<i>Incident Descriptor</i>	<b>MAJOR ACCIDENT</b>	<b>I-76 EXPRESS CLOSED</b>
<i>Incident Location</i>	<b>ON I-76 (WEST) EXPRESS</b>	
<i>Lanes Closed</i>	<b>AT WALT WHITMAN BRDG</b>	
<i>Ramp Closure Descr.</i>	<b>ALL LANES CLOSED</b>	
<i>Audience for Action</i>	<b>I-76 WEST EXPRESS CLOSED</b>	<b>PHILADELPHIA</b>
	<b>PHILADELPHIA</b>	<b>I-95</b>
<i>Action</i>	<b>I-95</b>	<b>USE I-676 NORTH</b>
	<b>USE I-676 NORTH</b>	
	<i>(8 Units of Information)</i>	<i>(4 Units of Information)</i>

**Assess Effects of Large Trucks on the Ability of Motorists to View the VMS Message**

The final step in the process is to assess the effects of large trucks in the traffic stream on the ability of motorists to see the VMS and read the message. Tables 8.14 through 8.17 on pages 8-21 and 8-22 should be studied to determine the percentage of motorists who will be able to see the VMS message (or consequently, the percentage who will not be able to see the VMS message because their visibility to the sign is blocked by large trucks). This information will help the VMS operator and the TOC manager to determine the potential effectiveness in communicating the message to the motorists in the traffic stream.

# MODULE 16. MESSAGE DESIGN EXAMPLE FOR INCIDENTS: PORTABLE VMSs

## TABLE OF CONTENTS

<b>16.1 OBJECTIVES AND SUMMARY .....</b>	<b>16-1</b>
<b>16A. INCIDENT EXAMPLE #3 LANES ARE (BLOCKED) CLOSED .....</b>	<b>16-2</b>
<b>16A.1 AFTER POLICE ARRIVE .....</b>	<b>16-2</b>
<b>DEFINE SITUATION DETAILS .....</b>	<b>16-3</b>
Analyze Incident and Incident Scene Characteristics .....	16-3
<b>DESIGN MESSAGE FOR VMS ON SAME HIGHWAY AND RELATIVELY     CLOSE TO THE INCIDENT (PORTABLE VMS #1) .....</b>	<b>16-4</b>
Identify VMS Characteristics.....	16-4
Review Conditions at the VMS Location .....	16-4
Identify Diversion Route Characteristics .....	16-4
Set Objectives .....	16-5
Establish Initial Maximum Allowable Number of Units of Information in the Message Based on VMS Type and Freeway Operating Speeds.....	16-5
Assess Whether the Message Must be Reduced Because of Local Geometric Sight Distance Restrictions to the VMS .....	16-6
Assess Whether the Message Must be Reduced Because of Local Environmental Sight Distance Restrictions to the VMS Due to Rain or Fog .....	16-6
Finalize the Maximum Allowable Units of Information in the Message .....	16-6
Define Basic VMS Message to Satisfy Motorist Information Needs .....	16-6
Reduce the Number of Message Units if Necessary .....	16-8
Format the Message .....	16-9
Adjust Message to Fit on Existing VMS .....	16-9
Adjust Message to Fit on 3 Lines or Less .....	16-10
Finalize VMS Message .....	16-11
Assess Effects of Large Trucks on the Ability of Motorists to View the VMS Message .....	16-12
<b>DESIGN MESSAGE FOR VMS ON DIFFERENT HIGHWAY THAN THE     INCIDENT (PORTABLE VMS #2).....</b>	<b>16-13</b>
Identify VMS Characteristics.....	16-13
Review Conditions at the VMS Location .....	16-13
Identify Diversion Route Characteristics .....	16-13
Set Objectives .....	16-14
Establish Initial Maximum Allowable Number of Units of Information in the Message Based on VMS Type and Freeway Operating Speeds.....	16-14

Assess Whether the Message Must be Reduced Because of Local Geometric  
Sight Distance Restrictions to the VMS .....16-15

Assess Whether the Message Must be Reduced Because of Local  
Environmental Sight Distance Restrictions to the VMS Due to Rain or  
Fog .....16-15

Finalize the Maximum Allowable Units of Information in the Message .....16-15

Define Basic VMS Message to Satisfy Motorist Information Needs .....16-15

Reduce the Number of Message Units if Necessary .....16-17

Format the Message .....16-19

Adjust Message to Fit on Existing VMS .....16-19

Adjust Message to Fit on 3 Lines or Less .....16-19

Finalize VMS Message .....16-21

Assess Effects of Large Trucks on the Ability of Motorists to View the VMS  
Message .....16-22

# MODULE 16. MESSAGE DESIGN EXAMPLE FOR INCIDENTS: PORTABLE VMSs

## 16.1 OBJECTIVES AND SUMMARY

The objectives of Module 16 are to illustrate the:

- VMS message design process that is detailed in [Module 10](#) for incidents;
- Application of several design principles for messages displayed on portable VMSs; and
- Large amount of motorist information needs that must be omitted when a portable VMS is used.

Table 16.1 is a summary of the incident and diversion characteristics message design principles illustrated in the examples in this Module.

<b>Table 16.1 Summary of Incident Characteristics and VMS Message Design Principles Illustrated in Module 16</b>			
<b>Incident Characteristics and VMS Message Design Principles</b>	<b>Example 3 (Page 16-2)</b>		
	<b>Portable VMS</b>		
	<b>Close To Incident</b>	<b>Far From Incident</b>	<b>On Other Freeway</b>
Police have not arrived			
Police arrived	X		X
Lanes Blocked	X		X
Freeway Blocked			
Lanes Closed	X		X
Freeway Closed			
No diversion			
Soft diversion	X		
Diversion to Type 1 or Type 2 diversion route			X
Diversion to Type 3 or Type 4 diversion route			
Diversion to Type 5 diversion route			
Diversion to Type 6 diversion route			
Not a logical diversion route			X
Reducing units of information by omitting incident descriptor	X		X
Reducing units of information by omitting audience	X		X
Splitting a message into two frames	X		X
Use of abbreviations	X		X



## 16A. INCIDENT EXAMPLE #3 LANES ARE (BLOCKED) CLOSED

### 16A.1 AFTER POLICE ARRIVE

The location of the accident and VMSs are shown in Figure 16.1. Since no large overhead VMSs are located upstream of the incident, portable VMSs are positioned at the following locations:

- Portable VMS #1 located on Route 42 North, upstream of Route 168; and
- Portable VMS #2 located on Route 55 North, upstream of Route 322.

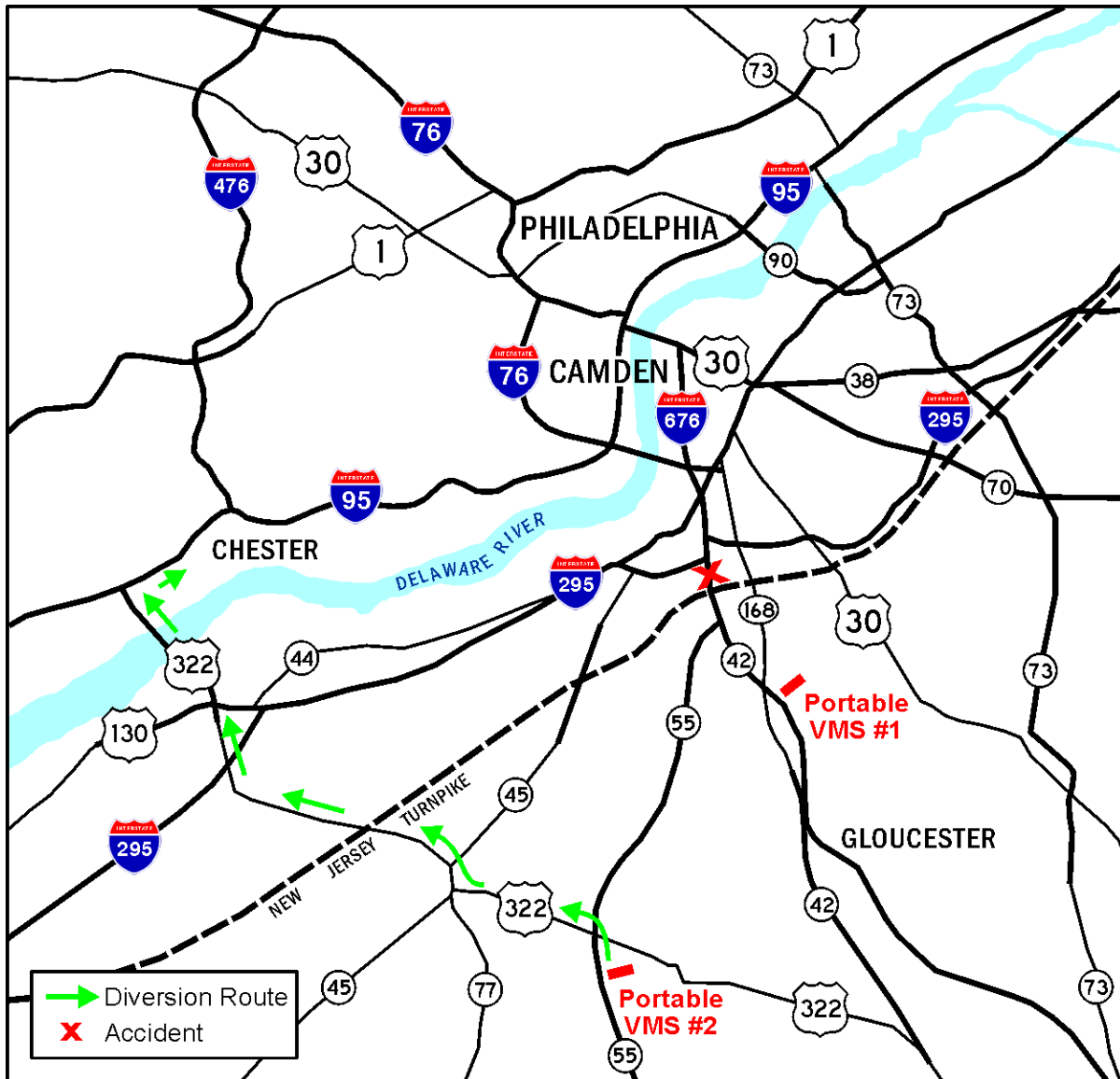

Figure 16.1 Locations of Accident and Variable Message Signs for Example 3

## DEFINE SITUATION DETAILS

### Analyze Incident and Incident Scene Characteristics

**1. What happened?**

The Traffic Operations Center (TOC) personnel confirm that a major vehicle accident occurred. There appears to be a fatality.

**2. Where?**

On northbound Route 42, upstream of I-295.

**3. What lanes (how many) lanes are affected?**

Three of four lanes are closed.

**4. What is the current time?**

It is now 6:00 a.m.

**5. How long do you expect the incident to block the lanes?**

The nature of the accident with a fatality indicates that the accident will block three lanes until about 8:00 a.m.

**6. What is the effect on traffic?**

Congestion will be severe. Route 42 North carries high traffic volumes during the morning peak periods. The primary destinations are Philadelphia and I-95 via I-76 West across the Walt Whitman Bridge. The Walt Whitman Bridge is a major structure over the Delaware River, and is one of a few number of routes from New Jersey across the river to Philadelphia and to I-95.

**7. Are the police on the scene to direct traffic or close the freeway?**

The police have arrived and are controlling traffic.

**8. Did the Emergency Incident Response Team arrive at the scene and implement a preplanned traffic control plan including detour signing and trailblazers along the preplanned diversion (detour) route?**

The Team moved and positioned two portable VMSs to advise motorists. One VMS is placed on Route 42 North, upstream of Route 168; and the other is placed on Route 55, upstream of Route 322.

**DESIGN MESSAGE FOR VMS ON SAME FREEWAY AND RELATIVELY CLOSE TO THE INCIDENT (PORTABLE VMS #1)****Identify VMS Characteristics****1. Where is the VMS located in relation to the incident/closure?**

Portable VMS #1 is located on Route 42 North, upstream of the Route 168 exit. This location is on the same highway as the incident and relatively close to the incident.

**2. What type of VMS is being used?**

The sign is a light emitting diode (LED) VMS.

**3. How many lines and characters per line on the VMS?**

The portable VMS has three lines, 8 characters per line.

**Review Conditions at the VMS Location****1. What is the traffic operating speed at the VMS location?**

Speeds are about 50 miles per hour at the VMS location.

**2. Are there any geometric features (vertical or horizontal curves) which will adversely affect the motorists' sight distance to the VMS?**

Previous field inspections revealed that there are no geometric features that will adversely affect the motorists' sight distance to the VMS.

**3. What are the current natural lighting conditions?**

It is a bright sunlit day.

**4. Is there rain or fog at the VMS location? If so, what are the degrees of each?**

There is no rain or fog.

**Identify Diversion Route Characteristics****1. Is a primary diversion route available?**

Previous evaluations of candidate routes and information on guide signs along these routes led to the determination that an alternative route is available for motorists who are traveling on Route 42 North and who intend to connect with I-76 and cross the Walt Whitman Bridge to Philadelphia and/or I-95.

The previous review of the guide signs showed that the Route 168 North exit appears on a side-mounted Advance Guide Sign and on the Exit Sign.

The primary alternative route for motorists is as follows:

- RT-42 North to RT-168 North;
- RT-168 North to I-295 South; then
- I-295 South to I-76 West across the Walt Whitman Bridge to Philadelphia and I-95.

**2. Is the primary diversion route complex for motorists?**

The VMS operator has determined the primary alternative route is complex and requires giving motorists three highway numbers and cardinal directions. This will be too much information to display for the motorists who are traveling in excess of 45 mph on Route 42 North. Also, motorists have a variety of route choices to take across the Delaware River to Philadelphia and I-95 after they leave Route 42 North at Route 168. Each route is too complex to display on the VMS. However, since the majority of the motorists are commuters, they should have knowledge of the possible routes.

**3. Are police or traffic control personnel directing traffic at critical locations along the diversion route, or are guide signs available along the route to provide positive guidance to motorists?**

The police are controlling traffic only at the accident scene and not on the arterial streets.

**4. Will a diversion message be displayed? If so, what type?**

Because of the nature, severity and potential duration of the incident, it is desirable to display a diversion message. However, because of the issues discussed above, only a soft diversion message will be displayed.

**Set Objectives**

Based on the information in the previous sections, the VMS operator establishes the following objectives to achieve with the VMS:

- Inform motorists of the incident and location of the incident; and
- Recommend that Route 42 North motorists located south of the Route 168 exit and use other routes to Philadelphia and to I-95.

Because the incident is not blocking all of the lanes and the VMS is on the same highway and relatively close to the incident, the steps given in [Section 10.1 LANE CLOSURE \(BLOCKAGE\) INCIDENTS](#) on page 10-1 will be used to define the Basic VMS Message.

---

**Establish Initial Maximum Allowable Number of Units of Information in the Message Based on VMS Type and Freeway Operating Speeds****Step 1 – Determine Freeway Operating Speed at the VMS Location.**

The freeway operating speed at the VMS location was determined to be 50 miles per hour.

**Step 2 – Determine the Initial Maximum Allowable Number of Units of Information in the Message from [Table 8.2, page 8-5](#).**

Based on the sun position (low in the east) the VMS is in a washout environment. Thus, it is initially determined from [Table 8.2](#) that a maximum allowable of four units of information can be displayed on the VMS.

---

### Assess Whether the Message Must be Reduced Because of Local Geometric Sight Distance Restrictions to the VMS

#### **Step 3 – Determine Whether There are Sight Distance Restrictions to the VMS Because of a Vertical Curve Using the Guidelines in Section 8.3 UNITS OF INFORMATION REDUCTIONS FOR VERTICAL CURVES – LED CMSs on page 8-6.**

An examination of the data in Section 8.3 indicates that no reductions from the initial maximum allowable four units of information need to be made because no vertical curve geometric sight distance restriction exists. Therefore, go directly to Step 5.

#### **Step 5 - Determine Whether There are Sight Distance Restrictions to the VMS Because of a Horizontal Curve Using the Guidelines in Section 8.4 UNITS OF INFORMATION REDUCTIONS FOR HORIZONTAL CURVES – LED CMSs on page 8-10.**

An examination of the data in Section 8.4 indicates that no reductions from the initial maximum allowable four units of information need to be made because of no horizontal curve geometric sight distance restriction exists. Therefore, go directly to Step 7.

---

### Assess Whether the Message Must be Reduced Because of Local Environmental Sight Distance Restrictions to the VMS Due to Rain or Fog

#### **Step 7 – Determine Whether Rainfall Near the VMS Exceeds 2 Inches per Hour.**

There is no rainfall. Therefore, go directly to Step 9.

#### **Step 9 – Determine Whether Fog Exists Near the VMS.**

No fog. Therefore, go directly to Step 11.

---

### Finalize the Maximum Allowable Units of Information in the Message

#### **Step 11 – Based on Steps 1 through 10, Finalize the Maximum Allowable Number of Units of Information in the Message.**

There are no reductions to the maximum allowable units of information found in Table 8.2. Therefore, it is allowable to use up to four units of information on the VMS.

---

### Define Basic VMS Message to Satisfy Motorist Information Needs

#### **Step 12 - Select Incident Descriptor Message Element from Table 6.1, page 6.2.**

*Incident Descriptor:*                      **MAJOR  
ACCIDENT**

**Step 13 – Select *Incident Location* Message Element from Table 6.2, page 6-3.**

*Incident Location:*                   **NEAR  
I-295**

The term *NEAR I-295* is used in lieu of *AT I-295* to inform motorists that the incident is upstream of I-295 and that they will need to travel through severe congestion in order to reach the I-295 exit ramp. *NEAR I-295* is more descriptive of the location of the incident.

**Step 14 - Determine Whether the Police or Traffic Control Personnel Arrived to Control Traffic at the Incident Site**

“Yes.” Therefore, continue to Step 15.

**Step 15 - Select *Lanes Closed* Message Element from Table 6.3, page 6-4.**

*Lanes Closed:*                       **3 LANES  
CLOSED**

**Step 16 – Establish Whether the *Effect on Travel* Message Element is Implied by the *Lanes Closed* Message Element.**

“Yes.” Since three of four lanes are closed, it can be implied that major congestion will be present. Therefore, go directly to Step 18.

**Step 18 - Establish Whether Diversion Action Should be Recommended.**

“Yes.” Therefore, go directly to Step 20.

**Step 20 - Establish Whether “Soft” Diversion Should be Recommended.**

“Yes.” Therefore, continue to Step 21.

**Step 21 - Select *Action* Message Element from Table 6.6, page 6-7.**

*Action:*                               **USE  
OTHER  
ROUTES**

Go to Step 23.

**Step 23 – Establish Whether *Action* Message Is for a Select Group of Motorists**

“Yes.” Therefore, continue to Step 24.

**Step 24 – Select *Audience for Action* Message Element from Table 6.8, page 6-9.**

In this case, it is important to communicate the action to motorists heading to Philadelphia and to motorists heading to I-95 located on the west side of Philadelphia.

*Audience for Action:*           **PHILADELPHIA  
I-95**

**Step 25 – Establish Whether a Good Reason for Motorists to Follow Action is Implied in *Lanes Closed* and *Lane Closure Location* Message Elements.**

“Yes.” Therefore, continue to Step 26.

**Step 26 –Examine Whether the Diversion Route Will Be Perceived by Motorists as Being a Most Logical Route.**

No specific alternative route is given. Therefore, go directly to Step 28.

**Summary**

In summary, the following Basic VMS Message is suggested:

<i>Incident Descriptor:</i>	<b>MAJOR ACCIDENT (1 unit)</b>
<i>Incident Location:</i>	<b>NEAR I-295 (1 unit)</b>
<i>Lanes Blocked:</i>	<b>3 LANES CLOSED (1 unit)</b>
<i>Audience for Action:</i>	<b>PHILADELPHIA (1 unit) I-95 (1 unit)</b>
<i>Action:</i>	<b>USE OTHER ROUTES (1 unit)</b>

The Basic VMS Message contains six units of information.

**Reduce the Number of Message Units if Necessary**

**Step 28 – Examine Whether the Number of Informational Units in the Basic VMS Message is Greater than the Maximum Allowable in Step 11.**

An examination of the Basic VMS Message reveals that the message contains six units of information which exceeds the maximum allowable four units. Therefore, continue to Step 29.

**Step 29 - Omit *Incident Descriptor* Message Element According to Guidelines in the Section on *Combining Message Elements for Incident Messages* beginning on page 9-15.**

Using the guidelines beginning on page 9-15, the Basic VMS Message is revised to read:

**3 LANES  
CLOSED (1 unit)  
NEAR  
I-295 (1 unit)  
PHILADELPHIA (1 unit)  
I-95 (1 unit)  
USE  
OTHER  
ROUTES (1 unit)**

The message has been reduced to five units of information. Therefore, continue to Step 30.

**Step 30 – Examine Whether the Number of Informational Units in the Basic VMS Message is Greater than the Maximum Allowable in Step 11.**

An examination of the Basic VMS Message reveals that the message now contains five units of information which exceeds the maximum allowable four units. Therefore, continue to Step 31.

**Step 31 - Examine Whether the Message Contains More Than One Audience for Action (Destination) Message Element.**

The revised Basic VMS Message contains two *Audiences for Action* (Destinations), namely, Philadelphia and I-95. Therefore, continue to Step 32.

**Step 32 – Omit All but One Audience for Action (Destination) Message Elements.**

It was established that it is more important to sign for Philadelphia than for I-95. Therefore, I-95 is omitted from the message.

**Step 30 – Examine Whether the Number of Informational Units in the Basic VMS Message is Greater than the Maximum Allowable in Step 11.**

The current message is as follows:

3 LANES  
CLOSED (1 unit)  
NEAR  
I-295 (1 unit)  
PHILADELPHIA (1 unit)  
USE  
OTHER  
ROUTES (1 unit)

The message has been reduced to four units of information. Therefore, go directly to Step 35.

---

**Format the Message****Step 35 – Format the Message According to Guidelines in the Section on *FORMATTING MESSAGES* on page 9-6.**

The message is formatted according to the guidelines on page 9-6. Therefore, continue to Step 36.

---

**Adjust Message to Fit on Existing VMS****Step 36 – Determine Whether the VMS has 4 Lines.**

“No”, the VMS has three lines. Therefore, continue to Step 37.

**Step 37 – Determine Whether the VMS has 3 Lines.**

“Yes”, the VMS has three lines. Therefore, continue to Step 38.



---

## Adjust Message to Fit on 3 Lines or Less

### Step 38 – Determine Whether the Message Can Be Displayed on 3 Lines or Less.

“No”, the message cannot be displayed on three lines or less. Therefore, continue to Step 39.

### Step 39 – Split Message Into 2 Frames According to Guidelines in Section 9.1 *SPLITTING MESSAGES* on page 9-1.

Using the guidelines found in the section on *SPLITTING MESSAGES*, the message is split into the following two frames:

<b>3 LANES</b>	<b>PHILADELPHIA</b> (1 unit)
<b>CLOSED</b> (1 unit)	<b>USE</b>
<b>NEAR</b>	<b>OTHER</b>
<b>I-295</b> (1 unit)	<b>ROUTES</b> (1 unit)
(frame 1)	(frame 2)

### Step 40 – Examine Whether 3 or Fewer Decision-Relevant Units of Information are Displayed on Each of the Frames.

“Yes”, each frame has only two units of information. Therefore, go directly to Step 42.

### Step 42 – Examine Whether the Message Elements are Split in Such a Way That a Part of One Message Element is on the Same Line as Part of a Second Message Element.

“No.” Therefore, go directly to Step 44.

### Step 44 – Examine Whether the Message or Any of the Message Lines Are Too Long to Fit in the Available VMS Space.

“Yes.” The line containing the term *PHILADELPHIA* exceeds the eight-character maximum. Therefore, continue to Step 45.

### Step 45 – Apply Abbreviations to Selected Words According to Guidelines in the Section on *USING ABBREVIATIONS*, page 9-10.

*PHILADELPHIA* is abbreviated as *PHILA*. In addition, the “I” is omitted from *I-295* resulting in the abbreviated Interstate number 295. Continue to Step 46.

### Step 46 – Examine Whether the Application of Abbreviation Guidelines Adequately Reduced the Length of the Message Lines and the Entire Message Can Fit in the Available VMS Space.

“No.” The entire message cannot fit in the available VMS space. Therefore, continue to Step 47.

### Step 47 – Omit Information According to Guidelines in the Section on *PRIORITY REDUCTION PRINCIPLES* on page 9-20 and Reformat Message.

An examination of the four-unit message indicates that the term *PHILA* must be omitted in order to fit the message on a three-line portable VMS. Omitting *PHILA* from the message results in the following message:

<p><b>3 LANES CLOSED NEAR 295</b> <i>(frame 1)</i></p>	<p><b>USE OTHER ROUTES</b> <i>(frame 2)</i></p>
--	---

Continue to Step 48.

**Finalize VMS Message**

**Step 48 - Review Message for Inconsistencies and Incompatibility.**

An examination of the VMS message indicates that there are no inconsistencies in the message. Each frame can stand on its own merits. And it does not matter which of the two frames is read first by a motorist. The motorist should understand the entire message. Therefore the message can be accepted as final and can be displayed or stored in a message file. The following represents the final message:

<p><b>3 LANES CLOSED NEAR 295</b> <i>(frame 1)</i></p>	<p><b>USE OTHER ROUTES</b> <i>(frame 2)</i></p>
--	---

*The above example illustrates that a large amount of motorist information needs that must be omitted when a portable VMS is used.*

**Summary**

<b>Table 16.2 Comparison of VMS #1 Basic VMS Message to Satisfy Motorist Information Needs and Final Message For Incident #2 After Police Arrive</b>		
<b>Basic VMS Message Elements</b>	<b>Basic VMS Message to Satisfy Motorist Information Needs</b>	<b>Final Message</b>
<i>Incident Descriptor</i>	MAJOR ACCIDENT	3 LANES CLOSED
<i>Incident Location</i>	NEAR I-295	NEAR 295
<i>Lanes Blocked</i>	3 LANES CLOSED	
<i>Audience for Action</i>	PHILADELPHIA	
<i>Action</i>	I-95 USE OTHER ROUTES	USE OTHER ROUTES
	<i>(6 Units of Information)</i>	<i>(3 Units of Information)</i>

---

**Assess Effects of Large Trucks on the Ability of Motorists to View the VMS Message**

The final step in the process is to assess the effects of large trucks in the traffic stream on the ability of motorists to see the VMS and read the message. [Tables 8.14 through 8.17](#) on pages 8-21 and 8-22 should be studied to determine the percentage of motorists who will be able to see the VMS message (or consequently, the percentage who will not be able to see the VMS message because their visibility to the sign is blocked by large trucks). This information will help the VMS operator and the TOC manager to determine the potential effectiveness in communicating the message to the motorists in the traffic stream.

## DESIGN MESSAGE FOR VMS ON DIFFERENT HIGHWAY THAN THE INCIDENT (PORTABLE VMS #2)

### Identify VMS Characteristics

**1. Where is the VMS located in relation to the incident/closure?**

Portable VMS #2 is located on Route 55 North, upstream of the Route 322 exit.

**2. What type of VMS is being used?**

The sign is a light emitting diode (LED) VMS.

**3. How many lines and characters per line on the VMS?**

The portable VMS has three lines, 8 characters per line.

### Review Conditions at the VMS Location

**1. What is the traffic operating speed at the VMS location?**

Speeds are about 35 miles per hour at the VMS location.

**2. Are there any geometric features (vertical or horizontal curves) which will adversely affect the motorists' sight distance to the VMS?**

Previous field inspections revealed that there are no geometric features that will adversely affect the motorists' sight distance to the VMS.

**3. What are the current natural lighting conditions?**

It is a bright sunlit day.

**4. Is there rain or fog at the VMS location? If so, what are the degrees of each?**

There is no rain or fog.

### Identify Diversion Route Characteristics

**1. Is a primary diversion route available?**

Previous evaluations of candidate routes and information on guide signs along these routes led to the determination that an alternative route is available for motorists who are traveling on Route 55 North and who intend to connect with I-76 and cross the Walt Whitman Bridge to Philadelphia and/or I-95.

The primary alternative route for motorists is as follows:

- RT-55 North to RT-322 West;
- RT-322 West across the Commodore Berry Bridge to I-95; and
- I-95 North to Philadelphia.

**2. Is the primary diversion route complex for motorists?**

Motorists must travel on a route with several traffic signals, with lower operating speeds, and one that requires the motorists to travel a longer distance and in a direction away from the primary Route 55 North route. Thus, the Route 322 alternative route may not be considered by most motorists as the most logical route.

Since signing to Philadelphia and/or I-95 would not appear on the guide signs on Route 322 immediately after the motorists turn onto the highway from Route 55, the route would be recommended for and used primarily by commuter drivers.

**3. Are police or traffic control personnel directing traffic at critical locations along the diversion route, or are guide signs available along the route to provide positive guidance to motorists.**

The police are controlling traffic only at the accident scene and not on the Route 322 alternative route.

**4. Will a diversion message be displayed? If so, what type?**

Because of the nature, severity and potential duration of the incident, it is desirable to display a diversion message.

**Set Objectives**

Based on the information in the previous sections, the VMS operator establishes the following objectives to achieve with the VMS:

- Inform motorists of the incident and location of the incident; and
- Recommend that Route 55 North motorists located south of the Route 322 exit and use Route 322 to I-95 and Philadelphia.

Because the incident is not blocking all of the lanes and the VMS is on a different highway than the incident, the steps given in Section *10.1 LANE CLOSURE (BLOCKAGE) INCIDENTS*, [page 10-14](#) will be used to define the Basic VMS Message.

---

**Establish Initial Maximum Allowable Number of Units of Information in the Message Based on VMS Type and Freeway Operating Speeds****Step 1 – Determine Freeway Operating Speed at the VMS Location.**

The freeway operating speed at the VMS location was determined to be 35 miles per hour.

**Step 2 – Determine the Initial Maximum Allowable Number of Units of Information in the Message from [Table 8.2, page 8-5](#).**

Based on the sun position (low in the east) the VMS is in a washout environment. Thus, it is initially determined from Table 8.2 that a maximum allowable of five units of information can be displayed on the VMS.

---





**Step 27 – Select One Good Reason for Following Action Statement Message Element from Table 6.27, page 6-29.**

*Good Reason:* **BEST  
ROUTE TO  
[Audience(s) for Action]**

**Summary**

In summary, the following Basic VMS Message is suggested:

*Incident Descriptor:* **MAJOR  
ACCIDENT (1 unit)**

*Incident Location:* **NEAR  
I-295 (1 unit)**

*Lanes Blocked:* **3 LANES  
CLOSED (1 unit)**

*Audience for Action:* **PHILADELPHIA (1 unit)  
I-95 (1 unit)**

*Action:* **USE  
RT-322  
NORTH (1 unit)**

*Good Reason:* **BEST  
ROUTE TO  
[Audience(s) for Action] (1 unit)**

The Basic VMS Message contains seven units of information.

---

**Reduce the Number of Message Units if Necessary**

**Step 28 – Examine Whether the Number of Informational Units in the Basic VMS Message is Greater than the Maximum Allowable from Step 11.**

An examination of the Basic VMS Message reveals that the message contains seven units of information that exceeds the maximum allowable five units. Therefore, continue to Step 29.

**Step 29 - Omit Incident Descriptor Message Element According to Guidelines in the Section on Combining Message Elements for Incident Messages beginning on page 9-15.**

Using the guidelines beginning on page 9-15, the Basic VMS Message is revised to read:



**3 LANES**  
**CLOSED** (1 unit)  
**NEAR**  
**I-295** (1 unit)  
**PHILADELPHIA** (1 unit)  
**I-95** (1 unit)  
**USE**  
**RT-322**  
**NORTH** (1 unit)  
**BEST**  
**ROUTE TO**  
*[Audience(s) for Action]* (1 unit)

The message has been reduced to six units of information.

**Step 30 – Examine Whether the Number of Informational Units in the Basic VMS Message is Greater than the Maximum Allowable from Step 11.**

“Yes.” An examination of the Basic VMS Message reveals that the message contains six units of information which exceeds the maximum allowable five units. Therefore, continue to Step 31.

**Step 31 - Examine Whether the Message Contains More Than One Audience for Action (Destination) Message Element.**

“Yes.” The revised Basic VMS Message contains two *Audiences for Action* (Destinations), namely, Philadelphia and I-95. Therefore, continue to Step 32.

**Step 32 – Omit All but One Audience for Action (Destination) Message Elements.**

It was established that it is more important to sign for Philadelphia than for I-95. Therefore, *I-95* is omitted from the message.

**Step 33 – Examine Whether the Number of Informational Units in the Basic VMS Message is Greater than the Maximum Allowable from Step 11.**

The current message is as follows:

**3 LANES**  
**CLOSED** (1 unit)  
**NEAR**  
**I-295** (1 unit)  
**PHILADELPHIA** (1 unit)  
**USE**  
**RT-322**  
**NORTH** (1 unit)  
**BEST**  
**ROUTE TO**  
*[Audience for Action]* (1 unit)

The message has been reduced to five units of information that does not exceed the maximum allowable of five units. Therefore, go directly to Step 35.

---

## Format the Message

### Step 35 – Format the Message According to Guidelines in the Section on *FORMATTING MESSAGES* on page 9-6.

The message is reformatted as follows:

**3 LANES  
 CLOSED  
 NEAR  
 I-295  
 BEST  
 ROUTE TO  
 PHILADELPHIA  
 USE  
 RT-322  
 NORTH**

Continue to Step 36.

---

## Adjust Message to Fit on Existing VMS

### Step 36 – Determine Whether the VMS has 4 Lines.

“No”, the VMS has three lines. Therefore, continue to Step 37.

### Step 37 – Determine Whether the VMS has 3 Lines.

“Yes”, the VMS has three lines. Therefore, continue to Step 38.

---

## Adjust Message to Fit on 3 Lines or Less

### Step 38 – Determine Whether the Message Can Be Displayed on 3 Lines or Less.

“No”, the message cannot be displayed on three lines or less. Therefore, continue to Step 39.

### Step 39 – Split Message Into 2 Frames According to Guidelines in Section 9.1 *SPLITTING MESSAGES* on page 9-1.

Using the guidelines found in the section on *SPLITTING MESSAGES*, the message is split into the following two frames:

<b>3 LANES</b> <b>CLOSED</b> ( <i>1 unit</i> ) <b>NEAR</b> <b>I-295</b> ( <i>1 unit</i> )  <i>(frame 1)</i>	<b>BEST</b> <b>ROUTE TO</b> ( <i>1 unit</i> ) <b>PHILADELPHIA</b> ( <i>1 unit</i> ) <b>USE</b> <b>RT-322</b> <b>NORTH</b> ( <i>1 unit</i> )  <i>(frame 2)</i>
--	--

**Step 40 – Examine Whether 3 or Fewer Decision-Relevant Units of Information are Displayed on Each of the Frames.**

“Yes.” Therefore, go directly to Step 42.

**Step 42 – Examine Whether the Message Elements are Split in Such a Way That a Part of One Message Element is on the Same Line as Part of a Second Message Element.**

“No.” Therefore, go directly to Step 44.

**Step 44 – Examine Whether the Message or Any of the Message Lines Are Too Long to Fit in the Available VMS Space.**

“Yes.” The first frame requires four lines, and the second frame requires six lines of the eight-character per line VMS. In addition, the term *PHILADELPHIA* exceeds the eight-character maximum. Therefore, continue to Step 45.

**Step 45 – Apply Abbreviations to Selected Words According to Guidelines in the Section on USING ABBREVIATIONS, page 9-10.**

*PHILADELPHIA* is abbreviated as *PHILA*. *ROUTE* is abbreviated as *RTE*; *NORTH* is abbreviated as *N*. These changes result in the following message:

<b>3 LANES</b>	<b>BEST RTE</b>
<b>CLOSED</b>	<b>TO PHILA</b>
<b>NEAR</b>	<b>USE</b>
<b>I-295</b>	<b>RT-322 N</b>
<i>(frame 1)</i>	<i>(frame 2)</i>

Continue to Step 46.

**Step 46 – Examine Whether the Application of Abbreviation Guidelines Adequately Reduced the Length of the Message Lines and the Entire Message Can Fit in the Available VMS Space.**

“No.” The entire message cannot fit in the available VMS space. Therefore, continue to Step 47.

**Step 47 – Omit Information According to Guidelines in Guidelines in the Section on PRIORITY REDUCTION PRINCIPLES on page 9-20 and Reformat Message.**

An examination of the message indicates that it can fit on the VMS if the route designations are omitted. That is, “*I-*” is omitted from *I-295* and “*RT-*” is omitted from *RT-322*. In addition, the space must be omitted between 322 and *N*. ***These changes are OK only for peak period commuter motorists. Non commuters would have difficulty in understanding the message.*** The changes result in the following message:

<b>3 LANES</b>	<b>BEST RTE</b>
<b>CLOSED</b>	<b>TO PHILA</b>
<b>NEAR 295</b>	<b>USE 322N</b>
<i>(frame 1)</i>	<i>(frame 2)</i>

Continue to Step 48.

**Finalize VMS Message**

**Step 48 - Review Message for Inconsistencies and Incompatibility**

An examination of the VMS message indicates that there are no inconsistencies in the message. Each frame can stand on its own merits. And it does not matter which of the two frames is read first by a motorist. The motorist should understand the entire message. Therefore the message can be accepted as final and can be displayed or stored in a message file. The following represents the final message:

<b>3 LANES</b>	<b>BEST RTE</b>
<b>CLOSED</b>	<b>TO PHILA</b>
<b>NEAR 295</b>	<b>USE 322N</b>
<i>(frame 1)</i>	<i>(frame 2)</i>

*The above example illustrates the large amount of motorist information needs that must be omitted. It also illustrates the need to rely on the motorists' understanding that the numbers in the incident location and action message elements represent specific highways, that is I-295 and RT-322.*

**Summary**

<b>Table 16.3 Comparison of VMS #1 Basic VMS Message to Satisfy Motorist Information Needs and Final Message For Incident #2 After Police Arrive</b>		
<b>Basic VMS Message Elements</b>	<b>Basic VMS Message to Satisfy Motorist Information Needs</b>	<b>Final Message</b>
<i>Incident Descriptor</i>	MAJOR ACCIDENT	3 LANES CLOSED
<i>Incident Location</i>	NEAR I-295	NEAR 295
<i>Lanes Blocked</i>	3 LANES CLOSED	
<i>Audience for Action</i>	PHILADELPHIA I-95	
<i>Action</i>	USE RT-322	USE 322
<i>Good Reason</i>	NORTH BEST ROUTE TO [destination]	BEST RTE TO PHILA
	<i>(7 Units of Information)</i>	<i>(5 Units of Information)</i>

---

**Assess Effects of Large Trucks on the Ability of Motorists to View the VMS Message**

The final step in the process is to assess the effects of large trucks in the traffic stream on the ability of motorists to see the VMS and read the message. [Tables 8.14 through 8.17](#) on pages 8-21 and 8-22 should be studied to determine the percentage of motorists who will be able to see the VMS message (or consequently, the percentage who will not be able to see the VMS message because their visibility to the sign is blocked by large trucks). This information will help the VMS operator and the TOC manager to determine the potential effectiveness in communicating the message to the motorists in the traffic stream.

# APPENDIX A. MESSAGE LENGTH REDUCTIONS FOR VERTICAL CURVES

## A.1 THEORY

Vertical curve designs are based on providing adequate stopping sight distance to a small object located in the travel lane for a motorist traveling at the design speed of the curve. The AASHTO *Policy on Geometric Design of Highways and Streets* recommends the use of a parabolic vertical curve to connect two intersecting grade lines. Near worst-case conditions are assumed for driver perception-reaction time, pavement friction, driver eye and roadway object heights, and other factors that influence a driver's ability to safely stop a vehicle. Basic geometry is then used to define the relationship between the length of curve required to provide a given sight distance (when the sight distance is less than the length of the curve):

$$L = \frac{AS^2}{100 \left( \sqrt{2h_1} + \sqrt{2h_2} \right)^2} \quad (1)$$

where,

L = length of parabolic curve (ft)

A = algebraic difference in grades (%)

S = required stopping sight distance

$h_1$  = driver eye height (ft)

$h_2$  = roadway object eye height (ft)

The above equation can be rearranged to describe the sight distance available as a function of the length of curve provided, as shown below:

$$S = 10 \left( \sqrt{2h_1} + \sqrt{2h_2} \right) \sqrt{\frac{L}{A}}$$

Written in this manner, it is possible to assess how different object heights influence the available sight distance (or "reading" distance) for a given curve (defined by its length L and grade difference A). More importantly, the available sight distance of an object at any height above the roadway can be related to the stopping sight distance ( $S_{ssd}$ ) used for vertical curve design purposes using the simple ratio shown below (with the second subscript in the numerator denoting the new object height). Note that the constant, L, and A all drop out of the equation:

$$\frac{S_1}{S_{ssd}} = \frac{\sqrt{2h_{11}} + \sqrt{2h_{21}}}{\sqrt{2h_{1ssd}} + \sqrt{2h_{2ssd}}} \quad (2)$$

For  $S_{ssd}$  design purposes, an object height ( $h_{2ssd}$ ) of 0.5 ft is commonly assumed. VMSs, on the other hand, are located considerably higher above the road, and so will have a greater sight (reading) distance available to them. The driver eye height assumed for calculations is the same ( $h_{11} = h_{1ssd}$ ) regardless of the object being considered (current guidelines use a driver eye height of 3.5 ft. Labeling  $h_{21}$  as the height of a VMS ( $h_{VMS}$ ) and the other variables with their assumed values yields the following relationship:

$$\frac{S_{DMS}}{S_{ssd}} = \frac{\sqrt{7} + \sqrt{2h_{DMS}}}{\sqrt{7} + \sqrt{1}} \quad (3)$$

This ratio can then easily be solved for different VMS mounting heights to determine the available reading distance to the sign in relation to the stopping sight distance provided by that vertical curve. Figure A.1 presents a plot of the relationship between VMS height above the road and this sight distance ratio. As an example, a portable VMS located 7 feet above the roadway on a crest vertical curve would yield a sight distance that is approximately 1.7 times that of the stopping sight distance provided by that curve. Likewise, a permanent overhead-mounted VMS located 26 feet above the roadway (a fairly common mounting height) provides a relative sight distance to the sign that is about 2.7 times the stopping sight distance.

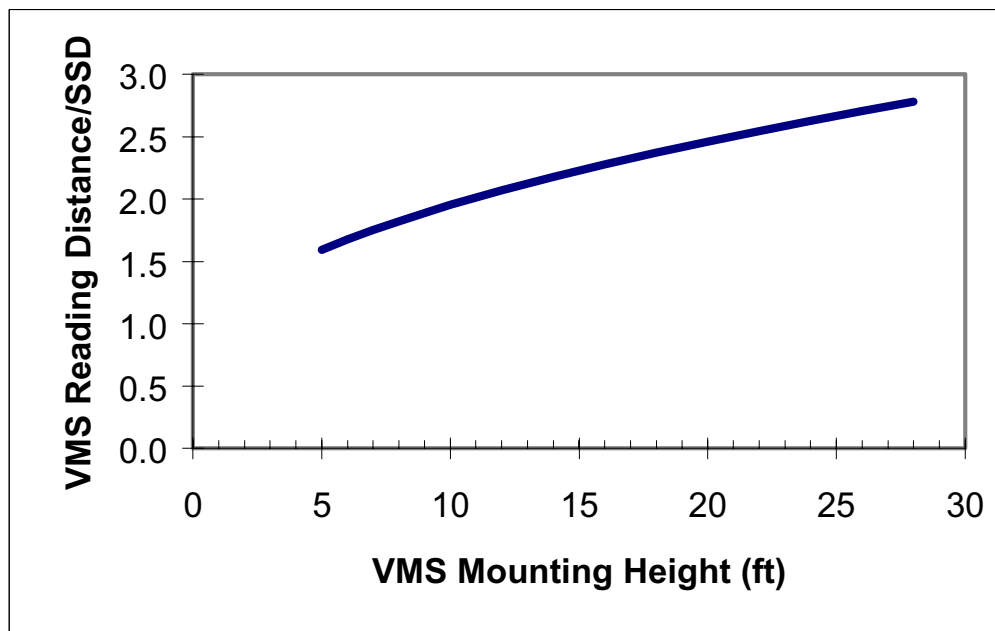
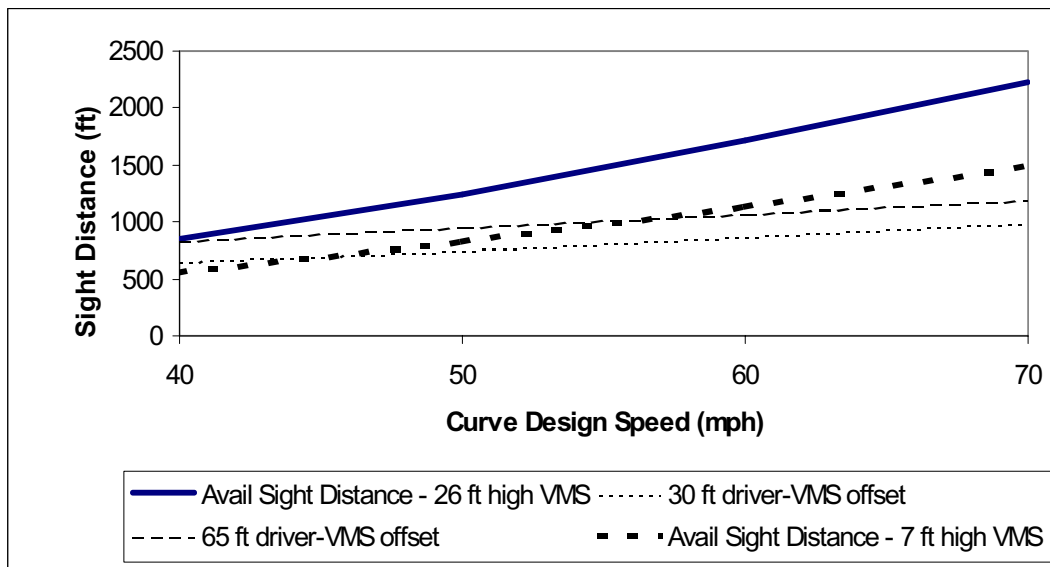

Figure A.1 Ratio of VMS Reading Distance to Stopping Sight Distance

The relationship depicted in Figure A.1 can then be used with design information about the vertical curve to estimate the available reading distance to the sign. The analyst either uses the curve design criteria directly (L and A) to compute  $S_{ssd}$ , or uses the stated design speed of the curve to estimate  $S_{ssd}$  from tables already provided in most state roadway design manuals or from AASHTO policy.

In most cases, permanent overhead VMS generally have adequate available reading distances to allow typical-length messages to be used. Conditions where this may not be the case include situations where actual operating speeds on the facility exceed the design speed of the curve, or in situations where a considerable lateral offset exists between the driver’s eye and the center of the VMS. To illustrate this point, Figure A.2 presents a plot of the actual available reading distance to a VMS mounted 26 ft above the roadway on vertical curves with design speeds ranging from 25 to 70 mph. Also plotted on Figure C.2 are the required reading distances for a message presenting 4 units of information (as defined by Dudek & Huchingson) to the driver (current guidelines recommend this as an upper limit for presentation) on a VMS that has a lateral offset from the driver of 30, 65, and 100 feet. According to guidelines, such a message would require 8 seconds of reading time to properly perceive and interpret the information. Two points should be evident from this figure. First, conditions where required reading distance to a VMS may exceed the available reading distance of that VMS are more likely to occur at lower design speeds. The second point to note, however, is that a significant lateral offset between the driver and the VMS can significantly increase the required reading distance to the sign and create message constraints even up to fairly high design speeds. It should be intuitive that these constraints will be even more significant for portable VMSs that are typically lower in height.



**Figure A.2 Available Versus Required Reading Distance to a VMS on a Vertical Curve For a Four-Unit Message (26 ft VMS Mounting Height)**



## A.2 PROCEDURE

Generally speaking, permanent VMS mounted above the travel lanes are not affected by the presence of crest vertical curves. Vertical curvature is established based on safe stopping sight distances to a rather small (i.e., 6-inch) object located in the roadway, based on the design speed of the roadway. The high (20 to 25 ft) typical mounting heights of permanent VMS provide viewing distances over the curve that usually exceed the visual capabilities of the signs themselves. However, this is often not the case for portable VMS positioned on the shoulder of the roadway. Furthermore, conditions where actual operating speeds are higher than the design speed of the vertical curve can sometimes provide less viewing time than is normally assumed to exist.

To assess the potential influence of the vertical curve, the operator requires the following information for the VMS of interest:

- Maximum sign viewing offset (ft), which is the sum of
  - the number of lanes a driver must look across to view the sign, and
  - the actual sign offset distance from the edge of the travel lanes,
- Sign mounting height (ft),
- Design speed of the curve (mph),
- Curve length (ft), and
- Expected operating speed on the curve (mph).

Tables A.1 and A.2 are provided to help evaluate whether a vertical curve is constricting the viewing of a permanent or portable VMS, respectively. The operator selects the appropriate table and finds the actual design speed of the curve, VMS mounting height, and sign viewing offset (the operator should extrapolate if actual mounting heights and viewing offsets are not found in the table). The selected cell defines the available viewing travel distance that a motorist has available to read a message on the sign. This distance is then compared to the length of the vertical curve. If the curve is longer than the available viewing distance, the operator computes the available viewing time over the curve (if the curve is shorter, there will not be a viewing constraint due to the vertical curve). Available viewing time is defined by equation 1:

$$\text{Viewing Time} = \left( \frac{\text{Viewing Distance}}{\text{Operating Speed} \cdot 1.467} \right) \quad (4)$$

In this equation, viewing time is in seconds, viewing distance is in feet, and operating speed in miles per hour (the 1.467 is a multiplier to convert the units to seconds). The available viewing time can then simply be divided by 2 to compute the number of units of information that can be read and processed by motorists.

<b>Table A.1 Available Permanent VMS Viewing Distance over Vertical Curves</b>						
<b>Vertical Curve Design Speed (mph)</b>	<b>Available Viewing Distance While Traveling (ft)</b>					
	<b>VMS Mounting Height = 20 feet</b>			<b>VMS Mounting Height = 25 feet</b>		
	<b>VMS Over Lanes</b>	<b>VMS Viewing Offset:20 feet</b>	<b>VMS Viewing Offset: 60 feet</b>	<b>VMS Over Lanes</b>	<b>VMS Viewing Offset: 20 feet</b>	<b>VMS Viewing Offset: 60 feet</b>
30	490	305	80	530	345	120
35	620	435	210	670	485	260
40	800	615	390	870	685	460
45	980	795	570	1060	875	650
50	1170	985	760	1260	1075	850
55	1350	1165	940	1460	1275	1050
60	1600	1415	1190	1730	1545	1320
65	1780	1595	1370	1930	1745	1520
70	2090	1905	1680	2260	2075	1850
75	2300	2115	1890	2490	2305	2080

<b>Table A.2 Available Portable VMS Viewing Distance over Vertical Curves</b>				
<b>Vertical Curve Design Speed (mph)</b>	<b>Available Viewing Distance While Traveling (ft)</b>			
	<b>VMS Mounting Height = 7 feet</b>		<b>VMS Mounting Height = 10 feet</b>	
	<b>VMS Viewing Offset:20 feet</b>	<b>VMS Viewing Offset: 60 feet</b>	<b>VMS Viewing Offset: 20 feet</b>	<b>VMS Viewing Offset: 60 feet</b>
30	235	5	275	45
35	325	95	375	145
40	375	145	515	285
45	585	355	665	435
50	715	485	815	585
55	845	615	955	725
60	1025	795	1155	925
65	1155	925	1295	1065
70	1375	1145	1545	1315
75	1525	1295	1705	1475

For simplicity, the VMS offsets shown in [Tables A.1 and A.2](#) should be selected to represent worst-case viewing conditions. That is, it should reflect the lateral distance from a motorist travelling in the lane farthest from the VMS to the middle of the VMS sign (including adjacent travel lanes, shoulder, actual VMS offset from the edge of pavement, and one-half of the width of the VMS itself).

The following examples illustrate how the tables are used to estimate reading times for permanent and portable over crest vertical curves.

### A.3 EXAMPLE 1

A 3-line, 15-character VMS (26 feet wide mounted 20 feet above the travel lanes) is located in the middle of a 20-foot median on a four-lane freeway with a 6-foot inside paved shoulder. The sign is placed on the downstream end of a 1200-foot crest vertical curve. The design speed of the curve is 60 mph, as is the average operating speed of traffic on that facility. Does the curve constrain the amount of information that can be presented on the VMS?

#### VMS VIEWING OFFSET

Worst-case viewing conditions are from the right shoulder lane. Assuming that the driver is located one-third of a lane in from the lane line, the viewing offset is the sum of that one-third of a lane, the other travel lane to the left, the 6-foot paved shoulder, and one-half of the median.

$$\text{Viewing offset} = 12/3 + 12 + 6 + 10 = 32 \text{ feet}$$

Since this is not shown in [Table A.1](#), one must interpolate between the 20-foot and 60-foot offset distances. Using a 60 mph design speed, the available reading distance for a VMS mounted 20 feet above the roadway is 1415 feet at a 20-foot viewing offset and 1190 feet at a 60-foot viewing offset. A linear interpolation indicates the available reading distance at a 32-foot offset to be approximately 1350 feet. This is less than the curve length, so is assumed to be the available viewing distance to the sign. Therefore,

$$\text{Viewing Time} = \left( \frac{1350 \text{ feet}}{60 \text{ mph} \cdot 1.47} \right) = 15 \text{ seconds}$$

This indicates that there is enough viewing distance for 7 or 8 units of information to be viewed by motorists. Since this exceeds both the 4 units of information typically assumed as the limit of driver information processing capability from a VMS and the typical legibility distance of the VMS itself, the vertical curve does not constrain VMS readability in this example.

## A.4 EXAMPLE 2

In this example, a 3-line, 15-character VMS (also 26 feet wide mounted 20 feet above the roadway) is located to the right of a six-lane urban arterial. The sign is positioned such that the center of the sign is 15 feet from the edge of pavement. It is located at the downstream end of a 600-foot crest vertical curve that is designed for 35 mph. However, average operating speeds on that facility are currently closer to 45 mph. Does the curve constrain the amount of information that can be presented on the VMS?

Worst-case viewing conditions are from the left lane. Assuming the driver is located one-third of a lane in from the lane line, the viewing offset is the sum of the driver lateral position in the left lane, the other two travel lanes to the right, and the remaining distance to the middle of the sign.

$$\text{Viewing offset} = 12 + 24 + 15 = 51 \text{ feet}$$

Since this is not shown in [Table A.1](#), one must interpolate between the 20-foot and 60-foot distances. Using a 35 mph design speed, the available reading distance for a VMS mounted 20 feet above the roadway is 435 feet at a 20-foot viewing offset and 290 feet at a 60-foot viewing offset. A linear interpolation indicates the available reading distance at a 51-foot offset to be approximately 320 feet. This is less than the curve length of 600 feet, and so is assumed to be the available viewing distance to the sign. Therefore,

$$\text{Viewing Time} = \left( \frac{320 \text{ feet}}{45 \text{ mph} \cdot 1.47} \right) = 5 \text{ seconds}$$

Dividing this value by two indicates that the sign can be seen only far enough to read and process two to three units of information. Consequently, the vertical curve does constrain VMS readability in this example.

## A.5 EXAMPLE 3

Example 3 characteristics are identical to Example 1, except that a portable VMS with a 7-foot mounting height is used.

$$\text{VMS offset} = 32 \text{ feet}$$

Using a 60 mph design speed, the available viewing distance for a VMS mounted 7 feet above the roadway is 1025 feet at a 20-foot viewing offset and 795 feet at a 60-foot viewing offset. A linear interpolation indicates the available reading distance at a 32-foot offset to be approximately 960 feet. This is less than the 1200-foot curve length, so is assumed to be the available viewing distance to the sign. Therefore,

$$\text{Viewing Time} = \left( \frac{960 \text{ feet}}{60 \text{ mph} \cdot 1.47} \right) = 11 \text{ seconds}$$

This corresponds to 5 or 6 units of VMS information (11 seconds divided by 2). Since this exceeds the 4 units of information typically assumed as the limit of driver information processing capability from a VMS, the vertical curve does not constrain VMS readability in this example.

## A.6 EXAMPLE 4

The details for this example remain the same as in Example 2. However, a 3-line, 8-character VMS 7 feet above the roadway is to be located to the right of a six-lane urban arterial. The sign is positioned such that the center of the sign is 15 feet from the edge of pavement. It is located at the downstream end of a 600 foot vertical crest curve that is designed for 35 mph. However, average operating speeds on that facility are currently closer to 45 mph. Does the curve constrain the amount of information that can be presented on the VMS?

Viewing offset = 51 feet

Since this is not shown in [Table A.2](#), one must interpolate between the 20-foot and 60-foot distances. Using a 35 mph design speed, the available reading distance for a VMS mounted 7 feet above the roadway is 325 feet at a 20-foot viewing offset and 95 feet at a 60-foot viewing offset. A linear interpolation indicates the available reading distance at a 47-foot offset to be approximately 170 feet. This is less than the curve length of 600 feet, so is assumed to be the available viewing distance to the sign. Therefore,

$$\text{Viewing Time} = \left( \frac{170 \text{ feet}}{45 \text{ mph} \cdot 1.47} \right) = 2.5 \text{ seconds}$$

This time would allow a driver to process approximately 1 unit of information. Since this is much less than the 4 units of information typically assumed as the limit of driver information processing capability from a VMS, the vertical curve does constrain VMS readability in this example. More importantly, such a low available viewing time indicates a significant problem with placing a portable VMS at this proposed location. In this situation, the operator or designer would be better off by finding a better placement location, such as before the start of the curve itself.

## APPENDIX B. MESSAGE LENGTH REDUCTIONS FOR HORIZONTAL CURVES

Design criteria for horizontal curvature is based on driver comfort and the friction between the tires and the roadway. With respect to VMS visibility and viewing time, horizontal curvature generally does not impact permanent VMS mounted over travel lanes. Likewise, permanent VMS mounted adjacent to the travel lanes (in the median or off to the right) will extend above most obstructions that may exist on the roadside and so not be affected by any horizontal curvature (although certain spot obstructions such as overhead signs or luminaires may be more problematic to VMS viewing on horizontal curves).

However, the situation is different for portable VMS placed on the side of the road within the curve (on the right side of a right-hand curve, on the left side of a left-hand curve). If an object (construction vehicle, tree, etc.) is located close to the edge of a roadway on the same side as the VMS, a driver in the closest lane may not be able to see around the object and fully read and comprehend the message. The following sections describe the analysis theory and then a process to follow to assess whether an obstruction may constrain the reading time of a portable VMS around a horizontal curve. The procedure is approximate in that it does not consider the effects of spiral curves sometimes used in horizontal curve design, and so provides slightly conservative answers.

### B.1 THEORY

Although horizontal curves are generally not a problem for permanently-mounted overhead VMS, they can often cause sight distance problems for portable VMS located to the side of the road because of roadside obstructions blocking the driver's view around the curve. [Figure B.1](#) illustrates the analysis of the roadside obstruction situation graphically, as depicted in AASHTO policy. The worst-case condition for this situation occurs for the driver traveling in the far right lane. Key variables defining sight distance are the radius of the curve,  $R$ , and the offset of the sight obstruction from the travel path of the vehicle,  $M$ , as indicated by the following equation (other key variables noted in [Figure B.1](#) are also defined below):

$$M = R \left( 1 - \cos \frac{S}{2R} \right) \quad (1)$$

where,

$M$  = distance from inside travel lane to obstruction, ft

$S$  = sight distance around curve, ft

$R$  = curve radius, ft

$s$  = offset between edge of far right shoulder lane and the VMS, ft

$L$  = lane width, ft

$\theta = \frac{1}{2}$  angle subtended by a sight distance chord around obstruction

$\phi =$  angle between end of the sight distance chord and location of the VMS

Unlike the vertical curve analysis, VMS mounting height does not enter into consideration of horizontal curve reading distance calculations. However, lateral placement of the sign relative to the roadway has a key impact upon the available sight distance to the sign. The effect of this placement is to reduce the length of the travel arc around the curve to where the VMS intersects the chord defining the sight distance around the obstruction (see Figure B.1).

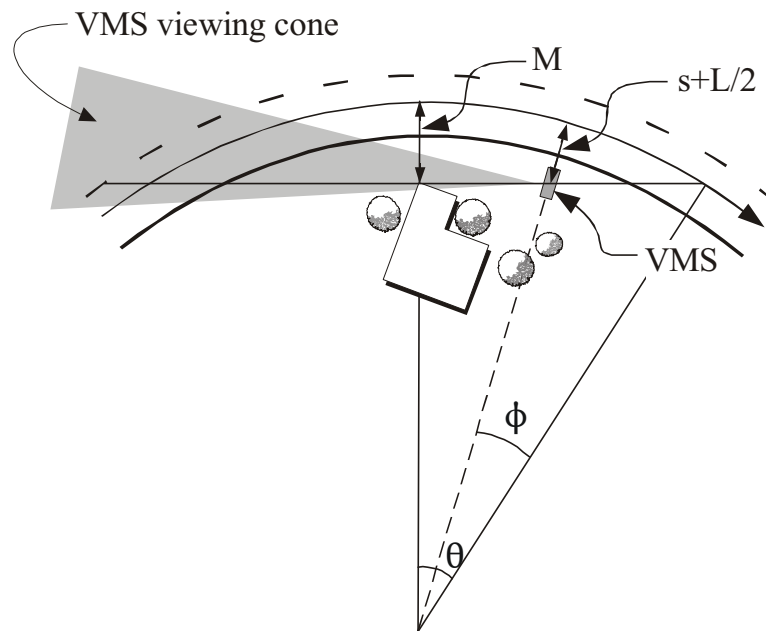

**Figure B.1 Geometry of Horizontal Curve Sight Obstruction to a VMS**

To analyze the effective sight distance to the sign in this situation, the above equation must first be rewritten and solved for the normal sight distance around the curve, as defined below (note that the trigonometric relationships are calculated in terms of radians and not degrees):

$$S = 2R \cos^{-1} \left( 1 - \frac{M}{R} \right) \quad (2)$$

The amount of travel distance around the curve to where the VMS is located off of the side of the road can be computed by determining the angle  $\phi$  in Figure B.1. This can be accomplished using

the mathematical relationships between  $M$ ,  $R$ ,  $s+L/2$  (with  $s$  equal to the sign offset and  $L$  equal to the lane width),  $\theta$ , and  $\phi$ :

$$\frac{R - M}{R - s - \frac{L}{2}} = \cos(\theta - \phi) \quad (6)$$

By rearranging this equation and substituting  $\cos^{-1}(1-M/R)$  for  $\theta$ , a solution for  $\phi$  is obtained that is strictly dependent on  $M$ ,  $R$ ,  $s$ , and  $L$ :

$$\phi = \cos^{-1}\left(1 - \frac{M}{R}\right) - \cos^{-1}\left(\frac{R - M}{R - s - \frac{L}{2}}\right) \quad (7)$$

The travel distance along the curve bisected by the angle  $\phi$  is simply  $R\phi$ , where  $\phi$  is defined in terms of radians instead of degrees. Subtracting this value from the original sight distance ( $S$ ) yields the following relationship:

$$\text{Available Sight Distance} = R \left[ \cos^{-1}\left(1 - \frac{M}{R}\right) + \frac{1}{2} \cos^{-1}\left(\frac{R - M}{R - s - \frac{L}{2}}\right) \right] \quad (8)$$

The available sight distance around the horizontal curve can then be compared to the required reading distance of the VMS for a driver traveling at a given speed. [Figure B.2](#) provides an example of the calculated reading distances to a VMS located 3 feet from the edge of the travel lane around a horizontal curve where an obstruction is present (similar figures could be calculated for different VMS offsets).

Assuming that the analyst wants to display a message requiring eight seconds to read on a facility with operating speeds at 70 mph, a minimum of 820 feet reading distance would be necessary. From [Figure B.2](#), this would require a minimum curve radius of approximately 1300 feet if the obstruction were located 80 feet from the travel lane, and over 2950 feet if the obstruction were located only 10 meters (30 feet) from the travel lane. Depending on the design characteristics of the curve (i.e., AASHTO policy allows curve radii near these values, depending on superelevation rates used), it is possible that this reading distance would not be available within the curve. The analyst would then have to choose between moving the obstruction farther away from the curve (if it a portable object such as a construction vehicle) or reducing the message length by reducing the units of information on the VMS.



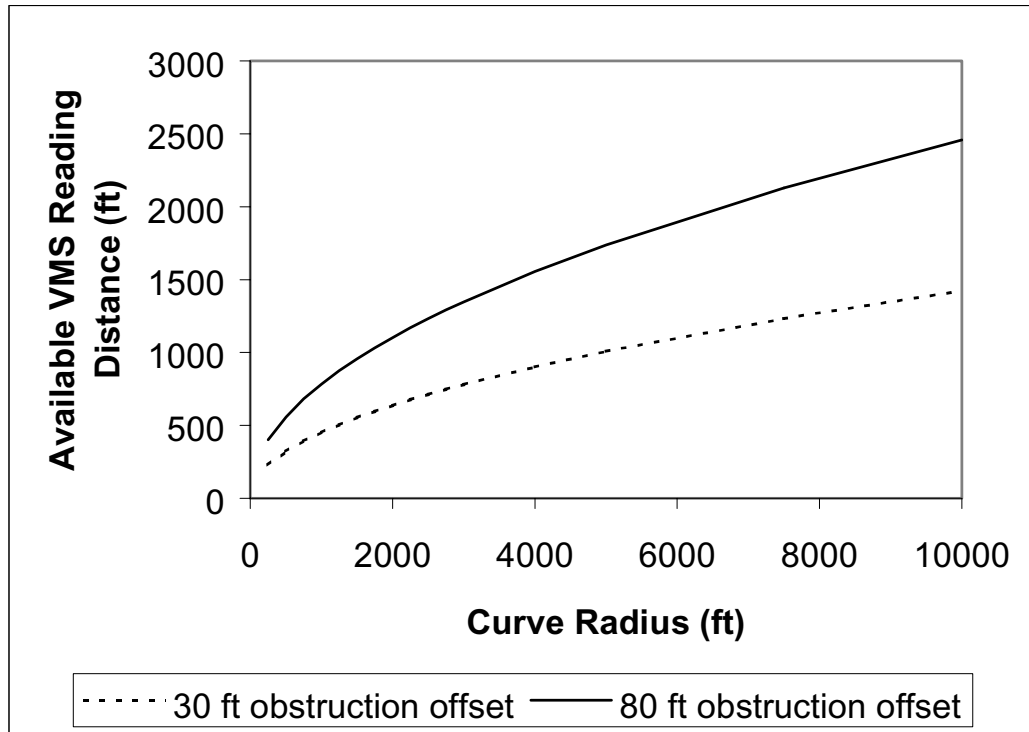

**Figure B.2 Example of Available Reading Distance Around a Horizontal Curve (VMS Offset 3 Feet From Edge of Travel Lanes)**

## B.2 PROCEDURE

To determine whether a potential horizontal curve sight distance restriction to a portable VMS exists, the operator must have the following information at hand:

- Radius of the curve (ft),
- Length of the curve (ft),
- Distance of VMS to edge of the travel lane (ft),
- Distance of a potential sight obstruction from the edge of the travel lane (ft), and
- Expected operating speed of vehicles traversing the curve (mph).

Although horizontal curve design typically starts with a design speed, many curves use radii longer than the minimum required. Consequently, the more detailed geometric information (curve radii and length of curve) is needed to evaluate possible horizontal curve sight restrictions.

Using the above information about the curve, Table B.1 or B.2 is used to determine the possible restricted viewing distance around a sight obstruction on the curve. If the appropriate sign offset, curve radius, and/or sight obstruction offset is not listed, the viewing distance value must be interpolated. This distance is then compared to the length of the horizontal curve, and to the estimated distance between the VMS and the sight obstruction. If both exceed the value

determined in Table B.1 or B.2, then the possibility exists for the sign to be obstructed. The estimated viewing distance is then converted to a corresponding viewing time using equation 1. Finally, the available viewing time is used to estimate the number of units of information that could be presented to motorists on the VMS at that location.

The following examples illustrate the procedure.

### B.3 EXAMPLE 1

A portable VMS is to be placed two feet from the edge of travel lanes on a rural highway upstream of a work zone towards the end of a long (2500 ft) horizontal curve. Traffic speeds on the roadway average 65 mph. A bridge overpass abutment is located upstream of the VMS along the curve as well. The abutment is 50 feet from the edge of the travel lane. The curve radius is 1500 feet. Is the viewing distance of the VMS constrained by the bridge abutment?

Using Table B.1 for the two-foot VMS offset, the available viewing distance around the curve for an obstruction located 50 feet from the roadway is 750 feet. The length of the curve is longer than this value, and so the analysis proceeds to the computation of available viewing time. A motorist traveling 65 mph around the curve will have the following available time:

$$\text{Viewing Time} = \left( \frac{750 \text{ feet}}{65 \text{ mph} \cdot 1.47} \right) = 8 \text{ seconds}$$

This time allows 4 units of information of information to be presented on the VMS. This is considered the maximum amount of information that a motorist can perceive and process while driving. Therefore, the horizontal curve does not constrict the amount of information that can be presented on the VMS.

### B.4 EXAMPLE 2

A portable VMS is to be used to assist in providing trailblazer information along a detour route for a section of freeway. The sign will be placed 10 feet from the travel lanes. The diversion route is an urban arterial with vehicle operating speeds about 40 mph. The operating agency is contemplating the location of the sign towards the end of the 750-foot horizontal curve with curve radius of 500 feet. A brick wall located 20 feet from the roadway is used to separate the roadway from the adjacent neighborhood. Does the curve constrain the amount of information that can be presented on the VMS?

Using Table B.2, the available viewing distance for an obstruction 20 feet from the roadway is 250 feet. This is less than the length of horizontal curve.

<b>Table B.1 Available VMS Reading Distances Around a Horizontal Curve: 2-Ft VMS Offset</b>							
<b>Curve Radii (ft)</b>	<b>Edge of Travel Lane to Obstruction (ft)</b>						
	<b>10</b>	<b>20</b>	<b>50</b>	<b>100</b>	<b>150</b>	<b>200</b>	<b>250</b>
250	100	180	310	460	580	680	790
500	150	250	430	630	790	920	1040
750	180	310	530	770	950	1110	1250
1000	200	360	610	890	1100	1280	1440
1250	230	400	680	990	1220	1420	1600
1500	250	440	750	1080	1340	1550	1750
1750	270	470	800	1170	1440	1670	1880
2000	290	500	860	1250	1540	1790	2010
2250	310	530	910	1320	1630	1890	2130
2500	320	560	960	1390	1720	2000	2240
2750	340	590	1010	1460	1800	2090	2350
3000	360	620	1050	1520	1880	2180	2450
4000	410	710	1210	1760	2170	2520	2820
5000	460	790	1360	1960	2420	2810	3150
7500	560	970	1660	2400	2970	3440	3850
10000	650	1120	1920	2770	3420	3970	4450

<b>Table B.2 Available VMS Reading Distances Around a Horizontal Curve: 10-Ft VMS Offset</b>							
<b>Curve Radii (ft)</b>	<b>Edge of Travel Lane to Obstruction (ft)</b>						
	<b>10</b>	<b>20</b>	<b>50</b>	<b>100</b>	<b>150</b>	<b>200</b>	<b>250</b>
250	N/A	150	300	450	570	680	780
500	N/A	210	410	620	780	920	1040
750	N/A	250	510	750	940	110	1250
1000	N/A	290	580	870	1080	1270	1430
1250	N/A	330	650	970	1210	1410	1590
							1730
1500	N/A	360	710	1060	1320	1540	1870
1750	N/A	380	770	1140	1420	1660	1990
2000	N/A	410	820	1220	1520	1770	2110
2250	N/A	440	870	1290	1610	1880	2220
2500	N/A	460	920	1360	1700	1980	2330
							2430
2750	N/A	480	960	1430	1780	2070	2800
3000	N/A	500	1000	1490	1860	2160	3130
4000	N/A	580	1160	1720	2140	2490	3820
5000	N/A	650	1290	1920	2390	2780	4410
7500	N/A	790	1580	2350	2920	3400	
10000	N/A	920	1830	2710	3370	3930	

N/A Reading sight distance not available for any message.

The available viewing time to the VMS along this curve will be

$$\text{Viewing Time} = \left( \frac{250 \text{ feet}}{40 \text{ mph} \bullet 1.47} \right) = 4 \text{ seconds}$$

This is only enough time to present 2 units of information to drivers on the VMS. The operating agency will need to make sure that the message displayed on this VMS contains only 2 units of information, or else select another location for the VMS.

## APPENDIX C. MESSAGE LENGTH REDUCTIONS FOR RAIN AND FOG

Both rain and fog can influence the amount of information that can be presented on a VMS. Both conditions deteriorate the amount of light that is coming from the VMS (either direct illumination from the light pixels on the VMS or reflected by the VMS from other light sources such as the sun, overhead lighting, or automobile headlights). This reduces the contrast between the sign legend and its background. If the contrast becomes too low, motorists cannot read the VMS message.

For light-emitting VMS, contrast ratios are at their minimums on bright, sunny days because the sun increases the background luminance of the signs. Under cloudy conditions, the luminance of the legend will be much greater than the background and create very large contrast ratios. Unfortunately, data on typical VMS background luminance or contrast ratios on cloudy, rainy, or foggy days is not available (in actuality, there may not be a true “typical” cloudy day anyway). Conversely, contrast ratios for light-reflecting VMS decrease as external lighting levels decrease, becoming zero (or nearly so) as the amount of light falling on the sign reaches zero. Consequently, it is the light-reflecting technologies for which this section is most appropriate.

### C.1 THEORY

#### EFFECT OF RAINFALL UPON LEGIBILITY

Light traveling through rainfall in the atmosphere is attenuated, which causes a reduction in the apparent luminance and contrast of an object. Mathematically, the influence of rain (which affects the light transmissivity of the atmosphere) can be described in terms of its effect on the apparent illumination of an object using Allard’s law established back in the 1870s:

$$E = I \frac{t^d}{d^2}$$

where,

E = apparent illumination at some distance from the object

I = light intensity of the object at its source

t = transmissivity coefficient of the medium over which light is traveling

d = distance from the object to the point where illumination is being measured

The difficulty in applying this relationship to the interpretation of rainfall effects is in relating it to a factor which can be easily measured and is readily available. Intuitively, light attenuation should be related to rainfall intensity. Empirical observations have suggested this to be the case. In one instance, researchers estimated that a 1-in/hr rainfall rate reduces visibility by about 30

percent, and a 2-in/hr rainfall rate reduces visibility by about 50 percent. Often, a coefficient of atmospheric extinction term (s) is used instead of the transmissivity coefficient to describe the optical extinction phenomenon caused by rainfall. These two coefficients are related in the following simple manner:

$$t = e^{-s}$$

A relationship, originally developed by Atlas, was found in the literature which expresses the atmospheric extinction coefficient as a function of rainfall intensity:

$$s = \frac{5.85 R^{0.63}}{10,000}$$

where,

s = atmospheric extinction coefficient

R = rainfall intensity, inches/hour

These relationships can then be combined in order to estimate the influence of rainfall upon the apparent illuminance of an object. To illustrate, Figure C.1 presents the relative reduction in the illuminance of a VMS as a function of the distance to that object for various rainfall intensity rates.

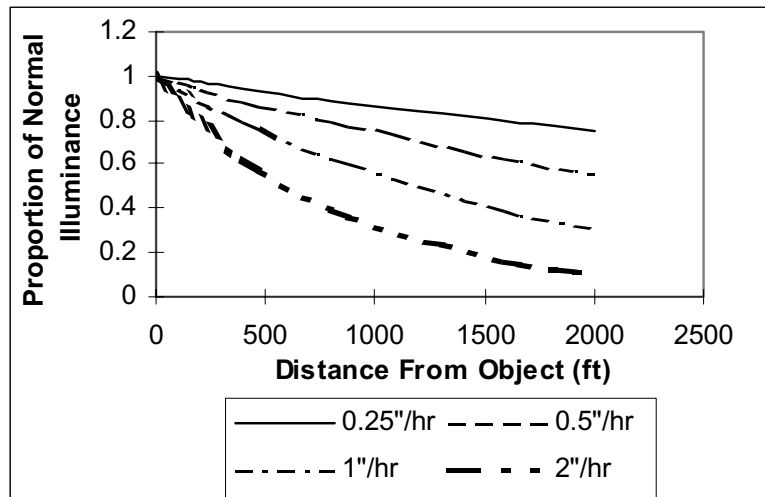

Figure C.1 Effect of Rainfall Upon the Apparent Illuminance of a VMS.

The reduction in illuminance from a VMS due to rainfall may or may not impact its legibility, depending on the design characteristics of the sign. As will be discussed more thoroughly in a latter section of this Appendix, there exists a fairly wide range of luminance values (which are inherently related to sign illuminance) and contrast ratios which provide fairly consistent

performance in terms of message legibility. In adverse weather conditions, a given rainfall rate may or may not have an impact upon legibility, depending on the luminance level normally being provided by the sign. If the rainfall rate is excessive enough to reduce the apparent sign luminance below minimum requirements, a degradation in legibility will occur. On the other hand, if the reduction in sign luminance caused by the rain still provides adequate contrast, no significant change in legibility would be expected. Since the occurrence of rain in the daytime typically reduces ambient lighting levels (as compared to bright sunlight), a reduced VMS luminance would not automatically reduce contrast levels below minimum acceptable thresholds. The effect of rain at night would be to also reduce sign luminance values, but again contrast levels are already so great that the reduction would need to be extremely severe in order to adversely affect legibility. In fact, it could be envisioned that rainfall could actually be beneficial somewhat to nighttime legibility if the normal VMS luminance levels were at or slightly above optimum levels, and were approaching irradiation conditions.

A final note is required in this section, however. The above mathematical model does not take into consideration the potential for light scatter due to water on the windshield that might simulate irradiation conditions. Nor does the model account for the periodic obscuring of the sign as the windshield wipers pass over the driver's line of sight. Such influences will likely be extremely vehicle and driver dependent, and beyond representation in any reasonable model.

### EFFECT OF FOG ON LEGIBILITY

Allard's law can also be used to theorize the effect that fog has upon VMS legibility. Again, however, the difficulty becomes in relating the transmissivity coefficient to an easily measurable and interpretable factor describing fog intensity or density. Unlike rainfall intensity, no relationship was found in the literature to relate fog characteristics to an atmospheric extinction or transmissivity coefficient. Several fog warning systems which are in place worldwide utilize fog detection equipment that measure changes in atmospheric transmissivity over some distance. However, these systems are designed to determine when fog is present (and to enact appropriate warning devices), not to relate how the fog affects visibility and legibility.

Rather than attempt to work directly with Allard's law, researchers looked for alternative approaches to relate VMS legibility to fog characteristics. Researchers were able to identify a relationship which relates the apparent contrast of an object to its "normal" contrast as a function of the visibility range of the atmosphere. This relationship, as expressed by Duntley, is as follows :

$$C_{\text{apparent}} = C_{\text{inherent}} e^{\frac{-3.912V}{R}}$$

where,

$C_{\text{apparent}}$  = Apparent contrast of object viewed as some distance under given degraded atmospheric visibility conditions

$C_{\text{inherent}}$  = Inherent contrast of object under perfect visibility conditions

$V$  = Atmospheric visibility range

$R$  = Distance at which object is being viewed



The National Weather Service describes atmospheric visibility ranges as part of its normal operations, and so is a factor that is easily accessible. Duntley's relationship can be used to generate a plot describing the relative reduction in contrast as a function of viewing distance and atmospheric visibility ranges. This is shown in Figure C.2.

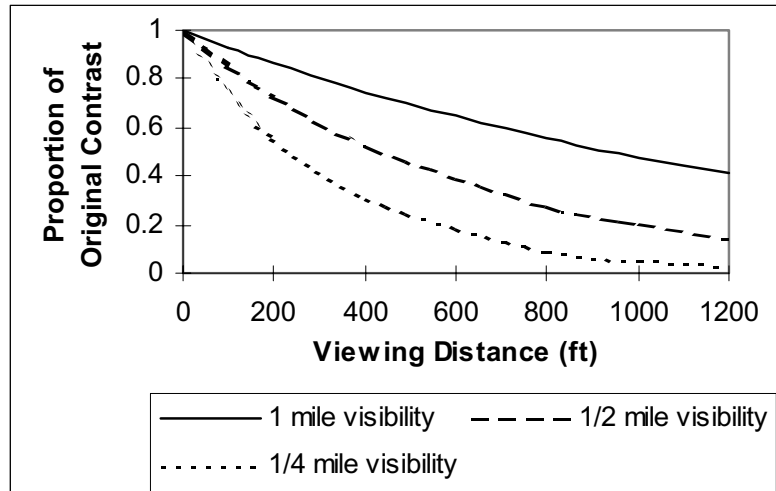

**Figure C.2 Effect of Fog on VMS Contrast Levels**

Figure C.2 illustrates the dramatic effect that fog will have upon VMS legibility during daytime conditions. For example, fog which limits atmospheric visibility to 0.5 mile will reduce the apparent contrast of a VMS message viewed at 800 feet by nearly 50 percent. If the fog is heavier (i.e., 0.25 mile visibility), contrast levels of the VMS viewed at 800 feet will be cut by 90 percent.

As with rainfall impacts upon VMS legibility, reductions in legibility caused by fog are dependent upon the normal contrast levels generated by the sign. Legibility distances are affected once degraded contrast levels fall below minimum levels (described later in this memorandum). The use of contrast as the primary measure for assessing VMS legibility does create problems in considering nighttime conditions, however. Contrast levels at night are nearly infinite, and so the impact of fog is not easily interpreted from the above equation or graph. It is conceivable that fog could have a negligible impact on nighttime legibility because of these high contrast levels originally (or might even enhance legibility slightly by reducing the effects of irradiation when the VMS luminance levels are too high). On the other hand, the above mathematical model does not take into consideration the effects of light scatter and refraction of the vehicle headlights back to the driver, which would raise the apparent ambient light levels at the driver's eye and possibly reduce contrast levels (and thus legibility distances).

## C.2 PROCEDURE

This section presents a very simple procedure to check whether the VMS viewing distance desired for a given message will result in a contrast ratio that exceeds the minimum required under a given fog condition. [Figure C.2](#) presents contrast reduction factors for daytime fog conditions. The analyst selects the desired VMS viewing distance and the appropriate fog condition. The value read from the y-axis is the reduction factor that is applied to the normal contrast ratio for that particular sign.

The following general guidelines are suggested for initial contrast ratios in daylight, but overcast conditions. The reflective disk values are based on some TTI data and published literature for sunny conditions (which are probably slightly higher than would be achieved in overcast conditions). The values for light-emitting VMS are values observed by TTI under sunny conditions, increased by approximately 50 percent to account for lower ambient light when the sky is overcast. Data is needed in the future to better define these ranges.

VMS Type	Normal Contrast Ratio Range
Reflective Disk	5-10
Light-Emitting	20-50

The following example illustrates how [Figure C.2](#) would be used to assess whether weather conditions would affect the necessary visibility distance of the VMS.

## C.3 EXAMPLE 1

A permanent LED VMS is located in the middle of a 6-lane freeway (offset between the motorist in the right lane and the middle of the VMS is 60 ft). A fog that rolled in the previous evening is still present the next morning as the peak period begins, limiting visibility to about  $\frac{3}{4}$  mile. A series of messages designed for use during peak period incidents on that sign have been developed with four units of information and are stored at the control center for downloading. Traffic speeds have only reduced slightly (i.e. 60 mph). Can the original messages with four units of information be used in this foggy condition?

### PROCEDURE:

1. [Figure C.2](#) is used with a  $(2 \times 4 \times 60 \times 1.47 + 300) = 1004$  foot required visibility distance (the 300 feet is the additional distance required for the lateral offset) and an extrapolation between the 1 mile and  $\frac{1}{2}$  mile visibility curves.
2. The resulting adjustment factor is 0.4.
3. It is assumed that the VMS normally generates a contrast ratio of approximately 25 in normal weather. Multiply this value by the 0.4 adjustment factor.
4. The resulting ratio, 10 is within the optimum range. No adjustments are needed.

## **C.4 EXAMPLE 2**

Assume the same conditions as previous, but assume that the technology is a reflective disk VMS with a normal contrast ratio in the morning peak of approximately 8.

### **PROCEDURE:**

The same adjustment factor (0.4) is used to multiply by the normal contrast ratio (8). The product is 3.2, which is at the lower threshold of human performance. Given that driving in adverse weather typically increases the demand for the motorist's attention, the VMS operator may be better served to reduce the length of the messages to only three units of information (so that the message can be read in six seconds or less) on this day.

## APPENDIX D. EFFECTS OF LARGE TRUCKS ON VMS LEGIBILITY

Large trucks can be a major cause of sight obstructions to VMS. Vehicles travelling closely behind or adjacent to a truck may be limited in the amount of time that they have to read a VMS. If they follow too closely, they may not be able to see the VMS at all. This can occur in some instances for permanent overhead VMS. However, the majority of concerns relating to trucks pertain to the portable VMS located off to the side of the travel lanes.

Evaluating truck obstructions of VMS requires a slightly different analysis approach. This is because a motorist has the ability to adjust his or her speed slightly relative to that of a truck and find a travel position that allows for adequate viewing. However, as the number of trucks on the roadway increases, the amount of roadway space that a motorist can travel in with an unobstructed view decreases. If the number of vehicles travelling on the facility approaches or exceeds the number that can “fit” into the unobstructed viewing spaces, then some motorists will not be able to read all of a VMS message. Depending on the specific message being presented, this can begin to create operational problems on the facility.

### D.1 THEORY

Large trucks can significantly obstruct a motorist’s reading distance to a VMS. Vehicles traveling closely behind or adjacent to a truck may be limited in the amount of time they have to read a VMS, or may not be able to see the VMS at all. This can occur in some instances for VMS mounted directly over the travel lanes. However, the majority of concerns relating to trucks pertain to VMS located off to the side of the travel lanes.

Others have noted the problems that trucks create with respect to obstructing both roadside and overhead signing. Unfortunately, only limited efforts have been undertaken to date to quantify the magnitude of the obstruction problem. Furthermore, those who have tried to assess the impacts have only addressed simple signing situations having limited reading time requirements.

Evaluating truck obstructions of a VMS requires a slightly different analysis approach than that used for horizontal and vertical curvature. This is because a motorist has the ability to adjust his or her speed slightly relative to that of a truck and find a travel position that allows for adequate viewing. However, as the number of trucks on the roadway increases, the amount of roadway space that a motorist can travel in with an unobstructed view decreases. If the number of vehicles travelling on the facility approaches or exceeds the number that can “fit” into the unobstructed viewing spaces, then some motorists will not be able to read all of a VMS message. Depending on the specific message being presented, this can begin to create operational problems on the facility.

To analyze the roadside-mounted (i.e., portable) VMS visibility problem, the proportion of driving area on a roadway where visibility distances to a VMS are unacceptable (i.e., less than required viewing times) is computed. [Figure D.1](#) illustrates the geometrics of this situation for a

shoulder lane passenger vehicle and truck (this could occur either on a multi-lane roadway or on a two-lane, two-way highway). The analysis process relies on the assumption that VMS reading must be completed within the 10° driver cone of vision. Simple trigonometric relationships are then used establish the minimum acceptable passenger vehicle-truck separation for side-mounted VMS positioned at a given offset distance from the edge of the travel lane.

The minimum gap size required for the passenger vehicle driver to read the VMS is the difference between the required sight distance (S) and the sign-to-back-of-truck-distance (x). Using the equations illustrated in Figure D.1, this can be written as:

$$\text{Minimum Gap} = S \left( 1 - \frac{(L - TW) + s}{\frac{2}{3}L + s} \right) \tag{1}$$

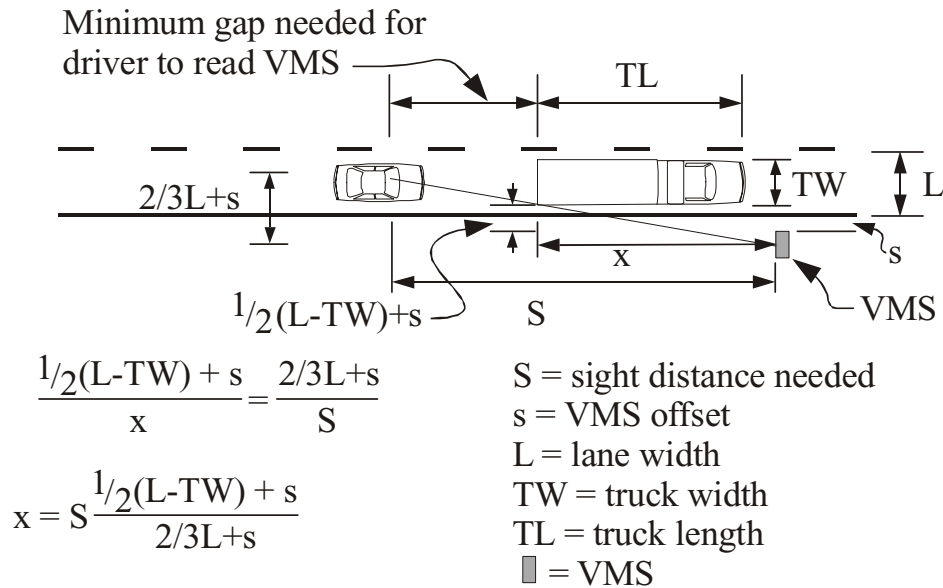

**Figure D.1 Effect of a Truck on Shoulder Lane Vehicles Seeing a VMS**

Figure D.2 presents a similar analysis when a truck is in the shoulder lane and a passenger vehicle is in the adjacent lane. Because the motorist in a passenger vehicle in this scenario can see the roadside both in front of and behind the truck from this adjacent lane, the situation is analyzed in two phases. The first phase considers how far back the passenger vehicle can be relative to the truck and still be able to adequately read the VMS by looking in front of the truck (depicted in Figure D.2a). The second phase addresses how far behind the truck the passenger vehicle must be in order to read the VMS from behind the truck (shown in Figure D.2b).

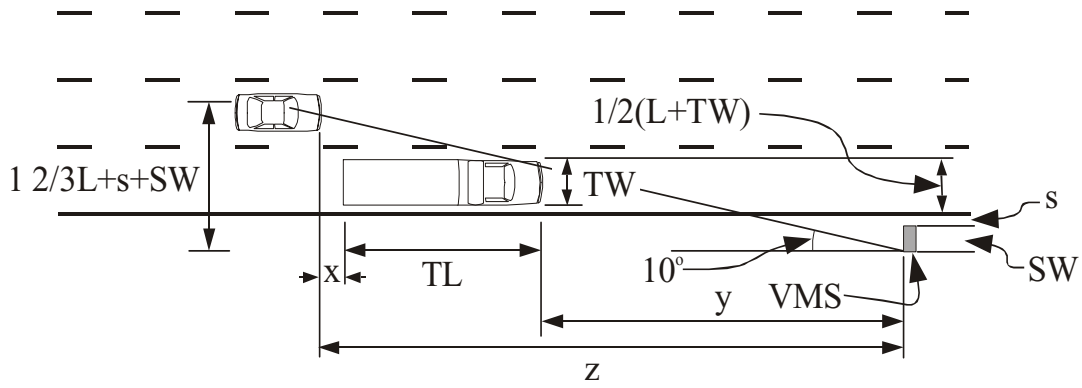

$$y = [1/2(L + TW) + s+SW] / \tan 10^\circ$$

$$z = [1 2/3L + s+SW] / \tan 10^\circ$$

(a)

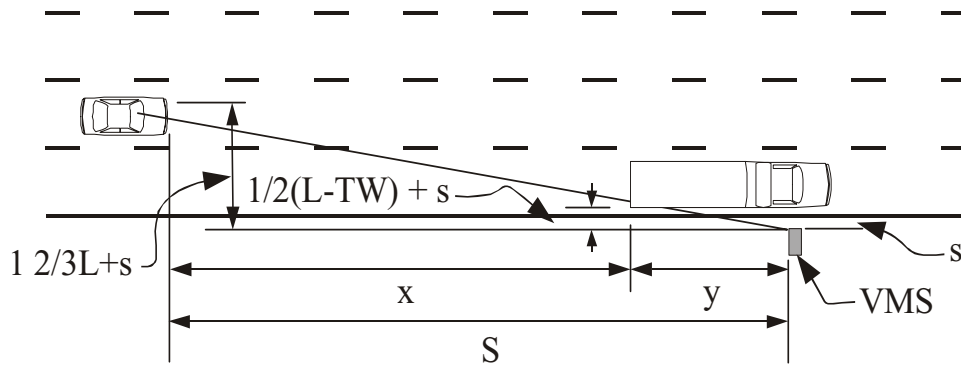

$$y = S \left( \frac{1/2(L-TW) - s}{1 2/3L+s} \right)$$

(b)

**Figure D.2 Effect of a Truck on Adjacent Lane Vehicles Seeing a VMS**

The distance between these two locations (equal to the sum of the variable x from both figures) defines the roadway section in the adjacent lane next to the truck where a driver cannot adequately read the VMS message. In Figure D.2a, the location of the passenger vehicle relative to the back of the truck can be written as follows:

$$x = z - y - TL = \frac{\frac{z}{6}L - \frac{1}{2}TW}{\tan 10^\circ} - TL \quad (2)$$

where,

L = lane width

TL = truck length

TW = truck width

The other variables are as defined in the figure. This position reflects the fact that the reading of the message needs to be completed before the sign is out of the driver 10° cone of vision. If a vehicle is any farther behind the front of the truck than position x, the VMS will become obscured before reaching that critical cone of vision and thus the full reading distance needed will not be provided.

Likewise, the variable x in [Figure D.2b](#) is defined in terms of lane width, truck width, and VMS offset as shown in the following equation:

$$x = S - y = S \left( 1 - \frac{\frac{1}{2}(L - TW) + s}{1\frac{2}{3}L + s} \right) \quad (3)$$

This allows the driver to experience the full reading VMS distance from behind the truck. If the driver is any closer to the back of the truck, the needed reading distance will not be achieved. With the variable x in both equations defined relative to the same location on the truck, their sum defines the length of roadway in that adjacent lane where VMS viewing is not adequate.

The same type of analysis is valid for each lane to the left of the truck. Then, the total effect of a single truck is the sum of inadequate viewing lengths in each lane. The same type of approach is then used to evaluate the influence of trucks in other lanes (the relative offset of the VMS will be measured to the next lane, though). In general, the influence of these trucks in the left lanes will be much less significant than for the trucks in the right shoulder lane *when the VMS are positioned to the right of the travel lanes.*

Once the impact of an individual truck in each of the travel lanes has been estimated in terms of the length of lane segment that is obscured, the next step in the analysis is to determine whether adequate “viewing capacity” exists for the traffic that is using the facility.

## D.2. PROCEDURE

The analysis procedure to assess the impact of large trucks upon VMS viewing time requires an iterative process that begins with a required viewing distance corresponding to particular VMS message of interest. This distance is simply the number of units of information being presented multiplied by two seconds each (i.e., the necessary viewing time), and then multiplied by the average travel speed of the vehicle. Other data required at this point in the analysis include the following:

- The number of travel lanes on the facility,
- The lateral offset of the VMS to the travel lanes,
- the volume of traffic on the roadway per direction,
- the percent of traffic that is comprised of large trucks, and
- an estimate of how truck traffic distributes itself among the available travel lanes (i.e., what percentage travels in the shoulder lane, what percentage travels in the next adjacent lane, etc.).

The procedure consists of the following steps:

1. Divide the total traffic volume on the roadway into an auto volume and truck volume (truck volume is equal to the total volume multiplied by the percent of trucks on the roadway; the auto volume is then the total volume minus the truck volume)
2. Estimate the truck volume in each lane (based on local data, as there does not exist true “typical” truck lane distributions. It is known that most trucks travel in the right lane).
3. Estimate the density of trucks in each lane per mile (truck volume in each lane divided by the average travel truck speed). Estimate average automobile density (auto volume divided by average speed).
4. Estimate the necessary viewing distance for a particular VMS message of interest (as described above)
5. Select the appropriate truck influence table (Table [D.1](#) or [D.2](#)) for the roadway being analyzed. Enter the table using the necessary viewing distance to find the truck influence distance for each truck in each lane. This distance represents the space around each truck where a motorist will not be able to obtain the desired viewing distance for the VMS message.
6. Multiply the influence distance of each truck in each lane by the number of trucks in each lane and sum these distances over all lanes. This is the total truck viewing influence per mile.
7. Subtract the total truck viewing influence distance per mile from the total available viewing distance in the absence of trucks (equal to the number of travel lanes multiplied by 5280 feet per mile). The result is the lane distance per mile where acceptable viewing distance to the VMS is attainable.
8. Divide the available viewing distance by the minimum space needed by each automobile while travelling down the roadway. As a conservative value, this is estimated to be equal to vehicle spacing near capacity conditions (between approximately 120 and 165 feet per automobile). Multiply this by the average speed of traffic on the roadway to estimate the volume that represents the automobile “viewing capacity” on that roadway section for that particular VMS message.



9. Divide the automobile volume on the roadway by the automobile “viewing capacity.”
10. If the ratio is significantly less than unity ( $< 1$ ), then there exists adequate space on the roadway to view the VMS message of interest.

If the ratio approaches or exceeds unity, inadequate viewing capacity exists, and many motorists will not have enough viewing time of the VMS to read the message in its entirety. If this occurs, the analyst must reduce the VMS message in order to reduce the necessary viewing distance. The analysis then returns to step 4 to reassess the available viewing capacity for the reduced message. This process continues until an acceptable auto-volume-to-available-viewing-capacity ratio is achieved.

This process is more easily understood in the context of the following examples.

### D.3 EXAMPLE 1

A portable VMS is to be placed alongside a two-lane facility (one lane per direction) upstream of a shoulder work zone scheduled between 9 am and 3 pm. The facility has no paved shoulder, so the VMS is located 2 feet from the edge of the travel lane. Traffic volumes on the facility are approximately 600 vehicles per hour, with 25 percent of these being large trucks (average length of 75 feet). Travel speeds on the roadway are 70 mph. Can the VMS message designer use a message that contains four units of information?

#### PROCESS:

1. Truck volume =  $0.25 \times 600 = 150$  trucks/hour; auto volume =  $600 - 150 = 450$  autos /hour
2. All truck traffic will be located in the single lane
3. Truck density =  $150/70 = 2.1$  trucks per mile
4. Estimated VMS viewing distance =  $4 \text{ units} \times 2 \text{ sec/unit} \times 70 \text{ mph} \times 1.47 \text{ fps/mph} = 823$  feet
5. Estimate each truck’s influence distance for a viewing distance of 823 (extrapolated in Table D.1) = 590 feet
6. Compute total truck influence distance =  $590 \text{ ft/truck} \times 2.1 \text{ trucks/mile} = 1240 \text{ ft/mile}$
7. Compute lane distance where acceptable viewing occurs =  $5280 \text{ ft/mile} - 1240 \text{ ft/mile} = 4040 \text{ ft/mile}$
8. Estimate available automobile viewing capacity =  $4040 \text{ ft per mile} \div 140 \text{ ft per automobile} = 28.9$  automobiles per mile. Multiply this value by 70 mph to estimate the available viewing capacity of 2023 automobiles per hour.
9. Compare ratio of automobile demand to available viewing capacity  $\Rightarrow 450 \div 2023 = 0.22$ . Since this is significantly less than unity, the roadway section is expected to have sufficient space where adequate viewing of the VMS message can occur. No reduction in reading time of 8 seconds is required.

<b>Table D.1 Influence Distance of Each Truck (Ft): 2-Ft VMS Offset From Travel Lanes</b>				
<b>Necessary Viewing Distance for VMS Message (Ft)</b>	<b>Lane that Truck is Located In (1 is the shoulder lane)</b>			
	<b>1</b>	<b>2</b>	<b>3</b>	<b>4</b>
2-Lane Highway: 100'	138			
200'	200			
300'	263			
400'	325			
500'	388			
600'	450			
700'	513			
800'	575			
900'	638			
1000'	700			
4-Lane Highway: 100'	240	103		
200'	386	132		
300'	531	160		
400'	677	189		
500'	822	217		
600'	967	245		
700'	1113	274		
800'	1258	302		
900'	1404	331		
1000'	1549	359		
6-Lane Highway: 100'	281	177	93	
200'	515	259	112	
300'	750	341	130	
400'	984	423	149	
500'	1218	505	167	
600'	1453	587	185	
700'	1687	669	204	
800'	1922	751	222	
900'	2156	833	240	
1000'	2391	916	259	
8-Lane Highway: 100'	281	194	93	89
200'	582	342	179	102
300'	909	490	262	116
400'	1235	638	345	129
500'	1561	786	427	143
600'	1888	933	510	157
700'	2214	1081	593	170
800'	2540	1229	675	184
900'	2866	1377	758	197
1000'	3193	1525	840	211

<b>Table D.2. Influence Distance of Each Truck (Ft): 10-Ft VMS Offset From Travel Lanes</b>				
<b>Necessary Viewing Distance for VMS Message (Ft)</b>	<b>Lane that Truck is Located In (1 is the shoulder lane)</b>			
	<b>1</b>	<b>2</b>	<b>3</b>	<b>4</b>
2-Lane Highway: 100'	110			
200'	144			
300'	179			
400'	214			
500'	249			
600'	283			
700'	318			
800'	353			
900'	388			
1000'	422			
4-Lane Highway: 100'	190	96		
200'	286	117		
300'	381	138		
400'	477	158		
500'	572	179		
600'	668	200		
700'	764	221		
800'	859	242		
900'	955	263		
1000'	1050	283		
6-Lane Highway: 100'	214	159	90	
200'	382	223	105	
300'	549	288	120	
400'	717	352	135	
500'	884	416	149	
600'	105	480	164	
700'	1219	545	179	
800'	1387	609	194	
900'	1555	673	209	
1000'	1722	738	224	
8-Lane Highway: 100'	214	167	90	87
200'	422	287	134	98
300'	667	407	193	110
400'	913	528	251	121
500'	1159	648	310	133
600'	1405	768	369	144
700'	1651	888	428	156
800'	1897	1009	487	168
900'	2142	1129	545	179
1000'	2388	1249	604	191

## D.4 EXAMPLE 2

A portable VMS is to be placed alongside a six-lane facility (three lanes per direction) to assist in the management of a downstream incident. The VMS is located 10 feet from the edge of the travel lane. Traffic volumes on the facility are approximately 4500 vehicles per hour, with 10 percent of these being large trucks (average length of 75 feet). Local data indicates that 80 percent of the truck traffic uses the right travel lane, with 10 percent of trucks using the center and median lanes. Travel speeds on the roadway are 60 mph. Can the VMS message designer use a message that contains four units of information?

### PROCESS:

1. Truck volume =  $0.10 \times 4500 = 450$  trucks/hour; auto volume =  $4500 - 450 = 4050$  autos/hour
2. Truck volumes per lane will be  $0.80 \times 450 = 360$  trucks/hour in the shoulder lane,  $0.10 \times 450 = 45$  trucks/hour in the center and median lanes.
3. Truck density:  $360/60 = 6$  trucks/mile in the shoulder lane,  $45/60 = 0.75$  trucks/mile in center and median lanes
4. Estimated VMS viewing distance =  $4 \text{ units} \times 2 \text{ sec/unit} \times 60 \text{ mph} \times 1.47 \text{ fps/mph} = 705$  feet
5. Estimate each truck's influence distance for a viewing distance of 705 (extrapolated in [Table D.1](#)) = 1220 feet for the shoulder lane, 545 feet in the center lane, and 179 feet in the median lane.
6. Compute total truck influence distance:
  - $1220 \text{ ft/truck} \times 6 \text{ trucks/mile} = 7320 \text{ ft/mile}$  for shoulder lane trucks
  - $545 \text{ ft/truck} \times 0.75 \text{ trucks/mile} = 410 \text{ feet/mile}$  for median lane trucks
  - $179 \text{ ft/truck} \times 0.75 \text{ trucks/mile} = 130 \text{ feet/mile}$  for shoulder lane trucks
  - 7,860 feet/mile obstructed viewing due to trucks
7. Compute lane distance where acceptable viewing occurs
  - $5280 \text{ ft/mile} \times 3 \text{ lanes} - 7,860 \text{ ft/mile} = 7980 \text{ ft/mile}$
  - ====> only 7980 lane feet per mile has viewing conditions that offer 705 feet of viewing distance to the VMS
8. Estimate available automobile viewing capacity =  $7980 \text{ ft per mile} \div 140 \text{ ft per automobile} = 57$  automobiles per mile. This equates to a viewing capacity volume of  $57 \times 60 = 3420$  autos/hour
9. Compare ratio of automobile demand to available viewing capacity =  $4050 \div 3420 = 1.2$ . Since this is greater than unity, the roadway section will not have sufficient space where adequate viewing of the VMS message can occur. Reductions in the number of units of information are required.

Based on these calculations, suppose that the analyst then adjusts the VMS message to 2 units of information. To check whether this is acceptable, the analyst returns to step 4 in the process and proceeds through the process again.

4. Estimated required VMS viewing distance =  $2 \times 2 \times 60 \times 1.47 = 355$  feet

5. Estimate each truck's influence distance for a viewing distance of 355 (extrapolated in Table D.2) = 635 feet for the shoulder lane, 320 feet in the center lane, and 125 feet in the median lane.
6. Compute total truck influence distance:  
635 ft/truck \* 6 trucks/mile = 3,810 ft/mile for shoulder lane trucks  
320 ft/truck\*0.75 trucks/mile = 240 feet/mile for median lane trucks  
125 ft/truck\*0.75 trucks/mile = 95 feet/mile for shoulder lane trucks  
4,145 feet/mile obstructed viewing due to trucks
7. Compute lane distance where acceptable viewing occurs  
5280 ft/mile\* 3 lanes – 4,145 ft/mile = 11,695 ft/mile
8. Estimate available automobile viewing capacity = 11,695 ft per mile ÷ 140 ft per automobile = 84 automobiles per mile. This equates to a viewing capacity volume of 84\*60=5,015 autos/hour
9. Compare ratio of automobile demand to available viewing capacity = 4050 ÷ 5015 = 0.80. Since this is less than unity, the roadway section will have sufficient space where adequate viewing of the VMS message can occur.

It should be noted that a demand to available viewing capacity ratio less than unity does not guarantee that all automobile drivers will see the VMS for the required viewing distance, only that there is potential space within the traffic stream as a whole where adequate viewing is possible. Some motorists may still choose to travel immediately behind, or adjacent to, the large trucks and have their view obstructed. Unless they adjust their position relative to the truck, they will still miss the VMS message. From an operational standpoint, however, the lower the demand to available viewing capacity ratio, the less likely that automobile drivers are likely to travel in obstructed viewing locations around large trucks, and the greater the likelihood of reaching the intended audience with the VMS message.