

# ENHANCEMENT, DEPLOYMENT, AND TESTING OF A TRAFFIC AND CONTROLLER DATA COLLECTION SYSTEM

Final Report

KLK711

N10-05



National Institute for Advanced Transportation  
Technology

University of Idaho

**NIATT**

Dr. Michael Dixon, Dr. Ahmed Abdel-Rahim, and Dr. Richard Wall

March 2010

## **DISCLAIMER**

The contents of this report reflect the views of the authors, who are responsible for the facts and the accuracy of the information presented herein. This document is disseminated under the sponsorship of the Department of Transportation, University Transportation Centers Program, in the interest of information exchange. The U.S. Government assumes no liability for the contents or use thereof.

1. Report No.	2. Government Accession No.	3. Recipient's Catalog No.	
4. Title and Subtitle Traffic and Controller Data Collection System Enhancement		5. Report Date March 2010	
		6. Performing Organization Code KLK711	
7. Author(s)  Dixon, Dr. Michael, Abdel-Rahim, Dr. Ahmed, Wall, Dr. Richard		8. Performing Organization Report No. N10-05	
9. Performing Organization Name and Address  National Institute for Advanced Transportation Technology University of Idaho PO Box 440901; 115 Engineering Physics Building Moscow, ID 83844-0901		10. Work Unit No. (TRAIS)	
		11. Contract or Grant No. DTRT07-G-0056	
12. Sponsoring Agency Name and Address  US Department of Transportation Research and Special Programs Administration 400 7th Street SW Washington, DC 20509-0001		13. Type of Report and Period Covered Final Report: August 2007 – July 2009	
		14. Sponsoring Agency Code USDOT/RSPA/DIR-1	
15. Supplementary Notes:			
16. Abstract:  The primary objective of this project was to enhance NIATT's ability to obtain high-quality traffic operations data at one or more signalized intersections. This project finalized an upgrade to NIATT's existing portable video data collection system. The first phase of the upgrade acquired and assimilated the primary data collection system components, such as cameras, portable power sources, video servers, and wireless video transmission. Specifically, this project acquired the means and knowledge for NIATT researchers to professionally store, transport, and install the equipment at the site. In addition, controller data logging capabilities were built to be integrated with the data collection system in the future. This final report constitutes a summary of the system components, instructions regarding their use for field data collection, field experience regarding their installation, and beta test results to demonstrate system feasibility.			
17. Security Classif. (of this report) Unclassified	18. Security Classif. (of this page) Unclassified	19. No. of Pages 33	20. Price ...

---

## Table of Contents

List of Figures .....	ii
List of Tables .....	ii
1. Introduction.....	1
2. Project Objective.....	1
3. Mobile Data Collection System .....	2
I. Data collection system accessories and field installation instructions .....	3
II. Wireless modems to incorporate additional data into the video view.....	3
Important notes for future use.....	5
III. Data collection beta-test and modification.....	5
IV. Pilot data collection study .....	7
Lessons learned from pilot test .....	7
V. Develop and validate an automated tool to obtain controller-based performance measures .....	10
Data logging device - overview .....	10
Using the data logging device to monitor intersection operations.....	15
VI. Microcontroller-based controller monitoring and adjustment .....	16
4. Conclusions and Recommendations .....	20
I. Mobile Data Collection System .....	20
II. Microcontroller-Based Controller Monitoring and Adjustment .....	22
III. Controller data logger.....	22
5. References.....	23
Appendix A: Instructions for Setting Up the MDCS.....	24
I. Introduction .....	24
II. Site selection .....	24
III. Equipment inventory and item descriptions.....	26
Appendix B: Instructions for setting up RackVision inputs .....	32
General trouble shooting.....	33

## List of Figures

Figure 1: Communicating contact closure information. ....	4
Figure 2: Data logging device in a hardware-in-the-loop model setting. ....	11
Figure 3: Data logging device connection to TS1 cabinet. ....	12
Figure 4: Connection to TS2 Type 1 cabinet. ....	12
Figure 5: Connection to TS2 Type 2 cabinet. ....	12
Figure 6: Sample of data logging device output files. ....	14
Figure 7: Examples of time-occupancy plots for different detectors. ....	16
Figure 8: Detector 1 occupancy and actuation comparison. ....	18
Figure 9: Phase status comparison. ....	18
Figure 10: Next phase comparison chart. ....	19

## List of Tables

Table 1: Item Inventory and Description .....	27
Table 2: RackVision Input Connector Pinouts .....	33

## 1. Introduction

Traffic engineering research requires high-resolution comprehensive data on highways and intersections detailing driver behavior, vehicle-vehicle interaction, and vehicle-control interaction. The purpose of this project was to acquire the ability to collect this data through constructing and field-testing a Mobile Data Collection System (MDCS). The MDCS, developed and tested in this project, uses a set of up to twelve video cameras, time stamp generators, and two video servers to collect and store traffic data that can be used for analysis. Cameras are connected to the time stamp generators and to the servers either through hardwired cables or through wireless communications. A portable power supply powers the entire system, where two generators power the hardwired cameras and batteries power the wireless cameras.

This report describes traffic data collection using the MDCS and testing different aspects of this system in the field. The report is organized into four sections. Section 2 describes the objectives of the project. Section 3 explains the MDCS and is organized into five subsections describing the new MDCS and a method for monitoring controller input/output throughout the data collection process. Section 4 makes concluding remarks and recommendations for future research.

## 2. Project Objective

The primary objective of this project was to enhance NIATT's ability to obtain high quality traffic operations data at signalized intersections. Meeting this objective helped satisfy the NIATT UTC goals 1 and 3. Specific instances of how this project helped meet this objective are listed below the corresponding goals and are as follows:

*Goal 1: Reduce congestion and improve safety by developing arterial traffic management tools that can be used by practitioners and researchers.*

This project addressed this goal by deploying and testing a new portable 12-camera video data collection system. This data collection system simultaneously collects traffic data over multiple intersections and in greater detail than previous data collection systems used at NIATT. Field data were extracted to create a database obtained from the videos taken during the deployment of the data collection system. This database supports developing and testing traffic signal control

strategies using realistic simulation environments. In addition, the database allows researchers to develop and test new performance measures to enable more effective evaluation and control of arterial traffic systems.

*Goal 3: Increase the number of faculty and students in our research and education programs to enhance the transportation workforce.*

The database created by using the MDCS will be used for transportation workforce enhancement efforts. One example is the Federal Highway Administration (FHWA) project: Transportation Education Development Pilot Program (TEDPP), headed by Professor Michael Kyte. The project uses video captured by the MDCS that documents traffic progression and congestion propagation through a corridor to introduce students to the concept of coordination.

Activities conducted as part of this project helped finalize and upgrade NIATT's mobile video-based data collection system. The first phase of the upgrade, conducted as part of an earlier project, acquired and assimilated the basic data collection system components such as cameras, portable power sources, video servers, and wireless video transmission.

This project has two objectives: 1) design, build, and acquire the means to store, transport, and install a mobile data collection system; and 2) modify the controller data logging device, created in previous projects, to enhance the data collection system by logging controller input and output data throughout the data collection time. The technical product of this project is a data collection system that is capable of collecting and archiving high-quality high-resolution data needed to further NIATT research objectives in three areas: arterial traffic flow theory, improved traffic control strategies, and improved performance measurement.

### **3. Mobile Data Collection System**

This section is subdivided into six sections. The first section identifies the accessories required to install the data collection equipment and field installation instructions. The second section contains instructions for displaying additional data into the video using a wireless modem. Section three describes a demonstration test designed to assess system functionality and modifications to the data collection system based on the assessment. Section four describes an implementation of the data collection system near Seattle at two adjacent intersections. Section

five discusses the concept of developing real-time traffic controller monitoring using a data logging device. Section six describes a less intrusive data logging alternative, based on a microprocessor that monitors the traffic signal system using National Transportation Communications for ITS Protocol (NTCIP) compliant communications.

### **I. Data collection system accessories and field installation instructions**

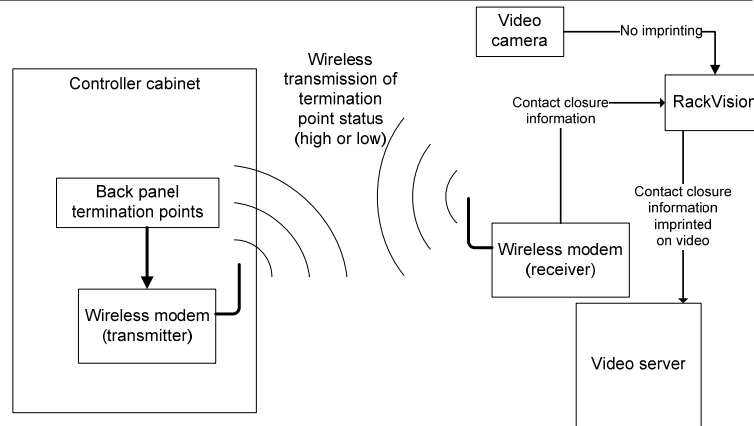
One of the primary characteristics of any portable field data collection is the ease and speed of setting up the equipment in the field. The set-up time must be minimal with no interruption to the intersection's traffic operation. It may not be feasible to install the entire system the same day as the data collection. Items like wireless cameras and accompanying infrastructure can be installed the previous day. The same is true for data collection infrastructure that must be installed in the controller cabinet. Detailed instructions and tips for setting up the MDCS are provided in Appendix A.

### **II. Wireless modems to incorporate additional data into the video view**

Traffic controller cabinets need to be closed and cannot interfere with the operation of the signal controller. As a result, cabinet data retrieval had to be designed so data transfer could be done without opening the cabinet and using available cabinet back panel terminals. This project used wireless modems suggested by Darcy Bullock of Purdue University as the data transmission means, because wireless modem products exist that readily transmit contact closure data to receivers external to the cabinet.

The transmitting modem is used to share information across the system. A transmitting modem is installed in the controller cabinet and a receiving modem is installed outside of the cabinet in the vicinity of the video recorder. As shown in Figure 1, the contact closure information is obtained by connecting to the appropriate termination points in the controller cabinet back panel and transmitting them out of the cabinet using a transmitter/receiver pair of wireless modems.





**Figure 1: Communicating contact closure information.**

Four additional modems were used to increase data collection capacity. These were purchased from Encom Wireless, based on colleague recommendations and the modem specifications satisfied the project requirements of radio signal strength needed to penetrate the controller cabinet walls. Each modem has a set of eight input and eight output channels and can be programmed to receive and transmit data in the form of contact closures (i.e. high or low voltage). In addition, they can be programmed to operate on different frequencies and to communicate only with specific modems. On-site frequency availability can be assessed by connecting a laptop to a modem and running the provided software utility.

Researchers anticipate modest data transmission distance requirements of no more than 0.5 miles. In locations without line-of-site obstructions, the Encom wireless modem communication can range as far as 20 miles (Encom, 2011). One limitation associated with the device is the frequency of updates over the wireless modem. The update frequency is not known and seems to vary depending on the intensity of bandwidth used by other devices sharing the same communication frequency. This update frequency constraint may only become an issue in situations where subsecond time stamp resolution is required. In addition, buildings and dense foliage may impede communications, reducing the available bandwidth or all together blocking communications.

Prior access to the controller cabinet plans is important to determine the best means to connect to terminals that will report phase and detector status. This is vital because, in some cases, the required connections may not be readily apparent to the assisting technician. This could cause

delays in the data collection or even inaccurate wiring, resulting in recording the status for incorrect phases and detectors.

Autoscope RackVision video processor boards are used to process and distribute the video signal to the rest of the system and to the wireless modems. Details of setting up the RackVision inputs, troubleshooting tips, and pinouts are provided in Appendix B.

### ***Important notes for future use***

While the wireless modems readily transmit controller state data, the utility of the wireless modems will dramatically improve if the users take the following steps:

- Acquire **connection knowledge** for different cabinet configurations. Ask the technician working with you for information describing how to connect to 24VDC connections for phase status and detector status.
- Assess the site conditions for the **best available frequency** to transmit the data.
- Understand the **bandwidth capacity**.
- Determine how **bandwidth changes** with on-site noise and transmission distance.
- Determine how much **bandwidth is used** for a given channel for a given rate of change in status.
- Create a **robust connection** between the modem and the cabinet.
- Prior to data collection, **test successful transmission** of all data. For phase status, this should be feasible, but detector status will be more problematic because it changes randomly and frequently.

### **III. Data collection beta-test and modification**

The data collection system was beta-tested in two instances. During beta testing the wireless modems were not used, because of limited access to controller cabinets. All other components were tested to show the technology worked properly. During the tests, the project team found the following challenges/constraints and ways to address them:

**Connection voltage differences:** The data collection system components function on a variety of voltages. Clearly mark and observe all connection voltages. Digital multi meters were

purchased and used to verify connection voltages for compatibility with data acquisition equipment.

**Communications are pole specific:** If the transmitter is operating on the horizontal pole, the receiver needs to as well: The antenna orientation is determined by the antenna in the transmitter box and cannot be changed. Prior to installing the transmitter, record the transmitter pole (antenna orientation) and adjust the receiver antenna to receive communications in the same pole orientation.

**I/O box responsiveness and damage:** A keyboard with a joystick controls the pan, tilt, and zoom for each of the cameras (see Table 2 in Appendix A). An I/O box acts as an interface and converts the data signals between the keyboard and cameras. This I/O data box is sensitive to handling. To avoid handling too much, install it on the cabinet door and/or handle with care. Specific care should be taken when plugging into the Novus Micro battery cabinet for power at a wireless camera site. This is because reversing the connections or connecting to inconsistent voltages greater than 12 VDC will damage the I/O box.

**Limited circumference for Astro Brac mounting cables:** Cameras installed in remote locations, with no immediate access to power, require additional portable power. This was accomplished using a Novus Micro, a portable uninterrupted power supply designed to be used in outdoor environments. It is much more convenient to install the Novus Micro near the ground, attached to the pole with an Astro Brac. Unfortunately, this is where a power or luminaire pole circumference is largest and may exceed the Astro Brac cable length needed. Fortunately, the cable was intended to be wrapped twice around the pole, but can accommodate the weight of the Novus Micro with just one wrap.

**Camera mounting challenges:** When installing four cameras and two receiver antennas on the top of the telescoping mast, the space is very crowded. There is space to setup as needed, but there is often insufficient time to package a solution while in the field. Pre-installation should involve arranging the equipment to suit the site specific characteristics for data collection. Once an appropriate arrangement is found for a specific site, store the corresponding parts together and, if possible, still assembled. In addition, note the cameras used to verify the arrangement such that those same cameras will be selected for the same site. To increase flexibility, additional

camera mounting bars should be arranged as well as the actual camera mounts, and mounting screws.

**Practice equipment set-up:** Because of the detailed nature of this work, users of the MDCS should be intensely involved in practicing setting up this equipment. Practice should include not only setup, but also testing to the point of turning on and verifying the equipment to ensure that all elements of the system are functional and that everyone involved understands how system components function together for the purpose of debugging.

#### **IV. Pilot data collection study**

For the pilot data collection, the project team selected a site near Seattle, WA, the interchange of 164<sup>th</sup> Street SW and I-5. Greg Wagner of WSDOT and Jim Bloodgood of Snohomish County DOT cooperated with this effort. For the first field study, two intersections on the west side of the interchange were recorded with the MDCS. Snohomish County cameras were used for a broader view of the arterial. The reduced scope met project objectives as each component of the data collection system was tested as a functioning system for more than one intersection. Future field studies at this location would include recording five intersections; two on the west side, and three on the east side of the freeway.

#### ***Lessons learned from pilot test***

**Pre-trip camera preparation:** Before deploying the cameras, equipment should be tested prior to each field installation by doing the following:

1. Verify all camera and antenna connections prior to field installation to ensure that they have the proper voltages and are not sensitive to cable movements (i.e. no electrical shorts).
2. Ensure camera shield integrity for rainy conditions.
3. Verify all camera control connections work properly.

**Wireless video:** Wireless video is functional, but is very sensitive to line-of-sight conditions. In the case of this field test, consistent wireless communication was achieved over distances as far as one half mile. Foliage and advertising signs will be the most common obstructions if communicating close to a straight section of roadway. Based on the field test, it was found that it

is difficult to predict transmission quality until setting up the devices in the field. One step that could be taken to assess transmission quality prior to field installation is to acquire a Radio Signal Strength Measurement System (RSSMS). Researchers could survey prospective installation locations with the RSSMS much more quickly, significantly reducing the risk of broken radio communications.

**Snohomish County facilities:** Facilities in the Everett Traffic Management Center (TMC) are extensive. Building and maintaining a good relationship with various traffic management entities is an important part of gaining permission to gather real-world traffic data. Most traffic centers are willing to work with researchers if the data collected is also shared with them. Their extensive knowledge, inquisitive nature, and desire to collaborate was much appreciated.

**Time synchronization routine:** To synchronize the Snohomish County traffic videos with the MDCS videos, stop watches were used in the following sequence.

1. Stop watches started at the TMC at the start of a new minute on their TMC clock.
2. Snohomish county TMC clock time recorded.
3. Stop watch positioned in the field of view of each U of I camera before and/or after traffic data recording.

**Night time/early morning camera visibility:** The camera view quality is very sensitive to lighting conditions. If street lights are not present and it is night time then the quality will be poor, especially when facing the oncoming traffic headlights.

**Setup time:** When installing two different camera sites (wired), installation required about two hours utilizing four people. However, this could be shortened by approximately one half hour if the equipment were preinstalled in the cabinets at a previous time (except the video servers).

**Server boot problem:** After installation, the team encountered a problem booting one of the servers. The server would not accept input from the keyboard to enter the access password. Fortunately, after powering up repeatedly, the server accepted keyboard input. The server operating system and software were updated and the server boot problem has not recurred.

---

**Server time to record and data storage:** The video servers automatically write over previous video, once the hard drive is full. To avoid recording over previous videos, the record times must be set such that when the servers are on in preparation to burn DVDs, they will not concurrently record.

**Video file transfer:** Before data analysis can be performed, the video must be downloaded to a computer. This is done by burning DVD's from the video server. The time needed to transfer video files to DVDs was significant. Transferring footage for four cameras on one server and three cameras on the other server for two different two hour time periods equated to 14 different DVDs. To burn one DVD for one camera required approximately 45 minutes. Transferring all the video files from the pilot study took over 10 hours. A means for transferring the files over a high-speed network connection would make this process much more efficient. There may be a current server function that allows this and Pelco representatives will be consulted for additional information on this subject.

Data were extracted from the video to support research on three topics.

1. Queue spillback detection and response strategies.
2. Acquiring phase green time utilization as a performance measure and for traffic control diagnostics.
3. Field test of traffic state detection, a methodology developed in an earlier thesis for which congested field traffic conditions were not available to test the methodology.

The MDACS traffic data provided videos from which vehicle events could be extracted. These events were processed to determine information such as vehicle turning movement volumes, detector status, queue length, queue spillback times, and phase status. With this information, researchers developed simulation models, extracted performance measures, and performed validation tests.

---

## V. Develop and validate an automated tool to obtain controller-based performance measures

One key issue with traffic operations research is access to high quality information to make traffic control decisions. One tactic taken to address this was to add system detectors to the traffic signal system for the sole purpose of collecting data. Because these detectors were not intended for control functions, they could be placed in locations better suited for data collection. However, this problem is costly as it requires additional detection. Another alternative is to better utilize information available from existing detectors.

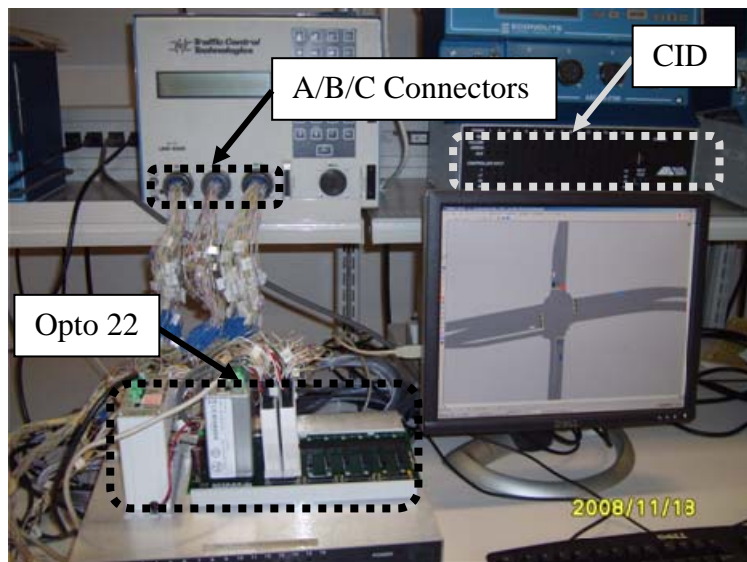
This section describes how existing detector information was captured with a real-time interface between a data logger and traffic controller. The data logger monitors the data exchanged through the A, B, C, and D connectors and transmits it via Ethernet to a central computer, where the data are stored in a database. This section also describes the data logging device system implementation.

### ***Data logging device - overview***

In an integrated traffic signal system, real-time monitoring can be accomplished through the central or closed-loop software that communicates with the traffic signal controllers. There are a few significant issues with this approach. The only data available is data that are explicitly collected by the vendor of the closed-loop or central system. Only average values for detector states and signal states are usually collected. This is a huge limitation when one wants to evaluate second by second performance of either control logic or detection technology. In addition, just because data are retrieved by the closed-loop or central system does not imply they will be easily accessible. This may require complicated direct database access.

An alternative option to achieve this real-time monitoring is to use instrumentation at each cabinet that is connected to controller inputs and outputs. This approach has several potential advantages. The data items that can be monitored are not limited by what data items are collected or the frequency they are collected by the vendor of the closed-loop or central system software. Intelligent data acquisition devices can be embedded in the signal cabinet that execute data tabulation logic and are remotely accessible via IP based communication.

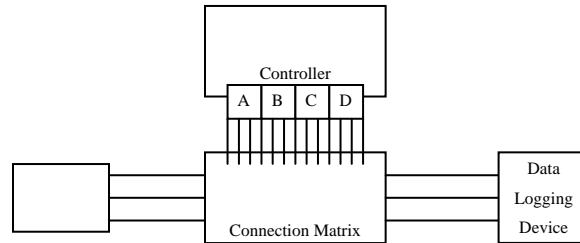
Figure 2 shows the proposed data logging instrumentation in a hardware-in-the-loop simulation setting. This data logging device instrumentation is based upon the Opto 22 family of Ultimate I/O Brains and SNAP IDC 5 modules (Bullock, 2003). The modules are connected to the traffic controllers through the A/B/C connectors. The controllers are also connected to a computer that runs a microscopic simulation model through a controller interface device.



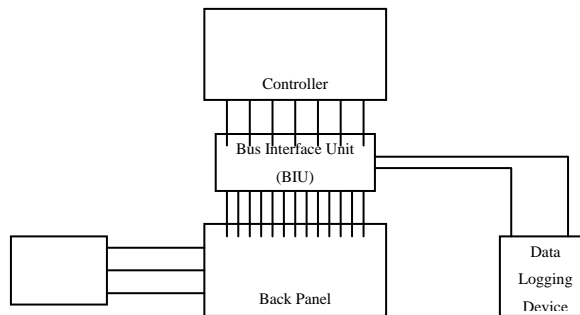
**Figure 2: Data logging device in a hardware-in-the-loop model setting.**

In a standard NEMA TS1 style cabinet, the wiring harness would be connected using the connection matrix on the back panel of the cabinet shown in Figure 3. In a NEMA TS2 Type1 style cabinet, the controller communicates with the cabinet using serial connection through the cabinet’s Bus Interface Unit (BIU). The communication link from the controller uses the RS-485 communication format in combination with the NEMA standard TS-2 command frames. The data logging device connection to a TS2 Type1 cabinet is done through serial cables from the controller to the data logging device. The TS2 Type 1 mode of connection is represented in Figure 4.



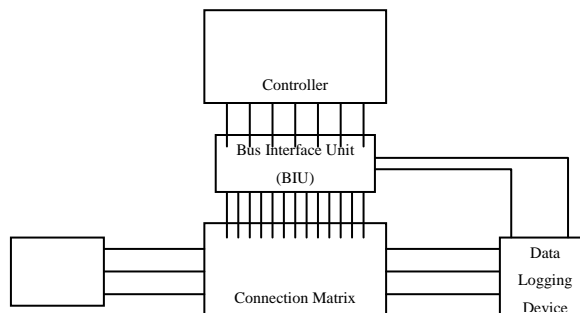


**Figure 3: Data logging device connection to TS1 cabinet.**



**Figure 4: Connection to TS2 Type 1 cabinet.**

As can be seen from Figure 5, there are two options to connect the data logging device in a NEMA TS2 Type 2 style cabinet. The first is to connect the device to the connection matrix on the back panel as that of the NEMA TS1 cabinet. The second is through a serial connection with the controller.



**Figure 5: Connection to TS2 Type 2 cabinet.**

The data logging device function is to record the communication exchanged between the detector and the controller and between the controller and signal heads. It will also record any other special calls such as preemption. In essence, the device monitors activities in all input and output communication channels to and from the controllers. Each time step, it scans the status of all input/output channels and records the state of each channel (on or off). The data is then stored in a log file which can be accessed through the Ethernet port. The data recorder is capable of recording time steps as small as 10 ms. However, as most cabinets update communication channel status every 100 ms, an equivalent time resolution time would be appropriate for traffic signal system monitoring applications.

Data recorded by the data logging device includes: date, time, and the status of each communication channel on the time step. Figure 6 shows a sample of the data logging device files for status of detector and signal timing. A value of “-1” represents the case when the communication channel is “On” and a value of “0” represents the case when the communication channel is “Off”.

	A	B	C	D	E	F	G
1	Date	Time	Ph1_Veh_Call	Ph2_Veh_Call	Ph3_Veh_Call	Ph4_Veh_Call	Ph5_Veh_Call
2	3/13/2008	16:02:04	0	-1	0	0	0
3	3/13/2008	16:02:04	0	-1	0	0	0
4	3/13/2008	16:02:05	0	-1	0	0	0
5	3/13/2008	16:02:05	0	-1	0	0	0
6	3/13/2008	16:02:05	0	-1	0	0	0
7	3/13/2008	16:02:05	0	-1	0	0	0
8	3/13/2008	16:02:05	0	-1	0	0	0
9	3/13/2008	16:02:05	0	-1	0	0	0
10	3/13/2008	16:02:05	0	-1	0	0	0
11	3/13/2008	16:02:05	0	-1	0	0	0
12	3/13/2008	16:02:05	0	-1	0	0	0
13	3/13/2008	16:02:05	0	-1	-1	0	0
14	3/13/2008	16:02:06	0	-1	-1	0	0
15	3/13/2008	16:02:06	0	-1	-1	0	0

a) Detector sample

	A	B	C	D	E	F	G	H
1	Date	Time	Ph1_Green.	Ph1_Red.	Ph1_Yellow.	Ph2_Green.	Ph2_Red.	Ph2_Yellow.
2	3/13/2008	16:02:04	-1	0	-1	-1	0	-1
3	3/13/2008	16:02:04	-1	0	-1	-1	0	-1
4	3/13/2008	16:02:05	-1	0	-1	-1	0	-1
5	3/13/2008	16:02:05	-1	0	-1	-1	0	-1
6	3/13/2008	16:02:05	-1	0	-1	-1	0	-1
7	3/13/2008	16:02:05	-1	0	-1	-1	0	-1
8	3/13/2008	16:02:05	-1	0	-1	-1	0	-1
9	3/13/2008	16:02:05	-1	0	-1	-1	0	-1
10	3/13/2008	16:02:05	-1	0	-1	-1	0	-1
11	3/13/2008	16:02:05	-1	0	-1	-1	0	-1
12	3/13/2008	16:02:05	-1	0	-1	-1	0	-1
13	3/13/2008	16:02:05	-1	0	-1	-1	0	-1
14	3/13/2008	16:02:06	-1	0	-1	-1	0	-1
15	3/13/2008	16:02:06	-1	0	-1	-1	0	-1

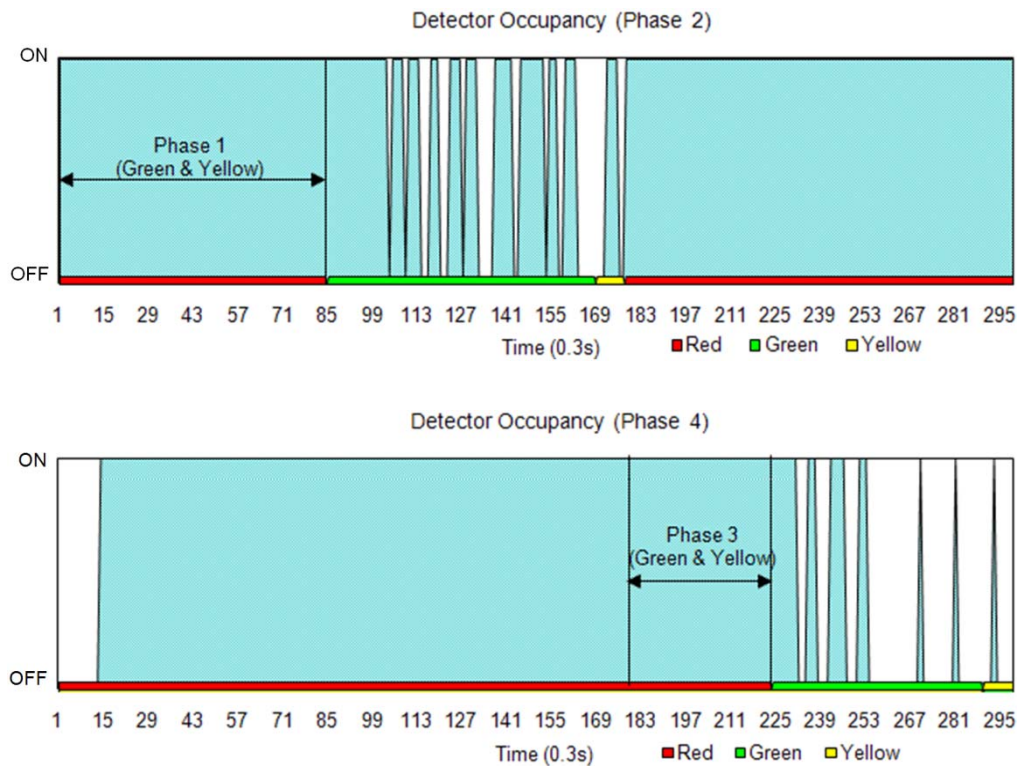
b) Signal state and timing sample

**Figure 6: Sample of data logging device output files.**

Figure 6(a) shows the status of different vehicle detectors using a 100 ms resolution. Detector occupancy and vehicle count can be directly calculated from these raw detector data principally based on the discontinuity distribution of occupancy time followed by unoccupancy time. Figure 6(b) shows the signal indication status for different phases. Average cycle length and the duration of green, red, and yellow intervals can be directly calculated from the raw signal state and timing data.

### ***Using the data logging device to monitor intersection operations***

Figure 7 shows an example of continuous time-occupancy plots for two stop bar detectors for phases 2 and 4 of a signalized intersection. On-status is represented by the plot being high and the opposite is true for off-status. Signal indications are shown along the x-axis. The detector status is updated at 100 ms intervals, a typical rate for a standard cabinet to update the I/O channel status information. The detector and phase status data provide disaggregate and aggregate information. Disaggregate analysis yields the likelihood that phase 2 may not have cleared the queue, whereas the opposite is clearly the case for phase 4. This can be seen by noting the frequency with which the detector status is on during green. Aggregate information, such as average detector occupancy and unoccupancy time, green time utilization, and reliable vehicle counts are also available from this logged data. Information of this sort can be directly applied to evaluate and improve signal timing plans.



**Figure 7: Examples of time-occupancy plots for different detectors.**

## VI. Microcontroller-based controller monitoring and adjustment

Advances in processing power are making it possible to use microcontrollers for monitoring and adjusting signal controller operations. If the traffic controller had an Ethernet port and was NTCIP compliant, then a microcontroller would be an effective means of incorporating custom performance measurement methods and traffic control strategies. Communications using the NTCIP protocol were programmed into a Rabbit microcontroller. With this communication protocol, the following functions were programmed on the microcontroller and tested in a hardware-in-the-loop simulation (HILS) environment:

- Monitor controller state
  - a. phase status
  - b. detector status
  - c. detector occupancy

- 
- Review controller settings
    - a. max green
    - b. min green
    - c. extension time
    - d. phase plan (protected left option)
  - Revise controller settings
    - a. max green
    - b. min green
    - c. extension time
    - d. phase plan (protected left option)

The purpose of these tests was to determine the microcontroller’s capability to do the following:

- Record controller data,
- Process controller data to compute performance measures such as green time utilization, detector occupancy, and presence of queue spillback, and
- Determine a necessary control response and communicate the required adjustment back to the controller.

Testing results showed that there were some sub-second variations between the controller’s actions and microcontroller recordings, caused by the ¼ second communications frequency. These were evident when comparing VISSIM’s detector status to the same data recorded by the microcontroller. Figure 8 compares detector occupancy data recorded by the microcontroller and data recorded by VISSIM, where the VISSIM data is the ground truth. This figure only illustrates stop bar detector occupancy data, but these data are representative of results recorded at other detectors. The microcontroller occupancy and simulation occupancy are very similar, with only a few minor variations. The variations occurred when communication of the detector status lagged and this can be seen by noting the “difference in actuation” line, which represents the difference between the microcontroller and VISSIM recorded actuations (differences give non-zero values). These differences tended to occur when queue conditions were dynamic on the detector, because a single ¼ second lag in communication is more likely to result in a missed actuation.

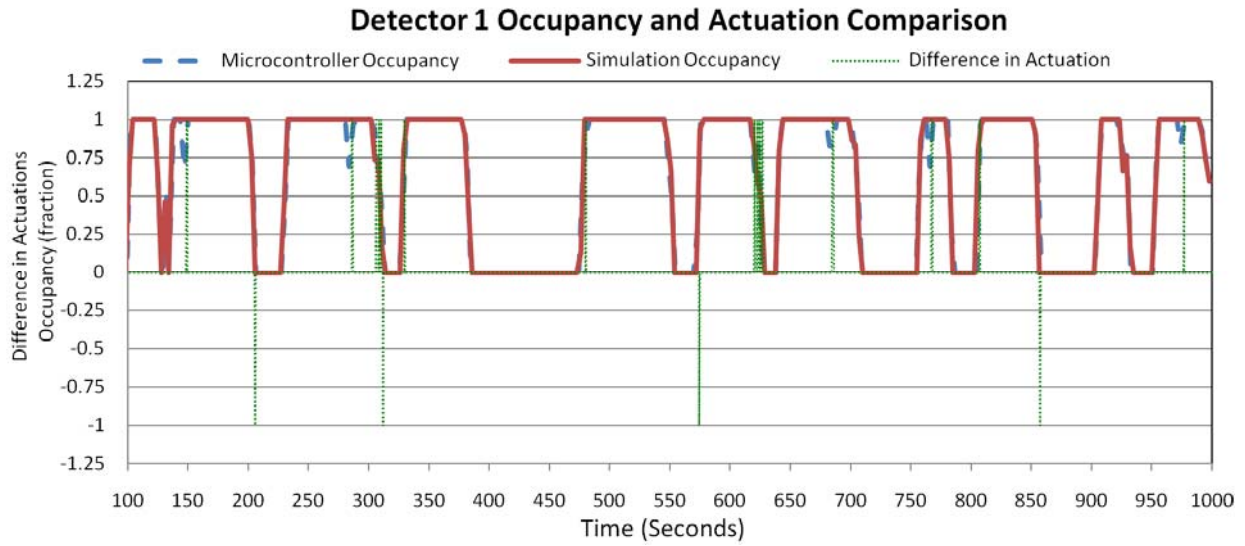


Figure 8: Detector 1 occupancy and actuation comparison.

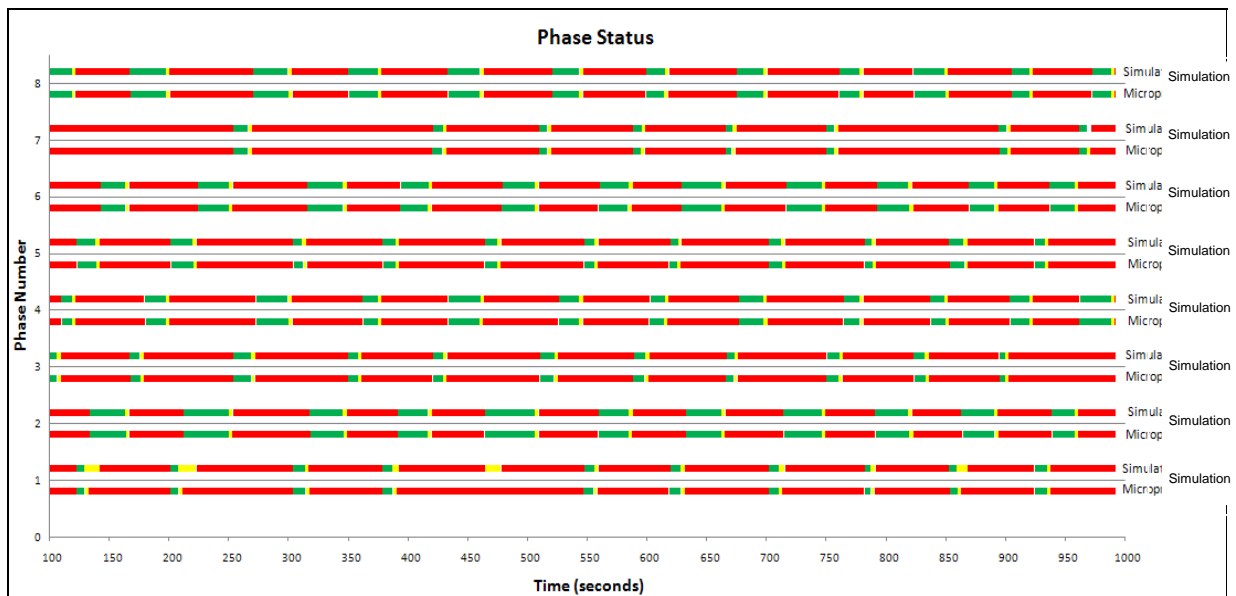
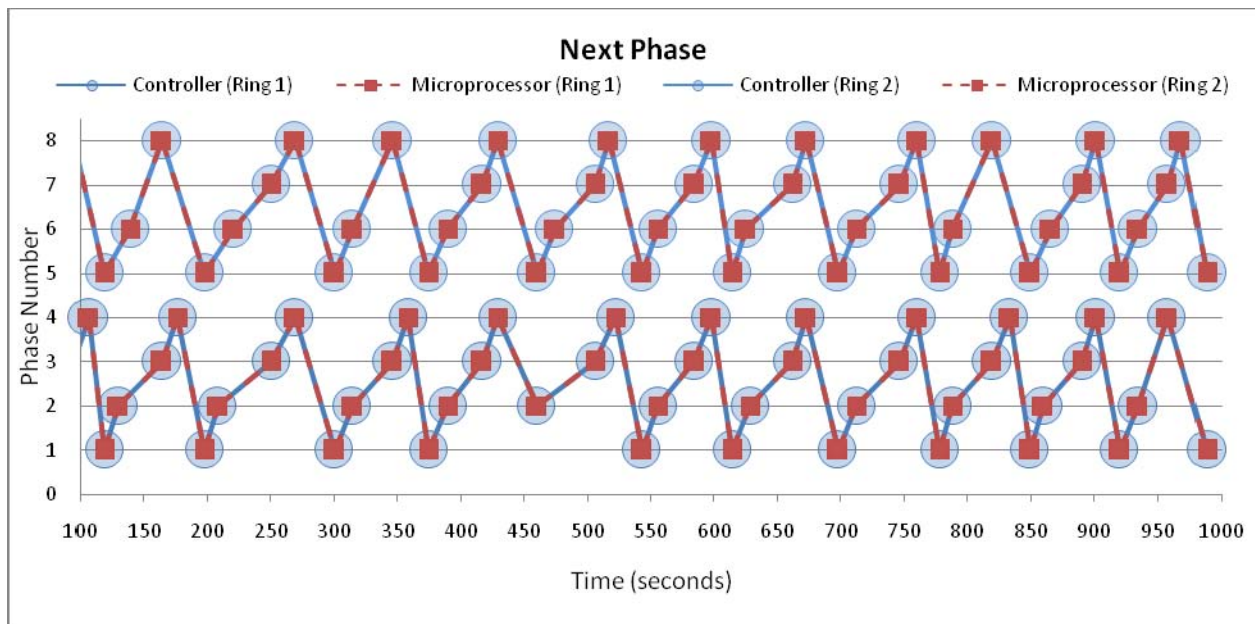


Figure 9: Phase status comparison.

Another test compared the controller status recorded by the microcontroller to the same recording in VISSIM output. For both the microcontroller and VISSIM recordings, Figure 9 shows the phase status for all eight phases. The two recordings were very similar, with some variations in the yellow and red indications for phase 1.

Another test was conducted to assess the microcontroller’s ability to determine when to terminate a phase and which phase will be next. For this test, a similar approach to that taken for phase status was taken for monitoring the next phase status in the controller and the results are summarized in Figure 10. The comparison is exact, suggesting that the slight variations between vehicle actuations do not inhibit the microcontroller’s ability to correctly implement split second phase termination decisions, such as phase gap out.



**Figure 10: Next phase comparison chart.**

Based on the test results, microcontroller processing and communications with the controller appear to be more than adequate to support additional developments in traffic control algorithms and strategies. This finding is significant, because researchers, engineers, and controller manufacturers can develop and test control algorithms and strategies in HILS, subject to the controller I/O capabilities and NTCIP objects. All that is required is a NTCIP compliant controller with an Ethernet port.

More information about HIL/microcontroller infrastructure and testing can be found in a paper written by S.K. Monsur, Michael Dixon, and Ahmed Abdel-Rahim and presented by the project team at the IEEE Intelligent Transportation Systems Conference (Monsur, 2009).



---

## 4. Conclusions and Recommendations

This project involved work in three areas. One was in deploying the mobile data collection system. Another was in microcontroller-based controller monitoring and adjustment. The third was in finalizing the controller data logging device to collect detailed controller data. This section discusses the conclusions and recommendations for each of these areas.

### I. Mobile Data Collection System

The research team prepared data collection equipment and methods for implementing in the field. Each of the items used for mobile data collection are high quality and capable of collecting high resolution video data. The MDCS is also complicated, and because of its sophistication it is important to learn how to use the system and to use it regularly - at least two or three times a year. This will maintain and improve researchers' ability to use the system, as well as regularly augment the high fidelity traffic database at NIATT for the transportation research community to use.

As would be expected, the system requires consistent maintenance and upkeep. Typical maintenance items include wire connection checks, battery recharging, server drive cleaning and firmware upgrades, and equipment organization/storage. Items likely to be damaged in normal use are wire connections and the camera control I/O box. Developing and using a procedures manual, and keeping a maintenance log should mitigate most common problems.

Results from the field deployment were such that the following recommendations should be considered:

1. A strong familiarization with wireless communications using the wireless modems and cameras is needed, especially with the wireless modems. Future development should include a focused effort in establishing how to determine available bandwidths and equating this to capacity to communicate contact closure status.
2. Wire connections must be checked and, if necessary, modified to ensure that all connections will function properly in the field with minimal risk of power overload and short circuits.

The majority of the project efforts were dedicated to preparing the mobile data collection system for field implementation. Information collected with the MDCS have many applications in research. Recommendations for future mobile data collection system applications are listed below.

1. Expand the NGSIM database of congested conditions to enable research in the following areas:
  - a. Heavy vehicle car-following
  - b. Queue discharge upstream of queue spillback
  - c. Application of IQA
  - d. Analysis of protected/permitted Highway Capacity Manual methodologies
  - e. Field test traffic signal performance measurement methods
2. Expand the NGSIM database to include improved phase status data synchronization with traffic data to facilitate research in driver response to yellow indication.

Recording the video data and data extraction are important parts of the data collection process. Given high quality traffic videos of sufficient scope, data extraction quality largely determines the applicability of the traffic data to any research question. Data extraction quality is a function of cost and capability. Extracting data manually is costly and subject to human error. Two recommendations to alleviate the cost and human error are listed below.

1. Expand the Traffic Tracker software in the following ways:
  - a. Index vehicle events (keyboard trigger actuations) to video frames of the traffic video currently being played in order to acquire a time stamp (in terms of frames).
  - b. Provide options to pause, rewind, fast forward, fast rewind, step forward, and step backward.
  - c. Provide the option to read the time stamp generator output displayed in the video to acquire a time stamp.
2. Adapt and modify the NGSIM software in the following ways:
  - a. Allow camera installations closer to the roadway.
  - b. Allow camera installations at multiple locations.

- 
3. Develop a method to integrate controller data logger records with the corresponding traffic video after the data collection is complete, circumventing the need for using Autoscope RackVision hardware.

## **II. Microcontroller-Based Controller Monitoring and Adjustment**

A microcontroller will be a very useful tool for monitoring traffic controller operations and its utility will increase as manufacturers release more objects describing the controller state and settings. One limiting aspect of this approach to controller monitoring is similar to that of the controller data logger and that is the update frequency via the Ethernet port, which is limited to around 0.25 seconds. Despite this slow update frequency, microcontroller data records compared very favorably to the benchmark data sets for detector status, detector occupancy, phase status, and phase sequence.

Future traffic control research should employ the microcontroller in the following ways:

1. Develop a standard for a multiple-microcontroller network to facilitate traffic control research in a system of traffic controllers.
2. Develop a virtual microcontroller to function in a software-in-the-loop simulation (SILS) environment.
3. Develop tutorials for graduate students, providing focused instruction on how to apply the Rabbit microcontroller in a HILS environment.

## **III. Controller data logger**

Controller data logging was not implemented in the field during this research project. Instead, wireless modems were used to acquire the data. Inadequate familiarity with the agency facilitating the data collection effort limited our ability to request switching their A, B, and C connectors for data logger versions. For controller data logging to take place, researchers need time to demonstrate the data logger functions, how it fits within the controller cabinet, and verify that it will not interfere with controller operations.

Two useful future additions to the current controller data logger are listed below:

- 
1. Record the controller data on a local hard drive in the cabinet, for situations where Ethernet is not available.
  2. Allow wireless download of the hard drive contents on demand.

## **5. References**

Monsur, S.K., Dixon, M.P., Abdel-Rahim, A., 2009. Integrating External Control Logic in Traffic Signal Operations: A prototype and Proof of Concept. IEEE Intelligent Transportation Systems Society Conference.

Bullock, D., “Real Time Traffic Signal Interface Panel” City of Moscow, Idaho Signal Integration Project”, Unpublished Project Memorandum, April 2003.

Encom Wireless. COMPAK I/O 8P Brochure. [http://www.encomwireless.com/document-centre/doc\\_download/135-commpak-io-8p](http://www.encomwireless.com/document-centre/doc_download/135-commpak-io-8p). Accessed July 2011.

## **Appendix A: Instructions for Setting Up the MDCS**

### **I. Introduction**

Installing the equipment used to collect data involves a planning process, agency cooperation, and field installation. These three efforts vary in complexity depending on the extent of the data being collected. This section emphasizes the installation effort. First, the site selection section describes the issues to consider when deciding where to locate the data collection equipment. Next, the equipment inventory section briefly lists the quantity and description of the data collection system components. Finally, directions for installing each item in the data collection system are either given in this document or the reader is referred to another document to allow more detailed explanation.

### **II. Site selection**

The issues associated with selecting the best site to locate the data collection equipment depend on the factors listed below and each of these is discussed in greater detail below.

- field of view of important traffic events
- utility lines
- terrain and vegetation
- controller cabinet access
- line-of-sight for wireless devices
- pole access
- parking
- security

**Field of view:** The field of view must be such that the cameras located at the site can be oriented to record important field events, such as queue discharge at the stop bar, signal indications, and queue length. Several factors affect field of view quality. One is the ability to setback the equipment from the intersection to broaden the camera perspectives. It is usually best to locate the cameras on the corner opposite to the approach they record. This is especially the case when stop bar traffic events and queue length are of interest. However, if video detection will be

employed to process the videos then it is best to be closest to the intersection, minimizing vehicle occlusion errors.

**Utility lines:** These are a hazard to avoid when placing telescoping masts.

**Terrain and vegetation:** One factor affecting equipment placement is the severe slopes and dense vegetation. Severe slopes create situations where the telescoping mast either cannot be leveled or it cannot be secured to the ground sufficiently to avoid sliding. Dense vegetation will interfere with equipment set up and tall tree/bushes will obstruct field of view.

**Controller cabinet access:** If electronic access to the controller cabinet is necessary, then it is simplest to place the equipment next to the controller and use hardwired connections to transmit the data to a recording device inside the cabinet. In some cases, it may be possible to extend the wire outside the cabinet through an existing conduit. In the event that this is not possible, then wireless transmission must be used. In either case, it is best to locate the data collection equipment close to the cabinet to maximize cabinet access possibilities. If only wireless access is permitted then being close to the cabinet will increase the signal strength.

**Line of sight for wireless devices:** Wireless transmission requires line-of-sight between the transmitting and receiving devices. Vegetation, buildings, roadside signing, and roadside utilities will interfere with wireless communications. Some devices have radio signal strength indicators (RSSI) to assess the quality of the current radio device locations. If the RSSI indicates weak communications then shifting the device location on the horizontal or vertical plain to a less obstructed line-of-sight may improve the signal strength.

**Pole access:** When installing a wireless camera, it is simplest to mount the camera and auxiliary equipment on existing infrastructure (e.g., signal mast, luminary pole, utility pole, etc.). In many cases, poles are not located at the ideal camera location. So, deciding on the final installation location frequently involves sacrificing the camera field of view quality and/or signal strength.

**Parking:** The data collection equipment is sizable. So, being able to unload the equipment within 50 to 100 ft of the site is important.

**Security:** Much of the data collection system rests on the ground. To minimize the risk of theft, most of the electrical equipment can be stored in the electrical cabinets. Even so, someone must remain at the site at all times to monitor the equipment, answer public questions, and discourage public interference. However, depending on the surrounding area, individuals will be exposed to some personal risk while monitoring the equipment. To minimize security problems, it is best to locate the equipment in areas in full view of a public area, but that does not call for direct attention from the driving public.

### **III. Equipment inventory and item descriptions**

The major components of the data collection system that require installation with each implementation of this system are described in the following table. For each item, the name, quantity, and a brief description of the item are given. In general, the description includes a picture that illustrates the item and explains the item's role in the data collection system.

**Table 1: Item Inventory and Description**

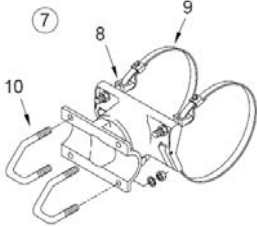











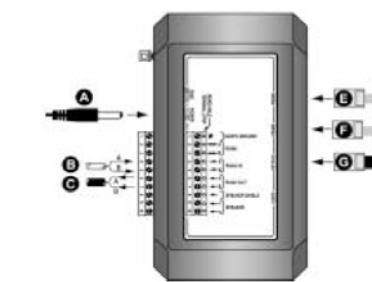
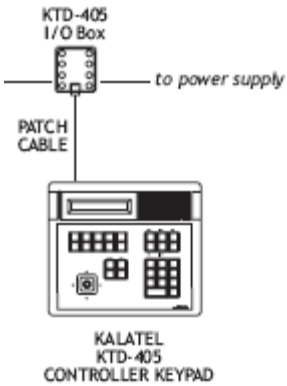

Item Name	Quantity	Description of item its use
Astro Brac	4	<p>The band mount option is shown here, but only the cable mount is in the inventory. This bracket is made of aluminum and is used to fasten the Novus Micro to a pole. The U-bolt (see item 10 in the figure) fastens the device or a pipe by inserting it into the U-bolt and tightening the corresponding nuts at the ends of the U-bolts. This device is used to mount the Novus Micro portable power system to poles by inserting the pipe extending from the back of the Novus Micro into the U-bolts mentioned previously.</p> 
Mini Brac	8	<p>As shown in the picture, this device mounts to a pole by wrapping a cable around the pole and fastening it there. A pipe is then fixed to the Mini Brac by inserting its threaded end into the threaded hole. Cameras, antennas, and other devices are fastened to the pipe.</p> 
Pelco DVR 5100 Video Server (includes keyboard and mouse)	2	<p>This is a digital video server that temporarily stores video footage for up to 16 cameras, simultaneously. Users can access the server from the front panel or through the Ethernet. For reviewing videos, web access provides greater functionality. Install this on the top pullout shelf of the outdoor enclosure. All camera footage is recorded in one of these video servers. For wireless cameras, the remote camera receivers are connected to the server instead of the cameras themselves. Once the data collection period has ended, modify the video recording times to eliminate any additional recording if the server were to remain on.</p> 
AG 1725: Premier wireless receiver	4	<p>This runs off of 12 VDC power and requires a 120 VAC to 12 VDC power converter at the head end site. The user manual is available as a pdf file. Two important aspects for installing this device are 1) the antenna alignment must be consistent with the alignment of the transmitter and 2) both the receiver and transmitter need to be at least 10 ft above the ground. Both of these issues are discussed in detail in the manual.</p>  
AG 1725: Wireless transmitter	4	<p>This transmits the remote camera video stream wirelessly to the head end site. Use the VR1T to power this unit, because it requires 12 VDC power.</p> 
Multimeter	2	<p>Use this device to check power connection quality when equipment failures occur. The most frequent cause of unintended equipment power down is a poor power connection.</p>



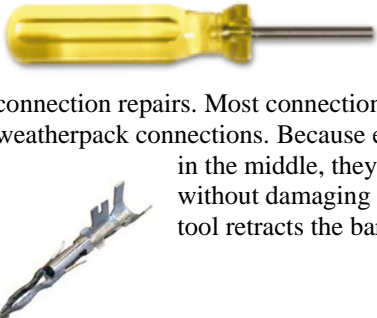




Table 1: Item Inventory and Description (continued)

Item Name	Quantity	Description of item its use	Item Name
Time stamp generator	12	<p>Front</p>  <p>TG50</p> <p>WG50</p>	<p>Back</p>  <p>TG50 and WG50</p>
Rackvision	7		
Wireless modem (comes with configuration software "ControlPAK" on CD)	6		
GE SECURIT KLC-15HS: Monitor	2		
Totevision LCD 565: Portable monitor	2		<p>This is used to view camera output at the remote installation sites. This performs best with battery power, because the custom made cables have connectors that establish unreliable connections. Brightness of the view is directly related to battery charge.</p>
I/O box	2		<p>Control connections are marked as RS422 out A and B ("C" cable in the diagram). See KTD-405 for additional details. The cable from the keypad is the "F" cable in the diagram.</p>





**Table 1: Item Inventory and Description (continued)**

Item Name	Quantity	Description of item its use
GE SECURIT KTD-405: Keyboard	2	 <p>This controls the dome cameras (pan, tilt, and zoom), where the I/O box acts as the interface between the keypad and the cameras. Note that this unit must be directly connected to cameras through the I/O box to control them. This means that remote cameras must be positioned while the installer is at the remote location. This unit uses 12 VDC power. So, at the remote location its power is converted through the VR1T. At the head end location, its power comes through the 120VAC to 12VDC device. CAT 8 cable connects the keypad with the I/O box.</p>
Pneumatic mast	2	
Cable for head end 24 VAC power/camera control	2	This cable connects power and control to four cameras mounted on the mast. The power source is the EU 2000i generator and the control source is the KTD-405 I/O box. Requires the VR1T to convert power to 12 VDC for the transmitter.
Power/control splitter box	2	This splits power and control from the head end cable to the each of the cameras on the mast.
BNC (40 ft)	12	RG59 20 SOL BC FPE 95% BC BRD SHD PVC JKT CM CCTV 75 OHM BLK
BNC (20 ft)	4	See above
BNC (10 ft)	6	See above
BNC (6 ft)	6	See above
Cable for transmitter 24 VAC power/camera control	4	This takes power and control to a wirelessly transmitted camera and transmitter. The power source is the Novus Micro battery back and the control source is the KTD-405 I/O box. Requires the VR1T to convert power to 12 VDC for the transmitter and the KTD-405 I/O box.

**Table 1: Item Inventory and Description (continued)**

Item Name	Quantity	Description of item its use
Tools -weatherpack terminal removal tool	1	 <p>This tool facilitates weatherpack connection repairs. Most connections for power and control occur using weatherpack connections. Because each terminal (shown below) is barbed in the middle, they cannot be extracted for repairs without damaging the connection. Inserting the removal tool retracts the barbs in order to extract the terminal.</p>
Tools -weather pack crimping tool	1	 <p>This tool crimps the terminal flanges around the cable wires for a tight reliable connection.</p>
Novus Micro 300-24 portable power supply	4	 <p>This is the portable power supply used to power cameras, transmitters, and other devices at remote installations that do not afford direct access to power. This device is mounted using the Astro Brac, describe previously. A pipe is mounted on the back of each Novus Micro so that it extends beyond the top of the enclosure. Mount the Novus micro by inserting this pipe into the U-bolts of the Astro Brac.</p> <p>This device charges with a 120 VAC input and outputs 24 VAC. Detailed operating instructions are contained in a hardcopy document. Alpha (the manufacturer) updated the on-line version to reflect its recent change in the Novus Micro control module (contained in the upper half of the enclosure), but the electronic document's consistency with the Novus Micro 300-24 version used in the data collection system was not verified. As a result, it is recommended that the hardcopy version be used.</p>
GE SECURIT KTA-C3-H1C: Kalatel Cyberdome Video Camera	12	 <p>These cameras come as a kit and assume they will be mounted on a wall. A separate pole mount plate does come with them, allowing other media for mounting them. U-bolts were provided to mount the cameras to a pipe. Aluminum blocks were milled to insert into the pole mount and attach them to standard camera mounts.</p>
Manfrotto camera mounts	8	 <p>The aluminum blocks insterted into the pole mount fasten to the camera mount, shown here. Other mounts are included in this system and they operate similarly to this one.</p>

**Table 1: Item Inventory and Description (continued)**

Item Name	Quantity	Description of item its use
Hoffman outdoor enclosure	2	 <p>Install most of the electronic equipment inside these enclosures to protect them from the elements. Items that go inside are as follows: video server, Rackvisions, wireless modems, time stamp generators, two power converters (120 VAC to 24 VAC; 120 VAC to 12 VDC), and I/O box. Intall each enclosure on a stand to level the encolsure and provide space to insert cables through the three entry points at the base. The following cables should come through the base: bnc video cables (one for each camera), extension power chord from the power generator, video monitor power cable, CAT 5 cable from the control pad to the I/O box, power and control cable to cameras on the mast, and power cable to the wireless receivers.</p>
EU 2000i: Power generator	2	 <p>One full tank should last at least 8 hours at peak load. Even so, check the tank regularly and fill, as there is no fuel level indicator.</p>
KTP 24: Power converter 120 VAC to 24 VAC	6	 <p>This is the unit used to convert 120 VAC to 24 VAC. Cameras powered off of the generator use this for their power. This has sufficient capacity (100 watts) to power all six cameras at the head end site.</p>
Power converter 120 VAC to 12 VDC	2	<p>This is the unit used to convert 120 VAC to 12 VDC to power the wireless video receivers at the head end location. Only one is needed to power two receivers.</p>
VR1T: Power converter 24 VAC to 12 VDC	4	 <p>These units convert 24 VAC to 12 VDC, providing power from the Novus Micro for the transmitters and the KTD 405 I/O box at the remote camera locations. It would be best to have eight of these, two for each camera location. This would allow one for the KTD-405 I/O box and one for the transmitter at each location.</p>

## **Appendix B: Instructions for setting up RackVision inputs**

The following instructions explain the steps needed to set up the RackVision inputs to display on the screen when they are activated. Each input will display a text message on the screen when it is activated. These instructions will explain exactly the steps that you must follow in order to do so.

1. Open Autoscope Network Browser; you will be asked if you want to learn the network now. Select Yes.
2. Double click on the RackVision that is connected to the computer. This can be located by the yellow lightning symbol located to the left of the unit in question. (This will open the AutoScope Detector Editor)
3. Select View/Inputs-Outputs. You will be asked if your Rackvision will use an external I/O from a Detector Port Master. Select Yes.
4. On the Configure Inputs/Outputs screen, go to the lower right corner and from the pull down tab next to the Detector Port Master select Mini-Hub II.
5. Select the “Local TS1 In” tab.
6. Click and drag the desired inputs onto the Detector Editor Screen. A text box containing the input name should appear on the screen. Table 2 defines the pins in terms of inputs and outputs.
7. Double click the input name to change the settings for the input. In the settings you can change the background, on and off colors, text that is displayed on the screen, and size of the font. Modify the text to reflect the data the detector represents (e.g., 2GRN for phase 2 green).

Note: The Detector Style must remain Label. Also, selecting either the foreground or background to State will determine how the detector displays the input. For example, if the background is set to State the background will change colors as the input is activated while the foreground will remain the same.

- 
8. Once the detector settings and position are satisfactory, select File/Send To AutoScope to upload the created file to the RackVision. You will be prompted to save the created or altered file, saving is not required but recommended.

### **General trouble shooting**

- If the Network Browser does not recognize any AutoScopes make sure the RackVision is plugged in and connected to the PC with the 7-pin connector.
- If the inputs do not appear on the TV screen after having been uploaded, make sure that the “Visible” tab in the detector settings is toggled on.

**Table 2: RackVision Input Connector Pinouts**

Pin	Definition
1	Output 1
2	Output 2
3	Output 3
4	Output 4
5	Output 5
6	Output 6
7	Output 7
8	Output 8
9	Input 1
10	Input 2
11	Input 3
12	Input 4
14	LOGIC GND
15	+24 VDC