

2015

**STRIDE**

Southeastern Transportation Research,  
Innovation, Development and Education Center

# Final Report

## Workshop for Managed Lanes on Arterials



Yafeng Yin, Ph.D., University of Florida

Siriphong Lawphongpanich, Ph.D., University of Florida

October 2015



### **Disclaimer**

The contents of this report reflect the views of the authors, who are responsible for the facts and the accuracy of the information presented herein. This document is disseminated under the sponsorship of the Department of Transportation University Transportation Centers Program, in the interest of information exchange. The U.S. Government assumes no liability for the contents or use thereof.

### **Acknowledgment of Sponsorship**

This work was sponsored by a grant from the Southeastern Transportation Research, Innovation, Development and Education (STRIDE) Center, a U.S. DOT Region 4 grant-funded University Transportation Center.

## TABLE OF CONTENT

Table of Content .....	ii
List of Tables .....	iii
List of Figures .....	iv
Executive Summary .....	vii
1. Background.....	8
2. Objective.....	9
3. Workshop Description.....	10
4. Workshop Outcomes .....	11
4.1. Survey Results.....	11
4.2. Comments From Participants .....	14
4.3. Suggestions For A Proof-Of-Concept Study Location .....	17
5. Conclusions .....	19
Appendix A: Presentations slides .....	20
Appendix B: Pictures from the workshop.....	30

## LIST OF TABLES

<u>Table</u>	<u>Page</u>
4.1: Summary of opinion from both locations .....	11
4.2: Summary of opinion in percentages from both locations .....	12
4.3: Survey results from District 1 .....	13
4.4: Survey results from District 4 and Broward MPO .....	13
4.5: Survey results from District 6 .....	13
4.6: Survey results from District 7 and MetroPlan Orlando .....	14

## LIST OF FIGURES

<u>Figure</u>	<u>Page</u>
B-1: Dr. Lawphongpanich in District 6’s auditorium.....	30
B-2: Dr. Yin in District 6’s auditorium.....	30
B-3: Dr. Lawphongpanich in Mike Rippe Auditorium, District 1.....	31
B-4: Dr. Yin in Mike Rippe Auditorium, District 1 .....	31

## LIST OF AUTHORS

Yafeng Yin, Ph.D., University of Florida; [yafeng@ce.ufl.edu](mailto:yafeng@ce.ufl.edu)

Siriphong Lawphongpanich, Ph.D., University of Florida, [Lawphong@ise.ufl.edu](mailto:Lawphong@ise.ufl.edu)

## ACKNOWLEDGEMENTS

We greatly appreciate the assistance from the following individuals in making the necessary arrangements for the workshop whose outcomes are reported herein.

- Ms. Lisa Colmenares, Intermodal Systems Development Office, District 6, Florida Department of Transportation
- Mr. J. Darryll Dockstader, Research Center, Florida Department of Transportation
- Ms. Jennifer Fortunas, Systems Planning Office, Florida Department of Transportation
- Dr. Chris Francis, Transportation Statistics Office, Florida Department of Transportation
- Mr. Nathan Hicks, Systems Planning Office/CDM Smith, Florida Department of Transportation
- Ms. Jennifer A. Stults, Intermodal Systems Development Office, District 1, Florida Department of Transportation

## EXECUTIVE SUMMARY

The workshop on arterial managed lanes on was held twice, once on October 19, 2015 in the auditorium of Florida Department of Transportation (FDOT) District 6 in Miami, Florida and the other on October 20, 2015 in Mike Rippe Auditorium of FDOT District 1 in Bartow, Florida. The workshop (a) disseminated results from our study on extending the managed-lane concept to arterials, (b) solicited opinion regarding managed lanes on arterials from FDOT personnel and those from metropolitan planning organizations, and (c) obtained suggestions for a proof-of-concept study location. The latter is in an effort to further advance the concept of managed lanes when the results from the study are positive.

There were 25 participants from District 1, 4, 6 and 7, MetroPlan Orlando, and Broward MPO. These participants prefer the following definition for arterials:

*“An arterial is a high-capacity urban road whose primary function is to deliver traffic from collector roads to freeways, and between urban centers at the highest level of service possible. Speed limits are typically between 30 and 50 mph.”*

Seven types of managed lanes were presented. They include (1) high-occupancy vehicles or HOV lanes, (2) high-occupancy toll or HOT lanes, (3) express-toll lanes, (4) bus-only lanes, (5) bus-only toll lanes, (6) truck-only lanes, and (7) truck-only toll lanes. The following table summarizes the opinion of the 25 participants.

Questions	Yes	No	May be
Can HOV lanes improve mobility on arterials in your district?	9	5	11
Can HOT lanes improve mobility on arterials in your district?	8	5	12
Can express toll lanes improve mobility on arterials in your district?	3	5	17
Can bus-only lanes improve mobility on arterials in your district?	8	4	13
Can bus-only toll lanes improve mobility on arterials in your district?*	5	9	10
Can truck-only lanes improve mobility on arterials in your district?	2	13	10
Can truck-only toll lanes improve mobility on arterials in your district?	1	16	8

\*One person forgot to answer this question.

In the above table, HOV (33%), HOT (32%), and bus-only (32%) lanes receive the most “yes” vote and bus-only toll (37%), truck-only (52%), and truck-only toll (64%) lanes receive the most “no” vote. However, the number of “may be” votes for all seven types are significant. Except for the truck-only toll lanes, at least 40% of the participants are ambivalent about the benefits of managed lanes on arterial mobility. For truck-only toll lanes, 64% of workshop participants do not believe that truck-only toll lanes are possible in Florida because they requires two lanes—the additional lane is to allow trucks to pass slow-moving ones.



## 1. BACKGROUND

Managed lanes have been successfully implemented on freeways across the United States. In Project BDV32 977-01 for Florida Department of Transportation (FDOT), the authors explored the possibility of extending the concept of managed lanes to arterials in order to further improve the efficiency of busy Florida roads. They examined (a) types of managed lanes that can be successfully deployed on arterials in Florida, (b) identified tools for evaluating their performance, and (c) investigated ways to coordinate the deployment and operations of these lanes on a network of freeways and arterials. Their research indicates that high-occupancy vehicle (HOV) lanes, high-occupancy/toll (HOT) lanes, express-toll (ET) lanes, and bus-only lanes are suitable for implementation on Florida's arterials. In the final report, details concerning the design, financing, and implementation of these lanes are discussed along with traffic management schemes such as intersection treatment, segment management (e.g., vehicle eligibility, hours of operation, and pricing), and enforcement schemes.

## 2. OBJECTIVE

The main objective of this workshop is to promulgate the research findings from FDOT Project BDV32 977-01. The focus is twofold. One is to inform FDOT, its districts, Florida's Turnpike Enterprise and their partners of the potentials of using managed lanes on arterials to improve their efficiency and the road networks to which they are connected. The other is to solicit concerns and recommendations on, if the potential exists, further advancing the concept of managed lanes on Florida's arterials. In particular, workshop participants were asked to provide suggestions for locations to conduct a proof-of-concept study that uses a computer simulation to assess the benefits and costs of managed lanes on Florida's arterials.

### 3. WORKSHOP DESCRIPTION

The workshop was held twice, once on October 19, 2015 in the auditorium of FDOT District 6 in Miami, Florida and the other on October 20, 2015 in Mike Rippe Auditorium of FDOT District 1 in Bartow, Florida. At both locations, the workshop lasted approximately 3.5 hours and consisted of the following:

- Presentations by Drs. Siriphong Lawphongpanich and Yafeng Yin on existing arterial managed lanes in the United States and the identification and selection of strategies for managed lanes on Florida’s arterials. (Appendix A provides the slides for the presentations.)
- Discussion with participants on issues related to the potential and issues concerning implementing managed lanes on Florida’s arterials.
- Conducting a survey concerning the possibility of improving the mobility on arterials using the following seven types of managed lanes:
  - High-occupancy vehicles or HOV lanes
  - High-occupancy/toll or HOT lanes
  - Express-toll lanes
  - Bus-only lanes
  - Bus-only toll lanes
  - Truck-only lanes
  - Truck-only toll lanes

The total number of participants at the two locations is 25. On October 19, there were 9 participants in Miami and three of whom were from District 4, five from District 6, and one from Broward Metropolitan Planning Organization (MPO). On October 20, 16 individuals attended the workshop in Bartow and ten of whom were from District 1, five from District 7, and one from MetroPlan Orlando. The next section summarizes the results from our survey and provides lists of comments from participants and suggestions for our proof-of-concept study location.

## 4. WORKSHOP OUTCOMES

The sections below describe results from our survey, comments from participants, and suggestions of our proof-of-concept study location.

### 4.1. SURVEY RESULTS

In FDOT Project BDV32 977-01, the authors identify seven types of managed lanes with potentials to improve the mobility on Florida’s arterials. As listed in the previous section, they include (1) high-occupancy vehicles or HOV lanes, (2) high-occupancy/toll or HOT lanes, (3) express-toll lanes, (4) bus-only lanes, (5) bus-only toll lanes, (6) truck-only lanes, and (7) truck-only toll lanes.

Below, Tables 4.1 to 4.7 summarize the participants’ opinion regarding the seven types of managed lanes. Among them, HOV (33%), HOT (32%), and bus-only (32%) lanes received the most “yes” votes (see Table 4.2) and bus-only toll (37%), truck-only (52%), and truck-only toll (64%) lanes received the most “no” votes. However, the number of “may be” votes for all seven types are significant. Except for the truck-only toll lanes, at least 40% of the participants are ambivalent about the benefits of managed lanes on arterial mobility. For truck-only toll lanes, 64% of workshop participants do not believe that this type of managed lanes can improve arterial mobility. The discussion during the workshop indicates that the participants agree with the literature on the requirements imposed by truck-only toll lanes. This type of managed lanes requires two lanes. The additional lane is necessary to allow trucks to pass slow-moving ones. When compared to the other six types of managed lanes, this two-lane requirement is a significant challenge for funding and implementing truck-only toll lanes.

**Table 4.1:** Summary of opinion from both locations

Questions	Yes	No	May be
Can HOV lanes improve mobility on arterials in your district?	9	5	11
Can HOT lanes improve mobility on arterials in your district?	8	5	12
Can express toll lanes improve mobility on arterials in your district?	3	5	17
Can bus-only lanes improve mobility on arterials in your district?	8	4	13
Can bus-only toll lanes improve mobility on arterials in your district?*	5	9	10
Can truck-only lanes improve mobility on arterials in your district?	2	13	10
Can truck-only toll lanes improve mobility on arterials in your district?	1	16	8

\*One person forgot to answer this question.

**Table 4.2:** Summary of opinion in percentages from both locations

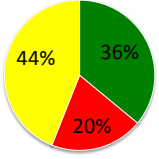
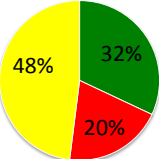
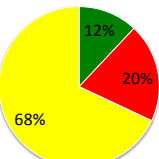
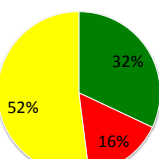
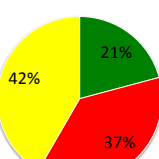
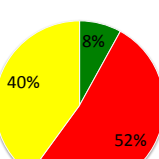
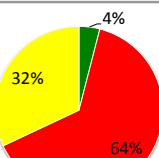
<b>Questions</b>	
<b>Can HOV lanes improve mobility on arterials in your district?</b>	
<b>Can HOT lanes improve mobility on arterials in your district?</b>	
<b>Can express toll lanes improve mobility on arterials in your district?</b>	
<b>Can bus-only lanes improve mobility on arterials in your district?</b>	
<b>Can bus-only toll lanes improve mobility on arterials in your district?</b>	
<b>Can truck-only lanes improve mobility on arterials in your district?</b>	
<b>Can truck-only toll lanes improve mobility on arterials in your district?</b>	

Note: Green = "Yes", Red = "No", Yellow = "May be"

Tables 4-3 to 4-6 separate the results in Table 4-1 by FDOT districts and MPOs. Similar to the pattern in Table 4-1, the same two sets of managed lanes receive the most “yes” and “no” votes and a significant number is unsure of the benefits from managed lanes on arterial mobility in each table.

**Table 4.3:** Survey results from District 1

Questions	Yes	No	May be
Can HOV lanes improve mobility on arterials in your district?	4	3	3
Can HOT lanes improve mobility on arterials in your district?	3	3	4
Can express toll lanes improve mobility on arterials in your district?	0	3	7
Can bus-only lanes improve mobility on arterials in your district?	1	4	5
Can bus-only toll lanes improve mobility on arterials in your district?	1	6	3
Can truck-only lanes improve mobility on arterials in your district?	1	4	5
Can truck-only toll lanes improve mobility on arterials in your district?	0	7	3

**Table 4.4:** Survey results from District 4 and Broward MPO

Questions	Yes	No	May be
Can HOV lanes improve mobility on arterials in your district?	1	0	3
Can HOT lanes improve mobility on arterials in your district?	1	0	3
Can express toll lanes improve mobility on arterials in your district?	0	0	4
Can bus-only lanes improve mobility on arterials in your district?	3	0	1
Can bus-only toll lanes improve mobility on arterials in your district?*	1	0	2
Can truck-only lanes improve mobility on arterials in your district?	0	3	1
Can truck-only toll lanes improve mobility on arterials in your district?	0	3	1

\*One person forgot to answer this question.

**Table 4.5:** Survey results from District 6

Questions	Yes	No	May be
Can HOV lanes improve mobility on arterials in your district?	1	2	2
Can HOT lanes improve mobility on arterials in your district?	2	0	3
Can express toll lanes improve mobility on arterials in your district?	2	0	3
Can bus-only lanes improve mobility on arterials in your district?	1	0	4
Can bus-only toll lanes improve mobility on arterials in your district?	1	1	3
Can truck-only lanes improve mobility on arterials in your district?	1	2	2
Can truck -only toll lanes improve mobility on arterials in your district?	1	2	2

**Table 4.6:** Survey results from District 7 and MetroPlan Orlando

Questions	Yes	No	May be
Can HOV lanes improve mobility on arterials in your district?	3	0	3
Can HOT lanes improve mobility on arterials in your district?	2	2	2
Can express toll lanes improve mobility on arterials in your district?	1	2	3
Can bus-only lanes improve mobility on arterials in your district?	3	0	3
Can bus-only toll lanes improve mobility on arterials in your district?	2	2	2
Can truck-only lanes improve mobility on arterials in your district?	0	4	2
Can truck-only toll lanes improve mobility on arterials in your district?	0	4	2

#### 4.2. COMMENTS FROM PARTICIPANTS

While there are many definitions for an arterial in the literature, the definition preferred by the workshop participants is below.

*“An arterial is a high-capacity urban road whose primary function is to deliver traffic from collector roads to freeways, and between urban centers at the highest level of service possible. Speed limits are typically between 30 and 50 mph.”*

The definition presented during the workshop describes an arterial as a road with a limited access. This characterization is not representative of Florida’s arterials that have many access points and/or intersections. Some also suggested that arterials for managed-lane implementations should be functionally classified as principal arterials or higher and with Class 2, 3, or 4 access classification standards.

Below are actual comments from participants.

##### District 1:

- The definition of arterials seemed accurate, the only change I would suggest is that arterials can have limited access features, but most don’t.
- Another item that will pose an issue for the implementation of median, or left, managed lanes are the abundance of median openings that exist on arterials. Continuous left turn lanes also pose an issue towards managed lanes implementation.
- HOV and HOT lanes might be beneficial on the beach access roads to the Sarasota/Manatee barrier islands area. There are high numbers of tourists during peak season and congestion is high.

- Arterials are already quite congested. It is unlikely to work (managed lanes on arterials) given that not enough through lanes are available compared to freeways. Another factor is the constant ingress/egress due to driveways and side streets.
- There are high truck volumes on some of our arterials. A truck-only lane might help to ease traffic flow.
- For HOV lanes, you need to provide incentives for HOVs.
- For bus-only lanes, you need to provide incentives for buses to get people to park-n-ride.
- For truck-only lanes, there are some heavy freight corridors that may benefit (Port Manatee).
- You need to consider roundabouts in your study.
- For HOV and HOT lanes, may be in the coastal communities and counties where seasonal traffic volume is highest and most severe congestion occurs.
- For truck-only lanes, worth considering on some select roads mainly in Polk County where truck volume is highest around the Lakeland and Winter Haven urban areas. However, it would be difficult to add extra lanes.

#### **District 4 and Broward MPO:**

- I think HOV lanes will not work in South Florida due to the lack of enforcement. I believe people will still ride in those lanes so you might as well change them.
- I feel that the current state of the arterials in our district isn't conducive to managed lanes. If managed lanes were to be implemented, it would require very costly infrastructure upgrades and so may not be beneficial in the long run. The only arterial managed lanes I feel may be feasible are the bus-only lanes and this would only be on a few street corridors.
- HOV lanes along arterials that intersect or terminate into the freeway system would have potential for success.
- Bus-only lanes would be very beneficial on specific arterials with high transit demands, especially arterials that lead to other transit hubs (i.e., train stations, mobility hubs, etc.)
- Truck-only lanes would be hard to implement or justify unless near ports or other commerce.
- Any tolling systems would be difficult to implement/manage/regulate.
- FDOT's Generalized LOS tables uses 1,950 pcphpl as the saturation flow rate and .44 g/C. These figures can be applied to develop the rule of thumb threshold for converting general



purpose lane to other types of managed lanes. Again, we should ensure, after the conversion, a ML has higher passenger throughput than before.

- Some thoughts should be given to incorporating access management classifications on implementing arterial managed lanes – from both the perspectives of using it as a criterion for feasibility assessment and reclassification after the implementation.
- Within Orlando urban area, signal timing has been effective in managing congestion on arterials. In time, it will no longer be a strategy that reduces the demand.

#### **District 6:**

- Eliminate limited access from the arterial definition.
- D6 includes many facilities at very high congestion levels. All these strategies, if used correctly, can be of assistance to improve mobility in the district and region.
- Truck-only lanes on freight facilities also can assist.
- In Miami Dade County, there are not many HOV lanes.
- District Six (Miami/Dade County) has several opportunities for implementing express-toll lanes on arterial roadways. Would suggest to screen the criteria based on functional classification standards (principal arterials or higher) and access classification standards (Class 2, 3 or 4)
- Would suggest to not consider with bike lanes or high pedestrian corridors (too many conflicts).

#### **District 7 and MetroPlan Orlando:**

- Florida has arterials with high driveway density with limited right-of-way. Try focusing on these aspects.
- On arterials where operation is at capacity, it might be difficult to implement without tolling the HOV lanes.
- If the arterials are limited access, these strategies will/could help.
- Most of our arterials have a V/C > 1.0 during peak hours. It would be difficult to implement successfully.
- Bus only lanes and queue jumps would benefit to arterials in FL. Other methods may be too difficult to implement due to access needs from side streets.

### 4.3. SUGGESTIONS FOR A PROOF-OF-CONCEPT STUDY LOCATION

Below is a list of suggestions for our proof-of-concept study location.

#### District 1:

- US 98 from Memorial to Griffin. **Type:** no suggestion.
- US 41 in many locations might benefit from managed lanes. Unfortunately, my experience is too limited to pinpoint an appropriate location. **Type:** no suggestions
- US 27 from Highlands County to Lake County/Polk County line. **Type:** Prohibit trucks in outer lanes somehow.
- Desoto Bridge, Bradenton. **Type:** Reversible Lane by time of day.
- Green Bridge, Bradenton. **Type:** Reversible Lane by time of day.
- I-4. **Type:** HOV
- I-75. **Type:** HOV
- San Carlos Blvd., Summerlin to Fort Myers, Beaea (?)/Estero Blvd. **Type:** Bus-only and HOT lanes
- Colonial Blvd from Homestead Rd. to Fowler. **Type:** HOT Lanes
- US 41 (anywhere in D1). **Type:** Bus-only and HOT lanes
- US 41 and US 301 in Manatee/Sarasota Counties. **Type:** HOT/HOV lanes
- US 41 in Lee and Collier Counties. **Type:** HOT/HOV lanes

#### District 4:

- Hollywood Blvd., Cypress Creek Rd., Oakland Park Blvd. **Type:** HOT lanes.
- SR 7, University Dr. **Type:** Bus-only lanes.
- Broward Blvd. **Type:** Bus-only lanes.
- US 441. **Type:** Bus-only lanes.
- Okeechobee Blvd., any 8-lane sections in Palm Beach County. **Type:** HOT and/or Bus-only lanes
- Any roadway (6 lanes) E-W in Broward County with large directionality. **Type:** Reversible HOT lanes.
- University Dr. (Broward) between Cleary Blvd. and Nova Dr. **Type:** HOV or Bus-only lanes, HOT if technology available.
- Broward Blvd. from Pine Island Rd. to US 1. **Type:** HOV or Bus-only lanes.
- Sunrise Blvd. from University to I-95. **Type:** HOV or Bus-only lanes.
- SR-80 in Palm Beach has grade separations at intersections between Turnpike and I-95. **Type:** HOV or HOT Lanes.

**District 5:**

- SR 50 between JYR and SR 436. **Type:** HOT lanes
- SR 436 between SR 50 and 408. **Type:** HOT lanes
- SR 192 between I4 and TKE. **Type:** HOT lanes
- SR 50 from Gunn to Florida. **Type:** Express lanes
- Fowler from Nebraska to I-75. **Type:** Bus-only lanes

**District 6:**

- US 1 between I-95 and SW 152 St. **Type:** HOT lanes.
- Kendall Dr. between US 1 and SW 137 Ave. **Type:** HOT and Bus-only lanes.
- SR 953 between SR 526 and SR 836. **Type:** HOT and Bus-only lanes.
- As part of our on-going projects, we have here in D6 three BRT proposed corridors: (1) NW 27<sup>th</sup> Ave. from NE 215 St. to MIC, (2) Flagler Street from HEFT to US1, and (3) Kendall Dr.
- US 1 south of 95. **Type:** HOV and HOT lanes.
- Kendall Drive. **Type:** Bus-only lanes.
- Flagler. **Type:** Bus and Bike lanes.
- E-W roadways in Miami Dade County (see the list of 10 corridors from Miami Dade County (CMP corridors). **Type:** HOT (toll) lanes.
- US 1 from I-95 to SW 152 St. **Type:** Express lanes with no charge to buses.
- HEFT from US 27 to SR 836. **Type:** Truck only lanes, the trucks are predominantly rock haulers and need to be on a separate facility.
- SR 836 from HEFT to I-95. **Type:** Express lanes with no charge to buses.

**District 7:**

- SR 60 (Brandon Blvd.) between US 301 to Valrico Rd. **Type:** HOV or may be HOT
- Dale Mabry Hwy. between Kennedy Blvd. and South of Interbay Blvd. **Type:** HOV and/or may be HOT.
- SR 580 Hillsborough Ave. between Veterans expressway and 47<sup>th</sup> St. **Type:** HOV and/or may be HOT.
- US 19 Pinellas County (limited access). **Type:** All.

## 5. CONCLUSIONS

The workshop (a) disseminated results from our study on extending the managed-lane concept to arterials, (b) solicited opinion regarding managed lanes on arterials from FDOT personnel and those from metropolitan planning organizations, and (c) obtained suggestions for a proof-of-concept study location. The latter is in an effort to further advance the concept of managed lanes when the results from the study are positive.

## APPENDIX A: PRESENTATIONS SLIDES

---

### Managed Lanes on Arterials

Workshop

Siriphong (Toi) Lawphongpanich Industrial & Systems Engineering University of Florida Lawphong@ise.ufl.edu	Yafeng Yin Civil & Coastal Engineering University of Florida Yafeng@ce.ufl.edu
---	---

---

UF UNIVERSITY OF FLORIDA 1

### Introduction

---

- We recently completed a study titled “Deployment Strategies of Managed Lanes on Arterials” that
  - Examine strategies for deploying managed lanes on arterials.
  - Identify tools for evaluating their performance.
  - Investigate ways to coordinate the deployment and operations of these lanes on arterials

---

UF UNIVERSITY OF FLORIDA 4

### Agenda

---

- Introduction
- Objectives
- Review of managed-lane deployments on arterials
- Identification and selection of managed-lane strategies for arterials
- A survey

---

UF UNIVERSITY OF FLORIDA 2

---

### WORKSHOP OBJECTIVES

---

UF UNIVERSITY OF FLORIDA 5

---

### INTRODUCTION

---

UF UNIVERSITY OF FLORIDA 3

### Workshop Objectives

---

- Share some of our findings
- Proof-of-concept study
  - Use a simulation study to access costs and benefits of managed lanes on arterials.
  - FDOT wants to select a study site with significant impacts and potential for implementation.
- Solicit your opinion concerning
  - Potential study sites
  - Types of managed-lanes on arterials
    - For study site selection

---



UF UNIVERSITY OF FLORIDA 6

Review

## ARTERIAL MANAGED LANES



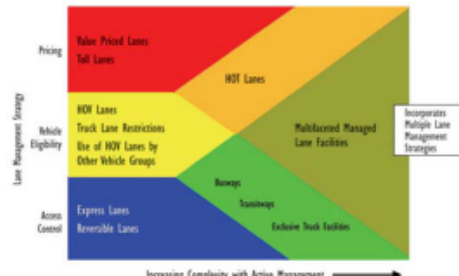

### Types of Managed Lanes

### Characteristics of arterials

- An arterial is a high-capacity urban road whose primary function is to deliver traffic from collector roads to freeways, and between urban centers at the highest level of service possible.
- Many arterials are limited-access roads, or feature restrictions on private access.
- Speed limits are typically between 30 and 50 mph.

### Types of Arterial Managed Lanes

- **HOV Lanes:** Allow access to vehicles with the required number of occupants or more and, perhaps, motorcycles, electric and hybrid vehicles.
- **HOT Lanes:** Allow access to non-HOV for a fee
  - There is no HOT lanes on arterials in the U.S.
- **Express-Toll (ET) Lane:** Every vehicle must pay tolls to access
  - The distinction between HOT and ET lanes in practice is unclear.
    - I-405 Express Toll Lanes in Seattle allow free access to carpools, vanpools, motor cycles, and transit.
    - All vehicles pay tolls on I-95 Express-toll Lanes near Baltimore.
  - There is no express-toll lane on arterials in the U.S.





### Managed Lanes

- Managed lanes refer to “highway facilities or a set of lanes where operational strategies are proactively implemented and managed in response to changing conditions.”
  - FHWA highlights three types of strategies: pricing, vehicle eligibility, and access control.



### Types of Arterial Managed Lanes

- **Bus-Only Lanes:** Allow access only to buses
- **Bus-Toll Lanes:** Allow access to other types of vehicles of a fee
  - There is no bus-toll lane on arterials in the U.S.
- **Truck-Only Toll (TOT) and Truck-Only lanes:** Allow access only to trucks with and without fees.
  - There are very few truck-only facilities in the U.S. (none on arterials).
  - There is no truck-only toll lane in the U.S.

## EXAMPLES: HOV LANES

## Arterial HOV Lanes: Others

Location	Year opened	Length (mile)	Travel Time Saving (min)
Airport Rd., Seattle	1993	3.4	1
Hasting St., Vancouver	1996	4.3	3
Eglinton Ave., Toronto	1993	7	3.0 AM Peak 2.5 PM Peak
Capitol Expy., Santa Clara	1997	3.8	1.1 AM Peak 0.4 PM Peak
Montague Expy., Santa Clara	1983	5.4	3.8 AM Peak 0.0 PM Peak
San Tomas Expy., Santa Clara	1982	7.2	3.1 AM Peak 2.9 PM Peak

## Arterial HOV Lanes: Montague Expressway

- **Type:** Concurrent flow HOV lane
- **Location:** Santa Clara, California
- **Year opened:** 1983
- **Length:** 5.4 miles
- **Occupancy requirement:** 2+
- **Violation rates:**
  - 34% (AM) and 22% (PM) at Zanker Rd. intersection
  - 61% (AM) and 64% (PM) at Trade Zone Blvd. intersection
- **Vehicles using HOV lane at peak hour:** 188 (AM), 235 (PM)
- **Vehicles using GP lanes at peak hour:** 1,732 (AM), 1,336 (PM)



## EXAMPLES: BUS-ONLY LANES

## Arterial HOV Lanes: Santa Fe Drive

- **Type:** Concurrent flow HOV lane
- **Location:** Denver, Colorado
- **Year opened:** 1986
- **Length:** 7.5 miles (northbound), 5.7 miles (southbound)
- **Occupancy requirement:** 2+
- **Lane of road used:** left lane



## Bus-only Lanes: Spring Street

- **Type:** Contraflow bus lane
- **Location:** Los Angeles, CA
- **Length:** 1.5 miles
- **Bus Volume:** 140 -150 peak hour
- **Bus speeds increased by about 15% on both Spring Street and Main Street**
- **Other vehicle speed increased by 20-40%**



### Bus-only Lanes: Madison Avenue

- **Type:** Concurrent Flow Bus Lane
- **Location:** New York, NY
- **Length:** 0.85 mile
- **Bus Volume:** 150 -180 peak hour
- **Initially,** travel time savings of 5-6 minutes
- Travel time reliability and bus ridership increased
- **After 20 years,** average bus speed reduces to only 6.5 mph due to blocked bus lanes



### Managed-Lane Strategies

- A managed-lane strategy is defined as a combination of three aspects, including the type of the managed lane, its design and implementation, and associated traffic management schemes.
  - For example, a busy-only lane can be placed on the median of a two-way arterial or is a contraflow lane at a one-way arterial. Further, various traffic management schemes, such as transit signal priority and queue jumps, may be provided to enhance its performance.

### Bus-only Lanes: Others

Location	Route	Length (mile)	Average Speed (MPH)	Average Ridership (weekday)
Everett, WA	Swift BRT-SR 99	16.7	24	4,300
Eugene, OR	Franklin EmX	4	17	6,000
Los Angeles, CA	705 La Cienega-Vermont Rapid	14.1	12.5	7,994
New York, NY	M15	8.5	10	57,000
Nashville, TN	Route 56 BRT Gallatin Road	12	14	1,800
Washoe County, NV	RTC RAPID	4.2	11.3	3,000

### Types of Managed Lanes

- Types to consider
    - High-occupancy-vehicle (HOV) lanes
    - Bus-only lanes
    - ~~Truck-only lanes~~
    - High-occupancy-toll (HOT) lanes
    - Express-toll (ET) lanes
    - Bus-toll lanes
    - ~~Truck-toll lanes~~
- } Toll Lanes

### Identification and Selection of Arterial Managed Lane Strategies

**Yafeng Yin**

*Professor, Department of Civil and Coastal Engineering  
Director, Transportation Research Center*

### Design and Implementation

- The design and implementation of a managed lane involves six aspects:
  - Layout and placement
  - Lane length and width
  - Lane separations
  - Signs and markings
  - Access points
  - Pedestrian and bicycle conflicts



Layout and Placement

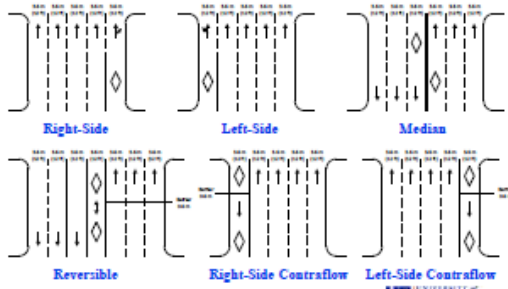

Layout and Placement (Cont'd)



Median Bus-Only Lanes, Taipei, Taiwan

Layout and Placement (Cont'd)

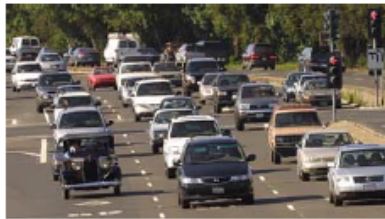

Right-Side Managed Lane in Santa Clara County, CA

Layout and Placement (Cont'd)



Median HOV Lanes, Seoul, Korea

Layout and Placement

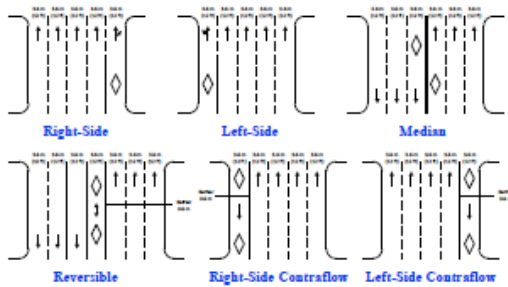

Layout and Placement

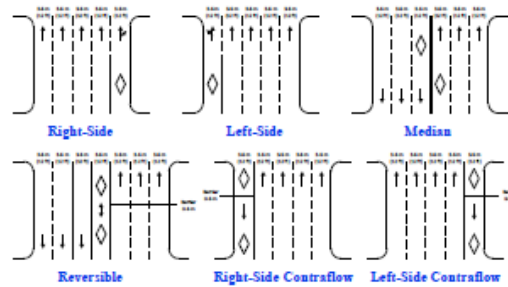

### Layout and Placement (Cont'd)



Reversible Managed Lane on Lion Gate Bridge, Stanley Park, Vancouver

### Layout and Placement (Cont'd)

Layout	Pros	Cons
Right-side	Easy to implement	Parking and deliveries need to be addressed
Left-side	Offer higher speed and do not affect curb activities	Inconvenient for local transit and left-turn vehicles at GP lanes
Median	Offer higher speed and do not affect curb activities	Inconvenient for local transit and left-turn vehicles at GP lanes
Reversible	Make use of capacity in the non-peak direction and do not affect curb activities	Inconvenient for local transit and left-turn vehicles at GP lanes
Right-side contraflow	Make use of capacity in the non-peak direction	Usually limited to bus-only lanes
Left-side contraflow	Make use of capacity in the non-peak direction	Usually limited to bus-only lanes and need to address the bus stop issue

### Layout and Placement

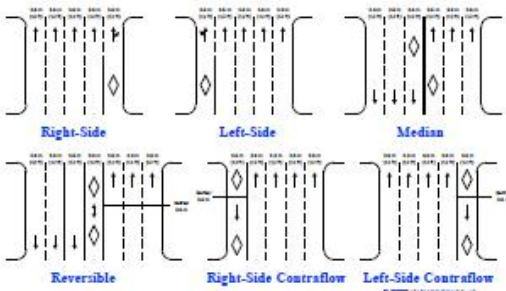

### Lane Length and Width

- The length of a managed lane may vary from one to several blocks, depending on its purpose
- All lanes are typically 3.6 m wide, not less than 3.3 m, except that:
  - If there are active pedestrian movements, it should be 4.0 to 4.3 m
  - If there are barrier separations, it should be 0.6 to 1.2 m wider

### Layout and Placement (Cont'd)



Right-Side Contraflow Bus-Only Lane in San Juan, Puerto Rico

### Lane Separations

- There are three primary types of separation, including striping, buffer separation using plastic tubes, and concrete barriers



Buffer-Separation in 95 Express, Florida Concrete Barriers in I-15 Express, San Diego

### Lane Separations (Cont'd)

Separation Type:	Advantages:	Disadvantages:
Striping	Cheapest to implement; very low maintenance cost; unconstrained access of emergency and police vehicles	Higher number of violations; safety and operational concerns
Plastic Tubes	Require less right-of-way; less installation cost than concrete barriers; easier enforcement than striping; easy access for emergency vehicles	More expensive than striping; higher maintenance cost
Concrete Barriers	Eliminate unlawful weaving; improve safety; reduce mental stress of drivers	Very high construction cost; limit the access of emergency and police vehicles; wider buffer area

### Signs and Markings

- Signs and markings need to be provided to highlight the operations of managed lanes. All of them need to be remarkable and easy to understand
- Their design and implementation should follow the Manual of Urban Traffic Control Devices (MUTCD)

### Lane Separations (Cont'd)



Reversible Managed Lane on Lion's Gate Bridge, Stanley Park, Vancouver

### Signs and Markings (Cont'd)



Example of HOV Signs



Example of Marking: on Managed Lane

### Lane Separations (Cont'd)



Median Bus-Only Lanes, Taipei, Taiwan

### Access Points

- The design of access points will largely depend on the type, layout and placement of a managed lane and the means of separation
  - For contraflow managed lanes, access points usually begin and end at intersections
  - For concurrent managed lanes, access points may be continuous
- Frequent access points provide convenience to drivers but may cause safety issues and interrupt traffic flow

### Access Points (Cont'd)

- A weave lane can sometimes added to better maintain speed and flow in the managed lane

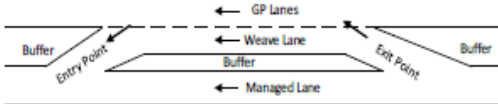

Example of Weave Lane used for Access Points Design

### Traffic Management Schemes

- Various traffic management schemes can be used to enhance the performance of arterial managed lanes. They fall into one of the following three categories:
  - Intersection treatment
  - Segment management
  - Enforcement

### Pedestrian and Bicycle Conflicts

- If managed lanes are newly added, the pedestrian conflicts need to be considered carefully
  - Mid-street refuge islands can be provided as well as pedestrian skywalks or tunnels
  - The walking phase of signal control can be made longer and the vehicle speed limit set to be lower
- For curb-side concurrent managed lanes, one bicycle lane can be added next to the managed lane or the lane can be widened to accommodate bicycles

### Intersection Treatments

- Queue jump
  - Provide the priority of passage to vehicles on managed lanes at intersections
- Signal control
  - Offer eligible vehicles additional preferential treatment
- Turning movement management
  - Prohibit or limit turning movements of GP vehicles that will interfere with the operations of managed lanes

### Pedestrian and Bicycle Conflicts (Cont'd)



Examples of Managed Lanes Accommodating Bicycles

### Queue Jump



### Queue Jump

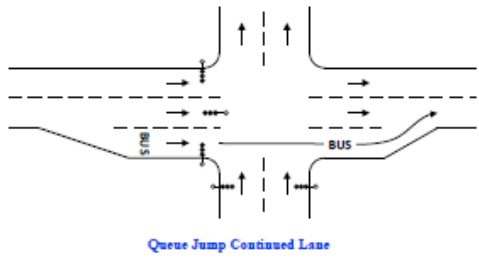

Queue Jump Continued Lane

### Signal Control

- **Signal timing**
  - Coordinate signals along the direction of managed lanes
  - Designate a phase to managed lanes at certain intersections
- **Signal priority**
  - Provide early green or green extension to accommodate the passing of an eligible vehicle at a signalized intersection

### Queue Jump (Cont'd)

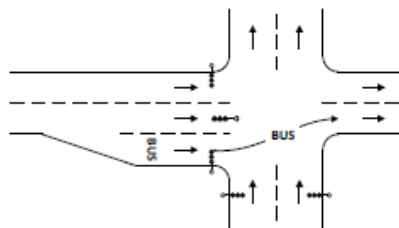

Queue Jump Lane with Designated Signal

### Segment Management

- **Speed limits**
  - Limit the difference of speed limits between managed and GP lanes near access points
  - Variable speed limits should not be deployed for the purpose of preventing traffic flow breakdown or eliminating shockwaves, as they are expected to achieve at freeways
- **Pricing strategies**
  - Set a right toll price for the successful operation of HOT and ET lanes

### Queue Jump (Cont'd)

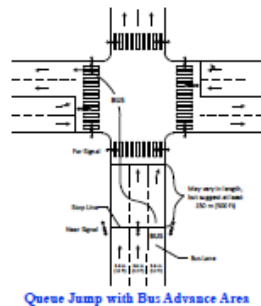

Queue Jump with Bus Advance Area

### Pricing Strategies

- **Zone-based toll structure**
  - A motorist pays a toll when entering a new zone
- **Origin-specific toll structure**
  - Depend on where the motorist enters the facility
- **OD-based toll structure**
  - Depend on the origin and destination of the motorist
- **Distance-based toll structure**
  - Depend on the distance that the motorist travels on the facility

### Pricing Strategies (Cont'd)

Toll structure	Pros	Cons
Zone-based	Easy to implement, particularly when expanded from a single-segment HOT facility	Additional lane changes at the beginning of each zone may cause disruptions; difficulty of balancing utilization of capacity and the disruptions caused by lane changes
Origin-specific	Easy to implement and convenient for users	Inefficient utilization of capacity possible inequality concerns
OD-based	Effectively manage demand and utilize capacity	More costly to implement
Distance-based	No equity concern	More costly to implement inefficient utilization of capacity

### Automatic Enforcement (Cont'd)

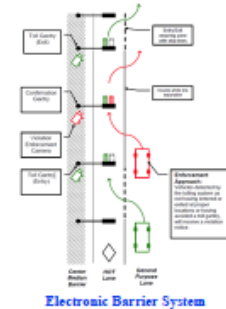

Electronic Barrier System

### Automatic Enforcement

- Violation types
  - Vehicle eligibility violations
  - Unauthorized entries/exits
- Key technologies
  - Near-infrared camera
  - Electronic barrier system

### Selection and Screening Process

- Managed lane selection and screening process
  - Identification of qualified corridors
  - Selection of managed lane type
  - Selection of traffic management schemes
- Criteria for qualified corridors
  - High traffic volume
  - High level of congestion during peak hour
  - Importance to a managed lane network

### Automatic Enforcement (Cont'd)



Near-Infrared Camera

### Selection and Screening Process

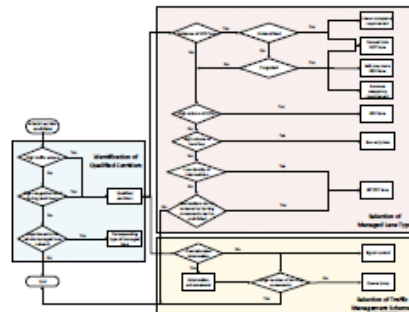

## APPENDIX B: PICTURES FROM THE WORKSHOP

October 19, 2015: District 6's Auditorium, Miami, Florida.



**Figure B-1:** Dr. Lawphongpanich in District 6's auditorium



**Figure B-2:** Dr. Yin in District 6's auditorium

October 20, 2015: Mike Rippe Auditorium, District 1, Bartow, Florida



Figure B-3: Dr. Lawphongpanich in Mike Rippe Auditorium, District 1



Figure B-4: Dr. Yin in Mike Rippe Auditorium, District 1