



KFB



PB99-173973

# PRT

## — a Suitable Transport System for Urban Areas in Sweden?

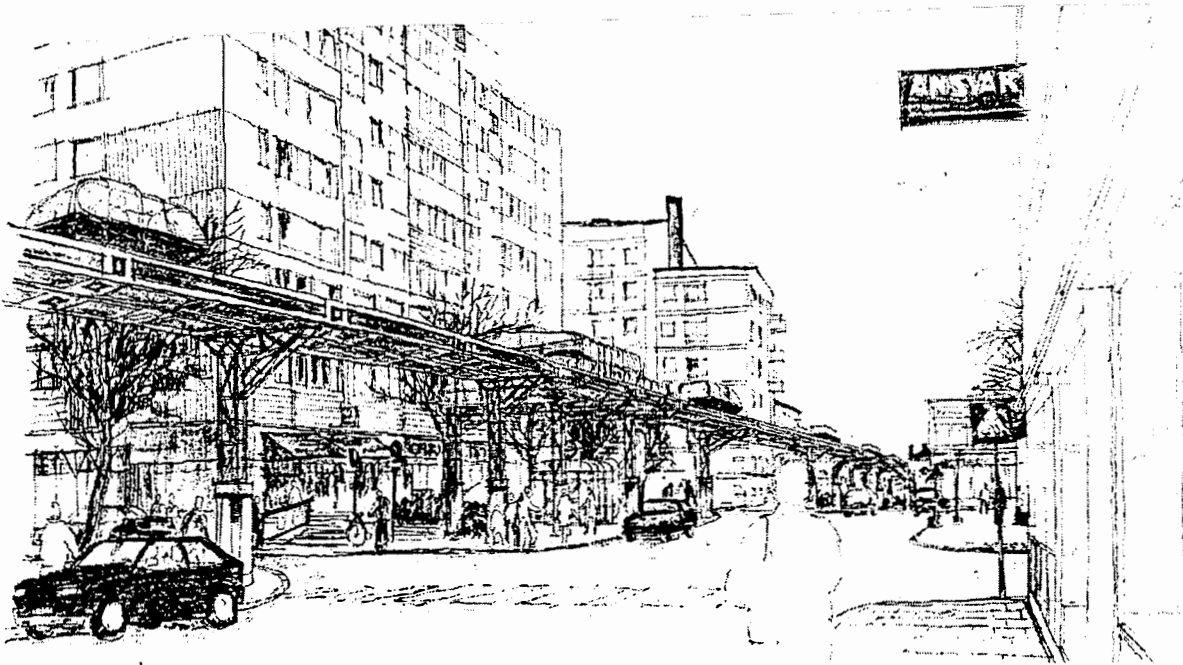

*Ingmar Andréasson*

REPRODUCED BY: **NTS**  
U.S. Department of Commerce  
National Technical Information Service  
Springfield, Virginia 22161

*KFB-Rapport 1998:38*

**PRT – a suitable transport system for urban areas in Sweden?**  
FÖRFATTARE/AUTHOR  
**Ingmar Andréasson**  
SERIE/SERIES  
**KFB-Rapport 1998:38**  
ISBN 91-88371-11-5

ISBN 91-88371-11-5  
PUBLICERINGSDATUM/DATE PUBLISHED  
**December 1998**  
UTGIVARE/PUBLISHER  
**KFB – Kommunikationsforskningsberedningen, Stockholm**  
KFBs DNR 1994-0221

### **REFERAT (Syfte, Metod, Resultat)**

Föreliggande rapport sammanfattar temaforskningsprogrammet "Avancerade persontransportsystem" utfört vid Chalmers Tekniska Högskola under åren 1994-97. Programmet syftar till att utreda om förarlös kollektivtrafik av typen "spårtaxi" kan vara lämplig för svenska tätorter.

Olika forskningsdiscipliner har behandlat frågan från sina respektive utgångspunkter. Institutionen för Konsumentteknik har bedömt användarnas möte med tekniken, Stadsbyggnad har bedömt intrånget i stadsbilden, Byggnadsmekanik har studerat bankonstruktion, LogistikCentrum har med simulering studerat trafikering, nätutbyggnad och resandeunderlag och Nationalekonomi har bedömt samhällsekonomin.

Slutsatserna är:

- Tekniken för spårtaxi finns tillgänglig
- Spårtaxi är en möjlig lösning i små och medelstora tätorter
- Spårtaxi har kapacitet att ersätta bussar och spårvagnar
- Spårtaxi kan inte ersätta tunnelbana och tåg
- Spårtaxi accepteras av resenärerna
- Spårtaxi kan halvera dagens kollektiva restider
- Spårtaxi kan ersätta 20-25% av dagens bilresor
- Spårtaxi kan vara samhällsekonomiskt lönsam
- Visuellt intrång är största hindret
- Ytterligare forskning kring bankonstruktioner behövs

### **ABSTRACT (Aim, Method, Results)**

This report summarizes a thematic research programme "Advanced transit systems" performed at Chalmers University of Technology during the years 1994-97. The programme aims to investigate if Personal Rapid Transit (PRT) may be a suitable system for urban areas in Sweden.

Various research disciplines have treated the problem each from their perspective. The department of Consumer Behaviour studied user encounter with technology, City Planning studied the impact on cityscape, Structural Mechanics studied guideway design, Logistic Center used simulation to analyze operations, implementation and travel demand and finally Economics estimated social costs and benefits.

The conclusions are:

- PRT technology is available
- PRT is a possible solution for small and medium-sized urban areas
- PRT has capacity to replace buses and light rail
- PRT cannot replace subway and commuter train
- PRT could be accepted by travellers
- PRT can reduce transit trip times to half
- PRT may attract 20-25% of present car trips
- PRT may be socially profitable
- Visual impact is the main obstacle
- Further research on guideway design is needed

- 
- I Kommunikationsforskningsberedningens – KFB – publikationsserier redovisar forskare sina projekt. Publiceringen innebär inte att KFB tar ställning till framförda åsikter, slutsatser och resultat.
  - KFB-rapporter försäljs genom Fritzes Offentliga Publikationer, 106 47 Stockholm; tel 08-690 91 90; fax 08-690 91 91; e-post: fritzes.order@liber.se hemsida: www.fritzes.se Fritzes ger också upplysningar om priser och leveransvillkor
  - Övriga KFB-publikationer beställs och erhålls direkt från KFB. Man kan dessutom abonnera på tidningen KFB-Kommuniké.
  - KFB Reports are sold through Fritzes', S-106 47 Stockholm, Sweden. Other KFB publications are ordered directly from KFB



# PRT

— a Suitable Transport System for Urban  
Areas in sweden?

*Ingmar Andréasson*



## Foreword

This report summarises the results of the "Advanced Transit Systems" research programme carried out at Chalmers University of Technology between 1994 and 1997. The programme consists of projects that have attempted from different perspectives to shed light on the conditions and possibilities for and consequences of introducing personal rapid transit (PRT) in urban areas in Sweden. The projects included in the programme were led by researchers from different departments at Chalmers and the University of Göteborg:

Professor Elsa Rosenblad, Consumer Behaviour, Chalmers  
Anders Hagson, technical licenciate, City and Traffic Planning, Chalmers  
Professor Nils-Erik Wiberg, Structural Mechanics, Chalmers  
Olof Johansson, civil engineer and Ph.D., Economics, U. of Göteborg  
Ingmar Andréasson, Ph.D., Chalmers and LogistikCentrum AB

As the member in charge, I have reported to a board made up of the following people:

Hans Björnsson (Chairman), Chalmers  
Torsten Davidsson, Housing Department  
Kjell Jansson, SIK A Stockholm  
Bengt Wennerberg, Trade Secretariat in Göteborg  
Göran Jonsson, Traffic Office in Göteborg  
Gunnar Lagerqvist, City Planning Office in Göteborg  
Håkan Jansson/Nils Edström, KFB  
Karl-Olov Fentorp, Swedish National Board for Industrial and Technical  
Development (assistant  
Henrik Graf/Stefan Stridh, BFR

The research programme was initiated and financed by the Swedish Transport and Communication Research Board (KFB). Publication of this report does not imply that KFB supports any of the opinions, conclusions or results found herein.

This report was translated from Swedish by Janet Vesterlund.

Gothenburg, December 14, 1998-12-14



Ingmar Andréasson

## Contents

Summary	3
1. Thematic research at Chalmers	4
1.1 Thematic programme “Advanced Transit Systems”	4
1.2 Need for new public transport systems	5
1.3 The concept of personal rapid transit	5
2. Survey of PRT systems	7
2.1 Some PRT systems	7
2.2 System parameters	12
2.3 Comparisons of characteristics	15
3. The user’s encounter with new technology	17
3.1 Deep interviews of VR travellers	17
3.2 Focus group interviews	20
3.3 Comparison between deep interviews and focus groups	20
4. PRT in cityscape – demands and acceptance	22
5. Guide-way design	25
5.1 Preliminary beam section	25
5.2 Need for research	26
6. Traffic strategies and network extension	27
6.1 Safe distances	27
6.2 Choice of route	28
6.3 Synchronous or asynchronous control	28
6.4 Weaving	29
6.5 Vehicle movements in stations	30
6.6 Redistribution of empty vehicles	32
6.7 Ride-sharing in PRT systems	33
6.8 Extension of PRT networks	33
6.9 Double or single guide-way	34
6.10 Dynamic simulation	36
7. PRT travel demand	37
7.1 Interaction with route services	37
7.2 Mode shift from automobile trips	38
8. Socio-economic assessment	42
9. Conclusions	45
Literature	46

## Summary

A multidisciplinary research programme, “Advanced Transit Systems”, was carried out at Chalmers University of Technology and the University of Göteborg. We studied primarily personal rapid transit systems (PRT), that is small vehicles without drivers running on their own guide-way and taking one or more passengers the quickest route to their destination without stopping on the way.

The purpose of the programme was to assess whether this type of system may be suitable for urban areas in Sweden. The program consisted of the following sub-projects:

1. Inventory of systems
2. The user's encounter with the technology
3. Personal rapid transit in cityscape
4. Guide-way design
5. Traffic strategies and network extension
6. PRT travel demand
7. Socio-economic assessment

The conclusions are that

- The technology for PRT systems is available
- PRT systems are a possible solution for small and medium-sized urban areas
- PRT has the capacity to replace buses and trams
- PRT can not replace subways and commuter trains
- PRT will be accepted by travellers
- PRT can reduce transit travel times by 50%
- PRT can attract 20-25% of today's automobile trips
- PRT can be socio-economically viable
- The main obstacle is visual intrusion
- There is a need for research in guide-way designs

# **1. Thematic research at Chalmers**

## **1.1 Thematic programme “Advanced Transit Systems”**

We conducted a multidisciplinary, thematic programme at Chalmers University of Technology at the Section for the Economics and Organisation of Technology during the years 1994-97. The programme was called “Advanced Personal Transit Systems”, was financed by KFB and involved researchers from different areas of expertise at Chalmers and the University of Göteborg.

In the programme, we studied personal transit systems that will be better able to compete with the private automobile than today’s public transport systems. We concentrated our efforts around a type of advanced system that in a direct translation from Swedish would be called “guide-way taxi” and which is generally called in English Personal Rapid Transit (PRT). PRT is based on ideas that were first introduced in the 1960s but are only now technically mature owing to developments in computer and communication technology. Our purpose in this thematic programme was to investigate whether this technology can be suitable for urban areas in Sweden.

The programme consisted of seven research projects whose results are summarised in their own chapters in this report.

1. Inventory of systems
2. The user’s encounter with the technology
3. Personal rapid transit in cityscape
4. Guide-way design
5. Strategies for operation and expansion
6. Travel demand
7. Socio-economic evaluation of PRT in Göteborg

The programme was led by Dr. Ingmar Andréasson from LogistikCentrum in Mölndal.



## 1.2 Need for new public transport systems

Today's public transport can not compete with the automobile! A sign of this is that automobile trips increase by an average of 1.5% each year at the same time as public transport trips decrease by more than 2% per year (Swedish SLTF statistics). If this trend is allowed to continue, automobile driving and the total amount of traffic will increase by 35% while public transport will decrease by 35%. Traffic already consumes about half of the surface area of many cities. A further increase in traffic and road space would strangle the life of the city. Despite this, new shopping centres are planned primarily for those who drive automobiles, and investments in roads overshadow investments in public transport.

Most of those who travel by public transport today do so not because this public transport is attractive but because they do not own automobiles. It is obvious that new solutions are necessary to match the attraction of the automobile and that they must offer the qualities that currently make most people prefer the automobile. Personal rapid transit is an attempt to offer such a solution.

## 1.3 The concept of personal rapid transit

*PRT is a system with small driverless vehicles running on demand on their own guide-way offering individual direct trips without stops.*

PRT has no timetable and no fixed routes. The vehicle departs when the passenger so orders, he or she travels alone or with company of their own choice. Vehicles wait for passengers rather than the opposite. The vehicle chooses the most rapid route and makes no stops until it has reached its destination.

The system functions like a taxi on its own guide-way – individual trips with public transit vehicles. Each individual vehicle is used by many travellers during a day. PRT is designed to offer the travel quality of the automobile without its disadvantages. This allows greater mobility with less crowding, accidents, disturbance to the environment and energy consumption.

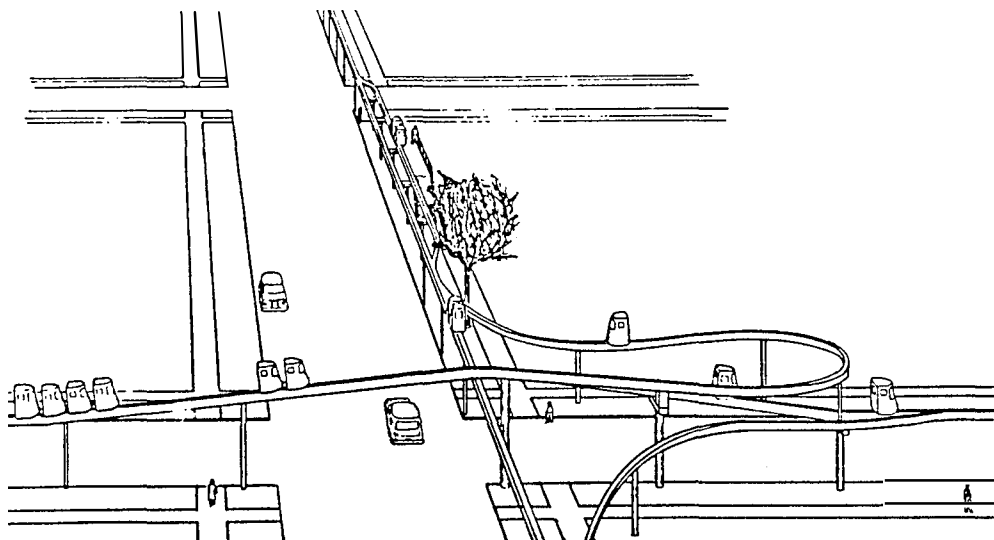

Figure 1.1 PRT according to Fichter 1964

The idea of PRT was first introduced in 1964 by Donn Fichter in the United States. The greatest amount of knowledge today about the design and application of PRT comes from a multidisciplinary group at the University of Minnesota led by Professor Edward J. Anderson.

PRT is intended to offer a high travel standard that can compete with that of the automobile. It is thus necessary for the trip to be able to be carried out spontaneously, along the most rapid route and without stops. To avoid stops on the way, the stations must be off-line (on side-tracks). Without off-line stations, parked vehicles would extend travel times and the guide-way capacity would be dramatically reduced (at least 30 seconds between vehicles). Only certain end stations without through traffic can be designed on the main line.

As trips are individual and have no unnecessary stops, there will not be many passengers in each vehicle – only those who choose to travel together. Small vehicles are also light and permit more slender guide-way designs. Without ride-sharing, it can be assumed that there would be the same load as in present day automobiles – typically 1.2-1.3 persons. With ride-sharing, we have reached an average load of 2.4 persons (not including empty vehicles). There is no reason to make the vehicles larger than for 3-5 persons.

Performance and safety during acceleration and braking require seated passengers. Emergency braking would otherwise be limited, making safety distances increase and capacity decrease.

It is reasonable that the system can transport wheel-chairs and assistants to handicapped people.

As the vehicles are small, there must be many vehicles running at short time head-ways. E.g. a two second head-way, two passengers per vehicle (some ride-sharing) and 30% empty vehicles give a line capacity of 2400 trips/hour on a single guide-way. In terms of capacity, most bus and tram lines can be replaced by PRT.

Short time head-ways are possible only if the vehicle switches and the guide-way itself lacks moving parts. Following vehicles can then switch in different directions without delay. The guide-ways take too long to switch (at least five seconds), and it must be possible for approaching vehicles to stop in time before the switch if it should be jammed or in the wrong position. Guide-way switches require long time head-ways (typically 30 seconds), which reduces capacity.

Choice of route and switching must be automatic so that it is safe and simple for the user. The control system must ensure that no conflicts occur in merges, that the vehicles are switched to the most rapid route to their destinations and that empty vehicles are redistributed according to expected demand.

## 2. Survey of PRT systems

In automated systems, vehicles run without drivers. Most automated systems are trams, subway trains or vehicles without drivers running on fixed routes. There is a global total of about 80 installations of automated transit systems carrying over 2 million trips each day, and the number is rising. Many applications with small vehicles are found at airports, amusement parks and theme parks.

Safety in the automatic systems has been demonstrated to be at least as high as in manual systems. The most important reason for the greater safety is that the systems are separated from other traffic.

As one activity in the programme, we wrote to all the developers of advanced transit systems that we were able to trace. Here, an advanced system means that there is some type of demand-responsive control of route and/or departure times.

The concept of an “advanced” system includes, besides PRT, also systems based on larger vehicles (Group Rapid Transit). With larger vehicles, passengers must be grouped in time and space to increase the loads. GRT vehicles follow fixed routes with intermediate stops, although departure times can be controlled by demand.

Dual-mode or ambi-systems have vehicles that can be driven both on their own guide-way and in mixed traffic. The guide-way network can be made using a course mesh (typically a five-km mesh width) since the first and last stretches can be driven manually. Dual-mode is more suitable for longer distances (to, from and between neighbourhoods in large cities) than as a network inside city centres.

### 2.1 Some PRT systems

We are familiar with ten PRT concepts, projects or systems in the world. No true PRT system is as yet in commercial operation, but all are in different stages of development.

A Japanese system, CVS, was operated as early as 1976 at an exhibition. Over a period of seven months, CVS transported 800,000 passengers without any incident and with a total availability of 98.2%.

A PRT-like system has been in operation for 23 years in the university city of Morgantown in West Virginia, U.S. The system has 73 vehicles and five stations, all on separate tracks. The vehicles are rather large (eight sitting and 12 standing passengers) but choose their route individually as in a PRT system and can be driven at 7.5-second head-ways. About 45 million passengers have been transported to this time. The operational experience is good, with 99.8% reliability.

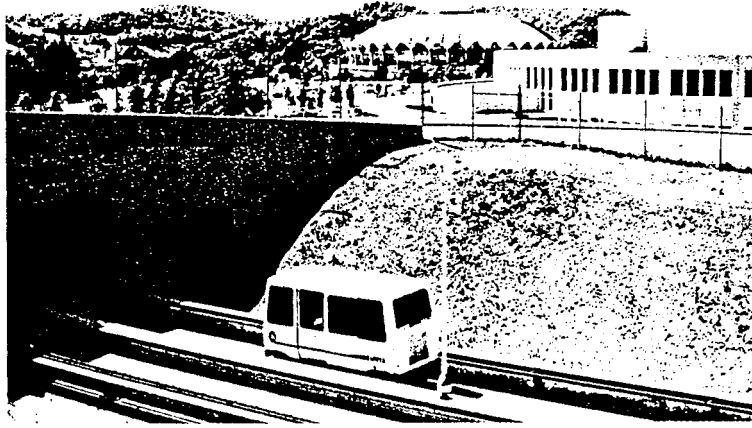

Figure 2.1 PRT in Morgantown in operation since 1975

On the following pages, there will be a brief description of seven PRT systems (in alphabetical order). In this report, we have excluded systems with guide-way switches and systems that are controlled manually. Important data are then summarised in a table, and characteristics that distinguish the systems are discussed. Further information on PRT and other innovative personal transport systems can also be found at the internet address: <http://weber.u.washington.edu/^jbs/itrans/>

## CULOR

Computerised Ultra Light Overhead Guide-way (CULOR) is a new system idea from Lycoming College in Williamsburg, Pennsylvania, U.S.A. The innovator, Jon Bogle, has refrained from seeking a patent and offers his ideas to whoever would like to develop them. CULOR consists of suspended vehicles under a pipe-shaped beam with current collectors and electric motors inside the beam. The control system is decentralised, with computers and extra batteries in the vehicles. On high-speed lines between towns, the vehicles are connected electro-magnetically into trains for less air resistance. The vehicles and beams are designed to be as simple and light as possible.

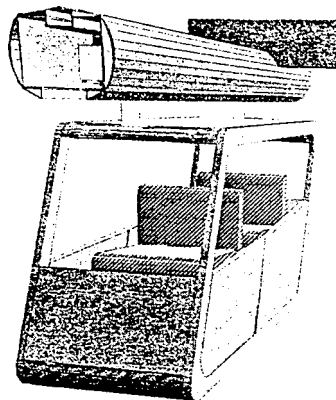

Figure 2.2 CULOR (USA)

## FlyWay

The Swedish FlyWay system is an elevated beam system for suspended vehicles of different sizes. The beam is also able to carry automobiles on hanging platforms. The vehicles can be lowered at stops by extending the arm by which they are suspended, thus making elevated stations unnecessary. Development is on a concept level with small resources.

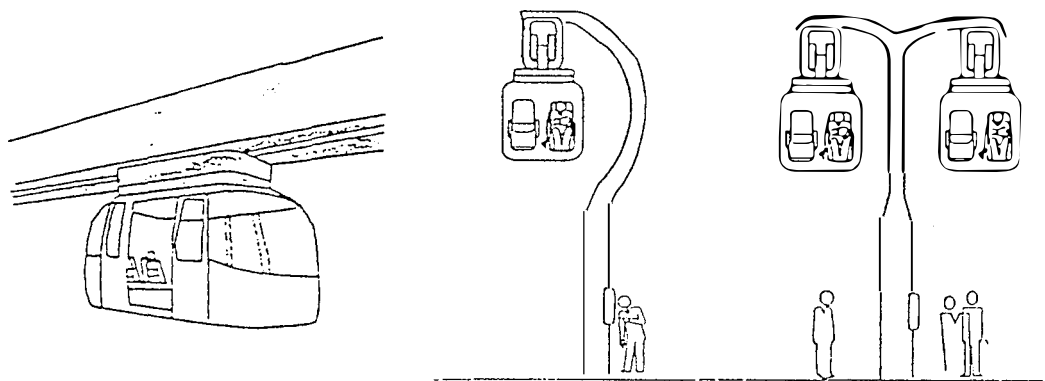

Figure 2.3 FlyWay (Sweden)

## Pathfinder

Pathfinder (U.S.A.) is a suspended, battery-operated vehicle for four to five passengers for which driving and switching take place inside a box girder. The station guide-way can be lowered so that the vehicle stops at ground level. Current collectors charge the battery at stations and provide extra power in ascending ramps that can slope up to 15%. A full-scale model of the vehicle has been built in Seattle, and testing is planned.

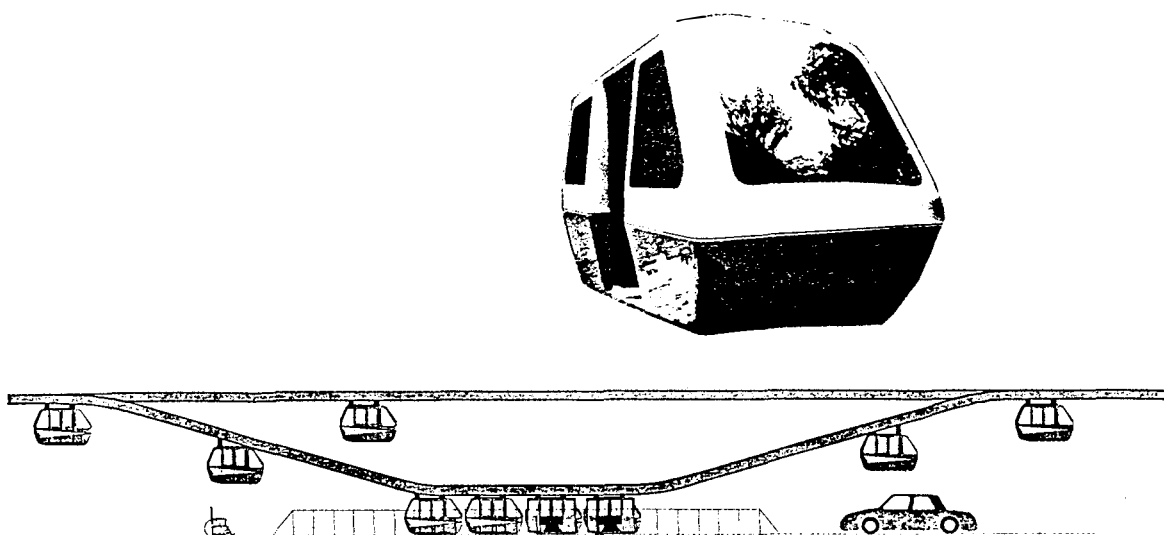

Figure 2.4 Pathfinder (USA)

## PRT 2000

Raytheon's PRT 2000 is the most fully developed system to this time. The concept is based on multidisciplinary research by a group headed by professor Ed Anderson at the University of Minnesota, which still owns the patent. About 300 million SEK (1 USD = 8 SEK) have been invested in its development, and the cost has been divided between Raytheon and Chicago Regional Transit Authority. A test track is in operation with three vehicles at Raytheon's facility outside of Boston.



Figure 2.5 PRT 2000 from Raytheon (USA)

## SkyCab

The Swedish SkyCab is a PRT concept with automobile-like vehicles with rubber wheels that are electrically powered on an encapsulated guide-way. With modern battery technology, the electrical supply can be limited to charging while the vehicles are standing at stations or other charging areas. The vehicles have front-wheel steering, and switching is performed by following antennas in the guide-way. Work has proceeded in co-operation with, among others, Swedish NCC construction company.

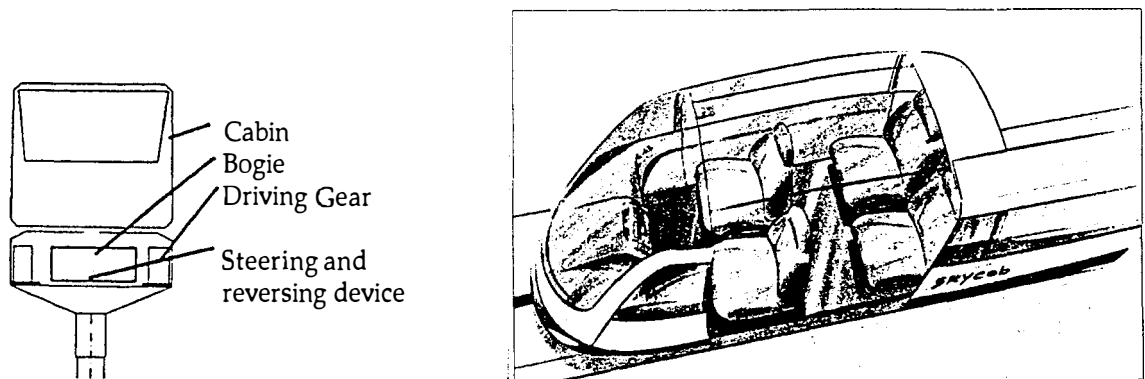

Figure 2.6. SkyCab (Sweden)

## ULTRA

ULTRA is an acronym for Urban Light TRANsport and was developed at the University of Bristol in Great Britain. A vehicle resembling an automobile drives automatically with current collectors in a cement guide-way shaped like a trough. Funds are being sought for a three-year development period and a prototype. The city of Bristol is positive and has assigned alternative locations for the purpose. Co-operating partners include the Rover Group, British Steel and Airbus.

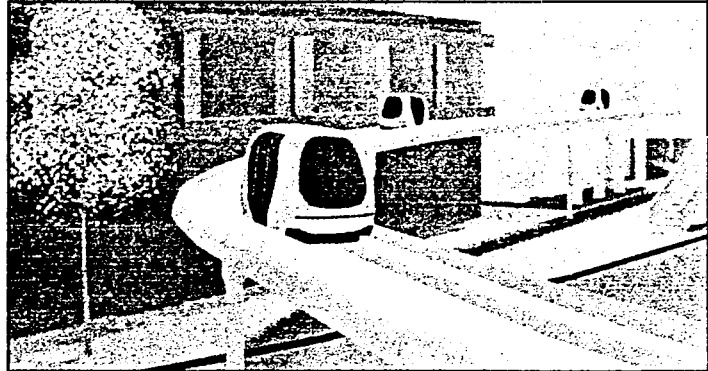
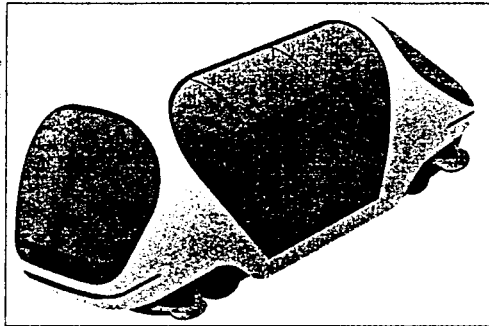

Figure 2.7. ULTRA (Great Britain)

## Ultra-Wave PRT

Ultra-Wave Guided PRT is a linear motor-driven suspended vehicle with rubber wheels moving along the lower flange of an I-beam. The guide-way is extremely slender. Electricity is supplied inductively from the beam. Three small loops without switches and without off-line stations have been built in Great Britain. It is said that both guide-way switching and vehicle switching are possible. The developer, PRT Systems in Chicago, is a small company focussing on the propulsion system.

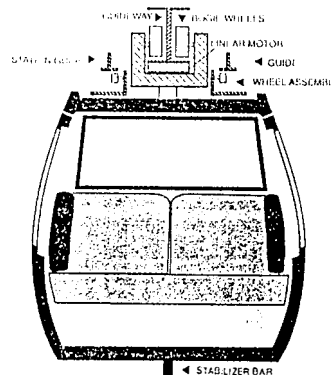

Figure 2.8. Ultra-Wave PRT (USA)

## 2.2 System parameters

Important information is compiled in Table 2.1 and commented upon below.

System	Guideway/ vehicle	Switching	Propulsion	Vehicle cap.	Guideway WxH m	Vehicle LxWxH m	Head- way secs	Theor. capacity pass/t	Max speed kph	Curve radius m	Slope %	Support spacing m	System cost MSEK/km	State of developm.
CULOR	beam suspended	guide-wheels in beam	rotary power rail	2	0,7x0,7	3,5x1,0x1,5			90			30	13	concept
FlyWay	beam suspended	guide-wheels in beam	rotary DC rail	5	0,8x1,1	3,3x1,7xH				8	10	38	66	concept
Pathfinder	beam suspended	guide-wheels in beam	rotary battery	5	0,4x0,5	2,1x1,9x1,2	2	9000	32	6	15	19	50-60	vehicle prototype
PRT 2000	covered U supported	switch wheels to guide rail	rotary DC rail	4	1,8x1,8	3,4x1,6x1,6	2,5	5760	49	18	10	37	79	test track with control
SkyCab	covered U supported	front steering by cable	rotary battery	4	1,5x0,6	3,5x1,5x1,5	1,6	9000	54	20	10	24	24	concept
ULTRA	concrete U supported	steering against wall	rotary AC rail	4			2	7200	80				12	concept
Ultra-Wave	I-beam suspended	moving beam or vehicle switch	LIM in guideway	5	0,3x0,2	3,4x1,7x1,6	1	18000	64	5	8	18	20	commercial no switches

Table 2.1. System parameters

The guide-way is made of steel if nothing else is indicated. Although PRT can be operated on the ground level (with fences) or in a tunnel, an elevated guide-way will be the most common choice. Of the systems mentioned, four are suspended and three are systems with supported vehicles.

It is possible for two of the suspended systems to be lowered to ground level at stations, which is an advantage considering that it would not then be necessary to build stations with elevators and escalators. The disadvantage is that the vehicles, as those in the Pathfinder system, must brake in downward ramps and accelerate in upward ramps or, as in the FlyWay system, have a lowering mechanism on each vehicle (which would be heavy, expensive and time-consuming).

Suspended systems require more lateral space, as there must be a certain amount of space next to supporting structures and between parallel guide-ways to accommodate the swaying of the vehicles.

The ride feeling hanging from under a beam is different from that of riding on a supporting guide-way. The cabin inclines naturally in curves and at acceleration and retardation. The lateral forces in the cabins are reduced, but the feeling can also be unpleasant. Moreover, people may feel uncomfortable by not being able to see the guide-way from the windows of the cabins.

An important difference between suspended and supported vehicles is the height. A beam must be built at least 2.5 meters higher than a supporting guide-way with the same clearance height. It is a matter of discussion as to which of the two causes the least visual disturbance. Beams for suspended vehicles are of a monorail type and are thus more slender (have smaller dimensions) than supporting guide-ways, which are about as wide as the vehicles running on them. Figure 2.9 shows a cross-section profile (guide-way and vehicle) of the different systems on the same scale.



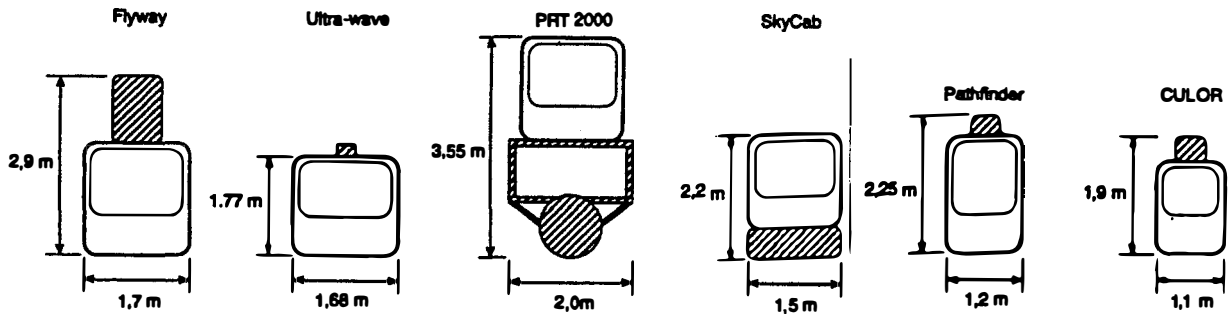

Figure 2.9. Comparative dimensions of guide-ways and vehicles (Stockholm Regional Planning Office)

All suspended systems have narrow beams causing less shadow and less visual intrusion from an oblique perspective.

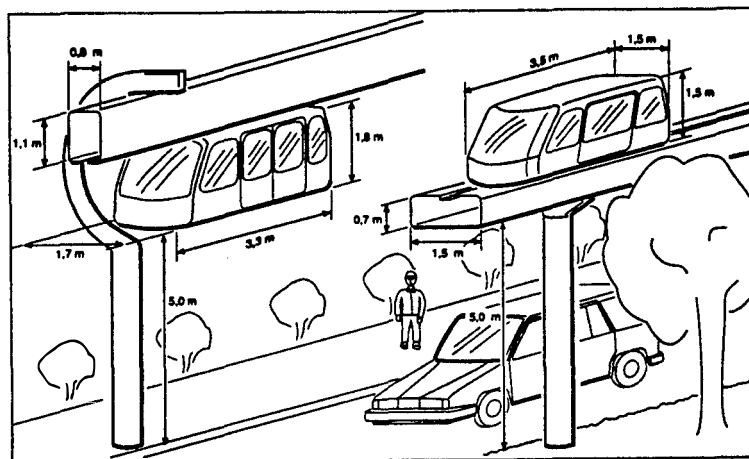

Figure 2.10. Perspective of suspended and supported systems (Stockholm Regional Planning Office)

Some of the systems have more than one size of vehicles and guide-ways. Then we have shown the size that is most suitable for a PRT system. Vehicle capacities of over four passengers can seldom be used in PRT operations.

The time head-way (the smallest safe time interval between vehicles) is limited by speed, reaction time and braking ability in the event of an unexpected stop of the vehicle ahead. Emergency braking is limited by requirements on comfort, which do not differ between the systems. The reaction time should also be similar in the different systems.

Consequently, the time head-way is essentially determined by the speed and is not different between systems. Seat belts or airbags may enable shorter time head-ways.

More than one speed is sometimes given, of which we have shown the highest. High speeds require longer time head-ways and thus imply a lower line capacity. High speeds also require large curve radii but offer at the same time shorter travel times, and thus fewer vehicles are needed.

The theoretical line capacity is calculated on the basis of time head-ways and the size of vehicles. The line capacity is indirectly determined by the time head-way which in turn depends on the maximum speed. The practical capacity is considerably lower than the theoretical capacity (typically 25%), depending upon the proportion of empty vehicles (typically about 30%) and degree of ride-sharing (about 1.5 passengers/vehicle). Larger size than four-passenger vehicles do not increase the practical capacity to any great extent because all the seats can seldom be used.

We have indicated the smallest given curve radius although it may require speed reductions. The radius is normally determined by speed and comfort requirements in curves. Most systems can be controlled so that the vehicles reduce their speed in curves. All systems can or would be able to bank the guide-way in curves (suspended vehicles tilt naturally) which allows a higher speed with acceptable comfort. The curve radius should not be greater than 20 meters for the guide-way to fit into existing street crossings. With a distance between buildings of 18 meters, a circular guide-way curve, two meters wide can be kept at least six meters from all facades in a street crossing.

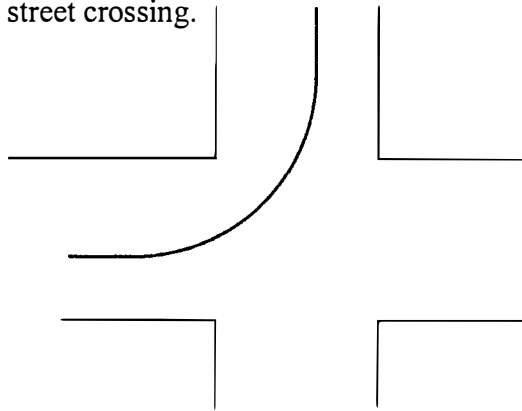

Figure 2.11. Guide-way curve with a 20-meter radius in a street crossing with 18 meters facade distance.

All the systems reported except for Ultra-Wave have good climbing ability and can manage 10% upward and downward slopes. Such steep roads do not normally occur on the ground. Pathfinder can manage a slope of 15%, which is a great advantage, especially when the guide-way comes down to ground level at stations.

Different values are sometimes given for the distance between supports. We have taken the largest indicated, although this may require a reinforced guide-way. Stronger beams allow for a greater distance between supports.

System costs are given as total cost per system kilometre. When the supplier indicated unit costs, we calculated a system cost based on a standard system with five kilometres of single guide-way, eight stations, 40 vehicles and a control system, which coincides with the proposed system for Rosemont in Chicago.

The same value (2 million SEK) is assumed for station costs in all systems. The suppliers' different cost figure for stations is reflecting differences in design more than characteristics that differ between systems.

Raytheon states the highest overall cost. This may to some extent be due to their heavy design. At the same time, Raytheon has come farthest in its development and can thereby make better estimates than other suppliers.

The development stages differ greatly between the systems. The only system that has been tested with a control system is PRT 2000. Ultra-wave has a system in commercial operation, but it has no switches and a simple control system. Pathfinder has a vehicle prototype. Others have more or less developed concepts consisting of drawings, simulations and other analyses on paper. CULOR does not have the ambition to develop its system idea itself.

An important factor about which we have poor information is the degree of industrial backing. Raytheon carries out industrial development with very large resources, but we do not know how far others have come with associating themselves with companies that are prepared for a development of that kind. Most indicate that they have contacts that can be activated when the time comes.

A related question is the availability of financing. If financing had existed, the development would already have taken place. Several indicate that they do have potential financiers. The fact that they have not come farther in their development can be interpreted such that financiers are waiting until there is an order or at least a more concrete client interest.

### **2.3 Comparison of characteristics**

The characteristics that differ between systems are summarised in Table 2.2. Positive and negative deviations from the others are marked with a plus or minus.

It is meaningless to add up the number of pluses and minuses. The characteristics are important and relevant to different extents depending upon the application.

The Swedish weather with snow and ice places special requirements on driving and braking. Linear motor operation (Ultra-Wave), which is completely independent of friction, is ideal in this respect. On the other hand, linear motor operation is not a completely mature technique. The next best with respect to weather is a beam guide-way for suspended vehicles, since the driving surfaces are well protected inside the beam, with the opening on the lower side. Friction can always be ensured by heating the guide-way, but this is a very energy consuming solution.

The opportunity for stations on the ground level is interesting (FlyWay and Pathfinder).

	Tolerance to Weather	Ground-level Stations	Curve radius	Climbing	Visual Intrusion	Development resources	Customer interest	Swedish development
CULOR	+				+	-		
FlyWay	+	+	+					+
Pathfinder	+	+	+	+	+			
PRT 2000					-	+	+	
SkyCab								+
ULTRA							+	
Ultra-Wave			+	-	+			

Table 2.2. Evaluation of systems

Swedish city environments generally have narrow street areas, more so than is the norm in, for example, the United States. The curve radius is thus an important parameter for us.

In areas that have steep uphill areas, the limitation of a 10% slope implies problems (detours). Ultra-Wave's climbing ability is poor.

In our opinion, the visual disturbance is generally the greatest restriction to the introduction of a PRT system in many Swedish environments. The problem is greatest in areas where there are older buildings.

CULOR does not have the necessary industrial support (development stage). There are probably more that also lack sufficient support, but they should be given the chance to report on this.

The two Swedish systems, FlyWay and SkyCab, allow the possibility for industrial development in Sweden, which is an industrial and trade advantage. SkyCab works together with Swedish NCC construction company. PRT 2000 is expected to involve development of guide-ways within Swedish Skanska company.

### **3. User encounter with technology**

A study carried out by the Institute for Consumer Behaviour identified and described potential target groups for PRT systems and pointed out their requirements and desires in their meeting with this new technology. The study shows what traveller problems can be solved by a new, advanced personal transport system. It also describes the conditions for the acceptance of PRT from a user perspective.

The questions in the study concerned:

- Who will finally use such systems?
- Can these systems attract travellers from other types of traffic, especially automobile drivers?
- What trust do people have in travel in vehicles without drivers?
- How is travelling alone or enclosed with other travellers experienced?
- Will people trust the automatic system to take them to their destinations?
- How is being transported above ground level experienced?

Traditional mode choice models answer other types of questions than those posed above. There are no travellers of PRT systems to be interviewed or studied. People's feelings, attitudes and behaviour in their meeting with this new technology are very difficult to study and predict. It is thus necessary to carry out model studies that pattern reality very closely.

In an attempt to study people's meeting with this new technology in a setting as close to reality as possible, a part of this study was made in so called virtual reality (VR). A sub-study was carried out as detailed interviews in an actual PRT vehicle with VR technology, and another sub-study was done as focus group interviews.

#### **3.1 Deep interviews with VR travellers**

With the help of virtual reality (VR) technology, a guide-way of a proposed PRT network was modelled at Lindholmen in Göteborg. The work was carried out as a student project at the VR centre in the area. A video was made of an intended trip in a simulated PRT vehicle, see Figure 3.1. A guide-way four to five meters above the ground and surrounding houses, nature and traffic were modelled in a natural way with appropriate sound.

Thirteen persons participated in the study, chosen from the institute's address register of persons who had previously participated in evaluation studies. Out of the study subjects, five were exclusively public transport users (one of whom was a user of taxi services for the elderly and handicapped) and eight were automobile drivers, of whom several also used public transport. The persons were between 25 and 72 years, six men and seven women. The public transport users were either youngsters or older people. Most of the automobile drivers were middle aged, although two were older.

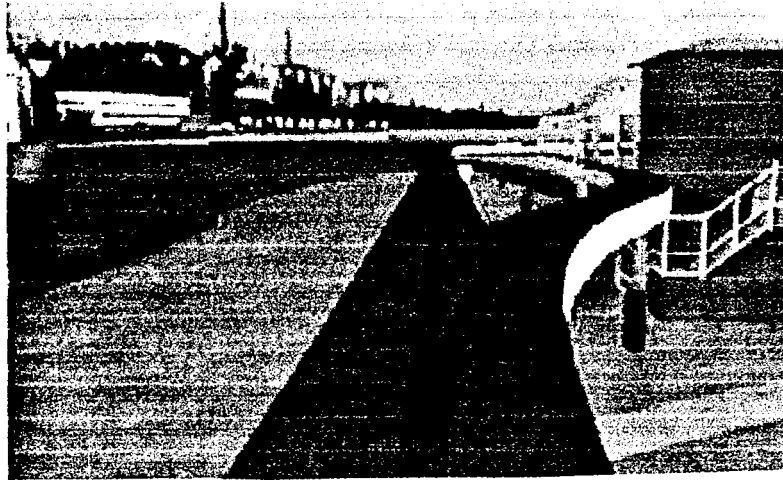

Figure 3.1. Picture from the VR animation of a PRT guide-way at Lindholmen

The study subject first received general information about PRT according to the following:

PRT is:

- A taxi without driver running on a guide-way four to five meters above other traffic
- A complement to existing public transport
- Vehicle waits for passengers at a station
- Starts when someone wishes to travel (24 hours a day)
- No stops on the way and no transfers
- Passengers ride alone or together with the co-passengers of their choice
- Line capacity comparable to tramway (many vehicles)
- Investment and operations cheaper than tram
- Taxi service at bus fare

How do you travel?

- Go to the nearest station
- Enter your destination at the ticket machine
- Take your ticket to the first free vehicle
- Insert your ticket and sit down
- The door will close and the vehicle will start to move
- Undisturbed trip without other passengers

What if?

- There are video cameras at stations
- The door will not close if there are too many passengers in the vehicle
- There is an emergency call system directly to the control centre
- The stop button stops at the first stop
- Duplicated current supply, motors and computers
- Emergency battery and run-flat tyres
- Stops unless a clear signal is given
- Can be pushed to the nearest station

A full-scale model of Raytheon's system, PRT 2000, on exhibit at Eriksberg in Göteborg, was used for showing the film and making the interviews. A television screen was placed in the vehicle at the windshield while the study subject and interviewer sat facing forward across from the screen. The interviews were semi-structured and were carried out by an experienced interviewer. The total session with each study subject took about one hour.



Figure 3.2. Deep interviews in a full-scale model with video monitor placed at the windshield.

The conclusions from the deep interviews were:

1. All the study subjects were positive toward PRT.
2. If PRT existed in Göteborg, they would choose to use it for more or less frequent trips.
3. All the study subjects had faith in the technology for the automated trip without a driver. They felt safe during the trip.
4. The greatest conflict appears to be the visual disturbance to the city environment. Half of the study subjects could not accept the effect of the PRT guide-way on the older city environment. It can be accepted on certain traffic corridors but not in the city centre. These statements are in conflict, however, with the desired availability. The conclusion is thus that great care should be used in the design and placement of the guide-way.
5. The environmental questions were unexpectedly important, particularly among the automobile drivers. Attention was paid to the positive environmental effects of PRT in different environments.
6. Certain questions concerning the manoeuvring of the vehicles in emergency situations, communication with surroundings and so forth had been experienced as unclear. Better design of the safety systems is necessary, including e.g. the possibility for manual manoeuvring of the vehicles when they start and manual control of the doors. Certain interior details in the vehicle should be modified to make the trip more comfortable.
7. The use of the VR technology was successful. The study subjects reported that they had the impression of travelling four to five meters above the ground. This opens new possibilities for more realistic prototype studies using VR technology.

### **3.2 Focus group interviews**

The focus group is a variation of the group interview, which means that a group of eight to ten persons holds a conversation about a particular subject under the guidance of a moderator. The moderator focuses the discussion on one or more predetermined themes.

Each group convened for two hours. After a short presentation and a video film (the same as was used in the detailed interviews), the group's spontaneous comments were recorded. The participants were then asked two by two to note four positive and four negative judgements about PRT. When all these had been reviewed by the whole group, a general discussion was held according to the question scheme. Finally, an exercise was carried out on the theme "Would you consider becoming a PRT customer? – conditions and requirements".

The following questions were found to be most important:

- Safety issues, desires concerning supervisory personnel or at least camera monitors. The lack of safety at stations during night hours was a source of concern.
- There was faith in the technology and the automated system.
- Problems concerning fear of heights were relatively small in the group but it was felt that this could be difficult for some passengers.
- The visual effect on the city environment was felt to be so disturbing that it was considered impossible to have a guide-way in the city centre.
- The vehicle was considered to be attractive and somewhat futuristic.
- The most important positive judgements were speed and environmental aspects.
- The most important negative judgements were lack of safety and high costs.

Similar interviews were made in Rosemont in the Chicago region in 1996. The results of the Swedish and the American studies show very good agreement. The most important statements made in the Rosemont study were:

- Concept and technical solutions were considered to be exciting and futuristic.
- Security concerning undesired passengers in the vehicle was considered poor. The alarm function and emergency exit in the vehicle were questioned.
- Security at stations when a passenger was alone during evening hours was considered to be poor. A desire for supervision was expressed.
- The capacity of the system during rush hours was questioned.

The results of these two independent studies support one another.

### **3.3 Comparison between deep interviews and focus groups**

The responses given in the deep interview and in the focus groups were in complete agreement in the following questions:

- A height of four to five meters over the ground was not a problem.
- The visual disturbance to the city environment can not be accepted in the old area in the city centre but was acceptable along routes leading into the centre.
- Obvious advantages of PRT are its limited environmental impact and its speed.



- Problems travelling with PRT were foreseen for older people, persons who are frightened of heights and allergic persons.
- The walking distance to PRT should not exceed about 500 meters or a five to ten-minute walk.

Automobile drivers are a group of potential PRT users that are expected to have demands other than those placed by public transport riders of today. The demands made by automobile drivers and public transport users were different in the following areas:

- Automobile drivers saw the lack of supervisory personnel as a serious problem, while public transport users were more concerned about alarm functions and emergency exits.
- Automobile drivers could consider a maximum of 500 meters' walking distance (without baggage), while public transport users could accept the same walking distance as they had today, which corresponds to up to 800 meters.

In summary, the automobile drivers showed a sceptical wait-and-see attitude in which PRT was considered to be expensive and ugly in the city environment. The public transport users had a more positive attitude and saw the system as fast, admittedly ugly in the city environment but better adapted to the environment than the current system.

#### 4. PRT in cityscape – demands and acceptance

The Department of Urban Planning has studied requirements and consequences for the city structure and city environment in the event of the introduction of PRT systems in Swedish cities. The studies have focussed on the city environment of Gävle, where a PRT system is considered according to studies made by the City Planning Office there. Computer generated guide-ways and moving vehicles have been overlaid on video films. In this way, moving pictures can be created of how the traffic environment in Gävle would be affected by a PRT system.



Figure 4.1. Photomontage of a PRT system along Västra vägen

New elements are introduced into the city environment with a PRT system: supporting structures, guide-ways and moving vehicles. The supporting structures can be given a double function by integrating them with benches, bicycle stands, outdoor lighting etc. To avoid a visual barrier effect, the supporting structures should be as narrow or transparent as possible and should be spaced at as great a distance as possible. The placement of the structures can be used in a positive way to create street space for which priority is given to environmental concerns: narrowing roads, giving priority to pedestrian and bicycle traffic, creating parking areas or planting green areas.

The guide-way is a continuously horizontal element that has not previously existed in the city environment. The continuous line can be softened by dividing the guide-way up with trellis work or panels. PRT interacts most with the second stories of the buildings, which have to this time not been affected as much as the ground floor by changes in shop windows, signs, awnings and entrance-ways.

The intention is to design the PRT vehicle in Gävle to look like a traditional tram.

The PRT will pass through many different types of environments: buildings from the 1960s, buildings in the classic style from the 1920s, Swedish romantic style, the Jugend style, architecture from the 1980s, older wooden buildings, parks, open landscape, industry etc. These environments place individual demands on adaptation while the PRT system itself allows only limited opportunity for variation.

The guide-way can be varied with different panels, and the supporting structures can be designed in different ways for the different environments.

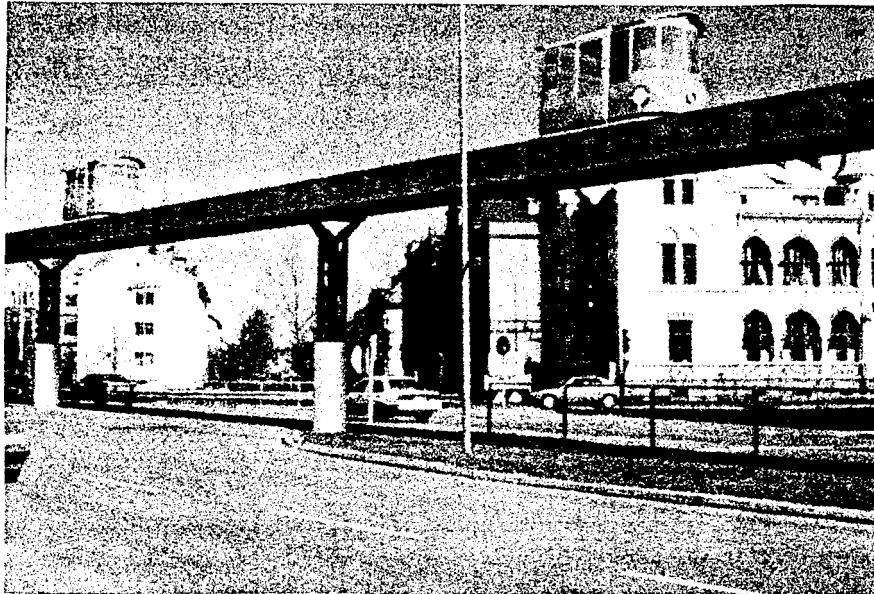

Figure 4.2 Photomontage of a PRT system at Bergsgatan in Gävle

The collision protection around the supporting structures blends in with sidewalks and street covering. The trellis work creates a certain amount of transparency – the traffic sign is a greater visual obstruction.

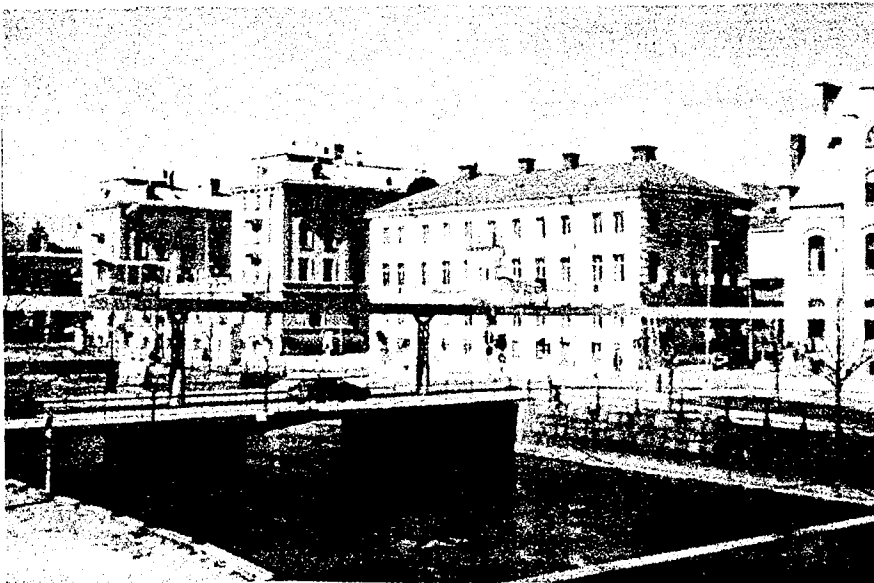

Figure 4.3. Picture from a computer animation of the passage over Gävleån at the Seamen's Church.

The picture shows an interesting city picture in terms of cultural history, with a number of buildings, a pier, water and a bridge. The city picture contains strong horizontal lines that reduce the significance of the guide-way.

Most Swedish cities have central areas that are of national interest for cultural environments. Of Sweden's 28 cities with over 30,000 inhabitants (except Stockholm, Göteborg and Malmö), there are areas of national interest in 24. Such areas are protected by the Natural Resource Act, the Planning and Building Act and the Historical Culture Act. This protection now applies not only to individual buildings but even to complete areas. New buildings and structures must be designed with consideration to these values. While a careful design is possible, these acts provide possible grounds for protests and objections on the part of individual property owners.

The conditions in Gävle are complicated by the fact that the entire stretch of guide-way to be built in the first stage is located in areas declared to be of national cultural interest. The consequence of this is that great care must be taken concerning colour, form and choice of materials in the design of the PRT system. There are also strict requirements on adaption of the system to the existing environments.

The Planning Office in Gävle and architects from FFNS designed and adapted a PRT guide-way to the city environment of central Gävle. They write in their report that the visual intrusion of the track system to the city environment can be avoided by careful architectural design of supporting structures, guide-way beams, vehicles and stations and good adaptation to the street environment and surrounding buildings. Their conclusion is that *a carefully designed and well functioning PRT guide-way is judged to have a good possibility of being a positive element in the city environment in Gävle in spite of significant visual intrusion.*

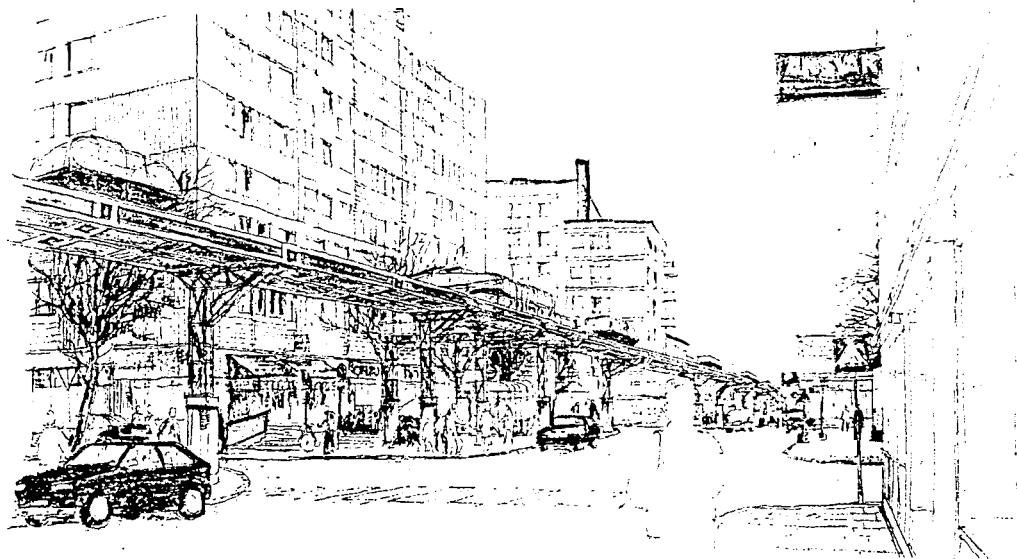

Figure 4.4. Taken from the Gävle city atmosphere study by the Office of Technology.

## 5. Guide-way design

PRT guide-ways can be placed at ground level, in tunnels below ground level or elevated above ground. It acts as a barrier when it is placed on ground level, and tunnels are expensive. For these reasons, most PRT systems are expected to be built as elevated guide-ways on supporting structures. The guide-way with its supporting structures, foundations and stations normally account for about 70% of the total investment in a PRT system. It is difficult to place supporting structures in such a way that they do not interfere with electric and telephone cables, water, sanitation, heat and gas pipes under the surface. At the same time, the visual disturbance caused by an elevated guide-way is one of the greatest hurdles to the introduction of PRT systems.

The guide-way design affects cost, span and visual intrusion and can thus be decisive for the possibility of introducing a PRT system. Professor Nils-Erik Wiberg led a pre-study on design solutions to enable narrow, light guide-ways allowing for spans between supporting structures and simple foundations.

### 5.1. Preliminary beam section

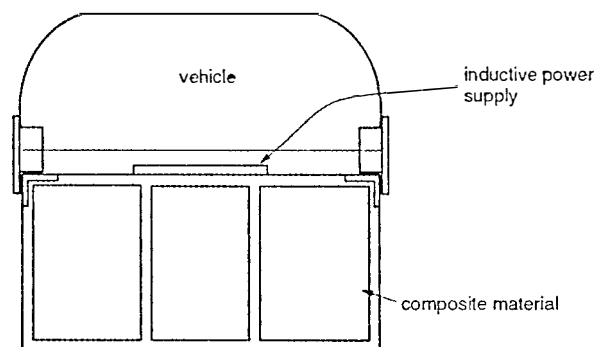

Figure 5.1. Cross-section of beam and vehicle

Work is focussing on a supported guide-way for a small, automobile-like vehicle. With hanging vehicles, the pillars must be made higher with greater strains in the ground foundations. A converted electric vehicle is presumed to be furnished with railway wheels turned inside out so that it is able to steer on a simple rectangular box girder. The power supply can be inductive between guide-way and vehicles. Alternatively, there may be a linear motor where the passive part is in the vehicle. By using lightweight composite material and closed, hollow profiles, the weight can be kept low. The beam sections can be both curved and super-elevated in curves. They are supported by pillars with expansion joints.

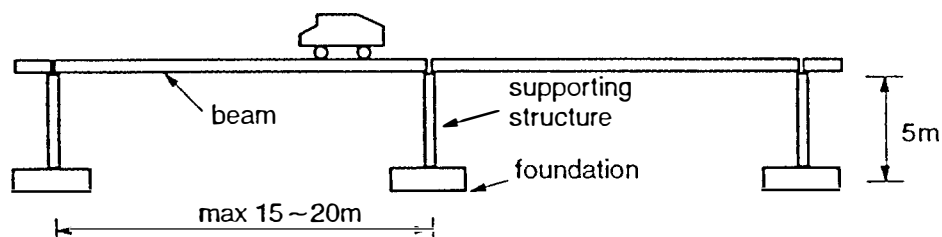

Figure 5.2. Beams supported by pillars

The ground foundations are assumed to be designed to have a slab of fiber concrete distributing loads over a larger surface. Piling, which is both expensive and time consuming, is normally assumed to be avoided owing to the light weight of the guide-way, supporting structures and vehicles.

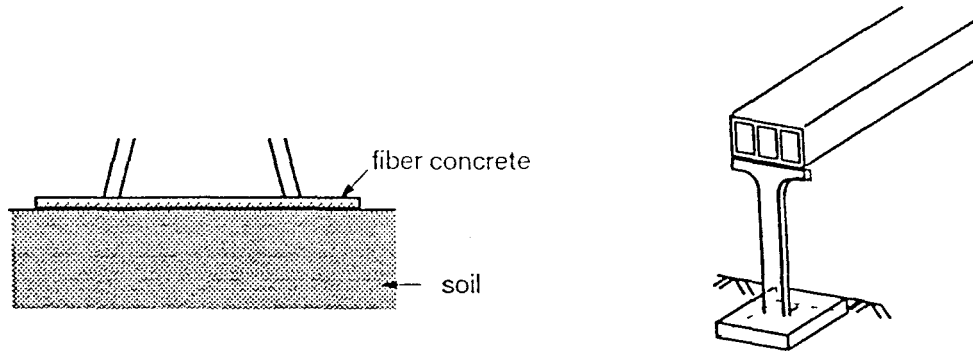

Figure 5.3. Ground foundation with slab

In switching, there are grooves in the guide-way for the wheel flanges. Switching is performed by a lever arm coming down from the vehicle on the inner side of the switch.

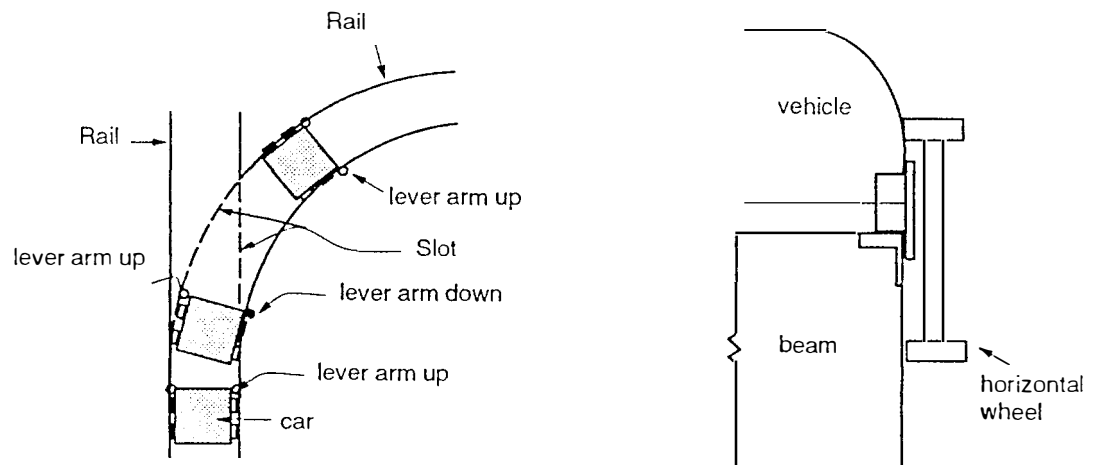

Figure 5.4. Switching with lever arm

## 5.2. Need for research

Before a solution according to the above can be realised, there is a need for further research in several areas:

- Design of beams and supports, choice of material (e.g. glass fibre) and production method
- Ground foundation for light-weight designs
- Dynamic stress and interaction between vehicles, guide-ways, pillars, foundation and ground
- Modification of vehicles with respect to wheels, switching, inductive transfer and control system.

## 6. Traffic strategies and network extension

PRT is individualised transport with vehicles departing on demand and taking the fastest route to the destination without intermediate stopping. PRT systems pose very interesting traffic management challenges.

The vehicle occupancy is estimated to be similar to that of today's taxi, i.e. an average of 1.2-1.5 passengers. All proposed PRT systems have small vehicles with room for 3-5 passengers. To fill up larger vehicles, it would be necessary to introduce timetables and/or to make stops along the way. Hence a great deal of PRT's attractiveness and competitiveness would be lost if larger vehicles were used. Small vehicles are also light, and the guide-ways could therefore be made narrow, light and relatively cheaply.

To achieve sufficient capacity with small vehicles, there must be a large number of vehicles running at short time head-ways. When stations are located off-line, vehicles need not stop on the guide-way blocking other vehicles. Off-line stations are also necessary for direct trips without intermediate stops.

The following fundamental problems must be solved:

- choice of fastest route
- prevent tendencies toward congestion
- giving priority in weaving points
- advancing vehicles within stations
- redistribution of empty vehicles.

Beyond the above, we have also studied the following aspects:

- ride-sharing in PRT systems
- integration with route services
- strategies for extending networks

This chapter describes how we have approached the above problems.

### 6.1 Safety distances

The distance between vehicles is normally chosen so that a requirement called "brick-wall stop" requirement is fulfilled. This requirement implies that if a vehicle for some reason suddenly stops, the next vehicle will have time to discover this, make a decision to stop and activate its brakes so that a collision is avoided or at least does not cause any damages. The higher the speed, the greater the time head-way must be. At 36 km/hour, a vehicle length of 3.5 meters, a reaction time of 0.1 second and emergency brakes activated gradually over 0.5 second to  $6 \text{ m/second}^2$ , this demand means a smallest time head-way of 1.6 seconds or 16 meters distance headway (nose to nose).

No safety distance is needed between two vehicles without passengers. There, the operator is free to make his own risk assessment as only hardware is at risk. We have allowed empty vehicles to drive somewhat faster so that it is possible for them they to form platoons.

In this way, guide-way capacity can be increased by up to 80% depending on the mix of empty and loaded vehicles. It is advantageous for several empty vehicles to come in a row so that the shorter distances can be exploited. The mix can be controlled by the way in which vehicles are merged in weaving points.

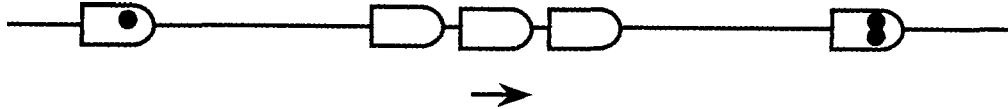

Figure 6.1. Platoon driving with empty vehicles

## 6.2 Choice of route

Each PRT vehicle finds the fastest route to its destination. Each switching point has access to a table with the best choice or time to each destination. When a vehicle enters a link, that vehicle calls the next switch point giving its destination. The switch computer then answers right or left according to the fastest route. The fastest route tables are recalculated when necessary, taking consideration to driving times on links during the recent period.

We have taken the planning one step further. We consider the latest observed driving times at the next links while the remaining driving time is taken from tables. This allows immediate reaction to disturbances on the nearest downstream links.

## 6.3 Synchronous and asynchronous control

Synchronous control implies that all vehicles move at the same speed along movable "gaps", like on a belt. A vehicle is not allowed out onto the main guide-way before a central computer has checked that there is a free gap all the way from start to destination. The vehicles need not brake along the way, but there may be a wait on the acceleration track before entering the main line. The search for a free space becomes more difficult the larger the network is, especially when many vehicles are in motion. The principle can work, however, and we have simulated it for systems up to 11,000 vehicles.

The method of synchronous control has one major flaw – it is sensitive to disturbances. If a vehicle breaks down or cannot maintain its speed, the entire plan breaks down and must be recalculated. For this reason, we have abandoned synchronous control. With asynchronous control, vehicles are allowed out onto the main line as soon as there is free space. Conflicts in weaving points are solved by making vehicles slow down or stop. Queues may develop, but the risk can be decreased by intelligent route choices.



## 6.4 Weaving

Conflicts can occur at merge points. At each merge point, there is a computer determining which vehicles may pass and which may have to reduce speed or stop. We have proposed the point synchronous control principle for solving merge conflicts. Point synchronous control is a combination of synchronous and asynchronous control. At a certain distance before a weaving point, the vehicle calls a computer in the merge point. Each vehicle is given a time slot for passage by the merge computer. Each vehicle can then regulate its own speed so that the weaving point is passed at the given time. For safety the distance to the next vehicle in front is measured continuously so that safe distance is maintained. Empty vehicles in a platoon can be let through in the same time slot.

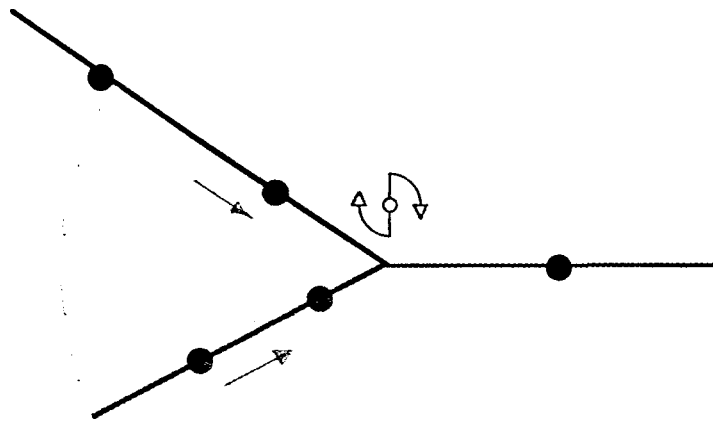

Figure 6.2. Point synchronous control

In the choice between vehicles from the two incoming links, priority is given to collecting empty vehicles into platoons and also to avoiding queues growing backwards past the next upstream switch.

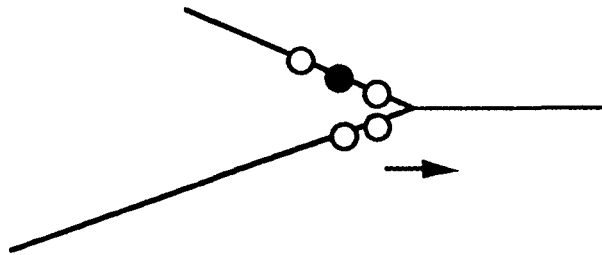

Figure 6.3. Weaving

## 6.5 Moving vehicles within stations

All stations are located on side tracks whose length must allow space for:

- Switching out so that slowing vehicles do not disturb traffic on the main line (15 meters)
- Braking (20 meters)
- Queue of vehicles before the platform
- Platform spaces for vehicles being debarked, waiting for passengers and being embarked
- Acceleration (20 meters)
- Switching out onto the main line (15 meters)

The station guide-way will be minimum 70 meters, plus four meters for each vehicle position. The stations can be designed in different ways according to figures 6.4 and 6.5.

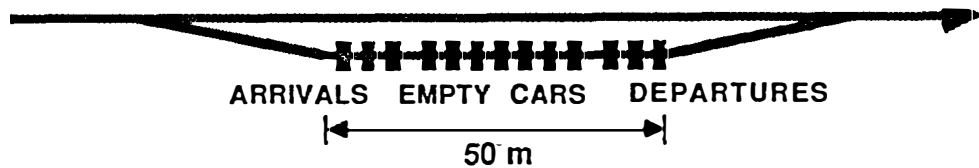

Figure 6.4. Station according to the principle debarking – empty vehicles – embarking

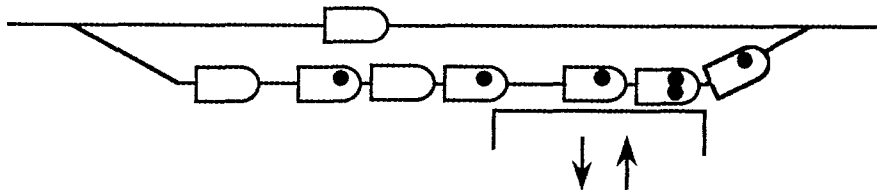

Figure 6.5. Station for combined debarking and embarking

Our assessment is that the need for space and visual intrusion are the decisive factors in the design of stations. Combined debarking and embarking allows short platforms but does not allow room for empty vehicles. When vehicles come in with debarking passengers, empty vehicles must sometimes be dispatched in order to make room at the platform. This arrangement makes the planning of empty vehicles more difficult and leads to more empty vehicle movements. The empty vehicle problem can be solved, however, and availability can improve with empty vehicles kept moving. During off-peak periods, some of the vehicles are parked in a depot – they would be in the way if they were parked at stations.

We studied how vehicles should advance within stations for the greatest possible debarking and embarking capacity. As soon as there is space, as many vehicles as possible advance as far as possible. When the passengers in a vehicle have debarked, waiting passengers are allowed to enter that vehicle at the same position. If no passengers are waiting, the vehicle moves forward as far as possible to make room for vehicles behind it.

Using simulation, we estimated the passenger capacity of stations depending on the number of vehicle spaces. We made the assumption that debarking and embarking times are an average of 5 seconds, a minimum of 2 seconds and a maximum of 15 seconds for a group of average 1.3 passengers. We further assumed door opening and closing times of 1.5+1.5 seconds and that movements within stations is at 9 kph. The station capacity (total number of debarking and embarking passengers) was estimated according to the diagram below.

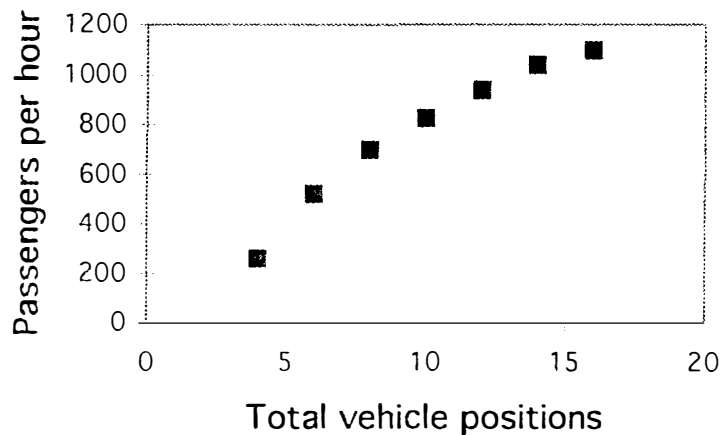

Figure 6.6. Station capacity

The diagram shows the capacity for 1 - 7 platform positions corresponding to a total of 4 - 16 positions on the station track. Space is needed for at least as many vehicles waiting in front of the platform as there is room for at the platform. The first platform positions can each handle 250 passengers while additional positions are used to less and less advantage. There is little gain making the platform longer than 7 or 8 positions. For stations with more than 1200 passengers per hour, it is better to divide the station into more than one platform.

The last waiting position is kept free for incoming vehicles with passengers. Nevertheless, it happens occasionally that there is no room on the station track for an incoming vehicle, in which case it is forced to continue on the main line. If it is an empty vehicle, it is given a new destination and another vehicle is called if necessary. If it is a loaded vehicle, it must make a round trip and come back again. We have dimensioned the stations so that, in heavy traffic, it will be necessary to turn away no more than 1-2% of incoming loaded vehicles.

## 6.6 Redistribution of empty vehicles

An interesting challenge is the redistribution of empty vehicles in a PRT network. Empty vehicles end up where many passengers disembark while the need for vehicles exists where many people embark. There is generally a lack of balance between embarking and disembarking passengers at the same station. The problem is most difficult at rush hours when many travel in the same direction. In the extreme case that all passengers are making the same trip, the vehicles will be empty about 50% of the time. In the centre of an urban area, the traffic is distributed over a number of different destinations, which makes the situation somewhat easier. During daytime hours, trips are also spread out to a greater extent and the availability of free vehicles is better. The larger the network, the more difficult the demands because driving times increase while the acceptable waiting time does not. When there is a lack of vehicles, it is often too late to call one. With short platforms at stations, it is also important to dispatch empty vehicles quickly and make room for arriving vehicles.

The problem of evening out too many and too few vehicles without taking consideration to the time order is the classic transport problem, and methods have been developed for finding the optimum solution. We solve the classic transport problem of expected deficits and surpluses during a period, e.g. a 15-minute period, using a standard method called "transportation simplex". Lists are stored from the static solution of stations to which vehicles are to be sent or from which vehicles are to be called.

In the case of PRT, decisions must be made immediately for vehicles to be sent away. The lists from the static solution are used for successive decisions in the following way:

- surpluses and deficits are calculated for each station continuously considering passenger queues, vehicles at a station, oncoming vehicles etc.
- in the case of a momentary surplus, vehicles are dispatched to the greatest deficit on the send list or, as a second alternative, to the greatest deficit of other stations
- in the case of a deficit, vehicles are called from the nearest upstream (according to driving time) station on the list that has vehicles available or, as a second alternative, from other stations with vehicles available

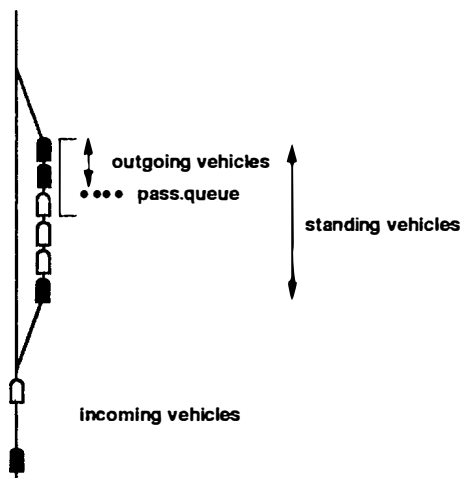

Figure 6.7. Surpluses and deficits of vehicles at a station

The result for an intended network in central Göteborg with 50 stations and 580 vehicles is for peak hours:

- 63% of all vehicles drive with passengers
- 28% of all vehicles drive without passengers
- 9% of all vehicles stand at a station

In this case, passengers had to wait an average of 1 minute for a free vehicle with 99% of waiting times less than 2.8 minutes.

During off-peak hours, some of the vehicles are sent to the depot. We can allow a higher proportion of remaining vehicles to drive empty in order to keep waiting times short.

### **6.7 Ride-sharing in PRT systems**

The fundamental concept in a PRT system is individual trips without waiting times. There is only a small probability that someone else will make the exact same trip at the exact same time.

Travel flows are more concentrated in rush hour traffic, and travellers return day after day. With time, passengers recognise other passengers making the same trips as they do. We suggest that the travel fee should be based on vehicle trips and not on passenger trips, which would encourage voluntary ride-sharing. The effect would be greatest during rush hour traffic, but it is also the rush hour need for vehicles that determines the number of vehicles in the fleet. During other times in a 24-hour period, there is normally an surplus of vehicles and thus no need for ride-sharing.

A differentiation can also be made in ticket prices such that those who accept being matched by the system with other passengers pay a lower price. They are then encouraged to wait (a maximum of three minutes) in order to enable a shared ride. In the event of queues, the ticket computer knows whether more than one passenger has ordered the same destination and can advertise "next vehicle to station X" so that ride-sharers can embark. This type of ride-sharing reduced the need for vehicles in Gävle by 35%.

Even greater savings can be made if stops are permitted along the way. We studied a variation of ride-sharing with stops for debarking passengers as long as the detour would not be too great (a maximum of 30%). No new passengers were allowed to embark and thus there was no risk for unknown co-travellers. The vehicle savings with two extra stops was 57% in Gävle, and the load was an average of 2.1 passengers per vehicle.

### **6.8 Extension of a PRT network**

One objection to PRT systems is that the system will not be sufficiently attractive until it is fully developed so that all local trips can be made using it. It is true that the network will be more attractive and the use of it better the more trips that can be made without transfers. Still, the most important thing is the use in relation to the cost. Out of the total cost, about 70% is capital costs for the guide-way and stations. A reasonable measurement of the effectiveness is thus the number of daily trips per kilometre of guide-way.

In earlier studies in Gävle with the cost estimations that were made then, we calculated that the total cost per trip was comparable with bus traffic if there is a daily trip per two meters of guide-way. A small network can also be cost effective if it is designed so that the number of trips per kilometre of guide-way is high.

To achieve a reasonable financial situation during early stages of extension of the system, it must be started in the area in which many internal trips are expected. Introductory stages should thus include points of attraction that generate a heavy flow of trips, such as train stations, squares or malls, hospitals, schools etc.

A reasonable strategy is therefore to

1. Begin with a small network in the city centre including most trip ends
2. Expand on the basis of additional trips per additional guide-way length
3. Discontinue when the number of trips per length of guide-way becomes too low.

An extension plan for Gävle was developed with these guidelines. The results are shown in the figure below.

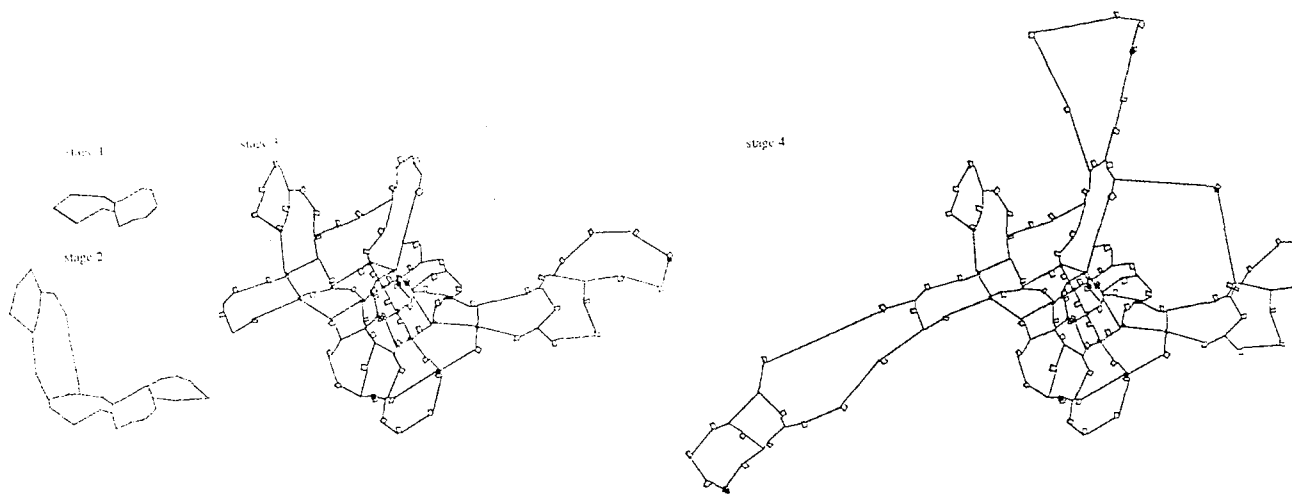

Figure 6.8. Extension stages for Gävle

The most suitable areas for PRT systems are small and medium size urban areas with residential areas, work places, a link with regional communication, business centres and services.

### 6.9 Double or single guide-way

All traffic on guide-ways is in the same direction. Two guide-ways in opposite directions can be mounted together to make a double guide-way.

The advantages of double guide-ways are:

- + fewer supporting structures
- + lower cost per kilometre of guide-way
- + the visual disturbance is concentrated to fewer places

The disadvantages of a double guide-ways are:

- complicated intersections
- a wider street area is needed between opposite building facades
- greater visual disturbance in one place

Stations with traffic in both directions complicate trip assignment because travel demand can not be distributed in advance between the two directions. The assumption is made that passengers choose the best direction of departure for each trip. If he makes an bad choice of direction, the only consequence is that the trip gets somewhat longer (around a mesh in the network).

In our network designs, we preferred single guide-ways because they are easier to fit into the city environment. By separating the two guide-ways, more people can reach stations within a short walking distance. We also attempted to separate four-way intersections into three-way intersections to avoid separate levels of guide-way.

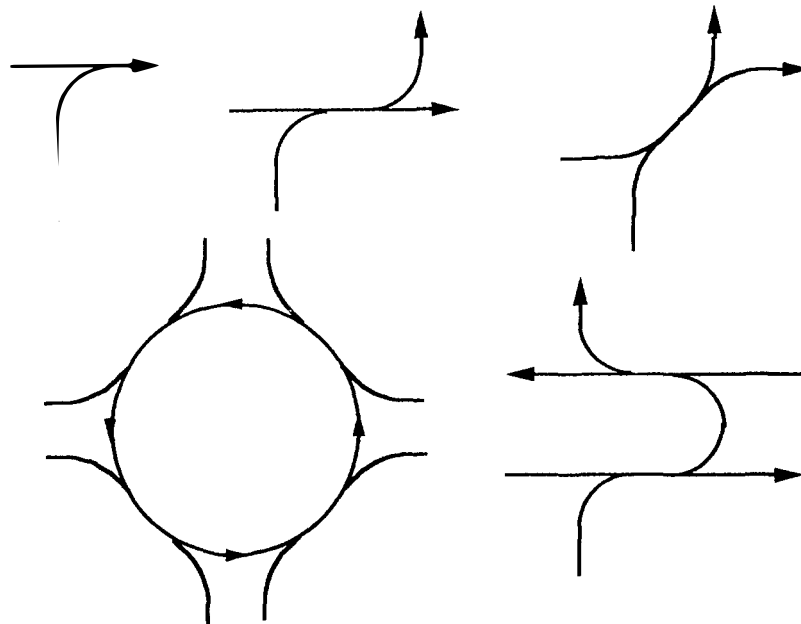

Figure 6.9. Types of single-level intersections

## 6.10 Dynamic simulation

The various ideas about the control of PRT systems have been implemented in simulation models – for the movement of the vehicles at stations and for the entire PRT network. We can set model parameters to represent systems with different characteristics. Using the simulation models, we evaluated the principles for route choice, management of empty vehicles and ride-sharing.

The guide-way network is described by its links, merges and diverges. Trip demand is given as a matrix from which passengers are randomly generated. Results from a simulation include measures of travel standard, such as waiting times and travel times in each relation. The use of resources is calculated for vehicles, guide-way links and stations.

The simulation can be followed by an animation of vehicles and passenger queues on the computer screen. Vehicles are given different colours depending on how many passengers they hold. The simulation model has been applied to systems with up to 17,000 vehicles.

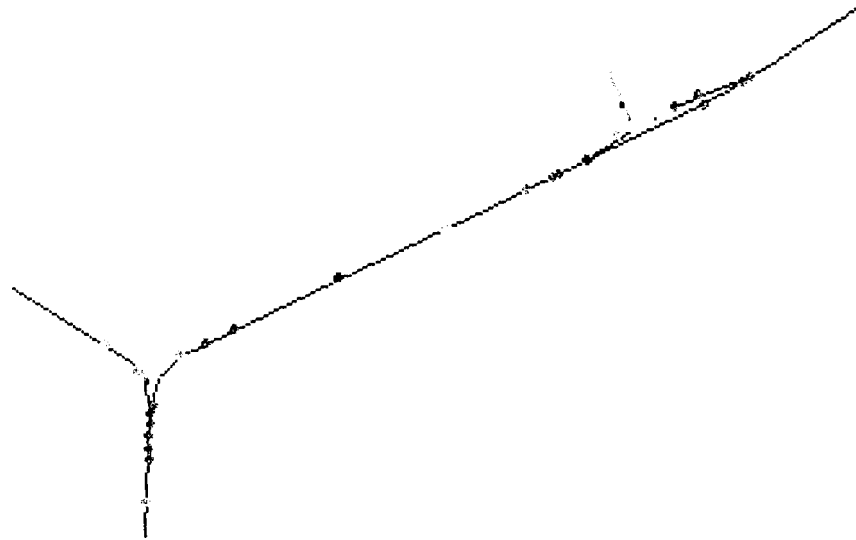

Figure 6.10. Snapshot of an animation of a PRT system



## 7. PRT travel demand

### 7.1 Interaction with conventional transit

When PRT systems are introduced into Swedish cities, they will for the foreseeable future co-exist with today's route services with buses, trams, subways or trains. A probable use of PRT is for local distribution and collection around a commuter train or subway station together with the local services that are often located around stations. There are normally also connecting regional bus lines.

We developed a special type of traffic network analysis for the calculation of trip routes, travel standard, passenger loads and transfers in combined PRT and conventional transit networks. Traditional traffic network analyses can not handle demand-actuated traffic. Our model is based on the same principles as are used in the VIPS software (available from VIPS AB in Göteborg) for transit network analysis. We added a description of the PRT network with links, nodes, stations and average waiting times to the description of the transit network and service frequencies. In the analysis, travel time components are calculated for all alternatives and the demand is distributed on alternative routes under the assumption that travellers make rational choices (minimising their disutility). The trips are distributed at each embarking stop over acceptable route alternatives according to the probability that each acceptable route is the first to depart.

We also developed a dynamic simulation model in which passengers are randomly generated, wait and take the first acceptable route departure or PRT vehicle. When the passenger is on a vehicle, the best debarking stop is determined depending on the destination. When the passenger has debarked, a calculation is made as to whether it is best for him to walk to another stop, go to a PRT station or stop and wait for a route departure. The model calculates travel time components (walking time, waiting time, riding time and transfer times) for each passenger and loads for each vehicle and link. Consideration can be taken to the capacity of each vehicle, availability of vehicles and timetable departure times.

At the request of Göteborg's Traffic Office, we analysed the redistribution of today's public transport trips in the case of the introduction of a small PRT network in the city centre. Figure 6.1 shows the route network for the Göteborg region with a PRT network in the centre of the city. The network consists of 32 kilometres of guide-way and 50 stations.

Today's public transport is assumed to be left unchanged, so that the PRT system will be an added option for public transport passengers. Furthermore, we have assumed free transfers between traditional public transit modes and PRT vehicles.

The public transport network analyses of the combined transport and PRT network indicated that 23% of all transport passengers in the Göteborg region would shorten their travel time so much that it was worthwhile for them to make extra transfers to or from PRT. Out of all trips to and from the city centre, 40% would benefit from using the PRT system.



Figure 7.1. PRT system as a part of the Göteborg region's public transport network

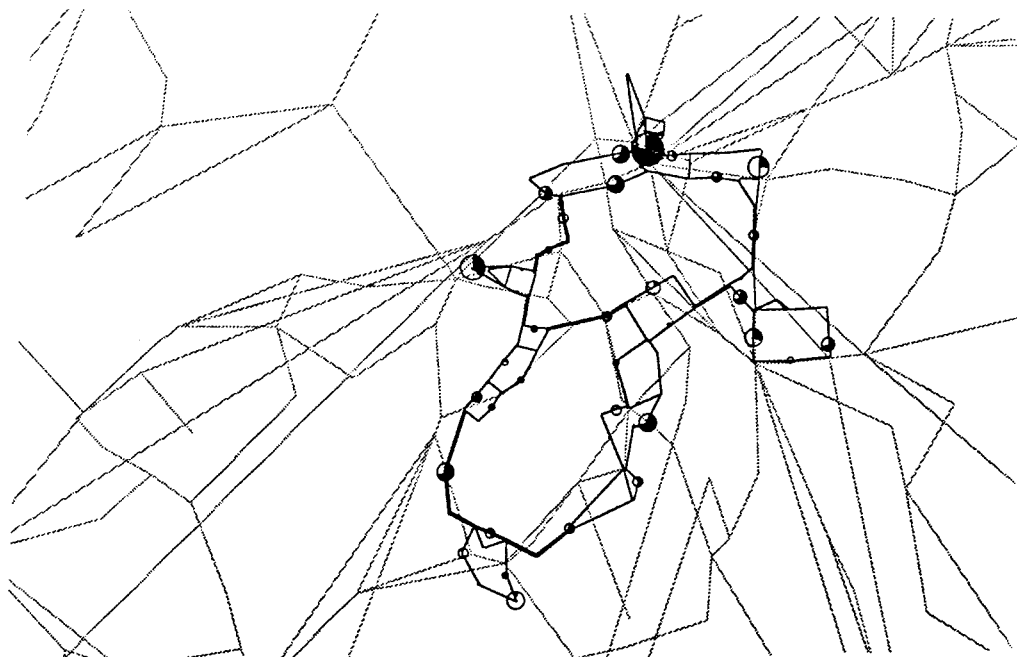

Figure 7.2. Debarking and embarking PRT in the mixed network

As an average over all trips in the region, the travel time would decrease by 4%. For passengers who use PRT, the improvement is 18%. The travel time improvement is 56% for trips that can be completed within the PRT network.

## 7.2 Mode shift from automobiles

No travel habit surveys can be made with PRT before a system has been introduced. There are two approaches to estimating trips before a system is established.

One way is to interview potential passengers, give them a picture of the PRT alternative with video animations etc. and then ask which mode of travel would be chosen under different conditions, such as walking distance, waiting times and fares. The method is called "stated preferences" and has been used for PRT travel estimations in Chicago, for example.

It is known from experience that what is chosen in reality (revealed preferences) is not always in agreement with what has been stated. We have chosen to estimate PRT travel on the basis of the passengers' actual choice between existing travel alternatives. From these choices, travellers' values of time components and costs can be estimated. If we assume that times and costs are valued in the same way with PRT, we can draw conclusions about expected travel with PRT.

We have used as a basis a travel habit survey with 5,100 interviews and trip diaries, carried out in 1989 in the Göteborg region. We applied models estimated by the Swedish consulting firm Transek, in our estimation of mode choice with a PRT network in Central Göteborg. The models are of a so called logit type with the following form.

$$\text{Portion of public transport trips} = \frac{\exp(-\text{transit disutility})}{\exp(-\text{transit disutility}) + \exp(-\text{automobile disutility})}$$

where exp is the exponential function  $\exp(x)=e^x$  and travel disutility is a composite of travel time components (walking time, waiting time, travel time, transfer time) and cost (public transport fare and operating cost for automobile).

Transek evaluated the following parameters for work trips from the travel habit survey in the Göteborg region (1 USD = 8 SEK):

Value of time	24.10 SEK/h
Logit coefficient for travel time in minutes	-0.0169
Weight of walking time	1.6 * riding time
Weight of waiting & transfer time	2.8 * riding time

We applied these models to observed trips with automobiles and public transport from travel surveys in 1994. The models take into consideration variable automobile cost (1.30 SEK per km) and transit fare (8.80 SEK per one-way trip). We used a parking cost in the city centre (44 SEK for work trips) to calibrate the model against observed differences in mode choice between the city centre and the rest of the region.

When consideration has been taken to differences in time and cost between automobile and public transport, it is seen that today's travellers have a preference for automobile trips, which in Göteborg corresponds to 20.75 SEK per trip. If times and costs for the alternatives were the same, it would be necessary to charge the automobile alternative with this sum before the alternatives could be seen as equal. The automobile preferences is interpreted as the effect of the other factors that are not included in the model, such as:

- need to plan the trip in advance
- uncertainty about transfers
- comfort of the automobile (seats, climate, stereo etc.)

- travelling in privacy

PRT is designed to offer the qualities of the automobile as far as possible. One of the interview questions in the project "user's encounter with technology" (see chapter 3) was how PRT was perceived – as an automobile or as a small bus, with respect to the travel standard. The answers indicated that PRT was seen as something in the middle between automobile and bus. In the estimation of the choice of travel model with PRT, we have used an automobile preference over PRT that is 50% of the current preference over conventional transit. This assumption has a great influence on the results and shows that the way in which PRT is perceived in other respects than time and cost is indeed important.

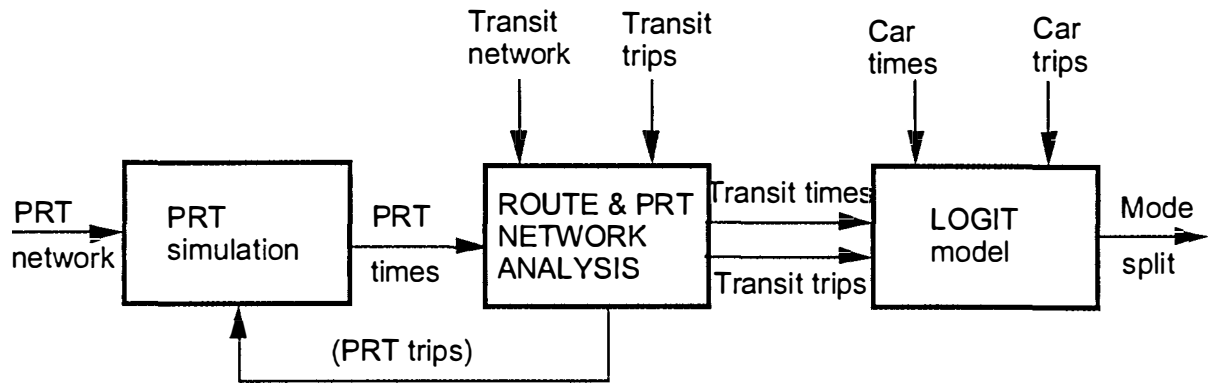

Figure 7.3. Models for network analysis and choice of travel mode

The model for the choice of travel mode was applied to the choice between automobile and public transport trips in the Göteborg region. When the model had been calibrated for today's public transport travel, we supplemented the public transport network with the intended PRT network in the centre of Göteborg. We did not take consideration to possible changes in travel habits (trip frequency and destination) but studied only the change-over from automobile to public transport with today's trips. The travel mode choice model estimates the portion of public transport trips before and after PRT, and we estimated trips transferred to public transport with the formula

$$\text{Transferred trips} = (\text{New transit share} - \text{Old transit share}) * \text{Total trips}$$

We studied the effect of the PRT system as it was sketched for central Göteborg according to figure 7.4.

The assumed speed is 36 km/h. With 580 PRT vehicles, we arrive at an average waiting time of 1 minute.

We studied the effect of PRT on work trips, shopping and leisure trips respectively. School trips were considered to be captive to public transport and business trips captive to automobile.

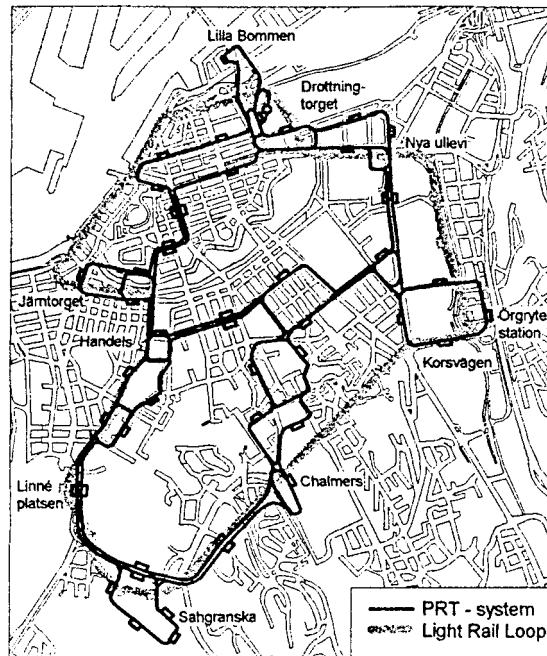

Figure 7.4. PRT network for central Göteborg

The following results were achieved for work trips:

- Public transport travel time within the PRT area falls from 16 to 9 minutes
- The share of transit trips increases from 63% to 75% (an increase in transit trips of 19%)
- 32% of automobile trips in the area shift to PRT
- 4 times as many automobile trips shift to transit in the rest of the region (4% of all automobile trips)

As expected, the shift is largest for those who can make their entire trip with PRT. A smaller proportion of travellers in the region who can use PRT for a part of their trip also choose not to use their automobiles. In absolute number, the new travellers from the region are dominant.

The results for other trips (except school and business trips) were:

- The share of transit trips rises from 19% to 34% within the PRT area (+82%)
- 19% of automobile trips in the area shift to PRT
- Small effect outside the area

For total trip-making (all trip purposes), the results are:

- Transit travel increases by 48% in the area
- 23% of automobile trips in the area shift to PRT

This is a good result, difficult to achieve in any other way. For example, doubling the frequency of all transit services in the entire Göteborg region would give a smaller effect based on the same forecasting method. An increase in service of this size, calculated according present contracts, would cost 930 million SEK per year, not including capital costs for new trams and garages. In contrast the cost for PRT is estimated to be 90-140 million SEK per year, including capital costs.

## 8. Socio-economic assessment

PRT is relatively expensive to build (although not more expensive than trams) but cheap to operate since it does not require a great deal of personnel. The socio-economic profits have primarily to do with the high travel standard, which decreases the travel disutility for both today's public transport passengers and automobile drivers shifting to public transport. The standard for the remaining automobile drivers also becomes better as there is less congestion on streets. Furthermore, society profits from fewer accidents, less disturbance to the environment and less road maintenance. Many pedestrians and bicyclists will choose PRT and thus increase their mobility.

Olof Johansson, PhD in national economics at the University of Göteborg, has evaluated the socio-economic effects of introducing PRT. The calculation includes the following costs and benefits:

### Socio-economic costs

- investments in guide-ways, stations, vehicles and control system (annual capital cost)
- operation and maintenance costs
- decrease in tax revenues from automobiles

The investment costs were recalculated as an annual cost with the annuity method and 4% real interest. Fixed assets were written off over 50 years and vehicles and control system over 10 years.

### Socio-economic benefits

- + reduction in travel times
- + increase in fare revenues
- + reduction in external effects

The external effects are (1 USD = 8 SEK):

- + fewer accidents (0.22 SEK per automobile km)
- + decrease in air pollution (0.36 SEK per automobile km)
- + less congestion on roads (0.69 SEK per automobile km)
- + less noise pollution (0.02 SEK per automobile km)
- + less road maintenance (0.02 SEK per automobile km)

For the example of central Göteborg, we used cost estimations from previous studies in Gävle and transferred trips according to the calculations of chapter 6. The greatest benefit is in travel times, and it is today's public transport passengers that gain the most.

Gains in travel time (Million SEK per year)

Work trips		
Existing public transport passengers		63
Additional passengers from automobile driver category		10
Additional passengers from pedestrian & cycle category		10
School trips		21
Other trips		
Existing public transport passengers		35
Additional passengers from automobile driver category		21
Additional passengers from pedestrian & cycle category		20
Total value travel time benefits		180

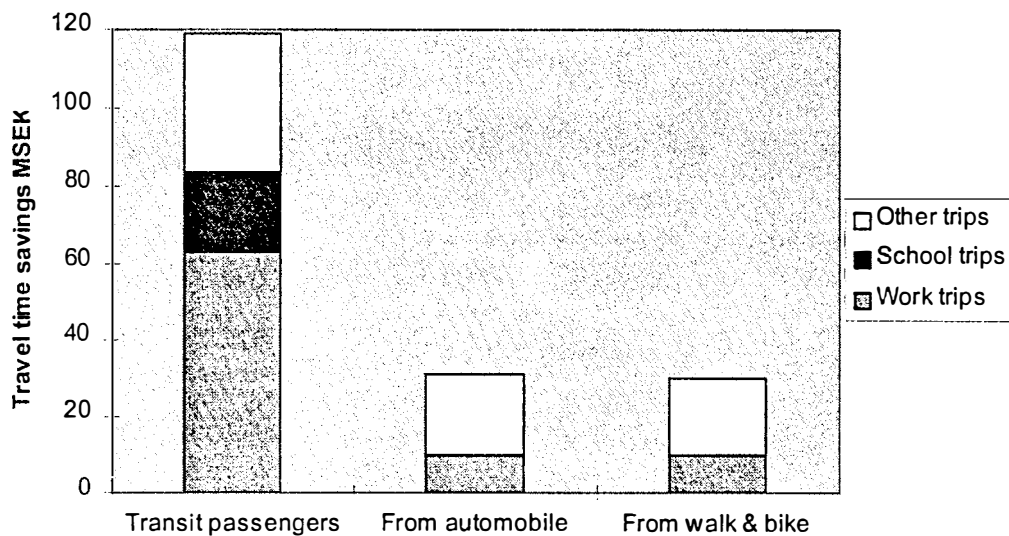

Figure 8.1. Travel time benefits with PRT in central Göteborg

The socio-economic assessment of PRT in central Göteborg is summarised below.

Increase in fare revenues	+150
Value of travel time savings	+180
Reduction in external effects	+25
Capital costs	-192
Operations and maintenance	-111
Tax effects	-46
 Total socio-economic surplus per year	 +6 million SEK (+2%)

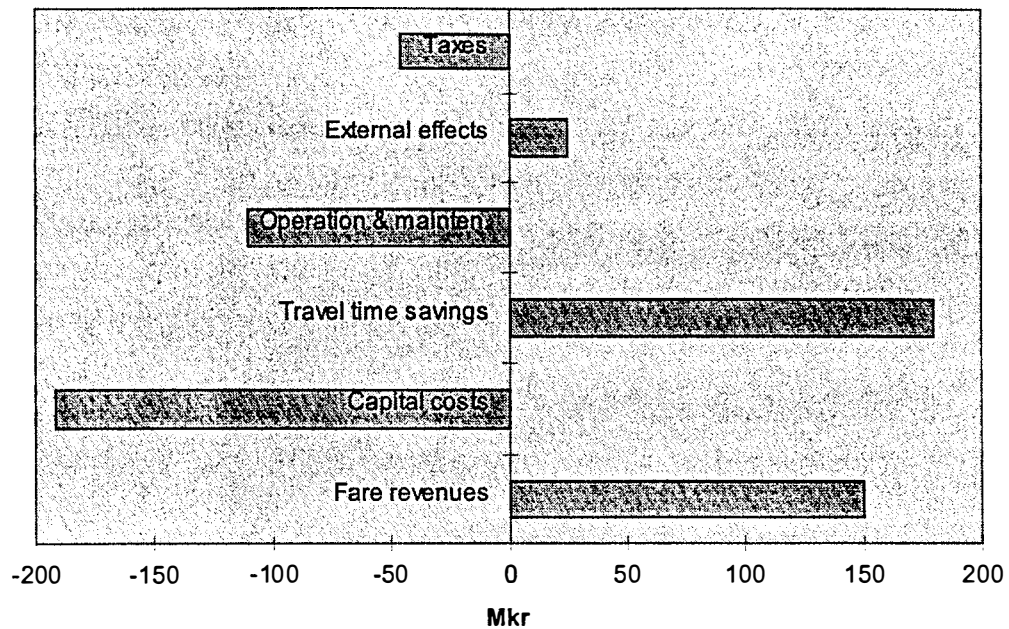

Figure 8.2. Socio-economic benefits and costs of PRT in central Göteborg

The calculations contain considerable uncertainty. Our conclusion is that a PRT system can be socio-economically profitable in areas in which there are many potential new transit users. A separate calculation should be made for each PRT installation under consideration.

The visual disturbance to the city environment has not been possible to evaluate monetarily, although the interviews showed that this disturbance is important for the acceptance of a PRT system.

In the future, the environmental effects are expected to be valued higher, and congestion and wage costs will increase, which will contribute to a better calculation. On the other hand, automobiles will become cleaner, which will have the opposite effect.

A decision to build a PRT system can not be based only on the factors above. Other factors that may be decisive include:

- availability of physical space
- aesthetics and the city environment
- building permits and public complaints
- general opinion
- access to investment money
- possible national funding
- general societal development
- political courage



## 9. Conclusions

We have drawn the following conclusions from our work with PRT systems in the thematic research programme "Advanced Transit Systems" at Chalmers University of Technology. The conclusions are also based on PRT research at LogistikCentrum since 1990.

- The technology for PRT systems is available
- PRT systems are a possible solution for small and medium-sized urban areas
- PRT has the capacity to replace buses and trams
- PRT can not replace subways and commuter trains
- PRT will be accepted by travellers
- PRT can reduce transit travel times by 50%
- PRT can attract 20-25% of today's automobile trips
- PRT can be socio-economically viable
- The main obstacle is visual intrusion
- There is a need for research in guide-way designs

## Literature

Literature with relevance to or association with the thematic Programme "Advanced Transit System" is listed below in chronological order.

A-C Alvehag, P Malmén and J Sundberg, PRT – for passenger transport (in Swedish), TFK report 1992:7

I Andréasson, Simulation of PRT in Gävle – report of the Simspårt project (in Swedish), KFB Dno 90-291-732

I Andréasson, Simulation of large PRT systems for Swedish cities, Proceedings of the 4<sup>th</sup> APM Conference in Las Colinas 1993

B Blide, PRT in Göteborg (in Swedish), Utredningsetapp 2 (kommuntäckande system). Traffic Office report 8:1993

B Blide, PRT in Göteborg (in Swedish), Utredningsetapp 3 (centrala staden). Traffic Office report 12:1994

I Andréasson, Vehicle Distribution in Large PRT Systems, Transportation Research Record No 1451, National Academy Press, Washington DC 1994

I Andréasson, Analysis of PRT mixed with buses and trams. Proceedings of the 27<sup>th</sup> ISATA Conference in Aachen 1994 p 545 ff

E Gustavsson and T Kåberger, Energy consumption with PRT – a comparison with automobiles and buses (in Swedish), VTI meddelande nr 737, 1994

I Andréasson, Interaction between Route Traffic and PRT (in Swedish), KFB Dnr 93-409-732

I Andréasson, Study of PRT in Gävle. Analysis of extension stages (in Swedish), City Planning Office of Gävle, KFB nr 1995:2

P Kautzky, B Salomonson, B Holmqvist, Study of PRT in Gävle (in Swedish), Delrapport Stadsbild, KFB 1995:10

B Holmqvist, Study of PRT in Gävle (in Swedish), Summary report, City Planning Office Dec 95

I Andréasson, Demand modelling for PRT competing with bus and car. Paper for the 5<sup>th</sup> APM Conference in Paris 1996

I Andréasson and L Fabian, Research and development in Advanced Transit Systems – Surveys of Academic and Industry Efforts. Chalmers, School for Management of Technology 1996

A Hagson and M Reneland, PRT in Swedish Cities (in Swedish) Stads- och trafikplanering Rapport 1996:4

I Andréasson, Applicability of PRT in Swedish Cities, Internatioanl Conference of PRT and other Emerging Systems, Minneapolis 1996

E Rosenblad, The Rider's Impression of a Simulated Trip by PRT, International Conference of PRT and other Emerging Systems, Minneapolis 1996

G Tegnér, Market Demand and Social Benefits of a PRT System – a model evaluation for the city of Umeå, International Conference of PRT and other Emerging Systems, Minneapolis 1996

N-E Wiberg, Advanced Transit System Beam/Track Design, Chalmers Structural Mechanics 1996

A-C Alvehag, Pilot system with PRT – Pre-study on possibilities and conditions (in Swedish), Stockholm Regional Planning Office PM nr 7 1997

I Andréasson, Pre-study for a pilot project with PRT in the Stockholm area – Characteristics differing between systems (in Swedish), Stockholm Regional Planning Office 1997

I Andreasson, Quasi-Optimum Redistribution of Empty PRT Vehicles, 6<sup>th</sup> Conference of Automated People Movers, Las Vegas 1997

O Johansson, Are PRT Systems Socially Profitable? National Economy, Gothenburg University 1997

E Rosenblad, PRT travellers – User encounter with new technology (in Swedish), Chalmers Consumer Behaviour Report 1997:10



Förteckningar över KFBs olika publikationsserier, bl a

- Rapporter
  - Meddelanden
  - KFB-Information
  - Publikationer inom KFBs bio- och elprogram
- kan erhållas från KFB.

**KFB (The Swedish Transport and Communications Research Board)** is a government agency with planning, initiating, coordinating and supporting functions in Swedish transport and communications research. KFB's activities encompass transportation, traffic, postal services and telecommunications, as well as the impact of transports and communications on the environment, traffic safety and regional development.

KFB is also responsible for information and documentation within its areas of responsibility.

**Postal address:** Box 5706, S-114 87 Stockholm, Sweden

**Visiting address:** Linnégatan 2, Stockholm

**Phone:** 08-459 17 00; Int: +46 8 459 17 00

**Fax:** 08-662 66 09; Int: +46 8 662 66 09

**Internet Home page:** [www.kfb.se](http://www.kfb.se)