

# Interlaboratory Variability of Slip Coefficient Testing for Bridge Coatings

PUBLICATION NO. FHWA-HRT-14-093

DECEMBER 2014



U.S. Department of Transportation  
**Federal Highway Administration**

Research, Development, and Technology  
Turner-Fairbank Highway Research Center  
6300 Georgetown Pike  
McLean, VA 22101-2296

## FOREWORD

Bolted connections are a critical part of nearly every steel bridge. Individual components are assembled together in the field using high-strength bolts, and frictional connections are specified to ensure appropriate connection performance throughout the life of the bridge. The coatings used on the faying surface of the connections must demonstrate a predetermined friction coefficient for the overall connection to attain its required frictional resistance. This friction coefficient is defined by a test method governed by the Research Council for Structural Connections (RCSC). In recent years, there has been concern within the bridge engineering community that ambiguities within the test method might increase the variability of reported friction coefficients.

This report outlines the findings and recommendations from a round-robin laboratory study on slip coefficients of organic zinc-rich primers for steel bridges. Prior to this work, variability of slip coefficients attained for the same coatings were noted by coating manufacturers despite no changes in formulation. This study was conducted to quantify the variability and recommend changes to RCSC to reduce the variability. Overall, it was found that participating labs followed the RCSC procedure but were sometimes reporting very different slip coefficients for identical coatings. The major finding was the manner in which each lab measured slip displacement, which contributed to the greatest variability in frictional coefficient results. It is recommended that RCSC clarify its intended method for measuring slip deformation. Once implemented, it is anticipated that the revised test method will appropriately quantify coating frictional coefficients and thus ensure proper connection performance. This report would benefit those in charge of specifying and testing steel bridge coatings including coating manufactures, RCSC, State transportation departments, researchers, and design consultants.

Jorge E. Pagán-Ortiz  
Director, Office of Infrastructure  
Research and Development

### Notice

This document is disseminated under the sponsorship of the U.S. Department of Transportation in the interest of information exchange. The U.S. Government assumes no liability for the use of the information contained in this document.

The U.S. Government does not endorse products or manufacturers. Trademarks or manufacturers' names appear in this report only because they are considered essential to the objective of the document.

### Quality Assurance Statement

The Federal Highway Administration (FHWA) provides high-quality information to serve Government, industry, and the public in a manner that promotes public understanding. Standards and policies are used to ensure and maximize the quality, objectivity, utility, and integrity of its information. FHWA periodically reviews quality issues and adjusts its programs and processes to ensure continuous quality improvement.

## TECHNICAL REPORT DOCUMENTATION PAGE

1. Report No. FHWA-HRT-14-093	2. Government Accession No.	3. Recipient's Catalog No.	
4. Title and Subtitle Interlaboratory Variability of Slip Coefficient Testing for Bridge Coatings		5. Report Date December 2014	
		6. Performing Organization Code:	
7. Author(s) Justin Ocel, Ph.D., P.E. (FHWA) Robert Kogler Mir Ali (FHWA)		8. Performing Organization Report No.	
9. Performing Organization Name and Address Rampart, LLC 422 E Jefferson Street Falls Church, VA 22046		10. Work Unit No.	
		11. Contract or Grant No. DTFH61-10-D-00017-T-13004	
12. Sponsoring Agency Name and Address Office of Infrastructure Research and Development Federal Highway Administration 6300 Georgetown Pike McLean, VA 22101-2296		13. Type of Report and Period Covered Final Report August 2013–July 2014	
		14. Sponsoring Agency Code HRDI-40	
15. Supplementary Notes The work reported herein was conducted under subcontract to Professional Service Industries, Inc., of Herndon, VA, as part of FHWA's Support Services for the Structures Laboratories contract. Justin Ocel (FHWA) provided technical oversight/assistance and drafted portions of the final report. The Contracting Officer's Representative was Fasil Beshah, HRDI-40.			
16. Abstract All steel bridge systems need some type of a corrosion protection scheme to ensure a serviceable life. The most common approach is to use a multilayered paint system with a zinc-rich primer. In addition to corrosion performance, other factors need to be considered in the selection of the corrosion protection system. Steel bridges are usually fabricated in smaller components and assembled onsite using high-strength bolted connections with slip-critical connections. Slip-critical connections use the high clamping force of the bolt to develop frictional shear stresses in excess of the load demand such that slip within the connection would not be expected under service loads.  Primers used on faying surfaces of slip-critical connections must demonstrate a predetermined level of slip resistance in accordance with the Research Council of Structural Connections (RCSC). This study seeks to evaluate the details of the RCSC slip test specification as applied by four different laboratories. A commonly manufactured set of test panels spanning five typical organic zinc-rich primers was tested independently and in parallel by four laboratories. The data were compared, and subtle yet important variations in test approach taken by each lab are discussed. Recommendations are provided for revisions to the RCSC test protocol to reduce variability.			
17. Key Words Organic zinc, Steel bridges, Primer, Slip critical, Connections, High-strength bolts, Slip coefficients		18. Distribution Statement No restrictions. This document is available to the public through the National Technical Information Service, Springfield, VA 22161. <a href="http://www.ntis.gov">http://www.ntis.gov</a>	
19. Security Classif. (of this report) Unclassified	20. Security Classif. (of this page) Unclassified	21. No. of Pages 61	22. Price N/A

# SI\* (MODERN METRIC) CONVERSION FACTORS

## APPROXIMATE CONVERSIONS TO SI UNITS

Symbol	When You Know	Multiply By	To Find	Symbol
<b>LENGTH</b>				
in	inches	25.4	millimeters	mm
ft	feet	0.305	meters	m
yd	yards	0.914	meters	m
mi	miles	1.61	kilometers	km
<b>AREA</b>				
in <sup>2</sup>	square inches	645.2	square millimeters	mm <sup>2</sup>
ft <sup>2</sup>	square feet	0.093	square meters	m <sup>2</sup>
yd <sup>2</sup>	square yard	0.836	square meters	m <sup>2</sup>
ac	acres	0.405	hectares	ha
mi <sup>2</sup>	square miles	2.59	square kilometers	km <sup>2</sup>
<b>VOLUME</b>				
fl oz	fluid ounces	29.57	milliliters	mL
gal	gallons	3.785	liters	L
ft <sup>3</sup>	cubic feet	0.028	cubic meters	m <sup>3</sup>
yd <sup>3</sup>	cubic yards	0.765	cubic meters	m <sup>3</sup>
NOTE: volumes greater than 1000 L shall be shown in m <sup>3</sup>				
<b>MASS</b>				
oz	ounces	28.35	grams	g
lb	pounds	0.454	kilograms	kg
T	short tons (2000 lb)	0.907	megagrams (or "metric ton")	Mg (or "t")
<b>TEMPERATURE (exact degrees)</b>				
°F	Fahrenheit	5 (F-32)/9 or (F-32)/1.8	Celsius	°C
<b>ILLUMINATION</b>				
fc	foot-candles	10.76	lux	lx
fl	foot-Lamberts	3.426	candela/m <sup>2</sup>	cd/m <sup>2</sup>
<b>FORCE and PRESSURE or STRESS</b>				
lbf	poundforce	4.45	newtons	N
lbf/in <sup>2</sup>	poundforce per square inch	6.89	kilopascals	kPa
<b>APPROXIMATE CONVERSIONS FROM SI UNITS</b>				
Symbol	When You Know	Multiply By	To Find	Symbol
<b>LENGTH</b>				
mm	millimeters	0.039	inches	in
m	meters	3.28	feet	ft
m	meters	1.09	yards	yd
km	kilometers	0.621	miles	mi
<b>AREA</b>				
mm <sup>2</sup>	square millimeters	0.0016	square inches	in <sup>2</sup>
m <sup>2</sup>	square meters	10.764	square feet	ft <sup>2</sup>
m <sup>2</sup>	square meters	1.195	square yards	yd <sup>2</sup>
ha	hectares	2.47	acres	ac
km <sup>2</sup>	square kilometers	0.386	square miles	mi <sup>2</sup>
<b>VOLUME</b>				
mL	milliliters	0.034	fluid ounces	fl oz
L	liters	0.264	gallons	gal
m <sup>3</sup>	cubic meters	35.314	cubic feet	ft <sup>3</sup>
m <sup>3</sup>	cubic meters	1.307	cubic yards	yd <sup>3</sup>
<b>MASS</b>				
g	grams	0.035	ounces	oz
kg	kilograms	2.202	pounds	lb
Mg (or "t")	megagrams (or "metric ton")	1.103	short tons (2000 lb)	T
<b>TEMPERATURE (exact degrees)</b>				
°C	Celsius	1.8C+32	Fahrenheit	°F
<b>ILLUMINATION</b>				
lx	lux	0.0929	foot-candles	fc
cd/m <sup>2</sup>	candela/m <sup>2</sup>	0.2919	foot-Lamberts	fl
<b>FORCE and PRESSURE or STRESS</b>				
N	newtons	0.225	poundforce	lbf
kPa	kilopascals	0.145	poundforce per square inch	lbf/in <sup>2</sup>

\* SI is the symbol for the International System of Units. Appropriate rounding should be made to comply with Section 4 of ASTM E380. (Revised March 2003)

## TABLE OF CONTENTS

<b>INTRODUCTION.....</b>	<b>1</b>
<b>OBJECTIVE .....</b>	<b>1</b>
<b>METHODOLOGY .....</b>	<b>3</b>
<b>RCSC TEST DESCRIPTION.....</b>	<b>4</b>
<b>SPECIMEN PREPARATION .....</b>	<b>5</b>
<b>IMPLEMENTATION OF RCSC PROCEDURE .....</b>	<b>6</b>
Lab 1 .....	6
Lab 2 .....	8
Lab 3 .....	9
Lab 4 .....	11
<b>EXPERIMENTAL RESULTS.....</b>	<b>13</b>
<b>VARIATION IN RESULTS LAB TO LAB .....</b>	<b>15</b>
<b>VARIATION DUE TO PAINT THICKNESS .....</b>	<b>19</b>
<b>OUTLIER ANALYSIS.....</b>	<b>20</b>
<b>OTHER IDENTIFIED CONCERNS.....</b>	<b>21</b>
<b>CONCLUSIONS .....</b>	<b>23</b>
<b>RECOMMENDATIONS.....</b>	<b>25</b>
<b>APPENDIX A. DATA PLOTS.....</b>	<b>27</b>
<b>APPENDIX B. PRECISION AND BIAS ANALYSIS.....</b>	<b>39</b>
<b>APPENDIX C. AGING STUDY .....</b>	<b>47</b>
<b>REFERENCES.....</b>	<b>55</b>

## LIST OF FIGURES

Figure 1. Illustration. Test plate.....	4
Figure 2. Illustration. RCSC compression slip test setup .....	5
Figure 3. Illustration. Lab 1 testing system.....	6
Figure 4. Illustration. Lab 2 testing system.....	8
Figure 5. Illustration. Lab 3 testing system.....	10
Figure 6. Illustration. Lab 4 testing system.....	11
Figure 7. Graph. Mean slip coefficient for each coating system tested at each test lab using existing RCSC failure criterion .....	15
Figure 8. Graph. Load versus slip displacement response of two LVDTs from lab 4 for specimen C2-1 .....	17
Figure 9. Graph. Mean slip coefficient for each coating system tested at each test lab only using peak load response .....	19
Figure 10. Graph. Load versus slip displacement curves for lab 1 coating A1 .....	28
Figure 11. Graph. Load versus slip displacement curves for lab 2 coating A1 .....	28
Figure 12. Graph. Load versus slip displacement curves for lab 3 coating A1 .....	28
Figure 13. Graph. Load versus slip displacement curves for lab 1 coating A2 .....	29
Figure 14. Graph. Load versus slip displacement curves for lab 2 coating A2 .....	29
Figure 15. Graph. Load versus slip displacement curves for lab 3 coating A2 .....	29
Figure 16. Graph. Load versus slip displacement curves for lab 4 coating A2 .....	29
Figure 17. Graph. Load versus slip displacement curves for lab 1 coating B1 .....	30
Figure 18. Graph. Load versus slip displacement curves for lab 2 coating B1 .....	30
Figure 19. Graph. Load versus slip displacement curves for lab 3 coating B1 .....	30
Figure 20. Graph. Load versus slip displacement curves for lab 1 coating B2 .....	31
Figure 21. Graph. Load versus slip displacement curves for lab 2 coating B2 .....	31
Figure 22. Graph. Load versus slip displacement curves for lab 3 coating B2 .....	31
Figure 23. Graph. Load versus slip displacement curves for lab 1 coating C1 .....	32
Figure 24. Graph. Load versus slip displacement curves for lab 2 coating C1 .....	32
Figure 25. Graph. Load versus slip displacement curves for lab 3 coating C1 .....	32
Figure 26. Graph. Load versus slip displacement curves for lab 4 coating C1 .....	32
Figure 27. Graph. Load versus slip displacement curves for lab 1 coating C2 .....	33
Figure 28. Graph. Load versus slip displacement curves for lab 2 coating C2 .....	33
Figure 29. Graph. Load versus slip displacement curves for lab 3 coating C2 .....	33
Figure 30. Graph. Load versus slip displacement curves for lab 4 coating C2 .....	33
Figure 31. Graph. Load versus slip displacement curves for lab 1 coating D1 .....	34
Figure 32. Graph. Load versus slip displacement curves for lab 2 coating D1 .....	34
Figure 33. Graph. Load versus slip displacement curves for lab 3 coating D1 .....	34
Figure 34. Graph. Load versus slip displacement curves for lab 1 coating D2 .....	35
Figure 35. Graph. Load versus slip displacement curves for lab 2 coating D2 .....	35
Figure 36. Graph. Load versus slip displacement curves for lab 3 coating D2 .....	35
Figure 37. Graph. Load versus slip displacement curves for lab 1 coating E1.....	36
Figure 38. Graph. Load versus slip displacement curves for lab 2 coating E1.....	36
Figure 39. Graph. Load versus slip displacement curves for lab 3 coating E1.....	36
Figure 40. Graph. Load versus slip displacement curves for lab 4 coating E1.....	36
Figure 41. Graph. Load versus slip displacement curves for lab 1 coating E2.....	37

Figure 42. Graph. Load versus slip displacement curves for lab 2 coating E2.....	37
Figure 43. Graph. Load versus slip displacement curves for lab 3 coating E2.....	37
Figure 44. Graph. Load versus slip displacement curves for lab 4 coating E2.....	37
Figure 45. Graph. Labs within material for $h$ -statistic considering the 0.02-inch slip criterion...	41
Figure 46. Graph. Materials within lab for $h$ -statistic considering the 0.02-inch slip criterion....	41
Figure 47. Graph. Labs within material for $k$ -statistic considering the 0.02-inch slip criterion...	42
Figure 48. Graph. Materials within lab for $k$ -statistic considering the 0.02-inch slip criterion....	42
Figure 49. Graph. Labs within material for $h$ -statistic considering just the peak load criterion ..	43
Figure 50. Graph. Materials within lab for $h$ -statistic considering just the peak load criterion ...	43
Figure 51. Graph. Labs within material for $k$ -statistic considering just the peak load criterion...	44
Figure 52. Graph. Materials within lab for $k$ -statistic considering just the peak load criterion....	44
Figure 53. Illustration. Overall view of modified slip measuring device mounted to a specimen .....	48
Figure 54. Illustration. Upper bracket detailing of modified slip measuring device .....	48
Figure 55. Illustration. Lower bracket detailing of modified slip measuring device.....	49
Figure 56. Graph. Comparison of slip behavior with cure time for coating A1 .....	50
Figure 57. Graph. Comparison of slip behavior with cure time for coating A2.....	50
Figure 58. Graph. Comparison of slip behavior with cure time for coating B1 .....	50
Figure 59. Graph. Comparison of slip behavior with cure time for coating B2 .....	50
Figure 60. Graph. Comparison of slip behavior with cure time for coating C1 .....	51
Figure 61. Graph. Comparison of slip behavior with cure time for coating C2 .....	51
Figure 62. Graph. Comparison of slip behavior with cure time for coating D1 .....	51
Figure 63. Graph. Comparison of slip behavior with cure time for coating D2.....	51
Figure 64. Graph. Comparison of slip behavior with cure time for coating E1 .....	52
Figure 65. Graph. Comparison of slip behavior with cure time for coating E2 .....	52

## LIST OF TABLES

Table 1. Test matrix of coatings and labs .....	3
Table 2. Results of slip coefficient testing considering existing RCSC failure criteria .....	14
Table 3. Results of slip coefficient testing considering just peak load failure criteria .....	18
Table 4. Deviations from manufacturer’s recommended DFT .....	20
Table 5. <i>h</i> -statistic considering 0.02-inch failure criteria .....	39
Table 6. <i>h</i> -statistic considering just peak load failure criteria .....	39
Table 7. <i>k</i> -statistic considering 0.02-inch failure criteria .....	40
Table 8. <i>k</i> -statistic considering just peak load failure criteria .....	40
Table 9. Precision statistics considering 0.02-inch requirement.....	45
Table 10. Precision statistics considering just peak load.....	45
Table 11. Slip coefficient results of aging study.....	49
Table 12. Comparison of slip coefficients between 10-day and extended cure.....	53



## INTRODUCTION

Steel bridge components are frequently secured together with high-strength bolts to facilitate erection of the entire bridge. In applications where the connection is subjected to tension or reversal loads, the American Association of State Highway and Transportation Officials (AASHTO) *Load and Resistance Factor Design Bridge Design Specifications* (LRFD BDS) requires that they be designed as a “slip-critical” connection.<sup>(1)</sup> Slip-critical connections are a class of bolted connections where the transfer of force from one element to the next is through friction rather than bearing on the bolts. To develop the required frictional resistance, two elements are required: a minimum clamping force from the bolts that is ensured through proper installation techniques and a surface with a guaranteed minimum level of slip resistance, which can also be referred to as a “friction coefficient” or “surface condition factor” per AASHTO.

The AASHTO LRFD BDS specifies three possible surface condition factors, which are referred to by class (A through C). Class A has a surface condition factor of 0.33, while class B has a surface factor of 0.50. Class C only pertains to galvanized surfaces and is not relevant to this report. Typically, most designers would specify a class B slip resistance because it requires the least number of bolts to meet the design requirements. An unpainted and blast-cleaned surface can achieve class B slip resistance, but if a coating is applied on the faying surface, that coating must demonstrate that it can meet class B slip resistance. Coating manufacturers demonstrate this property through testing. For bridges, coating systems are regularly evaluated through the AASHTO National Transportation Product Evaluation Program (NTPEP). One of the evaluation criteria of NTPEP is qualifying the slip resistance of primers used in bridge coating systems, as it is the zinc-rich primer that will be the coating on the faying surface.

The test to evaluate slip resistance is specified in the Research Council on Structural Connections’ (RCSC) *Specification for Structural Joints Using High-Strength Bolts*.<sup>(2)</sup> Appendix A of the publication defines the testing method to determine the surface condition factor for coatings used on steel. In the rolling evaluation cycles run by NTPEP, while inorganic zinc-rich primers tend to easily pass class B slip, organic zinc-rich primers have shown mixed and inconsistent performance in slip testing. In recent years, there has been a propensity of organic zinc-rich primers to fail class B slip resistance where previously they demonstrated class B slip resistance. The new data have been anecdotally described to “just barely fail” class B slip resistance, though much of the data were proprietary being paid for by paint manufacturers and not available for public consumption. Depending on the entity, the differences in slip resistance have been blamed on the testing agencies, the coating manufacturer, and/or the test method. This report presents an objective view of the RCSC test method.

## OBJECTIVE

The objective of this study was to take a comprehensive but neutral look at slip resistance of organic zinc-rich primers to understand the variables that control results and cause variation or error in the slip testing results. To understand the variability associated with the test method, this work focuses on the RCSC test method through an interlaboratory variability testing regime of

four different labs, five different organic zinc-rich primers, and two coating thicknesses. The goal of the testing was to make recommendations for a more robust testing procedure.

## METHODOLOGY

A total of four labs took part in this study: a Federal research lab, an academic research lab, and two commercial labs. The two commercial labs were the only two labs known in the country at the time of this study that perform commercial RCSC slip testing services. One of the four labs only participated in half the study due to contracting difficulties. The ASTM E691-13 specification offers a guide for framing an interlaboratory variability study, including the suggestion that at least eight laboratories be engaged.<sup>(3)</sup> The scope of this project and the fact that a limited pool of laboratories in the United States are capable of running this test resulted in a smaller sample of participating laboratories.

Five coatings were evaluated. All were organic zinc-rich primers that represent materials widely used in and marketed to the bridge industry. Each coating was tested at two different thicknesses (+1 and +2 mil) over the manufactures' recommended dry film thickness (DFT). The RCSC procedure requires testing at +2 mil to ensure that a casual buildup of the coating due to overspray and other causes does not jeopardize the coating's performance. The +1-mil thickness specimens were tested to understand if the extra coating thickness may be a cause of the organic zinc-rich primers not passing class B slip resistance. To maintain an objective view of the test procedure, anonymity of the labs and coatings will be preserved throughout the remainder of this report and only referred to generically.

Each test is referred to by an alpha-numeric code in the form of "XY-Z" where "X" refers the letter of the coating, and "Y" is either "1" or "2" depending on the coating thickness over the recommended DFT. "Z" is a number ranging from 1 to 5 to designate the specimen number as the test protocol requires testing five replicate specimens. Therefore, specimen B2-4 refers to the fourth specimen of the series from coating B with a +2-mil thickness. Table 1 outlines the matrix of test series along with the participating labs as well as the date of slip testing.

**Table 1. Test matrix of coatings and labs.**

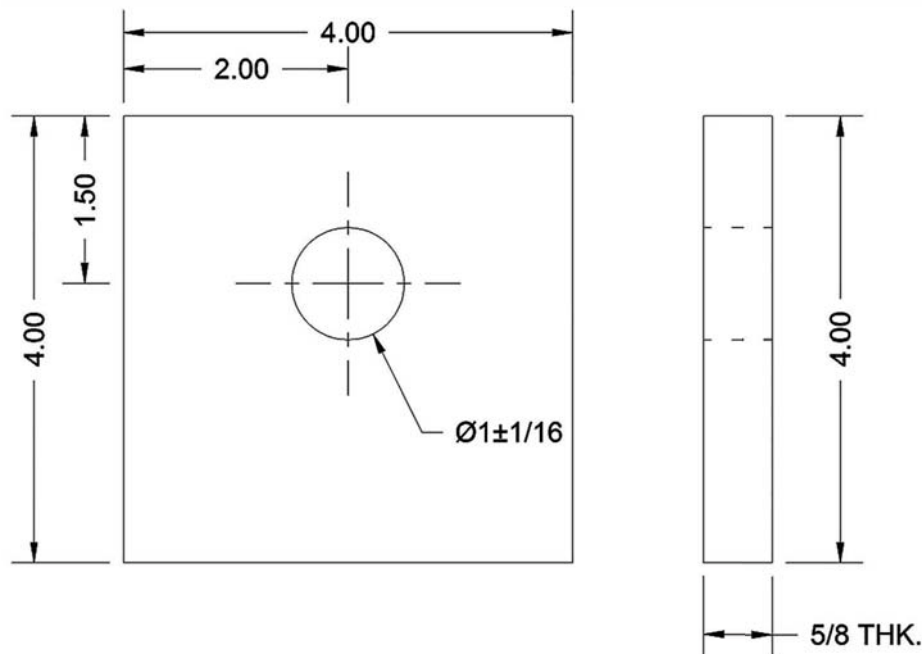
<b>Series</b>	<b>Labs Participating</b>	<b>Date Tested</b>
D1	1-3	11/15/2013
D2	1-3	12/13/2013
A1	1-3	1/10/2014
B2	1-3	1/24/2014
B1	1-3	2/7/2014
E1	1-4	2/21/2014
E2	1-4	3/7/2014
C1	1-4	3/21/2014
C2	1-4	4/4/2014
A2	1-4	4/18/2014

## RCSC TEST DESCRIPTION

The RCSC test procedure dictates the specimen size and means of testing. Each sample is comprised of three identical plates. The test plate dimensions are shown in figure 1. The 4- by 4- by  $\frac{5}{8}$ -inch test plate contains a 1-inch-diameter hole centered 1.5 inches from one edge. The 1-inch hole in the test plate is required to ensure that the specimens have sufficient room for slippage to occur. Thermally cut edges are not permitted but suggest that plates could be milled, as rolled, or saw cut. Plates should have yield strength between 36 and 50 ksi.

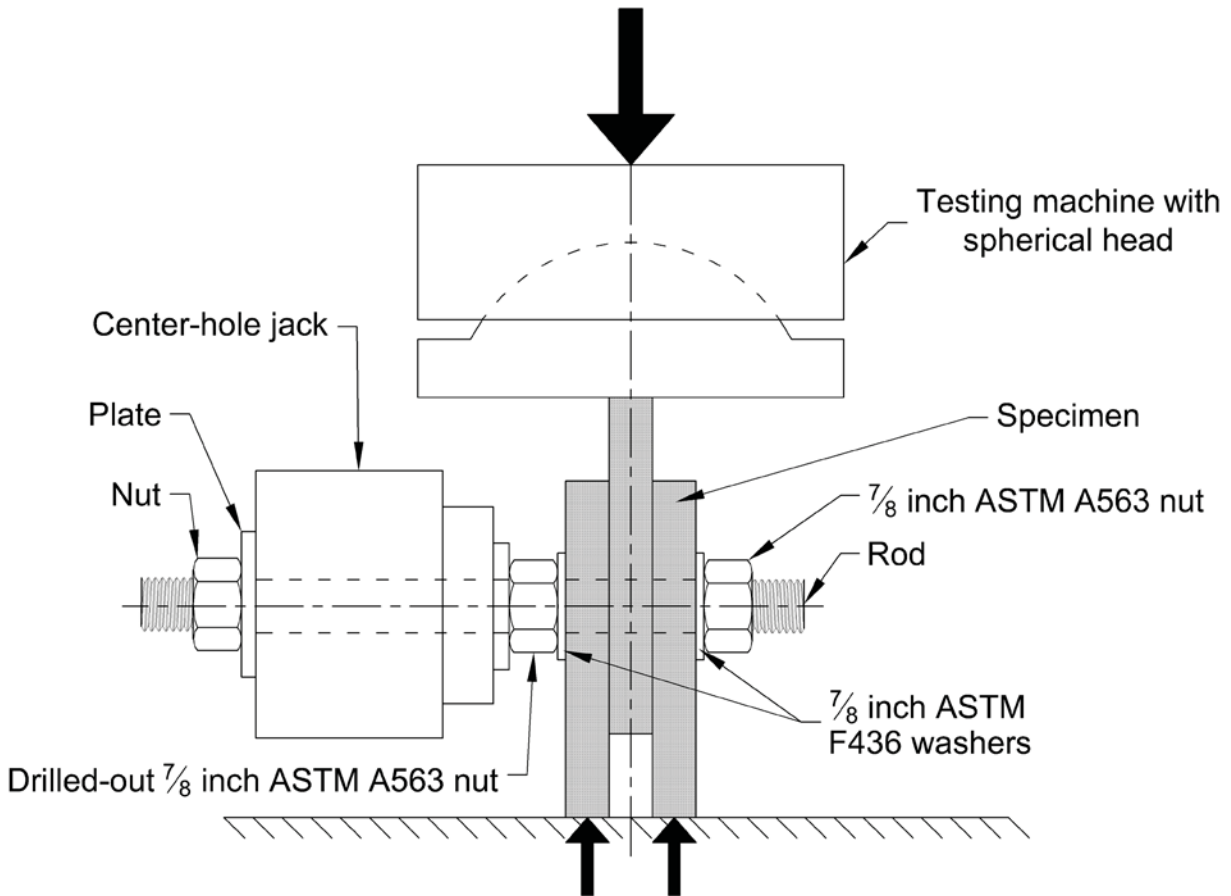
The three plates are stacked together, and the middle plate is rotated 180 degrees from the outer two. This is shown in figure 2 along with a generic representation of the loading system. A rod passes through the three test plates and is tensioned via an external hydraulic jack that clamps the three plates together. The clamping load is imparted on the plates through ASTM A563 nuts and ASTM F436 washers so the test accurately represents the loading conditions of a tensioned high-strength bolt.<sup>(4,5)</sup> The stack of three plates is then placed between a compression testing apparatus with fixed and spherical loading platens.

A clamping force of  $49 \pm 0.5$  kip tolerance is mandated by the RCSC protocol to start the test. Then a 1-kip vertical load is applied to the specimen, and the slip monitoring sensors are zeroed out. The test is completed by continuing to apply a vertical load until a slip displacement of 0.05 inch is achieved. The vertical loading rate should not exceed 0.003 inch per minute nor 25 kip per minute. Failure is defined as the peak load or the load at a slip of 0.02 inch, whichever comes first. The slip coefficient for each specimen is defined as the failure load divided by two times the clamping load. Five tests (replicates) are run, and the average slip value from all the tests is used for categorizing the coating as class A or B.



Note: Units are shown in inches.

**Figure 1. Illustration. Test plate.**



**Figure 2. Illustration. RCSC compression slip test setup.**

## **SPECIMEN PREPARATION**

All test samples were coated by one lab and shipped to the other three labs for testing. Using only one lab for specimen preparation ensured that any variability from this was at a minimum throughout the testing program. In general, testing occurred once every 2 weeks between November 2013 and April 2014. Test samples were received either on a Wednesday or Thursday at each lab, with testing occurring on the Friday of the same week. This ensured there was at least a day for the samples to condition themselves to the local environment of the lab, and the total cure time was the same between all the labs at the time of testing.

All test plates used were abrasive blast cleaned with 100 percent steel grit to obtain a surface roughness between 2.0 and 3.0 mil. The test plates were coated using a semi-automated control arm fitted with an airless spray gun. The electronically controlled spray gun was positioned approximately 18 inches from the panel surfaces to prevent any runs or buildup of excess paint. During the coating application process, the test plates were mounted in horizontal racks to achieve double-sided application, while the adjustable traverse rate on the spraying apparatus maintained the desired target wet film thickness.

Due to research constraints of all labs testing on the same day, the total cure time was strictly maintained to 10 days for all primers. This allowed for primer application on Tuesday the week

before testing followed by 6 to 7 days curing under controlled conditions of  $72 \pm 2$  °F and  $50 \pm 5$  percent relative humidity before packaging and shipping to the other three labs. Priority shipping was employed to maximize cure time under controlled conditions prior to packaging and to minimize transit time when conditions were uncontrolled. Prior to packaging, DFT was measured on each surface, and surfaces were matched to have similar DFTs. A table was provided to each lab indicating the stacking order of the individual plates to ensure the DFTs matched up. For each testing series, each lab received 20 test plates—15 were for the 5 replicate specimens and 5 were considered spares.

## IMPLEMENTATION OF RCSC PROCEDURE

Each lab was visited once either by the project sponsor or by the sponsor’s representative to observe its specific practices in conducting the RCSC protocol. The following sections contain commentary regarding the specifics of the loading systems, lab-specific procedures, and other observations that may be sources of variability. The observer(s) tried not to interfere with normal testing operations and only made notes of observations.

One item the observers looked for in each lab was whether or not the individual labs were exercising proper calibration of their load and displacement devices. In particular, traceability was looked for with load measuring devices and if documentation could be traceable to the National Institute of Standards and Technology (NIST) load standards.

### Lab 1

The testing concept used in lab 1 is shown in figure 3. An existing 1,000-kip compression machine was used to apply the vertical load, while a separate 60-kip hollow core jack was used to apply the horizontal clamping load.

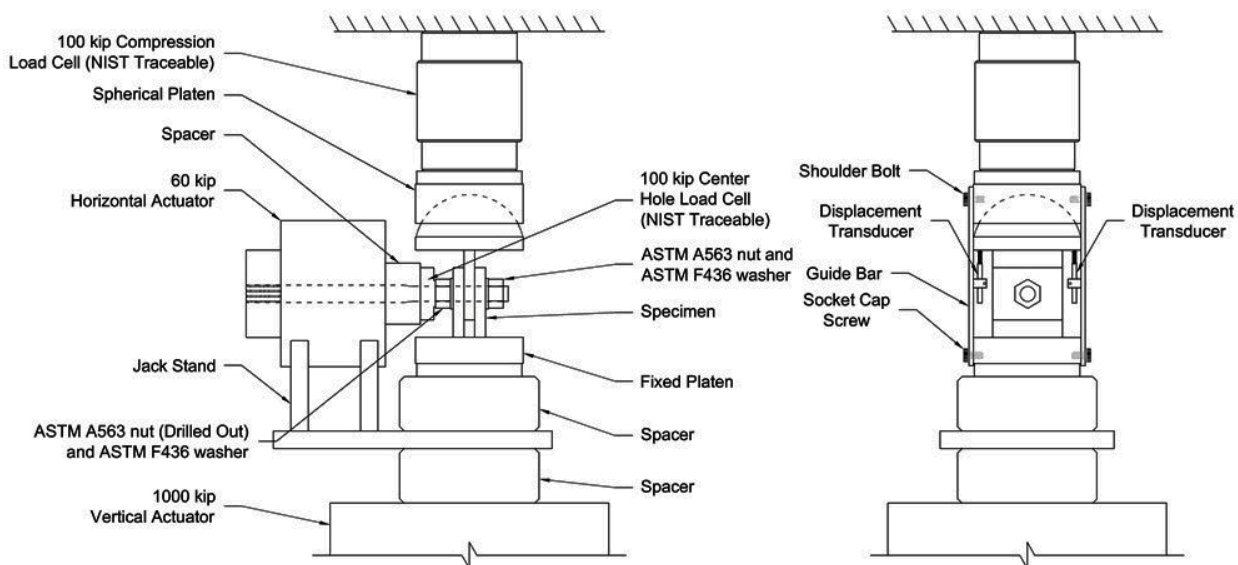


Figure 3. Illustration. Lab 1 testing system.

The loading rod that clamped the plates together was custom fabricated for this test setup. It was fabricated from an SAE 4340 alloy that was heat treated to a Rockwell C hardness between 38 and 42, which should yield strength properties equal to or higher than an ASTM A490 bolt.<sup>(6)</sup> The rod had a  $\frac{7}{8}$ -inch diameter where it passed through the test plates with a threaded end to accept a  $\frac{7}{8}$ -inch-diameter ASTM A563 nut but had a 1-inch diameter where it passed through the horizontal jack.<sup>(4)</sup> The horizontal jack had a custom end plate with a threaded hole in the center in which the load rod screwed into directly. A jack stand was also fabricated to support the horizontal jack such that the loading rod was in alignment with the holes in the test plates.

Both the horizontal and vertical jacks were servo valve controlled in a closed-loop feedback system and were operated by a computer control system. The vertical jack could be run in either displacement or load control. The load feedback was from a 100-kip compression load cell mounted above the spherical platen, while the displacement feedback was from a linear variable differential transformer (LVDT) mounted internally to the actuator piston. The horizontal load could only be maintained in load control either via a 100-kip center hole load cell or with strain gauges mounted directly to the loading rod. For the first four test series, the center hole load cell was used for feedback to the horizontal jack. It was difficult using this load cell, and it was later abandoned, being replaced with four strain gauges mounted directly to the loading rod in a full bridge configuration.

Slip displacement was monitored with two LVDTs. The LVDTs were secured to a bracket that screwed to the fixed and spherical platens (see figure 3). The bracket allowed vertical alignment of the two LVDTs to be maintained throughout testing and kept them centered on the test plates. This way of mounting the LVDTs essentially measured the displacement of the platen surfaces, assuming that is was equal to the actual slip displacement.

Prior to testing, built-up paint on the test plate edges in contact with the platens was sanded off. Installing the test plates first required slipping a drilled out  $\frac{7}{8}$ -inch-diameter nut onto the loading rod followed by a  $\frac{7}{8}$ -inch washer. Then the three test plates were slid onto the rod in the sequence provided followed by a  $\frac{7}{8}$ -inch washer, and a nut was screwed to the end of the loading rod. Wedges were used to support the center test plate such that its bottom surface of the hole touched the bottom of the loading rod. This allowed for the maximum amount of slip displacement. At this point, the horizontal jack was commanded to apply the 49-kip clamping load. Since this was in load control, this load was generally maintained within  $\pm 0.01$  kip, which was well within the RCSC tolerances.

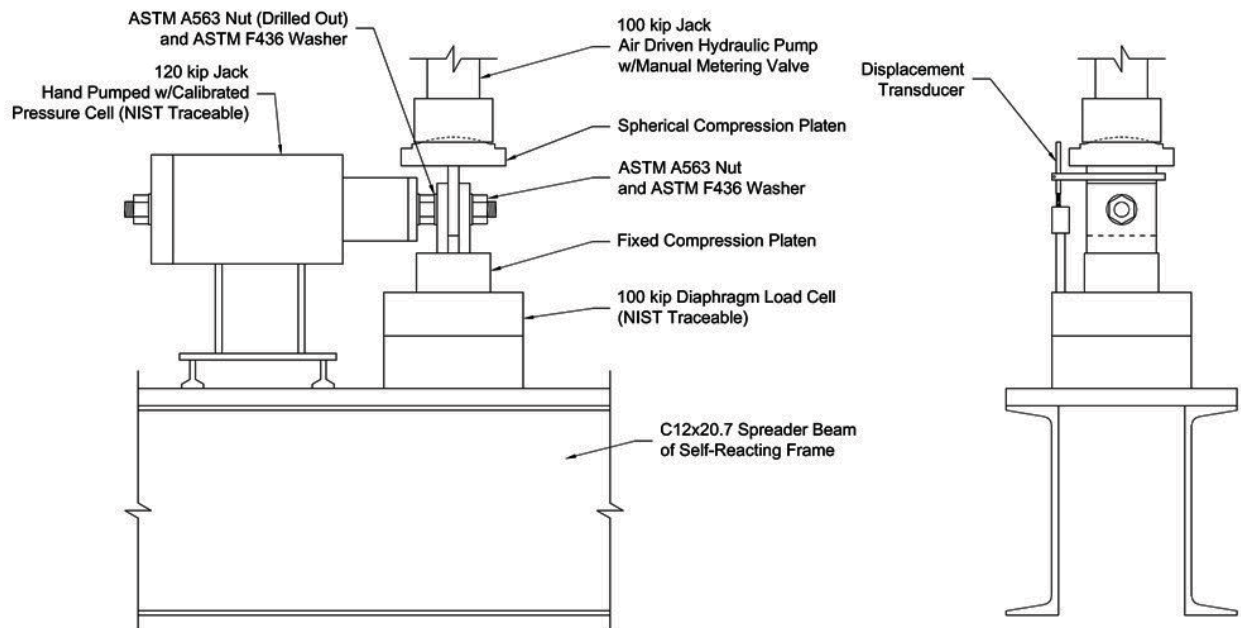
Once the clamping load was set, the vertical actuator was commanded in load control to apply 1 kip of vertical load. Then the two LVDTs were installed and set so their stroke was maximized. The hydraulic computer control system could also collect data, and the LVDT signals were electrically offset to have an initial reading of 0 inch. At this point, the test could begin. The vertical actuator was commanded in displacement control to a rate of 0.003 inch per minute. The feedback LVDT was inside the actuator, which measures the slip of the specimens as well as compliance of the testing machine; therefore, the slip rate was slightly less than the commanded slip rate. The test continued at this rate until an average slip displacement of 0.025 inch was achieved. Next the loading rate was increased to 0.01 inch per minute. The test was terminated after a total average slip of 0.05 inch was achieved.

An independent observer witnessed the testing at lab 1 on December 13, 2013. In general, no deviations could be identified from the RCSC procedure. Overall testing of five specimens took about 2.5 h to conduct. It is interesting to note that roughly half of this overall test period was dedicated to mounting and aligning specimens and ensuring verticality of the slip load plane. Also of note is the utility of the data acquisition system during the initial loading stages of each test replicate. Since the data were acquired and could be observed quantitatively in real time by the operator, adjustments and observations of any minor test deviations could be noted and corrected by the operator if noticed early enough in the test run. This differs from the graphical method of data collection which requires a greater degree of real-time (experience-based) interpretation.

In addition, the use of the load and displacement control functionality of the setup in lab 1 allowed the operator to remain “hands free” during the loading process in order to focus his or her attention on the data stream rather than minor adjustments and/or catching and easing the load prior to slip failure.

## Lab 2

The testing concept used in lab 2 is shown in figure 4. The test arrangement employs a dedicated load frame equipped with an air-driven hydraulic jack for vertically loading the specimens. The vertical load is measured with a 100-kip diaphragm load cell that is installed in line with the load train. The clamping force is supplied by a hand-pumped hydraulic jack with a calibrated pressure cell linked to a digital readout visually monitored throughout each test run to ensure consistent compressive load is applied to the sample throughout.



**Figure 4. Illustration. Lab 2 testing system.**

The three specimen plates were loaded onto the rod. The lab had its own custom spacer plate to place under the center plate to elevate it to produce the maximum possible amount of slip. The nut was hand-tightened to clamp the plates together enough such that the center plate would not



move. Once completed, the spacer plate was removed. A clamping force of  $49 \pm 0.5$  kip was applied to the test assembly using the digital readout as a guide. It was observed that the clamping load was stable throughout testing, only requiring the operator to pump additional pressure one or two times through testing. The force only varied by approximately 0.2 kip throughout testing.

Once the clamping force was applied, a custom LVDT holding bracket was slid over the middle plate and tightened to the center plate with thumb screws. This bracket only held one LVDT that was referenced off the load cell beneath the specimen via an extended threaded rod that affixed the load cell to the self-reacting frame. A special thumb nut with a machine flat surface was threaded onto the top of this extended threaded rod. Turning the thumb nut allowed for quick adjustment of the LVDT into its desired range. The vertical jack was extended so that it contacted the top edge of the center test plate.

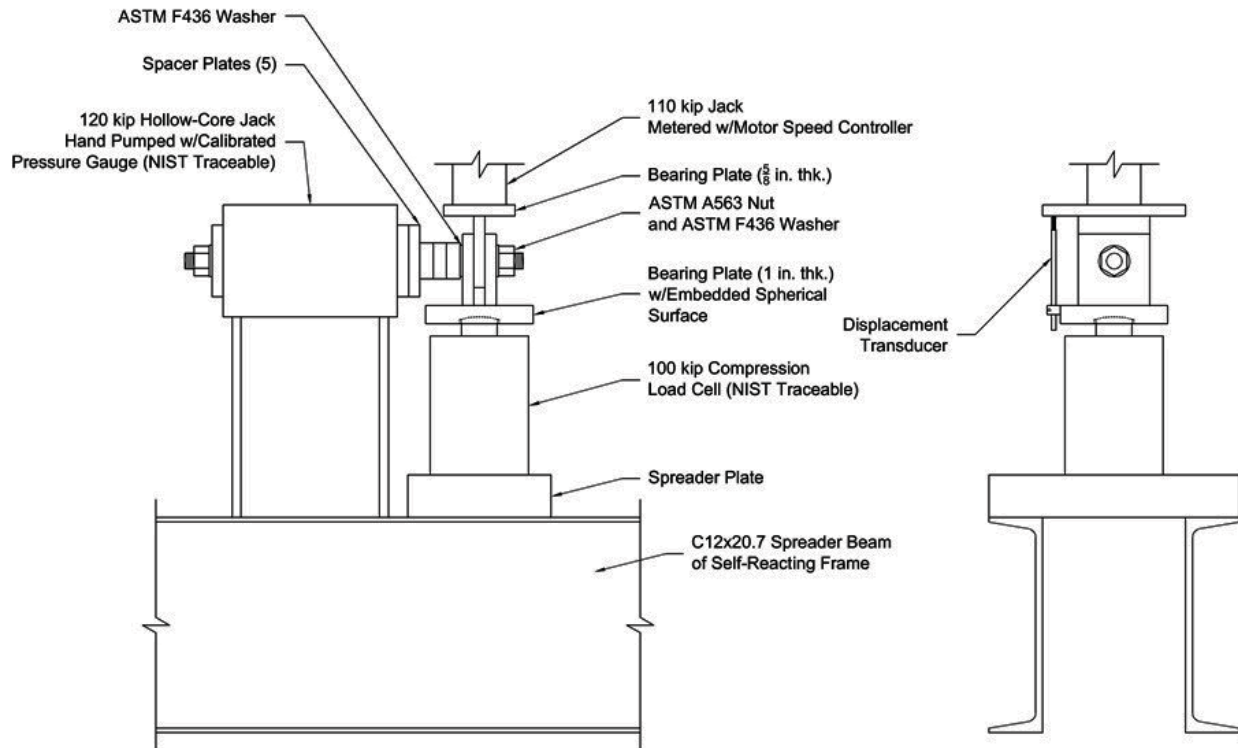
Lab 2 recorded vertical load and slip displacement from the single LVDT using an analog X-Y plotter. Before vertical loading began, the pen was lowered. Vertical loading commenced, and the operator could control the loading rate through a metering valve. There was no direct way to measure load or slip loading rate, though the operators said that after testing many specimens, they had a general sense of how many seconds the plotter could traverse 0.4 inch in the X and Y directions to be in conformance with the RCSC loading rates. An independent observer, using a stopwatch, found that the rates were within the RCSC specification, although this was only verified for one specimen. The self-reacting frame used was flexible, and as the specimen began to lose stiffness, the operator had to continually watch the plotter and slow down the loading rate with the metering valve. If this was not done, the frame would unload itself onto the specimen, and the center plate would crash onto the loading rod. “Crashing” indicates instances when the middle plate slipped suddenly into bearing on the loading rod with an unexpected bang. Provided the specimen did not crash, loading stopped after 0.05 inch of slip occurred.

The observation of a testing series occurred on April 4, 2014. The load frame had three calibration stickers affixed to it for the two load cells on one LVDT. All were less than 1 year old. In general, no gross deviations from the testing specification were identified. Overall, testing took approximately 90 min to test the five specimens. The following observations were noted as possible sources of variability. Generally, the specimens were loaded without a great deal of care to ensure they were centered within the load train. Some specimens were tested with a visual offset from the center of approximately 0.25 inch either front-to-back or side-to-side. The LVDT was visually inclined away from vertical axis of the load train, likely around a 5-degree deviation. Finally, in testing of one specimen, the vibration from the air-assisted hydraulic jack shook loose the electrical connection between the LVDT digital readout boxes (mounted directly to the load frame) and the X-Y plotter. This forced the pen all the way to the edge of the paper in the X-direction, and it only moved in the Y-direction until the connection could be reestablished. The operators mentioned that this had occurred in the past.

### **Lab 3**

The testing arrangement and equipment used in lab 3 is depicted in figure 5. A 60-kip jack was used to provide the horizontal compressive load to the test plates. The jack was loaded with

hydraulic pressure provided by a hand pump and load read out with an analog pressure gauge. The pressure gauge was calibrated against an in-house known traceable load cell. This cell is sent out for calibration on an annual basis. During the test, the gauge on the hand pump was observed for any deviation or loss of load. Typically, little detectable load loss is ever observed during the test.



**Figure 5. Illustration. Lab 3 testing system.**

The vertical compressive load was applied using a self-reacting frame with a 110-kip jack linked to a pump powered by a motor controller with a dial setting (i.e., a rheostat). The motor controller only regulated the rotation rate of the pump. As a result, the rate of oil flow into the jack was constant, but this did not translate into a constant load or displacement rate on the jack because of the frame compliance. The rheostat on the motor controller was set on the same rate for every test (the rate was chosen based on experience of running so many tests by the lab). The operator verbally indicated that it was within the RCSC limits. The load during the test was read from a digital readout linked to the vertical load cell. A single LVDT was used to measure displacement. The vertical slip load and LVDT displacement signals were sent to an analog X-Y plotter, which traced the load-displacement profile during each test.

The specimens were placed within the test rig using an experience-based method of visual best alignment. This process was aided with a dedicated pre-marked ruler and a calibrated 20-mil shim. The 20-mil shim was used to check that the LVDT calibration was correct by placing it between the LVDT and the upper platen and verifying the plotter moved the correct distance. Once verified, the shim was removed. After visual alignment, the system was loaded to 1 kip, the pen was dropped onto the plotter paper, and the test was conducted. An independent observer

noted that despite attempts to visually align the load train, there were still eccentricities ranging up to 0.25 inch that were noticeable.

Data acquired during the test consisted of the load versus slip displacement curve for each test as acquired by the X-Y plotter and the visual capture of the maximum vertical load obtained at the point of slip by the test operator. This visual notation of the maximum slip load was reconciled to the plot for the test run, and the slip coefficient was calculated.

Because of frame compliance and not adjusting the motor controller during testing, as the specimen began to lose stiffness, slip displacements of 0.05 inch could not be achieved by lab 3 and were routinely terminated after a slip displacement of just 0.02 inch. Lab 3 operators interpreted the RCSC definition of failure as the larger of the peak load or load at a slip of 0.02 inch, so there was no value in displacing beyond 0.02 inch anyways because that data did not provide any value in terms of the RCSC failure criterion. The lab also had a policy to terminate tests if the vertical load reached between 60 and 65 kip. At this load, the specimen was well past the point of interest in terms of coating qualification for class B, and it was deemed safer for the test operator to not load higher than 65 kip. These interpretations of the RCSC test procedure allowed for five runs to be conducted in a fairly short timeframe, and to be conveniently plotted on the same sheet of X-Y paper.

#### Lab 4

The slip tests conducted in lab 4 were performed in an existing 100-kip universal testing machine with a 30-ton center hole hydraulic jack applying the clamping force to the test plates. The overall test setup is shown in figure 6. The horizontal jack was arranged in series with a 100-kip load cell to allow monitoring of the clamping force. This jack and load cell were placed in a wood cradle constructed to hold them in horizontal alignment; this wood cradle also had four leveling feet supporting it to allow leveling of the clamping system and alignment with the test specimens. A  $\frac{7}{8}$ -inch threaded rod (heat treated for additional strength) was inserted through the jack and load cell and held in place against the load cell with a plate washer and  $\frac{7}{8}$ -inch nut. Due to the large diameter of the actuator's center hole, the threaded rod was able to shift significantly when not engaged. To minimize displacement at this interface, a plastic spacer was fabricated and placed over the  $\frac{7}{8}$ -inch threaded rod to ensure a tight fit between the elements. A plate washer and  $\frac{7}{8}$ -inch nut (which has its threads drilled out to enable free movement along the threaded rod) were then placed on the threaded rod against the jack.

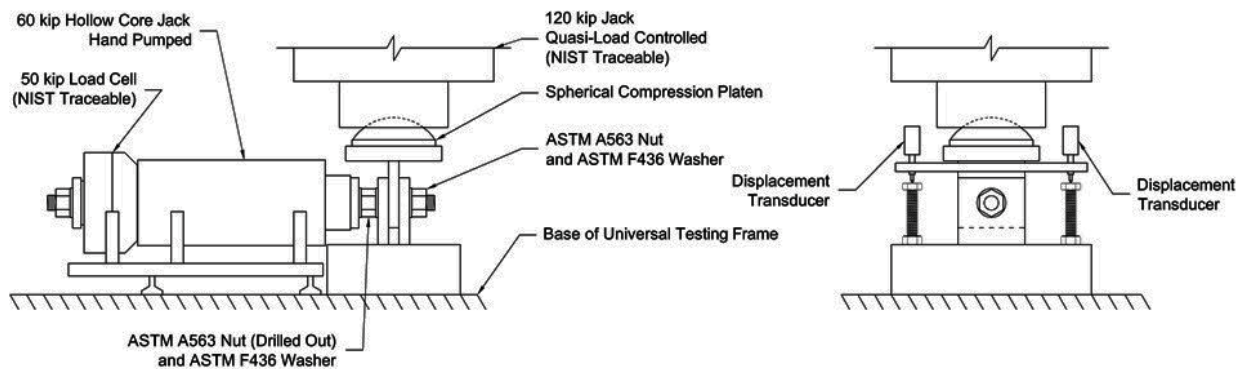


Figure 6. Illustration. Lab 4 testing system.

At the beginning of each test, a  $\frac{7}{8}$ -inch washer was placed over the drilled-out nut, and the test plates were placed on the rod in the configuration provided. The test plates sat on a 3-inch-thick steel plate to allow alignment with the clamping system. This plate also held the bolts that the LVDTs bore against. A  $\frac{7}{8}$ -inch washer and nut were then attached to the threaded rod and tightened until the middle test plate was aligned with the spherical head installed on the 100-kip testing machine. The middle plate was then raised until the bottom of its hole was in contact with the threaded rod (to ensure maximum possible slip) and then held in place with two wooden wedges. The horizontal jack was then extended (by use of a hand pump) until 49 kip of clamping force was applied. Due to creep in the coatings and bleeding in the actuator, this load often slowly dropped over time, so additional pumping was needed over the course of the test to maintain the clamping load within the 0.5-kip tolerance of the RCSC specifications. During clamping, the test plates often underwent a small shift in position upon initial contact with the actuator. Due to this shift, the plates could move out of alignment such that one test plate did not bear against the reaction surface. Thus, after clamping, a visual inspection of the plates was conducted to confirm contact between both plates and the bearing surface.

Once the test plates were properly aligned and clamped, the displacement bracket was attached. The bracket is an aluminum plate that has a slot machined out of its middle that allows it to fit over the middle test plate. The bracket has two additional holes drilled near its ends that allow the installation of two LVDTs. The bracket was centered on the middle plate, leveled, and then held in place by two thumb screws which bore against the middle test plate. Once installed, the LVDTs reacted against two 0.25-inch threaded rods installed in the 3-inch bearing plate, which were raised or lowered to the prescribed starting position of the LVDTs. A diagram of this displacement system is shown in figure 6. The LVDTs had a 0.2-inch stroke and were set at the beginning of each test 0.05 inch from their fully extended position to allow the maximum slip measurement while still allowing for small upward movements due to potential rotation of the test specimens.

To remove initial settlement from the data, the spherical head was lowered onto the middle test plate until a vertical load of 5 kip was applied. The spherical head was then raised until the vertical load reduced to 1 kip, and then the LVDTs were zeroed. The data acquisition system began taking readings from both LVDTs, the clamping load cell, and the load output from the test machine at approximately 1-s intervals, and the test machine began applying additional load. A maximum displacement rate of 0.003 inch per minute was the controlling limit for the tests, but the test machine could only be run in load control. Thus, the spherical head applied load at a rate of approximately 8 kip per minute, which kept the displacement rate below 0.003 inch per minute until slip of the specimen. The test machine had a built-in maximum displacement rate at this load rate, which prevented uncontrolled displacement after the test specimen reached a peak load. After reaching a maximum load, this inherent displacement rate was maintained until the specimen reached a total slip of 0.05 inch when the test was terminated.

## EXPERIMENTAL RESULTS

It is important to note that it was found that all labs involved in this test program followed the specification testing procedures as dictated in the RCSC specification. The only exception was that lab 3 did not use a drilled-out nut on one side of the specimen as dictated by the RCSC specification. The testing arrangement and procedures used at each lab, although slightly different, were all found to fall within the letter of the specification. Therefore, data were found to be valid for direct comparison.

The raw data from each lab and coating in terms of the slip coefficient are reported in table 2 using the existing RCSC failure definition of either peak load or load at 0.02 inch of slip. The main body of this report presents only a limited statistical analysis. The ASTM E691-13 specification dictates a variety of statistical measures that need to be reported as part of an interlaboratory variability study.<sup>(3)</sup> Since the test matrix did not strictly follow the guidance of ASTM E691-13, those statistical measures are of limited use. Regardless, all the ASTM E691-13 statistical measures are presented in appendix B for reference, though their exact results should be interpreted carefully.

Table 2 also reports the average and coefficient of variation (COV) for sets of five samples that were tested by each lab and for each coating. Figure 7 displays all the slip data for each coating and lab. Each bar in the graph has error bars that are symmetrically plotted based on the COV value. The load versus slip plots for every specimen, from each lab, and each coating can be found in the appendix A. Two of the labs recorded data on analog X-Y plotters, and scans of the plotter paper had to be manually encoded into a spreadsheet so uniformity of the plots could be shown. It was universally interpreted by the labs that the intent of the RCSC specification was to assume that zero slip had occurred when 1.0 kip of vertical load was applied to the specimen. Therefore, some of the datasets strictly began from a point of 1.0 kip of load and zero slip displacement, and other labs continuously recorded the data and manually subtracted off the displacement at 1.0 kip when determining failure load using the 0.02-inch displacement criteria. For uniformity of the data presentation in the appendix, for the two labs that recorded all the data, their curves were shifted in the X-direction such that the curves intersected the y-axis at 1.0 kip.

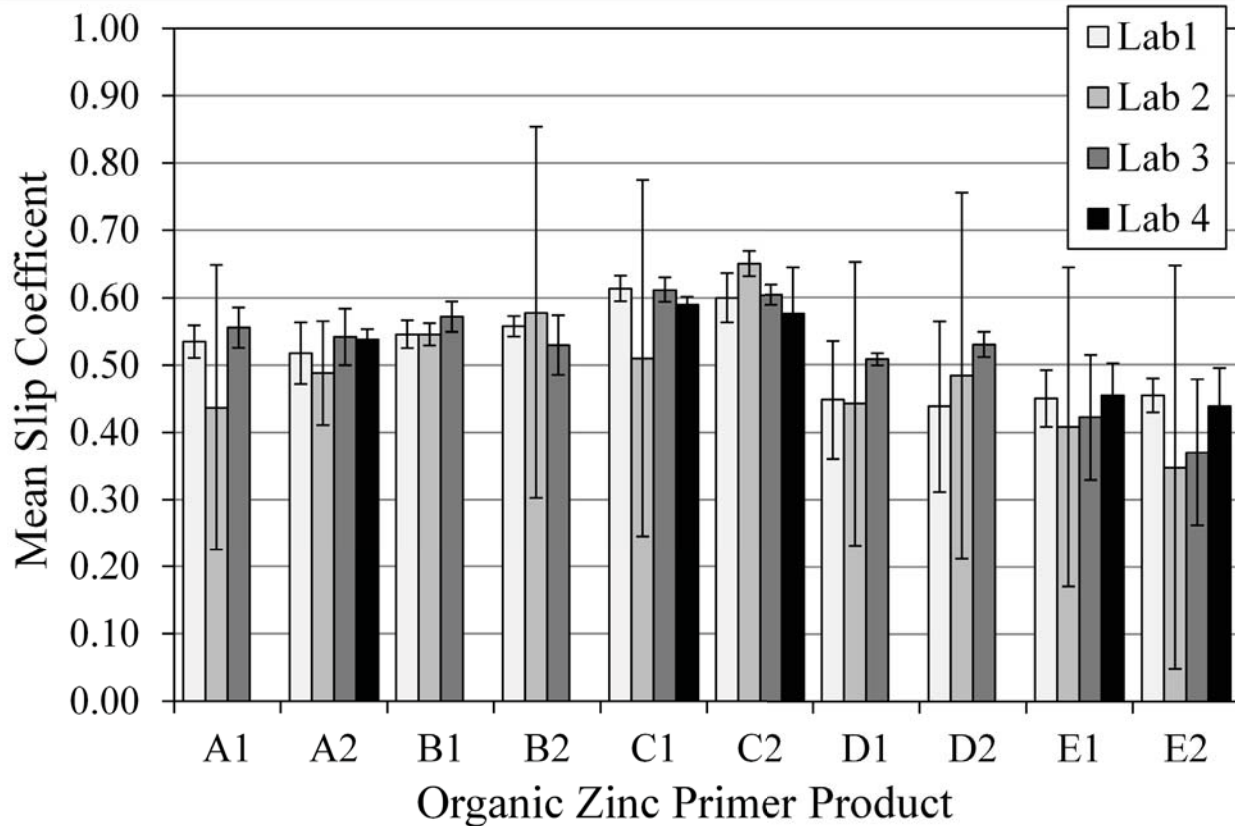
**Table 2. Results of slip coefficient testing considering existing RCSC failure criteria.**

Lab	Specimen	Coating									
		A1	A2	B1	B2	C1	C2	D1	D2	E1	E2
1	1	0.55	0.53	0.55	0.57	0.61	0.60	0.46	0.46	0.47	0.45
	2	0.54	0.48	0.54	0.55	0.61	0.62	0.48	0.34	0.44	0.45
	3	0.52	0.51	0.56	0.55	0.62	0.61	0.38	0.47	0.47	0.44
	4	0.53	0.54	0.53	0.56	0.63	*	0.46	0.45	0.43	0.47
	5	0.52	0.53	0.55	0.56	0.60	0.57	0.46	0.47	0.44	0.46
<b>Average</b>		<b>0.53</b>	<b>0.52</b>	<b>0.55</b>	<b>0.56</b>	<b>0.61</b>	<b>0.60</b>	<b>0.45</b>	<b>0.44</b>	<b>0.45</b>	<b>0.45</b>
<b>COV</b>		<b>0.025</b>	<b>0.046</b>	<b>0.021</b>	<b>0.015</b>	<b>0.019</b>	<b>0.036</b>	<b>0.087</b>	<b>0.127</b>	<b>0.042</b>	<b>0.025</b>
2	1	0.51	0.48	0.54	0.54	0.29	0.65	0.31	0.51	0.47	0.35
	2	0.306	0.43	0.54	0.74	0.60	0.63	0.50	0.27	0.47	0.18
	3	0.441	0.51	0.55	0.72	0.58	0.65	0.53	0.52	0.47	0.34
	4	0.392	0.53	0.54	0.54	0.47	0.66	0.38	0.63	0.25	0.44
	5	0.535	0.49	0.56	0.35	0.61	0.66	0.49	0.49	0.38	0.43
<b>Average</b>		<b>0.44</b>	<b>0.49</b>	<b>0.55</b>	<b>0.58</b>	<b>0.51</b>	<b>0.65</b>	<b>0.44</b>	<b>0.48</b>	<b>0.41</b>	<b>0.35</b>
<b>COV</b>		<b>0.211</b>	<b>0.077</b>	<b>0.016</b>	<b>0.275</b>	<b>0.265</b>	<b>0.019</b>	<b>0.211</b>	<b>0.272</b>	<b>0.237</b>	<b>0.300</b>
3	1	0.57	0.57	0.56	0.51	0.61	0.60	0.51	0.53	0.40	0.37
	2	0.56	0.55	0.56	0.55	0.61	0.59	0.51	0.52	0.38	0.41
	3	0.55	0.51	0.57	0.51	0.63	0.61	0.50	0.54	0.48	0.33
	4	0.57	0.53	0.59	0.52	0.60	0.61	0.51	0.54	0.41	**
	5	0.53	0.55	0.58	0.56	0.61	0.61	0.51	0.52	0.44	**
<b>Average</b>		<b>0.56</b>	<b>0.54</b>	<b>0.57</b>	<b>0.53</b>	<b>0.61</b>	<b>0.60</b>	<b>0.51</b>	<b>0.53</b>	<b>0.42</b>	<b>0.37</b>
<b>COV</b>		<b>0.030</b>	<b>0.042</b>	<b>0.023</b>	<b>0.044</b>	<b>0.018</b>	<b>0.015</b>	<b>0.009</b>	<b>0.019</b>	<b>0.092</b>	<b>0.108</b>
4	1		0.54			0.59	0.57			0.45	0.46
	2		0.53			0.58	0.51			0.48	0.46
	3		0.53			0.60	0.59			0.46	0.40
	4		0.54			0.59	0.60			0.42	0.43
	5		0.55			0.59	0.61			0.46	0.44
<b>Average</b>			<b>0.54</b>			<b>0.59</b>	<b>0.58</b>			<b>0.45</b>	<b>0.44</b>
<b>COV</b>			<b>0.016</b>			<b>0.012</b>	<b>0.069</b>			<b>0.048</b>	<b>0.057</b>

\* The hole edge distance was out of tolerance on one plate, and the specimen could not be tested.

\*\* The loading rod broke, and the last two specimens could not be tested within the designated 24-h period.

Note: Blank cells indicate that lab 4 did not participate in the coating series.



**Figure 7. Graph. Mean slip coefficient for each coating system tested at each test lab using existing RCSC failure criterion.**

From the average calculated slip coefficients for each primer tested, it is clear that different coatings have different slip coefficients. In the aggregate for organic zinc-rich primers as a class of coatings, those values appear to straddle the class B specification value of 0.5. For the five organic zinc-rich primers that were tested, coatings B and C exceeded class B slip resistance for all the labs that participated. Coating E unanimously qualified only as class A by all labs that participated. Coatings A and D were classified as class A or B depending on the testing lab. Coating A was classified as class A by lab 2 and as class B by the other three labs. Coating D was classified as class B by lab 3 and as class A by the other labs. Therefore, it is apparent that the differences inherent in the test approaches used by each lab can be important to the pass or fail result for a specific coating.

#### **VARIATION IN RESULTS LAB TO LAB**

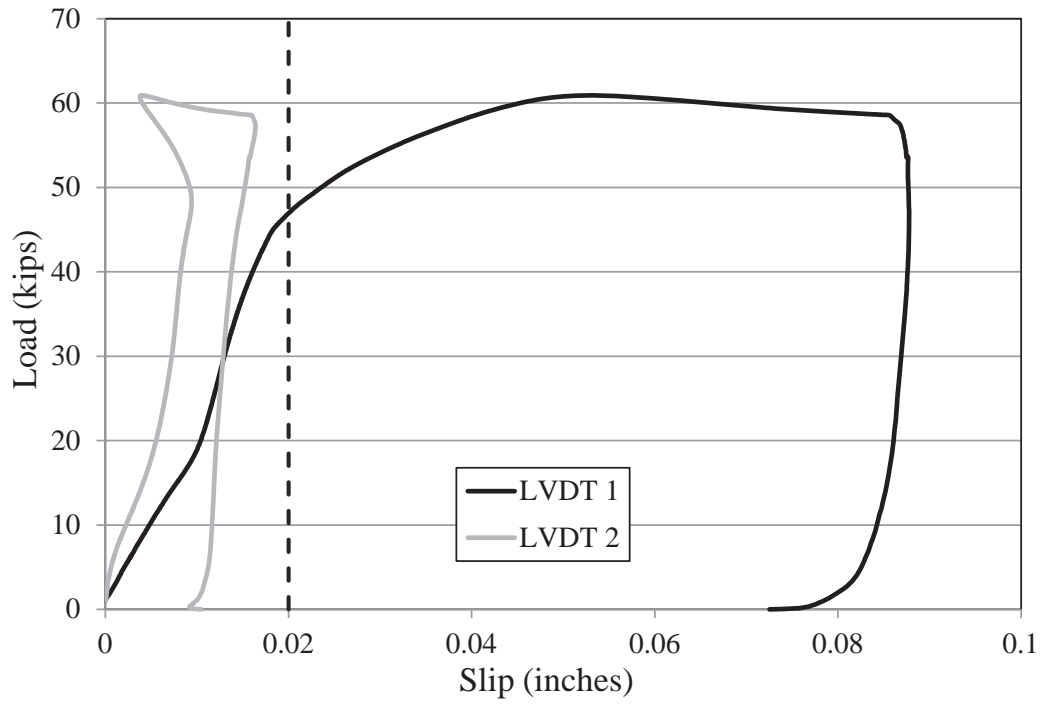
In comparing the mean slip values as shown in figure 7, there is no discernable trend of one lab consistently producing higher or lower numbers than the other labs. However, the error bars for lab 2 were consistently much larger than the other labs. When the COVs were averaged across all the coatings tested by each lab, it was found that labs 1–4 had an average COV of 0.044, 0.188, 0.040, and 0.040, respectively. Clearly, the data indicate that variability is quite consistent between labs 1, 3, and 4 and different in lab 2.

The load versus slip displacement plots in appendix A are useful to further understand the differences between the labs. The plots from lab 2 demonstrated a very “soft” response where there was more slip displacement per given load than the other labs (e.g., the secant slope of the load versus slip curve from the initial load to the peak load is not as steep as the other labs). Lab 3 had a very “stiff” response with some plots, demonstrating almost no slip as the load increased (e.g., the secant slope of the load versus slip curve from the initial load to the peak load was nearly infinite at times). The three plots shown in appendix A for coating A1 highlight this the best, where the peak loads actually did not change much between the three participating labs. However, because of the “soft” response from lab 2, the load at 0.02-inch of slip controlled the failure criterion (per RCSC) for that lab, leading to failure loads much less than the peak load and contributing to their higher level of scatter.

The observers tried to discover why labs 2 and 3 produced peak loads that were similar but had vastly different slip displacement responses. It is a nuance, but careful inspection of figure 3 through figure 6 show that labs 2 and 3 only used one displacement transducer to monitor the slip displacement. Since the RCSC specification requires that a spherical platen be used to load the specimens, there is a chance that the middle plate of the specimen can rotate about the loading rod during the test. Measurement errors from only one displacement transducer would either be additive or subtractive depending on the rotation of the middle plate. This explains the soft and stiff responses of lab 2 and 3. The displacements measured by lab 2 also contained the fictitious displacement of the spherical platen rotating towards the transducer, whereas it rotated away for lab 3. In fact, this is why some of the plots from lab 2 tended to hook backwards as if slip decreased as load increased (see figure 19, figure 21, figure 22, and figure 32 in appendix A). It also explains some of the peculiar results attained by lab 2, in particular the abnormal responses for specimens B2-3, D1-2, and D2-4. To highlight the notion, the load versus slip data recorded from each LVDT used by lab 4 for specimen C2-1 is shown in figure 8, which shows that the response from each of the two displacement measurements were quite different. In terms of the RCSC failure criterion for this example, if only LVDT 2 was used, the peak load controlled failure, and the failure load was 60.9 kip. If LVDT 1 was used, the 0.02-inch slip criterion controlled failure, and the failure load was 46.9 kip. Therefore, the coating was classified as class A using only LVDT 1 and class B using only LVDT 2. This highlights the need for two displacement transducers to be averaged together to be used in lieu of one. Otherwise, the use of one transducer must be referenced to rigid (non-rotating) points on the loading system.

To further show the effect of variability using one displacement measuring device, all data were reanalyzed ignoring the 0.02-inch slip failure criterion, and the slip coefficients were calculated using just the peak loads. The slip coefficient data based on just the peak load response are shown in table 3 and figure 9. When looking at just the peak load data, for many of the coatings where lab 2 deviated considering the 0.02-inch criteria, the average was closer to the other three labs as well a reduction in scatter. This further indicates that the measurement technique of slip displacement was the major factor in variability between labs.





**Figure 8. Graph. Load versus slip displacement response of two LVDTs from lab 4 for specimen C2-1.**

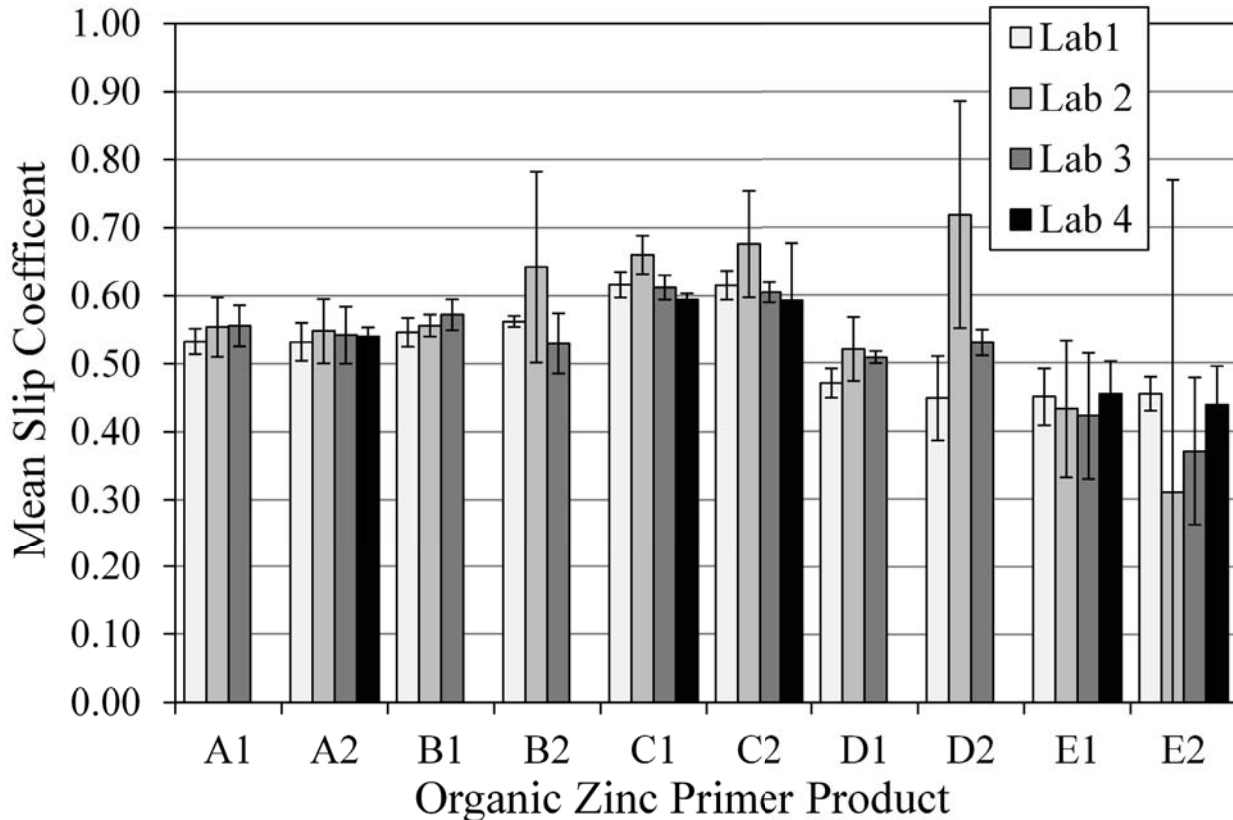
**Table 3. Results of slip coefficient testing considering just peak load failure criteria.**

Lab	Specimen	Coating									
		A1	A2	B1	B2	C1	C2	D1	D2	E1	E2
1	1	0.54	0.53	0.55	0.57	0.62	0.60	0.46	0.46	0.47	0.45
	2	0.54	0.51	0.54	0.56	0.61	0.63	0.48	0.40	0.44	0.45
	3	0.52	0.55	0.56	0.56	0.62	0.61	0.47	0.47	0.47	0.44
	4	0.53	0.54	0.53	0.56	0.63	*	0.48	0.45	0.43	0.47
	5	0.52	0.53	0.55	0.56	0.60	0.62	0.46	0.46	0.44	0.46
<b>Average</b>		<b>0.53</b>	<b>0.53</b>	<b>0.55</b>	<b>0.56</b>	<b>0.62</b>	<b>0.62</b>	<b>0.47</b>	<b>0.45</b>	<b>0.45</b>	<b>0.45</b>
<b>COV</b>		<b>0.019</b>	<b>0.028</b>	<b>0.021</b>	<b>0.008</b>	<b>0.019</b>	<b>0.021</b>	<b>0.021</b>	<b>0.062</b>	<b>0.042</b>	<b>0.025</b>
2	1	0.56	0.54	0.55	0.56	0.65	0.65	0.51	0.52	0.46	0.35
	2	0.52	0.51	0.55	0.74	0.64	0.77	0.55	0.80	0.47	0.18
	3	0.57	0.56	0.56	0.74	0.66	0.65	0.54	0.70	0.46	0.14
	4	0.54	0.55	0.55	0.58	0.66	0.66	0.51	0.75	0.39	0.44
	5	0.58	0.58	0.57	0.59	0.69	0.65	0.49	0.82	0.38	0.44
<b>Average</b>		<b>0.55</b>	<b>0.55</b>	<b>0.56</b>	<b>0.64</b>	<b>0.66</b>	<b>0.68</b>	<b>0.52</b>	<b>0.72</b>	<b>0.43</b>	<b>0.31</b>
<b>COV</b>		<b>0.043</b>	<b>0.047</b>	<b>0.016</b>	<b>0.140</b>	<b>0.028</b>	<b>0.078</b>	<b>0.047</b>	<b>0.167</b>	<b>0.100</b>	<b>0.460</b>
3	1	0.57	0.57	0.56	0.51	0.61	0.60	0.51	0.53	0.40	0.37
	2	0.56	0.55	0.56	0.55	0.61	0.59	0.51	0.52	0.38	0.41
	3	0.55	0.51	0.57	0.51	0.63	0.61	0.50	0.54	0.48	0.33
	4	0.57	0.53	0.59	0.52	0.60	0.61	0.51	0.54	0.41	**
	5	0.53	0.55	0.58	0.56	0.61	0.61	0.51	0.52	0.44	**
<b>Average</b>		<b>0.56</b>	<b>0.54</b>	<b>0.57</b>	<b>0.53</b>	<b>0.61</b>	<b>0.60</b>	<b>0.51</b>	<b>0.53</b>	<b>0.42</b>	<b>0.37</b>
<b>COV</b>		<b>0.030</b>	<b>0.042</b>	<b>0.023</b>	<b>0.044</b>	<b>0.018</b>	<b>0.015</b>	<b>0.009</b>	<b>0.019</b>	<b>0.092</b>	<b>0.108</b>
4	1		0.54			0.59	0.62			0.45	0.46
	2		0.53			0.60	0.51			0.48	0.46
	3		0.54			0.60	0.59			0.46	0.40
	4		0.54			0.59	0.60			0.42	0.43
	5		0.55			0.59	0.64			0.46	0.44
<b>Average</b>			<b>0.54</b>			<b>0.59</b>	<b>0.59</b>			<b>0.45</b>	<b>0.44</b>
<b>COV</b>			<b>0.013</b>			<b>0.009</b>	<b>0.084</b>			<b>0.048</b>	<b>0.057</b>

\* The hole edge distance was out-of-tolerance on one plate, and the specimen could not be tested.

\*\* The loading rod broke, and the last two specimens could not be tested within the designated 24-h period.

Note: Blank cells indicate that lab 4 did not participate in the coating series.



**Figure 9. Graph. Mean slip coefficient for each coating system tested at each test lab only using peak load response.**

#### VARIATION DUE TO PAINT THICKNESS

The RCSC procedure requires reporting the coating DFTs. However, for this study, that information could lose the anonymity of the five specific coatings. Therefore, table 4 shows the average deviation of the DFTs from the target thickness considering all the test plates used for each series. A negative deviation represents a DFT thinner than the target and vice versa for a positive deviation. The control of the application relative to target application was within 1 mil for all but one of the sets of panels. The table also reports the difference between the average DFTs of the +1- and +2-mil targets (i.e., the difference should ideally be 1 mil). For coatings A–E, the differences were actually 0.9, 1.7, 0.7, 2.7, and 0.2 mil, respectively.

The far right column in table 4 reports the difference in the average slip coefficient between the +1- and +2-mil specimens using lab 1 data only. The data from labs 2 and 3 were not used because of the disparity noted previously with the slip measurement. Data from lab 4 were not used because the lab did not test all coatings. However, based on lab 1 data, thickness variations ranging from 0.2 to 2.7 mil caused no appreciable change in slip coefficient. The testing of manufacturer recommended thickness specifications of +1 versus +2 mil (as required in the RCSC specification) for each of the coating systems did not seem to be the determining factor in whether a coating qualified as class A or B.

**Table 4. Deviations from manufacturer’s recommended DFT.**

<b>Coating</b>	<b>Deviation from Target Thickness (mil)</b>	<b>Real Difference in Thickness Between targeted +1- and +2-mil Coatings (mil)</b>	<b>Difference in Slip Coefficient Between +1- and +2-mil Coatings using Lab 1 Data</b>
A1	- 0.3	0.9	-0.01
A2	- 0.2		
B1	- 0.6	1.7	0.01
B2	+ 0.7		
C1	- 1.3	0.7	-0.01
C2	- 0.6		
D1	- 0.8	2.7	-0.01
D2	+ 0.9		
E1	+ 0.5	0.2	0.00
E2	- 0.3		

## **OUTLIER ANALYSIS**

During the study, there was some discussion of the proper treatment of outliers in the datasets. Although there were several replicates which appeared to have a high variance from the mean, an analysis of the dataset did not point to any single data point as a true statistical outlier. That is, no data point showed an excursion of two standard deviations from the mean for the set. This result is in part a result of the fact that the mean for each dataset was only generated from a set of five replicates. It also indicates that for those datasets where an apparent outlier existed, there was generally a larger standard deviation for the dataset.

However, regardless of statistical significance, it is clear that within some of the datasets, there were replicates which provided results that conflict with the other four replicates. Given the care to maintain consistency in preparation, application, and cure of the panels used in this testing, there is no apparent physical reason (related to the paint) for extremely low slip results for a single replicate. Therefore, it must be assumed that there is an occasional result which deviates from the group due to slight but important differences in testing protocol (loading rate, alignment, equipment function, etc.). For this reason, it is worth considering instituting a protocol which allows some measure of judgment on the part of the test agent to either retest extra, duplicate panels, or dismiss a single data point when calculating slip coefficient. Given the fact that there were only five replicates in this test protocol, the use of a sixth panel as a replacement for a questionable data point may be a prudent testing option to consider. Of course, this substitution should require a substantive justification from the testing agent. Out of the 175 total replicates tested by the 4 labs in this program, a total of 3 (lab 1 C2-4 and lab 3 E2-4 and E2-5) were not reported due to testing difficulties. But there were other points that were reported that may have been considered questionable (primarily low) by testing agents if that option had been available. The inclusion of a sixth sample would be a small incremental (possibly negligible) cost and would allow reporting of five results with more confidence. Specifically, this approach could potentially be applied in cases such as lab 1 D2-2 and D1-3

and lab 2 D2-2, C1-1, and A1-3 which all show exaggerated low load profiles compared to the other replicates in their respective sets.

## **OTHER IDENTIFIED CONCERNS**

The operation of the test in quasi-load control (labs 2 and 3) was perfectly acceptable under the specification; however, this mode of control creates some practical issues that make the test somewhat more difficult and may introduce some of the errors seen in the results. The use of load control requires the operator to focus his or her primary attention on the load control mechanism to capture the end result of the test while still attempting to “catch” the end point and quickly unload the test apparatus prior to full dramatic slip of the coating. This phenomenon is clearly a focus point of the test operators in both of these labs, and it requires a majority of their attention while also focusing on maintaining a consistent lateral compressive load and visually capturing the highest slip load on their readout. Without digital data recording and a fail-safe device on the very high slip load, this is a large responsibility to ask of a single operator.

Additionally, the periodic crashing of the slip load onto the rod has real consequences. Three of the four labs involved in this study had rods break during this test program. The specific causes of these breaks involved various causes, from improper heat treatment of one rod to improper material selection of another rod. Breaks were also due to repeated (unintended) impact loading of the rod with the slip load. Other rods did not break but were replaced due to significant bending. Bent rods are another source of error in the alignment and test results. The protocols at the labs should be addressed to either eliminate the possibility of load crash through the use of a combined load and displacement control (as in labs 1 and 4) or through the modification of the test rigs to minimize the effect of the impact of the load through an attenuating device.

Both labs 1 and 4 reported difficulties in attaining proper alignment after the clamping load had been applied for some specimens. For various reasons, the outer plates would sit flat on the lower plate under no load, but application of the 49-kip clamping load would cause one of them to uplift at times. It was not a general alignment issue with the load frame as it only happened for a small number of specimens. Lab 1 investigated the problem further and found in many cases the outer plates are never fully in contact with the lower platen. After clamping, a piece of paper could be placed under the plates, sometimes unperceivable to the eye. However, under vertical load, the paper could no longer freely move under the specimen, though it was observed that the piece of paper could freely be placed between the horizontal jack and the saddle. It was determined that if one outer plate had more gap under it than the other, the vertical load would force both into contact with the platen, though that would also rotate the horizontal jack off its support. When this happened, there was a characteristic load versus slip curve that had two plateaus. Examples of this can be found in the appendix A, specifically with the following:

- Lab 1 specimens D1-3 and D2-2.
- Lab 2 specimens A1-3, B2-5, and C1-1.
- Lab 4 specimens C1-2 and C2-1.

The double plateau load/slip curves have fictitious slip displacement because the reported displacement is actually shakedown of the bearing surfaces into the loading platens. This led to a soft response curve where failure would likely be controlled by the 0.02-inch slip criterion.

## CONCLUSIONS

The following list represents the major findings from this study:

- All labs participating in this study followed procedures that differed slightly in terms of equipment, test process, specimen alignment, and data acquisition. However, all lab procedures fell within the mandates of the current RCSC specification. Data generated by all labs in this study were deemed acceptable for comparison.
- The variability seen between the labs was likely related to subtle but important differences in the construction of their test apparatus and the method used to measure the slip displacement during the test. More variation was deemed possible using only one displacement measuring device versus two. The current RCSC specification allows for one displacement measuring device provided it measures "... movement of the loading head relative to the base."(pg. 71)<sup>(2)</sup> The current RCSC language is unclear whether the loading head is above or below the spherical bearing.
- The slip coefficients measured for the representative group of five organic zinc-rich primers fell close to the specification limit of 0.5 for class B. Some coatings fell under class B, while others fell just short to be classified as class A. The data clearly indicate that the specific choice of primer material can be important in terms of meeting class B for slip, and at times the result could change based on the testing agency.
- Differences in results observed for coatings applied at manufacturers' recommended thickness of +2 mil versus the same coatings applied at +1 mil did not exist.
- The impact of the 0.02-inch slip offset requirement to define failure during the test (as required in the specification) can be an important factor in limiting the calculated slip load for a particular coating. For the vast majority of the data from most of the labs, the 0.02-inch criterion did not play a factor in the result, but for selected replicates, this factor was important. It was thought the method used to measure the displacement was more of an influence than the 0.02-inch value itself.





## RECOMMENDATIONS

Based on the observations of the participating labs and the data produced by them, this study offers the following suggested changes to the RCSC for appendix A of its *Specification for Structural Joints Using High-Strength Bolts*:<sup>(2)</sup>

- If RCSC maintains the current procedure wherein the slip coefficient is strictly determined as the average of five specimens, it should allow testing agents the ability to test one extra plate and to ignore an outlier data point.
- RCSC should consider restructuring its requirements for the test apparatus to mandate the use of more than a single slip measurement point during the test. This second point should be placed in a plane such that it can effectively monitor any undesired measurement error caused by specimen rotation or eccentric loading.
- The test method should be modified such that tolerances are imposed to ensure symmetry of the load train and reduce the eccentricities as much as possible between the jacks and specimen. A  $\pm 1/8$ -inch tolerance is recommended.
- RSCS should consider eliminating the requirement stating that tests be conducted until 0.05 inch of slip occurs. The test method specifies reporting the maximum load that is observed during the test up through the attainment of a 0.02-inch average slip. Information obtained after 0.02 inch of slip is not explicitly reported in the results. If RSCS wants to keep the existing requirement, it should consider allowing an increase of the rate of loading after 0.02 inch of average slip has been achieved.
- RCSC should consider redrafting the test method language to focus on using digital data acquisition in lieu of analog X-Y plotters.
- RCSC should consider eliminating the load and displacement rate limits on the test. In lieu of them, the test method could suggest the maintenance of a rate of loading until 0.02 inch of slip and that the test from start through 0.02 inch of slip should be completed within a fixed timeframe.



## APPENDIX A. DATA PLOTS

This appendix contains the load versus slip plots for all specimens tested as part of the interlaboratory variability study. For each coating series, the plots are scaled uniformly for the three or four labs participating to highlight the differences between individual laboratory practice in conducting the RCSC test. Lab 4 only participated in half of the coating series.

For some graphs, the individual data plots within them may be so close to each other that it is difficult to discern one line from the other. To assist readers, a black dashed line has been drawn intersecting all plots at one section. The dashed line is connected to a leader line that connects to the legend. The order of the legend from top to bottom correlates to the order in which the dashed line intersects the individual plots. The intersected plot furthest from the leader is the top entry in the legend, and the intersection closest to the leader is at the bottom of the legend.

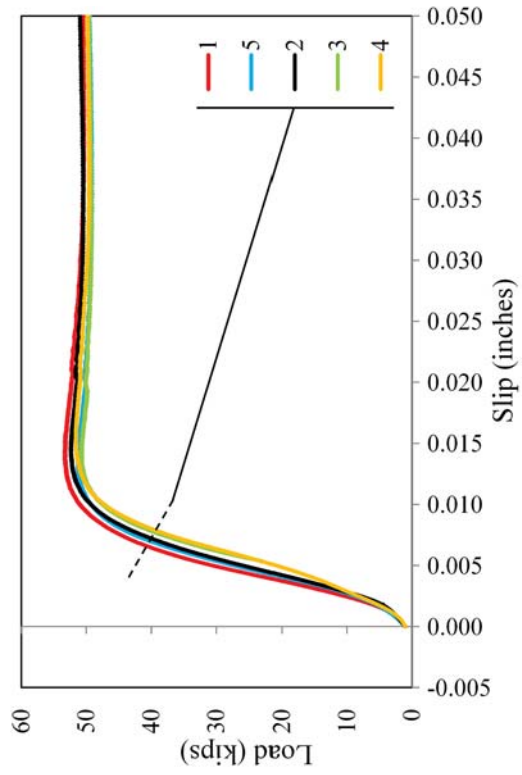


Figure 10. Graph. Load versus slip displacement curves for lab 1 coating A1.

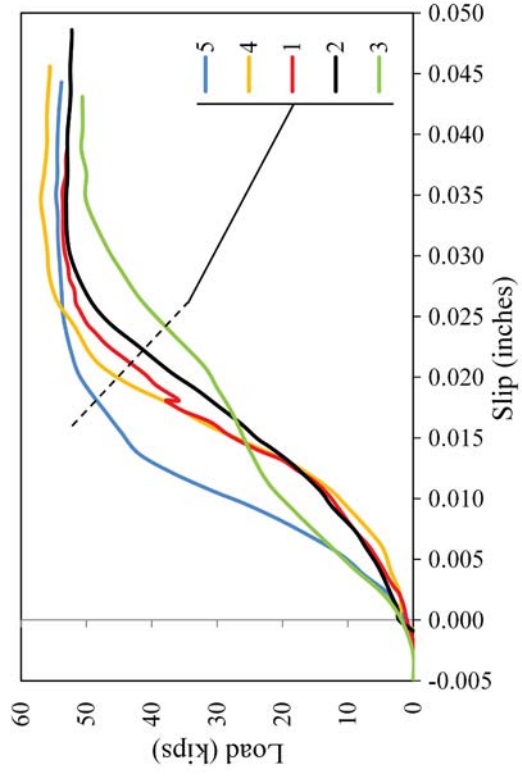


Figure 11. Graph. Load versus slip displacement curves for lab 2 coating A1.

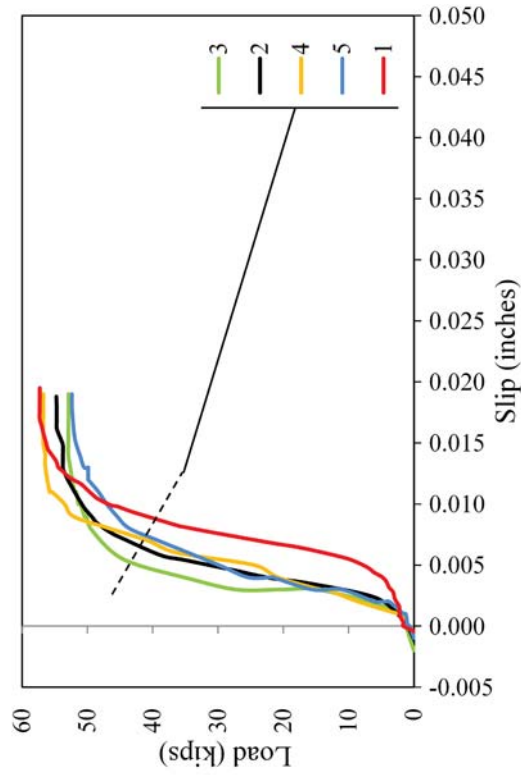


Figure 12. Graph. Load versus slip displacement curves for lab 3 coating A1.

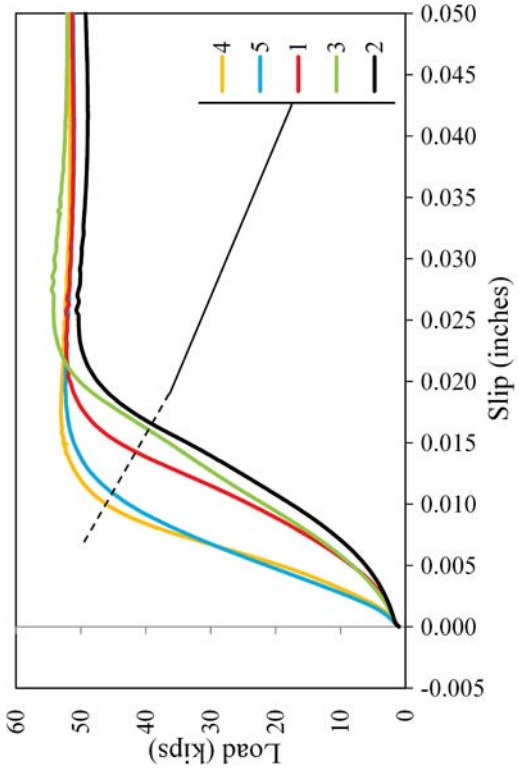


Figure 13. Graph. Load versus slip displacement curves for lab 1 coating A2.

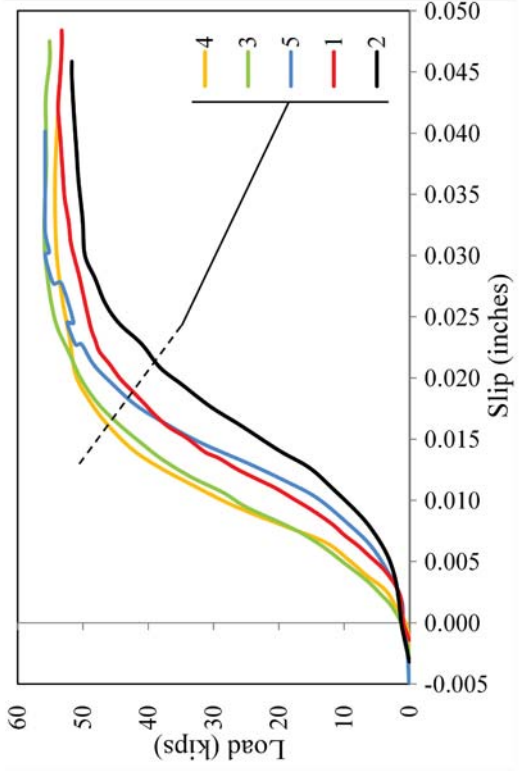


Figure 14. Graph. Load versus slip displacement curves for lab 2 coating A2.

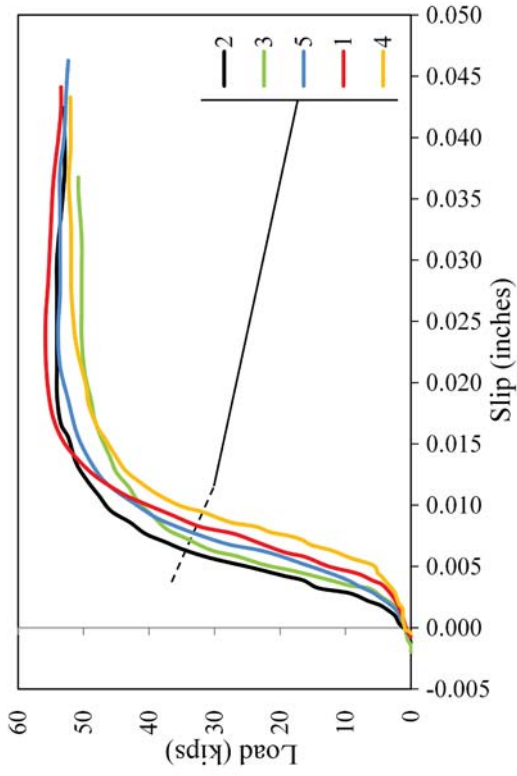


Figure 15. Graph. Load versus slip displacement curves for lab 3 coating A2.

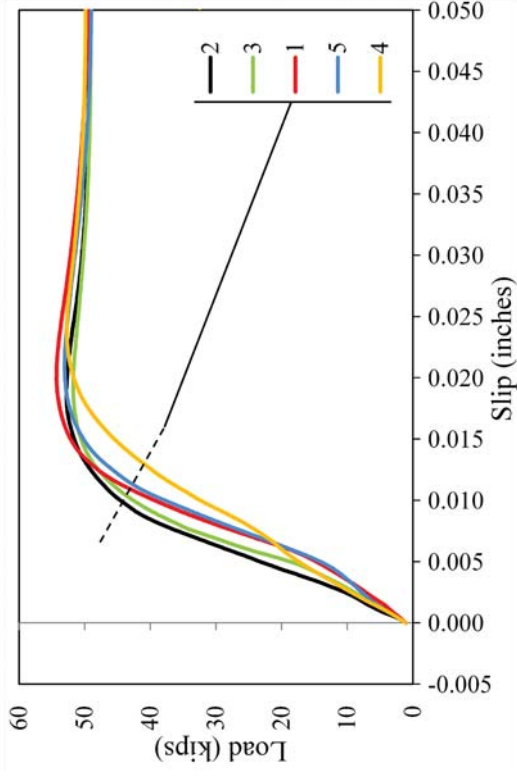


Figure 16. Graph. Load versus slip displacement curves for lab 4 coating A2.

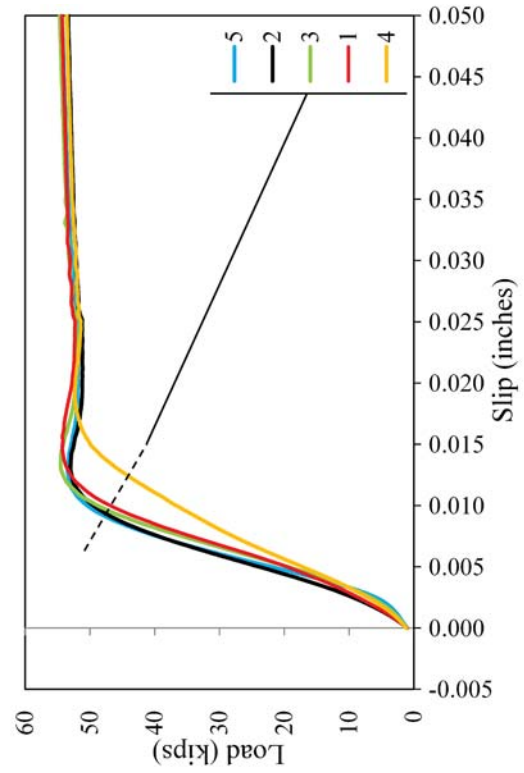


Figure 17. Graph. Load versus slip displacement curves for lab 1 coating B1.

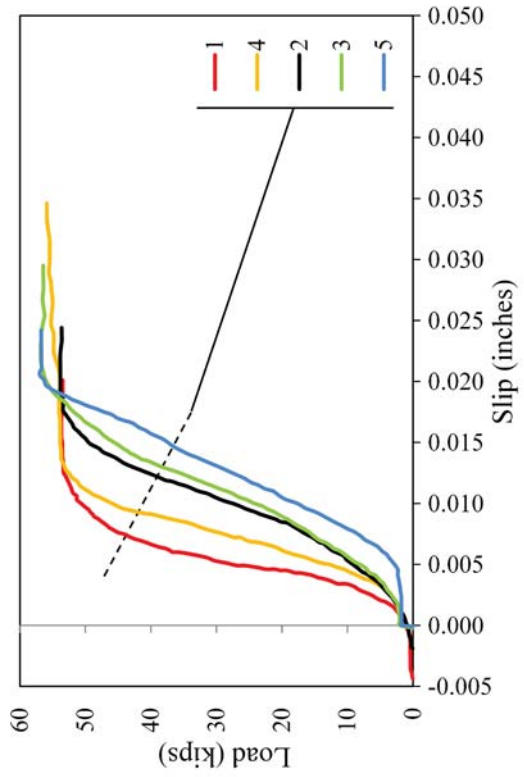


Figure 18. Graph. Load versus slip displacement curves for lab 2 coating B1.

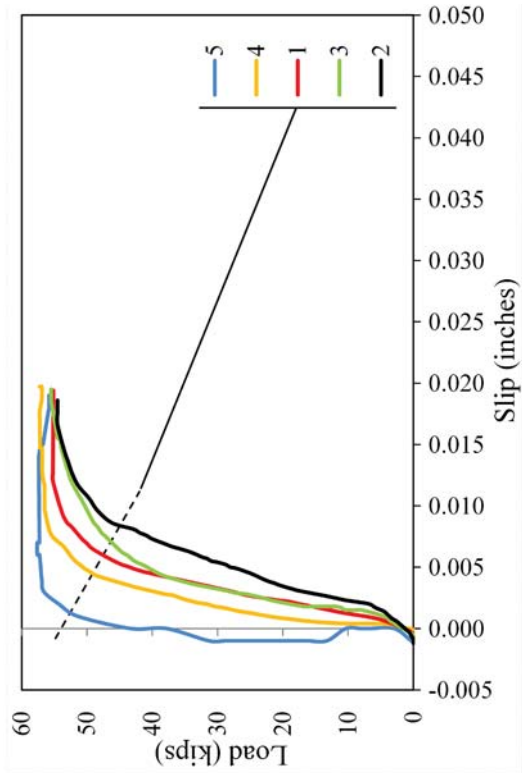


Figure 19. Graph. Load versus slip displacement curves for lab 3 coating B1.

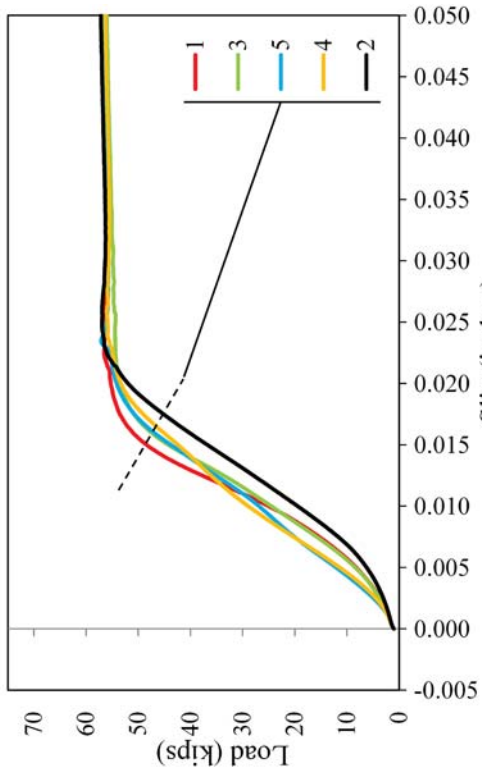


Figure 20. Graph. Load versus slip displacement curves for lab 1 coating B2.

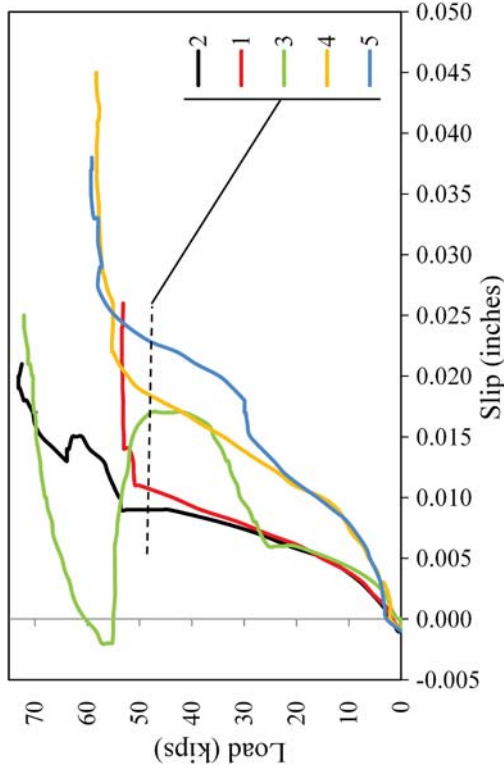


Figure 21. Graph. Load versus slip displacement curves for lab 2 coating B2.

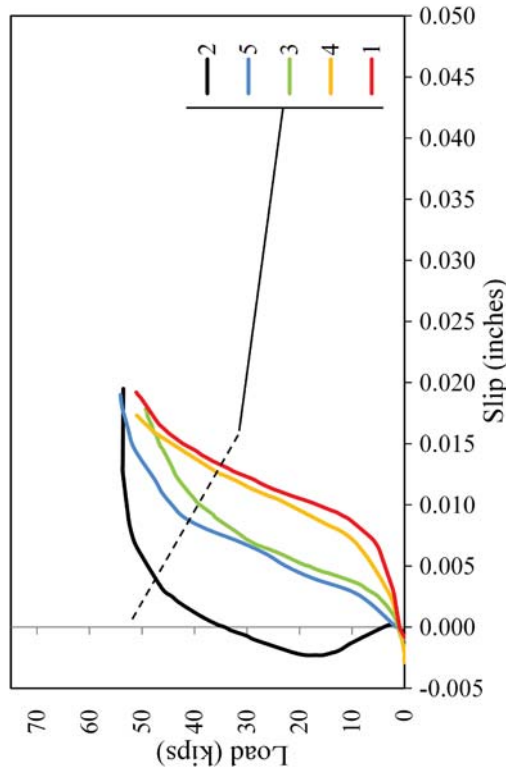


Figure 22. Graph. Load versus slip displacement curves for lab 3 coating B2.

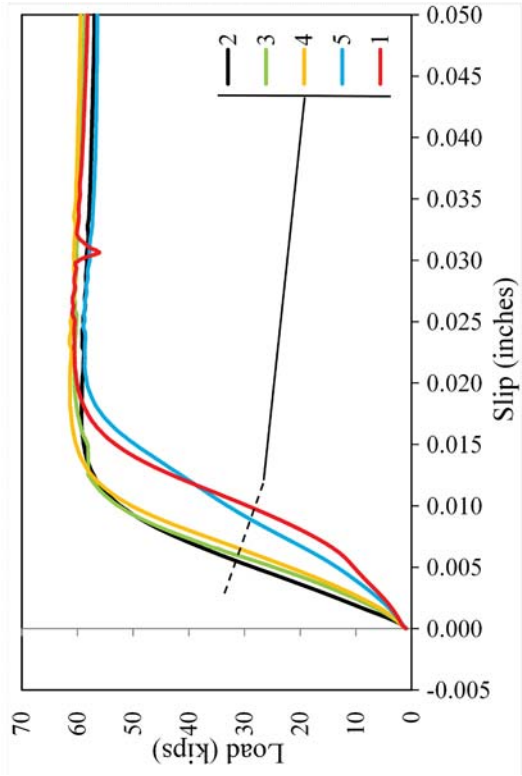


Figure 23. Graph. Load versus slip displacement curves for lab 1 coating C1.

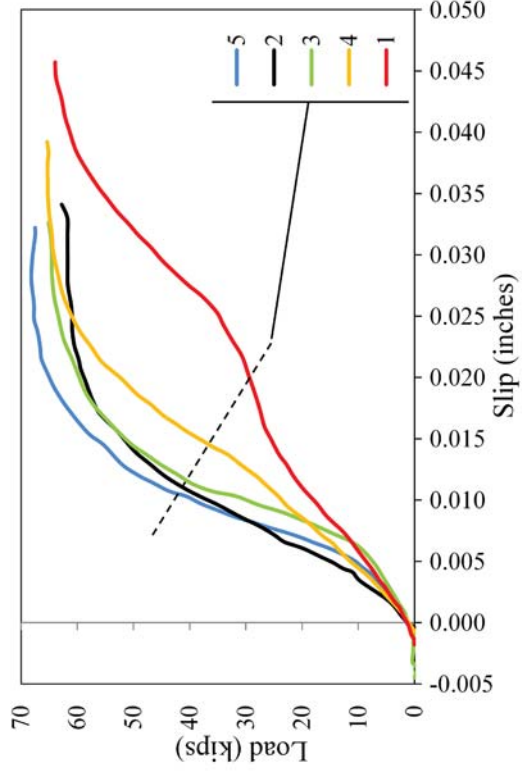


Figure 24. Graph. Load versus slip displacement curves for lab 2 coating C1.

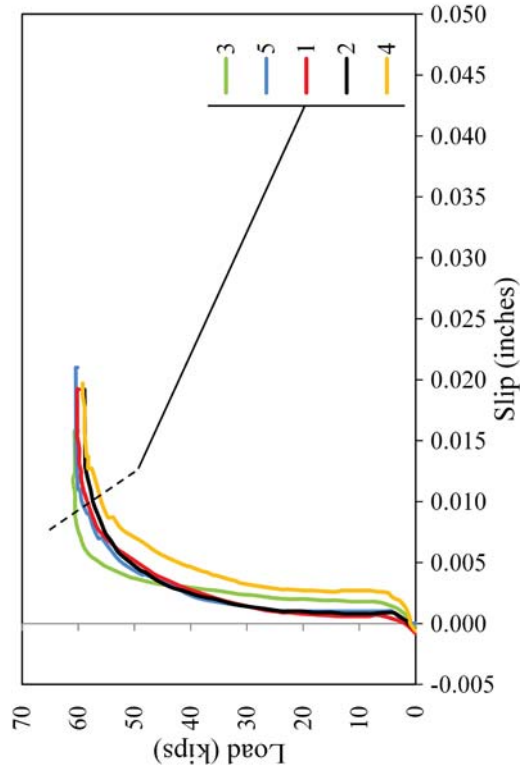


Figure 25. Graph. Load versus slip displacement curves for lab 3 coating C1.

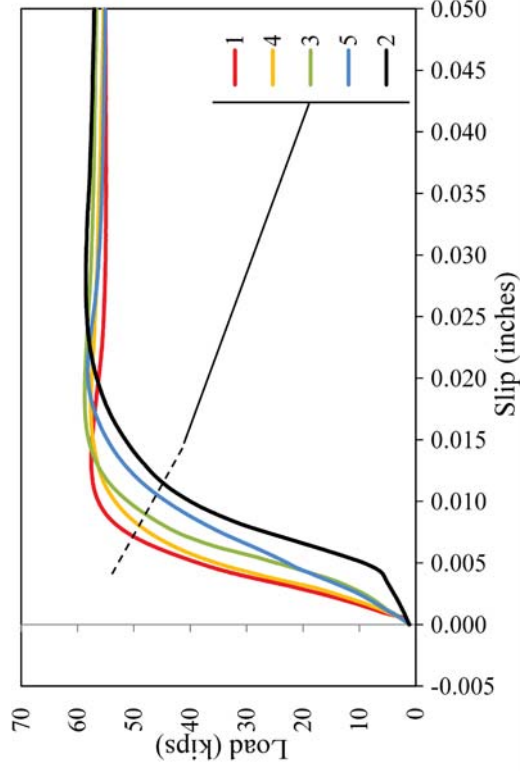


Figure 26. Graph. Load versus slip displacement curves for lab 4 coating C1.



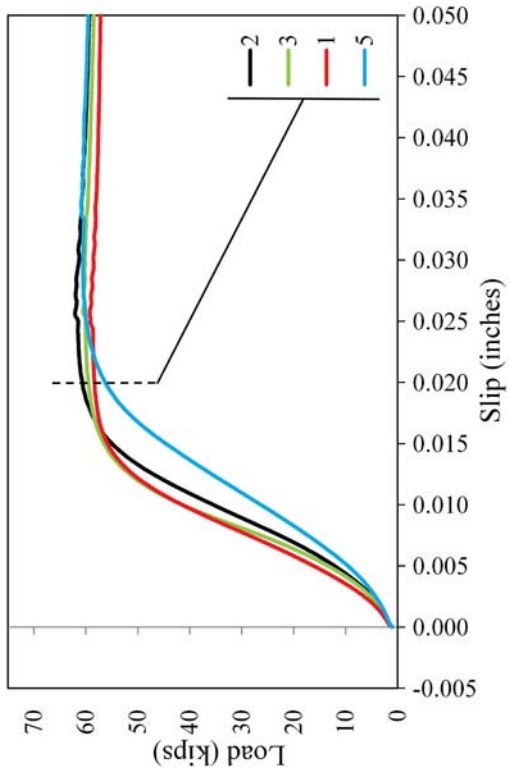


Figure 27. Graph. Load versus slip displacement curves for lab 1 coating C2.

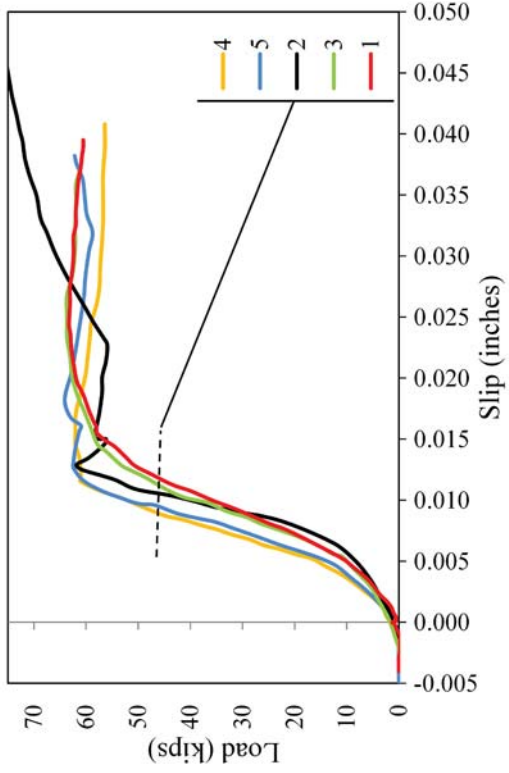


Figure 28. Graph. Load versus slip displacement curves for lab 2 coating C2.

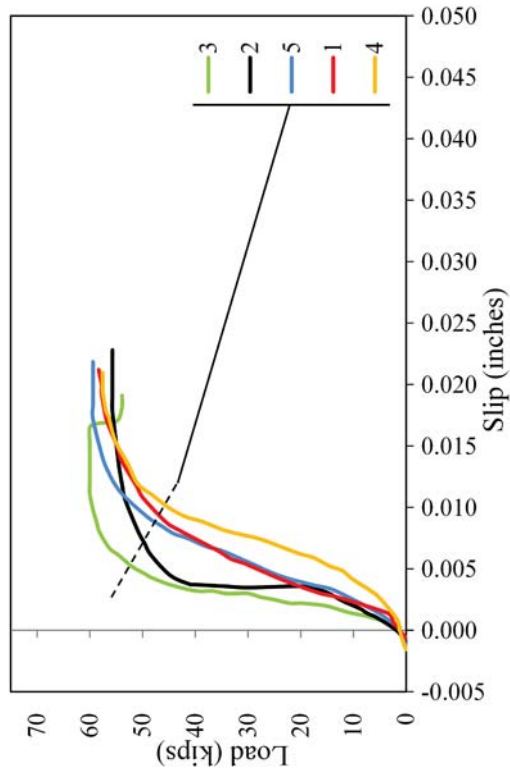


Figure 29. Graph. Load versus slip displacement curves for lab 3 coating C2.

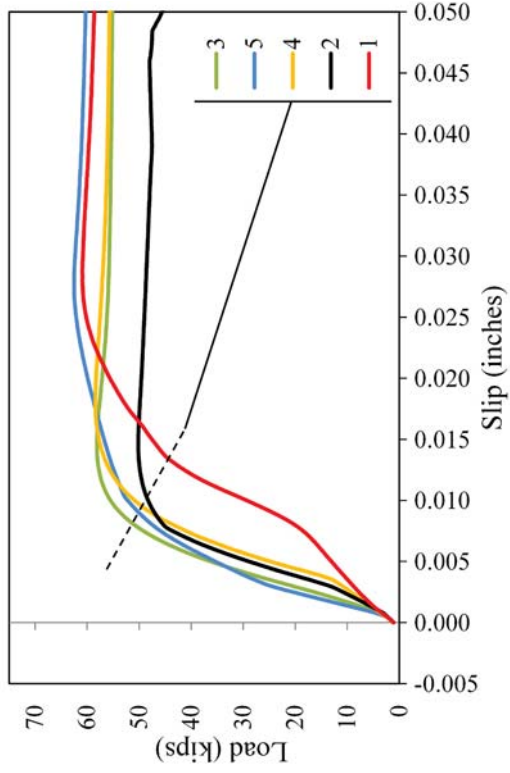


Figure 30. Graph. Load versus slip displacement curves for lab 4 coating C2.

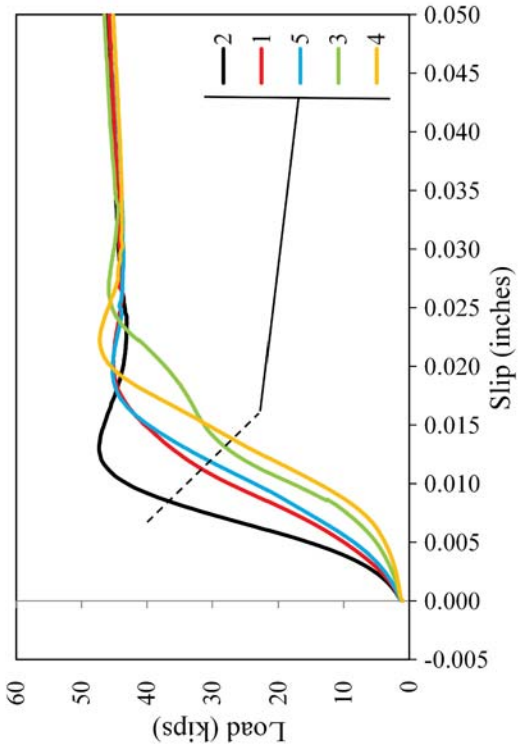


Figure 31. Graph. Load versus slip displacement curves for lab 1 coating D1.

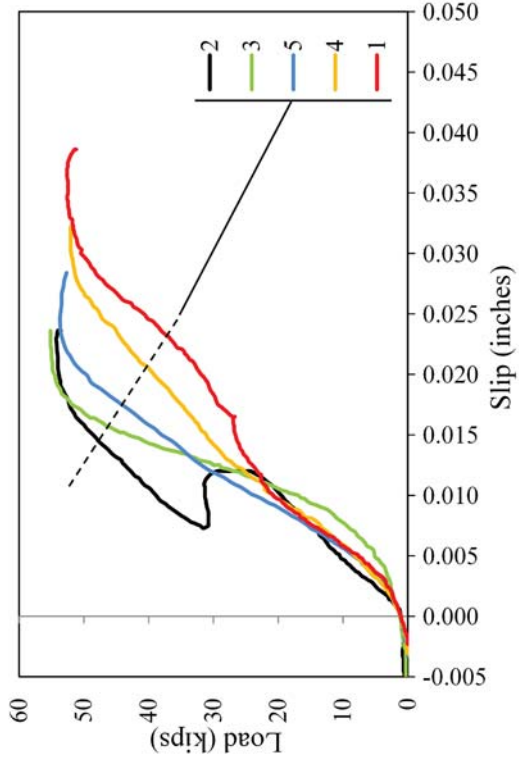


Figure 32. Graph. Load versus slip displacement curves for lab 2 coating D1.

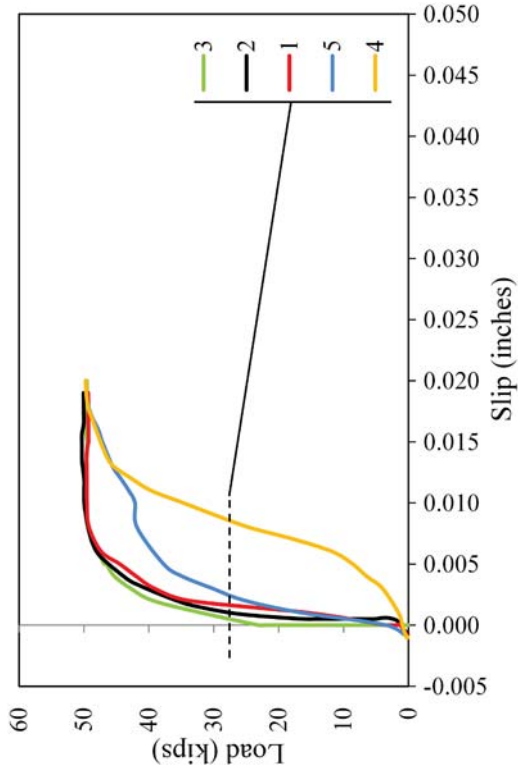


Figure 33. Graph. Load versus slip displacement curves for lab 3 coating D1.

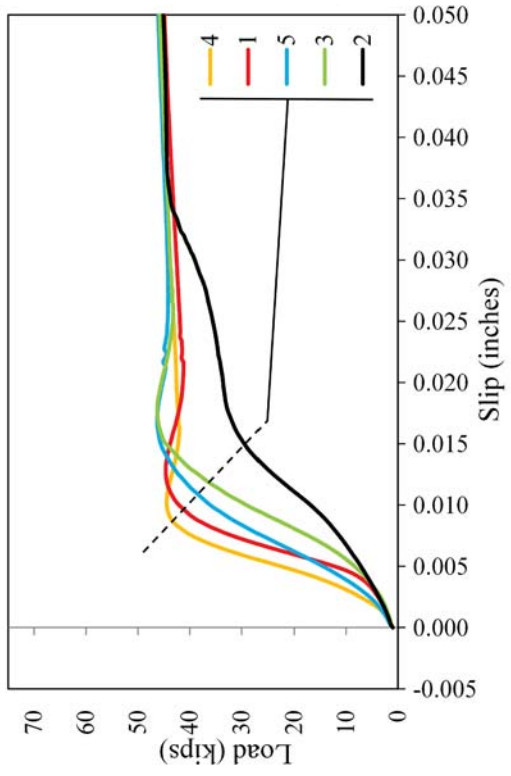


Figure 34. Graph. Load versus slip displacement curves for lab 1 coating D2.

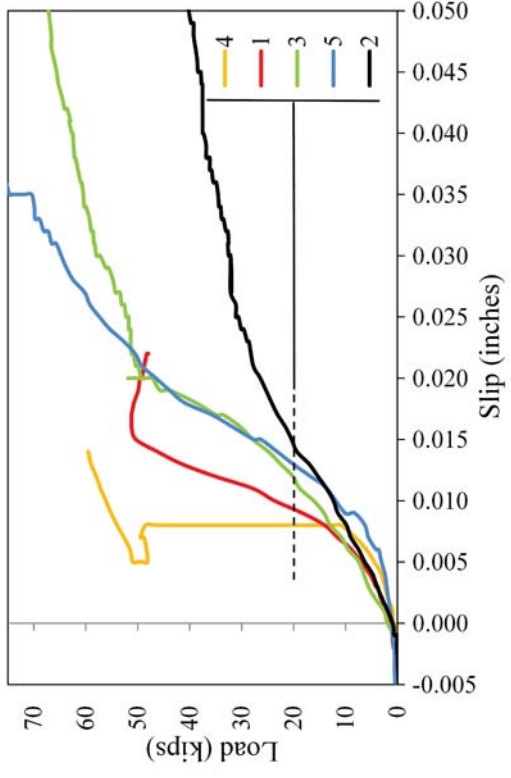


Figure 35. Graph. Load versus slip displacement curves for lab 2 coating D2.

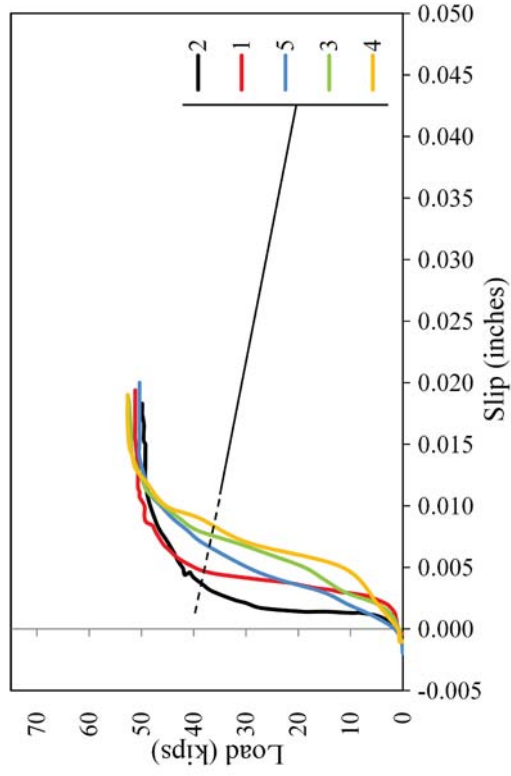


Figure 36. Graph. Load versus slip displacement curves for lab 3 coating D2.

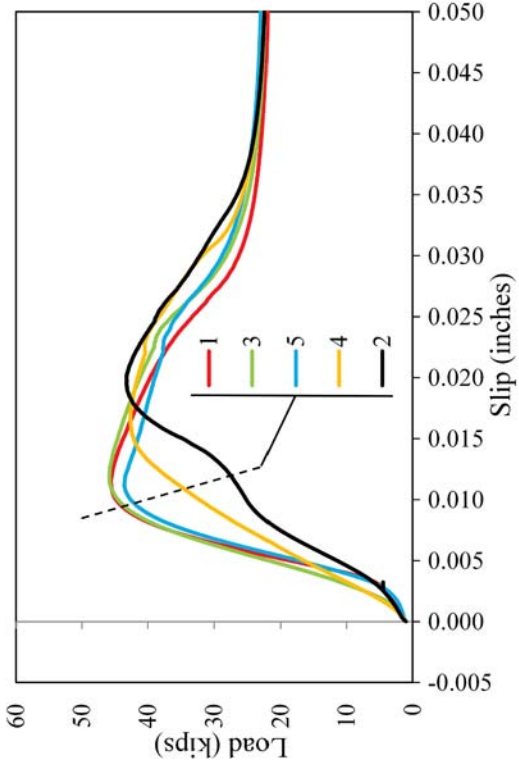


Figure 37. Graph. Load versus slip displacement curves for lab 1 coating E1.

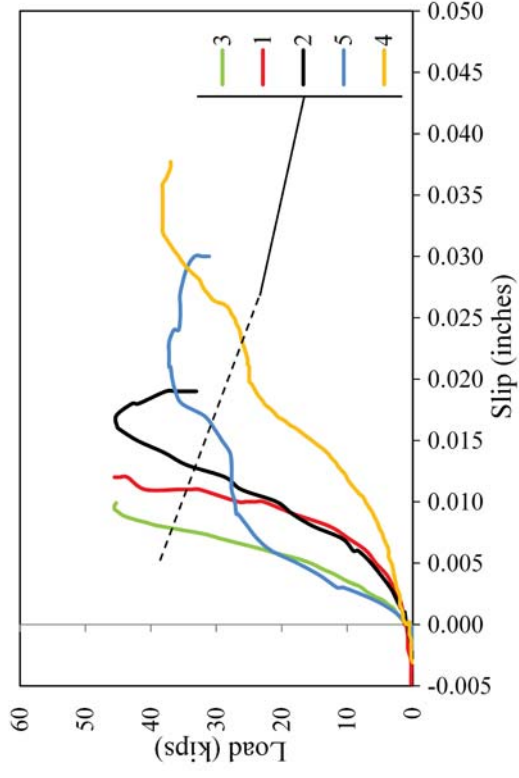


Figure 38. Graph. Load versus slip displacement curves for lab 2 coating E1.

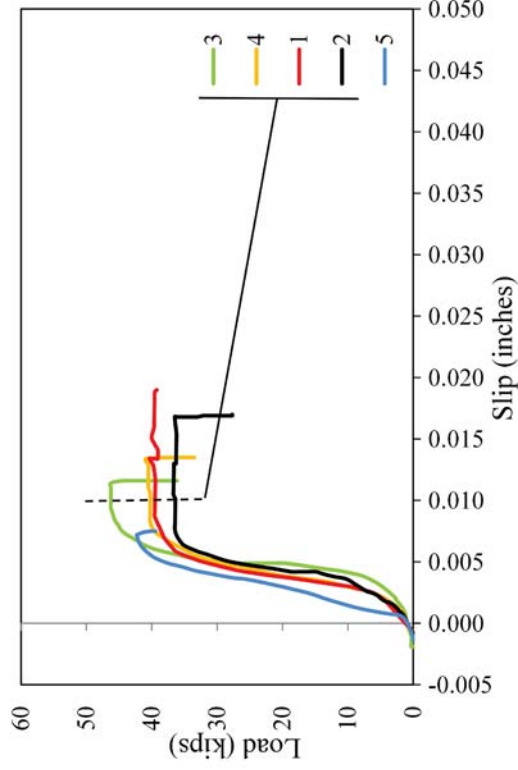


Figure 39. Graph. Load versus slip displacement curves for lab 3 coating E1.

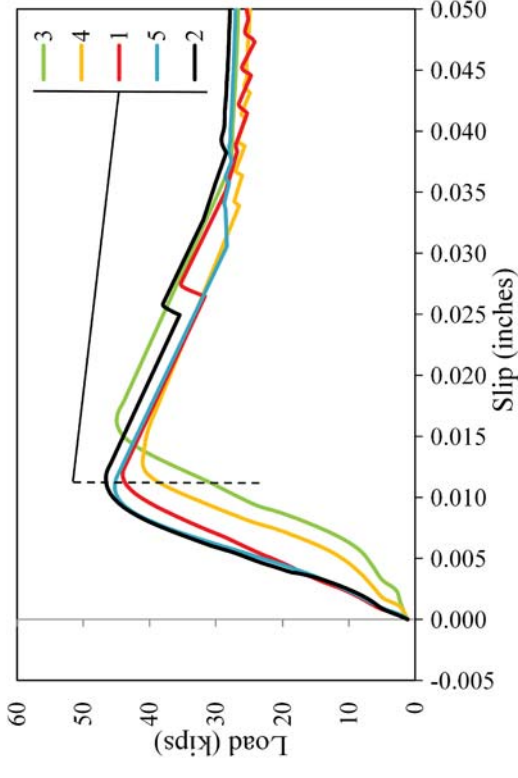


Figure 40. Graph. Load versus slip displacement curves for lab 4 coating E1.

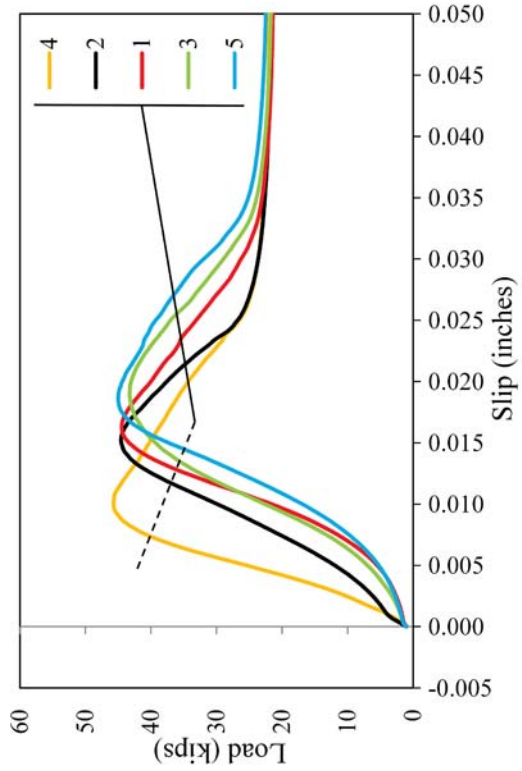


Figure 41. Graph. Load versus slip displacement curves for lab 1 coating E2.

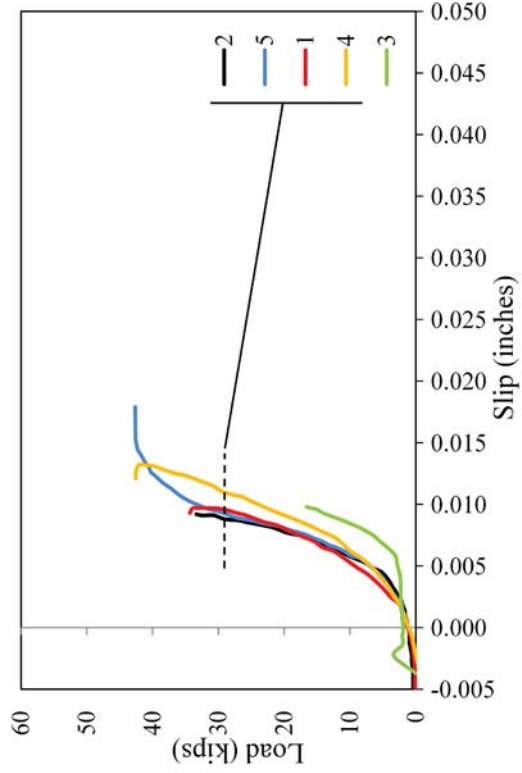


Figure 42. Graph. Load versus slip displacement curves for lab 2 coating E2.

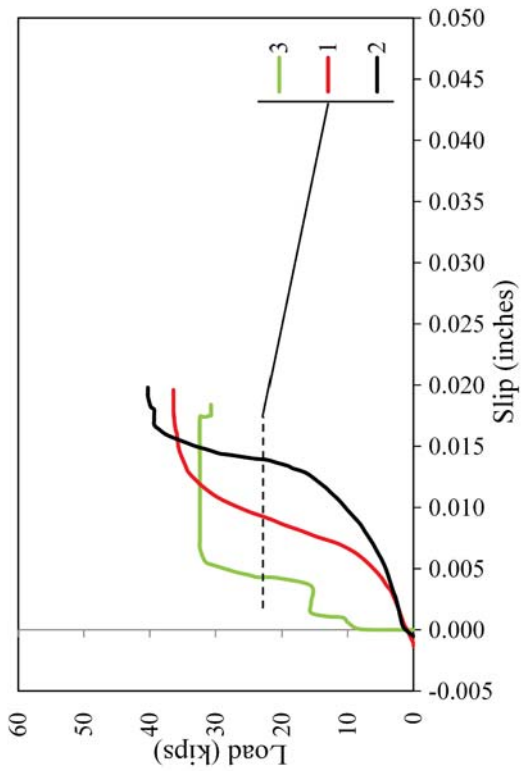


Figure 43. Graph. Load versus slip displacement curves for lab 3 coating E2.

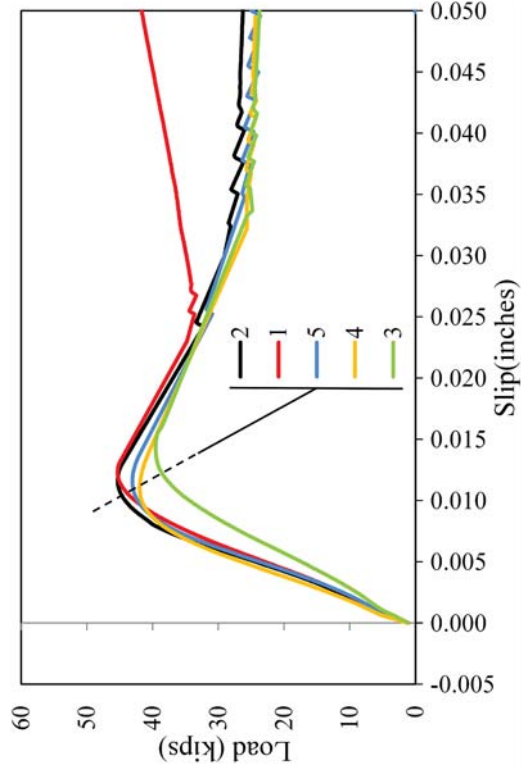


Figure 44. Graph. Load versus slip displacement curves for lab 4 coating E2.



## APPENDIX B. PRECISION AND BIAS ANALYSIS

The data collected in this study were analyzed according to the ASTM E691-13 standard since its goal is to establish the precision and bias of a test method.<sup>(3)</sup> That standard cautions that a well-designed interlaboratory variation study should use around 30 labs to evaluate a test procedure, with 8 as a minimum. Recall that this study only included four participating laboratories. Therefore, the statistical analysis procedures set forth in ASTM E691-13 are presented in this appendix, although it is advised that its value in defining precision and bias is very low and should only be used to look for trends.

In the *Experimental Results* section of this report, it was described that the variation between the labs was dominated by the displacement measurement technique, and slip displacement measurements were the major source of the variation. The ASTM E691-13 statistics are presented two ways in this appendix. First, they are calculated with the slip coefficient considering the peak load or 0.02-inch slip displacement failure criterion. Second, they are calculated using just the peak load for the slip coefficient calculation.

For brevity, not all the statistical calculations are presented in this appendix. The main calculations of interest as far as ASTM E691-13 is concerned are *h*- and *k*-consistency statistics. The *h*-consistency statistic evaluates the variability of each lab average to the average amongst all the labs. The *k*-consistency statistic evaluates the variability of a given lab with respect to the overall average. The raw data for *h* and *k* are presented in table 5 through table 8 for each of the two failure criterion. For each calculation, a critical value was also determined based on a 95 percent confidence interval.

**Table 5. *h*-statistic considering 0.02-inch failure criteria.**

Lab	Coating									
	A1	A2	B1	B2	C1	C2	D1	D2	E1	E2
1	0.38	-0.14	-0.58	0.11	0.66	-0.24	-0.49	-1.00	0.74	1.00
2	-1.13	-1.36	-0.58	0.94	-1.46	1.37	-0.66	0.00	-1.15	-1.06
3	0.76	0.83	1.15	-1.05	0.62	-0.11	1.15	1.00	-0.52	-0.63
4		0.67			0.17	-1.02			0.92	0.69

Note: Blank cells indicate lab 4 did not participate in the coating series.

**Table 6. *h*-statistic considering just peak load failure criteria.**

Lab	Coating									
	A1	A2	B1	B2	C1	C2	D1	D2	E1	E2
1	-1.15	-1.13	-0.87	-0.28	-0.23	-0.19	-1.12	-0.84	0.69	0.92
2	0.45	1.28	-0.22	1.11	1.42	1.45	0.81	1.10	-0.46	-1.25
3	0.70	0.10	1.09	-0.83	-0.28	-0.47	0.31	-0.26	-1.18	-0.35
4		-0.25			-0.92	-0.79			0.96	0.68

Note: Blank cells indicate lab 4 did not participate in the coating series.

**Table 7. *k*-statistic considering 0.02-inch failure criteria.**

Lab	Coating									
	A1	A2	B1	B2	C1	C2	D1	D2	E1	E2
1	0.24	0.94	1.01	0.09	0.17	0.91	0.67	0.67	0.35	0.20
2	1.69	1.48	0.79	1.71	1.98	0.51	1.60	1.59	1.79	1.81
3	0.31	0.90	1.16	0.25	0.16	0.37	0.08	0.12	0.72	0.70
4		0.33			0.10	1.67			0.41	0.43

Note: Blank cells indicate lab 4 did not participate in the coating series.

**Table 8. *k*-statistic considering just peak load failure criteria.**

Lab	Coating									
	A1	A2	B1	B2	C1	C2	D1	D2	E1	E2
1	0.55	0.76	0.97	0.08	0.90	0.34	0.73	0.37	0.57	0.15
2	1.31	1.33	0.91	1.68	1.48	1.41	1.54	1.69	1.34	1.89
3	1.00	1.20	1.11	0.43	0.90	0.25	0.30	0.14	1.19	0.54
4		0.49			0.43	1.35			0.67	0.33

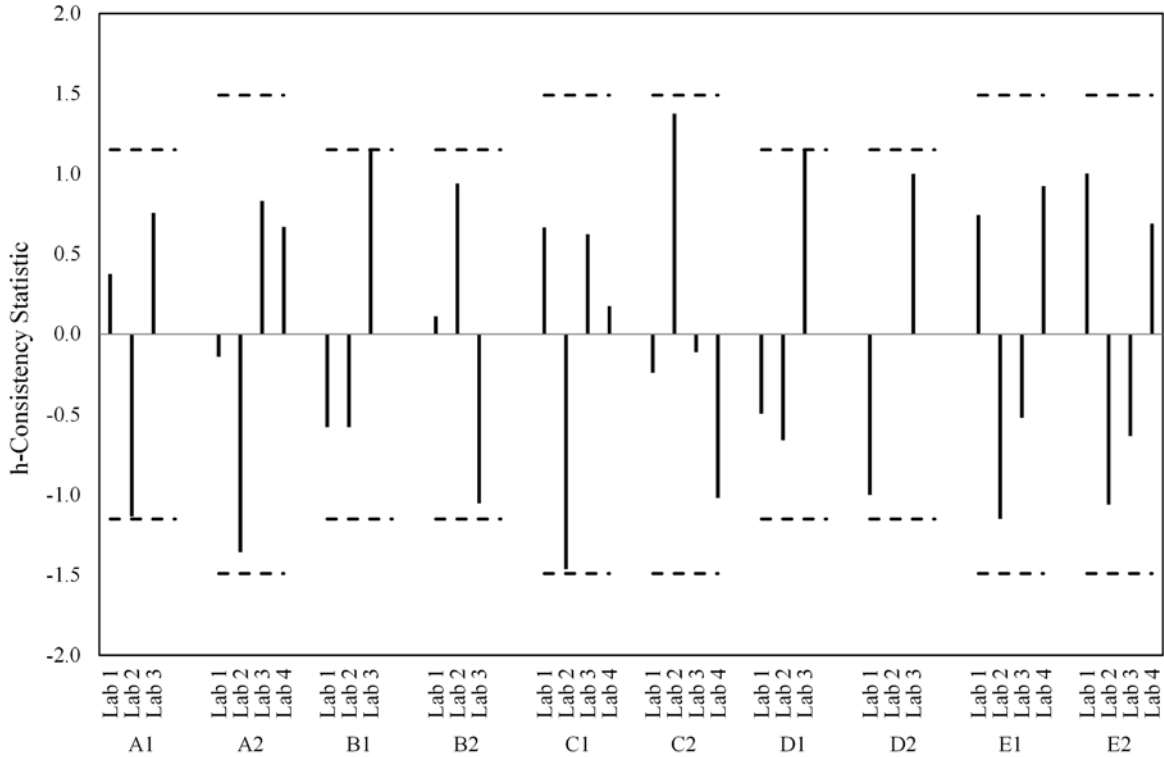
Note: Blank cells indicate lab 4 did not participate in the coating series.

The data are also shown in figure 45 through figure 52. Two plots are presented for each of the two statistics and for each of the two failure criterion: one for the laboratories within a material and one for materials within a lab. For the *h*-statistic, the critical value is a function of the number of labs participating in a certain material. Since lab 4 only participated in half the testing, there are two sets of critical values depending on whether each material was tested by three or four labs. In each of the graphs, black dashed lines represent the critical values. Because of the changing critical values, the black dashed lines appear saw-toothed when plotting materials within a lab and as a step function when plotting labs within a material.

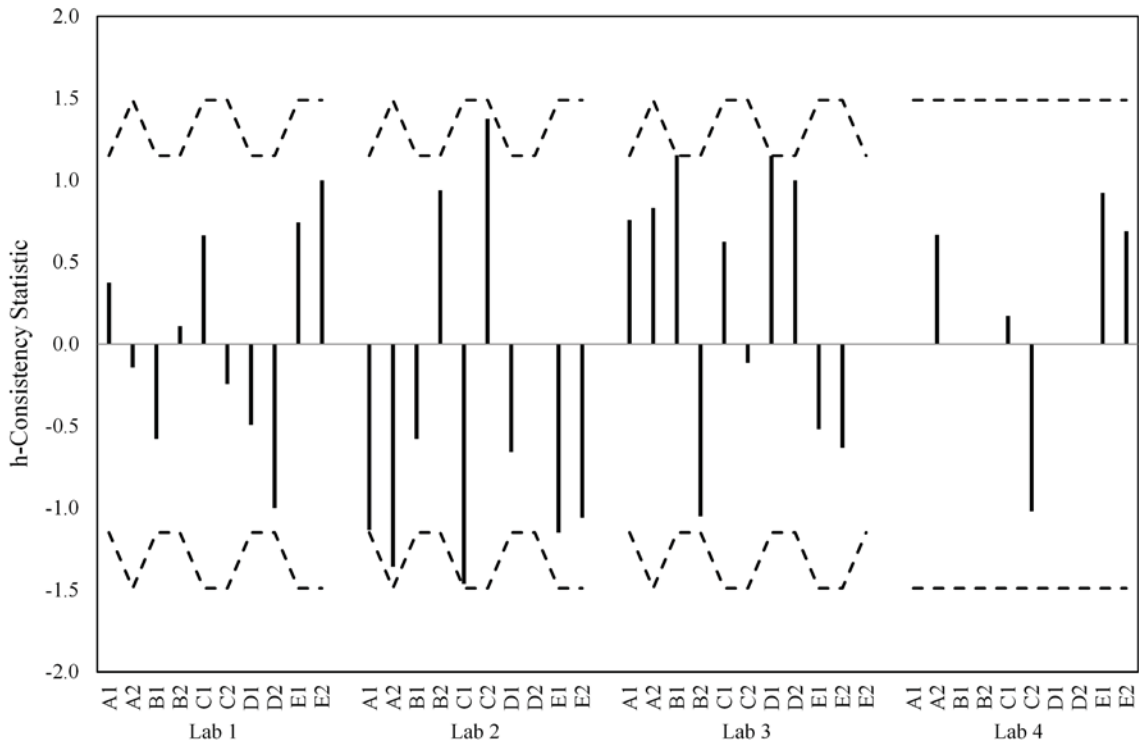
Provided all the labs produced similar data, it would not be expected that any *h*-statistic data would exceed the critical values, and inspection of the plots finds this to be the case. The ASTM E691-13 specification also alludes to the notion that there should be no expected pattern in these plots.<sup>(3)</sup> That is, data per lab could have both positive and negative *h* values, or a lab could be entirely positive provided there are an equal number of labs that are all negative. The *h*-statistic data for both criteria do not have any discernable pattern and all fall with the 95 percent confidence limits.

The critical values for the *k*-statistic are a function of the number of participating labs and number of replicates tested in each series. Since lab 4 did not participate in all series and because the number of replicates varied from three to five, there are multiple critical *k*-statistic values. As in the graphs for the *h*-statistic, black dashed lines are plotted for the critical *k*-statistic values. Since the *k*-statistic can only be a positive value, the parameter to look for is if a lab or material exceeds the critical *k*-statistic value. Inspecting the *k*-statistic graphs for lab 2 highlights the lab's differences. When considering the 0.02-inch failure criteria, 7 of the 10 materials for lab 2 had a *k*-statistic in excess of their critical values, while all other labs were much lower than their critical values (see figure 47 and figure 48). When using just the peak load criteria, lab 2 only exceeded the critical *k*-statistic value for 3 of the 10 materials, and variability was overall closer to the other 3 labs (see figure 51 and figure 52).

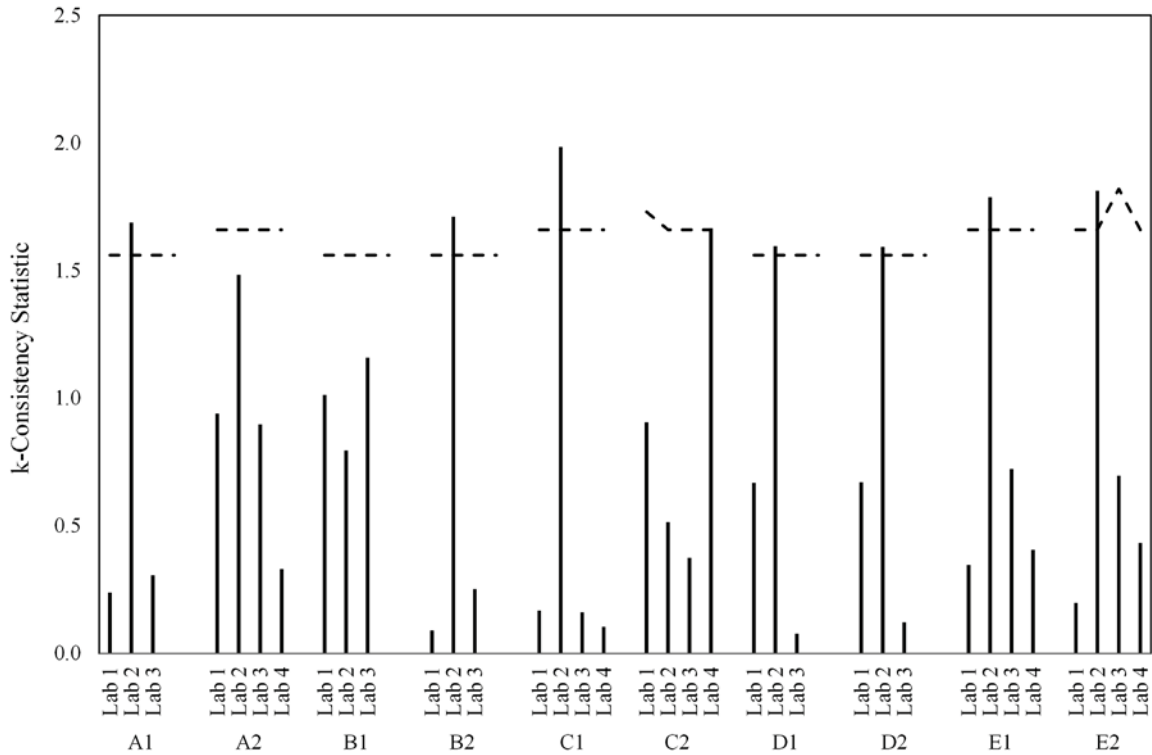




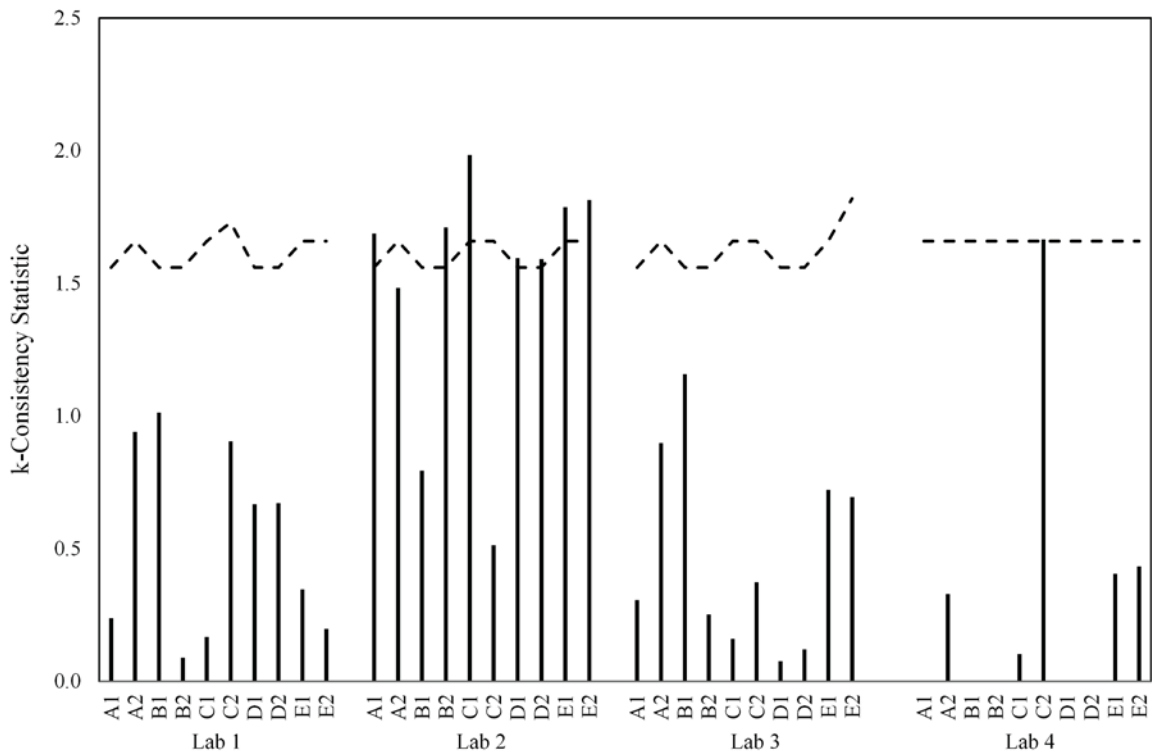
**Figure 45. Graph. Labs within material for  $h$ -statistic considering the 0.02-inch slip criterion.**



**Figure 46. Graph. Materials within lab for  $h$ -statistic considering the 0.02-inch slip criterion.**



**Figure 47. Graph. Labs within material for  $k$ -statistic considering the 0.02-inch slip criterion.**



**Figure 48. Graph. Materials within lab for  $k$ -statistic considering the 0.02-inch slip criterion.**

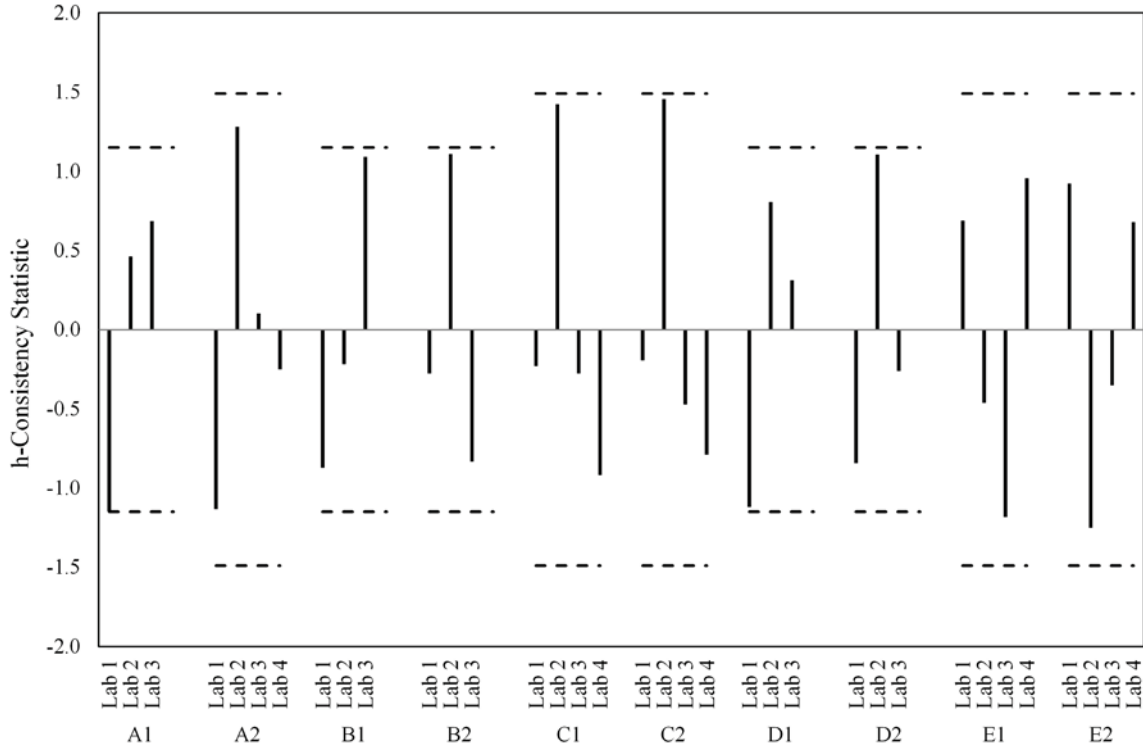


Figure 49. Graph. Labs within material for  $h$ -statistic considering just the peak load criterion.

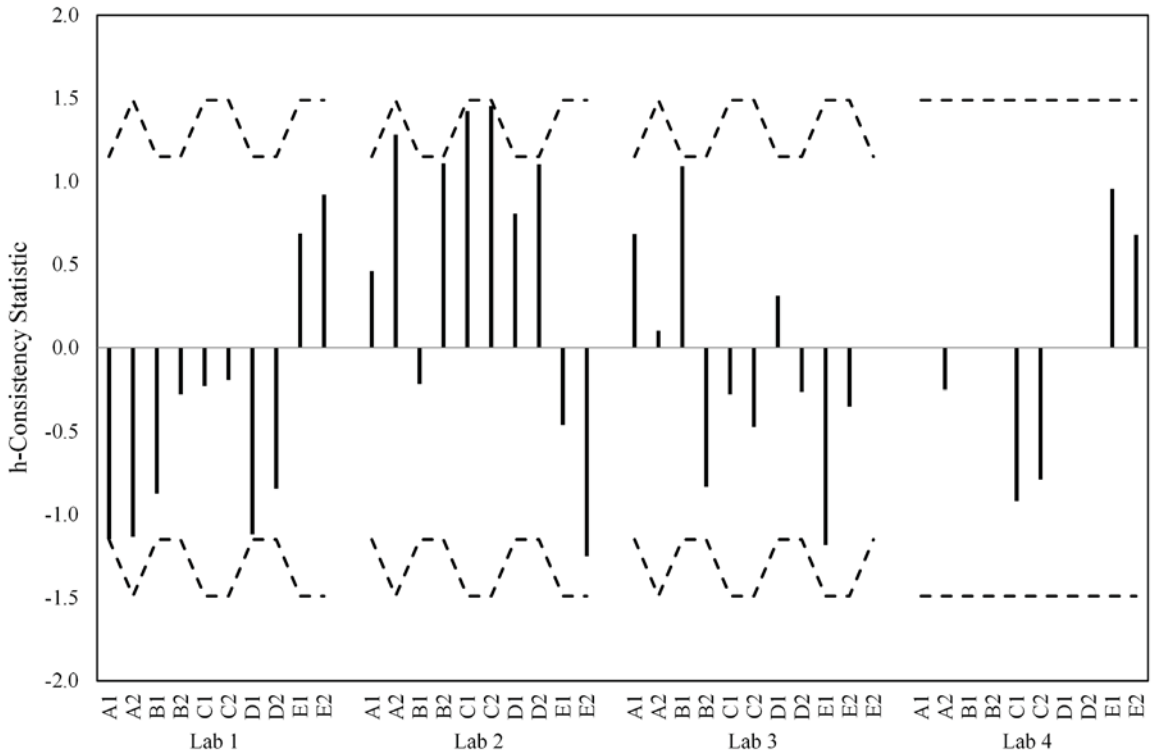
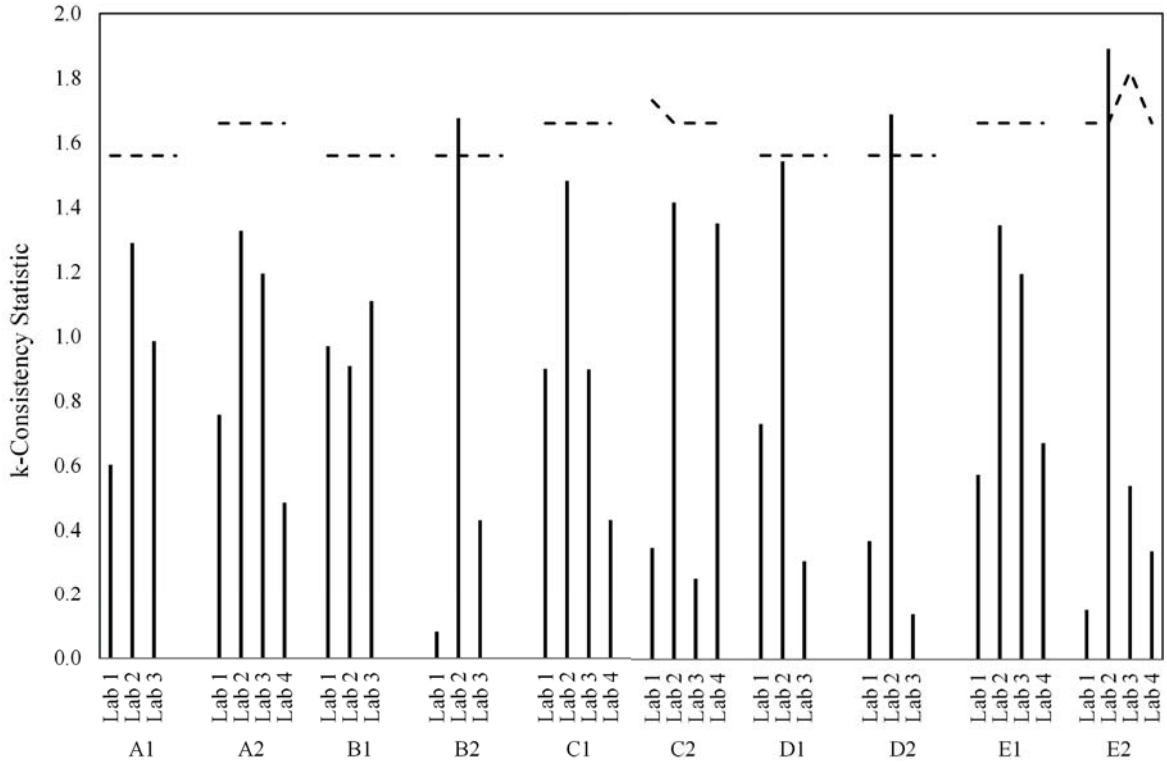
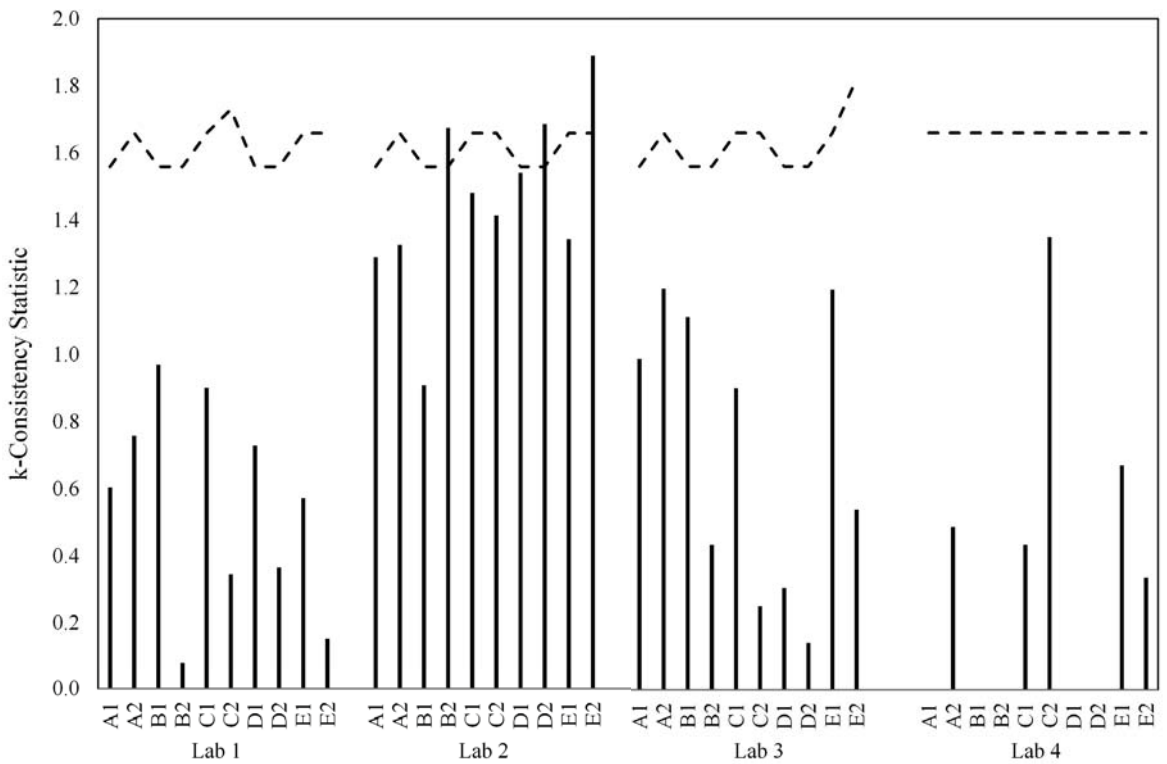


Figure 50. Graph. Materials within lab for  $h$ -statistic considering just the peak load criterion.



**Figure 51. Graph. Labs within material for  $k$ -statistic considering just the peak load criterion.**



**Figure 52. Graph. Materials within lab for  $k$ -statistic considering just the peak load criterion.**

Table 9 and table 10 report the other precision statistics required to be output by the ASTM E691-13 specification when considering the 0.02-inch failure criteria and when using just peak loads.<sup>(3)</sup> Since there were only four labs, the repeatability and reproducibility statistics can become skewed. However, comparing the standard deviation of repeatability and reproducibility between the two tables shows many of the test series have lower variation when using just the peak load criterion. This is further proof that the displacement measurements and the 0.02-inch failure criteria were the major factor in the large standard deviation.

**Table 9. Precision statistics considering 0.02-inch requirement.**

<b>Coating Series</b>	<b>Average</b>	<b>Standard Deviation</b>	<b>Repeatability Standard Deviation (within lab)</b>	<b>Reproducibility Standard Deviation (between labs)</b>	<b>Repeatability Limit* (within lab)</b>	<b>Reproducibility Limit** (between labs)</b>
A1	0.51	0.063	0.055	0.080	0.15	0.22
A2	0.52	0.025	0.025	0.034	0.07	0.09
B1	0.55	0.015	0.011	0.018	0.03	0.05
B2	0.56	0.024	0.093	0.087	0.26	0.24
C1	0.58	0.049	0.068	0.078	0.19	0.22
C2	0.61	0.031	0.024	0.037	0.07	0.10
D1	0.47	0.036	0.058	0.064	0.16	0.18
D2	0.48	0.046	0.083	0.087	0.23	0.24
E1	0.43	0.022	0.054	0.053	0.15	0.15
E2	0.40	0.051	0.057	0.073	0.16	0.20

\* The value below which the absolute difference between two individual test results obtained under repeatability conditions may be expected to occur with a probability of approximately 95 percent.

\*\* The value below which the absolute difference between two test results obtained under repeatability conditions may be expected to occur with a probability of approximately 95 percent.

**Table 10. Precision statistics considering just peak load.**

<b>Coating Series</b>	<b>Average</b>	<b>Standard Deviation</b>	<b>Repeatability Standard Deviation (Within Lab)</b>	<b>Reproducibility Standard Deviation (Between Labs)</b>	<b>Repeatability Limit* (Within Lab)</b>	<b>Reproducibility Limit** (Between Labs)</b>
A1	0.55	0.013	0.017	0.019	0.05	0.05
A2	0.54	0.006	0.019	0.018	0.05	0.05
B1	0.56	0.013	0.012	0.017	0.03	0.05
B2	0.58	0.057	0.054	0.075	0.15	0.21
C1	0.62	0.029	0.012	0.031	0.03	0.09
C2	0.62	0.037	0.036	0.048	0.10	0.14
D1	0.50	0.026	0.015	0.029	0.04	0.08
D2	0.57	0.138	0.071	0.152	0.20	0.43
E1	0.44	0.015	0.033	0.033	0.09	0.09
E2	0.39	0.066	0.074	0.094	0.21	0.26

\* The value below which the absolute difference between two individual test results obtained under repeatability conditions may be expected to occur with a probability of approximately 95 percent.

\*\* The value below which the absolute difference between two test results obtained under repeatability conditions may be expected to occur with a probability of approximately 95 percent.



## APPENDIX C. AGING STUDY

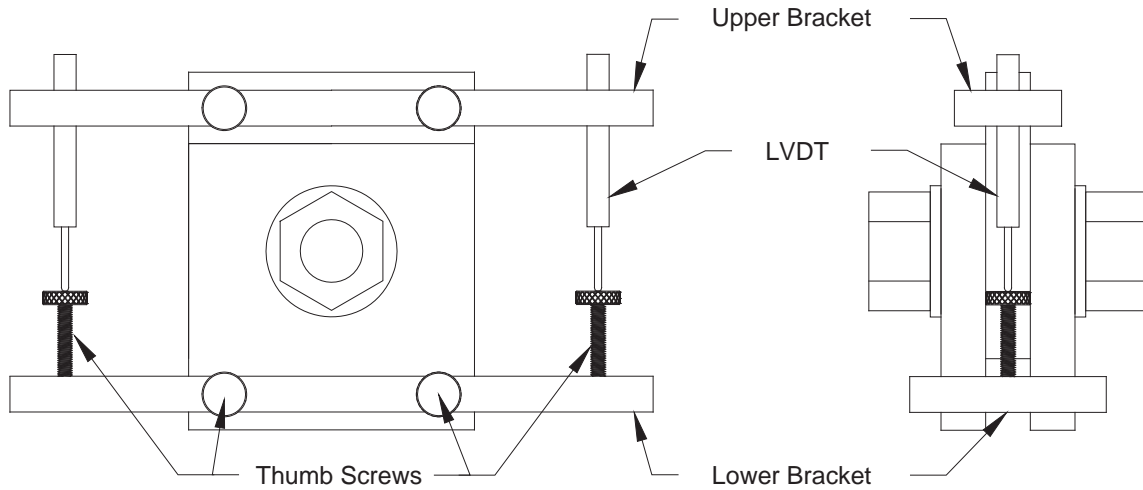
The *Specimen Preparation* section of this report indicated that each lab participating in the variability study received 20 test plates for each coating series. The intent was to test five specimens, and an extra five plates were available if the situation arose where one of the primary plates was untestable for any reason. At the end of the variability study, each participating lab sent all their extra plates back to lab 1. Lab 1 then matched the extra plates from each coating series together based on DFT similarities to form additional specimens. The intent of the extra specimens was two-fold: to see if additional curing time would change the slip coefficient and to assess an alternate way to measure slip displacements.

The question regarding aging effects was posed midway through the project and not addressed as part of developing the main variability study. In bridge fabrication, sometimes it is the case that the fabricated steel will sit in the primed condition for many months before slip-critical connections are ever assembled. Since the slip coefficient is based on recommended manufacturer cure time, it was thought that organic zinc-rich primers may continue to cure and harden beyond this period. If the primer continues to harden, then it is possible the slip coefficient could decrease (i.e., harder surfaces would tend to not stick together as easily).

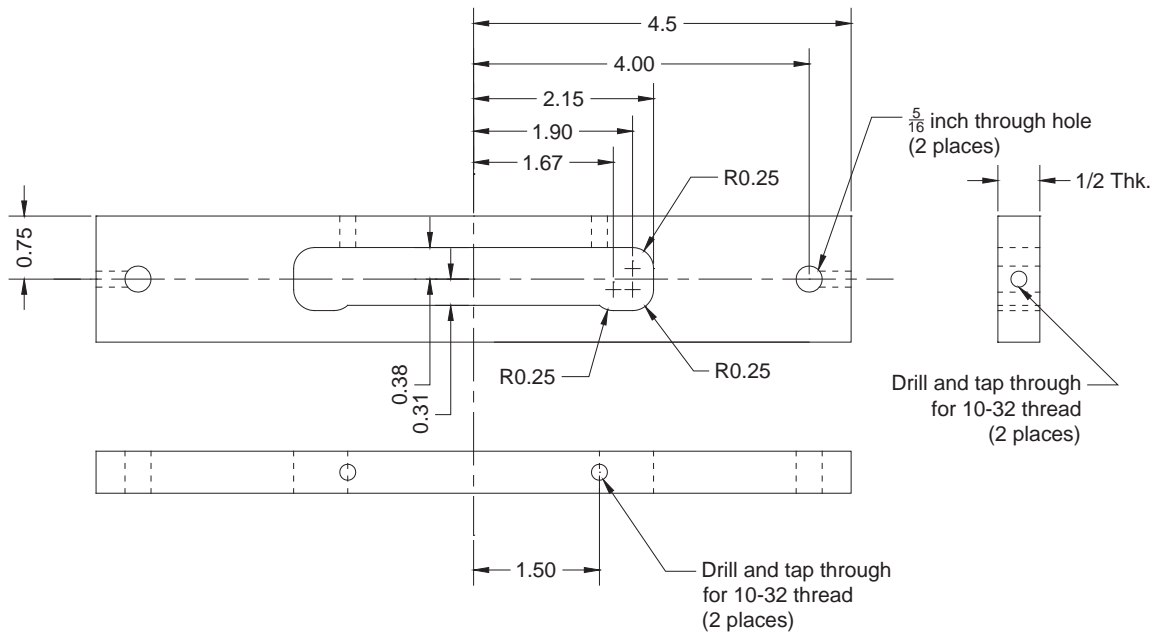
The alternate slip displacement measuring technique was conceived in the middle of the variability study, but it was not explored to avoid introducing additional variables during the variability study. Since each lab was effectively measuring the slip as the displacement between the loading platens, all labs observed a soft slip response as the loading systems settled into each specimen. The notion was to get the LVDTs to measure slip displacement within the specimen, not between the loading platens as illustrated in figure 53. Close-up views of individual pieces are shown in figure 54 and figure 55.

The number of specimens that were tested for aging effects varied between one and six specimens depending on the coating series. This occurred because for some coating series, either the labs used the extra plates as part of the variability study or the DFTs on them could not be matched with others available to make a viable specimen.

The aging study began after RCSC had begun to digest the preliminary results from the interlaboratory variability study. As such, RCSC had formed a task group to make recommendations to modify their testing specification, and the aging study was used to test some of the preliminary ideas. Mostly, the aging specimens were tested according to the existing RCSC specification except for two modifications. First, after clamping, the specimens were preloaded with 5 kip of vertical load and then unloaded to 0 kip of vertical load to set the specimen against the platens. Second, the test began from a state of 0 kip of vertical load, whereas in the variability study, it was implied that testing should begin from 1 kip of vertical load. The preload step was ignored when testing the five specimens of coating A2 to test if that step was necessary with the modified displacement measuring device.



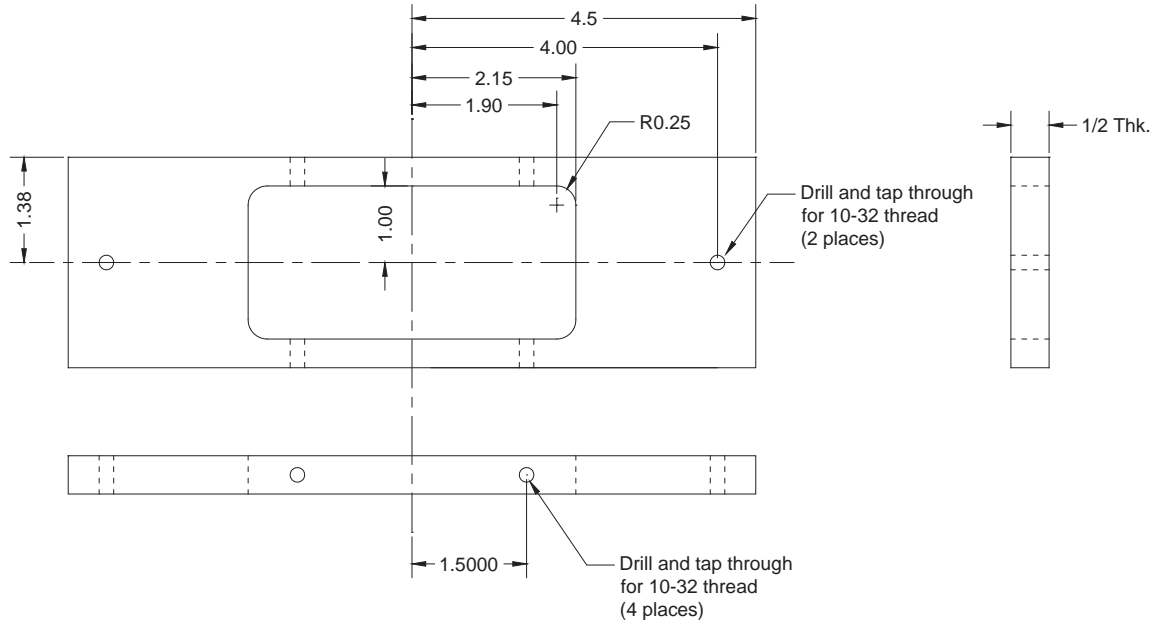
**Figure 53. Illustration. Overall view of modified slip measuring device mounted to a specimen.**



Note: Units are shown in inches.

**Figure 54. Illustration. Upper bracket detailing of modified slip measuring device.**





Note: Units are shown in inches.

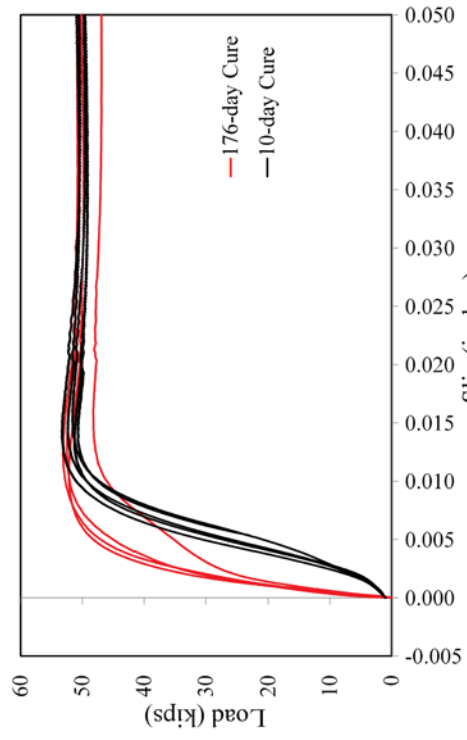
**Figure 55. Illustration. Lower bracket detailing of modified slip measuring device.**

The results of the aging study are presented in table 11 in terms of the slip coefficient for each specimen. The total cure time for each coating is also shown. The load versus slip displacement plots comparing the aged (i.e., extended cure) specimens to those tested at lab 1 as part of the interlaboratory study are shown in figure 56 through figure 65 for each of the 10 coating series. The graphs clearly indicate a stark contrast in the initial loading behavior between the 10-day and extended cure specimens. That is, the 10-day cure specimens with LVDT referencing platen motion demonstrate a soft initial nonlinear response indicative of shakedown of the specimens into the loading platens, whereas the extended cure specimens with modified LVDT holder all showed initially linear behavior with no shakedown response. This was observed for all 10 coating series, including A2 that did not preload the specimen to 5 kip before testing.

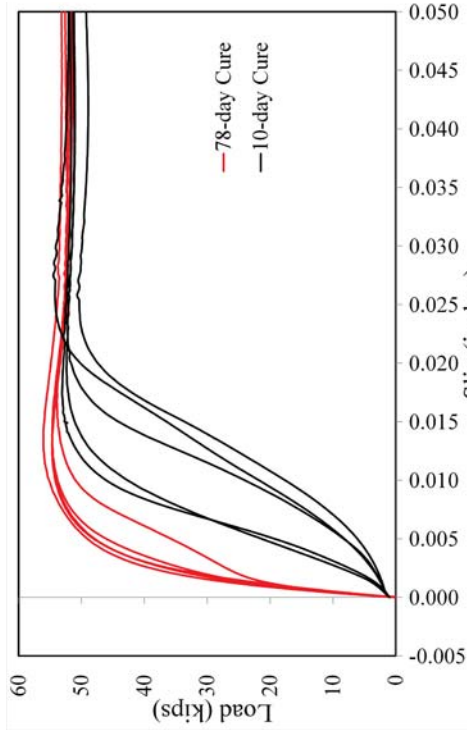
**Table 11. Slip coefficient results of aging study.**

Specimen	Coating									
	A1	A2	B1	B2	C1	C2	D1	D2	E1	E2
1	0.54	0.56	0.50	0.54	0.63	0.65	0.52	0.51	0.47	0.46
2	0.49	0.56	0.53	0.52	0.62	0.64		0.50	0.47	0.48
3	0.54	0.55	0.46		0.62	0.63		0.48	0.49	0.48
4	0.53	0.56	0.48		0.63	0.63			0.47	0.45
5		0.57			0.63					0.47
6										0.46
Cure (days)	176	78	149	163	108	94	232	204	135	122

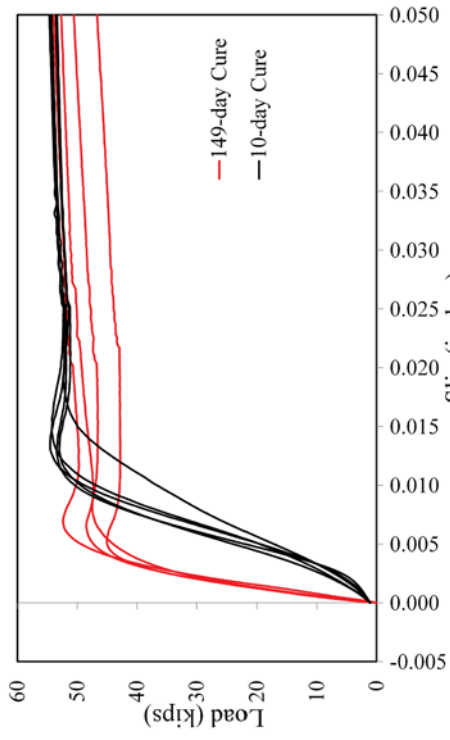
Note: Blank cells indicate that there were not enough spare plates to make more specimens.



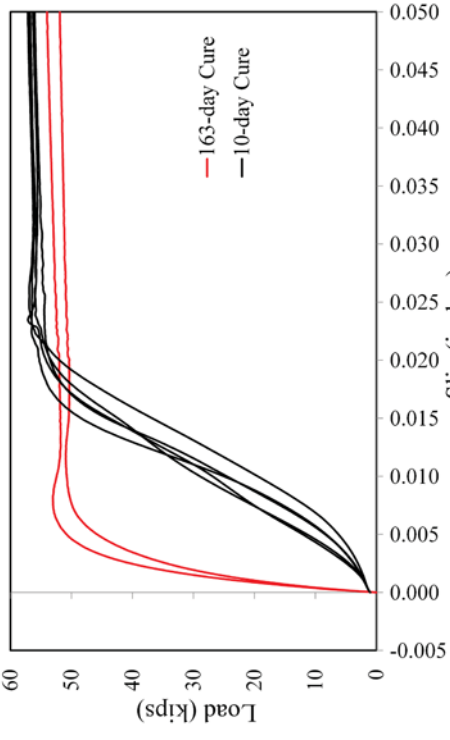
**Figure 56. Graph. Comparison of slip behavior with cure time for coating A1.**



**Figure 57. Graph. Comparison of slip behavior with cure time for coating A2.**



**Figure 58. Graph. Comparison of slip behavior with cure time for coating B1.**



**Figure 59. Graph. Comparison of slip behavior with cure time for coating B2.**

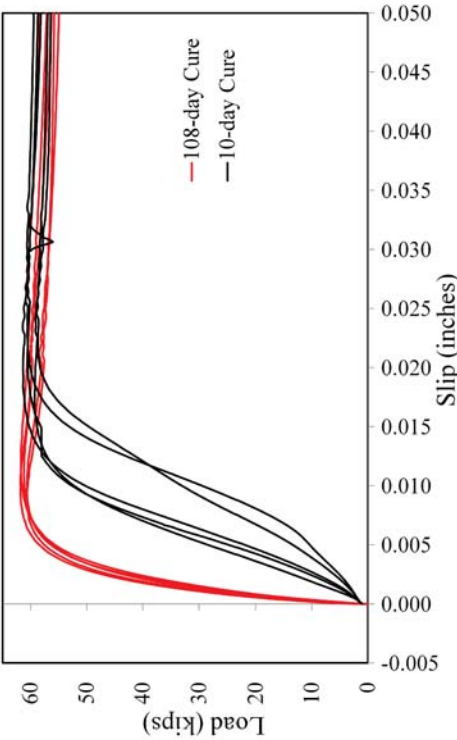


Figure 60. Graph. Comparison of slip behavior with cure time for coating C1.

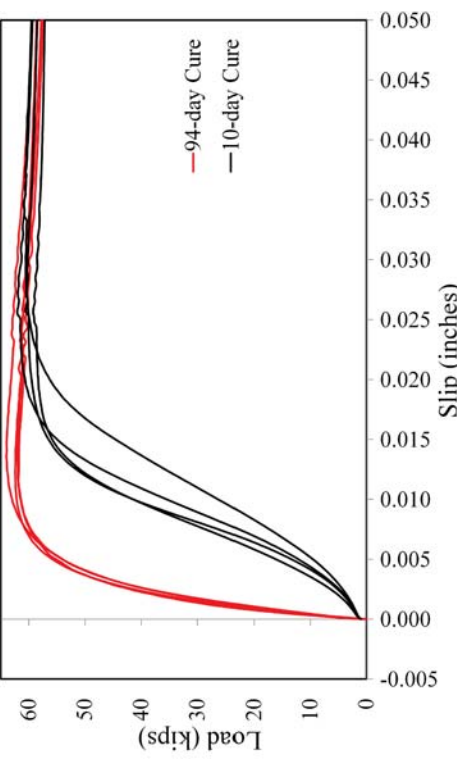


Figure 61. Graph. Comparison of slip behavior with cure time for coating C2.

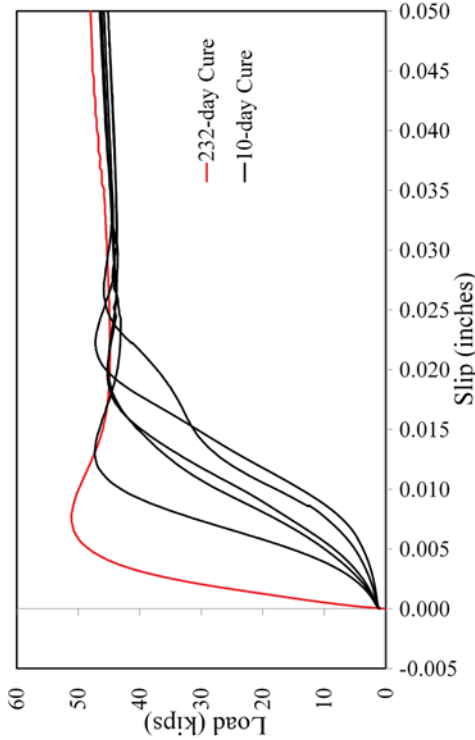


Figure 62. Graph. Comparison of slip behavior with cure time for coating D1.

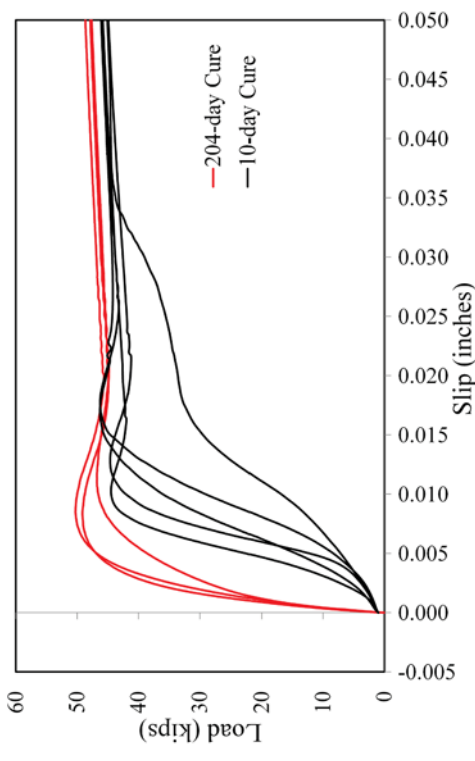
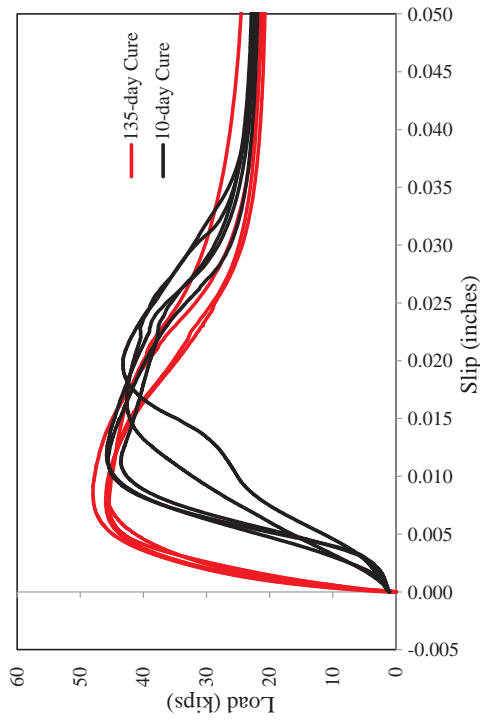
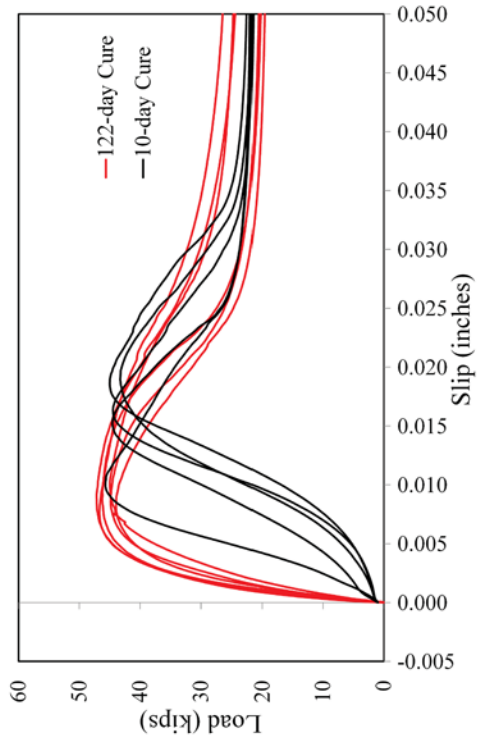


Figure 63. Graph. Comparison of slip behavior with cure time for coating D2.



**Figure 64. Graph. Comparison of slip behavior with cure time for coating E1.**



**Figure 65. Graph. Comparison of slip behavior with cure time for coating E2.**

Table 12 compares the average slip coefficients attained from the aging study to those from the interlaboratory variability study using the peak load ignoring the 0.02-inch criteria. When using the modified measuring device, none of the specimens ever came close to being controlled by the 0.02-inch displacement criteria. COV is not presented in table 12 since each coating series had different numbers of specimens, many not even having enough specimens to make a viable COV calculation. The final row in the table presents the difference in slip coefficients between the aging and variability portions of the overall study. Mostly, the average slip coefficient increased with the extended cure time. The one noted exception is coating B, which exhibited more variability and overall reduced average slip coefficient with an extended cure at both the +1- and +2-mil thicknesses.

**Table 12. Comparison of slip coefficients between 10-day and extended cure.**

<b>Coating</b>	<b>Extended Cure Average</b>	<b>10-Day Cure Average</b>	<b>Difference</b>
A1	0.53	0.53	0.00
A2	0.56	0.53	0.03
B1	0.50	0.55	-0.05
B2	0.53	0.56	-0.03
C1	0.63	0.62	0.01
C2	0.64	0.62	0.02
D1		0.47	
D2	0.50	0.45	0.05
E1	0.47	0.45	0.02
E2	0.47	0.45	0.02

Note: Blank cells indicate that only one specimen could be tested for coating D1 with the extended cure, and an average could not be calculated. Because an average could not be calculated for the extended cure, the difference relative to the 10-day cure could not be calculated either.



## REFERENCES

1. AASHTO. (2012). *AASHTO LRFD Bridge Design Specifications*, 6th Edition, American Association of State Highway and Transportation Officials, Washington, DC.
2. RCSC. (2009). *Specification for Structural Joints Using High-Strength Bolts*, Research Council on Structural Connections, Chicago, IL.
3. ASTM E691-13. (2013). “Standard Practice for Conducting an Interlaboratory Study to Determine the Precision of a Test Method,” *Book of Standards Volume 14.02*, ASTM International, West Conshohocken, PA.
4. ASTM A563-07a. (2014). “Standard Specification for Carbon and Alloy Steel Nuts,” *Book of Standards Volume 01.08*, ASTM International, West Conshohocken, PA.
5. ASTM F436-11. (2011). “Standard Specification for Hardened Steel Washers,” *Book of Standards Volume 01.08*, ASTM International, West Conshohocken, PA.
6. ASTM A490-12. (2012). “Standard Specification for Structural Bolts, Alloy Steel, Heat Treated, 150 ksi Minimum Tensile Strength,” *Book of Standards Volume 01.08*, ASTM International, West Conshohocken, PA.

