

TRCLC 15-11
August 30, 2017

**Assessing transit oriented development strategies with
a new combined modal split and traffic assignment
model**

FINAL REPORT

Guangchao Wang, Ph.D.

Anthony Chen, Ph.D.

Ziqi Song, Ph.D.

Songyot Kitthamkesorn, Ph.D.

Department of Civil and Environmental Engineering

Utah State University

Logan, UT 84322



Transportation Research Center
for Livable Communities

**Technical Report
Documentation Page**

1. Report No. TRCLC 15-11	2. Government Accession No. N/A	3. Recipient's Catalog No. N/A	
4. Title and Subtitle Assessing transit oriented development strategies with a new combined modal split and traffic assignment model		5. Report Date August 30, 2017	
		6. Performing Organization Code N/A	
7. Author(s) Guangchao Wang, Anthony Chen, Ziqi Song, and Songyot Kitthamkesorn.		8. Performing Org. Report No. N/A	
9. Performing Organization Name and Address Department of Civil and Environmental Engineering Utah State University Logan, UT 84322		10. Work Unit No. (TRAIS) N/A	
		11. Contract No. TRCLC 15-11	
12. Sponsoring Agency Name and Address Transportation Research Center for Livable Communities (TRCLC) 1903 W. Michigan Ave., Kalamazoo, MI 49008-5316		13. Type of Report & Period Covered Final Report 4/1//2015 - 8/30/2017	
		14. Sponsoring Agency Code N/A	
15. Supplementary Notes			
16. Abstract Transit oriented development (TOD) has emerged in recent years as a promising paradigm to promote public transportation, increase active transportation usage, mitigate congestion, and alleviate air pollution. However, there is a lack of analytic studies investigating the benefits of TOD quantitatively. Two major challenges of modeling a multimodal transportation network with TOD areas are: (1) failing to consider differences in feasible travel options available to different households in TOD areas may lead to inaccurate representations of travelers' mode choice behavior, and (2) route overlapping is one of the major concerns in the route choice models used in the traffic assignment problem for predicting traffic pattern. The purpose of this study is to quantitatively assess TOD strategies with a new combined modal split and traffic assignment (CMSTA) problem that is capable of explicitly considering captive travel behavior and route overlapping. We conduct the assessment of TOD strategies in a multimodal transportation network. The assessment focuses on evaluating the effectiveness of TOD strategies in terms of mode share and vehicle miles travelled (VMT).			
17. Key Words Dogit, Paht-size Logit, Combined Modal Split and Traffic Assignment Problem, Transit-oriented Development		18. Distribution Statement No restrictions.	
19. Security Classification - report Unclassified	20. Security Classification - page Unclassified	21. No. of Pages	22. Price N/A

Disclaimer

The contents of this report reflect the views of the authors, who are solely responsible for the facts and the accuracy of the information presented herein. This publication is disseminated under the sponsorship of the U.S. Department of Transportation's University Transportation Centers Program, in the interest of information exchange. This report does not necessarily reflect the official views or policies of the U.S. government, or the Transportation Research Center for Livable Communities, who assume no liability for the contents or use thereof. This report does not represent standards, specifications, or regulations.

Acknowledgments

This research was funded by the US Department of Transportation through the Transportation Research Center for Livable Communities (TRCLC), a Tier 1 University Transportation Center.

Table of Contents

Chapter 1: Introduction 2

Chapter 2: Literature Review 4

 2.1 TOD’s Impacts on Travel Behavior..... 4

 2.2 Transit Captivity 5

 2.3 Evaluation of TOD Strategies 6

Chapter 3: A New Combined Modal Split and Traffic Assignment Problem 7

 3.1 Dogit Model 7

 3.2 Dogit-PSL Model..... 8

Chapter 4: Numerical Results 10

Chapter 5: Concluding Remarks 15

References 16

Chapter 1: Introduction

After decades of decline in transit ridership, public transportation has gained popularity in the past two decades. The public transportation ridership in the US grew 36 percent from 1995 to 2008, almost three times the amount of the population growth at 14 percent and substantially more than the growth for vehicle miles at 21 percent (CTOD, 2014). TOD has emerged in recent years as a promising paradigm to promote public transportation, increase active transportation usage, mitigate congestion, and alleviate air pollution. The term TOD was coined by Peter Calthorpe as “*moderate and high density housing, along with complementary public uses, jobs, retail and services, concentrated in mixed-use developments at strategic points along transit systems*” (Calthorpe, 1993). It emphasizes the physical integration and linkage of public transportation investments and urban land development at or near a transit station (Cervero, 2013). Although the theoretical definitions for a TOD vary in the literature, typical TODs share some core features: moderate- to high-density development, mixed land use, and high-quality transit services (e.g., Calthorpe, 1993; Bernick and Cervero, 1997; Parker *et al.*, 2002). Renne and Ewing (2013) examined the development patterns in fixed-transit stations across the US and found that the number of TOD stations increase by 23.7 percent from 1,325 stations in 2000 to 1,640 stations in 2010.

Traditional transportation planning models assume that all travelers face the same set of mode choices. However, failing to consider differences in feasible travel options available to different groups of travelers may lead to inaccurate representations of travelers’ mode choice behavior. This is an important issue in the context of modeling transit users’ travel behavior, because many transit users have no access to personal transportation or unable to drive because of age, disability, income or family circumstances. They are often defined as transit captive users, or transit-dependent users. In contrast, transit choice users are those who feel the transit option is superior to other travel options in terms of time, cost, convenience and comfort (Polizin *et al.*, 2000; Beimborn *et al.*, 2003). In addition, route overlapping is one of the major concerns in the route choice models used in the traffic assignment problem for predicting traffic pattern in the transportation network (see Prashker and Bekhor (2004) and Chen *et al.* (2012) for a detailed

description of the different approaches for handling the route overlapping problem). Therefore, it is critically important to explicitly consider captive travel behavior in mode choice and route overlapping in route choice to better predict the modes and routes that trips will take, resulting in traffic forecasts for the highway system and ridership forecast for the transit system. With a better behavioral model that explicitly considers captive travel behavior in mode choice and route overlapping in route choice, evaluating TOD strategies is expected to be more accurate and effective.

A popular approach to consider both mode choice and route choice is the CMSTA problem (Florian, 1977; Abdulaal and LeBlanc, 1979; and Fernandez et al., 1994). The CMSTA problem can resolve the inconsistency issue of the sequential travel demand forecasting procedure between the modal split and traffic assignment steps. However, the conventional CMSTA models do not account for captive travelers in the mode choice step (i.e., all travelers are assumed to have the same choice set, such as car, transit, non-motorized mode) and/or route overlapping in the route choice step (i.e., deterministic user equilibrium model or multinomial logit (MNL) stochastic user equilibrium model). Therefore, this paper proposes a new CMSTA model to overcome the shortcomings of not considering captive travelers and route similarities under congested networks. Specifically, a dogit model (Gaudry and Dagenais, 1979) is adopted to model the modal split problem by accounting for captive behavior (i.e., a traveler cannot choose car if he/she does not own a car) in the mode choice step, and a path-size logit (PSL) model (Ben-Akiva and Bierlaire, 1999) is used to account for route overlapping in the route choice step. The objective of this paper is to quantitatively assess TOD strategies with the new CMSTA model.

Chapter 2: Literature Review

2.1 TOD's Impacts on Travel Behavior

TOD makes public transportation a more appealing travel option to people living in a TOD by providing proximity to transit stations as well as high-quality and reliable transit services. As a result, TOD not only boosts transit ridership but also induces higher transit mode share. [Cervero \(1994\)](#) investigated transit-based housing near rail stations in Bay Area cities served by Bay Area Rapid Transit (BART) and found that residents are five to seven times as likely to commute by rail transit as the average resident-worker in the same city. [Lund et al. \(2004\)](#) also demonstrated that TOD residents have higher rates of transit use in California. Residents living near transit stations are about five times more likely to commute using transit than residents in comparable areas. [Renne \(2005\)](#) studied over 100 TODs in 12 regions across the US and found that TOD residents are two to five times more likely to commuter on transit as compare to the average resident of the same region. In cities with higher levels of transit accessibility, such as San Francisco and Washington, D.C., higher shares of transit commuting were found in TODs. [Evans et al. \(2007\)](#) reviewed several TOD studies conducted in California and Oregon, and inferred that upon relocation into TODs transit mode share gains for commuter trips range from 2 percent or smaller in California TODs to about 15 percent in Portland TODs depending on existing transit use in TODs. [Jeihani et al. \(2013\)](#) employed the seemingly unrelated regression (SUR) method to model the effect of TOD on mode share in Washington, D.C. and Baltimore. They concluded that after controlling for socio-demographic factors trips originating from a TOD have about 4.7 percent and 2.5 percent increase in transit mode share in Washington, D.C. and Baltimore, respectively. [Zamir et al. \(2014\)](#) investigated TODs in Washington D.C., and Baltimore using the 2007 to 2008 National Household Travel Survey data. They found that TOD residents made more trips by all modes of transportation but fewer trips by auto, and trips made by TOD residents are generally shorter trips. [Nasri and Zhang \(2014\)](#) analyzed the VMT of TOD residents in Washington D.C., and Baltimore. Their regression analysis indicated that people

living in TODs tend to drive less, reducing their VMT by around 38% in Washington D.C. and 21% in Baltimore.

2.2 Transit Captivity

Household auto ownership level, i.e., car availability, has huge impact on travelers' mode choice behavior in TODs. [Lund et al. \(2004\)](#) found that among surveyed station-area residents with no vehicle available in their household, 79 percent of trips are made by transit. In contrast, households with one vehicle available have a 27 percent transit mode share, and households with two or more vehicles available only travel about 10 percent in transit. [Cervero \(2007\)](#) reported that station-area residents from zero-car households are 14 times more likely to commute by rail than those from three-car households.

TOD residents tend to own fewer cars and may be inclined to reduce household car ownership after moving into a TOD ([Arrington and Cervero, 2008](#)). [Switzer \(2002\)](#) conducted a survey at the Center Commons TOD in Portland, Oregon and found that 30 percent of respondents own fewer cars than they did previously and 37 percent of respondents do not own any vehicle. [Renne \(2005\)](#) analyzed the 2000 census data and revealed that households living in TODs own an average of 0.9 cars while non-TOD households own 1.6 cars on average in 2000. More recently, [Renne and Ewing \(2013\)](#) analyzed the 2010 census data and found that the average number of vehicles available per household in TODs is 0.65 in 2010.

In terms of the portion of transit captive users, about 30 percent of the population aged 5 years or older is identified as transit captive users, and they contribute about 70 percent of all transit trips at the national level ([Polizin et al., 2000](#)). In another study conducted in Portland, Oregon ([Beimborn et al, 2003](#)), among 6,578 work trips identified, 419 of these were made by bus or rail transit. In about half of the transit trips, travelers indicated they had no automobile available for that trip, and hence these trips are deemed as transit captive trips. [Lane \(2008\)](#) defined transit captive users as “residents under age 16, women over age 65, and poverty-level incomes aged 18–64” since they are demographically dependent on transit. Based on the census data, the

percentage of transit captive users ranges from 26 percent in Tulsa, Oklahoma to 54 percent in Kansas City, Missouri. [Kim and Ulfarsson \(2012\)](#) conducted an on-board passenger survey of MetroLink, the light-rail system in St. Louis. They found that 368 of the 824 riders surveyed (45 percent) stated that they do not have a private car available for the trip. [Krizek and El-Geneidy \(2007\)](#) concluded that for transit systems that provide reliable services in the US, such as Chicago Transit Authority (CTA) and County Metropolitan District of Oregon (TriMet) in Portland, choice users can outweigh captive riders.

2.3 Evaluation of TOD Strategies

[Cervero et al. \(2004\)](#) noted that relatively few studies have been carried out to investigate the benefits of TOD quantitatively. The approaches for evaluating TOD strategies primarily can be grouped into two categories: empirical study of travel survey data and transportation network modeling approach. Most empirical studies are statistical analysis/modeling of travel survey data to examine how effective TOD strategies are in terms of changing travel behavior in TODs, e.g., increasing transit ridership and mode share, reducing car ownership in TODs. The impact of TOD strategies is usually evaluated at the station level (see, e.g., [Cervero \(1994\)](#); [Lund et al. \(2004\)](#); [Arrington and Cervero \(2008\)](#); [Renne \(2005\)](#); [Zamir et al. \(2014\)](#); [Nasri and Zhang \(2014\)](#)). On the other hand, the transportation network modeling approach can provide the overall impacts of TODs at the network/regional level. Notably the four-step travel demand model has been employed to quantify benefits of TOD strategies in Austin, Texas ([Zhang, 2010](#)) and New Jersey and New York City ([Mudigonda et al., 2014](#)). [Cervero \(2006\)](#) pointed out limitations of the four-step models in accessing impacts of TODs, however, alternative models are also provided to complement the traditional four-step models to gain analytical insights.

Chapter 3: A New Combined Modal Split and Traffic Assignment Problem

In this section, we provide background on the dogit model, and then we provide an equivalent MP formulation for the dogit-PSL model, which provides the dogit mode choice solution and the PSL route choice solution.

3.1 Dogit Model

Gaudry and Dagenais (1979) originally proposed the dogit model to permit flexibility in handling the choice among specific pairs of alternatives to be consistent with the independence from irrelevant alternatives (IIA) property of the multinomial logit (MNL) model, while allowing the choice among other pairs not to possess the IIA property.

The dogit model has been applied to different issues to secure user captivity, such as the mode choice application (Gaudry, 1980), destination choice application (Chu, 1990, 2011, 2012), and customer loyalty in product shopping behaviors (Bordley, 1990). The dogit mode choice probability is given in the following form:

$$P_{ij}^m = \frac{\exp(V_{ij}^m) + \eta_{ij}^m \sum_{n \in M_{ij}} \exp(V_{ij}^n)}{\left(1 + \sum_{n \in M_{ij}} \eta_{ij}^n\right) \sum_{n \in M_{ij}} \exp(V_{ij}^n)} \quad (1)$$

where P_{ij}^m = probability that an individual will select travel mode m between O-D pair ij .

V_{ij}^m = deterministic component of the utility of travel mode m between O-D pair ij .

η_{ij}^m = captivity parameter related to mode choice m , $\eta_{ij}^m \geq 0, \forall m \in M_{ij}$.

This probability choice model is called the dogit model. It was designed to identify users who are captive to a particular alternative and those who have a complete choice set. The model allows

the choice among specific pairs of alternatives to be consistent with the independence from the IIA axiom, as in a logit model, and also permits the choice among other pairs not to follow the IIA axiom. Rearranging Eq. (1) yields

$$\begin{aligned}
 P_{ij}^m &= \frac{\eta_{ij}^m}{1 + \underbrace{\sum_{n \in M_j} \eta_{ij}^n}_{\text{Captive share}}} + \frac{1}{1 + \underbrace{\sum_{n \in M_j} \eta_{ij}^n}_{\text{Free-choice share}}} \underbrace{\frac{\exp(V_{ij}^m)}{\sum_{n \in M_j} \exp(V_{ij}^n)}}_{\text{Logit assignment}}, \\
 &= \eta_{ij}^m \mathcal{G}_{ij} + \mathcal{G}_{ij} \kappa_{ij}^m
 \end{aligned} \tag{2}$$

where $\kappa_{ij}^m = \exp(V_{ij}^m) / \sum_{n \in M_j} \exp(V_{ij}^n)$, $\forall m \in M_{ij}, ij \in IJ$ and $\mathcal{G}_{ij} = 1 / (1 + \sum_{n \in M_j} \eta_{ij}^n)$, $\forall ij \in IJ$. The first part on the right hand side (RHS) of Eq. (2) denotes the choice probability due to captivity to the mode m ; the second part is the classical MNL choice probability based on observable mode utility. The mode choice probability ratio between the two alternatives is given as

$$\frac{P_{ij}^m}{P_{ij}^n} = \frac{\eta_{ij}^m \mathcal{G}_{ij} + \mathcal{G}_{ij} \kappa_{ij}^m}{\eta_{ij}^n \mathcal{G}_{ij} + \mathcal{G}_{ij} \kappa_{ij}^n} = \frac{\eta_{ij}^m + \kappa_{ij}^m}{\eta_{ij}^n + \kappa_{ij}^n}, \tag{3}$$

When η_{ij}^m and η_{ij}^n equal 0, travellers are free to choose from the whole choice set and the choice probability ratio depends only on the utility differences between the two choices (i.e., the IIA property), so the above ratio collapses to the logit case; when η_{ij}^m and η_{ij}^n are larger than zero and some travellers are captive to modes m and n , the probability ratio depends not only on the utility differences between modes m and n , but also on the utility of other available mode alternatives; thus, the IIA property may not hold in the dogit probability model.

3.2 Dogit-PSL Model

This section modifies the MNL model to the dogit model to permit flexibility in handling the choice among specific pairs of modes to be consistent with the independence from the IIA

property of the MNL model, while allowing the choice among other mode pairs not to possess the IIA property.

$$\begin{aligned}
 \min Z = & Z_1 + Z_2 + Z_3 + Z_4 + Z_5 + Z_6 \\
 & v_{ma} = \sum_{ij \in IJ} \sum_{r \in R_{ij}^m} f_{ij}^{mr} \delta_{ij}^{mra} \\
 & \sum_{m \in M_{ij}} \sum_{a \in A} \int_0^{v_{ma}} h_{ma}(\omega) d\omega + \frac{1}{\theta} \sum_{ij \in IJ} \sum_{m \in M_{ij}} \sum_{r \in R_{ij}^m} f_{ij}^{mr} (\ln f_{ij}^{mr} - 1) \\
 & - \frac{1}{\theta} \sum_{ij \in IJ} \sum_{m \in M_{ij}} \sum_{r \in R_{ij}^m} f_{ij}^{mr} \ln \varpi_{ij}^{mr} + \frac{1}{\gamma} \sum_{ij \in IJ} \sum_{m \in M_{ij}} [(q_{ij}^m - \vartheta_{ij} \eta_{ij}^m q_{ij}^m) \ln (q_{ij}^m - \vartheta_{ij} \eta_{ij}^m q_{ij}^m) \\
 & + (q_{ij}^m - \vartheta_{ij} \eta_{ij}^m q_{ij}^m) \ln (1/q_{ij}^m \vartheta_{ij})] - \frac{1}{\theta} \sum_{ij \in IJ} \sum_{m \in M_{ij}} q_{ij}^m (\ln q_{ij}^m - 1) - \sum_{ij \in IJ} \sum_{m \in M_{ij}} q_{ij}^m \Psi_{ij}^m.
 \end{aligned} \tag{4-a}$$

s.t.

$$\sum_{m \in M_{ij}} q_{ij}^m = q_{ij}, \quad \forall ij \in IJ, \tag{4-b}$$

$$\sum_{r \in R_{ij}^m} f_{ij}^{mr} = q_{ij}^m, \quad \forall m \in M_{ij}, ij \in IJ, \tag{4-c}$$

$$q_{ij}^m \geq 0, \quad \forall m \in M_{ij}, ij \in IJ, \tag{4-d}$$

$$f_{ij}^{mr} \geq 0, \quad \forall r \in R_{ij}^m, m \in M_{ij}, ij \in IJ, \tag{4-e}$$

where f_{ij}^{mr} is the traffic flow on path r using mode m between O-D pair ij , and v_a is the traffic flow on link a . Z_1 is the logit SUE section, Z_2 and Z_3 are the entropy items related to the overlapping issue, Z_4 is related to the captive mode choices, and Z_5 and Z_6 are related to the logit SUE section. Eqs. (4-b) and (4-c) define the flow conservation constraint and (4-d) and (4-e) define the non-negative constraint.

Chapter 4: Numerical Results

In this section, we use the Nguyen -Dupuis network in Figure 1 to demonstrate the impacts of TOD strategies on the network performance. Two network performance measures are considered: modal split and the mode- and network-specific VMT. For the TOD strategy evaluation problem, we consider three sub-networks, i.e., the auto network, the transit network, and the bicycle network as presented in Figure 1. The three sub-networks connect four O-D pairs, (1, 2), (1, 3), (4, 2), and (4, 3) with the O-D demand of 500, 700, 500, and 300 travelers per hour, respectively. The link characteristics of the auto network are given in Table 1. We assume a normalized free-flow speed as 1 on all the links in the auto network. The transit network has one dedicated line connecting each O-D pair that has the same link length and free-flow speed as the auto lines. All the links in the transit network have a capacity of 800 persons per hour. The auto and transit link travel times are assumed to follow the BPR function:

$$t_a = h_a^0 \left(1 + \theta (v_a / c_a)^n \right). \quad (5)$$

where $\theta = 0.15$ and $n = 4$ for auto, and $\theta = 0.5$ and $n = 2$ for transit. As for the bicycle network, it has the same link length as the other two sub-networks; however, it has a lower and constant travel speed normalized as 0.6. The bicycle travel times are assumed to be constant for each line. The bicycle users have an exogenous attractiveness of 7.5 units, which comes from lower travel costs, lower carbon footprints, and healthier travel choices. Similarly, an extra 2.5 units of exogenous attractiveness is imposed on the transit mode. The mode and route dispersion parameters are set to 1.5 and 1.2, respectively. The average occupancy for transit is set to 9.2 (Rubin et al., 2010).

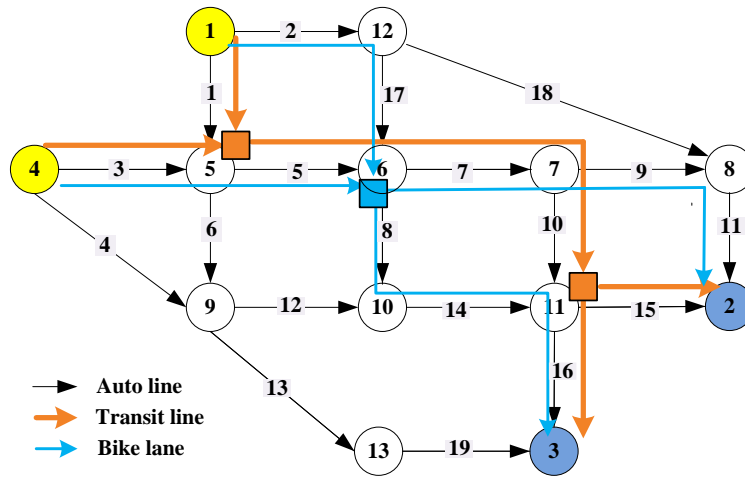

FIGURE 1. Topology of the Nguyen and Dupius Network

Table 1. Characteristics of the auto network

Auto	Distance (km)	FFTT (minute)	Capacity (vph)	Auto	Distance (km)	FFTT (minute)	Capacity (vph)
Link 1	2.5	2.5	400	Link 11	2.75	2.75	350
Link 2	2.5	2.5	300	Link 12	2.5	3.5	400
Link 3	2.5	2.5	350	Link 13	3.75	3.75	400
Link 4	3.75	3.75	400	Link 14	2.5	2.5	400
Link 5	2.5	2.5	350	Link 15	2.5	2.5	350
Link 6	3.5	3.5	300	Link 16	2.5	2.5	400
Link 7	2.25	2.25	400	Link 17	3.0	3.0	300
Link 8	2.5	2.5	200	Link 18	8.5	8.5	300
Link 9	2.25	2.25	200	Link 19	4.75	4.75	400
Link 10	2.75	2.75	250				

Suppose the implementation of a TOD area improves transit service quality (e.g., free-flow transit travel time) through increasing transit service frequency or introducing more reliable transit services, such as a subway or a bus rapid transit system. We tested three scenarios after the implementation of the TOD strategy, where the free-flow transit travel time is assumed to decrease by 10%, 20% and 50%, respectively. Furthermore, we assume some travelers are captive to the transit mode due to social and economic constraints, the related mode captivity parameters for each O-D pair are set to 0.25, 0.35, 0.20, and 0.40, respectively.

Table 2 and Figure 2 illustrate the equilibrium modal split results under different transit FFFT scenarios for the MNL-PSL and the dogit-PSL models. In general, traffic flows transfer from both car and bicycle mode into the transit mode after implementing the TOD strategy in Zone 1 (the transit FFFTs decrease for the related transit links). The overall transit share increases steadily between each O-D pair and also at the network level. However, as shown in Figure 3, the overall transit flows increase much faster in the MNL-PSL model than those in the dogit-PSL model. The car and bicycle flows decrease slower in the dogit-PSL model accordingly. These results demonstrate that ignorance of captive mode users tends to overestimate the impact of TOD strategy on the mode split results.

As for the VMTs in each mode, we can observe similar trends (see Table 3). In the MNL-PSL model, the car VMTs decrease as the transit mode becomes more attractive and some car users shift to transit mode, therefore, the overall motorized VMTs decrease. The non-motorized VMTs (bicycle VMTs) also decreases due the same reason. The dogit-PSL model shows similar trends in each mode, however, the percentage of increase in transit VMTs is smaller than that in MNL-PSL model for all three scenarios.

Table 2. Modal splits in different scenarios for the MNL-PSL and dogit-PSL models

O-D pair	Base scenario						Transit FFFTs improve 10%					
	MNL-PSL			Dogit-PSL			MNL-PSL			Dogit-PSL		
	Car	Transit	Bike	Car	Transit	Bike	Car	Transit	Bike	Car	Transit	Bike
O-D 1	261.7	160.3	78.0	256.2	170.6	73.3	241.1	200.9	58.0	238.2	206	55.9
O-D 2	299.6	307.0	93.4	302.6	308.8	88.6	272.5	361.0	66.5	276.1	359.8	64.1
O-D 3	222.3	137.7	139.9	224.3	142.9	132.7	221.1	158.9	120.0	222.4	162.7	114.9
O-D 4	185.7	69.9	44.4	156	109.1	34.9	180.0	81.0	39.0	151.7	117.2	31.1
Sum	969.3	675.0	355.7	939.1	731.4	329.5	914.7	801.8	283.5	888.4	845.7	266
O-D pair	Transit FFFTs improve 20%						Transit FFFTs improve 50%					
	MNL-PSL			Dogit-PSL			MNL-PSL			Dogit-PSL		
	Car	Transit	Bike	Car	Transit	Bike	Car	Transit	Bike	Car	Transit	Bike
O-D 1	214.6	244.7	40.7	213.7	246.6	39.8	86.8	405.8	7.4	87.9	404.7	7.4
O-D 2	240.4	415.2	44.4	243.7	413.2	43.2	95.6	597.5	6.9	94.9	598.4	6.7
O-D 3	219.7	180.6	99.8	220.3	183.6	96.1	193.5	264.4	42.0	192.7	266.4	40.9
O-D 4	172.9	93.8	33.3	146.4	126.7	26.9	131.8	152.9	15.4	113.6	173.4	13
Sum	847.6	934.3	218.2	824.1	970	205.9	507.8	1420.5	71.7	489.1	1,442.9	68

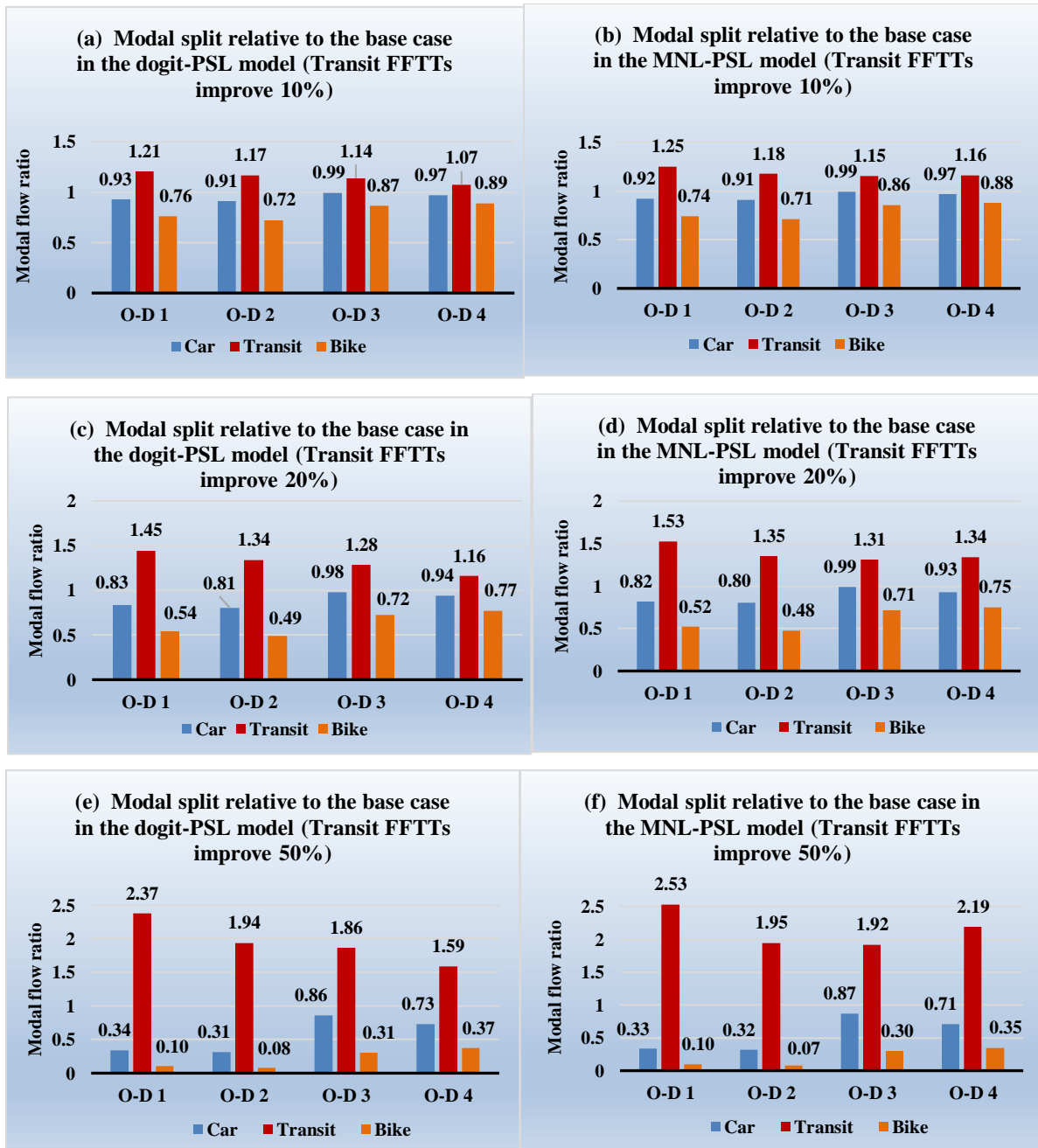

FIGURE 2 Modal Splits in Different Scenarios for the MNL-PSL and Dogit-PSL Models

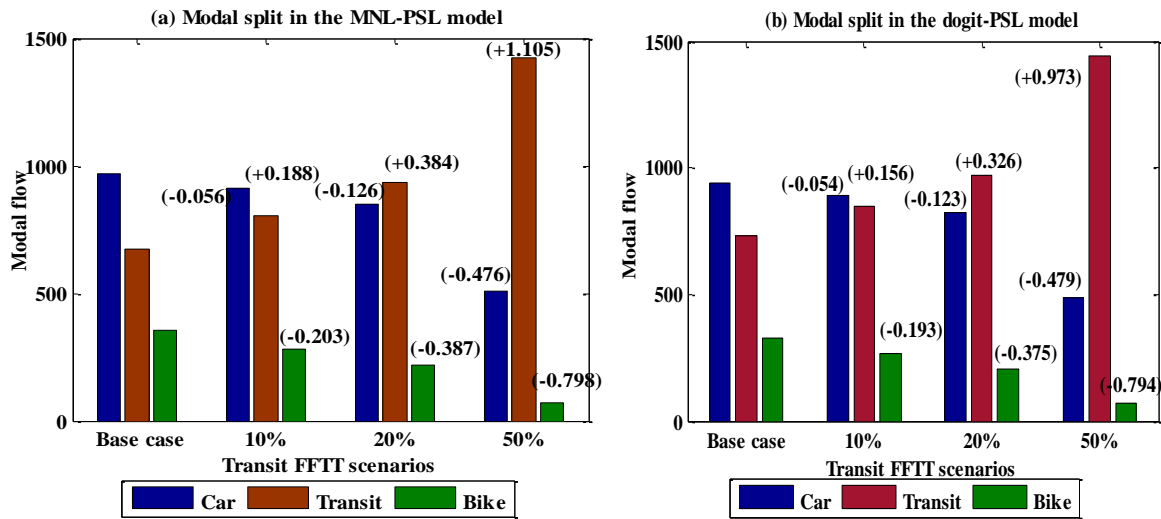

FIGURE 3 Network Modal Splits in the MNL-PSL and the Dogit-PSL Models under Different Scenarios

Table 3. Mode and network VMTs under different transit FFTT improvement scenarios

Mode	MNL-PSL				Dogit-PSL			
	Base case	10%	20%	50%	Base case	10%	20%	50%
Car	12,374.1	11,649.5 (-0.059)*	10,763.8 (-0.130)	6,373.9 (-0.485)	11,992.6	11,318.9 (-0.056)	10,470.7 (-0.127)	6,141.6 (-0.488)
Transit	917.1	1,089.3 (+0.188)	1,269.4 (+0.384)	1,930 (+1.105)	993.8	1,149.0 (+0.156)	1,318.0 (+0.326)	1,960.5 (+0.97)
Bike	4,477.6	3,561.6 (-0.205)	2,734.8 (-0.389)	891.4 (-0.801)	4,147.9	3,341.7 (-0.194)	2,581.3 (-0.378)	844.7 (-0.796)
Sum	13,226.4	12,024.1 (-0.091)	10,716.7 (-0.190)	6,855.5 (-0.482)	17,134.2	15,809.7 (-0.077)	14,370.1 (-0.161)	8,946.8 (-0.478)

* This cell means VMT for car decreases 5.9 percent compared with the base case after implementing the TOD strategy.

Chapter 5: Concluding Remarks

In this study, we provided a new mathematical programming formulation for the CMSTA problem that explicitly considers captive travel behavior in mode choice and route overlapping in route choice. Specifically, the dogit model was adopted to permit flexibility in modeling captive travel behavior by allowing certain choice to be IIA as in the MNL model and other choice to be non-IIA, and the PSL model selected to account for route overlapping problem in a transportation network. The dogit-PSL CMSTA model simultaneously determines both mode choice and route choice with consideration of captive travelers and route overlapping problems.

Numerical examples were performed to demonstrate the captive travel behavior in mode choice and route overlapping in route choice. Through the numerical results, we found that ignoring mode captivity can lead to biased results in evaluating the impacts of TOD strategies. When transit captivity is in presence, the MNL-PSL model tends to generate higher transit mode share and larger percentage of increase in transit VMTs compared with the dogit-PSL model, and thus overestimate the benefits of TOD strategies. However, we are cautious about generalizing this conclusion because the results could be sensitive to parameter settings and network topology. In future research, we plan to conduct the evaluation of TOD strategies in more realistic network settings using the proposed dogit-PSL model.

References

1. Abdulaal, M., and L.J. LeBlanc. Methods for combining modal split and equilibrium assignment models. *Transportation Science* Vol.13, Issue 4, 1979, pp. 292-314.
2. Arrington, G.B., and R. Cervero. TCRP Report 128: Effects of TOD on Housing, Parking, and Travel. *Transportation Research Board*, Washington, D.C., 2008.
3. Beimborn, E., M. Greenwald, and X. Jin. Accessibility, connectivity, and captivity: impacts on transit choice. *Transportation Research Record* No. 1835, 2003, pp. 1–9.
4. Bernick, M., and R. Cervero. *Transit Villages in the 21st Century*. McGraw-Hill, New York, 1997.
5. Bordley, R.F. The dogit model is applicable even without perfectly captive buyers. *Transportation Research Part B* Vol. 24, Issue 4, 1990, pp. 315-323.
6. Ben-Akiva, M., and M. Bierlaire. Discrete choice methods and their applications to short-term travel decisions. In Hall R. (ed.) *Handbook of Transportation Science, International series in operations research and management science*, Vol. 23, 1999, Kluwer, Boston.
7. Calthorpe, P. *The Next American Metropolis: Ecology, Community, and the American Dream*. Princeton Architectural Press, Princeton, 1993.
8. Center for Transit Oriented Development (CTOD). *Trends in Transit-Oriented Development 2000–2010*. Federal Transit Administration. Washington, D.C., 2014.
9. Cervero, R. Transit-based housing in California: evidence on ridership impacts, *Transport Policy*, Vol. 1, Issue 3, 1994, pp. 174-183.
10. Cervero, R., S. Murphy, C. Ferrell, N. Goguts, Y-H. Tsai, G.B. Arrington, J. Boroski, J. Smith-Heimer, R. Golem, P. Peninger, E. Nakajima, E. Chui, R. Dunphy, M. Myers, and S. McKay. Transit-Oriented Development in the United States: Experiences, Challenges, and Prospects. Transit Cooperative Research Program (TCRP) Report 102. *Transportation Research Board*, Washington DC, 2004.
11. Cervero, R. Alternative Approaches to Modeling the Travel-Demand Impacts of Smart Growth. *Journal of the American Planning Association*, Vol. 72, Issue 3, 2006, pp. 285-295.
12. Cervero, R. Transit-oriented development's ridership bonus: a product of self-selection and public policies. *Environment and Planning A* Vol. 39, Issue 9, 2007, pp. 2068–2085.
13. Cervero, R. Transit-oriented development and land use. In *Transportation Technologies for Sustainability*, 2013, pp. 947–958.
14. Chen, A., S. Pravinongvuth, X. Xu, S. Ryu, and P. Chootinan. Examining the scaling effect and overlapping problem in logit-based stochastic user equilibrium models. *Transportation Research Part A* Vol. 46, Issue 8, 2012, pp. 1343-1358.
15. Chu, Y.L. Combined trip distribution and assignment model incorporating captive travel behavior. *Transportation Research Record* No. 1285, 1990, pp. 70-77.
16. Chu, Y.L. Distribution and assignment of compulsory and discretionary traffic. *Transportation Research Record* No. 2263, 2011, pp. 73-81.
17. Chu, Y.L. Network equilibrium model with dogit and nested logit structures. *Transportation Research Record* No. 2302, 2012, pp. 84-91.
18. Evans, J. E., R. H. Pratt, A. Stryker, and J. R. Kuzmyak. Transit Cooperative Research Program (TCRP) Report 95: Transit-Oriented Development-Traveler Response to Transportation System Changes. *Transportation Research Board*, Washington, D.C., 2007.
19. Florian, M. A traffic equilibrium model of travel by car and public transit modes. *Transportation Science*, Vol. 11, Issue 2, 1977, pp. 166-179.
20. Gaudry, M.J.I., and M.G. Dagenais. The dogit model. *Transportation Research Part B* Vol. 13, Issue 2, 1979, pp. 105-111.
21. Gaudry, M.J.I. Dogit and logit models of travel mode choice in Montreal. *The Canadian Journal of Economics* Vol. 13, Issue 2, 1980, pp. 268-279.
22. Jeihani, M., L. Zhang, A. Ardeshiri, A. Amiri, A. Nasri, K. R. Zamir, and B. Baghaei. *Development of a Framework for Transit-Oriented Development (TOD)*. Maryland State Highway Administration, Baltimore, MD, 2013.

23. Kim, S., and G. F. Ulfarsson. Commitment to Light Rail Transit Patronage: Case Study for St. Louis MetroLink. *Journal of Urban Planning and Development*, Vol. 138, Issue 3, 2012, pp. 227–234.
24. Krizek, K. J., and A. El-Geneidy. Segmenting preferences and habits of transit users and non-users. *Journal of Public Transportation*, Vol. 10, Issue 3, 2007, pp. 71-94.
25. Lane, B. W. Significant characteristics of the urban rail renaissance in the United States: A discriminant analysis. *Transportation Research Part A: Policy and Practice*, Vol. 42, Issue 2, 2008., 279-295.
26. Lund, H., R. Cervero, and R. Willson. *Travel Characteristics of Transit-Oriented Development in California*. California Department of Transportation, Oakland, CA, 2004.
27. Mudigonda, S., K. Ozbay, O. Ozturk, S. Iyer, and R. B. Noland. Quantifying Transportation Benefits of Transit-Oriented Development in New Jersey. *Transportation Research Record* No. 2417, 2014, pp. 111–120.
28. Nasri, A., and L. Zhang. The analysis of transit-oriented development (TOD) in Washington, D.C. and Baltimore metropolitan areas. *Transport Policy*, Vol. 32, 2014, pp. 172-179.
29. Parker, T., M. McKeever, g. Arrington, and J. Smith-Heimer. *Statewide Transit-Oriented Development Study: Factors for Success in California*. California Department of Transportation, Sacramento, CA, 2002.
30. Polizin, S. E., X. Chu, and J. R. Rey. Density and captivity in public transit success: observations from the 1995 nationwide personal transportation study. *Transportation Research Record: Journal of the Transportation Research Board* No. 1735, 2000, pp. 10–18.
31. Prashker, J.N., and S. Bekhor. Route choice models used in the stochastic user equilibrium problem: A review. *Transport Reviews* Vol. 24, Issue 4, 2004, pp. 437-463.
32. Renne, J. L. *Transit Oriented Development: Measuring Benefits, Analyzing Trends, and Evaluating Policy*. Rutgers University, NJ, 2005.
33. Renne, J. L., and R. Ewing. *Transit-Oriented Development: An Examination of America's Transit Precincts in 2000 & 2010*. University of New Orleans, New Orleans, LA, 2013.
34. Rubin, T., M. Lowe, B. Aytakin, and G. G. Debate. Does Bus Transit Reduce Greenhouse Gas Emissions. 2010. <http://reason.org/news/show/does-bus-transit-reduce-greenhouse>. Accessed August 29, 2017.
35. Switzer, C. *The Center Commons Transit Oriented Development: A Case Study*. Master of Urban and Regional Planning Thesis, Portland State University, OR, 2002.
36. Zamir, K. R., A. Nasri, B. Baghaei, and L. Zhang. Effects of Transit-Oriented Development on Trip Generation, Distribution, and Mode Share in Washington, D. C., and Baltimore, Maryland. *Transportation Research Record: Journal of the Transportation Research Board* No. 2413, 2014, pp. 45–53.
37. Zhang, M. Can Transit-Oriented Development Reduce Peak-Hour Congestion? *Transportation Research Record* No. 2174, 2010, pp. 148–155.