

**USE OF ADDITIONAL LIGHTING
FOR TRAFFIC CONTROL AND
SPEED REDUCTION IN WORK
ZONES**

Final Report

SPR 791



Oregon Department of Transportation

USE OF ADDITIONAL LIGHTING FOR TRAFFIC CONTROL AND SPEED REDUCTION IN WORK ZONES

Final Report

SPR 791

by

John A. Gambatese and Ali Jafarnejad
School of Civil and Construction Engineering
Oregon State University
101 Kearney Hall
Corvallis, OR 97331

for

Oregon Department of Transportation
Research Section
555 13th Street NE, Suite 1
Salem OR 97301

and

Federal Highway Administration
1200 New Jersey Avenue SE
Washington, DC 20590

February 2018

1. Report No. FHWA-OR-18-10		2. Government Accession No.		3. Recipient's Catalog No.	
4. Title and Subtitle Use of Additional Lighting for Traffic Control and Speed Reduction in Work Zones				5. Report Date -February 2018	
				6. Performing Organization Code	
7. Author(s) John A. Gambatese and Ali Jafarnejad				8. Performing Organization Report No.	
9. Performing Organization Name and Address Oregon Department of Transportation Research Section 555 13 th Street NE, Suite 1 Salem, OR 97301				10. Work Unit No. (TRAIS)	
				11. Contract or Grant No.	
12. Sponsoring Agency Name and Address Oregon Dept. of Transportation Research Section and Federal Highway Admin. 555 13 th Street NE, Suite 1 1200 New Jersey Avenue SE Salem, OR 97301 Washington, DC 20590				13. Type of Report and Period Covered Final Report Fall 2015-Winter 2017	
				14. Sponsoring Agency Code	
15. Supplementary Notes					
16. Abstract: Performing roadway construction work at night exposes workers to hazards that are not present or as great during the daytime. Working at night requires illuminating the area where work is taking place in order to provide sufficient lighting for the workers to see their work and to illuminate the workers. Work area lighting may also have a positive impact on the speed of passing vehicles. Based on previous studies (e.g., SPR 751 and 769) vehicle speed reduction in the work zone during nighttime operations is assumed to be due in part to the lighting provided to conduct the work. The present study evaluated the impact of temporary work zone lighting on vehicle speeds. The study includes case studies on multi-lane preservation projects in Oregon in which different types of lighting systems were implemented: a light tower, balloon light, and a personal, wearable light. The research findings indicate that additional temporary roadway lighting helps to make workers more visible to motorists and equipment operators, and leads to slightly higher vehicle speeds. Implementation of additional temporary roadway lighting is recommended where the work operations contain concerns regarding visibility. Personal, wearable lights are also recommended for workers who are located away from large equipment and other light sources.					
17. Key Words Nighttime Work Zone, Safety, Temporary Lighting, Speed Reduction, Preservation Projects			18. Distribution Statement Copies available from NTIS, and online at http://www.oregon.gov/ODOT/Programs/Pages/Research-Publications.aspx		
19. Security Classification (of this report) Unclassified		20. Security Classification (of this page) Unclassified		21. No. of Pages 196	22. Price

SI* (MODERN METRIC) CONVERSION FACTORS

APPROXIMATE CONVERSIONS TO SI UNITS					APPROXIMATE CONVERSIONS FROM SI UNITS				
Symbol	When You Know	Multiply By	To Find	Symbol	Symbol	When You Know	Multiply By	To Find	Symbol
<u>LENGTH</u>					<u>LENGTH</u>				
in	inches	25.4	millimeters	mm	mm	millimeters	0.039	inches	in
ft	feet	0.305	meters	m	m	meters	3.28	feet	ft
yd	yards	0.914	meters	m	m	meters	1.09	yards	yd
mi	miles	1.61	kilometers	km	km	kilometers	0.621	miles	mi
<u>AREA</u>					<u>AREA</u>				
in ²	square inches	645.2	millimeters squared	mm ²	mm ²	millimeters squared	0.0016	square inches	in ²
ft ²	square feet	0.093	meters squared	m ²	m ²	meters squared	10.764	square feet	ft ²
yd ²	square yards	0.836	meters squared	m ²	m ²	meters squared	1.196	square yards	yd ²
ac	acres	0.405	hectares	ha	ha	hectares	2.47	acres	ac
mi ²	square miles	2.59	kilometers squared	km ²	km ²	kilometers squared	0.386	square miles	mi ²
<u>VOLUME</u>					<u>VOLUME</u>				
fl oz	fluid ounces	29.57	milliliters	ml	ml	milliliters	0.034	fluid ounces	fl oz
gal	gallons	3.785	liters	L	L	liters	0.264	gallons	gal
ft ³	cubic feet	0.028	meters cubed	m ³	m ³	meters cubed	35.315	cubic feet	ft ³
yd ³	cubic yards	0.765	meters cubed	m ³	m ³	meters cubed	1.308	cubic yards	yd ³
NOTE: Volumes greater than 1000 L shall be shown in m ³ .									
<u>MASS</u>					<u>MASS</u>				
oz	ounces	28.35	grams	g	g	grams	0.035	ounces	oz
lb	pounds	0.454	kilograms	kg	kg	kilograms	2.205	pounds	lb
T	short tons (2000 lb)	0.907	megagrams	Mg	Mg	megagrams	1.102	short tons (2000 lb)	T
<u>TEMPERATURE (exact)</u>					<u>TEMPERATURE (exact)</u>				
°F	Fahrenheit	(F-32)/1.8	Celsius	°C	°C	Celsius	1.8C+32	Fahrenheit	°F

*SI is the symbol for the International System of Measurement

ACKNOWLEDGEMENTS

The authors would like to acknowledge the input of the ODOT Research Unit and Technical Advisory Committee. The Technical Advisory Committee members are:

Matthew Wilson, ODOT

Ernest Kim, ODOT

Scott McCanna, ODOT

Nick Fortey, Federal Highway Administration

Joe Squire, ODOT

Jon Lazarus, ODOT Research Unit

The authors would like to thank all those who participated in the interviews, case studies, and survey from around Oregon and the US. Without their input, the valuable information received from the research would not be available. Additional appreciation is expressed to the many additional OSU graduate students who assisted with data collection for the research (Ali Karakhan, Kasim AlOmari, Ding Liu, Chuma Nnaji, and Mohammad Pakravan), and Matthew Durbin, graduate student in Public Health and Human Sciences at OSU, who assisted with the survey preparation, distribution, and analysis.

DISCLAIMER

This document is disseminated under the sponsorship of the Oregon Department of Transportation and the United States Department of Transportation in the interest of information exchange. The State of Oregon and the United States Government assume no liability of its contents or use thereof.

The contents of this report reflect the view of the authors who are solely responsible for the facts and accuracy of the material presented. The contents do not necessarily reflect the official views of the Oregon Department of Transportation or the United States Department of Transportation.

The State of Oregon and the United States Government do not endorse products of manufacturers. Trademarks or manufacturers' names appear herein only because they are considered essential to the object of this document.

This report does not constitute a standard, specification, or regulation.

TABLE OF CONTENTS

1.0	INTRODUCTION.....	13
1.1	BACKGROUND.....	13
1.2	GOALS AND OBJECTIVES.....	14
1.3	RESEARCH SCOPE AND METHODS	15
1.4	BENEFITS	18
1.5	IMPLEMENTATION	18
2.0	WORK ZONE ILLUMINATION SYSTEMS AND DEFINITIONS	19
2.1	GLOSSARY	19
2.2	MINIMUM ILLUMINATION LEVELS	20
2.3	LAMPS	21
2.4	TYPES OF LIGHTING SYSTEMS USED FOR WORK ZONES	23
2.4.1	<i>Temporary Lighting Systems.....</i>	<i>23</i>
2.4.2	<i>Portable Lighting Systems</i>	<i>23</i>
2.4.3	<i>Mobile Equipment-Based Systems and Factory-Installed Lights on Equipment</i>	<i>26</i>
2.5	PERSONAL LIGHTING	27
2.5	HIGH-VISIBILITY SAFETY APPAREL.....	28
3.0	CURRENT PRACTICE AND LITERATURE.....	33
3.1	WORK ZONE LIGHTING DESIGN AND CHALLENGES	34
3.1.1	<i>Work Zone Lighting Design.....</i>	<i>34</i>
3.1.2	<i>Flagger Illumination.....</i>	<i>36</i>
3.1.3	<i>High-Visibility Apparel.....</i>	<i>37</i>
3.1.4	<i>Lighting Glare</i>	<i>37</i>
3.1.5	<i>Impact of Lighting on Motorists</i>	<i>38</i>
3.2	FEDERAL/STATE STANDARDS, GUIDELINES, AND SPECIFICATIONS	38
3.2.1	<i>Federal Standards and Guidelines</i>	<i>38</i>
3.2.2	<i>State Agency Practices.....</i>	<i>42</i>
3.3	OREGON NIGHTTIME WORK ZONE STANDARDS, GUIDELINES, AND SPECIFICATIONS	46
3.3.1	<i>ODOT 2015 Standard Specifications.....</i>	<i>46</i>
3.3.2	<i>Oregon Temporary Traffic Control Handbook (OTTCH)</i>	<i>46</i>
3.3.3	<i>OR-OSHA Construction Safety and Health Standards</i>	<i>47</i>
3.3.4	<i>ODOT Short Term Traffic Control Handbook for Night Operations (2002).....</i>	<i>47</i>
3.3.5	<i>Optimum Illumination for Nighttime Flagger Operations, ODOT</i>	<i>47</i>
4.0	SURVEY OF CURRENT PRACTICE.....	49
4.1	SURVEY PREPARATION AND DISTRIBUTION	49
4.2	SURVEY RESULTS AND ANALYSIS	50
4.2.1	<i>Respondent Demographics</i>	<i>50</i>
4.2.2	<i>Use of Work Zone Lighting Systems</i>	<i>53</i>
4.2.3	<i>Impacts, Inhibitors, and Enablers of Work Zone Lighting Systems</i>	<i>56</i>
4.2.4	<i>Use of Personal Lighting Devices.....</i>	<i>57</i>
4.2.5	<i>Analysis of Results</i>	<i>58</i>
5.0	DOCUMENTATION OF WORK OPERATIONS.....	61

5.1	PROJECT 1: US-26 BROOKWOOD PARKWAY/HELVETIA INTERCHANGE	61
5.2	PROJECT 2: US-101 BETWEEN WHEELER AND WILSON RIVER	65
5.3	PROJECT 3: I-84 CASCADE LOCKS TO HOOD RIVER	70
6.0	IDENTIFICATION OF POTENTIAL LIGHTING STRATEGIES	75
6.1	FOCUS GROUP SURVEY	75
6.1.1	Survey Preparation and Distribution.....	75
6.1.2	Survey Results and Analysis.....	76
6.2	FIELD DEMONSTRATION EVALUATION	81
6.3	SUMMARY OF POTENTIAL LIGHTING STRATEGIES	84
7.0	PILOT TESTING OF LIGHTING STRATEGIES	87
7.1	LIGHTING STRATEGIES AND TESTING ACTIVITIES.....	87
7.2	PILOT TESTING RESULTS	90
7.2.1	Balloon Light	90
7.2.2	Light Tower.....	96
7.2.3	Comparison of Light Tower with 0° Offset Angle, Light Tower, with a 45° Offset Angel, Balloon Light, and No Additional Lighting Equipment	104
7.3	SUMMARY OF PILOT TESTING RESULTS.....	106
8.0	FIELD IMPLEMENTATION AND TESTING (CASE STUDIES)	109
8.1	PROJECT IDENTIFICATION	109
8.2	DATA COLLECTION	110
8.2.1	Temporary Lighting Equipment.....	110
8.2.2	Traffic Control Analyzer.....	112
8.2.3	Radar Speed Gun.....	116
8.2.4	GPS Tracker	117
8.2.5	Video Camera	117
8.2.6	Personal Protective Equipment	117
8.3	CASE STUDY #1: I-84 JORDAN ROAD TO MULTNOMAH FALLS	118
8.4	CASE STUDY #2: I-5 MEDFORD TO ASHLAND	121
8.5	CASE STUDY #3: I-84 MOSIER TO THE DALLES	126
9.0	RESULTS, ANALYSIS, AND EVALUATION	127
9.1	CASE STUDY #1: I-84 JORDAN ROAD TO MULTNOMAH FALLS	127
9.2	CASE STUDY # 2: I-5 MEDFORM TO ASHLAND	143
9.3	SPEED ANALYSIS	159
9.3.1	Impact of Additional Light (Case Study #1).....	159
9.3.2	Impact of Halo Light (Case Study #1)	161
9.3.3	Impact of Radar Speed Sign (Case Study #1).....	162
9.3.4	Impact of Additional Light (Case Study #2).....	164
9.3.5	Impact of Halo Light (Case Study #2)	166
9.3.6	Impact of Radar Speed Sign (Case Study #2).....	167
9.4	ADDITIONAL OBSERVATION FROM CASE STUDIES.....	168
10.0	CONCLUSIONS	175
11.0	RECOMMENDATIONS AND FUTURE WORK	179
12.0	REFERENCES.....	181
APPENDIX		

TABLE OF FIGURES

Figure 2.1: Portable Trailer-mounted Light Tower with Mast Lowered and Mast Raised	24
Figure 2.2: Light Tower Luminaire Orientation (ATSSA, 2013).....	25
Figure 2.3: Balloon Lights Mounted on Paver (left) and Tripod (right; Gambatese 2005)	25
Figure 2.4: Tripod-Mounted Floodlights (left) and Spotlights (right) (Gambatese, 2005).....	26
Figure 2.5: Halo Light™ by Illumagear (https://illumagear.com/safety-products/the-halo-light).....	28
Figure 2.6: High Visibility Apparel (ATSSA, 2009).....	29
Figure 2.7: Class 2 High Visibility Vests	30
Figure 2.8: Class 2 High Visibility Vests as Seen at Night from 20 feet (left) and 500 feet (right)	30
Figure 2.9: Class 3 High Visibility Vests	31
Figure 2.10: Class 3 High Visibility Vests as Seen at Night from 500 feet.....	31
Figure 2.11: (a) Class E Pants; (b) Class 3 High Visibility Apparel (combination of Class 2 and Class E); and (c) Class 3 High Visibility Apparel as Seen at Night from 500 feet (camera zoomed to show it better)	32
Figure 4.1: Respondent Company/Organization (n = 59).....	50
Figure 4.2: Respondent Years of Experience (n = 58).....	51
Figure 4.3: Respondent Construction Project Involvement (n = 58)	52
Figure 4.4: Respondent Amount of Time Spent on Jobsite during the Week (n = 58).....	52
Figure 4.5: Respondent Involvement in Working with Lighting Systems (n = 57).....	53
Figure 4.6: Lighting Systems Commonly Used by Respondents (n = 53).....	54
Figure 4.7: Ease of Lighting Equipment Implementation.....	56
Figure 4.8: Reasons for Wearing Lights while Working at Night (n = 32)	58
Figure 5.1: Brookwood Parkway/Helvetia Interchange Work Zone Layout	62
Figure 5.2: Spotter Working around Grinder and Dump Truck with Halo Light on Hard Hat and Flashing LED Vest	63
Figure 5.3: Grinder Showing Locations of Spotlights, each side (Red Circles)	64
Figure 5.4: Flagger under Portable Balloon Light and Researchers within approximately 15 feet Distance from the Light.....	65
Figure 5.5: US-101 Wheeler to Wilson River Paving Project Observation Site.....	66
Figure 5.6: Light Measurements at Different Distances (10 – 40 feet) from the Balloon Light (fc)	67
Figure 5.7: Flaggers at Latimer Rd. under Portable Balloon Light	67
Figure 5.8: Workers Wearing High Visibility Apparel and Head Light	68
Figure 5.9: Paver with LED Lights.....	69
Figure 5.10: Illumination at Different Distances (10 foot increments) Behind the Paver (fc).....	69
Figure 5.11: Example of Balloon Light Mounting for Density Technician Truck	70
Figure 5.12: Light Measurements (fc) around the Grinder	71
Figure 5.13: Light Measurements at Different Distances in Front of Paver	71
Figure 5.14: Front of Paver with Recommended Location for Adding a Spotlight (red circle)	72
Figure 5.15: Worker in Location without any Temporary or Permanent Lighting.....	73
Figure 6.1: Participant Work Organization (n = 11).....	77
Figure 6.2: Participants Distributed by Work Position (n = 11)	77
Figure 6.3: Years of Experience of Participants (n = 11)	78
Figure 6.4: Percentage of Daily Work by Participants in Roadway Work Zones.....	78
Figure 6.5: Recommended Location for Adding Additional Lighting to Reduce Vehicle Speed	79
Figure 6.6: Positions of Worker relative to Lighting Equipment for Demonstration	83
Figure 6.7: Ranking of Worker Position based on Visibility of Worker	83
Figure 7.1: Plan View of Roadway showing Grid Layout for Light Measurements	89
Figure 7.2: Light Meter used for Illumination Measurements.....	90
Figure 7.3: Sirocco 2000 Balloon Light (Airstar Sirocco 2-M 2x 1000W HA Manual)	90
Figure 7.4: Worker at Different Distances from Balloon Light.....	92
Figure 7.5: High Visibility Apparel under Balloon Light from 100 feet Away.....	93
Figure 7.6: Worker at Different Positions relative to Balloon Light	94
Figure 7.7: Illumination Intensity, Facing in the Direction of the Balloon Light (fc)	95
Figure 7.8: Illumination Intensity, Facing towards the Oncoming Traffic (fc)	96

Figure 7.9: Light Tower Used in Pilot Testing	97
Figure 7.10: Visibility of Worker from Different Distances to Light Tower.....	99
Figure 7.11: Comparison of High Visibility Apparel under Light Tower from 100 feet Away	100
Figure 7.12: Comparison of Worker Visibility at Different Positions relative to Light Tower	102
Figure 7.13: Illumination Intensity (fc), Facing Direction of Light Tower (light tower, 0° offset angle)	103
Figure 7.14: Illumination Intensity (fc), Facing Direction of Oncoming Traffic (light tower, 0° offset angle)	104
Figure 7.15: Visibility of Worker under Different Lighting Equipment from 100 feet Away	105
Figure 7.16: Visibility of Worker under Different Lighting Equipment from 500 feet Away	106
Figure 8.1: Light Tower used on I-84 Jordan Road to Multnomah Falls (Case Study #1).....	111
Figure 8.2: Balloon Light used on I-84 Jordan Road to Multnomah Falls (Case Study #1).....	112
Figure 8.3: NC-350 Portable Traffic Analyzer (M.H. Corbin 2017).....	112
Figure 8.4: Sensor Calibration: Recorded Speed vs. Actual Speed for Sensor #101.....	114
Figure 8.5: Placement of Portable Traffic Analyzer using Adhesive Tape (Gambatese and Jafarnejad, 2015)	115
Figure 8.6: Example of Traffic Analyzer Layout and Location in Work Zone	116
Figure 8.7: Radar Speed Gun.....	116
Figure 8.8: Figure 8.8: ITrail GPS Logger used for Tracking Construction Equipment (www.kjbsecurity.com).....	117
Figure 8.9: Location of Case Study #1 – I-84 Jordan Road to Multnomah Falls	118
Figure 8.10: Paver with Balloon Lights, I-84 Jordan Road to Multnomah Falls (Case Study #1)	120
Figure 8.11: Rollers with PCMS Signs, I-84 Jordan Road to Multnomah Falls (Case Study #1)	121
Figure 8.12: Location of Case Study #2 – I-5 -Medford to Ashland	122
Figure 8.13: Radar Speed Trailer with Balloon Light, I-5 Medford to Ashland (Case Study #2).....	124
Figure 8.14: Lighting Equipment used for I-5 Medford to Ashland-(Case Study #2).....	125
Figure 8.15: Paver Lighting, I-5 Medford to Ashland (Case Study #2).....	126
Figure 9.1: Daily Traffic Volume from 01:00–02:00, Total and by Vehicle Type (Case Study #1)	128
Figure 9.2: Hourly Traffic Volume on Day 3, Total and by Vehicle Type (Case Study #1).....	129
Figure 9.3: Traffic Volume Recorded by Different Sensors on Day 3 from 01:00-02:00 (Case Study #1)	131
Figure 9.4: Vehicle Speed (85th percentile) at Different Locations, Day 3, 23:00-24:00 (Case Study #1).....	134
Figure 9.5: Vehicle Speed (85th percentile) at Different Locations, Day 3, 0:00-01:00 (Case Study #1).....	135
Figure 9.6: Vehicle Speed (85th percentile) at Different Locations, Day 3, 01:00-02:00 (Case Study #1).....	135
Figure 9.7: Vehicle Speed (85th percentile) at Different Locations, Day 3, 02:00-03:00 (Case Study #1).....	136
Figure 9.8: Vehicle Speed (85th percentile) at Different Locations, Day 3, 03:00-04:00 (Case Study #1).....	136
Figure 9.9: Vehicle Speed (85th percentile) at Different Locations, Day 3, 04:00-05:00 (Case Study #1).....	137
Figure 9.10: Hourly Vehicle Speed (Mean Speed) in Work Zone (Sensor #774), Day 3 (Case Study #1)	138
Figure 9.11: Hourly Vehicle Speed (Mean Speed) at RWA Sign, Day 3 (Case Study #1)	139
Figure 9.12: Range of Vehicle Speeds at Different Locations, Day3, 01:00-02:00 (Case Study #1)	140
Figure 9.13: Variance in Vehicle Speed, Day 3, 01:00-02:00 (Case Study #1).....	141
Figure 9.14: Probe Vehicle Speed, Day 3, 23:07 (Case Study #1)	142
Figure 9.15: Probe Vehicle Speed, Day 2, 23:42 (Case Study #1)	142
Figure 9.16: Daily Traffic Volume in Work Zone, Sensor #748 (Case Study #2)	144
Figure 9.17: Hourly Traffic Volume in Work Zone (Sensor #748), Day 3 (Case Study #2).....	145
Figure 9.18: Traffic Volume at Different Sensors, Day 3, 01:00-02:00 (Case Study #2)	146
Figure 9.19: Vehicle Speed (85th percentile) at Different Locations, Day 3, 21:00-22:00 (Case Study #2).....	150
Figure 9.20: Vehicle Speed (85th percentile) at Different Locations, Day 3, 22:00-23:00 (Case Study #2).....	151
Figure 9.21: Vehicle Speed (85th percentile) at Different Locations, Day 3, 23:00-24:00 (Case Study #2).....	151
Figure 9.22: Vehicle Speed (85th percentile) at Different Locations, Day 3, 0:00-01:00 (Case Study #2).....	152
Figure 9.23: Vehicle Speed (85th percentile) at Different Locations, Day 3, 01:00-02:00 (Case Study #2).....	152
Figure 9.24: Vehicle Speed (85th percentile) at Different Locations, Day 3, 02:00-03:00 (Case Study #2).....	153
Figure 9.25: Vehicle Speed (85th percentile) at Different Locations, Day 3, 03:00-04:00 (Case Study #2).....	153
Figure 9.26: Vehicle Speed (85th percentile) at Different Locations, Day 3, 04:00-05:00 (Case Study #2).....	154
Figure 9.27: Hourly Vehicle Speed (Mean Speed) in Work Zone (Sensor #687) adjacent Balloon Light, Day 3 (Case Study #2).....	155
Figure 9.28: Hourly Vehicle Speed (Mean Speed) for each Test Day at RWA Sign (Case Study #2).....	156
Figure 9.29: Range of Vehicle Speeds at Different Locations, Day3, 01:00-02:00 (Case Study #2)	157
Figure 9.30: Variance in Vehicle Speed, Day 3, 01:00-02:00 (Case Study #2).....	157
Figure 9.31: Probe Vehicle Speed, Day 3, 22:36 (Case Study #2)	158
Figure 9.32: Probe Vehicle Speed, Day 5, 21:10 (Case Study #2)	158

Figure 9.33: Visibility of Workers Upstream and Downstream of Light	169
Figure 9.34: Visibility of Worker on Roadway without Additional Lighting	170
Figure 9.35: Visibility of Worker on Roadway with Class 3 Vest	170
Figure 9.36: Visibility of Worker on Roadway with Class 3 Vest and Pants plus Halo Light	171
Figure 9.37: Visibility of Worker next to Paver	171
Figure 9.38: Visibility of Worker Wearing Dirty Reflective Garments and Halo Light	172
Figure 9.39: Visibility of Worker Wearing Clean Reflective Garments without Halo Light	172
Figure 9.40: Paver Progress being Obstructed by Overpass due to Height of Balloon Light.....	173

TABLE OF TABLES

Table 2.1: Recommended Illumination Levels by Task (developed from Bryden and Mace 2002)	20
Table 3.1: Roadway Crash Statistics in Oregon Work Zones (ODOT, 2017a)	34
Table 3.2: OSHA Minimum Illuminance Levels (OSHA, 2015)	42
Table 4.1: Respondent Location (n = 64)	51
Table 4.2: Importance of Selection Criteria.....	55
Table 4.3: Impact of Lighting Systems on Project and Work Performance Criteria	56
Table 6.1: Evaluation of Visibility of Worker for Different Lighting Alternatives (n = 6).....	83
Table 6.2: Summary of the Focus Group Lighting Survey Results	84
Table 7.1: Light Testing Variables	88
Table 8.1: Work Zone Case Study Sites	110
Table 8.2: Technical Specifications of Portable Traffic Analyzer NC-200 and NC-350 (M. H. Corbin 2017)	113
Table 8.3: Sensor Data Adjustment Equations	114
Table 8.4: Testing Plan for I-84 Jordan Road – Multnomah Falls (Case Study #1)	119
Table 8.5: Testing Plan for I-5 Medford to Ashland (Case Study #2).....	123
Table 9.1: Change in the Truck Percentage on Different Testing Days (Case Study #1).....	130
Table 9.2: Hourly Summary of Vehicle Speed, Day 3 at RWA Sign (Case Study #1)	132
Table 9.3: Hourly Summary of Vehicle Speed, Day 3 in Middle of Work Zone, Sensor #748 (Case Study #1).....	133
Table 9.4: Change in the Truck Percentage on Different Testing Days (Case Study #2).....	146
Table 9.5: Hourly Summary of Vehicle Speed, Day 3 at RWA Sign (Case Study #2)	148
Table 9.6: Hourly Summary of Vehicle Speed, Day 3 in Work Zone, Sensor #748 (Case Study #2).....	149
Table 9.7: Descriptive Statistics of Recorded Speeds (Case Study #1)	160
Table 9.8: Speed Data ANOVA Test Results (Case Study #1)	160
Table 9.9: Results of Multiple Comparisons Games-Howell Post-Hoc Test (Case Study #1)	161
Table 9.10: Descriptive Statistics of Recorded Speed near Density Technician (Case Study #1).....	162
Table 9.11: Results of Two Sample T-test for Comparison of With and Without Halo Light (Case Study #1).....	162
Table 9.12: Descriptive Statistics of Vehicle Speed at RSS and Upstream of RSS, Day 2 (Case Study #1)	163
Table 9.13: Results of Two Sample T-test for Comparison of Mean Speed at RSS and before RSS, Day 2 (Case Study #1).....	163
Table 9.14: Summary of RSS Impact on Mean Speed (Case Study #1).....	164
Table 9.15: Speed Data Statistics Used for Comparison Between Light Tower and No Light, Northbound Direction (Case Study #2).....	164
Table 9.16: Results of Two Sample T-test for Comparison With and Without Light Tower, Northbound Direction (Case Study #2).....	165
Table 9.17: Speed Data Statistics Used for Comparison Between Light Tower and No Light, Southbound Direction (Case Study #2).....	165
Table 9.18: Results of Two Sample T-test for Comparison of Light Tower and No Light, Southbound Direction (Case Study #2).....	165
Table 9.19: Speed Data Statistics Used for Comparison Between Balloon Light and No Light, Southbound Direction (Case Study #2).....	165
Table 9.20: Results of Two Sample T-test for Comparison of Balloon Light and No Light, Southbound Direction (Case Study #2).....	166
Table 9.21: Descriptive Statistics of Recorded Speed at Density Technician, Northbound Direction (Case Study #2)	166
Table 9.22: Results of Two Sample T-test for Comparison of With and Without Halo Light, Northbound Direction (Case Study #2).....	166
Table 9.23: Descriptive Statistics of Recorded Speed at Density Technician, Southbound Direction (Case Study #2)	167
Table 9.24: Results of Two Sample T-test for Comparison of With and Without Halo Light, Southbound Direction (Case Study #2).....	167
Table 9.25: Descriptive Statistics of Vehicle Speed at RSS and Upstream of RSS, Day 3 (Case Study #2)	167
Table 9.26: Results of Two Sample T-test for Comparison of Mean Speed at RSS and before RSS, Day 3 (Case Study #2).....	168

Table 9.27: Summary of RSS Impact on Mean Speed (Case Study #2).....168

1.0 INTRODUCTION

This document is the final report for the “Use of Additional Lighting for Traffic Control and Speed Reduction in Work Zones” study. It describes the background and overall objectives and tasks for the study. In addition, it presents the results of all of the planned and executed research tasks. The report concludes with recommended guidelines for the inclusion of additional temporary lighting in work zones to positively impact vehicle speeds, and provides recommendations to ODOT and other transportation agencies for further research on the topic.

1.1 BACKGROUND

Much of the construction work that occurs on high-speed roadways takes place at night in order to minimize impacts to drivers. Research studies have pointed to a wide range of benefits associated with conducting construction work at night including reduced congestion and delay, decreased project duration, decreased material delivery time, and reduced economic impact of construction operations on the surrounding businesses (Shepard and Cottrel, 1985; McCall, 1999; Hancher and Taylor, 2001; Ellis, 2001; El-Rayes et al., 2007; Hassan et al., 2010a; 2010b). Despite these advantages, performing work at night also exposes workers to hazards that are not present or not as great during the daytime, such as the presence of impaired drivers, higher traffic speed, and lack of sufficient visibility for both workers and motorists (Shepard and Cottrel, 1985; Cottrell Jr, 1999; Hancher and Taylor, 2001; Ellis, 2001; El-Rayes and Hyari, 2003a). These factors can decrease work quality and worker safety, and increase the chance of accidents (Hassan et al., 2010a). As a result, special measures are often implemented during nighttime work to protect workers and motorists in work zones. Examples of additional safety measures include: workers wearing higher standards for reflective clothing (e.g., ANSI Class 3 versus Class 2), workers wearing light-emitting diode (LED) illuminated apparel, flaggers using lighted STOP/SLOW paddles, and the use of illuminated signs for traffic control.

Decreased visibility in the work zone is one of the main concerns of nighttime construction which can negatively impact both workers and drivers. Safety in the work zone, quality of work, and the morale of workers are all directly related to work zone lighting (Bryden and Mace, 2002). Working at night requires illuminating the area where work is taking place in order to provide sufficient lighting for the workers to see their work and the surrounding area. Nighttime brings a reduction in visibility for both workers and drivers. The loss of visibility for workers results in the need for supplemental lighting that satisfies the visibility requirements of workers. These requirements are determined by the work task and available contrast. The loss of visibility for drivers results not only from the absence of daylight and the inefficiency of head lighting, but also from the negative effects of glare produced by other vehicles, illuminated signs and other visual clutter, and possibly the illumination of the work zone itself (Bryden and Mace, 2002).

The potentially positive impact that work area lighting can have on vehicle speeds is promising for safety in a work zone. Adding lighting to areas where the construction or maintenance equipment, and typical work area lighting, are currently not present may be a low cost means of

making motorists more aware of workers on the roadway, reducing vehicle speeds throughout the work zone, and further protecting workers on the roadway. With the increasing need to adopt nighttime construction strategies in order to avoid disruption of traffic flow, state transportation agencies are experimenting with different types of lighting systems, such as balloon lights and personal, wearable lights. Conventional methods for illuminating work zones can be prone to producing glare for workers and for drivers. Compared to a standard lighting tower, for example, balloon lights have been reported to reduce glare significantly and provide more uniform lighting conditions at the site (Hassan et al., 2010b).

Implementation of additional lighting is expected to reduce the risk exposure of workers and motorists, lead to fewer worker injuries and fatalities in work zones, and improve mobility through work zones. Further research is needed to assess whether strategically adding lighting to work zones can lead to lower vehicle speeds, reduced speed variance, and lower speeds where workers on foot are present. Interest in exploring options for additional lighting exists amongst Oregon contractors and trucking companies. For example, the Engineering Enhancement Taskforce, formed as part of the ODOT Director's Work Zone Strategy Sessions, is made up of representatives from ODOT and the Oregon construction and trucking industries. The goal of the Taskforce is to identify and disseminate ways in which work zone safety can be improved, and improving work zone lighting is one of its priorities.

1.2 GOALS AND OBJECTIVES

The overall goal of this research is to assist ODOT with enhancing safety in its work zones and reducing the exposure of its employees and contractors to safety risks. To meet this goal, the research study is designed to: (1) determine whether additional lighting added at strategic locations throughout a work zone can benefit work zone safety for both motorists and drivers; and (2) develop recommended practices for strategic use of lighting systems in work zones to help control and reduce vehicle speeds. The following specific objectives were developed for the study:

1. Document current work area lighting systems and practices in preservation project work zones.
2. Determine the typical work patterns and activities in preservation project operations.
3. Identify potential strategies for additional illumination of work zones using available lighting systems.
4. Select and test one or more lighting strategies in an actual work zone to assess the impacts of the lighting on vehicle speeds, worker safety, contractor operations, and work performance.
5. Develop recommendations for ODOT for additional work zone lighting to enhance work zone safety.

Similar to prior research studies of work zone safety conducted by ODOT (e.g., SPR-751 and SPR-769), the present study focuses on preservation projects on high-speed roadways.

Specifically, the studied projects are re-paving projects on high-speed roadways with two travel lanes in each direction. Projects were selected that have paving work which extends a long distance to capture the cases when workers are not in the vicinity of well-lit equipment. The research targets those commercially available, temporary lighting systems commonly used by construction contractors in work zones (light tower and balloon light), which were also previously studied by ODOT in SPR-617. These types of lighting systems are the most commonly used systems in work zones and are initially assumed to be feasible options for providing additional lighting throughout the work zone. The study does not include designing, fabricating, and testing new or modified lighting systems. In addition, the study integrates assessment of reflective worker apparel and lighting worn by workers (wearable lighting) to assess whether these safety features contribute to the ability of the lighting systems to illuminate the workers and affect vehicle speeds.

1.3 RESEARCH SCOPE AND METHODS

To achieve the research goal and meet the stated objectives, eight primary research activities were planned for the study: (1) Documentation of lighting systems; (2) Survey of current practice; (3) Documentation of work operations; (4) Identify potential lighting strategies; (5) Pilot testing of lighting strategies; (6) Implement and test selected lighting strategies; (7) Data analysis and evaluation; and (8) Documentation and dissemination. Each of the planned activities is described in detail below.

Task 1: Documentation of Lighting Systems

As a first task, in order to gain a better understanding of the principles and practices of work area lighting, the research includes review of literature describing lighting terminology, specifications, and performance. This step includes developing definitions of pertinent terms such as luminaire, illumination, luminance, illuminance, glare, and uniformity. Different types of lamps and minimum illumination levels for different work area operations are reviewed and recorded, and commonly available lighting technologies and equipment are explained. Next, an in-depth review of academic and practice-oriented literature, including reports and procedure manuals germane to work zone lighting issues, is conducted. Special consideration is given to previous research studies on similar projects conducted by other transportation agencies and researchers.

To collect the literature, the researchers conducted a comprehensive search of archival publications and the Internet using on-line search engines. All documents found that were germane to the research topic were accessed and reviewed. Task 1 leads to the creation of an extended table of the available lighting systems for use during the research and in the future by ODOT. The table contains a description of each light system along with associated benefits, limitations to its use, and summaries of findings from prior research on the technology.

Task 2: Survey of Current Practice

This portion of the research includes surveying state DOTs, construction contractors, and other entities involved in roadway construction to document current and recommended practices, barriers, enablers, and impacts associated with work zone lighting systems. The survey

instrument selected was an electronic questionnaire. A short survey questionnaire was developed that included questions regarding the importance of lighting for nighttime highway construction work, the types of lighting and traffic control equipment presently used, and the types of technologies for lighting and for traffic control that should be used in the future for nighttime highway work. Pilot testing of the survey was conducted prior to its dissemination. The questionnaire was distributed via e-mail to state agencies and construction contractors in the Pacific Northwest and across the US.

Task 3: Documentation of Work Operations

This task is intended to provide an understanding of typical work patterns and lighting needs on highway preservation projects. In consultation with the TAC, the researchers selected and visited several ongoing ODOT projects. The researchers visited the project sites and monitored the work operations, especially with regard to those workers who are on the roadway a long distance from lighting and large equipment. The researchers recorded the operations, monitored worker movements and locations, and documented the equipment utilized and reflective clothing worn by the workers. The researchers also measured the level of illumination at the work locations. This task revealed situations in which workers are especially in need of additional lighting and opportunities for additional lighting.

Task 4: Identify Potential Lighting Strategies

This task involved conducting focus group sessions with ODOT personnel and construction contractors. The objective of this task was to identify and develop promising lighting strategies to implement and test in an active work zone. For example, one lighting strategy may be to have 250-watt, tripod-mounted flood lights set up where quality control personnel check pavement densities upstream of the rollers. The flood lights would be oriented and located such that they illuminate the personnel for on-coming traffic yet do not create disabling glare for the drivers. Another example, if sufficient shoulder width is available, may be to have a dedicated truck towing a portable light tower that follows the quality control personnel and illuminates the personnel as they conduct their work on the roadway.

As part of this task, the TAC was asked to recommend focus group participants from within ODOT and construction companies. The researchers then worked to plan, schedule, and conduct the focus group sessions. A total of 2-3 focus group sessions was targeted. Prior to the focus groups, the researchers developed possible strategies for additional lighting to present to the participants. Feedback on each of the lighting systems was solicited. The evaluation of possible strategies considered lighting system availability, cost, ease of implementation, potential for improving safety, and potential for incorporating the strategies in typical traffic control plans. Those lighting strategies that were deemed promising by the focus group participants, and fit within the research budget, were selected for testing.

Task 5: Pilot Testing of Lighting Strategies

Those lighting strategies selected in Task 4 were pilot tested under controlled, off-roadway conditions to further assess their feasibility and performance. Each selected lighting strategy was assessed to evaluate its potential for efficient and economic implementation, its ability to provide

effective lighting to illuminate workers, and associated limitations to its implementation. As part of the testing, the researchers determined recommended locations and orientations of the light systems to illuminate the workers without creating disabling glare for drivers. Light meters were used to measure the amount of illumination in the work area and on the worker. Standard reflective clothing was worn by participants involved in the testing to simulate working conditions.

In conjunction with the pilot testing, the researchers consulted with ODOT to select upcoming preservation projects on which to test each of the strategies as described in Task 6. The case study projects targeted were paving projects located on high-speed roadways with two lanes in each direction. A total of three case study projects were selected for the research study. ODOT assisted with initiating the case studies by contacting the paving contractor(s) regarding conducting the research on the projects, and making the needed contracting or change order requirements necessary to incorporate the research work into the paving projects.

Task 6: Implement and Test Selected Lighting Strategies

For Task 6, the researchers implemented the lighting strategies selected in Task 5 on each case study project. The researchers consulted with the TAC to determine which lighting strategies to implement on each project. Depending on the case study projects selected, it was planned to apply the lighting strategies under different work zone and traffic conditions (e.g., A-lane and B-lane, within a straight roadway section and near a horizontal curve, and different days of the week). Each selected lighting strategy was implemented during actual work operations.

The researchers monitored the installation, use, and removal of the light systems, videotaped the operations, and measured vehicle speeds as needed to assess each lighting strategy. For example, one night of testing was conducted without the light systems used (baseline case for comparison) and the next night of testing had the light systems implemented and turned on. The testing results of each technology were evaluated and compared based on a variety of criteria including: ease of implementation and use, and the impacts on vehicle speeds, speed variability, visibility of workers, worker productivity, and implementation cost. Upon the completion of testing, feedback on each lighting system was collected directly from the construction personnel involved in each case study project.

Task 7: Data Analysis and Evaluation

The data collected from the case study projects was analyzed to determine the effectiveness of each of the lighting strategies tested. The researchers compared the vehicle speeds, speed variability, and visibility of the workers associated with the baseline case (without the lighting system) to that when the light system is implemented and turned on. Where appropriate, multi-criteria decision analysis was applied to rank order the effectiveness of each light strategy. Such comparisons lead to a determination of the relative benefits provided by each light system in effectively and efficiently illuminating construction personnel.

Task 8: Development of Guidelines for Implementation

The researchers have prepared and submitted this final research report to ODOT for review and comment. The report presents the findings of the research and provides recommendations to

ODOT for implementation in practice. Following ODOT's review of the initial draft of the report, the report was revised based on the comments received from ODOT, and a final research report prepared and submitted to ODOT for publication.

1.4 BENEFITS

ODOT will benefit from the research by having comprehensive and accurate information about the use of additional lighting systems to improve safety in its work zones. The study will complement previous work zone safety and flagger illumination studies conducted by ODOT (e.g., SPR 617, 751 and 769) by providing additional knowledge of the performance of light systems in work zones. The study will also result in recommendations for designing additional light systems into traffic control plans on future projects. Implementation of additional lighting is expected to reduce the risk exposure of workers and motorists, lead to fewer worker injuries and fatalities in work zones, and improve mobility through work zones. Lastly, successful completion of the research and implementation of the research results are expected to strengthen the capability of ODOT to design illumination strategies for its work zones.

1.5 IMPLEMENTATION

The product of the research (this report) describes the identification and testing of lighting systems that are feasible and effective in illuminating workers and provides guidelines and recommendations for their use in practice. The results and product of the research can be used by the Statewide Construction and Maintenance Offices for planning construction and maintenance work. The research output can also be used by the Transportation Safety Division, and by the Transportation Safety Coordinators in each Region, as a resource for effectively designing work zones and planning construction and maintenance operations.

2.0 WORK ZONE ILLUMINATION SYSTEMS AND DEFINITIONS

This section of the report provides definitions of terms related to lighting that are used in the research study along with detailed descriptions of different types of lighting systems commonly used in roadway construction operations.

2.1 GLOSSARY

Luminaire: A light fixture attached to a support (e.g., tripod, mast, pole, or other supporting element). The luminaire contains the lamp used to produce light.

Lamp: A bulb or other device that produces light.

Illumination, Luminance, and Illuminance: The amount of light available for a specific task can be measured in either of two ways: as illumination or as luminance. These terms are frequently misunderstood and their understanding is important to competently design, implement, and manage lighting systems.

Illumination: The amount of light reaching a unit area of surface at a given time. Usually measured in lux, which is the SI unit of one lumen per square meter (lm/m^2). Foot-candle is the English unit; one foot-candle is the illuminance cast on a surface by a one-candela source one foot away. One foot candle is equal to approximately 10.764 lux.

Luminance: The amount of light or luminous flux leaving a surface in a given time. Usually measured in candelas per square meter (cd/m^2).

Illuminance: The amount of light falling on a surface, measured in foot-candles (US customary units) or lux (metric units). Illuminance is often used to describe the brightness of a surface. Illuminance may be increased by increasing the intensity of a light source, increasing the number of light sources, or decreasing the distance of the light sources from the surface area.

Illumination is the preferred metric for most construction lighting situations. The ability to perform the seeing task is directly related to the amount of light reaching the subject. Illumination is easily measured by a photometer placed on or adjacent to the work surface.

Luminance provides a better measure of the visibility of the subject target. Luminance is a more appropriate measure for visibility measurements. For example, for traffic control devices and worker safety clothing items, luminance or the amount of light reflected from these targets, is the appropriate measure of effectiveness. Luminance can be measured with a variety of specifically designed photometers (Ellis, 2001).

Luminance is difficult to measure without special equipment, but illuminance can be measured easily in the field using a relatively inexpensive light meter. The standards for illumination of work zones and other work environments are based on illuminance. Illuminance can be increased

by increasing the intensity of a light source, increasing the number of light sources, or decreasing the distance of the light sources from the work surface (Anani, 2015).

Glare: A condition of vision in which there is discomfort or a reduction in the ability to see details or objects, caused by an unsuitable distribution or range of illuminance, or by extreme contrasts (Anani, 2015). Glare can cause physical irritation and discomfort crews and passing motorists. Reducing glare effects can be accomplished through consideration of four factors: beam spread, mounting height, location, and aiming.

Uniformity: The uniformity of illuminance, defined as the ratio of the average illuminance to the minimum illuminance over the work area. For work areas, uniformity in a work area should not exceed 10:1, with 5:1 being more desirable (Bryden and Mace, 2002).

2.2 MINIMUM ILLUMINATION LEVELS

The amount of illumination needed for a specific work task depends on the work operation and surrounding environment. Recommended illumination levels have been investigated and are presented in current literature (e.g., Ellis and Amos, 1996). The National Cooperative Highway Research Program (NCHRP) Report #476, #498 and state and federal occupational safety standards, for example the Occupational Safety and Health Administration standards (OSHA, 2015), provide both recommended illumination levels and standards to be met in work places.

In the previous research studies mentioned above, the researchers assigned factor levels for different highway construction and maintenance tasks. By matching these tasks with non-highway tasks, the researchers used an average illumination level to suggest illumination categories and level for highway tasks. The researchers introduced three levels of illumination, Levels I, II, and III, as shown in Table 2.1. The recommended levels of average minimum illuminance (in lux) are 54, 108, and 216 for Levels I, II, and III, respectively. For example for concrete pavement construction or highway signing, the researchers recommend an average of 108 lux, and for cleaning and sweeping 54 lux is recommended. Table 2.1 shows additional details of different construction tasks and their related recommended average minimum illumination.

Table 2.1: Recommended Illumination Levels by Task (developed from Bryden and Mace 2002)

Examples of Tasks	Illumination Level	Average Minimum Maintained Illuminance
All work operations areas; setup of lane or road closures, lane closure tapers, and flagging stations	Level I	54 Lux (5 foot-candles*)
Areas on or around construction equipment; asphalt paving, milling, and concrete placement/removal	Level II	108 lux (10 foot-candles)
Pavement or structural crack/pothole filling; joint repair, pavement patching/repairs; installation of signal/electrical/mechanical equipment	Level III	215 lux (20 foot-candles)

*A foot candle (fc) is defined as unit of illumination that is equal to one lumen per square foot, or 10.764 lux.

2.3 LAMPS

Different types of electric lamps (light sources) are currently available and used for work zone lighting in the US. Each of the different types of lamps is described below.

Light Emitting Diode (LED): LEDs are designed for low power consumption, light weight, long life, and resistance to vibration and physical damage. The light produced by each individual LED module is highly directional, so most LED luminaries contain several modules aimed in different directions and a diffuser to spread the light.

Incandescent: Incandescent lamps use electric current passing through a wire filament, often tungsten, to create a high temperature in the filament that produces a glow, as well as high temperatures. The lamps have poorer efficiency than other lamp types since they produce a great amount of heat. Due to their inefficient use of electricity, future use of incandescent lamps is restricted by government regulations.

Halogen: Halogen lamps contain a tungsten filament surrounded by halogen gas. The lamps are not as energy-efficient as other types of lamps and generate a considerable amount of heat.

Metal Halide: Metal halide lamps use an electric arc passed through a gaseous mixture of vaporized mercury and metal halides. The most common metal halide compound used is sodium iodide. Metal halide lamps have high luminous efficacy of around 75 - 100 lumens per watt, which is about twice that of mercury vapor lamps and 3 to 5 times that of incandescent lamps.

Mercury Vapor: Mercury vapor lamps use an electric arc passed through vaporized mercury to produce light. These lamps are more energy efficient than incandescent and fluorescent lamps, have a relatively long bulb life, and produce a high intensity clear white light output. Mercury vapor lamps require a warm-up period of 4 to 7 minutes to reach full light output. Mercury vapor lamps are not a recommended light source for nighttime highway work (Hanna, 1996).

High Pressure Sodium (HPS): High pressure sodium lamps are an energy-efficient illumination source that produces pinkish-orange light. This type of lamp is frequently used for permanent roadway lighting. A warm-up time of approximately 5 minutes is required before the lamps reach full intensity. Because of the relatively long warm-up and cool-down times, HPS lamps are also inappropriate for situations where the lights must be turned on and off frequently.

Fluorescent: Fluorescent lamps are a low pressure mercury vapor gas discharge lamp that uses fluorescence to produce visible light. While fluorescent lamps are more energy efficient than incandescent lamps, fluorescent lamps are not a recommended light source for nighttime highway work (Hanna, 1996).

Table 2.2 provides a summary of the specifications and features of each type of lamp

Light Source	Lumen Output per Lamp	Efficacy (lumens per watt)	Life (hrs)	Color Adaptability	Degree of Light Control	Maint. of Lumen Output	Recommended Applications
Incandescent and tungsten halogen	Fair	Low (24)	Low (2,000)	High (Daylight white)	High	Fair	Task oriented lighting Equipment mounted lights Small areas Low mounting heights
Mercury vapor	Good	Fair (63)	High (24,000)	Fair to Good (Medium white)	Fair	Fair	Not recommended
Metal Halide	High	Good (110)	Good (10,000)	Good (Bright white)	Good	Good	Medium sized areas Good color rendition required Varied mounting heights
High pressure sodium	High	High (140)	High (24,000)	Fair (Soft, orange)	Good	High	Large areas Color rendition not important Varied mounting heights
Fluorescent	Low	Fair to good (85)	Fair (7,500)	Fair to High (Daylight white)	Fair	High	Not recommended
Light Emitting Diode (LED)	High	High (140-200)	High (50,000)	Fair to High (Yellow- Light Blue)	Good	Good	Task oriented lighting Equipment mounted lights landscape lighting, street and area lighting

2.4 TYPES OF LIGHTING SYSTEMS USED FOR WORK ZONES

Roadways often contain existing, permanent lighting to help drivers navigate the roadways. During construction, existing roadway lighting may not be sufficient to eliminate the need for additional lighting of the work zone. In some cases, existing lighting may not be present. To provide the necessary lighting during construction, construction crews typically employ light towers, balloon lights, or other types of commercially available lighting systems. Factors such as efficiency, ability to satisfy minimum requirements while controlling glare, amount of light required to perform the tasks and be seen, availability of power, light trespass, and cost also should be considered when selecting the types of lighting that are best suited for the work zone. El-Rayes and Hyari (2002) identified seven decision variables to be considered in the development of a lighting plan: 1) lighting equipment selection; 2) type of luminaire; 3) lamp lumen output; 4) luminaire height; 5) light tower positioning; 6) aiming angle of luminaires; and 7) light tower rotation around a vertical axis. Gambatese (2005) suggested that design objectives should consider the optimization of illuminance, glare, uniformity ratio, and lighting cost. Before the lighting system can be designed and a layout created, the user must choose among different lighting systems based on temporary, portable, and vehicle-mounted equipment.

2.4.1 Temporary Lighting Systems

Temporary lighting systems use existing or temporary poles to support luminaires. This type of system consists of any permanent roadway lighting fixture mounted on temporary poles and hard wired to an electrical system. The design of this type of system would normally be prepared by a lighting design professional. The system allows luminaires to be uniformly located on tall mast lighting poles that results in uniform lighting with low glare. These systems are immobile and, therefore, are typically used for projects where the work occurs at just one location for a long duration. The systems may be cost-effective when used to supplement an existing fixed lighting system, when the work activity will last a significant period, or both. A semi-permanent high-mast system composed of luminaires mounted on tall poles is an example of a temporary system. This type of system was first used by the NYSDOT in 2005 for a three-mile stretch of I-90 near Albany, NY (Freyssinier et al., 2008) where the system provided sufficient illumination for performing maintenance and construction activities, and resulted in high visual performance of workers with few shadows and low glare to workers and drivers.

2.4.2 Portable Lighting Systems

Portable lighting systems integrate the luminaire, power supply, and pole into one fixture that can easily be moved from one location to another. These are the most commonly-used lighting systems for mobile and short term construction projects. Portable systems may consist of either ground-mounted or trailer-mounted light towers. Portable trailer-mounted light towers can be easily transported throughout the project as well as easily raised into position at the work site. There are limited types of temporary lighting available for use during nighttime roadway construction, although new technologies and innovations may provide better options in the future. The most commonly used temporary lighting systems include those described below.

Portable Light Towers

Portable light towers, also referred to as light plants, consist of numerous luminaires (typically two to six light fixtures) mounted to a mast arm that is capable of holding the luminaires at various mounting heights. The mast arm is attached to a trailer with a generator that can be towed by a vehicle (Figure 2.1). The light fixtures are typically outfitted with 1,000 or 1,500 watt metal halide bulbs. If the number of watts is increased, the area illuminated also increases. The bulbs are not limited to metal halide and some light towers have the option of using high pressure sodium or tungsten halogen lights.



Figure 2.1: Portable Trailer-mounted Light Tower with Mast Lowered and Mast Raised

The mast on a portable light tower can typically raise the luminaires as high as 30 feet and most of the light towers have the ability to rotate 360 degrees. These capabilities allow the lighting to be adjusted as needed and can lead to larger amounts of area illuminated. Most light towers have an illumination range of 5 to 7 acres for towers containing four 1,000-watt lights. To prevent glare, the American Traffic Safety Services Association (ATSSA) recommends that these lighting systems should not be aimed toward traffic and should be aimed downward at the work and rotated outward no greater than 30 degrees from straight down unless the light has been designed specifically to prevent glare as depicted in Figure 2.2 (ATSSA, 2013).

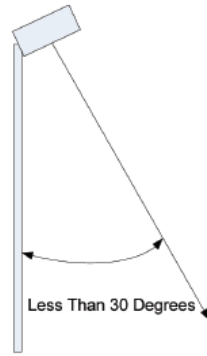

Figure 2.2: Light Tower Luminaire Orientation (ATSSA, 2013)

Light towers may also be affixed to paving machines, finishing machines, and milling machines. This type of equipment is the predominant system used on construction sites because of the large amount of light it produces, its relatively low cost to rent, high availability, and ease of operation and maintenance. Although easy to operate and maintain, these systems often provide more light than needed, which reduces their cost-effectiveness. Spacing and positioning of these devices in practice typically results in very non-uniform illumination, which, together with the low mounting height, often results in a severe glare hazard.

Balloon Lights

Balloon lights, developed by Airstar Space Lighting, consist of luminaires inflated with air or helium that are commonly mounted on portable stands or a vehicle. This type of lighting consists of a large balloon type luminaire that provides a fairly large area of evenly distributed light and is relatively glare-free. The balloons are made of custom-designed fabrics coated with special chemical treatments to make them rain and dust proof. Balloon lights have an illumination range of 108,000 to 432,000 square feet. The lamps are commonly installed on large equipment and trucks, and may also be placed on movable tripods. Figure 2.4 shows balloon lights mounted on a paver and on a tripod.



Figure 2.3: Balloon Lights Mounted on Paver (left) and Tripod (right; Gambatese 2005)

Other Trailer-Mounted Lights

Other types of trailer mounted lights are available. For example the Nite Lite is a portable construction light with a 400-watt metal halide lamp in a dome shaped luminaire that is coated with a light diffusing compound. The luminaire weighs 26 lbs (11.8 kg) with a diameter of 25 inches (0.635m), and stores securely in a custom foam-padded carry/storage case. The Nite Lite provides non-glaring, white light from a high-intensity gas-filled lamp ignited by microprocessor-controlled electronics. This technology allows the Nite Lite to provide a highly visible non-glaring light that can be powered by a 120-volt AC, 60-Hertz electrical source using a standard plug. Light output is rated at 42,000 lumens which can illuminate an area of 0.34 acres (1,395 m²).

Light Stands

Several other types of lighting equipment exist that are not classified as lighting towers or balloon lights. Light stands are common examples of other types of equipment available. These types of lighting systems are typically used for flagging operations or for smaller, focused areas of work. Most of these systems do not have a generator permanently attached to them and, if so, require a power source for their operation. Light stands generally have one to two luminaires containing lamps that provide output ranging from 500 to 1,500 watts each. The stands can be extended to a height of 6 to 12 feet (Gambatese, 2005). Figure 2.4 shows a tripod-mounted floodlight and a spotlight.



Figure 2.4: Tripod-Mounted Floodlights (left) and Spotlights (right) (Gambatese, 2005)

2.4.3 Mobile Equipment-Based Systems and Factory-Installed Lights on Equipment

Mobile equipment-mounted systems are located directly on maintenance and construction equipment. These systems generally do not conform to any criteria that may be used to calculate expected illuminance levels. As such, they should not be relied upon for the primary lighting for

areas or tasks requiring Level II or III lighting. All construction equipment (e.g., rollers, backhoes, loaders, and other equipment) operating in work areas not illuminated to a minimum of Level I illuminance must be equipped with floodlights that provide a minimum of 1 fc (10.8 lux) (Bryden and Mace, 2002). Construction equipment that operates solely in areas illuminated by tower lighting that meets the minimum lighting requirements do not require floodlights. In addition, headlights installed on most equipment do not normally provide adequate lighting for most work operations and, as a large component of glare, should not be used when facing any oncoming traffic.

Yellow flashing/rotating lights, which are also used to supplement illuminating lights, are similar to those found on trucks and paving equipment. These lights can either be mounted on the vehicle or to a stationary stand. Flashing lights are generally considered to be effective for attracting driver attention. When channelizing devices are used to mark isolated hazards or features, the addition of flashing lights may improve the likelihood of being noticed by drivers, and this effect may be greater at night when drivers are drowsy or otherwise impaired. Increased driver attention at the start of tapers is especially important, and flashing lights on the first two barrels, tubular markers, or other devices used to form the taper may help to ensure detection by approaching drivers (Bryden and Mace, 2002). The Institute of Transportation Engineers (ITE) has published standards for minimum light intensity, flash frequency, and color requirements for warning lights in a work zone. However the standards do not completely address the warning light usage in regards to worker and driver safety (Rea et al., 2016).

Likewise, flashing lights should be provided on barricades at road and ramp closures to attract and improve driver attention to the barricades. Barricade lights are a yellow light that typically contain a photocell detector to conserve battery power during daylight hours. These lights may also have a reflective boarder that helps to increase their visibility.

Steady-burn lights (flares) are intended to define the edge of the travel path. Considering the large device size and close spacing recommended in industry guidelines, and the experience of states such as New York and Iowa, it is doubtful that steady-burn lights on channelizing devices will provide any value in nighttime work zones (Bryden and Mace, 2002).

2.5 PERSONAL LIGHTING

Some workers may choose to wear personal lighting (“wearables”) while performing their work. Personal lighting devices are small, wearable lights that provide lighting to illuminate the work area and work task, and for illuminating the worker to improve visibility of the worker by others. The lights may be different colors, and are typically worn on the worker’s arm, hardhat, or vest. The Halo Light™ by Illumagear is an example of a light that is attached to a hardhat (Figure 2.5).



Figure 2.5: Halo Light™ by Illumagear (<https://illumagear.com/safety-products/the-halo-light>)

2.5 HIGH-VISIBILITY SAFETY APPAREL

High visibility apparel is clothing worn by workers that is designed to make the worker more visible to vehicular traffic and more discernible amidst their work environment. When used in conjunction with lighting systems, the use of high-visibility safety apparel allows motorists and equipment operators to see workers distinctly, reducing the risk of being struck by passing vehicles and construction equipment. Besides the lighting plan, which includes the layout for the light systems and a description of the equipment used, special safety issues need to be considered for nighttime construction work plans. Development of the plan should consider equipment warning devices and personal protective clothing (Hancher and Taylor, 2001).

Several Federal government agencies, including the Occupational Safety and Health Administration (OSHA) and Federal Highway Administration (FHWA), have prepared specific standards and guidance with regards to high visibility clothing based on ANSI/ISEA 107. The 2009 edition of the *Manual on Uniform Traffic Control Devices* (MUTCD) with revisions incorporated (FHWA, 2012) provides national guidance regarding lighting for all states and

refers to the ANSI/ISEA standard on the use of high-visibility safety apparel. The MUTCD includes the following recommendation:

“All workers exposed to the risks of moving roadway traffic or construction equipment should wear high-visibility safety apparel meeting the requirements of ISEA ‘American National Standard for High-Visibility Safety Apparel’ ...and labeled as ANSI 107-2004 standard performance for Class 1, 2, or 3 risk exposure.” — MUTCD 6D.03

Consistent with Federal standards, highway construction workers in Oregon must wear highly visible upper body garments. The colors must contrast with other colors in the area sufficiently to make the worker stand out. During nighttime work, the garments must also have reflective material present on all sides so that the worker is visible from a distance of 1,000 feet. ANSI/ISEA 107 provides performance criteria for the materials to be used in high visibility personal protective equipment, specifies minimum areas of reflective material on worker apparel, and, where appropriate, recommends locations for placement of the reflective materials. This standard focuses on the color and brightness of garments and headwear relative to the work environment and the combined use of fluorescent and retroreflective materials to make a person conspicuous in all light conditions, during the day and night. The standard offers three Performance Classes for garments (Classes 1, 2, and 3), based on worker hazards and tasks, complexity of the work environment or background, and vehicular traffic and speed conditions. There are also Class E and public safety apparel classes. Only Classes 2, 3, and E ensembles are acceptable for workers to wear within the right-of-way of Federal-aid-highways.

These safety garments consist of background material, retroreflective material, and combined-performance material. The background of the apparel is a colored fluorescent material intended to be highly visible. The retroreflective material consists of a material that reflects and returns the light back in a direction close to the direction from which it came. The combined-performance material is a combination of retroreflective and fluorescent material that can be counted towards the minimum area requirements for background material (see Figure 2.6). Each of the apparel classes is described in further detail below.



Figure 2.6: High Visibility Apparel (ATSSA, 2009)

Class 1 Garments

Class 1 garments are worn when there is a separation between worker and motor vehicles, the background is not complex, and vehicle/equipment speeds do not exceed 25 mph. Parking attendants, warehouse workers, and workers on sidewalks, are some examples of where this type of apparel can be worn.

Class 2 Garments

This type of apparel is used for work in inclement weather and/or areas with complex backgrounds, when a worker's attention may be diverted from approaching traffic, and when a worker is in close proximity to traffic. In addition, Class 2 garments are appropriate when vehicles and equipment travel at speeds greater than those specified for Class 1 apparel, such as for roadway construction workers, utility workers, and survey crews. Figures 2.7 and 2.8 show examples of Class 2 high visibility vests.

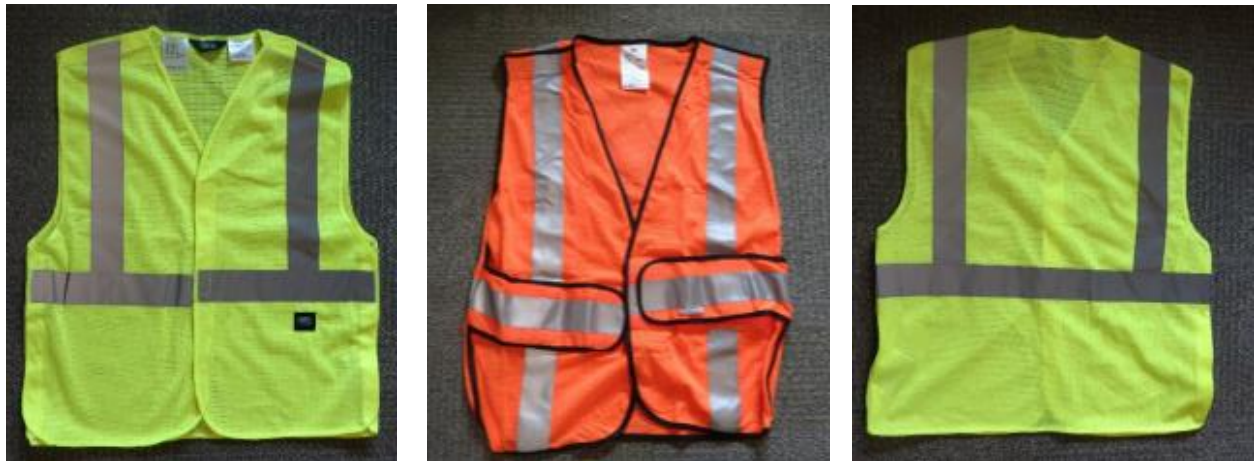

Figure 2.7: Class 2 High Visibility Vests



Figure 2.8: Class 2 High Visibility Vests as Seen at Night from 20 feet (left) and 500 feet (right)

Class 3 Garments

Class 3 garments are worn by workers exposed to high speed traffic and/or conditions where visibility of workers may be reduced, and for conditions where equipment operators perform tasks near pedestrian workers. These garments are needed when workers must be conspicuous through a full range of body motions at a minimum distance of 1,280 feet and identifiable as a person. Examples of such uses include: flaggers, roadway construction workers, utility workers, survey crews, and emergency responders. Figures 2.9 and 2.10 show examples of Class 3 high visibility vests.



Figure 2.9: Class 3 High Visibility Vests



Figure 2.10: Class 3 High Visibility Vests as Seen at Night from 500 feet

Class E Garments

Class E garments consist of the combination of a Class 2 or Class 3 vest with Class E pants or shorts. This combination creates a Performance Class 3 ensemble. The MUTCD recommends Performance Class 3 apparel for nighttime flagging even though illumination of the flagging station is required for night time work.



Figure 2.11: (a) Class E Pants; (b) Class 3 High Visibility Apparel (combination of Class 2 and Class E); and (c) Class 3 High Visibility Apparel as Seen at Night from 500 feet (camera zoomed to show it better)

3.0 CURRENT PRACTICE AND LITERATURE

The researchers conducted an extensive literature review to investigate and study existing research, standards, and practices related to nighttime work zone lighting. This section of the report is divided into three sub-sections that identify and discuss the following:

1. Papers and reports related to work zone lighting design, flagger illumination design, high visibility apparel, and lighting issues including glare and its impact on motorists
2. Federal and state guidelines, and DOT standards and specification for nighttime work
3. Standards, guidelines, and other documents related to nighttime work zone operation for the State of Oregon

Roadway work zones expose workers to high levels of risk. Table 3.1 shows roadway crash statistics in Oregon work zones from 2000 to 2015 (ODOT, 2017a). In 2014, one out of every 100 roadway fatalities that occurred in Oregon happened in a work zone. Both roadway workers and motorists are exposed to the danger of being involved in an accident in a work zone. The driver and passenger fatality and injury rate is higher than that of workers in work zones. Based on ODOT's crash data, from 2009-2013, 70% of work zone crashes occurred on interstate and state highways where vehicles travel at higher rates of speed (ODOT, 2015a).

Research has been conducted to identify the common causes of crashes on roadways and in construction work zones. The predominant factors contributing to crashes in work zones in Oregon from 2010 to 2014 (5-year average), were "following too closely" (tailgating) and "speed too fast" (Leidos, 2015). Some other causes that are commonly cited include: distracted driving, influence of alcohol/drugs, aggressive driving, and more hazardous roadway conditions (such as the presence of rain or snow). ODOT commonly performs preservation projects (e.g., repaving) at night to avoid peak traffic hours (ODOT, 2017b), which creates additional hazardous conditions not present in the daytime. High speed roadways are also a concern due to the high speeds and lower available reaction times.

Table 3.1: Roadway Crash Statistics in Oregon Work Zones (ODOT, 2017a)

Year	Total Crash Incidents in Work Zones	Work Zone Fatalities	Work Zone Involved Fatal and Serious Injury Crashes	Work Zone Involved Moderate and Minor Injury Crashes	Work Zone Involved Property Damage Only Crashes
2015	538	3	19	308	324
2014	512	4	14	261	271
2013	427	6	14	202	211
2012	429	6	22	227	180
2011	527	10	24	265	238
2010	490	9	24	237	229
2009	508	18	34	269	205
2008	505	5	30	236	239
2007	591	10	28	289	274
2006	533	5	26	241	266
2005	512	20	40	253	219
2004	493	12	36	218	239
2003	514	2	15	213	286
2002	421	5	20	160	241
2001	324	7	21	111	192
2000	351	5	19	308	324

3.1 WORK ZONE LIGHTING DESIGN AND CHALLENGES

This section provides a general discussion on lighting design criteria, impacts, and recommended practices that were found in journal or conference publications.

3.1.1 Work Zone Lighting Design

Initial efforts to develop illumination guidelines for nighttime highway work were presented by Ellis et. al (1995) who developed work zone lighting guidelines based on illumination criteria. Work zone lighting systems are usually temporary and are typically configured by persons who are not practicing lighting engineers. The researchers found that the following factors affected required illumination performance: importance and accuracy of the task; background reflection; speed; size of the object to be seen; and sight distance. As part of their study, the researchers quantified these factors using a rating of low, medium, or high. For different highway construction and maintenance tasks, the researchers then assigned factor levels. By matching these tasks with non-highway tasks, the researchers used an average illumination level to suggest illumination categories and levels for highway tasks. Based on their findings, the researchers introduced three categories of lighting as discussed in Section 2 above.

El-Rayes and Hyari (2003a; 2003b) developed an automated decision support system for lighting design in nighttime highway construction projects. To develop the decision support system, the

researchers used a multi-objective evolutionary algorithm (NSGA-II) to design the lighting system based on maximizing illuminance and uniformity ratio and minimizing glare and costs. The four functions of illuminance, uniformity, glare and cost were calculated in the model. Characteristics of lighting tower, work zone layout and type of work are entered as inputs of the model. The following variables were used in the model:

- Lighting equipment selection: including ground mounted towers, trailer mounted towers, and/or equipment mounted lighting fixtures
- Type of lamps: including metal halide lamps; high pressure sodium vapor lamps; halogen lamps, and low pressure sodium vapor lamps
- Lamp lumen output
- Mounting height
- Lighting tower location
- Luminaire aiming angle
- Lighting tower rotation

No single best solution in the multi-objective design was determined. The output of the model was a set of solutions that satisfy the design objectives stated by the designer.

El-Rayes and Hyari (2005a) presented a lighting design model, named CONLIGHT, which is capable of considering the specific requirements of nighttime highway construction operations. The model uses illuminance, uniformity, and glare as the primary criteria for selection of lighting designs. The difference between this model and that developed in 2003 was the removal of the impact of cost in the CONLIGHT model. The researchers used experimental testing to compare their model results with onsite performance. The results of this analysis indicated that there is close agreement between the results provided by the model and those measured on site.

Similar to their previous work, El-Rayes and Hyari (2005b) developed a subsequent multi-objective model to select the best alternative for lighting operations by using five different variables including: number of pieces of lighting equipment, equipment positioning, mounting height, aiming angle, and rotation angle.

Field experiments have been conducted to evaluate the performance of various lighting arrangements that are commonly found in nighttime highway construction zones (Hyari and El-Rayes, 2006). In this study, the researchers tested lighting performance in the work zone activity area, transition and termination areas, and flagger stations. In the examined transition and termination areas, the experimental results showed that ground-mounted lighting equipment on a tripod (with two 500-watt quartz lamps with a height of 3m) can provide the required illuminance and is more cost-effective than light towers when several of tripods are connected to a single portable generator. The results of the experiments indicated that the positioning of

ground-mounted luminaires above flagger stations can also satisfy the required lighting levels without causing objectionable levels of glare.

Based on a review of previous studies, Ullman and Finley (2007) found that the illumination requirement can be maintained in field practices, but the problem is meeting the maximum uniformity of 10:1 or 6:1 which was recommended by El-Rayes and Hyari (2005b). Other challenges of implementing work zone lighting were found to be: a lack of sufficient construction knowledge about lighting; difficulty with maintaining the uniformity of the light in mobile operations; difficulty properly setting up the light system without severe glare; and contractors not having any type of light measuring equipment to evaluate the light adequacy, glare, or light trespass. Also, in spite of the available studies and researcher recommendations about glare, its effect on motorists is still a big concern.

Research has been conducted on the implementation of semi-permanent high-mast lighting for nighttime road constructions (Bullough et al., 2008; Freyssinier et al. 2008). Although the cost of a semi-permanent high-mast system is approximately 16% higher than the cost of portable light towers, it's economic and societal benefit seems considerable. Such as system can shorten the construction time (the time saved every day without the necessity of setting up and removing the portable light towers) and amount of the risk to workers and drivers and traffic delays for motorists. By analysis of their project measurements, the high-mast lighting system provides a higher level of safety than the portable light towers for the construction workers and for the drivers traveling through the construction work zone. The most important factor for using this type of lighting system is the duration of the project. For highway projects with less than 6 months, it would not be feasible.

A research study conducted by the Illinois DOT involved measuring the glare from lighting systems and determining a more practical lighting specification for nighttime work zone operations (Huckaba, 2009). Based on the researcher's observations, the balloon lighting produced 10-15 percent less glare than other lighting equipment. Therefore, balloon lighting was found to be superior for minimizing glare. Balloon lights also provide a larger diameter of light for those working around the perimeter of equipment and on roadway shoulders. Consequently, one of the Illinois DOT's districts developed a specification that requires balloon lighting on all equipment used in paving operations including the milling machine, paving machine, sweepers, rollers, and at flagger stations. By applying this specification on one project, the researchers found that the lighting provided was adequate and glare-free. The lighting on the project, therefore, served as the model, and balloon lighting became the preferred lighting system. The research goal of providing a means for measuring glare was accomplished.

3.1.2 Flagger Illumination

Illumination of flaggers during nighttime operations has received attention from ODOT on a previous research study, "Optimum Illumination for Nighttime Flagger Operations, SPR 617 (Gambatese, 2005; Gambatese and Rajendran, 2012). For this study, the researchers evaluated the ability of different types of lighting equipment to illuminate flaggers during nighttime maintenance and construction operations. The results of the study show that the amount of light emitted from a light tower was more than needed to effectively illuminate flaggers and frequently created glare for motorists. The researcher resulted in recommendations for ODOT

regarding the amount of light, type of lighting system, and location and orientation of the lighting system on a project for different types of projects (mobile, stationary, short-term, long-term, etc.).

3.1.3 High-Visibility Apparel

Arditi et al. (2003) evaluated the types of high-visibility garments worn by construction workers and Illinois DOT personnel on Illinois highway projects as well as those used in other states. The performance of six high-visibility vests were investigated on actual construction/maintenance sites. Consolidated results obtained from the field tests that measured mean luminance values of the front faces and sides of the six safety vests and the perception of potential users of these vests indicated that the “Head Lite Roadstar 200” vest and the “Safetyline Minnesota Style” vest are significantly superior to the other four vests tested.

3.1.4 Lighting Glare

Glare is recognized as a major problem of current lighting systems in nighttime work zones (Hancher and Taylor, 2001). The key concern is the reduction of glare to both workers and oncoming traffic. In their study, Hancher and Taylor implemented the Airstar Balloon Light manufactured by Airstar, Inc. in place of traditional light towers to reduce the harmful effects of glare while providing ample site illumination. The study revealed the benefits of balloon lights to reducing glare during nighttime work operations.

Following the research by Hancher and Taylor (2001), further research was undertaken to measure light and glare characteristics of two balloon lighting systems in the field (Odeh et al., 2009; Hassan et al. 2010a; 2010b). Glare and lighting characteristics of balloon lights were compared to a conventional lighting system. The impact of height, aiming, and rotation angles on glare and lighting performance were investigated. The researchers found that while conventional light towers provide greater illuminance at the light source than balloon lights, the disability glare was greater for conventional light towers than balloon lights when mounted at the same height. Therefore, the height of the light tower should be increased as practically feasible to reduce the glare. Aiming angle and rotation angle for light towers should be kept as close as possible to zero degrees. When designing the lighting system in a work zone, providing the desirable amount of light should be considered with the disability glare concurrently.

Subsequent research focused more thoroughly on the glare experienced by drive-by motorists in lanes adjacent to nighttime work zones (El-Rayes et al., 2007). In this research, the researchers evaluated the impact of lighting parameters (i.e., type of light, height of light, aiming and rotation angles of light towers, and height of vehicle/observer) on glare levels generated by commonly-used construction lighting equipment. In addition, the impacts of the factors on the average horizontal illuminance and lighting uniformity ratio in the work area were determined. A practical model was developed to enable resident engineers and contractors to measure and control the levels of glare.

As part of the study, the researchers analyzed and compared the levels of glare and lighting performance generated by commonly-used construction lighting equipment including a balloon light, light tower, and Nite Light. The study also involved review of the DOT lighting standards

for glare control during nighttime work zone operations in Virginia, New York, California, Tennessee, Indiana, South Carolina, Delaware, Florida, and Oregon. The results show that glare caused by balloon lights in and around nighttime work zones can be controlled by setting the height of the light at 5.0m or higher. Glare caused by light towers in and around nighttime work zones can also be controlled by setting its height at 5.0m or higher and the rotation angles of its luminaires at 20° or less.

3.1.5 Impact of Lighting on Motorists

In another study (Finley et al., 2014), the researchers conducted a closed-course study to evaluate the impact of work zone lighting on the ability of drivers to detect low-contrast objects and workers wearing high-visibility vests. Three lighting conditions were set up: no lights (dark or base condition); a portable, trailer-mounted light tower; and a portable balloon light. Compared with the results for the dark scenarios, the results for the illuminated roadway section showed that properly installed temporary work zone lighting could increase the distance at which workers and low-contrast objects could be detected. Overall, all of the temporary work zone lighting conditions (even those with glare) resulted in worker detection distances that were greater than the stopping sight distance for the conditions studied.

3.2 FEDERAL/STATE STANDARDS, GUIDELINES, AND SPECIFICATIONS

State and Federal agencies provide standards that must be followed during highway maintenance and construction operations to ensure the safety of motorists, workers, and flaggers. As part of the literature review, standards published by different states and also national agencies were examined for content applicable to nighttime operations.

3.2.1 Federal Standards and Guidelines

A report by the National Cooperative Highway Research Program (Bryden and Mace, 2002) presents guidelines to assist highway agencies in developing and implementing a plan for nighttime work zones. The report cites loss of visibility as a significant factor during nighttime work. Nighttime maintenance and construction projects require additional lighting that will satisfy the visibility requirements of the workers. However, workers are not the only people affected. The driver's ability to detect objects, the flaggers, and the details of the road also decreases at night.

The guidelines have three sections. Section 1 contains information to help the user identify the minimum specification, set-up, and maintenance of each work zone design element including lighting, and other safety features. Section 2 includes information pertaining to the design of traffic control devices, other safety devices, and types of work zone lighting. Section 3 provides guidance for the implementation and operation of night work zones. The guidelines contain innovative procedures suggested by state DOTs to respond to special nighttime problems, such as control of glare, visibility of workers, and the need to improve conspicuity of traffic control devices. Lighting should be adequate to provide the minimum level of illuminance required in different work areas and for different tasks. Minimum luminaire requirements for each task are

mentioned in the report based on previous research by Ellis and Amos (1996), described in Section 2.2 above.

For flagger illumination, the report recommends providing temporary illumination for flaggers at locations that do not have existing light. Illumination should also be provided at locations that do have existing light. Illumination should be provided directly overhead rather than from the front or back in order to help eliminate glare.

The vests worn by flaggers should have reflective markings on the front and back. The flagger must be able to be seen from a distance of 1,000 feet under headlight illumination and the reflective tape must be visible from all motions. Ensuring adequate visibility of exposed flaggers is equally as important as for workers.

Bryden (2003) provides practices for performing mobile highway operations at night. The information presented in this report is based on a review of work zone manuals from a selection of state and local highway agencies, discussions with highway officials, and field observations of a select number of nighttime highway mobile work zone operations. In the illumination context, regardless of the lighting devices used, it is essential that the lighting devices provide adequate illumination, and that they do not result in glare that interferes with the driving or work tasks. With respect to luminaire position, for portable trailer-mounted luminaires or for fixed luminaires, elevating the light source as high as possible, and aiming it downward, reduces glare and improves illumination of the work surface. Mobile operations mostly dealt with machine-mounted equipment. For light sources attached to work vehicles, especially for mobile operations, it is difficult to position the lights very high. Auxiliary floodlights mounted on the front of the vehicle, and directed onto the pavement markings, often supplement conventional headlamps. Additional work lights in mobile operations also may need to be positioned higher on the truck to provide good visibility for workers to operate the equipment, and to place and retrieve traffic cones from the vehicle. It is essential to consider the overhead clearance requirements of the vehicle when positioning all vehicle-mounted lights so that they do not substantially increase glare.

This handbook provides detailed information about the work lights mounted on vehicle including their types, mounting locations and provided illumination. Although trailer mounted light towers can provide lighting for large work areas, they have a limited application for mobile night operations because of difficulties in setting up and raising the tower at each work location. Instead of trailer mounted light towers using the balloon-type luminaires attached to the work vehicle may be rigged such that they can be quickly raised into position at each work location, and lowered for travel between sites. Also balloon lights can provide uniform, glare-free illumination over a sizeable area. They are capable of lighting a larger area than vehicle-mounted flood lamps, and are easier to raise and lower than tower-mounted luminaries.

The report also stresses that workers involved in nighttime mobile operations should wear high-visibility apparel. This clothing must be orange, yellow, yellow-green, or fluorescent versions of these colors, and must include retroreflective materials for night use. As a minimum, the garment must be visible for a distance of 1,000 ft., and must clearly identify the wearer as a person. For night highway operations, either Class 2 or Class 3 garments should be considered. In addition,

these garments must be used whenever the worker is outside the vehicle, even for a very short period.

NCHRP published a comprehensive guideline that presents the findings of a research project conducted by the University of Florida (Ellis et al., 2003). The guidelines include recommendations for: (a) illumination of nighttime highway work; (b) work zone illumination design; and (c) the use of temporary roadway lighting for nighttime construction and maintenance. The guidelines address such concerns as visibility requirements, lighting equipment, lighting configuration and arrangement, lighting system design, system operation and maintenance, and economic considerations.

Shane et al. (2012) provide a guideline for practices and strategies for nighttime operations that address the safety of both the contractor's and owner's personnel, the safety of the traveling public, the quality of the as-built facility, productivity, risk, and construction nuisances to both neighbors and workers. In Chapter 3 of the document, lighting requirements for highway construction as well as potential lighting guidelines for different nighttime construction activities are explained. Chapter 5 of the document discusses the effect of lighting on safety. The authors of the document recommend using high-mast lighting and non-glare balloon lights, instead of portable light towers.

Most of the existing guidance documents provide minimum specifications for certain general categories of work zone tasks. However, a tool is available to help state DOTs and local agencies improve their work zone lighting designs (ATSSA, 2013). The tool and guideline are based on determining the work activities to find the appropriate light level, determining the area that needs to be illuminated, and selecting the lighting sources and their locations. The tool is primarily based on DOT agency specifications for nighttime work zone operations.

Manual on Uniform Traffic Control Devices (MUTCD)

Chapter 6 of the *Manual on Uniform Traffic Control Devices* (MUTCD), published by FHWA in 2009 and revised in 2012 (FHWA, 2012), discusses the use of temporary traffic control. These guidelines address all types of traffic control during nighttime maintenance and construction. Information related to lighting operations is provided in Chapter 6F.81 and 6F.82. The following selections are from the MUTCD that relate to nighttime operations:

On the subject of floodlights, the MUTCD provides general guidance for different work operations and worksite conditions as follows:

“Utility, maintenance, or construction activities on highways are frequently conducted during nighttime periods when vehicular traffic volumes are lower. Large construction projects are sometimes operated on a double-shift basis requiring night work. When nighttime work is being performed, floodlights should be used to illuminate the work area, equipment crossings, and other areas.”

Except in emergency situations, illumination of flagger stations is required at night. Also in no case shall floodlighting be permitted to create disabling glare for approaching road users,

flaggers, or workers. The adequacy of the floodlight placement and elimination of potential glare can best be determined by driving through and observing the floodlighted area from each direction on the main roadway after initial floodlight setup.

Specific illumination levels are found in only two places in the entire MUTCD Part 6. In Section 6F.81, Floodlights, reference is made to 50 lux (5 foot candles) illumination for general activities and 216 lux (20 foot candles) illumination for high levels of precision and extreme care. In Section 6G.19, Temporary Traffic Control During Nighttime Hours, reference is made to 50 lux (5 foot candles) illumination for general activities, 108 lux (10 foot candles) illumination for activities around equipment, and 216 lux (20 foot candles) illumination for high levels of precision and extreme care. Both of these statements in the MUTCD are identified as support conditions.

The MUTCD includes a specific high-visibility apparel standard for flaggers during daytime and nighttime activities. Flaggers should wear high-visibility safety apparel that meets the Performance Class 2 or 3 requirements of ANSI/ISEA 107–2004 (FHWA, 2012). The MUTCD recommends using Class 3 with headwear for a flagger during nighttime work.

The MUTCD regulates the color of a safety garment as follows: “The apparel background (outer) material color shall be fluorescent orange-red, fluorescent yellow-green, or a combination of the two as defined in the ANSI standard. The retroreflective material shall be orange, yellow, white, silver, yellow-green, or a fluorescent version of these colors, and shall be visible at a minimum distance of 1,000 feet. The retroreflective safety apparel shall be designed to clearly identify the wearer as a person.”

When viewing the worker from a distance of more than 600-700 feet, it would be hard to identify the person without any additional light present. No study was found that involved investigating this issue. In addition, no studies were found that addressed the issue of potentially misinterpreting the person wearing a reflective vest or pants as some other roadway feature, such as a barrel, when looking from far distance.

American National Standard for High-Visibility Safety Apparel (ANSI/ISEA, 2010)

ANSI/ISEA 107-2010, issued by the American National Standards Institute (ANSI) and the International Safety Equipment Association (ISEA), provides guidelines for high-visibility and reflective apparel including recommendations for the design, performance, and use of vests, jackets, jumpsuits, trousers, and harnesses. The safety garments are categorized into three classes (1, 2, and 3) depending on the type of construction operation, the wearer’s that are involved, and the degree of exposure to traffic on a highway.

OSHA Standards for Construction (29 CFR Part 1926)

The Occupational Safety and Health Administration (OSHA) regulations for lighting requirements in nighttime construction are limited to the illuminance criterion and do not address the remaining criteria of lighting uniformity, glare, and light trespass (OSHA, 2015). OSHA specifies the minimum illuminance levels for different construction operations, as shown in Table 3.2.

Table 3.2: OSHA Minimum Illuminance Levels (OSHA, 2015)

Area of Operation	Minimum Illuminance, lux (fc)
General construction areas, concrete placement, excavation and waste areas, access ways, active storage areas, loading platforms, refueling, and field maintenance areas	32 (3)
General construction area lighting	54 (5)
Indoors: warehouses, corridors, hallways, and exitways	54 (5)
Tunnels, shafts, and general underground work areas (Exception: minimum of 108 lux is required at tunnel and shaft heading during drilling, mucking, and scaling)	54 (5)
General construction plant and shops (e.g., batch plants, screening plants, mechanical and electrical equipment rooms, carpenter shops, rigging lofts and active store rooms, mess halls, and indoor toilets and workrooms)	108 (10)
First aid stations, infirmaries, and offices	323 (30)

In 29 CFR 1926.28(a) of the OSHA Safety and Health Regulations for Construction, the standard explicitly states that the employer is responsible for requiring workers to wear the appropriate personal protective equipment (PPE) in all operations where an exposure to hazardous conditions exists or where the standard indicates the need for using such equipment.

3.2.2 State Agency Practices

In addition to federal standards and guidelines, some state departments of transportation have their own lighting specifications for nighttime work zones. In addition, other states are developing or conducting research about lighting. In this section of the report, a brief review of the state DOT efforts, including their standards or reports, are briefly reviewed.

Illinois DOT

The Illinois Department of Transportation (IDOT) has conducted a number of studies on the appropriate lighting levels for nighttime construction work zones. That work is reflected in their standard specifications that provide details of lighting levels for specific operations. In one of their research studies by El-Rayes et al. (2003), the researchers published their results for the evaluation of lighting for highway construction operations in Illinois. This effort had five phases including: literature review, surveys, evaluate and recommend lighting design criteria for nighttime construction operations, field tests of various lighting arrangements, and finally recommendations for complying with requirements. Similar to previous studies, the main challenges of lighting nighttime construction were reported to be: insufficient lighting, non-uniformity of lighting, and glare to road users. The researchers developed design criteria for lighting levels, lighting uniformity, glare, and light trespass during nighttime highway construction operations. The lighting level requirements are mostly based on lighting requirements discussed in Section 2.2 of this report. The researchers developed a recommended

minimum illuminance levels for 27 highway construction activities. In developing the lighting requirement, they used professional societies, such as IESNA and CIE, OSHA standards, results obtained from surveyed resident engineers and contractors, available standards of state DOTs, and field experiments. A maximum lighting uniformity ratio of 6 is recommended in their report. Glare and light trespass are recommended to be controlled in and around construction sites.

Based on their research results, Florida, Missouri, Oregon, Washington, New York, Maryland, Mississippi, North Carolina, California, and Michigan were found to have lighting standards for nighttime construction. Also, the Illinois and New Jersey DOTs developed and proposed guidelines for nighttime work operations at that time. Some of those standards, such as those in Missouri and Washington DOTs, have just a very limited specification about nighttime lighting and some of them, such as those in New York and North Carolina DOTs, are very comprehensive regarding the practice of nighttime work zone lighting. A comparison of these limited provisions reveals that there is a lack of consensus among state DOTs on the lighting requirements for nighttime highway construction operations.

The researchers also found that high pressure sodium and metal halide lamps are the most widely used types of lamps in nighttime construction operations, but metal halide lamps provide better visibility in outdoor environments and improved peripheral vision. However, the useful life of metal halide lamps is shorter and also the lamps need additional time to warm up. Recommendations for lighting arrangements in nighttime operations, including fixed locations and mobile operations, are given in the report (El-Rayes et al. 2003).

In another study (Steele et al., 2013a), the researchers studied the effectiveness of warning lights on nighttime channelization devices in nighttime work zones (with and without lights on drums). The research showed that, when unprompted, most drivers did not perceive a difference or respond any differently in nighttime work zones using lights on drums than in those without lights. This finding is consistent with the field experiments, which showed no significant difference in driving performance indicators, including speed and lateral lane position. In fact, the rest area surveys showed that drivers actually remembered more details and more precision in details for the work zones without lights on drums, indicating that they can better focus on other important work zone factors when the drums do not contain lights.

Experimental studies at three work zones showed no significant difference in vehicle speeds for the cases of drums with and without lights. Moreover, in a subsequent study (Steele et al., 2013b), the researchers evaluated the effectiveness of warning lights on nighttime highway operations, including mobile lane closures, incident responses, and police activities. The research showed that drivers view current vehicle-mounted warning lights as highly visible, attention-getting, and effective at conveying the message caution/alert. However, intense lights can cause discomfort glare, and multiple light sets on individual vehicles, or multiple vehicles at a location, can be distracting, annoying, or anxiety-inducing. The researchers found that there was no difference in vehicle speeds for the base and experimental cases. Further research in different states might be needed to verify the results of their study.

New York State DOT

The New York State Department of Transportation (NYSDOT) standard specifications for portable work-zone illumination are among the most comprehensive standards. NYSDOT's Standard Specifications (May 1, 2008) are as follows:

All workers involved in nighttime operations shall wear protective helmets and nighttime apparel in accordance with ANSI-107-05A High Visibility Apparel at all times. Vehicles operating on the pavement of a closed roadway or travel lane shall display four-way flashers or rotating amber beacons at all times. Vehicles using headlights, except for rollers and vehicles retrieving channelizing devices, shall travel facing in the same direction as adjacent traffic in order to avoid glare and confusion to drivers; this requirement means that vehicles need to be driven to the next exit and travel upstream in the opposite lanes in order to circle back around.

Equipment: Light Towers. Light towers shall be provided as a primary means of illumination, and shall provide Level I illumination throughout the work space. They may be supplemented to the extent necessary by lighting fixtures mounted on construction equipment to provide Level II or Level III illumination where required for paving, milling and similar moving operations. Light towers shall be sturdy and free-standing without the aid of guy wires or bracing, and shall be capable of being moved as necessary to keep pace with construction operations. Light towers shall be positioned to minimize the risk of being impacted by traffic on the roadway or by construction traffic or equipment.

Light Towers on Paving, Milling, and Finishing Machines. If needed to supplement portable and/or trailer mounted light towers, towers shall be affixed to paving, milling, and finishing machines to provide the required level of illumination for the specified distance in front of and behind the machine.

Construction Equipment Lights. All construction equipment, including rollers, backhoes, loaders, and other equipment operating in areas not illuminated to a minimum of Level I Illumination, shall be equipped with a minimum of two 500 watt flood lights facing in each direction to provide a minimum of 1 foot-candles of horizontal illumination measured 60 feet in front of and behind the equipment.

Illumination Requirements. Tower-mounted luminaires, whether fixed, portable, trailer-mounted, or equipment mounted, shall be of sufficient wattage and/or quantity to provide the required level of illumination and uniformity over the area of operation. The uniformity of illumination, defined as the ratio of the average illumination to the minimum illumination over an area requiring an indicated illumination level, shall not exceed 5:1. Illumination levels on approach roadways should be increased sequentially to prevent motorists from becoming disoriented by rapid changes from full dark to very bright conditions.

- a. Level I illumination shall be provided a minimum of 400 feet ahead and 800 feet behind a paving or milling machine, or for the entire area of concrete placement or pavement work if less than 1500 feet. The only exception to the requirement for Level I illumination throughout the area of construction operations is that finish rollers can work beyond the area of Level I illumination using floodlights mounted on the roller.
- b. Level II (10 foot-candles). Level II illumination shall be provided for flagging stations, asphalt paving, milling, and concrete placement and/or removal operations, including bridge decks, 50 feet ahead and 100 feet behind a paving or milling machine.
- c. Level III (20 foot-candles). Level III illumination shall be provided for pavement or structural crack filling, joint repair, pavement patching and repairs, installation of signal equipment or other electrical/mechanical equipment, and other tasks involving fine details or intricate parts and equipment.

Glare Control. Tower-mounted luminaires shall be aimed either generally parallel or perpendicular to the roadway. Luminaires shall be aimed such that the angle between the center of the beam axis and the vertical mounting pole is no greater than 45E. No luminaires shall be permitted that provide a luminous intensity greater than 20,000 candelas at an angle of 72E above the vertical. Except where prevented by overhead utilities or structures, towers shall be extended to their full working height when in use to reduce glare and provide uniform illumination.

Virginia DOT

Cottrell (1999) collected information through a survey of all state DOTs (56% response rate), and also VDOT resident engineers (40% response rate) to find the problems related to traffic control for nighttime work zones. In addition, seven work zones during nighttime operations were visited, and the researchers interviewed contractor personnel. Finally, the researchers obtained feedback from motorists (some VDOT employees selected to drive through one or two work zones) about traffic control problems.

The research revealed that the major problem of nighttime work zones is poor visibility. Impaired drivers or higher average speed were also recognized through the survey as two major problems. Poor visibility of traffic control devices and workers, and also glare, were identified as problems through site observations and drivers feedback. In one of their site inspections, the researchers found that the retroreflective vests worn by workers are not visible when workers are bending over the marking machine.

Based on the study results, the researchers suggested improving the visibility of traffic control devices, workers, and working equipment. This may be done, for example, by using drums instead of cones. Highly visible vests, pants, and caps can increase the visibility of workers. Other options include placing removable bands over clothing at a level slightly above the wrist, elbow, ankles, and knees. Also, retroreflective hardhats should be required. NYSDOT requires the use of retroreflective hardhats. VDOT removed retroreflective stripes from its standard issue

hardhat a long time ago because of the chemical reaction between the glue attaching the stripe and the plastic shell. The researchers also recommended using the NYSDOT guidelines for better visibility of working equipment.

Florida DOT

The Florida Department of Transportation (FDOT) has a detailed nighttime construction lighting specification. The FDOT specification contains definitive illumination levels that should be achieved and specifies possible lighting equipment that could be used to achieve appropriate lighting levels.

New Jersey DOT

The New Jersey Department of Transportation (NJDOT) published an article addressing lighting levels in the General Provisions of its Standard Specifications for Road and Bridge Construction (2007). In addition, the NJDOT provision has a number of requirements concerning worker visibility during nighttime construction.

Alabama DOT

Vecellio and McCarthy (2006) conducted a very thorough review of the New Jersey, Florida, Georgia, North Carolina, Alabama, Rhode Island, Michigan, and Nova Scotia DOT's specifications for nighttime operations in place in 2006. Some of the states, such as Georgia and Michigan, included a very limited specification about nighttime lighting, while the specifications in other agencies, such as those in Nova Scotia, were very comprehensive regarding the practice of nighttime work zone lighting. The Alabama DOT prepared a sample specification covering lighting requirements for nighttime work to use for future nighttime work zone specifications.

3.3 OREGON NIGHTTIME WORK ZONE STANDARDS, GUIDELINES, AND SPECIFICATIONS

3.3.1 ODOT 2015 Standard Specifications

The ODOT 2015 Standard Specifications (ODOT, 2015b) contain highway illumination installation specifications in Section 00970 and nighttime flagger illumination in Section 00225. Also, for paving operations a minimum of 10 foot-candles needs to be provided for the paving equipment including paver and roller, during the period from 30 minutes after sunset to 30 minutes before sunrise.

3.3.2 Oregon Temporary Traffic Control Handbook (OTTCH)

The Oregon Temporary Traffic Control Handbook (OTTCH) (ODOT, 2011) provides a reference for the standards and practices for temporary traffic control in work zones in place continuously for three days or less on public roads in Oregon. The handbook is based on the principles set forth in Part 6 of the MUTCD and the Oregon MUTCD Supplements. The current edition is the 2011 edition. For nighttime operations, the manual provides the following guidelines:

- Use enough lighting to provide a safe work environment. Avoid creating glare for oncoming traffic.
- All temporary traffic control devices (TCD) shall be retro reflective, including signs, channelization devices, and flagger STOP/SLOW paddles.
- Floodlights should be used to illuminate the work space, flagger stations, equipment crossings and other areas such as nearby intersections during nighttime operations. Research indicates that 50 lux (five foot candles) is a desirable nighttime illumination level where workers are active. If everything in the light is clearly visible, the lighting level is satisfactory.

The OTTCH also provides some lighting instructions to create a safe work environment for flaggers.

3.3.3 OR-OSHA Construction Safety and Health Standards

The Oregon Occupational Safety and Health Division (OR-OSHA) publishes safety and health standards for employees. Division 3 of the standards applies specifically to the safety of workers on construction sites (OR-OSHA, 2012). Within Division 3, illumination on construction sites is covered in Section 1926.56 of Subdivision D – Occupational Health and Environmental Controls, which is the same as the OSHA illumination requirements shown in Table 3.1. These standards apply to all work conducted on construction sites and are derived from the specifications provided in the American National Standards Institute (ANSI) standard ANSI A11.1-1965, R1970. The OR-OSHA standards for construction do not specify worksite conditions or processes specific to the illumination of flaggers during nighttime operations.

3.3.4 ODOT Short Term Traffic Control Handbook for Night Operations (2002)

The ODOT Short Term Traffic Control Handbook for Night Operations (2002) provides a quick reference for controlling traffic through short-term work zones on public roads in Oregon during hours of darkness. The manual is based on Part 6 of the MUTCD. Short-term is defined as a single shift of 12 hours or less for routine work and 24 hours or less for emergency operations. The manual requires keeping illumination to the minimum necessary to perform the work, and aiming the light so that there is no glare within the travel lanes, or else evenly illuminate the whole roadway width.

3.3.5 Optimum Illumination for Nighttime Flagger Operations, ODOT

As part of a previous ODOT study, Gambatese (2005) developed a guideline for flagger lighting for nighttime construction projects. Four different types of light equipment that are widely available for construction projects – a light tower, 12-volt spotlight, 12-volt high intensity discharge (HID) floodlight, and balloon lights – were evaluated. Each configuration was tested in terms of illumination, glare, uniformity, and visibility in an urban/suburban setting, ease of use, mobility, and cost. The study did not include an assessment of hue (color) of the lights.

Following laboratory testing and tests under controlled condition, the 12-volt spotlight and 12-volt HID floodlight received the highest rank when considering illumination, glare, uniformity, visibility in an urban/suburban setting, ease of use, mobility, and cost. When ease of use, mobility, and cost are excluded, the light tower with 2,000-watts output performed the best. The glare produced by the light tower with this output, however, was greater than the spotlight and floodlight, but it illuminated the roadway and flagger very well.

The researchers conducted field tests and found that the floodlight works better than the spotlight to illuminate the flagger when the flagger moves around the flagging area. Motorist glare is a concern with the light tower, but not with the 12-volt spotlight and 12-volt HID floodlight. Finally, spotlights are not suitable and not recommended for highway construction flagging because of their low illumination area coverage. The study results have been incorporated into existing ODOT documents for reference and implementation in practice.

4.0 SURVEY OF CURRENT PRACTICE

Task 2 of the Work Plan consisted of performing a survey of the construction industry to gather information on current practices with respect to work zone illumination and lighting systems. Comprehensive information about work zone lighting was desired from different state transportation agencies and construction contractors across the US. To achieve this objective, the researchers conducted an online survey in order to improve the chances of a greater geographical spread and response rate.

4.1 SURVEY PREPARATION AND DISTRIBUTION

As the first step to conduct the survey, the researchers prepared a questionnaire. The questionnaire consisted of three sections of questions:

- **Personal Demographics:** This section included questions about the participant's position, education, background, and experience in the transportation industry and working with lighting systems.
- **Lighting Systems used in Practice:** In this section, the participants were asked about the lighting systems typically implemented in work zones and their perspectives of different types of lighting systems in terms of ease of use, selection criteria, and performance. Questions were also included that solicited inhibitors and enablers of implementing work zone lighting. Lastly, this section asked the participants about the extent to which they wear personal lighting while working at night.
- **Additional Comments and Feedback:** This section concluded the survey by allowing the participants an opportunity to share any additional comments about work zone lighting and provide their name and contact information if they would be willing to be contacted for further questioning related to the research.

A draft questionnaire was first developed for the TAC's review, and then revised to incorporate the TAC's input. The draft survey was reviewed and subsequently approved by the Institutional Review Board (IRB) of OSU. A copy of the questionnaire is provided in the Appendix.

The online survey was hosted and administrated through the Qualtrics survey system supported by OSU (<http://main.oregonstate.edu/qualtrics>). The survey questions prepared were coded into the Qualtrics system, and a link to the survey online created for distribution via e-mail.

The targeted population for the survey were those personnel working in highway construction in the Pacific Northwest and across the US, including state DOT personnel and construction contracting personnel. Based on this targeted population, the researchers created a distribution list from the following sources: Alumni contact list of the School of Civil and Construction Engineering (CCE) at OSU; Associated General Contractors (AGC) Oregon-Columbia Chapter Highway Construction Committee; and a general online search of personnel in the construction departments of each state DOT; and additional contacts known to the researchers in the Eugene, OR area. Using these sources, a distribution list of 317 contacts was created.

The researchers sent an e-mail to each of the names on the distribution list that described the research study, invited participation in the survey, and included the online link to the survey. The survey was distributed initially on January 13, 2016 to all of the targeted participants. Follow-up e-mails to non-respondents were sent between February 2 and February 8, 2016. Of the 317 initial e-mails distributed, 12 were returned due to expired or unknown e-mail addresses. As a result, the survey was distributed to a total of 305 participants.

4.2 SURVEY RESULTS AND ANALYSIS

A total of 67 survey responses were received, resulting in a 22.0% response rate. Out of these responses, 54 were fully complete and included in the analysis; however, the remaining responses received contained sufficient data to warrant including them in various parts of the analysis.

4.2.1 Respondent Demographics

The responses to the demographic questions indicate a diverse set of respondents. The majority of responses came from general contractor employees (56%) and owner/agencies (39%), with a small percentage (5%) from subcontractors. Figure 4.1 presents the distribution of the 59 respondents to this question based on employer type.

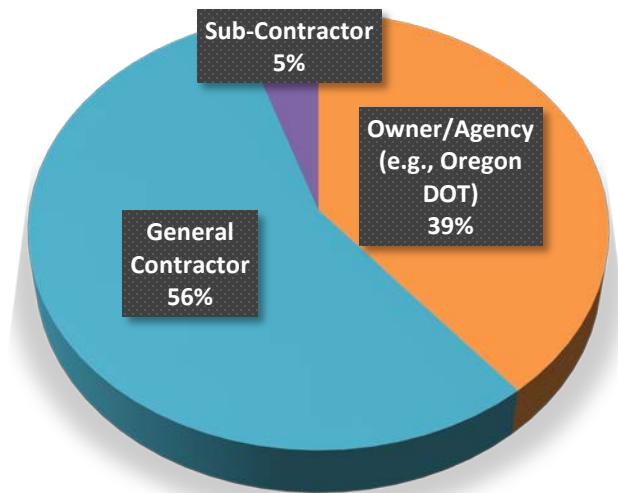

Figure 4.1: Respondent Company/Organization (n = 59)

The sample population included those involved in the transportation industry across the US. Responses were received from all regions of the US as indicated in Table 4.1. The majority of responses came from Oregon.

Table 4.1: Respondent Location (n = 64)

State	Alabama	Arizona	California	Colorado	Indiana	Louisiana	Massachusetts	Michigan	Nevada	New Jersey	New York	North Carolina	North Dakota	Ohio	Ontario	Oregon	Pennsylvania	Rhode Island	South Carolina	Tennessee	Texas	Washington	West Virginia
Number of Respondents	1	1	6	6	1	1	1	1	1	1	2	1	2	3	2	19	2	1	2	1	1	6	2

The title/position of the respondents was primarily some type of manager at the project or organizational level (e.g., Project Manager, Operations Manager, Area Manager). Additionally, a high percentage of respondents have titles of engineer, such as Project Engineer and Resident Engineer. The responses come from very experienced personnel; 90% of the respondents have over 10 years of experience working in construction. As can be seen in Figure 4.2, in terms of experience in highway design/construction, 57% of the respondents have more than 20 years of experience, 33% have 10-20 years of experience, and 9% have 5-10 years of experience.

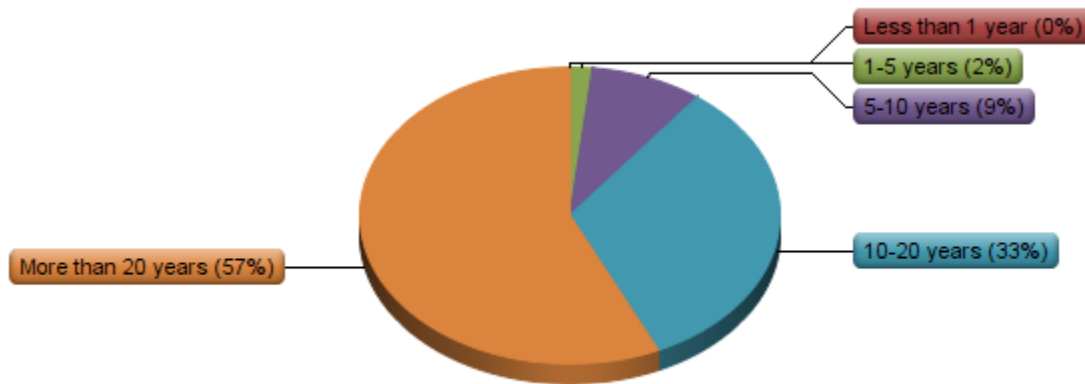

Figure 4.2: Respondent Years of Experience (n = 58)

This experience covers a wide range of projects. Figure 4.3 shows the types of projects in which the respondents are typically involved in. According to the 58 respondents to this question, the majority of projects are preservation projects (59%) and bridges/structures (55%). Repair/replacement projects amounted to 29% of the work, and 19% for maintenance.

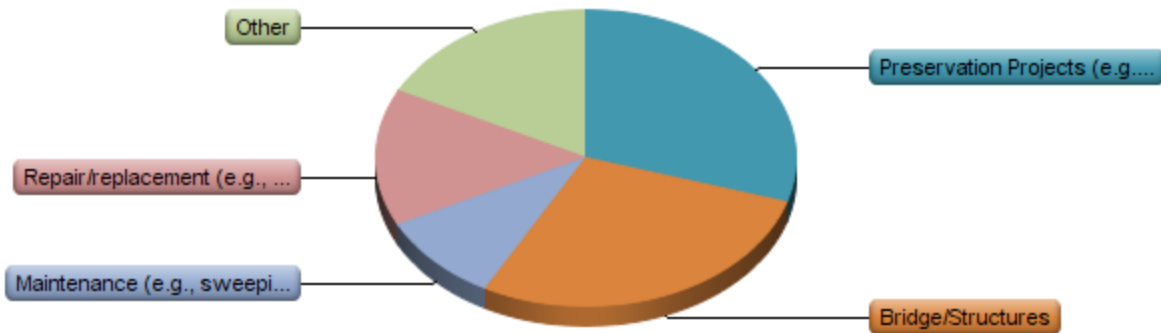

Figure 4.3: Respondent Construction Project Involvement (n = 58)

The questionnaire asked about the extent to which this experience involves working on a construction/maintenance site. Figure 4.4 shows the percentage of time during the work week in which the respondents are typically on a construction/maintenance site. The majority of respondents (43%) spend from 1%-20% of their work week on a jobsite. Twelve percent of the respondents spend 100% of their time on construction/maintenance sites.

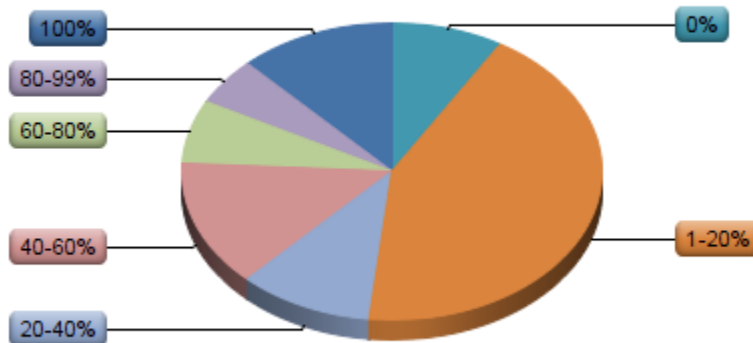

Figure 4.4: Respondent Amount of Time Spent on Jobsite during the Week (n = 58)

Importantly as well is the extent to which the respondents, as part of their work tasks, are involved in decisions related to work zone lighting. When asked, “As part of your work responsibilities, are you tasked with determining the type of lighting system(s) to use on projects?”, approximately half (47%) of the 58 respondents who answered this question responded “Yes”. Additionally, the respondents were asked about the extent to which they are involved in locating, moving, orienting, adjusting, and/or maintaining work zone lighting

systems on projects. Figure 4.5 shows the number of responses for different levels of involvement. Fifty-eight percent of the respondents are somewhat involved, involved, or very involved with these tasks.

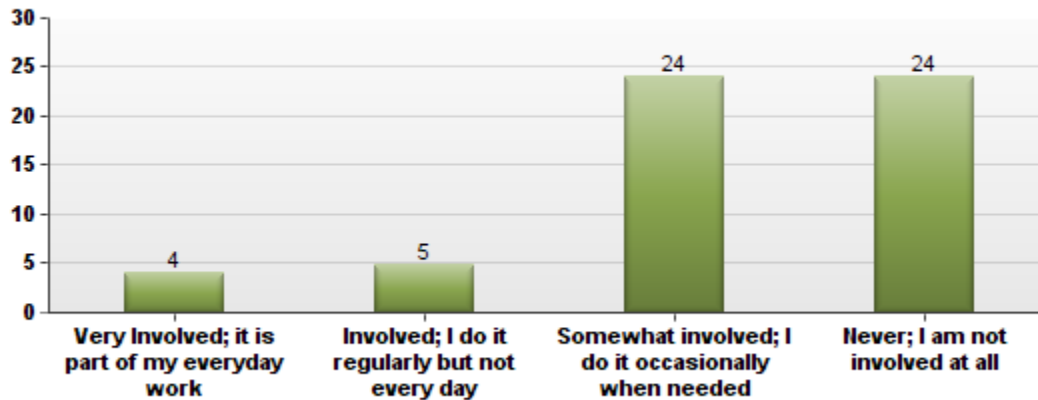

Figure 4.5: Respondent Involvement in Working with Lighting Systems (n = 57)

4.2.2 Use of Work Zone Lighting Systems

The survey questionnaire explored the common practices associated with the use of lighting systems during nighttime work. As described above, a variety of different types of lighting systems are available and used including light towers and balloon lights, both attached and not attached to equipment. The respondents could select any or all of the types of lighting listed that can apply to this question. Figure 4.6 shows, according to the respondents' perspectives, those types of lighting systems that are commonly used during nighttime work. As seen in the figure, a portable light tower/light plant is the most commonly used type of lighting system (96% of respondents). In addition, except for a light tower which has its own power source, lighting equipment of any type that is attached to a vehicle or heavy equipment is used more often than those not attached to a vehicle or heavy equipment. Direct connection to a power source, such as a generator or vehicle/equipment battery, is an important factor when considering ease of use and mobility of a lighting system.

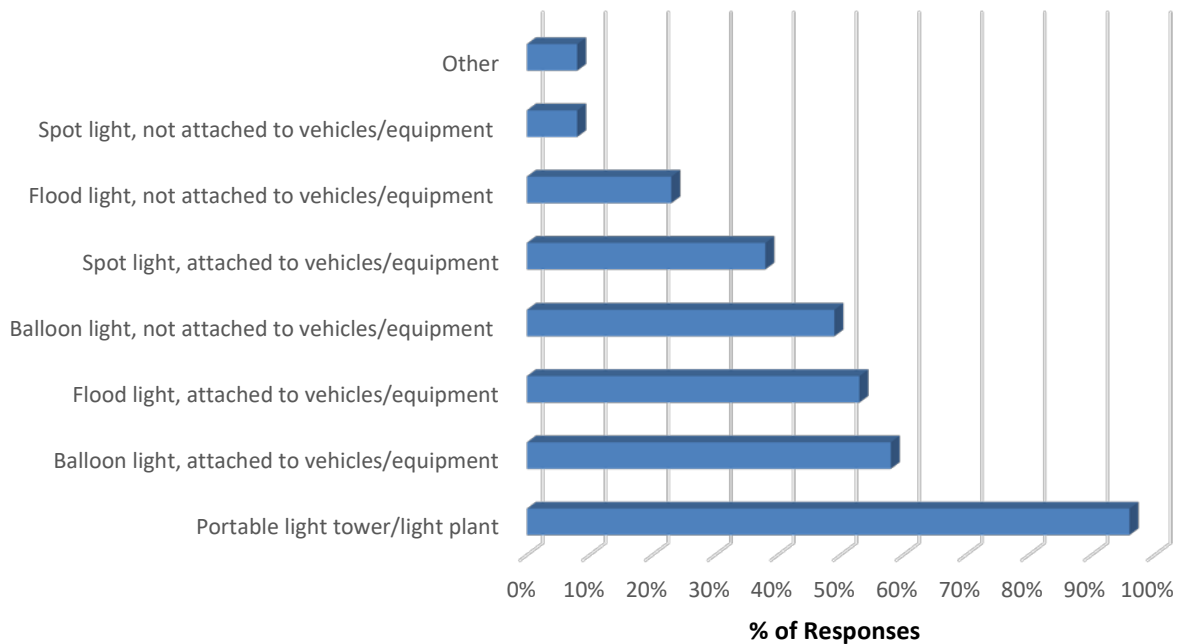

Figure 4.6: Lighting Systems Commonly Used by Respondents (n = 53)

When planning the use of lighting systems for nighttime work, in addition to the type of lighting system, the location of where to place the system must be determined. The respondents were asked, “Where are lighting systems typically used on your projects during nighttime work? (Select all that apply)”. Based on the 53 responses to this question, the lighting systems are predominantly located on large equipment (85% of respondents), at flagger stations (81%), and where workers are present on the roadway (81%). Lighting systems are located at large equipment, but not attached to the equipment, to a lesser extent (43% of respondents).

The respondents were asked to provide their perspective on criteria used to select the type of lighting system to use. To understand which criteria are considered and, of those considered, which is important, the respondents were given a list of possible criteria and asked, “For each of the selection criteria listed below, please indicate the extent to which the criteria is considered important when selecting a lighting system to use during nighttime operations on a project. Use a scale of 1 to 5, where 1 = Not important, and 5 = Very important.” The responses are summarized in Table 4.2. Those criteria that are considered the most important are: amount of light emitted, ability to move/relocate, ease of operation, impact of the light on passing traffic, and availability. While not specified in the question, it could be assumed that when rating the “impact of light on passing traffic” criterion, the respondents were considering the impact of the light on the driver’s sight rather than the impact on vehicle speed.

Table 4.2: Importance of Selection Criteria

Selection Criteria	Importance of criteria when selecting a lighting system to use (1 = Not important, and 5 = Very important)			
	Mean	Min.	Max.	Std. Dev.
Amount of light emitted (n = 48)	4.60	1	5	0.82
Ability to move/relocate (n = 48)	4.54	2	5	0.77
Ease of operation (n = 48)	4.48	2	5	0.85
Impact of light on passing traffic (n = 47)	4.38	2	5	0.95
Availability (n = 45)	4.33	2	5	0.83
Height to which it can be raised (n = 47)	4.09	2	5	0.93
Size of the system (n = 48)	4.08	1	5	1.01
Amount of maintenance required (n = 48)	3.85	1	5	1.18
Cost (purchase or lease) (n = 47)	3.81	1	5	1.12
Time required to demobilize system (n = 47)	3.68	1	5	1.20
Already own it (n = 39)	3.64	1	5	1.22
Type of light emitted (n = 47)	3.47	1	5	1.14
Ability to change amount of light emitted (n = 47)	3.19	1	5	1.26
Time required for lamps to turn on (n = 47)	3.06	1	5	1.24
Expected lifespan of bulbs (n = 46)	3.02	1	5	1.20

The questionnaire also narrowed the focus to the ease with which each lighting system is used on a project. The question posed was, “Please rate the ease of implementation and use of each of the following lighting systems. Use a scale of 1 to 5, where 1 = Very difficult to implement and use, and 5 = Very easy to implement and use.” The responses to this question are shown in Figure 4.7. Those systems that are attached to a vehicle/equipment were viewed as being the easiest to implement and use. When attached to a vehicle or other equipment, the mean response for a floodlight, balloon light, and spotlight were 4.36, 4.28, and 4.25, respectively. The respondents rated a portable light tower as easy to implement, with a mean rating of 3.94.

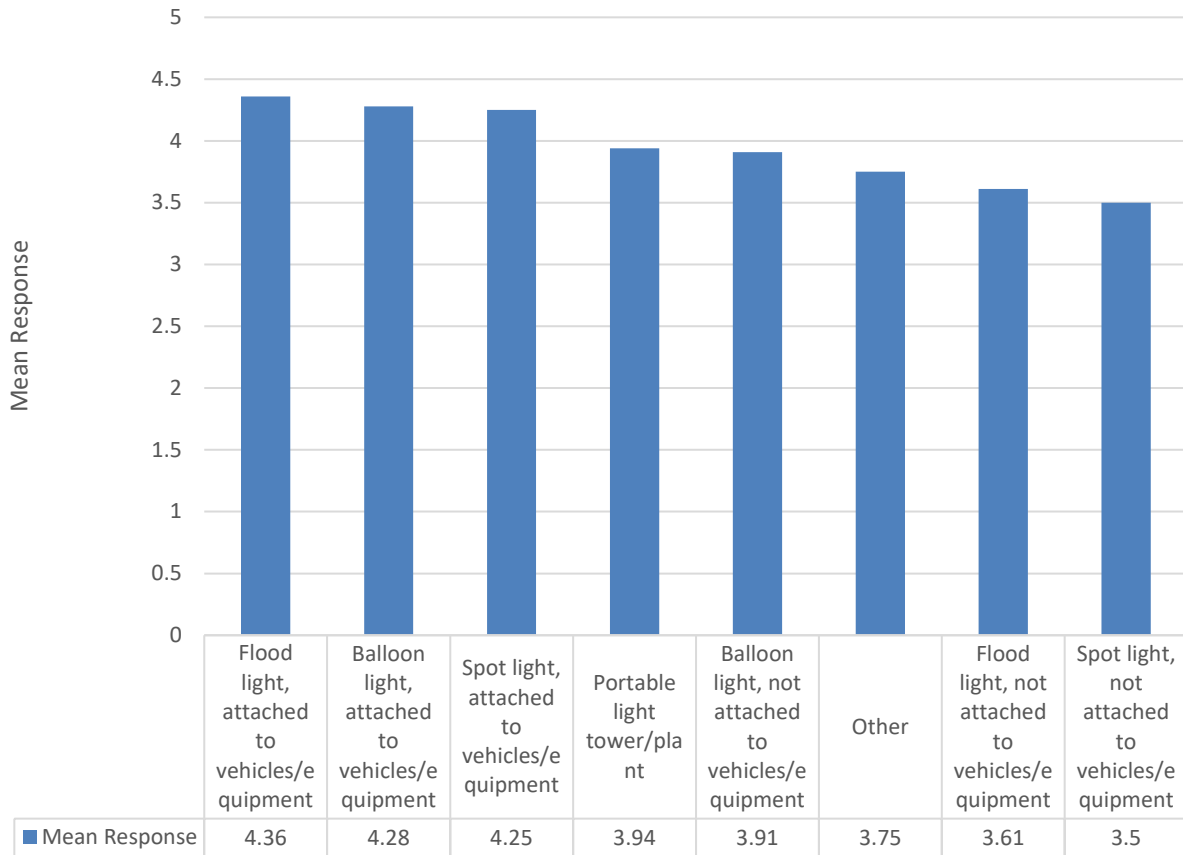

Figure 4.7: Ease of Lighting Equipment Implementation

4.2.3 Impacts, Inhibitors, and Enablers of Work Zone Lighting Systems

One of the survey questions explored the impacts of lighting systems. The respondents were asked the following question: “For each of the project and work performance criteria listed below, please indicate the extent to which the criterion is impacted by the use of lighting systems during nighttime operations. Use a scale of 1 to 5, where 1 = No impact, and 5 = Significant impact.” Table 4.3 shows the results.

Table 4.3: Impact of Lighting Systems on Project and Work Performance Criteria

Project and Work Performance Criteria	Impact of Lighting System (1 = No impact, and 5 = Significant impact)			
	Mean	Minimum	Maximum	Std. Dev.
Worker safety (n = 51)	4.86	4	5	0.35
Work quality (n = 50)	4.56	3	5	0.70
Quality of work zone (n = 50)	4.54	3	5	0.71
Worker productivity (n = 51)	4.43	3	5	0.64
Project costs (n = 51)	3.63	1	5	1.04
Speed of passing vehicles (n = 51)	3.61	1	5	1.25

An open-ended question asked the participants to provide their perspectives on inhibitors of implementing and using lighting systems during nighttime operations. A variety of different responses were provided. The most commonly mentioned inhibitor was difficulty in operating the system during work operations, which was mentioned by almost 25% of the respondents.. Road geometry, including shoulder width and other space constraints, was also highly cited as an inhibitor. Power source, cost, and glare were other important factors that the respondents indicated can adversely affect implementation and use.

In addition to inhibitors, the participants were asked about those factors that enable implementation and use of lighting systems. The enablers mentioned most frequently by the respondents were the location of the work zone and having adequate space to set up the light system. Other recognized enablers are: work access, ease of use of the system, and when required by project specifications.

4.2.4 Use of Personal Lighting Devices

When asked whether the participant regularly wears any type of lighting while working at night (e.g., a lighted arm band, head light, etc.), 51% of the 51 participants who responded to this question answered “Yes”. Of those respondents who wear a light while working at night, all indicated that they wear a head lamp or hard hat light. Two respondents indicated that they also use flashlights, one uses lighted arm bands, and another uses an LED vest.

The respondents wear lighting devices for a variety of reasons. The survey question allowed them to select different reasons that apply. Figure 4.8 shows the common reasons for wearing lights from the 32 respondents who answered this question. The respondents are predominantly wearing the lights to help illuminate their work area, because it makes them feel safer, and to help them perform their work task. Seven of the nine respondents (78%) who are required to use personal lighting feel safer when they use personal lighting devices.

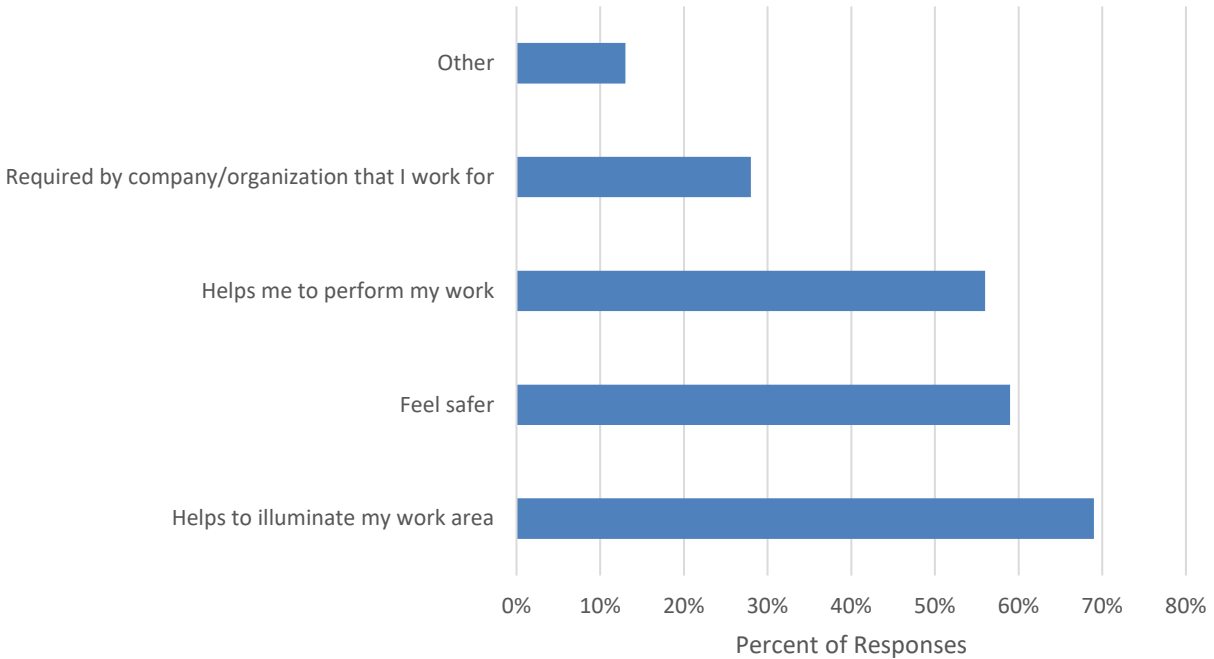

Figure 4.8: Reasons for Wearing Lights while Working at Night (n = 32)

4.2.5 Analysis of Results

The survey responses afforded an opportunity to statistically compare respondent perspectives according to demographic characteristics and other survey responses. For this analysis, Chi-squared tests of the data were conducted to determine whether there is an association between two independent variables. Based on the Chi-squared tests, the associations described below were found to be statistically significant ($p\text{-value} < 0.05$). At least 30 responses (data points) are needed for a high level of confidence in the results of Chi-squared tests. It should be noted that the low number of responses received reduces the level of accuracy in the result.

- There is a significant association seen between job title and the perceived impact of lighting systems on the speed of vehicles ($p\text{-value} = 0.01$). Those respondents who listed their title/position as Project Manager tended to rate lighting systems as having a greater impact on vehicle speeds.
- There is a significant association between number of years of experience and whether the cost (purchase or lease) of a lighting system is considered as a selection criteria ($p\text{-value} = 0.00$). Those respondents with more years of experience tended to indicate that cost is less of a factor when considering lighting systems to use on a project.
- There is a significant association between number of years of experience and whether availability of a lighting system is considered as a selection criteria ($p\text{-value} = 0.03$).

Those respondents with more years of experience tended to indicate that availability is a greater factor in the consideration of lighting systems to use on a project.

- There is a significant association between number of years of experience and the perceived impact of lighting systems on project cost (p-value = 0.00). Those respondents with more years of experience tended to rate lighting systems as having a greater impact on project costs.
- There is a significant association between the type of projects worked on and whether amount of maintenance required is considered as a selection criteria (p-value = 0.01). Those respondents who work primarily on preservation projects tended to view amount of maintenance required as less of a decision factor when considering lighting systems to use on a project.

5.0 DOCUMENTATION OF WORK OPERATIONS

This section of the report is intended to provide an understanding of typical work patterns and lighting needs on highway preservation projects. In consultation with the TAC, the researchers visited three ongoing ODOT projects. The researchers monitored the work operations, especially with regard to those workers who are on the roadway a long distance from lighting and large equipment. The researchers recorded the operations, monitored worker movements and locations, and documented the equipment utilized and reflective clothing worn by the workers. In addition, the researchers measured the level of illumination at various work locations.

5.1 PROJECT 1: US-26 BROOKWOOD PARKWAY/HELVETIA INTERCHANGE

Brookwood Parkway is a heavily used north/south arterial roadway that connects multi-modal commuters and truck traffic between Highway 26 and Tualatin Valley Highway (OR-8). The section of Brookwood Parkway between Meek Road and Shute Road carries approximately 28,000 vehicles a day. In order to meet the rapidly increasing commercial and residential development in the area, Brookwood Parkway between Meek and Shute is being widened to three lanes in each direction. Additional improvements include consistent bicycle and pedestrian facilities on both sides of the roadway, a new storm drainage system, utility upgrades, traffic signal modifications and street lighting. Some sections of the center median will also require reconstruction. Figure 5.1. shows the project location.

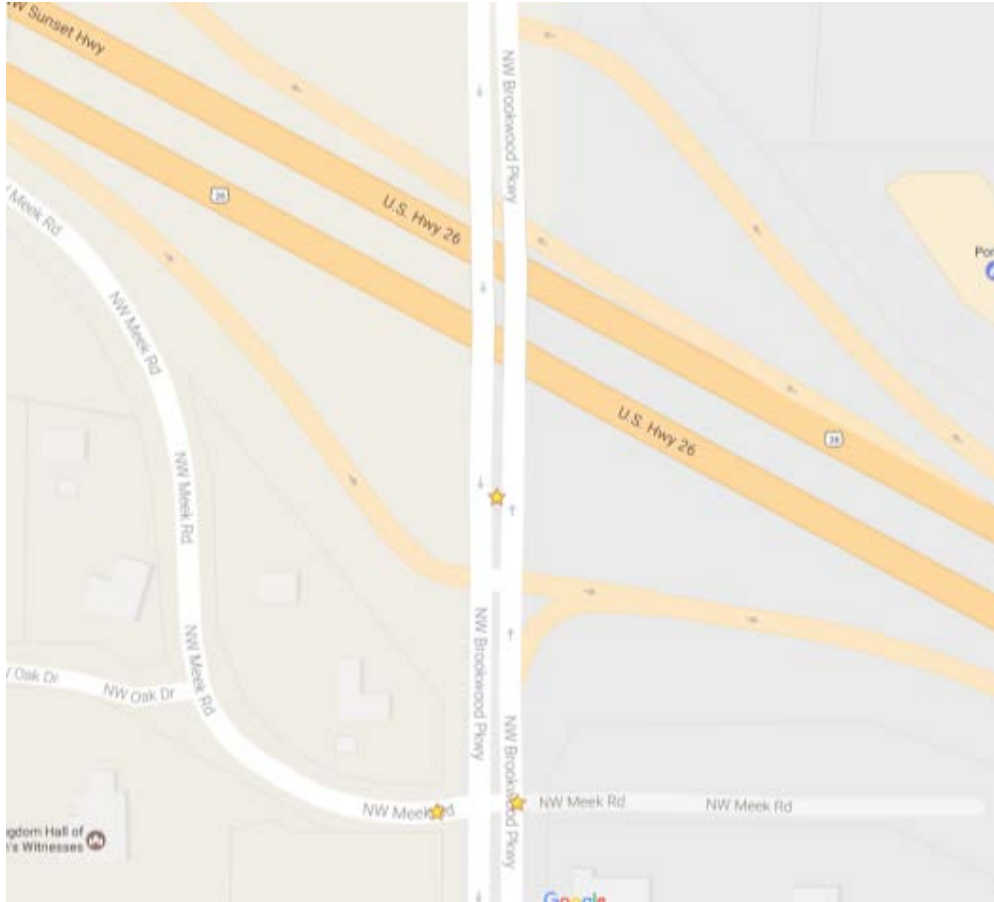

Figure 5.1: Brookwood Parkway/Helvetia Interchange Work Zone Layout

The scope of the Brookwood Parkway/Helvetia Interchange project includes the following elements:

- Constructing a new westbound US-26 to southbound Brookwood Parkway exit loop ramp
- Reconstructing the westbound US-26 entrance ramp from Helvetia Road
- Widening the Brookwood Parkway overcrossing to accommodate additional northbound and southbound lanes over US-26. Once complete, there will be two northbound lanes, three southbound lanes, and a left turn lane on the bridge.
- Adding sidewalks and bike lanes within the interchange area
- Extending the northbound right-turn lane from Brookwood Parkway to the eastbound US-26 entrance ramp

The Brookwood Parkway widening project is being managed by Washington County and was not an ODOT project. The 55 mph speed limit north of Evergreen was temporarily reduced to 45 mph for the safety of the workers and drivers.

The researchers visited the site on May 9, 2016. On that night, the operations consisted of grinding the southbound slow lane of Brookwood Parkway between US-26 and Meek Road. Flagger stations with a portable light (balloon light) were located on Meek Road and also on Brookwood Street. The contractor closed two southbound traffic lanes. There was no shoulder present, so the traffic was channelized into one passing lane for each direction and controlled by the flagger near the signal for turning onto the US-26 on-ramp. The US-26 off-ramp was closed.

A spotter was present who controlled backing up of equipment during the operation. The spotter wore a yellow Class 3 vest and Class E pants, and used a Halo light around his hard hat. The spotter also wore a red LED flashing vest. Figure 5.2 shows the spotter working near the grinder and dump truck while wearing the high visibility apparel with the red LED flashing vest.



Figure 5.2: Spotter Working around Grinder and Dump Truck with Halo Light on Hard Hat and Flashing LED Vest

The grinding operation generally uses only the lights located on the grinding equipment. The grinder used on this project had mobile lights at various locations on its perimeter. The grinder, a Terex PR-800-7, has two rear tail lights and 10 operational lights (five on each side). There are four lights on the conveyor (two each side). These lights are shown in Figure 5.3 with the red circles. Standing at the rear of grinder when facing the traffic, the light meter recorded 12.9 fc. On the side of the grinder the amount of light is 12.1 fc, and under the conveyor it is 6 fc.

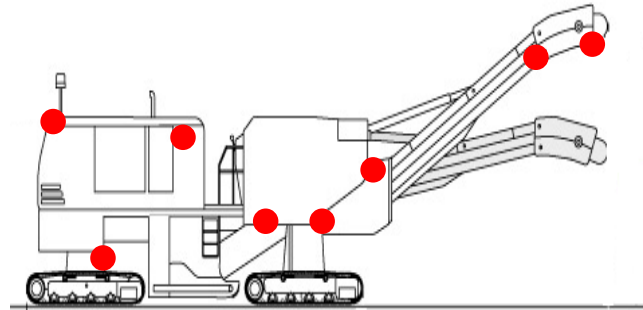

Figure 5.3: Grinder Showing Locations of Spotlights, each side (Red Circles)

A permanent roadway lighting fixture was located at the intersection which emitted 3 fc at the roadway surface. Workers and flaggers wore Class E pants and a reflective vest, which together are considered Class 3 (Figure 5.4). Flaggers also used a night wand or flashlight for better visibility. In the vicinity of the balloon light where the flagger was working, the light meter recorded 3.1 fc when facing the light, and 0.9 fc when facing in the direction of the traffic (back to the light) where there are no permanent street lights. Near the north flagger station where permanent street lights are located, the amount of light varied from 4.4 to 7.5 fc, facing the traffic and facing the light. These values were recorded where the flagger stands. Under the balloon light, the light measurements varied from 13 fc to 25 fc for the three portable balloon lights at the different flagger stations.

Using portable lights with a suitable height for the flaggers when they wear Class 3 vest and pants makes the flaggers highly visible for the drivers. Also, having additional personal protective equipment such as a Halo light around their hard hat and a flashing wand or flashlight could increase the safety of workers through better recognition during nighttime operations. When the spotter is located around the grinder (within 10 feet), there is enough light to highlight the spotter both for construction equipment operators and passing motorists. However, beyond that immediate area, in the case where no other permanent or portable lights are present, there is no light to illuminate the spotter. In that situation, high visibility apparel and personal protective equipment are two measures which help drivers to recognize the workers.



Figure 5.4: Flagger under Portable Balloon Light and Researchers within approximately 15 feet Distance from the Light

5.2 PROJECT 2: US-101 BETWEEN WHEELER AND WILSON RIVER

This paving project was located on Highway 101 between Wilson River (MP 64.2) and Barview (MP 53.3), just south of Rockaway Beach. The project involved removing the current damaged asphalt and replacing it with a new surface. There is one traffic lane in each direction at this location on US-101. The work got underway with lane closures starting at 6:00pm and continuing until 7:00am the next morning, Traffic control was provided by flaggers and a pilot vehicle, and nighttime delays lasted up to 20 minutes. The posted speed limit on this section of the roadway was 45 mph.

At the time of observation, the project activities were taking place in the northbound lanes of Highway 101, at the Latimer Rd. intersection. The flaggers were located north and south of the intersection to control traffic travelling on Highway 101. There was also a flagger on the east entrance to the intersection on Latimer Rd. to control vehicles entering onto Highway 101 (Figure 5.5).

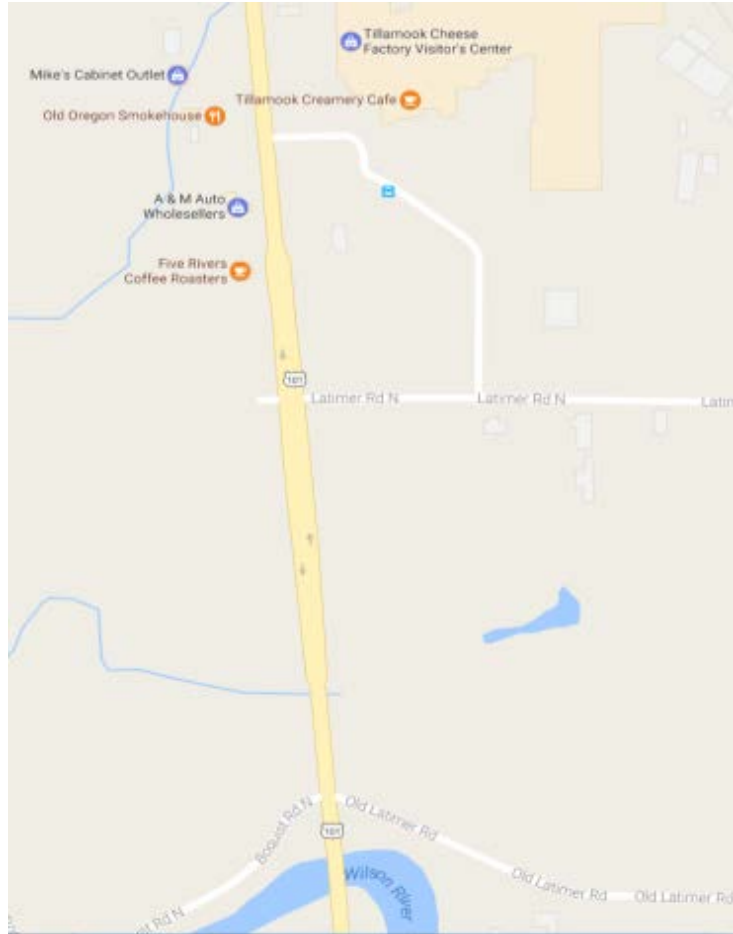

Figure 5.5: US-101 Wheeler to Wilson River Paving Project Observation Site

The light equipment at the flagging stations was a typical balloon light, manufactured by Multiquip Company (Globug Lighting System). The height of light was 12 feet. Figure 5.6 shows the amount of illumination recorded by the light meter at different distances (10 foot increments) from the balloon light. Directly under the balloon light, the light meter recorded 100 fc. The flagger lighting equipment provided the minimum 5 fc (Level I) of illumination required in Oregon for a flagging station as described in Section 3.

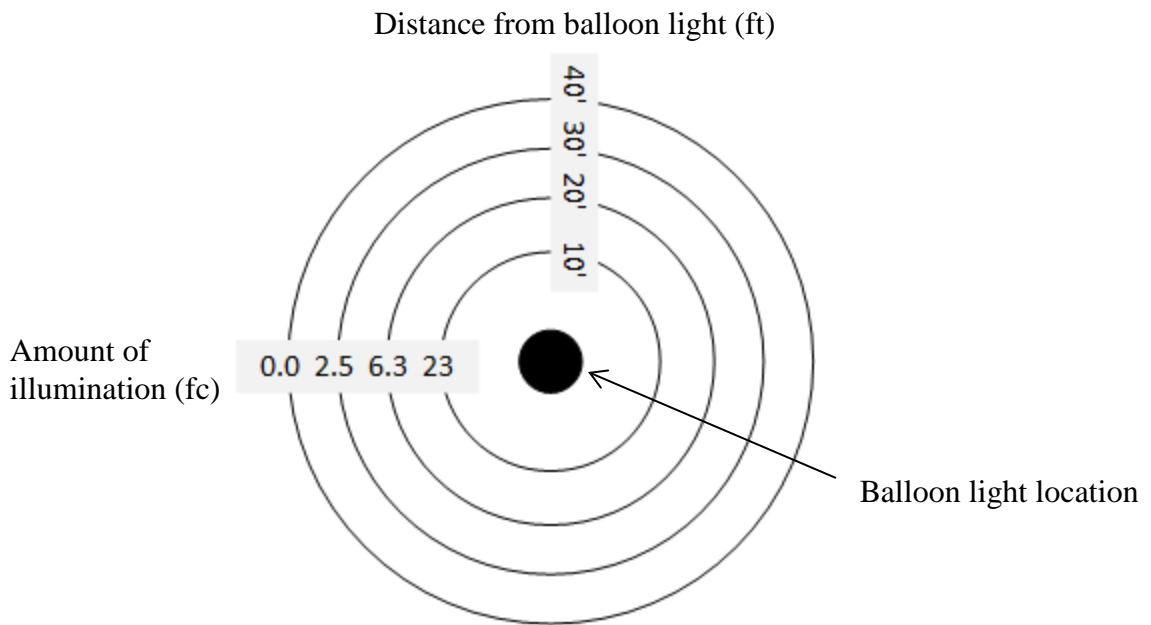

Figure 5.6: Light Measurements at Different Distances (10 – 40 feet) from the Balloon Light (fc)

The flaggers wore personal protective equipment including reflective pants and a reflective jacket (Figure 5.7) that met the standard for reflective apparel discussed in Section 3. The flaggers also used a blinking Stop/Slow paddle and a night wand. The flaggers usually stood approximately 4 feet away from the balloon light. Other workers in the vicinity wore Class 3 vest and reflective leg gaiters. In addition, some workers used head lights (see Figure 5.8).



Figure 5.7: Flaggers at Latimer Rd. under Portable Balloon Light



Figure 5.8: Workers Wearing High Visibility Apparel and Head Light

Similar to the previous observation on Brookwood Parkway, there are permanent street lights at the intersection of Latimer Rd. and US-101. The amount of illumination from these lights at the roadway surface is 4.5 fc. Similar to the previous project, the grinder had regular mobile lights attached to its perimeter. The paver had LED lights mounted on a custom-made post attached to the back of the paver (Figure 5.9). The contractor stated that the reason they used LED lights as opposed to balloon lights was so that the lights did not attract bugs around the paver. The amount of illumination recorded at different distances (10 foot increments) behind the paver with the LED lights is shown in Figure 5.10. The amount of illumination on the side of paver ranged from 1.4 fc at the head of paver to 24 fc at the tail of the paver.



Figure 5.9: Paver with LED Lights

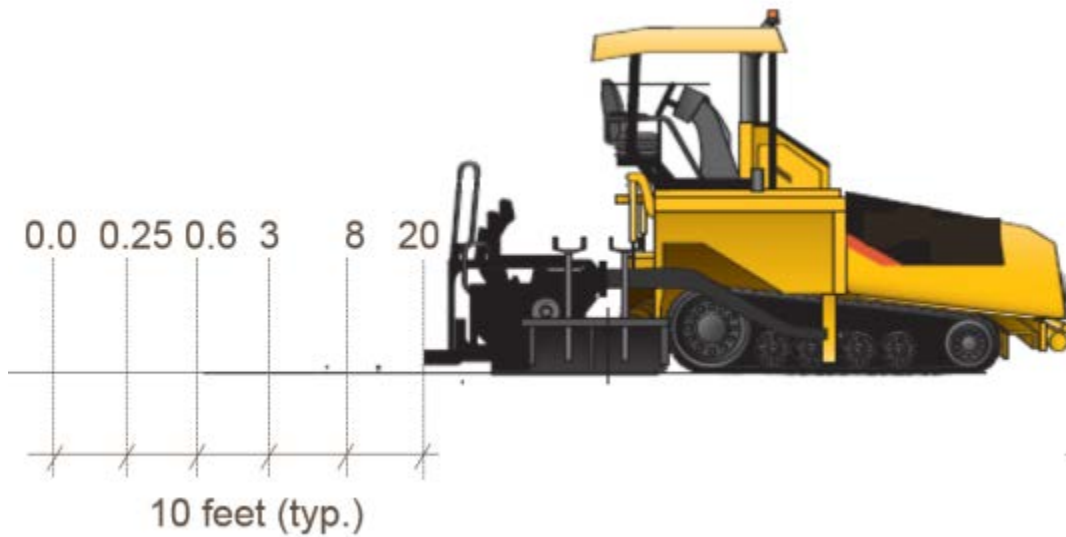

Figure 5.10: Illumination at Different Distances (10 foot increments) Behind the Paver (fc)

A density technician was located at the end of the paving train. Density technicians usually work on foot behind the paver where there is no other source of light. Therefore, wearing a Halo light

in addition to Class 3 vest and pants would help to increase the visibility of the density technicians to passing motorists. A personal, wearable light can also help provide better visibility of the work operation for the worker. Another option for providing density technicians more light is to add an additional light on top of their trucks. The light could be attached to the hitch at the rear of the truck. However, for a density technician, because he/she needs to frequently access the equipment through the tailgate of the truck, the light may be better located immediately behind the truck cab (Figure 5.11).



Figure 5.11: Example of Balloon Light Mounting for Density Technician Truck

5.3 PROJECT 3: I-84 CASCADE LOCKS TO HOOD RIVER

This paving project involved paving 18 miles of Interstate 84 between Cascade Locks and Hood River. The researchers observed one night of the project while the paving work was taking place in the westbound slow lane (B-lane) at MP 50. Each direction of the roadway at this location has two travel lanes. During the paving operation, the contractor closed the paving lane and left the adjacent lane open for passing traffic. The construction company was the same company that worked on the US-101 project, and the same equipment was used. As shown previously in Figure 5.9, the paver had special LED lights attached to a post at the rear of the paver.

No flagging control was employed on this project; there was only a slow lane closure during the observation. Workers on the roadway wore a Class 3 vest and gaiters. Equipment operators wore a Class 2 vest. The regulatory speed limit was reduced from 55 mph to 50 mph.

Light measurements around the grinder are shown in Figure 5.12. The high values of illumination shown in the figure are recorded directly under the light. The paver used on this project was the same paver as that used on the US-101. Figure 5.10 above shows the light measurements upstream of the paver, and Figure 5.13 shows light measurements downstream of the paver. It can be seen that just beyond 10 feet away from paver there was almost no light present.

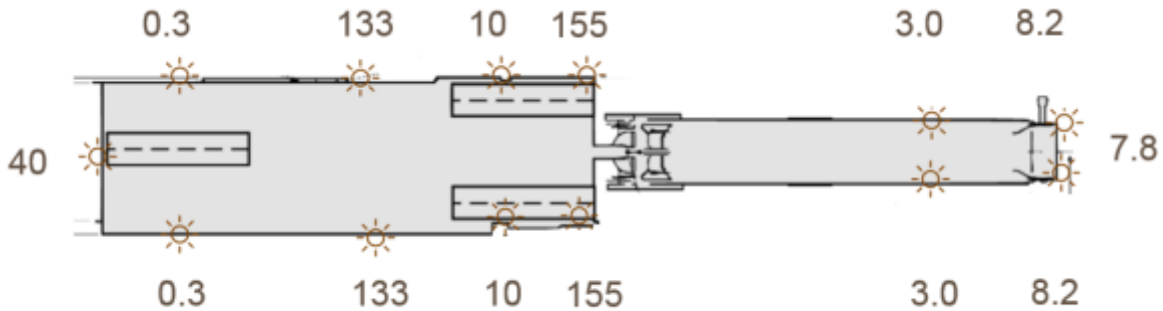

Figure 5.12: Light Measurements (fc) around the Grinder

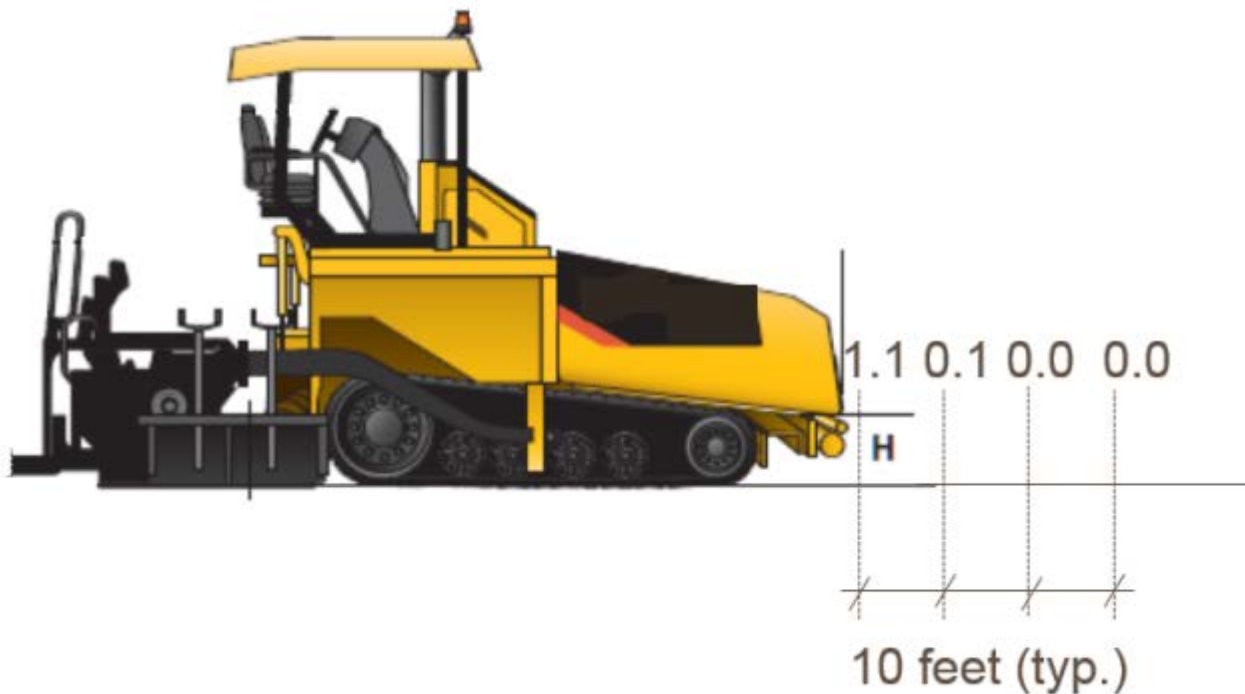

Figure 5.13: Light Measurements at Different Distances in Front of Paver

Lights were attached to the rollers which provided additional light for paver workers and brightened the working area around the paver. However, the lights shined straight ahead, parallel to the roadway surface, and appeared to create glare for motorists travelling in the opposite

direction and for workers in the area. To reduce the glare, the lights should be pointed towards the roadway surface. Locating a similar light on the front of the paver, and directing the light towards the construction worker (dump person), would help illuminate the worker for oncoming traffic (Figure 5.14). Having the dump person wear a Halo light would be another option to increase the visibility of the worker for equipment operators and oncoming motorists.



Figure 5.14: Front of Paver with Recommended Location for Adding a Spotlight (red circle)

When no light system is present (temporary or permanent), the light meter recorded between 0.2 and 0.5 fc in the middle of the working lane (closed lane) when a passenger car with its headlights on passed by in the opposite direction. Based on the low value of illumination recorded without any other light systems present, workers in these locations may not be very visible to passing motorists (Figure 5.15).



Figure 5.15: Worker in Location without any Temporary or Permanent Lighting

6.0 IDENTIFICATION OF POTENTIAL LIGHTING STRATEGIES

This task involved conducting a focus group survey with ODOT personnel and construction and traffic control contractors. The objective of this task was to identify and develop promising lighting strategies to implement and test in an active work zone. For example, one lighting strategy may be to have 2000-watt, tripod-mounted balloon lights set up where quality control personnel check pavement densities upstream of the rollers.

Identifying potential lighting strategies was conducted into two phase. Phase 1 involved a survey of ODOT personnel, and construction and traffic control contractors in Oregon. Phase 2 involved a demonstration of different lighting system and personal high visibility safety apparel to the group of ODOT personnel under controlled condition without any traffic at the Corvallis airport. Those lighting strategies that were deemed promising by the focus group participants in both phases, and fit within the research budget, were selected for field testing.

6.1 FOCUS GROUP SURVEY

In order to determine current lighting equipment uses, problems, limitations, impacts on traffic speed, and, finally, potential lighting strategies, a survey was conducted among ODOT personnel and construction and traffic control contractors in the State of Oregon.

6.1.1 Survey Preparation and Distribution

The researchers developed a survey document that contained questions organized into five sections as follows:

- *Lighting system selection:* In this section, the participants were asked about the recommended lighting systems for use in high speed roadway work zones to reduce the speed of passing vehicles.
- *Lighting system location:* This section included questions about the location of temporary lighting systems to reduce speed in the work zones.
- *High visibility apparel:* In this section, participants were asked about the high visibility apparel which they wear and the perceived impact of the apparel on the vehicle speed.
- *Personal work light:* This section focused on personal work lights, such as the Halo light, worn by workers which can make workers more visible to passing motorists during nighttime operations.
- *Personal demographics:* The last section of the survey included gathering some basic information about the participant's company, position, and experience.

The draft survey was reviewed and subsequently approved by the Institutional Review Board (IRB) of OSU. A copy of the survey questionnaire is provided in the Appendix.

The targeted population for the focus group survey were those personnel working in highway construction in the State of Oregon, including ODOT personnel and construction and traffic control contracting personnel. Based on this targeted population, the researchers created a distribution list from the following sources: alumni contact list of the School of Civil and Construction Engineering (CCE) at OSU; Associated General Contractors (AGC) Oregon-Columbia Chapter Highway Construction Committee; and a general online search of personnel in the construction departments of ODOT; and additional contacts known to the researchers in the Eugene, Oregon area. Using these sources, a distribution list of 35 contacts was created. The three groups (ODOT personnel, construction contractors, and traffic control contractors) received a similar survey which focused on their opinions and past experiences with nighttime construction. The researchers sent an e-mail to each of the names on the distribution list. The e-mail described the research study, invited participation in the survey, and included both an electronic file with the questionnaire and an online link to the survey. The online survey was hosted and administrated through the Qualtrics survey system supported by OSU (<http://main.oregonstate.edu/qualtrics>). After some follow-up e-mails to non-respondents, a total of 11 survey responses were received from the initial 35 list of participants (31% response rate).

6.1.2 Survey Results and Analysis

6.1.2.1 Participant Demographics

Of the 11 participants in the focus group survey, five (45%) work for a general contracting firm, five (45%) work for a DOT, and one (9%) work for a subcontracting firm (see Figure 6.1). Most of participants (64%) are project managers, two (18%) are project engineers, and only one (9%) is a member of a traffic control crew (Figure 6.2). Figure 6.3 shows that all of the participants have more than five years of industry experience with the exception of just one participant. The percentage of participants' daily work activities in a roadway work zone, shown in Figure 6.4, indicates that most of the survey participants' daily work is not in a roadway work zone.

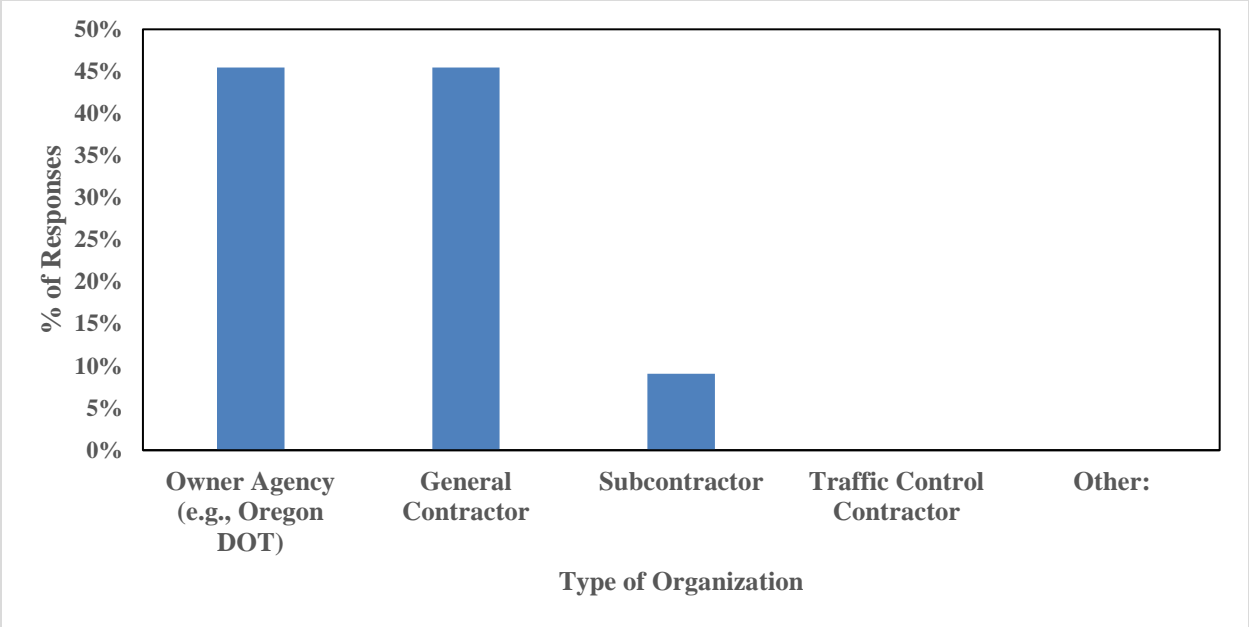

Figure 6.1: Participant Work Organization (n = 11)

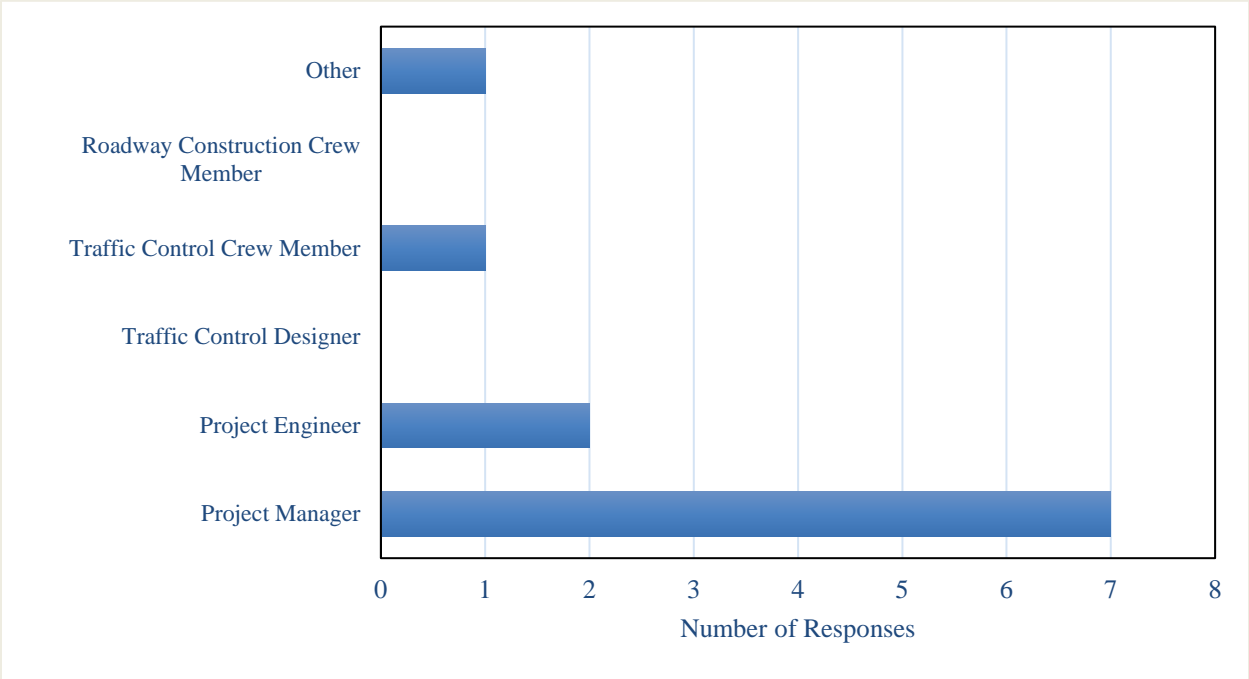

Figure 6.2: Participants Distributed by Work Position (n = 11)

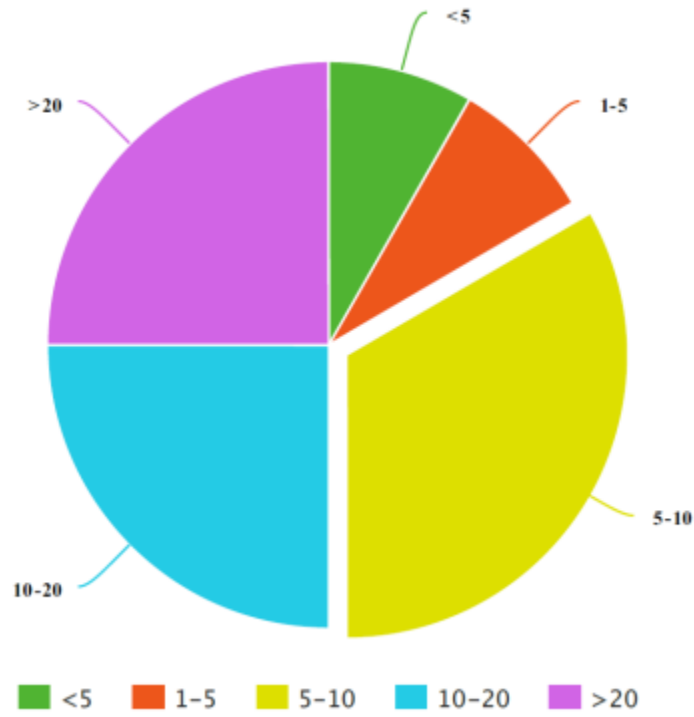

Figure 6.3: Years of Experience of Participants (n = 11)

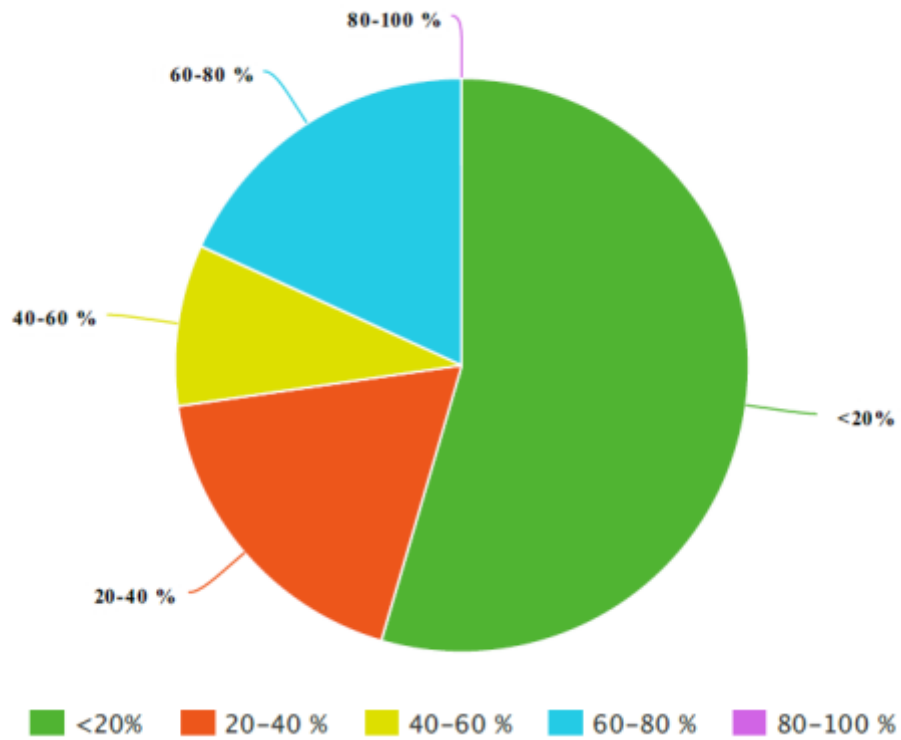

Figure 6.4: Percentage of Daily Work by Participants in Roadway Work Zones

6.1.2.2 Lighting System Location

Each highway construction work zone is composed of four distinct areas including (1) advance warning area, (2) transition area, (3) activity area, and (4) termination area. In this section of survey, participants were asked to choose between the four work zone areas the most effective area for setting up the light equipment to reduce the vehicle speeds. Figure 6.5 shows the results from this question. The activity area was identified by the most participants (10 participants, 91%) as the best location for the lighting equipment. Eight participants also indicated that the transition area would be a beneficial spot for the equipment. One of the participants also suggested locating the light equipment in the advance warning area to enable speed reduction of passing vehicles. The termination area was not recognized as an area where the light equipment would have an impact on speed reduction, likely because it is downstream of the work area.

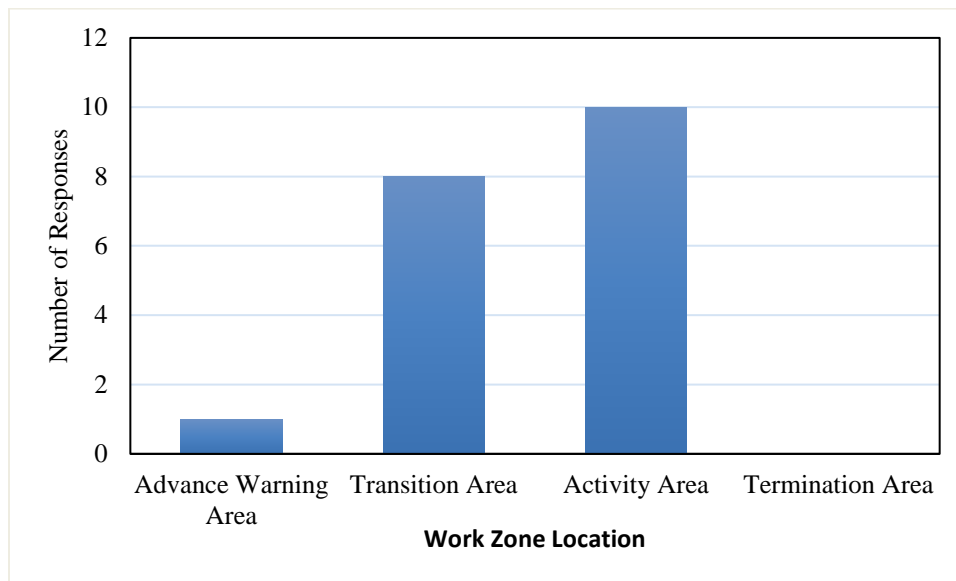

Figure 6.5: Recommended Location for Adding Additional Lighting to Reduce Vehicle Speed

One of the participants also recognized the benefits of adding flashing lights in combination with the temporary lighting. The participant recommended adding a flashing amber beacon light at the first road work ahead sign and then having a lighting system just prior to the start of the transition area and placed as required in the work zone to illuminate equipment, especially those very near the buffer space.

The participants were also asked about the factors that they consider when selecting and locating a lighting system for work zones. The color of the light, angle of the light to the traffic, lighting brightness, type of operation (moving or stationary), cost, durability, surrounding neighborhood, existing lighting, weather conditions, and state patrol presence are factors participants consider when deciding on the lighting strategy for nighttime work zones.

6.1.2.3 Lighting System Selection

All of the survey participants recommended using balloon lights in high speed roadway work zones to reduce the speed of passing vehicles. Five of the participants also recommended a light tower for speed reduction in the work zone. Easy setup, mobility, crashworthiness, and less glare are reasons that participants gave for recommending the use of balloon lights, especially for operations related to a flagger. However, one respondent believes that a light tower works better than a balloon light for stationary operations such as a flagger station. On the other hand, balloon lights work better when mounted on a piece of moving equipment.

The participants felt that arrow and sign boards, flash lights, and Halo lights are other types of equipment recommended for use in the work zone to reduce the speed of passing vehicles. Wind speed and height of the light are two impacting factors mentioned that should be considered during light setup. The participants also stated that worker position with respect to the light has significant impact on their visibility. Sometimes a difference of just a few feet can make a large difference in their visibility.

6.1.2.4 Personal (Wearable) Work Light

The survey also explored the impact of personal work lights worn by workers, such as a Halo light, on worker visibility and vehicle speed. Some participants felt that personal lights are effective in increasing visibility while others did not feel the same way. The participants recognized that, when workers wear a personal light, drivers may see the light from a long distance away, but not necessarily recognize the worker. Two respondents mentioned that, from a long distance, the Halo light looks like a vehicle headlight. In addition, some people wearing personal lights complain about weight of the light and its brightness, and therefore may not be highly utilized by workers. Another concern regarding personal lights could be the opposite effect of the light on the reflectivity of personal protective equipment. Using a personal light for a select few highly exposed workers, such as a dump person, traffic control personnel, spotters, inspectors, or anyone who is separated from the light, is also recommended. Lastly, smaller personal lights (e.g., arm band, head band, etc.) are likely more effective at increasing visibility and recognition when the worker wearing the light is moving and giving the driver the sense that someone is moving in the area.

6.1.2.5 High Visibility Apparel

In this section of survey, participants were asked about high visibility worker apparel and its impact on the speed of passing vehicles in the work zone. Based on manuals in the literature, the researchers identified three categories of apparel for work zones including Class 2 vest, Class 3 vest, and Class 2 vest plus Class E pants. In highway work zones, workers wearing only a Class 2 vest is not consistent with the requirements; workers should wear at least a Class 3 vest. There is no requirement for wearing a Class 3 vest plus Class E pants, so this combination was not included in the option list in the survey.

A total of seven participants selected Class 3 vest as the apparel for best visibility during nighttime operations. The remaining four participants selected Class 2 vest plus Class E pants as appropriate working apparel. However, some of the participants commented that wearing Class 3 vest and Class E pants would be the best option.

Most of the respondents also felt that high visibility apparel can have an impact on the speed of passing vehicles in the work zone. The participants commented that drivers will slow down for workers when they are visible, especially in large numbers or close to the travel way. Utilizing lighted arm bands or other wearable lights was recommended for more visibility. It should be noted that wearing reflective apparel (non-light emitting) is only effective if there are vehicle headlights or other lights shining on the apparel.

6.2 FIELD DEMONSTRATION EVALUATION

A field demonstration evaluation of alternative lighting strategies was conducted in order to gain a better understanding of views and opinions of people who are involved in highway construction and to identify the best strategies for further field testing in actual work zones. An advantage of the demonstration is also the open-ended nature of discussions; the potential existed for innovative concepts to be suggested by participants.

For the demonstration, a total of six people from ODOT participated. The participants were asked to evaluate the visibility of a worker under a light tower and a balloon light. For the light tower, both zero and 45 degree offset angles were tested. For each of the three lighting alternatives (light tower with zero angle, light tower with 45 angle, and balloon light), visibility of a person when wearing each of following personal safety apparel was evaluated:

- Class 3 vest
- Class 3 vest + pants
- Class 3 vest + pants + Halo light (halo mode)
- Class 3 vest + pants + Halo light (hi-visibility mode)

For each case, a vehicle with its headlights turned on and shining in the direction of the worker was located at the location where the participants were standing. This vehicle was intended to replicate the illumination of the worker due to the headlights of the driver's vehicle.

The purpose of the field demonstration was to gain additional understanding of the effectiveness and limitations of the identified lighting systems and apparel. Specifically, the demonstration aimed to determine the following:

- An understanding of the visibility of workers under different lighting and apparel conditions and at different distances
- The best location of a worker relative to the light equipment for high visibility
- Effectiveness of a wearable light with respect to visibility

- Additional comments regarding barriers, limitations, or drawbacks of the lighting systems, reflective apparel, and wearable light.

The participants were asked several questions for each alternative set-up. For the first question, the participants rated the visibility of the worker under each lighting system when the worker wore one of the four combinations of personal safety apparel. This evaluation was performed at three locations: 500, 1,000 and 1,500 feet upstream of the location of the worker and light. Each situation was scored between 1 to 5 with 1 representing not clearly visible and 5 representing very visible. A summary of the mean of each alternate is shown in Table 6.1. The results shows that, with respect to the personal protective equipment, Class 3 vest only received the lowest mean rating (the least visible), and Class 3 + Pants + Halo light in hi-visibility mode had the highest mean rating (the most visible). Based on the type of high visibility apparel and the distance of the observer, none of the three light equipment strategies (Light tower with 0 angle degree, light tower with 45 angle degree, balloon light) is clearly better; i.e., none was found to be better or worse than the others in all situations.

The participants were also asked about the best location of the worker relative to the location of the lighting equipment. This question included six different locations of the worker on the roadway. The light was positioned a few feet from the fog line on the roadway shoulder. As shown in Figure 6.6, the worker was located upstream of the light (positions 5 and 6 in Figure 6.6), immediately adjacent the light (positions 1 and 4), and downstream of the light (positions 2 and 3) in both the lane adjacent the light and in one lane away from the light. Standing one lane away from the light (positions 3, 4, and 5) was intended to represent the situation when there is insufficient room to place the light in the shoulder adjacent the working lane, and the light is placed on the other side of the roadway from the worker. Positions 2 and 3 were 20 feet downstream of the light, and positions 5 and 6 were 20 feet upstream of the light.

Participant responses show that when the worker is 20 feet downstream of the light (positions 2 and 3), he/she is more visible to the drivers than when he/she is upstream or next to the light (positions 1, 4, 5, and 6). Based on the results of this question, when the worker is both downstream of the light and working in the lane adjacent the light (position 2), the worker is in the most visible location. In addition, when the worker is both in front of the light (upstream) and working in the lane adjacent the light (position 6), the worker is in the least visible situation. The overall results of the ratings with respect to each position are illustrated in Figure 6.7. It was clear to the participants that when standing in positions 5 and 6 (upstream of the light), the worker is not very visible.

Table 6.1: Evaluation of Visibility of Worker for Different Lighting Alternatives (n = 6)

Distance from worker and light (ft)	Mean Rating (1 = Not clearly visible; 5 = Clearly visible)											
	Light Tower, 0° offset angle				Light Tower, 45° offset angle				Balloon Light			
	Class 3	Class 3 + Pants	Class 3 + Pants + Halo	Class 3 + Pants + Halo (Hi)	Class 3	Class 3 + Pants	Class 3 + Pants + Halo	Class 3 + Pants + Halo (Hi)	Class 3	Class 3 + Pants	Class 3 + Pants + Halo	Class 3 + Pants + Halo (Hi)
500	3.67	4.33	4.42	4.67	3.83	4.00	4.50	4.75	4.17	4.33	4.50	4.67
1,000	3.50	4.17	4.42	4.42	3.67	4.00	4.08	4.25	3.33	3.83	4.25	4.42
1,500	2.83	2.83	3.17	3.33	2.67	3.08	3.50	3.92	2.50	3.17	3.58	3.58

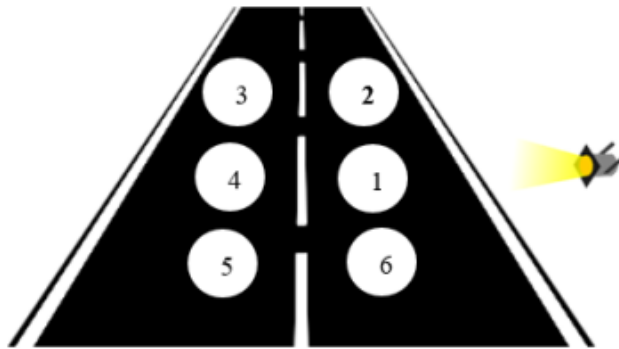

Figure 6.6: Positions of Worker relative to Lighting Equipment for Demonstration

Visibility of Worker						
	2	3	1	4	5	6
Worker Position	2	3	1	4	5	6

Figure 6.7: Ranking of Worker Position based on Visibility of Worker

6.3 SUMMARY OF POTENTIAL LIGHTING STRATEGIES

The field demonstration provided useful information to guide the subsequent selection and testing of the lighting systems. Table 6.2 shows a summary of how each focus group responded to the survey questions. All respondents recommended using balloon lights in high speed roadway work zones to reduce the speed of passing vehicles. Two of the five respondents from both the owner agency and general contractor personnel also recommended using a light tower to decrease speeds in high speed work zones. For the best location of where to add temporary lighting in the work zone, a greater number of owner agency personnel than general contractor personnel selected the work zone activity area.

Table 6.2: Summary of the Focus Group Lighting Survey Results

	Lighting System selection			Lighting System Location					High Visibility Apparel			
	Light Tower	Balloon Light	Total	Advance Warning Area	Transition Area	Activity Area	Termination Area	Total	Class 2	Class 3	Class 2 + Class E	Total
Owner Agency (e.g., ODOT)	2	5	5	0	3	5	0	5	0	3	2	5
General Contractor	2	5	5	0	4	4	0	5	0	3	2	5
Subcontractor	1	1	1	1	1	1	0	1	0	1	0	1
Traffic Control Contractor	0	0	0	0	0	0	0	0	0	0	0	0
Total	5	11	11	1	8	10	0	11	0	7	4	11

With respect to the questions about high visibility apparel, similar responses were received from the general contractor personnel and owner agency personnel. Most of the participants selected Class 3 vest for high speed roadway work zones as effective for making the worker visible to passing motorists. Therefore, it was found that there is no difference between general contractor and owner agency responses in the selection of the light system, its location, and worker apparel for high speed work zones.

Based on the focus group survey and field demonstration evaluation, both the balloon light and light tower could be a feasible option to add in the highway work zones to reduce the speed of passing vehicles. Balloon lights, because of their easy setup, mobility, crashworthiness, and low glare, are recommended more than a light tower. However, some people believe that a balloon light might work better when mounted on a piece of moving equipment for mobile operations. Both the transition area and the activity area are recommended for adding additional lighting and to test how traffic speed could be affected by the lights.

For worker safety apparel, the more reflectivity the apparel has, the more visible the worker is in a work zone, as long as there is light shining on the worker. Wearing a Class 3 vest and pants is

recommended most often by all participants. In addition, some participants recommended using additional personal light equipment such as flash lights or Halo lights. For the Halo light, using the hi-visibility mode (flashing mode) is recommended the most. Importantly, a worker standing in a location relative to the light that allows for as much light as possible to fall on the worker is also very important for the visibility of the worker.

In the next section of the report, further observations and evaluations of the lighting are described. Specifically, the pilot testing of the lighting strategies are conducted to assess the visibility of workers under the balloon light and light tower when wearing different high visibility apparel and the Halo light. This additional pilot testing was intended to provide a better understanding of the visibility in different situations in the work zones.

7.0 PIOLOT TESTING OF LIGHTING STRATEGIES

Pilot testing of the lighting equipment was conducted as an initial evaluation of the selected lighting strategies. The testing included the lighting equipment, high visibility apparel, and other personal safety equipment under controlled, off-roadway conditions. Each strategy was assessed to find the best lighting strategy for actual field testing and to determine its feasibility, performance, and limitations during implementation. Selected lighting strategies were assessed to evaluate their potential for efficient and economic implementation, their ability to provide effective lighting to illuminate workers, and associated limitations to their implementation. As part of the testing, the researchers determined recommended location and orientation of the light systems, along with an effective amount of light emitted to illuminate the workers without creating disabling glare for drivers. Light meters was used to measure the amount of illumination in the work area and on the worker. Standard reflective clothing was worn by the researchers to simulate working conditions.

7.1 LIGHTING STRATEGIES AND TESTING ACTIVITIES

A two lane roadway adjacent to the Corvallis Airport (SW Plumley St.) was selected to perform the pilot testing. There was no traffic on the road which allowed for observing the light systems from a great distance without any interruptions. The roadway is located on a sufficient distance from the airport lighting and surrounding area lighting such that there was no impact from the surrounding lights on the testing.

The testing was performed on a straight section of roadway, which is oriented in a north-south direction. The light equipment was placed near the end of the road so that there was enough distance away from the light for observations at different distances. Markings were placed on the roadway in the upstream direction at 50, 100, 500, and 1,000 feet away from the light. The markings were used for setting the camera at different distances from the light to capture photos and to compare the visibility of different strategies.

Based on the availability of the equipment, consultation with the TAC, results of the survey and focus groups, a balloon light and light tower were selected for inclusion in the testing. Other lighting systems such as flood light and spot light were not selected for this part of the study because the lights typically do not provide enough lumens to illuminate the work area as reported from previous research (SPR 617).

Visibility of the worker was evaluated with the balloon light, the light tower at 0 degrees offset angle, the light tower at 45 degrees offset angle, and no light equipment present. In all cases, a passenger car was located at the same distance as the observation with its headlights turned on and pointed towards the light. One of the researchers posed as a worker on the roadway, wearing either the Class 2 vest only, Class 2 vest plus Class E pants, or Class 3 vest only. For each condition, another researcher took photos of the worker from four different distances away from the light (50, 100, 500 and 1,000 feet). While taking the photos, the car headlights were turned on next to the photographer to simulate the actual working situation on the road when there is a moving vehicle next to the activity area on preservation projects.

Observations also were conducted while the researcher wearing the reflective apparel stood in four different locations with respect to the light: immediately adjacent the light and downstream of the light in both the lane next to the light or in one lane away from the light (positions 1, 2, 3, and 4 in Figure 6.6).

The researchers also investigated the visibility of worker while wearing the Halo light. The researchers monitored the visibility at different distances to the light (50, 100, 500 and 1,000 feet), different locations of the worker on the roadway with respect to the light (positions 1-4), and with the worker wearing different high visibility apparel (Class 2 vest, Class 3 vest, and Class 2 + pants). Each of the observations was made both with the Halo light turned on and with the Halo light turned off. Table 7.1 shows the different variables considered during pilot testing.

Table 7.1: Light Testing Variables

	Variables considered for pilot testing				
	Light equipment	Distance away from light (ft)	High visibility apparel worn	Position of worker on roadway (see Figure 6.6)	Halo light status
Options for each variable	Balloon light	50	Class 2 vest	1	On
	Light tower, 0° offset angle	100	Class 2 vest + Pants	2	Off
	Light tower, 45° offset angle	500	Class 3 vest	3	
	No light	1000		4	

In addition to taking photos and observing the worker under different situations, a test grid was marked on the roadway at the light location as shown in Figure 7.1 to measure illuminance in the lighting area. The grid extended across both travel lanes, and for a distance of 60 feet in each roadway direction with 10-foot increments for a total length of 120 feet. Illumination was measured near the road fog lines, on the yellow lane line between the two lanes, and at the middle of each lane.

A light meter was used to measure the amount of light (illuminance) for all of the light equipment configurations and outcome measures. The light meter used in the study was an Extech Datalogging Light Meter, Model 401036 (Figure 7.2). The light meter can measure light intensity from 0.01 to 20,000 foot-candles or lux, and has four measurement ranges (20, 200, 2,000, and 20,000 Fc or Lux). Light readings are taken by a remote, high accuracy silicon photo-diode light sensor that has a basic accuracy of $\pm 3\%$. On each grid node, the illumination was measured at three feet above the roadway surface. Illumination measurements were taken two times for each lighting equipment; one with the researcher facing in the direction of the light, and one with the researcher facing in the direction of the oncoming traffic.

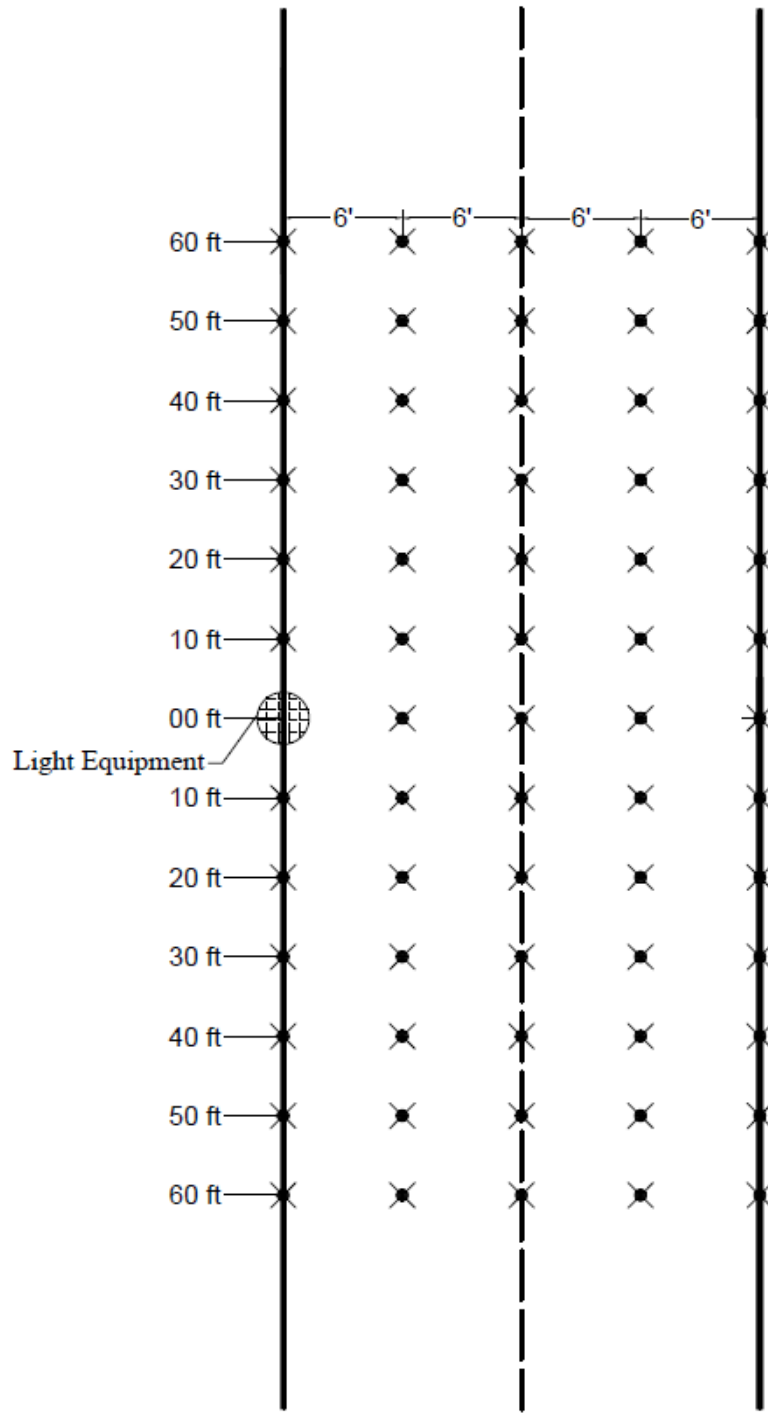

Figure 7.1: Plan View of Roadway showing Grid Layout for Light Measurements



Figure 7.2: Light Meter used for Illumination Measurements

7.2 PILOT TESTING RESULTS

7.2.1 Balloon Light

The balloon light used for this study was a Sirocco 2000 mounted on a tripod. This is a 110-volt system containing two 1,000-watt halogen lamps surrounded by an envelope (balloon) with a diameter of 3 feet and height of 2 feet. The balloon self-inflates. The light can be raised to a height of 19.5 feet (Figure 7.3), and can be easily transported within its cylindrical PVC case. The total weight without the stand is 24 pounds. For operating the light, a generator with at least 3KVA is required.



Figure 7.3: Sirocco 2000 Balloon Light (Airstar Sirocco 2-M 2x 1000W HA Manual)

When combining all of the variable options shown in Table 7.1, there are hundreds of possible combinations to test for the visibility of the worker using the balloon light. Adding more variables, such as the balloon light power, type of lamp, height, and additional observation distances, increases the number of combinations significantly. Simulating all of the possible cases was not possible for the research study, nor a goal of the study. Therefore, for the pilot testing, just the effect of the type of apparel, observation distance, location to the light, and presence of the Halo light was investigated. A comparison of the different cases while one variable was changed and others were fixed, is provided below to present the results.

Impact of distance to the light

The researchers observed the worker from 50, 100, 500 and 1,000 feet away from the balloon light to see how well the worker was recognizable at different distances. Photos from every distances were taken while the apparel, location to the light, and presence of Halo light were varied. Figure 7.4 shows an example when for the case when the worker wore a Class 2 vest and pants at position 2 (upstream of the light in the lane adjacent to the light), and when the Halo light was turned off.



Figure 7.4: Worker at Different Distances from Balloon Light

(a) top left, 50 feet; (b) top right, 100 feet; (c) bottom left, 500 feet; (d) bottom right, 1,000 feet

Impact of high visibility apparel and Halo light

Observation of the worker under four conditions with respect to apparel and the Halo light are shown in Figure 7.5. The observations were made with the worker wearing a Class 2 vest only, Class 2 vest and Halo light turned on, Class 2 vest and pants (no Halo light), and Class 2 vest and pants and Halo light turned on. A Class 3 vest only was not included as an observation during the pilot testing because a Class 3 vest contains the same amount of reflectivity area as the

combination of a Class 2 vest and pants. Therefore, just the comparisons of the Class 2 vest and Class 2 vest plus pants with the Halo light on and off were considered.



Figure 7.5: High Visibility Apparel under Balloon Light from 100 feet Away

(a) top left, Class 2 vest; (b) top right, Class 2 vest and Halo light turned on; (c) bottom left, Class 2 vest and pants; and (d) bottom right, Class 2 vest and pants and Halo light turned on

Location of worker relative to the light equipment

Another important variable for visibility of the worker is the location of worker relative to the light. Sometimes just a few feet away from the light could have a big impact on visibility. Figure

7.6 shows a comparison between different locations of worker relative to the light. Based on this picture comparison, when the worker is located 20 feet downstream of the balloon light, the worker appears brighter than when located immediately adjacent to the light.



Figure 7.6: Worker at Different Positions relative to Balloon Light

(a) top left, 20 feet downstream of light and in lane farthest from the light; (b) top right, 20 feet downstream of light and in lane adjacent to the light; (c) bottom left, immediately adjacent light and in lane farthest from light; and (d) bottom right, immediately adjacent to light and lane next to the light

In addition to taking photos and comparing the visibility of the worker based on different variables, the illumination produced by the balloon light was measured using a light meter. On each grid node shown in Figure 7.1, the illumination was measured when the balloon light was turned on. Figure 7.7 shows the levels of illumination recorded throughout the grid. As mentioned above, a passenger car with its headlights on was present during the observations. The amount of illumination ranges from 0 fc far from the light to the 28 fc under the light. The illumination was recorded three feet above the ground while the researchers faced in the direction of the light (no shading affects). It can be seen that after 30 feet distance from the light, the illumination is less than 1 foot candle which is not enough for any construction work. The amount of the light with the researcher facing in the direction of the oncoming traffic (shading impacts present) is shown in Figure 7.8. The values in Figure 7.8 show the illumination level 10 feet upstream of the light (+10), next to the light (0), and 10 feet downstream of the light (-10). The amount of illumination upstream of the light when facing in the direction of the oncoming traffic was significantly less than the illumination level next to and downstream of the light, and mostly less than 1 fc. This value does not represent the amount of reflection the driver can see on the worker with the reflective apparel. Measuring the light reflection requires a luminance meter which was not available for this study.

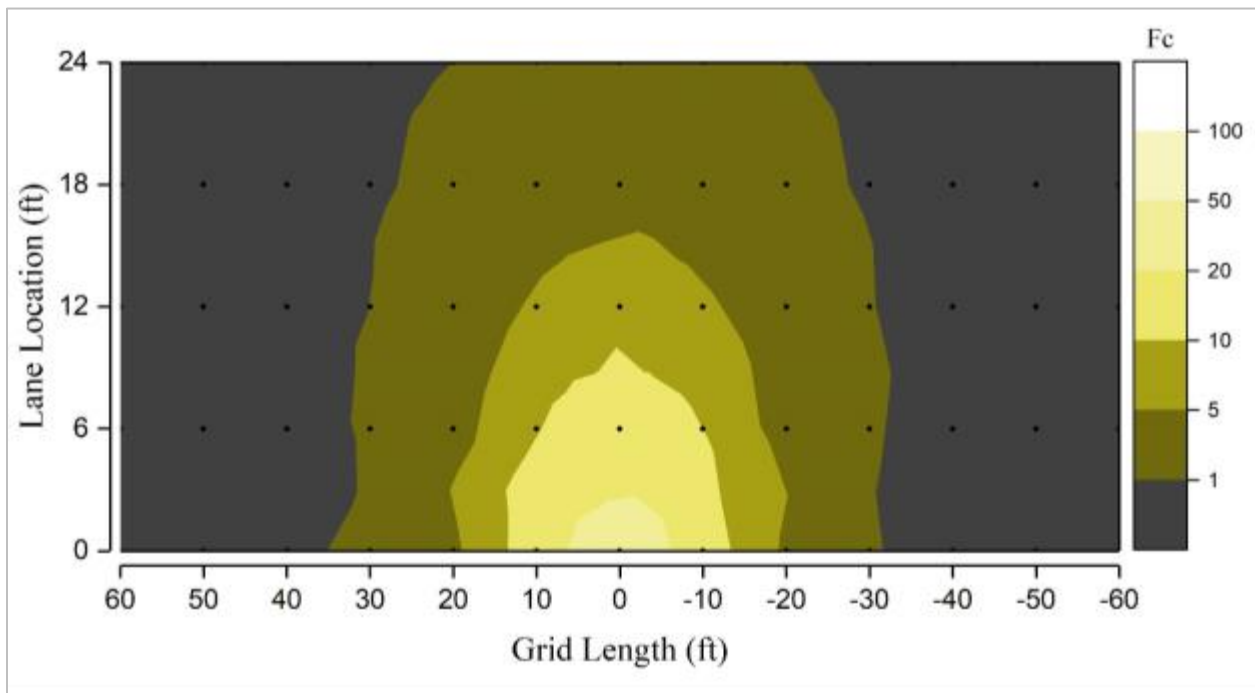

Figure 7.7: Illumination Intensity, Facing in the Direction of the Balloon Light (fc)

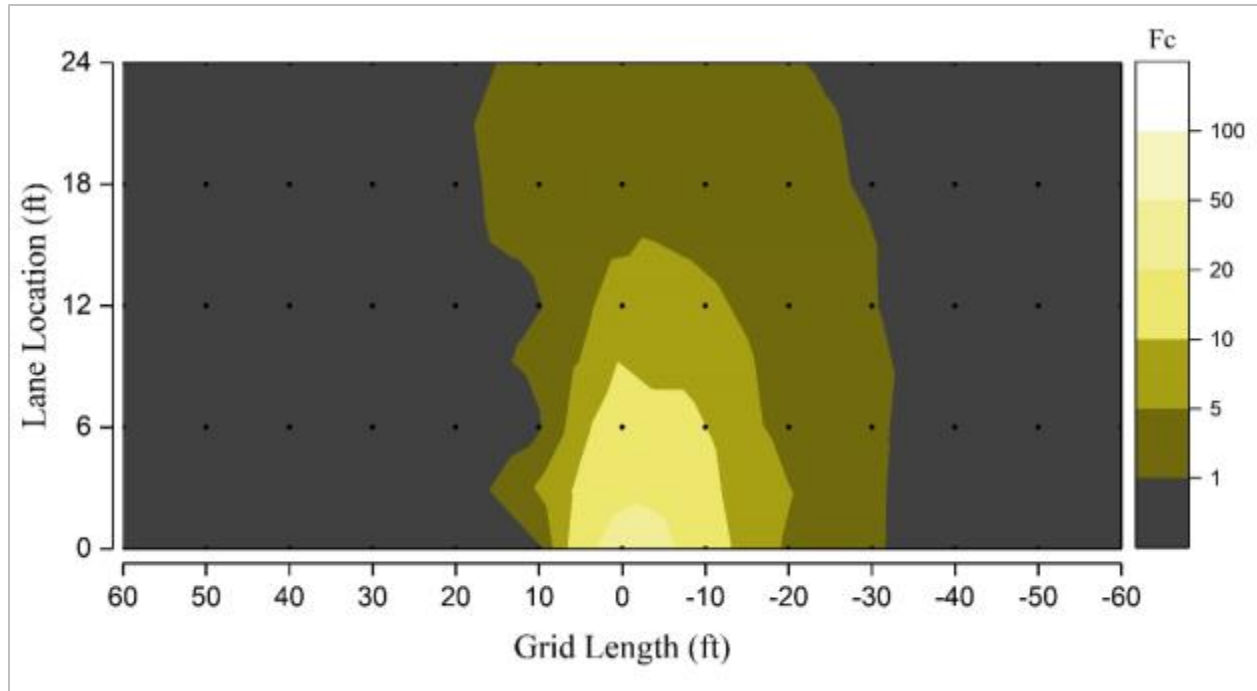

Figure 7.8: Illumination Intensity, Facing towards the Oncoming Traffic (fc)

7.2.2 Light Tower

The light tower used for this study was a Genie TML-4000, owned by the OSU Facilities Services Department. The tower has four luminaires, each one containing a 1,000-watt metal halide HID lamp. The luminaires are mounted on a mast that can extend up to 28.5 feet in height. Each luminaire is made of durable cast aluminum and contains a tempered glass lens. The mast is connected to a generator that powers the lights. The generator sits on a trailer for towing behind a vehicle. Figure 7.9 shows a picture of the light tower with and without the tower raised and two luminaires turned on.



Figure 7.9: Light Tower Used in Pilot Testing

There are many combinations of cases to test visibility for the light tower (0° offset angle or 45° offset angle) when combining all variable options. Adding additional light tower variables, such

as light tower output level, offset angles, aiming angle, height, or location significantly increases the number of possible cases to test. Simulating all the potential cases was not the goal of this research. Therefore, similar to the balloon light, only the impact of the apparel, observation distance to the light, location to the worker relative to the light, and presence of the Halo light were investigated. A comparison of different cases while one variable was changed and others fixed is provided below. For comparison between the light tower and a 2,000-watt balloon light, just two light tower luminaires were turned on which provided 2,000 watt output. To create less glare

for passing motorists, the mast was raised up to 25 feet. The luminaires were aimed at the middle of the lane adjacent to the light tower so that the light would illuminate the working area and produce less glare for passing traffic.

Distance to the light

Similar to the balloon light observations, visibility of the worker was assessed at distances of 50, 100, 500 and 1,000 feet away from the light. The goal was to evaluate whether the worker is visible and recognizable as a worker from each distance. Photos were taken from each distance with different reflective apparel, position relative to the light, and presence of the Halo light. An example is shown in Figure 7.10. The figure shows the case when the worker wore a Class 2 vest and pants at position 2 (downstream of the light in the lane adjacent the light) and the Halo light was turned off under the light tower with 0° offset angle. It can be seen that worker can be recognized easily from distances of 50 and 100 feet away. From 500 feet away, under the 2,000 watt light tower with Class 2 vest and pants, the worker can be recognized, but from 1,000 feet it is not very clear that a person is present.



Figure 7.10: Visibility of Worker from Different Distances to Light Tower

(a) top left, 50 feet; (b) top right, 100 feet; (c) bottom left, 500 feet; (d) bottom right, 1,000 feet

High visibility apparel and Halo light

Observations of the worker under four scenarios with different types of reflective apparel and personal lighting are shown in Figure 7.11. The figure shows the conditions with just a Class 2 vest, a Class 2 vest and Halo light turned on, a Class 2 vest and pants, and a Class 2 vest and pants and Halo light turned on. As can be seen in the photos, it appears that the worker is more visible when wearing a Class 2 vest and pants than only a Class 2 vest. When there is additional

light near the activity area, similar to this situation in which there is a light tower present, there is little difference in visibility of the worker with Halo light on and the Halo light off.



Figure 7.11: Comparison of High Visibility Apparel under Light Tower from 100 feet Away

(a) top left, Class 2 vest; (b) top right, Class 2 vest and Halo light turned on; (c) bottom left, Class 2 vest and pants; (d) bottom right, Class 2 vest and pants and Halo light turned on

Location of worker relative to the light equipment

Similar to the observations that were made of the balloon light, the visibility of the worker at four different positions on the roadway relative to the light tower was evaluated. Figure 7.12 shows a comparison between these four locations (positions 1, 2, 3, and 4 as shown in Figure 6.6). For these observations, the worker was wearing a Class 2 vest and pants with the Halo light turned off. As was observed with the balloon light, the worker is visible in all four positions, with greater visibility when positioned downstream of the light tower (positions 2 and 3).



Figure 7.12: Comparison of Worker Visibility at Different Positions relative to Light Tower

(a) top left, downstream of the light in the lane farthest from the light (position 3); (b) top right, downstream of the light in the lane adjacent to the light (position 2); (c) bottom left, next to the light in the lane farthest from the light (position 4); (d) bottom right, next to the light in the lane adjacent to the light (position 1)

In addition to taking photos of the worker under various conditions with the light tower, the amount of illumination under the light tower was measured using a light meter. Figure 7.13 shows the levels of illumination recorded throughout the roadway grid. The amount of illumination ranges from 0 fc at 60 feet away from the light to 75 fc directly under the light.

Illumination levels were recorded three feet above the ground while the researchers faced in the direction of the light (no shading impacts). It can be seen that greater than 50 feet from the light tower, the amount of illumination is less than 1 fc, which is not enough for any construction work.

The amount of illumination when the researcher faces the direction of the oncoming traffic is shown in Figure 7.14. The illumination values in this figure are shown at locations downstream of the light. The amount of illumination at locations upstream of the light when facing in the direction of the oncoming traffic were all less than 1 fc. It is important to remember that the values shown are not the amount of reflection from the worker that the driver sees. Measuring the amount of light reflection requires a luminance meter which was not available for this study.

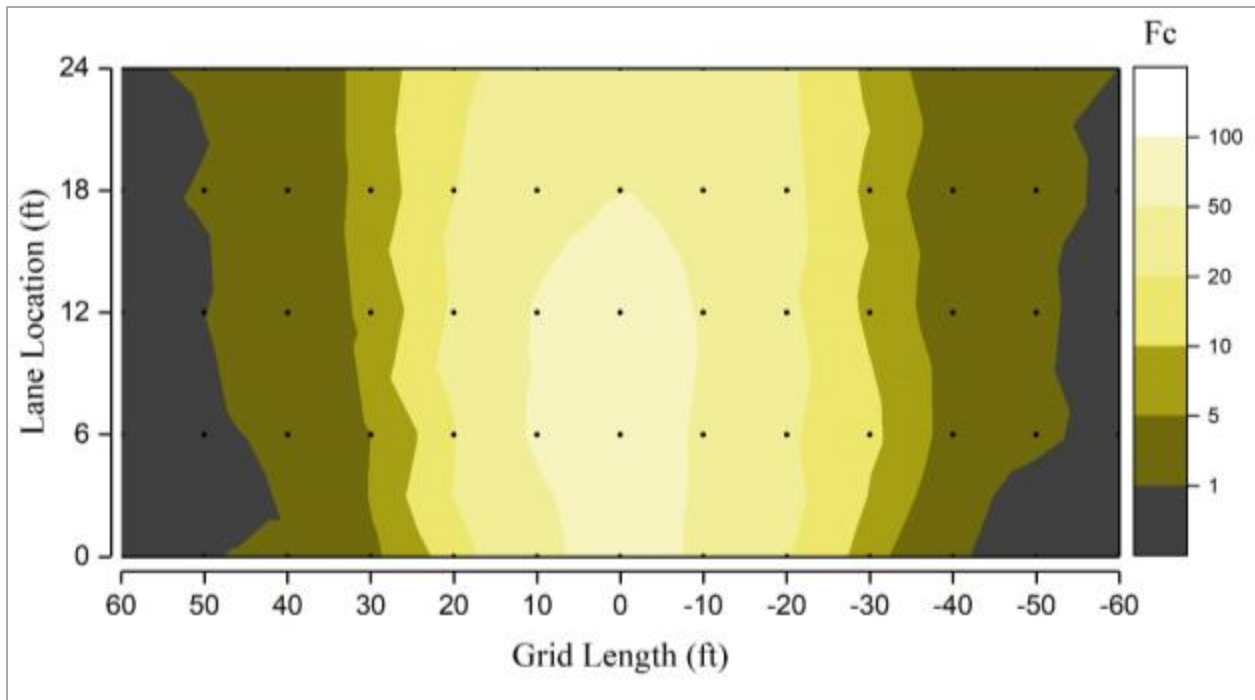

Figure 7.13: Illumination Intensity (fc), Facing Direction of Light Tower (light tower, 0° offset angle)

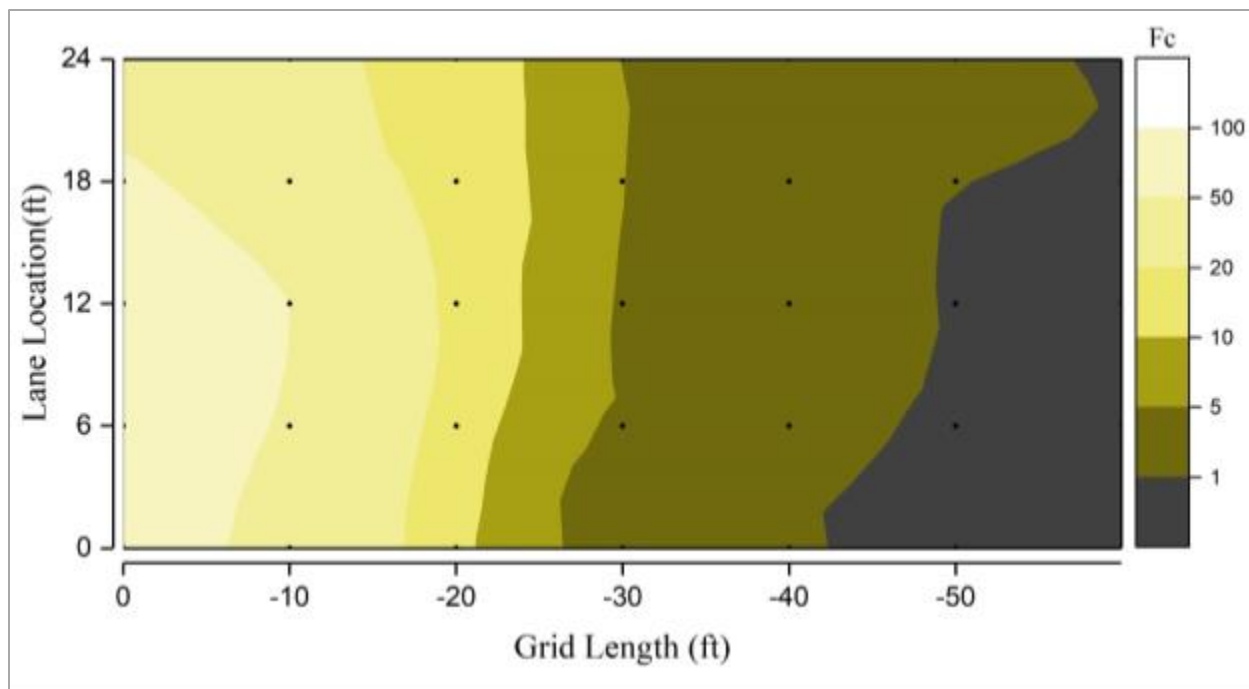

Figure 7.14: Illumination Intensity (fc), Facing Direction of Oncoming Traffic (light tower, 0° offset angle)

7.2.3 Comparison of Light Tower with 0° Offset Angle, Light Tower, with a 45° Offset Angel, Balloon Light, and No Additional Lighting Equipment

Figure 7.15 shows an example of the visibility of the worker from a distance of 100 feet away with the worker standing 20 feet downstream of the light and wearing a Class 2 vest and pants. The figure shows that the lighting equipment (balloon light and light tower) can illuminate a limited area in the vicinity of the light, typically approximately 30-50 feet from the light location. Outside this area there is little or no light. When passing traffic is close to the activity area such as would be the case shown in Figure 7.15, the worker can be seen in all cases at 100 feet distance even without any additional light. However, when observing from a farther distance such as 500 feet away, as illustrated in Figure 7.16, there is significant difference in visibility between when there is light and when there is no light. Without additional light, it is very difficult for a driver to recognize that there is ongoing work and a worker is present when 500 feet away.



Figure 7.15: Visibility of Worker under Different Lighting Equipment from 100 feet Away

(a) top left, no light; (b) top right, balloon light; (c) bottom left, light tower, 0° offset angle; (d) bottom left, light tower, 45° offset angle



Figure 7.16: Visibility of Worker under Different Lighting Equipment from 500 feet Away

(a) top left, no light; (b) top right, balloon light; (c) bottom left, light tower, 0° offset angle; (d) bottom right, light tower, 45° offset angle

7.3 SUMMARY OF PILOT TESTING RESULTS

The pilot testing results reveal that a worker can be recognized easily from a distance of 50 and 100 feet away from the worker both with and without any additional lighting. From a distance of 500 feet away under the 2,000-watt light tower and the balloon light with the worker wearing a Class 2 vest and pants, the worker can be recognized. However, from 1,000 feet away or more under similar conditions, it is not very clear that there is a worker present. At the farther

distances (1,000 feet and farther) just the light is visible without recognition of anything else present. When closer than 1,000 feet, the workers are typically recognizable. Considering vehicle stopping distance, having any additional light in the highway work zone can help drivers better recognize workers and react at a safe distance.

The results suggest that a Class 2 vest and pants makes a person more visible as a worker than when just wearing a Class 2 vest only. When there is additional light near the activity area, such as a light tower or balloon light, there is not much difference in visibility between the cases when the Halo light is on and when the Halo light is off. However, when there is no additional light available (e.g., no light tower or balloon light), there is a big difference between in visibility with the Halo light turned on and with the Halo light turned off. Without the Halo light, the worker is less visible.

The surrounding light near the camera is different in some photos since it was not possible to change between different lighting systems because of the long warming up time for the light tower. The research team does not believe that the surrounding light levels impacted the results. When comparing the photos in the figures above, it should be remembered that the photos were taken with a regular DSLR camera with 18-55 mm lens during the nighttime. For future research on worker visibility, it is recommended that a professional photography camera be used under different lighting situations by quantifying the reflected light.

8.0 FIELD IMPLEMENTATION AND TESTING (CASE STUDIES)

One of the research tasks was to test the use of additional temporary lighting equipment and strategies in actual roadway work zones to assess the impacts of the lighting on vehicle speeds, worker safety, contractor operations, and work performance. In addition, ODOT elected to incorporate high-visibility apparel and personal lighting, in combination with temporary roadside lighting, to investigate the impacts of these types of personal protective equipment (PPE) on vehicle speeds. The research tasks, described in this section of the report, consist of an explanation of the field data collection on three short-term preservation projects on high-speed roadways in the State of Oregon. The projects were studied in August and September 2016. On each case study project, travel speeds, length of traveling vehicles, and the time of passing were recorded at several locations within the work zones.

In all case studies, in addition to the lighting prescribed in the existing traffic control plans, the temporary lighting equipment included a balloon light and light tower, which were placed in the work zones some nights and at specific locations. For comparison, some nights the lighting systems were placed in the work zone, but with the lights turned off to use as a baseline (control) case. Portable traffic analyzers (speed sensors) were located at multiple locations prior to and within the work zone to measure the impact of the lighting equipment on vehicle speeds at different locations and with respect to specific pieces of construction equipment during each work shift. In addition, at various times during the work period, the researchers had one or more workers wear the Halo Light.

Based on information provided by the contractors, it was assumed that all of the workers were typically wearing a Class 3 vest and pants. For safety purposes, the researchers did not ask any of the workers to wear reflective apparel with less reflective area (e.g., wear a Class 2 vest only or Class 3 vest only). The researchers documented the personal protective equipment (PPE) worn by the workers per work shift in each case study.

8.1 PROJECT IDENTIFICATION

The selection of suitable work zones was crucial to the study. Initially, information on anticipated maintenance and construction projects throughout the State of Oregon was provided by ODOT and downloaded from the Tripcheck.com and Oregon.gov websites. To be suitable for data collection, the work zones had to meet the following qualifications:

- Nighttime construction;
- Multi-lane, high speed roadway;
- Traffic control plan contained one closed lane for construction activities and at least one open lane for passing traffic. Passing vehicles needed to be free to travel at their normal or mandated reduced speed. Therefore, projects controlled by a flagger or pilot car were not suitable;

- Contained enough working shifts to test the different lighting equipment (at least three nighttime shifts); and
- Located in Oregon and accessible to the researchers.

After contacting the ODOT project managers to obtain detailed information about each potential project, three project sites were selected for data collection (Table 8.1). All sites were on Interstate freeways with one open lane for passing traffic.

Table 8.1: Work Zone Case Study Sites

Route Number	Project Location	Region	Number of Lanes Each Direction	Number of Lanes Open to Traffic	Normal Regulatory Speed Limit/ WZ Reduced Speed Limit (mph)	Dates of Study
I-84	Jordan Road to Multnomah Falls	1	2	1	60 / 50	8/15 – 8/20
I-5	Medford to Ashland	3	2	1	65 / 50	8/30 – 9/2 and 9/6 – 9/8
I-84	Mosier to The Dalles	4	2	1	65 / 50	10/2 – 10/3

8.2 DATA COLLECTION

Various types of data were collected on each case study project to understand the impact of using additional lighting equipment on high speed roadway work zones. The data collected includes the passing vehicle characteristics (vehicle type, speed, length, time of day, etc.). In addition, for each project, characteristics of the work zone, construction equipment, worker apparel, and general observations made by the researchers were collected during the case studies. To collect the data, a variety of different pieces of equipment, tools, and resources were used by the researchers, including traffic control analyzers (sensors), a speed gun, a video camera, lighting equipment (including light tower and balloon light) high visibility apparel, Halo light, and light meter. The pieces of research equipment used for the data collection are described below.

8.2.1 Temporary Lighting Equipment

Portable Light Tower

On each case study, a standard light tower (light plant) was used that is similar to that described in Section 7.2.2. The light towers were equipped with four light fixtures, each containing 1,000-watt lamps, mounted to a mast arm capable of holding the luminaires at various mounting heights (Figure 8.1). The actual light towers were provided by the contractor through a separate arrangement with ODOT. Although each piece of lighting equipment was different for each case

study, the researchers determined that all were typical standard light towers and the light levels met at least the minimum qualifications for use on these jobs (Level I, II or III). During the course of the case studies, the contractor moved the light towers to the locations specified by the researchers.



Figure 8.1: Light Tower used on I-84 Jordan Road to Multnomah Falls (Case Study #1)

Balloon Light

For each case study, a balloon light described in Section 7.2.1 was also implemented. The balloon light consisted of a large balloon-type luminaire atop a portable tripod mast and powered by a portable generator. Figure 8.2 shows the balloon light, a Sirocco 2000 mounted on a tripod with two 1,000-watt halogen lamps surrounded by an envelope (balloon) that is 3 feet in diameter and 2 feet tall.



Figure 8.2: Balloon Light used on I-84 Jordan Road to Multnomah Falls (Case Study #1)

8.2.2 Traffic Control Analyzer

A total of 13 NC-200 portable traffic analyzers manufactured by Vaisala, and four NC-350 traffic analyzers (newer model) manufactured by the M.H. Corbin, were used to collect vehicle data on the roadways (in 2013 Vaisala sold the traffic analyzer product line to M.H. Corbin). Figure 8.3 shows an example of an NC-350 traffic analyzer and a cover used to protect the analyzer when on the roadway.

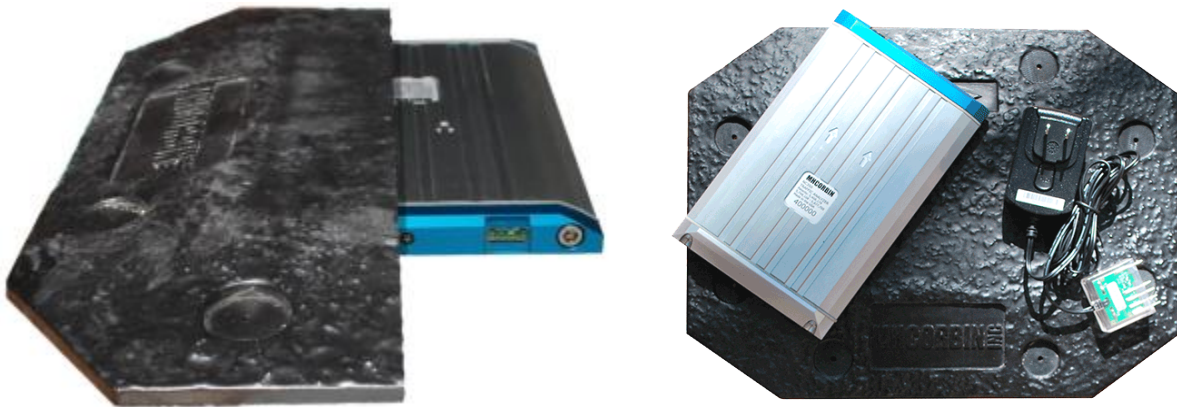

Figure 8.3: NC-350 Portable Traffic Analyzer (M.H. Corbin 2017)

The traffic analyzer is designed to provide accurate traffic counts, speed, and classification (vehicle length) data. The analyzer is placed directly in the traffic lane to measure and record the passing traffic. The sensor utilizes Vehicle Magnetic Imaging (VMI) technology to count the number of passing vehicles and detect vehicle speed and length. The newer traffic analyzer model, NC-350, has the capability of wirelessly communication via Bluetooth to transmit the recorded data. Table 8.2 shows the technical specifications of the NC-200 and NC-350 portable traffic analyzer.

Table 8.2: Technical Specifications of Portable Traffic Analyzer NC-200 and NC-350 (M. H. Corbin 2017)

Criterion	Specification
Housing Material	Extruded/anodized aluminum
Ultimate Bearing Strength	88,000 psi (607 MPa)
Dimensions	7.125 x 4.625 x 0.5 inches
Weight	1.3 lbs
Operating Temperature	-4 °F to +140 °F
Sensor	GMR magnetic chip for Vehicle Magnetic Imaging
Memory	Micor Serial Flash: 3MB
Battery	Lithium-ion rechargeable (can last for up to 21 days without recharging)
Capacity	Up to 300,000 vehicles or 21 days per study, whichever occurs first
Vehicle Detection	Detects vehicles between 5 to 120 mph
Accuracy length classification	+/- 4 ft, 90% of the time
Accuracy speed classification	+/- 4 mph, 90% of the time
Accuracy vehicle count determination	+/- 1%, 95% of the time

8.2.2.1 Traffic Control Analyzer Calibration

Prior to using the traffic analyzers on actual projects, tests of the accuracy of the analyzers were conducted to calibrate the analyzers and determine how different the speeds recorded by the analyzers were from the actual vehicle speeds. Having this information then allows for adjusting the speeds recorded during each case study to the actual vehicle speeds. For the calibration test, all sensors were tested under controlled condition near the Corvallis Airport. The researchers drove over the sensors 2-4 times at speeds ranging from 27 mph to 65 mph with a compact car, a mid-size car, and a pickup truck. The adjustment for each sensor is calculated based on the regression lines from the recorded speed vs. actual speed. Each sensor has a specific three digit identification number. The result of calibration test for sensor #101 is shown in Figure 8.4 as an example. The equations used for final adjustment of speed data collected on the case study projects are presented in Table 8.3. In the table, the variable x represents the speed recorded by the sensor, and the variable y is the adjusted speed to use in the analysis. Overall, some traffic control analyzers showed recorded vehicle speed with more than 10 percent error before calibration, but by using the adjustment equations their recorded speeds were very close to the actual vehicle speeds.

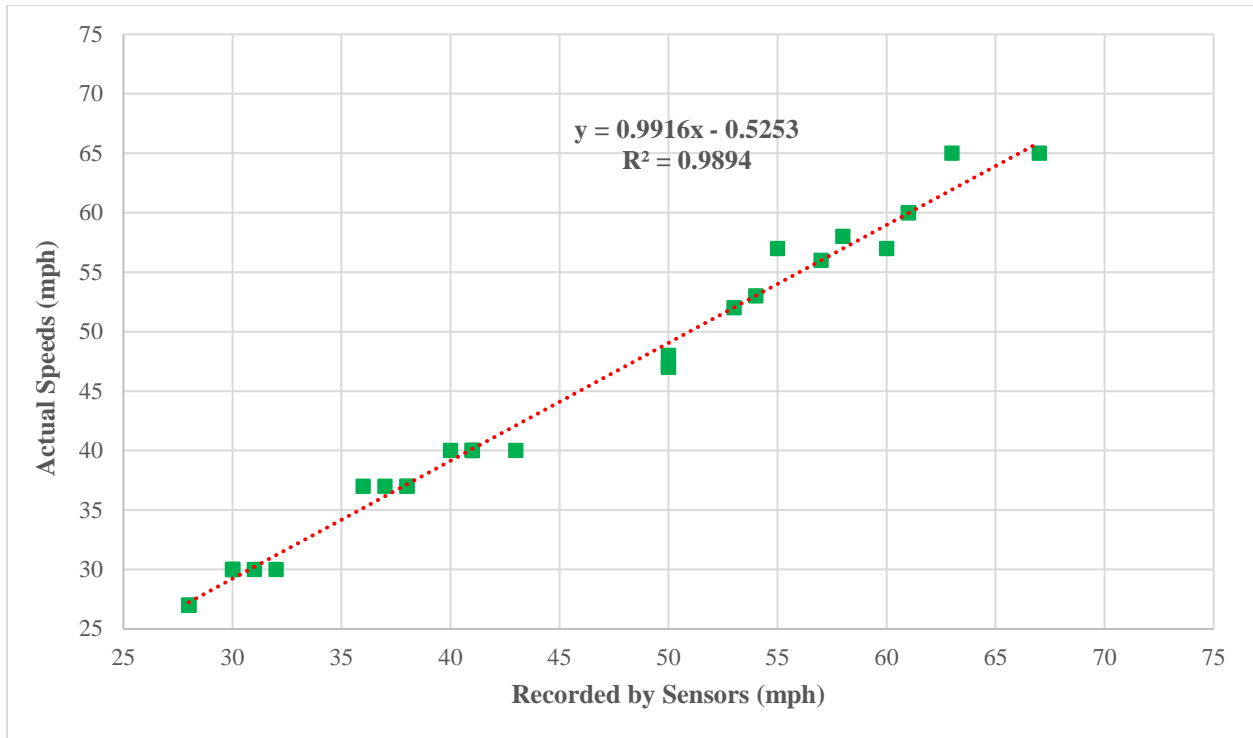

Figure 8.4: Sensor Calibration: Recorded Speed vs. Actual Speed for Sensor #101

Table 8.3: Sensor Data Adjustment Equations

Sensor ID#	Adjustment Equation**
101	$y = 0.9916x - 0.5253$
102	$y = 0.7624x + 5.7773$
103	$y = 1.318x - 5.8361$
105	$y = 1.2694x - 3.6264$
106	$y = 1.0816x - 1.1321$
107	$y = 0.8427x + 2.65$
108	$y = 1.1581x - 3.2035$
216	$y = 0.863x + 4.6449$
379	$y = 1.0541x - 1.297$
687	$y = 0.9048x + 1.3913$
748	$y = 0.9988x - 0.9912$
774	$y = 1.0893x - 2.0651$
816	$y = 0.9801x + 0.0075$
305*	$y = 1.1174x - 3.5767$
317*	$y = 0.8931x + 0.1791$
318*	$y = 0.9066x + 0.6729$
325*	$y = 0.9409x - 0.7549$

*: New traffic analyzer (NC-350)

** : x = speed recorded by the sensor; y = adjusted speed to use in the analysis

8.2.2.2 Traffic Control Analyzer Placement

For all of the case studies, prior to the start of work during each night of data collection, all of the traffic analyzers were programmed to start recording data at the designate time. The sensors were secured to the pavement using adhesive tape which completely covered the analyzer cover and the analyzer. Figure 8.5 shows an example of how adhesive tape was used to keep the analyzer at the desired location. The adhesive tape used for the study was Tapecoat M860 Pavement Repair Coating. This tape is primarily used to repair cracks in concrete and asphalt surfaces. According to the data sheets provided by the manufacturer, Tapecoat M860 is made of a pre-formed, cold-applied, self-adhering material that is impermeable to water and salt (Tapecoat 2012). While the researchers were placing sensors on the pavement, the lane in which the sensors were placed was closed by contractor traffic control trucks and the traffic in the adjacent lane typically slowed down .



Figure 8.5: Placement of Portable Traffic Analyzer using Adhesive Tape (Gambatese and Jafarnejad, 2015)

To fully understand motorist behavior and vehicle speed through the high-speed preservation work zones, 10 to 15 portable traffic analyzers were placed on the pavement for each case study during every working shift. The first two analyzers were placed near the first “Road Work Ahead” (RWA) sign to capture vehicle speeds before the vehicles enter the work zone. One analyzer was placed at the end of the taper. Other analyzers were placed in the travel lane at increments of approximately every quarter mile in the working area. Figure 8.6 shows an example of a plan view of the portable traffic analyzer placement for a typical night. There was also a density technician truck located at various distances upstream of the rollers. The locations of the portable traffic analyzers are indicated with rectangles in the figure. The sensors remained in place during the entire

duration of the work on each work night. At the end of each work night, the sensors were removed and the speed data downloaded for analysis. The sensors were then reprogrammed for testing during the next work shift. The location of sensors was dependent on the existing signs, traffic control devices, the roadway conditions and features, and the planned work progress for each night.

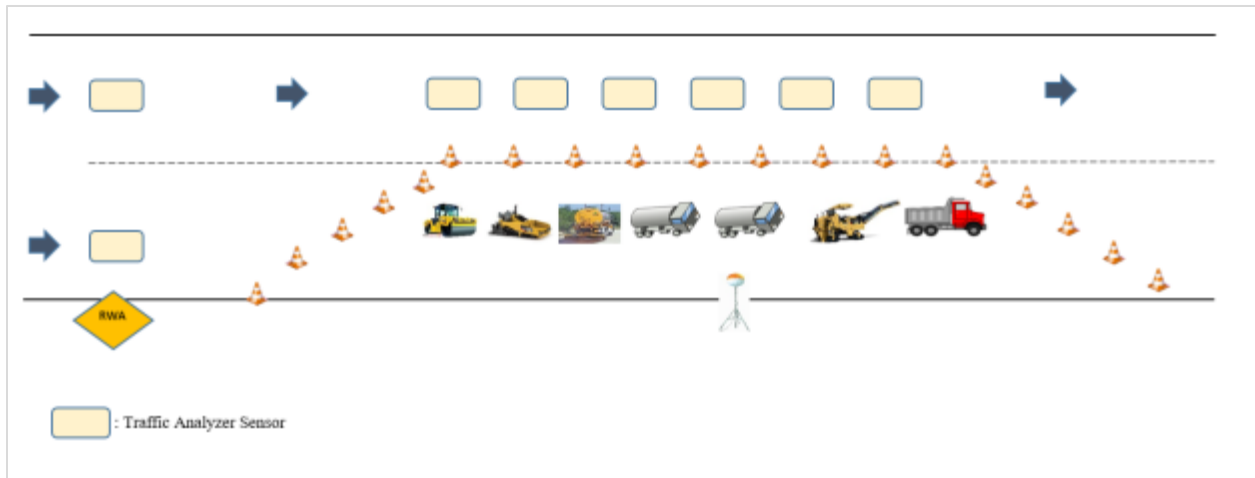

Figure 8.6: Example of Traffic Analyzer Layout and Location in Work Zone

8.2.3 Radar Speed Gun

A radar speed gun was also used to measure and verify the vehicle speeds at specific locations in the work zone. The researchers selected several locations within the work zone to monitor traffic speeds. The researchers held the speed gun for a 5-minute period of time and recorded vehicle speeds. Using the speed gun is an auxiliary method to provide supplementary data for further analysis and verification of the speeds recorded by the portable traffic analyzers. Figure 8.7 shows the speed gun used in the research. The accuracy of the speed gun is ± 1 mph and the speed range is 10-200 mph.



Figure 8.7: Radar Speed Gun

8.2.4 GPS Tracker

Three GPS trackers (Trail by SleuthGear - H6000) were used to record the locations of the grinder, paver, and density technician during the entire paving operation (Figure 8.8). Collecting the location of the equipment helped the researchers during the data analysis, specifically to determine the impact of distance to construction equipment on vehicle speed. The small GPS loggers can be placed in a magnet box and attached to any metal surface on vehicles or construction equipment. The Itrail unit is very small (1.5" x 1.5" x 0.5") and light (5 oz), and last for 16 hours on one charge.



Figure 8.8: Figure 8.8: ITrail GPS Logger used for Tracking Construction Equipment (www.kjbsecurity.com)

8.2.5 Video Camera

In order to obtain the speed profile of an individual vehicle passing through the entire work zone, and to understand how the speed of a vehicle changes throughout the work zone, the researchers used a probe vehicle to follow a randomly selected vehicle through the work zone. Using a video camera in the probe vehicle, the researchers videotaped selected vehicles as the vehicles passed through the work zone. At selected times during each night of testing, the researchers followed a vehicle through the work zone, driving behind and at the same speed as the vehicle. The researchers selected both cars and trucks to follow. In some cases the vehicle's speed was dictated by the vehicle(s) in front of it (e.g., a car trailing behind a dump truck driving slowly). While driving, the researchers videotaped the vehicle and documented the location and vehicle speed approximately every quarter mile. In addition, the researchers documented the vehicle's speed at significant roadway features and traffic control devices, and when passing construction equipment. Each night of testing the researchers videotaped typically 2 or 3 vehicles travelling through the work zone.

8.2.6 Personal Protective Equipment

To assess recognition of the workers, the researchers initially planned to compare the impact of different high visibility apparel worn by the workers with the speed of the passing vehicles. The plan was to have workers wear different reflective apparel during each work shift, including wearing a Class 2 vest, Class 3 vest, and Class 2 vest and pants. After discussions with ODOT staff and traffic control supervisors on the case study projects, it was assumed that most of the workers wear a Class 2 vest and pants or a Class 3 vest and pants. As a result, to prevent any

safety issues for the workers, the test of different high visibility apparel was omitted from the case studies. However, the impact of wearing additional personal lighting equipment was included in the study. Two workers, the density technician and dump person, who are on foot and typically located adjacent to high speed traffic without extra light and protection, were asked to wear a Halo light. The workers were asked to turn on the light during the following hours: 21:00-22:00, 0:00-02:00, and 04:00-05:00 in each working shift. During other working hours, the workers wore the Halo light, but turned it off. Based on this application of the light, the impact of having additional personal lighting equipment was investigated by comparing vehicle travel speeds when the Halo light was turned on to the vehicle travel speeds when the Halo light was turned off.

8.3 CASE STUDY #1: I-84 JORDAN ROAD TO MULTNOMAH FALLS

The first case study project was located in Multnomah County, east of Troutdale, next to the Columbia River. The work operation consisted of asphalt concrete paving of 14 miles of I-84 from Jordan Road (Exit 18) to Multnomah Falls (Exit 31). Figure 8.9 shows the location of the project.



Figure 8.9: Location of Case Study #1 – I-84 Jordan Road to Multnomah Falls

Data was collected while the contractor paved the eastbound slow lane (B-lane) of I-84 on five consecutive nights from Monday, August 15 to Friday, August 20. The highway in this location has two lanes in each direction with a shoulder on the south side of the road and a median in the middle. The posted regulatory speed limit is 60 mph for cars and 55 mph for trucks. During the paving operation, the regulatory speed limit was reduced to 50 mph in the work zone. There was one open lane for passing traffic, separated by cones from the activity area during paving operation. The operation typically started at 19:00 each day and ended at 07:00 the following day. However on most testing days, placing the sensors for the research took place at 22:00 due to needed coordination and support from the contractor. Considering each sensor needs time to warm up and calibrate itself to the local conditions, reliable data for the case study was gathered from 23:00 on this case study. To avoid traffic delays, the highway was not fully closed while placing the sensors in the roadway. The contractor conducted a rolling slow down to support the research team in placing all of the sensors on the pavement. At the end of the work shift, before

the traffic volume became too heavy (at approximately 05:00), the sensors were removed from the roadway in the same manner, data was downloaded from each sensor, and the sensors were reprogrammed for the next night.

The testing plan for each night is shown in Table 8.4. The initial plan for the first day was to place temporary lighting including the balloon light and light tower in advance of the work zone and monitor the impact on vehicle speed. Importantly, the researchers did not want the location of the light to be too far from the work zone. If the light is extremely far, the drivers may not pay much attention or care about it because they cannot see the work being conducted. Due to road shoulder width and safety concerns, on the first night the temporary light equipment was placed at a safe location in advance of the work zone, just at the end of the taper. To compare the difference between the light tower and balloon light, both lights were placed at this location and switched on and off alternately every hour starting at 23:00. The research team started with the balloon light. Days 2 and 5 were control nights and no additional portable light equipment was placed in the work zone. On the third day of testing, the light tower was placed in the middle of the work zone on the right shoulder next to the working lane. On the fourth night of testing, the balloon light was placed in the middle of work zone. The light tower and balloon light were not moved during each night and stayed turned on the whole night.

Table 8.4: Testing Plan for I-84 Jordan Road – Multnomah Falls (Case Study #1)

Day	Day of Week	Date	Paving Operation Lane	Direction	Light Equipment	Light Location
1	Mon.	8/15-8/16	Slow lane	EB	Balloon light and light tower	End of Taper
2	Tu.	8/16-8/17	Slow lane	EB	None (control night)	Not applicable
3	Wed.	8/17-8/18	Slow lane	EB	Light tower	Middle of the work zone
4	Th.	8/18-8/19	Slow lane	EB	Balloon light	Middle of the work zone
5	Fri.	8/19-8/20	Slow lane	EB	None (control night)	Not applicable

The light tower used in this case study had three 1,000-watt lamps turned on and with an aiming angle less than 30 degrees. The luminaires were raised to a height of 21 feet. The balloon light was an Airstar with a 2,000-watt halogen lamp that used during the pilot test. In addition, separate from other research study, the contractor mounted five balloon lights on the paver to illuminate the working area around the paver as shown in Figure 8.10.



Figure 8.10: Paver with Balloon Lights, I-84 Jordan Road to Multnomah Falls (Case Study #1)

Additional traffic control measures were present in the work zone as part of the traffic control plan for the project. The contractor placed a radar speed sign (RSS) on a trailer near the taper. The RSS showed the vehicle's speed, and also had a black and white regulatory "SPEED 50" sign attached to it. There were three rollers used during paving operation, each with a portable changeable message sign (PCMS) mounted on its top. The sign alerted drivers about the workers in advance of the paver (Figure 8.11). The rollers had headlights on each end to help illuminate in the work area. However, the headlights on the rollers were aimed directly towards the oncoming traffic which, based on field observations, likely caused some glare for the passing motorists. As indicated above, some states specify that headlights on construction equipment shall not be used in work zones if the equipment is oriented such that the lights shine in the direction of oncoming traffic.



Figure 8.11: Rollers with PCMS Signs, I-84 Jordan Road to Multnomah Falls (Case Study #1)

8.4 CASE STUDY #2: I-5 MEDFORD TO ASHLAND

The second case study project was a paving project on Interstate 5 (Pacific Highway) between Ashland (MP 19) to Medford (MP 27). The project included grinding two inches of open graded mix and replacing it with 2 inches of dense grade mix. The working operation was from 19:00 to 07:00 each day. Figure 8.12 shows the location of the project. In this figure, the locations of the speed sensors on different nights are indicated by the yellow stars.

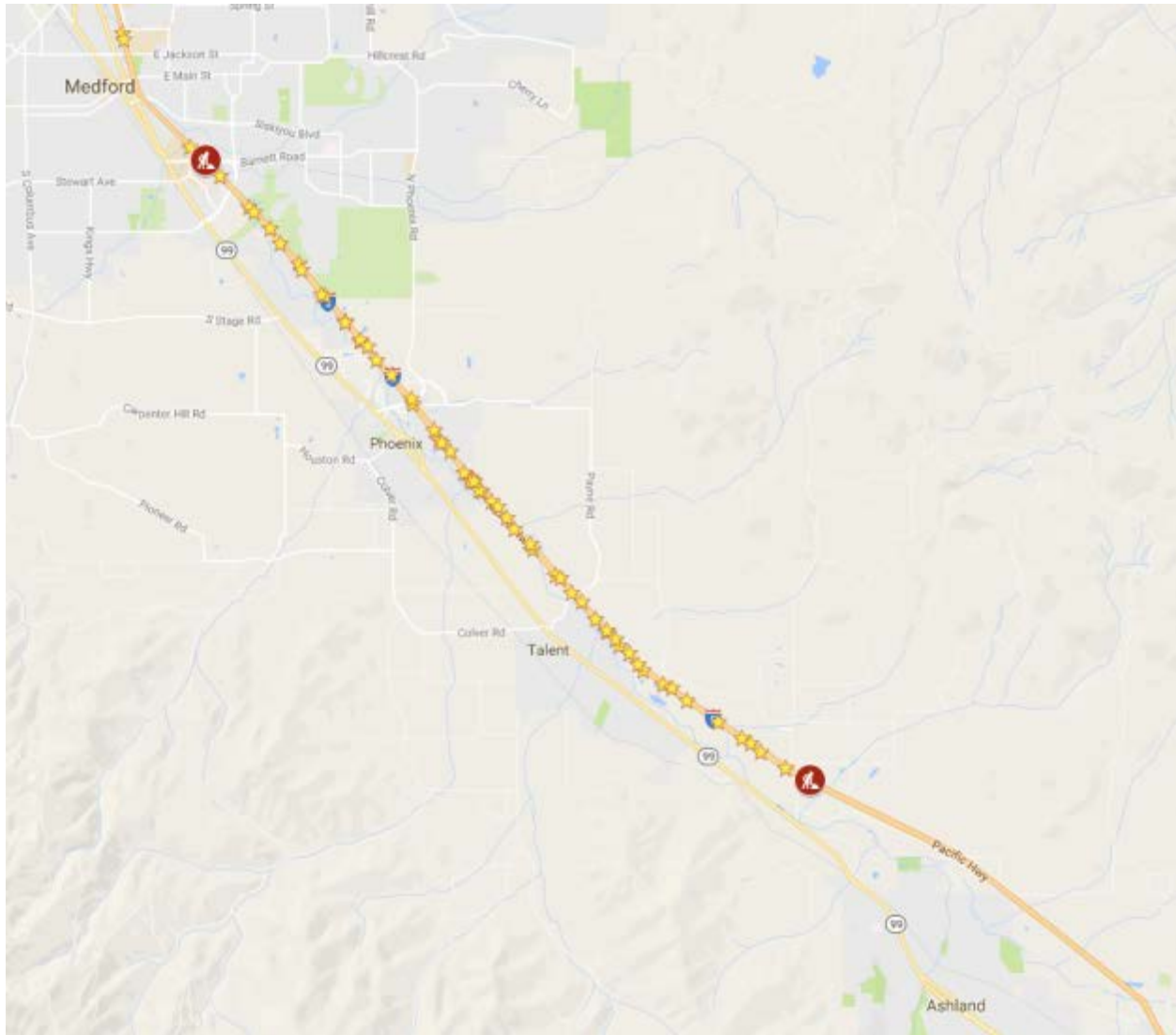

Figure 8.12: Location of Case Study #2 – I-5 -Medford to Ashland

Data collection took place on working days (Tuesday, Wednesday and Thursday nights) between August 30 and September 8. The roadway in this location is a north/south road with 2 lanes in each direction separated by a median. The posted regulatory speed limit is 65 mph for cars and 55 mph for trucks. During the paving operation, the regulatory speed limit was reduced to 50 mph in the work zone. One passing lane remained open, separated from the activity area by a line of cones during the paving operation. Similar to Case Study #1, the goal was to test the impact of different portable lighting equipment on vehicle speed and identify preferable locations for the lights. The testing plan involved collecting at least three nights of test data in each direction of the project. However, because of a limited number of days which the paving work was going to take place, the researchers conducted two nights of testing in the northbound direction and three nights of testing in the southbound direction. Details of testing plan are provided in Table 8.5.

Table 8.5: Testing Plan for I-5 Medford to Ashland (Case Study #2)

Day	Day of Week	Date	Paving Operation Lane	Direction	Light Equipment	Light Location
1	Tu.	8/30-8/31	Slow lane	NB	Light tower	Middle of the work zone
2	Wed.	8/31-9/1	Slow lane	NB	None (control night)	Not applicable
3	Th.	9/1-9/2	Slow lane	SB	Balloon light	Middle of the work zone
4	Tu.	9/6-9/7	Slow lane	SB	Light tower	Middle of the work zone
5	Wed.	9/7-9/8	Slow lane	SB	None (control night)	Not applicable

Similar to Case Study #1, every night two traffic analyzers (sensors) were put down on the roadway at the RWA sign to capture normal traffic speed prior to the work zone. Other sensors were placed throughout the work zone every quarter mile to record vehicle speeds in the work zone. The sensors remained on the roadway during the entire working shift and were removed at the end of each shift. At the end of each work shift, recorded data was downloaded and the sensors reprogrammed again for the next night. On this case study project, every night the sensors were placed on the pavement before 20:30. Considering the required 30 minutes to warm up and calibrate for the NC-200 sensors, vehicle travel speeds were recorded every night from 21:00 to 05:00 the next morning.

On this project, as shown in Figure 8.13, the contractor placed a trailer-mounted RSS in the work zone after the taper with a balloon light next to it. The intent of the RSS and balloon light was to help reduce the speed of passing vehicles to 50 mph. Later in the night, another radar speed trailer was added a quarter of a mile after the first radar speed trailer.



Figure 8.13: Radar Speed Trailer with Balloon Light, I-5 Medford to Ashland (Case Study #2)

Portable lighting equipment used in this case study was the Airstar 2,000-watt halogen balloon light used on Case Study #1, and a light tower provided by the contractor with four 1,000-watt metal halide lamps. When illuminating the activity area with the light tower, just two of its four lamps were turned on to be comparable with the balloon light and produce less glare for passing traffic (see Figure 8.14). The balloon light and light tower were raised to heights of 15 feet and 21 feet, respectively.



Figure 8.14: Lighting Equipment used for I-5 Medford to Ashland-(Case Study #2)

As shown in Figure 8.15, the paver used by the contractor on this project had one balloon light at the rear left side, and one attached lighting mast with a combination of LED light and two spot lights on the right side. These lights were in addition to the paver headlights and side lights.



Figure 8.15: Paver Lighting, I-5 Medford to Ashland (Case Study #2)

8.5 CASE STUDY #3: I-84 MOSIER TO THE DALLES

The last case study project was a paving project located on Interstate 84 between Mosier and The Dalles. This project was started after several delays on September 30. Initial work activities involved paving the westbound shoulder. Since there was not a wide, safe place to put the light equipment, the researchers chose not to place any lighting equipment on the first night of testing and considered that night as a control night (no additional lighting present).

On the second night of testing, the project continued on October 2 with paving in the slow lane (B-lane) in the eastbound direction of I-84 (opposite direction than on the first night of paving). The light tower and balloon light were placed in the middle of the work zone, and the lights alternated each hour with regards to which light was turned on.

Before placing the sensors for data collection on the third night of testing, the work operations were canceled because of bad weather. ODOT decided to reschedule the remaining paving work on the project for completion the next year. Therefore, data from only one control night (westbound direction, shoulder paving) and one treatment night (light tower and balloon light, eastbound direction, slow lane paving) was available. Data on additional nights of testing was not available for analysis.

The confounding variables associated with comparing different traffic directions, which resulted to different traffic volume and speed, and also a different paving lane (during slow lane paving the open traffic lane was narrower which could lead to a decrease in the passing vehicle speeds) could lead to the inaccurate comparisons of the data. Therefore, this case study was omitted from further analysis. Only Case Studies #1 and #2 are included for further analysis.

9.0 RESULTS, ANALYSIS, AND EVALUATION

The data collected from the case study projects was downloaded from the traffic analyzers for analysis. As explained above, Case Studies #1 and #2 had enough data for analysis. For each case study, traffic volume, vehicle speeds, and speed variability with the baseline case (without the lighting system) were compared to that when the light system was implemented and turned on. In this section of the report, descriptive statistics of data collected on each case study are presented first, and then the results of the analyses are presented. With all of the traffic analyzers used and the multiple periods of testing, a very large amount of data was collected on each case study. In addition, multiple quantitative analyses were conducted on each case study. As a result, the number of tables and figures generated for each case study is quite extensive. Therefore, in the body of the report, only representative tables and figures are provided in order to clearly and efficiently communicate the results and findings of each case study. All of the tables and figures created as part of the analyses are provided in the Appendix for further detail and reference if needed.

For all of the case study data presented below, the data has been adjusted to take into account the error in the traffic analyzers as described in the previous section of this report. Additionally, analyses are only conducted within each case study; analytical comparisons between different case studies are not made. The differences in site conditions, vehicle distribution, test layout, and maintenance work operations between each case study limit confidence in the comparisons due to the confounding factors.

9.1 CASE STUDY #1: I-84 JORDAN ROAD TO MULTNOMAH FALLS

On this case study, data was collected from 23:00 until 05:00 the next morning on each night of testing. Figure 9.1 shows an example of the number of vehicles passing for Case Study #1, from 01:00 to 02:00 on all five days of testing as recorded by a sensor in the middle of the work zone. There is some difference in the number of passing vehicles on different days. In general, it can be seen that Days 1 to 4 are very similar in the number of passing vehicles, and the number of passenger cars (vehicles <25 feet in length) and trucks (vehicle >25 feet in length). On Day 5, a higher number of vehicles was recorded than on the other days.

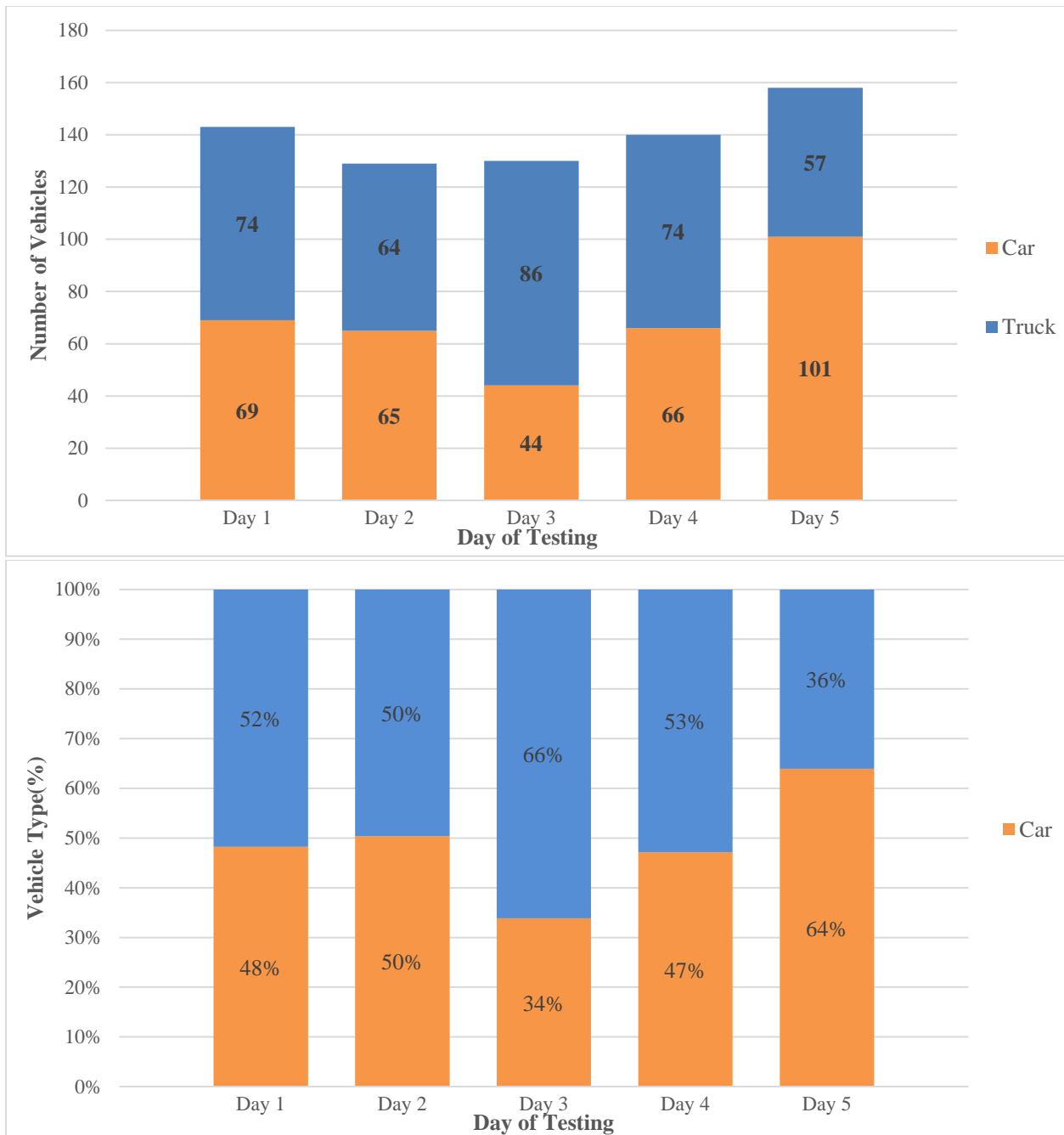

Figure 9.1: Daily Traffic Volume from 01:00–02:00, Total and by Vehicle Type (Case Study #1)

Figure 9.2 shows how the number of passing vehicles changed in the work zone over the course of one night of testing (Day 3). At the start of recording, between 23:00-24:00 the total number of vehicles was 238, which included 157 passenger cars and 81 trucks. Later in the work shift, total number of vehicles decreased to 159 vehicles. The minimum number of vehicles on most testing days occurred from 02:00 to 03:00. At 03:00, the number of vehicles typically started to

increase. Then from 04:00-05:00, total number of vehicles was typically approximately the same as the total number of vehicles from 23:00-24:00 at the start of testing.

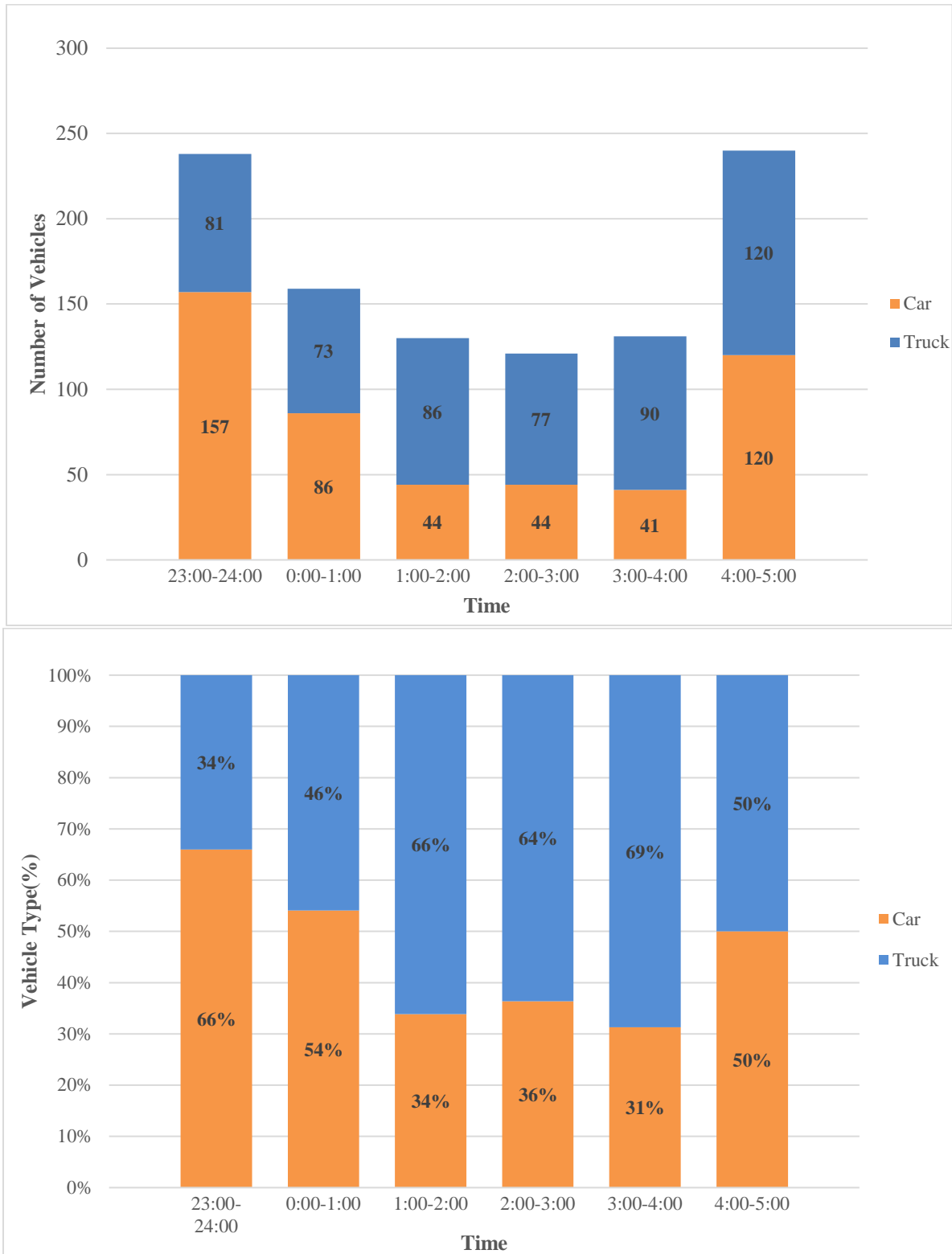

Figure 9.2: Hourly Traffic Volume on Day 3, Total and by Vehicle Type (Case Study #1)

Table 9.1 presents the minimum and maximum percentage of trucks on each day and the related time. The truck percentage varied from approximately 30% to 60% on most days. Between 23:00 and 24:00 the truck percentage was at its lowest, and from 02:00 to 03:00 or 03:00-04:00 it was at its highest. Because there is enough data for each category of passenger cars and trucks, and there is not much variation in the total traffic volume and the truck percentage on different days, no impact on the comparison between speeds on different days is anticipated from the different traffic volumes each day.

Table 9.1: Change in the Truck Percentage on Different Testing Days (Case Study #1)

Minimum and Maximum Truck Percentage and Related Time				
	Percentage		Time	
	Min	Max	Min	Max
Day 1	34%	62%	23:00 - 24:00	03:00 - 04:00
Day 2	40%	61%	23:00 - 24:00	02:00 - 03:00
Day 3	34%	69%	23:00 - 24:00	03:00 - 04:00
Day 4	32%	58%	23:00 - 24:00	02:00 - 03:00
Day 5	26%	56%	23:00 - 24:00	03:00 - 04:00

An example of variation in the number of vehicles recorded by the different sensors is shown in Figure 9.3. This figure shows traffic recorded at different locations including at the RWA sign and all of the sensors in the work zone from 01:00-02:00 on the 3rd day of testing. Since there was not an open on-ramp or off-ramp in the work zone, the total number of vehicles recorded by the different sensors in the work zone should be the same. However, as seen in the figure, there is a small variation between the different sensors. The lowest number of passing vehicles was 118 as recorded by sensor #325, and the highest number of passing vehicles was 139, recorded by sensor #106. When passing vehicles traveled close to each other, the traffic sensors usually consider them as a single vehicle which could be a reason for this difference in the number of recorded vehicles.

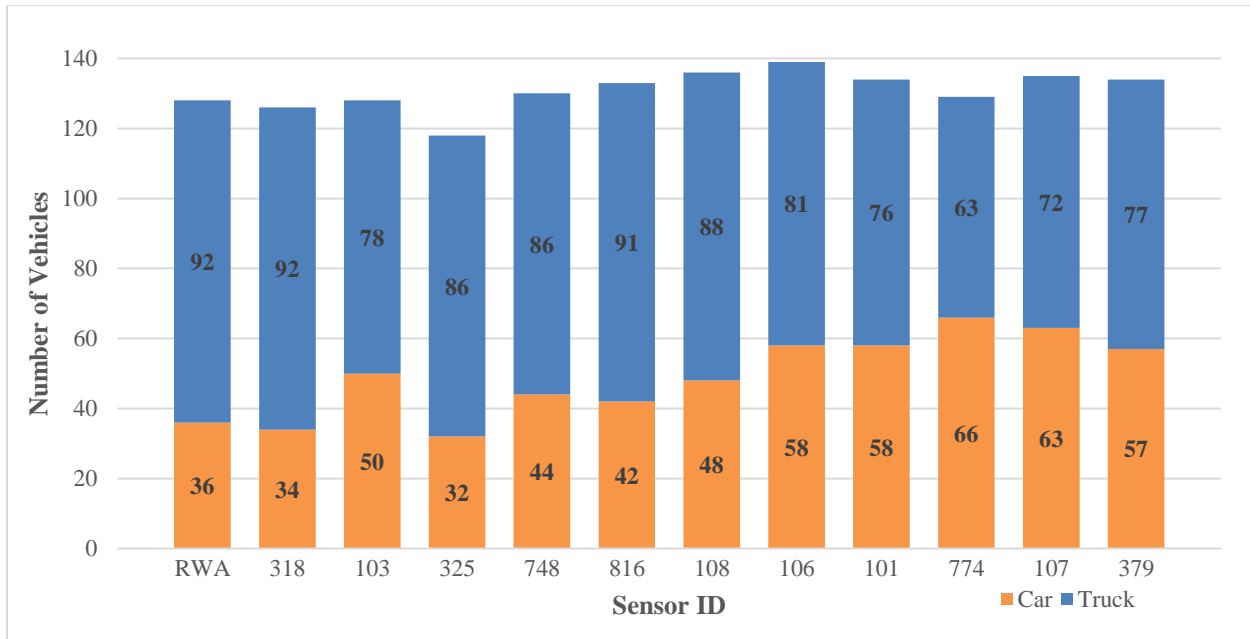

Figure 9.3: Traffic Volume Recorded by Different Sensors on Day 3 from 01:00-02:00 (Case Study #1)

Table 9.2 presents a summary of the vehicle speeds recorded for all vehicles at the Road Work Ahead (RWA) sign location on Day 3 with the light tower turned on and located in the middle of work zone. In this table, data is the combination of data from two sensors placed near the RWA sign in both the slow lane (B-lane) and fast lane (A-lane). As shown in the table, mean speed varies from 61.6 mph from 03:00-04:00 to 65.2 mph from 23:00-24:00. For the entire recorded time during the test period, the average speed was 64.0 mph. This table shows the data prior to the work area at the RWA sign where the posted speed limit was 60 mph. The 85th percentile speed for the entire recording time was 73.4 mph. This value ranged from 74.6 mph to 67.2 mph throughout the test period.

Table 9.2: Hourly Summary of Vehicle Speed, Day 3 at RWA Sign (Case Study #1)

Vehicle Speed (all vehicles)	Time						
	Total	23:00-24:00	00:00-01:00	01:00-02:00	02:00-03:00	03:00-04:00	04:00-05:00
MPH							
< 10	0.0%	0.0%	0.0%	0.0%	0.0%	0.0%	0.0%
10-14	0.0%	0.0%	0.0%	0.0%	0.0%	0.0%	0.0%
15-19	0.1%	0.4%	0.0%	0.0%	0.0%	0.0%	0.0%
20-24	0.0%	0.0%	0.0%	0.0%	0.0%	0.0%	0.0%
25-29	0.1%	0.0%	0.0%	0.0%	0.0%	0.0%	0.4%
30-34	0.0%	0.0%	0.0%	0.0%	0.0%	0.0%	0.0%
35-39	0.2%	0.4%	0.0%	0.0%	0.0%	0.8%	0.0%
40-44	0.5%	0.4%	0.8%	0.8%	1.0%	0.0%	0.4%
45-49	2.6%	3.4%	1.5%	2.3%	1.9%	1.6%	3.4%
50-54	9.1%	7.7%	6.1%	10.9%	12.6%	12.9%	7.6%
55-59	20.1%	16.6%	19.1%	23.4%	24.3%	27.4%	16.9%
60-64	26.9%	20.4%	32.1%	32.8%	25.2%	26.6%	28.3%
65-69	20.8%	22.1%	21.4%	12.5%	20.4%	21.8%	23.2%
70-74	9.4%	14.0%	9.9%	8.6%	7.8%	2.4%	9.3%
>=75	10.1%	14.5%	9.2%	8.6%	6.8%	6.5%	10.5%
Total # of vehicles	958	235	131	128	103	124	237
Average speed	64.0	65.2	64.2	62.7	62.9	61.6	64.1
St. Dev.	9.0	9.5	7.9	7.8	8.3	7.5	9.0
85th percentile	73.4	74.6	70.7	72.4	69.8	67.2	72.5
Min	18.9	18.9	43.0	44.8	43.0	36.8	26.6
Max	98.1	88.1	83.2	84.1	93.6	89.2	98.1
Range	79.2	69.1	40.2	39.3	50.6	52.4	71.5

Similarly, Table 9.3 shows a summary of the vehicle speeds over the same period recorded in the work area, specifically at sensor #748. Similar tables for other sensors and on other days of testing are provided in the Appendix. As seen in the table, the average speed varies between 45.5 mph and 51.6 mph. It appears that the average speed increased slightly from the start of recording at 23:00 to the end of testing at 05:00. The posted regulatory speed limit in the work zone was reduced to 50 mph. The average speed reduced from 64 mph at the RWA sign to 45.9 mph in the middle of the work zone.

Table 9.3: Hourly Summary of Vehicle Speed, Day 3 in Middle of Work Zone, Sensor #748 (Case Study #1)

Vehicle Speed (all vehicles)	Time						
	Total	23:00-24:00	00:00-01:00	01:00-02:00	02:00-03:00	03:00-04:00	04:00-05:00
MPH							
< 10	0.0%	0.0%	0.0%	0.0%	0.0%	0.0%	0.0%
10-14	0.0%	0.0%	0.0%	0.0%	0.0%	0.0%	0.0%
15-19	0.2%	0.0%	0.0%	0.8%	0.8%	0.0%	0.0%
20-24	0.4%	1.3%	0.0%	0.0%	0.8%	0.0%	0.0%
25-29	1.0%	2.9%	0.6%	0.8%	0.0%	0.0%	0.4%
30-34	5.0%	8.8%	6.3%	5.4%	0.8%	3.8%	2.9%
35-39	9.9%	11.3%	11.9%	10.0%	10.7%	9.9%	6.7%
40-44	26.4%	26.9%	25.2%	33.1%	29.8%	27.5%	20.8%
45-49	26.6%	26.5%	26.4%	26.9%	35.5%	29.0%	20.8%
50-54	16.0%	11.8%	19.5%	16.2%	11.6%	16.8%	19.6%
55-59	6.4%	5.5%	6.9%	2.3%	4.1%	6.9%	10.0%
60-64	3.7%	2.5%	1.9%	2.3%	3.3%	0.8%	8.8%
65-69	1.7%	0.8%	0.0%	1.5%	0.8%	2.3%	3.8%
70-74	1.2%	0.8%	0.6%	0.8%	0.8%	0.8%	2.5%
>=75	1.6%	0.8%	0.6%	0.0%	0.8%	2.3%	3.8%
Total # of vehicles	1019	238	159	130	121	131	240
Average speed	45.9	45.5	46.6	46.0	47.0	47.8	51.6
St. Dev.	9.9	9.2	7.6	7.4	7.9	8.7	10.7
85th percentile	53.9	52.9	53.9	52.6	51.9	54.9	62.9
Min	19.0	23.0	30.0	19.0	19.0	31.0	26.0
Max	90.9	85.9	77.9	70.9	87.9	79.9	90.9
Range	71.9	62.9	47.9	51.9	68.9	48.9	64.9

Placing several traffic analyzer throughout the work zone provides the opportunity available to view the vehicle speeds at various locations within the work zone. Figures 9.4 to 9.9 show how the 85th percentile vehicle speed changed from the RWA sign to the end of the work zone on Day 3 of testing. During each testing period, the locations of the grinder, paver, and density technician were tracked with a GPS unit attached to them to allow for correlating their location with the vehicle speeds. In the figures, paver location is identified by a dash-dot line with the letter “P” in each end. When there are two paver lines, the first line represents the location of

paver at the start of that time duration, and the second line shows its location at the end of that time duration. For example, Figure 9.4 shows that at 23:00, the paver was between two sensors located at milepoints 22.8 and 23.0, and later at midnight, the paver was at milepoint 23.5. Similarly, the density technician is presented by a dashed double-dotted line with the letter “D” at each end. The location of the radar speed sign is shown by a double-dash dot line with the letter “R” at each end. Also, the location of the light is shown by a double-dashed line with the letter “L” at each end. The grinder progressed passed the last sensor before 23:00 on Day 3 and therefore its location is not shown in these figures.

Figures 9.4 - 9.9 show that the 85th percentile speed of passenger cars is typically 5 to 10 mph higher than the 85th percentile speed of trucks. In just a few instances, for example at MP 22.8, from 23:00-24:00, the 85th percentile speed of trucks was higher than the 85th percentile speed of passenger cars. The 85th percentile speed of all vehicles was commonly approximately 70-75 mph at the RWA sign. After the RWA sign, the speed decreased gradually in the work zone until approximately the radar speed sign location. There is also a decrease in the 85th percentile speed at the sensor before and after radar speed sign. After the vehicles passed the radar speed sign, if there was no construction equipment present, the vehicle speed increased. The lowest speed occurred typically near the paver with the 85th percentile speed ranging from approximately 40-42 mph. There is not any noticeable change in 85th percentile speed around the light tower on this night of testing until 03:00 when the light tower was in the middle of the paving train. After 03:00 when there was no equipment around the light and all of the paving equipment had already passed the light (Figure 9.8 and Figure 9.9), there is a subtle decrease in 85th percentile speed adjacent the light.

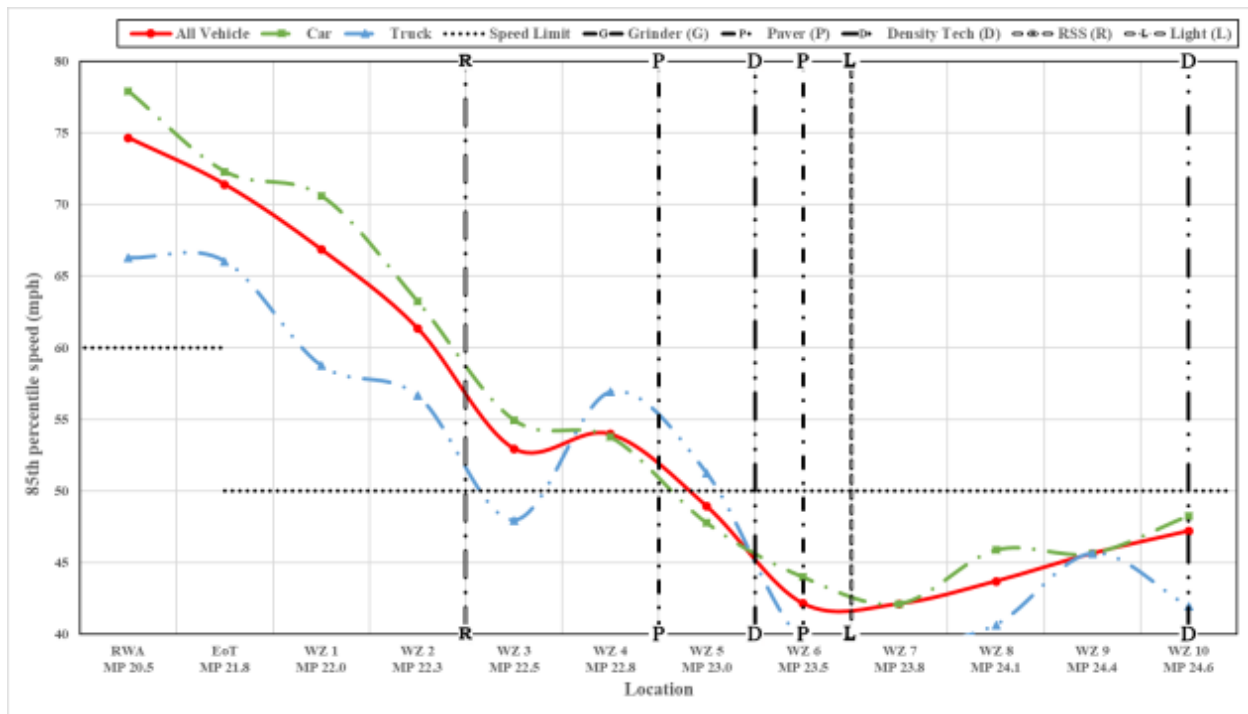

Figure 9.4: Vehicle Speed (85th percentile) at Different Locations, Day 3, 23:00-24:00 (Case Study #1)

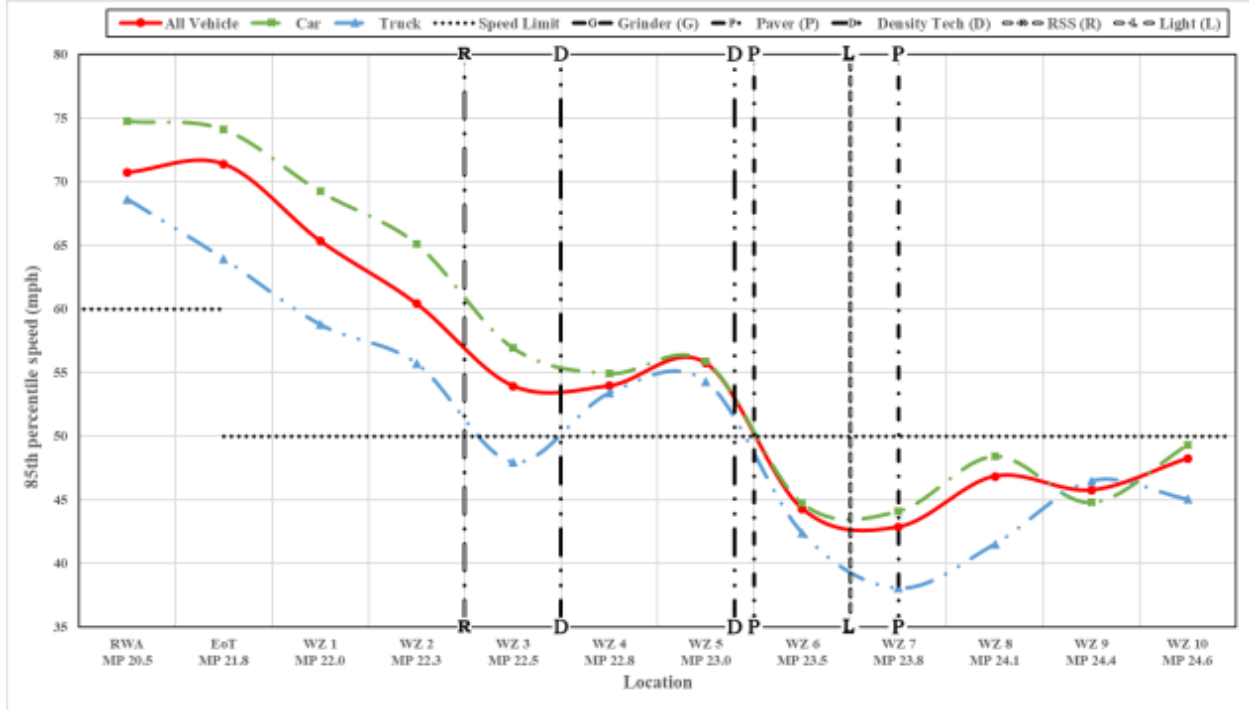

Figure 9.5: Vehicle Speed (85th percentile) at Different Locations, Day 3, 0:00-01:00 (Case Study #1)

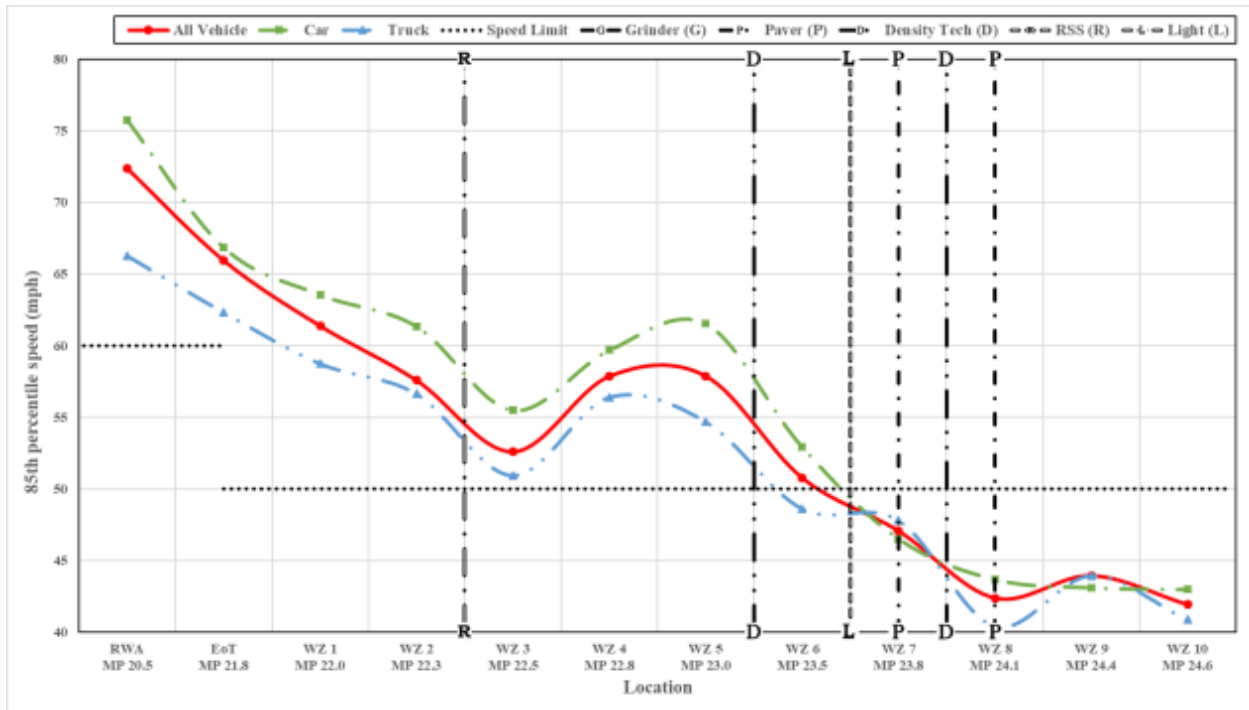

Figure 9.6: Vehicle Speed (85th percentile) at Different Locations, Day 3, 01:00-02:00 (Case Study #1)

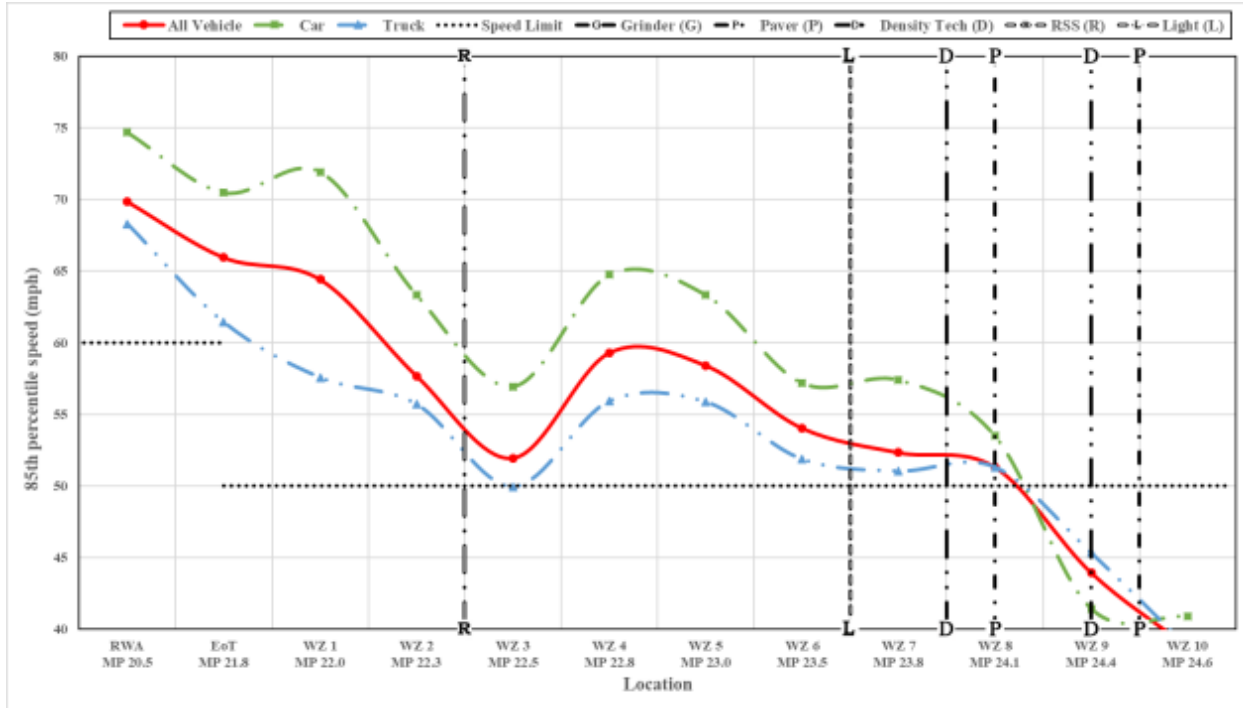

Figure 9.7: Vehicle Speed (85th percentile) at Different Locations, Day 3, 02:00-03:00 (Case Study #1)

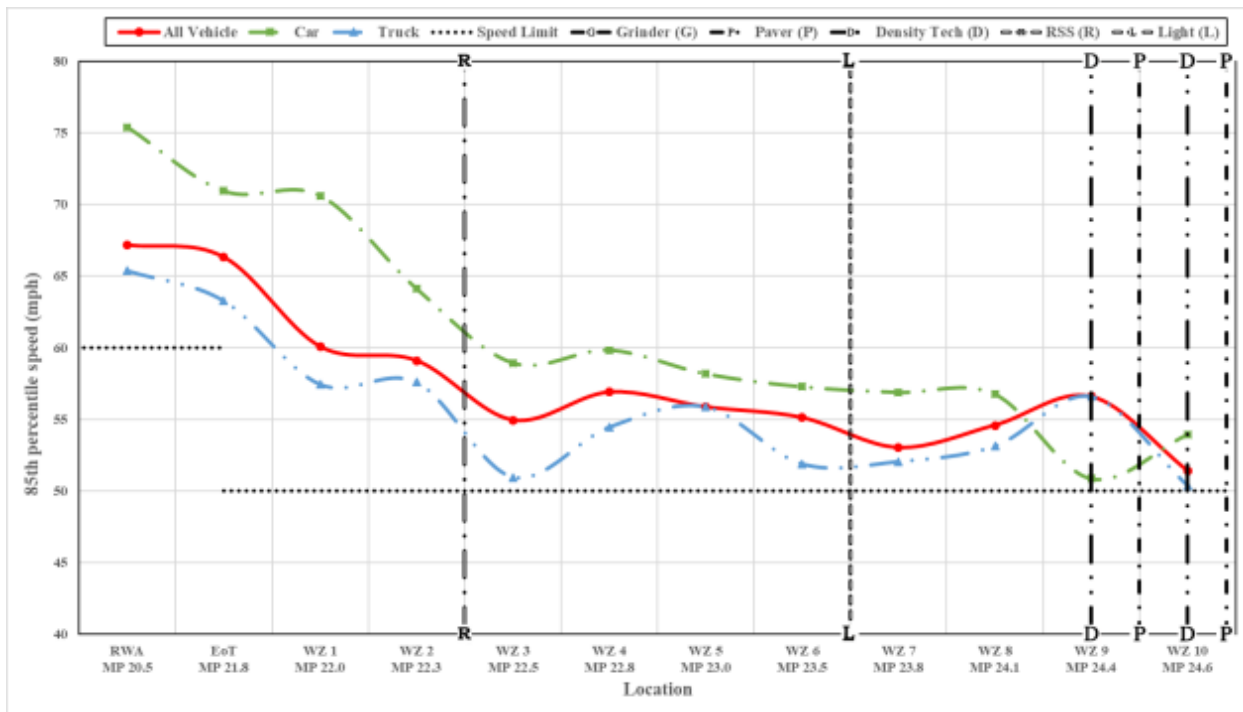

Figure 9.8: Vehicle Speed (85th percentile) at Different Locations, Day 3, 03:00-04:00 (Case Study #1)

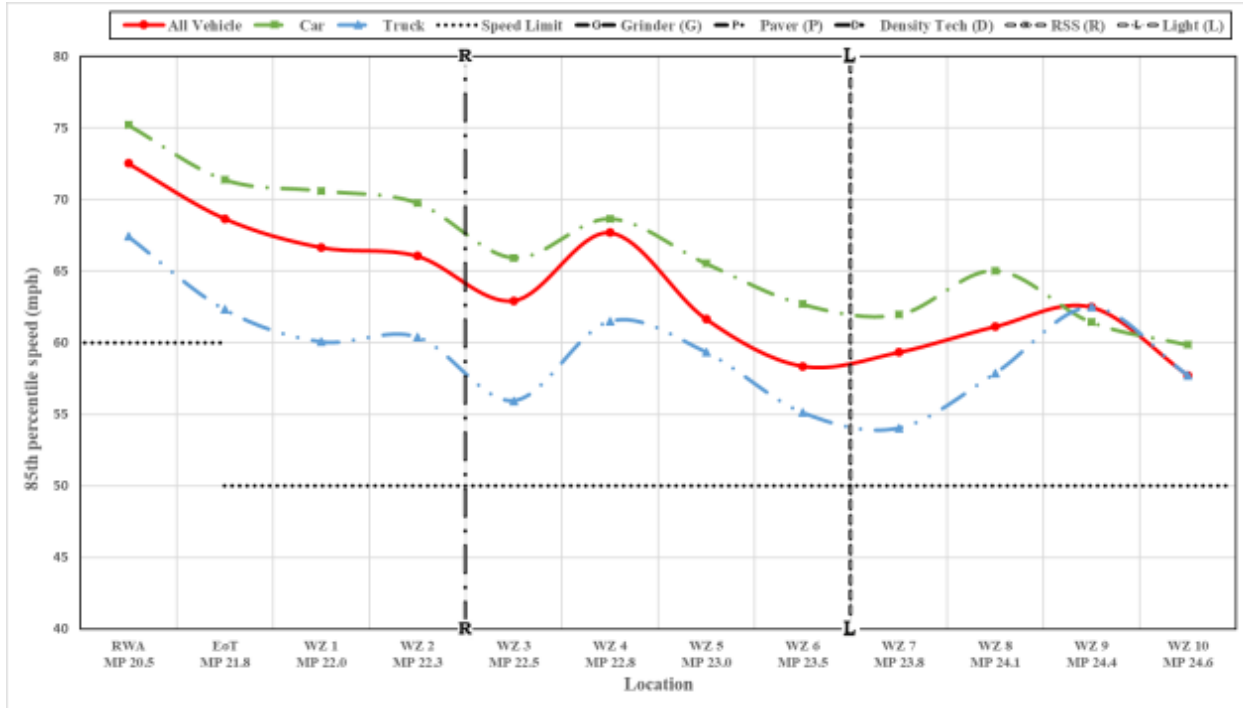

Figure 9.9: Vehicle Speed (85th percentile) at Different Locations, Day 3, 04:00-05:00 (Case Study #1)

The impact of the presence of the paving equipment on vehicle speeds is further illustrated in Figure 9.10. This figure shows how the average speed recorded at a specific location (sensor #774) in the work zone changed during the paving operation on one night of testing (Day 3). At the start of recording at this sensor, the grinder had already passed the sensor and other equipment, such as the tack truck and sweeper, were in the vicinity of the sensor. The average speed of all travelling vehicles was approximately 37 mph between 23:00 and 01:00. Later, from 01:00 to 02:00 when the paver was near the sensor, the average speed was the lowest average speed (33 mph) of all the times in that night. After the paver passed the sensor, the vehicles speed gradually increased back to the normal speed at 50 mph.

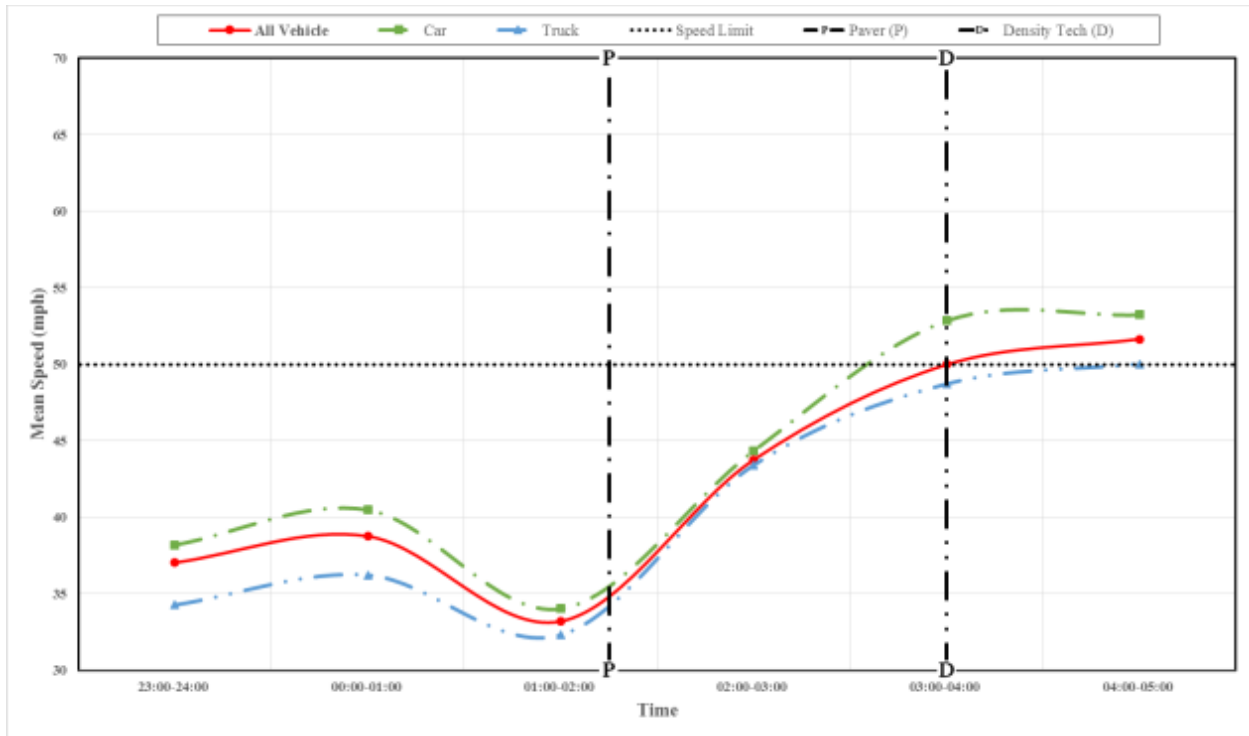

Figure 9.10: Hourly Vehicle Speed (Mean Speed) in Work Zone (Sensor #774), Day 3 (Case Study #1)

It is likely that vehicle speed in the work zone depends on the speed of vehicles prior to the work zone. Figure 9.11 shows how the mean speed at the RWA sign changed during different hours on each day of testing compared to the 60 mph posted regulatory speed limit in this case study. On the first day of testing, the slow lane traffic analyzer sensor did not work properly, therefore, there is no line reported for Day 1 in the figure. The mean speeds on Day 2 (control night), Day 3 (light tower), and Day 4 (balloon light) are very similar with very low variation between 62-64 mph most of the time. On Day 5 (second control night), the figure shows a mean speed of approximately 1-2 mph more than the mean speed on other days.

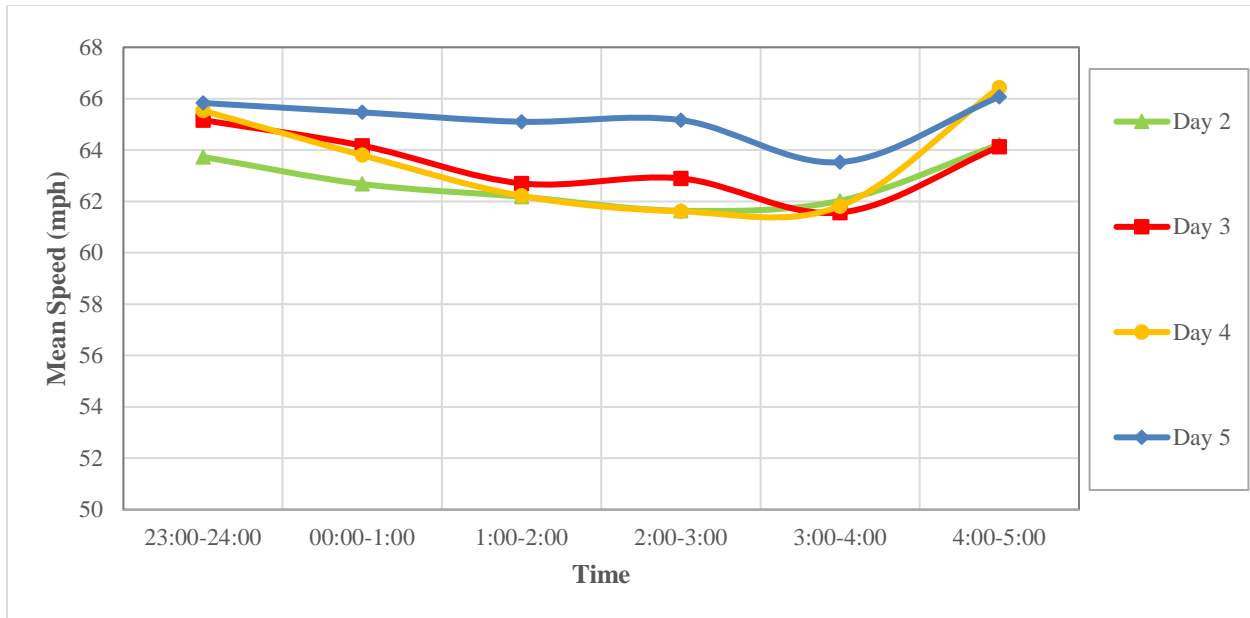

Figure 9.11: Hourly Vehicle Speed (Mean Speed) at RWA Sign, Day 3 (Case Study #1)

Figure 9.12 focuses on the speed difference between vehicles in the work zone. The two blue dashed lines in the figure show the minimum and maximum speeds recorded at different location in the work zone. Typically in the work zone a low range of speed (i.e., little difference in speed from the slowest to the fastest vehicle) is desirable in order to have a safer work zone. In most cases on different nights of testing, the lowest range of speeds (difference between the minimum speed and maximum speed) occurred near the radar speed sign. The highest range of speed occurred near the paving equipment. A high range in speed may be due in part to the construction vehicles that slow down in the work zone in order to enter into the work area.

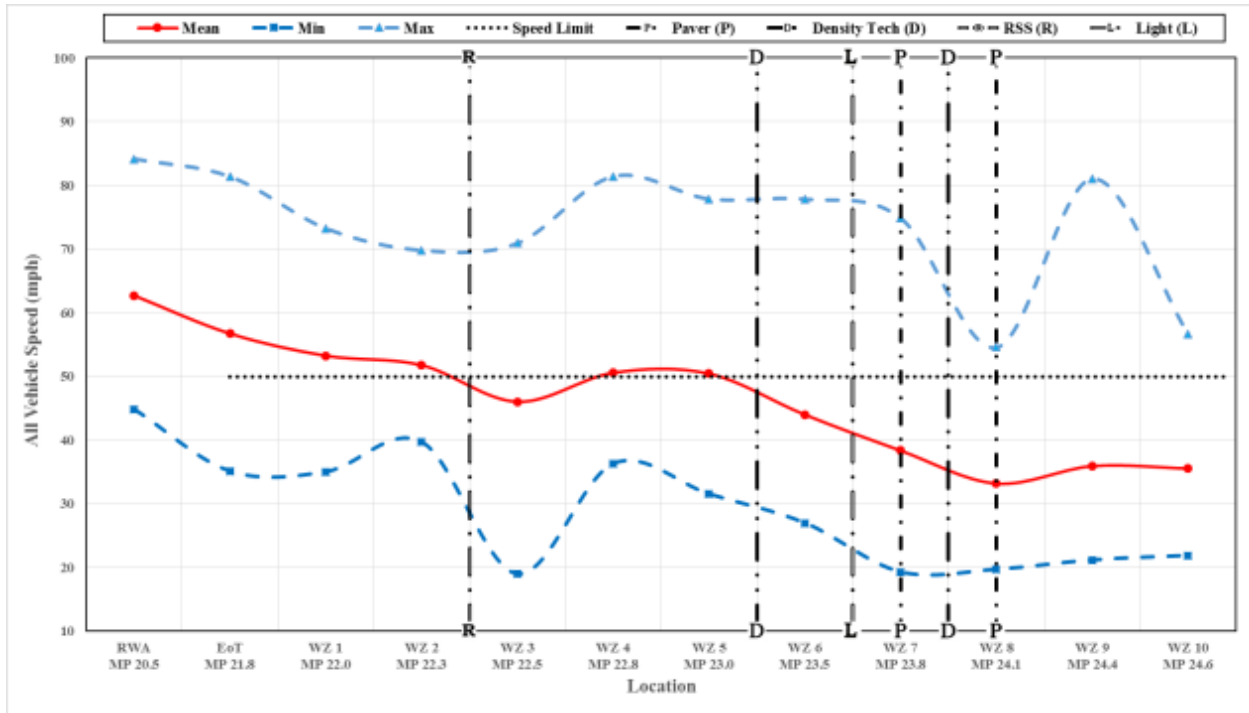

Figure 9.12: Range of Vehicle Speeds at Different Locations, Day3, 01:00-02:00 (Case Study #1)

Based on the results of previous studies, speed variance is identified as a factor in work zone crashes (i.e., as speed variance increases, the risk of crashes increases). To understand how the speed variance changed during the work zone testing period, an example of the speed variance is illustrated in Figure 9.13. Based on this figure and similar figures provided in the Appendix, the speed variance near location of the RSS is the lowest, and near the paving equipment the speed variance is the highest. At the RSS, when drivers see their speed displayed, most will adhere to the posted speed limit. As a result the variance in speed at the RSS is lower than in other sections of the work zone. Near the paving equipment, some vehicles reduced their speed and some passed with their regular speed. Therefore, there is a higher variance in the vicinity of each piece of paving equipment. There is no change in speed variance with and without the additional light turned on.

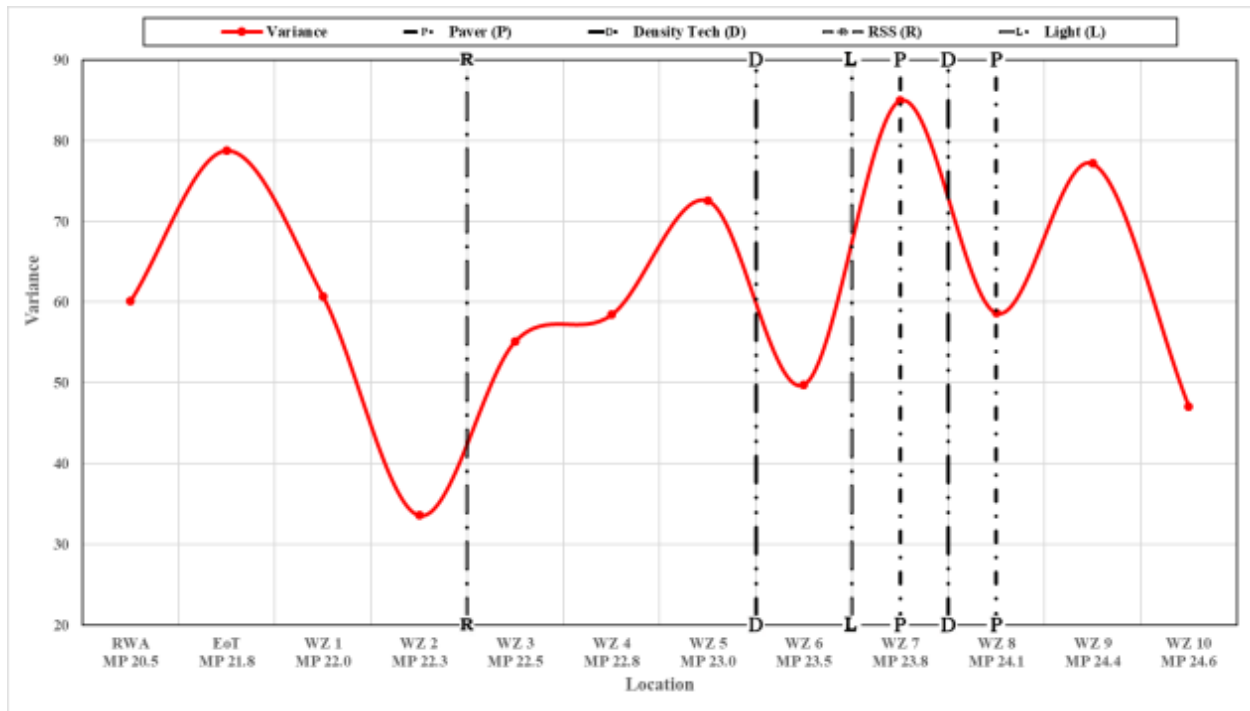

Figure 9.13: Variance in Vehicle Speed, Day 3, 01:00-02:00 (Case Study #1)

Lastly, the researchers performed multiple vehicle passes through the work zone on each night of testing to observe how individual vehicle speed changed in different location throughout the entire length of work zone. To collect this data, a random passing vehicle was selected in advance of work zone. The researchers followed that vehicle and recorded its speed at the RWA sign and every quarter mile in the work zone. Figure 9.14 shows an example of the speed recorded by the probe vehicle on Day 3 (light tower turned on). The figure shows that the speed at the RWA was 70 mph. Then, the speed decreased to 60 mph at the end of the taper and reduced to 55 mph at the initial section of the work zone. The vehicle's started to reduce more, dropping to 45 mph when the vehicle approached the rollers behind the paver. At the paver the speed is the lowest (18 mph). Downstream of the paver, the speed increased to 45 mph and the vehicle maintained this speed until it passed the grinder. At the light tower, which was mid-way between the paver and grinder, there was no change in the speed trend. Figure 9.15 shows similar information while the probe vehicle recorded speed on the second night of testing (control night). For the second case shown (Figure 9.15), the maximum reduction in speed similarly occurred near the paver and nearby asphalt dump trucks.

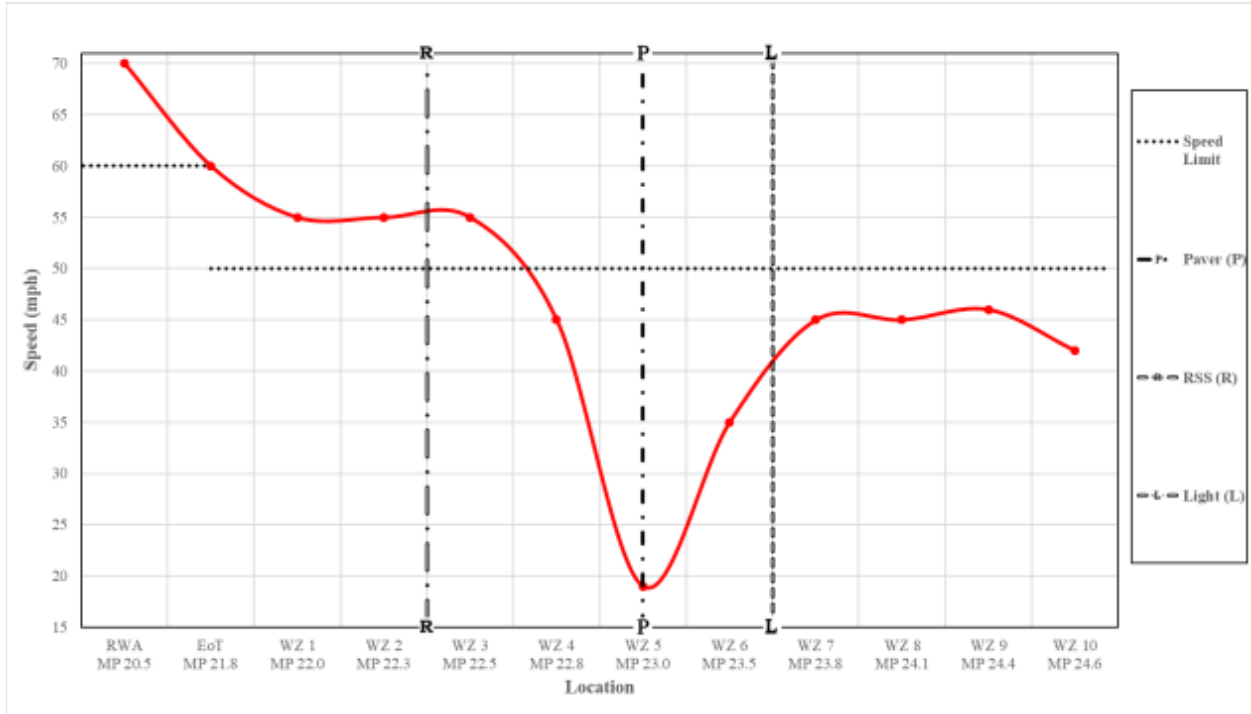

Figure 9.14: Probe Vehicle Speed, Day 3, 23:07 (Case Study #1)

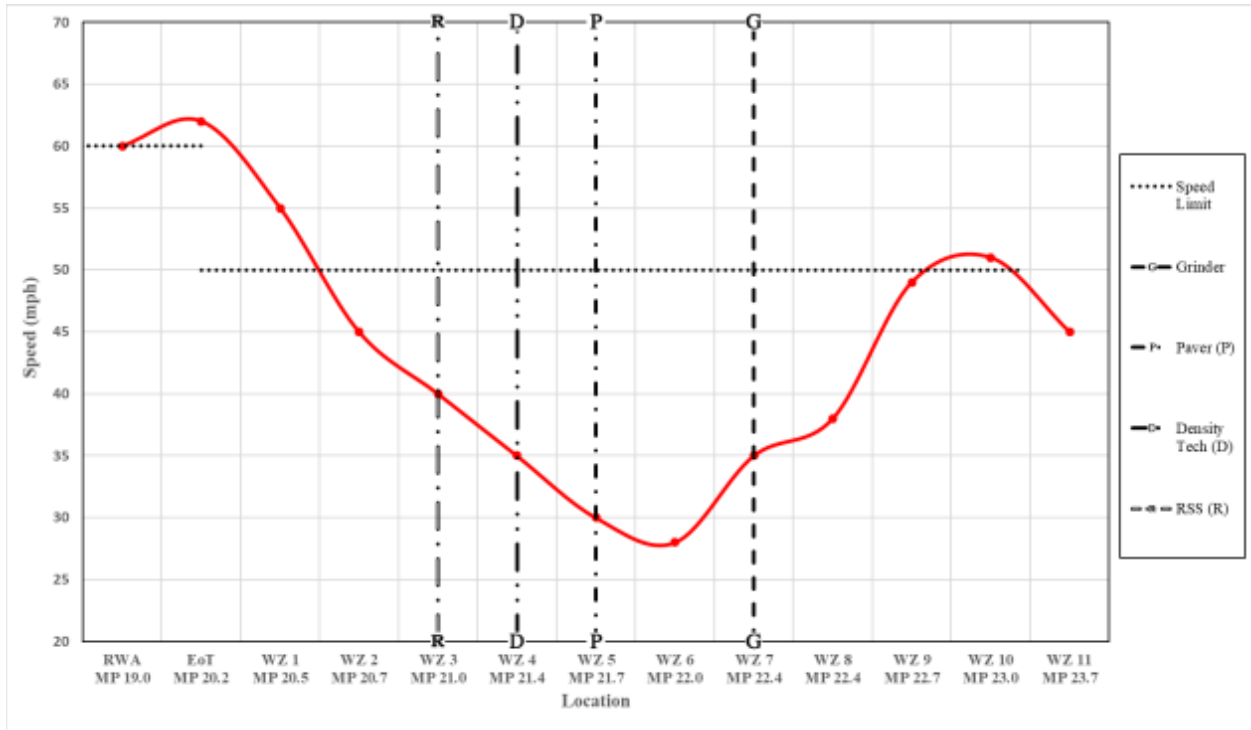

Figure 9.15: Probe Vehicle Speed, Day 2, 23:42 (Case Study #1)

9.2 CASE STUDY # 2: I-5 MEDFORM TO ASHLAND

This section presents data and results from the second case study project, I-5 Medford to Ashland. The first two nights of data relate to the paving of the northbound slow lane (B-lane) and the other three nights are from paving of the southbound slow lane. Tables and figures provided in this section are similar to those provided for Case Study #1 above. Only one example of each type of figure and table is presented and discussed below; the additional tables and figures related to Case Study #2 are provided in the Appendix.

Figure 9.16 shows an example of the variation in the number of vehicles and the percentage of passenger cars (vehicles <25 feet in length) and percentage of trucks (vehicles > 25 feet in length) that passed through the work zone on each test day. The volumes on the first two days, which are related to the northbound paving, are similar to each other with nearly 150 passing vehicles during the sample time (01:00-02:00). Day 4 (light tower) and Day 5 (control night), which are related to the southbound paving, are also similar to each other with 45% of trucks during 01:00-02:00. Day 3 (balloon light) had the highest number of passing vehicles between all days of testing. In this case study, data were recorded from 21:00 until 05:00 the next day for every night of testing. Figure showing the volumes during the other time durations are provided in the Appendix. In general, the number of passing vehicles and percentage of cars and trucks varied from one day to the next. Generally, Days 1 and 2 (both northbound paving) are similar to each other in the percentage of trucks in most hours of recorded data. Days 3 and 4 (both southbound paving) are also similar to each other in percentage of trucks during different hours of testing.

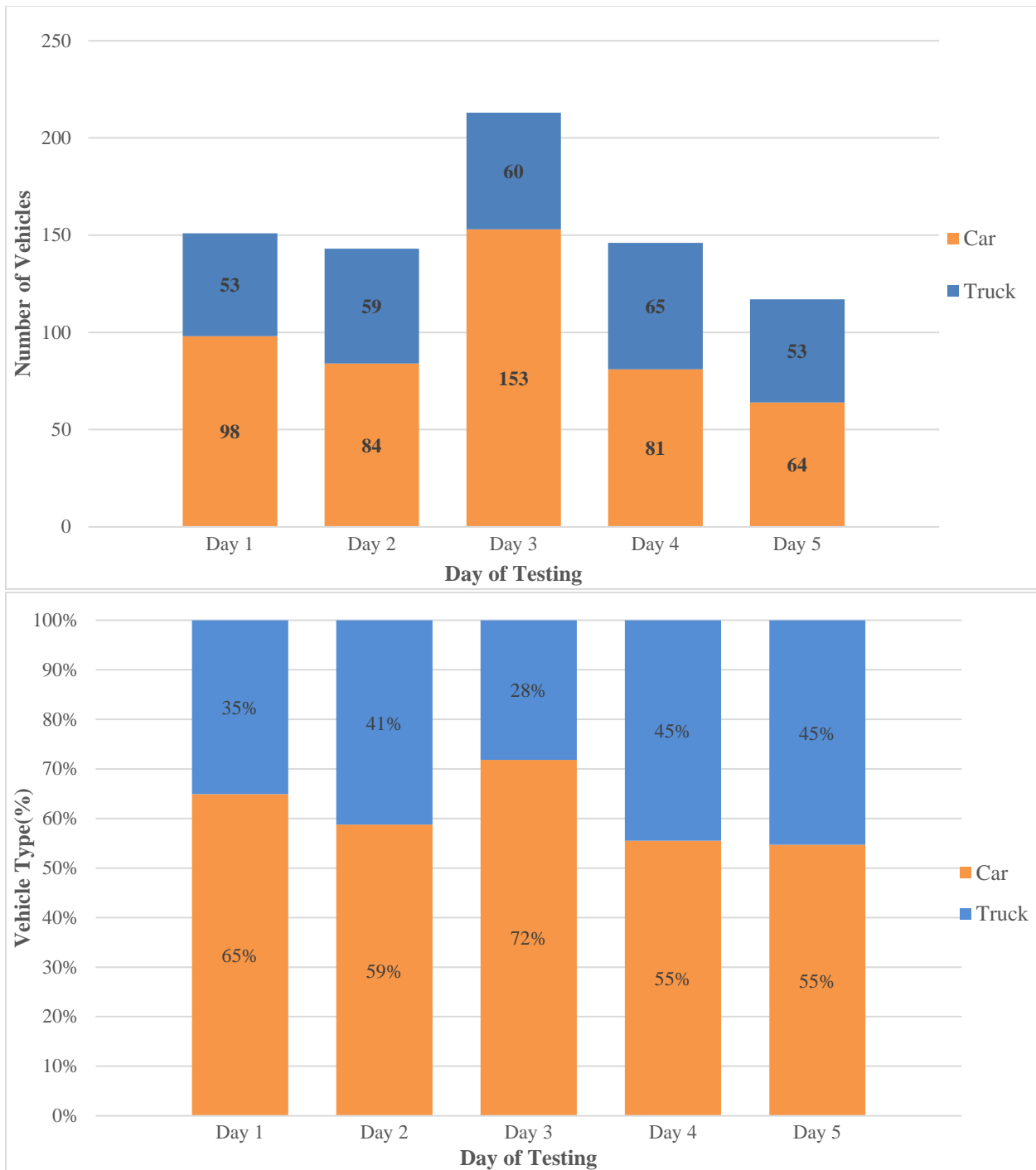

Figure 9.16: Daily Traffic Volume in Work Zone, Sensor #748 (Case Study #2)

Figure 9.17 displays how traffic volume changed during different hours in the work zone on Day 3 of testing. The highest number of vehicles was recorded at the start of data collection every night at 21:00. Traffic volume decreased every hour until 02:00 or 03:00, and then it increased. The trend is very similar in all nights of testing. It can be seen that truck percentage is the lowest at 21:00, increased gradually until 04:00, and then started to decrease.

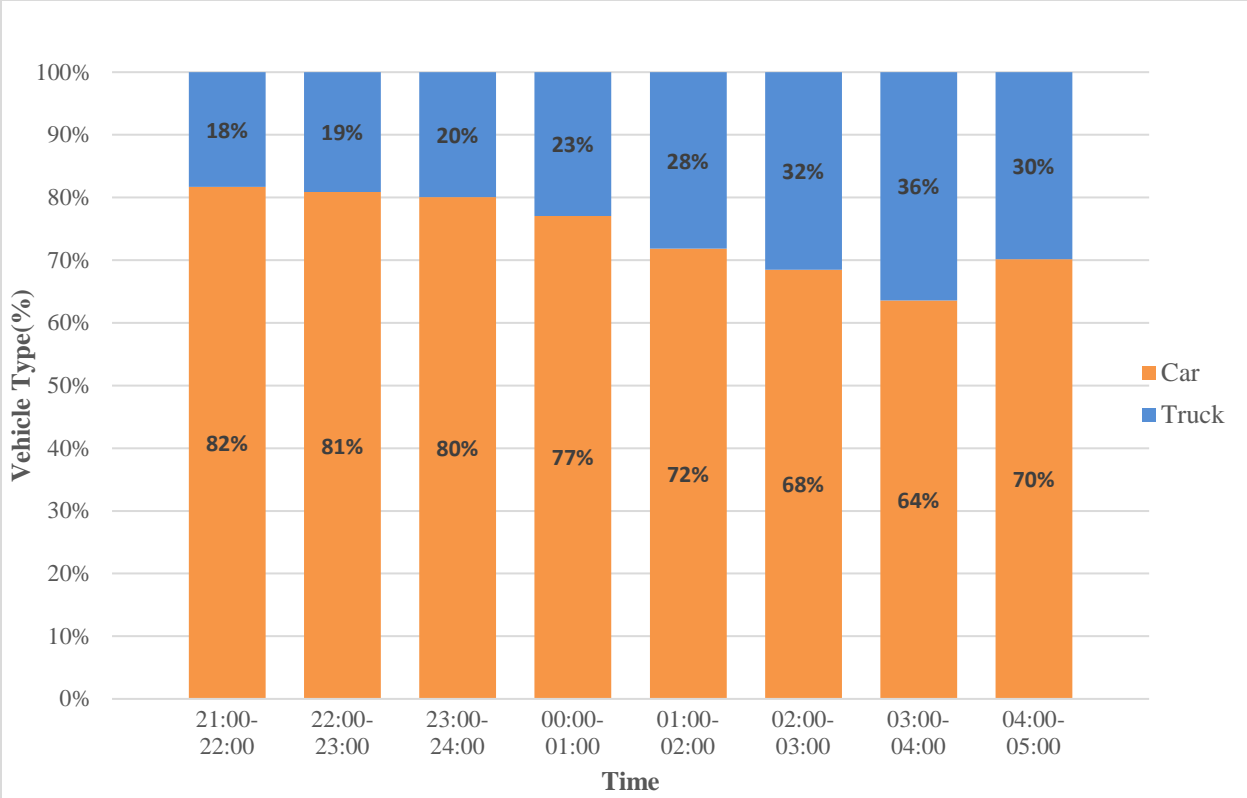
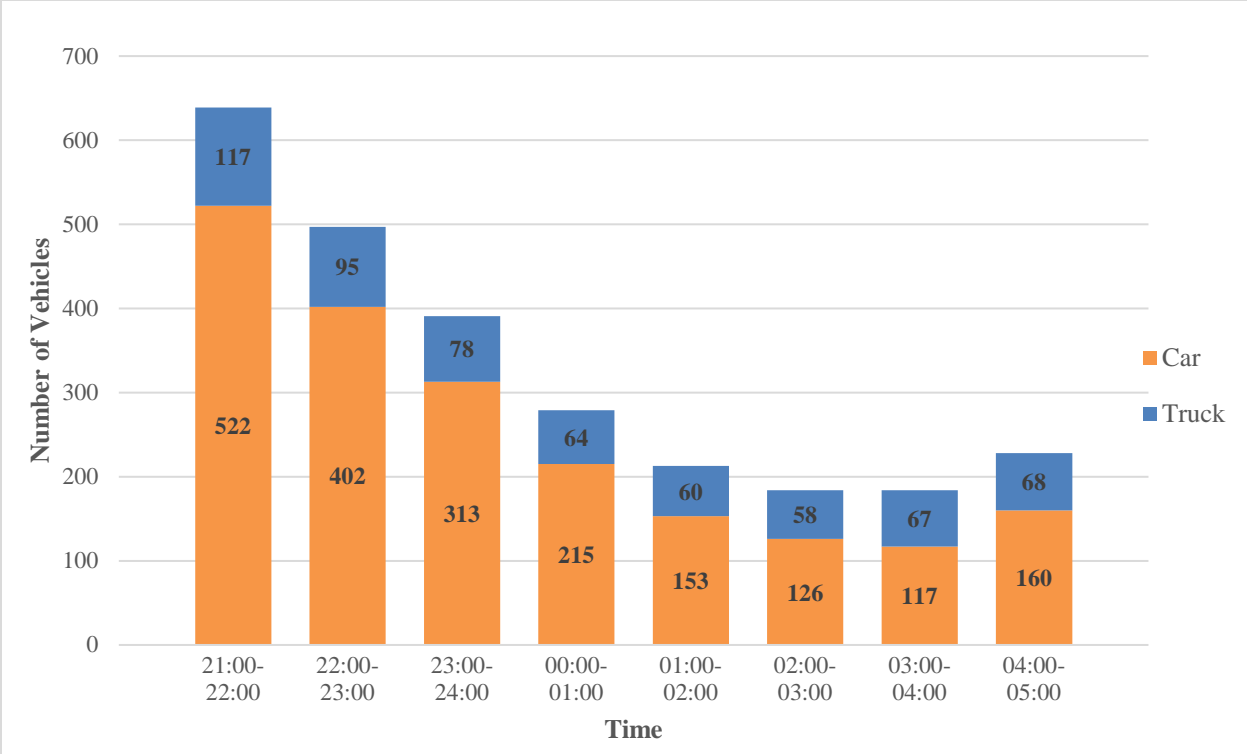

Figure 9.17: Hourly Traffic Volume in Work Zone (Sensor #748), Day 3 (Case Study #2)

Table 9.4 presents the minimum and maximum percentage of trucks each day of testing and the related time. Truck percentage ranged from 10% to 54%. The minimum percentage of trucks was recorded between 21:00 and 22:00 on most days. The maximum truck percentage time is different on each day, and was after midnight and between 01:00 and 04:00. Traffic volume recorded by different sensors in the work zone should be equal, but because of sensor error when two vehicles are travelling close to each other, there is some difference in the number of passing vehicles in different sensors. Figure 9.18 shows an example of passing traffic volume recorded by different sensors placed in the entire work zone. This data is related to recorded data on Day 3 between 01:00 and 02:00. Although some sensors, especially sensors #316, #325, and #216, show lower numbers of passing vehicles, the relative percentages of passenger cars and trucks are very similar in all sensors.

Table 9.4: Change in the Truck Percentage on Different Testing Days (Case Study #2)

Minimum and Maximum Truck Percentage and Related Time				
	Percentage		Time	
	Min	Max	Min	Max
Day 1	10%	43%	21:00 - 22:00	03:00 - 04:00
Day 2	18%	41%	23:00 - 24:00	01:00 - 02:00
Day 3	18%	36%	21:00 - 22:00	03:00 - 04:00
Day 4	21%	51%	21:00 - 22:00	03:00 - 04:00
Day 5	21%	54%	21:00 - 22:00	02:00 - 03:00

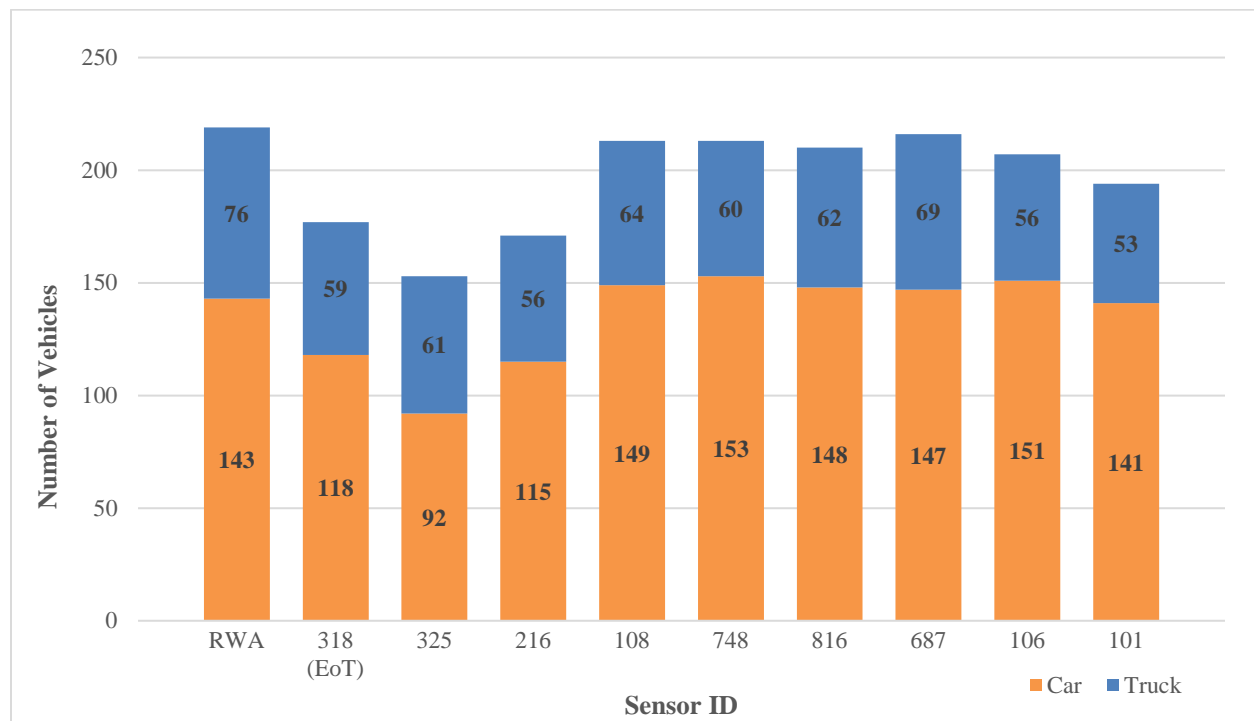

Figure 9.18: Traffic Volume at Different Sensors, Day 3, 01:00-02:00 (Case Study #2)

Table 9.5 presents a summary of the vehicle speeds recorded for all vehicles at the RWA sign location on Day 3 when the balloon light was placed in the middle of the work zone. Similar to Case Study #1, data in this table is the combination of data from two sensors placed near the RWA sign in both the slow lane and fast lane. There is not much variation in the mean speed during different time durations on each night of testing. Mean speed varied from 58.6 mph between 21:00 and 22:00 to 61.8 mph between 00:00 and 01:00 on the 3rd night of testing. For the entire recorded time on that night, the mean speed was 59.9 mph. The table shows the speeds outside of the work zone at the RWA sign where the posted speed limit was 65 mph. The 85th percentile speed for the entire recording time was 66.9 mph. This value ranged from 65.4 mph to 69.9 mph throughout the test period.

Table 9.5: Hourly Summary of Vehicle Speed, Day 3 at RWA Sign (Case Study #2)

Vehicle Speed (all vehicles)	Time								
	Total	21:00-22:00	22:00-23:00	23:00-24:00	00:00-01:00	01:00-02:00	02:00-03:00	03:00-04:00	04:00-05:00
MPH									
< 10	0.0%	0.0%	0.0%	0.0%	0.0%	0.0%	0.0%	0.0%	0.0%
10-14	0.0%	0.0%	0.0%	0.0%	0.0%	0.0%	0.0%	0.0%	0.0%
15-19	0.0%	0.0%	0.0%	0.0%	0.0%	0.0%	0.0%	0.0%	0.0%
20-24	0.1%	0.0%	0.2%	0.2%	0.0%	0.5%	0.0%	0.0%	0.0%
25-29	0.0%	0.0%	0.0%	0.0%	0.0%	0.0%	0.0%	0.0%	0.0%
30-34	0.1%	0.0%	0.4%	0.0%	0.0%	0.0%	0.0%	0.0%	0.0%
35-39	0.1%	0.0%	0.2%	0.2%	0.0%	0.0%	0.0%	0.0%	0.0%
40-44	0.5%	1.0%	0.4%	0.5%	0.4%	0.0%	0.6%	0.6%	0.0%
45-49	4.4%	7.2%	3.3%	3.3%	1.9%	5.0%	7.3%	2.3%	2.8%
50-54	21.7%	26.5%	25.2%	19.3%	15.7%	21.9%	18.8%	16.6%	17.8%
55-59	27.2%	26.1%	26.8%	28.4%	24.7%	24.7%	27.9%	35.4%	28.0%
60-64	24.9%	23.7%	26.0%	23.6%	28.1%	21.9%	24.2%	25.1%	26.9%
65-69	12.0%	8.3%	9.2%	14.8%	14.2%	13.7%	11.5%	13.7%	17.1%
70-74	5.1%	3.8%	4.3%	5.5%	10.1%	6.4%	5.5%	4.6%	3.5%
>=75	3.9%	3.4%	3.9%	4.1%	4.9%	5.9%	4.2%	1.7%	3.8%
Total # of vehicles	2728	709	488	419	267	219	165	175	286
Average speed	59.9	58.6	59.2	60.3	61.8	60.4	59.9	60.1	60.7
St. Dev.	7.4	7.5	7.4	7.6	7.2	8.1	7.3	6.4	6.7
85th percentile	66.9	65.4	65.7	67.9	69.9	68.3	66.6	66.3	67.2
Min	23.4	41.1	23.4	23.4	43.4	23.4	44.8	43.9	48.4
Max	94.8	94.8	85.8	89.2	85.8	85.8	80.6	83.6	84.7
Range	71.4	53.6	62.4	65.8	42.5	62.4	35.7	39.6	36.3

Vehicle speed in the work zone is lower than normal speed at the RWA sign. The mean speed values vary between 35.6 mph and 49.7 mph. The mean speed increased from the start of recording at 21:00 to the end of testing at 05:00. The posted regulatory speed limit in the work zone was 50 mph. Mean speed decreased from 59.9 mph at the RWA sign to 41.1 mph in the middle of the work zone. Table 9.3 shows a summary of the vehicle speeds over the same period

recorded in the work area, specifically at sensor #748. Similar tables for other sensors and on other days of testing are provided in the Appendix.

Table 9.6: Hourly Summary of Vehicle Speed, Day 3 in Work Zone, Sensor #748 (Case Study #2)

Vehicle Speed (all vehicles)	Time								
	Total	21:00-22:00	22:00-23:00	23:00-24:00	00:00-01:00	01:00-02:00	02:00-03:00	03:00-04:00	04:00-05:00
MPH									
< 10	0.0%	0.0%	0.0%	0.0%	0.0%	0.0%	0.0%	0.0%	0.0%
10-14	0.0%	0.0%	0.0%	0.0%	0.0%	0.0%	0.0%	0.0%	0.0%
15-19	0.5%	0.6%	0.8%	0.8%	0.0%	0.0%	0.0%	0.5%	0.0%
20-24	2.8%	6.9%	3.8%	1.8%	0.7%	0.9%	0.0%	0.0%	0.0%
25-29	9.4%	19.9%	9.7%	11.3%	6.1%	1.9%	1.1%	2.2%	0.4%
30-34	17.8%	26.9%	25.8%	22.0%	15.8%	8.9%	4.9%	3.8%	0.4%
35-39	21.8%	23.5%	24.3%	26.1%	26.5%	23.5%	17.4%	14.7%	6.6%
40-44	21.8%	12.5%	20.9%	22.8%	29.0%	31.9%	28.3%	25.0%	22.4%
45-49	14.2%	4.2%	10.3%	11.0%	13.3%	19.7%	29.9%	28.3%	28.5%
50-54	7.3%	2.8%	2.4%	3.8%	5.7%	11.7%	13.0%	16.8%	22.4%
55-59	2.3%	0.6%	0.6%	0.3%	2.2%	1.4%	4.9%	6.0%	10.5%
60-64	1.0%	0.5%	0.4%	0.0%	0.7%	0.0%	0.5%	2.2%	6.6%
65-69	0.3%	0.6%	0.2%	0.3%	0.0%	0.0%	0.0%	0.5%	0.9%
70-74	0.4%	0.8%	0.8%	0.0%	0.0%	0.0%	0.0%	0.0%	0.9%
>=75	0.1%	0.2%	0.0%	0.0%	0.0%	0.0%	0.0%	0.0%	0.4%
Total # of vehicle	2615	639	497	391	279	213	184	184	228
Average speed	41.1	35.6	38.0	38.2	40.7	42.6	45.0	46.0	49.7
St. Dev.	8.9	8.6	8.1	7.1	7.0	6.6	6.2	7.4	7.3
85th percentile	49.9	43.0	45.0	46.0	47.0	49.9	51.9	53.9	56.9
Min	19.0	19.0	19.0	19.0	23.0	21.0	29.0	19.0	30.0
Max	78.9	78.9	73.9	65.9	63.9	57.9	60.9	67.9	76.9
Range	59.9	59.9	54.9	46.9	41.0	37.0	32.0	48.9	46.9

Figures 9.19 – 9.26 show how the 85th percentile speed changed from the RWA sign location to the end of the work zone on Day 3. Similar to Case Study #1, the locations of the grinder, paver and density technician were tracked with a GPS unit attached to them to understand their impact

on vehicle speed. The figures show that the 85th percentile speed of travelling vehicles decreased from 65-70 mph at the RWA sign to a lower speed at the end of the taper (EoT) at MP 27.8. Speed continued decreasing until the location of the RSS. Then, if paving equipment was near the RSS (from 22:00-23:00), the decreasing trend would continue and after passing the paver the speed started to increase. Otherwise after the RSS (without paving equipment also present) the speed increased and then decreased again downstream near the paver. The sensor near the light (on this day, it was the balloon light) shows another drop in 85th percentile vehicle speed.

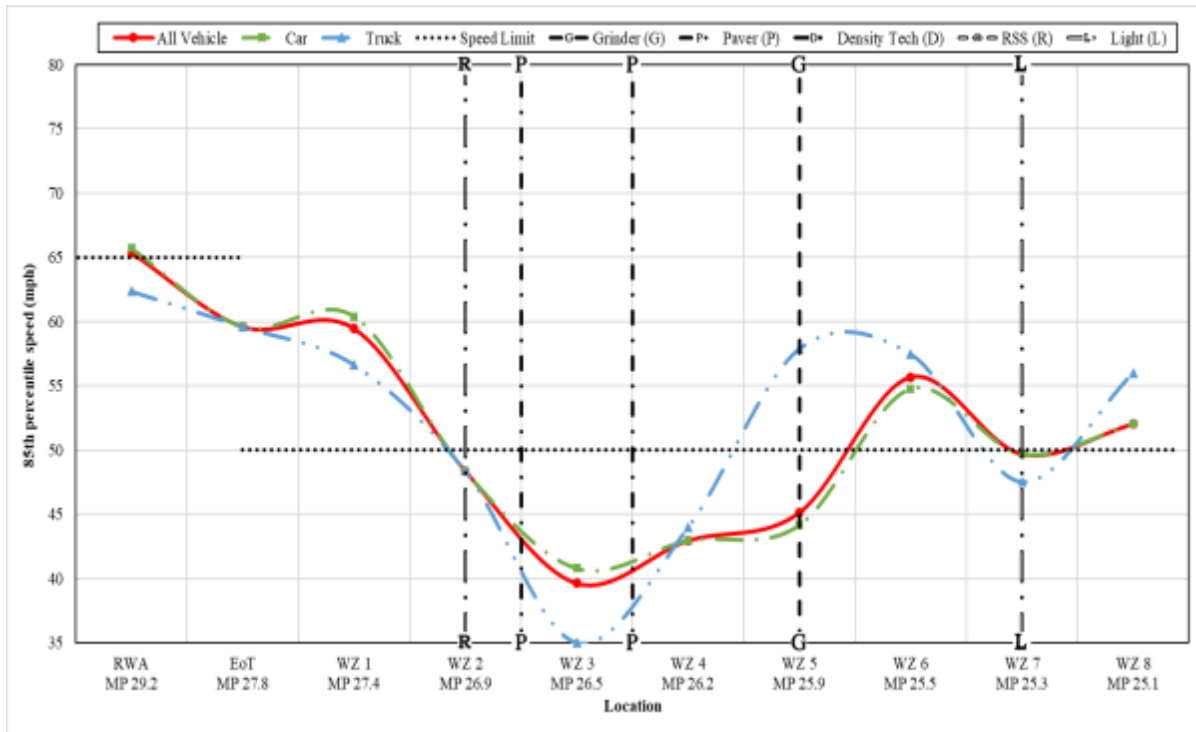

Figure 9.19: Vehicle Speed (85th percentile) at Different Locations, Day 3, 21:00-22:00 (Case Study #2)

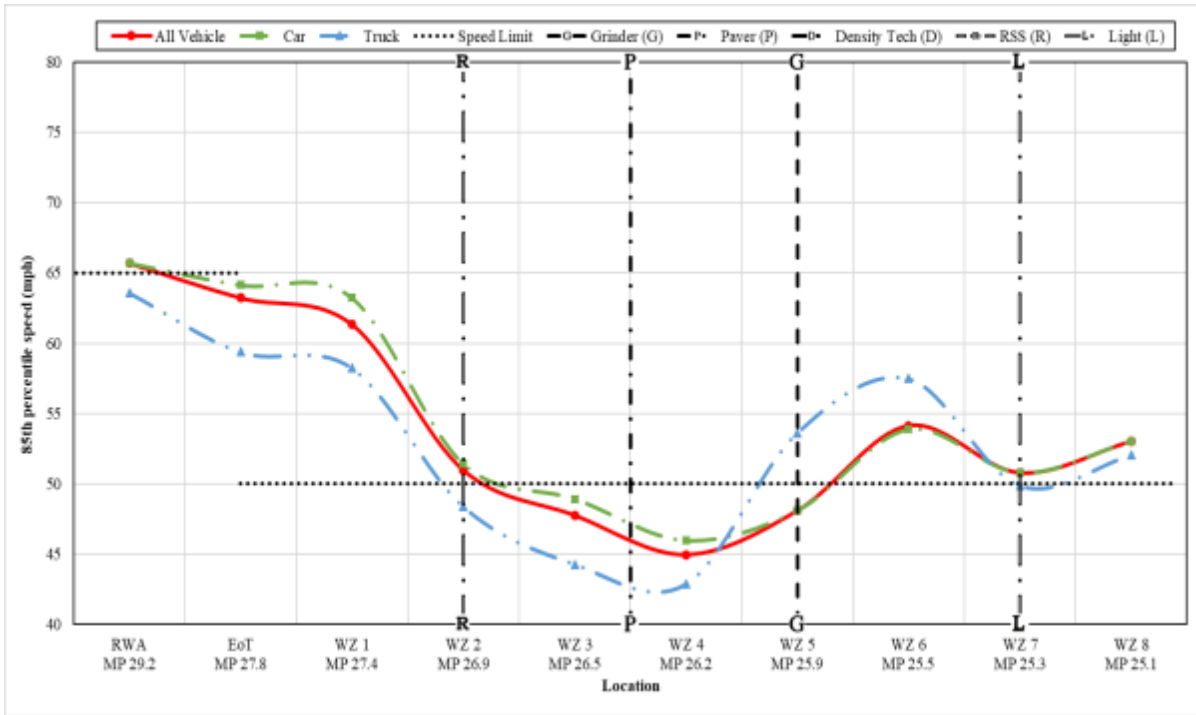

Figure 9.20: Vehicle Speed (85th percentile) at Different Locations, Day 3, 22:00-23:00 (Case Study #2)

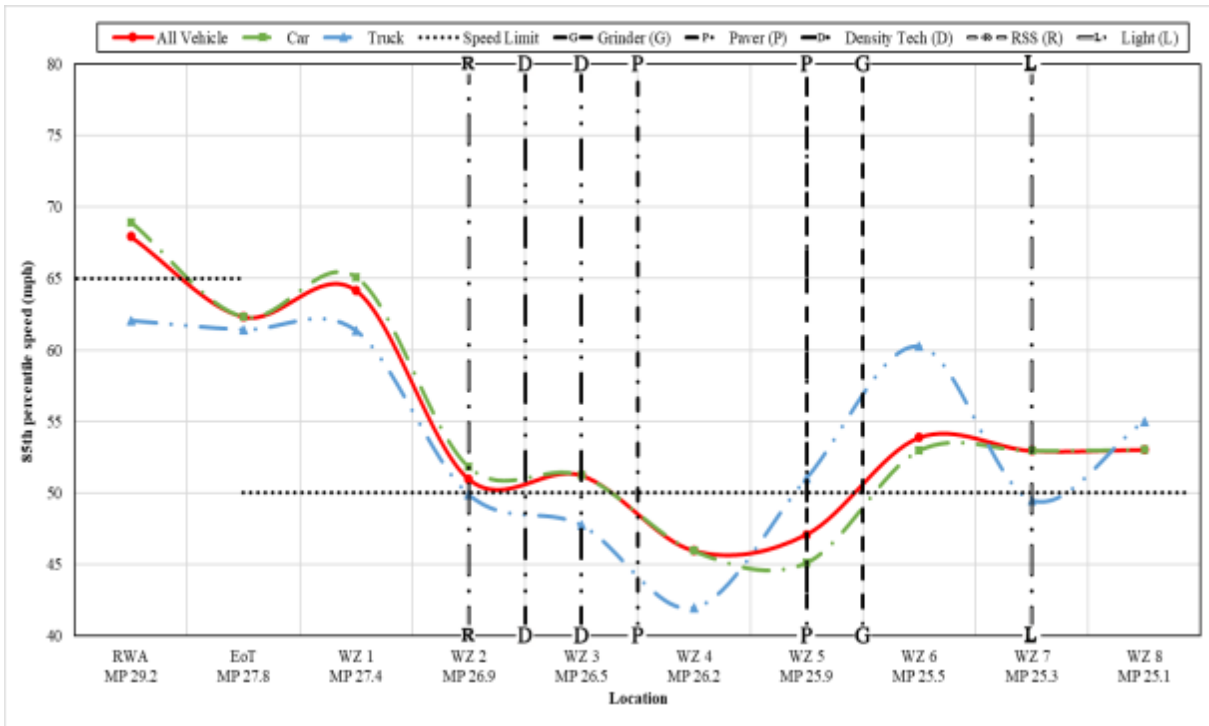

Figure 9.21: Vehicle Speed (85th percentile) at Different Locations, Day 3, 23:00-24:00 (Case Study #2)

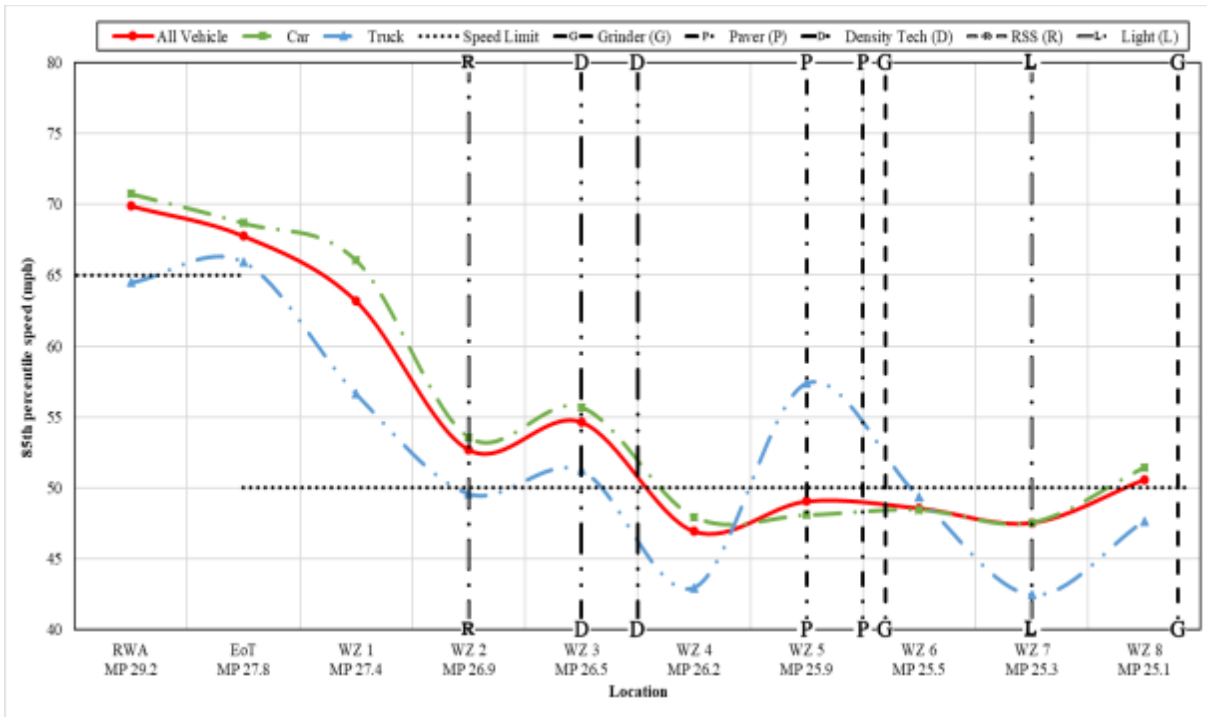

Figure 9.22: Vehicle Speed (85th percentile) at Different Locations, Day 3, 0:00-01:00 (Case Study #2)

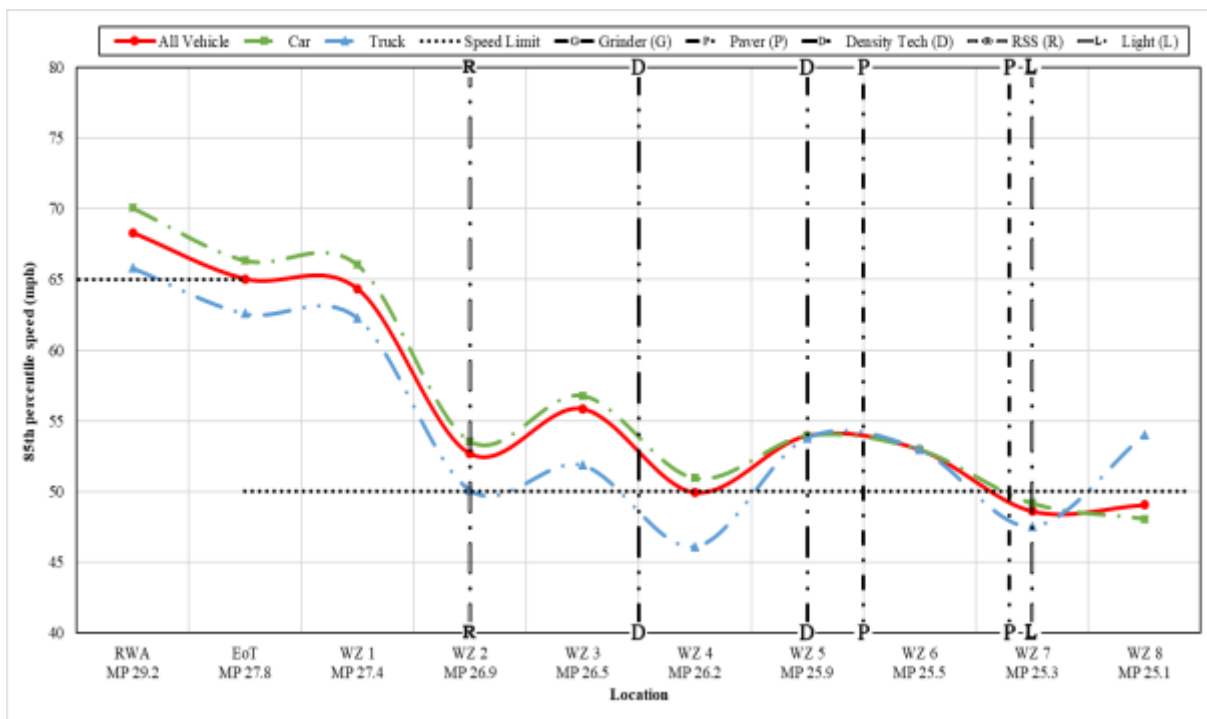

Figure 9.23: Vehicle Speed (85th percentile) at Different Locations, Day 3, 01:00-02:00 (Case Study #2)

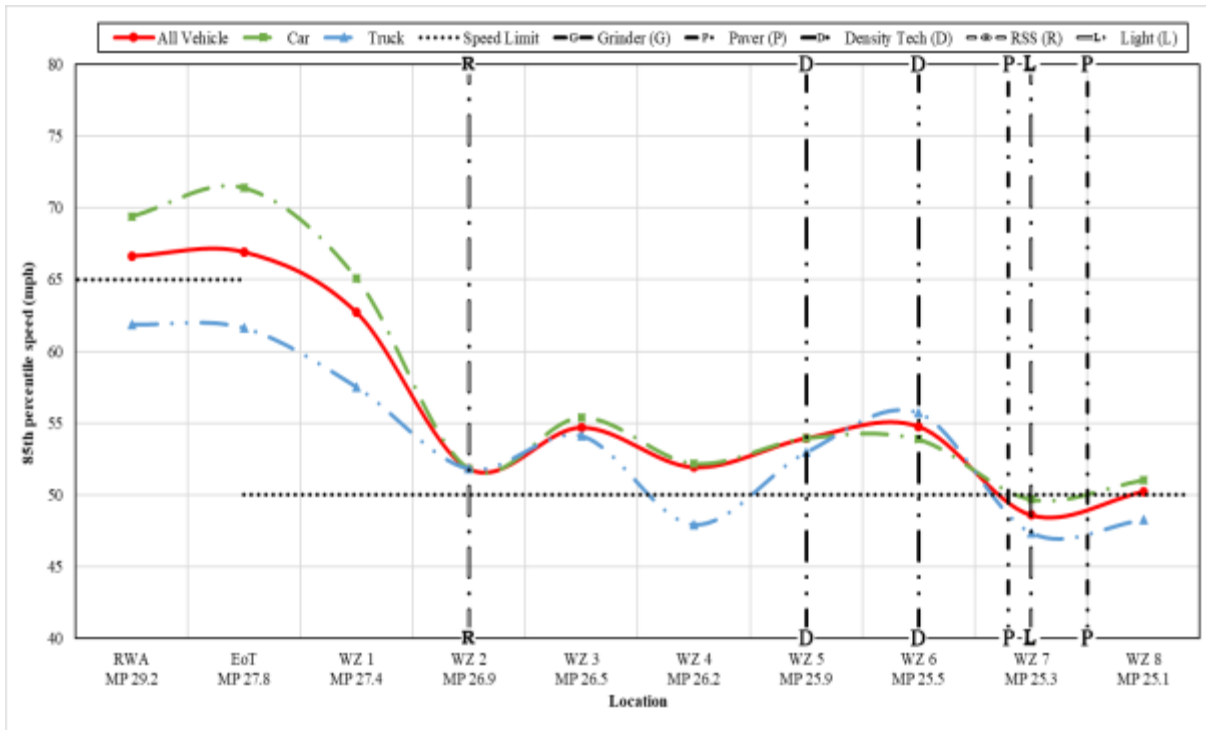

Figure 9.24: Vehicle Speed (85th percentile) at Different Locations, Day 3, 02:00-03:00 (Case Study #2)

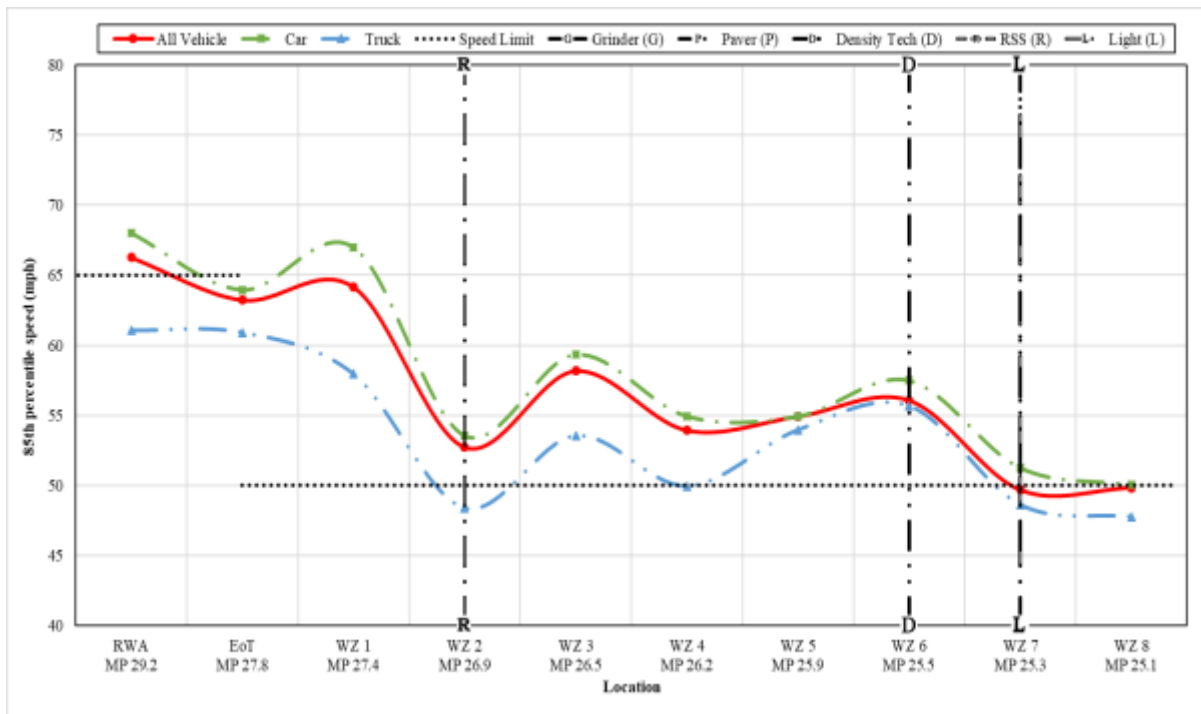

Figure 9.25: Vehicle Speed (85th percentile) at Different Locations, Day 3, 03:00-04:00 (Case Study #2)

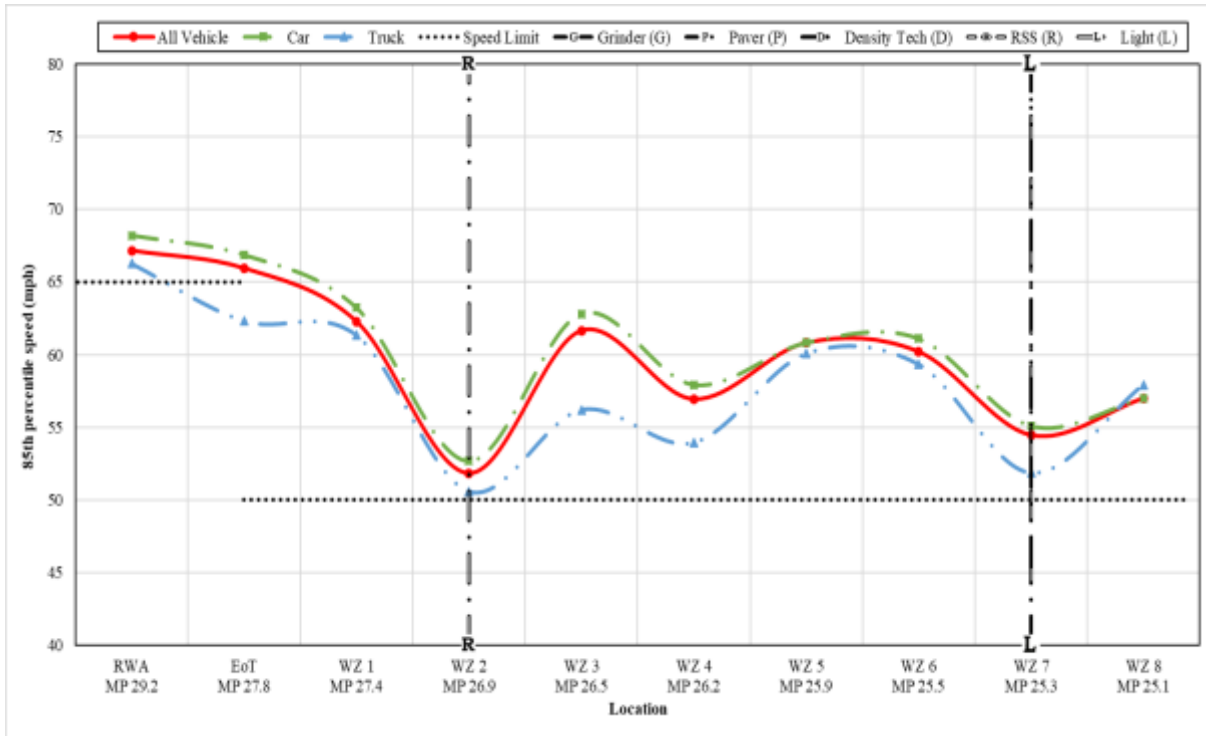

Figure 9.26: Vehicle Speed (85th percentile) at Different Locations, Day 3, 04:00-05:00 (Case Study #2)

Change in mean vehicle speed in the vicinity of the light is illustrated in Figure 9.27. Before the presence of the paving equipment, from 21:00 to midnight, the mean speed was relatively constant at 44 mph. When the grinder reached the light, the mean speed decreased to 39 mph. At 02:30 in the morning, when the paver was near the light, the mean speed was ranged from 41-42 mph for all vehicles. After the paver passed the light, mean speed increased back to 44 mph until 04:00. Finally, after 04:00, the mean speed was approximately 50 mph.

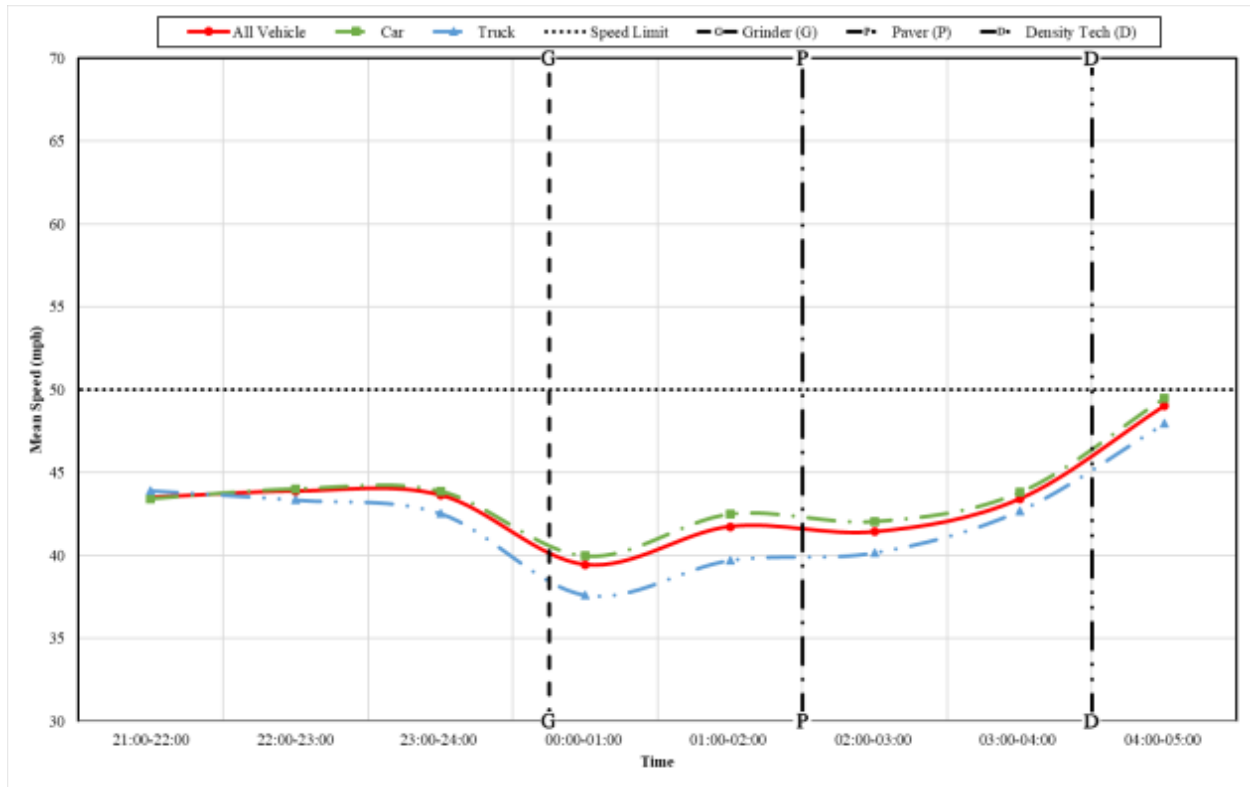

Figure 9.27: Hourly Vehicle Speed (Mean Speed) in Work Zone (Sensor #687) adjacent Balloon Light, Day 3 (Case Study #2)

It is likely that the speed in the work zone depends on the speed of the vehicles prior to the work zone. Figure 9.28 shows how the mean speed at the RWA sign changed during different hours of each day of testing compared to the 65 mph posted regulatory speed limit in this case study at the RWA sign. The mean speed ranged between 58 mph and 63 mph. Mean speed was approximately 60 mph most of the time, which is less than the 65 mph speed limit. Mean speed on Day 5 was higher than the mean speed recorded on the other testing days.

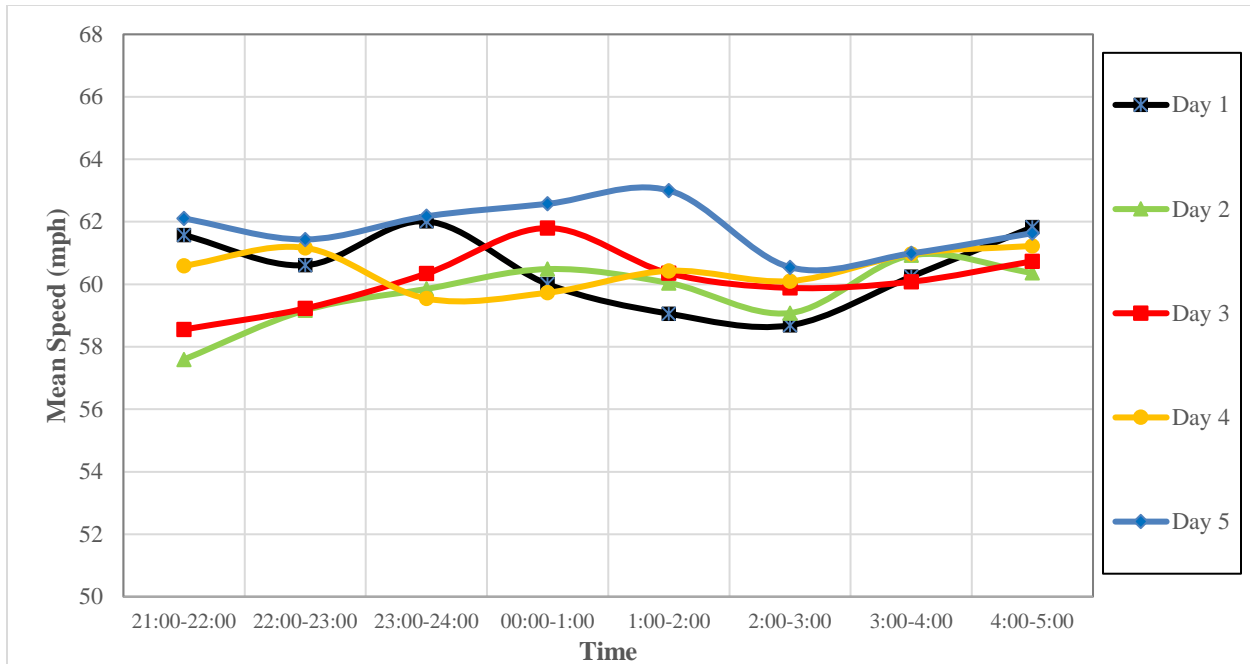

Figure 9.28: Hourly Vehicle Speed (Mean Speed) for each Test Day at RWA Sign (Case Study #2)

Figures 9.29 and 9.30 show that, similar to Case Study #1, speed variance at the RSS is lower than at other locations in the work zone. The difference between the minimum and maximum speed at the RSS is less than at other locations in the work zone and also at the RWA sign. The maximum recorded speed by the sensor at the RSS location is significantly less than at other locations. Also, the minimum speed at this location is not too different than the posted reduced speed limit of 50 mph at the RSS. Lower speed variation can result a lower rate of crashes. At the light location, there is no noticeable change in the speed variance. Speed variance is high near the paving equipment; some vehicles reduced their speed significantly while other vehicles did not change their speed. In addition, because of dump trucks pulling in and out near the paver and the grinder, when public vehicles followed a dump truck their speed also decreased and was consistent with the dump truck speed. Therefore, the sensors near the paver and grinder recorded very low speeds as well as regular speeds which results in a high speed variation.

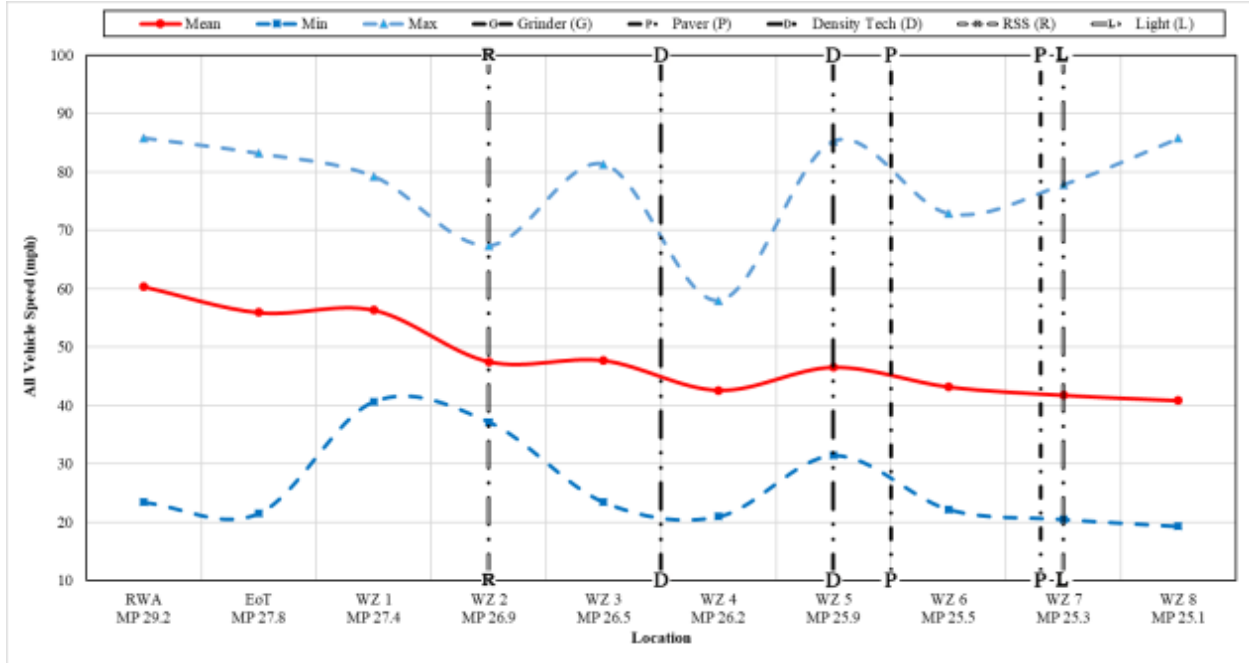

Figure 9.29: Range of Vehicle Speeds at Different Locations, Day3, 01:00-02:00 (Case Study #2)

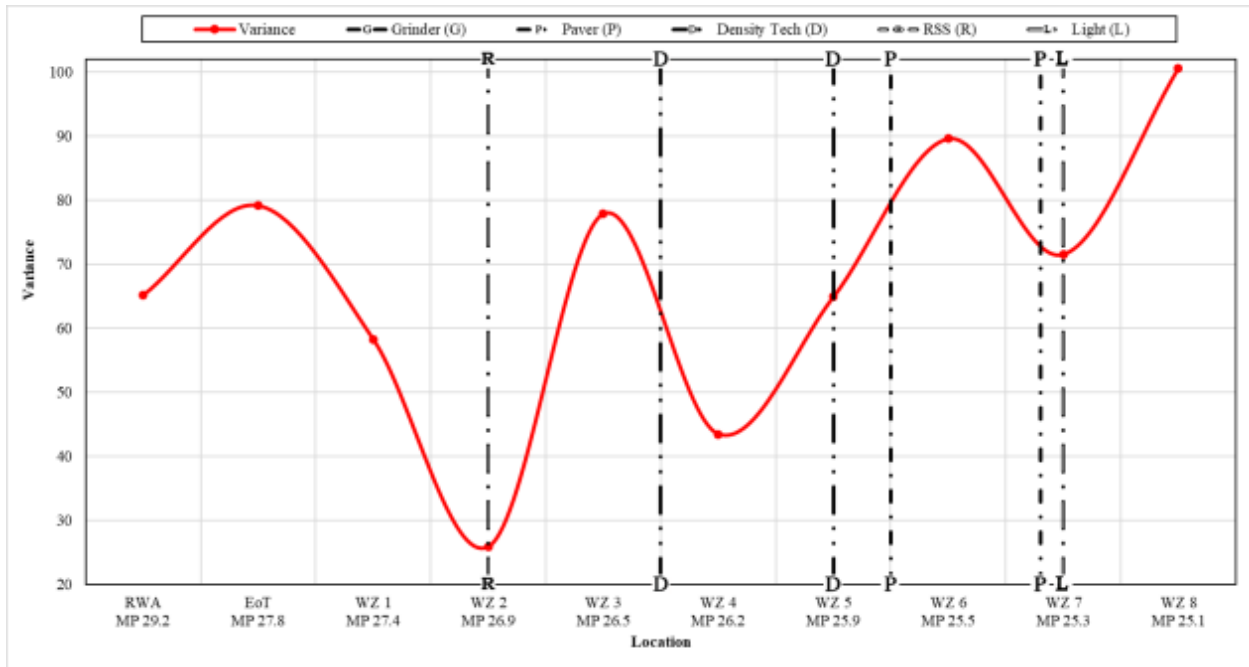

Figure 9.30: Variance in Vehicle Speed, Day 3, 01:00-02:00 (Case Study #2)

Finally, every night the researchers performed multiple probe vehicle passes through the work zone to monitor the nature of the traffic throughout the entire length of the work zone. Figures 9.31 and 9.32 show an example of probe vehicle results in the southbound direction, one with the balloon light in the work zone (Day 3) and one without any additional light (Day 5). The

decrease in speeds as the vehicles approach the paving equipment is evident in these figures. There is no evidence of a decrease in speed when vehicles approach the light. In most cases, there is a decrease in speed adjacent the RSS as well.

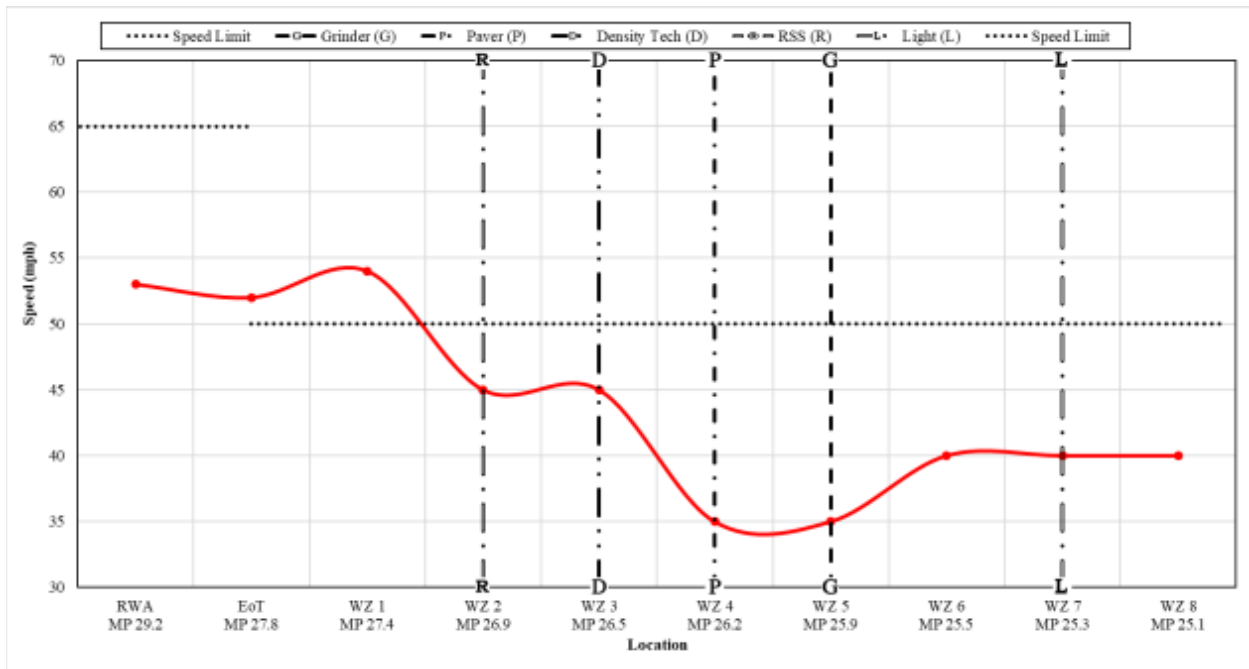

Figure 9.31: Probe Vehicle Speed, Day 3, 22:36 (Case Study #2)

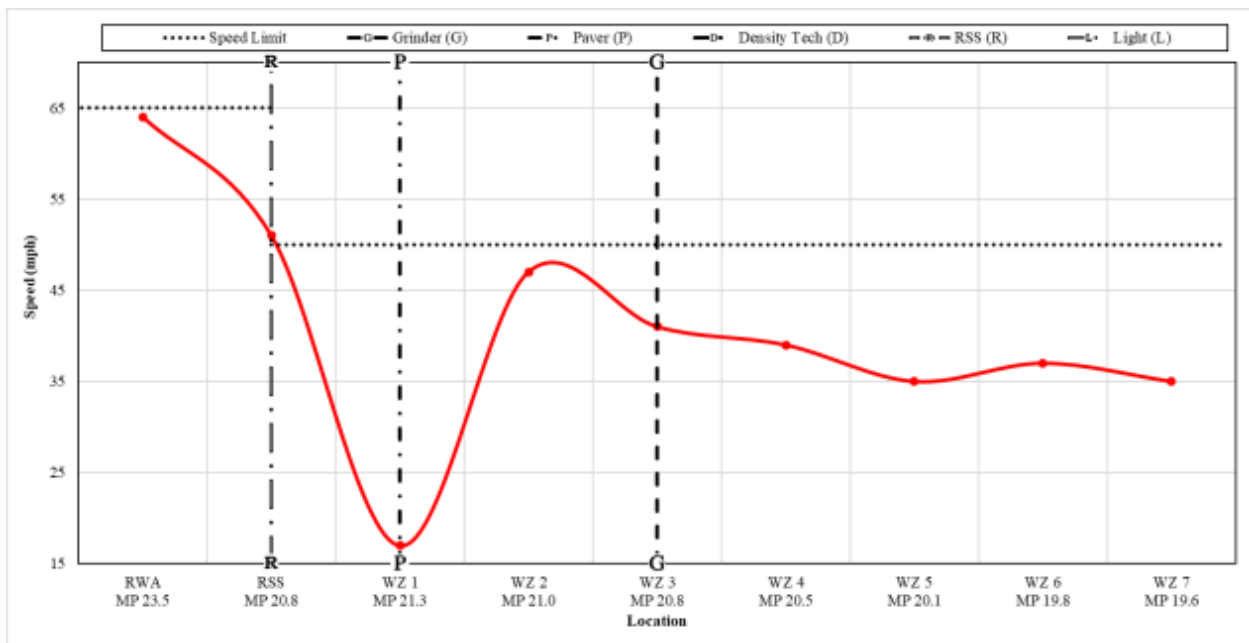

Figure 9.32: Probe Vehicle Speed, Day 5, 21:10 (Case Study #2)

9.3 SPEED ANALYSIS

Various statistical tests were performed to analyze the speed data. While the original intent of this project was to test the impact of additional portable lights in the roadway work zone on vehicle speed, the data afforded additional investigation of the impact of the Halo light and the impact of the RSS on vehicle speed. Because of confounding variables, such as road condition, posted speed limit, time of operation, and data collected, it was not possible to compare the speed data of Case Study #1 to the speed data of Case Study #2. Therefore, for the data analyses, the speed data from each night of testing in each case study was compared to the speed data of other nights of the same case study.

9.3.1 Impact of Additional Light (Case Study #1)

To determine the impact of the light, speed data from the sensors upstream, next to, and downstream of the portable light equipment was considered for comparison. For the nights of testing without additional lighting equipment, speed data was considered from the sensors which were placed at a similar location in the paving operation during nights with the additional lights present. As explained in the previous chapter, there was no additional light present on Days 2 and 5 (control nights). There was a light tower and balloon light in the middle of the work zone on Day 3 and Day 4, respectively. In Case Study #1, on Day 1, the portable light tower and balloon light were placed at the start of the work zone for the whole night. The RSS was also at the same location. The figures in the previous section show that the RSS has an impact on vehicle speed. To see the impact of the light on Day 1, the impact of the RSS on this night of testing should be investigated. For the investigation of light impact, Day 1 can be considered as another control night when investigating the speed data from the sensors in the middle of the work zone.

To understand the effectiveness of the portable lights, its impact should be separated from that of other variables such as the RSS, and especially the paving equipment. Previous studies, and also the descriptive statistics of both case studies described above, show a very significant speed reduction around the paving equipment. As a result, the impact of the equipment could outweigh and hide any impact of the portable light when the equipment is close to the light.

In Case Study #1, there is not enough speed data to consider just the impact of the light when there is not any paving equipment in the vicinity of the light. On both nights with the light tower and the balloon light, the light was located in the middle of the paving train, between the grinder and paver most of the time.

Considering the issues mentioned above, descriptive statistics of the speed data to test the impact of the light are illustrated in Table 9.7. In order to compare several means simultaneously, a one-way analysis of variance (ANOVA) test was utilized to determine if the speed means were similar on different nights. The results of the one-way ANOVA tests for all 5 nights of this case study are shown in Table 9.8.

The analysis indicated significant difference in the mean speed among different nights. However, the magnitude of the effect size ($20,611.846 / 1,504,383.386 = 0.14$) indicates a small effect. The results indicate that although there is a difference in mean speed on different nights, it is not

practically significant. That is, when a difference is found to be statistically significant, the result does not necessarily indicate that the difference is large, important, or helpful. The result simply provides confidence that there is a difference. A general problem with traditional statistics is that if there is a large enough number of data points (as is the case for the many vehicles recorded for the case study), almost any difference or any correlation will be significant.

Table 9.7: Descriptive Statistics of Recorded Speeds (Case Study #1)

Day	No. of Data Points	Mean Speed (mph)	Std. Deviation	Std. Error	95% Confidence Interval for Mean		Minimum Speed (mph)	Maximum Speed (mph)
					Lower Bound	Upper Bound		
Day 1 (LT/BL at RWA)	1992	39.57	10.371	0.232	39.116	40.028	19.72	97.06
Day 2 (Control Night 1)	2579	41.35	13.143	0.259	40.846	41.861	19.31	100.54
Day 3 (Light Tower)	3015	42.75	10.333	0.188	42.378	43.116	19.31	92.70
Day 4 (Balloon Light)	2988	43.16	9.993	0.183	42.805	43.522	19.31	99.46
Day 5 (Control Night 2)	2114	40.83	9.830	0.214	40.410	41.248	19.31	92.97
Total	12688	41.74	10.889	0.0967	41.554	41.933	19.31	100.54

Table 9.8: Speed Data ANOVA Test Results (Case Study #1)

Source of Variation	Sum of Squares	Degrees of Freedom	Mean Square	F	Sig.
Between Groups	20,612	4	5,152.962	44.047	0.000
Within Groups	1,483,772	12,683	116.989		
Total	1,504,383	12,687			

A more in depth analysis was performed to investigate the specific differences between different nights of testing. For this analysis, the Games-Howell multiple comparison test for each of the five nights were performed, with the results shown in the Table 9.9. The Games-Howell test is used when there are different sample sizes and variance. The table shows that there is no significant difference in the mean speed between control night 1 (Day 2) and control night 2 (Day 5). Also, there is no significant difference in the mean speed between the light tower (Day 3) and balloon light (Day 4).

The mean speed when there was a light present (Day 3 and Day 4) is approximately 2 mph more than when there was no additional light in the work zone (Day 2 and Day 5). The difference is statistically significant but not practically significant. Drivers having better visibility of the work zone could be a reason for higher speed when there is a light present.

Table 9.9: Results of Multiple Comparisons Games-Howell Post-Hoc Test (Case Study #1)

Day (I) Treatment	Day (J) Treatment	Mean Difference (I-J)	Std. Error	Sig.	95% Confidence Interval	
					Lower Bound	Upper Bound
LT/BL @ RWA	Control Night 1	-1.782*	0.348	0.000	-2.731	-0.833
	Light Tower	-3.175*	0.299	0.000	-3.991	-2.359
	Balloon Light	-3.592*	0.296	0.000	-4.398	-2.785
	Control Night 2	-1.257*	0.316	0.001	-2.119	-0.396
Control Night 1	LT/BL@RWA	1.782*	0.348	0.000	0.833	2.731
	Light Tower	-1.393*	0.320	0.000	-2.266	-0.520
	Balloon Light	-1.809*	0.317	0.000	-2.674	-0.945
	Control Night 2	0.525	0.336	0.521	-0.391	1.441
Light Tower	LT/BL@RWA	3.175*	0.299	0.000	2.359	3.991
	Control Night 1	1.393*	0.320	0.000	0.520	2.266
	Balloon Light	-0.417	0.262	0.505	-1.133	0.299
	Control Night 2	1.918*	0.285	0.000	1.140	2.695
Balloon Light	LT/BL@RWA	3.592*	0.296	0.000	2.785	4.398
	Control Night 1	1.809*	0.317	0.000	0.945	2.674
	Light Tower	0.417	0.262	0.505	-0.299	1.133
	Control Night 2	2.334*	0.281	0.000	1.567	3.102
Control Night 2	LT/BL@RWA	1.257*	0.316	0.001	0.396	2.119
	Control Night 1	-0.525	0.336	0.521	-1.441	0.391
	Light Tower	-1.918*	0.285	0.000	-2.700	-1.140
	Balloon Light	-2.334*	0.281	0.000	-3.102	-1.567

*: The mean difference is significant at the 0.05 level.

9.3.2 Impact of Halo Light (Case Study #1)

The impacts of high visibility apparel and a personal light on the visibility of the workers were discussed in the previous chapter. In this study, by recording the passing vehicle speeds using the traffic analyzers, the impact of the use of a personal light on vehicle speed was investigated. For all nights of testing on both case studies, the density technicians wore a Halo light while conducting their work. The Halo light was turned on between midnight and 02:00, and also from 02:00-04:00; during the other times of their work shift the light was turned off.

In this section, the speed data from the sensors in the vicinity of the density technician when the Halo light was turned on are compared to the speed data when it was turned off. Based on the GPS tracker unit carried by the density technicians, their location to the sensors was recorded. The researchers found that density technicians move upstream and downstream regularly to conduct their work, and stay mostly upstream of the paver. However there were short durations of time when the GPS unit showed that the technicians were downstream of the paver. Because of the large number of data points, it is not possible to track the exact location of the density

technicians relative to the nearest sensor corresponding to that location every second during the testing period. Therefore, based on the observations and GPS unit data which indicated the technicians were located upstream of the paver most of the time, for simplicity the speed data recorded by the sensors more than 0.0 to 0.4 miles behind the paver was considered as the vehicle speeds corresponding to the location of the density technicians. A two-sample t-test statistical analysis was performed to determine the impact of the Halo light worn by the technicians. Table 9.10 shows the descriptive statistics of vehicle speeds around the density technicians when the light was tuned on and off. The results of the two sample t-tests for the cases with and without the Halo light turned on, shown in Table 9.11, indicate that there is no significant difference in the travelling vehicle mean speed when the Halo light is turned on compared to without the Halo Light.

Table 9.10: Descriptive Statistics of Recorded Speed near Density Technician (Case Study #1)

Halo Light Status	N	Mean Speed (mph)	Std. Deviation	Std. Error Mean
OFF (without Halo light)	2874	40.25	10.932	0.204
ON (with Halo light)	2461	40.70	11.655	0.235

Table 9.11: Results of Two Sample T-test for Comparison of With and Without Halo Light (Case Study #1)

	Levene's Test for Equality of Variances		T-test for Equality of Means						
	F	Sig.	t	df	Sig. (2-tailed)	Mean Difference	Std. Error Difference	95% Confidence Interval of the Difference	
								Lower	Upper
Equal variances assumed	5.777	0.016	-1.448	5333	0.148	-0.448	0.310	-1.055	0.159
Equal variances not assumed			-1.441	5089.52	0.150	-0.448	0.311	-1.058	0.162

9.3.3 Impact of Radar Speed Sign (Case Study #1)

Previous ODOT studies showed that an RSS is an effective control for reducing speed in work zones. During data collection in the present research, an RSS was located in the work zone on all nights of testing. For better understanding of vehicle speed in this research, the impact of the RSS on vehicle speed in the work zone was investigated. In the first case study, the difference in the mean speed between an upstream sensor and a sensor next to the RSS was considered. During the first night of testing, the sensor upstream of the RSS was at the RWA sign, so no comparison was determined for Day 1. Comparisons were made on the other nights of testing. The results show that there is a statistically significant difference between the mean speed recorded by the sensor adjacent the RSS and that recorded by the sensor upstream of the RSS. This difference ranges between 5.9 mph to 8.2 mph on different nights of testing. The mean

speed difference is from 11 to 14 percent. Considering all nights together, the mean speed at the RSS is 6.6 mph (12%) less than the mean speed at the sensor upstream of the RSS.

Table 9.12 presents an example of the speed statistics at the sensor adjacent to the RSS and the sensor immediately upstream of the RSS. The data analyzed was that collected on the second night of data collection. The table reveals that the mean speed at the RSS was 44.65 mph while the mean speed at the sensor before the RSS was 51.55 mph. Similar tables for other nights of testing are provided in the Appendix.

Table 9.12: Descriptive Statistics of Vehicle Speed at RSS and Upstream of RSS, Day 2 (Case Study #1)

Sensor	N	Mean Speed (mph)	Std. Deviation	Std. Error Mean
Pre-RSS	967	51.55	8.874	0.285
At RSS	986	44.65	8.842	0.282

The results of two sample t-tests examining the difference between the speed data of the sensor next to the RSS and the sensor before the RSS are shown in Table 9.13. The tests indicate that there is a significant difference between the mean speed at the RSS and the mean speed at the sensor upstream of the RSS. Mean speed at the RSS is 6.9 mph less than the mean speed at the sensor before the RSS. A summary of the impact of the RSS on all nights of testing for this case study is provided in Table 9.14.

Table 9.13: Results of Two Sample T-test for Comparison of Mean Speed at RSS and before RSS, Day 2 (Case Study #1)

	Levene's Test for Equality of Variances		T-test for Equality of Means						
	F	Sig.	t	df	Sig. (2-tailed)	Mean Difference	Std. Error Difference	95% Confidence Interval of the Difference	
								Lower	Upper
Equal variances assumed	3.613	0.057	17.214	1951	0.000	6.901	0.401	6.115	5.687
Equal variances not assumed			17.213	1949.954	0.000	6.901	0.401	6.115	5.687

Table 9.14: Summary of RSS Impact on Mean Speed (Case Study #1)

	Day				
	1	2	3	4	5
Mean speed (mph): Before RSS / At RSS	--*	51.5 / 44.6	53.6 / 47.6	56.8 / 48.6	58.4 / 51.3
Speed decrease (mph)	Not applicable	6.9	5.9	8.2	7.1
Percentage speed reduction	Not applicable	13%	11%	14%	12%
RSS sensor ID#	318	748	748	216	216
Previous sensor ID#	--*	216	325	325	325
Distance between sensors (miles)	--*	0.3	0.2	0.3	0.2

*: Previous sensor located at RWA sign, therefore comparison not consistent with other days.

9.3.4 Impact of Additional Light (Case Study #2)

Similar to Case Study #1, different statistical tests were conducted on the data collected for Case Study #2 to evaluate the impacts of the light, Halo light, and RSS. In Case Study #2, sensors were placed earlier in the day than for Case Study #1, which provided an opportunity to collect data related to the light equipment before the paver reached the light. Therefore, the impact of the light can be investigated without any confounding impact of the paving equipment. For statistical analysis, only the speed values from the sensors which were more than 0.6 miles behind the paver were considered for analysis. In addition, similar to Case Study #1, speed data from sensors upstream, next to, and downstream of the portable light equipment is considered for comparisons. For the nights of testing without additional lighting equipment present, to increase consistency in the data analyzed, speed data was considered from sensors which were placed at similar locations in the paving operation as those sensors during nights with additional lighting present.

An initial analysis evaluated the presence of the light tower on vehicle speed. Table 9.15 shows that the mean speed when there was a light tower in the work zone was 50.20 mph in the northbound direction, while the mean speed when there was not any additional lights at a similar sensor location in the work zone was 48.16 mph. The difference in mean speeds is statistically significant (Table 9.16).

Table 9.15: Speed Data Statistics Used for Comparison Between Light Tower and No Light, Northbound Direction (Case Study #2)

Light Status	N	Mean Speed (mph)	Std. Deviation	Std. Error Mean
Without Light	368	48.16	7.766	0.405
With Light Tower	713	50.20	8.672	0.325

Table 9.16: Results of Two Sample T-test for Comparison With and Without Light Tower, Northbound Direction (Case Study #2)

	Levene's Test for Equality of Variances		T-test for Equality of Means						
	F	Sig.	t	df	Sig. (2-tailed)	Mean Difference	Std. Error Difference	95% Confidence Interval of the Difference	
								Lower	Upper
Equal variances assumed	2.918	0.088	-3.796	1079	0.000	-2.040	0.538	-3.095	-0.986
Equal variances not assumed			-3.931	816.97	0.000	-2.043	0.519	-3.059	-1.022

For the southbound direction, data was collected on three nights of testing. The results are shown in Tables 9.17 to 9.20. Figures 9.17 and 9.18 show the results relative to the light tower, and Figures 9.19 and 9.20 show the results for the balloon light. The results reveal similar findings to the analysis for the northbound direction: the mean speed when there was a light in the work zone was higher than without any light in the work zone.

Table 9.17: Speed Data Statistics Used for Comparison Between Light Tower and No Light, Southbound Direction (Case Study #2)

Light Status	N	Mean Speed (mph)	Std. Deviation	Std. Error Mean
With Light Tower	503	45.81	7.156	0.319
Without Light	219	43.93	7.285	0.492

Table 9.18: Results of Two Sample T-test for Comparison of Light Tower and No Light, Southbound Direction (Case Study #2)

	Levene's Test for Equality of Variances		T-test for Equality of Means						
	F	Sig.	t	df	Sig. (2-tailed)	Mean Difference	Std. Error Difference	95% Confidence Interval of the Difference	
								Lower	Upper
Equal variances assumed	0.489	0.485	3.223	720	0.001	1.877	0.583	0.734	3.021
Equal variances not assumed			3.200	408.355	0.001	1.877	0.587	0.724	3.031

Table 9.19: Speed Data Statistics Used for Comparison Between Balloon Light and No Light, Southbound Direction (Case Study #2)

Light Status	N	Mean Speed (mph)	Std. Deviation	Std. Error Mean
With Balloon Light	697	49.00	8.972	0.340
Without Light	219	43.93	7.285	0.492

Table 9.20: Results of Two Sample T-test for Comparison of Balloon Light and No Light, Southbound Direction (Case Study #2)

	Levene's Test for Equality of Variances		T-test for Equality of Means						
	F	Sig.	t	df	Sig. (2-tailed)	Mean Difference	Std. Error Difference	95% Confidence Interval of the Difference	
								Lower	Upper
Equal variances assumed	2.455	0.117	7.608	914	0.000	5.068	0.666	3.761	6.376
Equal variances not assumed			8.473	443.724	0.000	5.068	0.598	3.893	6.244

9.3.5 Impact of Halo Light (Case Study #2)

An analysis related to the impact of the Halo light on vehicle speed was performed similar to that done for Case Study #1. For simplicity, as mentioned for Case Study #1, the speed data from the sensors upstream of the paver (a distance from 0.0 to 0.4 miles from the paver) was considered as the speed corresponding to the location of the density technicians. A two-sample t-test statistical analysis was performed to find the impact of the Halo light on the speed of the passing vehicles. Tables 9.21 and 9.22 show the descriptive statistics and the results of the t-tests, respectively, for the northbound direction of traffic. As indicated in the tables, there is no significant difference in the mean vehicle speeds with the Halo light turned on compared to when it is turned off.

Table 9.21: Descriptive Statistics of Recorded Speed at Density Technician, Northbound Direction (Case Study #2)

Halo Light Status	N	Mean Speed (mph)	Std. Deviation	Std. Error Mean
OFF (without Halo Light)	2230	43.09	8.753	0.185
ON (with Halo Light)	1802	43.01	10.438	0.246

Table 9.22: Results of Two Sample T-test for Comparison of With and Without Halo Light, Northbound Direction (Case Study #2)

	Levene's Test for Equality of Variances		T-test for Equality of Means						
	F	Sig.	t	df	Sig. (2-tailed)	Mean Difference	Std. Error Difference	95% Confidence Interval of the Difference	
								Lower	Upper
Equal variances assumed	28.90	0.000	0.289	4030	0.773	0.087	0.302	-0.505	0.680
Equal variances not assumed			0.284	3512.81	0.777	0.087	0.308	-0.516	0.691

Similarly, Tables 9.23 and 9.24 show the descriptive statistics and t-test results, respectively, for the southbound direction traffic. The results are the same in that there is no significant difference in the mean vehicle speed when the Halo light is turned on compared to when it is turned off.

Table 9.23: Descriptive Statistics of Recorded Speed at Density Technician, Southbound Direction (Case Study #2)

Halo Light Status	N	Mean Speed (mph)	Std. Deviation	Std. Error Mean
OFF (without Halo Light)	3226	41.49	9.026	0.159
ON (with Halo Light)	3053	41.49	10.156	0.184

Table 9.24: Results of Two Sample T-test for Comparison of With and Without Halo Light, Southbound Direction (Case Study #2)

	Levene's Test for Equality of Variances		T-test for Equality of Means						
	F	Sig.	t	df	Sig. (2-tailed)	Mean Difference	Std. Error Difference	95% Confidence Interval of the Difference	
								Lower	Upper
Equal variances assumed	14.102	0.000	-0.005	6277	0.996	-0.001	0.242	-0.476	0.474
Equal variances not assumed			-0.005	6096.59	0.996	-0.001	0.243	-0.478	0.475

9.3.6 Impact of Radar Speed Sign (Case Study #2)

For each night of testing, the difference in the mean speed between the speeds recorded in the sensor upstream of the RSS and the sensor next to the RSS was considered. On Day 2 and Day 5, the sensors were placed after (downstream of) the RSS, so the difference in mean speed could not be calculated. Therefore, the calculations were performed for just Days 1, 3, and 4. The results reveal that there is a statistically significant difference between mean speed of the vehicles at the sensor adjacent the RSS and the sensor upstream of the RSS. This difference was 14.4 mph for traffic in the northbound direction, and between 7.4 and 11.2 mph for traffic travelling in the southbound direction. The mean speed at the RSS was between 13 and 25 percent less than the mean speed at the sensor upstream of the RSS. Descriptive statistics and results of two sample t-test for Day 3 are illustrated in Table 9.25 and Table 9.26, respectively. A summary of the difference in mean speed at the RSS and prior to the RSS in this case study is also provided in Table 9.27.

Table 9.25: Descriptive Statistics of Vehicle Speed at RSS and Upstream of RSS, Day 3 (Case Study #2)

Location	N	Mean Speed (mph)	Std. Deviation	Std. Error Mean
Pre-RSS	1872	55.37	7.361	0.170
At RSS	2001	48.02	6.151	0.138

Table 9.26: Results of Two Sample T-test for Comparison of Mean Speed at RSS and before RSS, Day 3 (Case Study #2)

	Levene's Test for Equality of Variances		T-test for Equality of Means						
	F	Sig.	t	df	Sig. (2-tailed)	Mean Difference	Std. Error Difference	95% Confidence Interval of the Difference	
								Lower	Upper
Equal variances assumed	72.311	0.000	33.822	3871	0.000	7.355	0.218	6.929	7.781
Equal variances not assumed			33.622	3654.75	0.000	7.355	0.219	6.926	7.784

Table 9.27: Summary of RSS Impact on Mean Speed (Case Study #2)

	Day				
	1	2	3	4	5
Mean speed (mph): Before RSS / At RSS	57.43 / 43.19	NA	55.4 / 48.0	59.3 / 48.0	NA
Speed decrease (mph)	14.4	NA	7.4	11.2	NA
Percentage speed reduction	25%	NA	13%	19%	NA
RSS sensor ID#	325	NA	325	325	NA
Previous sensor ID#	106	NA	216	216	NA
Distance between sensors (miles)	0.4	--	0.5	0.4	--

9.4 ADDITIONAL OBSERVATION FROM CASE STUDIES

During the course of the case studies, the researchers observed the work operations, site conditions, traffic patterns, and worker behaviors. All of these factors are important considerations when evaluating impacts to vehicle speed and determining how to create safe work zones for both workers and motorists. In some cases, the researchers observed conditions that supported the findings of the testing described above or that highlighted additional issues of importance and concern.

As described in previous sections of the report, the field demonstration and pilot testing confirmed the need for additional lighting to make the workers visible during nighttime operations. A light shining on a worker who is wearing reflective apparel makes the worker visible to oncoming motorists. However, when the worker walks just a short ways away from the lighting so that the worker is between the light and the oncoming vehicle (i.e., upstream of the light), visibility of the worker dramatically decreases. This effect was also observed in the case studies as shown in Figure 9.33. The figure shows a work crew around a paver with two workers highlighted (by red circles). One worker is standing slightly downstream of the balloon light and is illuminated and easily seen. The other highlighted worker is located upstream of the light and is not as visible even though the worker is wearing reflective apparel. To ensure that workers on foot are visible, the workers should stand downstream of the light. However, due to the work operations, location of equipment, location of the light, and required work tasks, standing

downstream of the lighting is not always possible. To help mitigate the lack of visibility when standing upstream of the light, workers can wear a personal light (wearable), such as a Halo light on their hardhat or on their vest.



Figure 9.33: Visibility of Workers Upstream and Downstream of Light

Workers on foot in locations immediately adjacent to the travel lane are particularly exposed to high speed traffic. For these workers, wearing highly visible garments and using a personal light like a Halo light can help them be more visible to oncoming motorists. Figures 9.34, 9.35, and 9.36 illustrate this point. The figures show workers (outlined by the red circle) on the roadway in similar surrounding light conditions but wearing different apparel, both with and without a Halo light. The photos were taken while driving in the travel lane adjacent to the work area. The Halo light and additional reflectivity on the worker in Figure 9.36 makes the worker much more visible to passing motorists. For comparison, Figure 9.37 shows a worker from a farther distance away wearing reflective apparel and illuminated by paver lights.



Figure 9.34: Visibility of Worker on Roadway without Additional Lighting



Figure 9.35: Visibility of Worker on Roadway with Class 3 Vest



Figure 9.36: Visibility of Worker on Roadway with Class 3 Vest and Pants plus Halo Light

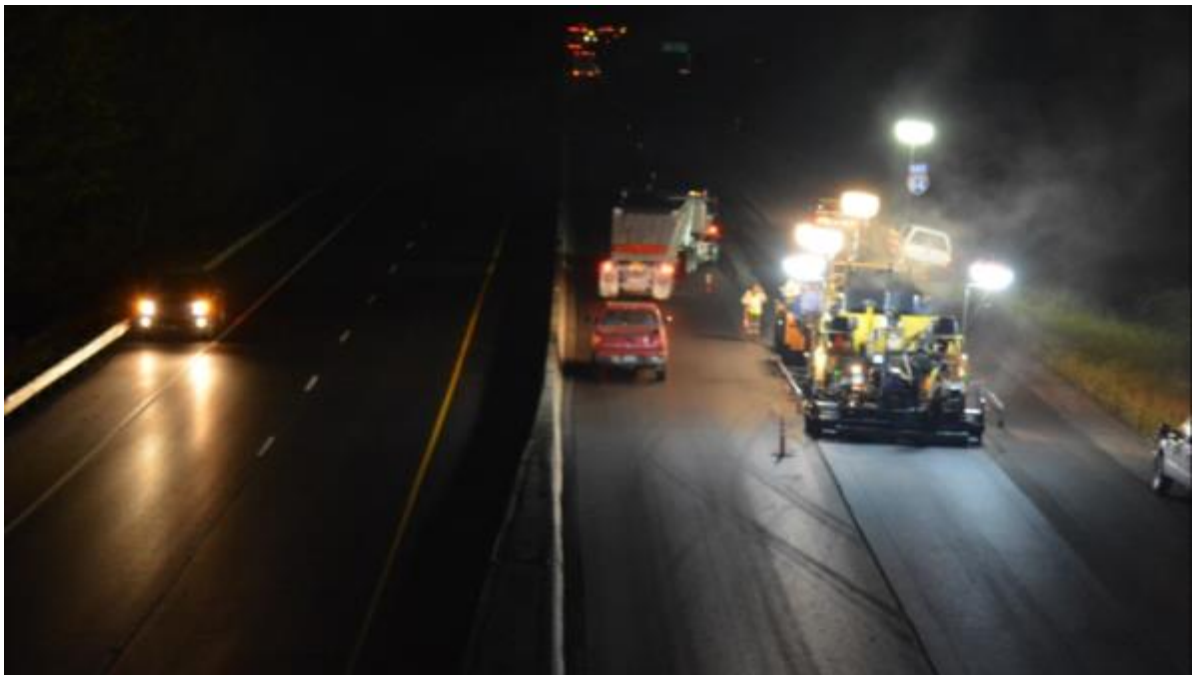

Figure 9.37: Visibility of Worker next to Paver

The quality and condition of the reflective apparel is also an issue of concern. The work operations and outdoor conditions of the work site can get the reflective apparel dirty. When covered with dust and dirt, the apparel does not reflect the light as well. Figures 9.38 and 9.39 show comparisons of dirty and clean reflective apparel for workers in similar roadway and lighting conditions. The worker wearing clean reflective garments is easier to see.



Figure 9.38: Visibility of Worker Wearing Dirty Reflective Garments and Halo Light



Figure 9.39: Visibility of Worker Wearing Clean Reflective Garments without Halo Light

Another concern on some mobile projects is the height of the lighting placed on equipment. Overhead structures such as bridges and signs may limit the height of lighting on equipment that is intended to pass under the structure during the course of the work operations. Figure 9.40, for example, shows a case where the balloon light mounted on a mast on a paver was too high for the equipment to pass under an overpass. Consideration should be given to the maximum height of lighting systems mounted on equipment based on the elevated structures on a project.



Figure 9.40: Paver Progress being Obstructed by Overpass due to Height of Balloon Light

10.0 CONCLUSIONS

As presented above, the objective of the research study was to investigate the impacts of additional temporary roadway lighting on the speed of passing vehicles in construction work zones. The initial premise posed was that additional lighting would help bring attention to the work zone and result in lower vehicle speeds. Added to the study was an investigation of how workers wearing high visibility apparel and personal lights also affects vehicle speeds. For those workers who are on foot, away from the construction equipment and other sources of lighting, the additional reflective apparel and personal lighting makes them more visible to oncoming motorists. It was hypothesized that increasing the visibility of workers in this way will also cause vehicle speeds to decrease.

In the present study, the researchers conducted pilot testing of the lighting systems, a national survey of construction personnel, and a focus group survey of ODOT and construction personnel to gain a better understanding of the application of current lighting equipment used on highway projects. Application of the lighting on actual case study projects was then conducted to evaluate the impacts of the lighting in practice. In addition, different high visibility apparel and a personal light (Halo light) were examined in all phases of the study. Two types of temporary roadway lighting systems, a light tower and balloon light, were placed on highway preservation projects to determine their impact on vehicle speed. Multiple nights of testing were performed on each case study to collect vehicle speed data under different treatments. Vehicle speed, vehicle length, and time of passing through the work zone were recorded by placing traffic analyzers (sensors) in the travel lanes throughout the work zone. The locations of the grinder, paver and density technician during the work shift were tracked by GPS units throughout each testing period to understand the impact of construction equipment on vehicle speed.

The quantitative analyses of the collected speed data from the two case study projects provided evidence of the impact of additional lights on vehicle speed. The following is a summary of the conclusions that can be drawn from the case study analyses as well as from the survey, focus group demonstration, and pilot testing conducted in the study:

Current practice:

- Providing additional temporary lighting in work zones on preservation projects with the sole intent of decreasing vehicle speeds is currently not a typical construction practice. Lighting is typically provided in practice to illuminate the work area and increase the visibility of the workers.
- Portable, trailer-mounted light towers (light plants) and balloon lights attached to vehicles and equipment are the most common types of lighting equipment used in highway construction projects.
- Mobility of additional temporary lighting systems is a priority on construction projects, especially for mobile operations such as repaving on high-speed roadways.
- Orienting a portable light tower to shine in the direction of the traffic approaching in either direction, or aiming the light tower at an angle that does not direct the light

down towards the roadway, can create disabling glare for oncoming motorists and construction equipment operators. Glare from construction equipment headlights can also create a hazard for motorists and equipment operators. The type, amount, location, and orientation of lighting should be considered when planning highway construction operations in order to reduce disabling glare and provide a visible and clear path through the work zone.

- The amount of the light emitted, ease of moving the light equipment (mobility), and ease of equipment operation are the top three criteria used by construction personnel when selecting lighting equipment for construction projects.
- Power source, cost, road geometry (including shoulder width and other space constraints), the security of additional lights against theft, and attracting bugs during warm seasons are additional issues that are considered when selecting lighting equipment. In addition, for tripod mounted systems, the ability of the light to remain standing in high winds is another important factor that can adversely affect implementation and use.

Vehicle speed:

- There is a statistically significant difference in mean speed when an additional temporary light (light tower or balloon light) is present on the roadway in the work zone compared to when a light is not present. The mean vehicle speed when there is a light tower or balloon light in the middle of the work zone is 1.8 to 5 mph **greater** than when there is no additional temporary light present in the work zone. Increasing the amount of lighting in, and therefore visibility of, the work zone, may cause drivers to feel more safe, have greater confidence in their assessment of the work zone, bring greater attention to the work zone, or result in other similar impacts to driver risk assessment and driving behavior, all of which could cause the drivers to increase their speed. Further research is needed to determine why speed differs with the additional temporary light present.
- There is no significant difference in mean vehicle speed when comparing the presence of the light tower to the presence of the balloon light in the work zone.
- When comparing vehicle speed adjacent to the density technician who is wearing a Halo light, there is no statistically significant difference in mean speed of the passing vehicles when the Halo light is turned on compared to when the Halo light is turned off. The results of the pilot testing, however, suggest that a personal (wearable) light such as a Halo light increases worker recognition and visibility of the worker when there is no other additional light in the vicinity.
- Mean vehicle speed at the RSS is between 5.8 and 11.2 mph less than the mean speed at approximately a quarter mile before the RSS. The variance in vehicle speed is also typically lower at the RSS. Lower variance represents less difference in the speed of the passing vehicles and therefore less chance of a crash due to speed differential.

- A vehicle's speed varies as it travels through the work zone. At the RWA sign, the speed of the passing vehicle can be considered as the "normal" speed. As the vehicles approach the work area, the vehicles initially slow down at the taper and then reduce their speed gradually in the beginning of the work zone. Generally, vehicles travel at a lower speed when approaching and passing the paving equipment such as the paver, sweeper, tack truck, and grinder. Greater reduction in speed occurs near the larger pieces of equipment that have mobile lighting attached to the equipment and extensive worker activity in the immediate vicinity. After the vehicles pass by the equipment, their speed typically increases. If another piece of equipment is encountered, the vehicles slow down again. The changes in speed at and between the equipment typically repeat until all of the equipment is passed. If no other equipment is encountered, vehicle speed remains high and constant through to the end of the work zone. These findings are consistent with the results of previous ODOT studies (e.g., SPR 751, SPR 769, and OR-RD-16-09).

Visibility of Workers:

- Overall, the addition of both the balloon light and light tower resulted in worker detection distances that were greater with the lights turned on than without the lights on. Similar to the findings of previous lighting studies (e.g., Finely et al. 2014), properly installed temporary work zone lighting helps to increase the distance at which workers and low-contrast objects can be detected.
- The density technician, dump person, spotters, "stick-and-stomp" workers, and traffic control crew members are examples of personnel who are regularly on foot on the roadway throughout the work shift, placing them in locations of high exposure to oncoming traffic. In many cases the density technician, "stick-and-stomp" workers, and traffic control crew members are located in areas where there is no additional light provided by the construction equipment. For the dump person, spotters, and other workers who are on foot on the roadway and working adjacent to large construction equipment, visibility of the workers may be blocked by the presence of the equipment and the visibility minimized when the equipment blocks the light from illuminating the workers. Worker position with respect to the light has a significant impact on all of these workers being visible to oncoming motorists and equipment operators. Sometimes a difference of just a few feet can make a big difference in their visibility.

Work zone crashes occur due to different causes. Driver distraction, driver error, driving behavior, roadway conditions, visibility, and worker error are example causes of accidents. Vehicle speed can accentuate the risk of a crash. Higher vehicle speed has been associated with increased risk of crashes on roadways. For work zones, the roadway conditions are typically different and less predictable than when the work zone is not present. Reducing vehicle speed in work zones is also recognized as an means to help prevent crashes in work zones.

In addition to speed, safe passage through work zones requires an obvious, consistent, predictable, and well-maintained path through the entire work zone. Driver visibility and recognition of the traffic control measures, workers, and equipment are important considerations as well. Increasing awareness of the features and conditions of the roadway helps to prevent crashes. While the present research reveals that adding temporary roadway lighting does not necessarily lead to reductions in vehicle speed, it can improve visibility of the workers and awareness of the work operations. Similarly, wearing personal lights and highly reflective apparel and equipment helps to increase visibility of the construction activity area and the workers in the work zone. The additional lighting, whether on the roadway or on the worker, helps to increase driver recognition that a worker is present. Both of these conditions – higher visibility and greater driver awareness – help to improve safety performance in highway work zones.

Furthermore, visibility of workers to equipment operators is also a significant concern. Additional lighting, whether a light tower or balloon light located on the roadway, a mobile light attached to the equipment, or a personal light worn by the workers, also help to make the workers visible to the equipment operators.

11.0 RECOMMENDATIONS AND FUTURE WORK

The findings from the present research highlight practices that aid in maintaining the safety of workers on mobile operations during nighttime construction. Provided below are recommendations for implementation of the research findings in practice. Importantly, the recommendations are designed to help make workers as visible as possible and increase motorist and equipment operator awareness of and attention to workers in the work zone. Consideration should be given to the applicability of each recommendation based on the project and site conditions, and feasibility of implementation.

- Add an additional light on the roadway where workers on foot will likely congregate in order to increase the visibility of the workers by passing motorists and equipment operators.
- Attach a balloon or other portable, non-glare-producing light to the density technician's vehicle to illuminate the density technician's work area and illuminate the technician when walking on the roadway. A light attached to the vehicle will ensure that the light remains with the technician as the work progresses down the roadway. In conjunction with this practice, when on the roadway, the technician needs to stand downstream of the light so that the light illuminates the technician for oncoming traffic.
- When a light tower or other light is used on a project, orient the light to prevent creating glare for motorists and equipment operators.
- If not already present, consider adding lights on the front and rear of each piece of construction equipment in the paving train to illuminate the workers on foot on the roadway between each piece of equipment. For example, a light could be added to the front of the paver to help illuminate the dump person. Care should be taken to orient the lights so that they do not create glare for the motorists and equipment operators.
- Attach a radar speed sign (RSS) to the top of one or more rollers to help decrease the speed of vehicles near the equipment. Attaching the RSS to a roller ensures that the RSS moves with the work operation as it progresses down the roadway. A similar RSS could also be added to other pieces of equipment in the paving train.
- Provide training to workers regarding where to stand relative to work zone lighting to maximize their visibility.
- Have workers, especially those who are typically on foot on the roadway, wear at least a Class 3 vest and pants. Ensure that the reflective apparel is clean to maximize reflectivity.
- For those workers who are typically not near large equipment, have the workers wear a personal (wearable) light in addition to their reflective apparel. If it causes no distraction for other workers, consider using a wearable light with flashing mode to

help attract the attention of passing motorists and distinguish the worker from other surrounding equipment containing static lights.

During the course of the data collection and analysis, additional questions arose regarding the performance of lighting equipment, limitations of the present research, and ideas for other potential traffic control measures. The applicability of the research to all preservation projects is dependent on the number and types of tests performed. The number of workers on the case studies who wore the Halo light, for example, was limited due to the number of available Halo lights and the available workers to wear the lights. Further research that includes additional workers wearing personal lights will increase confidence in the research results and provide more detailed guidance on their use.

A significant consideration of any paving project is mobility of equipment and workers. Equipment that is not mobile severely limits the feasibility of using the equipment. Lighting systems that are attached to the equipment will be more applicable and acceptable than those that are stationary. As mentioned above, additional lighting on the front and rear of each piece of equipment can further illuminate workers on foot that are located between each piece of equipment. The benefits of such lighting and impacts on worker safety, and potential negative impacts on glare for motorists and equipment operators, is another recommended area of future research.

Lastly, the present research focused on mobile paving projects. The research should be expanded to other types of projects as well. Additional investigation into the impacts of lighting systems on vehicle speed is needed for stationary projects on high-speed roadways.

12.0 REFERENCES

Anani, S. Work Zone Illumination Design: Guidance Strategies to Specify Appropriate Work Zone Lighting Plan”. MS Thesis, University of Wisconsin-Milwaukee, Aug. 2015.

ANSI/ISEA. *American National Standard for High-Visibility Safety Apparel*. American National Standards Institute (ANSI) and the International Safety Equipment Association (ISEA), ANSI/ISEA 107-2010. 2010. <https://safetysitequipment.org/standard/ansiisea-107-2010/>.

Arditi, D., J. Shi, M. Ayrancioglu, D.-E. Lee. *Nighttime Construction: Evaluation of Worker Safety Issues*. Project VD-H2, FY00/01, Report No. ITRC FR 00/01-1. Illinois Transportation Research Center, 2003.

ATSSA. *High-Visibility Safety Apparel in Highway Work Zones*. American Traffic Safety Services Association (ATSSA). 2009. <http://www.transportation.nebraska.gov/ref-man/WorkerVisibility.pdf>.

ATSSA. *Nighttime Lighting Guidelines for Work Zones: A Guide for Developing a Lighting Plan for Nighttime Work Zones*. American Traffic Safety Services Association (ATSSA), April 2013.

Bryden, J. *Traffic Control Handbook for Mobile Operations at Night: Guidelines for Construction, Maintenance, and Utility Operations*. Publication FHWA-SA-03-026. U.S. Department of Transportation, Federal Highway Administration. 2003.

Bryden, J.E. and D.J. Mace. *Guidelines for Design and Operation of Nighttime Traffic Control for Highway Maintenance and Construction*. National Cooperative Highway Research Program (NCHRP) Report #476. National Academy Press, Washington, D.C. 2002.

Bullough, J., J. Freyssinier, M. Rea. Implementing Semipermanent High-Mast Lighting for Highway Construction Projects. In *Transportation Research Record, Journal of the Transportation Research Board, No. 2055*. TRB, National Research Council, Washington, D.C., 2008, pp. 49–52.

Cottrell, B.H. Jr. *Improving Night Work Zone Traffic Control*. Publication VTRC 00-R8. Virginia Transportation Research Council, Charlottesville, VA. Aug. 1999.

Ellis, R. Jr. Lighting Fundamentals for Nighttime Highway Construction. In *Construction and Materials Issues*, ASCE, 2001, pp. 96-105.

Ellis, R. Jr. and S. Amos. Development of Work Zone Lighting Standards for Nighttime Highway Work. In *Transportation Research Record, Journal of the Transportation Research Board, No. 1529*, TRB, National Research Council, Washington, D.C., 1996, pp. 35–42.

Ellis, R.D., S.J. Amos, and A. Kumar. *Guidelines for Work Zone Illumination Design*. Transportation Research Board,, National Research Council, Washington, D.C., July 1995.

Ellis, R. Jr., S.J. Amos, and A. Kumar. *Illumination Guidelines for Nighttime Highway Work*. Report #498. National Cooperative Highway Research Program (NCHRP), Transportation Research Board, National Research Council, Washington, D.C., 2003.

El-Rayes, K. and K. Hyari. Automated DSS for Lighting Design of Nighttime Operations in Highway Construction Projects. In *Proceedings of the 19th ISARC*, International Association for Automation and Robotics in Construction (ISARC), Washington, D.C., 2002, pp. 135-140.

El-Rayes, K. and K. Hyari. Lighting Design Requirements for Highway Nighttime Construction. In *Proceedings of the Construction Research Congress*, American Society of Civil Engineers, 2003a.

El-Rayes, K. and K. Hyari. *Automated DSS for Lighting Design of Nighttime Operations in Highway Construction Projects*. Special Publication. 135-142. National Institute of Science and Technology (NIST), 2003b.

El-Rayes, K. and K. Hyari. CONLIGHT: Lighting Design Model for Nighttime Highway Construction. In *Journal of Construction Engineering and Management*, Vol. 131(4), ASCE, 2005a, pp. 467–476.

El-Rayes, K. and K. Hyari. Optimal Lighting Arrangements for Nighttime Highway Construction Projects. In *Journal of Construction Engineering and Management*, Vol. 131(12), ASCE, 2005b, pp. 1292–1300.

El-Rayes, K., L. Liu, F. Pena-Mora, F. Boukamp, I. Odeh, M. Elseifi, and M. Hassan. *Nighttime Construction: Evaluation of Lighting Glare for Highway Construction in Illinois*. Research Report FHWA-ICT-08-014. Illinois Center for Transportation, Dec. 2007.

FHWA. *Manual on Uniform Traffic Control Devices (MUTCD)*. Federal Highway Administration, U.S. Department of Transportation, Washington, D.C., 2012, <http://mutcd.fhwa.dot.gov/>.

Finley, M., K. Weimert, J. Miles. Impact of Work Zone Lighting on Driver's Detection of Objects. In *Transportation Research Record, Journal of the Transportation Research Board*, No. 2458, TRB, National Research Council, Washington D.C., 2014, pp. 56–64.

Freyssinier, J., J. Bullough, and M. Rea. Performance Evaluation of Semipermanent High-Mast Lighting for Highway Construction Projects. In *Transportation Research Record, Journal of the Transportation Research Board*, No. 2055, TRB, National Research Council, Washington D.C., 2008, pp. 53–59.

Gambatese, J.A. *SPR 617: Optimum Illumination for Nighttime Flagger Operations*. Publication FHWA-OR-RD-06-05. Oregon Department of Transportation (ODOT) and U.S. Department of Transportation, Federal Highway Administration (FHWA), August 2005, http://www.oregon.gov/ODOT/TD/TP_RES/docs/reports/optimum.pdf.

Gambatese, J.A. and A. Jafarnejad. *Evaluation of Radar Speed Display for Mobile Maintenance Operations*. Publication OR-RD-16-09. Oregon Department of Transportation (ODOT) and U.S.

Department of Transportation, Federal Highway Administration (FHWA) December 2015.
http://www.oregon.gov/ODOT/Programs/ResearchDocuments/RSS_Final_Report_OR_RD_16_09.pdf

Gambatese, J.A. and S. Rajendran. Flagger Illumination during Nighttime Construction and Maintenance Operations. In *Journal of Construction Engineering and Management*, Vol. 138(2), ASCE, 2012, pp. 250–257.

Gambatese, J.A. and Zhang, F. *SPR 769: Safe and Effective Speed Reductions for Freeway Work Zones Phase 2*. Publication FHWA-OR-RD-15-04. Oregon Department of Transportation (ODOT) and U.S. Department of Transportation, Federal Highway Administration (FHWA), September 2014.
http://www.oregon.gov/ODOT/Programs/ResearchDocuments/SPR769_HighSpeed_Final.pdf

Gambatese, J.A., F. Zhang, and A.M. Vahed. *SPR 751: Implementing Speed Reductions at Specific Interstate Work Zones from 65 Mph to 35 Mph*. Publication FHWA-OR-RD-13-11. Oregon Department of Transportation (ODOT) and U.S. Department of Transportation, Federal Highway Administration (FHWA), February 2013.
http://www.oregon.gov/ODOT/Programs/ResearchDocuments/SPR751_SpeedReductions.pdf

Hancher, D. and T. Taylor. Nighttime Construction Issues. In *Transportation Research Record, Journal of the Transportation Research Board, No. 1761*, TRB, National Research Council, Washington D.C., 2001, pp. 107–115.

Hanna, A.N. Illumination Guidelines for Nighttime Highway Work. In *Research Results Digest No. 216*. National Cooperative Highway Research Program (NCHRP), Transportation Research Board, National Research Council, Washington, D.C., 1996, pp. 1-5.

Hassan, M.M., I. Odeh, I., and K. El-Rayes. New Approach to Compare Glare and Light Characteristics of Conventional and Balloon Lighting Systems. In *Journal of Construction Engineering and Management*, ASCE, 137(1), 2010a. pp. 39–44.

Hassan, M.M., I. Odeh, and K. El-Rayes. Glare and Light Characteristics of Conventional and Balloon Lighting Systems. Paper No. 10-0389. In: 89th Annual Meeting of the Transportation Research Board, Washington, D.C., Jan. 11-15, 2010b.

Huckaba, D.A. Research Pays Off: Safer Nighttime Construction Zones through Better Lighting: Illinois Develops and Applies Practical Guidelines. In *TR News 260*, Jan.-Feb. 2009.

Hyari, K. and K. El-Rayes. Field Experiments to Evaluate Lighting Performance in Nighttime Highway Construction. In *Construction Management and Economics*, Routledge, 24, 2006, pp. 591–601.

Leidos *Oregon Work Zone Safety Implementation Plan: Final Report*. Leidos, Sept. 23, 2015.

Odeh, I., K. El-Rayes, and L. Liu. Field Experiments to Evaluate and Control Light Tower Glare in Nighttime Work Zones. In *Journal of Construction Engineering and Management*, ASCE, 135(9), 2009, pp. 911–919.

ODOT *Oregon Temporary Traffic Control Handbook (OTTCH)*. Oregon Department of Transportation (ODOT), 2011. <http://www.oregon.gov/ODOT/HWY/TRAFFIC-ROADWAY/Pages/ottch.aspx>.

ODOT *Oregon Work Zone Safety Implementation Plan*, Oregon Department of Transportation (ODOT), 2015a.

ODOT *2015 Standard Specifications*. Oregon Department of Transportation (ODOT), 2015b. http://www.oregon.gov/ODOT/HWY/SPECS/Pages/2015_Standard_Specifications.aspx.

ODOT *Oregon and National Work Zone Safety Statistics 2017*, Oregon Department of Transportation, 2017a. http://www.oregon.gov/ODOT/TS/Pages/workzonesafety.aspx#Research_and_Statistics, accessed May 2017.

ODOT *Work Zone Safety Fact Sheet & Safety Tips*. Oregon Department of Transportation, 2017b. https://www.oregon.gov/ODOT/TS/docs/Workzone/2017_WorkZoneFactSheet.pdf, accessed May 2017.

OR-OSHA *Oregon Occupational Safety & Health Code*. Division 3, Oregon Administrative Rules, Chapter 437. Oregon Occupational Safety & Health Division (OR-OSHA), Oregon Department of Consumer & Business Services, 2012. http://www.orosha.org/standards/div_3.html.

OSHA *Safety and Health Regulations for Construction*. Publication 29 CFR 1926. Occupational Safety and Health Administration, US Department of Labor, 2015.

Rea, M.S., J.D. Bullough, L.C. Radetsky, N.P. Skinner, and A. Bierman, (2016) "Toward the development of standards for yellow flashing lights used in work zones." *Lighting Research & Technology*, 1477153516670935.

Shane, J.S., Kandil, A.A., and Schexnayder, C.J. (2012). "A Guidebook for Nighttime Construction: Impacts on Safety, Quality, and Productivity." National Cooperative Highway Research Program (NCHRP) Report #726, Transportation Research Board, National Research Council, Washington, DC.

Shepard, F.D. and B.H. Cottrell, Jr. *Benefits and Safety Impact of Night Work Zone Activities*. FHWA Report FHWA/RD-84/097. US Department of Transportation, Washington, DC, 1985.

Steele, D.A., Zabecki, J.L.M., and Zimmerman, L. (2013a). "Improving the Effectiveness of Nighttime Temporary Traffic Control Warning Devices, Volume 1: Evaluation of Lights on Nighttime Work Zone Channelization Devices." Illinois Center for Transportation, Research Report No. FHWA-ICT-13-029, Oct. 2013.

Steele, D.A., Zabecki, J.L.M., and Zimmerman, L. (2013b). "Improving the Effectiveness of Nighttime Temporary Traffic Control Warning Devices, Volume 2: Evaluation of Nighttime Mobile Warning Lights." Illinois Center for Transportation, Research Report No. FHWA-ICT-13-032, Nov. 2013.

Ullman, G. and Finley, M. (2007). "Challenges to Implementation of Work Zone Lighting Guidelines." *17th TRB Visibility Symposium*, College Station, TX, April 17-19, 2007.

Vecellio, R.L. and McCarthy, J.R. (2006). "Lighting Specifications for Nighttime Construction Work Zones on Active Highways." Final Report 930-470, Dec. 2006.

APPENDIX A

A.0 SURVEY QUESTIONNAIRE

1. Personal Demographics

1.1 What type of company/organization do you work for?

- Owner agency (e.g., Oregon DOT)
- General Contractor
- Sub-Contractor
- Vendor
- Other: _____

1.2 What is your job title/position?

- Project Manager
- Project Engineer
- Traffic Control Designer
- Safety Officer
- Safety Equipment Supplier
- Road Maintenance Crew
- Traffic Control Crew
- Other: _____

1.3 How many years of experience do you have in highway design/construction?

- Less than 1 year
- 1 - 5 years
- 5 - 10 years
- 10 - 20 years
- More than 20 years

1.4 What types of projects do you typically work on? (Select all that apply.)

- Preservation projects (e.g., re-paving)
- Bridge/structures
- Maintenance (e.g., sweeping, striping, vactoring)
- Repair/replacement (e.g., guardrail repair)
- Other, please describe: _____

1.5 Approximately what percentage of your typical work week do you spend on a construction or maintenance site?

- 0%
- 1 – 20%
- 20 – 40%
- 40 – 60%
- 60 – 80%
- 80 – 99%
- 100%

1.6 To what extent are you involved with locating, moving, orienting, adjusting, and/or maintaining work zone lighting systems on your projects?

- Very involved; it is part of my everyday work
- Involved; I do it regularly but not every day
- Somewhat involved; I do it occasionally when needed
- Never; I am not involved at all

1.7 As part of your work responsibilities, are you tasked with determining the type of lighting system(s) to use on projects?

- Yes
- No

2. Lighting Systems Used in Practice

2.1 What type(s) of work zone lighting systems are commonly used on your projects during nighttime work? (Select all that apply.)

- Portable light tower/light plant
- Balloon light, attached to vehicles/equipment
- Balloon light, not attached to vehicles/equipment (e.g., on a portable tripod)
- Spot light, attached to vehicles/equipment
- Spot light, not attached to vehicles/equipment (e.g., on a portable tripod)
- Flood light, attached to vehicles/equipment
- Flood light, not attached to vehicles/equipment (e.g., on a portable tripod)
- Other, please describe: _____

2.2 Where are lighting systems typically used on your projects during nighttime work? (Select all that apply.)

- On large equipment (e.g., paver)
- At large equipment, not attached to the equipment
- At flagger station
- Where workers are present on the roadway

At other locations. Please describe: _____

2.3 Please rate the ease of implementation and use of each of the following lighting systems. Use a scale of 1 to 5, where 1 = Very difficult to implement and use, and 5 = Very easy to implement and use.

	1	2	3	4	5	I don't Know
Portable light tower/plant	<input type="radio"/>	<input type="radio"/>	<input type="radio"/>	<input type="radio"/>	<input type="radio"/>	<input type="radio"/>
Balloon light, attached to vehicles/equipment	<input type="radio"/>	<input type="radio"/>	<input type="radio"/>	<input type="radio"/>	<input type="radio"/>	<input type="radio"/>
Balloon light, not attached to vehicles/equipment	<input type="radio"/>	<input type="radio"/>	<input type="radio"/>	<input type="radio"/>	<input type="radio"/>	<input type="radio"/>
Spot light, attached to vehicles/equipment	<input type="radio"/>	<input type="radio"/>	<input type="radio"/>	<input type="radio"/>	<input type="radio"/>	<input type="radio"/>
Spot light, not attached to vehicles/equipment	<input type="radio"/>	<input type="radio"/>	<input type="radio"/>	<input type="radio"/>	<input type="radio"/>	<input type="radio"/>
Flood light, attached to vehicles/equipment	<input type="radio"/>	<input type="radio"/>	<input type="radio"/>	<input type="radio"/>	<input type="radio"/>	<input type="radio"/>
Flood light, not attached to vehicles/equipment	<input type="radio"/>	<input type="radio"/>	<input type="radio"/>	<input type="radio"/>	<input type="radio"/>	<input type="radio"/>
Other, please describe: _____	<input type="radio"/>	<input type="radio"/>	<input type="radio"/>	<input type="radio"/>	<input type="radio"/>	<input type="radio"/>

2.4 For each of the selection criteria listed below, please indicate the extent to which the criteria is considered important when selecting a lighting system for nighttime operations on a project. Use a scale of 1 to 5, where 1 = Not important, and 5 = Very important.

	1	2	3	4	5	I don't Know
Size of system	<input type="radio"/>	<input type="radio"/>	<input type="radio"/>	<input type="radio"/>	<input type="radio"/>	<input type="radio"/>
Height to which it can be raised	<input type="radio"/>	<input type="radio"/>	<input type="radio"/>	<input type="radio"/>	<input type="radio"/>	<input type="radio"/>
Ability to move/relocate	<input type="radio"/>	<input type="radio"/>	<input type="radio"/>	<input type="radio"/>	<input type="radio"/>	<input type="radio"/>
Ease of operation	<input type="radio"/>	<input type="radio"/>	<input type="radio"/>	<input type="radio"/>	<input type="radio"/>	<input type="radio"/>
Amount of light emitted	<input type="radio"/>	<input type="radio"/>	<input type="radio"/>	<input type="radio"/>	<input type="radio"/>	<input type="radio"/>
Ability to change the amount of light emitted	<input type="radio"/>	<input type="radio"/>	<input type="radio"/>	<input type="radio"/>	<input type="radio"/>	<input type="radio"/>
Type of light emitted	<input type="radio"/>	<input type="radio"/>	<input type="radio"/>	<input type="radio"/>	<input type="radio"/>	<input type="radio"/>
Time required for lamps to turn on	<input type="radio"/>	<input type="radio"/>	<input type="radio"/>	<input type="radio"/>	<input type="radio"/>	<input type="radio"/>
Expected lifespan of bulbs	<input type="radio"/>	<input type="radio"/>	<input type="radio"/>	<input type="radio"/>	<input type="radio"/>	<input type="radio"/>
Time required to demobilize the system	<input type="radio"/>	<input type="radio"/>	<input type="radio"/>	<input type="radio"/>	<input type="radio"/>	<input type="radio"/>
Amount of maintenance required	<input type="radio"/>	<input type="radio"/>	<input type="radio"/>	<input type="radio"/>	<input type="radio"/>	<input type="radio"/>
Impact of the light on passing traffic	<input type="radio"/>	<input type="radio"/>	<input type="radio"/>	<input type="radio"/>	<input type="radio"/>	<input type="radio"/>
Cost (purchase or lease)	<input type="radio"/>	<input type="radio"/>	<input type="radio"/>	<input type="radio"/>	<input type="radio"/>	<input type="radio"/>
Availability	<input type="radio"/>	<input type="radio"/>	<input type="radio"/>	<input type="radio"/>	<input type="radio"/>	<input type="radio"/>
Already own it	<input type="radio"/>	<input type="radio"/>	<input type="radio"/>	<input type="radio"/>	<input type="radio"/>	<input type="radio"/>
Other, please describe: _____	<input type="radio"/>	<input type="radio"/>	<input type="radio"/>	<input type="radio"/>	<input type="radio"/>	<input type="radio"/>

2.5 For each of the project and work performance criteria listed below, please indicate the extent to which the criterion is impacted by the use of lighting systems during nighttime operations. Use a scale of 1 to 5, where 1 = No impact, and 5 = Significant impact.

	1	2	3	4	5	I don't Know
Worker productivity	<input type="radio"/>	<input type="radio"/>	<input type="radio"/>	<input type="radio"/>	<input type="radio"/>	<input type="radio"/>
Work quality	<input type="radio"/>	<input type="radio"/>	<input type="radio"/>	<input type="radio"/>	<input type="radio"/>	<input type="radio"/>
Worker safety	<input type="radio"/>	<input type="radio"/>	<input type="radio"/>	<input type="radio"/>	<input type="radio"/>	<input type="radio"/>
Speed of passing vehicles	<input type="radio"/>	<input type="radio"/>	<input type="radio"/>	<input type="radio"/>	<input type="radio"/>	<input type="radio"/>
Project cost	<input type="radio"/>	<input type="radio"/>	<input type="radio"/>	<input type="radio"/>	<input type="radio"/>	<input type="radio"/>
Quality of work zone	<input type="radio"/>	<input type="radio"/>	<input type="radio"/>	<input type="radio"/>	<input type="radio"/>	<input type="radio"/>
Other, please describe: _____	<input type="radio"/>	<input type="radio"/>	<input type="radio"/>	<input type="radio"/>	<input type="radio"/>	<input type="radio"/>

2.6 Please describe factors/conditions that inhibit implementing and using lighting systems during nighttime operations?

2.7 Please describe factors/conditions that enable implementing and using lighting systems during nighttime operations?

2.8 Do you regularly wear any type of lighting while working at night (e.g., lighted arm band, headlight, etc.)?

Yes

No

If yes, please describe: _____

2.9 If you regularly wear any type of lighting while working at night, for what reason(s) do you wear the lighting? (Select all that apply.)

- Required by company/organization that I work for
- Feel safer
- Helps to illuminate my work area
- Helps me perform my work
- Other, please describe: _____

3. Additional Comments

3.1 Please share any additional comments/opinions regarding the use of lighting systems during nighttime operations in work zones

3.2 Optional: If you are willing to be contacted to answer additional questions about the use of lighting systems in work zones, please provide your contact information:

Name: _____ (Optional)

Phone: _____ (Optional)

E-mail: _____ (Optional)

Thank you for participating in the survey. We appreciate your time and input.

APPENDIX B

B.0 FOCUS GROUP SURVEY QUESTIONNAIRE

1. Lighting System Selection

1.1 Which of the following types of temporary lighting systems do you recommend using in high speed road work zones, specifically pavement preservation projects, to help decrease the speed of passing vehicles? If applicable, you may select both types of systems for different situations. For example, a balloon light may be recommended for a flagging station while a light tower is recommended for a work activity area.



Light Tower

Balloon Light

1.2 Please list other types of temporary lighting systems that you would recommend to help decrease the speed of passing vehicles in nighttime work zones.

1.3 Please provide suggestions for temporary lighting equipment specifications including power output, height, aiming angle, glare, or other variable which can be important in examining their effectiveness in increasing safety and reducing the traffic speeds in work zones.

2. Lighting System Location

2.1 Using the figure below, please indicate the location(s) where you think the temporary lighting system (e.g., light towers or balloon light) should be placed in the work zone (advance warning area, transition area, activity area, termination area, and/or other specific location in the work zone) to most effectively reduce the speed of passing vehicles in the work zone.

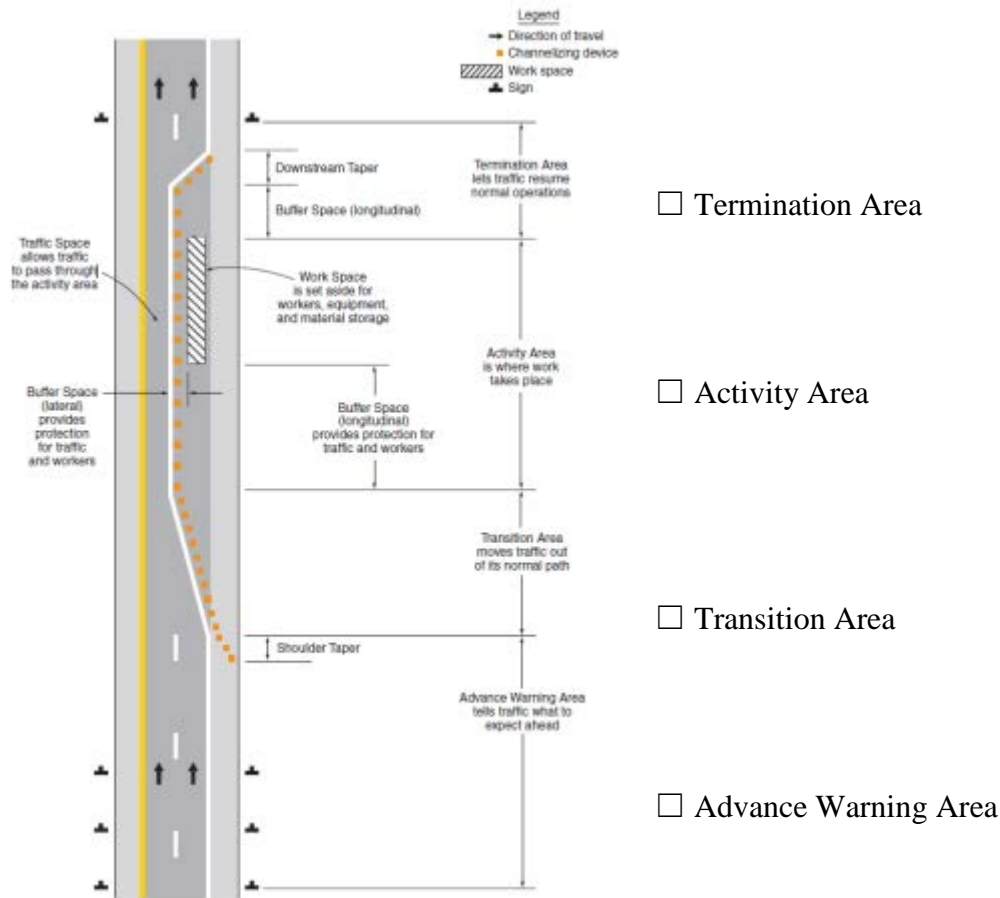

2.2 What factors, in addition to type of lighting system and lighting location, are important to consider when deciding on a lighting strategy for nighttime work zones?

2.3 Please provide any additional comments or suggestions about the use and location of temporary lighting equipment.

3. High Visibility Apparel

3.1 What type of high visibility worker apparel do you think is appropriate for highway nighttime operations: Class 2, Class 3, or Class 2 + Class E? Please check the appropriate box below.

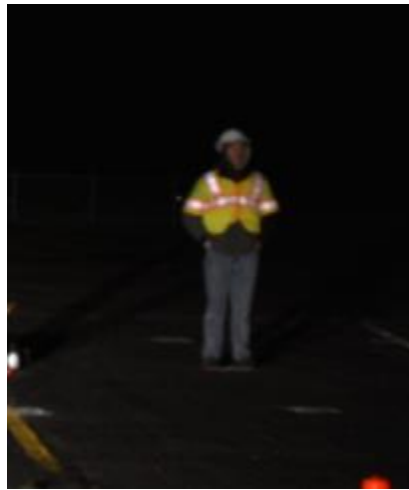
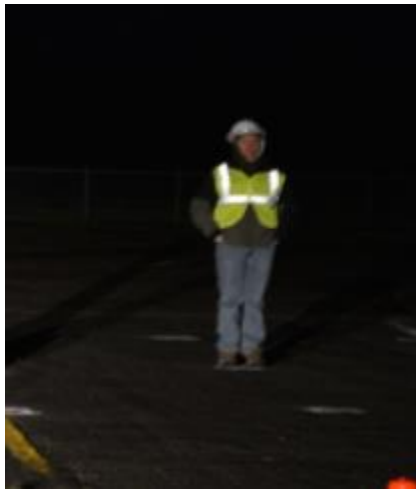

Class 2

Class 3

Class 2 + Class E

3.2 Do you think high visibility apparel can have an impact on the speed of passing vehicles in the work zone? Explain your answer.

3.3 Please provide any additional comments or suggestions about the use and effectiveness of high visibility worker apparel.

4. Personal Work Light

4.1 Do you think that a personal work light worn by workers, such as a Halo Light, makes workers more visible to passing vehicles in a nighttime work zone? Explain your answer.

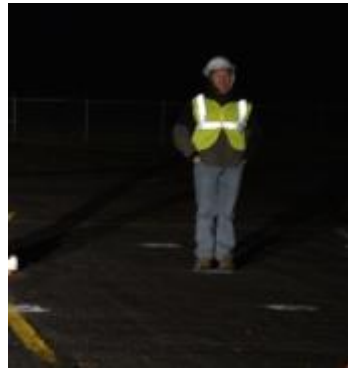
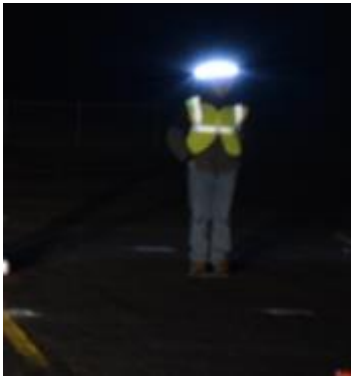

4.2 Do you think that a personal work light worn by workers, such as a Halo Light, has an impact on the speed of passing vehicles in a nighttime work zone? Explain your answer.

4.3 Which workers would you recommend wear a personal work light such as a Halo Light (e.g., all workers, or specific workers)? Explain your answer.

4.4 Please provide any additional comments or suggestions about the use and effectiveness of personal work lights worn by workers such as a Halo Light or other personal work lights.

5. Personal Demographics

5.1 What type of company/organization do you work for?

- Owner Agency (e.g., Oregon DOT)
- General Contractor
- Subcontractor
- Traffic Control Contractor
- Other: _____

5.2 What is your job title/position?

- Project Manager
- Project Engineer
- Traffic Control Designer
- Traffic Control Crew Member
- Roadway Construction Crew Member
- Other: _____

5.3 How many years of experience do you have in highway construction?

- Less than 1 year
- 1-5 years
- 6-10 years
- 11-20 years
- More than 20 years

5.4 What percentage of your daily work activities is performed in roadway work zones?

- Less than 20%
- 21-40%
- 41-60%
- 61-80%
- 81-100%

APPENDIX C

C.0 FOCUS GROUP DEMONSTRATION QUESTIONNAIRE

Work Zone Lighting Equipment Demonstration Focus Group (07/07/2016, Corvallis Airport)

Q1: To what extent is it clear that there is a worker present? Please use a scale of 1 to 5 as follows: 1 = not clearly visible, 5 = very visible

Distance	Light Tower, 0°				Light Tower, 45°				Balloon Light			
	Class 3	Class 3 + Pants	Class 3 + Pants + Halo	Class 3 + Pants + Halo (Hi)	Class 3	Class 3 + Pants	Class 3 + Pants + Halo	Class 3 + Pants + Halo (Hi)	Class 3	Class 3 + Pants	Class 3 + Pants + Halo	Class 3 + Pants + Halo (Hi)
500 ft												
1000 ft												
1500 ft												

Q2: In which position is the worker more visible (at 1000 feet)?

- 1
 2
 3
 4

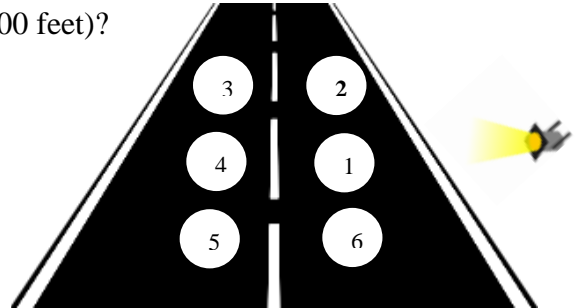

Q3: To what extent does the blinking Halo Light (Hi-Alert mode) help make the worker visible?

Q4: Please provide additional comments regarding barriers, limitations, or drawbacks of the lighting systems, reflective apparel, and Halo Light.

APPENDIX D

D.0 CASE STUDY RESULTS AND ANALYSIS

The case studies provided a very large amount of data for analysis, too much to include in one report file. The full set of figures and tables associated with all of the case study data and analyses is included in the separate Appendix file.