



BDV25-977-13

Final Report

Naturalistic Bicycling Behavior Pilot Study

PREPARED FOR:
Florida Department of Transportation



November 2017



Center for Urban Transportation Research
University of South Florida
4202 E. Fowler Ave., CUT100, Tampa, FL 33620-5375

Naturalistic Bicycling Behavior Pilot Study

BDV25-977-13

Final Report

Prepared for:



Florida Department of Transportation

Trenda McPherson, Project Manager

Fred Heery, P.E., Co-Project Manager

Prepared by:



USF Center for Urban Transportation Research

Pei-Sung Lin, Ph.D., P.E., PTOE

Achilleas Kourtellis, Ph.D.

Srinivas Katkoori, Ph.D.

Cong Chen, Ph.D.

Lucas Cruse, AICP

November 2017

DISCLAIMER

The opinions, findings, and conclusions expressed in this publication are those of the authors and not necessarily those of the State of Florida Department of Transportation.

UNIT CONVERSION TABLE

APPROXIMATE CONVERSIONS TO SI UNITS

SYMBOL	WHEN YOU KNOW	MULTIPLY BY	TO FIND	SYMBOL
LENGTH				
in	inches	25.4	millimeters	mm
ft	feet	0.305	meters	m
yd	yards	0.914	meters	m
mi	miles	1.61	kilometers	km

SYMBOL	WHEN YOU KNOW	MULTIPLY BY	TO FIND	SYMBOL
AREA				
in ²	squareinches	645.2	square millimeters	mm ²
ft ²	squarefeet	0.093	square meters	m ²
yd ²	square yard	0.836	square meters	m ²
ac	acres	0.405	hectares	ha
mi ²	square miles	2.59	square kilometers	km ²

SYMBOL	WHEN YOU KNOW	MULTIPLY BY	TO FIND	SYMBOL
VOLUME				
fl oz	fluid ounces	29.57	milliliters	mL
gal	gallons	3.785	liters	L
ft ³	cubic feet	0.028	cubic meters	m ³
yd ³	cubic yards	0.765	cubic meters	m ³
NOTE: volumes greater than 1000 L shall be shown in m ³				

SYMBOL	WHEN YOU KNOW	MULTIPLY BY	TO FIND	SYMBOL
MASS				
oz	ounces	28.35	grams	g
lb	pounds	0.454	kilograms	kg
T	short tons (2000 lb)	0.907	megagrams (or "metric ton")	Mg (or "t")

SYMBOL	WHEN YOU KNOW	MULTIPLY BY	TO FIND	SYMBOL
TEMPERATURE (exact degrees)				
°F	Fahrenheit	5 (F-32)/9 or (F-32)/1.8	Celsius	°C

SYMBOL	WHEN YOU KNOW	MULTIPLY BY	TO FIND	SYMBOL
ILLUMINATION				
fc	foot-candles	10.76	lux	lx
fl	foot-Lamberts	3.426	candela/m ²	cd/m ²

SYMBOL	WHEN YOU KNOW	MULTIPLY BY	TO FIND	SYMBOL
FORCE and PRESSURE or STRESS				
lbf	poundforce	4.45	newtons	N
lbf/in ²	poundforce per square inch	6.89	kilopascals	kPa

TECHNICAL REPORT DOCUMENTATION PAGE

1. Report No.	2. Government Accession No.	3. Recipient's Catalog No.	
4. Title and Subtitle Naturalistic Bicycling Behavior Pilot Study		5. Report Date November 2017	
		6. Performing Organization Code	
7. Author(s) Pei-Sung Lin, Achilleas Kourtellis, Srinivas Katkoori, Cong Chen, and Lucas Cruse		8. Performing Organization Report No.	
9. Performing Organization Name and Address Center for Urban Transportation Research (CUTR) University of South Florida 4202 E. Fowler Ave., CUT100 Tampa FL 33620		10. Work Unit No. (TRAIS)	
		11. Contract or Grant No. BDV25-977-13	
12. Sponsoring Agency Name and Address Florida Department of Transportation (FDOT) 605 Suwannee St., MS 30 Tallahassee, FL 32399-0450		13. Type of Report and Period Covered Final Report, 6/2/2014–11/30/2017	
		14. Sponsoring Agency Code	
15. Supplementary Notes			
16. Abstract Bicyclists experience disproportionate rates of injuries and fatalities compared to other road users. The safety for bicyclists is of particular concern in Florida, where bicyclist fatality rates were nearly triple the national average in 2015. This naturalistic bicycling behavior pilot study was conducted to collect data from actual rides of a sample of 100 participants in the Tampa Bay area. The project team successfully designed, developed, and produced bicycle data acquisition systems to conduct comprehensive data collection for the pilot study. Results of the study provided valuable insight in the following six areas: (1) understanding behavior, experience, and interactions between bicyclists and drivers making right turns at intersections (right hook); (2) understanding behavior, experience, and interactions between bicyclists and drivers making left turns at intersections (left hook); (3) understanding behavior, experience, and interactions between bicyclists and drivers at night; (4) understanding bicyclist route-choice decisions with given origins and destinations; (5) assessing bicycling behaviors of bicyclists with and without formal bicycle-riding training; and (6) analyzing bicycle crashes or close calls and determining their contributing factors. The data analysis also showed the effects of age, gender, and self-reported risk and distraction proneness on bicycling behaviors. Based on the research findings from the pilot study, the project team recommended implementable countermeasures in education, engineering, and enforcement to significantly improve bicycle safety.			
17. Key Word Naturalistic bicycling behaviors, pilot study, bicycle safety, driver interaction, countermeasures		18. Distribution Statement	
19. Security Classif. (of this report)	20. Security Classif. (of this page)	21. No. of Pages 104	22. Price

ACKNOWLEDGMENTS

The research team is very grateful for the excellent guidance, coordination, and support provided by Project Manager Trena McPherson and Co-Project Manager Fred Heery from the Florida Department of Transportation (FDOT). We appreciate the full support and encouragement from FDOT Research Center Manager Darryll Dockstader, Research Performance Coordinator David Sherman, former Florida's Pedestrian and Bicycle Safety Champion Billy Hattaway, and Chief Safety Officer Lora Hollingsworth. The research team sincerely thanks Tim Mulligan of Cycling Savvy for providing the cycling training class to selected participants in this research. We would also like to thank and recognize the contributions of our research assistants at the CUTR, including Nouredine Elmehraz, Dinesh Pashapu, Arunbalaji Prithiviraj, Michael Bato, Zhao Zhang, Navid Farahbakhsh, Courtney Cleland, Priyanka Atluri, and Henna Panati, and Omkar Dokur from the Department of Electrical Engineering at University of South Florida, for their efforts related to bicycle data acquisition development; participant recruitment and management; data collection, validation, and compilation; and data review and analysis. The research team gratefully acknowledges all other administrators, faculty, staff, and students at CUTR who supported our efforts in this project. Finally, we would also like to thank all participants of this naturalistic bicycling behavior pilot study.

EXECUTIVE SUMMARY

INTRODUCTION

Transportation system planning and design in the past has focused largely on the needs of automobiles, whereas nationally, bicycling has been making a comeback as a viable and popular mode of transportation. Unfortunately, bicyclists experience disproportionate rates of injuries and fatalities compared to other road users. According to the Florida Department of Highway Safety and Motor Vehicles (DHSMV), in 2014, a total of 7,077 bicycle crashes and 6,680 injuries resulted in 135 bicyclists killed—an increase of 77.6%, from 76 in 2010. The safety of bicyclists is of particular concern in Florida, where bicyclist fatality rates were nearly triple the national average in 2015.

Many factors influence how and where bicyclists ride their bicycles, including roadway facilities, traffic conditions, environmental conditions, and interactions with other roadway users. A thorough understanding of the behavior of bicyclists, the facilities they use, and their interactions with other roadway users would provide an in-depth understanding of the factors, risks, and causes contributing to bicycle crashes or close calls. That understanding can offer better bicycle facility planning and design, engineering improvements, roadway user education, and law enforcement to significantly improve bicycle safety. A naturalistic bicycling behavior study is an effective approach to better understand bicycling behaviors via analyzing naturalistic bicycling behavior data collected from study participants with cameras and sensors installed on their bicycles over a specific period of time.

The collection of naturalistic bicycling behavior data could support numerous bicycle safety research topics to better understand bicycling behavior and develop effective countermeasures to improve bicycle safety and reduce bicycle-related fatalities, serious injuries, and crashes. A literature review was conducted in the initial stages of this project to identify previous studies that dealt with naturalistic bicycle data. The findings from previous studies and a discussion on the differences with this study are also provided in this report.

PROJECT OBJECTIVES

The major objectives of this research included the following:

- 1) Develop a cost-effective Bicycle Data Acquisition System (BDAS) capable of collecting key naturalistic bicycling behavior data under various environmental conditions.
- 2) Recruit 100 participants from the Tampa Bay area to participate in the naturalistic bicycling behavior pilot study.
- 3) Collect estimated 2,000-participant-hour naturalistic bicycling behavior data and develop a database for analysis.
- 4) Analyze collected naturalistic bicycling behavior data based on the six specific research topics and provide results of the analysis.
- 5) Develop a process for using the collected naturalistic bicycling behavior data to conduct bicycle behavior research and data analysis.
- 6) Provide research findings and recommendations of countermeasures from this pilot study to improve bicycle safety and benefit future large-scale naturalistic bicycling behavior studies.

STUDY SITE PREPARATION AND PARTICIPANT RECRUITMENT

Major tasks for this study included finalization of the study area, preparation of facility for the study, determination of participant sample size, approval by the University of South Florida (USF) Institutional Review Board on human subject research, development of a data collection system, and all the activities necessary to recruit and manage participants, and install and remove data collection devices on participants' bicycles. In this research, the greater Tampa Bay area, including Hillsborough County and Pinellas County, was chosen to be the study area, given that both have high numbers of bicycle commuting trips and bicyclist crashes.

In this study, 100 participants were included to provide a sufficient sample for statistically significant analyses. The participant sample size was stratified based on three age groups: 18–25, 26–45, and 45+. In total, recruited participants included 57 in age group 18–25, 33 in age group 26–45, and 10 in age group 45+.

BICYCLE DATA ACQUISITION SYSTEM (BDAS) DEVELOPMENT

A Bicycle Data Acquisition System (BDAS) was developed to collect naturalistic bicycling data from the recruited participants. The BDAS is a portable low-energy embedded system comprising several components:

- Custom Printed Circuit Board (PCB) with components (sensors) and Arduino Duo microcontroller for rear module
- Custom PCB with components and Arduino Duo microcontroller for front module
- Enclosure for rear module
- Enclosure for front module

The BDAS is capable of performing a number of tasks:

- In standby or sleep mode, wakes up with movement of bicycle.
- Performs self-check on “health” of all sensors and cameras.
- Connects to smartphone app running on participant phones and provides health-check data.
- App sends check message to server for analysis.
- Automatically records front and rear camera data; front, right, and rear sensor data; ambient temperature; 3-axis acceleration; 3-axis gyroscope; light level; and GPS information.
- Stops recording when no movement is detected.
- Smartphone app presents a survey of six questions to participant and collects information for trip; when submitted, survey responses are sent to server for analysis.

The BDAS system was fully tested and calibrated to ensure normal functionality before mass production and installation on participant bicycles for data collection.

NATURALISTIC BICYCLING DATA COLLECTION AND REVIEW PROCESS

The naturalistic bicycling data collected included:

- Video from forward- and rear-facing cameras
- Distance data from four sensors, one for each side of bicycle
- GPS (global positioning system) data for location and route every one second

-
- Accelerometer data on three axes
 - Gyroscope data on three axes (pitch, roll, yaw)
 - Light level for environment conditions
 - Origin, destination, trip length, and trip reason; input from participant

The extracted and reviewed naturalistic bicycling behavioral data included video data and digital data of bicycle trips from study participants via cameras mounted on the front and rear sides of the bicycle. Four graduate students were trained to review the data and identify information related to intersection or road segment geographic features, bicyclist and driver behavior, and traffic control schemes when the bicycle was approaching an intersection or when a close call event occurred.

Five major supportive datasets were collected to assist the analysis of bicycling behavior and safety performance, including post-trip questionnaire data, participant demographic questionnaire data, participant riding experience questionnaire data, participant frequency of risky behavior questionnaire data, and participant perception of risky behavior questionnaire data. The privacy of participants is essential, and therefore, all data are anonymous.

DATA ORGANIZATION AND ANALYSIS METHODS

The data were validated by conducting data type checks, image checks, consistency checks, range checks, and format checks. After data validation, they were compiled into a comprehensive and integrated dataset, which was further divided into different groups for analysis regarding a variety of research interests, such as daytime and nighttime bicycling events, intersections with different traffic controls, bicycling events from bicyclists with professional training and without professional training, etc.

Quantitative data analysis was used to provide quantifiable and easy-to-understand results. Comparisons of bicyclist and driver compliant behavior with traffic rules was conducted between different bicyclist demographic and behavior features, such as gender, age group, and risk and distraction characteristics.

Chi-square tests were used to determine whether the proportion of certain features was different across multiple groups. All hypothesis tests were conducted at a minimum confidence level of 90%.

RESEARCH RESULTS

The data analysis helped to investigate the following six key bicycle safety topics, including:

- 1) Understanding behavior, experience, and interactions of bicyclists and drivers making right turns at intersections (right hook).
- 2) Understanding behavior, experience, and interactions between bicyclists and drivers making left turns (left hook).
- 3) Understanding behavior, experience, and interactions between bicyclists and drivers at night.
- 4) Understanding bicyclist route-choice decisions with given origins and destinations.
- 5) Assessing bicycling behaviors of bicyclists with and without formal bicycle-riding training such as CyclingSavvy.
- 6) Analyzing bicycle crashes and close calls and determining their contributing factors.

Findings on Bicyclist Behaviors

- **Bicyclist risky and distractive behaviors by gender** – Based on self-evaluation, more female than male bicyclists were classified into the groups of “High Risk” (26.7% vs. 20.0%) and “High Distraction” (33.3% vs. 15.0%). The differences were significant at a 95% confidence level regarding both risk and distraction.
- **Bicyclist risky and distractive behaviors by age** – Younger bicyclists (age 18–25) took significantly more risks than those in age groups 26–45 and 45+; younger bicyclists (age 18–25) were also significantly more likely to be distracted than mid-age bicyclists (age 26–45) and older bicyclists (age 45+). No older bicyclists (age 45+) were identified as “High Risk” or “High Distraction,” making them the safest group among all age groups. The differences were significant in terms of both risk and distraction at a 95% confidence level.
- **Bicyclist compliance in daytime/nighttime** – The proportion of compliance with general traffic rules for bicyclists was 88.1% in the daytime and 87.5% in the nighttime, indicating that bicyclists showed similar patterns to comply with the general traffic rules. The proportion difference was not significant at a 90% confidence interval.
- **Bicyclist behaviors in daytime/nighttime by biking location** – Based on biking location distribution, bicyclists were more conservative and stayed in their right-of-way and safe locations under nighttime conditions; in the daytime, bicyclists were relatively more aggressive and tended to violate pedestrian signals if they had good visibility and clear distance from potential collisions.
- **Bicyclist light and reflective item use in nighttime riding** – Examination of bicycle light and reflective item usage at night revealed that the majority of the recruited participants had good awareness of safe riding in terms of riding at night with bicycle lights on and wearing or equipping bicycles with reflective items to increase visibility.
- **Bicyclist route choice preference by trip purpose (given origin and destination)** – Familiar routes were the most favored for all trip purposes and accounted for 81.4% of all commuting trips, 68.9% of all recreation trips, and 79.3% of all shopping trips. In general, bicyclists were more likely to choose less familiar routes for recreation purposes than for commuting and shopping purposes.
- **Safety influence of professional cycling training** – The proportion of non-compliant behavior was 7.5% for bicyclists with professional training and 12.3% for those without professional training, indicating that professional training increased bicyclist compliance. This difference was not significant at a 90% confidence level. Professional cycling training could boost the confidence of bicyclists using bike lanes and helped them better manage riding in a bike lane.
- **Bicyclist compliance by gender and age** – Male bicyclists showed a higher proportion of compliance than female bicyclists, and the difference was significant at a 95% confidence level. Older bicyclists demonstrated the highest proportion of compliance, followed by mid-age bicyclists and younger bicyclists. The proportion difference between older and younger bicyclists was also significant at a 95% confidence level.
- **Bicyclist compliance by risk and distraction groups** – Bicyclists in the “Low Risk” group were more likely to comply with general traffic rules than those in the “High Risk” group, but the difference was not significant due to small sample size. Bicyclists in the “Low Distraction” group were more likely to comply with general traffic rules than those in the “High Distraction” group, and this difference was significant at a 95% confidence level.

Findings on Interactions between Bicyclists and Drivers

- **Interactions between bicyclists and turning vehicles** – Young bicyclists were more likely to get involved in close calls or conduct non-compliant behavior when interacting with turning vehicles. In all turning-vehicle observations, it was found that at-fault bicyclist non-compliant or risky behavior and close calls were associated with young bicyclists.
- **Close call analysis between bicyclists and turning vehicles** – Three close calls were found between bicyclists and right-turning vehicles; no close calls were observed between bicyclists and left-turning vehicles. In these close calls, 66.7% were due to vehicles failing to yield bicyclist right-of-way, and 33.3% were due to the bicyclist crossing the intersection during a “Do Not Walk” pedestrian signal.
- **Driver compliance analysis in interacting with bicyclists in daytime and nighttime** – The proportion of compliance for observed drivers was 85.8% in the daytime, and the major driver non-compliant behavior was failing to yield to bicyclist right-of-of-way. In the nighttime, it was reported by participants based on their experience that drivers were very likely to fail to yield to bicyclists due to limited visibility. Given the limited observations for drivers during nighttime in this study, no conclusions could be drawn.
- **Close call analysis between bicyclists and passing vehicles** – Lack of dedicated bike lanes, wider bike lanes, and/or sidewalks was the main reason for close calls with passing vehicles; sufficient bicycle lane width is necessary to reduce close call risk with passing vehicles.

RECOMMENDATIONS OF IMPLEMENTABLE COUNTERMEASURES

The research findings from this naturalistic bicycling behavior pilot study resulted in the identification of implementable safety improvements that could be considered to put into practice to significantly improve bicyclist safety. The potential implementable countermeasures in education, engineering and enforcement are recommended as follows:

- Conduct educational outreach to more young bicyclists to improve their safe bicycling behavior.
- Conduct educational outreach to more female bicyclists to improve their safe bicycling behavior.
- Encourage professional cycling training to improve bicyclist riding control and safety.
- Conduct educational outreach to bicyclists regarding passing through intersections with caution.
- Conduct educational outreach to drivers to enhance yielding behaviors at intersections.
- Conduct educational outreach to drivers to keep safe distances from bicyclists when passing or overtaking them.
- Conduct educational outreach on reflective equipment use.
- Establish through bike lanes to reduce conflicts between bicyclists and turning vehicles at signalized intersections.
- Add bike lanes, increase bike lane width, implement buffer bike lanes, and/or build protected cycle tracks on roads with bicycle volume.
- Apply reflective green-colored pavement markings on existing and new bike lanes.
- Improve lighting conditions on roads with bicycle volume.
- Conduct three-stage high-visibility enforcement for both drivers and bicyclists with a focus on education.

TABLE OF CONTENTS

Disclaimer	iii
Unit Conversion Table.....	iv
Technical Report Documentation Page	v
Acknowledgments	vi
Executive Summary	vii
List of Figures.....	xv
List of Tables	xvii
1. Introduction.....	1
1.1 Background	1
1.2 Project Objectives	1
1.3 Report Organization	2
2. Literature Review	3
2.1 Summary of Previous Naturalistic Cycling Studies.....	6
2.2 Advancement from Previous Studies	6
2.2.1 Participants.....	6
2.2.2 Locations.....	6
2.2.3 Data Collection Period.....	6
2.2.4 Data Collected.....	8
3. Study Site Preparation	9
3.1 Finalization of Study Site.....	9
3.1.1 Final Study Area	9
3.1.2 Stratified Target Sample	10
3.1.3 Supporting Data	10
3.1.4 Institutional Review Board for Human Subjects Research.....	10
3.2 Design and Development of BDAS	10
3.2.1 Audiovisual Recording	11
3.2.2 Data Storage and Synchronization.....	12
3.2.3 Power Management	13
3.2.4 System Software	13
3.3 Preparing Study Site.....	15
3.3.1 Staff Training.....	15

3.3.2	Preparation of Facilities	15
4.	Testing, Finalization, and Production of BDAS.....	16
4.1	Testing BDAS	16
4.2	Finalization of the BDAS.....	16
4.3	Production of BDAS	17
5.	Participant Recruitment and Management.....	21
5.1	Planned and Actual Samples	21
5.2	Recruitment	21
5.3	Participant Scheduling.....	22
5.4	Participant Enrollment and Drop-Out	22
5.5	Participant Privacy and Personally Identifiable Information	23
6.	Installation, Maintenance, and Removal of BDAS on Participant Bicycles.....	24
6.1	Installation of BDAS	24
6.2	Maintenance of BDAS	24
6.3	Removal of BDAS	26
7.	Data Validation, Compilation, and Analysis.....	27
7.1	Data Review, Validation, Compilation, and Organization.....	27
7.1.1	Data Review	27
7.1.2	Data Compilation	28
7.1.3	Data Validation	29
7.2	Analysis of Behaviors of Bicyclists and Drivers and Their Interactions	29
7.2.1	Data Analysis	29
7.2.2	Data Analysis Results and Findings	29
8.	Research Findings, Recommendations of Countermeasures, and Conclusions.....	49
8.1	Research Findings on Bicyclist Behaviors.....	49
8.2	Research Findings on Interactions between Bicyclists and Drivers	50
8.3	Recommendations on Implementable Countermeasures	50
8.3.1	Education Countermeasures.....	50
8.3.2	Engineering Countermeasures	52
8.3.3	Enforcement Countermeasures	56
8.4	Lessons Learned.....	57
8.4.1	Participant Recruitment	58

8.4.2	Installation of Equipment.....	58
8.4.3	Participant Management	58
8.4.4	Equipment Management	58
8.4.5	Study Management	59
8.5	Conclusions	59
	References	60
	Appendix A – Informed Consent Form	61
	Appendix B – Recruitment Flyers	65
	Appendix C – Study Website	68
	Appendix D – Demographics Questionnaire	72
	Appendix E – Bicycling History Questionnaire	75
	Appendix F – Frequency of Risky Behavior Questionnaire	80
	Appendix G – Perception of Risk Behavior Questionnaire	84

List of Figures

Figure 2-1 Bicycle side view with camera and sensor coverage.	5
Figure 2-2 Bicycle top view with camera and sensor coverage.....	5
Figure 3-1 Final study area.	9
Figure 3-2 Interconnection of major modules in proposed video system.....	11
Figure 3-3 Power management schematic diagram.	13
Figure 3-4 Flowchart of data acquisition software.	14
Figure 4-1 Rear enclosure with holes for camera and sensors, on a bicycle carrier rack.	17
Figure 4-2 Front enclosure with holes for camera and sensors.	17
Figure 4-3 Front module assembly.	18
Figure 4-4 Rear module assembly.	18
Figure 4-5 Rear module inside enclosure.	19
Figure 4-6 Front module inside enclosure.	19
Figure 4-7 Rear and front modules assembled and ready for installation.	19
Figure 4-8 Front module and rear module of BDAS installed on bicycle.	20
Figure 6-1 BDAS App for Android users.	25
Figure 6-2 Screenshots of travel survey app.....	25
Figure 7-1 Comparison of risk and distraction levels by gender and age.....	31
Figure 7-2 Comparison of bicyclist compliance by close call availability in right-turn vehicle events.	32
Figure 7-3 Bicyclist and driver compliance by time.....	33
Figure 7-4 Biking location analysis by time and bike lane setting.	34
Figure 7-5 Frequency of bicycling without lights on during nighttime riding.	35
Figure 7-6 Frequency of reflective item use in bicycling.	36
Figure 7-7 Spatial distribution of all trips with post-trip survey.	37
Figure 7-8 Route choice distribution for commuting trips.	38
Figure 7-9 Route choice distribution for group fitness trips.....	38
Figure 7-10 Route choice distribution for individual fitness trips.....	39
Figure 7-11 Route choice distribution for leisurely individual rides.....	39
Figure 7-12 Route choice distribution for leisurely social rides.....	40
Figure 7-13 Route choice distribution for shopping trips.....	40
Figure 7-14 Route choice distribution by major trip purpose.....	41
Figure 7-15 Behavior comparison between bicyclists with and without professional cycling training.	42
Figure 7-16 Distribution of close calls by type.....	44
Figure 7-17 Proportion of close calls with passing vehicles by bike lane setting and biking location.	45
Figure 7-18 Comparison of bicyclist compliance by gender.	46
Figure 7-19 Comparison of bicyclist compliance by age.	46
Figure 7-20 Comparison of bicyclist compliance by risk group.....	47
Figure 7-21 Comparison of bicyclist compliance by distraction group.....	48

Figure 8-1 Example CyclingSavvy training courses: (<i>left</i>) cone-weave training, (<i>right</i>) city tour of intimidating road features for riding.....	51
Figure 8-2 Reflective bicycle equipment and clothing.....	52
Figure 8-3 Implementation of through bike lane at intersection.....	53
Figure 8-4 Bike lane implementations in Florida to improve bicyclist safety – (<i>upper left</i>) buffered bike lane, (<i>upper right</i>) protected cycle track with median, (<i>lower left</i>) protected cycle track with pole separation, (<i>lower right</i>), protected cycle track with green-colored bike lanes.	54
Figure 8-5 Green-colored bike lane in West Palm Beach (<i>upper left</i>), Tampa (<i>upper right</i>), Tallahassee (<i>lower left</i>) and Miami Beach (<i>lower right</i>).....	55
Figure 8-6 Night biking with and without street lighting – with sufficient lighting (<i>left</i>) and without lighting (<i>right</i>).	55

List of Tables

Table 2-1 Summary of Previous Naturalistic Cycling Studies	7
Table 3-1 Participant Stratification	10
Table 3-2 Task Sequence and Time Required to Acquire Single Frame.....	12
Table 5-1 Method of Recruitment for Participants	21
Table 6-1 Health Status Messages	26
Table 8-1 Summary of Education, Engineering, and Enforcement Countermeasures	56

1. INTRODUCTION

1.1 Background

Transportation system planning and design in the past has focused largely on the needs of automobiles, whereas nationally, bicycling has been making a comeback as a viable and popular mode of transportation. Unfortunately, bicyclists experience disproportionate rates of injuries and fatalities compared to other road users. According to the Florida Department of Highway Safety and Motor Vehicles (DHSMV), in 2014, a total of 7,077 bicycle crashes and 6,680 injuries resulted in 135 bicyclists killed—an increase of 77.6%, from 76 in 2010. The safety of bicyclists is of particular concern in Florida, where bicycle fatality rates were nearly triple the national average in 2015.

Many factors influence how and where bicyclists ride their bicycles, including facilities, environmental conditions, and interactions with other roadway users. A thorough understanding of the behavior of bicyclists, the facilities they use, and their interactions with other roadway users would provide an in-depth understanding of the factors, risks, and causes contributing to bicycle crashes. That understanding can give way to better bicycle facility planning and design, engineering improvements, law enforcement, and roadway user education to significantly improve bicycle safety. A naturalistic bicycling behavior study is an effective approach to fully understand bicycling behaviors via analyzing naturalistic bicycling behavior data collected via cameras and sensors over a specific period of time. This Naturalistic Bicycling Behavior Pilot Study aimed to (1) develop a cost-effective Bicycle Data Acquisition System (BDAS), (2) collect and analyze naturalistic bicycling behavior data, (3) answer gender-specific research questions, and (4) provide research findings and recommendations to improve bicycle safety, and benefit future large-scale naturalistic bicycling behavior studies in Florida and other U.S. states.

The collection of naturalistic bicycling behavior data also could support numerous bicycle safety research topics to better understand bicycling behavior and develop effective countermeasures to significantly improve bicycle safety and reduce bicycle-related fatalities, serious injuries, and crashes. A literature review was conducted in the initial stages of the project to identify previous studies that dealt with naturalistic bicycle data. The major studies and findings and a discussion on the differences with this study are presented further in this document.

1.2 Project Objectives

The major objectives of this research include the following:

- Develop a cost-effective Bicycle Data Acquisition System (BDAS) capable of collecting key naturalistic bicycling behavior data under various environmental conditions.
- Recruit 100 participants from the Tampa Bay area to participate in the naturalistic bicycling behavior pilot study.
- Collect estimated 2,000-participant-hour naturalistic bicycling behavior data and develop a database for analysis.
- Analyze collected naturalistic bicycling behavior data based on the six specific research topics and provide results of the analysis.
- Develop a process for using the collected naturalistic bicycling behavior data to conduct bicycle behavior research and data analysis.

- Provide research findings and recommendations of countermeasures from this pilot study to improve bicycle safety and benefit future large-scale naturalistic bicycling behavior studies.

1.3 Report Organization

This report is organized as follows. Chapter 2 describes the existing literature and previous studies at the start of the study. Chapter 3 describes the preparation of the study site and design of the bicycling behavioral data collection system. Chapter 4 summarizes the testing and production efforts for the data collection system. Chapter 5 describes the efforts conducted for recruitment and management, and Chapter 6 discusses the work performed for installation, maintenance, and removal of the data collection systems on participant bicycles. Chapter 7 describes the data validation, compilation, and analysis, and Chapter 8 summarizes the findings and recommendations of the research.

2. LITERATURE REVIEW

The use of bicycles equipped with instruments to measure riding conditions is a growing field, with the first experiments occurring within the past decade. Studies have been conducted in both urban and rural locations to address research questions ranging from holistic assessments of safety to observing specific behaviors given a set of selected location, circumstantial, and individual participant variables. Research using instrumented bicycles to observe and answer operational questions in a naturalistic setting has occurred primarily in Europe, followed by Asia; the fewest studies have occurred in North America.

This literature review focused on studies specifically related to the development and implementation of a naturalistic data collection system for bicycles. Not covered were fundamental modal safety research or the development or application of naturalistic data recording systems for other modes of transportation. A majority of the studies using instrumented bicycles focused on a limited set of data to answer specific questions. The most common research from literature examined the issues of the behaviors and separation provided by vehicles overtaking bicycles in the United Kingdom (UK) [1], [2], the state of Wisconsin in the U.S. [3], and Taiwan [4].

One of the earliest studies involving an instrumented bicycle to answer specific questions was conducted in 2007 [1]. The study, conducted in the UK with one bicycle equipped with an ultrasonic distance sensor, sought to identify the influence of various factors on the separation provided by an overtaking vehicle, including bicyclist riding position relative to the road edge, vehicle type, whether the bicyclist was wearing a helmet, and the apparent gender of the bicyclist. The study results indicated that motorists make assumptions about expected bicyclist behavior based on visual assessment.

The study completed by Chapman and Noyce in 2012 is one of the only completed experiments using an instrumented bicycle in North America [3]. Their study built on the work done by Walker [1] and evaluated the specific research question of the lateral clearance provided by drivers overtaking cyclists on rural roads in Dane County, Wisconsin. The study results indicated that drivers tended to provide twice the legally-required passing separation of 3 feet, which was consistent whether the roadway did or did not have a shoulder or bike lane, over 80 hours of observation. Chapman and Noyce developed a data collection system focusing only on their primary research question, rather than a more-robust system that could be transferred to other related-research. A notable outcome from the study was that while passing vehicles generally provided adequate separation, they often passed in potentially unsafe locations or situations.

A study conducted in Melbourne, Australia, used video only and comprised a total of 128 hours from 13 participants [5]. The focus of the study was identifying and classifying events including collisions, near-collisions, and incidents. Unlike most studies, researchers mounted video cameras on bicyclist helmets rather than the frame or handlebars. The primary goal of the research was to evaluate cyclist head movement and looking behavior, which justified the choice of camera location to answer that specific set of questions. The study required regular participant interaction with batteries and memory cards, which may have influenced behavior.

Building on the work done by Johnson et al. [5] discussed above, an experiment conducted in Gothenburg, Sweden, included 12 participants and added kinematics such as a brake force sensor

[6]. The user interface included a push button for the cyclist participants to log safety-relevant events and also required that they start and stop a recording device to conserve memory and battery capacity. One of the primary goals of the study was to observe situations and behavior without any influence from the observer. However, the requirement of continued interaction with the recording device by participants may result in some modified behavior.

An experiment conducted by Gustafsson and Archer completed for Stockholm, Sweden, had a specific goal of identifying and categorizing problems [7]. The experiment involved 18 experienced commuter cyclists riding 17 specific routes 10 times in each direction. The experiment included the recording of GPS route data and video on handlebars, requiring daily interaction to maintain memory cards and batteries. The study also included completion of daily diaries by participants with a noted issue of information. A valuable element of this experiment was a model for how instrumented bicycles can be used to study specific locations of interest.

Dozza and Werneke in 2014 showed that naturalistic bicycling data can identify and assess how specific location factors can predict the risk of critical events [8]. Their study provided 5 instrument-equipped bicycles for 16 participants, and data collected included video, GPS, inertial activity, and brake force sensors. An advancement provided by this research was an evaluation of the sampling rate needed to acquire the desired data resolution, resulting in storage of 100 Hz for kinematic data types [9]. An improvement from past studies was the use of a means of automatically starting and stopping the recording without requiring participant intervention. The study represents the most complete and sophisticated naturalistic bicycling study completed to date. This naturalistic bicycling behavior pilot study sponsored by the Florida Department of Transportation (FDOT) aimed to engage and collect up to five times the number of participants and quantity of data while also collecting additional data types.

Based on the reviewed literature on previous naturalistic bicycling studies, it is clear that very few researchers in the U.S. and none in Florida have taken on the approach of this pilot study. The experiments completed to date in the literature generally focused on developing instrumentation that can answer only a limited set of specific research questions. This pilot study collected a range of data types in a format to answer a set of six major research questions and provided a breadth of data that would facilitate answering questions not yet posed. Based on the literature review, this pilot study is the first to collect all combined data types proposed, to include front and rear video, GPS, gyroscope and accelerometer, with added audio, temperature, light metering, and four-directional proximity sensors.

Figure 2-1 shows the location of the BDAS and coverage of the front and rear cameras and distance sensors for this study. Figure 2-2 shows the bicycle top view and the approximate coverage of the four distance sensors, for front, rear, left, and right coverage, as well as the two cameras facing forward and backward to capture the surroundings.

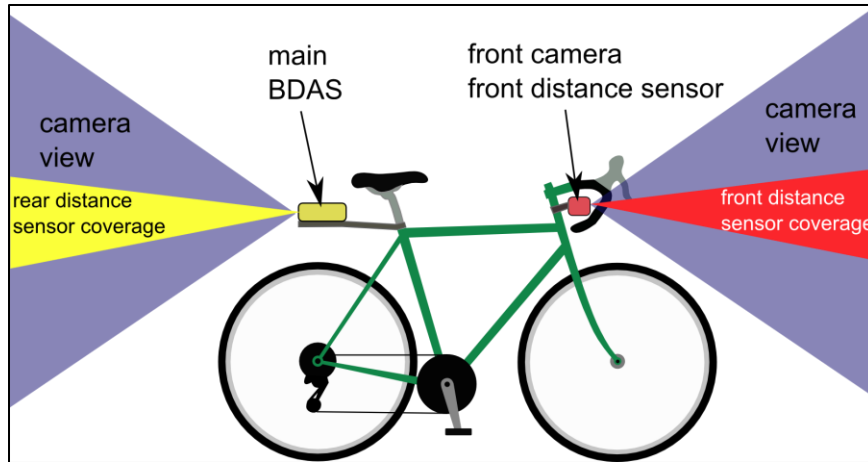

Figure 2-1 Bicycle side view with camera and sensor coverage.

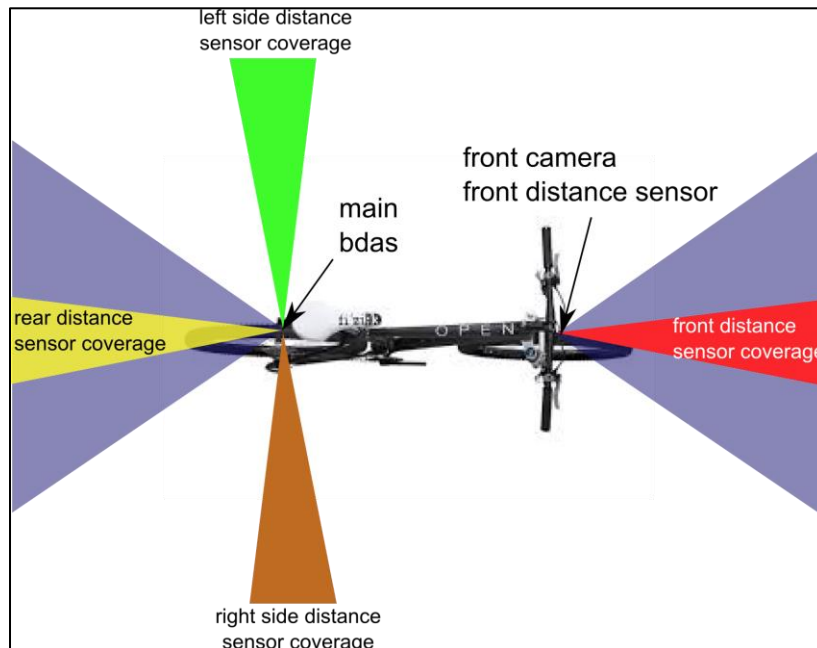

Figure 2-2 Bicycle top view with camera and sensor coverage.

This study attempted to observe bicyclists in the most natural conditions possible. Previous experiments required that participants continually interact and maintain recording devices. A primary design component of this study is that participants did not have to interact with the instruments at all; instead, we relied on motion detection to turn the instruments on and off, enhanced battery and memory capacity to maximize data collection potential, and used wireless communications technology to continually and remotely monitor and communicate with the devices. Most completed studies required that participants use a bicycle provided through the study; this study added the recording instruments to the participants' personal bicycles, thereby reducing the potential for modified behavior that could result from riding an unfamiliar bicycle.

2.1 Summary of Previous Naturalistic Cycling Studies

Table 2-1 shows a summary of the studies described earlier. Most studies had equipped bicycles and provided them to participants to ride either on predetermined routes or on their own route choice. The differences with this study are the number of participants (100) and that the equipment was installed on each participant's bicycle for a more naturalistic data collection. In addition, interaction with the equipment was minimal.

2.2 Advancement from Previous Studies

Previous studies generally used a small number of participants with a stratification based on a narrow pool such as commuters and members of a university campus and covered only a limited selection of locations. Advancements in this study from previous studies are that the scale of data collection is far larger and the data collection occurred automatically with as little interaction as possible from participants to accommodate the “naturalistic” aspect of the study. The differences between previous studies described above and this study are many and are described in the following sections.

2.2.1 Participants

This study collected data using a total of 100 participants, far more than previous studies. The participants were recruited in three waves of approximately 30 each to maximize use of the BDAS units. One main requirement for participation was the use of roads, not trails, and the number of miles traveled per week.

2.2.2 Locations

Previous studies focused on a main area or route to establish how riders react or behave under certain conditions on that corridor. This study did not require riders to ride on any specific routes; rather, they were allowed to ride anywhere they wanted, on their own schedule and time. Route choice was one of the research questions that could be answered using the collected data.

2.2.3 Data Collection Period

Data were collected for a minimum of 15 hours of riding for each participant—more than previous studies—to obtain the best possibility of answering the research questions. Most participants for this pilot study had more than 20 hours of riding data collected.

Table 2-1 Summary of Previous Naturalistic Cycling Studies

#	Year	Title	Objective	Sensors	Participants
1	2006	Driver Overtaking Bicyclists: Objective Data on the Effects of Riding Position	Identify factors influencing riding position of bicycle based on vehicle passing distance	Distance proximity sensor, camera	1
2	2010	The Effect of Cycle Lanes on the Proximity between Motor Traffic and Cycle Traffic	Establish influence of bike lane width to vehicle passing distance	Camera	1
3	2010	Naturalistic Cycling Study: Identifying Risk Factors for On-Road Commuter Cyclists	Identify risk factors for collisions/near-collisions involving on-road commuter cyclists and drivers	Cameras	13
4	2012	Observations of Driver Behavior During Overtaking of Bicycles on Rural Roads	Understand behavior of drivers passing bicycles on rural roads	Cameras, GPS, ultrasonic range sensor	1
5	2012	Understanding Bicycle Dynamics and Cyclist Behavior from Naturalistic Field Data	Establish methods and equipment in collecting naturalistic cycling data	Cameras, GPS, accelerometer, gyroscope, brake force	20
6	2012	Piloting the Naturalistic Methodology on Bicycles	Investigate effort to adapt naturalistic driving methodology to bicycles at SAFER	Cameras, GPS, accelerometer, gyroscope, magnetometer, brake force, speed	17
7	2013	The Use of Quasi-Naturalistic Riding Behavior Methods to Investigate Bicyclists; Behaviors When Motorists Pass	Investigate how vehicle-related factors, road-related factors, and bicyclist-related factors influence motorist decisions about initial passing distances and bicyclist behaviors after motorists started to pass	GPS, accelerometer, gyroscope, distance sensors, proximity, steering angle, cameras	34
8	2013	A Naturalistic Study of Commuter Cyclists in the Greater Stockholm Area	Describe and pinpoint accessibility and safety problems, generate accessible geographical interface that could serve as traffic planning tool for cycle network improvement	GPS, camera	22
9	2014	Introducing Naturalistic Cycling Data: What Factors Influence Bicyclists	Establish bicyclists risk on road	Camera, GPS, inertia units, brake force	16

2.2.4 Data Collected

Given the large scale of this study and advancements in technology, the research team collected different kinds of data to obtain the best possible information for analysis. During previous studies, bicycles were equipped with a device capable of collecting specific data for the study. For example, if the research focused on the distance between a bicycle and passing vehicles, a device recorded that distance only. In this study, many sensors were used to collect a variety of data to provide multiple inputs to answer research questions. The data collected include:

- Video from forward- and rear-facing cameras
- Distance data from four sensors, one for each side of bicycle
- GPS (global positioning system) data for location and route every one second
- Accelerometer data on three axes
- Gyroscope data on three axes (pitch, roll, yaw)
- Light level for environment conditions
- Origin, destination, trip length, and trip reason; input from participant

3. STUDY SITE PREPARATION

3.1 Finalization of Study Site

3.1.1 Final Study Area

The study area for this research was the greater Tampa Bay area, which includes Hillsborough and Pinellas counties. It was important to include both counties and not just Hillsborough since many commuter trips occur between counties, with origins in one county and destinations in the other. Also, the area is in the jurisdiction of FDOT District 7, and local knowledge of the roads is an important resource for the project’s success as a pilot project. Figure 3-1 shows the study area.

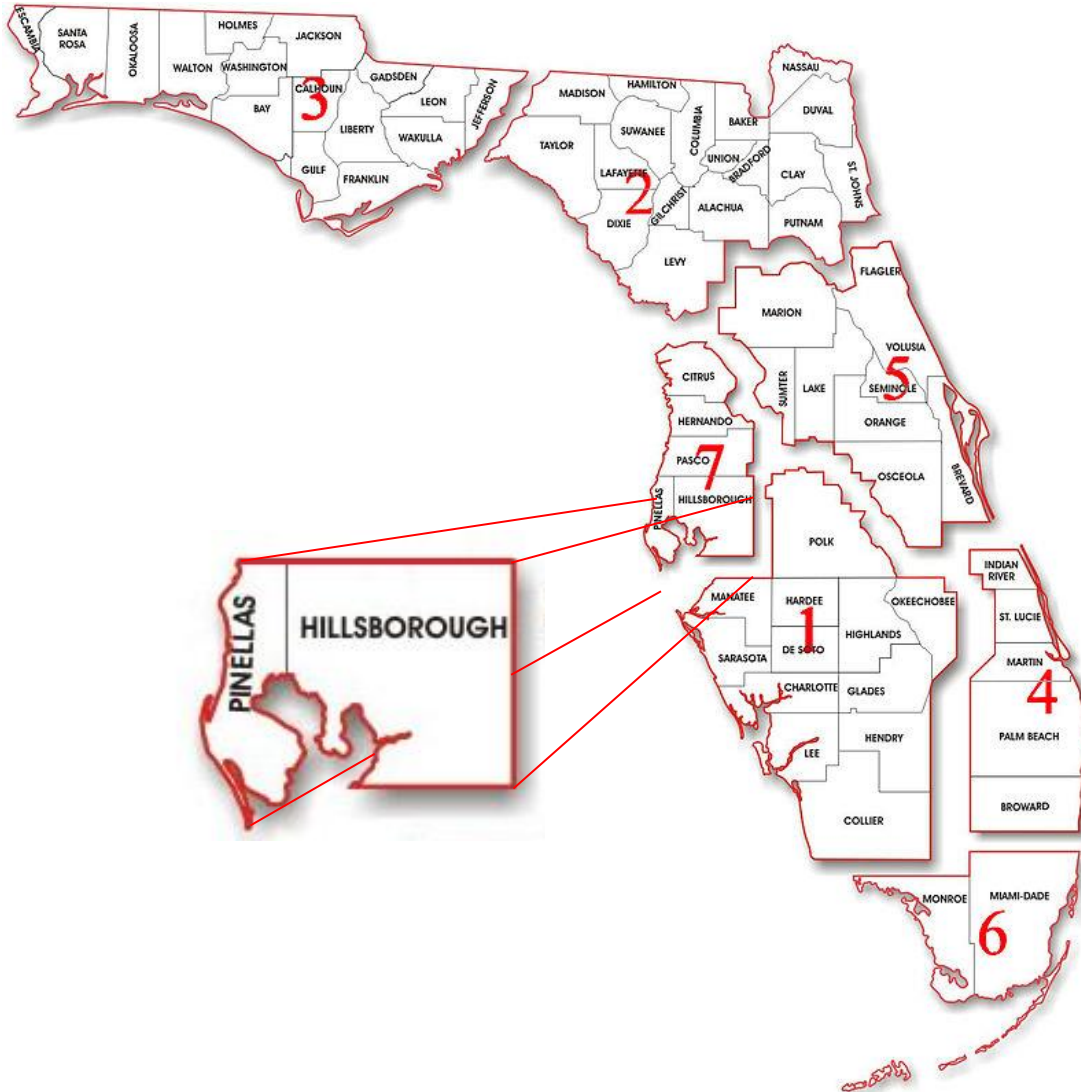

Figure 3-1 Final study area.

In addition, the Center for Urban Transportation Research (CUTR) is located on the University of South Florida Tampa campus in north Hillsborough County. The proximity to participants was important to resolve issues that arose with the data collection equipment.

3.1.2 Stratified Target Sample

This pilot study included 100 participants to provide enough sample for statistically significant analyses and for a larger naturalistic study to be considered in the future. The pilot study was designed to collect data from specific age/gender groups. The planned and actual samples of participants are shown in Table 3-1. The recruitment filtered participants to achieve this stratification, but lack of interest or availability of specific age group/gender combinations changed the target sample.

Table 3-1 Participant Stratification

#	Age Group	Planned Sample			Actual Sample		
		Male	Female	Totals	Male	Female	Totals
1	18–25	17	17	34	36	21	57
2	26–45	17	17	34	24	9	33
3	45+	16	16	32	8	2	10
	Total	50	50	100	68	32	100

3.1.3 Supporting Data

Available supporting data for the study area included crash data from the FDOT State Safety Office (SSO), Signal 4 Analytics, the DHSMV FIRES portal, and roadway information data from the Road Information Database (RID) created during the SHRP2 Naturalistic Driving Study. In addition, GIS shapefiles with supplemental information were obtained from the FDOT GIS webpage. Demographic data were available from the U.S. Census Bureau. The latest available crash data from DHSMV showed that in 2013, a total of 6,969 bicycle crashes resulted in 135 fatalities and 6,520 injuries in Florida. The two counties that comprise the study area (Hillsborough and Pinellas) had 512 and 574 bicycle crashes in 2013, respectively, and 11 fatalities each. Based on the average number of crashes for 2011–2013, Pinellas County ranked 3rd and Hillsborough County ranked 5th statewide in bicycle crashes. Based on information from the U.S. Census Bureau, Hillsborough County had population of 1,316,298 persons and Pinellas County had a population of 938,098 persons in 2014.

3.1.4 Institutional Review Board for Human Subjects Research

This study was considered research with human subjects and, as such, an Institutional Review Board (IRB) must approve the study, procedures, and communication with participants. The USF IRB serves the USF community for any research studies involving human subjects. An application was submitted, and the USF IRB approved the informed consent form (Appendix A) as well as the recruiting materials (Appendix B) and website (Appendix C).

3.2 Design and Development of BDAS

The BDAS is a compact and portable low-energy embedded system that uses sensors and logs data for retrieval and was designed and developed by the CUTR team for this naturalistic bicycling behavior pilot study. The main system purposes and requirements were as follows:

- Should collect synchronized data from front and rear video cameras, date and time, speed, acceleration, GPS coordinates, gyro readings, proximity distance data, audio and light data.
- Should run for 30 hours of bicycle ridership without any user intervention; this was made possible through a low power design that can run continuously on a portable battery.
- Should communicate with a smart phone app at start and end of a ride.
- Should have large enough storage capacity to accommodate and store data for 40 hours.

3.2.1 Audiovisual Recording

To identify bicyclist behavior and environmental crash hazards, many hours of ride data are required. As the BDAS is powered by a battery, design of a video and audio recording system with low power was of main concern. The specifications for the video system are:

- desired frame rate at least 15 frames per sec (fps)
- desired resolution 640 x 480 pixels
- maximum power consumption 100 mA@12 V

Figure 3-2 shows how the three major modules are interconnected.

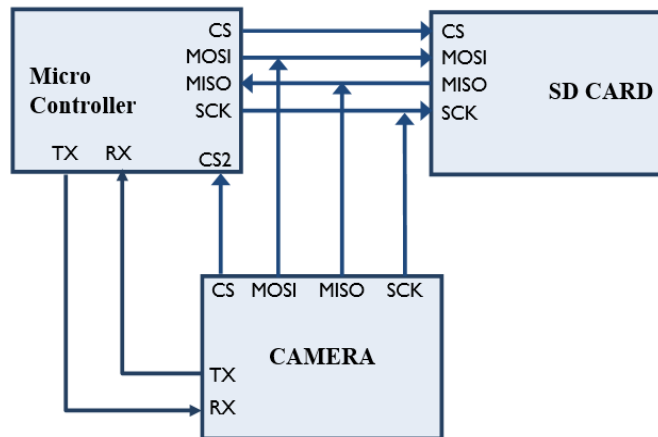

Figure 3-2 Interconnection of major modules in proposed video system.

Camera Module

Based on the specifications, different camera modules were explored. Specifically, the following cameras were considered: the OV7670 camera module, the C3088 camera module, the TTL Serial JPEG camera, and the RadioShack camera module (VC0706). Based on time constraints and video quality specification, the RadioShack camera module was chosen for video recording because of its capability of generating JPEG images, whereas other candidate cameras generated the images in RAW format with large file sizes. The image processor in the VC0706 could generate JPEG images at 640 x 480 pixel resolution. Using this module, the required frame rate of 15 fps was achieved. It supported both SPI and UART interfaces for data collection and communication with the device, respectively. Support for a composite video output was also available in this module, in which the focus of the lens could be adjusted. All communication with the camera was done using UART (frame length, resume, and stop), and actual frame data

was received through the SPI interface. This module worked in the master mode when it used the SPI interface.

Microcontroller

For choosing the microcontroller, the governing factor was the camera module. The camera module’s SPI interface is in master mode by default; hence, the controller should be chosen in such a way that it supports an SPI slave interface with a minimum RAM of 32 KB. An Arduino DUE (Controller Specs: 32-bit ARM core, Atmel SAM3X8E ARM Cortex-M3, 96 KB SRAM [two banks: 64 KB and 32 KB]) was used. In this version, there is enough RAM to receive a complete image and write to an SD card at a speed of 6 MHz. As this microcontroller has 96 MHz, clock ISR routines execute much faster, so the drawback of previously tested microcontrollers was overcome. A larger RAM and faster clock speed of the Arduino DUE resulted in a frame rate of 15 fps for the camera.

Secure Digital (SD) Memory Card

The memory card reached up to 10 MB/sec non-fragmented sequential write speed through SPI communication protocol; a class-10 card was selected for faster processing speeds and secure data.

3.2.2 Data Storage and Synchronization

As frame size varied from 10–32 KB, the frame rate of both modules (front and back) was not constant. The file size of each frame changed because of varying lighting conditions and scenes. The front camera module had variable frame rate of 12–16 fps, and the back camera module had variable frame rate of 10–14 fps. Therefore, synchronization between the two modules and all other sensor data was required. In this system, all non-visual sensor data were collected between capturing of frames. The time taken was 300 ms for every 4 frames. The sensor data were collected from an accelerometer, gyro, and proximity sensor, which took 50 ms, for a total of 350 ms for 4 frames. This cycle repeated every 350 ms. The primary timing constraints were:

- capturing video at 12 fps from front camera module
- capturing video at least 10 fps from back camera module
- measuring distance with each proximity sensor 4 times per second
- measuring acceleration and inclination 4 times per second
- measuring GPS coordinates once per second

Table 3-2 shows the breakdown of the time required for the different tasks involved in collecting a frame data, assuming frame size to be 25 KB.

Table 3-2 Task Sequence and Time Required to Acquire Single Frame

Get Frame Length	Get Frame through SPI	Resume and Write to SD Card	Stop	Total
3	40 ms@6 MHz	40 ms	2	85 ms

3.2.3 Power Management

The power consumption of a complete (front and back module) system was estimated to be 3.6 watts. As the system was powered by a portable battery (10 Ah), the system should automatically shut off in idle mode to save power. A power management system was developed to automatically power on when motion was detected for a certain period of time. It also monitored the idle condition to power off the system when the system was not moving. Figure 3-3 shows schematic of the proposed power management with three components—accelerometer (ADXL362), coin cell battery (2 V), and load switch with level shift (Si1869DH).

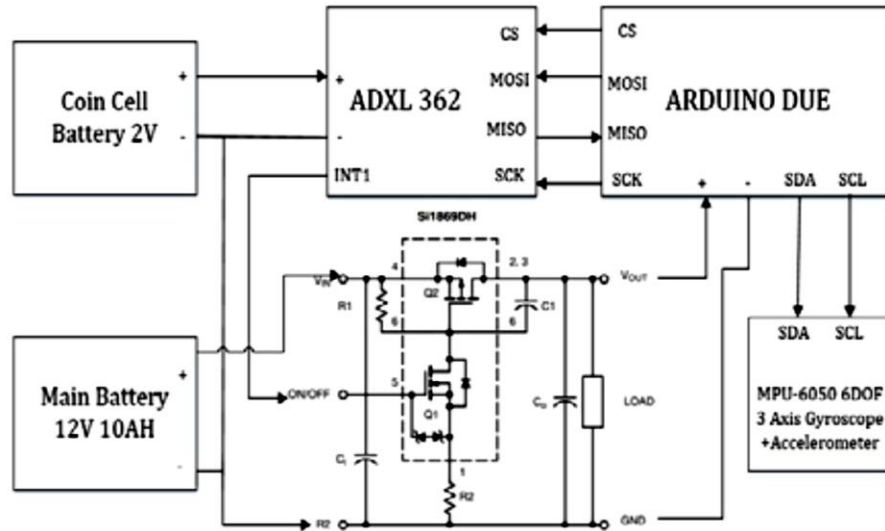

Figure 3-3 Power management schematic diagram.

An Ultra-low Power Accelerometer ADXL362 was used to detect the presence of motion. This accelerometer could be configured in such a way that it generated INT1 (output logic high) and maintained this logic even in absence of motion until INT1 was cleared by a microcontroller. Thus, there was no abnormal power shutdown when there was no motion.

3.2.4 System Software

Figure 3-4 shows the flowchart for the software running on the microcontroller. The system was powered when motion was detected for at least five seconds (user-defined threshold), with the help of power management module, as discussed above. After initialization, the system ran diagnostics on the sensors. Upon success, it enabled GPS logging and entered into the main loop in which sensed data were acquired. For every four video frames, the remaining sensors were sampled once.

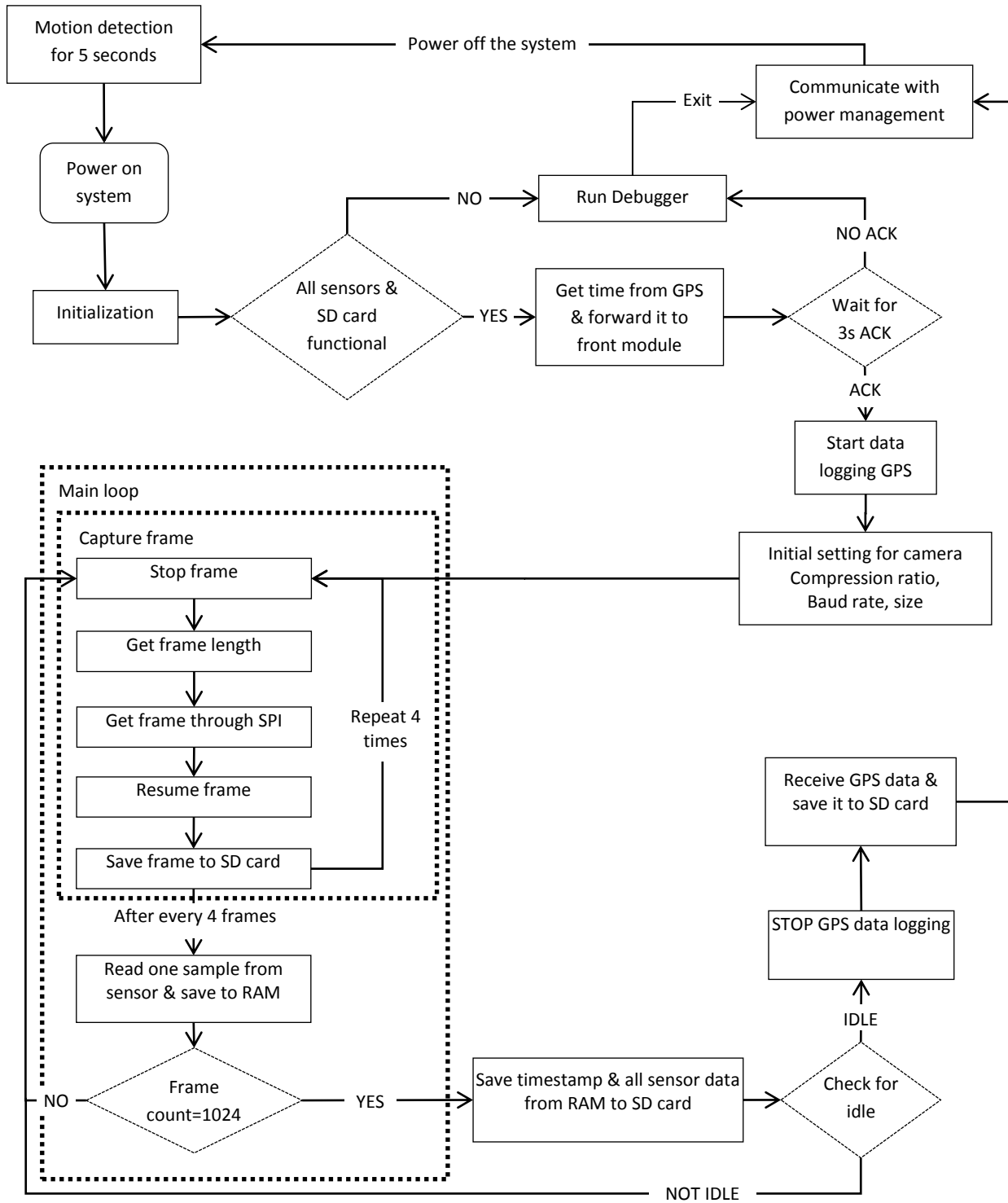

Figure 3-4 Flowchart of data acquisition software.

3.2.5 Preparing Study Site

Study site preparation included all the activities necessary to start recruiting participants and install the BDAS on their bicycles, including organizing project staff, management, and facilities to successfully plan and conduct the project.

3.2.6 Staff Training

All staff who were responsible for contacting participants, educating them, obtaining consent, and interacting with them were required to receive specific training from IRB on how to correctly perform their duties. This training was available online, and all staff were required to be registered and part of the IRB study file. The main staff members and their duties were:

- Recruiters – contact participants who signed up on the website, answer questions, schedule appointments.
- Assessors/technicians – obtain informed consent from participants, install BDAS on their bicycle, provide maintenance if necessary (change batteries, storage cards, replace system, etc., on an as-needed basis).
- Study coordinator – prepare IRB applications and keep them up to date, provide information to participants, manage aspects of participant involvement.
- Study manager – supervise all staff and make decisions on handling special cases of participation, provide guidance on eligibility, keep documents up to date, safeguard data.

All above staff participated in specific training for their duties that were designed to streamline the process.

3.2.7 Preparation of Facilities

The participants were invited to the CUTR research lab at USF Research Park, which offered space for assessment of participants (talking questionnaires and signing consent forms) and installation of the BDAS on their bicycles. Alternatively, participants could opt to have a study staff member meet them at their residence to install the BDAS at their convenience. The data were stored onto a server purchased specifically for the project and could be accessed by a secure connection from the lab space. The server had a storage capacity of 20 terabytes (TB), which was deemed sufficient for storage and backup of collected data.

4. TESTING, FINALIZATION, AND PRODUCTION OF BDAS

4.1 Testing BDAS

The BDAS was capable of performing a number of tasks:

- In standby or sleep mode, wakes up with movement of bicycle.
- Performs self-check on “health” of all sensors and cameras.
- Connects to smartphone app running on participants’ phones, provide health-check data.
- App sends check message to server for analysis.
- Starts recording the following:
 - Front camera
 - Rear camera
 - Front distance sensor
 - Right distance sensor
 - Rear Distance sensor
 - Ambient temperature
 - 3 axis acceleration
 - 3 axis gyroscope
 - Light level
 - GPS coordinates
- Stops recording when no movement is detected.
- Smartphone app presents survey of six questions to participant and collects information for trip. Submitted survey is sent to server for analysis.

The BDAS, including both hardware and firmware, was tested extensively to perform the tasks and store the data described above. Each participant was expected to download and install the app (for iOS and Android) and use it while participating in the study.

4.2 Finalization of the BDAS

The BDAS was finalized in its latest version of software and allowed the research team to enter the participant ID (assigned at the beginning of the study) on each system so all collected data were associated with this unique number. Several steps were taken to ensure that the BDAS could be produced in bulk.

The BDAS comprised several components:

- Custom Printed Circuit Board (PCB) with components (sensors) and Arduino Duo microcontroller for rear module
- Custom Printed Circuit Board (PCB) with components (sensors) and Arduino Duo microcontroller for front module
- Enclosure for rear module
- Enclosure for front module

The custom PCB boards were contracted from a company that made boards with provided specifications. The plastic enclosures were purchased in bulk and modified at the CUTR lab to house the PCB and Arduino boards. Figure 4-1 shows the enclosure for the rear module, which

includes the boards and battery for the system. Figure 4-2 shows the enclosure for the front module.



Figure 4-1 Rear enclosure with holes for camera and sensors, on a bicycle carrier rack.



Figure 4-2 Front enclosure with holes for camera and sensors.

The system was powered with a two 12 VDC 9800 mAh batteries connected in parallel. This battery was chosen for its capacity, weight, form factor, capability of multiple charges, and its ability to power the system for 35–40 hours, which allowed it to collect the required data without battery replacement. The same applied to the SD cards, which stored the data for the front and rear modules; each was capable of storing at least 30 hours of data before being replaced.

4.3 Production of BDAS

All components of BDAS were purchased separately. Several components were assembled by the PCB company that made the custom boards, and the remainder were assembled by the CUTR team. Figure 4-3 shows the board (*left*), the board assembled with components (*middle*) from the PCB company, and the final front module (*right*) with camera, ultrasonic sensor, microcontroller, and SD card ready to be housed in the enclosure. Figure 4-4 shows the same board (*left*), which

was designed to be used for front and back with different components, and the full rear module (*right*) with camera, three ultrasonic sensors, temperature and light sensor, SD card, Bluetooth module, GPS module and accelerometer, and gyro modules.

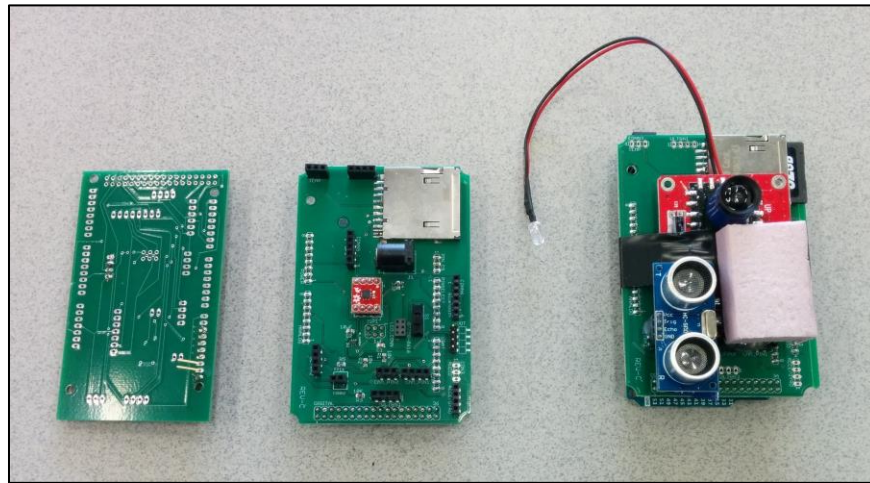

Figure 4-3 Front module assembly.

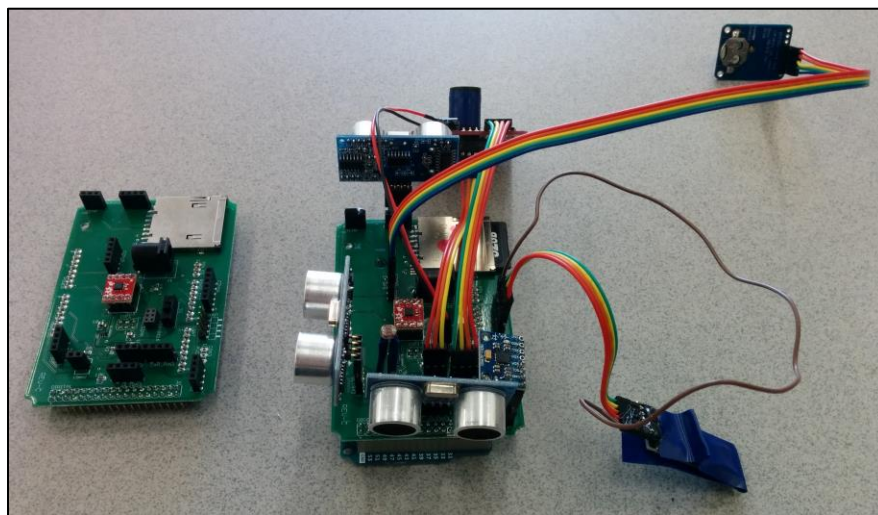

Figure 4-4 Rear module assembly.

The BDAS modules were housed inside the enclosure, as shown in Figure 4-5 and Figure 4-6. All systems were assembled and ready to be housed in the enclosure, as shown in Figure 4-7.

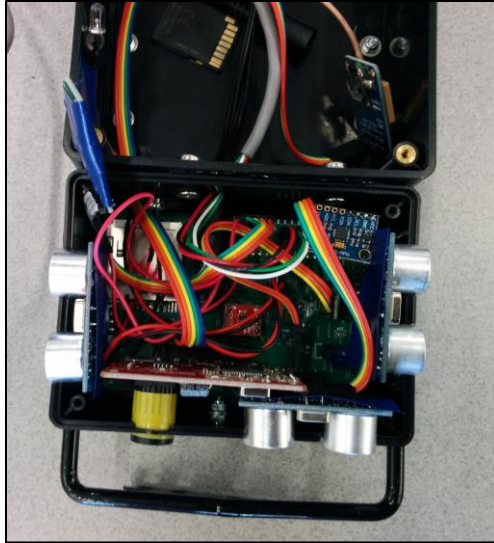

Figure 4-5 Rear module inside enclosure.



Figure 4-6 Front module inside enclosure.

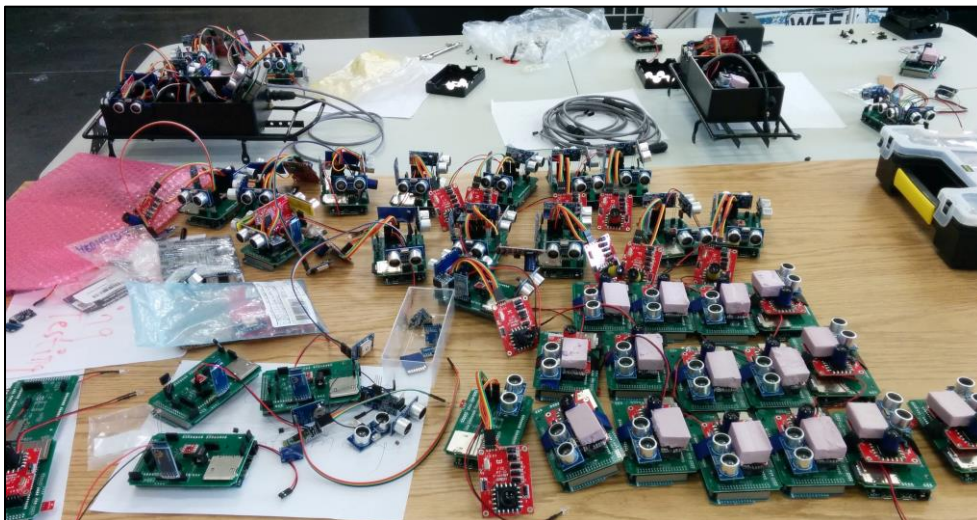

Figure 4-7 Rear and front modules assembled and ready for installation.

Participants had a rack installed on their bicycles that holds the rear module, and the front module was secured on the frame of the bicycle, as shown in Figure 4-8.



Figure 4-8 Front module and rear module of BDAS installed on bicycle.

The production of BDAS was limited to 30–35 units. For 100 participants, the modules were installed in several waves for data collection of the study.

5. PARTICIPANT RECRUITMENT AND MANAGEMENT

The CUTR team used traditional methods to actively recruit potential study participants, including through emails, flyers, posters, meetings, and word-of-mouth. Potential participants were asked to sign up for the study through a website specifically designed to provide information about the study and to collect basic information about the participants. Study staff contacted participants either by phone or email and asked questions to confirm eligibility. If the participant was eligible, he/she was asked to make an appointment to complete the consent process, assessment, and installation of the equipment on their bicycle. Participants were given a \$30 incentive in the form of a prepaid VISA gift card and were asked to use a smartphone application to log their rides. After completion of their time in the study, they were contacted to schedule an appointment to remove the equipment from their bicycle and to receive the remaining \$70 of their incentive payment. The following subsections detail the process followed for each participant.

5.1 Planned and Actual Samples

As with most studies, participants in the study made up the sample population. A total of 100 participants were included to provide enough samples for statistically significant analyses for this study, and for a larger naturalistic study to be conducted in the future. The planned vs. actual participant demographics are shown in Table 3-1. The planned vs. actual differences were due to lack of enough recruited participants in each cell or time limits on the study.

5.2 Recruitment

Recruitment activities occurred over a 10-month period. An announcement email was sent to local bicycle advocates, bicycle clubs, and USF student organizations, and traditional recruiting was conducted by distributing flyers and placing posters at bicycle shops and repair stores, by using flyer hangers on bicycles on the USF Tampa and St. Pete campuses and in the downtown Tampa area, and through word-of-mouth. Recruitment was successful in getting interested people to sign up for the study, as shown in Table 5-1. All participants were directed to the study's website to provide their information to be selected for participation. Recruitment occurred at the following locations:

- USF Tampa campus
 - University Student Center (Marshall Center, Bull Market)
 - University library
 - Central bike racks near multiple classrooms
 - Bike racks outside student housing (on and off campus)
 - Bike racks around parking garages
- USF St. Pete campus
 - University Student Center
 - Bike racks outside classrooms
- Bicycle shops
 - University Bicycle Center, 1220 E Fletcher Avenue, Tampa, FL 33612
 - Oliver's Cycle Sports, 18055 Highwoods Preserve Parkway, Tampa, FL 33647
 - Carrollwood Bicycle Emporium, 14407 N. Dale Mabry Highway, Tampa, FL 33618

- Additional recruits (via flyer or word-of-mouth)
 - CUTR walk-ins
 - Referrals
 - Phone-ins
 - Posted study summary on bicycle websites

Table 5-1 Method of Recruitment for Participants

Method	Count	Participated in Study
Email	7	3
Phone	9	5
Sign-up sheet	80	19
Unknown	37	5
Website*	221	68
Total	354	100

* Participants reported website as method of recruitment but many learned about study from flyers or in person with recruitment staff.

The recruitment flyers and website are provided in Appendix B and Appendix C.

5.3 Participant Scheduling

Participants who signed up on the study website provided basic contact information. Study staff communicated with participants via email or phone to obtain bicycle type information and schedule appointments to conduct the study. Each participant was expected to make at least two appointments:

- Initial appointment to give consent and have BDAS installed on their bicycle
- Final appointment to remove BDAS after completion of participation

More appointments were scheduled between the initial and final appointments on a case-by-case basis if required for either of the following reasons:

- BDAS malfunctioned before completion and needed maintenance
- Participant involved in incident (e.g., crash), to retrieve data before completion time

5.4 Participant Enrollment and Drop-Out

After the participant’s initial appointment, study staff obtained informed consent from him/her to participate in the study, as required by IRB regulations. After signing the informed consent document, the participant was considered to be enrolled in the study. The four IRB-approved questionnaires were obtained from each participant—Demographic Information, Riding Experience, Frequency of Risky Behavior, and Perception of Risky Behavior shown in Appendices D–G. Participants were given instructions on how to operate the smartphone app that accompanied the BDAS (the BDAS itself did not require any action from participants).

Participants were enrolled and participated in the study on a voluntary basis, and could withdraw from the study at any time for any reason. Participants who withdrew had the BDAS removed

from their bicycles and were given pro-rated compensation. Only one participant withdrew from the study early for personal reasons.

5.5 Participant Privacy and Personally Identifiable Information

Based on IRB guidelines, participant information must be protected and secured. In particular, any Personally Identifiable Information (PII) (name, phone number, address, etc.) must be saved in a separate and secure file so there is no way to link the data collected with any PII. For this reason, all participants were assigned a randomly-generated participant ID that was used in place of their name for all related data including questionnaires and data collected from BDAS.

6. INSTALLATION, MAINTENANCE, AND REMOVAL OF BDAS ON PARTICIPANT BICYCLES

6.1 Installation of BDAS

Eligible participants were contacted by CUTR staff via email, phone call, or text (any preferred method noted from participants) to schedule an appointment for BDAS installation. The eligibility of a participant was mainly determined by the type of bicycle he or she rode, as no road bicycles were included in the study due to their delicate frame and possibility of damage. The following tasks were performed during the BDAS installation appointment:

- Read and sign informed consent document giving permission to participate.
- Complete four intake questionnaires.
- Have BDAS installed on bicycle, including smartphone app.
- Receive first installment of compensation (\$30).

Approximately 80% of the initial installation appointments were at CUTR's Intelligent Transportation Systems laboratory at the USF Research Park; the other 20% were at a location chosen by the participant who could not come to the lab. There were 136 initial appointments for installation of the BDAS, with 36 no-shows and 100 successful installations of the device. The average time for the initial appointment was 45 minutes.

6.2 Maintenance of BDAS

The BDAS was designed and produced along with a smartphone app for Android and iOS users. The app, shown in Figure 6-1, created a connection with the BDAS via Bluetooth wireless communication. The app was always running in the background. When the BDAS was switched on because a study participant shook his/ her bicycle, it established a connection and sent device health data to the app, which then transmitted the health message to the study server at USF. In addition, the app presented a short travel survey to the user to complete after each ride that asked questions about the ride that just ended. The purpose of the survey was to use it as a filter for a major event/interaction that might occur between a participant and a vehicle. The survey as shown in the app is presented in Figure 6-2.

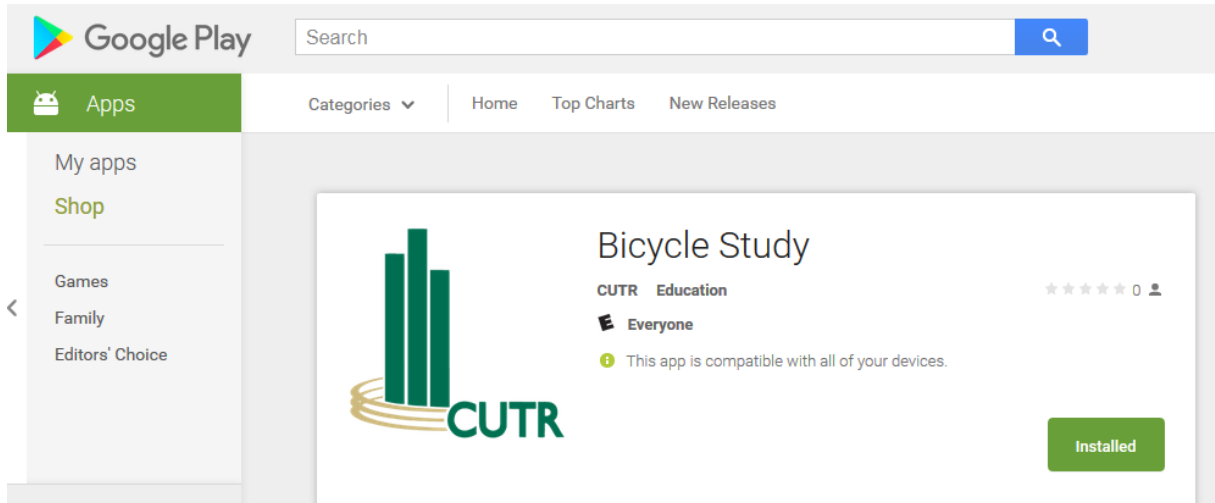

Figure 6-1 BDAS App for Android users.

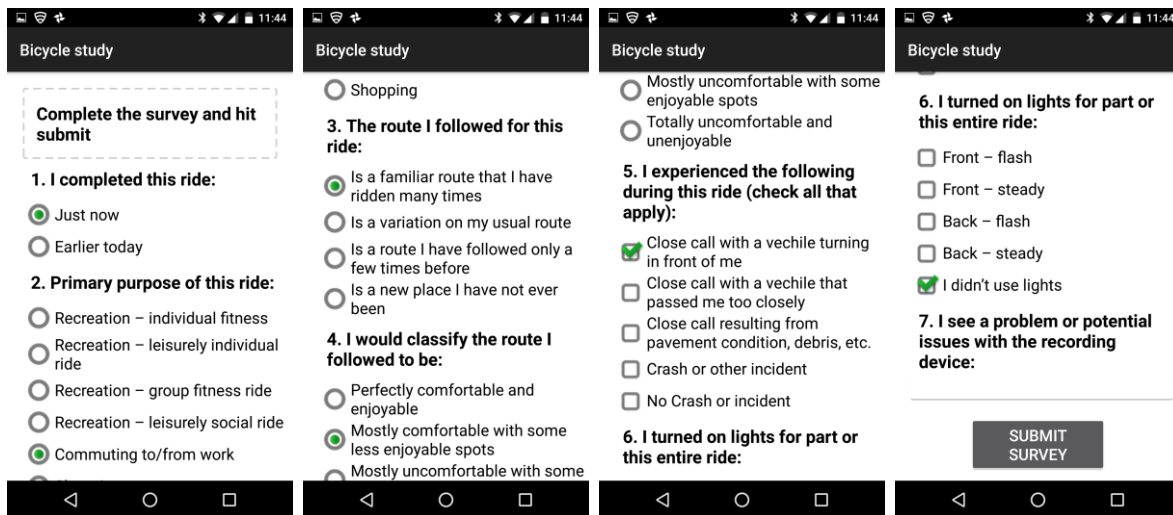

Figure 6-2 Screenshots of travel survey app.

Answers to Question 5, “I experienced the following during this ride,” were especially useful to gauge when a bicyclist felt he/she had an interaction with a vehicle or other event and flag it for further analysis. Maintenance of the BDAS was scheduled based primarily on the health status report of the BDAS unit that reported a maintenance request or malfunction.

Table 6-1 shows an example of a participant health check status as received on the study’s server. For status of the SD card, camera, and accelerometer, “1” means working OK, and the distance sensors show the latest recorded distance in cm. The light level shows the sensor’s value (0–4000) and battery voltage from 12.67 V max to 9.0 V min.

Table 6-1 Health Status Messages

Entry #	Participant ID*	SD card status	Camera status	Acc. status	SD card size (MB)	Left Dist. (cm)	Right Dist. (cm)	Front Dist. (cm)	Temp. (F°)	Light level	Battery voltage (VDC)	Date & time
895	xxx	1	1	1	32127.3	5	2	3	75.45	3676	12.34	2/27/17 18:11:54.08
894	xxx	1	1	1	32160.6	0	24	13	75.45	2020	3.91	2/27/17 18:05:53.03
893	xxx	1	1	1	32181.4	5	2	5	74.35	3014	3.85	2/27/17 17:01:11.32
892	xxx	1	1	1	32181.4	5	3	3	74.38	3417	3.86	2/27/17 17:00:00.25
891	xxx	1	1	1	32181.4	22	2	3	74.44	3169	12.25	2/27/17 16:55:47.46
890	xxx	1	1	1	32171.2	1	26	0	77.34	329	12.39	2/27/17 16:45:16.55
889	xxx	1	1	1	32181.4	6	3	3	75.45	3965	12.25	2/27/17 16:43:21.59
888	xxx	1	1	1	32181.4	6	3	3	75.6	3712	12.26	2/27/17 11:46:02.55

Note: Participant ID is a three-digit randomly-assigned number. Per IRB rules, it is not shared outside approved research staff.

When any sensor was not working, the SD card size showed low storage, or the battery voltage showed low voltage, the participant was contacted to schedule an appointment for maintenance, which included troubleshooting the device’s connections, replacing the BDAS with a new system to allow more time to troubleshoot at the lab, or replacing the battery. Maintenance appointments occurred at the lab or at the participant’s preferred location if he/she could not come to the lab. There were 40 maintenance appointments for this study.

6.3 Removal of BDAS

After each participant completed his/her time in the study filling the SD card with data, CUTR study staff made an appointment to remove the BDAS and provide the participant with the \$70 remainder of his/her payment. There were 100 uninstall appointments (all participants), and the average duration for the final appointment for uninstallation of BDAS was about 5 minutes.

7. DATA VALIDATION, COMPILATION, AND ANALYSIS

The naturalistic bicycling behavior data collected through the BDAS provide a wealth of information regarding bicycling behavior on roadways, sidewalks, and intersections. This chapter documents the effort in validating, compiling, and analyzing the collected data to examine the bicyclist behaviors and the interactions between bicyclists and drivers.

Two major tasks were conducted for data validation, compilation, and analysis. The first task was to review, validate, compile, and organize all naturalistic bicycling behavior data in a database that can be retrieved and used for research and analysis in a variety of ways. The second task was to analyze bicyclist behaviors based on the following six key bicycle safety topics to understand the behaviors of bicyclists and drivers and their interactions:

- a) Understanding behavior, experience, and interactions of bicyclists and drivers making right turns at intersections (right hook).
- b) Understanding behavior, experience, and interactions of bicyclists and drivers making left turns at intersections (left hook).
- c) Understanding behavior, experience, and interactions between bicyclists and drivers at night.
- d) Understanding bicyclist route-choice decisions with given origins and destinations.
- e) Assessing bicycling behaviors of bicyclists with and without formal bicycle-riding training such as CyclingSavvy.
- f) Analyzing bicycle crashes or close calls and determining their contributing factors.

Detailed efforts and findings for each major task are presented below.

7.1 Data Review, Validation, Compilation, and Organization

7.1.1 Data Review

The study area for bicycling trip data collection was the greater Tampa Bay area, including Hillsborough and Pinellas counties, as shown previously in Figure 3-1. The extracted and reviewed naturalistic bicycling behavioral data include video data and digital data of bicycle trips from study participants via cameras mounted on the front and rear sides of their bicycles. Four graduate students were trained to review the data and identify the following information when a bicycle was approaching an intersection or when a close call event occurred:

- Trip date and starting time
- Trip time in terms of daytime or nighttime
- Intersection type (Regular Intersection, Road Segment Intersecting with Driveway, Other [specify], or “N/A”)
- Intersection control scheme (Signal, Stop Sign, Yield Sign, No Control, Other [specify])
- Close call identification (Close Call, No Close Call)
- Close call type (Close Call with Turning Vehicle, Close Call with Vehicle Passing Too Closely, Close Call Due to Pavement Condition or Debris)
- Bicycle lane presence (Bicycle Lane Available, Bicycle Lane Not Available)
- Bicycle lane location (between Thru and Right-turn Lane, On Right of Right-turn Lane)
- Bicycle location at event (Sidewalk, Bike Lane, Sharing Road [with normal traffic])

- Bicycle action (Bicycle Yield [including Stop], Bicycle Not Yield, Bicycle Shift [shift lateral location to pass/avoid], Bicycle Not Shift, Other [specify])
- Vehicle action (Vehicle Yield [including Stop], Vehicle Not Yield, Vehicle Shift [shift lateral location to pass/avoid], Vehicle Not Shift, Other [specify])
- Bicycle direction (Right-way Riding [with traffic direction], Wrong-way Riding)
- Vehicle direction (Same as Bicycle, Opposite of Bicycle, Angle Intersect, Other [specify in "Note"])
- Bicycle turn (No Turn [straight], Left Turn, Right Turn, U-Turn, Other [specify])
- Vehicle turn (No Turn [straight], Left Turn, Right Turn, U-Turn, Other [specify])
- Vehicle signal at intersection (Green, Red, Yellow, N/A [if no traffic signal])
- Bicycle signal at intersection (Walk, Flashing [count down], Do Not Walk, N/A [if no pedestrian signal])
- Vehicle compliance with traffic rules (Comply, Not Comply)
- Bicycle compliance with traffic rules (Comply, Not Comply)

7.1.2 Data Compilation

Five major supportive datasets were collected to assist the analysis of bicycling behaviors and safety performance, including post-trip questionnaire data, participant demographic questionnaire data, participant riding experience questionnaire data, participant frequency of risky behavior questionnaire data, and participant perception of risky behavior questionnaire data.

As documented in Section 6.2, a short travel survey was conducted through a smart phone app after each ride to serve as a filter for a major event/interaction that might occur between a participant and a vehicle. (See Figure 6-2 for survey questions.)

In addition to the post-trip survey, four questionnaires were conducted to collect the detailed demographics and bicycling behavior information, including:

- **Demographics Questionnaire** – designed to collect detailed demographic information for each participant, including age, gender, race, education level, job title, household income, etc. (see full questionnaire in Appendix D). All variables in this survey were considered as potential factors in data analysis.
- **Riding Experience Questionnaire** – designed to collect the bicycling history information of each participant in the past 12 months before project recruitment, including major trip purpose, bicycling facility preference, crash/conflict history, bicycle training course, etc. (see full questionnaire in Appendix E). All variables in this survey were considered as potential factors in data analysis.
- **Frequency of Risky Behavior Questionnaire** – designed to collect risky behavior frequency information of each participant in the past 12 months before project recruitment, including red light running, quick lane changing, non-yielding to pedestrians, texting while bicycling, etc. (see full questionnaire Appendix F). All variables in this survey were considered as potential factors in data analysis.
- **Perception of Risky Behavior Questionnaire** – designed to collect the perception of each participant on risky bicycling behavior. The same risky behaviors as the frequency of risky behavior questionnaire were used in this questionnaire. (see full questionnaire

Appendix G). All variables in this survey were considered as potential factors in data analysis.

7.1.3 Data Validation

The data were validated by conducting data type checks, image checks, consistency checks, range checks, and format checks. After validation, data were compiled into a comprehensive and integrated dataset, which was further divided into different groups for analysis regarding a variety of research interests, such as daytime and nighttime bicycling events, intersections with different traffic controls, bicycling events from bicyclists with professional training and without professional training, etc. Each group was further divided into subgroups for detailed analysis.

7.2 Analysis of Behaviors of Bicyclists and Drivers and Their Interactions

7.2.1 Data Analysis

Quantitative data analysis was used for this research to provide quantifiable and easy-to-understand results regarding the six questions. Chi-square tests were used to determine whether the proportion of a certain feature was different across multiple groups. For example:

$H_0: P_{M-Risk} = P_{F-Risk}$
(proportion of high-risk bicyclists in male bicyclist group
is same as that in female bicyclist group)

$H_a: P_{M-Risk} \neq P_{F-Risk}$
(proportion of high-risk bicyclists in male bicyclist group
is different from that in female bicyclist group)

Comparisons of bicyclist and driver compliance with traffic rules were conducted between different bicyclist demographic and behavior features, such as gender, age group, and risk and distraction characteristics. The higher the proportion of compliance observed, the better the safety performance is. All hypothesis tests were conducted at a minimum confidence level of 90%. The data label on the graphs shows the sample size and percentage for each feature shown.

7.2.2 Data Analysis Results and Findings

7.2.2.1 Impacts of Bicyclist Risk and Distractive Characteristics on Compliant Behaviors

Questions regarding the following risky and preventive behaviors in the Participant Riding History Questionnaire and the Participant Frequency of Risky Behavior Questionnaire were used to assess bicyclist risky behavioral characteristics (responses listed in parentheses):

- Risky Behavior:
 - Run red lights (0-never, 1-rarely, 2-sometimes, 3-often)
 - Take more risk because of being in a hurry (0-never, 1-rarely, 2-sometimes, 3-often)
 - Ride shortly after drinking alcohol or using recreational drugs (0-never, 1-rarely, 2-sometimes, 3-often)
 - Turn from a wrong lane at an intersection (0-never, 1-rarely, 2-sometimes, 3-often)
 - Pass when visibility is reduced (0-never, 1-rarely, 2-sometimes, 3-often)

- Ride at night without lights on (0-never, 1-rarely, 2-sometimes, 3-often)
- Ride against traffic on the roadway (0-never, 1-rarely, 2-sometimes, 3-often)
- Preventive Countermeasures:
 - Signal turns (3-never, 2-rarely, 1-sometimes, 0-often)
 - Wear or equip your bicycle with brightly colored or reflective items (3-never, 2-rarely, 1-sometimes, 0-often)
 - Wear a helmet while bicycling (3-never, 2-rarely, 1-sometimes, 0-often)
 - Use a mirror affixed to your helmet or handlebars while bicycling (3-never, 2-rarely, 1-sometimes, 0-often)

A comprehensive Risk Score was calculated in Eq. (1) based on the responses, and the weight for each question was defined based on engineering judgment. For example, it is understandable that “Run red light” and “Ride shortly after drinking alcohol or using recreational drugs” are more likely to lead to severe bicyclist injuries and, therefore, were assigned a higher weight than other risk factors. Similarly, “Wear a helmet while bicycling” and “Wear or equip your bicycle with brightly colored or reflective items” are more effective for bicyclist protection at crash occurrence or during nighttime conditions and, therefore, were assigned with higher weights than other preventive countermeasures.

$$\begin{aligned} \text{Risk Score} = & 2 \times \text{Run red lights} + \text{Take more risk because of being in a hurry} + 2 \\ & \times \text{Ride shortly after drinking alcohol or using recreational drugs} + \text{Turn from a} \\ & \text{wrong lane at an intersection} + \text{Pass when visibility is reduced} + 2 \times \text{Ride at night} \\ & \text{without lights on} + 2 \times \text{Ride against traffic on the roadway} + \text{Signal turns} + 2 \times \\ & \text{Wear or equip your bicycle with brightly colored or reflective items} + 2 \times \text{Wear a} \\ & \text{helmet while bicycling} + \text{Use a mirror affixed to your helmet or handlebars while} \\ & \text{bicycling} \end{aligned} \quad (1)$$

Using this definition, a Risk Score has a minimum theoretical value of 0 and a maximum theoretical value of 51. Therefore, to appropriately evaluate driver risk levels and maintain a comparable sample size in each risk group, risk levels were defined as follows:

- High Risk Group – Risk Score greater than or equal to 26 (26–51)
- Low Risk Group – Risk Score less than 26 (0–25)

In this analysis, the minimum Risk Score was 3 and the maximum score was 38 among all drivers.

The following question in the Participant Frequency of Risky Behavior Questionnaire was used to determine the level of bicyclist distraction:

- Smoke, text, or talk on phone while bicycling (never, rarely, sometimes, often)

Based on the responses from participants, distraction levels were defined as follows:

- High Distraction Group – response was either “sometimes” or “often”
- Low Distraction Group – response was either “never” or “rarely”

According to the above definitions, 90 recruited bicyclists with valid and complete survey responses were considered in this research, and the distributions of risky and distractive bicyclists by bicyclist characteristics are shown in Figure 7-1.

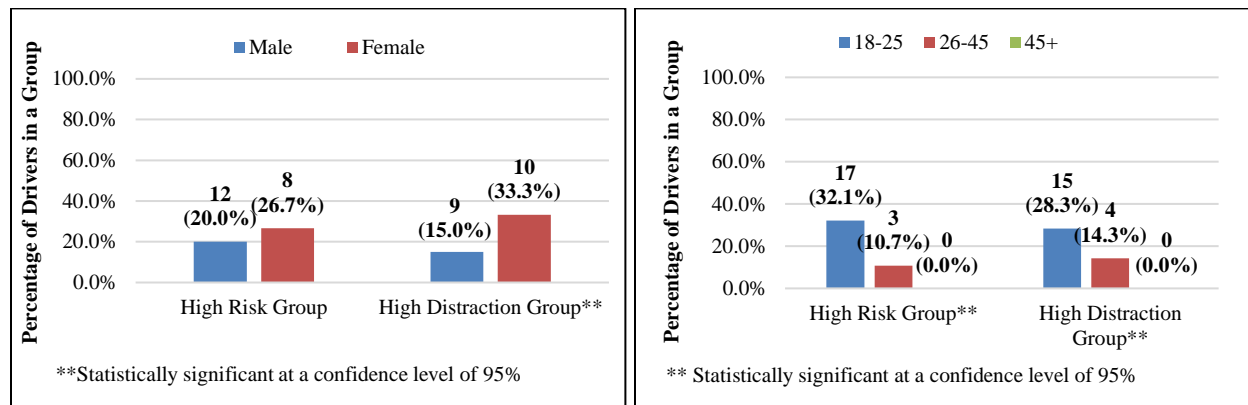

Driver Demographics		Risk Level			Distraction Level		
		High Risk Counts	Total Counts	% in High Risk Group	High Distraction Counts	Total Counts	% in High Distraction Group
Gender	Female	8	30	26.7%	10	30	33.3%
	Male	12	60	20.0%	9	60	15.0%
Age Group	18–25	17	53	32.1%	15	53	28.3%
	26–45	3	28	10.7%	4	28	14.3%
	45+	0	9	0.0%	0	9	0.0%

Figure 7-1 Comparison of risk and distraction levels by gender and age.

- Per self-evaluation, more female than male bicyclists were classified into the groups of “High Risk” (26.7% vs. 20.0%) and “High Distraction” (33.3% vs. 15.0%). The difference was significant in terms of distraction at a 95% confidence level.
- Per self-evaluation, younger bicyclists (age 18–25) took significantly more risks than those in age groups 26–45 and 45+; younger bicyclists (age 18–25) were also significantly more likely to be distracted than mid-age bicyclists (age 26–45) and older bicyclists (age 45+). No older bicyclist (age 45+) were identified as “High Risk” or “High Distraction”, making them the safest group among all the age groups.
- The differences between younger (age 18–25) and older (age 45+) bicyclists were significant at a 95% confidence level regarding both the proportion of “High Risk” bicyclists and the proportion of “High Distraction” bicyclists.

7.2.2.2 Analyses of Behavior, Experience, and Interactions between Bicyclists and Drivers Making Right Turns at Intersections

The naturalistic bicycling data were reviewed by four fully-trained graduate students, and 611 bicycling events from 63 different bicyclists were recorded, including bicyclists crossing intersections and bicyclists encountering close call with passing vehicles on road segments. Among the 611 valid data review records, 24 were associated with drivers making right turns.

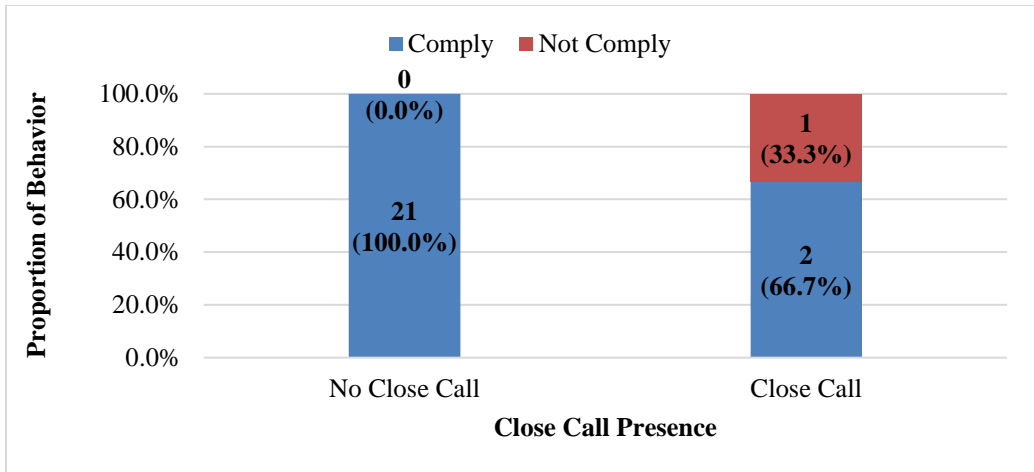

Close Call Availability	Non-Compliant Counts	Compliant Counts	Total Counts	% Compliant Behaviors
No Close Call	0	21	21	100.0%
Close Call	1	2	3	66.7%

Figure 7-2 Comparison of bicyclist compliance by close call availability in right-turn vehicle events.

- Close Call Analysis – three close calls occurred with turning vehicles, and all were between bicyclists and right-turning vehicles, where the bicyclists proceeded straight through the intersections. Two were due to vehicles failing to yield bicyclist right-of-way, and one was due to the bicyclist crossing the intersection during a “Do Not Walk” pedestrian signal. The bicyclist crossing the intersection during the “Do Not Walk” pedestrian signal was a young (age 18–25) male bicyclist belonging to both the “High Risk” and “High Distraction” groups and was without professional cycling training. Both bicyclists in the other two close call events belonged to both the “Low Risk” and “Low Distraction” groups and were without professional cycling training.
- For the other 21 records of right-turning vehicles without close calls, it is found that the bicyclists complied with general traffic rules in all 21 incidents, and there are no records of bicyclists riding against traffic. Vehicle non-compliance with general traffic rules were found in four records, where the driver did not yield bicyclist right-of-way and made a right turn, so the bicyclist had to yield to the vehicle.
- Only one event occurred in nighttime; the other 23 occurred in daytime.
- It is also found in the data review that, bicyclists often maintained the same speed when crossing an intersection rather than slowed down and crossed progressively with special caution. This often occurred when bicyclists came from the intersecting crosswalk or from behind on the right side of vehicles, and drivers were starting to turn. Therefore, enhancing the education of bicycling with caution in professional cycling training courses is recommended.

7.2.2.3 Analyses of Behavior, Experience, and Interactions between Bicyclists and Drivers Making Left Turns at Intersections

Among the 611 valid data review records, only eight were associated with drivers making left turns. Given the limited number of records with left-turning vehicles, detailed analyses are presented as follows:

- No close calls were observed between bicyclists and left-turning vehicles.
- All bicyclists were riding in the same direction as the traffic flow; none were riding against traffic.
- One event of vehicle non-compliance was observed, where the left-turning vehicle did not yield to the bicyclist on the crosswalk when the pedestrian signal was “Walk.”
- Bicyclist risky behavior was observed in one record; at the approach of a T-intersection composed of a left-turn lane, a right-turn lane, and a bike lane, the bicyclist switched from riding in the bike lane to sharing the road with vehicle traffic when approaching the intersection and made a left-turn from the right-turn lane. This bicyclist was a young (age 18–25) female belonging to the “Low Risk” and “High Distraction” groups and was without professional cycling training.
- All these events occurred during daytime.

7.2.2.4 Analyses of Behavior, Experience, and Interactions between Bicyclists and Drivers at Night

Among the 611 valid data review records, 40 were associated with nighttime conditions and 571 were associated with daytime events. Figure 7-3 shows the distribution of bicyclist and driver compliance with general traffic rules and regulations during daytime and under nighttime conditions.

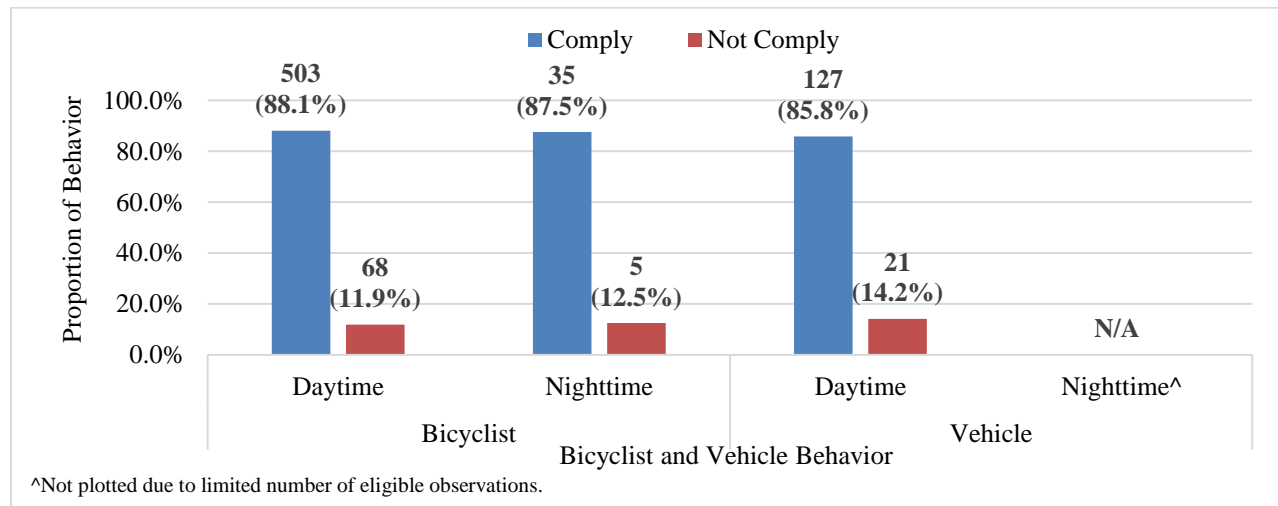

Figure 7-3 Bicyclist and driver compliance by time.

- The proportion of compliance for bicyclists was 88.1% daytime and 87.5% nighttime, indicating that bicyclists showed similar patterns of complying with general traffic rules and regulations; the difference between these two proportions was not significant at a 90% confidence interval.
- The proportion of compliance for observed drivers was 85.8% in daytime. Only one driver was observed during nighttime interacting with bicyclists, failing to yield bicyclist right-of-way. Given the limited observations for drivers during nighttime, no conclusions could be drawn at this time. However, it was reported by the participants based on their experience that drivers were very likely to fail to yield to bicyclists due to limited visibility at night.
- Detailed examination revealed that most bicyclist non-compliance was associated with proceeding under pedestrian “Do Not Walk” signal, and some were associated with riding against traffic. Most driver non-compliance was associated with failure to yield bicyclist right-of-way.

Figure 7-4 shows the bicyclist behavior analysis results in terms of biking locations under different combined daytime/nighttime and bike lane presence/absence scenarios.

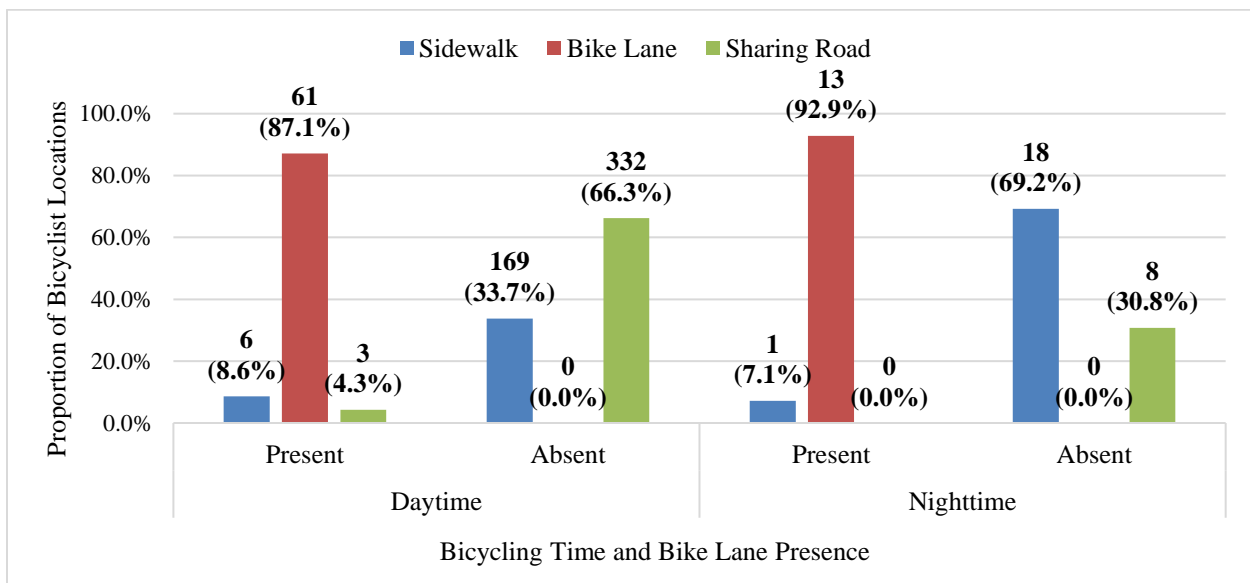

Figure 7-4 Biking location analysis by time and bike lane setting.

- During nighttime, if a bike lane was available, most bicyclists used it for riding, except in one record in which the bicyclist used the sidewalk instead; if not available, bicyclists preferred to use the sidewalk rather than share the road with vehicle flow in most conditions (69.2%). It should be noted that the behavior of bicyclists sharing the road with vehicle flow also depended on the availability of a sidewalk on certain roads. These

results are reasonable since bicyclists' highest choice was using designated bike lanes, followed by sidewalk and sharing the road with traffic. In addition, sharing the road with vehicle flow was usually associated with higher crash risk than the other two locations and, therefore, was the least favorite choice.

- In the daytime when a bike lane was available, bicyclists were most likely to ride in the bike lane (87.1%). However, some variations were found—there were six observations (8.7%) with bicyclists riding on the sidewalk and three (4.3%) with bicyclists sharing the road with vehicle flow. When a bicycle lane was not available, bicyclists shared the road with vehicle flow in most conditions (66.3%) and used the sidewalk otherwise. Similarly, the behavior of bicyclists sharing the road with vehicle flow also depended on sidewalk availability on certain roads.
- Comparing the results during daytime and nighttime conditions, bicyclists were more conservative and stayed in their right-of-way and safe locations under nighttime conditions, whereas in the daytime, bicyclists were relatively more aggressive and tended to violate pedestrian signals if they had good visibility and clear distance from potential collisions.
- Figure 7-5 shows the frequencies of bicycling without lights on when the participants rode at night, with 42.2% never riding at night without bicycle lights on, 31.1% rarely riding at night without bicycle lights on, 17.8% sometimes riding at night without lights on, and only 8.9% often riding at night without bicycle lights on. Therefore, the majority (73.3%) of recruited participants had good awareness of safe riding at night regarding bicycle light use.

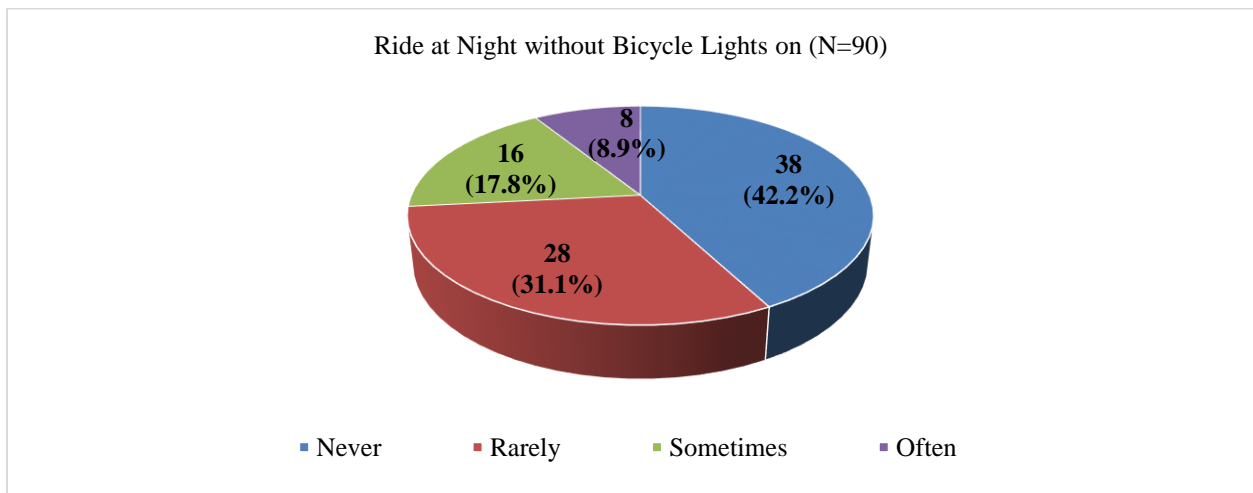

Figure 7-5 Frequency of bicycling without lights on during nighttime riding.

Figure 7-6 shows the frequencies of reflective item use when bicycling, either wearing reflective vests or equipping bicycle with reflective items, with 37.8% wearing reflective vests or equipping bicycle with reflective items often, 24.4% sometimes, 22.2% rarely, and 15.6% never. In general, the majority (62.2%) of recruited participants had good awareness of safe riding in terms of using reflective items to increase visibility.

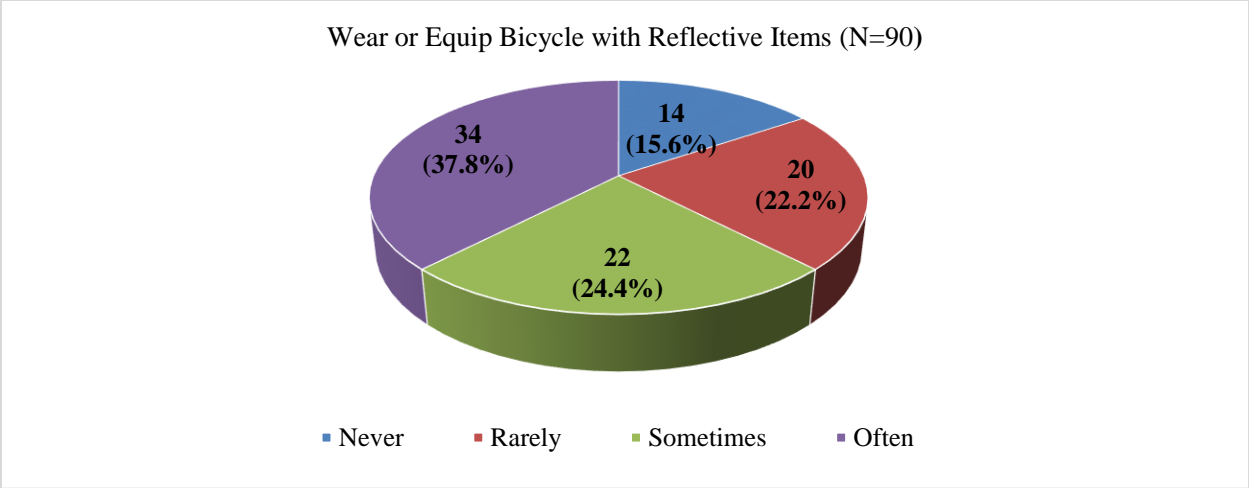

Figure 7-6 Frequency of reflective item use in bicycling.

7.2.2.5 Analysis of Bicyclist Route Choice Decisions with Given Origins and Destinations

After each bicycle ride, participants were asked to complete a post-trip survey regarding trip purpose, trip comfort, route choice, close call existence, bicycle light use, etc., through a smartphone app developed by CUTR, as shown previously in Figure 6-1 and Figure 6-2. After removing incomplete and erroneous post-trip survey data, 836 trips had a complete and meaningful post-trip survey and were plotted in ArcGIS environment, as shown in Figure 7-7. As shown, most of this trip data was collected in three regions: the USF area, the Tampa downtown area, and the St. Petersburg downtown area, all of which are highly-populated regions.

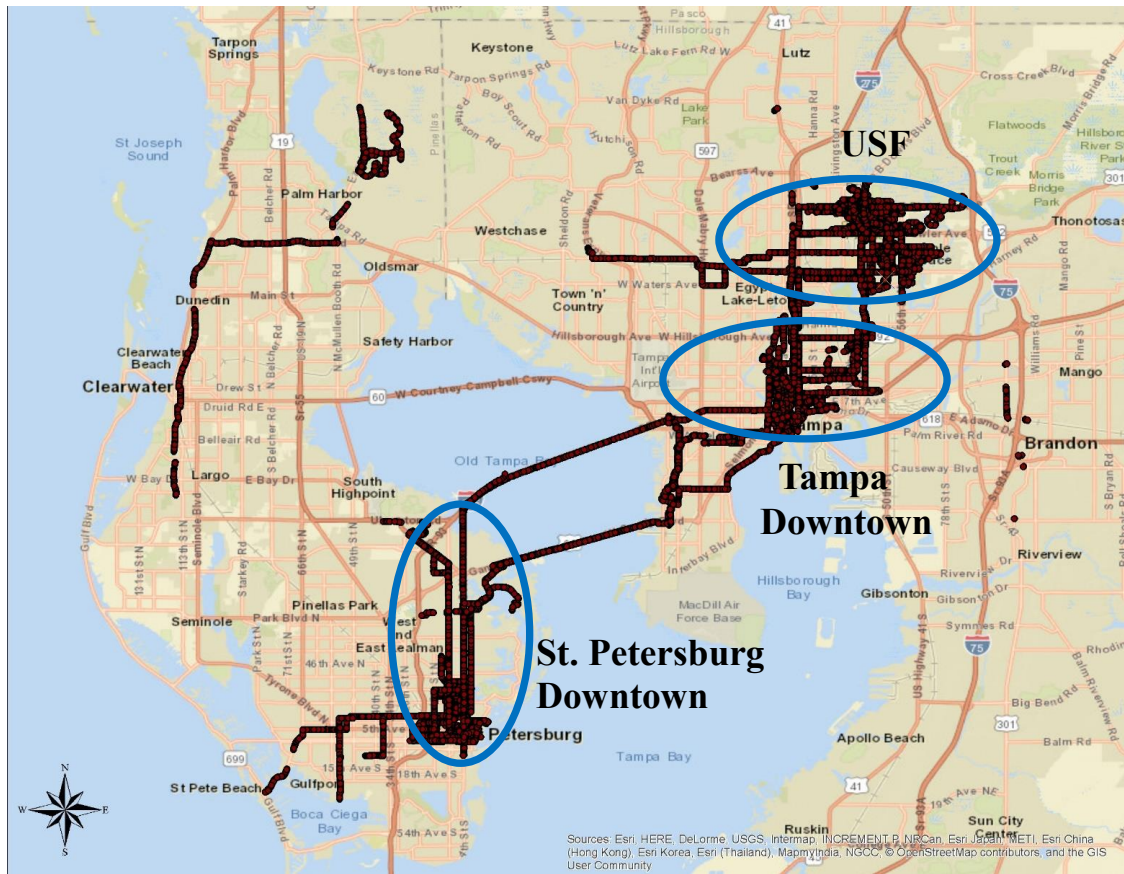

Figure 7-7 Spatial distribution of all trips with post-trip survey.

It is understandable that trips with clearly-given origin and destination locations generally have a specific trip purpose. For example, a ride between home/apartment and school is generally a school commute trip, and a ride from home to a commercial area is usually for shopping or leisure. Therefore, two major trip features were examined: the major purpose of the immediate trip (Question 2 in Figure 6-2) and the reason the participant chose the route for that trip (Question 3 in Figure 6-2). The distribution of route choice reasons for each major trip purpose is shown in Figure 7-8 through Figure 7-14. The major findings regarding route choice distribution for different trip purposes are presented as follows.

Figure 7-8 shows the route choice distribution for commuting trips, with 81.4% of commuting trips on familiar routes that had been ridden many times, and 12.8% of trips on a variation of the usual route. In addition, 3.7% of commuting trips were on routes followed only a few times, and 2.1% were on new routes not used before. These findings indicate that bicyclists likely choose familiar routes for commuting trips to ensure travel time reliability and reduce unnecessary delay, and may choose a variation of the usual route to run an errand or avoid en-route delay. Unfamiliar and new routes accounted for less than 6% of all commuting trips, showing that route familiarity and on-time arrival are mainly considered in commuting trips.

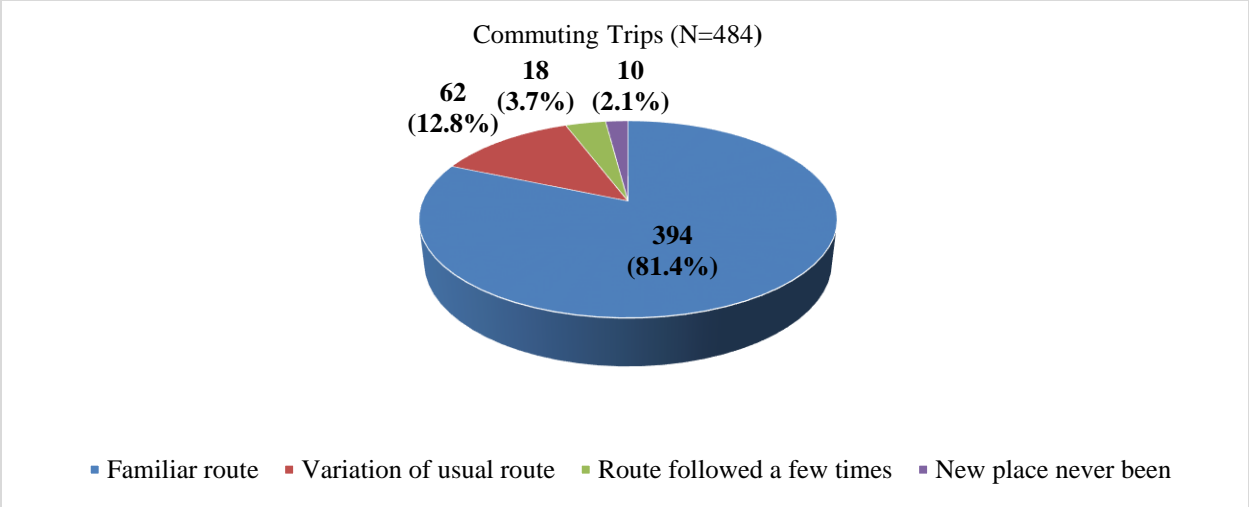

Figure 7-8 Route choice distribution for commuting trips.

Figure 7-9 shows the route choice distribution for group-fitness recreation trips. Although data for only 9 trips of this type were collected, obvious variations were found on route choice preference, with 44.4% on a route that was followed a few times and 33.3% on a familiar route. Additionally, 11.1% of all trips were on a variation of the usual route, and 11.1% were on new routes not used before. This indicates that bicyclists making group-fitness recreation trips showed increasing interest in unfamiliar routes and new routes for group-fitness rides for fun or exploration, with familiar and variation routes accounting for only 20% of total trips.

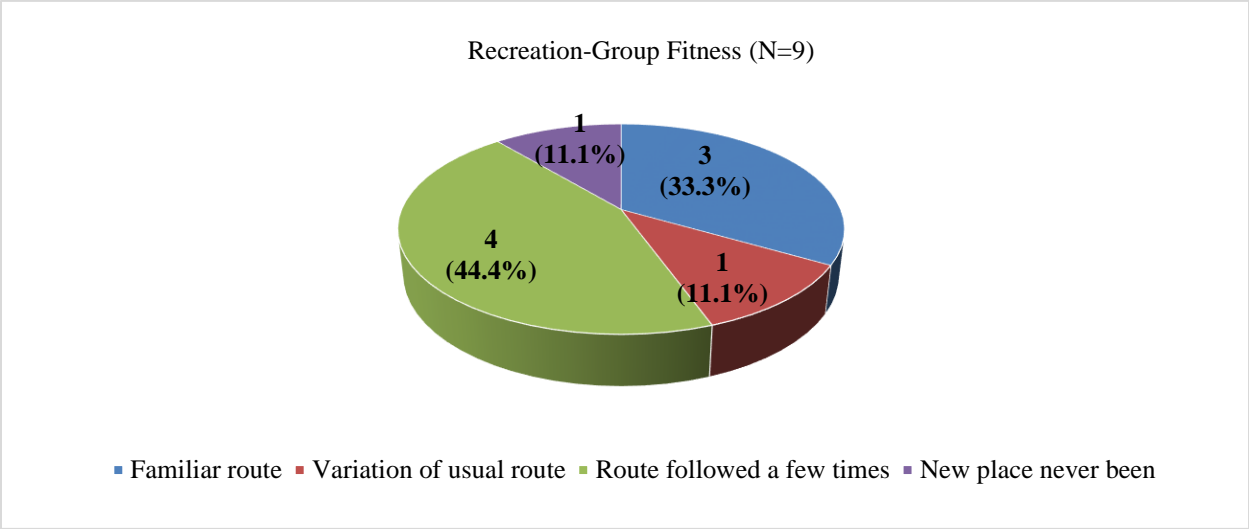

Figure 7-9 Route choice distribution for group fitness trips.

Figure 7-10 shows the route choice distribution for individual-fitness recreation trips, with 85.5% on familiar routes that had been ridden many times. Variation of usual routes and routes followed a few times accounted for 6.9% and 5.5% of all individual fitness trips, respectively. Additionally, only 2.1% of all trips were on new routes that had not been used before. These results indicate that, for individual fitness trips, bicyclists prefer to take familiar routes. A

possible reason is that bicyclists on familiar routes have more confidence on travel time, trip safety, trip length, etc., and can better manage their trips.

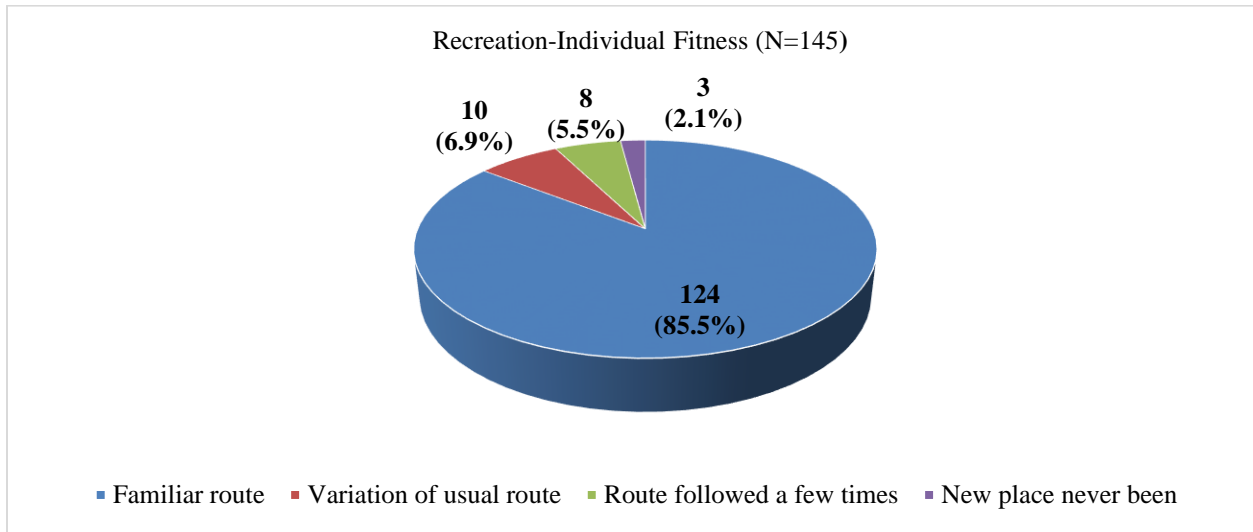

Figure 7-10 Route choice distribution for individual fitness trips.

Figure 7-11 shows the route choice distribution for leisurely individual riding trips, with 63.1% on familiar routes that had been ridden many times and 16.9% on routes followed a few times. Additionally, 10.8% of all the trips were on new routes not used before, and 11.1% were on a variation of the usual route. Comparing the results in Figure 7-10, although different in individual proportions, similar route choice distributions are clear. A possible reason is that bicyclists on familiar routes have more confidence in travel time, trip safety, trip length, and other related concerns but have slightly increasing interest on less familiar routes for leisure purposes.

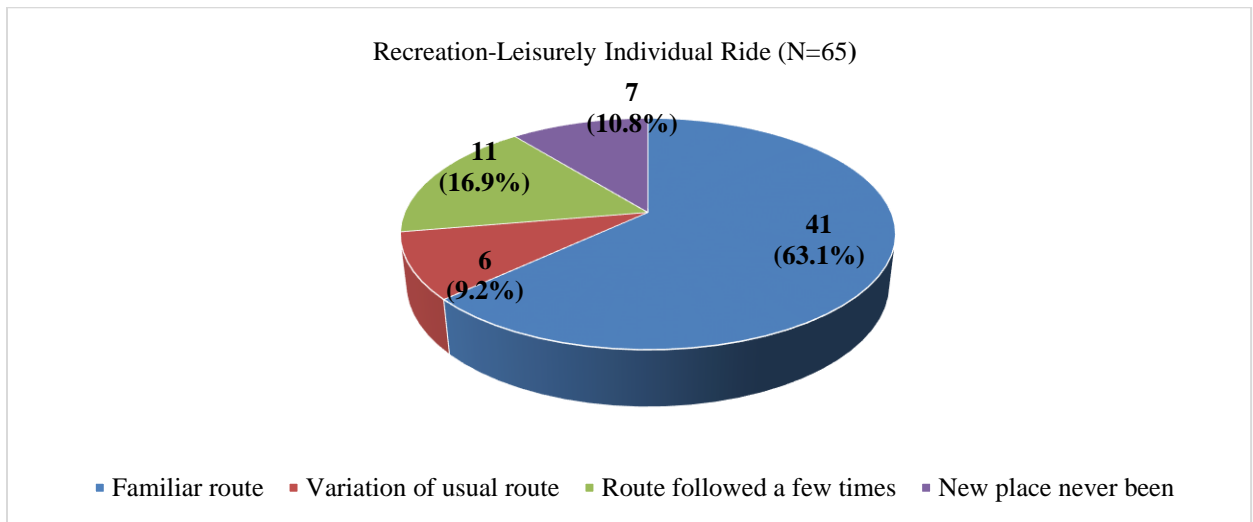

Figure 7-11 Route choice distribution for leisurely individual rides.

Figure 7-12 shows the route choice distribution for leisurely social rides. It was found that the proportions of route choices vary significantly, with 35.3% of all leisurely social rides were on familiar routes that had been ridden many times, the largest proportion of all the route choices. Bicyclists showed equal interest in routes followed a few times and new places, with each accounting for 27.5% of all leisurely social rides. Only 9.8% of all leisurely social rides were on a variation of the usual routes. These results indicate that for leisure purposes, bicyclists show increasing interest in less familiar routes such as those followed a few times or new routes.

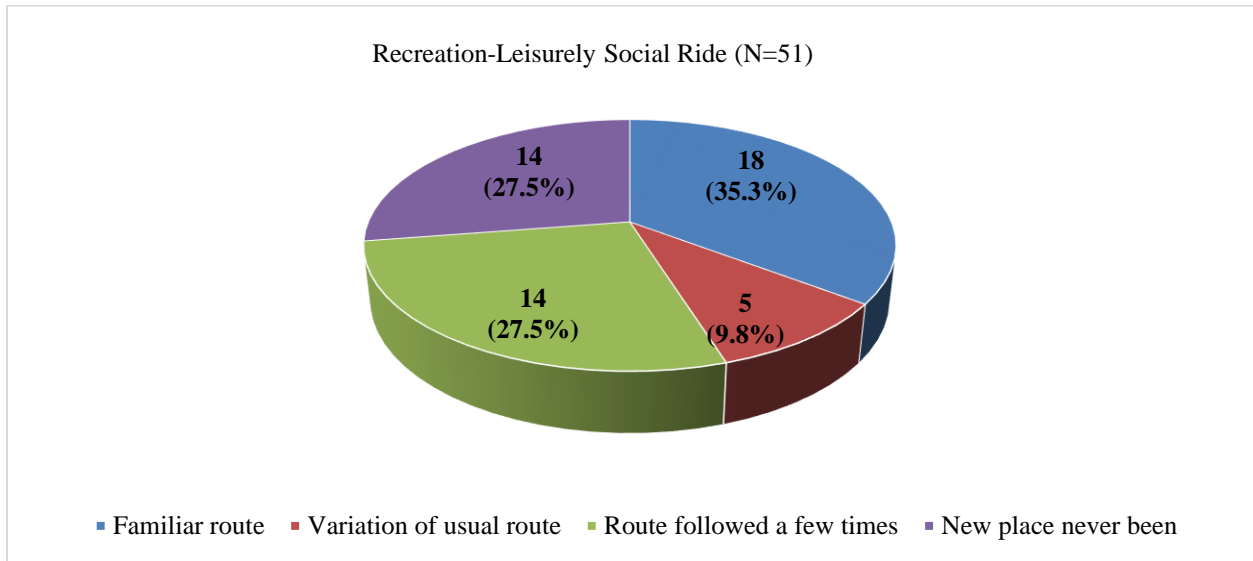

Figure 7-12 Route choice distribution for leisurely social rides.

Figure 7-13 shows the route choice distribution for shopping trips, with 79.3% of all shopping trips on a familiar route and 13.4% on a variation of the usual route. Additionally, 4.9% of all trips were on a new route and another 2.4% were on a route followed a few times. These findings indicate that bicyclists prefer to take more familiar routes when going shopping, such as a familiar route that has been ridden many times and variations of usual routes.

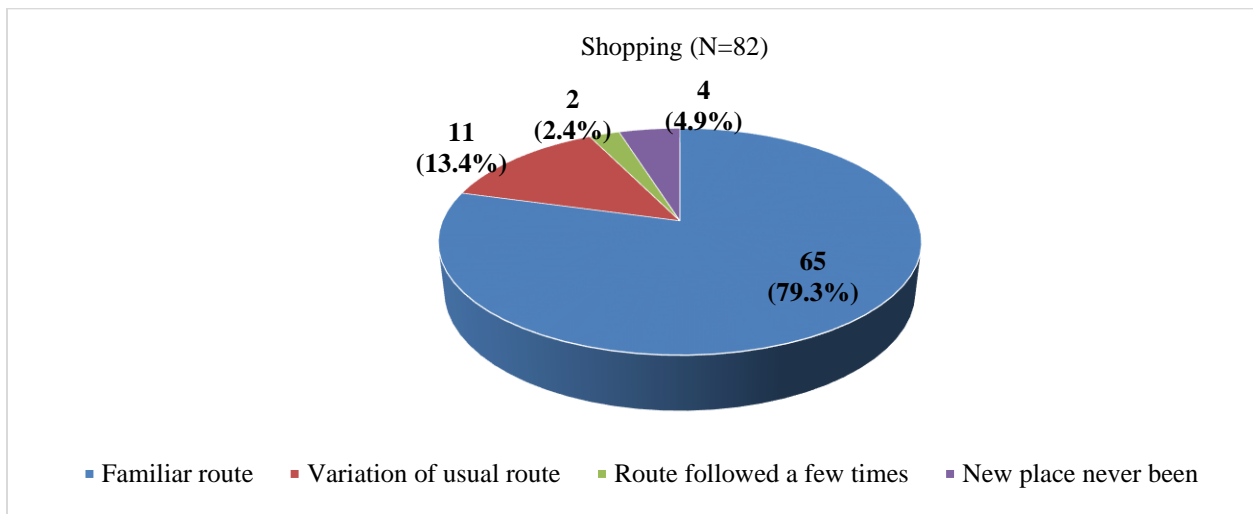
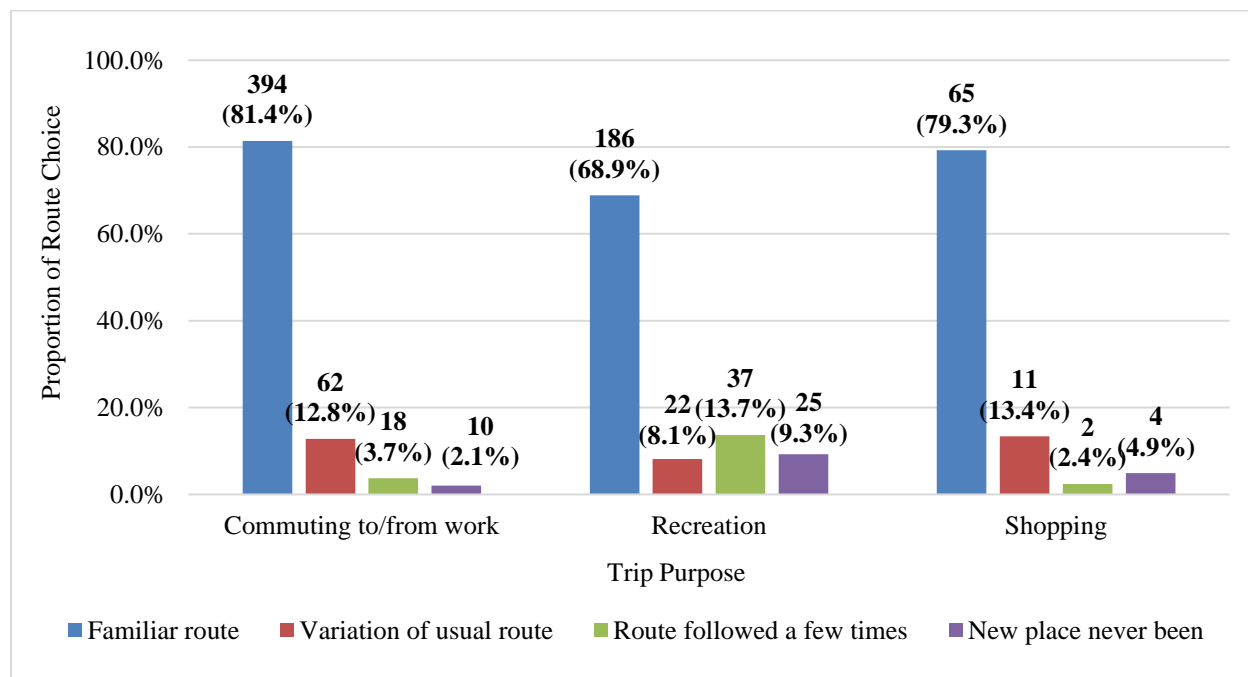

Figure 7-13 Route choice distribution for shopping trips.

Combining all recreation trips, the route choices distributions for three major trip purposes are illustrated in Figure 7-14. As shown, familiar routes were the most favorable choice for all trip purposes and accounted for 81.4% of all commuting trips, 68.9% of all recreation trips, and 79.3% of all shopping trips. Variations of the usual routes were the second most popular route choice for commuting and shopping trips, accounting for 12.8% and 13.4% of all trips, respectively. For recreation trips, routes followed a few times were the second favorite choice and accounted for 13.7% of all recreation trips. Overall, bicyclists were more likely to choose less familiar routes for the purpose of recreation than for commuting and shopping purposes.



Trip Purpose	Familiar Route	Variation of Usual Route	Route Followed a Few Times	New Place Never Been	Total
Commuting to/from work	394	62	18	10	484
Recreation	186	22	37	25	270
Shopping	65	11	2	4	82

Figure 7-14 Route choice distribution by major trip purpose.

Additionally, participants provided valuable descriptive inputs on their route choice preferences regarding traffic safety, travel delay, roadway and intersection features etc., including the following:

- For commuting trips to/from work, participants chose the shortest route that provided either a bike lane or sidewalk. A popular behavior for these participants was to avoid roads without bike lanes, if possible, preferring to use back roads to commute because they did not feel comfortable sharing the road with vehicles. (For instance, several interviewed participants stated that they tried to avoid Bruce B Downs Boulevard with high vehicle speeds in Tampa where there are no bike lanes or sidewalks in certain segments under construction, instead using N 37th Street or N 42nd Street when commuting from their residence to USF. Other intersections avoided included N 56th

Street & E Fletcher Avenue and E Fletcher Avenue & USF Palm Drive due to heavy and fast traffic.)

- Professional cycling training increased bicyclist confidence in using bike lanes. After training, participants noted that they preferred using bike lanes instead of a sidewalk to commute to work.
- If alternative routes were available, most participants considered traffic safety as the first priority when choosing bike routes, but some contrasts were found for experienced bicyclists. Riding experience was also associated with participant occupation; some who worked as delivery persons and spent many riding hours daily in downtown areas preferred the shortest or most time-efficient route during working hours.

7.2.2.6 Assessment of Bicycling Behaviors of Bicyclists with and without Formal Bicycle-riding Training

To evaluate the safety effect of formal bicycle-riding training, seven participants took formal bicycle-riding training classes from CyclingSavvy (<http://cyclingsavvy.org/>). The difference in the proportion of compliance with traffic rules for bicyclists with and without formal bicycle-riding training is illustrated in Figure 7-15.

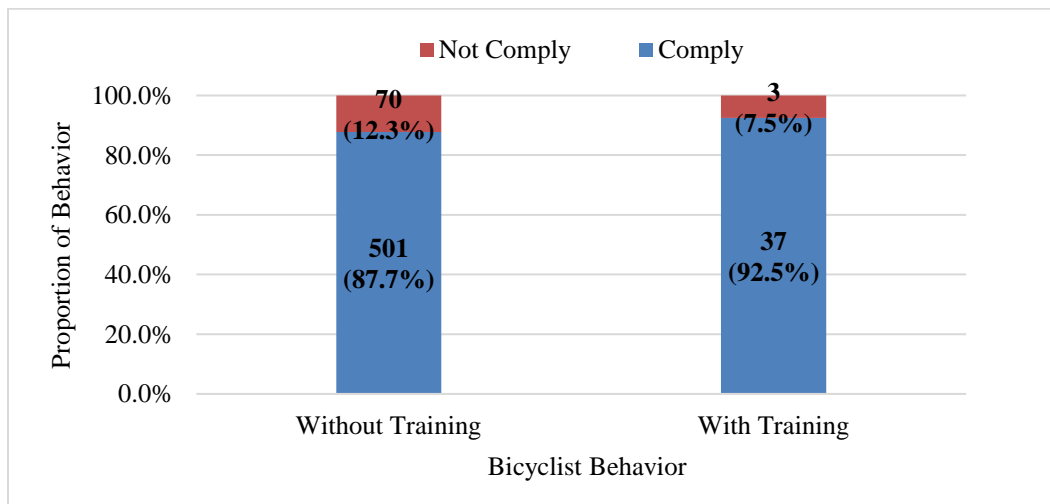

Professional Training	Bicyclist Behavior	Count	Total Counts	Proportion of Behaviors
With Training	Comply	37	40	92.5%
	Not Comply	3		7.5%
Without Training	Comply	501	571	87.7%
	Not Comply	70		12.3%

Figure 7-15 Behavior comparison between bicyclists with and without professional cycling training.

As shown, trained bicyclists had a slightly higher proportion of compliance with general traffic rules and regulations, at 92.5% for all recorded events; those without professional training complied at 87.7%. The proportions of non-compliance were 7.5% for bicyclists with professional training and 12.3% for those without professional training. A significance test revealed that the difference in the proportion of compliance between these two groups was not

significant at a 90% confidence level due to a small sample size for the professional cycling training group.

A further examination of these non-compliant behaviors revealed the following:

- Among the three non-compliance records from bicyclists with CyclingSavvy training, one indicated that the bicyclist turned left while the pedestrian signal indication was “Do Not Walk,” one showed that the bicyclist continued riding while the pedestrian signal was “Do Not Walk,” and one showed that the bicyclist rode against vehicle traffic.
- Among the 70 non-compliance records from bicyclists without CyclingSavvy training, similar to those mentioned in Section 7.2.2.4, most were associated with proceeding through the intersection under a pedestrian “Do Not Walk” signal, and some were associated with riding against traffic.

7.2.2.7 Analyses of Bicycle Crashes or Close Calls and Contributing Factors

1) Crash Analysis

From the collected trip data, only one bicycle crash was recorded, and it was observed and analyzed separately. In this crash, the bicyclist was waiting to turn left across the street but was hit by a vehicle from behind that had tried to overtake the bicyclist from the left but failed to keep a safe distance and caused a clipping crash. The vehicle’s bumper made a contact with the back tire of the bicycle. Three major causes of this crash could be identified through the collected video data:

- It occurred on a two-way road with one lane on each direction, no bike lane or sidewalk, and insufficient roadside space for bicycling, so the bicyclist had to share the road with vehicle traffic.
- There was no mid-block crosswalk to provide the bicyclist with the higher right-of-way for left-turn crossing.
- The driver was impatient and tried to pass at a relatively high speed since the oncoming traffic was about to stop for the bicyclist to turn.

Based on these findings, it was concluded that insufficient bicycling infrastructure and right-of-way and driver violation behavior were two major factors leading to bicyclist crashes.

2) Close Call Analysis

In this pilot study, 22 close calls were observed, including three with turning vehicles and 19 with passing vehicles, accounting for 13.6% and 86.4%, respectively, as shown in Figure 7-16. The distance data between bicyclists and vehicles were collected in the study by the equipped sensors (Table 6-1) and used to help determine close calls. A minimum distance of three feet (91.5 cm) between a bicyclist and a passing vehicle was used to verify close calls between bicyclists and passing vehicles.

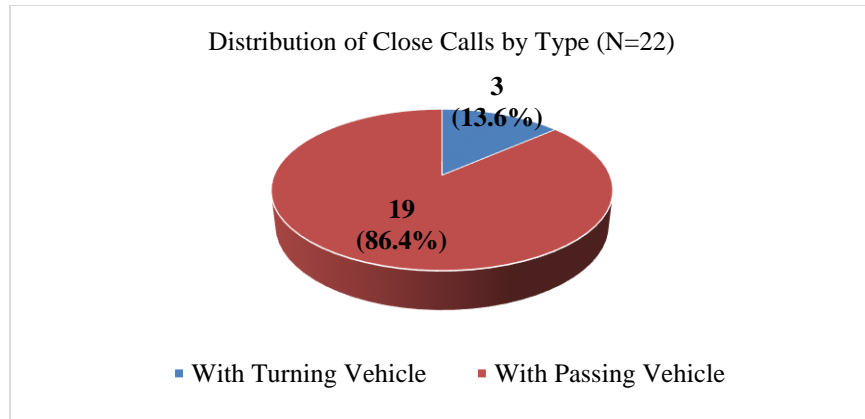
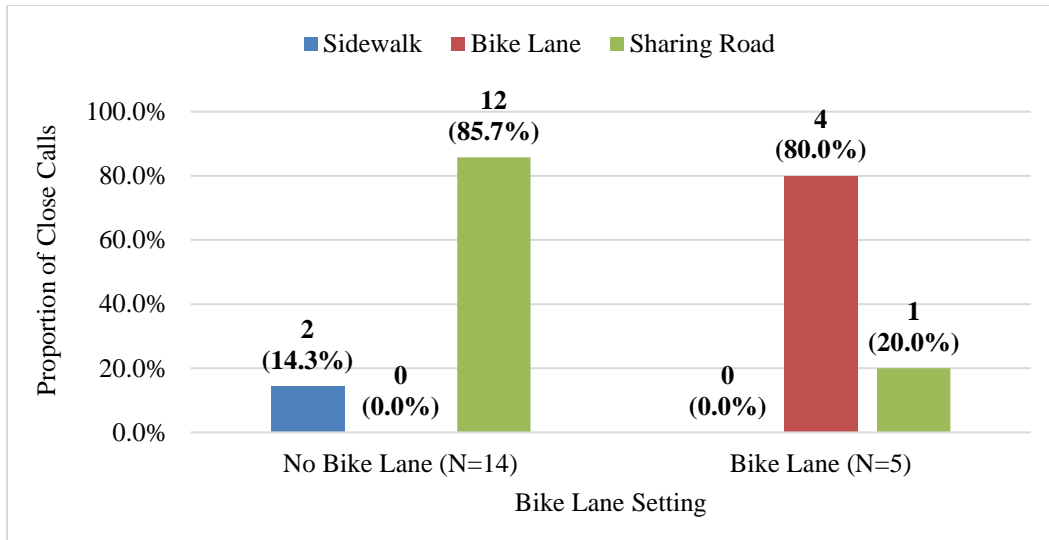

Figure 7-16 Distribution of close calls by type.

All three close calls were associated with right-turning vehicles, with two due to vehicles failing to yield bicyclist right-of-way. Both bicyclists in these two close call events belonged to both the “Low Risk” and “Low Distraction” groups and were without professional cycling training. The other close call was due to the bicyclist’s violation of crossing the intersection under a “Do Not Walk” pedestrian signal (red signal indication), while the vehicle turned right on red legally and almost failed to yield to the bicyclist. The bicyclist crossing the intersection during the “Do Not Walk” pedestrian signal was a young (age 18–25) male bicyclist belonging to both the “High Risk” and “High Distraction” groups and was without professional cycling training.

As noted in Section 7.2.2.2, bicyclists often maintained the same speed when crossing an intersection, rather than slowing down and crossing progressively with caution. This often occurred when bicyclists came from the intersecting roadway or crosswalk or from behind on the right-side bike lane or sidewalk, and drivers were starting to turn. Therefore, it is recommended that professional cycling training courses to emphasize caution when crossing intersections.

Figure 7-17 shows the proportion of close calls with passing vehicles by bike lane setting and bicyclist location. Close calls occurred when there was not a sufficient safety gap between bicyclists with passing vehicles. Among the 19 close calls with passing vehicles, 5 occurred when a bike lane was present and 14 occurred when a bike lane was not available. Among the five close calls with passing vehicles when a bike lane was present, four (80.0%) occurred when the bicyclists rode in the bike lanes and one (20.0%) occurred when the bicyclist rode in the traffic lane even though a bike lane was present. Among the 14 close calls when there was not a bike lane, 85.7% occurred when bicyclists shared the road with vehicle flow, and 14.3% occurred when bicyclists rode on the sidewalk that was next to the traffic lane.



Time	Bike Location			Total
	Sidewalk	Bike Lane	Sharing Road	
No Bike Lane	2	0	12	14
Bike Lane	0	4	1	5

Figure 7-17 Proportion of close calls with passing vehicles by bike lane setting and biking location.

Therefore, it is concluded that:

- The lack of dedicated bike lanes, wider bike lanes, and/or sidewalks is a primary reason for close calls with passing vehicles, where bicyclists have to share the limited road space with vehicle flow.
- In bicycle lane design, sufficient bicycle lane width is beneficial for reducing the risk of close calls with passing vehicles.
- Professional cycling training can boost the confidence of bicyclists using bike lanes and help them better manage their bicycles and keep sufficient lateral distance with passing vehicles.

Due to the limited data observed, the research team did not examine the effect of driver demographic and behavior characteristics on the occurrence of close calls with passing vehicles to avoid any unreliable conclusions. Further data collection with sufficient sample size is desired to extend this analysis.

7.2.2.8 Overall Analysis on Bicyclist Compliant Behavior

Bicyclist compliance patterns were examined regarding bicyclist demographic and behavior factors, including gender, age group, risk group, and distraction group. To accurately evaluate the influence of these factors on bicyclist compliance, records from bicyclists with professional cycling training were not included in the analysis. Detailed analyses are presented as follows.

Figure 7-18 compares bicyclist compliance by gender, showing that male bicyclists had a higher proportion of compliance (90.2%) than female bicyclists (83.9%). The difference in the proportion of compliance between males and females is significant at a 95% confidence level.

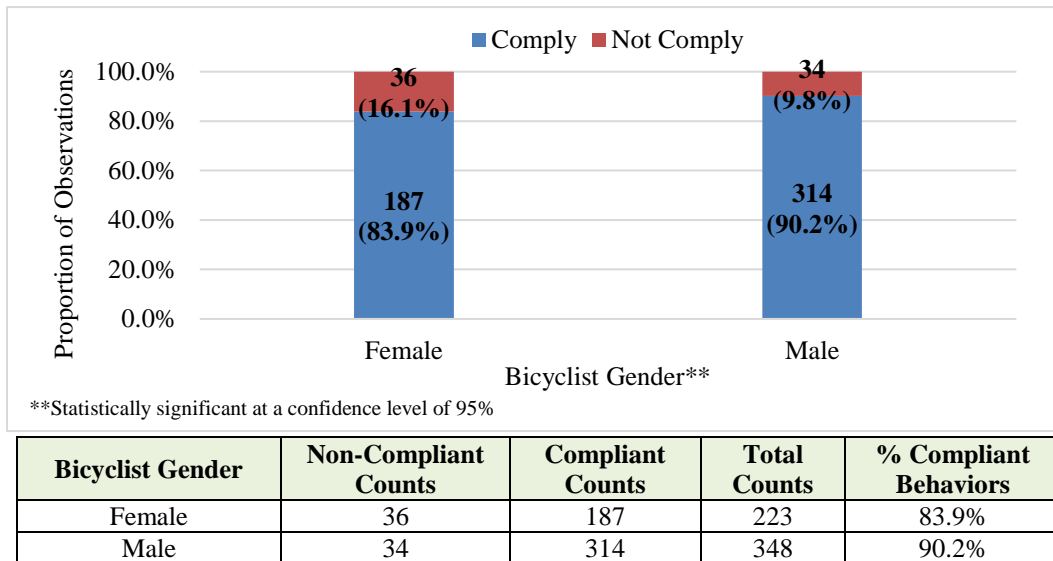

Figure 7-18 Comparison of bicyclist compliance by gender.

Figure 7-19 compares bicyclist compliance by age. Overall, older (age 45+) bicyclists demonstrated the highest proportion of compliance (99.1%), followed by mid-age bicyclists (age 26–45) (89.1%) and younger bicyclists (age 18–25) (80.6%). The largest difference in the proportions of compliance was between older (age 45+) and younger (age 18–25) bicyclists, and this difference was significant at a 95% confidence interval. These results also indicate that older bicyclists are the safest group among all the age groups and younger bicyclists are most likely to perform aggressive bicycling and failing to comply with general traffic rules and regulations.

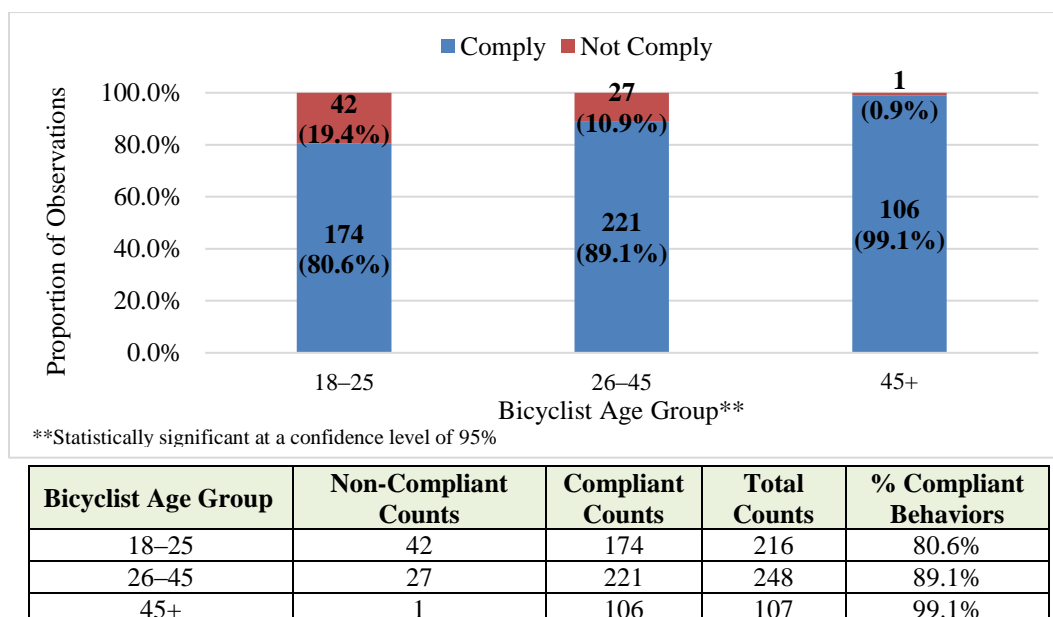

Figure 7-19 Comparison of bicyclist compliance by age.

To link subjective risk and distraction to objective behavior observations, compliant behaviors were compared by risk and distraction levels. Figure 7-20 compares bicyclist compliance by risk group and shows that bicyclists in the “Low Risk” (88.2%) group were more likely to comply with general traffic rules and regulations than those in the “High Risk” group (80.6%), which is reasonable. Due to the limited number of non-compliance records for “High Risk” bicyclists, a valid significance test could not be conducted.

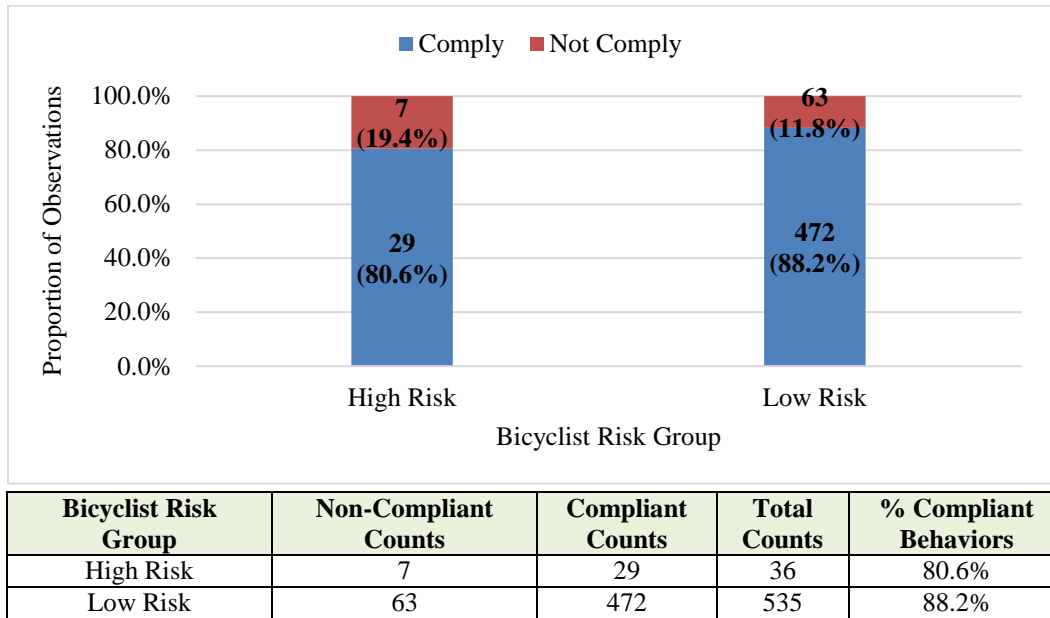
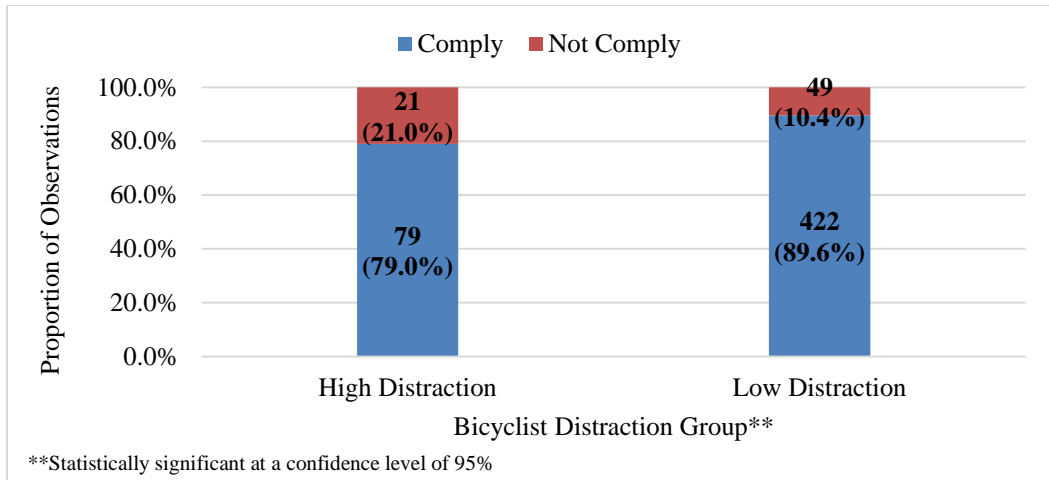

Figure 7-20 Comparison of bicyclist compliance by risk group.

Figure 7-21 compares bicyclist compliance by distraction group and shows that bicyclists in the “Low Distraction” (89.6%) group were more likely to comply with general traffic rules than those in the “High Distraction” group (79.0%), which is also reasonable. The difference in the proportions of bicyclist compliance between the “High Distraction” and “Low Distraction” groups was significant at a 95% confidence level.



Bicyclist Risk Group	Non-Compliant Counts	Compliant Counts	Total Counts	% Compliant Behaviors
High Distraction	21	79	100	79.0%
Low Distraction	49	422	471	89.6%

Figure 7-21 Comparison of bicyclist compliance by distraction group.

8. RESEARCH FINDINGS, RECOMMENDATIONS OF COUNTERMEASURES, AND CONCLUSIONS

Based on the analysis results, the research findings and recommendations of countermeasures from this naturalistic bicycling behavior pilot study are provided in this chapter. It should be noted that, given limited samples for certain bicyclist demographic and behavior characteristics (i.e., young bicyclists involved in close calls, bike lane setting and biking locations, etc.), these results provide excellent insight into bicycling behaviors and the interactions between bicyclists and vehicles, but they do not necessarily cover all of bicyclist behaviors and interactions; as such, it is desired to further fine-tune these results based on larger datasets.

8.1 Research Findings on Bicyclist Behaviors

- **Bicyclist risky and distractive behaviors by gender** – Based on self-evaluation, more female bicyclists than male bicyclists were classified into the groups of “High Risk” (26.7% vs. 20.0%) and “High Distraction” (33.3% vs. 15.0%). The differences were significant at a 95% confidence level regarding both risk and distraction.
- **Bicyclist risky and distractive behaviors by age** – Younger bicyclists (age 18–25) took significantly more risks than those in age groups 26–45 and 45+; younger bicyclists (age 18–25) were also significantly more likely to be distracted than mid-age bicyclists (age 26–45) and older bicyclists (age 45+). No older bicyclist (age 45+) were identified as “High Risk” or “High Distraction,” making them the safest group among all age groups. The differences were significant for risk and distraction at a 95% confidence level.
- **Bicyclist compliance in daytime/nighttime** – The proportion of compliance with general traffic rules for bicyclists was 88.1% in daytime and 87.5% in nighttime, indicating that bicyclists showed similar patterns to comply with the general traffic rules. The proportion difference was not significant at a 90% confidence interval.
- **Bicyclist behaviors in daytime/nighttime by biking location** – Based on biking location distribution, bicyclists were more conservative and stayed in their right-of-way and in safe locations under nighttime conditions; in the daytime, bicyclists were relatively more aggressive and tended to violate pedestrian signals if they had good visibility and clear distance from potential collisions.
- **Bicyclist light and reflective item use in nighttime riding** – Examination of bicycle light and reflective item usage at night revealed that the majority of participants had good awareness of safe riding at night with bicycle lights on and wearing or equipping bicycles with reflective items to increase visibility.
- **Bicyclist route choice preference by trip purpose (given origin and destination)** – Familiar routes were the most favored for all trip purposes and accounted for 81.4% of all commuting trips, 68.9% of all recreation trips, and 79.3% of all shopping trips. In general, bicyclists were more likely to choose less familiar routes for the purpose of recreation than for commuting and shopping purposes.
- **Safety influence of professional cycling training** – The proportion of non-compliance was 7.5% for bicyclists with professional training and 12.3% for those without professional training, indicating that professional training increased bicyclist compliance. This difference was not significant at a 90% confidence level. Professional cycling training could boost the confidence of bicyclists using bike lanes and help them better manage riding in bike lanes.

- **Bicyclist compliance by gender and age** – Male bicyclists showed a higher proportion of compliance than female bicyclists, and the difference was significant at a 95% confidence level. Older bicyclists demonstrated the highest proportion of compliance, followed by mid-age bicyclists and younger bicyclists. The proportion difference between older and younger bicyclists was also significant at a 95% confidence level.
- **Bicyclist compliance by risk and distraction groups** – Bicyclists in the “Low Risk” group were more likely to comply with general traffic rules than those in the “High Risk” group, but the difference was not found to be significant due to a small sample size. Bicyclists in the “Low Distraction” group were more likely to comply with general traffic rules than those in the “High Distraction” group, and this difference was significant at a 95% confidence level.

8.2 Research Findings on Interactions between Bicyclists and Drivers

- **Interactions between bicyclists and turning vehicles** – Young bicyclists were more likely to get involved in close calls or conduct non-compliant behavior when interacting with turning vehicles. It was found in all turning-vehicle observations that at-fault bicyclist non-compliant or risky behavior and close calls were both associated with young bicyclists.
- **Close call analysis between bicyclists and turning vehicles** – Three close calls were found between bicyclists and right-turning vehicles; no close calls were observed between bicyclists and left-turning vehicles. In these close calls, 66.7% were due to vehicles failing to yield bicyclist right-of-way, and 33.3% were due to the bicyclist crossing the intersection during a “Do Not Walk” pedestrian signal.
- **Driver compliance analysis in interacting with bicyclists in daytime and nighttime** – The proportion of compliance for observed drivers was 85.8% in daytime, and the major driver non-compliance was failing to yield to bicyclist right-of-way. In nighttime, participants reported based on their experience that drivers were very likely to fail to yield to bicyclists due to limited visibility. Given the limited observations for drivers during nighttime in this study, no conclusions could be drawn.
- **Close call analysis between bicyclists and passing vehicles** – The lack of dedicated bike lanes, wider bike lanes, and/or sidewalks is the main reason for close calls with passing vehicles, and sufficient bicycle lane width is necessary to reduce close call risk with passing vehicles.

8.3 Recommendations on Implementable Countermeasures

The research findings from this pilot study resulted in the identification of implementable safety improvements that could be considered to put into practice to significantly improve bicyclist safety. The potential implementable countermeasures in education, engineering, and enforcement are recommended as follows.

8.3.1 Education Countermeasures

- **Conduct educational outreach to young bicyclists to improve their safe bicycling behavior** – Young bicyclists (age 18–25) exhibit riskier and more distracted behaviors than bicyclists in other age groups, and both non-compliant bicyclists in close calls with a right-turning vehicle and risky bicyclists in interactions with left-turning vehicles were young bicyclists. Additionally, young bicyclists show the highest proportion of non-

compliance among all age groups. Educational efforts should focus on young bicyclists to improve their safe bicycling behavior.

- **Conduct educational outreach to female bicyclists to improve their safe bicycling behavior** – Female bicyclists tend to take more risks and are more distracted than male bicyclists, and female bicyclists exhibit a higher proportion of non-compliance than males. Therefore, educational efforts should focus on female bicyclists to improve their safe and compliant bicycling behavior.
- **Encourage professional cycling training to improve bicyclist riding control and safety** – Bicyclists with professional cycling training demonstrate a higher proportion of compliant behavior than those without, and professional training could increase bicyclist confidence in using bike lanes and help them better manage riding within a bike lane. Hence, professional cycling training (such as cone-weave training, city tour of intimidating road features, etc.) should be encouraged among bicyclists to improve bicycling safety. Photos of example CyclingSavvy training courses are shown in Figure 8-1.



Figure 8-1 Example CyclingSavvy training courses:
(left) cone-weave training, (right) city tour of intimidating road features for riding.

- **Conduct educational outreach to bicyclists regarding passing through intersections with caution** – From video observations in this pilot study, bicyclists often maintained the same speed when crossing an intersection rather than slowing down and crossing progressively with caution. This often occurred when bicyclists came from an intersecting roadway or from behind on a right-side bike lane or sidewalk and drivers were starting to make right turns. Educational outreach should focus on educating bicyclists to pass through intersections with caution.
- **Conduct educational outreach to drivers to enhance yielding behaviors at intersections** – This pilot study showed that most drivers at fault or in close calls with bicyclists at signalized intersections did not yield to bicyclists when making turns. Educational efforts for drivers should focus on traffic rules and laws with respect to interactions between drivers and bicyclists, especially on yielding to bicyclists when they make right or left turns at intersections.
- **Conduct educational outreach to drivers to keep safe distances from bicyclists when passing or overtaking them** – Most close calls in this study between bicyclists and vehicles occurred when vehicles passed bicyclists without keeping safe distances. When passing bicycles, drivers should allow adequate space to avoid sideswiping bicyclists or

causing them to overcorrect to avoid a vehicle. According to Florida Statutes 316.083, “The driver of a vehicle overtaking a bicycle or other nonmotorized vehicle must pass the bicycle or other nonmotorized vehicle at a safe distance of not less than 3 feet between the vehicle and the bicycle or other nonmotorized vehicle.” It is essential to educate drivers on the importance of keeping safe distances when passing or overtaking a bicycle.

- **Conduct educational outreach on reflective equipment use** – Although the majority of participants showed good awareness of safe riding by using reflective equipment (clothing or bicycle equipment), as shown in Figure 8-2, a considerable number did not use reflective equipment as a routine. Educational efforts are recommended to increase the use of reflective equipment among bicyclists to increase riding safety.

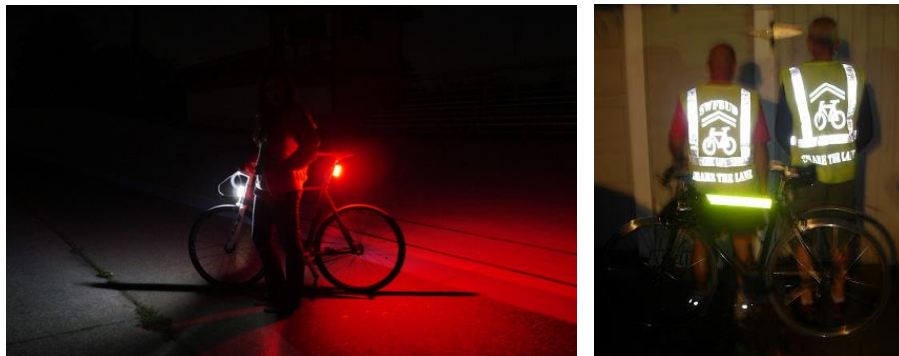

Figure 8-2 Reflective bicycle equipment and clothing.

8.3.2 Engineering Countermeasures

- **Establish through bike lanes to reduce conflicts between bicyclists and turning vehicles at intersections** – Bicyclists were likely to get involved in conflicts or close calls with turning vehicles when approaching or at intersections. According to the *NACTO Urban Bikeway Design Guide* [10] and the *Florida Intersection Design Guide 2015* [11], through bike lanes could provide bicyclists with guidance to follow their preferred path and alert vehicles to expect to yield to bicyclist right-of-way. Therefore, it is recommended to add through bike lanes to reduce conflict potential between bicyclists and turning vehicles at signalized intersections. Figure 8-3 shows the implementation of a through bike lane on eastbound Fletcher Avenue approaching the Fletcher & Bruce B Downs intersection in Tampa, Florida.



Figure 8-3 Implementation of through bike lane at intersection.

- Add bike lane, increase bike lane width, implement buffer bike lanes, and/or build protected cycle tracks on roads with bicycle volume** – Most close calls between bicyclists and passing vehicles occur where there is no bike lane and sidewalk and bicyclists must share the road with vehicle traffic flow, or where the bike lane is not sufficiently wide and bicyclists lack confidence to ride safely within it. Additionally, it is understandable that a wide vehicle lane could encourage drivers to speed, which increases the risk of colliding with nearby bicyclists. Therefore, it is necessary to add bike lanes on roadways with bicycle volume, such as buffered bike lanes or protected cycle tracks, and to maintain sufficient bike lane width to boost the confidence of bicyclists in using bike lanes. Traffic engineers, managers, or decision-makers should consider “borrowing” space from wide vehicle lanes to increase bike lane width, reduce vehicle speeding potential, and maintain the safety distances between bicyclists and passing vehicles. Figure 8-4 shows a series of examples of bike lane implementation to increase bicyclist safety.





Figure 8-4 Bike lane implementations in Florida to improve bicyclist safety – (upper left) buffered bike lane, (upper right) protected cycle track with median, (lower left) protected cycle track with pole separation, (lower right), protected cycle track with green-colored bike lanes.

- **Apply reflective green-colored pavement markings on existing and new bike lanes –** Colored pavement within a bicycle lane could increase the visibility of the facility, identify potential areas of conflict, and reinforce bicyclist right-of-way. Reflective green-colored pavement markings should be added to existing and new bike lanes to provide additional safety for bicyclists, especially during nighttime. Figure 8-5 shows the implementation of reflective green-colored bike lanes in West Palm Beach, Tampa, Tallahassee, and Miami Beach, Florida.

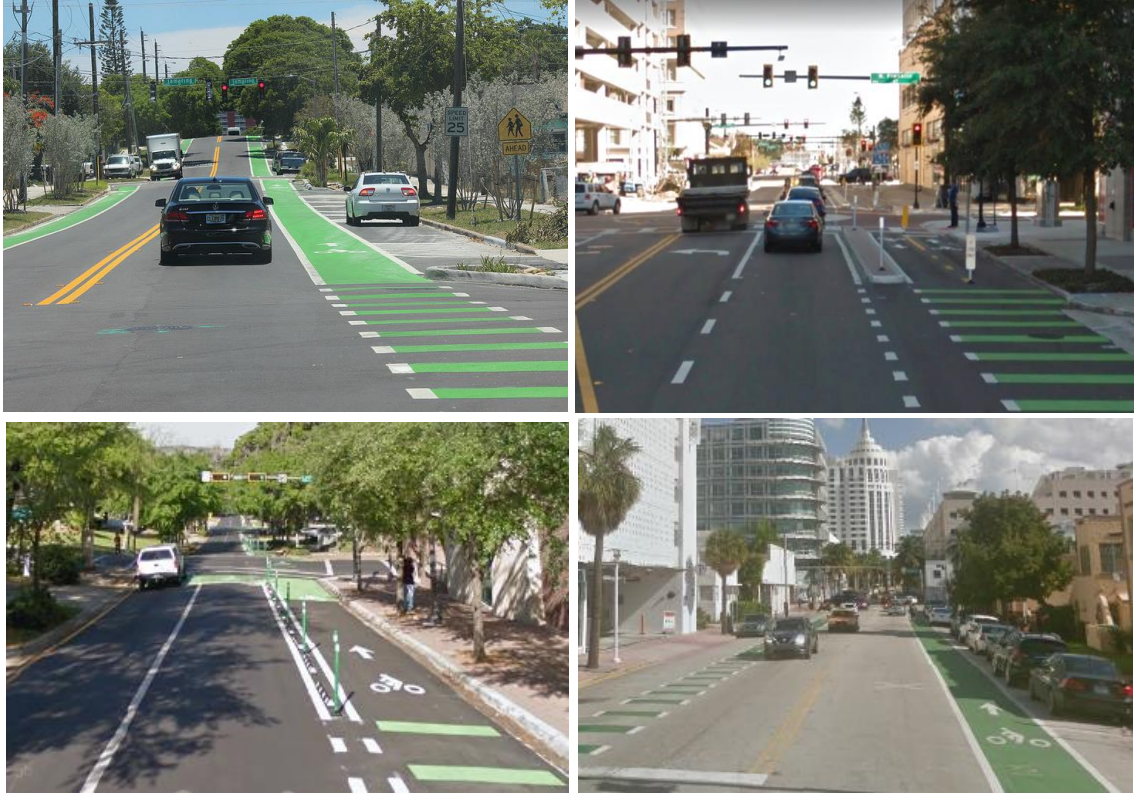

Figure 8-5 Green-colored bike lane in West Palm Beach (*upper left*), Tampa (*upper right*), Tallahassee (*lower left*) and Miami Beach (*lower right*).

- **Improve lighting conditions on roads with bicycle volume** – Bicyclists have increased potential of being hit on roadways where the lighting condition is inferior, even though the majority of the study participants had good awareness of nighttime riding safety. Therefore, it is recommended to increase the lighting conditions on roadways with bicycle volume. Figure 8-6 shows the contrast of bicycling at night with and without sufficient street lighting.



Figure 8-6 Night biking with and without street lighting – with sufficient lighting (*left*) and without lighting (*right*).

8.3.3 Enforcement Countermeasures

- Conduct three-stage high-visibility enforcement (HVE) for both drivers and bicyclists with the focus on education** – The research findings from this pilot study indicate that drivers not yielding to bicyclists at intersections when making turns and not keeping safe distances from bicyclists when passing or overtaking them were the two major safety concerns to the safety of bicyclists. It was also found that drivers were very likely to fail to yield to bicyclists due to limited visibility at nighttime for roads without street lighting or proper lighting levels, so bicycle lights, reflective equipment, and reflective clothing are crucial for bicycle safety at night. Florida Statutes Sec. 316.2065 regulates required lighting on Florida bicycles used at night, requiring that bikes ridden at night have a light visible from 500 feet from the front and 600 feet from the back. Therefore, three-stage enforcement efforts, including education, warnings, and citations, are recommended to improve driver yielding behaviors at intersections and keep safe distances from bicyclists when passing or overtaking them and to increase the use of bike lights in nighttime riding. The focus of this three-stage enforcement for both drivers and bicyclists should be on education, not citation [12].

Table 8-1 summarizes the research outputs and corresponding countermeasures from the education, engineering, and enforcement perspectives.

Table 8-1 Summary of Education, Engineering, and Enforcement Countermeasures

Outputs	Countermeasures	
	Type	Actions
<ul style="list-style-type: none"> • More female bicyclists than male bicyclists were classified into “High Risk” (26.7% vs. 20.0%) and “High Distraction” (33.3% vs. 15.0%) groups. • Male bicyclists showed a higher proportion of compliance than female bicyclists. • Younger bicyclists (age 18–25) showed the lowest proportion of compliance than those in age groups 26–45 and 45+. • Young bicyclists were most likely to be involved in close calls or conduct non-compliant behavior when interacting with turning vehicles. • The proportion of non-compliance was 7.5% for bicyclists with professional training and 12.3% for those without professional training. • Bicyclists maintained the same speeds when crossing intersections but caution was needed. • Most drivers at fault or in close calls with bicyclists at signalized intersections did not yield to bicyclists when making turns. 	Education Countermeasures	a. Educational outreach to young bicyclists
		b. Educational outreach to female bicyclists
		c. Encouragement of professional cycling training on biking control and safety
		d. Educational outreach to bicyclists to pass through intersections with caution
		e. Educational outreach to drivers to enhance yielding behavior
		f. Educational outreach to drivers to keep safe distances from bicyclists when passing

<ul style="list-style-type: none"> • Most close calls in this pilot study between bicyclists and vehicles occurred when vehicles passed bicyclists without keeping safe distances from the bicyclists. • A considerable number of study participants did not use reflective equipment as a routine. 		<p>g. Educational outreach to bicyclists on reflective equipment use</p>
<ul style="list-style-type: none"> • Most drivers at fault or in close calls with bicyclists at signalized intersections did not yield to bicyclists when making turns. • Proportion of compliance for observed drivers was 85.8% in daytime; major driver non-compliance was failing to yield to bicyclist. • Most close calls between bicyclists and vehicles occurred when vehicles passed bicyclists without keeping safe distances from bicyclists. • Lack of dedicated bike lanes, wider bike lanes, and/or sidewalks was main reason for close calls with passing vehicles. • At nighttime, drivers were very likely to fail to yield to bicyclists due to limited visibility. 	<p>Engineering Countermeasures</p>	<p>a. Establishment of through bike lanes at intersections</p>
		<p>b. Implementation of wider bike lanes, buffered bike lanes, and protected cycle tracks</p>
		<p>c. Application of reflective green-colored bike lanes</p>
		<p>d. Improvement of lighting conditions on roads with bicycle volume</p>
<ul style="list-style-type: none"> • Major concerns of bicyclist safety were non-yielding behaviors at intersections and passing bicyclists without keeping safe distance. • At nighttime, drivers were very likely to fail to yield to bicyclists due to limited visibility. • Although most participants were aware of safe riding by using reflective equipment and clothing, many did not use it as a routine while riding at night. 	<p>Enforcement Countermeasures</p>	<p>a. Three-stage high-visibility enforcement on drivers and bicyclists with focus on education</p>

8.4 Lessons Learned

This pilot study provided an opportunity to collect data on bicyclist behavior and interactions with drivers on Florida roads. The data collection equipment was specifically designed for maximum data collection. Being a pilot, the research team encountered several challenges that were solved but that could be enhanced in the future for additional work or for other teams. A summary of the most important lessons is provided below.

8.4.1 Participant Recruitment

- Recruiting participants was a big challenge in this pilot study. It is recommended that the recruitment of participants start early, at least two months before they are needed.
- In general, the team found older (age 45+) participants were the most difficult to recruit. Since no data on bicyclist population was available, there was no method for comparison to the sample population. The study aimed to collect even data among general age group/gender cohorts. For the highest recruiting return, it is important to understand the study targets with each recruiting method, so that areas of exposure are selected based on the interests and underlying motivations of that population.

8.4.2 Installation of Equipment

- It is important to keep participants informed about delays that might occur during the installation process. In general, participants were cooperative and accommodating when problems arose. The equipment installed was fairly simple and required little time to install (generally less than one hour).
- Having an internal (local) database to track information (including participant call records, consent form versions, appointment history, and participant contact information), proved to be an essential tool.
- It was beneficial to collect all information needed to determine eligibility, including a photo of the bicycle intended for use before the appointment. The team used a screening questionnaire on the recruitment website to identify ineligible participants or less-than-ideal bicycles.

8.4.3 Participant Management

- Participants moved and changed phone numbers with surprising frequency. It was helpful to check on current addresses and phone numbers when scheduling appointments.
- Text messaging and e-mailing were helpful for scheduling younger participants.
- Several student participants took a break in the summer time between semesters. Even though the team made it a point to ask and identify the participants' plans for travel, some did not convey those, resulting in some participants running out of battery and storage and not being able to return for equipment maintenance in a timely manner. Since the number of BDAS was limited, some equipment was not being used optimally.
- The incentive was given in installments, with the majority (70%) provided at the end of the study when equipment was returned. Since this return was essential for data retrieval, this method incentivized most participants to complete the study and return the equipment.

8.4.4 Equipment Management

- The equipment was bench-tested prior to each installation. Kits were assembled, including all components ready for installation. This was essential in reducing the time spent to troubleshoot issues during installations.
- All retrieved equipment was re-tested, and malfunctioning components were changed with enough frequency to have ready-to-use kits available. However, due to a limited number of kits, during certain periods there were more participants available than kits ready.

- Although the equipment was tested, it is important to have a testing protocol after installation to ensure/validate correct placement and data collection so the collected data are representative of the data needed.

8.4.5 Study Management

- It is important for processes to be flexible to accommodate changing scenarios. Although the study was planned in detail, certain aspects had to be modified and adapted because of changing conditions. This was encountered during the development of the equipment, and during the recruitment/installation of the equipment.
- For a large study of this kind, multiple checks of the processes and data should be conducted at frequent intervals so errors are captured and resolved in a timely manner and subsequent data is corrected.

8.5 Conclusions

This pilot study sponsored by FDOT was one of the largest naturalistic bicycling behavior studies in the U.S., with 100 participants recruited. The project team successfully designed, developed, and produced bicycle data acquisition systems to conduct comprehensive data collection for qualitative and quantitative analyses of bicyclist behaviors and the interactions between bicyclists and drivers.

Results of the study provided valuable insight in the following six areas: (1) understanding behavior, experience, and interactions between bicyclists and drivers making right turns at intersections (right hook); (2) understanding behavior, experience, and interactions between bicyclists and drivers making left turns at intersections (left hook); (3) understanding behavior, experience, and interactions between bicyclists and drivers at night; (4) understanding bicyclist route-choice decisions with given origins and destinations; (5) assessing bicycling behaviors of bicyclists with and without formal bicycle-riding training; and (6) analyzing bicycle crashes or close calls and determining their contributing factors. The data analysis also showed the effects of age, gender, and self-reported risk and distraction proneness on bicycling behaviors and interactions with vehicles.

Based on the research findings from the pilot study, the project team recommended implementable countermeasures in education, engineering, and enforcement to significantly improve bicycle safety. This pilot study also built the foundation for other bicycle-related research and will benefit future large-scale naturalistic bicycling behavior studies.

REFERENCES

- [1] I. Walker, “Drivers Overtaking Bicyclists: Objective Data on the Effects of Riding Position, Helmet Use, Vehicle Type and Apparent Gender,” *Accident Analysis and Prevention*, vol. 39, no. 2, pp. 417–425, Mar. 2007.
- [2] J. Parkin and C. Meyers, “The Effect of Cycle Lanes on the Proximity Between Motor Traffic and Cycle Traffic,” *Accident Analysis and Prevention*, vol. 42, no. 1, pp. 159–165, Jan. 2010.
- [3] J. Chapman and D. Noyce, “Observations of Driver Behavior During Overtaking of Bicycles on Rural Roads,” *Transportation Research Record: Journal of the Transportation Research Board*, vol. 2321, pp. 38–45, Dec. 2012.
- [4] K.-H. Chuang, C.-C. Hsu, C.-H. Lai, J.-L. Doong, and M.-C. Jeng, “The Use of a Quasi-Naturalistic Riding Method to Investigate Bicyclists’ Behaviors When Motorists Pass,” *Accident Analysis and Prevention*, vol. 56, pp. 32–41, Jul. 2013.
- [5] M. Johnson, J. Charlton, J. Oxley, and S. Newstead, “Naturalistic Cycling Study: Identifying Risk Factors for On-road Commuter Cyclists,” *Annals of advances in automotive medicine. Association for the Advancement of Automotive Medicine. Annual Scientific Conference*, vol. 54, pp. 275–283, 2010.
- [6] M. Dozza, J. Werneke, and A. Fernandes, “Piloting the Naturalistic Methodology on Bicycles,” in *International Cycling Safety Conference 2012*, 2012.
- [7] L. Gustafsson and J. Archer, “A Naturalistic Study of Commuter Cyclists in the Greater Stockholm Area,” *Accident Analysis and Prevention*, vol. 58, pp. 286–298, Sep. 2013.
- [8] M. Dozza and J. Werneke, “Introducing Naturalistic Cycling Data: What Factors Influence Bicyclists’ Safety in the Real World?,” *Transportation Research Part F: Traffic Psychology and Behaviour*, vol. 24, pp. 83–91, May 2014.
- [9] M. Dozza and A. Fernandez, “Understanding Bicycle Dynamics and Cyclist Behavior From Naturalistic Field Data,” *IEEE Transactions on Intelligent Transportation Systems*, vol. 15, no. 1, pp. 376–384, Feb. 2014.
- [10] National Association of City Transportation Officials, *NACTO Urban Bikeway Design Guide*. New York, NY: NACTO, 2011.
- [11] Florida Department of Transportation Roadway Design Office, *Florida Intersection Design Guide 2015*. Tallahassee, FL: Florida Department of Transportation, 2015.
- [12] Florida Legislature, *2017 Florida Statutes Sec. 316.2065: Bicycle Regulations*. USA, 2017.

APPENDIX A – INFORMED CONSENT FORM

Study ID:CR1_Pro00020434 Date Approved: 4/9/2016 Expiration Date: 4/9/2017



Informed Consent to Participate in Research Information to Consider Before Taking Part in this Research Study

IRB Study # Pro00020434

You are being asked to take part in a research study. Research studies include only people who choose to take part. This document is called an informed consent form. Please read this information carefully and take your time making your decision. Ask the researcher or study staff to discuss this consent form with you, please ask him/her to explain any words or information you do not clearly understand. We encourage you to talk with your family and friends before you decide to take part in this research study. The nature of the study, risks, inconveniences, discomforts, and other important information about the study are listed below.

We are asking you to take part in a research study called: **Naturalistic Bicycle Study**

The person who is in charge of this research study is Dr. Pei-Sung Lin. This person is called the Principal Investigator. However, other research staff may be involved and can act on behalf of the person in charge.

The research will be conducted at the Center for Urban Transportation Research at the University of South Florida.

This research is being sponsored by the Florida Department of Transportation.

Purpose of the study

The purpose of this study is to:

- Collect naturalistic bicycling data and conduct analysis to better understand the reasons behind bicycle-vehicle crashes, how bicyclists interact with drivers, how they choose their routes, and what they do in case of a near-miss incident.

Study Procedures

If you take part in this study, you will be asked to:

- Spend approximately one hour in the initial setup for the study during which you will be asked to answer questions on your bicycling habits, experience and travel patterns. You will also be asked basic demographic information (age, gender, education).
- During this first hour, a device called the Bicycle Data Acquisition System will be installed on your bicycle to collect the data.
- The device will record data when the bicycle moves automatically and it will shut off when the bicycle is idle.

- If you own a smartphone, you will be asked to use an application to answer 5-6 questions at the end of each ride (trip) and log your ride.
- You are expected to provide a total of 30-35 hrs of riding in an estimated 2-3 month period.
- During this period, it is expected that the researchers may have to contact you to collect the data from the device and change storage card. Also if the system reports a problem, you will be contacted to change the system. The study staff will visit you at your convenience to perform these procedures or you may come to the CUTR lab at USF.
- The device will record video (forward, backward) of the road, audio of you and the ambient noise, temperature, light level, GPS coordinates, acceleration, G-forces and distance between your bicycle and other objects up to a 15 feet in all directions (front, back, left, right).
- The data will be stored in the device until retrieval. The GPS coordinates, and audio can be identifiable to your person. The data will be secured and encrypted for your protection.
- The data will be kept in a secure database stored at CUTR at USF. Access will be provided to only qualified researchers who are approved to work with the data.
- Any data collected during this study that personally identifies you or that could be used to personally identify you will be treated with confidentiality. As soon as you begin participating in this study, your name and other identifying information will be separated from the raw data collected while you ride your bicycle and replaced with a number. That is, your raw data will not be attached to your name, but rather to a number (for example, Bicyclist 0011). The raw data collected while you ride will be encrypted (made unreadable) from the moment it is collected until it is transferred to one or more secure central storage location. Your name also will be separated from any data about you, either provided by you in response to questionnaires or gathered by researchers during the study and will be replaced by the same driver number (for example, Bicyclist 0011).

Total Number of Participants

About 130 individuals will take part in this study at USF.

Alternatives

You do not have to participate in this research study.

Benefits

While there are no direct benefits to you from this research, you may find this study interesting. No promise or guarantee of benefits is being made to encourage your participation. Participation will help to improve the body of knowledge regarding riding behavior and safety and interaction with drivers. Participation may also help us design safer roadways in future years and/or policies towards improving bicycle safety.

Risks or Discomfort

This research is considered to be minimal risk. That means that the risks associated with this study are the same as what you face every day while you ride your bicycle. There are no known additional risks to those who take part in this study.

Compensation

You will be paid a total of \$100 if you complete all the scheduled study visits and provide the minimum hours of data (30-35 hrs). The compensation will be provided in the form of 2 payments. The first payment will be \$30 given at the time of installation for the initial setup. The second payment of up to \$70 will be provided at the end recording the 30-35 hours of riding and return of the equipment. In the situation where you do not provide the 30-35 hours of data, a prorated amount will be provided based on the following schedule: \$20 for every 10 hours, and extra \$10 for return of the equipment. The number of hours will always be rounded up.

Cost

There will be no additional costs to you as a result of being in this study.

Privacy and Confidentiality

We will keep your study records private and confidential. Certain people may need to see your study records. By law, anyone who looks at your records must keep them completely confidential. The only people who will be allowed to see these records are:

- The research team, including the Principal Investigator, study coordinator, and all other research staff.
- Certain government and university people who need to know more about the study. For example, individuals who provide oversight on this study may need to look at your records. This is done to make sure that we are doing the study in the right way. They also need to make sure that we are protecting your rights and your safety.
- Any agency of the federal, state, or local government that regulates this research. This includes the Department of Health and Human Services (DHHS) and the Office for Human Research Protection (OHRP).
- The USF Institutional Review Board (IRB) and its related staff who have oversight responsibilities for this study, staff in the USF Office of Research and Innovation, USF Division of Research Integrity and Compliance, and other USF offices who oversee this research.
- The sponsors of this study and contract research organization: Florida Department of Transportation.

We may publish what we learn from this study. If we do, we will not include your name. We will not publish anything that would let people know who you are.

Voluntary Participation / Withdrawal

You should only take part in this study if you want to volunteer. You should not feel that there is any pressure to take part in the study. You are free to participate in this research or withdraw at any time.

You can get the answers to your questions, concerns, or complaints

If you have any questions, concerns or complaints about this study, or experience an adverse event or unanticipated problem, call Dr. Pei-Sung Lin at 813-974-4910.

If you have questions about your rights as a participant in this study, general questions, or have

complaints, concerns or issues you want to discuss with someone outside the research, call the USF IRB at (813) 974-5638.

Consent to Take Part in this Research Study

It is up to you to decide whether you want to take part in this study. If you want to take part, please sign the form, if the following statements are true.

I freely give my consent to take part in this study and authorize that my bicycle riding information as agreed above, be collected/disclosed in this study. I understand that by signing this form I am agreeing to take part in research. I have received a copy of this form to take with me.

Signature of Person Taking Part in Study

Date

Printed Name of Person Taking Part in Study

Statement of Person Obtaining Informed Consent

I have carefully explained to the person taking part in the study what he or she can expect from their participation. I hereby certify that when this person signs this form, to the best of my knowledge, he/she understands:

- What the study is about;
- What procedures and devices will be used;
- What the potential benefits might be; and
- What the known risks might be.

I can confirm that this research subject speaks the language that was used to explain this research and is receiving an informed consent form in the appropriate language. Additionally, this subject reads well enough to understand this document or, if not, this person is able to hear and understand when the form is read to him or her. This subject does not have a medical/psychological problem that would compromise comprehension and therefore makes it hard to understand what is being explained and can, therefore, give legally effective informed consent. This subject is not under any type of anesthesia or analgesic that may cloud their judgment or make it hard to understand what is being explained and, therefore, can be considered competent to give informed consent.

Signature of Person Obtaining Informed Consent

Date

Printed Name of Person Obtaining Informed Consent

APPENDIX B – RECRUITMENT FLYERS



We want you (and your friends)...

To allow a low profile data collection system to be installed on your bicycle for up to 3 months.

Because...

Understanding how people ride and interact with drivers and the road, will lead to safer roadways and training programs.

Why should I participate?

You get to know that you have helped improve bicycle safety. In 2013 6,969 bicycle crashes resulted in 6,520 injuries, an increase of 8% from 2012 and 135 deaths, an increase of 16% from 2012.

We realize you will have to take time out of your life to participate so there is compensation of \$100 for study completion.

What will you do to my bicycle?

We will install instruments that will collect video, audio and other data for each ride. There will be no permanent damage to your bicycle.

Am I eligible?

You are eligible if you:

- Are 18 and older,
- Have a bicycle and ride for commute or recreation
- Ride a minimum of 3-4 hrs a week
- Are able to read and complete questionnaires
- Live in the greater Tampa Bay area

What do I have to do?

Go to www.BicycleStudy.org for more information or call **813-974-6833**. We will schedule an appointment for you to answer some questionnaires and get the data collection system installed on your bicycle. The process takes about 1 hour. Then you just have to let our techs visit you once a month to collect the data from your bicycle.

Data kept confidential. IRB# Pro00020434

www.BicycleStudy.org

USF RESEARCHERS WANT YOUR HELP...



We want you (and your friends)...

To allow a low profile data collection system to be installed on your bicycle for up to 3 months.

Because...

Understanding how people ride and interact with drivers and the road will lead to safer roadways and training programs.

Why should I participate?

You get to know that you have helped improve bicycle safety. In 2013 6,969 bicycle crashes resulted in 6,520 injuries, an increase of 8% from 2012 and 135 deaths, an increase of 16% from 2012.

We realize you will have to take time out of your life to participate so there is compensation of \$100 for study completion.

What will you do to my bicycle?

We will install instruments that will collect video, audio and other data for each ride. There will be no permanent damage to your bicycle.

Am I eligible?

You are eligible if you:

- Are 18 and older
- Have a bicycle and ride for commute or recreation
- Ride a minimum of 3-4 hrs a week
- Are able to read and complete questionnaires
- Live in the greater Tampa Bay area

What do I have to do?

Go to www.BicycleStudy.org for more information or call **813-974-6833**. We will schedule an appointment for you to answer some questionnaires and get the data collection system installed on your bicycle. The process takes about 1 hour. Then you just have to let our techs visit you once a month to collect the data from your bicycle.

Data kept confidential. IRB# Pro00020434

www.BicycleStudy.org

USF RESEARCHERS WANT YOUR HELP...



The Naturalistic Bicycle Study is a large research effort directed at improving bicycle safety in Florida and in the United States. The study will help researchers gain a deeper understanding of the interaction between bicyclists and drivers, roadway infrastructure and training programs. It will lead to safer roadways, and driver-bicyclist training programs. The Naturalistic Bicycle Study will look at how people normally ride by installing cameras and sensors on people's own bicycles. The study is being conducted at the Center for Urban Transportation Research at the University of South Florida and it will have up to 130 participants. Compensation provided at \$100/rider. Data kept confidential.

The Center for Urban Transportation Research (CUTR) at the University of South Florida (USF) is seeking individuals who:

- Are age 18 and older
- Own and ride a bicycle for commute or recreation
- Ride a minimum of 3-4 hrs per week
- Are able to read and complete questionnaires
- Will allow a data collection system to be installed on their personal bicycle for up to 3 months.
There will be no permanent changes to the bicycle.
- IRB# Pro00020434



If interested, contact us at **813-974-6833** or jsummerlin1@cutr.usf.edu
For more information about the project please visit:

<http://www.BicycleStudy.org>



Naturalistic Bicycle Study	Ph: 813-974-6833 www.BicycleStudy.org Email: jsummerlin1@cutr.usf.edu
Naturalistic Bicycle Study	Ph: 813-974-6833 www.BicycleStudy.org Email: jsummerlin1@cutr.usf.edu
Naturalistic Bicycle Study	Ph: 813-974-6833 www.BicycleStudy.org Email: jsummerlin1@cutr.usf.edu
Naturalistic Bicycle Study	Ph: 813-974-6833 www.BicycleStudy.org Email: jsummerlin1@cutr.usf.edu
Naturalistic Bicycle Study	Ph: 813-974-6833 www.BicycleStudy.org Email: jsummerlin1@cutr.usf.edu
Naturalistic Bicycle Study	Ph: 813-974-6833 www.BicycleStudy.org Email: jsummerlin1@cutr.usf.edu
Naturalistic Bicycle Study	Ph: 813-974-6833 www.BicycleStudy.org Email: jsummerlin1@cutr.usf.edu
Naturalistic Bicycle Study	Ph: 813-974-6833 www.BicycleStudy.org Email: jsummerlin1@cutr.usf.edu
Naturalistic Bicycle Study	Ph: 813-974-6833 www.BicycleStudy.org Email: jsummerlin1@cutr.usf.edu
Naturalistic Bicycle Study	Ph: 813-974-6833 www.BicycleStudy.org Email: jsummerlin1@cutr.usf.edu
Naturalistic Bicycle Study	Ph: 813-974-6833 www.BicycleStudy.org Email: jsummerlin1@cutr.usf.edu
Naturalistic Bicycle Study	Ph: 813-974-6833 www.BicycleStudy.org Email: jsummerlin1@cutr.usf.edu
Naturalistic Bicycle Study	Ph: 813-974-6833 www.BicycleStudy.org Email: jsummerlin1@cutr.usf.edu
Naturalistic Bicycle Study	Ph: 813-974-6833 www.BicycleStudy.org Email: jsummerlin1@cutr.usf.edu
Naturalistic Bicycle Study	Ph: 813-974-6833 www.BicycleStudy.org Email: jsummerlin1@cutr.usf.edu
Naturalistic Bicycle Study	Ph: 813-974-6833 www.BicycleStudy.org Email: jsummerlin1@cutr.usf.edu
Naturalistic Bicycle Study	Ph: 813-974-6833 www.BicycleStudy.org Email: jsummerlin1@cutr.usf.edu
Naturalistic Bicycle Study	Ph: 813-974-6833 www.BicycleStudy.org Email: jsummerlin1@cutr.usf.edu
Naturalistic Bicycle Study	Ph: 813-974-6833 www.BicycleStudy.org Email: jsummerlin1@cutr.usf.edu
Naturalistic Bicycle Study	Ph: 813-974-6833 www.BicycleStudy.org Email: jsummerlin1@cutr.usf.edu
Naturalistic Bicycle Study	Ph: 813-974-6833 www.BicycleStudy.org Email: jsummerlin1@cutr.usf.edu
Naturalistic Bicycle Study	Ph: 813-974-6833 www.BicycleStudy.org Email: jsummerlin1@cutr.usf.edu

APPENDIX C – STUDY WEBSITE

Website: www.bicyclestudy.org

Accessed: 10/27/17

Naturalistic Bicycling Behavior Pilot Study

Funded by the Florida Department of Transportation



MOTIVATION FOR STUDY

Transportation planning and design in the past has focused largely on the needs of automobiles, whereas nationally, bicycling has been making a comeback as a viable and popular mode of transportation. Unfortunately, bicyclists experience disproportionate rates of injuries and fatalities compared to other roadway vehicle types. The research agenda comes at a critical time for bicycle safety in the state of Florida. Specifically:

- Bicycle fatality rates in Florida were nearly triple the national average in 2013.
- According to the Florida Department of Highway Safety and Motor Vehicles, in 2013, a total of 6,969 bicycle crashes resulted in 135 bicyclists killed – an increase of 16.4 percent from 2012 – and 6,520 injured.



OBJECTIVES

[back to top](#)

The main objective of this study is to identify bicyclists' behavior based on the facilities they use, interactions with other roadway users, and risk factors taken while riding. The knowledge gained can provide a way to better bicycle facility planning and design, engineering improvements, enforcement efforts, and roadway user education providing significant improvements for the overall safety of bicyclists. A naturalistic bicycling behavior study is an effective approach to fully understand bicycling behaviors via analyzing naturalistic bicycling behavior data collected via cameras and sensors over a specific period of time. The study will incorporate 100 bicyclists in the Tampa Bay area.

ELIGIBILITY

[back to top](#)

Anyone who rides a bicycle for commuting purposes and lives in the Tampa Bay Area is eligible to participate. The study will include ages 18 and up for a limited number of participants. Recreational only riders will be considered if travel occurs on city roads (not trails). To be eligible you have to ride an average of 3-4 hours a week to produce 30 - 35 hours of riding data for each participant in the limited time the study will run.

WHAT YOU HAVE TO AGREE TO

[back to top](#)

All participants will have to agree to the study and sign an informed consent approved by the USF IRB (Institutional Review Board). The consent can be found [here](#).

RISKS OF PARTICIPATION

[back to top](#)

The equipment (BDAS) used to collect data for the study is designed to add minimal weight on the bicycle and will be mounted in a way not to interfere with regular riding. Therefore the risks to subjects are expected to be none or minimal.

Note: The equipment includes video cameras. If you ride into an area where cameras are not allowed, including certain military and intelligence locations, and certain manufacturing facilities, there is a risk that you may be detained or arrested or that your bicycle may be impounded.

BENEFITS OF PARTICIPATION

[back to top](#)

- You may find the experience interesting.
- Participation will help to improve the body of knowledge regarding bicycling behavior and increase bicycle safety.
- Participation may also help us design improved bicycle facilities and roadways in future years.
- While compensation is not considered a benefit per se, you will be compensated for your participation.

FAQs

[back to top](#)

1. Who is eligible to participate in this study?

Anyone who rides a bicycle for commuting purposes and lives in the Tampa Bay Area. Recreational only riders will be considered if travel occurs on city roads (not trails). To be eligible you have to ride an average of 3-4 hours a week to be able to produce the goal of 30-35 hours of riding for each participant in the given time (2-3 months).

2. Is there payment for my participation?

Participants will be paid a total of \$100 if they complete all the scheduled study visits and provide the minimum hours of data (30-35 hours). The compensation will be provided in the form of two payments. The first payment will be \$30 for initial setup and installation of the equipment on their bicycle. The remaining \$70 will be provided after completion of the 30-35 hours and return of the equipment. The payments will be made in the form of pre-paid visa cards.

3. What happens if I decide to quit before completing the required 30-35 hours of data?

If you would like to withdraw from the study before completion, you will be paid a prorated amount from the \$70 depending on how many hours completed and return of the equipment.

4. How long does it take for registration and installation?

Approximately one hour. Informed consent of the approved study by the Institutional Review Board (IRB) must be signed, baseline questionnaires answered, and the equipment (BDAS) installed on your bicycle on the day of your appointment.

5. Where do I go to get the equipment installed?

We prefer for you to bring your bicycle to our lab at 3720 Spectrum Blvd Suite 110, Tampa, FL 33612 (IDRB building on the USF-Tampa campus). In case you cannot come to the USF lab, we can arrange a staff member to come to you.

6. Can my data be used against me?

All data will be stored on secure servers at the Center for Urban Transportation Research and only qualified researchers will have access to it. If a collision occurs while the equipment is installed, the data may be used only if you choose to release them.

7. Does the participant have to interact with the equipment?

The equipment turns on and off automatically based on movement. A Smartphone app installed on your smartphone (if you have one) will send diagnostic data to the research team, and they will contact you to schedule a time to change the battery and hard drive. Participants do not have the option to switch off the device while riding. Participants will also be asked to fill out a few questions after each ride via a smartphone application.

8. What is included in the equipment?

The equipment weighs approximately 3 pounds. The BDAS includes the following components: 2 cameras (forward facing and backward facing), 4 ultrasonic sensors (front, left, right, back) sensing distance between rider and other objects up to 15 feet, 3 axis- accelerometer, gyroscope, Global Positioning System (GPS) sensor, temperature sensor, lighting level sensor, microphone (for ambient sound) and a Smartphone (Android, iPhone) application. The equipment will be installed on the frame of your bicycle with brackets that will not damage your bicycle. A bike rack may be used in the back if you don't have one already installed.

9. Do I have to attend any training in order to participate?

No, however, Cycling Savvy courses will be offered to a limited amount of participants as part of the study on a first come first serve basis.

[CLICK HERE TO DOWNLOAD THE CONSENT FORM](#)

**If you are interested in participating and have further questions, please call 813-974-6833,
or input your information below in the contact form, and a staff
member will contact you to answer questions and sign you up for the study.**

CONTACT FORM [back to top](#)

FIRST NAME:

LAST NAME:

GENDER: Male Female

AGE:

ZIP CODE OF RESIDENCE:

EMAIL:

PHONE:

PREFERRED METHOD OF CONTACT: Phone Email

PREFERRED TIME TO CONTACT IF BY PHONE: 9am - 12pm 12pm - 2pm 2pm - 7pm

NUMBER OF HOURS OF RIDING ON AVERAGE PER WEEK:

ARE YOU INTERESTED IN TAKING A PROFESSIONAL BICYCLE RIDING SKILL CLASS: Yes No

WHAT TYPE OF RIDER WOULD YOU SAY YOU ARE: Recreational Commuter

WHAT TYPE OF BICYCLE DO YOU HAVE:

IS YOUR BICYCLE ALUMINUM OR CARBON FIBER? Aluminum Carbon Fiber

WHERE DO YOU NORMALLY COMMUTE TO AND FROM?

DO YOU USUALLY RIDE ON THE STREET, BIKE LANES, SIDEWALKS, OR TRAILS? Yes No

HOW OFTEN DO YOU RIDE ON A TRAIL?

WILL YOU HAVE ANY CHANGES IN YOUR BICYCLING SCHEDULE OVER THE NEXT FEW MONTHS? Yes No

APPENDIX D – DEMOGRAPHICS QUESTIONNAIRE

A Note on Privacy

This survey is anonymous.

The record kept of your survey responses does not contain any identifying information about you unless a specific question in the survey has asked for this. If you have responded to a survey that used identifying information, you can rest assured that the identifying information is not kept with your responses. It is managed in a separate database, and will only be updated to indicate that you have (or haven't) completed this survey. There is no way of matching identifying information with survey responses in this questionnaire.

There are 19 questions in this questionnaire.

1. Age:
2. Gender
 - a) Male
 - b) Female
3. Ethnicity
 - a) Hispanic or Latino
 - b) Not Hispanic or Latino
4. What is your race?
 - a) Black or African American
 - b) White or Caucasian
 - c) Asian
 - d) American Indian or Alaskan Native
 - e) Native Hawaiian or Other Pacific Islander
 - f) Other:
5. What is your country of birth?
6. What is the highest level of education you have completed? Please choose only one of the following:
 - a) Some high school
 - b) High school diploma or G.E.D.
 - c) Some education beyond high school but no degree
 - d) College degree
 - e) Some graduate or professional school, but no advanced degree (e.g., J.D.S., M.S. or Ph.D.)
 - f) Advanced degree (e.g., J.D.S., M.S. or Ph.D.)

7. What is your marital status? Please choose only one of the following:
 - a) Single
 - b) Married
 - c) Divorced
 - d) Widow(er)
 - e) Unmarried partners

8. What is your current work status? Please choose only one of the following:
 - a) Not working outside the home
 - b) Part-time
 - c) Full-time

9. What is your current job title or profession? Please write your answer here:

10. What is your family's annual household income (from all sources and before taxes)? Please choose only one of the following:
 - a) Under \$29,000
 - b) \$30,000 to \$39,999
 - c) \$40,000 to \$49,999
 - d) \$50,000 to \$69,999
 - e) \$70,000 to \$99,999
 - f) \$100,000 to \$149,999
 - g) \$150,000+

11. How many people including yourself live at home with you?

12. What are the other individuals' gender and age?
 - a) Individual 1 gender: Individual 1 age:
 - b) Individual 2 gender Individual 2 age:
 - c) Individual 3 gender: Individual 3 age:
 - d) Individual 4 gender: Individual 4 age:
 - e) Individual 5 gender: Individual 5 age:
 - f) Individual 6 gender: Individual 6 age:

13. What is your ZIP code?

14. Do you have a driver's license?
 - a) Yes
 - b) No

15. At what age did you receive your driver license?

16. How many vehicles are there in your household?

17. How many bicycles are there in your household?

18. How many bicycles do you own that are for your personal use?

19. Approximately how many miles do you bicycle a week?

Thank you for completing this questionnaire.

APPENDIX E – BICYCLING HISTORY QUESTIONNAIRE

A Note on Privacy

This questionnaire is anonymous.

The record kept of your survey responses does not contain any identifying information about you unless a specific question in the survey has asked for this. If you have responded to a survey that used identifying information, you can rest assured that the identifying information is not kept with your responses. It is managed in a separate database, and will only be updated to indicate that you have (or haven't) completed this survey. There is no way of matching identifying information with survey responses in this questionnaire.

There are 28 questions in this questionnaire.

For the following questions please think about the last 12 months and answer if you had experienced any of the following:

1. What is the trip purpose of your most common bicycling ride?
 - a) Recreation – individual fitness
 - b) Recreation - leisurely individual ride
 - c) Recreation – group fitness ride
 - d) Recreation – leisurely social ride
 - e) Commuting to/from work
 - f) Shopping

2. If you could only choose one type of facility, where would you choose to bicycle?
 - a) Paved trail not along a roadway
 - b) Sidewalk
 - c) Protected bikeway along a roadway
 - d) Bike lane
 - e) Travel lane

3. Experience the following conflicts with motorized vehicles:

Right Hook	Left Cross	Close Passing	Not Yielding	Door Opening
a) Never	a) Never	a) Never	a) Never	a) Never
b) Rarely	b) Rarely	b) Rarely	b) Rarely	b) Rarely
c) Sometimes	c) Sometimes	c) Sometimes	c) Sometimes	c) Sometimes
d) Often	d) Often	d) Often	d) Often	d) Often

4. Have been in a crash with a motorized vehicle:

Right Hook	Left Cross	Close Passing	Not Yielding	Door Opening
a) Never	a) Never	a) Never	a) Never	a) Never
b) Rarely	b) Rarely	b) Rarely	b) Rarely	b) Rarely
c) Sometimes	c) Sometimes	c) Sometimes	c) Sometimes	c) Sometimes
d) Often	d) Often	d) Often	d) Often	d) Often

5. If you have had a crash with a motorized vehicle, who was at fault?

- a) You
- b) Motorist

6. Have a crash due to the following:

- a) Sand
- b) Gravel
- c) Pothole
- d) Leaves (slippery)
- e) Guy wires
- f) Overhanging vegetation

7. If you were in a crash that didn't involve a motorized vehicle, where did it occur?

- a) Paved trail not along a roadway
- b) Sidewalk
- c) Protected bikeway along a roadway
- d) Bike lane
- e) Travel lane

8. Have a close call (near-crash) due to the following:

- a) Sand
- b) Gravel
- c) Pothole
- d) Leaves (slippery)
- e) Guy wires
- f) Overhanging vegetation

9. Have been stopped by a police officer while bicycling?

- a) Never
- b) Rarely
- c) Sometimes
- d) Often

10. Have a crash with another bicyclist?

- a) Never
- b) Rarely
- c) Sometimes
- d) Often

11. Have issues with any certain class or roadway user?

- a) Never
- b) Rarely
- c) Sometimes
- d) Often

12. Have encounters with dogs?

- a) Never
- b) Rarely
- c) Sometimes
- d) Often

13. Do you ride alone?

- a) Never
- b) Rarely
- c) Sometimes
- d) Often

14. Do you ride in groups?

- a) Never
- b) Rarely
- c) Sometimes
- d) Often

15. Who does the maintenance on your own bike?

- a) You do all of your own maintenance
- b) You do minor maintenance yourself and have other repairs done at a shop
- c) Have everything done at a professional bike shop
- d) A friend

16. In your opinion, bicyclists are safest when riding close to the edge of the roadway.

- a) Yes
- b) No

17. Do you practice lane control?

- a) Never
- b) Rarely
- c) Sometimes
- d) Often

18. Do you signal turns?
- a) Never
 - b) Rarely
 - c) Sometimes
 - d) Often
19. Do you move left on approaches to intersections to prevent right hooks?
- a) Never
 - b) Rarely
 - c) Sometimes
 - d) Often
20. Did you ever take a bicyclist training course?
- a) Yes --- Kind/name:How long ago?
 - b) No
21. Are you a certified instructor of any bicyclist training courses?
- a) Yes -- Kind/name: Since when?
 - b) No
22. Would you be interested in taking an advanced rider training course?
- a) Yes
 - b) No
23. Do you wear any specific clothing to bicycle?
- a) Never
 - b) Rarely
 - c) Sometimes
 - d) Often
24. Do you wear or equip your bicycle with brightly colored or reflective items?
- a) Never
 - b) Rarely
 - c) Sometimes
 - d) Often
25. When you bicycle at night, you use the following (check all that apply)
- a) No lights
 - b) Front lights in flash mode
 - c) Front lights in steady mode
 - d) Rear lights in flash mode
 - e) Rear lights in steady mode
 - f) Lights mounted on bicycle
 - g) Lights mounted on helmet
 - h) Lights on body or carried pack

26. Do you wear a helmet while bicycling?

- a) Never
- b) Rarely
- c) Sometimes
- d) Often

27. Do you use a mirror affixed to your helmet or handlebars while bicycling?

- a) Never
- b) Rarely
- c) Sometimes
- d) Often

28. Have you ever rented a bicycle from a bike share program? (check all that apply)

- a) Never
- b) Casual user, Name Systems
- c) Annual member, Name Systems

Thank you for completing this questionnaire.

APPENDIX F – FREQUENCY OF RISKY BEHAVIOR QUESTIONNAIRE

A Note on Privacy

This survey is anonymous.

The record kept of your survey responses does not contain any identifying information about you unless a specific question in the survey has asked for this. If you have responded to a survey that used identifying information, you can rest assured that the identifying information is not kept with your responses. It is managed in a separate database, and will only be updated to indicate that you have (or haven't) completed this survey. There is no way of matching identifying information with survey responses in this questionnaire.

There are 20 questions in this questionnaire.

In the past 12 months while riding, how often did you...

1. Run red lights? (choose one answer)
 - a) Never
 - b) Rarely
 - c) Sometimes
 - d) Often

2. Take risks while riding because it's fun, like jumping off a curb or riding in a zig-zag?
 - a) Never
 - b) Rarely
 - c) Sometimes
 - d) Often

3. Change lanes quickly or ride between stopped traffic to be the first in line when light turn green?
 - a) Never
 - b) Rarely
 - c) Sometimes
 - d) Often

4. Go through a stop sign without stopping?
 - a) Never
 - b) Rarely
 - c) Sometimes
 - d) Often

5. Not yield the right of way to pedestrians?
 - a) Never
 - b) Rarely
 - c) Sometimes
 - d) Often

6. Take more risks because you are in a hurry?
 - a) Never
 - b) Rarely
 - c) Sometimes
 - d) Often

7. Smoke, text or talk on the phone while bicycling?
 - a) Never
 - b) Rarely
 - c) Sometimes
 - d) Often

8. Misjudge the edge of lane, trail or sidewalk?
 - a) Never
 - b) Rarely
 - c) Sometimes
 - d) Often

9. Ride shortly after drinking alcohol or using recreational drugs?
 - a) Never
 - b) Rarely
 - c) Sometimes
 - d) Often

10. Yell or make an angry gesture at motorists, other bicyclists or pedestrians?
 - a) Never
 - b) Rarely
 - c) Sometimes
 - d) Often

11. Brake too quickly resulting in a skid or the rear tire lifting up resulting in going over the handlebars?
 - a) Never
 - b) Rarely
 - c) Sometimes
 - d) Often

12. Turn from a wrong lane at an intersection?
- a) Never
 - b) Rarely
 - c) Sometimes
 - d) Often
13. Ride with under-inflated tires?
- a) Never
 - b) Rarely
 - c) Sometimes
 - d) Often
14. Pass where visibility was obscured?
- a) Never
 - b) Rarely
 - c) Sometimes
 - d) Often
15. Ride at night without lights on
- a) Never
 - b) Rarely
 - c) Sometimes
 - d) Often
16. Attempt to pull away from a stop in the wrong gear?
- a) Never
 - b) Rarely
 - c) Sometimes
 - d) Often
17. Pass stopped cars at a light on the right side (no bike lane)?
- a) Never
 - b) Rarely
 - c) Sometimes
 - d) Often
18. Ride against traffic on the roadway?
- a) Never
 - b) Rarely
 - c) Sometimes
 - d) Often

19. Ride the wrong way on a one way street?

- e) Never
- f) Rarely
- g) Sometimes
- h) Often

20. Ride against traffic in a marked bike lane?

- a) Never
- b) Rarely
- c) Sometimes
- d) Often

Thank you for completing this questionnaire.

APPENDIX G – PERCEPTION OF RISK BEHAVIOR QUESTIONNAIRE

A Note on Privacy

This survey is anonymous.

The record kept of your survey responses does not contain any identifying information about you unless a specific question in the survey has asked for this. If you have responded to a survey that used identifying information, you can rest assured that the identifying information is not kept with your responses. It is managed in a separate database, and will only be updated to indicate that you have (or haven't) completed this survey. There is no way of matching identifying information with survey responses in this questionnaire.

There are 20 questions in this questionnaire.

If you were to engage in the following actions, how do you think they would affect your risk of being in a crash? (Please choose one answer)

1. Run red lights?
 - a) No Greater Risk
 - b) Some Greater Risk
 - c) Moderately Greater Risk
 - d) Much Greater Risk
 - e) Significantly Greater Risk

2. Take risks while riding because it's fun, like jumping off a curb or riding in a zig-zag?
 - a) No Greater Risk
 - b) Some Greater Risk
 - c) Moderately Greater Risk
 - d) Much Greater Risk
 - e) Significantly Greater Risk

3. Change lanes quickly or ride between stopped traffic to be the first in line when light turn green?
 - a) No Greater Risk
 - b) Some Greater Risk
 - c) Moderately Greater Risk
 - d) Much Greater Risk
 - e) Significantly Greater Risk

4. Go through a stop sign without stopping?
 - a) No Greater Risk
 - b) Some Greater Risk
 - c) Moderately Greater Risk
 - d) Much Greater Risk
 - e) Significantly Greater Risk

5. Not yield the right of way to pedestrians?
 - a) No Greater Risk
 - b) Some Greater Risk
 - c) Moderately Greater Risk
 - d) Much Greater Risk
 - e) Significantly Greater Risk

6. Take more risks because you are in a hurry?
 - a) No Greater Risk
 - b) Some Greater Risk
 - c) Moderately Greater Risk
 - d) Much Greater Risk
 - e) Significantly Greater Risk

7. Smoke, text or talk on the phone while bicycling?
 - a) No Greater Risk
 - b) Some Greater Risk
 - c) Moderately Greater Risk
 - d) Much Greater Risk
 - e) Significantly Greater Risk

8. Misjudge the edge of lane, trail or sidewalk?
 - a) No Greater Risk
 - b) Some Greater Risk
 - c) Moderately Greater Risk
 - d) Much Greater Risk
 - e) Significantly Greater Risk

9. Ride shortly after drinking alcohol or using recreational drugs?
 - a) No Greater Risk
 - b) Some Greater Risk
 - c) Moderately Greater Risk
 - d) Much Greater Risk
 - e) Significantly Greater Risk

10. Yell or make an angry gesture at motorists, other bicyclists or pedestrians?
 - a) No Greater Risk
 - b) Some Greater Risk
 - c) Moderately Greater Risk
 - d) Much Greater Risk
 - e) Significantly Greater Risk

11. Brake too quickly resulting in a skid or the rear tire lifting up resulting in going over the handlebars?
- a) No Greater Risk
 - b) Some Greater Risk
 - c) Moderately Greater Risk
 - d) Much Greater Risk
 - e) Significantly Greater Risk
12. Turn from a wrong lane at an intersection?
- a) No Greater Risk
 - b) Some Greater Risk
 - c) Moderately Greater Risk
 - d) Much Greater Risk
 - e) Significantly Greater Risk
13. Ride with under-inflated tires?
- a) No Greater Risk
 - b) Some Greater Risk
 - c) Moderately Greater Risk
 - d) Much Greater Risk
 - e) Significantly Greater Risk
14. Pass where visibility was obscured?
- a) No Greater Risk
 - b) Some Greater Risk
 - c) Moderately Greater Risk
 - d) Much Greater Risk
 - e) Significantly Greater Risk
15. Ride at night without lights on
- a) No Greater Risk
 - b) Some Greater Risk
 - c) Moderately Greater Risk
 - d) Much Greater Risk
 - e) Significantly Greater Risk
16. Attempt to pull away from a stop in the wrong gear?
- a) No Greater Risk
 - b) Some Greater Risk
 - c) Moderately Greater Risk
 - d) Much Greater Risk
 - e) Significantly Greater Risk

17. Pass stopped cars at a light on the right side (no bike lane)?

- a) No Greater Risk
- b) Some Greater Risk
- c) Moderately Greater Risk
- d) Much Greater Risk
- e) Significantly Greater Risk

18. Ride against traffic on the roadway?

- a) No Greater Risk
- b) Some Greater Risk
- c) Moderately Greater Risk
- d) Much Greater Risk
- e) Significantly Greater Risk

19. Ride the wrong way on a one way street?

- a) No Greater Risk
- b) Some Greater Risk
- c) Moderately Greater Risk
- d) Much Greater Risk
- e) Significantly Greater Risk

20. Ride against traffic in a marked bike lane?

- a) No Greater Risk
- b) Some Greater Risk
- c) Moderately Greater Risk
- d) Much Greater Risk
- e) Significantly Greater Risk

Thank you for completing this questionnaire.