



U.S. Department of Transportation
Federal Aviation Administration

FINAL PROJECT REPORT

Form Approved:
O.M.B. No. 2120-0559
9/30/2013

PART I - PROJECT IDENTIFICATION INFORMATION

1. Institution and Address	2. FAA Program	3. FAA Award Number
	4. Award Period From To	5. Cumulative Award Amount
6. Project Title		

PART II - SUMMARY OF COMPLETED PROJECT (For Public Use)

--

PART III - TECHNICAL INFORMATION (For Program Management Uses)

1. ITEM (Check appropriate blocks)	NONE	ATTACHED	PREVIOUSLY FURNISHED	TO BE FURNISHED SEPARATELY TO PROGRAM	
				Check (X)	Approx. Date
a. Abstracts of Theses					
b. Publication Citations					
c. Data on Scientific Collaborators					
d. Information on Inventions					
e. Technical Description of Project and Results					
f. Other (specify)					
2. Principal Investigator/Project Director Name (Typed)	3. Principal Investigator / Project Director Signature 			4. Date	



Project 030

National Jet Fuels Combustion Program – Area #6: Referee Swirl-Stabilized Combustor Evaluation/Support

Steven Zabarnick¹, Scott Stouffer¹, Matthew Dewitt¹, Tonghun Lee²
University of Dayton Research Institute, University of Illinois²

*this report covers portion of University of Illinois

Project Lead Investigator

Tonghun Lee
Associate Professor
Mechanical Science & Engineering
University of Illinois at Urbana-Champaign
1206 W. Green St.
Urbana IL 61801
517-290-8005
tonghun@illinois.edu

University Participants

University of Illinois at Urbana-Champaign

- P.I.(s): Tonghun Lee, Associate Professor
- FAA Award Number: 13-C-AJFE-UI-004
- Period of Performance: 12/1/2014 to 11/30/2015
- Task(s):
 1. Optimize and apply laser diagnostics for application in the Referee Combustor.

Project Funding Level

Funding Level: \$140K

Cost Share: In-kind academic time of the PI, Lab Renovation Cost by Department for Diagnostics Work

Investigation Team

- Eric Mayhew (Graduate Student, University of Illinois at Urbana-Champaign): Execution of laser and optical diagnostics at GATech.
- Rajavasanth Rajasegar (Graduate Student, University of Illinois at Urbana-Champaign): Optimization of laser diagnostics strategy.
- Stephen Hammack (Graduate Student, University of Illinois at Urbana-Champaign): Execution of laser and optical diagnostics at GATech.

Project Overview

The goal of this study is to develop, conduct, and analyze advanced laser and optical measurements in the referee combustor (WPAFB, Bldg. 490, RC 152) selected by the ASCENT National Fuel Combustion Program. We will conduct advanced spatially resolved high-speed Planar imaging as well as other advanced diagnostic measurements which can provide insight into the physicochemical response of the combustion process for various alternative fuels. Moreover, the results will provide data for development of new predictive combustion models in ASCENT. Once fully characterized, the standard referee combustor rig can streamline and simplify fuel certification procedures outlined in the ASTM D4054 (Standard Practice for Qualification and Approval of New Aviation Turbine Fuels and Fuel Additives) through minimization of full-scale engine testing.

Task 1 – Optimize and apply laser and optical diagnostics for application in the Referee Combustor

University of Illinois at Urbana-Champaign

Objective(s)

The main objectives of the work in this proposal are to work with UDRI and AFRL in carrying out diagnostics measurements for the referee combustor. The following tasks will guide this collaboration:

- Identify the operating conditions and key parameters for detection in the referee combustor
- Evaluate and modify the referee combustor at AFRL for laser and optical diagnostics
- Design laser and optical diagnostics setup and assist in the fuel screening process
- Analyze data and pass on data to modeling groups in combustion program

Research Approach

Diagnostics Optimization and Setup

The main goal here is the development of multi-phase high-speed diagnostics using 2D imaging to understand the combustion instabilities at the operational boundaries and flame dynamics. The goal will be to apply selected measurements from PLIF, PIV, and/or chemiluminescence (10 to 50 kHz). Additional high fidelity measurements from AFRL may be integrated with our efforts. In both PLIF and PIV, we will look to target OH and CH radicals in the flame. When required, we may employ high power low repetition PLIF measurements to look at various other flame properties such as nitric oxide generation (226 nm, Nd:YAG pumped dye laser) and/or formaldehyde (355 nm, Nd:YAG laser). For high speed chemiluminescence measurements, we plan to utilize a series of high speed intensified cameras around the referee combustor. For the high PLIF measurements, we plan to first utilize a conventional 10 Hz PLIF laser system and ultimately move to a high speed dye laser (Sirah) pumped by a high speed diode pumped Nd:YAG (Edgewave). AFRL is in possession of a 200 W Edgewave system which may be deployed for the studies. Energy per laser pulse at these conditions maybe small (~30 $\mu\text{J}/\text{pulse}$) and light collection from the PLIF will be enhanced using a f/1.8 UV lens from Cerco.

Quantification of the LIF Signal and Light Sheet Integration

To ensure that the signal is fully quantified, we set out to build and calibrate a small scale flat flame burner for use in the referee rig. The combustor will be fully calibrated at Illinois using a combination of laser absorption and multi-line nitric oxide LIF thermometry. By calibrating the intensity of the setup with the flat flame combustor, we can assess first order values for concentration of radical concentrations in the flame. One critical issue in the referee combustor is to insert a light sheet into the combustion chamber itself as there are only side windows for detection and no top view or bottom view window for propagation of the laser sheet.

During the year, significant effort was made to develop a method of inserting a laser sheet into the referee combustor using optical engineering. As noted above, the referee combustor does not have top or bottom windows for inserting a laser beam and therefore require creative means for both pitching of the laser sheet into the combustor as well as detection. Several methods were proposed and two are shown in Figure 3. During this year, a mockup SLA of the referee combustor was constructed at Illinois and these light sheet integration methods were tested. They are expected to be integrated into the actual referee combustor in the following years.

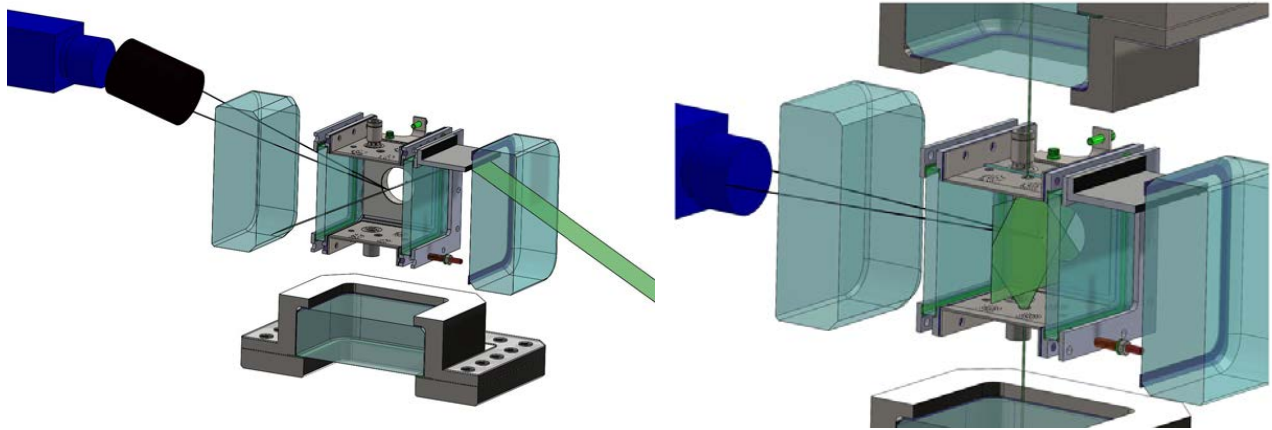

Figure 1: Methods of light sheet integration to the referee combustor. Left side shows a Scheimpflug setup coupled with a reflected beam while the right shows the rapid expansion of a single beam.

High-Speed Shadowgraph and Chemiluminescence Imaging of the Referee Rig

During July 2015, 10 kHz shadowgraph was implemented on the Area 6 referee rig with the primary objective of obtaining the fuel spray cone angle. Shadowgraph images were taken of steady state combustion for each of the C-1, C-5, and A-2 fuels over a range of equivalence ratios. For the C-1 fuel, the equivalence ratios tested were: 0.1, 0.098, 0.096, and 0.095. For the C-5 and A-2 fuels, the equivalence ratios tested were: 0.1, 0.098, 0.096, 0.095, 0.0925, 0.09, and 0.0875. All of the data was taken with an air temperature of 250 °F, fuel temperature of 120 °F, combustor pressure of 30 psia, and a ΔP of 3%. Fuel spray tests were also conducted without combustion over the same range of equivalence ratios; a representative set of shadowgraph images of the fuel spray tests are shown in Figure 1. The images taken are currently being processed to obtain spray cone angle and RMS intensity along the centerline and at the edge of the spray.

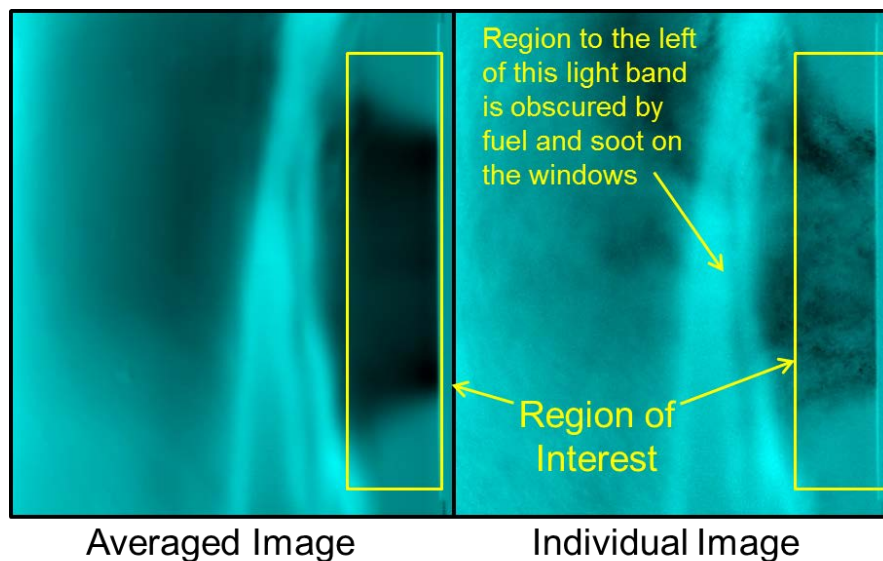

Figure 2: Sample shadowgraph images of an A-2 fuel spray test

During the same measurement campaign, 10 kHz OH*, CH*, and C₂* chemiluminescence images were taken at the same combustion conditions as the shadowgraph images described above. The chemiluminescence was captured using a Photron SA-5 intensified with a LaVision High Speed IRO with a Cerco f/2.8 UV lens. The OH* chemiluminescence was captured by using a Semrock Brightline 320/40 bandpass filter, the CH* chemiluminescence was captured using a Semrock Brightline 427/10 bandpass filter, and the C₂* chemiluminescence was captured using a Semrock Brightline 494/20 bandpass filter. The white vertical stripe shows sooting on the windows of the combustor during these runs, showing the difficulties of running in an actual combustor with real kerosene fuels.

Through discussions in the diagnostics subcommittee, several aspects of the data will be analyzed and transferred over to the modeling groups in the first pass. These include the angle of the spray as shown by the cold shadowgraph images as well as the OH* and CH* chemiluminescence signals. Additionally, we will provide contours of the OH* generated in the flame as well as some relative intensities between the various chemiluminescence signals. This type of data will enable the modeling teams to anchor their models and ensure that the flow characteristics of their simulations are accurate. All the information will be placed on a grid system so that the PIs can ensure that their computations are to scale. Sample images of OH*, CH* and C₂* are shown in Figure 2.

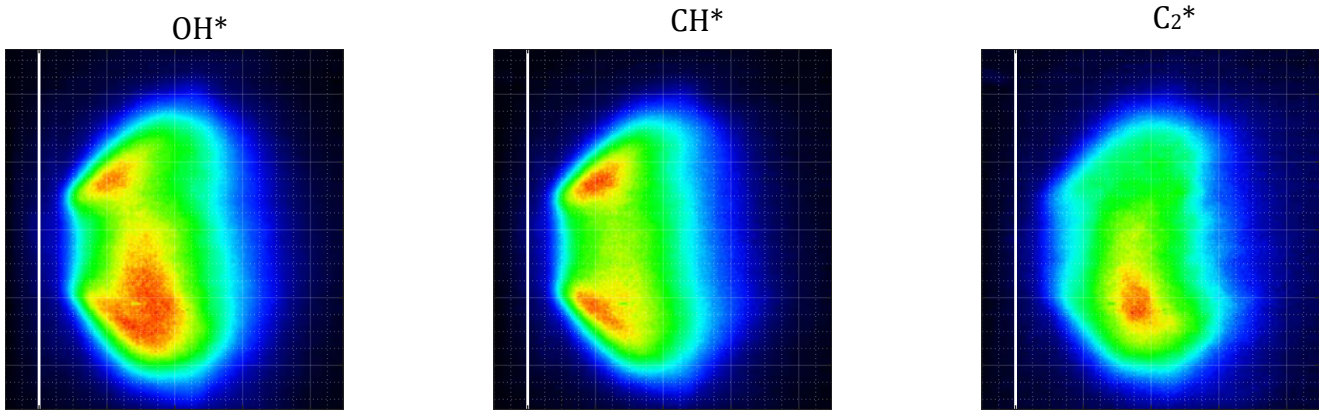

Figure 3: Representative averaged, normalized chemiluminescence images of OH*, CH*, and C₂* of the C-5 fuel at an equivalence ratio of 0.096

The origin, as shown in Figure 3, is defined as the intersection of the rig centerline and the deflector plate. This location is chosen, rather than the injector tip, as it is the furthest upstream that can be seen with the camera placed perpendicular to the flow direction. There is noticeable asymmetry in the averaged chemiluminescence images shown in Figure 3, a phenomenon that appears at all equivalence ratios for the A-2 and C-5 fuels. The flame lobe in the lower half of the combustor is larger and is located further from the rig centerline than the lobe in the upper half of the combustor. One possible explanation for this is that the recirculation of larger, unevaporated droplets that survive in the flame long enough for gravitational effects to become significant, results in more fuel vapor located in the bottom half of the combustor. The flames for C-1 are symmetric about the centerline; this is possibly due to C-1's low cetane number, leading to the flame being anchored on the spray cone.

The OH* count intensity, normalized by the maximum possible counts, as a function of time is shown in Figure 4 for the C-5 at a global equivalence ratio of 0.096. There is a noticeable oscillation in the OH* chemiluminescence intensity, corresponding to oscillation in flame heat release. Fourier analysis of the OH* signal (CH* and C₂* as well) demonstrates that the oscillation occurs at a frequency of 268 Hz. Heat release oscillation, as revealed by the chemiluminescence, occurs in A-2 and C-1 as well, but the oscillation is much stronger for C-5, particularly at equivalence ratios about 0.095.

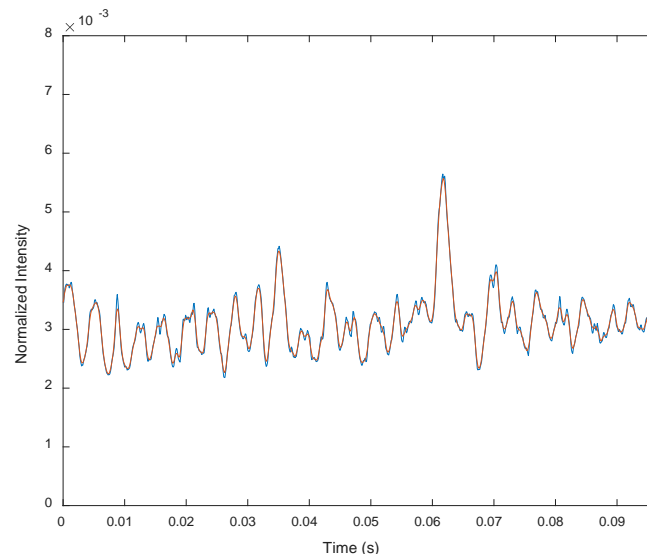

Figure 4: Normalized OH* intensity as a function of time for C-5 at an equivalence ratio of 0.096

Milestone(s)

Milestones from Each Period

Proposed (3 Month): At the 3 month mark, we will conclude the analysis of the experimental setup and start to modify the optical access of the referee combustor. Simultaneously, we will pursue development of the diagnostics with AFRL.

Achieved: Design of the laser setup complete and fabrication of calibration torch started. Construction on a mockup of the referee combustor begins at Illinois to test out the laser sheet feasibility.

Proposed (6 Month): At the 6 month mark, we should be well into building the experimental setup and modification of the referee combustor for optical access. We should also have made considerable progress in optimization of the CH PLIF strategy in the laboratory as well as commenced in the development of 50 kHz PLIF of OH for deployment in the referee combustor. Preliminary fuel screening measurements using high speed chemiluminescence will be carried out during this phase.

Achieved: CH PLIF is demonstrated at AFRL in a separate lab and is ready for deployment. 50 kHz OH PLIF is also ready for deployment. Measurement plans are pushed back slightly to accommodate for fuel screening in the referee combustor. Design of a multi-species chemiluminescence and shadowgraph setup commences.

Proposed (9 Month): At the 9 month mark, we should have completed the combustor optical access modifications and also conducted an initial shakedown of the tests. The diagnostics setup should also be completed and tested. We will start to share diagnostics data with other groups, notably 2, 4, and 6.

Achieved: Chemiluminescence measurements of C₂, OH and CH along with shadowgraph measurements of the fuel spray in a cold flow are completed.

Proposed (12 Month): At the 12 month mark, we should have obtained an initial set of data for the 10 Hz OH PLIF. Depending on the progress we may also have some preliminary data set for 10 and/or 50 kHz OH PLIF. We should be fully prepared to implement high speed PLIF measurements for year 2.

Achieved: Data analysis of the chemiluminescence measurements to begin. Test of the light sheet insertion in the referee combustor to begin.

Major Accomplishments

Equipment was purchased and set up to circumnavigate the difficulties associated with conducting PLIF imaging in the referee rig. Two techniques were developed and demonstrated on a 3D printed SLA model of the referee combustor: a technique inserting a laser sheet at an angle and imaging using a Scheimpflug setup and a technique inserting a rapidly expanding sheet through the central primary dilution jet hole and imaging perpendicularly.



High repetition rate shadowgraph and chemiluminescence imaging was conducted on the referee rig near lean blowout. Shadowgraph imaging demonstrates that the fuel spray can be imaged in combusting and non-combusting conditions. The analysis of the shadowgraph images will yield spray angles near the deflector plate, an important validation parameter for the modeling groups. The chemiluminescence imaging shows pronounced asymmetry in the average flame for A-2 and C-5, revealing that gravitational effects may be significant for fuels that are not anchored on the spray cone (e.g. C-1). Preliminary analysis of the OH* count intensity over time shows that there is oscillation at 268 Hz, particularly for the C-5 flame. Average flame shape, relative average flame intensity, and flame dynamics are important qualitative validation parameters for the modeling teams.

Publications

None

Outreach Efforts

None

Awards

None

Student Involvement

Three graduate students (listed above) have participated in this project on a rotational basis to address various aspects of the project. Rajivasanth designed and fabricated the calibration burner to be used in the referee combustor, and conducted experiments to determine the actual concentration of radical concentrations in the flame. Two other students (Stephen Hammack and Eric Mayhew) made multiple trips to AFRL to make test measurements in the high shear combustor. This included assisting in the setup of the laser and optics as well as participating in the actual measurements.

Plans for Next Period

In year II of the NJFCP, an effort will be made to fully integrate the laser sheet in the referee combustor. We also expect to continue assisting in their effort to take images in the referee combustor and analyze the data. The high speed laser systems are already at AFRL and will be ready for deployment when we can find a window of run time in the referee combustor. Finally, we will assist with quantification of the referee combustor using the calibration torch built for this project at the University of Illinois.