

Feasibility of Lane Closures Using Probe Data

FINAL REPORT

Submitted by

Steven I-Jy Chien, Ph.D.
Professor of Civil and Environmental Engineering
New Jersey Institute of Technology
Newark, NJ 07102-1982
Phone: (973) 596-6083
E-mail: chien@njit.edu



NJDOT Research Project Manager
Giri Venkateela

In cooperation with

New Jersey
Department of Transportation
Division of Research and Technology
And
U. S. Department of Transportation
Federal Highway Administration

DISCLAIMER STATEMENT

The contents of this report reflect the views of the authors who are responsible for the facts and the accuracy of the data presented herein. The contents do not necessarily reflect the official views or policies of the New Jersey Department of Transportation or the Federal Highway Administration. This report does not constitute a standard, specification, or regulation.

1. Report No. FHWA-NJ-2017-005	2. Government Accession No.	3. Recipient's Catalog No.	
4. Title and Subtitle Feasibility of Lane Closures Using Probe Data		5. Report Date April 2017	
		6. Performing Organization Code	
7. Author(s) Steven Chien, Lazar Spasovic, Joyoung Lee, Kyriacos Mouskos, Bo Du		8. Performing Organization Report No.	
9. Performing Organization Name and Address John A. Reif, Jr. Department of Civil and Environmental Engineering New Jersey Institute of Technology University Heights Newark, NJ 07102-1982		10. Work Unit No.	
		11. Contract or Grant No. NJDOT 2011 – 01	
12. Sponsoring Agency Name and Address N.J. Department of Transportation Federal Highway Administration 1035 Parkway Avenue U.S. Department of P.O. Box 600 Transportation Trenton, NJ 08625-0600 Washington, D.C.		13. Type of Report and Period Covered Final Report Oct. 2013 – Dec. 2015	
		14. Sponsoring Agency Code	
15. Supplementary Notes			
16. Abstract To develop an adequate traffic operations management and congestion mitigation plan for every roadway maintenance and construction project requiring lane closures, transportation agencies need accurate and reliable estimates of traffic impacts associated with pertinent maintenance and construction projects, and the corresponding roadway capacity reductions. The current analytical model used by most agencies for this purpose is based on traditional volume/capacity formulae and deterministic traffic queuing modeling method. NJDOT recognizes the shortcomings of these methods that often result in inaccurate estimates of the impact of lane closures in terms of vehicle delays and the associated costs. These estimates may be significantly improved by utilizing the probe-vehicle data. The objective of this research project is to develop a methodology for integrating probe-vehicle data into the traffic impact analysis model, and to develop a user-friendly software tool that would implement the calculation methodology.			
17. Key Words Work Zone, Delay, Speed, Prediction, Artificial Neural Network, Multivariate Non-Linear Regression, Probe-Vehicle Data, Big Data		18. Distribution Statement No Restrictions.	
19. Security Classification (of this report) Unclassified	20. Security Classification (of this page) Unclassified	21. No of Pages 105	22. Price

ACKNOWLEDGEMENTS

The authors would like to acknowledge the support of the New Jersey Department of Transportation (NJDOT) particularly Paul Thomas, Giri Venkateela, and Camille Crichton-Summers (Bureau of Research). The authors would also like to thank the following members of the Research Selection and Implementation Panel: Mike Pilsbury, Jeevanjot Singh, Wasif Mirza, William Kingsland, James Hadden, and Dhanesh Motiani (Transportation Systems Management). These individuals offered valuable comments and suggestions on the research resulting in an improved product.

The Work Zone Interactive Management Application – Planning (WIMAP-P) database portion of the research was administered through City University of New York’s (CUNY) Center of Institute for Transportation Systems. Their support is both acknowledged and appreciated. In addition to Dr. Kyriacos Mouskos, notable individuals from the Civil and Environmental Engineering Department at CUNY include Dr. Neville Parker, Dr. Camille Kamga, and Patricio Vicuna.

The WIMAP-P Data Collection/Analysis and Model/Software Development portions of the research were administered through New Jersey Institute of Technology. In addition to Drs. Steven Chien, Lazar Spasovic, and Joyoung Lee, the following individuals from the Interdisciplinary Program for Transportation contributed to the research: Bo Du, Brijesh Singh, Branislav Dimitrijevic, Liuhui Zhao, and Mohammed Hasan.

TABLE OF CONTENTS

	Page
EXECUTIVE SUMMARY	1
I. INTRODUCTION.....	4
1.1 Background.....	4
1.2 Objective	5
II. LITERATURE REVIEW	6
2.1 Work Zone Delay Prediction Models	6
2.2 Probe-vehicle Technologies	7
2.3 Software for Lane Closure Impact Analysis	11
2.4 Summary	13
III. WIMAP-P DATABASE (DB).....	13
3.1 Data Sources and Data Collection.....	14
3.2 Data Processing	16
3.3 Database (DB) Development.....	20
IV. THE WORK ZONE SPEED PREDICTION MODELS	22
4.1 The ANN Model.....	22
4.1.1 The Freeway ANN Model	23
4.1.2 The Arterial ANN Model	27
4.2 The Multivariate Non-linear Regression Model.....	28
4.2.1 The Freeway MNR Model	28
4.2.2 The Arterial MNR Model.....	30
V. MODEL EVALUATION AND ANALYSIS.....	31
5.1 Freeway Model Performance	31
5.2 Arterial Model Performance	32
5.3 Summary of Performance Evaluation	33
VI. WIMAP-P SOFTWARE	33
6.1 Graphical User Interface (GUI).....	34
6.2 Work Zone Impact Prediction	34
6.3 Report Generator	38
VII. WIMAP-P PERFORMACE MEASURES AND APPLICATIONS	39

7.1 WIMAP-P Performance Measures.....	39
7.2 A Freeway Work Zone Case Study	41
7.3 An Arterial Work Zone Case Study.....	45
VIII. BENEFITS AND COSTS	49
8.1 Benefits	49
8.2 Costs	50
IX. CONCLUSIONS	51
9.1 Findings	52
9.2 Future Extensions	54
9.3 Future Research	54
APPENDIX A - CUNY Data Processing and Management.....	56
A.1 CUNY ITS Data Model Development Server Characteristics.....	56
A.2 CUNY ITS Application Server Characteristics	56
A.3 WIMAP-P Dimensions.....	56
A.4 WIMAP-P Measures.....	57
A.5 SAMPLE SQL QUERY	58
APPENDIX B - Quality Assurance (QA) Analysis	61
B.1 Background.....	61
B.2 WIMAP-P Freeway Model.....	61
B.3 WIMAP-P Arterial Model	65
APPENDIX C - WIMAP-P Applications.....	69
C.1 Application to Freeway Work Zones.....	69
C.2 Application to Arterial Work Zones.....	78
APPENDIX D - NJDOT RUCM Approach.....	86
APPENDIX E - WIMAP-P User Manual	90
REFERENCES.....	99

LIST OF FIGURES	Page
Figure 1.1 WIMAP-P system architecture	5
Figure 3.1 WIMAP-P DB overview	14
Figure 3.2 Data processing diagram	17
Figure 3.3 WIMAP-P DB architecture.....	20
Figure 3.4 WIMAP-P INRIX data CUBE structure	21
Figure 4.1 Configuration of the proposed ANN model.....	23
Figure 4.2 Inputs of the freeway ANN model.....	24
Figure 4.3 Proposed freeway ANN model	27
Figure 4.4 Inputs of the arterial ANN model	28
Figure 4.5 Proposed arterial ANN model.....	29
Figure 6.1 WIMAP-P homepage	34
Figure 6.2 Work zone impact prediction module	35
Figure 6.4 Work zone impact prediction results	37
Figure 6.5 The WIMAP-P report.....	38
Figure 7.1 Work zone location on I-78 in Springfield, NJ.....	41
Figure 7.2 Traffic distribution on I-78 WB at MP 49.3.....	41
Figure 7.3 WIMAP-P parameter input module.....	42
Figure 7.4 15-min traffic volume distribution.....	43
Figure 7.5 WIMAP-P speed heat map.....	43
Figure 7.6 Speed difference diagram	44
Figure 7.7 Work zone location on US-46 in Little Ferry, NJ.....	46
Figure 7.8 WIMAP-P parameter input module.....	46
Figure 7.9 15-min traffic volume distribution.....	47
Figure 7.10 WIMAP-P speed heat map.....	47
Figure 7.11 Speed difference diagram	48
Figure B.1 A sample of testing heat maps (freeway).....	65
Figure B.2 A sample of testing heat maps (arterial)	69

Figure C.1 Work zone location on I-280 in Harrison, NJ	70
Figure C.2 Hourly traffic distribution on I-280 EB at MP 14.6	70
Figure C.3 WIMAP-P parameter input module	71
Figure C.4 15-min traffic volume distribution	72
Figure C.5 WIMAP-P speed heat map generation	72
Figure C.6 Speed difference diagram.....	73
Figure C.7 Work zone location on I-287 in Morristown, NJ	74
Figure C.8 Hourly traffic distribution on I-287 NB at MP 31	75
Figure C.9 WIMAP-P parameter input module	75
Figure C.10 15-min traffic volume distribution	76
Figure C.11 WIMAP-P speed heat map generation	76
Figure C.12 Speed difference diagram.....	77
Figure C.13 Work zone location on US-130 in Willingboro, NJ	78
Figure C.14 WIMAP-P parameter input module	79
Figure C.15 15-min traffic volume distribution	80
Figure C.16 WIMAP-P speed heat map generation	80
Figure C.17 Speed difference diagram.....	81
Figure C.18 Work zone location on US-130 in Dayton, NJ.....	82
Figure C.19 WIMAP-P parameter input module	83
Figure C.20 15-min traffic volume distribution	84
Figure C.21 WIMAP-P speed heat map generation	84
Figure C.22 Speed difference diagram.....	85

LIST OF TABLES	Page
Table 2.1 - List of probe-vehicle technologies	10
Table 2.2 - Other examples of lane closure analysis software	13
Table 3.1 - Sample data extracted from 2014 OpenReach	18
Table 3.2 - Processed 2014 OpenReach sample data.....	19
Table 3.3 - Server specifications	21
Table 3.4 - Sample query results using the WIMAP-P DB CUBE	22
Table 4.1 - Number of work zones for various types of lane closures	25
Table 4.2 - Training algorithms for the ANN model	26
Table 4.3 - RMSEs of the ANN models	26
Table 4.4 - Capacity reduction factors γ and R_o	30
Table 4.5 - The freeway MNR model coefficients.....	30
Table 4.6 - The arterial MNR model coefficients	31
Table 5.1 - Lane closure configuration on freeways.....	31
Table 5.2 - RMSE of freeway ANN and MNR models	32
Table 5.3 - R^2 of freeway ANN and MNR models.....	32
Table 5.4 - Lane closure configuration for arterials	32
Table 5.5 - RMSE of arterial ANN and MNR models.....	33
Table 5.6 - R^2 of arterial ANN and MNR models	33
Table 7.1 - Comparison of queue delay and cost (freeway)	45
Table 7.2 - Comparison of queue delay and cost (arterial).....	48
Table 8.1 - Work zone software comparison	50
Table A.1 - CUNY ITS data model server characteristics.....	56
Table A.2 - CUNY ITS application server characteristics	56
Table A.3 - WIMAP-P dimensions descriptions.....	57
Table A.4 - WIMAP-P measure descriptions	57
Table B.1 - Test samples by lane configuration and region (freeways).....	62
Table B.2 - RMSE distribution (freeways)	62

Table B.3 - Number of freeways for consistency test	63
Table B.4 - Parameters of hypothetical work zones on freeways	64
Table B.5 - Number of hypothetical freeway work zones for consistency test.....	64
Table B.6 - Test samples by lane configuration and region (arterials)	66
Table B.7 - RMSE distribution (arterials)	66
Table B.8 - Number of hypothetical work zones (arterials).....	67
Table B.9 - Parameters of hypothetical work zones (arterials)	68
Table B.10 - Number of hypothetical work zones (arterials).....	68
Table C.1 - Comparison of queue delay and cost (freeway)	74
Table C.2 - Comparison of queue delay and cost (freeway)	77
Table C.3 - Comparison of queue delay and cost (arterial)	82
Table C.4 - Comparison of queue delay and cost (arterial)	85
Table D.1 - Traffic capacities.....	86
Table D.2 - Measured work zone capacity - freeway section	87
Table D.3 - Freeway work zone analysis.....	87
Table D.4 - Freeway: work zone delay calculation	88
Table D.5 - Freeway: queue delay cost computation (NJDOT RUCM)	89

ACRONYMS

AADT – Annual Average Daily Traffic
ANN – Artificial Neural Network
FHWA – Federal Highway Administration
GPS – Geographic Positioning System
GUI – Graphical User Interface
HERT-ST – Highway Economic Requirement System - State Version
ITS – Intelligent Transportation Systems
MAC – Medium Access Control
MNR- Multivariate Non-linear Regression
NJDOT- New Jersey Department of Transportation
NJCMS – New Jersey Congestion Management System
QDC – Queue Delay Cost
RMSE – Root Mean Square Error
 R^2 – Coefficient of Determination
RUC – Road User Cost
RUCM – Road User Cost Manual
SLD – Straight Line Diagram
SRI – Standard Route Identifier
TMC – Traffic Message Channel
USDOT- United States Department of Transportation
WIMAP-P – Work Zone Interactive Management Application - Planning

EXECUTIVE SUMMARY

Roadway rehabilitation and reconstruction projects usually require traffic lane and/or shoulder closures. In the US, 67% of federal funds were spent for roadway projects towards system preservation efforts during 2011 and 2013. These activities resulted in reduced travel time reliability and increased delays, crashes, wasted fuel, and overall frustration for commuters. Furthermore, road users in the US lose approximately 552 million gallons of fuel and 482 million hours every year sitting in traffic jams caused by work zones.

To improve the quality of life, protect the environment, and facilitate commerce, it is desirable to develop a tool that can accurately predict work zone impacts, such as a delay over space and time, as well as evaluate the effectiveness of congestion mitigation strategies. The objective of this research was to develop an on-line software application herein called the **Work Zone Interactive Management Application - Planning (WIMAP-P)**, an easy-to-use and easy-to-learn tool for effectively and efficiently predicting the traffic impact caused by work zone lane closures on urban and rural freeways and arterials.

The WIMAP-P tool required the fusion of various data sources which were utilized to develop the corresponding database (DB). The main DBs that were gathered from various agencies and private sectors are: OpenReach, Plan4Safety, SLD, NJCMS, and INRIX:

- **OpenReach DB** contains all the characteristics of each work zone, which is provided by TRANSCOM; the dataset used is from 2013 and 2014 with more than 20,000 records.
- **Plan4Safety DB** contains all crash characteristics for the New Jersey roadways; it is used to screen work zones where accidents occurred; the years 2013 and 2014 were used for the analysis and a total number of more than 550,000 records were sourced for the analysis.
- **Straight Line Diagrams (SLD) DB** contains the roadway geometry for all main roadways in New Jersey; the 2014 SLD DB was used for the analysis and a total number of more than 100,000 records were used for the analysis.
- **New Jersey Congestion Management System (NJCMS) DB** has hourly traffic volumes for the weekdays; the hourly traffic volumes from the year 2012 were used for the analysis, having a total set of more than 7,000 records.
- **INRIX DB** has Traffic Message Channel (TMC) historical travel times at a one-minute aggregation level; the TMCs are INRIX's own system of dividing the roadway into segments. These TMC travel times and the NJCMS traffic volume data are the primary data that are used to predict the speed upstream of each

work zone. The INRIX data from years 2013 and 2014 were used for the analysis with approximately 2 billion speed records reported from more than 5,000 TMCs.

The Artificial Neural Network (ANN) and Multivariate Non-linear Regression (MNR) modeling approaches are adapted to predict delays caused by work zones on freeways and arterials in New Jersey. The variables considered were determined based on the Pearson and Spearman correlation test to investigate the significance of each variable in the model. The variables include: 1) normal speed, 2) traffic volume, 3) work zone length, 4) work zone duration, 5) work zone starting time, 6) ratio of open lanes to number of lanes, 7) number of signalized intersections in work zone, and 8) number of intersections in the upstream segment of work zone.

A total of 466 work zones on both freeways and arterials were used to develop the model, which had a complete set of data. More than 19,000 work zones were excluded from the development due to an incomplete number of data. A set of 141 work zones was used to validate the model. The performance of the ANN and MNR models was evaluated using RMSE and R^2 . It was found that the ANN model is seen as slightly more accurate for predicting delays of historic work zones, but the MNR model demonstrated better reliability and consistency in predicting delays of work zones in places where there are no historic data. A web-based graphical user interface was developed to provide an easy-to-use and intuitive access for interacting with the MNR model, which enables users to better visualize the results.

The major advantages of WIMAP-P are:

- It is GIS-based, allowing all the roadway geometry and characteristics for the NJ freeways, arterials, and the surrounding network for the planning of lane closure locations to be displayed in an intuitively-mannered fashion;
- It is a user friendly system that fuses together roadway geometry, traffic volume, and speed details by integrating data in a data warehouse from the OpenReach, Plan4Safety, SLD, NJCMS, and INRIX databases;
- The graphical user interface facilitates the input data and analysis in an efficient and reasonably intuitive manner while producing graphical results and customized reports that could be directly inputted into any report or presentation, as necessary; and
- The main contribution of the WIMAP-P tool is the prediction of the spatio-temporal speed changes and queue spill-back onto the upstream links caused by work zones on New Jersey freeways and arterials, and its capability to compute the corresponding work zone delay, queue delay, and the associated costs.

The main capabilities and limitations of WIMAP-P are:

- It is capable of producing speed predictions up to 10 miles upstream of a work zone;
- It is applicable for New Jersey's freeways and arterials, where NJCMS (2012) volume counts and INRIX speed information are available;
- It is applicable for work zones that are planned for weekdays and weekends. Note that the weekend traffic volumes were converted from the weekday traffic volumes in NJCMS using the preliminary weekend reduction factors; and
- While the WIMAP-P provides the work zone number of lanes automatically where a work zone is located, careful verification should be performed by the users; and
- It is applicable for crash-free work zones only. WIMAP-P does not predict the accident-risk probability due to a work zone and the corresponding impact on the upstream speed/delay.

The WIMAP-P can be further improved as follows:

- Enhance the developed MNR model using work zones implemented during weekends as soon as the validated hourly traffic volumes become available for both Saturday and Sunday;
- Employ Big Data warehousing/analysis techniques to efficiently handle large-scale data; and
- Continuously update the traffic flow, speed and roadway geometry data or incorporate similar data from other sources.

I. INTRODUCTION

1.1 Background

Transportation systems, especially roadway networks, are a major part of our civil infrastructure and form an integral component for the movement of passengers and goods, thus aiding in progressive economic development. Severe weather conditions, heavy usage, and growing traffic demands deteriorate the condition and functioning of the interconnected road network over time. This makes it necessary to conduct regular road rehabilitation and reconstruction projects, all of which require different configurations of lane closures depending on when and where these activities occur. Closing a lane or even a shoulder of a road segment will cause disruptions in traffic flow, especially during peak hours. These disruptions result in travel delays and often significantly increase travel times due to reduced capacity, which leads to increased road user costs; and excess delays caused by lane closures in work zones are typically unavoidable. Furthermore, traveler delay is considered as a critical factor in making key decisions about staging and scheduling for roadway reconstruction projects. The 1998 FHWA report identifies this issue and recommends the development of a sound tool to estimate and quantify work zone delays.⁽⁷²⁾ Developing a method to estimate the road user cost, delay and related traffic measures (i.e., speed, queue length, emissions, etc.) can aid in implementing appropriate counter measures to mitigate the impacts, which is important for successful work zone management. Hence, developing a sound tool that provides reliable predictions for speed, delay and queue development due to work zone activities will help move traffic more efficiently and reduce motorist inconvenience by effectively planning work phasing and arranging detour routes.

Traditionally, parametric approaches have been widely used to predict work zone delay because they are explainable and applicable to various combinations of traffic flow and capacity conditions. However, due to the limitations in capturing traffic and roadway conditions, the accuracy and reliability of those models could be reduced. Non-parametric approaches, such as machine learning techniques, have the ability to recognize traffic patterns and adjust predicted results dynamically. Furthermore, the availability of vehicle speed and travel time data captured through probe vehicles enhances the accuracy in predicting work zone delays, compared to using an analytical method. However, if the training samples are not sufficient, then the prediction results for the conditions that did not exist in the training samples will not be reliable. In this study, a multi-layer feed-forward Artificial Neural Network (ANN) and a Multivariate Non-linear Regression (MNR) models were developed with the use of probe-vehicle data to predict spatial and temporal delays caused by a work zone on freeways and arterials in New Jersey.

1.2 Objective

The objective of this study is to develop a work zone lane-closure congestion impact prediction system, consisting of a work zone speed prediction model and web-based, user-friendly software that interacts with various NJDOT data sources in an effective and efficient manner. This system, called **Work Zone Interactive Management Application-Planning (WIMAP-P)**, is expected to support state and local traffic construction and operations, as well as support the planning efforts of staff and construction contractors to predict the speed, delay and delay costs caused by each planned work zone on New Jersey's freeways and arterials. The main characteristics of the proposed WIMAP-P are outlined next.

1.3 System Overview

The WIMAP-P system architecture comprises of three specific modules interacting together to generate the required results (Figure 1.1):

1. Database;
2. Work Zone Speed Prediction Model; and
3. Traffic Measure Display Software Tool.

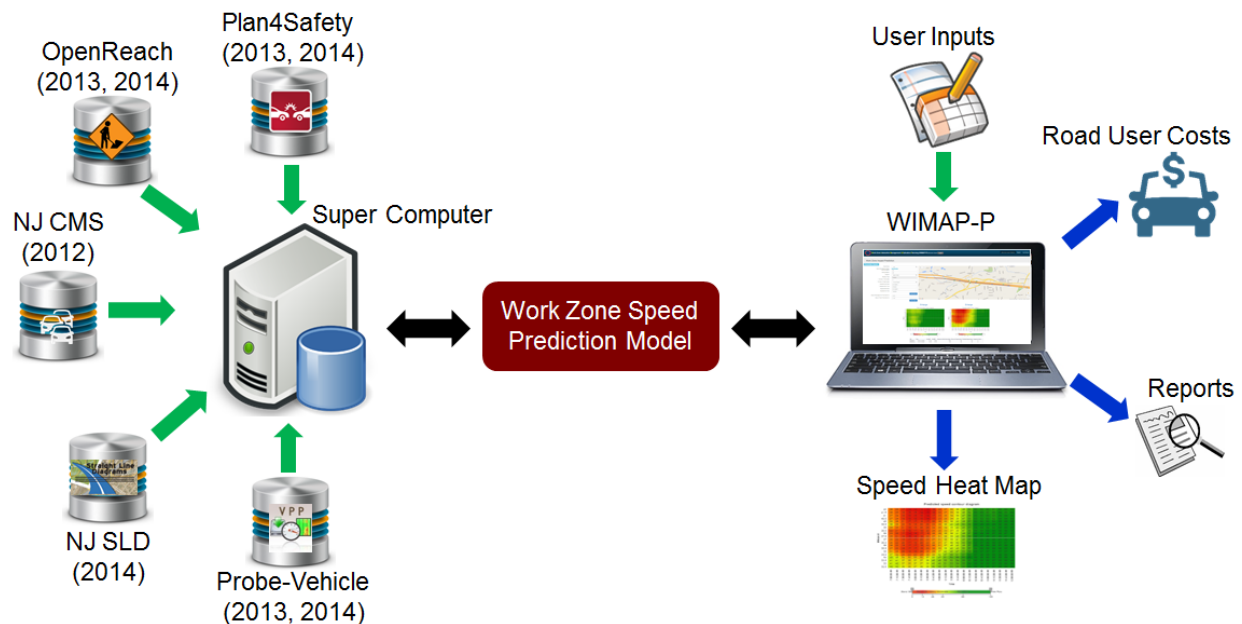

Figure 1.1 WIMAP-P system architecture

The database is developed based on the data feeds from several sources, including Plan4Safety, OpenReach, NJ Straight Line Diagram (SLD), New Jersey Congestion Management System (NJCMS), and INRIX. The delay is predicted through a model developed using the data retrieved from the sources listed above. The software accepts user-specified work zone characteristics (i.e., the location, the date and duration of the

lane closure, number of closed lanes, etc.) and activates a background user delay model for speed and delay prediction utilizing user-specified inputs (i.e., an expected work zone related information) and its database on road geometry and traffic speed information. After running the model, the Graphical User Interface (GUI) shows the predicted work zone speed over time and its corresponding normal speed diagram. Finally, the software generates the report of user delay prediction from the expected work zone lane closure event.

II. LITERATURE REVIEW

This section presents a comprehensive review of the work zone delay prediction models, probe vehicle technologies, analytical methods and software applications for lane closure impact analysis.

2.1 Work Zone Delay Prediction Models

Travel delay is defined as the extra time motorists experience while traveling on a road segment due to reduction in capacity, such as lane closures. ^(1,2,3) Predicting travel speeds and the associated delay caused by a work zone plays a critical role in developing effective traffic management plans and predicting the corresponding queue delay cost (QDC). Numerous methods have been developed, which can be generally categorized into three groups: parametric, non-parametric and simulation.

Deterministic queuing theory is a commonly used parametric approach in predicting work zone delay. ^(1,4-7) It has been in practice for decades and implemented by both the federal and state transportation agencies (e.g., FHWA and various State DOTs in Alabama, Florida, Illinois, New Jersey, Ohio, Oklahoma, Washington, etc.). The critical inputs of the deterministic queuing model are the approaching volume, roadway capacity under normal and work zone conditions, and duration of the work zone. ⁽⁶⁻¹⁰⁾ The deterministic queuing model is suitable for predicting a delay for planning purposes, but it fails to provide accurate prediction under traffic operations wherein there are time-varying and congested traffic conditions. ⁽¹¹⁾ These models have a limited ability to analyze the spatial and temporal congestion impacts caused by work zones.

Another well-known parametric approach for predicting work zone delay is shockwave theory, which was developed by Lighthill and Whitham and Richards. ^(12,13) Shockwave theory assumes that traffic flow is analogous to fluid flow and employs a flow-speed-density relationship to analyze the transition of traffic flow over space and time. The length of a physical queue can be determined based on a specified demand and capacity. Many parameters have to be determined with sufficient traffic volume and speed data under normal and work zone conditions, such as jam density, capacity, critical density, free-flow speed and speed at capacity. ⁽²⁾ However, such traffic flow

parameters are usually unavailable and therefore non-practical for state-side utilization, but method should be considered when available for implementation.

Although the concept of parametric approach is widely applied, it is difficult to accurately predict spatial and temporal delays by a simple analytical formula; it does not capture the time-dimensional impact of the traffic flow characteristics within and upstream of the work zone accurately. In addition to upstream traffic flow arrivals and capacity, other factors affecting work zone delay include traffic characteristics (e.g., vehicle composition, driving behavior, etc.), road geometric condition (e.g., number of lanes, grades, lane width, ramp junctions, etc.) and work zone types (e.g. number of lane closures), which cannot be expressed by the parametric models. Therefore, numerous non-parametric approaches (e.g., ANN and k-Nearest Neighbors Methods) were introduced. Since the concept of the McCulloch–Pitt neuron introduced in the early 1940s, ⁽¹⁴⁾ ANN has been evolving towards more precise and powerful models for pattern recognition and prediction. Several studies have successfully applied ANN (i.e., Boltzmann, radial basis function, and multi-layer feed-forward neural networks) to predict work zone delay. ⁽¹⁵⁻¹⁷⁾ However, using the probe-vehicle data to predict temporal and spatial work zone delays has yet to be encountered.

Researchers have also quantified work zone delay ⁽¹⁸⁻²⁰⁾ through microscopic traffic simulation. Simulation models, once they are well calibrated, are capable of generating high fidelity traffic measures under various work zone configurations. CORSIM, ⁽²¹⁾ VISSIM, ⁽²²⁾ QUEWZ, ⁽²³⁾ Quick Zone, ⁽²⁴⁾ and PARAMICS ⁽²⁵⁾ are among the most widely used models. However, in order to develop a simulation model, comprehensive and historical traffic volume origin-destination trip tables and speed data, high computational resources, time-consuming parameter calibration, and long running time are required. ⁽²⁶⁾ Among these, the most difficult to obtain is the historical upstream arrival traffic flow rate due to the unavailability of traffic flow sensors throughout the transportation network. This limitation makes microscopic simulators almost infeasible to predict work zone delay.

2.2 Probe-vehicle Technologies

Probe-vehicle technologies directly measure the travel time of vehicles equipped with radio-frequency communication tags. There are two basic techniques for generating these time stamps: discrete and continuous. For the discrete technique, a vehicle electronic toll tag (e.g., E-ZPass) or Bluetooth signal is read as a vehicle passes fixed reader locations along the roadway. The Bluetooth and toll tag calculate the travel time as the difference between the time stamp on the downstream reader and the time stamp on the upstream reader. ⁽²⁷⁾ Probe data provided by commercial vendors (i.e., INRIX, ⁽²⁸⁾ TomTom, ⁽²⁹⁾ and HERE ⁽³⁰⁾) are mainly produced by GPS-based tracking systems that capture vehicle movements almost continuously within a very small time interval (e.g., 1 second). ⁽³¹⁾ It is assumed that the travel time of tagged vehicles in a vehicle stream represents the true travel time of all (tagged and non-

tagged) vehicles in the stream. These methods capture the actual volume of all tagged vehicles while the portion of non-tagged vehicles remains unknown.

Previous studies have indicated that the probe-vehicle speed data (i.e., INRIX) is reliable for travel time prediction.⁽³²⁻³⁵⁾ One of the most notable activities of using probe-vehicle technology is the I-95 Corridor Coalition project,⁽³⁵⁾ which demonstrates that probe-vehicle data is accurate under a variety of traffic conditions, including congestion caused by incidents. However, it is very challenging to use probe-vehicle data for developing work zone delay models, as traffic volume data under normal and work zone conditions are not available. Despite an increasing attention in modeling work zone delay prediction,^(12,19,25) only a few studies have examined the spatial and temporal impacts of incidents with traffic volume and speed data collected by loop detectors. Some of the popular probe-vehicle technologies are discussed in the next few sections.

Bluetooth

Bluetooth is an open wireless communication platform used to connect myriad electronic devices. Many computers, car radios and dashboard systems, PDAs, cellular phones, headsets, and other personal equipment are or can be Bluetooth-enabled to streamline the flow of information between devices.⁽³⁸⁾ Manufacturers typically assign unique Median Access Control (MAC) addresses to Bluetooth-equipped devices. Bluetooth-based travel time measurement involves identifying and matching the MAC addresses of Bluetooth-enabled devices carried by motorists, when passing a detector. Since MAC addresses are not tracked when the device is sold within the marketplace, these unique addresses can be detected and matched without establishing a relationship to personal or otherwise sensitive information, thus keeping the traveling public and their personal information anonymous.^(36,38) The sample size of data is also critical in providing accurate and up-to-date travel times. Research conducted by the University of Maryland suggests that a four percent detection rate is required for roadways of 36,000 AADT or greater.⁽³⁹⁾ Roads with lower volumes would require a larger match percentage to attain an adequate sample. A study by Tarnoff, et al.⁽⁴⁰⁾ has discussed that 5-7% of vehicles in a traffic stream have Bluetooth enabled devices, which would be considered an adequate sample size.

Toll Tag

The toll tags developed for electronic toll collection can be used by their readers, deployed at various points on a roadway network to obtain average travel time and speed information. There are four components in a toll tag travel time system: electronic tags, antennas, readers, and a central computing and communication facility.⁽³⁶⁾ As a vehicle with an electronic tag passes underneath a toll tag reader, the time and toll tag identification number are recorded. If the same vehicle passes the next reader location, the travel time and average speed between the two locations can be determined. The toll tag identification number can be coded to protect privacy. Sample size requirements for a toll tag travel time system depend on the market penetration of the toll tags.

Ferman, et al. ⁽⁴¹⁾ suggests that a three percent penetration rate on freeways and 5% on arterials is adequate. According to the New Jersey Turnpike Authority, more than 70% of the vehicles registered in New Jersey have E-Z Pass toll tags. ⁽⁴²⁾

INRIX

The INRIX traffic speeds are generated by blending data from a variety of sources. The primary source of INRIX data is GPS-enabled vehicle fleets (e.g., delivery vans, taxi cabs, and long-haul trucks). This data is supplemented through sensor-based data and GPS-equipped mobile devices. ⁽⁴³⁾ The collected data is compiled into an average speed profile for most freeways and arterials. The initial system spans from New Jersey to Georgia covering more than 7,000 center line miles of freeways and 38,000 arterial miles. ⁽⁴⁴⁾ INRIX data attributes consist of three levels: real-time data for the specific segment, historical data (e.g., road reference speeds), and the combination of real-time and historical data. ⁽⁴⁵⁾ White, et al. ⁽⁴⁶⁾ suggested that because INRIX data is based largely on fleet-based GPS probe vehicles, its use may be an issue for arterials due to a reduced sample size and the fact that commercial vehicles operate differently than other vehicles in terms of their acceleration and deceleration characteristics. Data quality specifications are in effect when traffic flow exceeds 500 vehicles per hour and apply to both freeways and arterials. ⁽⁴⁷⁾

Radar

A radar detection system is a non-intrusive radar-based system operating in the microwave band. It needs to be mounted on a roadside pole above a certain height. The radar sensor provides per-lane presence, volume, occupancy, and speed, as well as classification information in up to 12 user-defined detection zones. Output information is provided to existing controllers via contact closure and to other computing systems by serial port, IP communication port, or by an optional radio modem. A single radar unit can replace multiple inductive loop detectors and the attendant controller. RTMS (Remote Traffic Microwave Sensor), one of the more advanced radar detector technologies, functions under all weather conditions and is virtually maintenance free. The detection range of one RTMS is 200 feet, which provides coverage for up to eight lanes of traffic. ⁽⁴⁸⁾

Table 2.1 summarizes the various probe-vehicle technologies with their advantages, disadvantages, coverage, sample size requirements, and costs.

Table 2.1 - List of probe-vehicle technologies

Technology	Advantages	Disadvantages	Coverage	Sample Size Requirements	Cost	Sources
Bluetooth	<ul style="list-style-type: none"> • Easy and fast to deploy • Continuous data collection • No disruption of traffic • Provides travel time and speed 	<ul style="list-style-type: none"> • High installation cost • Multiple reads from one vehicle • No occupancy or traffic density information 	Freeways and arterials	<ul style="list-style-type: none"> • Freeways – 4% detection rate required for roadways > 36,000 AADT • 5-7% of vehicles have Bluetooth enabled devices 	<ul style="list-style-type: none"> • \$3,500 to \$6,000 per device • Processing software: \$600 to \$1,000 per year 	(36,37,38,48)
Toll Tag	<ul style="list-style-type: none"> • Technology is mature • Simple to install and maintain • Accurately provide speed and travel time 	<ul style="list-style-type: none"> • Sample size depends on market penetration • High installation cost 	Freeways and arterials	<ul style="list-style-type: none"> • Sample size depends on market penetration • Min. required: Freeways – 3%, Arterials – 5% 	<ul style="list-style-type: none"> • \$30,000 per mile 	(36,43,47) (49,50)
INRIX	<ul style="list-style-type: none"> • No installation or maintenance cost for transportation agencies • Continuous data collection • No disruption of traffic • Provides travel time and speed 	<ul style="list-style-type: none"> • Fairly accurate on freeways • Less accurate on arterials • Speed calculation method is not known 	Freeways and arterials	<ul style="list-style-type: none"> • Sample size varies • Protected by nondisclosure agreement 	<ul style="list-style-type: none"> • Mobilization: \$ 150/centerline mile • Annual Fee: \$750 per centerline mile 	(36)
Radar	<ul style="list-style-type: none"> • Technology is mature • Easy to maintain • Insensitive to weather conditions • Cover multiple lanes • Provides spot speed, volume, and occupancy data 	<ul style="list-style-type: none"> • High installation cost • Unable to detect stopped vehicles 	Freeways and arterials	<ul style="list-style-type: none"> • No specific requirement 	<ul style="list-style-type: none"> • \$18,000 to \$38,000 for one site 	(36,49,51)

2.3 Software for Lane Closure Impact Analysis

iPeMS

iPeMS is a commercial traffic data collecting, processing, and analyzing tool to assist traffic engineers in assessing the performance of the freeway system. It is an enhanced model from PeMS, ⁽⁵²⁾ which was originally developed by the University of California, Berkeley, in cooperation with Caltrans. This tool collects real-time traffic data from deployed ITS sensors, saves them in a database, and presents this information in various forms to traffic operators and planners. It also allows users to query freeway traffic data and to compute various performance measures. In addition to determining the spatial and temporal impacts of the existing lane closures on the freeway, iPeMS also provides travel time predictions in which the algorithms combine historical and real-time data. However, the longest prediction period is 30 minutes from the starting time. ⁽⁵³⁾

QUEWZ

Memmott and Dudek developed a model called Queue and User Cost Evaluation of Work Zone (QUEWZ), ⁽²³⁾ which has been commonly used to estimate user costs resulting from lane closures. The model was designed to evaluate work zones on different types of highways, considering percentage of trucks, work zone configuration, hourly traffic volumes, and queuing length. QUEWZ-98 is the most recent version of the QUEWZ family of programs, which can identify lane closure schedules that minimize work zone related delay. It is reported that the QUEWZ-98 model is applicable to work zones on freeways or multilane divided highways with up to six lanes in each direction and any number of lanes closed in one or both directions. ⁽⁵⁴⁾

RILCA

The Rutgers Interactive Lane Closure Application (RILCA) is an interactive computer tool for planning lane closures for work zones that was developed for the New Jersey Turnpike Authority (NJTA)-Garden State Parkway (GSP) division. Bartin, et al. ⁽⁵⁵⁾ found that RILCA could provide various analyses and visualization options to plan lane closures interactively, obtain traffic volume information, determine the maximum queue length, and estimate the time of clearance. However, the disadvantages of RILCA include: (1) Oversimplified formulae to estimate queue length and delay; (2) No real-time traffic data; and (3) Lane closure analyses on only the NJ Turnpike and GSP.

WZCAT

The **Work Zone Capacity Analysis Tool** (WZCAT) analytical software program was developed by the Wisconsin Department of Transportation. ⁽⁵⁶⁾ The main objective of this tool is to predict delays and queues for short-term work zone closures. WZCAT is developed based on the concept of deterministic queuing analysis through basic input/output analysis. This tool was developed to function as an add-on program that

operates within Microsoft Excel. Although WZCAT has a simple structure, it is not able to produce identical queuing patterns to the observed field data and it significantly overestimates the queue length. Furthermore, the queuing pattern estimated was not similar to what was observed.

QuickZone

QuickZone is a work zone delay impact analysis tool developed by the FHWA. It is a Microsoft Excel-based application that facilitates software customization through an open source code. This tool is capable of calculating the average traffic delay and maximum queue length that could result from lane closures or restriction in both urban and suburban work zones. The advantages of using QuickZone are the following:

- Delivery of highly comprehensive and detailed output.
- Adoption of the approach of modeling traveler response to prevailing traffic conditions, such as route changes, peak spreading and mode shifts.

The main limitation of QuickZone is its detailed data requirements for the main line where the work zone is installed, and alternative diversion roadways upstream of the work zone. It will cost time for users to gather all the data inputs that are necessary to implement QuickZone. ⁽⁵⁷⁾

Other Software

In addition to the software discussed above, other types of lane closure analysis software were reviewed and are summarized in Table 2.2.

Table 2.2 - Other examples of lane closure analysis software

State	Software Name	Findings
2006, Tennessee ⁽⁵⁸⁾	Lane Closure Decision Support System (LCDSS)	<ul style="list-style-type: none"> Developed a web-based tool to estimate queue length and delay based on HCM methodology for lane closures on Tennessee roads.
2008, Florida ⁽⁵⁹⁾	N/A	<ul style="list-style-type: none"> Developed a non-linear regression model to estimate work zone travel speed, saturation flow rate, queue delay, and queue length for two-lane roadway work zones (with a lane closure).
2009, Alabama ⁽⁶⁰⁾	N/A	<ul style="list-style-type: none"> Presented the results of research done to determine the need for an update of the queue estimation portion of ALDOT's lane closure analysis tool, a Microsoft Excel-based "Lane Rental Model" whose work zone capacity values are based on the 1994 Highway Capacity Manual.
2010, Oregon ⁽⁶¹⁾	Web-based Work Zone Traffic Analysis (WZTA)	<ul style="list-style-type: none"> Estimated project and corridor work zone delays by using the deterministic methodology. The thresholds used by WZTA are based on decades of on-the-job experience, technical observation and engineering evaluation.

2.4 Summary

This chapter presented a literature review of the methods and software types that are used throughout the United States in predicting traffic flow characteristics when work-zones are present. The literature review initially focuses on various work zone delay prediction approaches. The main limitations of these approaches generally include the unavailability of pertinent traffic flow data, especially those that require historical volume in the vicinity of the work zone. In this study the proposed models are developed to predict spatial-temporal speeds upstream of a work zone with lane closures, based on readily available probe-vehicle data to predict temporal and spatial work zone delays. Therefore, various probe-vehicle technologies used in real-time traffic surveillance systems and lane closure impact analysis tools were discussed.

III. WIMAP-P DATABASE (DB)

This chapter presents the main characteristics of the WIMAP-P DB, which is based on the available data sources for NJ highways that are related to the work zone activities.

3.1 Data Sources and Data Collection

To develop a sound model for predicting speed/delay caused by an expected work zone with lane closures on New Jersey's freeways and arterials, the process requires a significant amount of data from five main databases:

- OpenReach DB: work zone type, date and location of the work zone, lanes closed, duration, and length.
- Plan4Safety DB: severity, location, and starting time.
- NJ-SLD DB: road type, number of lanes, distance, speed limit, signalized intersection location, and interchange location.
- NJCMS DB: weekday traffic volumes and truck percentage.
- Probe-vehicle DB: traffic volumes and speeds for highway segments.

The overview of these databases is shown in Figure 3.1.

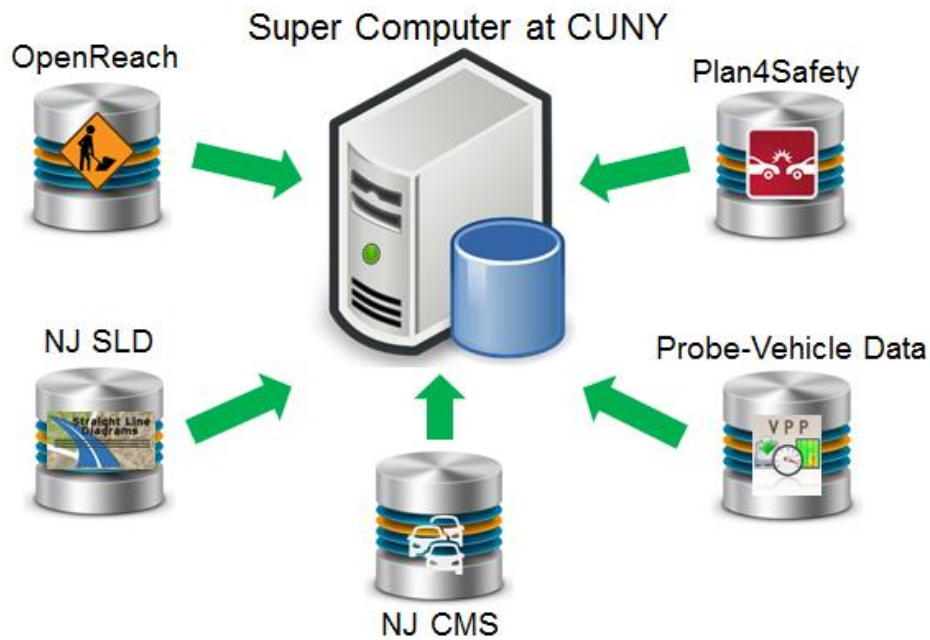

Figure 3.1 WIMAP-P DB overview

OpenReach DB

The work zone data was extracted from TRANSCOM's incident reporting system (OpenReach¹). It contains a list of work zones with location, starting and ending mileposts, description, duration and length. The WIMAP-P DB was populated with additional information related to each work zone by adding the corresponding SRI, direction and number of lanes-closed information (Tables 3.1 and 3.2). A data cleaning procedure was followed to identify and remove abnormal records (e.g., work zone created date was later than closed date, work zone facility name was not reported, number of closed lanes were not mentioned in "Event Description", etc.). A total of 466 records on both New Jersey freeways and arterials out of more than 20,000 OpenReach work zone events in 2013 and 2014 were applied to develop the proposed WIMAP-P.

Plan4Safety DB

The crash data was obtained from the Plan4Safety DB, which is a multi-layered decision support program and created for the NJDOT to aid the studies conducted by transportation engineers, planners, enforcement, and decision makers in New Jersey's transportation and safety agencies. It helps to analyze crash data in geospatial and tabular forms.⁽⁶²⁾ Similar to the NJDOT Crash Record, Plan4Safety provides crash location, date and time of the crash. This database is used for screening out crash-related work zone events in order to analyze mobility impacts that are caused purely by work zone activities. It is noted that work zone activities with the presence of crashes or other incidents is expected to be a future extension of the WIMAP-P as it was not part of this project.

NJ-SLD DB

The roadway inventory and geometry data of each work zone event (e.g., SRI, functional classification, total number of lanes, and presence of signalized intersections), was based on the most recent NJDOT 2014 Straight Line Diagram (SLD) DB. The SLD, initially designed as a planning tool, is a one-dimensional graphical depiction of a section of roadway and its related data which includes the Interstate freeways, the US highways, and the State routes. The SLD system, including the data repository and software, is maintained by NJDOT's Bureau of Transportation Data Development. By using SRI and mileposts obtained from SLD, the travel speed within work zones and upstream of work zones can be identified. Further the main geometric characteristics of the work zone such as direction, speed limit, and number of lanes were used to develop the WIMAP-P system.

¹ The OpenReach is operated and maintained by TRANSCOM. It receives work zone and incident data from various sources including NJDOT, which are then uploaded into the OpenReach platform for storage and dissemination to other TRANSCOM member agencies, traveler information provides, and the general public via the 511 traveler information system.

NJCMS DB

The weekday traffic flow data, necessary for the analysis of work zone impacts, were obtained from the most recent 2012 New Jersey Congestion Management System (NJCMS), a data management and data analysis system used primarily by the Bureau of Systems Planning to estimate congestion measures for New Jersey highways. The highway links in the NJCMS tables are identified by SRI or Route Name (e.g., I-80, or NJ-21), and by begin and end mileposts. The link traffic volume information in NJCMS was tied to work zones identified in OpenReach DB by using these unique link identifiers. Traffic flow data was then used to calculate link volumes in conjunction with work zone information for the model development.

Probe-vehicle Traffic Speed Data

The main traffic speed data that are used to develop the WIMAP-P system are historical speed data from INRIX. The historical INRIX speed data is anonymously collected from GPS-enabled vehicles and mobile devices through Traffic Message Channel (TMC) and compiled into 1-minute-average speed measurements. This historic 1-minute speed data were aggregated into 15-minutes of speed data for each TMC located upstream of each work zone that was used to develop the WIMAP-P. There are more than 5,000 TMCs in New Jersey, covering interstate highways, US highways, and state routes. The INRIX raw data, which included more than 4 billion records, was collected for 24 hours a day over a 2-year period, from January 2013 to December 2014. This time period, including weekdays, weekends, peak, and non-peak hours, adequately reflected real traffic conditions before, during, and after work zone activities.

3.2 Data Processing

The process to define the working DB that is utilized by the WIMAP-P, called WIMAP-P DB, was based on the availability and applicability to predict the work zone speed and delay as required by the proposed prediction model. The data was evaluated in terms of data structure, compatibility and usability for WIMAP-P. A demonstrative chart of the data process that is followed to develop the WIMAP-P DB is shown in Figure 3.2. The major issues encountered during data processing are described below.

OpenReach: Discrepancies between the scheduled work zone time and location and the data reported by OpenReach were found. Work zone records with insufficient data (i.e., begin and end MPs and times, lane closures, etc.) were excluded in the model development process.

INRIX: While the INRIX speed was reported on a TMC basis, which has only starting and ending coordinates, the corresponding work zone (OpenReach DB) is based on the NJ SLD. These two data sources could not be cross-referenced with each other. Therefore a conversion methodology to associate INRIX TMC information and SLD

information needed to be developed. Hence the WIMAP-P DB fused the INRIX TMC data to the SRI-based OpenReach data.

SLD: The number of lanes of a few segments in SLD is inconsistent with the actual situation. For example, the lane counts may include travel lanes in opposite direction or center turn lane. These SLD records were manually corrected for model development.

NJCMS: The SRI coded in NJCMS is non-directional, which has been manually corrected to match the directional SRI coded in SLD DB. With this correction, the link traffic volume by direction can be accurately stored in the working database. Note that the weekend traffic volumes were converted from the weekday traffic volumes in NJCMS using the preliminary weekend reduction factors.

Plan4Safety: The SRI in Plan4Safety is different from the SLD. The WIMAP-P DB developed contains manually fused data from the Plan4Safety and the SLD such that all the crash data had the same SRI consistent to the SLD SRI.

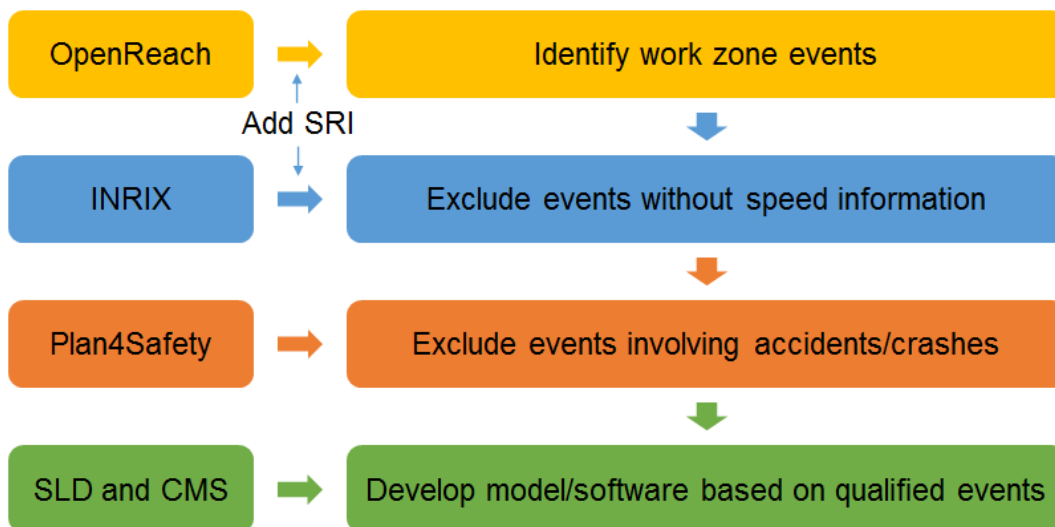

Figure 3.2 Data processing diagram

Table 3.1 - Sample data extracted from 2014 OpenReach

Event ID	Facility Name	Created at Date Time	Closed at Date Time	Event Type	Event Description	From Mile Marker	To Mile Marker
72747501	I-295	5/1/14 09:00	5/1/14 14:00	Construction	NJ DOT - TOC South: Construction, construction on I-295 southbound North of Exit 60 - I-195/NJ 129 (Hamilton Twp) to Exit 61 - Arena Dr (Hamilton Twp) right lane closed until 2:00 P.M.	60.5	61.4
72747901	I-80	5/1/14 09:00	5/1/14 15:00	Construction	NJ DOT - STMC: Construction, guard rail repairs on I-80 both directions between East of Exit 12 - CR 521/Hope-Blairstown Rd (Frelinghuysen Twp) and West of Exit 26 - US 46 (Mount Olive Twp) left lane closed for repairs until 3:00 P.M.	14	26
72748401	I-78	5/1/14 09:00	5/1/14 15:00	Construction	NJ DOT - STMC: Construction, pothole repair on I-78 both directions West of Exit 26 - CR 665/Rattlesnake Bridge Rd (Readington Twp) to East of Exit 41 - Dale Rd to Plainfield Ave (Watchung) right lane closed until 3:00 P.M.	26.7	42.7
72764701	I-80	5/1/14 20:00	5/2/14 06:00	Construction	NJ DOT - STMC: Construction, milling on I-80 eastbound between Exit 53 - NJ 23/US 46 (Wayne Twp) and Exit 57 - NJ 19 (Paterson) 3 left lanes closed for repairs until 6:00 A.M. 10-15 minute delay.	53.6	58.2

Table 3.2 - Processed 2014 OpenReach sample data

Event ID	Facility Name	SRI	Direction	Created At Date Time	Closed At Date Time	Event Type	Event Description	From Mile Marker	To Mile Marker	Closure Lane
72747501	I-295	00000295_S	SOUTHBOUND	5/1/14 09:00	5/1/14 14:00	Construction	NJ DOT - TOC South: Construction, construction on I-295 southbound North of Exit 60 - I-195/NJ 129 (Hamilton Twp) to Exit 61 - Arena Dr (Hamilton Twp) right lane closed until 2:00 P.M.	60.5	61.4	Right lane
72747901	I-80	00000080__	EASTBOUND	5/1/14 09:00	5/1/14 15:00	Construction	NJ DOT - STMC: Construction, guard rail repairs on I-80 eastbound between East of Exit 12 - CR 521/Hope-Blairstown Rd (Frelinghuysen Twp) and West of Exit 26 - US 46 (Mount Olive Twp) left lane closed for repairs until 3:00 P.M.	14	26	Left lane
72748401	I-78	00000078__	EASTBOUND	5/1/14 09:00	5/1/14 15:00	Construction	NJ DOT - STMC: Construction, pothole repair on I-78 eastbound between West of Exit 26 - CR 665/Rattlesnake Bridge Rd (Readington Twp) to East of Exit 41 - Dale Rd to Plainfield Ave (Watchung) right lane closed until 3:00 P.M.	26.7	42.7	Right lane
72764701	I-80	00000080__	EASTBOUND	5/1/14 20:00	5/2/14 06:00	Construction	NJ DOT - STMC: Construction, milling on I-80 eastbound between Exit 53 - NJ 23/US 46 (Wayne Twp) and Exit 57 - NJ 19 (Paterson) left lane closed for repairs until 6:00 A.M. 10-15 minute delay.	53.6	58.2	Left lane

3.3 Database (DB) Development

The WIMAP-P DB was developed using the CUNY ITS computing resources, which provided adequate amounts of data storage and computing processing, in order to handle the large data resources that are needed to process and execute the proposed prediction model. The architecture, procedure, data sources and server specifications are outlined next.

WIMAP-P DB Architecture

The WIMAP-P DB system architecture is depicted in Figure 3.3. Among the main functions of the DB is the utilization of the INRIX speed data to produce 15-minute average speed data for weekdays and weekends, which are then sent to WIMAP-P to produce predicted speeds within and upstream of the lane closure location.

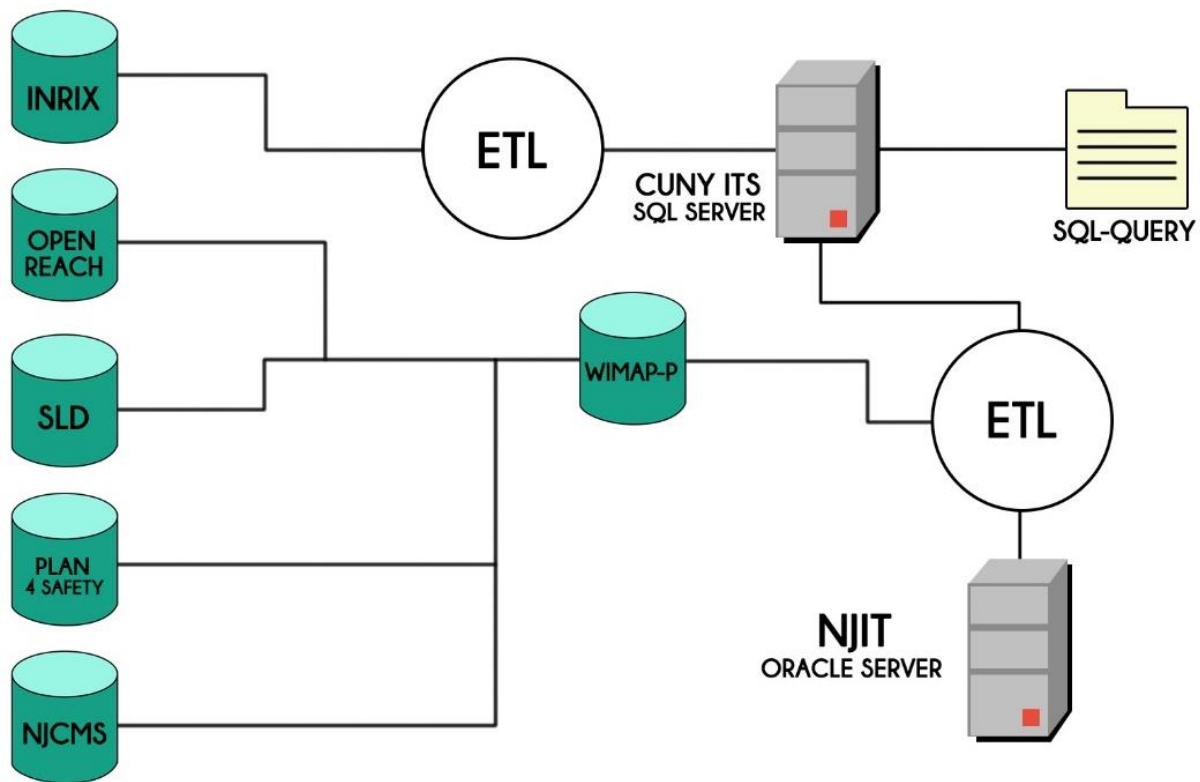

Figure 3.3 WIMAP-P DB architecture

The CUNY ITS server system is comprised of two servers. The server names and their functionalities are discussed in Table 3.3. The characteristics of each server are provided in Appendix A. Based on the needs of the application, the model may require adding more data sources or handling modifications of a specific data source in the database. To accommodate these, the data model is changed first at the development server and is subsequently applied to the application server. All data is stored in the second server and at an external storage device for redundancy. The NJIT server was

used exclusively for the development of the speed prediction model. Once a new version of WIMAP-P is developed, it is uploaded to the CUNY server. The CUNY ITS server receives the INRIX data from the NJIT server, where it is first extracted, transformed, and loaded onto the SQL server for data analysis. The data is then transformed using the CUBE data structure as depicted in Figure 3.4.

Table 3.3 - Server specifications

Server	Functions
Windows Xeon Server	Used to develop the base database (DB) model to produce the necessary parameters as required by the WIMAP-P. Used to speed up the model development using the CUBE concept.
SGI Altix 4700 with 40 CPU	Fulfils two functions <ul style="list-style-type: none"> • To process the WIMAP-P queries faster. • To store the data for present and future use.

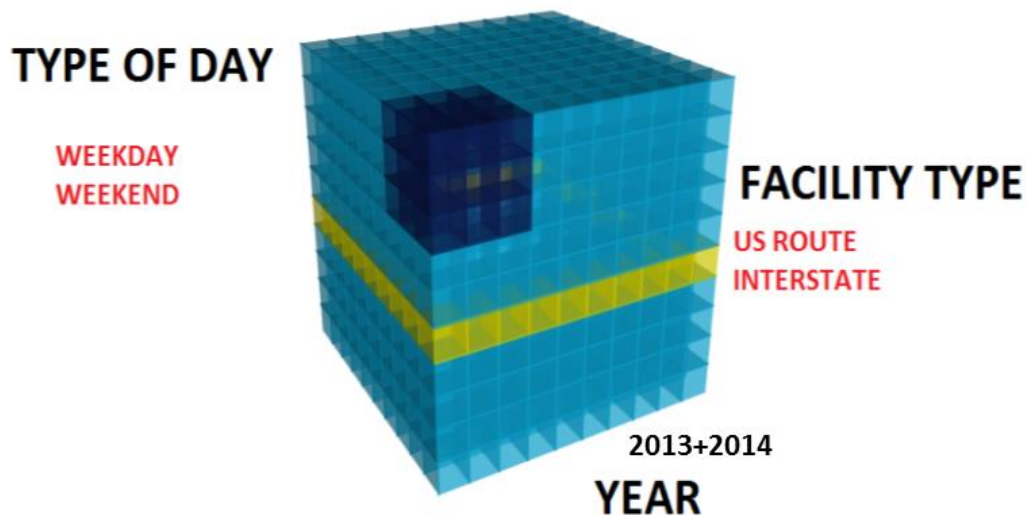

Figure 3.4 WIMAP-P INRIX data CUBE structure

The CUBE is defined to support the development of the WIMAP-P system and comprises a total of eight dimensions and five measures that are tabulated in Appendix A. The user has the capability to define the CUBE that will best serve as the model development of choice. Additional dimensions and measures may be defined as the model progresses. Table 3.4 presents sample results for an SQL query using the CUBE data structure. The complete query used in the development process can be found in Appendix A.

Table 3.4 - Sample query results using the WIMAP-P DB CUBE

TMC CODE	YEAR	MONTH	INTERVAL			SPEED			COUNT
			ID	MINIMUM	MAXIMUM	AVERAGE	MINIMUM	MAXIMUM	
120+04349	2013	1	1	0:00	0:15	62.21	57	72	280
120+04349	2013	1	3	0:30	0:45	62.06	55	69	189
120+04349	2013	1	4	0:45	1:00	63.47	56	74	193
120+04349	2013	1	5	1:00	1:15	61.82	59	68	175
120+04349	2013	1	6	1:15	1:30	60.69	59	64	148
120+04349	2013	1	7	1:30	1:45	61.98	53	67	199
120+04349	2013	1	8	1:45	2:00	61.69	55	66	244
120+04349	2013	1	9	2:00	2:15	61.63	56	75	181
120+04349	2013	1	10	2:15	2:30	61.41	57	68	180
120+04349	2013	1	11	2:30	2:45	61.42	56	68	136
120+04349	2013	1	12	2:45	3:00	61.06	56	66	157

IV. THE WORK ZONE SPEED PREDICTION MODELS

Two models, including a Multi-layer Artificial Neural Network (ANN) Model and a Multivariate Non-linear Regression (MNR) Model, were developed to predict speeds caused by work zones on New Jersey’s freeways and arterials. This chapter describes the basic configuration of the ANN and MNR models followed by identification of inputs for its implementation on freeways and arterials, respectively.

4.1 The ANN Model

In the presence of a work zone, the normal traffic flow conditions are expected to be disturbed due to the reduction in capacity within the influence area of the work zone. This disruption may be minor or very severe depending mainly on the relationship of the upstream roadway capacity, upstream traffic volume and the downstream (work zone area) capacity. It is expected that in most cases the corresponding upstream speed will be reduced, unless the upstream arrival traffic flow is less than the downstream capacity. The congestion is expected to continue to propagate, depending on arriving traffic volume and the residual capacity of the work zone segment. In order to predict the spatial-temporal upstream and work zone speed, the work zone characteristics (e.g. work zone length and duration), road geometry (e.g. number of lanes and grade), and traffic conditions (e.g. volume and speed) were considered for the model development. (2,15,26,63)

The general configuration of the ANN model is shown in Figure 4.1. The input variables are illustrated in the left column including work zone length, work zone duration, work zone lane width, etc. The input variables are selected based on the result of the Pearson and Spearman correlation tests and data availability. (64,65) Briefly, the Pearson correlation evaluates the linear relationship between two variables while the Spearman

correlation evaluates the non-parametric relationship between the variables. The closer the value is to 1 or -1, the stronger the correlation between the variables. ⁽⁶⁶⁾ The weights of input variables can be justified via a training algorithm, such as Levenberg-Marquardt, Bayesian regularization, or scaled conjugate gradient algorithms. ^(15,17,25)

It is worth noting that the predicted speeds can be extended up to 10 miles upstream of the work zone and 2 hours after the work zone is removed, in the absence of any incident during the analysis period. These limits were determined based on the 2013 and 2014 freeway and arterial work zone data collected in New Jersey. The above configuration forms the framework for both the freeway and arterial work zone delay prediction models whose development processes are discussed next.

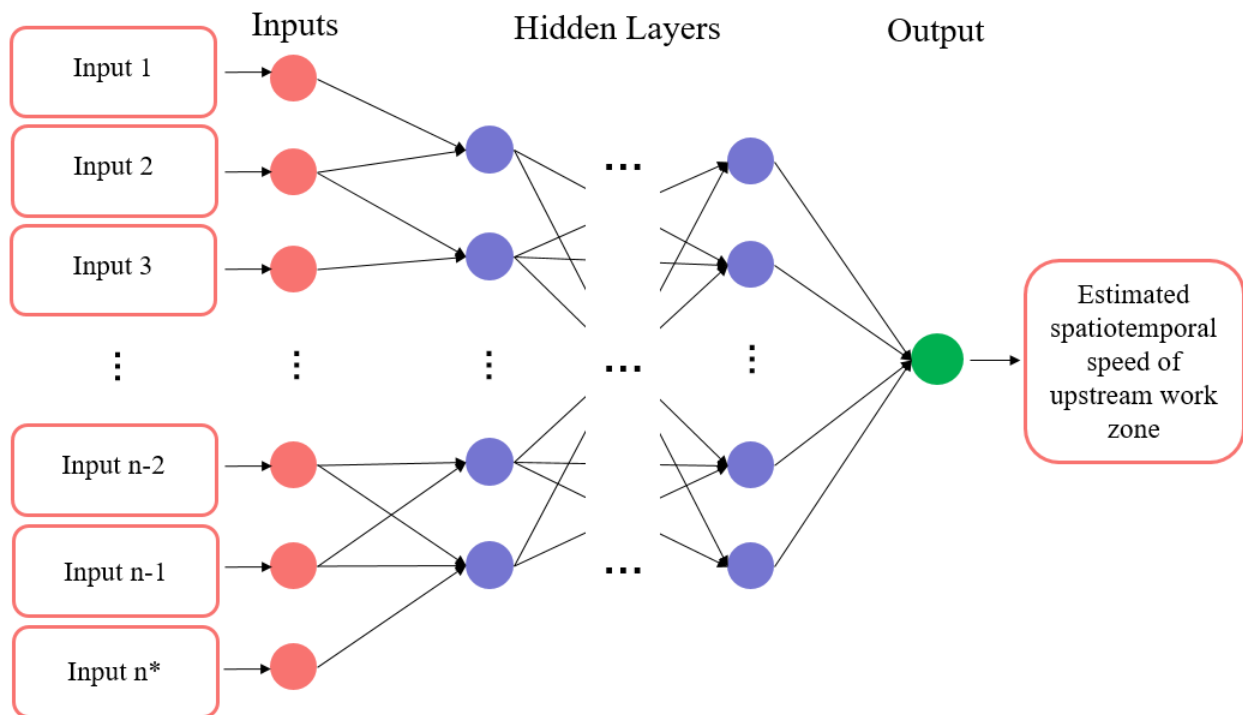

Figure 4.1 Configuration of the proposed ANN model

4.1.1 The Freeway ANN Model

Traditional delay prediction methods (i.e. deterministic queuing and shockwave models) and simulation models require traffic counts as a key input for model development. However, traffic volume data is not available everywhere and are sometimes outdated. This issue proved the predicted work zone speeds unreliable. If the work zone configuration and spatial-temporal probe-vehicle speed data under normal and work zone conditions are available, the proposed model is able to capture work zone delay without traffic volume information. Based on this theory, attention was provided to

* n = Total number of desirable inputs.

identify the factors affecting the speed of upstream work zones. By assessing the database and conducting a correlation test (i.e., Pearson and Spearman), the average speed (y_{ij}) of the upstream work zone TMC segment i at time j can be formulated as a function of factors as follows:

$$y_{ij} = F(s_{ij}, x_1, x_2, x_3, x_4) \quad (4.1)$$

where:

- s_{ij} = Normal speed of segment i at time j ;
- x_1 = Work zone length;
- x_2 = Work zone duration;
- x_3 = Work zone starting time; and
- x_4 = Ratio of opened lanes to number of lanes.

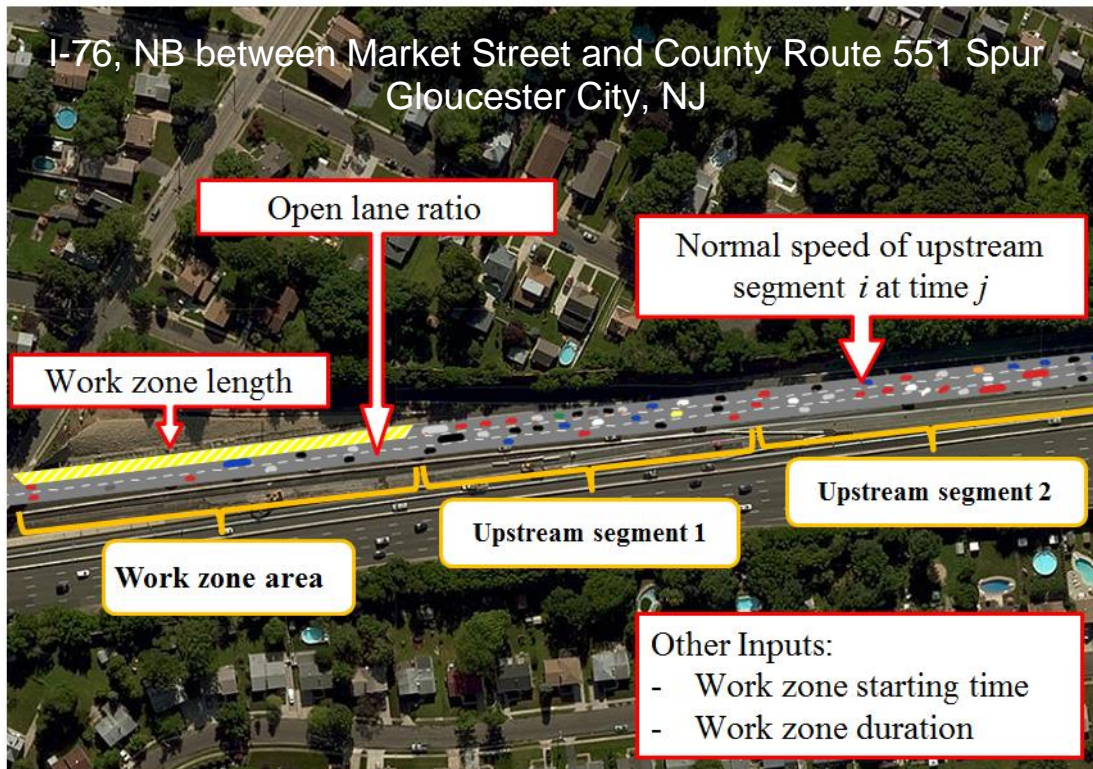

Figure 4.2 Inputs of the freeway ANN model

For each lane closure type presented in Table 4.1 (i.e., 2-lane, 3-lane, and 4⁺ lane closures), the first randomly selected 70% of the work zone data were used to train the ANN model; the following 20% work zone data were used for model validation; and the last 10% of work zone data were used for testing.

Table 4.1 - Number of work zones for various types of lane closures

		Types of Lane Closures		
		Shoulder Closure	1-lane Closure	2-lane Closure
No. of Lanes per Direction	2	10	62	-
	3	30	104	12
	4 and more	7	36	13

To improve the delay prediction accuracy, the training algorithm, and number of hidden layers and neurons of the ANN model must be carefully determined. In this study, the RMSE formulated as Eq. 4.2 is selected as the primary criterion to assess prediction accuracy. The RMSE denotes the variability between the predicted and INRIX reported speeds upstream of a work zone.

$$RMSE = \sqrt{\sum_{i=1}^m \sum_{j=1}^n (\hat{y}_{ij} - y_{ij})^2} \quad (4.2)$$

where:

\hat{y}_{ij} = predicted speed of segment i at time j (mph);

y_{ij} = INRIX reported speed of segment i at time j (mph);

i = the i th roadway segment upstream of the work zone ($1 \leq i \leq m$);

j = the j th time interval after the work zone started ($1 \leq j \leq n$);

m = the number of roadway segments upstream of the work zone; and

n = the number of time intervals (e.g. 15 minutes per interval) between work zone starting and ending times.

The RMSE provides the extent of the deviation in the results predicted by the ANN model from the INRIX reported speed. Therefore, a low RMSE indicates better accuracy due to the small deviation and greater proximity to the reported speed. Hence the numbers of hidden layers and neurons that yielded the lowest RMSE were selected. Table 4.2 depicts the RMSEs for the three training algorithms provided by the MATLAB Neural Network Toolbox.⁽⁶⁷⁾ Considering a single layer ANN model with 10 neurons, the Levenberg-Marquardt (LM) algorithm must be considered because it yielded the lowest RMSE value.

Table 4.2 - Training algorithms for the ANN model

Training Algorithms	RMSE (mph)
Levenberg-Marquardt (LM)	2.0
Bayesian Regularization (BR)	2.5
Scaled Conjugate Gradient (SCG)	2.7

Using the LM algorithm, Table 4.3 shows the RMSE of single layer and 2-layer models for work zones occurring on a 3-lane freeway. It was found that there is no substantial difference between single and 2-layer ANN models. Hence a one-layer ANN model with 10 neurons is sufficient to provide output with satisfactory accuracy along with the benefit of reduced computation time as compared to a multi-layer ANN model. It was also found that the one-layer ANN model with 10 neurons is satisfactory for both 2-lane (i.e. RMSE = 4.4 mph) and 4⁺-lane (i.e. RMSE = 1.5 mph) work zones.

Table 4.3 - RMSEs of the ANN models

	No. of Neurons		RMSE (mph)
	Layer 1	Layer 2	
1-layer ANN	3	-	2.4
	10	-	2.0
2-layer ANN	4	3	2.2
	5	5	3.0
	10	10	2.3

The finalized configuration of the proposed freeway ANN model for predicting the speed upstream of a work zone is shown in Figure 4.3. It has an input layer with five neurons representing different input variables, one optimized hidden layer with 10 neurons, and an output layer with one neuron representing the predicted speed of an upstream work zone.

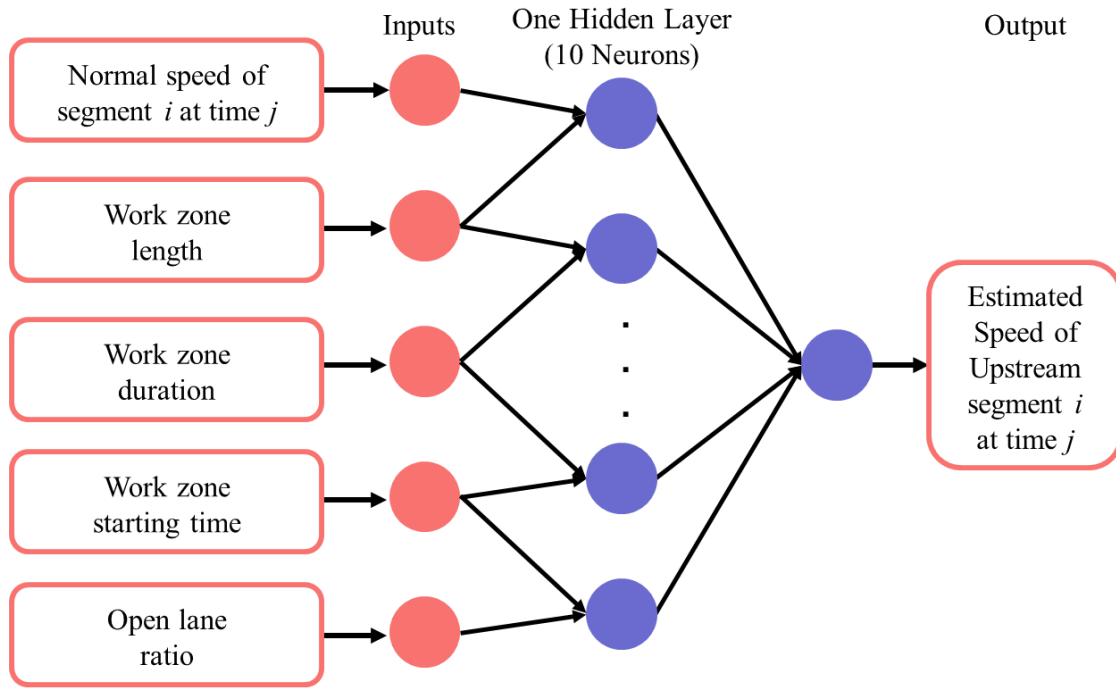

Figure 4.3 Proposed freeway ANN model

4.1.2 The Arterial ANN Model

The arterial model was developed using similar logic as the freeway ANN model. Apart from the factors affecting the speed of the upstream work zone on freeways, the arterial model would require the consideration of additional factors, namely the number of non-signalized intersections and signalized intersections present in or upstream of the work zone. The average speed (y_{ij}) of upstream work zone TMC segment i at time j on an arterial roadway network can be formulated as a function of factors as follows:

$$y_{ij} = F(s_{ij}, x_1, x_2, x_3, x_4, x_5, x_6) \quad (4.3)$$

where:

- s_{ij} = Normal speed of segment i at time j ;
- x_1 = Work zone length;
- x_2 = Work zone duration;
- x_3 = Work zone starting time;
- x_4 = Ratio of open lanes to number of lanes;
- x_5 = Number of signalized intersections in work zone; and
- x_6 = Number of intersections in segment i upstream of work zone.

Figure 4.4 depicts the input variables used in the arterial ANN model. Similar to Freeways, these variables are used for tuning the values of the weights and biases of the network to optimize network performance.

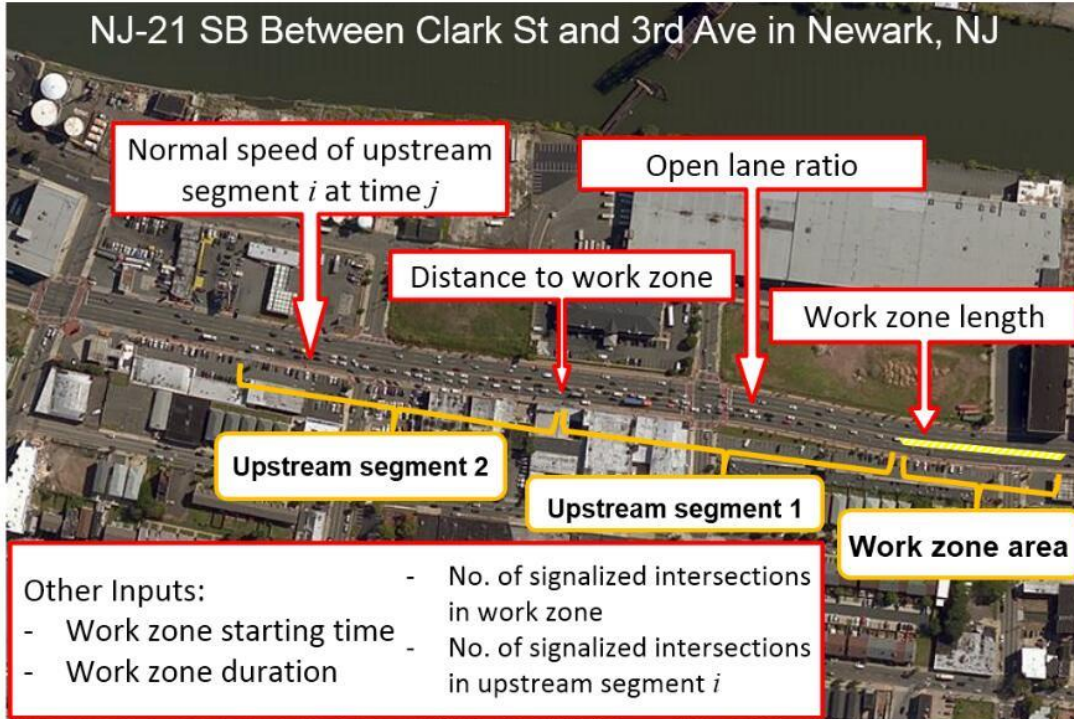

Figure 4.4 Inputs of the arterial ANN model

The optimal numbers of hidden layers and neurons are determined based on the lowest RMSE. The developed ANN models consist of one hidden layer with 10 neurons. The finalized architecture of the proposed arterial ANN model for predicting the speed upstream of a work zone is shown in Figure 4.5.

4.2 The Multivariate Non-linear Regression Model

Apart from the ANN model the WIMAP-P software also links a Multivariate Non-linear Regression (MNR) work zone speed prediction model. This model was developed to assist in predicting work zone speed for situations in which the ANN model performance is limited due to the absence of sufficient historical work zone data.

4.2.1 The Freeway MNR Model

The freeway MNR model was formulated for different lane configurations namely, 2-lane, 3-lane and 4-lane, which is formulated as Eq. 4.4.

$$y_{ij} = ax_i(1 - \alpha) + b \frac{S_{ij}}{1 + e \left(\frac{Q_{ij}}{C_w} \right)^f} + cx_i\alpha + d \quad (4.4)$$

where:

y_{ij} = Work zone speed of segment i at time j ;

s_{ij} = Normal speed of segment i at time j ;
 x_i = Distance from segment i ;
 Q_{ij} = Traffic volume of segment i at time j ;
 C_w = Work zone capacity;
 a, b, c, d, e, f = Arrays of freeway model coefficients; and
 α = A binary variable of time j (0: work zone exists; 1: work zone is removed).

The work zone capacity (C_w) is approximated as a product of normal capacity (C), work zone capacity reduction factor (γ) and open lane ratio (R_o). Thus,

$$C_w = C * \gamma * R_o \quad (4.5)$$

The values of capacity reduction factors γ and R_o as shown in Table 4.4 were calibrated based on historic work zone data. Note that both γ and R_o are equal to 1 after the work zone has been removed. Table 4.5 illustrates the values of freeway MNR model coefficients with respect to different lane configurations, which were also calibrated based on historic work zone data.

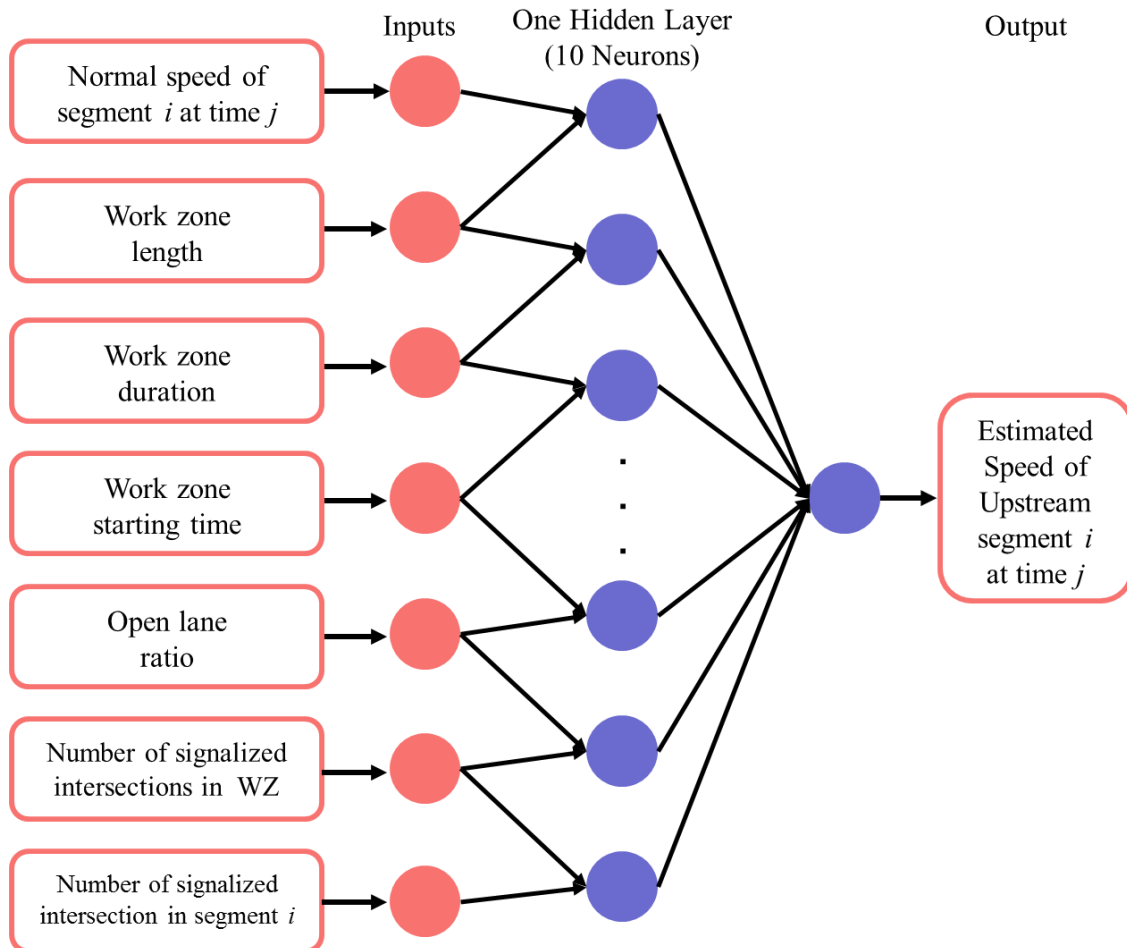

Figure 4.5 Proposed arterial ANN model

Table 4.4 - Capacity reduction factors γ and R_o

Lane Closure Configuration	2-lane		3-lane		4-lane	
	γ	R_o	γ	R_o	γ	R_o
Shoulder Closure	0.9	1	0.95	1	0.95	1
1-lane Closure	0.5	0.5	0.6	0.66	0.7	0.75
2-lane Closure	-	-	0.5	0.33	0.6	0.5
3-lane Closure	-	-	-	-	0.5	0.25

Table 4.5 - The freeway MNR model coefficients

Lane Configuration	Coefficients					
	a	b	c	d	e	f
2-lane	0.55	1.13	-0.64	-9.35	0.1	2.87
3-lane	0.43	1.13	-4.11	-7.28	0.1	2.04
4-lane and more	0.68	1.24	-0.38	-18.49	0.1	2

4.2.2 The Arterial MNR Model

The arterial MNR model was formulated as Eq. 4.6, considering 2-lane and 3-lane roads.

$$y_{ij} = ax_i(1 - \alpha) + b \frac{s_{ij}}{1 + g \left(\frac{Q_{ij}}{C_w} \right)^h} + cn_{wz} + dn_{tmc} + ex_i\alpha + f \quad (4.6)$$

where:

C_w = Work zone capacity (see Eq. 4.5);

a, b, c, d, e, f, g, h = Arrays of arterial model coefficients;

α = A binary variable of time j (see Eq. 4.4);

n_{wz} = Number of signalized intersections within the work zone; and

n_{tmc} = Number of intersections in segment i upstream of work zone.

Table 4.6 provides the values for the constants used in the arterial MNR equation with respect to the different lane configurations.

Table 4.6 - The arterial MNR model coefficients

Lane Configuration	Coefficients							
	<i>a</i>	<i>b</i>	<i>c</i>	<i>d</i>	<i>e</i>	<i>f</i>	<i>g</i>	<i>h</i>
2-lane and less	0.6	1.01	-0.1	-0.9	-2.76	3.33	0.1	1.5
3-lane and more	0.5	1.56	-0.06	-0.36	-1.76	-23.38	0.1	1.48

V. MODEL EVALUATION AND ANALYSIS

To assess the overall performance of the ANN and MNR models for predicting speeds caused by work zone activities on freeways and arterials, a detailed analysis was conducted. The study incorporated the entire work zone data for the years 2013 and 2014, where a total of 466 work zones were identified on both New Jersey freeways and arterials. The data was further classified based on their respective regions (i.e., North, Central and South) complemented by the number of lanes per direction (i.e., 2-lane, 3-lane, and 4 or more lanes).

5.1 Freeway Model Performance

The freeway ANN and MNR models were evaluated using 84 (30%) out of 274 identified work zone records in 2013 and 2014. These records covered a total of 8 work zone types as shown in Table 5.1. The RMSEs and R^2 under lanes per direction and type of lane closure by regions for both the ANN and MNR models are summarized in Tables 5.2 and 5.3, respectively. It was found that the ANN model outperforms the MNR model for testing with historic work zone data in terms of RMSE or R^2 . The 3-lane MNR model yielded the lowest RMSE (4.0 mph) and the highest R^2 (0.69) against the 2-lane and 4-lane ones because more work zone sites were available for the model development (44 vs. 23 and 17, respectively). The quality assurance analysis of the freeway MNR model is discussed in Appendix B.

Table 5.1 - Lane closure configuration on freeways

No. of Lanes per Direction	Shoulder Closure	1-lane Closure	2-lane Closure
2-lane	✓	✓	N/A
3-lane	✓	✓	✓
4-lane	✓	✓	✓

Table 5.2 - RMSE of freeway ANN and MNR models

No. of Lanes per Direction	No. of Work Zones	RMSE (mph)				
		MNR				ANN
		North	Central	South	Overall	Overall
2-lane	23	7.3	9.4	4.0	9.0	4.4
3-lane	44	4.0	3.0	3.0	4.0	2.0
4-lane	17	7.0	8.0	N/A	7.0	1.5
Total	84				5.9	2.9

Table 5.3 - R² of freeway ANN and MNR models

No. of Lanes per Direction	No. of Work Zones	R ²				
		MNR				ANN
		North	Central	South	Overall	Overall
2-lane	23	0.50	0.41	0.63	0.48	0.81
3-lane	44	0.76	0.65	0.62	0.69	0.90
4-lane	17	0.60	0.65	N/A	0.62	0.91

5.2 Arterial Model Performance

The Arterial ANN and MNR models were evaluated using 57 (30%) of 192 identified work zone records in 2013 and 2014. These records covered a total of 7 work zone types as shown in Table 5.4. Similar to the freeway model, the RMSE and R² values of the ANN and MNR model are summarized in Tables 5.5 and 5.6, respectively. The quality assurance analysis of the arterial MNR model is discussed in Appendix B.

Table 5.4 - Lane closure configuration for arterials

No. of Lanes per Direction	Shoulder Closure	1-lane Closure	2-lane Closure
2-lane	✓	✓	N/A
3-lane	✓	✓	✓
4-lane	N/A	✓	✓

Table 5.5 - RMSE of arterial ANN and MNR models

No. of Lanes per Direction	No. of Work Zones	RMSE (mph)	
		ANN	MNR
2-lane	37	5.3	9.0
3-lane and more	20	4.5	10.8
Total	57	5.0	10.3

Table 5.6 - R² of arterial ANN and MNR models

No. of Lanes per Direction	No. of Work Zones	R ²	
		ANN	MNR
2-lane	37	0.89	0.64
3-lane and more	20	0.87	0.72

5.3 Summary of Performance Evaluation

The evaluation results indicated that both the ANN and MNR models performed satisfactorily in comparing historic work zone speed data under different lanes per direction and type of lane closures on both freeways and arterials. A low RMSE with the ANN model indicates slightly better speed prediction accuracy due to the small window of possible deviation and greater proximity to the INRIX reported speed. However, because the historic work zones (served as training samples) are not sufficient to cover work zones crossing the peak period, the prediction results for some conditions are not reliable. With this concern, the MNR model is recommended and linked with WIMAP-P to predict spatial-temporal speeds because it is able to be applied to various combinations of traffic flow and capacity conditions.

VI. WIMAP-P SOFTWARE

The MNR model is supported by a user-friendly web-based interface, which provides users an easy and intuitive tool for interacting with the MNR model. The ability to visualize the results through color coded or tabulated representations enables users to better comprehend the situation and to develop more effective mitigation plans and conduct experimentations with alternative scenarios. This section describes the major components and features provided by the software tool to users. More details regarding operating the software are documented in the user manual (Appendix E), which can also be downloaded from the WIMAP-P software homepage.

6.1 Graphical User Interface (GUI)

The WIMAP-P GUI is developed in Microsoft Visual Studio 2010 with Microsoft ASP.Net and Google Maps API. A Snapshot of the homepage of WIMAP-P is shown in Figure 6.1.

The screenshot displays the WIMAP-P homepage with the following elements:

- Header:** "Work Zone Interactive Management Application-Planning (WIMAP-P)" with a logo on the left and "Welcome Guest! Logout" on the right.
- Navigation:** "Work Zone Impact Prediction" and "User Manual" tabs.
- Buttons:** "Show Quick Instructions" and "Review Volume Data".
- Inputs:**
 - Route Name: Select Route (dropdown)
 - Direction: Select Direction (dropdown)
 - Route Milepost Range: Start Milepost (text), End Milepost (text)
 - Roadway Type: (text)
 - Number of Lanes: (text)
 - Number of Closed Lanes: Select no. of closed lanes (dropdown)
 - Start Date: (text)
 - Start Time: (text)
 - End Date: (text)
 - End Time: (text)
 - Value of Passenger Car Time (\$/veh-hr): 18.15 (text)
 - Value of Truck Time (\$/veh-hr): 30.25 (text)
- Map:** A Google Map showing the New Jersey and Pennsylvania region, with major cities like New York, Philadelphia, and Baltimore visible.
- Define how the queue should be determined:**
 - If speed is below:
 - 75% of historic average speed
 - 75% of historic average speed or below LOS (Level of Service) D Speed. LOS D
 - Highway: 35 mph, Arterial: 15 mph
 - Historic average speed minus(MPH): 0 (spinners)
- Buttons:** "Show Result", "Download PDF Report", "Download Excel Report".

Figure 6.1 WIMAP-P homepage

The intuitive web-based interface serves as the portal that allows the user to input the necessary roadway information for the built-in lane closure delay prediction model. Currently, it has two main modules: work zone impact prediction and report generator.

6.2 Work Zone Impact Prediction

The MNR model is applied to predict delay caused by work zones on New Jersey's freeways and arterials. The WIMAP-P software is developed to post information graphically and consists of the freeway and arterial work zone planning modules. The application combines the freeway and arterial models into a single work zone impact prediction module. Depending upon the user inputs such as route, mile-post range and direction, the application can independently identify whether the roadway segment under analysis is categorized as a freeway or arterial and apply the appropriate model for analysis. This further enhances the ease of use of the application, as users would not require any pre-requisite knowledge regarding roadway segment type or the appropriate model to use for analysis.

The work zone impact prediction module is shown as an example in Figure 6.2, where the left panel allows users to specify the information required for the prediction, while the right panel is a map that will zoom to the roadway of interest automatically. Once a user specifies the route information, WIMAP-P will retrieve the roadway geometry information from the SLD DB, such as the number of lanes in that particular roadway segment. This function also allows users to visually confirm the location of a proposed work zone According to the tentative plan for lane closure; the user can specify the number of closed lanes, including an option for shoulder closure only, and the associated date and time.

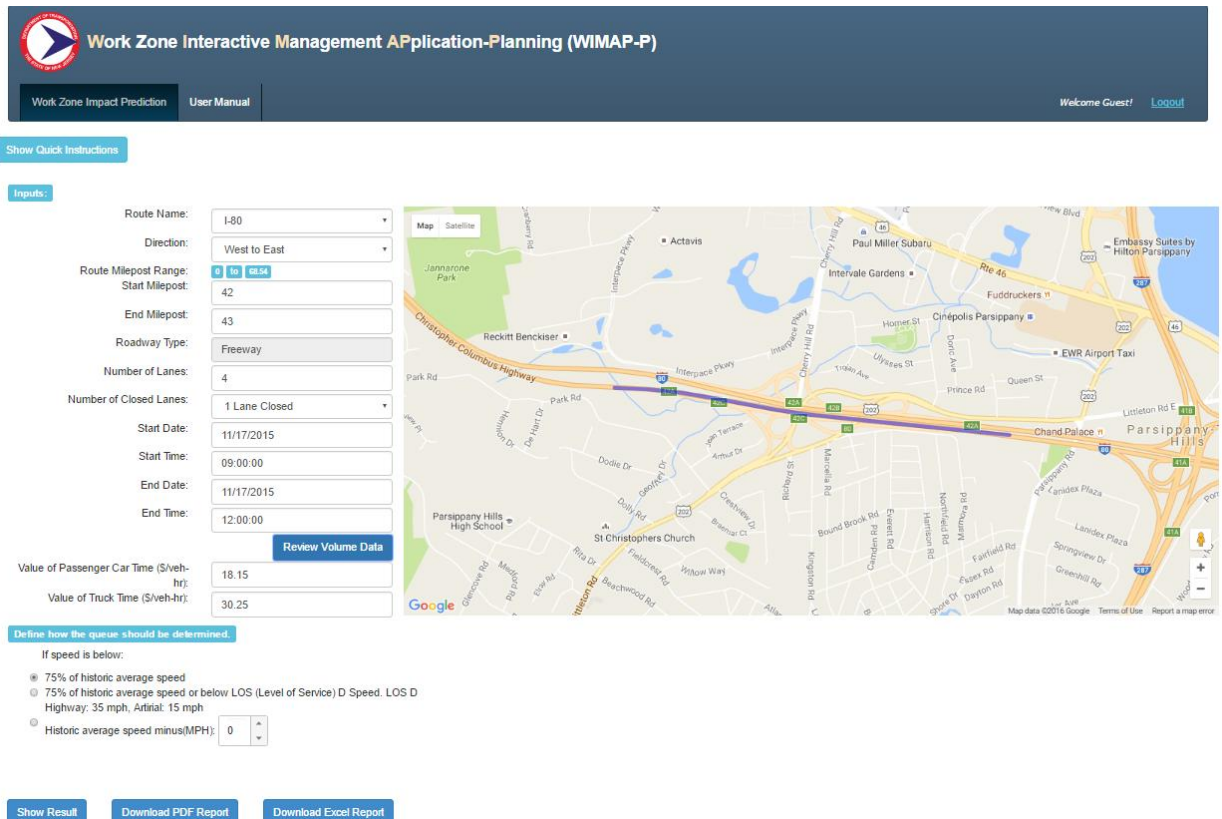

Figure 6.2 Work zone impact prediction module

Before examining the work zone impact prediction results, users can view the hourly volume distribution¹ approaching the work zone by clicking “Review Volume Data” (see Figure 6.3), which allows users to examine the volume changes over space and time. If the traffic counts of a study work zone site are different from those that NJCMS summarized in the table, a user-specified parameter (in percentages) is offered to adjust the volumes.

¹ Traffic volumes obtained from NJCMS DB ⁽⁷⁰⁾.

Review Volume										
		<input checked="" type="radio"/> Increase by <input type="radio"/> Decrease by		<input type="text" value="0"/>	Percent	<input type="button" value="Apply Changes"/>				
ROUTE	SRI_CMS	BEGINMP	ENDMP	VOL 8:00 AM	VOL 9:00 AM	VOL 10:00 AM	VOL 11:00 AM	VOL 12:00 PM	VOL 1:00 PM	VOL 2:00 PM
I-80	00000080__	39.57	42.46	7329	5827	4182	4086	4266	4237	4545
I-80	00000080__	38.81	39.57	7511	5167	3105	3222	3784	3759	3991
I-80	00000080__	37.63	38.81	7763	6041	4691	4309	4233	4075	3999
I-80	00000080__	35.33	37.63	7346	5797	4502	4134	4062	3910	3818
I-80	00000080__	34.65	35.33	6791	5045	3922	3626	3562	3429	3142
I-80	00000080__	34.02	34.65	6791	5045	3922	3626	3562	3429	3142
I-80	00000080__	33.58	34.02	5399	4128	3206	2944	2893	2784	2893
I-80	00000080__	30.61	33.58	5176	4217	3275	3008	2956	2844	2957

Figure 6.3 Hourly traffic volume counts table

After reviewing traffic volume counts, users may select one of the three methods below to determine the queue (see the bottom part in Figure 6.2):

- 75% of historic average speed – The status of queue is positive at a segment whose speed falls below 75% of the historic average speed. The historic average speed is specific to the time of a day and the day of a week for each segment, and is calculated based on the speeds collected in 2014. More detailed information can be found in Chapter 7.
- 75% of historic average speed or LOS (Level of Service) D Speed – The status of queue is positive at a segment whose speed falls below 75% of the historic average speed or LOS D speed (i.e., LOS D on Highways: 35 mph; LOS D on Arterials: 15 mph).
- Historic average speed – The status of queue is positive at a segment whose speed falls below the historic average speed. This measure will show predicted queue over space and time that is “worse than normal.” Users are also able to enter an “offset” into this option. For example, if users enter “Historic average speed minus 5 mph” then the queue is determined for any time when speeds are 5 mph lower than normal speed for each segment upstream of the work zone.

With all the required information, WIMAP-P can generate results as shown in Figure 6.4. The queue is determined if the predicted speed is below 75% of historic average speed in this case. The generated figures include 15-min traffic volume distribution diagram (top left of Figure 6.4), speed difference diagram (top right of Figure 6.4), normal speed (upstream of the work zone) contour diagram (bottom left of Figure 6.4), and predicted speed (upstream of the work zone) contour diagram (bottom right of Figure 6.4).

The 15-min traffic volume¹ distribution diagram allows users to examine the volume changes over space and time. The speed difference diagram illustrates the difference between the normal and predicted speed prior to the work zone over space and time, which is helpful to speculate the work zone impact. WIMAP-P also displays the INRIX speed in normal conditions and predicted speed in work zone conditions of the selected roadway, which enables user to better assess the impact of the proposed lane closure. Moreover, a table at the bottom of Figure 6.4 is generated in addition to the speed

¹ Traffic volumes obtained from NJCMS DB ⁽⁷⁰⁾.

contour diagrams, which provides detailed information on the influence of work zone lane closures over time periods. The adjustment bar below each diagram offers users with more flexibility in displaying the range of the speed. Similarly, WIMAP-P can be applied to assess the impact of a work zone on arterials in New Jersey.

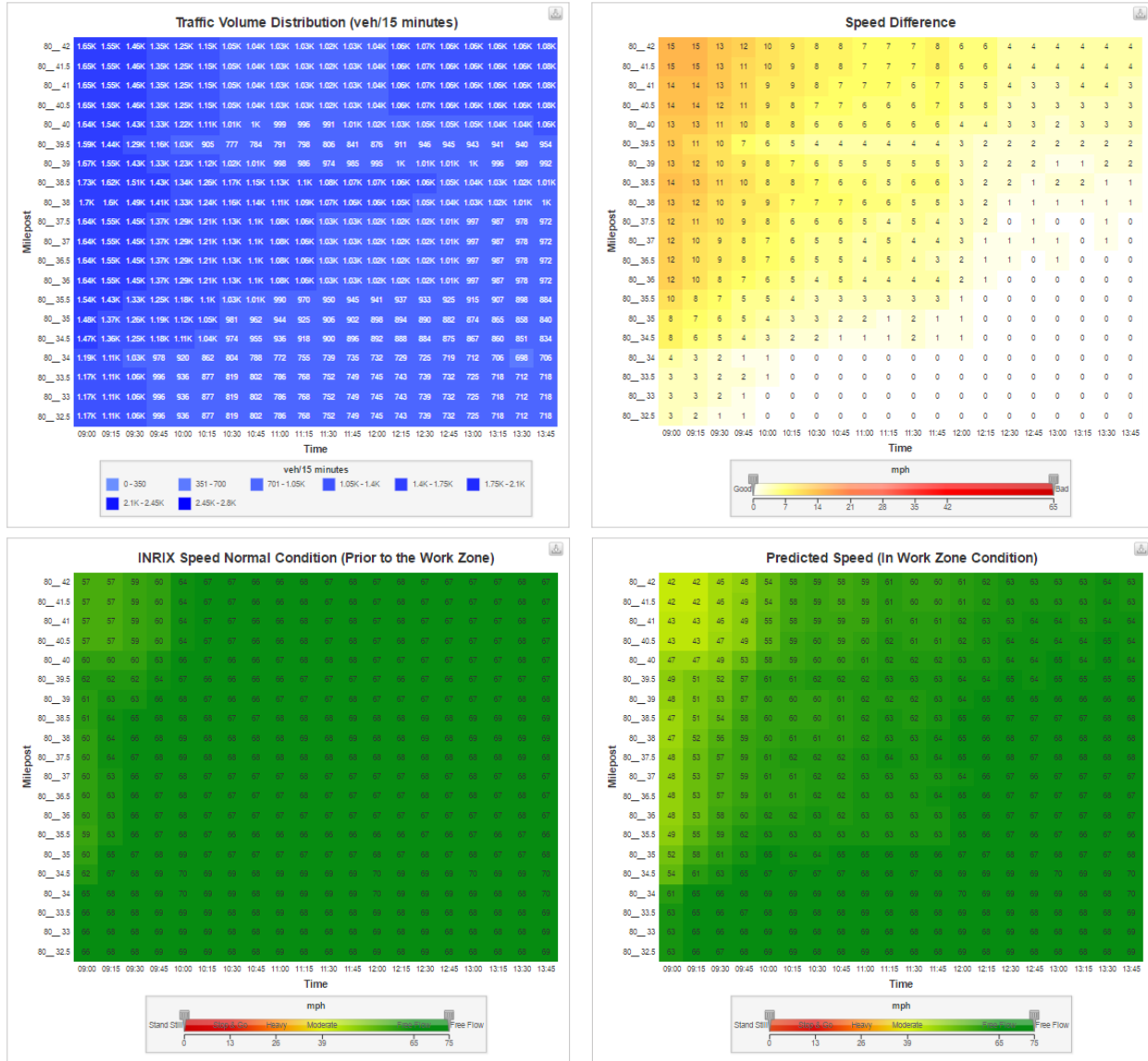

[EXPORT](#)

SRI	Time	Start MP	End MP	Distance to Work Zone (miles)	INRIX Speed (mph)	Predicted Speed (mph)	Car Volume (veh/15 minutes)	Truck Volume (veh/15 minutes)	Congested? (Y/N)
00000080__	11/17/15, 9:00 AM	41.50	42.00		0.50	57	42	1,524	121 Yes
00000080__	11/17/15, 9:00 AM	41.00	41.50		1.00	57	42	1,524	121 Yes
00000080__	11/17/15, 9:00 AM	40.50	41.00		1.50	57	43	1,524	121 No
00000080__	11/17/15, 9:00 AM	40.00	40.50		2.00	57	43	1,524	121 No
00000080__	11/17/15, 9:00 AM	39.50	40.00		2.50	60	47	1,516	120 No

Figure 6.4 Work zone impact prediction results

6.3 Report Generator

The report generator allows the user to generate a report of lane closure impacts based on the default template of WIMAP-P. The report contains all the necessary information for the roadway segment of interest as well as the predicted speed. For instance, a report generated for the lane closure of I-80 from milepost 42 to milepost 43 from 9:00 am to 12:00 pm plus two hours after the work zone removed is illustrated in Figure 6.5. This report not only presents the impact of a proposed lane closure in a logical and concise manner, it also assists agencies and contractors in preparing project documentation. It is noted that the volume showed in the online report is the hourly volume approaching the work zone.

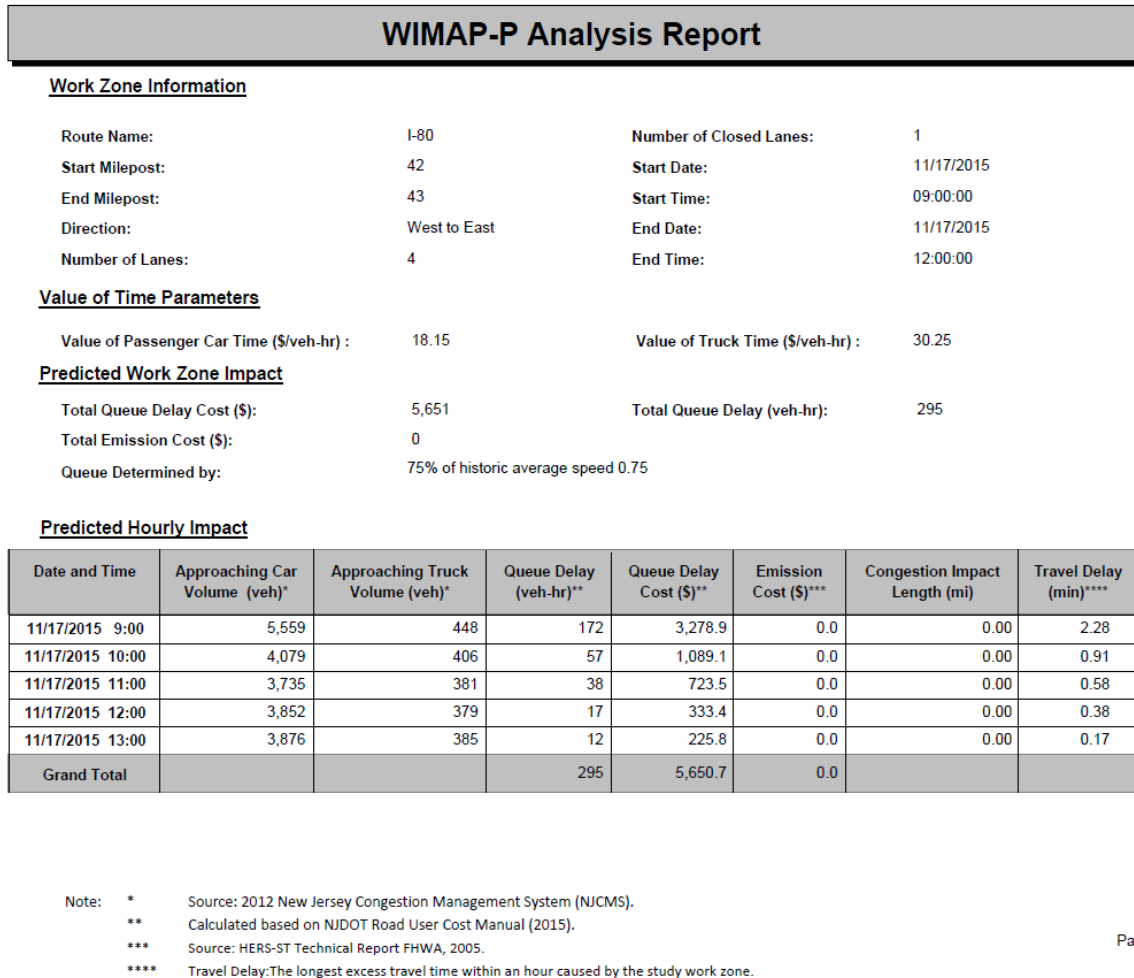

Figure 6.5 The WIMAP-P report

VII. WIMAP-P PERFORMANCE MEASURES AND APPLICATIONS

This chapter presents the performance measures that the WIMAP-P software produces and their potential application to support the planning of work zones for NJDOT. The following section details the WIMAP-P performance measures and discusses its applications on work zone impact analysis.

7.1 WIMAP-P Performance Measures

This section discusses the capabilities of the WIMAP-P model in predicting work zone performance measures namely:

1. Work zone Delay (D)
2. Congestion Impact Length at time j (L_j)
3. Emission Cost (C_e)

Before predicting these performance measures, it is important to identify the spatial and temporal boundaries of the impacted area which are determined by comparing the predicted speed (\hat{y}_{ij}) to the normal speed (s_{ij}) for each segment i at time j , and this method has also been applied in previous studies. ^(11, 20)

- If the predicted speed of segment i at time j is less than or equal to 75% of the normal speed (i.e. $\hat{y}_{ij} \leq 0.75s_{ij}$), segment i is considered positively affected by the work zone at time j . \hat{y}_{ij} , therefore, is deemed as part of the congestion impact length.
- If \hat{y}_{ij} is greater than 75% of the normal speed (i.e. $\hat{y}_{ij} > 0.75s_{ij}$), segment i is considered negatively affected by the work zone at time j .

Therefore, the upstream segment i at time j is associated with a binary value (i.e. 0 or 1) to determine the spatial and temporal work zone impact boundaries. Thus,

$$\alpha_{ij} = \begin{cases} 1 & \text{if } \hat{y}_{ij} \leq 0.75s_{ij} \\ 0 & \text{otherwise} \end{cases} \quad (7.1)$$

where:

α_{ij} = A binary variable of roadway segment i at time j ; and

s_{ij} = Normal speed of segment i at time j (mph).

All the roadway segments that are assigned a binary value of 1 (i.e. $\alpha_{ij} = 1$) are considered in prediction of the work zone performance measure discussed below.

Work Zone Delay

With the determined spatial-temporal region, the work zone delay (D), can be calculated by Eq. 7.2.

$$D = \frac{\sum_{\forall \alpha_{ij}=1} \left\{ \max \left[L_i \left(\frac{1}{\hat{y}_{ij}} - \frac{1}{s_{ij}} \right) V_{ij}, 0 \right] \right\}}{\sum_{\forall \alpha_{ij}=1} V_{ij}} \quad (7.2)$$

where:

D = The average upstream delay caused by work zone (hr/veh);

l_i = The length of freeway segment i (mi); and

V_{ij} = The traffic counts of segment i at time j (veh).

Congestion Impact Length

The congestion impact length at time j can be measured as the total length of upstream segments negatively affected by the work zone at time j . The maximum congestion impact length is the greatest congestion impact length within the work zone duration plus two hours after the work zone is removed given in Eq. 7.3.

$$L_j = \sum_{\forall \alpha_{ij}=1} l_i \quad (7.3)$$

where L_j = is the congestion impact length at time j (mi).

Emission Cost

Work zone activities have adverse effects on the environment through additional vehicle emissions resulting from reduced speeds and queuing. ⁽⁶⁸⁾ According to the HERT-ST Technical Report, ⁽⁶⁹⁾ the emission cost can be calculated as the differential between emissions costs resulting from work zone activities and recurrent conditions given in Eq. 7.4.

$$C_e = \sum_{\forall \alpha_{ij}=1} V_{ij} l_i (e_{\hat{y}_{ij}} - e_{s_{ij}}) \quad (7.4)$$

where:

C_e = The total emission cost caused by work zone (\$/zone);

V_{ij} = The volume of roadway segment i at time j (veh);

$e_{\hat{y}_{ij}}$ = The emission damage cost at the predicted work zone speed \hat{y}_{ij} (\$/veh-mi);

and

$e_{s_{ij}}$ = The emission damage cost at the normal speed s_{ij} (\$/veh-mi).

7.2 A Freeway Work Zone Case Study

A 2-mile work zone with two-lane closure was deployed on a 3-lane segment of the westbound interstate freeway 78 (I-78) in October 2015 and shown in Figure 7.1. The work zone was designated for a resurfacing operation from 11:00 PM to 6:00 AM. The estimated AADT was 61,094 vehicles with 14% trucks, based on data which was obtained from the NJCMS DB (2012).⁽⁷⁰⁾ Note that the average user cost per car-hour is \$12.75/hr, and the average user cost per truck-hour is \$21.25/hr for calculating QDC⁽⁷¹⁾. The hourly traffic distribution for weekday traffic is shown in Figure 7.2.

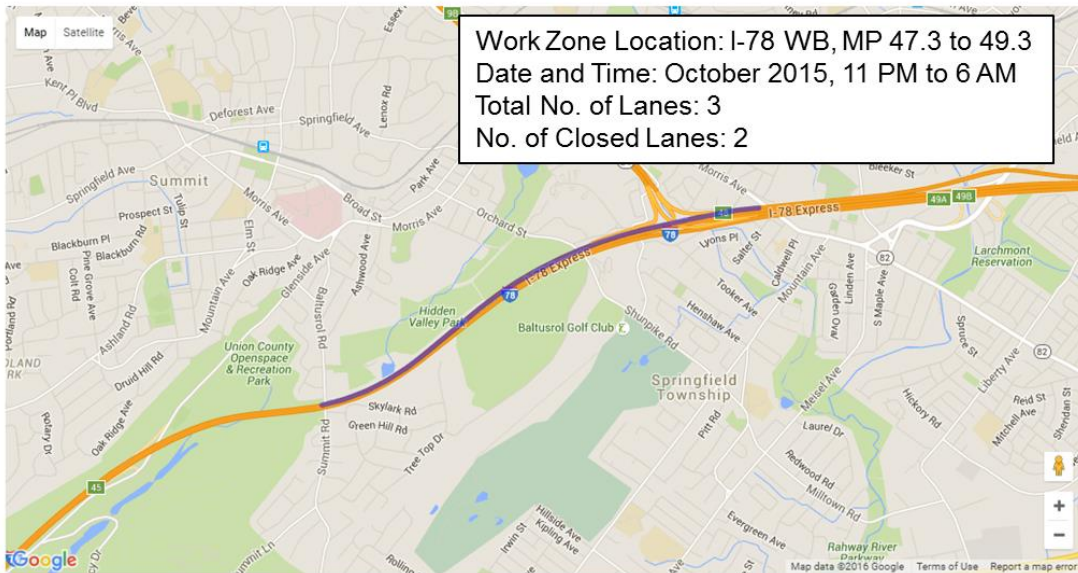

Figure 7.1 Work zone location on I-78 in Springfield, NJ

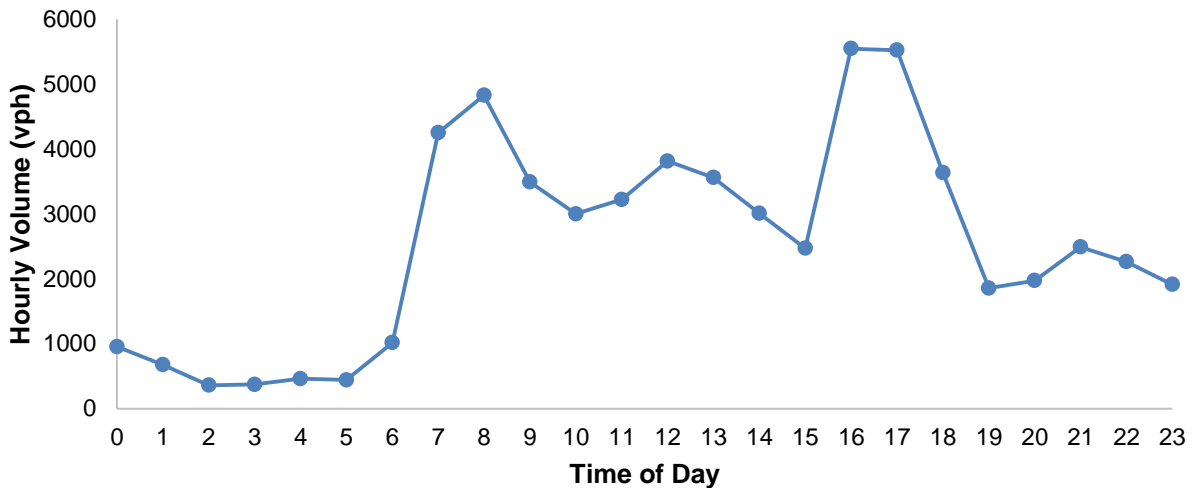

Figure 7.2 Traffic distribution on I-78 WB at MP 49.3

WIMAP-P Inputs

The work zone parameter input module is shown in Figure 7.3, where the left panel allows user to specify the information required for the prediction, such as work zone location (i.e., route name, start and end mileposts), number of closed lanes, start and end date and time. The right panel in the same figure is a map that is flexible and allows users to zoom in and out on the road network near the study work zone.

Work Zone Interactive Management Application-Planning (WIMAP-P)

Work Zone Impact Prediction User Manual Welcome Guest! Logout

Show Quick Instructions

Inputs:

Route Name: I-78

Direction: East to West

Route Milepost Range: 0 to 47.3440

Start Milepost: 47.3

End Milepost: 49.3

Roadway Type: Freeway

Number of Lanes: 3

Number of Closed Lanes: Shoulder Closed

Start Date: 10/14/2015

Start Time: 23:00:00

End Date: 10/15/2015

End Time: 06:00:00

Review Volume Data

Value of Passenger Car Time (S/veh-hr): 18.15

Value of Truck Time (S/veh-hr): 30.25

Define how the queue should be determined.

If speed is below:

- 75% of historic average speed
- 75% of historic average speed or below LOS (Level of Service) D Speed. LOS D Highway: 35 mph, Arterial: 15 mph
- Historic average speed minus(MPH): 0

Show Result Download PDF Report Download Excel Report

Figure 7.3 WIMAP-P parameter input module

WIMAP-P Results

With a moving average smoothing method, the 15-min traffic volume distribution over space and time prior to the work zone that are based on NJCMS volumes can be displayed after users specify the work zone information (see Figure 7.4). After computation, WIMAP-P furnishes results in the form of speed contour maps for both recurrent and predicted work zone speed. This chromatic representation of speed over space and time allows users to visualize the changes and its corresponding impact. Figure 7.5 shows the speed contour maps obtained after analysis of the work zone on I-78. The difference between normal and predicted speeds prior to the work zone can be visualized in Figure 7.6.

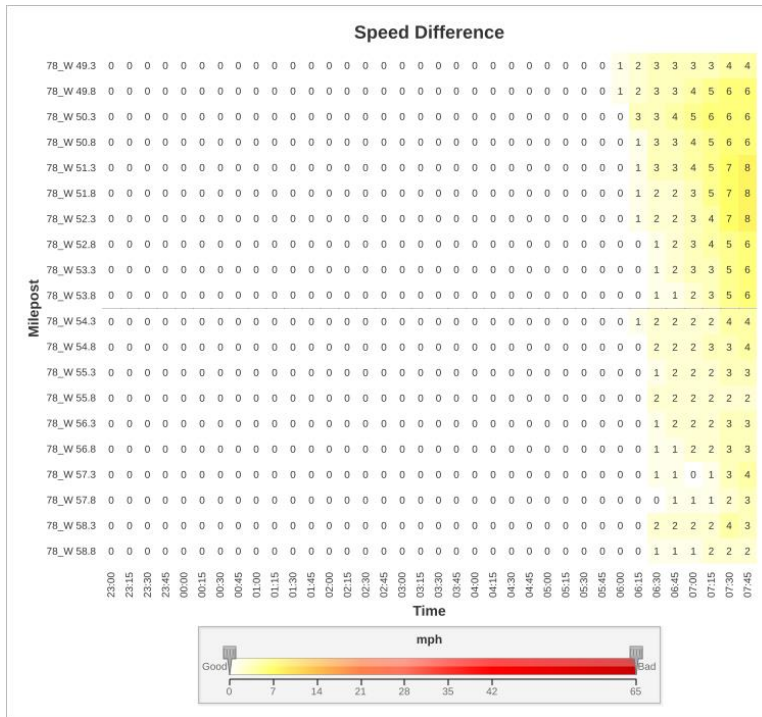

Figure 7.6 Speed difference diagram

The results are also provided in the form of systematic tabulated report. The report generated by the application provides a brief summary of the proposed work zone information that is provided by the user. In addition to this summary, the report tabulates the predicted and normal speed, car and truck volume, the delay and the delay costs that are associated with every 0.5 miles of roadway segment from the designated work zone.

Queue Delay Cost (QDC)

An analysis was conducted by comparing the QDC predicted by WIMAP-P and the NJDOT Road User Cost Manual (RUCM). WIMAP-P harnesses the MNR model to approximate the excess travel time in the presence of a work zone. Unlike previous methods which adopted a common work zone speed and unrestricted speed values, the MNR model breaks the route section upstream of a work zone into several smaller segments, computes the unrestricted speed (average speed reported by INRIX without incident at the same time where the work zone is placed), and predicts the speeds affected by the work zone on each segment, and then determines the added travel time (or called queue delay). It was found that WIMAP-P helps in predicting congestion impact closer to the INRIX reported speed which the NJDOT RUCM method could not explain. Based on the case study introduced earlier in this section, Table 7.1 summarizes the predicted delay and cost from the two methods against the INRIX reported speed.

Table 7.1 - Comparison of queue delay and cost (freeway)

Approach	Queue Delay (veh-hr)	Queue Delay Cost (\$)
NJDOT RUCM (2001) ¹	0	0
WIMAP-P	36.4	495
INRIX	36.0	490

As congestion occurred, the congestion impact length and emission cost are calculated by using Eqs. 7.3 and 7.4 with WIMAP-P, respectively. QDC is computed from the predicted average queue delay, multiplied by the average traffic volume of the affected segments and the average costs per car-hour and truck-hour. Note that the MNR model was developed to predict the speed and queue delay cause by a work zone over space and time. The work zone delay cost (within the work zone) is the product of average work zone delay, traffic volume through the work zone, and average costs per car-hour and truck-hour (same as the NJDOT RUCM method).

According to the results illustrated in Table 7.1, it was found that WIMAP-P outperforms the NJDOT RUCM method in terms of the proximity to the INRIX reported speed data. WIMAP-P gives a difference of \$5 for QDC and a difference of 0.4 veh-hr of the queue delay. Two additional case studies of road constructions on I-280 and I-287 were conducted and discussed in Appendix C.

7.3 An Arterial Work Zone Case Study

A work zone on a 2-lane road with 1-lane closure was located on US-46 eastbound from MP 69.2 to MP 70.0, and was scheduled from 10:00 pm to 6:00 am in May 2015 as shown in Figure 7.6. The traffic data, retrieved from NJCMS DB (2012), ⁽⁷⁰⁾ indicated an average of 10% truck traffic through the work zone. Note that the average costs per car-hour and truck-hour are the same as what were considered in the previous freeway case study.

¹ The NJDOT RUCM calculation tables are presented in Appendix D.

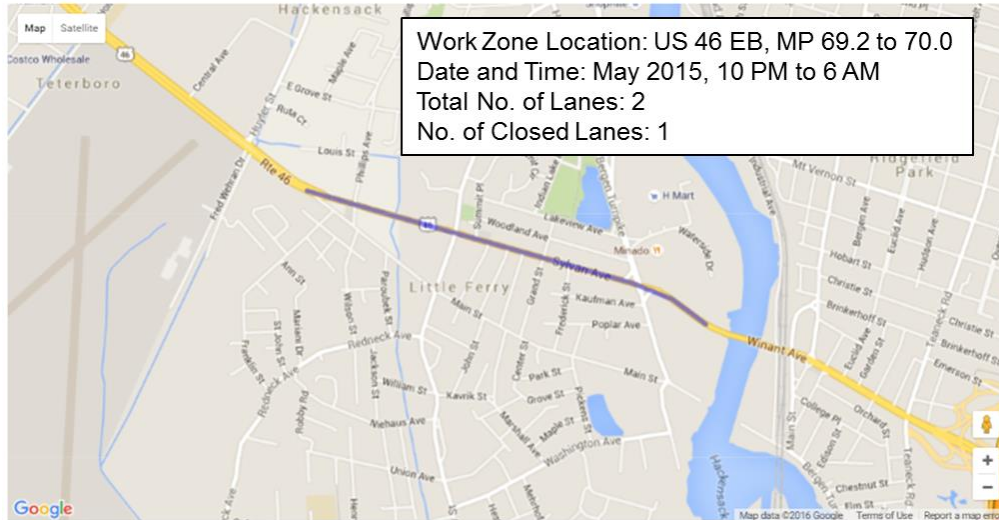

Figure 7.7 Work zone location on US-46 in Little Ferry, NJ

WIMAP-P Inputs

Similar to the freeway work zone case, after the user inputs the work zone information, the WIMAP-P will automatically display the work zone location in the left panel, as shown in Figure 7.8.

Figure 7.8 WIMAP-P parameter input module

WIMAP-P Results

Figure 7.9 shows the 15-min traffic volume distribution over space and time prior to the work zone on US-46 EB. After computation, the WIMAP-P furnishes results in the form speed contour maps for both recurrent and predicted work zone speed as shown in Figure 7.10. In addition, the difference between normal and predicted speeds prior to the work zone can be found in Figure 7.11.

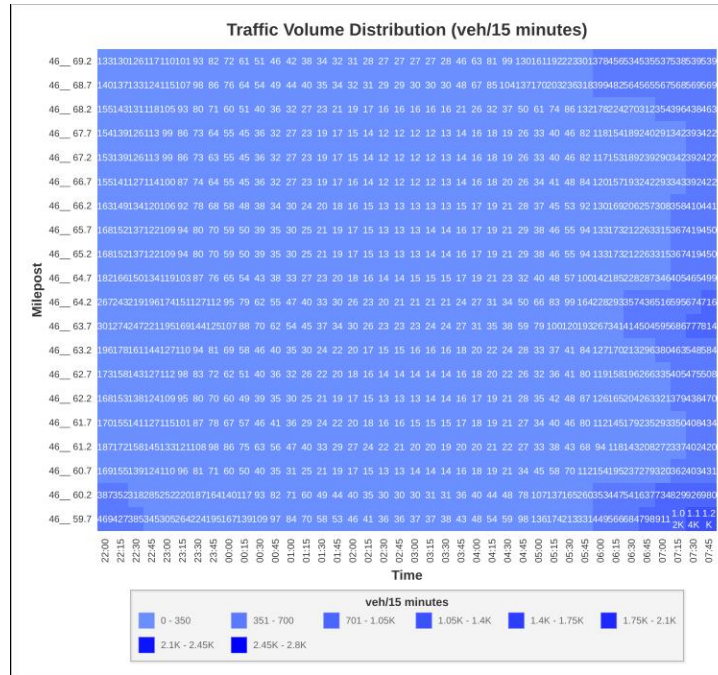

Figure 7.9 15-min traffic volume distribution

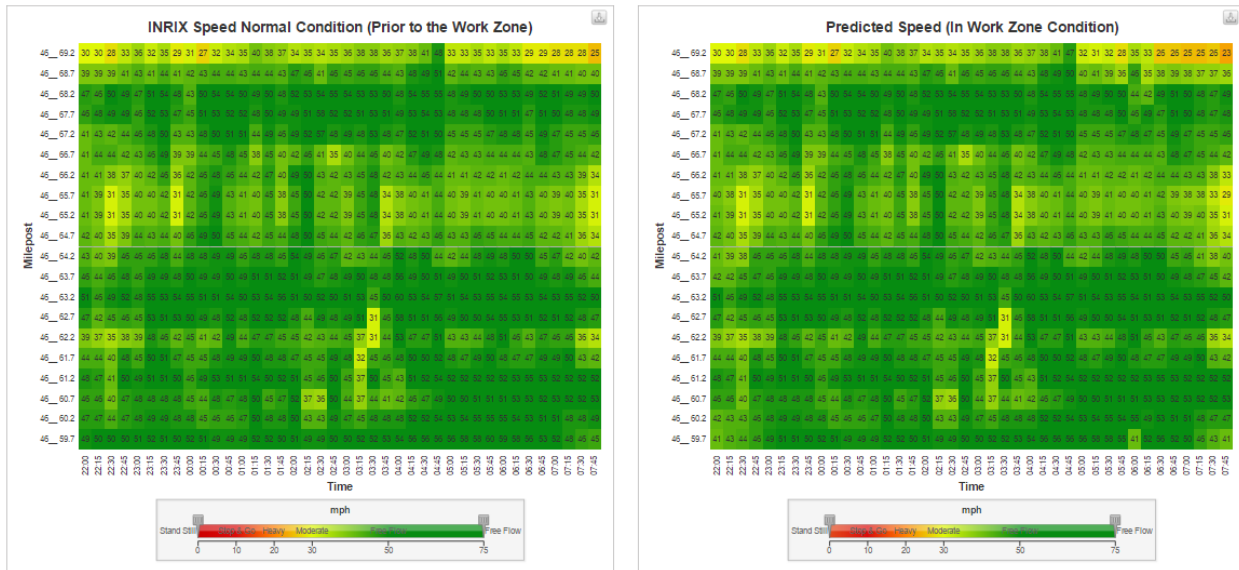

Figure 7.10 WIMAP-P speed heat map

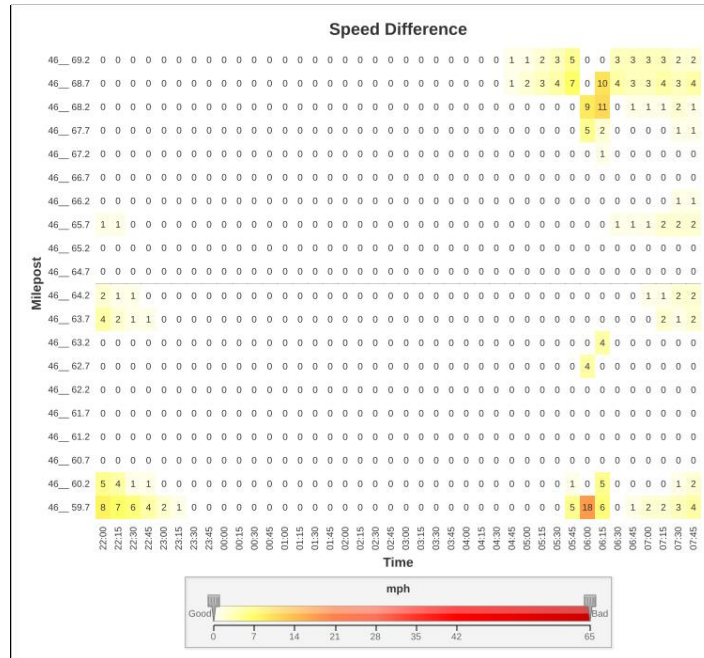

Figure 7.11 Speed difference diagram

The results are also provided in the form of systematic tabulated report. The report generated by the application provides a brief summary of the proposed work zone information provided by the user. In addition to this summary, the report tabulates the predicted and normal speed, car and truck volume, the delay and delay cost associated with every 0.5 miles of roadway segment from the designated work zone.

Queue Delay Cost (QDC)

As mentioned earlier, the NJDOT RUCM does not furnish the calculation details regarding work zone activity on arterial roadway networks, Hence for these case studies an assessment of proximity to a real world scenario achieved by the WIMAP-P model is presented.

Table 7.2 illustrates the queue delays and costs predicted by WIMAP-P and estimated based on INRIX reported speed data. It was found that the queue delays and costs predicted by WIMAP-P are very close to those estimated using INRIX reported speed.

Table 7.2 - Comparison of queue delay and cost (arterial)

Approach	Queue Delay (veh-hr)	Queue Delay Cost (\$)
NJDOT RUCM (2001)	N/A	N/A
WIMAP-P	9.6	131
INRIX	15.6	212

Comparing the INRIX reported speed data and the WIMAP-P results, a difference of \$81 QDC and a difference of 6 veh-hr queue delay are observed. Two additional roadway construction case studies on US130 were conducted to assess the arterial model. The detail discussions of these case studies are summarized in Appendix C.

VIII. BENEFITS AND COSTS

This chapter presents the main benefits and costs of the WIMAP-P software.

8.1 Benefits

1. **More accurate prediction of queue delay and cost:** The advantage of this modeling approach for delay prediction is the employment of normal and work zone speeds (produced by probe-vehicle data) to develop the MNR model. It was found that the work zone upstream speed and delay predicted by WIMAP-P were less than 15% difference from the reported speed (INRIX), which outperforms the method suggested in the NJDOT RUCM. Work zone speed prediction accuracy may be further improved by tuning the MNR model with more work zone data.
2. **Ease of use and quick analysis:** WIMAP-P has minimal and easily available input data requirements, such as the work zone location and schedule. The system will automatically display the work zone location on a map and produce the speed and other traffic measure estimates. This is a more convenient and time saving alternative than other cost-prohibitive micro-simulation models that have more intensive data requirements. The analysis is quick, and inputting data for a typical work zone network should take less than 5 minutes. Once the data is entered, WIMAP-P can produce temporal-spatial results in graphic and tabular formats in less than 1 minute.
3. **More effective work zone congestion mitigation plans:** WIMAP-P provides a user-friendly interface with various analytical and graphical tools to assist traffic engineers in better comprehending the data and in making judicious decisions on other aspects, such as the design of an effective work zone congestion mitigation plan or the more accurate predictions of queue delay cost by understanding the spatial and temporal work zone impact. The user is capable of changing the start and end time of the work zone, and producing the corresponding performance measures using WIMAP-P, and in choosing the best schedule, according to the NJDOT's and the contractor's objectives.
4. **Ability to assess work zone impacts on the connecting route in the upstream:** WIMAP-P is able to predict speeds over space and time on the connecting route if it is falling within the 10 miles upstream area of the work zone.

5. **Ability to assess work zone impacts on arterials:** WIMAP-P expands the capability of NJDOT engineers and planners to analyze work zone impacts on arterials that cannot be calculated with the NJDOT RUCM.
6. **Incentive and disincentive benefits:** If traffic count information associated with the work zone sites is available, WIMAP-P can be further enhanced to produce more reliable contractor costs, over-run penalties and early job completion data. Through the application of WIMAP-P, better planning strategies can be devised to further reduce additional charges such as lane rent cost.

Table 8.1 - Work zone software comparison

Characters and Parameters	QuickZone	QUEWZ	CORSIM	WIMAP-P
Network Design/Data Assembly Time (hrs)	2 to 6	1 to 2	2 to 6	< 0.1
Data Input Time (hrs)	1.5 to 2.5	1	2 to 3	< 0.1
Data Analysis Time (min)	< 1	< 1	5	<2 ¹

8.2 Costs

In general the cost for developing WIMAP-P was \$450,341, and that amount was distributed into the following categories:

- Labor cost to collect data, process data and develop the model/software application;
- Device purchasing, deployment and operation costs for data collection activities; and
- Database purchasing and storing cost.

Building new applications will require some investment throughout the development and implementation process. WIMAP-P, being a web-based application, would require procedures for server maintenance or database management to be conducted periodically. Building the database used by the model would also require investment in various data collection/gathering and processing activities. Furthermore, with a growing database, the necessity to house an adequate storage system also comes into play.

¹ The required data analysis time may vary depending on the work zone duration and internet speed.

IX. CONCLUSIONS

With increasing roadwork activities that are necessary to rehabilitate and revitalize the roadways in the United States, planning lane closures for roadwork has drastically demanded more accurate predictions on the impact of lane closures. It is crucial to be able to precisely predict the lane closure impacts to minimize both the cost and traffic congestion induced by roadwork. In response to this challenge, the research team developed a user-friendly, web-based work zone analysis tool called WIMAP-P.

In this project, the research team reviewed state-of-the-art work zone analyses including the main software systems developed by various agencies, such as iPeMS, RILCA, and QUEWZ. Given the availability of probe-vehicle travel time and speed data, and the unavailability of traffic volumes for the majority of the roadways in the State of New Jersey, the team developed an MNR model and an ANN model to predict the speed upstream of a work zone, and this capability was then embedded into the WIMAP-P software. The developed WIMAP-P is a tool that can be used to support state and local traffic construction, operations, planning staff, and construction contractors to:

- Quantify and display temporal-spatial corridor speed/delay predictions resulting from capacity decreases in work zones on New Jersey freeways and arterials.
- Identify delay impacts of alternative project phasing plans.
- Conduct tradeoff analyses between construction costs and delay costs.
- Examine the impacts of construction staging by location, time of day (peak versus off-peak), and season (summer versus winter).
- Assess travel demand measures and other delay mitigation strategies.
- Help establish work completion incentives.

For example, WIMAP-P could be used to predict the costs of conducting work at night instead of during the day, to change the starting and ending times, and to compare the impact of several time schedules on traffic flow conditions, or to divert the traffic to one road versus another road during different phases of construction. The costs, traffic delays, and potential backups can be predicted for both an average day of work and for the whole life cycle of construction. WIMAP-P can also analyze the advantages of various strategies for minimizing the projected traffic delays. These mitigation strategies might include the retiming of signals on detour routes to help traffic flow more smoothly, planning a media campaign to publicize the planned work zones, or using traveler information systems that allow drivers to plan ahead and choose other routes if possible.

On analyzing work zone impact, the WIMAP-P application has yielded more accurate results in predicting spatial-temporal delays and costs, compared with those estimated by NJDOT RUCM. It is worth noting that the delays and costs caused by a work zone on arterials can be predicted using WIMAP-P but are unable to be determined using NJDOT RUCM.

9.1 Findings

While developing WIMAP-P, the research team identified a wealth of insights, challenges, areas of potential improvement, and opportunities available to agencies in the areas of work zone impact assessment, data collection, and performance measurement, all of which are summarized below.

Performance Measures Used to Assess Mobility in Work Zones

A set of performance measures associated with work zones on New Jersey freeways and arterials were identified:

- Work Zone Delay (D)
- Queue Length (Q)
- Emission Cost (C_e)

The developed WIMAP-P tool can be applied to predict temporal-spatial speed affected by the studied work zones.

Data Collected to Compute Work Zone Performance Measures

A good work zone mobility data management system tends to provide a more effective use of the data. The development and implementation of an electronic database system provides the ability to be tracked and updated with future and current lane closure information. The advancements in Intelligent Transportation Systems (ITS) and increased availability in low-cost technologies and data sources have made the collection of mobility data in work zones more feasible. Although the full work zone ITS deployment is a cost-intensive project, the expansion in ITS resources and increase of availability of portable low cost devices have made the data collection processes more accessible. Furthermore, access to third-party mobility data on routes without agency surveillance and control equipment is also making work zone mobility data more readily available.

The main data sources that were made available and gathered to develop the WIMAP-P DB include INRIX probe-vehicle travel time/speed data for each of the segment TMC's (as defined by INRIX), TRANSCOM's OpenReach work zone DB whose corresponding data is provided by the NJDOT, the NJDOT's roadway geometry SLD DB, the NJDOT's crash DB as provided by the Rutgers Traffic Safety Resource Center, and traffic volume data from the NJDOT's Congestion Management System (CMS) for a limited number of roadways and locations. A set of simulated data was also developed and utilized using the VISSIM microscopic simulator at various NJ State roadway locations. During the data processing phase of the project, the following work zone related data deficiencies were identified:

Work Zone Data Deficiencies

- The length of a work zone and the corresponding starting/ending times are initially set by NJDOT. However, this information is finalized by the contractor who demarcates the work zone. OpenReach DB needs to be updated based on the contractor's finalized work zone schedule.
- The traffic counts information at the scenes of work zones are important measures for predicting speed and delay, which is not available at most places. The hourly traffic volumes recorded in NJCMS DB are thus used for model development.
- The OpenReach and INRIX DBs do not include the SRI information. In addition, INRIX DB also lacks the mileposts of TMCs. This problem has been fixed manually in this project. However, this issue will occur as new TMCs are defined in the New Jersey's freeways and arterials.
- The SLD DB sometimes includes the total number of lanes for both directions, including turn lanes of traffic for the SLD segment (i.e., MP 57.4 – MP 59.4 on US-1).
- Consequently the prediction accuracy with WIMAP-P will decrease, as the actual work zone locations and schedules are inconsistent with those reported in the OpenReach DB.

Uses of Performance Measures and Data for Work Zone Mobility Improvement

The main performance measures that the WIMAP-P predicts for each work zone upstream speed/delay, upstream queue length, emissions cost, and the corresponding queue delay cost. An accurate prediction of the expected speed, delay and queue length will aid the NJDOT to plan the start and end of each work zone more efficiently. This can be accomplished through the use of WIMAP-P as a tool to conduct various start-end scenarios for each work zone and to quantify the potential charges to contractors in cases where the original schedule is not followed (without the permission of the NJDOT) or changed.

A set of mitigation measures could be considered to offset the potential negative impacts of a work zone, including such measures as conveying the potential negative impacts to travellers which in turn would aid them in making alternative routing plans and/or changing their trip for a later/earlier time. Although not demonstrated during this phase of the project, the tool can be applied to evaluate the impact of a proposed route diversion and the optimization of the staging of work zones.

9.2 Future Extensions

Future extensions of the developed WIMAP-P are listed below:

- (1) Incorporation of better technologies and methodologies to collect traffic volume data associated with work zones on New Jersey's roadways. The inclusion of traffic volume at 15-minute time intervals within the MNR and ANN models will greatly enhance prediction accuracy, which is currently based on NJCMS hourly traffic volumes. More accurate traffic counts information will substantially improve the reliability of WIMAP-P and produce more accurate results regarding the upstream speed, queue delay and QDC. Such extensions will allow the NJDOT engineers to identify the optimal start and end times of each work zone, which will further improve the traffic flow operation of each facility.
- (2) Develop a self-updating WIMAP-P database by gathering data from various sources in an automated manner wherever feasible. Modifying and standardizing the existing database with the inclusion of common fields of information, in order to facilitate effective communication between sources that would reduce the time required for manual processing and improve productivity. The NJDOT personnel with the research team of NJIT and CUNY could aid in identifying outliers in the data and exclude them from the database using automated machine learning and manual techniques.
- (3) Traffic Message Channels (TMCs) can play a key role in collecting mobility and safety data, identifying issues that arise, and providing information to the public regarding current work zones within its surveillance zone. INRIX has redefined the length of the TMCs, which are now smaller. The WIMAP-P performance can be elevated if it utilizes these smaller TMCs, as it will more accurately predict the speed and queue length for each time interval.
- (4) Establish a periodic or continuous upgrading WIMAP-P:
 - User Interface;
 - Automated Reports; and
 - Connectivity to the corresponding databases.

9.3 Future Research

The prototype of WIMAP-P focused on delay prediction and impact analysis for freeway/arterial work zone planning. It is noted that on-going efforts for the future extension of WIMAP-P includes developing an innovative Big Data management framework to cover a wide range of data sources. It is also worth addressing that roadway traffic conditions change over time, leading to changed recurring speed and travel time patterns, which will in turn exert influence on the impacts of lane closures. In order to keep up with the ever-changing traffic pattern, the speed and delay prediction

models employed in WIMAP-P shall be periodically updated to include newly collected work zone and probe-vehicle data for model calibration.

Future studies of the developed WIMAP-P are listed below:

- (1) Establish a specific ITS system with real-time communications to the NJDOT TMC and/or TRANSCOM's OpenReach systems for work zones that will include but not be limited to:
 - Traffic flow counts, speed and travel time under recurrent and work zone conditions;
 - Capacity upstream, within, and downstream of the work zone;
 - Work zone start/end location devices (e.g., GPS with wireless communication);
 - Work zone start/end time stamps and queue length; and
 - Number of lanes/shoulder closed, including the corresponding start/end time stamps.

- (2) Establish a robust system for data gathering and storage using redundant hardware and software such that WIMAP-P and all related functions of the NJDOT and its associates (e.g., researchers, consultants, traveler information providers, etc.) that are dependent on the availability of such data may continue to work smoothly on a 24-hour basis, while ensuring data integrity. NJDOT must decide upon data that is required to measure performance, invest the necessary resources to obtain that data, and decide how the measures that are computed shall be used to affect decisions for a given project.

- (3) WIMAP-P can be further extended to include the network impact of a work zone. This would require the implementation of a network module such as a hybrid Dynamic Traffic Assignment (DTA) plus a microscopic traffic simulator where the DTA will model a large network both downstream and upstream of the work zone and the microscopic simulator will focus on a smaller area within the vicinity of the work zone. Such an expanded model will have the following functions:
 - Network-wide, OD paths, link, TMC, traffic flow characteristics under normal and work zone conditions;
 - Crash module analysis; and
 - A work zone optimal staging module.

APPENDIX A - CUNY Data Processing and Management

A.1 CUNY ITS Data Model Development Server Characteristics

Table A.1 - CUNY ITS data model server characteristics

S.No.	Components	Description
1	Model	Server Direct Supermicro Xeon
2	Processor	Inter® Xeon ® CPU E5-2640 v2-2.00Ghz 16 cores
3	Installed Memory (RAM)	64.00 GB
4	System Type	64-bit Operation System, x64-based processor
5	Hard Drive	4.71 TB
6	Database	SQL Server
7	Storage	16TB External Hard Disk (12 TB available)

A.2 CUNY ITS Application Server Characteristics

Table A.2 - CUNY ITS application server characteristics

S.No.	Components	Description
1	Model	SGI Altix 4700
2	Processor	Intel ® Itanium ® CPU 14 cores
3	Installed Memory (RAM)	64.00 GB
4	System Type	LINUX
5	Hard Drive	4 TB
6	Database	PostgreSQL

A.3 WIMAP-P Dimensions

The following dimensions were defined to support the WIMAP-P development shown in Table A.3.

Table A.3 - WIMAP-P dimensions descriptions

Dimensions	Description
Year	The year the data were collected
Month	The month the data were collected
Day	The day the data were collected
Time Interval	<p>The time interval applied to aggregate the data were collected. The length of the time interval is user defined. The default value for the WIMAP-P is 15-minutes.</p> <ul style="list-style-type: none"> • ID: The ID of the time interval. • Minimum: The starting time of the time interval. • Maximum: The ending time of time interval. <p>All these are derived by SQL query</p>
TMC	The TMC segment where the data were gathered as defined by INRIX.
Facility Type	The facility type is either freeway (Interstate) or arterial (US Route).
Type of Day	The type of day value is user defined. The default value for WIMAP-P is either Weekdays or Weekend. This could be further broken down to each day of the week if desired.
Percentile Speed	The percentile is used to screen speed low and high value outliers from the data. It is user defined where the default value is < 5% and > 95%.

A.4 WIMAP-P Measures

The following measures were defined to support the WIMAP-P development as shown in Table A.4.

Table A.4 - WIMAP-P measure descriptions

Measure	Description
Speed	<p>The average speed for the corresponding time interval of the day</p> <ul style="list-style-type: none"> • Standard deviation: The corresponding standard deviation of the speed. • Minimum: The corresponding minimum speed. • Maximum: The corresponding maximum speed.
Count	The number of speed observations for the corresponding time interval of the day.
Min	The minimum speed for the corresponding time interval of the day.
Max	The maximum speed for the corresponding time interval of the day.

A.5 SAMPLE SQL QUERY

Presented below is a Sample SQL Query for the US Highway data for February, 2014 used in the database development of WIMAP-P:

```
CREATE NONCLUSTERED INDEX [day_week] ON [dbo].[US_Highway_feb_2014_1] ([day_week] ASC) WITH  
(PAD_INDEX = OFF, STATISTICS_NORECOMPUTE = OFF, SORT_IN_TEMPDB = OFF, IGNORE_DUP_KEY =  
OFF, DROP_EXISTING = OFF, ONLINE = OFF, ALLOW_ROW_LOCKS = ON, ALLOW_PAGE_LOCKS = ON) ON  
[PRIMARY]
```

GO

```
=====
```

```
update [US_Highway_feb_2014_1] set time_range_fk_id= time_range.time_range_id
```

```
from time_range
```

```
where CONVERT(time, [measurement_tstamp], 102) between min_intervalo and max_intervalo
```

```
go
```

```
=====
```

```
update [US_Highway_feb_2014_1] set dw=0 where (day_week=1 or day_week=7)
```

```
go
```

```
=====
```

```
update [US_Highway_feb_2014_1] set dw=1 where dw is null
```

```
go
```

```
=====
```

```
CREATE CLUSTERED INDEX [ix_cluster3] ON [dbo].[US_Highway_feb_2014_1] ([tmc_code] ASC,  
[time_range_fk_id] ASC, [dw] ASC) WITH (PAD_INDEX = OFF, STATISTICS_NORECOMPUTE = OFF,  
SORT_IN_TEMPDB = OFF, IGNORE_DUP_KEY = OFF, DROP_EXISTING = OFF, ONLINE = OFF,  
ALLOW_ROW_LOCKS = ON, ALLOW_PAGE_LOCKS = ON) ON [PRIMARY]
```

GO

```
=====
```

```
SELECT [tmc_code], [time_range_fk_id], COUNT(dw)as max_len
```

```
into US_Highway_feb_2014_we_maxrecords
```

```
FROM [US_Highway_feb_2014_1]
```

```
where [dw]=0
```

```
group by [tmc_code], [time_range_fk_id]
```

```
go
```

```
=====
```

```
SELECT [tmc_code], [time_range_fk_id], COUNT(dw)as max_len
```

```

into US_Highway_feb_2014_wd_maxrecords
FROM [US_Highway_feb_2014_1]
where [dw]=1
group by [tmc_code], [time_range_fk_id]
=====
SELECT *, ROW_NUMBER() OVER(PARTITION BY tmc_code,time_range_fk_id ORDER BY speed ) AS "Row
Number"
into we_US_Highway_feb_2014_1
FROM [US_Highway_feb_2014_1]
where dw=0
go
=====
SELECT *, ROW_NUMBER() OVER(PARTITION BY tmc_code,time_range_fk_id ORDER BY speed ) AS "Row
Number"
into wd_US_Highway_feb_2014_1
FROM [US_Highway_feb_2014_1]
where dw=1
-- note i aggregate max length to the table wd and we
go
=====
update [we_US_Highway_feb_2014_1] set [we_US_Highway_feb_2014_1].max_len=agg.max_len
from US_Highway_feb_2014_we_maxrecords agg WITH (NOLOCK)
where [we_US_Highway_feb_2014_1].tmc_code=agg.tmc_code and
       [we_US_Highway_feb_2014_1].time_range_fk_id=agg.time_range_fk_id and
       [we_US_Highway_feb_2014_1].[dw]=0
go
=====
update [wd_US_Highway_feb_2014_1] set [wd_US_Highway_feb_2014_1].max_len=agg.max_len
from US_Highway_feb_2014_wd_maxrecords agg WITH (NOLOCK)
where [wd_US_Highway_feb_2014_1].tmc_code=agg.tmc_code and
       [wd_US_Highway_feb_2014_1].time_range_fk_id=agg.time_range_fk_id and
       [wd_US_Highway_feb_2014_1].[dw]=1
go

```

```
=====
update we_US_Highway_feb_2014_1 set percentile=round(CAST([Row Number] AS float)/ CAST([max_len] AS
float),6)
```

```
go
```

```
update wd_US_Highway_feb_2014_1 set percentile=round(CAST([Row Number] AS float)/ CAST([max_len] AS
float),6)
```

```
go
```

```
=====
```

```
-- querie 1/2
```

```
--wd_US_Highway_2014 = weekday
```

```
select tmc_code,time_range_fk_id, avg(speed) as avg_speed, stdev(speed) as stdev_speed, max(speed) as
max_speed, min(speed) as min_speed, count(speed) as count_speed
```

```
into wd_US_Highway_feb_2014_output
```

```
from wd_US_Highway_feb_2014_1 y
```

```
where ([percentile]>=0.05 and [percentile]<=0.95)
```

```
group by [tmc_code], time_range_fk_id
```

```
go
```

```
=====
```

```
-- querie 2/2
```

```
--we_US_Highway_2014 = weekend
```

```
select tmc_code, time_range_fk_id, avg(speed) as avg_speed, stdev(speed) as stdev_speed, max(speed) as
max_speed, min(speed) as min_speed, count(speed) as count_speed
```

```
into we_US_Highway_feb_2014_output
```

```
from we_US_Highway_feb_2014_1 y
```

```
where ([percentile]>=0.05 and [percentile]<=0.95)
```

```
group by [tmc_code], time_range_fk_id
```

```
=====
```

```
SELECT [tmc_code], [time_range_fk_id], [min_intervalo], [max_intervalo], [avg_speed], [stdev_speed], [max_speed],
[min_speed], [count_speed]
```

```
FROM wd_US_Highway_feb_2014_output INNER JOIN [time_range] ON [time_range_id]=[time_range_fk_id]
```

```
ORDER BY 1, 2
```

```
-- wd_US_Highway_feb_2014_output
```

APPENDIX B - Quality Assurance (QA) Analysis

B.1 Background

The WIMAP-P Work-zone analysis software for freeways and arterials was developed using a sample of 274 freeway work zones and 192 arterial work zones that were undertaken by the NJDOT during the years of 2013 and 2014. The research team randomly selected 70% of these work zones for developing the models and the remaining 30% were used for testing the model performance, following the standard practices for model validation and quality assurance.

The WIMAP-P quality assurance (QA) analysis was conducted by investigating the accuracy and reliability of the proposed speed prediction models for work zone on freeways and arterials in New Jersey. The “ground truth” was based on the travel time/speed data gathered from the INRIX database for each work zone influence time period that for the aforementioned 274 freeway and 192 arterial work zones that occurred during the years of 2013 and 2014. The QA analysis is focusing on evaluating the accuracy and reliability of the work zone speed prediction models for New Jersey’s freeways and arterials, which is presented next and includes two parts: (1) accuracy/reliability test with historical work zone data and (2) consistency test with various hypothetical work zone configurations.

B.2 WIMAP-P Freeway Model

Accuracy/Reliability Test with Historic Work Zone Data

The freeway work zone travel time/speed prediction model was based on a data set of 274 work zones which were selected due to the completeness of their data that were deemed useful in developing the model – Many freeway work zones (more than 12,000) that occurred during 2013 and 2014 were excluded from the model development due to insufficient data (see Chapter 3 for the process followed to screen the work zone data for 2013 and 2014). The research team used 70% (190) of these work zones for model development and 30% (84) of them for testing the model performance. The steps taken to assess the model accuracy/reliability are listed below.

Step 1: Classify the randomly selected 84 freeway work zones by lane configuration (i.e., 2-lane, 3-lane, and 4-lane) and location (i.e., North, Central, and South NJ). The corresponding data distribution per lane and region of the selected work zones are illustrated in Table B.1. Note that no qualified work zone was selected on 4-lane freeways in South NJ as the corresponding data for the years 2013, 2014 were found to be insufficient to be included in the model development.

Table B.1 - Test samples by lane configuration and region (freeways)

No. of Lanes per Direction	Region		
	North	Central	South
2-lane	8	10	5
3-lane	20	16	8
4-lane	13	4	0

Step 2: Run each work zone with the freeway model of the WIMAP-P and compute the Root Mean Square Error (RMSE) based on the predicted speeds against the INRIX reported speeds. A smaller RMSE indicates a greater accuracy of the model.

Step 3: Based on the computed RMSE associated with each test work zone, the average RMSEs were computed and classified into 3 categories (i.e., < 5 mph, 5 - 10 mph, and 10 - 15 mph), which are also arranged by lane configuration and region as shown in Table B.2.

Table B.2 - RMSE distribution (freeways)

No. of Lanes per Direction	RMSE Range	Region		
		North	Central	South
2-lane	< 5 mph	25%	20%	60%
	5 - 10 mph	63%	50%	40%
	10 - 15 mph	12%	30%	0%
3-lane	< 5 mph	85%	81%	100%
	5 - 10 mph	15%	19%	0%
	10 - 15 mph	0%	0%	0%
4-lane	< 5 mph	62%	50%	0%
	5 - 10 mph	23%	25%	0%
	10 - 15 mph	15%	25%	0%
Overall	< 5 mph	66%	57%	85%
	5 - 10 mph	27%	30%	15%
	10 - 15 mph	7%	13%	0%

Main findings from Table B.2:

- (1) The predicted speeds of work zones on 3-lane freeways produced the most accurate and reliable (100% RMSE < 10 mph) predictions, followed by work zone speeds on 2-lane (average 83% RMSE < 10 mph) and 4-lane (average 82% RMSE < 10 mph) freeways.
- (2) Overall, the predicted speeds of work zones in the southern NJ area is relatively stable and accurate (100% RMSE < 10 mph), followed by Northern NJ (93% RMSE < 10 mph) and Central NJ (87% RMSE < 10 mph).

Consistency Test with Hypothetical Work Zone Data

The step procedure for conducting a consistency test for the arterial model is discussed below:

Step 1: Classify the historical data (i.e., normal speed from INRIX, volume from NJCMS, roadway geometry from SLD) by lane configuration (i.e., 2-lane, 3-lane, and 4-lane). The numbers of freeways under these configurations are listed in Table B.3.

Table B.3 - Number of freeways for consistency test

No. of Lanes per Direction	No. of Freeways with Available Data
2-lane	14
3-lane	6
4-lane	5

Step 2: For each freeway identified in Step 1, divide the freeway into 10-mi segments and place a work zone at the end of these segments sequentially. For a 50-mi freeway, there are 5 configurations. A work zone is placed at 10, 20, 30, 40, and 50 miles away from the start of the freeway.

Step 3: Develop various scenarios based on the work zone determined in Step 2 with combination of the work zone parameters (i.e., duration, start time of day, open lane ratio, work zone length) listed in Table B.4. As a result, the total number of hypothetical work zones for the freeway type is 2,680 as illustrated in Table B.5.

Table B.4 - Parameters of hypothetical work zones on freeways

No. of Lanes per Direction	Parameters			
	Duration (hr)	Work Zone Starting Time	# of Closed Lanes	Work Zone Length (mile)
2-lane	2, 4, 6, 8, 10	7AM, 10AM, 4PM, 8PM	0*, 1	0.5, 1.0, 1.5, 2.0
3-lane	2, 4, 6, 8, 10	7AM, 10AM, 4PM, 8PM	0, 1, 2	0.5, 1.0, 1.5, 2.0
4-lane	2, 4, 6, 8, 10	7AM, 10AM, 4PM, 8PM	0, 1, 2, 3	0.5, 1.0, 1.5, 2.0

*: 0 represents shoulder closure.

Table B.5 - Number of hypothetical freeway work zones for consistency test

No. of Lanes per Direction	No. of Hypothetical Work Zones
2-lane	1,480
3-lane	880
4-lane	320
Total	2,680

Step 4: Given that with the number of work zone configurations, it was too large to manually input them into the WIMAP-P, a MATLAB program was developed to process historical normal speed and traffic volume, execute the speed prediction model, and generate the speed heat maps. For each work zone scenario, the team assessed the heat maps based on predicted speeds and reported speeds (INRIX).

As illustrated in Figure B.1, a 0.5-mile, 10-hour work zone is placed on Route 42 at Milepost 14. The recurrent normal speeds and predicted work zone speeds are illustrated vertically with respect to the number of lane closures and horizontally with respect to the starting time of the work zone.

Main findings:

In Figure B.1, the predicted work zone speeds seem to be consistently affected by different lane closures and traffic volumes associated with the work zone sites on freeways:

- (1) The work zone speed reduces as the number of lane closures increases (compare all heat maps in Column 2);

- (2) The work zone speed reduces as the traffic volume increases;
- (3) The work zone speed reduction impact is greater in the peak period than that in the non-peak period (compare heat maps in Columns 2, 4, and 6 of Row 1); and
- (4) The speed recovers slowly as the work zone end time approaches the peak period (compare heat maps in Column 2 of Row 1).

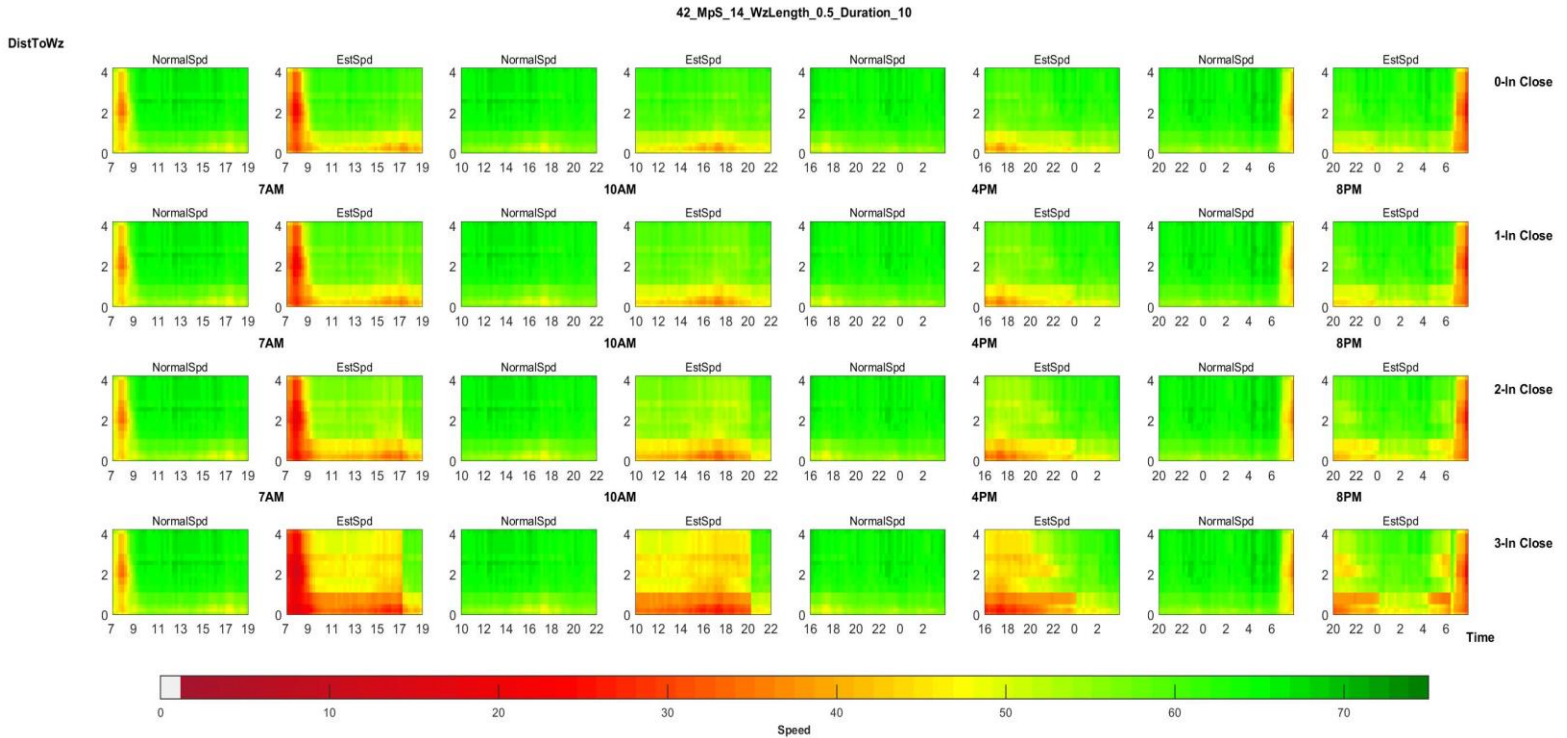

Figure B.1 A sample of testing heat maps (freeway)

B.3 WIMAP-P Arterial Model

Accuracy/Reliability Test with Historic Work Zone Data

The arterial work zone travel time/speed prediction model was based on a data set of 192 work zones which were selected due to the completeness of their data that were deemed useful in developing the model – Similar to the WIMAP-P freeway model, many arterial work zones (more than 9,000) that occurred during 2013 and 2014 were excluded from the model development due to insufficient data. The research team used 70% (135) of these work zones for model development and 30% (57) of them for testing the model performance. The steps taken to assess the model’s accuracy/reliability are listed below.

Step 1: Classify the 57 randomly selected arterial work zones by lane configuration (i.e., 2-lane, 3 or more lanes) and location (i.e., North, Central, and South NJ). The corresponding data distribution per lane and region of the selected arterial work zones are illustrated in Table B.6.

Table B.6 - Test samples by lane configuration and region (arterials)

No. of Lanes per Direction	Region		
	North	Central	South
2-lane	13	14	10
3 or more lanes	5	8	7

Step 2: Run each work zone with WIMAP-P and compute Root Mean Square Error (RMSE) based on predicted speeds and INRIX reported speeds. A smaller RMSE indicates greater accuracy.

Step 3: Based on the computed RMSE associated with each test work zone, the average RMSEs were computed and classified into 4 categories (i.e., < 5 mph, 5 - 10 mph, 10 - 15 mph, and 15 - 25 mph), which are also arranged by lane configuration and region as shown in Table B.7.

Table B.7 - RMSE distribution (arterials)

No. of Lanes per Direction	RMSE Range	Region		
		North	Central	South
2-lane	< 5 mph	23%	36%	40%
	5 - 10 mph	23%	21%	40%
	10 - 15 mph	39%	36%	20%
	15 - 25 mph	15%	7%	0%
3 or more lanes	< 5 mph	20%	25%	29%
	5 - 10 mph	40%	25%	43%
	10 - 15 mph	40%	37%	28%
	15 - 25 mph	0%	13%	0%
Overall	< 5 mph	22%	32%	35%
	5 - 10 mph	28%	23%	41%
	10 - 15 mph	39%	36%	24%
	15 - 25 mph	11%	9%	0%

Main findings from Table B.7:

- (1) The predicted speeds of work zones on 3⁺-lane arterials produced the most accurate (average 60% RMSE < 10 mph) speed predictions, followed by work zone speeds predicted on 2-lane (average 59% RMSE < 10 mph) arterials.
- (2) Overall, the predicted speeds of work zones in the southern NJ area was found to be relatively stable and accurate (76% RMSE < 10 mph), followed by Central NJ (55% RMSE < 10 mph) and Northern NJ (50% RMSE < 10 mph).

Consistency Test with Hypothetical Work Zone Data

The step procedure for conducting a consistency test for the arterial model is discussed below:

Step 1: Classify the historical data (i.e., normal speed from INRIX, volume from NJCMS, roadway geometry from SLD) by lane configuration (i.e., 2-lane, 3-lane, and 4-lane). The numbers of arterials under these configurations are listed in Table B3.3.

Step 2: For each arterial identified in Step 1, divide the arterial into 10-mi segments and place a work zone at the end of these segments sequentially. For a 50-mi arterial, there are 5 configurations. A work zone is placed at 10, 20, 30, 40, and 50 miles away from the start of the arterial.

Step 3: Develop various scenarios based on the work zone determined in Step 2 with a combination of the work zone parameters (i.e., duration, start time of day, open lane ratio, work zone length) listed in Table B.8. As a result, the total number of hypothetical work zones for the arterial type is 7,360 as illustrated in Table B.8.

Table B.8 - Number of hypothetical work zones (arterials)

No. of Lanes per Direction	Parameters	
	Number of Roadways with Available Data	Number of Hypothetical Work Zones
2-lane	58	5,960
3-lane	15	840
4-lane	11	560

Table B.9 - Parameters of hypothetical work zones (arterials)

No. of Lanes per Direction	Parameters			
	Duration (hr)	Work Zone Starting Time	# of Closed Lanes	Work Zone Length (mile)
2-lane	2, 4, 6, 8, 10	7AM, 10AM, 4PM, 8PM	0*, 1	0.5, 1.0, 1.5, 2.0
3-lane	2, 4, 6, 8, 10	7AM, 10AM, 4PM, 8PM	0, 1, 2	0.5, 1.0, 1.5, 2.0
4-lane	2, 4, 6, 8, 10	7AM, 10AM, 4PM, 8PM	0, 1, 2, 3	0.5, 1.0, 1.5, 2.0

*: 0 represents shoulder closure.

Table B.10 - Number of hypothetical work zones (arterials)

No. of Lanes per Direction	No. of Hypothetical Work Zones
2-lane	5,960
3-lane	840
4-lane	560
Total	7,360

Step 4: Given that with the number of work zone configurations, it was too large to manually input them into the WIMAP-P, a computer program was developed using MATLAB to process historical normal speed and traffic volume, execute the speed prediction model, and generate the speed heat maps. For each work zone scenario, the team assessed the heat maps based on predicted speeds and the reported speeds (INRIX).

As illustrated in Figure B.2, a 2-mile, 2-hour work zone is placed on Route 37 at Milepost 2. The recurrent normal speeds and predicted work zone speeds are illustrated vertically with respect to the number of lane closures and horizontally with respect to the starting time of the work zone.

Main findings:

Similar to the results of testing freeway work zones, the predicted work zone speeds seem consistently affected by different lane closure configurations and traffic volumes associated with the work zone sites on arterials:

- (1) The work zone speed reduces as the number of lane closures increases (compare the heat maps in Column 2/4/6/8);

- (2) The work zone speed reduces as the traffic volume increases;
- (3) The work zone speed reduction impact is greater in the peak period than that in the non-peak period (compare heat maps in Columns 2, 4, 6, and 8 of Row 1); and
- (4) The speed recovers slowly as the work zone end time approaches the peak period (compare heat maps in Column 2, 4, 6, and 8 of Row 1).

37_MpS_2_WzLength_2_Duration_2

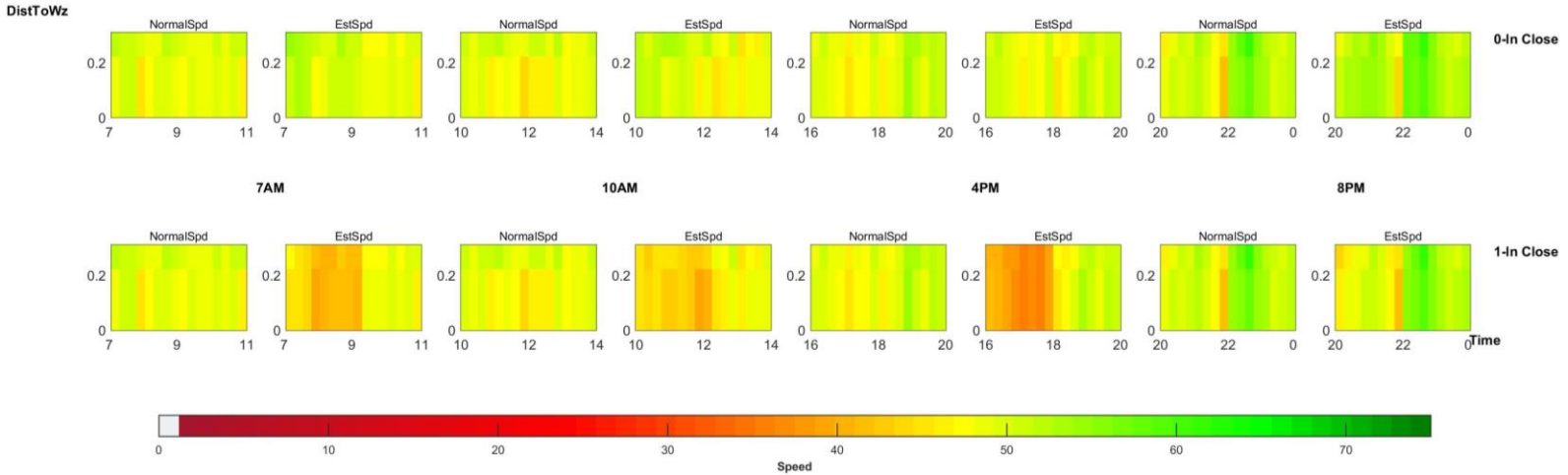

Figure B.2 A sample of testing heat maps (arterial)

APPENDIX C - WIMAP-P Applications

C.1 Application to Freeway Work Zones

Case 1: Freeway Work Zone on I-280 EB

I-280, an urban interstate freeway in New Jersey spanning a total length of 17.85 miles, provides a spur from I-80 in Parsippany-Troy Hills, Morris County to I-95 in Kearny, Hudson County. It is also known as an auxiliary route of I-80. The project limits included the work zone at the eastbound traffic lanes on the mainline I-280 between Exit 15 - NJ 21, Newark (MP 14.5) and Exit 16 - Essex St, Harrison (MP 15.0). The location of the project is shown in Figure C.1.

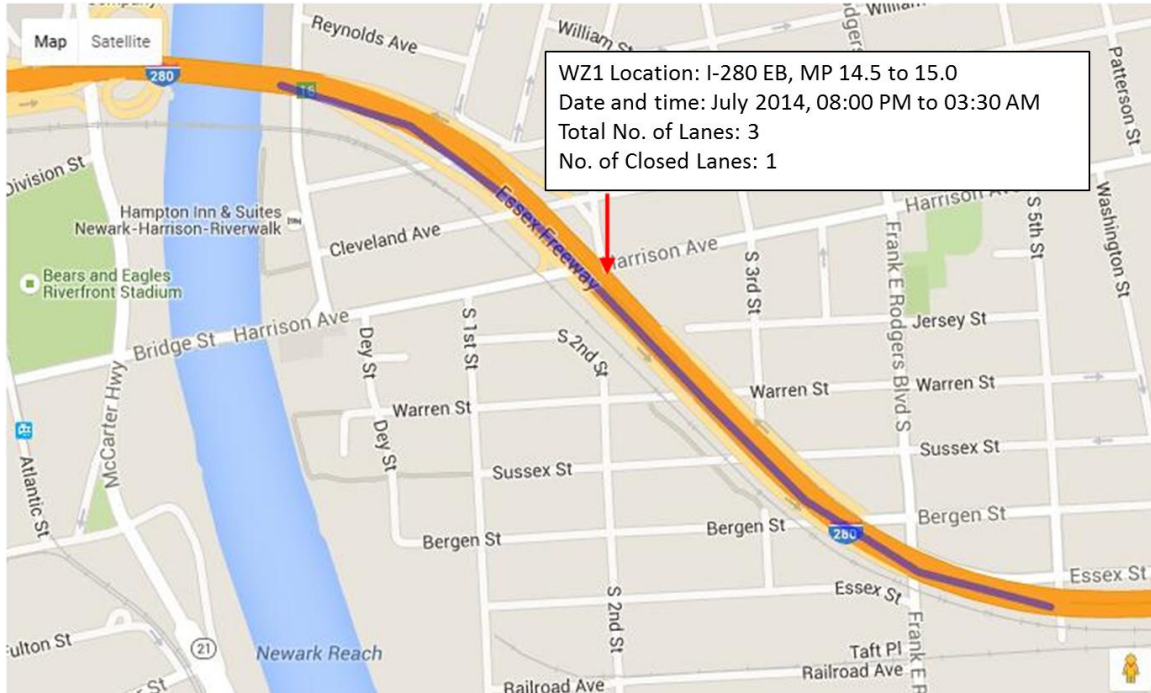

Figure C.1 Work zone location on I-280 in Harrison, NJ

The eastbound direction of I-280 mainline has 3 lanes. The work zone was designated for a bridge construction operation due to which the left lane of the mainline remained closed for repairs from 8:00 PM to 3:30 AM. The estimated AADT in the eastbound direction was 41,737 vehicles with an average of 12% trucks which was obtained from NJCMS DB (2012) ⁽⁷⁰⁾. It is also to be noted that the average user cost per car-hour of \$12.75/hr and the average user cost per truck-hour of \$21.25/hr was considered in computation of the QDC ⁽⁷¹⁾. The hourly traffic distribution for weekday traffic is shown in Figure C.2.

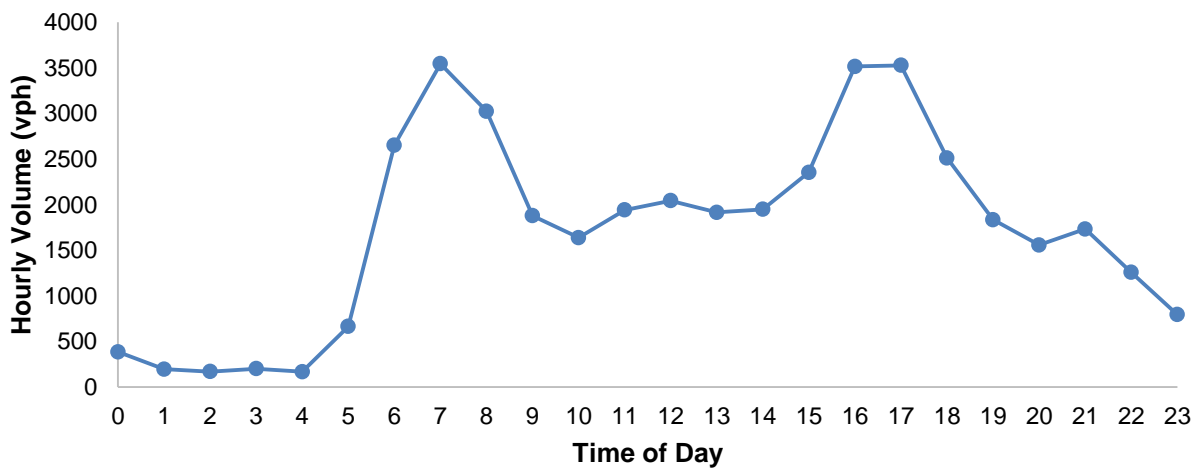

Figure C.2 Hourly traffic distribution on I-280 EB at MP 14.6

WIMAP-P Inputs

The work zone parameter input module is shown as in Figure C.3, where the left panel allows a user to specify the information required for the prediction, such as the work zone location (i.e., route name, start and end mileposts), the number of closed lanes, and the start and end date and time. The right panel of the same figure is a map that will offer the flexibility to zoom in and out on the road network adjacent to the study work zone.

Work Zone Interactive Management Application-Planning (WIMAP-P)

Work Zone Impact Prediction User Manual Welcome Guest! Logout

Show Quick Instructions

Inputs:

Route Name: I-280
Direction: West to East
Route Milepost Range: Start Milepost: 14.5 End Milepost: 15
Roadway Type: Freeway
Number of Lanes: 3
Number of Closed Lanes: 1 Lane Closed
Start Date: 07/16/2014
Start Time: 20:00:00
End Date: 07/17/2014
End Time: 03:30:00
Review Volume Data
Value of Passenger Car Time (\$/veh-hr): 18.15
Value of Truck Time (\$/veh-hr): 30.25

Define how the queue should be determined.

If speed is below:

- 75% of historic average speed
- 75% of historic average speed or below LOS (Level of Service) D Speed. LOS D Highway: 35 mph, Arterial: 15 mph
- Historic average speed minus(MPH): 0

Show Result Download PDF Report Download Excel Report

Figure C.3 WIMAP-P parameter input module

WIMAP-P Results

In Figure C.4, the 15-min traffic volume distribution over space and time prior to the work zone can be displayed when users specify the study work zone information. After computation, WIMAP-P then furnishes results in the form of speed contour maps for both recurrent and predicted work zone speed. This chromatic representation of speed over space and time allows users to easily visualize the changes and its corresponding impact. Figure C.5 shows the speed contour maps obtained after analysis of the work zone on I-280. The difference between the normal and predicted speeds prior to the work zone can be found in Figure C.6.



Figure C.4 15-min traffic volume distribution

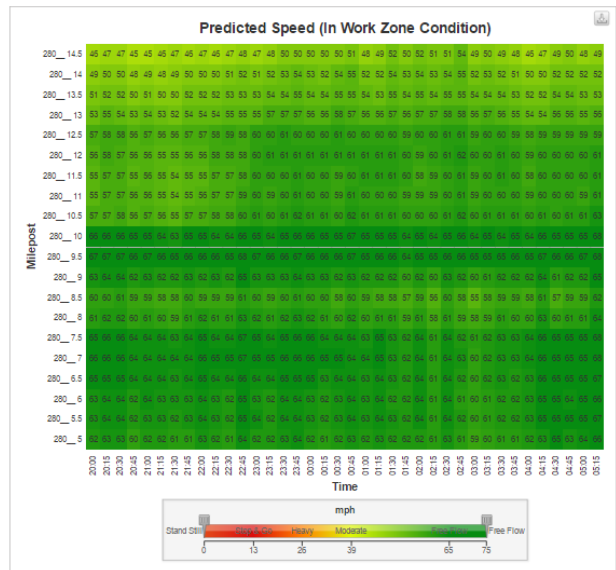
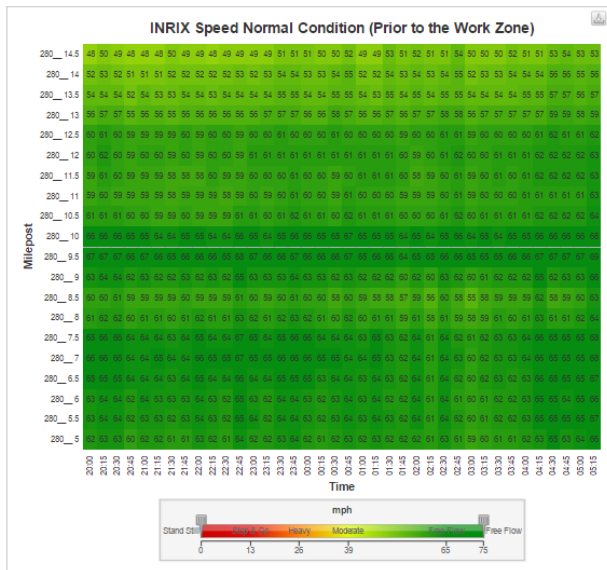

Figure C.5 WIMAP-P speed heat map generation

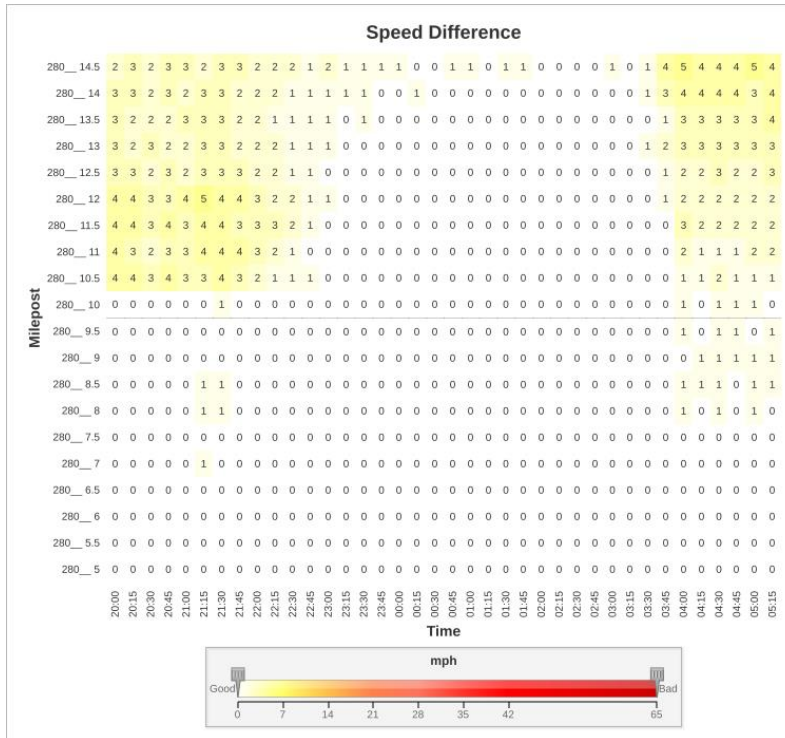

Figure C.6 Speed difference diagram

The results are also provided in the form of a systematic tabulated report. The report generated by the application provides a brief summary of the proposed work zone information that was provided by the user. In addition to this summary, the report tabulates the predicted and normal speed, car and truck volume, and the delay and delay cost associated with every 0.5 miles roadway segment from the designated work zone.

Queue Delay Cost (QDC)

An analysis was conducted by comparing the QDC values suggested by the proposed WIMAP-P model and the method used in the NJDOT Road User Cost Manual (RUCM). The WIMAP-P harnesses the MNR model to approximate the excess travel time in the presence of a work zone. Unlike previous methods which adopted a common work zone speed and unrestricted speed values, the MNR model breaks the route section affected by a work zone into several smaller segments. The model predicts the work zone speed and computes the unrestricted speed (the average INRIX reported speed without incident condition at the same time where the work zone is placed) for each segment to determine the added travel time (or called queue delay). It was found that this dynamic nature of WIMAP-P helps in predicting congestion impact closer to the real world scenario which the NJDOT RUCM method could not explain. Based on the case study introduced earlier in this section, Table C.1 summarizes the predicted delay and cost from the two methods against the INRIX reported speed.

Table C.1 - Comparison of queue delay and cost (freeway)

Approach	Queue Delay (veh-hr)	Queue Delay Cost (\$)
NJDOT RUCM (2001)	0	0
WIMAP-P	47.8	650
INRIX	44.8	609

As congestion occurred, the queue length and emission costs are calculated by using Eqs. 7.3 and 7.4, respectively, with WIMAP-P. The QDC is the product of the predicted average queue delay, the average traffic volume of the affected segments, and the average costs per car-hour and truck-hour. Note that the MNR model was developed to predict the speed and queue delay cause by a work zone over space and time. The work zone delay cost (within the work zone) is determined by the product of the average work zone delay, the traffic volume through the work zone, and the average costs per car-hour and truck-hour (same as the NJDOT RUCM method).

According to the results illustrated in Table C.1, it was found that the WIMAP-P method outperforms the NJDOT RUCM method in terms of the proximity to the INRIX reported speed data. The WIMAP-P model gives a difference of \$41 for QDC and a difference of 3 veh-hr for the associated queue delay.

Case 2: A Freeway Work Zone on I-287 NB

The work zone under consideration is located on I-287 northbound with mile markers ranging from 31 to 32. The work zone was scheduled on August 2014 from 7:00 pm to 11:00 pm. The roadway section under consideration has a total number of 3 lanes with 1 lane closure. The location of the work zone is given in Figure C.7.

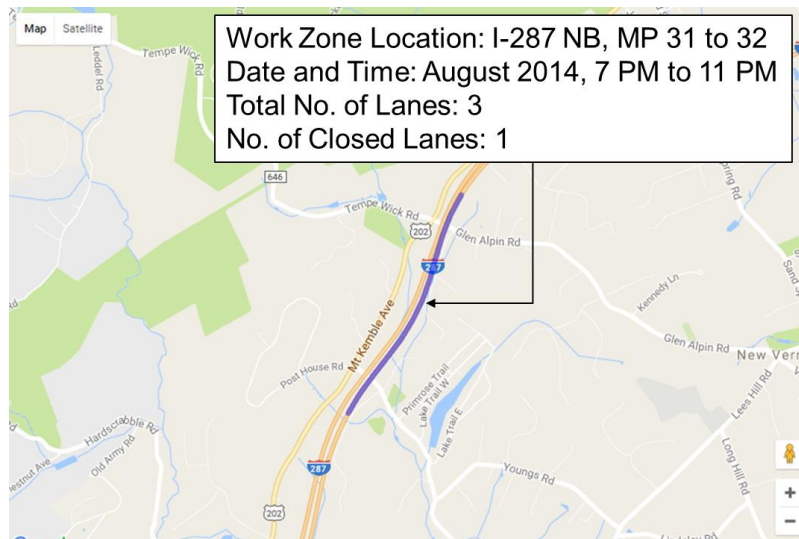

Figure C.7 Work zone location on I-287 in Morristown, NJ

The work zone was designated for a construction operation, and due to this, one lane of the mainline remained closed for repairs from 7:00 pm to 11:00 pm. The traffic volume data was obtained from NJCMS ⁽⁷⁰⁾ as illustrated in Figure C.8, which consists of 10% of trucks. Note that the average user costs per car-hour and truck-hour are the same as considered in the previous study (i.e. I-280).

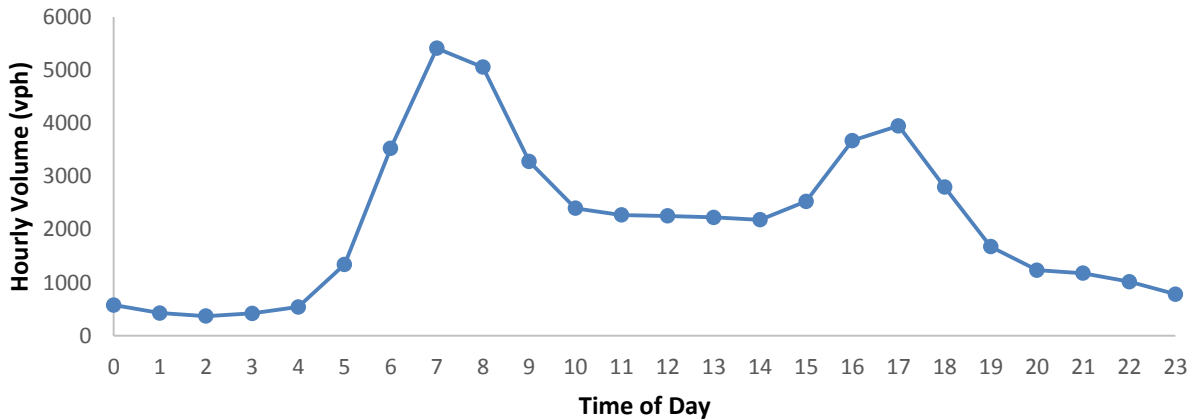

Figure C.8 Hourly traffic distribution on I-287 NB at MP 31

WIMAP-P Inputs

Figure C.9 shows the general interface with the required information provided by the users in the Parameter Input module.

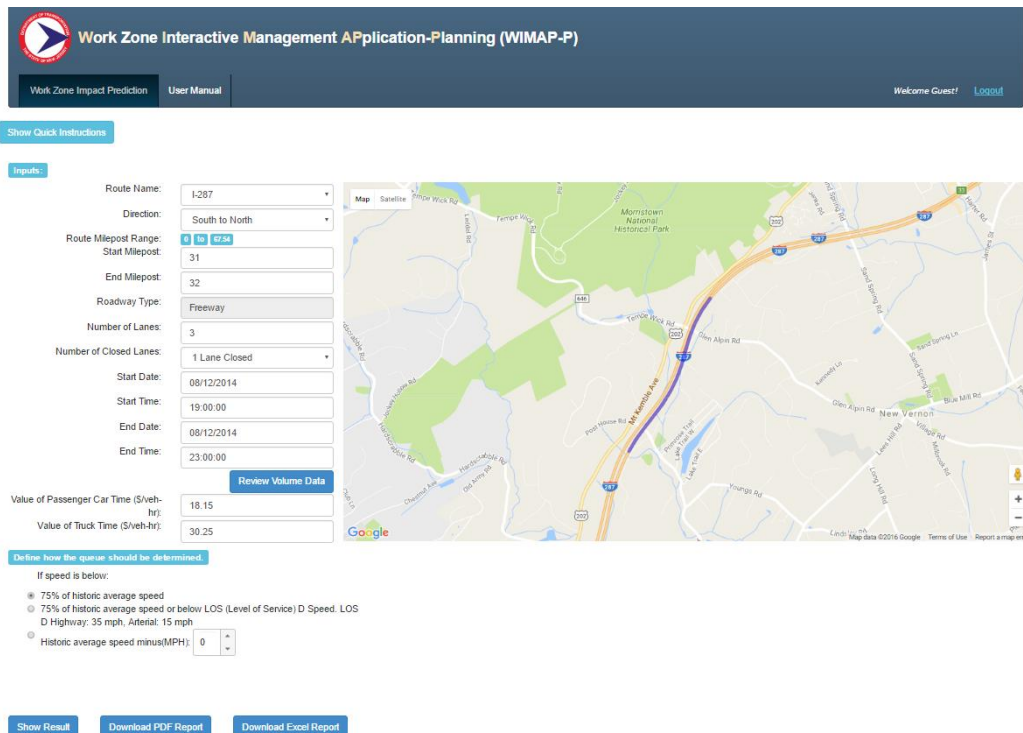

Figure C.9 WIMAP-P parameter input module

WIMAP-P Results

In Figure C.10, the 15-min traffic volume distribution over space and time prior to the work zone can be displayed when users specify the study work zone information. After computation, WIMAP-P then furnishes results in the form of speed contour maps for both the recurrent and predicted work zone speed. This chromatic representation of speed over space and time allows users to visualize the changes and its corresponding impact. Figure C.11 shows the speed contour maps obtained after analysis of the work zone on I-287. The difference between normal and predicted speeds prior to the work zone can be found in Figure C.12.

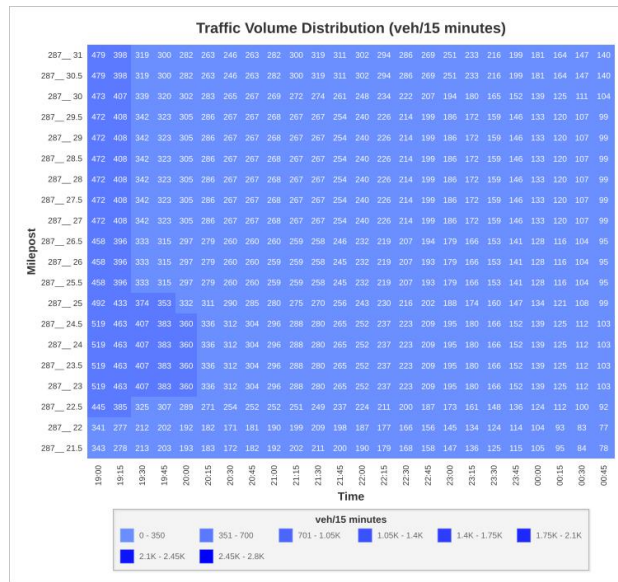

Figure C.10 15-min traffic volume distribution

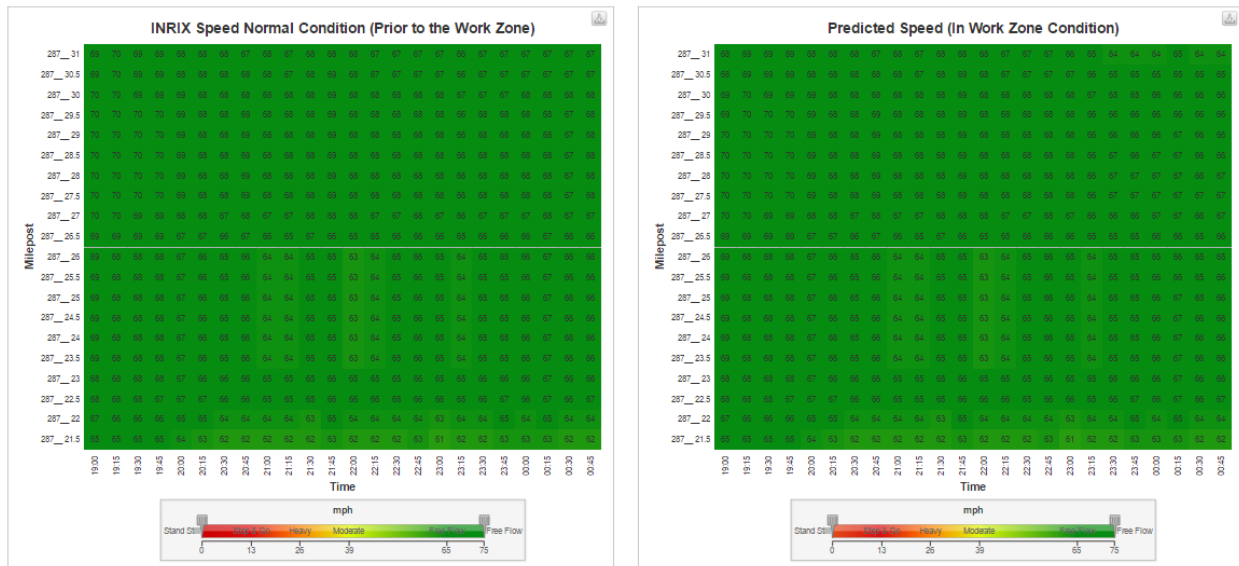

Figure C.11 WIMAP-P speed heat map generation

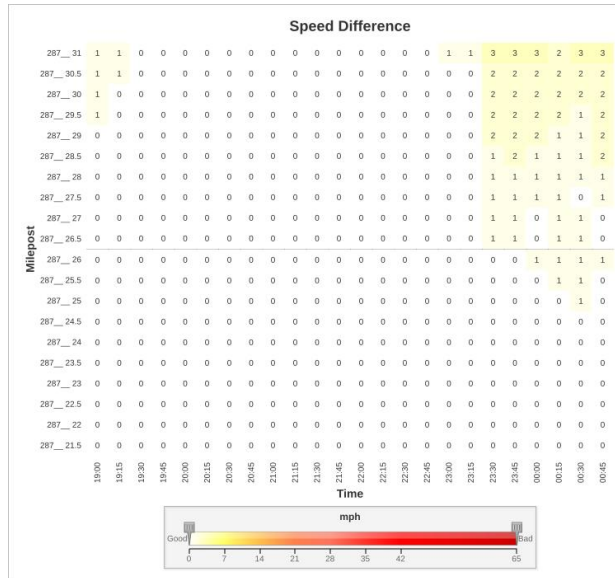

Figure C.12 Speed difference diagram

The results are also provided in the form of a systematic tabulated report. The report generated by the application provides a brief summary of the proposed work zone information provided by the user. In addition to this summary, the report tabulates the predicted and normal speed, car and truck volume, and the delay and delay cost associated with every 0.5 miles roadway segment from the designated work zone.

Queue Delay Cost (QDC)

The QDCs predicted by the WIMAP-P and the NJDOT RUCM methods are compared and illustrated in Table C.2.

Table C.2 - Comparison of queue delay and cost (freeway)

Approach	Queue Delay (veh-hr)	Queue Delay Cost (\$)
NJDOT RUCM (2001)	0	0
WIMAP-P	0.8	11
INRIX	3.0	41

The queue delay, congestion impact length and emission cost prediction are based on Eqs. 7.2 - 7.4 presented in Chapter VII. It was found that the queue delay and the associated QDC predicted by WIMAP-P is closer to the estimated delay based on INRIX reported speeds.

C.2 Application to Arterial Work Zones

Case 1: An Arterial Work Zone on US-130 NB

This work zone (3-lane with 1-lane closure) was located on US-130 Northbound between MP 43.6 and MP 43.9, and was scheduled to start from 9:00 am to 1:00 pm on March 2014, as illustrated in Figure C.13. The study work zone was located on a segment of roadway with 3 lanes, with one lane closure (from 9:00 am to 1:00 pm) on US-130 NB. The traffic volume data was obtained from NJCMS DB, ⁽⁷⁰⁾ and consisted of 90% cars and 10% trucks through the work zone.

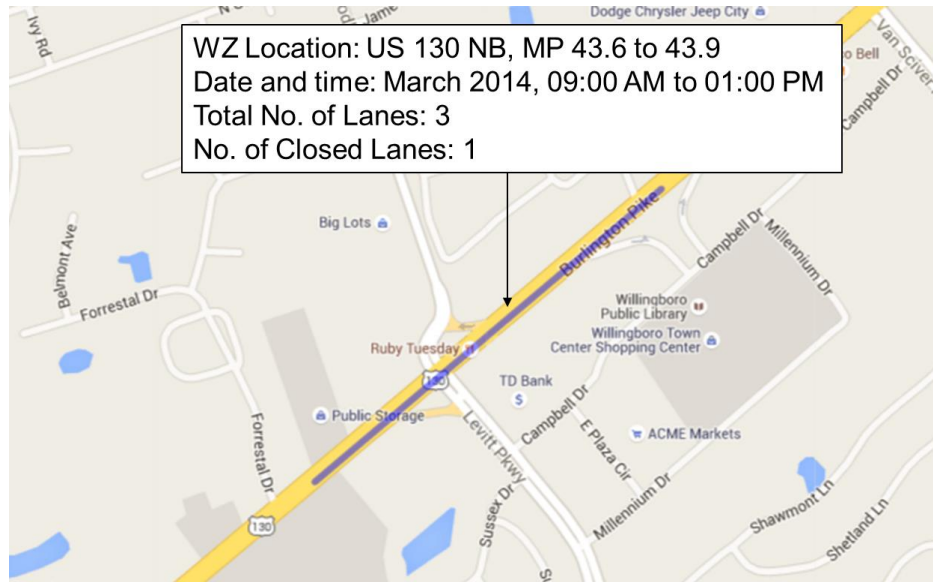

Figure C.13 Work zone location on US-130 in Willingboro, NJ

WIMAP-P Inputs

Figure C.14 shows the general interface with the required information provided by the users in the Parameter Input module.

Show Quick Instructions

Inputs:

Route Name:

Direction:

Route Milepost Range:

 Start Milepost: to

 End Milepost:

Roadway Type:

Number of Lanes:

Number of Closed Lanes:

Start Date:

Start Time:

End Date:

End Time:

Value of Passenger Car Time (S/veh-hr):

Value of Truck Time (S/veh-hr):

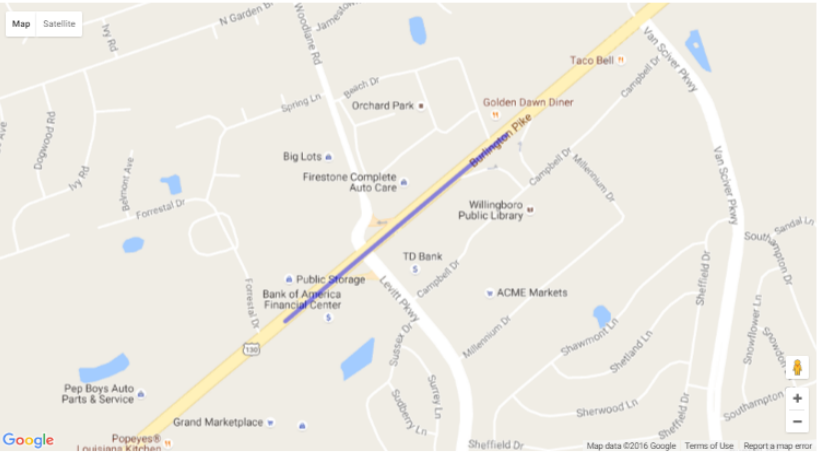

Define how the queue should be determined.

If speed is below:

- 75% of historic average speed
- 75% of historic average speed or below LOS (Level of Service) D Speed.
 - LOS D Highway: 35 mph, Arterial: 15 mph
- Historic average speed minus(MPH):

Figure C.14 WIMAP-P parameter input module

WIMAP-P Results

Figure C.15 shows the 15-min traffic volume distribution over space and time prior to the work zone. Then, WIMAP-P furnishes results in the form speed contour maps for both recurrent and predicted work zone speeds, as shown in Figure C.16. In addition, the difference between normal and predicted speeds prior to the work zone can be found in Figure C.17.

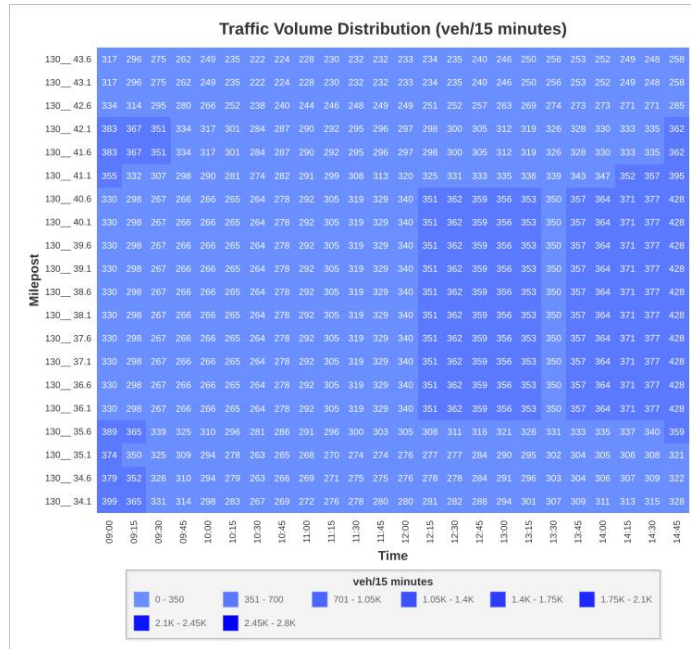

Figure C.15 15-min traffic volume distribution

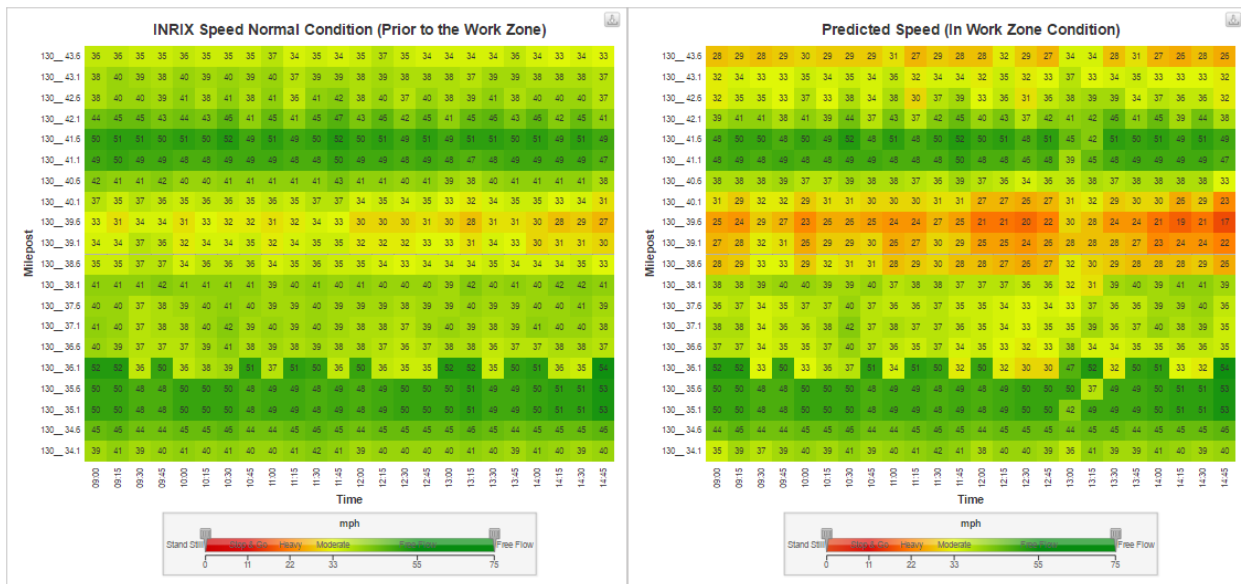

Figure C.16 WIMAP-P speed heat map generation

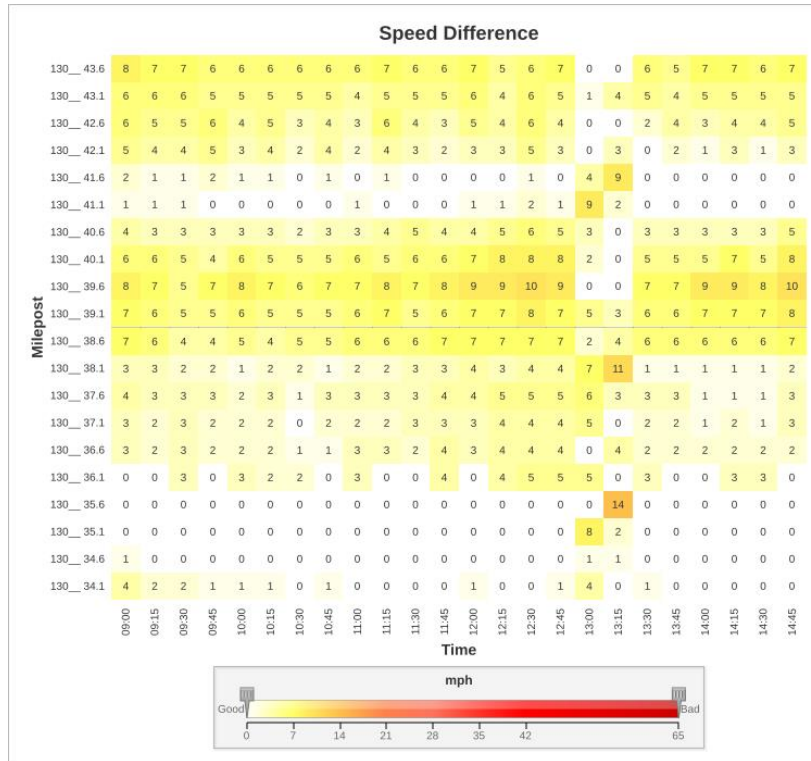

Figure C.17 Speed difference diagram

The results are also summarized in a tabulated report, which includes basic work zone information provided by the user and impact analysis results, including predicted vs. normal speed, car and truck volumes, delay and the associated costs over space and time.

Queue Delay Cost (QDC)

As mentioned earlier, the NJDOT RUCM does not furnish the calculation details regarding work zone activity on arterials. Hence, an assessment of proximity to a real world scenario achieved by the WIMAP-P model is presented.

Table C.3 illustrates the queue delays and costs predicted by WIMAP-P and compared with the estimated data that was based on INRIX reported speed. It was found that both the queue delay and costs predicted by WIMAP-P are very close to those estimated using the INRIX reported speed, with a difference of \$126 QDC and a difference of queue delay of 9.2 veh-hr.

Table C.3 - Comparison of queue delay and cost (arterial)

Approach	Queue Delay (veh-hr)	Queue Delay Cost (\$)
NJDOT RUCM (2001)	N/A	N/A
WIMAP-P	156.8	2,133
INRIX	147.6	2,007

Case 2: An Arterial Work Zone on US-130 NB

The study work zone is located on a segment (2-lane with 1-lane closure) US-130 NB from MP 78 to MP 79.2, and the lane closure was scheduled from 9:00 am to 11:00 pm in March 2014, and shown in Figure C.18. The traffic volume data was obtained from NJCMS DB ⁽⁷⁰⁾ consisting of 90% cars and 10% trucks through the work zone.

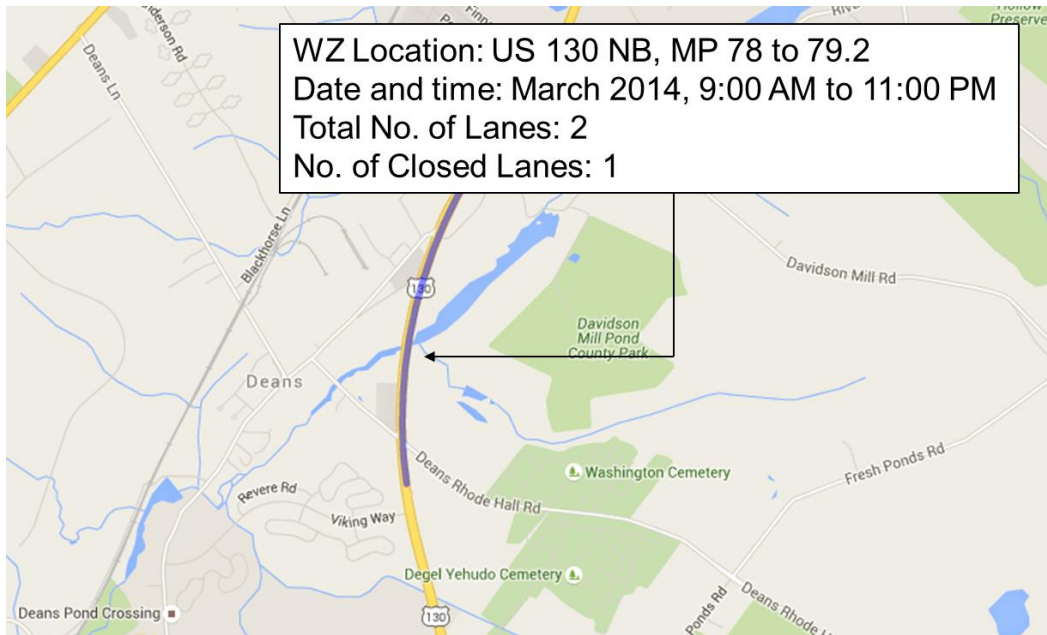

Figure C.18 Work zone location on US-130 in Dayton, NJ

WIMAP-P Inputs

Figure C.19 shows the general interface with the required information provided by the users in the Parameter Input module.

Work Zone Interactive Management Application-Planning (WIMAP-P)

Work Zone Impact Prediction
User Manual
Welcome Guest! [Logout](#)

Show Quick Instructions

Inputs:

Route Name:

Direction:

Route Milepost Range:

Start Milepost:

End Milepost:

Roadway Type:

Number of Lanes:

Number of Closed Lanes:

Start Date:

Start Time:

End Date:

End Time:

[Review Volume Data](#)

Value of Passenger Car Time (\$/veh-hr):

Value of Truck Time (\$/veh-hr):

Define how the queue should be determined.

If speed is below:

- 75% of historic average speed
- 75% of historic average speed or below LOS (Level of Service) D Speed.
LOS D Highway: 35 mph, Arterial: 15 mph
- Historic average speed minus(MPH):

Show Result

Download PDF Report

Download Excel Report

Figure C.19 WIMAP-P parameter input module

WIMAP-P Results

Figure C.20 shows the 15-min traffic volume distribution over space and time prior to the work zone. After computation, WIMAP-P then furnishes results in the form speed contour maps for both recurrent and predicted work zone speeds as shown in Figure C.21. In addition, the difference between normal and predicted speeds prior to the work zone can be found in Figure C.22.

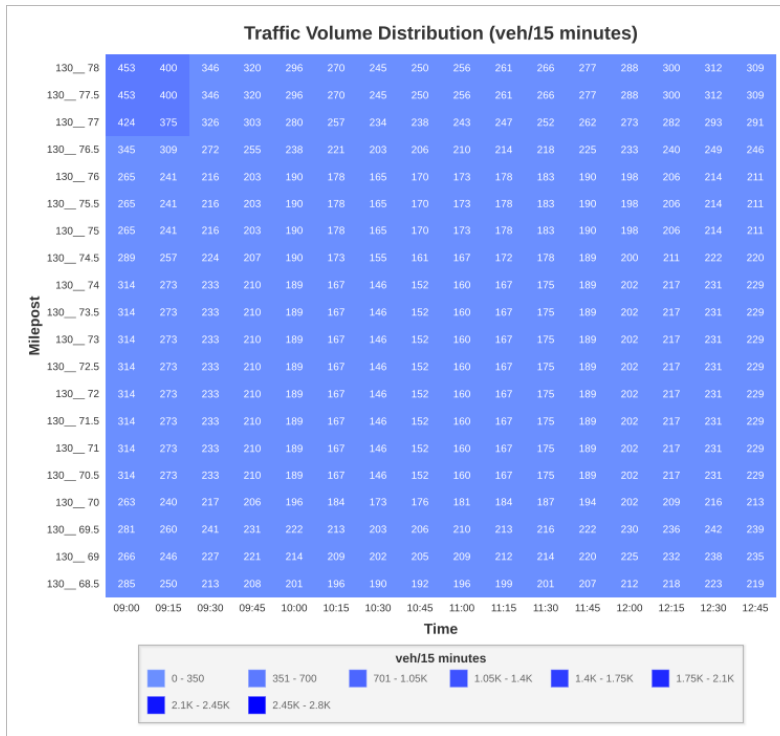

Figure C.20 15-min traffic volume distribution

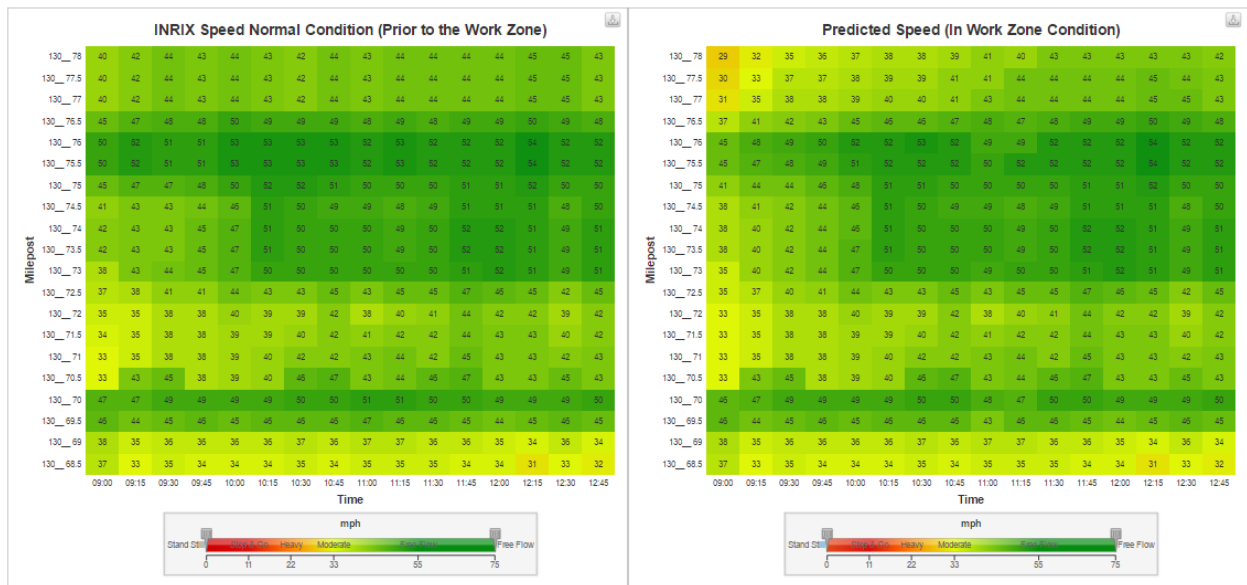

Figure C.21 WIMAP-P speed heat map generation

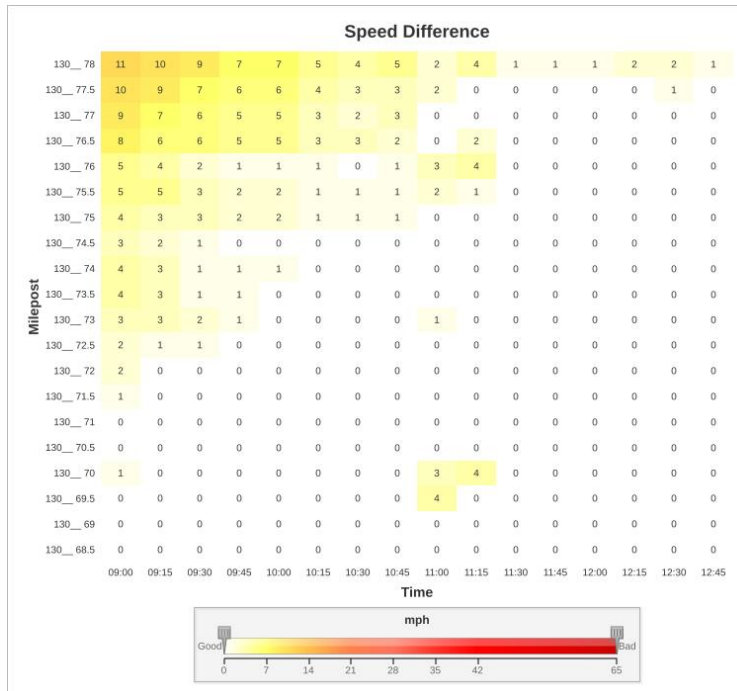

Figure C.22 Speed difference diagram

The results are also provided in the form of a systematic tabulated report. The report generated by the application provides a brief summary of the proposed work zone information provided by the user. In addition, the report tabulates the predicted and normal speed, car and truck volume, and the delay and delay cost associated with every 0.5 miles of the roadway segment from the designated work zone.

Queue Delay Cost (QDC)

As mentioned earlier the NJDOT RUCM method does not furnish the calculation details regarding work zone activities on arterials. Table C.4 summarizes the results predicted by WIMAP-P and estimated with the INRIX reported speed.

Table C.4 - Comparison of queue delay and cost (arterial)

Approach	Queue Delay (veh-hr)	Queue Delay Cost (\$)
NJDOT RUCM (2001)	N/A	N/A
WIMAP-P	33.4	454
INRIX	44.8	610

The queue delay, congestion impact length and the emission cost predictions are based on the Eqs. 7.2 - 7.4 presented in Chapter VII. It was found that the predicted delay with WIMAP-P is close to the estimates using the INRIX reported speed.

APPENDIX D - NJDOT RUCM Approach

For the freeway work zone (Case 1 in Appendix C), the real-time traffic volume data is not readily available and the traffic volume data from the NJCMS DB (2012) are applied. ⁽⁷⁰⁾ Before conducting the computation, certain important criteria and assumptions must be identified:

- A studied time period from 8:00 PM to 3:30 AM was taken into consideration. Justification of this time frame is met with the correlation of the work zone operation.
- Assume the percentage of trucks utilizing the route in the selected time period is considered as 10%.
- Average user cost per car hour is \$12.75/hr.
- Average user cost per truck hour is \$21.25/hr.
- The work zone speed is generally 10mph -15mph less than the unrestricted speed. The unrestricted speed is generally assumed the posted speed limit of the section operating in an unrestricted flow condition. Following this, the unrestricted speed of the studied segment as 50 mph; hence, the work zone speed is assumed as 40 mph.

As mentioned before in Case 1 of Appendix C, the selected section of the I-280 EB mainline is comprised of 3 lanes. The closure of one lane was required for carrying out work zone operations, and all traffic operations were supported by the remaining two open lanes. Capacity of the roadway in both normal and work zone scenarios are given in the NJDOT RUCM as illustrated in Table D.1.

Table D.1 - Traffic capacities

S.No.	Facility Type	Ideal Capacity
1	Freeway-4 lanes	2,200 Passenger Cars per hour per lane
2	Freeway-6 or more lanes	2,300 Passenger Cars per hour per lane
3	Multilane Highway	2,200 Passenger Cars per hour per lane
4	Two-Lane Highway	1,400 Passenger Cars per lane (*)
5	Signalized Intersection	1,900 Passenger Cars per hour of green per lane

Source: NJDOT RUCM (2001), Table 3.1.

(*) For 50/50 volume, split by direction.

Table D.2 - Measured work zone capacity - freeway section

Number of Direction Lanes		Number of Studies	Average Capacity		Recommended Value (*) veh/lane/hour
Normal	Open		Vehicle per hour	Vehicle per lane per hour	
3	1	7	1,170	1,170	1,200
2	1	8	1,340	1,340	1,300
5	2	8	2,740	1,370	1,400
4	2	4	2,960	1,480	1,500
3	2	9	2,980	1,490	1,500
4	3	4	4,560	1,520	1,500

Source: NJDOT RUCM (2001), Table 3.2.

(*) Values may be increased 100 veh/lane/hour when work zone is protected with Jersey barrier.

Work zone road capacity counted in vehicle/per/hour is taken as the number of lanes multiplied by the capacity provided in Table D.2. With one lane closure on a 3-lane freeway, the work zone capacity is 2,400 vph. Table D.3 depicts the calculation procedure suggested by the NJDOT RUCM. ⁽⁷¹⁾

Table D.3 - Freeway work zone analysis

Work Zone: I-280 Eastbound between MP 14.5 to 15		Normal Capacity: 6,900								
Percent Trucks: 10%		Percent Cars: 90%								
Directional ADT: _____		Year: 2014								
		Work Zone/Detour Capacity: 2,400								
		Lanes Under Normal Operation: 3								
3.1(A)	3.1(B)	3.1(C)	3.1(D)	3.1(E)	3.1(F)	3.1(G)	3.1(H)	3.1(I)	3.1(J)	3.1(K)
Time Period (hour)	Hourly Traffic (%)	Vehicle Demand (vph)	Lanes Open (#)	Roadway Capacity (vph)	Queue Rate (vph)	Queued Vehicles (vph)	Average Queued Vehicles (vph)	Vehicles that Travel Work Zone (vph)	Vehicles that Travel Detour (vph)	Vehicles that Travel Queue (vph)
12-1 AM		508	2	2,400	-1,892	0	0	508	0	0
1-2		357	2	2,400	-2,043	0	0	357	0	0
2-3		293	2	2,400	-2,107	0	0	293	0	0
3-4		368	2	2,400	-2,032	0	0	368	0	0
⋮				⋮				⋮		
10-11										
11-12 PM										
12-1										
⋮				⋮				⋮		
8-9		2,028	2	2,400	-372	0	0	2,028	0	0
9-10		1,676	2	2,400	-724	0	0	1,676	0	0
10-11		1,372	2	2,400	-1,028	0	0	1,372	0	0
11-12		887	2	2,400	-1,513	0	0	887	0	0
TOTALS								7,489		

The queue rate is calculated as the difference between the hourly capacity of the facility and the unrestricted hourly demand during each hour of the day. The queuing rate is the hourly rate at which vehicles accumulate, or, if negative, dissipate from any queue that may exist. A physical queue develops when the queue rate is greater than zero. ⁽⁷¹⁾ In this scenario, the approaching volume is too small compared to the capacity provided. Hence, either negative queue rates are obtained or no queue is formed.

Under unrestricted flow conditions, the number of vehicles that travel through the work zone is generally seen as the traffic demand on the facility during the hours when the work zone is in place. The total number of vehicles travelling through the work zone was 7,489 vph as shown in Table D.3. Based on the NJDOT RUCM, the added travel time caused by the work zone can be computed using the following formula:

$$\text{Added travel time} \left(\frac{\text{hr}}{\text{veh}} \right) = \frac{d}{V_W} - \frac{d}{V_U} \quad (\text{A5.1})$$

where:

- d = Work zone length (mi);
- V_W = Work zone speed (mph); and
- V_U = Unrestricted speed (mph).

Table D.4 - Freeway: work zone delay calculation

Work Zone Length (mile)	Work Zone Speed (mph)	Unrestricted Speed (mph)	Work Zone Travel Time at Unrestricted Speed (hr/veh)	Work Zone Travel Time at Work Zone Speed (hr/veh)	Added Time to Travel Work Zone (hr/veh)
0.6	40	50	0.012	0.015	0.003

The QDC is calculated for specific vehicle classes, and is the product of the percentage of class and the volume, additional travel time delay, and the average user cost per vehicle. Table D.5 shows the calculation based on the NJDOT RUCM. The QDC is computed by multiplying the total QDC by a 50% reduction factor. The reduction factor is used to accommodate for variations in traffic data, roadway capacities, and cost rates.

Table D.5 - Freeway: queue delay cost computation (NJDOT RUCM)

3.5(A)	3.5(B)	3.5(C)	3.5(D)	3.5(E)	3.5(F)	3.5(G)	3.5(H)
Road User Cost Component	Vehicle Class	Percent Class (%)	Total Vehicles (#)	Added Travel Length (mile/veh)	Added Time (hr/veh)	Cost Rate (\$/veh-hr, \$/mile)	Road User Cost (\$)
Queue Delay (Added Time)	CAR	90	0		0.000	12.75	0
	TRUCK	10	0		0.000	21.25	0
Queue Idling VOC (Added Cost)	CAR	90	0		0.000	0.6821	0
	TRUCK	10	0		0.000	0.7845	0
Work Zone Delay (Added Time)	CAR	90	7,489		0.003	12.75	258
	TRUCK	10	7,489		0.003	21.25	48
Circuitry Delay (Added Time)	CAR						
	TRUCK						
Circuitry VOC (Added Cost)	CAR						
	TRUCK						
Total Vehicles that Travel Queue:			0	Daily Road User Cost		306	
Total Vehicles that Travel Work Zone:			7,489	Calculated Road User Cost (CRUC)		153	
Total Vehicles that Travel Detour:			0	Number of Work Zone Days		1	
Percent Passenger Cars:			90%	Total Road User Cost		153	
Percent Trucks:			10%				

APPENDIX E - WIMAP-P User Manual

E.1 General Requirements

WIMAP-P is a web based application and hence requires minimal system requirements and no physical installation to access it. Listed below are the supported browsers required for the optimal functioning of the application:

- Google Chrome (Recommended)
- Mozilla Firefox (Recommended)
- Internet Explorer

E.2 Application Features

The WIMAP-P application furnishes the users with multitudes of useful features, a brief summary of each is given below:

ID	Feature	Description
1	Freeway Work Zone Model	A MNR model capable to handle work zone activities on freeway road segment along with its influence.
2	Arterial Work Zone Model	A MNR model capable to handle work zone activities on arterial road segment along with its influence.
3	Register Member	The application adopts a secure channel of accessibility hence requiring users to register.
4	Report	Parameter inputs and results from the user-specified MNR model are summarized in a standardized report.

E.3 Login Instructions

Before accessing, the WIMAP-P application requires to create a secure channel of accessibility which is facilitated by a unique username and password. To access the application, user must visit the URL: <http://transprod04.njit.edu/WiMAPPP/>.

For first time users, accessibility can be established by:

- Guest profile to access the main application U/I.
- Alternatively the administrator has control in adding new users to access the application.

E.4 User Interface

Work Zone Interactive Management Application-Planning (WIMAP-P)

Work Zone Impact Prediction | User Manual | Welcome Guest! | Logout

Show Quick Instructions

Inputs:

Route Name: Select Route

Direction: Select Direction

Route Milepost Range:

Start Milepost:

End Milepost:

Roadway Type:

Number of Lanes:

Number of Closed Lanes: Select no. of closed la

Start Date:

Start Time:

End Date:

End Time:

Review Volume Data

Value of Passenger Car Time (\$/veh-hr): 18.15

Value of Truck Time (\$/veh-hr): 30.25

Define how the queue should be determined:

If speed is below:

- 75% of historic average speed
- 75% of historic average speed or below LOS (Level of Service)
- D Speed, LOS D Highway: 35 mph, Arterial: 15 mph
- Historic average speed minus (MPH):

Show Recall | Download PDF Report | Download Excel Report

ID	Title	Description
1	Title Bar	Information with application title, username logged in and option to logout.
2	Nav Bar	Combination of multiple tabs supporting various user operations.
3	Input Instructions	Information of active user operation.
4	Input Module	Inputs of route configuration to execute work zone planning model.
5	Map Module	Graphical representation of route configuration from input module.

E.5 Input Parameters

Listed below is the description of various input parameters required to use the application.

The screenshot shows a web form titled "Inputs:" with various input fields and buttons. The form is organized into sections. The first section contains fields for Route Name, Direction, Route Milepost Range (Start and End Milepost), Roadway Type, Number of Lanes, and Number of Closed Lanes. The second section contains date and time fields (Start Date, Start Time, End Date, End Time) and a "Review Volume Data" button. The third section contains fields for Value of Passenger Car Time and Value of Truck Time. The fourth section is titled "Define how the queue should be determined." and contains three radio button options: "75% of historic average speed", "75% of historic average speed or below LOS (Level of Service) D Speed. LOS D Highway: 35 mph, Arterial: 15 mph", and "Historic average speed minus(MPH):" with a numeric input field set to 0. At the bottom of the form are three buttons: "Show Result", "Download PDF Report", and "Download Excel Report".

Numbered callouts (1-18) point to the following elements:

- Route Name dropdown
- Direction dropdown
- Start Milepost input
- End Milepost input
- Roadway Type dropdown
- Number of Lanes input
- Number of Closed Lanes dropdown
- Start Date input
- Start Time input
- End Date input
- End Time input
- Review Volume Data button
- Value of Passenger Car Time input
- Value of Truck Time input
- Define how the queue should be determined. header
- 75% of historic average speed radio button
- 75% of historic average speed or below LOS (Level of Service) D Speed. LOS D Highway: 35 mph, Arterial: 15 mph radio button
- Historic average speed minus(MPH): input field
- Show Result button
- Download PDF Report button
- Download Excel Report button

ID	Title	Description
1	Route Name	Select a route name from a list of freeways and arterials in New Jersey.
2	Direction	Dropdown user selection of either primary or secondary direction.
3	Start & End Milepost Range	Automatically populates the range of milepost pertaining to the selected route name.
4	Start Milepost	User input (integer) defining the beginning of milepost of work zones
5	End Milepost	User input (integer) defining the ending of milepost of work zone.
6	Roadway type	Depending upon the route name, direction, and milepost range. The application can identify and display if the roadway segment under analysis is freeway or arterial.
7	Number of Lanes	Automatically populates the total number of lanes based on specified route name and milepost range.
8	Number of Closed Lanes	Selection of number of closed lanes ranging from shoulder closure up to 4 lanes closed.
9	Start Date	User input (mm/dd/yyyy) of work zone start date selected from build-in calendar layout.
10	Start Time	User input (hh:mm:ss) of work zone start time selected from drop down
11	End Date	User input (mm/dd/yyyy) of work zone end date selected from build-in calendar layout.
12	End Time	User input (hh:mm:ss) of work zone end time selected from drop down.
13	Show Volume Data	Displays hourly traffic counts obtained from NJCMS (2012).
14	Value of Passenger Time	Input the value of time for passenger cars (\$/veh-hr).
15	Value of Truck Time	Input the value of time for trucks (\$/veh-hr).
16	Define the queue	Select different definitions of the queue. More details can be found in the final report.
17	Show Result	Displays result.
18	Download Report	Download output report in PDF or Excel formats.

E.6 Execution Procedure

Step 1: Select “Work Zone Impact Prediction” Tab

User can begin interacting with the application by selecting an appropriate option from the "Nav bar". It must also be noted that the “Work Zone Impact Prediction” option is active by default upon loading of the application.

[Show Quick Instructions](#)

Inputs:

Route Name:

Direction:

Route Milepost Range:

Start Milepost:

End Milepost:

Roadway Type:

Number of Lanes:

Number of Closed Lanes:

Start Date:

Start Time:

End Date:

End Time:

[Review Volume Data](#)

Value of Passenger Car Time (\$/veh-hr):

Value of Truck Time (\$/veh-hr):



Define how the queue should be determined.

If speed is below:

- 75% of historic average speed
- 75% of historic average speed or below LOS (Level of Service)

D Speed. LOS D Highway: 35 mph, Arterial: 15 mph

Historic average speed minus(MPH):

[Show Result](#) [Download PDF Report](#) [Download Excel Report](#)

Depending upon the user inputs (e.g., route name, direction, and milepost range), WIMAP-P can detect the roadway type and select the appropriate model for analysis namely:

- Freeway Work Zone Planning Model; or
- Arterial Work Zone Planning model

Step 2: Assign Input Parameters

The input parameters can be assigned values by the users. A sample input is shown below. More details regarding the description of the variables and the guidelines can be found in Section E.5.

Work Zone Interactive Management Application-Planning (WIMAP-P)

Work Zone Impact Prediction | User Manual | Welcome Guest! | Logout

Show Quick Instructions

Inputs:

Route Name: I-80

Direction: West to East

Route Milepost Range: 0 to 68.54

Start Milepost: 42

End Milepost: 43

Roadway Type: Freeway

Number of Lanes: 4

Number of Closed Lanes: 1 Lane Closed

Start Date: 04/02/2015

Start Time: 08:00:00

End Date: 04/02/2015

End Time: 11:00:00

Review Volume Data

Value of Passenger Car Time (\$/veh-hr): 18.15

Value of Truck Time (\$/veh-hr): 30.25

Show Result | Download PDF Report | Download Excel Report

By clicking "Review Volume Data" button in the image above, user can review volume changes over space and time.

Review Volume

Increase by
 Decrease by
 Percent

ROUTE	SRI_CMS	BEGINMP	ENDMP	VOL 7:00 AM	VOL 8:00 AM	VOL 9:00 AM	VOL 10:00 AM	VOL 11:00 AM	VOL 12:00 PM	VOL 1:00 PM
I-80	00000080__	39.57	42.46	6551	7329	5827	4182	4086	4266	4237
I-80	00000080__	38.81	39.57	6822	7511	5167	3105	3222	3784	3759
I-80	00000080__	37.63	38.81	7763	7763	6041	4691	4309	4233	4075
I-80	00000080__	35.33	37.63	7346	7346	5797	4502	4134	4062	3910
I-80	00000080__	34.65	35.33	7027	6791	5045	3922	3626	3562	3429
I-80	00000080__	34.02	34.65	7027	6791	5045	3922	3626	3562	3429
I-80	00000080__	33.58	34.02	5399	5399	4128	3206	2944	2893	2784
I-80	00000080__	30.61	33.58	5176	5176	4217	3275	3008	2956	2844

The next step would involve displaying the results after executing the model. This step can be accessed by clicking the "Show Results" button in the image above.

Step 3: Display Prediction Results

On clicking the "Show Result" button, the WIMAP-P can generate results as shown below. The results include 15-min traffic volume distribution diagram, speed difference diagram, normal speed and predicted speed contour diagrams. Normal and predicted speeds are also displayed in a tabulated format as shown below.

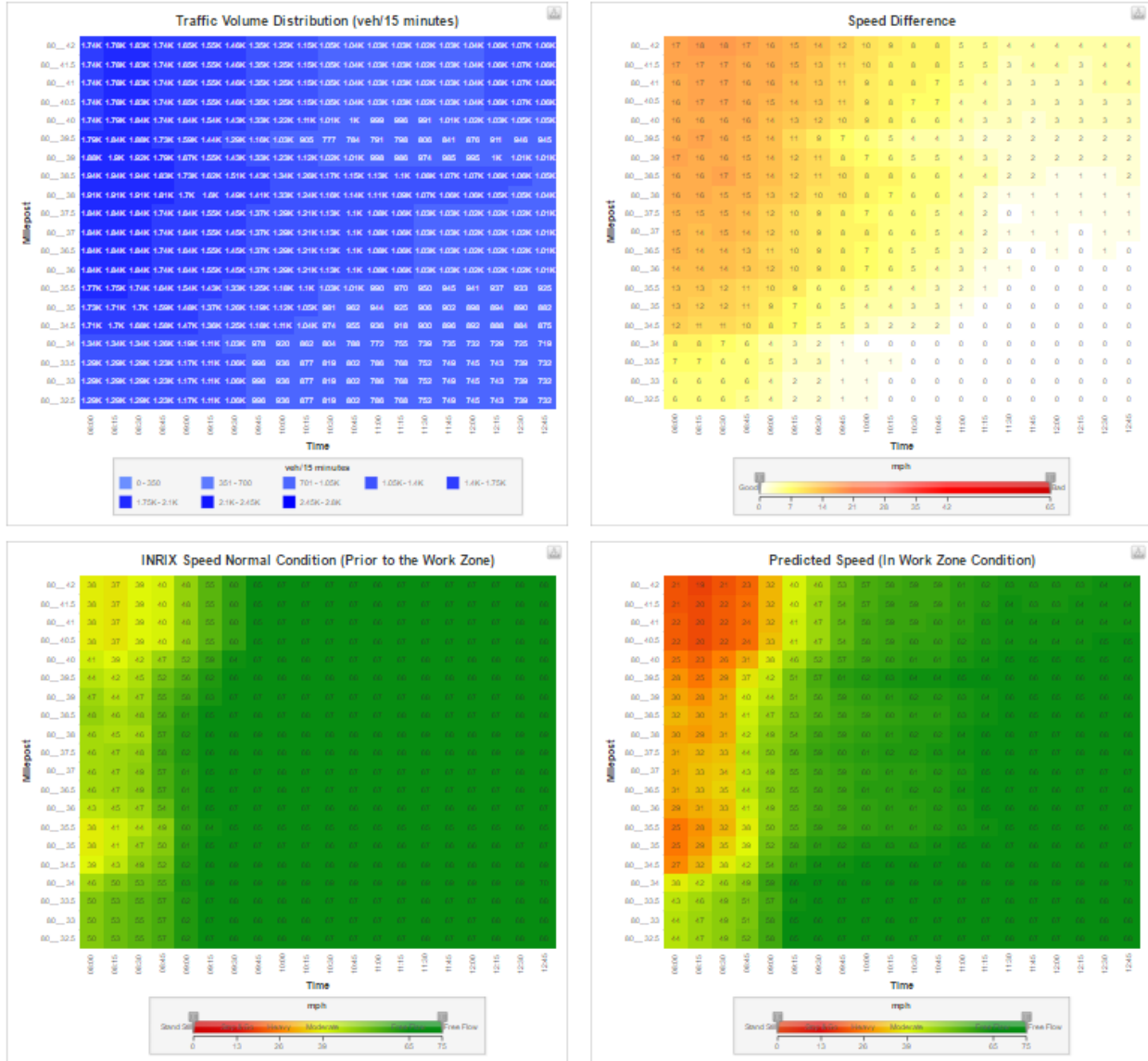

BRI	Time	Start MP	End MP	Distance to Work Zone (miles)	INRIX speed (mph)	Predicted speed (mph)	Car Volume (veh/15 minutes)	Truck Volume (veh/15 minutes)	Congested? (Y/N)
00000080__	4/2/15, 8:00 AM	41.50	42.00		0.50	38	21	1,607	128 Yes
00000080__	4/2/15, 8:00 AM	41.00	41.50		1.00	38	21	1,607	128 Yes
00000080__	4/2/15, 8:00 AM	40.50	41.00		1.50	38	22	1,607	128 Yes
00000080__	4/2/15, 8:00 AM	40.00	40.50		2.00	38	22	1,607	128 Yes
00000080__	4/2/15, 8:00 AM	39.50	40.00		2.50	41	25	1,615	128 Yes
00000080__	4/2/15, 8:00 AM	39.00	39.50		3.00	44	28	1,660	132 Yes
00000080__	4/2/15, 8:00 AM	38.50	39.00		3.50	47	30	1,746	139 Yes
00000080__	4/2/15, 8:00 AM	38.00	38.50		4.00	48	32	1,798	143 Yes

E.7 Reading Heatmaps

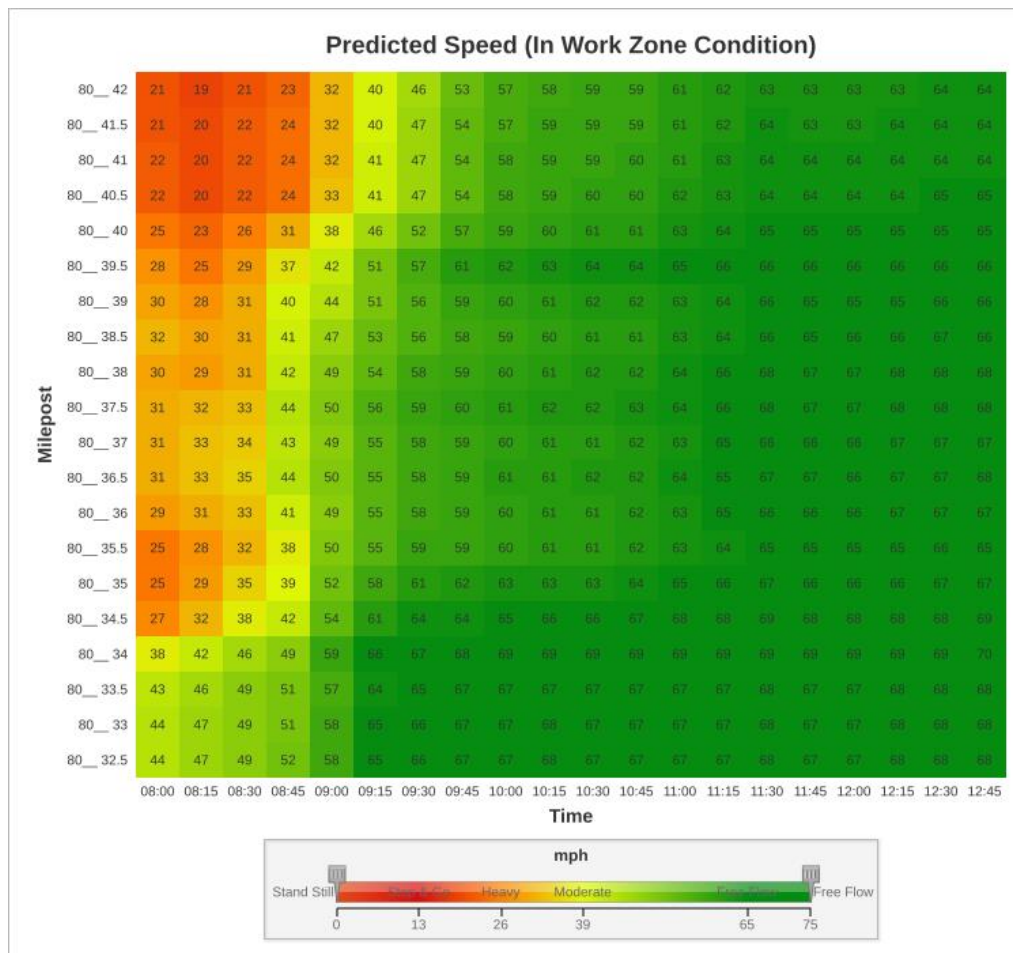

Note: Image used only for illustration purpose.

As the figure shown above, a speed heat map follows a grid structure with time on the x axis and distance from the work zone measured with milepost on the y axis. A designated range of speed is represented by a unique color code. This gives the users enhanced and ease of visualization of the change in the speed and its variation without having to invest much time. The change in speed is also linked to the traffic condition on the roadway network.

The color code and its description are given below:

	GREEN	Free Flow Speed
	YELLOW	Moderate Traffic
	ORANGE	Heavy Traffic
	RED	Stop and Go

E.8 Report Generatopm Procedure

The WIMAP-P application is equipped with the provision to generate downloadable reports for both freeway and arterial roadway networks. This can be initiated through download report options in the input module (see Section E.5). A sample of the report generated is shown below:

WIMAP-P Analysis Report							
Work Zone Information							
Route Name:	I-80	Number of Closed Lanes:	1				
Start Milepost:	42	Start Date:	04/02/2015				
End Milepost:	43	Start Time:	08:00:00				
Direction:	West to East	End Date:	04/02/2015				
Number of Lanes:	4	End Time:	11:00:00				
Value of Time Parameters							
Value of Passenger Car Time (\$/veh-hr) :	18.15	Value of Truck Time (\$/veh-hr) :	30.25				
Predicted Work Zone Impact							
Total Queue Delay Cost (\$):	19,333	Total Queue Delay (veh-hr):	1,014				
Total Emission Cost (\$):	16						
Queue Determined by:	75% of historic average speed 0.75						
Predicted Hourly Impact							
Date and Time	Approaching Car Volume (veh)*	Approaching Truck Volume (veh)*	Queue Delay (veh-hr)**	Queue Delay Cost (\$)**	Emission Cost (\$)***	Congestion Impact Length (mi)	Travel Delay (min)****
4/2/2015 8:00	6,568	522	745	14,176.2	16.4	8.00	7.33
4/2/2015 9:00	5,559	448	185	3,531.5	0.0	0.00	2.91
4/2/2015 10:00	4,079	406	55	1,056.1	0.0	0.00	0.89
4/2/2015 11:00	3,735	381	17	332.7	0.0	0.00	0.40
4/2/2015 12:00	3,852	379	12	237.1	0.0	0.00	0.19
Grand Total			1,014	19,333.5	16.4		
Note:	* Source: 2012 New Jersey Congestion Management System (NICMS).						
	** Calculated based on NJDOT Road User Cost Manual (2015).						
	*** Source: HERS-ST Technical Report FHWA, 2005.						
	**** Travel Delay: The longest excess travel time within an hour caused by the study work zone.						

It is noted that the volume showed in the online report is the hourly volume approaching to the work zone. This report not only presents the impact of a proposed lane closure in a logical and concise manner, but it also assists agencies and contractor in preparing project documentation.

REFERENCES

1. Weng, J. and Q. Meng. "Estimating Capacity and Traffic Delay in Work Zones: An Overview." In *Transportation Research Part C: Emerging Technologies*, Vol. 35, 2013, pp. 34-45.
2. Habtemichael, F. G., M. Cetin, and K. A. Anuar. "Methodology for Quantifying Incident-Induced Delays on Freeways by Grouping Similar Traffic Patterns." Presented at *94th Transportation Research Board Annual Meeting*, Washington, D.C., 2015.
3. Ullman, G. L., J. L. Timothy, and T. Scriba. *A Primer on Work Zone Safety and Mobility Performance Measurement*. US Department of Transportation, Federal Highway Administration, 2011.
4. Abraham, C. M. and J. J. Wang. *Planning and Scheduling Work Zones Traffic Control*. US Department of Transportation, Federal Highway Administration, 1981.
5. Dudek, C. L. and S. H. Richards. "Traffic Capacity through Urban Freeway Work Zones in Texas." In *Transportation Research Record: Journal of the Transportation Research Board*, No. 869, Transportation Research Board of the National Academies, Washington, D.C., 1982, pp. 14-18.
6. Chien, S., and P. Schonfeld. "Optimal Work Zone Length for Four-lane Highways." *Journal of Transportation Engineering*, Vol. 127, No.2, 2001, pp. 124-131.
7. Du, B. and S. Chien. "Feasibility of Shoulder Use for Highway Work Zone Optimization." In *Journal of Traffic and Transportation Engineering*, Vol. 1, No.4, 2014, pp. 235-246.
8. Tang, Y. and S. Chien. "Scheduling Work Zones for Highway Maintenance Project Considering Variable Time-cost Relation." In *Transportation Research Record: Journal of the Transportation Research Board*, No. 2055, Transportation Research Board of the National Academies, Washington, D.C., 2008, pp. 21-30.
9. McCoy, P.T., M. Pang, E.R. Post. "Optimum Length of Two-lane Two-way No-passing Traffic Operation in Construction and Maintenance Zones on Rural Four-lane Divided Highways." In *Transportation Research Record: Journal of the Transportation Research Board*, No. 773, Transportation Research Board of the National Academies, Washington, D.C., 1980, pp. 20-24.
10. Jiang, Y. "Estimation of Traffic Delays and Vehicle Queues at Freeway Work Zones." at *80th Transportation Research Board Annual Meeting*, Washington D.C., 2001.

11. Chung, Y. "Quantification of Non-recurrent Congestion Delay Caused by Freeway Accidents and Analysis of Causal Factors." In *Transportation Research Record: Journal of the Transportation Research Board*, No. 2229, Transportation Research Board of the National Academies, Washington, D.C., 2011, pp. 8-18.
12. Lighthill, M. J. and G. B. Whitham. On Kinematic Waves. II. "A Theory of Traffic Flow on Long Crowded Roads." *Proc. R. Soc. Lond. Ser. Math. Phys. Sci.*, Vol. 229, No. 1178, 1955, pp. 317–345.
13. Richards, P. I. "Shock Waves on the Highway." *Oper. Res.*, Vol. 4, No. 1, 1956, pp. 42–51.
14. Adeli, H. and S.L. Hung. *Machine Learning - Neural Networks, Genetic Algorithms, and Fuzzy Sets*. NY: John Wiley and Sons, 1995.
15. Karim, A. and H. Adeli. "Radial Basis Function Neural Network for Work Zone Capacity and Queue Estimation." *Journal of Transportation Engineering*, Vol. 129, No. 5, 2003, pp. 494-503.
16. Jiang, X. and H. Adeli. "Freeway Work Zone Traffic Delay and Cost Optimization Model." *Journal of Transportation Engineering*, Vol. 129, No. 3, 2003, pp. 230-241.
17. Ghosh-Dastidar, S. and H. Adeli. "Neural Network-Wavelet Microsimulation Model for Delay and Queue Length Estimation at Freeway Work Zones." *Journal of Transportation Engineering*, Vol. 132, No. 4, 2006, pp. 331-341.
18. Chien, S., D. G. Goulias, S. Yahalom, and S. M. Chowdhury. "Simulation-Based Estimates of Delays at Freeway Work Zones." *Journal of Advanced Transportation*, Vol. 36, 2002, pp. 131-156.
19. Meng, Q. and J. Weng. "Cellular Automata Model for Work Zone Traffic." In *Transportation Research Record: Journal of the Transportation Research Board*, No. 2188, Transportation Research Board of the National Academies, Washington, D.C., 2010, pp. 131-139.
20. Chung, Y., H. Kim, and M. Park. "Quantifying Non-Recurrent Traffic Congestion Caused by Freeway Work Zones Using Archived Work Zone and ITS Traffic Data." *Transportmetrica*, Vol. 8, No. 4, 2012, pp. 307-320.
21. Chien, S., D. G. Goulias, S. Yahalom, and S. M. Chowdhury. "Simulation-based Estimates of Delays at Freeway Work Zones." *Journal of Advanced Transportation*, Vol. 36, 2002, pp. 131-156.

22. Edara, P., C. Sun, and Z. Zhu. *Calibration of Work Zone Impact Analysis Software for Missouri*. Missouri Department of Transportation, 2013.
23. Memmott, J. L. and C. L. Dudek. "Queue and User Cost Evaluation of Work Zones (QUEWZ)." In *Transportation Research Record: Journal of the Transportation Research Board, No. 979*, Transportation Research Board of the National Academies, Washington, D.C., 1985, pp. 12-19.
24. Chitturi, M. and R. Benekohal. "Comparison of QUEWZ, FRESIM and QuickZone with Field Data for Work Zones." At 83rd Transportation Research Board Annual Meeting, Washington, D.C., 2004.
25. Chan, H.W. "Traffic Delay Due to Lane Closure." Bachelor of Engineering Dissertation, Department of Civil Engineering, National University of Singapore, 2002.
26. Edara, P. K. and B. H. Cottrell. "Estimation of Traffic Mobility Impacts at Work Zones: State of the Practice." Presented at 86th Transportation Research Board Annual Meeting, Washington, D.C., 2007.
27. Cambridge Systematics, Inc. Travel Time Data Collection – White Paper. http://www.camsys.com/pubs/WhitePaper_OD_TTData_Collection.pdf. Accessed June 28, 2015.
28. INRIX Website: <http://www.inrix.com/>. Accessed June 14, 2015.
29. TomTom Website: http://www.tomtom.com/en_us/. Accessed June 14, 2015.
30. HERE Website: <http://www.here.com/>. Accessed June 14, 2015.
31. Mudge, R., Mahmassani, H., Haas, R., Talebpour, A., and L. Carroll. *Work Zone Performance Measurement Using Probe Data*. FHWA-HOP-13-043, 2013.
32. Chen, H. and H. Rakha. "Agent-Based Modeling Approach to Predict Experienced Travel Times." Presented at 93rd Transportation Research Board Annual Meeting, Washington D.C., 2014.
33. Haghani, A., M. Hamedi, and K. F. Sadabadi. "I-95 Corridor Coalition Vehicle Probe Project." University of Maryland, College Park, 2009.
34. Elhenawy, M., H. Chen, and H. Rakha. "Dynamic Travel Time Prediction Using Genetic Programming." Presented at 93rd Transportation Research Board Annual Meeting, Washington, D.C., 2014.
35. I-95 Corridor Coalition, "Vehicle Probe Project General Benefits White Paper", 2010.

36. Cambridge Systematics, Inc., Travel time data collection – White Paper. http://www.camsys.com/pubs/WhitePaper_OD_TTDData_Collection.pdf, accessed May 28, 2014
37. Mudge, R., Mahmassani, H., Haas, R., Talebpour, A., Carroll, L. *Work Zone Performance Measurement Using Probe Data*. FHWA-HOP-13-043, 2013.
38. Bluetooth Travel Time Technology Evaluation - Using the BlueTOAD. Trafficcast http://trafficcast.com/docs/PennDOT_BlueTOAD_final_report_incl_charts_4_Jan_2010.pdf, accessed May 21, 2014.
39. Puckett, D. and Vickich, M., *Bluetooth-Based Travel Time/Speed Measuring Systems Development*. University Transportation Center for Mobility Project Number 09-00-17, 2010.
40. Tarnoff, P., Wasson, J., Young, S., Ganig, N., Bullock, D., and Sturdevant, J.. “The Continuing Evolution of Travel Time Data Information Collection and Processing.” Paper submitted for presentation at the Transportation Research Board Annual Meeting, 2009.
41. Ferman, M., Blumenfeld, D. and Dai, X.. “An Analytical Evaluation of a Real-Time Traffic Information System Using Probe Vehicles.” In *Journal of Intelligent Transportation Systems*. Volume 9, No. 1, 2005, pp. 23-34.
42. New Jersey Turnpike Authority Website: <http://www.state.nj.us/turnpike/ez-pass.html>, accessed May 21, 2014.
43. Seymour, E., Chaudhary, N., Middleton, D., Brydia, R., and Miller, L.. *White Paper: State of ITS Industry and Assessment of Project Types*. FHWA/TX -11/0-6672-1, 2011.
44. INRIX Announces Pan-European Road Traffic Information, INRIX Website: <http://www.inrix.com/pressrelease.asp?ID=48>, accessed June 2, 2014.
45. Middleton, D., Rajbhandari, R., Brydia, R., Songchitruksa, P., Kraus, E., Hernandez, S., Cheu, K., Iragavarapu, V., and Turner, S. *Synthesis of TXDOT Uses of Real-Time Commercial Traffic Data*. FHWA/TX-12/0-6659-1, 2011.
46. White, J. and Porter, M.. “El Segundo Area ITS Project: Arterial Traveler Information – Is it Possible?” Presented at the ITE Western District 2010 Annual Meeting, San Francisco, California, 2010.

47. Request for Proposal for Traffic Data and Associated Services along the I-95 Corridor. RFP No. 82085N, issued by the University of Maryland College Park, April 27, 2007.
48. Mendez, M. *Work Zone Performance Data Collection – Way to blue*. Thinking Highway Website: <http://www.bitcarrier.com/sites/default/files/ThinkingHighways.pdf>, accessed May 20, 2014.
49. Vo, T. *An Investigation of Bluetooth Technology for Measuring Travel Times on Arterial Roads: A Case Study on Spring Street*. MS thesis. Georgia Institute of Technology, Atlanta, 2011.
50. Wright, J. and Dahlgren, J. *Using Vehicles Equipped with Toll Tags as Probes for Providing Travel Times*. California Partners for Advanced Transit and Highways, 2000.
51. Mimbela, L. and Klein, L. A Summary of Vehicle Detection and Surveillance Technologies use in Intelligent Transportation Systems. FHWA Website: <http://www.fhwa.dot.gov/policyinformation/pubs/vdstits2007/05.cfm>, accessed May 28, 2014.
52. The Freeway Performance Measurement System (PeMS) http://paleale.eecs.berkeley.edu/~varaiya/papers_ps.dir/PeMSTutorial.pdf, accessed June 2, 2014.
53. Choe, T., Skabardonis, A., and Varaiya, P. “Freeway performance measurement system: operational analysis tool.” *Transportation Research Record: Journal of the Transportation Research Board*, 1811(1), pp. 67-75, 2002.
54. Benekohal R., Kaja-Mohideen, A. and Chitturi, M.. *Evaluation of Construction Work Zone Operational Issues: Capacity, Queue and Delay*, Illinois Transportation Research Center, Edwardsville, IL, ITRC FR 00/01-4. 2003.
55. Bartin, B., Ozbay, K., and Mudigonda, S.. “Interactive Lane Closure and Traffic Information Tool Based on a Geographic Information System.” *Transportation Research Record: Journal of the Transportation Research Board*, 2272(1), pp. 44-55, 2012.
56. TOPS, *Work Zone Capacity and Analysis Tool (WZCAT) Calibration/Validation*, Research Report, Traffic Operations and Safety laboratory, University of Wisconsin-Madison, January 2007.
57. Robert G. Batson, Daniel S. Turner, Paul S. Ray, Mengxiao Wang, Ping Wang, Randy Fincher, and Jon Lanctot, *Work Zone Lane Closure Analysis Model*, Publication ALDOT 930-72, Alabama Department of Transportation, 2009.

58. Lane Closure Decision Support System (LCDSS) website: <https://www.tdot.tn.gov/lcdss/>, accessed July 20, 2014.
59. Washburn, S., Hiles, T., Heaslip, K. *Impact of Lane Closure on Roadway Capacity: Development of a Two-Lane Work Zone Lane Closure Analysis Procedure (Part A)* (No. TRC-FDOT-59056-a-2008). Florida Department of Transportation, 2008.
60. Turner, D., Ray, P., Wang, M., Wang, M., Fincher, M., Lanctot, M., and Cui, Q.. *Work Zone Lane Closure Analysis Model* (No. ALDOT 930-721). University Transportation Center for Alabama, 2009.
61. Oregon Department of Transportation. *Web-Based Work Zone Traffic Analysis Tool Users' Guide*, 2010.
62. Plan4Safety website, <http://cait.rutgers.edu/tsrc/plan4safety>. Accessed on May 29, 2015.
63. Taylor, D. R., S. Muthiah, B.T. Kulakowski, K. M. Mahoney, and R. J. Porter. "Artificial Neural Network Speed Profile Model for Construction Work Zones on High-speed Highways." *Journal of Transportation Engineering*, Vol. 133, No. 3, 2007, pp. 198-204.
64. Bai, Y. and Y. Li. *Determining Major Causes of Highway Work Zone Accidents in Kansas (Phase 2)* (No. K-TRAN: KU-06-1). Kansas Department of Transportation, 2007.
65. Gambatese, J. A. and M. Johnson. *Work Zone Design and Operation Enhancements. Research Final Report SPR 669*. Oregon Department of Transportation, 2010.
66. Minitab Support Website: <http://support.minitab.com/en-us/minitab-express/1/>. Accessed on July 2, 2015.
67. MATLAB Neural Network Toolbox. The MathWorks, Inc., Natick, Mass., 2014.
68. Mallela, J., and S. Sadasivam. *Work Zone Road User Cost – Concepts and Applications*. Publication FHWA-HOP-12-005. FHWA, U.S. Department of Transportation, 2011.
69. FHWA, *Highway Economic Requirements System-State Version*, Technical Report, Federal Highway Administration, Washington, DC, 2005.

70. Chien, S., and K. Ozbay. *Development of New Jersey Rates for the NJCMS Incident Delay Model*. Publication FHWA-NJ-2008-001. New Jersey Department of Transportation, 2012.
71. NJDOT Road User Cost Manual. Available from:
<http://www.state.nj.us/transportation/eng/documents/RUCM/>.
72. FHWA, *Meeting the Customer's Needs for Mobility and Safety During Construction and Maintenance Operations*, Technical Report, Federal Highway Administration, Washington, DC, 1998.