

INTELLIGENT CRUISE CONTROL FIELD OPERATIONAL TEST FINAL REPORT -- VOLUME I, II & III

NOTE TO READER:

THIS IS A LARGE DOCUMENT

Due to its large size, this document has been segmented into multiple files. All files separate from this main document file are accessible from links ([blue type](#)) in the [table of contents](#) or the body of the document.



U.S. Department
of Transportation

**National Highway
Traffic Safety
Administration**



DOT HS 808 849

May 1998

**Final Report
Volume I: Technical Report**

Intelligent Cruise Control Field Operational Test

This publication is distributed by the U.S. Department of Transportation, National Highway Traffic Safety Administration, in the interest of information exchange. The opinion, findings, and conclusions expressed in this publication are those of the author(s) and not necessarily those of the Department of Transportation or the National Highway Traffic Safety Administration. The United States Government assumes no liability for its contents or use therefore. If trade or manufacturer's name or products are mentioned, it is because they are considered essential to the object of the publication and should not be construed as an endorsement. The United States Government does not endorsement products or manufacturers.

1. Report No. DOT HS 808 849		2. Government Accession No.		3. Recipient's Catalog No.	
4. Title and Subtitle Intelligent Cruise Control Field Operational Test (Final Report)				5. Report Date May 1998	
				6. Performing Organization Code	
7. Author(s) P. Fancher, R. Ervin, J. Sayer, M. Hagan, S. Bogard, Z. Bareket, M. Mefford, J. Haugen				8. Performing Organization Report No. UMTRI-98-17	
9. Performing Organization Name and Address The University of Michigan Transportation Research Institute 2901 Baxter Road, Ann Arbor, MI 48109-2150				10. Work Unit No. (TRAIS)	
				11. Contract or Grant No. DTNH22-95-H-07428	
12. Sponsoring Agency Name and Address National Highway Traffic Safety Administration U.S. Department of Transportation 400 7th Street S.W. Washington, D.C. 20590				13. Type of Report and Period Covered Final Report Sept. 1995 to July 1998	
				14. Sponsoring Agency Code	
15. Supplementary Notes UMTRI's partners in the FOT are Automotive Distance Control Systems (ADC) GmbH, Haugen Associates, and the Michigan Department of Transportation. The Volpe National Transportation Systems Center is to produce a separate report as the independent evaluator.					
16. Abstract This document reports on a cooperative agreement between NHTSA and UMTRI entitled Intelligent Cruise Control (ICC) Field Operational Test (FOT). The main goal of the work is to characterize safety and comfort issues that are fundamental to human interactions with an automatic, but driver-supervised, headway-keeping system. Volumes I and II of this report describe the work done to prepare and instrument a fleet of 10 passenger cars with infrared ranging sensors, headway-control algorithms, and driver interface units as needed to provide an adaptive-cruise-control (ACC) functionality, and these volumes present results and findings deriving from operational testing lasting from July 1996 to September 1997. The vehicles were given to 108 volunteer drivers to use for two or five weeks as their personal cars. An extensive data base covering objective and subjective results has been assembled and analyzed. The central finding presented here is that ACC is remarkably attractive to most drivers. The research indicates that, because ACC is so pleasing, people tend to utilize it over a broad range of conditions and to adopt tactics that prolong the time span of each continuous engagement. Notwithstanding having some concerns, field test participants were completely successful at operating ACC over some 35,000 miles of system engagement. In examining the results, the researchers observe that the role played by the driver as the supervisor of ACC entails subtle issues whose long-term safety and traffic impacts are unknown. These issues pertain to the shared-control nature of ACC driving requiring a fine match to the perceptual and cognitive behavior of drivers in a safety-central task that affects others driving nearby. Thus, while offering great promise for improving the quality of the driving experience, ACC implies an inherent necessity for human-centered design. Volume III of the report covers the operation of a serial string or dense cluster of passenger cars equipped with an ACC system (see separate documentation page in Volume III).					
17. Key Words Adaptive or Intelligent Cruise Control, Headway or Longitudinal Control, Crash Avoidance, ACC, ICC, Platoon, String, Cluster, Field Operational Test			18. Distribution Statement Unrestricted		
19. Security Classif. (of this report) None		20. Security Classif. (of this page) None		21. No. of Pages 530	22. Price

SI* (MODERN METRIC) CONVERSION FACTORS

APPROXIMATE CONVERSIONS TO SI UNITS					APPROXIMATE CONVERSIONS FROM SI UNITS				
Symbol	When You Know	Multiply By	To Find	Symbol	Symbol	When You Know	Multiply By	To Find	Symbol
LENGTH					LENGTH				
in	inches	25.4	millimeters	mm	mm	millimeters	0.039	inches	in
ft	feet	0.305	meters	m	m	meters	3.28	feet	ft
yd	yards	0.914	meters	m	m	meters	1.09	yards	yd
mi	miles	1.61	kilometers	km	km	kilometers	0.621	miles	mi
AREA					AREA				
in ²	square inches	645.2	square millimeters	mm ²	mm ²	square millimeters	0.0016	square inches	in ²
ft ²	square feet	0.093	square meters	m ²	m ²	square meters	10.764	square feet	ft ²
yd ²	square yards	0.836	square meters	m ²	m ²	square meters	1.195	square yards	yd ²
ac	acres	0.405	hectares	ha	ha	hectares	2.47	acres	ac
mi ²	square miles	2.59	square kilometers	km ²	km ²	square kilometers	0.386	square miles	mi ²
VOLUME					VOLUME				
fl oz	fluid ounces	29.57	milliliters	mL	mL	milliliters	0.034	fluid ounces	fl oz
gal	gallons	3.785	liters	L	L	liters	0.264	gallons	gal
ft ³	cubic feet	0.028	cubic meters	m ³	m ³	cubic meters	35.71	cubic feet	ft ³
yd ³	cubic yards	0.765	cubic meters	m ³	m ³	cubic meters	1.307	cubic yards	yd ³
MASS					MASS				
oz	ounces	28.35	grams	g	g	grams	0.035	ounces	oz
lb	pounds	0.454	kilograms	kg	kg	kilograms	2.202	pounds	lb
T	short tons (2000 lb)	0.907	megagrams (or "metric ton")	Mg (or "t")	Mg (or "t")	megagrams (or "metric ton")	1.103	short tons (2000 lb)	T
TEMPERATURE (exact)					TEMPERATURE (exact)				
°F	Fahrenheit temperature	5(F-32)/9 or (F-32)/1.8	Celcius temperature	°C	°C	Celcius temperature	1.8C + 32	Fahrenheit temperature	°F
ILLUMINATION					ILLUMINATION				
fc	foot-candles	10.76	lux	lx	lx	lux	0.0929	foot-candles	fc
fl	foot-Lamberts	3.426	candela/m ²	cd/m ²	cd/m ²	candela/m ²	0.2919	foot-Lamberts	fl
FORCE and PRESSURE or STRESS					FORCE and PRESSURE or STRESS				
lbf	poundforce	4.45	newtons	N	N	newtons	0.225	poundforce	lbf
lbf/in ²	poundforce per square inch	6.89	kilopascals	kPa	kPa	kilopascals	0.145	poundforce per square inch	lbf/in ²

* SI is the symbol for the International System of Units. Appropriate rounding should be made to comply with Section 4 of ASTM E380.

(Revised September 1993)

Table of Contents

VOLUME I

EXECUTIVE SUMMARY	12
1.0 INTRODUCTION TO THE REPORT.....	17
2.0 BACKGROUND, OBJECTIVES, AND INTENT	20
2.1 PROJECT BASIS.....	20
2.2 PROJECT OBJECTIVES	20
2.3 RETROSPECTIVE SUMMARY OF THE PROJECT APPROACH	21
3.0 THE TEST METHOD.....	24
3.1 THE ACC SYSTEM.....	25
3.1.1 ADC ODIN-4 System.....	26
3.1.2 ACC Control Algorithm	30
3.1.3 Sensor Calibration and Alignment.....	38
3.1.4 Human-Machine Interface.....	39
3.2 THE VEHICULAR TEST PLATFORM	42
3.2.1 The Base Vehicle	43
3.2.2 Provisions for the Integration of the ACC System.....	44
3.2.3 Preparation of Each Vehicle for Use in Field Data Collection	47
3.2.4 System Characterization Procedure and Results	49
3.3 THE DATA-ACQUISITION SYSTEM	50
3.3.1 The DAS Package.....	51
3.3.2 The Collected Variables	57
3.3.3 Automatic Recovery of Trip Data via Cellular Modem.....	64
3.3.4 Recovery of All Data From One Driver From the Hard Disk.....	67
3.3.5 The Quality of GPS-Derived Range Versus Sensor Range	68
3.4 THE EXPERIMENTAL DESIGN	69
3.4.1 Power Analysis	70
3.4.2 Sampling Frame.....	70
3.5 MANAGEMENT OF TEST PARTICIPANTS.....	71
3.5.1 The Basis For Human Use Approval and Pilot Testing	71
3.5.2 Participant Recruitment and Screening.....	72
3.5.3 Participant Orientation.....	73
3.6 MANAGEMENT OF TEST VEHICLES	74
3.6.1 Data Downloading	75
3.6.2 Sensors Check.....	76
3.6.3 Functionality Check.....	79
3.6.4 Vehicle Maintenance	83
3.6.5 Preparation for the Next Driver.....	84

3.7 OPERATIONAL ISSUES LEADING TO MODIFICATIONS	84
3.7.1 System Modifications	84
3.7.2 Wintertime Issues	85
4.0 CONTENTS OF THE DATA SET	87
4.1 ARCHIVED DATABASE	87
4.1.1 Subjects.mdb Database	87
4.1.2 DriverXXX.mdb Database	87
4.1.3 ICCXXX.mdb Database	91
4.2 REORGANIZED & AUGMENTED DATABASES	93
4.2.1 Database Reorganization	93
4.2.2 Database Additions	94
4.3 INVALID DATA AND KNOWN ANOMALIES	94
4.4 DRIVER RELATED DATA	96
4.4.1 Summary of Driver Biographic Data	96
4.4.2 The Myers-Briggs Type Inventory	102
4.4.3 Driving Style Questionnaire Results	106
5.0 DATA-PROCESSING METHODS	114
5.1 HISTOGRAMMING	114
5.1.1 Histograms Collected On-Board the FOT Vehicles	117
5.1.2 Additional Histograms	118
5.1.3 Methodology of Approximating Probability From Histograms	119
5.2 TIME HISTORY PROCESSING	121
5.2.1 Capturing of Nontarget-Related Time-History Events	122
5.2.2 Subsetting the Time-History Record	122
5.2.3 Capturing of Target-Related Time-History Events	124
5.2.4 Data Cleansing and Target Identification	124
5.3 PHASE SPACE PRESENTATION	126
5.4 SUBJECTIVE INFORMATION FROM QUESTIONNAIRES, DEBRIEFING AND FOCUS GROUPS	128
5.4.1 Detailed ACC System Questionnaire	128
5.4.2 Participant Debriefing	128
5.4.3 Focus Group Activities	129
5.5 PROCESSING DATA ASSOCIATED WITH TRANSITION EVENTS	129
5.6 DRIVER CHARACTERIZATION METHODS	130
5.7 PROCESSING DATA ASSOCIATED WITH GPS	135
6.0 BEHAVIORAL CHARACTERISTICS OF INDIVIDUAL DRIVERS	136
7.0 SUMMARY STATISTICS OF THE DRIVING EXPOSURE	144
7.1 EXPOSURE BY TIME AND MILEAGE FOR DIFFERENT DRIVER GROUPS	145
7.1.1 Driving Mode Exposure Time as Depends Upon Speed Range and Driver Age	149
7.1.2 The ACC and CCC Exposure Time of Nonusers Versus Users	149

7.1.3 Exposure Distance	152
7.2 EXPOSURE BY TIME AND MILEAGE FOR INDIVIDUAL DRIVERS	156
7.3 EXPOSURE BY ROAD TYPE.....	160
7.3.1 Exposure by Road Type and Velocity	160
7.3.2 Exposure By Road Type And Driving Mode	163
7.4 SUMMARY OF TRIP AND TRIP DURATION FOR THE FOT DRIVERS.....	164
8.0 BASIC RELATIONSHIPS ILLUSTRATING DRIVING PERFORMANCE.....	167
8.1 OBSERVATIONS PERTINENT TO MANUAL DRIVING	167
8.1.1 Observations on Manual Throttle Modulation	167
8.1.2 Observation and Theory on Manual Headway Modulation.....	170
8.1.3 Influence of Age, CCC Usage, and Gender on Manual Driving Style.....	182
8.1.4 Distributions of Manual Braking Behavior	188
8.2 ACC PERFORMANCE IN DRIVING SCENARIOS	201
8.2.1 Observations pertaining to ACC headway modulation.....	207
8.2.2 Driving style during ACC driving.....	209
8.2.3 Headway Time (Th) Selection	212
8.2.4 Observations pertaining to ACC braking events	215
8.3 BASIC COMPARISONS OF ACC OPERATION WITH MANUAL.....	220
8.3.1 Comparison Based Upon Headway Time Margins	220
8.3.2 The Influence of ACC on Driving Style.....	224
8.3.3 Observations Pertaining to Braking Events	232
8.3.4 Observations and Comparisons Concerning Following and Closing Situations.....	234
8.4 BASIC RESULTS FROM QUESTIONNAIRES.....	244
8.4.1 Questionnaire Results Showing Overall Satisfaction and Utility	244
8.4.2 Statistically Significant Differences Related to Age, CCC Usage, and Exposure to ACC	251
8.5 BASIC RESULTS FROM FOCUS GROUPS.....	257
9.0 PRESENTATION OF RESULTS BY ISSUE	263
9.1 IMPACT OF CONTROL MODE ON UTILIZATION CHOICES	263
9.1.1 Utilization Levels in ACC Versus CCC Modes of Control	263
9.1.2 The Basic Determinants of ACC Utilization Level.....	266
9.1.3 Trends in ACC Utilization Level With Tenure of Use	270
9.1.4 Relationship Between Utilization Level and Driver Opinions	271
9.2 ISSUES OF SYSTEM OPERATION ENCOUNTERED BY THE ACC DRIVER	274
9.2.1 Operating Experience While Establishing and Maintaining Engagement	274
9.2.2 Conditions Prompting Driver Intervention on ACC Control.....	282
9.2.3 Cut-In Behavior of Other Drivers as a Function of ACC Headway Time	294
9.2.4 Speeding Behavior in ACC Versus Manual Control.....	300

9.3	SUBJECT APPRAISAL OF COMFORT AND CONVENIENCE.....	304
9.3.1	Comfort as Associated With the Time of Exposure to ACC	305
9.3.2	System Characteristics Possibly Contributing to Ease of Use.....	306
9.3.3	Comfort as Associated With the Relief of Certain Driving Stresses	307
9.3.4	High Comfort Ratings Notwithstanding Certain Nuisances	307
9.4	SUBJECTS CRITIQUE OF SYSTEM FEATURES.....	308
9.4.1	No ACC Response to Stopped Objects.....	309
9.4.2	Target Loss (or Late-Acquire) on Curves.....	313
9.4.3	Deceleration Due to a False Detection.....	313
9.4.4	Delayed, Weak Acceleration Back Toward Set Speed	314
9.4.5	Minimum Speed of Retained Engagement While Tracking	315
9.4.6	Performance in Bad Weather	316
9.4.7	Driver's Use of Set Speed	317
9.4.8	Use of Headway Adjustments	318
9.4.9	Traffic Environment in Which ACC Was Utilized	321
9.4.10	Limited Level of (Throttle + Downshift) Deceleration Authority	322
9.4.11	ACC-Applied Deceleration as an Attention Prompt (or Cue).....	324
9.4.12	Requirement For ACC Controls and Displays.....	324
9.4.13	Driver's Vigilance With ACC	325
9.5	IMPLICATIONS OF IMPACT ON SAFETY	327
9.5.1	Objective Results Having Possible Safety Implications	328
9.5.2	Subjective Results Having Possible Safety Implications.....	334
9.6	RESULTS HAVING IMPLICATIONS FOR TRAFFIC FLOW	337
9.7	IMPLICATIONS FOR FUEL USAGE.....	342
10.0	SUMMARY OF FINDINGS AND OBSERVATIONS	345
10.1	UTILIZATION CHOICES	346
10.1.1	Versus Length of Exposure.....	346
10.1.2	Versus Type of Trip	346
10.1.3	Versus Traffic Environment.....	347
10.1.4	Versus Type of Road.....	347
10.1.5	Versus Driver's Aggressiveness	347
10.2	IMPACT OF ACC ON INDIVIDUAL'S DRIVING TASKS	348
10.2.1	Closing In.....	348
10.2.2	Following.....	349
10.2.3	Cut-In Reaction	349
10.3	IMPLIED COLLECTIVE TRAFFIC IMPACT	350
10.3.1	Safety	350
10.3.2	Traffic Flow	353
10.3.3	Energy Use.....	354

10.4 SYSTEM FUNCTIONALITY REACTION	354
10.4.1 Headway Adjustment	355
10.4.2 False Alarms	355
10.4.3 Missed Targets.....	355
10.4.4 Acceleration Level	356
10.4.5 Deceleration Level	356
10.4.6 Weather.....	357
10.5 COMFORT AND CONVENIENCE REACTION.....	357
10.5.1 Ease of Learning.....	358
10.5.2 Ease of Use	358
10.5.3 Utility Versus CCC and Manual.....	358
10.5.4 Driving Alertness	358
10.5.5 Product Purchase Appeal	359
11.0 CONCLUDING REMARKS AND RECOMMENDATIONS	360
11.1 THE CENTRAL FINDING.....	360
11.2 RECOMMENDATIONS.....	361
11.2.1 On studying the Collected FOT Data Further	361
11.2.2 On the Need for Fundamental Understanding on Driver Supervision of ACC	362
11.2.3 On the Need for Direct Measurement of ACC’s Energy Impact	362
11.2.4 On the Need to Explore the Traffic Impacts of ACC in Greater Detail.....	363
11.2.5 On Examining the Naturalistic Use of ACC-With-Braking	363
11.3 CONCLUDING COMMENT	365
REFERENCES	366

VOLUME II

APPENDIX A —	
DESCRIPTION OF THE DATA ARCHIVE AS A PERMANENT RESOURCE	372
A.1 DRIVER DATABASE DOCUMENTATION	372
A.2 ICC DATABASE DOCUMENTATION.....	373
A.3 SUBJECT DATABASE DOCUMENTATION	414
APPENDIX B — SUMMARY OF ACC SYSTEM QUESTIONNAIRE RESPONSES	417
APPENDIX C — SUMMARY OF EXPOSURE MEASUREMENTS FOR ALL DRIVERS AND DRIVER GROUPS	451
APPENDIX D — FORMS USED IN RECRUITING PARTICIPANTS.....	505
D.1 INFORMATION LETTER - ACC FIELD OPERATIONAL TEST.....	505
D.2 INFORMED CONSENT FORM -ACC FIELD OPERATIONAL TEST.....	507

APPENDIX E — SYSTEM CHARACTERIZATION PROCEDURE.....	511
E.1 TEST 1: CLOSING-IN ON A PRECEDING VEHICLE	512
E.2 TEST 2: CHANGING TO A NEW HEADWAY.....	514
E.3 TEST 3: MANUALLY ACCELERATING.....	517
APPENDIX F — CHRONOLOGY OF DRIVERS, VEHICLES, SYSTEMS, AND EVENTS.....	520
F.1 ALGORITHM'S VERSION HISTORY	520
F.2 SENSOR'S SOFTWARE VERSIONS.....	521
F.3 FAR OFF SENSORS	522
F.4 ASSIGNMENT SUMMARY	522

VOLUME III

EXECUTIVE SUMMARY.....	534
1.0 BACKGROUND.....	535
2.0 DESCRIPTION OF THE VEHICLE OPERATIONS AND PROCEDURES	536
2.1 LONGITUDINAL STRING TESTS.....	536
2.2 CLUSTER TESTS	537
3.0 OBSERVATIONS AND OBJECTIVE RESULTS FOR THE FOUR-VEHICLE STRING TESTS.....	538
3.1 DRIVER OBSERVATIONS	538
3.1.1 Naturalistic occurrence of vehicle strings.....	538
3.1.2 Harmonic nature of FOT vehicles in a string.....	538
3.1.3 Effect of a four-vehicle string on other traffic	539
3.2 OBJECTIVE RESULTS.....	539
4.0 OBSERVATIONS AND OBJECTIVE RESULTS FOR THE EIGHT-VEHICLE STRING TESTS	543
4.1 TWO-LANE INTERSTATE HIGHWAY	543
4.2 DRIVER OBSERVATIONS	543
4.2.1 Formation concerns.....	543
4.2.2 Harmonic nature of FOT vehicles in a string.....	544
4.2.3 Effect of an eight-vehicle string on other traffic.....	544
4.3 THREE-LANE INTERSTATE HIGHWAY	545
4.4 DRIVER OBSERVATIONS	545
4.4.1 Formation concerns.....	545
4.4.2 Harmonic nature of FOT vehicles in a string.....	545
4.4.3 Effect of an eight-vehicle string on other traffic.....	545
4.5 OBJECTIVE RESULTS.....	546
5.0 OBSERVATIONS AND OBJECTIVE RESULTS FOR THE EIGHT-VEHICLE CLUSTER TESTS	549

5.1 DRIVER OBSERVATIONS FOR CLUSTER TEST 1	549
5.2 OBJECTIVE RESULTS	550
5.3 DRIVER OBSERVATIONS FOR CLUSTER TEST 2	551
6.0 CONCLUSIONS	552
6.1 TEST METHODOLOGY	552
6.2 INTERACTIONS BETWEEN MULTIPLE ACC VEHICLES AND NEARBY TRAFFIC	553
6.3 FUTURE TEST POSSIBILITIES	554
REFERENCES	555

Executive Summary

A field operational test was conducted in which a group of 108 volunteers drove, as their personal car, a passenger vehicle equipped with an adaptive cruise control (ACC) system. The ACC system was incorporated into a fleet of ten passenger cars, each employing a grille-mounted sensor that detects vehicles ahead and controls both the speed and headway of the test vehicle so that the driver can proceed through moderate freeway traffic without adjusting cruise buttons or touching the throttle or brake.

The field test placed the ACC-equipped vehicles in the hands of 108 randomly-invited citizens for use as their personal car for two weeks for 84 of the driver/participants and, during the later stages of the project, 24 drivers were given the vehicle for a total of five weeks. In this manner, the vehicles were put into naturalistic use, without constraining where the person drives, or when, or how. Each driver was also free to choose between operating manually or with conventional cruise control during the first week and between manual or ACC driving during the second (or subsequent) weeks. The table below summarizes the scope of usage covered by these drivers (“CCC” in this table and through the report refers to the usage of conventional cruise control). Approximately 35,033 of the mileage was covered with ACC control actually engaged out of a total of 114,044 miles representing 11,092 individual driving trips. (ACC was used in 2,364 of the 11,092 trips.) No crashes occurred during ACC driving. Persons drove primarily in Michigan but some also undertook long trips within the United States.

No. of Drivers: 108	All Trips		CCC Used	ACC Used	Manual
Distance, miles	114,044		10,764	35,033	68,247
Duration, hours	3,049		165	534	2350

The ACC system under study here can be described in terms of the sensor, the commander/controller, and the driver's interface. The sensor is an infrared device that measures distance and the rate of closure to vehicles in the lane ahead, steering its sensing beam to the right or left as needed to follow lane curvature. The commander/controller acts on the sensory data to modulate the throttle and also downshift the transmission as required to satisfy the driver-selected minimum for headway or spacing to a vehicle ahead. Since brakes are not incorporated into this ACC system, the vehicle has only modest deceleration available for controlling headway — a characteristic that is believed to figure strongly in the field experience reported here. The driver selects among three minimum

headway buttons ranging from “closer” to “farther” and otherwise operates the ACC system through the normal cruise control buttons located on the face of the steering wheel.

The results of the field test, as drawn from instrumented measurements on-board each vehicle and from questionnaires answered by each participant, allow comparison of the ACC driving experience with those of both manual and CCC forms of control. The results also support detailed study of how drivers interact with ACC and how their driving tactics adapt to it. For the most part, the findings follow from one central observation. That is, because people are remarkably attracted to ACC and to its relief of driving stress, they choose to engage the system under as broad a set of driving conditions as possible and they seek to prolong each episode of system engagement. Four aspects of this central observation are summarized below.

ACC Comfort and Attractiveness

The overwhelming majority of participants were comfortable with ACC and were very attracted to this mode of driving. ACC’s appeal derives partly from the relief of a sort of “throttle stress” that otherwise comes from the surprisingly busy and inefficient motions of the throttle pedal that are applied during manual driving. Evidence also supports the view that constraints on human ability to perceive range and relative velocity during manual headway control impose a form of “headway stress” that is also greatly reduced by ACC. Since ACC automatically manages most headway conflicts, it also substantially reduces the interruptions that commonly burden CCC driving. The field test shows that virtually all drivers learn to use ACC comfortably within hours or, at most, a few days and have settled into fairly stable patterns of system usage within a few weeks.

Utilization of ACC

A surprisingly significant, but perhaps obvious, point influencing all of the collected data on ACC driving is that the driver chooses when to use the system. Since driving conditions become judged by the individual as either favorable or unfavorable for ACC usage, all ACC test results derive from the *combination* of a) the driving conditions that prevail once the ACC choice is made and, b) the outcome of driver/system interactions under those conditions. Although the total group of 108 drivers utilized ACC in more than 50% of all miles traveled at speeds above the 35 mph minimum for ACC control, the utilization rates for individual drivers ranged from less than 20% to almost 100% under comparable conditions. That is, very individualized choices are being made about when to use ACC. While freeway environments tended to dominate the observed usage pattern,

participants used ACC twice as much on non-freeway roads as they had used CCC on the same kinds of roads.

The higher rate of ACC usage on surface streets and local highways may be quite significant since these driving environments are more laden with traffic conflict and complexity for the overall driving task. The test data support an hypothesis that pending ACC products that employ automatic braking will experience higher levels of utilization and more non-freeway usage than was seen here with an ACC system that did not incorporate braking. (Clearly, the rates of utilization will be so high, regardless of the braking feature, that motor vehicle travel in the United States will some day be massively exposed to ACC operations if such products reach high levels of penetration in the vehicle population.)

The Driver in an ACC-Supervisory Role

Once the driver has engaged the ACC system, the abiding tactic is to just “let ACC do it,” for as long as seems prudent given the prevailing traffic condition. Throughout the engagement period, then, the driver serves as a “supervisor” over ACC, continually monitoring its limited-authority control activity to determine when manual intervention is needed. Because ACC automatically manages most headway conflicts that do arise, the driver learns to withhold such intervention when conflicts first develop so as to let the ACC controller resolve the situation, if possible. As an apparent result of this tactic for prolonging ACC engagement, relatively higher deceleration levels are observed when the driver does intervene by braking. ACC disengagements were seen to occur, for example, at twice the deceleration levels of disengagements from conventional cruise control, when the driver braked to resolve a headway conflict.

Many participants reported that they especially valued the deceleration cue that can be felt immediately when the ACC controller begins to slow down. While this cue is beneficial for drawing attention to an arising conflict (should the driver be delayed in observing it) evidence suggests that some persons may be relaxing their overall vigilance in some way that adapts to this apparently reliable cue. Future research should strive to determine whether ACC drivers are reducing their visual surveillance of the overall driving scene, perhaps on the misperception that the automatic deceleration cue offers some kind of general-purpose alerting mechanism (which in reality it does not since ACC sensing coverage is narrowly limited).

Manual Driving Behavior as the Baseline for Interpreting ACC

The inherent manual driving style of the individual serves to predispose many aspects of interaction with ACC. A method for classifying the longitudinal control style of individuals was developed in this study, showing that the “tailgater” style, for example, is largely foiled under ACC control. Such persons thus either become “converted” to a more relaxed mode of headway-keeping or choose to turn the system off when it simply impedes their rapid progress through the traffic stream. While all drivers tended toward substantially longer headways under ACC relative to manual control, younger people generally preferred the shortest headway selection available while older persons preferred the longest. Persons in their sixties tended to utilize ACC the most, apparently having found that the properties of this particular system meshed quite well with their more-typically conservative driving style. Significant differences also existed between persons who had previously been users of CCC and those who had not. The CCC users tended to more readily adapt and broadly utilize ACC, although the majority of non users nevertheless rated ACC as an attractive feature that they would also wish to buy. On the flip side, some 5% of participants described themselves as “very uncomfortable” with ACC and unlikely to use it in the future.

Conclusion

Certain conclusions from this field test can be stated quite definitely. It is obvious that the ACC system worked very well, that people learned to use it quickly, and that its great appeal caused it to be heavily utilized. ACC usage definitely serves to lengthen typical headway clearances and even cultivates a less aggressive driving style in many persons. Thus it is easy to argue that ACC will become a highly successful automotive product, if attractively marketed.

The data also show surprisingly high levels of deceleration that prevail when the brake is used to disengage ACC. Less definite results that probably link with this observation relate to subtle aspects of human interaction with this system. Certain safety issues appear to be embedded within these subtleties, but their net effect cannot be predicted. What can be said is that product versions of ACC that incorporate braking are likely to amplify the significance of these subtleties beyond what was seen here.

Moreover, the “shared-control” nature of ACC driving seems to require that system designs be finely matched to the perceptual and cognitive behavior of drivers. Headway control is, after all, a safety-central task that intimately involves the driver in a way that also affects others operating nearby. While offering great promise for improving the

quality of the driving experience, ACC poses an inherent necessity for human-centered design and does not fit a “business as usual” outlook for either automotive product development or highway operations.

1.0 Introduction to the Report

This document constitutes the final report on a cooperative agreement between NHTSA and UMTRI concerning a field operational test (FOT) of intelligent cruise control (ICC). The ICC systems employed in this study are known as and referred to as *adaptive cruise control* (ACC) by the partners in the FOT. UMTRI's partners in the FOT are Automotive Distance Control Systems (ADC) GmbH (a joint business venture of Leica and Temic to develop and market advanced distance-control technology), Haugen Associates, and the Michigan Department of Transportation.

This FOT is part of the U.S. DOT's Intelligent Transportation Systems (ITS) program. In general terms, the purpose of this type of FOT is to help to bridge the gap between research and development and the deployment of ITS technology. The tests permit an evaluation of how well newly developed ITS technologies work under real operating conditions, and they assess the benefits and public support for the product or system. Accordingly, this FOT has been conducted in naturalistic transportation service using volunteer drivers. The study is unlike traditional research experiments in which the test conditions are deliberately bounded. Rather the FOT may be compared to a drug test in which the goal is to see if the product is effective in actual usage and if there are any unanticipated side effects. In this study the goals are (1) to see how effective an ACC system may be in providing safer following distances and the convenience of less stressful driving and (2) to determine if any unforeseen difficulties appear to warrant further study.

Per the U.S. DOT's requirements for FOTs, the program involves an independent evaluation, which in this case was led by personnel from U.S. DOT's Volpe National Transportation Systems Center (VNTSC). Volpe is aided in their evaluation effort by their subcontractor, Science Applications International Corporation (SAIC). Although there is an open exchange of test data, plans, and ideas between the partner's group and the independent evaluator's group, this report is entirely the responsibility of UMTRI and its partners.

The material presented here has been prepared by UMTRI to provide NHTSA with an understanding of the conduct and findings of the field operational test (FOT). To that end, this report summarizes the approach and methods used in the FOT and presents results and findings deriving from the testing activities now completed.

Although a particular ACC system was utilized in this project, it is intended that this report characterize issues that, to the maximum extent possible, are fundamental to

human interaction with an automatic driver-selected headway-keeping system. Nevertheless it is clear that specific features of the fielded system have directly determined various details in the human use of these ACC vehicles.

The field-test vehicles are ten 1996 Chrysler Concorde sedans that were purchased and modified to incorporate an ACC functionality. The vehicles were equipped with Leica ODIN 4 infrared ranging sensors. These prototype sensors are part of an electronics package that provides range and range-rate information in a form that is convenient for use in assembling and evaluating an ACC system. Based upon this framework developed by Leica/ADC, a headway control algorithm was created by UMTRI and installed in the vehicles.

A communication network was developed so that the conventional cruise-control system existing on the vehicle could be used as a velocity controller that responds to commands from the headway control unit (“commander” unit). This network also included communication with the transmission controller in the vehicle so that a transmission downshift from fourth to third gear could be used to extend the control authority of the ACC system, thereby increasing the deceleration capability of the system without using the vehicle’s braking system. In addition, the vehicles were extensively instrumented to collect data on driving performance and the driving environment. All of these systems and features functioned in the field operational tests that began in July 1996 and ended in September 1997.

The results presented here portray the driving experience of 108 volunteer driver/participants who operated one of the ten ACC-equipped passenger cars. A total of 84 drivers operated a vehicle for one week without ACC and the next week with ACC available. In addition, 24 drivers had one week without ACC and the next four weeks with ACC available in order to examine the effects of longer exposure to ACC driving. All driving took place within the driver/participants’ natural driving environment.

The results and findings presented in this report use the set of data from the 108 driver/participants to address questions associated with the following operational issues:

- the nature of speed and headway keeping behavior of drivers with and without an ACC system
- when, where, and how drivers use ACC
- driver's ability to adapt to different driving situations while using ACC
- concerns with ACC operation
- the levels of comfort and convenience and safety drivers associate with ACC
- the performance of a current state-of-the-art ACC system

After brief remarks in section 2 covering background information on the ACC project, the main body of the report starts by describing the FOT methodology including considerable detail on the ACC system, the vehicle platform, the data-acquisition system, the experimental design, and the management of the driver/participants and the vehicle systems. Section 4 presents information on the structure of the objective data set that has also been archived for future use. The section includes data related to the characteristics of the drivers. Methods for processing data are discussed briefly in section 5. Measures describing the manual driving behavior of each driver participant are presented in section 6. The driving exposure obtained in the project is quantified in section 7. Sections 8 and 9 presents results and findings concerning driving performance and ACC system issues. A summary of findings is given in section 10 and concluding statements and recommendations are presented in section 11.

2.0 Background, Objectives, and Intent

2.1 Project Basis

Intelligent, or adaptive, cruise control systems (ICC or ACC) are under active development by car companies and their suppliers throughout the world. Such systems, which automatically control headway or range to a vehicle in front, are intended to become the next logical upgrade of conventional cruise control (CCC). However, validation of the comfort, convenience, and safety implications (positive and negative) of such systems has heretofore not been undertaken using normal consumers as test subjects.

This project constituted a field operational test (FOT), which has involved more than a hundred such test subjects. The FOT was intended to serve as the transition between research and development and the full-scale deployment of ACC technologies. The test permitted an evaluation of how well a newly developed ACC technology would work under real operating conditions and an assessment of the benefits and public acceptance of this ACC system.

2.2 Project Objectives

The general goal of this project was to characterize issues that are fundamental to human interaction with an automatic headway-keeping system. The extent to which this goal is realized clearly depends upon the extent to which results from using this particular ACC system can be generalized to other ACC systems.

In addressing this overall goal, the field operational test strives to:

- evaluate the extent to which ACC systems will be safe and satisfying when used by the public
- consider the influences of key system properties such that the results can help in finalizing the design of production systems
- identify design and performance issues that call for further development, market research, industry recommended practices, or public policy
- contribute to the evolutionary process leading to the deployment of ACC systems as a user service
- develop an understanding of how the functionality provided by ACC systems contributes to the safety and comfort of real driving

- qualify how drivers use and appraise the functional properties provided by ACC systems
- develop an appreciation for the public issues and societal benefits to transportation associated with ACC systems

2.3 Retrospective Summary of the Project Approach

Figure 1 provides a conceptual overview of the FOT. As illustrated in the figure, the work in the project has involved (1) designing a field test using ideas concerning an analysis structure and an experimental design, (2) collecting exposure information using the testing methodology developed in the project, and (3) processing the resulting large database of field test data to address pertinent issues and their associated items as listed at the bottom of Figure 1. As evidenced in this report, the project has addressed, discovered, and reported important aspects and findings pertaining to all of the items listed in Figure 1.

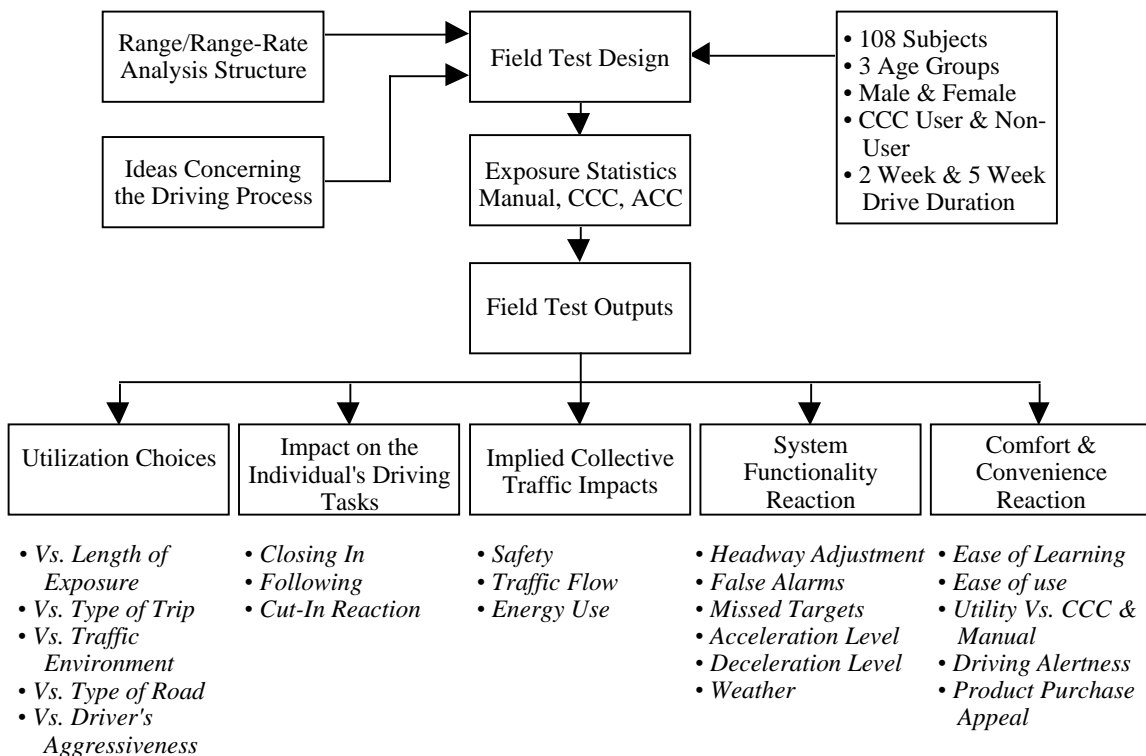

Figure 1. An overview of this field operational test

When operating in a naturalistic environment, it is not easy to answer questions concerning why a particular event happened, but the approach used in this project involved expending considerable effort in attempting to account for why drivers made the

choices they did and why they behaved the way they did. It is believed that such efforts are fundamental to the evolution of a science of driving suitable for use in evaluating the influences of advanced technology.

The findings from this FOT range from almost philosophical considerations concerning the purposes of field tests to specific results and observations concerning ACC functionality, comfort and convenience, utilization, manual driving, and the driver as the supervisor of the ACC system. The following discussion provides philosophical insights on the FOT. The remainder of the report addresses ACC systems per se.

The experience of conducting this field operational test has led to an increased appreciation and understanding of the incredible complexity of driving in a naturalistic environment. This point follows from the observation that, in a typical experiment, the number and scope of choices available to the driver/participant is intentionally limited and well defined. In contrast, in a naturalistic field test the driver/participants choose when, where, and how to drive. This means that, due to the almost unlimited variations of choice and the complexity of the driving environment, certain events may appear to be similar to others but there are always some differences between them.

Even so, the naturalistic features of this FOT have provided the opportunity to investigate and create mental images (models) of how the driver's cognitive skills, rules, and knowledge processes influence manual, CCC, and ACC driving. However, there is no direct method for measuring how a driver's cognitive processes are functioning —at best one can only infer what drivers are thinking by examining objective data revealing what the drivers did and by interpreting subjective data covering driver opinions.

Based upon the experience of having conducted this FOT, the following retrospective view of the purposes of FOTs is offered:

An FOT serves to provide

1. information indicating whether the system under study functions as expected in naturalistic use, whether drivers will use the system in actual transportation service, and whether people will like the system
2. discoveries that are answers to questions no one thought or knew how to ask, other than to ask generic open-ended questions, such as: Could there be any undesirable side effects? or, Are there any surprising benefits?

The researchers conducting an FOT are faced with a dilemma regarding the scope of the study. On the one hand, issues pertaining to safety, traffic flow, and the like call for gathering huge amounts of data for very many samples of the system, almost to the point

of full deployment. On the other hand, practical considerations limit the scope of the study in size and period of time. The net result is that the researchers feel comfortable answering questions pertaining to item 1 on how the system functions, how it is utilized, and liked (even though they could be misled, given the enormity and complexity of the undertaking), but they have reservations about doing more than pointing out observations pertaining to the discoveries alluded to in item 2 above.

3.0 The test method

Figure 2 provides a conceptual overview of the FOT methodology. As illustrated in the figure, the work done to provide a test system has involved acquiring system elements, assembling ACC systems and installing them in the test vehicles, designing and building a data-acquisition system, and arranging for a pool of drivers.

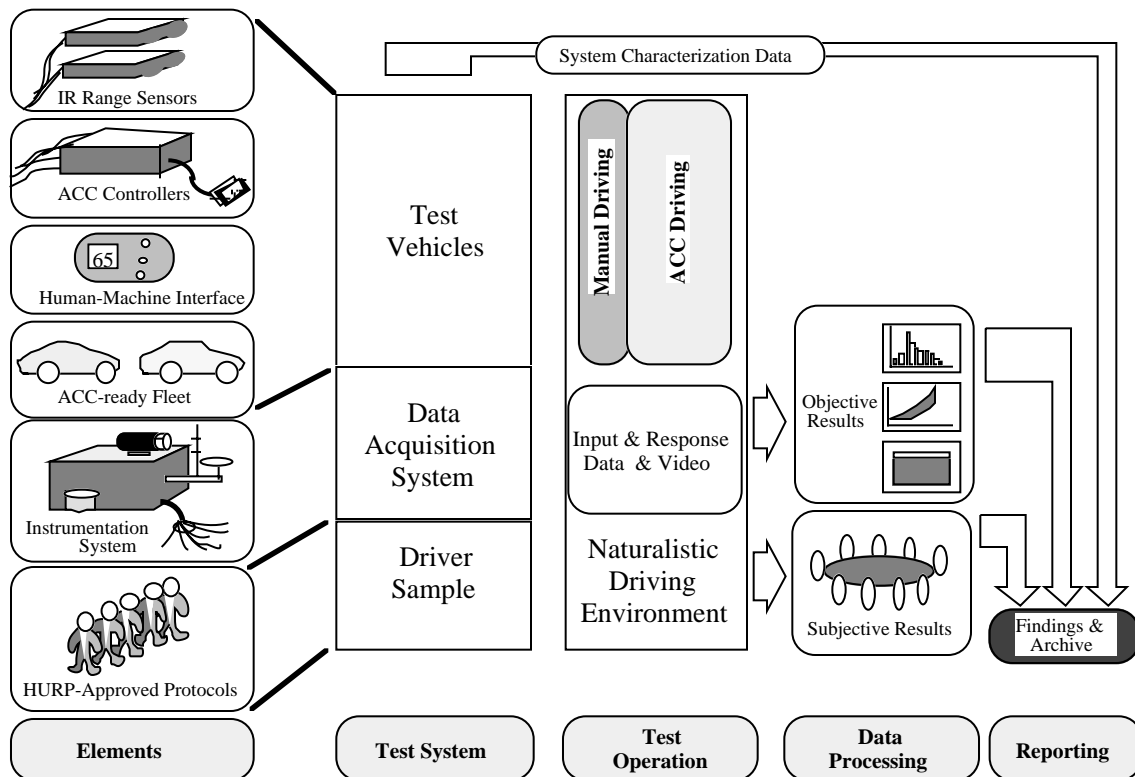

Figure 2. FOT Methodology overview

Key elements of the project approach are:

- use of infrared-based ACC sensors and associated electronic systems, which are engineering prototypes designed by Leica of Switzerland and have been provided under contract by ADC, a joint venture of Leica and TEMIC
- development and installation of headway-control algorithms and communication links as needed to provide ACC functionality in the 10 test vehicles
- development and installation of human-machine interfaces as needed to provide ACC functionality in the 10 test vehicles

- development and installation of a data-acquisition system (DAS) providing quantitative data regarding various driving performance measures along with measures of the driving environment (including video and GPS data)
- selection of test subjects through cooperation with the Michigan Secretary of State office, filling specific cells of subjects for age and CCC system level of familiarity. The basis for use of test subjects entailed meeting requirements of the NHTSA Human Use Review Panel (HURP) protocols
- familiarization training whereby drivers undergo training with UMTRI human factors personnel and then drive the test cars unaccompanied for periods of either two or five weeks (the first week of test car use is restricted to manual driving to provide a basis for comparison with the later ACC driving)
- data acquisition providing quantitative data regarding various driver-performance parameters both at the end of each trip via cellular phone and when the vehicle is returned to UMTRI to change drivers
- driver qualitative data, obtained through survey questionnaires, debriefings and focus group meetings

3.1 The ACC System

The ACC system provides headway-control functionality by adapting the speed of the host vehicle. The driver is provided with the capability to set some of the system's parameters, so as to tailor its operation to individual preferences. The system performs the following functional operations:

- establish and maintain a desired range if there is a preceding target vehicle present, with reference to one of three driver-selectable headway settings — nominally 1.0, 1.4 or 2.0 seconds
- automatically accelerate and decelerate smoothly to maintain desired headway; automatically accelerate to the driver-selected set speed when a target disappears
- establish and maintain a desired speed (set speed) if there is no preceding target
- inform the driver of the detection of a target ahead and of the operating status of the ACC
- decelerate the car when necessary, using throttle reduction; provide added deceleration by transmission downshifting if needed

- ignore targets that have a velocity less than 0.3 of the speed of the ACC vehicle to eliminate false alarms from fixed objects
- minimize any failure to detect targets that have poor reflective characteristics or unusual geometry.

An overview of the layout of the ACC system, with its connections to other components in the vehicle is provided in Figure 3. The various elements in the figure and their functionality are discussed in detail in this section through section 3.3.

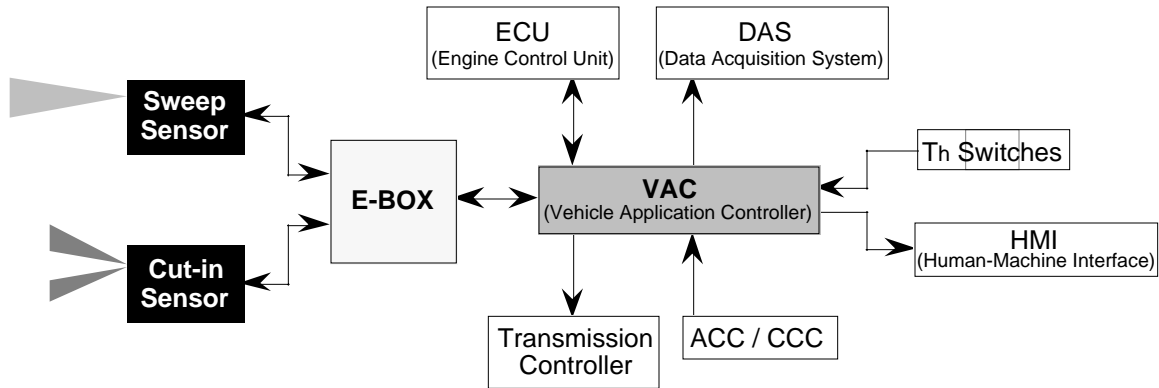

Figure 3. The ACC system layout and its connections

3.1.1 ADC ODIN-4 System

The ACC system includes headway sensors, an E-BOX and a VAC, each of which is described below. The headway sensor is a two-sensor combination which includes a main sweep sensor and a cut-in sensor. The E-BOX provides the electrical interface to the sensors, power supply, and the solid-state gyro. The VAC is the hardware/software unit that provides serial interface to the vehicle, data-acquisition system, and to the human-machine interface (HMI).

ODIN4 Headway Sensors

The ODIN-4 headway-sensing system as implemented in the FOT is composed of two separate sensors: a sweep sensor and a cut-in sensor. The pair of sensors is being used to maximize target detection performance in near- and far-field ranges. The sensor respective coverage areas are illustrated in Figure 4.

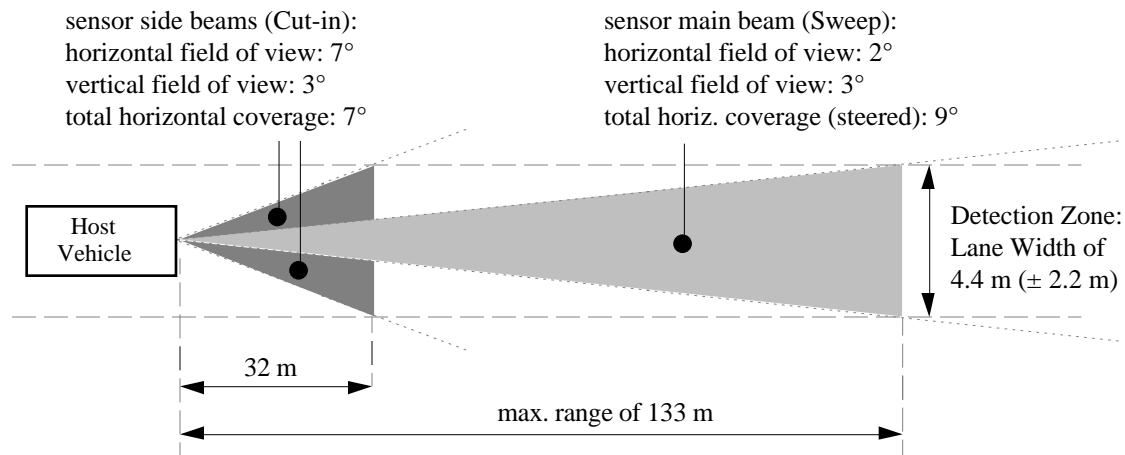

Figure 4. ODIN4 sensors coverage areas

The sweep sensor is a steered laser beam, which is directed left or right using data from a solid-state gyro, which dynamically responds to path curvature. This sensor detects targets in the far field (6 to 150 meters). The considered range, however, of the sweep sensor caused to be limited when the vehicle is on curves, as a function of curve radius. The gyro sends instantaneous curve-radius data to the sensor to steer the beam in the direction of the curve radius. The gyro does not have the capability to predict the road geometry in front of the vehicle. The sensor may lose a target in its lane or acquire a false target in adjacent lanes when the curve radius of the road is ± 500 meters or less. This may also occur during transition to or from a curved segment of the road, since the sweep sensor is steered only in response to the instantaneous path curvature of the host vehicle. Clearly, any target lying outside of the beam covered geometry will not be detected.

The gyro provided with the ODIN4 sensors requires a maximum reset time of 1.7 seconds. If high yaw rate is produced by the vehicle before the gyro is stabilized, it may establish a “false zero,” so that when the vehicle is driven straight forward, the sensor will be “looking” sideways. It takes 300 milliseconds to direct the beam from its far-right to the far-left position across the 9-degrees field of view.

The cut-in sensor has a fixed beam and limited range. The primary function of this sensor is to detect vehicles that might cut in close to the front of a test vehicle (0 to 30 meters).

Both sensors operate by transmitting pulses of infrared light energy at a wavelength of 850 nanometers. The time of flight for an echo pulse to be received is used to determine range and range rate to a target vehicle.

The sensors are connected in a token ring configuration, and they report one single target. Safety is built into this configuration so that if one sensor fails both sensors would shut down. Outputs from the sensors system include range and range-rate information for the most relevant target. A relevant target is a target whose speed is at least 30% of the speed of the equipped vehicle. This means that stationary targets and targets otherwise traveling less than 30% of the speed of the host vehicle will be ignored. Two update rates are utilized depending on the distance to the target. The minimum update rate is 10 Hz, and the maximum is 100 Hz.

There are several conditions that limit the sensor's ability to detect vehicles at the maximum detection range.

The infrared sensor's performance has been specified based on measurements of a standard target with a reflective surface. Though vehicle regulations require some reflective surfaces such as license plates and warning lights, if these reflective surfaces of target vehicles are missing or obstructed (by mud, luggage, or objects being transported, etc.), these vehicles could be detected at a reduced range.

The wavelength of the infrared laser is 850 nanometers which is close to visible light. Atmospheric conditions (rain, snow, road spray) that obscure human vision also limit the Infrared sensor as well. The infrared sensor does not have the ability to see through what the eye cannot. The sensor's front glass must therefore be kept clean if performance is to be assured. Contaminants such as road spray, snow, mud, etc. inhibit the sensor's ability to transmit and receive laser energy.

In addition to target-related information, the sensors also provide a measure that is indicative of weather-based observation. This measure takes on a numerical value called *backscatter*. As the name implies, backscatter is a measure indicating the relative amount of transmitted laser energy scattered back by the ambient conditions, and that is received by the sensor. Road spray, rain, snow, and fog are examples of ambient conditions that will cause the infrared beam to scatter and to reflect back into the sensor's receiver. Since Infrared laser technology is based on vision, it was assumed that this backscatter information might be used to deduce the prevailing visibility.

Leica performed in 1995 extensive experiments to correlate maximum visibility and maximum detection range as a function of backscatter index (BSI). The results of these tests are installation-dependent: mounting the sensors behind the windshield, mounting them at the grill, and mounting them below the grill. As one might expect, the variance of these tests is high: The higher the mounting is, the less susceptible the sensors are to road-

level spray and contaminants, and therefore similar visibility conditions will result in a lower BSI reading than if the sensors are mounted in the grill or below it. Clearly, below-the-grill mounting will produce the highest BSI reading for given visibility conditions. These tests result in curve-fit expressions that established empirical relationships between visibility distance and backscatter values for each installation. A qualitative illustration of these empirical relationships is provided in Figure 5. In this figure, the empirical relationships are bounded by a maximum range value that is determined by the sensor's ranging limits, and by some maximum backscatter value that represents ambient conditions beyond which the sensor's reading are not acceptable at any range.

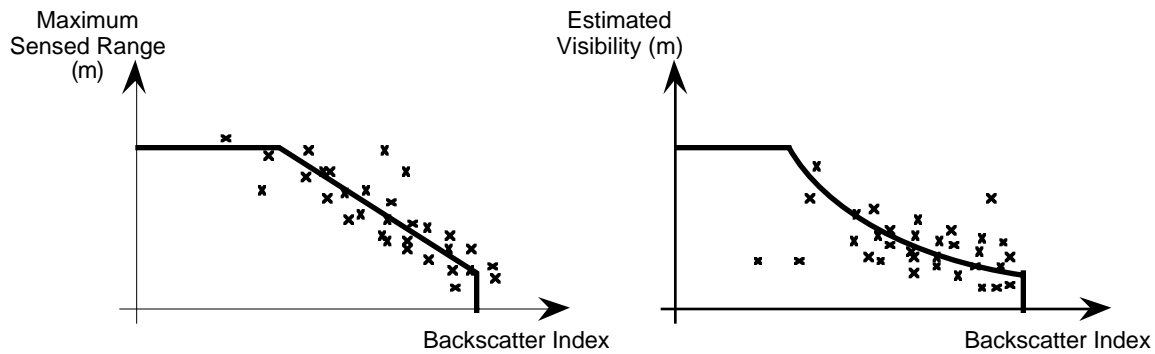

Figure 5. Empirical relationships based on backscatter index

During the design stages of the FOT, we tried to verify these relationships, so that they could be used in the control algorithm. However, only a limited application was eventually made of the backscatter index employing it as a feature in the ACC control algorithm (see sections 3.1.2 and 3.7.2).

E-Box

The E-Box contains the solid-state gyro, the system power supply, electrical interfaces to the sensors and to the VAC, and an external power supply. It features CAN Bus and RS232 serial interface connections that are used for system diagnostic and troubleshooting when the need arises.

Vehicle Application Controller (VAC)

The VAC contains software code and algorithms, including the UMTRI code and algorithms, used to provide the ACC control functions.

The following functions and algorithms are provided via the VAC:

- compute desired speed to achieve ACC functionality
- compute when added deceleration by means of downshift is needed

- communicate with the original equipment (OEM) engine controller unit (ECU) to command the desired speed, receive cruise switch activity, read actual vehicle speed, get throttle position and brake pedal activity
- provide hardware interface to the transmission controller for activating downshift
- read driver's setting of headway switches
- read hardware input establishing the cruise operation mode (ACC or CCC)
- send data to data-acquisition system
- communicate with the E-Box
- activate and control the driver's display

3.1.2 ACC Control Algorithm

In this project an approach that uses speed to control headway is employed. The ACC control algorithm has three main conceptual features: (1) it will maintain the speed desired by the driver if no impeding traffic prevails, (2) it will adjust speed as needed to maintain headway with respect to slower traffic, and (3) it will autonomously switch back and forth between the above two operational modes. Figure 6 illustrates this concept.

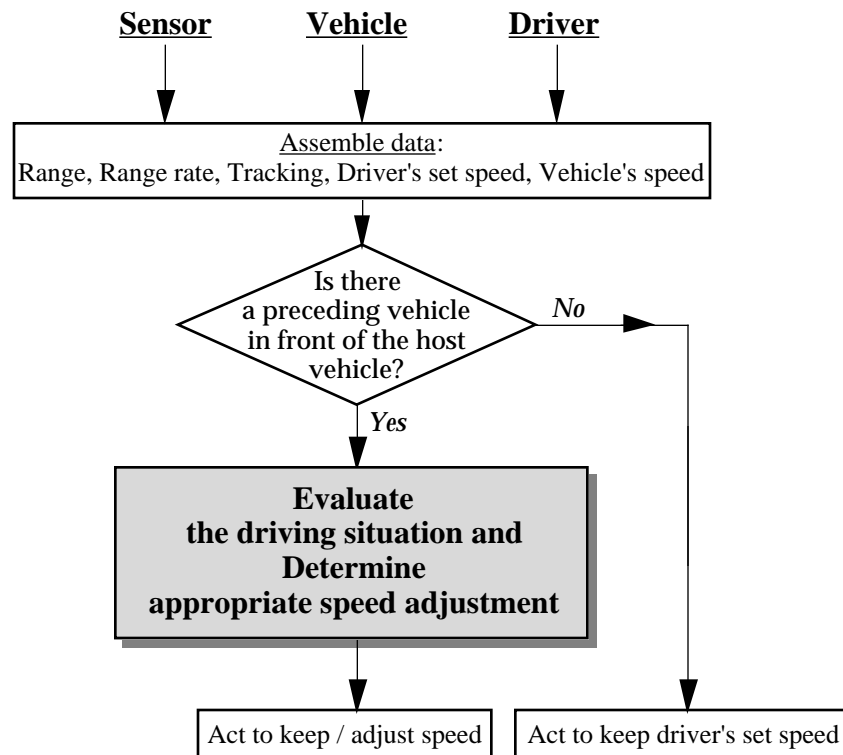

Figure 6. Employing speed to control headway

In the figure, the shaded block entitled “Evaluate the driving situation and Determine appropriate speed adjustment” hosts the control algorithm. The logic of that control

algorithm is based on several premises which constitute the system's characteristics from the standpoint of function and operation:

- Driver's actions always take precedence over the system's.
- The system will never attempt to reach a speed higher than the driver's set speed.
- If the driver brakes — the system does not automatically reengage thereafter.
- If the driver accelerates — the system automatically reengages thereafter (using the previous set speed and headway parameters).
- When speed change is required, it is executed in a controlled and smooth way.
- System's authority is applied gradually:
 - acceleration: from partial throttle application to full throttle application
 - deceleration: from no-throttle coast down to downshifting of the transmission
- Targets that are not a preceding vehicle are ignored.
- Preceding vehicles beyond 525 ft are ignored.
- Preceding vehicles slower than 0.3 of host vehicle's speed are ignored.

Fundamental Quantities

Figure 7 provides a sketch showing the basic motion variables that are used in the headway controller.

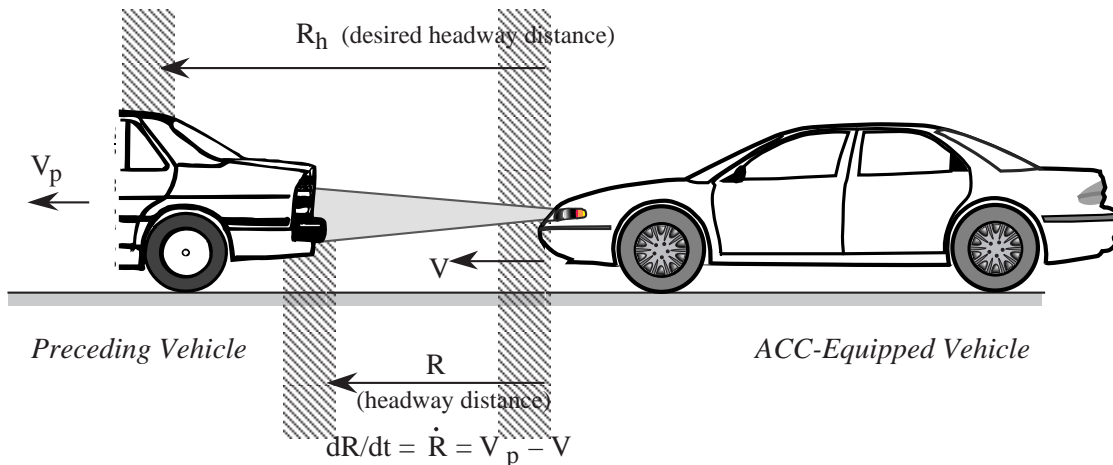

Figure 7. Headway control

The following fundamental quantities are needed to describe headway and speed control:

- V_p — velocity of the preceding vehicle
- V — velocity of the ACC-equipped vehicle
- R — range from the ACC-equipped vehicle to the preceding vehicle

R_h — desired range from the ACC-equipped vehicle to the preceding vehicle (In the situation shown in Figure 7, the ACC-equipped vehicle is closer to the preceding vehicle than the desired range.)

dR/dt — range-rate, the relative velocity between the vehicles (Range rate is also denoted by R_{Dot} in this report.)

Knowledge of these quantities plus the accelerations of these vehicles allows a complete kinematic analysis of the relative motion between the following and preceding vehicles.

Algorithm Design

The range-versus-range-rate diagram (Figure 8) is useful for explaining the concepts behind the headway control algorithm employed in the ACC system used in the FOT. Conceptually, the control objective is to perform headway control in accordance with the following equation:

$$T \cdot \frac{dR}{dt} + R - R_h = 0 \quad (1)$$

where the coefficient T determines the closing rate and serves as a control-design parameter. The equation for the control objective appears as a straight line in the range-rate/range diagram, and the slope of that line is $-T$. See the line labeled “Dynamics line for headway control” in Figure 8.

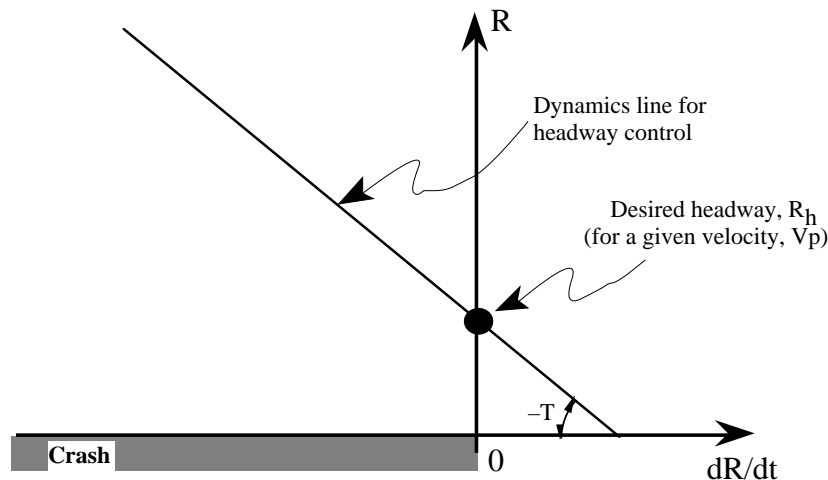

Figure 8. Range rate versus range

For the system to follow the control objective and to perform satisfactorily, the value of the parameter T should correspond to the dynamic properties of the vehicle, and it cannot be selected too arbitrarily. A small value (i.e., the line in Figure 8 appears more horizontal) will represent a vehicle that can respond quickly with either high deceleration

values (in the $dR/dt < 0$ side of the plot) or high acceleration values (in the $dR/dt > 0$ side). Similarly, a large value (i.e., the line in Figure 8 appears steeper) will represent a vehicle with limited deceleration and acceleration capabilities. If too small a value is selected for T , the resultant commanded speed will call for decelerations (or accelerations) that exceed the available control authority. Selecting a high value for T will not challenge the control authority, but it will cause the speed-adaptation process of the ACC vehicle to be objectionably long and unnatural. The availability of control authority in the FOT vehicles is bounded by the coastdown-with-downshift deceleration on one hand, and on the other hand by the response of the OEM engine controller to speed commands. Following characterization and optimization tests, the value of $T = 11$ sec. was used in the design of the particular system employed in the FOT.

The point at $R = R_h$ and $dR/dt = 0$ is the ultimate objective for the ACC equipped vehicle. The desired headway at steady following is a linear function of V_p , the velocity of the preceding vehicle, viz.,

$$R_h = V_p \cdot T_h \quad (2)$$

where T_h is the desired headway time, which is a control-system parameter. (In the ACC system used in the FOT, the driver can change T_h . See section 3.1.4.)

The headway distance varies with velocity, thereby providing a fixed margin in time for the system or the driver to react to changes in the speed of the preceding vehicle. The underlying concept here is similar to that which is behind the commonly used advice, "Allow one car length for each ten miles per hour of speed."

The speed of the preceding vehicle is given by:

$$V_p = dR/dt + V \quad (3)$$

using equation (3), measurements of V , R , and dR/dt are sufficient to evaluate the terms in equations (1) and (2). This means that the difference between the desired control state and our current situation, expressed as an error (e) in velocity is as follows:

$$e = dR/dt + \frac{(R - R_h)}{T} \quad (4)$$

where the quantities on the right side of the equation are evaluated using inputs from the sensors and the values of the control parameters, T and T_h .

For a vehicle with a cruise-control system, there is already an existing velocity-control system. To make a headway and speed control, one needs to send a velocity command (V_c) to the cruise-control unit, so that the desired headway will be attained and maintained. The general idea is that if the preceding vehicle is too close, one must slow

down. If the preceding vehicle is far away, one speeds up (but does not exceed the driver's set speed).

As in sliding control methodology [1], equation (1) may be considered as a "sliding surface" towards which the controller attempts to converge, while equation (4) describes the prevailing error at any given time. Considering equations (3) and (4) together, the error is minimized to zero when the vehicle speed becomes:

$$V = V_p + \frac{(R - R_h)}{T} \quad (5)$$

This velocity value can be viewed as the desired speed for the ACC-equipped vehicle, or the velocity command (V_c) to achieve the desired headway (R_h), viz.,

$$V_c = V_p + \frac{(R - R_h)}{T} \quad (6)$$

Equation (6) is the basis for a simple design method for extending (or adapting) a speed controller to include an outer control loop that achieves a headway-control function.

A major consideration with such an approach is the amount of control authority (also discussed earlier in the context of the parameter T). If, for example, the ACC-equipped vehicle travels at 70 mph and the prevailing conditions call for a commanded speed (V_c) of 60 mph, the vehicle can only decelerate so fast before the control authority saturates (its coast-down deceleration). During the time that $V \neq V_c$ the error is also not zero, and the expression given by equation (1) is not satisfied. In graphical terms, we cannot follow the straight line (the control objective) in Figure 8 when the deceleration (or acceleration) has been saturated at the system's maximum control authority. The further we get from the control objective line, the more critical our situation becomes from a headway-keeping standpoint, and hence the more urgent our response should be.

From the discussion above, it appears that one might divide the range-versus-range-rate space portrayed in Figure 8 into zones based on response urgency, or in other words, based on deceleration levels that are required to attain certain headway clearances (and to avoid a crash).

A trajectory of constant relative deceleration (a) in the range-versus-range-rate space is described by:

$$R = R_a + \frac{\left(\frac{dR}{dt}\right)^2}{2 \cdot a} \quad (7)$$

Equation (7) describes a parabola that intersects the vertical axis (range) at some point R_a (see Figure 9). This point can be viewed as a design factor which may vary from some arbitrary headway threshold all the way down to zero, when crash avoidance is the objective. The higher the parabola's deceleration rate is, the more "flat" the parabola becomes.

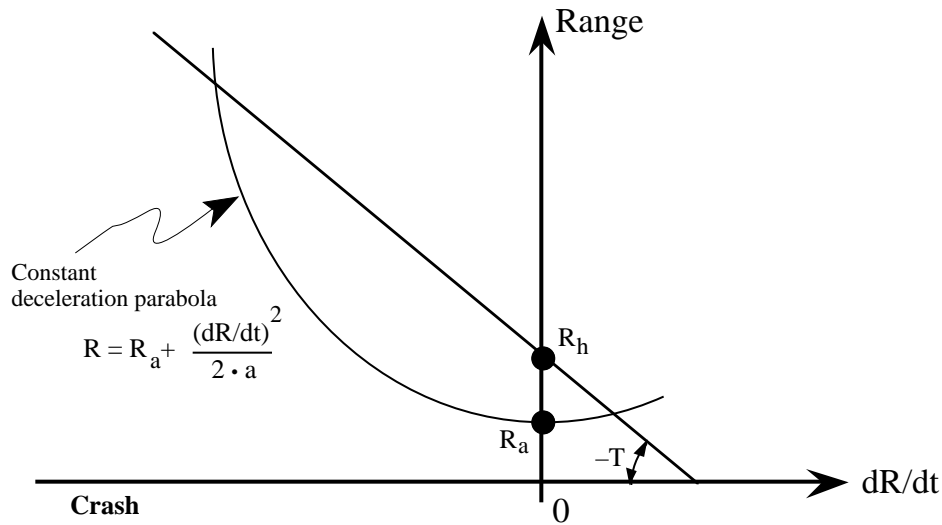

Figure 9. Constant deceleration parabola

With regards to the particular control algorithm employed in the FOT vehicles, the design value of constant deceleration (a) used was 0.05 g. This value corresponds to the Concorde's coast-down deceleration on a flat road at highway speeds. As long as the range and range-rate data from the sensors are above the parabola, the vehicle uses only coast down to decelerate. However, if the sensor data are below the parabola, then even with full coast-down authority the ACC-equipped vehicle will end up closer than R_a to the preceding vehicle. In order to avoid that situation, higher deceleration rate (that is, control authority) is needed.

The software of the electronic transmission controllers in the ten test vehicles has been modified in cooperation with the Chrysler Corporation. This modification allows the control algorithm to command a single transmission downshift. By downshifting, a deceleration rate of about 0.07 g can be obtained. This added deceleration (compared to 0.05 g by coast down only) provides for a higher control authority. With the more flat parabola that is associated with higher deceleration, the range/range-rate trajectory might get back above the parabola and eventually achieve a headway range that is above R_a , or even closer to the objective R_h .

Low-Visibility Function

The overall performance level of this, or any similar ACC system mainly depends upon the ability of the sensors to properly provide information about preceding vehicles. The infrared sensors used in the field test were susceptible to visibility conditions (see discussion in section 3.1.1). For the high-seated driver the visibility may seem acceptable, but because the sensors were mounted in the grill, they could be “blinded” by lower-level road-spray. If the system was engaged and operating, and the prevailing visibility conditions changed so as to cause degradation in the performance of the sensor (without the driver being aware of it), the driver could be placed in a potentially unsafe situation where the system did not respond to what he might have thought was a normal scenario. It was determined that the algorithm must incorporate a function that, under conditions that may inhibit the ability of the sensor to perform, the driver will be notified, and the system will disengage.

Using the backscatter index information reported by the sensors, a threshold value of 50 was established. Once the threshold was crossed for more than 2 continuous seconds, the low-visibility function was triggered. The outcome of triggering the low-visibility function depends upon the status of the ACC system, and is outlined in Table 1.

Table 1. Low-Visibility function

System Status Prior to Trigger	Outcome of Trigger
<i>Engaged</i> (system is actively controlling the speed of the vehicle)	<ul style="list-style-type: none">• Coast down• Illuminate low-visibility light (Figure 14)• Sound buzzer for 2 seconds
<i>Standby</i> (system is turned on, but not actively controlling the speed of the vehicle)	<ul style="list-style-type: none">• Illuminate low-visibility light

Once the function was triggered during a system engagement, the driver had to take action (i.e., disengage the system manually) before being able to reengage it. From the driver’s perspective, the system had simply issued a warning that visibility is bad, whereupon the vehicle started slowing down. When the weather constraint dissipated, the “low-visibility” lamp would go out, thereupon permitting manual reengagement of ACC.

Control Architecture

A depiction of the architecture of this ACC system that uses throttle and transmission algorithms to control speed and headway is shown in Figure 10. The figure shows the sensor's range and range-rate signals as inputs to the control system. The velocity of the ACC-equipped vehicle serves as the feedback signal used in an outer control loop and in two inner loops: one inner loop for throttle actuation and the other inner loop for transmission downshift actuation.

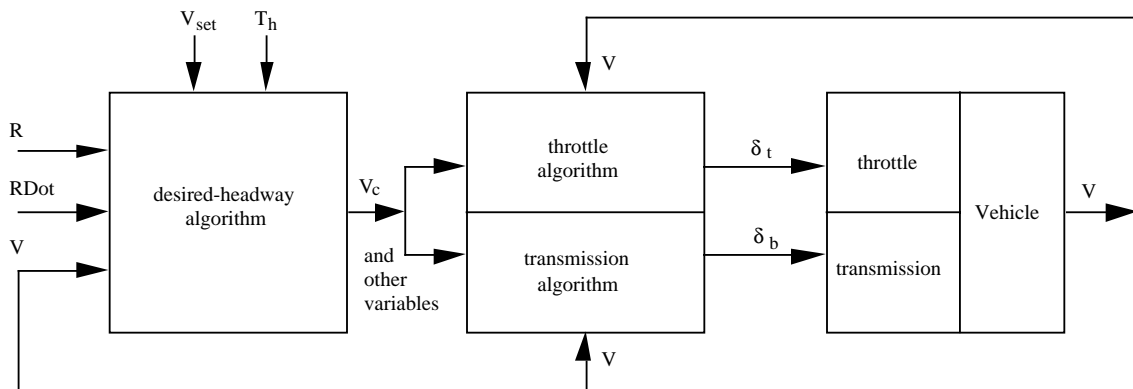

Figure 10. Control architecture for FOT ACC system

The control concept is based upon an overall goal for the ACC system. This goal is expressed by equation (1). At any given time, the system's state relative to that goal is given by the error in equation (4). When the goal is obtained, the error becomes zero.

In order to better explain the control idea, its basic generalized form is illustrated in Figure 11.

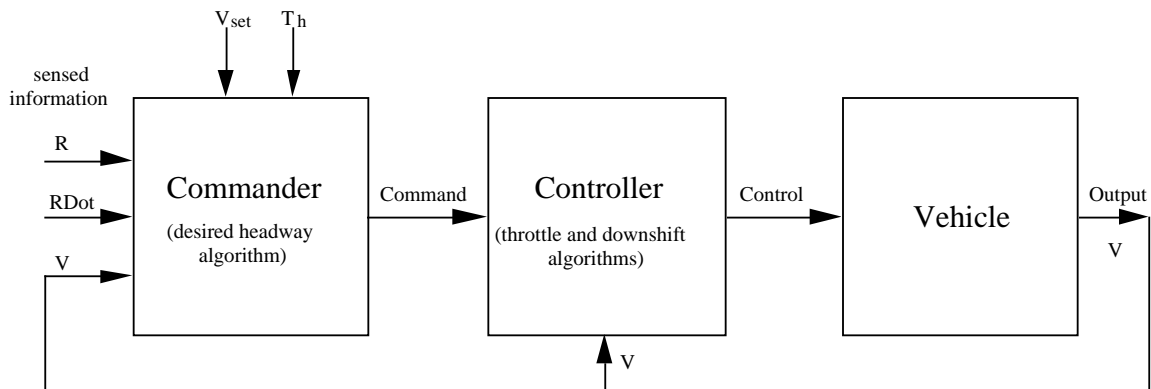

Figure 11. Control architecture with a commander

The outer loop (which includes the inner loop as a special actuation loop) involves a "commander" element that looks at the sensed information, including the velocity of the

vehicle and the external quantities R and $R\dot{D}$ and decides what “command” to give to the “controller.” The controller uses this command to generate control signals that cause the vehicle to respond in a manner that is consistent with the goal.

Throughout the above discussion, the variable T_h , which is the desired headway time for following, has been shown to hold a prime importance. Clearly, it is a variable whose value greatly depends upon individual preferences. The design of the ACC system employed in this FOT allows the driver to select one of three possible values for that variable. The functional structure of the system is depicted in a block-diagram form in Figure 12.

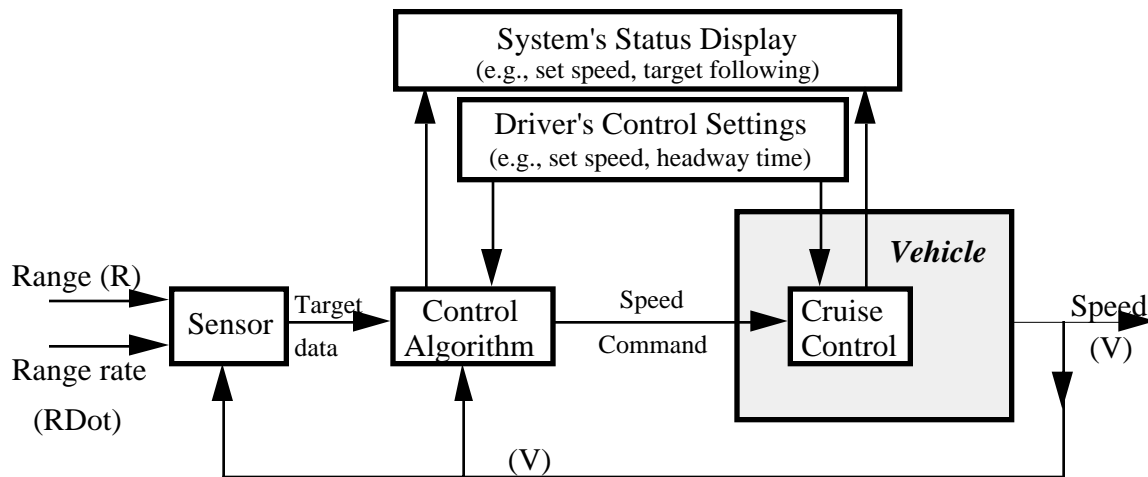

Figure 12. ACC System structure

In this design the driver can also provide other inputs that are essential to the operation of the ACC system: engaging/disengaging the system, setting speed, or pressing the brake. At the same time the system provides the driver with feedback about its operating status: what the set speed is, what its activation state is, and whether targets are tracked.

3.1.3 Sensor Calibration and Alignment

Both the sweep and cut-in sensors need to be aligned when installed on a vehicle. When properly aligned, the beam of the sweep sensor will be tilted in azimuth at an angle α relative to the vehicle’s true-running centerline, so that at a range of 120m, the beam’s center will overlap with the center of the lane. Similarly, the aligned cut-in sensor is tilted in azimuth at an angle β , and the beam’s center coincides with the center of the lane at a range of 30m. These range values (120m and 30m) are determined by the maximum range of the sweep and cut-in sensors respectively. A top-view depiction of the alignment objective is provided in Figure 13. In addition, the sensors must also be aligned in terms

of elevation, so as to avoid energy reflections from the ground. Azimuth and elevation adjustments are made using set screws in the installation kits.

Loading of the vehicle (weight in trunk) without load stabilization may impact the vertical alignment of the sensor in that the front end of the vehicle would be higher. No means of self stabilization was provided in this installation.

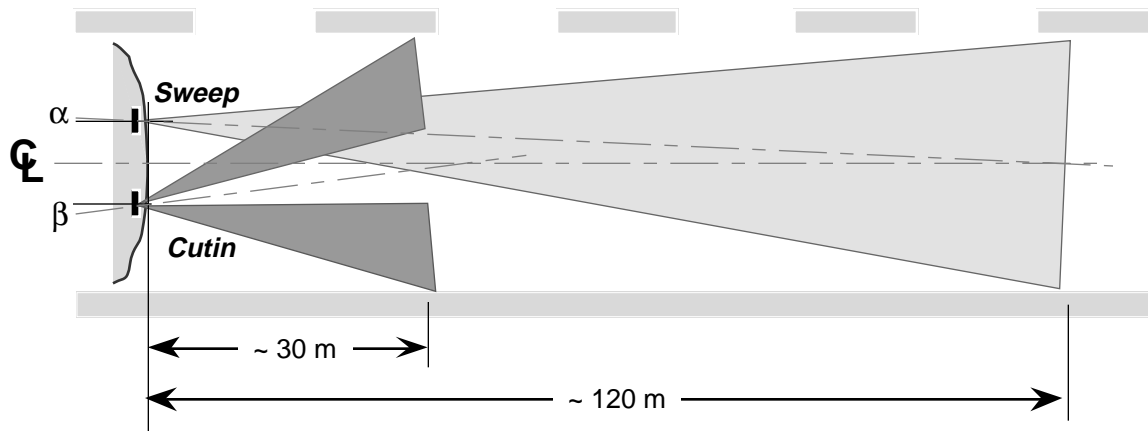

Figure 13. Top view of aligned sensor beams

3.1.4 Human-Machine Interface

An integral part of the ACC system was the driver interface. The interface used for conventional cruise control was maintained in its OEM configuration and incorporated into the control of the ACC system. However, several new elements were added in order to accommodate use of ACC. The driver interface is illustrated in Figure 14.

The items in the headway controller's driver interface included a display for presenting the set speed to the driver, a light accompanied by an audible tone for indicating when visibility was poor, and a light for indicating when the ACC system had recognized a preceding vehicle. In addition there was a set of switches for the driver to use in selecting headway time (labeled as "HEADWAY" in Figure 14). The right-most button was labeled "Farther," the left-most button was labeled "Closer," and the center button was unlabeled. By pushing one of these buttons the driver could select nominal headway times of 2.0, 1.0, and 1.4 seconds, respectively.

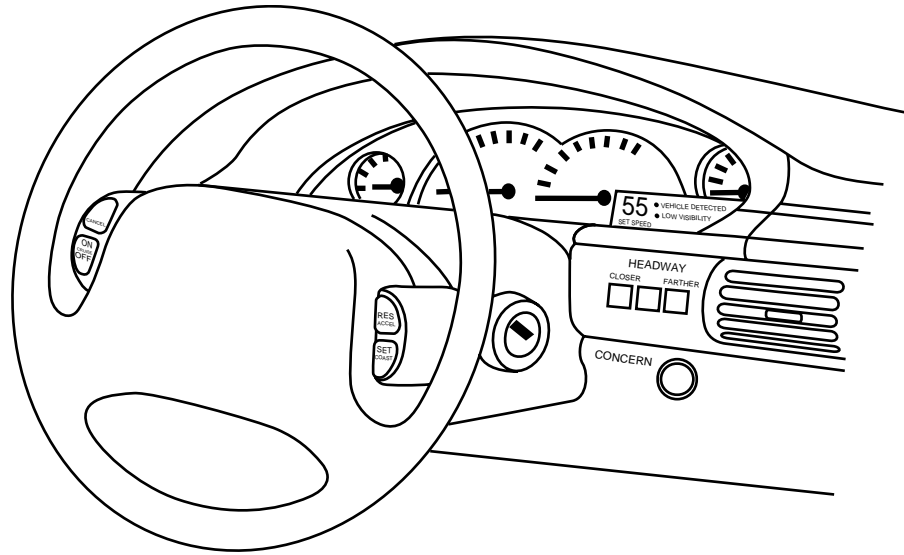

Figure 14. Chrysler Concorde instrument panel with ACC controls and displays

Headway Adjustment Control

The control for adjusting headway was composed of three buttons (Switchcraft® Series 6700 Multi-station Switches). These buttons were interlocked with lock-out such that a solenoid release would prevent more than one button from being depressed. The buttons for headway adjustment were white in color and illuminated only when the vehicle headlamps are on. The face of each button was 16 mm square and had a travel of 4.75 mm. Positive identification was achieved through snap feel and back illumination. Barriers were installed between buttons to guide fingertips away from adjacent buttons and prevent inadvertent actuation. The headway adjustment control was located on the driver's right-hand side (see Figure 14). The location of the control relative to the line of sight was down and to the right not more than 36 degrees of visual angle. The labeling for the control was composed of white lettering on a black background. The subtended visual angle of the characters was not less than 17 minutes of arc.

Concern Button

The so-called concern button was a device that allowed the participants to mark in the data stream an event in time at which they had become concerned or dissatisfied with the performance of the ACC system. The button was an illuminated flush-mounted momentary-contact pushbutton, with the button face flush with the button bezel. The button face was 12.5 mm in diameter and had a travel of 3 mm. The button was yellow in color, and illuminated only when the vehicle headlamps were on. The concern button was located at the top of the knee bolster, on the driver's right-hand side (see Figure 14). The

location of the button relative to the line of sight was down and to the right not more than 34 degrees of visual angle. The labeling for the control was composed of white lettering on a black background, where the subtended visual angle was not less than 17 minutes of arc.

Conventional Cruise Control Interface

The switches for operating the conventional cruise-control system were also used in the operation of the ACC system. The vehicle's manufacturer established this interface. The switches for turning the cruise control on, off, canceling, setting, resuming, accelerating, and coasting were all located on the face of the steering wheel (see Figure 14). These controls consisted of two three-position rocker switches (on-none-on configuration) located on either the left or right side of the steering wheel hub. The switch surfaces were approximately rectangular, measuring 54 mm in length and 17.5 mm in width. The location of the switches relative to the line of sight was down and to the right or left not more than 38 degrees of visual angle. The labels were white capital characters on a black background. The subtended visual angle of the characters was not less than 17 minutes of arc. These buttons were not back illuminated. During ACC operation, each tap on the rocker side labeled "ACCEL" increased the set speed by 2 mph, and each tap on the side labeled "SET" decreased the set speed by 2 mph.

Set Speed Display

Two seven-segment light-emitting-diode (LED) digits displayed the vehicle's set speed. These digits were green in color, and illuminated to approximately 75 cd/m² in daytime conditions (headlamps off) and 5 cd/m² in nighttime conditions (headlamps on). The subtended visual angle of the digits was not less than 25 minutes of arc. The set speed display was located in the rightmost portion of the instrumentation cluster (see Figure 14). The location of the set speed display relative to the line of sight was down and to the right not more than 29 degrees of visual angle. The labeling for the display was composed of white lettering on a black background. The subtended visual angle of the characters was not less than 17 minutes of arc.

Sensor Status Displays

Two LEDs were used to display the ACC sensor status. The first display, indicating a "vehicle detected" condition, was a green LED that indicated that the ACC system had a valid target in its path. This LED would only illuminate when a valid target was present. The display was illuminated to approximately 75 cd/m² in daytime conditions (headlamps off) and 5 cd/m² in nighttime conditions (headlamps on). The subtended visual angle of

the vehicle-detected display was not less than 11 minutes of arc. The vehicle-detected display was located in the rightmost portion of the instrumentation cluster, and to the immediate right of the set speed display (see Figure 14). The location of the vehicle-detected display relative to the line of sight was down and to the right not more than 32 degrees of visual angle. The labeling for the display was white lettering on a black background. The subtended visual angle of the characters was not less than 17 minutes of arc.

The second display, low visibility, was a series of red LEDs that indicated that the ACC system could not properly function due to reduced visibility or system failure. This display would only illuminate when reduced visibility or system failure existed. The display was illuminated to approximately 75 cd/m^2 in daytime conditions (headlamps off) and 5 cd/m^2 in nighttime conditions (headlamps on). The subtended visual angle of the low visibility display was not less than 11 minutes of arc. The low visibility display was located in the rightmost portion of the instrumentation cluster, and to the immediate right of the set speed display (see Figure 14). The location of the low-visibility display relative to the line of sight was down and to the right not more than 32 degrees of visual angle. The labeling for the display comprised black lettering on a clear background. The subtended visual angle of the characters was not less than 17 minutes of arc. When on, the red LEDs back illuminated a label stating “Low Visibility.”

The low-visibility display also included an auditory component that was provided to the driver whenever the ACC system could not properly function due to reduced visibility or system failure. The auditory component of the low visibility display was characterized as a warble tone with a center frequency of $2400 \pm 500 \text{ Hz}$. The intensity of the auditory component was not more than 80 dB at the position of the driver’s ear, with a duration of 2 seconds. The auditory component of the display was only provided at the initial onset of the low visibility criteria.

3.2 The Vehicular Test Platform

The test platform refers to the complete, integrated ACC and data-acquisition packages on-board the vehicle, in a “ready-to-roll” configuration. It includes the instrumented vehicle with ACC functionality, and all the necessary driver interface elements to enable ACC operation. This section describes the base vehicle which served as the automotive platform in the field test, the provisions that had to be made for the integration of the ACC system, and the activities that took place to ensure a proper, safe functionality of the test platform each time it was delivered to a participant.

3.2.1 The Base Vehicle

The vehicles procured for this project were '96 Chrysler Concordes. The Chrysler Concorde is a five-passenger sedan which belongs to the family of Chrysler LH-platform cars. This family also includes the Dodge Intrepid, Eagle Vision, Chrysler New Yorker and Chrysler LHS. The New Yorker and LHS have bigger trunks and C-shaped C-pillars, but other than these features they are mechanically similar to the other cars.



Figure 15. Chrysler Concorde

The primary motivation for using the Chrysler Concorde as the FOT vehicle platform was based on ADC's prior experience with integrating an ACC system onto the Chrysler LH platform. Early experience indicated that a careful tailoring of the ACC application to the selected vehicle must be made if good performance is to be ensured. Tailoring requires suitability of the electronics interface and matching of the control system parameters to the longitudinal response properties of the vehicle. ADC's earlier integration experience with the Chrysler LH platform was found to be most helpful during the pretesting task of designing the system's installation.

The following are highlights from the vehicle's specification, which also served as guidelines when procuring the cars:

1. Model — 1996 Chrysler Concorde LX, option package 26C
2. Engine — 3.5-liter (215 CID) 24-valve V6, 214 hp, 221 lb-ft
3. Transmission — four-speed automatic transaxle with overdrive, electronically controlled
4. Brakes — power-assisted, 4-wheel disc antilock system.

5. Steering — variable assist, speed-sensitive rack-and-pinion power steering with tilt steering column
6. Suspensions — front: Independent system with gas-charged (MacPherson-type) struts and double ball-joint stabilizer bar; rear: independent multilink suspension
7. Mirrors — inside mirror has a power antiglare system; both external mirrors are remotely controlled and heated
8. Dual Air Bags — driver and front-seat passenger are both protected by an air bag supplemental restraint system
9. Rear Defroster — electric heating elements fused to the glass of the rear window
10. Trunk — low-liftover edge of open trunk, and large cargo space to accommodate both luggage and data-collection equipment
11. Other equipment — factory installed seat belts for all passengers, cruise control, power windows and locks, and air conditioning; antitheft alarm installed separately

3.2.2 Provisions for the Integration of the ACC System

Within the framework of this field operational test, one of UMTRI's functions was to be the system integrator. ADC provided the sensors and control modules as parts, the vehicle was delivered in its standard configuration off the dealer's lot, and the specially designed human-machine interface (HMI) was assembled separately. The components of the ACC system had to be installed in the vehicle, communication links with some of its electronic control units (ECU) had to be provided, and installation of the HMI was to be made in a way that would ensure an integrated, functional ACC system that could be field tested. These activities for all the ten vehicles in the FOT fleet were performed by UMTRI, and they are described in this section.

In addition to the vehicle-wide wiring work, the integration task of the ACC system was focused in four main areas of activity: (1) sensors at front grill and bumper, (2) transmission controller and power supply in the engine compartment, (3) HMI and ECU interface in the dashboard area, and (4) VAC and E-BOX in the trunk. Figure 16 on the next page shows these areas, and also a list of the activities related to the integration of the ACC system. Many of the subsystems shown involved substantial preassembly before they could be installed. Also of significance was the installation and routing of a wire harness that provided power and data connectivity between the different systems. The sequence of the tasks was optimized to help avoid repeated disassembly and modification of the vehicle components and existing subsystems.

- 1. Fabricate instrumentation chassis
- 2. Install VAC and E-Box in instrumentation chassis
- 3. Assemble & check instrumentation chassis
- 4. Modify grill and front bumper cover
- 5. Install sensors and mounting brackets
- 6. Fabricate board & box for brake lamp mod
- 7. Fabricate HMI circuit board
- 8. Modify ADC's HMI controller box
- 9. Stuff & assemble HMI display
- 10. Remove dashboard, center console, and rear seats
- 11. Fabricate sensors Plexiglas covers
- 12. Fabricate sensor foam inserts

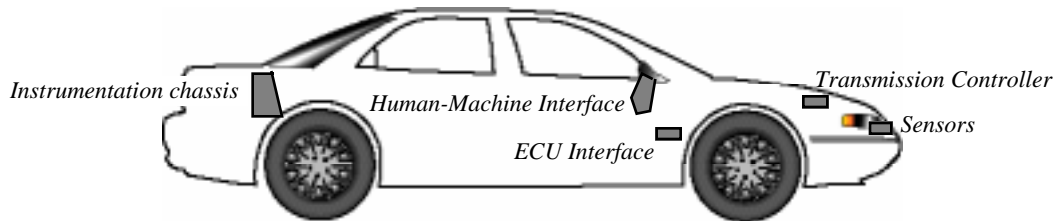

- 13. Add vehicle-wide supplemental wiring
- 14. Install connectors on wiring
- 15. Dress wiring
- 16. Install brake lamp mod box
- 17. Install & connect instrumentation chassis
- 18. Re-install seat belts & back seat
- 19. Modify trunk carpet
- 20. Install HMI controller
- 21. Install HMI display and hood
- 22. Install HMI cover & labels
- 23. Install buzzer
- 24. Fuse and attach battery connections
- 25. Fabricate and mount ECU interface connector
- 26. Connect and verify communication to the ECU
- 27. Modify Chrysler's transmission connector
- 28. Modify Chrysler's transmission software
- 29. Install wire to Chrysler's transmission controller
- 30. Shrink-wrap sensor connectors
- 31. Align sensors; modify mounting as needed
- 32. Install sensor foam inserts
- 33. Install cut-in Plexiglas cover

Figure 16. ACC System installation checklist

Sensors

With the sensors, ADC provided an installation kit, which includes an adjustable mounting. Once the sensor is installed into this mounting, it is possible to adjust its orientation using several adjustment means. Installing the sensors in the vehicle involved modifying the adjustable mounting, affixing it to the vehicle's front bumper, and modifying the grill to accommodate the sensors.

The adjustable mounting includes a subframe onto which the sensor is attached. This subframe can be slid up or down, and it can also be rotated in azimuth and elevation. To accommodate installation in the grill between the bumper and the cooling radiator, it was necessary to modify some parts of the adjustable mounting. Special brackets were fabricated and welded to the bumper frame, and the modified adjustable mountings were bolted onto these brackets.

Special openings were cut in the grill to accommodate the sensors. Also, provisions were made to allow access to the adjustment screws of the mountings without any parts removal. The installed sensors are shown in Figure 17. The transmitter and receiver of the

sweep sensor are shown on the driver's side of the grill; those of the cut-in sensor are shown on the passenger's side of the grill.

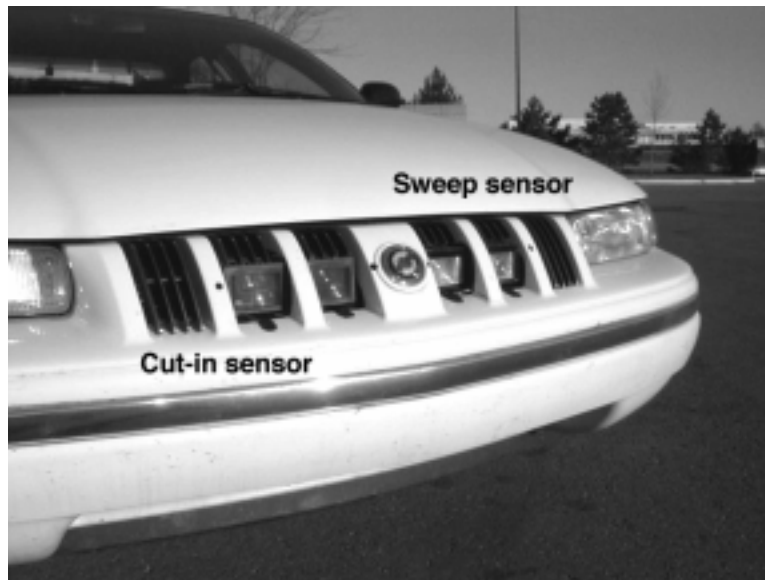

Figure 17. Sensors installed in the grill

Item number 33 in Figure 16 is “Install cut-in Plexiglas cover.” During the early stages of the field test it became evident that the glass lenses of the cut-in sensor were quite fragile. That fact, combined with the forward, low mounting introduced a problem of the glass lens breaking quite often. The sweep sensor did not have this problem, since it had a lens that was made of a much thicker glass. ADC provided a solution for the problem in the form of protective Plexiglas covers that were glued to the lenses. As a preemptive measure, a Plexiglas cover was installed onto the sweep sensor as well. These covers were proven effective in the course of the FOT.

Transmission Controller

Using a special-purpose communication tool (DRB-2) provided by Chrysler, UMTRI personnel modified the software of the electronic transmission controllers in the ten test vehicles. This modification was needed to allow the transmission to downshift by command from the control algorithm (see discussion under “ACC Control Algorithm”).

VAC and E-Box

The VAC and the E-Box are housed together with the data-acquisition system (DAS) module. Though not necessary for the operation of the ACC system, the DAS installation had to be completed for the VAC / E-Box to be mounted and connected.

The DAS housing is mounted in the vehicle's trunk compartment adjacent to the rear surface of the rear passenger seat. An enclosing structure of Dow blue Styrofoam (R-10.8) with cover was provided to contain the electronics package within a thermally stabilized environment. This covering was modified to suit the particular demands of each temperature season. The covering also protected the equipment from damage or tampering by the participants. The structure consumed about a third of the trunk, however it did not interfere with access to the spare tire. Figure 18 shows the VAC and E-BOX mounted in the DAS housing in the trunk (without the covering).

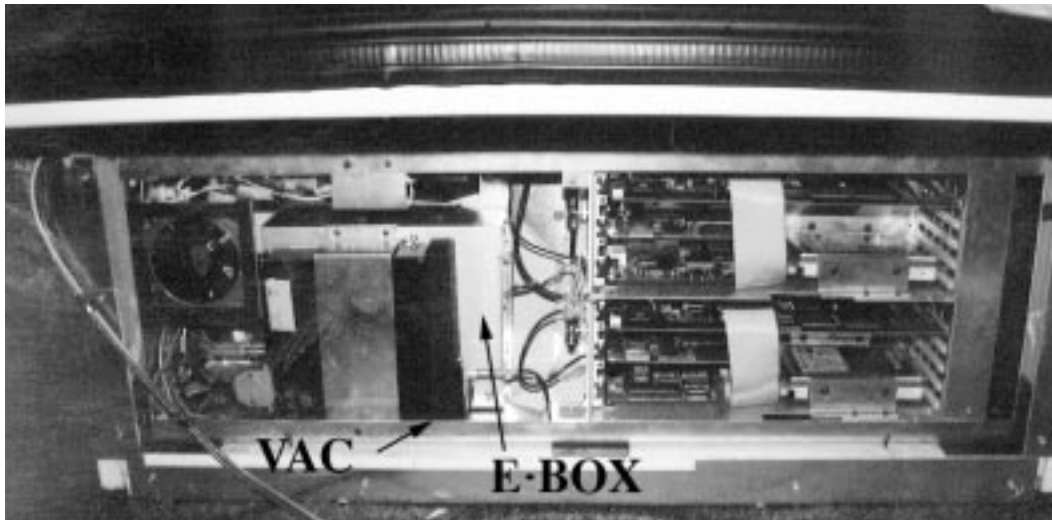

Figure 18. VAC / E-Box in the DAS housing

3.2.3 Preparation of Each Vehicle for Use in Field Data Collection

Data were collected in the FOT vehicles from four sources: (1) VAC – data from the ACC system and from the vehicle, (2) GPS system – geographic location data, (3) HMI – driver input data, and (4) video camera – visual samples of the forward scene. Provisions had to be made to store the data and to transmit selected data summaries back to UMTRI via a cellular modem. Figure 19 shows these data sources, and also a list of the activities related to the installation of the DAS system.

A general view of the data acquisition chassis as it is mounted in its insulated box in the trunk is provided in Figure 18. The primary DAS components that were mounted within the chassis are a data processor subsystem, a video processor subsystem (subsystems include disk drives, power supplies, and I/O support cards, shown as the racks on the right of Figure 18), the GPS receiver, cellular modem transceiver, environmental controller, 12V batteries, and the power delivery system.

- | | |
|--|--|
| <input type="checkbox"/> 1. Fabricate instrumentation chassis | <input type="checkbox"/> 6. Build up camera assembly |
| <input type="checkbox"/> 2. Install VAC and E-Box in instrumentation chassis | <input type="checkbox"/> 7. Add supplemental wiring |
| <input type="checkbox"/> 3. Assemble & check instrumentation chassis | <input type="checkbox"/> 8. Install connectors on wiring |
| <input type="checkbox"/> 4. Fabricate cover plate attachment | <input type="checkbox"/> 9. Dress wiring |
| <input type="checkbox"/> 5. Fabricate GPS antenna backplate | <input type="checkbox"/> 10. Mount cellular antenna |

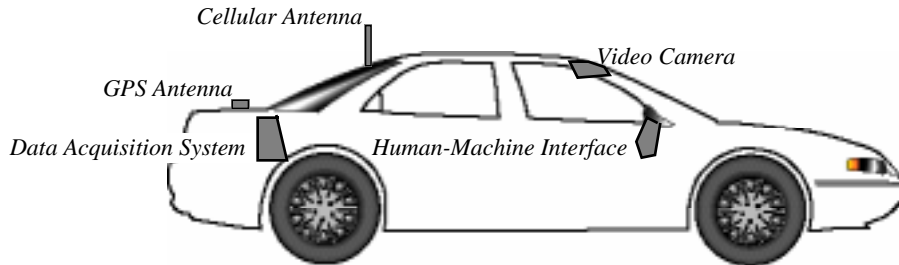

- | | |
|--|--|
| <input type="checkbox"/> 11. Mount GPS antenna | <input type="checkbox"/> 16. Defeat "Rec" air button |
| <input type="checkbox"/> 12. Install & connect instrumentation chassis | <input type="checkbox"/> 17. Reinstall seat belts & back seat |
| <input type="checkbox"/> 13. Remove dashboard | <input type="checkbox"/> 18. Modify trunk carpet |
| <input type="checkbox"/> 14. Install concern button | <input type="checkbox"/> 19. Position and install video camera |
| <input type="checkbox"/> 15. Wire concern button | <input type="checkbox"/> 20. Fuse and attach battery connections |

Figure 19. DAS System installation checklist

Following the installation and preparation, each vehicle was given a final verification checkout. This checkout consisted of the following tasks:

- power-up check
- ACC communications check
- HMI communication check (LED & buttons algorithm)
- ACC functional check
- cellular data transfer
- alarm installed and functioning
- verify equipment tracking sheet
- mileage run-in

GPS

The GPS system uses a Trimble six-channel receiver model SVeeSix-CM3. The receiver is mounted inside the DAS insulated housing in the trunk, and the active antenna is mounted on the center of the trunk lid. The original mounting of the antenna was modified, and a backplate was added to allow screwing the antenna to the lid (instead of a magnetic attachment). Also, the antenna wire was reconnected to provide a more protected route.

Human-Machine Interface

The “Concern” button, which allows the driver to provide some input regarding his or her observation of the ACC functionality, is part of the HMI. It is mounted on the dashboard (see Figure 14), and it is wired to the DAS in the trunk.

Video Camera

The CCD video camera is mounted on the inside of the windshield, behind the rear-view mirror (see Figure 20). It has a wide-angle forward view, and it continuously digitizes and stores captured video to internal buffers in the video computer of the DAS.



Figure 20. Forward-looking CCD camera

Cellular Communication

The cellular communications system consists of an AT&T KeepInTouch 14.4-Kbps cellular modem, a Motorola 3-watt transceiver, and an antenna. The modem and the transceiver are located within the DAS chassis, and the antenna is mounted at the top of the rear windshield.

3.2.4 System Characterization Procedure and Results

Tests to characterize the performance of the overall system were conducted by UMTRI engineers on public roads covering a broad set of operating scenarios. Each test elicited a certain response that served as a meaningful description of system properties. Data were collected using the same data-acquisition package as was installed in each car for operational testing. Test variables that were controlled include the host vehicle speed, lead vehicle speed, state of the control system, and relatively simple steering and braking maneuvers. In each test, the properties of the system were characterized independent of human behavioral variables. A comprehensive description of the characterization-tests procedure is provided in appendix E, which also includes example plots of test results.

Each of the test measurements was conducted with negligible road grade and head wind. Further, some of the tests required that a *co-op vehicle* be engaged to execute preplanned interactive movements between the host vehicle and a preceding vehicle. In these cases, the co-op vehicle was simply another passenger car driven by a collaborating staff member.

3.3 The Data-Acquisition System

The data-acquisition system installed in the ACC-equipped vehicles was designed to collect, process, and store both numerical and video data files using two on-board computers to quantify aspects of the driving process that are pertinent to the control of speed and the headway gap relative to the closest preceding vehicle. The data were collected and stored on a trip-per-trip basis. Once a trip was completed, an on-board computer sent summary data via cellular phone to a server at the base station. These data were mainly in the form of histograms and trip summary numerics computed on-line to describe features of the trip. After two to five weeks in typical transportation service in the field operational test, the ACC vehicles were returned to the base station and time histories of pertinent variables such as range, range-rate, and velocity plus GPS and video data were downloaded.

Figure 21 shows the general flow of the numerical and video data. This section focuses on the acquisition and transfer of the data (the left side of the figure). Sections 4 and 5 provide a detailed discussion of the processing and the permanent storage of the data on CD-ROM.

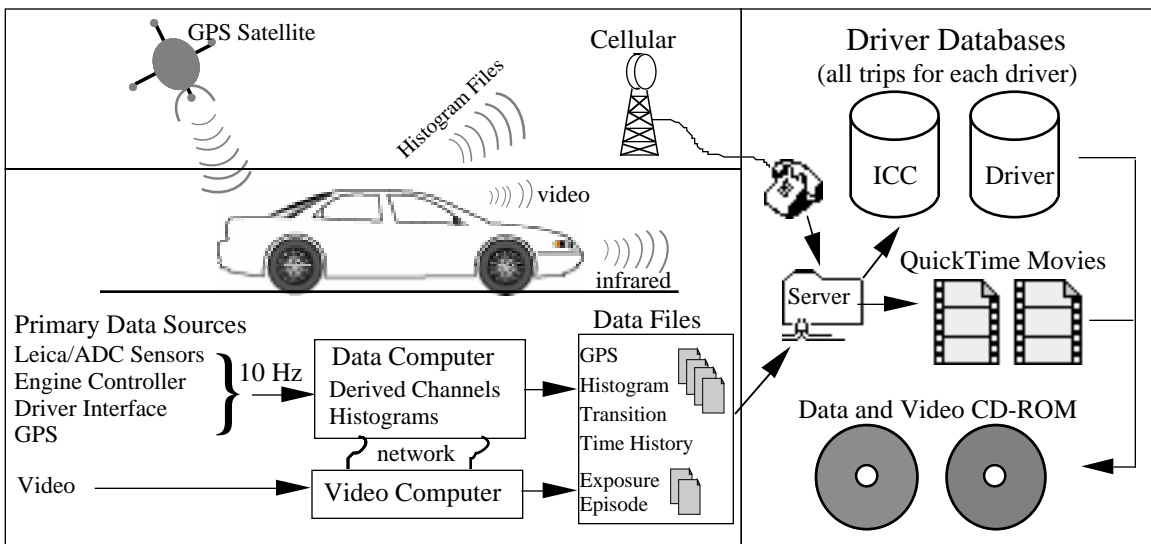

Figure 21. Data flow for the field operational test

The main part of the DAS was located in the insulated chassis in the trunk (see Figure 18), containing the processing, storage, and transceiving elements of the system. A depiction of the data sources and the location of the DAS elements in the vehicle is provided in Figure 19. This overall section describes the set of measurement techniques employed in collecting, online processing, and transferring of the data. Details of the design of the data-acquisition package and the many forms of data that were collected are also provided.

3.3.1 The DAS Package

The data-acquisition system consists of five subsystems (see Figure 22 for a block diagram of the system):

- power, interface, and control
- main computer
- GPS
- cellular communications
- video computer

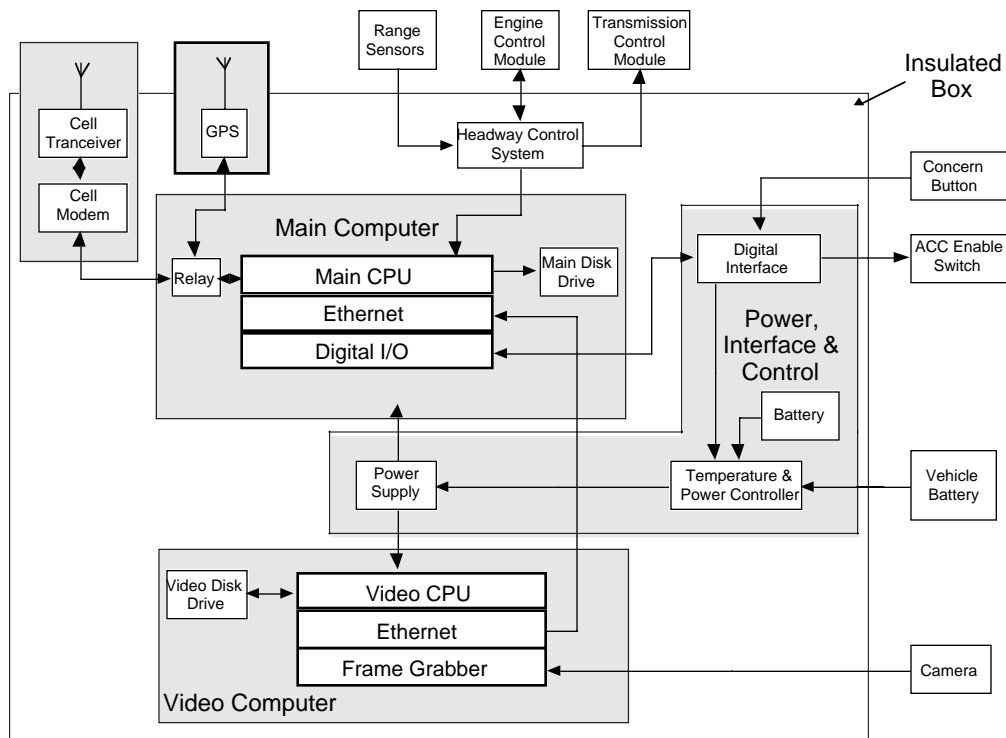

Figure 22. Data-acquisition system hardware

Power, Interface, And Control

The power, interface, and control subsystem provides power sequencing of the various components and closed-loop heating or cooling of the chassis. It includes:

- two triple-output (5, +-12 volt) ac-dc converters for the computers
- 9-volt regulator for camera power
- 3-volt lithium battery for the GPS battery-backup RAM
- three 12-volt 17.5 amp-hour lead acid batteries
- microcontroller with 11 channel 10-bit A/D and 12 digital inputs/outputs
- circulation and exhaust fans
- 50-watt heater
- three temperature sensors

The microcontroller continuously monitors the chassis and camera temperatures, battery voltages, and state of the ignition switch and updates histograms of these variables in nonvolatile memory (EEPROM). The histograms are downloaded and inspected via an RS232 serial line when the participant returns the vehicle.

The vehicle power system and the chassis batteries are connected only when the ignition is on. Power for heating and cooling of the system comes from the three chassis batteries. The camera temperature is maintained above -5 degrees C by turning it on (self-heating). If the temperature of the chassis goes below 4 degrees C, a 50-watt heating element and a circulation fan are activated. The microcontroller ceases closed-loop heating when the battery voltage drops below 10.0 volts. This assures that the chassis can be powered up when the next ignition-on event occurs. If the chassis temperature is out of operating range (2 degrees to 50 degrees C), the microcontroller does not turn the computers on and logs a missed trip in its EEPROM.

Main Computer

The main computer system collects and records data from the headway-control system, the vehicle (via the headway-control system), and the GPS system. The data are organized by trip (ignition-on to ignition-off). The main computer system also performs on-line data processing to generate derived channels, histograms, summary counts, and video episode triggers. The main computer includes:

- a five-slot passive backplane and chassis
- an IBM-AT compatible CPU card with 90 MHz Pentium processor, 16 MB RAM, two serial ports, printer port, and hard disk controller
- 1.6 GB hard disk drive

- Ethernet network adapter
- digital I/O expansion card

Figure 23 shows how the system operates. When the vehicle is started, the interface and control system activates the main system, which turns on the GPS and video systems. The GPS system sends (via an RS-232 serial line) encoded position and velocity packets every time it computes a new position. The main system decodes these packets, calculates grade and heading from the velocity information, and stores the time, latitude, longitude, altitude, grade, and heading to a position file. The GPS time at power-up is used to set the main and video computer clocks.

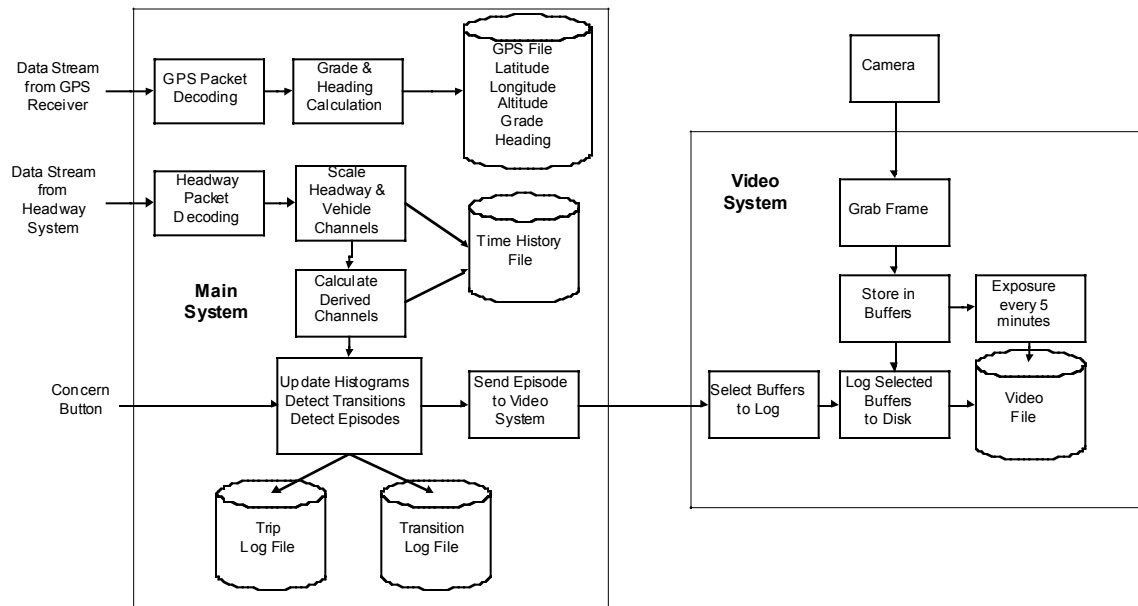

Figure 23. Data acquisition system operation

The headway controller sends (via a second RS-232 serial line) an encoded packet of information every 0.1 seconds. The main system decodes this packet and extracts the appropriate sensor and vehicle information channels. Derived channels are then calculated and selected information is logged to a time-history file. The next section describes the data channels and the derived channels. Some logical channels are logged to a transition file. Each transition-file record indicates a channel number, the time of the false-to-true transition, and the duration that the signal was true.

An episode-processing task monitors the incoming primary and calculated channels for the occurrence of significant episodes (e.g., ACC overrides, near encounters, concern button presses, etc.). When an episode is detected, the main system logs it to the transition file and sends a message (via Ethernet network) to the video system. The time

of each episode is used as a pointer into the time history files for further investigation of the driving environment. Transition counts, histograms, errors, and other trip summary information are logged to a trip log at the end of each trip.

When a trip ends, the main system turns off the GPS and video systems and activates the cellular system to transfer data to UMTRI. Once the transfer is completed (or fails, see section 3.3.3), the main computer signals the microcontroller, which turns the computer off.

Video Computer

The video computer system continuously samples output from a windshield-mounted camera. It saves 2.5-second exposures every 5 or 10 minutes and 30-second episodes when triggered by the main system. The video computer includes:

- a five-slot passive backplane and chassis
- an IBM-AT compatible CPU card with 90 MHz Pentium processor, 32 MB RAM, two serial ports, printer port, and hard disk controller
- 2.1GB disk drive
- Ethernet network adapter
- CX100 Frame Grabber

The CX100 frame grabber is programmed to capture an image of 486 rows by 512 pixels in NTSC high-resolution mode. Each image frame contains two interlaced fields (243 rows by 512 pixels) as shown in Figure 24.

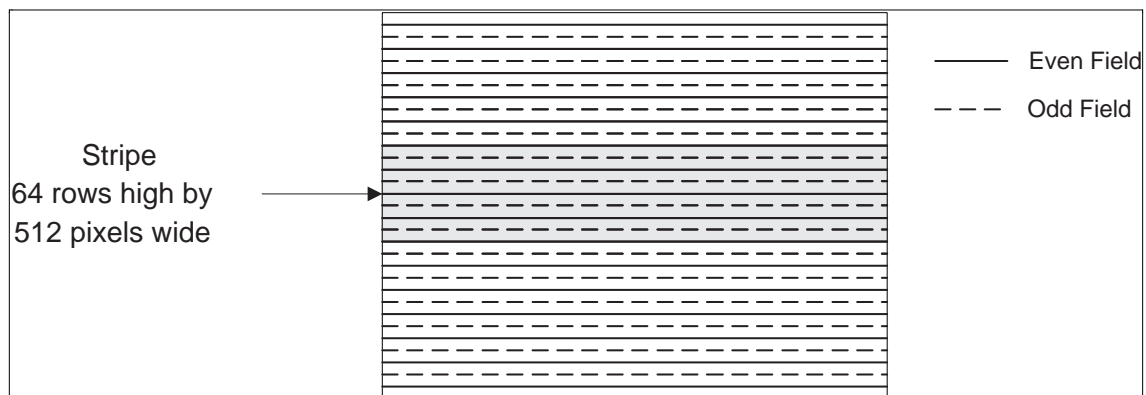

Figure 24. Video image frame structure

The video software samples a stripe from the even field, which is 64 rows by 512 pixels, every six frames, or 0.1 seconds. The stripe is marked with a date/time stamp derived from the system clock, which reflects the time the stripe was copied into a stripe

buffer (not the time the frame grabber digitized the field) and stored in a stripe buffer selected from a pool of 600 buffers.

The system maintains a circular list of the last 300 stripes. At 5-minute intervals, an exposure task wakes up and saves the last 25 stripes (2.5 seconds) to a file (819,200 bytes). The system hard disk contains 420 contiguous preallocated exposure files labeled from “1.exp” to “420.exp.” The files are created once and never deleted, which minimizes write time and prevents the disk from becoming fragmented. They are overwritten in sequential order, and a current list of file and driver-trip information is stored in a directory file called “director.exp.”

When the main system detects an episode, it sends a message that contains the episode type, driver number, trip number, date/time stamp, and the importance of the episode (a number between 0.0 and 1.0). The video system copies the list of the last 300 buffers and increments the buffer-use counts so they will not be returned to the “available” or “free” pool until they are written to disk. The episode is scheduled to be recorded after a 15-second wait period. If another more important episode occurs during this period, the previously scheduled one is deleted and the new one is scheduled. Thus cascaded triggers that are close in time generate only one video episode. The system hard disk contains 160 contiguous preallocated episode files (9,830,400 bytes each) labeled from “1.epi” to “160.epi.” Table 2 shows the nine types of episodes that vie for this file space.

Table 2. Episode types

Episode Type	Minimum	Maximum
Concern button	50	50
Manual Brake Intervention - 1 st week	10	50
Manual Near Encounter - 1 st week	10	50
Cruise Brake Intervention	10	50
Cruise Near Encounter	10	50
Manual Brake Intervention - 2nd week	20	50
Manual Near Encounter - 2nd week	20	50
ACC Brake Intervention	20	50
ACC Near Encounter	20	50

The episodes files are filled in order from 1 to 160 as long as the number of each type is less than its maximum. Once all of the files are filled, a set of preemption rules applies. The current list of episodes is stored in a directory file called “director.epi.”

The exposures and episode binary files are converted to “QuickTime movies,” which can be played on Macintoshes or PCs running Windows (3.1, 95, or NT). The images are doubled in height to recapture the original aspect ratio (only the even rows are contained in the sample) and compressed. The resulting exposure movies are 200 to 350 K bytes in size. The longer episodes are from 3.5 to 4 Megabytes. The first frame of each movie is a title frame showing the driver number, trip number, date/time of the trigger or exposure, and the importance. Subsequent frames display the frame number and frame timestamp at the bottom. Figure 25 shows a frame from an episode movie.



Figure 25. Snapshot from an episode movie

GPS

The GPS system uses a six-channel receiver (which tracks up to eight satellites) with real-time clock and active antenna that is mounted on the center of the trunk lid [2]. The receiver stores the almanac, ephemeris, and configuration data in battery-backup RAM. This minimizes the time from power-up to first computed position. If the receiver has been powered down for less than four hours, the saved data are considered valid and the acquisition time is typically less than 30 seconds. If more than four hours, the time to first fix is around 40 seconds.

The main computer communicates with the receiver via a 9600 baud RS232 serial line using a binary packet protocol that permits full control of the receiver’s operating parameters and output format. Table 3 on the next page shows the packets that are automatically sent by the receiver and processed by the data-acquisition software.

Table 3. GPS Packet information

Packet Type	Description
Health	Satellite tracking status and operational health of the receiver
Time	GPS time reported in weeks since January 6, 1980 and seconds since Sunday morning at midnight of the current week
Position	Single precision position in Latitude-Longitude-Altitude (LLA) coordinates
Velocity	Single precision velocity in East-North-Up (ENU) coordinates

The main computer causes the receiver to operate in 3D-manual and over-determined modes. Position and velocity packets are sent twice a second as long as at least four satellites are visible. Reacquisition time for a momentary satellite loss is typically under 2 seconds. The over-determined 3D solution (which smoothes the position output and minimizes discontinuities caused by constellation changes) requires five or six visible satellites.

Cellular Communications

The cellular communications system consists of an AT&T KeepInTouch 14.4-Kbps cellular modem that uses the Enhanced Throughput Cellular protocol, a 3-watt transceiver, and a window-mounted antenna. The main data acquisition and communications programs maintain a list of trip files to be transmitted to the UMTRI server. When a trip is completed, the data are transferred to UMTRI (see discussion in section 3.3.3). The system then executes a disconnect script and turns itself off.

3.3.2 The Collected Variables

Primary and Derived Channel

The numerical data flow starts with the collection of 38 primary signals at a rate of 10Hz from various sources on-board each FOT vehicle. These sources are shown on the left in Figure 21 and include ADC's infrared sensors, the vehicle's engine control unit, the video camera, the GPS, and the driver/vehicle interface. A list of the 38 primary signals is given in Table 4. This table shows the name, type, description, and units of each signal. It also has a column called Logged. This column indicates if the signal is permanently stored on disk. Some of the logical signals are stored in a more compact format than that used for time histories. This format is explained later in this section under Transition Files. The following nomenclature is used in the column "Logged" to indicate which file the data is logged into: "H" – time history; "G" – GPS history, "T" – transition table.

Table 4. Primary channels

Name	Type	Description	Units	Logged
AccMode	Integer	0=off, 1=standby, 2=Not Operating On a Target (NOOT), 3= Operating On a Target (OOT)		H
Accel	Logical	True if accel button is pressed		T
AccEnable	Logical	True after 1st week		
Altitude	Float	Altitude	m	G
Backscatter	Float	Backscatter (0 to 1023)		H
Blinded	Logical	True if ODIN 4 blinded bit is on		
Brake	Logical	True if brake pedal is pressed		H
Cancel	Logical	True if cancel button is pressed		T
AccOn	Logical	True if cruise or ACC switch is on		
Cleaning	Logical	True if ODIN 4 cleaning bit is on		
Coast	Logical	True if coast button is pressed		T
Concern	Logical	True if concern button is pressed		T
CurveRadius	Float	Curve radius	ft	
Date/Time	Double	UTC Days since 12/30/1899 + fraction of day	days	H
Downshift	Logical	True if controller requests downshift		T
EastVelocity	Float	East velocity, + for east	m/sec	
EcuError	Logical	True when a VAC to ECU communication error occurs		
HeadwayTime	Float	Selected headway time	sec	
HeadwaySwitch	Integer	headway switches , 1,2, or 4		
Latitude	Float	Latitude, + for north	radians	G
Longitude	Float	Longitude, + for east	radians	G
NetworkError	Logical	True when a DAS to Video communication error occurs		
NewTarget	Logical	True for .3 sec with new target		H
NorthVelocity	Float	North velocity, + for north	m/sec	
Range	Float	Distance to target	ft	H
RDot	Float	Rate of change of range	ft/sec	H
ReducedRange	Logical	True if ODIN 4 reduced range bit is on		
Resume	Logical	True if resume button is pressed		T
Set	Logical	True if set button is pressed		T
Throttle	Float	Throttle percent		H
Tracking	Logical	True when tracking a target		H
UpVelocity	Float	Up velocity, + for up	m/sec	
VacError	Logical	True when a VAC to DAS communication error occurs		
VacTime	Float	Time since ignition switch was turned on (based on VAC system clock)	min	H
ValidTarget	Logical	Tracking AND Velocity > 25mph		H
VCommand	Float	Velocity commanded by controller	ft/sec	H
Velocity	Float	Vehicle velocity	ft/sec	H
VSet	Float	Cruise speed set by driver	ft/sec	H

The numerical data processing begins as these primary channels are read into the memory of the DAS. The computer then calculates what are called *derived channels*. These channels are combinations and manipulations of the primary signals. Examples of derived channels include: V_p (velocity of the preceding vehicle), road grade, distance, near, following, etc. There are 67 derived channels. The 31 floating-point derived channels are given in Table 5. The remaining 36 are logical channels and are listed in Table 6. Both tables show the name of the derived signal, a description (which includes its derivation), units, and whether it is logged to disk.

Table 5. Floating point derived channels

Name	Description	Units	Logged
AverageBackscatter	20 second moving average of Backscatter		
AverageDNearEncounter	4 second moving average of DNearEncounter	g's	H
AverageVDot	4 second moving average of -VDot	g's	H
CDot	Derivative of DegreeOfCurvature	deg/sec	H
D	$R\dot{D}ot^2 / (2 \cdot (Range - 0.7 \cdot Vp) \cdot 32.2)$	g's	
DecelAvoid	$R\dot{D}ot^2 / (2 \cdot Range \cdot 32.2)$	g's	H
DegreeOfCurvature	5728.996 / CurveRadius	deg	H
Distance	Integral of velocity	miles	H
DistanceEngaged	Integral of velocity while engaged	miles	
DNearEncounter	$R\dot{D}ot^2 / (2 \cdot (Range - 0.3 \cdot Vp) \cdot 32.2)$	g's	H
DScore	if DScoreRegion then DScore = (D-0.03) / 0.47; if TScoreRegion then DScore = 1		H
EngMaxAvgDNear	Maximum value of AverageDNearEncounter while EngNearEncounter is true	g's	
EngMaxAvgVDot	Maximum value of AverageVDot while EngBrakeIntervention is true	g's	
Flow	Velocity / (Range + L)	veh/sec	
Grade(GPS)	$UpVelocity / \sqrt{(NorthVelocity^2 + EastVelocity^2)}$		G
Heading	Heading angle calculated from NorthVelocity and EastVelocity	deg	G
HeadwayTimeMargin	Range / Velocity	sec	H
Hinderance	Velocity / Vset		
ManMaxAvgDNear	Maximum value of AverageDNearEncounter while ManNearEncounter is true	g's	
ManMaxAvgVDot	Maximum value of AverageVDot while ManBrakeIntervention is true	g's	
RangeCheck	$0.7 \cdot Vp + R\dot{D}ot^2 / (2 \cdot 0.5 \cdot 32.2)$	ft	
RangeNear	$0.5 \cdot Vp + R\dot{D}ot^2 / (2 \cdot 0.1 \cdot 32.2)$	ft	
Rpt03	$Range - R\dot{D}ot^2 / (2 \cdot 0.03 \cdot 32.2)$	ft	
Thpt03	Rpt03/Vp if RDot < 0 or Range/Vp if RDot >= 0	sec	H
TimeToImpact	-Range / Rdot	sec	H
TrackingError	TimeConstant • Rdot + Range – Th • Vp	ft	
TScore	if TScoreRegion then TScore = (0.7-Th0) / 0.7		H
VDot	Derivative of Velocity / 32.2	g's	H
VehicleResp	VCommand - Velocity	fps	
Vp	Velocity + RDot	fps	H
VpDot	Derivative of Vp / 32.2	g's	H

Table 6. Logical derived channels (Velocity, V, is in mph in Tables 6,7, and 8)

Name	Description	Logged
AccBi	15-sec oneshot - AccEnable AND EngBrakeIntervention	T
AccFollowing	Following AND $0.9Rh < Range < 1.1Rh$	H
AccNe	15-sec oneshot - AccEnable AND EngNearEncounter	T
AccTracking	AccMode > 2	
AlwaysTrue	Always True	
BackscatterWarn	Backscatter > 50	H
CccBi	15-sec oneshot - NOT(AccEnable) AND EngBrakeIntervention	T
CccNe	15-sec oneshot - NOT(AccEnable) AND EngNearEncounter	T
Closing	NOT(Near) AND RDot < -5	H
Cutin	Range < RangeNear AND RDot > 0	H
DScoreRegion	ValidTargetVgt35 AND RDot <= 0 AND Range > RangeCheck	
Engaged	AccMode > 1	T
EngBrakeIntervention	15-sec oneshot - Brake AND Vgt40 AND AverageVDot > 0.05 AND WasEngaged	
EngNearEncounter	15-sec oneshot – ValidTargetVgt40 AND AverageBackscatter < 10 AND AverageDNearEncounter > 0.05 AND WasEngaged	
Following	NOT(Near OR Cutin) AND $-5 \leq RDot \leq 5$	H
HeadwayLong	True if long headway switch is pressed	T
HeadwayMedium	True if medium headway switch is pressed	T
HeadwayShort	True if short headway switch is pressed	T
LDegOfCurvature	$ DegreeOfCurvature > 3$ AND $V > 50$	
LVpDot	$VpDot < -0.05g's$ AND $V > 35$	
Man1Bi	15-sec oneshot - NOT(AccEnable) AND ManBrakeIntervention	T
Man1Ne	15-sec oneshot - NOT(AccEnable) AND ManNearEncounter	T
Man2Bi	15-sec oneshot - AccEnable AND ManBrakeIntervention	T
Man2Ne	15-sec oneshot - AccEnable AND ManNearEncounter	T
ManBrakeIntervention	15-sec oneshot - Brake AND Vgt40 AND AverageVDot > 0.05 AND NOT WasEngaged	
ManNearEncounter	15-sec oneshot – ValidTargetVgt40 AND AverageBackscatter < 10 AND AverageDNearEncounter > 0.05 AND NOT WasEngaged	
Near	Range < RangeNear AND RDot < 0	H
Separating	NOT(Cutin) AND RDot > 5	H
Stopped	Velocity < 3	
TScoreRegion	ValidTargetVgt35 AND RDot <= 0 AND Range <= RangeCheck	
ValidTargetVgt35	ValidTarget AND $V > 35$	
ValidTargetVgt50	ValidTarget AND $V > 50$	
Vgt35	Velocity > 35	
Vgt40	Velocity > 40	
Vgt50	Velocity > 50	
WasEngaged	True if engaged within the last 15 seconds	

Floating-Point Histograms

During each trip some of the primary and derived floating-point channels are made into histograms by the on-board computer. The counting and binning for the histograms is done “on-the-fly” as the signals are derived and processed. Table 7 shows the twenty-seven floating-point histograms that were being made and permanently stored. If data for a particular histogram are collected continuously during a trip, its enabling channel is listed as “Always True.” For other histograms the enabling channel is either a primary or derived logical channel and it must be true in order for counting to occur in that particular histogram. For example, the throttle histogram is only loaded when the enabling channel, Velocity > 35 mph, is true.

Table 7. Floating-point histograms

Name	Source Channel	Enabling Channel	Sorting Channel
BackScatterFhist	Backscatter	Vgt35	None
CDotFhist	CDot	Vgt35	Engaged
DecelAvoidFhist	DecelAvoid	ValidTargetVgt35	Engaged
DegOfCurvatureFhist	DegreeOfCurvature	Vgt35	Engaged
DScoreFhist	DScore	DScoreRegion	Engaged
FlowFhist	Flow	ValidTargetVgt50	Engaged
HindranceFhist	Hindrance	Engaged	None
HtmFhist	HeadwayTimeMargin	Following	Engaged
RangeFhist	Range	ValidTarget	Vgt35
RangeFollowingFhist	Range	Following	Engaged
RangeVgt35FhistV	Range	ValidTargetVgt35	Engaged
RDotFhist	RDot	ValidTarget	Vgt35
RDotVgt35Fhist	RDot	ValidTargetVgt35	Engaged
Thpt03Fhist	Thpt03	ValidTargetVgt35	Engaged
ThrottleFhist	Throttle	Vgt35	Engaged
TimeToImpactFhist	TimeToImpact	ValidTargetVgt35	Engaged
TrackingErrorFhist	TrackingError	AccTracking	None
TScoreFhist	TScore	TScoreRegion	Engaged
VCommandFhist	VCommand	Vgt35	Engaged
VDotFhist	VDot	Always True	Vgt35
VDotVgt35Fhist	VDot	Vgt35	Engaged
VehnessFhist	VehicleResp	Engaged	AccTracking
VelocityFhist	Velocity	Always True	None
VelocityVgt35Fhist	Velocity	Vgt35	Engaged
VpDotVgt35Fhist	VpDot	ValidTargetVgt35	Engaged
VpFhist	Vp	ValidTargetVgt35	Engaged
VSetFhist	VSet	Engaged	None

As shown in Table 7, most histograms have a sorting channel. The sorting channel separates the counts into two histograms depending on the state of the sorting channel variable. For example, the sorting channel for the Throttle histogram is the Engaged logical channel. When this channel is true, that is, the velocity of the test vehicle is being controlled by either conventional or adaptive cruise control, one set of bins for the throttle histogram is filled. If the driver turns the cruise control off, then engaged is false, and the other set of bins for the throttle histogram is filled. (Of course, in this example the vehicle must maintain a speed greater than 35 mph for either set of bins to be filled because the enabling channel is $Velocity > 35$ mph). In short, there are really two histograms when a sorting channel is used.

One two-dimensional histogram is processed by the DAS. This is a normalized range, range-rate histogram. The normalizing channel is the speed of the preceding vehicle (V_p). The histogram is enabled by the ValidTargetVgt50 logical channel and is sorted by the Engaged channel.

Besides creating histograms, the DAS also calculates three statistical figures for each histogram. These figures are the most likely value (which histogram bin has the greatest number of counts), the mean and the variance, where the later two are defined as follows:

$$mean = \bar{x} = \frac{\sum_{i=1}^{nbins} x_i \cdot n_i}{\sum_{i=1}^{nbins} n_i} \quad (8)$$

and

$$variance = \frac{\sum_{i=1}^{nbins} (\bar{x} - x_i)^2 \cdot n_i}{\sum_{i=1}^{nbins} n_i - 1} \quad (9)$$

where:

- \bar{x} = mean,
- $nbins$ = number of bins,
- n_i = count in each bin, and
- x_i = value of the bin center

Logical Histograms

There are twenty logical histograms recorded by the DAS for each trip of each test vehicle. Table 8 shows the names, source channels, enabling channels and sorting channels for these histograms. Unlike the floating-point histograms, the logical histograms all have five bins. The first bin records the number of transitions (count of false-to-true changes) for the logical source channel. The second and third bins contain

the number of counts that the source channel was true and false, respectively. The fourth and fifth bins contain the number of counts that corresponds to the longest consecutive time that the source channel was true and false, respectively. The enabling and sorting channels have the same meaning as in the floating-point histograms.

Table 8. Logical histograms

Name	Source Channel	Enabling Channel	Sorting Channel
AccFollowingLhist	AccFollowing	ValidTargetVgt35	Engaged
AccTrackingLhist	AccTracking	Engaged	None
BackscatterWarnLhist	BackscatterWarn	Vgt35	Vgt35
BlindedLhist	Blinded	Vgt35	Engaged
BrakeLhist	Brake	Vgt35	WasEngaged
CleaningLhist	Cleaning	Vgt35	Engaged
ClosingLhist	Closing	ValidTargetVgt35	Engaged
CutinLhist	Cutin	ValidTargetVgt35	Engaged
DScoreRegionLhist	DScoreRegion	ValidTargetVgt35	Engaged
FollowingLhist	Following	ValidTargetVgt35	Engaged
LVpDotLhist	LVpDot	ValidTargetVgt35	Engaged
NearLhist	Near	ValidTargetVgt35	Engaged
NewTargetLhist	NewTarget	Vgt35	Engaged
ReducedRangeLhist	ReducedRange	Vgt35	Engaged
SeparatingLhist	Separating	ValidTargetVgt35	Engaged
TrackingLhist	Tracking	Vgt35	Engaged
TScoreRegionLhist	TScoreRegion	ValidTargetVgt35	Engaged
ValidTargetLhist	ValidTarget	AlwaysTrue	Engaged
ValidTargetVgt35Lhist	ValidTarget	Vgt35	Engaged
ValidTargetVgt50Lhist	ValidTarget	Vgt50	Engaged

3.3.3 Automatic Recovery of Trip Data via Cellular Modem

When a trip ends and the ignition switch is turned off, the main system turns off the GPS and video systems and activates the cellular system. The trip-data files are then transferred to the UMTRI server using standard Internet protocols (FTP, TCP/IP, and PPP) over cellular communication.

The system executes a connection script that initializes the modem (which usually connects at rates of 4800, 7200, or 9600 baud), dials the phone, and logs in to the server with a PPP account name and password. If the call is not answered (busy cellular system or server) a second attempt is made. Files are transferred using FTP until either all the files in the list have been sent or 5 minutes has lapsed since the driver turned off the ignition.

The primary motive for incorporating such automatic data recovery is twofold: diagnostic information concerning the system's operation, and a certain level of monitoring of how the vehicle is being operated. Continual monitoring of the remotely collected data permits tracking the ACC usage and determination of the possible need for administrative intervention (for example, if the ACC system is not being used by the subject at all).

The files sent via the phone lines contain histogram, trip summary, and diagnostic information that allows different levels of remote surveillance of the components of the DAS. Table 8 shows the trip summary information. Error flags provide a quick summary of the major components of the DAS and the ACC system, while more detailed histograms can be used to find problems that manifest themselves within the various data streams. For example, a sensor that continually reports the same range would be detected by plotting the range histogram as is shown in the top of Figure 26, whereas a sensor that functions properly will report a more evenly distributed histogram (bottom of Figure 26). The data in the figure are histogrammed as a frequency distribution function.

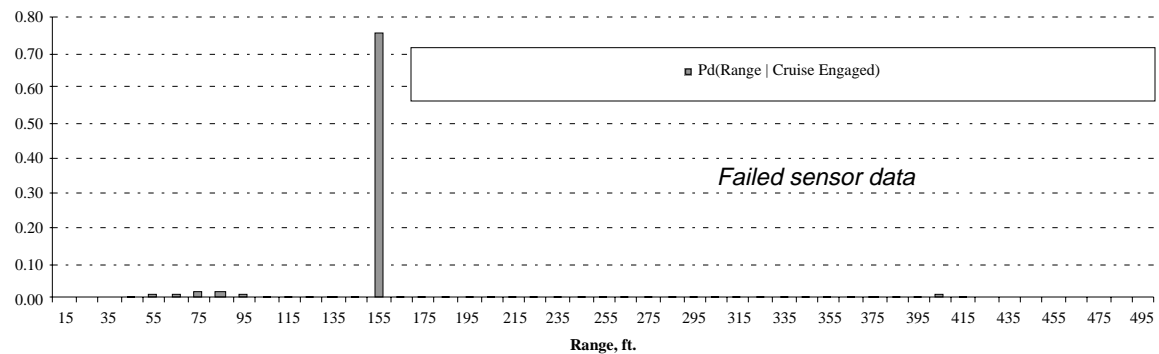

Pd(Range | Cruise Engaged); 0.9 Hrs; 1 Trips; 155.0 Most Likely Value; 168.7 Mean; 64.0 SDev.

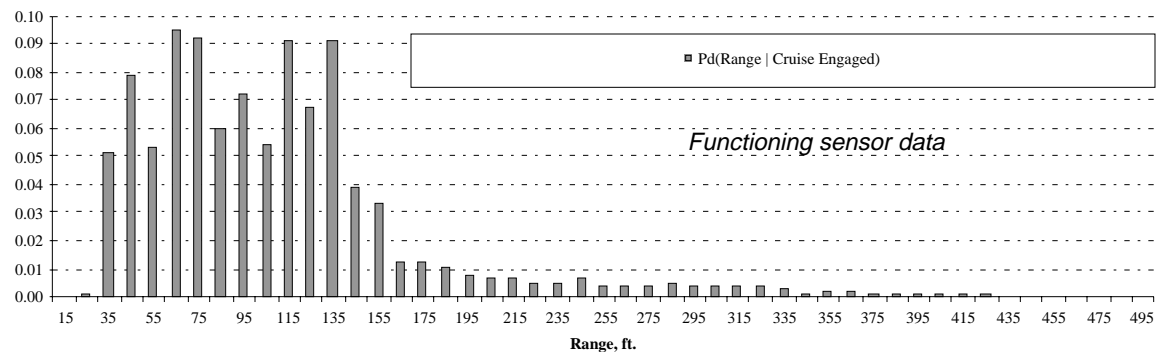

Pd(Range | Cruise Engaged); 0.2 Hrs; 1 Trips; 65.0 Most Likely Value; 110.7 Mean; 64.1 SDev.

Figure 26. Data samples from a failed and from a functioning sensors

Table 9. Trip Summary Information

Field Name	Description
AccBi	Count of brake interventions while ACC is engaged
Accel	Count of Accel button hits
AccEnable	Switch indicating if ACC or CCC is enabled
AccNe	Count of near encounters while ACC is engaged
AccOn	Count of ACC button hits
Blinded	Count of blinded transitions
Brake	Count of brake pedal applications
Cancel	Count of cancel button hits
CccBi	Count of brake interventions while CCC is engaged
CccNe	Count of near encounters while CCC is engaged
Cleaning	Count of cleaning transitions
Coast	Count of coast button hits
Concern	Count of concern button hits
Distance	Distance traveled during the trip, miles
DistanceEngaged	Distance traveled with the cruise control is engaged, miles
Downshift	Count of down shift transitions
DriverID	Driver identification number
Duration	Duration of the trip, minutes
EcuError	Count of ECU error transitions
EndAltitude	Altitude of the end of the trip
EndLatitude	Geographical latitude of the end of the trip
EndLongitude	Geographical longitude of the end of the trip
EndTime	End time of trip, days since 12/30/1899 + fraction of day
Engaged	Count of ACC engaged transitions
FileError	Count of file system error transitions
GpsError	Count of GPS error transitions
Man1Bi	Count of manual brake interventions while CCC is enabled
Man1Ne	Count of near encounters while CCC is enabled
Man2Bi	Count of manual brake interventions while ACC is enabled
Man2Ne	Count of near encounters while ACC is enabled
NetworkError	Count of network error transitions
NewTarget	Count of new target transitions
OdinError	Count of Odin error transitions
ReducedRange	Count of reduced range transitions
Resume	Count of resume button hits
Set	Count of set button hits
StartAltitude	Altitude of the start of the trip
StartLatitude	Geographical latitude of the start of the trip
StartLongitude	Geographical longitude of the start of the trip
StartTime	Start time of trip, days since 12/30/1899 + fraction of day
Stopped	Count of vehicle stops transitions
SystemError	Count of system error transitions
Tracking	Count of tracking transitions
TripID	Trip identification number
VacError	Count of VAC error transitions
ValidTarget	Count of valid target transitions
Version	DAS software version number
Vgt50	Count of velocity greater than 50 mph transitions

3.3.4 Recovery of All Data From One Driver From the Hard Disk

When a car returns to UMTRI, the on-board Ethernet network is connected to the building network and the data are transferred to the project server from both the main and the video computers.

Data Files Formats

For each trip, the DAS records and saves ten different file formats. Four of these files contain the numerical information for the trip and the other six contain the video information.

The numerical files are named using the template : Mode D D D T T T File Type.bin Where the first character is the mode, the next three indicate the driver, next three indicate the trip number, and the last is the file type. Table 10 defines the mode and file type characters. For example, a time-history file for a first week trip (trip 15) by driver 88 would be labeled M088015H.bin.

Table 10. Mode and file type descriptions

<i>Mode</i>	<i>Description</i>	<i>File Type</i>	<i>Description</i>
M	1 st week -ACC disabled	H	Time-History Files
A	2 nd -5 th week -ACC enabled	G	GPS Files
		T	Transition files
		E	Histogram files

A short description of each file formats follows.

- *GPS Files* - The GPS data are written in a time-history format to the DAS hard disk. The channels of this file include time, latitude, longitude, altitude, grade, and heading. These data are written to the file at 0.5 Hz. Typically, these files are 60KB in size. In addition to logging a complete record of the test vehicle's position, start and end latitude, longitude, and altitude, GPS coordinates for each trip are saved in a more accessible format within the histogram file type.
- *Histogram files* - The data for all the floating-point and derived histograms are saved in the histogram files. These files are between 11 and 15 KB. The histogram files also contains a trip summary table. Unlike the other DAS files, the histogram files are also transferred to UMTRI at the end of each trip via the cellular phone that is built into the DAS system. These files are then monitored as they are received to

- identify problems with the test equipment or anomalous results. Test drivers can then be contacted and appropriate measures taken to correct the problem.
- *Transition files* - The transition file format is a concise way of tracking logical events that occur relatively infrequently, such as cruise-control button pushes by the driver. Instead of recording these events in a time-history format (which can consume large amounts of disk storage space) a table containing the event name, its start time, and duration is constructed. Using this information, a time-history of the logical variable can be recreated if necessary. Transition files are typically less than 1 KB in size. (These variables are denoted by a “T” in the logged column of the tables above.)
 - *Time-History files* - With the exception of the video files, the time-history files constitute the bulk of the data storage and archive. There are thirty-six channels in each time history file (denoted by an “H” in the logged column of the tables above). For an average trip a time history file is 1.3 MB.
 - *Video files* - There are two types of video files: exposure and episode. Episodes are the capture of event-related video of 30 seconds duration. There can be from 0 to 160 episode files per driver. These files are named “0.epi” – “159.epi” and are 9.8 MB in size. Exposure files provide a brief video sample (2.5 seconds) recorded every 5 to 10 minutes¹ regardless of the operational state. This information is used to derive a regular spot-record of the highway and traffic conditions. There can be up to 420 exposure files per driver. These files are named “0.exp” – “419.exp” and are 0.8 MB in size. The episode and exposure files are never erased but their contents are overwritten. The files “director.epi” and “director.exp” are directories for these files. Finally, the “episode.log” and “exposure.log” files record a text message describing each video as it is written.

3.3.5 The Quality of GPS-Derived Range Versus Sensor Range

To demonstrate the GPS system, data were collected using two FOT vehicles driven together on the same route. The range-sensor data collected by the DAS on the following FOT vehicle was used together with the geometric distance based on the GPS latitude, longitude, altitude signals between the two vehicles to produce a “new” three-

¹ The sampling interval was eventually lowered to 5 minutes following an analysis of the trip-summary information from the first group of drivers. This approach gave a more complete picture of the driving environment for each trip and made better use of the storage capability of the hard disk on the video DAS.

dimensional, intra vehicle range signal. These two range vectors indicated very close agreement as shown in time histories of each in Figure 27.

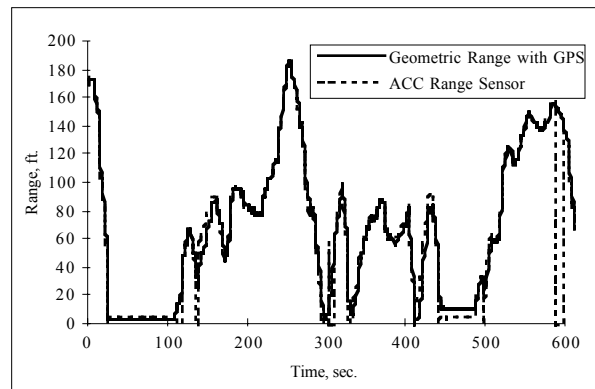

Figure 27. GPS Time history example

3.4 The Experimental Design

Following a detailed ACC orientation and instruction, accompanied by a research professional, each driver/participant first operated the assigned vehicle in the manual or conventional cruise-control modes for one week (approximately 5.5 days). While driving in either the manual or conventional cruise-control modes data from the range sensor and other transducers were collected continuously to capture the individual's normal car-following behavior, but ACC was initially disabled. The same participant then operated the vehicle for a period of one week (approximately 6.5 days) to one month (approximately 26.5 days) under manual control or using the ACC system (note, then, that conventional cruise control was not available to drivers after the first week). Use of the test vehicles by anyone other than the trained participant was strictly prohibited.

Consenting drivers operated the test vehicle in an unsupervised manner, simply pursuing their normal trip-taking behavior using our test vehicle as a substitute for their personal vehicle. Objective data in digital form were recovered periodically throughout the day from each test vehicle using cellular modem. Qualitative (subjective) information was recovered using questionnaires, exit interviews, and focus groups.

Continual monitoring of the remotely collected data permitted tracking the ACC usage and determination of the possible need for administrative intervention (for example, if the vehicle was not being used by the subject at all.) The objective data were processed to derive suitable measures of the convenience and safety-related aspects of ACC operation, relative to the manual and conventional cruise-control driving behavior of each test participant. The primary emphasis in the experimental design was on

relatively long exposures of individual lay drivers and upon a sampling scheme that roughly mirrored the population of registered drivers, but with simple stratification that reflected variables previously seen to interact with the manual-versus-ACC driving paradigm.

3.4.1 Power Analysis

The experimental design was based in part on findings from the FOCAS project [3], [4], and a series of two power analyses performed by the Center for Statistical Consultation and Research at the University of Michigan. Specifically, the independent variables of participant age and conventional-cruise-control usage were previously found to influence both objective and subjective dependent measures. Using data first from the FOCAS project (the within-class variance associated with driver age and cruise usage), the dependent measures range, range rate and velocity were used to perform a power analysis in order to estimate the number of participants (sample size) that may be required in the FOT. Power analysis determines an experiment's ability to detect treatment effects, the ability to demonstrate that a phenomenon exists if it truly does exist. The level of significance selected for the power analysis was 0.05. The initial power analysis that was based on the FOCAS data estimated that just over 180 participants would be required in the FOT.

Once the FOT began, a second power analysis was performed using data collected from the first 38 participants. In the second analysis the three modes of driving (manual, conventional cruise control, and adaptive cruise control) were added to the two previously determined independent variables (driver age and cruise usage). The dependent measures used in the analysis were range, range rate and velocity. The level of significance selected for the second power analysis was again 0.05. While the initial power analysis estimated that 180 participants would be required, the second analysis estimated that slightly more than 100 participants were required. The difference in the two estimates was associated with several differences between the first and second analyses. Specifically, the second analysis concentrated on velocities greater than 35 mph, where the first analysis considered all velocity ranges. Furthermore, the data used in the second analysis was a larger sample than the first, thereby reducing the influence of any outlying data.

3.4.2 Sampling Frame

Using the estimate from the second power analysis, the total number of participants and the experimental design were defined. Only the independent variables associated with driver characteristic (age, conventional-cruise-control usage, and duration of exposure to ACC)

were treated in the context of a controlled experimental design. Other variables such as weather, road type, and time-of-day were uncontrolled in the sense that they represented whatever situations the driver encountered in his or her normal driving pattern.

The controlled independent variables included three levels of participant age (20 to 30, 40 to 50, 60 to 70 years) two levels of conventional-cruise-control usage (rarely/never use, frequently use), and two levels associated with the duration of participation (2 weeks or 5 weeks). The gender of participants was balanced in each cell. Because giving a participant a research vehicle for 5 weeks represented a significant investment of resources, and the novelty effect associated with first-time cruise-control users was to be avoided in this duration of exposure, only participants who reported themselves a priori as being frequent cruise-control users were included in the 5-week sample. Figure 28 shows a graphical representation of this experimental design.

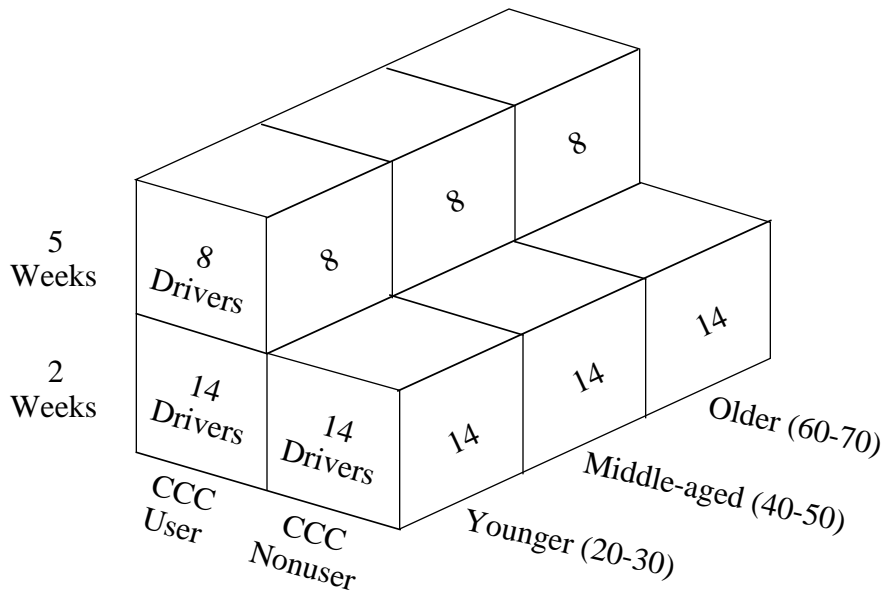

Figure 28. Graphical representation of the experimental design

3.5 Management of Test Participants

3.5.1 The Basis For Human Use Approval and Pilot Testing

Since ACC has not yet reached the maturity of a commercial product, the systems were treated as engineering prototypes. Thus, the ACC implementation in our test vehicles, and the protocols for its use, were subjected to careful preliminary testing before operational testing began.

Two phases of pilot testing were performed covering both supervised and unsupervised driving. Six volunteer drivers were included in each of the two pilot testing phases. In the supervised testing phase, participants received the standard instruction and were accompanied on a 2.5-hour route through metropolitan Detroit on interstate and state highways. During supervised testing ACC was always available to the participants. The overall scope of issues for full operational testing was scrutinized, including the performance of the ACC system, functioning of the instrumentation and remote data-recovery system, the quality of the recovered data, and details of participant recruitment and orientation methods.

The application by which approval was sought for the use of human participants in supervised pilot testing was submitted early in the contract period. Approval was received from the Human Use Review Panel (HURP), NHTSA, USDOT on the 27th of February, 1996. An application seeking additional approval from the University of Michigan was submitted to the Human Subjects in Research Review Committee (HSRRC), Institutional Review Board Behavioral Sciences Committee. Approval from the University was also received in late February 1996.

The second phase of pilot testing (unsupervised) was similar to the operational test condition in that six participants were not accompanied by a researcher. Each participant in this phase of pilot testing possessed the research vehicle for a 2-day period. Again, participants received the standard instruction. The Human Use Review Panel (HURP), NHTSA, USDOT approved the application that sought approval for the use of human participants in unsupervised pilot testing in April, 1996. An application seeking additional approval from the University of Michigan was submitted to the Human Subjects in Research Review Committee (HSRRC), Institutional Review Board Behavioral Sciences Committee. Approval from the University was received May 14, 1996. This approval also addressed full scale operational testing on the basis of the first pilot test.

3.5.2 Participant Recruitment and Screening

Participants were recruited with the assistance of the Michigan Secretary of State (Michigan's driving license bureau). A random sample of 6,000 driving records was drawn from the population of licensed drivers in eight counties in South Eastern Michigan. These eight counties included major metropolitan areas, as well as rural areas of the state (all within approximately a 1-hour drive of UMTRI).

All information obtained through the Department of State records was treated with strict confidentiality. An initial screening of driver records excluded persons on the basis of the following criteria: a) they possessed more than four (citation) points on their total driving record, b) they had more than two crashes, c) they had one crash resulting in a serious injury or fatality, and d) they had been convicted of either driving while intoxicated or under the influence of alcohol or a controlled substance.

Potential participants identified from the Department of State records were contacted through U.S. mail to solicit their participation in the field operational test. The initial contact, via postcard, did not mention the nature of the study but indicated only that participants would be asked to drive a car and would receive financial compensation for their time. Interested persons were asked to call UMTRI. A total of 443 individuals contacted UMTRI with an interest in participating. Each individual was screened by a research assistant to ensure that they met the predetermined qualifications for participation. Screening questions included the individual's age, conventional-cruise-control usage, and an estimate of the miles driven in the previous 12 months. An 8,000-mile minimum annual mileage threshold was required for a driver to qualify, with some modification of this requirement for older drivers. Individuals who met the qualifications and were needed to satisfy the experimental design, received a brief overview of the field test. The final selection of participants was dependent upon the match of an individual with a cell in the experimental design, and upon the subject's availability for taking and returning a test vehicle per the test schedule. Potential participants were further informed of any benefits or risks associated with participation. If individuals found the conditions of participation to be generally agreeable, and after a series of screening questions were answered, a specific date and time was arranged for the participant to visit UMTRI for orientation and training.

3.5.3 Participant Orientation

Each participant was required to read an information letter that outlined the study procedures, protocol, risks, and benefits (appendix D). Furthermore, participants were required to acknowledge their awareness and acceptance of these conditions by signing an informed-consent form (appendix D). Participant orientation and training began with an introduction to the research vehicle provided in an 18-minute instructional video, which was followed by a briefing provided by a researcher. The instructional video covered the three principle areas: the location of standard controls and displays on the Chrysler Concord including use of the vehicle's safety equipment (air bag, seat belt, ABS, etc), use of the vehicle's conventional cruise control, and use of the ACC system

and the field operational test. This video included comprehensive information regarding the use of both conventional and adaptive cruise-control systems.

Participants received hands-on instruction for the research vehicle and ACC system. The experimental apparatus are identified and purposes explained. Accompanied by a researcher, each participant experienced the ACC operation during the orientation drive. This was done to ensure the participant's understanding of the research vehicle and ACC-system use. The orientation drive lasted approximately 25 minutes and was conducted on a local section of state highway (in normal midday traffic). The researcher that provided the orientation was thereafter the primary point of contact for the participant should any questions or concerns arise regarding the research vehicle or ACC system. Each research vehicle was equipped with a cellular telephone that could be used by participants to contact researchers as necessary. Two researchers carried pagers, having one common number, at all times. Participants were assured of contacting a researcher, if the need arose, on a 24-hour-a-day basis.

Once participants completed the orientation and were comfortable with their understanding of the ACC system, they left with the ACC-equipped research vehicle. The scheduled date and time the vehicle was to be returned was included in materials located in the glove compartment. These materials included a copy of the instructional videotape so that participants could review the instructions for ACC-system use (as well a manual outlining all the material included in the video for persons without access to videotape players), a map of Michigan, a log book in which to make comments, emergency contact information, and a copy of the informed-consent form.

3.6 Management Of Test Vehicles

Maintenance and monitoring of the test fleet, from both the automotive and the system operation aspects, were vital to the success and safety of the field operational test. The likelihood that some drivers would treat the vehicles in less than a conservative manner, combined with the complexity of the on-board system, made the maintenance task challenging.

To have a successful study with as few unexpected problems as possible, a fairly rigorous "punch list" of items needed to be processed before a new test subject was given an FOT vehicle. The overall procedure UMTRI followed between drivers is given in Table 11. (This list is specific to the "turnaround" of each test vehicle and does not include procedures for orienting the FOT drivers.) This list also includes an estimate of the time of each task.

Table 11. General list of vehicle handling between FOT drivers

Task description	Time est., hrs.
<ul style="list-style-type: none"> • Download temperature and voltage histograms 	0.50
<ul style="list-style-type: none"> • Copy and backup all driver data (time history and video) from the vehicle DAS and load driver databases. 	4.00
<ul style="list-style-type: none"> • Record current sensor alignment (noting any misalignment that may have occurred during usage by last driver.) and realign sensors if necessary 	0.75
<ul style="list-style-type: none"> • Assess the quality of the sensor signal to anticipate sensor failures. 	0.75
<ul style="list-style-type: none"> • Replace sensors or related equipment if necessary 	1.00
<ul style="list-style-type: none"> • Perform periodic maintenance on the vehicle if necessary 	1.00
<ul style="list-style-type: none"> • Prepare and clean the vehicle for the next subject. 	0.75
<ul style="list-style-type: none"> • Verify the functionality of the ACC system and create a permanent record of the system behavior using a predefined set of driving maneuvers. 	0.75
<ul style="list-style-type: none"> • Verify that the DAS system is working correctly and reinitialize the system for the next driver 	0.75

The order of tasks shown in Table 11 was followed as closely as possible. In some cases scheduling problems made this difficult, but the goal was to do the characterization and functionality driving test last. This was done to reduce the likelihood of possible failures at the start of and during a subject’s test period. However, this did not eliminate all surprises, such as dead vehicle batteries or sudden sensor failures, and in these situations the practice was to have at least one FOT vehicle as a backup.

3.6.1 Data Downloading

The DAS and video systems were programmed to operate as FTP servers when commanded via plugging in a switch box to the configuration connector (accessible in the trunk). The dedicated Ethernet line to the project server was connected to the on-board network allowing remote download control. Table 12 summarizes the data recovery tasks.

Table 12. Data Recovery and Validation

Task	Description
Data File Transfer	Transfer the time history, GPS, transition, and histogram files
Database Loading	Load the time history, GPS, and transition files into tables within the driver database. Load any histogram files not transferred over the phone into the database.
Data Audit	Run validation queries on loaded databases. Look for missing files or trips. Compare miles driven from odometer readings to the distance traveled from the trip table.
Video File Transfer	Inspect the “log” files to determine which episode and exposure files to transfer (i.e., only those filled by this driver). Transfer the raw video episodes and exposures, directory files, and log files.
Video Renaming	Run the rename program that uses the directory files to rename the episode and exposure files (e.g., 1.epi or 123.exp) using the template DDDTTTNN.mov where “DDD” is the driver number, “TTT” is the trip number and “NN” is the episode or exposure number.
Tape Backup	Copy the raw video files to tape and archive. Copy the raw data files and the database to tape and archive.
QuickTime Movies	Run a program from networked Macintosh computers to transform the raw frame-grabbed images into QuickTime movies. This was usually an overnight procedure.
Data CD	Burn data CD with the binary files, the video directory and log files, the driver database, and the “Icc” database.
Video CD	Burn video CD(s) with movie files.
Transfer to Evaluator	Inform evaluator’s representative of any known problems with the data from this driver. Provide copies of video and data CDs

3.6.2 Sensors Check

The headway sensors used in this project are prototype sensors. As such, certain inspections and maintenance activities were required to be performed periodically to maintain the sensors’ operative status. Part of the routine maintenance activities was dedicated to the sensors. These activities included sensor alignment and sensor inspection

(by means of both software and hardware). As a result of sensor inspection, additional maintenance activities often ensued.

The laser beams from the sensors are well defined by the optical cone on the front end of the sensor. The shape of the beam is rectangular and the beam is visible using a special infrared scope. Being able to see the signature of the laser beam as it illuminated a “target” positioned in front of the vehicle, is very useful when conducting sensor alignment.

The geometry that prescribes the required orientation of the sensors is outlined in section 3.1.3. A dedicated area for sensor alignment was prepared in UMTRI, and special-purpose items were fabricated, namely,

- a quick-attachment jig with a laser-beam pointer to accurately mark the vehicle’s centerline
- a board with adjustable “targets” that could be accurately positioned (within 1 mm) both vertically and horizontally

When properly aligned, the beam signatures of the sweep and the cut-in sensors would be centered on their respective targets. Because of deviations in the exact location of the sensors across the fleet of ten cars, the targets on the aligning board had to be specially set for each vehicle. An *aligning template sheet* was prepared for each vehicle, in which the calculated position of the targets was based on the accurate location of the sensors as they were installed in the particular vehicle. Figures 29 and 30 show the signatures of the sweep and the cut-in sensors respectively (these pictures were taken using special infrared film).

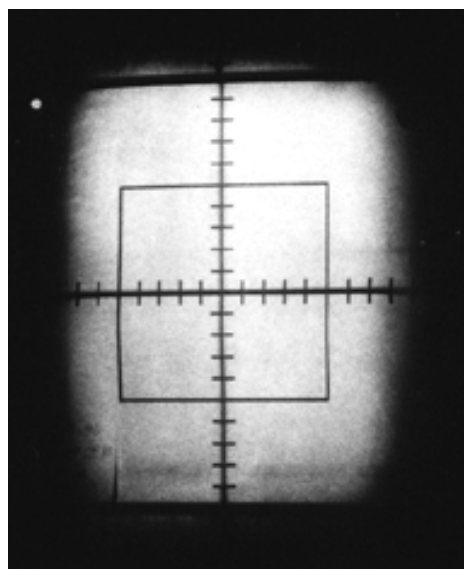

Figure 29. The sweep sensor beam centered on its target

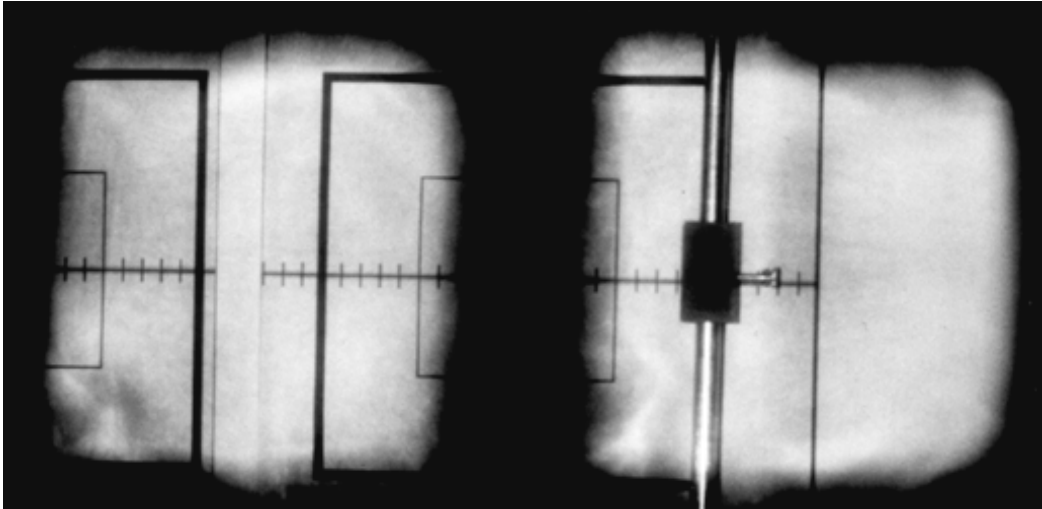

Figure 30. The cut-in sensor twin beams illuminate the aligning target

Each time a sensor was replaced, and also periodically every two months, the information on the aligning template sheets was verified by repeating the measurement of the installation geometry.

Being prototype sensors that were still in a development stage, the sensors' operative status had to be evaluated periodically by means of software diagnostic tools. The infrared beam is modulated using a mechanical component within the sensor called the *chopper*. As the test progressed it was found that, since the sensors were mounted externally, the cold temperatures of Michigan's winter affected the operation of the chopper to a point that it could cease functioning. To address this situation, ADC provided UMTRI with diagnostic tools to assess the "health" status of the chopper and help identifying those choppers whose performance might be deteriorating. The graphic display in the top part of Figure 31 on the next page shows the signature of a healthy chopper, and the bottom part depicts a chopper that failed shortly thereafter. Furthermore, the system was capable of self-detecting a failed sensor, in which case the HMI would display an error code to driver.

In addition, the sensor's software employs over 40 parameters which had to be verified periodically, and the overall sensor performance characteristics had to be ascertained. For that purpose an *acceptance protocol* was established by ADC which included a list of about 30 measures, with pass/fail values for each measure.

During each predelivery procedure (see Table 11 on page 60), sensor-related activities were performed. These activities included checking the alignment, recording the results, and correcting as needed. Almost each time that the alignment was checked,

the 30 measures of the acceptance protocol and the 40 sensor parameters were also validated.

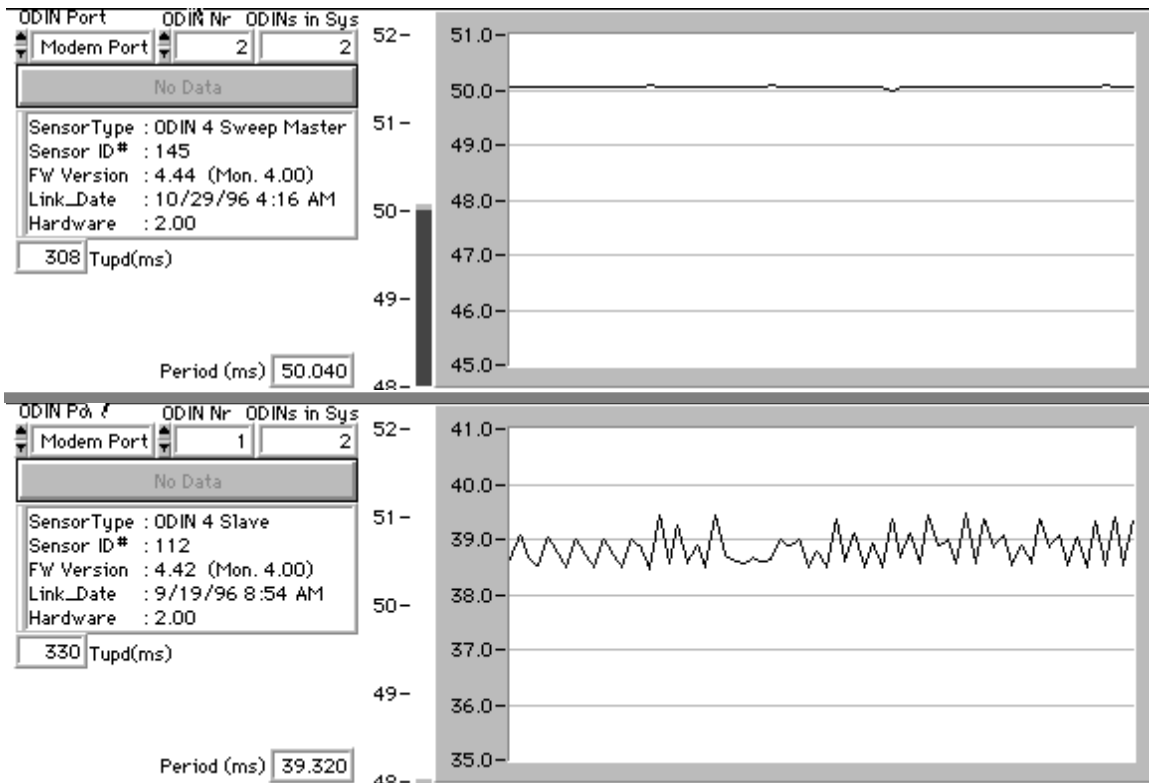

Figure 31. Chopper data analysis

3.6.3 Functionality Check

The functionality check consisted of more than driving the FOT vehicle. A check list of pre- and posttest tasks helped ensure that each FOT vehicle went into the field in a suitable state of readiness. Table 13 below summarizes all the checks done to each FOT vehicle before and after the driving test was performed. The driving test is outlined below. For a complete analysis of the vehicle and ACC system characterization see section 3.2.4, appendix E, and also [5], [6].

Table 13. Pre- and postfunction test check list.

Pretest	
Video Software	Update exposure video software. Exposures for 5-week drivers were taken every 10 minutes; 2-week drivers every 5 minutes.
Download Verification	Verify that the previous driver's electronic data (both time history and video) has been downloaded from the vehicle.
DAS Inspection	Inspect the DAS to ensure that it has been properly enclosed within its thermally stabilized chassis.
Vehicle Inspection	Walk-around inspection of the vehicle and its undercarriage.
System Countdown	Start the vehicle and verify the startup 10-second countdown. The countdown allowed more time for the system's yaw-rate gyro to stabilize and also any temporary sensor or communication errors to be cleaned up. ² .
Posttest	
download data	Connect the DAS to the network server and download all files created during the functionality test.
re-initialize the video	Download an episode video and delete all video directory files.
driver number and fuse date	Enter the next driver number and set the fuse date that indicates when to switch from CCC to ACC during the test.
exposure time	Verify that the exposure videos are being taken at the correct time interval.
load database	Load the time history, GPS, transition, and histograms files into tables within that vehicles characterization database.
verify data	Inspect the tables to verify that the main computer of the DAS is recording all the test results.
verify video	Transfer a 30-second episode video to a QuickTime movie and view for image quality, focus, exposure, and camera direction.
clean-up video drive	Delete the video logs and directory files.
clean-up data drive	Verify that data from the previous driver has been copied and backed up before deleting data files from the main computer to free up storage space for the next driver.
re-build video directories	Run the vehicle for at least five minutes to allow video directory files to be rebuilt.
test cell-phone	Turn off vehicle and verify cell phone connection and data transfer.
Label Vehicle with driver number and fuse date	Put a sign in the vehicle's window indicating that the vehicle is now ready for the indicated driver and should not be driven until the test subject is ready to take the vehicle.

² Early in the study it was found that temporary errors would display on the human-machine interface. It was felt that these may confuse drivers and cause unnecessary restarts so a countdown was introduced to reduce the display of these errors and provide additional time for the yaw-rate gyro to stabilize and the DAS to initialize.

The driving test took place on a 15-mile route that included an arterial and an interstate highway near UMTRI. The purpose of the test was a) to verify that the ACC system worked correctly, and b) document the performance of the vehicle for future reference. Figure 32 shows a GPS map of the route used for this test. This is an actual plot of the GPS longitude and latitude coordinates from one of the tests. (To keep the figure as simple as possible the axis labels have been eliminated.) In general the legend indicates the type of road and the type of test that was done before an FOT vehicle was given to a subject.

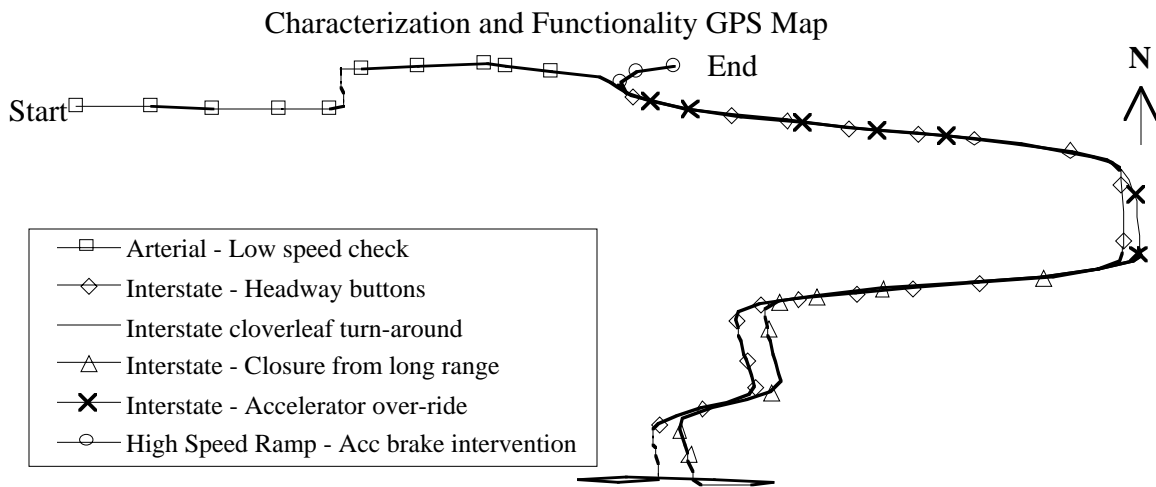

Figure 32. GPS route for functionality driving test

Some of the tests outlined below involve a second, confederate vehicle. Typically, the best candidate for this vehicle was a heavy truck. Trucks made good targets not because of their larger size but due to other characteristics, such as: a) they travel at consistent speeds, b) they tend to not change lanes and, c) they are not likely to exit on the local ramps (thus prematurely interrupting a test).

The tests were performed during light traffic times (i.e., avoiding early morning and late afternoon rush hour) and when weather conditions were good and roads were dry.

Low-speed check

The first test took place on an arterial road leading to the highway near UMTRI. This test, called a low-speed check, simply made sure that the system would automatically disengage when the vehicle speed went below the cut-off velocity (approximately 25 mph). It also verified that the system would not engage (using both the set and resume buttons) below the cut-off velocity.

Headway buttons

This test involved switching between the three user-selected headway buttons. The test was performed on the southbound portion of the interstate and required the most time and distance of all the tests. After finding a confederate vehicle, the ACC was engaged using a set-speed well above the speed of the target vehicle. The test started by selecting either a 1.0- or 2.0-second headway and allowing the vehicle to reach a steady-state condition. After approximately 15 seconds of steady-state following, the middle, 1.4-second, button was selected. Then after the vehicle reached a steady-state following condition at this headway time, the remaining headway button was selected and a steady-state condition maintained. Finally, the driver selects the button used at the beginning of the test and allows the vehicle to return to the original headway time.

Closure from long range

The closure from long range test was difficult to perform on all driving tests. It required a long stretch of open highway and a relatively slow moving target. (In some cases an open stretch of highway could be found but excessive speeds were required to close in on a distant target within the time and distance of the test route. At other times there was just too much traffic. In these cases, the test was not performed.) Also complicating this test was the entering and exiting of local traffic along the test route. However, there was one section of northbound interstate where the conditions for this test were more likely. For this test a 1.4-second headway button was selected and the ACC system was engaged with a relatively high set-speed (typically 70 to 76 mph). The test starts with the target vehicle beyond the maximum range (approx. 400 ft) of the ACC sensor. The FOT vehicle was then allowed to acquire, close in, and reach a steady-state following condition behind a target vehicle. The steady-state condition was maintained for approximately 15 seconds before the test finished.

Manual override

In the manual override test, the driver engaged the ACC system using the 1.4-second headway button and reached a steady-state following condition behind an impeding vehicle. Then using the accelerator pedal the driver slowly closed in on the target until the ACC system commanded a transmission downshift at which point the accelerator pedal was released. The FOT vehicle was then allowed to separate from the target and return to a steady-state following condition.

ACC brake Intervention

The ACC brake intervention helped verify the video capture and triggering mechanisms. At the end of the functionality test the driver simply did an aggressive ACC brake intervention on the interstate exit ramp. The level of deceleration caused a video episode event to be triggered such that a 30-second video was taken. This video was then viewed in the posttest checkout to verify that the DAS and video system were operating satisfactorily.

Other activities

In addition to the maneuvers outlined above, the driving test also verified other aspects of ACC system functionality. Namely, all the standard cruise-control buttons were pressed and ACC-commanded transmission downshift and activation of the brake lights were tested. Finally, during the test an effort was made to assess the quality of the sensor alignment by passing other vehicles and moving laterally within the driving lane in an effort to acquire vehicles in the adjacent lane.

3.6.4 Vehicle Maintenance

Vehicle maintenance encompassed efforts by UMTRI staff and work performed by an authorized Chrysler service shop. The maintenance task was carried out through three subtasks, as follows:

- home-base inspection — Each time a test vehicle was brought back to UMTRI between subjects, it was thoroughly checked. A comprehensive checklist was prepared and evaluated to ensure the safety, readiness, and functionality of all automotive systems
- OEM maintenance — Needed repairs and periodic maintenance per the manufacturer-recommended schedule were to be performed by an authorized Chrysler service shop in Ann Arbor, Michigan. From the standpoint of service, the test fleet was quite unique. That is, expensive equipment items and new wiring had been installed throughout the vehicle, and OEM equipment had been modified (e.g., wired access to the engine controller, new transmission software, etc.). For these reasons, one dedicated point of Chrysler service was selected—a dealer who agreed to assign dedicated maintenance personnel who were acquainted with the special nature of our vehicles. The intention was that the fleet would be serviced only by the selected dealer unless road emergencies necessitated other arrangements.

3.6.5 Preparation for the Next Driver

Upon the return of an FOT vehicle to UMTRI, each car was thoroughly inspected and prepped prior to being sent out with another participant. Log-in mileage was recorded and any personal effects that the driver left in the car were collected and the driver was promptly notified. Fluid levels were checked and filled as needed. The exterior and the interior of the car were cleaned. The trunk was checked for the cellular phone and phone manual. The following items were checked and replaced if they were found to be missing from the glove compartment: the car's owner's manual, the FOT instructional video and written supplement, a log book and pen, and a Michigan map. Finally, the tire air pressure was checked and adjusted if necessary.

3.7 Operational Issues Leading To Modifications

The field operational test was conducted over a period of 14 months, which were preceded by 10 months of intensive preparation. Given the time, the amount of the precursory tasks, and the nature of the test, it became clear that all operational issues could not be forecasted, and that modifications would become inevitable. Appendix F lists the various versions of the different system components, and also the corresponding implementation dates and the drivers affected. This section describes the operational issues that surfaced during testing, and the modifications that ensued.

3.7.1 System Modifications

System modifications included changes to the sensor software, the control algorithm, and the data-acquisition system. The sensor software involves proprietary code that was provided by ADC. The algorithm and the data acquisition were developed by UMTRI, the details of whose modifications are provided herein.

Control Algorithm and Sensor Software Changes

A detailed list of the algorithm versions is provided in appendix F. Versions prior to 9.17 were used only in the pilot testing and the development stages. Version 9.18 through version 9.27 were developed primarily to address the following issues:

- ensure better startup sequence of the system
- minimize premature downshifting and slowdown beginning at excessive range
- correct for potential confusion of the driver regarding the engagement state of the system
- improve fidelity of the data signals that the algorithm sends to the DAS
- minimize unexplained disengagements of the system

- provide better feedback to driver when system failure occurs

The sensor software was modified by ADC to correct for false target detections under certain peculiar conditions, and to improve the reliability of the chopper.

Data-Acquisition Software Changes

Table 14 summarizes the changes made to the data-acquisition software. The trip table contains a field called “Version” that documents the version of the DAS software used for each trip.

Table 14. DAS Software Changes

Version 1 to 2	Changed Source of velocity channel to new filtered velocity (created in VAC to prevent system dropouts).
Version 2 to 3	Removed 1.6 second error in synchronization of video computer. Added distance channel to time history. Added 20-second moving average of backscatter to get rid of near encounter episodes caused by “spray targets.” Changed video exposure interval from 10 minutes to 5 minutes. Fixed reporting of network error problem in “e” file.
Version 3 to 4	Changed maximum number of exposures from 400 to 420. Fixed problem with episode prioritization when disk is full (the most severe episodes were not always saved). Created two versions of video software: 5-min exposure intervals for 2-week drivers and 10-min exposure intervals for 5-week drivers.

3.7.2 Wintertime Issues

It was known from the beginning that snow, rain, and ambient moisture could inhibit the sensor’s ability to perform (see discussion in section 3.1.1). The initial design incorporated a feature for disabling the system in rain and fog based on backscatter information from the sensor. However, shortly after winter started and operation under snowy conditions commenced, it became evident that snow-related issues could not be addressed by backscatter.

The sensors were mounted outside, in the vehicle’s grill (see Figure 17). Under snowy conditions, they would become covered with snow, sleet, and ice quite rapidly. This type of opaque cover, however, would seldom make the backscatter reading go high enough to trigger system shutdown such as occurs under strong rain or fog conditions. It

is possible that a different installation method or location would have enabled a better automatic identification of snow- or ice-covered sensors. A different design of the protective Plexiglas cover, for example, could contribute to such automatic detection. That type of activity, however, was beyond the scope of the field test and, hence, was not fully explored.

The outcome of a blinded, snow-covered sensor would often be an ACC-equipped vehicle that acts just like a standard CCC-equipped car: It does not respond to slower-moving vehicles. The driver then needs to realize the situation and act accordingly by taking control and disengaging the system. Once the problem has been identified by the research team, drivers were warned and instructed not to operate the system under snow or ice conditions. An amendment to the participant instruction for wintertime use of the ACC system stated the following:

Because snow and salt-spray “blind” the sensors, we do not want you to drive with Adaptive Cruise Control if it is actively snowing OR if the temperature is below 45 F AND the roads are predominantly wet. The sensors will be unable to track vehicles and the system will not decelerate in response to slower moving vehicles. The car is safe to drive in the snow and when the roads are wet or slushy. We just do not want you to drive using Adaptive Cruise Control under these conditions. Please remember the following:

- *Again, do not drive using Adaptive Cruise Control if it is snowing or if the temperature is below 45F and the roads are predominantly wet.*
- *The sensors are cleaned whenever you clean the windshield. Please clean the windshield each time that you start the car and before driving away. A good time to do this is during the system countdown.*
- *Under no circumstances do we want you to pull off the road to clean the sensors. If the system is not performing properly, and you suspect that the sensors are dirty, try cleaning the windshield. If this does not resolve the problem, wait until you are at a gas station or until you arrive at your destination to check the sensors.*
- *Adaptive Cruise Control is a convenience feature and not a collision avoidance system. You are to be in control of the vehicle at all times.*

At the same time we sought to fix the problem.

After consulting with ADC and conducting various measurements under snowy conditions, we concluded that the backscatter signal could not be used to indicate with any degree of certainty that the sensor is covered with snow or ice. A solution for removing the blocking layer (ice or snow) from the sensors, however, was successfully devised. Jet sprays similar to those used in windshield washers were installed, together with specially fabricated containers for storing a quantity of washer fluid, and drivers were instructed about washer activation.

4.0 Contents of the Data Set

To facilitate the exchange, validation, and analysis of the FOT data, all nonvideo information on vehicles and participants was loaded into a commercial database format (Microsoft Access). The term “Archived ACC FOT Database” refers to a logical or conceptual data set, not to a single database file. The database files for each individual driver were burned on CDROM and delivered to the evaluator’s on-site representative usually within a week of each car’s return. A second “UMTRI ACC FOT Database” was developed from the same files by reorganizing and recombining the original database files to optimize query development and execution. Finally, this reorganized database has been augmented with new tables as new processing methods have been developed.

4.1 Archived Database

The archived data base consists of one “subjects.mdb” database, 108 “driverxxx.mdb” database files, and 108 “Iccxxx.mdb” database files. “xxx” is a placeholder for the driver number (i.e., driver001.mdb). These databases are fully described in appendix A.

4.1.1 Subjects.mdb Database

All subject information is contained in the “Subjects.mdb” database. The four main tables are listed in Table 15. All tables are keyed by the “DriverID” field (a unique number assigned in chronological order from 1 to 117). (Please note that 117 individuals became engaged as drivers in this field test, although the data from only 108 of them was finally identified as the valid test sample.) The information in these tables comes from the questionnaires described later in Section 4.4.

Table 15. Subject Database Tables

DriversMain	Sanitized version of driver biographical information
DrivingStyleQuestionnaire	Driving style questionnaire results
MBti	Meyers-Briggs Type Inventory
PQv2p0	ACC System Questionnaire

4.1.2 DriverXXX.mdb Database

The bulk of the FOT data is contained in the 108 driver databases. Figure 33 on the next page shows a block diagram of the conversion from binary files to tables in the

database. Each binary file (e.g., A002055H.bin) is written to a table (A002055H) with the same name. The driver database contains three tables (G, H, and T) for each trip.

An Access form (including embedded VisualBasic code to read the binaries) as shown in Figure 34 was used to load the driver databases. The driver databases average 154 Mbytes in size and vary from 38 Mbytes for a 2-week driver who drove 234 miles to 596 Mbytes for a 5-week driver who drove 5,572 miles.

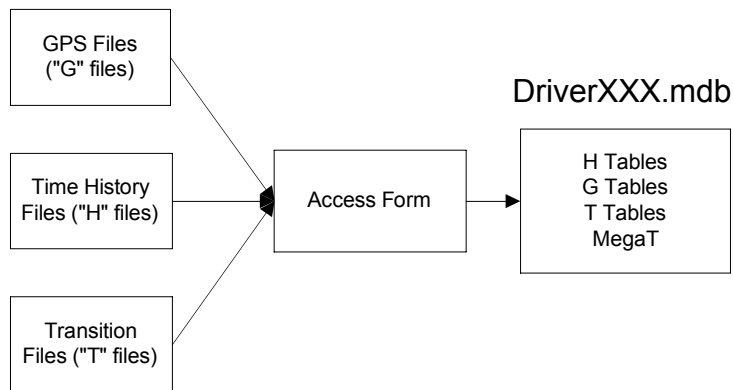

Figure 33. Driver Database Loading

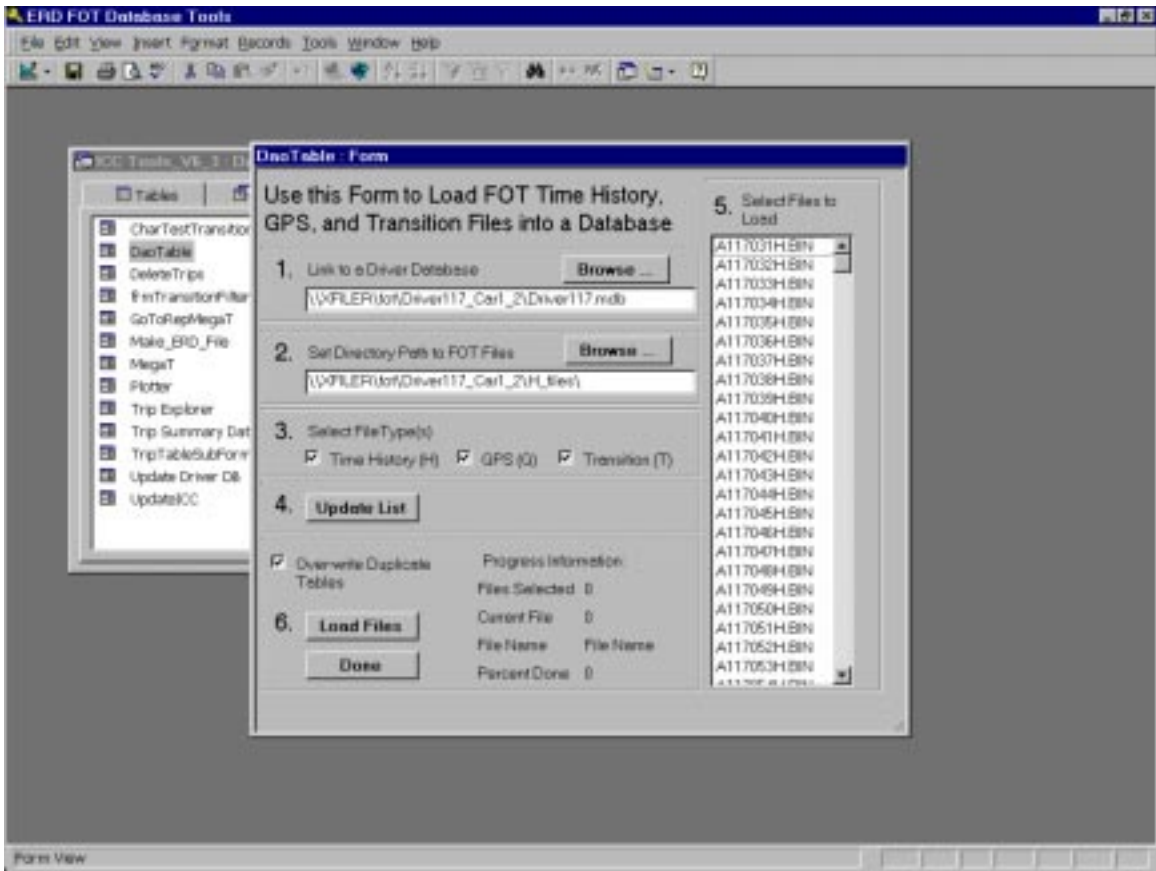

Figure 34. Driver database form

Table 16 lists the fields in the “H” tables. These tables are indexed by the “Time” field (for drivers 39-117). They are loaded in chronological order at a nominal sampling rate of 10 records per second. These channels were defined in section 3.3.2.

Table 16. “H” Table Channels

AccFollowing	AccMode	AverageDNearEncounter
AverageVDot	Backscatter	BackscatterWarn
Brake	CDot	Closing
Cutin	Date/Time	DecelAvoid
DegreeOfCurvature	Distance	DNearEncounter
DScore	Following	HeadwayTimeMargin
Near	NewTarget	Range

RDot	Separating	Thpt03
Throttle	TimeToImpact	Tracking
TScore	VacTime	ValidTarget
VCommand	VDot	Velocity
Vp	VpDot	VSet

Table 17 lists the fields in the “G” tables. These tables are indexed by the “GpsTime” field (for drivers 39-117). They are loaded in chronological order at a nominal sampling rate of two records per second.

Table 17. “G” Table Channels

Grade
Heading
Latitude
Longitude
GpsTime

The transition, or “T”, tables are organized to record state transitions of logical variables. A channel appears in the table only on a false-to-true transition. Table 18 shows an example “T” table for an ACC trip. Table 19 lists the names corresponding to the values in the “ChannelID” field. The “Time” value used in all of the FOT tables is a double precision real number where the number to the left of the decimal point is the number of days since December 31, 1989 (i.e., 1 is January 1, 1990) and the fractional part is the fraction of the day (e.g., .5 is noon). The time is not local but UTC or Coordinated Universal Time. The first time in Table 18, 35697.8788800926, corresponds to **September 24 1997 21:05**. For ChannelIDs from 200 to 210 the third column is the duration that the channel was true (e.g., the third row shows the ACC turned on for 730.68 seconds). Channels 300 to 308 are by definition, 15 seconds long and so the third column records the importance of the event (e.g., the second row shows a manual second-week brake intervention with a peak AverageVDot of .176 g’s).

Table 18. Example transition table

Time	ChannelID	Duration or Importance
35697.8788800926	209	2088.98
35697.8888925926	304	0.1758168
35697.8903489583	200	730.68
35697.8924773148	308	0.3242722
35697.8938149306	304	0.2884986
35697.8942534722	207	260.63
35697.8942534722	201	0.1099999
35697.8985337963	304	0.2090617

Table 19. “T” Table Channels

ChannelID	Name	ChannelID	Name
200	AccOn	210	HeadwayLong
201	Set	300	Concern
202	Coast	301	AccBi
203	Resume	302	CccBi
204	Accel	303	Man1Bi
205	Cancel	304	Man2Bi
206	Downshift	305	AccNe
207	Engaged	306	CccNe
208	HeadwayShort	307	Man1Ne
209	HeadwayMedium	308	Man2Ne

After all the “T” tables were loaded, a new “MegaT” table was constructed by adding “DriverID” and “TripID” information to each transition and appending all transitions into one table.

4.1.3 ICCXXX.mdb Database

Figure 35 shows the process of loading the “E” files into an “ICC” database. The “E” files include the trip summary information and histograms that were sent to the server via cellular phone. About four times a day, the program illustrated in Figure 36 was run to load the files into their appropriate “ICC” database. These new data were then examined to check for proper operation of the DAS and ACC subsystems.

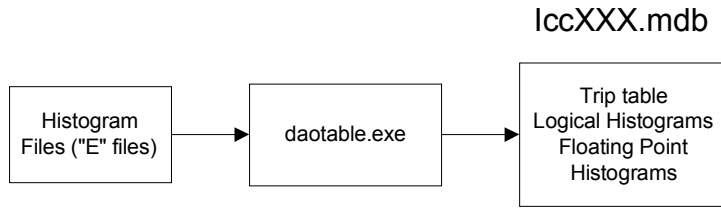

Figure 35. ICC Database Loading

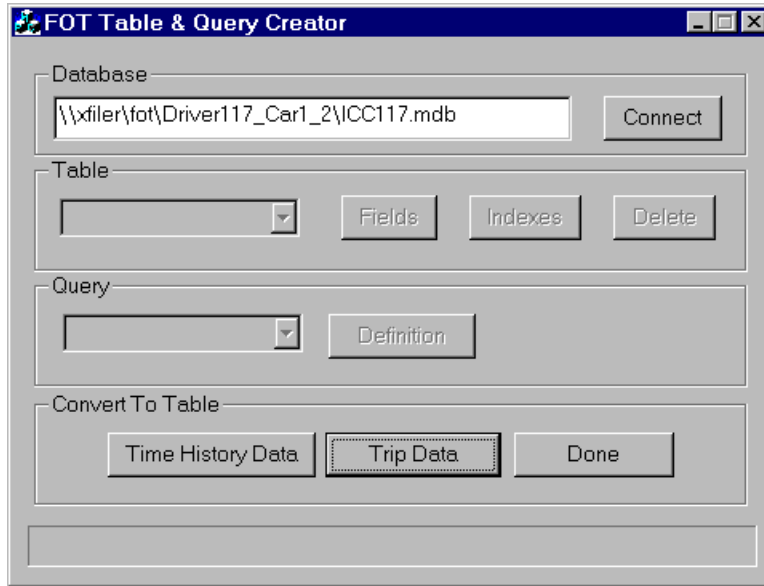

Figure 36. ICC Loading program

Tables 20 and 21 on the next page list the floating point and logical-histogram table names. The histogram tables with a sorting channel are keyed by “DriverID”, “TripID”, and sorting channel (e.g., “Engaged”). The remaining tables are keyed by the “DriverID” and “TripID” fields. The “ICC” databases average 2.5 Mbytes in size.

Table 20. Floating Point Histogram Tables

BackScatterFhist	CDotFhist	DecelAvoidFhist
DegOfCurvatureFhist	DScoreFhist	FlowFhist
HindranceFhist	HtmFhist	RangeFhist
RangeFollowingFhist	RangeVgt35FhistV	RDotFhist
RDotVgt35Fhist	Thpt03Fhist	ThrottleFhist
TimeToImpactFhist	TrackingErrorFhist	TScoreFhist
VCommandFhist	VDotFhist	VDotVgt35Fhist
VehnessFhist	VelocityFhist	VelocityVgt35Fhist
VpDotVgt35Fhist	VpFhist	VSetFhist

Table 21. Logical Histogram Tables

AccFollowingLhist	AccTrackingLhist	BackscatterWarnLhist
BlindedLhist	BrakeLhist	CleaningLhist
ClosingLhist	CutinLhist	DScoreRegionLhist
FollowingLhist	LVpDotLhist	NearLhist
NewTargetLhist	ReducedRangeLhist	SeparatingLhist
TrackingLhist	TScoreRegionLhist	ValidTargetLhist
ValidTargetVgt35Lhist	ValidTargetVgt50Lhist	

4.2 Reorganized & Augmented Databases

The database design of the archived data described above was optimized for prompt delivery and not for ease of analysis. Section 4.2.1 describes how the data were reorganized and placed on the FOT server to enable all team members to access and query the same data set. Section 4.2.2 describes some of the new data derived from additional processing.

4.2.1 Database Reorganization

All of the ICCXXX.mdb database information for each driver was combined into a master database called IccMaster.mdb. A master transition table for all drivers was created and called MegaT.mdb. In addition, the H tables and G tables were combined into

master tables. New values of V_{dot} and V_{pDot} were computed using differentiation algorithms that employ future as well as past values of stored data.

4.2.2 Database Additions

The reorganized database was processed to provide new information as indicated in Table 22.

Table 22. Database additions

Database	Description
Brake	table of braking events
Button	accel, decel, and headway time records
Disengagements	type and condition of disengagement circumstances
Engagements	type and condition of engagement circumstances
Gps	home and work coordinates.
Streams	driving situations, e.g., closing, cut-in, following, etc.
Video	episode and exposure tables

4.3 Invalid Data and Known Anomalies

The InvalidTrips table in the IccMaster database contains at least one record for each trip reported by the DAS via the cellular phone. If no problems were reported for the trip, an InvalidCode of “0” is recorded. Table 23 on the next page shows the codes and corresponding trip information. The codes are not mutually exclusive. For example, a trip with a sensor error could have two entries in the invalid trips table: one with a value of “4” and one with a value of “8.”

Figure 37 on the next page illustrates a sensor anomaly commonly found when an ACC car is following a vehicle on a wet road. The lead car is approximately 110 feet ahead of the ACC car. Some of the time the sensor reads the correct range but often the spray becomes a “target” and the sensor reports a range of about 15 feet. For the first 38 drivers, this anomaly would have generated a near encounter video. A moving average (20 seconds) of backscatter threshold of 10 was added to the triggering logic to prevent videos of these events. Trips with many of these false near encounters were marked with the invalid code of “6” as shown in Table 23.

Table 23. Invalid data summary

InValid Code	Description	Number of Trips	Hours	Miles
0	Valid Trip	11,092	3050.9	114,083.6
1	EcuError	384	54.7	1,037.2
2	Phantom target	1	1.8	119.9
3	Invalid counts in a histogram	1	0.3	5.1
4	Driver had a sensor error	86	36.7	2,006.7
5	Malfunction of the headlight switch	68	18.5	678.0
6	More than 10 near encounters and BS >60	73	130.1	7,786.6
7	Cancel button counts during manual driving	1	0.2	4.8
8	OdinError	86	38.8	1770.9
9	Zero length trip	56	0	0
10	Negative duration	7	0	0
11	Nondesignated driver trip	3	9.2	426.5
12	Valid trip but computer malfunction	2	4.6	265.9
13	Invalid trip due to computer malfunction	35	0.3	4.5
14	Backscatter > 1023 per form in BS database	26	5.5	189.7
15	E-Box error	47	12.9	458.6
16	Removed due to inactivity	81	21.7	846.2
17	Removed due to too many drivers in cell	151	46.3	1665.0
18	VpDot has excessive negative counts	2	1.91	98.3

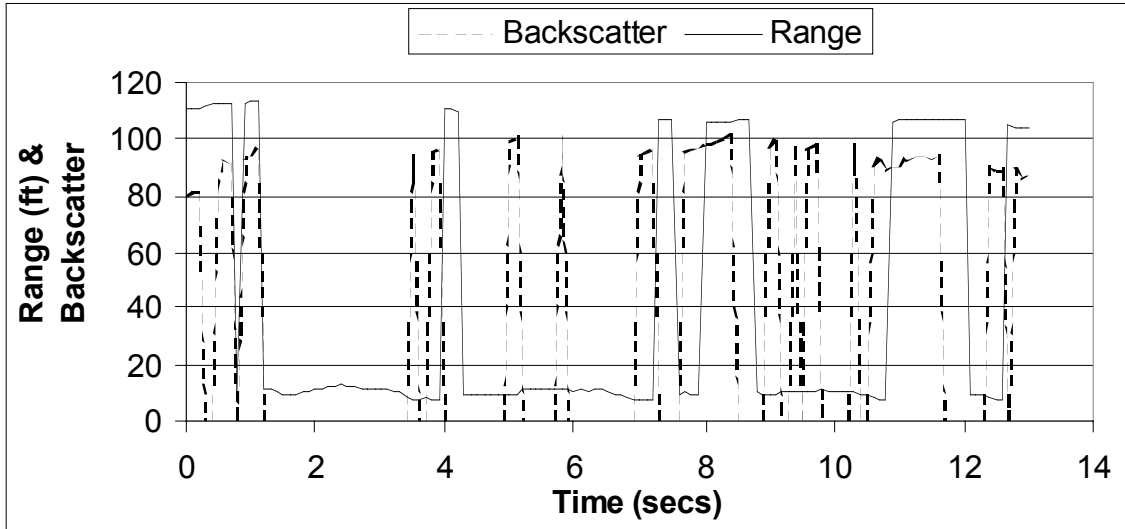

Figure 37. Spray targets

4.4 Driver Related Data

4.4.1 Summary of Driver Biographic Data

Biographical (background) information was collected from each of the participants (see Table 24 on the next page). This information, in addition to the participant's complete driving record as provided by the Michigan Department of State, Secretary of State's Office, was cataloged in the subject.mdb database according to participant number. Table 25, which spans the next few pages, provides some summary information for each of the 108 participants, including their age, gender, conventional-cruise-control usage, the duration of their participation, miles driven in the 12 months prior to participation, and city in which they lived. A visual depiction of the geographic distribution of the participants is provided in Figure 38 below. The mean and standard deviation of participant age for each of the three age groups are provided in Table 26. Table 27 provides the mean miles driven in the 12 months prior to participating in the ACC FOT by participant group.



Figure 38. Geographic distribution of the participants

Table 24. Biographical information form

Background Questionnaire

First Name _____ Last Name _____

Home Address _____

Work City _____ State _____ Zip _____

Home Phone _____ Best time to reach you at home _____

Work Address _____

Work City _____ State _____ Zip _____

Work Phone _____ Times at work _____

Occupation _____ Date of Birth _____

Social Security Number _____ Driver's License Number _____

How long have you been driving? _____

Year/Make/Model of the vehicle that you are currently driving _____

Your average highway speed _____

The average miles per trip (Please consider all of the driving that you do. A trip is defined from when you start you car until you turn off your car at your destination i.e. not a round trip) _____

The total number of miles that you drove last year _____

Of the miles that you drove last year, what percentage of the miles were traveled on:

rural roads? _____

city roads? _____

highways? _____

100%

The number of moving violations that you have had in the past 12 months? _____

Gender _____ Male _____ Female

Smoker _____ Yes _____ No

Do you wear contacts or glasses? Yes No

When you drive on the highway, how would you describe your cruise control usage? Would you say that you use cruise control;

Never or rarely Frequently

Table 25. Summary of Driver Data

Sort Count	Driver ID #	Age	Gender	Cruise Usage	5 week?	Miles Traveled Last Year	Home City
1	27	20-30	Female	Nonuser	FALSE	20000	Novi
2	31	20-30	Female	Nonuser	FALSE	15000	Detroit
3	38	20-30	Female	Nonuser	FALSE	10000	Ann Arbor
4	39	20-30	Female	Nonuser	FALSE	15000	Trenton
5	44	20-30	Female	Nonuser	FALSE	20000	Westland
6	45	20-30	Female	Nonuser	FALSE	12000	Grosse Pointe
7	49	20-30	Female	Nonuser	FALSE	10000	Fowlerville
8	4	20-30	Male	Nonuser	FALSE	10000	Ypsilanti
9	41	20-30	Male	Nonuser	FALSE	30000	Detroit
10	63	20-30	Male	Nonuser	FALSE	20000	Beverly Hills
11	93	20-30	Male	Nonuser	FALSE	3000	Ann Arbor
12	98	20-30	Male	Nonuser	FALSE	30000	Farmington Hills
13	109	20-30	Male	Nonuser	FALSE	20000	Southfield
14	114	20-30	Male	Nonuser	FALSE	15000	Ypsilanti
15	10	20-30	Female	User	FALSE	15000	Redford
16	15	20-30	Female	User	FALSE	16000	Farmington Hills
17	30	20-30	Female	User	FALSE	9000	Leslie
18	42	20-30	Female	User	FALSE	15000	Ann Arbor
19	50	20-30	Female	User	FALSE	17000	Detroit
20	51	20-30	Female	User	FALSE	30000	Ann Arbor
21	52	20-30	Female	User	FALSE	13000	Troy
22	33	20-30	Male	User	FALSE	40000	Dexter
23	37	20-30	Male	User	FALSE	17000	Dearborn Heights
24	54	20-30	Male	User	FALSE	18000	Jackson
25	59	20-30	Male	User	FALSE	15000	Northville
26	60	20-30	Male	User	FALSE	16000	Ann Arbor
27	61	20-30	Male	User	FALSE	30000	Pontiac
28	64	20-30	Male	User	FALSE	15000	Northville

29	1	40-50	Female	Nonuser	FALSE	375	Pontiac
30	23	40-50	Female	Nonuser	FALSE	7000	Grass Lake
31	25	40-50	Female	Nonuser	FALSE	8000	Detroit
32	26	40-50	Female	Nonuser	FALSE	10000	Bloomfield Hills
33	29	40-50	Female	Nonuser	FALSE	12000	Grosse Pointe Woods
34	80	40-50	Female	Nonuser	FALSE	18000	Novi
35	84	40-50	Female	Nonuser	FALSE	12000	Temperance
36	34	40-50	Male	Nonuser	FALSE	15000	Grosse Pointe Park
37	75	40-50	Male	Nonuser	FALSE	23000	Saline
38	94	40-50	Male	Nonuser	FALSE	10000	Royal Oak
39	102	40-50	Male	Nonuser	FALSE	19000	Berkley
Sort Count	Driver ID #	Age	Gender	Cruise Usage	5 week?	Miles Traveled Last Year	Home City
40	111	40-50	Male	Nonuser	FALSE	30000	Macomb
41	112	40-50	Male	Nonuser	FALSE	20000	Brighton
42	117	40-50	Male	Nonuser	FALSE	18000	Plymouth
43	5	40-50	Female	User	FALSE	15000	Ann Arbor
44	6	40-50	Female	User	FALSE	20000	Brighton
45	8	40-50	Female	User	FALSE	25000	Brighton
46	9	40-50	Female	User	FALSE	40000	Howell
47	12	40-50	Female	User	FALSE	25000	Canton
48	21	40-50	Female	User	FALSE	49999	Grosse Pointe Farms
49	24	40-50	Female	User	FALSE	20000	Jackson
50	3	40-50	Male	User	FALSE	10000	Saline
51	14	40-50	Male	User	FALSE	16000	Clinton Township
52	17	40-50	Male	User	FALSE	16000	Trenton
53	22	40-50	Male	User	FALSE	15000	Royal Oak
54	35	40-50	Male	User	FALSE	19000	Troy
55	74	40-50	Male	User	FALSE	12000	Lincoln Park
56	105	40-50	Male	User	FALSE	35000	Saline
57	43	60-70	Female	Nonuser	FALSE	5000	Lake Orion
58	46	60-70	Female	Nonuser	FALSE	5300	Oak Park
59	82	60-70	Female	Nonuser	FALSE	4000	Madison Heights
60	83	60-70	Female	Nonuser	FALSE	5000	Birmingham
61	91	60-70	Female	Nonuser	FALSE	12000	Rochester Hills
62	95	60-70	Female	Nonuser	FALSE	7000	West Bloomfield
63	106	60-70	Female	Nonuser	FALSE	10000	Northville
64	103	60-70	Male	Nonuser	FALSE	30000	Ann Arbor
65	107	60-70	Male	Nonuser	FALSE	20000	Ann Arbor
66	108	60-70	Male	Nonuser	FALSE	8000	Ann Arbor
67	110	60-70	Male	Nonuser	FALSE	20000	Clarkston

68	113	60-70	Male	Nonuser	FALSE	20000	Sterling Heights
69	115	60-70	Male	Nonuser	FALSE	20000	Rochester Hills
70	116	60-70	Male	Nonuser	FALSE	15000	Oak Park
71	13	60-70	Female	User	FALSE	15000	Lansing
72	48	60-70	Female	User	FALSE	32000	Livonia
73	57	60-70	Female	User	FALSE	15000	Brighton
74	65	60-70	Female	User	FALSE	5000	Monroe
75	67	60-70	Female	User	FALSE	20000	Ann Arbor
76	69	60-70	Female	User	FALSE	12000	Dearborn Heights
77	72	60-70	Female	User	FALSE	10000	West Bloomfield
78	7	60-70	Male	User	FALSE	24000	Brighton
79	11	60-70	Male	User	FALSE	18000	Livonia
Sort Count	Driver ID #	Age	Gender	Cruise Usage	5 week?	Miles Traveled Last Year	Home City
80	18	60-70	Male	User	FALSE	15000	Northville
81	19	60-70	Male	User	FALSE	15000	Temperance
82	20	60-70	Male	User	FALSE	15000	Southgate
83	32	60-70	Male	User	FALSE	25000	Ann Arbor
84	47	60-70	Male	User	FALSE	15000	Brooklyn
85	56	20-30	Female	User	TRUE	30000	Holt
86	73	20-30	Female	User	TRUE	15000	Lansing
87	79	20-30	Female	User	TRUE	12000	Monroe
88	87	20-30	Female	User	TRUE	20000	Ypsilanti
89	55	20-30	Male	User	TRUE	10000	Livonia
90	68	20-30	Male	User	TRUE	40000	Birmingham
91	76	20-30	Male	User	TRUE	20000	East Lansing
92	89	20-30	Male	User	TRUE	25000	Allen Park
93	88	40-50	Female	User	TRUE	45000	St. Clair
94	96	40-50	Female	User	TRUE	25000	Grosse Pointe Farms
95	99	40-50	Female	User	TRUE	20000	Troy
96	104	40-50	Female	User	TRUE	20000	Farmington Hills
97	78	40-50	Male	User	TRUE	25000	Ann Arbor
98	81	40-50	Male	User	TRUE	23000	MI
99	92	40-50	Male	User	TRUE	36000	Brighton
100	100	40-50	Male	User	TRUE	30000	Canton
101	70	60-70	Female	User	TRUE	20000	Whitmore Lake
102	77	60-70	Female	User	TRUE	12000	Southfield
103	90	60-70	Female	User	TRUE	18000	Howell
104	97	60-70	Female	User	TRUE	25000	Ann Arbor
105	40	60-70	Male	User	TRUE	12000	Northville
106	62	60-70	Male	User	TRUE	19000	Redford

107	66	60-70	Male	User	TRUE	25000	Oxford
108	85	60-70	Male	User	TRUE	36000	Beverly Hills

Table 26. Mean and standard deviation of participant age, by age group

Age Group	Mean Age	Standard Deviation of Age
20 – 30 years old	24.42	2.81
40 – 50 years old	44.17	3.17
60 – 70 years old	64.75	2.98

Table 27. Mean and standard deviation of miles driven in the previous 12 months by group

Group	Mean Miles Driven	Standard Deviation of Miles Driven
<i>Age:</i>		
20-30	18555.55	8436.127
40-50	20677.05	10709.91
60-70	16230.55	7891.363
<i>Cruise Usage:</i>		
Nonuser	14611.30	7653.526
User	20954.53	9287.547
<i>Duration:</i>		
2 week	19523.78	9192.275
5 week	23458.33	9103.172
<i>Gender:</i>		
Females	16642.11	9833.805
Males	20333.33	8181.894

4.4.2 The Myers-Briggs Type Inventory

Additional background information collected from each participant included a Myers-Briggs Type Inventory. The Myers-Briggs Type Inventory, or MBTI, was created in the 1940s based on Carl Jung’s theories about personality categories and the differences in personality type. The test is used to analyze eight personality preferences that people use to determine a distinct pattern of behavioral preference. The purpose of the MBTI is not to predict behavior but to classify individuals according to preferences — how people

prefer to express themselves, evaluate others, act on feelings, etc. Applications of MBTI range from career counseling to organizational restructuring to communication and management training. The MBTI has also been highly correlated with scales of aggression, self confidence, and management skills. It was thought that this tool might provide insight into personality variables and how they correlate with recorded variables of driving behavior.

Each participant completed an MBTI consisting of about 125 questions. The four scales measured by the MBTI are as follows: Extraversion-Introversion (coded with either E or an I), Sensing-Intuition (coded with either S or an N), Thinking-Feeling (coded with either T or an F), and Judging-Perceiving (coded with either J or a P). The eight preferences combine to produce one of sixteen personality types. Each participant's MBTI was scored, and these scores are listed in Table 28. For a complete description of the sixteen personality types, and details regarding the MBTI, see *Type* by Isabel Briggs Meyers, Consulting Psychologists Press, Inc., 1987.

Table 28. Myers-Briggs Type scores for each participant

Sort Count	Driver ID #	Age	Gender	MBTI
1	27	20-30	Female	ISFJ
2	31	20-30	Female	ESTJ
3	38	20-30	Female	ISTJ
4	39	20-30	Female	ESFJ
5	44	20-30	Female	ISTP
6	45	20-30	Female	INFJ
7	49	20-30	Female	ESFP
8	4	20-30	Male	INTJ
9	41	20-30	Male	ESTJ
10	63	20-30	Male	INTJ
11	93	20-30	Male	ENTJ
12	98	20-30	Male	ISTP
13	109	20-30	Male	ISTP
14	114	20-30	Male	ENFP
15	10	20-30	Female	ESFP
16	15	20-30	Female	INTJ
17	30	20-30	Female	ESFP
18	42	20-30	Female	ESTJ
19	50	20-30	Female	INFJ
20	51	20-30	Female	INFP
21	52	20-30	Female	ESFJ

Sort Count	Driver ID #	Age	Gender	MBTI
22	33	20-30	Male	ISTJ
23	37	20-30	Male	ENTJ
24	54	20-30	Male	ENFP
25	59	20-30	Male	ENTP
26	60	20-30	Male	ESTP
27	61	20-30	Male	ENTP
28	64	20-30	Male	ISTJ
29	1	40-50	Female	ESTJ
30	23	40-50	Female	INFP
31	25	40-50	Female	ISTJ
32	26	40-50	Female	ESFP
33	29	40-50	Female	ISTJ
34	80	40-50	Female	ESTJ
35	84	40-50	Female	ESFJ
36	34	40-50	Male	ISFJ
37	75	40-50	Male	INTJ
38	94	40-50	Male	ENFP
39	102	40-50	Male	ISTJ
40	111	40-50	Male	ESTJ
41	112	40-50	Male	ISTP
42	117	40-50	Male	ISTJ
43	5	40-50	Female	ISTJ
44	6	40-50	Female	ISFJ
45	8	40-50	Female	ESTJ
46	9	40-50	Female	ISTJ
47	12	40-50	Female	ENFJ
48	21	40-50	Female	INFP
49	24	40-50	Female	ISFJ
50	3	40-50	Male	INTJ
51	14	40-50	Male	INTP
52	17	40-50	Male	ISTJ
53	22	40-50	Male	ESTJ
54	35	40-50	Male	ISTJ
55	74	40-50	Male	ESTJ
56	105	40-50	Male	ISTJ
57	43	60-70	Female	ISFJ
58	46	60-70	Female	INFP
59	82	60-70	Female	ISTP
60	83	60-70	Female	ENTJ
61	91	60-70	Female	ISTJ
62	95	60-70	Female	ESFJ
63	106	60-70	Female	ESTJ

Sort Count	Driver ID #	Age	Gender	MBTI
64	103	60-70	Male	ISFP
65	107	60-70	Male	INFJ
66	108	60-70	Male	INTJ
67	110	60-70	Male	ENFP
68	113	60-70	Male	ENFP
69	115	60-70	Male	ESTJ
70	116	60-70	Male	ISTJ
71	13	60-70	Female	ISFJ
72	48	60-70	Female	ESTJ
73	57	60-70	Female	ESFJ
74	65	60-70	Female	ISTJ
75	67	60-70	Female	ENFJ
76	69	60-70	Female	ESTJ
77	72	60-70	Female	ESTJ
78	7	60-70	Male	ESTJ
79	11	60-70	Male	ESTJ
80	18	60-70	Male	ESTJ
81	19	60-70	Male	ESTJ
82	20	60-70	Male	ESFP
83	32	60-70	Male	INFP
84	47	60-70	Male	ESFJ
85	56	20-30	Female	ISTJ
86	73	20-30	Female	INTP
87	79	20-30	Female	ESTJ
88	87	20-30	Female	ESFJ
89	55	20-30	Male	ISFJ
90	68	20-30	Male	INFJ
91	76	20-30	Male	ISTJ
92	89	20-30	Male	ISTJ
93	88	40-50	Female	ENFP
94	96	40-50	Female	ISTP
95	99	40-50	Female	ESFJ
96	104	40-50	Female	ESFJ
97	78	40-50	Male	ISTJ
98	81	40-50	Male	ISTJ
99	92	40-50	Male	ENTP
100	100	40-50	Male	ENFJ
101	70	60-70	Female	INTJ
102	77	60-70	Female	ESTJ
103	90	60-70	Female	ISTP
104	97	60-70	Female	ESFJ
105	40	60-70	Male	ENFP

Sort Count	Driver ID #	Age	Gender	MBTI
106	62	60-70	Male	ESTJ
107	66	60-70	Male	ISFJ
108	85	60-70	Male	ESTP

4.4.3 Driving Style Questionnaire Results

Prior to and just after participating in the FOT, each participant completed a driving style questionnaire. These questionnaires were developed specifically for the FOT as a means for participants to self-report their level of aggressive driving behavior, and have not been validated as data-collection instruments elsewhere. The two questionnaires, pre-FOT and post-FOT, contained almost identical questions. However, the questionnaire that participants completed prior to driving the ACC vehicle was only concerned with manual driving behavior. The post-FOT questionnaire was only concerned with the participant's driving behavior while using ACC. The questions asked included an assessment of speed traveled relative to other traffic, passing habits, and headway keeping. The complete pre- and post-FOT driving style questionnaires are listed in Tables 29 and 30.

Table 29. Pre-FOT, manual driving style questionnaire

Driving Style Questionnaire

Please complete the following questionnaire and **circle only one answer** for each question. The answers you provide will in no way affect your participation so answer as freely as you can.

When driving, do you generally travel: (Circle one answer)

- a. faster than the surrounding traffic
- b. at a speed similar to the surrounding traffic
- c. slower than the surrounding traffic

When driving, do you find yourself: (Circle one answer)

- a. passing other vehicles more often than you were passed
- b. passing other vehicles just as often as you were passed
- c. being passed by other vehicles more often than you passed

Do you pass other vehicles on their passenger side (i.e., use a lane designated for slower traffic in order to pass): (Circle one answer)

- a. frequently
- b. occasionally
- c. rarely

When following another vehicle, the distance you maintain between your vehicle and the preceding vehicle is: (Circle one answer)

- a. a distance which was shorter than that maintained by surrounding traffic
- b. a distance similar to that maintained by surrounding traffic
- c. a distance which was longer than that maintained by surrounding traffic

When driving, which is most likely to affect the distance you maintain between your vehicle and the preceding vehicle: (Circle one answer)

- a. your speed
- b. traffic density

c. your schedule

Do you ever avoid traveling in conditions where you might encounter heavy traffic: (Circle one answer)

- a. frequently
- b. occasionally
- c. rarely

Table 30. Post-FOT, manual driving style questionnaire

Driving Style Questionnaire

Please complete the following questionnaire and **circle only one answer** for each question. The answers you provide will in no way affect your participation so answer as freely as you can.

When driving the ACC vehicle, did you generally travel: (Circle one answer)

- a. faster than the surrounding traffic
- b. at a speed similar to the surrounding traffic
- c. slower than the surrounding traffic

When driving the ACC vehicle, did you find yourself: (Circle one answer)

- a. passing other vehicles more often than you were passed
- b. passing other vehicles just as often as you were passed
- c. being passed by other vehicles more often than you passed

When driving the ACC vehicle, did you pass other vehicles on their passenger side (i.e., use a lane designated for slower traffic in order to pass): (Circle one answer)

- a. frequently
- b. occasionally
- c. rarely

When following another vehicle in the ACC vehicle, the distance you maintained between your vehicle and the preceding vehicle was: (Circle one answer)

- a. a distance which was shorter than that maintained by surrounding traffic

- b. a distance similar to that maintained by surrounding traffic
- c. a distance which was longer than that maintained by surrounding traffic

When driving in the ACC vehicle, which was most likely to affect the distance you maintained between your vehicle and the preceding vehicle: (Circle one answer)

- a. your speed
- b. traffic density
- c. your schedule

Did you ever avoid traveling in conditions where you might encounter heavy traffic while driving the ACC vehicle: (Circle one answer)

- a. frequently
- b. occasionally
- c. rarely

The design of both questionnaires was of the multiple-choice type. Each possible answer was assigned a score such that the sum of the answers could be computed per driver, and the sum scores potentially used in a classification scheme of driver behavior, or to examine the score relationship with observed/recorded dependent measures of performance. Driver scores could range from six to eighteen, where the lower the driver's score, the less aggressive their driving habits were considered to be. Below is an example of one of the questions, and the score methodology.

Do you pass other vehicles on their passenger side (i.e. use a lane designated for slower traffic in order to pass): (Circle one answer)

- a. frequently*
- b. occasionally*
- c. rarely*

For this question, answer *a* was assigned a value of 3, answer *b* was assigned a value of 2 and answer *c* was assigned a value of 1. These scores are broken down for the three independent variables of the experimental design (participant age, conventional cruise control usage, and duration of participation in the operational test) as well as participant gender in Table 31. A summary of individual participant driving style scores is provided in Table 32.

Table 31. Summary of driving style questionnaire results by independent variable¹

Group	No Change in score from Pre to Post	Increased score Pre to Post (more aggressive)	Decreased score Pre to Post (less aggressive)
<i>Age:</i>			
20-30	8	17	11
40-50	12	11	13
60-70	12	10	14
<i>Cruise Usage:</i>			
Nonuser	13	15	14
User	19	23	24
<i>Duration²:</i>			
2 week	12	18	12
5 week	7	5	12
<i>Gender:</i>			
Females	19	14	21
Males	13	24	17

Table 32. Individual participant driving-style scores, pre- and post-FOT

Sort Count	Driver ID #	Age	Cruise Usage	5 week?	Gender	Difference
1	27	20-30	Nonuser	FALSE	Female	Less Aggressive
2	31	20-30	Nonuser	FALSE	Female	Less Aggressive
3	38	20-30	Nonuser	FALSE	Female	No Change
4	39	20-30	Nonuser	FALSE	Female	No Change
5	44	20-30	Nonuser	FALSE	Female	Less Aggressive
6	45	20-30	Nonuser	FALSE	Female	No Change
7	49	20-30	Nonuser	FALSE	Female	Less Aggressive
8	4	20-30	Nonuser	FALSE	Male	Less Aggressive
9	41	20-30	Nonuser	FALSE	Male	More Aggressive
10	63	20-30	Nonuser	FALSE	Male	More Aggressive
11	93	20-30	Nonuser	FALSE	Male	Less Aggressive
12	98	20-30	Nonuser	FALSE	Male	More Aggressive
13	109	20-30	Nonuser	FALSE	Male	Less Aggressive

¹ Values in the table represent the number of participants falling under the three possible categories (no change in aggressivity, increased aggressivity, and decreased aggressivity).

² For the “2 weekers,” only the “Users” are listed (by design, all 5 weekers were Users).

Sort Count	Driver ID #	Age	Cruise Usage	5 week?	Gender	Difference
14	114	20-30	Nonuser	FALSE	Male	More Aggressive
15	10	20-30	User	FALSE	Female	More Aggressive
16	15	20-30	User	FALSE	Female	More Aggressive
17	30	20-30	User	FALSE	Female	No Change
18	42	20-30	User	FALSE	Female	Less Aggressive
19	50	20-30	User	FALSE	Female	No Change
20	51	20-30	User	FALSE	Female	More Aggressive
21	52	20-30	User	FALSE	Female	Less Aggressive
22	33	20-30	User	FALSE	Male	More Aggressive
23	37	20-30	User	FALSE	Male	More Aggressive
24	54	20-30	User	FALSE	Male	No Change
25	59	20-30	User	FALSE	Male	More Aggressive
26	60	20-30	User	FALSE	Male	More Aggressive
27	61	20-30	User	FALSE	Male	More Aggressive
28	64	20-30	User	FALSE	Male	More Aggressive
29	1	40-50	Nonuser	FALSE	Female	More Aggressive
30	23	40-50	Nonuser	FALSE	Female	No Change
31	25	40-50	Nonuser	FALSE	Female	Less Aggressive
32	26	40-50	Nonuser	FALSE	Female	No Change
33	29	40-50	Nonuser	FALSE	Female	Less Aggressive
34	80	40-50	Nonuser	FALSE	Female	Less Aggressive
35	84	40-50	Nonuser	FALSE	Female	More Aggressive
36	34	40-50	Nonuser	FALSE	Male	No Change
37	75	40-50	Nonuser	FALSE	Male	No Change
38	94	40-50	Nonuser	FALSE	Male	More Aggressive
39	102	40-50	Nonuser	FALSE	Male	No Change
40	111	40-50	Nonuser	FALSE	Male	No Change
41	112	40-50	Nonuser	FALSE	Male	More Aggressive
42	117	40-50	Nonuser	FALSE	Male	More Aggressive
43	5	40-50	User	FALSE	Female	No Change
44	6	40-50	User	FALSE	Female	More Aggressive
45	8	40-50	User	FALSE	Female	Less Aggressive
46	9	40-50	User	FALSE	Female	No Change
47	12	40-50	User	FALSE	Female	No Change
48	21	40-50	User	FALSE	Female	Less Aggressive

Sort Count	Driver ID #	Age	Cruise Usage	5 week?	Gender	Difference
49	24	40-50	User	FALSE	Female	More Aggressive
50	3	40-50	User	FALSE	Male	No Change
51	14	40-50	User	FALSE	Male	Less Aggressive
52	17	40-50	User	FALSE	Male	More Aggressive
53	22	40-50	User	FALSE	Male	More Aggressive
54	35	40-50	User	FALSE	Male	More Aggressive
55	74	40-50	User	FALSE	Male	Less Aggressive
56	105	40-50	User	FALSE	Male	No Change
57	43	60-70	Nonuser	FALSE	Female	More Aggressive
58	46	60-70	Nonuser	FALSE	Female	More Aggressive
59	82	60-70	Nonuser	FALSE	Female	No Change
60	83	60-70	Nonuser	FALSE	Female	No Change
61	91	60-70	Nonuser	FALSE	Female	More Aggressive
62	95	60-70	Nonuser	FALSE	Female	Less Aggressive
63	106	60-70	Nonuser	FALSE	Female	Less Aggressive
64	103	60-70	Nonuser	FALSE	Male	No Change
65	107	60-70	Nonuser	FALSE	Male	More Aggressive
66	108	60-70	Nonuser	FALSE	Male	Less Aggressive
67	110	60-70	Nonuser	FALSE	Male	Less Aggressive
68	113	60-70	Nonuser	FALSE	Male	More Aggressive
69	115	60-70	Nonuser	FALSE	Male	No Change
70	116	60-70	Nonuser	FALSE	Male	More Aggressive
71	13	60-70	User	FALSE	Female	No Change
72	48	60-70	User	FALSE	Female	Less Aggressive
73	57	60-70	User	FALSE	Female	Less Aggressive
74	65	60-70	User	FALSE	Female	More Aggressive
75	67	60-70	User	FALSE	Female	No Change
76	69	60-70	User	FALSE	Female	Less Aggressive
77	72	60-70	User	FALSE	Female	More Aggressive
78	7	60-70	User	FALSE	Male	More Aggressive
79	11	60-70	User	FALSE	Male	More Aggressive
80	18	60-70	User	FALSE	Male	Less Aggressive
81	19	60-70	User	FALSE	Male	No Change
82	20	60-70	User	FALSE	Male	Less Aggressive
83	32	60-70	User	FALSE	Male	No Change

Sort Count	Driver ID #	Age	Cruise Usage	5 week?	Gender	Difference
84	47	60-70	User	FALSE	Male	Less Aggressive
85	56	20-30	User	TRUE	Female	Less Aggressive
86	73	20-30	User	TRUE	Female	More Aggressive
87	79	20-30	User	TRUE	Female	No Change
88	87	20-30	User	TRUE	Female	No Change
89	55	20-30	User	TRUE	Male	More Aggressive
90	68	20-30	User	TRUE	Male	More Aggressive
91	76	20-30	User	TRUE	Male	Less Aggressive
92	89	20-30	User	TRUE	Male	More Aggressive
93	88	40-50	User	TRUE	Female	Less Aggressive
94	96	40-50	User	TRUE	Female	Less Aggressive
95	99	40-50	User	TRUE	Female	More Aggressive
96	104	40-50	User	TRUE	Female	Less Aggressive
97	78	40-50	User	TRUE	Male	No Change
98	81	40-50	User	TRUE	Male	Less Aggressive
99	92	40-50	User	TRUE	Male	Less Aggressive
100	100	40-50	User	TRUE	Male	Less Aggressive
101	70	60-70	User	TRUE	Female	Less Aggressive
102	77	60-70	User	TRUE	Female	No Change
103	90	60-70	User	TRUE	Female	No Change
104	97	60-70	User	TRUE	Female	No Change
105	40	60-70	User	TRUE	Male	No Change
106	62	60-70	User	TRUE	Male	Less Aggressive
107	66	60-70	User	TRUE	Male	Less Aggressive
108	85	60-70	User	TRUE	Male	Less Aggressive

5.0 Data-Processing Methods

A goal of this FOT was to assess the influence of ACC on the driving task. A variety of data-processing procedures were employed to make this assessment. These procedures ranged from examining signals derived in real time by the DAS installed in the FOT vehicles to investigating time-indexed records (i.e., time histories) stored in a database format for enabling flexible query generation and data interconnectedness. The data processing fell into two general processes. The first involved the real-time, on-board processing of the primary and derived signals into histograms. The second was the cleansing, manipulating, and reduction of time-history signals such as velocity, range, and their derivatives. Histograms were created both on-board the FOT vehicles as the data were collected and also generated after the fact using the stored time-history records. The time-history data were processed to find certain types of driving patterns such as closing, separating, following, and braking. These patterns or events were found using rule-based methods and were processed to provide quantitative measures of the influences of driver characteristics, control-system properties, and vehicle characteristics on driving performance. This section describes the prominent data-processing methods used in this FOT.

5.1 Histogramming

A large part of the data analyses and processing for this FOT involved the creation and display of histograms. (See section 5.1.3.) The reasons for the extensive use of histograms in this study are the following:

- Histograms are compact in terms of computer memory and data file size (an important consideration for files being transferred over cellular phone in the FOT vehicles) and require a fixed amount of memory for storage.
- Histograms can easily be combined to aggregate data across trips or drivers.
- Histograms contain counts that are directly proportional to the driving time represented by the histogram.
- Histograms can be used to approximate certain statistics such as mean, median, and standard deviation.

The last observation in the above list is important because summary statistics are a useful and common means for characterizing the differences between individual drivers and groups of drivers.

To demonstrate the last point in the list above, Table 33 shows the difference between the mean, standard deviation, and median values for the headway-time-margin measure, H_{tm} , for two drivers using their histograms and time-history data. The table shows that the mean and standard deviation values are nearly identical for both drivers, while the histogram median values show the largest difference, as they are limited by the bin width resolution of the histogram.

Table 33. Example of H_{tm} statistics generated by histogram and time-history data

	Driver	Count	Mean	Std. Dev.	Median	25 th Percentile	75 th Percentile
Histogram	10	74839	1.127861	0.6812	0.900	0.600	1.400
Time-history	10	74839	1.127863	0.6813	0.898	0.601	1.469
Histogram	55	16123	1.723944	0.7382	1.700	1.100	2.300
Time-history	55	16123	1.723839	0.7378	1.722	1.151	2.377

To probe the histograms created during the FOT, a special computer tool called the *trip explorer* was developed. The main purpose of the tool was to produce graphic displays of the histogram data. The tool is based on the idea that histograms can be combined for different drivers and groups of drivers, as long as they are combined using the raw counts within the common bins of the histograms. This tool takes advantage of Structured Query Language (SQL) to calculate the aggregate histograms. It also has a built-in filtering option that allows any value of an existing histogram to serve as a filter for selecting a subset of trips or drivers. An example of this approach was used in the interim FOT report where in various histograms that were shown for all trips, the mean velocity was above 44 ft/sec [6]. The main input screen for the trip explorer is shown in Figure 39.

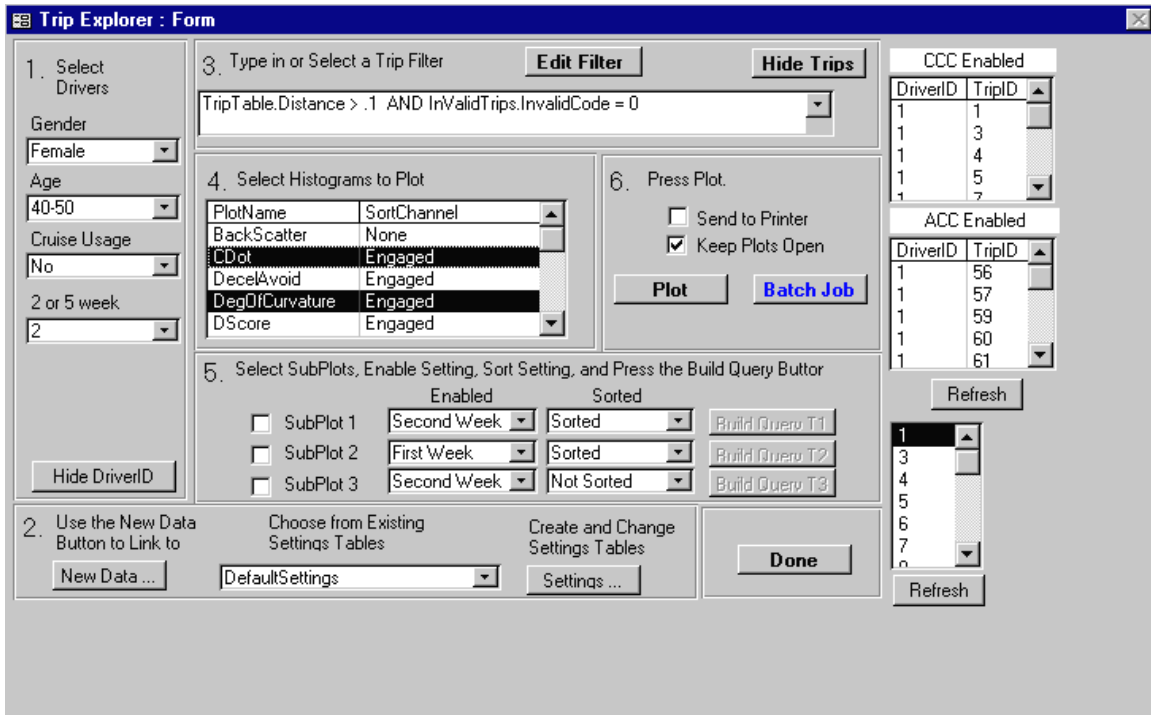

Figure 39. FOT trip explorer tool for displaying histograms

Figure 40 shows an example plot generated using the trip explorer tool. The plot shows the ACC engaged headway-time-margin for cruise users in all three age groups. The histogram is shown as a frequency distribution, which means that each bin of the histogram has been normalized by the total count of all bins.

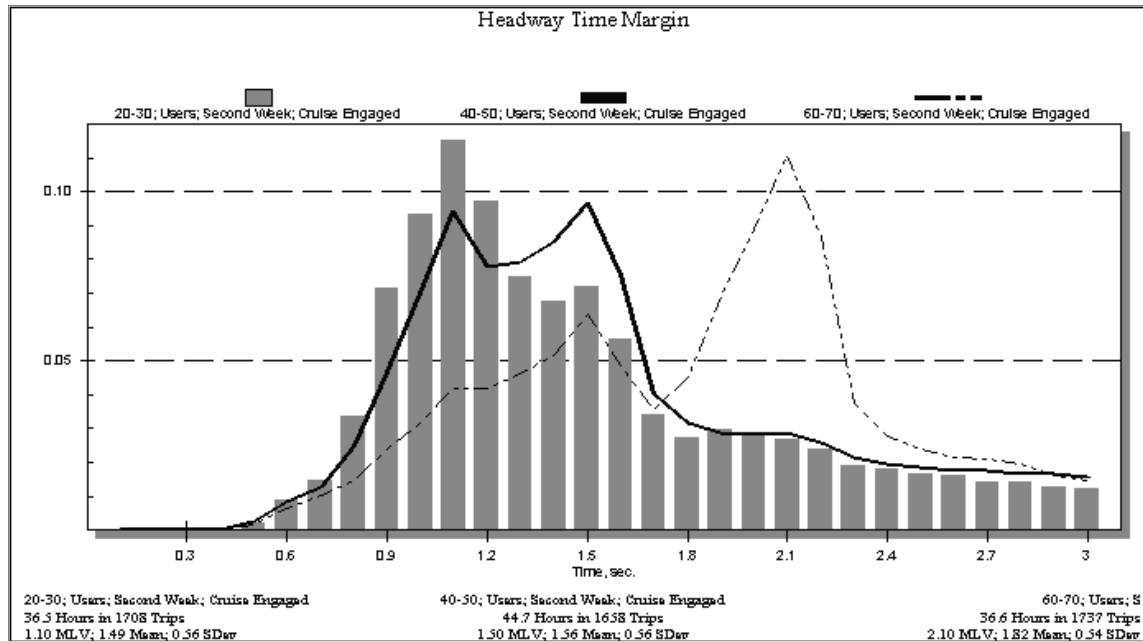

Figure 40. Example headway-time-margin histogram for cruise users

5.1.1 Histograms Collected On-Board the FOT Vehicles

In total there were 27 floating-point histograms, 20 logical histograms, and one two-dimensional histogram created on-board the FOT vehicles as they were being driven by the test subjects. These histograms are listed in section 3.3.2. A majority of these histograms are velocity-dependent in that they were only collected at velocities above a certain threshold (most often 35 mph, the enabling velocity for cruise control). However, it was soon learned that velocity has a large influence on cruise usage, thereby prompting the development of more histograms that were, themselves, a function of velocity.

All the floating-point histograms created during the FOT needed to be defined in terms of their bin characteristics. These characteristics include the number of bins, the starting bin center value, and most importantly the bin width. The bin width value is critical because a poor choice can result in artificially large counts or a bias in a particular bin or set of bins. Binning errors were generally avoided in the FOT by setting the bin width of a given signal to an integer multiple of the resolution of that signal. For example, all histograms of velocity had a bin width of 4.4 ft/sec which is an integer multiple (6, in this case) of the velocity signal resolution of 0.73 ft/sec. In addition to defining the number of bins, start bin center, and bin width, each histogram had unbounded end bins to capture counts that fell outside of the defined bin range.

5.1.2 Additional Histograms

Ten additional histograms were created using the time-history records from the 108 FOT test subjects. These histograms were like those generated on the vehicles, in that they used the same bin values and spacing, except that they were made with an additional dimension, which typically was velocity. A list of these newly created histograms is given in Table 34. Figure 41 is an example of a two-dimensional histogram.

Table 34. Two-dimensional histograms

Name	1st Source Channel	2nd Source Channel	Enabling Channel	Sorting Channel
Rdot/VVHist	Rdot/Velocity	Velocity	ValidTarget	Engaged
RRdotFhist	Range/Velocity	Rdot/Velocity	ValidTarget	Engaged
RRdotSFhist	Range/Velocity	Rdot/Velocity	Eng., ValTgt, 1.0 sec. Th	None
RRdotMFhist	Range/Velocity	Rdot/Velocity	Eng., ValTgt, 1.4 sec Th	None
RRdotLFhist	Range/Velocity	Rdot/Velocity	Eng., ValTgt, 2.0 sec Th	None
HtmVHist	Range/Velocity	Velocity	ValidTarget	Engaged
TtiVHist	TimeToImpact	Velocity	ValidTarget	Engaged
RangeVHist	Range	Velocity	ValidTarget	Engaged
DecAvdVHist	DecelAvoid	Velocity	ValidTarget	Engaged
Rdot/RVHist	Rdot/Range	Velocity	ValidTarget	Engaged

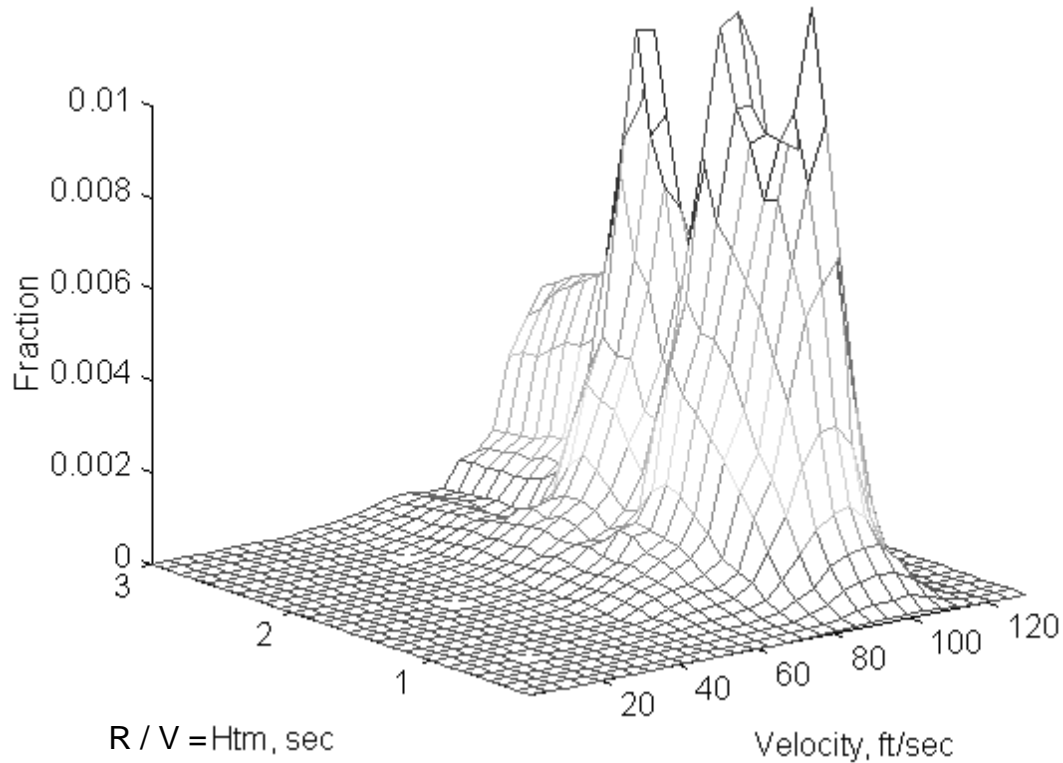

Figure 41. Two-dimensional histogram of velocity and Htm for ACC driving mode

5.1.3 Creation and Interpretation of Histograms

This section discusses how the data have been processed to create histograms. It also presents certain symbols associated with that process.

Although histograms are used in many applications, they are not commonly used to display results from vehicle dynamics and control studies. It is common practice to use time-histories to display the time sequence of events in vehicle dynamics studies. However, due to the quantity of data gathered in this study, histograms have been employed as a means of collapsing the time dimension so as to present large sets of data in a compact form. This approach results in the loss of time dependent relationships but it does provide a means for communicating and examining features of huge amounts of raw data to aid in identify interesting and illuminating patterns. The goal is the discovery of new knowledge about the phenomena involved in driving even if the process involves using unusual approaches or interpretations to penetrate the data. (In this context for example, the use of histograms to condense time-histories of dynamic variables may appear as an unconventional approach to some practitioners in the area of vehicle dynamics.)

The basic information portrayed in the histograms are counts of how often the data fall within a defined subset (sometimes referred to as a bin) of a larger, parent set of data made up of two or more bins (subsets). The ratio of the counts within a particular bin to the total number of counts in all of the bins corresponding to a given variable can be viewed as an approximation to the chance, likelihood, or probability that the variable takes on a value that falls within that particular bin. In a sense, this ratio (the fraction of the number of members of the parent set falling within the subset) represents the observed frequency of occurrence, and a complete set of these ratios for a single variable describes a one-dimensional distribution of observed frequencies for that variable.

One use of the histograms, common in this study, is to compare results based upon whether a logical variable (as opposed to a floating-point variable) is true or false. An example of a logical variable is whether the adaptive cruise control is engaged or not. In another example, the driver's age variable has been assigned three discrete levels (older, middle age, and younger) rather than being treated as a continuous variable. In this case, the data have been organized and presented to compare three histograms—one for each age group as shown in Figure 40. (In this figure bars are used to represent the younger drivers, while line segments indicative of middle aged and older drivers are used to connect the observed frequencies of occurrence assigned at the bin centers employed in the histograms.)

In the context of this discussion, the symbol “ $Fb(\cdot | \cdot)$ ” is introduced to represent a descriptive operator acting on two pieces of information. For example, the result from $Fb(ACC | V_i)$ represents the observed frequency that the driver is using ACC given that the velocity lies within a particular range of velocities. V_i serves to identify this range of velocities where V_i equals the value of the center of the bin in question. Inequalities are also used to define the conditional constraints on velocity in certain cases where the bins have broad widths.

Usually bar charts and graphs of lines connecting the observed frequencies (plotted at bin centers) are presented for a number of bins. In these cases the result of using the $Fb(\cdot | \cdot)$ operator repeatedly over a number of bins or subsets of data is symbolized as $Pd(\cdot | \cdot)$. For example, $Pd(ACC | V)$ represents the set of observed frequencies of occurrence of the use of ACC for a number of velocity bins. The reverse expression $Pd(V | ACC)$ also has meaning. It represents the distribution of the observed chance (frequency) that the driver is operating within various velocity ranges (bins) under the condition that the driver is using the ACC system. Although it is not a statistically rigorous and conventional interpretation, both $Pd(ACC | V)$ and $Pd(V | ACC)$ are seen as

possible indications of the shape or pattern of an underlying conditional probability density function, although the underlying analytic form for each distribution is unknown and unexplored here. However, the main use of the Pd graphical presentation is to provide an orderly labeling scheme for the descriptive results that are obtained by the normalized processing of sets and subsets of data. This type of labeling appears in many figures. For examples, see figures 63, 72, 99, 100, 108, etc.

These concepts for labeling the results of data processing can be extended to multiple dimensions and conditions but it is difficult to envision how to make plots when more than two variables are involved. There are however some two-dimensional histograms presented and in these cases the third “vertical” axis is the observed frequency (fraction of the parent set) for each bin defined by subsets of data for the two variables involved. See figure 41 for an example. The results shown in Figure 41 could be further processed to make a one-dimensional histogram for Htm simply by accumulating (adding) the values for the cells of the velocity variable corresponding to each value of Htm. In this manner higher dimensional histograms can be reduced to lower dimensional histograms.

From a certain perspective the whole database covering each 0.1 second of information could be condensed to a giant n-dimensional array of the counts in each cell or bin of the array—essentially eliminating the time dimension (variable) from the data. Then lower dimensional arrays could be built by combining counts pertaining to the variables removed. Various conditions defining pertinent subsets of the data set could also be used in establishing special arrays of data for use in examining interesting situations. However, using graphical methods to examine and compare the patterns involved means reducing the data to various combinations of one- and two-dimensional histograms. This is what has been done in this study to address matters and issues that are pertinent to the study. However, there could well be important relationships, requiring more than one or two dimensions for their description, which cannot be viewed directly using the histogramming techniques employed in this study.

5.2 Time History Processing

The data-acquisition system on each FOT vehicle collected and permanently stored a time-history file (identified by an “H” appended to the file name) for all time during a trip. The time-history file contains 35 channels (described earlier in section 3.3). These data were logged to the file at 10 Hz and were stored in individual files for each trip taken by a FOT driver.

The size of the time-history files varies depending upon the length of the trip and can be computed by multiplying the length of each record in the file (113 bytes) by the length of the trip in tenths of a second. In the FOT the 108 drivers accumulated a total of over 3000 hours of trip time, which translates into approximately 12.2 gigabytes of time-history data. (This does not include the GPS, transition and histogram files collected for each trip.) As of this writing, 12.2 gigabytes is considered to be a rather large data set for processing on desktop computers, and therefore, inquiring of these data in a timely manner required careful planning and implementation of modern data-handling software. This section will discuss the different methods used to query the time-history data set. These inquiries fall into two general categories: those that are related to having and tracking a valid impeding (or “target”) vehicle and those that are independent of the target state.

5.2.1 Capturing of Nontarget-Related Time-History Events

The time-history records for all the FOT drivers were processed to identify the start, end, and intermediate conditions for several types of events. These events were brake-pedal application, engagement of the cruise-control system, headway-button selection during ACC engagement, and selection of the various cruise-control input buttons (set, resume, coast, and acceleration). All of these events have identifiable start and end times in the time-history record and in some cases (engagements and button selections) these times (or their start time and duration) have been captured and stored in the transition file for the event.

These events are classified as nontarget related because they are primarily identified in the time history record by their start and end times and are independent of an impeding vehicle. For example, a driver can apply the brake pedal at any time during a trip regardless of other vehicles (at their own peril, of course). However, identifying time-history segments that are characterized as “following” or “closing” are defined by and can only occur in the presence of an impeding vehicle. This is not to say that targets are not important during nontarget-related events, but that such events are not dependent upon them.

5.2.2 Subsetting the Time-History Record

The approach to processing of the time-history data involved building independent database tables of events that could be related and joined with other database tables. In general there were three distinct event tables for each event type. The first consisted of a start time-history record for the event. The second consisted of an end time-history record

for the event, and the third consisted of calculated or summary values that characterize the time between the start and end of the event.

The start or end time-history tables contained the complete record — all 35 channels for the instant in time that marks the start or end of the event. The third table contained calculated values that characterize the different signals between the start and end times. The contents of the third table can vary depending upon the type of event. The braking event table, for example, is rather simple and contains a maximum deceleration value, a 2-second filtered maximum deceleration value, and a target flag indicating whether there was a change in targets during the brake application.

Common among all three-event tables are fields that allow them to be joined together. Typically, these are the driver identification number, trip number, and an event number. The combination of these three fields creates a unique reference to each event and allows them to be joined together creating the equivalent of one large table. Numerical operations can then be done to calculate other summary statistics or to create a list of values across all events that then can be made into a histogram. An example of this type of operation is the calculation of average deceleration for a braking event. In this case, the change in velocity during the event is divided by the duration of the event. All of these values are easily accessed from the start and end event tables.

There are some exceptions to having three tables characterizing these event types. In some cases, particularly with cruise-control button pushes, a single record in the time-history table may describe the event. Events like button taps are simply captured in the time-history record by a value changing from one record to the next. In these cases only one table may be sufficient for further analysis or characterization. Regardless of the number of tables needed to capture the events, each event continues to be uniquely identified within the table allowing it to be joined with other database tables. Similarly, if the start and end tables of an event have been defined, any number of other tables that describe the event can be created. For example, consider that a table already exists containing the average velocity during a cruise-control engagement and that there is a need for the maximum velocity for each engagement. Then instead of changing the table containing the average value, a new table is created with the maximum values. The proper identification fields are added to this new table allowing it to form a one-to-one alignment with the other tables describing this event. Using the methods described here the database continues to grow with “value-added” tables that characterize in some way the FOT experience.

5.2.3 Capturing of Target-Related Time-History Events

To analyze and process events related to the presence of an impeding vehicle, a set of tables were created for each driver that identified the segments of the time-history record where a valid target was present. The events in these tables, called streams, are primarily defined by GPS time values indicating the start and end of the stream along with summary statistics that describe how some of the primary signals varied during the stream. Creation of the streams tables decreases processing time because it allows direct access to the records in the time-history table that correspond to times when an impeding vehicle is present. Other efficiencies resulted by using a subset of the stream table to identify stream events within certain velocity ranges or with initial and final range values that meet the criteria of a driving conflict scenario. Specific driving scenarios that used the streams table are discussed in sections 8.2 and 9.2.3. Derivation of the streams tables, which included cleansing of the range and range-rate signals, is discussed in the next section.

5.2.4 Data Cleansing and Target Identification

There are many reasons why the range data coming from the sensor may have dropouts or large instantaneous jumps. Some of these drastic changes are real and reflect the sensors inability to “see” completely around curves or to detect a target lying out near the extreme distance threshold of the sensor. Still other glitches are just momentary target losses which occur for no apparent reason. When these range and range-rate signals are plotted, it is clear that the target was temporarily lost (or that a false target was picked up) and that the range values are inaccurate during these large breaks in the signal.

When the streams tables were created, a simple set of rules was used to identify, document, and ultimately remove these large changes in the range and range-rate signals. Figure 42 shows a 120-second snapshot of an original and corrected range signal. In this example, the original signal shows six large dropouts where the signal is lost and a zero range value is recorded in the time-history file. It is clear that the loss of the range signal resulted from some anomaly and undoubtedly the range value should simply have continued during these short lapses. It is also fairly certain that the FOT vehicle was following the same target throughout this 2-minute time period.

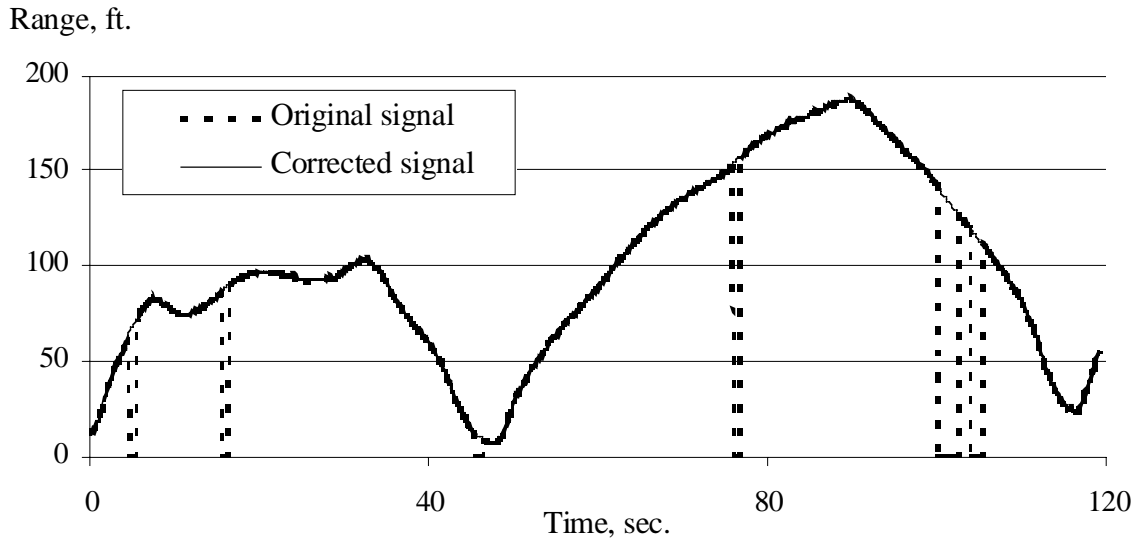

Figure 42. Original and corrected range signal

To identify temporary dropouts and false targets a two-step approach was used in the data processing of the stream tables. Both steps were incorporated into a computer program that would analyze, on a trip-by-trip basis, the range and range-rate values recorded in the time-history tables for each FOT driver. The first step in the program verified that once a stream was initiated, the next set of range and range-rate values were within reasonable thresholds. Given the following:

- R_t is range at time t
- R_{t+1} is range at the next time step
- \dot{R}_t is range-rate at time t
- \dot{R}_{t+1} is range-rate at the next time step
- $R_{threshold}$ is range threshold (5 ft)
- $\dot{R}_{threshold}$ is the range-rate threshold (3.2 ft/sec)
- $R_{maxthreshold}$ is maximum range threshold value (20 ft)
- $\dot{R}_{maxthreshold}$ is the maximum range-rate threshold value (24 ft/sec)

The next range and range-rate points became part of the stream if the following two relationships were true:

$$|\dot{R}_t - \dot{R}_{t+1}| < \dot{R}_{threshold}$$

$$|(R_t + \dot{R}_t \cdot 0.1) - R_{t+1}| < R_{threshold}$$

If either one of these relationships failed then the program began to “look ahead” in range and range-rate for values that were likely a continuation of the original stream. The

look-ahead time was limited to 3.0 seconds and the reference for comparing the new points within this time period was always the range and range-rate values that prevailed just prior to the failure to satisfy either one of the inequalities given above. The stream continued if all of the conditional statements below were satisfied:

$$\begin{aligned} \left| \dot{R}_t - \dot{R}_{t+i} \right| &< \dot{R}_{\max threshold} \\ \left| R_t - R_{t+i} \right| &< R_{\max threshold} \\ \left| R_t + \left(\left(\left(\dot{R}_t + \dot{R}_{t+i} \right) / 2 \right) \cdot (0.1 \cdot i) \right) - R_{t+i} \right| &< R_{threshold} \end{aligned}$$

If these conditions are met, then the range or range-rate deviation is marked in the streams table as a discontinuity and classified depending on the relative magnitude of the range deviation. The different types of range deviations or “blips” are given in Table 35. The table shows two fields. The first is an identification number that is used for sorting and searching for the different types of streams. The second field is a description. The different types of range blips have identification numbers equal to or larger than 610.

Table 35. Stream identification numbers

Identification Number	Description
600	Range stream
601	Zero range stream
610	Zero range dropout
611	Range blip up
612	Range blip down
613	Range blip (up and down)

To account for all time in the trip files, a zero range stream (identification number of 601) has been defined. This type of stream accounts for all time when not in a range stream (identification number 600) and there is no target. In summary, all driving time is accounted for by either a range stream or a zero range stream and blips or dropouts occur only during a range stream.

5.3 Phase Space Presentation

The study of driver control of headway is facilitated by the use of range-versus-range-rate diagrams. There is a considerable body of literature, particularly with regard to nonlinear systems, in which a time-varying quantity (such as range) is plotted versus its derivative with respect to time (such as range rate). This approach has already been used in section

3.1.2 to explain the headway control algorithm used in this ACC system. The information presented there provides an exemplar case of a phase-space presentation using R versus Rdot (dR/dt).

This same type of presentation is used in explaining driver control of headway and in comparing ACC to manual control in section 8.0. Furthermore, lines having special properties for dividing the driving situation into different types are readily displayed using the R versus Rdot phase space. For example, constant deceleration lines and lines that represent human perceptual thresholds on the rate of change of visual angle are useful constructs for interpreting data. Also, the closing, following, separating, near, and cut-in driving situations can be defined using boundaries selected in the R-versus-Rdot phase space.

As observed in [7], the R-versus-Rdot phase diagram has the following generic properties (which apply as well to all phase spaces such as V versus Vdot or Θ versus Θ dot, where V is velocity and Θ is visual angle) as demonstrated in Figure 43:

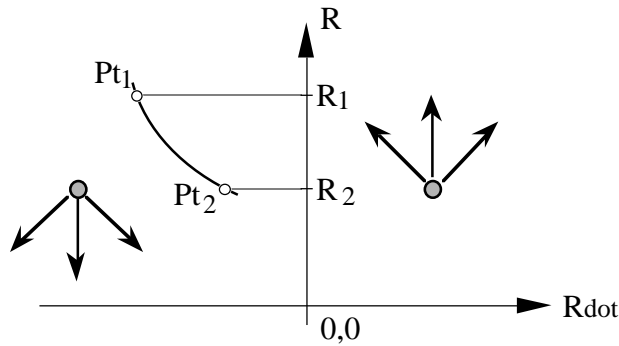

Figure 43. Trajectories in the R-versus-Rdot space

- Trajectories in the left-hand side must go down towards smaller R because Rdot is negative.
- Trajectories in the right-hand side must go up towards larger R.
- The time to go from Pt1 to Pt2 along a trajectory (defined by a relationship presenting Rdot as a function of R) is given by equation (10). This means that trajectories with small values of |Rdot| take a long time to traverse and, vice versa, large |Rdot| values correspond to short time periods.

$$\Delta t = \int_{R_1}^{R_2} \frac{dR}{Rdot} \quad (10)$$

5.4 Subjective Information from Questionnaires, Debriefing and Focus Groups

Subjective data were obtained following the participant's use of an ACC-equipped research vehicle. All subjective information collected from participants (questionnaire data, debriefing comments, and focus group transcriptions) was cataloged in the "Subjects.mdb" database (see section 4.1.1) according to participant number and question number, for questionnaire and focus-group data.

5.4.1 Detailed ACC System Questionnaire

Upon return of the ACC-equipped vehicle, each participant was required to complete a detailed questionnaire that included 44 questions. Four questions were open ended, allowing the participant to provide written comment; eight questions were rank order for preference (mostly addressing the use of manual control, conventional cruise control, or ACC in various scenarios); and the remaining questions were anchored, Likert-type, scale questions with numbers ranging from 1 to 7. A complete copy of the detailed questionnaire and descriptive statistics associated with the observed responses is provided in appendix B. A summary of the results is presented in section 8.4.

For each of the rank order and Likert-type questions, the overall mean and standard deviation of responses were calculated. In addition, means and standard deviations were calculated according to the three independent variables of the experimental design (participant age, conventional-cruise-control usage, and duration of participation in the operational test). For each of the rank-order questions, the mean and standard deviation of rank were similarly reported.

5.4.2 Participant Debriefing

Once participants had completed all of the subjective questionnaires, at least one researcher spent 10 to 30 minutes with each participant in order to review their questionnaire responses and examine entries made in the vehicle's log book. The researcher(s) often posed questions to participants in order to clarify responses to certain questionnaire items, requests for a more complete description of events that were recorded in the vehicle's log book, and general questions regarding their overall experience with ACC. It was common during debriefings that participants provided anecdotal evidence of the conditions under which they used ACC, their likes and dislikes of the system, and posed questions of the researchers concerning things such as system

costs and availability. All comments, often in an abbreviated form, were entered into the representational database along with all other subjective information.

5.4.3 Focus Group Activities

The purpose of the focus groups was to gain additional information from the participants about their experiences with the ACC research vehicle. Attending a focus group gave participants the opportunity to expand on their answers to the detailed questionnaire, as well as on any other feedback they provided during the debriefing. Furthermore, the interaction between focus group participants sparked conversation that frequently reminded participants of previously unreported experiences, thereby providing additional insight into the participants' opinions, reasoning and perhaps even their driving behavior.

Each focus group typically lasted approximately 2 hours. During this time, a series of seventeen questions were asked. The same questions were asked in each of the 10 focus groups. All seventeen questions are provided in section 8.5, and are followed there by a brief summary of participant responses.

5.5 Processing Data Associated With Transition Events

During the FOT there were over 100,000 transition events logged by the DAS on the test vehicles. These events included button pushes, transmission down-shifting, video capture flags, cruise engagements, and headway button selections. They are classified as transition events due to their on-off or boolean nature. A transition event is defined by a start time for the event, an identification number, and a duration. This simple record of information creates a complete time history for these events without the repetition and data-storage requirements needed if they were stored in the continuous time-history record captured on the FOT vehicles.

Aside from the computer memory and storage advantages of defining events in this manner, there is also a computational efficiency to having all these events stored in one FOT database. By combining all transition events for all drivers, summary counts and queries could be generated across all test subjects with one statement (as opposed to time-history processing, which required a query for each driver in the test). This allows quick and efficient processing of these types of events. Furthermore, transition events, when stored this way, contain the necessary information to efficiently go to the corresponding time in the time-history records for further processing of signals stored in a time-history format. (In essence, the transition table acts as a bookmark table for direct access to other data that help describe the driving environment during the transition period.)

The transition tables also provided the basic outline for processing of other events such as cut-in, road-type, and braking. These events were defined and saved in separate database tables with their start time, duration and a unique identifier. Then further processing of the other FOT data during this event time could be done by simply using the transition bookmarks as a pointer into the corresponding time-history database for each FOT driver.

5.6 Driver Characterization Methods

This section presents two methods used in this report to rate drivers and their driving style. (One could imagine and select many other methods but these are the ones employed herein to classify driving behavior.)

The ultimate purpose of examining manual driving style is to compare manual driving with ACC driving. However, another purpose of rating driving style is to classify the manual driving behavior of the 108 drivers who participated in the FOT. In an individual sense, there have been 108 different driver behaviors involved in a test activity that employed ten identical vehicles equipped with identical sensors. Earlier sections of this report have described in considerable detail those vehicles and the testing procedures associated with their use. In keeping with the thrust of those earlier sections, a methodology for rating drivers is described here. (The results of applying these methods for describing each driver are presented later in section 6.)

One simple measure of driving style is the percentage of time, expressed as a frequency, for a driver to be in the near region of the range-versus-range-rate space. Figure 44 provides a graphical definition of the near region. The near region is defined by the following boundaries:

$$Rdot < 0 \text{ and } R < 0.5 Vp + [(Rdot)^2/2(0.1g)] \quad (11)$$

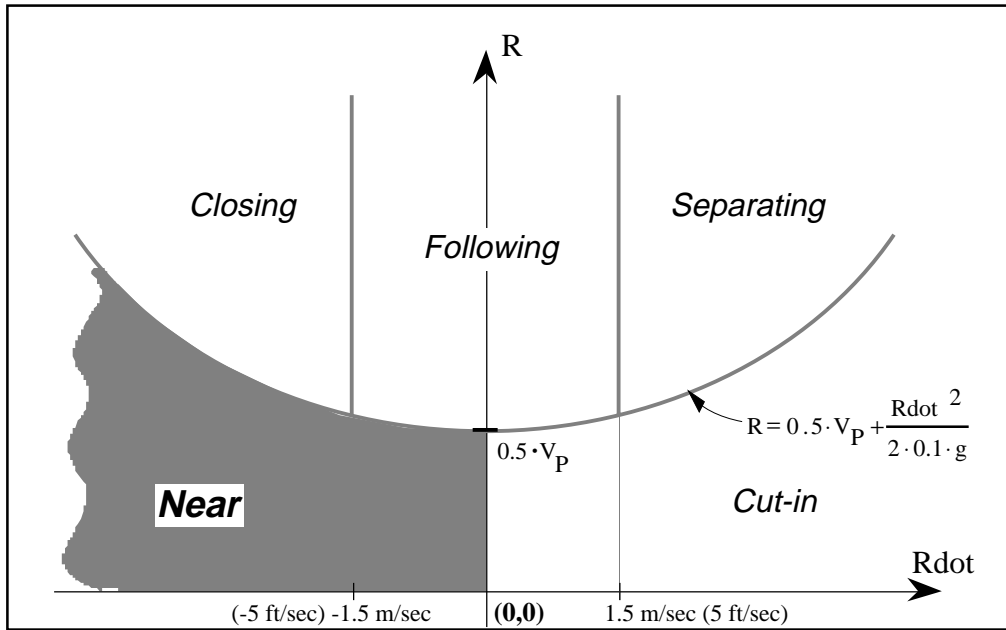

Figure 44. Near region in the range-versus-range-rate space

The frequency of being in the near region is called *confliction* in this report. For example, the confliction value averaged over all drivers operating manually at speeds above 35 mph is 0.024. However (for example), driver number 25 (the driver with identification number 25) had a confliction of 0.005. This means that the likelihood that driver number 25 will have a near-region conflict is much smaller than the likelihood of a near-region conflict as determined for all drivers.

Although confliction is a useful numeric for studying driver tendencies to have near encounters with other vehicles, it does not provide a detailed understanding of the driving style of each individual. Previously, FOT data had been used to develop driver classifications called *hunters*, *gliders*, and *followers*. [8] Based on those initial ideas, an expanded classification scheme has been developed. The tails of the R/V and Rdot/V distributions for each driver are now used in classifying driving style.

The new classification scheme quantifies driving styles at highway speeds above 55 mph (80.7 ft/sec, 24.5 m/sec) using the following boundaries, which are displayed in the normalized range-versus-range-rate diagram presented in Figure 45:

$$R/V \leq 0.65 \text{ sec}, R/V \geq 2.25 \text{ sec}, Rdot/V \leq -0.075, \text{ and } Rdot/V \geq 0.075. \quad (12)$$

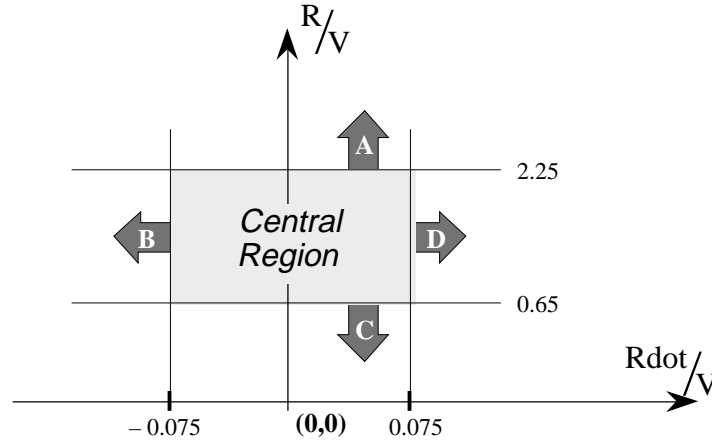

Figure 45. Boundaries used in defining driving styles

These boundaries and the data associated with a given driver are used to evaluate certain frequencies symbolized as A, B, C, and D:

$$A = P(R/V > 2.25) \quad (13)$$

$$B = P(Rdot/V < -0.075) \quad (14)$$

$$C = P(R/V < 0.65) \quad (15)$$

$$D = P(Rdot/V > 0.075) \quad (16)$$

where $P(\dots)$ means the frequency of the event enclosed in the parentheses.

The quantity A is a measure of the “far” tendency of a driver; B represents the “fast” tendency; C represents “close”; and D represents “slow.”

In order to use a technique known as “small multiples” [9] to display and compare driving styles between individual drivers, the frequencies A, B, C, and D for a given driver are displayed as illustrated in Figure 46.

Seven items appearing in Figure 46 are used in classifying driving style. The items used are A, B, C, and D plus the products AB, BC, and AD. These products are proportional to the areas of three of the four triangles shaded in Figure 46. For example, the triangle associated with AD is characterized by the labels “far” and “slow” in Figure 46. The area of this triangle provides a graphical indication of the amount of driving that

is characterized by the tendency to drive slower and farther away than other drivers. If A and D are large, then the area AD/2 of the AD triangle will be large. In a similar manner, the triangles AB and BC are related to “far” and “fast” and “fast” and “close” respectively.

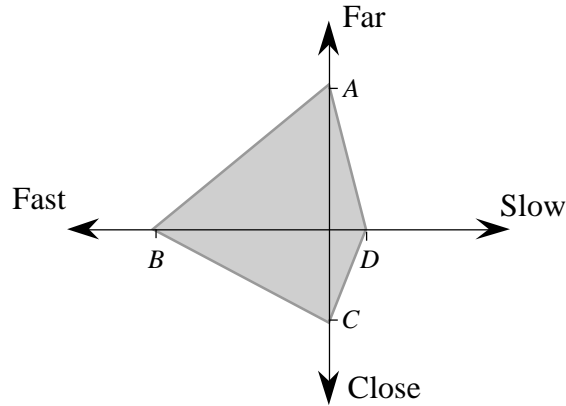

Figure 46. Plotting the quantities that define driving styles

The triangle CD, if it were to be used, would be related to driving at close range while traveling slower than the preceding vehicle. Since this is a physically difficult situation to maintain, it has not been used in rating driving style.

The 75th percentiles for values of the seven items defined above are determined by examining the data for all 108 drivers. This information is used to classify drivers using the following names to provide a descriptive portrayal of five types of driving styles:

1. “Ultraconservative” means that AD or D is greater than the 75th percentile.
Ultraconservative means an unusual tendency towards far and/or slow driving.
2. “Planner” means that AB or B or A is greater than the 75th percentile. Planner means an unusual tendency towards far and/or fast driving.
3. “Hunter/tailgater” means that BC or C is greater than the 75th percentile.
Hunter/tailgater means an unusual tendency towards fast and/or close driving.
4. “Extremist” means that the driver satisfies more than one of the above tendencies.
This means that types 1, 2, and 3 are not resolved until the extremist designation has been considered.
5. “Flow conformist” means that the driver satisfies none of the above. A flow conformist tends to travel at the same speed as other cars and at approximately the median headway time gap.

The process of classifying drivers starts with determining the 75th percentile as illustrated by the example portrayed in Figure 47. Once the drivers with tendencies to operate in the tails of the distributions are determined, they are classified into one of the five classifications listed above. For example, driver number 55 is classified as a planner, which means the tendency to travel relatively fast while somehow planning ahead to be able to remain far away from the vehicle ahead. Figure 48 shows how driver number 55 is represented using the frequencies of far, fast, close, and slow driving.

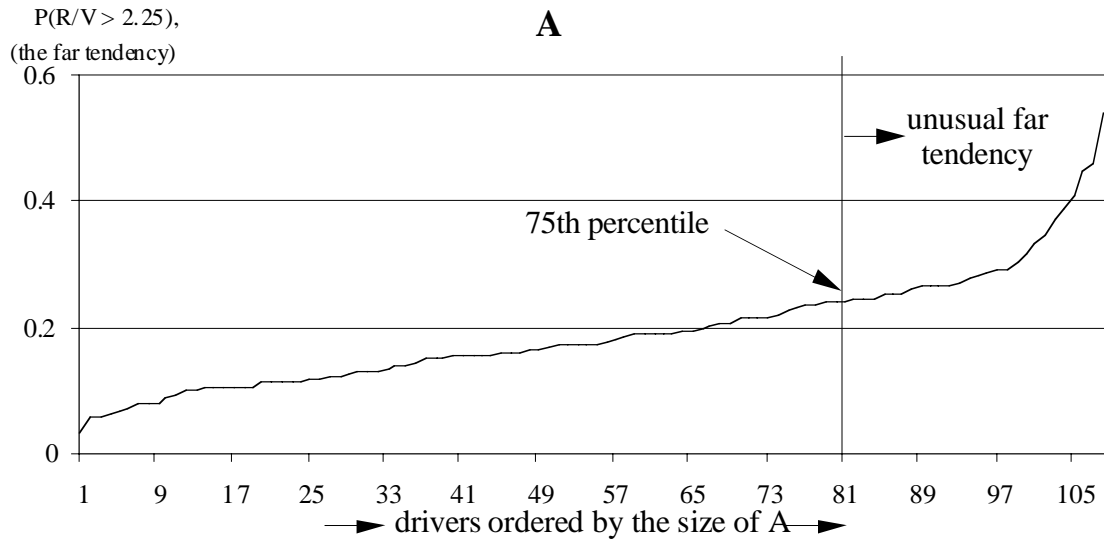

Figure 47. Example showing 75th percentile of $P(R/V > 2.25)$ seconds)

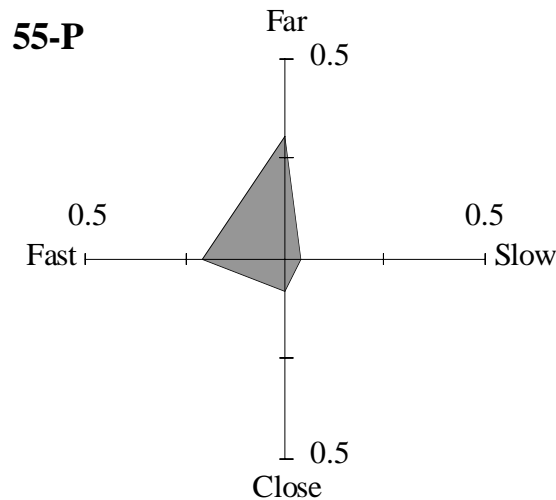

Figure 48. Example of a planner (driver number 55)

Representations like Figure 48, displayed as “small multiples” or “miniatures,” are used in section 6 to compare driving styles.

5.7 Processing Data Associated With GPS

The GPS data collected in the FOT served three general purposes. The primary purpose was to determine the type of roads traveled during the test. This task was handled by the FOT’s independent evaluator. Using a database of road class, location, and names, the GPS data from the vehicles were mapped into the road database to determine the most likely road being used by the FOT driver. The road mapping data was limited to southeast Michigan, so trips by FOT drivers that went outside of the mapping region were not identified by the mapping program. These data served as the primary source of road-type information presented in this report and also served as supporting evidence that speed may serve as a reasonable surrogate for some road types.

The GPS data were also used to identify trip types and to diagnose DAS problems. By knowing the GPS location of a driver's home and work a subset of trips was labeled as work commutes. The GPS data also served as a way to document where the vehicle traveled during the test and aided in the diagnosis of some of the problems encountered during the test. (For example, the files transferred over the phone for one FOT driver showed some premature restarts of the DAS related to excessive temperatures. The GPS information showed the driver was in one of the southern states during this period and weather reports confirmed relatively high ambient temperatures.)

Finally, the GPS did serve as another means of measuring the distance between two FOT vehicles. This information was used early in the study as a means of verifying the range sensors on the vehicles. Figure 49 shows the distance between two FOT vehicles as measured by the range sensor and by the differential GPS signal logged by both vehicles.

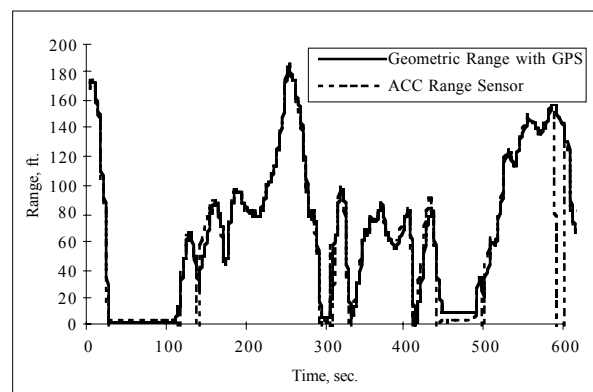

Figure 49. GPS Time history example

6.0 Behavioral Characteristics of Individual Drivers

This section presents descriptive results for individual drivers using the methods presented in section 5.6. These results include confliction ratings and driving style classifications for each driver.

Confliction is a measure of the driver's tendency to close in on another vehicle in a manner that results in a relatively short range, given the rate of closure. The confliction numeric chosen for this study is the observed frequency of operating in the near region of the range-versus-range-rate space. Table 36 lists the confliction values for each of the 108 drivers along with other characteristics of these drivers. The driver's identification number is given in the third column of the table. Pertinent driver characteristics as well as pertinent driving exposure numerics are also given in the table. Confliction values (as given in the next to last column) are seen to cover the range of frequencies from 0.002 to 0.121. Apparently there is a wide range of behavior extending from drivers who are very unlikely to have a near encounter with another vehicle to those who tend to travel in the near region quite frequently. Even without considering the implications with respect to safety, traveler comfort, or traffic flow, a high or low value of confliction appears to be a measure that discriminates between drivers.

Table 36. Confliction and driving style by driver (ordered in increasing confliction)

Measure	Mode	ID	Test Time	Age	Cruise Usage	Gender	Trips	Transitions	Time True	Time False	Prob.	Style
----- 0th percentile -----												
Near	Manual	116	2	60-70	Nonuser	Male	12	22	99	49317	0.002	Ultra
Near	Manual	104	5	40-50	User	Female	64	196	978	439905	0.002	Flow C
Near	Manual	48	2	60-70	User	Female	21	46	219	93121	0.002	Ultra
Near	Manual	82	2	60-70	Nonuser	Female	13	35	232	70030	0.003	Plan
Near	Manual	35	2	40-50	User	Male	38	87	477	141642	0.003	Extrem
Near	Manual	67	2	60-70	User	Female	18	27	120	33837	0.004	Ultra
Near	Manual	20	2	60-70	User	Male	13	45	260	70345	0.004	Extrem
Near	Manual	45	2	20-30	Nonuser	Female	22	55	356	88128	0.004	Ultra
Near	Manual	95	2	60-70	Nonuser	Female	13	28	121	29758	0.004	Ultra
Near	Manual	6	2	40-50	User	Female	24	43	206	50336	0.004	Plan
Near	Manual	113	2	60-70	Nonuser	Male	28	78	653	157186	0.004	Ultra
Near	Manual	115	2	60-70	Nonuser	Male	27	47	286	66837	0.004	Ultra
Near	Manual	102	2	40-50	Nonuser	Male	40	349	2423	529291	0.005	Ultra
Near	Manual	106	2	60-70	Nonuser	Female	22	38	294	63788	0.005	Ultra
Near	Manual	25	2	40-50	Nonuser	Female	25	55	390	84181	0.005	Ultra
Near	Manual	72	2	60-70	User	Female	13	46	279	56242	0.005	Flow C
Near	Manual	46	2	60-70	Nonuser	Female	20	37	165	31592	0.005	Ultra
Near	Manual	83	2	60-70	Nonuser	Female	7	40	158	29482	0.005	Ultra
Near	Manual	40	5	60-70	User	Male	40	112	888	163726	0.005	Plan
Near	Manual	49	2	20-30	Nonuser	Female	32	169	1506	276308	0.005	Flow C
Near	Manual	22	2	40-50	User	Male	16	25	245	44399	0.005	Ultra
Near	Manual	96	5	40-50	User	Female	66	229	1722	256894	0.007	Flow C
Near	Manual	69	2	60-70	User	Female	27	77	567	83987	0.007	Flow C

Measure	Mode	ID	Test Time	Age	Cruise Usage	Gender	Trips	Transitions	Time True	Time False	Prob.	Style
Near	Manual	107	2	60-70	Nonuser	Male	17	80	792	117114	0.007	Extrem
Near	Manual	38	2	20-30	Nonuser	Female	6	10	52	7342	0.007	Ultra
Near	Manual	108	2	60-70	Nonuser	Male	15	39	199	27603	0.007	Ultra
Near	Manual	92	5	40-50	User	Male	32	97	779	106336	0.007	Flow C
----- 25th percentile -----												
Near	Manual	13	2	60-70	User	Female	19	56	257	34787	0.007	Extrem
Near	Manual	66	5	60-70	User	Male	65	138	1079	145869	0.007	Plan
Near	Manual	9	2	40-50	User	Female	36	109	1049	134431	0.008	Extrem
Near	Manual	93	2	20-30	Nonuser	Male	37	117	700	87600	0.008	Plan
Near	Manual	110	2	60-70	Nonuser	Male	46	247	1821	223787	0.008	Flow C
Near	Manual	34	2	40-50	Nonuser	Male	37	161	1720	206780	0.008	Flow C
Near	Manual	23	2	40-50	Nonuser	Female	19	43	232	27246	0.008	Ultra
Near	Manual	65	2	60-70	User	Female	21	110	1357	138207	0.010	Flow C
Near	Manual	30	2	20-30	User	Female	32	67	420	42065	0.010	Plan
Near	Manual	47	2	60-70	User	Male	19	46	513	49726	0.010	Plan
Near	Manual	68	5	20-30	User	Male	78	809	9269	834892	0.011	Flow C
Near	Manual	5	2	40-50	User	Female	38	138	1504	134299	0.011	Plan
Near	Manual	15	2	20-30	User	Female	20	134	1162	96630	0.012	Flow C
Near	Manual	18	2	60-70	User	Male	30	64	491	40696	0.012	Flow C
Near	Manual	11	2	60-70	User	Male	28	62	507	40778	0.012	Plan
Near	Manual	94	2	40-50	Nonuser	Male	28	150	1634	128871	0.013	Flow C
Near	Manual	61	2	20-30	User	Male	46	317	3755	283013	0.013	Plan
Near	Manual	63	2	20-30	Nonuser	Male	92	239	2270	170890	0.013	Plan
Near	Manual	79	5	20-30	User	Female	74	222	2009	148376	0.013	Plan
Near	Manual	54	2	20-30	User	Male	41	192	1281	93088	0.014	Flow C
Near	Manual	57	2	60-70	User	Female	18	63	417	30276	0.014	Ultra
Near	Manual	75	2	40-50	Nonuser	Male	49	219	1785	128167	0.014	Plan
Near	Manual	91	2	60-70	Nonuser	Female	20	36	300	20722	0.014	Ultra
Near	Manual	8	2	40-50	User	Female	33	106	2068	142566	0.014	Ultra
Near	Manual	81	5	40-50	User	Male	91	349	4010	256295	0.015	Flow C
Near	Manual	44	2	20-30	Nonuser	Female	91	469	3201	200003	0.016	Extrem
Near	Manual	97	5	60-70	User	Female	80	457	2332	142662	0.016	Flow C
----- 50th percentile -----												
Near	Manual	105	2	40-50	User	Male	28	202	2343	139061	0.017	Flow C
Near	Manual	37	2	20-30	User	Male	44	178	1720	101476	0.017	Hunter
Near	Manual	90	5	60-70	User	Female	36	169	2176	121079	0.018	Flow C
Near	Manual	62	5	60-70	User	Male	100	220	2062	113803	0.018	Extrem
Near	Manual	55	5	20-30	User	Male	101	259	3093	164305	0.018	Plan
Near	Manual	7	2	60-70	User	Male	28	270	5905	301283	0.019	Plan
Near	Manual	77	5	60-70	User	Female	107	369	4692	235545	0.020	Flow C
Near	Manual	56	5	20-30	User	Female	75	371	5823	280963	0.020	Flow C
Near	Manual	21	2	40-50	User	Female	30	141	1708	81609	0.021	Hunter
Near	Manual	43	2	60-70	Nonuser	Female	26	83	716	33516	0.021	Extrem
Near	Manual	70	5	60-70	User	Female	47	391	1900	88377	0.021	Ultra
Near	Manual	117	2	40-50	Nonuser	Male	42	406	4865	218734	0.022	Flow C
Near	Manual	98	2	20-30	Nonuser	Male	23	252	2925	130525	0.022	Extrem
Near	Manual	24	2	40-50	User	Female	13	43	471	20835	0.022	Extrem
Near	Manual	88	5	40-50	User	Female	48	499	6704	294114	0.022	Hunter
Near	Manual	29	2	40-50	Nonuser	Female	28	146	2708	114568	0.023	Plan
Near	Manual	111	2	40-50	Nonuser	Male	45	521	7279	302328	0.024	Hunter
Near	Manual	89	5	20-30	User	Male	101	830	9911	406198	0.024	Plan
Near	Manual	3	2	40-50	User	Male	21	94	1162	44891	0.025	Extrem
Near	Manual	100	5	40-50	User	Male	115	647	9596	367584	0.025	Flow C
Near	Manual	12	2	40-50	User	Female	39	168	2326	87355	0.026	Hunter
Near	Manual	39	2	20-30	Nonuser	Female	28	295	1956	71830	0.027	Flow C
Near	Manual	33	2	20-30	User	Male	37	485	2454	89699	0.027	Flow C
Near	Manual	99	5	40-50	User	Female	110	632	8487	302048	0.027	Hunter
Near	Manual	1	2	40-50	Nonuser	Female	34	136	3469	119256	0.028	Hunter
Near	Manual	17	2	40-50	User	Male	26	146	913	30088	0.029	Flow C

Measure	Mode	ID	Test Time	Age	Cruise Usage	Gender	Trips	Transitions	Time True	Time False	Prob.	Style
Near	Manual	84	2	40-50	Nonuser	Female	20	460	3031	98931	0.030	Flow C
----- 75th percentile -----												
Near	Manual	78	5	40-50	User	Male	74	714	4505	146629	0.030	Plan
Near	Manual	32	2	60-70	User	Male	40	194	2621	85209	0.030	Flow C
Near	Manual	74	2	40-50	User	Male	20	84	925	29437	0.030	Hunter
Near	Manual	19	2	60-70	User	Male	34	113	1649	47931	0.033	Hunter
Near	Manual	4	2	20-30	Nonuser	Male	47	377	8652	250152	0.033	Hunter
Near	Manual	76	5	20-30	User	Male	85	677	9831	274788	0.035	Hunter
Near	Manual	112	2	40-50	Nonuser	Male	45	376	4889	135643	0.035	Flow C
Near	Manual	103	2	60-70	Nonuser	Male	15	243	1910	52011	0.035	Extrem
Near	Manual	50	2	20-30	User	Female	80	470	7151	175416	0.039	Extrem
Near	Manual	80	2	40-50	Nonuser	Female	31	458	7006	169141	0.040	Hunter
Near	Manual	27	2	20-30	Nonuser	Female	17	94	2817	61714	0.044	Plan
Near	Manual	31	2	20-30	Nonuser	Female	33	446	6165	126521	0.046	Hunter
Near	Manual	109	2	20-30	Nonuser	Male	32	466	7497	147901	0.048	Hunter
Near	Manual	10	2	20-30	User	Female	33	233	6525	124573	0.050	Hunter
Near	Manual	52	2	20-30	User	Female	49	850	1252	207605	0.057	Hunter
Near	Manual	85	5	60-70	User	Male	132	1691	2796	436229	0.060	Hunter
Near	Manual	73	5	20-30	User	Female	100	1050	1979	307515	0.060	Hunter
Near	Manual	42	2	20-30	User	Female	14	186	4043	62639	0.061	Hunter
Near	Manual	14	2	40-50	User	Male	35	282	5866	89051	0.062	Hunter
Near	Manual	59	2	20-30	User	Male	46	658	1074	161924	0.062	Hunter
Near	Manual	51	2	20-30	User	Female	15	195	1987	29399	0.063	Extrem
Near	Manual	26	2	40-50	Nonuser	Female	20	411	4945	72878	0.064	Flow C
Near	Manual	64	2	20-30	User	Male	41	481	9562	139327	0.064	Hunter
Near	Manual	87	5	20-30	User	Female	125	1193	2237	318814	0.066	Hunter
Near	Manual	60	2	20-30	User	Male	25	177	3088	35312	0.080	Hunter
Near	Manual	41	2	20-30	Nonuser	Male	27	274	5156	52455	0.089	Extrem
Near	Manual	114	2	20-30	Nonuser	Male	41	1088	1659	120257	0.121	Hunter
----- 100th percentile -----												

The confliction information given in Table 36 is plotted in Figure 50. This figure shows that there is a gradual increase in confliction up to about the 81st driver in the order of increasing confliction (that is, up to the 75th percentile where the drivers in places 82 to 108 are in the last quartile in this plot of 108 drivers).

Probability of "Near"
(Confliction)

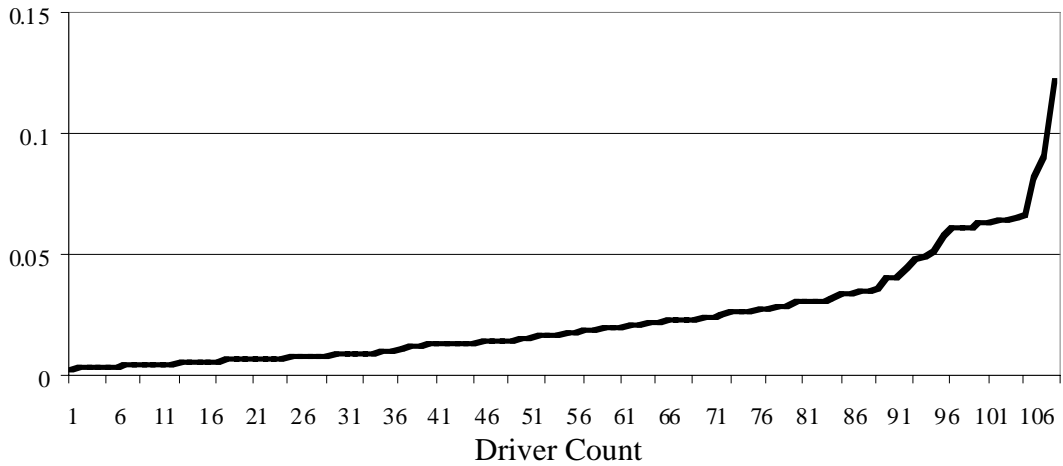

Figure 50. Confliction values from lowest to highest

The last three drivers in the plot have extraordinarily large values of confliction with frequencies of 0.08, 0.089, and 0.121 as listed in the table. The extreme confliction-related performance of these drivers could be due to chance (poor luck) but nevertheless the prospect of spending 8 to 12 percent of the time in the near region is reason to wonder how uncomfortable one would be when riding with these drivers.

Further insight into driver behavior can be obtained from results for the driving style classifications described in section 5.6. The last column of Table 36 provides a list specifying the driving style of each driver. Inspection of this table indicates that flow conformists (Flow C), planners (Plan), and extremists (Extrem) are fairly well spread out over the range of confliction. The ultraconservatives (Ultra) tend to be in the lowest quartile (below the 25th) with only one ultraconservative above the 50th percentile of confliction. The hunter/tailgaters (Hunter) tend to be above the 75th percentile with none of them below the 50th percentile of confliction. Apparently confliction level is strongly related to ultraconservative and hunter/tailgater tendencies as one might expect.

In order to allow the reader's eye to inspect the style of many drivers quickly, the small multiples technique has been used to create Figure 51. Each multiple appearing in the figure is based on the discussion accompanying Figure 46 in section 5.6. The multiples are arranged in an order determined by the driver's driving style first and then by the area of the "diamond" corresponding to the frequencies of A, B, C, and D representing far, fast, close, and slow as indicated in the key to Figure 51.

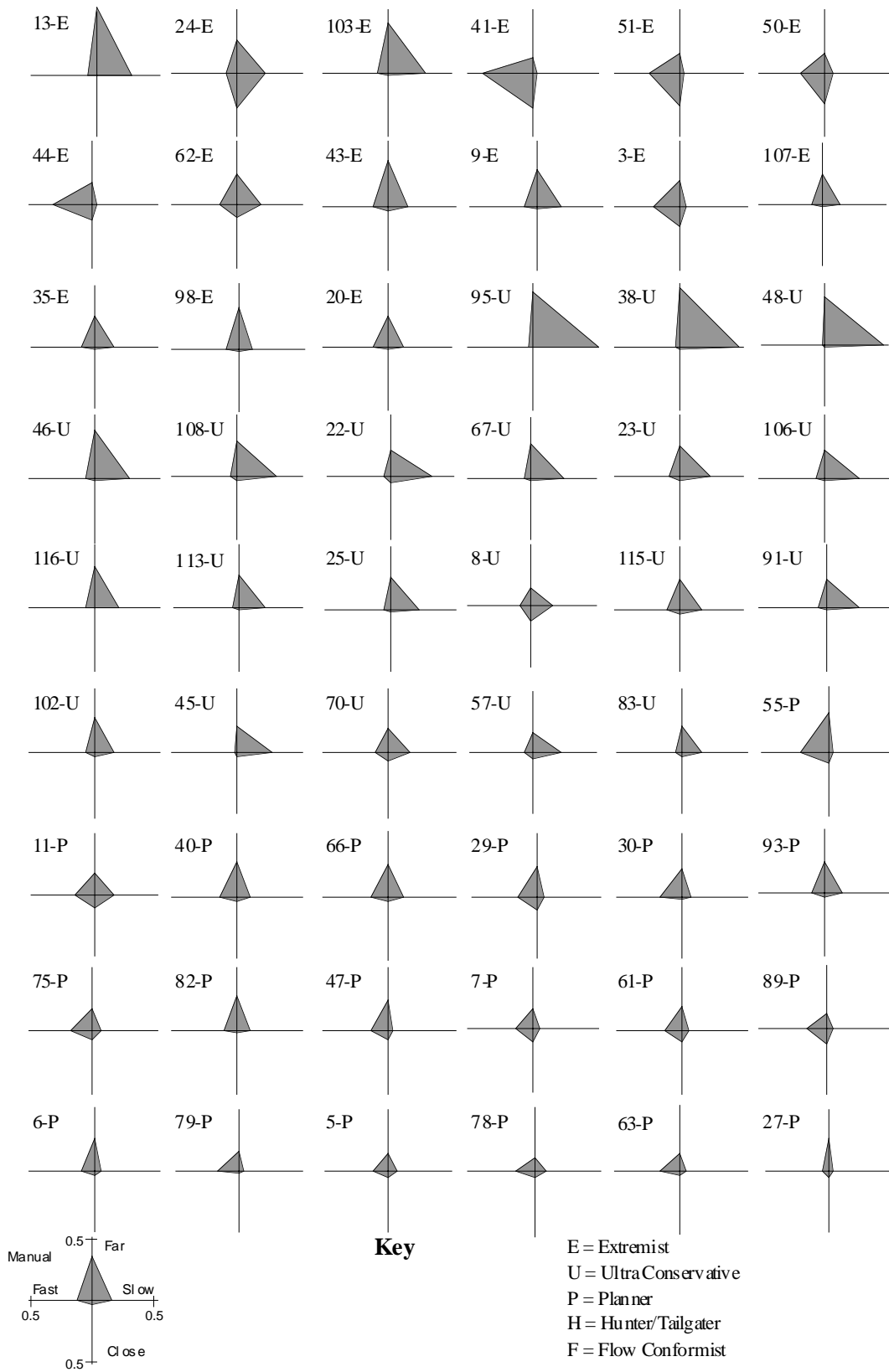
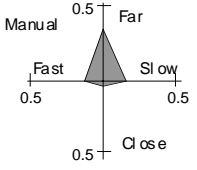
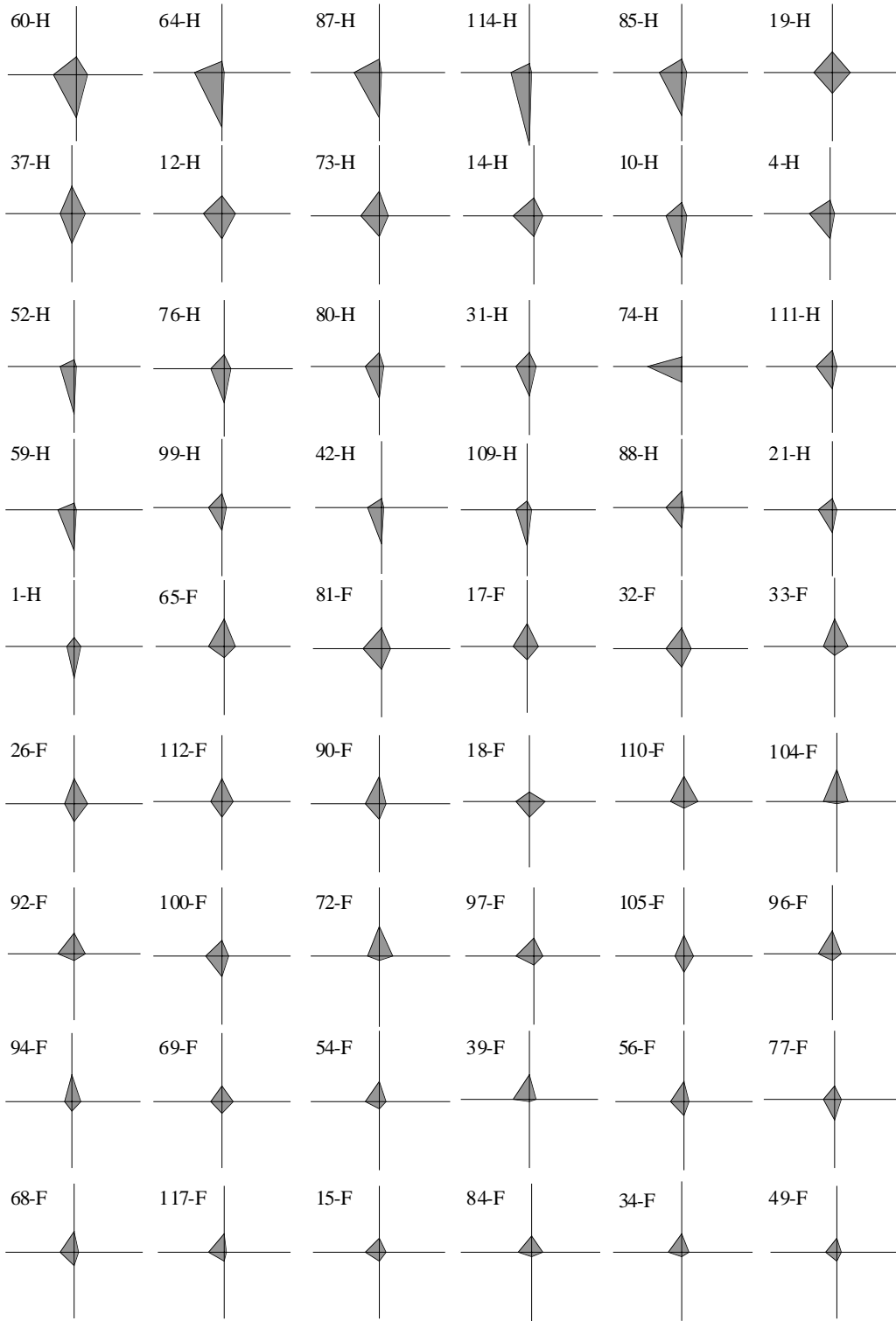

Figure 51. Manual driving behavior for individual drivers (velocity > 55 mph)



Key

- E = Extremist
- U = Ultra Conservative
- P = Planner
- H = Hunter/Tailgater
- F = Flow Conformist

Figure 51. Manual driving behavior for individual drivers (velocity > 55 mph) (*Cont.*)

The first fifteen drivers displayed in Figure 51 are extremists, which means that these drivers have more than one tendency to operate above the 75th percentile in some type of driving behavior. It can be seen that there are different types of shapes depending upon which driving factors (far, fast, close, or slow) contributed to the extremist rating.

Next are the ultraconservatives. There are 20 of them. The areas of some of these multiples are relatively large because there is ample opportunity to operate with slow and/or far properties in most driving situations. Clearly the miniatures for ultraconservatives tend to emphasize the slow and far factors. Many of these multiples are practically triangular in shape.

The 19 planners come next. The extremists, ultraconservatives, and planners make up one-half (54) of the drivers. The miniatures for the planners are distinguished by fast and far tendencies (note that the miniature for driver 55 is provided in an enlarged format in Figure 48 in section 5.6). It is interesting to note that there are many drivers who are able to work their way through traffic and remain far from the car ahead. Apparently going fast alone does not mean the driver is a hunter/tailgater. Being a planner means that the driver does not travel close to the car ahead. Somehow, either by the selection of roads and travel times or by very careful execution of driving tactics, the planner succeeds in traveling faster than the other vehicles nearby without getting close to them—the best of all worlds in some sense.

There are 25 hunter/tailgaters. Inspections of the corresponding miniatures shows that many of the hunter/tailgaters seem to be primarily tailgaters in the sense that they have a propensity for close travel even though they tend to go approximately at the speed of the car ahead of them. Driver number 114, who is a hunter and has the highest confliction rating, has a close factor that goes off of the scale allotted to the close dimension in these multiples. This means that the observed frequency of being closer than 0.65 seconds is more than 0.5 (that is, more than 50 percent of the time). It is interesting to note that hunter/tailgaters are the second most prevalent class of drivers according to the methods used here for classifying drivers.

The classification containing the most drivers is the flow conformist class. There are 29 flow conformists. The areas of the miniatures for the flow conformists tend to be smaller than those for the other classifications because these drivers have lower frequencies of being far, fast, close, or slow. Consequently, the miniatures for the last few flow conformists are remarkably small.

Although section 8 tends to emphasize combined descriptive statistics for groups of drivers, there is a need to remember that there are 108 different stories here. When it comes to issues such as those treated in section 9, the experiences and properties of particular individuals may be as important as the combined experience of groups of people.

7.0 Summary Statistics of the Driving Exposure

During the field test, from July 1996 through September 1997, a total of 117 subjects met the requirements of the driver screening process and were given a test vehicle. For these drivers, the on-board data-acquisition system (DAS) logged a total of 12,199 trips, 131,378 miles, and 3,432 hours of driving. However, not all drivers were used to constitute the sample of 108 that were needed to meet the requirements of the study's experimental design. Nine drivers were excluded from the study for reasons ranging from an accident to lack of use of the test vehicle. The driver number, vehicle number and the reason for excluding the nine deleted drivers are shown in Table 37. A more comprehensive discussion of problems known to exist in the data set and with the vehicles can be found in section 4.5.

Table 37. Drivers removed from the study

Driver	Car No.	Comments
2	3	No video capability – the car was struck from behind
16	8	Vehicle returned with sensor error
28	9	Bad fuse & headlight switch
36	4	Too many participants in Cell
53	0	Too many participants in Cell
58	1	E-box failure
71	9	Recalled - intended 5wk but subject stopped driving
86	5	Recalled - fuse & over temp
101	5	Headlight switch failure

For the remaining portion of this report, the results and findings will be based on the information collected from the set of 108 drivers. These data were also screened to remove any trips that were identified to contain problems and/or anomalies. For the entire set of 108 drivers, the *valid* data show a total of 11,092 trips, over 114,044 miles and a duration of 3,049 hours. The 108 drivers accumulated a total of 45,797 miles of engaged driving in both ACC and CCC, which results in an overall utilization (distance engaged / total distance) for both ACC and CCC modes of control of 40 percent. These statistics are shown in Table 38 along with per-driver average values for each exposure measure.

Table 38. Exposure summary for all drivers and for the individual average driver

Exposure	All Drivers	Average per Driver
Trips	11,092	102.7
Distance, miles	114,044	1,056
Manual distance	68,247	632
Engaged distance	45,797	424
Time, hours	3,049	28.2

Note: these average values are for all drivers taken as a group. The numbers are not corrected for different driver exposure times, more specifically two- and five-week test periods. A more comprehensive exposure summary that accounts for the different cells of the experimental design, along with road type and driving style is covered below.

7.1 Exposure by Time and Mileage for Different Driver Groups

Of the 3,051 hours driven in the FOT, manual driving comprised the largest component of the total time with 2350 hours (77 percent) in this mode while ACC and CCC engagement time constituted only 534 and 165 hours (17.5 and 5.4 percent), respectively. These numbers are shown in Figure 52. Certainly when considering the time spent on short trips and at low speed, (e.g., zero speed while waiting at traffic signals, stop signs, etc.) it is not too surprising that much of the time accumulated in the vehicles is in the manual mode.

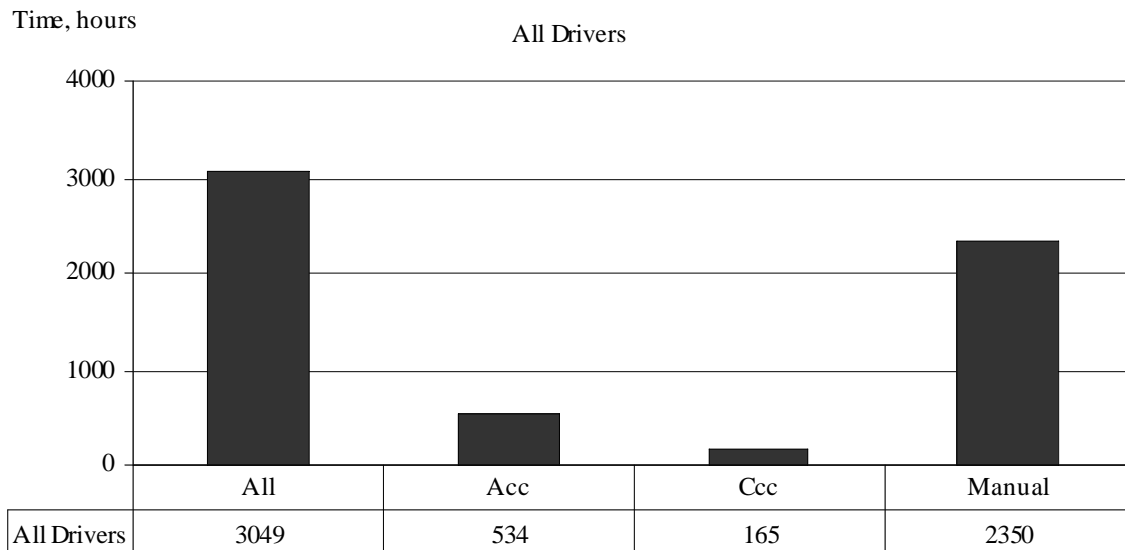

Figure 52. Exposure time for all drivers as function of driving mode

If exposure is measured in terms of distance, the relative percentages between modes change. Shown in Figure 53 are the distances traveled in each of the three driving modes. As the figure shows, of the 114,044 miles, 68,247 (59.8 percent) were driven in the manual mode, while 35,033 and 10,764 miles (30.7 and 9.5 percent) were driven with ACC or CCC engaged, respectively.

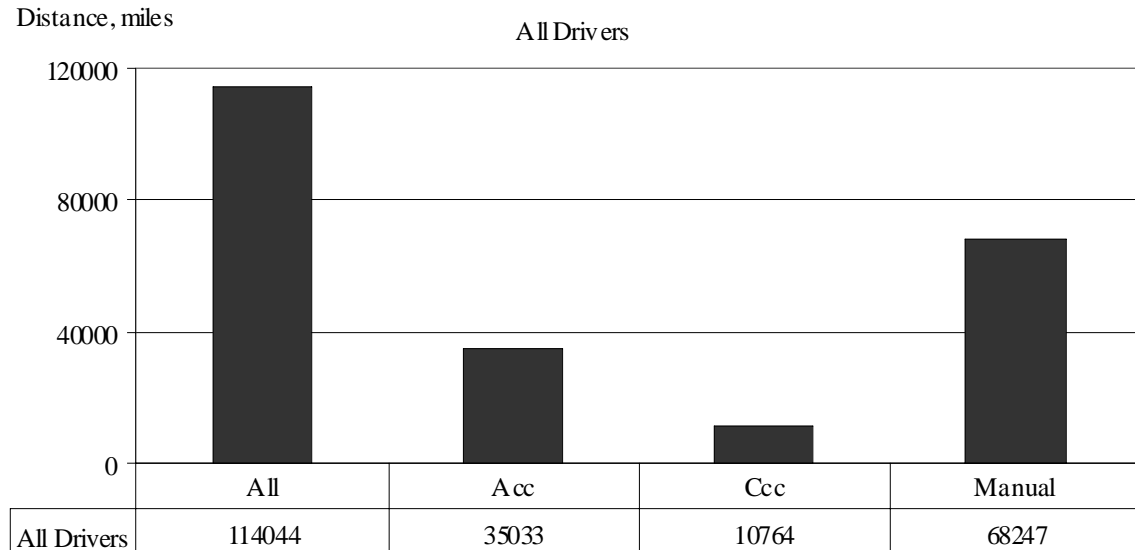

Figure 53. Exposure distance for all drivers as function of driving mode

However, to more fairly compare the manual experience with that of ACC (and CCC), the speed of the vehicle must be considered when accumulating time and distance in each mode. The cruise control in the FOT vehicles had a low speed cut-off velocity of approximately 30 mph. Hence, any time or distance accumulated at or below this speed only contributes to exposure in the manual mode. Furthermore, it was observed in the FOT that drivers are much more likely to use ACC or CCC on high-speed roads such as highways and interstates (see section 7.3 for details) and, therefore, at velocities that are typically above 55 mph. Given these observations, the exposure time and distance results have been further subdivided into two velocity ranges. The first range covers speeds between 35 and 55 mph, while the high-speed segment covers speeds from 55 to 85 mph.

An upper speed limit of 85 mph is used here since this is the highest set-speed value allowed by the ACC system. Data were collected above this velocity for both manual and engaged driving modes (the latter of which required manually overriding the ACC system in order to exceed 85 mph) but the time and mileages are insignificant relative to the exposure at speeds between 35 and 85 mph. In some figures, the 55-to-85-mph range is simply shown as 55 mph and above.

The following subsections (7.1.1 through 7.1.3) discuss exposure in terms of time and distance under the different driving modes, for all driver groups. The accompanying figures used to illustrate the exposure share the same format. Each figure is divided into three graphs showing different driver groups. For example, Figure 54 shows exposure time for three different velocity ranges. The top part (bar graph and table) of Figure 54 shows exposure time for all velocities and all drivers as a function of the different cells in the experimental design. The middle part (bar graph and table) of this figure, shows the exposure for only two-week drivers while the bottom part details the exposure for only five-week drivers. (Note: all five week drivers were “cruise users” by selection.)

Care must be exercised when comparing the different experimental design cells shown in these figures. For example, the left-most cells of the exposure time representing all drivers at all speeds (i.e., in the top graph and table of Figure 54) shows the amount of time in each driving mode for five-week and two-week drivers. The five-week and two-week drivers showed a total of 274 and 259 hours, respectively, with ACC engaged. Although it is true that in the aggregate the five-week drivers spent more time in ACC, this result is not true when normalized on a per-driver-week basis. There were 24 five-week drivers who each had an ACC-enabled time period of four weeks. Therefore, on average, each five-week driver used the ACC system for 2.85 hours per week. However, there were 84 two-week drivers who each had ACC enabled for a one-week period. Therefore, the average two-week driver had an ACC exposure of 3.1 hours per week. Having expressed this concern, it is clear that comparing exposure differences between the experimental design cells has to account for the underlying choices in the design of the FOT. The observations made in subsections 7.1.1 through 7.1.3 are based on exposure numbers that have a similar basis in terms of driver count and test period.

The driver groups shown in Figure 54 (and in the following figures) do not cover all the possible combinations. The reader should note, however, that appendix C presents a grand summary of exposures for all combinations of driver groups along with each of the possible driving modes and sample periods. The word “All” in appendix C refers to grouping of all possibilities for a given category. For example, “All” under the mode category aggregates across all driving modes, whereas, “All” in the gender category groups both male and female drivers together. In addition to the time and mileage summaries appendix C also provides a count field to indicate the number of drivers that constitute each grouping.

Time, hours

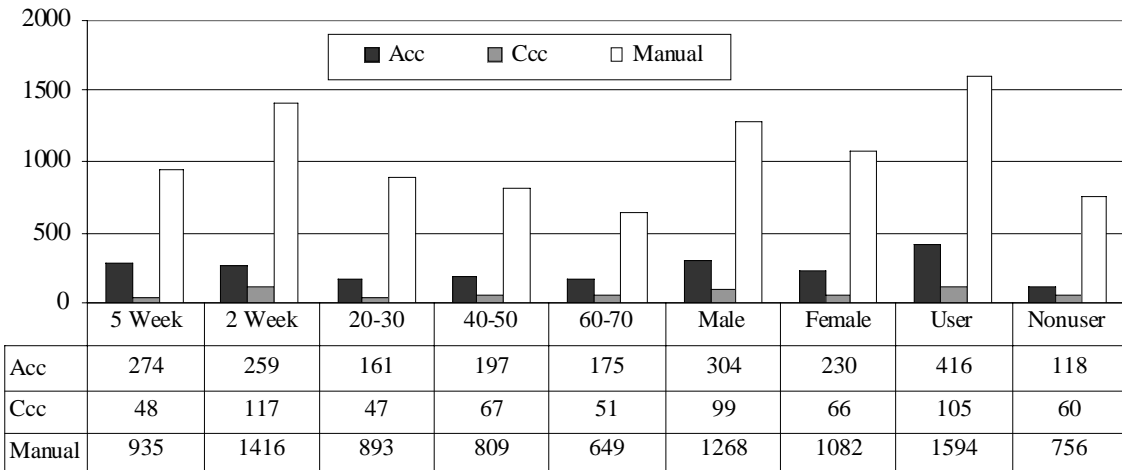

Time for 2 Week Drivers, hours

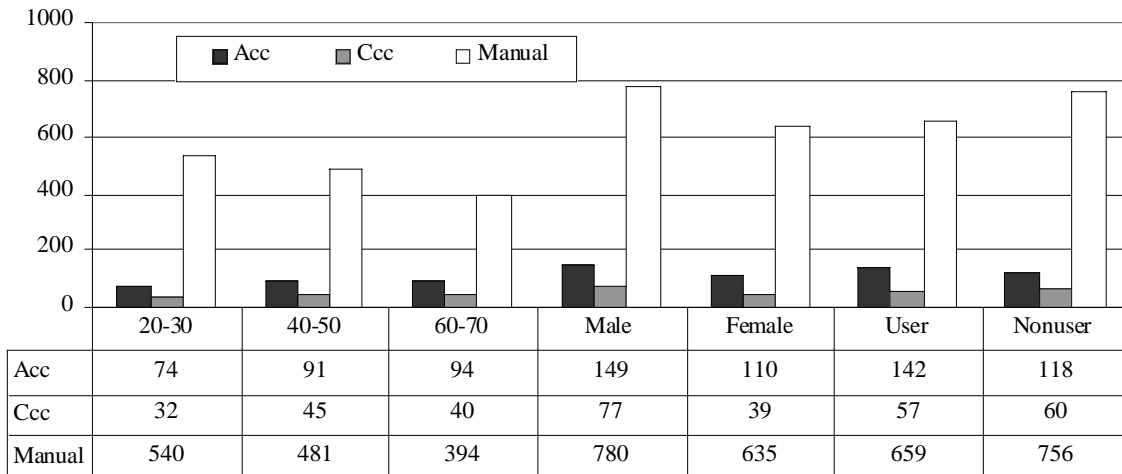

Time for 5 Week Drivers, hours

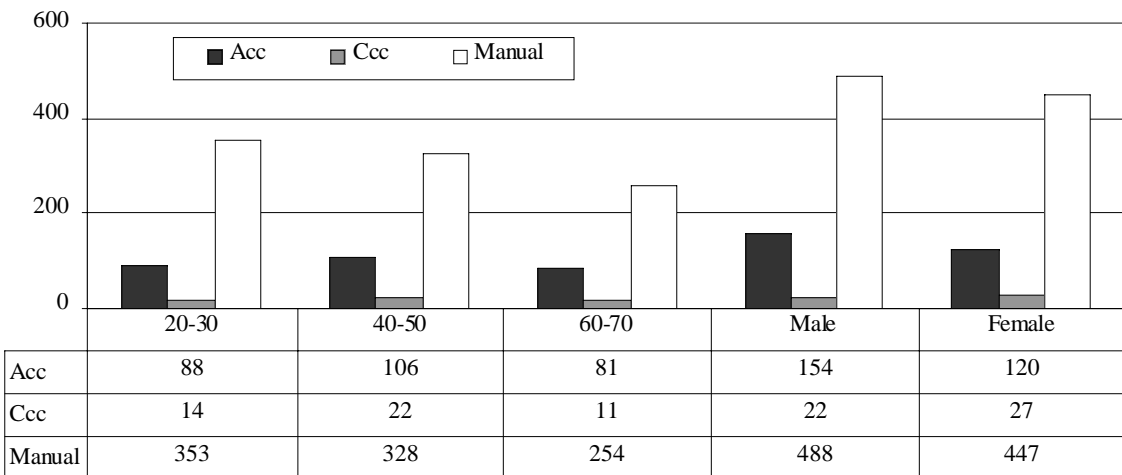

Figure 54. Exposure time for all velocities

7.1.1 Driving Mode Exposure Time as Depends Upon Speed Range and Driver Age

Overall, Figures 55 and 56 clearly show that driving-mode exposure time is dependent on speed. Figure 55 shows that for velocities between 35 and 55 mph, the time spent in the manual mode is clearly dominant. Figure 56, covering velocities above 55 mph, shows that the exposure time while in a cruise-engaged mode is larger than the manual-driving exposure. Furthermore, in many of the driver groupings (e.g., all five-week driver groups) exposure time in the ACC mode alone is larger than that of the manual mode for this velocity range.

In general, for the 35 to 55 mph velocity range shown in Figure 55, the 60-to-70-year-old group (both the two-week and five-week variety) shows more exposure to both ACC and CCC than any other age group or driver category. As a percentage of all driving, this group used a cruise mode approximately 20 percent of the time, while other driver groups averaged around 11 percent. This relatively high rate of exposure for the 60 to 70 year olds is also true at speeds above 55 mph. Although the relationship is not as striking at the high speed, it is still relevant and supports the general observation that choice of driving mode does have an age dependency and that 60 to 70 year old drivers are more likely than other age groups to use either CCC or ACC at all enabled velocities.

7.1.2 The ACC and CCC Exposure Time of Nonusers Versus Users

To compare nonuser and users, only the two-week data have an equal representation in terms of drivers and test time. Interestingly, for the 35 to 55 mph velocity range there is little difference in the amount of exposure time for drivers who classified themselves as users and nonusers. As shown in Figure 55 both groups used ACC for 17 hours at the lower speed range. When considering the higher speed range of Figure 56, however, the users do show more exposure to ACC but less to CCC.

Time, hours (35 mph <= Velocity < 55 mph)

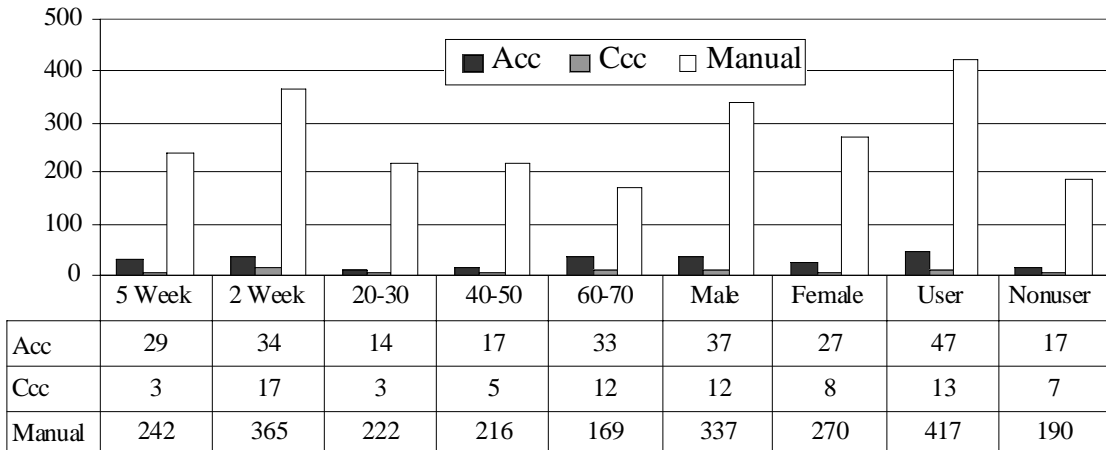

Time for 2 Week Drivers, hours (35 mph <= Velocity < 55 mph)

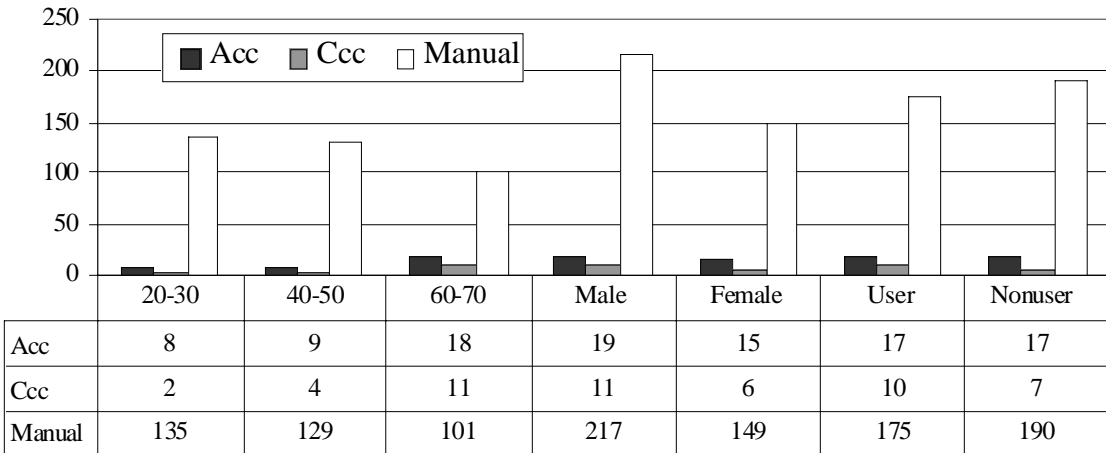

Time for 5 Week Drivers, hours (35 mph <= Velocity < 55 mph)

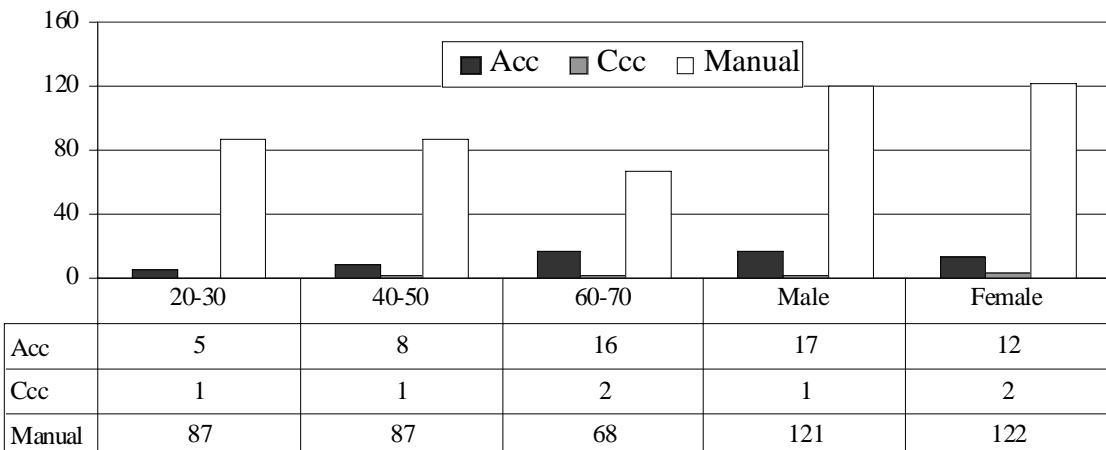
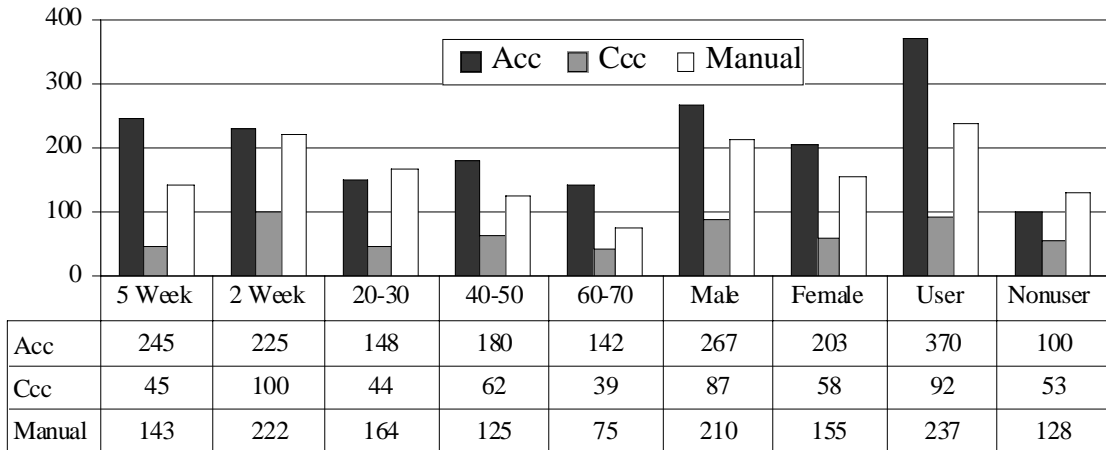
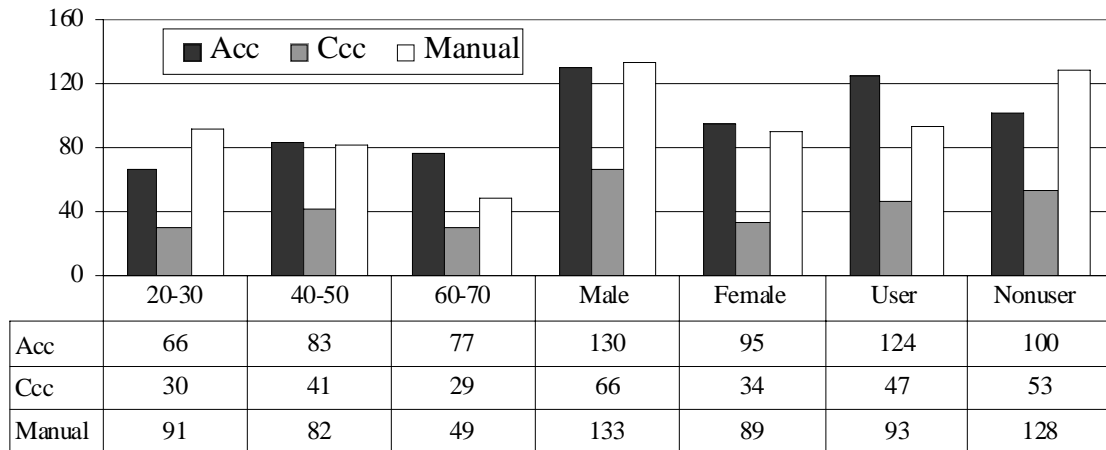

Figure 55. Exposure time for velocities between 35 and 55 mph.

Time, hours (Velocity > 55 mph)



Time for 2 Week Drivers, hours (Velocity > 55 mph)



Time for 5 Week Drivers, hours (Velocity > 55 mph)

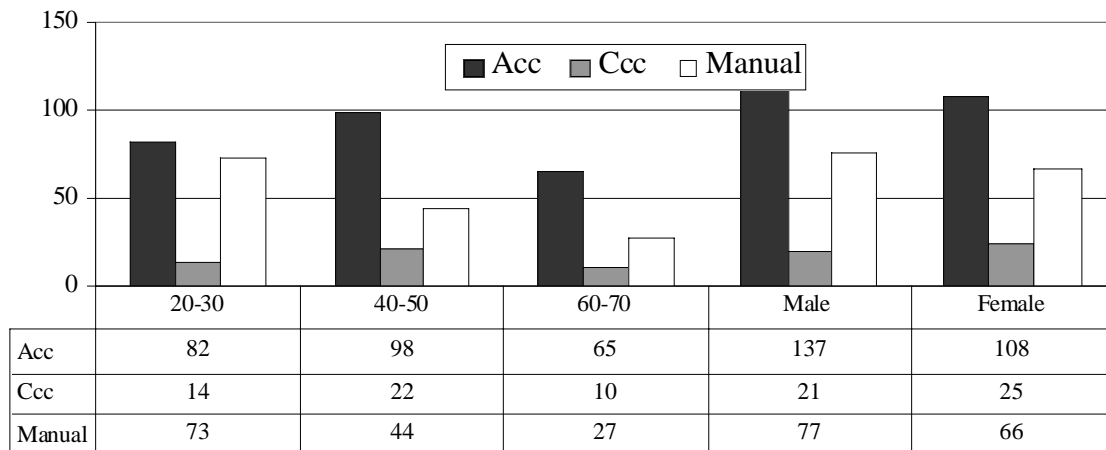

Figure 56. Exposure time for velocities above 55 mph

7.1.3 Exposure Distance

Exposure distances for the different driver groups and velocity ranges are shown in Figures 57 through 59. The trends and relationships observed in the exposure time can also be seen in the exposure distance results.

The largest differences between the exposure time and distance results can be observed when comparing Figures 54 and 57, which summarize the exposures over all velocities. Since time will accumulate faster than distance at slower speeds, large differences in the exposure contrast across the three driving modes for the various driver groups can be observed between these two figures. Figure 57 shows the larger representation of ACC and CCC exposure distance relative to that of manual driving than is seen in the time data of Figure 54.

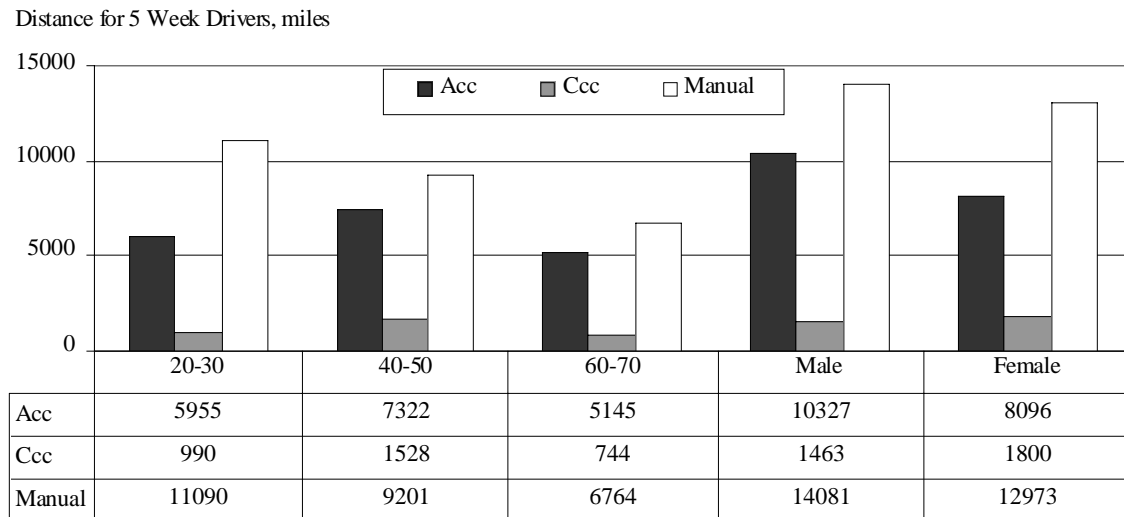
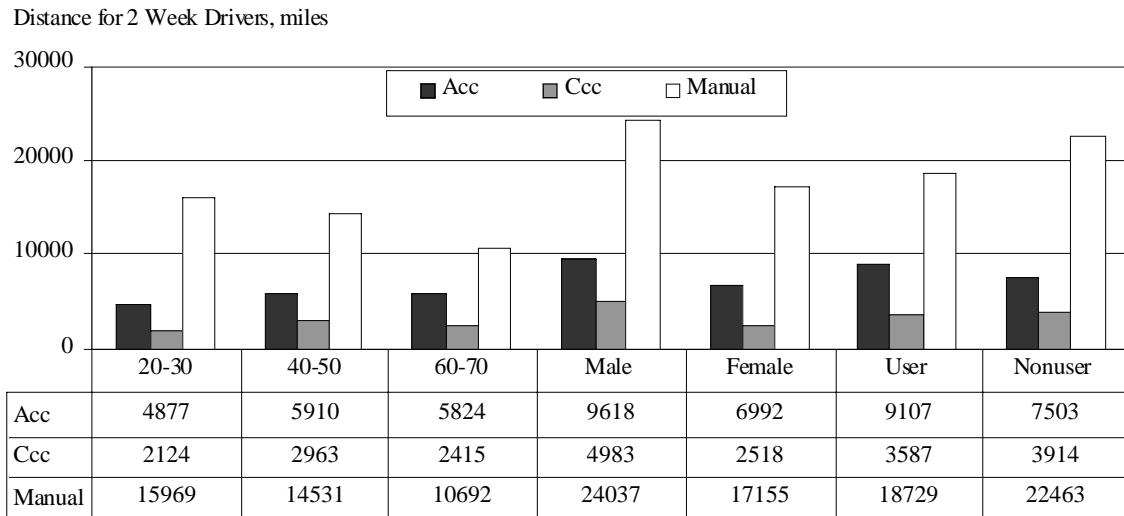
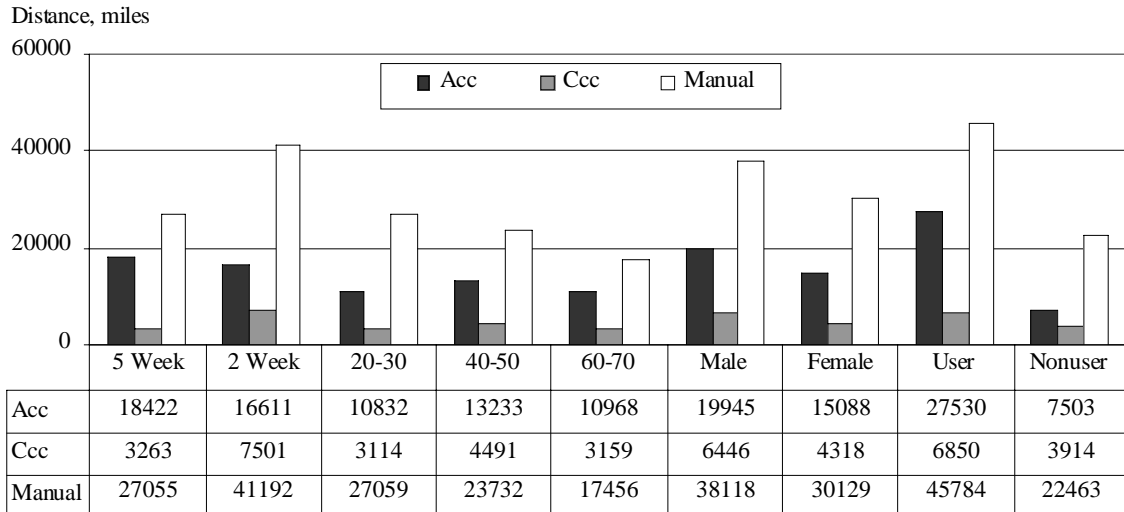
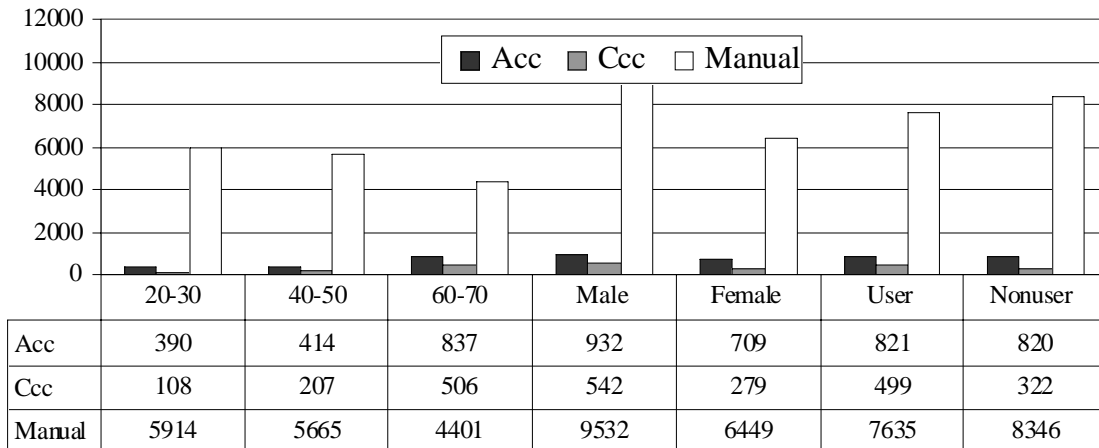
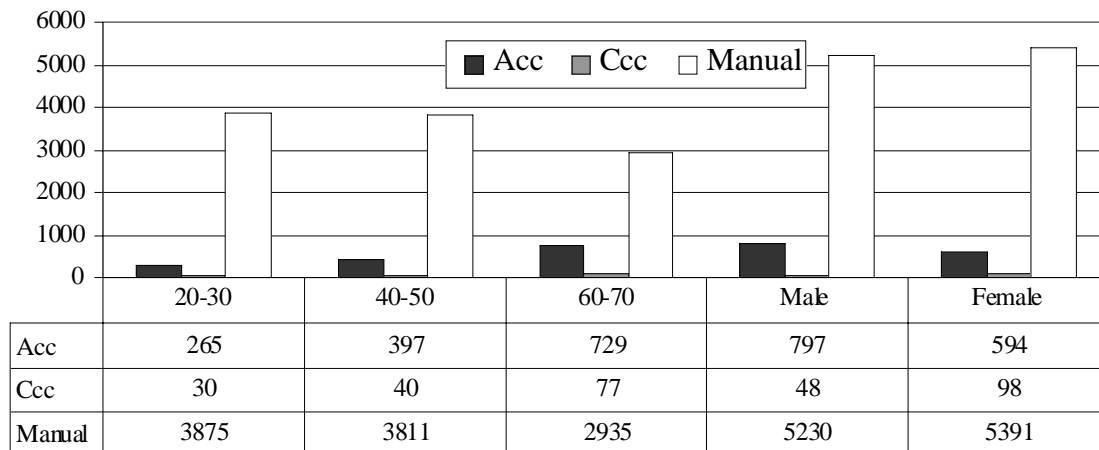

Figure 57. Exposure distance for all velocities

Distance for 2 Week Drivers, miles (35 mph <= Velocity < 55 mph)



Distance for 5 Week Drivers, miles (35 mph <= Velocity < 55 mph)



Distance, miles (35 mph <= Velocity < 55 mph)

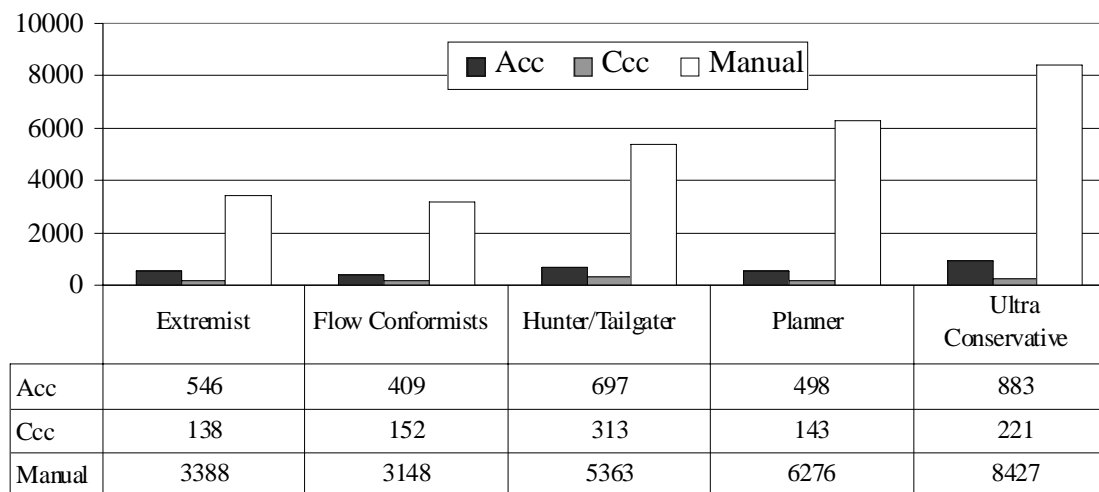
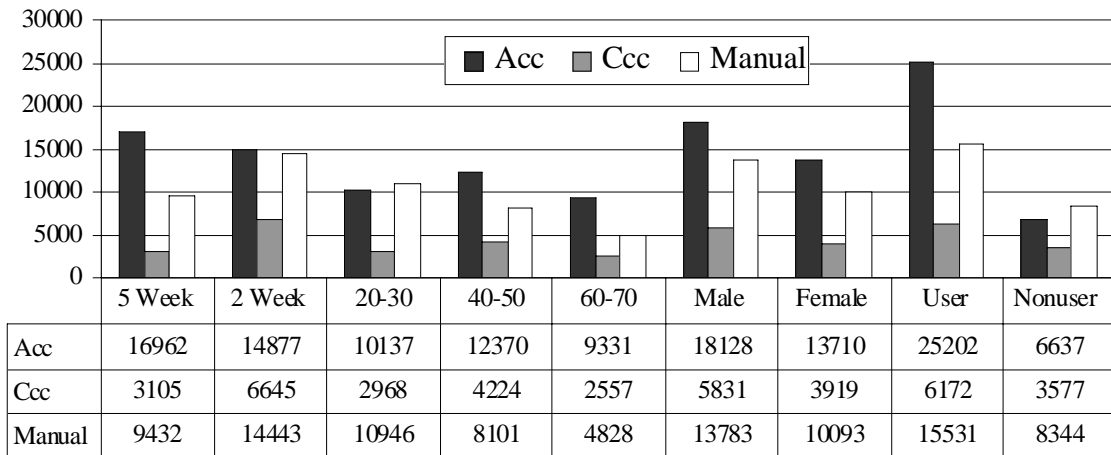
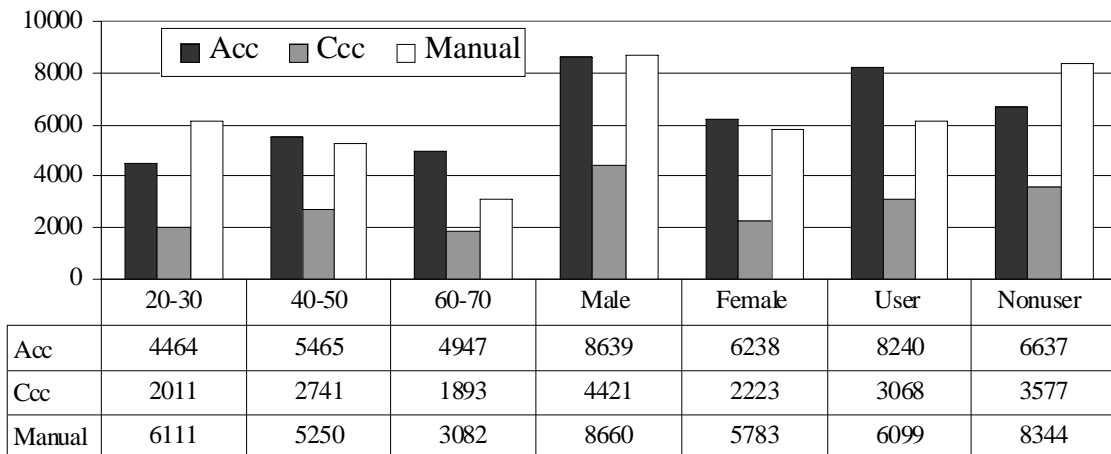

Figure 58. Exposure distance for velocities between 35 and 55 mph

Distance, miles (Velocity > 55 mph)



Distance for 2 Week Drivers, miles (Velocity > 55 mph)



Distance for 5 Week Drivers, miles (Velocity > 55 mph)

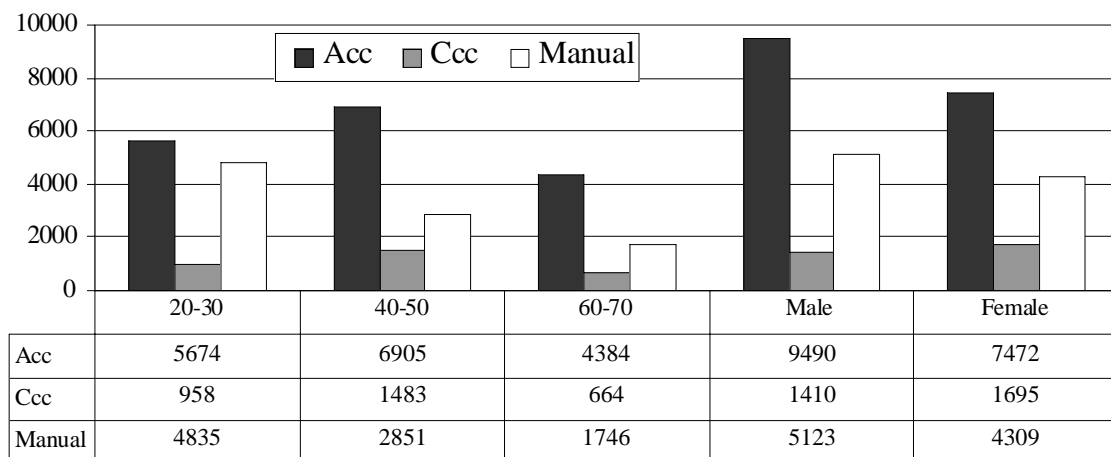

Figure 59. Exposure distance for velocities above 55 mph

7.2 Exposure by Time and Mileage for individual drivers

Exposure varied considerably across individuals during the FOT. In one case a five-week driver traveled a total of 3975 miles during the test period. At the other extreme a different driver logged only 227.7 miles. The five drivers that logged the most miles in all three driving modes are shown in Table 39. (Note that one of these is a two-week driver who traveled a total of 2829.4 miles in only twelve days.) Shown in the table is the general driver profile information along with the total number of miles traveled in ACC and CCC. Three out of five drivers in the table belong to the 20-to-30-year-old category. Of the five drivers, these three also had the least number of ACC miles. A female in the 40-to-50-year-old group who traveled 2339 out of a total of 3847 miles in ACC logged the most ACC miles. Only one driver had an unusually high exposure to CCC, traveling a total of 662.7 miles with CCC engaged.

Table 39. The five highest mileage drivers

ID	Test time	Age	Usage	Gender	Total, miles	MANUAL	ACC	CCC
68	5 Weeks	20-30	User	Male	3975.4	2766.9	1036.6	171.9
99	5 Weeks	40-50	User	Female	3847.5	1288.4	2339.5	219.6
89	5 Weeks	20-30	User	Male	3197.3	1702	1378.6	116.7
40	5 Weeks	60-70	User	Male	2977.0	877.5	2072.9	26.6
98	2 Weeks	20-30	Nonuser	Male	2829.4	1320.6	846.1	662.7

Table 40 shows the five drivers who accumulated the lowest total mileages during the FOT. All these drivers had the vehicle for two weeks. A 60-to-70-year-old nonuser female drove the shortest distance logging only 227.7 miles of which 63 and 9 were engaged in ACC and CCC, respectively. Of this group, driver 41, a male in the 20-to-30-year-old group drove the least distance in ACC. (It should be noted that five other drivers in the field test drove less than the indicated 36.8 miles in the ACC mode, ranging from 15.5 to 32.7 miles of ACC engagement. Of these drivers, four of them fell into the 20-to-30-year-old age category. For a complete list of miles driven in the different modalities see the tables of appendix C.)

Table 40. The five lowest mileage drivers

ID	Test time	Age	Usage	Gender	Total, miles	MANUAL	ACC	CCC
83	2 Weeks	60-70	Nonuser	Female	227.7	155.7	62.7	9.3
74	2 Weeks	40-50	User	Male	270.8	151.3	71.7	47.8
41	2 Weeks	20-30	Nonuser	Male	287.7	250.9	36.8	0.0
57	2 Weeks	60-70	User	Female	308.0	199.8	69.7	38.5
60	2 Weeks	20-30	User	Male	313.6	193.4	71.3	48.9

Figures 60 and 61 show ordered distributions, from lowest to highest, of distances driven in all three modes across the full 108-driver count for two-week and five-week drivers in the 35 to 55 mph and 55 to 85 mph speed ranges, respectively. Overall, the distributions are similar for both five- and two-week drivers. In both cases, a majority of the drivers traveled greater distances in the 35 to 55 mph speed range. Tables 41 and 42 below show the quartile values for the distributions shown in Figures 60 and 61.

Table 41. Minimum, maximum, and quartile distances for two-week drivers

Percentile	ACC, miles		CCC, miles		Manual, miles	
	35 to 55	55 to 85	35 to 55	55 to 85	35 to 55	55 to 85
Min.	0.0	15.5	0.0	0.0	47.3	11.0
25th	3.2	57.6	0.0	11.7	120.7	44.8
50th	14.0	98.4	1.4	39.3	166.1	113.1
75th	26.1	278.7	10.0	84.5	222.3	211.7
Max.	91.8	843.1	186.7	661.7	511.0	908.0

Table 42. Minimum, maximum, and quartile distances for five-week drivers

Percentile	ACC, miles		CCC, miles		Manual, miles	
	35 to 55	55 to 85	35 to 55	55 to 85	35 to 55	55 to 85
Min.	0.0	91.4	0.0	26.5	189.2	42.7
25th	18.1	236.1	0.1	64.1	372.5	127.0
50th	40.4	578.1	1.6	96.6	451.7	248.1
75th	80.0	982.6	9.9	171.5	498.8	453.2
Max.	184.0	2305.1	19.2	427.2	684.4	1900.1

Distance, miles

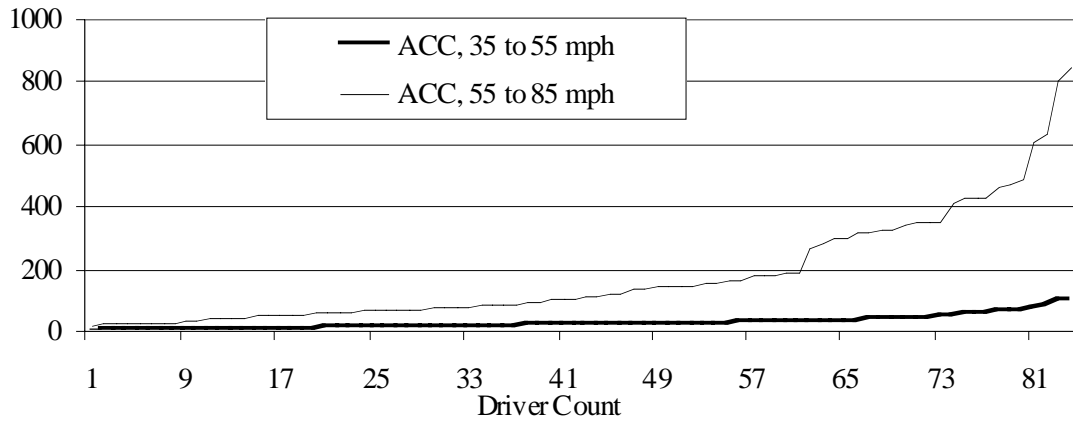

Distance, miles

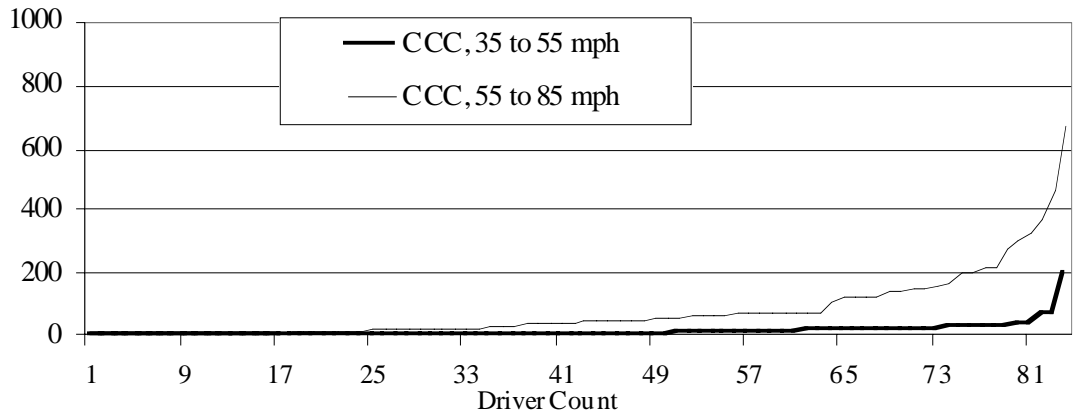

Distance, miles

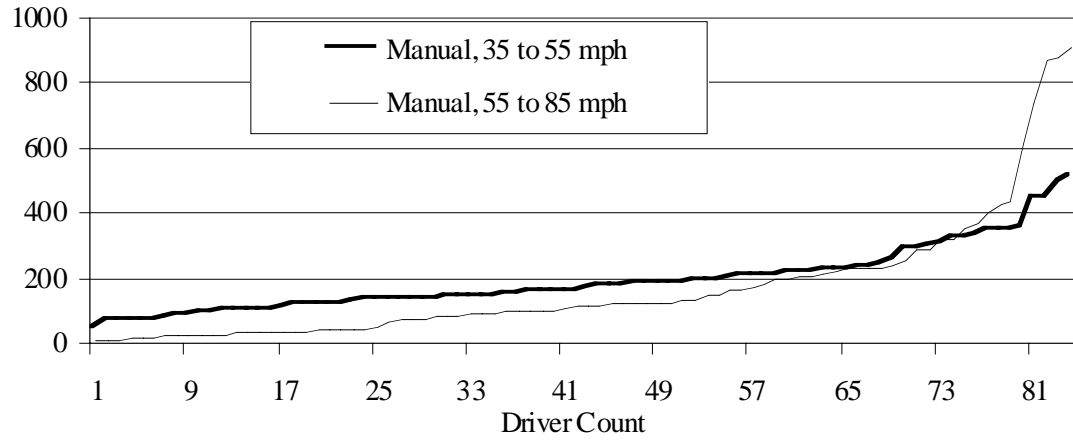
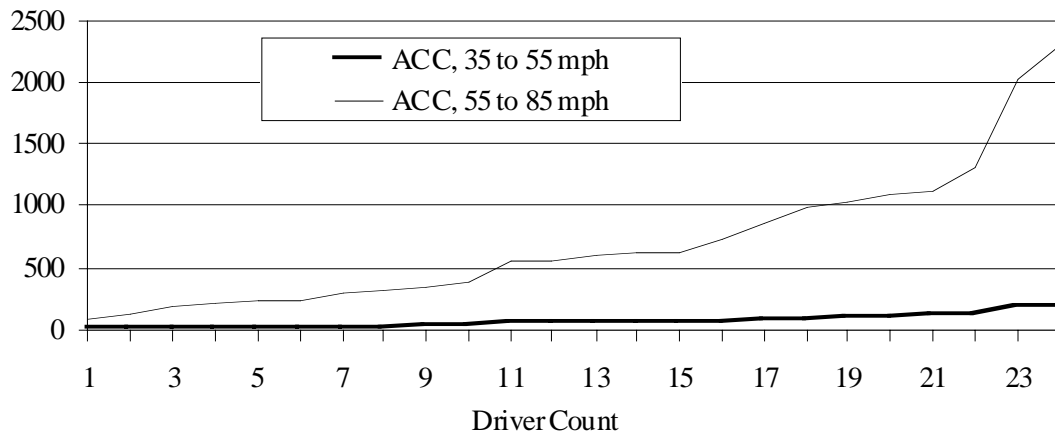
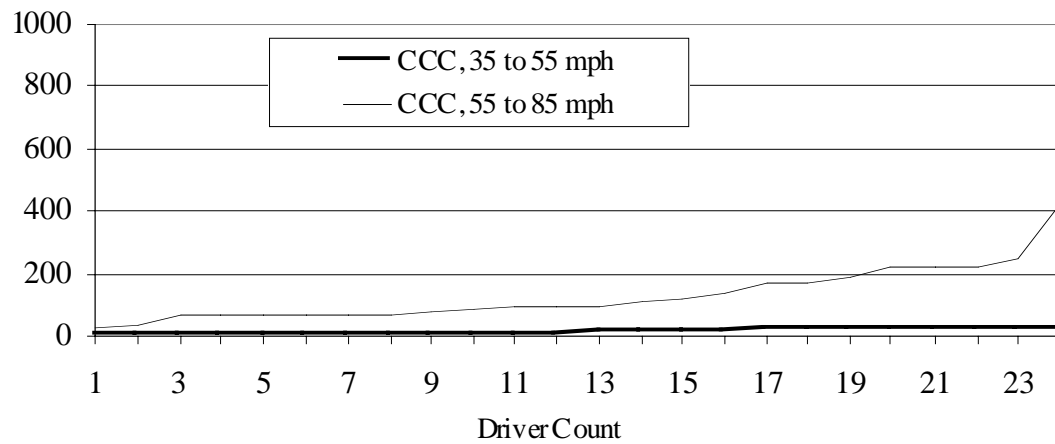

Figure 60. Distribution of distance traveled by all two-week drivers

Distance, miles



Distance, miles



Distance, miles

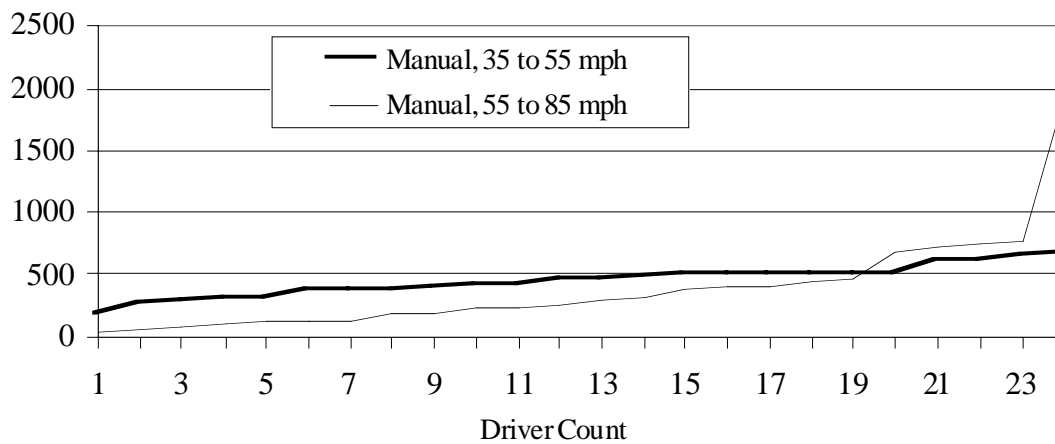

Figure 61. Distribution of distance traveled by five-week drivers

7.3 Exposure by Road Type

One application of the GPS data collected during the FOT was to track the types of roads that the subjects used during their test period. Using the latitude and longitude mapping coordinates that were saved by the DAS it was possible to use a database of roads and their GPS-mapped locations to identify the roads driven by each FOT subject. Processing of the GPS data and road-type database was done by the independent evaluator, Volpe, and their subcontractor SAIC. The different road types considered by the mapping algorithm are shown in Table 43. For the exposure presentation in this section, class 0 and classes 5 through 9 were all aggregated and labeled “Other.” The map-matching database was limited and only contained the latitudinal and longitudinal data for roads in SE Michigan. When a driver left the map coverage area the GPS coordinates recorded during those times were logged as being outside the mapping area and labeled “No Mapping Point.” The road-type exposure figures and tables presented in this section were generated using the results of this mapping process.

Table 43. FOT road classes

Road Type
Class0 - HighSpeedRamp
Class1 - Interstate
Class2 - StateHighway
Class3 - Arterial
Class4 - Collector
Class5 - LightDuty
Class6 - AlleyorUnpaved
Class8 - Unknown
Class9 - LowSpeedRamp
No Mapping Point

7.3.1 Exposure by Road Type and Velocity

Road-type exposure can be presented in terms of time spent on a particular road type or by the distance traveled on a road type. The exposure to road type described in this section covers both approaches.

Figure 62 shows the frequency distribution of operating on various road classes as a function of time and distance. The time and distance covered outside the mapping area is not shown in Figure 62, but it constituted a total of 40,346 miles and 805 hours of driving. This is approximately 40 percent of all mapped miles and 33 percent of all mapped time. If the NMP (no mapping point) data are added to that within the coverage area, approximately 79 percent of all time and 93 percent of all miles were accounted for with the mapping algorithm.¹ Figure 62 shows that over half of the distance and nearly 40 percent of the time was traveled on an interstate road within the mapping region. Arterial roads accounted for the next largest percentage of distance and time.

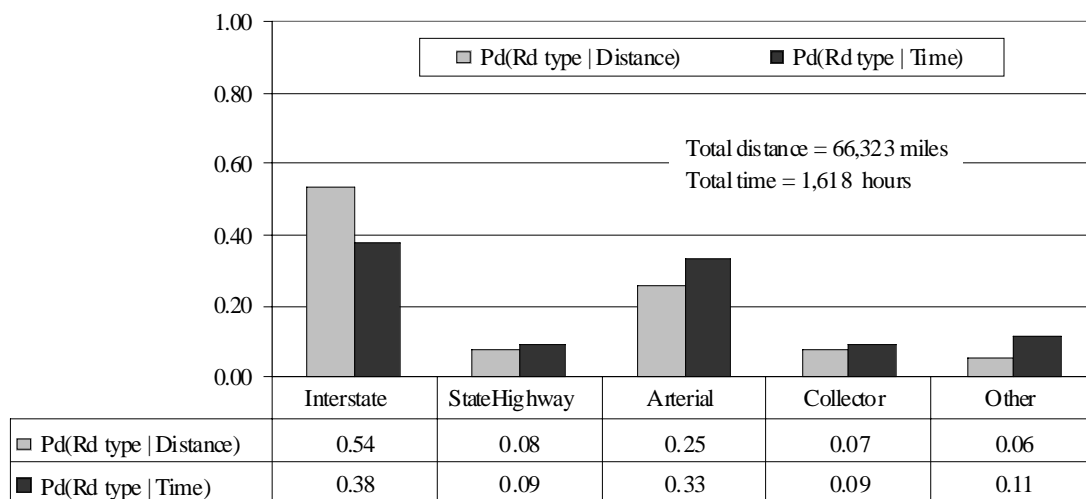

Figure 62. Frequency distribution of operating on various road types as a function of distance and time

The rest of the figures in this section will show only distributions based on the distance information collected in the road-type database.

Figure 63 shows the frequency distribution of operating on various road types for three velocity ranges. The most striking aspect of this figure is the large (91 percent) frequency of being on an interstate road if travelling at speeds above 55 mph. This finding is particularly useful because it indicates that velocity can serve as a reasonable

¹ These numbers are not closer to 100 percent for the following reasons: a) the GPS information was “lost” for some drivers due to problems with the acquisition hardware, b) the GPS data were temporarily not logged due to switching between available satellites, c) terrain obstruction, and d) initialization delays (“cold and warm startup”).

surrogate for road type. (This is exactly what is done later in this report, where the analysis of ACC, CCC, and manual driving is done for velocities above 55 mph or in speed ranges that include 55 mph and above.) Figure 63 also shows that operating on arterial roads is most probable at velocities below 55 mph.

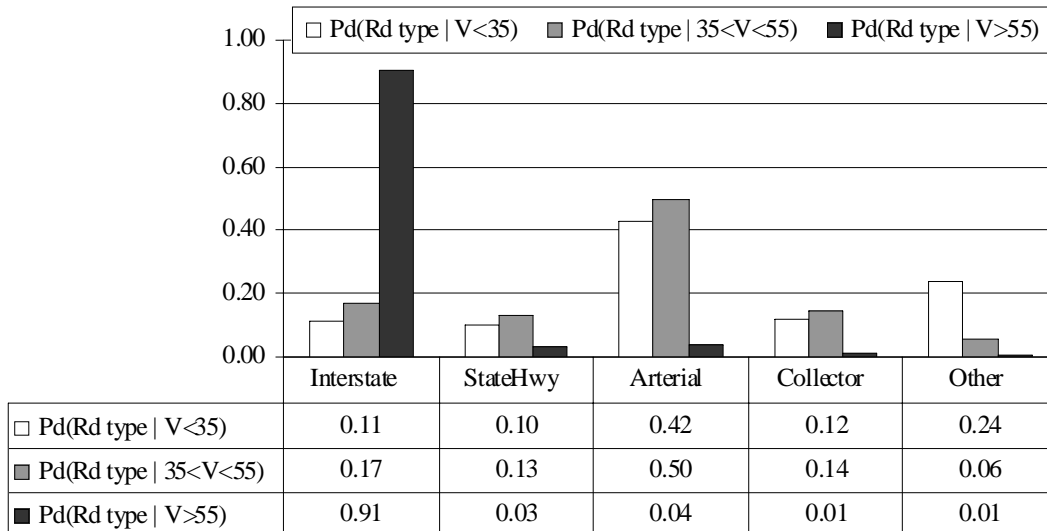

Figure 63. Frequency distribution of operating on various road-types for three velocity ranges

Figure 64 shows the frequency distribution of the same three velocity ranges when outside of the mapping region. Here 74 percent of the distance traveled outside the mapping area was done at speeds above 55 mph. It is likely that most of these miles were done on interstate road types based both on Figure 63 and upon the fact that most of these miles were accumulated during long trips taken by FOT drivers.

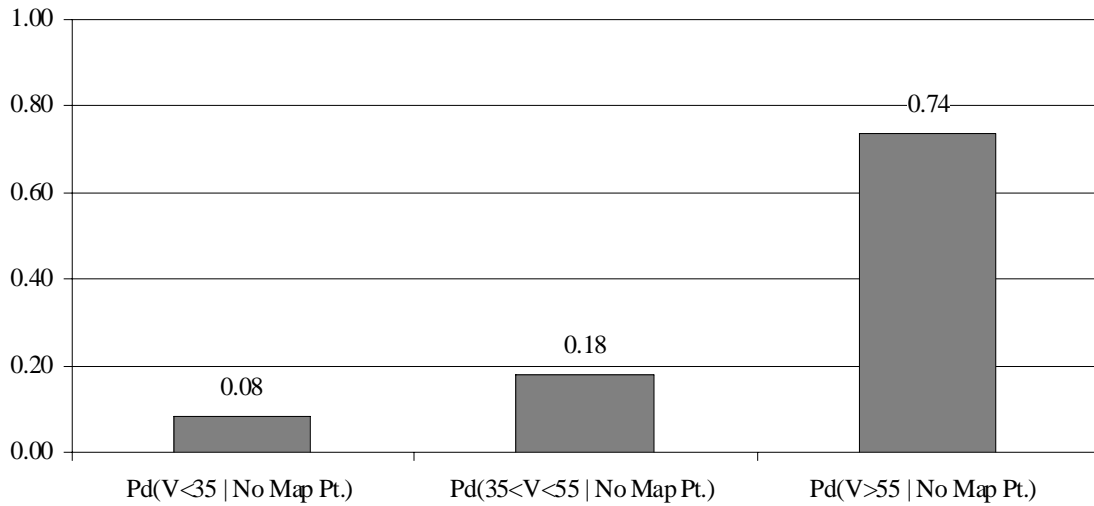

Figure 64. Frequency distribution of three velocity ranges when outside the mapping region

To appreciate the distance traveled outside the mapping area Figure 65 shows the continental US with the furthest points that drivers reached during their test period.



Figure 65. Map of the end of the furthest trip by the FOT drivers

7.3.2 Exposure By Road Type And Driving Mode

The data processing in this study made it possible to sort the distance traveled on each road type into the three different driving modes within the road-type mapping region. Figure 66 shows the frequency of road type for manual, ACC and CCC driving modes.

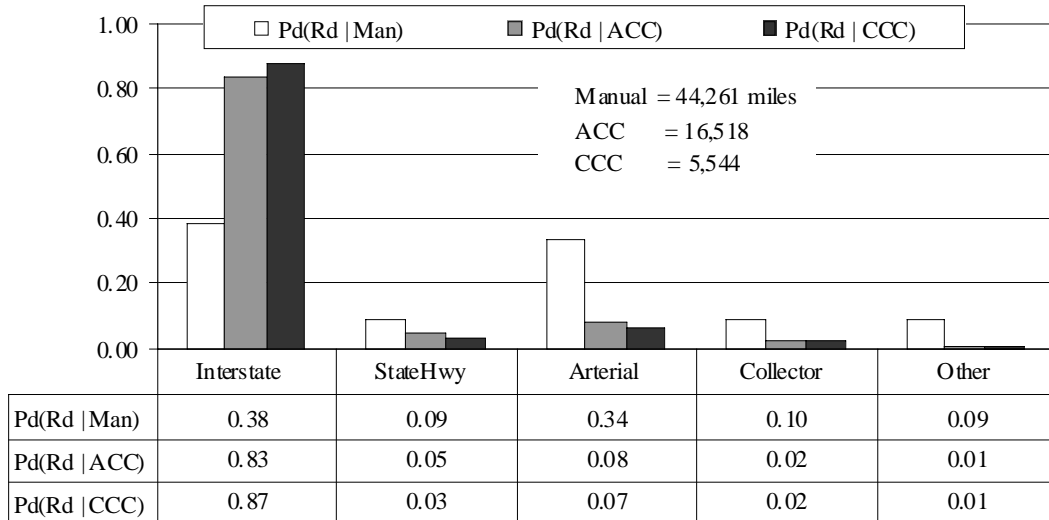

Figure 66. Frequency of road type for the three different driving modes

The figure clearly shows that most of the miles in all three modes occurred on interstate roads. This was particularly true for the cruise modes of driving where 83 percent of ACC miles and 87 percent of CCC miles were driven on interstate roads. Most of the manual driving (72 percent) was distributed between interstate and arterial road types.

Table 44 shows a summary of mapped and unmapped distance traveled for each driving mode during the study. The column named “Sum” in Table 44 shows the total for all mapped and unmapped distances and is based on the GPS data, whereas, the “Total dist.” column shows the total of all distance traveled in each mode based on the integration of the velocity time history records. The difference between these totals is shown as a percentage in the far right column of Table 44 indicating that over 90 percent of all distance traveled was accounted for by the GPS mapping algorithm.

Table 44. Summary of mapped and unmapped distance by driving mode

<i>Mode</i>	<i>Mapped</i>	<i>Not Mapped</i>	<i>Sum</i>	<i>Total dist.</i>	<i>Percent</i>
Manual	44,261	19,249	63,510	68,314	0.93
ACC	16,518	16,908	33,426	35,017	0.95
CCC	5,544	4,190	9,734	10,753	0.91

7.4 Summary of trip and trip duration for the FOT Drivers

Of the 11,092 trips logged during the study, 54 percent (5,950) had a duration of less than 10 minutes and 96 percent were less than 60 minutes long. The longest trip during the study was 905 minutes (over 15 hours) and was nearly three times longer than the next

longest trip². In all there were a total of 111 trips that were longer than 120 minutes. Figure 67 shows the distribution of trips as a function of duration for the entire study.

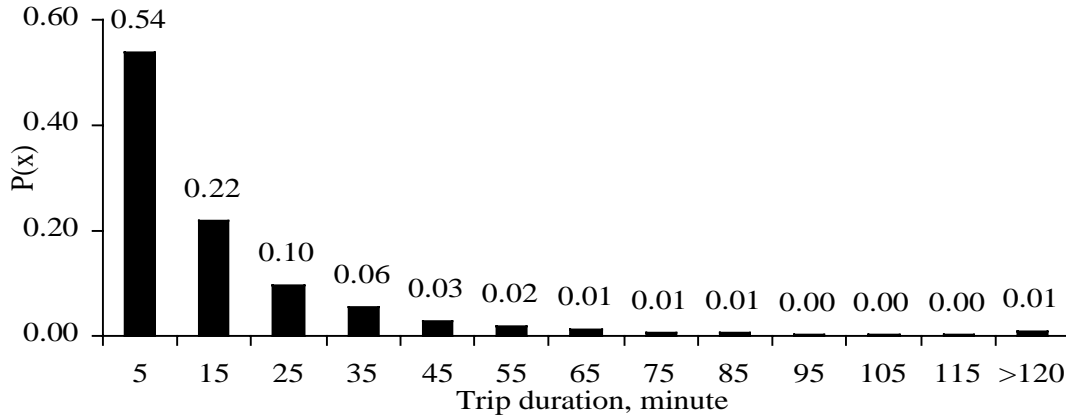

Figure 67. Distribution of trips as a function of trip length in minutes

Shown in Figure 68 is the distribution of trips as a function of day of the week, based on the start times of each trip. Friday and Saturday are the most popular days for FOT trips while Wednesday and Thursday are the least. This latter observation is probably a result of the experimental design, since two-week drivers were scheduled such that they would pick up a vehicle late on a Wednesday or Thursday and return it on Monday or Tuesday, thus being one or two days short of a full two weeks of vehicle usage.

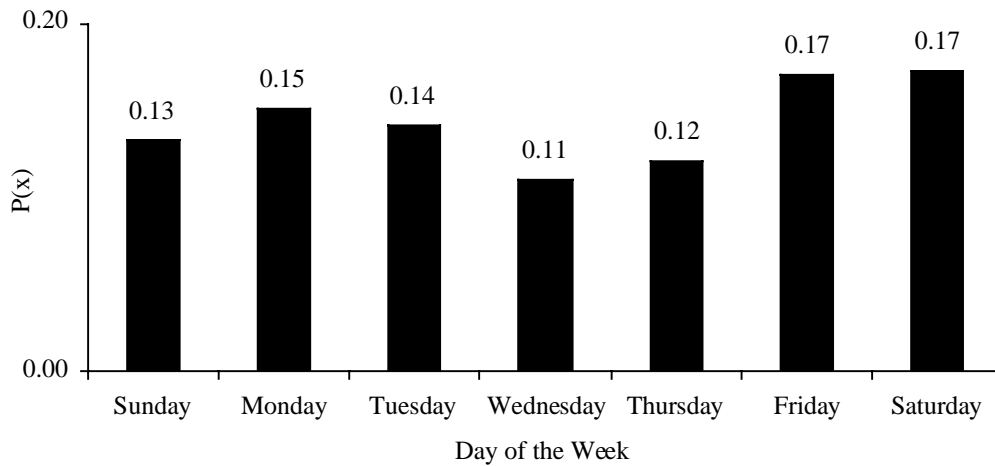

Figure 68. Distribution of trips as a function of day of the week

² Obviously the driver in this vehicle did not turn off the ignition while it was being re-fueled.

Similarly, a distribution of trip start times as a function of time of day is shown in Figure 69 using one-hour bins. (Data have been corrected for day-light-savings time changes.)

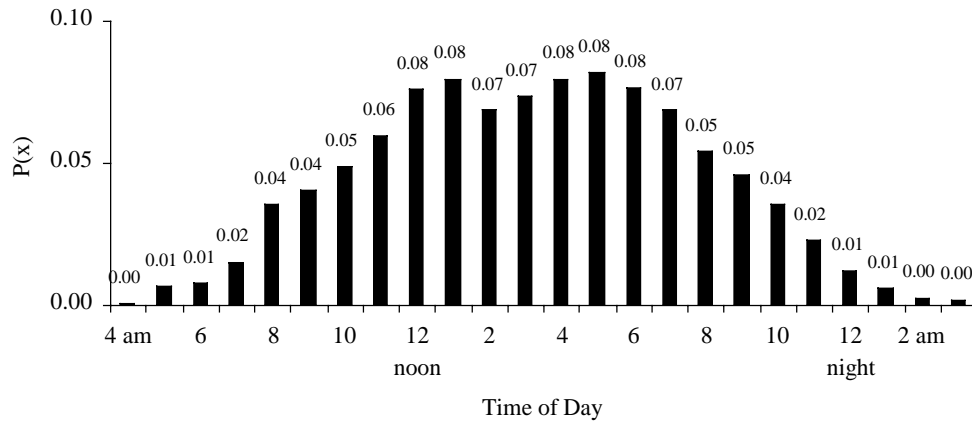

Figure 69. Distribution of trips as a function of time of day

Based on this distribution the most common time of trip starting is approximately 5 P.M. Not surprisingly, the least common time to start a trip was between 12 midnight and 6 in the morning. If it is assumed that there is daylight from 7 A.M. until 7 P.M. on average over the course of the study, then approximately 80 percent of the trips began while it was light outside.