

Evaluation of Cost Effective Protective Coatings for ODOT Snow & Ice Equipment

Prepared by:

Chelsea Monty

Christopher M. Miller

Alvaro Rodriguez

Prepared for:

The Ohio Department of Transportation,

Office of Statewide Planning & Research

State Job Number 134935

April 2016

Final Report



Technical Report Documentation Page

1. Report No. FHWA/OH-2016/11	2. Government Accession No.	3. Recipient's Catalog No.	
4. Title and Subtitle Evaluation of Cost Effective Protective Coatings for ODOT Snow & Ice Equipment		5. Report Date (Month and Year) April 2016	
		6. Performing Organization Code	
7. Author(s) Chelsea N. Monty, Christopher M. Miller, Alvaro Rodriguez		8. Performing Organization Report No.	
9. Performing Organization Name and Address The University of Akron 302 Buchtel Common Akron OH 44325		10. Work Unit No. (TRAIS)	
		11. Contract or Grant No. SJN 134935	
12. Sponsoring Agency Name and Address Ohio Department of Transportation Research Section 1980 West Broad St., MS 3280 Columbus, OH 43223		13. Type of Report and Period Covered Final Report	
		14. Sponsoring Agency Code	
15. Supplementary Notes Prepared in cooperation with the Ohio Department of Transportation (ODOT) and the U.S. Department of Transportation, Federal Highway Administration			
16. Abstract Current estimates suggest that the United States loses over \$220 billion dollars due to corrosion each year. The research results from this project further ODOT's effort to implement a corrosion prevention strategy that will increase public safety by preventing unexpected snow and ice equipment failures, decrease downtime, and provide cost savings through reduction in rust-related maintenance. Protective coatings could increase equipment lifetime and decrease maintenance costs, however, there is limited corrosion resistance performance data available. In this work, laboratory and in field testing were used in combination with cost-benefit analysis to identify cost-effective, field-tested coating systems. Based on these results, a draft standard operating procedure for coating equipment was developed proposing that extra features added to any new assembled dump truck should be painted with either Raptor or LCCOAT as a protective coating. Some of the parts to be coated include the rear hitch plate, hydraulics attachment plate assembly, front plow hoist/ frame/ bumper assembly, liquid deicer tank mounting hardware, and bed hoist subframe. Parts may be galvanized. Trucks in need of refurbishment should be stripped down (sandblasted, prepared and primed to industry standards) and painted to the specifications of the coating system. Trucks in no need of refurbishment should be maintained using visual inspection and coating reapplication where coating breakdown (exposed metal) occurs, in order to avoid the need for total refurbishment. Extra care should be taken to inspect the truck frame (front to back), bed hoist subframe, front plow hoist, front plow frame, front bumpers, rear hitch plate, liquid deicer tank mounting hardware, and hydraulics mounting plate assembly.			
17. Key Words Corrosion prevention coatings, laboratory testing, in field testing, predictive cost-benefit analysis, standard operating procedure		18. Distribution Statement No restrictions. This document is available to the public through the National Technical Information Service, Springfield, Virginia 22161	
19. Security Classif. (of this report) Unclassified Unclassified	20. Security Classif. (of this page) Unclassified	21. No. of Pages 237	22. Price \$221,804

Evaluation of Cost Effective Protective Coatings for ODOT Snow & Ice Equipment

Prepared by:

Chelsea N. Monty, Ph.D.

Alvaro Rodriguez

Department of Chemical Engineering

The University of Akron

Christopher M. Miller, Ph.D., P.E.,

Department of Civil Engineering

The University of Akron

April 2016

Prepared in cooperation with the Ohio Department of Transportation
and the U.S. Department of Transportation, Federal Highway Administration

The contents of this report reflect the views of the author(s) who is (are) responsible for the facts and the accuracy of the data presented herein. The contents do not necessarily reflect the official views or policies of the Ohio Department of Transportation or the Federal Highway Administration. This report does not constitute a standard, specification, or regulation.

ACKNOWLEDGMENTS

This project was conducted in cooperation with the Ohio Department of Transportation (ODOT). We would like to thank Paul Ensinger (District 4, Akron, OH), Frank Phillips (District 4, Hudson OH), Randy Steck (District 6, Delaware, OH), Chester Hazelton (District 6, Delaware, OH), Jamie Hendershot (District 10, Marietta, OH), Chad Folmer (District 10, Marietta, OH), Jeremiah Williams (Columbus, OH), and Brent Cruse, Ohio Penal Industries Superintendent - Vehicle Modification (Chillicothe, OH) their help and contribution to this work.

We would also like to thank Bruce Rose, Senior Coatings Applicator, Light Curable Coatings (Berea, OH), Ben Curatolo, President and Chief Scientist, Light Curable Coatings (Berea, OH), Tawny Zajc, Owner, LINE-X of Akron/Medina (Medina, OH), Mike McCulley, Westside Auto Paint and Supply (Akron, OH), Car Quest Auto Parts of Medina (Medina, OH), Ron Smith, Sales Manager, AZZ Galvanizing (Canton, OH), Billy Wright, Project Manager, Industrial Coating Solutions Inc. (Leland, NC), and Tom McNally, Production Manager, Ohio Structures Inc. (Canfield, OH) for aiding in the application of corrosion prevention coatings. We also thank Will Imes and Thomas Quick for their assistance in experimental setup of analysis.

Finally, this work would not have been completed without the help of students, faculty, and staff from The University of Akron including the following undergraduate students Michelle Ayers, Stuti Kapaida, Mary Teague, Benjamin Sauer, Brandon McFarland, Christopher Alcorn, Susan Kaya, Kamshat Dukenbaeva, and Christopher Stuffel and the high school students Simon Kirkendall and Michael Smith.



Ohio Department of Transportation

RESEARCH RESULTS

FACT SHEET

Evaluation of Cost Effective Protective Coatings for ODOT Snow & Ice Equipment 134935

This research presents the results from laboratory-scale and in field testing to evaluate protective coating systems for corrosion prevention on snow and ice equipment. In total, four organic coating systems and two metalized coating systems were tested on four metal surfaces. A cost-benefit model, based on laboratory data, suggests that exposed metal surfaces on new DOT snow and ice equipment should be coated with either Raptor or LCCOAT to protect against corrosion. DOT snow and ice equipment in need of refurbishment should be stripped down and coated with either Raptor or LCCOAT; trucks in no need of refurbishment should be maintained (visual inspection and coating touch-ups) as is in order to prevent the need for refurbishment. In field results corroborate the cost-benefit model, with further in field testing validation recommended.

Key Points

- Compared to white OEM and black enamel controls, four organic coatings and two metalized coatings were tested on four metal surfaces during laboratory and in field testing.
- Laboratory results were used in a cost-benefit model.
- Data suggest that exposed metal on new DOT snow and ice equipment should be coated with either Raptor or LCCOAT coating systems.
- Snow and ice equipment in need of refurbishment should be stripped down and coated with either Raptor or LCCOAT.
- Equipment in no need of refurbishment shows no cost benefit from application of additional coatings.

safety by preventing unexpected equipment failures, decrease downtime of snow and ice equipment, and provide cost savings through reduction in rust related maintenance.

Research Findings

Laboratory-scale and in field testing were used to evaluate effectiveness of coatings for corrosion prevention on snow and ice equipment. Answers from an internet/email survey combined with various interviews and garage visits were used to select coatings and metals for this study. A total of four organic coating systems (LCCOAT, LINE-X, Raptor, and Rhino Linings) were selected for application on four metals (carbon steel, aluminum, cast aluminum, cast iron). Galvanized and metalized carbon steel panels were also tested.

In order to simulate in field conditions, coatings were applied to bare metal samples and metal samples previously coated with white OEM or black enamel coatings. White OEM (Imron Elite Productive basecoat with an Imron Elite 8840S clearcoat) and black enamel (Imron Elite Productive basecoat and Rival RV35 topcoat) coatings were selected as baseline coatings as these coatings are found on the truck upon arrival from the factory. Winter conditions were simulated using accelerated corrosion testing. ASTM B117 accelerated corrosion testing on scribed and

unscribed metal samples was used to mimic the harsh conditions at the front of the salt truck; while, standard immersion testing on unscribed metal samples was used to mimic wet conditions underneath the truck. Laboratory was conducted using ASTM standards for accelerated corrosion testing and electrochemical standards for immersion testing based on pore resistance. In field testing was conducted on scribed carbon steel samples mounted to salt trucks and exposed to winter weather conditions on 8 salt trucks spanning two ODOT districts (4, 10) from December 2014-March 2015. In field testing can be used to draw preliminary conclusions; however, longer-term studies are necessary to determine long-term field performance.

Overall, LCCOAT and Raptor coating systems performed well in laboratory and in field testing. LINE-X and Rhino Linings coating systems showed good performance during laboratory and in field testing but do not have the same cost-benefit as other coatings tested.

Cost-benefit analysis was conducted for three scenarios: a new truck with only bare, exposed metal parts coated by ODOT, a new truck coated completely by ODOT, a refurbished truck sanded and completely coated by ODOT on sanded metal. As only carbon steel can be galvanized/metalized, this coating

Background

Current estimates suggest that the United States loses over \$220 billion dollars due to corrosion each year with 15% of that loss considered to be avoidable. The consensus points to the need for protective coatings to increase equipment lifetime and decrease maintenance costs, however, there is not sufficient information available to determine "best" practices. The research results from this project further ODOT's effort to implement a corrosion prevention strategy that will increase public

was not included in the cost-benefit analysis. Yearly maintenance cost for a standard truck was determined from 10-year per truck average maintenance cost over all ODOT districts for repair codes 254, 238, 239, and 347 from 2004-2014.

After coatings application, predicted maintenance costs were estimated using average laboratory-scale creep data for the 4 metals tested compared to a control. Laboratory data was used for the predictive maintenance cost, as a set of data on all metals of interest was obtained. Additionally, in field conditions are complex making it difficult to incorporate these results into a predictive model.

For Scenarios 1 and 3, the control is the average of the creep from scribe on bare metal samples (without an OEM coating) for the four metals tested; for Scenario 2, the control is the average of the creep from scribe for all controls tested (samples coated with an OEM coating).

Cost-benefit analysis shows that LCCOAT and Raptor coating systems are more economical for scenarios 1 and 3 (new truck with bare/exposed metal coated by ODOT, refurbished truck) and decrease the total cost to maintain the truck by 30% compared to the standard ODOT truck. This is a cost savings of approximately \$2000 over 10 years for scenario 1 and \$4000 over 10 years for scenario 3. LCCOAT and Raptor coating systems were also more economical for scenario 2 (a new truck coated completely by ODOT); however, there was not a statistically significant decrease in cost.

Overall ratings were given for laboratory, in field, and cost-benefit.

		Corrosion Rating (Laboratory)	Corrosion Rating (In-field)	Corrosion Rating (Cost-Benefit)	Total Ranking
Raptor	Bare	Good	Excellent	Excellent	1
	Black Enamel	Excellent	Excellent	Excellent	
	White OEM	Excellent	Excellent	Excellent	
LCCOAT	Bare	Excellent	Good	Excellent	2
	Black Enamel	Excellent	Excellent	Good	
	White OEM	Excellent	Excellent	Good	
Galvanized		Poor*	Excellent	N/A	3
Control	Black Enamel	Good	Excellent	Average	4
	White OEM	Average	Good	Average	
Rhino Linings	Bare	Fair	Excellent*	Fair	5
	Black Enamel	Excellent	Excellent	Fair	
	White OEM	Good	Excellent	Fair	
LINE-X	Bare	Good	Good	Average	6
	Black Enamel	Good	Good	Poor	
	White OEM	Good	Good	Poor	

*Galvanized underperforms in the laboratory because the coating does not undergo exposure cycles necessary to create protective layer on the surface of the metal

**Rhino Linings on bare metal appears to overperform in the field because the rust on the flat surface of the metal is not taken into account when measuring creep

These were used to determine a total rating of each coating system. Laboratory ratings were based on ASTM standards for accelerated corrosion testing and electrochemical standards for immersion testing based on pore resistance. In field ratings were based on ASTM standards for creepage from scribe. Cost ratings were based on percentile of cost to maintain truck for 10 years based on cost-benefit model. All coating systems tested (in field) are within one level of predicted value based on laboratory tests.

Recommendations

Based on the combination of laboratory-scale data, in field testing, and the cost-benefit analysis, an SOP was developed: Data suggest that exposed metal on new DOT snow and ice equipment should be coated with either Raptor or LCCOAT coating systems. Some of the parts to be coated include the rear hitch plate,

hydraulics attachment plate assembly, front plow hoist/ frame/ bumper assembly, liquid deicer tank mounting hardware, and bed hoist subframe. Parts may be galvanized. Trucks in need of refurbishment should be stripped down (sandblasted, prepared and primed to industry standards) and painted to the specifications of the coating system. Trucks in no need of refurbishment should be maintained using visual inspection and coating reapplication where coating breakdown (exposed metal) occurs in order to avoid the need for total refurbishment. Extra care should be taken to inspect the truck frame (front to back), bed hoist subframe, front plow hoist, front plow frame, front bumpers, rear hitch plate, liquid deicer tank mounting hardware, and hydraulics mounting plate assembly. Overall, yearly visual inspection and coating touch-ups on prepared surfaces are recommended, as well as thorough and detailed recording of all maintenance expenses.

ODOT Research Executive Summary Report



State Job Number: 134935

Ohio Department of Transportation
Office of Statewide Planning & Research
Research Section
1980 West Broad Street, Mail Stop 3280
Columbus, OH 43223
614-644-8135
Research@dot.ohio.gov
www.dot.state.oh.us/Research

Evaluation of Cost Effective Protective Coatings for ODOT Snow & Ice Equipment

FHWA Report Number:	FHWA/OH-2016/11
Report Publication Date:	April 2016
ODOT State Job Number:	134935
Project Duration:	16 months
Start Date:	8/7/2014
Completion Date:	12/7/2015
Total Project Funding:	\$221,804
Research Agency:	The University of Akron
Researchers:	Chelsea N. Monty, Christopher M. Miller, Alvaro A. Rodriguez
ODOT Technical Liaisons:	Jamie Hendershot, Paul Ensinger, Chad Folmer, Chester Hazelton

Project Background

Current estimates suggest that the United States loses over \$220 billion dollars due to corrosion each year with 15% of that loss considered to be avoidable. The consensus points to the need for protective coatings to increase equipment lifetime and decrease maintenance costs, however, there is not sufficient information available to determine “best” practices. The research results from this project further ODOT’s effort to implement a corrosion prevention strategy that will increase public safety by preventing unexpected equipment failures, decrease downtime of snow and ice equipment, and provide cost savings through reduction in rust related maintenance.

ODOT Research Final Report

State Job Number: 134935

Study Objectives

To complete this research four objectives were identified in order to provide a cost effective corrosion prevention strategy for winter maintenance equipment: 1) Data Collection and Evaluation of Current Practices and Reports on the Effectiveness and Use of Corrosion Protective Coatings, 2) Data Collection, 3) Benefit to Cost Analysis Using Commercially Available Corrosion Protective Coatings, 4) Development of "Standard Operating Procedure" for Selected Corrosion Protective Coating.

Description of Work

COATING SYSTEM	TYPE	PRODUCT	THICKNESS
White OEM	Basecoat	Imron Elite Productive	4 mils
		Activator 194S	
	Clearcoat	Imron Elite 8840S	
		Activator 194S	
Black Enamel	Basecoat	Imron Elite Productive	4 mils
		Activator 194S	
	Topcoat (Enamel)	Rival RV35	
		Activator RV135	
Galvanized	Hot dip galvanizing	AZZ Galvanizing	3 mils
Metalized	Thermo spray of zinc	Ohio Structures	8 mils
LCCOAT	Primer	Proprietary	8 mils
	Coating	Proprietary	
LINE-X	LINE-X XS 152	1A:1B mix ratio	60 mils
		A: Isocyanate	
		B: 75% Polyurethane/25% Polyurea	
Raptor	Adhesive promoter	U-POL Grip #4	7 mils
	Etch primer	U-POL Acid #8	
	Raptor	Raptor liner (polyurethane)	
Rhino Linings	Rhino Extreme 11-50	1A:1B mix ratio	30 mils
		A: Isocyanate	
		B: Resin	

Laboratory-scale and in field testing were used to evaluate effectiveness of coatings for corrosion prevention on snow and ice equipment. Answers from an internet/email survey combined with various interviews and garage visits were used to select coatings and metals for this study. All organic and metalized coatings suggested were tested, with the exception of Dolphin, as the vendor elected not to provide us with a sample for testing. A total of four organic coating systems (LCCOAT, LINE-X, Raptor, and Rhino Linings) were selected for application on four metals (carbon steel, aluminum, cast aluminum, cast iron). Galvanized and metalized carbon steel panels were also tested. The complete set of tested coating systems is given in the table above, along with supplier information. Each coating system contains several layers, made of a primer (or basecoat) and a topcoat (or clearcoat). In order to simulate in field conditions, samples were either coated on bare metal samples or on samples previously coated with white OEM or black enamel coating systems. White OEM (Imron Elite Productive basecoat with an Imron Elite 8840S clearcoat) and black enamel (Imron Elite Productive basecoat and Rival RV35 topcoat)

ODOT Research Final Report

State Job Number: 134935

coating systems were selected, as these coating systems are present on the truck from the factory. Throughout the report, coatings will be referred by the name given in the “coating system” column of the above table.

Winter conditions were simulated using accelerated corrosion testing. Experiments were carried out using ASTM B117 accelerated corrosion testing and standard immersion testing. ASTM B117 testing was used to mimic the harsh conditions at the front of the salt truck; while, immersion testing was used to mimic the wet conditions underneath the salt truck. For in field tests, carbon steel samples were mounted to the front and rear of eight salt trucks in two ODOT districts (4,10) from December 2014-March 2015. As expected, galvanized samples performed well during in field testing, as these samples need to form a protective oxide layer in order to provide optimum corrosion prevention. To form this layer, the sample must undergo exposure cycles that are not accounted for in B117 or standard immersion testing. Results from in field testing can be used to draw initial conclusions about the performance of the coating systems on winter maintenance equipment; however, longer-term testing is necessary before determination of a complete set of ratings. Overall, LCCOAT and Raptor coating systems performed well in laboratory and in field testing. LINE-X and Rhino Linings coating systems showed good performance during laboratory and in field testing but do not have the same cost-benefit as other coatings tested.

A cost-benefit analysis was performed to determine the potential economic benefits of coatings application. Yearly maintenance cost for a standard truck was determined from 10-year per truck average maintenance cost over all ODOT districts for repair codes 254, 238, 239, and 347 from 2004-2014. Costs were found using the ODOT EIMS Database and repair codes correspond to cab and body repairs associated with corrosion.

Cost-benefit analysis was conducted for three scenarios: a new truck with only bare, exposed metal parts coated by ODOT, a new truck coated completely by ODOT (scenario 1 plus coating used as a topcoat on white OEM or black enamel), a refurbished truck sanded and completely coated by ODOT on sanded metal. As only carbon steel can be galvanized/metalized, this coating was not included in the cost-benefit analysis. However, as these coatings performed well during in field testing exposed metals should be galvanized where appropriate (see SOP).

After coating application, predicted maintenance costs were estimated using average laboratory-scale creep data from the 4 metals tested compared to a control. Laboratory data was used for the predictive maintenance cost, as a set of data on all metals was obtained. Additionally, in field conditions are complex (e.g. varying temperatures, snow and ice conditions, indoor vs. outdoor overnight parking, deicers, washing strategies, locations) making it difficult to incorporate these results into a predictive model. For Scenarios 1 and 3, the control is the average of the creep from scribe on bare metal samples (without an OEM coating) for the four metals tested; for Scenario 2, the control is the average of the creep from scribe for all controls tested (samples coated with an OEM coating).

Research Findings & Conclusions

Overall ratings were given for laboratory, in field, and cost-benefit. These were used to determine a total rating for each coating system. Laboratory ratings were based on ASTM standards for accelerated corrosion testing and electrochemical standards for immersion testing based on pore resistance. In field ratings were based on ASTM standards for creepage from scribe. Cost ratings were based on percentile of cost to maintain truck for 10 years based on cost-benefit model. All coating systems tested (in field) are within one level of predicted value based on laboratory tests.

Cost-benefit analysis shows that LCCOAT and Raptor coating systems are more economical for scenarios 1 and 3 (new truck with bare/exposed metal coated by ODOT, refurbished truck) and decrease the total cost to maintain the truck by 30% compared to the standard ODOT truck. This is a cost savings of approximately \$2000 over 10 years for scenario 1 and \$4000 over 10 years for scenario 3. LCCOAT and Raptor coating systems were also more economical for scenario 2 (a new truck coated completely by ODOT); however, there was not a statistically significant decrease in cost.

Recommendations for Implementation of Research Findings



ODOT Research Final Report

State Job Number: 134935

Based on the combination of laboratory-scale data, in field testing, and the cost-benefit analysis, an SOP was developed: Data suggest that exposed metal on new DOT snow and ice equipment should be coated with either Raptor or LCCOAT coating systems. Some of the parts to be coated include the rear hitch plate, hydraulics attachment plate assembly, front plow hoist/ frame/ bumper assembly, liquid deicer tank mounting hardware, and bed hoist subframe. Parts may be galvanized. Trucks in need of refurbishment should be stripped down (sandblasted, prepared and primed to industry standards) and painted to specifications for coating system. Trucks in no need of refurbishment should be maintained using visual inspection and coating reapplication where coating breakdown (exposed metal) occurs, in order to avoid the need for total refurbishment. Extra care should be taken to inspect the truck frame (front to back), bed hoist subframe, front plow hoist, front plow frame, front bumpers, rear hitch plate, liquid deicer tank mounting hardware, and hydraulics mounting plate assembly.

		Corrosion Rating (Laboratory)	Corrosion Rating (In field)	Corrosion Rating (Cost-Benefit)	Total Ranking
Raptor	Bare	Good	Excellent	Excellent	1
	Black Enamel	Excellent	Excellent	Excellent	
	White OEM	Excellent	Excellent	Excellent	
LCCOAT	Bare	Excellent	Good	Excellent	2
	Black Enamel	Excellent	Excellent	Good	
	White OEM	Excellent	Excellent	Good	
Galvanized		Poor*	Excellent	N/A	3
Control	Black Enamel	Good	Excellent	Average	4
	White OEM	Average	Good	Average	
Rhino Linings	Bare	Fair	Excellent**	Fair	5
	Black Enamel	Excellent	Excellent	Fair	
	White OEM	Good	Excellent	Fair	
LINE-X	Bare	Good	Good	Average	6
	Black Enamel	Good	Good	Poor	
	White OEM	Good	Good	Poor	

*Galvanized underperforms in the laboratory because the coating does not undergo exposure cycles necessary to create protective layer on the surface of the metal

**Rhino Linings on bare metal appears to over perform in the field because the rust on the flat surface of the metal is not taken into account when measuring creep

TABLE OF CONTENTS

ACKNOWLEDGMENTS
1.1 TABLE OF FIGURES
1.2 TABLE OF TABLES

iv
xvii
xxiv



State Job Number: 134935

CHAPTER I: KEY POINTS	1
CHAPTER II: BACKGROUND	3
2.1 Problem Statement	3
2.2 Objectives and Goals of the Study	4
2.3 Overview of Approach	4
2.4 Corrosion Protective Coatings	6
2.5 Current Corrosion Prevention Strategies	10
2.5.1 Overview of Literature and Survey Results	10
2.6 Implementation of survey results	12
CHAPTER III: RESEARCH FINDINGS	15
3.1 Evaluation of Coatings at Preventing Corrosion on Metal Samples During Accelerated Corrosion Testing	15
3.1.1 Introduction	15
3.1.2 Experimental Procedure for Evaluating the Performance of Coatings Using Accelerated Corrosion Testing	16
3.1.3 Summary of Results: Accelerated Corrosion Testing	21
3.1.4 Overview of Effectiveness of Coatings at Reducing Corrosion on Metals During Accelerated Corrosion Testing	36
3.2 Evaluation of Coatings at Preventing Corrosion During Standard Immersion Testing	37
3.2.1 Introduction	37
3.2.2 Experimental Procedure for EIS testing on Coated Samples	37
3.2.3 Summary of Results for Immersion Testing on Coated Samples	39
3.2.4 Overview of Effectiveness of Coatings at Reducing Corrosion during Immersion Testing	45
3.3 Evaluation of Corrosion Protective Coatings During In field Testing	47
3.3.1 Introduction	47
3.3.2 Experimental Procedure for Evaluating the Performance of Coatings during In field Testing	47
3.3.3 Summary of In field Testing Results	48
3.3.4 Overview of Effectiveness of Coatings at Reducing Corrosion during In field Testing	51
3.4 Cost –Benefit Analysis of Corrosion Prevention Strategies	54
3.4.1 Introduction	54
3.4.2 Historical Maintenance Cost Evaluation (2004-2014)	54
3.4.3 Coating Material Cost Estimates	61
3.4.4 Annual Cash Flow Analysis	63
3.4.5 Overview of Cost-Benefit Analysis for Corrosion Prevention Coating	66
CHAPTER IV: RECOMMENDATIONS	69
4.1 Recommendations for Implementation	69
REFERENCES	72
APPENDIX A: SURVEY RESULTS	74
APPENDIX B: COATING ANALYSIS	99



State Job Number: 134935

APPENDIX C: CREEP RESULTS: B117	127
APPENDIX D: X-RAY DIFFRACTION RESULTS: B117 TESTING	140
APPENDIX E: STEREOMICROSCOPE IMAGES FROM B117 TESTING	150
APPENDIX F: IMAGE ANALYSIS OF UNSCRIBED COUPONS: B117 TESTING	162
APPENDIX G: EIS CIRCUITS: IMMERSION TESTING	176
APPENDIX H: IN FIELD PROCEDURES AND RESULTS	204
APPENDIX I: XRD: IN FIELD TESTING	216
APPENDIX J: STEREO IMAGES FROM IN FIELD TESTING	224
APPENDIX K: COST-BENEFIT ANALYSIS	243
APPENDIX L: ADDITIONAL BACKGROUND	251



State Job Number: 134935

1.1 TABLE OF FIGURES

Figure 2.4-1A: Effect of UV-curable coating on corrosion of an aluminum alloy after exposure to 3000 hours of salt spray testing. B. In field success of corrosion protective coating applied to winter maintenance equipment.7

Figure 2.4-2: Thermal spraying of metallic coatings onto the surface of metal substrates.8

Figure 2.4-3: Components of an organic coating9

Figure 3.1-1: Example of scribed coupons during accelerated corrosion testing. From left to right, bare carbon steel, white OEM coated carbon steel, black enamel coated carbon steel, bare aluminum, white OEM coated aluminum, bare cast aluminum, stainless steel, bare cast iron.22

Figure 3.1-2: Average creep from scribe for all coated and uncoated (control) samples after 336 hours of salt spray exposure23

Figure 3.1-3: Creep from scribe for coatings on carbon steel after 336 hours of salt exposure (bare carbon, galvanized, and metalized excluded from graph).24

Figure 3.1-4: Creep from scribe for coatings on cast iron after 336 hours of salt exposure (bare cast iron excluded from graph).25

Figure 3.1-5: Creep from scribe for coatings on aluminum after 336 hours of salt exposure.26

Figure 3.1-6: Creep from scribe for coatings on cast aluminum after 336 hours of salt exposure.27

Figure 3.1-7: Creep from scribe over time for A) aluminum and B) cast aluminum samples. Creep was determined every 336 hours.28

Figure 3.1-8: Example cross-sectional image of a coated carbon steel sample exposed to accelerated corrosion testing (B117) for 336 h. The sample is analyzed using stereo microscopy. Film delamination is defined as the distance under the coating where the coating has lost contact with the metal surface, allowing corrosion products to form.29

Figure 3.1-9: Delamination length of coated carbon steel samples after 336 hours of salt spray exposure.30



State Job Number: 134935

Figure 3.1-10: Ratio of delamination to creep distance for coated carbon steel samples after 336 hours of salt spray exposure.....31

Figure 3.1-11: Example of unscribed coated panels (galvanized) after salt spray exposure. From left to right, scans of the panels were taken each week for eight weeks.....32

Figure 3.2-1: Electrochemical three-electrode setup.....38

Figure 3.2-2: Theoretical impedance spectra used as training sets for good, intermediate and poor coating quality by plotting Z vs. frequency (Lee, 1998). In order to maintain consistency with other ratings, good is relabeled as excellent, intermediate as good, and fair as poor.....39

Figure 3.2-3: Water uptake over time for all surface treatments on carbon steel exposed to 0.6 M NaCl for 100 days.....42

Figure 3.2-4: Pore resistance over time for all surface treatments exposed to 0.6 M NaCl for 100 days.....44

Figure 3.3-1: Mounted scribed metal panels on the front bumper (top left) and rear underside (bottom left, right) of salt truck for exposure to winter conditions for 90 days.....48

Figure 3.3-2: Creep from scribe for each surface treatment with respect to location on the salt truck (front, back) after 90 days of in field exposure.....49

Figure 3.3-3: Average creep from scribe for all surface treatments after 90 days of in field exposure.....50

Figure 3.3-4: Delamination length for all surface treatments after 90 days of in field exposure.....51

Figure 3.4-1: Total Cost (Parts and Labor) Summary by Calendar Year for Repair Codes 254, 238, 239, and 347 from ODOT EIMS Database (2004-2014). Note: 2014 data is for the first six months only.....58

Figure B 1. Ultrasonic coating thickness gauge.....100

Figure B 2. Classification of adhesion test results.....121

Figure B 3. BYK Gardner Micro-Tri-Gloss 20/60/85° gloss meter.....123

Figure B 4. Conical mandrel test apparatus.....125



State Job Number: 134935

Figure B 5. (A) Distance along cone and corresponding mandrel size vs. percent elongation. (B) Correction for thickness of film..... 126

Figure C 1. Representative Creep rate measurements in mm of exposed metal panels to salt spray chamber for 336 hours. 132

Figure C 2. Control scribed metal panels exposed to the salt spray chamber..... 133

Figure C 3. Galvanized scribed metal panels exposed to the salt spray chamber. 134

Figure C 4. LCCOAT scribed metal panels exposed to the salt spray chamber..... 135

Figure C 5. LINE-X scribed metal panels exposed to the salt spray chamber..... 136

Figure C 6. Metalized scribed metal panels exposed to the salt spray chamber..... 137

Figure C 7. Raptor scribed metal panels exposed to the salt spray chamber. 138

Figure C 8. Rhino Linings scribed metal panels exposed to the salt spray chamber. 139

Figure D 1. XRD spectra of LinB. 141

Figure D 2. XRD spectra of RaB. 142

Figure D 3. XRD spectra of RhB. 143

Figure D 4. Diffraction spectra of magnetite in RaB..... 144

Figure D 5. Diffraction spectra of goethite in RaB..... 145

Figure D 6. Diffraction spectra of hematite in RaB..... 146

Figure D 7. XRD spectra of CS188. 147

Figure D 8. XRD spectra of CS205. 148

Figure D 9. Diffraction spectra of Simonkolleite in CS188 and CS205..... 149

Figure E 1. Preparation of cross-sections from coated metal panels for stereo microscopy imaging analysis. 150

Figure E 2. Carbon steel top, center and bottom cross-sections image of (A) control/black enamel and (B) control/white OEM systems after 336 hours exposure to accelerated corrosion testing (B117). 152

Figure E 3. Carbon steel top, center and bottom cross-sections image of (A) LCCOAT/bare metal, (B) LCCOAT/black enamel and (C) LCCOAT/white OEM systems after 336 hours exposure to accelerated corrosion testing (B117). 153



State Job Number: 134935

Figure E 4. Carbon steel top, center and bottom cross-sections image of (A) LINE-X/bare metal, (B) LINE-X/black enamel and (C) LINE-X/white OEM systems after 336 hours exposure to accelerated corrosion testing (B117). 154

Figure E 5. Carbon steel top, center and bottom cross-sections image of (A) Raptor/bare metal, (B) Raptor/black enamel and (C) Raptor/white OEM systems after 336 hours exposure to accelerated corrosion testing (B117). 155

Figure E 6. Carbon steel top, center and bottom cross-sections image of (A) Rhino/bare metal, (B) Rhino/black enamel and (C) Rhino/white OEM systems after 336 hours exposure to accelerated corrosion testing (B117). 156

Figure E 7. Average of corrosion density on carbon steel samples exposed to accelerated corrosion testing (B117) for each of the coating systems studied in this work. 158

Figure E 8. Film delamination length of a coated carbon steel sample exposed to accelerated corrosion testing (B117) for 336 h. 159

Figure E 9. Average of film delamination length of carbon steel panels exposed to accelerated corrosion testing (B117) for each of the coating systems studied in this work. 161

Figure F 1. Control unscrubbed metal panels exposed to the salt spray chamber 164

Figure F 2. Galvanized unscrubbed metal panels exposed to the salt spray chamber..... 165

Figure F 3. LCCOAT unscrubbed metal panels exposed to the salt spray chamber. 166

Figure F 4. LINE-X unscrubbed metal panels exposed to the salt spray chamber. 168

Figure F 5. Metalized unscrubbed metal panels exposed to the salt spray chamber. 169

Figure F 6. Raptor unscrubbed metal panels exposed to the salt spray chamber..... 170

Figure F 7. Rhino Linings unscrubbed metal panels exposed to the salt spray chamber. 172

Figure G 1. Electrochemical three-electrode setup..... 176

Figure G 2. Electrical equivalent circuit CPE used to fit the corrosion process of several coating systems..... 192

Figure G 3. Electrical equivalent circuit CPE with diffusion used to fit the corrosion process of several coating systems. 193

Figure G 4: Electrical equivalent (failed coating, FC) used to fit the corrosion process of coating systems..... 193

Figure G 5: Nyquist (left) and Bode (right) plots representing the electrochemical behavior of carbon steel panels coated with black enamel as a primary coating..... 194

Figure G 6: Nyquist (left) and Bode (right) plots representing the electrochemical behavior of carbon steel panels coated with white OEM as a primary coating. 194

Figure G 7: Nyquist (left) and Bode (right) plots representing the electrochemical behavior of carbon steel panels coated with LCCOAT..... 195

Figure G 8: Nyquist (left) and Bode (right) plots representing the electrochemical behavior of LCCOAT coated on carbon steel panels previously coated with black enamel. 195

Figure G 9: Nyquist (left) and Bode (right) plots representing the electrochemical behavior of LCCOAT coated on carbon steel samples previously coated with white OEM..... 196

Figure G 10: Nyquist (left) and Bode (right) plots representing the electrochemical behavior of carbon steel panels coated with LINE-X..... 196

Figure G 11: Nyquist (left) and Bode (right) plots representing the electrochemical behavior of LINE-X coated on carbon steel samples previously coated with black enamel. 197

Figure G 12: Nyquist (left) and Bode (right) plots representing the electrochemical behavior of LINE-X coated on carbon steel samples previously coated with white OEM..... 197

Figure G 13: Nyquist (left) and Bode (right) plots representing the electrochemical behavior of carbon steel panels coated with Raptor..... 198

Figure G 14: Nyquist (left) and Bode (right) plots representing the electrochemical behavior of Raptor coated on carbon steel samples previously coated with black enamel. 198

Figure G 15: Nyquist (left) and Bode (right) plots representing the electrochemical behavior of Raptor coated on carbon steel samples previously coated with white OEM..... 199



State Job Number: 134935

Figure G 16: Nyquist (left) and Bode (right) plots representing the electrochemical behavior of carbon steel panels coated with Rhino Linings..... 199

Figure G 17: Nyquist (left) and Bode (right) plots representing the electrochemical behavior of Rhino Linings coated on carbon steel samples previously coated with black enamel.....200

Figure G 18: Nyquist (left) and Bode (right) plots representing the electrochemical behavior of Rhino Linings coated on carbon steel samples previously coated with white OEM.....200

Figure G 19. Pore resistance of coating systems exposed to hydraulic fluids (AW32) over 21 days. Notice that LINE-X and Raptor have a large decrease in pore resistance, indicating a large uptake of motor oil into the coating. This may lead to a breakdown in the coating over time. Pore resistance of LCCCOAT on black enamel at day 0 was too large to be determined.202

Figure G 20. Coating capacitance of coating systems exposed to hydraulic fluids (motor oil) over 21 days. Notice that most coatings have a small decrease in coating capacitance, indicating an uptake of motor oil into the coating. On the other hand, Raptor shows an increase in coating capacitance. As AW32 is less corrosive than sodium chloride (see corrosion rate data below), an uptake of motor oil into the coating may actually protect the surface over time.202

Figure G 21. Corrosion rate (mmpy) of increasing weight percent (1,2,3,wt%) of AW32 and AW68 compared to 0.6 M NaCl. Notice that AW32 is less corrosive than 0.6 NaCl and corrosivity decreases as weight percent of motor oil increases. Corrosion rate was determined using polarization curves and Tafel analysis.....203

Figure H 1. Mounted scribed metal panels exposed to winter in field testing for 90 days.205

Figure H 2. Ohio annual snowfall and Ohio districts206

Figure H 3. Representative creep rate measurements in mm of exposed metal panels to winter in field testing for 90 days.....212

Figure H 4: Panels from District 4 salt trucks after 90 days of exposure in the winter of 2015213



State Job Number: 134935

Figure H 5: Panels from District 10 salt trucks after 90 days of exposure in the winter of 2015215

Figure I 1. XRD spectra of LinST.....217

Figure I 2. XRD spectra of RaST.....218

Figure I 3. XRD spectra of RhST.....219

Figure I 4. Diffraction spectra of magnetite in RaST.220

Figure I 5. Diffraction spectra of goethite in RaST.221

Figure I 6. Diffraction spectra of hematite in RaST.222

Figure I 7. Diffraction spectra of carbon oxide in RaST.223

Figure J 1. Carbon steel top, center and bottom cross-sections image of (A) control/black enamel and (B) control/white OEM systems after 90-day exposure to winter in field testing.226

Figure J 2. Carbon steel top, center and bottom cross-sections image of (A) LCCOAT/bare, (B) LCCOAT/black enamel, and (C) LCCOAT/white OEM systems after 90-day exposure to winter in field testing.227

Figure J 3. Carbon steel top, center and bottom cross-sections image of (A) LINE-X/bare, (B) LINE-X/black enamel, and (C) LINE-X/white OEM systems after 90-day exposure to winter in field testing.228

Figure J 4. Carbon steel top, center and bottom cross-sections image of (A) Raptor/bare, (B) Raptor/black enamel, and (C) Raptor/white OEM systems after 90-day exposure to winter in field testing.....229

Figure J 5. Carbon steel top, center and bottom cross-sections image of (A) Rhino/bare metal, (B) Rhino/black enamel and (C) Rhino/white OEM systems after 90-day exposure to winter in field testing.....230

Figure J 6. Average of corrosion density on carbon steel samples exposed to winter in field testing in District 4 for each of the coating systems studied in this work.....232

Figure J 7. Carbon steel top, center and bottom cross-sections image of (A) control/bare metal and (B) control/white OEM after 90-day exposure to winter in field testing.....234

State Job Number: 134935

Figure J 8. Carbon steel top, center and bottom cross-sections image of (A) LCCOAT/bare, (B) LCCOAT/black enamel, and (C) LCCOAT/white OEM systems after 90-day exposure to winter in field testing.235

Figure J 9. Carbon steel top, center and bottom cross-sections image of (A) LINE-X/bare, (B) LINE-X/black enamel, and (C) LINE-X/white OEM systems after 90-day exposure to winter in field testing.236

Figure J 10. Carbon steel top, center and bottom cross-sections image of (A) Raptor/bare, (B) Raptor/black enamel, and (C) Raptor/white OEM systems after 90-day exposure to winter in field testing.237

Figure J 11. Carbon steel top, center and bottom cross-sections image of (A) Rhino/bare, (B) Rhino/black enamel, and (C) Rhino/white OEM systems after 90-day exposure to winter in field testing.238

Figure J 12. Average of corrosion density on carbon steel samples exposed to winter in field testing in District 10 for each of the coating systems studied in this work.240

Figure J 13. Average of coating delamination length on carbon steel samples exposed to winter in field testing in District 4 and 10 for each of the coating systems studied in this work.242

Figure L 2: Overview of Corrosion on Snow and Ice Equipment.....252

Figure L 3: Metal coupons used to measure corrosion on winter maintenance vehicles. Corrosion rate was measured as weight lost over time due to exposure of the coupons to two different salt solutions (Xi and Xie 2002).254

TABLE OF TABLES

Table 2.4-1: ASTM tests for the evaluation of coatings9

Table 2.5-1: Survey Results Show that Coatings are Most Commonly Applied to Problem Areas on the Truck 11

Table 2.5-2: Rating of effectiveness of coating.....11

Table 2.5-3: Survey Results Show that Most Respondents Discontinued Use of Corrosion Prevention Coatings Due their Cost, Ineffectiveness, and Time Constraints.12



State Job Number: 134935

Table 2.6-1: Coatings and controls selected for evaluation in the current study. 14

Table 3.1-1: Design of experiments for current research project based on results obtained during online survey and interviews. **Stainless steel is used as a control. 15

Table 3.1-2: Application and curing time of the coating systems evaluated in this study. 18

Table 3.1-3: ASTM standards used in this work to evaluate coating properties. 18

Table 3.1-4: Adhesion of the tested coatings before accelerated corrosion testing. A complete breakdown of all coating properties can be found in Appendix B. 19

Table 3.1-5: Representative coating rating based on mean creep from scribe (mm) from ASTM D1654-08 standard. 20

Table 3.1-6: Representative coating rating based on area failed on an unscribed coated surface from ASTM D1654-08 standard. 21

Table 3.1-7: Representative coating rating for unscribed coated panels studied in this work. 33

Table 3.1-8: Degree of blistering and rusting of coated metal panels according to ASTM D714 and ASTM D610. 35

Table 3.2-1: Water uptake at 100 days for all surface treatments on carbon steel exposed to 0.6 M NaCl. 41

Table 3.2-2: Calculated pore resistances for coatings on carbon steel during immersion testing with 0.6 M NaCl at day 0 and after 100 days. 43

Table 3.2-3: Summary of laboratory corrosion ratings. Laboratory corrosion ratings are based off of ASTM standards and pore resistance of coatings (listed in chapter). 46

Table 3.3-1: Summary of effectiveness of coatings at reducing corrosion during in field testing for all surface treatments coated on carbon steel samples 53

Table 3.4-1: ODOT EIMS Database Repair Codes Analyzed as part of the Cost-Benefit Analysis. 55

Table 3.4-2: Total Cost (Parts and Labor) Summary by Repair Code from ODOT EIMS Database (2004-2014). 56

Table 3.4-3: Total Cost (Parts and Labor) Summary by Calendar Year for Repair Codes 254, 238, 239, and 347 from ODOT EIMS Database (2004-2014). 57

ODOT Research Final Report



State Job Number: 134935

Table 3.4-4: Total Cost (Parts and Labor) Summary by ODOT District for Repair Codes 254, 238, 239, and 347 from ODOT EIMS Database (2004-2014).....	59
Table 3.4-5: Total Cost (Parts and Labor) Summary by Selected Trucks from District 10 for All Repair Codes Evaluated in this Study (Organized by General Maintenance Category) from ODOT EIMS Database (2004-2014).	60
Table 3.4-6: Total Cost (Parts and Labor) Per Year by Selected Trucks from District 10 for All Repair Codes Evaluated in this Study (Organized by General Maintenance Category) from ODOT EIMS Database (2004-2014).	60
Table 3.4-7: Theoretical spread rate in ft ² /U.S. gallon of corrosion protective coatings.	61
Table 3.4-8: Prices of the coating systems used in this study in dollars per U.S. gallon.	62
Table 3.4-9: Labor time employed in the application and curing of the coating systems evaluated in this study.	62
Table 3.4-10: Total costs per coating per ft ² and total time needed in labor.....	63
Table 3.4-11: Cost to maintain a standard DOT salt truck for 10 years using average costs for maintenance and labor.....	64
Table 3.4-12: Percent change in creep for each surface treatment tested compared to its control.	65
Table 3.4-13: Overview of cost-benefit analysis for three scenarios	66
Table A 1: Survey Results for Question 1.....	74
Table A 2: Survey Results for Question 2.....	75
Table A 3: Survey Results for Question 3.....	77
Table A 4: Survey Results for Question 4.....	80
Table A 5: Survey Results for Question 5.....	81
Table A 6: Survey Results for Question 6.....	83
Table A 7: Survey Results for Question 7.....	84
Table A 8: Survey Results for Question 8.....	85
Table A 9: Survey Results for Question 9.....	86
Table A 10: Survey Results for Question 10.....	87
Table A 11: Survey Results for Question 11.....	88
Table A 12: Survey Results for Question 12.....	89



ODOT Research Final Report

State Job Number: 134935

Table A 13: Survey Results for Question 13.....	90
Table A 14: Survey Results for Question 14.....	91
Table A 15: Survey Results for Question 15.....	92
Table A 16: Survey Results for Question 16.....	93
Table A 17: Survey Results for Question 17.....	94
Table A 18: Survey Results for Question 18.....	95
Table A 19: Survey Results for Question 19.....	96
Table A 20: Survey Results for Question 20.....	97
Table A 21: Survey Results for Question 21.....	97
Table B 1. ASTM standards used in this work to evaluate coating properties.....	99
Table B 2. Coating thickness of galvanized metal panels.....	101
Table B 3. Coating thickness of LCCOAT on Al metal panels.	102
Table B 4. Coating thickness of LCCOAT on CA metal panels.....	103
Table B 5. Coating thickness of LCCOAT on CS metal panels.....	104
Table B 6. Coating thickness of LCCOAT on CFe metal panels.....	106
Table B 7. Coating thickness of LINE-X on Al metal panels.	107
Table B 8. Coating thickness of LINE-X on CA metal panels. (Please note that only one measurement was performed due to gauge limitations).....	107
Table B 9. Coating thickness of LINE-X on CS metal panels.....	108
Table B 10. Coating thickness of LINE-X on CFe metal panels.....	110
Table B 11. Coating thickness of Metalized on CS metal panels.....	110
Table B 12. Coating thickness of Raptor on Al metal panels.	111
Table B 13. Coating thickness of Raptor on CA metal panels.	112
Table B 14. Coating thickness of Raptor on CS metal panels.	113
Table B 15. Coating thickness of Raptor on CFe metal panels.....	114
Table B 16. Coating thickness of Rhino Linings on Al metal panels.	115
Table B 17. Coating thickness of Rhino on CA metal panels.....	116
Table B 18. Coating thickness of Rhino Linings on CS metal panels.....	117
Table B 19. Coating thickness of Rhino Linings on CFe metal panels.....	118
Table B 20. Coating hardness based on ASTM standard D3363.	120



State Job Number: 134935

Table B 21. Coating adhesion based on ASTM standard D3359..... 122

Table B 22. Coating specular gloss based on ASTM standard D523. 123

Table B 23. Coating impact resistance based on ASTM standard D2794..... 124

Table B 24. Flexibility of coatings studied in this work using ASTM standard D522..... 125

Table C 1. Creep rate (mm) of CS panels exposed to salt spray chamber for 336 hours. 128

Table C 2. Creep rate (mm) of Al panels exposed to salt spray chamber for 336 hours. 129

Table C 3. Creep rate (mm) of CA and CFe panels exposed to salt spray chamber for
336 hours. 130

Table C 4. Rating of failure at scribe. 131

Table D 1. Identification of scribed CS samples exposed to accelerated corrosion
testing..... 140

Table D 2. Identification of galvanized and metalized samples exposed to accelerated
corrosion testing. 146

Table E 1. Coating systems used in this study and evaluated under accelerated
corrosion testing for carbon steel panels. 151

Table E 2. Corrosion density on carbon steel samples exposed to accelerated corrosion
testing (B117) for each of the coating systems studied in this work. 157

Table E 3. Film delamination length of carbon steel samples exposed to accelerated
corrosion testing (B117) for each of the coating systems studied in this work..... 160

Table F 1. Unscribed coated metal panels evaluated in this study. 163

Table F 2. Representative coating rating based on area failed on an unscribed coated
surface from ASTM D1654 standard. 173

Table F 3. Representative coating rating for unscribed coated panels studied in this
work. 174

Table F 4. Degree of blistering and rusting of coated metal panels according to ASTM
D714 and ASTM D610. 175



State Job Number: 134935

Table G 1. EIS coating parameters for immersion testing of Control - Black Enamel on CS metal panel exposed to a 0.6M NaCl solution..... 178

Table G 2. EIS coating parameters for immersion testing of Control - White OEM on CS metal panel exposed to a 0.6M NaCl solution..... 179

Table G 3. EIS coating parameters for immersion testing of LCCOAT - Bare on CS metal panel exposed to a 0.6M NaCl solution. 180

Table G 4. EIS coating parameters for immersion testing of LCCOAT - Black Enamel on CS metal panel exposed to a 0.6M NaCl solution..... 181

Table G 5. EIS coating parameters for immersion testing of LCCOAT - White OEM on CS metal panel exposed to a 0.6M NaCl solution. 182

Table G 6. EIS coating parameters for immersion testing of LINE-X - Bare on CS metal panel exposed to a 0.6M NaCl solution. 183

Table G 7. EIS coating parameters for immersion testing of LINE-X - Black Enamel on CS metal panel exposed to a 0.6M NaCl solution..... 184

Table G 8. EIS coating parameters for immersion testing of LINE-X - White OEM on CS metal panel exposed to a 0.6M NaCl solution..... 185

Table G 9. EIS coating parameters for immersion testing of Raptor - Bare on CS metal panel exposed to a 0.6M NaCl solution. 186

Table G 10. EIS coating parameters for immersion testing of Raptor - Black Enamel on CS metal panel exposed to a 0.6M NaCl solution..... 187

Table G 11. EIS coating parameters for immersion testing of Raptor - White OEM on CS metal panel exposed to a 0.6M NaCl solution..... 188

Table G 12. EIS coating parameters for immersion testing of Rhino Linings- Bare on CS metal panel exposed to a 0.6M NaCl solution..... 189

Table G 13. EIS coating parameters for immersion testing of Rhino Linings- Black Enamel on CS metal panel exposed to a 0.6M NaCl solution. 190

Table G 14. EIS coating parameters for immersion testing of Rhino Linings- White OEM on CS metal panel exposed to a 0.6M NaCl solution. 191

Table H 1. Identification of salt trucks used in the evaluation of corrosion protective coatings during winter in field testing in District 4 and 10.....206

ODOT Research Final Report



State Job Number: 134935

Table H 2. Scribed carbon steel panels mounted in District 4 salt trucks.....	207
Table H 3. Scribed carbon steel panels mounted in District 10 salt trucks.....	208
Table H 4. Rating of failure at scribe.	209
Table H 5. Creep rate results for District 4 after exposure of carbon metal panels to winter in field testing.	210
Table H 6. Creep rate results for District 10 after exposure of carbon metal panels to winter in field testing.	211
Table I 1. Identification of scribed CS samples exposed to winter in field testing.....	216
Table J 1. Coating systems used in this study and evaluated under winter in field testing in District 4 for carbon steel panels for 90 days.	225
Table J 2. Corrosion density on carbon steel samples exposed to winter in field testing in District 4.	231
Table J 3. Coating systems used in this study and evaluated under winter in field testing in District 10 for carbon steel panels for 90 days.	233
Table J 4. Corrosion density on carbon steel samples exposed to winter in field testing in District 10.	239
Table J 5. Coating delamination length of cross-sections of corroded metal panels exposed to winter in field testing in district 4 and 10.	241
Table K 1: Cost of coating and maintenance for standard truck	243
Table K 2: Cost of coating and maintenance for truck coated with LCCOAT for scenario 1 (new truck with bare/exposed metal coated with LCCOAT)	243
Table K 3: Cost of coating and maintenance for truck coated with LINE-X for scenario 1 (new truck with bare/exposed metal coated with LINE-X)	244
Table K 4: Cost of coating and maintenance for truck coated with Raptor for scenario 1 (new truck with bare/exposed metal coated with Raptor)	244
Table K 5: Cost of coating and maintenance for truck coated with Rhino Linings for scenario 1 (new truck with bare/exposed metal coated with Rhino Linings)	245



ODOT Research Final Report

State Job Number: 134935

Table K 6: Cost of coating and maintenance for truck coated with LCCOAT for scenario 2 (scenario 1 plus LCCOAT as a topcoat on white OEM or black enamel)	245
Table K 7: Cost of coating and maintenance for truck coated with LINE-X for scenario 2 (scenario 1 plus LINE-X as a topcoat on white OEM or black enamel)	246
Table K 8: Cost of coating and maintenance for truck coated with Raptor for scenario 2 (scenario 1 plus Raptor as a topcoat on white OEM or black enamel)	246
Table K 9: Cost of coating and maintenance for truck coated with Rhino Linings for scenario 2 (scenario 1 plus Rhino Linings as a topcoat on white OEM or black enamel)	248
Table K 10: Cost of coating and maintenance for truck coated with white OEM and black enamel (standard truck) for scenario 3 (refurbishment of existing truck)	248
Table K 11: Cost of coating and maintenance for truck coated with LCCOAT for scenario 3 (refurbishment of existing truck)	249
Table K 12: Cost of coating and maintenance for truck coated with LINE-X for scenario 3 (refurbishment of existing truck).....	249
Table K 13: Cost of coating and maintenance for truck coated with Raptor for scenario 3 (refurbishment of existing truck).....	250
Table K 14: Cost of coating and maintenance for truck coated with Rhino Linings for scenario 3 (refurbishment of existing truck)	250



ODOT Research Final Report

State Job Number: 134935

LIST OF ACRONYMS

ASTM - American Society for Testing and Materials
CDOT- Colorado Department of Transportation
FHWA – Federal Highway Administration
HSM – Highway Safety Manual
IHRB - Iowa Highway Research Board
NCHPR – National Cooperative Highway Research Program
NACE- National Association of Corrosion Engineers
ODOT- Ohio Department of Transportation
OEM- Original Equipment Manufacturer
RWIS – Road Weather Information System
SAE- Society of Automotive Engineers
SCC- Stress Corrosion Cracking
SEM-Scanning Electron Microscope
TMS – Transportation Management Services
TRB – Transportation Research Board
UV-vis- Ultraviolet-visible
XRD - X-Ray Powder Diffraction



ODOT Research Final Report

State Job Number: 134935

LIST OF APPENDICES

APPENDIX A: SURVEY RESULTS

APPENDIX B: COATING ANALYSIS

APPENDIX C: CREEP RESULTS: B117

APPENDIX D: X-RAY DIFFRACTION RESULTS: B117 TESTING

APPENDIX E: STEREOMICROSCOPE IMAGES FROM B117 TESTING

APPENDIX F: IMAGE ANALYSIS OF UNSCRIBED COUPONS: B117 TESTING

APPENDIX G: EIS CIRCUITS: IMMERSION TESTING

APPENDIX H: IN FIELD PROCEDURES AND RESULTS

APPENDIX I: X-RAY DIFFRACTION RESULTS: IN FIELD TESTING

APPENDIX J: STEREO IMAGES FROM IN FIELD TESTING

APPENDIX K: COST-BENEFIT ANALYSIS

APPENDIX L: ADDITIONAL BACKGROUND

CHAPTER I: KEY POINTS

- Compared to white OEM and black enamel controls, four organic coatings and two metalized coatings were tested on four metal surfaces during laboratory and in field testing.
- During laboratory testing, coated metal samples were rated using ASTM accelerated corrosion testing standards (e.g. creep from scribe, percent of surface corroded, blister density) and standard immersion testing data (pore resistance over time).
- During in field testing, coatings were applied only to carbon steel as it was the most corrosive during accelerated corrosion testing. Coatings were again rated using ASTM accelerated corrosion testing standards. Metal samples were exposed to winter weather conditions (in field) on 8 salt trucks spanning two ODOT districts (4,10) from December 2014-March 2015.
- Data collected from laboratory results was used as a baseline for comparison of corrosion between surface treatments during a cost-benefit analysis. Historical maintenance records were used to determine maintenance cost per truck per year for a standard DOT salt truck. Coating cost was calculated assuming 100 ft² of surface coverage. Predicted maintenance cost was determined as a function of corrosion performance during detailed testing (compared to standard cost)
- Data suggest that exposed metal on new DOT snow and ice equipment should be coated with either Raptor or LCCOAT coating systems. Some of the parts to be coated include the rear hitch plate, hydraulics attachment plate assembly, front plow hoist/ frame/ bumper assembly, liquid deicer tank mounting hardware, and bed hoist subframe. Parts may be galvanized.
- Trucks in need of refurbishment should be stripped down (sandblasted, prepared and primed to industry standards) and painted based on the previous specifications.
- Trucks in no need of refurbishment should be maintained using visual inspection and coating reapplication where coating breakdown (exposed metal) occurs, in order to

ODOT Research Final Report

State Job Number: 134935

avoid the need for total refurbishment. Extra care should be taken to inspect the truck frame (front to back), bed hoist subframe, front plow hoist, front plow frame, front bumpers, rear hitch plate, liquid deicer tank mounting hardware, and hydraulics mounting plate assembly.

- In field studies performed in this work can be used to draw initial conclusions; however, longer-term studies are needed to determine performance of coatings during actual snow and ice conditions. In order to provide a more accurate cost-benefit analysis, a more complete set of in field data is necessary.

		Corrosion Rating (Laboratory)	Corrosion Rating (In field)	Corrosion Rating (Cost- Benefit)	Total Ranking
Raptor	Bare	Good	Excellent	Excellent	1
	Black Enamel	Excellent	Excellent	Excellent	
	White OEM	Excellent	Excellent	Excellent	
LCCOAT	Bare	Excellent	Good	Excellent	2
	Black Enamel	Excellent	Excellent	Good	
	White OEM	Excellent	Excellent	Good	
Galvanized		Poor*	Excellent	N/A	3
Control	Black Enamel	Good	Excellent	Average	4
	White OEM	Average	Good	Average	
Rhino Linings	Bare	Fair	Excellent**	Fair	5
	Black Enamel	Excellent	Excellent	Fair	
	White OEM	Good	Excellent	Fair	
LINE-X	Bare	Good	Good	Average	6
	Black Enamel	Good	Good	Poor	
	White OEM	Good	Good	Poor	

*Galvanized underperforms in the laboratory because the coating does not undergo exposure cycles necessary to create protective layer on the surface of the metal

**Rhino Linings on bare metal appears to perform well in the field because the rust on the flat surface of the metal is not taken into account when measuring creep

CHAPTER II: BACKGROUND

2.1 Problem Statement

Current estimates suggest that the United States loses over \$220 billion dollars due to corrosion each year and 15% of that loss is considered avoidable (Koch, Brongers, Thompson, Virmani, & Payer, 2002; Nixon & Xiong, 2009; Virmani, 2001). In winter maintenance, the chemicals used to keep roadways clear of snow and ice are highly corrosive to vehicles and equipment (Chance, 1974; The Salt Institute., 2013; Xi & Xie, 2002). Corrosion of snow and ice equipment is a major issue causing increased maintenance and repair costs, reduced vehicle life, and increased vehicle downtime. Statistics show that road salt causes approximately \$1500/ton of damage to vehicles, bridges, and the environment (Nixon & Xiong, 2009). The Ohio Department of Transportation (ODOT), for example, can spend \$10,000,000 a year on equipment parts and fleet maintenance.

Coatings are often applied to protect the bare metal from corrosive environments. These coatings have been shown to protect metal components from corrosion-causing conditions such as moisture, salt spray, oxidation, etc. Even with a protective coating, however, once a sufficient amount of chloride ions (from salt) pass through the coating to the underlying metal, a more aggressive and corrosive environment is formed that causes the coating to blister and peel-off (Barnhart, 2013). This is further accelerated when there are defects (e.g. breaches or holidays) on the surface of the coating. Therefore, long-term exposure of winter maintenance equipment to strong deicers will lead to corrosion even when the equipment is protected with corrosion protective coatings. For a more detailed description of corrosion of winter maintenance vehicles and a survey of previous work on the subject see Appendix L.

Although the consensus points to the need for a durable, cost effective coating, at present there is not sufficient information available to determine a “Best Practice” for increasing equipment lifetime and decreasing cost. The research presented here will determine a cost effective coating and a recommended application procedure for ODOT winter maintenance

State Job Number: 134935

equipment. Success of the project will provide ODOT with a corrosion prevention strategy that will increase public safety by preventing unexpected equipment failures, decrease downtime of snow and ice equipment caused by maintenance due to rusting issues, increase efficiency by decreasing downtime, and provide cost savings through reduction in rust related maintenance.

2.2 Objectives and Goals of the Study

The four objectives of this project were as follows:

- Objective 1 - Perform a thorough literature search on the effectiveness of corrosion protective coatings and document “best practice” for application of coatings as reported by ODOT and other state DOTs,
- Objective 2 - Assess selected, commercially-available, cost effective coatings on the laboratory scale,
- Objective 3 - Propose a deployment strategy for the corrosion protective coating consistent with current ODOT practices, and
- Objective 4 - Perform a cost-benefit analysis of the top-performing coating on all tested surfaces, including a deployment strategy based on current maintenance costs.

2.3 Overview of Approach

To meet the four objectives identified above and to provide a cost effective corrosion prevention strategy for winter maintenance equipment, this research team developed and completed four research tasks.

Task One: Data Collection and Evaluation of Current Practices and Reports on the Effectiveness and Use of Corrosion Protective Coatings

The goal of this task was to evaluate and summarize available data and reports from each of ODOT’s 12 districts, the central research office, the NACE Corrosion Network, Corrosion Prevention Association (CPA) and other state DOTs (e.g. PA, IN, IA, and WI) that are currently using corrosion protective coatings on their winter maintenance vehicles. Data



State Job Number: 134935

collection included site visits (to a garage in each ODOT district, or at a minimum of 5 garages) to understand ODOTs equipment and materials, telephone interviews, and a web-based survey that predominately focused on the application and use of corrosion protective coatings (e.g. type of coatings, location of coatings, application methods). The main scope of the questions in the web-based survey focused on:

- General maintenance questions involving use of corrosion protective coatings,
- The preferred commercially available coatings and the preferred application rate/method
- General in field performance of coated metal surfaces,
- Features of coating products that are liked and disliked, and
- Feedback including the effectiveness coating at preventing corrosion on metal surfaces.

Task Two: Data Collection

Using the information collected under Task One, coatings were identified and evaluated as potential corrosion prevention strategies. The feasibility of these options was evaluated based on results of laboratory experiments (accelerated corrosion testing, continuous immersion testing) and in field testing. Laboratory-scale testing was performed in the Monty Research Laboratory at the University of Akron and by members of the Monty Research Laboratory off-site at Light Curable Coatings in Berea, OH.

Task Three: Benefit to Cost Analysis Using Commercially Available Corrosion Prevention Coatings

Using the information from Tasks 1 and 2, a benefit-cost analysis was performed in order to compare the effect of coatings on overall cost, taking equipment maintenance and usable lifetime into consideration. Additionally, the effect of corrosion on the bare metal was determined in order to predict the cost effectiveness and extended lifetime of coated metals. For this comparison, the principal measures were total capital cost (incorporating initial maintenance equipment costs, replacement costs, and coating application costs), labor cost, and routine and emergency maintenance costs.

Task Four Development of “Standard Operating Procedure” for Selected Corrosion Protective Coating

State Job Number: 134935

Based on the corrosion reduction, durability, and coating lifetime (Task 2) and overall cost effectiveness (Task 3), Task four provided a written, step-by-step “standard operating procedure” for the application of the selected protective coating for ODOT Office of Equipment Management. The SOP was based on the most cost-effective coating determined in Task 3, and included a proposed strategy for application (initial application and frequency of reapplication), and was in compliance with ODOT Maintenance Administration Manual Section 900.

2.4 Corrosion Protective Coatings

Commercially available corrosion protective coatings can be composed of acrylics, alkyds, bituminous, amine epoxies, polyamide epoxies, coal tar epoxies, fusion-bonded epoxies, inorganic and organic zinc-rich primer, urethane, polyurethane and UV-cured coatings. Figure 2.4-1A shows the effect of a UV-cured coating developed at Light Curable Coatings on the corrosion of a 2024 aluminum alloy. Notice that after 3000 hours in a salt spray chamber, the coating had protected the aluminum from undergoing any visible corrosion.

Figure 2.4-1B shows the effect of in field implementation of corrosion protective coatings on protecting winter maintenance equipment from undergoing corrosion. The picture on the left is without a protective coating and the picture on the right is after application of a coating. Notice that there is less corrosion on the surface of the winter maintenance equipment with the protective coating.

State Job Number: 134935

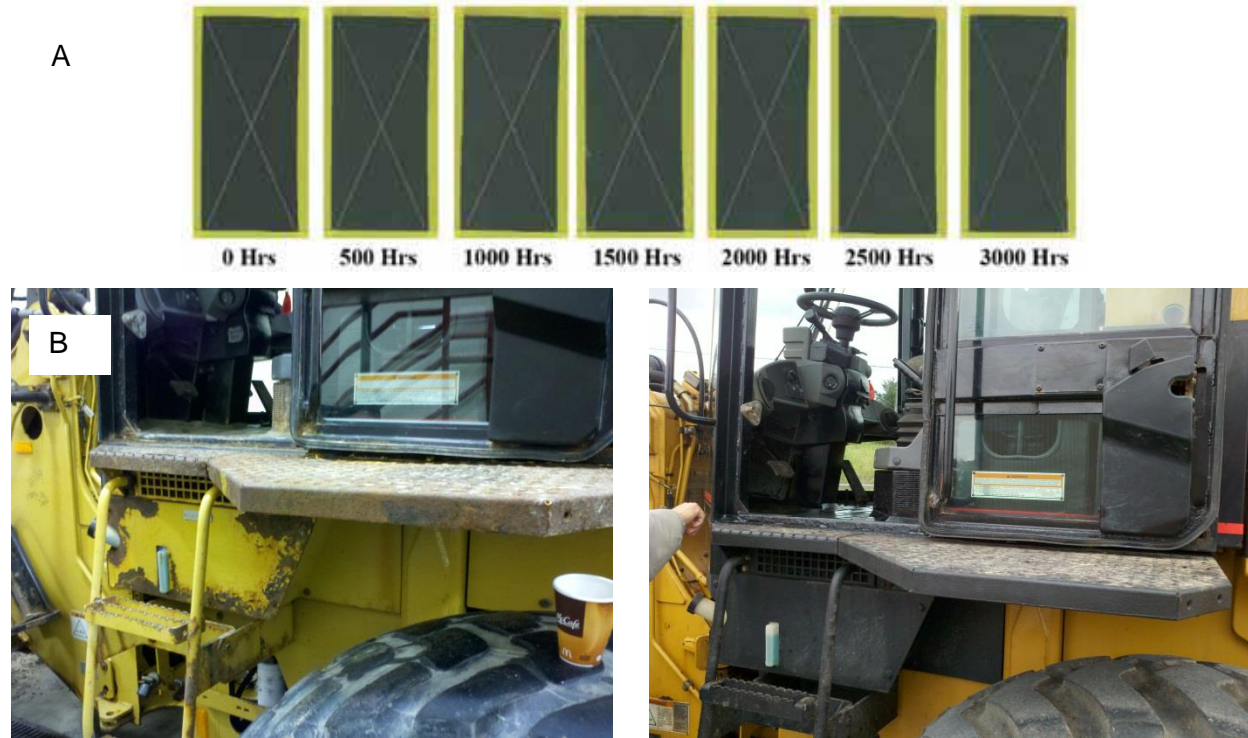

Figure 2.4-1A: Effect of UV-curable coating on corrosion of an aluminum alloy after exposure to 3000 hours of salt spray testing. B. In field success of corrosion protective coating applied to winter maintenance equipment.

Protective coatings are divided in three categories: organic, metallic and ceramic. Organic coatings are very versatile and are composed of three components as seen in Figure 2.4-3: solvent, resin and pigment (The Society for Protective Coatings, 2013). Not all organic coatings contain all three elements (pigment-free or solvent-free but not resin-free) and the variation of these components determines the properties of the coating. A good organic coating should perform well, according to ASTM standards, as well as be easily maintained, quick drying, economical, non-toxic, and easily applied (Angal, 2010). Metallic coatings offer corrosion resistance to steel substrates by several mechanisms including, barrier, sacrificial, or inhibition protection (Goodwin, Simpson). The most utilized application methods of metallic coatings are hot dipping and thermal spraying. Hot dipping provides metallurgical bonding of zinc, aluminum or zinc-aluminum alloys on the substrate; while in the thermal spray method, fine

State Job Number: 134935

materials are melted into small particles and sprayed onto the surface of the substrate at high speeds (see figure below) (Simpson, Fauchais). Accelerated corrosion tests are the most widely used technique for the determination of coating performance. However, in the case of zinc coatings, cyclic tests provide better comparative rankings among metallic coatings by allowing formation of oxides (Goodwin).

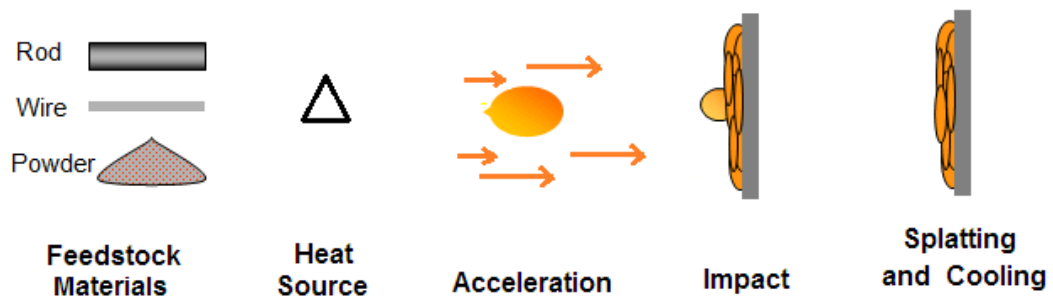

Figure 2.4-2: Thermal spraying of metallic coatings onto the surface of metal substrates.

Hot dipping requires four steps: (1) careful preparation by selecting proper venting and drainage of substrate; (2) cleaning is performed by immersion of the substrate in a hot alkali solution to remove organic compounds, acid pickling to treat rust and scale, and fluxing removes oxides that promote metallurgical bonding; (3) galvanizing involves immersion of the substrate into a bath of molten zinc at approximate temperatures of 840° F/449° C forming intermetallic layers; (4) quality control includes complete inspection and cleaning to guarantee any voids on the surface (AZZ Galvanizing). Hot dipping and thermal spraying will initially provide barrier protection, and then, zinc will start to corrode sacrificially in preference to steel by acting as the anode area involving metallic dissolution and production of electrons. Metallic coatings have a high degree of surface roughness making them suitable to the application of paints by enhancing adhesion compared to smooth steel surfaces (Goodwin).

State Job Number: 134935

Table 2.4-1: ASTM tests for the evaluation of coatings

ASTM Standard	ASTM Test Method
D3359	Adhesion by tape test
D4541 or D7234	Pull-off strength of coating
D1653	Permeability
D3363	Pencil hardness test
D522	Flexibility
D4060 or D968	Abrasion resistance
B117	Salt fog chamber
D2794	Impact resistance
D5402	Chemical resistance

When dealing with vehicular corrosion, one of the most important considerations is the performance of protective coatings. Certain coating properties are desired, including good adhesion, low permeability, uniform thickness, flexibility, abrasion resistant, weathering resistant, chemical and biological resistant - to provide long-term protection of substrates. The evaluation of coatings is performed by conducting ASTM standard tests such as the ones seen in Table 2.4-1.

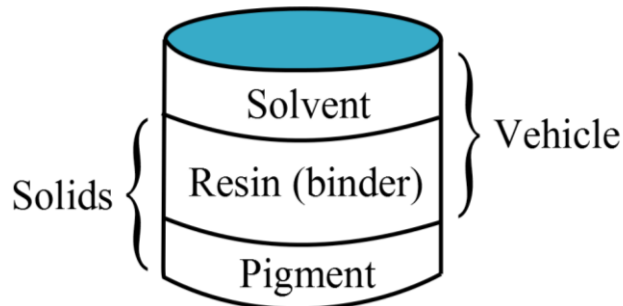

Figure 2.4-3: Components of an organic coating

State Job Number: 134935

2.5 Current Corrosion Prevention Strategies

As the main focus of this research was the evaluation of corrosion protective coatings strategies, an online survey was developed using Survey Monkey (surveymonkey.com) and distributed to Ohio DOT district managers via email as well as to DOT offices in Alaska, Idaho, Illinois, Iowa, New York State, North Dakota, Utah, Washington State and Wisconsin. This survey was also sent through The University of Iowa SNOW-ICE list. The majority of the questions focused on:

- General maintenance questions involving the incorporation of corrosion prevention coatings on snow and ice equipment,
- The preferred commercially available corrosion prevention coating and the preferred application rate/method,
- General in field performance of the corrosion prevention coatings on metal surfaces,
- Features within the coating products that the user likes and/or dislikes, and
- Feedback including the effectiveness of the coating on corrosion prevention and extending vehicle lifetime.

The online survey received a total of 75 responses from 13 states (OH, VA, WA, MN, NE, IL, WY, MT, ND, WI, NY, UT, NC) and from ODOT districts 2, 3, 4, 5, 6, 7, 8, 10, and 12. Raw data responses from this survey can be found in Appendix A. The majority of respondents to the online survey indicated that they use sodium chloride (salt) brine in their deicing protocol.

2.5.1 Overview of Literature and Survey Results

Of the 75 responses, 25% (18 respondents) use a coating as part of their corrosion prevention strategy. The majority of the respondents use a lubricant coating (not considered in this study) such as Fluid Film (67%) and SLIP Plate No. 1 (17%) with others using more traditional coatings (considered in this study) such as Rhino Linings (50%) and LINE-X (17%). The majority of respondents applied the coating with a brush or pump sprayer to common problem areas (Table 2.5-1) including plows, truck frames/underbodies, cab and chassis, brine pumps, and quick connect fittings. Coatings were most commonly applied to carbon steel, aluminum, cast aluminum, and cast iron.



State Job Number: 134935

Table 2.5-1: Survey Results Show that Coatings are Most Commonly Applied to Problem Areas on the Truck

	Response Percent	Response Count
Truck cab	66.7%	6
Truck bed	66.7%	6
Plow blades	22.2%	2
Truck frame	88.9%	8
Undercarriage	88.9%	8
Salt spreader	66.7%	6
Other (please specify)		2
<i>answered question</i>		9
<i>skipped question</i>		66

The average effectiveness of the coating was evaluated using visual inspection. Responses can be found in Table 2.5-2

Table 2.5-2: Rating of effectiveness of coating

	Very effective	Effective	Slightly effective	Not Sure	Average
	1	4	3	3	1.64

Overall, respondents found coatings to range from “slightly effective” to “effective”, based on the reduced appearance of rust on new and old metal surfaces. When asked what features they liked/disliked about the coatings most respondents answered that it was too soon for them to judge the performance. Respondents who have previously used corrosion prevention coatings liked the fact that it reduced rust on their equipment and listed limitations of coatings as the coating application (getting old metal clean), achieving complete coverage (getting all of the undercarriage), coating price, and selection.

ODOT Research Final Report

State Job Number: 134935

Of the 75% (53 respondents) of respondents that do not use a coating in their corrosion prevention strategy, 21.2% (11 respondents) have previously used a corrosion prevention coating. From those respondents listed cost (3), ineffectiveness of the coating (8), and time constraints (4) as the reason for the discontinued use of corrosion prevention coatings. Other respondents switched to stainless steel. The breakdown of the responses is highlighted in Table 2.5-3.

Table 2.5-3: Survey Results Show that Most Respondents Discontinued Use of Corrosion Prevention Coatings Due their Cost, Ineffectiveness, and Time Constraints.

	Response Percent	Response Count
Cost	33.3%	3
Ineffective	88.9%	8
Time constraints	44.4%	4
Other (please specify)		2
<i>answered question</i>		9
<i>skipped question</i>		66

2.6 Implementation of survey results

Based on the responses from the online survey and interviews with DOT personnel, five coatings and four metals were selected for laboratory investigation. All coatings suggested during data collection were tested in this study with the exception of Dolphin, as the vendor elected not to provide us with a sample for testing. A breakdown of the coatings is given in Table 2.6-1.

- Only 18% of respondents use corrosion prevention coatings.
- Respondents who use coatings focused on coating the cab, truck bed, frame, and undercarriage
- Respondents found coatings only slightly effective, on average.



ODOT Research Final Report

State Job Number: 134935

- A number of respondents discontinued use of corrosion prevention coatings due to cost, time constraints, and decreased effectiveness.

ODOT Research Final Report



State Job Number: 134935

Table 2.6-1: Coatings and controls selected for evaluation in the current study.

COATING SYSTEM	TYPE	PRODUCT	THICKNESS
White OEM	Basecoat	Imron Elite Productive	4 mils
		Activator 194S	
	Clearcoat	Imron Elite 8840S	
		Activator 194S	
Black Enamel	Basecoat	Imron Elite Productive	4 mils
		Activator 194S	
	Topcoat (Enamel)	Rival RV35	
		Activator RV135	
Galvanized	Hot dip galvanizing	AZZ Galvanizing	3 mils
Metalized	Thermo spray of zinc	Ohio Structures	8 mils
LCCOAT	Primer	Proprietary	8 mils
	Coating	Proprietary	
LINE-X	LINE-X XS 152	1A:1B mix ratio	60 mils
		A: Isocyanate	
		B: 75% Polyurethane/25% Polyurea	
Raptor	Adhesive promoter	U-POL Grip #4	7 mils
	Etch primer	U-POL Acid #8	
	Raptor	Raptor liner	
Rhino Linings	Rhino Extreme 11-50	1A:1B mix ratio	30 mils
		A: Isocyanate	
		B: Resin	

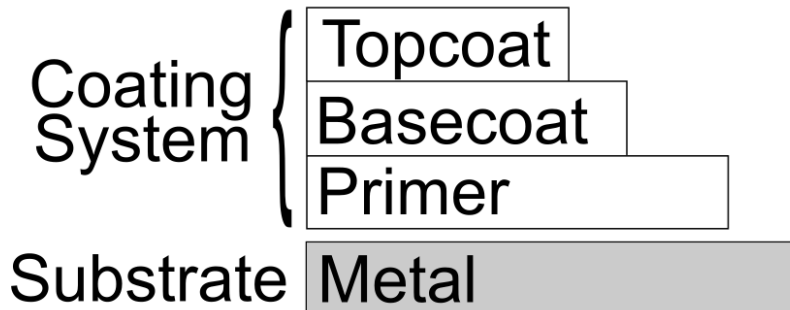



State Job Number: 134935

CHAPTER III: RESEARCH FINDINGS

3.1 Evaluation of Coatings at Preventing Corrosion on Metal Samples During Accelerated Corrosion Testing

3.1.1 Introduction

Table 3.1-1: Design of experiments for current research project based on results obtained during online survey and interviews. **Stainless steel is used as a control.

METALS	PRIMARY COATING	COATING SYSTEM						
		Control	Line-X	Rhino linings	LCCO AT	Raptor	Galvanized	Metalized
Carbon steel 1008	None		X	X	X	X	X	X
	White OEM	X	X	X	X	X		
	Black Enamel	X	X	X	X	X		
Al 2024	None		X	X	X	X		
	White OEM	X	X	X	X	X		
	Black Enamel	X						
Stainless steel 304**	None	X						
	White OEM							
	Black Enamel							
Cast iron	None	X	X	X	X	X	X	
	White OEM							
	Black Enamel							
Cast aluminum	None	X	X	X	X	X		
	White OEM							
	Black Enamel							

State Job Number: 134935

To evaluate the effectiveness of the corrosion protective coatings selected in Chapter 2, laboratory-scale accelerated corrosion testing was performed to compare effectiveness of corrosion protective coatings to original equipment manufacturer specifications (white automotive paint and black enamel). This evaluation focused on 4 metals of interest with stainless steel as a control. A complete design of experiments can be found in Table 3.1-1.

3.1.2 Experimental Procedure for Evaluating the Performance of Coatings Using Accelerated Corrosion Testing

3.1.2.1 Procedure for Coatings Application

Prior to applying the desired coating on the surface of the metal, proper surface preparation is required to avoid any contamination issues. Carbon steel (CS) 1008, aluminum (Al) 2024 and stainless steel (SS) 304 metal panels were purchased from Q-Lab Corporation, (Westlake, OH, USA) and received wrapped in volatile corrosion inhibitor (VCI) coated paper. Cast aluminum (CA) and cast iron (CFe) metal panels were purchased from McMaster-Carr and delivered with a protective film only available for CA panels. The surface of the metal panels was cleaned with the following rinsing procedure: DI water, ethanol, acetone and DI water.

Conventional air spray was used for coating application of black enamel, white OEM, LCCOAT and Raptor with Light Curable Coatings (LCCOAT) in charge of spraying these coatings. LINE-X and Rhino were sprayed at high temperature and high-pressure conditions by an external contractor. Galvanized samples were dip coated in molten zinc by AZZ Galvanizing and metalized panels were thermo sprayed with zinc on the surface of the metal by Ohio Structures.

White OEM and black enamel coating systems were prepared with the same base coat. This base coat is a 3:1 mixture in volume of DuPont Imron Elite Productive and Activator 194S. White OEM has a top clear coat prepared as a mixture by volume of 3:1 DuPont Imron Elite 8840S and Activator 194S. The black enamel system has a top coat of a mixture by volume of 6:1 Axalta Rival RV35 and Activator RV135.

ODOT Research Final Report

State Job Number: 134935

The galvanized and metalized systems were prepared and applied by AZZ Galvanizing (Canton, OH, USA) and Ohio Structures Inc. (Canfield, OH, USA), respectively.

LCCOAT (Berea, OH, USA) coating system is a solvent-free UV curable coating sprayed onto panels with approximately 1 mil of LCCOAT™ Gray Primer 022 and 2 mils of LCCOAT™ Black 203 topcoat. It should be noted that although testing was conducted at LCCOAT, no LCCOAT employees were involved in any of the testing.

LINE-X XS-152 is a flexible fire rated E-84 class A product with a composition of A: isocyanate and B:75% polyurethane/25% polyurea. This two-part system was sprayed by LINE-X of Akron/Medina (Medina, OH, USA) with a ratio in volume of 1A:1B.

Rhino Extreme 11-50 is a two-component, rapid curing, elastomeric pure polyurea lining system sprayed at high pressure with a 1:1 ratio of isocyanate and resin. Panels were sprayed by Industrial Coating Solutions Inc. (Leland, NC, USA).

Raptor is a three layer coating system from U-POL US, Inc. (Nazareth, PA, USA) composed of adhesive promoter (U-POL Grip #4), etch primer (U-POL Acid #8) and the Raptor liner topcoat tinted blue to make it distinctive from the other coatings evaluated.

Table 3.1-2 indicates the time for coating application and curing. The curing time reported encompasses curing time between coats and final curing time after application. Black enamel and white OEM required 5 minutes of curing between coats (3) and 3 days of curing after final coat was applied. Raptor needed an hour of curing between coats (3) and 7 days after final coat was applied.

After application, coatings properties were determined using ASTM standards (Table 3.1-3). Detailed experimental procedures for these tests and a complete of coating properties can be found in Appendix B. Table 3.1-4 lists the adhesion for the coatings before accelerated corrosion testing.

ODOT Research Final Report

State Job Number: 134935

Table 3.1-2: Application and curing time of the coating systems evaluated in this study.

Coatings	Application time (min/ft ²)	Curing time (h)
Black Enamel	2	72
White OEM	2	72
Galvanized	2	2
LCCOAT*	0.2	1
LINE-X	0.5	2
Metalized	2	2
Raptor	2	169
Rhino	0.5	2

*LCCOAT curing time is less than a minute per ft² (number has been rounded up)

Table 3.1-3: ASTM standards used in this work to evaluate coating properties.

ASTM Standard	ASTM Test Method
D6132	Thickness [1]
D3363	Pencil hardness test [2]
D3359	Adhesion by tape test [3]
D523	Specular gloss [4]
D2794	Impact resistance [5]
D522	Flexibility [6]

ODOT Research Final Report

State Job Number: 134935

Table 3.1-4: Adhesion of the tested coatings before accelerated corrosion testing. A complete breakdown of all coating properties can be found in Appendix B.

Coating System	Primary Coating	Metal	Adhesion
None	White OEM	CS	4B
None	Black Enamel	CS	1B
Galvanized	None	CS	N/A
Metalized	None	CS	N/A
Control	OEM	Al	0B
LCCOAT	None	Al	5B
LINE-X	None	Al	N/A
Raptor	None	Al	3B
Rhino	None	Al	N/A

3.1.2.2 Experimental Procedure for ASTM B117 Accelerated Corrosion Testing

Coated panels were scribed with a computerized New Hermes Vanguard 3400 Engraver. Scribe line depth was 0.008 inches and scribe line width was also 0.008 inches. Metal samples (coupons) were placed in a Singleton salt spray chamber. The pressure of the humidifying tower was kept between 12 and 18 psi (0.083 - 0.124 MPa), and its temperature between 114 and 121°F (45.55 - 49.44°C), while the chamber was maintained between 92 and 97°F (33.33 - 36.11°C) using a salt solution of 5 wt.% NaCl prepared in DI water. Effectiveness of the coating to prevent corrosion on the metal sample was evaluated using the standard ASTM D1654-08 procedures including visual inspection. The amount of rust creep from the scribe was the main test for the effectiveness of the coating at corrosion prevention (Table 3.1-5). Creep rate measurements of exposed metal panels to salt spray chamber (ASTM B117[2]) were determined using ImageJ (1.48v). Measurements were performed in duplicate.



State Job Number: 134935

Table 3.1-5: Representative coating rating based on mean creep from scribe (mm) from ASTM D1654-08 standard.

Creep from Scribe (millimeters)	Coating Rating	
0	10	Excellent
Over 0 to 0.5	9	
Over 0.5 to 1.0	8	
Over 1.0 to 2.0	7	Good
Over 2.0 to 3.0	6	
Over 3.0 to 5.0	5	Average
Over 5.0 to 7.0	4	
Over 7.0 to 10.0	3	Fair
Over 10.0 to 13.0	2	
Over 13.0 to 16.0	1	
Over 16 to more	0	Poor



State Job Number: 134935

Table 3.1-6: Representative coating rating based on area failed on an unscribed coated surface from ASTM D1654-08 standard.

Coating Area Failed (%)	Coating Rating	
No failure	10	Excellent
0 to 1	9	
2 to 3	8	
4 to 6	7	Good
7 to 10	6	
11 to 20	5	Average
21 to 30	4	
31 to 40	3	Fair
41 to 55	2	
56 to 75	1	
Over 75	0	Poor

Effectiveness of the coating to prevent corrosion on the unscribed coated samples was evaluated using the standard ASTM D1654-08 procedures based on area of the coating that failed after salt spray testing (Table 3-6). Analysis of the exposed metal panels to salt spray chamber (ASTM B117[2]) was determined using ImageJ (1.48v).

3.1.3 Summary of Results: Accelerated Corrosion Testing

3.1.3.1 Summary of Creep Results for Scribed Samples

Figure 3.1-1 shows an example of scribed, coated metal samples initially and after weeks one and two of salt spray exposure. From left to right the samples are: bare carbon steel, white OEM coated carbon steel, black enamel coated carbon steel, bare aluminum, white OEM coated aluminum, bare cast aluminum, bare stainless steel, and bare cast iron. Notice that the surfaces of carbon steel and cast iron are completely corroded. Images from Run 1 (accelerated corrosion data) are included in Appendix C.

State Job Number: 134935

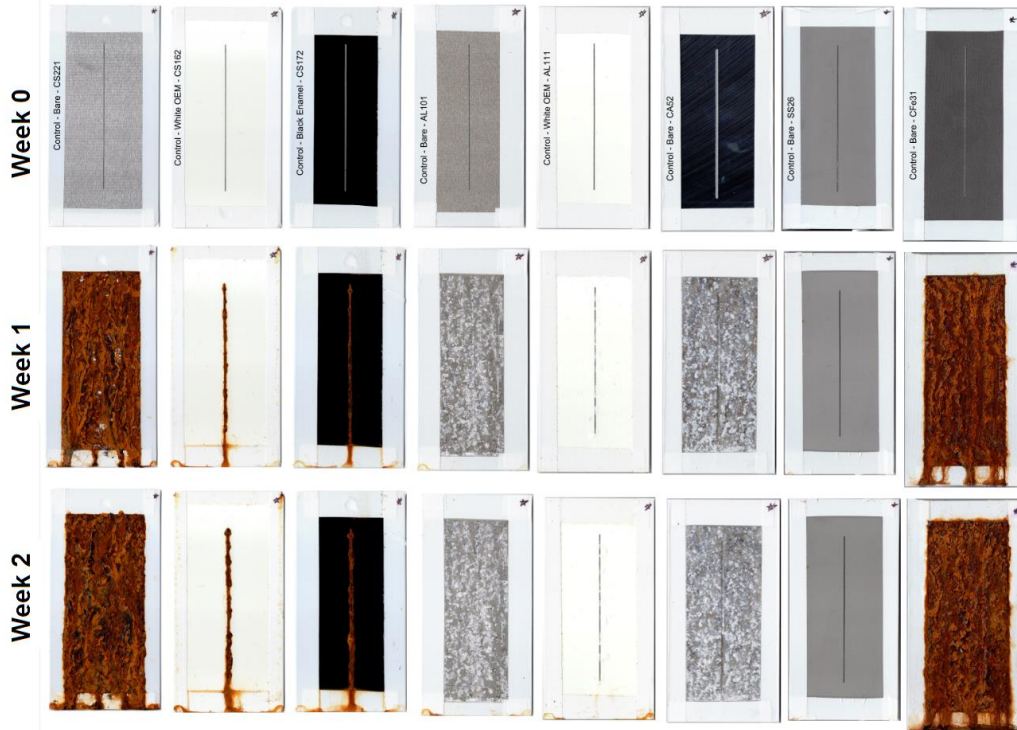

Figure 3.1-1: Example of scribed coupons during accelerated corrosion testing. From left to right, bare carbon steel, white OEM coated carbon steel, black enamel coated carbon steel, bare aluminum, white OEM coated aluminum, bare cast aluminum, stainless steel, bare cast iron.

Figure 3.1-2 provides an overview of the average creep from the scribe for coatings on carbon steel, aluminum, cast aluminum, and cast iron. Results from ASTM B117 testing shows that galvanized and metalized samples underperformed in laboratory tests and show complete failure of the coating (creep extends to edge of coupon). This was as expected, as these samples need to form a protective oxide layer in order to provide optimum corrosion prevention. To form this layer, the sample must undergo exposure cycles that are not accounted for in B117 testing. For this reason, the results from these samples are not shown in the figures presented in this chapter to allow for a better comparison of coatings. Results from these experiments can be found in Appendix C.

ODOT Research Final Report

State Job Number: 134935

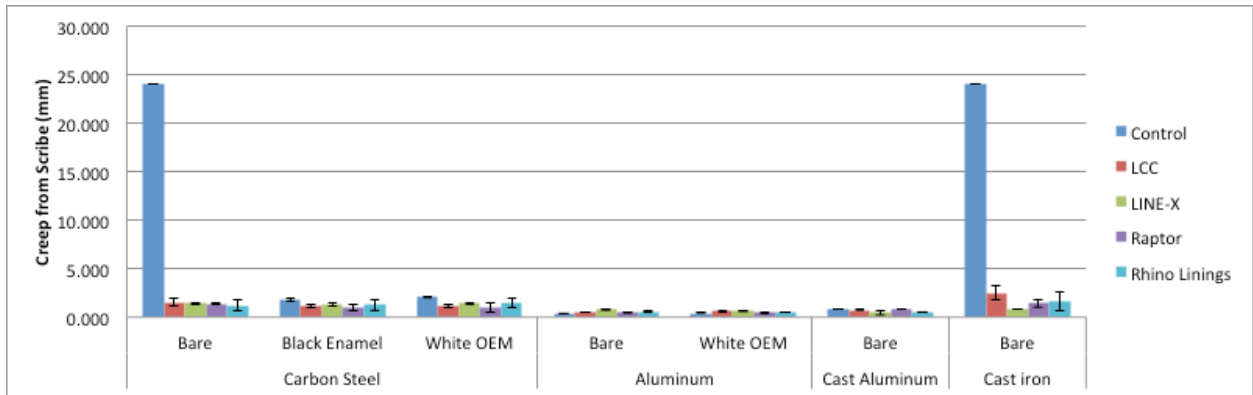

Figure 3.1-2: Average creep from scribe for all coated and uncoated (control) samples after 336 hours of salt spray exposure.

From Figure 3.1-2 one can see that the presence of a coating significantly reduces corrosion for bare carbon steel and cast iron samples. Creep from scribe for samples that are completely corroded are reported as 24 mm (half the width of the coupon). However, the addition of a corrosion protective coating has very little effect on the creep from scribe for aluminum and cast aluminum, after 8 weeks of testing. Figure 3.1-3 shows the creep from scribe for coated carbon steel, without the bare control and galvanized and metalized results to allow for ease in comparison. Notice that the majority of coatings show a decrease in creep from scribe, compared to black enamel and white OEM. It is also important to note that the samples coated with Rhino Linings have a very large standard error. This is most likely caused by the corrosion of the coating on the flat surface away from the scribe, making it difficult to actually measure creep from scribe. This trend will be seen further during testing of unscribed samples.

ODOT Research Final Report

State Job Number: 134935

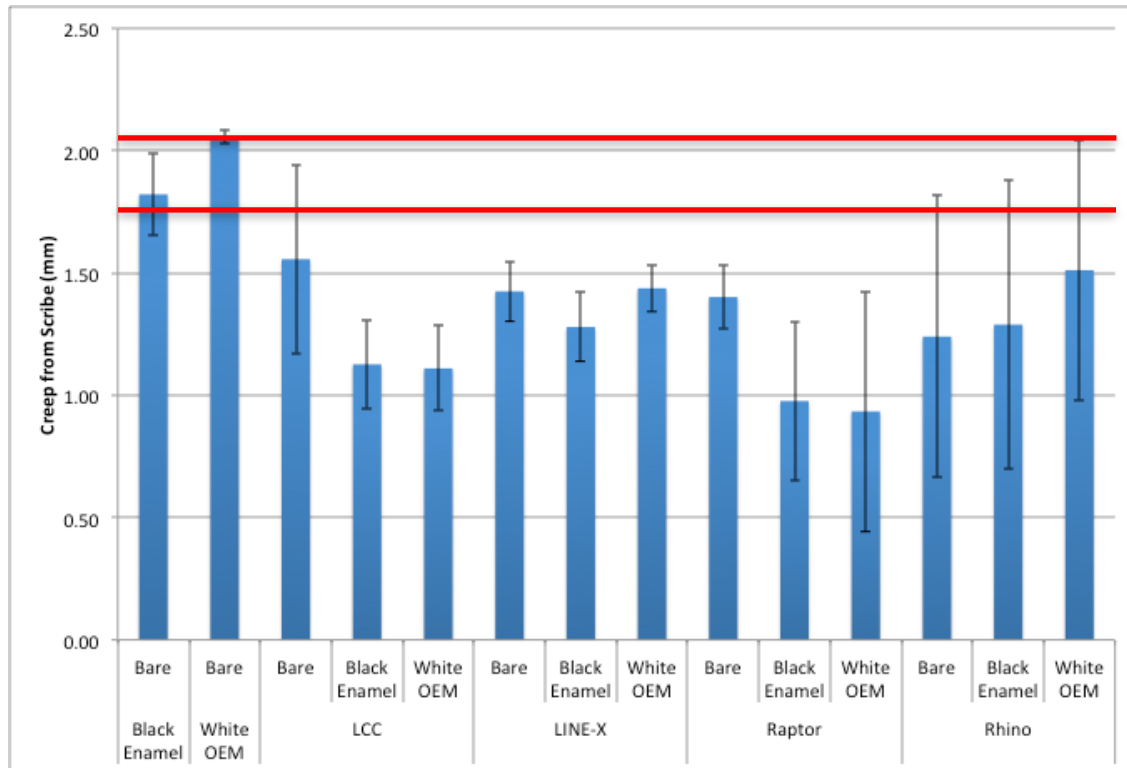

Figure 3.1-3: Creep from scribe for coatings on carbon steel after 336 hours of salt exposure (bare carbon, galvanized, and metalized excluded from graph).

Figure 3.1-4 shows the creep from scribe for cast iron samples after 336 hours of salt exposure, without the bare metals (uncoated) results to allow for ease in comparison. ANOVA analysis shows that there is no statistical significance of creep rate with respect to coating (p-value, 0.2). However, application of a corrosion prevention coating was necessary for reducing corrosion compared to the bare metal. The error in the creep rate of samples coated with Rhino Linings was very high, most likely due to the corrosion on the unscribed portion of the coating, making it difficult to determine creep from scribe.

State Job Number: 134935

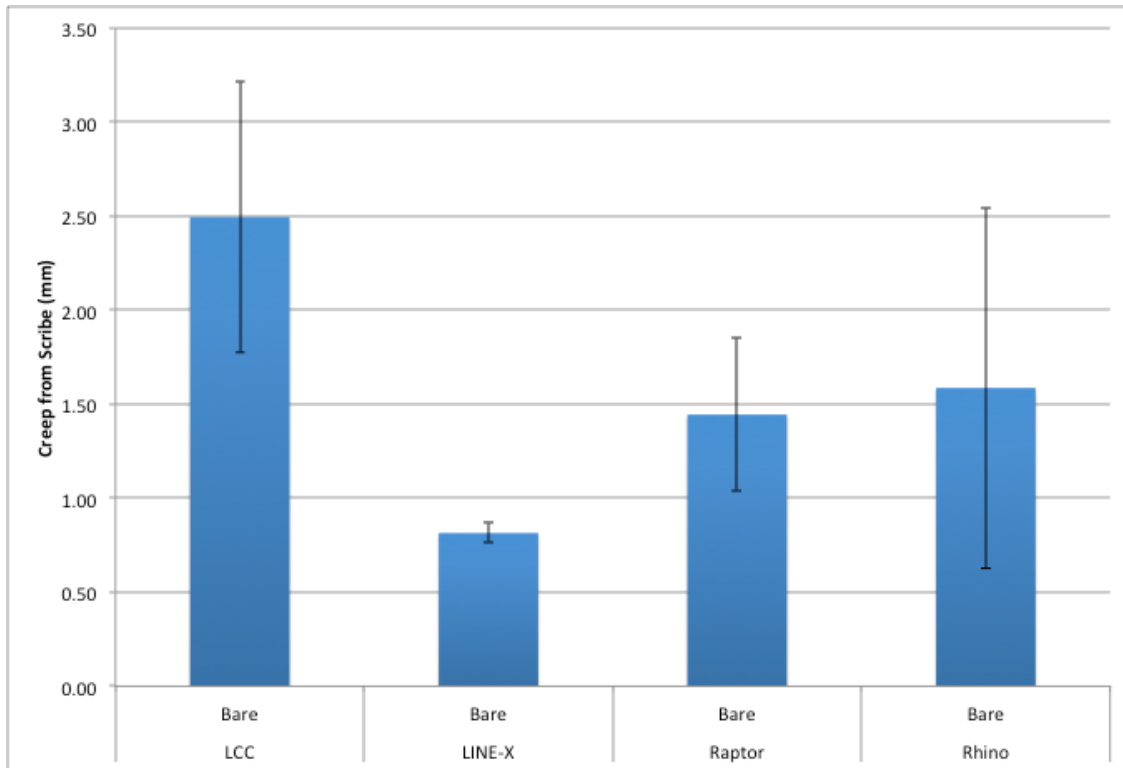

Figure 3.1-4: Creep from scribe for coatings on cast iron after 336 hours of salt exposure (bare cast iron excluded from graph).

Figure 3.1-5 and Figure 3.1-6 show the results of creep from scribe for aluminum and cast aluminum, respectively, after 336 hours of salt exposure. ANOVA analysis shows that there is a statistical significance between treatments (p-value of 0.001) for aluminum and no statistical difference between treatments for cast aluminum (p-value of 0.2). It is also important to note that the addition of a coating does not provide additional protection over the bare metal after 336 hours of salt spray exposure.

ODOT Research Final Report

State Job Number: 134935

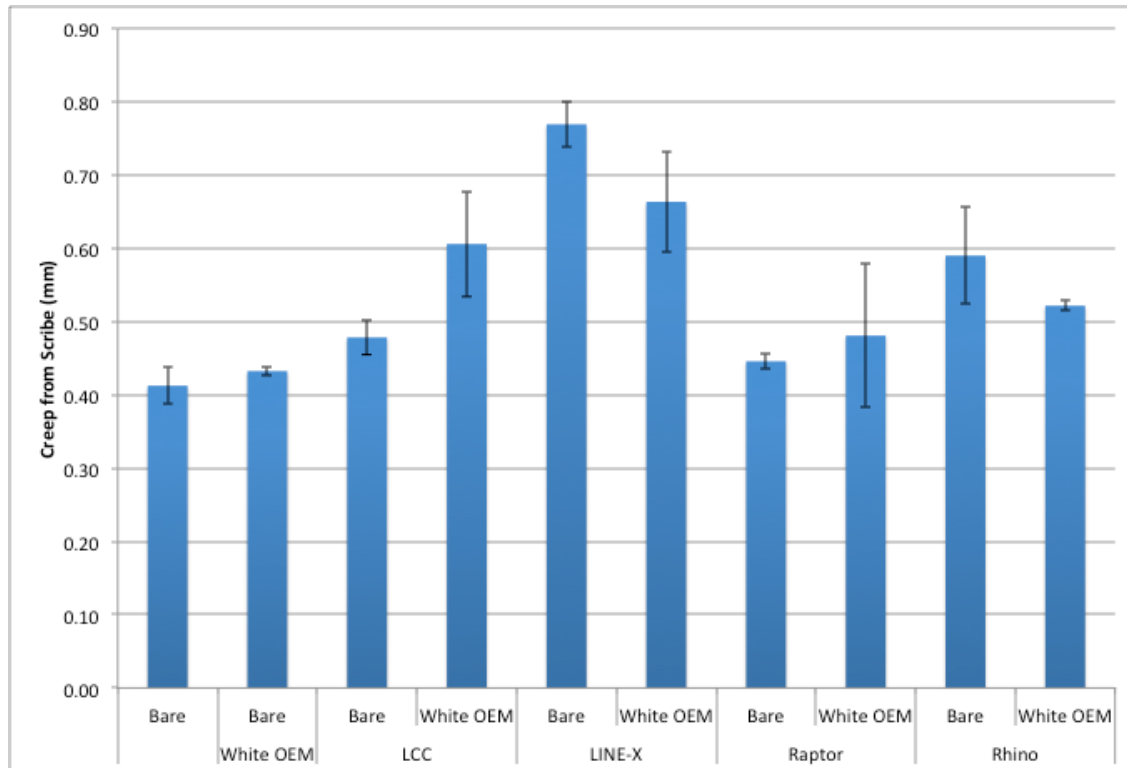

Figure 3.1-5: Creep from scribe for coatings on aluminum after 336 hours of salt exposure.

State Job Number: 134935

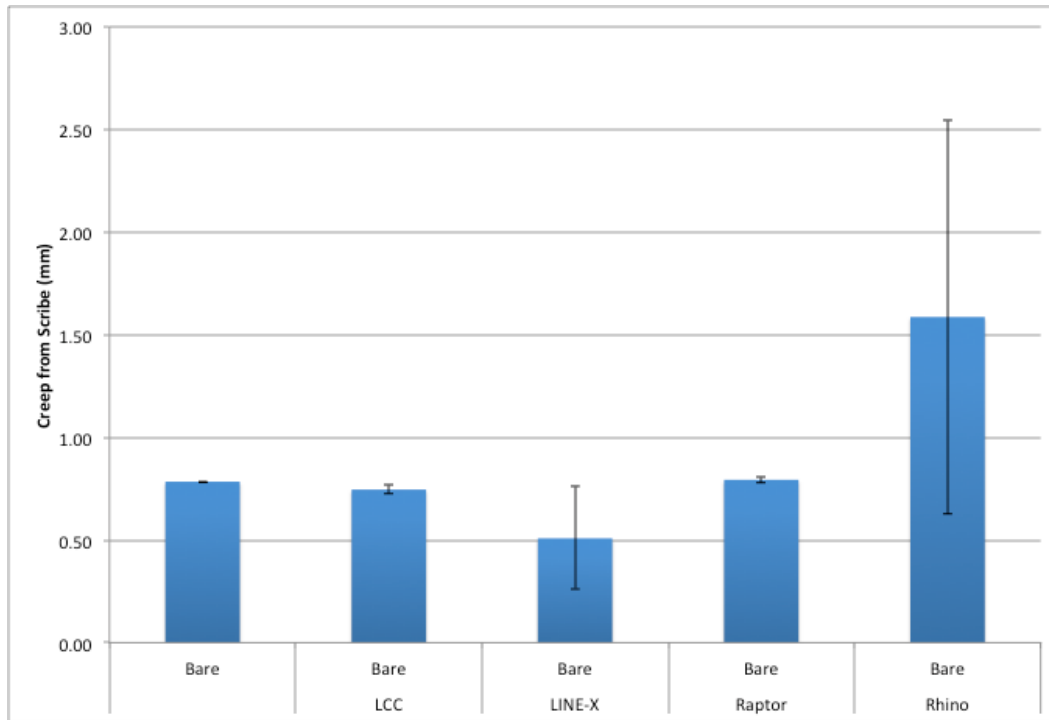

Figure 3.1-6: Creep from scribe for coatings on cast aluminum after 336 hours of salt exposure.

In order to determine the effect of coatings on aluminum and cast aluminum over time, scribed samples were run for 1344 hours and creep was determined every 336 hours. Results from this experiment can be found in Figure 3.1-7. Notice that for coated aluminum samples (Figure 3.1-7A), creep from scribe increases for samples coated with LINE-X (on bare aluminum or with a white OEM base coat). Other coatings do not see a significant increase in creep from scribe over time. Bare aluminum, however, is completely corroded after 1008 hours. These results indicate that, over time, corrosion prevention coatings are necessary to reduce corrosion on aluminum. For cast aluminum samples (Figure 3.1-7B), creep from scribe increases for samples coated with LCCOAT and LINE-X (on bare cast aluminum). Other coatings do not see a significant increase in creep from scribe over time. Bare cast aluminum, however, is completely corroded after 1008 hours. These results also indicate that, over time, corrosion prevention coatings are necessary to reduce corrosion on cast aluminum.

ODOT Research Final Report

State Job Number: 134935

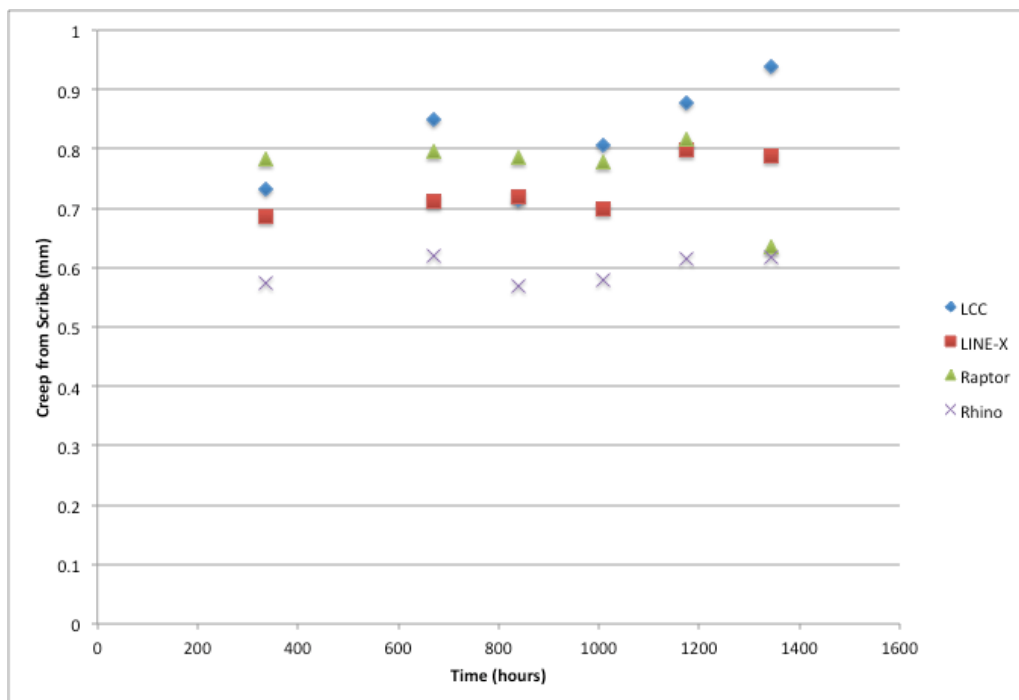
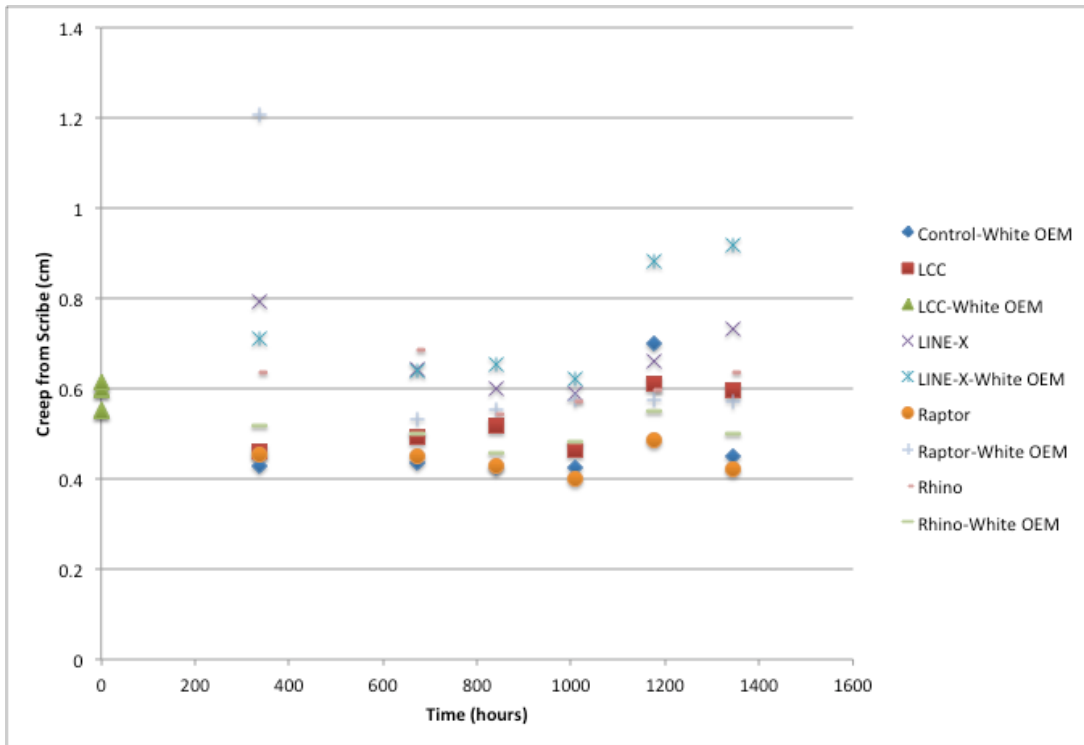

Figure 3.1-7: Creep from scribe over time for A) aluminum and B) cast aluminum samples. Creep was determined every 336 hours.

State Job Number: 134935

Coated and scribed carbon steel panels that have undergone accelerated corrosion testing (ASTM standard B117 [1]) for 336 hours were then analyzed using stereo microscopy imaging. Carbon steel panels were selected, as those metals samples exhibited the highest amount of corrosion. The experimental procedure is described in detail in Appendix E. Figure 3.1-8 shows a typical cross-sectional analysis of a coated carbon steel sample after 336 hour of salt spray exposure. Film delamination is defined as the distance under the coating where the coating has lost contact with the metal surface, allowing corrosion products to form. Measuring delamination length captures coating failure that cannot be seen with traditional surface analysis. A complete set of cross-sectional images for coated carbon steel samples can be found in Appendix E.

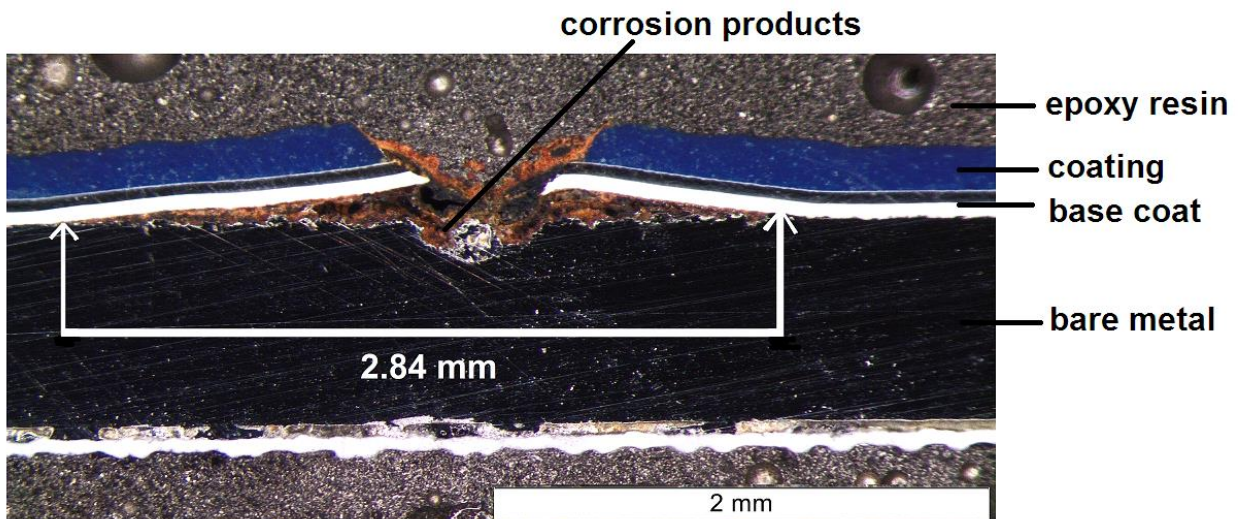

Figure 3.1-8: Example cross-sectional image of a coated carbon steel sample exposed to accelerated corrosion testing (B117) for 336 h. The sample is analyzed using stereo microscopy. Film delamination is defined as the distance under the coating where the coating has lost contact with the metal surface, allowing corrosion products to form.

ODOT Research Final Report

State Job Number: 134935

Figure 3.1-9 shows the delamination length of coatings on carbon steel samples after 336 hours of salt spray exposure. ANOVA analysis indicates that there is no statistical significance between treatments with respect to delamination length, indicating that the delamination is equal for all coatings and is most likely caused during scribing or preparation of metal samples for microscopy. However, Figure 3.1-10 shows the ratio of one half the delamination length to creep from scribe. A ratio above one indicates that the coating is failing at the surface and this failure is not captured using creep from scribe. LCCOAT, Raptor, and Rhino Linings all show surface treatments with ratios higher than one, indicating that these coatings might not be performing as well as creep results indicate.

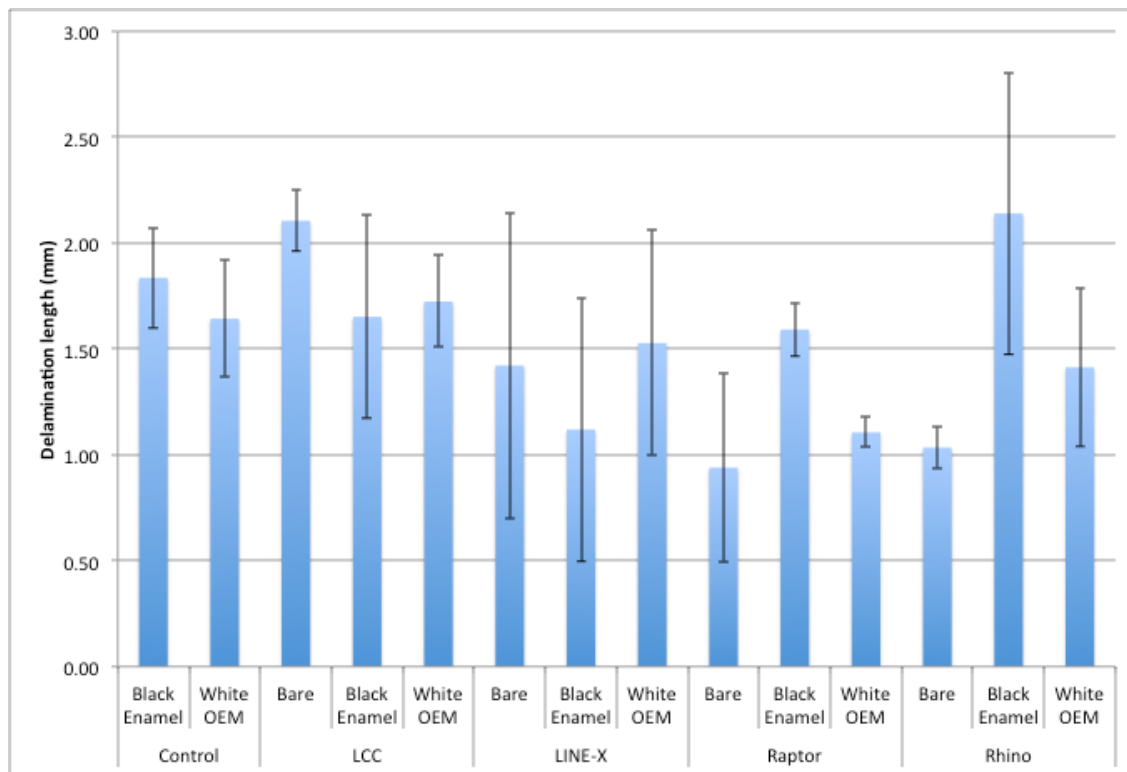

Figure 3.1-9: Delamination length of coated carbon steel samples after 336 hours of salt spray exposure.

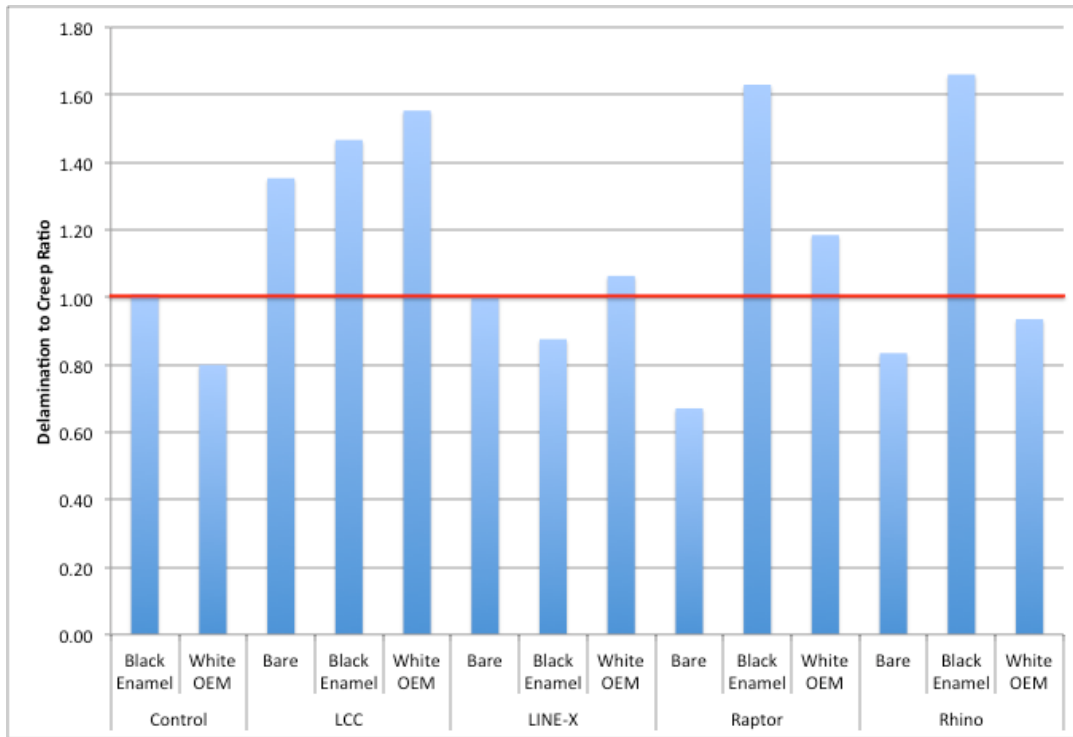

Figure 3.1-10: Ratio of delamination to creep distance for coated carbon steel samples after 336 hours of salt spray exposure.

3.1.3.2 Summary of Coating Rating Results for Unscribed Samples

Unscribed coated metal panels (coating procedure described previously) were placed in a salt spray chamber (Singleton Corporation, Cleveland, OH, USA) for 1344 hours (8 weeks) following the specifications from standard ASTM-B117 [1]. The pressure of the humidifying tower was kept between 12 and 18 psi, and its temperature between 114 and 121°F, while the chamber was maintained between 92 and 97°F using a salt solution of 5 wt.% NaCl prepared in DI water. Images were acquired using high-resolution scan imaging. An EPSON XP-310 scanner was used with settings of image type 24-bit color and resolution 600 dpi. Evaluated coatings were galvanized, light curable coating (LCCOAT), LINE-X, metalized, Raptor and Rhino Linings. The metals studied in this work were aluminum (Al), cast aluminum (CA), carbon steel (CS), cast

State Job Number: 134935

iron (CFe) and stainless steel (SS). Corrosion performance of unscribed metal panels was evaluated by imaging exposed panels every week (168 hours) using the ASTM standards presented in Table 3-6. A detailed experimental procedure and results summary can be found in Appendix F.



Figure 3.1-11: Example of unscribed coated panels (galvanized) after salt spray exposure. From left to right, scans of the panels were taken each week for eight weeks.

Figure 3.1-11 shows an example of unscribed coated panels after exposure to salt spray after 8 weeks. From left to right, scans were performed after each week of exposure. Notice that the sample becomes increasingly deteriorated over time. As mentioned previously, galvanized and metalized samples underperformed during salt spray testing. Again, this was expected because these samples need to undergo exposure cycles in order to form a protective oxide layer in order to provide optimum corrosion prevention.

Table 3.1-7 shows the representative coating rating for the unscribed coated panels after 8 weeks of exposure based on ASTM coating ratings (further described in Appendix F). It is important to note that a score of 10 means there is very little corrosion and a score of 0 means that the surface is completely corroded. Notice that most coated samples did not show corrosion on the unscribed metal samples, even after 8 weeks of exposure. Carbon steel and cast iron samples coated with LINE-X, however, showed

ODOT Research Final Report

State Job Number: 134935

some rust on the unscribed samples. Carbon steel panels coated with Raptor applied on a base coat of white OEM or black enamel also showed a small amount of corrosion. As mentioned during creep analysis, bare carbon steel and bare cast iron samples coated with Rhino Linings showed a complete breakdown in the coating. Additionally, carbon steel samples coated with Rhino Linings on a black enamel base coat were highly corroded.

Table 3.1-7: Representative coating rating for unscribed coated panels studied in this work.

Coating System	Primary Coating	Representative coating rating				
		CS	Al	CA	CFe	SS
None	None	-	-	-	-	-
None	Black Enamel	10				
None	White OEM	10	10			
Galvanized	None	0			0	
LCCOAT	None	10	10	10	10	
LCCOAT	Black Enamel	10				
LCCOAT	White OEM	10	10			
LINE-X	None	9	10	10	9	
LINE-X	Black Enamel	10				
LINE-X	White OEM	10	10			
Metalized	None	0				
Raptor	None	10	10	10	10	
Raptor	Black Enamel	9				
Raptor	White OEM	9	10			
Rhino Linings	None	0	10	10	0	
Rhino Linings	Black Enamel	6				
Rhino Linings	White OEM	10	10			

Rinsing each panel with DI water after completion of the exposure period and drying each of them with laboratory cleaning tissues measured the degree of blistering and rusting of coated panels. Coating ratings for blistering and rusting are determined by following standards ASTM D714[3] and ASTM D610[4] respectively. Results can be seen in Table 3.1-8. Notice that samples coated with black enamel, LCCOAT, LINE-X,



ODOT Research Final Report

State Job Number: 134935

Raptor, or Rhino Linings all show blistering on at least one metal with or without a base coat.

ODOT Research Final Report

State Job Number: 134935

Table 3.1-8: Degree of blistering and rusting of coated metal panels according to ASTM D714 and ASTM D610.

Coating System	Primary coat	Metal	Blistering	Rusting	
None	White OEM	CS	10	10	High amount of corrosion residue from edge
None	Black Enamel	CS	8F	10	Medium amount of corrosion residue from edge
None	White OEM	AL	10	10	Small amount of corrosion residue from edge
LCCOAT	None	CS	8F	10	Medium amount of corrosion residue from edge
LCCOAT	White OEM	CS	8F	10	Medium amount of corrosion residue from edge
LCCOAT	Black Enamel	CS	6F	10	Medium amount of corrosion residue from edge
LCCOAT	None	AL	2F	10	Small amount of corrosion residue from edge
LCCOAT	White OEM	AL	10	10	Small amount of corrosion residue from edge
LCCOAT	None	CA	8D	10	Small amount of corrosion residue from edge
LCCOAT	None	CFe	10	10	High amount of corrosion residue from edge
LINE-X	None	CS	6M	10	Medium amount of corrosion residue from edge
LINE-X	White OEM	CS	9D	10	Medium amount of corrosion residue from edge
LINE-X	Black Enamel	CS	9D	10	Small amount of corrosion residue from edge
LINE-X	None	AL	9D	10	Small amount of corrosion residue from edge
LINE-X	White OEM	AL	10	10	Small amount of corrosion residue from edge
LINE-X	None	CA	10	10	No corrosion residue from edge
LINE-X	None	CFe	10	10	High amount of corrosion residue from edge
Raptor	None	CS	2F	9S	Medium amount of corrosion residue from edge
Raptor	White OEM	CS	10	10	Medium amount of corrosion residue from edge
Raptor	Black Enamel	CS	10	10	Medium amount of corrosion residue from edge
Raptor	None	AL	10	10	Small amount of corrosion residue from edge
Raptor	White OEM	AL	10	10	Small amount of corrosion residue from edge
Raptor	None	CA	10	10	No corrosion residue from edge
Raptor	None	CFe	10	9G	High amount of corrosion residue from edge
Rhino	None	CS	10	10	Medium amount of corrosion residue from edge
Rhino	White OEM	CS	10	10	Medium amount of corrosion residue from edge
Rhino	Black Enamel	CS	10	10	Medium amount of corrosion residue from edge
Rhino	None	AL	10	10	Small amount of corrosion residue from edge
Rhino	White OEM	AL	10	10	Small amount of corrosion residue from edge
Rhino	None	CA	10	10	Small amount of corrosion residue from edge
Rhino	None	CFe	2M	10	High amount of corrosion residue from edge

State Job Number: 134935

3.1.4 Overview of Effectiveness of Coatings at Reducing Corrosion on Metals During Accelerated Corrosion Testing

- Coatings were applied to 4 different metals, stainless steel was tested as a control
- 4 different organic coatings were coated on bare and previously coated metal samples
- Metalized and galvanized coatings were used on bare carbon steel
- Coated metal samples were rated using ASTM accelerated corrosion testing standards
- Creep from scribe was used to evaluate coated and scribed metal samples
- Percent of surface corroded and blister density were used to evaluate unscribed coated metal samples
- Samples coated with white OEM perform well when the coating remains unscribed; however, the coating performs poorly once surface has a defect (scribe).
- Samples coated with black enamel also perform well when the coating is unscribed, although the coating shows a small degree of blistering. Once there is a defect (scribe) the coating performs poorly.
- Samples coated with LCCOAT perform well but the LCCOAT coating has more delamination at the surface of the metal than creep on the surface of the coating. Samples coated with LCCOAT also show a small amount of blistering.
- Samples coated with LINE-X show a large amount of creep from scribe
- Samples coated with Raptor perform well overall, especially when coated on a bare metal surface.
- Samples coated with Rhino Linings show a large amount of rust on the surface and therefore do not perform well in accelerated laboratory testing (despite having low creep from scribe and low delamination numbers).

State Job Number: 134935

3.2 Evaluation of Coatings at Preventing Corrosion During Standard Immersion Testing

3.2.1 Introduction

Visual inspection of the coatings can be subjective and does not provide any information about what is happening below the surface of the coating at the metal/coating interface. Electrochemical impedance spectroscopy (EIS) can be used to determine the protective ability of the coating as well as to determine the amount of water being absorbed into the coating layer through determination of pore resistance and coating capacitance. A decrease in pore resistance (or increase in coating capacitance) is indicative of an increase in the amount of conductive water molecules in the coating layer (Olivier and Poelman, 2012). In this section, the performance of coatings was evaluated using standard immersion testing with a sodium chloride solution. This evaluation focused on carbon steel coated with the organic coatings LCCOAT, LINE-X, Raptor, Rhino Lining coated on bare and metal samples previously coated with white OEM or black enamel. Galvanized and metalized samples were also tested and did not provide corrosion protection in standard immersion testing. Therefore, their results are not discussed in this chapter. Bare carbon steel was tested as a control. Detailed experimental procedure and results can be found in Appendix G.

3.2.2 Experimental Procedure for EIS testing on Coated Samples

The performance of coatings studied in this work was evaluated in the laboratory by electrochemical impedance spectroscopy (EIS). Measurements were acquired with a conventional three-electrode paint cell (see Figure G1), using a silver/silver chloride (Ag/AgCl) reference electrode from BASi (West Lafayette, IN, USA), a round Pt/Nb mesh electrode from Scribner Associates Inc. (Southern Pines, NC, USA), and a coated metal panel as the working electrode. A Gamry (Warminster, PA, USA) - Reference 600 Potentiostat/Galvanostat/ZRA was used for EIS measurements using an amplitude of 10 mV AC perturbation coupled with the open circuit potential over a frequency range of 10 kHz to 10 mHz.

State Job Number: 134935

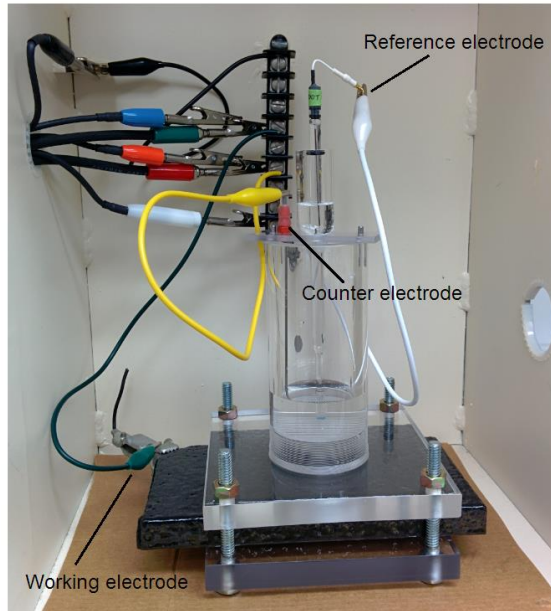
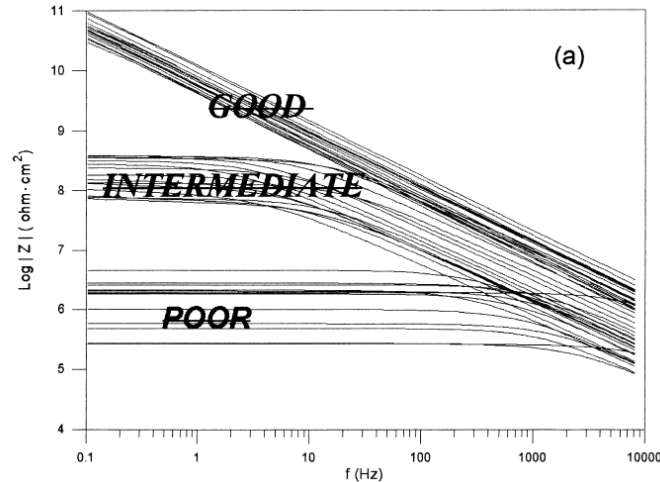

Figure 3.2-1: Electrochemical three-electrode setup.

Immersion testing was carried out at room temperature by monitoring each environment for at least 100 days using an electrolyte solution of 0.6 M NaCl. Immersion experiments were also carried out using various water and motor oil solutions to determine the uptake of motor oil into the coating. Polarization curves of the motor oil solutions were also performed. Results from motor oil experiments can be found in APPENDIX G. EIS results were fit and analyzed with software Gamry Echem Analyst Version 6.11 using circuits listed in Appendix G. Fitting parameters for each of the coating studied in this work are also presented in Appendix G. Figure 3.2-2 shows theoretical impedance spectra for good, intermediate, and poor coating quality by plotting resistance (Z) versus frequency (Hz) as well as coating ratings based on pore resistance.

State Job Number: 134935



Pore Resistance (Ohms*cm ²)	Coating Rating
Over 1x10 ¹⁰	10 Excellent (Good)
1x10 ⁷ -1x10 ⁹	7 Good (Intermediate)
1x10 ⁵ -1x10 ⁷	3 Fair (Poor)
Below 1x10 ⁵	0 Poor

Figure 3.2-2: Theoretical impedance spectra used as training sets for good, intermediate and poor coating quality by plotting Z vs. frequency (Lee, 1998). In order to maintain consistency with other ratings, good is relabeled as excellent, intermediate as good, and fair as poor.

3.2.3 Summary of Results for Immersion Testing on Coated Samples

In order to obtain a more quantitative measurement of coating performance during continuous immersion testing, EIS data (Bode and Nyquist plots) was fit using the equivalent circuits described in Appendix G. Water uptake and pore resistance were used as parameters for measuring corrosion resistance of the coating. Figure 3.2-3 shows the damage evolution profile for each surface treatment (coating + base coating) over 43 days, plotted as water uptake over time. The damage evolution profile was determined for coated carbon steel samples immersed in 0.6 M NaCl. The capacitance

State Job Number: 134935

of the coating is represented as $C = \epsilon_0 \epsilon_r A / d$, where ϵ_0 is the permittivity of free space, ϵ_r is the relative permittivity of the coating, A is the area of the coated surface, and d is the coating thickness. In general, the relative dielectric constant of the coating is at least an order of magnitude lower than that of water. Therefore, as water permeates into the coating an increase in coating capacitance is induced. Based on this phenomenon, percent water uptake can be calculated from coating capacitance over time from $\%water\ uptake = 100 (\log C_c(t) / \log C_c(0)) / \log 80$, where $C_c(t)$ is coating capacitance at time t, $C_c(0)$ is initial coating capacitance, and 80 is the approximate dielectric constant of water. An increase in water uptake indicates a loss in the corrosion protective properties of the coating and shows a reduction in the adhesion/cohesion of the coating. Values of coating capacitance for all surface treatments over time can be found in Appendix G.

Initially, all coating treatments are in the initiation stage, with the exception of Rhino Linings. In this stage, water steadily permeates the coating, inducing an increase in coating capacitance. Rhino Linings is too porous to determine an accurate number for water uptake, as water infiltrates that coating at day 0. Due to the porous nature of the coating, data from Rhino Linings is omitted during discussion of water uptake. After approximately 10 days, the coatings enter the activation phase of the damage evolution profile. During the activation phase, electrolyte reaches the bare metal, activating the surface. All coatings, with the exception of white OEM, are in the activation phase from days 10 to 100. Carbon steel samples coated with white OEM show complete coating failure after 100 days of immersion testing. From Figure 3.2-3, it is evident that there is a significant effect of surface treatment (coating) on water uptake into the coating during the activation phase of the damage evolution profile. A decrease in water uptake suggests that surface treatments create more of a barrier effect to water uptake. Water uptake for all surface treatments after 100 days is listed below.

ODOT Research Final Report

State Job Number: 134935

Table 3.2-1: Water uptake at 100 days for all surface treatments on carbon steel exposed to 0.6 M NaCl.

Coating System	Primary Coating	Water Uptake at 43 days (%)
None	Black Enamel	34.48%
	White OEM	Failed
LCCOAT	None	8.08%
	Black Enamel	10.59%
	White OEM	7.33%
Line-X	None	35.03%
	Black Enamel	22.03%
	White OEM	16.69%
Raptor	None	39.80%
	Black Enamel	20.04%
	White OEM	22.25%
Rhino Linings	None	Failed
	Black Enamel	15.53%
	White OEM	24.22%

State Job Number: 134935

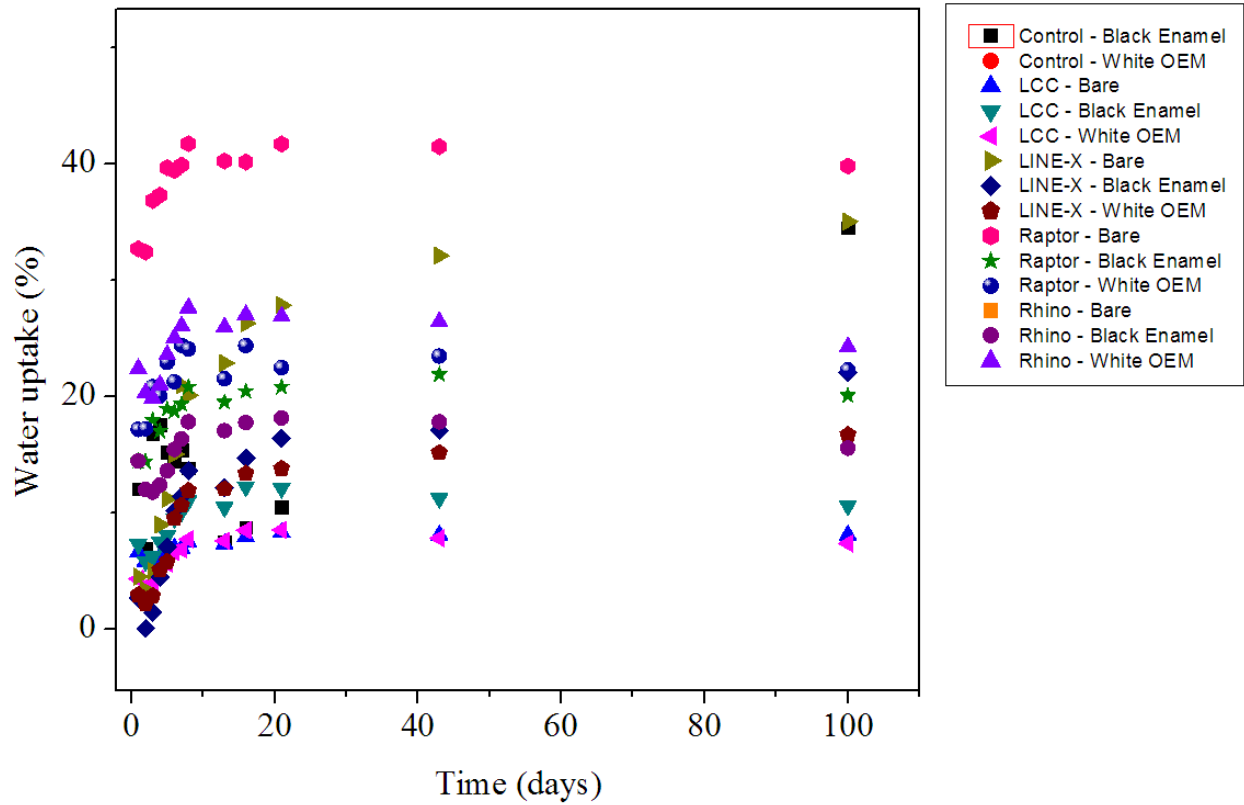

Figure 3.2-3: Water uptake over time for all surface treatments on carbon steel exposed to 0.6 M NaCl for 100 days.

ODOT Research Final Report

State Job Number: 134935

Figure 3.2-4 shows the pore resistance of each surface treatment over 100 days. Calculated values of pore resistance at days 0 and 100 can be found in Appendix G. Values of pore resistance above 10^{10} Ohm cm^2 are considered to be an indication of excellent coating quality; while pore resistances on the order of 10^7 Ohm cm^2 are considered an indication of fair coating quality. Based on pore resistance, all surface treatments containing LCCOAT maintain excellent coating quality over the course of 100 days, corroborating results from water uptake. The majority of samples begin the immersion testing with excellent coating quality and water uptake causes the coating to degrade over time. However, Rhino Linings coated on carbon steel exhibits poor coating quality throughout immersion testing, indicating that this coating allows water to reach the surface of the metal at the start of testing. These results further corroborate the high water uptake allowed by Rhino Linings as well as the poor performance of Rhino Linings during accelerated corrosion testing.

Table 3.2-2: Calculated pore resistances for coatings on carbon steel during immersion testing with 0.6 M NaCl at day 0 and after 100 days.

Coating System	Primary Coating	Rp(0)	Rp at 100 days
None	Black Enamel	3.05E+10	4.71E+05
	White OEM	1.52E+10	2.06E+07
LCCOAT	None	1.11E+12	5.66E+11
	Black Enamel	8.68E+11	1.20E+11
	White OEM	6.83E+11	3.49E+11
Line-X	None	8.77E+08	3.48E+07
	Black Enamel	7.59E+08	2.75E+07
	White OEM	6.51E+08	2.92E+07
Raptor	None	1.96E+08	1.85E+06
	Black Enamel	8.74E+10	1.43E+10
	White OEM	8.43E+10	7.27E+09
Rhino Linings	None	4.16E+03	6.14E+03
	Black Enamel	1.09E+11	4.07E+10
	White OEM	4.06E+10	1.44E+11

ODOT Research Final Report

State Job Number: 134935

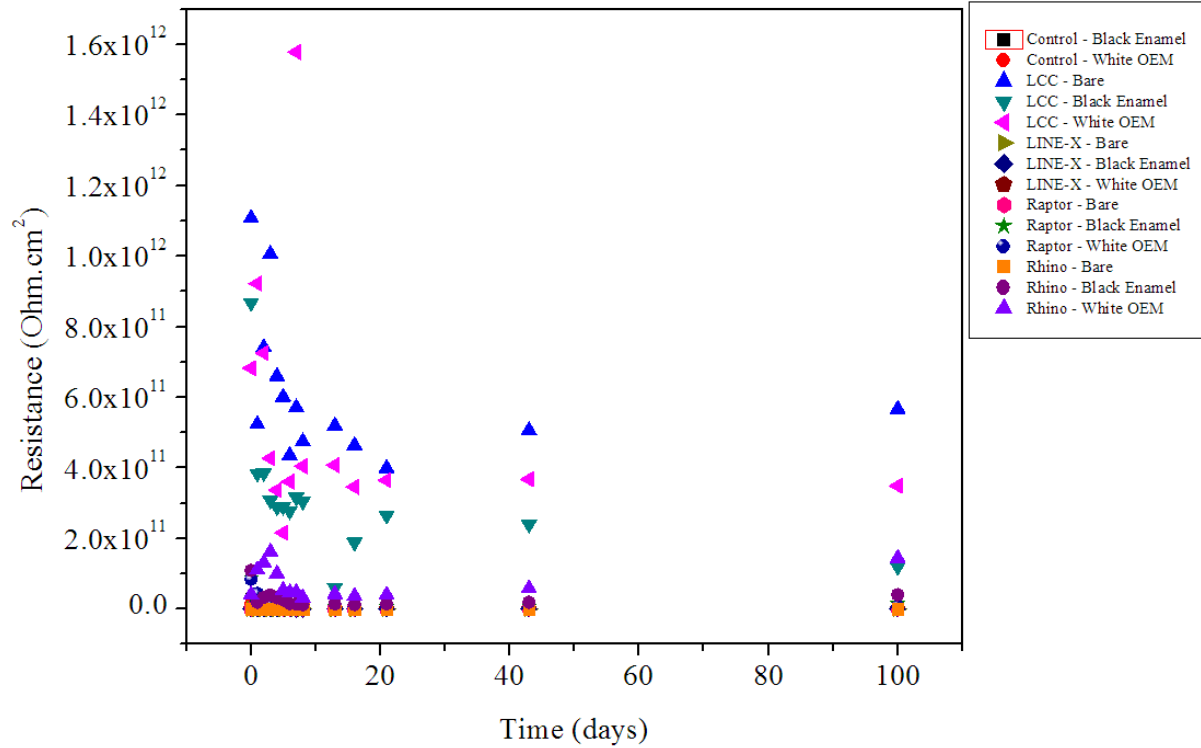

Figure 3.2-4: Pore resistance over time for all surface treatments exposed to 0.6 M NaCl for 100 days.

State Job Number: 134935

3.2.4 Overview of Effectiveness of Coatings at Reducing Corrosion during Immersion Testing

- Coatings were applied only to carbon steel as it was the most corrosive metal during accelerated corrosion testing
- 4 different organic coatings were coated on bare metal samples and on bare metal samples previously coated with white OEM or black enamel
- Metalized and galvanized coatings were used on bare carbon steel, results not shown in chapter
- Coated metal samples were tested using standard immersion testing in 0.6 M NaCl
- EIS data was fit using circuits shown in Appendix G.
- Coating capacitance (used to calculate water uptake) and pore resistance were used to evaluate surface treatments (coating and base coat)
- Samples coated with white OEM or black enamel degrade throughout testing due to water uptake into the coating. Samples coated with white OEM show complete coating failure after 100 days.
- Samples coated with LCCOAT perform well based on water uptake and pore resistance. All surface treatments of LCCOAT maintain good coating quality throughout immersion testing, indicating an inhibition of water uptake into the coating.
- All surface treatments containing LINE-X on carbon steel have high water uptake during testing. The amount of water uptake is most likely caused by the increased porosity of the LINE-X coating.
- Samples coated with the Raptor coating system on either white OEM or black enamel coatings maintain coating quality during testing; however, samples coated with Raptor on bare metal have increased water uptake and decreased pore resistance, indicating degradation in coating quality over time.
- Samples coated with Rhino Linings without a primary coating show no corrosion protection during immersion testing. Samples coated with Rhino Linings as a

ODOT Research Final Report

State Job Number: 134935

coating system on either black enamel or white OEM coating systems perform similarly to the primary coating alone.

Table 3.2-3: Summary of laboratory corrosion ratings. Laboratory corrosion ratings are based off of ASTM standards and pore resistance of coatings (listed in chapter).

Coating System	Primary Coating	Rp(0)	Rp(100)	Creep Rating	Unscribed Rating	Corrosion Rating (Laboratory)
Control	Black Enamel	Excellent	Poor	Good	Excellent	Good
Control	White OEM	Poor	Poor	Good	Excellent	Average
Galvanized		Poor	Poor	Poor	Poor	Poor
LCCOAT	Bare	Excellent	Excellent	Good	Excellent	Excellent
LCCOAT	Black Enamel	Excellent	Excellent	Good	Excellent	Excellent
LCCOAT	White OEM	Excellent	Excellent	Good	Excellent	Excellent
LINE-X	Bare	Good	Fair	Good	Excellent	Good
LINE-X	Black Enamel	Good	Fair	Good	Excellent	Good
LINE-X	White OEM	Good	Fair	Good	Excellent	Good
Raptor	Bare	Good	Poor	Good	Excellent	Good
Raptor	Black Enamel	Excellent	Excellent	Excellent	Excellent	Excellent
Raptor	White OEM	Excellent	Good	Excellent	Excellent	Excellent
Rhino Linings	Bare	Poor	Poor	Good	Poor	Fair
Rhino Linings	Black Enamel	Excellent	Excellent	Good	Good	Excellent
Rhino Linings	White OEM	Excellent	Poor	Good	Excellent	Good

State Job Number: 134935

3.3 Evaluation of Corrosion Protective Coatings During In field Testing

3.3.1 Introduction

To verify the results of laboratory-scale experiments, in field experiments were conducted in 2 ODOT districts over the span of approximately 90 days. During in field testing, carbon steel samples were coated with 4 organic coating systems on bare carbon steel and carbon steel previously coated with black enamel or white OEM primary coatings. Galvanized carbon steel samples were also tested. In order to determine the effectiveness of coatings at preventing corrosion in real winter maintenance conditions, results were compared to samples coated with black enamel or white OEM as controls.

3.3.2 Experimental Procedure for Evaluating the Performance of Coatings during In field Testing

The evaluation of coating performance was measured by determination of creep rate by following ASTM standard D1654[1] (Standard Test Method for Evaluation of Painted or Coated Specimens Subjected to Corrosive Environments). Coated panels were scribed with a computerized New Hermes Vanguard 3400 Engraver. Scribe line depth and width was 0.008 inch. Coated carbon steel (CS) metal panels were exposed to in field winter conditions from December 2014 to March 2015 by mounting (Figure 3.3-1) 10 different samples per truck (5 front and 5 back) on 8 different salt trucks in District 4 and 10 in the state of Ohio. Creep rate measurements were determined using ImageJ (1.48v) software. Detailed experimental procedure and results can be found in Appendix H.

State Job Number: 134935

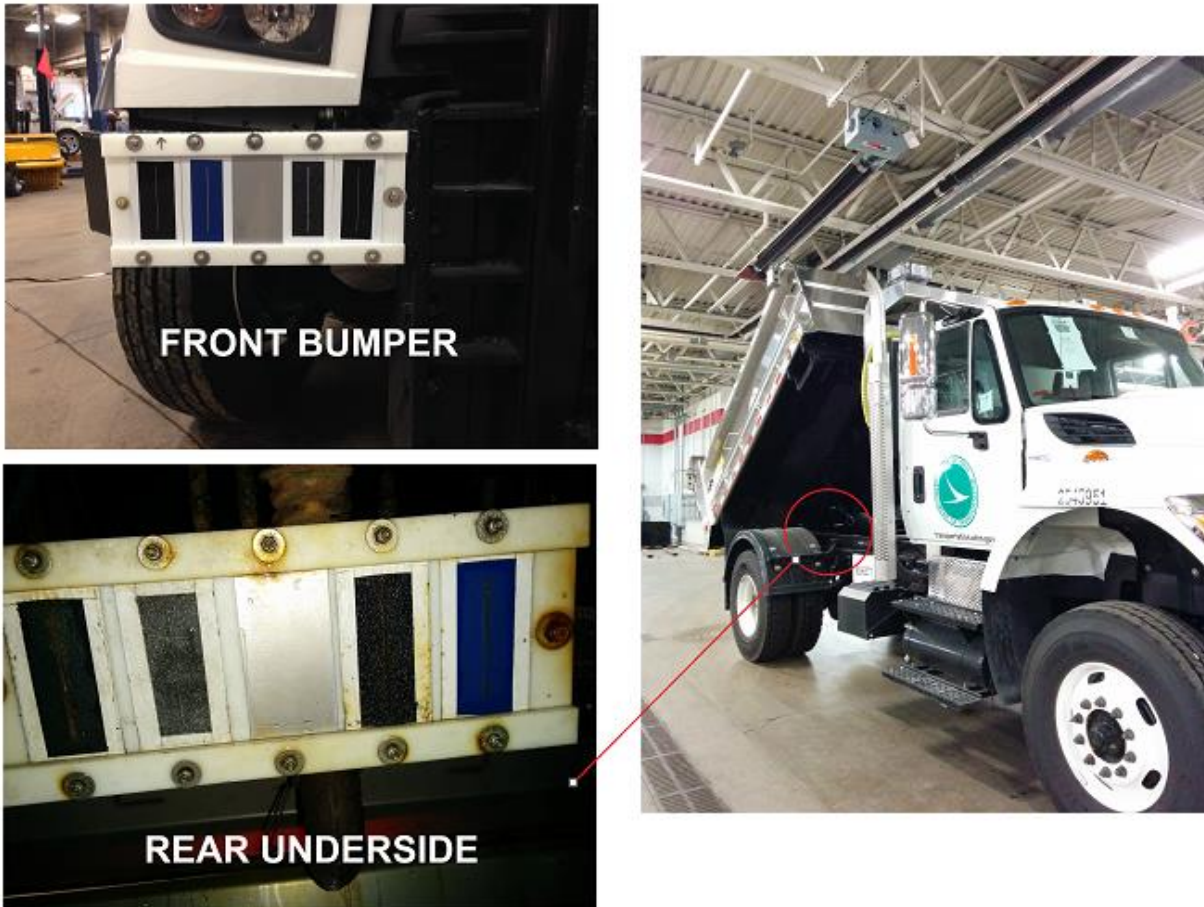

Figure 3.3-1: Mounted scribed metal panels on the front bumper (top left) and rear underside (bottom left, right) of salt truck for exposure to winter conditions for 90 days.

3.3.3 Summary of In field Testing Results

The average creep rate from scribe during in field testing is shown in Figure 3.3-2, based on the location of the panel on the salt truck (front, back). ANOVA analysis shows that there is no statistical significance between the location of the panel on the truck (p-value of 0.75) or the ODOT district tested (p-value of 0.50). Therefore, average creep based on surface treatment is calculated independently of location of panel on the salt truck and district tested (Figure 3.3-3). Images of each panel after 90 days of exposure are located in Appendix H.

ODOT Research Final Report

State Job Number: 134935

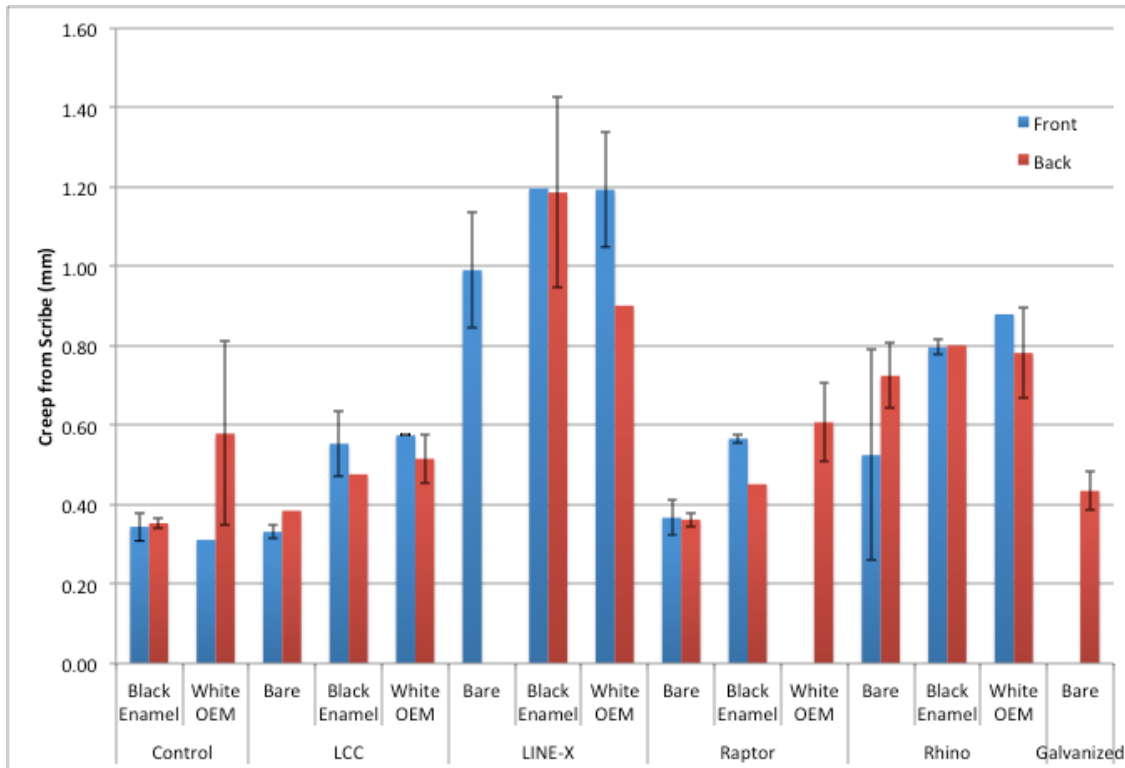

Figure 3.3-2: Creep from scribe for each surface treatment with respect to location on the salt truck (front, back) after 90 days of in field exposure.

ANOVA analysis of creep for all surface treatments shows that there is some statistical significance to surface treatment (p-value of 0.1) during in field experiments. Comparison of creep from scribe for all surface treatments tested during in field testing shows that primary coatings (black enamel, white OEM) outperform almost all coatings tested. Bare carbon steel samples coated with LCCOAT or Raptor without a primary coating outperformed white OEM, with respect to creep from scribe, by approximately 20%. Additionally, coatings applied to either the black enamel or white OEM primary coating showed significantly more creep from scribe than the primary coat alone. LINE-X had the highest creep from scribe, despite being the thickest coating, and surface treatments containing Rhino Linings had larger creep values, corroborating results obtained during continuous immersion testing. As expected, galvanized coatings performed well during in field testing due to the formation of a protective oxide layer during exposure cycles.

State Job Number: 134935

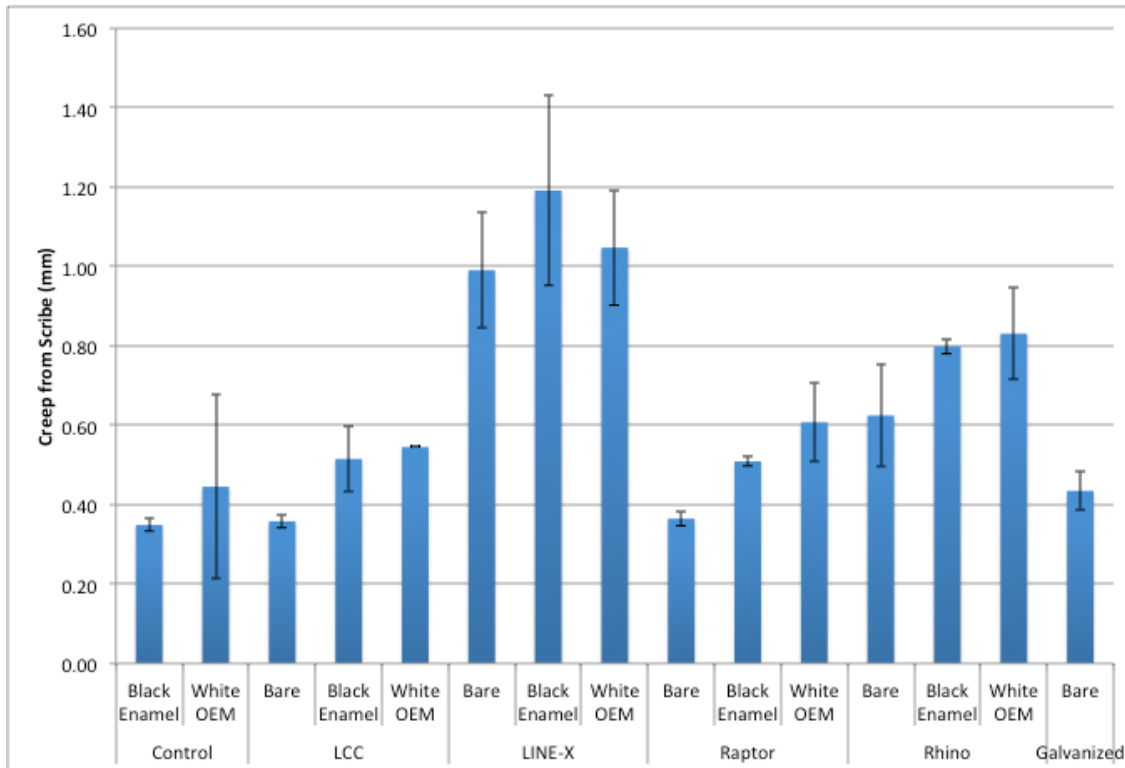

Figure 3.3-3: Average creep from scribe for all surface treatments after 90 days of in field exposure.

Figure 3.3-4 shows the delamination length of coatings on carbon steel samples after 90 days of in field exposure. Analysis indicates that there is no statistical significance between treatments with respect to delamination length, indicating that the delamination is equal for all coatings and is most likely caused during scribing or preparation of metal samples for microscopy. However, the delamination length for surface treatments involving LINE-X are much higher (on average) than the delamination length of other surface treatments, corresponding to the increased creep from scribe seen in Figure 3.3-3. Images showing the cross-section of each coating after exposure can be found in Appendix J.

State Job Number: 134935

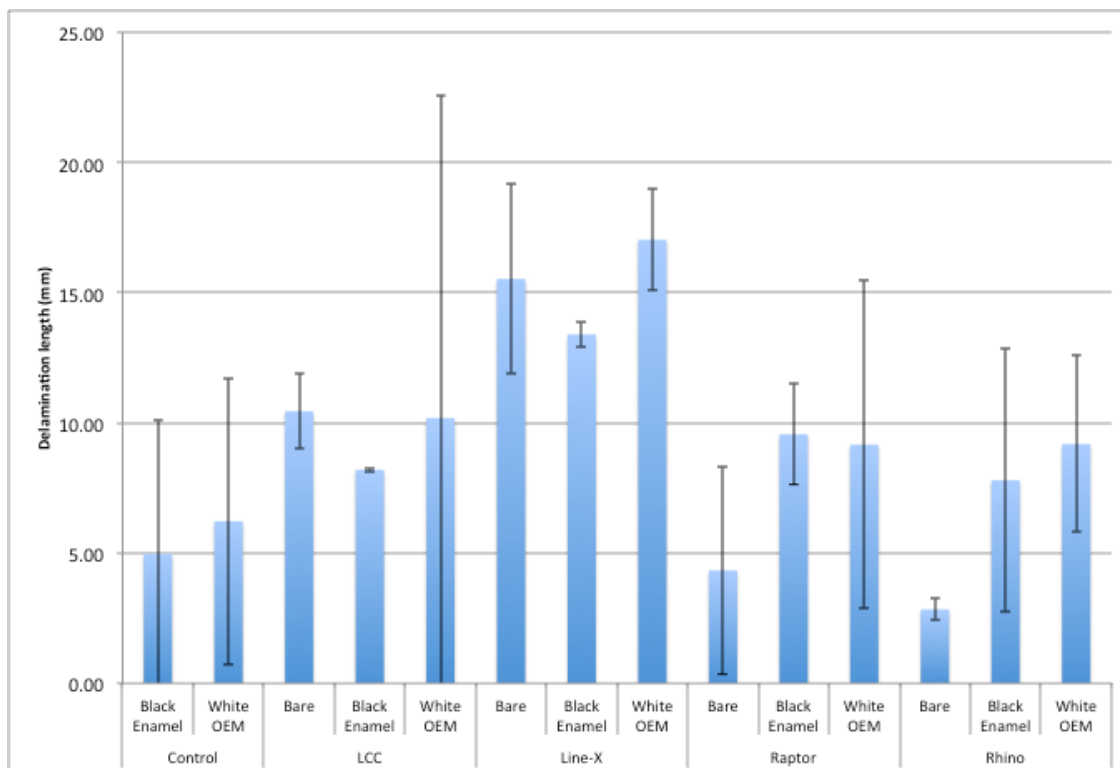

Figure 3.3-4: Delamination length for all surface treatments after 90 days of in field exposure.

3.3.4 Overview of Effectiveness of Coatings at Reducing Corrosion during In field Testing

Table 3.3-1 provides an overview of coating ratings based on in field testing on carbon steel. Coatings were rated based on creep rate from scribe during in field testing.

- Coatings were applied only to carbon steel as it was the most corrosive metal during accelerated corrosion testing
- 4 different organic coatings were tested on bare metal samples and metal samples previously coating with white OEM or black enamel coating systems
- Galvanized coatings on bare carbon steel were also evaluated
- Metal samples were mounted to salt trucks as shown in Appendix H.

ODOT Research Final Report

State Job Number: 134935

- Samples were exposed to winter weather conditions on 8 salt trucks spanning two ODOT districts (4, 10) from December 2014-March 2015
- There was no statistical difference in creep from scribe with respect to district tested or location of the panel on the salt truck
- White OEM and black enamel primary coatings outperformed almost all corrosion prevention coatings tested.
- LCCOAT and Raptor without a primary coating outperformed the white OEM primary coating, with respect to creep from scribe, by almost 20%. Both coatings on bare carbon steel performed comparably to the black enamel primary coating.
- All surface treatments containing LINE-X had the largest creep from scribe, despite being the thickest coating.
- Rhino Linings also had larger values of creep from the scribe, corroborating experimental results during continuous immersion testing.
- As expected, galvanized samples performed well, with respect to creep from scribe. Samples had comparable creep lengths to controls.
- In field studies performed in this work can be used to draw initial conclusions; however, longer-term studies are needed to determine performance of coatings during actual snow and ice conditions.

ODOT Research Final Report



State Job Number: 134935

Table 3.3-1: Summary of effectiveness of coatings at reducing corrosion during in field testing for all surface treatments coated on carbon steel samples

Coating System	Primary Coating	Corrosion Rating (In field)
Control	Black Enamel	Excellent
	White OEM	Good
Galvanized	None	Excellent
LCCOAT	Bare	Good
	Black Enamel	Excellent
	White OEM	Excellent
LINE-X	Bare	Good
	Black Enamel	Good
	White OEM	Good
Raptor	Bare	Excellent
	Black Enamel	Excellent
	White OEM	Excellent
Rhino Linings	Bare	Excellent*
	Black Enamel	Excellent
	White OEM	Excellent

State Job Number: 134935

3.4 Cost –Benefit Analysis of Corrosion Prevention Strategies

3.4.1 Introduction

The final tasks for this project were to conduct a cost-benefit analysis and provide proposed standard operating procedures (SOP) or technical specification guidance regarding coating of truck components. Details regarding this analysis are presented below in individual sections. The overall approach consisted of the following steps:

1. Evaluate historical maintenance costs for specific repair codes
2. Estimate coating costs per unit surface area for top performing coatings,
3. Estimate coating costs for specific parts-truck components as directed by ODOT personnel,
4. Perform cost-benefit analysis based on previous steps results and analysis, and
5. Provide technical specification guidance and recommendations for coating applications.

Each of the coatings evaluated in the laboratory and in the field were included in the cost analysis; with the exception of galvanized as it underperformed during laboratory testing.

3.4.2 Historical Maintenance Cost Evaluation (2004-2014)

Historical maintenance data for both single axle (254 series) and tandem axle (256 series) was obtained from ODOT’s EIMS database for the period of 1/1/2004 through 6/31/2014 (45,425 records of data), with a total of 1,624 trucks in the fleet as of 6/31/2014. After multiple discussions regarding the corrosion-related maintenance costs that have a relevant repair code for ODOT District 10, Table 3.4-1 summarizes the repair codes and a brief description for each repair code included in this cost analysis.

ODOT Research Final Report

State Job Number: 134935

Table 3.4-1: ODOT EIMS Database Repair Codes Analyzed as part of the Cost-Benefit Analysis.

Repair Code	Description
111	Brakes-Compressor/Air Supply/Dryer/Rpl/Rpr
121	Frame & Chassis – Frame Adjust/Repair
135	Frame & Chassis – Troubleshoot
289	Welding/Cutting
335	Welding/Fabrication
248	Cab & Body – Frames/Supports
254	Cab & Body - Sandblasting
238	Cab & Body - Painting/Spot
239	Cab & Body - Painting/Total
347	Cab & Body – Misc. Hardware/Rmv F/Paint Prep

The first review of this cost data was to summarize total cost (parts and labor) by repair code for 2004-2014 (Table 3.4-2). The total cost for all listed repair codes is \$9,213,712. Assuming a total fleet of 1,624 trucks and ten and a half years of data, total maintenance cost of \$9,213,712, this is an average expense of \$540.33 per truck per year. This value (\$540.33 per truck per year) is an important benchmark to remember, as it can be used as a first estimate of the opportunity benefit for applying coatings to truck components.



State Job Number: 134935

Table 3.4-2: Total Cost (Parts and Labor) Summary by Repair Code from ODOT EIMS Database (2004-2014).

Repair Code	Description	Total Cost	% of Total
111	Brakes-Compressor/Air Supply/Dryer/Rpl/Rpr	\$1,224,439	13.3%
121	Frame & Chassis – Frame Adjust/Repair	\$64,103	0.7%
135	Frame & Chassis – Troubleshoot	\$109,396	1.2%
289	Welding/Cutting	\$587,110	6.4%
335	Welding/Fabrication	\$1,924,827	20.9%
248	Cab & Body – Frames/Supports	\$338,641	3.7%
254	Cab & Body - Sandblasting	\$1,037,902	11.3%
238	Cab & Body - Painting/Spot	\$1,549,048	16.8%
239	Cab & Body - Painting/Total	\$2,053,978	22.3%
347	Cab & Body – Misc. Hardware/Rmv F/Paint Prep	\$324,269	3.5%
		\$9,213,712	

Cab and body-related painting expenses (Repair Codes 254,238,239, and 347) comprise 53.9% of the total. Other significant repair codes include welding/fabrication (Repair Code 335) at 20.9% of the total cost and brakes-compressor/air supply (Repair Code 111). Given the majority of the total cost is associated with four repair codes (254,238,239, and 347), these will be combined to examine any chronological or district-specific trends.

Table 3.4-3 and Figure 3.4-1 summarize the chronological results for Repair Codes 254, 238, 239, and 347. In general, the total cost associated with this maintenance activity has decreased over the last 10 years. The 3-year (2004-2006) running average was \$577,721 but has decreased to \$394,215 for the last full 3 years of data (2011-2013). This corresponds to an average per truck expense maximum in 2005 of \$359.94 and a much lower minimum per truck expense of \$191.49 in 2013.

ODOT Research Final Report

State Job Number: 134935

Table 3.4-3: Total Cost (Parts and Labor) Summary by Calendar Year for Repair Codes 254, 238, 239, and 347 from ODOT EIMS Database (2004-2014).

Year	Total Cost	3 Year Running Average	Average Cost Per Truck*
2004	\$582,225	--	\$358.51
2005	\$584,549	--	\$359.94
2006	\$566,388	\$577,721	\$348.76
2007	\$411,898	\$520,945	\$253.63
2008	\$521,959	\$500,082	\$321.40
2009	\$549,226	\$494,361	\$338.19
2010	\$500,682	\$523,956	\$308.30
2011	\$481,731	\$510,546	\$296.63
2012	\$389,931	\$457,448	\$240.11
2013	\$310,984	\$394,215	\$191.49
2014**	\$65,623	--	--

* Assumed fixed fleet total of 1,624 trucks to calculate average

** 2014 data for only first six months of the year

ODOT Research Final Report

State Job Number: 134935

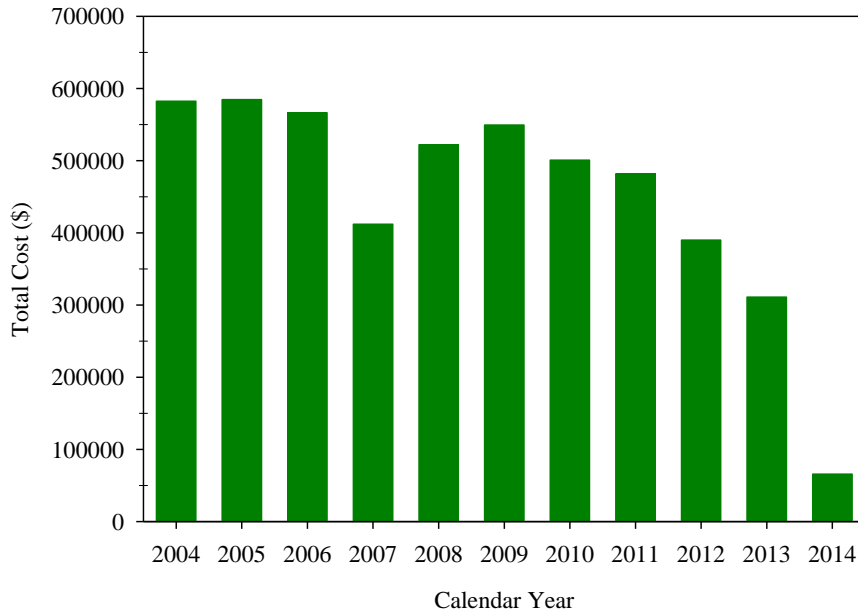

Figure 3.4-1: Total Cost (Parts and Labor) Summary by Calendar Year for Repair Codes 254, 238, 239, and 347 from ODOT EIMS Database (2004-2014). Note: 2014 data is for the first six months only.

After the chronological review, the next summary was to review total expenses by District. Table 3.4-4 is a breakdown of total costs for repair codes 254, 238, 239, and 347 (i.e. cab and body-related painting expenses). As expected because the truck fleet has a variable distribution amongst the Districts, the cost range is highly variable, varying from \$244,164 to \$831,793 (i.e. ignoring Other-non District assigned expenses). District 11 has the lowest cost total (4.6%) and District 10 has the highest percentage (15.7%). The last cost analysis breakdown was examination of the truck maintenance costs at the truck level. For this analysis, eight trucks from District 10 were selected from multiple counties and have all been in service for at least seven years.

ODOT Research Final Report

State Job Number: 134935

Table 3.4-5 shows the total cost analysis for each truck and Table 3.4-6 shows the maintenance cost analysis per year by maintenance category. Several important observations can be made from this truck level analysis. First, the paint-related expenses are representative of the distribution calculated for all of ODOT. The paint-related expenses are 60.0% (\$27,784/\$46,279) of the total for these eight trucks versus 53.9% for all of ODOT. Second, the median estimated cost per year for paint-related expense is \$422 per year, another benchmark value for future reference. Finally, the median expense per year was \$728, which is higher than the \$540 per year average calculated for all trucks previously, but not unexpected given such a small sample size (eight trucks).

Table 3.4-4: Total Cost (Parts and Labor) Summary by ODOT District for Repair Codes 254, 238, 239, and 347 from ODOT EIMS Database (2004-2014).

Repair Code	Total Cost	% of Total
D1	\$499,442	9.4%
D2	\$525,522	9.9%
D3	\$505,825	9.5%
D4	\$421,918	7.9%
D5	\$293,339	5.5%
D6	\$291,742	5.5%
D7	\$504,117	9.5%
D8	\$339,594	6.4%
D9	\$314,426	5.9%
D10	\$831,793	15.7%
D11	\$244,164	4.6%
D12	\$377,888	7.1%
Other	\$158,308	3.0%
	\$5,308,079	

ODOT Research Final Report

State Job Number: 134935

Table 3.4-5: Total Cost (Parts and Labor) Summary by Selected Trucks from District 10 for All Repair Codes Evaluated in this Study (Organized by General Maintenance Category) from ODOT EIMS Database (2004-2014).

Truck	Truck Year	County	Paint	Welding	Frame	Total
2544364	2004	Hocking	\$5,309	\$852	--	\$6,161
2544365	2004	Meigs	\$343	\$2,002	\$164	\$2,508
2544446	2005	Monroe	\$4,627	\$943	\$1,468	\$7,038
2544448	2005	Morgan	\$2,303	\$4,082	\$130	\$6,515
2544451	2005	Vinton	\$2,974	\$2,270	\$1,415	\$6,659
2544452	2005	Washington	\$7,744	\$1,546	\$930	\$10,220
2544569	2006	Athens	\$4,229	\$1,629	--	\$5,857
2545543	2007	Meigs	\$256	\$1,066	--	\$1,321
			\$27,784	\$14,388	\$4,107	\$46,279

Table 3.4-6: Total Cost (Parts and Labor) Per Year by Selected Trucks from District 10 for All Repair Codes Evaluated in this Study (Organized by General Maintenance Category) from ODOT EIMS Database (2004-2014).

Truck	Truck Year	County	Paint	Welding	Frame	Total
2544364	2004	Hocking	\$531	\$85	--	\$616
2544365	2004	Meigs	\$34	\$200	\$16	\$251
2544446	2005	Monroe	\$514	\$105	\$163	\$782
2544448	2005	Morgan	\$256	\$454	\$14	\$724
2544451	2005	Vinton	\$330	\$252	\$157	\$740
2544452	2005	Washington	\$860	\$172	\$103	\$1,136
2544569	2006	Athens	\$529	\$204	--	\$732
2545543	2007	Meigs	\$37	\$152	--	\$189

ODOT Research Final Report

State Job Number: 134935

		Median	\$422	\$186	\$15	\$728
--	--	--------	-------	-------	------	-------

3.4.3 Coating Material Cost Estimates

This section will estimate coating material costs per unit surface area coated. Table 3.4-7 shows the content of solids, film thickness (dry and wet) and theoretical spread rate (calculated from equation 1) of desired dry film thickness of 6 different coatings (galvanized, LCCOAT, LINE-X, metalized, Raptor and Rhino) and two base coats (white OEM and black enamel).

Table 3.4-7: Theoretical spread rate in ft²/U.S. gallon of corrosion protective coatings.

Coatings	Solids (vol.%)	Film Thickness (mils)		Theoretical spread rate (ft ² /U.S. gallon)
		Dry (DFT)	Wet (WFT)	
Black Enamel	40	4	10	160
White OEM	53	4	7.55	212
Galvanized	52	4	7.69	208
LCCOAT	100	4	4	400
LINE-X	100	60	60	26.7
Metalized	100	8	8	200
Raptor	57	7	12.28	130.3
Rhino Linings	100	30	30	53.3

$$\text{Theoretical spread rate} = \frac{1600 \times \% \text{ solids (in decimal form)}}{\text{Dry film thickness (in mils)}} \quad (1)$$

One U.S. gallon of paint will cover approximately 1600 ft² at 1 mil (25µm) thickness. The desired final coating thickness is defined as dry film thickness (DFT) and can only be determined after curing. Therefore, wet film thickness (WFT) is commonly measured with a stainless steel notched gauge according to ASTM standard D4414 and the expected DFT is calculated by the following relationship (for unthinned coatings).

$$\text{Dry film thickness} = \text{Wet film thickness} \times \% \text{ solids (in decimal form)} \quad (2)$$

ODOT Research Final Report

State Job Number: 134935

Table 3.4-8 displays the prices of coatings including additives and layers that make up the coating system such as adhesive promoters, primers, base coats, topcoats and clear coats.

Table 3.4-8: Prices of the coating systems used in this study in dollars per U.S. gallon.

Coatings	Price per gallon (\$)
Black Enamel	\$ 850.00
White OEM	\$ 800.00
Galvanized	\$ 200.00
LCCOAT	\$ 500.00
LINE-X	\$ 160.00
Metalized	\$ 200.00
Raptor	\$ 190.00
Rhino Linings	\$ 180.00

The time reported in Table 3.4-9 includes coating application and curing. Surface preparation is dependent on the degree required by the coating supplier as well as the method selected and the initial state of the substrate. For the purpose of this study, preparation time will be the same.

Table 3.4-9: Labor time employed in the application and curing of the coating systems evaluated in this study.

Coatings	Application time (min/ft ²)	Curing time (h)
Black Enamel	2	72
White OEM	2	72
Galvanized	2	2
LCCOAT*	0.2	1
LINE-X	0.5	2
Metalized	2	2
Raptor	2	169
Rhino Linings	0.5	2

*LCCOAT curing time is less than a minute per ft² (number has been rounded up) due to the UV-curing process.

ODOT Research Final Report

State Job Number: 134935

Conventional air spray was used for coating application of black enamel, white OEM, LCCOAT and Raptor. LINE-X and Rhino are sprayed at high temperature and high-pressure conditions. Galvanized samples were dip coated and metalized panels were thermo sprayed on the surface of the metal.

Table 3.4-10: Total costs per coating per ft² and total time needed in labor.

Coatings	Total cost of coating (\$)/ft ²	Total labor time (hours)
Black Enamel	\$5.31	17
White OEM	\$3.77	17
Galvanized	\$0.96	17
LCCOAT	\$1.25	2
LINE-X	\$6.00	5
Metalized	\$1.00	17
Raptor	\$1.46	17
Rhino Linings	\$3.38	5

The curing time reported above involves curing time between coats and final curing time after application. Black enamel and white OEM required 5 minutes of curing between coats (3) and 3 days of curing after final coat was applied. Raptor needed an hour of curing between coats (3) and 7 days after final coat was applied. The total cost of protective coating needed to cover an area of 100 ft² and the total labor hours are calculated from information presented below.

3.4.4 Annual Cash Flow Analysis

In order to determine the cost of coating and maintaining the average DOT salt truck, an average maintenance data cost per truck per year was taken from Table 3.4-3 based on 1624 trucks over the years 2004-2014 considering 4 maintenance codes. The calculated average maintenance cost per truck per year is listed in Table 3.4-11.

Coating costs were used as calculated in Table 3.4-10. Initial cost to coat the truck is considered to be included in the initial purchase cost and is not included in the

ODOT Research Final Report

State Job Number: 134935

year 0 cost. For Scenario 1, it was assumed that 300 ft² of metal were coated; for Scenarios 2 and 3, it was assumed that 1000 ft² of metal were coated. There is no maintenance cost in year 0. It is assumed that maintenance cost will increase yearly, due to inflation, following:

$$\text{Cost at year } n = \text{Maintenance cost} \times (1 + i)^n$$

where i is the inflation rate assumed to be 10%.

Table 3.4-11: Cost to maintain a standard DOT salt truck for 10 years using average costs for maintenance and labor.

Year	Coating Cost	Maintenance Cost per year	Total Annual Cost
0			\$-
1		\$378.04	\$378.04
2		\$415.84	\$415.84
3		\$457.42	\$457.42
4		\$503.17	\$503.17
5		\$553.48	\$553.48
6		\$608.83	\$608.83
7		\$669.71	\$669.71
8		\$736.68	\$736.68
9		\$810.35	\$810.35
10		\$891.39	\$891.39
	\$-	\$6,024.91	\$6,024.91

Cost-benefit analysis was conducted for three scenarios: a new truck with only bare/exposed metal parts coated by ODOT, a new truck coated completely by ODOT (scenario 1 plus coating used as a topcoat on white OEM or black enamel), a refurbished truck sanded and completely coated by ODOT on sanded metal. As only carbon steel can be galvanized/metalized, this coating was not included in the cost-benefit analysis. However, as these coatings performed well during in field testing exposed metals should be galvanized where appropriate (see SOP below). Predicted

ODOT Research Final Report

State Job Number: 134935

maintenance cost after coatings application was calculated using laboratory-scale creep data from the 4 metals tested compared to a control.

Predicted Maintenance Cost

$$= \text{Standard Maintenance Cost} \times \left(1 + \frac{\text{Creep}_{\text{coating}} - \text{Creep}_{\text{control}}}{\text{Creep}_{\text{control}}} \right)$$

As all of the metals of interest were tested during laboratory experiment, laboratory results were used to estimate the effectiveness of a given coating system at reducing corrosion and therefore maintenance cost per year per truck. The percent change in creep (comparison to control) is listed in Table 3.4-12 for each surface treatment. For Scenarios 1 and 3, the control is the average of the creep from scribe on bare metal samples (without a primary coating) for the four metals tested; for Scenario 2, the control is the average of the creep from scribe for all controls tested (samples coated with a primary coating).

Table 3.4-12: Percent change in creep for each surface treatment tested compared to its control.

	Average (compared to bare metal)	Average (compared to metal coated with OEM and black enamel)
LCCOAT	-43%	-48%
LINE-X	-35%	-43%
Raptor	-45%	-58%
Rhino Linings	-11%	-54%

Cost-benefit analysis shows that LCCOAT and Raptor coatings without a primary coating are more economical for scenarios 1 and 3 (new truck with bare/exposed metal coated by ODOT, refurbished truck) and decrease the total cost to maintain the truck by almost 40% compared to the standard ODOT truck. This is a cost savings of approximately \$2000 for scenario 1 and \$4000 for scenario 3 per truck over 10 years. LCCOAT and Raptor were also more economical for scenario 2 (a new truck coated completely by ODOT); however, there was not a statistically significant decrease in cost.

ODOT Research Final Report

State Job Number: 134935

In comparison to laboratory and in field testing, LINE-X and Rhino Linings are not economical and are shown to increase cost by up to 100%.

Table 3.4-13: Overview of cost-benefit analysis for three scenarios

Coating	Scenario 1		Scenario 2		Scenario 3	
	Cost to Operate for 10 years	Compared to Standard Truck	Cost to Operate for 10 years	Compared to Standard Truck	Cost to Operate for 10 years	Compared to Standard Truck
Standard Truck	\$6,024		\$6,024		\$10,567	
LCCOAT	\$3,808	-37%	\$4,535	-25%	\$6,766	-36%
LINE-X	\$5,725	-5%	\$9,691	61%	\$21,258	101%
Raptor	\$3,767	-37%	\$4,373	-27%	\$7,077	-33%
Rhino Linings	\$6,391	6%	\$7,451	24%	\$12,997	23%

3.4.5 Overview of Cost-Benefit Analysis for Corrosion Prevention Coating

Table 6-14 provides an overview of coating ratings based on total cost. Cost ratings were based on percentile of cost to maintain truck for 10 years based on cost-benefit model (see percentiles and ratings below).

- Data collected from laboratory experiments was used as a baseline for comparison of corrosion between surface treatments
- Historical maintenance records were used to determine maintenance cost per truck per year for a standard DOT salt truck
- Coating cost was calculated assuming 100 ft² of surface coverage
- Maintenance cost was a function of corrosion performance during detailed testing (compared to standard cost)
- Only carbon steel coated with LCCOAT or Raptor or galvanized bare carbon steel samples without a primary coating were more cost effective than the standard DOT salt truck.

ODOT Research Final Report

State Job Number: 134935

- Surface treatments with LCCOAT or Raptor as a coating on metal previously coated with white OEM or black enamel had comparable total costs to the standard DOT salt truck
- All surface treatments containing LINE-X had a larger total cost (almost double) the standard DOT salt truck.
- In order to provide a more accurate cost-benefit analysis, a more complete set of in field data is necessary.

ODOT Research Final Report

State Job Number: 134935

Table 6-14: Rating of surface treatments based on total cost for 10 years

		Cost to Maintain for 10 years	Coating Rating
Control	Black Enamel	\$6,025	Average
Control	White OEM	\$6,025	Average
LCCOAT	Bare	\$3,809	Excellent
LCCOAT	Black Enamel	\$4,535	Good
LCCOAT	White OEM	\$4,535	Good
LINE-X	Bare	\$5,726	Average
LINE-X	Black Enamel	\$9,691	Poor
LINE-X	White OEM	\$9,691	Poor
Raptor	Bare	\$3,768	Excellent
Raptor	Black Enamel	\$4,374	Excellent
Raptor	White OEM	\$4,374	Excellent
Rhino Linings	Bare	\$6,392	Fair
Rhino Linings	Black Enamel	\$7,452	Fair
Rhino Linings	White OEM	\$7,452	Fair

Percentile	Cost	Cost Rating	
0	\$3,768	10	Excellent
0.1	\$3,978	9	
0.2	\$4,374	8	
0.3	\$4,519	7	Good
0.4	\$4,773	6	
0.5	\$5,875	5	Average
0.6	\$6,025	4	
0.7	\$6,498	3	Fair
0.8	\$7,452	2	
0.9	\$9,019	1	
1	\$9,691	0	Poor



State Job Number: 134935

CHAPTER IV: RECOMMENDATIONS

4.1 Recommendations for Implementation

Corrosion Prevention Strategies on Snow and Ice Equipment
Proposed Standard Operating Procedure (SOP)
Ohio Department of Transportation (ODOT)

SCOPE:

This standard operating procedure is applicable to all Districts, Regions, Divisions, and Offices within the Ohio Department of Transportation.

PURPOSE:

The purpose of this proposed Standard Operating Procedure (SOP) is to establish statewide guidelines for implementation of the use of corrosion protective coatings on snow and ice equipment.

PROCEDURE:

I. New dump trucks

New dump trucks shall be painted with manufacturer's specifications. The cab, hood and fenders shall be painted with factory standard Imron Elite Productive basecoat with an Imron Elite 8840S clearcoat. Frame, front and rear axle, steering gears, propeller shafts and chassis shall be painted with Imron Elite Productive basecoat and Rival RV35 topcoat coatings. Wheels shall be powder coated and aluminum fuel tanks shall be unpainted.

For aftermarket finishing, a state agency will be in charge of servicing the trucks by welding, machining, fabricating and painting in addition to the installation of hydraulics, plow hitches, electrical wiring and paint stripes. Trucks will be inspected before being delivered to their respective counties.

Extra features added to any new assembled dump truck shall be painted with either the Raptor coating system or the LCCOAT coating system. Some of the parts to be

State Job Number: 134935

coated include the rear hitch plate, hydraulics attachment plate assembly, front plow hoist/ frame/ bumper assembly, liquid deicer tank mounting hardware, and bed hoist subframe. Parts may be galvanized. If the truck has additional exposed metal, the metal shall be painted with either Raptor or LCCOAT.

II. Existing dump trucks with state agency modifications

Existing dump trucks with state agency modifications in need of refurbishment shall be stripped down (sandblasting, preparing and primed to industry standards) and painted with either the Raptor coating system or the LCCOAT coating system. Additional modifications added at the state or district level shall also be coated following the above procedure for new trucks.

III. Existing dump trucks with state agency and district modifications

Trucks in no need of refurbishment should be maintained using visual inspection and coating reapplication in the areas where coating breakdown (exposed metal) has occurred, in order to avoid the need for total refurbishment. Extra care should be taken to inspect the truck frame (front to back), bed hoist subframe, front plow hoist, front plow frame, front bumpers, rear hitch plate, liquid deicer tank mounting hardware, and hydraulics mounting plate assembly.

MAINTENANCE:

In order to provide adequate confidence that the coated surfaces of a dump truck perform satisfactorily in service, it is suggested that an annual quality control process be followed. The recommended procedure to be conducted during the off-season will include: general visual inspection of coated surfaces by verifying that industrial specifications are met; and reporting any failure on the coating by assessing damages such as scratches, blisters, chips, cracks, holidays and other defects formed by normal operations.

After diagnosis of damages, coated surfaces should be recoated by properly preparing the surface by removing any dirt, defects or contaminants that could impede



ODOT Research Final Report

State Job Number: 134935

good adhesion of the coating system on the metal. Overall, yearly visual inspection and coating touch-ups on prepared surfaces are recommended, as well as thorough and detailed recording of all maintenance expenses.

State Job Number: 134935

REFERENCES

AZZ Galvanizing Services (2015) Galvanizing. 1–5.

Baroga, E. (2004). Washington State Department of Transportation's 2002-2003 Salt Pilot Project. Proceedings of the Sixth International Symposium on Snow Removal and Ice Control Technology, Spokane, WA.

Chance, R. L. (1974). "Corrosion, Deicing Salts, and the Environment." Materials Performance **12**(10): 16-22.

Fauchais P, Vardelle A (2012) Thermal Sprayed Coatings Used Against Corrosion and Corrosive Wear. Adv. Plasma Spray Appl.

Fitzgerald, J. H. I. (2000). Engineering of Cathodic Protection Systems. Uhlig's Corrosion Handbook. R. W. Revie. New York, NY, John Wiley & Sons. **2nd Edition**: 1061-1078.

Free, M.L., *Corrosion*, 44(2002), 2865-2870.

Goodwin F, Alhassan S (2005) Zinc. In: Baboian R (ed) Corros. tests Stand. Appl. Interpret., 2nd. Ed. ASTM International, West Conshohocken, PA, pp 525–530

Kish, J. R., N. J. Stead, et al. (2009). "Corrosion Control of Type 316L Stainless Steel in Sulfamic Acid Cleaning Solutions." Corrosion **65**(7): 491-500.

Lee, C. C.; Mansfeld, F. *Corrosion Science* **1998**, *41*, 439–461.

Malik et al, International Journal of Electrochemical Science, 6 (2011), 1927-1948.

ODOT Research Final Report

State Job Number: 134935

Motamedi, M. et al, "Effect of aging time on corrosion inhibition of cationic surfactant on mild steel in sulfamic acid cleaning solution," *Corrosion Science* 70 (2013) 46–54.

Olivier, Marie-Georges and Poelman, Mireille (2012). Use of Electrochemical Impedance Spectroscopy (EIS) for the Evaluation of Electrocoatings Performances, Recent Researches in Corrosion Evaluation and Protection, Prof. Reza Shoja Razavi (Ed.), ISBN: 978-953-307-920-2, InTech, DOI: 10.5772/33844. Available from: <http://www.intechopen.com/books/recent-researches-in-corrosion-evaluation-and-protection/use-of-electrochemical-impedance-spectroscopy-eis-for-the-evaluation-of-electrocoatings-performances>

Simpson T, Townsend H (2005) Metallic Coatings on Steel. In: Baboian R (ed) Corros. tests Stand. Appl. Interpret., 2nd. Ed. ASTM International, West Conshohocken, PA, pp 620–631

Uhlig, H. H. and R. W. Revie (1985). Corrosion Control- An Introduction to Corrosion Science and Engineering. New York, NY, John Wiley & Sons.

Xi, Y. and Z. Xie (2002). Corrosion Effects of Magnesium Chloride and Sodium Chloride on Automobile Components.

Xiong, W. A. N. a. J. (2009). Investigation of Materials for the Reduction and Prevention of Corrosion on Highway Maintenance Equipment.



State Job Number: 134935

APPENDIX A: SURVEY RESULTS

Table A 1: Survey Results for Question 1

Please enter the following contact information (we may follow up with additional questions):		
Answer Options	Response Percent	Response Count
Name:	100.0%	75
District	100.0%	75
Garage-Outpost Name	92.0%	69
State:	94.7%	71
Email Address:	94.7%	71
Phone Number:	92.0%	69
	<i>answered question</i>	75
	<i>skipped question</i>	0



State Job Number: 134935

Table A 2: Survey Results for Question 2

What deicing chemicals and materials are used by your facility (check all that apply)?		
Answer Options	Response Percent	Response Count
Sodium Chloride (Salt) Brine	88.9%	64
Calcium Magnesium Acetate	0.0%	0
Magnesium Chloride	8.3%	6
Calcium Chloride Liquid	75.0%	54
Calcium Chloride Flakes	8.3%	6
Potassium Acetate	5.6%	4
Sand-Grit	61.1%	44
Carbohydrate or Agricultural Based Solutions (i.e.; Beat Heat)	30.6%	22
Other (please specify)		11
answered question		72
skipped question		3

Number	Other (please specify)
1	Rock salt
2	Aquasalina, Grits
3	Aquasalina
4	Salt Brine
5	Salt
6	salt
7	M1000 and liquid corn salt Sand salt mix at 3:1 ratio used on rare occasions at
8	very low temps.
9	salt brine



ODOT Research Final Report

State Job Number: 134935

10 Strait granular salt

11 salt



State Job Number: 134935

Table A 3: Survey Results for Question 3

Which hydraulic fluid(s) is used at your facility?	
Answer Options	Response Count
	50
<i>answered question</i>	50
<i>skipped question</i>	25

Number	Response Text
1	UNAX AW150 32 WEIGHT
2	UNAX AW150 32 WEIGHT
3	AW 32
4	15w
5	aw032
6	AW32 HYD AW-32 Hydraulic Fluid
7	John Deere HyGard
8	Hydraulic Fluid
9	Multiguard Premium Universal Tractor Fluid
10	Tractor / Truck Hydraulic
11	Standard Fluid
12	Force America
13	Hytran Ultra Aw 32
14	AW 32
15	Unax AW 150 32 Weight

ODOT Research Final Report

State Job Number: 134935

- 16** AW32
15/40 motor oil.
- 17** hyd oil.
- 18** not sure
- 19** Premium AW 32 (Brand All Fleeta)
- 20** AW150 32weight
- 21** Multiguard AW 32
- 22** AW/32 Brand Name : Warren
Standard 10W
- 23** Case Hy-Tran
- 24** ODOT purchased
- 25** not sure
Universal Non Foam Hydraulic AW ISO 32

AW 32

CAT Hyro Advanced Hydraulic Oil SAE 10W (for
Track Excavators)

HyTran MAT 3540 (for CASE Loaders)
- 26** Multi G 134 (for New Holland Tractors)
- 27** aw32
- 28** chevron ISO32
- 29** Just your everyday AW-32 oil
- 30** Hy-Tran ultra
- 31** UNAX AW150 32 wt.
- 32** AW 32

ODOT Research Final Report

State Job Number: 134935

- 33** multiguard AW 32
- 34** Exxon/Mobile
- 35** Tractor Hydraulic
- 36** Standard ?
AW-32

- 37** Non-conductive AW-32
- 38** AW46
- 39** ATF and (17A) universal tractor fluid
Standard hydraulic fluid purchased through a low-bid
- 40** process.
- 41** unknown
- 42** Synthetic Transynd
- 43** Several types
- 44** Valvoline Anti-Wear 32 HVI
- 45** 032 and 052
- 46** THF
- 47** power trans 3
- 48** Phillips 66 Powertran Fluid
- 49** Conoco hy tran
- 50** 10 wght.



State Job Number: 134935

Table A 4: Survey Results for Question 4

Does your facility use corrosion protective coatings to protect vehicles during winter maintenance operations?		
Answer Options	Response Percent	Response Count
Yes	25.4%	18
No	74.6%	53
	<i>answered question</i>	71
	<i>skipped question</i>	4



State Job Number: 134935

Table A 5: Survey Results for Question 5

Which corrosion protective coating(s) does your facility use?		
Answer Options	Response Percent	Response Count
Plow-Slick	0.0%	0
LINE-X	16.7%	1
Rhino Linings	50.0%	3
SNO-FLO	0.0%	0
Snow Wax	0.0%	0
Snow Plow Coating	0.0%	0
Fluid Film	66.7%	4
Snow Plow Coating	0.0%	0
SLIP Plate No. 1	16.7%	1
WINTER SENTRY	0.0%	0
GALV-A-GUARD	0.0%	0
Electrocoat	0.0%	0
Galvax	0.0%	0
Nanocoatings	0.0%	0
Other (please specify)		6
answered question		6
skipped question		69

Number	Other (please specify)
1	no-stick & rust off
2	paint
3	penetrol
4	We don't consistently use any but we do make every effort to clean the machines with a neutralizer



ODOT Research Final Report

State Job Number: 134935

5 salt neutralizing Soap/ Chassis Saver Paint

6 n/a

ODOT Research Final Report

State Job Number: 134935

Table A 6: Survey Results for Question 6

What is your preferred coating application method?	
Answer Options	Response Count
	10
<i>answered question</i>	10
<i>skipped question</i>	65

Number	Response Text
1	brush
2	Pump sprayer
3	don't know
4	n/a
5	brush, garden sprayer
6	spray on
7	Sprayed on critical areas
8	Spray on per manufacturer
9	recommendations
10	n//a



State Job Number: 134935

Table A 7: Survey Results for Question 7

To which part(s) of the winter maintenance equipment do you apply the corrosion protective coating?	
Answer Options	Response Count
	9
<i>answered question</i>	9
<i>skipped question</i>	66

Number	Response Text
1	plows, truck frames/underbody
2	i don't
3	undercoating
4	all exposed
5	cab and chassis
6	brine pumps , quick connect fittings and hinges
7	Everything Live bottom trailer chains/flights, top coating steel beds,
8	under frame
9	n/a



State Job Number: 134935

Table A 8: Survey Results for Question 8

Which coated parts on your winter maintenance fleet are the most exposed to harsh conditions (e.g. truck beds, plow blades, etc.)?		
Answer Options	Response Percent	Response Count
Truck cab	66.7%	6
Truck bed	66.7%	6
Plow blades	22.2%	2
Truck frame	88.9%	8
Undercarriage	88.9%	8
Salt spreader	66.7%	6
Other (please specify)		2
<i>answered question</i>		9
<i>skipped question</i>		66

Number	Other (please specify)
	hydraulic valve
1	controls
2	n/a



State Job Number: 134935

Table A 9: Survey Results for Question 9

In your experience, to which parts on winter maintenance equipment is the application of a corrosion protective coating the most important?	
Answer Options	Response Count
	8
<i>answered question</i>	8
<i>skipped question</i>	67

Number	Response Text
1	frame, undercarriage
2	As much of the truck we could get protected, cab, undercarriage, electrical parts.
3	truck frame and front bumpers
4	undercarriage - truck frame
5	Any moving part on the truck or dispensing equipment
6	cab and chassis
7	brine pump
8	Pretty much everything

ODOT Research Final Report

State Job Number: 134935

Table A 10: Survey Results for Question 10

What are the most common metals to which corrosion protective coatings are applied?		
Answer Options	Response Percent	Response Count
Carbon Steel	87.5%	7
Aluminum	12.5%	1
Cast Iron	37.5%	3
Cast Aluminum	12.5%	1
Other (please specify)		1
<i>answered question</i>		8
<i>skipped question</i>		67

Number	Other (please specify)
	stainless
1	joints



State Job Number: 134935

Table A 11: Survey Results for Question 11

Are you concerned about the exposure of other, less common metals to harsh environmental conditions?		
Answer Options	Response Percent	Response Count
Yes	77.8%	7
No	22.2%	2
If yes, please specify which metals		4
<i>answered question</i>		9
<i>skipped question</i>		66

Number	If yes, please specify which metals
1	aluminum
2	all If it's not rubber or plastic eventually the salt will
3	destroy it
4	aluminum coolers

ODOT Research Final Report

State Job Number: 134935

Table A 12: Survey Results for Question 12

What are some of the limitations/difficulties in the application of the corrosion protective coating?	
Answer Options	Response Count
	9
<i>answered question</i>	9
<i>skipped question</i>	66

Number	Response Text
1	getting all the undercarriage
2	getting old metal clean
3	EPA
4	complete coverage, proper prep
5	sticky and gooey
6	inconsistency, hard to reach
7	Too many out there that simply don't work maintaining surface coverage on non-Rhino
8	products
9	because of price we do not apply coatings



State Job Number: 134935

Table A 13: Survey Results for Question 13

What types of inspection (visual/mechanical) and maintenance (e.g. washing/rinsing, touch-up) do you perform on the coating after application?	
Answer Options	Response Count
	8
<i>answered question</i>	8
<i>skipped question</i>	67

Number	Response Text
1	visual. touch up
2	visual general washing
3	visual / mechanical
4	Usually no touch up during winter. All coated areas are washed as part of normal cleanup
5	visual
6	few if any
7	NA
8	Fire hose wash down, pressure washer with salt neutralizing soap



State Job Number: 134935

Table A 14: Survey Results for Question 14

How often do you reapply the corrosion protective coating?		
Answer Options	Response Percent	Response Count
More than once a year	16.7%	1
Once a year	66.7%	4
Once every two years	0.0%	0
No need to reapply	16.7%	1
Other (please specify)		3
answered question		6
skipped question		69

Number	Other (please specify)
1	don't know
2	NA
3	Some surfaces several times per season



State Job Number: 134935

Table A 15: Survey Results for Question 15

What particular features of your corrosion protective coating do you like?	
Answer Options	Response Count
	5
<i>answered question</i>	5
<i>skipped question</i>	70

Number	Response Text
1	na
2	slows down rust Easy spray on application. Able to coat existing rusty areas. Only need to remove loose chunks of rust and open bubbled paint.
3	Stops rust and leaves a clear smooth coating.
4	adhesion
5	NA



State Job Number: 134935

Table A 16: Survey Results for Question 16

What particular features of your corrosion protective coating do you dislike?	
Answer Options	Response Count
	6
<i>answered question</i>	6
<i>skipped question</i>	69

Number	Response Text
1	na
2	does not last
3	Smell.
4	messy
5	NA
	unable to provide protection in coolers, hydraulic
6	valve bodies



State Job Number: 134935

Table A 17: Survey Results for Question 17

How would you rate the effectiveness of the coating at reducing corrosion in the field?						
Answer Options	Very effective	Effective	Slightly effective	Not Sure	Rating Average	Response Count
	1	4	3	3	1.64	11
Effectiveness assessment based on?						4
					<i>answered question</i>	11
					<i>skipped question</i>	64



State Job Number: 134935

Table A 18: Survey Results for Question 18

Have you used a corrosion protective coating in the past?		
Answer Options	Response Percent	Response Count
Yes	21.2%	11
No	78.8%	41
<i>answered question</i>		52
<i>skipped question</i>		23



State Job Number: 134935

Table A 19: Survey Results for Question 19

19. Why did you stop/discontinue use of the coating?		
Answer Options	Response Percent	Response Count
Cost	33.3%	3
Ineffective	88.9%	8
Time constraints	44.4%	4
Other (please specify)		2
answered question		9
skipped question		66

Number	Other (please specify)
1	Tried various coatings when fabricating brine makers. The primary coating we used was used on salt spreaders. When we switched from mild steel to stainless steel, it has not
2	be necessary.



State Job Number: 134935

Table A 20: Survey Results for Question 20

Can we contact you with any additional follow up questions?		
Answer Options	Response Percent	Response Count
Yes	82.8%	48
No	17.2%	10
answered question		58
skipped question		17

Table A 21: Survey Results for Question 21

Thank you for your input. Please make any other comments in the box below.	
Answer Options	Response Count
	10
answered question	10
skipped question	65

Number	Response Text
1	No longer have details on brine maker coatings used. All failed over time.
2	better wash equipment products and doing it as part of the snow event
3	We have undercoated inside floor boards of order trucks in the past.
4	You can contact the head of our Garage and Facilities Department for any other follow up questions. Thank you
5	contact via Email please if necessary

ODOT Research Final Report

State Job Number: 134935

- RE: Question #4. We do not use corrosion protection, but we do
- 6** use a rust inhibitor.
Many chemical companies out there make a lot of claims we have yet to see one that actually delivered. That's why we simply
 - 7** try to keep the equipment clean and lubricated.
 - 8** We use Salt-away to wash vehicles.
 - 9** We use Stainless Steel Dump Truck beds and Hoppers.
 - 10** Emails are the best contact option.



State Job Number: 134935

APPENDIX B: COATING ANALYSIS

Following ASTM standard testing methods performed the evaluation of coating properties. Refer to Table B1 for a complete list of ASTM standards used in this work.

Table B 1. ASTM standards used in this work to evaluate coating properties.

ASTM Standard	ASTM Test Method
D6132	Thickness [1]
D3363	Pencil hardness test [2]
D3359	Adhesion by tape test [3]
D523	Specular gloss [4]
D2794	Impact resistance [5]
D522	Flexibility [6]

Thickness - ASTM D6132

Thickness of the coatings studied in this work was evaluated by ASTM standard D6132(ref) (Standard Test Method for Nondestructive Measurement of Dry Film Thickness of Applied Organic Coatings Using an Ultrasonic Gage) using a coating thickness gauge for all substrates (see Figure B1).

Thickness of the dry film on metal panels was measured for 6 different coatings (galvanized, light curable coating (LCCOAT), LINE-X, metalized, Raptor and Rhino Linings) and two base coats (white original equipment manufacturer (OEM) and black enamel) for aluminum 2024 (Al), cast aluminum (CA), carbon steel 1010 (CS) and cast iron (CFe). CS panels had the two base coats and Al only had white OEM as a base coat. CA and CFe were coated on bare metal. Thickness results are shown in Tables B2-B19.

ODOT Research Final Report

State Job Number: 134935



Figure B 1. Ultrasonic coating thickness gauge.

ODOT Research Final Report

State Job Number: 134935

Table B 2. Coating thickness of galvanized metal panels.

CS - Bare - Galvanized				
Coupon Number	Thickness			
	1	2	3	Average
151	3.0	3.2	3.3	3.2
152	3.0	2.9	2.6	2.8
153	3.0	2.4	2.8	2.7
154	3.1	2.8	3.0	3.0
155	3.0	2.8	2.9	2.9
156	3.1	2.7	2.4	2.7
157	3.4	2.7	3.1	3.1
158	3.0	2.9	3.6	3.2
159	2.8	3.2	2.8	2.9
160	3.6	2.4	2.6	2.9
181	2.9	3.1	2.6	2.9
182	2.7	2.8	2.9	2.8
183	2.6	2.7	3.0	2.8
184	2.9	2.4	2.4	2.6
185	2.8	2.8	2.8	2.8
186	2.9	3.2	3.0	3.0
187	2.6	3.0	2.7	2.8
188	2.7	3.2	2.5	2.8
189	2.5	3.6	2.5	2.9
190	2.5	3.2	2.5	2.7
191	2.8	3.4	4.3	3.5
192	2.7	2.8	3.1	2.9
193	2.4	2.6	2.5	2.5
194	2.8	2.8	2.6	2.7
195	2.7	2.8	2.6	2.7
196	2.8	3.1	3.1	3
197	2.6	3.6	2.6	2.9
198	2.9	2.6	2.9	2.8
199	2.7	2.9	2.7	2.8
200	3.5	2.4	2.5	2.8



State Job Number: 134935

Table B 3. Coating thickness of LCCOAT on Al metal panels.

Al - Bare - LCCOAT				
Coupon Number	Thickness			
	1	2	3	Average
41	3.0	3.2	2.9	3.0
42	4.0	4.2	4.1	4.1
43	4.9	4.2	4.4	4.5
44	4.0	4.1	4.2	4.1
45	3.9	4.2	4.7	4.3
46	3.4	3.6	3.7	3.6
47	5.8	5.1	4.6	5.2
48	4.9	4.9	5.0	4.9
49	4.9	5.2	5.9	5.3
50	4.6	4.5	4.6	4.6

Al - White OEM					Al - White OEM - LCCOAT				
Coupon Number	Thickness				Thickness				
	1	2	3	Average	1	2	3	Average	Final
51	4.2	4.0	4.0	4.1	13.3	12.1	11.6	12.3	8.3
52	4.0	4.0	4.0	4.0	11.5	11.7	11.1	11.4	7.4
53	3.6	3.8	4.0	3.8	10.2	10.2	10.1	10.2	6.4
54	3.8	3.9	3.8	3.8	10.4	10.4	10.6	10.5	6.6
55	3.8	3.9	3.8	3.8	10.7	10.7	12.1	11.2	7.3
56	5.0	4.9	4.4	4.8	10.0	10.1	9.4	9.8	5.1
57	5.2	4.8	4.0	4.7	10.4	103.0	10.4	41.3	36.6
58	5.2	5.0	4.0	4.7	11.2	10.9	9.6	10.6	5.8
59	5.1	5.1	4.6	4.9	10.9	10.9	10.6	10.8	5.9
60	5.0	4.2	2.9	4.0	10.6	10.2	9.9	10.2	6.2
147	5.2	4.8	3.8	4.6	12.6	12.0	10.9	11.8	7.2
148	4.3	5.3	5.4	5.0	11.4	12.0	12.5	12.0	7.0
149	4.0	5.1	5.4	4.8	11.3	12.2	12.4	12.0	7.1
150	4.4	5.1	5.5	5.0	12.9	12.8	12.6	12.8	7.8

ODOT Research Final Report

State Job Number: 134935

Table B 4. Coating thickness of LCCOAT on CA metal panels.

CA - Bare - LCCOAT				
Coupon Number	Thickness			
	1	2	3	Average
21	5.8	5.9	6.0	5.9
22	5.5	5.5	5.7	5.6
23	5.7	5.6	5.7	5.7
24	5.8	6.1	6.0	6.0
25	7.1	6.5	5.8	6.5
26	7.1	6.4	5.7	6.4
27	5.6	5.5	6.0	5.7
28	6.5	6.6	6.6	6.6
29	5.7	5.7	5.7	5.7
30	6.3	6.2	5.8	6.1

ODOT Research Final Report



State Job Number: 134935

Table B 5. Coating thickness of LCCOAT on CS metal panels.

CS - Bare - LCCOAT				
Coupon Number	Thickness			
	1	2	3	Average
61	7.7	7.3	6.6	7.2
62	6.4	6.1	5.9	6.1
63	6.2	6.4	6.8	6.5
64	7.1	7.3	7.6	7.3
65	6.0	5.9	6.3	6.1
66	8.0	7.6	7.4	7.7
67	7.6	7.8	7.8	7.7
68	7.4	7.2	7.6	7.4
69	8.0	8.1	7.9	8.0
70	8.2	8.7	9.2	8.7

CS - White OEM					CS - White OEM - LCCOAT				
Coupon Number	Thickness				Thickness				
	1	2	3	Average	1	2	3	Average	Final
71	5.8	6.2	4.7	5.6	20.4	14.2	12.3	15.6	10.1
72	6.6	6.1	5.2	6.0	18.5	18.3	17.6	18.1	12.2
73	6.6	5.4	3.6	5.2	16.3	15.7	14.2	15.4	10.2
74	5.1	4.4	3.4	4.3	16.1	15.1	14.7	15.3	11.0
75	5.8	5.3	3.8	5.0	16.5	15.1	13.1	14.9	9.9
76	6.1	5.5	3.9	5.2	15.5	15.4	15.0	15.3	10.1
77	5.7	6.0	6.1	5.9	15.4	15.0	15.2	15.2	9.3
78	6.9	6.0	5.9	6.3	16.4	16.9	17.2	16.8	10.6
79	5.9	5.7	5.6	5.7	17.4	16.1	15.5	16.3	10.6
80	5.9	5.3	4.7	5.3	16.3	15.6	14.9	15.6	10.3
247	4.6	4.4	4.1	4.4	11.8	11.0	11.0	11.3	6.9
248	4.4	4.6	4.3	4.4	11.2	11.4	11.4	11.3	6.9
249	4.7	5.0	5.4	5.0	13.2	12.7	12.7	12.9	7.8
250	5.1	5.2	4.8	5.0	12.7	12.7	12.7	12.7	7.7

CS - Black Enamel					CS - Black Enamel - LCCOAT				
Coupon Number	Thickness				Thickness				
	1	2	3	Average	1	2	3	Average	Final



ODOT Research Final Report

State Job Number: 134935

81	4.1	4.0	3.8	4.0	11.1	11.2	10.6	11.0	7.0
82	7.7	7.5	7.1	7.4	15.6	15.0	14.6	15.1	7.6
83	4.6	4.6	4.2	4.5	13.4	13.3	12.8	13.2	8.7
84	4.4	4.4	4.4	4.4	12.2	12.9	14.0	13.0	8.6
85	4.4	4.4	4.2	4.3	13.8	13.9	14.0	13.9	9.6
86	4.9	4.4	4.6	4.6	15.2	13.2	12.1	13.5	8.9
87	4.4	4.2	4.9	4.5	12.6	12.8	13.0	12.8	8.3
88	4.6	4.2	4.3	4.4	13.1	13.5	12.6	13.1	8.7
89	8.6	8.6	8.1	8.4	17.8	17.1	16.2	17.0	8.6
90	7.5	8.1	7.4	7.7	15.3	15.8	14.6	15.2	7.6
234	4.9	4.6	3.7	4.4	7.8	7.8	7.1	7.6	3.2
235	4.6	4.6	4.0	4.4	7.1	7.3	6.6	7.0	2.6
236	4.7	4.3	4.0	4.3	7.0	6.7	6.5	6.7	2.4
237	5.1	4.9	4.0	4.7	7.1	6.9	6.3	6.8	2.1

ODOT Research Final Report

State Job Number: 134935

Table B 6. Coating thickness of LCCOAT on CFe metal panels.

CFe - Bare - LCCOAT				
Coupon Number	Thickness			
	1	2	3	Average
21	7.4	8.5	9.9	8.6
22	6.9	7.0	7.0	7.0
23	6.8	7.5	6.9	7.1
24	7.4	7.5	7.3	7.4
25	15.2	12.3	10.3	12.6
26	9.1	7.7	7.2	8.0
27	7.7	7.7	7.3	7.6
28	7.0	7.6	6.5	7.0
29	6.6	6.5	6.6	6.6
30	7.1	7.0	7.1	7.1



State Job Number: 134935

Table B 7. Coating thickness of LINE-X on Al metal panels.

Al - Bare - Line-X				
Coupon Number	Thickness			
	1	2	3	Average
1	66.1			66.1
2	68.0			68.0
3	65.0			65.0
4	65.0			65.0
5	65.0			65.0
6	65.0			65.0
7	65.0			65.0
8	65.0			65.0
9	63.3			63.3
10	65.0			65.0

Coupon Number	Al - White OEM				Al - White OEM - Line-X				
	Thickness				Thickness				
	1	2	3	Average	1	2	3	Average	Final
11	5.0	4.7	3.9	4.5	65.0			65.0	60.5
12	4.2	3.9	4.1	4.1	65.0			65.0	60.9
13	4.4	4.1	3.4	4.0	65.0			65.0	61.0
14	4.5	4.4	4.2	4.4	65.0			65.0	60.6
15	4.8	4.2	3.1	4.0	65.0			65.0	61.0
16	4.4	4.2	4.0	4.2	65.0			65.0	60.8
17	4.3	4.2	4.0	4.2	65.0			65.0	60.8
18	4.5	3.9	3.0	3.8	65.0			65.0	61.2
19	4.6	4.0	3.1	3.9	65.0			65.0	61.1
20	3.1	3.5	3.8	3.5	65.0			65.0	61.5

Table B 8. Coating thickness of LINE-X on CA metal panels. (Please note that only one measurement was performed due to gauge limitations)

CA - Bare - Line-X				
Coupon Number	Thickness			
	1	2	3	Average
(1-10)	60			60

ODOT Research Final Report

State Job Number: 134935

Table B 9. Coating thickness of LINE-X on CS metal panels.

CS - Bare - Line-X				
Coupon Number	Thickness			
	1	2	3	Average
1	76.9	76.1		76.5
2	73.5			73.5
3	66.4			66.4
4	69.5	66.1		67.8
5	73			73.0
6	73			73.0
7	74			74.0
8	68	70	66.2	68.1
9	68	71.2	64	67.7
10	73.8	71.1	62.3	69.1

CS - White OEM					CS - White OEM - Line-X				
Coupon Number	Thickness				Thickness				
	1	2	3	Average	1	2	3	Average	Final
11	5.0	4.1	3.4	4.2	74			74	69.8
12	4.6	3.9	2.8	3.8	73.6	77.6		75.6	71.8
13	4.4	3.9	2.8	3.7					
14	5.9	5.4	4.2	5.2	74.0			74.0	68.8
15	6.0	5.1	4.6	5.2	74.0			74.0	68.8
16	4.3	4.6	4.7	4.5	74.0			74.5	70.0
17	4.5	4.4	4.3	4.4	74.5			74.5	70.1
18	5.6	5.2	5.1	5.3	77.4	76.6	76.8	76.9	71.6
19	6.4	5.6	4.1	5.4	75.4			75.4	70.0
20	5.6	5.1	3.5	4.7	77.0			77.0	72.3

CS - Black Enamel					CS - Black Enamel - Line-X				
Coupon Number	Thickness				Thickness				
	1	2	3	Average	1	2	3	Average	Final
21	8.4	7.7	6.3	7.5	71.3			71.3	63.8
22	8.5	8.3	7.3	8.0	74			74	66.0
23	6.2	5.7	5.1	5.7	74			74	68.3
24	5.1	5.4	4.7	5.1	74.1	78.2	66.1	72.8	67.7



ODOT Research Final Report

State Job Number: 134935

25	5.5	5.2	4.9	5.2	74			74	68.8
26	5.0	4.8	4.7	4.8	74			74	69.2
27	4.4	4.5	4.6	4.5	74			74	69.5
28	5.1	4.8	4.0	4.6	74			74	69.4
29	7.7	7.4	6.2	7.1	74			74	66.9
30	5.1	4.4	4.0	4.5	74			74	69.5

ODOT Research Final Report

State Job Number: 134935

Table B 10. Coating thickness of LINE-X on CFe metal panels.

CFe - Bare - Line-X				
Coupon Number	Thickness			
	1	2	3	Average
1	73.6	65.2	62.3	67.0
2	75.0			75.0
3	75.0			75.0
4	73.1	70.9	74.5	72.8
5	65.7	68.2	69.1	67.7
6	64.2	59.1	67.2	63.5
7	71.3	70.3	76.7	72.8
8	69.9			69.9
9	61.9	70.3	63.2	65.1
10	68.1	63.8	68.9	66.9

Table B 11. Coating thickness of Metalized on CS metal panels.

CS - Bare				
Coupon Number	Thickness			
	1	2	3	Average
204	8.6	8.1	8.7	8.5
205	8.6	7.8	7.4	7.9
206	10.5	8.9	8.1	9.2
207	10.2	8.8	9.1	9.4
208	9.4	10.3	8.5	9.4
209	9.2	9.2	8.8	9.1
210	8.8	8.9	7.7	8.5
211	9.1	7.2	8.1	8.1
212	9.1	9.7	7.8	8.9
213	9.9	10.3	9.2	9.8
214	7.6	8.7	8.0	8.1
215	8.3	8.6	8.8	8.6

ODOT Research Final Report



State Job Number: 134935

Table B 12. Coating thickness of Raptor on Al metal panels.

Al - Bare - Raptor				
Coupon Number	Thickness			
	1	2	3	AVG
81	7.2	6.6	5.9	6.6
82	6.3	5.8	6.2	6.1
83	5.8	6.0	6	5.9
84	6.1	6.2	6.4	6.2
85	6.3	7.1	8.8	7.4
86	5.7	6.5	6.9	6.4
87	5.3	5.6	5.6	5.5
88	5.1	5.4	5.1	5.2
89	5.1	5.2	5.5	5.3
90	6.2	5.8	5	5.7

Coupon Number	Al - White OEM				Al - White OEM - Raptor				
	Thickness				Thickness				
	1	2	3	AVG	1	2	3	AVG	Final
91	2.5	2.3	2.2	2.3	13.5	13.5	14.8	13.9	11.6
92	4.4	4.8	4.9	4.7	13.9	14.4	14.3	14.2	9.5
93	4.9	4.6	4.6	4.7	12.8	13.1	13.5	13.1	8.4
94	4.6	4.5	4.7	4.6	14.3	14.4	14.4	14.4	9.8
95	4.3	4.7	4.7	4.6	13.0	12.9	12.8	12.9	8.3
96	5.0	4.4	3.3	4.2	13.3	13.1	11.6	12.7	8.4
97	4.9	4.5	3.5	4.3	13.6	12.7	11.4	12.6	8.3
98	5.2	4.5	3.5	4.4	15.4	13.5	11.7	13.5	9.1
99	5.0	4.3	2.7	4.0	16.5	14.7	12.1	14.4	10.4
100	4.8	4.5	4.3	4.5	14.7	13.6	13.5	13.9	9.4

ODOT Research Final Report

State Job Number: 134935

Table B 13. Coating thickness of Raptor on CA metal panels.

CA - Bare - Raptor				
Coupon Number	Thickness			
	1	2	3	Average
41	7.4	7.9	7.6	7.6
42	8.1	7.7	7.5	7.8
43	11.0	10.1	8.4	9.8
44	6.9	7.1	7.8	7.3
45	7.1	7.9	9.4	8.1
46	8.3	8.3	8.5	8.4
47	9.0	10.5	11.2	10.2
48	9.0	9.0	9.3	9.1
49	8.5	8.3	8.0	8.3
50	9.1	8.9	7.7	8.6



State Job Number: 134935

Table B 14. Coating thickness of Raptor on CS metal panels.

CS - Bare - Raptor				
Coupon Number	Thickness			
	1	2	3	Average
121	5.0	5.1	5.6	5.2
122	5.3	5.3	4.9	5.2
123	5.8	5.6	5.4	5.6
124	5.7	5.6	6.2	5.8
125	5.4	6.1	6.8	6.1
126	5.8	5.9	5.4	5.7
127	5.8	5.1	5.2	5.4
128	5.3	5.2	5.1	5.2
129	5.3	5.2	5.0	5.2
130	5.9	5.7	7.1	6.2

CS - White OEM					CS - White OEM - Raptor				
Coupon Number	Thickness				Thickness				
	1	2	3	Average	1	2	3	Average	Final
131	3.2	3.5	3.5	3.4	11.2	11.2	11.2	11.2	7.8
132	4.0	3.8	3.6	3.8	12.4	11.6	11.4	11.8	8.0
133	4.5	4.0	3.9	4.1	12.2	11.8	11.8	11.9	7.8
134	3.9	4.1	4.1	4.0	12	12.0	12.7	12.2	8.2
135	3.6	3.8	3.6	3.7	12.6	14.3	17.1	14.7	11.0
136	3.2	3.5	3.7	3.5	12.6	13.3	15.9	13.9	10.5
137	4.0	3.8	3.1	3.6	11.5	11.1	10.3	11.0	7.3
138	3.6	3.4	3.3	3.4	11.7	11.3	11.0	11.3	7.9
139	3.9	3.7	3.0	3.5	11.8	11.4	11.0	11.4	7.9
140	4.5	3.3	3.5	3.8	10.3	11	11	10.8	7.0

CS - Black Enamel					CS - Black Enamel - Raptor				
Coupon Number	Thickness				Thickness				
	1	2	3	Average	1	2	3	Average	Final
141	4.8	4.8	4.5	4.7	12.2	12.1	11.6	12.0	7.3
142	4.9	4.7	4.4	4.7	11.8	11.7	11.1	11.5	6.9
143	4.7	4.3	3.9	4.3	13.3	13.7	15.1	14.0	9.7
144	5.0	4.4	4.0	4.5	12.6	12.3	12.1	12.3	7.9

ODOT Research Final Report

State Job Number: 134935

145	5.0	4.5	4.1	4.5	13.8	12.5	11.5	12.6	8.1
146	5.0	4.8	4.2	4.7	12.8	12.4	11.4	12.2	7.5
147	5.4	4.9	4.8	5.0	13.4	12.8	13.7	13.3	8.3
148	5.8	5.2	5.5	5.5	12.7	12.9	13.2	12.9	7.4
149	5.9	5.6	5.4	5.6	14.5	13.6	14.5	14.2	8.6
150	6.1	5.6	5.5	5.7	15.3	15.4	17.5	16.1	10.3

Table B 15. Coating thickness of Raptor on CFe metal panels.

CFe - Bare - Raptor				
Coupon Number	Thickness			
	1	2	3	Average
41	13.4	12.9	10.8	12.4
42	10.2	11.1	10.6	10.6
43	9.6	9.3	8.7	9.2
44	11.0	10.1	10.5	10.5
45	11.5	10.0	9.9	10.5
46	8.4	9.0	9.6	9.0
47	10.1	9.2	9.4	9.6
48	9.1	9.0	9.2	9.1
49	9.6	9.7	9.1	9.5
50	9.7	10.1	12.3	10.7



State Job Number: 134935

Table B 16. Coating thickness of Rhino Linings on Al metal panels.

Al - Bare – Rhino Linings				
Coupon Number	Thickness			
	1	2	3	Average
21	26.8	22.9	22.3	24.0
22	24.5	26.8	27.2	26.2
23	27.4	34.0	29.9	30.4
24	29.0	23.2	26.7	26.3
25	25.5	31.2	23.3	26.7
26	25.7	22.5	24.6	24.3
27	32.7	27.4	23.2	27.8
28	30.9	24.3	20.2	25.1
29	31.5	25.5	21.8	26.3
30	25.4	31.4	22.0	26.3

Coupon Number	Al - White OEM				Al - White OEM – Rhino Linings				
	Thickness				Thickness				
	1	2	3	Average	1	2	3	Average	Final
31	3.8	3.5	2.9	3.4	24.8	31.5	30.3	28.9	25.5
32	3.4	3.5	3.5	3.5	23.9	28.8	23.2	25.3	21.8
33	3.9	3.9	3.1	3.6	31.1	32.9	28.5	30.8	27.2
34	3.3	3.5	3.6	3.5	27.9	30.4	30.6	29.6	26.2
35	3.4	3.5	3.4	3.4	23.9	29.1	24.7	25.9	22.5
36	3.7	3.6	2.9	3.4	24.7	22.8	25.8	24.4	21.0
37	3.6	3.6	2.8	3.3	24.0	26.4	32.0	27.5	24.1
38	4.0	4.2	4.6	4.3	25.0	26.2	27.2	26.1	21.9
39	4.6	4.2	4.3	4.4	27.4	26.2	28.6	27.4	23.0
40	4.0	4.0	4.1	4.0	32.5	33.6	27.9	31.3	27.3

ODOT Research Final Report

State Job Number: 134935

Table B 17. Coating thickness of Rhino on CA metal panels.

CA - Bare – Rhino Linings				
Coupon Number	Thickness			
	1	2	3	Average
11	42.5	49.3	51.3	47.7
12	45.1	50.1	51.1	48.8
13	44.6	40.3	40.3	41.7
14	62.4	64.6	62.3	63.1
15	41.3	47.6	48.3	45.7
16	45.7	45.2	42.2	44.4
17	33.7	40.8	42.1	38.9
18	23.5	26.9	40.7	30.4
19	32.4	32.5	29.6	31.5
20	23.2	28.5	28.8	26.8



State Job Number: 134935

Table B 18. Coating thickness of Rhino Linings on CS metal panels.

CS - Bare – Rhino Linings				
Coupon Number	Thickness			
	1	2	3	Average
31	24.8	27.1	28.5	26.8
32	27.9	33.4	31.3	30.9
33	26.6	26.6	28.1	27.1
34	26.0	36.0	25.5	29.2
35	30.1	30.9	25.8	28.9
36	33.2	31.8	33.7	32.9
37	28.3	24.5	23.4	25.4
38	23.8	28.2	24.7	25.6
39	25.6	32.3	25.5	27.8
40	39.5	30.2	35.6	35.1

CS - White OEM					CS - White OEM – Rhino Linings				
Coupon Number	Thickness				Thickness				
	1	2	3	Average	1	2	3	Average	Final
41	5.7	4.9	3.3	4.6	22.7	25.9	22.2	23.6	19.0
42	6.1	5.2	3.7	5.0	30.2	24.8	23.9	26.3	21.3
43	7.0	6.5	5.9	6.5	29.4	24.1	28.6	27.4	20.9
44	6.4	6.3	5.6	6.1	27.2	22.3	25.3	24.9	18.8
45	5.9	5.7	5.2	5.6	24.2	26.1	23.4	24.6	19.0
46	6.2	5.7	5.7	5.9	23.6	25.3	22.3	23.7	17.9
47	7.4	6.2	5.6	6.4	26.3	27.3	29.6	27.7	21.3
48	7.1	6.0	4.7	5.9	29.1	26.2	27.5	27.6	21.7
49	7.0	6.1	4.8	6.0	27.3	32.1	22.3	27.2	21.3
50	7.1	6.4	6.0	6.5	25.5	24.3	28.6	26.1	19.6

CS - Black Enamel					CS - Black Enamel – Rhino Linings				
Coupon Number	Thickness				Thickness				
	1	2	3	Average	1	2	3	Average	Final
51	8.4	8.4	7.7	8.2	23.1	26.9	20.0	23.3	15.2
52	8.3	8.3	7.5	8.0	22.8	28.3	22.1	24.4	16.4
53	7.1	6.8	6.5	6.8	25.4	26.6	24.5	25.5	18.7
54	8.1	8.1	7.9	8.0	29.2	24.8	28.0	27.3	19.3

ODOT Research Final Report

State Job Number: 134935

55	8.0	8.4	7.1	7.8	25.8	28.7	22.5	25.7	17.8
56	7.6	7.1	6.6	7.1	28.5	24.0	24.0	25.5	18.4
57	5.5	5.1	4.9	5.2	27.4	25.0	23.7	25.4	20.2
58	6.1	6.0	5.6	5.9	19.9	26.4	22.8	23.0	17.1
59	6.0	5.8	5.4	5.7	26.6	27.6	28.5	27.6	21.8
60	5.4	5.3	4.9	5.2	24.3	23.7	20.7	22.9	17.7

Table B 19. Coating thickness of Rhino Linings on CFe metal panels.

Cast Iron - Bare – Rhino Linings				
Coupon Number	Thickness			
	1	2	3	Average
11	31.8	28.9	31.4	30.7
12	31.9	32.1	35.6	33.2
13	32.0	28.5	24.1	28.2
14	29.9	30.3	30.7	30.3
15	29.9	35.4	26.7	30.7
16	32.0	24.4	21.9	26.1
17	28.2	24.5	27.4	26.7
18	23.5	21.9	23.4	22.9
19	20.9	27.5	21.7	23.4
20	22.7	25.2	25.5	24.5

Hardness - ASTM D3363

The hardness of the coatings studied in this work was evaluated by ASTM standard D3363(ref) (Standard Test Method for Film Hardness by Pencil Test) using a Gardco/Wolff Wilborn pencil scratch hardness test. Hardness is reported based on calibrated drawing leads according to the following scale:

6B - 5B - 4B - 3B - 2B - B - HB - F - H - 2H - 3H - 4H - 5H - 6H

Softer

Harder



ODOT Research Final Report

State Job Number: 134935

Table B20 shows the hardness of coatings used in this study on aluminum 2024. Please notice that galvanized and metalized coating systems were not evaluated using this procedure due to their distinctive interaction with the metal. Furthermore, LINE-X and Linings are not evaluated by this method due to their characteristic uneven and rough finish.



State Job Number: 134935

Table B 20. Coating hardness based on ASTM standard D3363.

Coating System	Primary Coating	Metal	Hardness
None	OEM	CS	8H
None	Black Enamel	CS	9H
Galvanized	None	CS	N/A
Metalized	None	CS	N/A
Control	OEM	Al	7H
LCCOAT	None	Al	8H
LINE-X	None	Al	N/A
Raptor	None	Al	9H
Rhino Linings	None	Al	N/A

Adhesion - ASTM D3359

The adhesion of the coatings studied in this work was evaluated by ASTM standard D3359(ref) (Standard Test Methods for Measuring Adhesion by Tape Test). Pull off adhesion is reported based on percentage of coated area removed by tape after cutting through the sample with a sharp razor blade. Figure B2 serves as a correlation guide (classification of adhesion test results).

Table B21 shows the adhesion of coatings used in this study on aluminum 2024. Please notice that galvanized and metalized coating systems were not evaluated using this procedure due to their distinctive interaction with the metal. Furthermore, LINE-X and Rhino Linings are not evaluated by this method due to thicknesses larger than 10 mils and their characteristic uneven and rough finish.

ODOT Research Final Report

State Job Number: 134935

CLASSIFICATION OF ADHESION TEST RESULTS		
CLASSIFICATION	PERCENT AREA REMOVED	SURFACE OF CROSS-CUT AREA FROM WHICH FLAKING HAS OCCURRED FOR SIX PARALLEL CUTS AND ADHESION RANGE BY PERCENT
5B	0% None	
4B	Less than 5%	
3B	5 - 15%	
2B	15 - 35%	
1B	35 - 65%	
0B	Greater than 65%	

Figure B 2. Classification of adhesion test results.

ODOT Research Final Report

State Job Number: 134935

Table B 21. Coating adhesion based on ASTM standard D3359.

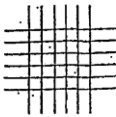
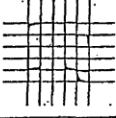
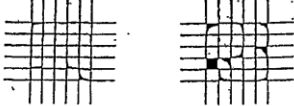
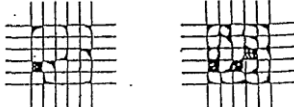
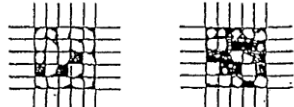
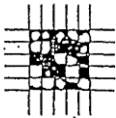
Coating System	Primary Coating	Metal	Adhesion
None	OEM	CS	4B
None	Black Enamel	CS	1B
Galvanized	None	CS	N/A
Metalized	None	CS	N/A
Control	OEM	Al	0B
LCCOAT	None	Al	5B
LINE-X	None	Al	N/A
Raptor	None	Al	3B
Rhino Linings	None	Al	N/A

ODOT Research Final Report

State Job Number: 134935

Specular gloss - ASTM D523

The specular gloss of the coatings studied in this work was evaluated by ASTM standard D523(ref) (Standard Test Method for Specular Gloss) using a BYK Gardner Micro-Tri-Gloss 20/60/85° gloss meter (see Figure B3). Gloss is associated with the visual observation of surface shininess and it is reported based on reflection of light from the specimen to a black glass standard. Table B22 shows gloss measurements of coatings studied in this work reporting 20, 60 and 85°.



Figure B 3. BYK Gardner Micro-Tri-Gloss 20/60/85° gloss meter.

Table B 22. Coating specular gloss based on ASTM standard D523.

Coating System	Primary Coating	Gloss		
		20°	60°	85°
None	OEM	81.5	91	92
None	Black Enamel	81.7	90.4	93
Galvanized	None	86.1	153	85.8
LCCOAT	None	83	91.5	96.1
LINE-X	None	1.4	10.9	7.8
Metalized	None	0.9	2.1	0.1
Raptor	None	0.9	9.6	12.1
Rhino Linings	None	0.2	1.8	1.6

ODOT Research Final Report

State Job Number: 134935

Impact - ASTM D2794

Direct and reverse impact testing of the coatings studied in this work was evaluated by ASTM standard D2794(ref) (Standard Test Method for Resistance of Organic Coatings to the Effects of Rapid Deformation (Impact)) using a vertical tube guiding a cylindrical weight. Metal panels received direct and reverse impact. Failure measurements are reported based on inch-pound weight resistance (max: 28). Table B23 shows weight resistance of coatings studied in this work after being exposed to direct and reverse impact.

Table B 23. Coating impact resistance based on ASTM standard D2794.

Coating System	Primary Coating	Metal	Impact (inch-pound)	
			Direct	Reverse
None	OEM	CS	28	8
None	Black Enamel	CS	28	28
Galvanized	None	CS	N/A	N/A
Metalized	None	CS	N/A	N/A
Control	OEM	Al	28	24
LCCOAT	None	Al	28	2
LINE-X	None	Al	28	28
Raptor	None	Al	28	4
Rhino Linings	None	Al	28	26

Flexibility - ASTM D522

Flexibility of the coatings studied in this work was evaluated by ASTM standard D522(ref) (Standard Test Methods for Mandrel Bend Test of Attached Organic Coatings) using a conical mandrel (see Figure B4). Metal panels were placed with two sheets of brown kraft wrapping paper on each side between the mandrel and the drawbar. The lever is moved 180° to bend the panel to approximately 135°. Any cracks are measured by using the chart in Figure B5. Results are displayed in Table B25 and show the elongation percentage of coatings employed in this study indicating its respective

State Job Number: 134935

thickness correction factor. LINE-X could not be measured due to its thickness higher than the gap between the mandrel and the drawbar.



Figure B 4. Conical mandrel test apparatus.

Table B 24. Flexibility of coatings studied in this work using ASTM standard D522.

Coating System	Primary Coating	Metal	Flexibility				
			End of cracking (in)	Elongation (%)	Correction for thickness of film	Thickness (mils)	Final elongation (%)
None	OEM	CS	0.125	26	1.1	4.9	31.39
None	Black Enamel	CS	0	32	1.6	5.2	40.32
Galvanized	None	CS	0	32	1.6	3	36.80
Metalized	None	CS	1.25	11	0.55	9.1	16.01
Control	OEM	Al	0	32	1.6	4.43	39.09
LCCOAT	None	Al	6	3	0.2	5.3	4.06
LINE-X	None	Al	Too thick	N/A	N/A	N/A	N/A
Raptor	None	Al	6	3	0.2	5.5	4.1
Rhino Linings	None	Al	0	32	1.6	24.26	70.82

ODOT Research Final Report

State Job Number: 134935

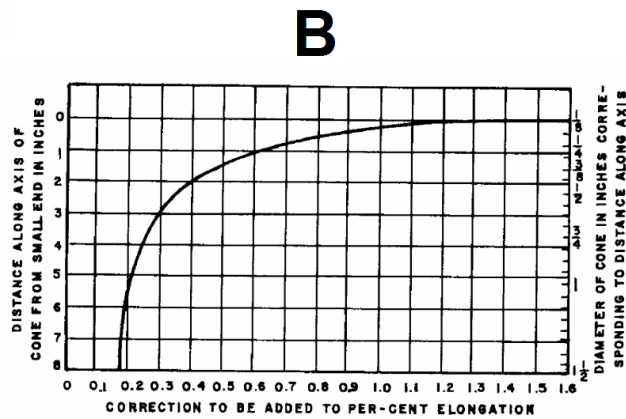
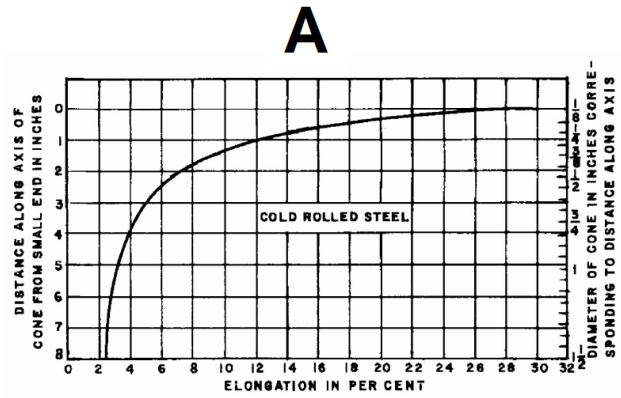

Figure B 5. (A) Distance along cone and corresponding mandrel size vs. percent elongation. (B) Correction for thickness of film.



State Job Number: 134935

APPENDIX C: CREEP RESULTS: B117

The evaluation of coating performance can be measured by determination of creep rate by following ASTM standard D1654[1] (Standard Test Method for Evaluation of Painted or Coated Specimens Subjected to Corrosive Environments). Coated panels were scribed with a computerized New Hermes Vanguard 3400 Engraver. Scribe line depth and width was 0.008 inch. Evaluated coatings were galvanized, light curable coating (LCCOAT), LINE-X, metalized, Raptor and Rhino. The metals studied in this work were aluminum (Al), cast aluminum (CA), carbon steel (CS) and cast iron (CFe). Creep rate measurements of exposed metal panels to salt spray chamber (ASTM B117[2]) were determined using ImageJ (1.48v) software and results are presented in Tables C1-C3. Creep rate for galvanized and metalized coated panels are not included due to a complete failure of the surface during salt spray exposure for 336 hours.

ODOT Research Final Report



State Job Number: 134935

Table C 1. Creep rate (mm) of CS panels exposed to salt spray chamber for 336 hours.

Carbon Steel						
Primary coating		Coating System				
		None	LCCOAT	LINE-X	Raptor	Rhino
None	Run 1		1.283	1.338	1.310	0.832
	Run 2		1.830	1.512	1.493	1.648
	AVG		1.557	1.425	1.402	1.240
	St dev		0.387	0.123	0.130	0.577
	Rate		7	7	7	7
		None	LCCOAT	LINE-X	Raptor	Rhino
Black Enamel	Run 1	1.940	1.255	1.180	0.747	0.872
	Run 2	1.703	0.998	1.378	1.207	1.707
	AVG	1.822	1.127	1.279	0.977	1.289
	St dev	0.167	0.181	0.140	0.325	0.590
	Rate	7	7	7	8	7
		None	LCCOAT	LINE-X	Raptor	Rhino
White OEM	Run 1	2.077	0.987	1.505	0.587	1.135
	Run 2	2.035	1.233	1.370	1.282	1.888
	AVG	2.056	1.110	1.438	0.934	1.512
	St dev	0.029	0.174	0.095	0.491	0.533
	Rate	6	7	7	8	7

ODOT Research Final Report

State Job Number: 134935

Table C 2. Creep rate (mm) of Al panels exposed to salt spray chamber for 336 hours.

Aluminum						
Primary coating		Coating System				
		None	LCCOAT	LINE-X	Raptor	Rhino
None	Run 1		0.495	0.747	0.438	0.543
	Run 2		0.462	0.792	0.453	0.637
	AVG		0.478	0.769	0.446	0.590
	St dev		0.024	0.032	0.011	0.066
	Rate		9	8	9	8
		None	LCCOAT	LINE-X	Raptor	Rhino
White OEM	Run 1	0.437	0.657	0.615	0.412	0.527
	Run 2	0.428	0.555	0.712	0.550	0.517
	AVG	0.433	0.606	0.663	0.481	0.522
	St dev	0.006	0.072	0.068	0.098	0.007
	Rate	9	8	8	9	8

ODOT Research Final Report

State Job Number: 134935

Table C 3. Creep rate (mm) of CA and CFe panels exposed to salt spray chamber for 336 hours.

Cast Aluminum					
Primary coating		Coating system			
		LCCOAT	LINE-X	Raptor	Rhino
None	Run 1	0.760	0.332	0.803	0.545
	Run 2	0.732	0.685	0.783	0.573
	AVG	0.746	0.508	0.793	0.559
	St dev	0.020	0.250	0.014	0.020
	Rate	8	8	8	8

Cast Iron					
Primary coating		Coating system			
		LCCOAT	LINE-X	Raptor	Rhino
None	Run 1	3.005	0.778	1.158	0.908
	Run 2	1.987	0.852	1.732	2.265
	AVG	2.496	0.815	1.445	1.587
	St dev	0.720	0.052	0.405	0.959
	Rate	6	8	7	7

Evaluation of scribed panels was determined by representative mean creepage from scribe (Figure C1) and a rating system can be used by following parameters in Table C4.



State Job Number: 134935

Table C 4. Rating of failure at scribe.

Representative Mean Creepage From Scribe		
Millimetres	Inches (Approximate)	Rating Number
Zero	0	10
Over 0 to 0.5	0 to $\frac{1}{64}$	9
Over 0.5 to 1.0	$\frac{1}{64}$ to $\frac{1}{32}$	8
Over 1.0 to 2.0	$\frac{1}{32}$ to $\frac{1}{16}$	7
Over 2.0 to 3.0	$\frac{1}{16}$ to $\frac{1}{8}$	6
Over 3.0 to 5.0	$\frac{1}{8}$ to $\frac{3}{16}$	5
Over 5.0 to 7.0	$\frac{3}{16}$ to $\frac{1}{4}$	4
Over 7.0 to 10.0	$\frac{1}{4}$ to $\frac{3}{8}$	3
Over 10.0 to 13.0	$\frac{3}{8}$ to $\frac{1}{2}$	2
Over 13.0 to 16.0	$\frac{1}{2}$ to $\frac{5}{8}$	1
Over 16.0 to more	$\frac{5}{8}$ to more	0

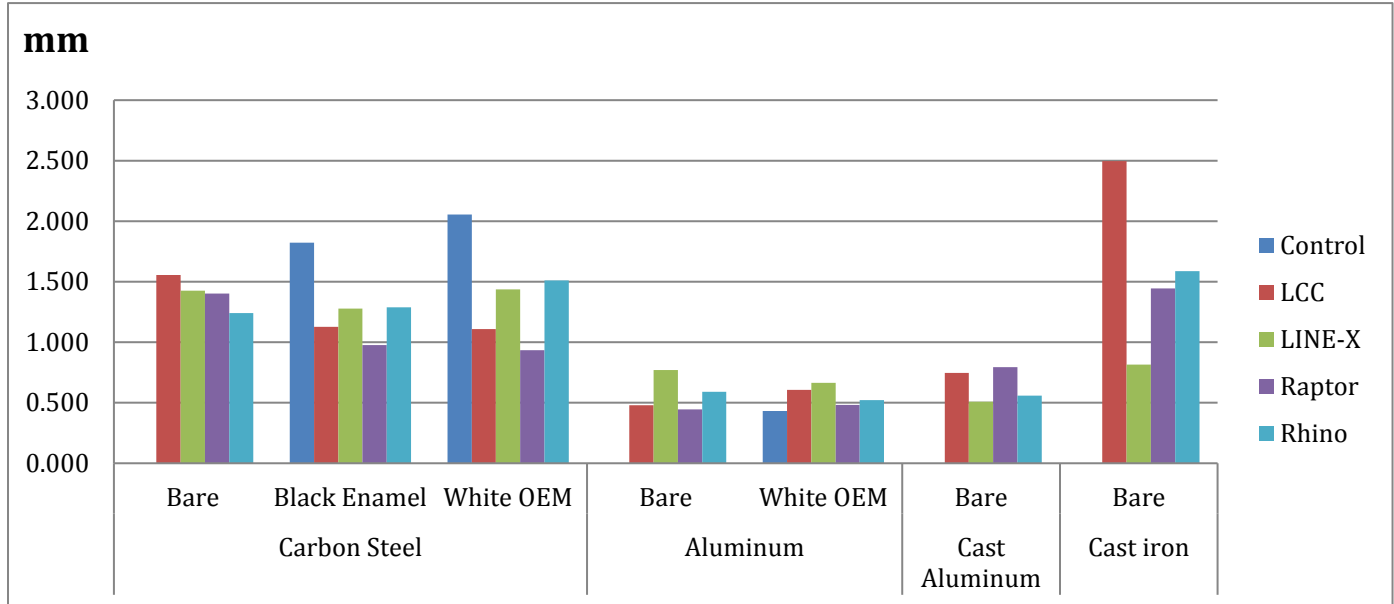

Figure C 1. Representative Creep rate measurements in mm of exposed metal panels to salt spray chamber for 336 hours.

Figures C2-C6 show the corrosion evolution of scribed coated panels exposed to the salt spray chamber for 336 hours. Control panels are presented in Figure C2 in the following order from left to right: CS-bare, CS-white OEM, CS-black enamel, Al-bare, Al-white OEM, CA-bare, SS-bare and CFe-bare.

State Job Number: 134935

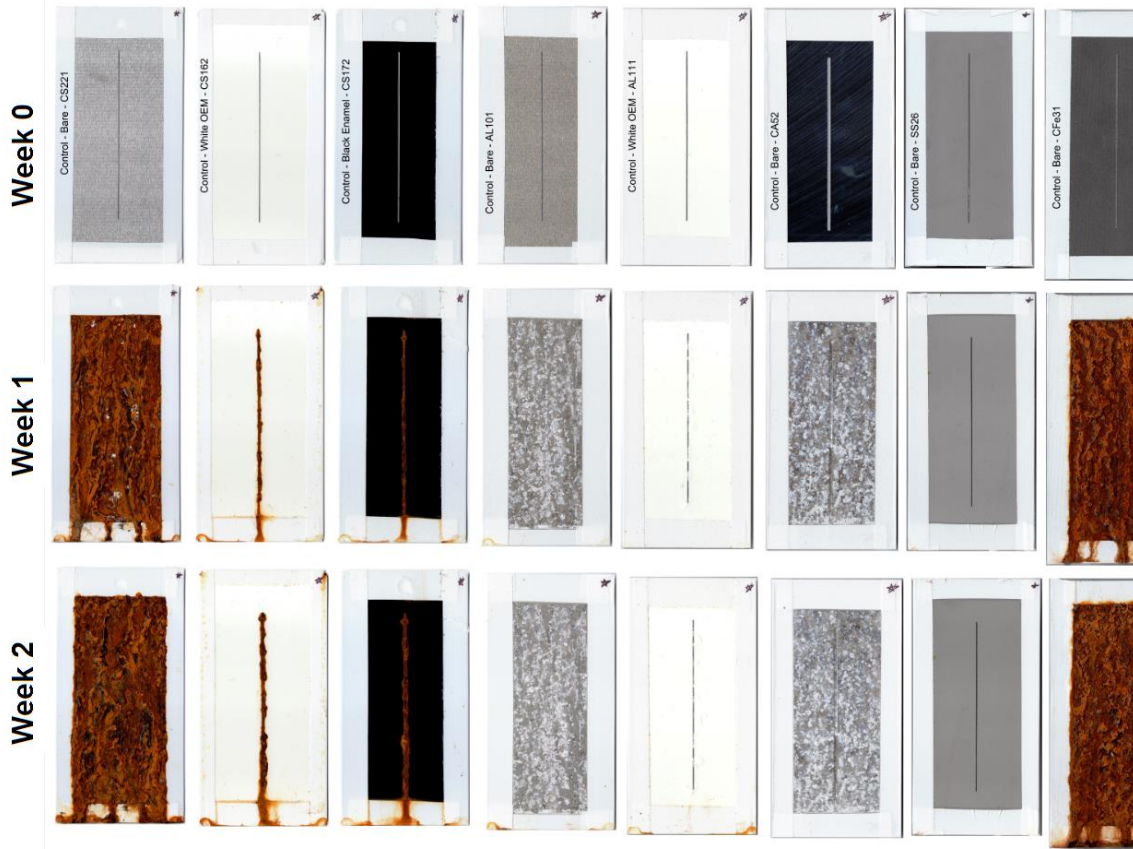

Figure C 2. Control scribed metal panels exposed to the salt spray chamber.

Figure C3 shows the corrosion evolution of galvanized scribed metal panels exposed to the salt spray chamber for 2 weeks. Panels are presented in the following order: CS-galvanized (top) and CFe-galvanized (bottom).

State Job Number: 134935

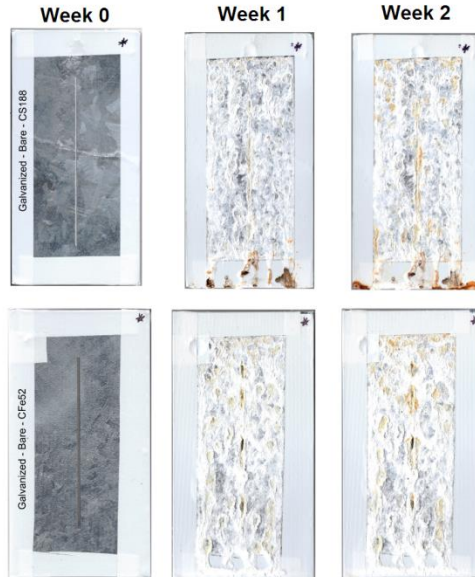

Figure C 3. Galvanized scribed metal panels exposed to the salt spray chamber.

Figure C4 shows the corrosion evolution of LCCOAT scribed metal panels exposed to the salt spray chamber for 2 weeks. Panels are presented in the following order from left to right: CS-bare-LCCOAT, CS-white OEM-LCCOAT, CS-black enamel-LCCOAT, Al-bare-LCCOAT, Al-white OEM-LCCOAT, CA-bare-LCCOAT and CFe-bare-LCCOAT.

State Job Number: 134935

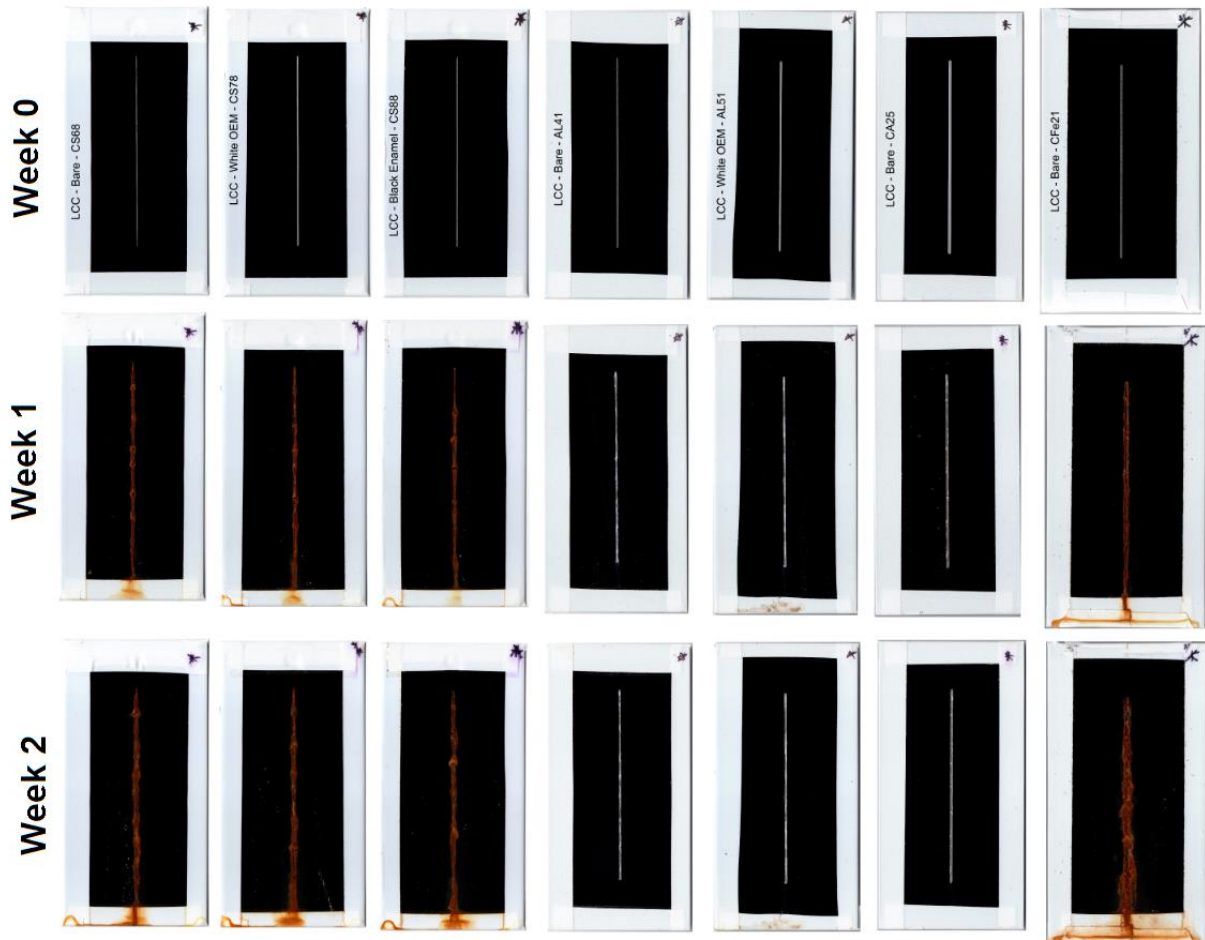

Figure C 4. LCCOAT scribed metal panels exposed to the salt spray chamber.

Figure C5 shows the corrosion evolution of LINE-X scribed metal panels exposed to the salt spray chamber for 2 weeks. Panels are presented in the following order from left to right: CS-bare-LINE-X, CS-white OEM-LINE-X, CS-black enamel-LINE-X, Al-bare-LINE-X, Al-white OEM-LINE-X, CA-bare-LINE-X and CFe-bare-LINE-X.

State Job Number: 134935

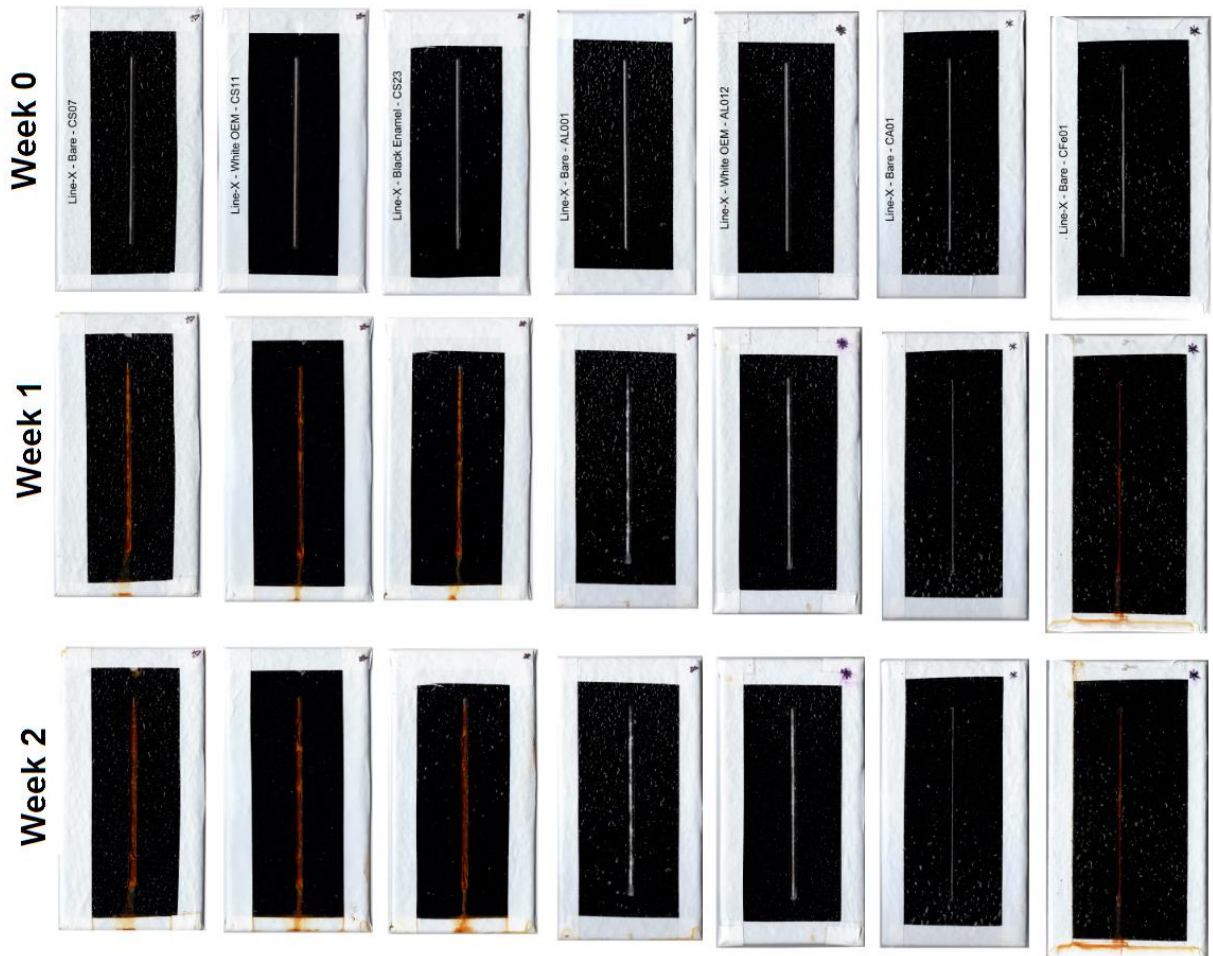

Figure C 5. LINE-X scribed metal panels exposed to the salt spray chamber.

Figure C6 shows the corrosion evolution of metalized scribed metal panels exposed to the salt spray chamber for 2 weeks. Only carbon steel panels were metalized.

ODOT Research Final Report

State Job Number: 134935

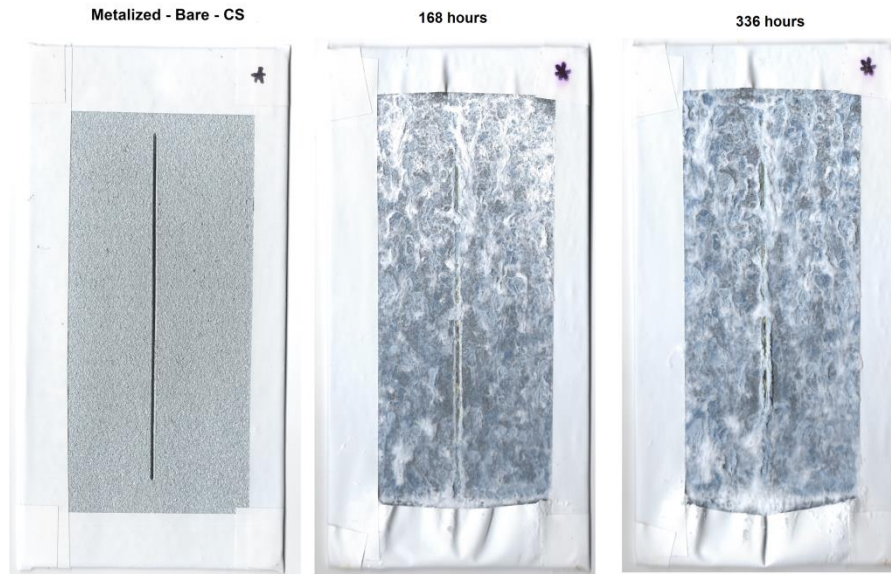

Figure C 6. Metalized scribed metal panels exposed to the salt spray chamber.

Figure C7 shows the corrosion evolution of Raptor scribed metal panels exposed to the salt spray chamber for 2 weeks. Panels are presented in the following order from left to right: CS-bare-Raptor, CS-white OEM-Raptor, CS-black enamel-Raptor, Al-bare-Raptor, Al-white OEM-Raptor, CA-bare-Raptor and CFe-bare-Raptor.

ODOT Research Final Report

State Job Number: 134935

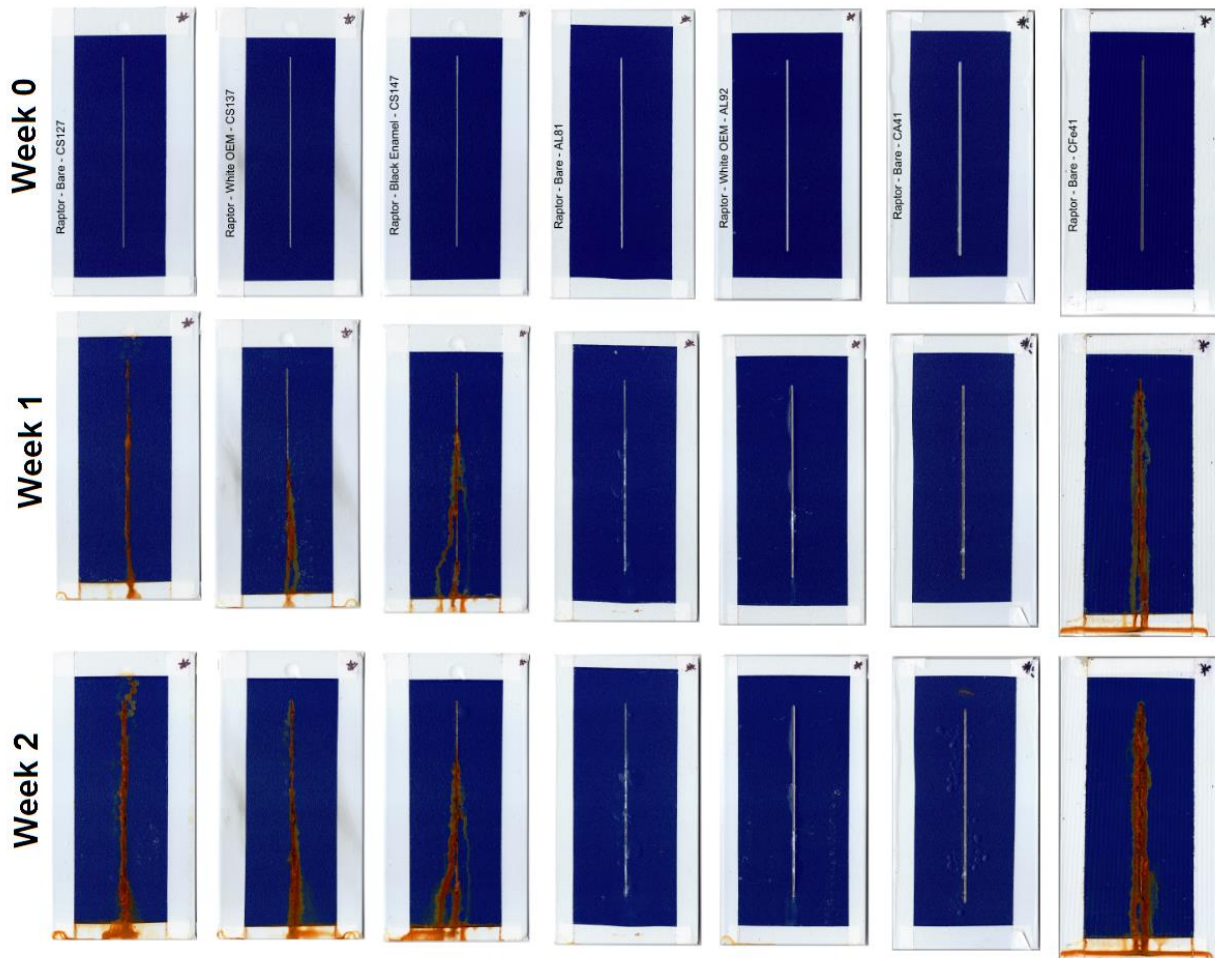

Figure C 7. Raptor scribed metal panels exposed to the salt spray chamber.

Figure C8 shows the corrosion evolution of Rhino Linings scribed metal panels exposed to the salt spray chamber for 2 weeks. Panels are presented in the following order from left to right: CS-bare-Rhino, CS-white OEM-Rhino, CS-black enamel-Rhino, Al-bare-Rhino, Al-white OEM-Rhino, CA-bare-Rhino and CFe-bare-Rhino.

State Job Number: 134935

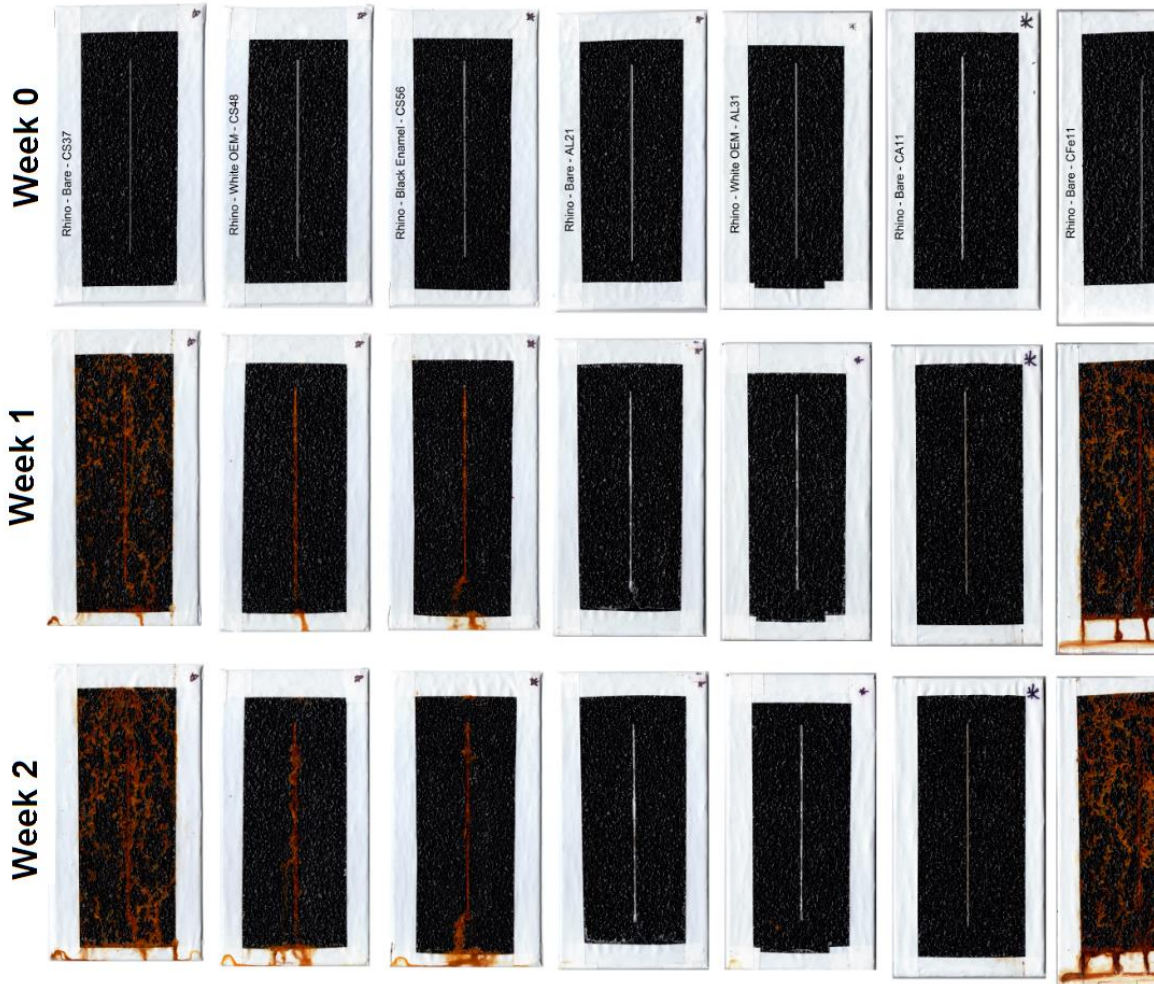

Figure C 8. Rhino Linings scribed metal panels exposed to the salt spray chamber.



State Job Number: 134935

APPENDIX D: X-RAY DIFFRACTION RESULTS: B117 TESTING

Characterization of iron oxides formed on the surface of three carbon steel (CS) coated metal panels exposed to accelerated corrosion testing (ASTM standard B117) using a salt spray chamber from Singleton Corporation (Cleveland, OH, USA) for 336 hours was performed by X-ray powder diffraction (XRD). Iron oxides were removed from the surface of CS panels scribe and collected between two glass slides. The iron oxide powder was then transferred to a glass holder and treated with acetone for purification. Table D1 shows the labeling of the selected CS samples.

Table D 1. Identification of scribed CS samples exposed to accelerated corrosion testing.

Identification	Coating	Primary coating	Panel #
LinB	LINE-X	None	7
RaB	Raptor	None	127
RhB	Rhino Linings	None	37

XRD spectra were measured with a Rigaku Ultima IV X-ray diffractometer (Rigaku Corporation, Tokyo, Japan) using filtered Cu-K-alpha radiation at 40 kV and 35 mA, scan speed: 1.0 deg./min, step width: 0.04 deg, scan axis: 2theta/theta, scan range: 5.0000 - 70.0000 deg, incident slit: 1 deg and continuous scan mode. XRD spectra are shown in figure D1, D2 and D3 for LinB, RaB and RhB respectively.

ODOT Research Final Report

State Job Number: 134935

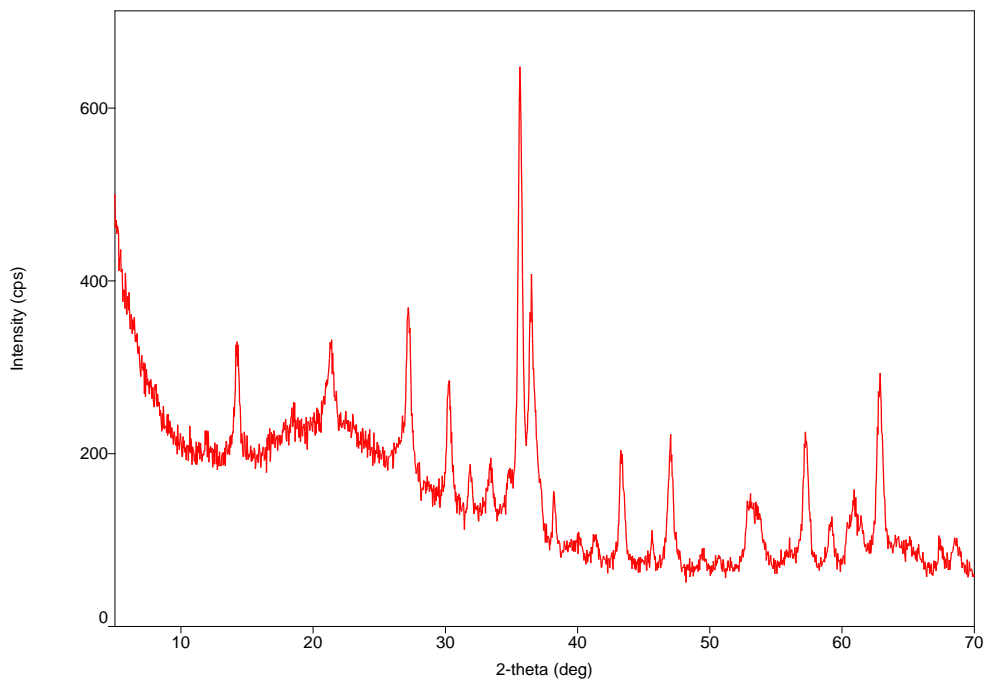

Figure D 1. XRD spectra of LinB.

ODOT Research Final Report

State Job Number: 134935

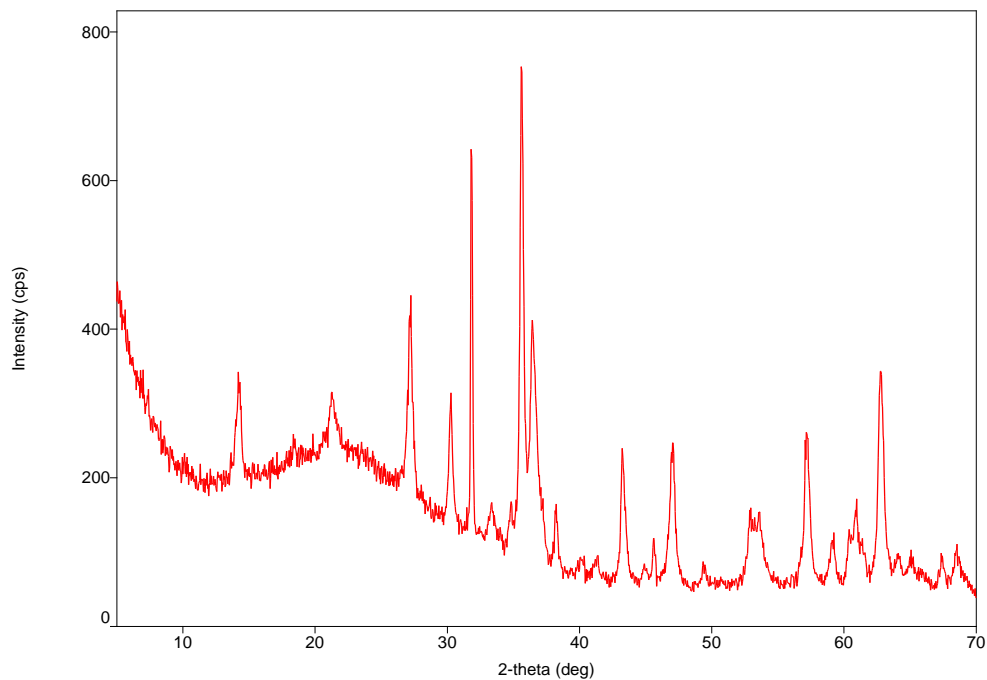

Figure D 2. XRD spectra of RaB.

State Job Number: 134935

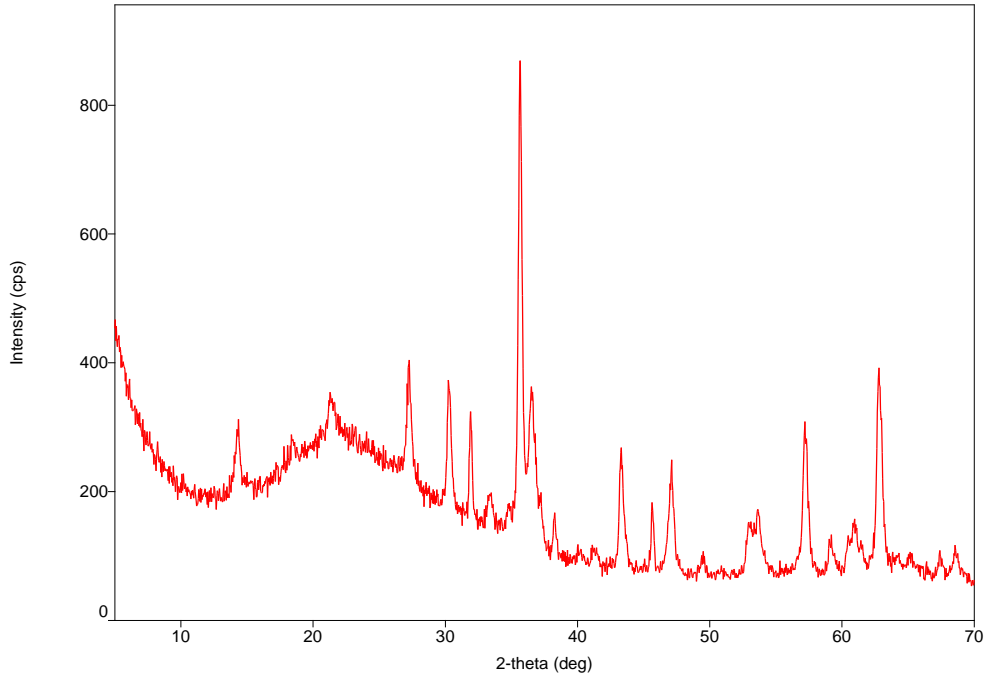

Figure D 3. XRD spectra of RhB.

Structural identification of corrosion products of scribed coated metal panels was performed with powder diffraction analysis software suite PDXL V2 from Rigaku Corporation. Diffraction spectra of corrosion products indicate the formation of magnetite ($Fe_2^{3+}Fe^{2+}O_4$), Goethite ($Fe^{3+}O(OH)$) and Hematite ($Fe_2^{3+}O_3$). Figures D4-D6 show the pattern of each of these species.

ODOT Research Final Report

State Job Number: 134935

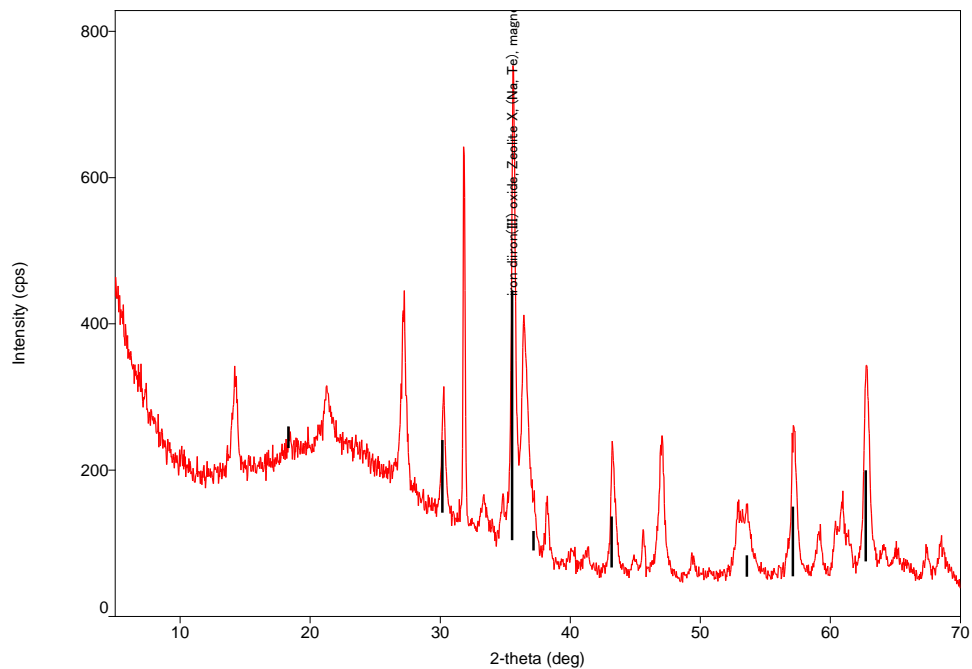

Figure D 4. Diffraction spectra of magnetite in RaB.

ODOT Research Final Report

State Job Number: 134935

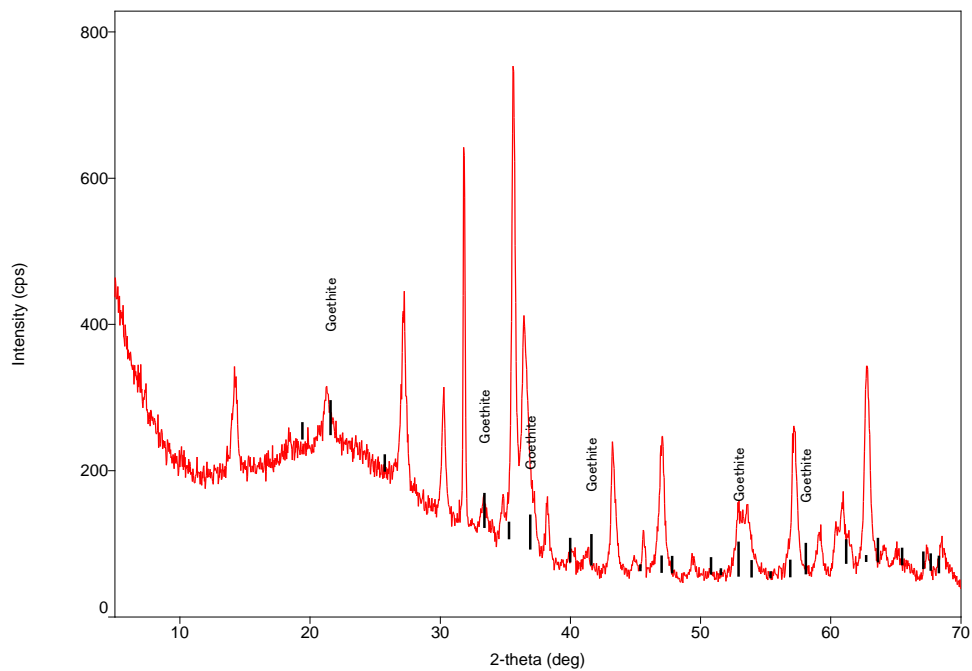

Figure D 5. Diffraction spectra of goethite in RaB.

ODOT Research Final Report

State Job Number: 134935

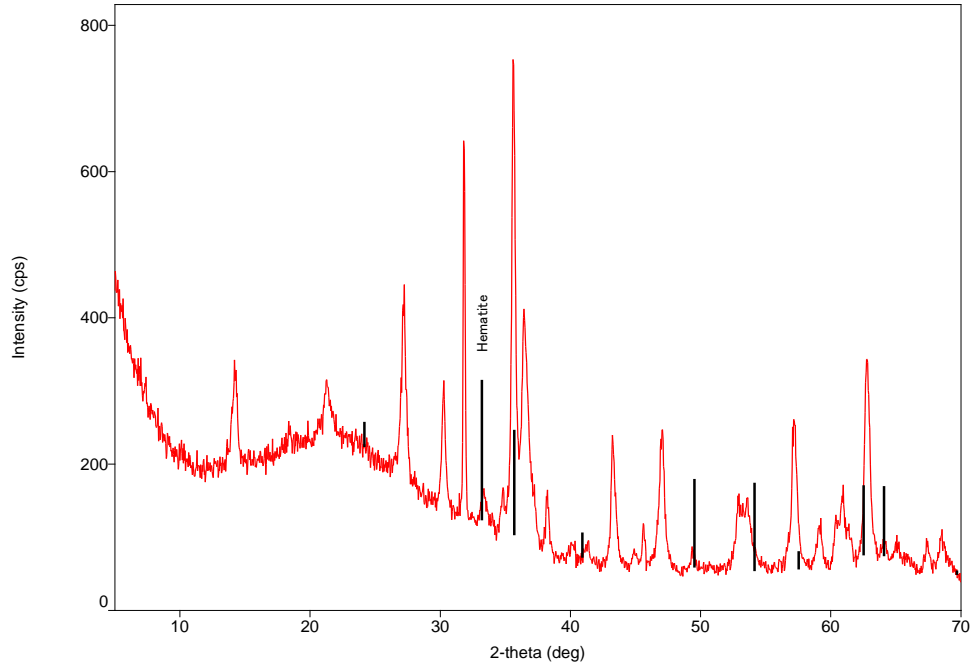

Figure D 6. Diffraction spectra of hematite in RaB.

Characterization of zinc oxides formed on the surface of galvanized and metalized carbon steel panels exposed to salt spray exposure was evaluated using the same procedure shown above. Table D2 shows the labeling of the selected samples. XRD spectra are shown in figure D7 and D8 for CS188 and CS205 respectively. Table D 2. Identification of galvanized and metalized samples exposed to accelerated corrosion testing.

Identification	Coating	Primary coating	Panel #
CS188	Galvanized	None	188
CSS205	Metalized	None	205

ODOT Research Final Report

State Job Number: 134935

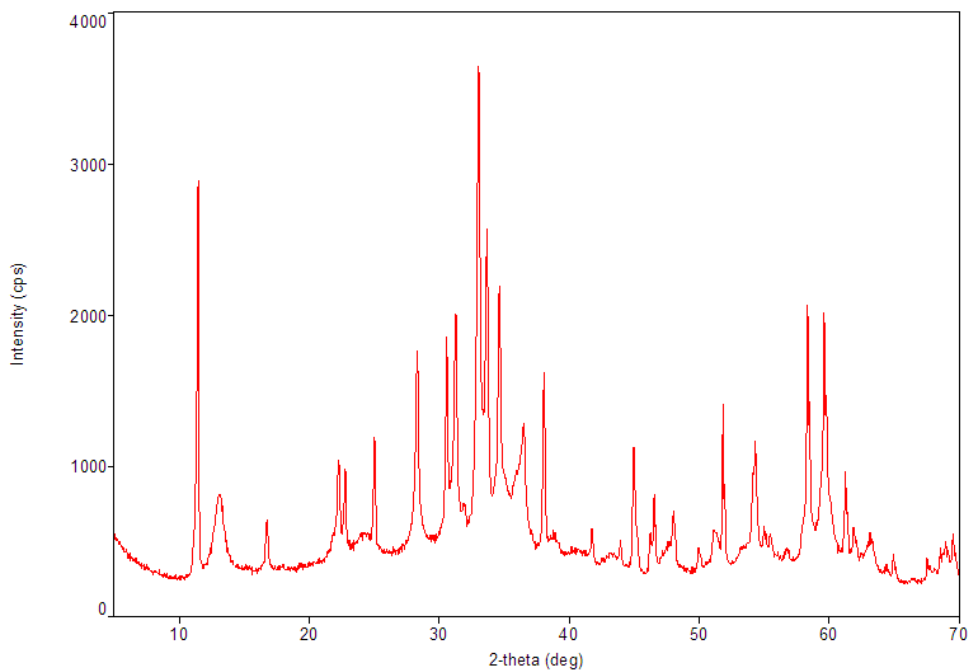

Figure D 7. XRD spectra of CS188.

ODOT Research Final Report

State Job Number: 134935

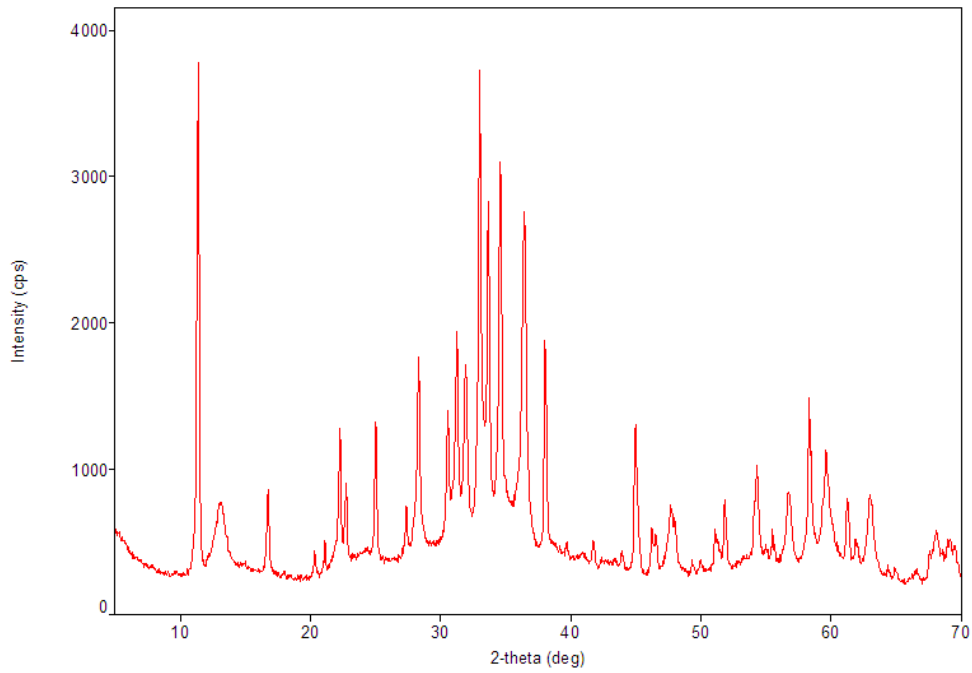

Figure D 8. XRD spectra of CS205.

State Job Number: 134935

Diffraction spectra of corrosion products of galvanized and metalized samples indicate the formation of the zinc oxide Simonkolleite ($Zn_5(OH)_8Cl_2 \cdot H_2O$) obtained from the following reaction: $5Zn^{2+} + H_2O + 8OH^- + 2Cl^- \rightarrow Zn_5(OH)_8Cl_2 \cdot H_2O$. Figure D9 shows the pattern for this compound (formed on the surface of both coatings).

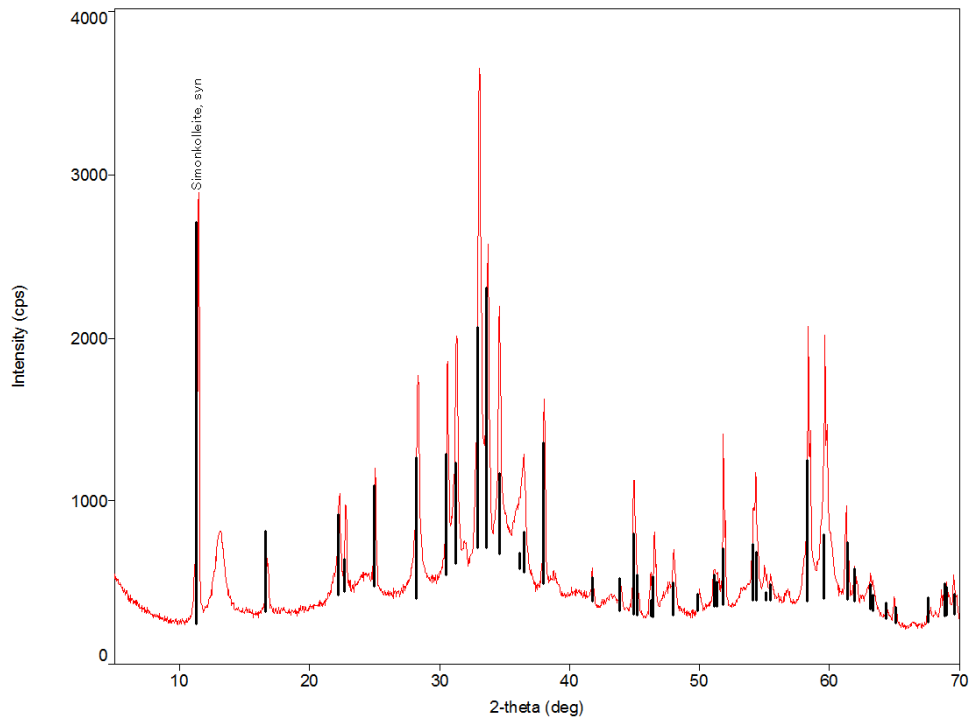

Figure D 9. Diffraction spectra of Simonkolleite in CS188 and CS205.

State Job Number: 134935

APPENDIX E: STEREOMICROSCOPE IMAGES FROM B117 TESTING

Scribed coated metal panels exposed to accelerated corrosion testing (ASTM standard B117 [1]) for 336 hours were analyzed using stereo microscopy imaging. Samples were cut in sections as seen in Figure E1 and mounted on a cold mount epoxy resin. Images were acquired using an Olympus SZX16 stereo microscope paired with a camera Olympus SC100 and processed using software CellSense standard 1.8.1 (Olympus Corporation, Tokyo, Japan) after preparing the samples by polishing the surface under standard ANSI silicon carbide papers of different grades ranging from 240 to 1200.

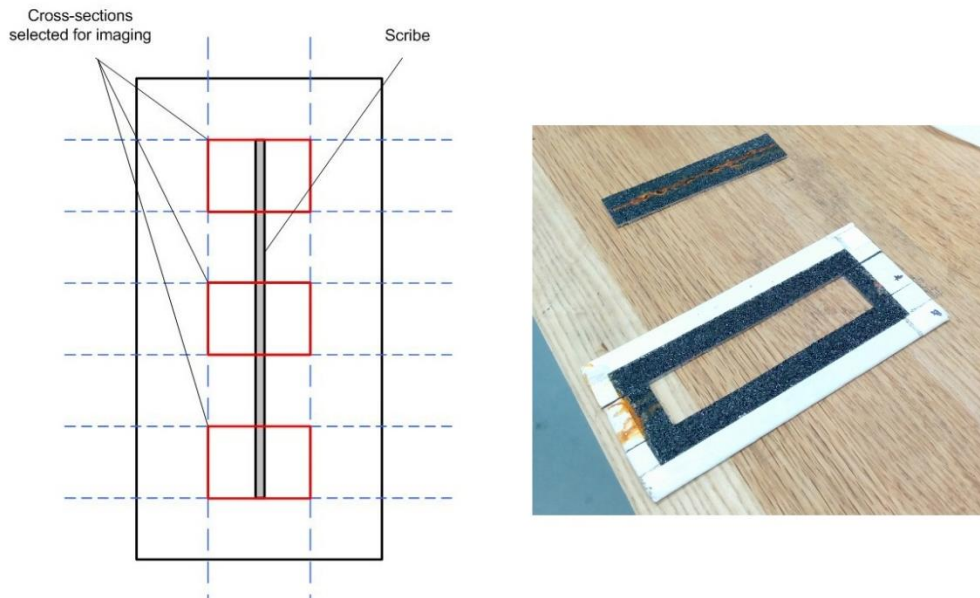

Figure E 1. Preparation of cross-sections from coated metal panels for stereo microscopy imaging analysis.

Cross-sections of corroded metal panels were analyzed to determine corrosion density and coating delamination length. Stereo images are presented in below by

ODOT Research Final Report

State Job Number: 134935

following the guide presented in Table E1. Images of the first set of experiments exposed to the salt spray chamber are shown in Figures E2-E6.

Table E 1. Coating systems used in this study and evaluated under accelerated corrosion testing for carbon steel panels.

Coating system	Coating system	Primary coating	Panel number	
			Run 1	Run 2
1	None	Black Enamel	172	173
2		White OEM	162	163
3	LCCOAT	None	68	69
4		Black Enamel	88	89
5		White OEM	78	79
6	LINE-X	None	7	8
7		Black Enamel	23	28
8		White OEM	11	18
9	Raptor	None	127	128
10		Black Enamel	147	148
11		White OEM	137	138
12	Rhino Linings	None	37	38
13		Black Enamel	56	58
14		White OEM	48	49

State Job Number: 134935

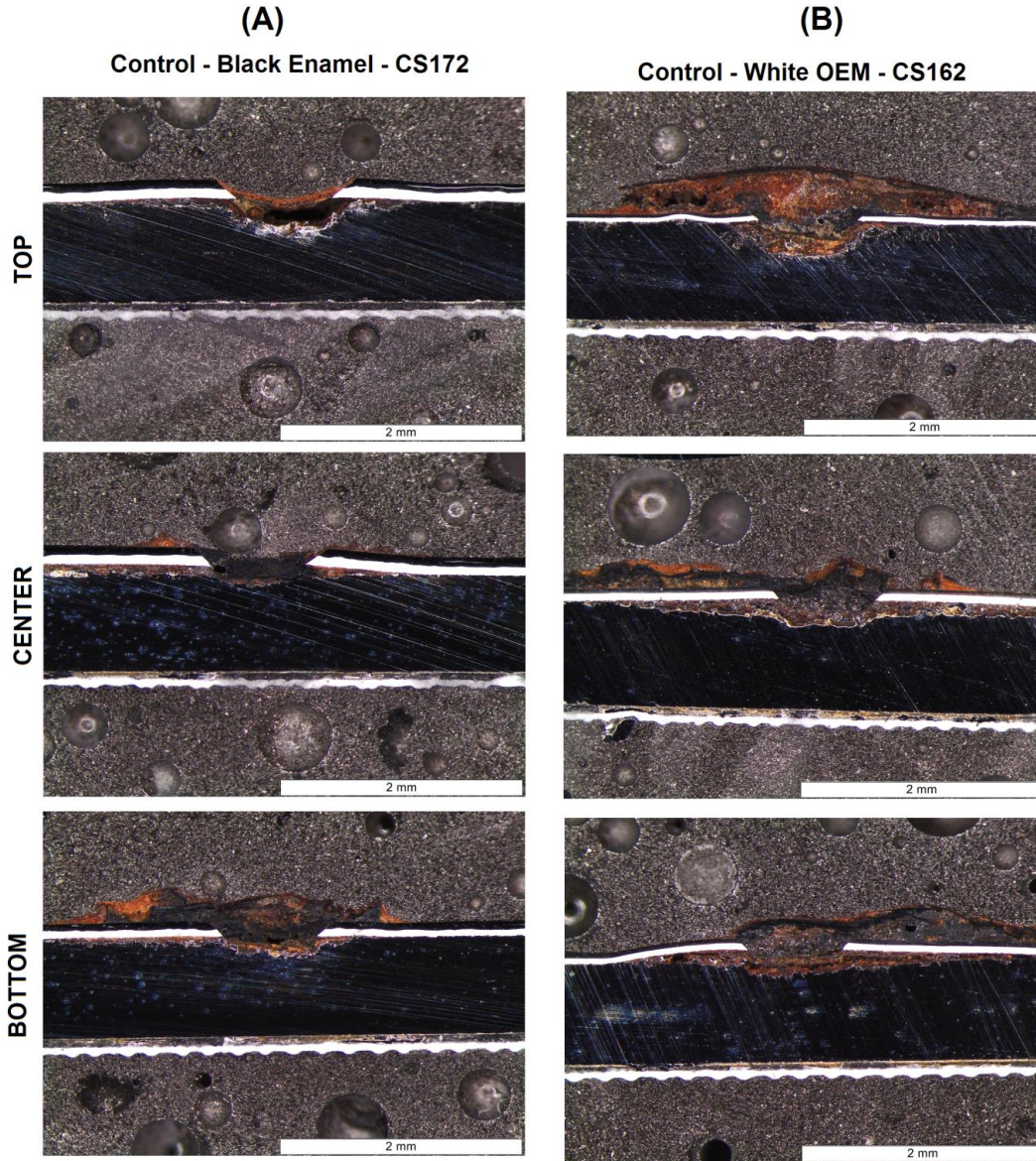

Figure E 2. Carbon steel top, center and bottom cross-sections image of (A) control/black enamel and (B) control/white OEM systems after 336 hours exposure to accelerated corrosion testing (B117).

State Job Number: 134935

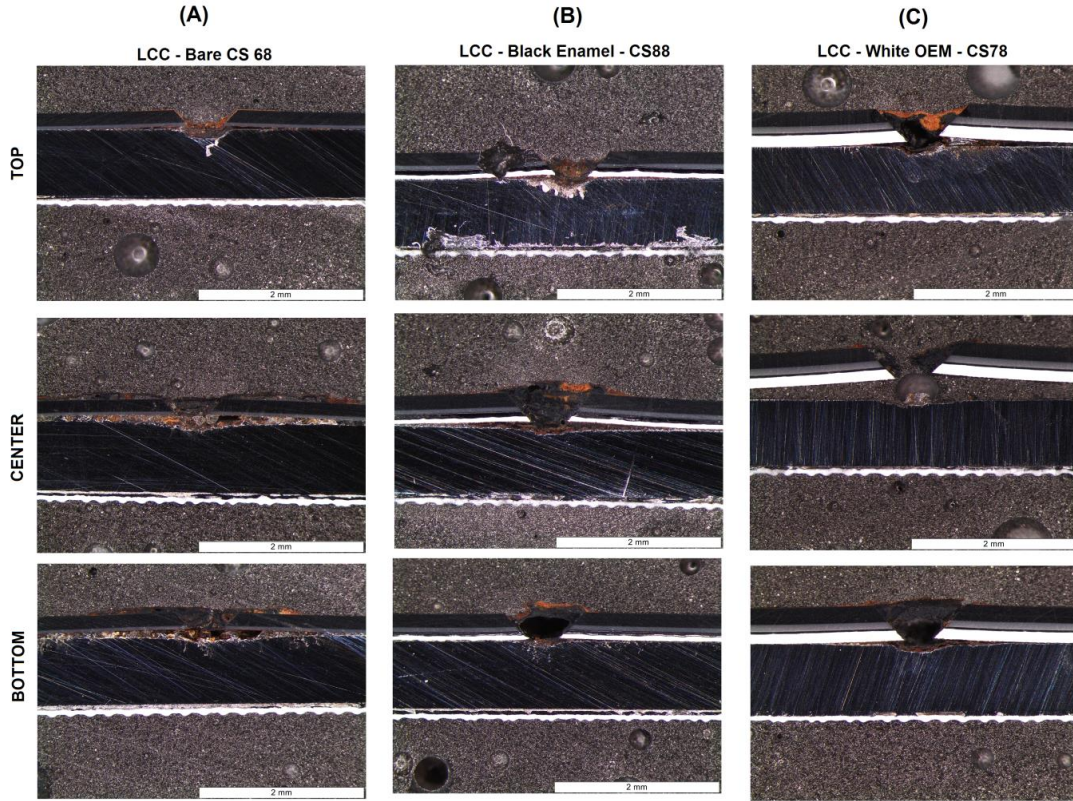

Figure E 3. Carbon steel top, center and bottom cross-sections image of (A) LCCOAT/bare metal, (B) LCCOAT/black enamel and (C) LCCOAT/white OEM systems after 336 hours exposure to accelerated corrosion testing (B117).

State Job Number: 134935

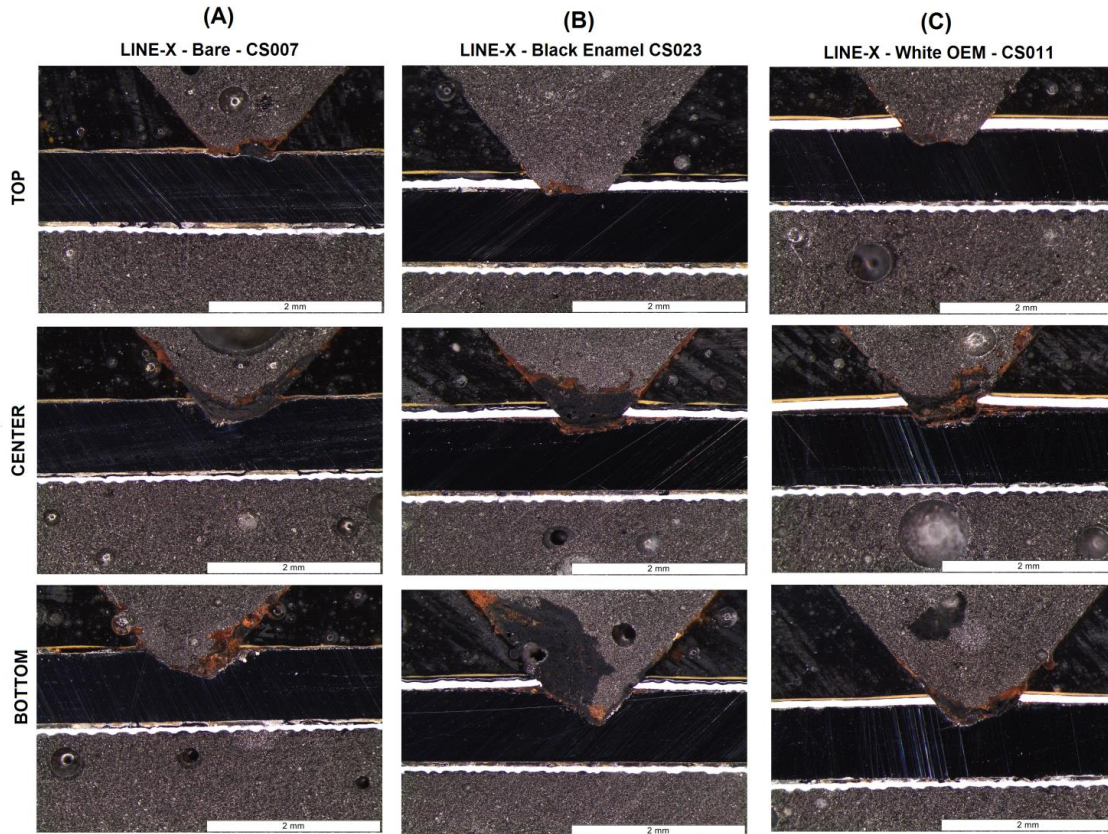

Figure E 4. Carbon steel top, center and bottom cross-sections image of (A) LINE-X/bare metal, (B) LINE-X/black enamel and (C) LINE-X/white OEM systems after 336 hours exposure to accelerated corrosion testing (B117).

State Job Number: 134935

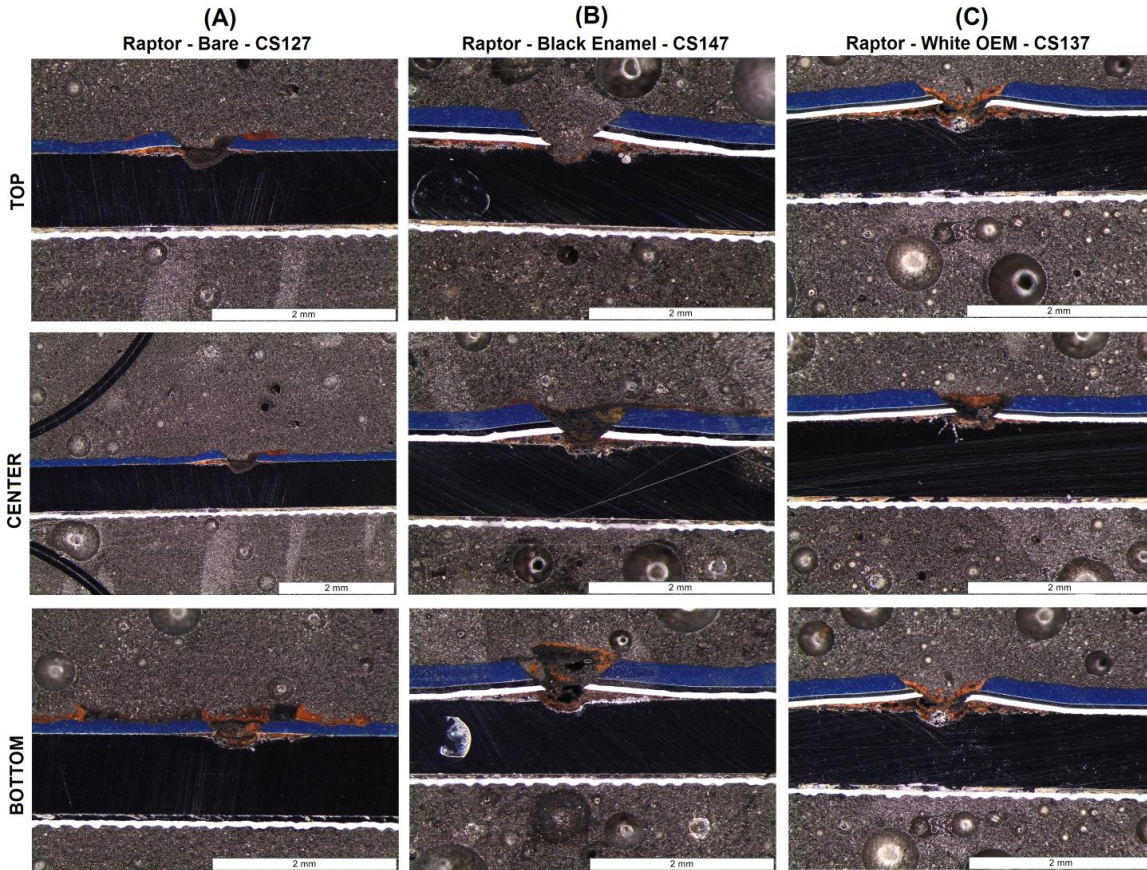

Figure E 5. Carbon steel top, center and bottom cross-sections image of (A) Raptor/bare metal, (B) Raptor/black enamel and (C) Raptor/white OEM systems after 336 hours exposure to accelerated corrosion testing (B117).

State Job Number: 134935

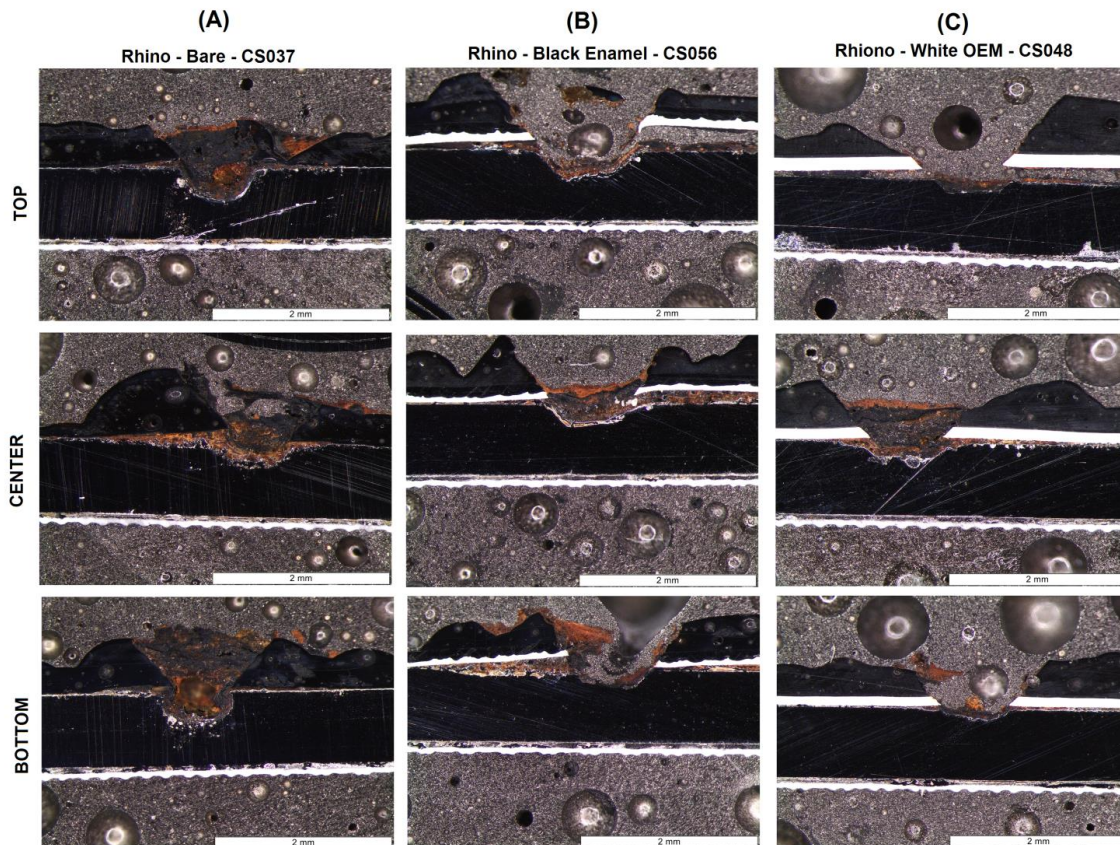

Figure E 6. Carbon steel top, center and bottom cross-sections image of (A) Rhino/bare metal, (B) Rhino/black enamel and (C) Rhiono/white OEM systems after 336 hours exposure to accelerated corrosion testing (B117).

Corrosion density was determined by imaging analysis using ImageJ (1.48v) software. Images were processed by measuring the corrosion products present on the cross section surface. The corrosion density of each cross section (top, center and bottom) and its average (Figure E7) are shown in Table E2.

ODOT Research Final Report

State Job Number: 134935

Table E 2. Corrosion density on carbon steel samples exposed to accelerated corrosion testing (B117) for each of the coating systems studied in this work.

Run 1						
Sample	Coating system	Primary Coating	Corrosion density (%)			
			Top	Center	Bottom	AVG
1	None	Black Enamel	1.08	0.63	0.44	0.72
2		White OEM	4.74	1.66	1.62	2.67
3	LCCOAT	None	0.43	0.85	1.10	0.79
4		Black Enamel	0.38	0.82	0.45	0.55
5		White OEM	1.16	0.17	0.57	0.63
6	LINE-X	None	0.97	1.17	2.35	1.49
7		Black Enamel	0.30	1.63	1.5	1.14
8		White OEM	0.25	1.91	1.05	1.07
9	Raptor	None	0.58	0.58	4.92	2.03
10		Black Enamel	0.62	0.47	0.97	0.69
11		White OEM	1.27	0.54	1.24	1.02
12	Rhino Linings	None	1.76	2.59	2.37	2.24
13		Black Enamel	0.33	1.31	0.67	0.77
14		White OEM	0.33	1.31	0.67	0.77
Run 2						
Sample	Coating system	Primary Coating	Corrosion density (%)			
			Top	Center	Bottom	AVG
1	None	Black Enamel	0.24	0.14	0.06	0.15
2		White OEM	0.02	0.10	0.40	0.17
3	LCCOAT	None	0.08	0.09	0.53	0.23
4		Black Enamel	0.04	0.06	0.02	0.04
5		White OEM	0.04	0.09	0.03	0.05
6	Line-X	None	0.35	0.29	0.21	0.29
7		Black Enamel	0.02	0.13	0.08	0.08
8		White OEM	0.05	0.06	0.08	0.06
9	Raptor	None	0.13	0.01	0.05	0.06
10		Black Enamel	0.05	0.17	0.08	0.10
11		White OEM	0.05	0.04	0.04	0.09
12	Rhino Linings	None	0.41	0.01	0.10	0.17
13		Black Enamel	0.54	0.46	-	0.50
14		White OEM	0.04	0.26	-	0.15

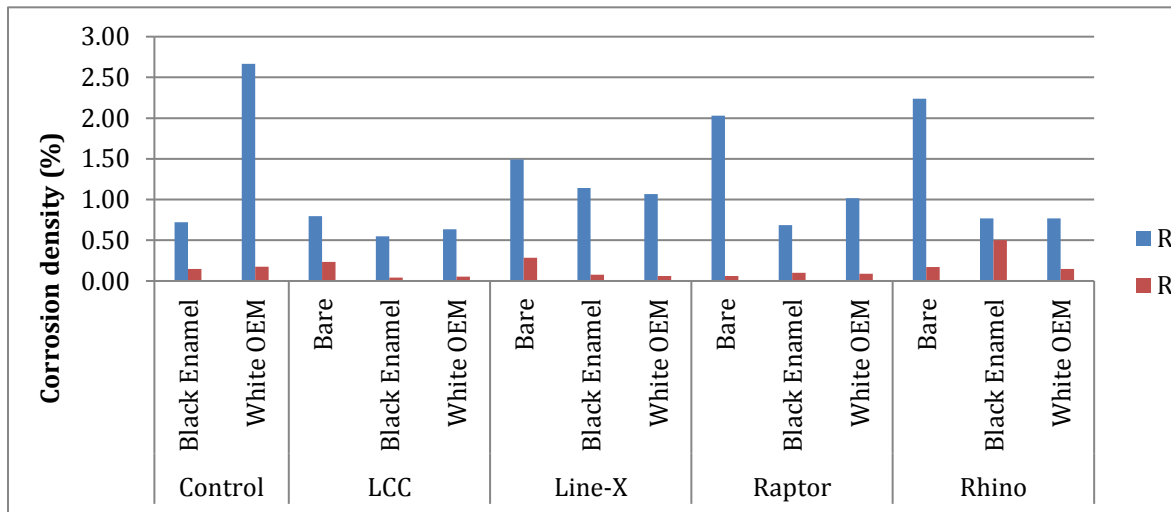

Figure E 7. Average of corrosion density on carbon steel samples exposed to accelerated corrosion testing (B117) for each of the coating systems studied in this work.

Film delamination length was measured by imaging analysis using ImageJ (1.48v) software. Images were processed by measuring the distance where the coating system delaminated from the surface of the bare metal at 3.2X magnification (Figure E8). Results are presented in Table E3 for each cross section (top, center and bottom) and its average is plotted in Figure E9.

State Job Number: 134935

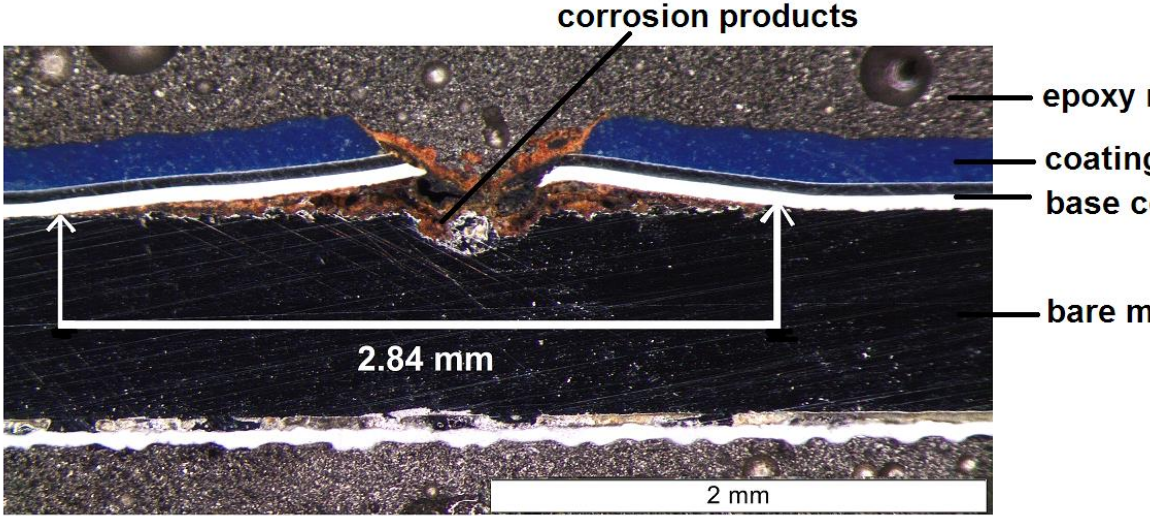

Figure E 8. Film delamination length of a coated carbon steel sample exposed to accelerated corrosion testing (B117) for 336 h.

ODOT Research Final Report

State Job Number: 134935

Table E 3. Film delamination length of carbon steel samples exposed to accelerated corrosion testing (B117) for each of the coating systems studied in this work.

Run 1						
Sample	Coating system	Primary Coating	Film delamination length (mm)			
			Top	Center	Bottom	AVG
1	None	Black Enamel	3.30	4.85	1.85	3.34
2		White OEM	3.09	3.91	1.68	2.89
3	LCCOAT	None	5.80	4.92	2.52	4.41
4		Black Enamel	1.30	4.27	2.30	2.63
5		White OEM	2.54	4.77	3.95	3.75
6	LINE-X	None	2.22	1.55	1.69	1.82
7		Black Enamel	1.89	1.44	0.75	1.36
8		White OEM	1.31	4.29	1.31	2.30
9	Raptor	None	1.29	0.96	1.49	1.25
10		Black Enamel	2.69	2.32	4.00	3.01
11		White OEM	2.78	1.37	2.79	2.31
12	Rhino Linings	None	1.50	2.58	2.55	2.21
13		Black Enamel	4.98	4.32	6.37	5.22
14		White OEM	2.33	2.58	5.15	3.35
Run 2						
Sample	Coating system	Primary Coating	Film delamination length (mm)			
			Top	Center	Bottom	AVG
1	None	Black Enamel	4.01	4.01	4.01	4.01
2		White OEM	3.39	3.64	4.01	3.68
3	LCCOAT	None	4.01	4.01	4.01	4.01
4		Black Enamel	4.01	3.93	4.01	3.98
5		White OEM	2.70	4.01	2.72	3.14
6	LINE-X	None	4.01	4.01	3.58	3.87
7		Black Enamel	1.39	3.96	4.01	3.12
8		White OEM	4.01	4.01	3.41	3.81
9	Raptor	None	2.48	3.32	1.73	2.51
10		Black Enamel	3.58	4.01	2.49	3.36
11		White OEM	2.74	1.25	2.34	2.11
12	Rhino Linings	None	2.71	1.02	2.05	1.93
13		Black Enamel	4.01	2.67	-	3.34
14		White OEM	1.42	3.18	-	2.30

ODOT Research Final Report

State Job Number: 134935

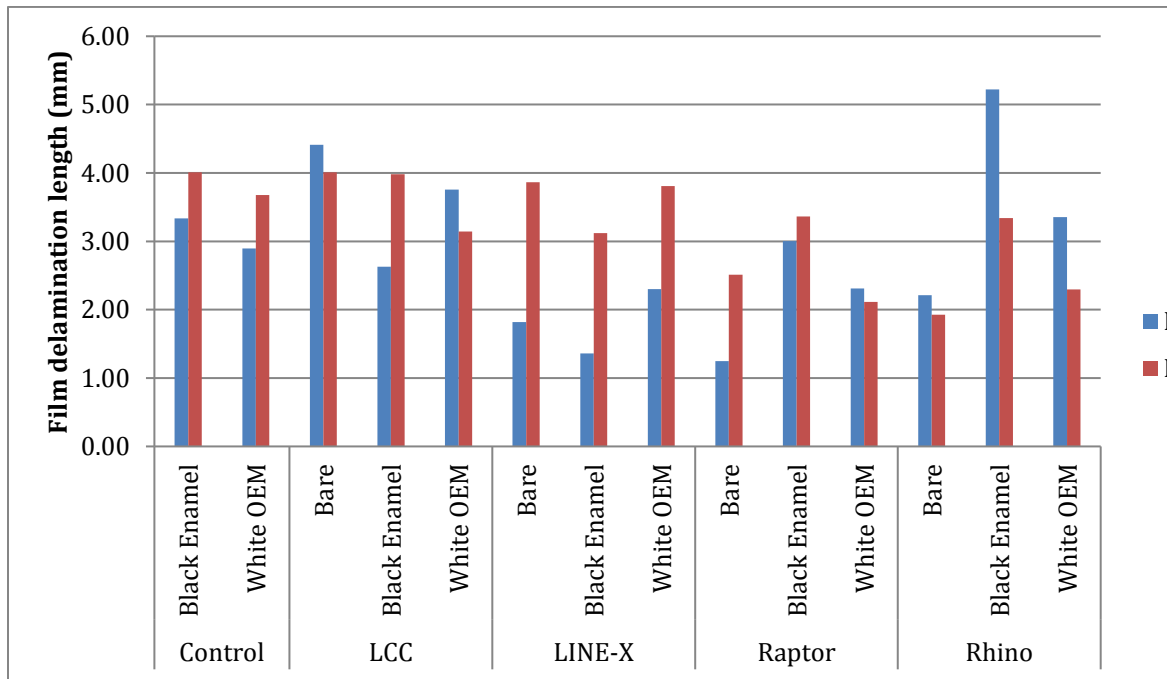

Figure E 9. Average of film delamination length of carbon steel panels exposed to accelerated corrosion testing (B117) for each of the coating systems studied in this work.

State Job Number: 134935

APPENDIX F: IMAGE ANALYSIS OF UNSCRIBED COUPONS: B117 TESTING

Unscribed coated metal panels were placed in a salt spray chamber (Singleton Corporation, Cleveland, OH, USA) for 1344 hours (8 weeks) following the specifications from standard ASTM-B117 [1]). The pressure of the humidifying tower is kept between 12 and 18 psi, and its temperature between 114 and 121°F, while the chamber is maintained between 92 and 97°F using a salt solution of 5 wt.% NaCl prepared in DI water.

Images were acquired using high resolution scan imaging. An EPSON XP-310 scanner was used with settings of image type 24-bit color and resolution 600 dpi. Evaluated coatings were galvanized, light curable coating (LCCOAT), LINE-X, metalized, Raptor and Rhino Linings. The metals studied in this work were aluminum (Al), cast aluminum (CA), carbon steel (CS), cast iron (CFe) and stainless steel (SS). Corrosion performance of unscribed metal panels (Table F1) was evaluated by imaging exposed panels every week (168 hours) and they are presented in Figures F1-7.

ODOT Research Final Report

State Job Number: 134935

Table F 1. Unscribed coated metal panels evaluated in this study.

Coating system	Primary Coating	Panel number				
		CS	Al	CA	CFe	SS
None	None	301	121	51	49	25
	Black Enamel	171				
	White OEM	161	130			
Galvanized	None	154			51	
LCCOAT	None	61	50	30	30	
	Black Enamel	81				
	White OEM	247	60			
LINE-X	None	10	10	10	10	
	Black Enamel	30				
	White OEM	20	20			
Metalized	None	207				
Raptor	None	130	90	50	50	
	Black Enamel	150				
	White OEM	140	100			
Rhino Linings	None	40	30	20	20	
	Black Enamel	60				
	White OEM	50	40			

Figure F1 shows the corrosion evolution of unscribed metal panels (control) exposed to the salt spray chamber for 8 weeks. Panels are presented in the following order from left to right: CS-bare, CS-white OEM, CS-black enamel, Al-bare, Al-white OEM, SS-bare, CA-bare and CFe-bare.

ODOT Research Final Report

State Job Number: 134935



Figure F 1. Control unscrubbed metal panels exposed to the salt spray chamber

ODOT Research Final Report

State Job Number: 134935

Figure F2 shows the corrosion evolution of galvanized unscribed metal panels exposed to the salt spray chamber for 8 weeks. Panels are presented in the following order: CS-galvanized (top) and CFe-galvanized (bottom).



Figure F 2. Galvanized unscribed metal panels exposed to the salt spray chamber.

Figure F3 shows the corrosion evolution of LCCOAT unscribed metal panels exposed to the salt spray chamber for 8 weeks. Panels are presented in the following order from left to right: CS-bare-LCCOAT, CS-white OEM-LCCOAT, CS-black enamel-LCCOAT, Al-bare-LCCOAT, Al-white OEM-LCCOAT, CA-bare-LCCOAT and CFe-bare-LCCOAT.

State Job Number: 134935

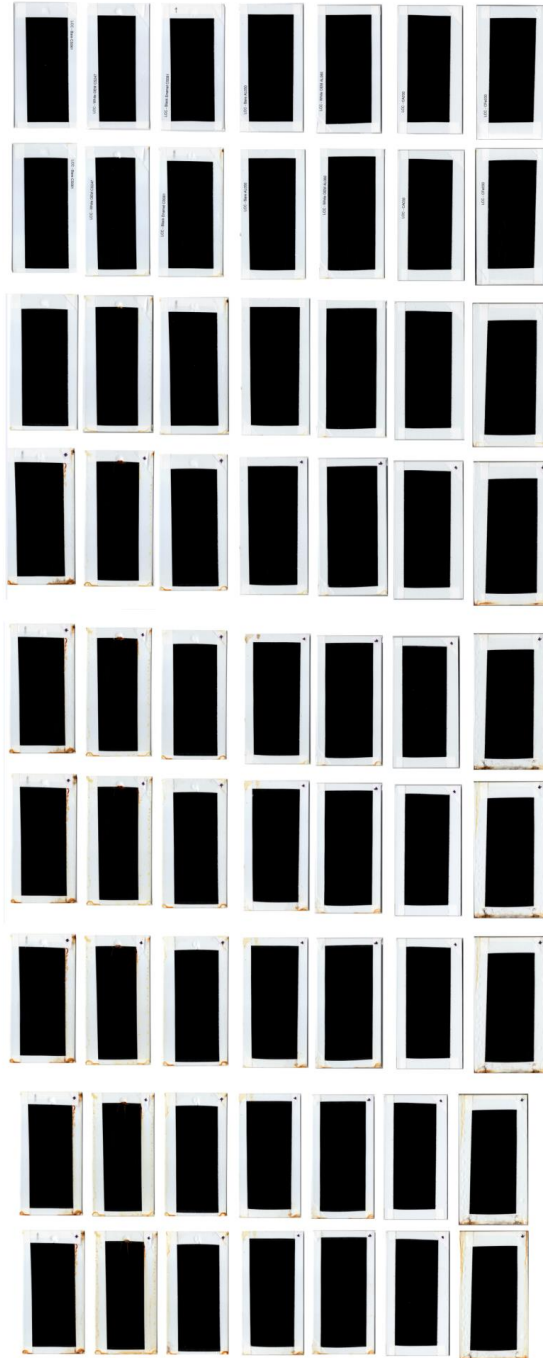

Figure F 3. LCCOAT unscrubbed metal panels exposed to the salt spray chamber.

ODOT Research Final Report

State Job Number: 134935

Figure F4 shows the corrosion evolution of LINE-X unscribed metal panels exposed to the salt spray chamber for 8 weeks. Panels are presented in the following order from left to right: CS-bare-LINE-X, CS-white OEM-LINE-X, CS-black enamel-LINE-X, Al-bare-LINE-X, Al-white OEM-LINE-X, CA-bare-LINE-X and CFe-bare-LINE-X.

State Job Number: 134935

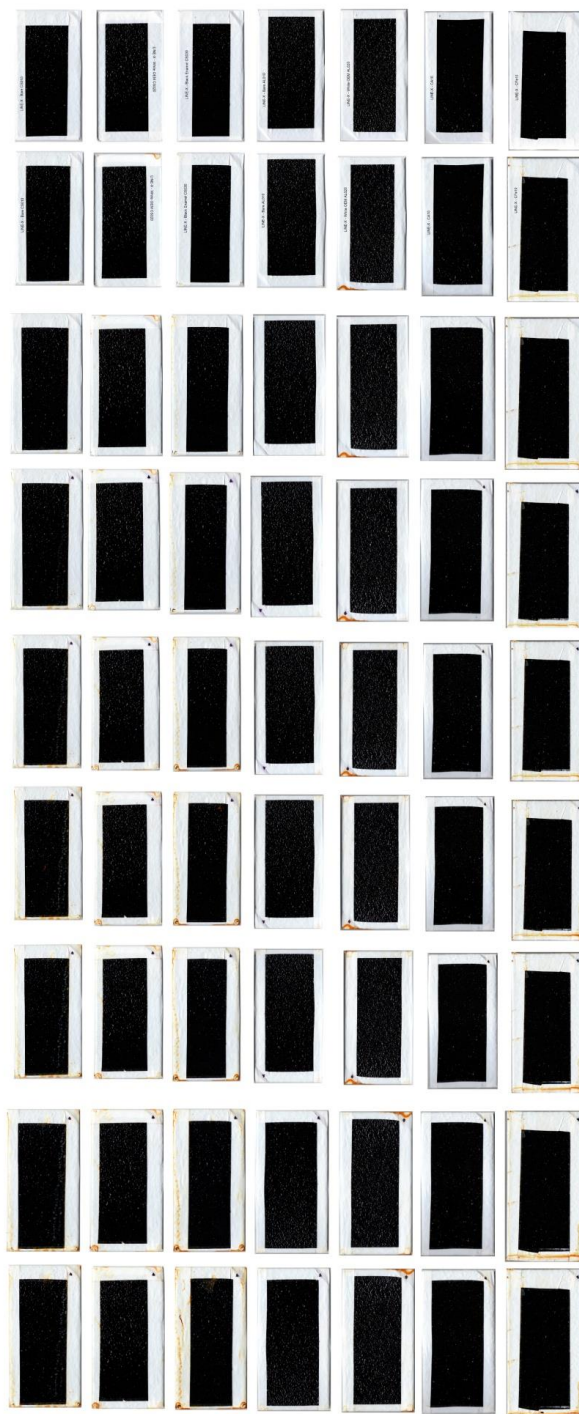

Figure F 4. LINE-X unscribed metal panels exposed to the salt spray chamber.

ODOT Research Final Report

State Job Number: 134935

Figure F5 shows the corrosion evolution of metalized unscribed metal panels exposed to the salt spray chamber for 4 weeks. Only carbon steel panels were metalized.



Figure F 5. Metalized unscribed metal panels exposed to the salt spray chamber.

Figure F6 shows the corrosion evolution of Raptor unscribed metal panels exposed to the salt spray chamber for 8 weeks. Panels are presented in the following order from left to right: CS-bare-Raptor, CS-white OEM-Raptor, CS-black enamel-Raptor, Al-bare-Raptor, Al-white OEM-Raptor, CA-bare-Raptor and CFe-bare-Raptor.

ODOT Research Final Report

State Job Number: 134935

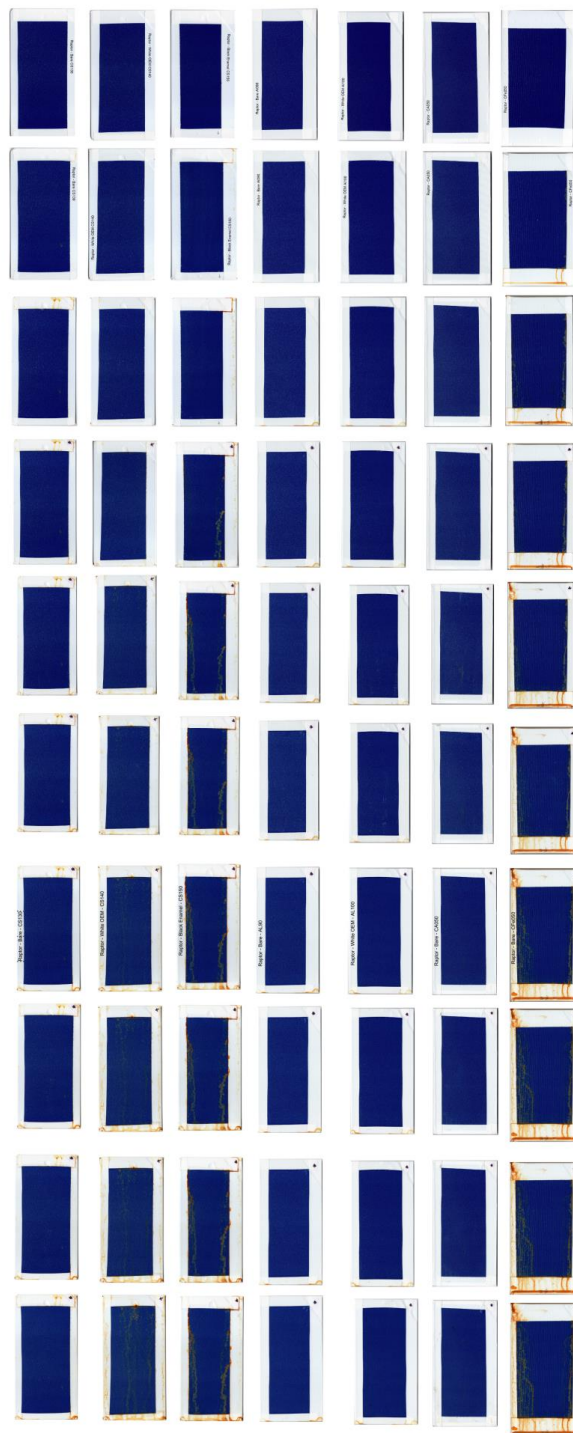

Figure F 6. Raptor unscribed metal panels exposed to the salt spray chamber.

ODOT Research Final Report

State Job Number: 134935

Figure F7 shows the corrosion evolution of Rhino Linings unscrubbed metal panels exposed to the salt spray chamber for 8 weeks. Panels are presented in the following order from left to right: CS-bare-Rhino, CS-white OEM-Rhino, CS-black enamel-Rhino, Al-bare-Rhino, Al-white OEM-Rhino, CA-bare-Rhino and CFe-bare-Rhino.

State Job Number: 134935

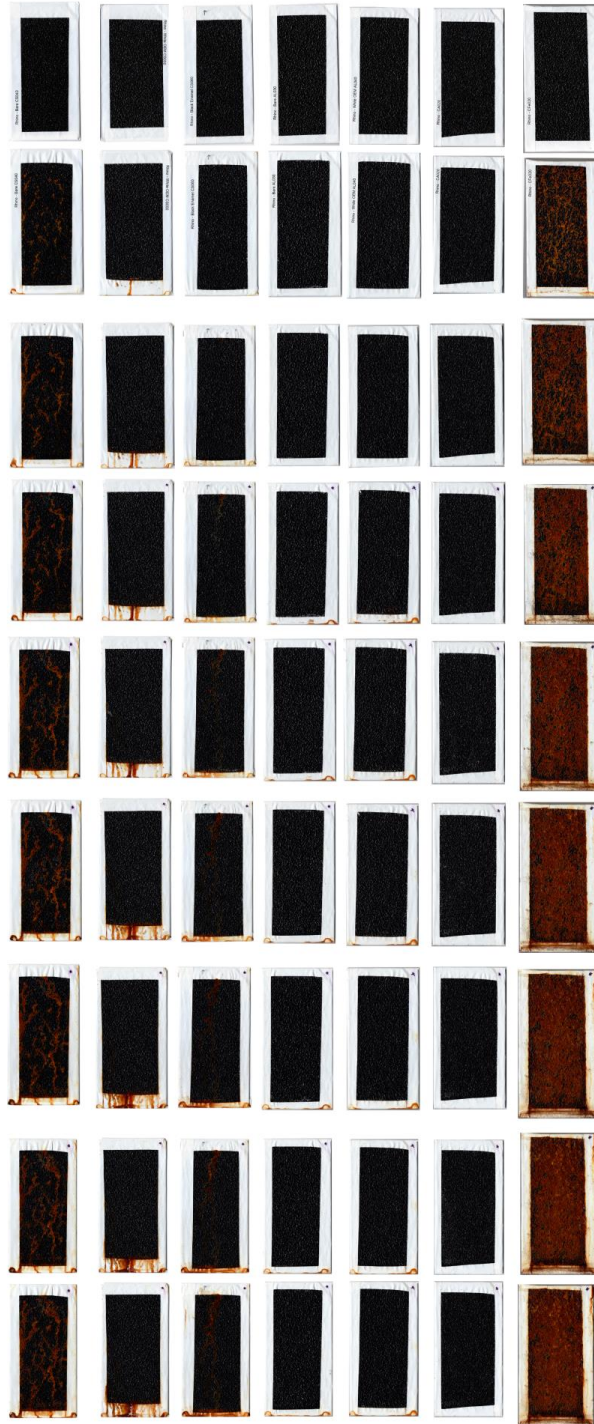

Figure F 7. Rhino Linings unscribed metal panels exposed to the salt spray chamber.

ODOT Research Final Report

State Job Number: 134935

Corrosion performance of unscribed coated panels exposed to the salt spray chamber was evaluated by rating each coating system using standard ASTM D1654[2]. Table F2 shows the relationship between coating failed area (%) and coating rating. Zero rating means that 75% of the test sample experienced corrosion or loss of coating. Results are presented in Table F3.

Table F 2. Representative coating rating based on area failed on an unscribed coated surface from ASTM D1654 standard.

Area Failed (%)	Coating Rating
No failure	10
0 to 1	9
2 to 3	8
4 to 6	7
7 to 10	6
11 to 20	5
21 to 30	4
31 to 40	3
41 to 55	2
56 to 75	1
Over 75	0



State Job Number: 134935

Table F 3. Representative coating rating for unscribed coated panels studied in this work.

Coating system	Primary Coating	Representative coating rating				
		CS	AI	CA	CFe	SS
None	None	N/A	N/A	N/A	N/A	N/A
	Black Enamel	10				
	White OEM	10	10			
Galvanized	None	N/A			N/A	
LCCOAT	None	10	10	10	10	
	Black Enamel	10				
	White OEM	10	10			
LINE-X	None	9	10	10	9	
	Black Enamel	10				
	White OEM	10	10			
Metalized	None	N/A				
Raptor	None	10	10	10	10	
	Black Enamel	9				
	White OEM	9	100			
Rhino Linings	None	0	10	10	0	
	Black Enamel	6				
	White OEM	10	10			

The degree of blistering and rusting of coated panels was measured by rinsing with DI water each panel after completion of the exposure period and drying each of them with laboratory cleaning tissues. Coating ratings for blistering and rusting are determined by following standards ASTM D714[3] and ASTM D610[4] respectively. Results are presented in Table F4.

ODOT Research Final Report

State Job Number: 134935

Table F 4. Degree of blistering and rusting of coated metal panels according to ASTM D714 and ASTM D610.

Coating system	Primary Coating	Metal	Blistering	Rusting	
None	White OEM	CS	10	10	High amount of corrosion residue from edge
None	Black Enamel	CS	8F	10	Medium amount of corrosion residue from edge
None	White OEM	AL	10	10	Small amount of corrosion residue from edge
LCCOAT	None	CS	8F	10	Medium amount of corrosion residue from edge
LCCOAT	White OEM	CS	8F	10	Medium amount of corrosion residue from edge
LCCOAT	Black Enamel	CS	6F	10	Medium amount of corrosion residue from edge
LCCOAT	None	AL	2F	10	Small amount of corrosion residue from edge
LCCOAT	White OEM	AL	10	10	Small amount of corrosion residue from edge
LCCOAT	None	CA	8D	10	Small amount of corrosion residue from edge
LCCOAT	None	CFe	10	10	High amount of corrosion residue from edge
LINE-X	None	CS	6M	10	Medium amount of corrosion residue from edge
LINE-X	White OEM	CS	9D	10	Medium amount of corrosion residue from edge
LINE-X	Black Enamel	CS	9D	10	Small amount of corrosion residue from edge
LINE-X	None	AL	9D	10	Small amount of corrosion residue from edge
LINE-X	White OEM	AL	10	10	Small amount of corrosion residue from edge
LINE-X	None	CA	10	10	No corrosion residue from edge
LINE-X	None	CFe	10	10	High amount of corrosion residue from edge
Raptor	None	CS	2F	9S	Medium amount of corrosion residue from edge
Raptor	White OEM	CS	10	10	Medium amount of corrosion residue from edge
Raptor	Black Enamel	CS	10	10	Medium amount of corrosion residue from edge
Raptor	None	AL	10	10	Small amount of corrosion residue from edge
Raptor	White OEM	AL	10	10	Small amount of corrosion residue from edge
Raptor	None	CA	10	10	No corrosion residue from edge
Raptor	None	CFe	10	9G	High amount of corrosion residue from edge
Rhino	None	CS	10	10	Medium amount of corrosion residue from edge
Rhino	White OEM	CS	10	10	Medium amount of corrosion residue from edge
Rhino	Black Enamel	CS	10	10	Medium amount of corrosion residue from edge
Rhino	None	AL	10	10	Small amount of corrosion residue from edge
Rhino	White OEM	AL	10	10	Small amount of corrosion residue from edge
Rhino	None	CA	10	10	Small amount of corrosion residue from edge
Rhino	None	CFe	2M	10	High amount of corrosion residue from edge

APPENDIX G: EIS CIRCUITS: IMMERSION TESTING

The performance of coatings studied in this work was evaluated in the lab by electrochemical impedance spectroscopy (EIS). Measurements were acquired with a conventional three-electrode paint cell (see Figure G1), using a silver/silver chloride (Ag/AgCl) reference electrode from BASi (West Lafayette, IN, USA), a round Pt/Nb mesh electrode from Scribner Associates Inc. (Southern Pines, NC, USA), and a coated metal panel as the working electrode. A Gamry (Warminster, PA, USA) - Reference 600 Potentiostat/Galvanostat/ZRA was used for EIS measurements using an amplitude of 10 mV AC perturbation coupled with the open circuit potential over a frequency range of 10 kHz to 10 mHz.

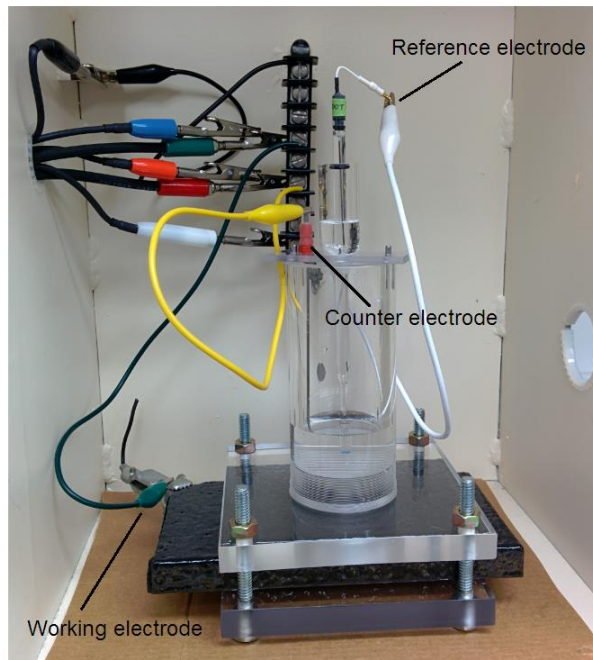

Figure G 1. Electrochemical three-electrode setup.

Immersion testing experiments were carried out at room temperature by monitoring each environment for 43days using an electrolyte solution of 0.6M NaCl. EIS results were fit and



ODOT Research Final Report

State Job Number: 134935

analyzed with software Gamry Echem Analyst Version 6.11. Parameters for each of the environments studied in this work are presented in Tables G1-G14.



ODOT Research Final Report

State Job Number: 134935

Table G 1. EIS coating parameters for immersion testing of Control - Black Enamel on CS metal panel exposed to a 0.6M NaCl solution.

Control - Black Enamel - CS177														
Parameter	0	1	2	3	4	5	6	7	8	13	16	21	43	100
Rp	3.05E+10	9.29E+08	8.74E+07	1.90E+08	9.47E+07	9.78E+07	6.87E+07	6.24E+07	6.37E+07	1.21E+07	9.57E+06	5.28E+06	1.83E+13	4.71E+05
Ru	4.37E+00	3.73E-03	9.56E-02	1.09E-01	1.04E+02	5.69E-03	1.76E-02	9.37E-02	5.22E-02	4.22E-02	1.71E-01	2.06E-02	1.04E-02	5.01E-03
Y0	5.65E-10	9.58E-10	7.67E-10	1.18E-09	1.22E-09	1.10E-09	1.06E-09	1.11E-09	1.04E-09	7.83E-10	8.29E-10	8.94E-10	1.97E-07	2.56E-09
alpha	9.33E-01	8.93E-01	9.16E-01	8.66E-01	8.69E-01	8.80E-01	8.86E-01	8.82E-01	8.91E-01	9.20E-01	9.16E-01	9.11E-01	4.47E-01	8.14E-01
Goodness of Fit	1.01E-02	5.40E-02	1.50E-01	1.72E-01	8.33E-02	5.91E-02	6.44E-02	6.38E-02	5.08E-02	1.32E-01	1.35E-01	6.48E-02	2.83E-02	2.81E-02
Goodness of Fit (KK)	3.39E-04	1.24E-03	4.03E-04	3.77E-04	5.08E-04	6.21E-04	4.71E-04	3.23E-04	2.81E-04	2.26E-04	2.38E-04	1.34E-04	5.79E-05	4.52E-04
Water uptake		12.03	6.96	16.80	17.54	15.18	14.42	15.40	13.81	7.45	8.73	10.47	133.59	34.48
Model	CPE													



ODOT Research Final Report

State Job Number: 134935

Table G 2. EIS coating parameters for immersion testing of Control - White OEM on CS metal panel exposed to a 0.6M NaCl solution.

Control - White OEM - CS239														
Parameter	0	1	2	3	4	5	6	7	8	13	16	21	43	100
Ru	6.76E-04	3.98E-02	6.20E-06	5.02E-07	3.11E-01	746.9	6.312	6.412	49.13	273	513.7	1.14E-01	1.92E-05	4.34E-02
Rp	2.74E+05	7.47E+08	1.28E+08	1.43E+08	8.94E+07	8.36E+07	7.14E+07	6.57E+07	6.14E+07	7.50E+07	6.20E+07	7.14E+07	4.28E+07	2.06E+07
Rct	6.76E+10	5.66E+07	2.37E+09	8.38E+08	1.88E+09	1.68E+09	5.53E+11	8.91E+11	8.07E+11	1.29E+11	5.62E+12	1.24E+09	5.10E+08	7.44E+05
Yo4	4.52E-10	6.32E-10	5.42E-10	4.67E-10	4.73E-10	4.85E-10	5.25E-10	5.45E-10	5.48E-10	5.23E-10	5.44E-10	5.61E-10	5.46E-10	4.75E-10
a5	9.64E-01	9.46E-01	9.60E-01	9.73E-01	9.73E-01	9.71E-01	9.69E-01	9.63E-01	9.63E-01	9.67E-01	9.66E-01	9.63E-01	9.65E-01	9.78E-01
Yo6	1.12E-17	6.21E-08	1.29E-11	1.46E-08	2.38E-08	3.17E-08	3.48E-08	3.54E-08	2.50E-08	3.10E-08	2.23E-08	1.52E-08	2.31E-07	3.99E-03
a7	2.55E-01	1	4.79E-01	7.52E-01	7.56E-01	7.42E-01	6.98E-01	6.05E-01	5.06E-01	5.21E-01	4.28E-01	5.59E-01	5.72E-01	7.37E-05
Goodness of Fit	1.33E-03	4.72E-02	1.06E-02	1.05E-02	8.45E-03	9.14E-03	4.20E-03	1.09E-03	6.07E-04	3.68E-03	2.43E-03	1.55E-03	7.40E-04	4.31E-03
Water uptake		512.01	318.56	478.91	490.14	496.66	498.81	499.22	491.24	496.15	488.64	479.87	541.95	764.65
Model	FC													



ODOT Research Final Report

State Job Number: 134935

Table G 3. EIS coating parameters for immersion testing of LCCOAT - Bare on CS metal panel exposed to a 0.6M NaCl solution.

LCCOAT - Bare - CS064														
Parameter	0	1	2	3	4	5	6	7	8	13	16	21	43	100
Rp	1.11E+12	5.24E+11	7.41E+11	1.01E+12	6.59E+11	6.01E+11	4.36E+11	5.71E+11	4.75E+11	5.19E+11	4.64E+11	3.99E+11	5.06E+11	5.66E+11
Ru	3.96E-04	3.08E-03	2.59E-02	5.22E-03	1.30E-03	1.64E-02	8.05E-06	6.33E-03	3.46E+00	1.40E-02	5.87E-03	1.92E-03	6.78E-02	1.49E-02
Y0	2.06E-10	2.74E-10	2.65E-10	2.64E-10	2.70E-10	2.72E-10	2.79E-10	2.79E-10	2.84E-10	2.83E-10	2.91E-10	2.96E-10	2.93E-10	2.93E-10
alpha	9.71E-01	9.69E-01	9.73E-01	9.73E-01	9.72E-01	9.71E-01	9.76E-01	9.71E-01	9.70E-01	9.71E-01	9.69E-01	9.68E-01	9.69E-01	9.71E-01
Goodness of Fit	8.64E-04	7.00E-04	6.33E-04	8.82E-04	1.06E-03	9.71E-04	3.26E-03	7.63E-04	9.07E-04	1.20E-03	1.33E-03	1.38E-03	1.10E-03	1.13E-03
Goodness of Fit (KK)	2.32E-04	2.01E-04	2.41E-04	4.08E-04	4.99E-04	4.12E-04	4.27E-04	2.88E-04	2.33E-04	3.79E-04	4.05E-04	4.73E-04	3.90E-04	3.90E-04
Water uptake		6.58	5.80	5.73	6.20	6.41	6.95	6.95	7.42	7.33	7.94	8.30	8.06	8.08
Model	CPE													



ODOT Research Final Report

State Job Number: 134935

Table G 4. EIS coating parameters for immersion testing of LCCOAT - Black Enamel on CS metal panel exposed to a 0.6M NaCl solution.

LCCOAT - Black Enamel - CS083														
Parameter	0	1	2	3	4	5	6	7	8	13	16	21	43	100
Rp	8.68E+11	3.84E+11	3.86E+11	3.08E+11	2.89E+11	2.90E+11	2.78E+11	3.16E+11	3.05E+11	6.08E+10	1.89E+11	2.65E+11	2.40E+11	1.20E+11
Ru	8.32E-03	4.62E-02	1.76E-02	6.40E-02	1.12E-01	1.41E-01	5.5	1.40E-01	9.03E-04	5.64E-02	1.41E-02	2.51E-02	2.36E-02	2.45E-01
Y0	1.46E-10	2.01E-10	1.89E-10	1.92E-10	2.03E-10	2.08E-10	2.22E-10	2.28E-10	2.38E-10	2.32E-10	2.50E-10	2.49E-10	2.39E-10	2.33E-10
alpha	9.64E-01	9.49E-01	9.56E-01	9.54E-01	9.49E-01	9.49E-01	9.46E-01	9.45E-01	9.43E-01	9.46E-01	9.40E-01	9.41E-01	9.52E-01	9.48E-01
Goodness of Fit	1.36E-03	3.76E-03	4.71E-03	8.78E-03	1.49E-02	1.49E-02	1.02E-02	4.48E-03	4.64E-03	8.14E-03	8.89E-03	6.41E-03	1.13E-02	9.55E-03
Goodness of Fit (KK)	2.53E-04	1.78E-04	1.07E-03	3.15E-03	6.89E-03	6.95E-03	2.38E-03	3.48E-04	3.01E-04	2.03E-03	2.36E-03	8.97E-04	1.37E-03	2.57E-03
Water uptake		7.24	5.83	6.21	7.49	8.03	9.49	10.09	11.05	10.46	12.23	12.07	11.22	10.59
Model	CPE													

ODOT Research Final Report



State Job Number: 134935

Table G 5. EIS coating parameters for immersion testing of LCCOAT - White OEM on CS metal panel exposed to a 0.6M NaCl solution.

LCCOAT- White OEM CS077														
Parameter	0	1	2	3	4	5	6	7	8	13	16	21	43	100
Rp	6.83E+11	9.22E+11	7.25E+11	4.27E+11	3.37E+11	2.16E+11	3.61E+11	1.58E+12	4.05E+11	4.08E+11	3.46E+11	3.65E+11	3.68E+11	3.49E+11
Ru	2.65E-02	6.11E-03	4.22E-02	1.24E-01	1.26E-01	2.07E-01	1.20E-01	1.10E-02	2.23E-02	7.05E-02	4.67E-02	1.09E-01	5.04E-02	6.28E-02
Y0	1.42E-10	1.72E-10	1.64E-10	1.70E-10	1.76E-10	1.82E-10	1.90E-10	1.92E-10	1.99E-10	1.98E-10	2.06E-10	2.06E-10	2.00E-10	1.96E-10
alpha	9.68E-01	9.59E-01	9.64E-01	9.60E-01	9.58E-01	9.56E-01	9.56E-01	9.60E-01	9.54E-01	9.56E-01	9.52E-01	9.53E-01	9.56E-01	9.59E-01
Goodness of Fit	9.60E-04	1.33E-03	2.27E-03	7.70E-03	1.73E-02	1.61E-02	6.32E-03	2.17E-03	1.77E-03	6.10E-03	5.31E-03	2.78E-03	4.51E-03	6.46E-03
Goodness of Fit (KK)	2.47E-04	2.22E-04	8.76E-04	3.47E-03	1.03E-02	8.48E-03	2.72E-03	4.05E-04	2.39E-04	2.41E-03	1.86E-03	8.09E-04	1.70E-03	2.54E-03
Water uptake		4.29	3.30	4.05	4.81	5.63	6.57	6.83	7.70	7.57	8.48	8.50	7.80	7.33
Model	CPE													



ODOT Research Final Report

State Job Number: 134935

Table G 6. EIS coating parameters for immersion testing of LINE-X - Bare on CS metal panel exposed to a 0.6M NaCl solution.

LINE-X - Bare - CS002														
Parameter	0	1	2	3	4	5	6	7	8	13	16	21	43	100
Ru	4.73E-03	2.52E-02	5.53E-01	1.01E-01	6.439	8.24E-02	8.82E+00	2.28E-03	36.56	8.44E-01	5.87E-02	3.46E-03	1.425	7.38E-03
Rp	8.77E+08	1.51E+08	1.33E+08	1.03E+08	6.30E+07	4.87E+07	3.47E+07	9.08E+06	2.39E+07	2.62E+07	2.37E+07	2.43E+07	2.78E+07	3.48E+07
Rct	4.32E+10	6.06E+09	5.92E+09	4.71E+09	1.97E+09	1.22E+09	7.04E+08	5.89E+08	3.36E+08	2.36E+08	1.47E+08	1.04E+08	6.16E+07	5.53E+07
Yo4	4.87E-11	7.47E-11	6.89E-11	7.16E-11	6.94E-11	7.04E-11	7.63E-11	1.87E-10	7.40E-11	7.90E-11	7.93E-11	7.86E-11	8.09E-11	8.41E-11
a5	9.46E-01	9.15E-01	9.26E-01	9.24E-01	9.30E-01	9.30E-01	9.29E-01	9.49E-01	9.30E-01	9.26E-01	9.27E-01	9.30E-01	9.31E-01	9.27E-01
Yo6	4.03E-09	4.91E-09	4.67E-09	5.01E-09	5.97E-09	6.59E-09	7.79E-09	1.01E-08	9.72E-09	1.10E-08	1.28E-08	1.36E-08	1.65E-08	1.87E-08
a7	6.87E-01	7.11E-01	7.50E-01	7.47E-01	7.39E-01	7.36E-01	7.07E-01	7.89E-01	7.06E-01	6.99E-01	6.91E-01	6.85E-01	6.53E-01	6.70E-01
Goodness of Fit	2.64E-03	2.59E-03	4.12E-03	4.44E-03	6.71E-03	6.39E-03	3.48E-03	6.59E-03	9.53E-04	1.91E-03	2.18E-03	1.03E-03	1.27E-03	8.67E-04
Goodness of Fit (KK)	2.99E-04	2.44E-04	1.57E-03	2.74E-03	5.19E-03	4.90E-03	2.51E-03	4.42E-03	3.57E-04	1.14E-03	1.24E-03	3.70E-04	5.25E-04	2.93E-04
Water uptake		4.49	3.34	4.95	8.95	11.20	15.03	20.95	20.07	22.86	26.27	27.81	32.08	35.03
Model	FC													

ODOT Research Final Report



State Job Number: 134935

Table G 7. EIS coating parameters for immersion testing of LINE-X - Black Enamel on CS metal panel exposed to a 0.6M NaCl solution.

LINE-X - Black Enamel - CS025														
Parameter	0	1	2	3	4	5	6	7	8	13	16	21	43	100
Ru	7.54E+01	2.71E+00	1.95E-03	4.56E-01	7.11E-01	9.24E+03	3.93E-02	3.05E-01	7.06E-01	4.64E-02	4.95E+03	4.25E-01	3.62E+03	967.1
Rp	7.59E+08	1.16E+08	1.01E+08	7.61E+07	4.97E+07	3.73E+07	2.77E+07	2.53E+07	2.09E+07	2.48E+07	2.14E+07	2.20E+07	2.33E+07	2.75E+07
Rct	5.11E+10	4.99E+10	5.14E+10	4.15E+10	2.35E+10	1.78E+10	1.37E+10	1.63E+10	1.21E+10	1.05E+10	8.91E+09	9.91E+09	1.01E+10	1.03E+10
Yo4	4.37E-11	6.04E-11	5.73E-11	5.42E-11	5.38E-11	5.22E-11	5.65E-11	5.99E-11	6.02E-11	8.02E-11	6.02E-11	6.46E-11	6.38E-11	7.94E-11
a5	9.60E-01	9.39E-01	9.48E-01	9.53E-01	9.56E-01	9.60E-01	9.56E-01	9.52E-01	9.51E-01	9.24E-01	9.54E-01	9.52E-01	9.54E-01	9.50E-01
Yo6	3.72E-10	4.18E-10	3.73E-10	3.96E-10	4.53E-10	5.07E-10	5.81E-10	6.14E-10	6.76E-10	6.34E-10	7.09E-10	7.63E-10	7.86E-10	9.78E-10
a7	7.43E-01	7.85E-01	8.02E-01	7.95E-01	7.88E-01	7.83E-01	7.85E-01	7.93E-01	7.91E-01	8.02E-01	7.86E-01	7.82E-01	7.77E-01	7.31E-01
Goodness of Fit	8.62E-04	1.10E-03	2.19E-03	3.55E-03	6.79E-03	7.21E-03	4.47E-03	1.53E-03	1.47E-03	4.77E-03	3.52E-03	1.95E-03	2.51E-03	3.05E-03
Goodness of Fit (KK)	3.48E-04	1.78E-04	9.41E-04	2.39E-03	4.75E-03	4.82E-03	1.78E-03	3.07E-04	2.71E-04	1.69E-03	1.35E-03	7.03E-04	9.48E-04	1.23E-03
Water uptake		2.65	0.03	1.41	4.47	7.03	10.17	11.41	13.62	12.14	14.70	16.38	17.04	22.03
Model	FC													



ODOT Research Final Report

State Job Number: 134935

Table G 8. EIS coating parameters for immersion testing of LINE-X - White OEM on CS metal panel exposed to a 0.6M NaCl solution.

LINE-X - White OEM - CS012														
Parameter	0	1	2	3	4	5	6	7	8	13	16	21	43	100
Ru	1.66E+02	1.78E+00	1.41E-08	5.45E-03	2.73E+00	4.50E-01	8.06E-03	1.02E+00	3.25E-01	3.98E-02	1.01E-01	6.77E-05	4.73E-01	1.84E-01
Rp	6.51E+08	7.64E+07	5.93E+07	5.14E+07	3.67E+07	3.21E+07	2.19E+07	2.02E+07	1.79E+07	1.89E+07	1.83E+07	1.93E+07	2.17E+07	2.92E+07
Rct	5.08E+10	6.25E+10	5.67E+10	4.16E+10	2.55E+10	1.35E+10	1.58E+10	2.74E+10	3.04E+10	1.56E+10	1.39E+10	1.85E+10	1.49E+10	1.55E+10
Yo4	4.93E-11	7.10E-11	6.87E-11	7.05E-11	7.15E-11	7.38E-11	7.34E-11	7.58E-11	7.55E-11	7.41E-11	8.03E-11	7.66E-11	8.56E-11	8.80E-11
a5	1.00E+00	9.37E-01	9.42E-01	9.41E-01	9.42E-01	9.41E-01	9.43E-01	9.45E-01	9.42E-01	9.49E-01	9.40E-01	9.47E-01	9.38E-01	9.41E-01
Yo6	4.38E-10	4.98E-10	4.81E-10	4.96E-10	5.46E-10	5.64E-10	6.63E-10	6.97E-10	7.37E-10	7.41E-10	7.86E-10	8.00E-10	8.49E-10	9.09E-10
a7	7.90E-01	8.23E-01	8.33E-01	8.35E-01	8.34E-01	8.45E-01	8.25E-01	8.33E-01	8.35E-01	8.35E-01	8.31E-01	8.35E-01	8.33E-01	8.18E-01
Goodness of Fit	3.67E-02	1.29E-03	2.53E-03	3.68E-03	6.48E-03	5.85E-03	4.16E-03	1.35E-03	1.30E-03	3.29E-03	3.32E-03	2.20E-03	2.31E-03	3.52E-03
Goodness of Fit (KK)	3.10E-04	2.72E-04	1.43E-03	2.63E-03	4.68E-03	4.26E-03	2.62E-03	3.97E-04	4.86E-04	2.01E-03	2.14E-03	1.20E-03	1.46E-03	2.52E-03
Water uptake		2.93	2.17	2.84	5.05	5.79	9.49	10.62	11.88	12.02	13.35	13.77	15.13	16.69
Model	FC													

ODOT Research Final Report



State Job Number: 134935

Table G 9. EIS coating parameters for immersion testing of Raptor - Bare on CS metal panel exposed to a 0.6M NaCl solution.

Raptor - Bare CS122														
Parameter	0	1	2	3	4	5	6	7	8	13	16	21	43	100
Rp	1.96E+08	9.37E+07	3.95E+07	3.11E+07	5.05E+07	3.09E+07	4.27E+07	6.45E+07	6.54E+07	7.54E+07	5.56E+07	6.96E+07	6.89E+07	1.85E+06
Ru	5.67E-02	1.75E-03	9.07E-03	9.48E-03	2.93E-03	7.19E-03	1.60E-03	2.72E-03	6.40E-05	5.67E-03	1.29E-03	2.89E-04	2.40E-03	2.64E-02
Y0	3.65E-10	1.53E-09	1.51E-09	1.83E-09	1.87E-09	2.07E-09	2.05E-09	2.09E-09	2.27E-09	2.12E-09	2.12E-09	2.26E-09	2.24E-09	2.09E-09
alpha	9.38E-01	8.84E-01	9.02E-01	8.90E-01	8.92E-01	8.88E-01	8.89E-01	8.99E-01	8.84E-01	8.90E-01	8.94E-01	8.88E-01	8.86E-01	8.98E-01
Goodness of Fit	3.84E-02	1.48E-02	9.26E-03	1.49E-02	1.34E-02	9.46E-03	7.03E-03	1.53E-02	1.26E-02	8.19E-03	9.39E-03	1.22E-02	1.16E-02	7.26E-03
Goodness of Fit (KK)	2.62E-03	2.20E-04	1.17E-03	5.27E-03	3.35E-03	2.20E-03	2.24E-04	2.30E-04	2.18E-04	6.22E-04	6.68E-04	6.34E-04	7.40E-04	3.97E-04
Water uptake		32.68	32.41	36.82	37.29	39.65	39.39	39.86	41.71	40.21	40.14	41.68	41.47	39.80
Model	CPE													



ODOT Research Final Report

State Job Number: 134935

Table G 10. EIS coating parameters for immersion testing of Raptor - Black Enamel on CS metal panel exposed to a 0.6M NaCl solution.

Raptor - Black Enamel CS 142														
Parameter	0	1	2	3	4	5	6	7	8	13	16	21	43	100
Rp	8.74E+10	1.87E+10	1.72E+10	5.91E+09	8.72E+09	4.94E+09	8.10E+09	6.71E+09	5.35E+09	6.99E+09	6.60E+09	6.43E+09	7.27E+09	1.43E+10
Ru	1.20E-02	2.05E-02	7.73E-03	3.26E-03	3.38E-02	2.73E-02	1.04E-02	4.24E-03	3.74E-03	9.05E-03	8.59E-03	1.23E-02	1.52E-03	1.67E-02
Y0	2.29E-10	4.30E-10	4.29E-10	5.02E-10	4.81E-10	5.23E-10	5.19E-10	5.33E-10	5.68E-10	5.37E-10	5.59E-10	5.68E-10	5.96E-10	5.50E-10
alpha	9.14E-01	8.91E-01	8.98E-01	8.89E-01	8.96E-01	8.93E-01	8.96E-01	8.98E-01	8.92E-01	8.99E-01	8.99E-01	8.96E-01	8.94E-01	8.99E-01
Goodness of Fit	2.09E-02	1.20E-02	2.08E-02	3.53E-02	2.95E-02	2.07E-02	1.02E-02	1.29E-02	9.79E-03	1.75E-02	1.65E-02	1.46E-02	1.62E-02	2.71E-02
Goodness of Fit (KK)	2.30E-04	5.34E-04	4.34E-03	1.59E-02	1.05E-02	6.50E-03	3.59E-04	4.44E-04	5.01E-04	3.46E-03	2.20E-03	2.20E-03	1.98E-03	5.92E-03
Water uptake		14.44	14.38	17.93	16.99	18.90	18.69	19.33	20.78	19.49	20.41	20.78	21.85	20.04
Model	CPE													



ODOT Research Final Report

State Job Number: 134935

Table G 11. EIS coating parameters for immersion testing of Raptor - White OEM on CS metal panel exposed to a 0.6M NaCl solution.

Raptor - White OEM - CS132														
Parameter	0	1	2	3	4	5	6	7	8	13	16	21	43	100
Rp	8.43E+10	4.38E+10	2.94E+10	7.76E+09	8.64E+09	7.85E+09	4.82E+09	6.23E+09	3.92E+09	4.75E+09	5.14E+09	3.18E+09	3.38E+09	7.27E+09
Ru	2.65E-02	2.81E-01	3.59E-01	2.22E-03	6.32E-02	1.92E-02	2.58E-02	6.55E-02	2.94E-02	2.94E-02	4.67E-03	9.21E-03	5.52E-03	6.61E-03
Y0	2.08E-10	4.42E-10	4.43E-10	5.19E-10	5.01E-10	5.69E-10	5.29E-10	6.06E-10	5.98E-10	5.34E-10	6.05E-10	5.58E-10	5.82E-10	5.53E-10
alpha	9.17E-01	8.85E-01	8.93E-01	8.84E-01	8.91E-01	8.83E-01	8.96E-01	8.82E-01	8.90E-01	9.03E-01	8.91E-01	9.04E-01	9.02E-01	9.03E-01
Goodness of Fit	2.37E-02	1.42E-02	2.49E-02	4.80E-02	4.39E-02	3.99E-02	1.98E-02	2.89E-02	2.50E-02	1.81E-02	4.08E-02	2.01E-02	1.87E-02	2.99E-02
Goodness of Fit (KK)	2.46E-04	5.42E-04	4.81E-03	1.91E-02	1.34E-02	6.00E-03	8.06E-04	5.60E-04	4.77E-04	3.22E-03	3.25E-03	2.07E-03	1.64E-03	8.14E-03
Water uptake		17.13	17.20	20.81	20.03	22.92	21.25	24.36	24.05	21.48	24.33	22.46	23.43	22.25
Model	CPE													



ODOT Research Final Report

State Job Number: 134935

Table G 12. EIS coating parameters for immersion testing of Rhino Linings- Bare on CS metal panel exposed to a 0.6M NaCl solution.

Rhino - Bare CS032														
Parameter	0	1	2	3	4	5	6	7	8	13	16	21	43	100
Ru	5.99E+02	2.13E+02	1.83E+02	1.86E+02	1.54E+02	1.30E+02	9.33E+01	8.75E+01	7.15E-05	1.46E+02	1.51E+02	1.77E+02	7.84E+01	519.4
Rp	4.16E+03	1.79E-03	1.91E+03	9.07E+02	2.12E+03	3.69E+03	4.39E+03	4.49E+03	5.35E+03	1.24E+04	3.05E-02	2.85E-03	4.87E-03	6.14E+03
Rct	6.65E+03	6.35E+04	3.92E+04	3.05E+04	2.42E+04	2.01E+04	1.76E+04	1.76E+04	1.23E+04	6.83E+04	1.07E+05	3.96E+04	4.66E+05	1.10E+09
Yo4	4.00E-08	2.25E-07	7.10E-07	3.75E-07	9.39E-07	1.90E-06	2.09E-06	1.90E-06	2.99E-06	4.69E-07	1.01E-06	2.49E-07	3.54E-06	3.13E-07
a5	9.73E-01	8.93E-01	7.84E-01	8.44E-01	7.53E-01	6.85E-01	6.63E-01	6.69E-01	6.11E-01	7.88E-01	7.62E-01	8.85E-01	6.07E-01	8.15E-01
Yo6	1.10E-07	1.70E-05	1.75E-05	2.29E-05	3.11E-05	9.67E-05	1.60E-04	2.01E-04	2.18E-04	8.31E-05	4.44E-05	1.66E-05	9.60E-05	8.37E-05
a7	1.00E+00	3.48E-01	4.43E-01	4.26E-01	4.50E-01	5.05E-01	5.19E-01	4.93E-01	4.56E-01	3.29E-01	1.17E-01	3.52E-01	7.66E-02	1.95E-01
Goodness of Fit	5.16E-01	1.02E-04	1.97E-05	3.07E-05	3.43E-05	4.71E-04	3.80E-04	4.32E-04	9.99E-04	6.24E-05	4.65E-04	7.21E-04	1.14E-03	6.71E-04
Goodness of Fit (KK)	1.20E-01	2.70E-06	3.55E-06	1.83E-06	1.05E-06	5.40E-06	5.64E-07	8.55E-07	1.32E-06	4.27E-06	3.98E-05	1.10E-05	7.95E-07	2.90E-04
Model	FC													



State Job Number: 134935

Table G 13. EIS coating parameters for immersion testing of Rhino Linings- Black Enamel on CS metal panel exposed to a 0.6M NaCl solution.

Rhino - Black Enamel - CS052														
Parameter	0	1	2	3	4	5	6	7	8	13	16	21	43	100
Rp	1.09E+11	1.89E+10	3.33E+10	3.92E+10	3.16E+10	2.58E+10	1.52E+10	1.39E+10	1.15E+10	1.45E+10	1.24E+10	1.41E+10	1.92E+10	4.07E+10
Ru	1.02E-01	6.26E-03	2.94E-02	7.40E-02	1.80E-02	3.50E-01	2.25E-01	8.58E+03	2.10E-02	3.67E-03	1.80E-02	1.43E-01	2.25E-02	3.13E-03
Y0	1.82E-10	3.43E-10	3.08E-10	3.05E-10	3.13E-10	3.30E-10	3.58E-10	3.72E-10	3.97E-10	3.84E-10	3.96E-10	4.03E-10	3.97E-10	3.60E-10
alpha	9.20E-01	8.79E-01	8.87E-01	8.88E-01	8.86E-01	8.81E-01	8.79E-01	8.91E-01	8.68E-01	8.72E-01	8.71E-01	8.68E-01	8.72E-01	8.82E-01
Goodness of Fit	2.18E-02	1.68E-02	1.45E-02	1.78E-02	2.08E-02	2.32E-02	2.29E-02	2.75E-02	1.47E-02	1.88E-02	1.90E-02	1.54E-02	1.46E-02	1.27E-02
Goodness of Fit (KK)	2.04E-04	3.11E-04	1.61E-03	3.48E-03	5.90E-03	5.98E-03	2.44E-03	5.14E-04	5.04E-04	2.81E-03	2.76E-03	1.53E-03	2.06E-03	3.05E-03
Water uptake		14.44	11.99	11.74	12.38	13.60	15.43	16.32	17.79	17.02	17.73	18.12	17.79	15.53
Model	CPE													



ODOT Research Final Report

State Job Number: 134935

Table G 14. EIS coating parameters for immersion testing of Rhino Linings- White OEM on CS metal panel exposed to a 0.6M NaCl solution.

Rhino - White OEM CS042														
Parameter	0	1	2	3	4	5	6	7	8	13	16	21	43	100
Rp	4.06E+10	1.11E+11	1.30E+11	1.62E+11	9.98E+10	5.37E+10	4.65E+10	4.79E+10	3.21E+10	4.23E+10	3.69E+10	4.04E+10	5.79E+10	1.44E+11
Ru	1.69E-02	1.90E-02	3.23E+00	4.94E+00	2.62E-01	1.36E-02	4.34E-02	7.74E-02	4.84E-03	8.30E-02	5.18E-02	4.75E-02	2.34E-02	1.39E-02
Y0	1.66E-10	4.42E-10	4.03E-10	3.96E-10	4.17E-10	4.66E-10	4.97E-10	5.20E-10	5.56E-10	5.17E-10	5.42E-10	5.39E-10	5.28E-10	4.80E-10
alpha	9.31E-01	8.40E-01	8.50E-01	8.51E-01	8.47E-01	8.38E-01	8.32E-01	8.29E-01	8.24E-01	8.31E-01	8.27E-01	8.34E-01	8.34E-01	8.44E-01
Goodness of Fit	9.27E-02	3.11E-02	3.05E-02	3.32E-02	3.49E-02	4.01E-02	3.42E-02	3.27E-02	3.37E-02	3.35E-02	3.41E-02	3.77E-02	2.75E-02	2.25E-02
Goodness of Fit (KK)	3.13E-03	3.84E-04	1.34E-03	2.35E-03	3.65E-03	3.97E-03	1.75E-03	5.16E-04	3.83E-04	1.74E-03	1.68E-03	1.07E-03	1.49E-03	1.98E-03
Water uptake		22.36	20.26	19.82	20.99	23.55	25.01	26.05	27.58	25.94	27.00	26.87	26.40	24.22
Model	CPE													

ODOT Research Final Report

State Job Number: 134935

EIS experimental results were fitted using electric equivalent circuits (ECC) based on modified versions of the standard Randles cell (capacitor and resistor in parallel). Their respective configurations are shown in Figures G2-G4. Parameters estimated using the equivalent electrical circuit (solution resistance (R_u), coating capacitance (C_c), and pore resistance (R_p)) were used to estimate corrosion. Replacing C_c , in Figure G2 with a constant phase element (CPE) accounts for the distortion of the capacitive layer due to electrode surface roughness and distribution/accumulation of charges. CPE is defined as $Z=Q^{-1}(j\omega)^{-n}$, where Z is impedance, j is the imaginary number, ω is angular velocity, and Q and n are frequency independent parameters. For a value of n equal to 1 ± 0.2 , the CPE corresponds to distortion of capacitance. The value of n can change over time, however, as electrolyte enters the pores of the coating and changes the surface and coating properties. For a value of n equal to 0.5 ± 0.1 the CPE corresponds to diffusion of molecules, with deviations from Fick's second law. Finally, a value of n equal to 0 ± 0.2 the CPE corresponds to distorted resistance. In Figures G2-G4 n is represented by the letter a . In Figure G3, an additional term is added in series to pore resistance (W_d) accounting for diffusion of ions through the coating, as NaCl permeates into the coating. Finally, when water reaches the surface of the coating, an additional capacitive layer is formed at the water/metal interface. This is represented by double layer capacitance (represented with a CPE, Y_0) in parallel with charge transfer resistance (R_{ct}) (Figure G4).

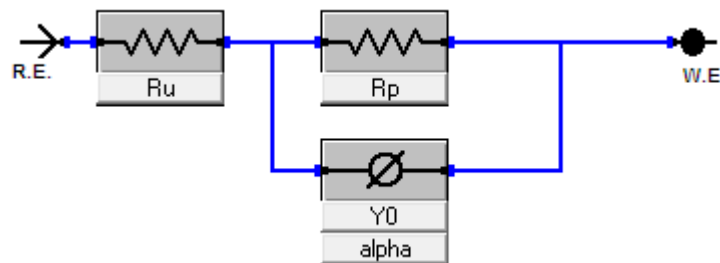

Figure G 2. Electrical equivalent circuit CPE used to fit the corrosion process of several coating systems.

State Job Number: 134935

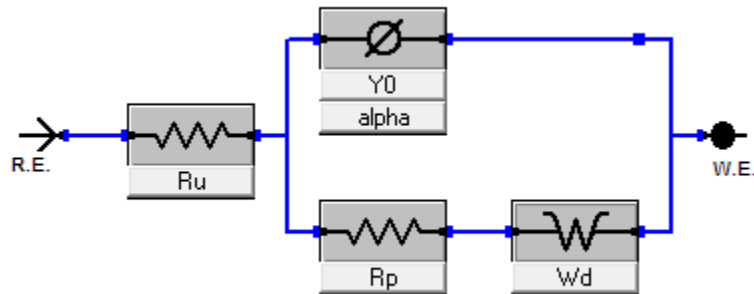

Figure G 3. Electrical equivalent circuit CPE with diffusion used to fit the corrosion process of several coating systems.

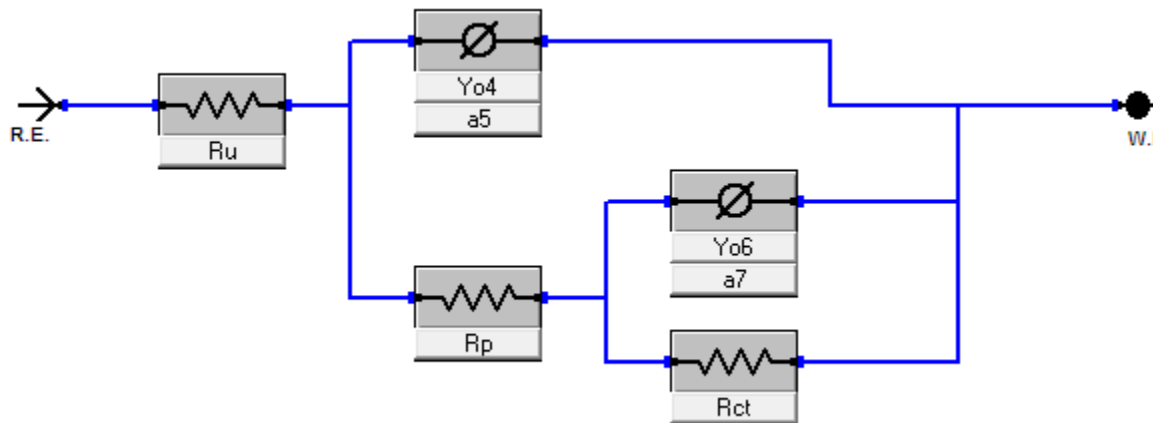

Figure G 4. Electrical equivalent (failed coating, FC) used to fit the corrosion process of coating systems.

ODOT Research Final Report

State Job Number: 134935

Experimental data is plotted below showing the evolution of the corrosion process for each of the coating systems studied in this work. Nyquist and Bode impedance illustrate the behavior of the different systems during immersion testing in 0.6 M NaCl solution for day 0, 7 and 43.

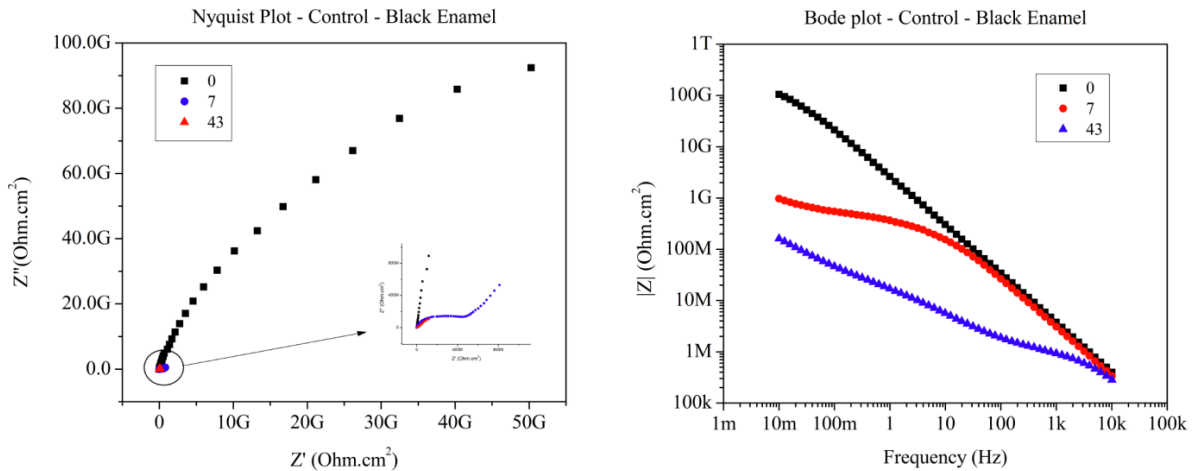

Figure G 5: Nyquist (left) and Bode (right) plots representing the electrochemical behavior of carbon steel panels coated with black enamel as a primary coating.

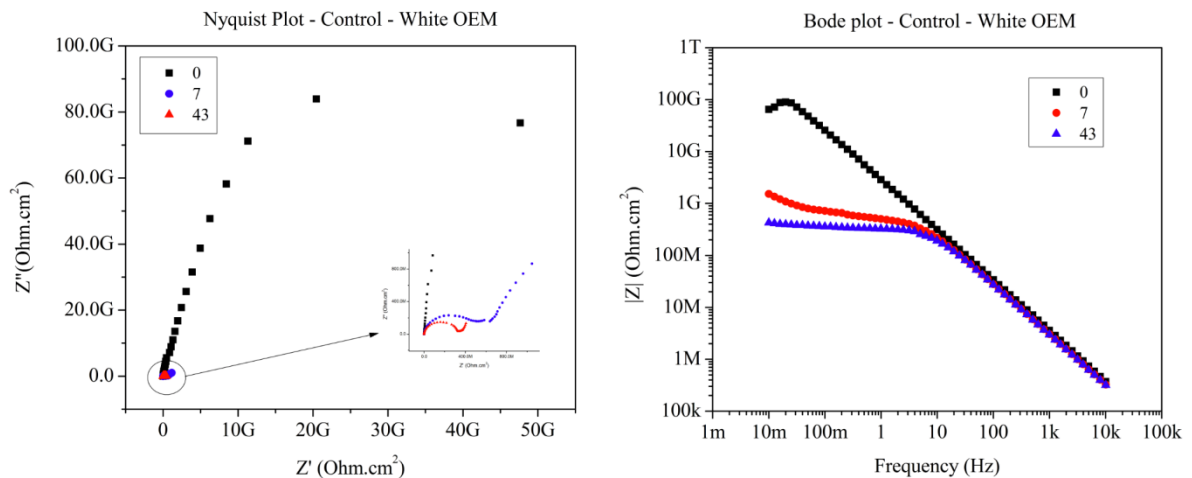

Figure G 6: Nyquist (left) and Bode (right) plots representing the electrochemical behavior of carbon steel panels coated with white OEM as a primary coating.

ODOT Research Final Report

State Job Number: 134935

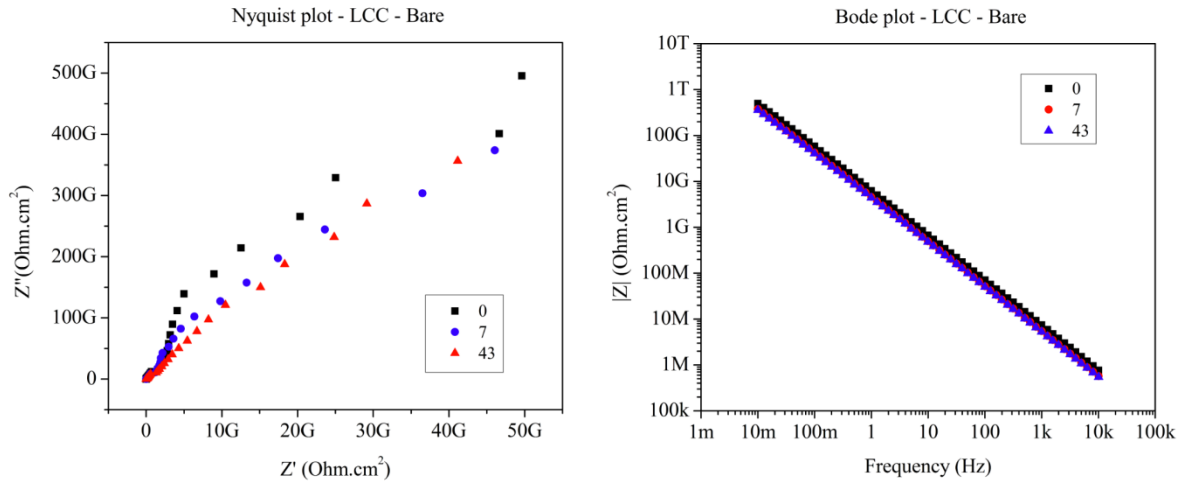

Figure G 7: Nyquist (left) and Bode (right) plots representing the electrochemical behavior of carbon steel panels coated with LCCOAT.

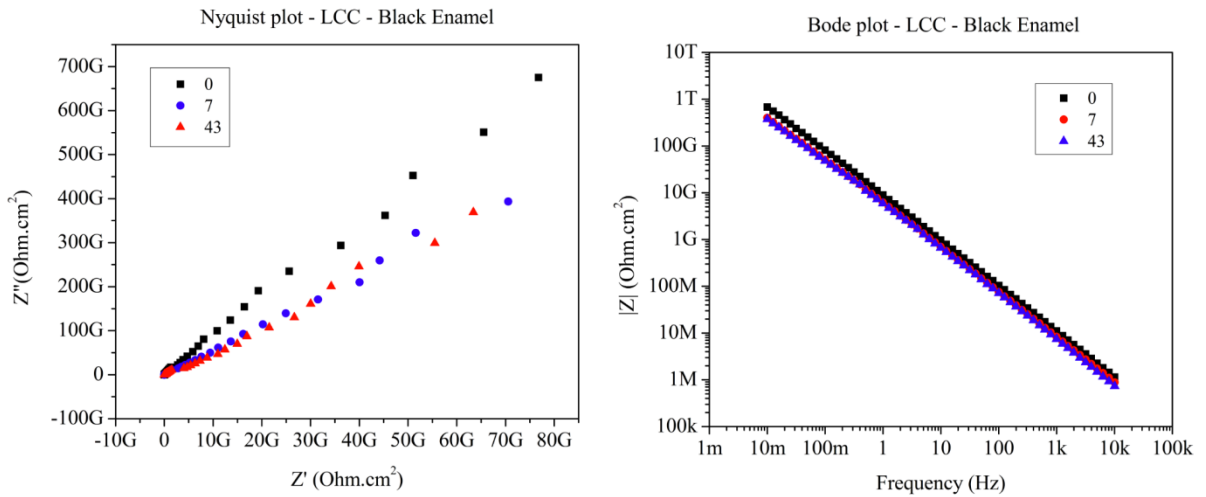

Figure G 8: Nyquist (left) and Bode (right) plots representing the electrochemical behavior of LCCOAT coated on carbon steel panels previously coated with black enamel.

State Job Number: 134935

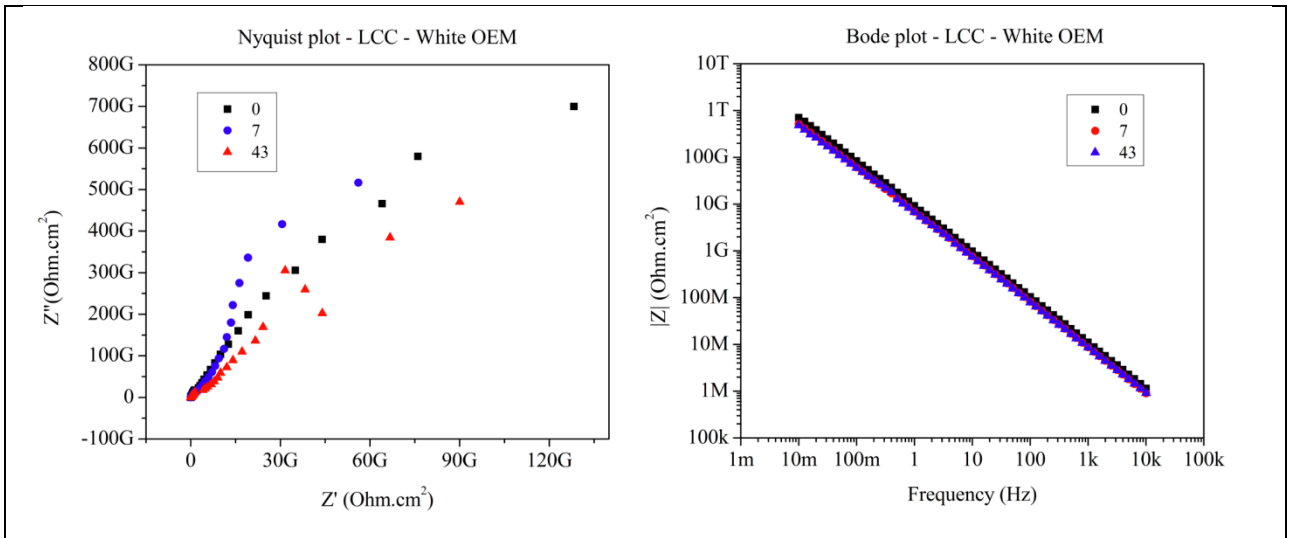

Figure G 9: Nyquist (left) and Bode (right) plots representing the electrochemical behavior of LCCOAT coated on carbon steel samples previously coated with white OEM.

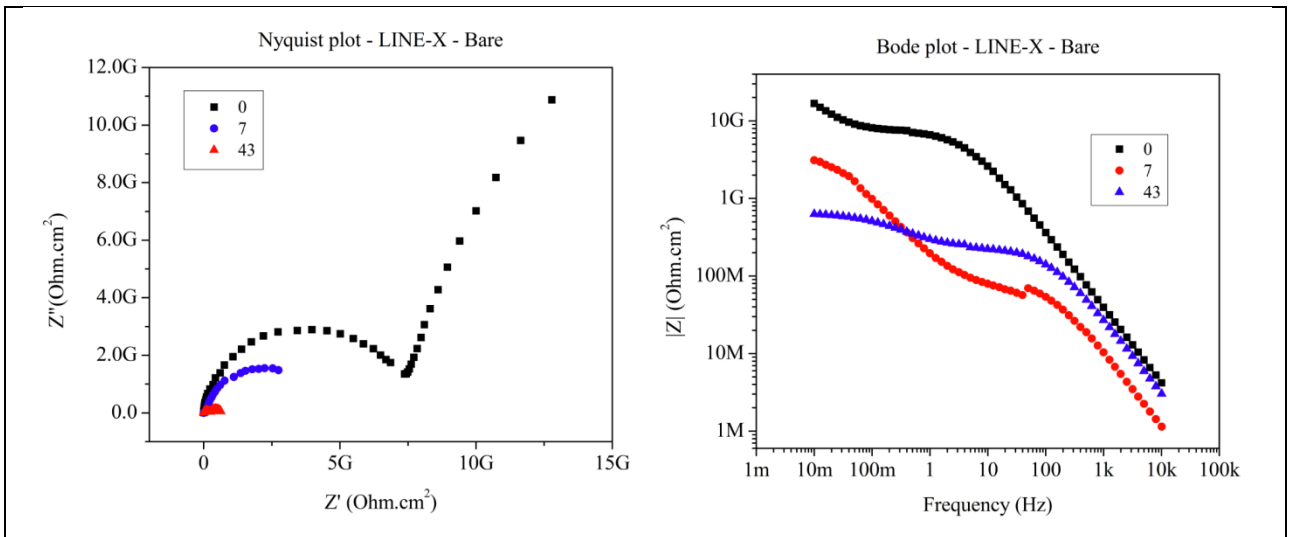

Figure G 10: Nyquist (left) and Bode (right) plots representing the electrochemical behavior of carbon steel panels coated with LINE-X.

State Job Number: 134935

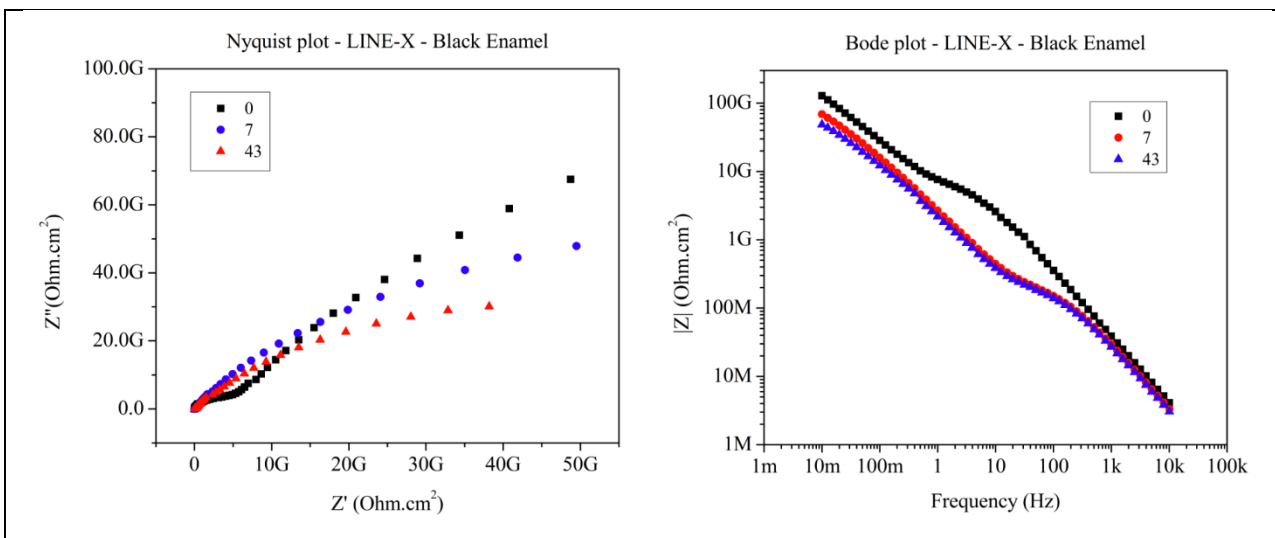

Figure G 11: Nyquist (left) and Bode (right) plots representing the electrochemical behavior of LINE-X coated on carbon steel samples previously coated with black enamel.

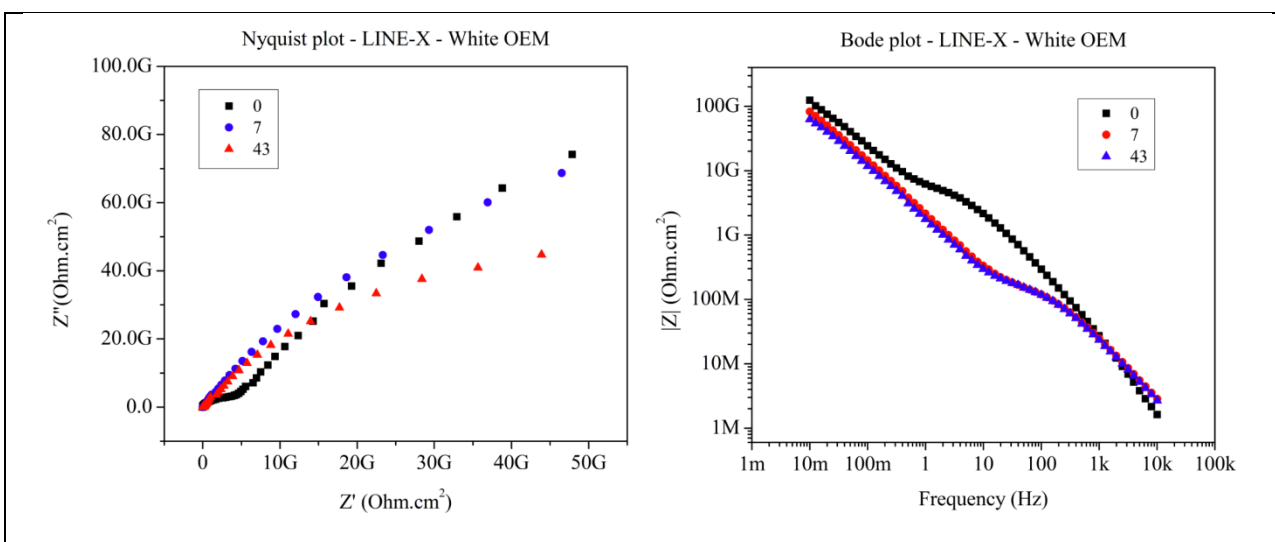

Figure G 12: Nyquist (left) and Bode (right) plots representing the electrochemical behavior of LINE-X coated on carbon steel samples previously coated with white OEM.

ODOT Research Final Report

State Job Number: 134935

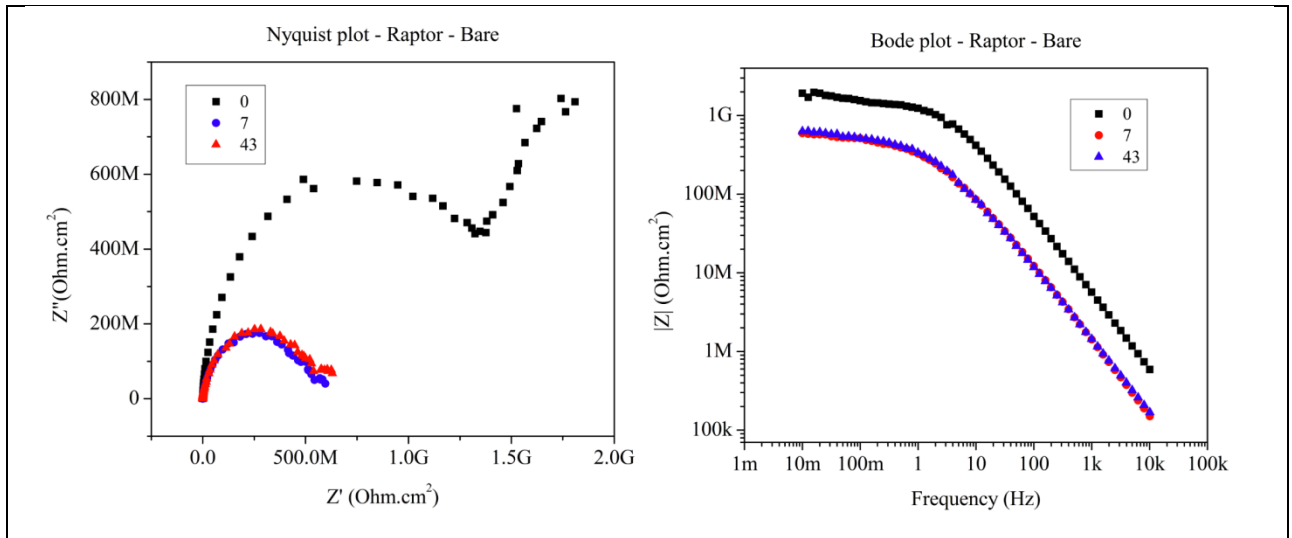

Figure G 13: Nyquist (left) and Bode (right) plots representing the electrochemical behavior of carbon steel panels coated with Raptor.

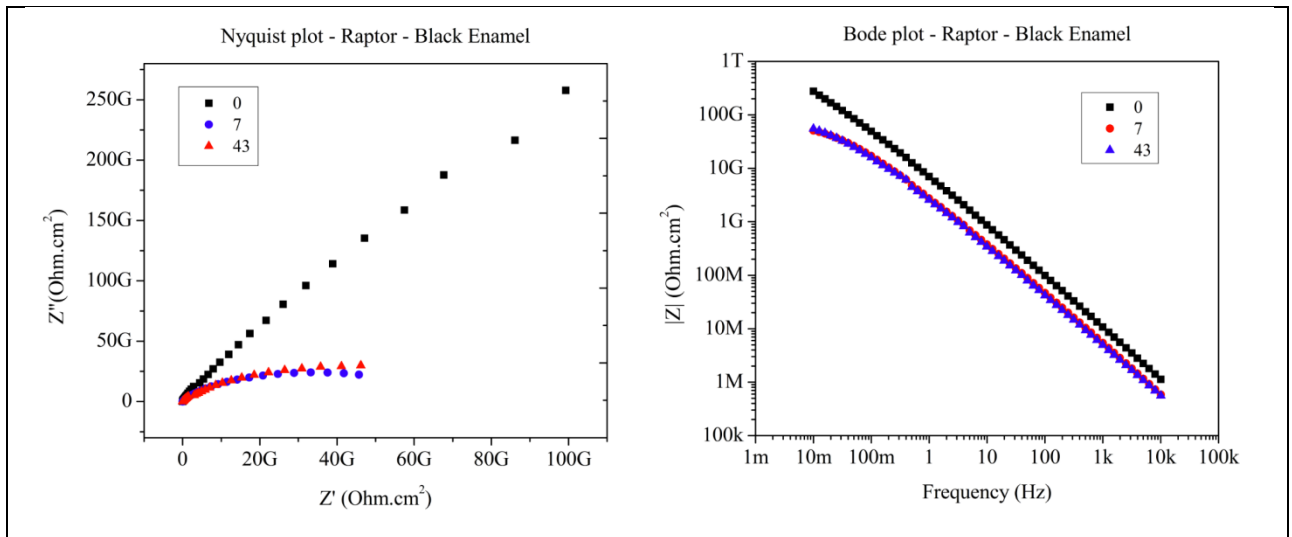

Figure G 14: Nyquist (left) and Bode (right) plots representing the electrochemical behavior of Raptor coated on carbon steel samples previously coated with black enamel.

State Job Number: 134935

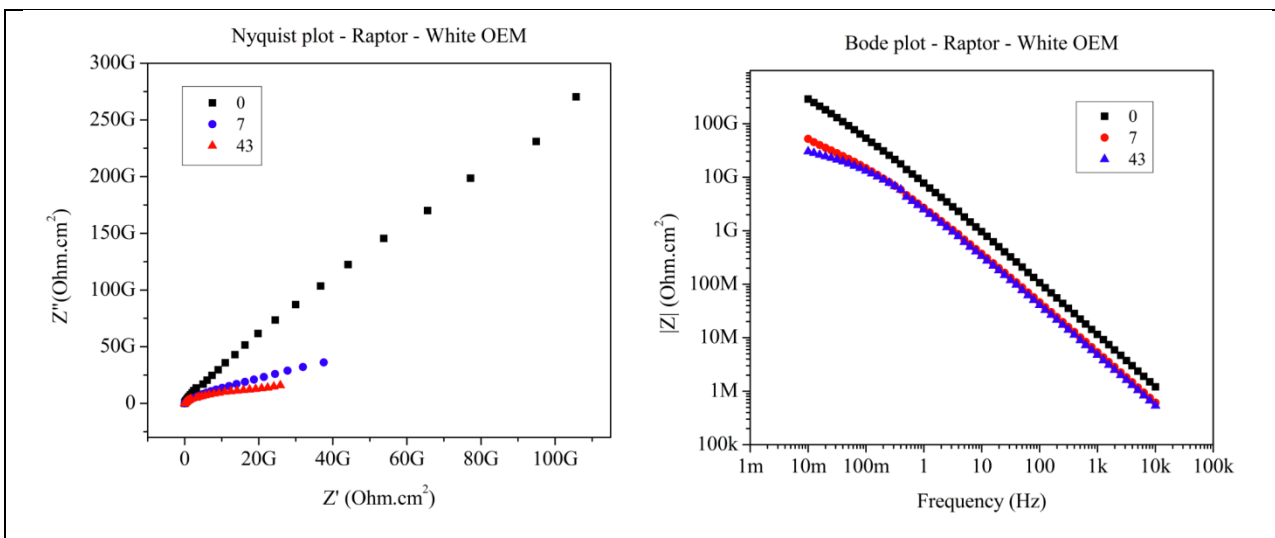

Figure G 15: Nyquist (left) and Bode (right) plots representing the electrochemical behavior of Raptor coated on carbon steel samples previously coated with white OEM.

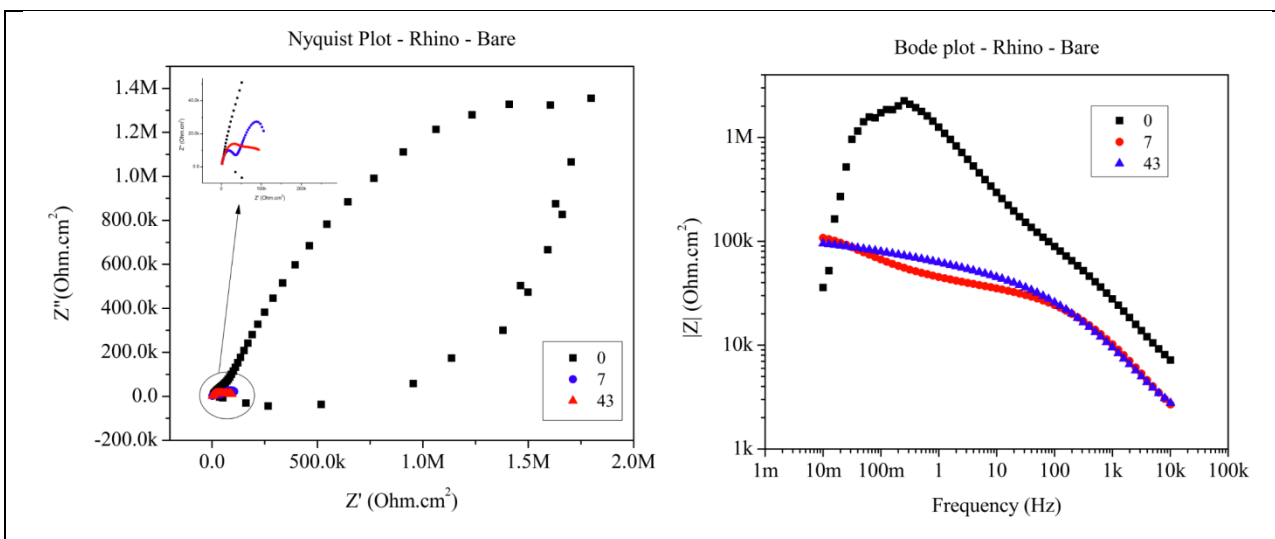

Figure G 16: Nyquist (left) and Bode (right) plots representing the electrochemical behavior of carbon steel panels coated with Rhino Linings.

ODOT Research Final Report

State Job Number: 134935

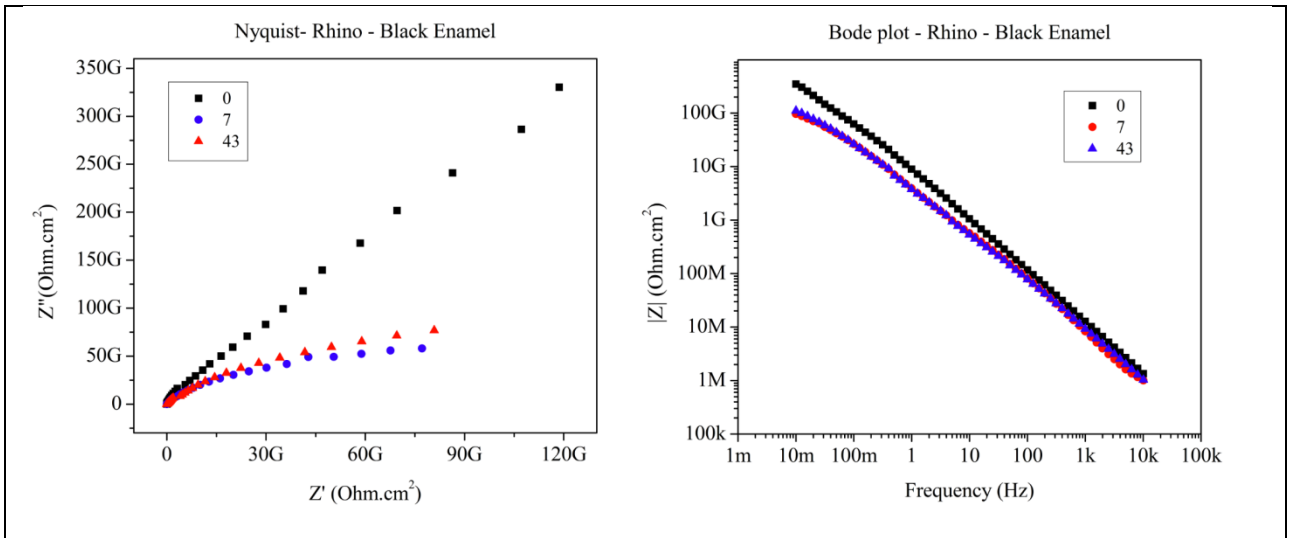

Figure G 17: Nyquist (left) and Bode (right) plots representing the electrochemical behavior of Rhino Linings coated on carbon steel samples previously coated with black enamel.

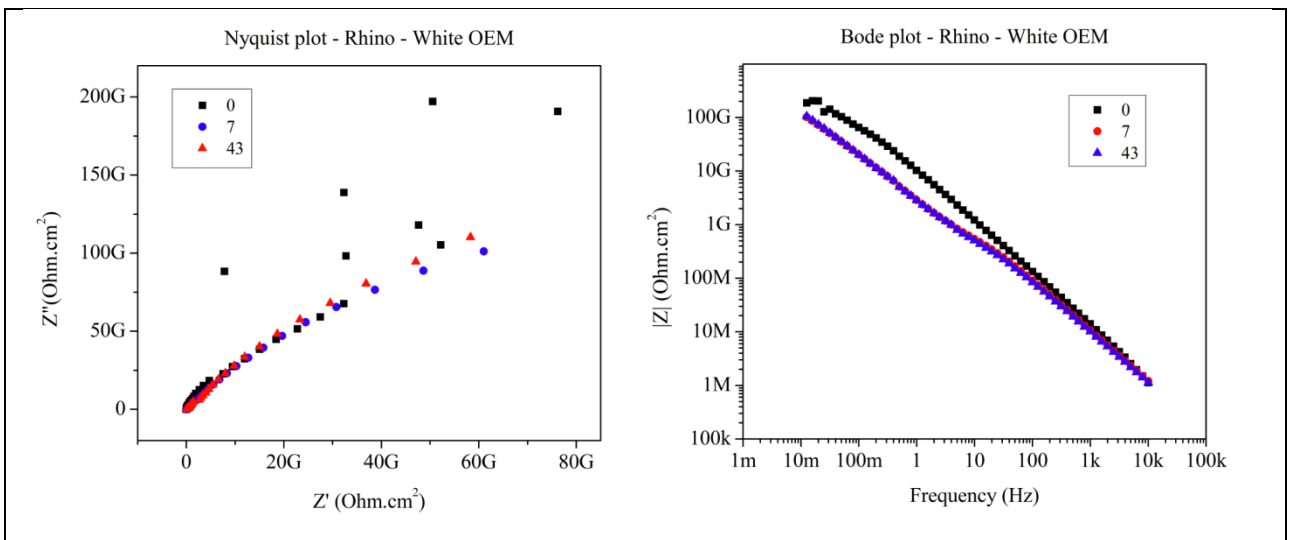

Figure G 18: Nyquist (left) and Bode (right) plots representing the electrochemical behavior of Rhino Linings coated on carbon steel samples previously coated with white OEM.

Figure G 5-**Error! Reference source not found.** show the Nyquist and Bode plots representing the electrochemical behavior of coated carbon steel panels for all coating systems on carbon steel. Nyquist plots were used to determine the appropriate equivalent circuit for parameter evaluation. All equivalent circuits used and the resulting fitting parameters can be found in Appendix G. Comparing Bode plots gives a quick overview of the overall performance of the surface treatment (coating) over time. For example, primary coatings (black enamel, white OEM) begin as “good” coatings and degrade to “intermediate” coatings over the 43 days of testing. LCCOAT, however, maintains a “good” coating performance throughout the 43 days. Coatings, such as LINE-X and Raptor, begin the testing as “intermediate” coatings, based on the shape of their Bode plots. However, the addition of a black enamel or white OEM primary coating underneath the Raptor coating increases the performance and coating quality over time. Rhino Linings, on the other hand, begins the test as a “poor” coating, due to the highly porous nature of the coating and performs similarly to black enamel and white OEM when applied on samples previously coated with said coating.

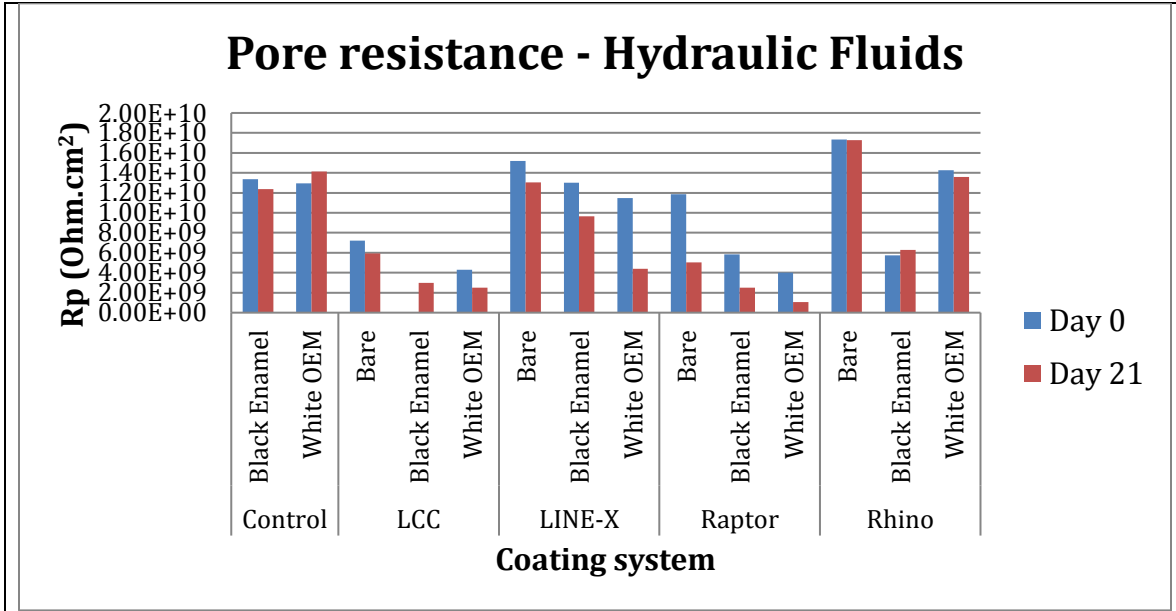

Figure G 19. Pore resistance of coating systems exposed to hydraulic fluids (AW32) over 21 days. Notice that LINE-X and Raptor have a large decrease in pore resistance, indicating a large uptake of motor oil into the coating. This may lead to a breakdown in the coating over time. Pore resistance of LCCCOAT on black enamel at day 0 was too large to be determined.

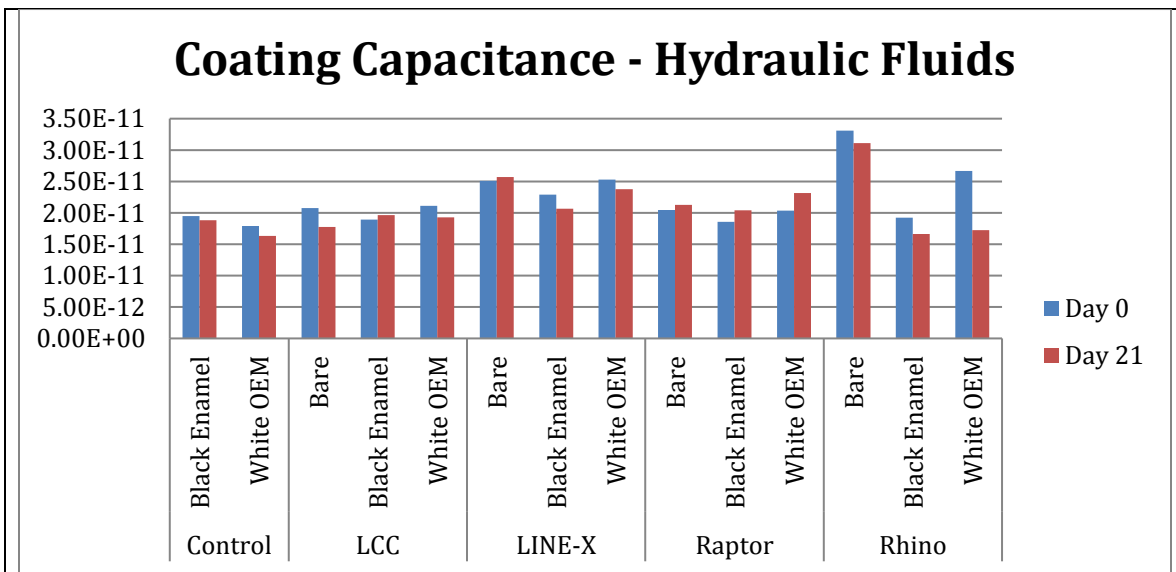

Figure G 20. Coating capacitance of coating systems exposed to hydraulic fluids (motor oil) over 21 days. Notice that most coatings have a small decrease in coating capacitance, indicating an uptake of motor oil into the coating. On the other hand, Raptor shows an increase in coating capacitance. As AW32 is less corrosive than sodium

State Job Number: 134935

chloride (see corrosion rate data below), an uptake of motor oil into the coating may actually protect the surface over time.

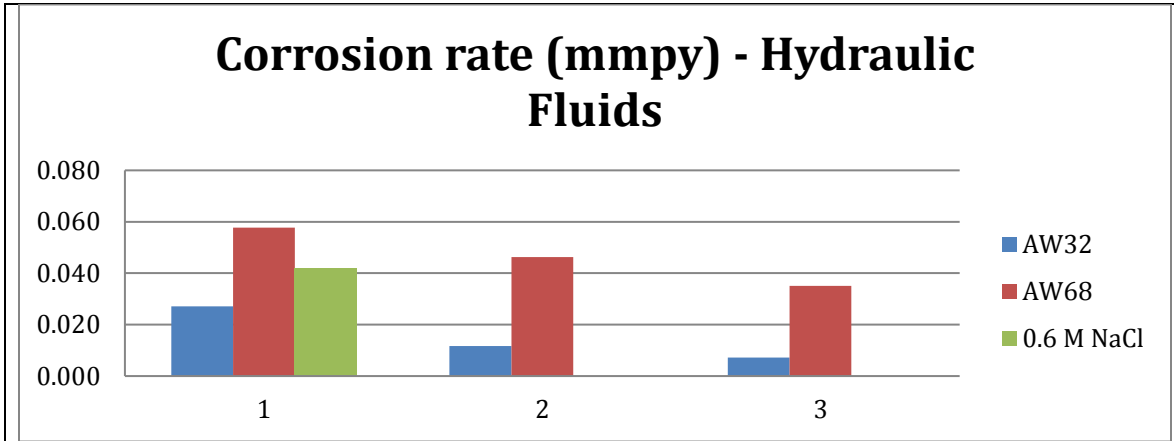

Figure G 21. Corrosion rate (mmpy) of increasing weight percent (1,2,3,wt%) of AW32 and AW68 compared to 0.6 M NaCl. Notice that AW32 is less corrosive than 0.6 NaCl and corrosivity decreases as weight percent of motor oil increases. Corrosion rate was determined using polarization curves and Tafel analysis.

APPENDIX H: IN FIELD PROCEDURES AND RESULTS

The evaluation of coating performance can be measured by determination of creep rate by following ASTM standard D1654[1] (Standard Test Method for Evaluation of Painted or Coated Specimens Subjected to Corrosive Environments). Coated panels were scribed with a computerized New Hermes Vanguard 3400 Engraver. Scribe line depth and width was 0.008 inch. Evaluated coatings were galvanized, light curable coating (LCCOAT), LINE-X, metalized, Raptor and Rhino Linings. Carbon steel (CS) metal panels were exposed to in field winter conditions from December 2014 to March 2015 by mounting (Figure H1) 10 different samples per truck in the front and back of 8 different salt trucks (see Table H1) in District 4 and 10 (Figure H2) in the state of Ohio. Creep rate measurements were determined using ImageJ (1.48v) software and results are presented in Tables H1-H2.

ODOT Research Final Report

State Job Number: 134935

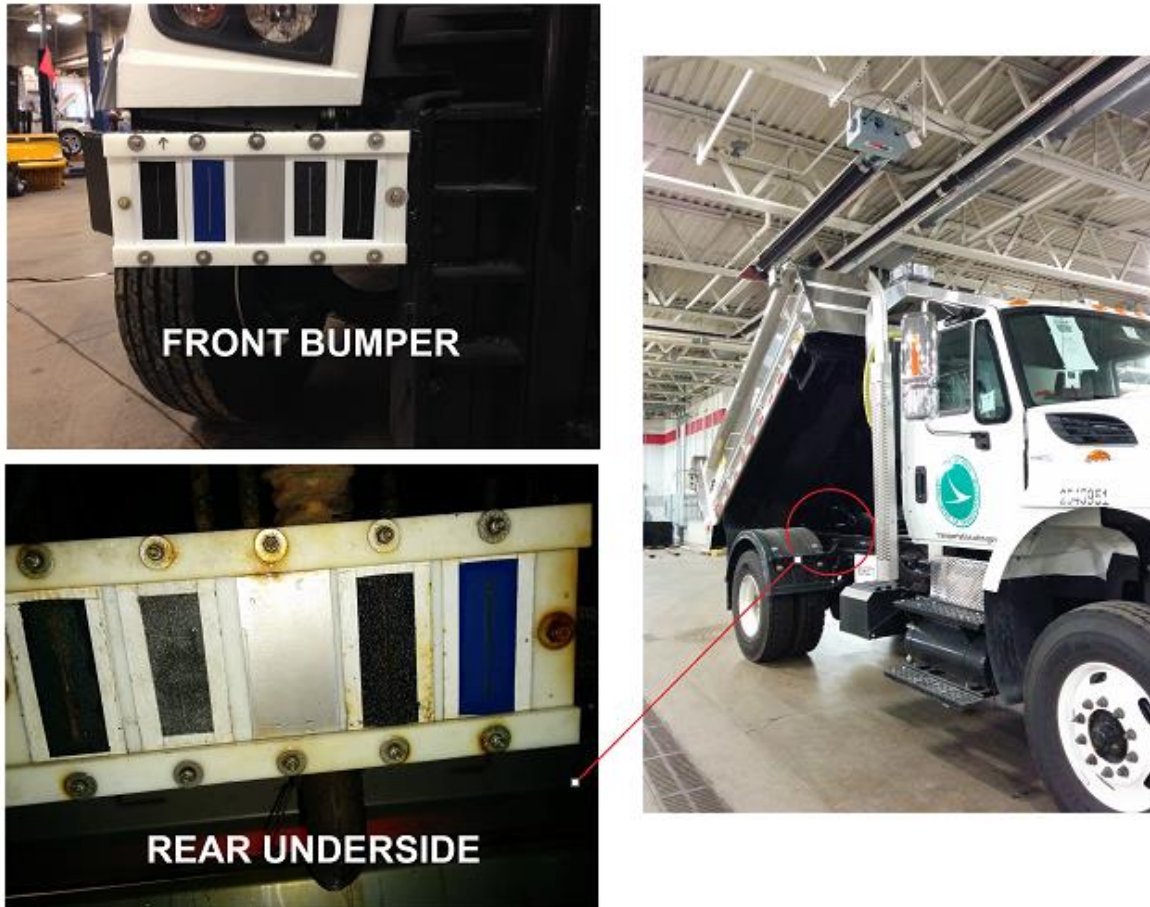
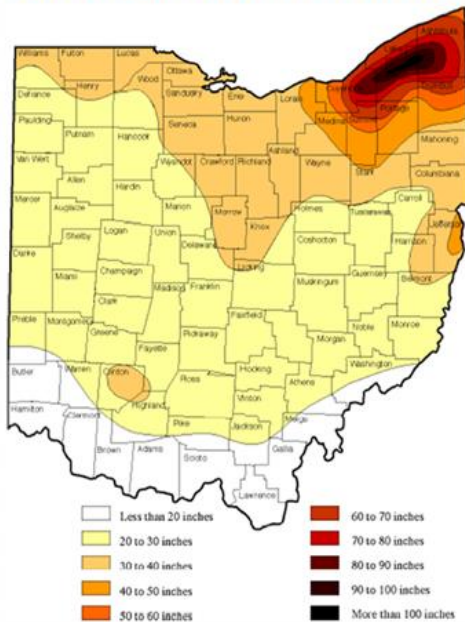

Figure H 1. Mounted scribed metal panels exposed to winter in field testing for 90 days.

State Job Number: 134935

Ohio Annual Snowfall



Ohio Districts



Figure H 2. Ohio annual snowfall and Ohio districts

Table H 1. Identification of salt trucks used in the evaluation of corrosion protective coatings during winter in field testing in District 4 and 10.

District 4					
Truck	Plate	County	Days	Miles	Type
1	T4 591	Summit	94	10158	Primary
2	T4 894	Summit	94	5948	Secondary
3	T4 747	Ashtabula	87	5923	Secondary
4	T4 851	Ashtabula	87	11416	Primary

District 10					
Truck	Plate	County	Days	Miles	Type
1	T10 714	Washington	87	5750	Primary
2	T10 658	Morgan	87	7068	Primary

ODOT Research Final Report

State Job Number: 134935

3	T10 646	Gallia	87	4438	Secondary
4	T10 521	Monroe	87	2613	Secondary

Table H 2. Scribed carbon steel panels mounted in District 4 salt trucks.

District 4							
Plate	Front			Panel #	Back		Panel #
		Primary Coating	Coating system		Primary Coating	Coating system	
T4 591	Truck 1	None	LINE-X	CS 001	Black enamel	LINE-X	CS 026
		White OEM	Control	CS 238	None	Galvanized	CS 151
		Stainless Steel		SS 001	Stainless Steel		SS 002
		Black enamel	Rhino	CS 051	None	Rhino	CS 035
		Black enamel	LCCOAT	CS 082	None	Raptor	CS 125
T4 894	Truck 2	White OEM	LCCOAT	CS 072	White OEM	Control	CS 244
		Black enamel	LINE-X	CS 027	Black enamel	Rhino	CS 055
		Stainless Steel		SS 03	Stainless Steel		SS 004
		Black enamel	Control	CS 233	None	LCCOAT	CS 066
		None	LCCOAT	CS 062	Black enamel	Control	CS 176
T 4 747	Truck 3	None	Raptor	CS 121	Black enamel	Raptor	CS 145
		White OEM	Raptor	CS 131	Black enamel	Control	CS 179
		Stainless Steel		SS 005	Stainless Steel		SS 006
		None	Galvanized	CS 181	None	LINE-X	CS 005
		White OEM	Rhino	CS 041	White OEM	LINE-X	CS 013
T 4 851	Truck 4	Black enamel	Raptor	CS 141	White OEM	Rhino	CS 044
		None	Rhino	CS 031	White OEM	Raptor	CS 135
		Stainless Steel		SS 007	Stainless Steel		SS 008
		White OEM	Control	CS 246	Black enamel	LCCOAT	CS 085
		White OEM	LINE-X	CS 017	White OEM	LCCOAT	CS 076

ODOT Research Final Report

State Job Number: 134935

Table H 3. Scribed carbon steel panels mounted in District 10 salt trucks.

District 10							
Plate	Front			Panel #	Back		Panel #
		Primary Coating	Coating system		Primary Coating	Coating system	
T 10 714	Truck 1	None	LCCOAT	CS 063	Black enamel	LCCOAT	CS 086
		White OEM	Raptor	CS 133	White OEM	LINE-X	CS 015
		Stainless Steel		SS 017	Stainless Steel		SS 018
		White OEM	Rhino	CS 046	Black enamel	Rhino	CS 054
		Black enamel	Control	CS 231	Black enamel	Raptor	CS 144
T 10 658	Truck 2	White OEM	LCCOAT	CS 073	White OEM	Control	CS 242
		None	LINE-X	CS 004	White OEM	LCCOAT	CS 075
		Stainless Steel		SS 019	Stainless Steel		SS 020
		None	Raptor	CS 123	Black enamel	LINE-X	CS 022
		Black enamel	LCCOAT	CS 084	Black enamel	Control	CS 180
T 10 646	Truck 3	White OEM	LINE-X	CS 014	None	Raptor	CS 124
		Black enamel	Raptor	CS 143	None	LINE-X	CS 003
		Stainless Steel		SS 021	Stainless Steel		SS 022
		Black enamel	LINE-X	CS 021	None	LCCOAT	CS 065
		None	Galvanized	CS 156	White OEM	Rhino	CS 045
T 10 521	Truck 4	Black enamel	Rhino	CS 053	White OEM	Raptor	CS 134
		Black enamel	Control	CS 232	None	Galvanized	CS 187
		Stainless Steel		SS 023	Stainless Steel		SS 024
		White OEM	Control	CS 241	None	Rhino	CS 034
		None	Rhino	CS 033	White OEM	Control	CS 243

Evaluation of scribed panels was determined by representative mean creepage from scribe and the rating system in Table H4.

ODOT Research Final Report

State Job Number: 134935

Table H 4. Rating of failure at scribe.

Representative Mean Creepage From Scribe		
Millimetres	Inches (Approximate)	Rating Number
Zero	0	10
Over 0 to 0.5	0 to $\frac{1}{64}$	9
Over 0.5 to 1.0	$\frac{1}{64}$ to $\frac{1}{32}$	8
Over 1.0 to 2.0	$\frac{1}{32}$ to $\frac{1}{16}$	7
Over 2.0 to 3.0	$\frac{1}{16}$ to $\frac{1}{8}$	6
Over 3.0 to 5.0	$\frac{1}{8}$ to $\frac{3}{16}$	5
Over 5.0 to 7.0	$\frac{3}{16}$ to $\frac{1}{4}$	4
Over 7.0 to 10.0	$\frac{1}{4}$ to $\frac{3}{8}$	3
Over 10.0 to 13.0	$\frac{3}{8}$ to $\frac{1}{2}$	2
Over 13.0 to 16.0	$\frac{1}{2}$ to $\frac{5}{8}$	1
Over 16.0 to more	$\frac{5}{8}$ to more	0

ODOT Research Final Report



State Job Number: 134935

Table H 5. Creep rate results for District 4 after exposure of carbon metal panels to winter in field testing.

Truck #	Location	Coating system	Primary Coating	Panel #	Creep rate (mm)	Rate
1	Back	Rhino Linings	None	35	0.667	8
		Raptor	None	125	0.375	9
		Line-X	Black Enamel	26	1.425	7
		Galvanized	None	151	0.440	9
	Front	Rhino Linings	Black Enamel	51	0.810	8
		LCCOAT	Black Enamel	82	0.630	8
		Control	White OEM	238	4.582	5
		Line-X	None	1	1.265	7
2	Back	LCCOAT	None	66	0.385	9
		Control	Black Enamel	176	0.343	9
		Control	White OEM	224	0.327	9
		Rhino Linings	Black Enamel	55	0.802	8
	Front	Control	Black Enamel	233	0.332	9
		LCCOAT	None	62	0.320	9
		LCCOAT	White OEM	72	0.575	8
		Line-X	Black Enamel	27	1.197	7
3	Back	Galvanized	None	181	0.365	9
		Rhino Linings	White OEM	41	0.718	8
		Raptor	None	121	0.350	9
		Raptor	White OEM	131	0.512	8
	Front	Line-X	None	5	0.937	8
		Line-X	White OEM	13	1.027	7
		Raptor	Black Enamel	145	0.558	8
		Control	Black Enamel	179	0.385	9
4	Back	LCCOAT	Black Enamel	85	0.477	9
		LCCOAT	White OEM	76	0.472	9
		Rhino Linings	White OEM	44	0.713	8
		Raptor	White OEM	135	0.583	8
	Front	Control	White OEM	246	1.912	7
		Line-X	White OEM	17	1.285	7
		Raptor	Black Enamel	141	1.508	7
		Rhino Linings	None	31	0.337	9

ODOT Research Final Report

State Job Number: 134935

Table H 6. Creep rate results for District 10 after exposure of carbon metal panels to winter in field testing.

Truck #	Location	Coating system	Primary Coating	Panel #	Creep rate (mm)	Rate
1	Back	Rhino Linings	White OEM	46	0.915	8
		Control	Black Enamel	231	2.978	6
		LCCOAT	None	63	3.787	5
		Raptor	White OEM	133	0.590	8
	Front	Rhino Linings	Black Enamel	54	0.783	8
		Raptor	Black Enamel	144	0.575	8
		LCCOAT	Black Enamel	86	0.565	8
		Line-X	White OEM	15	1.270	7
2	Back	Line-X	Black Enamel	22	1.188	7
		Control	Black Enamel	180	0.363	9
		Control	White OEM	242	0.630	8
		LCCOAT	White OEM	75	0.560	8
	Front	Raptor	None	123	0.337	9
		LCCOAT	Black Enamel	84	0.467	9
		LCCOAT	White OEM	73	1.902	7
		Line-X	None	4	0.978	8
3	Back	Line-X	Black Enamel	21	0.947	8
		Galvanized	Bare	156	0.468	9
		Line-X	White OEM	14	0.902	8
		Raptor	Black Enamel	143	0.452	9
	Front	LCCOAT	None	65	0.343	9
		Rhino Linings	White OEM	45	0.880	8
		Raptor	None	124	0.398	9
		Line-X	None	3	1.058	7
4	Back	Rhino Linings	None	34	0.783	8
		Control	White OEM	243	0.782	8
		Raptor	White OEM	134	0.747	8
		Galvanized	None	187	0.467	9
	Front	Control	White OEM	241	0.312	9
		Rhino Linings	None	33	0.713	8
		Rhino Linings	Black Enamel	53	1.035	7
		Control	Black Enamel	232	0.317	9

ODOT Research Final Report

State Job Number: 134935

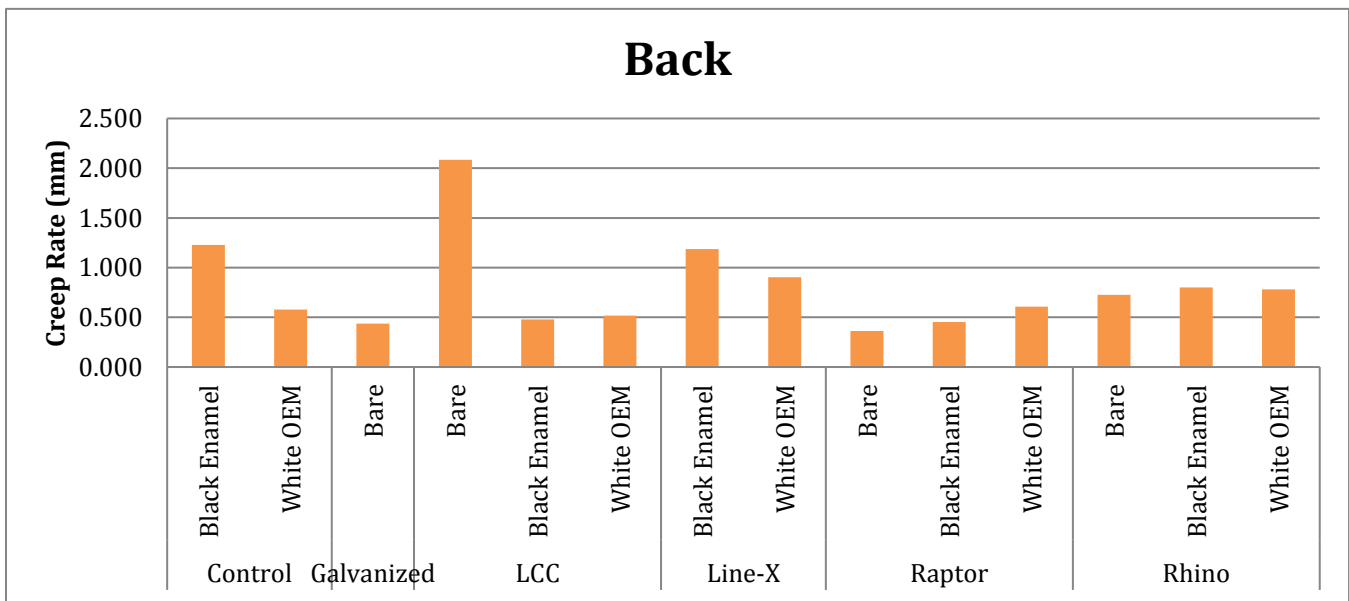
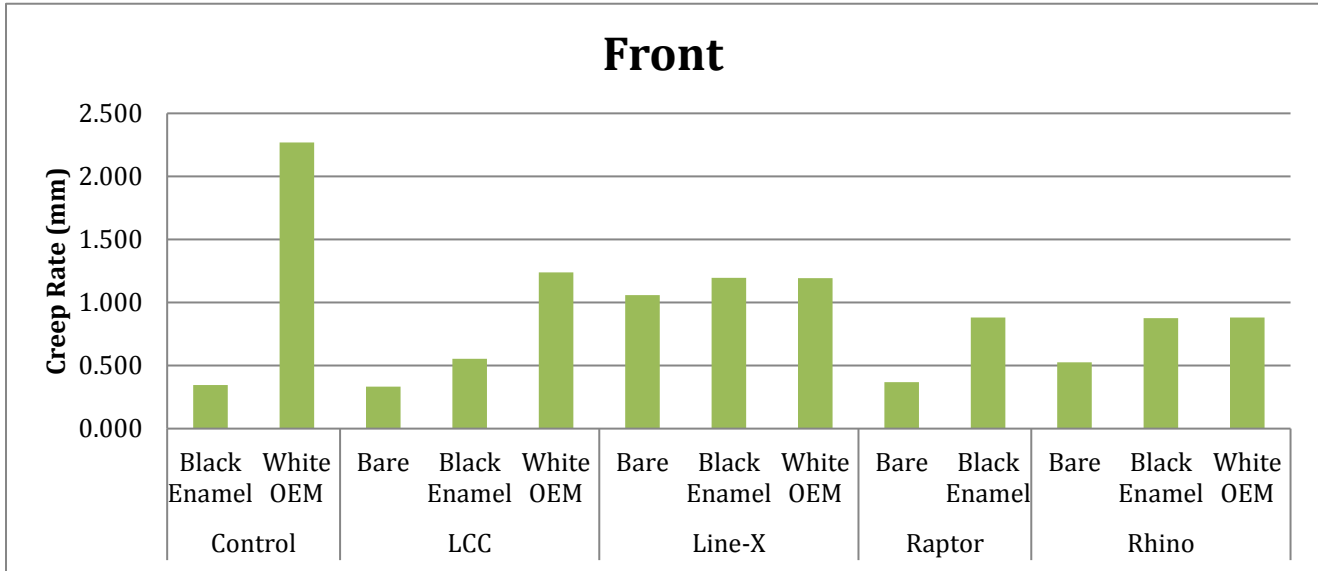

Figure H 3. Representative creep rate measurements in mm of exposed metal panels to winter in field testing for 90 days.

State Job Number: 134935

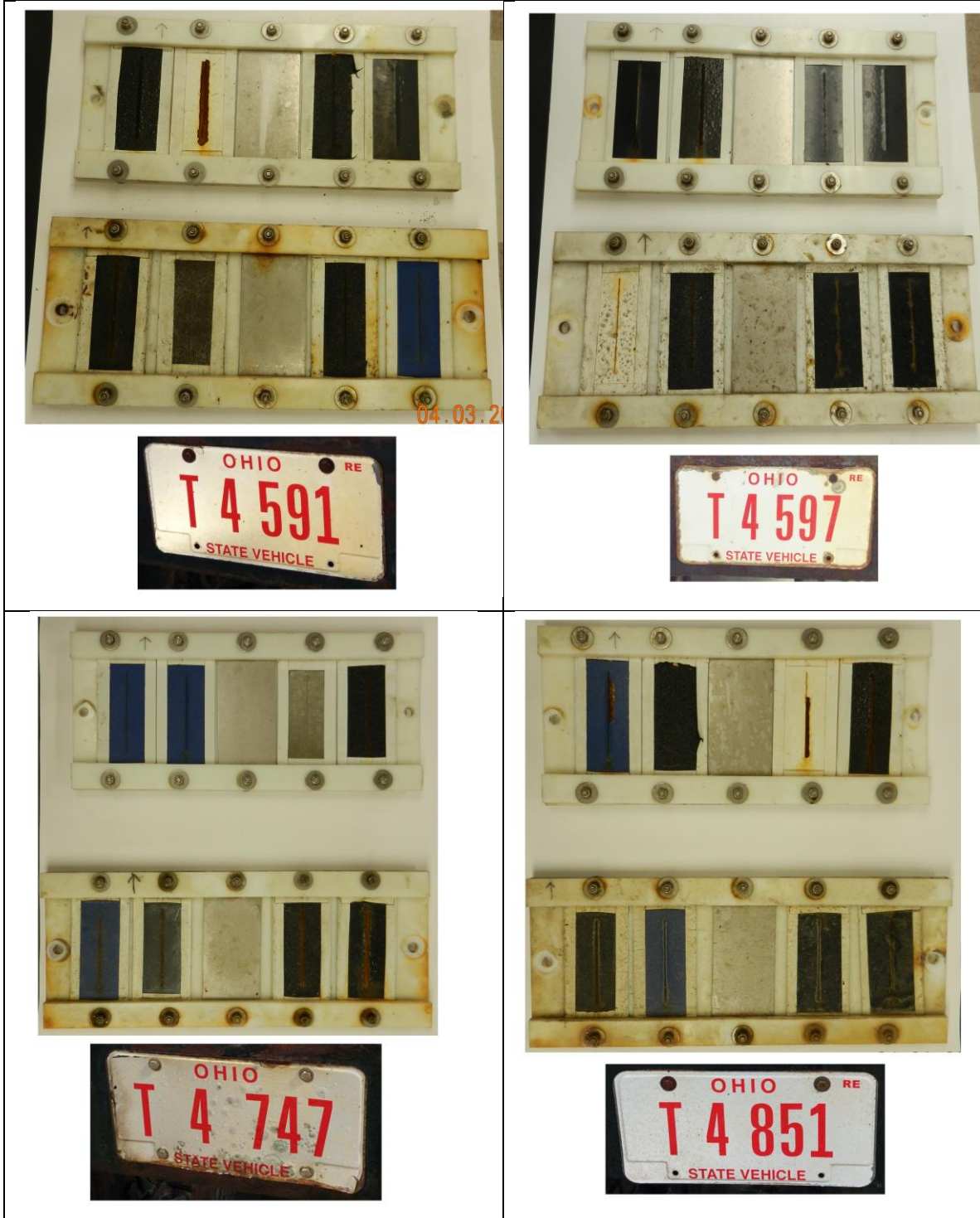

Figure H 4: Panels from District 4 salt trucks after 90 days of exposure in the winter of 2015

ODOT Research Final Report

State Job Number: 134935



ODOT Research Final Report

State Job Number: 134935

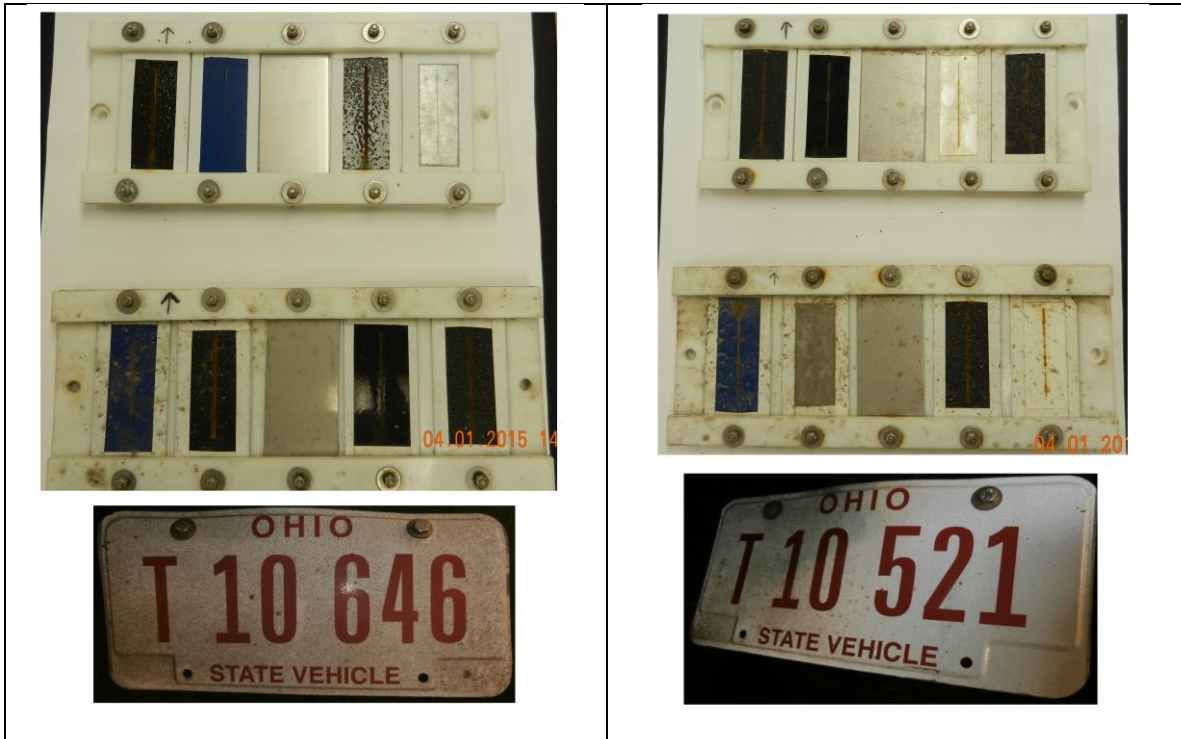

Figure H 5: Panels from District 10 salt trucks after 90 days of exposure in the winter of 2015



State Job Number: 134935

APPENDIX I: XRD: IN FIELD TESTING

Characterization of iron oxides formed on the surface of three carbon steel (CS) coated metal panels exposed to winter in field testing (mounted on salt trucks) for 90 days was performed by X-ray powder diffraction (XRD). Iron oxides were removed from the surface of CS panels scribe and collected between two glass slides. The iron oxide powder was then transferred to a glass holder and treated with acetone for purification. Table I1 shows the labeling of the selected CS samples.

Table I 1. Identification of scribed CS samples exposed to winter in field testing.

Identification	Coating system	Primary Coating	Panel #	Location	Truck #	Area
LinST	LINE-X	None	1	District 4	1	Front
RaST	Raptor	None	125	District 4	1	Back
RhST	Rhino Linings	None	33	District 10	4	Front

XRD spectra were measured with a Rigaku Ultima IV X-ray diffractometer (Rigaku Corporation, Tokyo, Japan) using filtered Cu-K-alpha radiation at 40 kV and 35 mA, scan speed: 1.0 deg./min, step width: 0.04 deg, scan axis: 2theta/theta, scan range: 5.0000 - 70.0000 deg, incident slit: 1 deg and continuous scan mode. XRD spectra are shown in Figure I1, I2 and I3 for LinST, RaST and RhST respectively.

ODOT Research Final Report

State Job Number: 134935

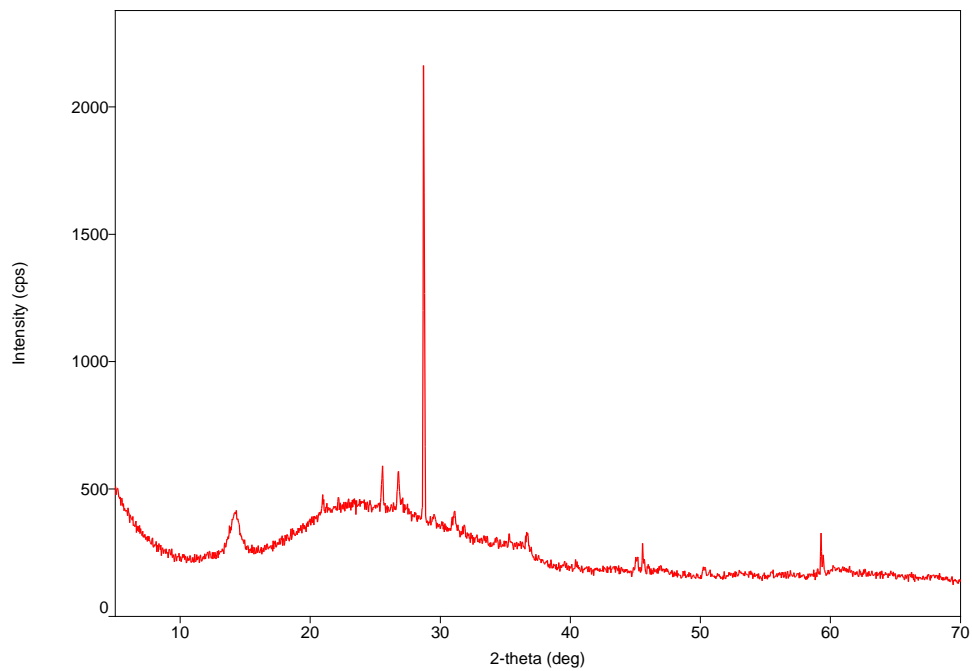

Figure I 1. XRD spectra of LinST.

ODOT Research Final Report

State Job Number: 134935

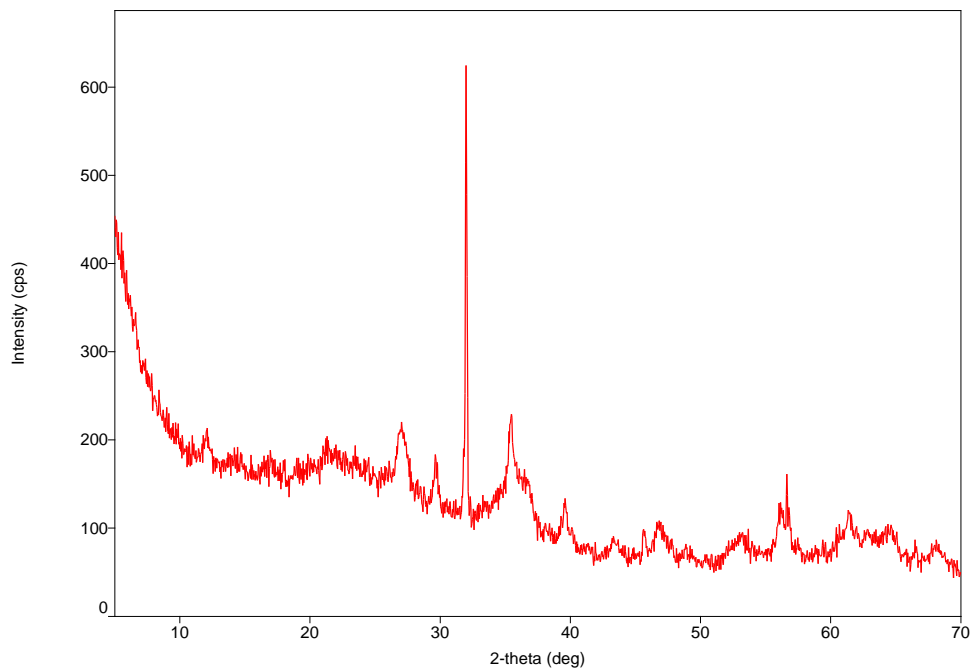

Figure I 2. XRD spectra of RaST.

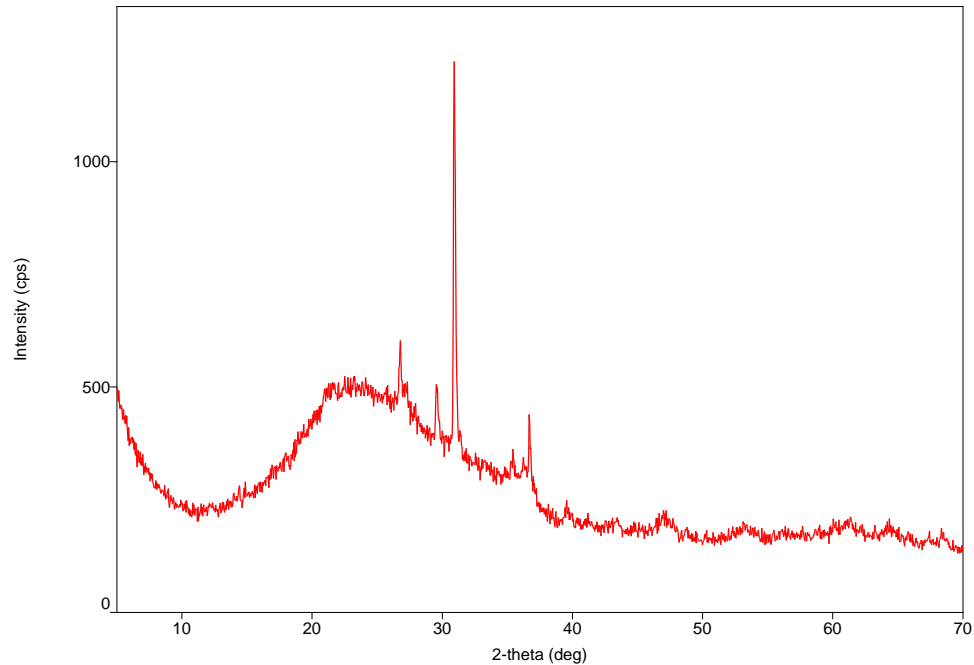

Figure I 3. XRD spectra of RhST.

Structural identification of corrosion products of scribed coated metal panels was performed with powder diffraction analysis software suite PDXL V2 from Rigaku Corporation. Diffraction spectra of corrosion products indicate the formation of magnetite ($Fe_2^{3+}Fe^{2+}O_4$), goethite ($Fe^{3+}O(OH)$) and hematite ($Fe_2^{3+}O_3$) and carbon oxide (CO_2). Figures I4-I7 show the pattern of each of these species.

ODOT Research Final Report

State Job Number: 134935

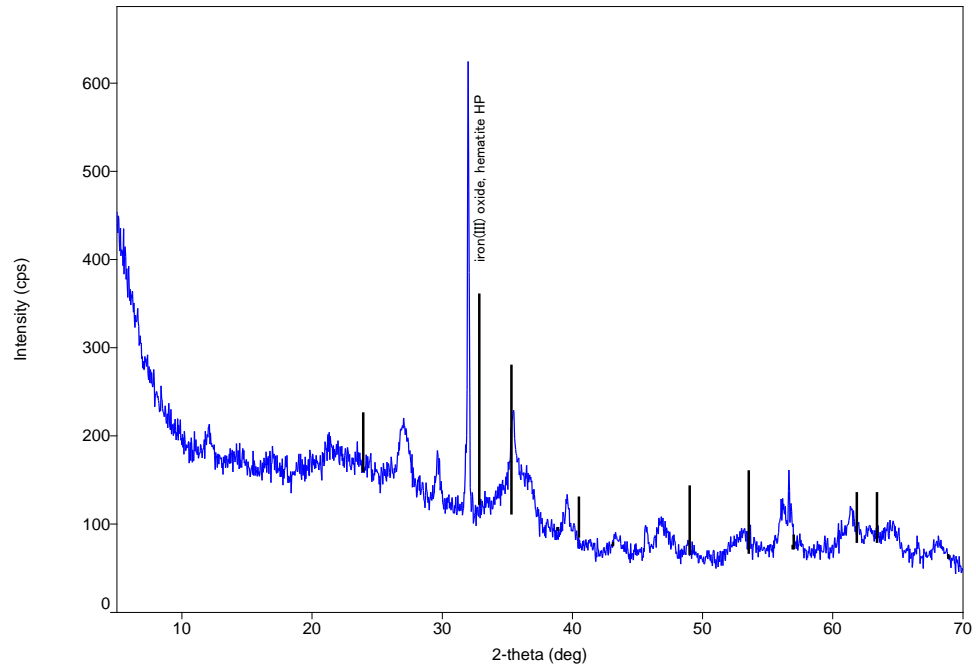

Figure I 4. Diffraction spectra of magnetite in RaST.

ODOT Research Final Report

State Job Number: 134935

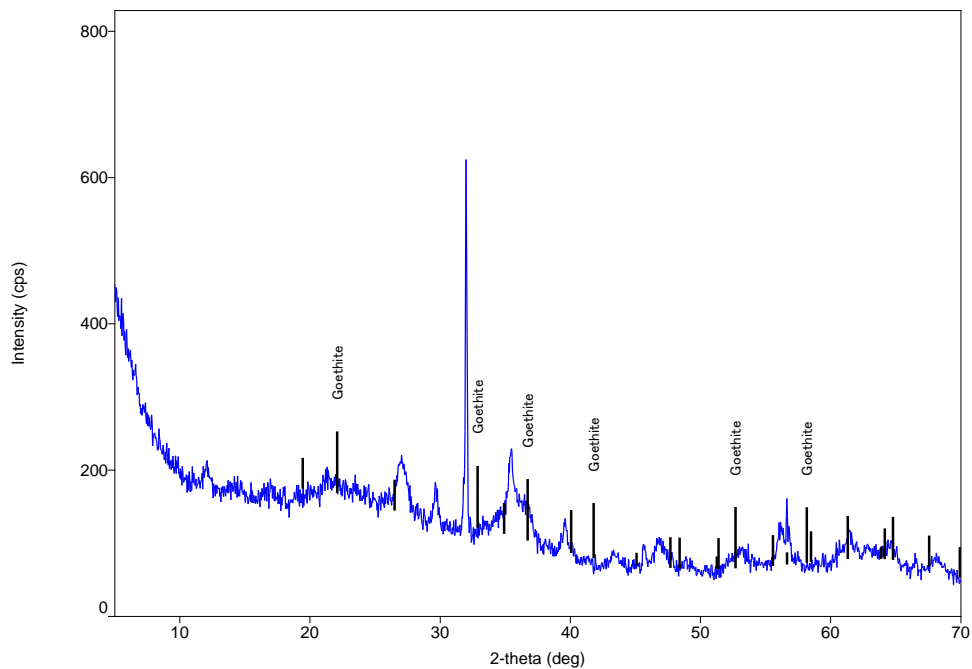

Figure I 5. Diffraction spectra of goethite in RaST.

ODOT Research Final Report

State Job Number: 134935

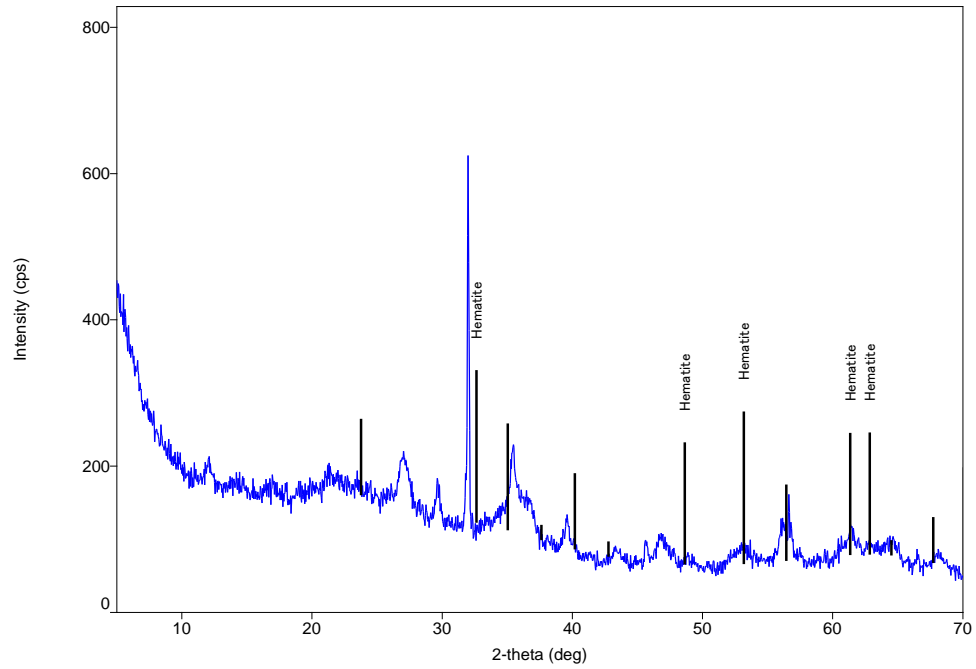

Figure I 6. Diffraction spectra of hematite in RaST.

ODOT Research Final Report

State Job Number: 134935

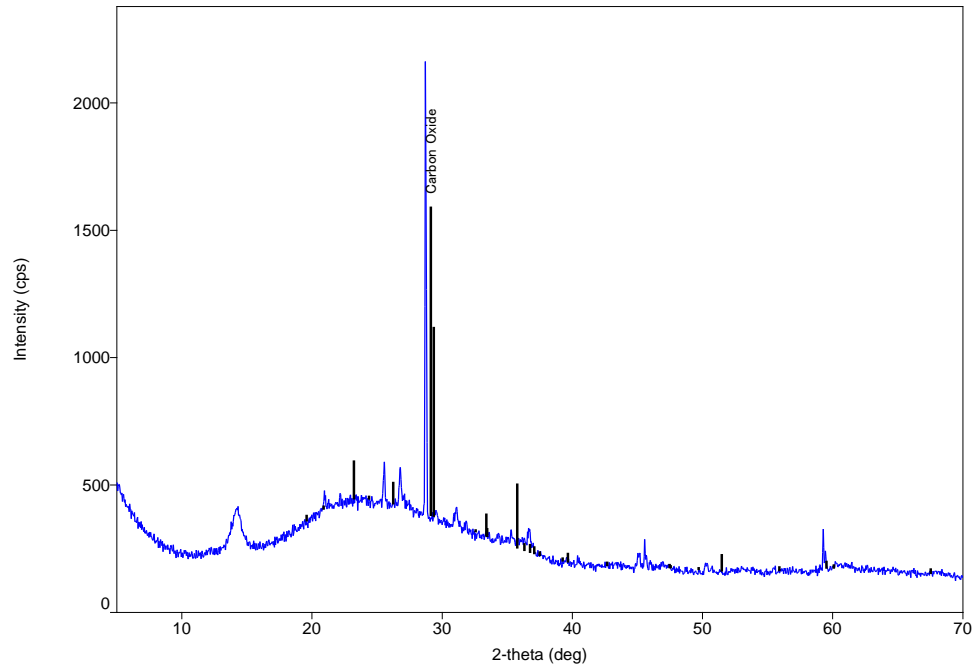

Figure I 7. Diffraction spectra of carbon oxide in RaST.

State Job Number: 134935

APPENDIX J: STEREO IMAGES FROM IN FIELD TESTING

Scribed coated metal panels exposed to winter in field testing for 90 days in District 4 and District 10 of Ohio Department of Transportation (ODOT) were analyzed using stereo microscopy imaging. Samples were cut in sections as seen previously in Appendix E (Figure E1) and mounted on a cold mount epoxy resin. Images were acquired using an Olympus SZX16 stereo microscope paired with a camera Olympus SC100 and processed using software CellSense standard 1.8.1 (Olympus Corporation, Tokyo, Japan) after preparing the samples by polishing the surface under standard ANSI silicon carbide papers of different grades ranging from 240 to 1200.

Cross-sections of corroded metal panels were analyzed to determine corrosion density and coating delamination length. Stereo images are presented below by following the guide in Table J1. Raw images for district 4 are shown in Figures J1-J5.

ODOT Research Final Report

State Job Number: 134935

Table J 1. Coating systems used in this study and evaluated under winter in field testing in District 4 for carbon steel panels for 90 days.

Panel #	Truck #	Location	Coating system	Primary Coating
179	3	Front	Control	Black Enamel
238	1	Front		White OEM
66	2	Back	LCCOAT	None
82	1	Front		Black Enamel
72	2	Front		White OEM
1	1	Front	Line-X	None
26	1	Back		Black Enamel
17	4	Front		White OEM
125	1	Back	Raptor	None
141	4	Front		Black Enamel
135	4	Back		White OEM
35	1	Back	Rhino Linings	None
51	1	Front		Black Enamel
41	3	Back		White OEM

State Job Number: 134935

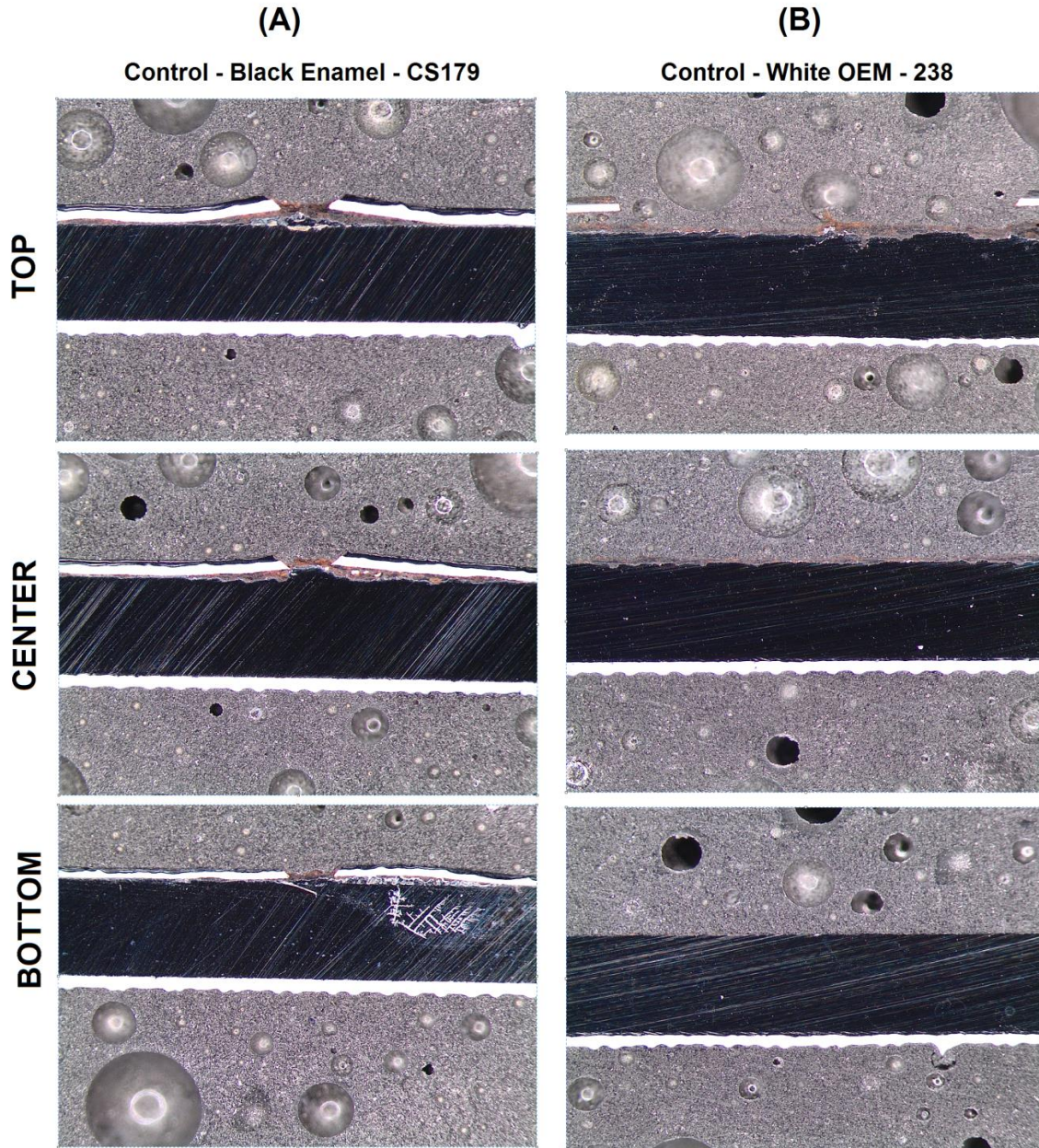

Figure J 1. Carbon steel top, center and bottom cross-sections image of (A) control/black enamel and (B) control/white OEM systems after 90-day exposure to winter in field testing.

State Job Number: 134935

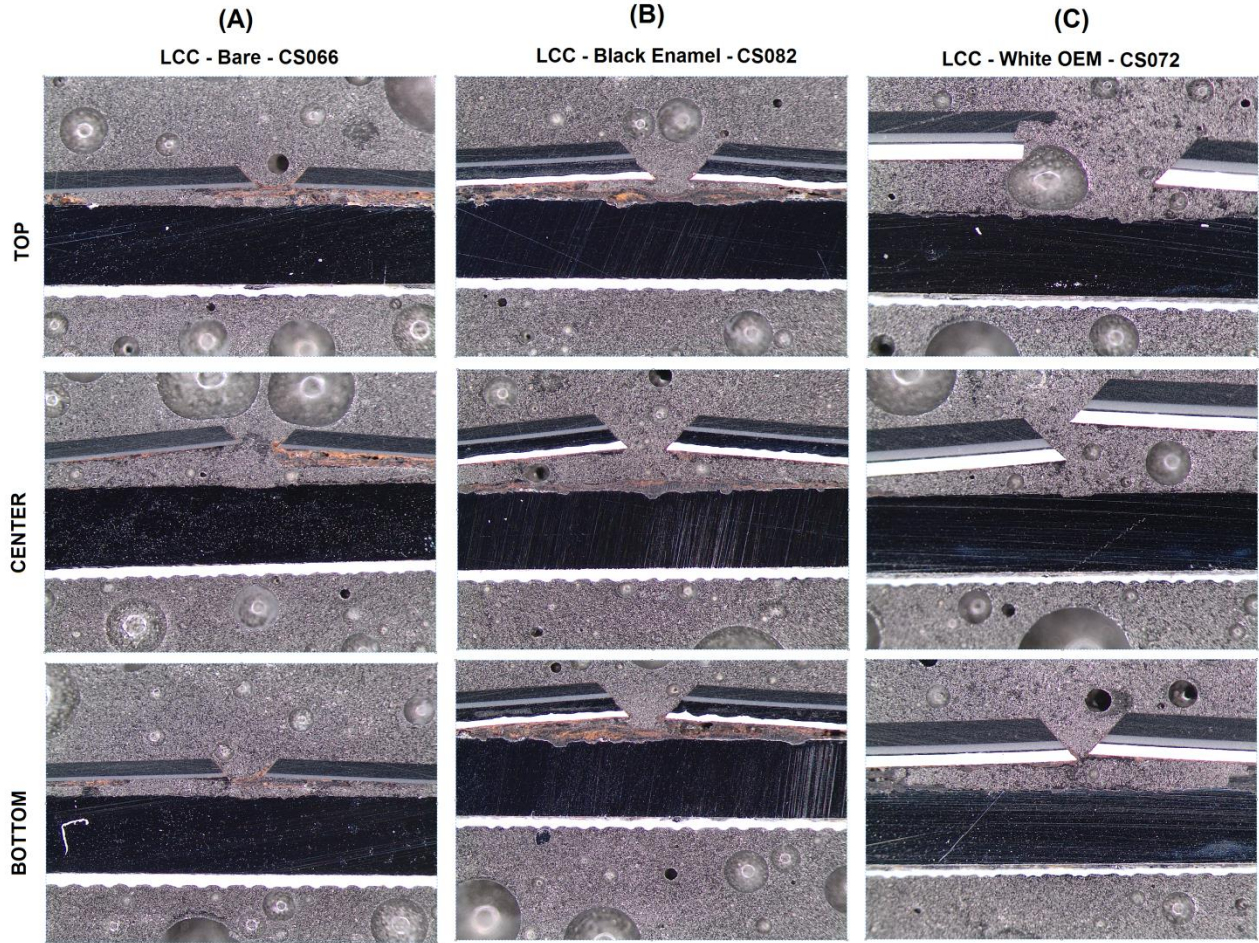

Figure J 2. Carbon steel top, center and bottom cross-sections image of (A) LCCOAT/bare, (B) LCCOAT/black enamel, and (C) LCCOAT/white OEM systems after 90-day exposure to winter in field testing.

State Job Number: 134935

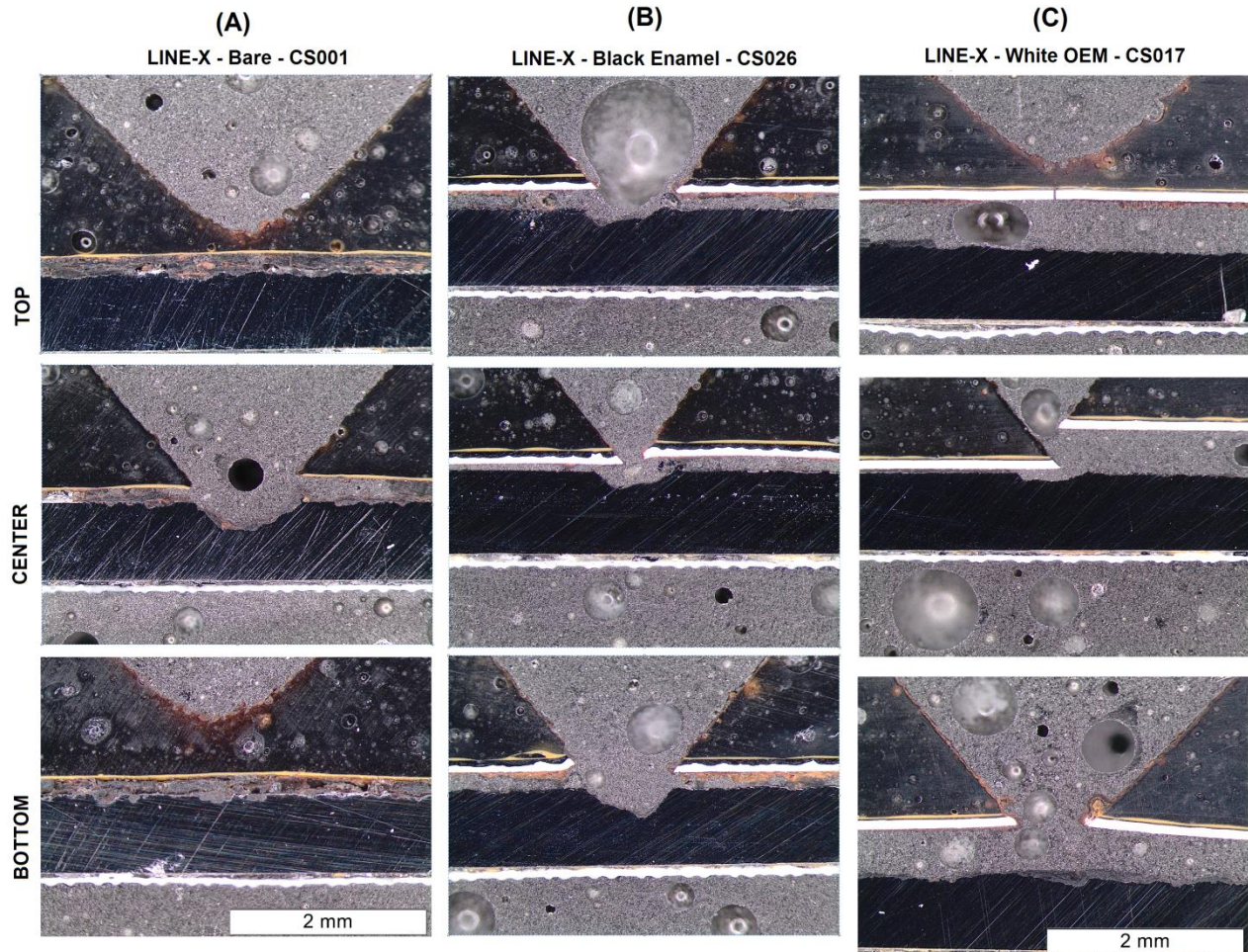

Figure J 3. Carbon steel top, center and bottom cross-sections image of (A) LINE-X/bare, (B) LINE-X/black enamel, and (C) LINE-X/white OEM systems after 90-day exposure to winter in field testing.

State Job Number: 134935

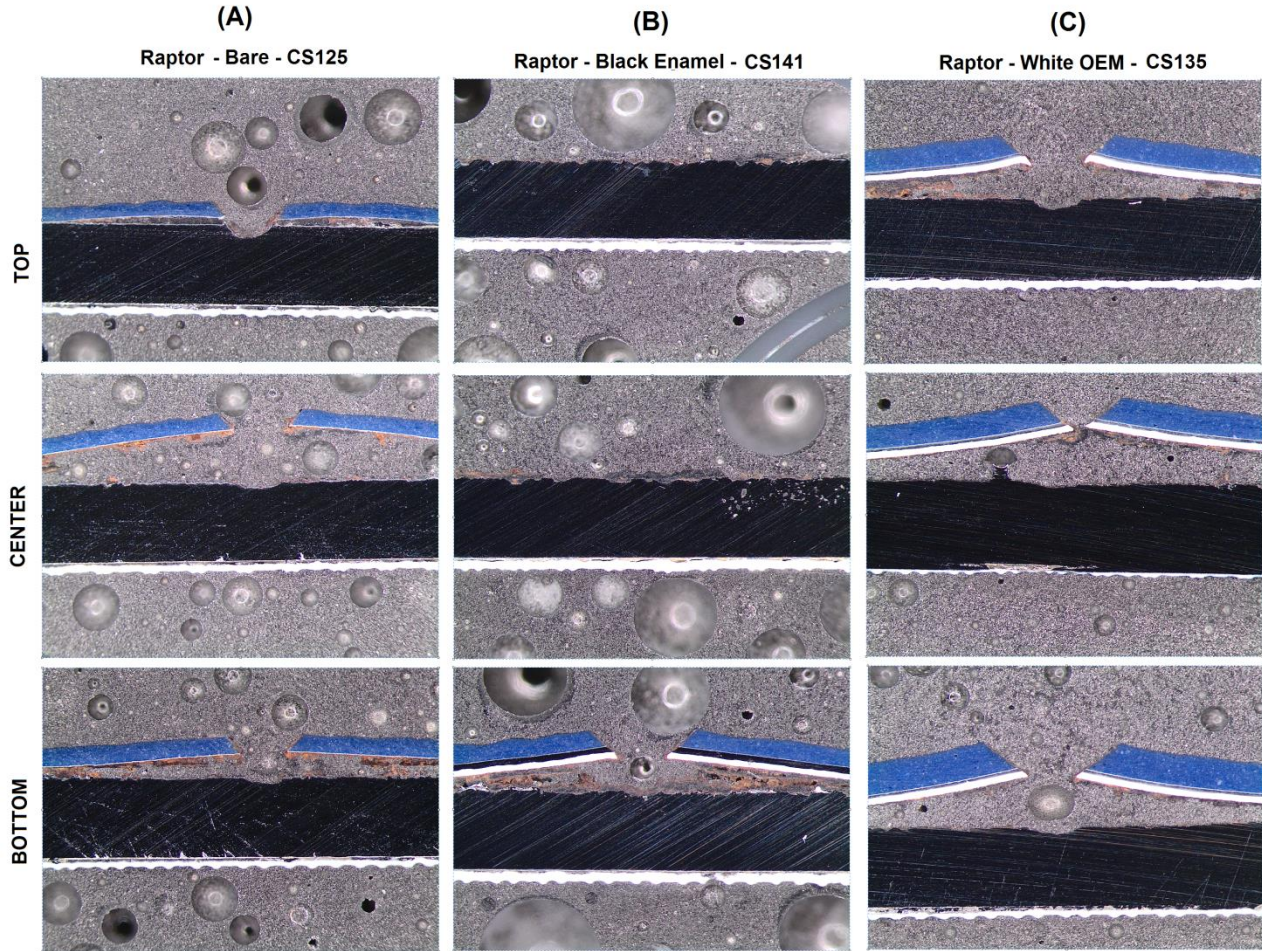

Figure J 4. Carbon steel top, center and bottom cross-sections image of (A) Raptor/bare, (B) Raptor/black enamel, and (C) Raptor/white OEM systems after 90-day exposure to winter in field testing.

State Job Number: 134935

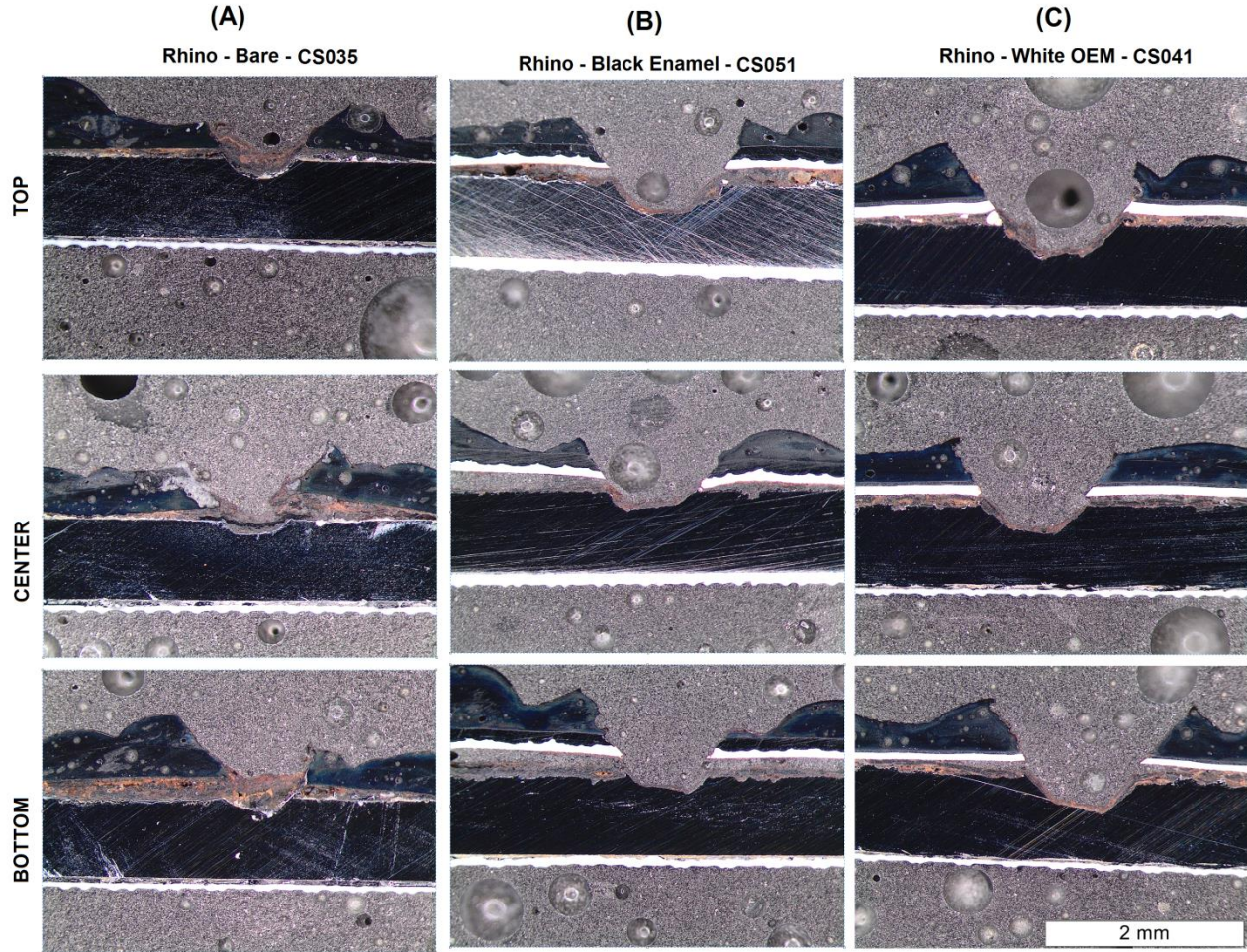

Figure J 5. Carbon steel top, center and bottom cross-sections image of (A) Rhino/bare metal, (B) Rhino/black enamel and (C) Rhino/white OEM systems after 90-day exposure to winter in field testing.

Corrosion density was determined by imaging analysis using ImageJ (1.48v) software. Images were processed by measuring the corrosion products present on the cross section surface. The corrosion density of each cross section (top, center and bottom) and its average are shown in Table J2 and plotted in Figure J6.

ODOT Research Final Report

State Job Number: 134935

Table J 2. Corrosion density on carbon steel samples exposed to winter in field testing in District 4.

Panel #	Coating system	Primary Coating	Corrosion Density %			
			Top	Center	Bottom	AVG
179	None	Black Enamel	0.058	0.136	0.033	0.076
238		White OEM	0.057	0.055	0.056	0.056
66	LCCOAT	None	0.128	0.177	0.059	0.121
82		Black Enamel	0.153	0.150	0.266	0.190
72		White OEM	0.044	0.072	0.071	0.062
1	Line-X	None	0.272	0.150	0.465	0.296
26		Black Enamel	0.278	0.134	0.290	0.234
17		White OEM	0.230	0.114	0.179	0.174
125	Raptor	None	0.010	0.088	0.333	0.144
141		Black Enamel	0.026	0.034	0.182	0.081
135		White OEM	0.061	0.028	0.035	0.041
35	Rhino Linings	None	0.203	0.076	0.319	0.199
51		Black Enamel	0.120	0.046	0.064	0.077
41		White OEM	0.054	0.110	0.148	0.104

ODOT Research Final Report

State Job Number: 134935

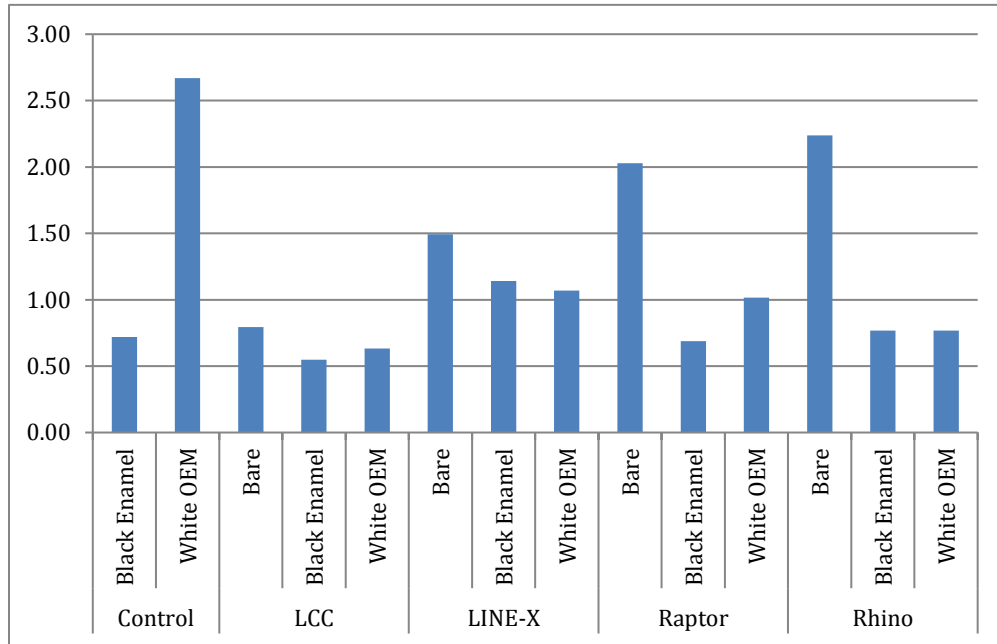

Figure J 6. Average of corrosion density on carbon steel samples exposed to winter in field testing in District 4 for each of the coating systems studied in this work.

Similarly to previous results, district 10 cross-sections of corroded metal panels were analyzed to determine corrosion density and coating delamination length. Table J3 indicates the metal panels selected from district 10 and their corresponding stereo images are shown in Figures J7-J11.

ODOT Research Final Report

State Job Number: 134935

Table J 3. Coating systems used in this study and evaluated under winter in field testing in District 10 for carbon steel panels for 90 days.

Sample	Truck #	Location	Coating system	Primary Coating	Coupon #
1	1	Back	None	Black Enamel	231
2	4	Back		White OEM	243
3	1	Back	LCCOAT	None	63
4	1	Front		Black Enamel	86
5	2	Front		White OEM	73
6	3	Front	Line-X	None	3
7	2	Back		Black Enamel	22
8	1	Front		White OEM	15
9	3	Front	Raptor	None	124
10	1	Front		Black Enamel	144
11	4	Back		White OEM	134
12	4	Back	Rhino Linings	None	34
13	4	Front		Black Enamel	53
14	1	Back		White OEM	46

State Job Number: 134935

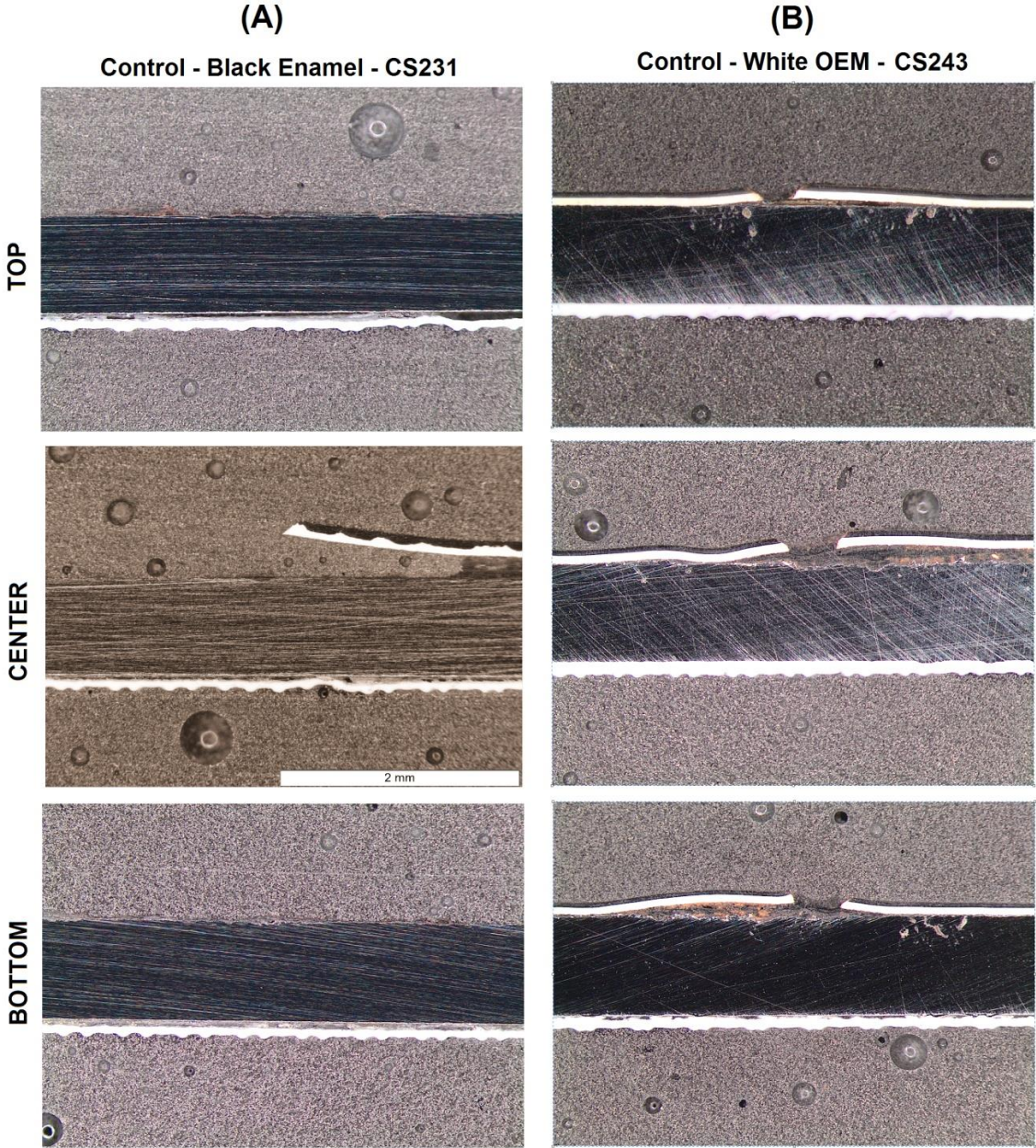

Figure J 7. Carbon steel top, center and bottom cross-sections image of (A) control/bare metal and (B) control/white OEM after 90-day exposure to winter in field testing.

State Job Number: 134935

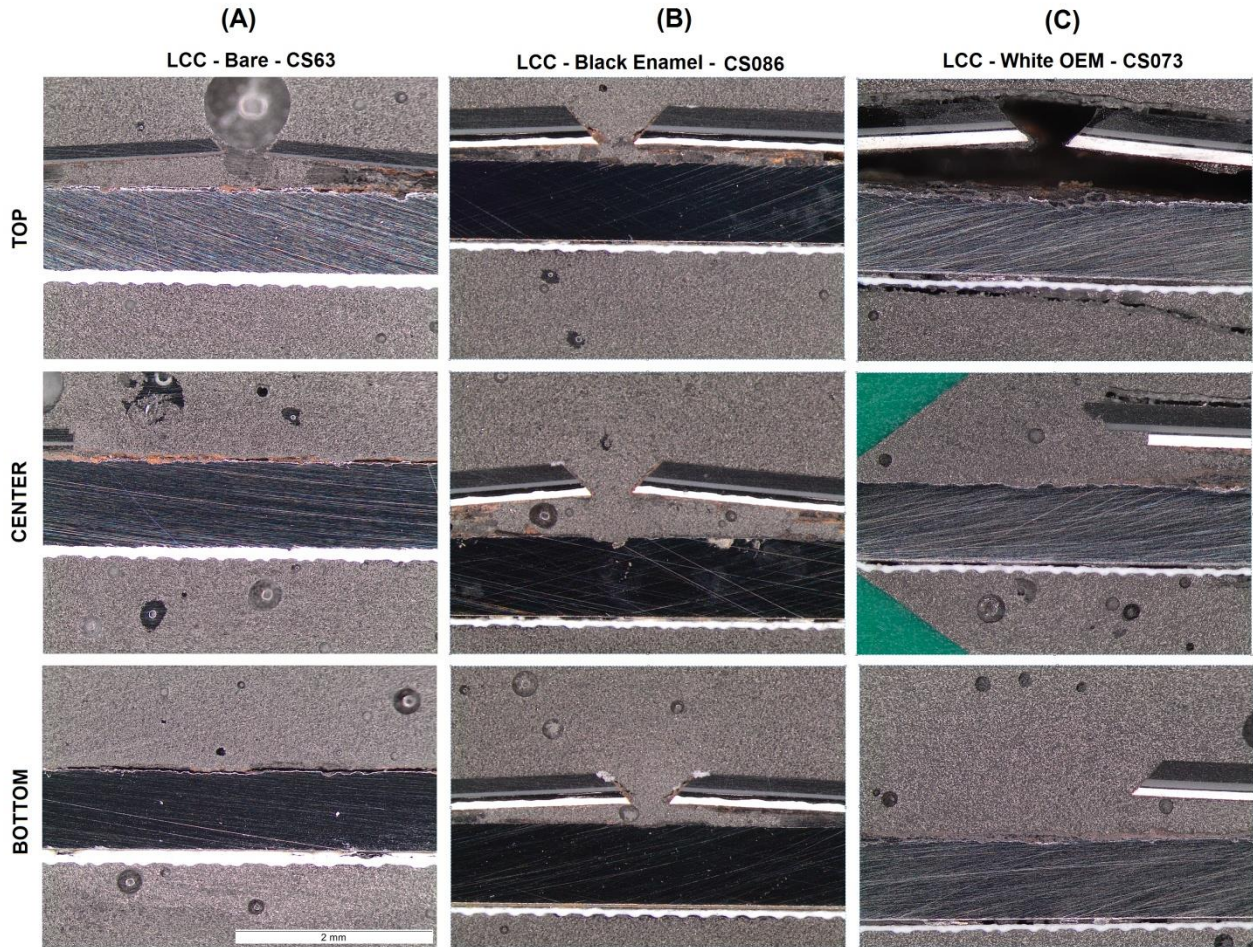

Figure J 8. Carbon steel top, center and bottom cross-sections image of (A) LCCOAT/bare, (B) LCCOAT/black enamel, and (C) LCCOAT/white OEM systems after 90-day exposure to winter in field testing.

State Job Number: 134935

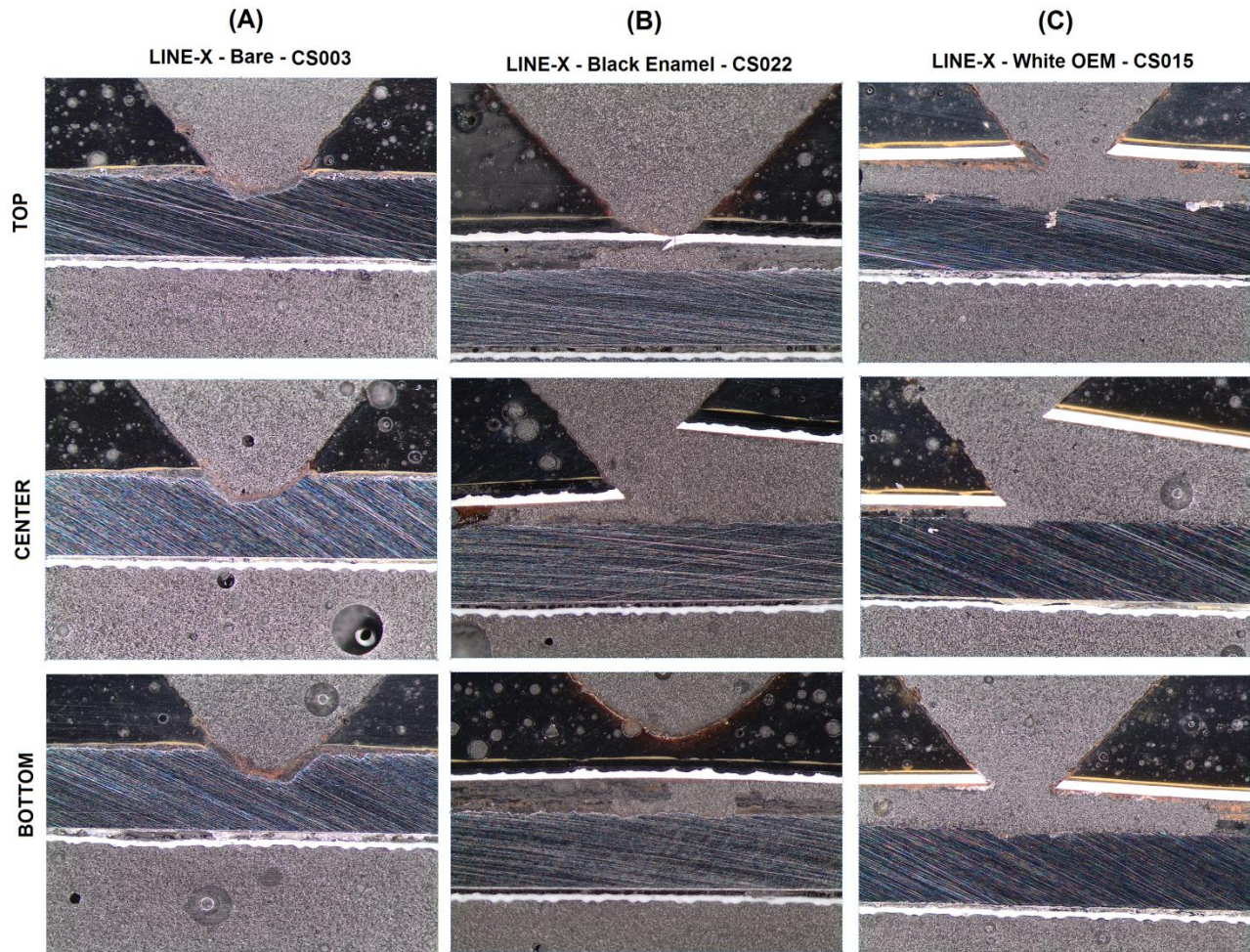

Figure J 9. Carbon steel top, center and bottom cross-sections image of (A) LINE-X/bare, (B) LINE-X/black enamel, and (C) LINE-X/white OEM systems after 90-day exposure to winter in field testing.

State Job Number: 134935

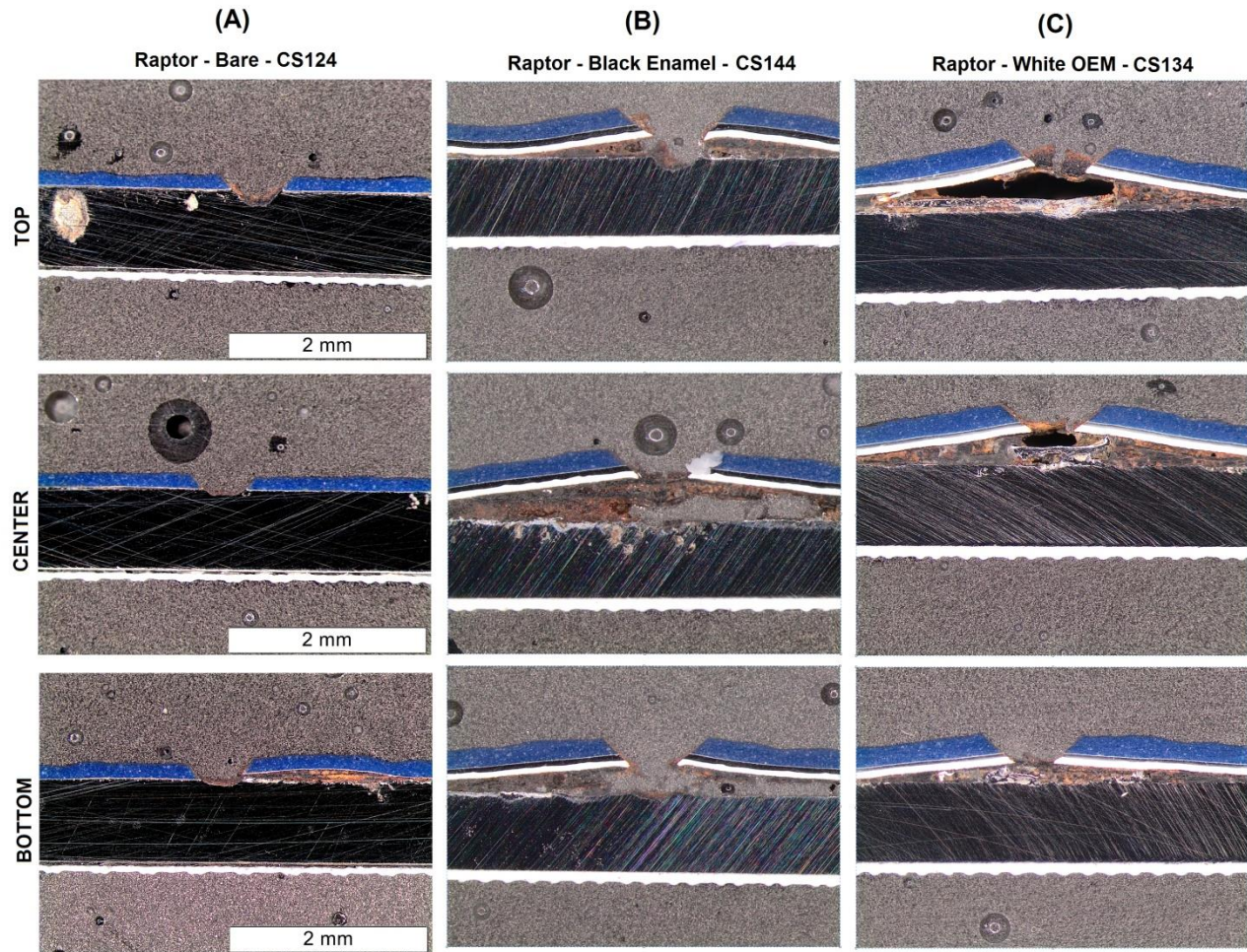

Figure J 10. Carbon steel top, center and bottom cross-sections image of (A) Raptor/bare, (B) Raptor/black enamel, and (C) Raptor/white OEM systems after 90-day exposure to winter in field testing.

State Job Number: 134935

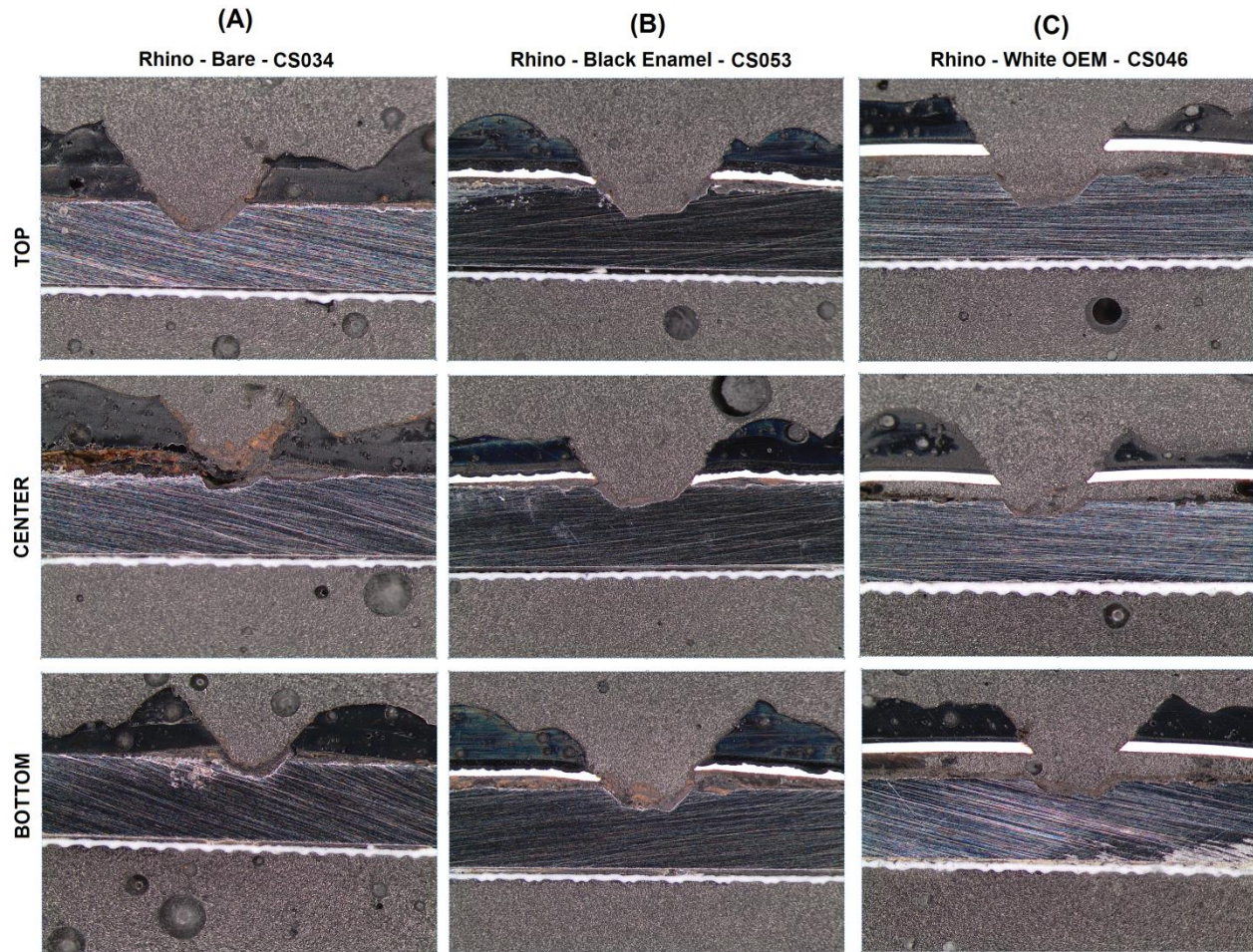

Figure J 11. Carbon steel top, center and bottom cross-sections image of (A) Rhino/bare, (B) Rhino/black enamel, and (C) Rhino/white OEM systems after 90-day exposure to winter in field testing.

Table J4 displays the corrosion density of each cross section (top, center and bottom) and its average (see also Figure J12).

ODOT Research Final Report

State Job Number: 134935

Table J 4. Corrosion density on carbon steel samples exposed to winter in field testing in District 10.

Sample	Coating system	Primary Coating	Corrosion Density %			
			Top	Center	Bottom	AVG
1	None	Black Enamel	0	0.009	0.149	0.053
2		White OEM	0.08	0.087	0.179	0.115
3	LCCOAT	None	0.181	0.373	0.166	0.240
4		Black Enamel	0.174	0.118	0.118	0.137
5		White OEM	0.069	0.048	0.065	0.061
6	LINE-X	None	0.174	0.174	0.071	0.140
7		Black Enamel	0.41	0.276	0.086	0.257
8		White OEM	0.164	0.108	0.269	0.180
9	Raptor	None	0.174	0.13	0.123	0.142
10		Black Enamel	0.092	0.43	0.086	0.203
11		White OEM	0.579	0.471	0.174	0.408
12	Rhino Linings	None	0.176	1.013	0.163	0.451
13		Black Enamel	0.074	0.079	0.195	0.116
14		White OEM	0.129	0.272	1.365	0.589

ODOT Research Final Report

State Job Number: 134935

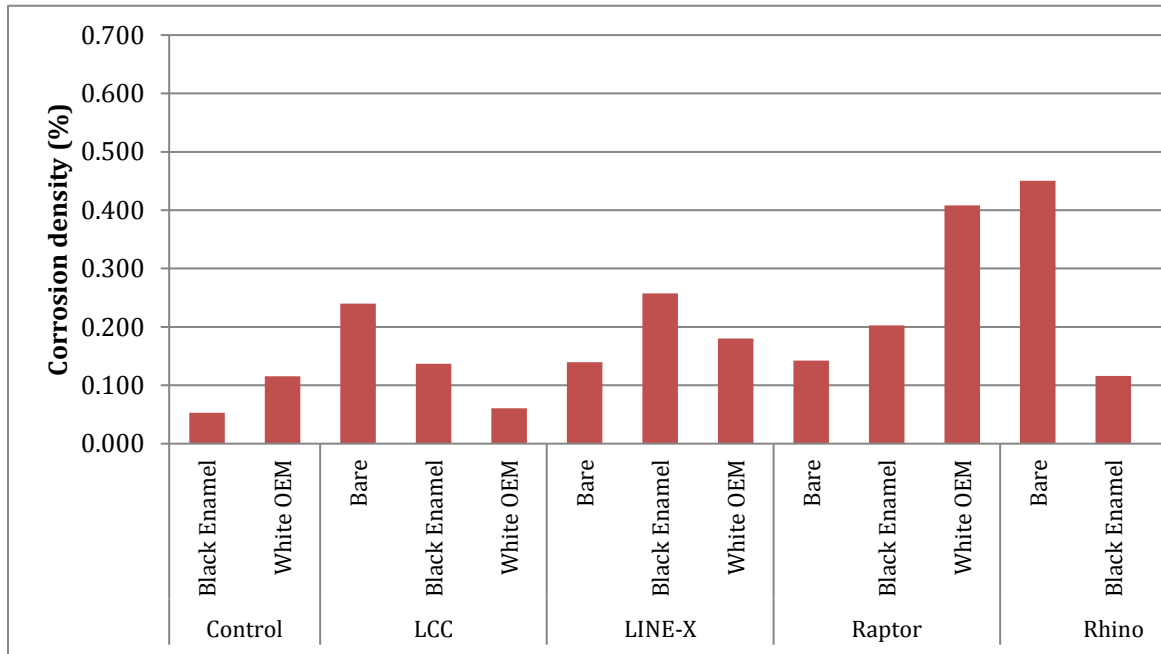

Figure J 12. Average of corrosion density on carbon steel samples exposed to winter in field testing in District 10 for each of the coating systems studied in this work.

ODOT Research Final Report

State Job Number: 134935

Coating/film delamination length results (Figure J13) were measured using ImageJ (1.48v) software and are presented in Table J5.

Table J 5. Coating delamination length of cross-sections of corroded metal panels exposed to winter in field testing in district 4 and 10.

Coating system	Primary Coating	Delamination (mm)	
		District 4	District 10
None	Black Enamel	1.35	8.60
	White OEM	10.12	2.33
LCCOAT	None	9.42	11.48
	Black Enamel	8.14	8.26
	White OEM	18.94	1.44
Line-X	None	12.95	18.11
	Black Enamel	13.75	13.05
	White OEM	18.41	15.66
Raptor	None	7.16	1.52
	Black Enamel	10.93	8.20
	White OEM	13.61	4.72
Rhino Linings	None	3.12	2.55
	Black Enamel	11.37	4.23
	White OEM	6.79	11.59

ODOT Research Final Report

State Job Number: 134935

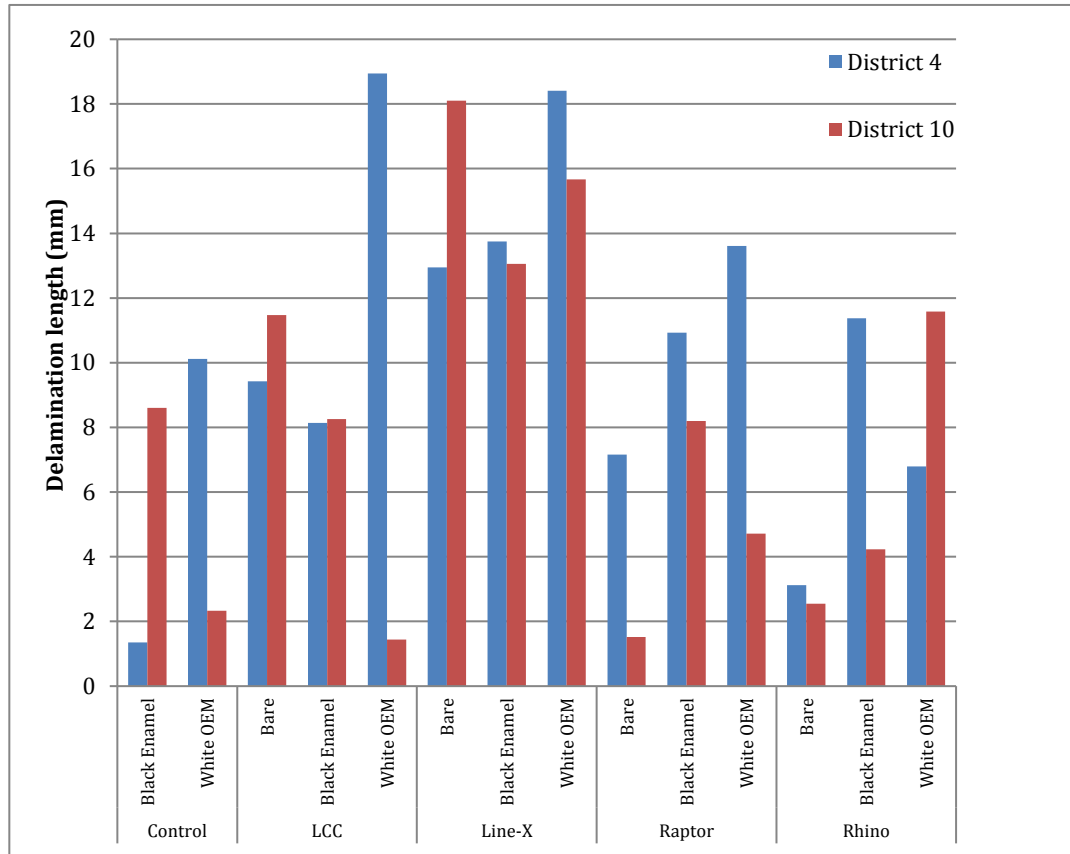

Figure J 13. Average of coating delamination length on carbon steel samples exposed to winter in field testing in District 4 and 10 for each of the coating systems studied in this work.

APPENDIX K: COST-BENEFIT ANALYSIS

Table K 1: Cost of coating and maintenance for standard truck

Year	Coating Cost	Maintenance Cost per year	Total Annual Cost
0			\$-
1		\$378.04	\$378.04
2		\$415.84	\$415.84
3		\$457.42	\$457.42
4		\$503.17	\$503.17
5		\$553.48	\$553.48
6		\$608.83	\$608.83
7		\$669.71	\$669.71
8		\$736.68	\$736.68
9		\$810.35	\$810.35
10		\$891.39	\$891.39
	\$-	\$6,024.91	\$6,024.91

Table K 2: Cost of coating and maintenance for truck coated with LCCOAT for scenario 1 (new truck with bare/exposed metal coated with LCCOAT)

Year	Coating Cost	Maintenance Cost per year	Total Annual Cost
0	\$375.00		\$375.00
1		\$215.44	\$215.44
2		\$236.98	\$236.98
3		\$260.68	\$260.68
4		\$286.75	\$286.75
5		\$315.42	\$315.42
6		\$346.97	\$346.97
7		\$381.66	\$381.66
8		\$419.83	\$419.83
9		\$461.81	\$461.81
10		\$507.99	\$507.99
	\$375.00	\$3,433.55	\$3,808.55

ODOT Research Final Report



State Job Number: 134935

Table K 3: Cost of coating and maintenance for truck coated with LINE-X for scenario 1 (new truck with bare/exposed metal coated with LINE-X)

Year	Coating Cost	Maintenance Cost per year	Total Annual Cost
0	\$1,800.00		\$1,800.00
1		\$246.31	\$246.31
2		\$270.94	\$270.94
3		\$298.04	\$298.04
4		\$327.84	\$327.84
5		\$360.62	\$360.62
6		\$396.69	\$396.69
7		\$436.36	\$436.36
8		\$479.99	\$479.99
9		\$527.99	\$527.99
10		\$580.79	\$580.79
	\$1,800.00	\$3,925.57	\$5,725.57

Table K 4: Cost of coating and maintenance for truck coated with Raptor for scenario 1 (new truck with bare/exposed metal coated with Raptor)

Year	Coating Cost	Maintenance Cost per year	Total Annual Cost
0	\$437.50		\$437.50
1		\$208.97	\$208.97
2		\$229.87	\$229.87
3		\$252.85	\$252.85
4		\$278.14	\$278.14
5		\$305.95	\$305.95
6		\$336.55	\$336.55
7		\$370.20	\$370.20
8		\$407.22	\$407.22
9		\$447.94	\$447.94
10		\$492.74	\$492.74
	\$437.50	\$3,330.43	\$3,767.93

ODOT Research Final Report

State Job Number: 134935

Table K 5: Cost of coating and maintenance for truck coated with Rhino Linings for scenario 1 (new truck with bare/exposed metal coated with Rhino Linings)

Year	Coating Cost	Maintenance Cost per year	Total Annual Cost
0	\$1,012.50		\$1,012.50
1		\$337.53	\$337.53
2		\$371.29	\$371.29
3		\$408.42	\$408.42
4		\$449.26	\$449.26
5		\$494.18	\$494.18
6		\$543.60	\$543.60
7		\$597.96	\$597.96
8		\$657.76	\$657.76
9		\$723.54	\$723.54
10		\$795.89	\$795.89
	\$1,012.50	\$5,379.43	\$6,391.93

Table K 6: Cost of coating and maintenance for truck coated with LCCOAT for scenario 2 (scenario 1 plus LCCOAT as a topcoat on white OEM or black enamel)

Year	Coating Cost	Maintenance Cost per year	Total Annual Cost
0	\$1,250.00		\$1,250.00
1		\$206.13	\$206.13
2		\$226.74	\$226.74
3		\$249.41	\$249.41
4		\$274.36	\$274.36
5		\$301.79	\$301.79
6		\$331.97	\$331.97
7		\$365.17	\$365.17
8		\$401.68	\$401.68
9		\$441.85	\$441.85
10		\$486.04	\$486.04
	\$1,250.00	\$3,285.14	\$4,535.14

ODOT Research Final Report

State Job Number: 134935

Table K 7: Cost of coating and maintenance for truck coated with LINE-X for scenario 2 (scenario 1 plus LINE-X as a topcoat on white OEM or black enamel)

Year	Coating Cost	Maintenance Cost per year	Total Annual Cost
0	\$6,000.00		\$6,000.00
1		\$231.61	\$231.61
2		\$254.77	\$254.77
3		\$280.24	\$280.24
4		\$308.27	\$308.27
5		\$339.09	\$339.09
6		\$373.00	\$373.00
7		\$410.30	\$410.30
8		\$451.34	\$451.34
9		\$496.47	\$496.47
10		\$546.12	\$546.12
	\$6,000.00	\$3,691.21	\$9,691.21

Table K 8: Cost of coating and maintenance for truck coated with Raptor for scenario 2 (scenario 1 plus Raptor as a topcoat on white OEM or black enamel)

Year	Coating Cost	Maintenance Cost per year	Total Annual Cost
0	\$1,458.33		\$1,458.33
1		\$182.94	\$182.94
2		\$201.24	\$201.24
3		\$221.36	\$221.36
4		\$243.50	\$243.50
5		\$267.85	\$267.85
6		\$294.63	\$294.63
7		\$324.10	\$324.10
8		\$356.51	\$356.51
9		\$392.16	\$392.16
10		\$431.37	\$431.37
	\$1,458.33	\$2,915.66	\$4,373.99



ODOT Research Final Report

State Job Number: 134935

ODOT Research Final Report

State Job Number: 134935

Table K 9: Cost of coating and maintenance for truck coated with Rhino Linings for scenario 2 (scenario 1 plus Rhino Linings as a topcoat on white OEM or black enamel)

Year	Coating Cost	Maintenance Cost per year	Total Annual Cost
0	\$3,375.00		\$3,375.00
1		\$255.80	\$255.80
2		\$281.38	\$281.38
3		\$309.52	\$309.52
4		\$340.47	\$340.47
5		\$374.52	\$374.52
6		\$411.97	\$411.97
7		\$453.17	\$453.17
8		\$498.48	\$498.48
9		\$548.33	\$548.33
10		\$603.16	\$603.16
	\$3,375.00	\$4,076.80	\$7,451.80

Table K 10: Cost of coating and maintenance for truck coated with white OEM and black enamel (standard truck) for scenario 3 (refurbishment of existing truck)

Year	Coating Cost	Maintenance Cost per year	Total Annual Cost
0	\$4,543.04		\$4,543.04
1		\$378.04	\$378.04
2		\$415.84	\$415.84
3		\$457.42	\$457.42
4		\$503.17	\$503.17
5		\$553.48	\$553.48
6		\$608.83	\$608.83
7		\$669.71	\$669.71
8		\$736.68	\$736.68
9		\$810.35	\$810.35
10		\$891.39	\$891.39
	\$4,543.04	\$6,024.91	\$10,567.95

ODOT Research Final Report

State Job Number: 134935

Table K 11: Cost of coating and maintenance for truck coated with LCCOAT for scenario 3 (refurbishment of existing truck)

Year	Coating Cost	Maintenance Cost per year	Total Annual Cost
0	\$1,250.00		\$1,250.00
1		\$346.15	\$346.15
2		\$380.76	\$380.76
3		\$418.84	\$418.84
4		\$460.73	\$460.73
5		\$506.80	\$506.80
6		\$557.48	\$557.48
7		\$613.23	\$613.23
8		\$674.55	\$674.55
9		\$742.00	\$742.00
10		\$816.20	\$816.20
	\$1,250.00	\$5,516.74	\$6,766.74

Table K 12: Cost of coating and maintenance for truck coated with LINE-X for scenario 3 (refurbishment of existing truck)

Year	Coating Cost	Maintenance Cost per year	Total Annual Cost
0	\$6,000.00		\$6,000.00
1		\$957.41	\$957.41
2		\$1,053.15	\$1,053.15
3		\$1,158.47	\$1,158.47
4		\$1,274.32	\$1,274.32
5		\$1,401.75	\$1,401.75
6		\$1,541.92	\$1,541.92
7		\$1,696.12	\$1,696.12
8		\$1,865.73	\$1,865.73
9		\$2,052.30	\$2,052.30
10		\$2,257.53	\$2,257.53
	\$6,000.00	\$15,258.70	\$21,258.70

ODOT Research Final Report

State Job Number: 134935

Table K 13: Cost of coating and maintenance for truck coated with Raptor for scenario 3 (refurbishment of existing truck)

Year	Coating Cost	Maintenance Cost per year	Total Annual Cost
0	\$1,458.33		\$1,458.33
1		\$352.59	\$352.59
2		\$387.85	\$387.85
3		\$426.63	\$426.63
4		\$469.30	\$469.30
5		\$516.23	\$516.23
6		\$567.85	\$567.85
7		\$624.63	\$624.63
8		\$687.10	\$687.10
9		\$755.81	\$755.81
10		\$831.39	\$831.39
	\$1,458.33	\$5,619.38	\$7,077.71

Table K 14: Cost of coating and maintenance for truck coated with Rhino Linings for scenario 3 (refurbishment of existing truck)

Year	Coating Cost	Maintenance Cost per year	Total Annual Cost
0	\$3,375.00		\$3,375.00
1		\$603.75	\$603.75
2		\$664.12	\$664.12
3		\$730.54	\$730.54
4		\$803.59	\$803.59
5		\$883.95	\$883.95
6		\$972.35	\$972.35
7		\$1,069.58	\$1,069.58
8		\$1,176.54	\$1,176.54
9		\$1,294.19	\$1,294.19
10		\$1,423.61	\$1,423.61
	\$3,375.00	\$9,622.22	\$12,997.22

APPENDIX L: ADDITIONAL BACKGROUND

The basic mechanisms of corrosion are well studied and understood. These include uniform corrosion, inter-granular corrosion, galvanic corrosion, crevice corrosion, pitting corrosion, erosion corrosion, stress corrosion cracking, biological corrosion, and selective leaching. Based on electrochemical theory, a complete corrosion reaction is divided into both anodic and cathodic reactions that occur simultaneously at discrete points on metal surfaces. Electrons are transferred between the anode and cathode found on either single metallic surfaces or dissimilar metals. When liquid is present, electrons are captured in solution and the metal gradually becomes ionic and dissolves into solution. Figure L 1 illustrates the basic galvanic cell associated with the corrosion of iron. When a water droplet is present on the surface, the cathode reduces oxygen from air forming hydroxide ions while the anode causes the dissolution of iron. Chloride ions found in deicing solutions do not chemically react with the metal surface; however, chloride ions accelerate the corrosion rate by acting as a medium or catalyst for the electrochemical reaction(Uhlig and Revie 1985; Fitzgerald 2000).

ODOT Research Final Report

State Job Number: 134935

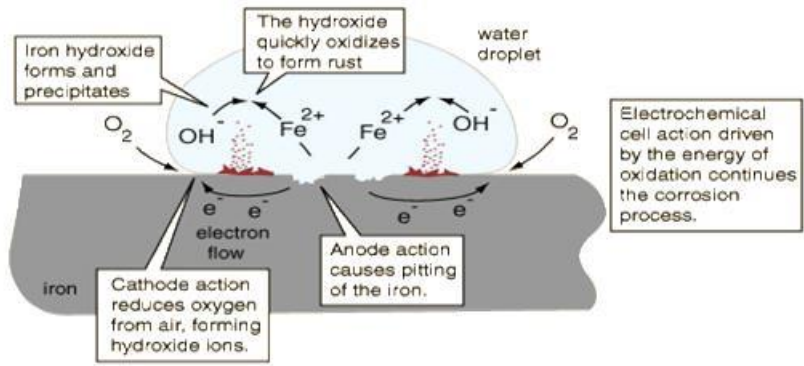

Figure L 1: Basic Mechanism for Iron Corrosion (figure taken from <http://hyperphysics.phy-astr.gsu.edu/hbase/chemical/corrosion.html>)

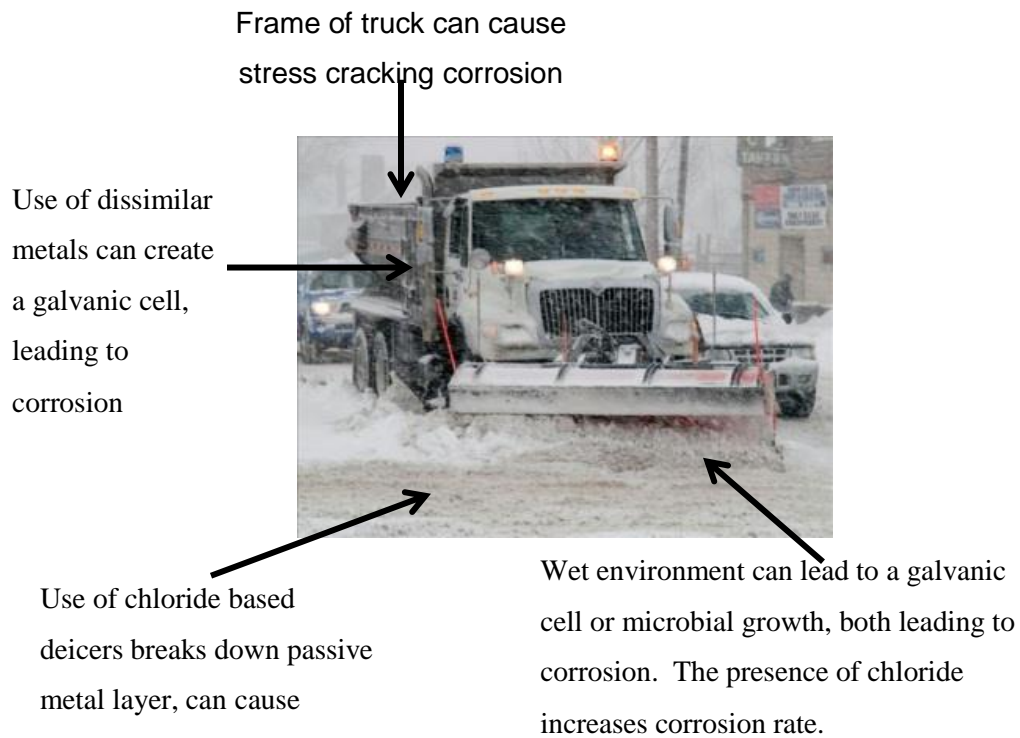

Figure L 2: Overview of Corrosion on Snow and Ice Equipment

ODOT Research Final Report

State Job Number: 134935

Figure L2 illustrates some of the main causes of corrosion for snow and ice equipment. Not all possible corrosion mechanisms are responsible for the deterioration of such equipment, but several are highly prevalent. Specific factors causing corrosion of snow and ice equipment are (1) the use of chloride based deicers breaks down the protective layer causing pitting corrosion, (2) the wet environment which allows for the easier creation of a galvanic cell, (3) high corrosion current of liquids, (4) penetration of liquids into areas not accessible by solids, (5) liquids may cause differential aeration, (6) presence of micro-organisms giving rise to biological corrosion, (7) presence of dissimilar metals found in many truck locations that can give rise to a galvanic cell, and (8) frame of the truck creating a load allowing for stress corrosion cracking (Xi and Xie 2002; Baroga 2004; Xiong 2009).

Several reports have been published to discuss the specifics of corrosion on winter maintenance equipment. The first study was conducted for the Colorado Department of Transportation (CDOT) and considered the effect of magnesium chloride versus sodium chloride on vehicular corrosion. This report found that there was significant corrosion on metal coupons placed on 10 different winter maintenance vehicles. Researchers found that corrosion was prevalent in both salt solutions and varied depending on conditions. This study, however, did not correlate corrosion to salt exposure or winter weather conditions and could therefore not correlate the effectiveness of laboratory experiments for the prediction of corrosion (Xi and Xie 2002).

State Job Number: 134935



Figure L 3: Metal coupons used to measure corrosion on winter maintenance vehicles. Corrosion rate was measured as weight lost over time due to exposure of the coupons to two different salt solutions (Xi and Xie 2002).

The second report was published by the Washington DOT Salt Pilot Project where a field-test was conducted along I-90 in Eastern Washington. In this work, steel and aluminum coupons were used to evaluate the effect of corrosion-inhibitors on vehicular corrosion. The researchers found that the corrosion-inhibited chemicals provided some level of corrosion reduction; however, the corrosion rates were not comparable to the results gathered from standard laboratory analysis. These two studies show the importance of testing corrosion reduction strategies in the field and also highlight the need for a predictive model to determine corrosion rate due to different environmental conditions (Baroga 2004).

In 2009, the Iowa Highway Research Board (IHRB) investigated materials for the reduction and prevention of corrosion on highway maintenance equipment. This study presented several conceptual solutions to mitigating corrosion in the field including 1) the use of inhibitors in ice control chemicals, 2) use of washing systems, 3) design changes, and 4) use of coatings. Investigators also determined that seven of eight responses to a survey on corrosion mitigation listed washing of vehicles as the primary role of corrosion prevention practices. One noted, “Anodes, protective coatings, etc. haven’t done nearly as much for our fleet as a good old fashioned shot of hot water with soap.” Another responder noted that “post storm washing and lubrication is the foundation to effective

ODOT Research Final Report

State Job Number: 134935

preventative maintenance.” Several other responders noted using salt neutralizing products such as Neutro-Wash to remove the chloride residue as frequently as after each event (Xiong 2009).

Most recently, in a report prepared by the Western Transportation Institute (WTI) and Montana State University for the Washington State Department of Transportation provided a laboratory assessment of the best practices to protect DOT equipment from corrosion. The researchers provided seven recommendations for implementation of corrosion prevention strategies including using corrosion-inhibited deicers, using corrosion-resistant materials, dehumidified storage, use of consistent wash procedures and corrosion protective coatings, and tracking the direct costs of corrosion. The researchers also suggested that future research be conducted on the use of salt removers and corrosion protective coatings on protecting DOT equipment from deicer corrosion including preventing premature failure of the coatings and the benefits of synergistic use of coatings and salt remover (Shi, Li, & Jungwirth, 2013).