

**APPENDIX A  
PRACTICE MANUAL**

# Practice Manual

## Structural Health Monitoring of Bridges with Fiber Bragg Gratings

FHWA-WY-16/06F



**State of Wyoming  
Department of Transportation**



**U.S. Department  
of Transportation  
Federal Highway  
Administration**



### Structural Health Monitoring of Highway Bridges Subjected to Overweight Trucks, Phase I – Instrumentation Development and Validation



By:

Richard J. Schmidt

Department of Civil and Architectural Engineering

University of Wyoming

Laramie, Wyoming 82071

March 2016

## **Acknowledgements**

This document is based largely on and excerpted from the Masters Theses by University of Wyoming graduate students Mr. Danial Maurais, Mr. Michael Jung, and Ms. McKenzie Danforth. Documentation of the schematic design and fabrication of instrumentation developed during the project has been prepared by Mr. James Branscomb, MSEE

**COPYRIGHT 2016** – State of Wyoming,  
Wyoming Department of Transportation,  
University of Wyoming

## Table of Contents

Overview .....	1
Chapter 1 – Fiber Splicing and Sensor Interrogation .....	2
Overview .....	2
Preparation .....	2
Coating Removal .....	3
Cleaving.....	4
Splicing.....	5
Reinforcing.....	6
Troubleshooting.....	7
Chapter 2 –SMARTSCAN Interrogation OPERATION.....	8
SmartScan Setup Instructions .....	9
SmartSoft Instructions.....	9
Chapter 3 – Installing, Protecting and Repairing Optical Fiber Sensors.....	12
Multiplexed Sensor System Design .....	12
Sensor Installation.....	13
Sensing Steel Elements .....	14
Sensing Concrete Elements.....	18
Chapter 4 – Temperature Compensation for FBG Sensors.....	23
Chapter 5 – Schematic Design and Fabrication of Instrumentation .....	26
Introduction .....	26
System Overview .....	27
Assembly Guidelines and Quick-Start Guides .....	33
Chapter 6 – Data Analysis Methods.....	42
Objective .....	42
Methodology for Determining the Instrumentation Plan.....	42
Instrumentation Plan .....	43
Factors Affecting Sensor Placement .....	43
Sensor Placement on Beams .....	44
Critical Longitudinal Locations .....	45
Vehicle Loading Plan .....	45
Experimental Test Vehicle.....	47

**Data Analysis ..... 48**  
**Use of Experimental Lateral Distribution Factor ..... 51**

## List of Figures

Figure 1.1 – Components of an optical fiber	2
Figure 1.2 – Protective sleeve	2
Figure 1.3 – Stripping outer coating of optical fiber	3
Figure 1.4 – Optical fiber strippers (left). Stripping of inner coating (right)	4
Figure 1.5 – Optical fiber with clear inside coating partially stripped	4
Figure 1.6 – Readied fiber cleaver	5
Figure 1.7 – Fiber aligned on cleaver	5
Figure 1.8 – Fiber aligned on splicing machine	6
Figure 1.9 – Well-prepared fibers	6
Figure 1.10 – Reinforcing tube heater	7
Figure 2.1 – SmartScan interrogator	8
Figure 2.2 – SmartSoft desktop icon	9
Figure 2.3 – SmartScan main window	10
Figure 3.1 – Interrogation overlap due to inadequate sensor spacing	12
Figure 3.2 – Protected FBG fiber on steel beam	15
Figure 3.3 – Bond resulting from notch-embedded epoxy procedure for concrete	18
Figure 3.4 – Minimum configuration for long-gage sensing of concrete using and FBG	19
Figure 3.5 – Photo of long-gage FBG installed on concrete beam	20
Figure 3.6 – Protection method 2 for fibers installed on concrete	22
Figure 4.1 – Temperature compensation FBG	25
Figure 5.1 – The FS2200 extended temperature BraggMETER by HBM FiberSensing	26
Figure 5.2 – Block diagram illustrating system component interactions	27
Figure 5.3 – Diagram of the finished printed circuit board (PCB)	28
Figure 5.4 – PCB circuit schematic PG 1	30
Figure 5.5 – PCB circuit schematic PG 2	31
Figure 5.6 – Pinout of the PCB GPIO pins relating to microcontroller ports	32
Figure 5.7 – AVRISPmkII and pinout of the PCB PDI programming port	32
Figure 5.8 – Diagram of appropriate connections to the data controller	34
Figure 5.9 – Data controller OLED screen indicating a successful startup	34
Figure 5.10 – Setup file for installing the system software	35
Figure 5.11 – Local Area Connection properties with TCP/IPv4 selected	35
Figure 5.12 – IP address and subnet mask to be entered as shown	36
Figure 5.13 – CS Native Demo program in Windows start menu after install	36
Figure 5.14 – Opening page of CS Native Demo software	37
Figure 5.15 – Windows display for controlling the FS2200 interrogator	38
Figure 5.16 – Network Settings tab displaying system IP and mask information	38
Figure 5.17 – Software page that displays upon connecting to RFID reader	39

Figure 5.18 – Window display for primary interrogator data acquisition	40
Figure 6.1 – Cross-sectional view with FBG sensors on the web and bottom flange	44
Figure 6.2 – Elevation view with critical locations for sensor placements	45
Figure 6.3 – Plan view with critical locations for sensor placements	45
Figure 6.4 – Vehicle load test plan	46
Figure 6.5 – Strain profile for girder with partially composite behavior	49
Figure 6.6 – Total moment for girder with partially composite behavior	50
Figure 6.7 – Analytical and experimental moments	50

## **List of Tables**

Table 6.1 – Factors taken into consideration for field testing	43
Table 6.2 – Potential controlling vehicle load combinations	47
Table 6.3 – Example comparison of analytical and experimental distribution factors	52



## OVERVIEW

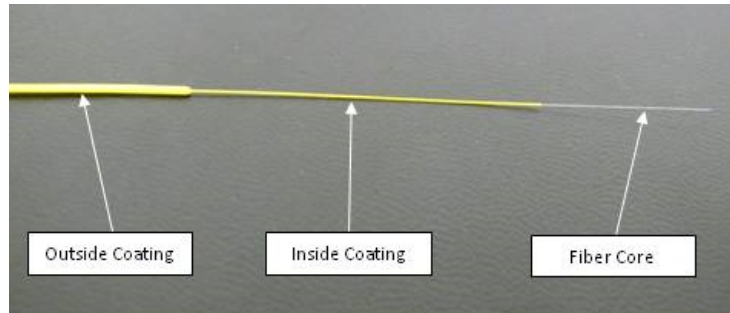
This report contains the essential elements of the WYDOT-MPC sponsored project: *Structural Health Monitoring of Highway Bridges Subjected to Overweight Trucks, Phase I – Instrumentation Development and Validation* required by bridge engineers and maintenance personnel to understand and implement a fiber Bragg grating (FBG) sensor network for structural health monitoring of bridges. The report contains the following parts:

1. Instructions for splicing optical fibers.
2. Instructions for operating the Smart Scan FBG interrogator.
3. Procedure for installing, protecting, and repairing optical fiber sensors on both concrete and steel host structures.
4. Methods for temperature compensation of FBG sensor readings.
5. Schematic design and fabrication of instrumentation to interrogate the sensor network and collect the sensor response.
6. Methods for data analysis to efficiently deliver system response parameters that are of direct use to bridge engineers.

# CHAPTER 1 – FIBER SPLICING AND SENSOR INTERROGATION

## Overview

Typical single-mode optical fibers are comprised of three distinct layers. There is the glass core ( $\varphi \approx 125 \mu\text{m}$ ), an inside coating ( $\varphi \approx 250 \mu\text{m}$ ), and an outside coating ( $\varphi \approx 850 \mu\text{m}$ ). These can be seen in Figure 1.1.

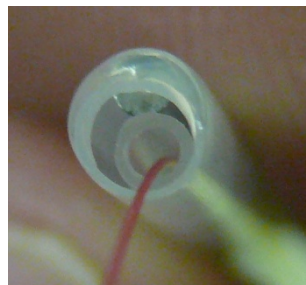


**Figure 1.1: Components of an optical fiber**

When splicing a fiber, the fiber core of two fibers is joined through an arc fusion process. In order to achieve this, the coatings must be removed, and the fiber core must be cleaved to provide a clean flat surface for the connection. The two fibers to be joined must then be aligned with extreme precision, and the fusing process can proceed. Once the fibers are joined, a protective sleeve must be affixed to reinforce this delicate connection.

## Preparation

To begin, all of the necessary tools shown in the following figures should be removed from the case: protective sleeves, strippers, cleaver and splicer. Next, plug in the splicer, and turn the white switch on the side of the machine to "A/C ON". Open the outside cover of the splicing machine, and lift the screen into position. Then, slide a protective sleeve onto one of the fibers that is to be joined, careful to place it within the inside tube as shown in Figure 1.2.



**Figure 1.2: Protective Sleeve**

## Coating Removal

As mentioned above, optical fibers are typically coated with two protective layers that must be removed before a splice can be performed. Some fibers, however, only have the thinner "inside" coating.

For fibers that have the additional outside coating, this layer should be stripped off independently from the inside coating. It is important to strip off enough of the outside coating so that it will not interfere with the cleaving and splicing instruments. Approximately 130 mm (5 in) should suffice. To do this, use regular 26 - 28 gauge wire strippers to notch around the coating as demonstrated in Figure 1.3; then use pliers to gently grip and pull the coating straight off of the fiber. It is important to pull the coating straight along the fiber; fibers are very weak in shear, and if the uncoated fiber is bent it is liable to break.



**Figure 1.3: Stripping outer coating of optical fiber.**

Once the end of the fiber has been reduced to just the inside coating and core, a length of the inside coating must be removed. This bare portion must be of adequate length to perform proper cleaving and alignment in the splicing instrument. Typically a length of about 40 mm (1.5 in) is sufficient. Depending on the type of inside coating used, it may be necessary to strip the coating, or to burn the coating off. Most fibers have a plastic type coating that should strip off easily using the proper optical fiber strippers. Some fibers however, have a slightly thinner coating that is hard and brittle. If this type of coating is stripped off it will either slip through the strippers without removing the coating, or it will break off along with the glass core. For these fibers it is necessary to use the burning method described below.

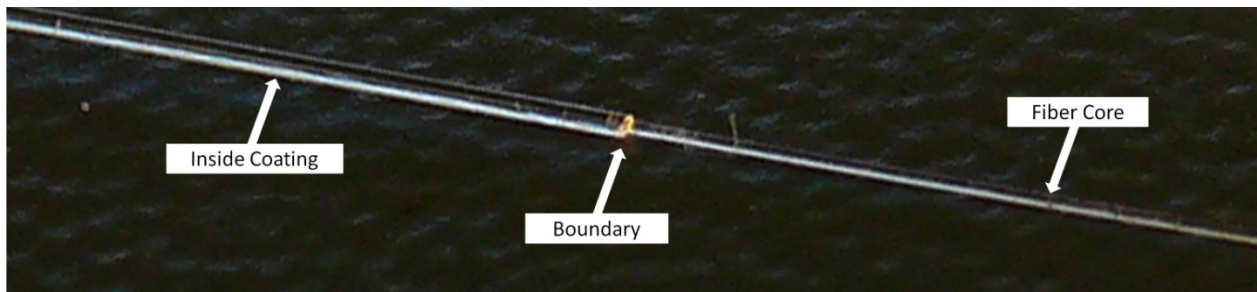
If the inside coating is of the plastic type then, it should be stripped. In order to strip the inside coating, insert the coated fiber into the small opening in the optical fiber strippers, squeeze the strippers, and slide them straight along the fiber toward the end. There will be some resistance, but it should not be difficult. Once again, it is important to pull the strippers straight along the fiber, as any bending can result in a broken fiber. See Figure 1.4 for photos of the optical fiber strippers. If the strippers move too easily, then the inside coating may already be stripped, or the coating may be of the more brittle type which must be burned off.



**Figure 1.4: Optical Fiber Strippers (left). Stripping of inner coating (right).**

If the fiber is of the type that must be burned off, use a lighter and briefly hold the fiber over the flame just long enough for the coating to turn black. Move the flame along the fiber burning off the length of coating that needs to be removed. Be careful not to hold the flame in one spot for too long as this can damage the fiber core. Next, take a soft tissue or chem-wipe, and coat it in *100% pure* isopropyl alcohol. Fold the tissue or wipe around the burned fiber, and gently pull the fiber straight through the wipe, repeating until the black remnants of the coating have been removed. If there are persistent spots of coating that will not wipe off, it may be necessary to quickly expose them to the flame again. Though, as long as the portion of fiber that is close to the cleave is clean, it is not necessary to make the whole length of bare fiber spotless.

The inside coating may be colored, or it may be clear. If it is clear, it is difficult to differentiate between the inside coating and the glass core, and you must look for the change in diameter to find the boundary between the coated fiber and the bare core as illustrated in Figure 1.5.

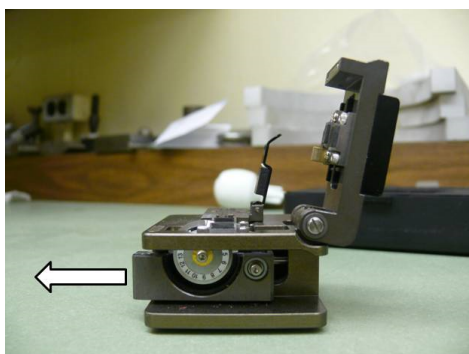


**Figure 1.5: Optical Fiber with clear inside coating partially stripped.**

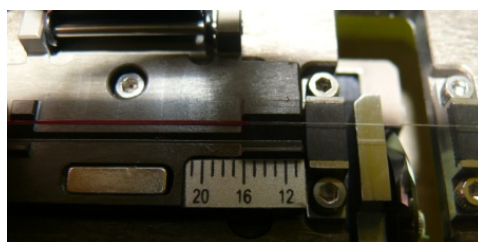
### **Cleaving**

Once a fiber has been properly stripped it must be cleaved to provide a flat uniform surface for bonding. Before proceeding, open both latches on the cleaver, and use the sliding carriage to position the cutting wheel out toward the user as depicted in Figure 1.6. Note; the cleaving wheel is extremely sharp and should not be touched.

There are two notches that run the length of the fiber cleaver. For single mode fibers the smaller notch should be used. The fiber must be laid straight and flat in the notch, and it must be aligned so that the boundary between the inside coating and the bare fiber core lies at the 16 mm (5/8 in) mark as shown in Figure 1.7. The bare fiber should span across the gap, and rest on the two pads on either side of the cutting wheel. The bare fiber should also overhang the edge of the far pad.



**Figure 1.6: Readied Fiber Cleaver**



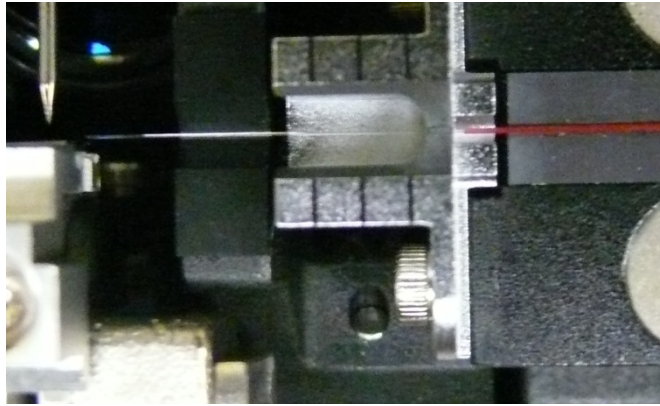
**Figure 1.7: Fiber aligned on Cleaver.**

Once the fiber is aligned, the first latch should be lowered to hold the fiber in place. Then check that the fiber is still aligned, and carefully lower the second latch. Push the cleaving wheel forward to cleave the fiber. Next, raise the latch over the cleaving wheel, and dispose of the loose piece of fiber. Then raise the other latch, move the fiber directly from the cleaver and align it in the splicing machine being careful not to touch the bare fiber end.

### **Splicing**

To align the fiber in the splicing machine, lift the inside cover and both latches (there are two latches per side). Then lay the fiber straight and flat on the surface ensuring that the fiber rests at the bottom of the V-notch, and align the boundary between the coating and bare fiber according to the reference printed on the inside cover. For fibers that have been stripped to 16 mm (5/8 in) as described in these instructions, the end of the coating should match up with the face of the notched metal plate as in Figure 1.8. Close the first latch, and check that the fiber is still aligned, and that the fiber is seated in the bottom of the V-notch, then close the second latch. Repeat these steps to prepare and align the second fiber.

Once both fibers are aligned, close the inside cover, and press the "SET" button. The splicing machine will bring the two fibers together, and burn off minor dust particles. Then the machine will pause and ask if the fibers are ok. Inspect the fibers on the screen to ensure that there are no clumps of dust, and that there is a well cleaved surface for splicing. Fibers that are good for splicing will look like those shown in Figure 1.9. If the fibers look good, press set again, and the splicer will attempt to align the fibers and splice them automatically. If the fibers do not look good, or if the machine fails to automatically splice the fibers, refer to the troubleshooting section.



**Figure 1.8: Fiber aligned on Splicing Machine**

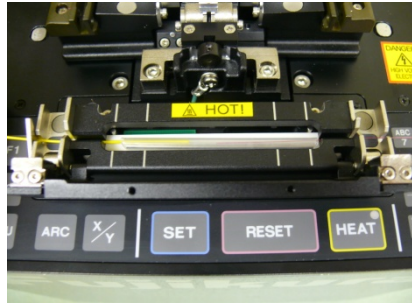


**Figure 1.9: Well-Prepared Fibers**

Once the fibers have been spliced, the machine will attempt to analyze the quality of the connection. This is not necessarily important, and can be canceled by pressing the reset button. Open the inner cover, and while gently holding the fiber in place lift the two latches on either side of the machine to release the newly joined fiber. Be careful while handling this newly joined fiber as the connection is quite delicate. Carefully slide the reinforcing tube over the newly spliced connection.

### **Reinforcing**

To reinforce the splice, open the cover and latches on the heating unit, shown in Figure 1.10, carefully slide the reinforcing tube over the newly spliced connection, pull back the metal catch on the left side of the heating unit, and set the covered splice into the heating area with the fibers set into the notches on the ends. Then, close the cover, and latches, and press the "HEAT" button. The machine will then heat up the shrinkwrapping reinforcing tube automatically. When it is finished, the machine will beep. Open the cover and latches, and remove the fiber from the machine. The splice is now complete.



**Figure 1.10: Reinforcing Tube Heater**

## Troubleshooting

### *Cleaving:*

A bad cleave will be apparent when viewing the fibers on the splicing screen. The ends of the fiber will be rounded or jagged rather than square. Fibers sometimes break in the cleaving device but not at the cleaving wheel. This result will not provide a good surface for splicing. If this happens:

- Make sure that enough of the inside coating has been removed so that it is not interfering with any parts of the cleaver.
- Ensure that there is a short length of fiber that overhangs the pad on the far side of the cleaving wheel
- Be very careful when lowering the latch above the cleaving wheel.

### *Splicing:*

- Dirty fibers will have black clumps or spots showing on the fiber when viewed through the splicing screen. The machine will attempt to burn off this dust when it brings the fibers together, but this is not always enough. If the fibers are too dirty to splice, remove the fiber, and gently pull it through a soft tissue or chem-wipe soaked in *100% pure* isopropyl alcohol.
- Dust can fall onto the mirrors and optics of the splicing machine. If there are a lot of spots on the splicing screen, take the air bulb, and direct air at the mirrors and lenses in the machine. Never blow with your mouth or use aerosols to do this.
- If there is an error of the “ZL Overrun”, “ZR Overrun”, or “Set Error” type, it means one or more fibers are not aligned properly in the machine. Try resetting both fibers.
- If the fibers are well cleaved, clean, and correctly aligned, but the splicer still can not make a splice, it may be necessary to manually operate the splicer. Instructions for doing this are listed in the Instruction Manual starting on page 33. If possible it is best to use the method with Automatically Initial GAP Setting, though this does not always work. When performing a manual splice, it helps to have the fiber connected to an interrogator, and adjust the fiber in the machine to maximize the intensity of the reported signal.

## CHAPTER 2 –SMARTSCAN INTERROGATION OPERATION

The SmartScan Interrogator shown in Figure 2.1 is a device used to measure the wavelength of a fiber Bragg grating (FBG). It must be connected to the internet or a computer network via the Ethernet port located at the bottom of the interrogator. The SmartScan communicates with a computer with the SmartSoft software through this network connection. The input located directly above the Ethernet port is the power input and must be plugged in before turning on the device. The switch located to the left of the power input is the on/off switch. The four inputs labeled CH1, CH2, CH3 and CH4 identify the four FBG input channels. In Figure 2.1 there is only one FBG fiber (yellow wire) plugged into the SmartScan CH1 input. In general, the device has the capability of having four FBG fibers plugged in each of the four inputs simultaneously. The device shown contains just two channels.



**Figure 2.1 – SmartScan Interrogator**

The Software that drives the SmartScan interrogator is called SmartSoft. SmartSoft (desktop icon shown in Figure 2.2) is used to adjust settings and view the data inputs of the FBGs. The following two sections provide more detailed instruction on the setup and use of the SmartScan interrogator and the SmartSoft software.

Note: The SmartSoft User Manual provides detailed instruction on all instrument operations and can be found at [www.smartfibres.com/docs/Example\\_SmartSoft\\_Manual.pdf](http://www.smartfibres.com/docs/Example_SmartSoft_Manual.pdf).





**Figure 2.2 – SmartSoft Desktop Icon**

### **SmartScan Setup Instructions**

- 1) First ensure that the SmartScan on/off switch is in the off position.
- 2) Plug the Ethernet cable and power cord into respective ports as described previously. The Ethernet cable must be connected to a computer or a local computer network.
- 3) Remove the white cap from the channel port and put in a safe place.
- 4) Remove the clear plastic cap from the plug end of the FBG cable and put in a safe place. Ensure that the exposed plug end and channel port are clean. Use compressed air to clean if needed.
- 5) Line up the notch on the FBG plug end with the groove on the channel port and push in the FBG plug. Screw the FBG plug end tight.
- 6) Switch on the SmartScan interrogator.

### **SmartSoft Instructions**

- 1) Make sure the SmartScan interrogator is turned on before opening the SmartSoft software.
- 2) Open the SmartSoft software. You will be prompted with an IP address window, which should already have the correct IP address entered. Click OK. In case of trouble with the IP address, see the SmartSoft User manual pg. 32 for further instructions.
- 3) The SmartSoft window has five main tabs at the top as seen in Figure 2.3. The Post Process Suite is not currently installed and should not be needed. The following steps will go through the remaining 4 tabs.
  - a. **Instrument Setup tab:** This tab has five sub-tabs that are used to adjust the settings of the FBG setup.
    - i. The **Acquisition rate** tab shows a plot of the Wavelength vs. Relative intensity (response spectra) of the FBG. It may take a few seconds for the response spectra and number labels to appear. If there is no response peak on the response spectra as seen in Figure 2.3 then there is something wrong with the setup. Possible problems could be a bad fiber splice or a bad connection. The number at the top of the response peak should match the labeled wavelength of the FBG when there is no strain on the FBG. Here it is also possible to set the frequency of the wavelength readings that

will be saved to the output data file for a given acquisition time. For example if you want two wavelength readings per second then set the sample size to 125. The acquisition rate is always set at 250 Hz. [ 250Hz / 125 samples = 2 readings per second.]

- ii. The **Gain Slots** tab is used for Enhanced Acquisition to assign individual wavelength windows to multiple FBGs. See SmartSoft User manual pg. 15 for more details.
- iii. The **Peak detection** tab is used to set a peak detection threshold on the reflected FBG wavelengths. This function filters out background reflection that is less than the FBG peaks. See SmartSoft User manual pg. 17 for more details.
- iv. The **Network** tab is used to change the IP address, subnet mask and gateway configurations. Such changes should only be necessary if network connections are altered. See SmartSoft User manual pg. 18 for more details.
- v. The **Load and Save** tab is used to save the instrumentation settings to a file that can be recalled during different sessions. See SmartSoft User manual pg. 19 for more details.

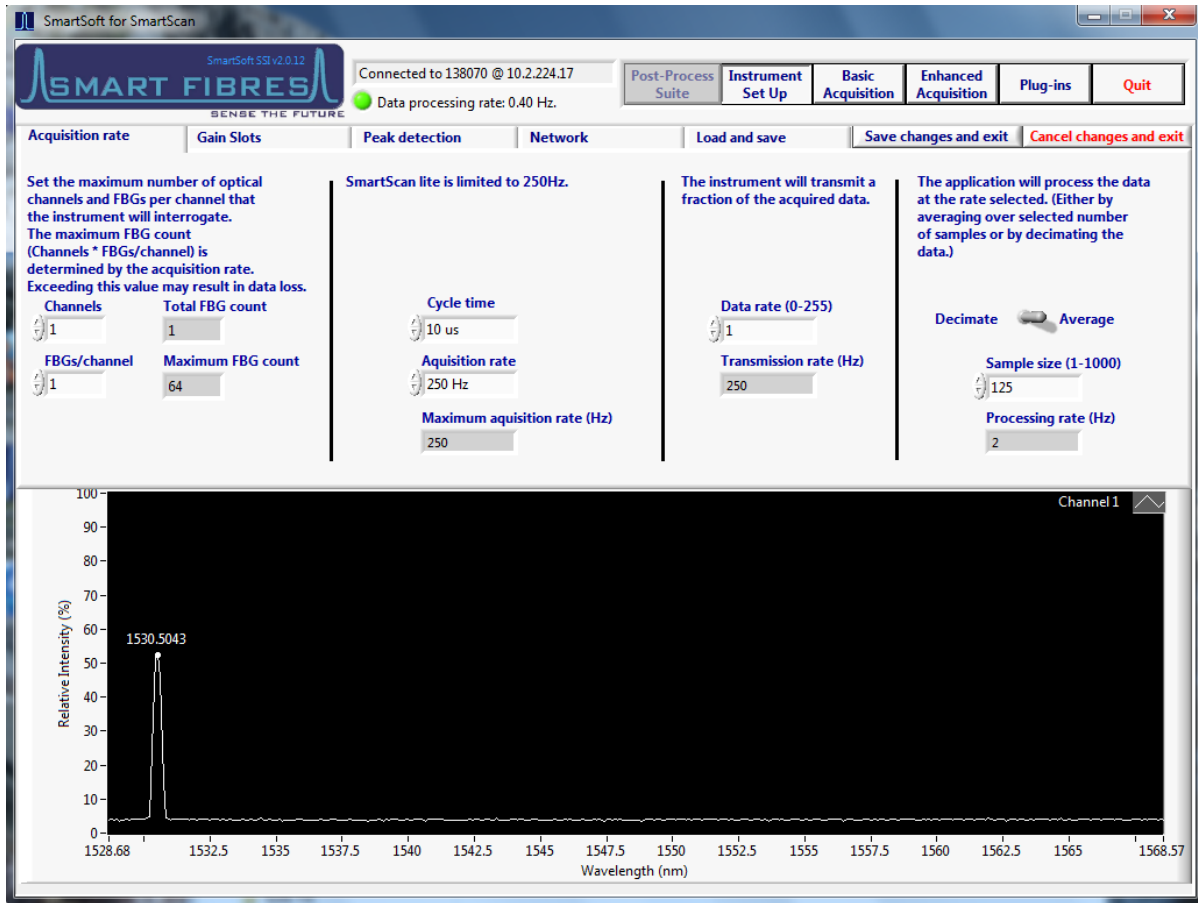


Figure 2.3 – SmartScan Main Window

- b. **Basic Acquisition tab:** This tab has three sub-tabs used to collect data from the FBGs over set time periods.
  - i. The *Spectrum* tab is used to view the spectrums of the FBGs of a specific channel. The channel being viewed can be changed. See SmartSoft User manual pg. 10 for more details.
  - ii. The *Sensors* tab has a table to the left which shows the wavelengths of the FBGs which updates every few seconds. To the right there is a log file box which is where the save location of the output data file is specified. Below that are the log controls. In the log time box enter the number of seconds that you would like to record wavelength data for. When you are ready to start recording, press the log button and a log progress bar will appear. See SmartSoft User manual pg. 11 for more details.
  - iii. The *Charts* tab is used to plot FBG variables such as temperature, strain, wavelength or pressure. See SmartSoft User manual pg. 12 for details.
- c. **Enhanced Acquisition tab:** The *Spectrum* tab has similar functions to those of the spectrum tab in the basic acquisition tab as described previously. See SmartSoft User manual pg. 21 for details.
  - i. The *Select sensors* tab allows the user to record data from a specific FBG sensor in a situation where there are multiple connected FBGs. The units of the wavelength can be set, and the sensor type can be selected. See SmartSoft User manual pg. 23 for details.
  - ii. The *Charts* tab has similar functions to those of the charts tab in the basic acquisition tab as described previously. Only the FBGs added in the select sensors tab will be selectable in the charts tab. See SmartSoft User manual pg. 27 for details.
  - iii. The *Graphic* tab can be used to import an image that can then be labeled with charts or graphs taken from the acquired FBG data. See SmartSoft User manual pg. 28 for details.
  - iv. The *Event capture* tab is used to record a plot of FBG wavelength data over a specified time period. The plot can be saved to file. See SmartSoft User manual pg. 29 for details.
  - v. The *Plugins* tab is used to run Lab View source code for more customized data acquisition. The software comes with a built in plugin setup for Fast Fourier Transform analysis. See SmartSoft User manual pg. 29 for details.
- d. **Plugins tab:** The *Plugins* tab serves the same function as the plugins tab described previously in the enhanced acquisition section.

# CHAPTER 3 – INSTALLING, PROTECTING AND REPAIRING OPTICAL FIBER SENSORS

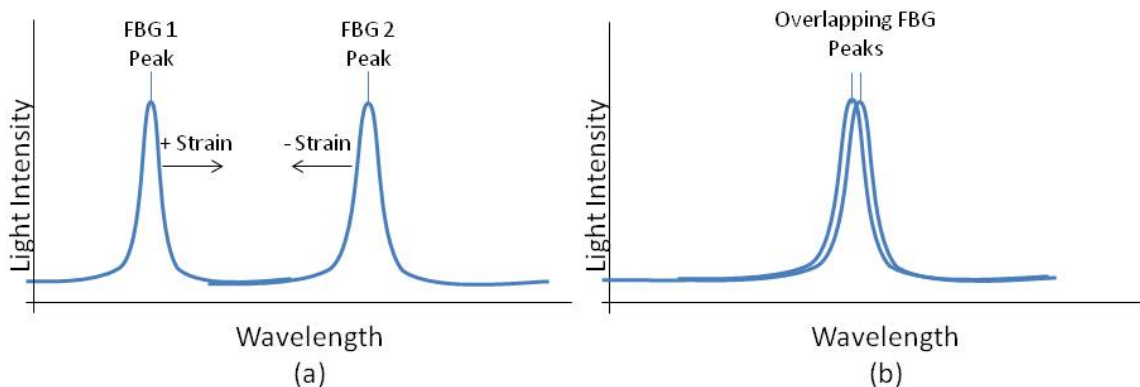
Methods were developed for installing, protecting, and replacing FBG sensors on bridges. Of primary concern was the feasibility and ease of using the installation methods in the field, the durability and ruggedness of the sensing system, and the practicality of repairing damaged fibers or sensors once installed.

## Multiplexed Sensor System Design

Multiplexing, or the ability to attach multiple sensors on a single channel, is one of the main advantages of using an FBG-based SHM system. It allows a single interrogator, which is generally the most expensive component of an FBG based system, to read a large number of sensors. Ideally, a single interrogator would be used to read all of the sensors on a bridge.

For a multiplexed FBG system, a sensor plan should be carefully developed prior to installing any sensors, to ensure that the operating wavelength spectrum of each channel of the interrogator is efficiently utilized. The operating spectrum of an interrogator is often the largest constraint on the number of sensors that can be effectively multiplexed, and interrogators with wider spectra or more channels will incur significant costs.

Therefore, consideration must be given to the wavelength range that multiplexed sensors will experience under operating conditions. If the reflected peaks from two FBG's on the same channel overlap during operation, interrogators cannot differentiate the light returning from the two sensors, and the reflected light will register as a single peak returning from a single FBG. This overlapped peak confuses the data collection, and renders those sensors ineffective. This problem occurs if the unstrained FBG peaks are not spaced far enough apart on the wavelength spectrum to allow for the wavelength shift caused by the strain conditions. An illustration of this issue is provided in Figure 3.1.



**Figure 3.1 - Interrogation Overlap Due to Inadequate Sensor Spacing**

(a) Unstrained sensor reflected peaks, (b) Strained sensor reflected peaks

The wavelength spacing can be adjusted by applying different magnitudes of pretension to the fibers while they are being adhered to the structure. Enough pretension can be applied to a fiber to cause a wavelength shift of about 4nm without causing concern for over-tensioning the fiber during the FBG service.

To prevent overlapping peaks, preliminary analysis of the expected structural behavior should be performed to determine the appropriate location and pretensioning necessary to place multiplexed FBGs with adjacent wavelengths. The maximum shift on the light spectrum will be dictated primarily by the maximum strain that the fiber will undergo while in operation. For a maximum strain of 0.003, the corresponding shift in wavelength is approximately 4nm.

The maximum expected wavelength shift due to strain provides an estimate on the necessary spacing between wavelength peaks, but one must be judicious in spacing FBG wavelengths to also maximize the number of sensors that can be multiplexed onto a single channel. In areas of the structure where large strains are unlikely to occur, the wavelength spacing may be reduced. However, if two fibers possess adjacent wavelength peaks on the spectrum and are likely to experience concurrent opposing strains (one fiber undergoing positive strain, while the other experiences negative strain), bringing the wavelength peaks toward each other, then the wavelength spacing between them should be increased appropriately. Often, care can be taken to place FBGs with adjacent wavelengths in areas of the structure that will undergo concurrent strains in the same direction allowing for a reduction in the wavelength spacing.

A sensor plan, which maps the locations of the FBGs on the structure with their corresponding wavelengths, helps to design an effective layout for the FBG sensors that can efficiently utilize the operational spectrum of the interrogator. System designers must determine appropriate wavelength spacing for the strains expected in the structural locations being measured.

### **Sensor Installation**

In adhering the fiber Bragg gratings to bridges, care must be taken to ensure good strain transfer and reliable readings. The fibers need to be aligned along the desired axis of strain measurement, and it must be ensured that the fibers are securely attached to the host material without any slack or buckling in the fiber across the sensing region. Slack and buckling in the fiber is prevented by applying a slight pretension to the fiber while adhering it to the host element.

While a nominal amount of pretension is necessary to ensure a sensor is installed straight and with a good bond, the specific amount of pretension necessary will be dictated by the wavelength required by the sensor plan. Often the sensors provided by an FBG manufacturer may not have base wavelengths corresponding to the necessary peak wavelengths required by the sensing plan. The peak wavelength can be increased by as much as 4 nm by applying pretension to the sensor during installation on the structure. Care must be taken not to over-tension the FBGs, as they can be brittle and have a tendency to break across the sensing region, which is slightly weakened during the manufacturing process. Therefore, when ordering FBGs it is important to order sensors with base wavelengths that vary all across the effective spectrum of the interrogator.

It was desired to develop a simple and effective method for adhering FBG sensors to steel and concrete elements. Of primary concern was achieving an effective bond capable of delivering adequate strain transfer to the FBG and devising an efficient method for installation that would be simple to perform in field conditions.

After an FBG is installed, the sensor and lead fiber must be protected from weather, vandals, and wildlife. For the portions of the optical fiber between sensors or leading to the interrogator, a much more durable fiber that is secured in a 900 micron plastic sleeve should be spliced in. This additional sleeve provides much more flexibility and durability than the standard acrylate coating. However, it would still be vulnerable to wildlife and vandals; so additional protection methods may be necessary.

Separate methods were developed for installing, protecting, and replacing FBG sensors for steel and concrete structures. The specific methodology is detailed in the following subsections.

### ***Sensing Steel Elements***

#### ***Installation of Bare Fibers on Steel Elements***

As steel is a homogeneous material, the strain sensor can be adhered directly to the region where measurement is desired. Adhering an FBG directly to the surface of steel elements using cyanoacrylate adhesive achieves satisfactory strain transfer. A specific type of adhesive that has proved useful for the installation procedure is a thickened fast-curing cyanoacrylate adhesive called Lightning Bond™, which comes with an activator spray that accelerates the curing process. Loctite™ produces a similar product. Applying the FBGs to the steel material with the proper pretension requires methodical precision. The method devised for achieving an adequate bond with the appropriate pretension is as follows:

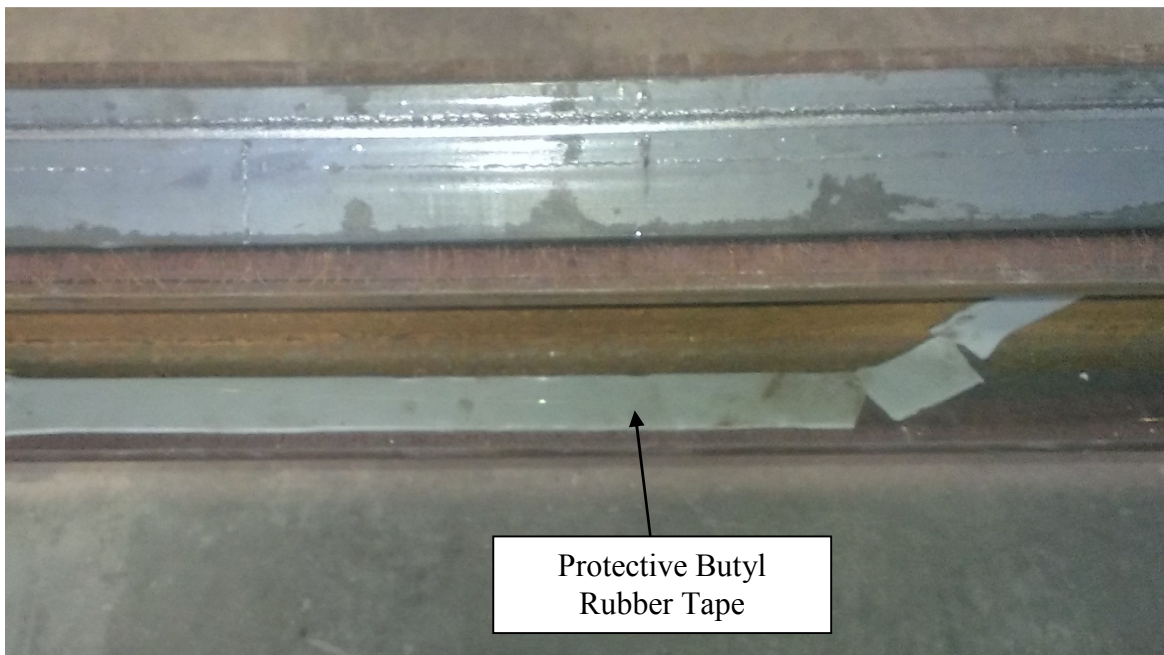
1. Remove any mill scale or paint using a grinder or wire brush. Then clean the material surface, removing all oil, and slightly roughen it with sand paper.
2. Carefully mark the location to be measured on the element and draw a straight line along the axis of measurement. Then position the fiber along the axis of measurement so that the FBG region of the fiber is positioned at the location of interest. Then tape one end of the fiber to the structure to aid in aligning the fiber for the next step.
3. Apply the cyanoacrylate adhesive approximately 50 mm (2 in) away from the sensing region along the axis of measurement. Set the fiber into the adhesive so that the FBG is aligned and positioned correctly and spray the activator over the adhesive region to accelerate the curing process. Hold the fiber in place until the adhesive cures (about 30 seconds).
4. Once the adhesive has cured apply the cyanoacrylate adhesive to the region to be measured ensuring a minimum adhesive length of 40 mm (1.5 in). Then, gently adjust the tension on the fiber until the target wavelength is achieved. Next, press the fiber against the steel so that it is aligned with the axis of measurement and in good contact with the adhesive. Hold the fiber steady, ensuring that it is tensioned to the appropriate wavelength, and apply the activator to the adhesive. Hold the fiber in place until the adhesive cures (about 30 seconds). As an alternative to manually holding the

fibers in place while the glue cures, a pair of flat clamps or strong magnets may be used to hold the fiber in tension against the steel member. For this approach, the fiber should be protected from the clamps or magnets using a thin piece of rubber or similar cushioning material. Prior to applying the activator spray, verify that the pre-tension is stable by monitoring the wavelength for any change.

5. Slowly release hold of the fiber while monitoring the wavelength for any significant drop in wavelength. If the wavelength of the applied FBG fails to stabilize at a higher wavelength than the base wavelength, then adequate bond has not been achieved. If a satisfactory bond is not achieved, refer to the subsequent replacement procedure.

### ***Protection on Steel Elements***

For steel material, application of a rugged, durable tape over the fiber is the simplest method for providing protection. The tape provides adequate protection and also holds the fibers in place. Fiber with the additional plastic protective coating should be spliced between FBG sensors to provide further durability under the tape. A modified butyl rubber tape produced by Permatite™ is recommended. The tape is rated for exterior exposure with a temperature range from -40°C to 120°C (-40°F to 250°F) and provides a watertight seal. The tape is approximately 3 mm (1/8 in) thick with a soft rubber or clay-like consistency, and it is available in various widths. The tape appears to bond well to steel, although no long term environmental exposure tests were performed. The steel should be clean and free of mill scale and oil prior to applying the tape. An example of this protection method is shown in Figure 3.2.



**Figure 3.2 - Protected FBG Fiber on Steel Beam**

### ***Replacement on Steel Elements***

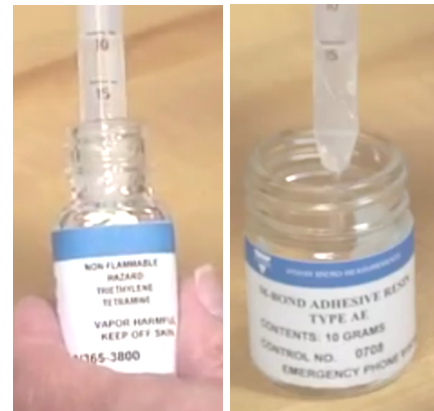
If a fiber breaks on a multiplexed channel, then the signal from all FBGs beyond the break will be lost. The location of the last FBG reflecting a signal back to the interrogator can be used to locate the break in the optical fiber, as the break will be located somewhere between this last reporting FBG and the next sensor on the fiber. To replace the damaged fiber, at least one foot of the protective tape must be removed from each side of the break to allow enough slack in the fiber to perform a splice. In regions where the lead fiber is protected by the additional sleeve, the tape can be carefully removed with a putty knife. In regions where the fiber lacks this protective sleeve it will be difficult to remove the tape without breaking the fiber.

If the break occurs near a sensor, where a fiber cannot be repaired by simply splicing in an additional length of fiber at the break, the damaged fiber will need to be removed and replaced. Once the tape has been removed, a putty knife or a razorblade can be used to scrape off the old fiber and adhesive. Sandpaper should be used to re-clean and roughen the surface. Then the new FBG can be spliced and installed according to the preceding installation instructions.

### ***Installation of Carrier-Mounted Sensors on Steel Elements***

The process for installing FBG sensors on a steel host varies when the sensors are mounted on a carrier, such as the case with Micron Optics' os3120 FBG sensors. The installation process is summarized below. An effective Youtube video is available at: <https://www.youtube.com/watch?v=PejlfJxzNmE>

1. Mix Epoxy: Fill dropper with Curing Agent 10 exactly to the number 10 and dispense the contents into the center of the jar of Resin AE. Immediately cap the bottle of Curing Agent 10 to avoid moisture absorption. Mix thoroughly for five minutes, using one of the plastic stirring rods. Discard the dropper after use.

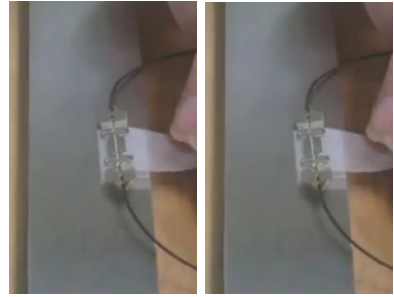


2. Prepare Surface: Sand the surface lightly to remove debris down to sound metal. Spray degreaser directly onto the surface and wipe down. Apply conditioner directly onto the surface. Use a new cloth to wipe the surface. Apply neutralizer directly onto the surface and wipe with a new cloth.

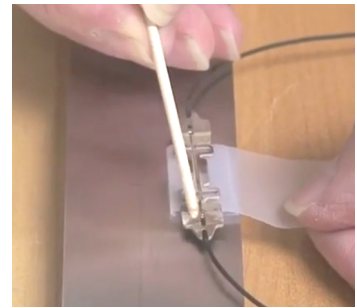




3. Position Sensor: Place the sensor along the axis of strain measurement. Tape the sensor to the surface, then pull back the tape on one side.



4. Apply Epoxy: Apply enough epoxy to cover each end of the sensor mount using a wooden dowel. Tape the sensor back on the surface.



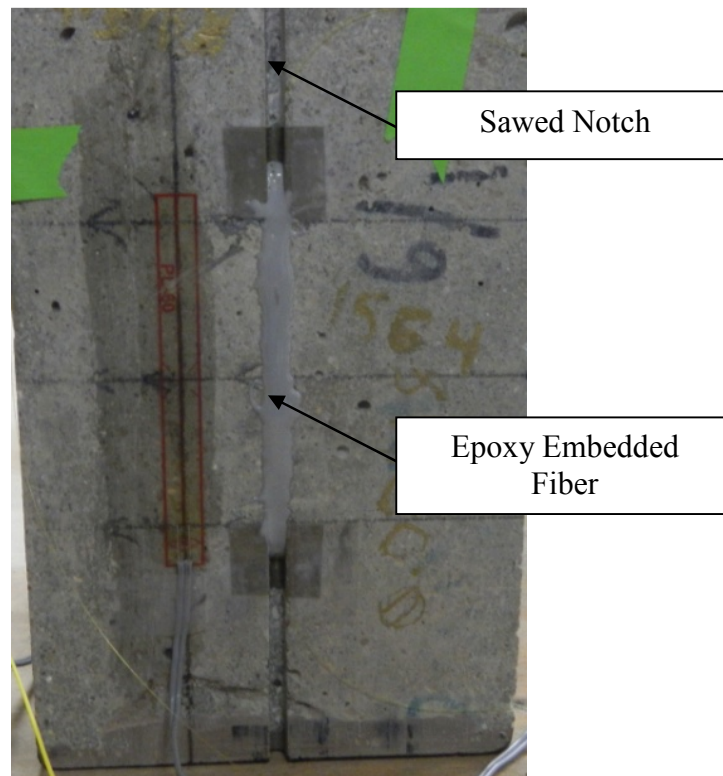
5. Cure Epoxy: Plate a metal plate over the os3120 and secure by taping. Clamp the plate to the surface. Allow epoxy to cure at room temperature for approximately six hours.



## ***Sensing Concrete Elements***

### ***Installation on Concrete Elements***

Because of the porous nature of concrete, it is difficult to achieve a high-quality, long-lasting bond using cyanoacrylate adhesive. In other studies, FBG fibers have been embedded in concrete using mechanical anchors or affixed to rebar. However, the intent here is on methods for installing an SHM system post-construction. Therefore, a method was necessary for applying FBG sensors to in-service concrete structures. The recommended approach is to adhere FBG sensors to concrete by placing the fiber in a shallow channel on the concrete surface, which can be cut using a masonry saw, and embedding the fiber in a stiff high-strength epoxy. The epoxy used in this study was Ultrabond 1300™. The resulting bond is shown in Figure 3.3.



**Figure 3.3 – Bond Resulting From Notch-Embedded Epoxy Procedure For Concrete Fiber Installation**

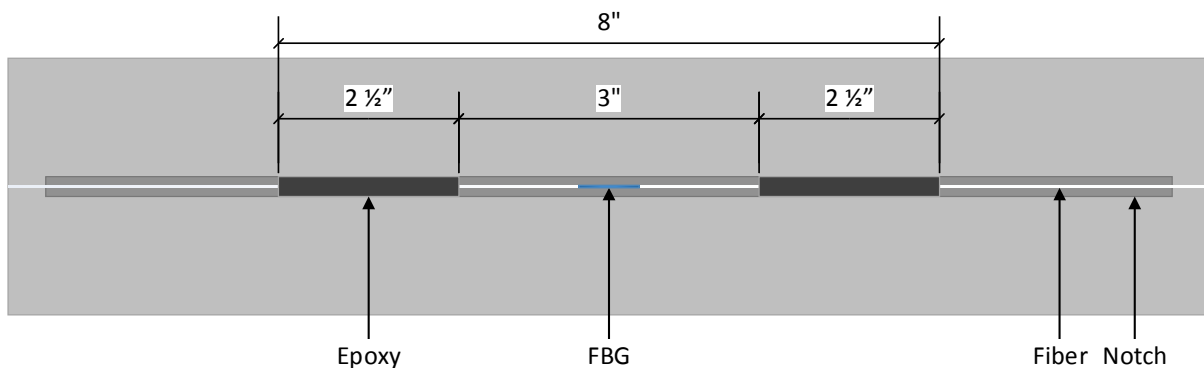
Based on physical, a bond length of 60 mm (2.4 in) is regarded as sufficient to achieve adequate strain transfer for fibers embedded at reasonable depths in saw notches 3 mm (1/8 in) wide and 3 mm (1/8 in) deep.

While embedding the fibers in a notch provides a good mechanism for strain transfer, it does present some accessibility challenges for installing fibers with adequate pretension. Furthermore, the majority of high-strength epoxies require at least 24 hours to fully cure. This makes it impractical for the fiber to be held in place manually until the epoxy reaches full strength. Therefore, a procedure was devised to apply an FBG fiber into a notch with adequate pretension and hold it in place long enough for the epoxy to cure. The devised method involves

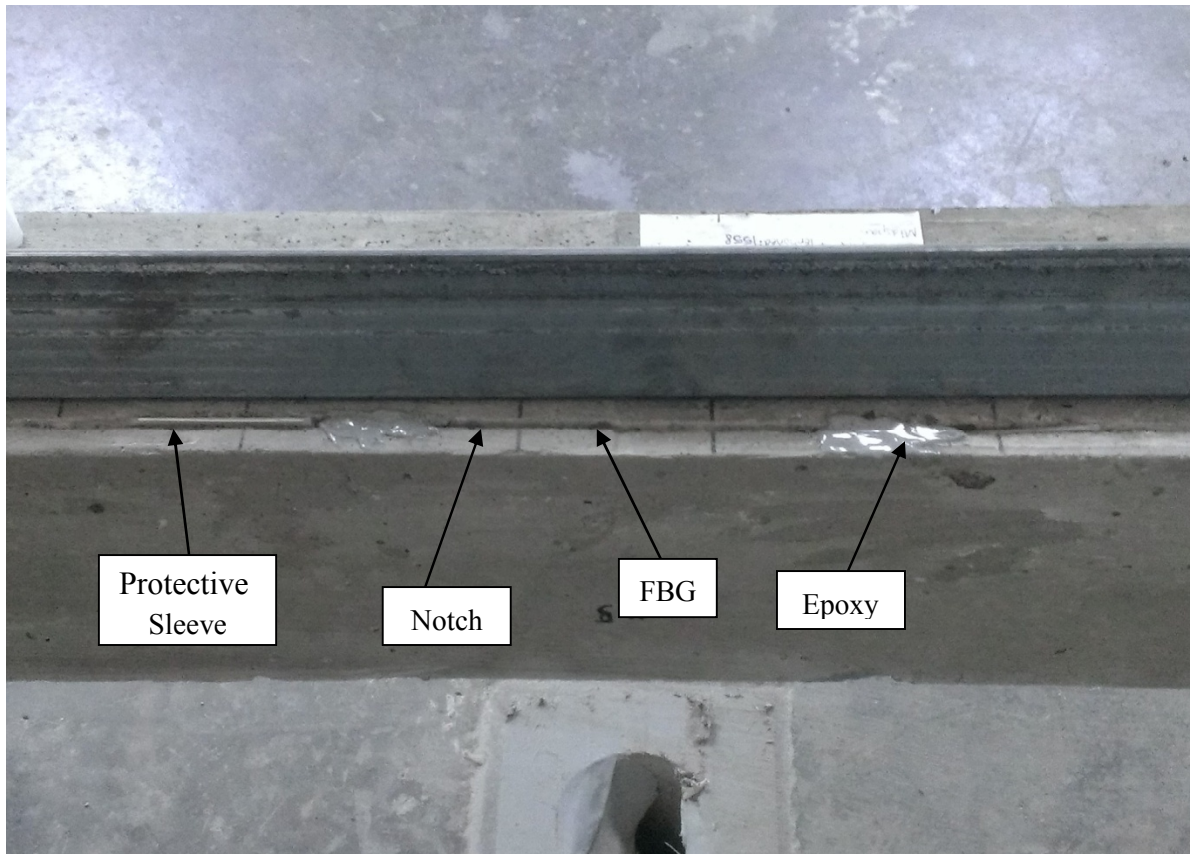
installing a heat-shrink protective sleeve on the fiber, which bonds to the fiber and provides a means to grasp and tension the fiber. These protective sleeves can be affixed to concrete using cyanoacrylate. While this bond is not adequate for permanent installation in service conditions, it is sufficient to hold the fiber in place temporarily while the epoxy cures. This procedure is presented in detail in the following installation instructions for concrete.

Unlike steel, concrete is a heterogeneous material and the strain field is not constant across the material. For normal strength concrete, the stiffer aggregate will strain less than the cementitious material. As the strain increases, cracks will form, creating regions where most of the deformation is distributed into crack widening and almost no strain is experienced by the regions between cracks. Thus, it is necessary to average the strain across a long gage length for concrete rather than sensing strain locally. A gage length of 20 cm (8 in) for concrete and asphalt materials is recommended.

The configuration devised to achieve a long-gage strain sensor with adequate bond length consists of a shallow notch in the host concrete structure with two regions of epoxy approximately 65 mm (2.5 in) long separated by an unepoxied region of at least 75 mm (3 in). The FBG is positioned in the center of the unepoxied region. A diagram of the long-gage FBG strain sensor is shown in Figure 3.4. This configuration shows the minimum gap between the epoxied regions. The strain over the epoxy region may not be uniform as the bond is developed. However, in the analysis the strain obtained will be treated as a reading at a localized point, likely located at a point of maximum strain. A photo of an FBG installed according to this configuration is shown in Figure 3.5. As the FBG is not directly affixed to the material, it is critical to maintain enough pretension in the fiber to prevent it from reaching a relaxed state during service. Therefore, the maximum expected compressive strain should be considered when determining the proper pretension to apply to the sensors for the system.



**Figure 3.4 – Minimum Configuration for Long-Gage Strain Sensing of Concrete Using an FBG**



**Figure 3.5 – Photo of Long-Gage FBG Installed on Concrete Beam**

The protocol developed for installing FBGs onto concrete members is as follows:

1. Prior to splicing the FBG into the channel line, slide a heat shrink protective sleeve onto each side of the FBG approximately 130 mm (5 in) away from the center of the sensor. Being careful to keep the sleeve in place on the fiber, set each sleeve into the heating unit on the splicer to bond it into place. Once the sleeves are in place, the FBG fiber can be spliced onto other fibers or leads following typical procedures.
2. Carefully mark the location to be measured on the host structure and draw a straight line along the axis of measurement. Then, using a 1/8 in thick masonry blade, cut a straight shallow notch into the beam along the axis of measurement approximately 3 mm (1/8 in) deep and 30 cm (12 in) long.
3. Align the fiber with the notch and mark off the locations for the FBG sensor, the unepoxied region [approximately 75 – 130 mm (3-5 in)], the epoxied regions on each side [65 mm (2.5 in)], and the protective sleeves. Then using these marks as a guide, apply a thin layer of cyanoacrylate adhesive to one of the protective sleeves and position it in the notch. Ensure that it is in the appropriate position, and firmly press it down until the adhesive cures.
4. Using a small flat head screwdriver or similar tool, distribute the epoxy into the bottom of the notch, filling it approximately halfway up in the epoxied regions.

*Note:* For sensors being installed overhead or on vertical faces, it may be necessary to wait approximately 10 minutes after mixing the two parts of the epoxy for it to establish adequate viscosity to prevent it from running.

5. Apply a thin layer of cyanoacrylate adhesive to the remaining unattached protective sleeve and to the corresponding region of the notch. Then, gently apply the appropriate pretension to the fiber and press the sleeve into the notch. Firmly hold the sleeve in place to maintain the pretension in the fiber. Then spray the activator on the cyanoacrylate adhesive and continue to hold the sleeve until the bond is secure.
6. Using the flathead screwdriver, fill the epoxy region to the top of the notch with epoxy, being careful not to damage the fiber. Then monitor the wavelength for any significant drop in wavelength. If the wavelength fails to stabilize above the base wavelength, it indicates an inadequate bond between the sensor and host material. If a satisfactory bond is not achieved, refer to the subsequent replacement procedure.

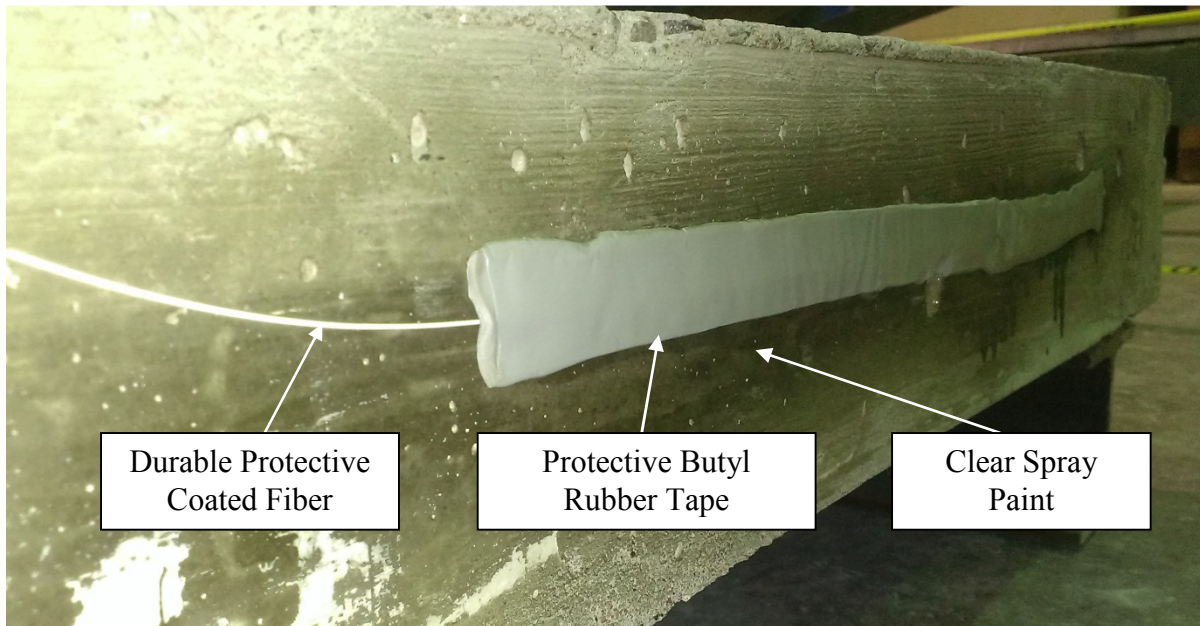
### ***Protection on Concrete Elements***

Affixing protective materials to concrete is more difficult than affixing to steel due to the rough surface, to which the tape does not adhere well. Two methods were developed to protect fibers attached to concrete elements.

The first method requires a more intricate installation process, but results in a more permanent system. However, if for some reason an element in the SHM system breaks, all of the sensors on the channel must be replaced. To begin, a notch is cut the full length of the bridge, and each sensor must be installed so that the fiber lies within the notch for the full length of the bridge. To ensure that the optical fibers fit into the notch, the fibers between sensors must be measured out to be the same length as the notch between sensors, so that the fibers can be installed onto the structure with very little slack. Once all of the sensors have been installed, the entire length of fiber for each channel is laid into the notch and covered with epoxy, except for the unepoxied regions where FBG's have been installed. Over the unepoxied regions, a thin 1-inch wide cover plate, made of either plastic or metal, can be attached to the concrete using epoxy to seal off the notch. This method results in a very durable, permanent system. However, the installation process is complicated by the necessity of having a taught fiber between sensors, and it can be cumbersome to saw a notch the full length of the bridge. Finally, if a problem is discovered in any of the sensors after the protection system is in-place, then the entire line of sensors must be cut out, and new sensors must be installed.

The second method does not provide as robust protection, however it is easier to implement, and it allows for repairs to be performed without replacing all of the sensors on a channel. For this method, shallow 30 cm (1 ft) long notches are cut at sensor locations, and the FBGs are installed according to the installation procedure. Between sensors the more durable fiber with a 900-micron protective sleeve is spliced leaving enough slack between sensors to maintain workability. A strip of clear spray paint is applied along the length of the element and allowed to dry in order to produce a smooth surface. Then the fiber is attached to the element using the butyl rubber tape discussed in the steel protection method section. The tape must be pressed firmly onto the concrete to ensure an adequate bond. If there is excess fiber, it can be

wound into a loop and covered with butyl rubber tape. Care must be taken not to wind the fibers into too tight of a loop, which would result in a loss of signal. A diameter of about 50 to 75 mm (2 to 3 in) is acceptable. The butyl rubber tape can be installed over the notched regions where sensors are installed, or a thin cover plate may be epoxied into place to provide extra protection for the bare fiber in the notch. A figure of the second protection method is shown in Figure 3.6.



**Figure 3.6 – Protection Method 2 for Fibers Installed on Concrete**

### ***Replacement on Concrete Elements***

If protection method 1 was used, and it is discovered that a sensor is not performing, then all of the fiber will need to be removed from the notch, and new sensors will need to be installed. The epoxy may be removed using a file and similar hand tools, or it may be easier to recut the notch using a masonry blade. Once all of the sensors are removed, new sensors must be installed and protected according to the previous instructions.

If protection method 2 was used, the butyl rubber tape can be gently removed from the structure using a putty knife. Care must be taken not to damage the underlying protective coated fiber. If the break occurred along the fiber between sensors, then the disjointed fiber ends can be stripped, cleaved, and spliced according to common practice. The fiber can then be re-adhered to the structure using a fresh strip of the butyl rubber tape.

If the break occurred at, or close to, the sensor, then the sensor will need to be replaced. If a cover plate was used, it should be removed by scraping the underlying epoxy away with a putty knife. Otherwise the butyl rubber tape can be removed by gently pulling it back using a putty knife. Enough of the lead fiber should be liberated to splice a new FBG onto the channel. To remove the old sensor, the epoxy can be removed with a file, and the glued fiber protectors can be pried out using a flathead screwdriver. Once the old fiber is removed and the notch is cleaned, a new sensor can be installed according to the preceding instructions.

## CHAPTER 4 – TEMPERATURE COMPENSATION FOR FBG SENSORS

FBG sensors are sensitive to changes in temperature and are not self-compensating for temperature variations. Therefore, it is necessary to separate the wavelength shift due to temperature variation from the wavelength shift due to mechanical strain in the host material. While the relationship between temperature and wavelength shift is well established (Eq. 4.1), measuring temperature introduces complexity to the system. It is easier to measure the temperature effect on wavelength directly by using an FBG that is isolated from mechanical strain, and directly subtracting this apparent strain from the other bonded sensors on the structure to determine the resulting mechanical strain. The computations for this procedure are illustrated in the following.

The relationship between temperature change  $\Delta T$  and wavelength shift is given by:

$$\Delta\lambda_T = \lambda_0(\alpha_A + \alpha_\eta)\Delta T \quad (4.1)$$

where:  $\Delta\lambda_T$  = wavelength shift due to temperature change  
 $\lambda_0$  = base wavelength of FBG  
 $\alpha_A$  = thermal expansion coefficient of fiber ( $\approx 0.55 \times 10^{-6}/^\circ\text{C}$ )  
 $\alpha_\eta$  = thermo-optic coefficient ( $\approx 8.60 \times 10^{-6}/^\circ\text{C}$ )  
 $\Delta T$  = change in temperature

For a given change in temperature, the strain sensing FBG would read a total wavelength shift of:

$$\Delta\lambda = \Delta\lambda_M + \Delta\lambda_T \quad (4.2)$$

where:  $\Delta\lambda$  = total wavelength shift  
 $\Delta\lambda_M$  = wavelength shift due to mechanical strain  
 $\Delta\lambda_T$  = wavelength shift due to temperature change

The relationship between strain and wavelength shift in an FBG is given by Equation 4.3.

$$\varepsilon = \frac{\lambda - \lambda_0}{G\lambda_0} \quad (4.3)$$

where:  $\varepsilon$  = strain  
 $\lambda$  = reflected wavelength  
 $\lambda_0$  = unstrained reflected wavelength  
 $G$  = gage factor (typically 0.78)

Rearranging Equation 4.3 gives:

$$\Delta\lambda_M = \lambda_0 G \varepsilon \quad (4.4)$$

where:  $G$  = FBG gauge factor  
 $\varepsilon$  = strain

Substituting for  $\Delta\lambda_M$  and  $\Delta\lambda_T$  gives:

$$\Delta\lambda = \lambda_0 G \varepsilon + \lambda_0 (\alpha_A + \alpha_\eta) \Delta T \quad (4.5)$$

The value for  $\Delta T$  can be obtained by the temperature compensating FBG by rearranging equation 4.1:

$$\Delta T = \frac{\Delta\lambda_{TC}}{\lambda_{0TC} (\alpha_A + \alpha_\eta)} \quad (4.6)$$

where the subscript  $TC$  denotes the values are obtained from the temperature compensating FBG sensor. Substituting equation 4.6 into equation 4.5 and simplifying results in the formula:

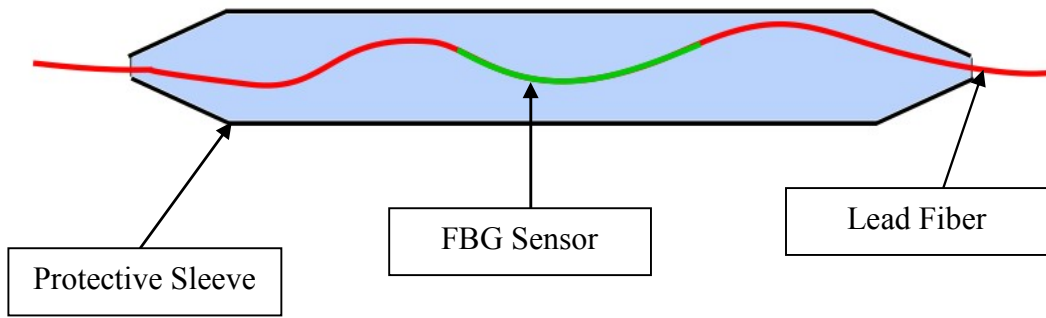
$$\Delta\lambda = \lambda_0 G \varepsilon + \frac{\lambda_0}{\lambda_{0TC}} \Delta\lambda_{TC} \quad (4.7)$$

Then solving equation 4.7 for strain  $\varepsilon$  gives the equation for field measured strain using a temperature compensating FBG sensor:

$$\varepsilon = \frac{\Delta\lambda - \frac{\lambda_0}{\lambda_{0TC}} \Delta\lambda_{TC}}{\lambda_0 G} \quad (4.8)$$

To measure the thermal effect on FBG readings, it was necessary to develop a method for isolating an FBG sensor from mechanical strain while providing adequate protection to ensure durable operation. To achieve this, an FBG sensor is inserted into a protective heat shrinking tube, which is typically used for protecting splices in optical fibers. Using a heat source, one of the tips is heated until it shrinks and achieves a bond with the fiber. Then the fiber is compressed to induce a buckled shape inside the protective sleeve. Then the other tip is heated to lock the fiber into place while being careful to maintain the buckled shape. The resulting protective sleeve is pinched at the ends, and a gap remains in the middle to allow the sleeve to expand and contract as temperature fluctuates without inducing mechanical strain in the fiber. The devised encasement for a temperature compensating FBG is illustrated in Figure 4.1.



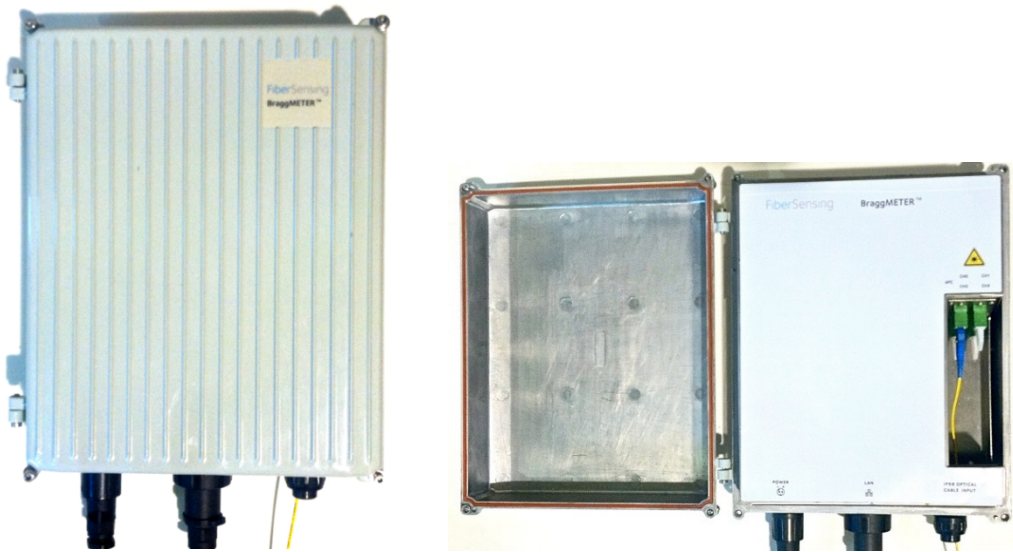


**Figure 4.1 – Temperature Compensation FBG**

# CHAPTER 5 – SCHEMATIC DESIGN AND FABRICATION OF INSTRUMENTATION

## Introduction

Field instrumentation necessary for the discrimination of bridge strain data based on critical events, such as the passing of an overloaded truck, primarily relies on a robust fiber Bragg grating (FBG) sensor interrogator, data processing microcontroller, and data storage capability. The FS2200 extended temperature BraggMETER by HBM FiberSensing was chosen as the FBG sensor interrogator for field deployment due to its programming capabilities, ethernet interface, and ability to handle harsh environments (Figure 5.1). The FBG interrogator strictly interrogates and interprets optical strain sensor response and transmits that data over a standard ethernet interface. Therefore, in a remote installation where power and data transmission requirements are to be minimized based on predetermined criteria, the designer is forced to build a low-power controller that will autonomously communicate with the interrogator on a localized basis.



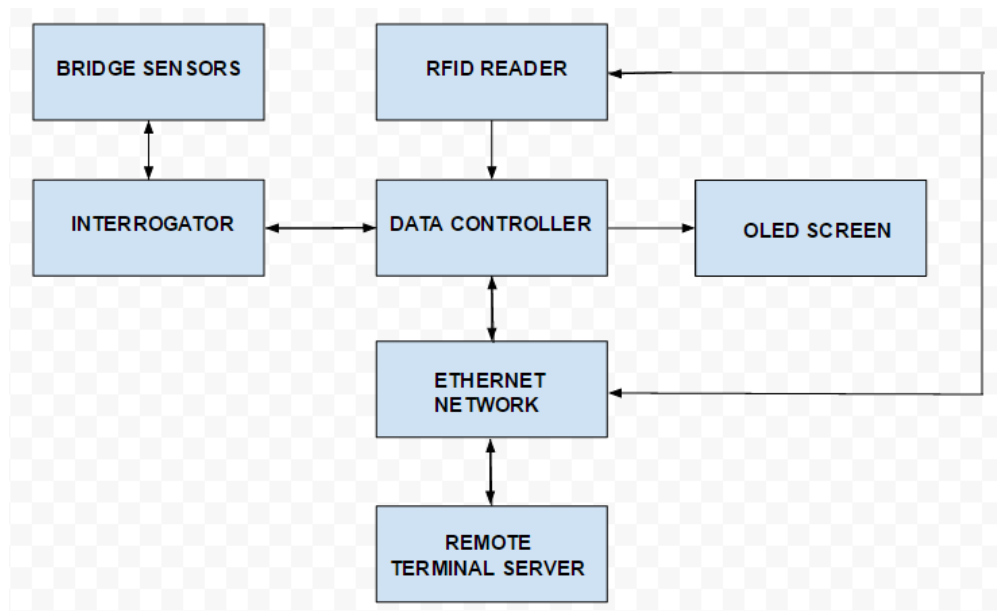
**Figure 5.1: The FS2200 extended temperature BraggMETER by HBM FiberSensing.**

The designed data controller can be programmed to only allow data that meets particular requirements (such as minimum or maximum strain) and/or be programmed to only allow data following a trigger from an external device [such as a radio frequency identification (RFID) reader]. The purpose of the data controller is to act as an intermediary between the interrogator and the network, through which decisions can be made based on predetermined parameters or an external trigger mechanism. For this system, an RFID reader was selected to provide a trigger response to the data controller in order to signal the beginning and end of a data transmission from the interrogator. The CS203 from Convergence Systems Limited was selected as the RFID

reader in conjunction with CS6710 RFID tags for this application. Before a description of the controller design is given, it is important for the reader to understand that the BraggMETER FS2200 has not been altered in any way. The interrogator still functions as it was originally intended (without the data controller), therefore, the user should refer to the operating manual for specific details concerning the operation of the FS2200, if it is to be used in this fashion.

### System Overview

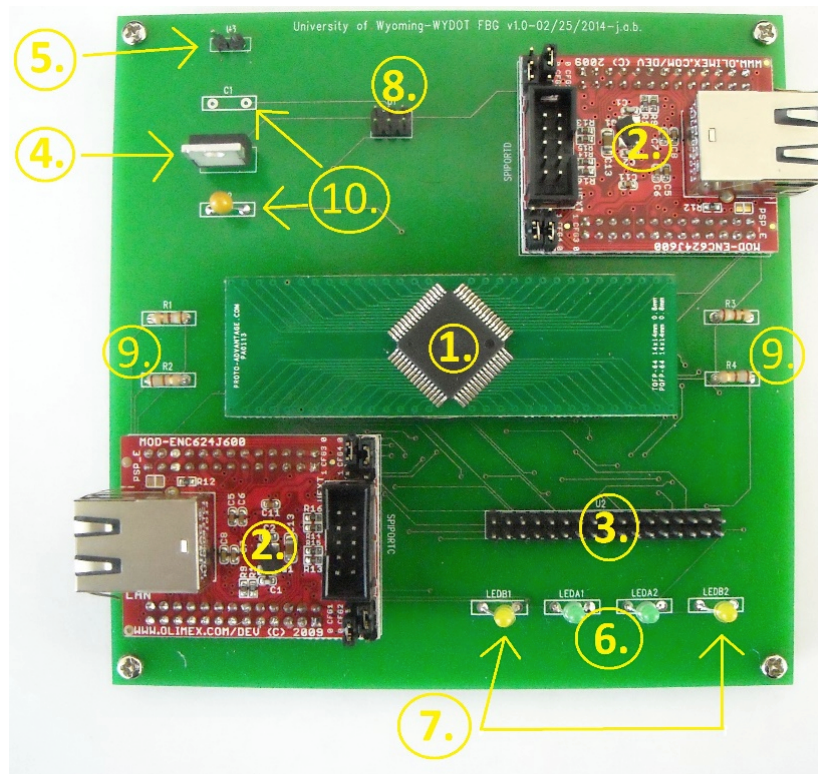
Figure 5.2 illustrates the basic interactions among components in the system. The optical bridge sensors connect to the four channels of the FS2200 interrogator through APC optical connectors (See Figure 5.1). Two CAT5e cables with RJ45 connectors extending from the data controller are used to connect the controller to the interrogator and the ethernet network. On the printed circuit board, two ethernet controllers are labeled “PORT C” and “PORT D” (see Figure 5.3). The ethernet controller labeled “PORT C” should be connected to the interrogator and the ethernet controller labeled “PORT D” should be connected to the network. The RFID reader is connected to the data controller through the provided general-purpose input/output (GPIO) cable from Convergence Systems Limited. The term “Ethernet Network” should be interpreted as a Cell Modem, Switch, Router, Radio, or by any intermediary ethernet equipment between the data controller and the network connected terminal server. The data controller and RFID reader can also be connected directly to the terminal server’s network interface card if there are enough ports available, otherwise a switch must be used. Nevertheless, it is important to mention that any device that is used to connect to the terminal server should support Auto-MDIX for the data controller to function properly.



**Figure 5.2: Block diagram illustrating system component interactions.**

The data controller consists primarily of two enc624J00 ethernet controllers, an Atxmega64a3 microcontroller, a 6-pin PDI programming port for the microcontroller, a 34-pin

GPIO microcontroller breakout port, and a power supply (see circuit schematics of Figures 5.3, 5.4, 5.5, 5.6 and 5.7). Data from the interrogator passes from the ethernet controller labeled PORT C, through the microcontroller, and to the terminal server or network through the ethernet controller labeled PORT D. Most of the GPIO pins are unused; exceptions are the organic light-emitting diode (OLED) screen and the RFID input. The OLED screen is connected to pins D3, VCC, and GND, whereas, the RFID is connected to pin A0. The ethernet controllers “talk” to the microcontroller over a serial peripheral interface (SPI), the OLED screen through a universal asynchronous receive transmit (UART), and the RFID through a simple on-off (0-3.3v) signal. There are two pairs of green and yellow colored LEDs on the circuit board that relate to both of the ethernet controllers. On the finished product, these LEDs have been brought out to the side of the enclosure that houses each controller. There is one green and one yellow LED for each controller. The green LED will illuminate when the ethernet controller has established a physical layer (PHY) connection and the yellow LED will illuminate when the ethernet controller either receives or transmits data from the server or client. The OLED Screen can be programmed further, but is currently used to give system information upon startup regarding initialization status with the network and interrogator.



**Figure 5.3: Diagram of the finished printed circuit board (PCB)**

The following components are identified in Figure 5.3:

1. Atmel Atxmega64a3 microcontroller.
2. Olimex mod-enc624J600 Ethernet controllers.
  - PORT C to Interrogator (on bottom as pictured).
  - PORT D to Network (on top as pictured).
3. General purpose input/output (GPIO) pins/UART/SPI/VCC/GND for OLED screen, RFID Reader, and future device implementation.
  - OLED Screen data pin on D3 (see Figure 5.6).
  - OLED Screen power pin on VCC (see Figure 5.6).
  - OLED Screen ground pin on GND (see Figure 5.6).
  - RFID GPIO pin on A0 (see Figure 5.6).
4. LM1085it-3.3v fixed voltage regulator (27V maximum input-to-output differential).
5. Voltage Supply.
6. LED Ethernet link status indicators for the two Ethernet controllers (programmable).
7. LED Ethernet activity indicators for the two Ethernet controllers (programmable).
8. PDI programming port for the Atxmega64a3 microcontroller.
9. 180 $\Omega$  current-limiting resistors for LED Ethernet indicators.
10. 10uF Bypass capacitors.

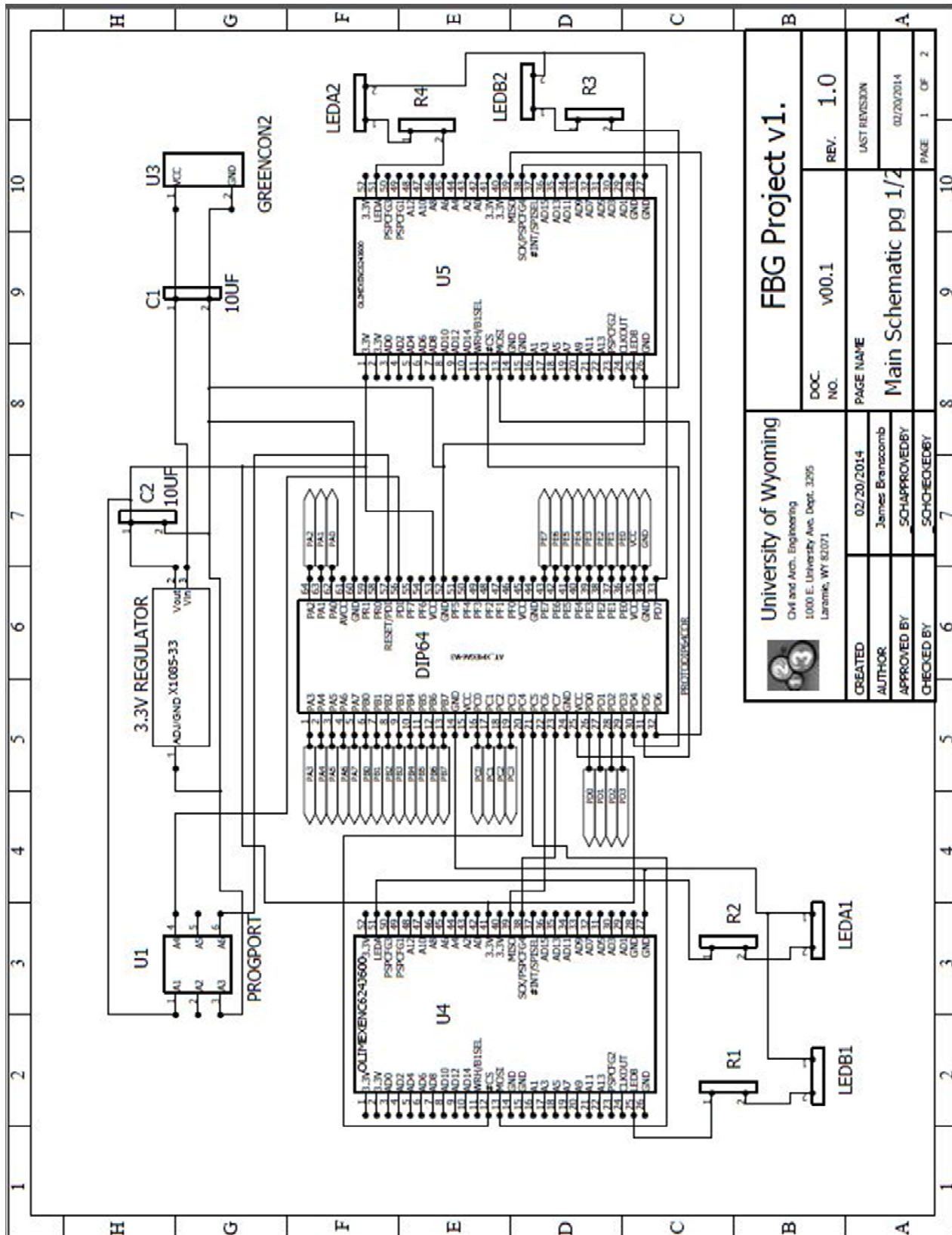


Figure 5.4: PCB circuit schematic PG 1

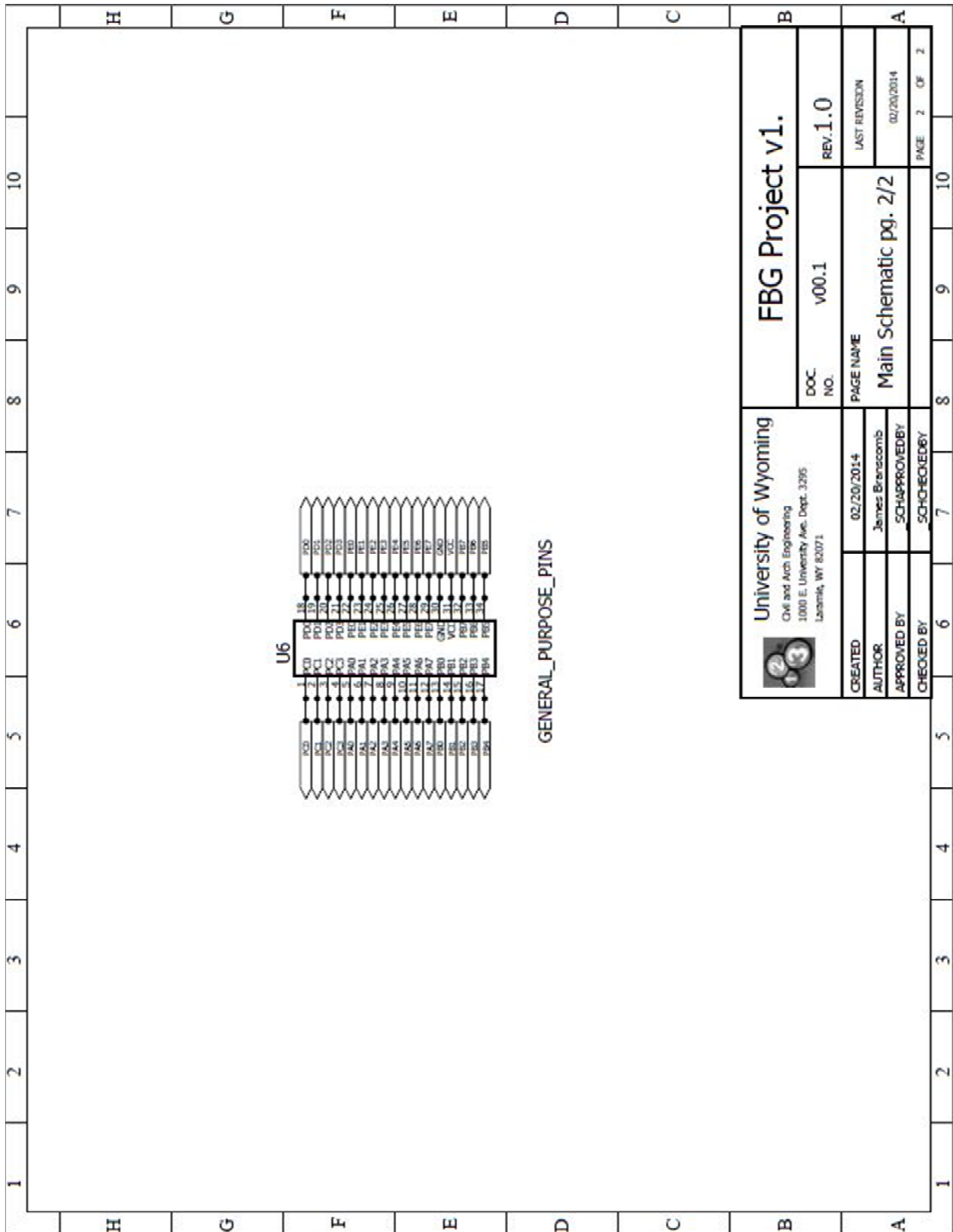
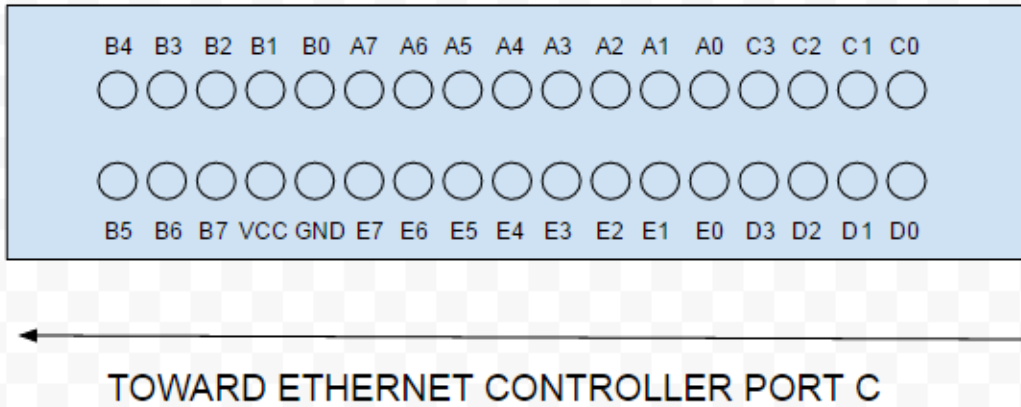


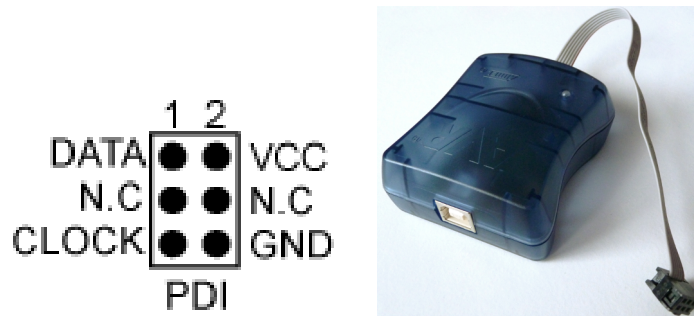
Figure 5.5: PCB circuit schematic PG 2

Figure 5.6 gives the orientation and pinout of the printed circuit boards (PCBs) microcontroller breakout pins. Each pin corresponds to a particular port on the Atxmega64a3. Pins that are not already dedicated to the OLED (VCC, GND, and D3) and the RFID (A0) can be used for future external additions. If these pins are used in the future, it will be necessary to program the Atxmega64a3 microcontroller accordingly.



**Figure 5.6: Pinout of the PCB GPIO pins relating to microcontroller ports**

The PCB has the built-in PDI programming port shown in Figure 5.7. For this development version, an AVRISPMkII in-system programmer by Atmel was used in conjunction with Atmel Studio 6.1 for all firmware programming of the Atxmega64a3. However, there are a number of programmers/debuggers available from Atmel that will also allow for programming the Atxmega64a3.



**Figure 5.7: AVRISPMkII and pinout of the PCB PDI programming port**



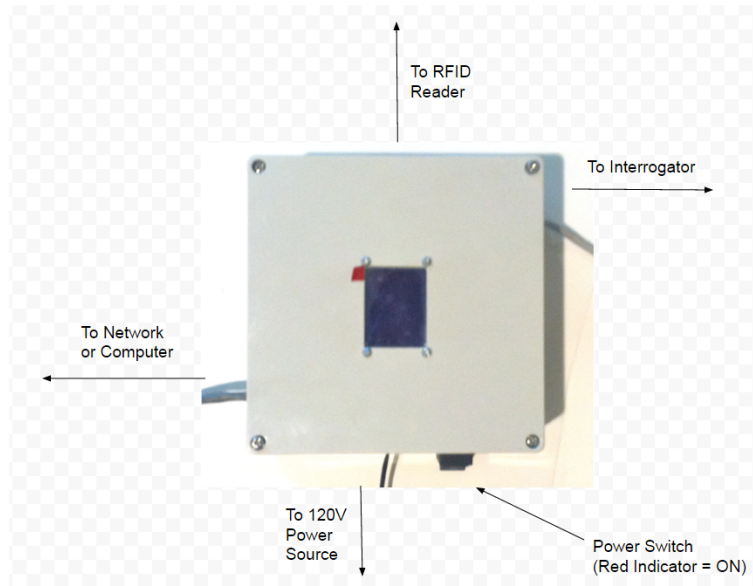
## Assembly Guidelines and Quick-Start Guides

Assembling the system is a matter of matching male-to-female plugs. The FS2200 Interrogator has three types of inputs: its power supply (connected through the provided cable), network input (connected to data controller as shown in Figure 5.8), and optical inputs for fiber Bragg grating (FBG) sensors. Plugging in the devices, one must be careful that the two CAT5e cables extending from the data controller are connected to the appropriate devices. Refer to Figure 5.8 for the proper orientation and connections of the data controller to the interrogator and the network. If it is necessary to remove the lid to the data controller enclosure, be careful to lift carefully as it is possible to pull loose the wires connecting the OLED screen to the PCB. A step-by-step assembly guide follows below. Both green lights should light up on each side of the data controller indicating the establishment of a PHY connection with the network and interrogator.

### Step-by-Step Assembly:

1. Plug the ethernet cable from the data controller into the interrogator local area network (LAN) input (see Figure 5.8).
2. Plug the ethernet cable from the data controller into the network switch (see Figure 5.8).
3. Plug the GPIO cable from the CS203 RFID reader into the blue female connector on the data controller (see Figure 5.8).
4. Plug the ethernet cable from the CS203 into the network switch.
5. Use an ethernet cable and plug the network switch into the computer.
6. Plug all optical sensors into the FS2200 FBG interrogator.
7. Plug all power cables (network switch, FS2200, CS203, data controller) into a 120V wall outlet and turn on the power switch to the data controller (see Figure 5.8). The OLED Screen on the data controller should indicate that the system initialized and running (Figure 5.9).

Note: The RFID reader and interrogator will power on automatically when plugged in. The interrogator will take some time to ready itself (refer to FS2200 user manual).



**Figure 5.8: Diagram of appropriate connections to the data controller**



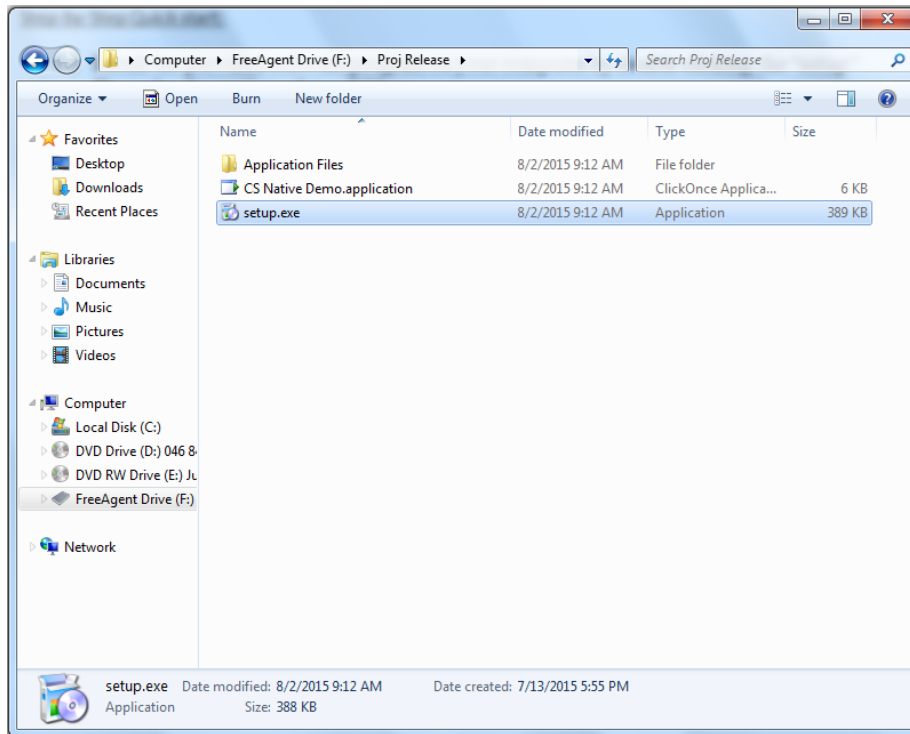
**Figure 5.9: Data controller OLED Screen indicating a successful startup**

### ***Software Overview***

The software required to run the system was built from a Convergence Systems Limited software development kit (SDK) and written in C# language in Visual Studio 2010. In particular, the visual studio solution “CSL Demo Apps for VS2008” was used as the base for the program. Several additional forms and functions were added to this solution to incorporate the data controller and interrogator. Any functionality in this software that is specific to the RFID reader can be found on the company website. The following quick start guide and subsequent figures describe the basic software operation, including the acquisition of interrogator strain sensor data.

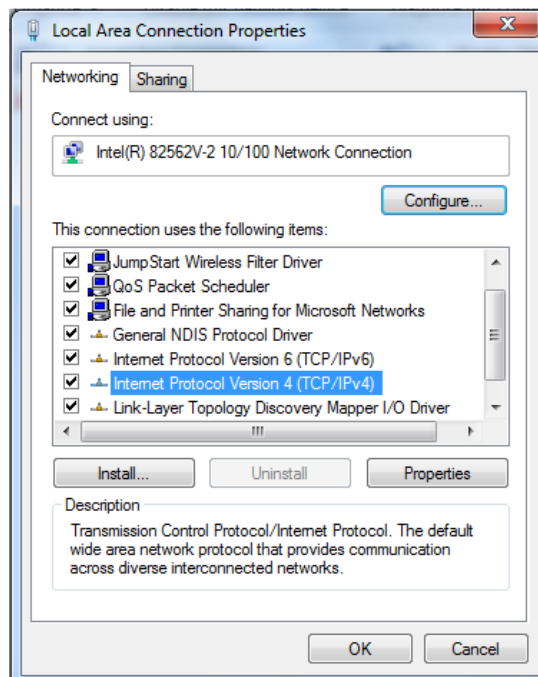
Step-by-Step Software Quick start:

1. Complete assembly as outlined in *Step-by-Step Assembly* above.
2. Install the provided software program on your computer by double clicking the “setup.exe” file under the project release folder (Figure 5.10).

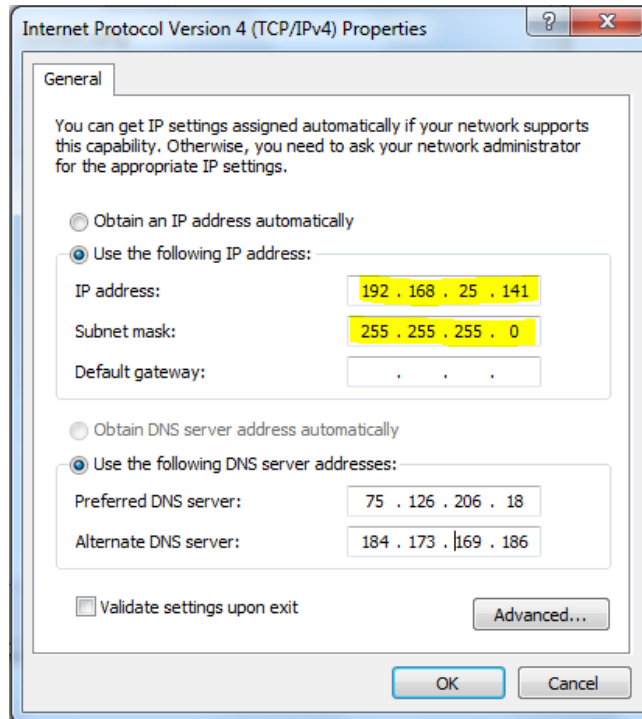


**Figure 5.10: Setup file for installing the system software**

3. Change the network adapter settings in the computer’s “Local Area Connection Properties” (Figure 5.11). Select the properties button and enter the information shown in Figure 5.12 for the IP address and Subnet mask. Click “OK” to save the changes.

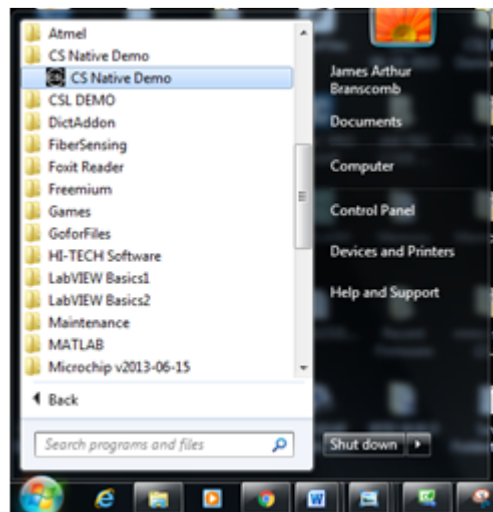


**Figure 5.11: Local Area Connection Properties with “Internet Protocol Version 4 (TCP/IPv4) selected. The user will click on the properties button to change IP settings**

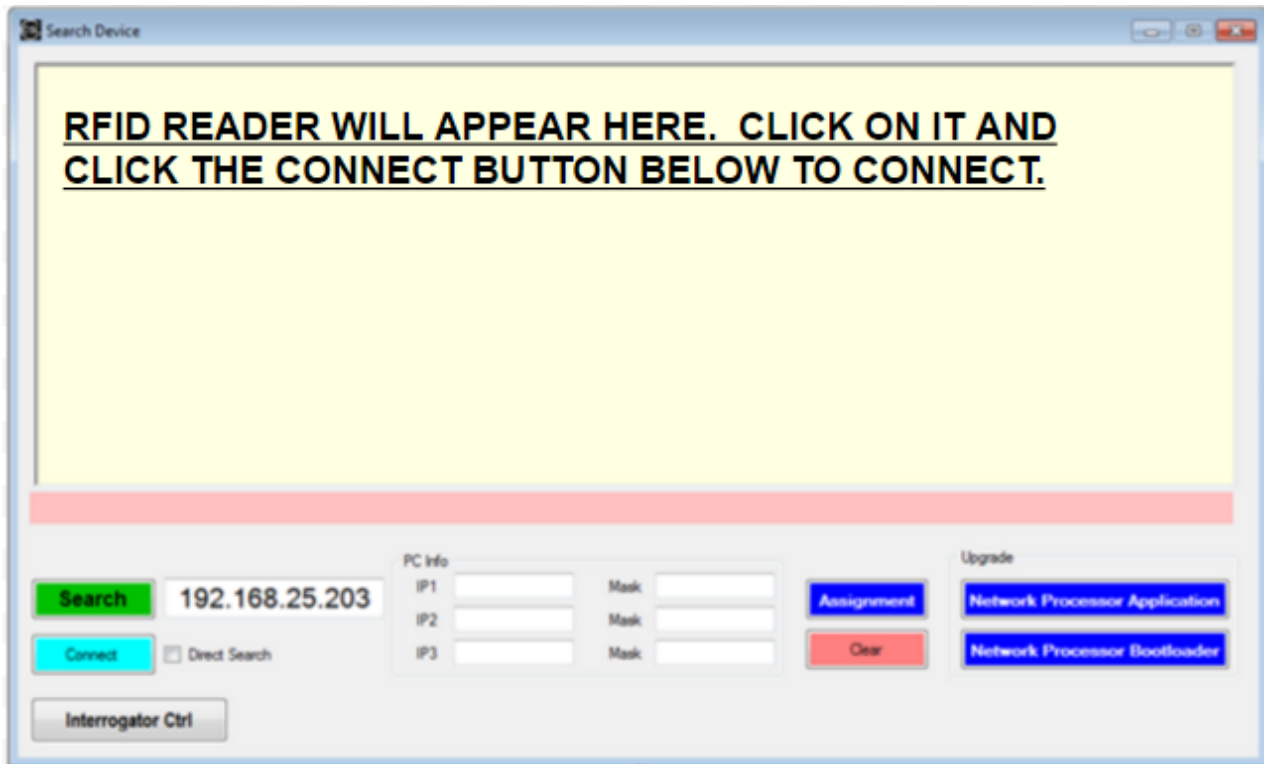


**Figure 5.12: IP address and Subnet mask to be entered as shown**

4. Open the installed program “CS Native Demo” through the windows start menu as shown in Figure 5.13. The opening page should look the same as that of Figure 5.14.



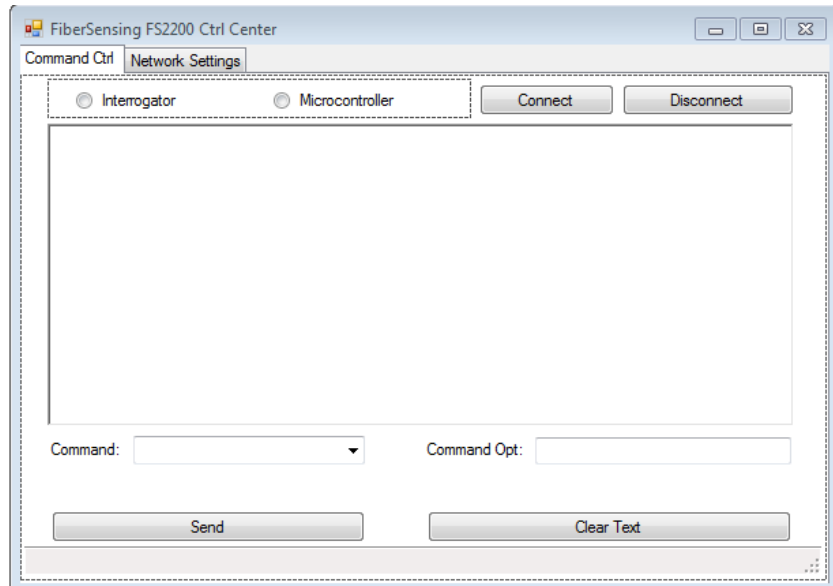
**Figure 5.13: CS Native Demo program in windows start menu after install**



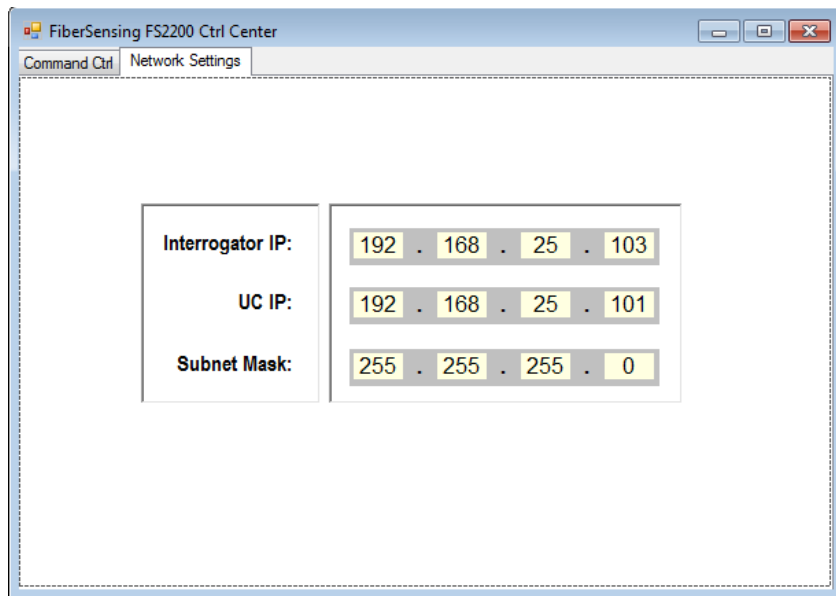
**Figure 5.14: Opening page of CS Native Demo software**

5. Click on the button labeled “Interrogator Ctrl” at the bottom left of the window as shown in Figure 5.14. This program is specific to the interrogator.
  - Clicking on the “Connect” button will establish a connection to the interrogator and subsequently display an “ACK” response in the informational box signaling a successful response from the interrogator.
  - After connecting to the interrogator, select the “Interrogator” radio button. This button will fill the drop down box labeled “Command:” with all available commands for the interrogator. After selecting the command, the command is sent through the “Send” button. Refer to the FS2200 user manual for all available commands and command options.
  - The “Microcontroller” radio button will populate the “Command:” drop down box with a few experimental and relatively untested data controller commands. For future expansion, various commands could be programmed into the data controller and sent in this manner. This allows for a quick way to change data controller settings without having to program the microcontroller through the use of a programmer/debugger in Atmel Studio.
  - When finished with the program, click the “Disconnect” button to disconnect the interrogator and data controller from the software.
  - The “Network Settings” tab in the upper left hand corner of the window is displayed in Figures 5.15 and 5.16. This is for informational purposes only and should not be changed. “Interrogator IP” lists the IP address that the interrogator is using. “UC IP”

lists the IP address that the data controller is set to and “Subnet Mask” is the system subnet mask.



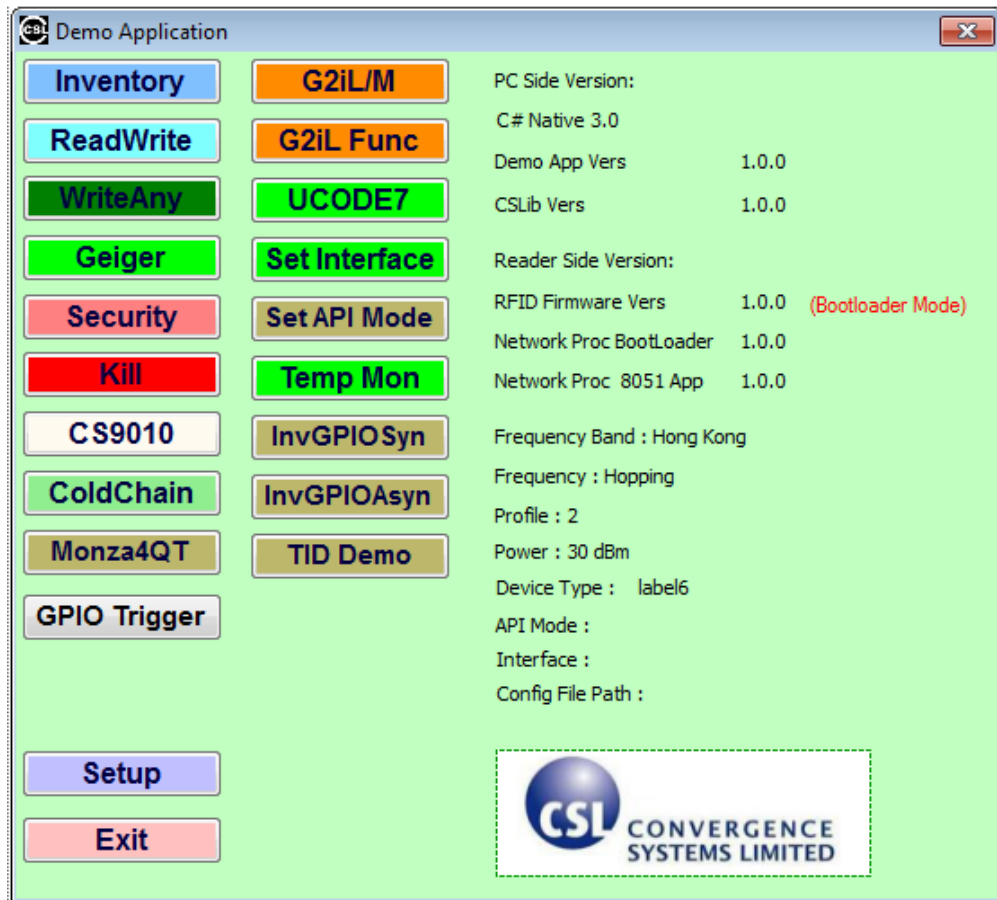
**Figure 5.15: Window display for controlling the FS2200 interrogator**



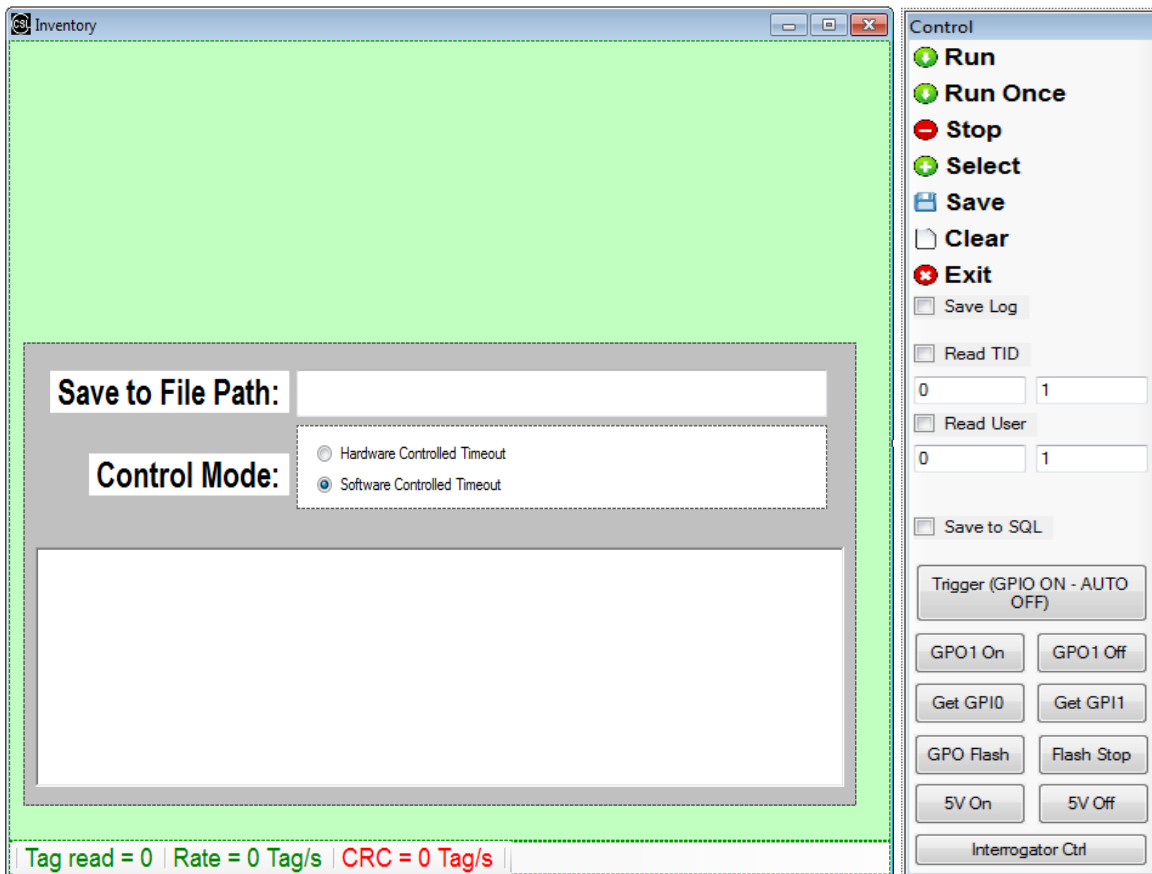
**Figure 5.16: Network Settings tab displaying system IP and mask information**

6. Close the program from the previous step (step 5.). The IP address for the RFID Reader should be the same as shown in Figure 5.14. Click the “Search” button. The program should find the RFID reader and display it in the top part of the window (Figure 5.14).

7. Once the software has found the RFID reader, select the found reader and click the connect button (Figure 5.14).
8. The window shown in Figure 5.17 should open and is primarily related to the RFID reader. If the user is to use these functions, refer to <http://www.convergence.com.hk/downloads-support-2/cs203/>. The main focus here is the button “GPIO Trigger”.
9. With the window shown in Figure 5.17 still open, select the button labeled “GPIO Trigger”. A window similar to that shown in Figure 5.18 will open.



**Figure 5.17: Software page that displays upon connecting to RFID Reader.**



**Figure 5.18: Window display for primary interrogator data acquisition**

- To set the system in data acquisition mode:
  - a) Copy and paste a file path that you want the data file to save to. Example:  
C:\users\yourname\desktop\  
**Note: be sure to place a backslash at the end of the file path**
  - b) Select either “Hardware Controlled Timeout” or “Software Controlled Timeout.”  
The definitions are as follows:
    - **Hardware Controlled Timeout:** This mode would be selected in a remote deployment. Selecting the “Hardware Controlled Timeout” radio button essentially places the data controller in a ready and waiting state. Meaning, the data controller is waiting for a physical signal from the RFID reader in order to begin releasing data to the network. Once the data controller receives the trigger from the RFID reader (meaning a vehicle with a RFID tag has been read by the reader), the data controller will automatically establish the necessary connections to the network and interrogator and begin releasing sensor data to the network for a predetermined amount of time (programmed into the Atxmega64a3 – currently set to approx. 30 seconds).



- **Software Controlled Timeout:** This mode would be selected in a local deployment. Selecting the “Software Controlled Timeout” radio button allows the entire data acquisition process to be controlled through the software from start to finish. Only the software is able to “see” that a tag has been read by the RFID reader and data is only passed through the data controller instead of acting as a client to the interrogator. After selecting the radio button for this option you will be prompted to enter a timeframe (in seconds) for which you would like the system to collect data.
- c) After selecting the appropriate radio button in step b), click the “Run” button. The system is now in a ready and waiting state. Once a tag is read by the RFID reader the yellow lights on the data controller should flash indicating the transference of strain data through the controller. Additionally, the table in the window of Figure 5.17 will display that particular tags data. The RFID reader can read multiple tags at once, however, the system will trigger only on the first tag read by the reader. The yellow lights will flash until the 30 seconds (hardware controlled) or user entered (software controlled) time has expired.
- d) After the system has finished transferring data (yellow lights on data controller have ceased flashing), the software program will automatically save the collected data at the location specified earlier with the date and time it was received.
- Refer to step 5 above regarding the button labeled “Interrogator Ctrl”.
  - Button “Trigger (GPIO ON-AUTO OFF)” was experimental and should not have any function.
  - Buttons “GP01 On”, “GP01 Off”, “Get GPIO”, “Get GPI1”, “GP0 Flash”, “Flash Stop”, “5V On”, and “5V Off” are specific to the GPIO output of the RFID reader and should **not** be clicked as part of a standard interrogator data acquisition. If the user is interested in these functions refer to the link shown in step 9.
  - Check boxes “Save Log”, “Read TID”, “Read User”, and “Save to SQL” are specific only to the RFID reader and are not needed as part of a standard interrogator data acquisition. Again, refer to the link in step 9 for further details.

## CHAPTER 6 – DATA ANALYSIS METHODS

### Objective

The primary interest in load rating of bridges expressed by WYDOT engineers was to obtain the lateral distribution factors (DFs) to validate or potentially improve the existing load ratings. The following discussion presents the process behind obtaining the DFs through the means of experimental field testing. A methodology used for instrumentation design for the Laramie River bridge on I-80 in Laramie, the instrumentation plan, the design vehicle loading plan, and the data collection and analysis procedures is included.

### Methodology for Determining the Instrumentation Plan

There are various methods used for field testing bridges to determine more accurate analyses of structures. A common method is to fully instrument a bridge with strain sensors, conduct field load rating tests, gather and analyze strain data to develop a field-tested model, and then compare this model to the analytical design model. By comparing the two models, a tuned analysis of the bridge can result in a quantitative representation of the structure's true behavior. While this method results in a fairly accurate representation of a bridge's response, the data acquisition system and analysis are costly and time consuming due to the price and number of sensors, installation time, and data reduction and analysis procedures. A tuned model and analysis of a bridge is not always necessary, depending on the goals of the field tests.

A simplified and economical field instrumentation plan may be implemented to measure accurate DFs. Then, these DFs can be used in an analytical rating, such as with BRASS- Girder, to determine more accurate load ratings. Past research has resulted in development of a total of six instrumentation plans to be used on slab-on-steel girder bridges. The premise is based on the idea that the majority of bridges have a higher capacity than design indicates. The following eight factors are known to contribute to additional bridge performance capacity, and these factors are not normally accounted for in initial design using specification procedures:

1. Impact factor.
2. Experimental dead load.
3. Actual dimensions.
4. Unintended composite action.
5. Lateral distribution factor.
6. Bearing restraint.
7. Longitudinal distribution.
8. Unaccounted system stiffness.

The bridge instrumentation plan can be developed based upon which of the eight factors are parameters of interest. The bridge engineer must decide which factors should be accounted for based upon an initial analysis, determining the complexity of the instrumentation plan for the field tests.

## Instrumentation Plan

The experimental response of the noncomposite Laramie River Bridge would include contributions from all eight factors that could affect the additional bridge capacity over design procedures as previously discussed. Because the purpose of instrumenting the bridge is to obtain DFs, several of these parameters are regarded as irrelevant for this field testing. These considerations are discussed in the following, as they formed the basis for developing the strain sensor instrumentation plan.

### *Factors Affecting Sensor Placement*

After careful consideration and input from WYDOT bridge engineers, it was decided that the DFs were the most vital parameters for establishing an experimental load rating capacity. The experimental DFs are input values for BRASS load rating analysis and affect the load rating of a structure. It provides bridge engineers a more accurate representation of the bridge's behavior and allows potentially higher load ratings without the cost to develop a fully tuned bridge model.

Since the objective of the field test is to determine the DFs, an instrumentation plan that determines the DFs has been developed; all other factors that affect the bridge response were considered irrelevant. Table 6.1 is a summary of the eight contributing factors and describes why each factor is or is not considered relevant for the purpose of this work.

**Table 6.1 – Factors Taken into Consideration for Field Testing**

<b>Contributing Factors</b>	<b>Considered</b>	<b>Reasoning</b>
1. Impact Factor	No	Expensive to determine as it involves in-depth static and dynamic testing and analysis.
2. Experimental Dead Load	No	Assumed to be equal to design dead loads.
3. Actual Dimensions	No	Assumed that actual dimensions are equal to design dimensions because measuring the true dimensions of each member would take additional time to complete during bridge inspections.
4. Unintended Composite Action	No	Cannot be relied upon for determining the ultimate capacity of a bridge.
5. Lateral Distribution	Yes	Can be quantified as an input factor for BRASS analysis, affecting the load rating of a structure. Can provide bridge engineers a general idea of the bridge's behavior in order to calculate a potentially higher load rating without the cost for a tuned bridge model.
6. Bearing Restraint	No	Cannot be relied upon for determining the ultimate capacity of a bridge.
7. Longitudinal Distribution	No	Is not quantified or accounted for as an input parameter to improve a calculated load rating through BRASS.
8. Unaccounted System Stiffness	No	Is not quantified or accounted for as an input parameter to improve a calculated load rating through BRASS.

### ***Sensor Placement on Beams***

In order to calculate an approximate DF for each girder, a single strain gage is required on the bottom flange of each girder. This would allow Equation 6.1 to be used:

$$DF = \frac{\varepsilon_{GirderMax}}{\sum \varepsilon_{AllGirders}} \quad (6.1)$$

where the DF for the girder of interest is equal to the maximum strain measured in that girder divided by the sum of all the girder strains at the critical locations. This approach is straightforward, however this simplified sensor configuration will result in approximated DFs, and it does not provide redundancy of experimental sensors or the means to calculate cross-sectional stress, moments, or the location of the neutral axis.

Although this was designed as a noncomposite bridge, the bridge will act with at least partially composite action. Because of this behavior, the location of the neutral axis must be determined in order to obtain a more accurate DF. By calculating the actual neutral axis location and total bending moment, the engineer is also able to check global equilibrium to validate the system's performance.

Instead of having a single FBG installed at the extreme fibers of the bottom flange, there will be a total of four FBGs. This will include two FBGs located on the web, each positioned at mid-depth of the girder but on different sides of the web. Additionally, two FBGs will be located on the underside of the bottom flange, each placed an equal distance away from the longitudinal center of the flange and the outside edge of the flange. This configuration is displayed in Figure 6.1.

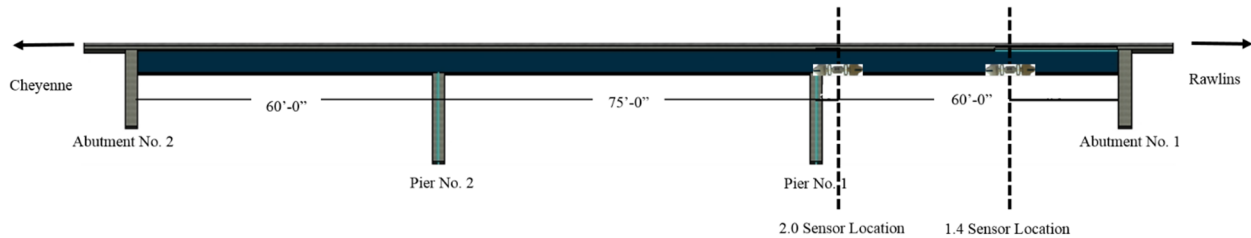


**Figure 6.1 – Cross-Sectional View with FBG Sensors on the Web and Bottom Flange**

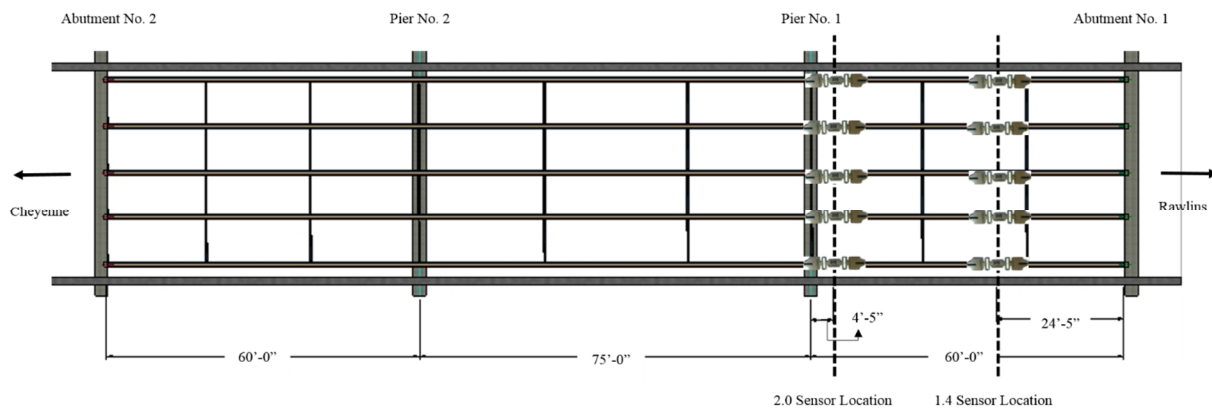
The strain measurements can be averaged at the two locations to remove the effects of weak axis bending and torsion. The two different locations for strain measurements allow the strain profile for the section to be calculated, and then the location of the neutral axis can be determined. This process is described later.

### Critical Longitudinal Locations

Based on results from the BRASS LFR load rating analysis, the critical cross section for sensor placement is at the 1.4 location, which is at 40 percent of the first span, and at the 2.0 location, which is the start of the second span. The 1.4 critical location is controlled by the following commercial vehicle configurations for the strength limit state: HS20, HS25, and Type 3. The 2.0 critical location is also controlled by the strength limit state for Type 3S2 and Type 3-3 vehicles. The critical locations are shown in an elevation view in Figure 6.2 and a plan view in Figure 6.3.



**Figure 6.2 – Elevation View with Critical Locations for Sensor Placements**



**Figure 6.3 – Plan View with Critical Locations for Sensor Placements**

One should note that the sensors are not directly placed at the 1.4 or 2.0 locations. By installing the sensors at a distance of the height of the girder away from locations of concentrated load or reaction, localized effects can be avoided. The 1.4 location of 7.3 m (24 ft) from abutment 1 was adjusted an additional 130 mm (5 in) due to a cross frame. The 2.0 sensor location also shifted 1.2 m (4 ft), 13 cm (5 in) toward abutment 1 to avoid concentrated load effects due to pier 1.

### Vehicle Loading Plan

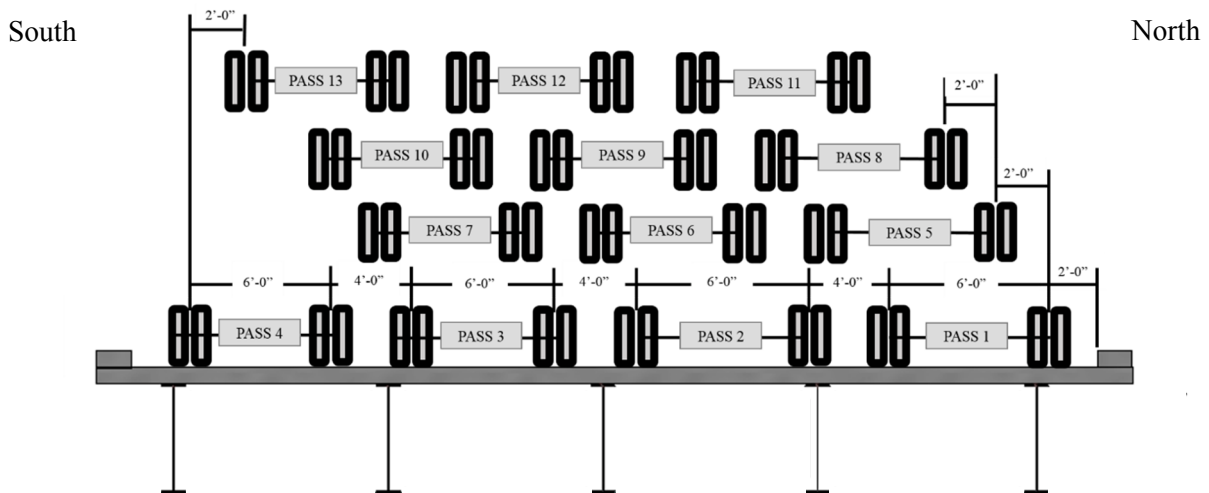
The purpose of developing a vehicle-loading plan is to determine the maximum resistance of each girder against a known load. It is important that each girder be tested for its maximum live-load effect under static testing of individual vehicle loads. Static testing can be accomplished by driving a vehicle at crawl speed. Most field tests are not completed with

multiple test load vehicles. Thus to induce the effect of multiple vehicles, the method of superposition is applied.

As long as the bridge stays within its elastic range, the effect from an individual vehicle can be added or superimposed on the effect of another vehicle when loaded in an adjacent lateral position. Field testing should take place first where an individual vehicle passes over the bridge in a predetermined lateral position. Based upon the field testing results, an engineer can determine which combinations of truck position caused the greatest stress in the girder of interest. The strain effects from the selected truck positions that cause the beam maximum stress can be superimposed, resulting in the maximum total strain induced from the vehicle passes on the girder of interest.

The design vehicle placement plan is displayed in Figure 6.4, where the principle of superposition should be used to maximize the load effects on each girder for a total of 13 passes. The outside wheel was placed 0.6 m (2 ft) from the right, or north, curb because the overhang on the north side is wider and should produce a greater DF. With a design lane load of 3 m (10 ft), four design vehicle loads are included. However, it is not expected that four lanes loaded would control.

From the north side, the design vehicle should be placed 0.6 m (2 ft) toward from the north curb for passes 1, 2, 3, and 4. Then the vehicle's path should be 0.6 m (2 ft) toward the south for passes 5, 6, and 7 and then another 0.6 m (2 ft) for passes 8, 9, and 10. Passes 11, 12, and 13 should be positioned 0.6 m (2 ft) north from the south most wheel load of pass 4. By completing each pass with an individual test vehicle, load combinations of design vehicles can dictate the maximized live-load effects of each girder. It is important that various traffic positions are tested to determine the worst-case scenario.



**Figure 6.4 – Vehicle Load Test Plan**

The tests are designed so that passes 1 through 13 are completed in sequential order with the layout of the passes marked on the bridge. As stated earlier, deflections should be measured throughout the duration of the testing. After the strain data is collected, the values should be

used to find stresses. By plotting stress versus time for the girder of interest, one is able to distinguish which load cases created the maximum moment on the girder. The critical vehicle passes must be selected, which forms a maximized load case combination. The combination should be checked to assure that the selected load cases all fit on the clear roadway width with 4-feet in between axles as some passes are overlapped in the vehicle load test plan. Superposition of the applicable load cases will determine the maximum response for each girder.

Table 6.2 gives examples of which vehicle load cases may maximize the live load effects of each girder and should be analyzed.

**Table 6.2 – Potential Controlling Vehicle Load Combinations**

<b>Girder</b>	<b>Load Combination</b>
South	Pass 3 + Pass 4
South Interior	Pass 3 + Pass 4 Pass 4 + Pass 12 Pass 12 + Pass 13
Middle	Pass 2 + Pass 3 Pass 6 + Pass 7 Pass 8 + Pass 9 Pass 9 + Pass 10 Pass 11 + Pass 12
North Interior	Pass 1 + Pass 2 Pass 5 + Pass 6
North	Pass 1 + Pass 2

***Experimental Test Vehicle***

The purpose of using an experimental load truck is to accurately measure the bridge’s strain responses to known loads using typical highway truck configurations. Typically during field testing, any type of available truck with the appropriate dimensions that can be loaded to the required axle weights may be used. When developing a field tested load rating factor using LFR Specifications, the load testing vehicle used must be analytically equated to an AASHTO approved vehicle. Often this approved vehicle is an HS20 design truck.

The determination of the DFs is based on the gage distance of the test vehicle, not the longitudinal configuration of the axles. Any load-testing vehicle that has wheel lines that are 6-feet apart can be utilized where the next adjacent vehicle is separated by 4-feet. This configuration creates a lane width of 10-feet used for applying the live load. An experienced bridge engineer should determine the actual weight placed in the testing vehicle, however it should not exceed the operating rating tonnage limit.

## Data Analysis

Ultimately, the goal of the Laramie River Bridge field testing is to determine the actual DFs. Although Equation 6.1 determines an approximate DF, it cannot determine girder moments. A more accurate procedure for determining the DF is to place additional sensors as shown in Figure 6.1 and determine individual girder moments and calculate the DF using Equation 6.2:

$$DF = \frac{M_{GirderMax}}{\left(\frac{\Sigma M_{AllGirders}}{2}\right)} \quad (6.2)$$

where  $M_{GirderMax}$  is the maximum moment in the girder of interest, and  $\Sigma M_{AllGirders}$  is the sum of the concurrent moments in the individual girders across the bridge section.

To account for one-lane loaded in order to compare to LFD DFs, the sum is divided by 2 because two vehicle wheels lines are applied. If for example, the superimposed load consisted of two vehicles to maximize the girder, the sum should be divided by 4, etc. Additionally, the multiple presence factors should be included. If one- or two-lanes loaded controls, then Equation 6.1 is multiplied by 1.0. If three- or more-lanes loaded controls, which is unlikely, Equation 6.1 is multiplied by 0.9.

Two methods are described for finding the maximum moment for the bridge girders. The first method assumes full composite action using the transformed section and could be used for a preliminary analysis. The second method is the more accurate and is recommended, as it takes into account the partial composite action from field testing.

The first method uses the calculation for the bending moment shown in Equation 6.3:

$$M_{Girder} = S_{TR} E \varepsilon \quad (6.3)$$

where  $E$  is equal to the modulus of elasticity of steel;  $\varepsilon$  is the maximum superimposed strain value obtained from field testing.  $S_{TR}$  is the transformed section modulus shown by Equation 6.4:

$$S_{TR} = \frac{I_{TR}}{c} \quad (6.4)$$

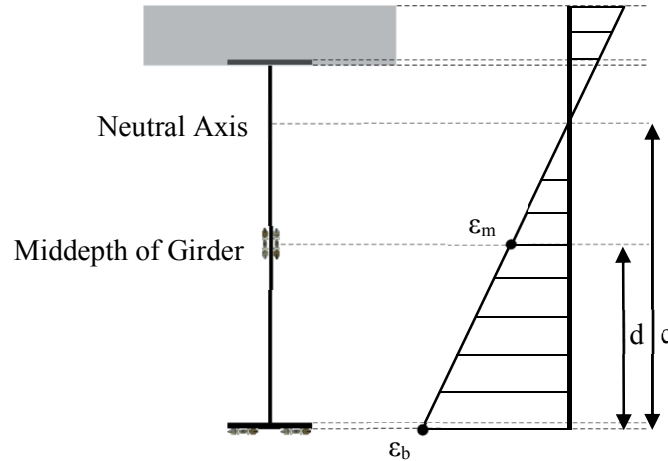
where  $I_{TR}$  is the transformed analytical moment of inertia of the cross section, and  $c$  is the distance to the neutral axis from the bottom of the bottom flange.

The strain sensor configuration described above allows the location of the neutral axis location to be determined as explained in Equation 6.5 and displayed in Figure 6.5.

$$c = \frac{\varepsilon_b}{(\varepsilon_b - \varepsilon_m)} d \quad (6.5)$$

where  $\varepsilon_b$  is the strain measured at the bottom of the bottom flange,  $\varepsilon_m$  is the strain measured at middepth of the girder, and  $d$  is the distance between the two sets of sensors.





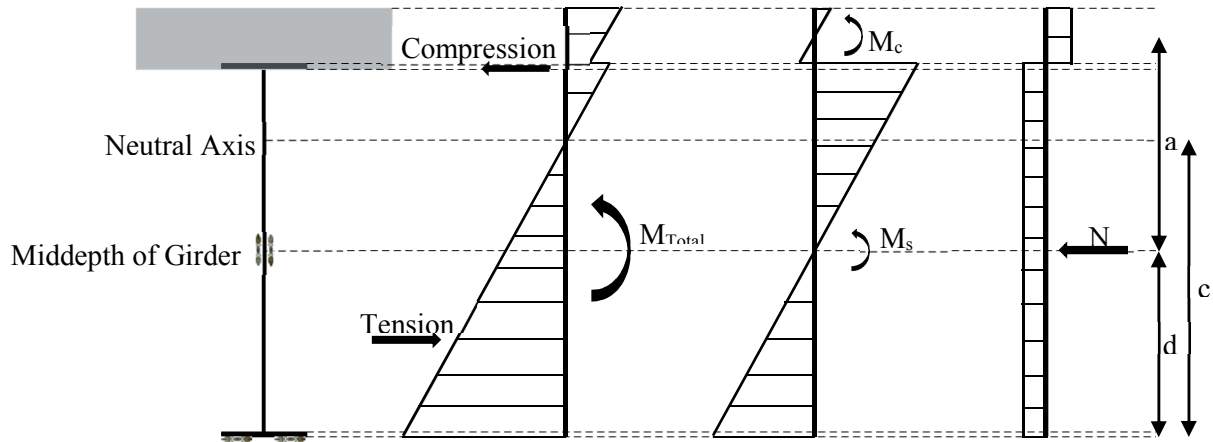
**Figure 6.5 – Strain Profile for Girder with Partially Composite Behavior**

The second method calculates the total moment shown in Equation 6.6. This calculation is useful because it takes into account the bending moment contributions from the steel girder and the concrete deck. This method accounts for the experimental moment of inertia, including the moment contribution of the concrete slab; yields more accurate DFs; and provides the means to complete a global equilibrium check.

$$M_{GirderTotal} = M_s + M_c + Na \quad (6.6)$$

where the total moment is equal to the sum of  $M_s$ , the steel girder bending about its own neutral axis,  $M_c$ , the concrete area bending about its own neutral axis, and  $Na$ , a function developed to quantify the unintended composite action between the steel and concrete.

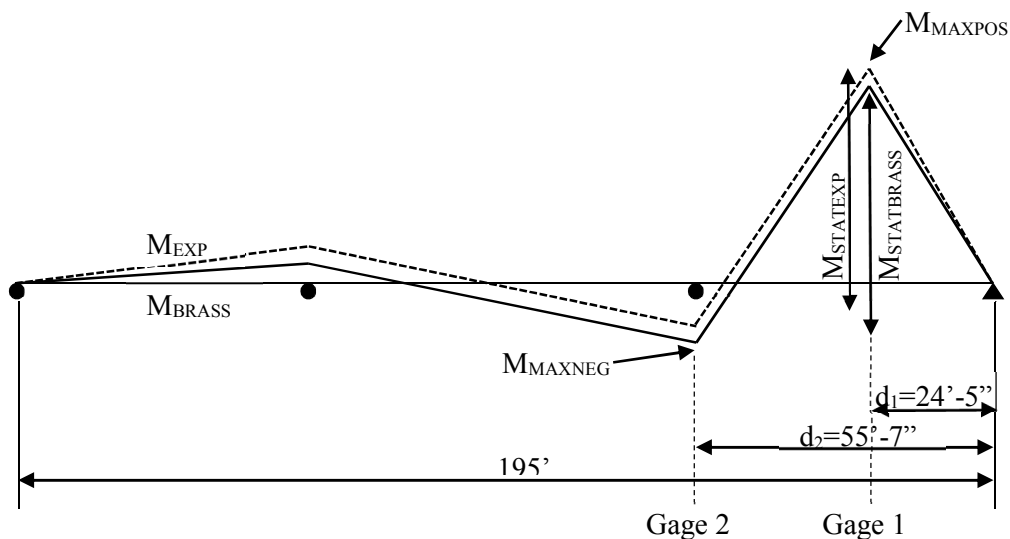
This process is demonstrated in Figure 6.6 where the total stress distribution is shown, and a breakdown of the individual total moment components is displayed. Typically a noncomposite beam would have the neutral axis close to middepth of the girder. Although the Laramie River Bridge was built to perform noncompositely, unintended composite action will occur. This behavior causes the neutral axis location to be higher than middepth of the girder where a larger area of the girder is in tension with the concrete area acting in compression.



**Figure 6.6 – Total Moment for Girder with Partially Composite Behavior**

Engineers are able to verify the accuracy of the system by checking that static equilibrium exists, where the sum of the moments in the girders is equal to the applied moment. Comparisons can be made between the experimental statical moments and the analytical statical moments to gain a better overall understanding of a bridge's true behavior. Often the bridge performs better than the design model.

Figure 6.7 is an example of the statical moment with the load located for maximum positive moment, the 1.4 location, plotted along the length of the Laramie River Bridge. The solid line represents moment results one might see from the BRASS-Girder file, while the dashed line represents possible experimental results from field testing. The figure also shows a strain gage located near the 1.4 location and another strain gage near the 2.0 location.



**Figure 6.7 – Analytical and Experimental Moments**

The experimental statical moment can be determined by Equation 6.7:

$$M_{STATEXP} = \frac{d_1}{d_2} \times M^{NEG-GAGE} + M^{POS-GAGE} \quad (6.7)$$

where  $d_1$  is equal to the distance to the strain gage located near the 1.4 location, and  $d_2$  is equal to the distance to the strain gage located near the 2.0 location.  $M^{NEG-GAGE}$  is the maximum negative moment measured by strain gage 2, and  $M^{POS-GAGE}$  is the maximum positive moment measured by strain gage 1.

The analytical moment can be determined by Equation 6.8:

$$M_{STATEXP} = \frac{d_1}{d_2} \times M^{NEG-BRASS} + M^{POS-BRASS} \quad (6.8)$$

where  $d_1$  is again equal to the distance to the strain gage located near the 1.4 location, and  $d_2$  is equal to the distance to the strain gage located near the 2.0 location.  $M^{NEG-BRASS}$  is the maximum negative moment from the BRASS-Girder analysis near the 2.0 location, and  $M^{POS-BRASS}$  is the maximum positive moment from the BRASS-Girder analysis near the 1.4 location.

### Use of Experimental Lateral Distribution Factor

The purpose of field testing the Laramie River Bridge is to obtain the accurate DFs as input parameters for BRASS-Girder. These input values are controlled by the user under the “Wheel Fractions” control panel, which uses the LFR Standard Specifications for load ratings. There are two options presented in the control panel: one-lane loaded and multiple-lanes loaded. If the input values are left empty, the load rating analysis will be determined automatically using the AASHTO Specification values. However, by specifying the field-tested DFs calculated from Equation 6.2, a more accurate load rating can be determined.

Again, it is important to have the DFs in the correct form because BRASS-Girder uses the values as a wheel fraction. When using Equation 6.2, one must take note of how many load vehicles create the maximum moment in the girder of interest because it affects the DFs. If the engineer is interested in comparing the experimental DFs with the analytical LRFR factors, the values should be in terms of lanes per girder, and determined by multiplying Equation 6.2 by 0.5 to account for two wheel lines per lane.

The user should calculate the experimental DFs for one-lane loaded and multiple-lanes loaded to input into BRASS-Girder. A table could be formed comparing the difference between the LFR Specifications versus the experimental DFs, where a percent difference is presented. An example of how this comparison may be arranged is displayed in Table 6.3 with the highlighted values examples of the BRASS-Girder input values.

**Table 6.3 – Example Comparison of Analytical and Experimental Distribution Factors**

Analysis	Bending Moment	One Lane Loaded		Two Lanes Loaded		Three Lanes Loaded	
		Interior Girder	Exterior Girder	Interior Girder	Exterior Girder	Interior Girder	Exterior Girder
Analytical	Positive and Negative	0.64	0.72	0.82	0.72	0.74	0.65
Experimental (Example)	Positive	<b>0.62</b>	0.58	0.61	<b>0.65</b>	0.59	0.53
	Negative	0.56	0.61	0.63	0.59	0.61	0.50
Percent Difference		14		21			

The experimental DFs for one-lane loaded for BRASS-Girder will be the maximum value from the 1.4 and 2.0 critical locations, including the interior and exterior girders for one-lane loaded. The maximum experimental value will be divided by the maximum LFD analytical value to obtain the percent difference; for this example the difference would be 0.62 divided by 0.72 to obtain a 14% improvement. The experimental DFs for multiple-lanes loaded will be the maximum value from the 1.4 and 2.0 locations, including the interior and exterior girders for two- or more-lanes loaded. Again, the maximum experiment value will be compared to the maximum LFD factor to obtain the percent difference of the DFs; for this example the difference would be 0.65 divided by 0.82 resulting in a 21 percent increase.