



**CONNECTED  
VEHICLE/INFRASTRUCTURE  
UNIVERSITY TRANSPORTATION  
CENTER (CVI-UTC)**

**Virginia Connected Vehicle Test Bed System  
Performance (V2I System Performance)**

# Virginia Connected Vehicle Test Bed System Performance (V2I System Performance)

---

Prepared for the Research and Innovative Technology Administration (RITA);  
U.S. Department of Transportation (US DOT)

## Grant Project Title:

Advanced Operations Focused on Connected Vehicles/Infrastructure (CVI-UTC)

## Consortium Members:

Virginia Tech Transportation Institute (VTTI),  
University of Virginia (UVA) Center for Transportation Studies,  
and Morgan State University (MSU).

## Submitted by:

Virginia Tech Transportation Institute  
3500 Transportation Research Plaza  
Blacksburg, VA 24061

### Program Director:

#### **Dr. Thomas Dingus**

Program Director, Connected Vehicle/Infrastructure  
University Transportation Center  
Director, Virginia Tech Transportation Institute  
Professor, Department of Biomedical Engineering and Mechanics  
at Virginia Tech  
[tdingus@vtti.vt.edu](mailto:tdingus@vtti.vt.edu)  
(540) 231-1501

### Report Authors:

#### **Reginald Viray**

Research Associate, Center for Advanced Automotive Research  
Virginia Tech Transportation Institute  
[rviray@vtti.vt.edu](mailto:rviray@vtti.vt.edu)  
(540) 231-1500

#### **Abhijit Sarkar**

Graduate Research Assistant,  
Virginia Tech Transportation Institute  
[asarkar@vtti.vt.edu](mailto:asarkar@vtti.vt.edu)  
(540) 231-1500

#### **Zac Doerzaph**

Director, Center for Advanced Automotive Research  
Virginia Tech Transportation Institute  
[zdoerzaph@vtti.vt.edu](mailto:zdoerzaph@vtti.vt.edu)  
(540) 231-1046

DUNS: 0031370150000

EIN: 54-6001805

Grant Funding Period: January 2012 – July 2016

Final Research Reports

May 1, 2016

# Disclaimer

---

*The contents of this report reflect the views of the authors, who are responsible for the facts and the accuracy of the information presented herein. This document is disseminated under the sponsorship of the U.S. Department of Transportation's University Transportation Centers Program, in the interest of information exchange. The U.S. Government assumes no liability for the contents or use thereof.*

## Connected Vehicle/Infrastructure UTC

---

The mission statement of the Connected Vehicle/Infrastructure University Transportation Center (CVI-UTC) is to conduct research that will advance surface transportation through the application of innovative research and using connected-vehicle and infrastructure technologies to improve safety, state of good repair, economic competitiveness, livable communities, and environmental sustainability.

The goals of the Connected Vehicle/Infrastructure University Transportation Center (CVI-UTC) are:

- Increased understanding and awareness of transportation issues
- Improved body of knowledge
- Improved processes, techniques and skills in addressing transportation issues
- Enlarged pool of trained transportation professionals
- Greater adoption of new technology

# Abstract

---

This project identified vehicle-to-infrastructure (V2I) communication system limitations on the Northern Virginia Connected Vehicle Test Bed. Real-world historical data were analyzed to determine wireless Dedicated Short Range Communication (DSRC) coverage gaps and overlaps. In addition, a simulated scalability test was run to determine the effects of network congestion on the system. The results from the real-world historical data showed that significant loss of signal occurred due to obstructions commonly found in complex highway systems, including overpasses and underpasses, elevated concrete roadways, and foliage. Consequently, care must be taken to minimize loss of signal when selecting an installation site for roadside equipment (RSEs). The deployment of multiple RSEs or repeaters may be necessary to maximize coverage in localized dead zones. The results from the scalability test showed that the current network architecture is not able to handle a large deployment of connected vehicles (CV). If a large scale of CV were to be deployed, an assessment of the current network design needs to be investigated to account for the number of vehicles and subsequent flow of data expected in the operational area.

# Acknowledgements

---

The principal investigators would like to thank the Connected Vehicle/Infrastructure – University Transportation Center for funding this project. In particular, the support and skill set provided by the Center for Technology Development at the Virginia Tech Transportation Institute proved instrumental in the execution of this research project. The authors would like to thank Jean Paul Talledo Vilela, Zeb Bowden, Mike Mollenhauer, Melissa Hulse, Leslie Harwood, the Virginia Department of Transportation (VDOT), and Iteris for assisting in the various phases of this study. It should be noted that this document should be considered a technical report and has not been peer-reviewed for the purposes of publication.

# Table of Contents

---

Background .....	1
Objectives.....	2
Literature Review.....	2
Performance Measures .....	4
Received Signal Strength Indicator (RSSI).....	4
Packet Delivery Rate (PDR).....	5
Inter Packet Gap (IPG) .....	5
Latency .....	5
Data Rate .....	5
T-Window Test .....	5
Loss of Consecutive Packet Probability Test .....	6
Signal Recovery Test.....	6
RSE Recovery Test.....	6
Global Positioning System (GPS) Error:.....	6
Environmental Considerations .....	6
Traffic .....	6
Road Characteristics .....	6
Road Type.....	7
Line of Sight (LOS)/No Line of Sight (NLOS).....	7
Driver Approach .....	7
Sensor Type .....	7
Methods.....	8
Northern Virginia Connected Vehicle Test Bed .....	8
Environment .....	9
Vehicles .....	10
Communications Network.....	13
Data Analysis and Simulation Testing.....	16
Real-World Historical Data.....	16
Simulated Scalability.....	17

Results.....	19
Real-World Historical Data.....	19
Simulated Scalability.....	35
Conclusions and Recommendations .....	38
Appendix A – RSE Communication Performance .....	40
References.....	185

# List of Figures

---

Figure 1. Projected Northern Virginia Connected Vehicle Test Bed data generation per hours of day.....	1
Figure 2. Signal blocked by large obstruction. ....	3
Figure 3. RCR test for V2X communication. Notation RSU[a]-[b][c]-P[d]-h[e]: RSU[a] is the ID of the RSE, [b] denotes if the OBU approaches (A) or drives away (D) from the RSE, [c] represents the cardinal point (N, S, E, W) from which the OBU approaches the RSE or to which the OBU drives away from the RSE, P[d] is the transmission power (dBm), and h[e] the RSE antenna height (meters) [4].....	3
Figure 4. Comparison of signal connectivity and recovery from different power level RSEs for a roundabout [4].....	4
Figure 5. VCC network.....	8
Figure 6. Test bed operating area.....	9
Figure 7. Test bed roadway characteristics.....	10
Figure 8. Study vehicles (antenna installations identified with red circles). ....	11
Figure 9. Test vehicle equipment diagram.....	11
Figure 10. Hirschman shark fin combined DSRC/GPS antenna. ....	12
Figure 11. Generalized VCC network topology. ....	13
Figure 12. RSE installation.....	14
Figure 13. RSE technical specifications [11].....	15
Figure 14. VCC Monitor.....	16
Figure 15. Collected RSE BSM location data. ....	17
Figure 16. Simulated scalability BSM data flow. ....	18
Figure 17. Northern Virginia Connected Vehicle Test Bed cross-RSE coverage. ....	19
Figure 18. Northern Virginia Connected Vehicle Test Bed All RSE-received BSMs. ....	21
Figure 19. Northern Virginia Connected Vehicle Test Bed contiguous RSE coverage and overlap. ....	22
Figure 20. Relative RSE to vehicle range grid. ....	23
Figure 21. RSE ID 9 PER map and range characterization plots. ....	28
Figure 22. RSE ID 9 PER heat map characterization plots. ....	29
Figure 23. RSE ID 17 IPG map and range characterization plots. ....	30
Figure 24. RSE ID 17 IPG heat map characterization plots. ....	31

Figure 25. RSE ID 17 roadway environment view.....	31
Figure 26. RSE ID 8 communication characteristics.....	33
Figure 27. South (top) and north (bottom) views from RSE ID 8 location. ....	34
Figure 28. LOS blocked view from vehicle to RSE ID 8. ....	35
Figure 29. Scalability response. ....	36
Figure 30. Scalability response (detail of first half of Figure 29).....	37
Figure 31. Scalability response (detail of second half of Figure 29).....	38

## List of Tables

---

Table 1. OBE Technical Specifications [11] .....	12
Table 2. BSM Data Elements [12].....	12
Table 3. Collected Performance Variables .....	13
Table 4. RSE Communication Ranges.....	25
Table 5. RSE Communication Performance per Vehicle Approach Vector – PER .....	26
Table 6. RSE Communication Performance per Vehicle Approach Vector – IPG .....	27
Table 7. RSE Communication Performance per Vehicle Approach Vector – Latency.....	27

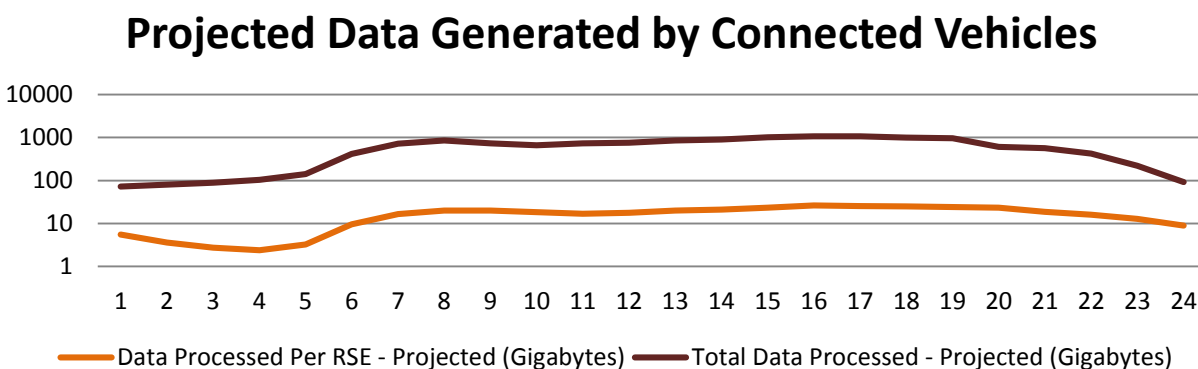


## Background

The Northern Virginia Connected Vehicle Test Bed was established to investigate the potential benefits and effects of a connected vehicle (CV) deployment. The test bed, which is located along I-66, I-495, VA-29, and VA-50 in Merrifield, Virginia, employs vehicle-to-vehicle (V2V) and vehicle-to-infrastructure (V2I) technology (collectively, vehicle-to-X [V2X]).

The benefits of a CV system hinge on the ability to securely transmit, receive, and process information. As more vehicles are instrumented with V2X technologies, in high-density traffic scenarios it is possible that a large number of vehicles transmitting simultaneously could create spectral congestion. In addition, networked devices may also be put under extreme processing load, backhaul networks may reach bandwidth limitations, and each interconnected device that processes network data may become a bottleneck.

The potential volume of data could reach 1,000 GB per hour. Figure 1 shows a projection of data transmitted by vehicles and processed by the infrastructure based on an hourly traffic distribution provided in a Federal Highway Administration (FHWA) report that observed I-66 west bound traffic density [1]. The projection assumes that all vehicles are transmitting 378-byte messages over the air (OTA) at a rate of 10 Hz, per Crash Avoidance Metrics Partnership (CAMP) research parameters [2]. The total projected data throughput was calculated by accounting for all other roadside equipment (RSE) in the network.



**Figure 1. Projected Northern Virginia Connected Vehicle Test Bed data generation per hours of day.**

Understanding the effect of such a load on the network is necessary to see if the performance of the system is negatively impacted. Although, research in V2V communications scalability has already been performed by entities such as CAMP, large-scale V2I-based research results are not readily available or are incomplete due to the lack of equivalent deployment sites. The Northern Virginia Connected Vehicle Test Bed provides an additional CV environment for testing the scalability of V2V communications—and notably one that sees some of the nation’s heaviest traffic. Adapting CAMP’s research methodology to the V2I infrastructure on the Northern Virginia Connected Vehicle Test Bed will not only help to verify the test bed’s functionality but will also provide additional insights that can serve the entire CV community.

## Objectives

The objective of this study was to investigate the ability of the infrastructure on the Northern Virginia Connected Vehicle Test Bed to handle increased network load. In an effort to identify system limitations, historical data were analyzed for coverage gaps and experimental studies were performed to test the dynamic environment and stress the wireless and backhaul networks. The results of these analyses

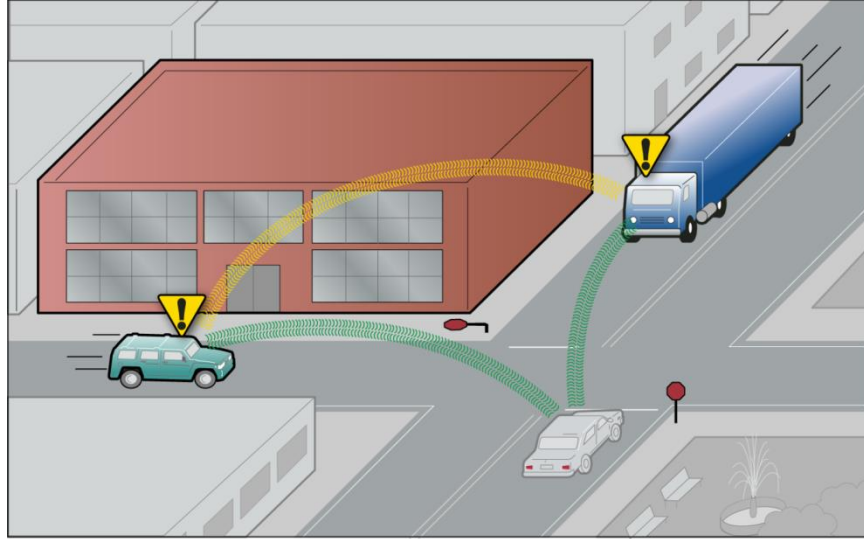
- identified physical locations with poor RSE Dedicated Short Range Communications (DSRC) receiver signal coverage;
- identified factors contributing to poor RSE DSRC receiver signal coverage;
- identified areas with multiple RSE signal coverage; and
- characterized the information technology (IT) infrastructure under increased network load.

By understanding what links break between equipped vehicles, RSEs, and network infrastructure, limitations can be characterized and improvements can be made when feasible. The outcomes of this study will support continued operation, planning, and maintenance of the Northern Virginia Connected Vehicle Test Bed from a network communications perspective.

## Literature Review

V2X communication should provide a real-time, reliable, low-latency communication pathway that enables any vehicle to communicate with another vehicle or RSE, although for different safety-critical events different tolerances are allowed. Over the last 10 years, several studies have evaluated the performance and reliability of the CV system in different environments. Paier, Tresch, Smely, Mechel, and Zhou [3] tested the performance of V2I by investigating the packet length, data rate, and vehicle speed in highway scenarios. Gozavez, Sepulcre, and Bauza [4] performed extensive experiments on V2I network functional ability in an urban environment by studying the effects of several physical aspects and parameters on the packet delivery rate. Bai and Krishnan [5] tested V2I system reliability from a communication and application point of view.

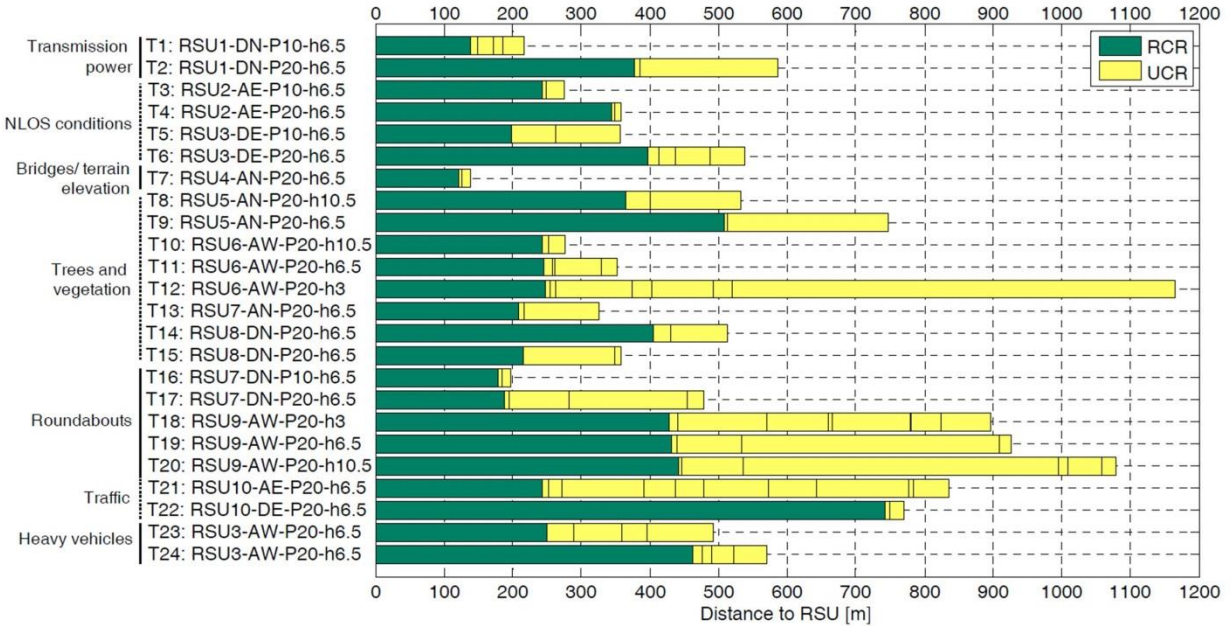
On-road testing has been performed to explore the behavior of V2X signal connectivity. Work from Paier et al. [3], Meireles, Boban, Steenkiste, Tonguz, and Barros [6], and Bohm, Lindstrom, Jonsson, and Larsson [7] is worth mentioning in this regard as the literature shows that one of the major problems for V2X connectivity is a large obstruction, such as a building, bridge, truck, or trees and vegetation. Figure 2 demonstrates one such scenario where the communication between the blue truck and the green car is obstructed by the red building.



Source: GAO.

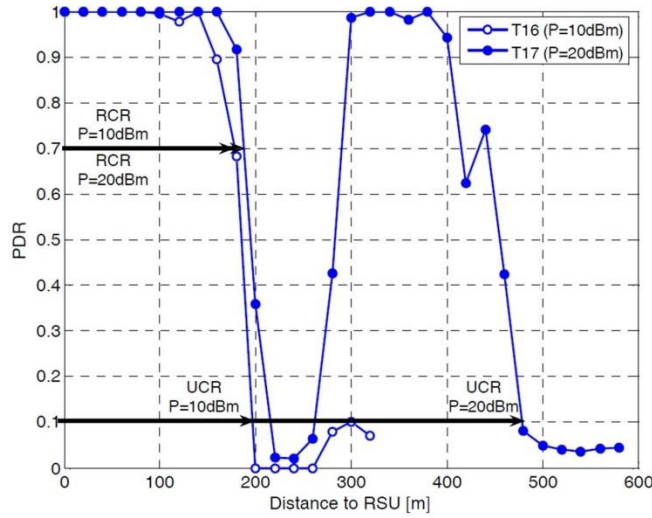
**Figure 2. Signal blocked by large obstruction.**

Gozalvez et al. [4] performed a detailed analysis of benchmark V2V communications in different real-world environments. These benchmarks included definitions of reliable communication range (RCR) and unreliable communication range (UCR) for RSEs. RCR is defined as the distance where at least 70% of the packets are delivered. (In other words, at most 30% of the packets sent by the onboard unit are lost.) The paper examined different intrinsic and extrinsic factors. Figure 3 summarizes the results.



**Figure 3. RCR test for V2X communication. Notation RSU[a]-[b][c]-P[d]-h[e]: RSU[a] is the ID of the RSE, [b] denotes if the OBU approaches (A) or drives away (D) from the RSE, [c] represents the cardinal point (N, S, E, W) from which the OBU approaches the RSE or to which the OBU drives away from the RSE, P[d] is the transmission power (dBm), and h[e] the RSE antenna height (meters) [4].**

In these results, the longer the green bar, the better the performance. It can also be deduced that the height of the RSE's antenna plays a significant role for several extrinsic factors. For construction like bridges, a higher placement of the RSE yields better results. For high-vegetation areas, a lower height is recommended. Higher power is better not only for increased RSE range, but also for recovering from a temporary signal loss. An interesting observation from Figure 3 is that when a vehicle traverses a roundabout, signal connectivity to the RSE is temporarily lost. In these cases, low-power RSEs often fail to recover but higher-power RSEs are capable of recovery. Figure 4 shows one such case for a roundabout.



**Figure 4. Comparison of signal connectivity and recovery from different power level RSEs for a roundabout [4].**

## Performance Measures

The literature review was used to identify standard evaluation measures that are useful to characterize the performance of communication networks. Although ten common measures are discussed below in the context of CV systems, only a few are assessed under this project. Details surrounding these specific measures are mentioned below and explained in detail in subsequent sections.

### Received Signal Strength Indicator (RSSI)

RSSI is very similar to path loss in a wireless communication environment. In general, path loss is calculated as

$$P_L = P_{T_x} - P_{R_x} = P_{L_0} + 10n \log_{10} \left( \frac{d}{d_0} \right) + X_f,$$

where  $P_{T_x}$  is the transmitted power,  $P_{R_x}$  is the received power,  $n$  is the path loss coefficient,  $d$  is the distance from the transmitter to the receiver,  $P_{L_0}$  is the reference path loss for reference distance  $d_0$ , and  $X_f$  represents the component for signal fading. The fading component can be modeled as a simple Gaussian or using a more complex model like a Rician model. A Gaussian model is generally characterized by a zero mean and a standard deviation of  $\sigma$ . In a Rician fading model,

the amplitude gain is generally characterized by a Rician distribution. The research documented in Mecklenbrauker et al. [8] has modeled the fading with more components to compute the path loss coefficient in diverse roadway environments.

### **Packet Delivery Rate (PDR)**

Understanding PDR performance is important for any wireless sensor network communication protocol. PDR performance is mainly a function of environment, the receiver characteristics, and the characteristics of the physical layer coding scheme. The work of Zhao and Govindan [9] provides a general framework to evaluate the packet delivery performance of a sensor network. One of the major metrics for such evaluation is PDR. It is measured by the number of packets received over the transmission. To be more precise, if in a given time window,  $T$ , a receiver receives  $N_{Rx}$  number of packets out of  $N_{Tx}$  number of packets sent out by the transmitter, then

$$PDR = \frac{N_{Rx}}{N_{Tx}}.$$

Alternatively, packet error rate (PER) is the ratio of the missed packets to the total number of packets sent. In a V2X scenario, we measure this quantity from the RSE's perspective, to test its performance:

$$PER = 1 - \frac{N_{Rx}}{N_{Tx}}.$$

For the definition of packet, we assume that the vehicle transmits 378 bytes of data OTA at a frequency of 10 Hz, per CAMP research parameters.

### **Inter Packet Gap (IPG)**

IPG signifies the time between dropped packets received by the RSE. In theory this should be governed by the packet emitting rate, 10 Hz for our case. Hence, if two consecutive packets are dropped, we would have an IPG of 200 ms.

### **Latency**

Latency is the time difference between the time when the packet is generated ( $t_{Tx}$ ) and when the packet is received ( $t_{Rx}$ ). In this work, we do not have time information for when the packet is received at the RSE, but we know when the packet is imported to the server. Assuming that the time delay from RSE to the server is uniform, we can take this as a measure for latency.

### **Data Rate**

The data rate plays a vital role both at the front end and the back end of the system. A higher data rate increases the chances of congestion at both ends. For the front end, a higher data rate might saturate the channel. At the back end, a higher data rate will demand more processing resources. Therefore, it is interesting to investigate the bottleneck limit by testing the effects of increasing the data rate.

### **T-Window Test**

The  $T$ -window reliability test determines if for a given time window,  $T$ , the RSE receives at least a single data packet. This reliability measure is important for application-specific evaluation.

### **Loss of Consecutive Packet Probability Test**

For a continuous transmission of packets, the loss of consecutive packet probability test characterizes the channel's behavior by measuring the distribution of the number of packets that are missed consecutively for any given situation.

### **Signal Recovery Test**

When a continuous connection is available for a moving transmitter or receiver, the signal may be lost temporarily due to an obstruction. For CV applications, it is worth looking at how the connection can be reestablished.

### **RSE Recovery Test**

The RSE recovery test is important particularly when an RSE recovers from a sudden data connection loss. This test mainly applies to the analysis of the back end.

### **Global Positioning System (GPS) Error:**

Although GPS error is another important parameter of V2I communication, it is not taken into consideration in this study.

### **Environmental Considerations**

When deploying wireless technologies, physical conditions in the environment need to be considered during the evaluation stage. The literature review helped to identify environmental conditions and scenarios that may influence the performance of a CV system.

### **Traffic**

For any vehicular application, traffic condition is a primary factor. In V2I applications, the presence of traffic increases not only the OTA data volume but the signal transmission path as well.

### **Road Characteristics**

The geographic setting of a road affects signal propagation and density.

- Dense urban areas have wide roads, numerous intersections with traffic signals, and a probability of a very high volume of vehicles. Large cities often have large buildings, close concrete structures, and more reflective surfaces for the traveling signal. Vehicle speeds are generally slow to moderate.
- Suburban areas have narrower roads with lesser traffic. Vehicle speeds are moderate, building heights are lower, and there may be more vegetation.
- Interstates and highways have the highest vehicle speeds of all the scenarios. Doppler spread might play a distinct role. Volume flow is moderate to low compared to dense urban areas.
- Rural areas have narrow and winding roads. Generally, the traffic density is low in these areas, but the vegetation density influences the signal transmission and fading characteristics.

- Areas with dense vegetation, especially areas with tall trees, may influence the transmission path. Dense vegetation can block the path between the transmitter and receiver, resulting in continuous data loss.

### **Road Type**

The configuration of roadways and intersections may also affect the signals used in V2X communication.

- Intersections: Urban scenarios have multiple intersections with signals. During high traffic volume, a particular intersection and associated RSEs may be congested with a high volume of data.
- Roundabout: Changes in a vehicle's heading while it navigates a roundabout may lead to temporary data loss when combined with the effect of the surroundings [4].
- Bridges: The elevation height of a bridge may often affect the behavior of the communication channel. Gozalvez et al. [4] have shown that the height difference between RSE and OBU plays a considerable role in the reliability of the data reception.
- Tunnels: The closed construction of a tunnel poses the greatest threat to the loss of data connection.

### **Line of Sight (LOS)/No Line of Sight (NLOS)**

The path between the receiver and transmitter varies depending on the situation, but it can be broadly categorized into LOS and NLOS. For the case of LOS, a direct path exists between the receiver and transmitter. For NLOS, there is no direct path, and the signal may follow a deflected path from the OBU to the RSE. This scenario may happen when there is a large obstruction between the transmitter and receiver, such as a heavy vehicle, vegetation, big structure, or building.

### **Driver Approach**

In a V2I scenario, the RSEs are located at a fixed location and the vehicles are the moving element. Therefore, the system has a stationary receiver and a moving transmitter. This affects the receiving rate of data at the RSEs. If the OBUs are emitting the packets at the rate of 10 Hz, the RSE will receive them at a different rate. This is known as Doppler shift. If we consider all the signal components and all the different paths of the traveling signal, the total shift between them is known as the Doppler spread. This in turn affects the coherence time of the network channel. Given this, it is important to evaluate the performance in cases when the vehicle is stationary, moving away from the RSE, and moving toward the RSE. The change in data rate not only affects performance parameters like PER or RSSI but at the same time demands a variable back-end capability for further computation.

### **Sensor Type**

The performance of a system under different scenarios largely depends on the type of sensor. This includes the power level, allowable burst rate, and the antenna cover design [8]. In this specific test, we only used one type of sensor; hence the variability introduced by sensor type was not a factor in this work and is beyond the scope of this report.

## Methods

Two distinct analyses were conducted to assess the performance of the Northern Virginia Connected Vehicle Test Bed. First, historical data were reviewed to determine where coverage gaps occur and identify what factors cause those gaps. Second, an experiment was performed that simulated increased load on the system to determine any performance issues that could affect scalability.

## Northern Virginia Connected Vehicle Test Bed

The Northern Virginia Connected Vehicle Test Bed was used as the primary testing location for this performance study. The Northern Virginia Connected Vehicle Test Bed is a real-world multimodal V2X test bed located along I-66, I-495, VA-50, and VA-29 in Northern Virginia. Of particular interest in this study were the RSEs that receive and route basic safety messages (BSMs) transmitted from instrumented vehicles to various networks and devices. The Northern Virginia Connected Vehicle Test Bed is part of a larger initiative, the Virginia Connected Corridors initiative, that includes the Virginia Smart Road at the Virginia Tech Transportation Institute (VTTI). Figure 5 diagrams how the VCC's resources are used to support various initiatives by the Virginia Department of Transportation (VDOT), United States Department of Transportation (U.S. DOT), third parties, VTTI, and the Connected Vehicle/Infrastructure University Transportation Center (CVI-UTC).

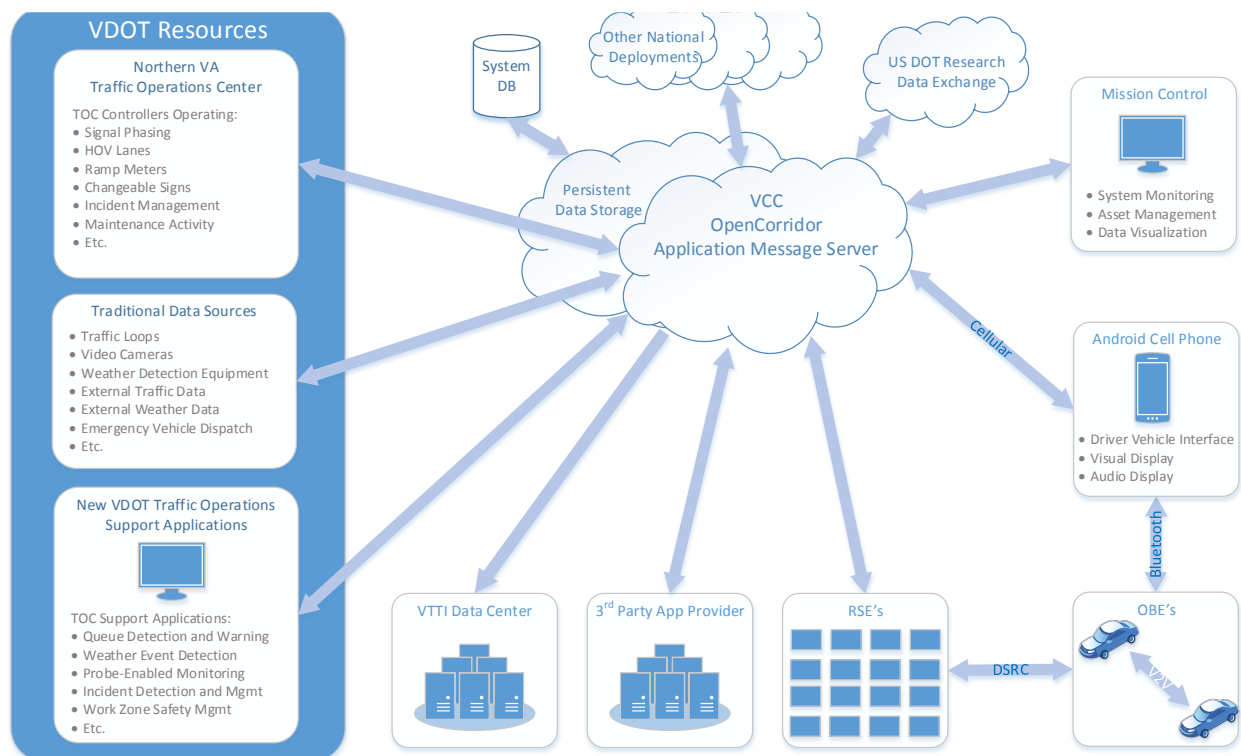


Figure 5. VCC network.



## Environment

The Northern Virginia Connected Vehicle Test Bed provides a diverse range of environments and roadway configurations that may impact V2X performance, including heavy traffic, overpasses, underpasses, exit ramps, intersections, buildings, and vegetation. Figure 6 is a map showing the general test bed operating area. The triangles on the map indicate the location of installed RSEs (Green and Red) and future RSE installation locations (Blue/Grey). Figure 7 highlights the unique environmental and roadway characteristics on the test bed. The figure, which consists of two Google Street View images, shows roadway environments which may present a challenge to effective OTA communication performance. Obstructions such as tall buildings, bridges and concrete wall valleys are present in the test environment. Depending on the location of the installed RSE and vehicle, the line of sight between the two may be obscured causing a decrease in communication performance. The impact of such obstructions on communications are investigated in the results section of this report.

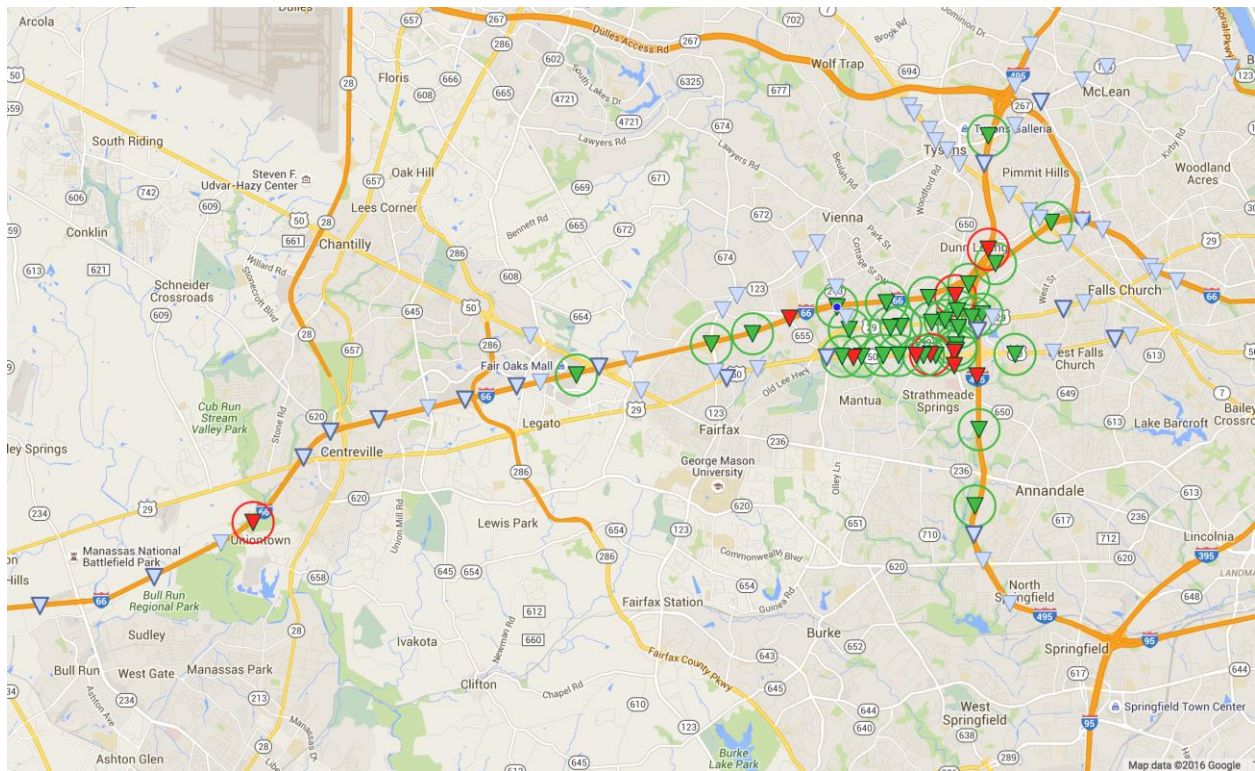


Figure 6. Test bed operating area.



**Figure 7. Test bed roadway characteristics.**

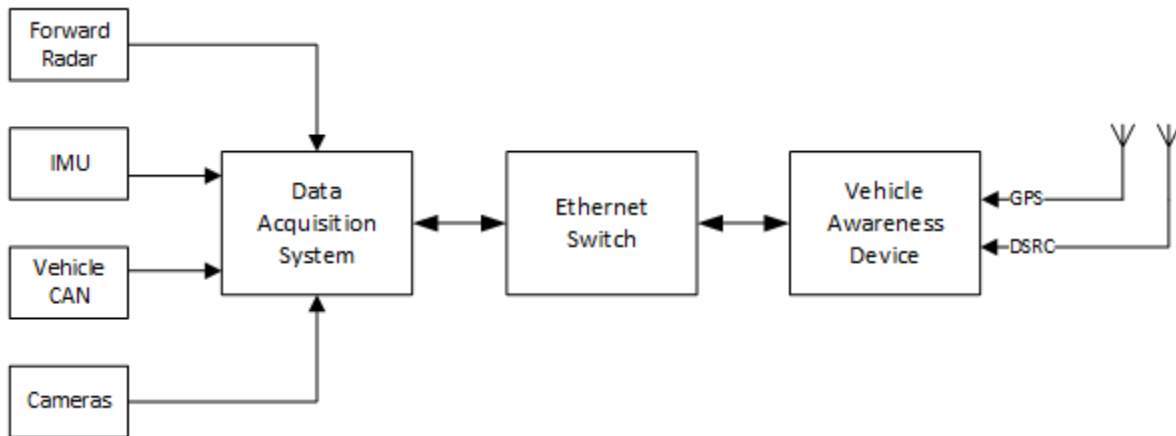
### **Vehicles**

To support various CV projects undertaken by VTTI and partners, BSM data from over 50 CV devices were captured by the RSEs and stored in a data warehouse. These devices belonged to various organizations, including CVI-UTC, VTTI, VDOT and third-party entities. Lessons learned from U.S. DOT-sponsored research have shown that the quality of the after-market integration of CV systems in vehicles has an impact on performance [10]. In particular, care must be taken with the mounting location of the antenna and the configuration of device parameters. To address this concern, only vehicles instrumented and certified by VTTI were analyzed for this study. This was done to “filter” out any vehicles that may not have been properly configured or that were operating in an atypical test configuration. Data from 22 vehicles were assessed. Figure 8 shows some of the study vehicles instrumented by VTTI.



**Figure 8. Study vehicles (antenna installations identified with red circles).**

All participating vehicles were instrumented with a DSRC onboard device. This device allowed for wireless communication of “official CV information,” such as BSM, Traveler Information Message (TIM), and Signal Phase and Timing (SPaT) messages. In addition, certain vehicles were integrated with a VTTI data acquisition system (DAS) that collected data from forward radar, an inertial measurement unit (IMU), the vehicle’s Controller Area Network (CAN), cameras, and DSRC onboard devices. The overall data collected from these sensors allowed for evaluation of system performance. Figure 9 depicts a generalized overview of the vehicle builds and component layout.



**Figure 9. Test vehicle equipment diagram.**

In this deployment, various DSRC suppliers were used, in particular the Savari MobiWAVE vehicle awareness device (VAD; see specifications in Table 1). This device uses an embedded GPS receiver to populate specific data elements in a standardized SAE 2735 DSRC BSM, as shown in Table 2. The VAD then uses the DSRC radio to transmit BSMs wirelessly at a rate of 10 Hz while also receiving BSMs from remote vehicles (RVs) via a Hirschman Shark fin Combined DSRC/GPS antenna (Figure 10). Selected BSM data elements and DSRC and GPS performance

variables served as the primary source to measure overall performance of the CVs as defined in Table 3.

**Table 1. OBE Technical Specifications [11]**

Device	Power	Wireless	GPS	Port	Antenna	Storage
VAD	12-V DC USCAR connector	1 25 dbm DSRC/Wi- Fi 5.15-5.9 GHz, 10, 20 MHz channels, 802.11a	$\pm 2$ m position accuracy, 50% Circular Error Probability (CEP)	1 Ethernet  1 RS- 232  2 USB  2 FAKRA	Multiband Wi-Fi/ DSRC/ GPS	Up to 512 MB internal, USB external

**Table 2. BSM Data Elements [12]**

Dynamic Content		Static Content
DSRC Message ID	Positional Accuracy	Vehicle Width
Message Count	Heading	Vehicle Length
Temporary ID	Transmission and Speed	Vehicle Height
Dsecond	Steering Wheel Angle	Vehicle Type
Latitude	Acceleration Set (Four Way)	
Longitude	Brake System Status	
Elevation	Event Flag	



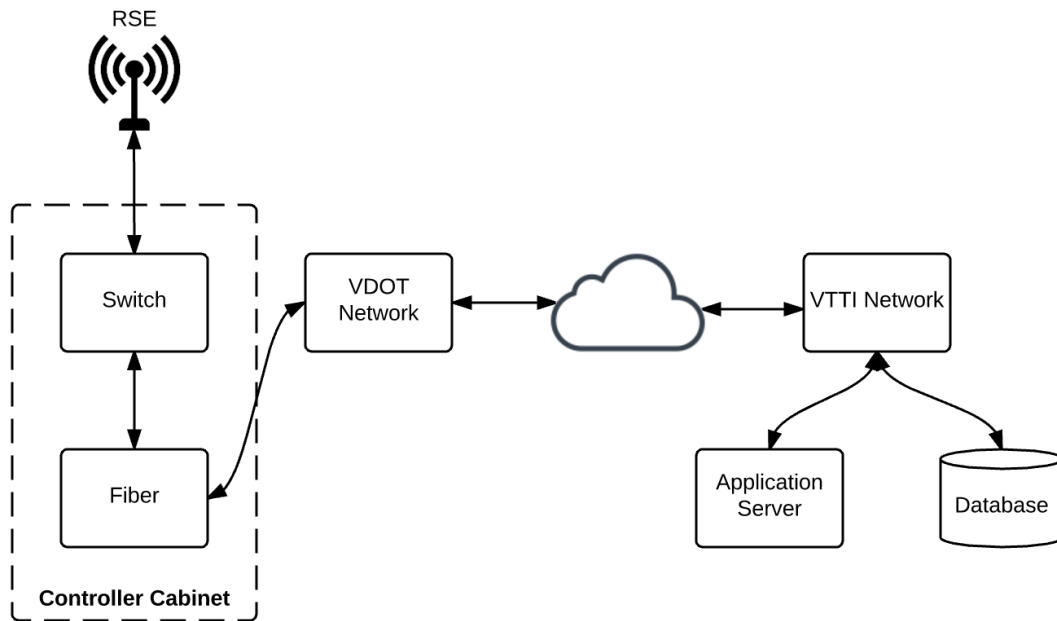
**Figure 10. Hirschman shark fin combined DSRC/GPS antenna.**

**Table 3. Collected Performance Variables**

Variables of Interest	Performance Focus	Use Case Definition
Latitude	Communication & Position	Vehicle geographic latitude used for location mapping and calculating relative distances between vehicles.
Longitude	Communication & Position	Vehicle geographic longitude used for location mapping and calculating relative distances between vehicles.
Heading	Communication & Position	Vehicle geographic heading used for location mapping and calculating relative distances between vehicles.
Message Count	Communication	Message number that increments by 1 per each message transmitted by a vehicle (i.e., 0, 1, 2, 3, 4, ... , 127). Value is used to determine the PER of a transmitting vehicle as received by a RSE.
Vehicle BSM Generation Timestamp	Communication	Value is used to determine the latency from transmission of message from vehicle to reception at VTTI application servers.
VTTI Server BSM Received Timestamp	Communication	Value is used to determine the latency from transmission of message from vehicle to reception at VTTI application servers.

**Communications Network**

Figure 11 is a system diagram detailing the generalized network topology of the VCC test bed. In brief, RSEs (see photo in Figure 12) along roadways on the test bed listen and forward BSMs through various nodes from a local VDOT network via the Internet to an external VTTI network.



**Figure 11. Generalized VCC network topology.**



**Figure 12. RSE installation.**

In total, 24 RSEs collected BSM traffic from the instrumented vehicles. In this deployment, the RSEs used in the test bed were Savari StreetWAVE Roadside Units (see Figure 13 for specifications). The advertised range of this RSE, as specified on the vendor's website, is approximately 400 to 500 m.

## Product Specifications

Component	Description
Processor	500Mhz AMD Geode LX800
Memory	256MB DDR DRAM
Storage	4GB Compact Flash
DSRC Radio	IEEE 802.11a 5Ghz, 600mW 28dBm TX, -94dBm RX Sensitivity
WiFi Radio	IEEE 802.11b/g 2.4Ghz, 400mW 26dBm TX, -97dBm RX Sensitivity
Channel Width	5/10/20/40 Mhz
DSRC & WiFi Antenna Connectors	N-Type Male
Ethernet	Two (2) 10/100 (RJ-45) ports with Auto Uplink™
Console	RS-232C interface
Power Supply	15V, 1.2A DC jack or Power over Ethernet.
Temperature	-31C to +75C
Dimensions	8" (L) x 8 1/2"(H) x 2 3/4" (D)
GPS	SiRF STAR III e/LP, 20 channel, USB based. Accuracy : 5m 2D RMS w/ WAAS, 10m 2D RMS w/o WAAS
Standards Compliance	IEEE 802.11 a/b/g/n, IEEE 802.11p, IEEE 1609.X
Security	WPA2, WPA, AES-CCMP, TKIP, 64/128bit WEP, IEEE 802.1x, MAC, IPSec & SSL
Enclosure	NEMA 67 rating, pole mount.

Figure 13. RSE technical specifications [11].

Upon receipt of the BSM, the RSE forwards the data over an Internet Protocol (IP) network that consists of various components, including Ethernet switches, fiber optic modems, and firewalls, before terminating at VTTI's network. Each network component between the RSEs and VTTI introduces a potential point where BSM data packets may be dropped or delayed. Further delays could be introduced due to the routing between the VDOT and VTTI networks, which is handled by an Internet Service Provider (ISP) and thus the communication path may not always stay consistent from message to message.

Once BSM data reach the VTTI network, several resources exist that allow for observation and measurement of communication network performance. VCC Monitor, an application server that provides real-time monitoring of BSM data and RSE health, is shown in Figure 14. This tool is used to quickly identify an RSE that may be experiencing issues and to support troubleshooting and maintenance activities.

The resource of most interest to this study, however, is the data warehouse that stores all complete BSM data captured by RSEs as defined in Table 2. This data warehouse is a relational database that is accessed to perform analysis on data collected from CVs operating on the test bed. In particular, Table 3 represents the data elements used to quantify the performance of communications on the test bed. The benefits of data generated in a real-world operating

environment provides for unique situations that cannot be replicated in staged experimental testing scenarios. The database provides a large volume of historical data consisting of naturalistic driving and seasonal environmental changes not easily replicated. Further, the vehicle kinematics in response to the operational environment represents driving behaviors typical of regions that can benefit from CV applications. By using this collected data, correlations can be made about specific environments and kinematics that impact the performance of communications.

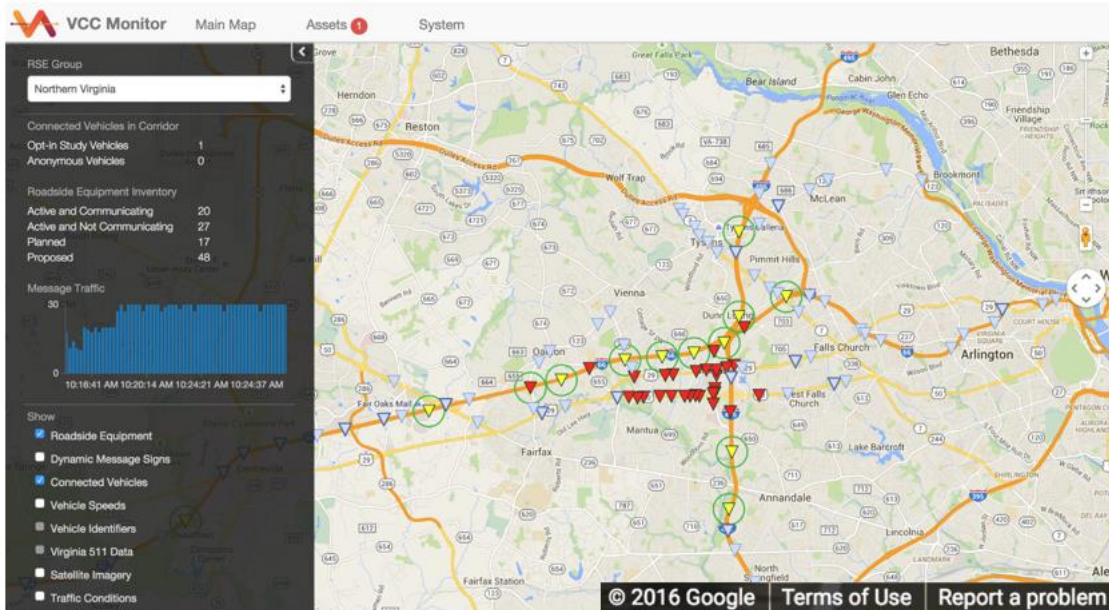


Figure 14. VCC Monitor.

## Data Analysis and Simulation Testing

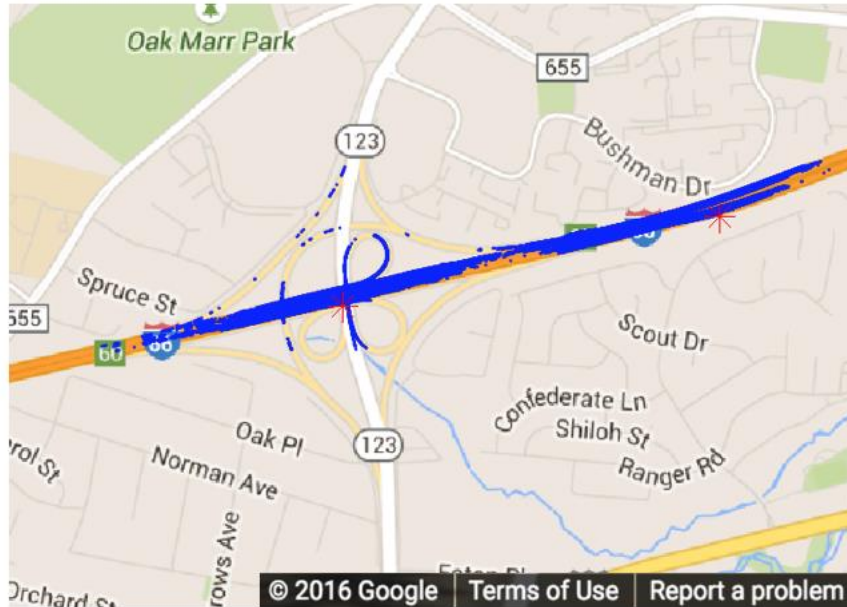
An analysis of real-world historical data and simulated scalability testing were undertaken to identify system limitations. By understanding the deficiencies between equipped vehicles, RSEs, and network infrastructure, limitations can be characterized and improvements made. The outcomes of this study will support continued operation, planning, and maintenance of the Northern Virginia Connected Vehicle Test Bed from an Intelligent Transportation System (ITS) network communications perspective.

### Real-World Historical Data

The purpose of the historical data analysis was to characterize the physical communication properties and performance between CVs and RSEs in the Northern Virginia Connected Vehicle Test Bed environment. For this test, data already collected in the test environment were used. The map in Figure 15 provides an example of the methodology. The map displays the GPS location data of all BSMs received by the RSEs, which are indicated by the red stars. As the figure shows, BSMs were not recorded for certain roadway sections even in the presence of multiple RSEs. This could be due to a number of reasons, such as loss of communication due to path loss ranges, LOS occlusion, or simply the vehicle did not traverse that specific roadway. Identification of these “dead spots” can be used to formulate plans on how to enhance coverage in these regions. Additionally, there may be locations where multiple RSEs picked up a BSM from one vehicle. Identifying these



areas can assist in a number of applications such as download/upload hand-off for any future V2I or infrastructure-to-vehicle (I2V) activities or congestion control.



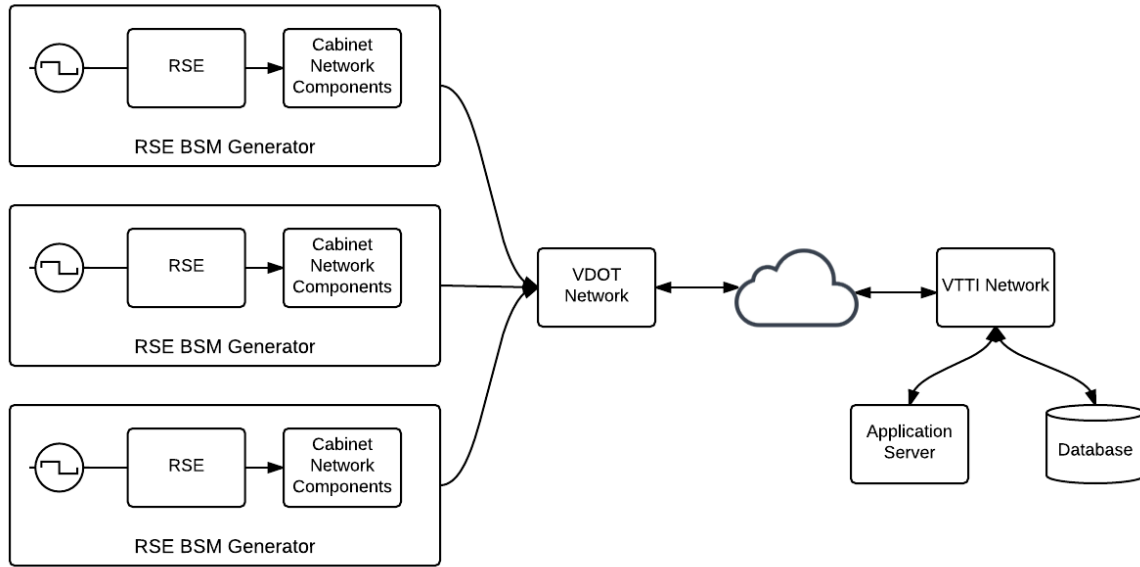
**Figure 15. Collected RSE BSM location data.**

The test procedures and analysis plans needed to meet the project objectives were as follows:

1. Leverage stored RSE data on the database to perform PER and IPG analysis with a focus on relative RSE-to-vehicle approach and departure trajectories.
2. Based on data analysis and corresponding map visualization plots, physical roadway locations with poor PER and IPG, intersecting RSE coverage zones, and none to a low number of BSM data received (e.g., side streets, highway exits) were identified.
3. Markers were applied to these locations on Google Maps. The Street View feature was used to identify any peculiar properties, such as an LOS obstruction between the vehicles and the RSEs.

### **Simulated Scalability**

The purpose of the simulated scalability test was to characterize the performance of the backhaul RSE network in the presence of an escalating BSM network load. Since the cost and effort required to instrument a large number of vehicles with OBUs would have considerable, a software application to generate BSMs locally on the RSE was developed. This application was locally installed on each RSE, and BSM traffic was generated based on a user-defined frequency and duration. Adjusting the frequency and duration of BSMs on the network in effect simulated a fluctuating number of DSRC-equipped vehicles traversing the physical test bed. The flow of data is depicted in Figure 16. The RSEs transmitted the locally generated, simulated data to a centralized VDOT network, which then forwarded the data to VTTI.



**Figure 16. Simulated scalability BSM data flow.**

As an example of the expected load an RSE network may experience, consider a traffic jam scenario in the east- and westbound directions of travel on I-66. An RSE with an effective range of 600 m will cover a stretch of roadway with eight lanes of traffic. If a traffic pileup occurs in both directions, approximately 800 vehicles will be in communication range of that RSE. Based on this worst-case estimate, a single RSE in the network will experience approximately a data demand of 24.2 Mbps. The calculations are as follows:

*600 m RSE range*

*6.0 m per car (4.5 m average car length + 1.5 m travel gap)*

*600 m RSE range / 6 m = 100 cars per lane*

*8 lanes \* 100 vehicles \* 10 Hz BSM Tx = 8 kHz BSM Tx rate per RSE*

*8 kHz \* 378 bytes = 3,024,000 bytes per second*

*3,024,000 bytes per second → 24.19 megabits/s → 3.024 megabytes/s*

Further, as Figure 17 shows, on the Northern Virginia Connected Vehicle Test Bed there is a potential for communication coverage overlap at the intersection of the two major interstates, I-66 and I-495. The green and red triangles represent RSEs with the transparent orange circles representing the effective communication coverage range of the RSE. At the intersection of circles, BSMs transmitted by a vehicle are essentially multiplied when transmitted through the network.



**Figure 17. Northern Virginia Connected Vehicle Test Bed cross-RSE coverage.**

It is expected that this method will be able to characterize the network response when exposed to a large number of DSRC-equipped vehicles. For this test, an approach was developed in which BSM load was escalated to simulate the presence of 1,500 CVs. Upon completion of the tests, analysis involved leveraging the stored BSM data to assess PER, IPG, and latency for the simulated BSM data as depicted in Figure 16. In the context of this specific study, these measures were defined as follows:

- PER – Percentage of BSMs dropped within a given timeframe for each RSE.
- IPG – Amount of time between dropped messages for each RSE.
- Latency – Amount of time between messages transmitted from the RSE and received by VTTI servers.

## Results

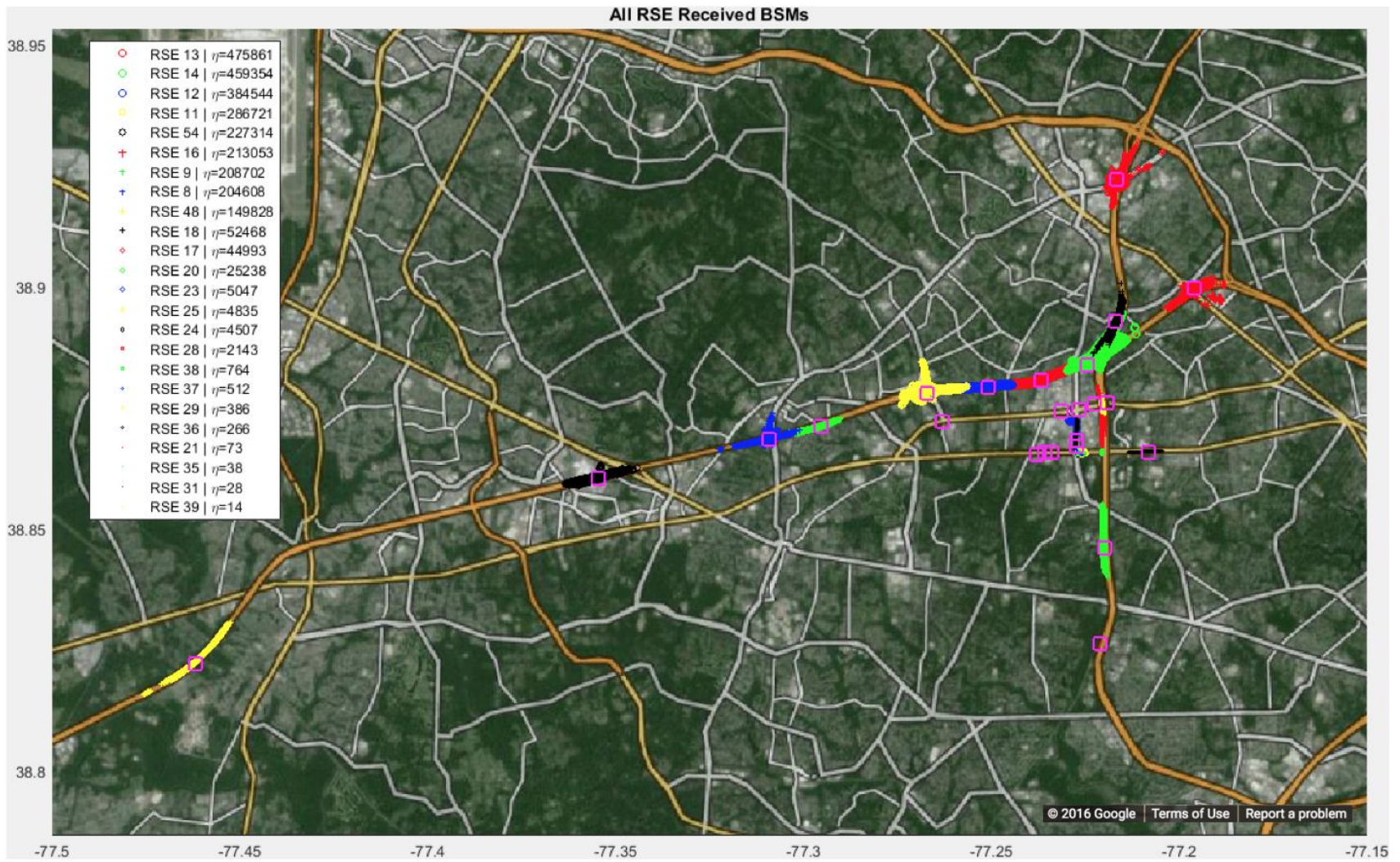
The results from the real-world historical data analysis and the simulated scalability testing are presented below.

### Real-World Historical Data

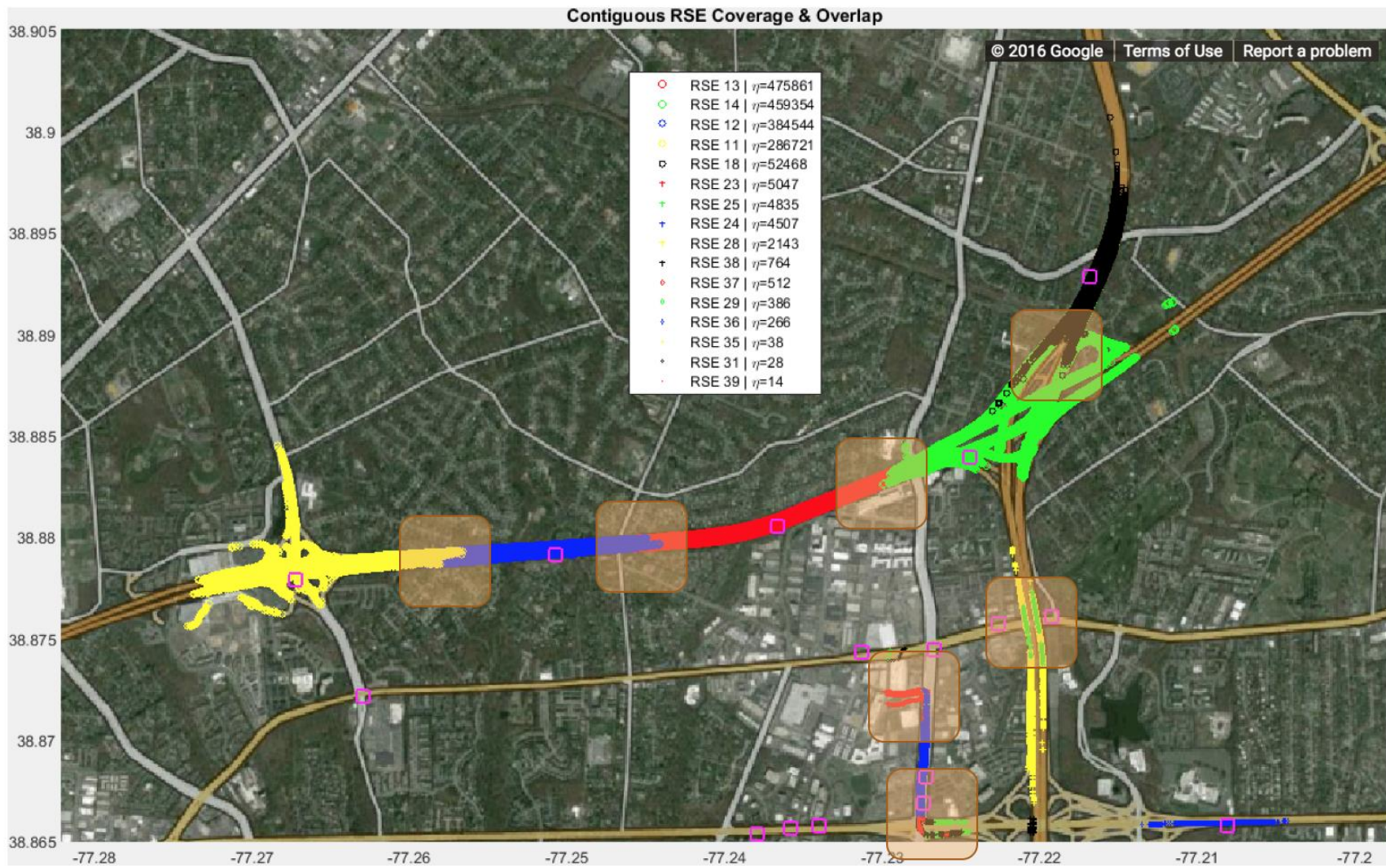
The map in Figure 18 depicts the location of all BSMs received by RSEs on the Northern Virginia Connected Vehicle Test Bed network collected in 2015. The RSEs are indicated by magenta squares. RSE-received BSMs are represented by various symbols and colors. The legend provides an RSE ID number and the total number of BSMs received by that RSE. As the plot presents,

several communication gaps exist. Proposed plans include installing RSEs at these locations, especially along I-66 and I-495. Filling in these gaps would provide contiguous communication coverage along the nation's busiest interstates. Although some RSEs did not receive BSMs that does not necessarily mean that the RSE had an issue. Rather, the case may be that a CV simply did not drive within the receiving range of that RSE.

Figure 19 zooms in on the intersection of I-66 and I-495 to illustrate contiguous communications coverage and overlap between RSEs as indicated by the transparent orange boxes. Depending on the application and need for the infrastructure to receive CV data, care must be taken in these zones to minimize duplication of data. On the other hand, overlap between RSEs provides for constant communication between infrastructure and vehicles, allowing for uninterrupted DSRC-based exchange of data. Potential applications such as downloading security certificates or uploading misbehavior reports may require continuous connection with servers.

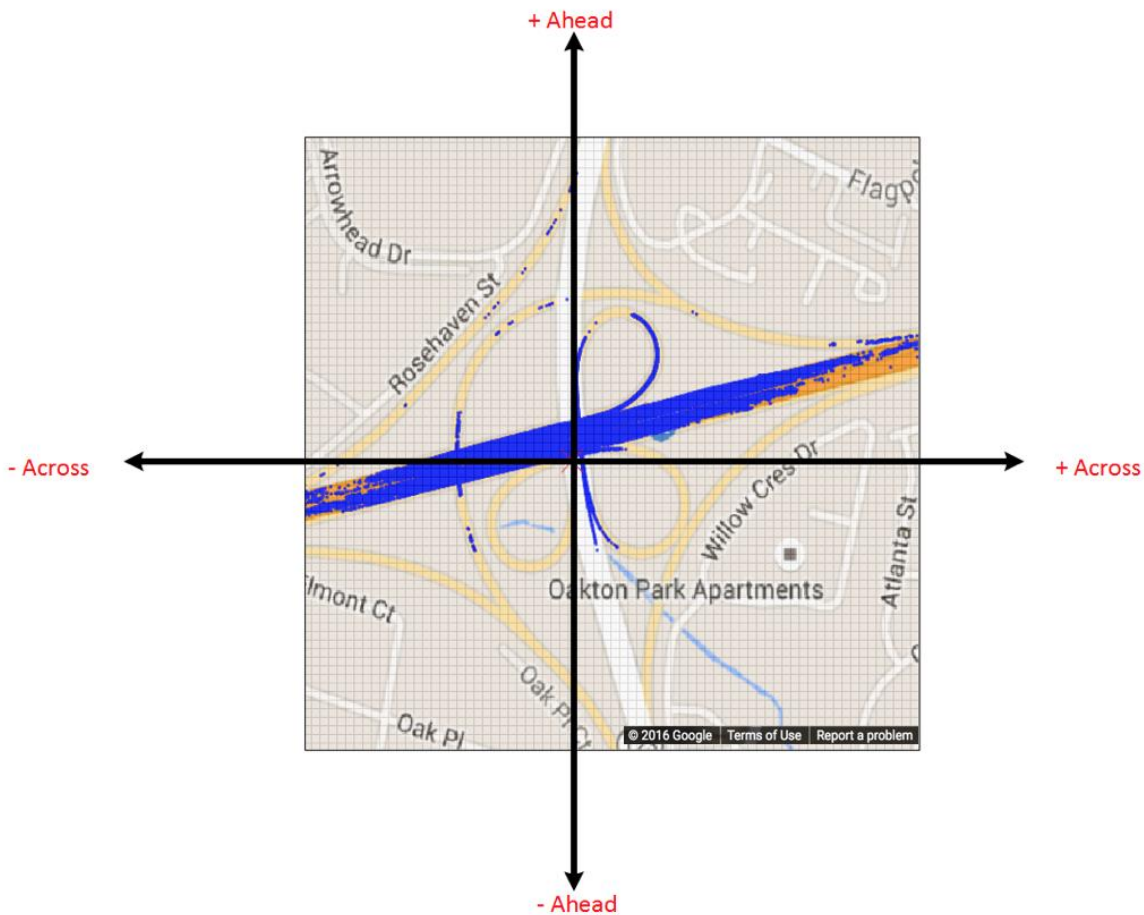


**Figure 18. Northern Virginia Connected Vehicle Test Bed All RSE-received BSMs.**



**Figure 19. Northern Virginia Connected Vehicle Test Bed contiguous RSE coverage and overlap.**

In an effort to understand the particular nuances for each RSE installation, a detailed communication characterization analysis was performed. Relative I2V distances and travel vectors between vehicles and RSEs were associated with performance measures such as PER, IPG, and latency to understand the impact on communications. Figure 20 depicts a coordinate system centered at the location of an RSE (0, 0). Relative ahead ranges are along the north/south y-axis. Across ranges are along the east/west x-axis. Ranges were calculated by using the GPS location of the static RSE (red X on plot) and the received BSM locations (blue dots on plot) from a dynamic vehicle traveling along the roadway. The ranged coordinate system allows for identification of devices and/or locations that may have communication performance issues.



**Figure 20. Relative RSE to vehicle range grid.**

Table 4 is a consolidated table indicating the maximum communication range per RSE. For each RSE, the table provides a unique identifier, roadway installation location, number of received BSMs, and maximum communication ranges. Maximum and minimum communication ranges can be thought of as a radius, while effective communication ranges are the diameter of communication coverage.

The table has been sorted based on the largest average effective communication range for both the ahead and across axes. Further, the range table has been conditionally color formatted to assist in identifying which RSEs are operating below their expected range. The conditional color formatting is a three color gradient scale where green indicates ideal, yellow moderate, and red poor performance. In general, the majority of RSEs have great communication range performance. As was mentioned previously, ranges are calculated based on received BSMs from a vehicle at a given location on a roadway. If a vehicle never traversed a roadway, those relative ranges were never received and therefore not accounted for in the table below. As an example, the RSEs along Virginia state roadways had a low number of received BSMs, indicating a low level of interaction with the CV fleet and therefore do not provide an accurate characterization of the ranges expected of the given RSE. In cases where a vehicle should have traversed a certain roadway path that is within the expected range of communication, such as an exit ramp, LOS factors may have degraded the communication performance.



**Table 4. RSE Communication Ranges**

<b>RSE ID</b>	<b>Roadway</b>	<b>Rx BSMs</b>	<b>Ahead Max. Range (m)</b>	<b>Ahead Min. Range (m)</b>	<b>Effective Ahead Range (m)</b>	<b>Across Max. Range (m)</b>	<b>Across Min. Range (m)</b>	<b>Effective Across Range (m)</b>	<b>Average Effective Range (m)</b>
48	I-66	149828	950.69	-712.84	1663.53	811.11	-1197.29	2008.40	1835.96
14	I-66	459354	1451.92	-148.61	1600.53	1135.05	-476.53	1611.58	1606.06
17	I-495	44993	904.95	-650.21	1555.16	1073.48	-258.89	1332.37	1443.76
8	I-66	204608	591.22	-225.97	817.19	688.98	-1188.18	1877.16	1347.17
11	I-66	286721	736.74	-252.52	989.26	920.21	-596.82	1517.03	1253.14
13	I-66	475861	444.77	-123.50	568.28	929.22	-881.17	1810.39	1189.33
18	I-495	52468	870.37	-741.31	1611.68	198.80	-536.49	735.29	1173.49
54	I-66	227314	287.28	-159.75	447.03	881.94	-768.84	1650.78	1048.90
16	I-66	213053	187.22	-478.89	666.11	699.61	-632.35	1331.96	999.04
20	I-495	25238	1004.33	-681.15	1685.48	59.34	-102.03	161.37	923.43
12	I-66	384544	92.20	-52.32	144.52	572.51	-949.82	1522.33	833.42
9	I-66	208702	214.87	-149.85	364.71	462.01	-823.85	1285.86	825.29
28	VA-29	2143	371.87	-1023.17	1395.05	-41.16	-216.22	175.06	785.06
25	VA-650	4835	621.15	-174.12	795.27	254.90	-28.67	283.56	539.42
24	VA-650	4507	482.66	-319.83	802.49	44.54	-38.99	83.53	443.01
23	VA-29	5047	-213.07	-612.99	399.92	-37.53	-265.72	228.19	314.06

Table 5, Table 6, and Table 7 **Error! Reference source not found.** show the collective results of communication performance analysis across all RSEs in the network. The key metrics PER, IPG, and latency were assessed based on the approach vector of the vehicle toward the RSE. By using the received BSM GPS position and heading, a general approach vector of the vehicle toward an RSE was determined and used to categorize the results. For example, if a vehicle’s heading trajectory is between 45 and 135 degrees, its approach vector is east. Approach vectors help in identifying any particular roadways that maybe problematic. Considering that the installation locations of RSEs are typically along intersecting roadways where routes are based on east/west and north/south flow of traffic, problematic roadways can be identified.

Similar to the previous table, cells have been conditionally color formatted to assist in identifying which approaches toward an RSE may be problematic. Additionally, the tables have been sorted based on the overall PER of each RSE from worst to best. From these results, the majority of RSEs have great communication performance, typically dropping less than 1 packet out of 10 every second. The IPG metric shows that if packets are dropped, then a typical packet gap of less than 100 ms is likely to occur when in communication with an RSE. Unlike PER and IPG, latency does not appear to have any correlation to packet drops. In general, the end-to-end, one-way trip of a BSM from vehicle to an application server was typically less than 200 ms.

**Table 5. RSE Communication Performance per Vehicle Approach Vector – PER**

RSE ID	Roadway	BSMs Rx	Overall - PER	East - PER	West - PER	South - PER	North - PER
11	I-66	286721	0.045	0.063	0.045	0.050	0.017
17	I-495	44993	0.043	0.055	0.191	0.044	0.029
28	VA-29	2143	0.042		0.033	0.045	
8	I-66	204608	0.037	0.045	0.033	0.045	0.011
14	I-66	459354	0.034	0.038	0.039	0.052	0.020
16	I-66	213053	0.027	0.023	0.019	0.041	0.023
12	I-66	384544	0.025	0.028	0.029	0.037	0.014
18	I-495	52468	0.025		0.175	0.045	0.013
54	I-66	227314	0.024	0.027	0.022	0.025	0.025
48	I-66	149828	0.024	0.021	0.015	0.016	0.052
9	I-66	208702	0.023	0.026	0.025		0.003
20	I-495	25238	0.022	0.020	0.029	0.026	0.006
13	I-66	475861	0.019	0.031	0.022	0.040	0.003
23	VA-29	5047	0.012	0.010		0.019	
24	VA-650	4507	0.012	0.010			0.024
25	VA-650	4835	0.009	0.009			

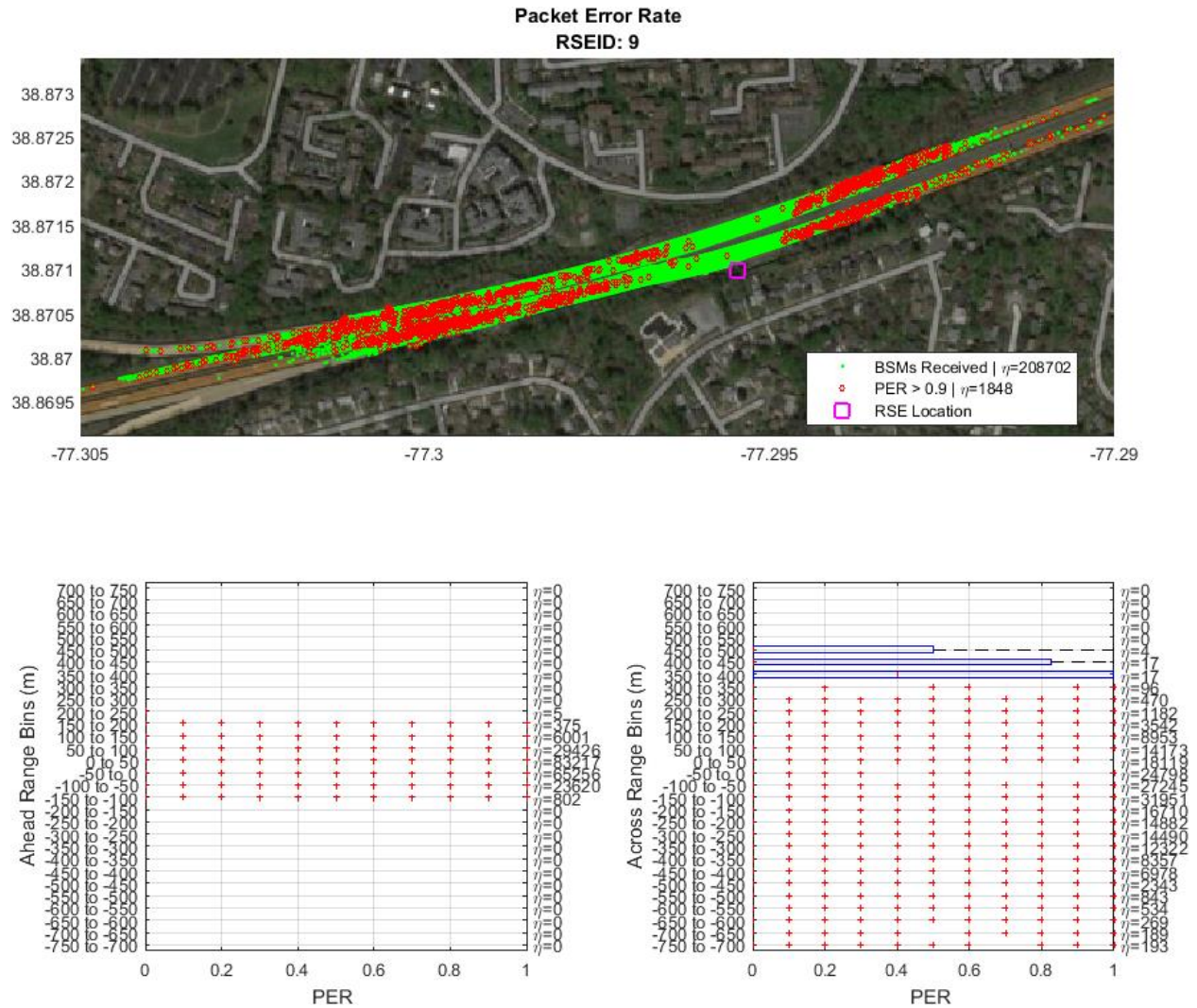
**Table 6. RSE Communication Performance per Vehicle Approach Vector – IPG**

RSE ID	Roadway	BSMs Rx	Overall - IPG (s)	East - IPG (s)	West - IPG (s)	South - IPG (s)	North - IPG (s)
11	I-66	286721	0.111	0.146	0.112	0.146	0.040
17	I-495	44993	0.137	0.248	0.930	0.112	0.075
28	VA-29	2143	0.094		0.078	0.100	
8	I-66	204608	0.097	0.104	0.084	0.198	0.058
14	I-66	459354	0.088	0.093	0.101	0.187	0.048
16	I-66	213053	0.084	0.075	0.059	0.131	0.066
12	I-66	384544	0.058	0.064	0.070	0.092	0.032
18	I-495	52468	0.059		0.305	0.100	0.035
54	I-66	227314	0.065	0.069	0.059	0.082	0.071
48	I-66	149828	0.064	0.053	0.036	0.041	0.156
9	I-66	208702	0.053	0.060	0.060		0.014
20	I-495	25238	0.053	0.044	0.069	0.060	0.023
13	I-66	475861	0.049	0.071	0.056	0.171	0.013
23	VA-29	5047	0.033	0.029		0.044	
24	VA-650	4507	0.045	0.044			0.049
25	VA-650	4835	0.027	0.027			

**Table 7. RSE Communication Performance per Vehicle Approach Vector – Latency**

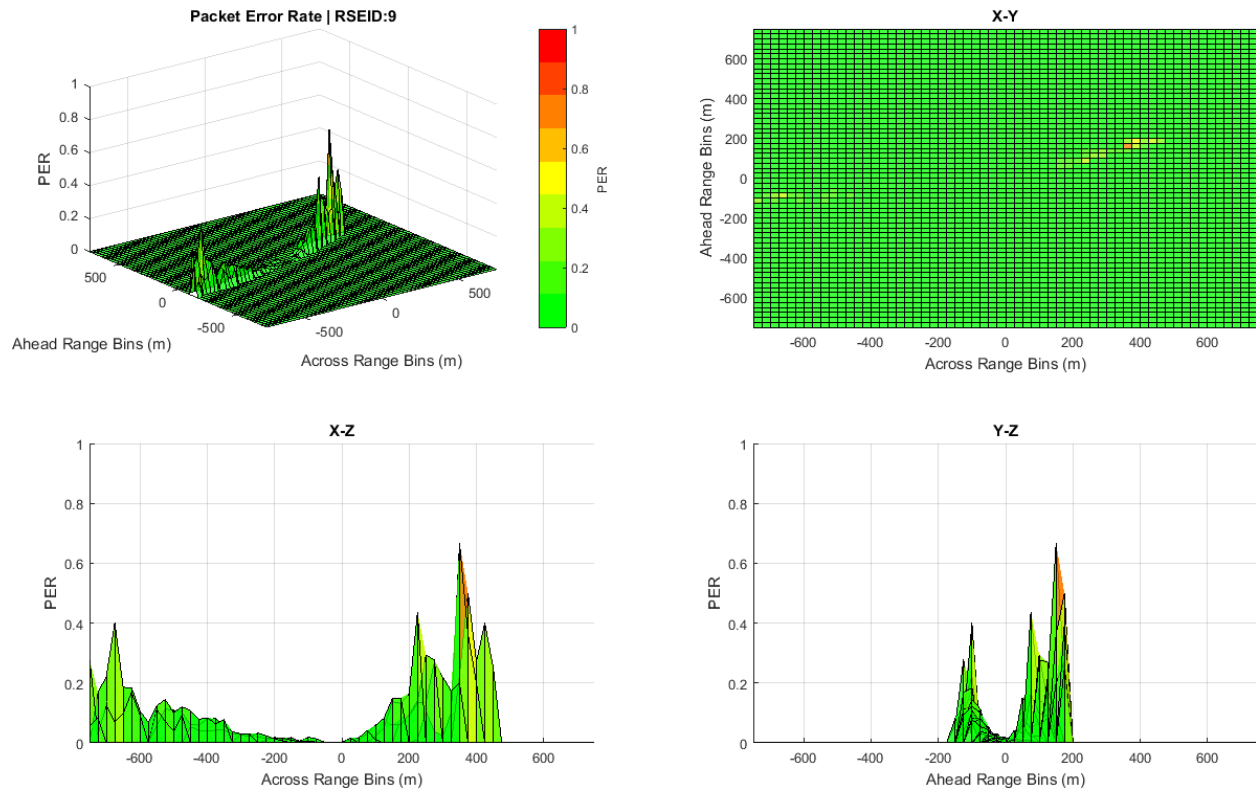
RSE ID	Roadway	BSMs Rx	Overall - Latency (s)	East - Latency (s)	West - Latency (s)	South - Latency (s)	North - Latency (s)
11	I-66	286721	0.151	0.156	0.153	0.149	0.145
17	I-495	44993	0.152	0.150	0.142	0.152	0.154
28	VA-29	2143	0.146		0.144	0.146	
8	I-66	204608	0.269	0.425	0.163	0.273	0.151
14	I-66	459354	0.179	0.159	0.234	0.151	0.155
16	I-66	213053	0.439	0.269	0.613	0.664	0.246
12	I-66	384544	0.168	0.159	0.194	0.146	0.148
18	I-495	52468	0.151		0.124	0.153	0.150
54	I-66	227314	0.222	0.278	0.190	0.187	0.198
48	I-66	149828	0.291	0.291	0.290	0.296	0.293
9	I-66	208702	0.214	0.293	0.159		0.151
20	I-495	25238	0.151	0.152	0.149	0.149	0.156
13	I-66	475861	0.166	0.155	0.185	0.151	0.149
23	VA-29	5047	0.142	0.141		0.148	
24	VA-650	4507	0.149	0.147			0.159
25	VA-650	4835	0.148	0.148			

From these results, several RSEs have ideal communication results, while others have issues pertaining to packet loss or latency. RSE ID 9 is an example of a unit that has ideal communication performance in terms of maintaining continuous communication with the infrastructure. Provided in **Error! Reference source not found.** Figure 21 is a zoomed-in detail of received BSMs plotted on a map for RSE 9. The magenta square designates the location of the RSE, green dots signify the location of a received BSM, and the red circles indicate locations where the performance metric is considered an outlier; in this case a PER greater than 0.9. For the received BSMs and performance metric outliers, the frequency of those samples is also provided in the legend. Below the map are the box plot results detailing the communication performance metric split between the various ahead and across range bins. The central red mark is the median, and the edges of the blue box are the 25<sup>th</sup> and 75<sup>th</sup> percentiles. The whiskers extending to the most extreme data points are not considered outliers; outliers are plotted individually as a red plus. The right-hand y-axis provides the count of samples in the bin detailed on the left-hand y-axis.



**Figure 21. RSE ID 9 PER map and range characterization plots.**

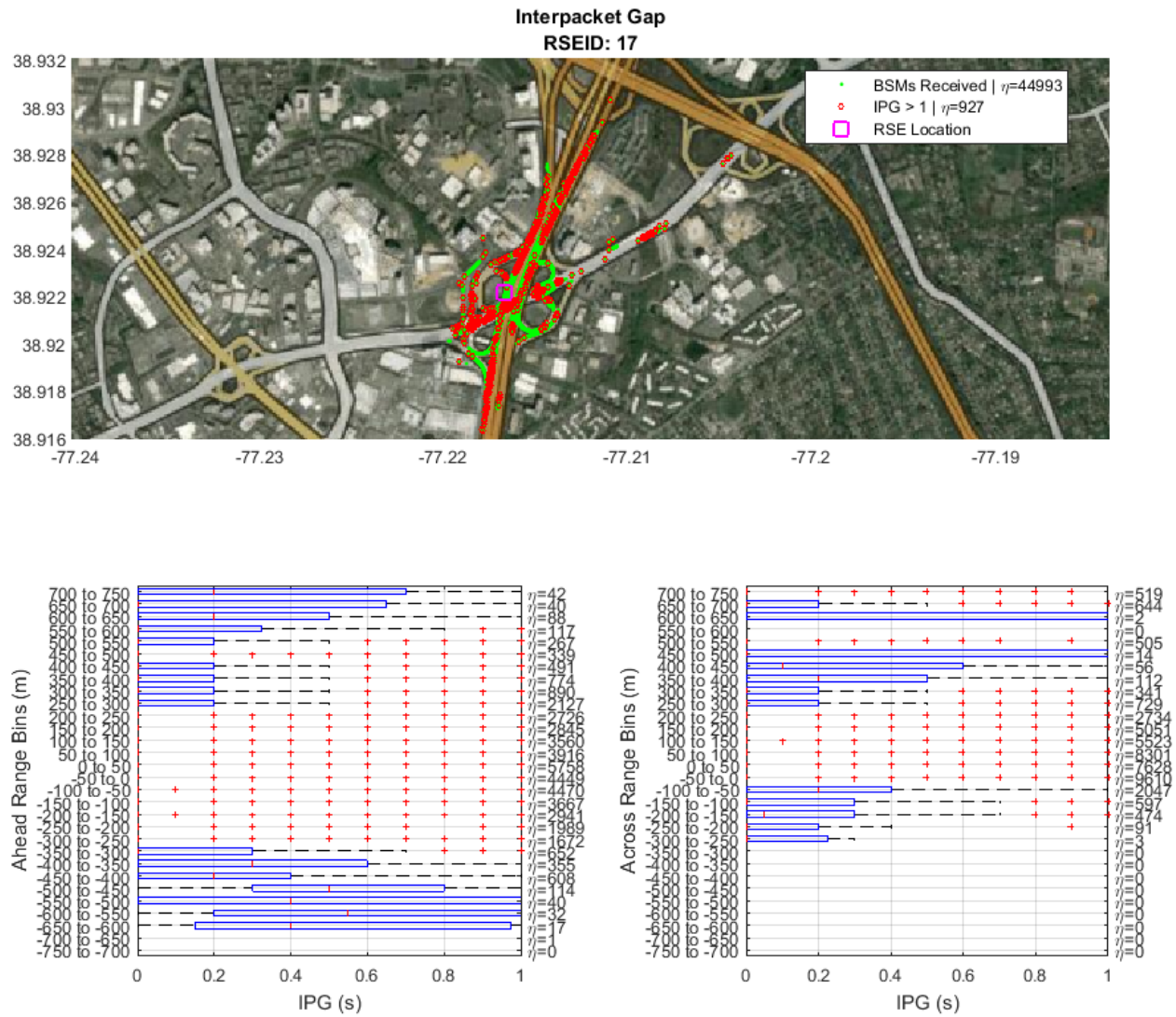
Figure 22 **Error! Reference source not found.** is a three-dimensional heat map detailing the average communication performance measure for RSE ID 9 binned every 50 m. In the top left view, a complete three-dimensional figure and scale are provided to detail the ranges and performance measure. In the bottom left, a cross-section view details the across ranges versus communications metric. In the bottom right, a cross-section view details the ahead ranges versus communications metric. In the top right, an overhead view (similar to an overhead satellite map view) details across versus ahead ranges.



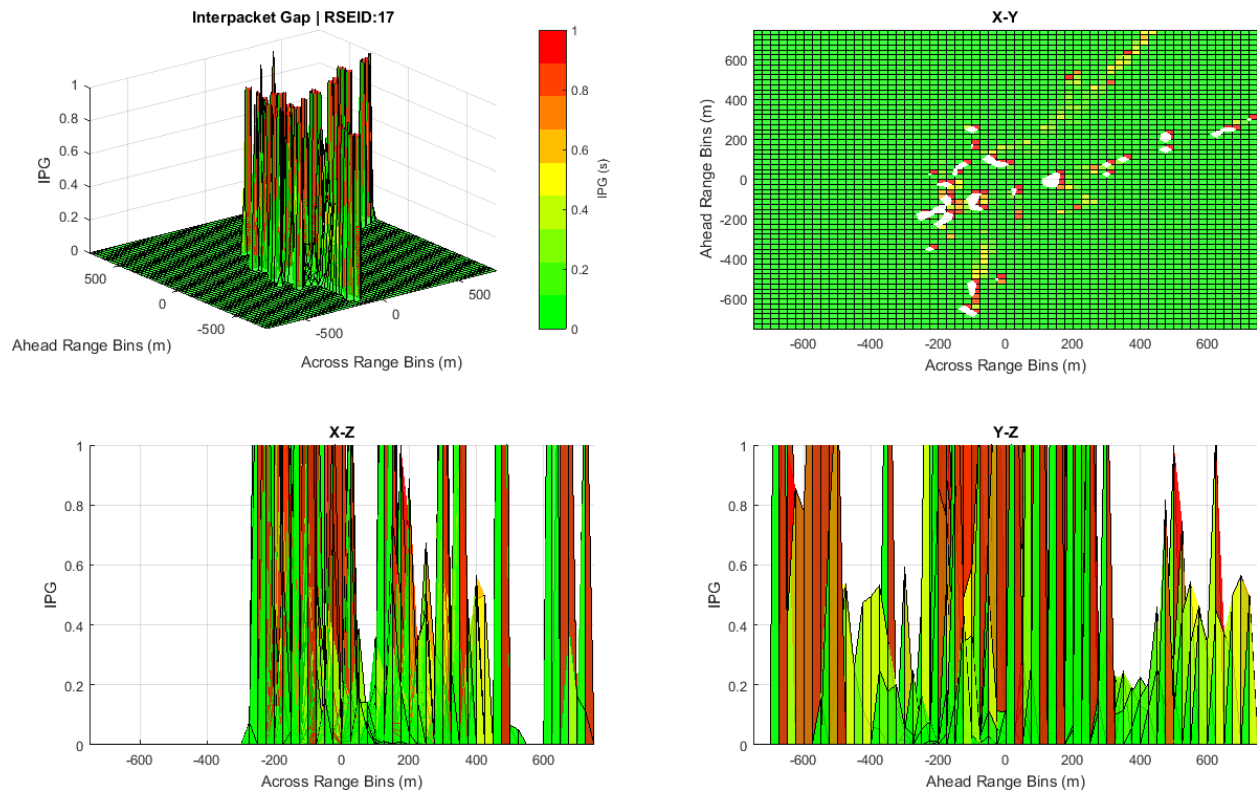
**Figure 22. RSE ID 9 PER heat map characterization plots.**

Considering the installation location of RSE ID 9 on the roadway, the expected traffic flow of vehicles will be east- and westbound. When reviewing the results from the maximum ranges of RSEs in Table 4, RSE ID 9 has a limited ahead communication range span due to the lack of a major roadway running in the north- and southbound directions.

Figure 23 **Error! Reference source not found.** and Figure 24 **Error! Reference source not found.** provide the results for RSE ID 17, a device that has questionable communication performance along the east- and westbound routes of travel. As the map in Figure 23 **Error! Reference source not found.** indicates, RSE ID 17 covers a complex roadway environment consisting of multiple overpasses, underpasses, and exit ramps (see Figure 25 **Error! Reference source not found.** for a Google Street View image of the location). Depending on the location of the vehicle, the signal between the vehicle and RSE maybe be occluded by roadway infrastructure, buildings, and/or foliage, which ultimately degrade packet-based communication performance.



**Figure 23. RSE ID 17 IPG map and range characterization plots.**



**Figure 24. RSE ID 17 IPG heat map characterization plots.**



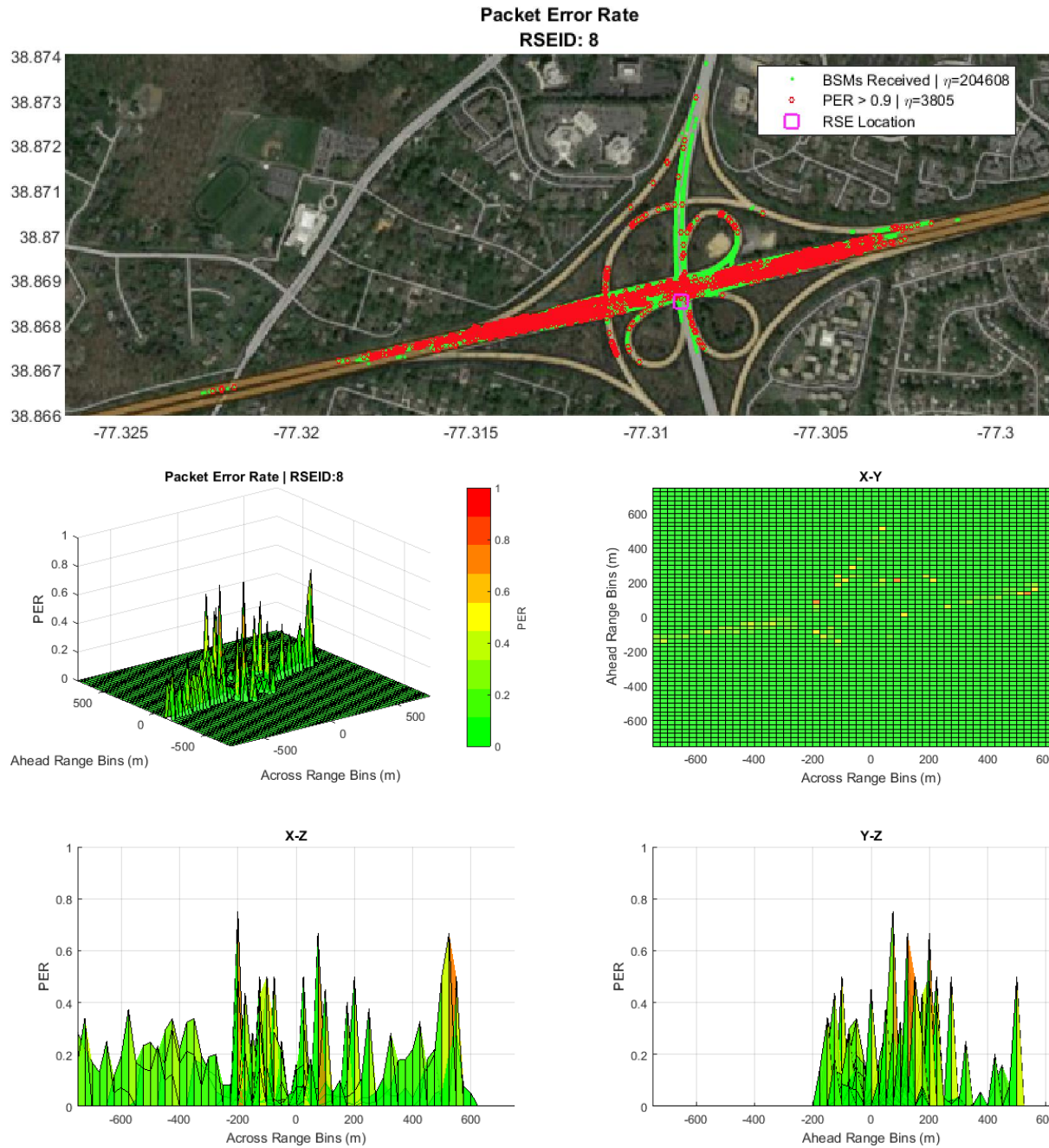
**Figure 25. RSE ID 17 roadway environment view.**

RSE ID 48 has above average latency measures for messages received from vehicles. The installation location of RSE ID 48 is approximately 7 miles away from the cluster of installed RSEs on the test bed. Based on this data, it is presumed that the physical distance away from the bulk of network communication equipment appears to have an impact on latency.

RSE ID 16 shows overall elevated latency issues, with particularly poor performance along the westbound and southbound vectors of travel. Details regarding the network configuration of this installation need to be explored to understand what is actually impacting the performance.

**Error! Reference source not found.**Figure 26 provides a map and heat map plots characterizing RSE ID 8's communications performance. As the figure shows, there is a drop of communication along the exit routes.**Error! Reference source not found.** Figure 27 displays the south and north views, respectively, from RSE ID 8. Figure 28**Error! Reference source not found.** displays the views from the vehicle, which illustrate that trees are obstructing a clear view of the RSE. In these figures, on the bottom left hand corner of the Google street view map is the roadway with several key icons. The person icon indicates the location on the roadway where the street view was taken and the red star indicates the location of the RSE as a point of reference. One interesting observation is that there is little communication south of the RSE. As the figure shows, the RSE is mounted on a pole that occludes signals originating south of the RSE.





**Figure 26. RSE ID 8 communication characteristics.**



Figure 27. South (top) and north (bottom) views from RSE ID 8 location.



**Figure 28. LOS blocked view from vehicle to RSE ID 8.**

## **Simulated Scalability**

The scalability test simulated increased CV traffic on the Northern Virginia Connected Vehicle Test Bed and tested the impact of the additional load on the network. As was explained in the Methods section, this test generated BSM data locally on the RSEs on the test bed. The BSM generator was a custom application with the ability to configure message transmission frequency and duration that ran on the RSE's Linux OS. Adjusting the transmission frequency simulated actual CV communication traffic on the infrastructure network. Considering that the BSM transmission frequency was set to 10 Hz, increasing the transmission frequency to 100 Hz produced the same amount of network traffic as 10 CVs. The generated data from the RSEs were then forwarded through the RSE cabinet network components, VDOT network, ISP, and Virginia Tech network to terminate at a VTTI application server.

The test run began with a single RSE's BSM transmission frequency being set to 15 kHz, which generated network traffic equivalent to 1,500 CVs. Each BSM transmitted was 378 bytes, thus generating 5.67 megabytes per second. Figure 29 through Figure 31 show the response of the network when subjected to the configured network transmission traffic. These results show that a significant number of packets were lost and a cyclic drop out of communications occurred. As Figure 29 illustrates, an extensive communication drop out occurred for approximately 4,000 seconds before the remainder of the data were received. Figure 30 zooms in to the first half of Figure 29 before the drop out, and Figure 31 zooms in to the last half of that figure after the drop out. In summary, a total of 16,200,000 messages were set to be sent, while only 1,081,251 were received, resulting in a loss of over 93% of the packets. Considering that our access to the network devices was limited, identification of the actual problematic network node was not possible. It is suspected that the flow of traffic was limited by a router with network management software that had security features enabled.

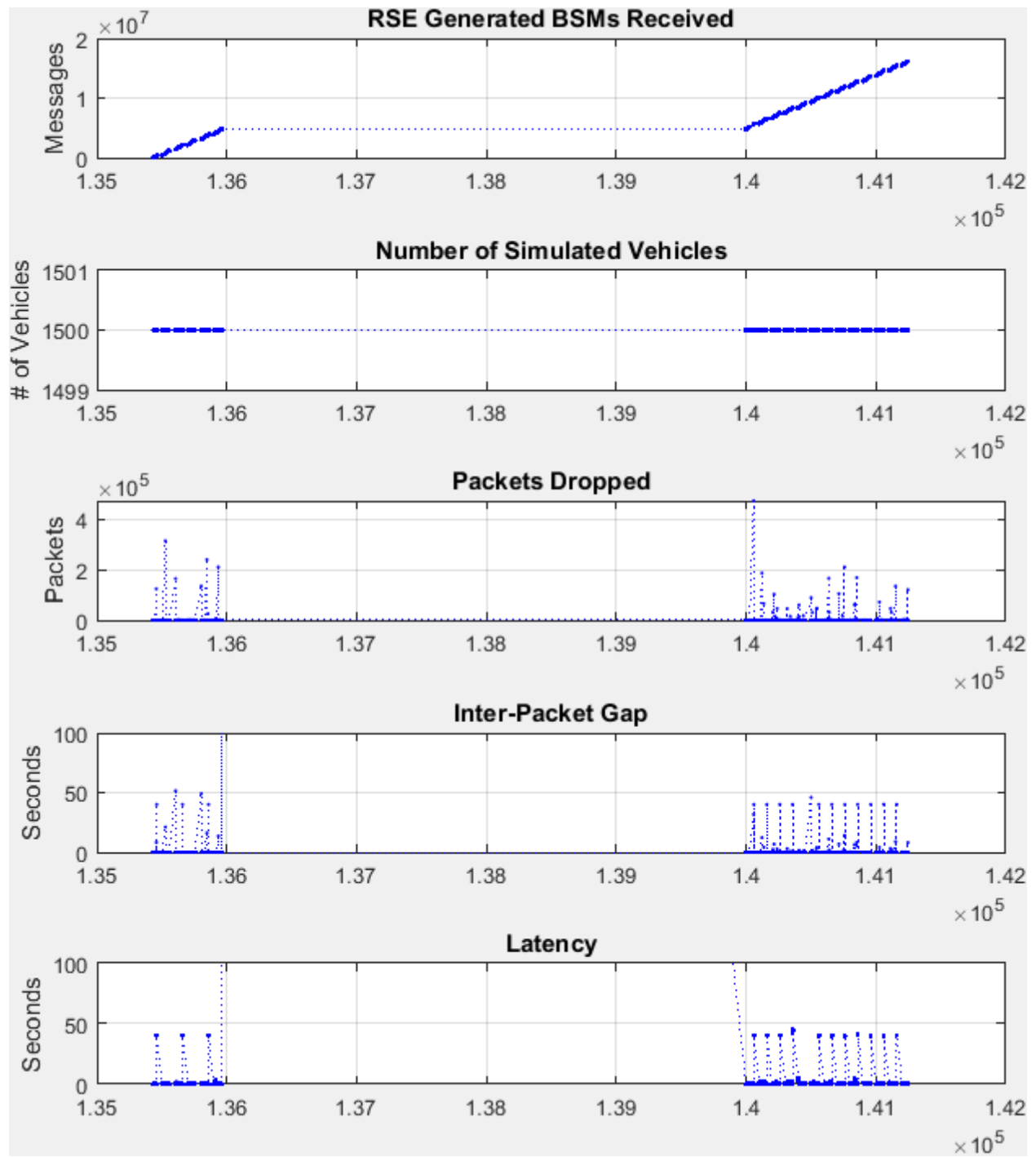


Figure 29. Scalability response.

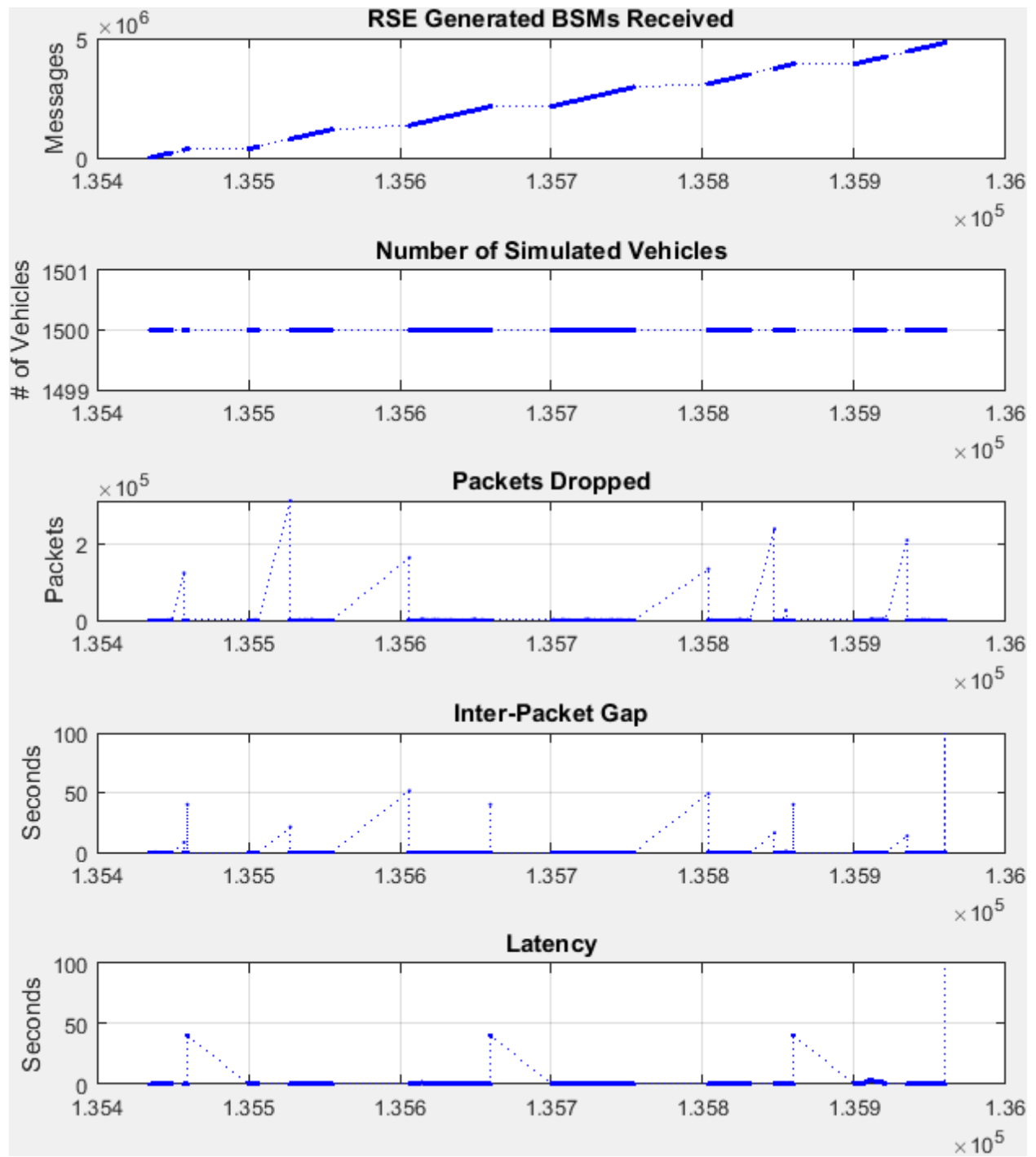


Figure 30. Scalability response (detail of first half of Figure 29).

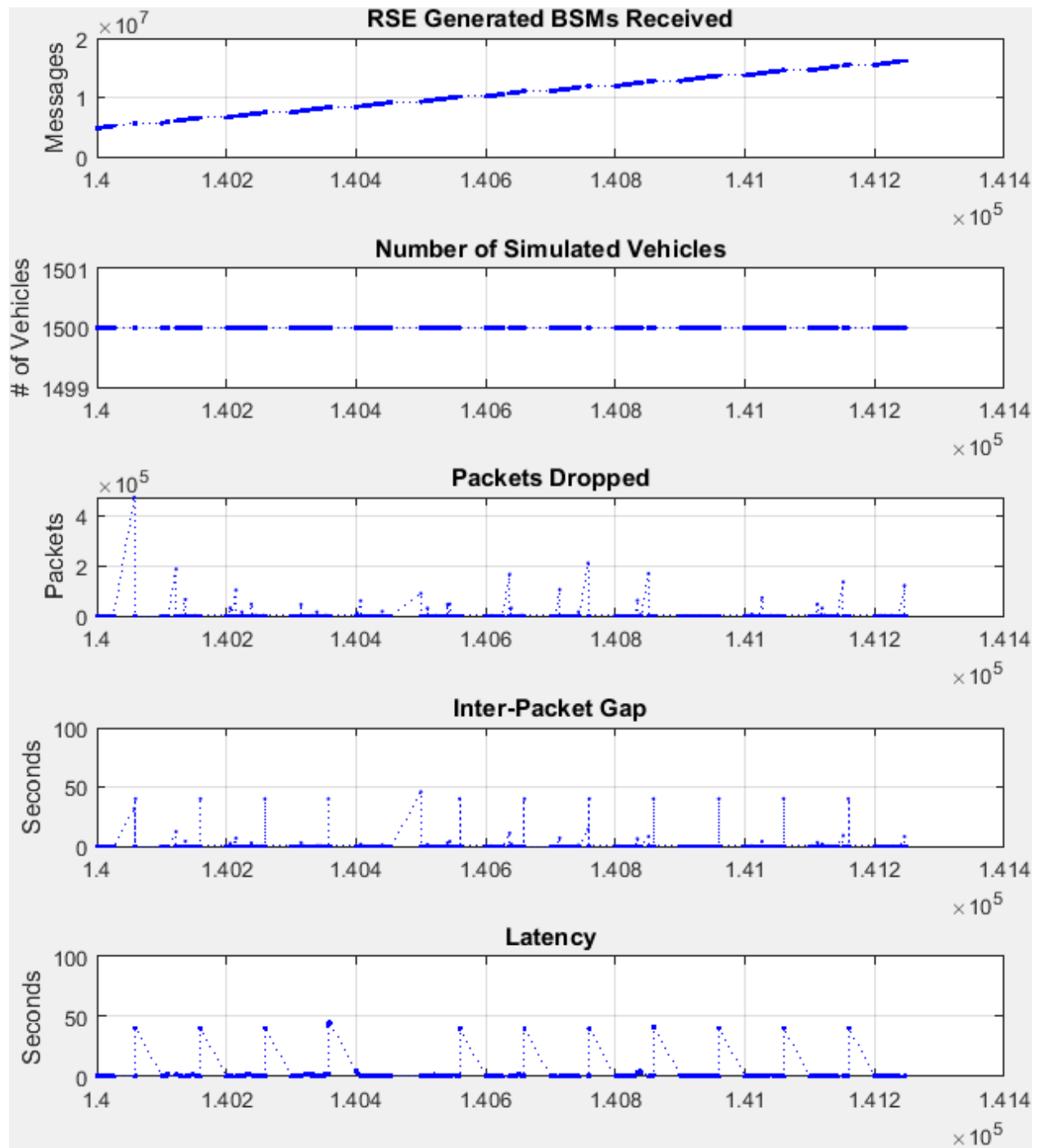


Figure 31. Scalability response (detail of second half of Figure 29).

## Conclusions and Recommendations

From the analysis using real-world, RSE-collected BSM data, it is evident that the impact of LOS obstructions between the vehicle and RSE is significant. As was presented in the results, complex highway systems include overpasses and underpasses that occlude signals, causing a drop in

communications performance. In addition to elevated concrete roadways, foliage, typically within exit ramps and highway medians, causes significant signal loss. Based on these observations, care must be taken when selecting an RSE installation site to avoid physical objects that may occlude signals from reaching the RSE. Further, deployment of multiple RSEs or repeaters may be necessary on more complex roadways to maximize coverage in localized dead zones.

The scalability results show that if the Northern Virginia Connected Vehicle Test Bed were to be exposed to a large deployment of CVs, many messages would not be forwarded. Assessment of the network requires coordination with VDOT and the ISP to assist in the identification of the problematic device(s). In particular, access to managed network devices, such as routers, may allow network traffic to be logged. If such logs could be produced, problematic components may be identified. On the other hand, the practicality of forwarding all BSMs needs to be considered. Depending on the particular application and message combinations, different strategies could be implemented to use or ignore messages.

The results and insight gained from this study will hopefully support existing and future V2I deployments. As the real-world results indicate, each location is likely to have its own unique environmental characteristics. The Northern Virginia Connected Vehicle Test Bed site is located on major U.S. interstates with intersecting overpasses and underpasses. For each site, an investigation of the roadway configuration needs to be conducted to identify potential LOS issues. Such information could be used to adequately determine ideal mounting locations and strategies to maximize RSE coverage.

Applications that plan on using BSM data need to factor in latency. The latency of a BSM received by an RSE typically has an ~200-ms delay before it arrives at the application server. Adding the time to process that data and then send a message back, the round trip time of the message is likely to be greater than 500 ms. Other considerations such as network traffic or outages can further add to the delay.

# Appendix/Appendices

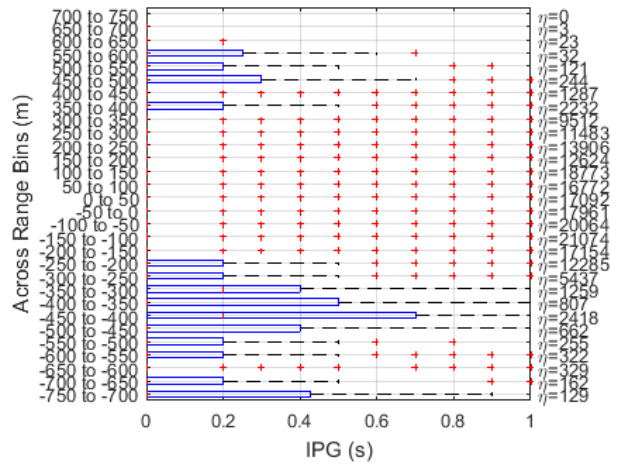
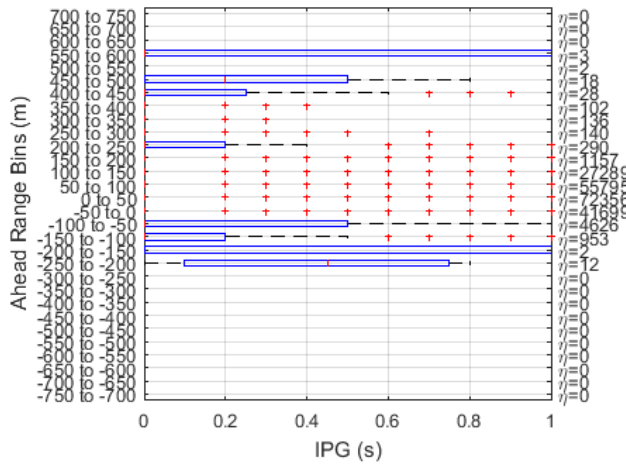
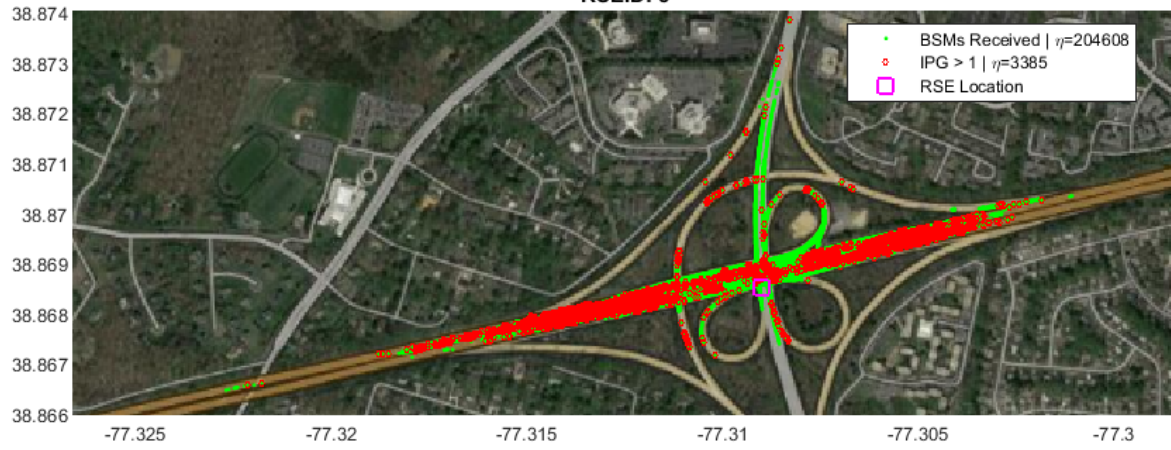
---

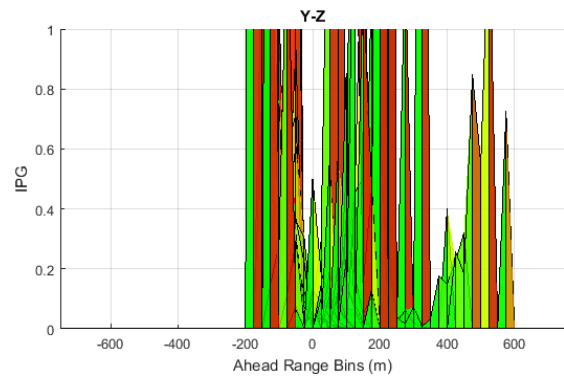
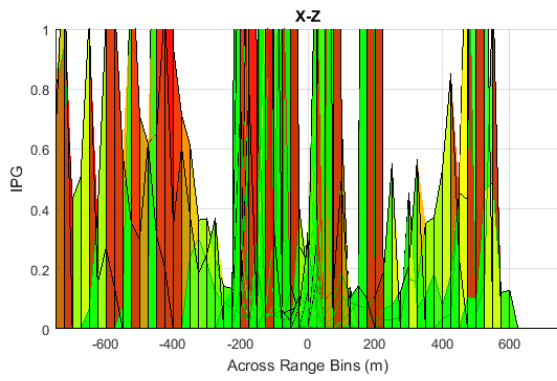
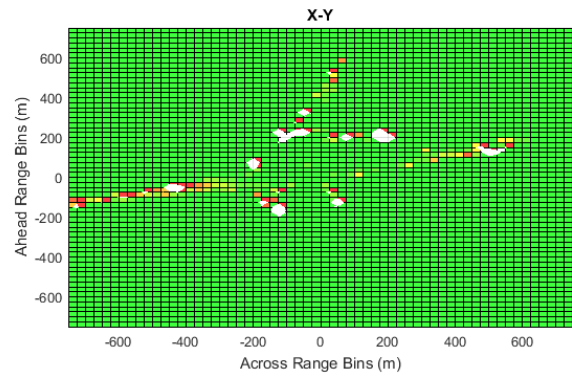
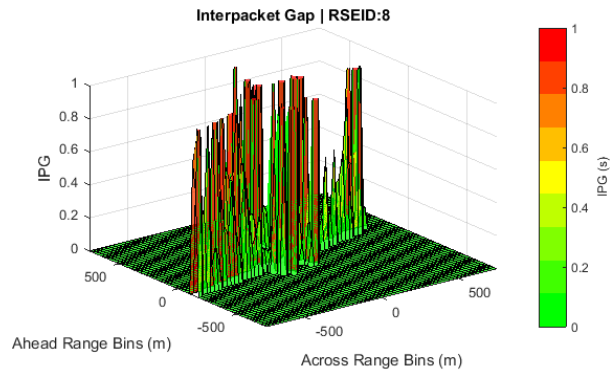
## **Appendix A – RSE Communication Performance**

This appendix provides the graphical results from the real-world historical data analysis that was conducted to determine coverage gaps and overlaps on the Northern Virginia Connected Vehicle Test Bed. The figures are organized in numeric order by RSE ID. Figures showing IPG, latency, and PER performance are provided for each RSE. For more information on the figures, please refer to the Real-World Historical Data section of the Results in the main report.

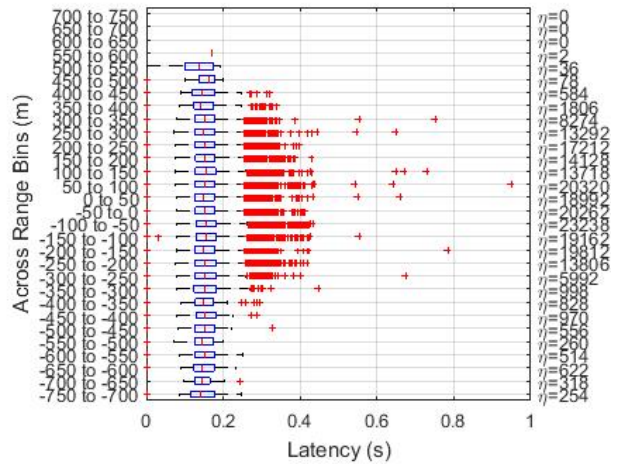
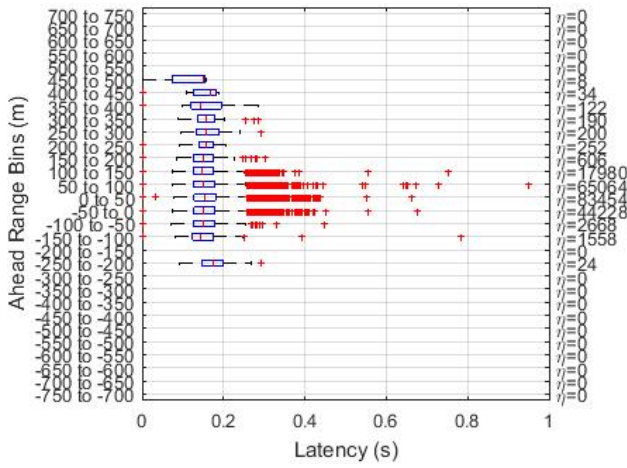


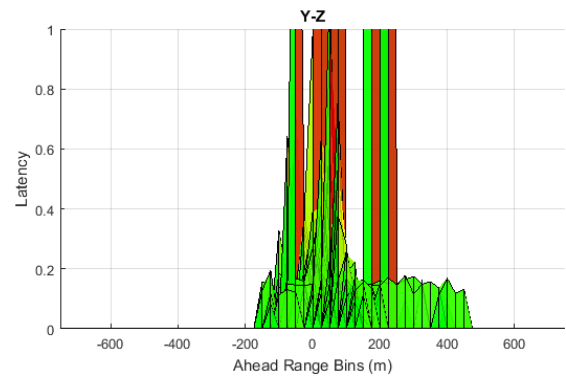
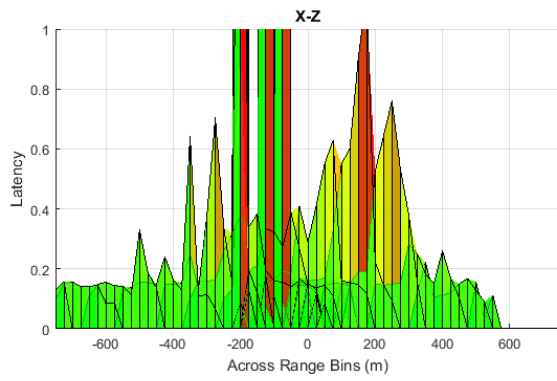
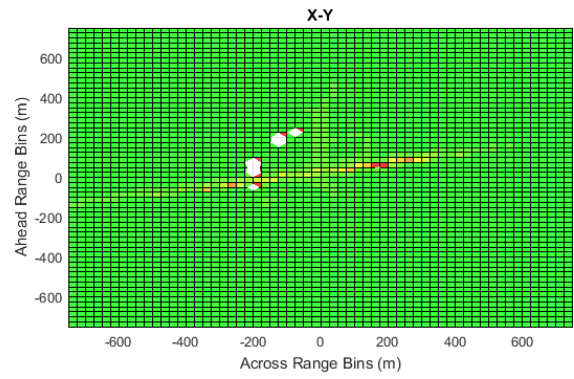
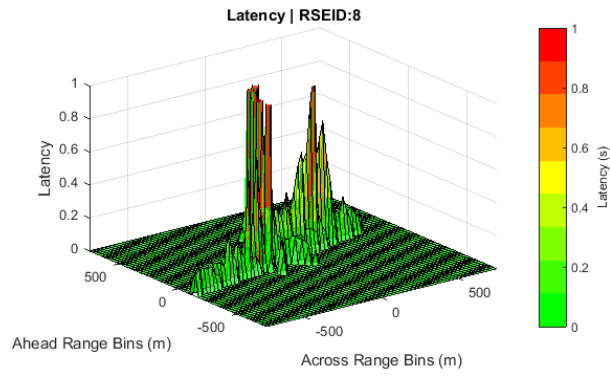
Interpacket Gap  
RSEID: 8



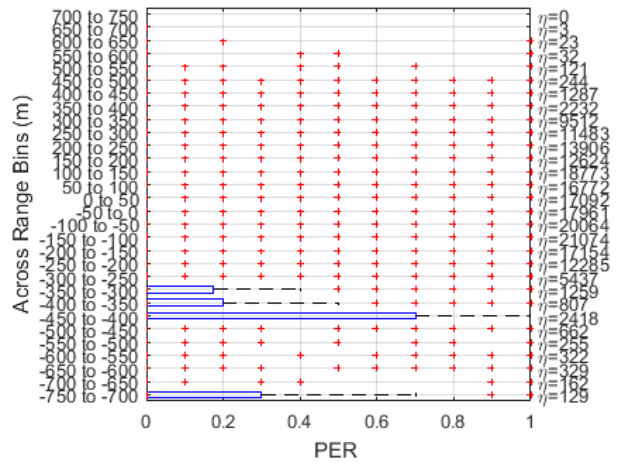
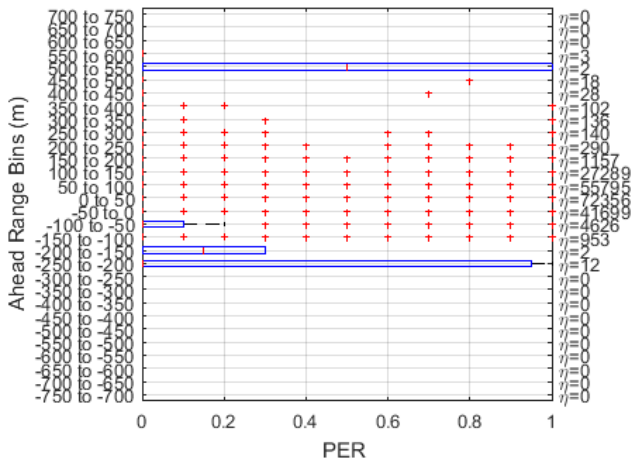


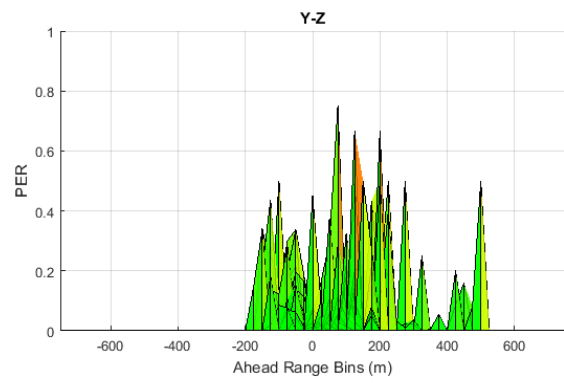
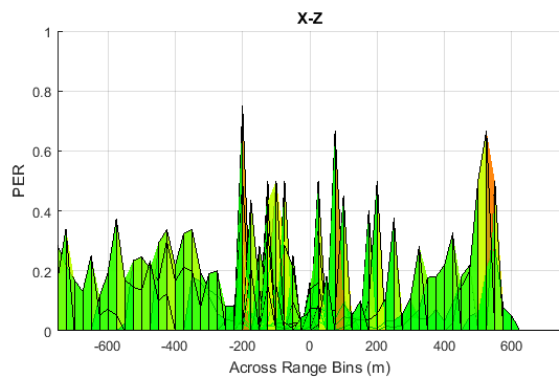
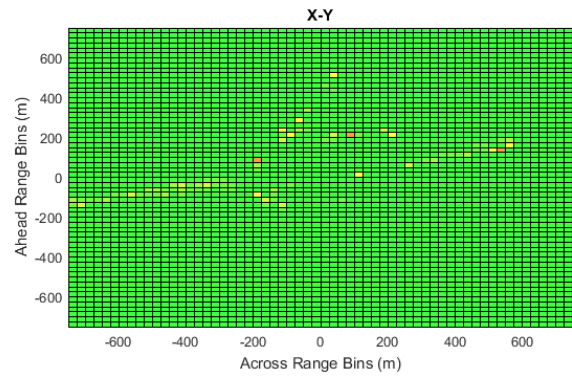
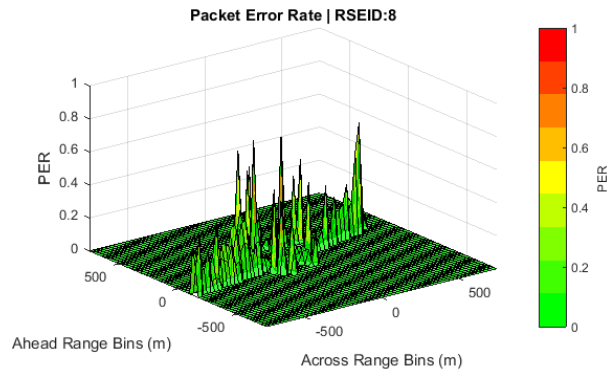
Latency  
RSEID: 8



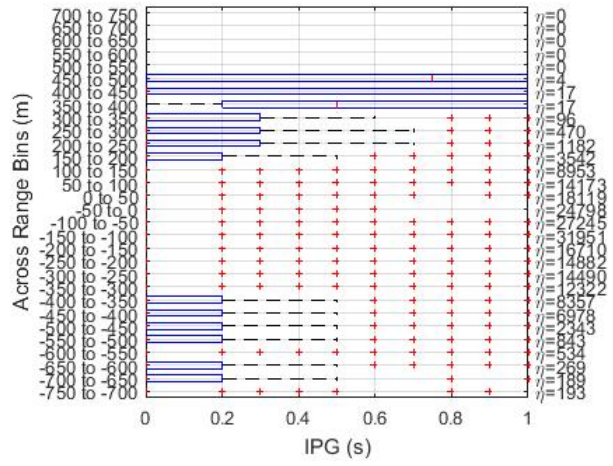
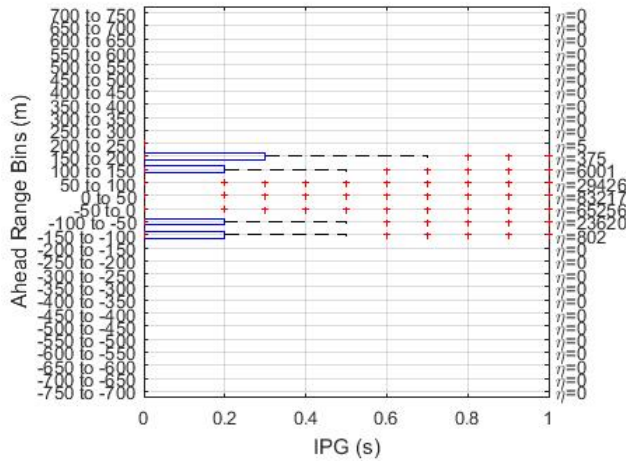
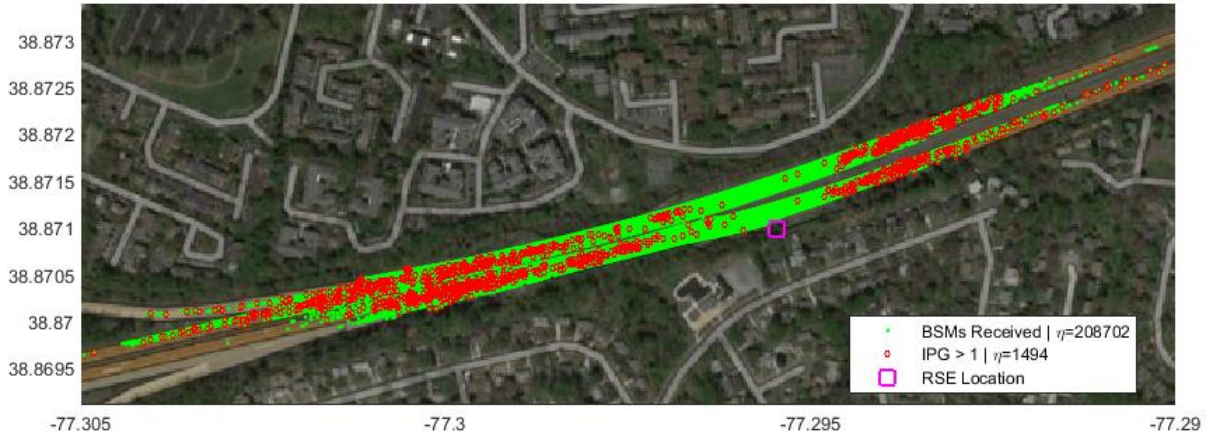


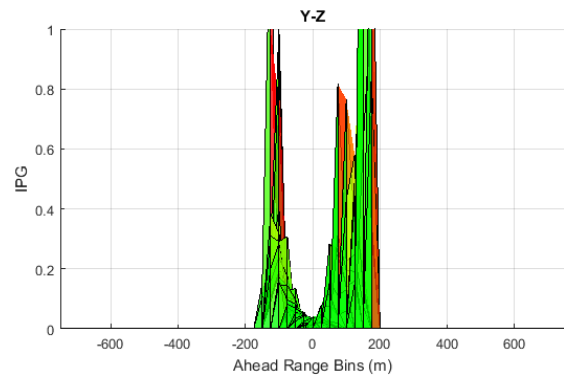
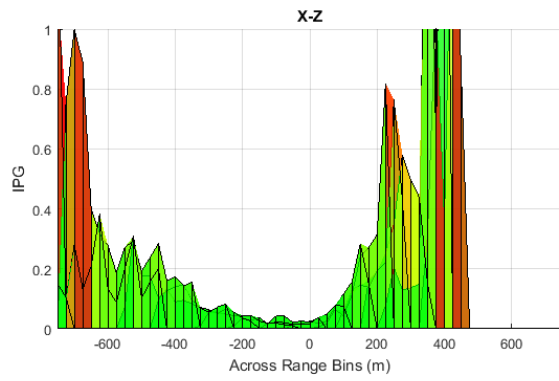
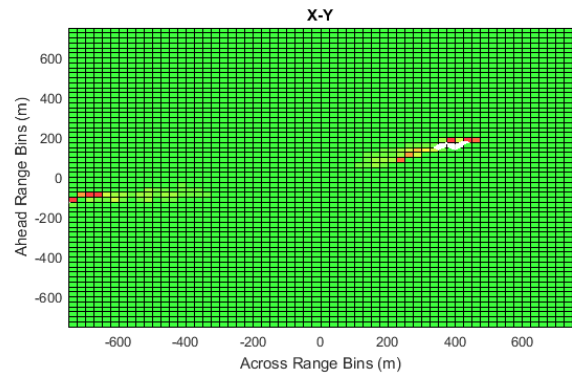
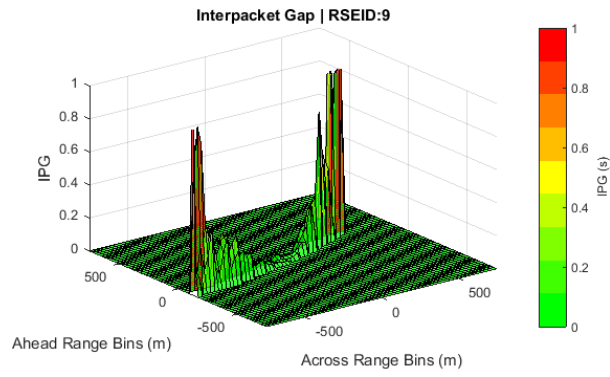
Packet Error Rate  
RSEID: 8





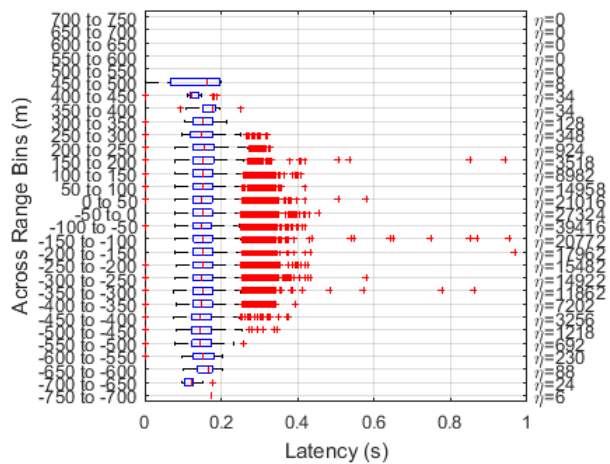
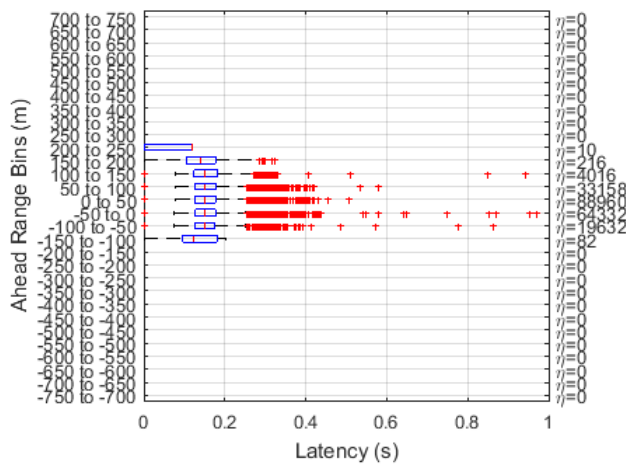
Interpacket Gap  
RSEID: 9

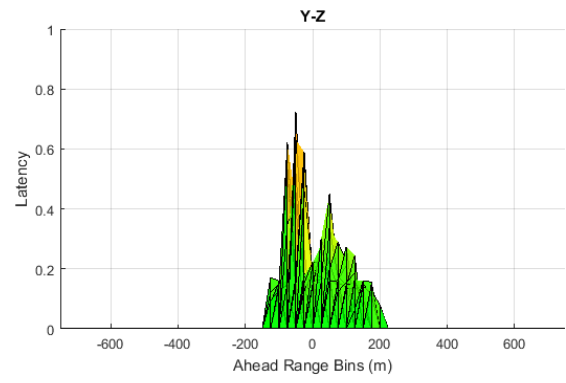
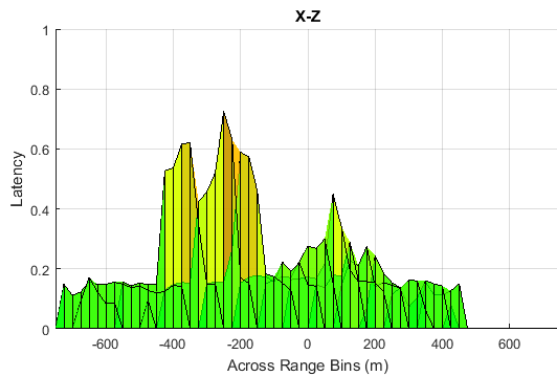
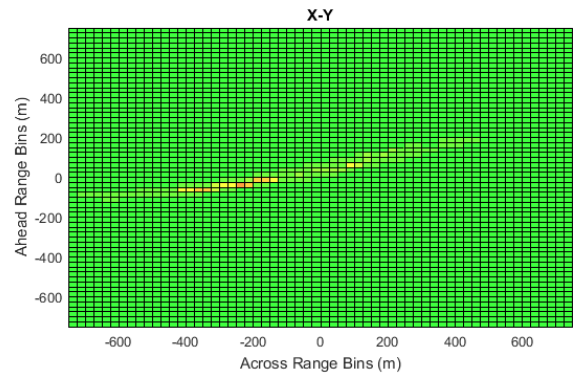
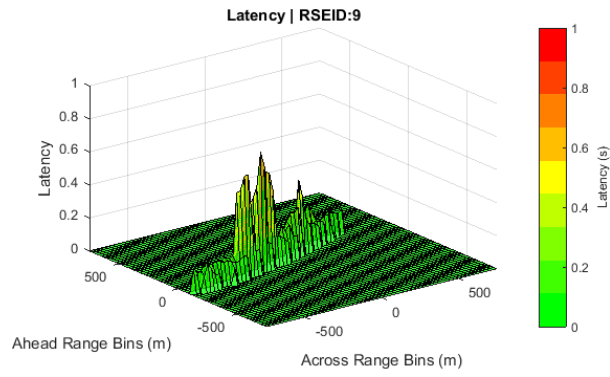




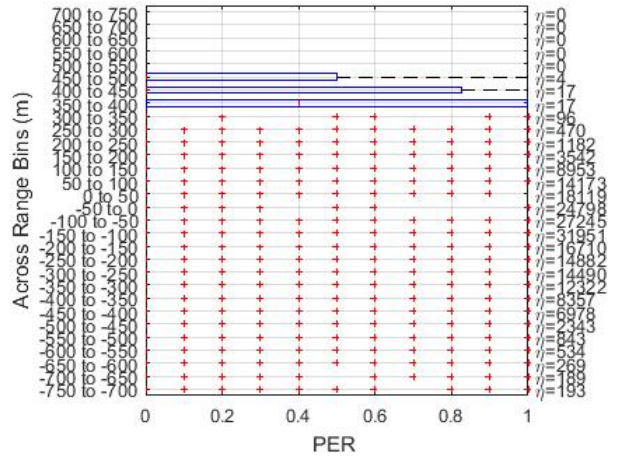
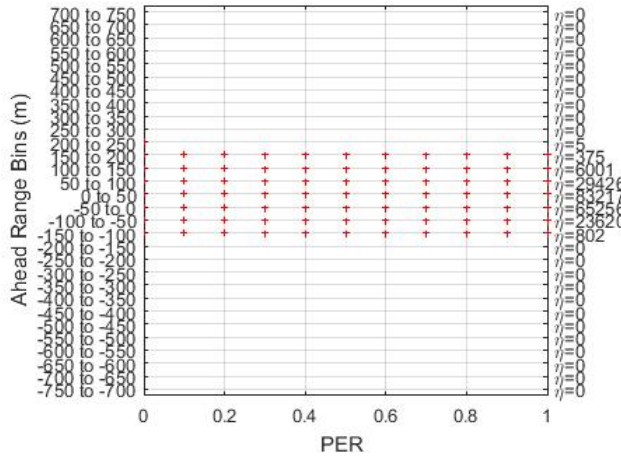
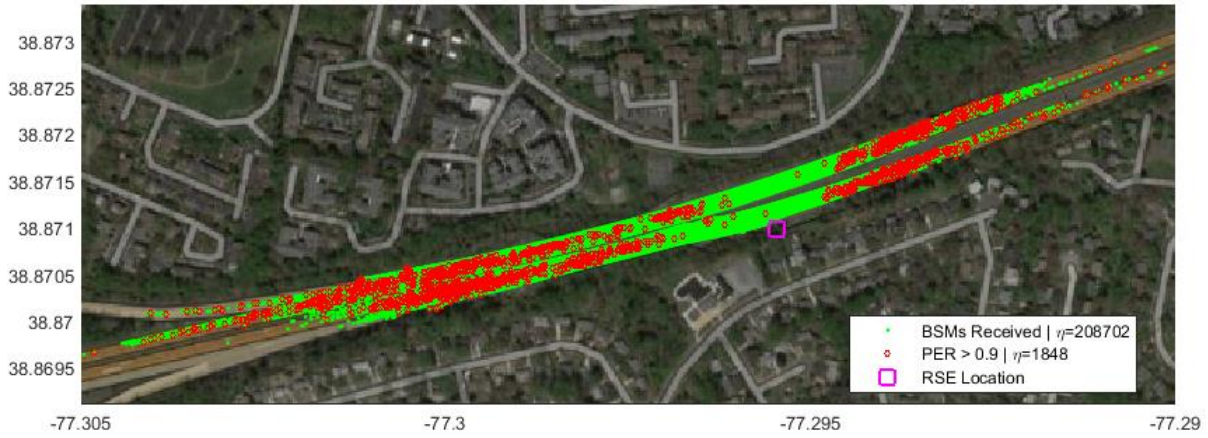


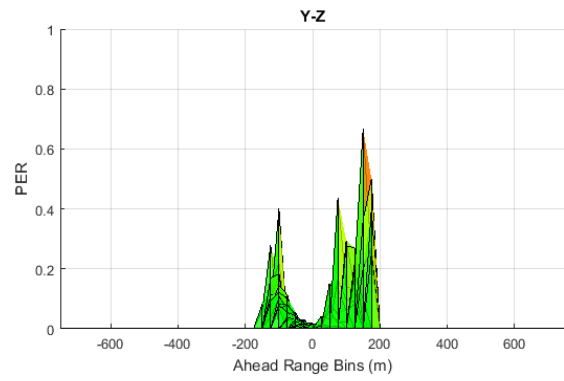
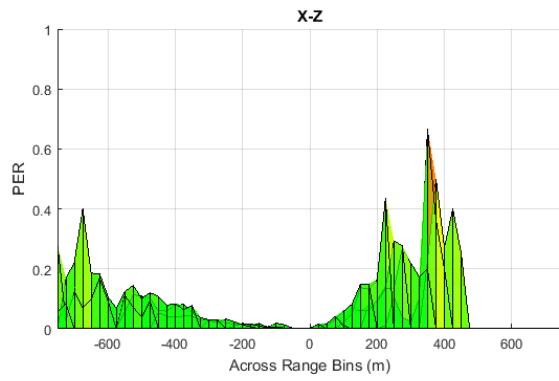
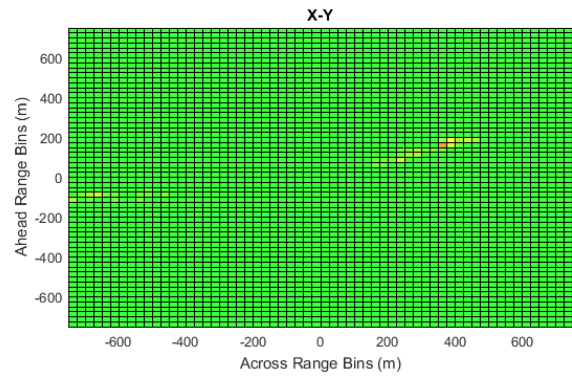
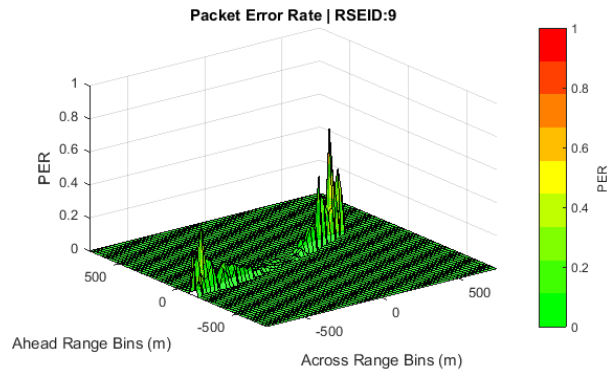
Latency  
RSEID: 9



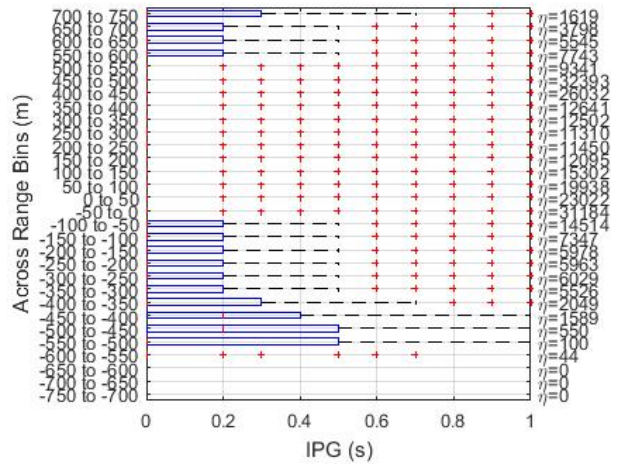
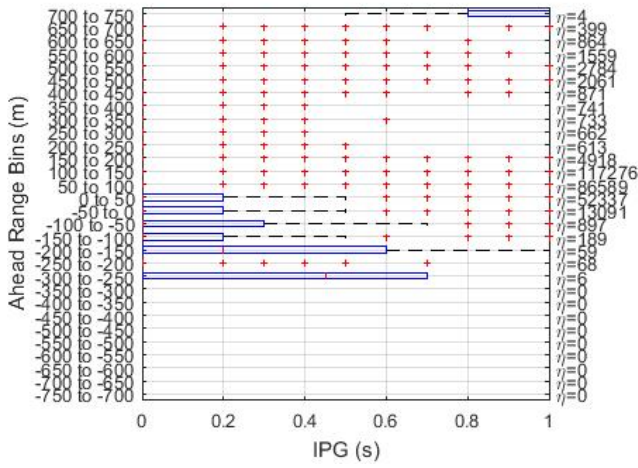


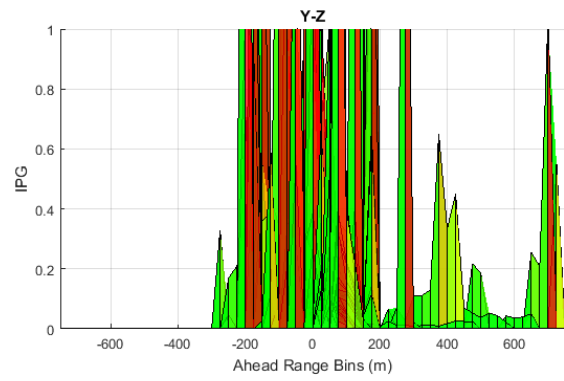
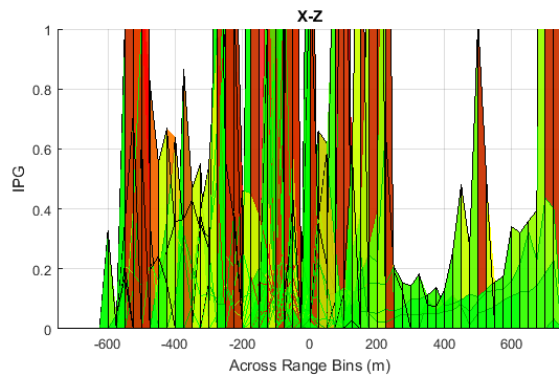
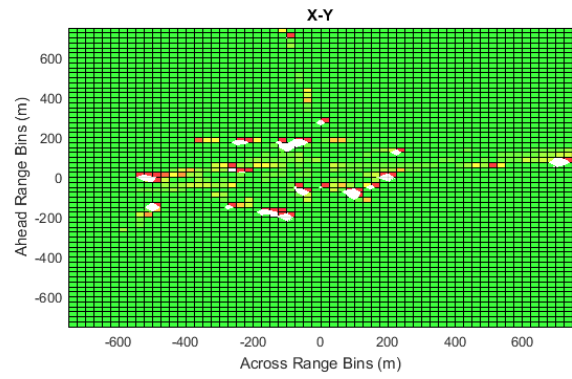
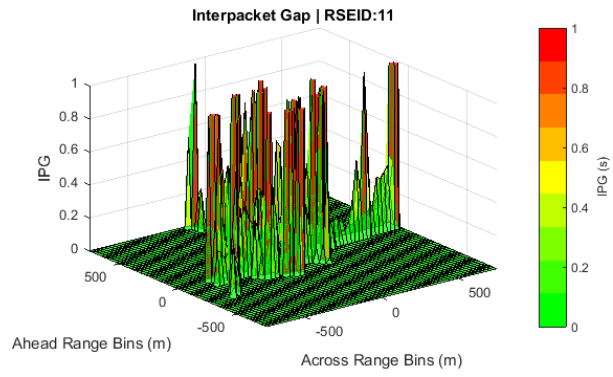
Packet Error Rate  
RSEID: 9



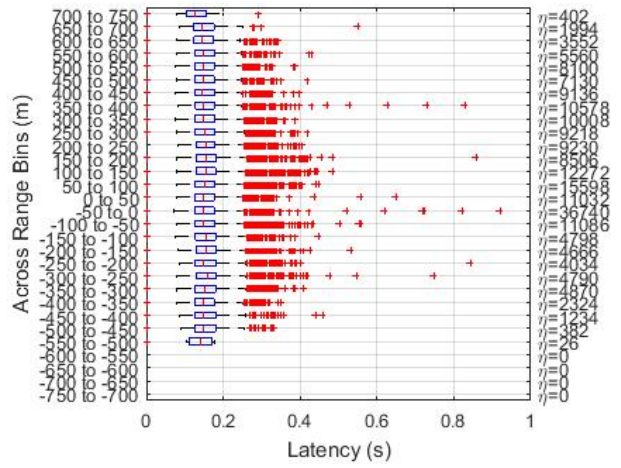
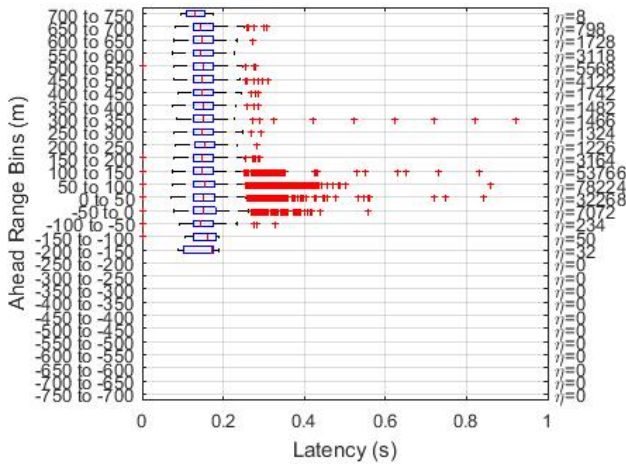


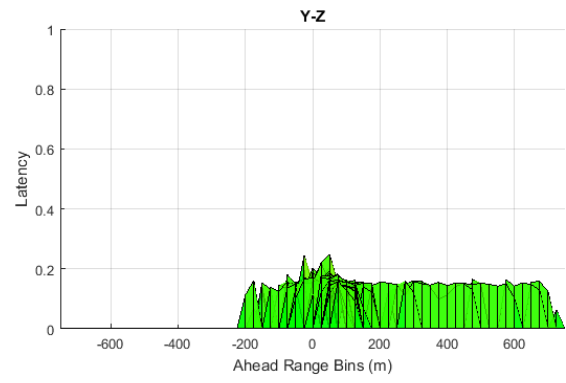
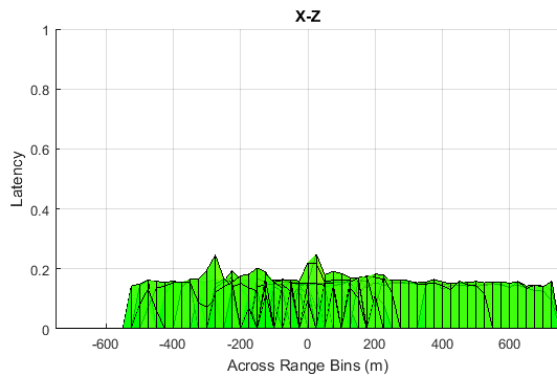
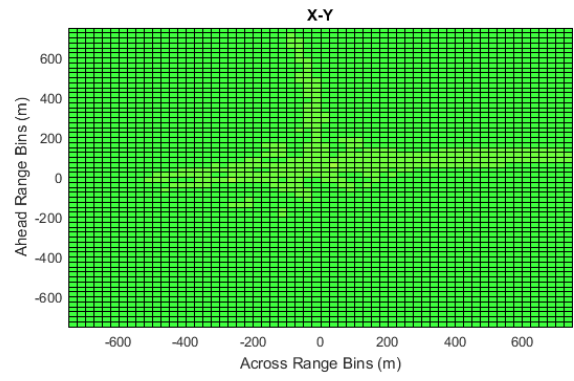
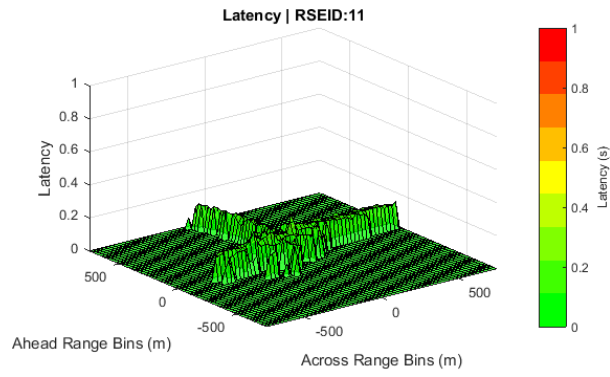
Interpacket Gap  
RSEID: 11





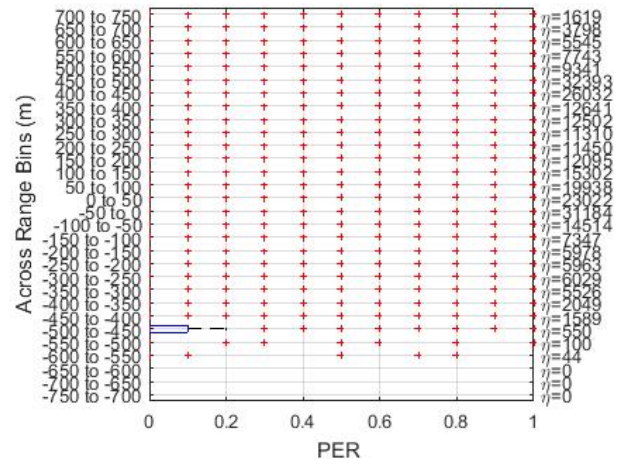
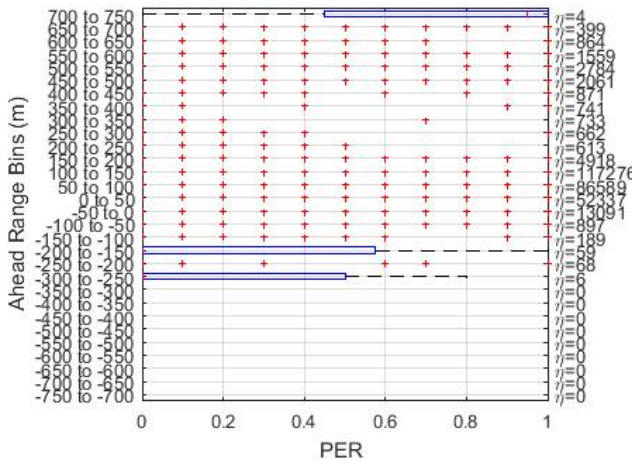
Latency  
RSEID: 11

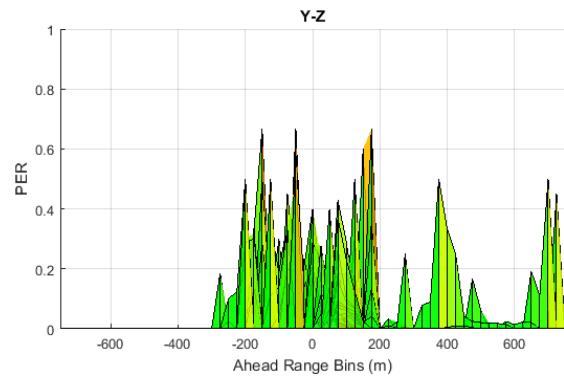
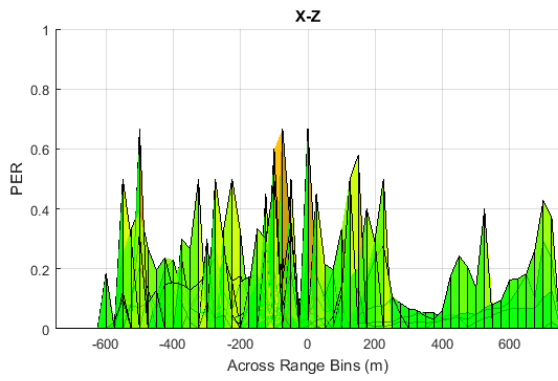
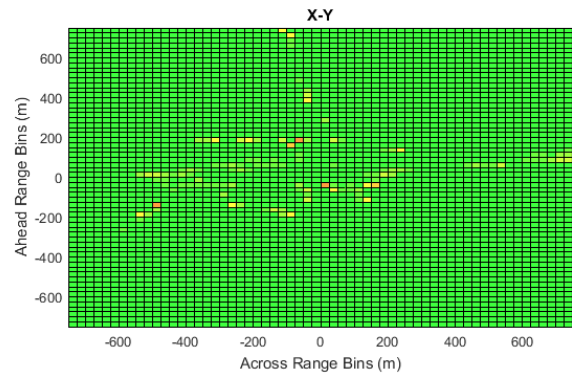




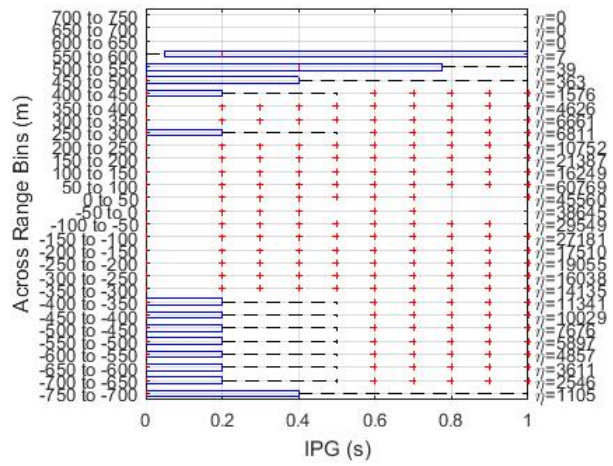
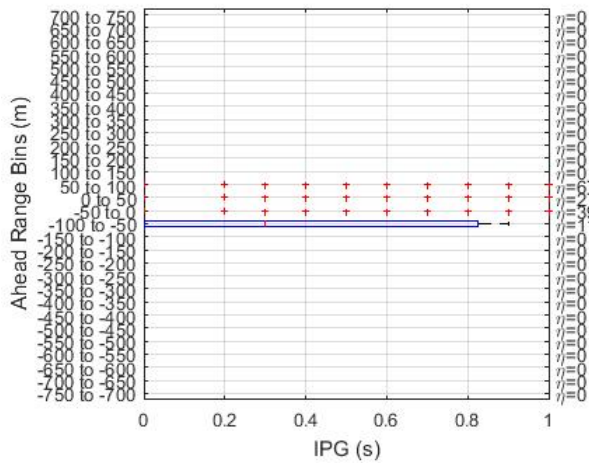
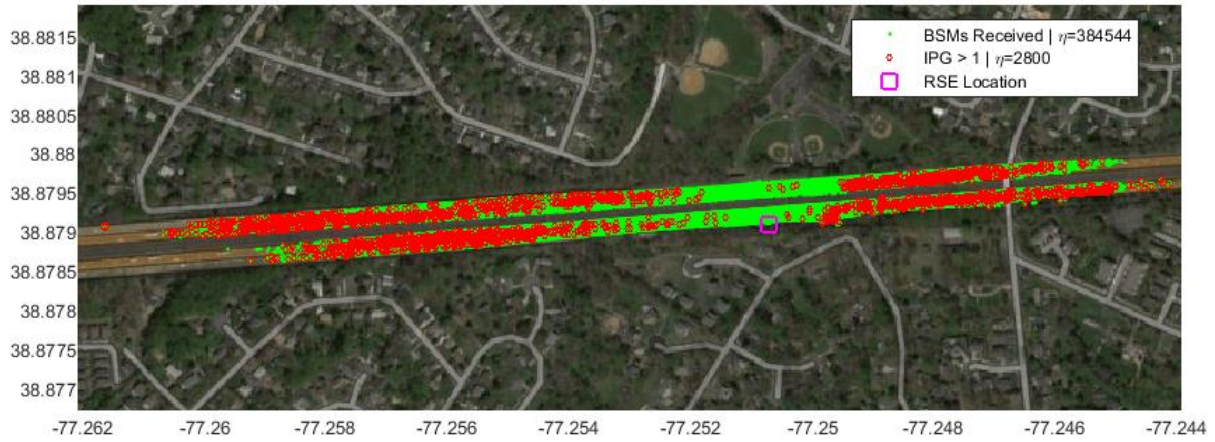


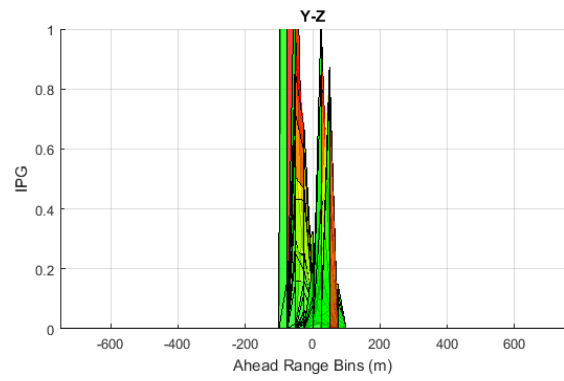
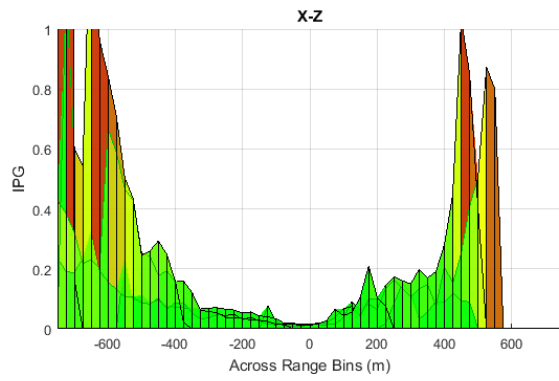
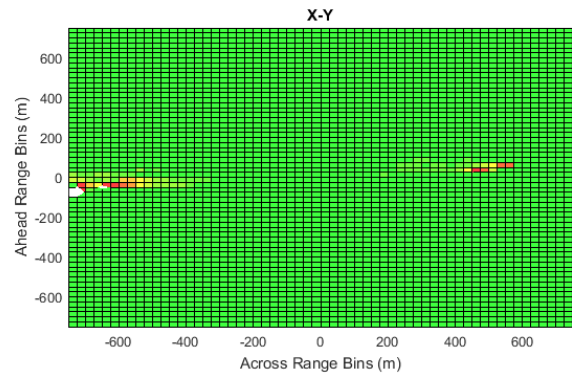
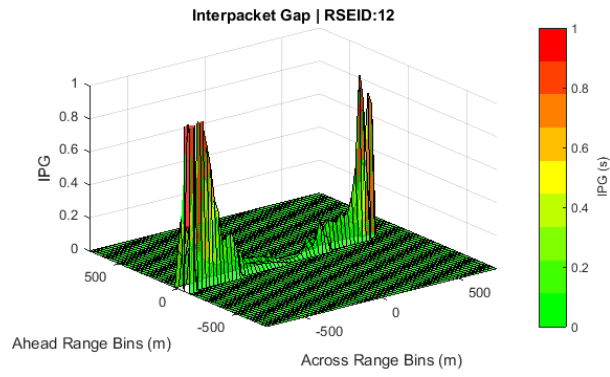
Packet Error Rate  
RSEID: 11



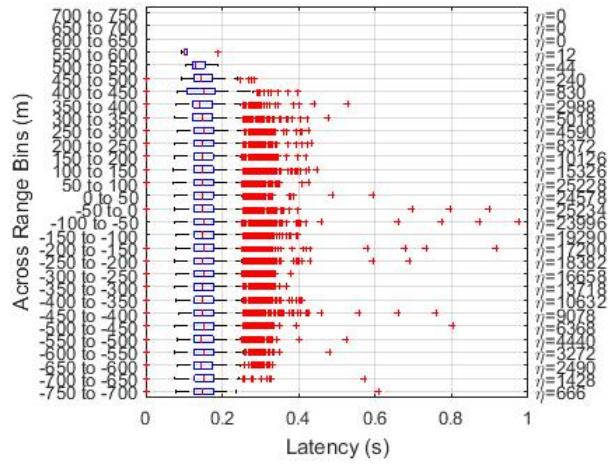
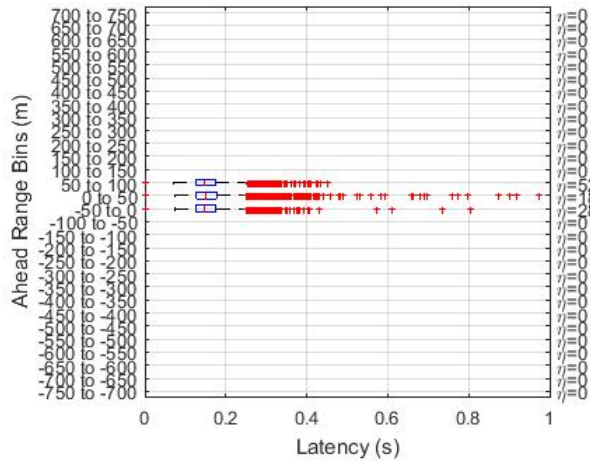


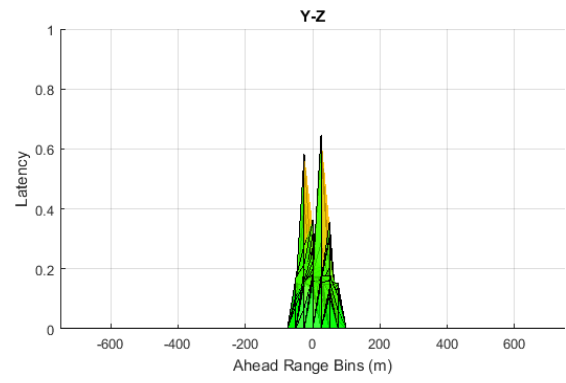
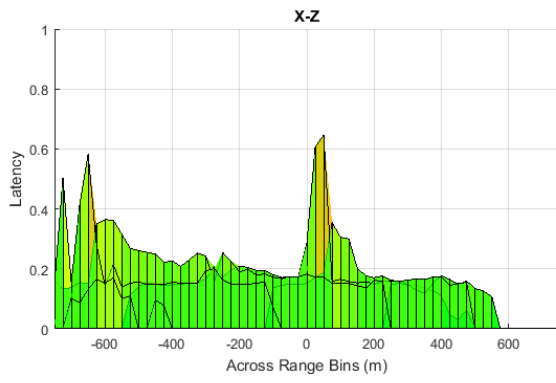
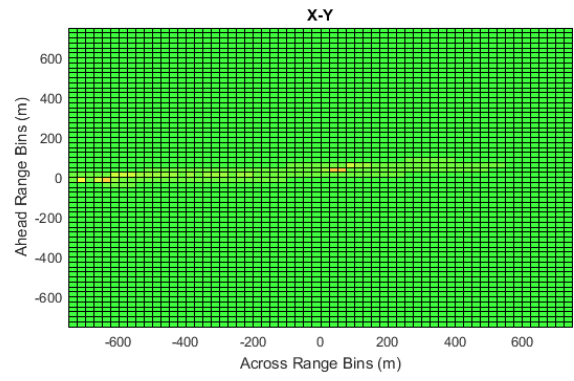
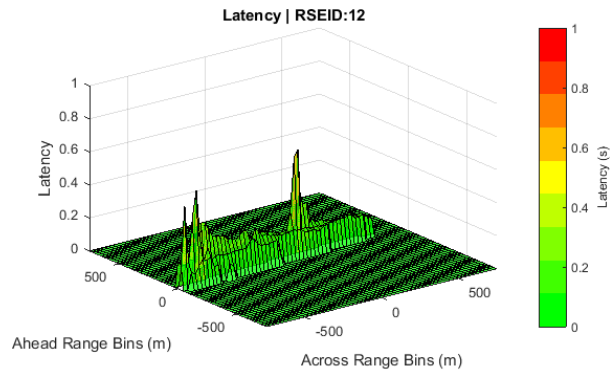
Interpacket Gap  
RSEID: 12



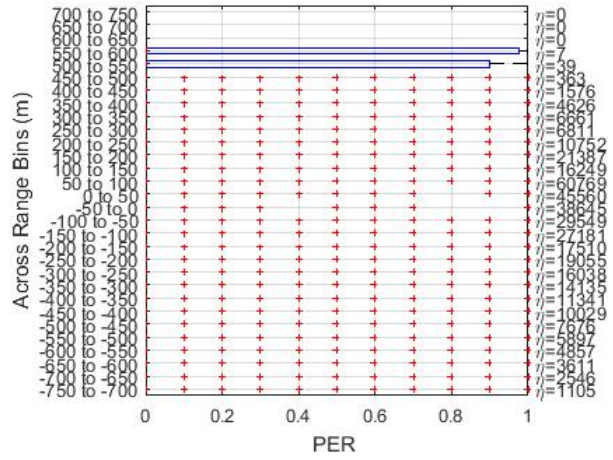
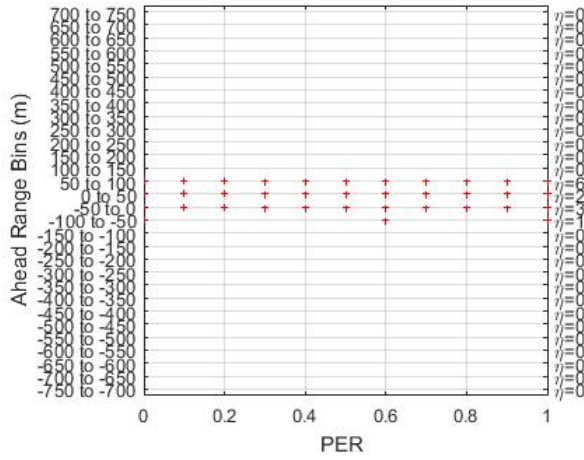
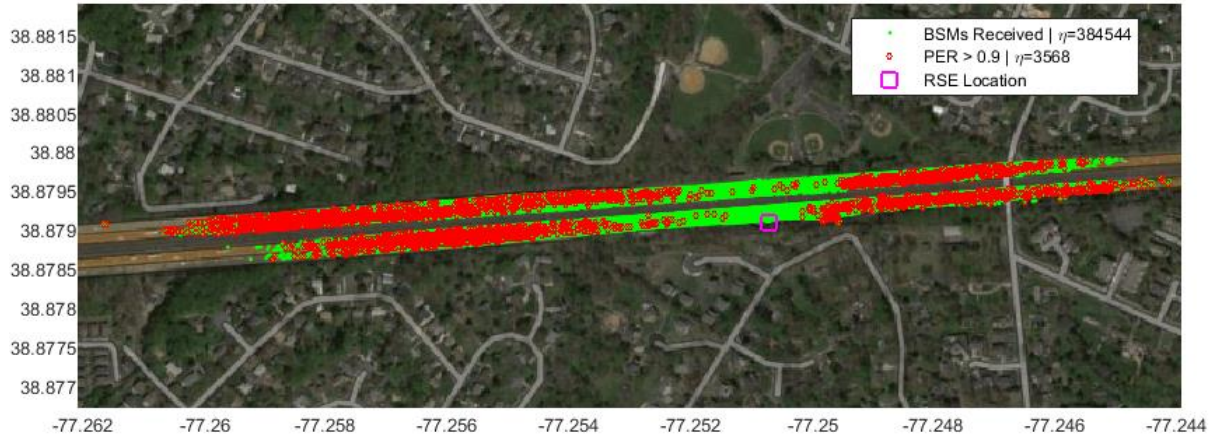


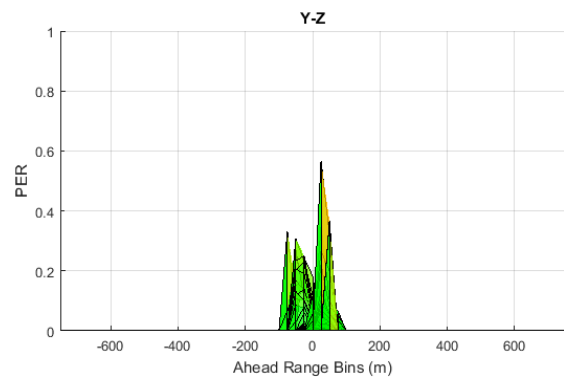
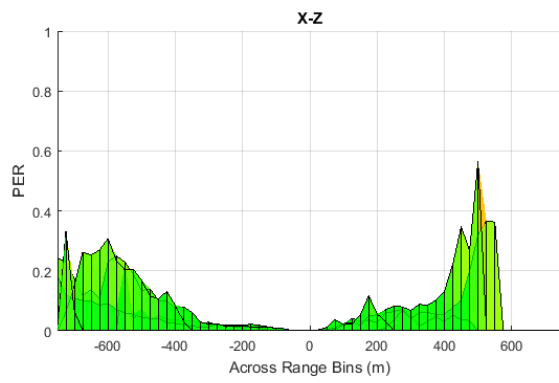
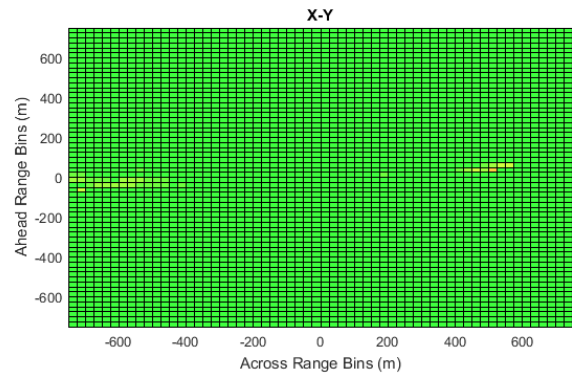
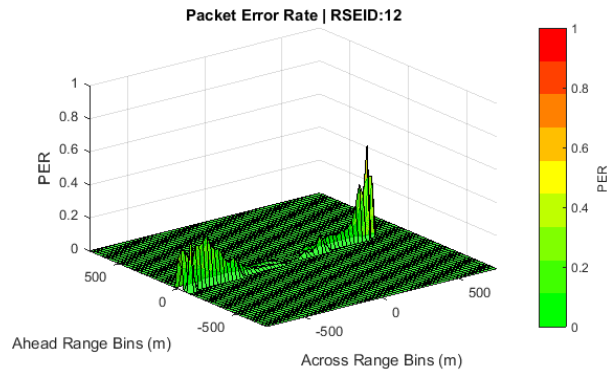
Latency  
RSEID: 12





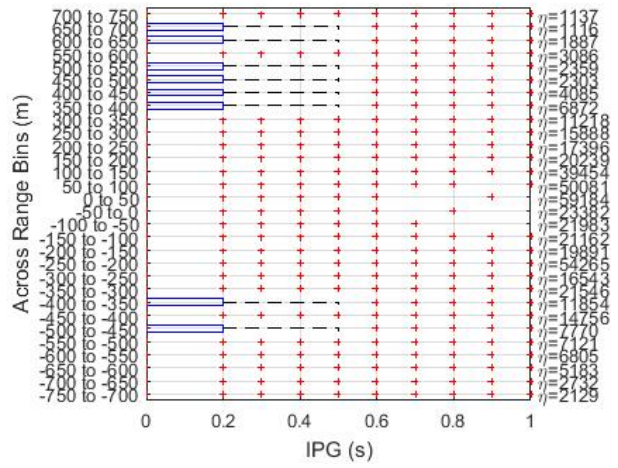
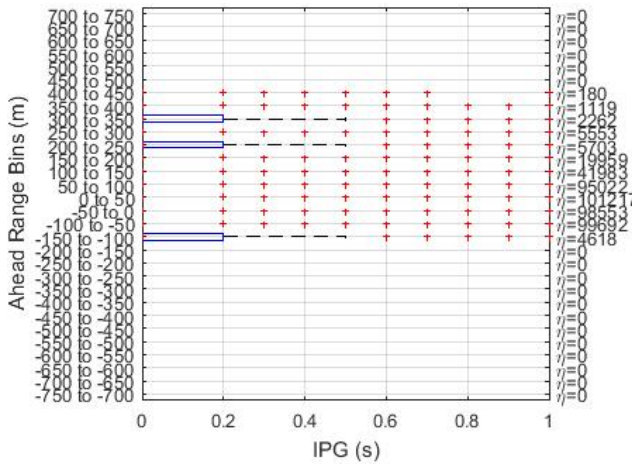
Packet Error Rate  
RSEID: 12

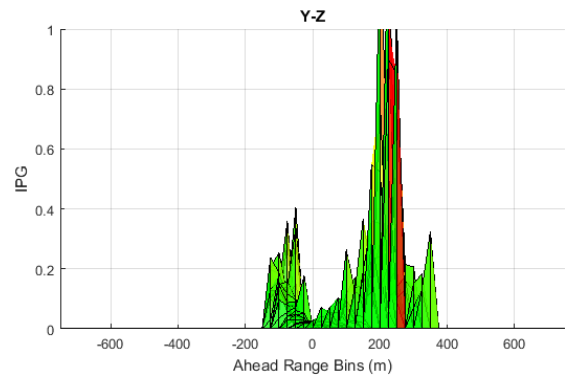
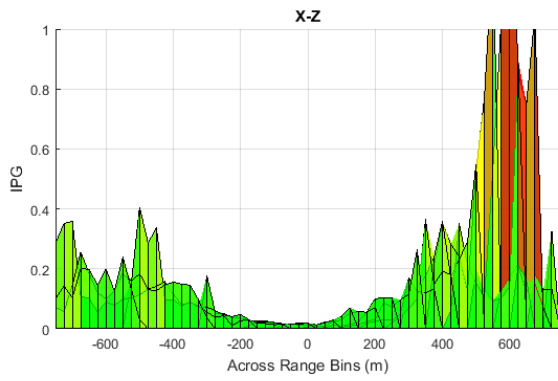
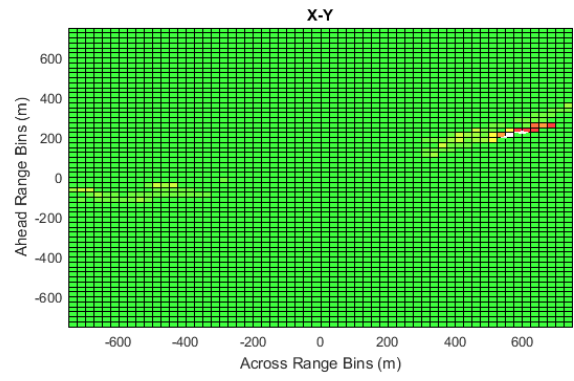
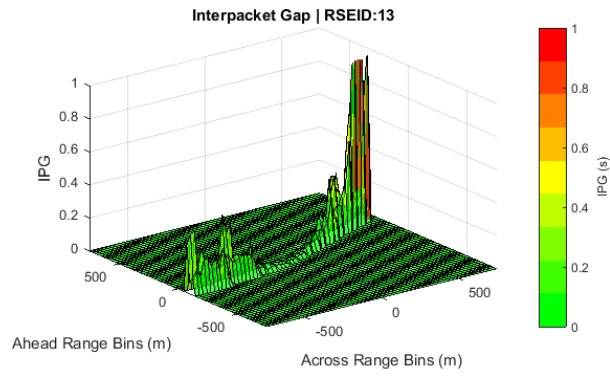




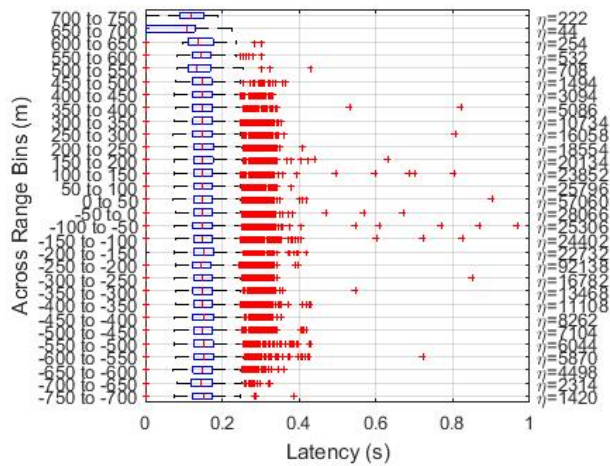
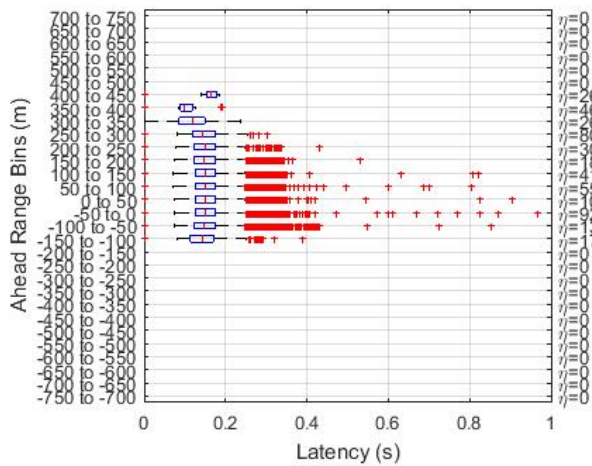


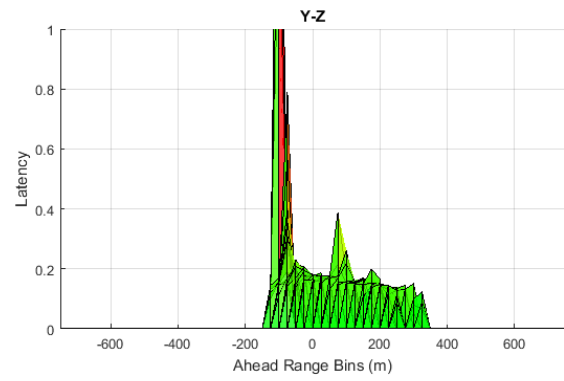
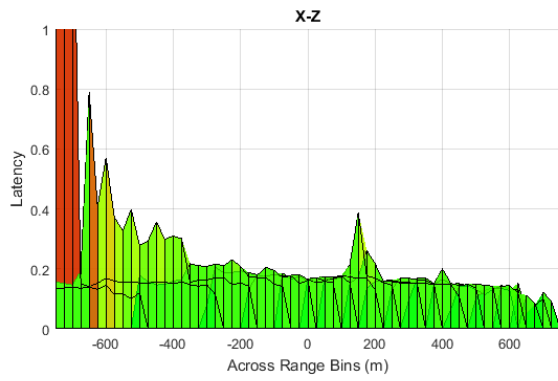
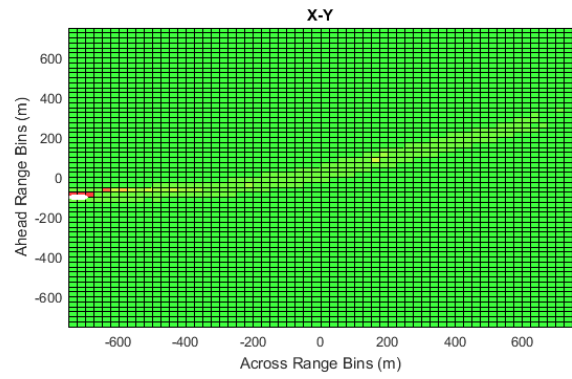
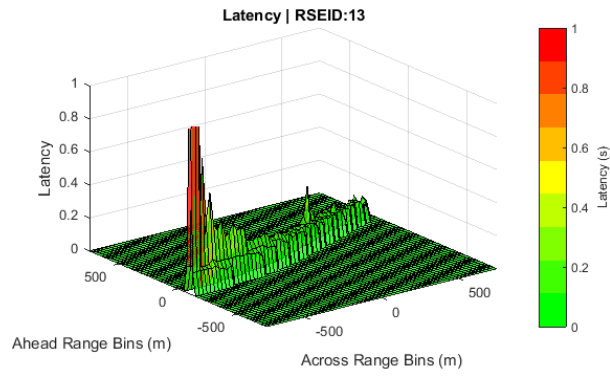
Interpacket Gap  
RSEID: 13



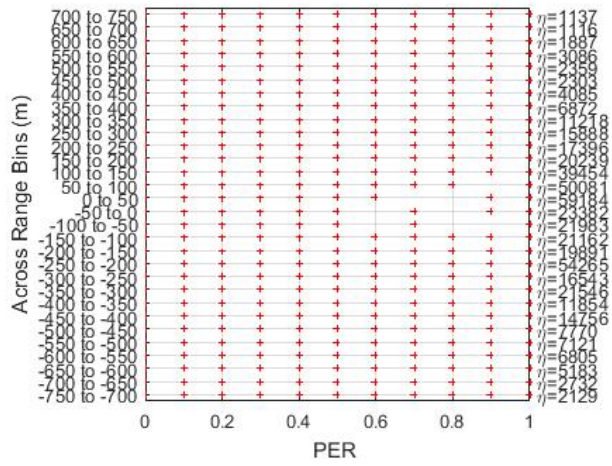
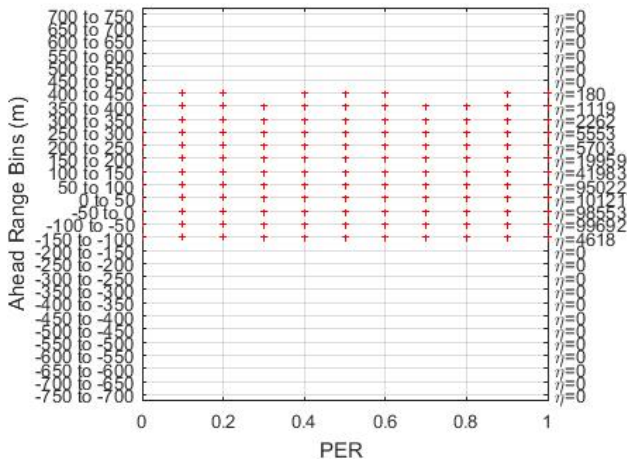


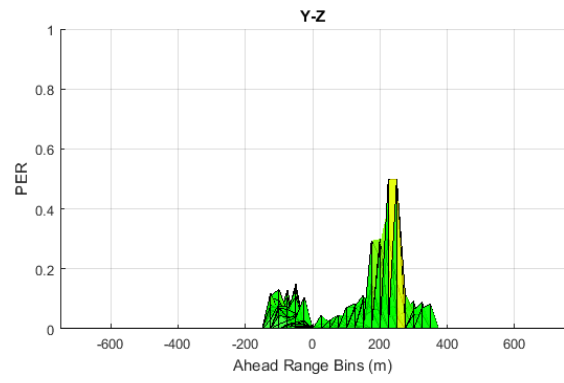
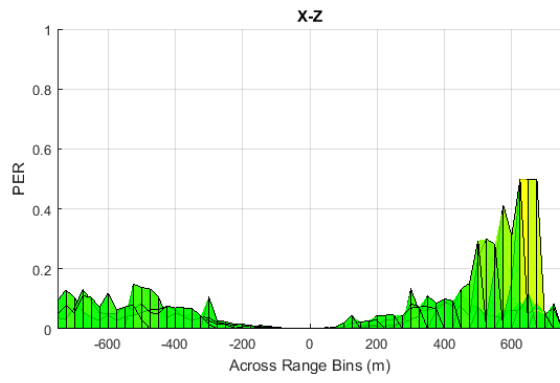
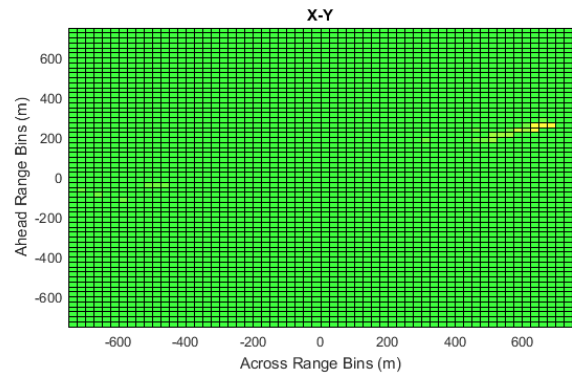
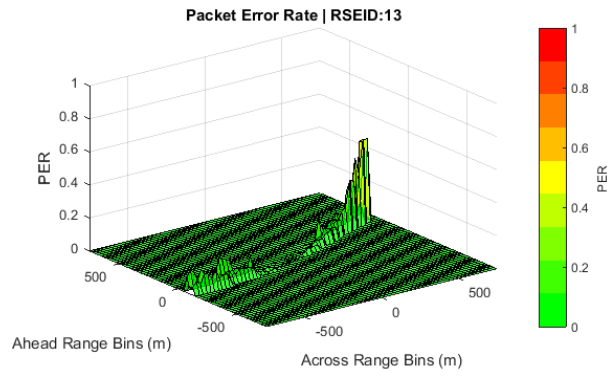
Latency  
RSEID: 13



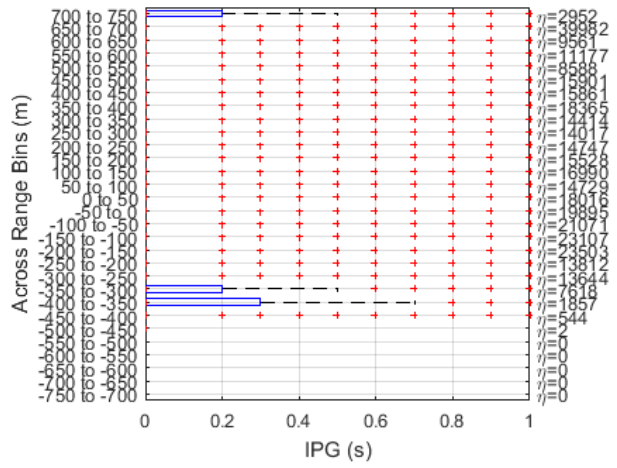
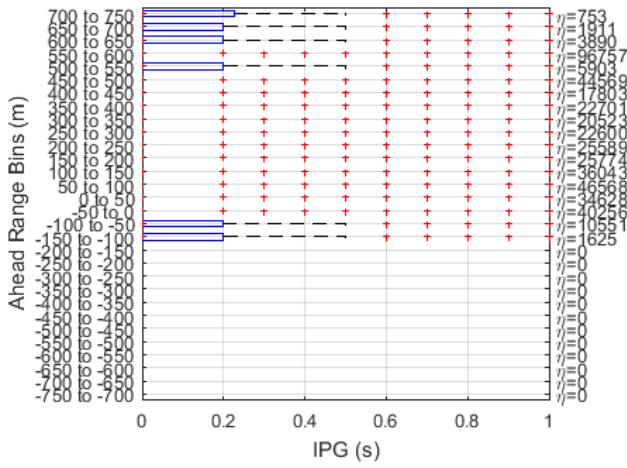


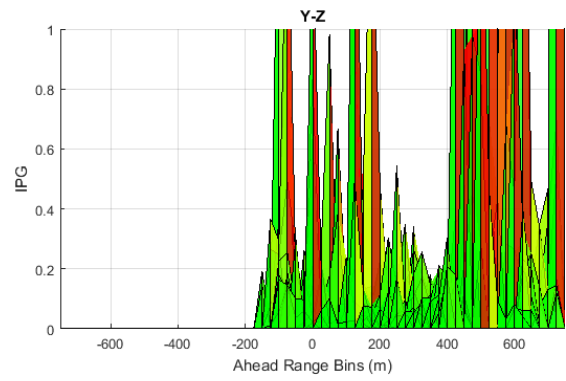
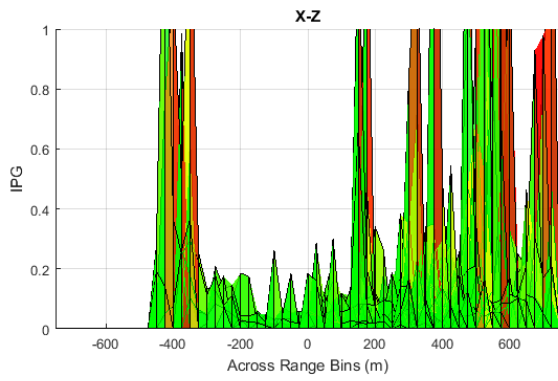
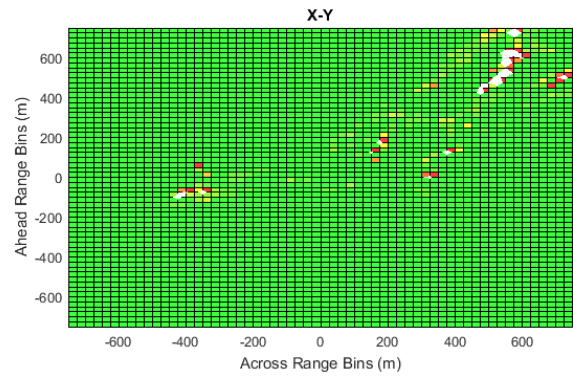
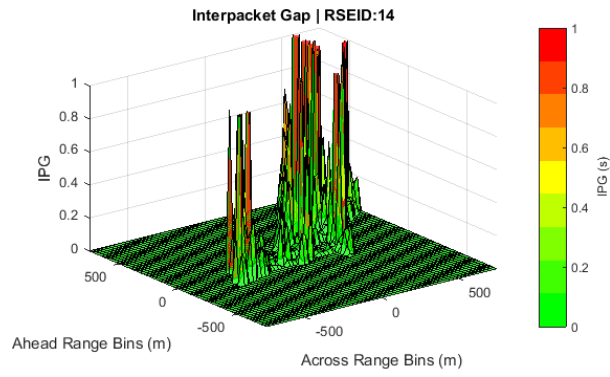
Packet Error Rate  
RSEID: 13





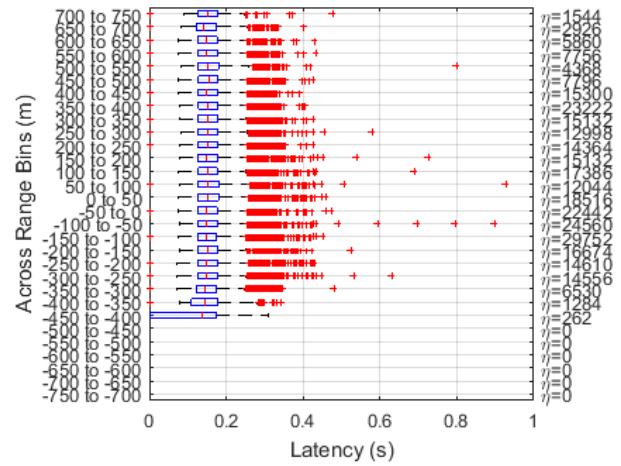
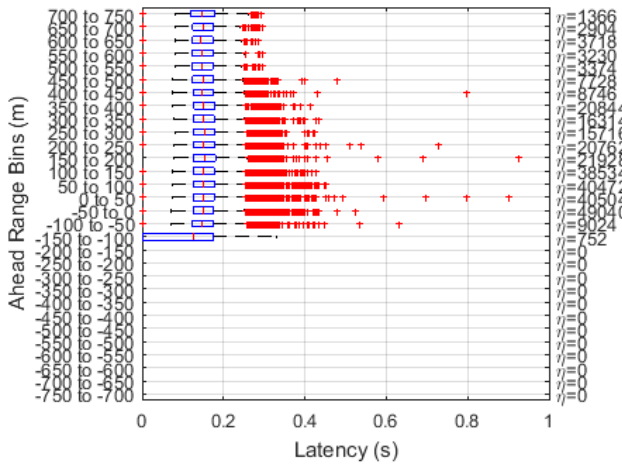
Interpacket Gap  
RSEID: 14

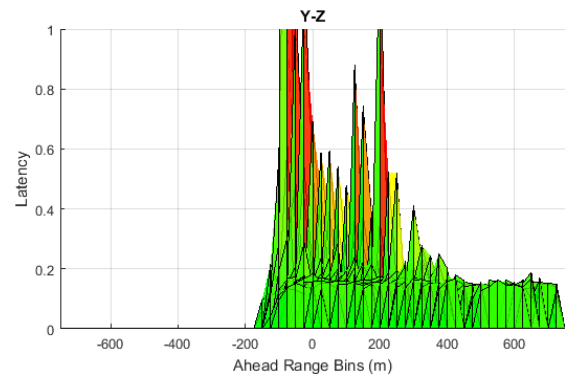
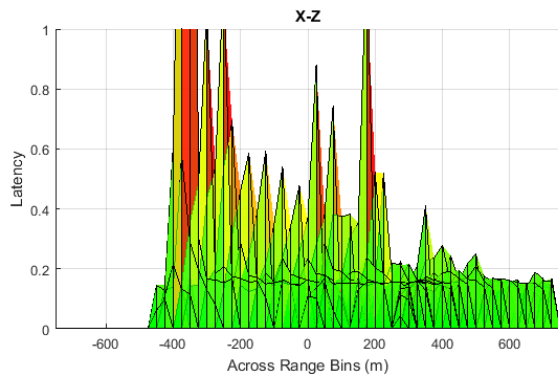
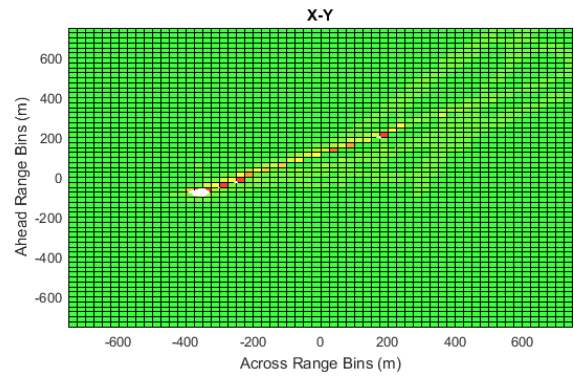
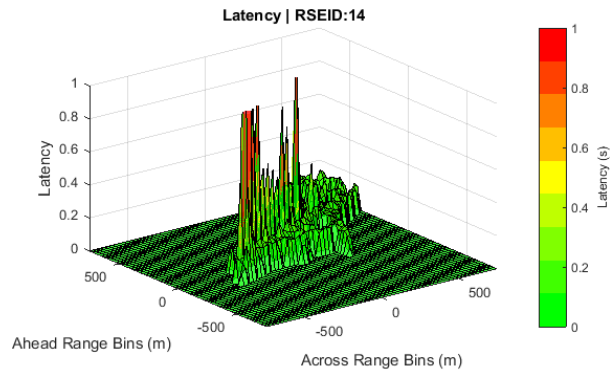




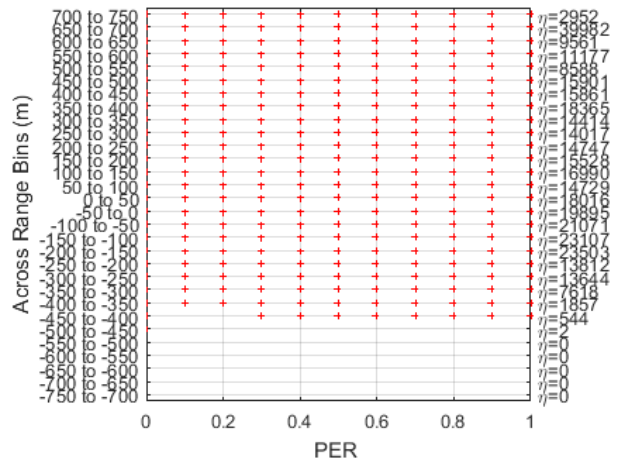
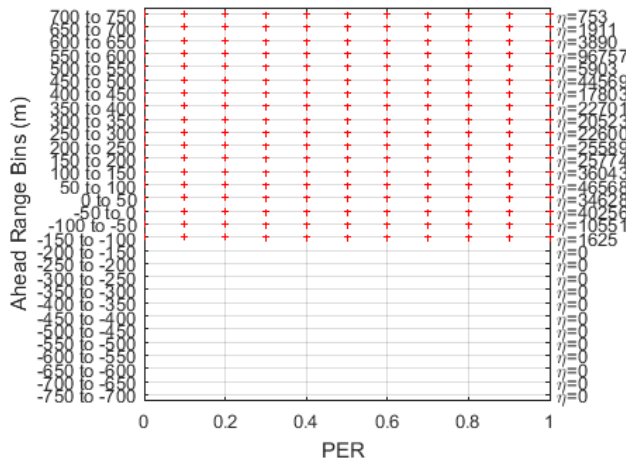


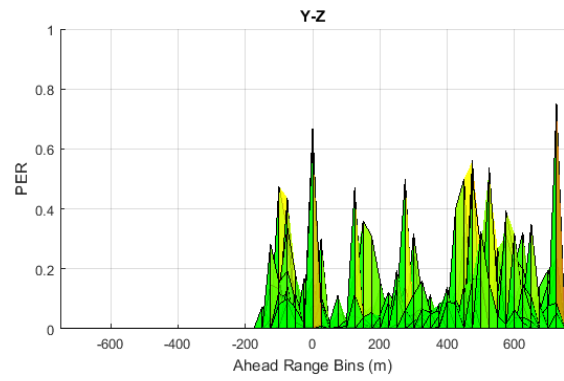
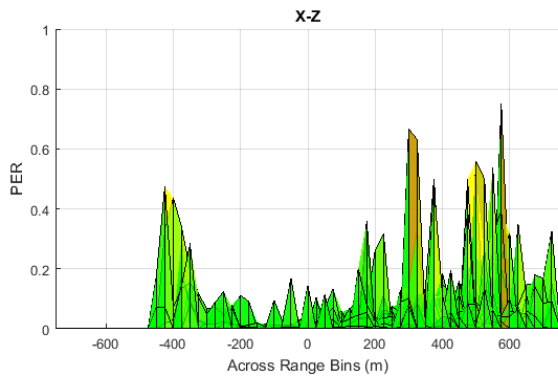
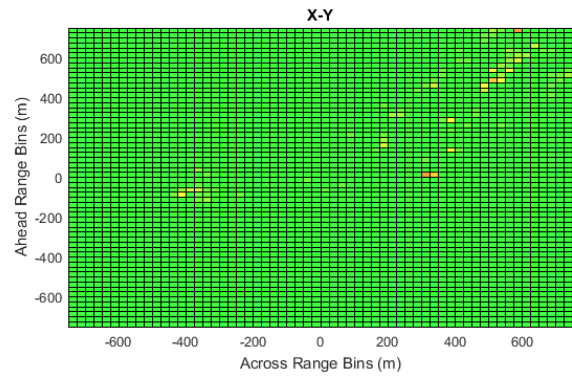
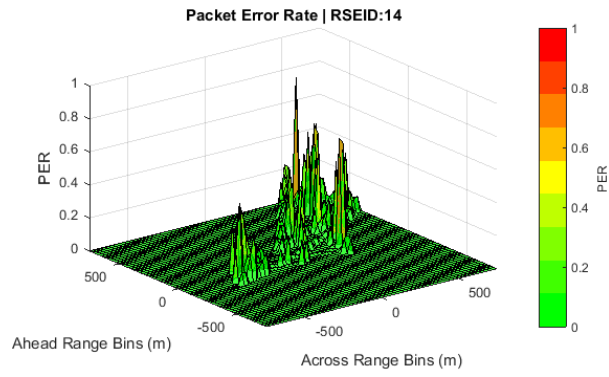
Latency  
RSEID: 14



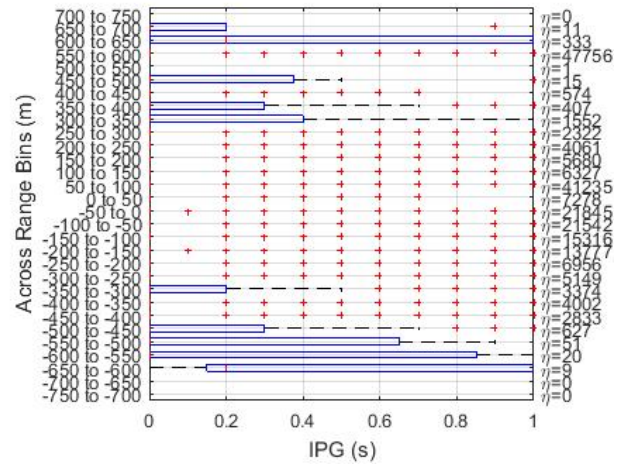
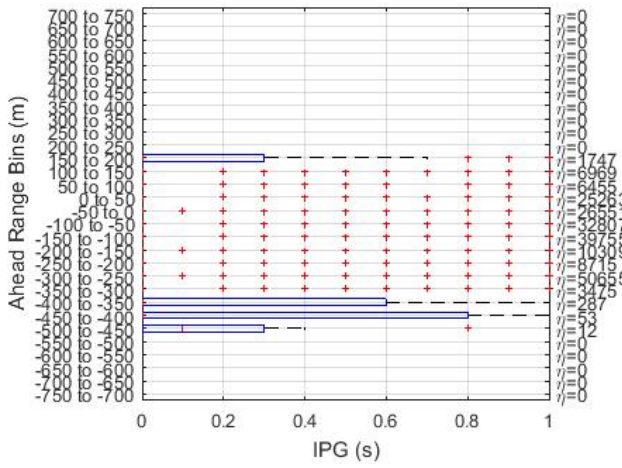
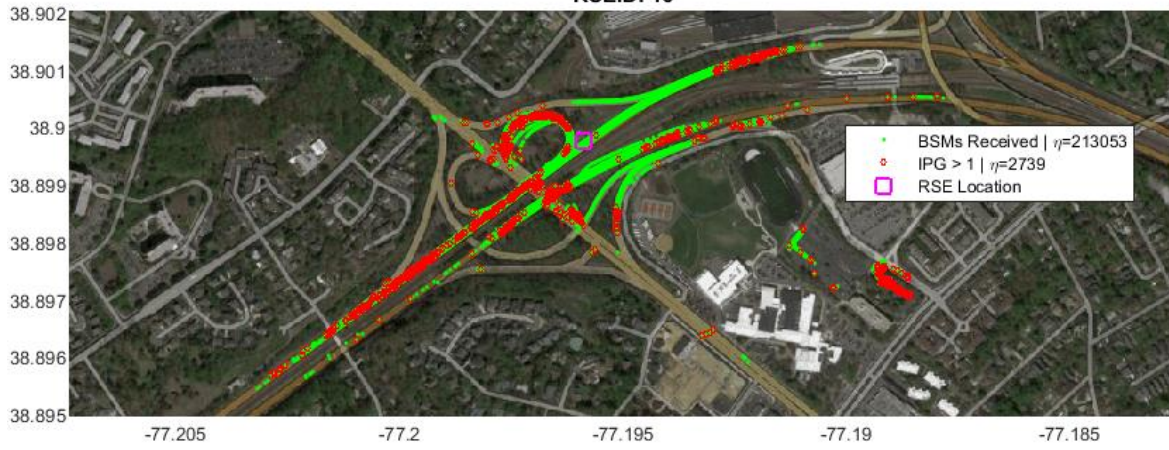


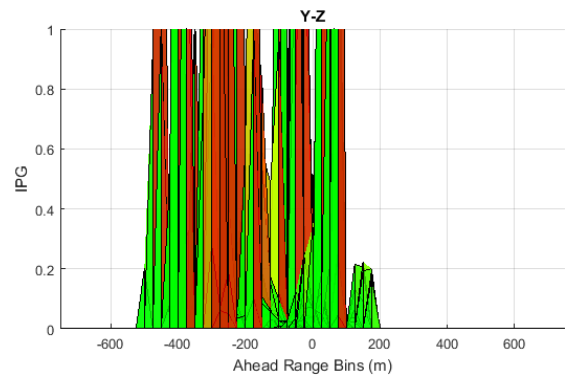
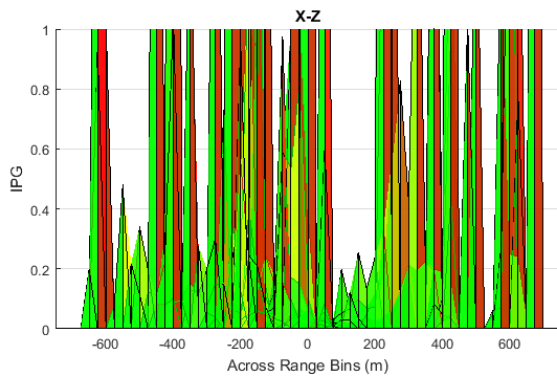
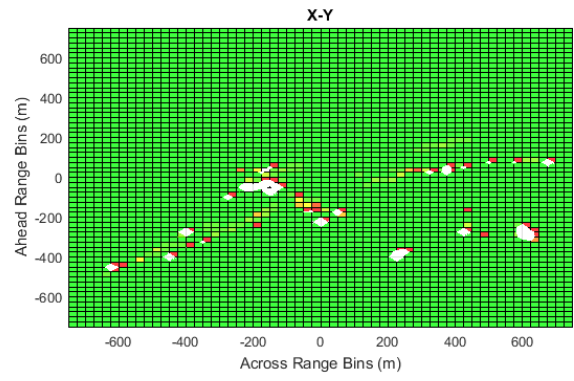
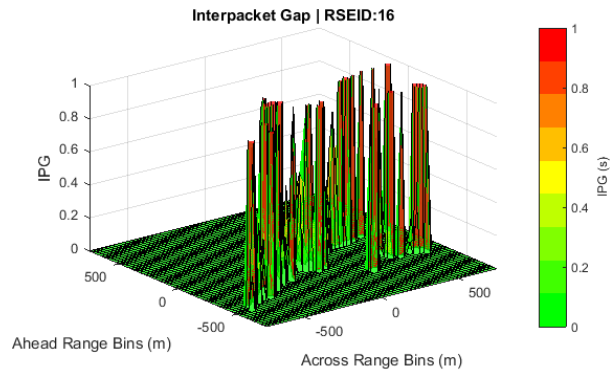
Packet Error Rate  
RSEID: 14



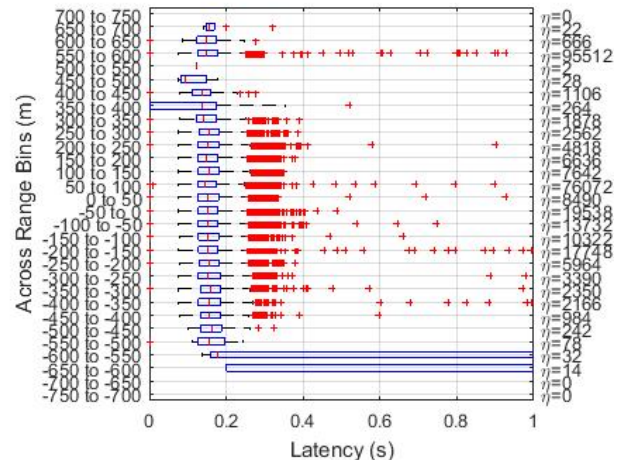
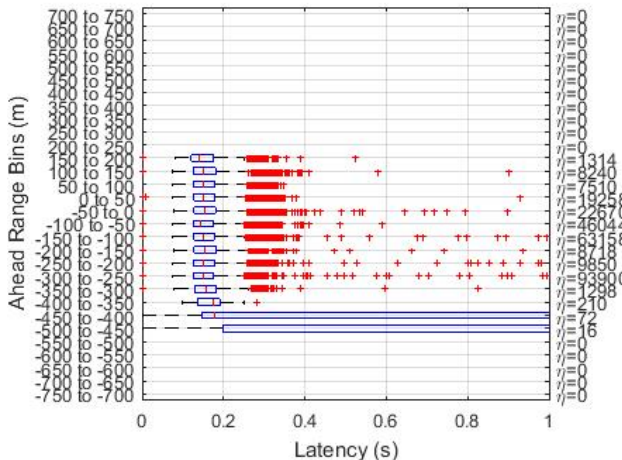


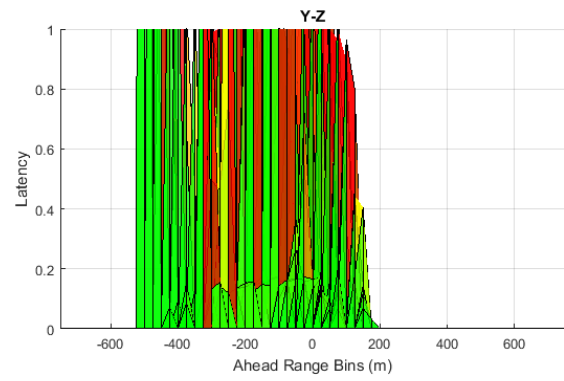
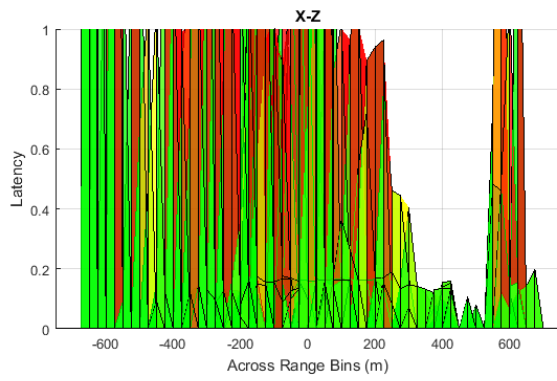
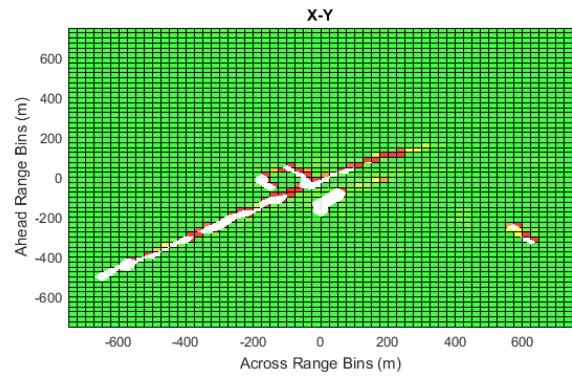
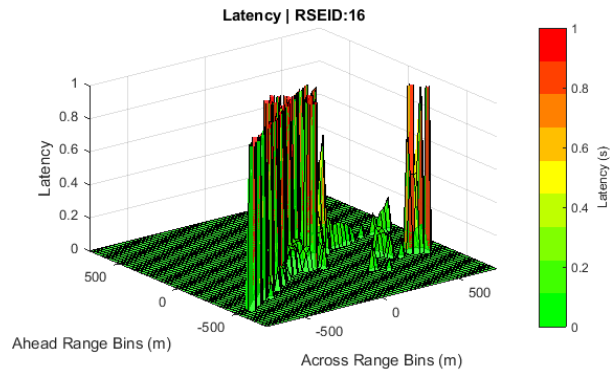
Interpacket Gap  
RSEID: 16





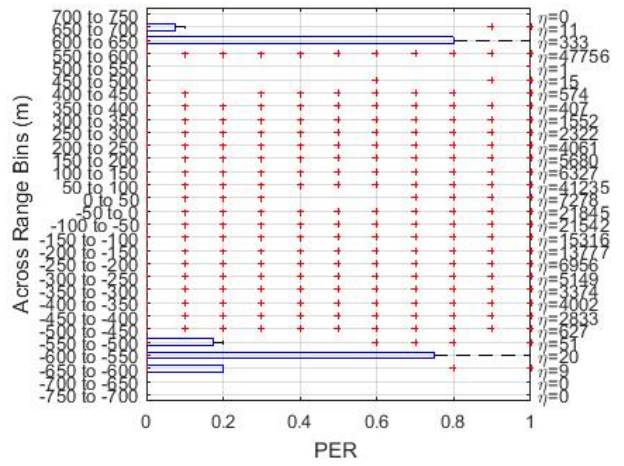
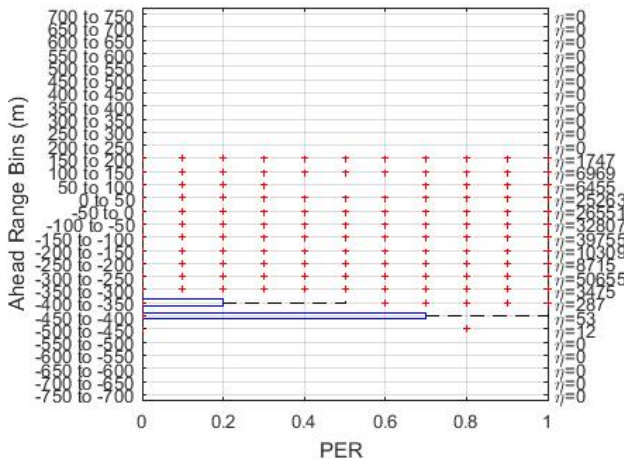
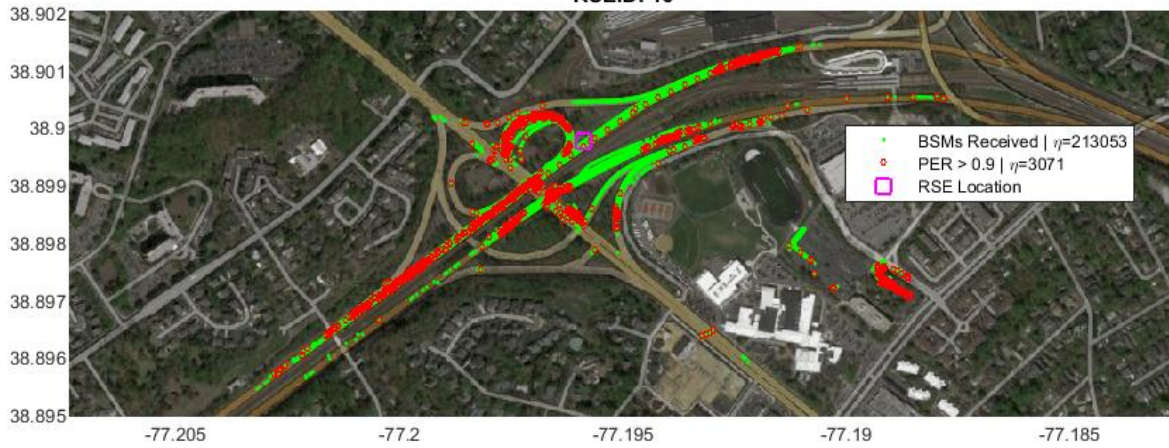
Latency  
RSEID: 16

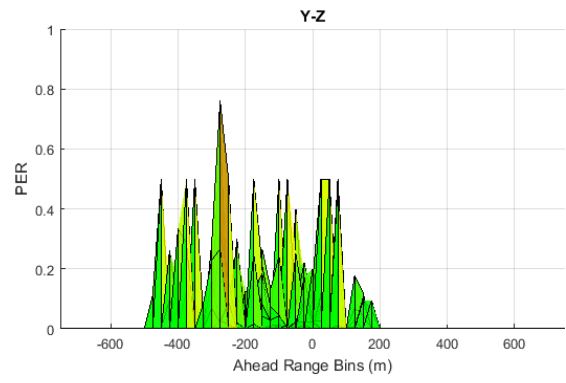
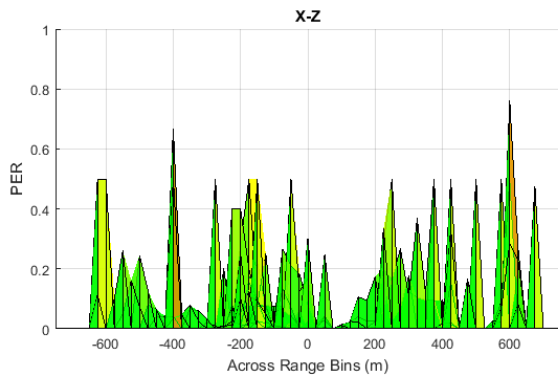
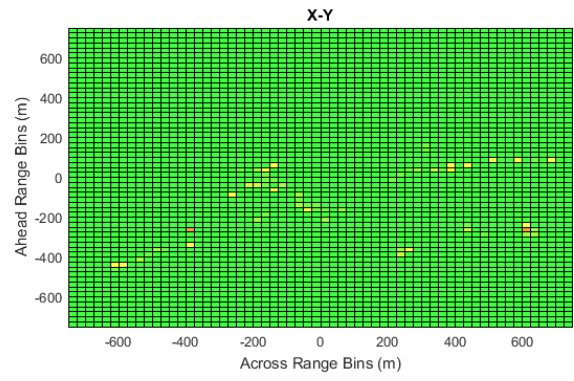
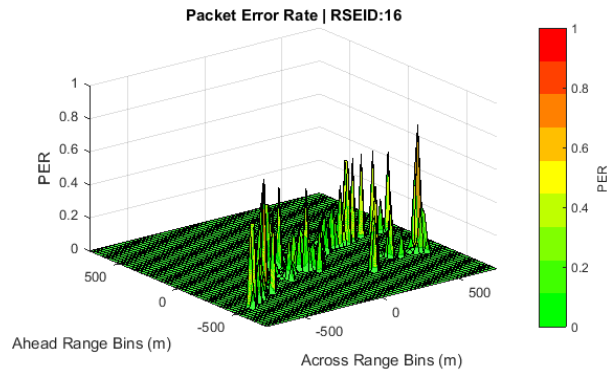




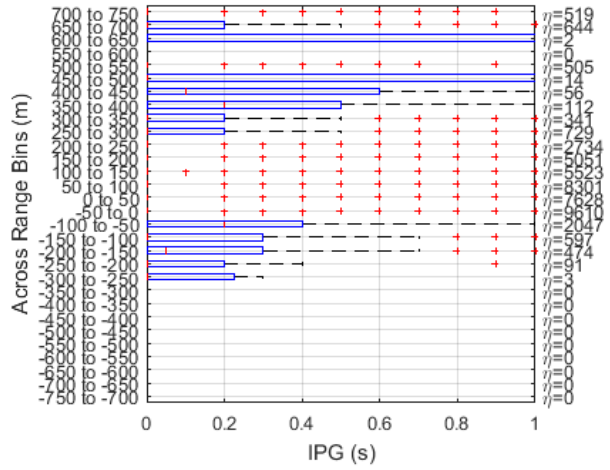
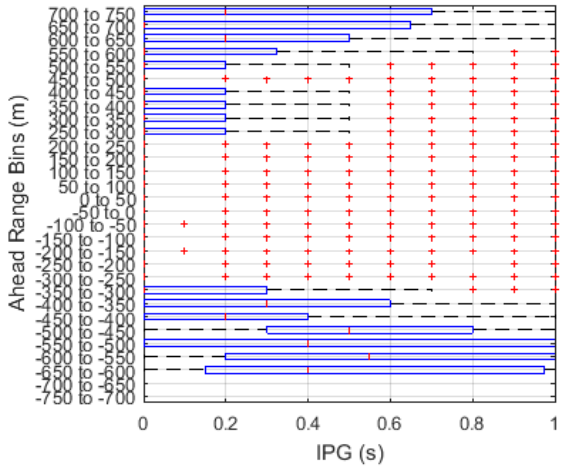
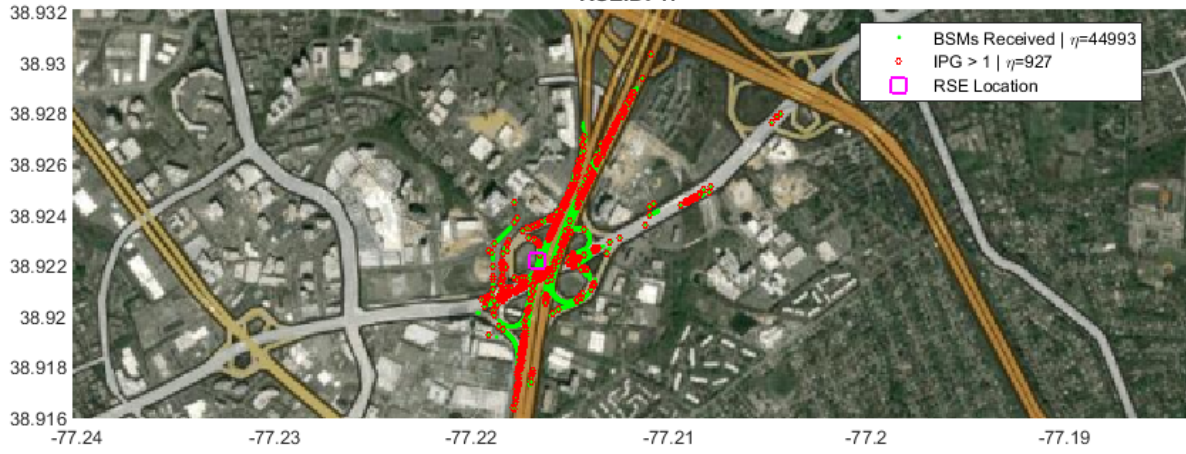


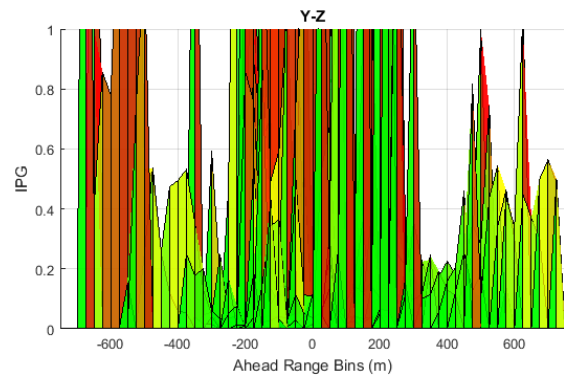
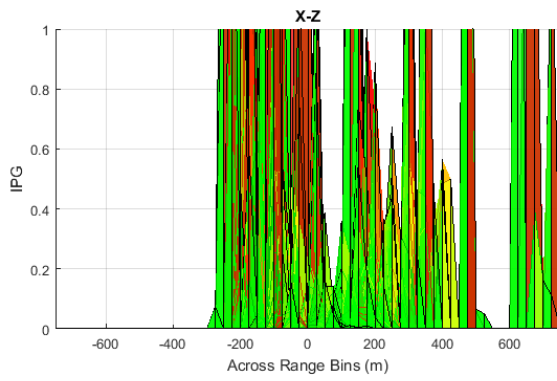
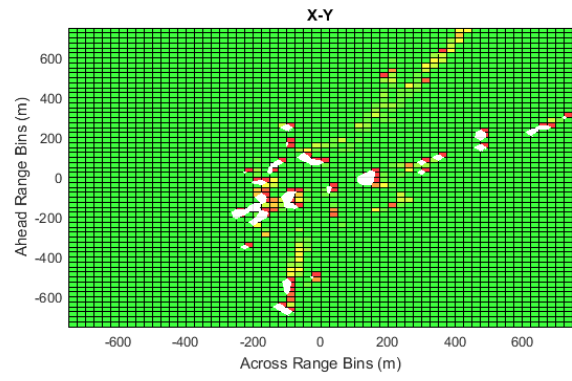
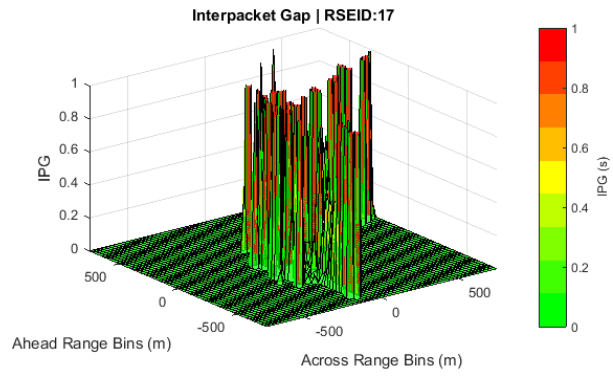
Packet Error Rate  
RSEID: 16



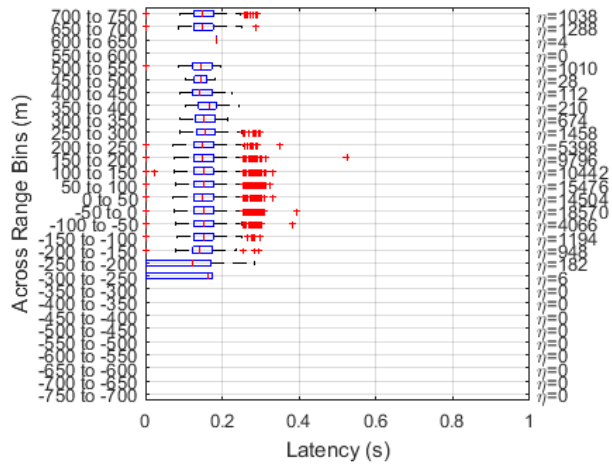
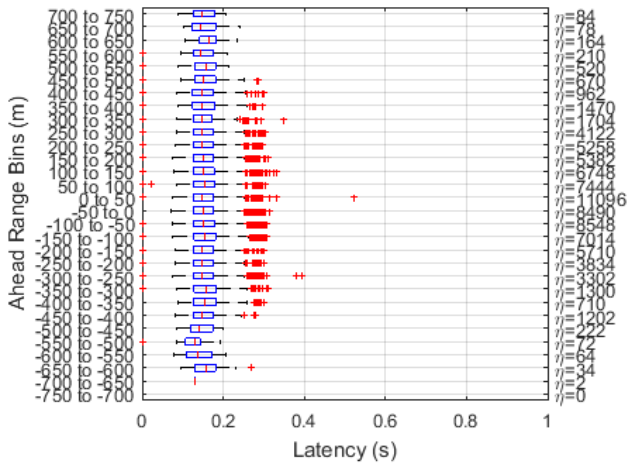


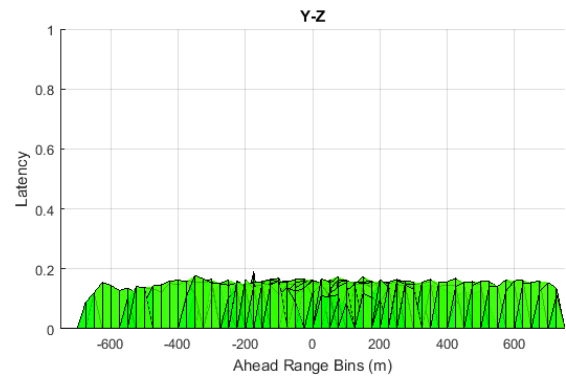
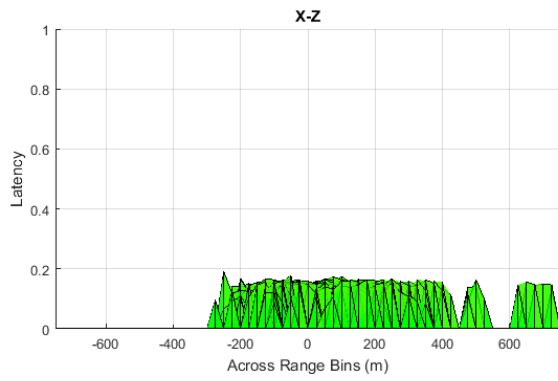
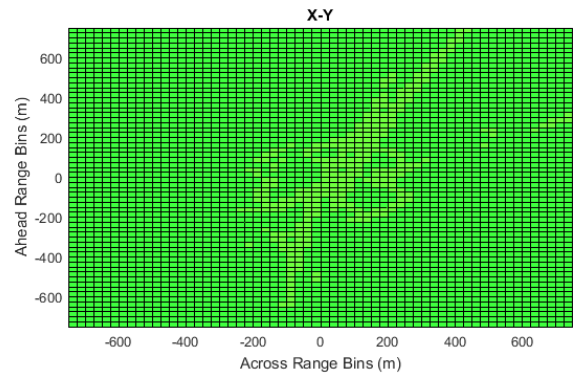
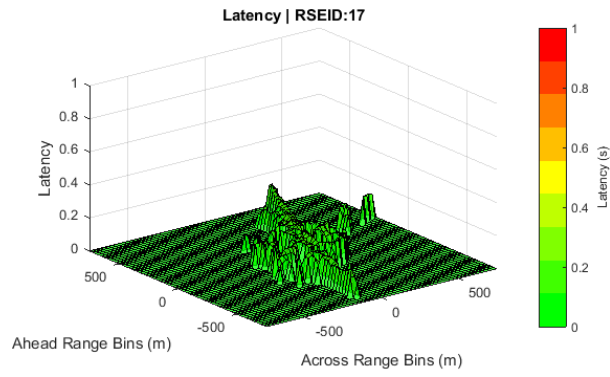
Interpacket Gap  
RSEID: 17



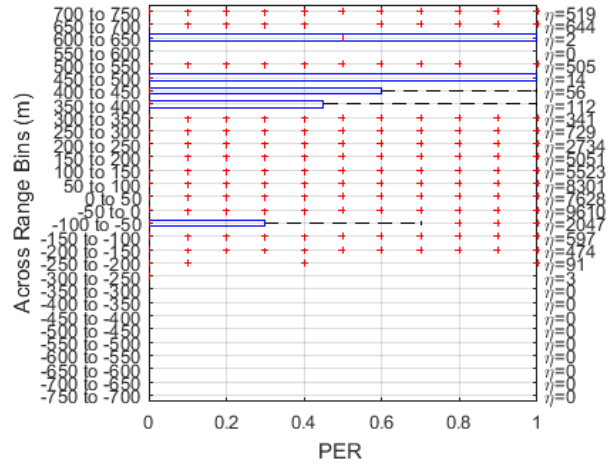
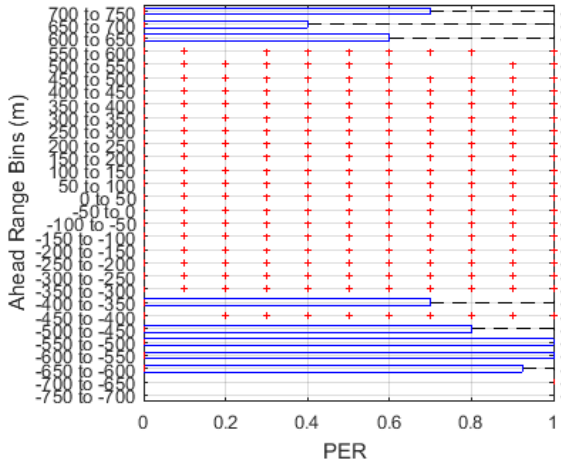
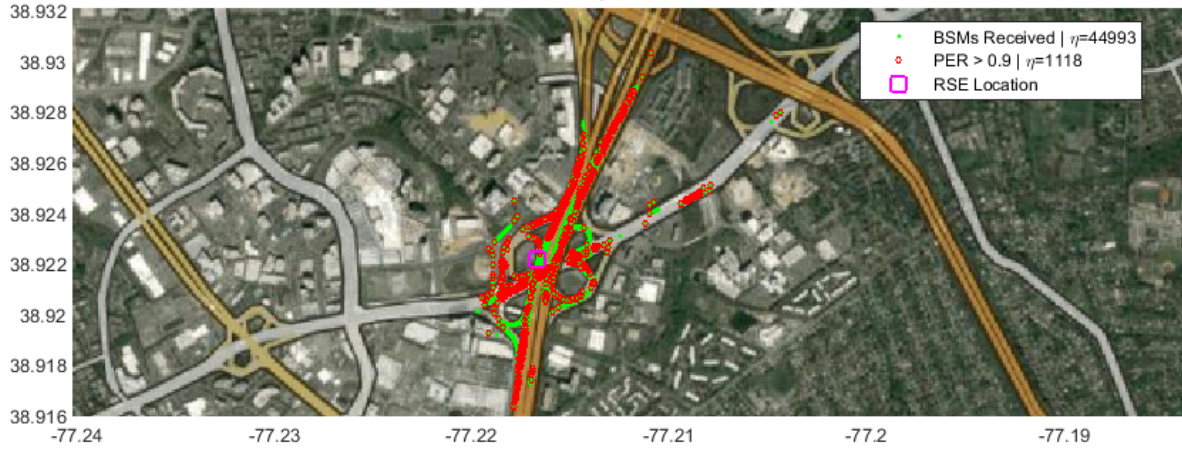


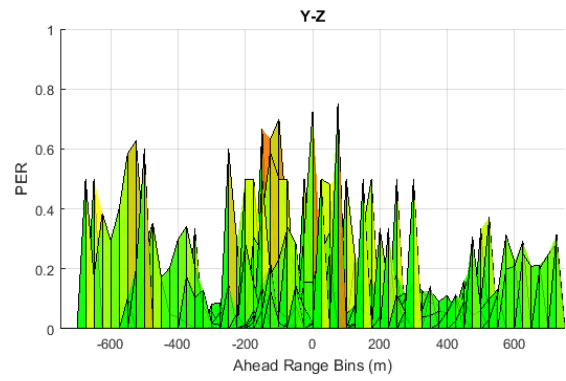
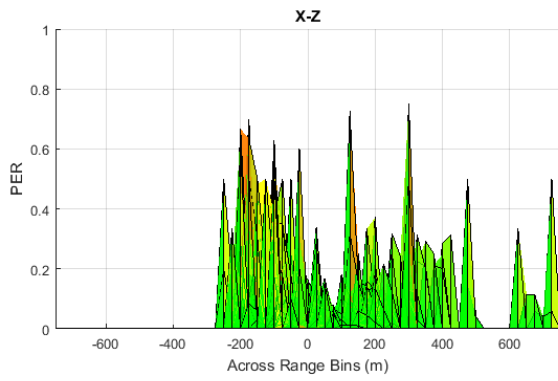
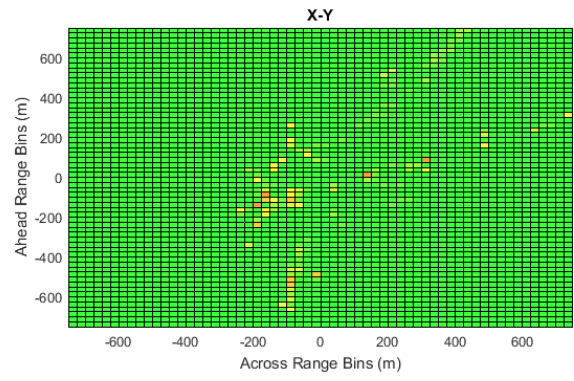
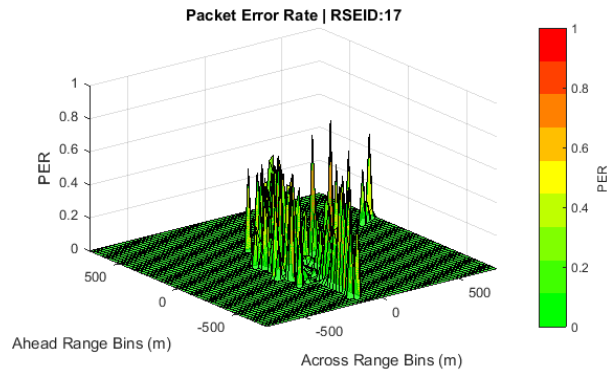
Latency  
RSEID: 17





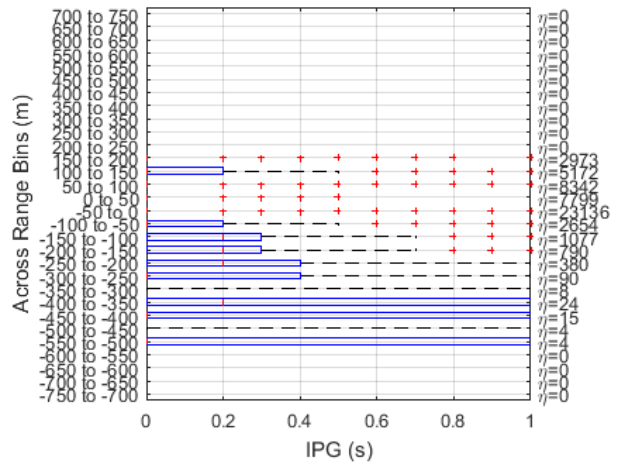
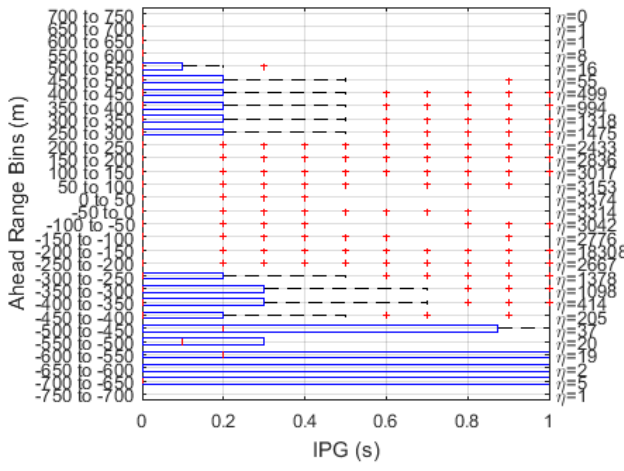
Packet Error Rate  
RSEID: 17

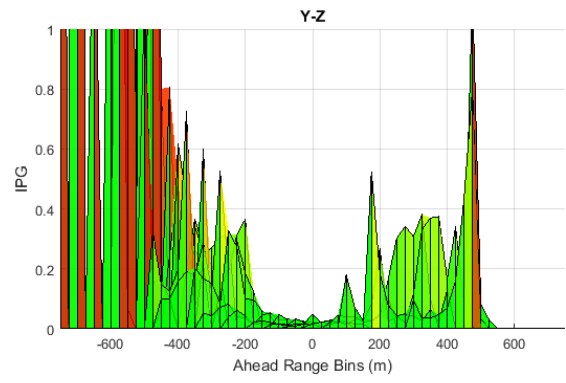
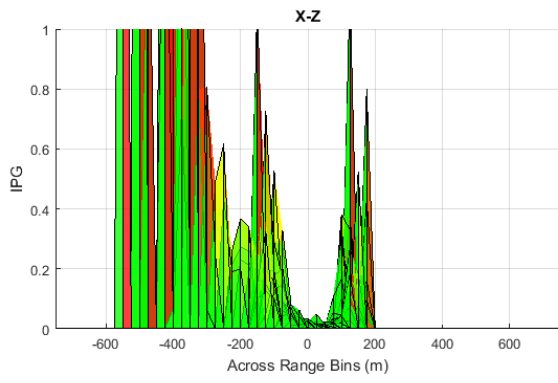
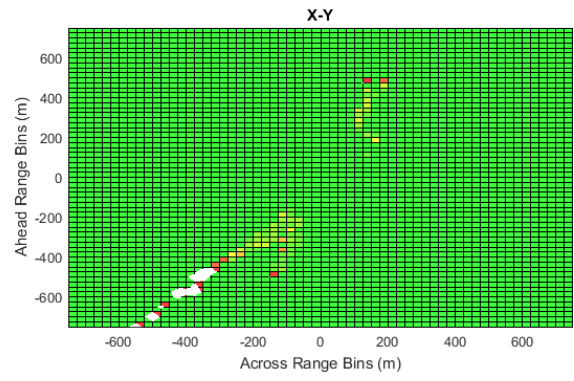
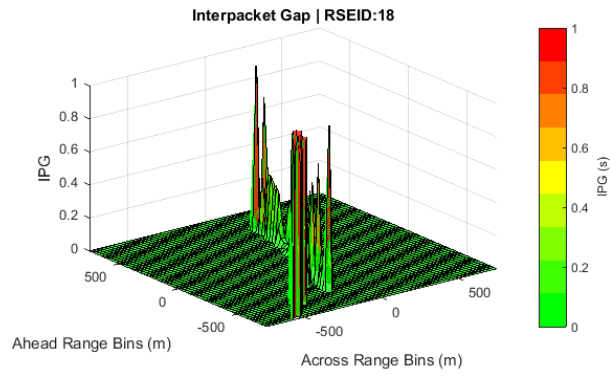


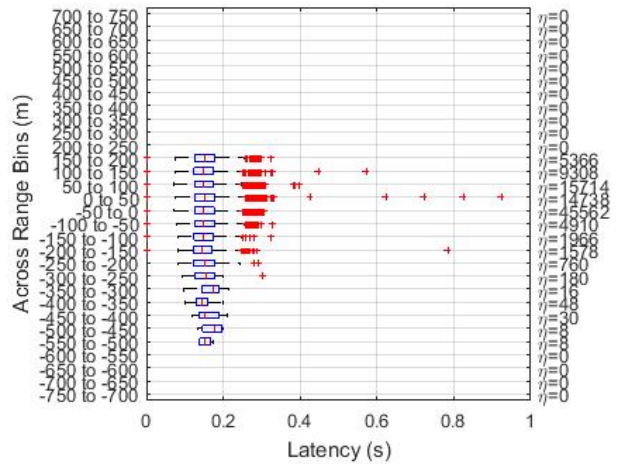
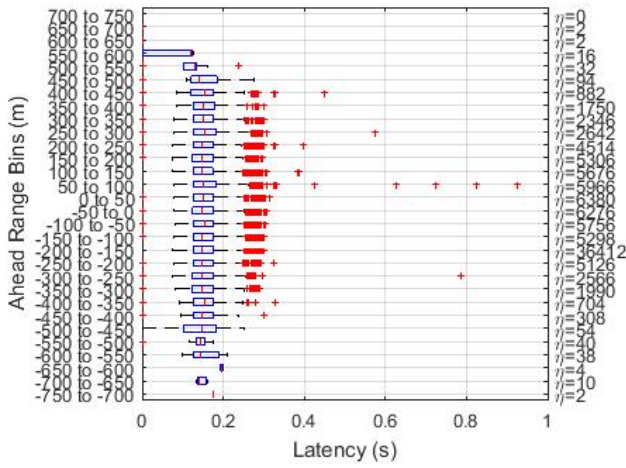


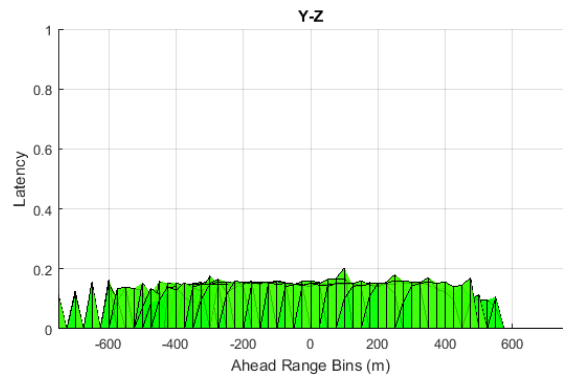
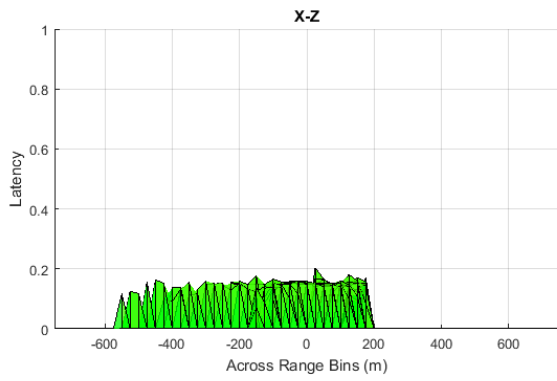
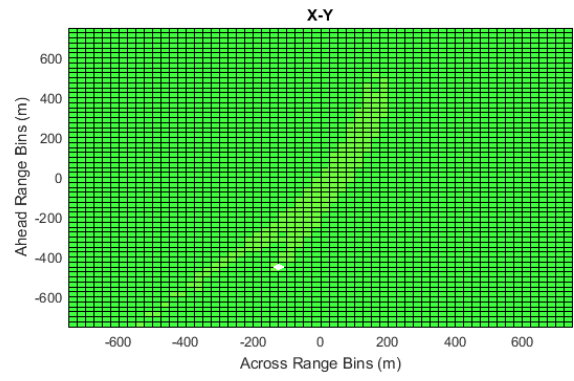
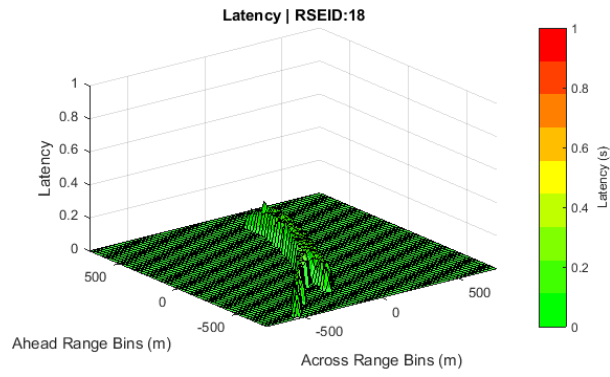


Interpacket Gap  
RSEID: 18

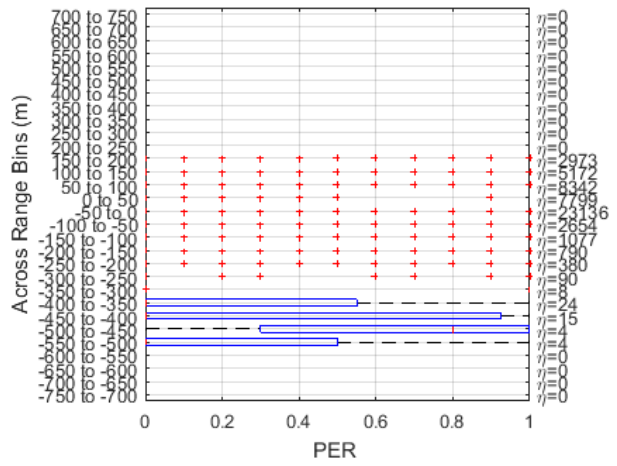
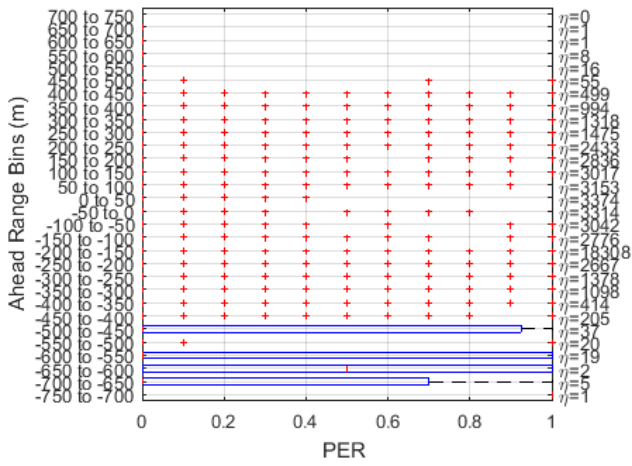


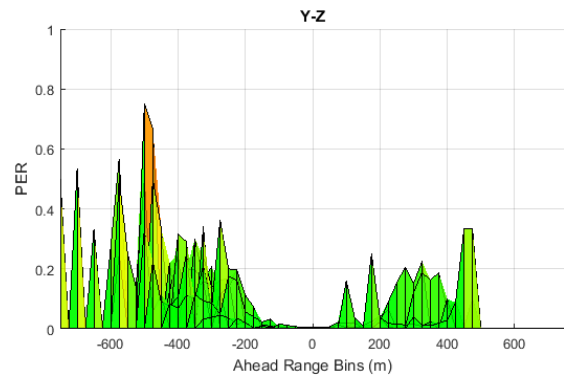
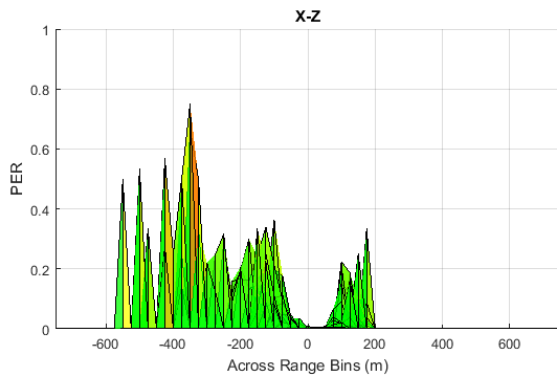
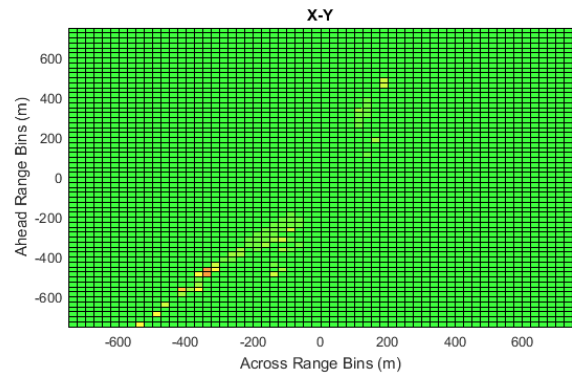
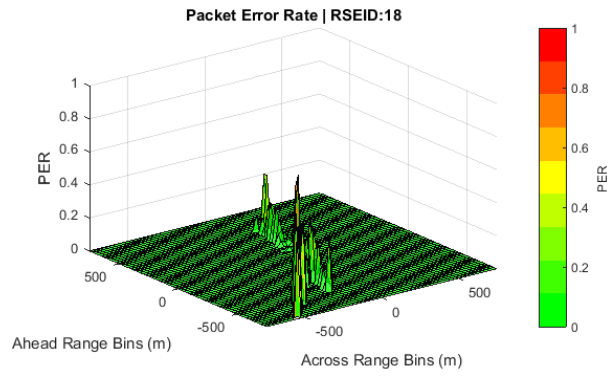




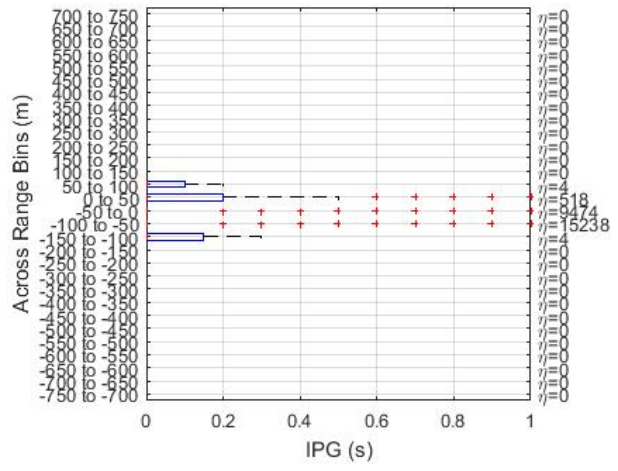
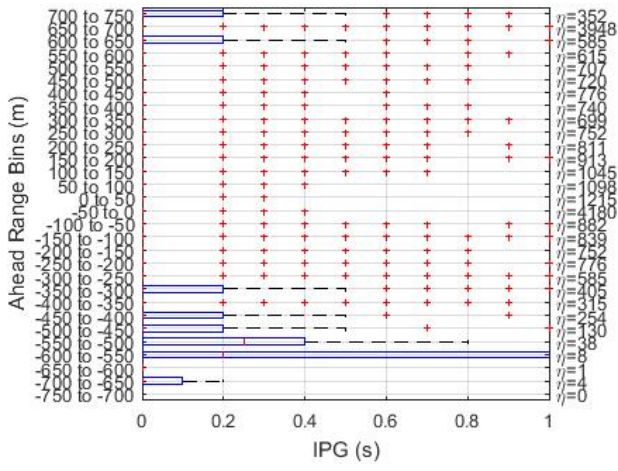


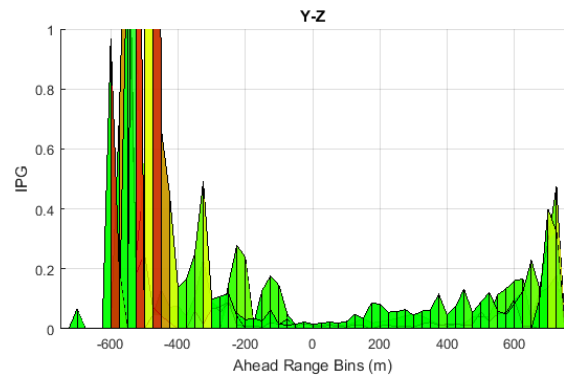
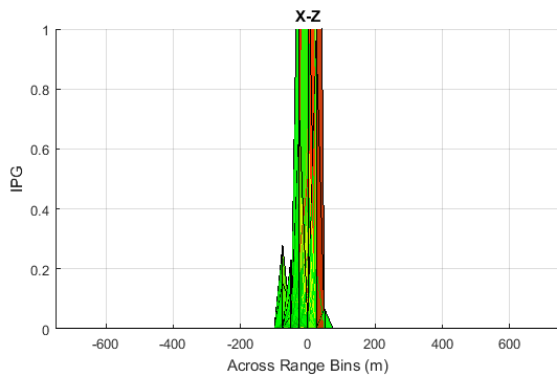
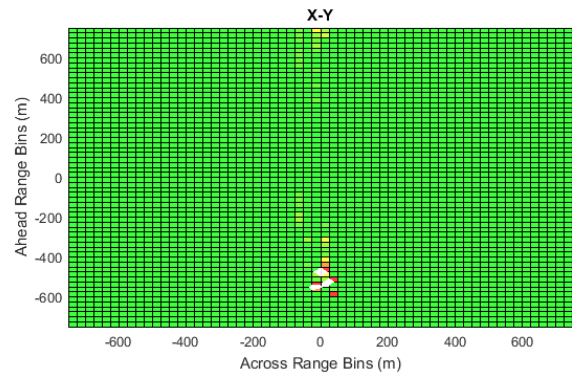
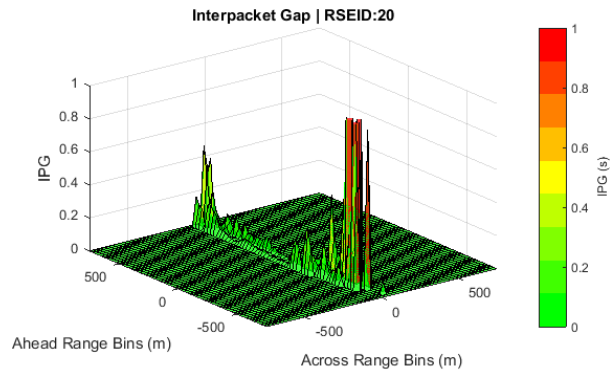
Packet Error Rate  
RSEID: 18





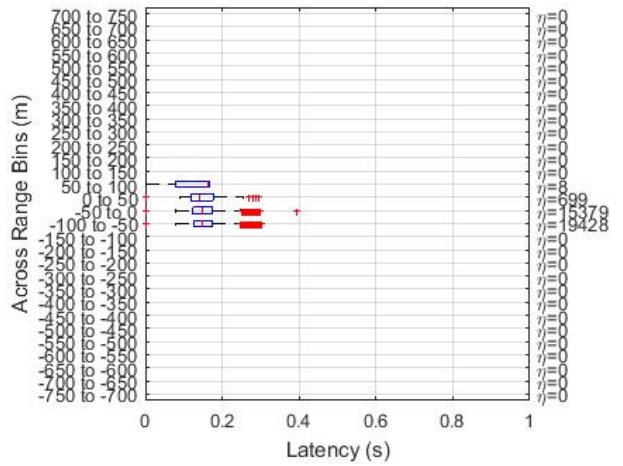
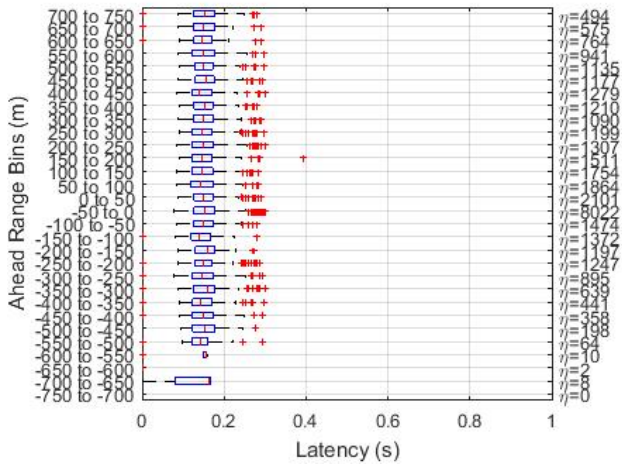
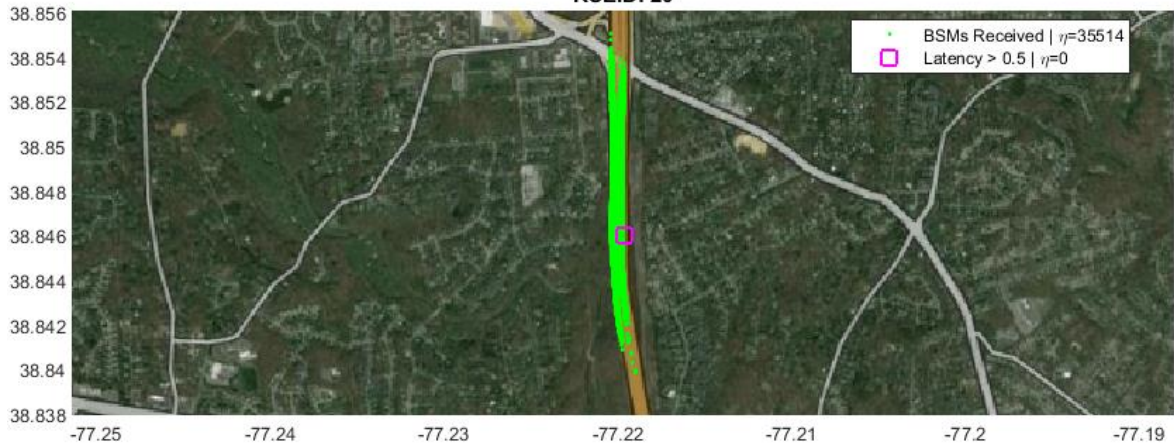
Interpacket Gap  
RSEID: 20

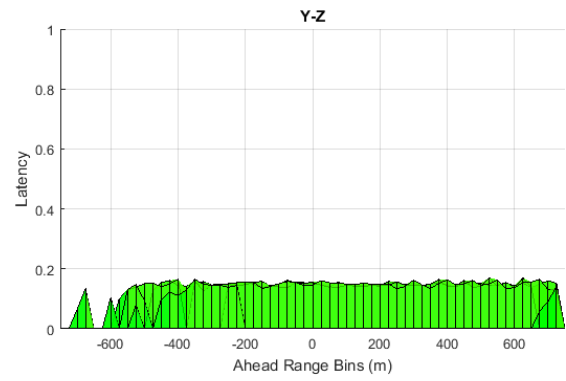
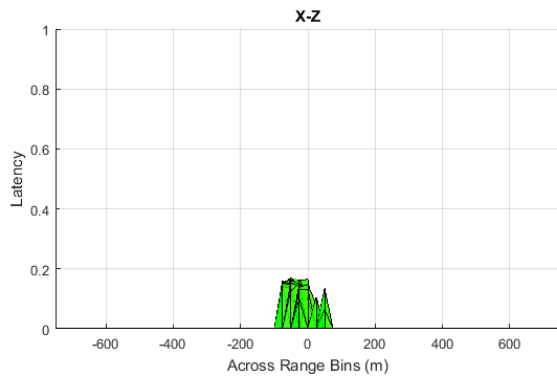
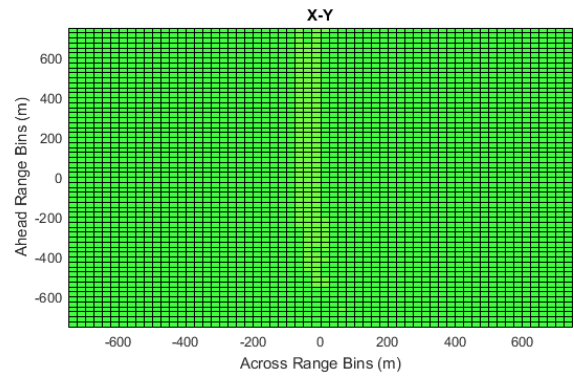
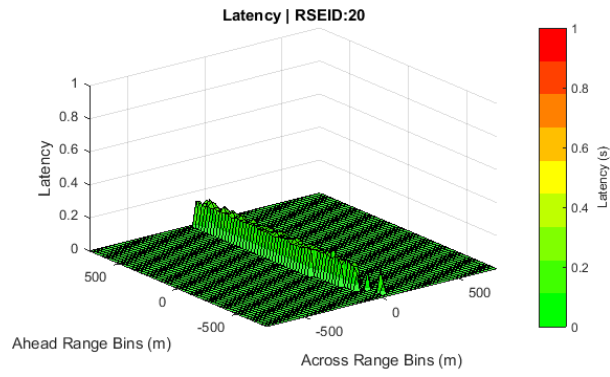




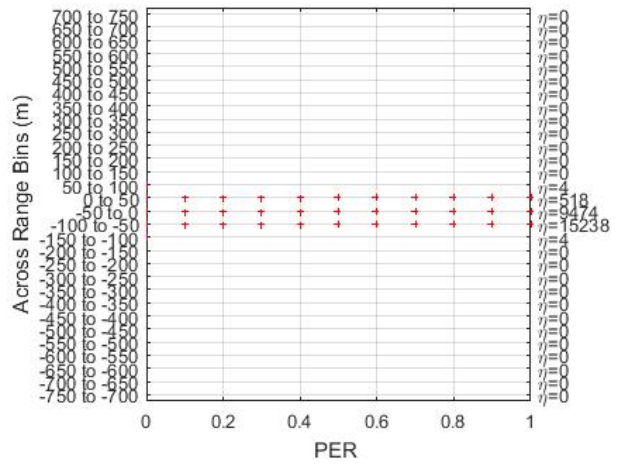
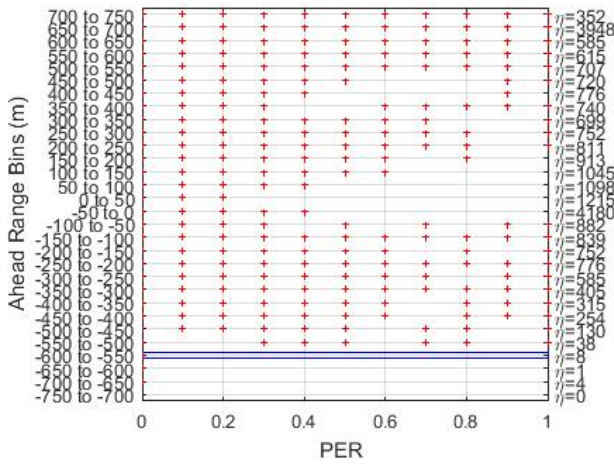


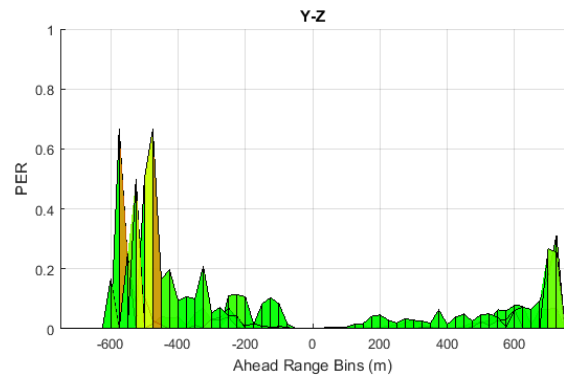
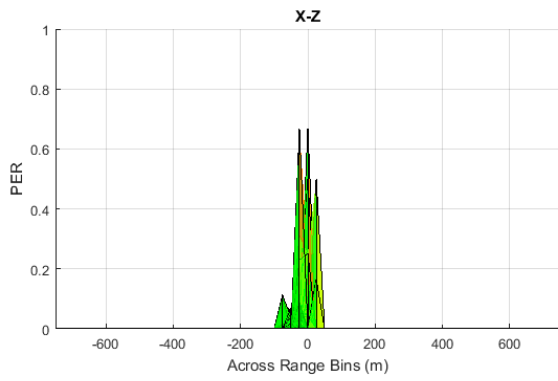
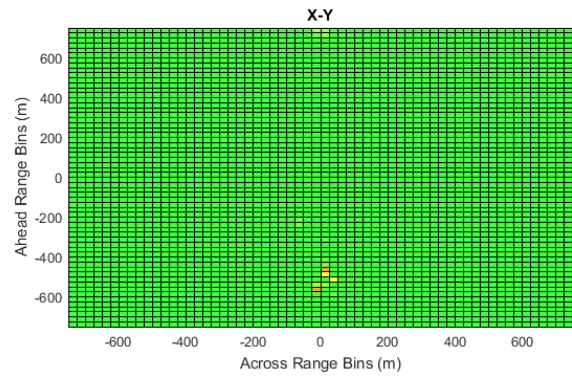
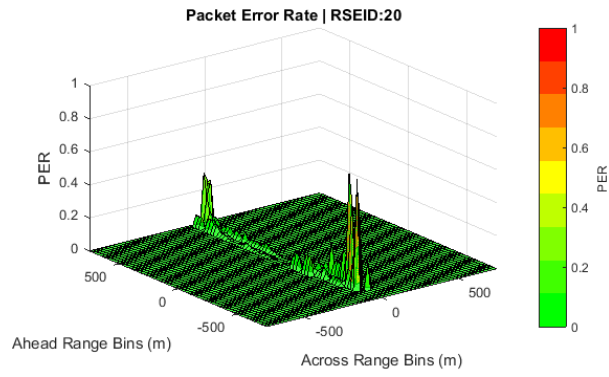
Latency  
RSEID: 20



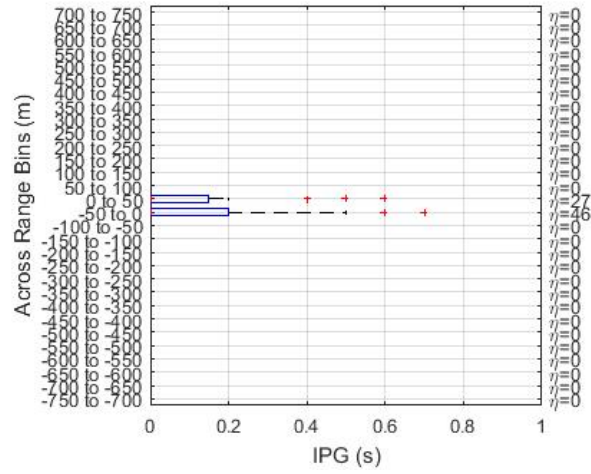
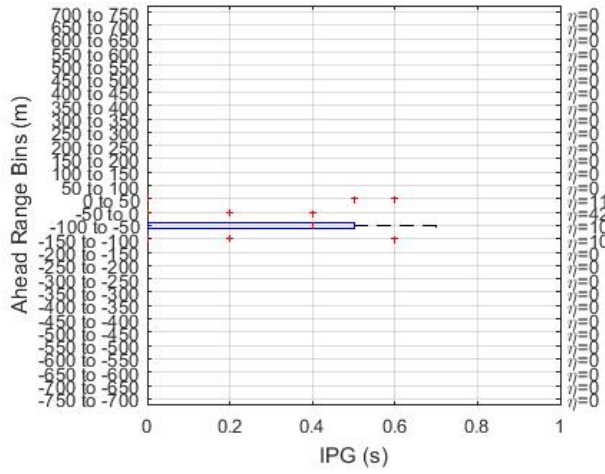


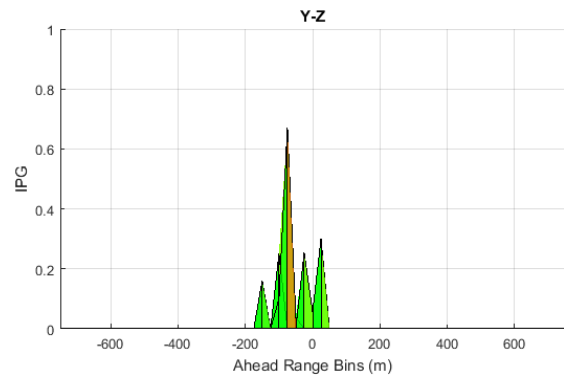
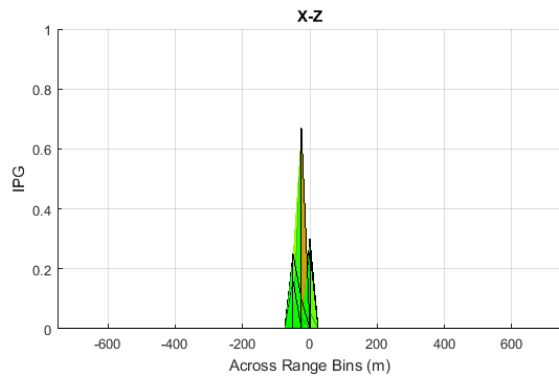
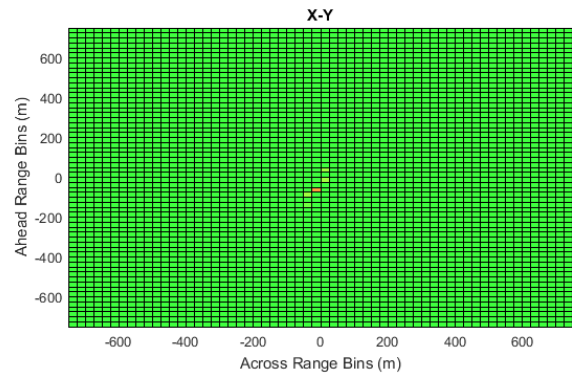
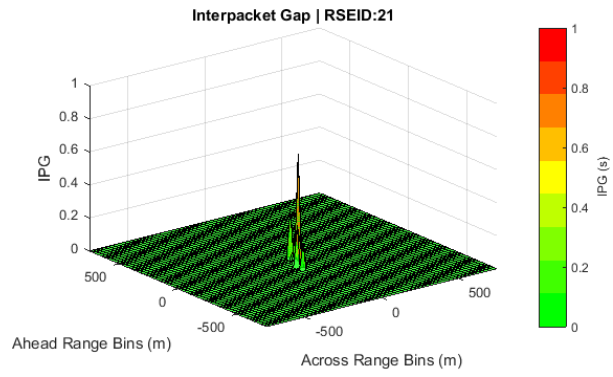
**Packet Error Rate  
RSEID: 20**



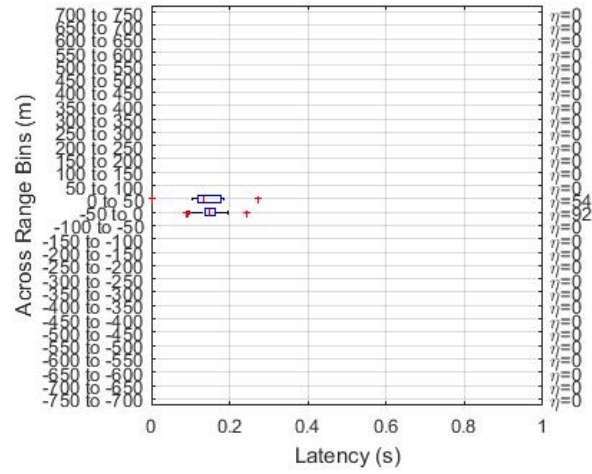
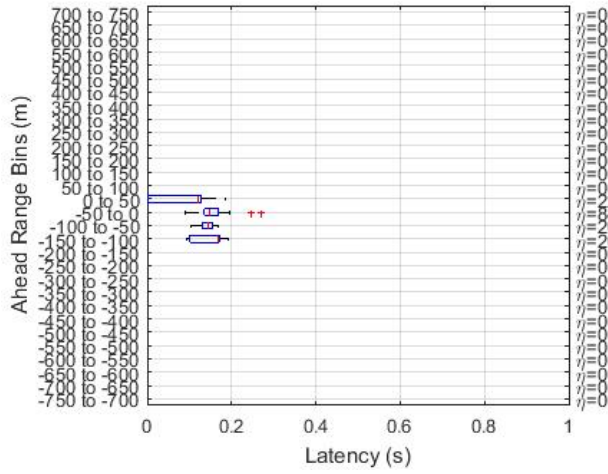


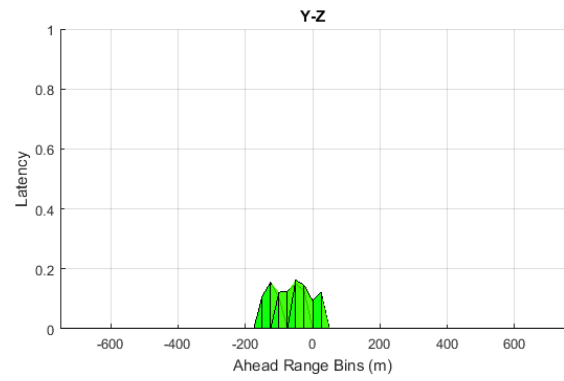
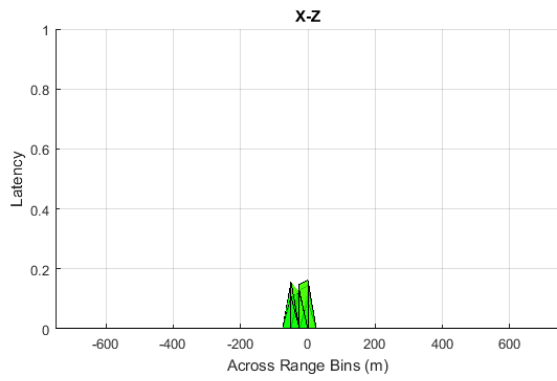
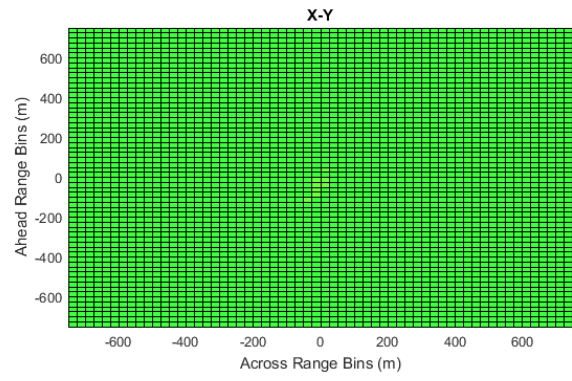
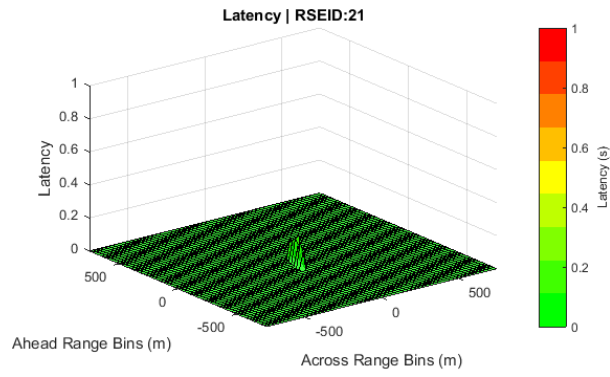
Interpacket Gap  
RSEID: 21





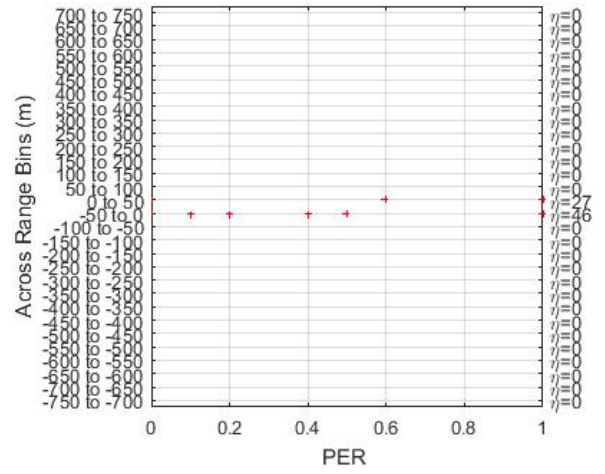
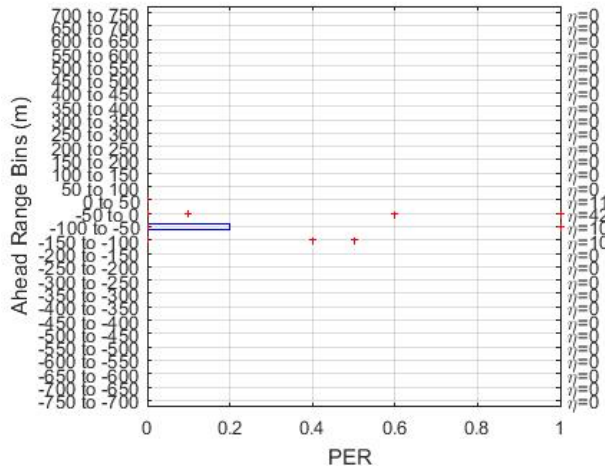
Latency  
RSEID: 21

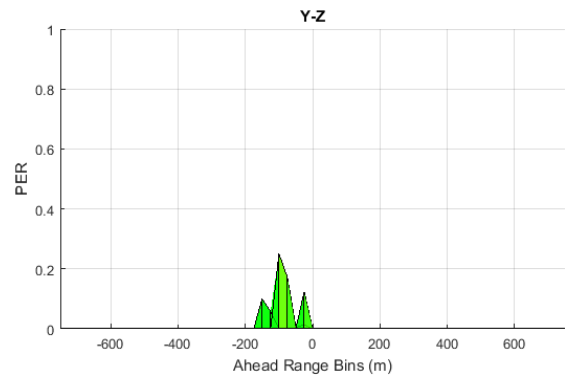
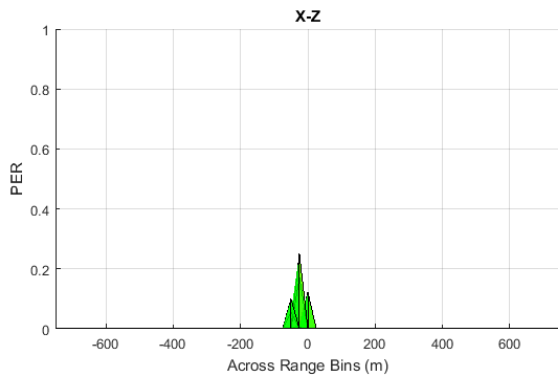
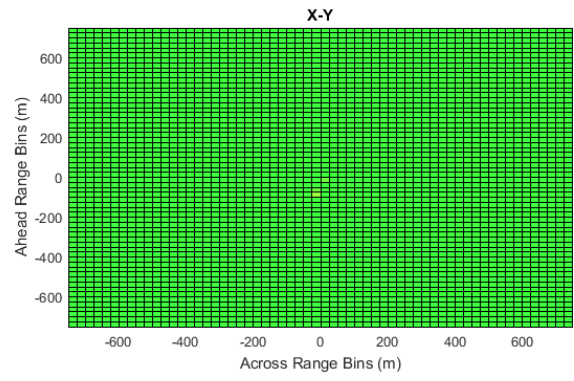
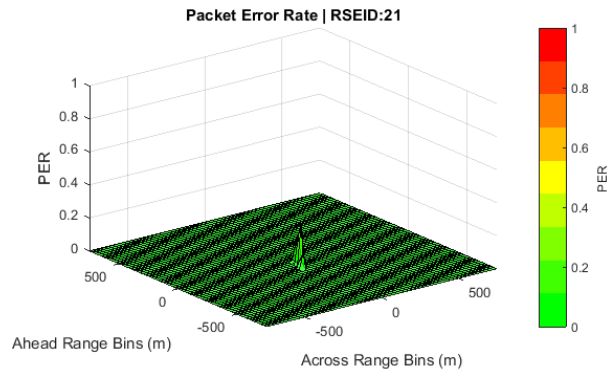




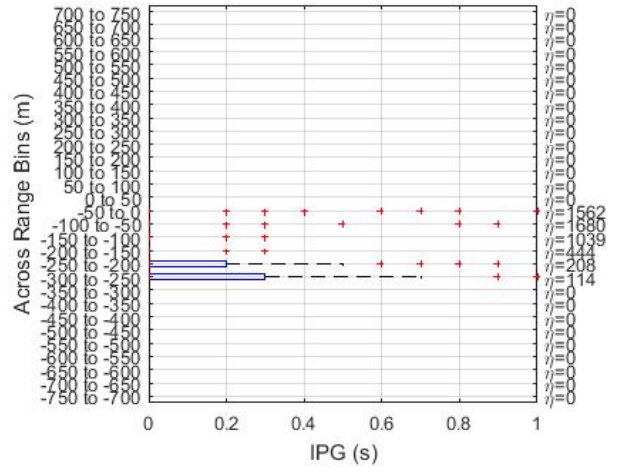
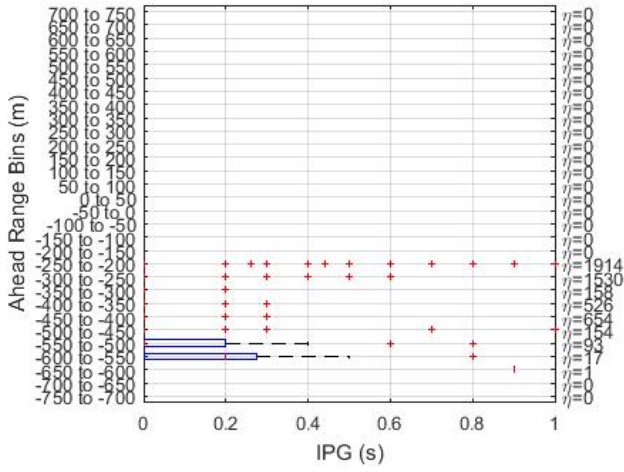


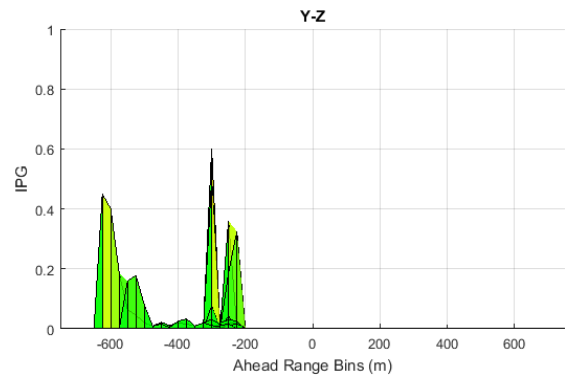
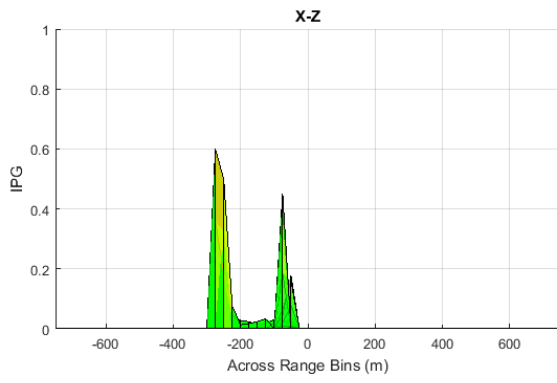
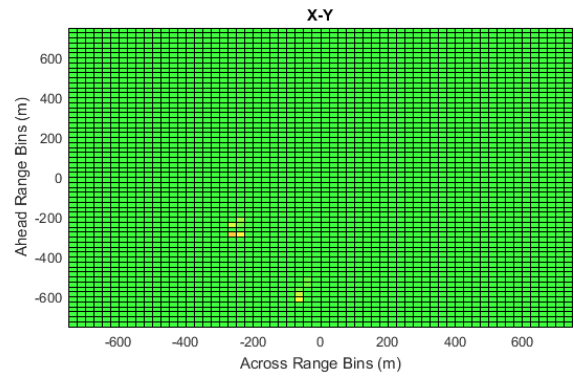
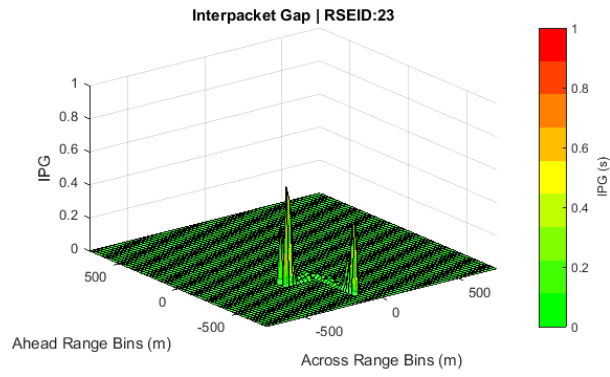
**Packet Error Rate  
RSEID: 21**



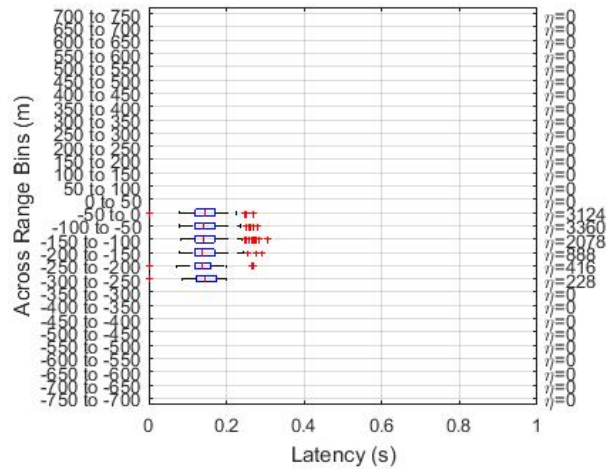
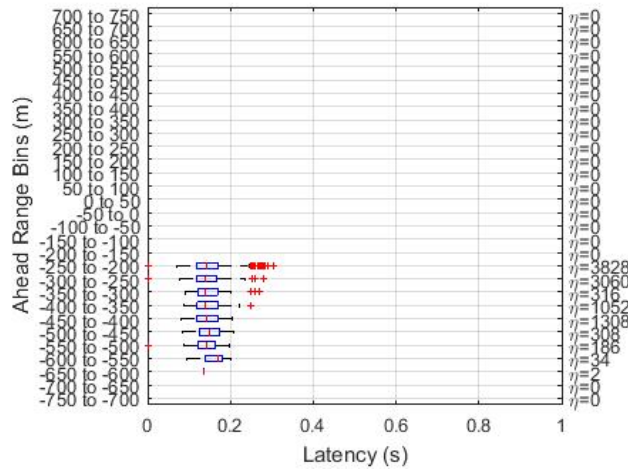


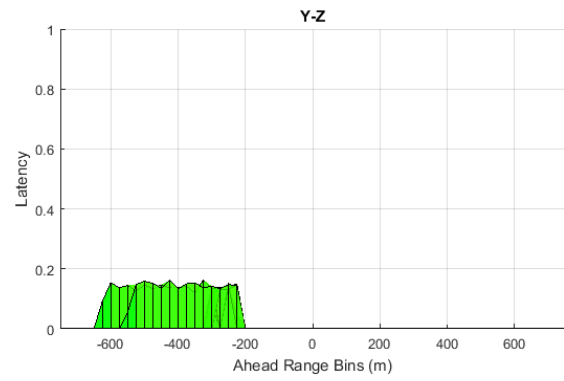
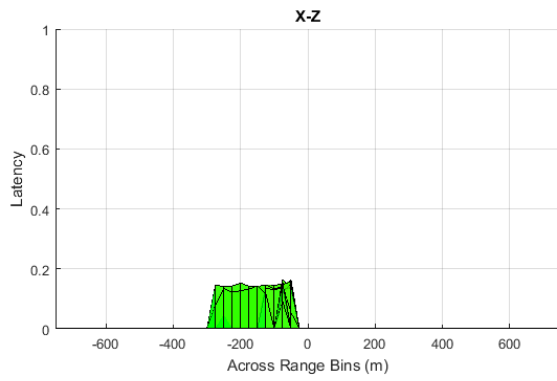
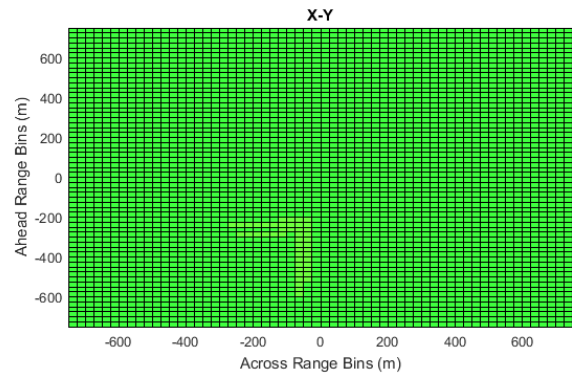
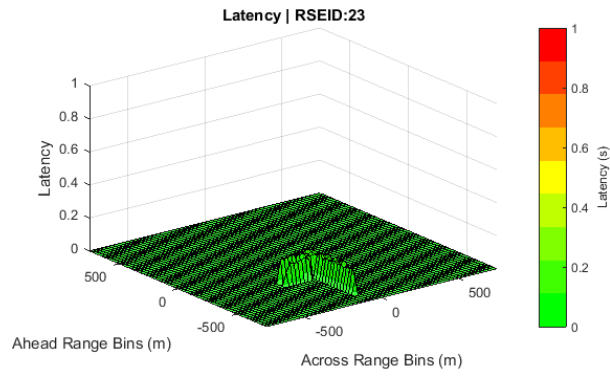
Interpacket Gap  
RSEID: 23



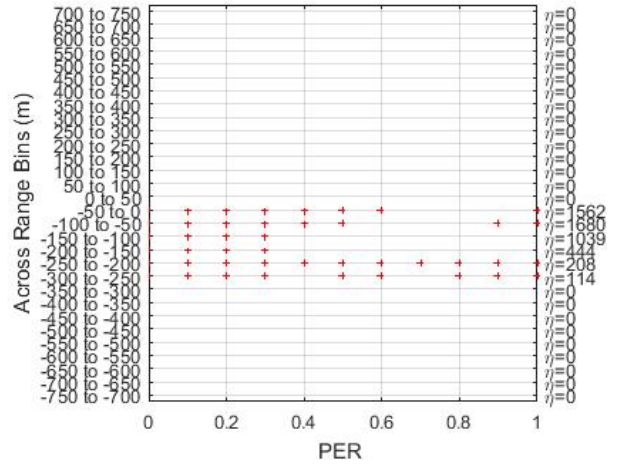
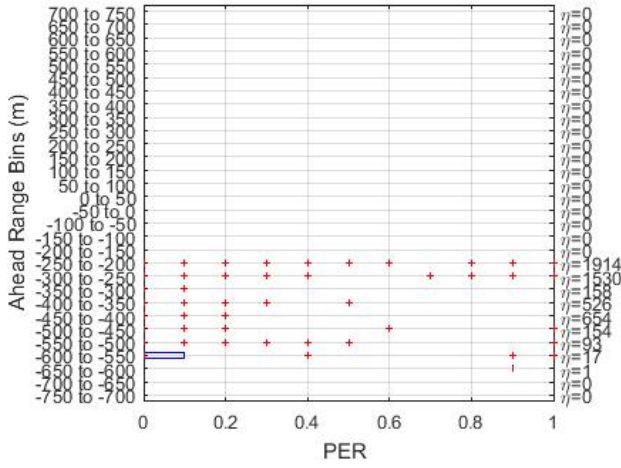


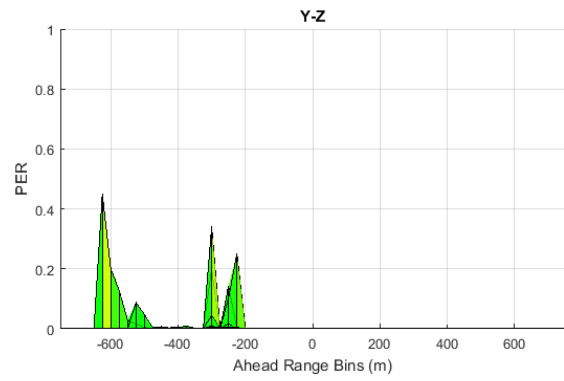
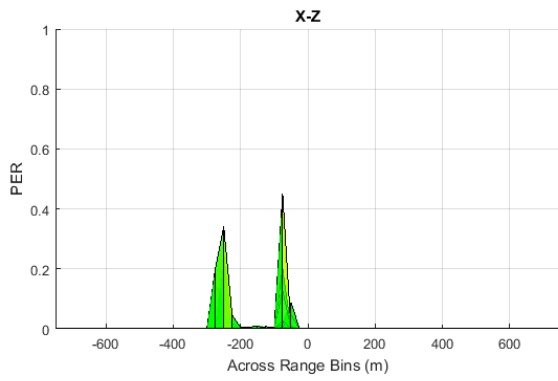
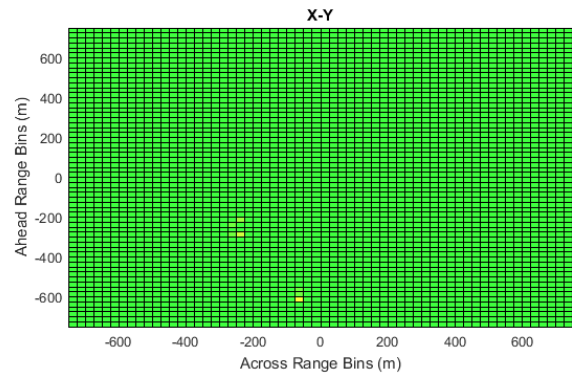
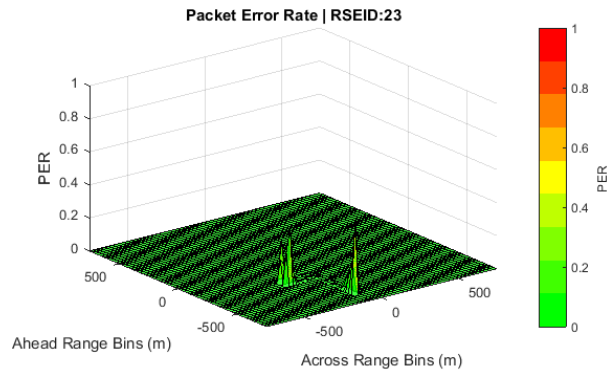
Latency  
RSEID: 23





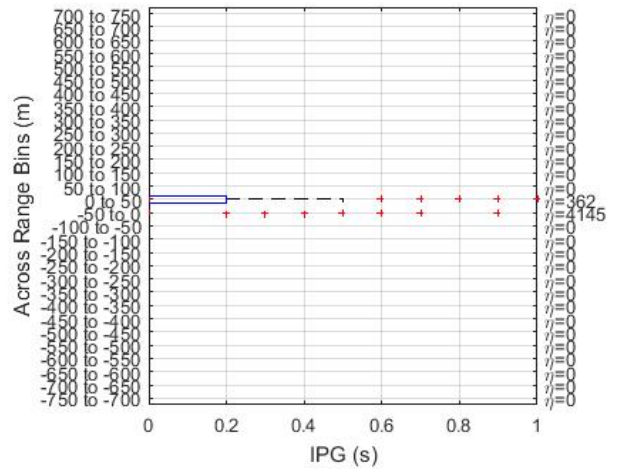
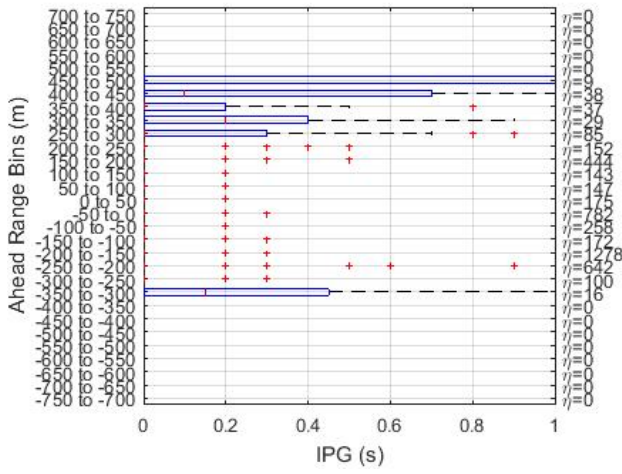
Packet Error Rate  
RSEID: 23

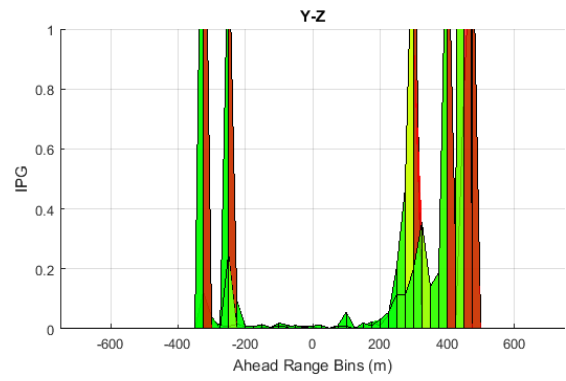
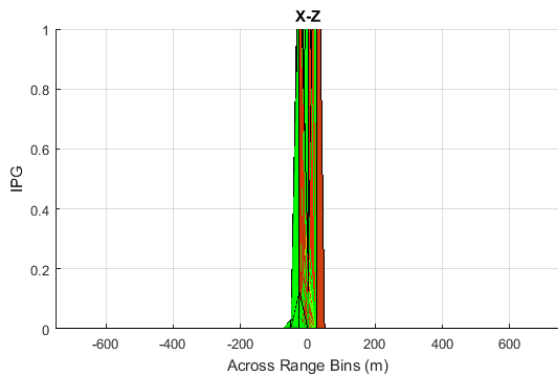
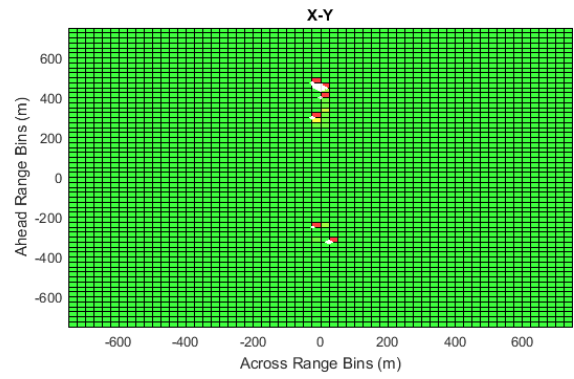
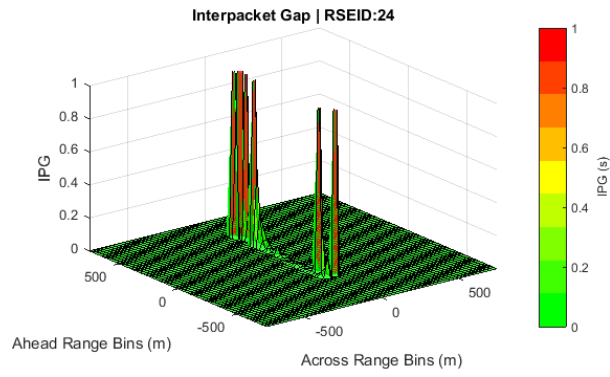




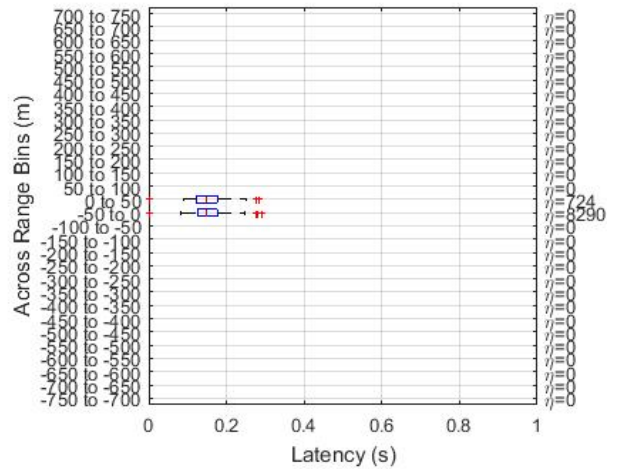
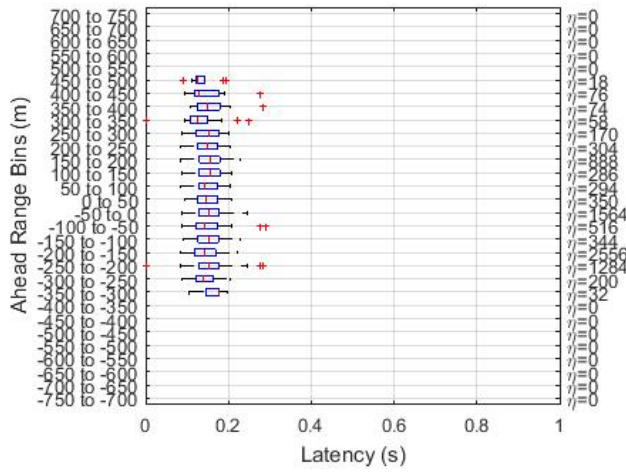


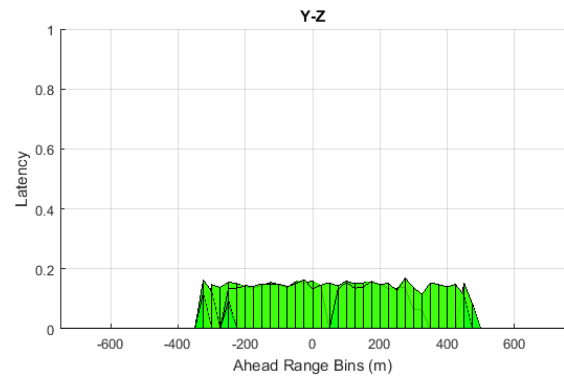
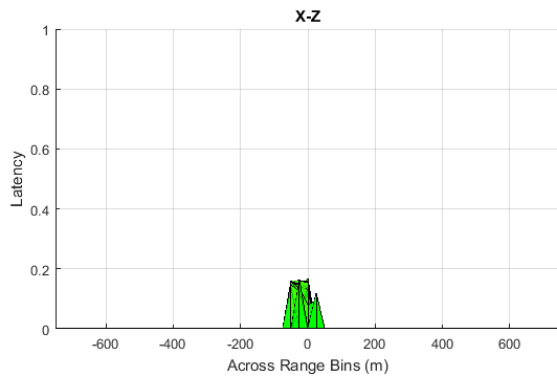
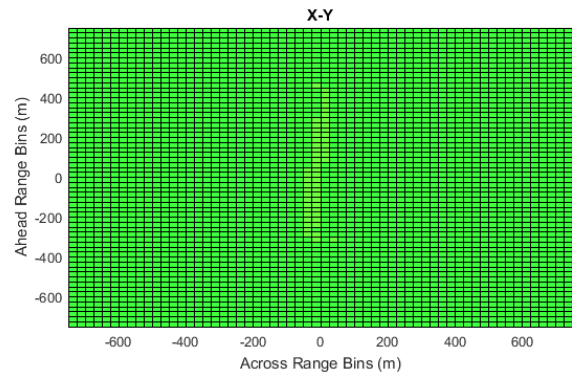
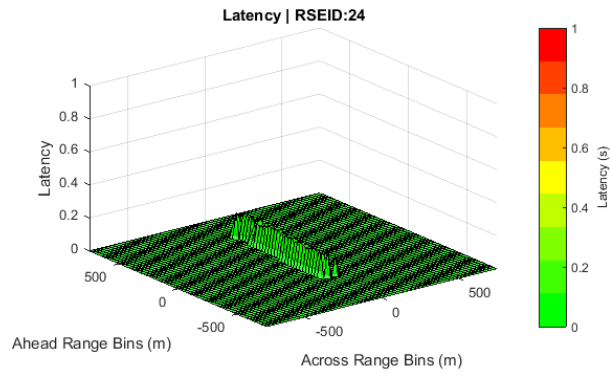
Interpacket Gap  
RSEID: 24



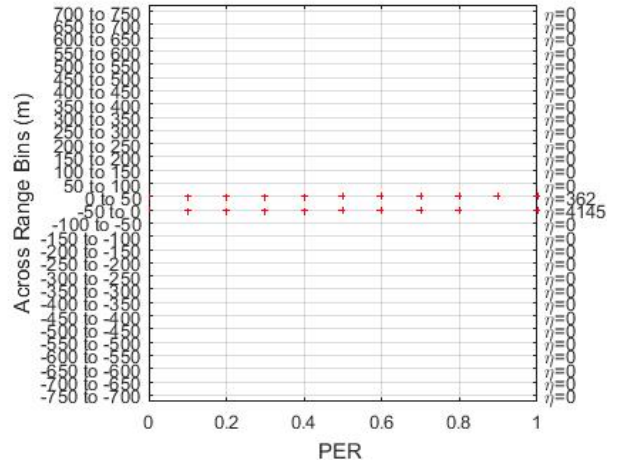
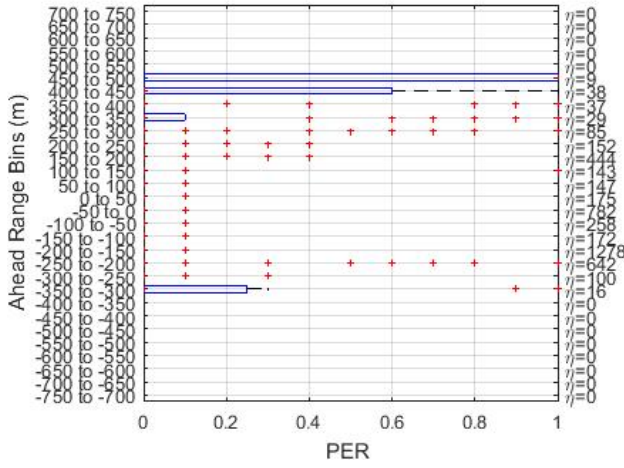


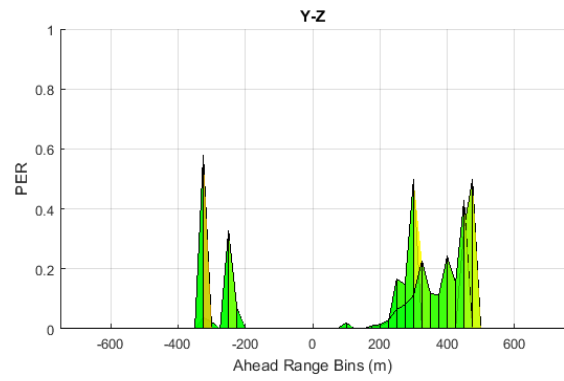
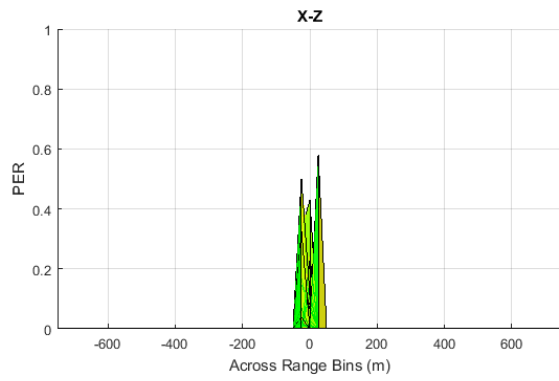
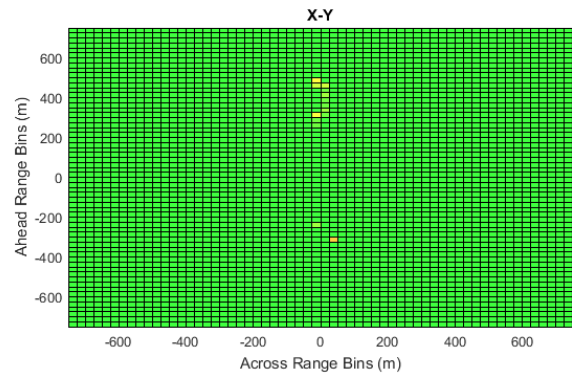
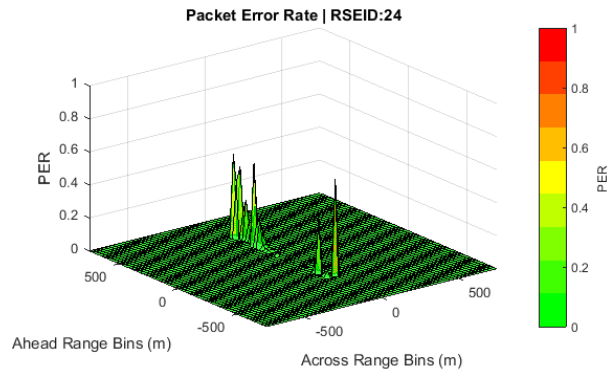
Latency  
RSEID: 24



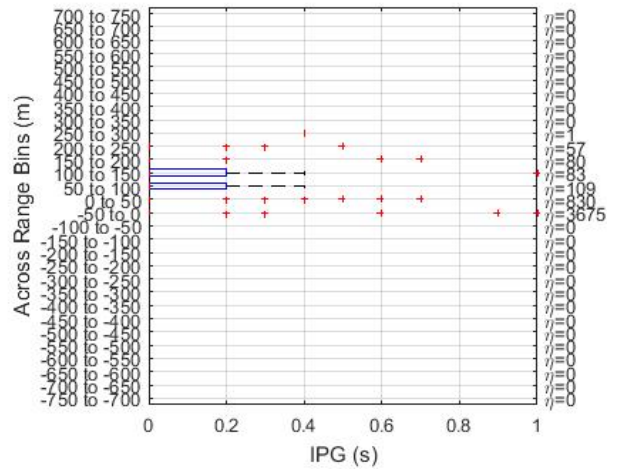
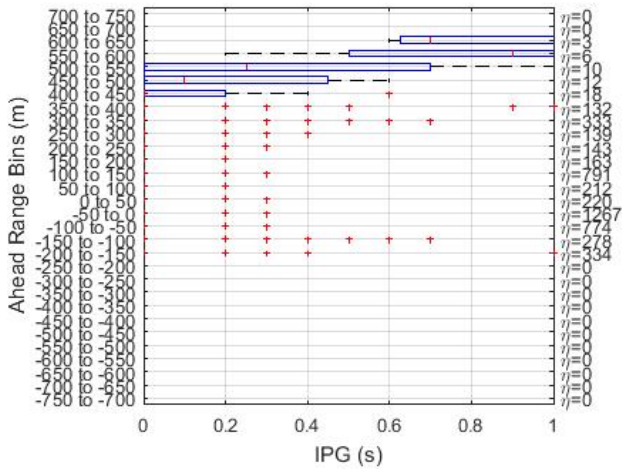


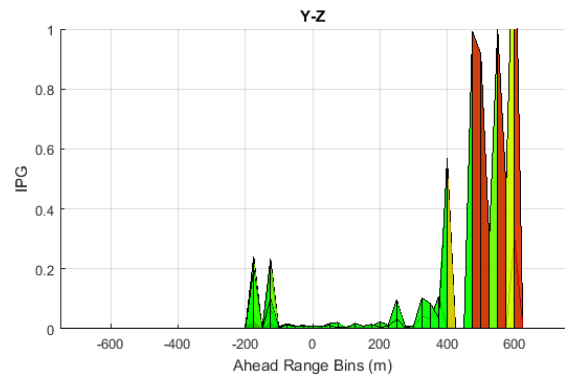
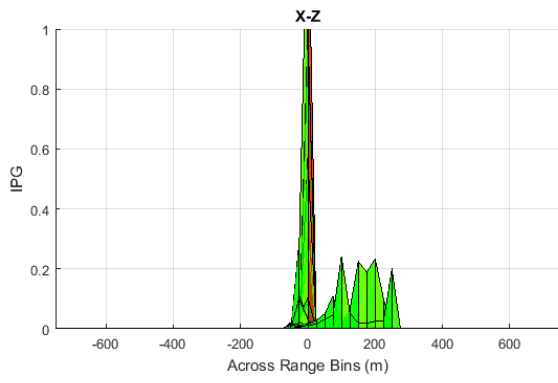
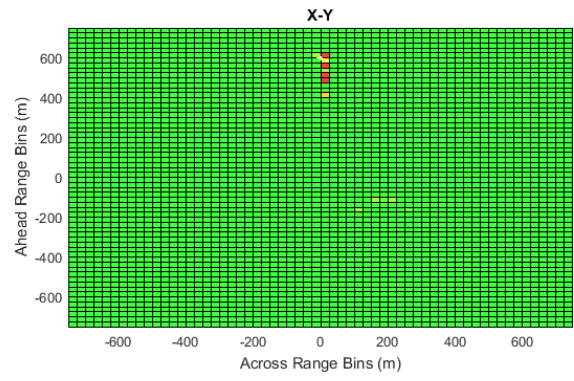
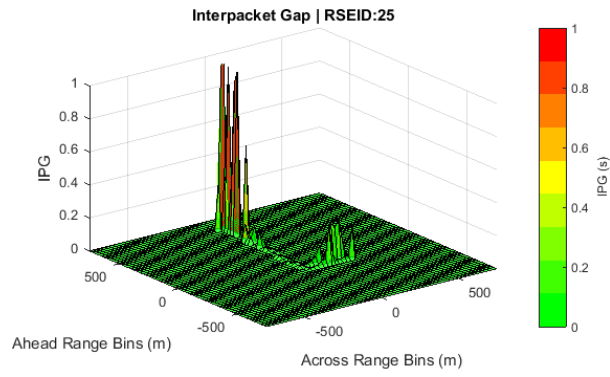
Packet Error Rate  
RSEID: 24





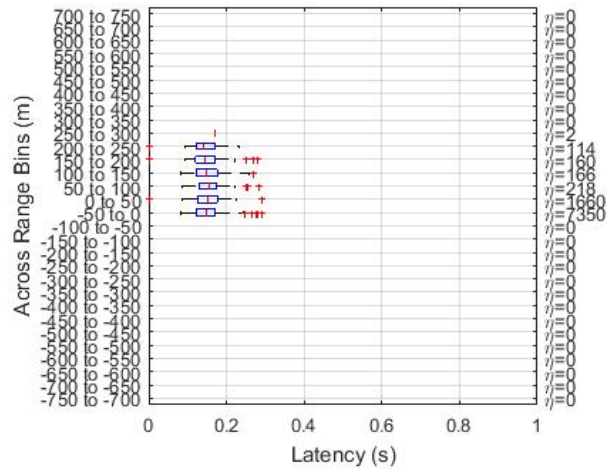
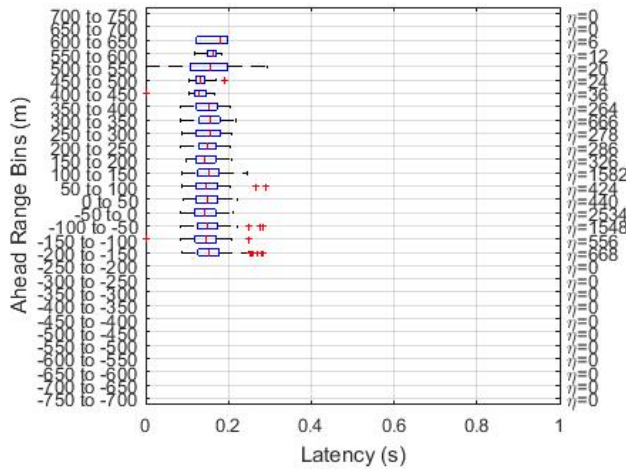
Interpacket Gap  
RSEID: 25

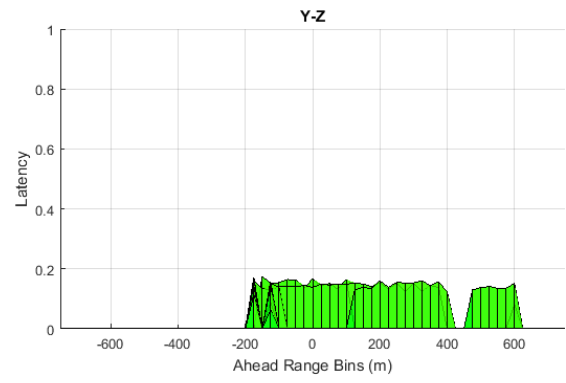
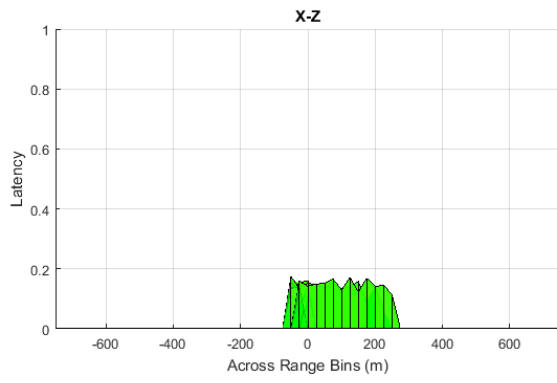
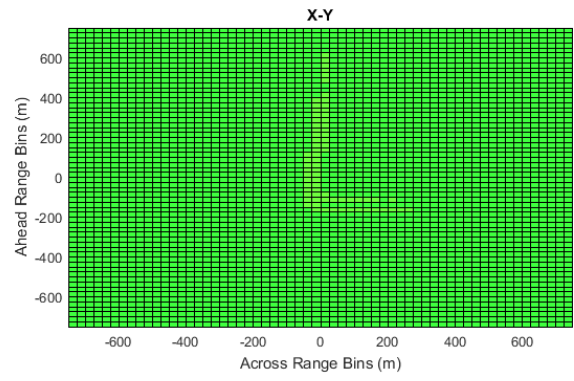
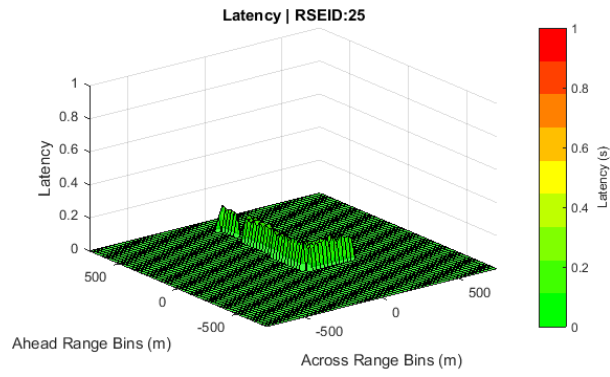




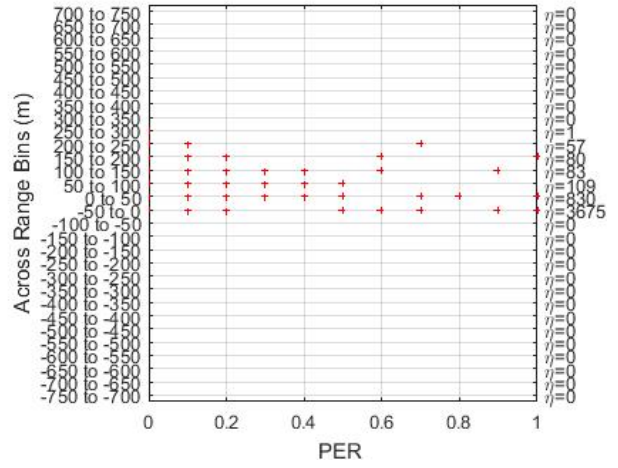
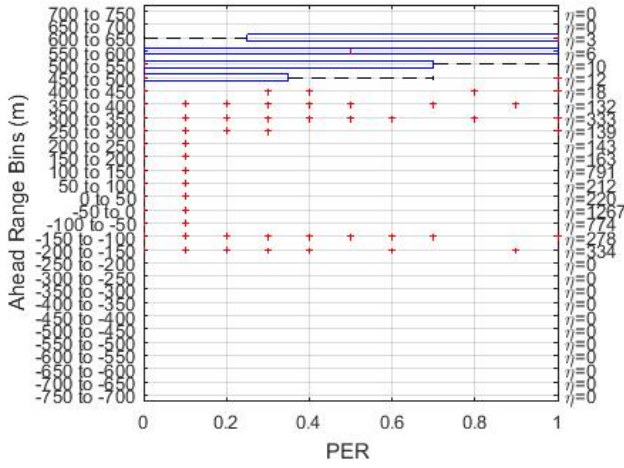


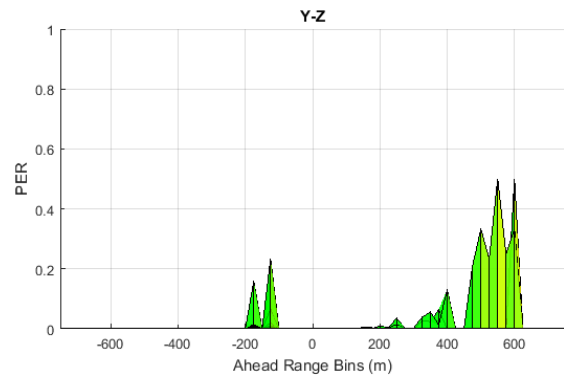
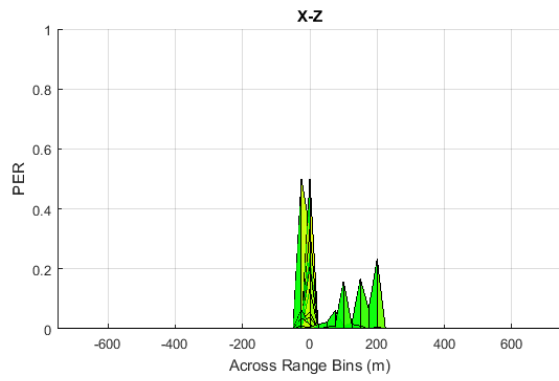
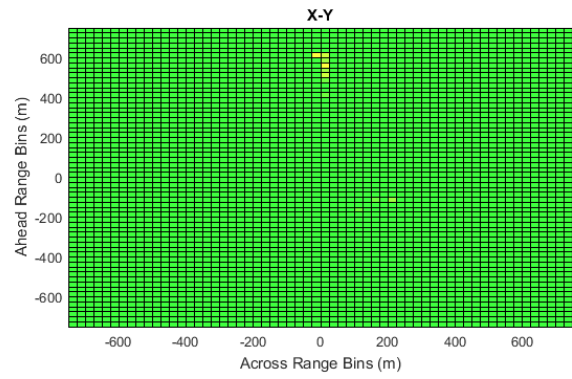
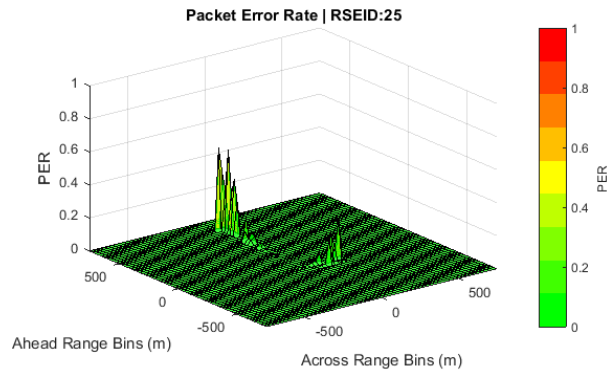
Latency  
RSEID: 25



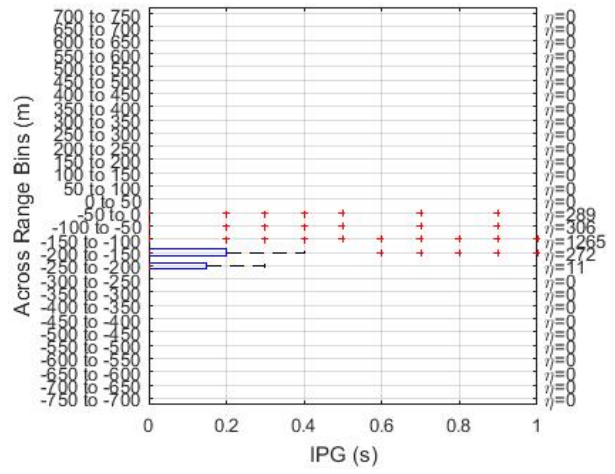
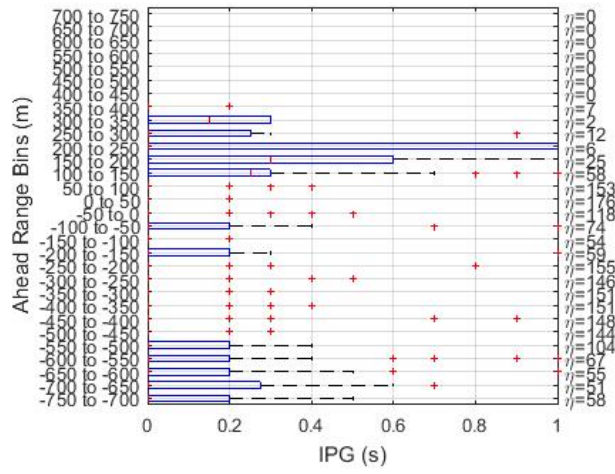


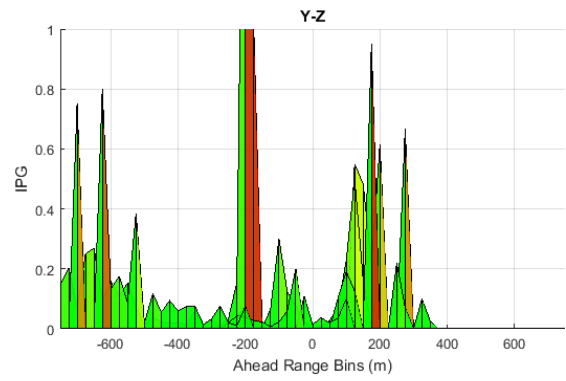
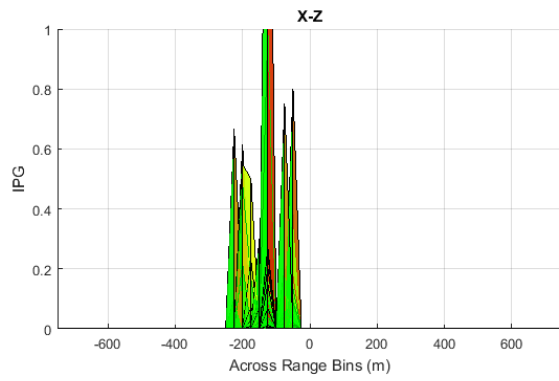
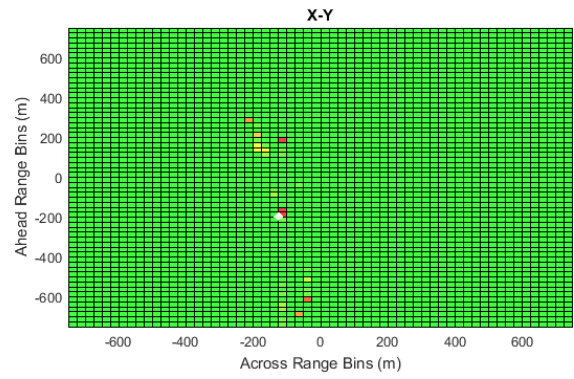
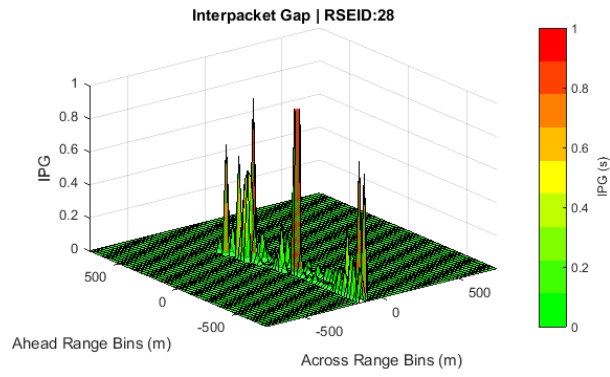
Packet Error Rate  
RSEID: 25



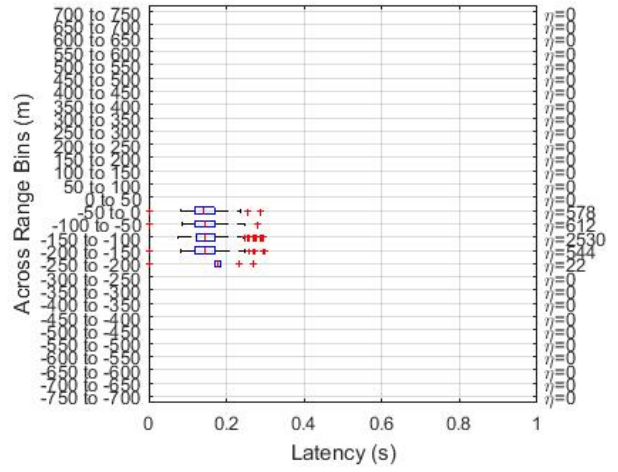
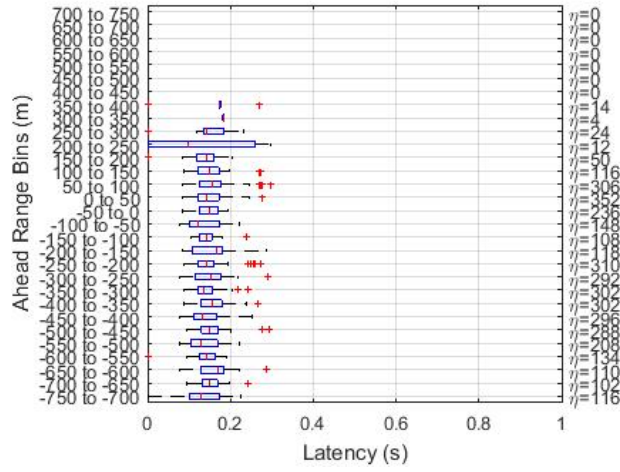


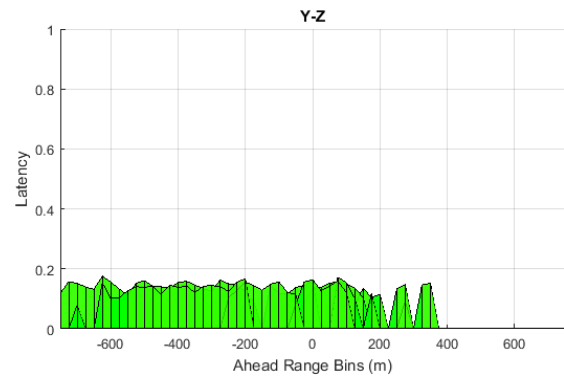
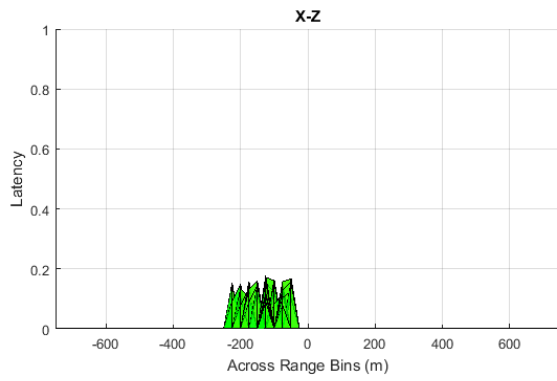
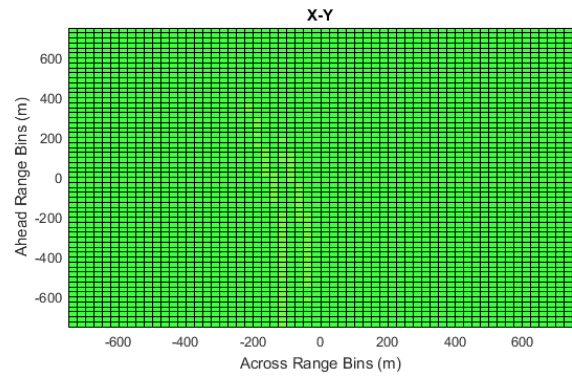
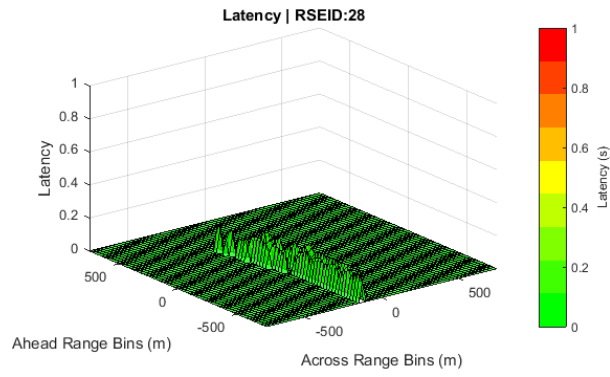
Interpacket Gap  
RSEID: 28





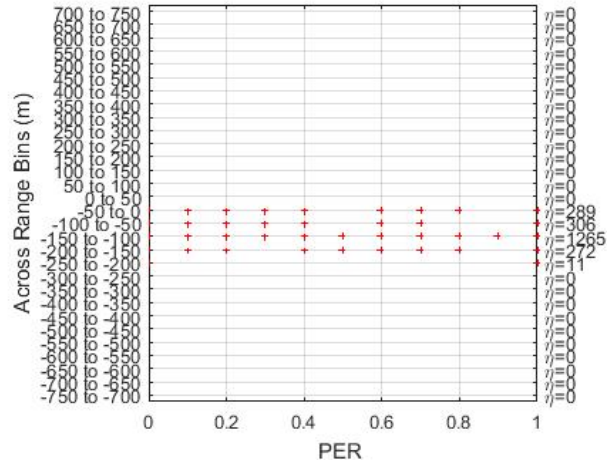
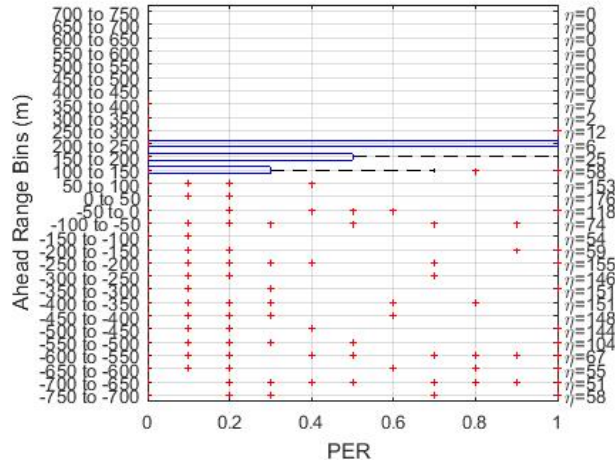
Latency  
RSEID: 28

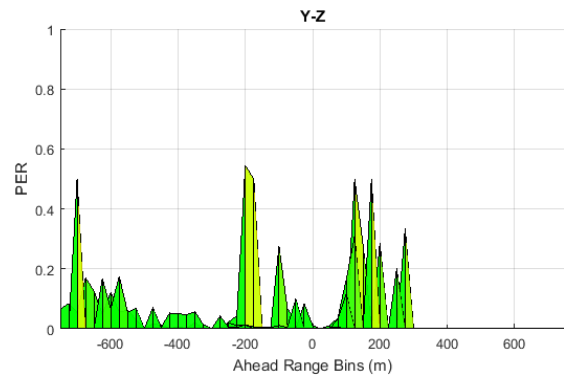
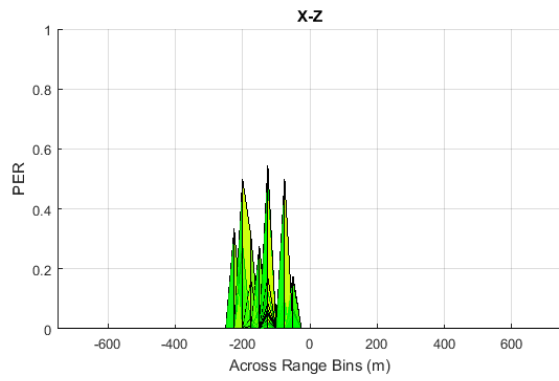
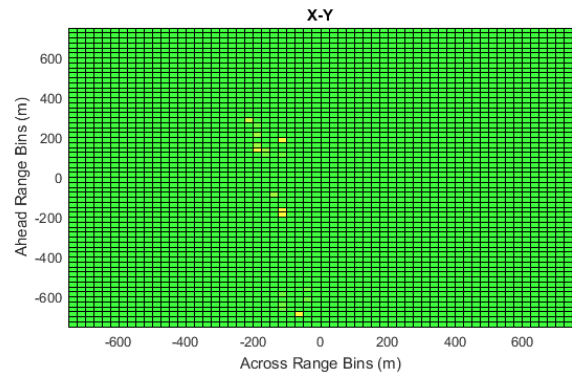
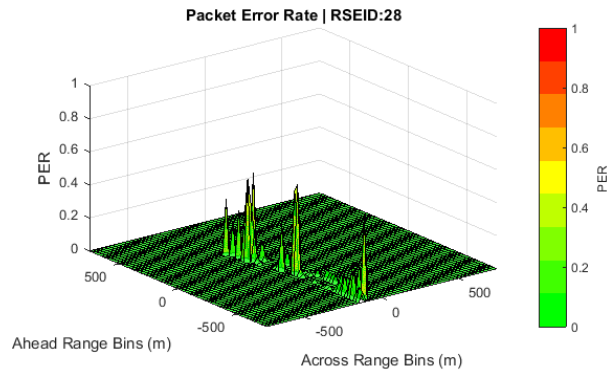




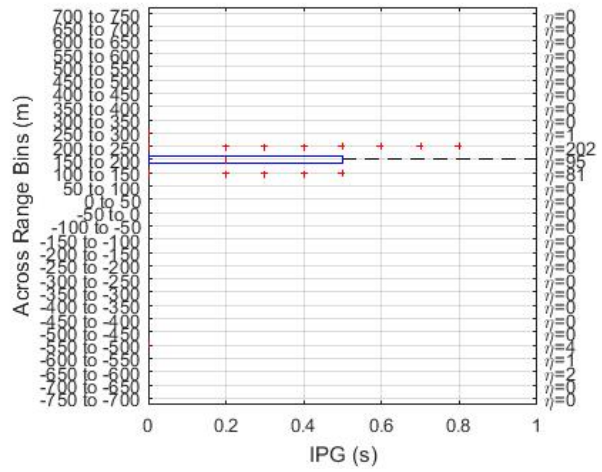
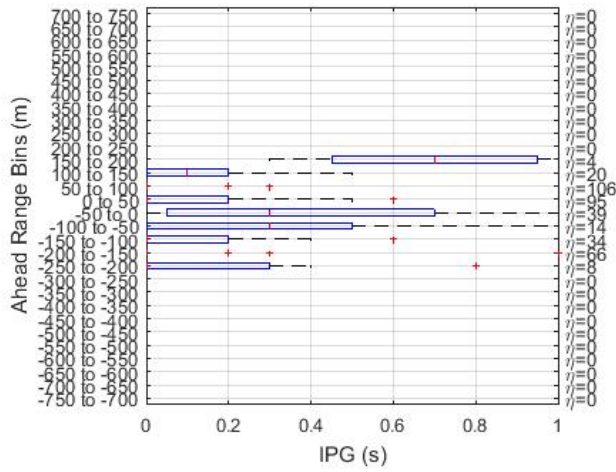


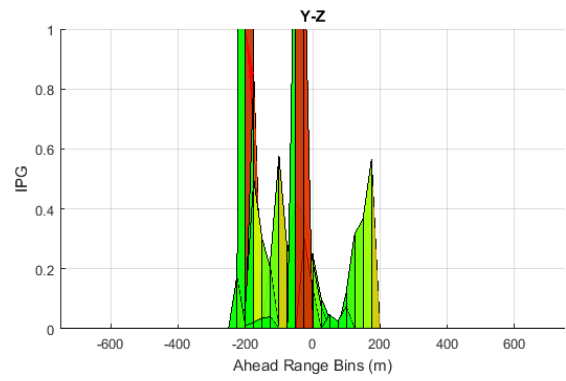
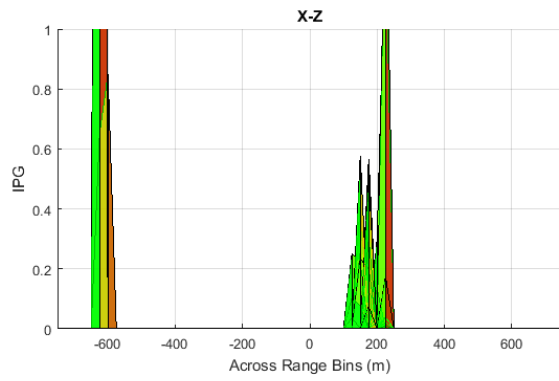
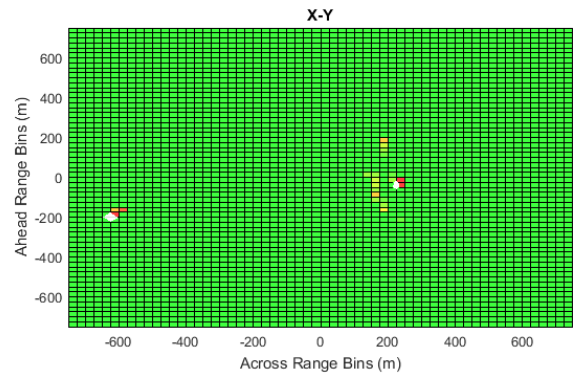
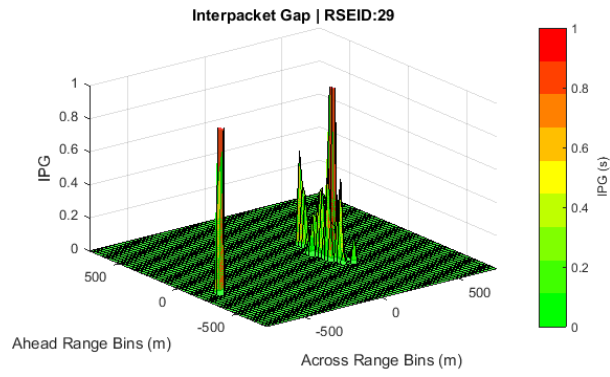
Packet Error Rate  
RSEID: 28



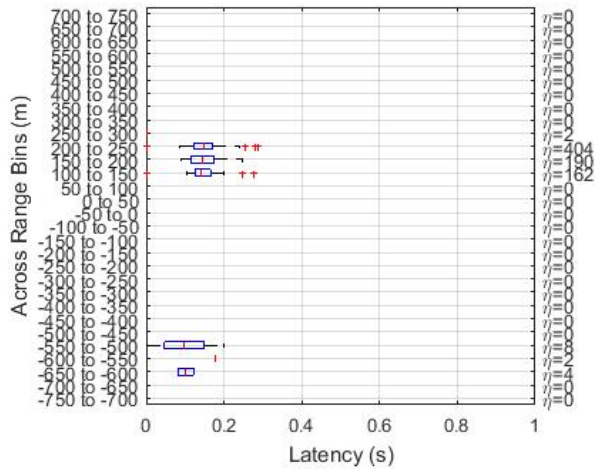
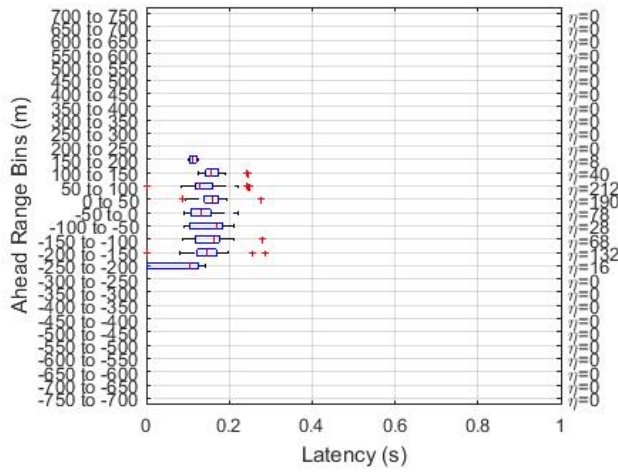


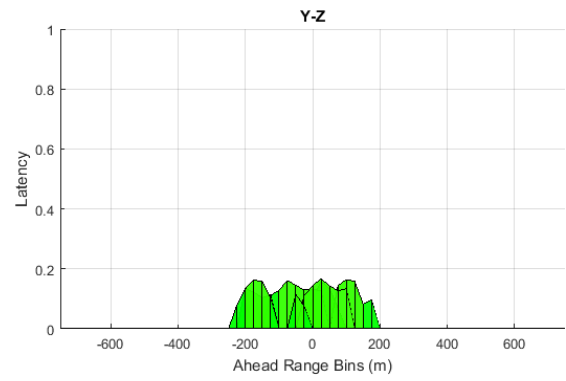
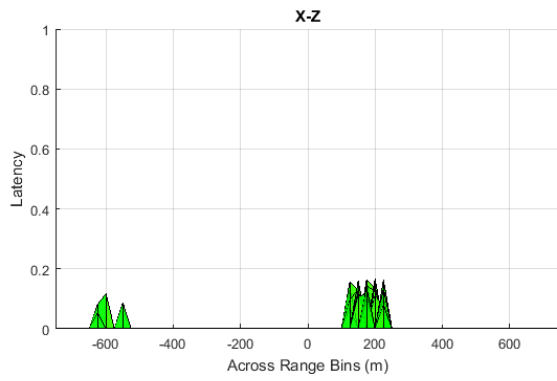
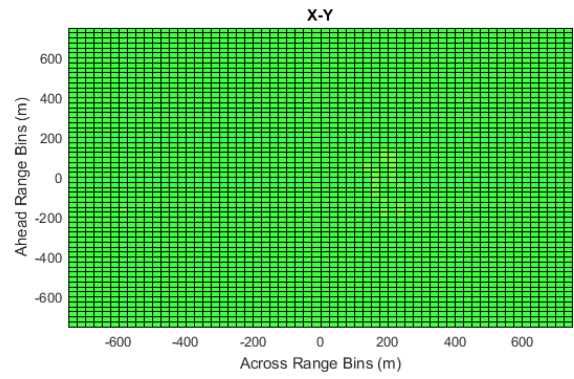
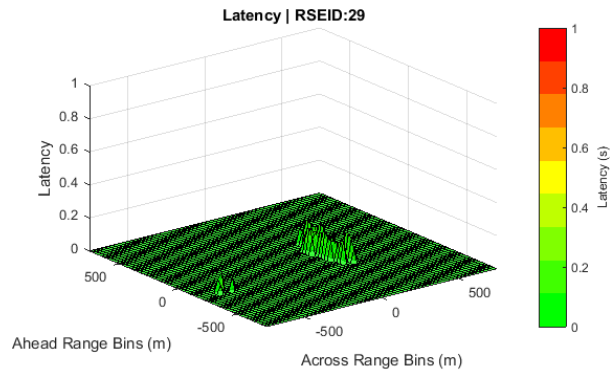
**Interpacket Gap  
RSEID: 29**



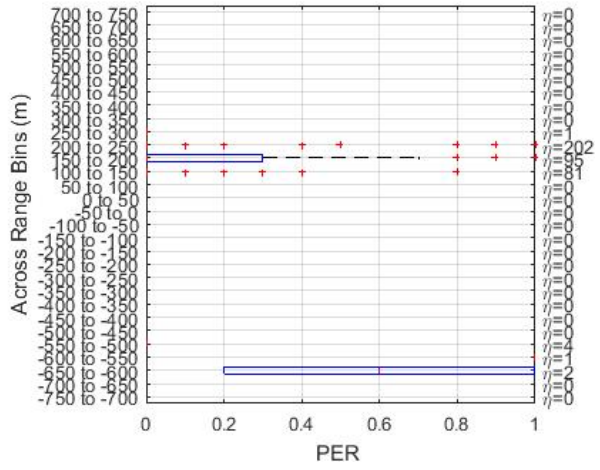
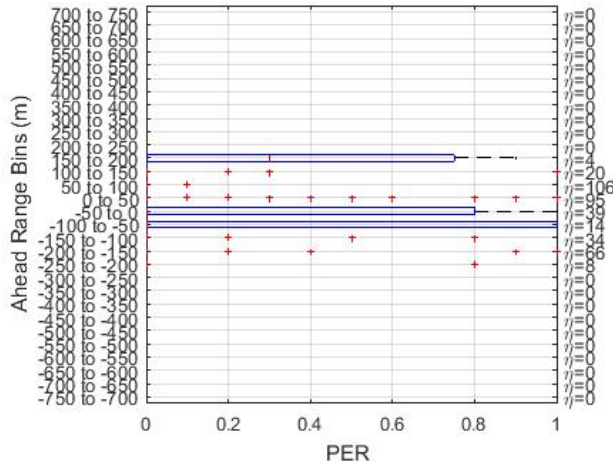


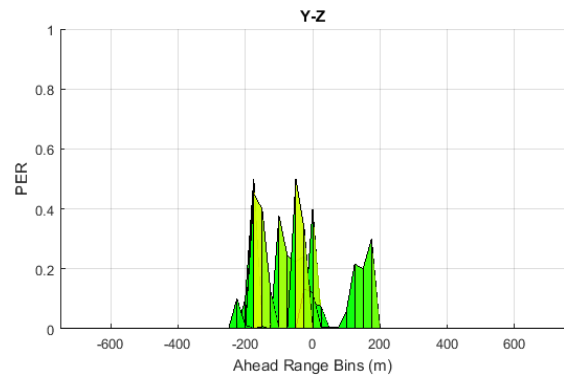
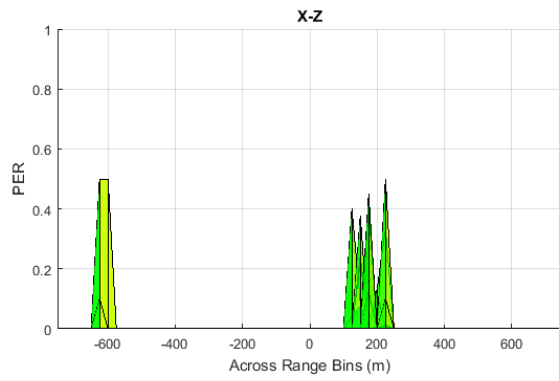
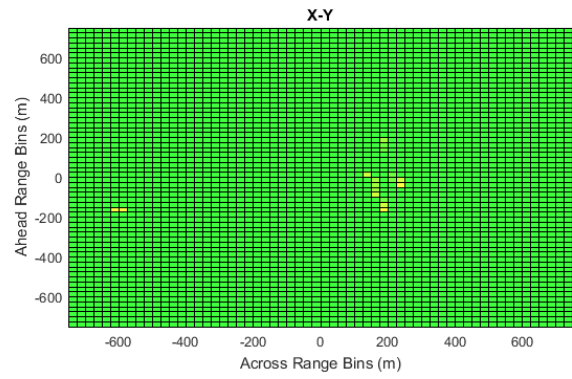
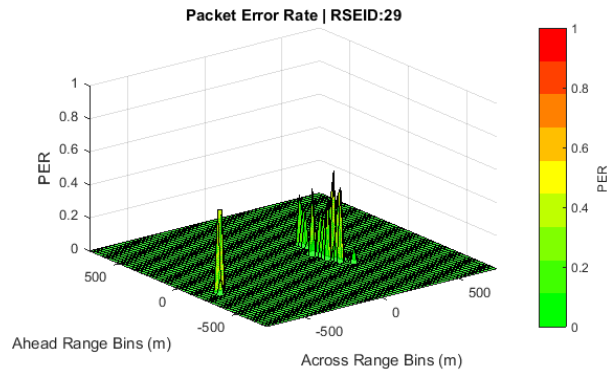
Latency  
RSEID: 29





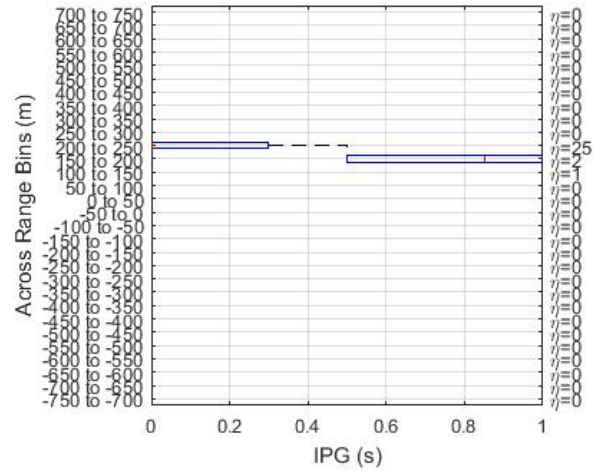
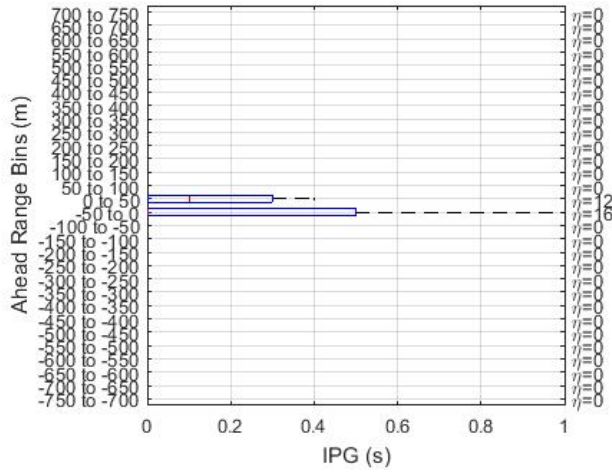
**Packet Error Rate**  
RSEID: 29

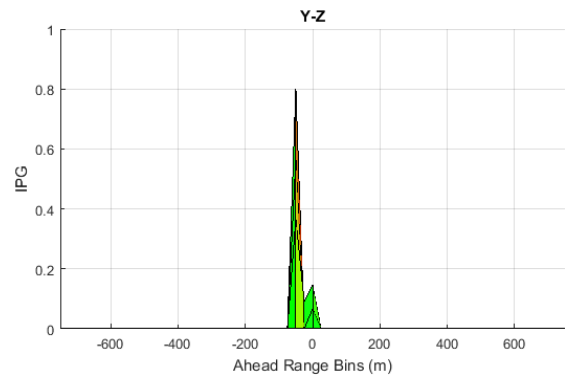
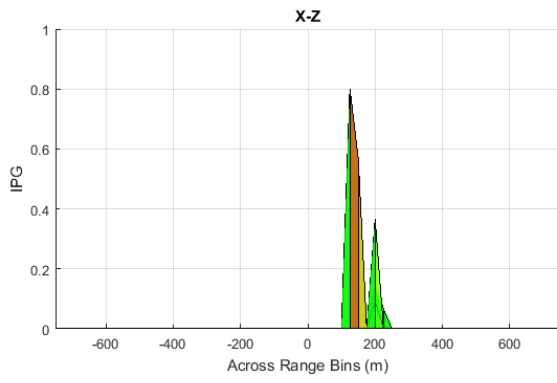
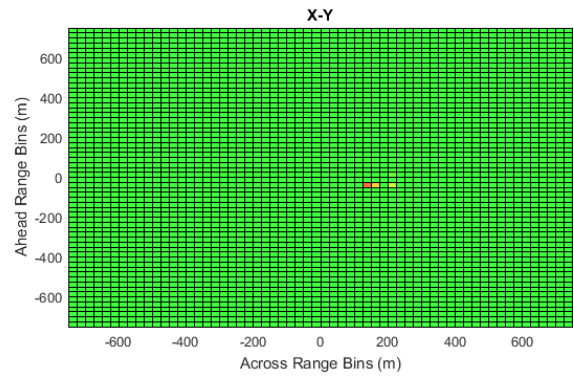
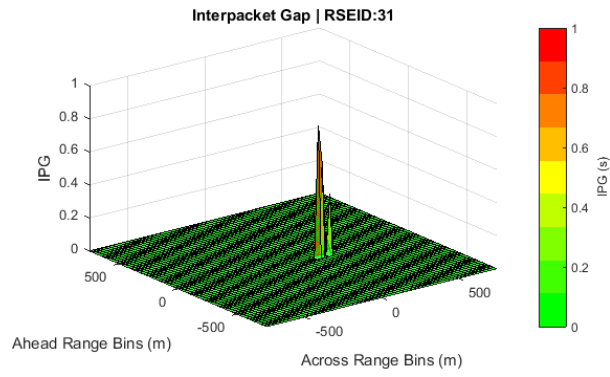




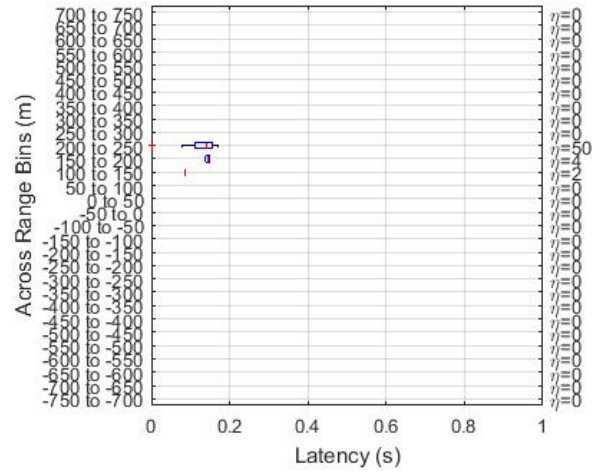
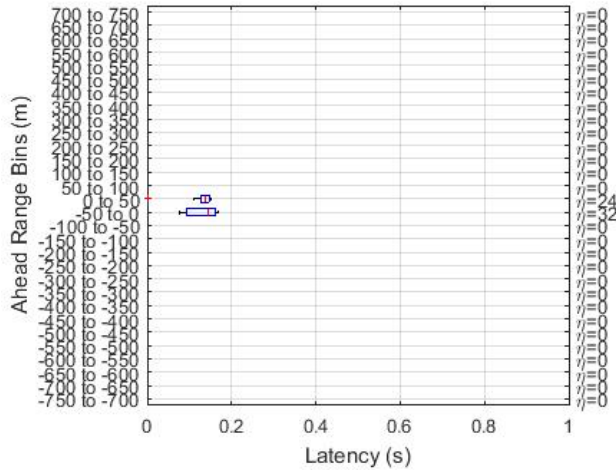


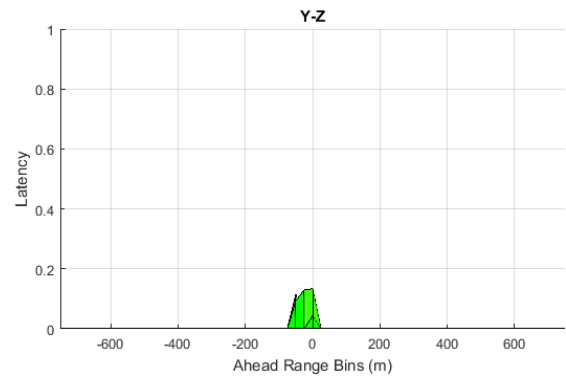
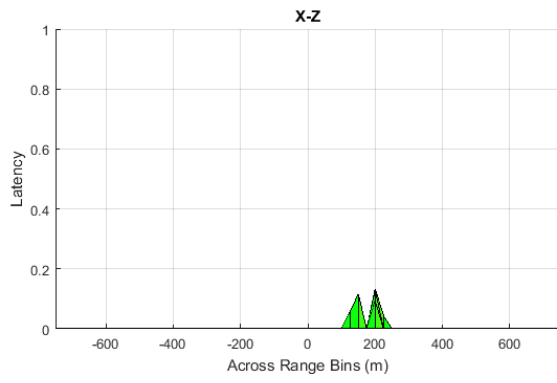
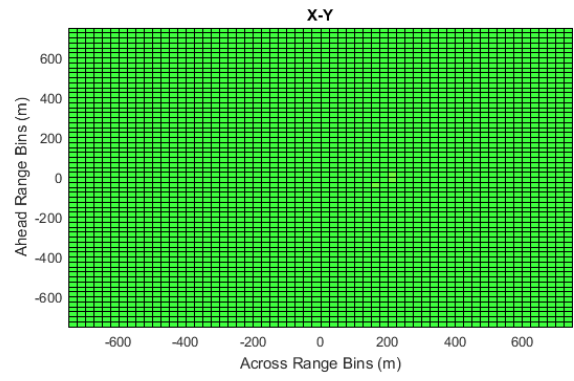
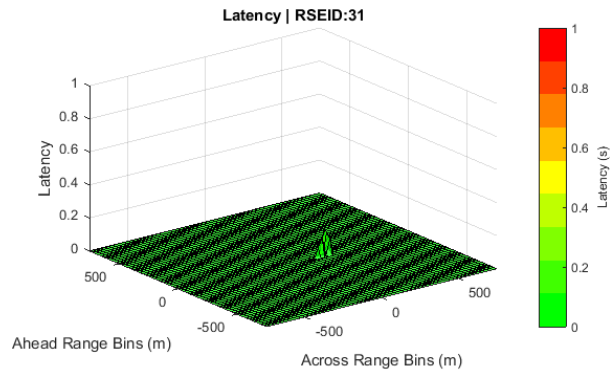
**Interpacket Gap  
RSEID: 31**



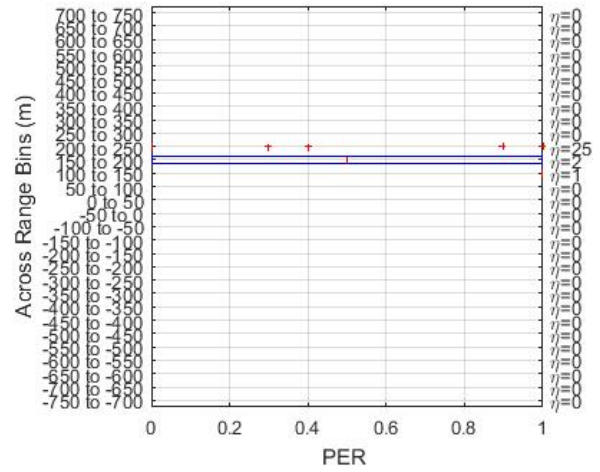
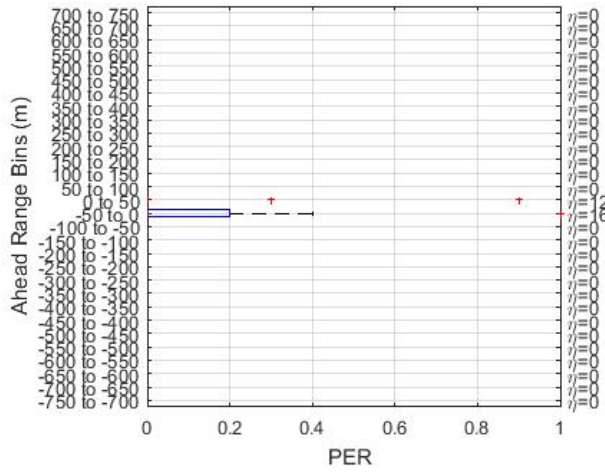


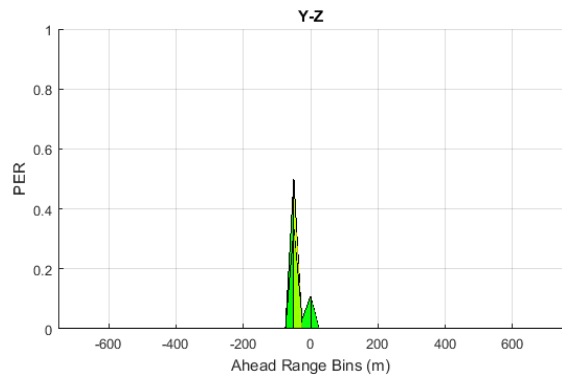
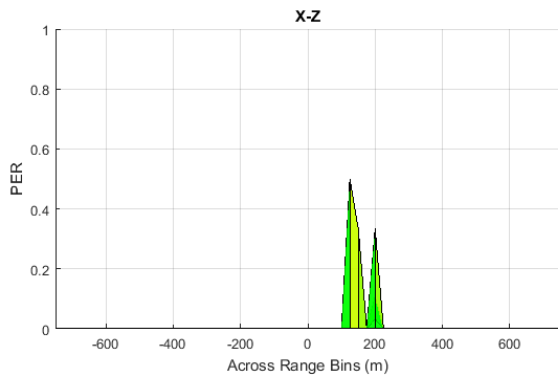
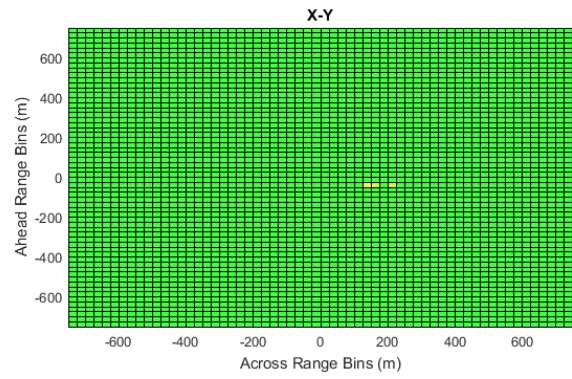
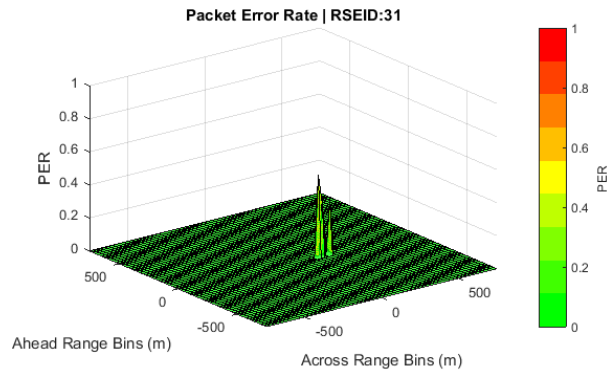
Latency  
RSEID: 31



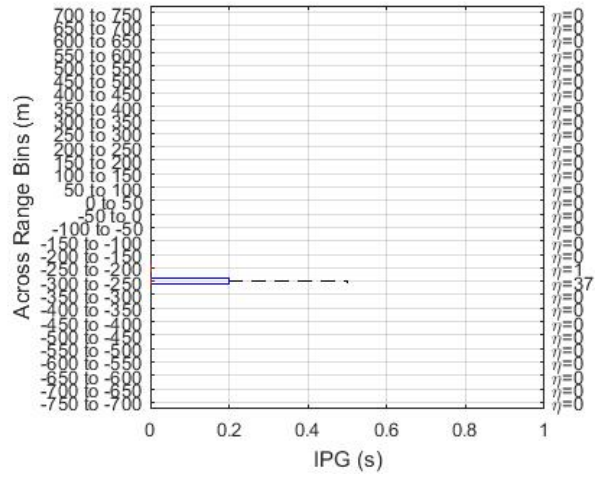
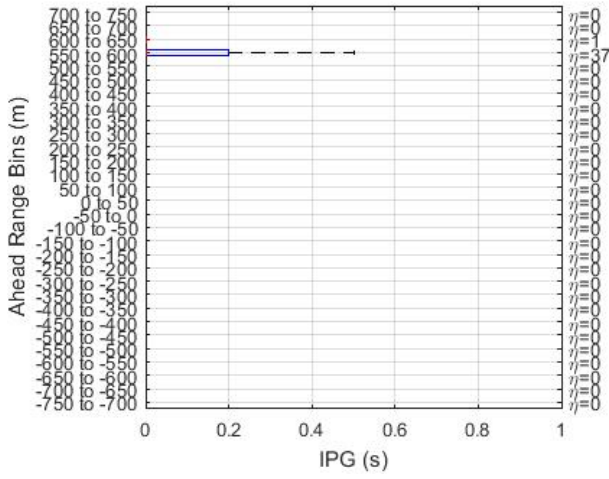
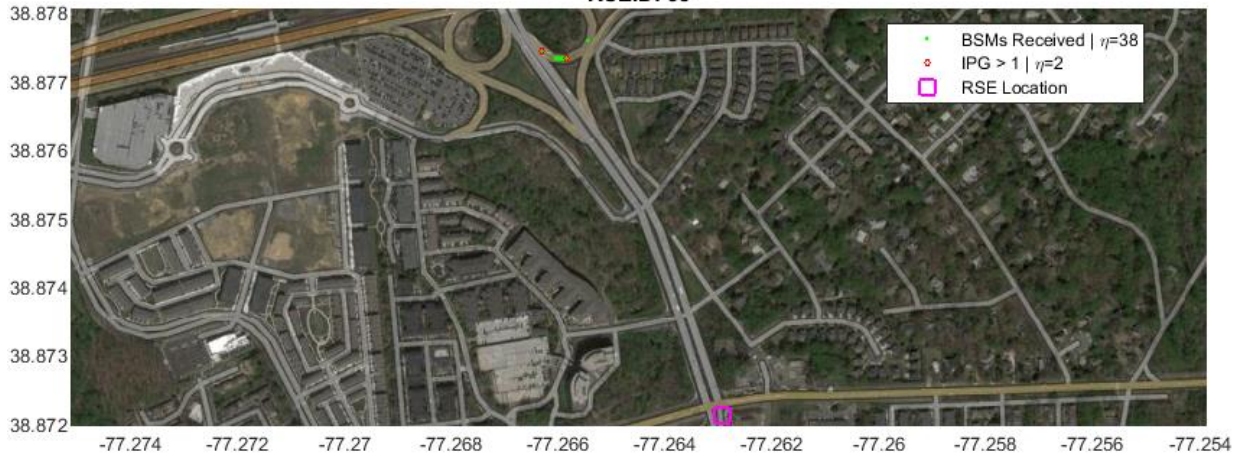


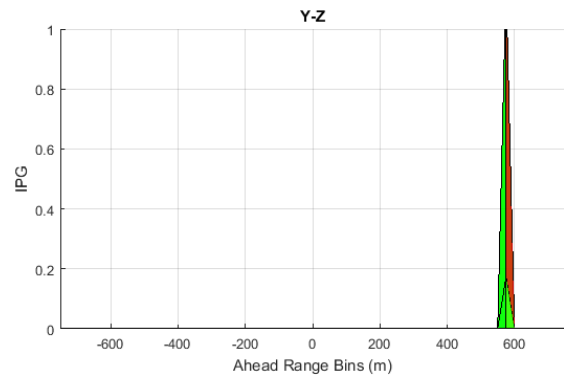
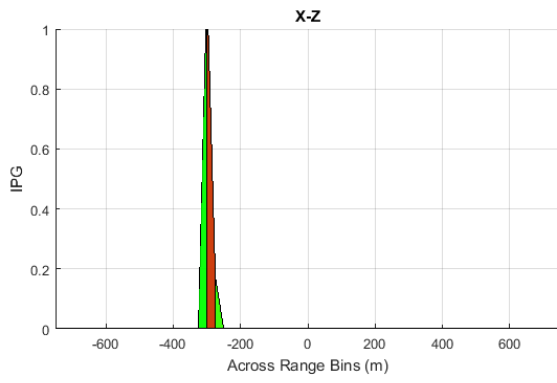
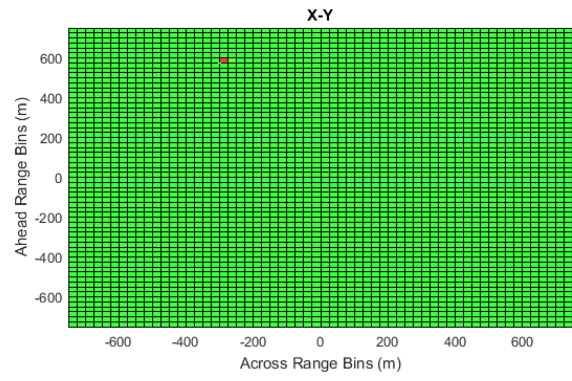
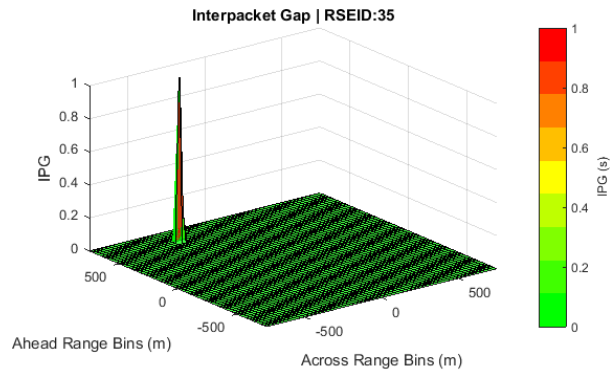
**Packet Error Rate  
RSEID: 31**





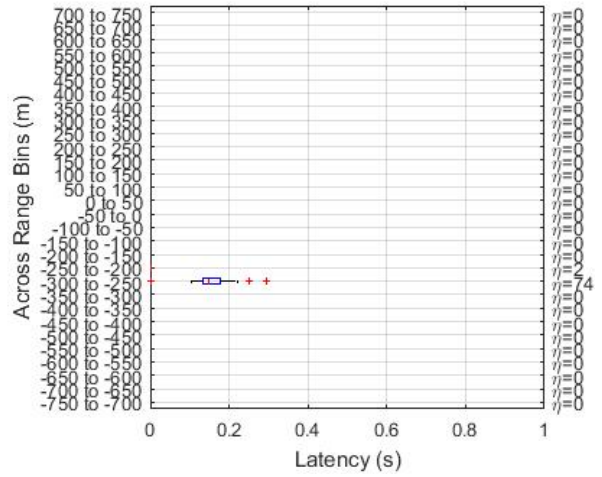
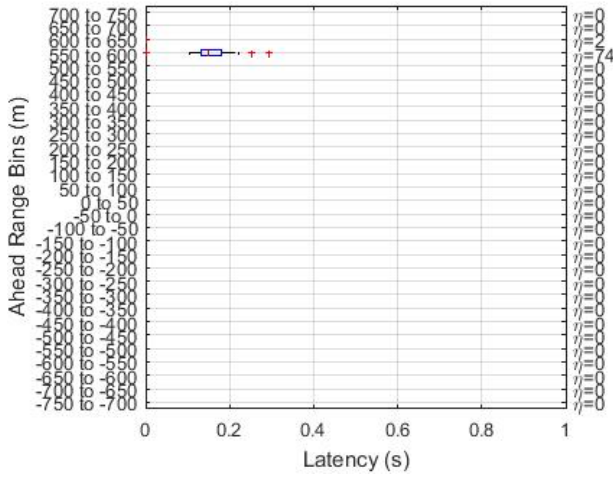
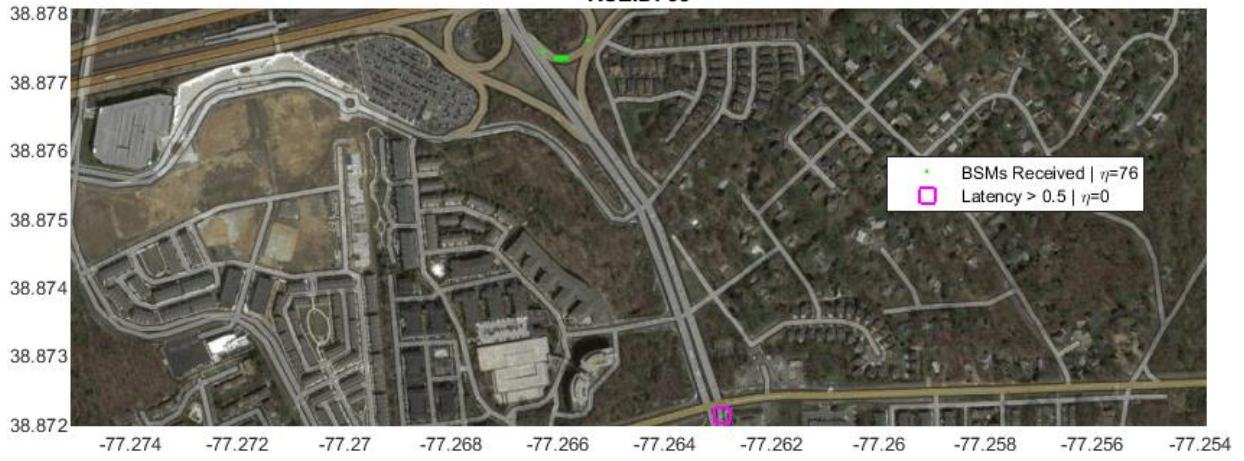
Interpacket Gap  
RSEID: 35

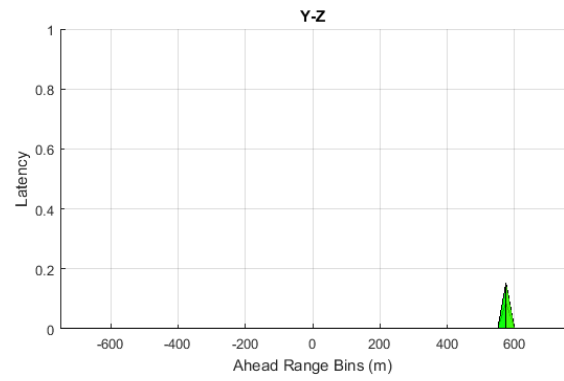
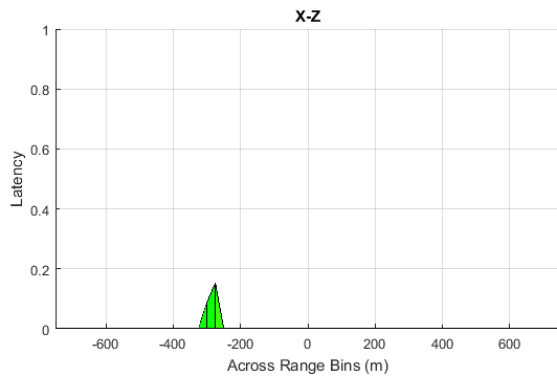
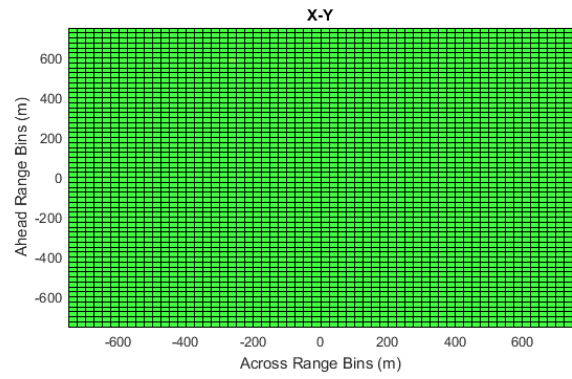
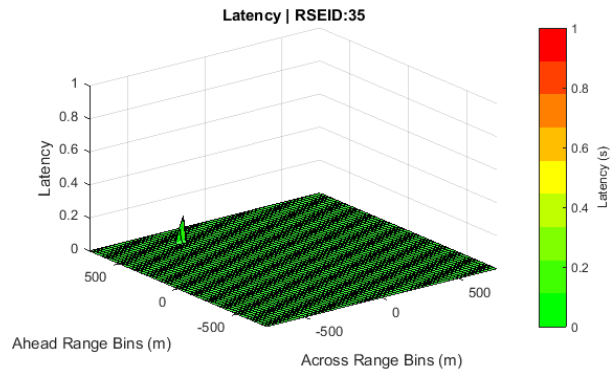




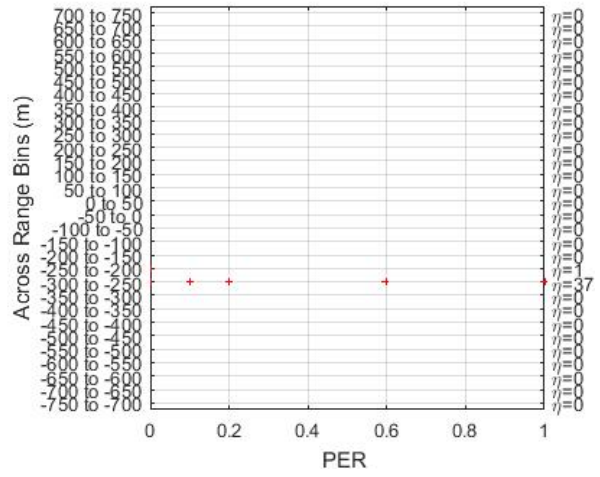
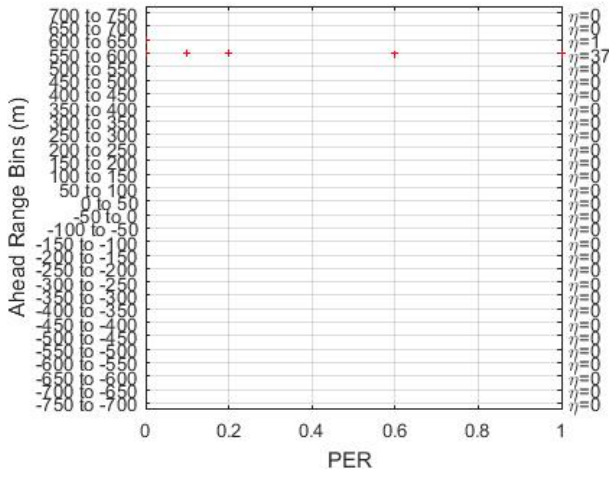
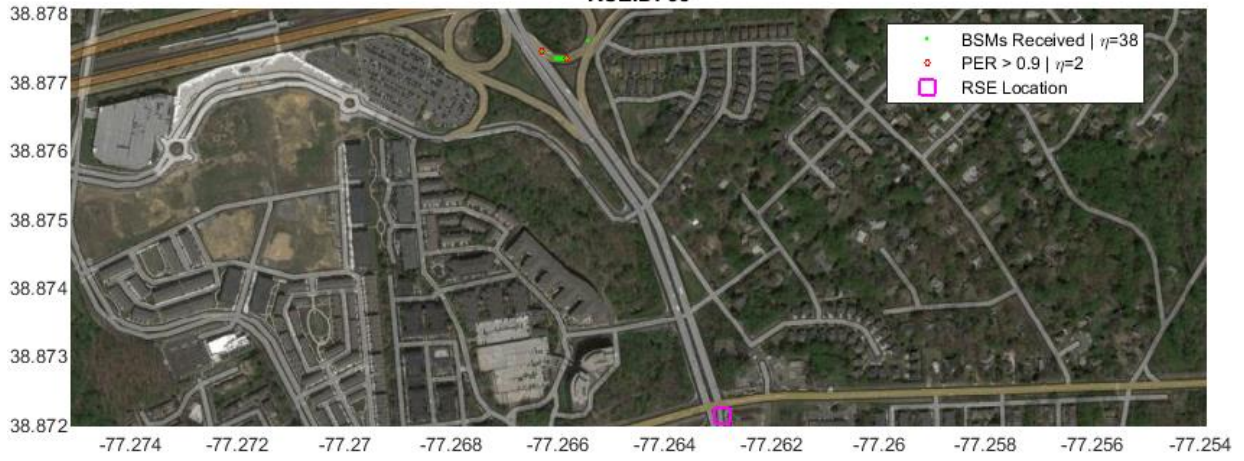


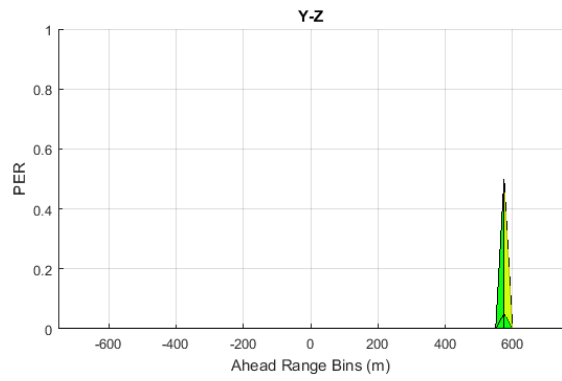
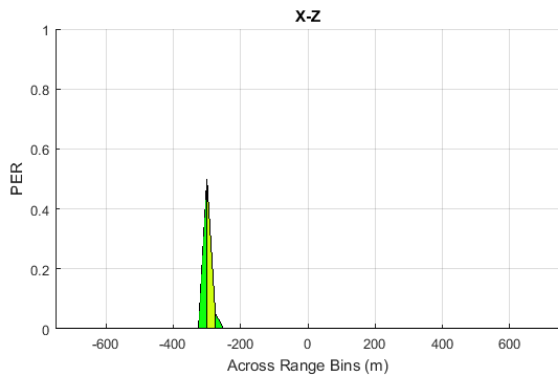
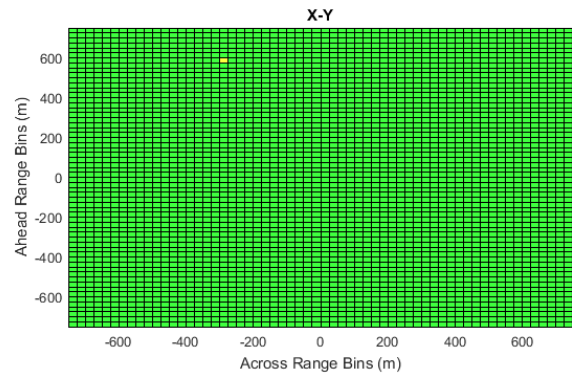
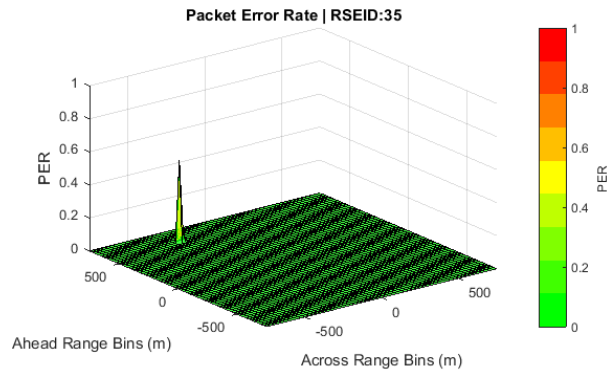
Latency  
RSEID: 35



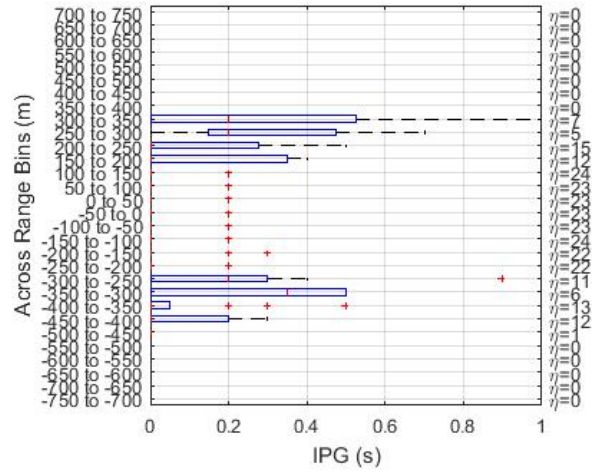
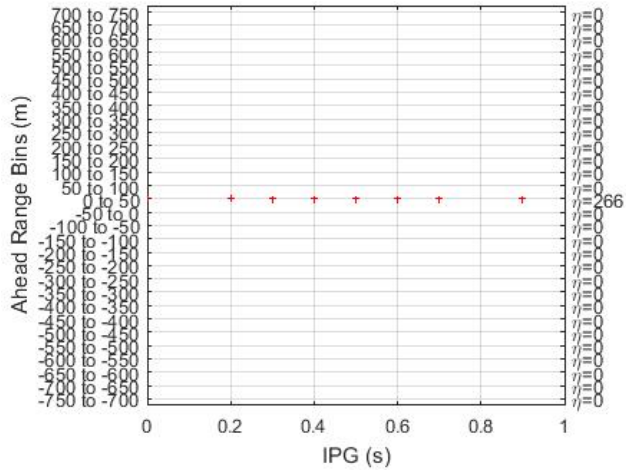


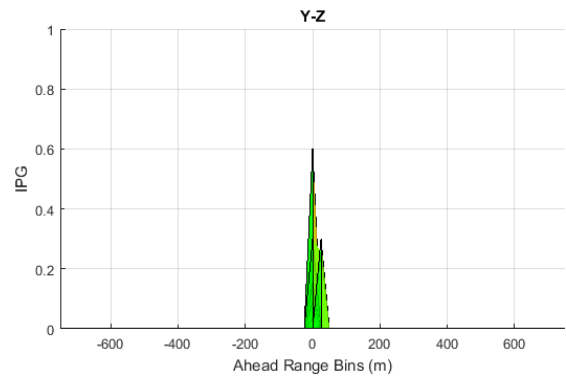
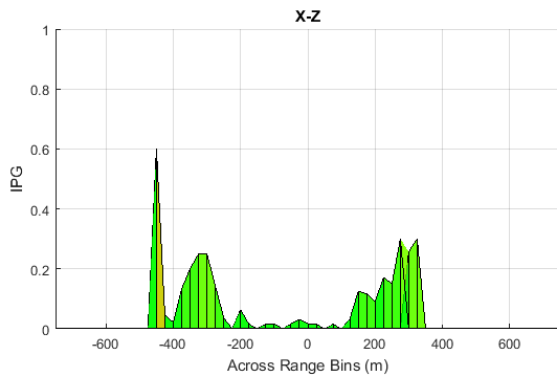
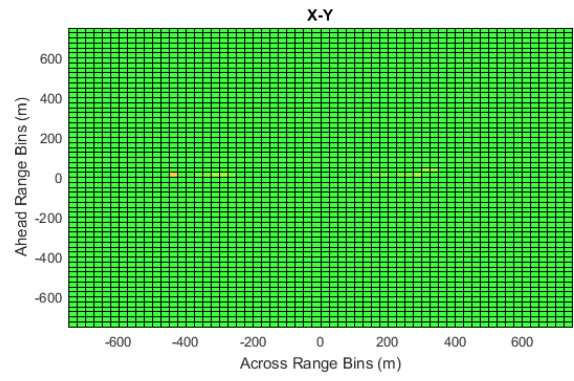
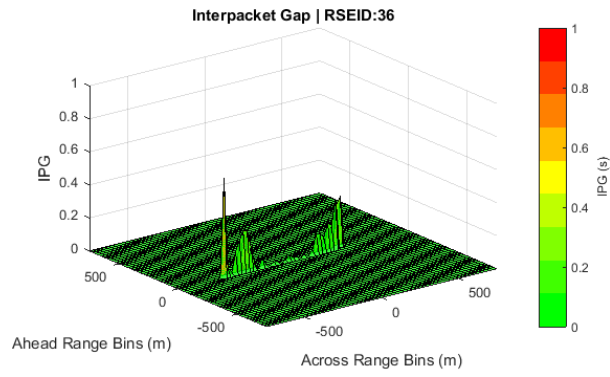
**Packet Error Rate  
RSEID: 35**



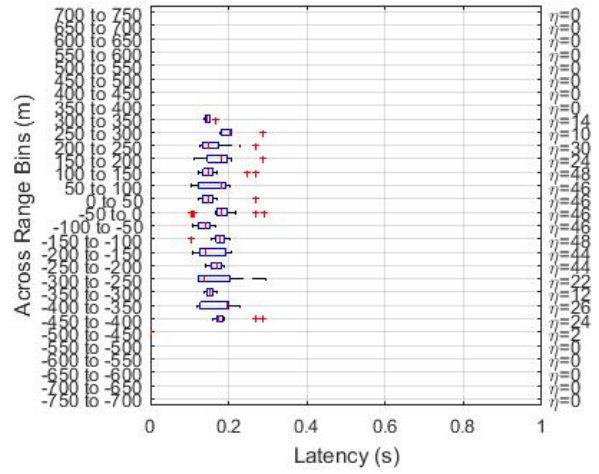
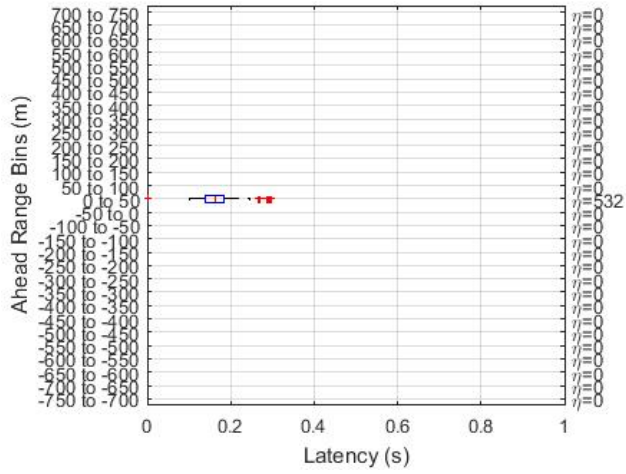


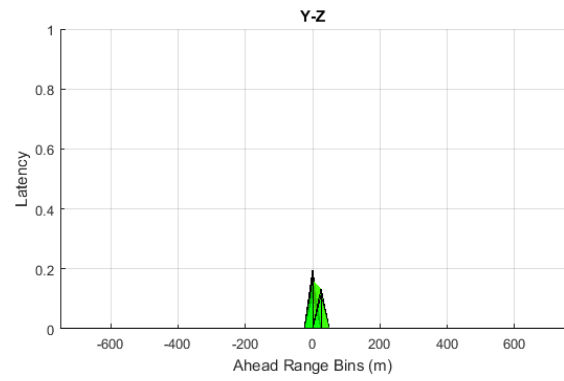
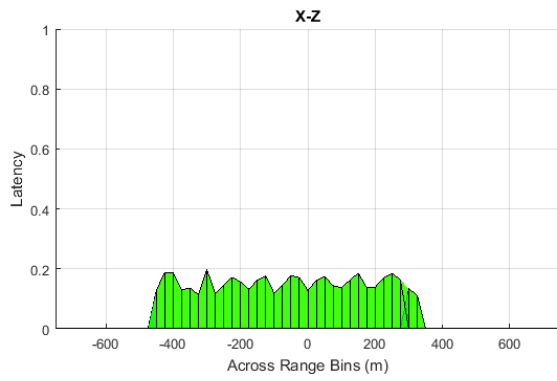
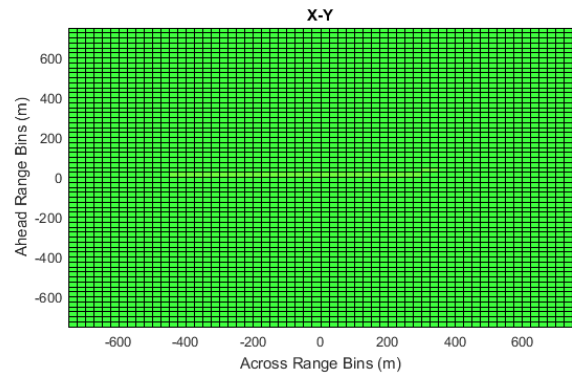
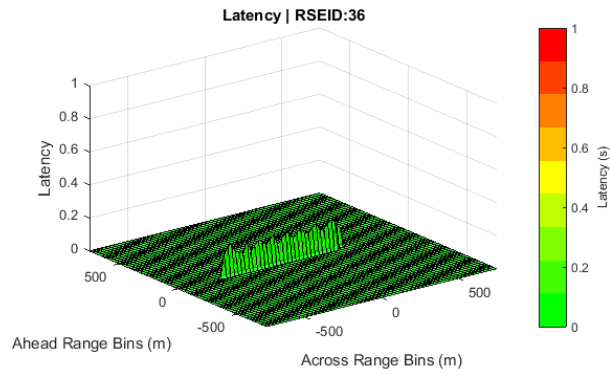
Interpacket Gap  
RSEID: 36





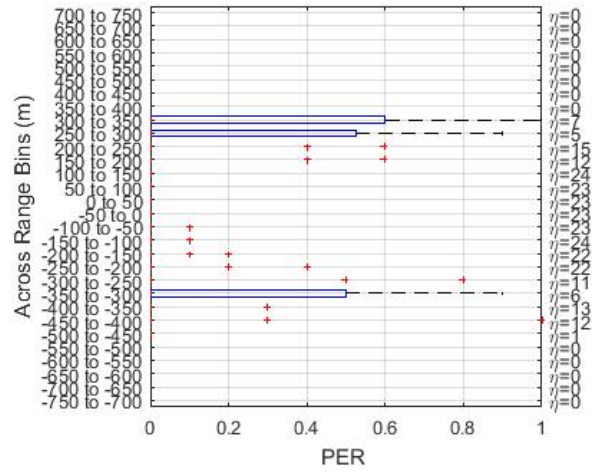
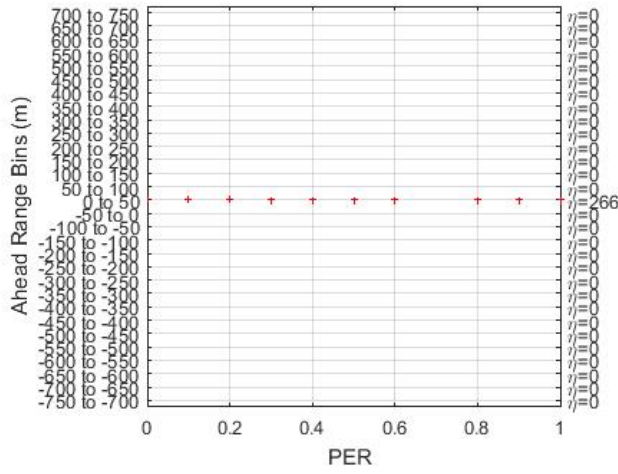
Latency  
RSEID: 36

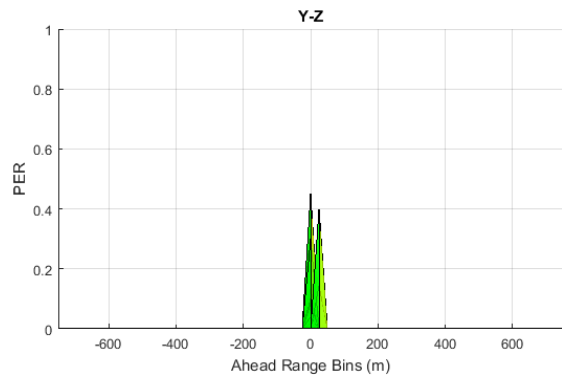
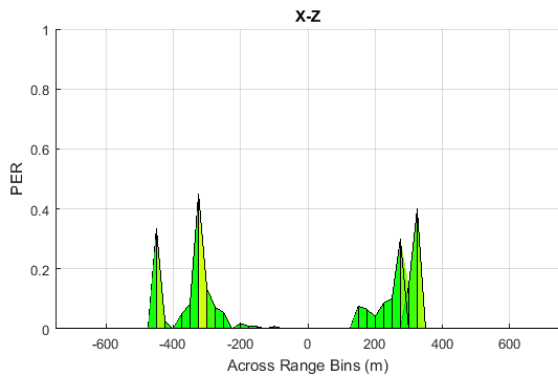
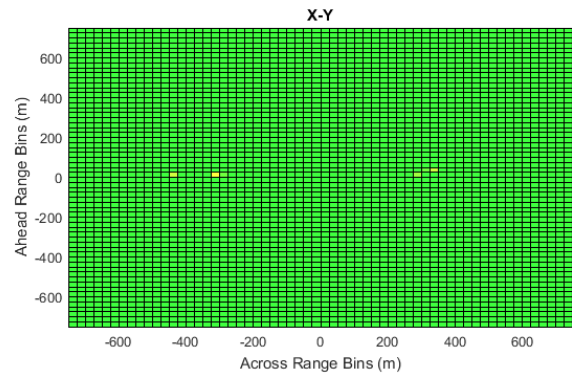
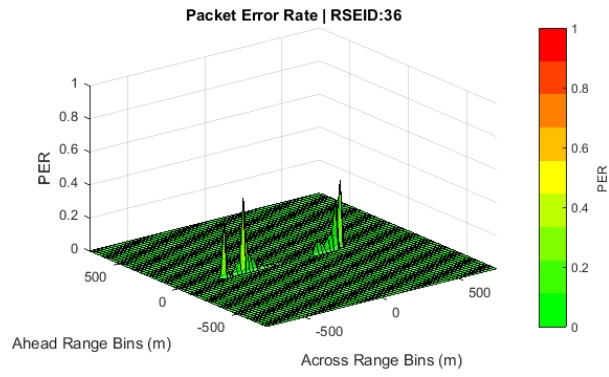




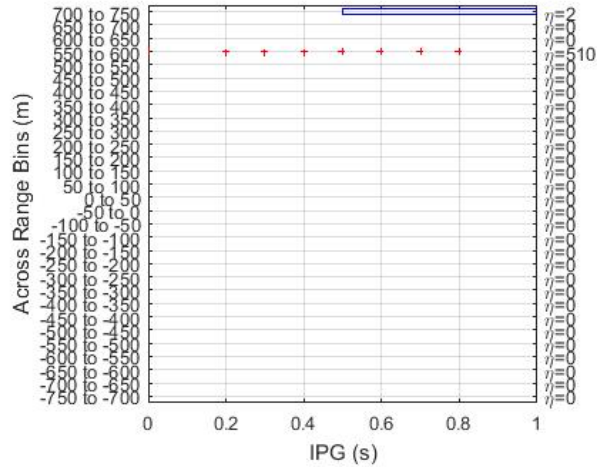
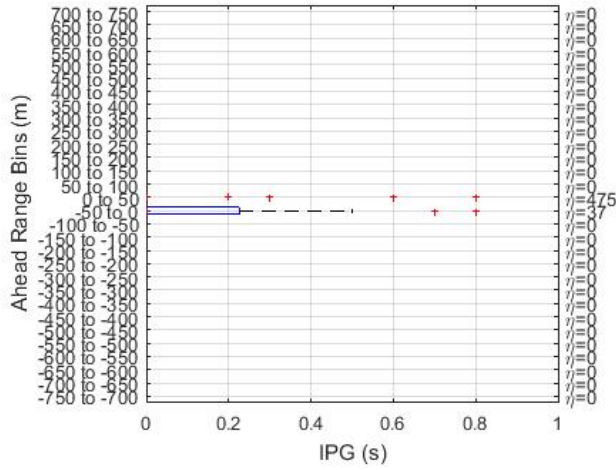


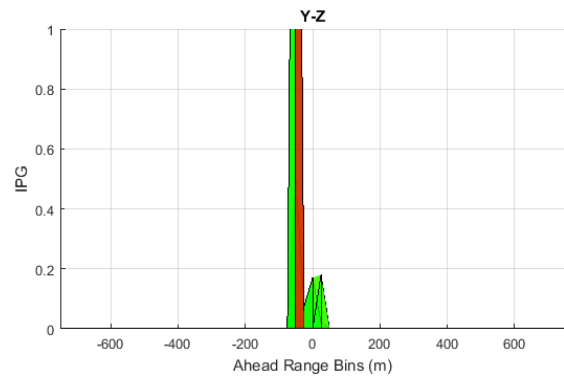
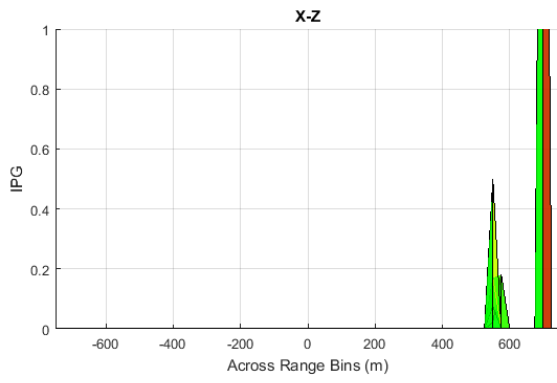
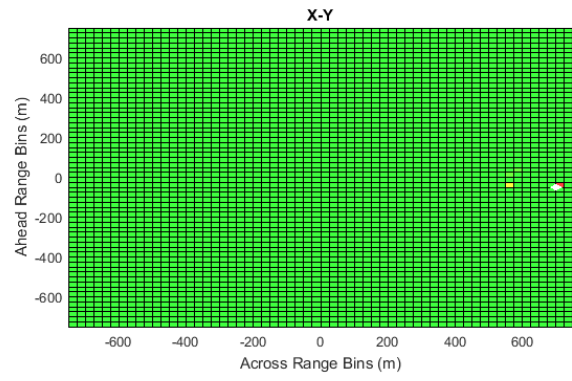
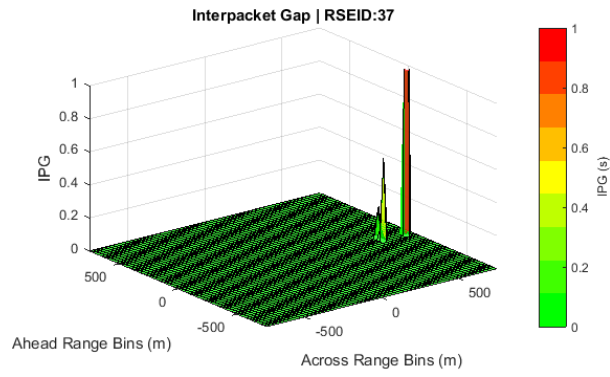
**Packet Error Rate**  
RSEID: 36



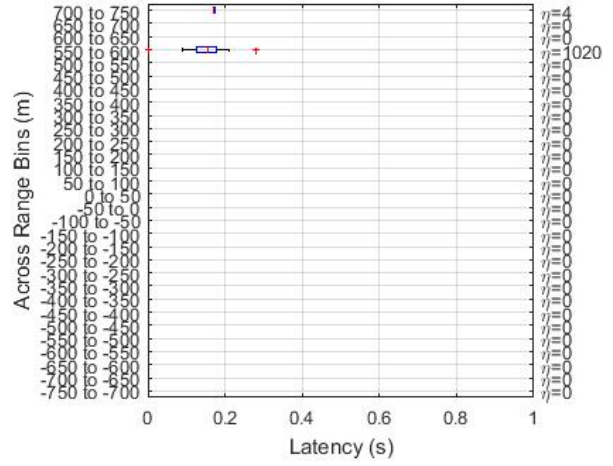
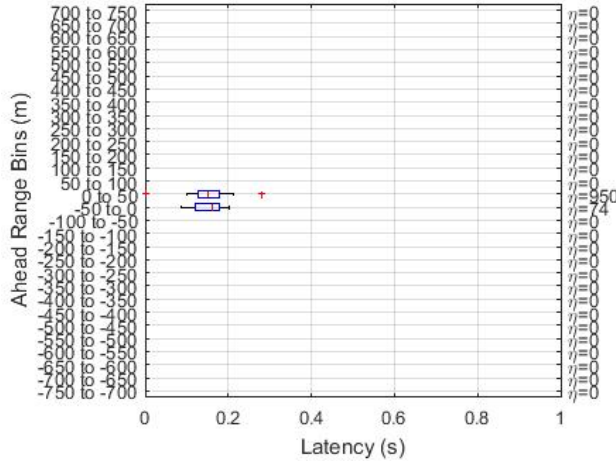


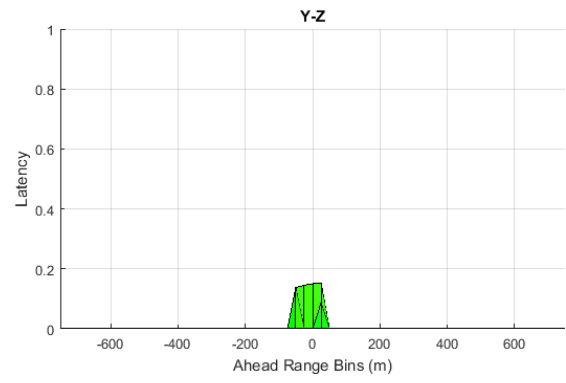
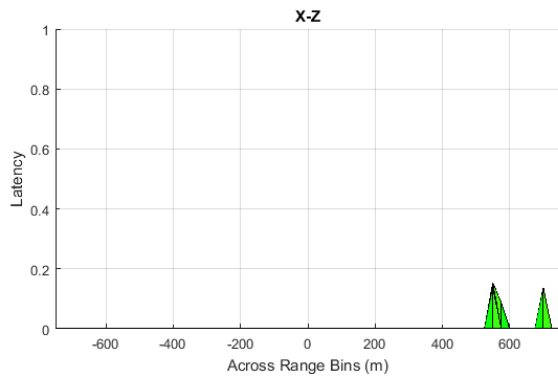
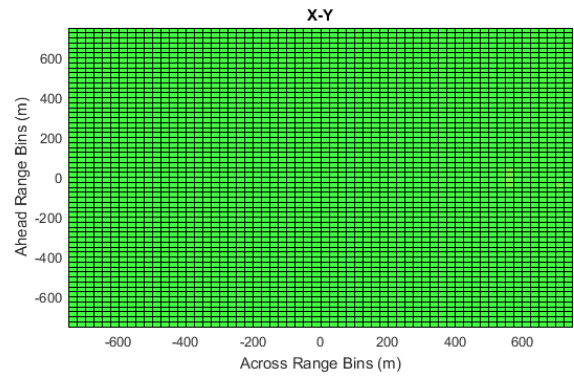
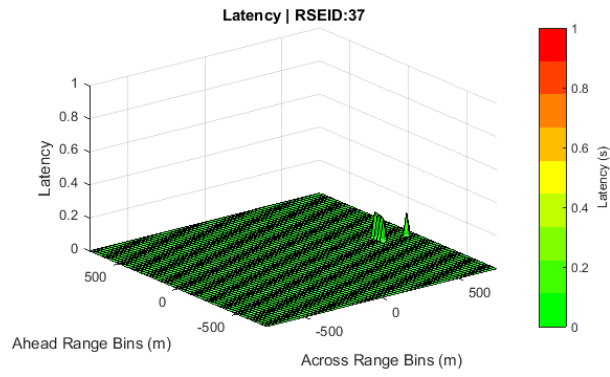
Interpacket Gap  
RSEID: 37



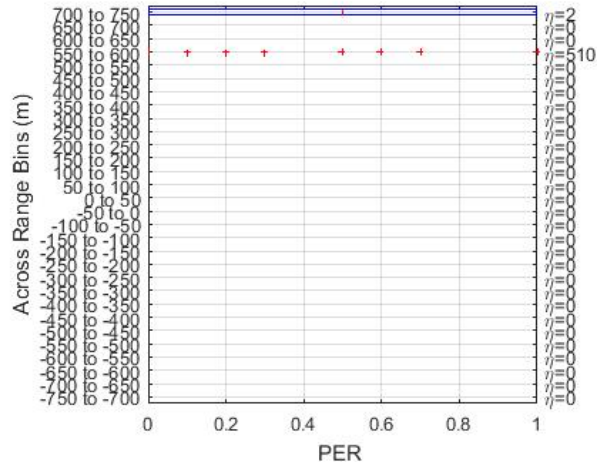
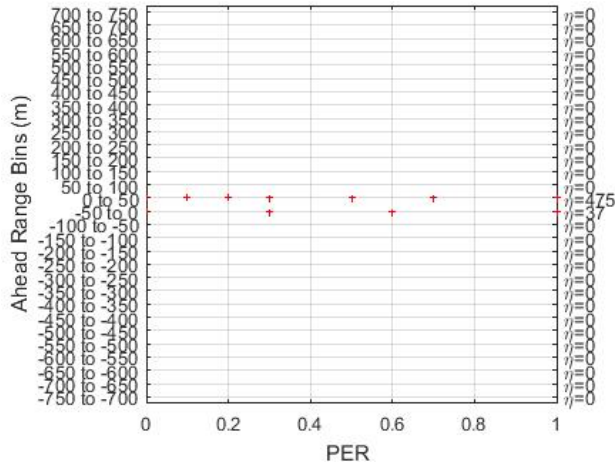


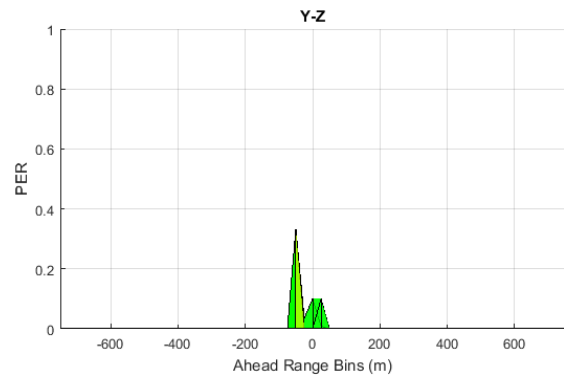
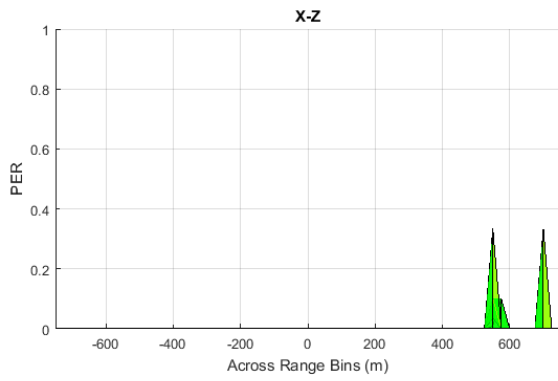
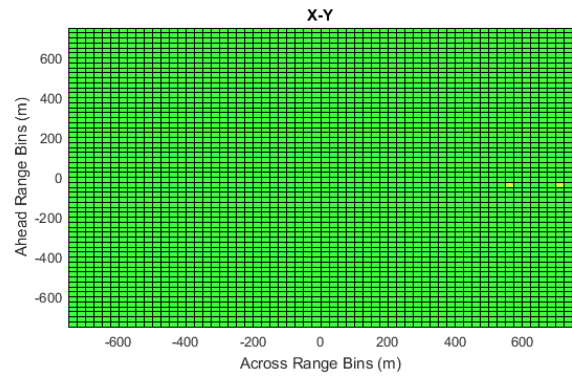
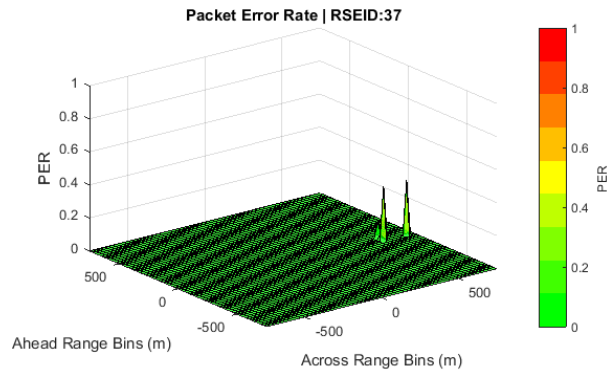
Latency  
RSEID: 37





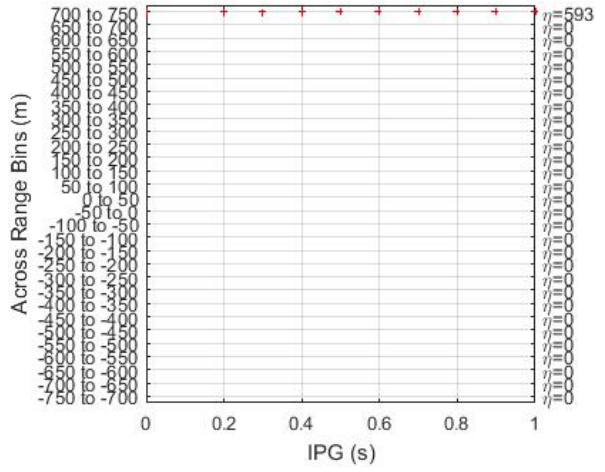
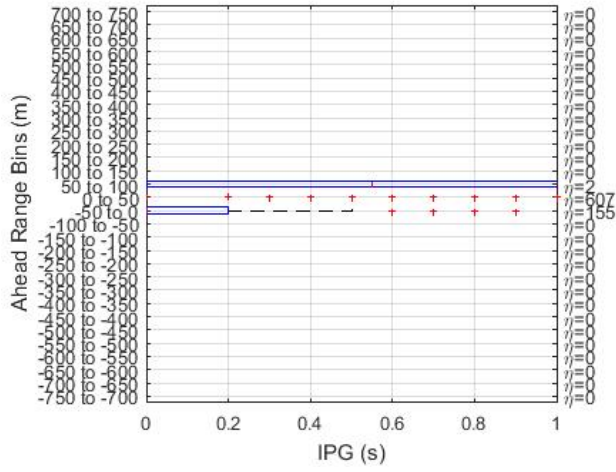
**Packet Error Rate  
RSEID: 37**

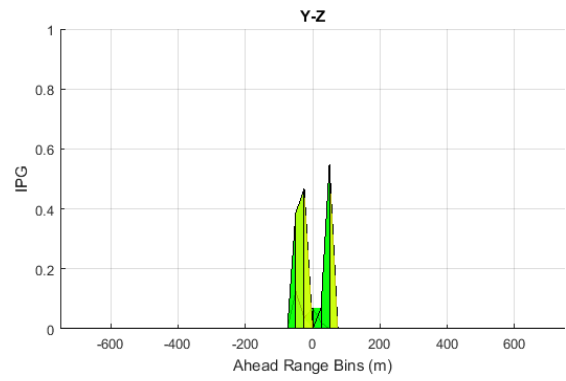
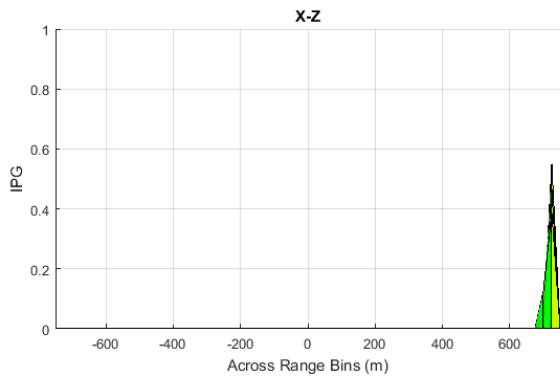
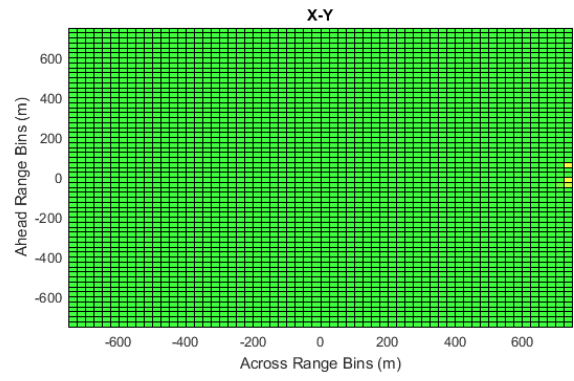
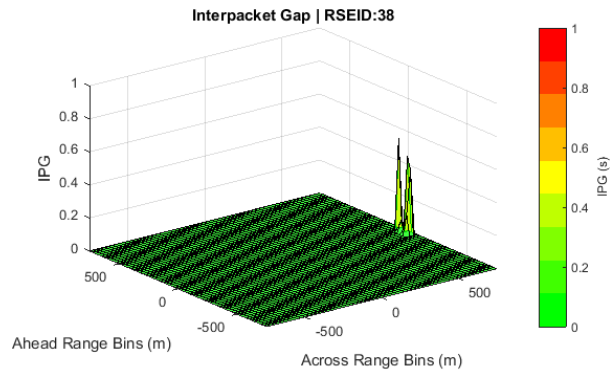




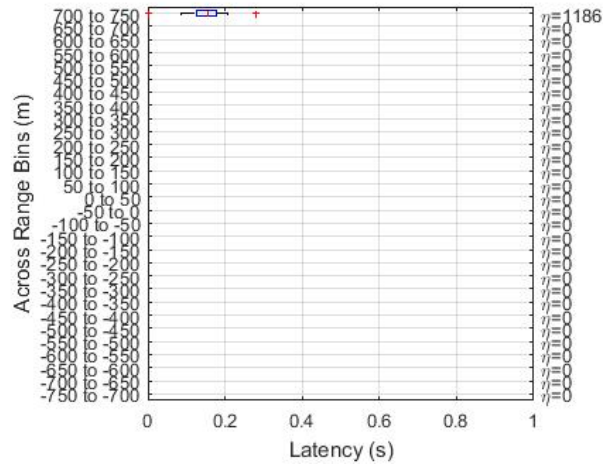
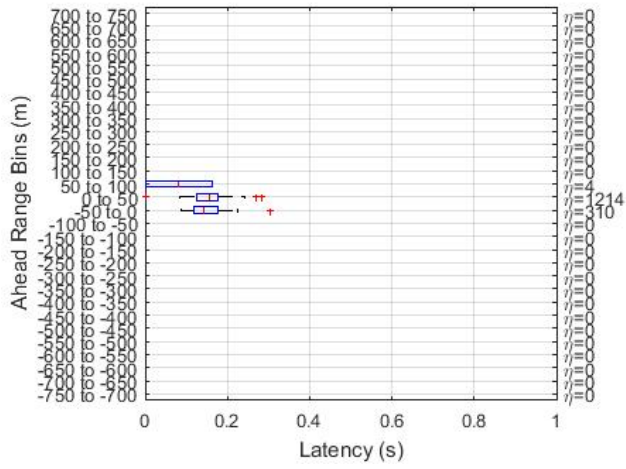


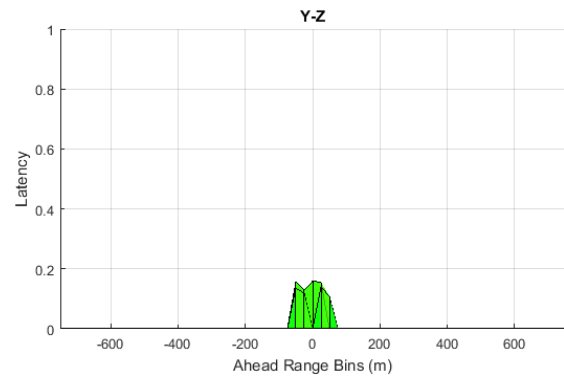
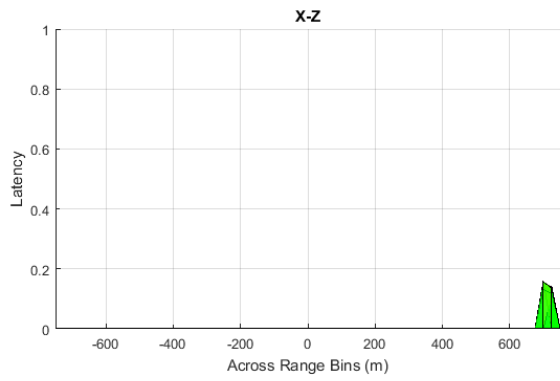
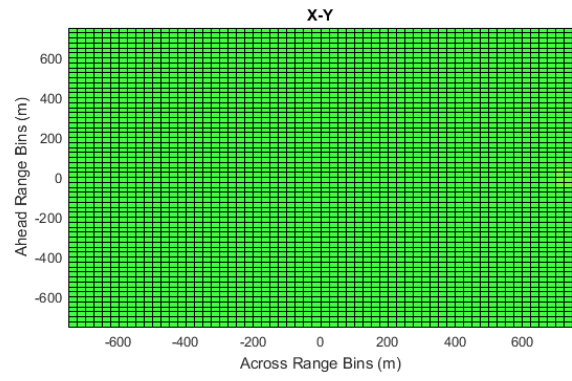
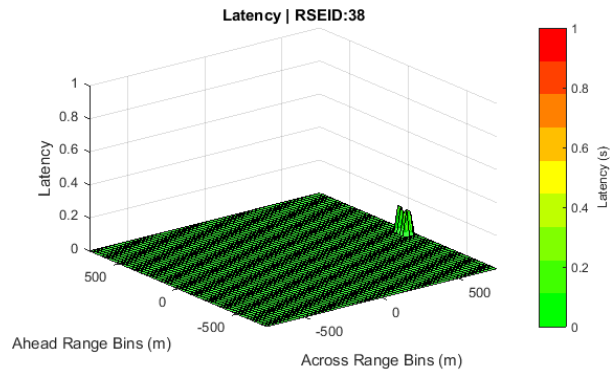
Interpacket Gap  
RSEID: 38



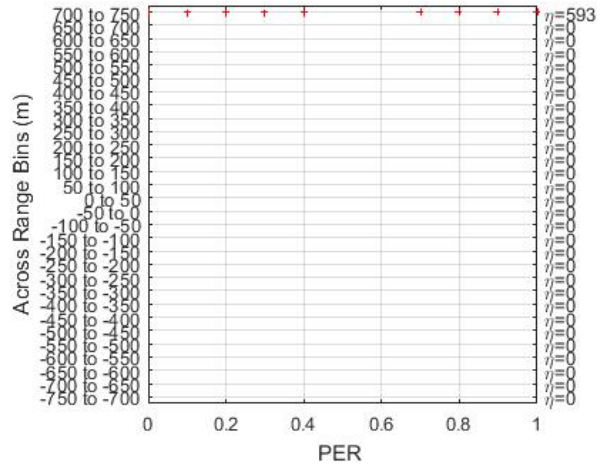
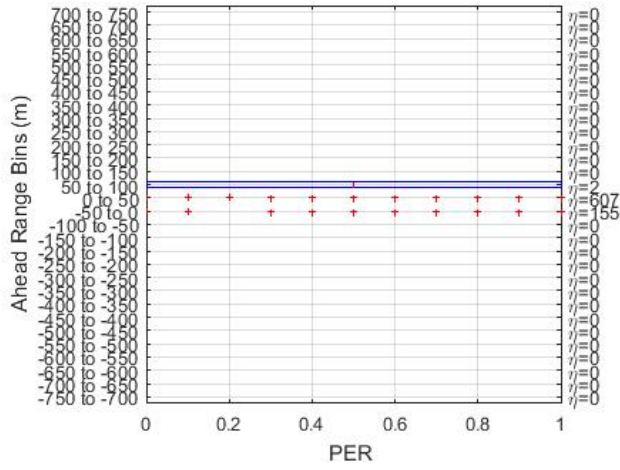


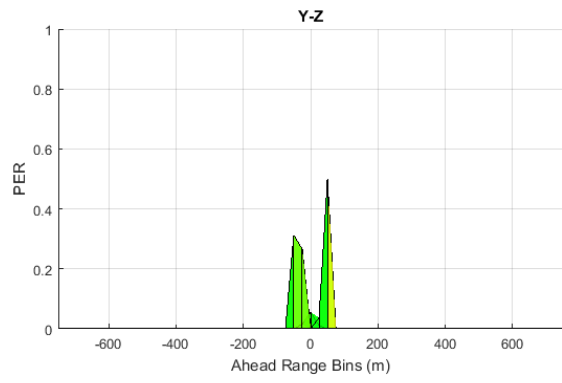
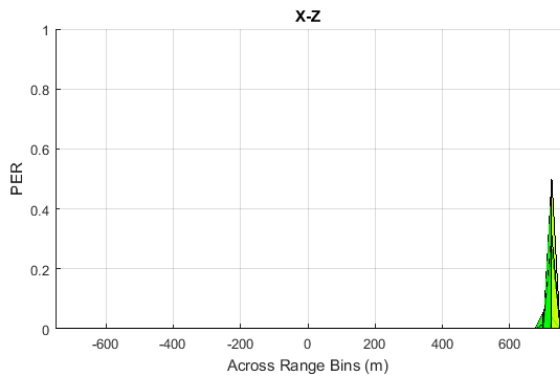
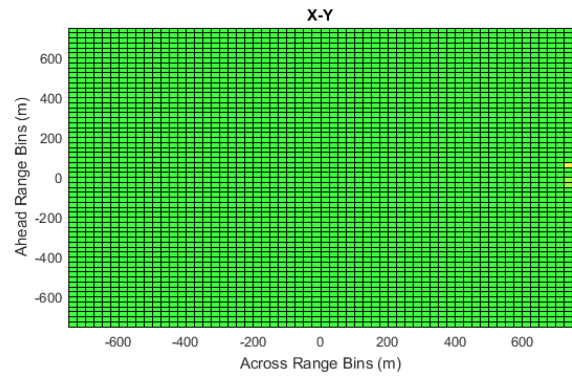
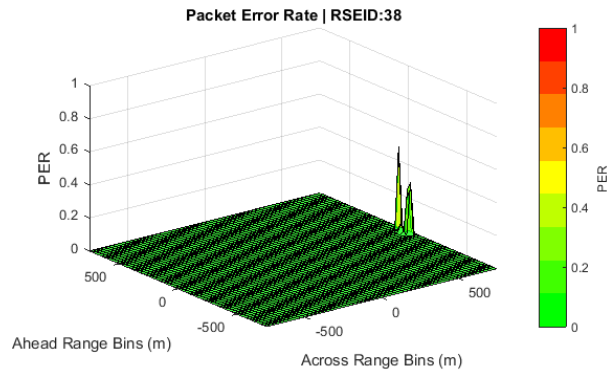
Latency  
RSEID: 38



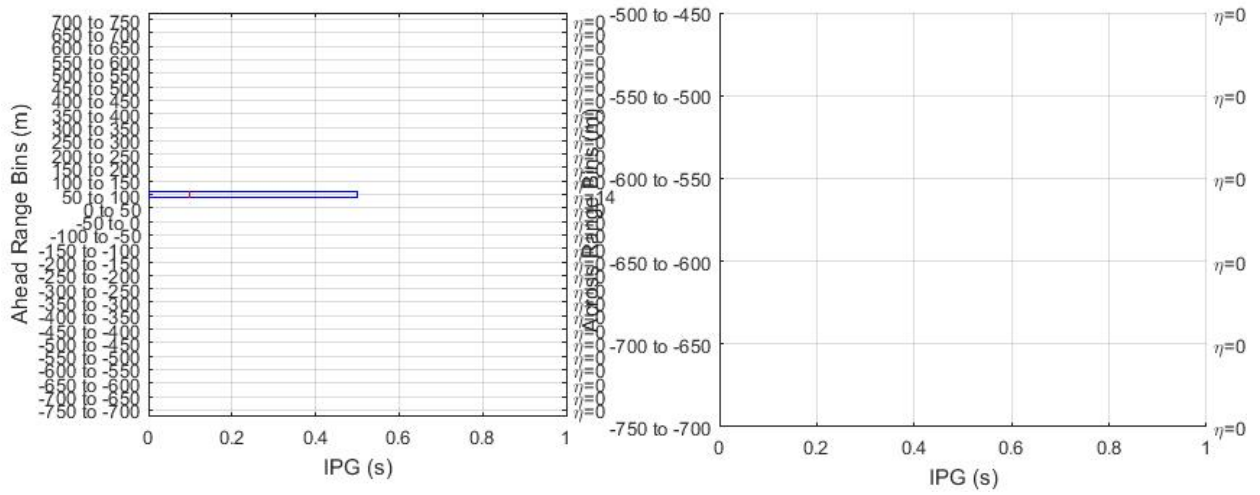


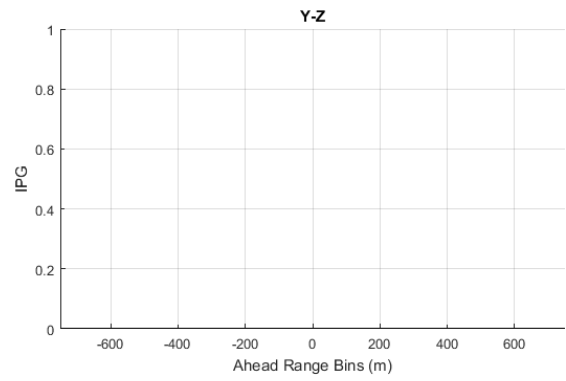
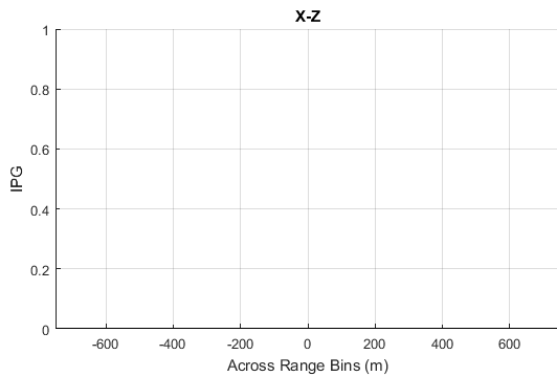
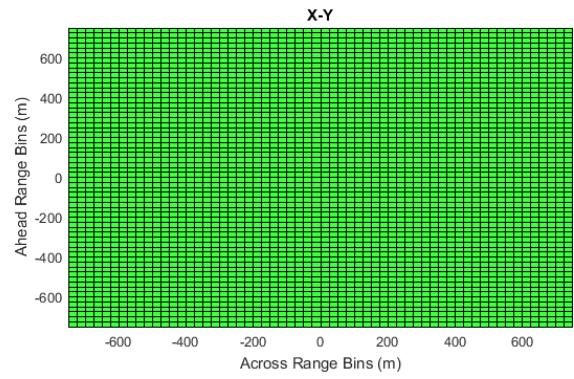
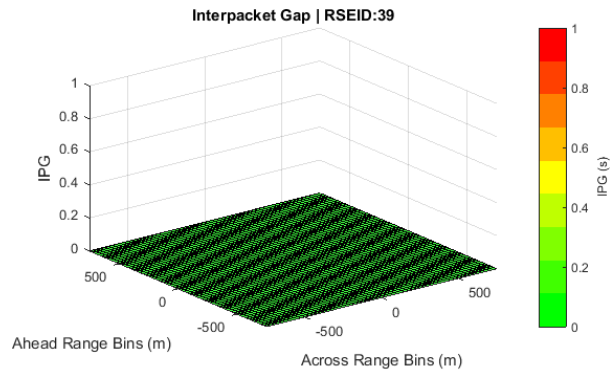
**Packet Error Rate**  
RSEID: 38





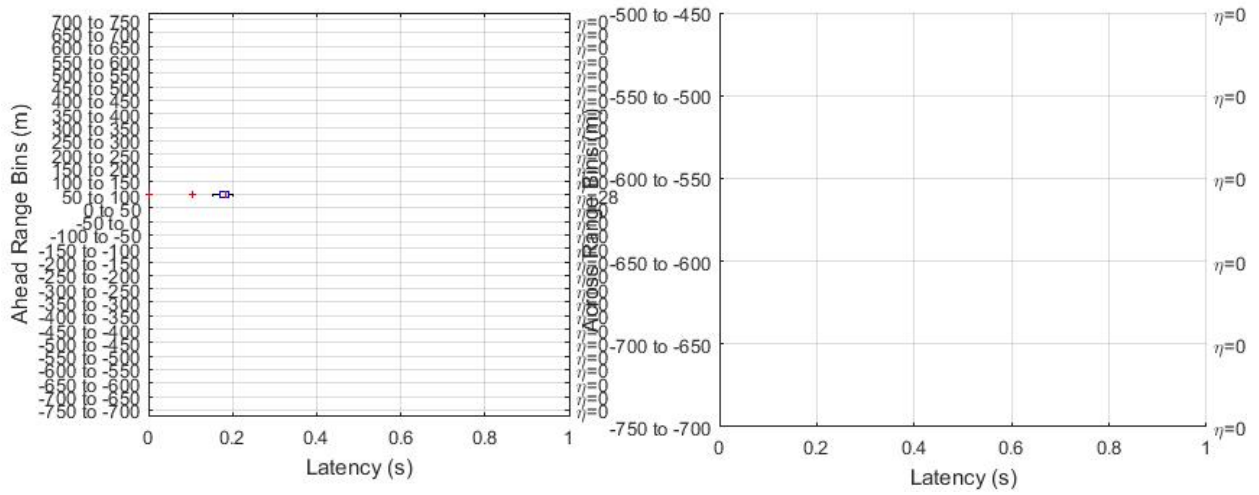
Interpacket Gap  
RSEID: 39

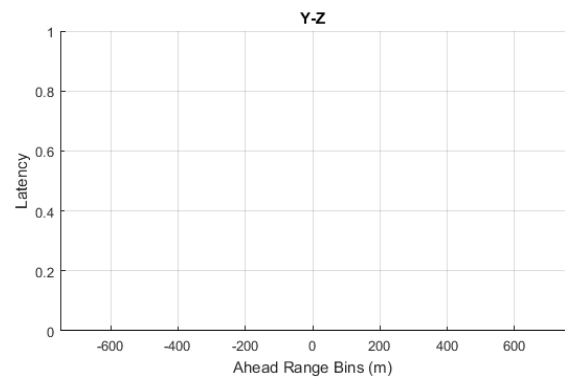
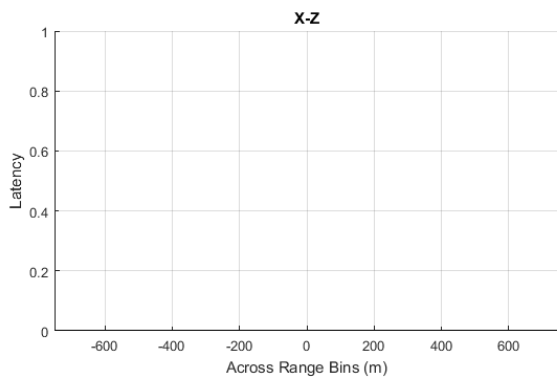
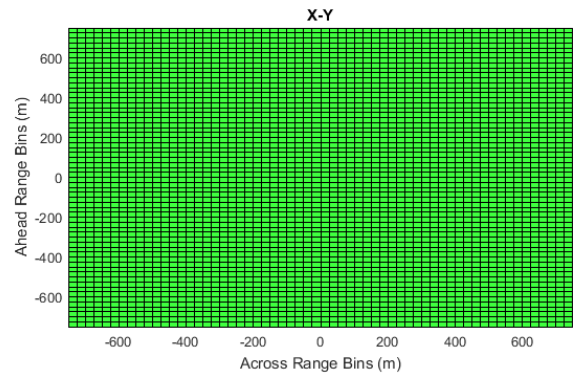
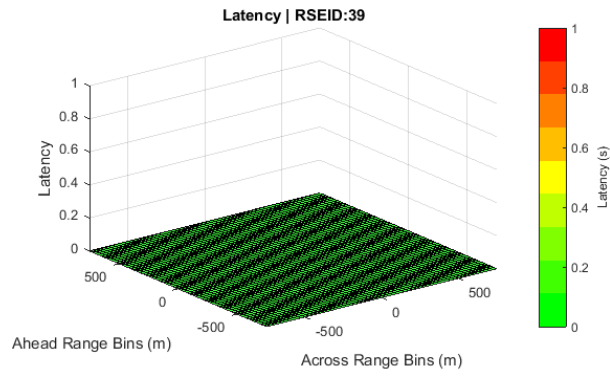




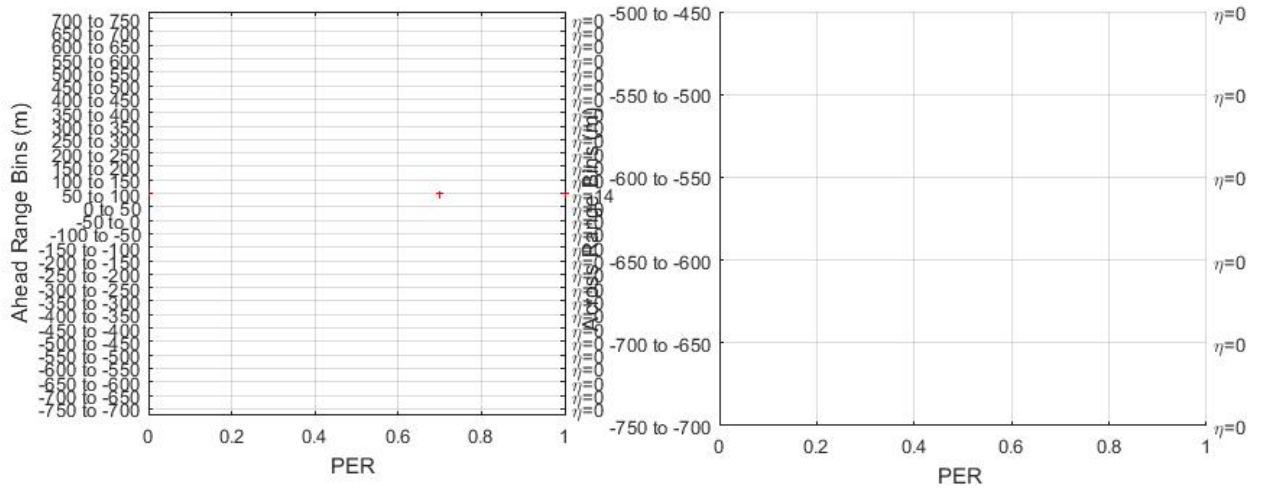


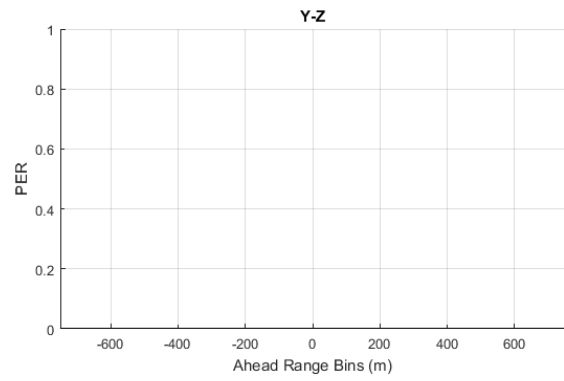
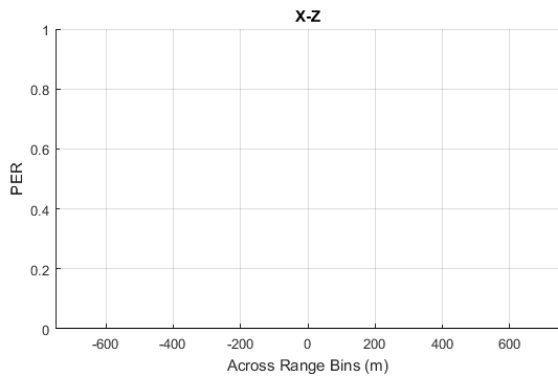
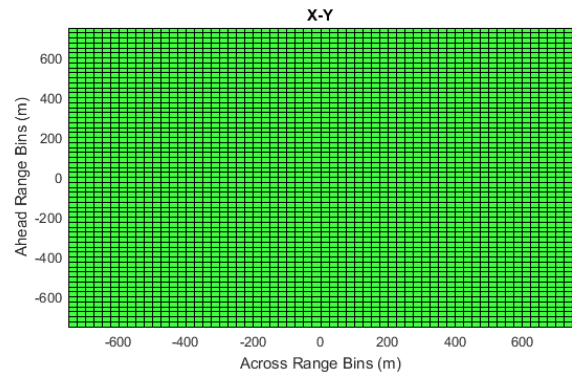
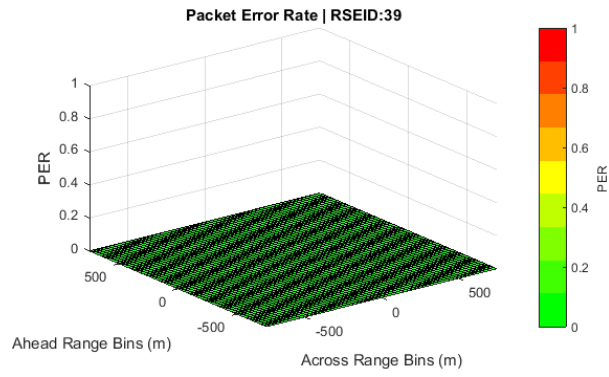
**Latency**  
RSEID: 39



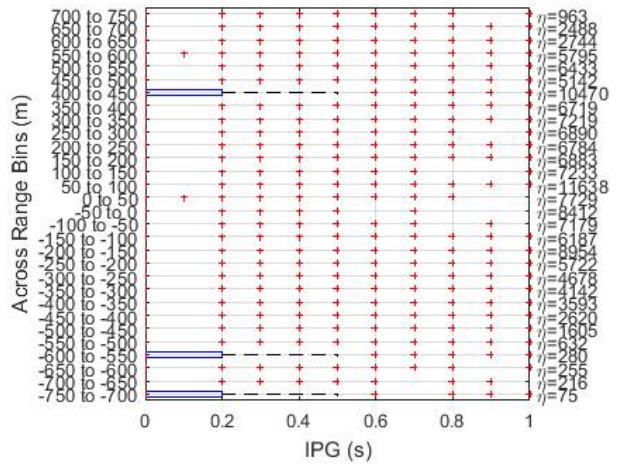
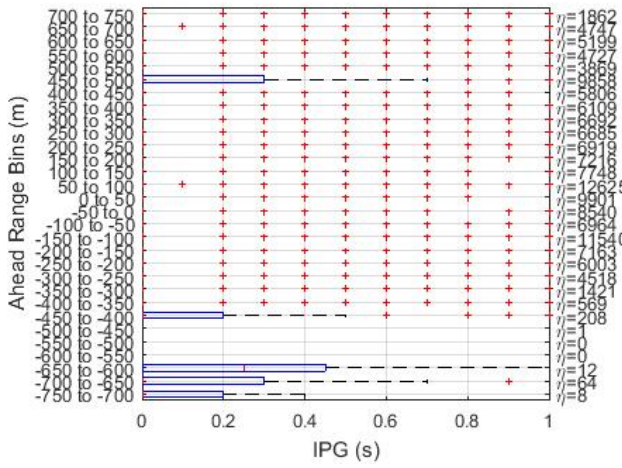


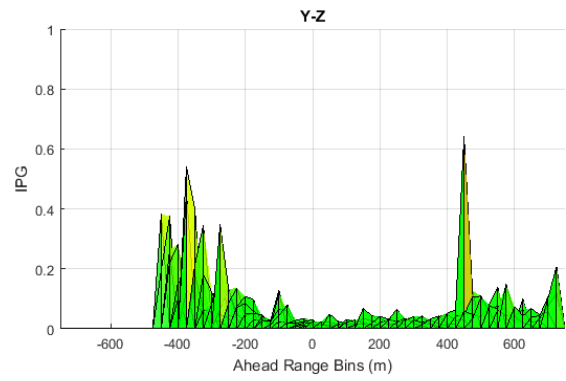
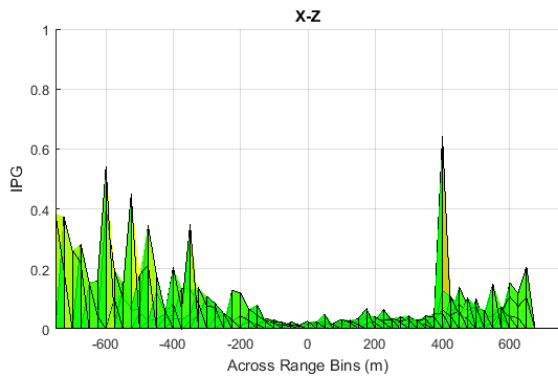
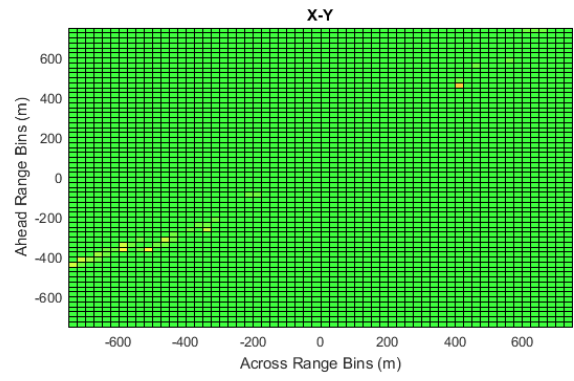
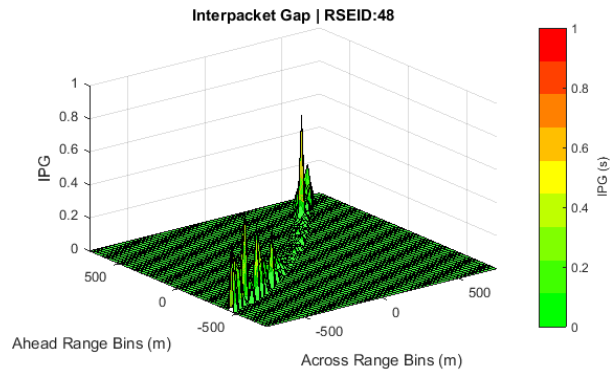
Packet Error Rate  
RSEID: 39



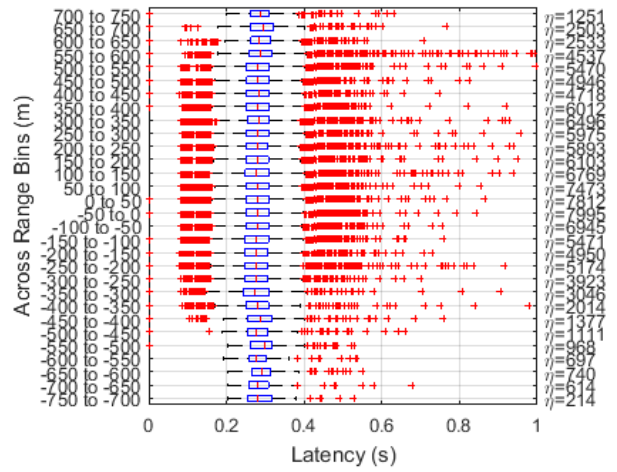
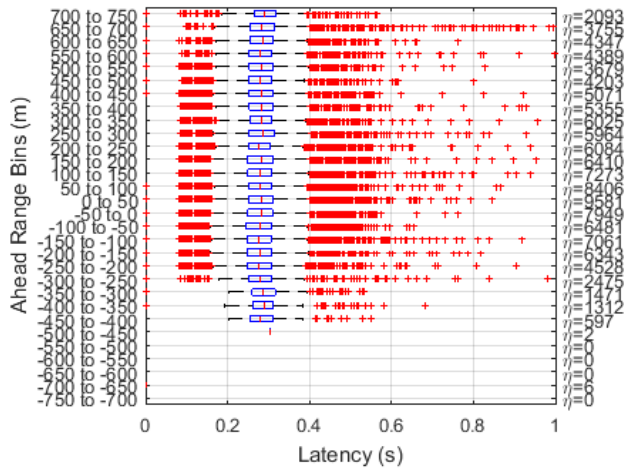
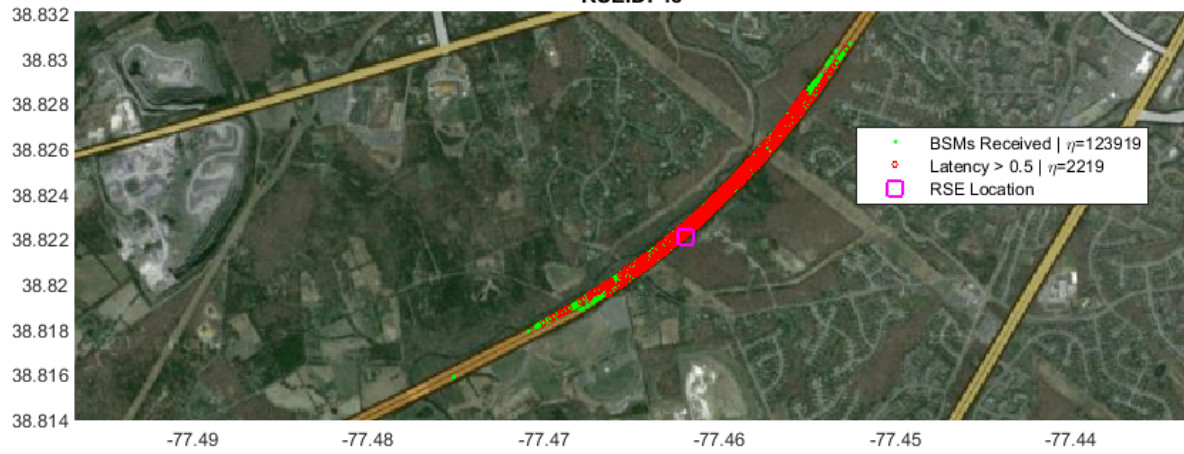


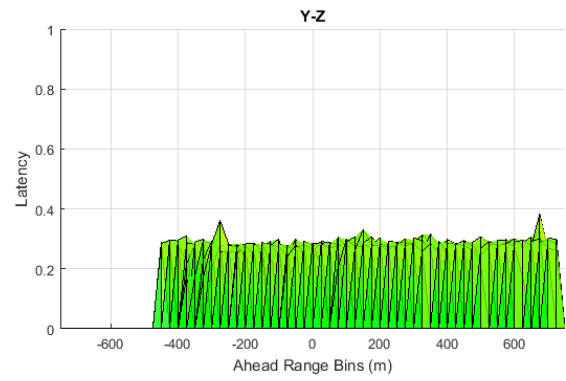
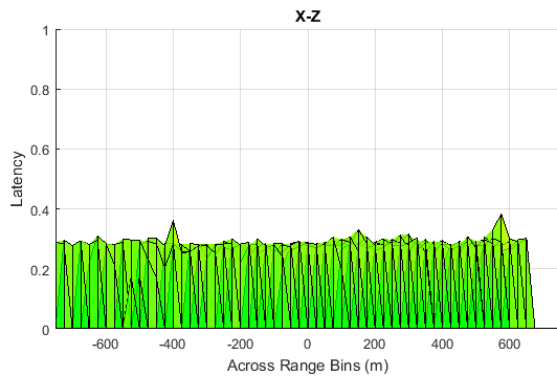
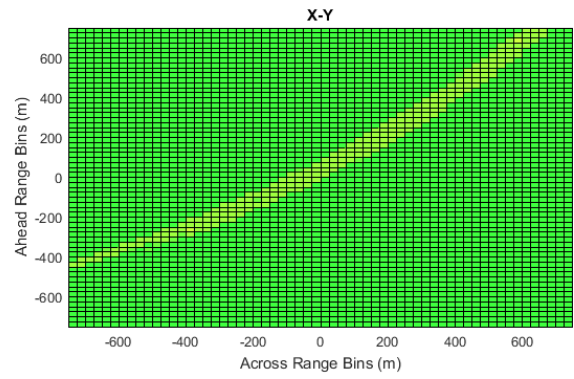
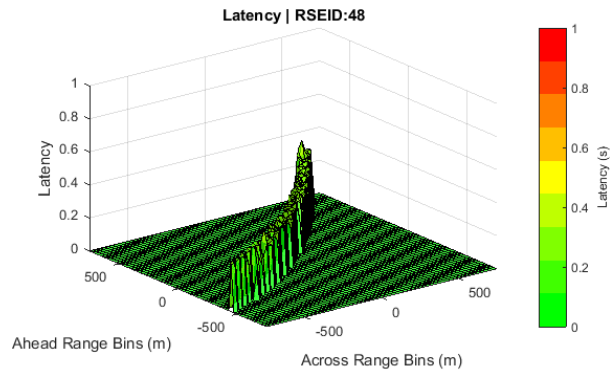
Interpacket Gap  
RSEID: 48





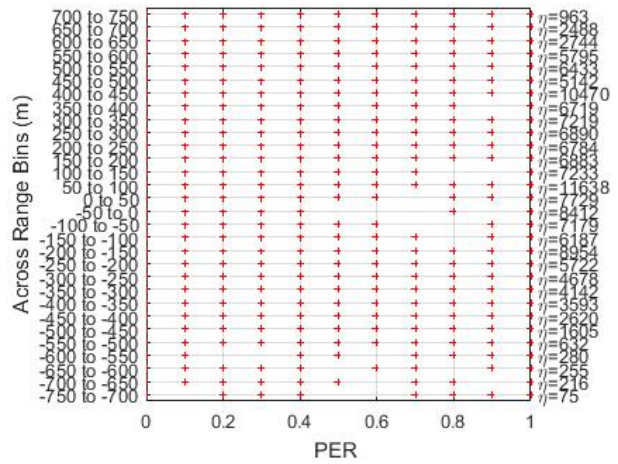
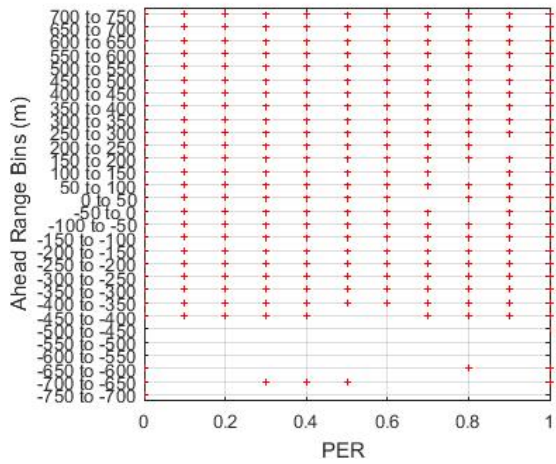
Latency  
RSEID: 48

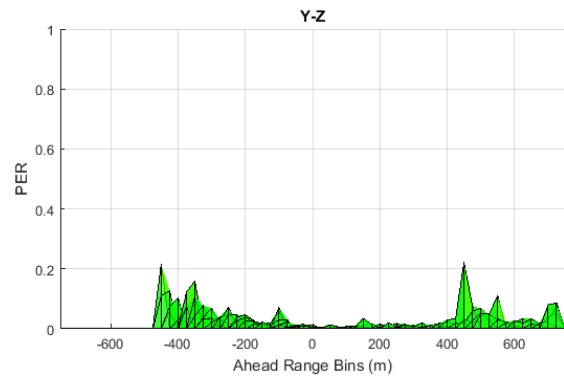
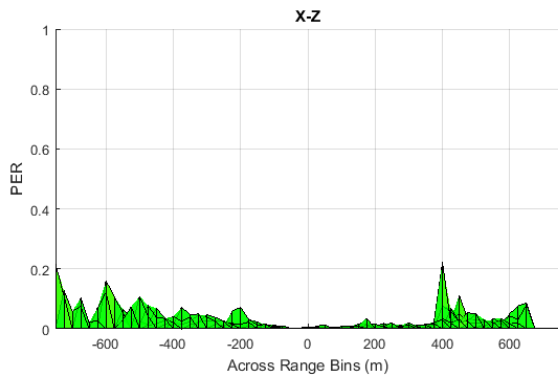
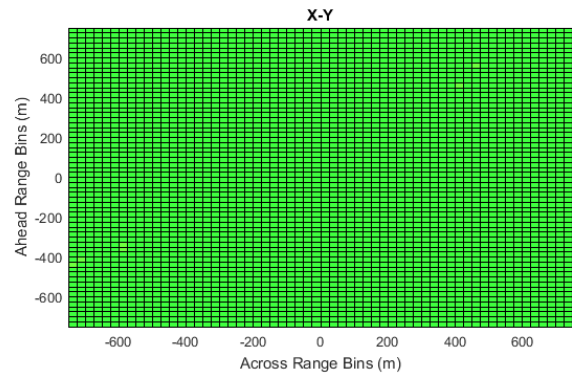
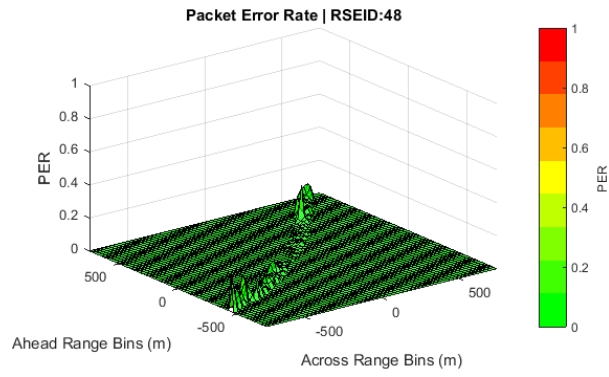




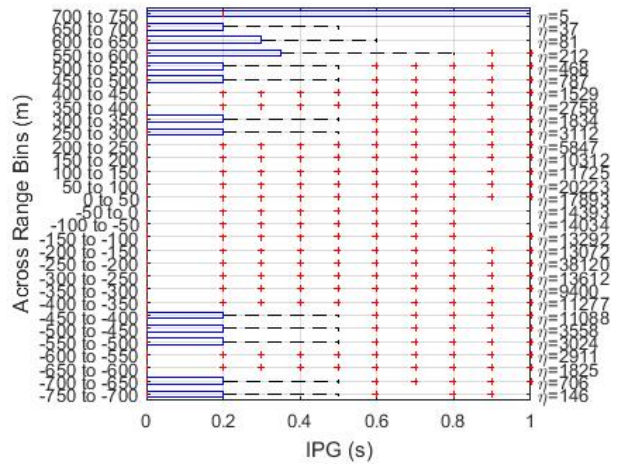
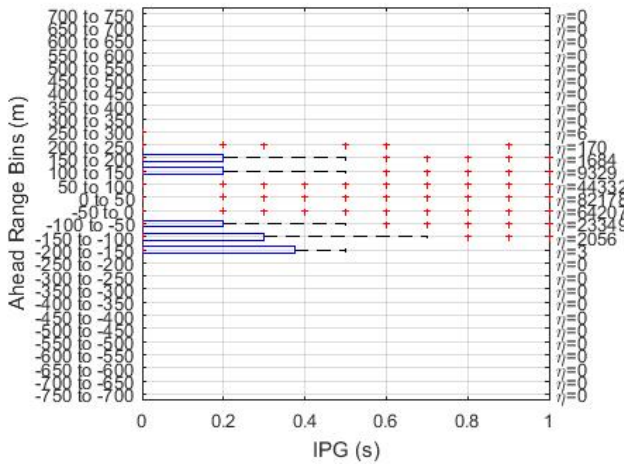
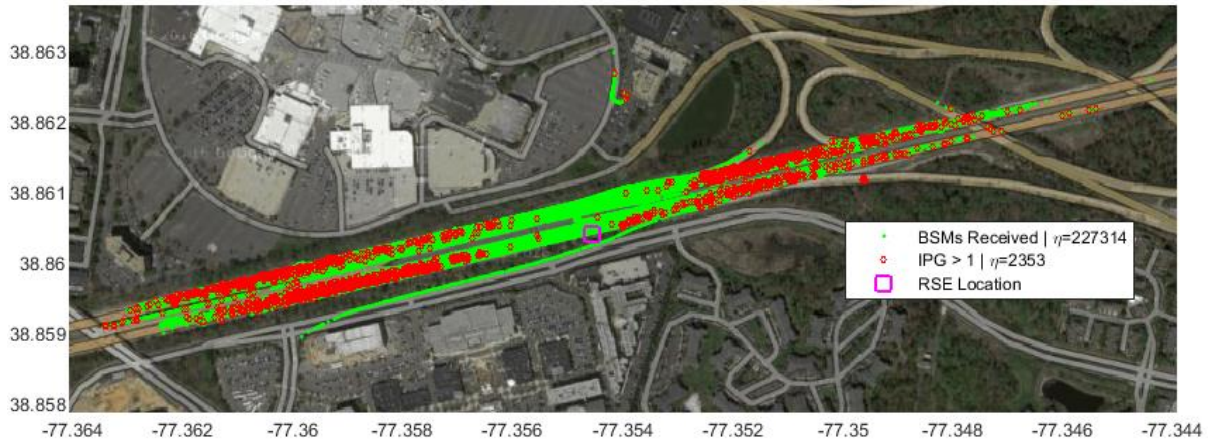


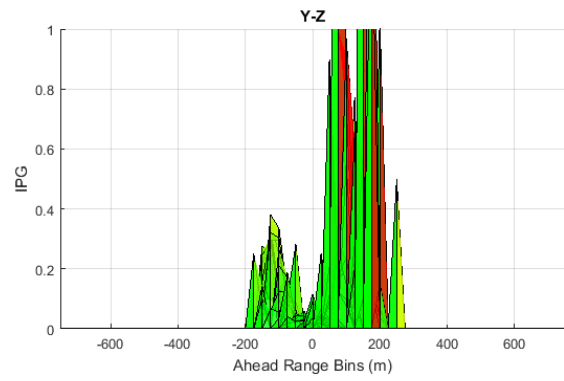
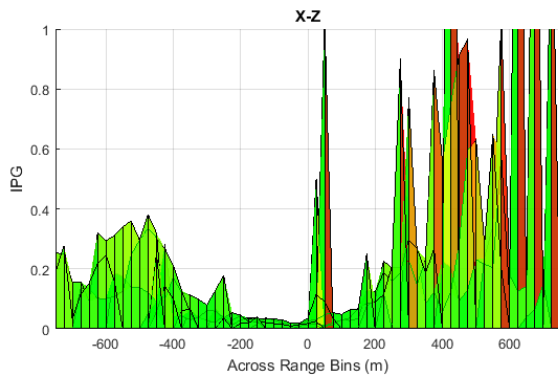
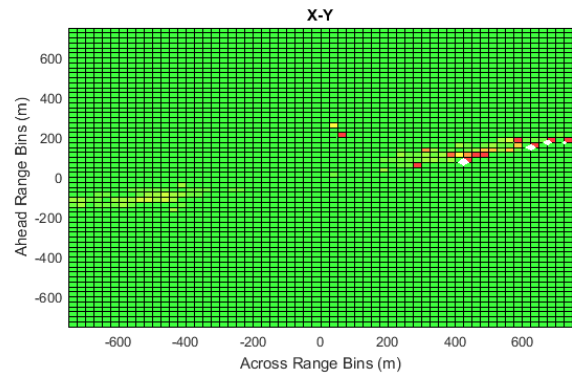
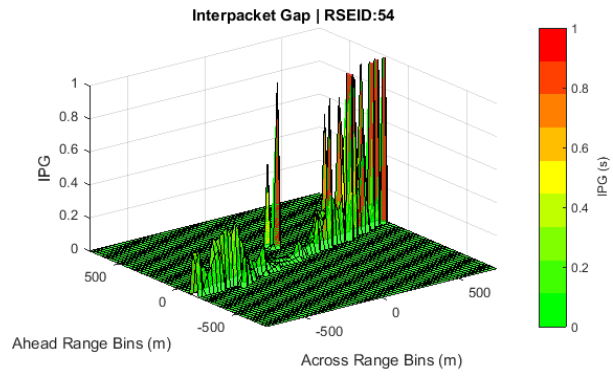
Packet Error Rate  
RSEID: 48



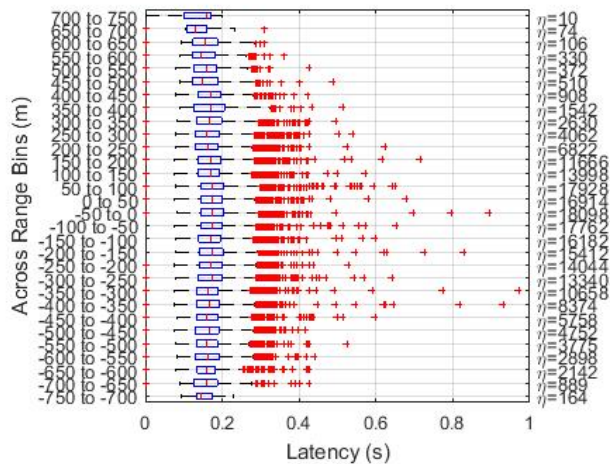
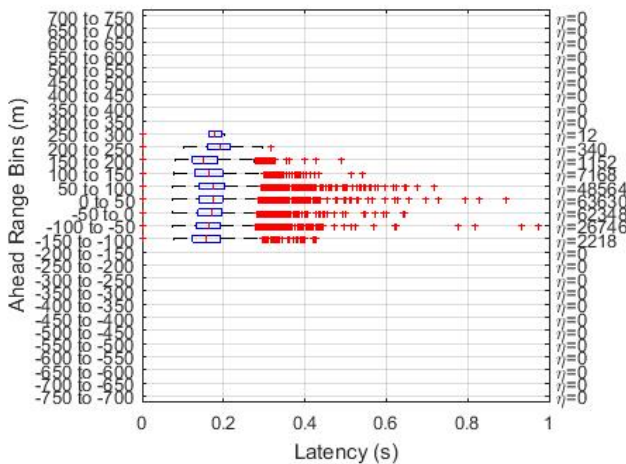
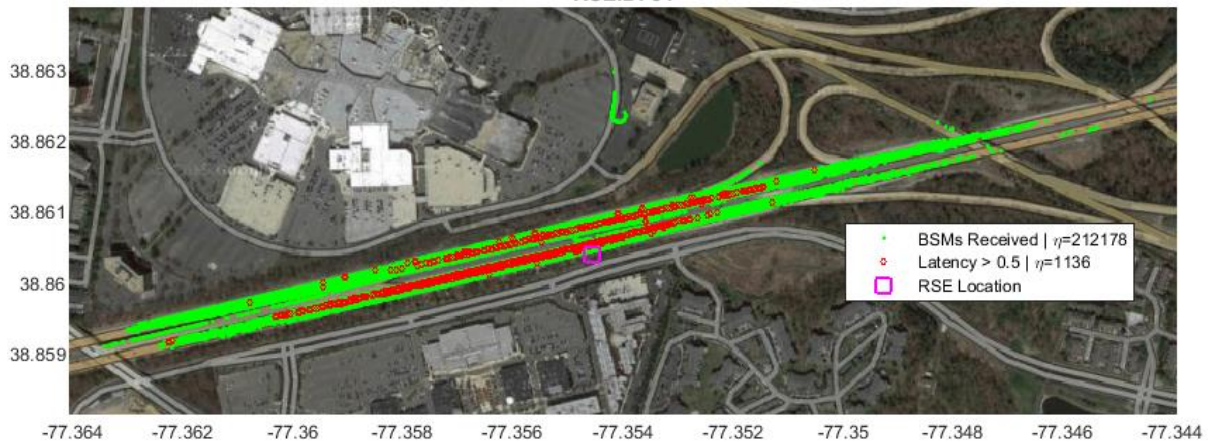


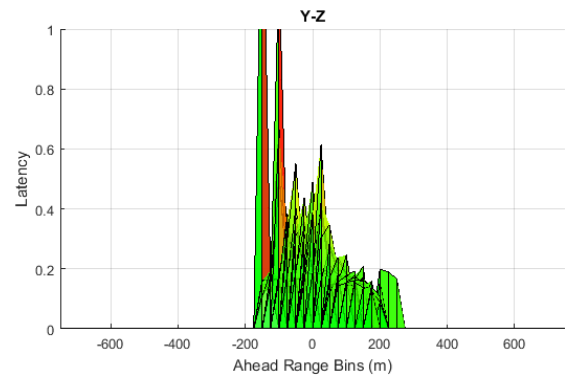
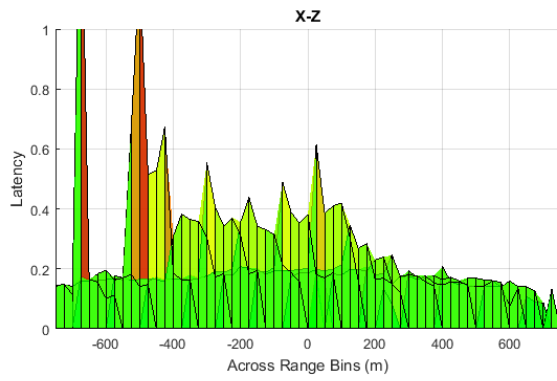
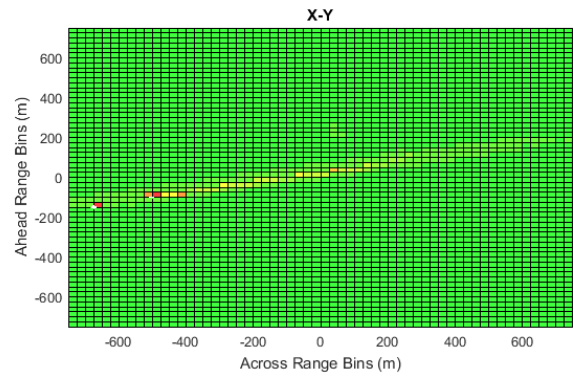
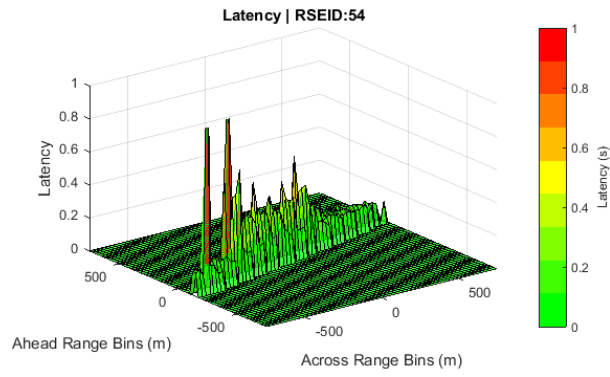
Interpacket Gap  
RSEID: 54



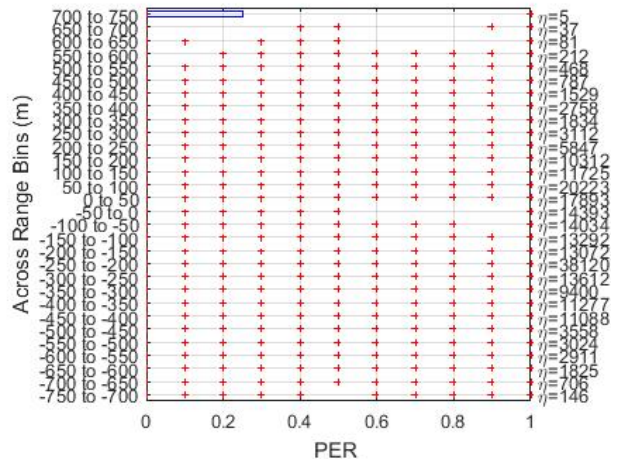
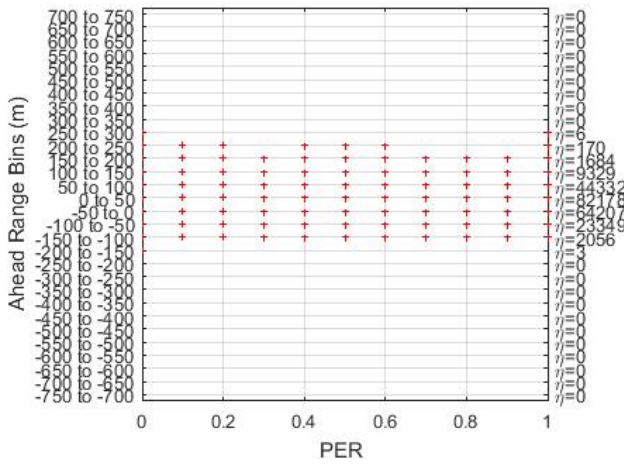
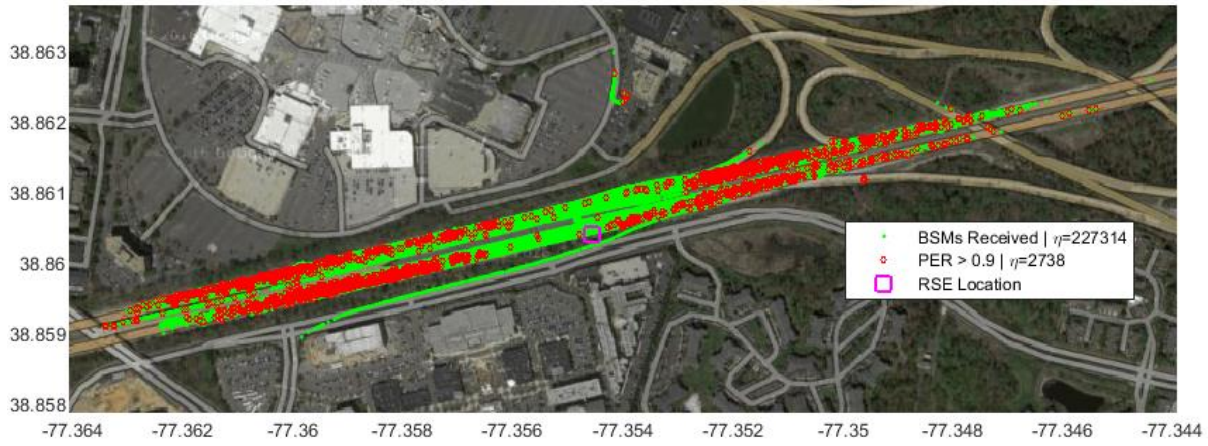


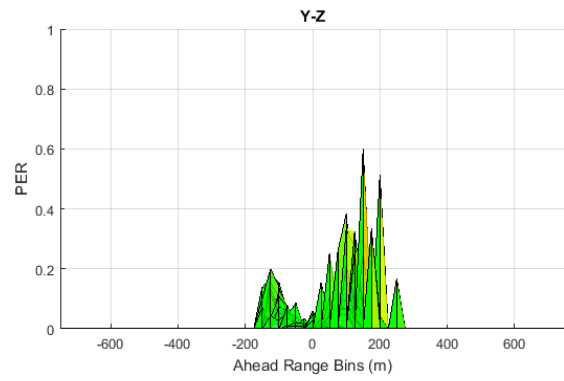
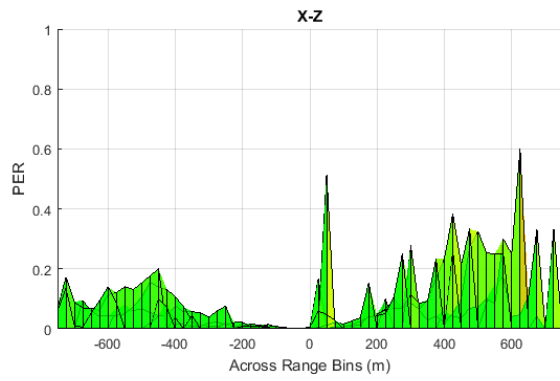
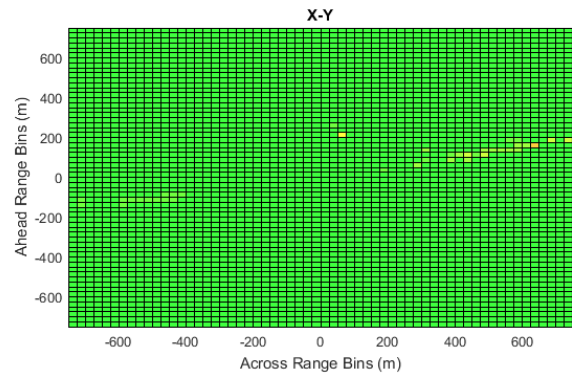
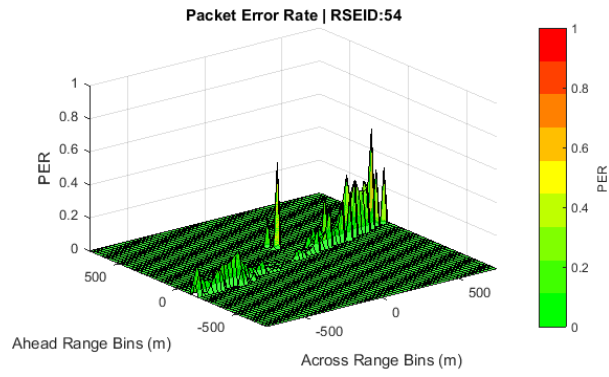
Latency  
RSEID: 54





Packet Error Rate  
RSEID: 54







## References

- [1] Federal Highway Administration. *Work Zone Road User Costs - Concepts and Applications*, FHWA-HOP-12-005, 2011.  
<http://ops.fhwa.dot.gov/wz/resources/publications/fhwahop12005/fhwahop12005.pdf>. Accessed December 2015.
- [2] National Highway Traffic Safety Administration. *Vehicle Safety Communications - Applications (VSC-A)*. Publication DOT HS 811 492A. NHTSA, U.S. Department of Transportation, 2011.  
<http://www.nhtsa.gov/DOT/NHTSA/NVS/Crash%20Avoidance/Technical%20Publications/2011/811492A.pdf>. December 2015
- [3] Paier, A., A. Tresch, D. Smely, P. Meckel, and Y. Zhou. Average Downstream Performance of Measured IEEE 802.11p Infrastructure-to-Vehicle Links. *2010 IEEE International Conference on Communications Workshops*, 2010, pp. 1-5.
- [4] Gozalvez, J., M. Sepulcre, and R. Bauza. IEEE 802.11p Vehicle to Infrastructure Communications in Urban Environments. *IEEE Communications Magazine*, Vol. 55, 2012, pp. 176-183.
- [5] Bai, F., and H. Krishnan. Reliability Analysis of DSRC Wireless Communication for Vehicle Safety Applications. *2006 IEEE Intelligent Transportation System Conference*, 2006, pp. 355-362.
- [6] Meireles, R., M. Boban, P. Steenkiste, O. Tonguz, and J. Barros. Experimental Study on the Impact of Vehicular Obstructions in VANETs. *2010 IEEE Vehicle Networking Conference (VNC)*, 2010, pp. 338-345.
- [7] Bohm, A., K. Lindstrom, M. Jonsson, and T. Larsson. Evaluating CALM M5-based Vehicle-to-Vehicle Communication in Various Road Settings through Field Trials. *2010 IEEE 35th Conference on Local Computer Networks (LCN)*, 2010, pp. 613-620.
- [8] Mecklenbrauker, C. F., A. F. Molisch, J. Karedal, F. Tufvesson, A. Paier, L. Bernadó, T. Zemen, O. Klemp, and N. Czink (2011). Vehicular Channel Characterization and Its Implications for Wireless System Design and Performance. *Proceedings of the IEEE*, Vol. 99, 2011, pp. 1189-1212.
- [9] Zhao, J., and R. Govindan. Understanding Packet Delivery Performance in Dense Wireless Sensor Networks. *Proceedings of the 1st International Conference on Embedded Networked Sensor Systems*, 2003, pp. 1-13.
- [10] Ahmed-Zaid, F., Krishnan, H., Vladimerou, V., Brovold, S., Cunningham, A., Goudy, R., . . . Viray, R. *Vehicle-to-Vehicle Safety System and Vehicle Build for Safety Pilot (V2V-SP) Final Report, Volume 2 of 2, Performance Testing*. NHTSA, U.S. Department of Transportation, 2014.
- [11] Savari. *MobiWAVE On Board Equipment*, 2012.  
<http://www.savarinetworks.com/files/MobiWAVE-DS-Family.pdf>. December 2015

- [12] SAE International. *SAE J2735 Surface Vehicle Standard - Dedicated Short Range Communication (DSRC) Message Set Dictionary*. SAE International, 2009.