

# Temporary Traffic Control Handbook

2016 Edition

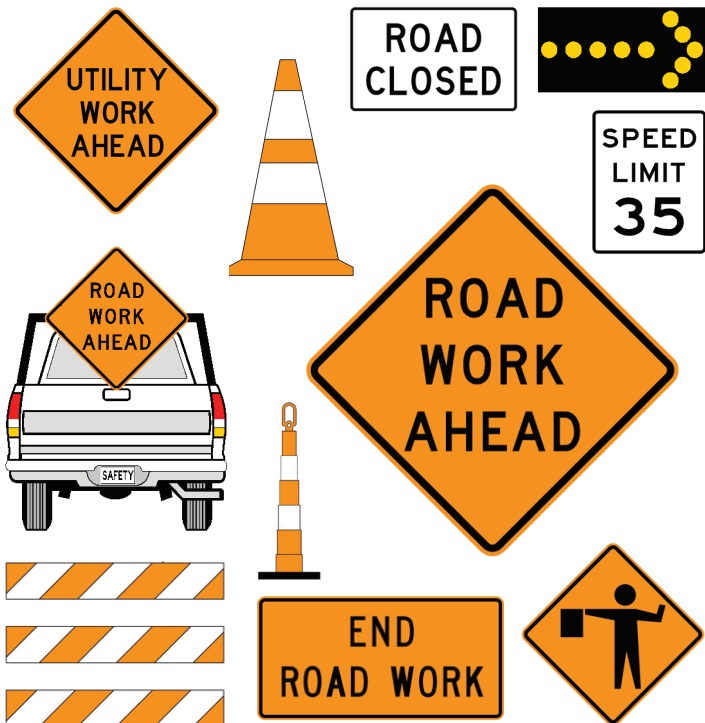

**Authors**

Paul Wiegand, P.E. and Beth Richards

**Address**

2711 S Loop Drive, Suite 4700  
Ames, Iowa 50010

**Disclaimer**

Neither Iowa State University nor this document's authors, editors, designers, illustrators, distributors, or technical advisors make any representations or warranties, expressed or implied, as to the accuracy of information herein and disclaim liability for any inaccuracies.

Iowa State University does not discriminate on the basis of race, color, age, ethnicity, religion, national origin, pregnancy, sexual orientation, gender identity, genetic information, sex, marital status, disability, or status as a U.S. veteran. Inquiries regarding non-discrimination policies may be directed to Office of Equal Opportunity, 3350 Beardshear Hall, Ames, Iowa 50011, Tel. 515 294-7612, email [eooffice@iastate.edu](mailto:eooffice@iastate.edu).

## TABLE OF CONTENTS

Introduction	2
Importance of Quality Traffic Control	2
Applicable Standards and References	3
Work Duration	4
Work Zone Temporary Traffic Control - Major Elements	5
Temporary Traffic Control Devices	9
Shadow Vehicles	19
Inspection and Documentation of Temporary Traffic Control	19
Flagging in Work Zones	20
High-Visibility Safety Apparel	20
Nighttime Operations	20
Accommodation of Pedestrians and Bicyclists	21
Road and Street Closures	22
General Notes for all TTC Examples	24
Legend	25
1. Work Beyond the Shoulder/Behind the Curb	26
2. Short-Duration or Mobile Operation on Shoulder	27
3. Work off of Pavement with Minor Encroachment onto Traveled Way	28
4. Lane Closure on Minor Street or Road	29
5. Lane Closure for Low-Volume Street or Road (Self-Regulating)	30
6. Work in Center of Low-Volume Street	31
7. Lane Closure for Short-Term or Moving Operations Using a Single Flagger	32
8. Lane Closure on Two-Lane Road Using Two Flaggers	33
9. Work in Vicinity of Highway-Rail Grade Crossing	34
10. Traffic Control for Outside Lane Closure of Street with Continuous Left Turn Lane	35
11. Traffic Control for Closure of Continuous Left Turn Lane	36
12. Street or Road Closure	37
13. Short-Duration Street or Road Closure	38
14. Street or Road Closure with Off-Site Detour	39
15. Lane Closure at an Intersection	40
16. Closure on the Far Side of an Intersection	41
17. Closure within an Intersection	42
18. Closure in Center of Intersection	43
19. Moving Operation on Two-Lane Roads	44
20. Mobile Operation on Multi-Lane Road	45
21. Sidewalk Detour	46
22. Sidewalk Diversion	47
23. Closure of Marked or Unmarked Crosswalk	48

## INTRODUCTION

This handbook provides a broad, easy to understand reference for temporary traffic control in work zones, addressing the safe and efficient accommodation of all road users: motorists, bicyclists, pedestrians, and those with special needs. When impacting a pedestrian facility, provide ten calendar days advance notification to the local jurisdiction and the National Federation of the Blind of Iowa ([www.nfbi.org](http://www.nfbi.org)).

The information presented is based on standards and guidance in the 2009 Edition of the Manual on Uniform Traffic Control Devices (MUTCD). References to the MUTCD sign designations in this handbook are shown in parentheses, e.g. (W20-1).

Not all the recommendations in this handbook will apply to every circumstance faced by local agencies, and each unique situation may not be addressed. Modifications of the typical applications in this handbook will be required to adapt to specific field conditions. Therefore, use engineering judgment, seeking the advice of experienced professionals and supervisors in difficult and complex interpretations. This handbook can be used as a reference for temporary traffic control in work zones on all city or county roadways. However, always check contract documents and local agency requirements for any pertinent modifications.

## IMPORTANCE OF QUALITY TRAFFIC CONTROL

The value of proper traffic control through work zones cannot be overemphasized. Three major reasons for providing quality temporary traffic control can be identified:

### **Safety**

Many crashes occur each year in Iowa work zones, resulting in death and injuries to motorists and workers. Appropriate levels of traffic control will help lessen the occurrence of work zone crashes.

### **Liability**

Improper use of temporary traffic control, deficiency of devices, or negligence may result in legal claims against a contractor, agency, or even individual workers. Complying with accepted standards and guidance could help avoid and reduce possible legal actions.

## Responsibility

Providing temporary traffic control in compliance with established practices is a requirement of the public trust; it's simply the right thing to do!

The MUTCD is incorporated into the Code of Federal Regulations and is recognized as the national standard for traffic control devices on all roads open to public travel in the nation. In addition, Iowa has adopted the MUTCD as the state standard (Iowa Code section 321.252 and Administrative Rule 761 - Chapter 130). Local agencies are required to adhere to the MUTCD requirements in Iowa Code Section 321.255. Always remember the MUTCD standard statements, "The responsibility for the design, placement, operation, maintenance, and uniformity of traffic control devices shall rest with the public agency or the official having jurisdiction," and "temporary traffic control plans and devices shall be the responsibility of the authority of a public body or official having jurisdiction for guiding road users." **Even though the authority for placing temporary traffic control is sometimes granted to others (contractors, utilities, etc.), the responsibility for requiring properly signed work zones remains with the agency that has jurisdiction over that road or street.**

## APPLICABLE STANDARDS AND REFERENCES

The MUTCD presents **minimum** standards only. Iowa has adopted the MUTCD as the official standard for traffic control, but many applications and practices in Iowa exceed national standards. The user should check for recent revisions of the MUTCD and state and local policies before selecting an appropriate application from this handbook. Ensure you have the most current version of this handbook.

### National Requirements

Other important federal requirements and guidance are available in Federal Highway Administration's (FHWA) *Standard Highway Signs* manual and the National Committee on Uniform Traffic Laws and Ordinances' *Uniform Vehicle Code*. Worker and flagger apparel recommendations and requirements from the American National Standards Institute (ANSI) have been adopted into the MUTCD. Information about worker and flagger apparel can be found through the International Safety Equipment Association (ISEA).

Complying with the *Proposed Accessibility Guidelines for Pedestrian Facilities in the Public Right-of-Way*, also known as the Public Right-of-Way Accessibility Guidelines or PROWAG, is especially important when accommodating pedestrians. The US Access Board is an excellent source for background and supplemental accessibility information ([www.access-board.gov](http://www.access-board.gov)). The Institute of Transportation Engineers' Traffic Control Devices Handbook also provides valuable supplemental guidance.

## **State Requirements**

When working on or near any road or street right-of-way where Iowa Department of Transportation (Iowa DOT) has jurisdiction, Iowa DOT requirements take precedence over this handbook.

## **Local Requirements**

Cities and counties may adopt ordinances and policies that apply to temporary traffic control - provided these meet or exceed the standards presented in the MUTCD. Verify local requirements before establishing any temporary traffic control on local roads and streets.

## **WORK DURATION**

Work duration is a major factor in determining the number and types of devices used in TTC zones. The duration of a TTC zone is defined relative to the length of time a work operation occupies a spot location. The five categories of work duration and their time at a location shall be:

- Long-term stationary is work that occupies a location more than 3 days.
- Intermediate-term stationary is work that occupies a location more than one daylight period up to 3 days, or nighttime work lasting more than 1 hour.
- Short-term stationary is daytime work that occupies a location for more than 1 hour within a single daylight period.
- Short duration is work that occupies a location up to 1 hour.
- Mobile is work that moves intermittently or continuously.

# WORK ZONE TEMPORARY TRAFFIC CONTROL - MAJOR ELEMENTS

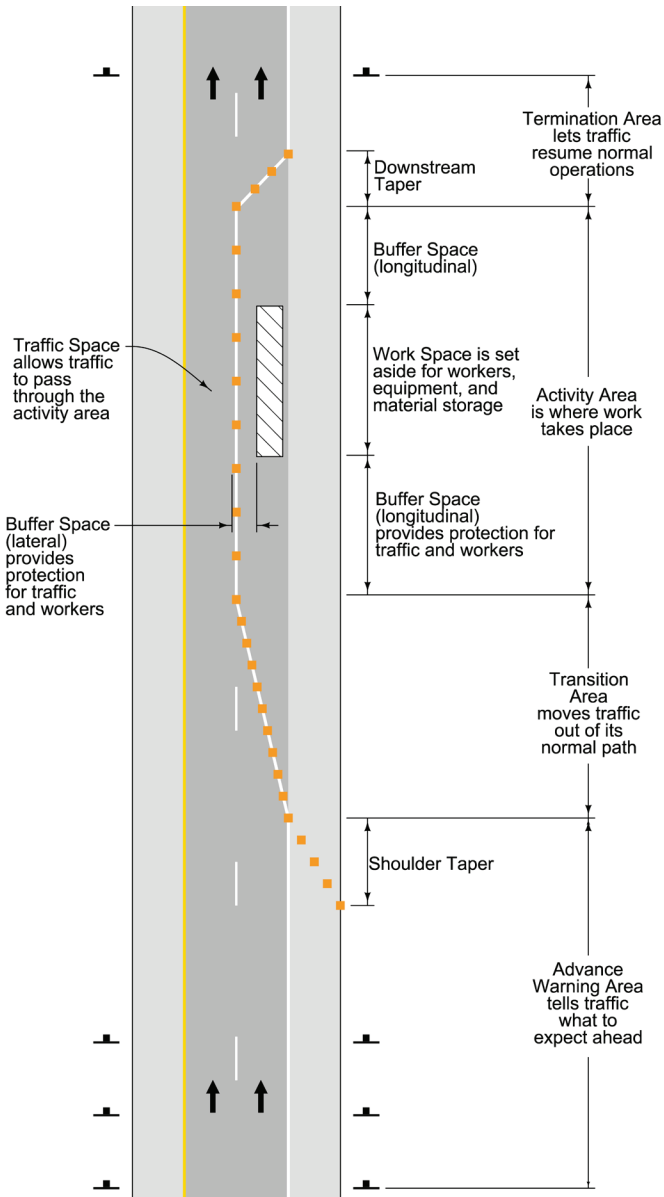

A typical work zone, designated with signs and various other traffic control devices, is defined as extending from the first advance warning sign or vehicle with amber, high-intensity, rotating, flashing, oscillating, or strobe light to an END ROAD WORK (G20-2) sign or other device beyond which traffic returns to normal paths.

Most work zones involving major traffic obstructions can be divided into four major areas: advance warning, transition, activity, and termination.

### **Advance Warning Area**

Advance warning is crucial to safety, and every work zone should include this important feature. Without effective warning, road users cannot be expected to react properly. The advance warning area is that section of roadway where road users are informed about the activity ahead. Depending on the type of road, traffic volumes and speeds, and degree of obstruction, advance warning might consist of a vehicle with amber, high-intensity, rotating, flashing, oscillating, or strobe light; single sign; or series of signs.

When a series of signs is required, information is presented in this order:

1. General information, such as ROAD WORK AHEAD (W20-1)
2. Description of activity or obstruction, such as RIGHT LANE CLOSED AHEAD (W20-5R) or ONE LANE ROAD AHEAD (W20-4)
3. Specific action, such as BE PREPARED TO STOP (W20-7b) or FLAGGER AHEAD (W20-7a)

### **Transition Area**

In a transition area, traffic is directed from the normal, intended path to a new course, such as from one lane to another. To accomplish this, the MUTCD requires channelizing. Channelization, or redirection of traffic, is usually accomplished with tapers.

### **Tapers**

Part 6 of the MUTCD discusses tapers in detail. Several types of tapers are available for work zones, depending on circumstances:

- Merging tapers are used for lane closures on multi-lane roadways.



- Shifting tapers divert traffic to alternate paths without closing lanes.
- Shoulder tapers can be used to delineate shoulder closures.

The recommended minimum length of all these taper types depends on the speed of approaching traffic and the width of the lane being closed. Lengths of merging tapers for various speeds are shown in Table 1.

Speed Limit (mph)	Taper Length (L) (ft)	Number of Devices	Spacing of Devices (ft)
20	80	5	20
25	125	6	25
30	180	7	30
35	245	8	35
40	320	9	40
45	540	13	45
50	600	13	50
55	660	13	55

\* This table does not apply to one lane, two-way (flagger) tapers.

Two other taper types do not depend on traffic speed or lane width: one lane, two-way taper (used mostly for flagging or self-regulating) or downstream (termination) taper.

One hundred feet is the maximum recommended length for a one-lane, two-way taper, but a length of 50 feet can benefit flagging operations. Refer to the Iowa DOT's *Flagger's Handbook* for more details. At least 100 feet for each closed lane is recommended for a termination taper length. For merging taper lengths on multi-lane roadways, see Table 1.

### Channelizing Devices

Several channelizing devices are available for use in tapers, including cones, vertical panels, drums, and barricades.

## Activity Area

The activity area of many work zones can be divided into three main parts: buffer space(s), work space, and traffic space.

### Buffer Space

Buffer spaces are recommended wherever workers are exposed to high-speed moving traffic. Neither work activity nor storage of equipment, vehicles, or material should occur within a buffer space.

**Longitudinal buffer spaces** are a safety protection for workers and road users. They give drivers space to recover in emergency situations. Like many other work zone dimensions, longitudinal buffer space is based largely on the traffic speed. Table 2 includes buffer lengths for various traffic speeds and are applicable to all temporary traffic control situations. The length of the longitudinal buffer space used may need to be modified based on site conditions.

Speed (mph)	Length (ft)
20-35	0 - 200
40	0 - 300
45	0 - 400
50	400
55	600

**Lateral buffer spaces** are especially effective in high-speed and heavy traffic situations where maximum possible separation of workers from moving vehicles is desired. Flaggers are often beneficial in these circumstances as well.

### Work Space

The work space is that area closed to traffic where maintenance and construction activities are accomplished. This area can be occupied by equipment, materials, and workers and should be made as secure and safe as possible.

## Traffic Space

Motor vehicles and other road users occupy the traffic space, also known as the open lane. Workers and equipment should respect this area and not intrude or otherwise hamper free movement of traffic in the open lane.

## Termination Area

The termination area begins at the end of the work space and extends to the END ROAD WORK (G20-2) sign, if posted. This sign is optional, but is recommended by the MUTCD. This sign is shown in all appropriate set up examples later in this handbook. A downstream or termination taper (50 to 100 feet) may be installed in this area for traffic guidance.

## TEMPORARY TRAFFIC CONTROL DEVICES

Traffic control devices are any signs, signals, markings or other items used to guide, warn, and regulate traffic. Traffic control devices are the major means of communication for road users; thus it is most important that design, condition, and placement be proper at all times. All devices used in work zones shall comply with the provisions of the MUTCD. In addition, sign design must comply with the *Standard Highway Signs* manual. The MUTCD requires all temporary traffic control devices to be promptly removed or covered when no longer needed.

## Signs

Signs are the most common type of work zone traffic control device, categorized into three types: regulatory, warning, and guide.

The MUTCD requires all signs to be retroreflective or illuminated when used at night. Roadway lights are not sufficient as illumination sources. Supplemental nighttime warning lights may be required in pedestrian or recreational areas.

## Regulatory Signs

Regulatory signs inform users about traffic laws and regulations. Because these signs impose legal obligations, they must be used properly and only with prior official authorization by the local agency. Regulatory signs are generally rectangular with a black legend and border on a white background. Exceptions include the STOP, YIELD, DO NOT ENTER, WRONG WAY, and ONE WAY signs. STOP (R1-1), ROAD CLOSED (R11-2), and SPEED LIMIT (R2-1) are all regulatory signs. Specific requirements for road closures are discussed in detail later in this handbook.



R1-1



R11-2



R2-1

## Warning Signs

Warning signs draw attention to conditions on or near the roadway that may not be readily apparent. These signs are generally diamond-shaped with an orange background and black lettering or symbols; although other colors are allowed for a few specific signs. Examples of common warning signs are the FLAGGER (W20-7a) and the ROAD WORK AHEAD (W20-1) sign. Advisory speeds on warning plaques are not enforceable; use for guidance only.



W20-1



W20-7



W21-6



W21-7

## Guide Signs

Guide signs advise drivers and pedestrians about navigating through the work zone. These signs are normally orange with black lettering. An example of a guide sign is END ROAD WORK (G20-2).



G20-2

## Sign Dimensions

Sign size and legend are critical for road user recognition and understanding. Based on traffic speed, use the following guidelines when deciding sign dimensions. For best performance, use larger signs, even in low-speed areas.

**High speed roadway (35 mph and above):** Advance warning signs shall be at least 48 inches by 48 inches. In general, uppercase lettering should be at least 7 inches high.

**Moderately low traffic volumes and speeds (25 to 35 mph):** The MUTCD allows 36 inches by 36 inches, with an uppercase lettering size of 5 inches.

**Low speed local roads and streets (25 mph or below):** Smaller advance warning signs, 30 inches by 30 inches, may be allowed, with sign messages short and symbols clear in meaning.

## Sign Installation

Consider the position of signs relative to the roadway and the spacing between the signs when installing temporary traffic control. The MUTCD requires that long-term stationary work zones (more than three consecutive days in one location) use post-mounted advance warning signs. Minimum dimensions for post-mounted signs are shown on the figure below.

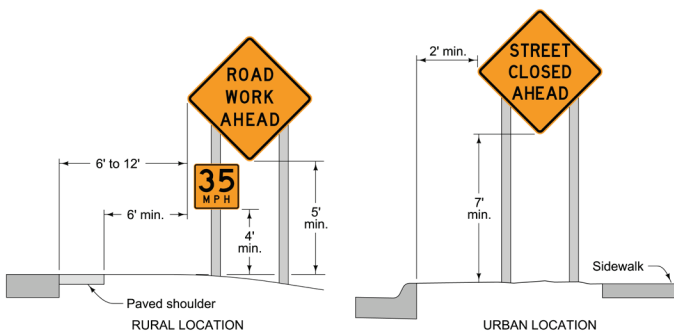

**Supplemental plaques** may be mounted 1 foot lower than the primary sign. If installed within the clear zone, sign supports shall be crashworthy or shielded. Signs should not be positioned on sidewalks or bicycle facilities in urban areas, and any signs with less than a 7 foot mounting height should not project more than 4 inches into pedestrian facilities.

**Portable sign mounting** is used for work zone applications lasting less than 3 days. The supports shall be crashworthy.

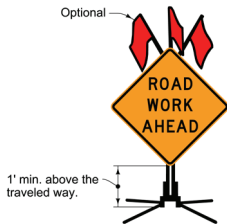

Several designs have been approved, but any used in the clear zone shall be crashworthy per the test and evaluation criteria of National Cooperative Highway Research Program (NCHRP) Report 350 or Manual on Assessing Safety Hardware (MASH). Fabric, roll-up, portable signs are popular because they are lightweight and easy to install. However, some designs are too flexible in windy conditions, degrading visibility. Flexible base portable signs that do not provide necessary stability in windy situations shall be adequately supported, or work activities must be terminated. Both the requirements for crashworthiness and adequate visibility shall be met with all work zone signs. Other installation methods for work zone signs include barricade and vehicle mounting.

**Barricade mounted signs** shall be at least 1 foot above the traveled way. In addition, signs on Type III barricades should not cover more than 50% of the top two rails and not more than 33% of all three rails.

**Vehicle-mounted signs** should be high enough for adequate visibility for approaching vehicles, suggested at least 4 feet above the ground surface.



## Spacing of Signs

Appropriate spacing is crucial for road users' reaction to work zone signs. Spacing depends on several factors, including speed of traffic, type of roadway, locations of intersections or major driveways, vertical and horizontal roadway alignment, and physical obstructions in the work area. If road users don't seem to be recognizing the signs, consider increasing the sign spacing and/or size and adding flags or warning lights.

The MUTCD contains guidance for minimum spacing of signs in Section 6C.04. A basic "rule of thumb" for warning sign placement is 4 to 8 times the speed limit in urban areas and 8 to 12 times the speed limit in rural locations. Table 3 illustrates these minimum guidelines.

Speed Limit (mph)	A
25	100
35	250
45	350
55	500

## Channelizing Devices

Channelizing devices warn about work zone conditions and guide road users through or around the work area. Several types of channelizing devices are available, including cones, vertical panels, channelizers, tubular markers, drums, and barricades - with new types continually being developed and approved. Promptly repair, clean, or replace any devices that are damaged, dirty, or deficient in retroreflectivity.

## Ballast

Ballast is often required to maintain position and stability of channelizing devices, and proper placement and type of ballast is important. Follow these guidelines:

- Never place ballast on top of channelizing devices; keep ballast on the lower part of the device.
- Use sandbags or weighted bases, and do not use items such as rocks, broken concrete, etc., for ballasting.

## Spacing of Devices

Like signs, spacing of channelizing devices in work zone applications depends primarily on traffic speed. A rule of thumb suggested by the MUTCD for maximum spacing is the speed limit when used in merging or shifting taper applications and twice the speed limit for tangent applications. Closer spacing should be considered where drivers might need more guidance, such as in horizontal curves or in low-speed applications.

**Table 4: Channelizing Device Spacing**

Speed Limit (mph)	Taper (ft)	Buffer (ft)	Work Space (ft)
25	25	50	50
30	30	60	60
35	35	70	70
40	40	80	80
45	45	90	90
50	50	100	100
55	55	110	110

## Types of Channelizing Devices

### Cones

Cones are required to be predominantly orange in color. Retroreflective striping is required for night use. To maintain proper position, ballasting as described earlier may be employed, or cones can be nested to increase weight and stability.

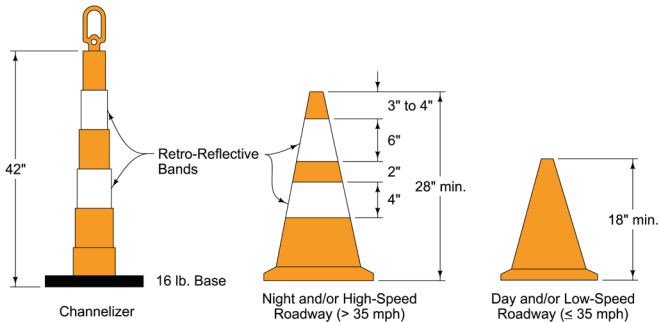



## Tubular Markers

Tubular markers have similar requirements as cones - predominantly orange, crashworthy, and retroreflective if used at night. Because of the narrow width (2 inch minimum), tubular markers are especially useful in restricted work areas. These devices must be securely ballasted or attached to the road surface to prevent movement.

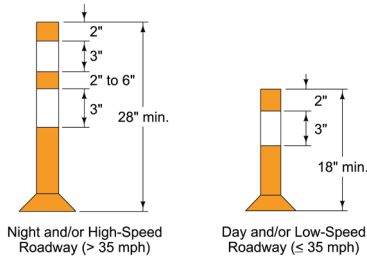

## Vertical Panels

Vertical panels provide greater visibility for road users than some other channelizing devices and can still be used in narrow work zone applications. Panels shall also have alternating retroreflective orange and white stripes, 4 or 6 inches wide, sloping downward at an angle of 45 degrees in the direction vehicular traffic is to pass. If warning lights are used with vertical panels, they must be securely fastened to prevent dislodging if struck by an errant vehicle. Proper ballasting should be used to maintain stability.

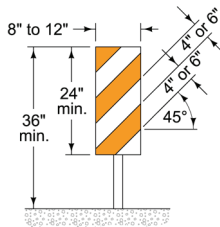

## Drums

Drums are very effective traffic control devices, especially for long-term applications. These devices shall be made with lightweight, deformable materials and alternating 4 to 6 inch wide orange and white retroreflective stripes. Drums made of metal are not allowed, and tops shall be securely fastened to prevent accumulation of debris. Using ballast on top of drums is not acceptable.

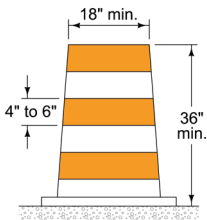

## Barricades

Barricades for work zone applications are available in three types: I, II, and III, differentiated primarily by the number of boards used. Barricades may be used individually or in groups to mark a specific condition. They may also be used in a channelization series, in either taper or tangent applications.

Type I barricades are generally used on conventional roads or city streets. Type I or Type II barricades are intended for work areas where traffic flow is maintained. Type II or Type III barricades are recommended on higher volume roadways. Type III barricades should be used to close or partially close a street or road. For complete closures, Type III barricades can be extended across the entire roadway or street or supplemented with fencing.

Using ballast, rocks, or broken concrete on top of barricades for stabilization is not allowed. Barricade rails shall feature alternating retroreflective orange and white stripes, 4 to 6 inches wide, sloping downward at a 45 degree angle in the direction traffic is expected to pass. As with vertical panels, properly placing the barricades is very important. If traffic is allowed to pass Type III barricades, retroreflective striping at the appropriate slope is required on both sides.

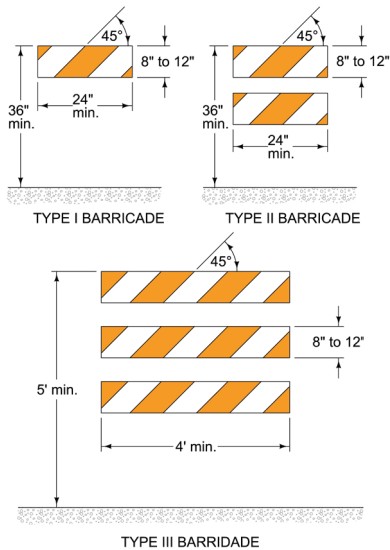

### Miscellaneous Devices for Channelizing

The MUTCD describes several other devices that can be used in channelization of vehicular and pedestrian traffic in work zones.

### Arrow Boards

As described in MUTCD Section 6F.61, arrow boards are signs with lighted elements capable of flashing or sequential displays. They are intended to be used with signs or other traffic control devices. The panels are rectangular and non-reflective black with yellow lights. The types of arrow boards used for temporary traffic control are:

- Type A: Suitable for low-speed urban streets
- Type B: Used on intermediate speed roadways or for maintenance and mobile operations
- Type C: Used for high-speed and high-volume applications

**Table 5: Minimum Requirements by Board Type**

Board Type	Board Size	Legibility Distance	Number of Elements
A	48 x 24 inches	1/2 mile	12
B	60 x 30 inches	3/4 mile	13
C	96 x 48 inches	1 mile	15

Arrow boards can be mounted in various ways, but they should be mounted at least 7 feet above the ground, except on vehicle-mounted arrow boards, which should be as high as practical. Amber, high-intensity, rotating, flashing, oscillating, or strobe lights are required when panels are mounted on vehicles. Boards shall be able to dim 50% for night operations. A caution mode is only allowed for two-lane or shoulder applications. The MUTCD does not allow a single arrow board to close more than one lane at a time.

Examples of the advance warning arrow board displays are below. Note right arrow is shown; left is similar.

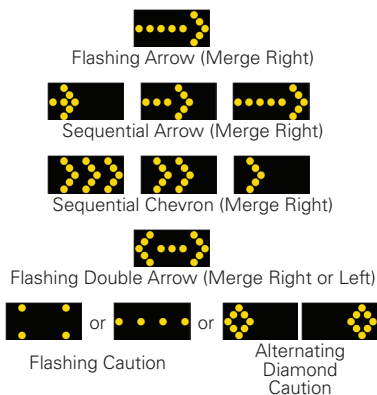

### Portable Changeable Message Sign (PCMS)

These devices have become more common in work zones on high-volume and high-speed roadways. A PCMS has a message panel, control system, power source, and transporting unit. Requirements and guidance for using these devices is presented in MUTCD Section 6F.60, and these provisions should be closely reviewed before using a PCMS. Effectiveness of a PCMS depends on how well drivers perceive and react to this device. Therefore, message visibility, length, clarity, and location to work activities are all critical for getting the most benefit from these devices. Current PCMS designs are not crashworthy, so place the devices off the roadway or behind a barrier.

## SHADOW VEHICLES

Shadow vehicles, equipped with two amber, high-intensity, rotating, flashing, oscillating, or strobe lights mounted on the rear of the vehicle, can be used to warn traffic of the operation ahead. The distance between the work vehicle and the shadow vehicle may vary according to terrain, type of work, or other factors. Whenever adequate stopping sight distance exists, the shadow vehicle should maintain the minimum distance to the work vehicle and proceed at the same speed. The shadow vehicle should slow down in advance of vertical or horizontal curves that restrict sight distance. The work and shadow vehicle should pull over periodically to allow traffic to pass. When an adequate shoulder is present, the shadow vehicle should use it for travel. If the work and shadow vehicle cannot pull over to allow traffic to pass, a DO NOT PASS (R4-1) sign may be placed on the shadow vehicle.

## INSPECTION AND DOCUMENTATION OF TEMPORARY TRAFFIC CONTROL

### Documenting Inspections

Monitoring work zone traffic control should be a priority for all transportation agencies. Observations cannot be substantiated unless properly recorded. Inspections and documentation should always be current and accurate. Entries should be brief and factual (no opinions). Never erase mistakes; always cross out errors and make corrections (eraser marks in a diary may raise credibility concerns). Consider taking a video or photographs of the traffic control immediately after it's installed. The TTC Zone Checklist on the last page of this handbook can be used to help with this documentation process.

## **Documenting Crashes in the Work Zone**

When establishing any documentation procedure for work zone crashes, ensure supervisory and legal staff are aware of these records. Special documentation for work zone crashes should consider using this guidance:

- Develop and follow standard procedures.
- Establish and maintain a relationship with local law enforcement.
- Record all pertinent information, but only facts - not opinions.
- Use standard forms, if available.
- Supplement with photos and police reports.
- Describe any resultant revisions in temporary traffic control.
- Analyze any crash data at the completion of the project.

## **FLAGGING IN WORK ZONES**

Flagging is commonly considered one of the most dangerous jobs in temporary traffic control. Visibility and recognition by drivers are very important for safe and efficient flagger operations. Iowa has adopted even more stringent standards for flagging activities; these are described in the Iowa DOT's *Flagger's Handbook* and should be carefully reviewed before beginning any flagging activities.

## **HIGH-VISIBILITY SAFETY APPAREL**

All workers within the right-of-way who are exposed either to traffic (vehicles using the road/street for purposes of travel) or to work vehicles and construction equipment within the TTC zone shall wear high-visibility safety apparel that meets the Performance Class 2 or 3 requirements of the ANSI/ISEA 107 publication entitled "American National Standards for High-Visibility Safety Apparel and Headwear" or equivalent revisions.

## **NIGHTTIME OPERATIONS**

MUTCD Section 6G.19 offers guidance and advice for temporary traffic control measures for nighttime operations. Traffic volumes are reduced at night, but the number of impaired drivers may increase. Impaired drivers and reduced visibility mean that additional steps need to be taken to ensure safe and efficient working conditions. Work areas should be

lighted to provide adequate visibility for work tasks and road users. Lighting shall not produce a disabling glare condition for approaching road users, flaggers, or workers. MUTCD Section 6F.82 describes specific requirements for lighting during night hours. Size and type of luminaries, mounting height, pole location, and positioning are all specified. The performance of the lighting should be observed immediately after implementation and then periodically during use. For flagging at night, comply with the Iowa DOT's Flagger's Handbook.

## **ACCOMMODATION OF PEDESTRIANS AND BICYCLISTS**

The MUTCD requires all road users to be controlled throughout work zones, including motorists, bicyclists, and pedestrians. When urban streets are being improved, needs of pedestrians and bicyclists should receive as much attention as the needs of motorists.

### **Pedestrians**

The Americans with Disabilities Act of 1990 requires suitable access for persons with disabilities, even in work areas. Temporary traffic control for pedestrians should consider the special needs of disabled pedestrians, including those with visual disabilities. MUTCD Sections 6D.01 and 6D.02 provides guidance for planning temporary traffic control for pedestrians:

- Pedestrians should not be led into conflicts with vehicles or work zone equipment.
- A safe and convenient path should be provided for pedestrians, closely replicating existing sidewalks.

Pedestrians shall be notified in advance if sidewalks will be closed. The MUTCD requires standard signs to be supplemented with alternative warnings such as audible messages or instructions to aid visually impaired pedestrians, if such a need is identified. In addition, a firm, stable, and slip resistant surface should be provided throughout the entire length of any temporary pedestrian facility. There should be no curbs or abrupt changes in grade or terrain that could cause tripping or be an obstacle to wheelchair use.

To avoid conflicts with work zone activities, pedestrian travel may need to be diverted. Moving work equipment across designated pedestrian paths should be avoided or at least minimized. Temporary traffic barriers should be

considered for safe separation when vehicular and pedestrian paths are relocated close together in long-term work areas. Mesh fencing, caution tape, rope, or chain strung between traffic control devices will not comply with standards in PROWAG and should not be used.

For additional guidance, refer to MUTCD Chapter 6D, SUDAS Design Manual Chapter 12, and the typical examples in this handbook.

## **Bicyclists**

Proper planning for bicyclists through and along work zones is as important as planning for motor vehicle traffic, especially in urban and suburban areas. According to the MUTCD, if the TTC zone affects the movement of bicyclists, adequate access to the roadway or shared use path shall be provided. On low volume roads or short work zones, standard traffic control practices are usually adequate. It is important to remove temporary signing, debris, and other obstructions from the edge of the roadway, bike lane, or shared use path after each day's work.

If a bike facility detour involves significant out of direction or distance travel, bicyclists will prefer to ride through the work zone. It is preferable to allow bicyclists to proceed as close to their original route as possible. On longer projects, a temporary bike lane or a wide travel lane may be needed. Advance work zone signs should not obstruct the bicyclist's path. Signs should be placed on the shoulder or planting strip rather than in the bike lane or on the shared use path. For additional guidance, refer to the AASHTO Guide for the Development of Bicycle Facilities, 4th Edition.

## **ROAD AND STREET CLOSURES**

Roadway improvements can generally be accomplished more efficiently and safely when vehicular traffic is detoured from the work area. However, access for local property owners and commercial interests must be maintained in many situations. Even though a street or road section is closed by official action, the agency must still consider appropriate temporary traffic control measures in that area even if only for local public traffic. Properly using specific regulatory signs is required.



## Temporary Traffic Control for Closures

Traffic control for closures can be considered in two different applications: outside the work area and inside the actual closed street or road section. MUTCD Part 6 includes specific requirements and guidance for temporary traffic control associated with closures. Some examples are included in the typical applications in this handbook.

When safety fence is needed, provide orange plastic mesh containing ultraviolet stabilizers with a height of 48 inches  $\pm$  2 inches. Maximum aperture opening of a nominal 4.5 square inches. Connect to posts or drums to keep the safety fence upright and tight. In lieu of safety fence, Type III barricades may be placed continuously across the shoulders and pavement.

While the messages on the following signs may seem similar, each must be used appropriately:

- ROAD (STREET) CLOSED (R11-2),
- LOCAL TRAFFIC ONLY signs (R11-3a), and
- ROAD CLOSED TO THRU TRAFFIC (R11-4).

MUTCD Section 6F.08 states that the ROAD (STREET) CLOSED (R11-2) sign shall not be used where road users are allowed to pass. For consistency, this handbook will use ROAD CLOSED signs on all applications; however, STREET CLOSED may be substituted when applicable to urban situations.

When local access (vehicular or pedestrian) is allowed in closed street or road sections, be sure to maintain an appropriate level of temporary traffic control, including

- warning signs,
- barricades and other channelizing devices at drop-offs, and
- fencing of excavations.

## GENERAL NOTES FOR ALL TTC EXAMPLES

1. Each example identifies a specific traffic control device set up. It may be necessary to combine two or more examples (such as a pedestrian example and vehicular example) in order to adequately address the TTC need.
2. Vehicle hazard lights may be used to supplement amber, high-intensity, rotating, flashing, oscillating, or strobe lights (hereinafter called vehicle warning lights), but they shall not be used alone.
3. Flags may be used to call attention to the advanced warning signs.
4. If a closure extends overnight, retroreflective sheeting shall be used on channelizing devices.
5. Speed limit refers to the legally established and signed speed limit.
6. Shadow and work vehicles should display vehicle warning lights.
7. If an arrow board is used on 2-lane roads, only the “caution” mode is allowed.
8. The position of the warning signs and channelizing devices should be adjusted for available sight distance.
9. Maximum spacing in feet between channelizing devices in a taper should be approximately equal to the speed limit.
10. Do not install temporary traffic control devices until work is ready to begin, and remove or cover all signs and devices promptly when they are not needed.
11. The END WORK (G20-2) signs shown on all examples are optional.

## LEGEND



Arrow board

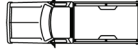

Shadow vehicle



Arrow board support or trailer



Sign (shown facing left)



Channelizing device



Surveyor



Direction of traffic



Amber, high-intensity rotating, flashing, oscillating, or strobe light (vehicle warning light)



Drum



Type III barricade



Flagger



Work space



Pedestrian channelizing device

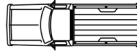

Work vehicle



Safety fence

**Table 6: Sign Spacing and Buffer Length**

Speed Limit (mph)	Sign Spacing (A) (ft)	Buffer Space (ft)
25	100	0 - 200
35	250	0 - 200
45	350	0 - 400
55	500	600

# 1. WORK BEYOND THE SHOULDER/BEHIND THE CURB

For workers and equipment operating more than 12 to 15 feet from the edge of the traveled way during daylight hours, such as mowing, litter pickup, and utility repair. The work area should be established on one side of the road only. No work or parking on the opposite side within 500 feet. The ROAD WORK AHEAD (W20-1) signs may be replaced with other appropriate signing such as SHOULDER WORK AHEAD (W21-5) or worker symbol signs. For a single daylight period or less, all signs and channelizing devices may be omitted, if a vehicle displays vehicle warning light(s).

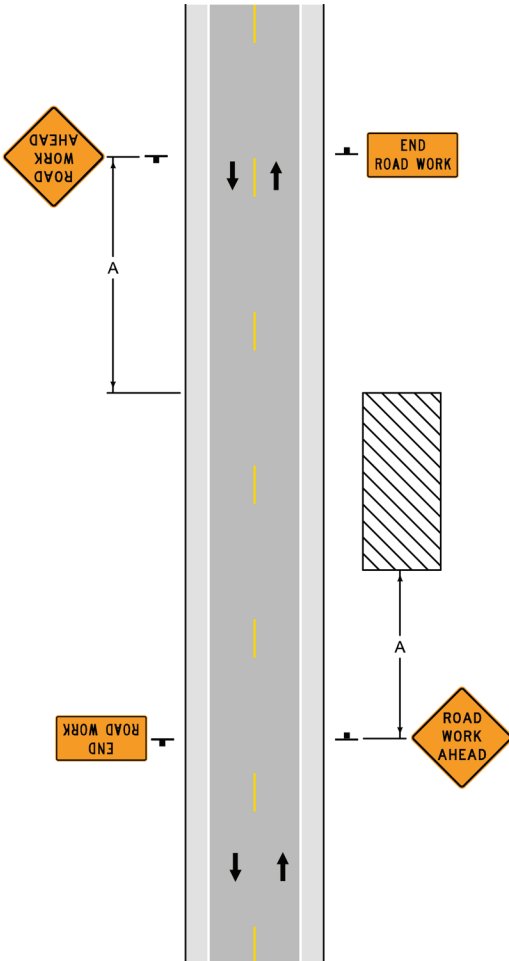

## 2. SHORT-DURATION OR MOBILE OPERATION ON SHOULDER

Use this layout in daylight hours where traffic flow is uninterrupted. When placing ground-mounted signs is practical (i.e., when multiple work locations are fairly close together), the advance warning sign and work should not be more than 5 miles apart. When the distance between the advance signs and the work is between 2 to 5 miles, a supplemental distance plaque with the ROAD WORK AHEAD (W20-1) sign or a ROAD WORK NEXT XX MILES (G20-1) sign should be used. If both of the following conditions are met, warning signs may be omitted when the work vehicle displays vehicle warning light(s):

- the distance between work locations is 1 mile or more
- the work vehicle travels at normal traffic speeds between locations

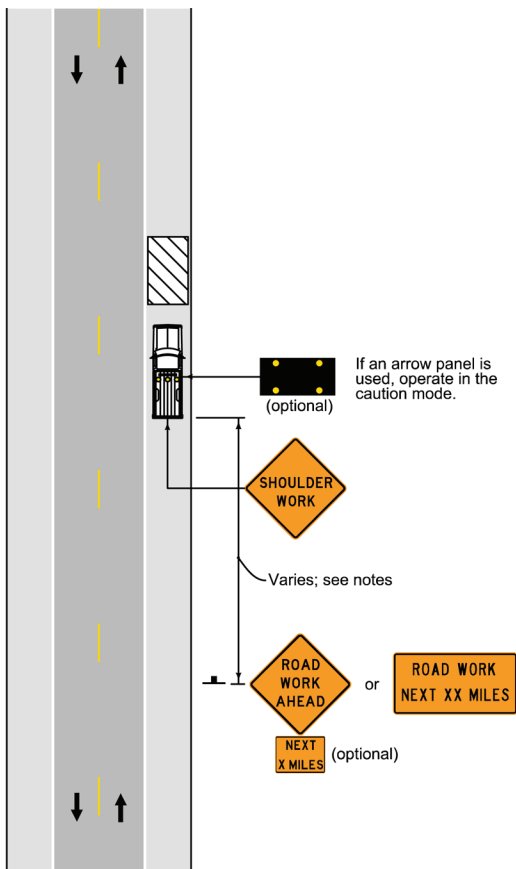

### 3. WORK OFF OF PAVEMENT WITH MINOR ENCROACHMENT ONTO TRAVELED WAY

Use only on a minor, low-speed street or road for items such as culvert work, shoulder work, utility operations, and guardrail installation. A lane closure should be considered for higher speed traffic conditions. Open lanes should be at least 10 feet wide as measured to the near face of the channelizing devices. For short-term use on low-volume, low-speed roadways without longer and wider heavy commercial vehicles, lanes may be a minimum of 9 feet wide. Where the opposite shoulder is suitable, traffic may be shifted by using closely spaced channelizing devices, provided that the lane is at least 10 feet wide. Additional advance warning may be appropriate, such as a ROAD NARROWS (W5-1) sign. For short-term work, the taper and channelizing devices may be omitted if using a shadow vehicle displaying vehicle warning light(s).

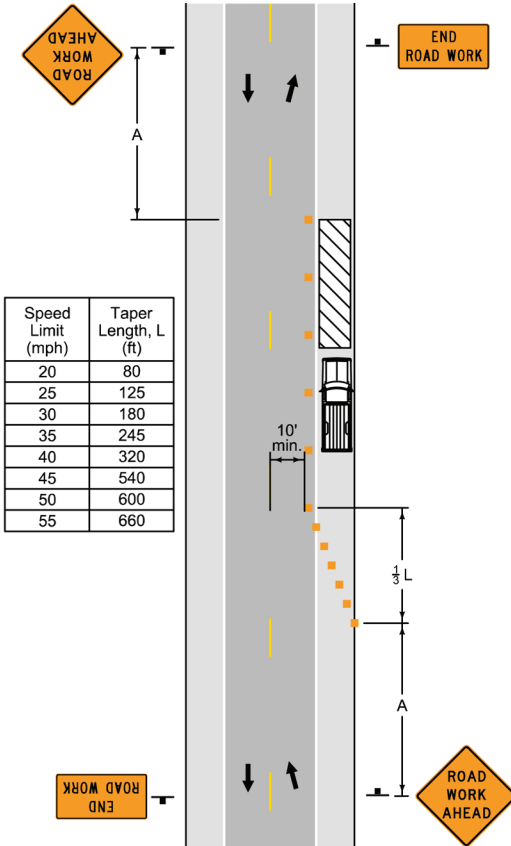

## 4. LANE CLOSURE ON MINOR STREET OR ROAD

Use on low-volume, low-speed roadways (paved or unpaved). Motor vehicle traffic may be self-regulating when the work space is short, drivers can see the roadway beyond, and volume is low. Use one or two flaggers when motor vehicle traffic cannot effectively self-regulate. For mobile operations or if work activity is less than an hour, a reduction in the number of devices may be offset by the use of work vehicles displaying vehicle warning light(s).

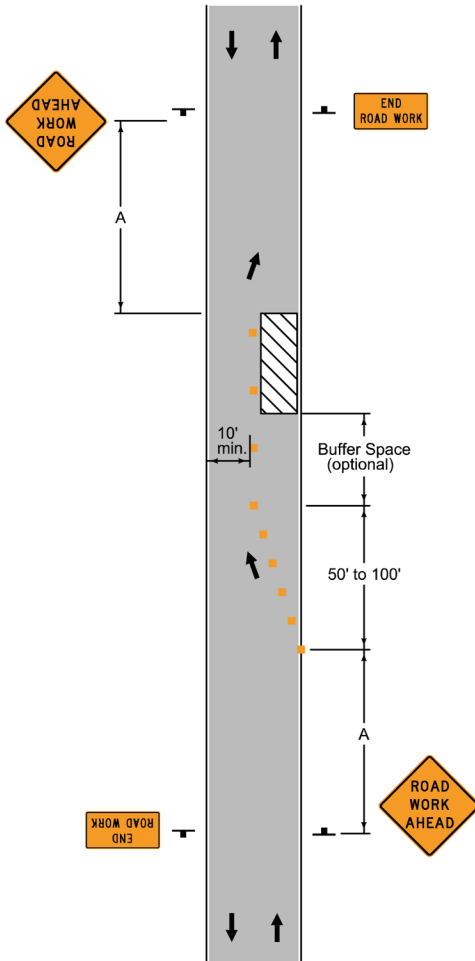

## 5. LANE CLOSURE FOR LOW-VOLUME STREET OR ROAD (SELF-REGULATING)

Use where average daily traffic is fewer than 400 vehicles and good sight distance is available. A typical application is patching that requires overnight closures. A work site must be at least 2,500 feet from a similar work site. No open holes should be left during nonworking hours. Temporary filling may be necessary. Private vehicles and unattended equipment should not be parked on the roadway. Materials, equipment, or stockpiled waste should be removed during nonworking hours.

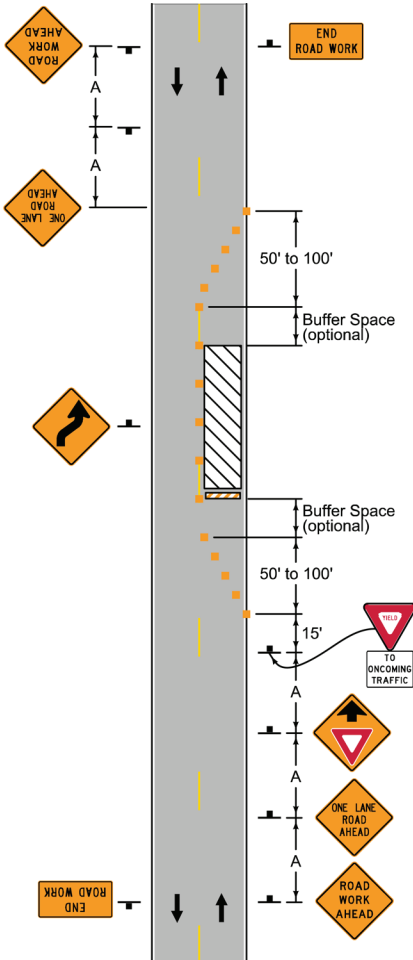



## 6. WORK IN CENTER OF LOW-VOLUME STREET

Use when patching, undertaking utility work, or surveying. Open lanes on either side of the center work space should be at least 10 feet wide as measured from the near edge of the channelizing devices to the edge of the pavement, paved shoulder, or face of curb. A lane width of 9 feet may be used for short-term stationary work when motor vehicle traffic does not include longer and wider heavy commercial vehicles. A work vehicle displaying vehicle warning light(s) may be used instead of the channelizing devices.

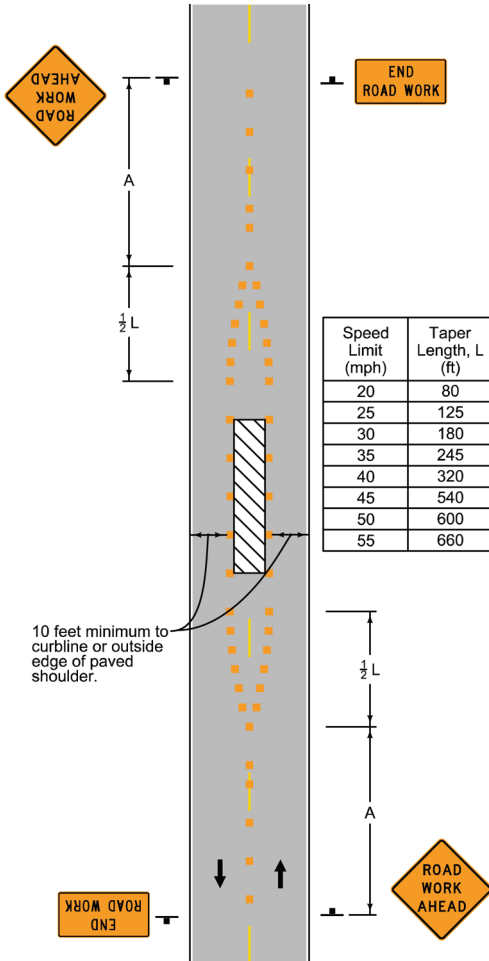

## 7. LANE CLOSURE FOR SHORT-TERM OR MOVING OPERATIONS USING A SINGLE FLAGGER

Use in daylight hours only, with traffic volumes fewer than 2,000 vehicles per day and good sight distance. No parking on opposite side of work area. Traffic in the open lane is allowed to flow freely. The flagger should stop the first vehicle in the closed lane from the position shown, and then move toward the centerline to stop other vehicles. A vehicle displaying vehicle warning light(s) may be substituted for the Type III barricade. A second flagger may be required when the flagger's view of approaching traffic in the open lane is less than 1/4 mile, or the work site is in an area of restricted sight distance (such as a No Passing Zone); and excessive traffic delays and conflicts are encountered. If a second flagger is required, use the next example layout.

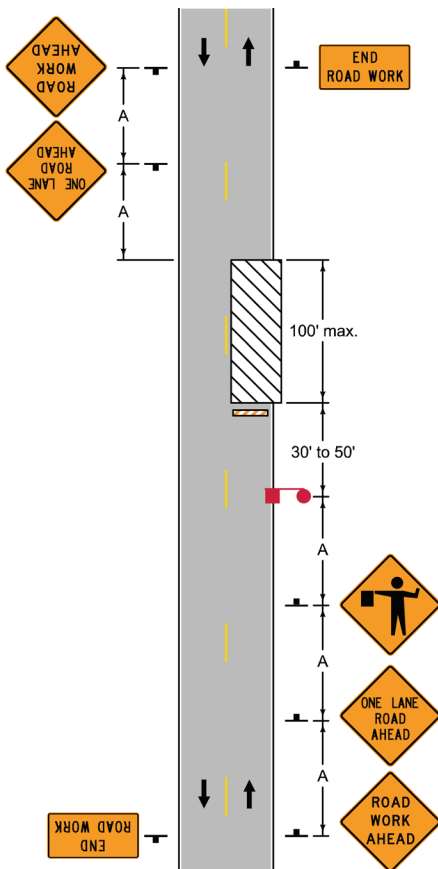

## 8. LANE CLOSURE ON TWO-LANE ROAD USING TWO FLAGGERS

A single flagger may be used for low-volume situations with short work zones on straight roadways. See Example 7. When used, the BE PREPARED TO STOP (W20-15) sign should be located between the Advance Flagger sign and the ONE LANE ROAD (W20-4) sign. Lighting shall be provided to mark flagger stations at night. See Example 9 for flagging in the vicinity of a highway-rail crossing.

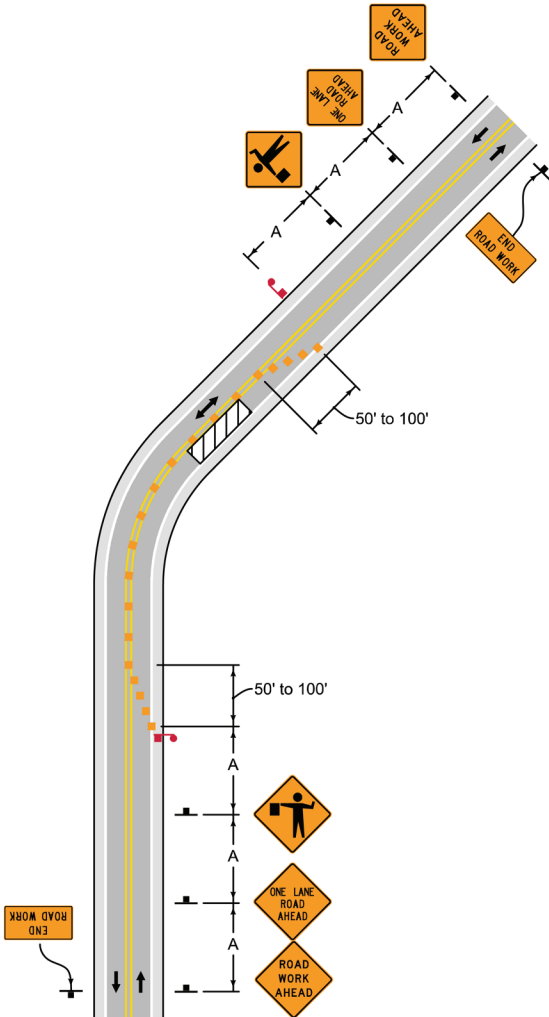

# 9. WORK IN VICINITY OF HIGHWAY-RAIL GRADE CROSSING

Coordinate with the railroad company early, before work starts. The railroad company may require railroad-supplied flaggers. When roadway work activities come within or near highway-rail grade crossings, take extra care to eliminate the possibility of lane restrictions, flagging, or other operations creating a situation where vehicles might be stopped within the highway-rail grade crossing, which is defined as 15 feet from the closest rail. In the example depicted, the buffer space of the activity area should be extended upstream of the highway-rail grade crossing (as shown) so that a vehicle backup created by the flagging operation will not extend across the highway-rail grade crossing.

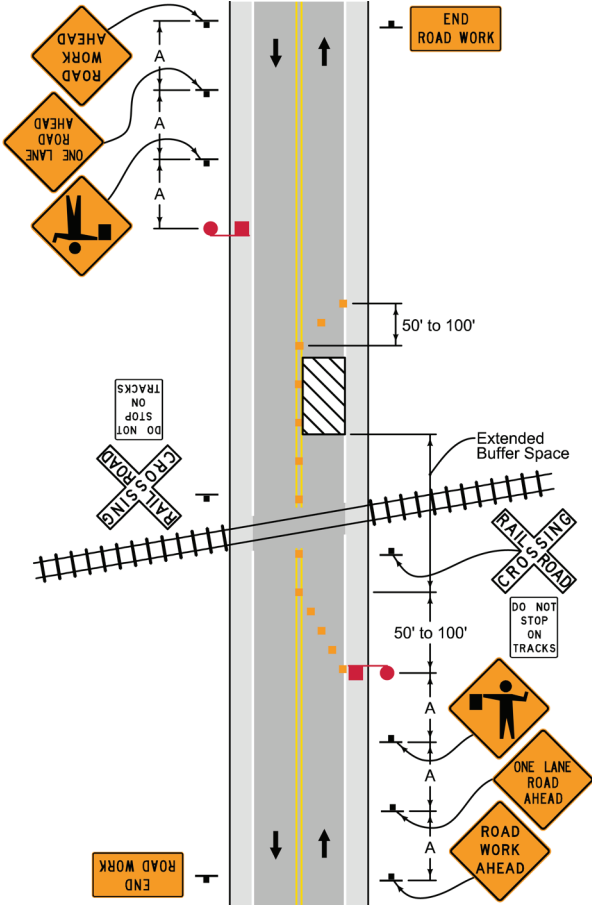

# 10. TRAFFIC CONTROL FOR OUTSIDE LANE CLOSURE OF STREET WITH CONTINUOUS LEFT TURN LANE

Intended for short-term applications in urban areas on a 3-lane street. Longer operations will require additional traffic control devices and retroreflective sheeting for use in non-daylight hours. Cones may be used as channelizing devices during daylight hours. Flaggers and additional traffic control devices may be required for higher traffic volumes or commercial areas.

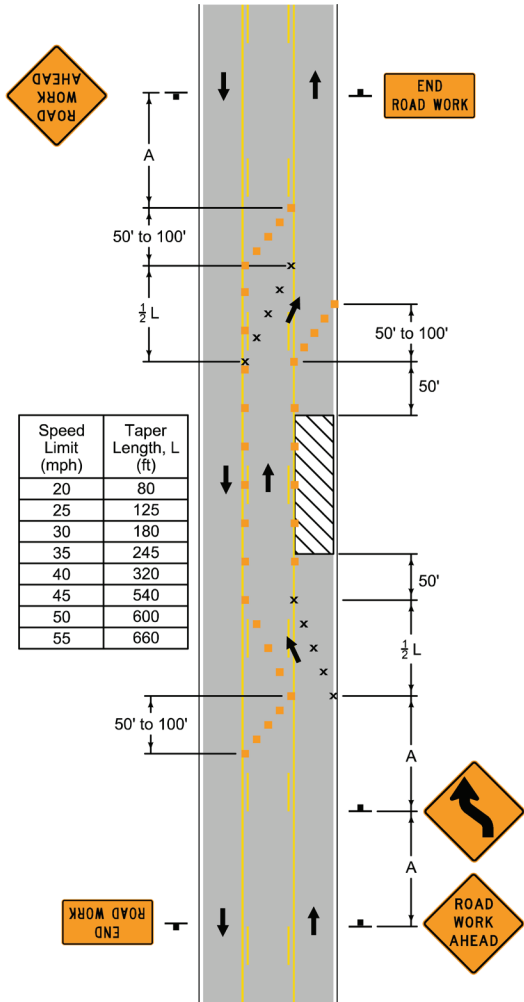

# 11. TRAFFIC CONTROL FOR CLOSURE OF CONTINUOUS LEFT TURN LANE

Intended for short-term applications in urban areas on 3-lane or 5-lane streets. Longer operations will require additional traffic control devices and retroreflective sheeting for use in non-daylight hours. Cones are used as channelizing devices during daylight hours. Additional traffic control devices may be required for higher traffic volumes or commercial areas.

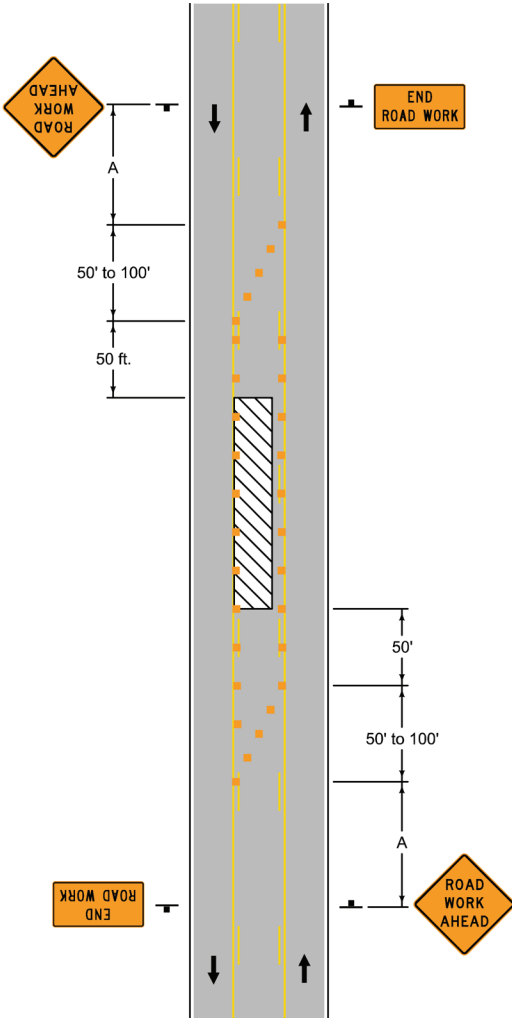

## 12. STREET OR ROAD CLOSURE

When distance “A” is less than 500 feet, the barricade should be placed in the middle of the traffic lane approaching the work area. A Type III barricade must be visible to both directions of traffic. The barricade may be omitted if the distance to the work area is less than 250 feet. Safety fence closures must be maintained to prevent unauthorized vehicles from passing through. Place staggered Type III barricades in the roadway after the last public road intersection prior to the closure. If local traffic is allowed to pass a Type III barricade, retroreflective sheeting is required on both sides of the barricade.

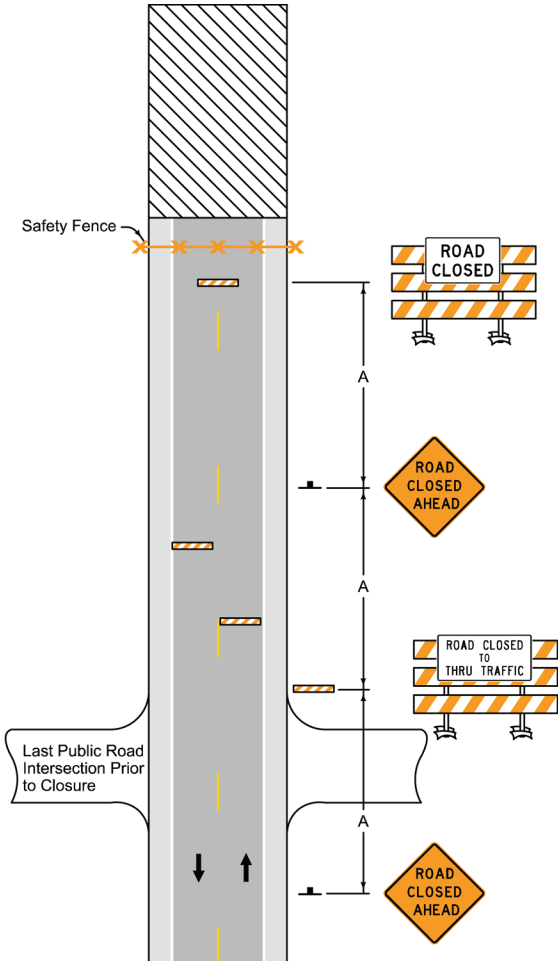

### 13. SHORT-DURATION STREET OR ROAD CLOSURE

Use for a planned, daytime closure that lasts less than 20 minutes. A law enforcement officer and/or a changeable message sign may be used on higher volume roads.

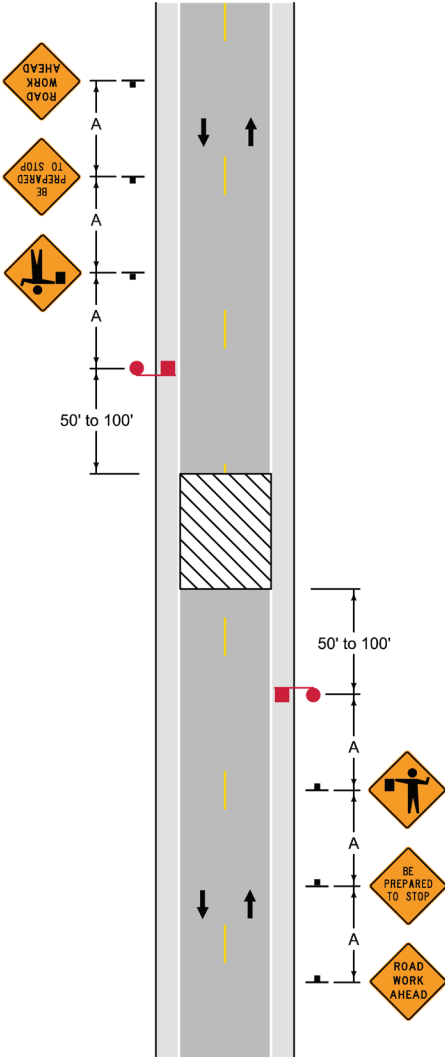



## 14. STREET OR ROAD CLOSURE WITH OFF-SITE DETOUR

Existing traffic control devices should be modified as needed for the duration of the detour. If the road is open to local traffic beyond the last intersection, the signs on Type III barricades may be located at the edge of the traveled way. If the road is closed beyond the intersection and local traffic volumes are low (for example, a few residences), the ROAD CLOSED (R11-2) and DETOUR (M4-10) signs may be placed on a Type III barricade in the center of the roadway. If local traffic is allowed to pass a Type III barricade, retroreflective sheeting is required on both sides of the barricade. A designated detour is required when closing a numbered road for more than 48 hours per Iowa Code Section 306.41.

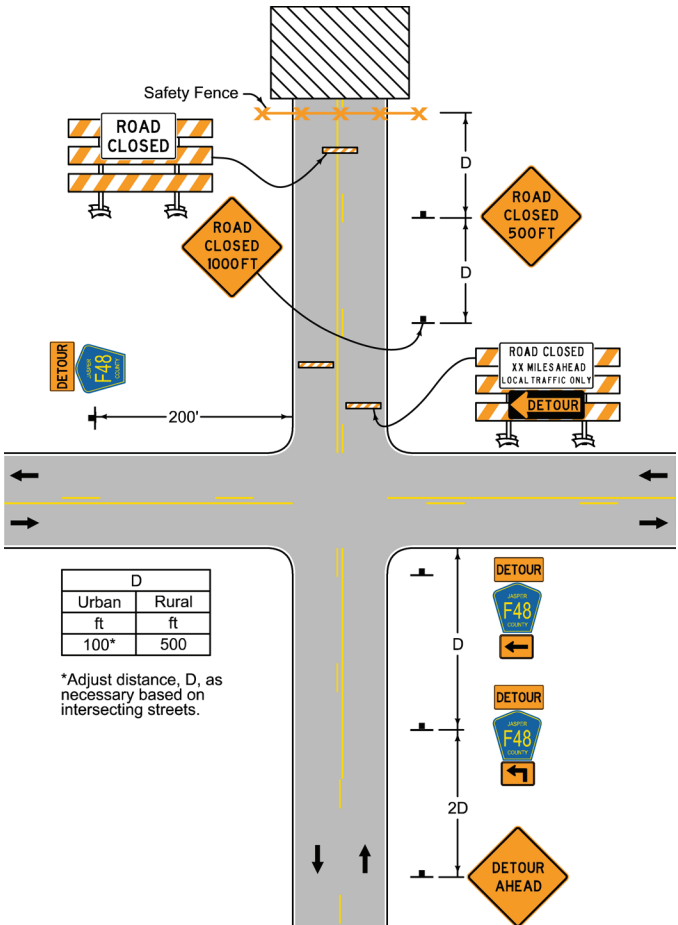

## 15. LANE CLOSURE AT AN INTERSECTION

If the work area extends across the crosswalk, the crosswalk should be closed using appropriate information and devices. For traffic signal maintenance, consider using law enforcement and/or a shadow vehicle. For intersection approaches reduced to a single lane, left-turning movements may be prohibited to maintain capacity for through motor vehicle traffic. Right lane closure shown; for left lane closures, modify sign messages and arrow board. Place arrow board within the closed lane behind the devices and as close to the beginning of the taper as practical, while keeping it on the paved surface.

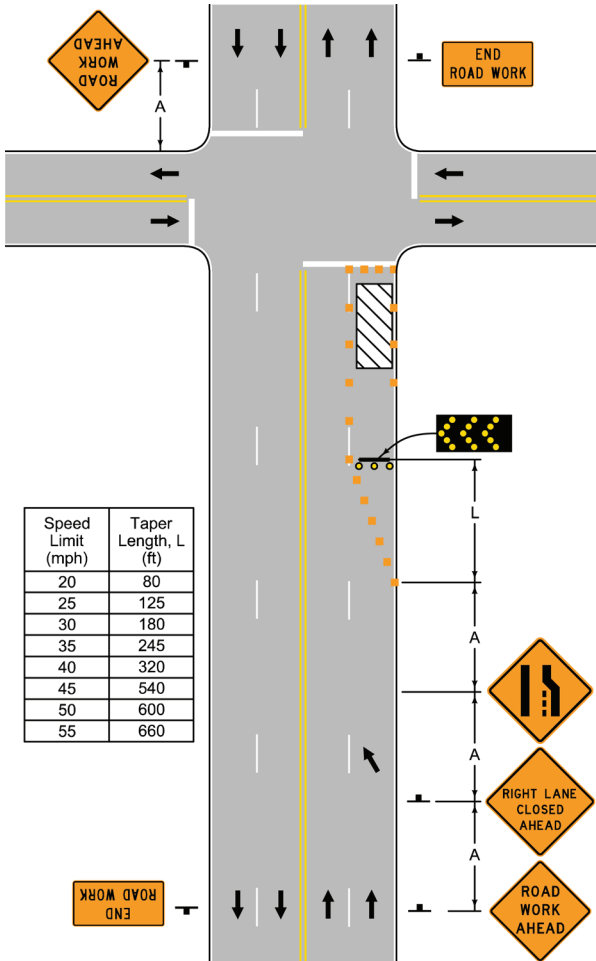

# 16. CLOSURE ON THE FAR SIDE OF AN INTERSECTION

If the work area extends across the crosswalk, the crosswalk should be closed using appropriate information and devices. For traffic signal maintenance, consider using law enforcement and/or a shadow vehicle. Right lane closure shown; for left lane closures, modify sign messages and arrow board.

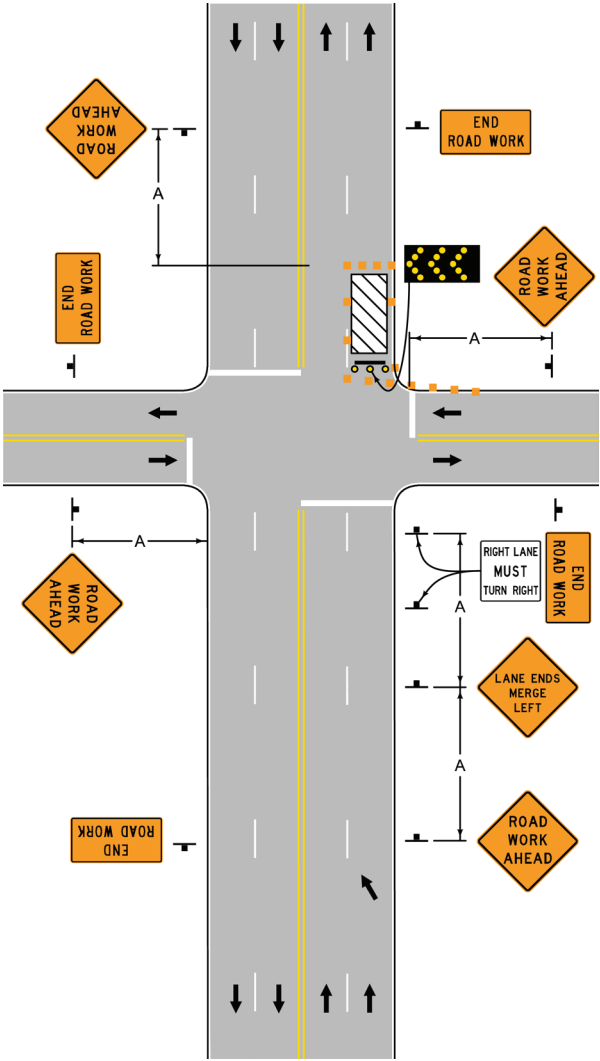

## 17. CLOSURE WITHIN AN INTERSECTION

The situation depicted can be simplified by closing one or more of the intersection approaches. If this cannot be done, and/or when capacity is a problem, motor vehicle traffic may be directed to other roads or streets. Positioning of flagger(s) is dependent upon the location of major driveways, physical characteristics of the intersection, and traffic flow. Adjustments may be necessary as the traffic flow changes throughout the day. Depending on traffic conditions, uniformed law enforcement officer(s) should be used to direct road users within the intersection. For short-duration work operations, the channelizing devices may be eliminated if a vehicle displaying vehicle warning light(s) is positioned in the work space. Turns can be prohibited as required by traffic conditions. Unless the streets are wide, it may be difficult to make certain turns, especially for large vehicles.

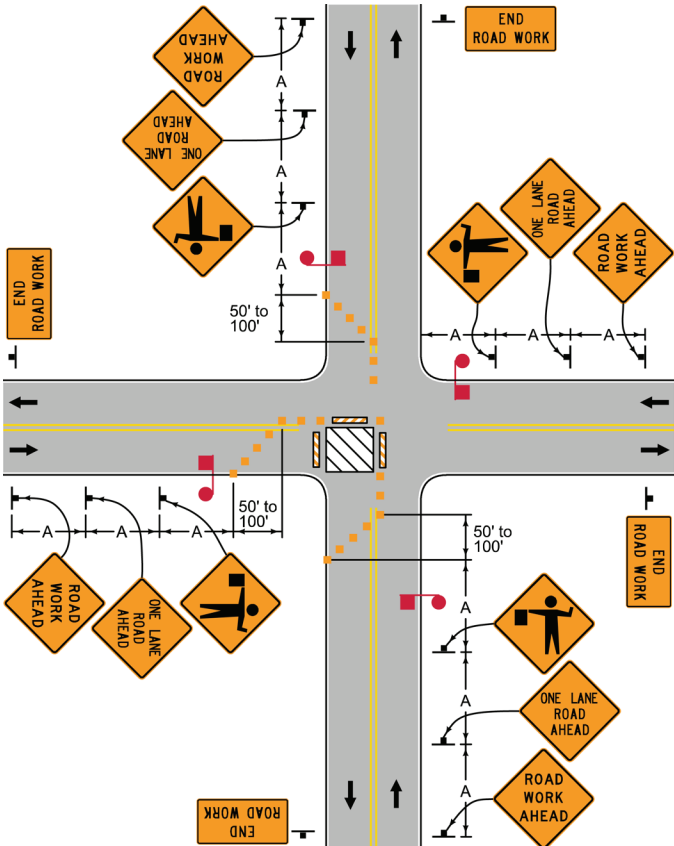

## 18. CLOSURE IN CENTER OF INTERSECTION

The situation depicted can be simplified by closing one or more of the intersection approaches. All lanes should be at least 10 feet wide when measured to the near face of the channelizing devices. For short-term use on low-volume, low-speed roadways that do not include large commercial vehicles, a minimum lane width of 9 feet may be used. Left turns may be prohibited as required by geometric and traffic conditions (unless the streets are wide, turning left may be impossible, especially for large vehicles). For short-duration work operations, the channelizing devices may be eliminated if a vehicle displaying vehicle warning light(s) is positioned in the work space. Arrow signs (W1-6) may be used to replace the KEEP RIGHT (R4-7) signs.

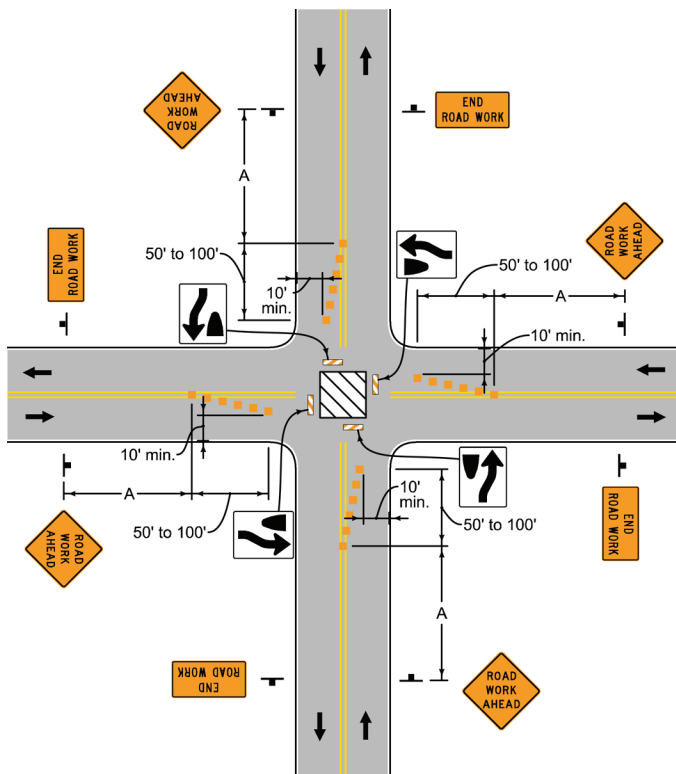

## 19. MOVING OPERATION ON TWO-LANE ROADS

Use for pavement marking and surface maintenance operations in daylight hours only. Vehicle-mounted signs shall be placed at an elevation so as not to be obscured by equipment or materials and fully visible to approaching traffic. Sign legends shall be covered or turned from view when work is not in progress.

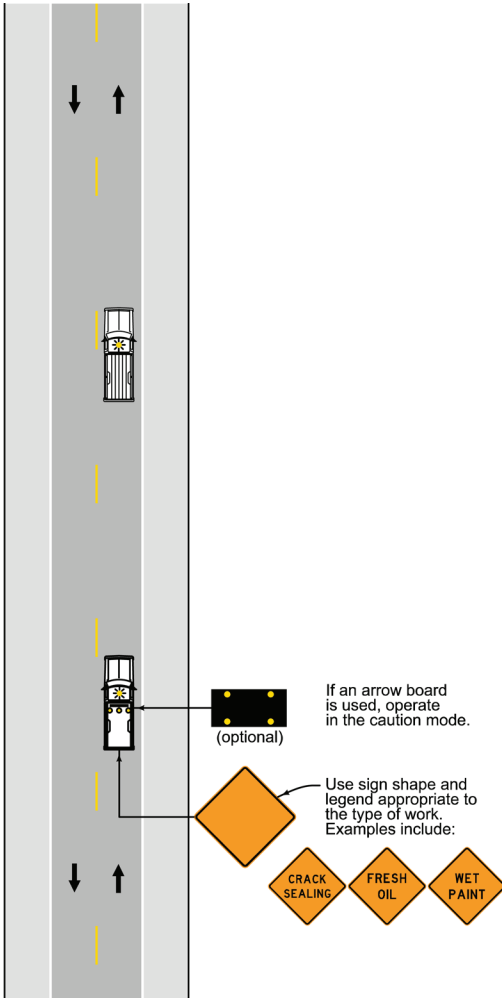

## 20. MOBILE OPERATION ON MULTI-LANE ROAD

Use in the daytime with slow moving operations such as pavement marking or surface maintenance. Work should normally be accomplished during off-peak hours on high-volume roadways, if possible. Vehicles used for these operations should be made highly visible with appropriate equipment such as vehicle warning light(s), flags, signs, or arrow board.

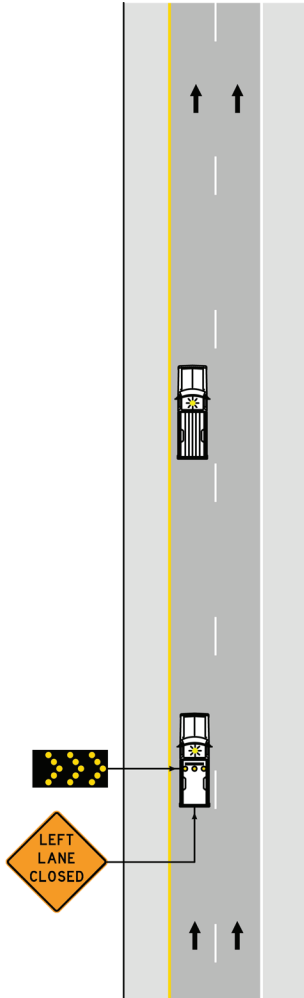

## 21. SIDEWALK DETOUR

Use when crosswalks or other pedestrian facilities are closed or relocated, temporary facilities shall be detectable and shall include accessibility features consistent with the features present in the existing pedestrian facility. Where high traffic speeds are anticipated, a temporary traffic barrier and, if necessary, a crash cushion should be used to separate the temporary sidewalks from vehicular traffic. Audible information devices should be considered where midblock closings and changed crosswalk areas cause inadequate communication for pedestrians with visual disabilities. Auxiliary lighting may be considered. Only the TTC devices related to pedestrians are shown. Other devices, such as lane closure signing or ROAD NARROWES (W5-1) signs, may be used to control vehicular traffic. For nighttime closures involving use of warning lights, meet the requirements of MUTCD 6F.83. Signs, such as KEEP RIGHT (LEFT) (R4-7, R4-8), may be placed along a temporary sidewalk to guide or direct pedestrians. Continuous barriers or fencing meeting PROWAG shall be used to secure work areas from pedestrians. Temporary walking surfaces shall be firm, stable, and slip resistant.

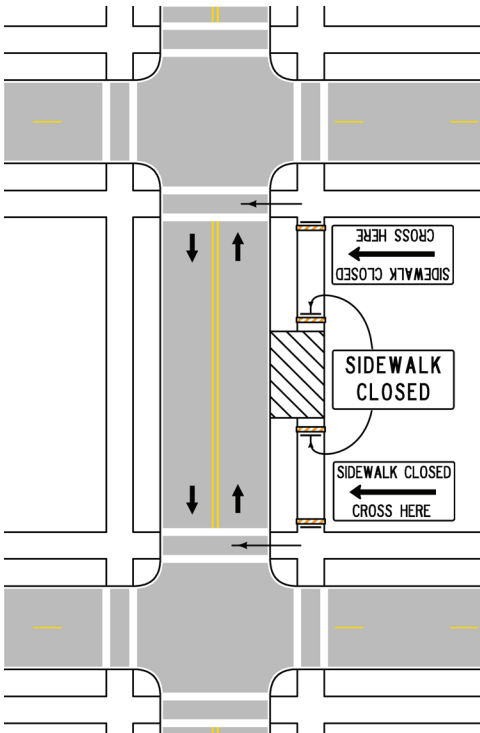



## 22. SIDEWALK DIVERSION

Use when crosswalks or other pedestrian facilities are closed or relocated, temporary facilities shall be detectable and shall include accessibility features consistent with the features present in the existing pedestrian facility. Audible information devices should be considered where midblock closings and changed crosswalk areas cause inadequate communication for pedestrians with visual disabilities. Protect pedestrians diverted to the traveled way with channelizing devices meeting PROWAG. Evaluate traffic volumes, speed, and make up to determine if detouring pedestrians is appropriate. Auxiliary lighting may be considered. Only the TTC devices related to pedestrians are shown. Other devices, such as lane closure signing or ROAD NARROWS (W5-1) signs, may be used to control vehicular traffic. Continuous barriers or fencing shall be used to secure work areas from pedestrians.

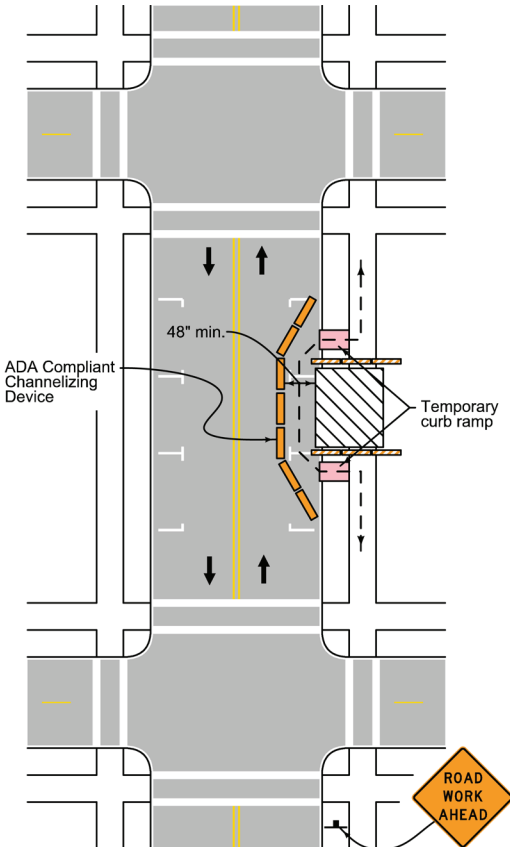

### 23. CLOSURE OF MARKED OR UNMARKED CROSSWALK

Use when undertaking street or utility maintenance activities that restrict crosswalk to less than 4 feet in width. When crosswalks or other pedestrian facilities are closed or relocated, temporary facilities shall be detectable and shall include accessibility features consistent with those present in the existing pedestrian facility. Audible information devices should be considered where midblock closings and changed crosswalk areas cause inadequate communication for pedestrians with visual disabilities. Auxiliary lighting may be considered. Lane closure signing or ROAD NARROWS (W5-1) signs may be used to control vehicular traffic.

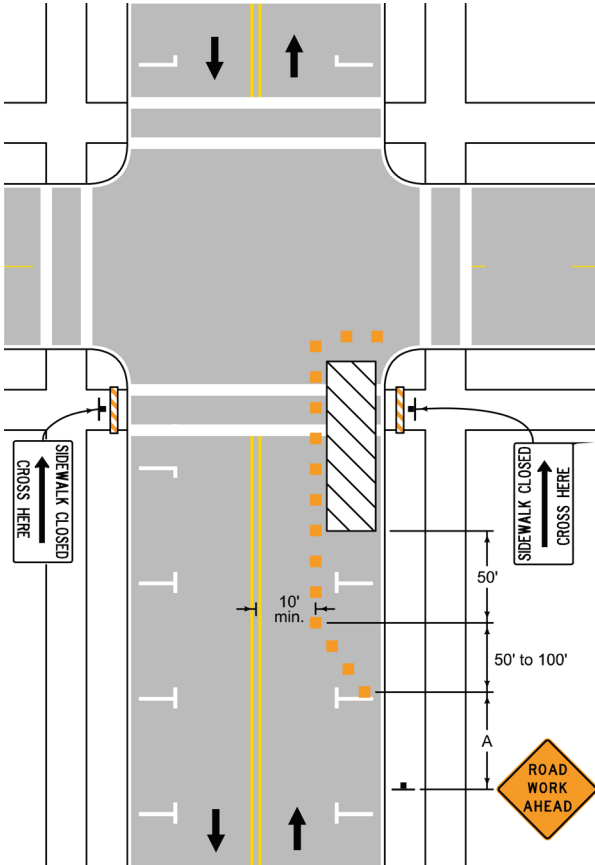

## Temporary Traffic Control (TTC) Zone Checklist

Project: _____	Inspector's Name: _____
Date: _____	Time of Day: _____
Overall appearance of TTC Zone: _____	
<b>A. DRIVE THRU</b> <ul style="list-style-type: none"> <li>• Maneuvers easy to follow?</li> <li>• Adequate warnings of hazards?</li> <li>• Signing clear?</li> <li>• Traffic control devices sufficiently visible?</li> <li>• Consistent with traffic control plan?</li> <li>• Comments: _____</li> </ul>	<b>D. ARROW BOARDS</b> <ul style="list-style-type: none"> <li>• All elements burning?</li> <li>• Placement?</li> <li>• Alignment?</li> <li>• Capable of dimming?</li> <li>• Consistent with traffic control plan?</li> <li>• Comments: _____</li> </ul>
<b>B. SIGNS</b> <ul style="list-style-type: none"> <li>• Need to be removed/repositioned/covered?</li> <li>• Need to be cleaned/replaced?</li> <li>• Need additional signs?</li> <li>• Existing signs need to be covered?</li> <li>• Sign supports crashworthy?</li> <li>• Adequate retroreflectivity?</li> <li>• Correct size?</li> <li>• Correct spacing?</li> <li>• Consistent with traffic control plan?</li> <li>• Comments: _____</li> </ul>	<b>E. PAVEMENT MARKINGS</b> <ul style="list-style-type: none"> <li>• Conflicting markings?</li> <li>• Retroreflective?</li> <li>• Proper width and length?</li> <li>• Comments: _____</li> </ul>
<b>C. CHANNELIZING DEVICES</b> <ul style="list-style-type: none"> <li>• Adequate taper length?</li> <li>• Device spacing?</li> <li>• Need for additional devices?</li> <li>• In need of repair/cleaning/replacement?</li> <li>• Adequate retroreflectivity?</li> <li>• Consistent with traffic control plan?</li> <li>• Comments: _____</li> </ul>	<b>F. FLAGGING</b> <ul style="list-style-type: none"> <li>• High visibility clothing?</li> <li>• Positioned appropriately?</li> <li>• Proper equipment?</li> <li>• Professional behavior?</li> <li>• Comments: _____</li> </ul>
<b>C. CHANNELIZING DEVICES</b> <ul style="list-style-type: none"> <li>• Corrective action required?</li> <li>• Urgent? _____</li> <li>  Within 3 days? _____</li> <li>  Within _____ days? _____</li> <li>• Comments: _____</li> <li>_____</li> <li>_____</li> <li>_____</li> <li>_____</li> </ul>	
Signed: _____	

Developed and Sponsored by

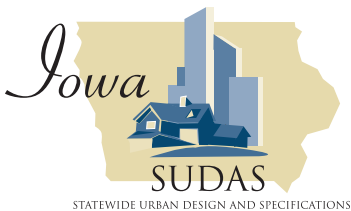

IOWA STATE UNIVERSITY  
Institute for Transportation