

HE  
18.5  
.A39  
no.  
DOT-  
TST-  
78-3

PORT NO. DOT-TST-78-3

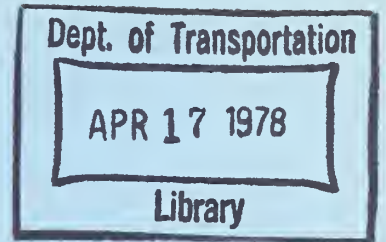

# FULLY AUTOMATED URBAN TRAFFIC SYSTEM



DECEMBER 1977

THIS DOCUMENT IS AVAILABLE TO THE PUBLIC THROUGH THE  
NATIONAL TECHNICAL INFORMATION SERVICE  
SPRINGFIELD, VIRGINIA 22161

Prepared for

**U.S. DEPARTMENT OF TRANSPORTATION**  
**Office of the Secretary**  
**Office of Research and Development Policy**  
**Washington, D.C. 20590**

NOTICE

This document is disseminated under the sponsorship of the Department of Transportation in the interest of information exchange. The United States Government assumes no liability for its contents or use thereof.

1. Report No. DOT-TST-78-3		2. Government Accession No.		3. Recipient's Catalog No.	
4. Title and Subtitle Fully Automated Urban Traffic System				5. Report Date December 1977	
				6. Performing Organization Code	
7. Author(s) B.M. Dobrotin      T.K.C. Peng G.R. Hansen      D.A. Rennels				8. Performing Organization Report No. JPL Publication 77-64	
9. Performing Organization Name and Address Jet Propulsion Laboratory 4800 Oak Grove Drive Pasadena, California 91103				10. Work Unit No. (TRAIS)	
				11. Contract or Grant No. DOT-AS-60067	
12. Sponsoring Agency Name and Address U.S. Department of Transportation Office of the Secretary 400 7th Street, S.W. Washington, D.C. 20590				13. Type of Report and Period Covered Final 7/76-8/77	
				14. Sponsoring Agency Code TST-10	
15. Supplementary Notes					
<div style="border: 2px solid black; padding: 5px; width: fit-content; margin: 0 auto;"> <p>Dept. of Transportation</p> <p>APR 17 1978</p> <p>Library</p> </div>					
16. Abstract					
<p>This report discusses the technical feasibility of automating urban traffic. Urban traffic is defined as non-freeway urban traffic, i.e. the flow of vehicles through city streets. Included within the scope of urban traffic are intersections, parking, left and right hand turns, lane changes and most importantly, interaction between vehicles and the roadside. This latter characteristic includes both vehicles and pedestrians.</p> <p>The goal of this automation study is to replace the driver with an automatic system which would perform the functions of guiding and routing the vehicle with a human's capability of responding to changing traffic demands. No geographical changes in the urban environment would be allowed.</p> <p>The problem was divided into four technological areas: guidance, routing, computing and communications. It was determined that the latter three areas were being developed independent of any need for fully automated urban traffic. However, a guidance system that would meet system requirements was not being developed, but was technically feasible.</p> <p>A guidance system that used TV data processing and dead reckoning navigation was postulated, and a specific development plan recommended.</p>					
17. Key Words Automated Vehicles Urban Traffic Control Guidance Systems			18. Distribution Statement Available to the Public Through the National Technical Information Service Springfield, Virginia 22161		
19. Security Classif. (of this report) Unclassified		20. Security Classif. (of this page) Unclassified		21. No. of Pages 125	22. Price

Prepared by the Jet Propulsion Laboratory,  
California Institute of Technology, for  
the U. S. Department of Transportation by  
agreement with the National Aeronautics  
and Space Administration.

## PREFACE

The work described in this report was performed by the Control and Energy Conversion Division of the Jet Propulsion Laboratory, under the cognizance of the Office of Civil Systems.

## ACKNOWLEDGMENTS

Many people have contributed to the development of the concepts presented in this report, by providing either support, guidance or information, and offering a forum for discussing the various ideas as they evolved.

Included in one or another of these areas are: Brooks Bartholow and Jerry Ward of DOT-Office of R&D Policy who initially supported the concept of automating urban traffic, Dan Rosen and Fred Okono of DOT-Federal Highway Authority, who provided background and discussion and Prof. Robert Fenton of Ohio State University who graciously gave to us his practical experience and demonstrated a working guidance system.

Within JPL appreciation is expressed for the support of Brad Houser, Jim Land and Gerry Meisenholder who offered comments and support. In addition, Howard Vivian and Bill Goss supplied material for the Appendixes.

## DEFINITION OF ABBREVIATIONS

LSI	-	Large Scale Integration
DCS	-	Directional Control Subsystem
NAS	-	Navigation Subsystem
WADS	-	Wide Area Detection Sensor
ERGS	-	Electronic Route Guidance System
O/D	-	Origin-Destination
PRT	-	Personal Rapid Transit
AI	-	Artificial Intelligence

## SUMMARY

This report presents conclusions, recommendations and discussions of the technical feasibility of providing an automated urban traffic system by the year 2000. Automated traffic is a system where the vehicle is operated on existing streets under machine control and the occupant is only a passenger: an automated automobile.

For the purposes of this report, urban traffic is defined as the normal movement of vehicles on surface city streets. Neither the city's geography, nor normal vehicle operating parameters are to be changed, except by normal (non automated) evolution. Freeways and other limited-access roads are not included in this study, particularly since they represent a more constrained class of problems.

The important criteria for technological feasibility is not existing technology, but that which will be available (for use or in production) within 20 to 25 years. While cost was not established as a basic parameter, implementations which could not be made at a reasonable cost were avoided. An example would be inertial navigation, which is expensive now and probably will remain so in the future.

The study was limited to technical feasibility only. Legal or social ramifications were not considered. Though partially automated traffic was considered, automation implementation strategy is not discussed, nor is any benefit assessment of automation included.

The results of this study support the conclusion that an automated urban traffic system can be technically feasible by the year 2000, if development of traffic-specific technologies is supported. Several required technologies, computing and communications, will develop independently of traffic applications. Another, automatic route selection, is being developed and tested in Japan and Germany. The technology of vehicle guidance is the area in which traffic oriented development at both the system and component levels needs to be done.



## CONTENTS

I.	INTRODUCTION -----	1-1
A.	AUTOMATION -----	1-1
B.	URBAN TRAFFIC -----	1-4
C.	AUTOMATION CRITERIA -----	1-6
D.	ADVANTAGES -----	1-7
E.	AUTOMATED URBAN TRAFFIC -----	1-8
F.	REQUIRED TECHNOLOGIES FOR A FULLY AUTOMATED URBAN TRAFFIC SYSTEM -----	1-9
II.	CONCLUSIONS AND RECOMMENDATIONS -----	2-1
A.	CONCLUSIONS -----	2-1
B.	RECOMMENDATIONS -----	2-2
III.	GUIDANCE -----	3-1
A.	DIRECTIONAL CONTROL -----	3-2
B.	NAVIGATION -----	3-4
C.	TRAFFIC STREAM CONTROL -----	3-4
D.	LANE CHANGES AND TURNS -----	3-5
E.	HEADWAY AND SIDE CLEARANCE -----	3-6
F.	ENTERING/EXITING INTERSECTIONS -----	3-7
G.	MONITORING ROADSIDE ENVIRONMENT -----	3-7
H.	INCIDENT ACCOMMODATION -----	3-8
I.	RECOMMENDED DEVELOPMENT -----	3-9
IV.	ROUTING -----	4-1
A.	TRAFFIC CONTROL ON SURFACE ROADS -----	4-1
1.	Signal Control Techniques -----	4-1
2.	Implementation of Area-Wide Control -----	4-2

3.	Applicability to the Automated Urban Traffic System -----	4-3
B.	ELECTRONIC ROUTE GUIDANCE SYSTEM (ERGS) -----	4-3
1.	Initial Development in the United States -----	4-3
2.	System Structure and Operating Principles -----	4-3
3.	Recent Development and Planned Demonstration in Japan and West Germany -----	4-6
4.	Applicability to the Automated Road Traffic System -----	4-6
C.	ROUTE ASSIGNMENT METHODS -----	4-9
1.	The Route Assignment Problem -----	4-9
2.	Generation of Route-Assignment Patterns -----	4-9
3.	Practical Considerations -----	4-10
4.	Application to the Automated Urban Traffic System -----	4-12
D.	CONCLUSIONS -----	4-13
1.	State of the Art -----	4-13
2.	A Workable Routing and Traffic Signaling System -----	4-14
3.	Further Research and Development -----	4-14
V.	COMPUTING -----	5-1
A.	INTRODUCTION -----	5-1
B.	COMPUTER PERFORMANCE AND RELIABILITY -----	5-1
C.	REQUIREMENTS FOR RELIABLE OPERATION -----	5-3
D.	ROBUSTNESS -----	5-5
E.	COMPUTING REQUIREMENTS -----	5-5
VI.	COMMUNICATION -----	6-1
A.	INTRODUCTION -----	6-1
1.	Assumptions and Constraints -----	6-1

2.	Communication Data Links -----	6-2
B.	PRIOR WORK -----	6-2
1.	Vehicle Communication -----	6-2
2.	Computer Communications -----	6-4
3.	Vehicle Communication Techniques -----	6-5
4.	Vehicle-Wayside Data -----	6-7
5.	Wayside Area-Central Data -----	6-8
6.	Concerns and Conclusions -----	6-9

REFERENCES (Listed after Sections)  
APPENDIXES

A.	GUIDANCE TECHNOLOGY -----	A-1
B.	A GUIDANCE SYSTEM EXAMPLE -----	B-1
C.	FIBER OPTIC ROTATION SENSOR FOR AUTOMATIC TRAFFIC CONTROL -----	C-1
D.	ARTIFICIAL RETINA -----	D-1
E.	A MATHEMATICAL PROGRAM FOR GENERATION OF OPTIMAL ROUTE-ASSIGNMENT PATTERNS -----	E-1
F.	TRAFFIC MANAGEMENT SCHEMES DEVELOPED FOR EXCLUSIVE GUIDEWAY PERSONAL RAPID TRANSIT SYSTEMS -----	F-1

Figures

1-1.	Typical Example of Robotics -----	1-2
4-1.	Elements of an Electronic Route Guidance System at an Intersection -----	4-5
4-2.	Electronic Route Guidance Project Area in Tokyo -----	4-7
4-3.	An Example of Destination Map for Route Guidance Around Cologne, West Germany -----	4-8
5-1.	Automated Roadway Hierarchy -----	5-2
A-1(a).	Magnetic Field Lines -----	A-4
A-1(b).	Amplitude Sensor Coils -----	A-4

A-2(a).	Phase Sensitive Detector -----	A-5
A-2(b).	Proportional Output -----	A-5
A-3(a).	Horizontal Component Detector for 2-Wire Pair -----	A-7
A-3(b).	Transposed Pair -----	A-7
A-4.	Vehicle Excited Loops -----	A-9
A-5.	Magnetic Nails or Rods -----	A-9
A-6.	Optical Reflectors -----	A-11
A-7.	Mechanical Groove -----	A-11
A-8.	Mechanical Fin -----	A-13
A-9.	Acoustic Discontinuity -----	A-13
A-10(a).	Two-Frequency Wire Pair -----	A-14
A-10(b).	Phase Pattern -----	A-14
A-11(a).	Helical Wire -----	A-16
A-11(b).	Two-Wire Pair -----	A-16
A-12.	Speed Control Block Diagram -----	A-21
B-1.	Traffic Flow Strategy. Street Layout Grid -----	B-4
B-2.	Maneuver and Intersection Strategy -----	B-6
B-3.	Guidance Layout -----	B-7
B-4.	Lane Coding and Lane Change Maneuver Scenario -----	B-10
B-5.	Logic Diagram Showing Computational Process of Lane Change -----	B-11
C-1.	Rotation Sensing Interferometer -----	C-3
D-1.	Artificial Retina -----	D-2
F-1.	Synchronous Merge System -----	F-4
F-2.	Quasisynchronous Merge System -----	F-4
F-3.	Comparison of Synchronous vs. Quasisynchronous Merge Systems -----	F-4

Tables

1-1. Automated Urban Vehicle Functions ----- 1-8  
3-1. Guidance Functions ----- 3-2



## SECTION I

### INTRODUCTION

#### A. AUTOMATION

Automation has progressed rapidly with the development, during the last decade, of smarter, smaller, faster, and cheaper computing technology, and has now taken on a new dimension: the ability to make decisions which require judgments. This new capability is called robotics or artificial intelligence. Whereas automation in the past has meant merely replacing the human's low-level control and muscular functions, increased data processing capabilities now available allow simulation of some higher level human functions. Robotics is being widely applied in such fields as industrial assembly, chemical analysis, data transmission and space exploration. A typical example is shown in Figure 1-1.

Digital computers, which have made this higher level of automation possible, have shrunk from room-sized machines to wrist watch-size devices, with a corresponding decrease in cost. This size reduction has been brought about by a process known as large scale integration (LSI) where thousands of electronic elements are formed on a small chip. This technique of manufacturing electronic devices has in itself been amenable to automation, reducing the price of complete computers to the point where they are being used in automobiles, home games, and for hobbyists.

Concurrent with the reduction in size and cost, has been an increase in the digital computer's operating speed which has moved robotics from the laboratory to the real world. Computer programs which were impractical with slower computers became viable when the programs could give responses with great speed. For example, visual data from TV cameras could be processed in seconds instead of hours, allowing industrial processes to depend on data previously restricted to human operators. This has been accomplished both by increasing computing speed and building special purpose hardware. One addition now takes 1/1,000,000 sec.

The small size, low cost, high speed digital computer, called a microcomputer, has been the basis for a large number of advanced techniques. The application of microcomputers to automobiles has started and can be expected to continue. Emission standards are being met by using microprocessors to sense engine operation and calculate the correct ignition timing. This use is an excellent demonstration of a low-cost consumer application which must be reliable in a usually hostile environment. It is a true indication that digital computers have arrived at the everyday level. Another application is the low-cost electronic wristwatch which uses a special purpose computer.



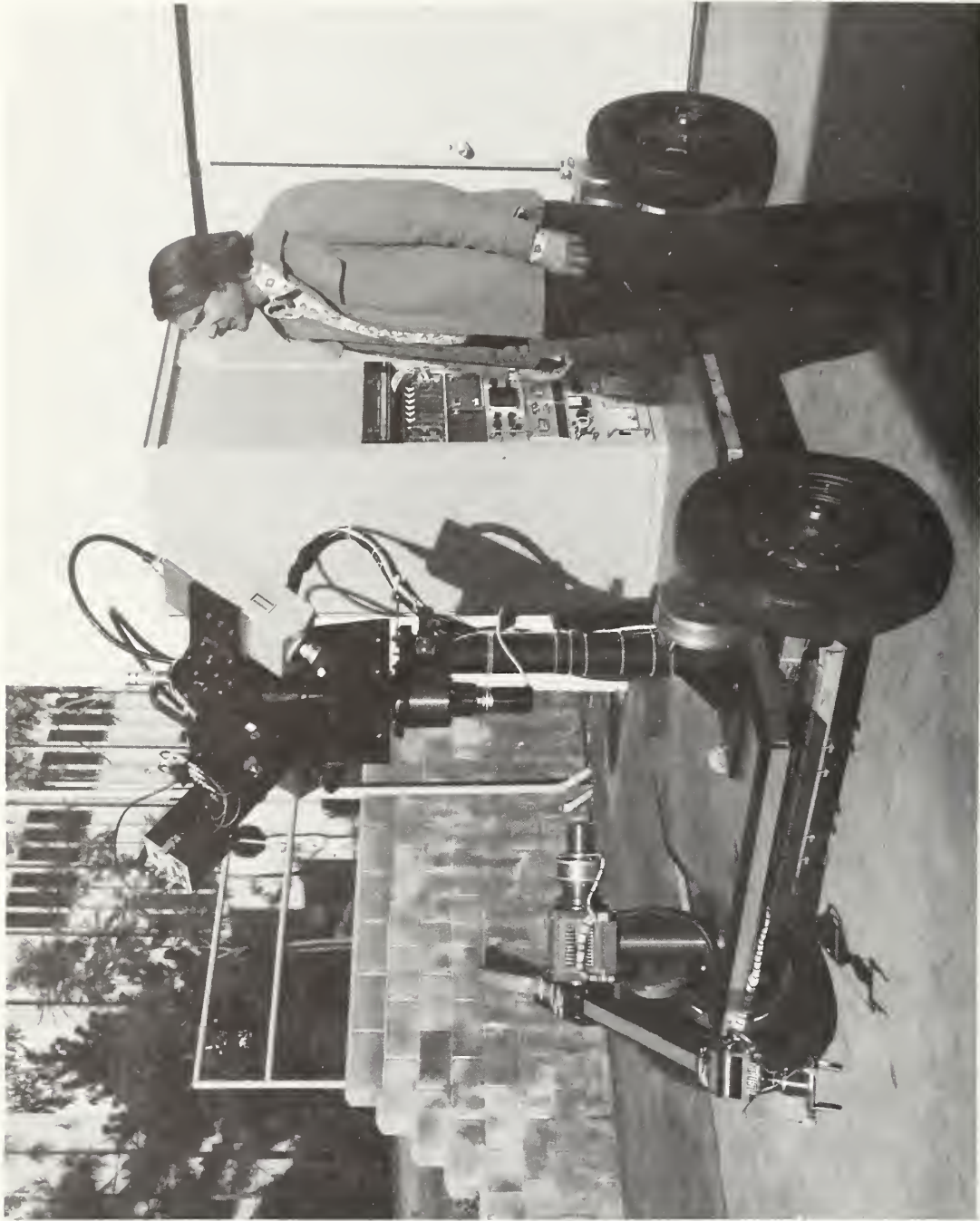

Figure 1-1. Typical Example of Robotics



The availability of microcomputers has encouraged development of computer networks where each computer performs a simple task and collectively a complex operation is performed. Industrial automation is one area where the capabilities of computer networks are being applied. Assembly and inspection are the last manufacturing areas where intensive human involvement is needed. Assembly involves judgment, visual identification and hand-eye coordination for a variety of tasks. Inspection requires both judgment and visual part scrutiny. With ever increasing labor costs, industrial countries such as Japan and the United States are investing millions of dollars to develop robots for use in factories. Already, commercial firms are producing robots for a variety of tasks such as welding, assembly, painting, and inspection. More capabilities are being added and costs are becoming directly competitive with human labor.

Automated vehicles are being developed by the United States and Russia for operation in areas which are hazardous for humans, such as coal mining, space exploration and underwater operations. An experimental, roving vehicle has been developed by the Jet Propulsion Laboratory which can identify a remote object, move to it and pick it up, all at a single request by the operator. Russia is interested in underwater vehicles which, with mechanical arms, can explore the ocean bottom for minerals. Again, these vehicles depend on digital computers and specialized sensors for their advanced capabilities.

A large amount of commercial data is being handled by digital computers. Banking transactions, inventory information, and credit card billing are all dependent on digital computers. The large volume of data used by present day businesses would be impossible to gather, process and exchange without the availability of computers. In conjunction with increased dependence on computers is the need to exchange data; from bank to bank or from main office to branch office. This has demanded new technology for inter-computer communications. The development of fiber optics, which uses a thin glass "wire" to replace metal wire, allows the use of light frequencies in transmission lines for a much higher data rate than that possible with radio frequencies.

In summary, a wide spectrum of technological advances have been made, and are still occurring, which permit automation to advance to the point where it can emulate some of the human's intelligence. The central impetus for this advance has been the vast improvement in the capabilities and availability of digital computers. The development of sophisticated microcomputers has led to specialized sensors, computing networks and intercomputer communications. Taken as a whole, these advanced sensory, data processing, and communication capabilities have led to practical applications in robotics and artificial intelligence.

Automation is being applied to urban transportation in several ways. First, automation is a major element in the advanced guideway transportation systems which are being developed. These systems have driverless automated vehicles on specialized guideways which are dispatched and routed by centralized computer systems. Switching and headway are shared at various levels between the vehicles and the central controller.

Second, automation technology is playing an increasingly important role in the efforts to improve the capacity, efficiency, and safety of urban automobile traffic. Computerized control of traffic signals to obtain optimum signal timing based on realtime traffic conditions are being tested. Automated motorist information systems are being developed to provide motorists with better information on traffic conditions in order to better distribute flow over the network.

Each of these efforts represents an attempt to apply automation to a limited version of the general problem of urban traffic. In the advanced guideway work, the complexities of the problem in terms of traffic control are reduced by eliminating intersections, multiple lanes, pedestrians, etc. in order to make the problem tractable. In traffic control, only the informational part of the system is automated while control of the vehicle and hence use of the information remains with the operators. The purpose of this report is to consider the general case of automating the urban traffic system as it currently exists with its multiple lanes, intersections, pedestrians, etc., used by a variety of individual vehicles. This is the problem of the automated automobile; a true auto-mobile. With total automation of urban traffic users are only passengers in their own vehicles. Thus, a complete "system" is needed which duplicates the functions presently expected of today's urban traffic system.

This report defines the problems of providing such a system capability and defines a conceptual system design which automates urban traffic and, most importantly, assesses the technological feasibility of the proposed scheme. This system approach provides an understanding of the level of automation which could be achieved using the technologies that are likely to develop in the next few decades and the additional technologies which will be required. For example, are available sensors adequate? Are the needed computer algorithms developed? And, most important, is the available technology directly applicable to urban traffic or must modifications be made? There also is the possibility that needed technology will be developed independent of any urban traffic requirement, and one may expect it to be available when needed.

## B. URBAN TRAFFIC

Urban traffic consists of individual vehicles sharing common usage of city streets. While the driver of each vehicle is responsible for that vehicle's operation, common fundamental rules are observed which allow a continuous, relatively smooth flow of traffic to exist. This is a multidirectional flow which has complex, random interactions, although the overall characteristics are quite predictable. Nevertheless, some description of urban traffic must be made which allows an automated scenario to be developed.

Urban traffic should be sharply differentiated from limited access roadway (or guideway) traffic. Characteristics of urban traffic which are different from guideway traffic are intersections, random vehicle entry and exit into the traffic stream and free access to the roadway for pedestrians. The guideway problem, which does not contain these three elements has had several solutions proposed. It is the more complex traffic rules and judgment situations as well as the pedestrian involvement that raises the level of the urban traffic problem over that of the guideway problem.

Automating urban traffic is not a problem of maintaining a single traffic function, such as traffic light offsets and splits, but rather one of automating several separate functions and allowing these functions to co-operate. A list of basic functions which must be performed can be developed by following the sequence of operations a single vehicle performs from start to finish of a journey.

First, the operator/passenger selects a destination prior to or upon entering the vehicle. Once seated in the vehicle, the engine is started and traffic entered. Entry requires observing traffic conditions and synchronizing the vehicle's motions with other vehicle's movements. Once in the traffic stream the operator/passenger guides the car along the roadway according to traffic conditions. Factors considered consist of number and speed of surrounding vehicles, road surface and condition, roadside information such as traffic signals, intersection conditions, other vehicles entering traffic and pedestrians. The vehicle's speed is varied, the selected lane is changed and the vehicle may even be stopped or started as conditions demand. The pre-selected destination can also be changed. Upon reaching the desired destination, the vehicle exits the traffic flow and the operator parks and leaves the car.

The above scenario describes a very dynamic, flexible sequence. Prior to entering the vehicle the user does not have to announce his intentions. During transit, the vehicle is driven in response to ad hoc traffic conditions; the operator can accommodate a wide variety of speeds, traffic levels and road conditions. The user is free to change the destination at any time. Control of the car's position on the roadway and relation to other cars is only as precise as needed. The vehicle is relatively free from the direct influence of other vehicles. Very rarely do two vehicles share a completely common journey. Nothing needs to be predetermined to any great extent.

Every step in the manual urban traffic scenario reflects the ability of humans to use judgment, make relative decisions and to control vehicle parameters (speed, position, etc.) on a relative basis. By establishing a minimal set of rules of the road, human control has made urban traffic into a very personal and flexible transportation system. It is completely different from freeway (or guideway) traffic, and to retain its advantages must remain so.



### C. AUTOMATION CRITERIA

Criteria must be established for an automated traffic system, so that none of the advantages of the present traffic system are lost, and so that the automated traffic system is realistic. These criteria must be meaningful so that they serve to guide the development in the remainder of this report.

A general criteria is to impose minimum change. It would be irrational to expect a complete city to be reorganized just for the sake of automation. Indeed, present applications of robotics are evolutionary where they are used; the revolution is in the ability to supply the automated service. Specific minimum change criteria are in the city and automobile configuration. Automation must be a minimal add-on in these areas. Therefore, it may be expected that the city's geographical character would only undergo minimal evolutionary changes. In addition, no attempt would be made to direct automotive technology. It would be assumed to be basically the same as at present, with natural evolution.

The basic question on the level of service cannot be assessed with any great accuracy at this time, but certainly a level equal to that provided by today's unautomated system is an initial goal (though only an initial goal.) Automation for automation's sake is not acceptable. Not only must automation relieve the passenger of the driving, but it must provide acceptable levels of flexibility, speed, comfort and safety. Without meeting present criteria in those areas, there is no rationale for public acceptance.

Flexibility of service is an additional criteria. This is what is attractive to present users and must be retained. The user must feel that the vehicle is dedicated to his or her personal service with the same freedom of use that presently exists. Individual destinations, the ability to change destinations and even routes, the lack of required replanning are all capabilities which must be retained.

Freedom of movement of pedestrians is another criteria. It is not reasonable to expect pedestrian barricades and overpasses to be constructed throughout a city. Pedestrians are used to having access to both crosswalks and curbs, and this must continue within reasonable limits. They certainly must be expected to obey rules for pedestrian safety.

Emergency situations establish another criteria. These fall into two classifications: emergency services such as police and fire, and emergencies within the urban traffic system. Presently, emergency situations are localized, i.e., emergency vehicles have right of way over other vehicles on a local basis, and vehicle or roadway failure is limited to areas of several blocks. The automated system must have an equivalent method of handling emergencies.

Criteria of cost and legal responsibility are not directly pertinent to this study. The technology needed for automation is relatively new and quickly developing. Certain items which are costly now will

undoubtedly be substantially cheaper in the future. Even cheaper methods of producing LSI circuits are predicted for the future, and system maintenance can be determined after the automated urban traffic system concept is clear. Therefore, cost estimates made at this time can be wildly inaccurate when the time comes to implement the system. In addition, legal requirements will change as automation is more widely applied.

Engineering criteria such as ease of use, system validation, failure recovery and other operating parameters should be established during detail design. However, performance criteria should be equal to or better than the present non-automated system.

#### D. ADVANTAGES

What are the advantages of automation? Clearly these should be distinct and measurable advantages. Industrial automation is measured in money and time; the cost of automation versus the cost of labor. Underwater exploration is measured in operational capability; what can be done with automation versus what can be done manually. Space exploration measures science return per spacecraft, i.e., the number and quality of scientific investigations. Similar measures must be established for traffic automation, both for justifying the needed technological development and to guide the development effort.

Three main advantages are clearly apparent: safety, thruput and serving the non-driving population. Other advantages will become apparent as automation is applied to traffic, as has been found in other automated areas; but these three are strong reasons for automating, and cover a wide range of specific benefits.

Safety is a prime consideration in any transportation system. Urban traffic accounts for 85% of the 50 thousand traffic deaths per year as well as the huge financial loss which is incurred by accidents. Automation can contribute in the specific areas of driver error and vehicle failures. In approximately 50% of the fatalities, the driver showed signs of intoxication. By eliminating any dependence on the driver's performance, this entire class of accidents could be eradicated, saving 25 thousand lives each year. In addition, the automation computing system would be continuously monitoring the performance of the vehicle, detecting failures and stopping the vehicle when necessary; thus providing a "fail safe" transportation system. Other safety features could also be built into an automated urban traffic system.

System thruput is an important parameter to any traffic engineer. Increasing roadway capacity, or even utilization, would provide a large benefit to a city, minimizing the congestion and lost time presently experienced. Automated urban traffic, by its very nature, would permit a more even flow of traffic. Vehicle routing would be optimized to relieve local saturation and give more even traffic flow. Operation of individual vehicles would be controlled so that traffic characteristics would be more predictable and adjusted to give the best system performance.

Another major reason for an automated urban traffic system is the capability for use by the non-driving population. Currently, many people, including the young, old and handicapped, are essentially disenfranchised because they cannot operate an automobile. An automated vehicle would eliminate this inequity in our transportation system. Additionally, a single vehicle need not be dedicated to a single person (or group) but could be used for several different trips, dropping off and picking up passengers as needed.

Several advantages are summarized above, and more will become apparent. Development of a new technology will cause an explosion in applications. Just as the development of the micro-computer made possible practical applications that were previously impractical, so automation of urban traffic will lead to other advantages as important as improved safety, thruput and utilization.

#### E. AUTOMATED URBAN TRAFFIC

A scenario for an automated urban traffic system follows. The sequential steps are listed in Table 1-1.

Table 1-1. Automated Urban Vehicle Functions

---

Route Selection
Automated System Entry
Vehicle Guidance
Directional Control of Vehicles
Monitoring and Taking Appropriate Action for:
Other Vehicles
Pedestrians
Road Conditions
Emergency Vehicles
Vehicle Condition
Unanticipated Problems (Vehicle Failure, etc.)
Locating Destination
Leaving Traffic and Discharging Passengers

---

Within an urban area, including the suburbs as well as the central city, a certain geographical area is equipped with an automated traffic system. A person desiring to use the system enters his/her vehicle, and enters a destination code on a computer terminal. Routing is supplied from a routing computer, which minimizes time, fuel consumption or some other parameter. Local conditions are considered in planning the trip and the vehicle's route is modified during the trip based on changes in these conditions. On-board computers and sensors measure the location of other vehicles and guide the vehicle along the safest path. Other roadside computers advise the vehicle of intersection conditions and the proper times to make turns. The vehicle monitors both the roadway and roadside for dangerous conditions such as ice or pedestrians and responds accordingly. At any time, the passenger may modify the destination through the vehicle's computer terminal. Upon reaching the destination, the vehicle is automatically placed into a parking area and the passenger may disembark.

Other additions to the basic scenario may be made. For example, with minimal additional complexities, the vehicle use can be transferred to another passenger. However, the basic scenario fulfills the functions presently performed within the present urban traffic system. It is this scenario that was examined in this report.

#### F. REQUIRED TECHNOLOGIES FOR A FULLY AUTOMATED URBAN TRAFFIC SYSTEM

In order to automate urban traffic, certain specific technologies must be applied. These may be considered the basic building blocks used to implement the functions needed. The arrangement of these technologies is arbitrary and must be defined. In this study, the technologies are grouped into four areas: route selection, guidance, communications, and computing.

Route selection consists of the mathematical techniques used for determining the "optimum" origin-destination routing. Optimum may represent several related solutions: minimum time, minimum distance or minimum congestion. In a completely deterministic system, routing may be accomplished prior to the trip. Once planned, the vehicle would be assigned a time-synchronized slot moving through the urban network. An alternate technique would be to plan the initial portion of the route, start the vehicle on its trip and plan the remainder of the route as a function of both the destination and the conditions the vehicle encounters along the route. In essence, route planning draws on theories of optimization, dynamic systems, and graphs and is being tested in Japan and Germany (Refs. 1 and 2) based on works previously done in the United States (Refs. 3 and 4).

Guidance encompasses directing the vehicle along the desired route, ensuring that the vehicle performs all the necessary actions needed to pass safely through the urban street network as well as traffic control. It not only includes lateral (lane) and longitudinal (distance) guidance, but includes determining the appropriate vehicle actions required by traffic. Guidance has a deterministic part and a judgmental part. The deterministic portion moves the vehicle along a



specific desired path. This portion is being studied both in the United States and in Europe. The judgmental part is not as well defined, but is needed to allow enough flexibility, such as collision avoidance capability, for a realistic operational traffic system. Development of this part of guidance technology can be viewed as proceeding under the categories of artificial intelligence (AI) and robotics. Research in robotics and AI is not aimed specifically at automating traffic, but is rather interested in allowing computers to make judgmental decisions, which may then be applied to traffic situations.

The last two functions to be listed are support technologies. This means that they are independent of any specific traffic function, but are needed to allow implementation of both route selection and guidance. Communication encompasses information (or data) transmission between the various components of the system. It may consist of either telecommunications or hard wire communications. Computing provides the means to implement data management and various mathematical algorithms or decision logic. For the purposes of this study, a hierarchial distributed digital computing system is assumed, based on past experience. Both of these technologies are being actively pursued in the United States with active application to traffic control.

In this report, each of these technologies is evaluated in terms of supporting development of automated urban traffic system. This is a top-down look into technologies required for systems. No attempt was made to address all of the problems which must be resolved to bring these technologies together into a fully operational system.



## SECTION I

### REFERENCES

1. "Comprehensive Automobile Control System," Research Assoc. for Comprehensive Automobile Control Technology, Japan Ministry of International Trade and Industry, Agency of Industrial Science and Technology, Tokyo, Japan, May 1975.
2. Groth, G. and Pilsak O., "An Electronic System for Individual and Active Route Guidance on Motorways," Traffic Control and Transportation Systems (edited by AFCET), American Elsevier, New York, 1974.
3. Rosen, D. A., Mamano, F. J., and Favout, R., "An Electronic Route Guidance System for Highway Vehicles," IEEE Transactions VT-19, pp. 143-152, 1970.
4. Stephens, B. W., Rosen, D. A., Mamano, F. J., Gibbs, W. L., "Third Generation Destination Signing: An Electronic Route Guidance System," Highway Research Record #265, 1968.



## SECTION II

### CONCLUSIONS AND RECOMMENDATIONS

#### A. CONCLUSIONS

An assessment of the material in the following chapters allows a reasonable set of conclusions to be made regarding the technical feasibility of developing a fully automated urban traffic system.

The purpose of this study was to investigate the technical feasibility of developing an automated urban traffic system. The first conclusion addresses this goal. Implementing such an automated system cannot be done immediately; but a majority of the technology is available and an automated urban traffic system can be ready for use by the end of the century. No technology breakthroughs are required for the development of a feasible automated urban traffic system.

The major development problem which keeps the system from being immediately realizable is the reproduction of human visual sensing capabilities as well as the judgment which allows a vehicle to be operated in a flexible manner, coping with random, though expected, traffic situations. The human vehicle guidance and decision making capabilities, obtained through years of training, are the primary differences between present (or planned) automated vehicles (Ref. 1) and a fully automated urban traffic system. The human accepts nondeterministic, inexact situations as a matter of course, while present control schemes rely on very deterministic and exact situations to produce controlled traffic.

The functions which must be mechanized for automated traffic are well understood; Prof. Fenton has given a very good list in 1970 (Ref. 2). It is the actual mechanization which is the problem. Extracting data from visual information and making decisions on semantic data (i.e., non-numeric data) have been human functions. However, it is in these two areas that the majority of robotics research is concentrated, and enough results have been reported in both visual (TV) data processing and decision making (Ref. 3) to allow a feasible system configuration to be developed, which utilizes a limited but useful reproduction of a human's visual and decision making capability.

Based on the above conclusion, a flexible guidance system and a vehicle-contained (on-board) traffic logic system are not available but are technologically feasible. A flexible guidance system is one where the vehicle is not guided along a precisely defined track such as wire, but rather is guided primarily by on-board equipment, updated by external references. This offers flexibility in accommodating directional changes (i.e. lane changes, etc.) and is capable of producing the desired accuracy. In addition, the vehicle needs the capability for assessing the traffic conditions and responding with the proper actions,

such as stopping, changing lanes or turning corners. This cannot be done by a central computer due to the computational and communications limitations. It would require a vast amount of central computing power and a very high communications data rate, resulting in decreased reliability.

Based on available technology, it is possible to come to very definite conclusions in the functional area of automatic routing as well as supporting technologies such as sensors, communications and computing.

Automatic routing is being developed as a driver aid both in the United States and abroad (Refs. 4 and 5). The basic technique should be applicable to both manual and automated vehicle control. Thus it may be assumed that automatic routing (or Electronic Route Guidance) will be developed independently of the needs of an automated urban traffic system, and will not be a limiting technology. However, automatic routing must be an integral part of the design of any automated vehicle control scheme, and routing consideration should be accommodated in any system design.

In addition, it appears that development of the supporting technologies of computing and communications will continue independent of traffic needs. Certainly, microelectronics development will continue (see Ref. 6) as will its application to automotive and traffic control electronics, especially in the area of computers (Ref. 7 and 8). These applications are a step towards automation in that they solve very practical problems towards using computers in an automotive environment. Communication techniques are also being developed and applied in many areas and this development will also continue independently of any automated system.

Sensor development is a critical item in any automated urban traffic concept. New sensor developments are making automatic vehicle guidance and control feasible. TV data is being used for automatically determining traffic conditions and presenting this information in 1-2 seconds (Ref. 9). Other types of optical sensors are being used for vehicle control (Ref. 10). When coupled with solid state TV sensors and high speed data processing techniques (Ref. 11), it appears that the sensor technology is available and needs to be applied to automated vehicle control.

## B. RECOMMENDATIONS

It is recommended that a phased development of an automated urban traffic system be undertaken. The initial work should be aimed at developing a technological base for an automated urban traffic system, with the end goal of demonstrating an engineering model of an automated vehicle and required roadside equipment which would work in the scenario described in Section 1. In addition, ongoing developments in automatic routing should be monitored, and routing/vehicle interfaces established to insure compatibility between vehicle development and routing development.

The automated vehicle development program should be divided into three phases: 1) a detailed system requirements analysis and conceptual design study, 2) a vehicle guidance development effort, and 3) a vehicle/traffic interaction capability development.

The first phase should have a goal of defining specific initial functional requirements, i.e., to establish a basis for the succeeding two development phases. Vehicle topics to be covered include: traffic operating logic for maneuvers (turns, lane changes, stops, etc.) operating mode sequences: (entering traffic, inner lane, etc), and guidance accuracies. In addition to vehicle control and interaction, requirements for vehicle/roadway interaction must be established including pedestrians, emergencies, parking, etc. The operation of a single vehicle must be examined and defined, not by itself, but as it would operate within a normal traffic stream.

Another part of the study would be definition of sensor requirements. Given the vehicle operational requirements, what is the information the vehicle must obtain to be able to meet those requirements and what sensors can provide that information? Alternative sensor concepts are identified in the next section, and tradeoffs are needed to establish the most promising sensors. Areas where intensive development are needed must be identified and alternative mechanizations proposed.

One area where sensor development is clearly needed is that of vehicle and pedestrian identification and location. Presently, the Wide Area Detection Sensor (WADS) is being developed to use TV (visual) data obtained from a stationary reference to locate and identify vehicles moving in one direction. Techniques for identifying vehicles and pedestrians from a moving reference are needed. Low-level information (i.e. relative velocity and position) needs to be quickly and simply extracted and supplied to the guidance system. This development work should be started as soon as the basic requirements are defined in the first phase study.

The second development phase would be to develop guidance techniques flexible enough to permit operation in a traffic system. The primary technique recommended here is the dead reckoning/fiducial mark technique. The primary problem foreseen is that of sensing and identifying the fiducial update marks, and this should be the first step in the development program. A reliable means of establishing the vehicles position at discrete points should be developed and tested. Next, straight lines performance should be validated and finally, maneuvers accomplished.

The final development effort should be in techniques for allowing the vehicle to interact with other vehicles as well as the roadside. This includes moving, entering and stopped vehicles as well as pedestrians. Testing of sensor and data processing elements should be done, using both cooperative and uncooperative targets. Response in

realistic situations should be evaluated. This phase is critical because it permits the vehicle to operate in a real environment, as opposed to a test situation cleared of any interfering objects or vehicles.

The final result of this three phase development program would be a demonstration vehicle which could allow the overall system performance to be evaluated, and a realistic estimate of the implementation costs and constraints of an automated urban traffic system.



## SECTION II

### REFERENCES

1. "Automated Guideway Transit - An Assessment of PRT and Other New Systems," United States Congress, Office of Technology Assessment, June 1975.
2. Fenton, R. E., "Automated Vehicle Guidance and Control, A State of the Art Survey," IEEE Transactions on Vehicular Technology, Vol. VT-19, No. 1, pp. 153-160, Feb. 1970.
3. Proceedings of the Fifth International Joint Conference on Artificial Intelligence, Cambridge, Mass., Aug. 1977. See especially sections on "Vision" and "Robotics".
4. Rosen, D. A., Mamano, F. J., and Favout, R., "An Electronic Route Guidance System for Highway Vehicles," IEEE Transactions VT-19, pp. 143-152, 1970.
5. "Comprehensive Automobile Control System," Research Assoc. for Comprehensive Automobile Control Technology, Japan Ministry of International Trade & Industry, Agency of Industrial Science & Technology, Tokyo, Japan, May 1975.
6. "A Survey of Microelectronics and Computers," Scientific American, Sept. 1977.
7. "Ford uses Microprocessors," Electronic Times, May 1977.
8. Hahn, J. et al., "The Microprocessor Approach to Local Controller Construction," Traffic Engineering, Apr. 1977.
9. "Wide Area Detection Sensor, Conceptual Design Study," FHWA-RD-77-86, Oct. 1977.
10. Johnston, A., and Meisenholder, G., "Control Techniques for Automated Mixed Traffic Vehicle," Joint Automatic Control Conference, San Francisco, Ca., June 1977.
11. Eskenazi, R., et al., "A Random Access Picture Digitizer, Display and Memory System," Fifth International Joint Conference on Artificial Intelligence, Cambridge, Mass., Aug. 1977.





## SECTION III

### GUIDANCE

The guidance technology area is the heart of the presently conceived automated traffic system. It essentially provides both the intelligence and motor functions needed to operate a vehicle in traffic. An automated vehicle must operate in a non-deterministic environment as well as develop deterministic, precise steering and speed outputs. Although a fully-automated guidance system does not exist, the basic building blocks do exist, and development is feasible.

Table 3-1 lists the various functions assigned to the guidance system. The rest of this chapter will be devoted to defining those functions, proposing possible mechanizations, and discussing integrating these functions into a cohesive guidance system which is rational and works as a unit.

The functions listed in Table 3-1 apply to vehicles and may be classified into two categories: those functions that are tied to an individual vehicle and those that determine its interaction with its environment. The first set of functions have parameters such as the state of the vehicle (position, velocity, etc.) and routing which are intrinsic to an individual vehicle, while the other functions have parameters which are shared between vehicles. An example would be the state of traffic during lane changing which requires cooperation between vehicles. Such a division then allows a separation into functions which can be mechanized without considering the overall traffic problem and those functions which must consider the interactions in a flow of traffic.

Such a division has been made in practice, with the net result of development being concentrated in the few areas where either single vehicles or non-interactive vehicle strings (i.e. where vehicles do not pass, or change their relative position). There are many straightforward solutions to mechanizing these single vehicle functions. Appendix A describes several techniques for providing vehicle directional control, and route selection is well described elsewhere. The real problem comes when the definition of automated traffic is extended from automation of individual vehicles to automation of traffic. A tradeoff must then be made between those functional mechanizations which are simple, workable and well developed, but cannot be extended to a complete traffic system, and those mechanizations which are more complex and relatively unproven but offer the capability of operating in real traffic. Therefore, during the following discussion it must be remembered that the functions and their specific mechanization must be considered in the context of their application to a traffic system.

Table 3-1. Guidance Functions

Functions	Parameters
Directional control	Position, heading, velocity
Navigation	Routing requirements Present position
Changing direction in:	
turns	Route requirements, direction, surrounding traffic
lanes	Route requirements, velocity, surrounding traffic
Headway/Side clearance maintenance (collision avoidance)	Surrounding traffic
Entering/exiting insertions	Route requirements, surrounding traffic
Monitoring roadside environment	Definition of dangerous conditions
Accommodating Incidents (stalled or emergency vehicles)	Surrounding traffic

A. DIRECTIONAL CONTROL

Directional control means steering the vehicle along the desired path at the desired speed. Both path and speed are given. This is a key function in that it performs a basic task which, if missing, would prevent any of the other functions from being performed.

Command inputs to the directional control subsystem (DCS) are generated by many other functions, and vary as traffic conditions vary. Therefore the DCS must be able to respond in a flexible manner, providing directional control in a variety of situations. A summary of directional control requirements includes straight as well as curved line lateral control, longitudinal control and speed control. Absolute accuracies are not required, but relative position with respect to other vehicles, curbs, etc., is. The DCS by itself does not need to maintain a current position log. That is done by the navigation subsystem (NAS).

One DCS mechanization has been developed, tested and proven satisfactory for lateral control. That is a wire following method. A detailed description of the system's operation is in Appendix A. In brief, the vehicle tracks a buried wire carrying an alternating current, steering through hydraulic servos. Such a system may be compared to a

railway, with the steering command generated electronically as opposed to mechanically through the rails. Switching is done by selecting wires with different control frequencies. Control and stability of this technique has been demonstrated at speeds over 100 km/h.

The wire following method provides good lateral control and is perfectly adequate for many situations, such as the JPL automated tram (Ref. 1). To add in the additional capabilities needed to make a complete DCS requires different, separate methods. These capabilities include velocity and longitudinal control. In addition, to use a wire following method for lane changes and intersection turns requires a network of buried wires similar to a railway.

In order to provide longitudinal, lateral and velocity control in a complete DCS using a single method, it is necessary to develop guidance techniques that are more compatible with the overall guidance system requirements than the buried wire method. Examining the requirements imposed by the parameters listed in Table 3-1, a conclusion may be drawn that absolute accuracy in directional control is not needed, but relative accuracy is important. That is, a vehicle does not need to guide exactly along the center of the lane, but needs to stay in the lane, providing clearance with the surrounding vehicles.

Wire guidance provides this relative accuracy by obtaining absolute accuracy. Parallel vehicles are centered over separate parallel wires and therefore cannot collide. This is a very deterministic technique. A more flexible technique appears to be on board (self contained within the vehicle) dead reckoning updated by external, roadway referenced fiducial marks. Note that any proposed system is open to the charge that it has not been demonstrated with roadway vehicles. The advantage is that such a DCS can easily be integrated into the overall traffic guidance system, and offers better ultimate capabilities than a buried wire based DCS. This concept will be explained more fully in following discussions.

A dead reckoning/fiducial mark DCS uses onboard sensors and a computer to calculate distance and direction traveled. Direction usually is measured against a gyroscopic reference, while distance measurements are obtained by odometers. Tests in off-road situations by tanks indicate a positional accuracy of ~10%. Therefore, a fiducial mark should be located about every 10 ft., allowing the dead reckoning system to update itself, assuming an acceptable error of one foot.

The practical mechanization of such a system depends on two factors: cost and accuracy. Special, very accurate sensors presently exist in the form of aerospace inertial sensors and "fifth wheels" used for special testing but these are too expensive for automotive use. The problem is to develop adequate sensors, as well as techniques for their use, which permit wide automotive use. It is possible to postulate such a system, but development work is required to prove the concept.

In addition, a dead reckoning system is more adaptable to turns and lane changes than a buried wire system. The dead reckoning system is independent of the electronic track of a buried wire, providing an

internal vehicle position. This enables the vehicle to perform non-straight line maneuvers such as lane changes at random positions, not just where a buried wire junction exists. This capability is a good example of mechanizing an independent vehicle function so that the function can fit into the overall traffic system.

## B. NAVIGATION

Basically, the proposed system consists of a solid-state (no moving parts) rate gyroscope, the present automotive type odometer and a digital computer. Development is needed for an automotive application of a solid state gyroscope, which is described in Appendix C. Additional development is needed for digital computer techniques which take the raw sensor data (angular rate, distance, and fiducial update), convert these data to position data and estimate errors as well as correcting them to give a more accurate position estimate. On line error estimation and correction are common aerospace practices which are usually used to give very high accuracies. The same estimation techniques can be used to improve the accuracy of a cheap, inexpensive dead reckoning system.

Another problem is the location and sensing of the fiducial marks. An initial concept is to locate these marks as lane marks are; on the street surface. These markers could then be easily installed, passive devices, containing encoded location information. An active (i.e., energy emitting) downward looking sensor could "read" these markers as the vehicle passed over them. Radar, sonar or laser sensors could be considered. The problem with downward looking sensors is that the surface of the street would be coated with ice, water or dirt, making it difficult for the sensor to "see" through the covering. An alternate approach is to have the fiducial information on the side of the road, and for the sensor to be sideways looking. If a second vehicle were in the way, the first vehicle could guide off the position of the second vehicle. Using digital computers allows the control scheme to make quick changes between data sources as well as operational modes. The encoding scheme for the fiducial marks could follow the pattern proposed by Bendix for the Electronic Route Guidance System (ERGS). Installation and maintenance of discrete surface mounted fiducial marks should be easier and cheaper than a buried wire system.

## C. TRAFFIC STREAM CONTROL

Given that a directional control system is available and the vehicle can be guided in a straight line, the remaining requirements may be grouped under traffic stream control. Traffic stream control may be defined as implementing the logic needed to maintain the correct relationship between all the vehicles in a traffic stream and the surrounding environment, as well as insuring that each individual vehicle is able to reach its desired destination.



Directional control has been developed, but traffic stream control has not at the present time, been totally automated. Driver Signaling Systems have been automated (Ref. 2), a limited amount of sensor development is under way (See Ref. 3), and simple headway control systems have also been investigated (Ref. 4). However, total control of the vehicle as it moves through traffic still rests with the driver; and his capabilities of sensing traffic conditions, evaluating the situation and generating the proper logic response have not been automated.

Those requirements shown in Table 3-1 under traffic stream control, while requiring some deterministic control for maneuvering the vehicle, are largely concerned with determining if the vehicle's intended path is acceptable given the location of the surrounding vehicles as well as the location of adjacent obstacles. Implementation of this logical capability is the heart of achieving an automated urban traffic system.

The functional implementations given below are system concepts which are presented to show that it is technically feasible to develop the sensors, data processing and logic needed to implement automated traffic control. While such a development represents an advance in the state of the art of traffic, it parallels automation advances in related fields such as aerospace and consumer industry (Ref. 5).

#### D. LANE CHANGES AND TURNS

Lane changes and turns are directional changes. Two things must be considered. First, is the input command to the DCS and the execution of that command by the DCS. Second is the interference of surrounding traffic. These two topics will be considered in sequence, though in reality they cannot be separated.

The maneuvers under consideration can be considered to have a dynamical trajectory which requires certain initial conditions to be met and certain end conditions to be reached. That is, a vehicle cannot make a turn around an intersection corner unless it is in a certain range of positions, and for each position, within a certain range of velocities. In addition, regardless of where the vehicle starts its turn, it must reach a proper end point without unacceptable deviation from the turning trajectory. In essence, certain kinematic and dynamic constraints must be met to make a successful lane change or turn. With a dead reckoning DCS, a wide range of initial conditions can be stored in the computer, and when the dead reckoning system calculates that the vehicle meets an acceptable subset of those conditions, the vehicle's DCS system is commanded to perform the desired maneuver. A buried wire system limits the vehicle to a single discrete path for any single maneuver. If traffic conditions or the vehicle's velocity are not correct, the maneuver cannot be completed and the vehicle must be rerouted.

The second consideration is that of traffic interaction. The problem is one of merging from one line of traffic into another. This problem has been considered from the viewpoint of a deterministic system, whereby the position and location of every car is known. The problem is thus reduced to developing a control law which drives the merging vehicle into an open slot (Ref. 6). This is known as the synchronous system. Such a mechanization requires individual vehicles to be controlled by an intersection computer, as well as requiring the intersection computer to have detailed information about each vehicle. The benefit of this approach is that information on all vehicles in the vicinity is taken into account, allowing comprehensive coordination of the movements of these vehicles. The drawback lies mainly in that it concentrates control at a single point, and in addition requires a high data rate between vehicles and the intersection computer. The technique is also restrictive since it requires assuring in advance that space will be available for all maneuvering vehicles.

An alternate solution is to develop a logic structure based on vehicles interacting between themselves, that will work in a continuous-flow traffic situation. This has not been developed and tested, but a conceptual mechanization based on intensity independent proximity sensors or scanning transponders is technically feasible (See Appendix B). Conceptually, each car would be able to sense the existence of the gap needed for a lane change or turn by sensing a vehicle's absence through data provided by either an optical proximity sensor or cooperating transponders. If the required gap was not present the maneuvering vehicle could change its position relative to the blocking vehicle and try again. Conversely, the blocking vehicle could be told by the merging vehicle to slow down.

Specific developments needed are sensors, logic and intervehicle communications. Possible sensor configurations include non-intensity dependent infrared proximity sensors, transponders and, possible scanning radar. Further sensor discussion is included at the end of the Guidance Section. Logic patterns must be developed, simulated and tested to determine what logic is needed with different sensor configurations, as well as the effect on traffic flow.

#### E. HEADWAY AND SIDE CLEARANCE

Headway maintenance is one area where analytical and development work has been done (See Refs. 4 and 7). The work has primarily been based on radar, which can give both range (distance) and range rate (relative velocity). The analytical work has mostly been concerned with stability of a string of vehicles. Two extensions are needed. First, a general headway control logic must be developed; one which can accommodate vehicles stopping and starting as well as the case where the vehicle is alone. The logic must also accommodate merging, and must work with the logic for lane changes and turns. Again, an overall systems viewpoint must be maintained.

Second, side clearance can become interconnected with the DCS if the fiducial marks are at the side of the road. Then if a second vehicle interferes with the line of sight between the first vehicle and the roadside, logic must permit the first vehicle to guide from the position of the second one. Thus the second vehicle becomes a reference for the first. Therefore it seems reasonable to impose a positional hierarchy on traffic where the vehicle nearest the fiducial marks provides guidance for the next vehicle in, etc.

#### F. ENTERING/EXITING INTERSECTIONS

Intersections are a primary difference between exclusive guideway traffic and urban traffic. The problems of interleaving vehicles traveling through the intersection and allowing for turns is fundamental to urban traffic. Appendix B shows an example of a conceptual system which ties intersection logic, lane changing and turns into an overall traffic pattern. This appendix shows that it is possible to develop traffic logic that can be reasonably implemented. The primary needs, again, are sensing the vehicle's surroundings well enough so that the vehicle can make an intelligent decision.

#### G. MONITORING ROADSIDE ENVIRONMENT

One basic rule of this study is to minimize the constraints imposed by automating urban traffic. Presently, the most common technique for handling the roadside environment in an automatic system is to eliminate any interaction between the roadside and the vehicle's right of way. While this simplifies traffic system operation, it is felt that installing barriers between the roadway and the road side greatly diminishes the social usefulness and acceptability of such a system. Fortunately, several alternatives are available to allow automated vehicles to accept some degree of vehicle/roadside interaction.

The problem may be defined as one of making vehicles capable of accommodating normal pedestrian interaction, as well as avoiding accidents with some abnormal actions. This may be done in two ways: identifying pedestrians and monitoring their movements. Pedestrian identification must be done on a passive basis; equipping pedestrians with a radio warning beacon would not be practical. The one sure passive signature of a pedestrian is shape. The problem then becomes one of sensing and processing enough data so that a person's shape can be identified.

The technique envisioned is that of image processing, a laboratory technology which is being applied to practical situations. Two applications are possible: image identification and tracking, and motion detection. This parallels the human brain's function, which has been shown to operate in two modes (Ref. 8). In the first mode, the brain identifies objects by shape, using semantic characteristics such as context and color. In the second mode, the brain detects motion only, and can determine reactions based on the direction of the motion. If



the motion is into a person's path, a reflexive action prevents collision. Both of these modes have been implemented in the laboratory. In the motion detection mode, nearby moving objects can be located and, if the path would intersect with the vehicle, countermeasures could be taken. One countermeasure could be to do more image processing and identify the object. If it was a pedestrian, a warning could be issued by the vehicle.

Since vision, or image data processing, seems to offer a method for solving all traffic sensing problems, a word of caution is advisable. Experience at JPL has shown that total reliance on vision is unacceptable. Again, the end-to-end information flow must be considered, from sensing to data processing, to decision, to resultant action. Humans do not obtain all environmental information through vision; they use touch, hearing, even smell. In the development of the JPL Rover (Ref. 9), it was found that the needed information could not be obtained from TV data. Too much data processing was needed, the resulting location accuracies were not good enough or the data simply could not be obtained from vision. Specialized data sources were developed, such as a force/torque sensor for feel. As mentioned before, an overall system concept had to be created, to allow every subsystem to play its proper role.

Development of solid state cameras (Ref. 10) which are small and rugged as well as microelectronics which allow TV data to be interfaced directly to a digital computer, are the initial steps toward practical application of image processing. The Wide Area Detection Sensor (WADS) being developed by the U.S. Federal Highway Administration is the first attempt at real time image processing for traffic monitoring. The artificial retina being developed jointly by Cal Tech and JPL takes the image processing capability one step further by allowing parallel processing of image data (Appendix D). Presently each picture element (pixel) must be processed individually, in sequence. The artificial retina has each pixel directly connected to a preprocessor which can extract the needed information. The next step is specific development of a vehicle-based image data sensor.

#### H. INCIDENT ACCOMMODATION

An important part of any traffic system, manual or automated, is the system's ability to accommodate unplanned incidents. This could include stalled vehicles, emergency situations such as fire engines or a blocked street and accidents. In short, the system must be able to tolerate undesired events, or else it cannot function in a real world. If a single vehicle unexpectedly stops, or an intersection becomes blocked, the traffic system cannot fail. This function of accommodation differs slightly from reliability as discussed in the section on computers. In accommodation, the system is responding to events largely external to itself.



The conceptual system structure proposed in this report takes advantage of two basic ideas: hierarchic control and an autonomous vehicle. These two concepts allow an automated traffic system to be extremely tolerant of anomalous events by both limiting the incident's effect and providing an immediate local accommodation in the incident's area.

Limiting the effect in essence supplies alternate routing for the vehicles that were scheduled to go through the blocked area. This is done by assigning new routing instructions from the area computer to the intersection computer, which will then guide vehicles away from the disturbance. In effect, closed paths on the network are opened until the roadway is cleared. The important point is that the failure of one intersection does not propagate into system failure.

Local accommodation is provided by navigating the vehicle in a manner so as to pass by the stalled vehicle or clear the street for an emergency vehicle. This is possible if the vehicle has a self contained DCS, which does not tie the vehicle to one specific path. Such a DCS permits the vehicle to detour from its assigned lane. This may either be a path around the stalled vehicle or clearing the way for an emergency vehicle. In either case the vehicle can re-acquire its path through the self contained DCS and fiducial marks.

## I. RECOMMENDED DEVELOPMENT

Development is recommended in two areas: guidance system logic and analysis and vehicle sensors. There is a strong interaction between the two areas and realistic concepts cannot be evaluated without developing both overall system concepts and verifying that the sensors can provide the needed data. Limited scale tests can be run to validate the analytical conclusions.

System development would consist of making an overall logic flow chart of the guidance subsystem and then assuring that it is both realistic and functional. Realistic is defined as being able to be mechanized, i.e. that data can be obtained, computer sizing is realistic, program run time is fast enough, etc. Analysis should be divided into two parts: first, that a nominal system is stable and, second, that the system will remain stable with random noise. Stability of flow through an intersection would be the first step, with the analysis gradually being extended to a network of intersections. Noise would be introduced through varying vehicle state parameters (speed, headway, etc.) as well as routing (a possible passenger decision).

The primary sensor development should be in the area of vision-based identification of a vehicle's surrounding. The Wide Area Detection Sensor, mentioned earlier, is the first sensor to apply vision data in real-time traffic situations, and operates in a fixed highway-based reference frame. A vehicle-based, moving reference frame, used to identify both vehicles and pedestrians requires intensive sensor and algorithm development.

Some of the sensors required are being generally developed for other uses. For example, the solid state rate sensor discussed in Appendix C is being considered for aerospace applications, and it is expected that some development will be done. However, the resultant sensor will be very precise and costly. An automotive application could not use the precision, nor would the cost be acceptable. Therefore, sensor development should be concentrated in areas where specialized development for traffic applications is warranted.

### SECTION III

#### REFERENCES

1. Johnston, A., Meisenholder, G., "Control Techniques for Automated Mixed Traffic Vehicle," Joint Automatic Control Conference, San Francisco, California, June 1977.
2. Rosen, D., et al., "An Electronic Route Guidance System for Highway Vehicles," IEEE Transactions on Vehicular Technology, Feb. 1970.
3. Hahn, J., et al., "The Microprocessor Approach to Local Controller Construction," Traffic Engineering, Apr. 1977.
4. Allard, R., et al., "An Automatic Headway Control System Using Microwave Telemetry," proceedings of the International Conference on Automobile Electronics, SAE Publication, p. 64, July 1976.
5. Proceedings of the Fifth International Symposium on Industrial Robots, ITT Research Institute, Chicago, Ill., Sept. 1975.
6. Athens, M., "A Unified Approach to the Vehicle Merging Problem," Transportation Research, Vol. 3, No. 1, Apr. 1969.
7. Pue, A., "A State Constraint Approach to Vehicle Follower Control Systems," JACC, San Francisco, Calif., June 1977.
8. "Humans Visual Response to Motion," Scientific American, Jan. 1977.
9. Dobrotin, B., Lewis, R., "A Practical Manipulator System," Fifth International Joint Conference on Artificial Intelligence, Cambridge, Mass., Aug. 1977.
10. Eskenazi, R., et al., "A Random Access Picture Digitizer, Display and Memory System," Fifth Joint Conference on Artificial Intelligence, MIT, Cambridge, Mass., Aug. 1977.



## SECTION IV

### ROUTING

Vehicle routing is a necessary function for the automated road traffic system considered in this study. A routing system selects, for each automated vehicle, one out of many possible routes for a destination. It also provides the hardware and logic for directing the vehicles at each intersection according to their assigned routes.

After reviewing the status of traffic control (Refs. 1, 2 and 3), in Section IV-A, we shall discuss route assignment and electronic route guidance, both of which are relatively recent developments and have not been implemented in an actual road network. Section IV-B discusses an electronic route guidance system concept (Ref. 1) and its planned demonstrations (Refs. 2 and 3). Section IV-C reviews several route assignment concepts (Refs. 4-8) in light of possible application to the automated urban traffic system. The conclusions are presented in Section IV-D.

#### A. TRAFFIC CONTROL ON SURFACE ROADS

Vehicle traffic on surface roads has been controlled mainly at intersections. Historically, traffic control at intersections has developed from the simple stop signs to traffic signals with controllable cycle and split patterns. With growing traffic demand, intersection control has been extended to include turn-only and straight-only lanes. The control logic at these intersections has also become more sophisticated to include signal coordination with the neighboring intersections. All this has been mainly for the purpose of improving traffic flow.

Recent development of traffic control has led to the implementation of comprehensive area-wide surveillance and control, with the help of an extensive network of modern computers and communication systems. Examples of large scale implementation of computerized traffic management may be found in many cities in the United States, such as Washington, D.C., and Los Angeles, in an earlier system in Toronto (see Ref. 9) and a recent system in Tokyo (Ref. 10). Advanced traffic management systems with an even higher degree of intelligence and comprehensiveness are the topics of current studies funded by the U.S. Federal Highway Administration (Ref. 11).

#### 1. Signal Control Techniques

A single intersection can optimize its traffic flow through adjustment of the cycle length and split of its signals. An artery can minimize stopping in both directions through signal synchronization or coordination of signal offsets along the artery (Refs. 12 and 13).



Computer programs have been developed to control area-wide traffic signals; one prominent example is the development of the DOT sponsored Urban Traffic Control Systems. Examples of traffic analysis programs include TEANSYT (Ref. 14) and SIGOP (Ref. 15). Comparative evaluations of these programs can be found in Gazis (see Ref. 12) and May (Ref. 16).

## 2. Implementation of Area-Wide Control

Modern area-wide traffic control is characterized by extensive gathering of traffic data over a wide area and by computerized data collection, data reduction, display, and adjustment of traffic control signals. Hierarchical structure of state-of-the-art computers is used to implement data handling and traffic control strategies which take into account area-wide traffic information and respond dynamically to changing environment.

An example of an advanced area-wide traffic control system is the recent large-scale implementation in the city of Tokyo (see Ref. 10). About 8,000 intersections in Tokyo have been included in a traffic control network which is equipped with digital computers and communication devices to perform the following functions:

- (1) On-line data collection over wide area for real-time control, surveillance, and display.
- (2) Dynamic formation of sub-areas of desirable cycle and split patterns.
- (3) Dynamic formation of three-offset patterns for extending the coverage of synchronized streets.
- (4) Dynamic selection of control modes to suit the prevailing traffic environment. These modes include STOP (minimizing stopping), DELAY (minimizing delay), CAPACITY (maximizing traffic flow), QUEUE (clearing a queue), and JAM (dispersing a traffic jam).
- (5) "Graceful degradation" of system performance. In case of malfunctions of the traffic control system, the traffic can still move orderly, though with reduced efficiency.

After implementation of the advanced area-wide traffic stream control system, the streets of Tokyo have experienced significant improvements in traffic conditions. Measurement on some representative streets has indicated, among other benefits, the following traffic improvement:

Journey time reduction:	13-31%
Reduction of stops:	24-45%
Increase of average speed:	14-48%

### 3. Applicability to the Automated Urban Traffic System

In view of the fact that the automated urban traffic system is assumed to operate on a future street network with basically the same two-dimensional network geometry as exists today, and pedestrians must still be allowed to cross the street, traffic control problems essentially similar to the existing problems must be addressed. Consequently, most current control concepts and techniques, in particular the modern area-wide traffic control system previously discussed, may be applicable to traffic control for the automated system.

The signal control system can conceivably be more effective as a regulator of traffic flow when it operates with an automated urban traffic system rather than with the existing system, for two principal reasons: (1) essentially complete information on the speed, location and route of every vehicle can be obtained through the communication links, allowing the signal control algorithms to be designed to take advantage of this information, and (2) the routes and speeds of all vehicles will be selected optimally by the system.

#### B. ELECTRONIC ROUTE GUIDANCE SYSTEM (ERGS)

This section describes the electronic route guidance system (ERGS). ERGS is perhaps the only comprehensive route guidance system concept developed so far and is a good candidate for implementing vehicle routing in the automated urban traffic system under study. The system was designed to provide individualized routing advice to drivers of properly equipped vehicles. The system concept is practicable enough that the first experimental operation of such a system is scheduled to begin this year (1977) in Japan (see Ref. 2).

##### 1. Initial Development in the United States

The system concept of the ERGS was initiated in the United States and, by the late 1960's, was quite comprehensively developed under the coordination of U.S. Federal Highway Administration (Ref. 17), before its termination in 1971 due to budgetary constraints. The original intent of the ERGS was to help unfamiliar drivers to reach their destinations successfully and to help all drivers find the best route available to them. An analysis of the routing problem as considered in ERGS was given by Stephens, et al. (Ref. 18). The development of ERGS from its conception to possible future applications was described by Rosen, et al. (see Ref. 1).

##### 2. System Structure and Operating Principles

The system contains the following elements:

- (1) On-board entry device for driver to input destination code.

- (2) On-board display unit for driver to receive turn instructions.
- (3) On-board antenna for communication.
- (4) Induction loop in the pavement connected to a roadside unit.
- (5) Road side unit consisting of a digital computer, with its front-end transmitter and receiver connected to the induction loop, and a data communication line connected to higher hierarchy computers.

An example configuration of the system is given in Figure 4-1, taken from Reference 19.

The system operates as follows: when the driver starts a trip, he determines his destination code from a directory or a map and enters the code word into the on-board entry device. The code word is kept in the memory of the device through the journey. When the vehicle approaches an intersection which is equipped with a road-side unit, the induction loop in the pavement activates the on-board equipment which transmits the destination code to the roadside unit via the induction loop. The computer in the roadside unit looks up its memory table and finds the turn instruction (left, right, straight, etc.) corresponding to the destination code. The instruction is then returned by the road-side unit to the vehicle through the communication loop. All this is accomplished in a fraction of a second before the moving vehicle leaves the induction loop. The turn instruction received on the vehicle is then displayed on the screen of the on-board unit for the driver to follow at the coming intersection. The two-way communication is repeated at every properly equipped intersection until the vehicle reaches its destination. The memory table in every roadside computer contains a turn instruction for every destination in the area. If a driver makes a mistake at an intersection, either because of the malfunction of the roadside computer or because of his failure to follow a valid instruction, he can still expect to receive a valid instruction at the next properly equipped intersection to route him from that point to his destination.

The memory tables in the roadside computers can be updated periodically, or in response to the changes of traffic conditions, to provide best routing instructions for the changing environment. These best routing instructions are generated in higher level computers which collect and analyze the latest area-wide traffic data and select optimal routing strategies for the upcoming traffic condition. These newly generated instructions are then sent to the roadside computers as current routing table until next update.

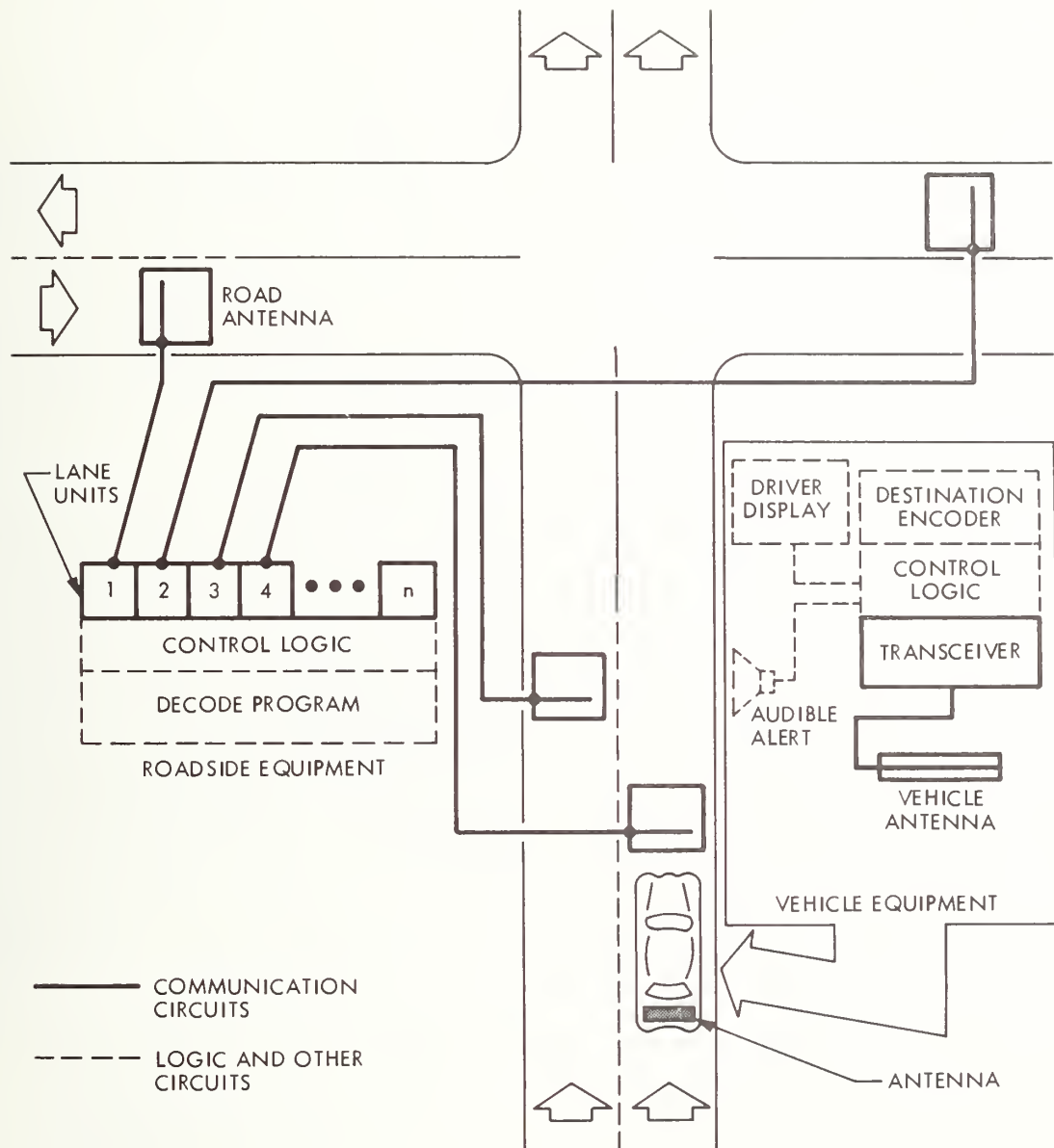

SOURCE: GENERAL MOTORS FOR U.S. DOT/FHA (REF. 19)

Figure 4-1. Elements of an Electronic Route Guidance System at an Intersection



### 3. Recent Development and Planned Demonstration in Japan and West Germany

The ERGS concept originally developed in the United States has been actively pursued in Japan (see Ref. 2) and West Germany (see Ref. 3). Reference 2 has reported on the comprehensive implementation plan to test the ERGS system in the southwest portion of Tokyo (Figure 4-2) in late 1977. The Japanese government, universities, the automobile industry, and the electronics industry have cooperated to bring about this project. In the Tokyo ERGS, general routing information about down stream traffic conditions will be displayed on roadside sign boards for the benefit of all drivers. Communication with individual vehicles will be implemented with the on-board display and key-in units equipped on a selected fleet of automobiles. The ERGS also communicates with the existing area-wide traffic control system, and in effect, becomes a part of the comprehensive metropolitan traffic control system. The outcome of the Tokyo experiment will undoubtedly provide important information on the operation and performance of the ERGS and valuable data on the practicality of existing route guidance concepts and algorithms.

While detailed information on the planned ERGS experiment in Germany is not available to us, Groth and Pilsak (see Ref. 3) have indicated similar system structure and operation principle. Instead of planning the system for intra-city traffic, Groth and Pilsak conceived of an implementation example with a destination chart covering the highway network of West Germany (see Figure 4-3 for a partial chart). The destinations are represented by 4-position code words, each position having 16 possibilities (letters A to P). Each code word is hierarchically organized as follows: the map of the covered area (in this case, West Germany) is first partitioned into divisions and two layers of subdivisions. Each division is then identified with a unique pair of letters in the first two positions of the destination code. The finest subdivision on the chart's which can be a small neighborhood or an exit ramp, is identified with a letter in the last position of the code. This hierarchical coding scheme was also developed in the early ERGS development in the United States (Ref. 17).

Such a hierarchical destination code would permit efficient handling of information and economical execution of routing algorithms. For example, if the destination is in a distant city, only the first two letters in the code word need to be considered for routing until the vehicle reaches the vicinity of the city. The last two letters in the code word will then be considered for finer routing in the city.

### 4. Applicability to the Automated Road Traffic System

The ERGS, as described in Section IV-B-2, is a good candidate for implementing automatic vehicle routing in the automated urban traffic system under study. As a candidate system, it offers the following major advantages:





SOURCE: RESEARCH ASSOC FOR COMPREHENSIVE  
AUTOMOBILE CONTROL TECHNOLOGY, JAPAN  
(REF. 2)

Figure 4-2. Electronic Route Guidance Project Area in Tokyo

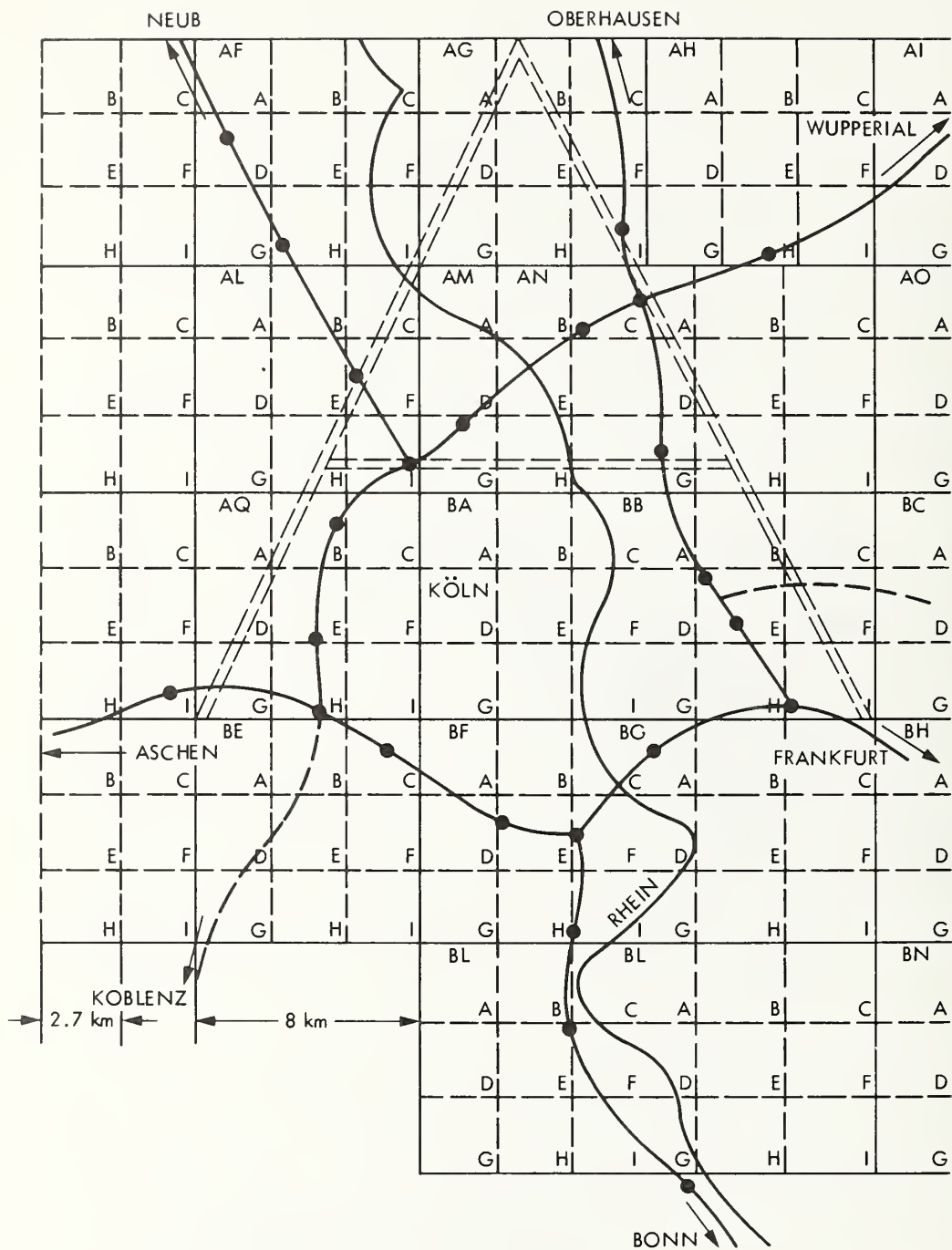

SOURCE: GOTH AND PILSAK  
(REF. 3)

Figure 4-3. An Example of Destination Map for Route Guidance Around Cologne, West Germany

- (1) Ease of implementation and management due to its periodic system structure (with intersections as basic units) and hierarchical processing and control structure.
- (2) Reliability of a routing information system with ample redundancy (destination-specified routing instruction provided at every intersection).
- (3) Reliability of an information storage concept which stores the routing information at the road-side rather than in an on-board processor, presumably, it is much harder to ensure the uniform maintenance of the computers in private vehicles than to keep the road-side units in good working conditions.

## C. ROUTE ASSIGNMENT METHODS

### 1. The Route Assignment Problem

The electronic route guidance system (ERGS) discussed previously provides a mechanism for implementing predetermined routing strategies. These strategies are coded into computer programs and reside in some routing computers as the major software of the ERGS. The routing strategies are determined from route assignment studies that address the fundamental question: How should the routes be assigned to the vehicles after knowing their origins and destinations?

In principle, there are many ways to assign available routes to the vehicles so that each vehicle can eventually arrive at its own destination. The major objective of route assignment is to select the best routes among the available ones to achieve efficiency in network traffic flow and to assure reasonable trip time for the individual vehicles. In order to generate computer-programmable algorithms to represent a route assignment strategy, the problem is usually formulated as a constrained optimization problem in the framework of mathematical programming.

### 2. Generation of Route-Assignment Patterns

A good example of the mathematical formulation is given in Reference 5. It deals with the following problem specifically: given the constant demand rates associated with specified origin-destination (O/D) pairs of a road network, and travel cost functions for each link of the network, the traffic assignment problem is to determine the flow rates on each path, or route, of the network. A description of the method that would lead to concrete solutions is given in Appendix E.

Iterative procedures are usually used to generate an optimal solution. Leventhal, Nemhauser and Trotter (See Ref. 5) suggested one procedure which greatly reduces the computation and makes solutions of large networks tractable. The procedure starts with a reasonable

subset of the set of all possible paths as the basis for optimization, performs the suboptimization so defined, and gradually enlarges the subset until the optimum condition for the original problem is satisfied.

This procedure is particularly suitable for practical application since one can select a few promising paths for each O/D pair (doing this on all the O/D pairs) according to a good judgment and then start the interaction. The suboptimal solution on the first iteration would already be a meaningful solution, and very likely a practical one.

### 3. Practical Considerations

a. Performance Criteria: System-Optimizing vs. User-Optimizing. Although many goals (travel time, total stops, energy use, pollutants emitted, etc.) can be incorporated in the performance function to be optimized, the most tangible one, and the one that also indicates the achievement of other goals, is the travel time. Understanding that other goals can be included, if desired, one can assume that the routes are assigned to minimize some monotone function of the travel time. There are largely two ways to formulate the minimization problem (See Refs. 5 and 7):

1) User-Optimizing Assignment. The routes are assigned to the vehicles so that the travel time of each individual vehicle is minimum on his assigned route among all possible routes. The traditional shortest-path routing (Refs. 20 and 21) is an example.

2) System-Optimizing Assignment. The routes are assigned so that the total travel time of all the traffic flow in the network is minimized. Many recent studies (e.g., Refs. 4, 5 and 7) have used this criterion.

The drawback of a user-optimizing assignment is that the road network may become congested for lack of network-level consideration. Therefore, the travel time for an individual vehicle may increase because of congestion, even if it has chosen the fastest route for itself. Yagar has reported the results of a corridor study (Ref. 22) and shown that system-optimizing assignment decreased the total travel time of a system using user-optimizing assignment by 0-26%. He also concluded that the actual traffic pattern demonstrated a total travel time between those of the user optimizing and the system-optimizing systems, and closer to the user-optimizing system. Simulation results of Maher and Akcelik (Ref. 23) on a simple network has shown a total saving of network travel time of 0-25% by the system-optimizing assignment over the user-optimizing assignment.



It is possible that under the system-optimizing assignment a few vehicles may be routed to take longer routes for the sake of overall travel time saving in the network. If unacceptably prolonged travel time is expected for these vehicles, the mathematical problem can conceivably be modified, by use of the quality constraints on individual travel time deterioration, to yield a compromise solution.

b. Travel-Time Characteristics of a Link. The route travel time usually contains the travel times on all the links of the route. The actual travel time of a vehicle on a link should depend on the degree of congestion, the turning direction of the vehicles, the traffic signaling and, in case of a fully automated system, the vehicle guidance logic on the link. But in order to keep the mathematical problem tractable, congestion has normally been the only explicitly considered parameter in the expression for link travel time. A realistic link travel time expression should at least also include the effects of turns and the expected queueing delays at the next intersection. Both have had significant impact on the actual travel time and demonstrated their influence on the choice of routes by ordinary drivers (avoiding left turns and using arteries with synchronized light signals). This inclusion should not cause too much difficulty to the mathematical problem.

c. Time and Space Dependent Variations of Traffic Flow. From time to time, the destination demands will vary at origins all over the network, and occasional traffic accidents will take place in various locations. All this causes variations in the traffic flow patterns and calls for adjustment of the routing strategy.

The simplest way to deal with these variations is to assume that the changes evolve slowly so that a static routing strategy can be computed for a more-or-less stationary traffic pattern in a suitable time period. When the period is over, another static routing strategy will be used for optimal routing in the next period (See Ref. 8). The routing strategies for the daily rush hours and light hours can be constructed this way.

The variations of traffic flow due to accidents or other emergencies need routing adjustment almost in real time. Fortunately, emergencies can be expected to affect only local traffic\* so that the routing algorithms for other parts of the network can stay unchanged.

While it is extremely difficult to properly formulate, and to solve, the optimization problem based on a time-varying network model, some recent development has helped to circumvent the difficulty. In

---

\*Preliminary results of a corridor traffic control study have shown analytically the decrease of effects of a perturbation as distance from the incidence cite increases (Ref. 24).



the context of freeway corridor control, Houpt and Athans (Ref. 18) have used the approach of computing static routing strategies for decidedly different traffic flow patterns and regulating the traffic flow in real time by signal control to maintain the traffic pattern close to an optimal pattern. In another freeway corridor, control logic (see Ref. 6) techniques of pattern matching are used to identify the measured traffic pattern with one of many stored patterns. The characteristics of the stored pattern and the best control already computed for the stored pattern will be used for the measured pattern.

#### 4. Application to the Automated Urban Traffic System

The route assignment concepts and the mathematical program to generate optimal flow pattern (distribution) among available routes provide the basis for developing practical routing algorithms for the automated urban traffic system. Once an optimal flow pattern is decided for a given O/D pattern in the network, the decision is processed in a system of routing computers and communicated to the individual vehicles in terms of specific routing instructions.

Both the generation of optimal flow patterns and the data processing needs to generate specific routing instructions take large amounts of computing, especially where the network is large and when the O/D demand is fast changing. With the limited speed and memory of computers, computations and data processing must be properly sequenced and modularized to make machine computation possible in a given time.

a. Reducing Computing Load in Traffic Assignment. There are several ways to reduce the computing load for the generation of desirable flow patterns:

1) Periodic Update of Static Optimal Patterns — allowing enough computing time for the generation of each pattern. The computing time must also be short enough compared with the variation of O/D demand to justify the use of static route assignment methodology.

2) Acceptance of Sub-Optimal Patterns — reducing computation by considering a selected subset, instead of the whole set, of all possible routes for mathematical programming.

3) Subdividing the Road Network into Smaller Districts — eliminating the need for optimizing over a large network with uniform detail. There could be optimal patterns for O/D pairs defined from district to district, and finer optimal patterns for O/D pairs defined from arc to arc, or node to node, in a district. This decomposition is implementable with computers organized in a hierarchy.

4) Pattern Matching Based on Off-Line, Pre-Computed Optimal Flow Pattern — allowing for fast responses to changing O/D patterns without the need for real-time computation. The typical O/D patterns are identified first; the optimal flow patterns are then computed off-line for these identified patterns. These O/D patterns and the associated optimal flow patterns are then stored in the computer memory. In daily operation, when an O/D demand pattern is detected by the traffic system, it will be identified with a similar O/D pattern stored in the computer and a stored flow pattern will be matched to it for immediate application.

b. Generating Vehicle Routing Instructions Based on the Chosen Flow Pattern.

1) Vehicle Memorizes its Designated Route. If each vehicle memorizes its own route through the road network, the route information can be obtained directly from the flow pattern. The vehicles with the same origin and destination will be assigned to various possible routes according to a probability distribution proportional to the flows on these routes. Each vehicle then remembers the route assigned to it.

2) Vehicle Memorizes its Destination Only — for Use in the ERGS Routing System. However, if the vehicle does not remember its route, but only carries its destination code and follows turn instructions given to it at the intersections, as in the case of ERGS described in Section IV-B-2, the optimal flow pattern must be transformed into destination-dependent turn instructions at each intersection. In other words, given a system-optimal flow pattern chosen according to the mathematical program in Appendix E, one must generate the probability distribution of turn instructions at each intersection for each destination. For example, when a vehicle with a destination  $j$  comes to an intersection, it will be told to turn left with probability 0.3, to turn right with probability 0, and to go straight with probability 0.7. A method is suggested in Appendix E to accomplish this transformation.

D. CONCLUSIONS

1. State of the Art

- (1) The modern area-wide signal control systems developed for conventional traffic can also be used in the automated urban traffic system to ensure safe and efficient traffic flow.

- (2) The electronic route guidance system (ERGS) concept developed to provide routing information to humanly driven vehicles is a good candidate for implementing vehicle routing strategies in an automated traffic system.
- (3) Routing strategies, algorithms, and instructions can be derived from existing route assignment methods. Many feasible algorithms and instructions can be generated, such as those discussed in Sections IV-C-2 and 4), for the automated traffic network to function properly. But optimal algorithms are more difficult to derive and compute.

## 2. A Workable Routing and Traffic Signaling System

The combination of the ingredients in conclusions (1), (2), (3) is sufficient to make the automated routing and traffic signaling work in an automated urban traffic system. To be specific, these ingredients are:

- (1) A modern area-wide signal control system with a good traffic signaling program such as TRANSYT,
- (2) An ERGS route guidance system with its equipment and operating principles as described in Section IV-B-2,
- (3) A static mathematical route-assignment program such as the one described in Section IV-C-2 which generates suboptimal flow distribution patterns on a set of feasible routes. These patterns are periodically updated to suit changing O/D demands.
- (4) A transformation algorithm, such as the one developed in Appendix E, which transforms the suboptimal flow patterns into intersection-resident, destination-oriented turn instructions.

## 3. Further Research and Development

To achieve efficient traffic routing, further work should emphasize research in the areas of large-network routing algorithms and coordination of routing and traffic-signaling strategies. This research should be directed toward a better understanding of the dynamic behavior of large traffic networks. Also, more efficient and practical methods of computation should be developed.

Further development of the ERGS concept and computer network configurations is needed for implementing city-wide routing and traffic management. Foreign ERGS experiments should be monitored. Domestic ERGS experiments should be considered as they could benefit not only current traffic systems but also fully-automated traffic systems.

## SECTION IV

### REFERENCES

1. Rosen, D.A., Mamano, F.J., and Favout, R., "An Electronic Route Guidance System for Highway Vehicles," IEEE Transactions VT-19, pp. 143-152, 1970.
2. "Comprehensive Automobile Control System," Research Assoc. for Comprehensive Automobile Control Technology, Japan Ministry of International Trade & Industry, Agency of Industrial Science & Technology, Tokyo, Japan, May 1975.
3. Groth G., and Pilsak, O., "An Electronic System for Individual and Active Route Guidance on Motorways," Traffic Control and Transportation Systems (edited by AFCET), American Elsevier, New York, 1974.
4. Hoshino, T., "Theory of Traffic Assignment to a Road Network," Traffic Flow & Transportation, G.F. Newel edited, American Elsevier, New York, 1971.
5. Leventhal, T., Nemhauser, G., Trotter, L., "A Column Generation Algorithm for Optimal Traffic Assignment," Transportation Science, Vol. 7, pp. 168-176, 1973.
6. "Development of Traffic Logic for Optimizing Traffic Flow in an Intercity Corridor," Part 1, prepared by Sperry Systems Management, Great Neck, New York, for U.S. DOT/FHA under contract DOT-FH-11-8738, April 1976.
7. Gershwin, S.B., "Dynamic Stochastic Control of Freeway Corridor Systems," Vol. II -- Steady State Optimal Traffic Assignment Using the Accelerated Gradient Projection Method, MIT report #ESL-R-609, Mass. Institute of Technology, Cambridge, Mass., August 1975.
8. Akcelik, R., Maher, M.J., "Route Control of Traffic in Urban Road Networks -- Review and Principle," Transportation Research, Vol. 11, pp. 15-24, 1977.
9. Hewton, J.T., "The Metropolitan Toronto Traffic Signal System," IEEE Proceedings, Vol. 56, pp. 577-599, April 1968.
10. Inose, H., "Road-Traffic Control with Particular Reference to Tokyo Traffic Control and Surveillance System," IEEE Proceedings, July 1976.
11. "1976 Federally Coordinated Program of Highway Research and Development," U.S. Dept. of Transportation, Federal Highway Administration, 1976.



12. Gazis, D.C. (ed.), "Traffic Science," John Wiley & Sons, New York, 1974.
13. Inose, H. and Hamada, T., "Road Traffic Control," Translation from Japanese edited by E. Posner, California Institute of Technology for U.S. DOT under Contract #DOT=OS-30169.
14. Robertson, D.I., "TRANSYT Method of Area Traffic Control," Traffic Engineering and Control, Vol. 11, pp. 276-281, 1969.
15. "SIGOP: Traffic Signal Optimization Program - A Computer Program to Calculate Optimum Coordination in a Grid Network of Synchronized Traffic Signals," Traffic Research Corporation, PB-173-738, 1966.
16. May, A.D., "Some Fixed-Time Signal Control Computer Programs," Traffic Control and Transportation Systems (edited by AFCET), American Elsevier Publishing Company, New York, 1974.
17. "ERGS - Electronic Route Guidance System," U.S. Dept. of Transportation, Federal Highway Administration, Office of Research and Development, Program Bulletin, April 1969.
18. Stephens, B.W., Rosen, D.A., Mammano F.J., Gibbs, W.L., "Third Generation Destination Signing: An Electronic Route Guidance System," Highway Research Record #265, 1968.
19. "A Design for an ERGS," Vol. 1, System Description, GM Research Laboratories for U.S. DOT-FHA under Contract FH-11-6626, Nov. 1968.
20. Rubin, F., "Routing Algorithms for Urban Rapid Transit," Transportation Research, Vol. 9, pp. 215-223, 1975.
21. Hillier, F.S. and Lieberman G.J., "Operations Research," page 217, Holden Day, San Francisco, 1974.
22. Yagar, S., "A Study of the Travel Patterns in a Corridor with Reference to the Assignment Principles of Wardrop," in Traffic Flow and Transportation (edited by G.F. Newell) American Elsevier, N.Y., 1971.
23. Maher, M.J. and Akcelik, R., "Route Control - Simulation Experiments," Transportation Research, Vol. 11, pp. 25-31, 1977.
24. Crosby, R., U.S. Dept. of Transportation (OST), Private Communication, May 1977.



## SECTION V

### COMPUTING

#### A. INTRODUCTION

The three key factors affecting the applicability of computers to a fully automated urban traffic system are computational power, cost, and reliability. Computers are required, at least at three hierarchic levels in an automated roadway network: (1) in vehicles for guidance, control and obstacle avoidance, (2) at intersections for local control and routing, (3) for regional control and traffic pattern optimization, and possibly (4) high-level control of a number of regions making up a large metropolitan area. Each level in the computing hierarchy imposes different computing requirements which will be discussed in subsequent sections.

Before examining the feasibility of an automated roadway, it is necessary to establish projections for computer technology ten to twenty years into the future when such a system might become operational. All the design approaches which appear feasible use thousands of small, highly reliable, computers. Due to their expected proliferation of use in cars and at intersections, these machines must be very cheap and be in the category of micro-computers. In order to be economically feasible, vehicle computers must cost on the order of \$100 since that expense is likely to be borne by the motorist. Intersection computers should be restricted to the order of \$1000 per computer while the regional control computers will be general-purpose computer systems with much higher allowed cost since fewer are required.

Figure 5-1 indicates the relative number of computers in the automated roadway hierarchy and the relative acceptable costs.

#### B. COMPUTER PERFORMANCE AND RELIABILITY

Microprocessor technology already provides considerable computing capability at low enough cost to be applied to vehicle and intersection applications. The automobile industry is already beginning to use microprocessors in 1978 models. With increasing pressures for fuel economy and pollution control, automotive microprocessors will be widely used.

The increase in performance in low-cost microprocessors seen over the last five years is quite remarkable. From the first 4-bit machine, the Intel 4004, to current bipolar machines, the increase in processing capability has been on the order of 20 to 50. While the 4004 would add a 4-bit number in 10  $\mu$ seconds, current machines such as the Intel 3000 or AMD 2900 will perform similar simple operation on 16-bit numbers in one microsecond. More efficient instruction sets and hardware multiply and divide have also improved performance beyond the tenfold increase in speed.

	# COMPUTERS	ORDER OF ACCEPTABLE COST	
REGIONAL AREA	1	$\$5 \times 10^5$	GENERAL-PURPOSE COMPUTING FACILITIES
INTERSECTION	500	$\$10^3$	MICROCOMPUTERS
VEHICLES	10,000	$\$10^2$	

Figure 5-1. Automated Roadway Hierarchy

Current microprocessors have achieved the speed of minicomputers and are being used in minicomputer applications. In terms of CPUs alone, microprocessors will soon rival the performance of general-purpose computer installations.

The major limitations of microcomputers are not the microprocessor (CPU chips) but rather the costs of memory systems and peripherals which will remain the largest area of cost.

It is not expected that a similar performance increase will occur in the next ten years in microprocessor technology unless new developments occur in computer architecture. Fundamental limitations of capacitance and requirements of reliability will probably limit the processor-memory cycle time to 25-50 nanoseconds. Microprocessors are beginning to mature as a new technology with a corresponding slowdown in growth.

To be conservative, we will assume a throughput of  $10^7$  instructions/second (including special purpose multiply and divide chips) for the target vehicle computer. This is consistent with other projections.

Memory is currently a limiting factor in the cost of microcomputer systems. However, the number of bits on a single chip has increased from 500 to 8000 in the last several years. It is expected that a figure of 65,000 bits/chips can be achieved before an automated roadway system is implemented. The target vehicle computer

will be assumed to have 65,000 x 16-bit words of memory at an acceptable cost.

An area which needs further development is nonvolatile bulk storage. Magnetic bubbles, MNOS, and other advanced bulk storage technologies have not developed to a point to determine if they will be economically feasible in a vehicle computer. However, bulk non-volatile storage will be required in intersection and regional control machines, and it is expected that  $10^5$  to  $10^6$  worth of bulk nonvolatile storage will be available for the intersection computers and one hundred to a thousand times more will be available in the regional control computers.

The peripheral subsystems associated with the various computers in the automated roadway system are described in other sections of this report. As in the majority of computer-based systems, they represent a preponderance of the total cost.

The reliability of microprocessors is not well established, but is thought to be in the area of  $10^5$  to  $10^6$  hours meantime to failure. Under the adverse environmental conditions of an automobile, somewhat lower reliability can be expected. As LSI technology advances, chips will become considerably more complex and, with smaller active areas, they will become more process sensitive. Thus, it is expected that the reliability of more advanced microprocessors will not improve significantly. (Electronic reliability will improve but will be offset, to a large extent, by increased circuit complexity.)

In any case, we are talking about average failure rates of once per year with a pessimistic assumption to once every 10 years if we are optimistic. Even the optimistic failure rate is unacceptable if computer failures can result in serious accidents. With 10,000 cars in the roadway system, we could expect three failures per day. Thus, computer reliability (as well as the reliability of all the other vehicle and roadway control subsystems) must be extended well beyond the current state-of-the-art in order to achieve a viable automated roadway system. The methodology of fault-tolerant design must be employed to produce a workable system.

#### C. REQUIREMENTS FOR RELIABLE OPERATION

Experience with automated transportation systems (e.g., BART which is several orders of magnitude simpler than the proposed automated urban traffic system) has shown reliability to be the most serious implementation problem. An outage may have two effects, (1) a large number of inconvenienced users who cannot get to their destination, and (2) accidents with a potential for astronomical legal costs, and public outrage which could easily result in early removal of such an automated system.

Being a physical system, equipment will fail, and sufficient redundancy must be built into the design so that in most instances the system will continue to operate properly in the presence of faults and when automated recovery is not feasible no accidents shall occur. The following techniques will be necessary to achieve the required reliability:

(1) Fault-Tolerant Computers.

The computers used in the vehicles, intersections, and regional control will be required to operate correctly, even in the presence of hardware faults. A technology has been developed in this area which allows construction of self-repairing computers which detect internal faults and utilize redundant parts. The cost of such machines is typically two to three times that of a nonredundant computer. Fault-tolerant computers have been developed primarily for an aerospace environment. Additional development is required for their routine use in high-volume transportation applications.

(2) Automated Diagnosis and Failure Management.

Fault-tolerant computers can be used as an automated repairman for the rest of the transportation system.

The vehicle computer must guarantee at all times that its vehicle is roadworthy. Before entering the roadway system, a thorough diagnosis of the vehicle must be made to determine if it can be allowed to enter. While the vehicle is in the roadway system, the vehicle computer must check for impending failures (such as overheating, a drop in oil pressure, and faults in the navigation and steering systems) and divert the vehicle from the traffic stream. Sufficient redundancy is required in the vehicle to provide for at least a safe stop, and normally diversion to side lanes upon failure.

The intersection controller must also be capable of detecting and immediately dealing with faults in its associated equipment. Automated switching to redundant elements will be required to i) keep the intersection operational, ii) find alternative communication paths if its connections to the regional computer or other intersections are disabled, and iii) operate the intersection in a safe but degraded mode if it cannot communicate with other computers.



At the lower levels of vehicle and intersection systems, faults must be detected and corrected in the order of a second because safety is involved. The higher-level regional computers are concerned with efficiency of traffic flow and their failures result in inconvenience. Typically, recovery times in minutes are acceptable at the regional control center.

- (3) The regional control computer must diagnose and utilize redundant paths in the communication system to provide reliable connections with the various intersections. It must compute alternative vehicle routing strategies to compensate for failures in the system.

#### D. ROBUSTNESS

When a fail-safe system is built with a multitude of checks and interlocks for safety, it often will not work because of the failures that it detects. Thus, the automated urban traffic system must exhibit the property of robustness, which is to say that vehicles should reach their destination even with failures in the network. This implies significant intelligence in the vehicle and intersection computers. The following are requirements which enhance robustness of the system:

- (1) Vehicles should reach their destination even if the regional control is down. It has been assumed in our study that the regional computer would periodically update the intersection computers with routing information so that when a vehicle presents its destination to each intersection, it will be routed in the proper direction (left, right, straight). If the intersection hears nothing from the regional computer, it can go back to a prestored standard routing algorithm. Though not optimally efficient, the vehicle should get to its destination.
- (2) The failure of an intersection should not prevent vehicles from reaching their destination. The fault-tolerant intersection computer must notify its neighbors to reroute traffic around the faulty intersection.
- (3) A faulty vehicle must, in most cases, be capable of removing itself from the traffic flow to prevent unacceptable bottlenecks.

#### E. COMPUTING REQUIREMENTS

Without detailed algorithms and mechanisms for routing, vehicle control, intersection and roadway implementations, obstacle avoidance, and other elements of the system, computer requirements can only be discussed in general terms. At this level, however, there are several



constraints inherent in the network design which heavily influence the computations.

- (1) The cost and error rate of communications between vehicles, intersections, and regional computers imply that one should try to minimize the (a) volume, (b) criticality, and (c) timing constraints on messages sent in the system. The amount of communications can grow out of bounds in this type of system without proper design constraints. Thus, autonomy is required at each level of computation so that each computer can operate with a minimum of direction.

For example, the vehicle must be responsible for its own obstacle avoidance, and interface with the guidance markers in the roadway. It must not expect responses from the intersection computer to occur with delays of less than several seconds. Similarly, the intersection computer must be sufficiently autonomous to allow several minutes to pass without an expected response from the regional computer.

- (2) The computers impose timing and memory constraints upon the system design. The network must be free of tight timing requirements. Similarly, each intersection needs to utilize memory efficiently. Clearly, the intersection cannot maintain a map of the entire automated roadway network for a large city. Computer storage and timing constraints impose a scheme where an intersection has detailed knowledge of its local and only fuzzy knowledge of more distant places. Thus, the allocation of "knowledge" within the system is constrained by computer capabilities.
- (3) Finally, the design of system hardware is greatly influenced by computer capability. A basic system with (a) gross proximity detectors for vehicle obstacle avoidance, (b) slot-following guidance, and (c) routing by intersection could be implemented with existing computer technology. The hardware operates in a rather gross fashion and does not make excessive demands upon the computer. Routing algorithms can be tailored to work with existing micro-computers also.

Improvements in capability can require and exceed any available computer technology. Optimization of routing may increase computer requirements by orders of magnitude. More importantly, the ability to see and avoid obstacles through image processing can become highly complex. The ability for a vehicle to see a bouncing ball and realize that a child may be following it, remain a long way beyond the state-of-the-art.

SECTION VI  
COMMUNICATION

A. INTRODUCTION

Communications to and from the vehicle are an obvious vital link in an automated network. This mode of communication, whether it is combined or separate from the guidance system, is needed to transmit destination and routing requests to the network system and to receive emergency messages over and above the normal guidance commands. The various computers required in the network must also communicate with each other under control of higher order computers in order for the system to work as a whole.

This section covers the assumptions and constraints of the various links and discusses communication techniques, both vehicular and inter-computer. Prior work is described and examples of investigated and developed systems are described. Some conclusions concerning each of the communication link types are presented.

1. Assumptions and Constraints

The lowest level of communication involving the greatest number of links is that from the wayside to the vehicles. These links are assumed to be duplicated at each intersection as the intersection is the lowest control level. This is not to eliminate the possibility of wider area links to the vehicle which could be used for messages of wider interest. The intersection includes the road segments midway to the next intersections.

It is also assumed that the vehicles are functionally equivalent. The same message sent to each vehicle should cause the same response. Similarly, the messages sent from the vehicle should be the same if sent for the same reason. Addresses or identity codes would naturally be different. Functional identity also requires that a certain minimum performance be assured in acceleration, braking, and steering. It also requires that the vehicles entering the system are mechanically fit, with enough gas and sufficient remaining useful life in tires, brakes, belts, etc. to complete the planned trip successfully.

The vehicles are assumed to follow prescribed paths through the critical paths in the intersection. No lane changes or difficult maneuvers are allowed in the intersection where collisions would bring the traffic flow to a standstill. Lane changes and merges are accomplished in the road segment prior to entering the intersection. The vehicles should move as if on rails with active headway control. This spacing control is supplemental to the on-board collision-avoidance equipment.

Some surveillance of the intersection is required to ascertain the cause and remedial action required in case of a breakdown in the intersection. This could be effected by motion detectors, but closed-circuit television is probably also likely as it is more informative as to the reasons for breakdown, and allows a fairly fast means of ascertaining the aid needed. Visual data links might be separate from the data links.

The use of a hierarchy of computers is also assumed with the lowest level being the intersection computer. Each intersection or wayside computer is in communication with adjacent wayside computers.

## 2. Communication Data Links

At least three separate communication links for data messages are needed in the hierarchical control computer configuration. The vehicle wayside computer for control in the intersection may involve many tens of vehicles at any instant. This link directs the cars through the intersection as well as providing traffic and pedestrian control. This link is the only one requiring radio or some other wireless link.

The second link is the wayside computer to the area computer. The topology of this link may be a loop configuration coupling all the wayside computers associated with an area computer on a common bus. The bus arrangement allows each intersection machine to communicate with adjacent machines directly. A central area machine with radial links to each wayside computer requires that the area computer participate in the data exchange at each intersection.

The area to central computer link can also be arranged either as a loop bus or radial net. In this case, a radial net is probably more appropriate, primarily because there is little need for the area computers to interact. The data messages at this level are more statistical in nature involving data for traffic summaries and management.

## B. PRIOR WORK

### 1. Vehicle Communication

The communications problem comparable to the vehicle-wayside link has received substantial attention in at least four areas: personal rapid transit, subways (also mines), surface rail, and freeway driver assistance.

Personal rapid transit, where the vehicles travel on dedicated guideways, is most similar to the automated network. Work in this area is most nearly applicable to the problem under study. The vehicles receive and initiate messages similar to those required for automated networks. Other similarities are that vehicle-to-roadway spacing is nearly the same as for passenger motor vehicles, and that speed, braking, and steering commands are usually needed. The guidance communication link is often a combined link with lateral and longitudinal control

on a buried wire using inductive coupling to the vehicle. The vehicle-to-wayside link is quite generally VHF radio.

Tunnel communications such as those needed for subway-train operations and mining work have been the subject of substantial effort. This work has some applicability, but there are significant differences. Rather than having only a sub-roadway installation possible, the overhead and sides of the tunnel are also available for support of the radiation element. Radio, rather than inductive coupling, is usually employed because of the need for greater two-way communication than in PRT. The inductive loops in PRT are primarily one-way links.

Systems developed for surface rail, particularly those techniques investigated for high-speed ground transport, are the most diverse — particularly in the frequencies used. Inductive loops at audio frequencies up to 50 GHz have been tried. Most of the higher frequency techniques rely on the relatively precise lateral positioning obtainable with rails. Waveguide or transmission lines alongside the track carry data to and from the trains. The coupling from train to line is usually accomplished by the train's carrying an "impedance discontinuity," which causes the line to radiate locally, and provides a means to get data onto the line.

Work on the freeway communications has been centered in two areas. One is a driver-assistance network employing a single frequency radiated from a network of directional receiver/transmitters. The limited range of each radio alongside the freeway allows a controller to determine the approximate location of a driver requesting assistance. A broadcast technique used also on surface streets and highways uses a buried antenna sending local-interest messages to be received on the AM car radio at a frequency not in use by a local commercial AM station.

Other wayside-to-vehicle links are employed in automatic vehicle-locating systems. These techniques operate in two principal ways. The first is the electronic signposts, which send identity codes continuously that are received by vehicles passing near them. The signposts are located at every — or principal — intersection, and each radiates a different code. The vehicle retransmits the code together with its own identity to a central location, which then determines where the vehicle is located by decoding the signpost code. In another vehicle-locating technique, the vehicle radiates a high-powered pulse sequence which is the vehicle identity. The time of arrival of this pulse train is precisely measured at several receiving sites, and a subsequent calculation determines where the vehicle is located from the relative times of arrival.

Other vehicular communication techniques are primarily voice-oriented and operate on mobile telephone as well as other commercial and non-commercial frequency allocations. Some vehicle communications, primarily in police applications, employ digital data transmission for operating hard-copy printers or displays in the vehicle. These same links allow direct computer access from a vehicle keyboard.



## 2. Computer Communications

Computer communications and/or data transmissions have used all of the traditional voice-transmission links. In computer application, these links are generally point-to-point rather than being area-wide broadcasts. The computer, being centrally located, is quite often called upon from several locations and a radial communication topology is most common.

Certain significant improvements in the quality of the communication are required for computer purposes as compared with voice transmission. The lack of redundancy in information content and the nearly equal importance of the data elements make computer communications much more sensitive to noise, interruptions, and switching transients. Voice communications on the other hand can tolerate trunk economy measures such as those that use the pauses in normal speech as opportunities to squeeze in other speech pockets. Computer communications usually require a dedicated link with a minimum of switch points.

To overcome this hardware restriction, considerable work has been done in packet net communications. These systems use data organized into messages which contain the destination and length of the message. The destination code is used to establish a "dedicated" path through the packet net for the length of time required for the message length. This technique allows switchpoints in the net for interconnecting different data users and sources but assures that switching will not be at inopportune times.

Information base exchanges where one central computer furnishes and receives data from many terminals is usually radial in nature. The existing telephone lines in a dial-up or dedicated conditioned mode are used. Low bit rates are common because of terminal and line limitations. Fund transfer computer communications require dedicated links with very low error probability and high reliability. These links are similar to some military links in that extreme security is also required. High bit rates are also common on these links.

Communications by and between computers have become very commonplace. More than 170 airlines throughout the world process many hundreds of millions data entries each year. These entries are for seat reservations, freight handling, and passenger movements. Newspapers also use short and long haul computer communications for automatic typesetting. Railroads also schedule, route, reassign, and assemble trains using computer communications over substantial distances.

Some companies with substantial experience in this area are: Control Data Corp., L. M. Ericsson (Stockholm), Hasler Ltd. (Perne), IBM, Olivetti (Ivrea, Italy), Phillips Telecommunications Industries (The Netherlands), Siemens/Italtel (Milan), and Telefonbau and Normalzeit GMBH (Frankfurt). These systems are all categorized as nets and are computer controlled communications systems whose purpose is to route data to (and from) computers.



Packet nets, where the data contains its destination as part of the coded information, have been used for some time in the ARPA net. The development of tariffed common carrier nets has taken about seven years from the research stage. It is now available to commercial users by such companies as Telenet Communications Corporation.

Some vehicular traffic control nets involving computer communications have been in use in Chicago, Los Angeles, Baltimore, Minneapolis, Dallas, and Tokyo. Most of these systems use a computer to collect data from widespread traffic monitors over dedicated telephone lines. In general, the data rates are quite low. They are mentioned here only to indicate that the traffic control community uses and is aware of computer communications methods.

### 3. Vehicle Communication Techniques

Vehicle communications systems in use and investigated have been, primarily, in three fields: inductive coupling, near field radio, and far field radio. Some minimal work has been performed in optical (infrared) and supersonic links for vehicle location applications.

Inductive loop systems use wires buried in the roadway in a closed configuration. Loops encompassing a small area (1 m x 2 m) have found widest application as vehicle counting and traffic control devices. The loop is tuned with a capacitor to be part of an oscillator circuit which is determined by the presence of the metallic vehicle. The frequencies employed are from the high audio frequencies to a few hundred kilohertz.

Small loops have been used by the New York Port Authority and the California Department of Transportation as inductive antennas for automatic toll billing of buses. The buses are equipped with an inductive receive and transmitter to reply to interrogations from the loop. The loop signals are sent continuously or may be initiated by vehicle presence.

Similarly, small loops are used by the Federal Republic of Germany to communicate route guidance data to a vehicle. The vehicle, in this case, initiates a request for guidance to the loops which are placed in the roadway, upstream from principal intersections. The destination code of the vehicle is examined by a wayside controller and a read only or table look up memory is used to determine if a straight ahead turn right or turn left command could be sent to the vehicle. The reply is sent through the same loop arrangement.

Larger loop arrays, sometimes stretching for miles, have been experimented with by several investigators. The best work seems to have been done at Ohio State by Fenton, et al. This work is primarily guidance and speed control oriented and, therefore, operates at low frequencies. The capability exists for wayside to vehicle messages at low rates.

Railroad tracks have served as inductive pickups for messages emanating from the trains. Train systems using periodically transposed loops between the tracks (e.g., the German Federal Railways) have used inductive loops for speed and positional control. The BART also uses inductive means for speed and other control messages and presence detection.

The inductive loop technology has been well explored and found to be an appropriate solution for simple low rate data communication between roadway and vehicle.

Low frequency radio at frequencies lower than the AM broadcast band (<540 kHz) is used by the Japanese National Railways in a car identifier system. These frequencies are also used in the Phillips (Netherlands) bus locator system. These systems are fixed message systems with the Phillips system broadcasting two out of five possible frequencies as a signpost identifier code for reception by buses that pass close by.

Standard AM broadcast frequencies are currently being used for limited local area messages. For example, the U.S. Forest Service in the Angeles National Forest advises motorists to tune to a certain frequency to receive snow condition broadcasts. These broadcasts are radiated from a long wire alongside the highway for a distance of about a mile. A similar message concerning parking and traffic at the Los Angeles airport has been operating for some time. These systems use very low power radiation resulting in a limited coverage area near the radiating wire.

Over 30 million citizen band (27 MHz) transceivers have been sold for personal communications. These frequencies have been employed for an electronic signpost automatic vehicle locating system. This signpost technique relies on both near and far field strengths of radiation to determine if the vehicle is close to (less than a block) or distant from (up to 2 or 3 blocks) the signpost. Near field is within about 2 wave-lengths (22 meters) of the signpost. This technique, installed by Hoffman Information and Identification, uses coded transmission modulation to transmit the signpost I.D. to passing vehicles (police cars) which are equipped to retransmit this I.D. code to a central location for vehicle position determination.

Very high frequency and ultra high frequency are currently in widespread use for vehicular communication by business, public safety, rail and other transportation interests. The preponderance of communications at these frequencies is voice. Some digital transmissions are being used in experimental and trial use to operate displays and keyboards for direct computer access by Kustom Inc, IBM, Xerox, ITT, Motorola, et al.

Leaky wave guide (250 MHz), leaky coaxial cables (450 MHz), and dielectric surface wave (500 MHz) have been studied for high speed ground transportation application. The RADIAX technique (leaky coax) by Wheeler Labs has found some application in vehicular communication, such as railroad yards.

There have been at least seven microwave systems in the 4 to 50 gigahertz region that have been investigated by Hughes, TRW, Sumitomo, Philco-Ford, and Applied Science Labs. All of these techniques relay on very close spacing between trackside radiator and the train mounted coupler. Additionally, the attenuation with distance is substantial; 3 db per inch is typical. Antennas which employ near field radiation are usually much smaller than a wavelength (3000 meters) and when buried are not particularly affected by environmental changes. On the other hand, high frequency systems which use directive antennas many wavelengths long are very much affected. One inch of salt slush may reduce the signal by 10 db. An air water interface such as in rain causes a 10 db signal reduction, and a fraction of an inch results in a diffraction and attenuation of the signal.

#### 4. Vehicle-Wayside Data

The data to be transferred over the vehicle-wayside link may include but is not limited to destination and routing, status, identity, occupancy, commands, and voice messages.

The destination or routing data needed from the vehicle may be transmitted once at the beginning of a journey and passed along to the appropriate wayside computers or transmitted on a continuous basis. The former method requires that the destination be accompanied by a vehicle identity code to establish the presence of the vehicle at each intersection. Continual broadcast as in the latter method requires only that the wayside computer route the vehicles as they arrive.

The identity code, regardless of its use, may be socially unacceptable for privacy reasons. Such a code would allow surveillance data to be developed on every vehicle using the automated network. A huge volume of location history data would accumulate and, undoubtedly, some data would be used improperly.

Status data from the vehicle might include velocity, position, and condition. The positional data may be relative to the intersection or absolute from an origin. Vehicle condition data is needed to establish that the vehicle has a very high probability of completing the planned trip. This condition would include the quantity of gasoline (or other fuel) and many other measurements, particularly those which contribute to sudden breakdown. An option exists as to whether an onboard vehicle processor will make the worthiness measurements, decide if they are within limits, and then send a single GO-NO GO signal to the wayside, or if the measurements will be assembled into a data package which is sent to the wayside where the decision is made. This area is the subject of another study currently in progress for the Department of Transportation.

Occupancy data can be used to establish priorities of service based on the number of passengers. Occupancy criteria might be applied to vans, taxis and busses as well as ordinary passenger vehicles.



Wayside-to-vehicle messages, which could be in either voice form of digital form, would activate a driver alarm. These messages could announce the presence of emergency vehicles, route changes, or local interest messages.

#### 5. Wayside Area-Central Data

The links communicating data from each computer level to the next and to others at the same level are dependent, naturally, on the data rates involved and the immediacy of the data to be transferred.

The wayside computers that are involved in the real-time control of the vehicles under their purview must have data from adjacent intersections indicating what vehicles are coming and how they should be routed, based on the destination. Additional data indicating traffic parameters and traffic-control status must be relayed to the area computer. The wayside computers are also the first recipients of routing requests from the vehicles as they enter the system, and must transfer this data to the area computer that determines area routing. The data rates for traffic parameters of count, speed, and occupancy for eight lanes entering a crossed intersection are only a few hundred bits per second. This value is an extrapolation from the bit rates required for freeway surveillance at maximum density. The data to and from other wayside computers on the same bus or link may total ten times this value, but it appears that dedicated conditioned land lines are sufficient to this task. The area computer would be on the same link in order to receive the traffic parameter and status data as well as sending routing-change data to the wayside computers.

The data from the area to the central computer is more statistical in nature. The data represents the averages of the traffic parameters and managerial-type data which allows the central computer to determine the quality of service being provided by the areas and the system as a whole. The data rates are much more difficult to predict, but it appears that much higher rates would be involved than can be accommodated by voice land lines. Dedicated coaxial lines, point-to-point microwave, or fiber-optic links may be required for this loop bus.

If images of the intersections are to be provided by closed-circuit television, then the decision must be made if one or two communication systems will be provided. The frequency bandpass or bit rate for television observations, even if the scan rate is much less than standard, is so much greater than the computer data rates that it becomes the overriding consideration. For this reason alone, television should probably be considered as a separate system.

## 6. Concerns and Conclusions

A problem area in intersection-to-vehicular communications is the transition from one intersection to the next, which may be either a communication dropout or spillover. If real-time control is to be maintained during the transitions, then a communication method must be used which can provide sharp transitions.

Each of the small-area radio techniques has been shown in vehicle-locating applications to require individual adjustment to control the radiation pattern to prevent overlaps. Voids in vehicle-location application are acceptable but probably not in a real-time control system. It appears that the inductive loops, at present, are the only means of controlling the radiation pattern or communication area closely.

Computer communications are developing rapidly because of the availability of computers and computing equipment. The data links required for the automated suburban network are within the present state of the art, and improvements in throughput and reliability are continuing for many reasons.





APPENDIX A  
GUIDANCE TECHNOLOGY

## APPENDIX A

### GUIDANCE TECHNOLOGY

#### A. INTRODUCTION

Automated highways, high-speed ground transit, guided transit, and personnel rapid transit all share the requirement for lateral and longitudinal guidance and control. Purely mechanical (e.g. tracks) or other lateral guidance techniques requiring no steering on the vehicle will not be addressed here. The longitudinal control refers to the means of maintaining speed and/or position on the right-of-way. Speed control and on-board headway sensors are part of the longitudinal control but will be discussed separately as will the automotive elements required for lateral control.

#### B. LATERAL GUIDANCE

The techniques for lateral guidance employ magnetic, electromagnetic, optical, acoustic, and very high frequency radio technologies. The most common technique is the "buried wire" used to guide very slow moving vehicles in warehouses, storage yards, hospitals, etc.

The buried wire has been the foundation of many experimental guidance studies employing passenger automobiles and buses; the former at speeds greater than 100 km/hr.

##### 1. Single Buried Wire

This technique employs a single wire, buried in a shallow groove, usually along the center line of a highway lane or the vehicle right-of-way. The term single wire means single loop as the wire used in a lane returns by another lane to form a loop. Similarly, in warehousing operations and the like, a complete circular route or loop is desired and the single wire loop describes the complete path.

The wire is excited with low frequency alternating current. The frequencies employed are generally less than 10 kHz where F.C.C. licensing is not required. Several loops covering different routes can share a common section of right-of-way by using different frequencies. The vehicles intended for the various routes then discriminate among the different frequencies to determine which wire should be followed.

The power required to energize the wire is usually modest with currents of about 1 ampere being typical. Large gauge wire is commonly used for mechanical strength and the inductance of the wire is the predominant impedance. The loop is usually tuned with capacitance at the generator to make a series resonant albeit low Q circuit.

The lines of equistrength magnetic field around the single wire are essentially concentric circles if the return wire is distant. When the wires are close together (e.g. less than a few meters), the lines of equal strength are no longer concentric but are circular with the centers displaced away from the wires as depicted in Figure A-1a. The effect of this lack of symmetry over the wire is to introduce a yaw component when the vehicle sensor to wire distance changes as in bounce and rebound.

Yaw motions are also introduced by distortions of the magnetic field. These distortions occur where the wire passes close to a ferrous mass such as a manhole cover, or bridge deck, or the reinforcing steel in concrete road surfaces.

Two types of sensors are used to provide the signals to follow the wire. These are amplitude comparators and phase sensitive detectors.

The amplitude comparator consists of two coils, one each side of the wire, as in Figure A-1b. As either coil moves toward the wire, the signal amplitude increases while the other coil output diminishes. The algebraic sum of the signals develops a right or left turning signal to cause the amplitudes to become equal by centering the sensor coils over the wire.

Amplitude sensors are usually positioned quite close to the wire and as a consequence the application is limited to slow moving vehicles. The sensor is also sensitive to amplitude variations which are caused by distortions of the field as mentioned before.

In an attempt to avoid some of the effects attributable to amplitude variations, a guidance sensor sensitive to only the phase (direction) of the magnetic field. This technique measures the relative phase of the vertical component of the field on each side of the wire with a linear array of vertically oriented coils (Figure A-2a). A horizontal coil provides a reference signal to a group of phase detectors, one for each vertical coil. The outputs of the phase detectors are either high or low depending on whether the inputs are in or out of phase. Each of the phase detector outputs is the input to the junction of a summing amplifier which is biased so that the output is zero when there are an equal number of high and low phase detector outputs. The summing amplifier output is a stepwise signal proportional (Figure A-2b) to the amount of offset either side of the wire which is positive one side and negative to the other side of the wire.

Experiments with the phase type sensor have indicated less than 1-1/2 cms lateral offset at speeds up to 120 km/hr.

It has also been determined experimentally that this type of sensor is relatively insensitive to the field concentrations caused by ferrous masses next to the wire.

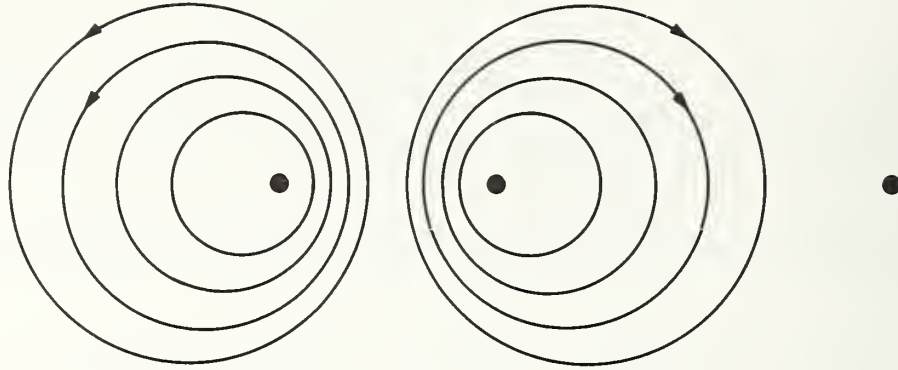

Figure A-1(a). Magnetic Field Lines

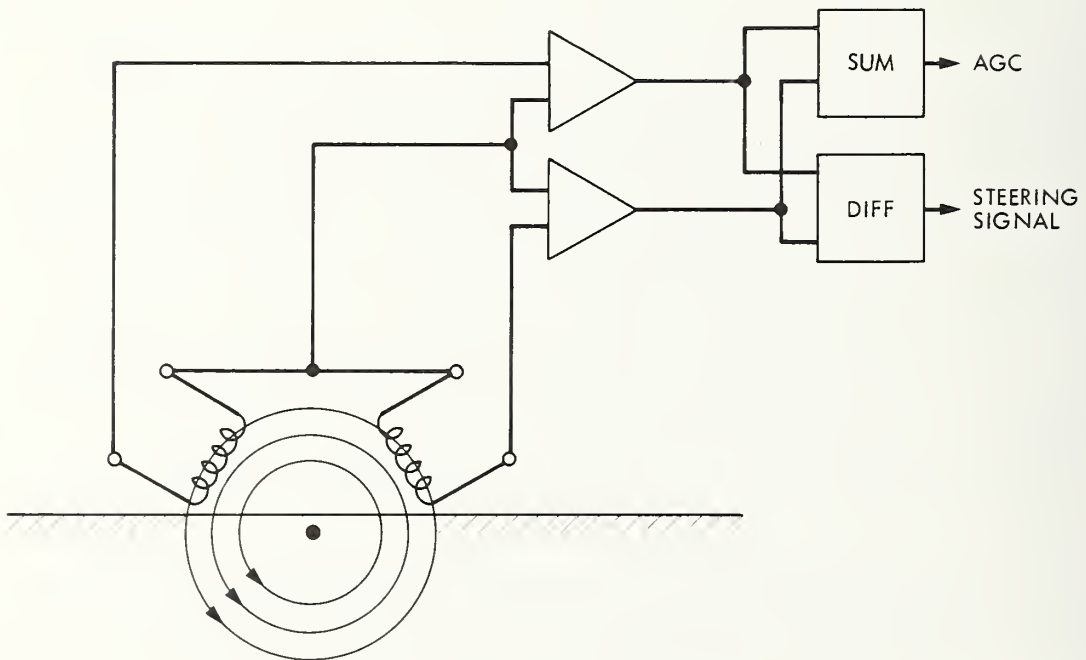

Figure A-1(b). Amplitude Sensor Coils



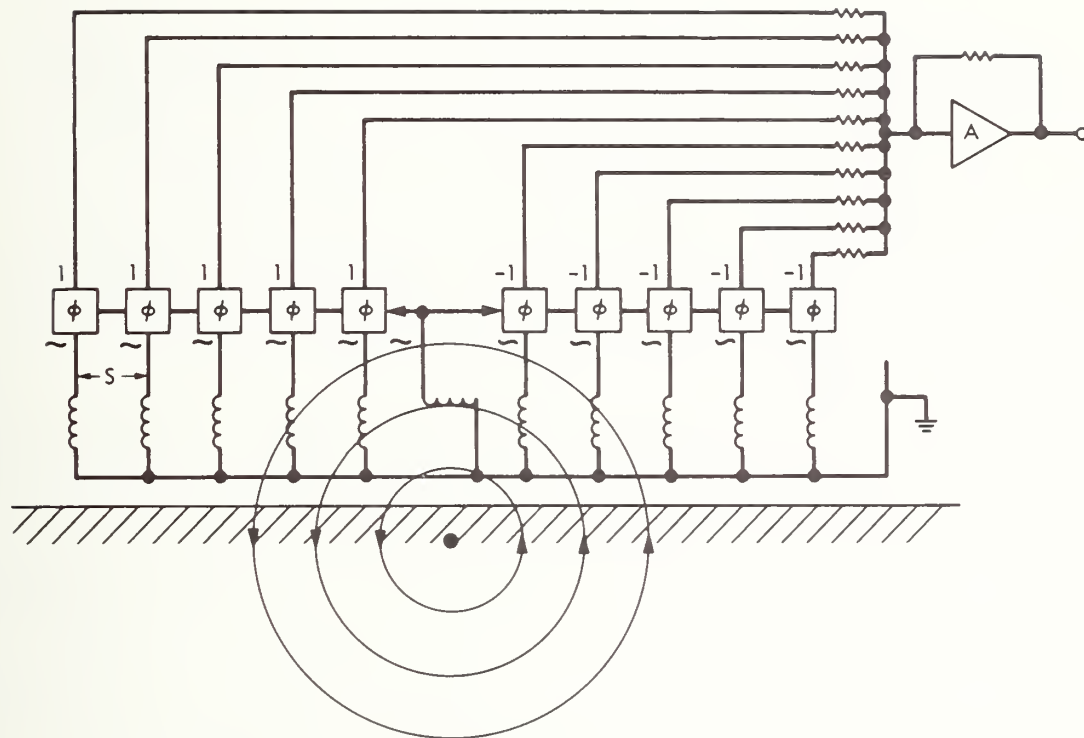

Figure A-2(a). Phase Sensitive Detector

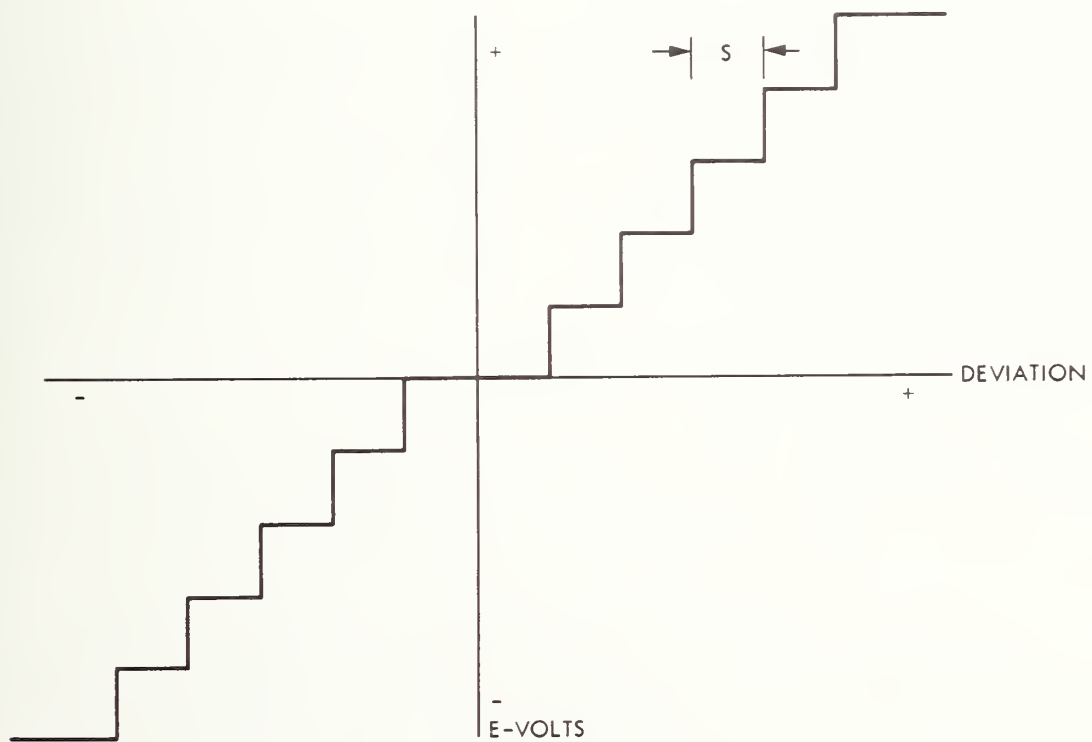

Figure A-2(b). Proportional Output

## 2. Parallel Wire Pairs

Two buried wires relatively close spaced in the center of the lane have also been used for lateral guidance. The magnetic field between the two wires, each carrying the same current in opposite directions, tends to be fairly uniform and is of the same polarity. These characteristics tend to complicate the vehicle sensor.

The two wires which form a close spaced loop have less self-inductance for a given length than the single wire which encloses a much larger area. Therefore, a longer length can be driven by a given generator. The lower inductance also allows higher frequencies to be used for signaling, speed control, or other communications.

The particular advantage of the two-wire system is that by transposing the wires at intervals (see Figure A-3b), both speed control and automatic positioning can be built into the design of the wire layout. Transposing the pair provides an alternating series of enclosed areas with opposite phases (instantaneous) of magnetism. A reference coil located to the rear of the lateral guidance sensor provides a reference from the area just being left which can be used to determine the phase of the area being entered. If the wires are transposed in the same groove, the amplitude of the magnetic field will drop to near zero as the sensor passes over the transposition and this effect can be used to count area crossings. Position can be determined by keeping track of the crossings and speed maintained by reckoning the time elapsed between successive crossings.

As stated, the lateral deviation sensor is somewhat more complex than the single wire sensor. While two amplitude comparing sensor coils can be used, two pairs of sensor coils will give better results by lessening the effect of ferrous masses near one of the wire pairs. Similarly, a phase sensitive sensor extending beyond the extent of the two wires as in Figure A-3a will yield a discriminator like curve as shown in Figure A-2b. The averaging effect of using the signals from two separate wires here also tends to lessen the effect of magnetic field anomalies.

## 3. Buried Wire Pair (Radio Frequency)

This technique is very similar to the low frequency pair but the spacing of the wire pair is much closer. Frequencies on the order of 5 MHz have been proposed using 300 ohm twin lead such as that for television antenna lead for the wire pair. Significant radiation at the frequency is avoided with the less than a centimeter spacing.

The wire pair is treated as a single wire for lateral guidance. The sensors rely on amplitude comparison to detect deviation, but phase information derived from transposition is used for longitudinal reference. Sensors are ferrite loop antennas for both amplitude and phase data.

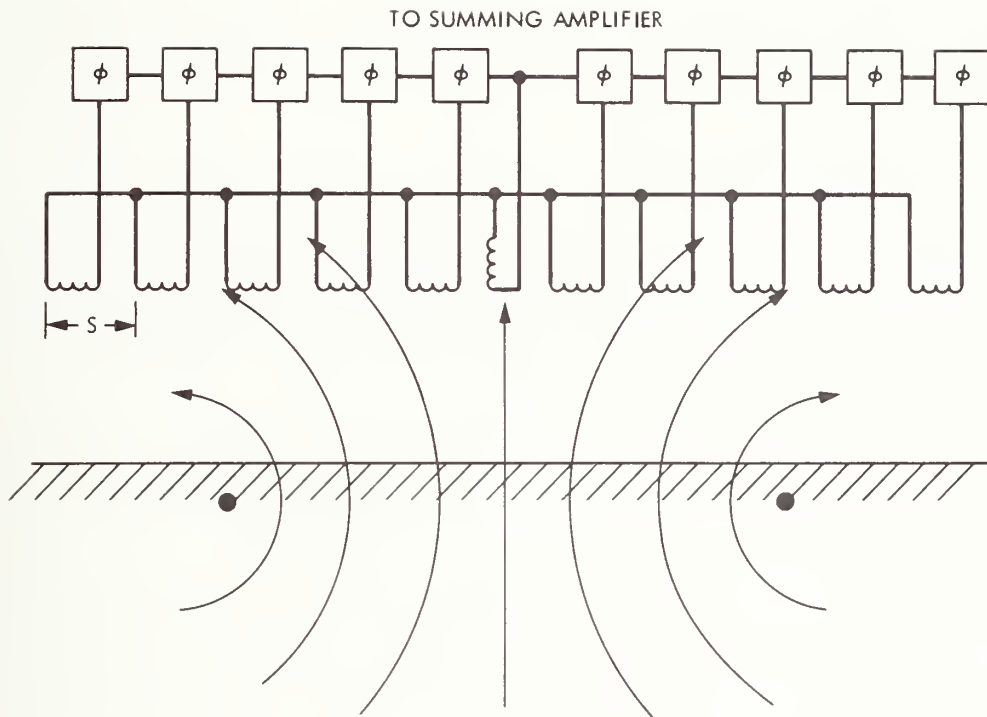

Figure A-3(a). Horizontal Component Detector for 2-Wire Pair

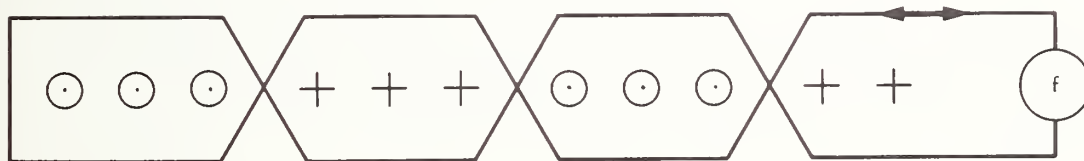

Figure A-3(b). Transposed Pair

The higher frequency allows the guidance signal to be used as a carrier for substantial command and control data to be sent to the vehicle. Compared to the less than 10 kHz used in the other pair cited, a data rate 500 times higher can be used.

#### 4. Vehicle Excited Wires

A passive guidance technique that does not require wayside generators uses buried resonant loops. The loops are arrayed as single turn, narrow rectangles Figure A-4, spaced as with the wire pairs, placed end to end with adjacent loops. Tuning of the loops is accomplished with a series capacitor.

An oscillator on the vehicle driving a coil beneath the vehicle provides the excitation to the buried loops. The lateral guidance sensors are the same as those used in twin wire systems. Similarly, the wires may be transposed for longitudinal reference.

This technique has some shortcomings. There is no communication link as in the foregoing methods. The exciting coil must be some distance from the sensor coils to allow them to function properly without being overloaded by direct signal. This distance, if the loops are not overlapped, requires that the vehicle travel without guidance until both coil and sensors are over the same loop.

#### 5. Shaped Antennas

Buried antennas at very high, ultra high, or radar frequencies have been tried for vehicular communication and may provide guidance capabilities. The frequencies employed allow the antenna to vehicle spacing to be greater than a wavelength. The antennas are usually many wavelengths long.

The utility of these antennas is highly dependent on weather factors. Salt slush is a highly dissipative medium and causes severe attenuation. Similarly, a fraction of an inch of ice overlay will cause a diffraction of the radiated pattern which would affect the guidance function. The air water interface also causes high attenuation.

#### 6. Magnetic "Nails"

A series of permanent magnets, driven into the roadway Figure A-5, along the center of the lane form the guides for this lateral control technique. Two sensors, one each side of the row of magnets, are used to compare the amplitudes as the vehicle travels down the road. The relative amplitude comparison together with angular position data from the steering gear form three inputs to an on-board computer. As each "nail" is sensed, the deviation from equal amplitudes is used to calculate an average directional signal to the steering.

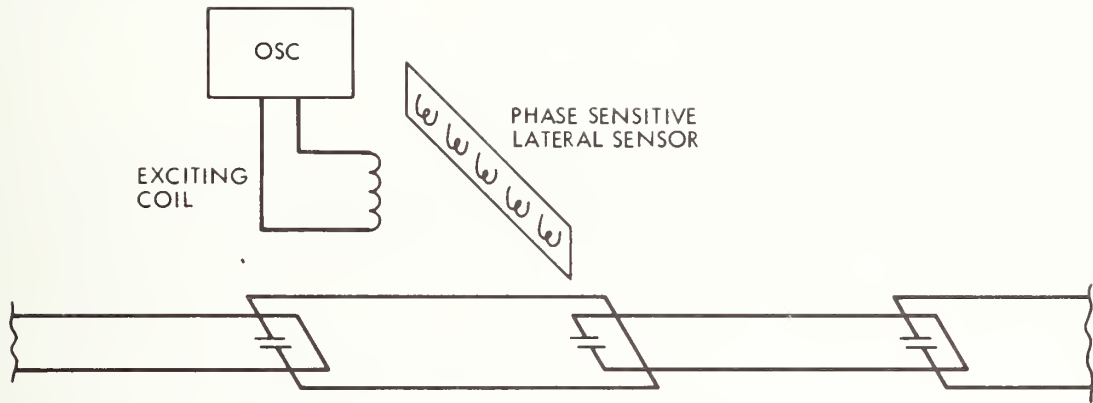

Figure A-4. Vehicle Excited Loops

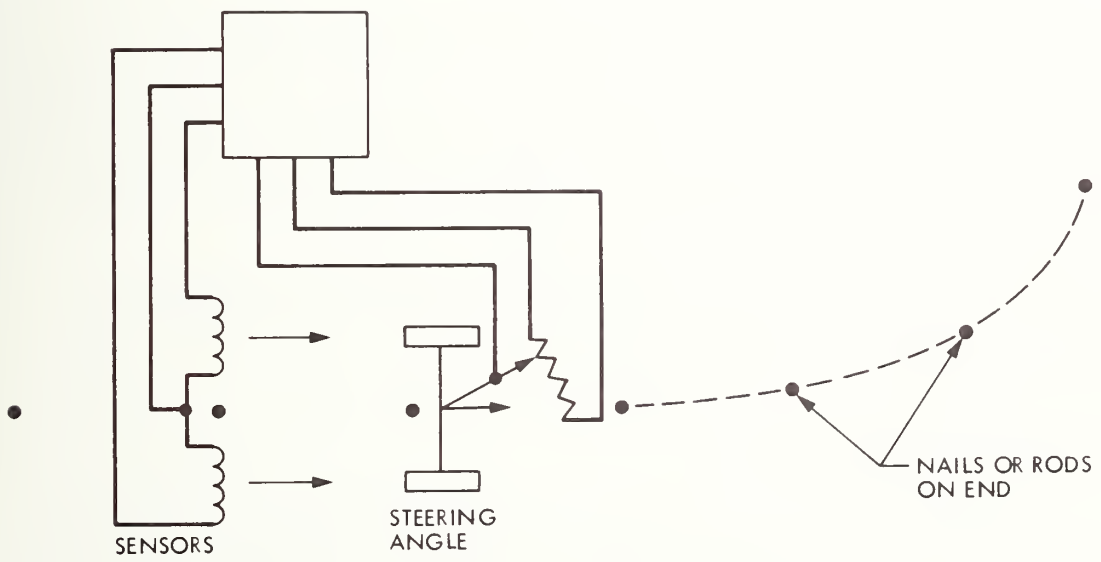

Figure A-5. Magnetic Nails or Rods



Two types of sensors may be used in this application: simple multiturn coils or magnetometers. The coils have the disadvantage that the peak signal amplitude is proportional to vehicle speed. The electronics required is relatively simpler than the magnetometer approach. The magnetometer, usually a second harmonic fluxgate, should maintain an output only dependent on the distance to the magnet and independent of speed but with more complex electronics.

#### 7. Magnetic Rods

This is merely another implementation of the previous approach with the rod shaped permanent magnets lying buried in a groove along the roadway center line. The same type of sensors may be employed. The magnets may be laid head to tail (N pole to S pole) or in a periodically reversed pattern creating a code for longitudinal control. Similarly, reversals in the "nail" polarity can be used to form binary codes for longitudinal control. The rods may also be arrayed orthogonally to the direction of travel and polarity coded, but this would be a very inefficient installation because of the large number of transverse grooves required.

The magnets could also be in thin flat forms that are glued to the pavement surface.

#### 8. Optical Reflectors

Plastic reflectors Figure A-6, similar to those now used as lane separators can form the reference line for lateral guidance. An illumination from beneath the vehicle would be directed at the reflectors. The reflected ray would be received by proportional or discrete sensors on the vehicle so that the lateral deviation could be detected or measured. The deviation together with the steering position would determine the direction and degree of correction to follow the reflector path.

This system would probably be very susceptible to weather conditions. Any residue of ice, snow, or water, or possibly dust might seriously degrade this approach.

#### 9. Mechanical Grooves

A groove or slot in the roadway Figure A-7 could provide a lateral reference. The vehicle sensor would be a flexible "feeler" to detect lateral force as the vehicle deviates from the correct path.

The technique is fraught with drawbacks. The groove would have to be kept clear of residue of all types; perhaps by the vehicle feeler or an air blast from the vehicle. Wear would be another problem as the velocities involved probably mitigate against the use of small rollers on the feelers.

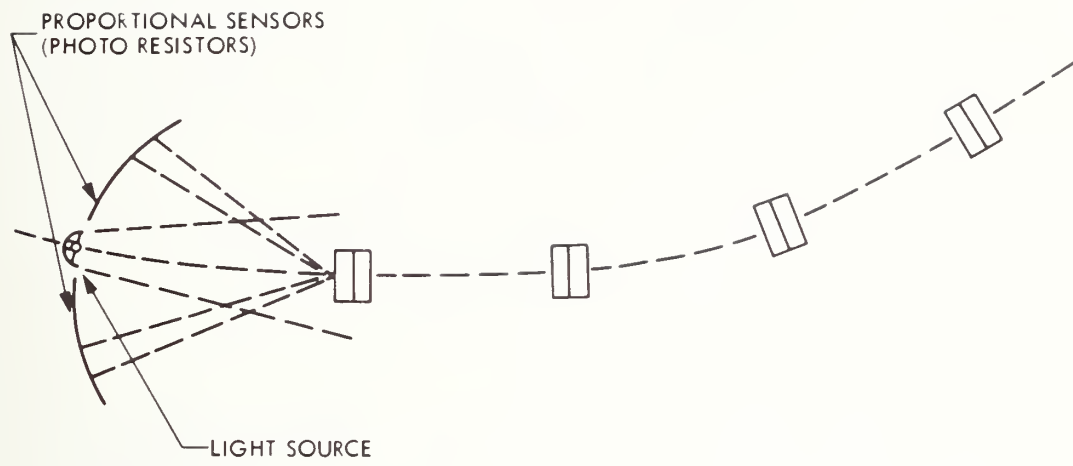

Figure A-6. Optical Reflectors

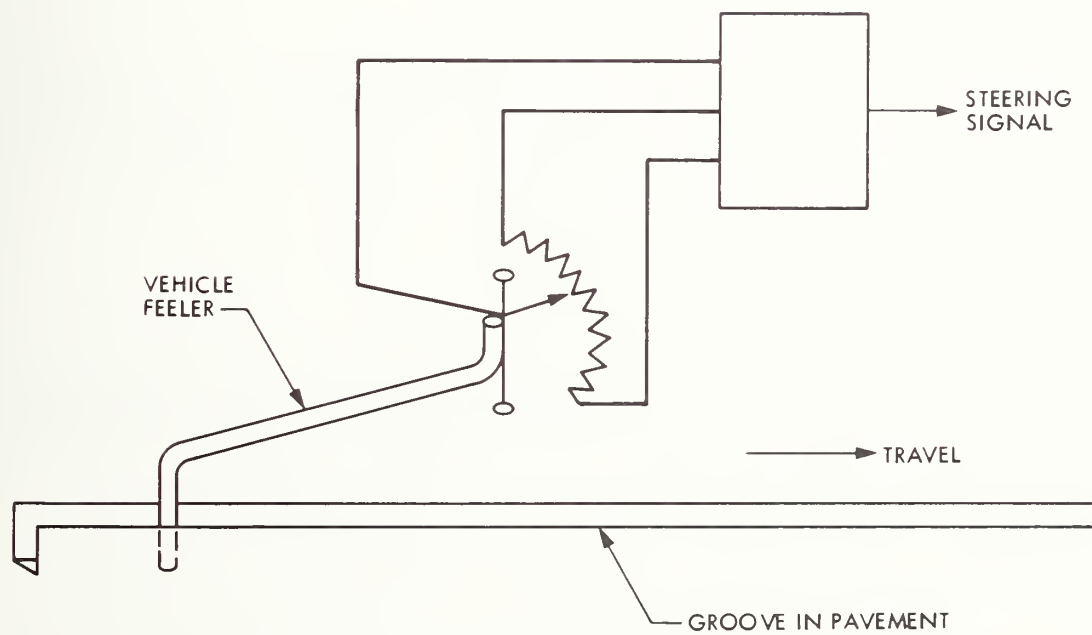

Figure A-7. Mechanical Groove

## 10. Mechanical Fin

This dual of the previous approach Figure A-8 is more practical than the groove. An elevated rubberoid or plastic, somewhat flexible, vertical fin can also supply the lateral reference. Feelers on the underside of the vehicle would be used to determine the relative position of the fin. The fin follower need only contact the fin at low speeds as an air cushion could be formed at higher speeds alleviating some wear problems. The fin is made flexible so that a vehicle may cross over it without rendering it useless.

Installation of the fin should not prove difficult. Weather effects may be adverse, particularly standing water and snow.

## 11. Acoustic Discontinuity

A method recently proposed would employ a plastic pipe or tube buried in the center of the lane Figure A-9. This cylinder would be fluid filled to provide a medium with a greatly different sound transmission speed compared to either air or pavement. The discontinuity in sound speed and consequently reflectance of sonic energy would provide the lateral reference data. The means to accomplish this, that is, the sensor design has not been established. How well this technique would work with residual rain, snow, or ice has also not been determined.

## C. LONGITUDINAL GUIDANCE

The control of the vehicle's motion along the roadway may be controlled by commands in concert with measurements made to the roadway or leading vehicles. This section concerns the methods of making the roadway measurements. Both distributed means and discrete fiducial references are discussed.

### 1. Two Frequency Method

This technique requires two nearly parallel wires Figure A-10a-- one excited at a frequency  $f$  and the other excited at the opposite end by a frequency  $f + \Delta f$ . A point where the relative phase of the two signals is constant tends to move toward the source of the lower frequency Figure A-10b. The velocity of such a point is  $C\Delta f/2f$  where  $C$  is the velocity of propagation along the wires. The spacing between points of the same phase difference is regular and inversely related to the phase velocity.

The constant velocity longitudinal reference established by the two frequencies is measured aboard the vehicle by an electronic phasemeter. The signal from the phasemeter is used in the speed control loop.

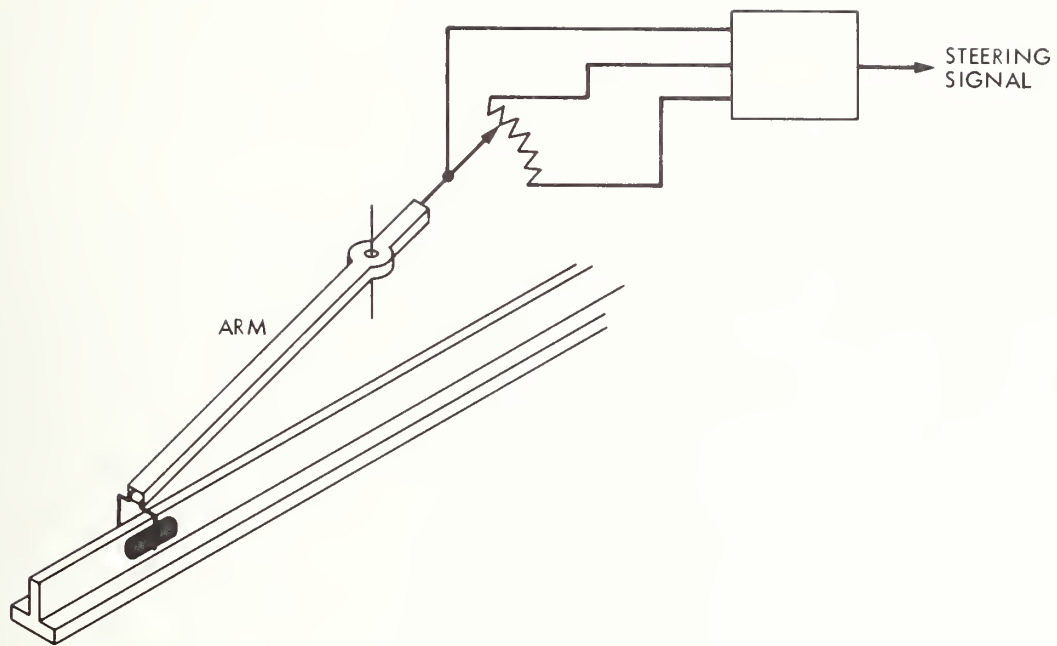

Figure A-8. Mechanical Fin

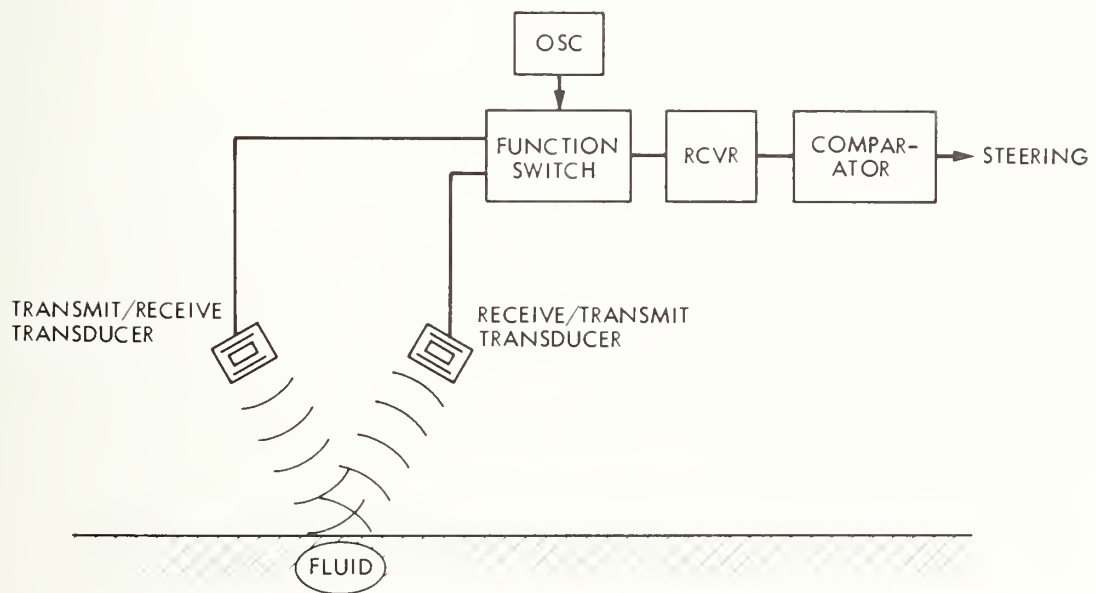

Figure A-9. Acoustic Discontinuity

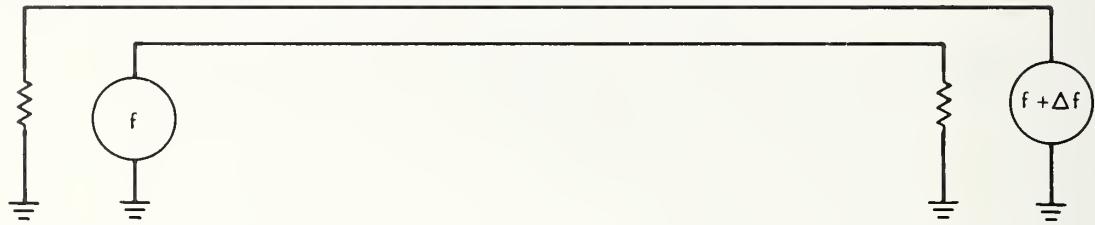

Figure A-10(a). Two-Frequency Wire Pair

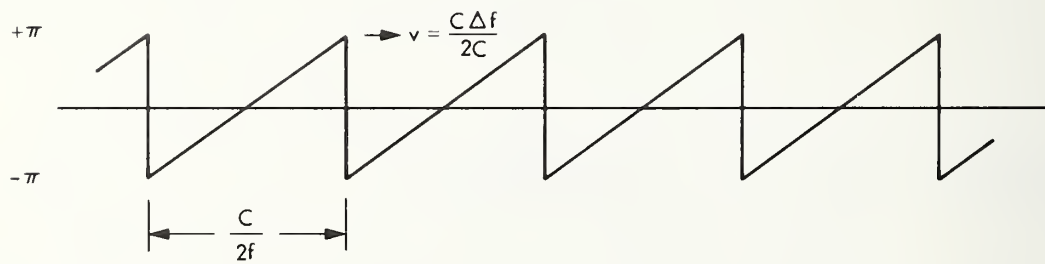

Figure A-10(b). Phase Pattern



The frequencies required seem to be fairly high as the fraction  $\Delta f/2f$  multiplies the speed of light to achieve the value for the vehicle velocity. A speed of 30 mph (48.3 km/hr) requires the fraction to be about  $1/(22 \times 10^6)$  or a  $\Delta f$  of 1 hertz between two frequencies of 11 MHz. State of the art technology can reliably reduce each of the frequencies by a thousand or more bringing the carriers into the frequency domain used for lateral guidance.

## 2. Helically Wound Wire Pair

An improvement over the prior method utilizes cables wound from two wire pairs. These cables are wound with a constant pitch of one foot or so Figure A-11a. When two of these cables are arrayed in parallel Figure A-11b along the roadway and excited properly, a stationary phase pattern is produced. The excitation to the pairs in each cable differs by 90 electrical degrees and is typically near 10 kHz which is suitable for lateral guidance. The one foot pitch in each cable results in a phase pattern that repeats every six inches. The electrical pitch that can be realized is the reciprocal of the sum of the reciprocals of each of the cable pitches. It can, therefore, be no greater than the tighter wound cable.

A vehicle traveling along the cables and equipped with a phase-meter to compare the signals from the two cables can count phase repetitions to determine position. The horizontal component of the signals from each cable is sensed with a multiturn coil as in lateral guidance methods. It was determined experimentally that with both cables having the same "hand" pitch direction resulted in some coupling between lateral and longitudinal motions of the sensors. By reversing the pitch direction of one of the cables, there appeared to be a first order cancellation of the coupling effect.

If, as in the previous method, the two cables are energized with slightly differing frequencies, the phase pattern can be made to move with a desired velocity and direction. The velocity is twice the frequency difference divided by the electrical pitch. A one hertz difference results in a two foot per second velocity.

The ratio of frequency difference to carrier frequency is not a function of the propagation velocity in this method. While the prior technique is realizable, this technique has three advantages. First, both generators can be located at the same end of the wire; second, the velocity is a function of controllable cable parameters; and third, the spacing between similar phase locations is not a function of frequency.

## 3. Transposed Wires

The utility of a wire pair periodically transposed as a position determining means was discussed in the lateral guidance section. The transpositions become fiducial marks and are obviously fixed at installation.

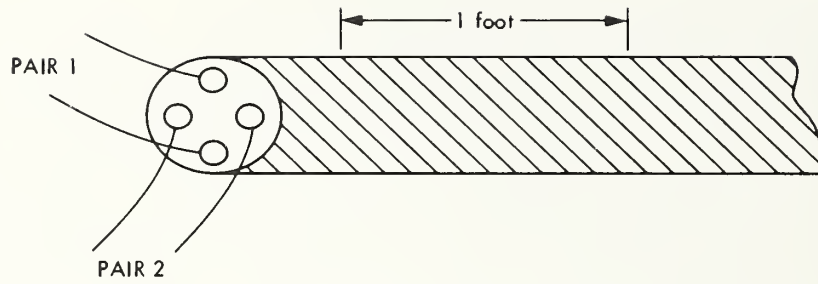

Figure A-11(a). Helical Wire

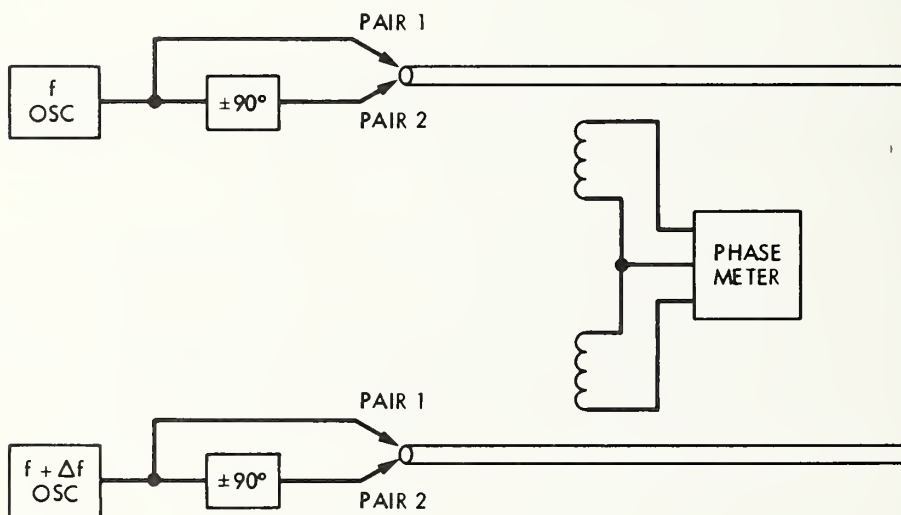

Figure A-11(b). Two-Wire Pair

#### 4. Single Wire with Shaped Return

This technique is more commonly used on rail transit where the wires can be disposed between the rails and not buried. A long wire loop is laid between the tracks--primarily for communication to the vehicle by inductive means. The return wire of the loop is laid in a serpentine, triangular, or square serrated pattern. This allows an additional sensing coil beneath the vehicle to be alternately in and out of the loop boundaries as the vehicle progresses. These transitions can then be counted for positioning and velocity control.

The technique might be adapted for nontracked vehicle use, but the burying of the shaped return wire would be difficult. The number of separate pavement cuts required would make this technique difficult to justify when compared with transposed wires.

#### 5. Fiducial Indexes

Discrete markers or reference points can be established for positioning and velocity measurement or control. The markers are either active or passive.

#### 6. Passive Markers

a. Metallic Plates. Small plates may be buried beneath or affixed to the pavement at intervals. The presence of these plates is detected by metal detection or magnetic sensors on the vehicle and the number of detections accumulated.

b. Rod Magnets. Vertical or horizontal magnets placed in the pavement can and are being used for fiducial data. In one application the magnets are arranged in coded sequences by having either the N or S pole topmost in a series of magnets. These then form a code for a particular location or distance from a previous location. The detector for this type of system is either a coil or magnetometer to detect the field and the polarity.

c. Dipoles. Burying short wire rods cut to predetermined lengths allows the detection of the reference by radar means. If the wires are cut to one-half wavelength at the frequency employed, substantial energy is reradiated when they are illuminated by the radar.

The sensor required on the vehicle entails a CW or pulsed very low power radar and receiver to detect the reradiated energy. The detections are counted or used for speed control.

A variation of the dipole method uses wires with a semiconductor diode in the center of two wires. These form parametric

reflectors which radiate energy at twice the frequency of the illuminating energy. This tends to simplify the receiver design as the effect of direct radiation has been eliminated.

## 7. Active Markers

a. Magnetometers. Magnetometers buried in the roadway are used for detecting automobiles, guideway transit vehicles, and trains. The magnetometer is essentially a presence detector which notes the passage of a vehicle and the duration of time that the vehicle is over it.

The magnetometer data is usually used in wayside traffic counting and measuring applications. It could also be used as the measuring device for issuing speed controlling commands.

b. Loop Detectors. The loop detector is a large, buried, few turn coil which detects the presence of vehicles by the change in inductance. The application and use has been primarily and could be the same as the magnetometer detector in speed controlling.

The loop does have the additional capability of being part of a communication system. This has been exploited in train and non-transit systems. Both the communication and detection processes can be used simultaneously.

c. Buried Radar Antennas. The antennas used for broadband communication with vehicles from beneath the roadway might also be used as presence detectors by reflected energy detection. The effects of weather residuals would need to be studied for this use.

## 8. Automotive Elements

a. Lateral Sensors. The lateral sensors for almost all of the techniques provide an output which is proportional to the amount of lateral deviation from the desired path. The proportional output may not be linear but in most instances is monotonic over the expected lateral motion that should occur. The lateral motion limit is usually reached when one of the sensors in the pair is above the desired lateral path or the output has reached a maximum value. Behavior of the sensor output beyond this limit is usually ignored and guidance there is determined by the technique used for path acquisition.

The magnetic field amplitude sensors, magnetic coils or magnetometers, as well as the radio frequency amplitude sensors, are positioned beneath the vehicle in close proximity to the roadway. The spacing between the sensors usually determines the extent of lateral motion possible. Similarly, the length of the phase sensitive magnetic array determines the amount of lateral motion possible.



b. Signal Conditioning. The AC signals from the sensors usually have to be amplified before processing. Vertical vehicular motions or other effects which cause common changes will effect the magnitude of most comparison voltages. Long term or short time changes in amplifier gain will cause spurious comparison voltages to be developed.

For these reasons, automatic gain control (AGC) and gain stability are both required. The time constant of the automatic gain must be such that the lateral motions to be detected are not disguised. One method derives the AGC from the sum of the two signals and applies the control equally to both amplifiers. Long term and short term gain stability can be assured by utilizing operational amplifier techniques where the gain is determined by stable passive components and not the active gain stages.

The sensors intended to derive phase data avoid most of the foregoing problems. The only requirements are that the gain bandwidth product of the amplifiers be adequate under minimum amplitude input and that phase distortion be avoided.

c. Processing. The comparison of the amplitude signals is accomplished by rectification (usually of opposite polarities) of the two signals. The resulting DC voltages are then summed in an operational amplifier to develop the lateral error voltage for steering. Analog to digital conversion of the rectified voltages for subsequent digital processing is also possible. Similarly, voltage-to-frequency conversion and subsequent frequency comparison may also be used.

The phase comparison is accomplished primarily with digital logic devices which can function as phasemeters, such as the exclusive-OR or the edge triggered flip-flop. The output of either of these devices is then filtered to develop the DC steering voltage.

The phase detector technique which uses a multiplicity of coils and phase detectors develops a steering signal proportional to offset but in a series of steps. To avoid the effect of the step discontinuities, the signal is integrated before being used for steering control.

d. Steering. The three most common steering mechanisms for passenger cars are the recirculating ball nut, worm and sector, and rack and pinion. Servos employed to drive these steering gears are electric and electric controlled hydraulic. Positional feedback, usually potentiometer controlled DC voltage, is common. Most attempts to automate the steering at the front wheels have had to provide a means of declutching the steering wheel. The steering wheel inertia is substantial and is greatly magnified in effect by the steering gear ratio. Owing to the large forces and relatively short motions involved, hydraulic linear actuators are used as in manually controlled power steering. The actuator drives the linkage connecting the front wheels.



Electric servomotors with worm and pinion gearing are used where the steering shaft and wheel are driven directly. This implementation requires that the electric motor be declutched or the worm be disengaged from the pinion gear to avoid inertia effects when the steering wheel is manually operated.

The servos to operate either of the power mechanisms are usually second order devices to achieve zero position error. Rate input is required and is normally a derived signal obtained by differentiation of the control signal from the sensor signal conditioner.

#### D. SPEED CONTROL

Continuous speed control is often determined by a modulation signal superimposed on the lateral guidance carrier or by tone or digital commands. Some continuous measurement of the vehicular velocity is required in addition to the positional data provided by the longitudinal guidance references, particularly with the widely spaced positional reference methods. The phase meter or point follower system has continuous speed control as a technique function and does not require other measurements. Figure A-12 is an overall block diagram of speed and position control functions.

##### 1. Sensors

A speedometer cable driven DC generator or drive line driven toothed wheel and proximity coil are the two most common velocity measuring devices providing electrical signals. The first yields a voltage and the second a frequency proportional to speed. These devices provide a speed measurement which has errors due to tire wear, inflation pressure changes, and wheel slip. The positional data available from the longitudinal sensors can be used to provide correctional data.

Continuous speed sensors which can measure true ground speed are available in three implementations. There are acoustic, radar, and laser mechanizations which provide a noncontact measure of the velocity of the roadway beneath the vehicle. The acoustic and radar methods rely on the doppler shift of the reflected energy which increases with increasing speed. The radar and acoustic devices are usually operated in a continuous wave mode and the illuminating energy directed forward toward the road at a downward angle. The reflected energy is compared with the radiated, and the beat frequency difference which is the measure of speed is extracted. The laser device is directed directly downward toward the road surface. The reflected "spot" contains a speckle pattern which moves with a velocity twice that of the reflecting surface. The forward component of the speckle pattern is extracted with a transverse diffraction grating and optically sensitive

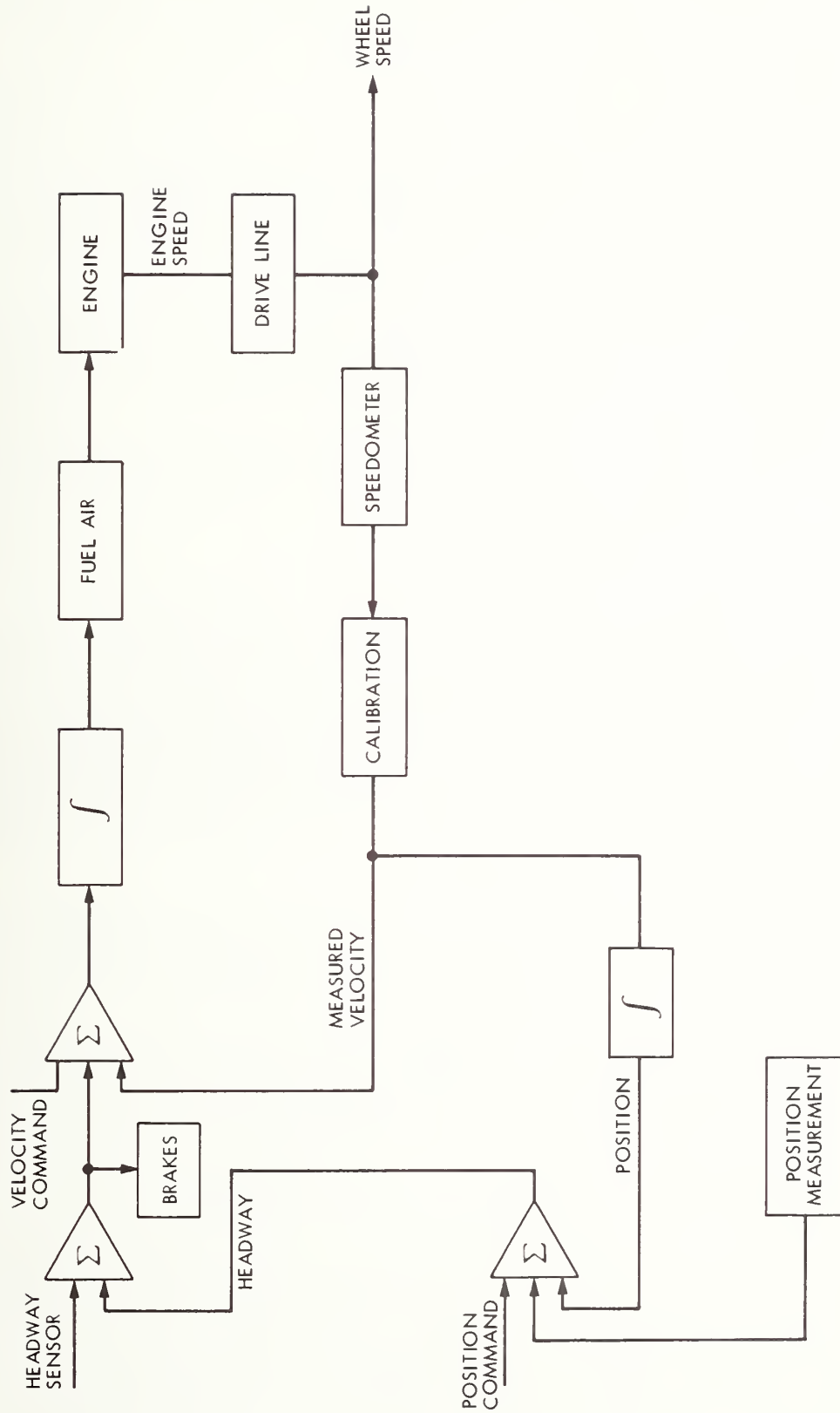

Figure A-12. Speed Control Block Diagram

detector. A phase locked loop or synchronous amplifier is then used to extract a frequency which is determined solely by the motion of the road and the physical configuration of the grating.

## 2. Signal Conditioning

The DC generator speed sensor provides a voltage which can be used without further modification. Some implementations might use a voltage-to-frequency conversion or analog to digital conversion for computer input.

The toothed wheel provides a frequency which must be amplified to be used. A tracking phase locked loop is normally used to eliminate amplitude variations and the ability to apply corrections to the frequency based on the positional signals.

The radar, acoustic, and laser instrument provide a frequency proportional to speed which needs no further conditioning.

## 3. Processing

Speed control by positional data points and commands, either stored on-board or sent to the vehicle, requires some method to measure the elapsed time between reference points. The speed command might be the time required to cover the distance between reference points. In this case a comparison of the commanded time value and measured elapsed time mode at each reference indicates whether the vehicle should speed up or slow down. The vehicle operates in an open-loop mode between corrections. A speedometer allows closed loop operation to be maintained by continuous adjustment of the speed in accord with the commanded value and previous correction.

Tone type speed control signals allow direct and continuous comparison of vehicle speedometers which yield a frequency output. The true ground speed devices need no calibration correction signals as do those operating through the vehicle wheels.

The speed commands may be times or tones but may also be the actual speed or a code representing the speed or an acceleration profile. The variations are many and the implementations with discrete logic elements can have very different topologies. The obvious differences tend to disappear when microprocessor implementation is used. The differences then show up in the software or program.

The processing for point follower speed control is merely a continuous closed loop system. Additional processing may be required if corrective actions are to be taken in the event the vehicle slips from one point to the next or advances due to overspeed. The action to be taken depends upon the entire system design including such factors as nominal speed, headway, braking ability, and headway sensing.

#### 4. Headway Sensors

Devices to determine if a safe distance exists ahead of a vehicle are somewhat akin to the traveling block system used by guided transit. If a certain distance ahead is clear, then maximum speed may be maintained. If an object is detected but still at some distance, then a moderate speed is to be observed. When the distance falls to some minimum, the following vehicle is obliged to stop.

Some transit systems have proposed headway sensors as the speed controlling device. In automotive service the prime emphasis has been to develop headway sensors for collision avoidance.

Headway sensors have been primarily radar based using continuous wave, ultra short pulse, and frequency swept (as a radar altimeter). Some have required cooperating reflectors on the rear of the preceding vehicle while others use parametric passive antennas as frequency doublers on the car ahead. Roadside clutter and opposing traffic have posed serious obstacles to the development of viable devices. Acoustic and laser techniques have and are being investigated, but they also have similar problems.

The headway sensor output is used as an overriding command to the speed control circuitry. The headway sensor is considered a vital function to vehicular safety.

A telemetry approach to headway sensing has been proposed whereby each vehicle transmits its position and speed to the vehicle nearby. This technique also transmits acceleration data. Each vehicle has a signal processor and becomes a part of a distributed computer guidance system.

#### 5. Actuators

Brake and throttle actuators which can perform under automatic control and not interfere with manual operation are needed for automotive application. These criteria are usually met with pneumatic devices with engine manifold and the atmosphere providing the force. Hydraulic actuators are also used but they are more difficult to decouple for manual operating conditions.

Position feedback is sometimes required from the actuators to the speed control servo. Potentiometers are commonly used in developmental systems, but these may be replaced with capacitance position to frequency sensors currently being developed.

#### E. GUIDANCE BASED TESTING

The lateral and longitudinal guidance elements interface in three functional areas on the automobile--steering, braking, and air-fuel



metering. The headway sensor system independently interfaces with the braking system and may also have fuel and ignition cut-off capabilities.

The automation required to perform lateral guidance can provide the means to measure the total free-play in the steering. This free-play is made up of looseness in steering arm and relay rod ends and the backlash in the steering gear box or rack and pinion assembly. The arm and rod ends are involved regardless of the type of steering mechanization or the automatic guidance servo. Position sensors to provide measures of the angular motion of each wheel together with the motion of the servo will determine the deadband in the arm and rod ends. These sensors may also be used to measure toe-in and steering geometry (not camber or caster). If the servo is above the steering gear, then the backlash is also included in the deadband, and a third position sensor will be necessary to apportion the looseness to the contributing elements.

There are and have been several original equipment and after market devices installed to help maintain constant vehicle speed. These devices use the revolutions of the speedometer cable as the speed reference and the servo typically uses manifold depression to provide a means of independently controlling throttle valve position. The servo is usually analog now, but speed control is a prime candidate for microprocessor control.

Current speed controls can provide a starting point for longitudinal control interfacing and also a means of determining some dynamic engine vehicle performance tests. The tests would probably be associated with step-wise speed increases of various amounts to determine if the accelerations indicate sufficient engine reserve for automatic operation. Detailed diagnosis for lack of engine reserve must rely on additional tests.

The longitudinal guidance system as well as the headway sensor must also interface with the braking system. In a like manner to accelerations, overall braking system performance checks could be made by commanded step-wise speed reductions. Again, more detailed measurements which are independent of the actuation means (i.e., automatic or manual) would be needed to determine pad or lining wear, brake line pressures, leak rate, fluid level, or any other factor which would be critical to braking performance.



## BIBLIOGRAPHY

21st Annual Conference, Vehicular Technology Group, IEEE,  
December 2-4, 1970, Washington, DC:

1. "Predicted Performance of a 450-MHz Digital Data Link for Cars,"  
C. T. McCoy, Philco Corp.
2. "DOT/OHSGT-Sponsored Communication Studies for High Speed Ground  
Vehicles," P. J. Larsen, DOT; O. G. Farah, Mitre Corp.
3. "A Variable Parameter Communication Line," David J. Bryant,  
A. G. Smith, D. L. Rebsch, R. L. Armstrong, TRW Systems Group.
4. "Buried Roadway Antennas for Vehicular Traffic Communications--  
General Considerations," F. P. Ziolkowski, C. K. H. Tsao,  
Raytheon Co.
5. "A Candidate Antenna (Coupling System) for Vehicular Communica-  
tion," H. J. Rowland, J. H. Pozgay, Raytheon Co.
6. "Communications and the Highway," William Borman, Motorola Inc.
7. "A Highspeed Inter-City Automated Highway System," Richard K. Boyd,  
TRW Systems Group.
8. "Evaluation of Separation Sensors for Guideway Vehicles,"  
Robert W. Schaaf, The Bendix Corp.

1971 IEEE Vehicular Technology Conference, December 7-8, 1971,  
Detroit, Mich.:

9. "Normal and Emergency Control of a String of Vehicles by Fixed-  
Reference Sampled-Data Control," Daniel E. Whitney,  
Masayoshi Tomizuka, MIT.
10. "Activity Center Transportation Automatic Control Subsystem,"  
Adrian Elich, Boyd Hartle, Monroe Postman, Philco-Ford; and  
Sam Rudofsky, Ford Motor Co.
11. "Principles of Automatic Guidance of Vehicles on a Lane by Means  
of Permanent Magnetic Nails and (On) Board Computer Control,"  
Rudolf Mahrt, A. E. G. Telefunken.
12. "The Vehicular Communications Research Project," Ransier F. Wright,  
Sylvania Sociosystems Products Org.; Richard C. LaVigne,  
Lyle Saxton, FHWA, Traffic Systems Division.

1972 IEEE Vehicular Technology Conference, December 6-8, 1972,  
Dallas, Texas:

13. "Longitudinal Reference Signal Generation and Its Use in Automatic Vehicle Control," R. J. Mayhan, T. R. Brinner, J. G. Bender, Ohio State University.
14. "On the Longitudinal Control of Ramp Vehicles," Teymour Eliassi, Robert E. Fenton, Ohio State University.

1973 IEEE Vehicular Technology Conference, December 3-5, 1973,  
Cleveland, Ohio:

15. "Transients in the Automotive Electrical System," Jack R. Morgan, Motorola Semiconductor Products Inc.

1976 IEEE Vehicular Technology Conference, March 24-26, 1976,  
Washington, D.C.:

16. "A Continuous Longitudinal Control Signal via the Low-Frequency Excitation of Helical Transmission Lines," Robert J. Mayhan, Ohio State University.
17. "Project METRAN, an Integrated Evolutionary Transportation System for Urban Areas," MIT Report No. 8.

8th Autumn Meeting, National Academy of Engineering, October 12,  
13, 1972, Washington, D.C.:

18. "The Relationship of Telecommunications to Urban Transportation," Arthur Goldsmith.

1976 Intersociety Conference on Transportation, July 18-23, 1976,  
Los Angeles, CA:

19. "Measurement of Vehicular Operations," Harry E. Burke.

International Conference on Automobile Electronics, July 6-8, 1976,  
London, U.K.:

20. "Automatic Speed Control System for Automobiles," R. L. Moody.
21. "A Drive-by-Wire Vehicle Control System for Severely Disabled Drivers," T.R.R.L.
22. "Automatic Headway Control System Based on the Use of a Microwave Link," R. Allard, R. L. Ford, J. T. Pinson, J. D. Roberts, Royal Radar Establishment; J. S. Dobson, T.R.R.L.

APPENDIX B  
A GUIDANCE SYSTEM EXAMPLE

## APPENDIX B

### A GUIDANCE SYSTEM EXAMPLE

The guidance system described in this section is one of a large number of possible semi-autonomous or fully computer controlled configurations. The concept is detailed below only to an extent sufficient to identify the general classes of equipment requirements and to define the principle interfaces.

The functions required of the guidance system are:

- (1) Lateral control during straight-ahead travel.
- (2) Longitudinal control of each car within its platoon.
- (3) Platoon discipline and headway control.
- (4) Lane change strategy and control.
- (5) Turn and parking entrance maneuvers.

The guidance concept described below is a semi-autonomous platooning system. Headway, lane change and turn functions are carried out autonomously by each car with the latter two based on receipt of commands from the intersection computer. Lane changing is accomplished in a hand-shaking fashion wherein the lane changing car signals its intent to merge, and cars in the merging lane yield to the newcomer. Turn and parking entrance maneuvers are performed as a part of the lateral guidance function where the car making a turn selects and follows a spur route.

The detailed design of any automatic guidance system is highly dependent on the specifics of its application. Many of the more populous cities in the United States where traffic congestion has become severe, have grown from settlements whose original locations were governed by their proximity to a harbor or navigable waterway. As a result, the street pattern has been laid out to follow the meanderings of a shoreline rather than to expedite traffic flow. In many cases also, cities have formed at the confluence of two rivers or at the mouth of a valley, forcing the street pattern to converge to one or more points based on the topology of the terrain. Even in the central plains states where topography is not a significant factor, cities have been planned about a circular pattern, in some cases, where the city center is at the hub and feeder streets fan out on radii. Oftentimes, the development has been centered about "main street" leading to a corridor type of growth which is extended in one direction and shallow in the other. As central districts formed, the areas around them filled in, eventually backing up to the next "main street", but even as they matured, the districts have tended to retain the rectangular density characteristic.

Clearly then, any model of a central district used in deriving an automatic vehicle guidance system must be highly generalized yet amenable to adjustment to fit the diverse situations to which the system will be applied. The model used in developing the concept of the semi-autonomous guidance system described below is highly simplistic and is therefore more representative of cities wherein topographical features have not had a dominant influence on the direction of development. As shown in Figure B-1, the street layout is a square grid. Consistent with current trends in many large congested districts, all streets are one way with alternate parallel streets assigned opposite directions of travel. In the initial analysis of the semi-autonomous guidance philosophy, the following traffic constraints have been assumed.

- (1) All vehicles are uniform in length, width, height and performance. (No trucks, buses, trailers, motorcycles, etc.)
- (2) No pedestrian traffic on streets at intersections or parking lot entrances.
- (3) No on-street parking.

Entry to the street system is controlled by an area computer through an intersection computer which allows entry on any North-South or East-West street at the perimeter of the grid or at any parking lot exit within the grid, at which points queues may form during peak demand periods. The intersection computers form platoons at the entrances to the grid and control lane assignments at the entries and at all points throughout the grid, co-ordinated through the area computer. In order to accomplish these functions, the intersection computers must have up-to-date information on the location of all cars and lane occupancy within the grid, which it is assumed will be obtained by interrogating each car as it crosses each intersection. Lane change and turn instructions will also be given to each car during the interrogation interval.

Figure B-1 depicts the position of platoons within the grid at three points in time. Each arrow represents a platoon whose distance from lead to trail car is indicated by the length of the arrow. Each platoon may be full or empty depending on system loading. Figure B-1(a) shows platoon positions at an initial instant of time whereas Figures B-1(b) and (c) show positions at successive one-half block intervals of travel. It will be observed that there is no cross traffic interference at intersections and that in Figures B-1(a) and (c) the pattern of flow around occupied blocks is opposite, i.e., clockwise in Figure B-1(a) and counterclockwise in Figure B-1(c). The latter observation leads to the conclusion that cars may make either left or right turns to reach their destinations. However, in refining the flow strategy below, a further constraint has been assumed that the central routing computer will program each car along a left-hand or right-hand route but not both.

The final constraint in the street model requires that adequate parking facilities be available at each block, that entrances be placed at mid-block, and vehicle handling and entrance geometry be handled in



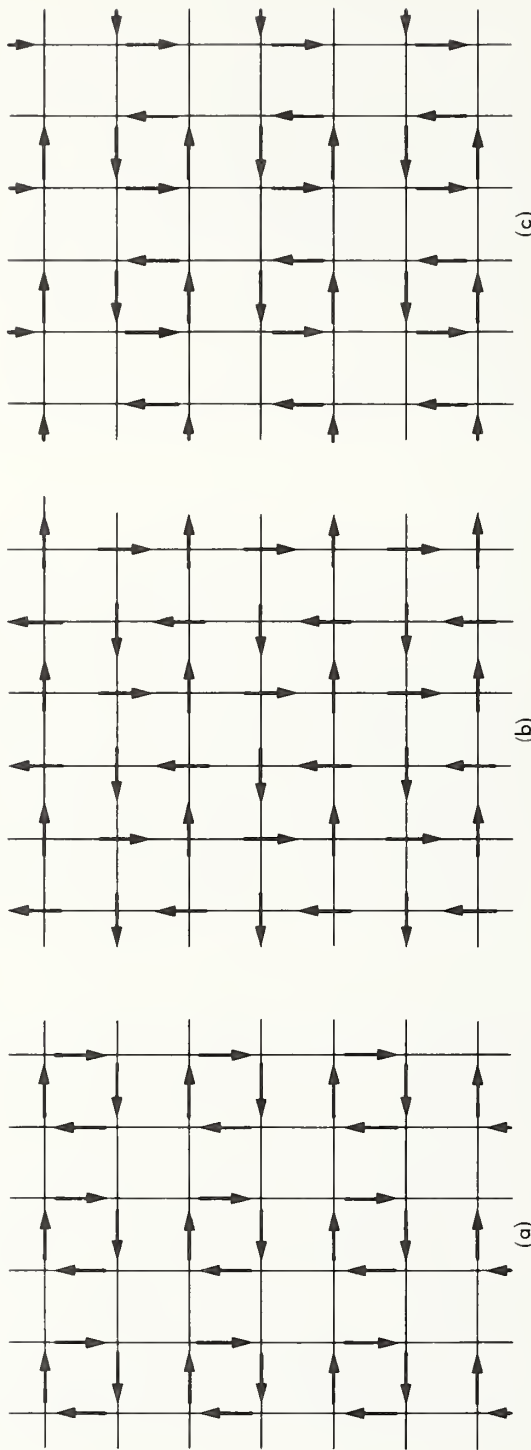

P = 0, 2, 4, . . . BLOCKS

P = +1/2, +2 1/2, +4 1/2, . . . BLOCKS

P = +1, +3, +5, . . . BLOCKS



Figure B-1. Traffic Flow Strategy. Street Layout Grid

a way that avoids the need for excessive slowdown before entry and prevents backup of cars into main thoroughfares. Cars will enter parking facilities from side streets only, i.e., streets at right angles to the main route direction of each car. Thus, a car programmed along an East-West street to its destination will enter a parking lot on the North-South street nearest to its destination within one block of its last turn.

The general rules of lane occupancy, lane change control and turn control are as follows:

- (1) Curb lanes are for near destination (1 to 2 blocks) and turning traffic only. Greater headway will be required to allow for turn slowdown.
- (2) Center lanes are allocated for near-distant and far-distant destination traffic (two or more blocks). Less headway will be required and cars will travel at higher speeds.
- (3) Adjacent high speed lane traffic is staggered in position to facilitate lane changing maneuvers.
- (4) On-turning cars will join the rear of platoons.
- (5) Lane changes will initiate just beyond intersections which are two blocks ahead of the next lane change or turn instruction. Only one lane change is allowed in a two block interval.

Figure B-2 depicts traffic flow at a typical intersection based on the above rules.

A conceptual layout is shown in Figure B-3 which also illustrates transition segments for turning traffic in the appropriate curb lanes at each intersection. Travel direction and lane identification information on each path continues uninterrupted from section to section from one end of the controlled zone to the other. Speed information is separately supplied by the area computer for each section and each segment within its section. The final segments of each section form an approach or transition zone at the entrance to the intersection. Figure B-3 also shows pickup loops at each intersection similar to those conceived for route guidance systems in Germany and Japan <sup>(1)(2)</sup>. These loops are used principally to transmit routing and lane change instructions from the intersection computer to each individual vehicle. However, in addition to the routing function, the lead car in each lane of a platoon will be so notified by the intersection computer on passage over the loops.

The on-board vehicle equipment consists of pickup coil(s) and appropriate discriminators, demodulators and/or decoders to extract the position error signal as well as identification and command information.

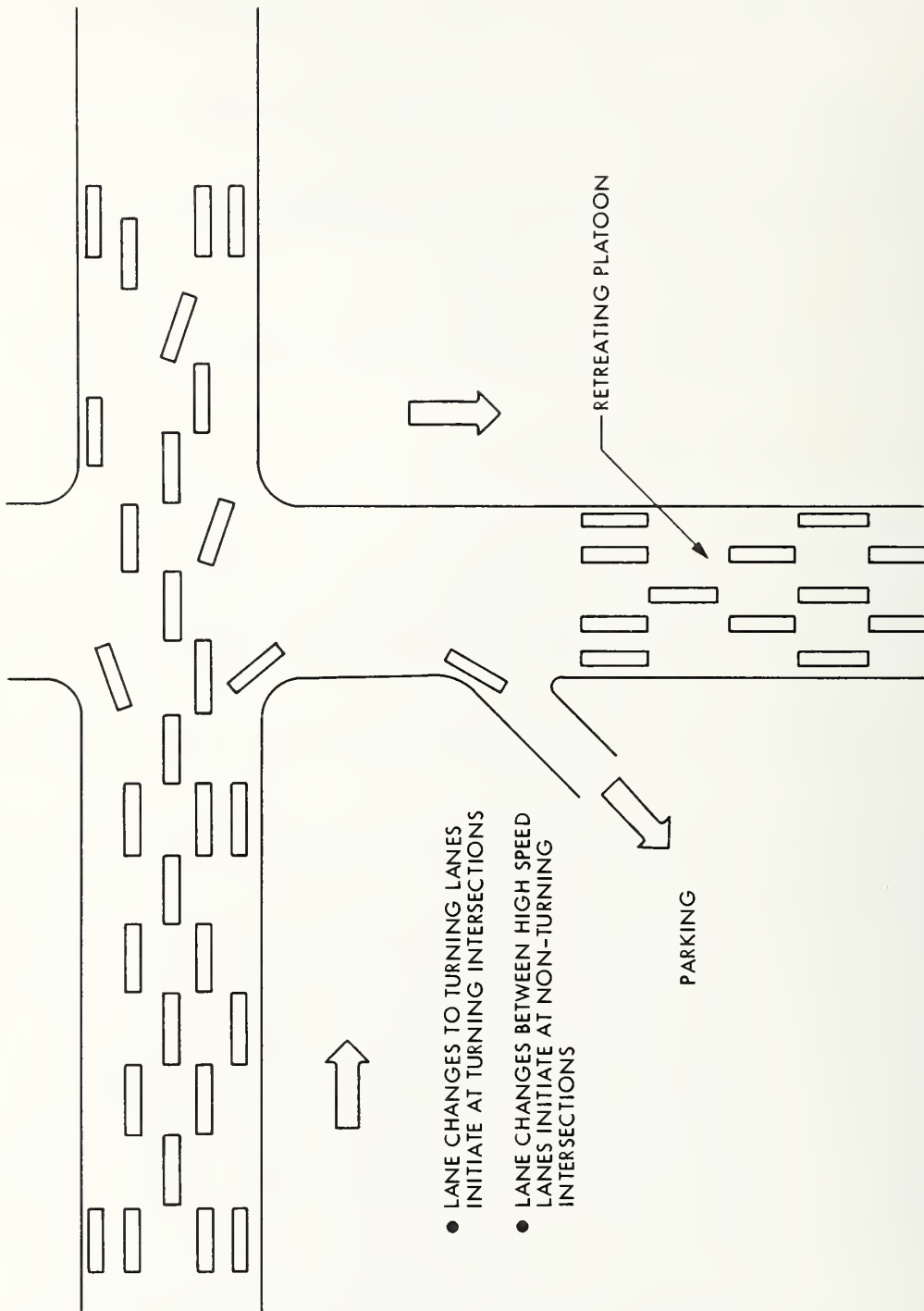

Figure B-2. Maneuver and Intersection Strategy

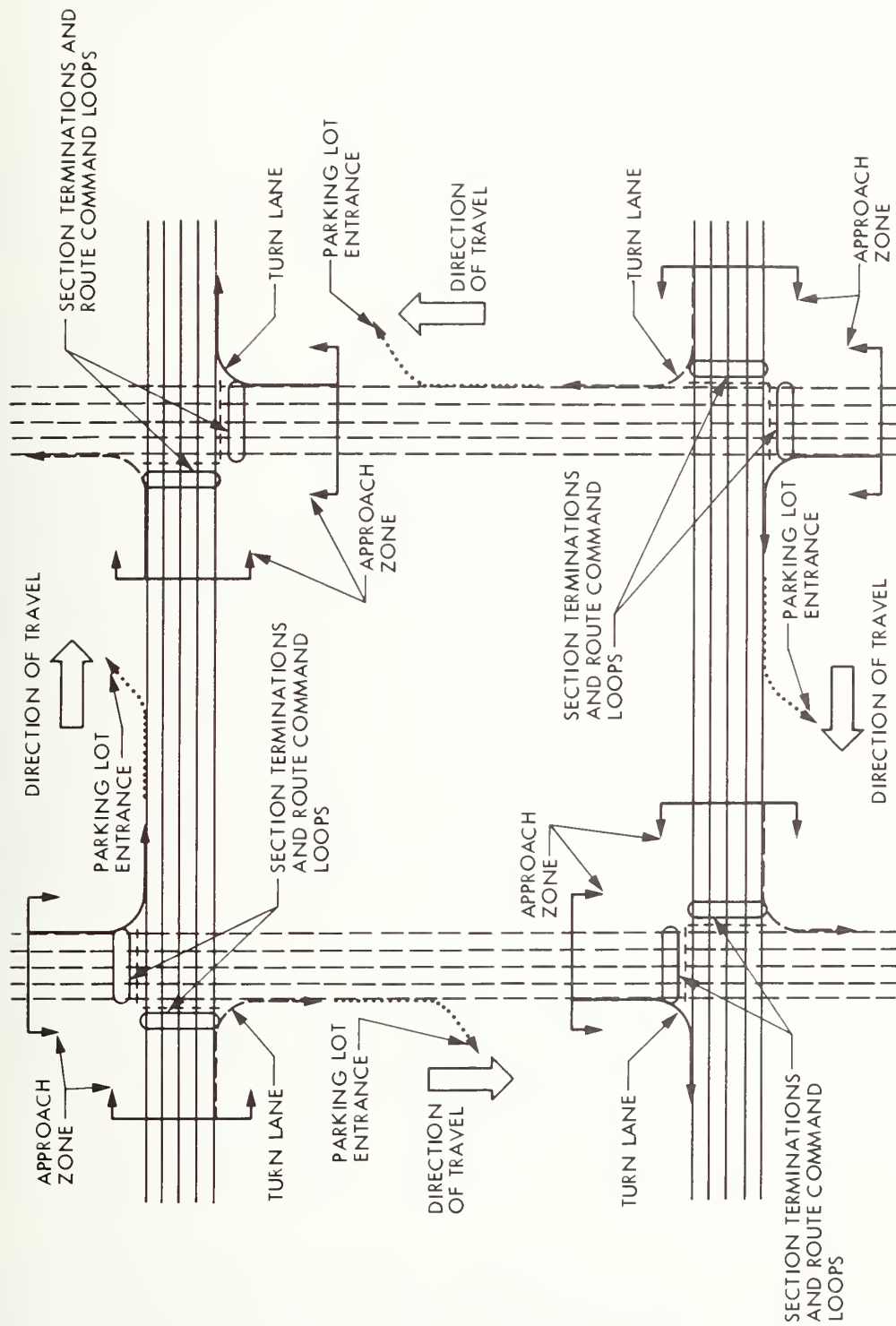

Figure B-3. Guidance Layout

The information carried by modulation of the carrier frequency is used by other guidance subsystems and is discussed in subsequent sections. Specifically, direction of travel information is used for turn and parking entrance maneuvers, lane identifications information is employed for lane change maneuvers, and speed command information is utilized for maintaining platoon discipline and headway control.

## HEADWAY CONTROL

### On-Board Equipment

Each car admitted to the controlled zone is equipped with fore and aft headway sensors. Before entry into the system, the headway sensors are checked at the entry station automatically. While the sensors can operate on any of a number of principles such as RF, optical or IR pulsed radar or crossed beam proximity schemes, the following basic specifications should apply:

- (1) Immunity to environmental conditions such as rain, fog, snow, lightning, etc.
- (2) Immunity to clutter and background such as glints, spurious radiation, multiple reflections, etc.
- (3) Self contained. While the sensors may be, and probably will be active, they should not require a cooperative response from the target object such as would be needed in a transponding system.
- (4) Fast response. No greater than one millisecond response delay.
- (5) Accuracy, repeatability and uncertainty. Sensors should maintain accuracy of less than 1 foot under all environmental conditions.
- (6) Range, resolution and linearity. Sensors should resolve clearance distance to within 1 foot over a range from 1 to approximately 150 feet. Total error from all causes should be less than 1 foot under all environmental conditions.

### Headway Control Strategy

The front and rear headway systems provide signals to the speed control routine of the on-board vehicle processor. Headway measurements are used as part of the platoon discipline and lane change systems and their functions are described in these sections.

## LANE CHANGING

### On-Board Equipment

Each car admitted to the controlled zone is equipped with special lane change equipment consisting of an active pencil beam azimuth



scanning transmitter-receiver (RF, optical or IR) which produces a coded signal, and an omni-directional transponder (RF, optical or IR) which receives and transmits coded signals in response to adjacent lane interrogations. The angular rate of the scanner is precisely controlled by an on-board clock and its scan position at any point in time is synchronized by an RF signal transmitted throughout the controlled zone so that the scan angle of all cars is the same, and is therefore known by all other cars. Lane identification is provided to all cars through a modulation code on the communication loops. Information from the lane change equipment, lane identification decoder and longitudinal headway sensors is integrated and processed in the on-board processor.

### Lane Change Strategy

The overall lane change strategy is based on local car-to-car hand-shaking control in which the car about to change lanes signals intent to cars already occupying the lane to which it will merge. The cars in the merging lane will then compute the front and rear longitudinal clearance to cars in their own lane as well as the projected clearance to the merging car in the adjacent lane. On the basis of the computations, cars in the merging lane will longitudinally yield to the extent possible to allow the merging car to enter their lane. The merging car also computes the projected fore and aft clearance to cars in the merging lane and initiates the lane change maneuver only if, 1) its computer determines that the new lane is clear, and 2) it receives confirming clearance signals from adjacent occupants in the merging lane. If the merging lane is unoccupied, the merging car acts on the basis of its own clearance determination in the absence of confirming responses.

In effect, the strategy departs from the present day rules of the road by allowing the merging car to have priority claim to the merging lane. However, the merging car is internally inhibited from exercising its claim until both it and the cars presently occupying the merging lane confirm that adequate clearance exists. The strategy thereby contains redundant provisions to protect against lateral lane changing collisions.

### Lane Changing Scenario

The codes of various lanes are depicted by colors in Figure B-4. Also, Figure B-4 shows the initial position of cars in the yellow and orange lanes just prior to the lane change maneuver scenario described below in which the yellow car merges with traffic in the orange lane to its right. A logic diagram showing the computational processes in each of the three affected cars is given in Figure B-5.

The lane change sequence is initiated on receipt of a lane change command from the intersection computer by the yellow car to change to the orange lane in preparation for a right hand turn two blocks hence. On receipt of the lane change command, the azimuth scanning transmitter of the yellow car automatically begins sweeping slightly less than a semi-circular zone to the right of its centerline with an orange code

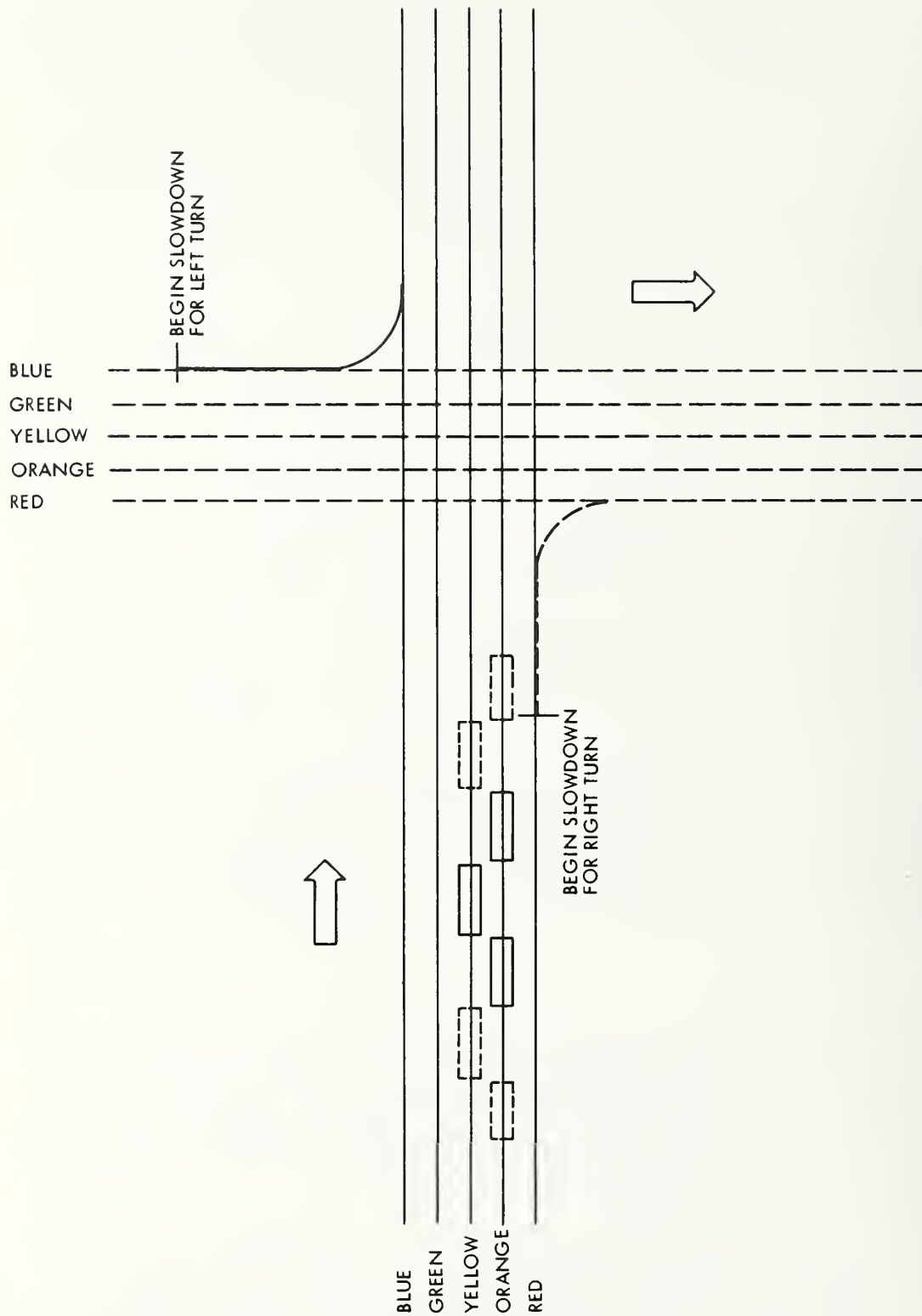

Figure B-4. Lane Coding and Lane Change Maneuver Scenario

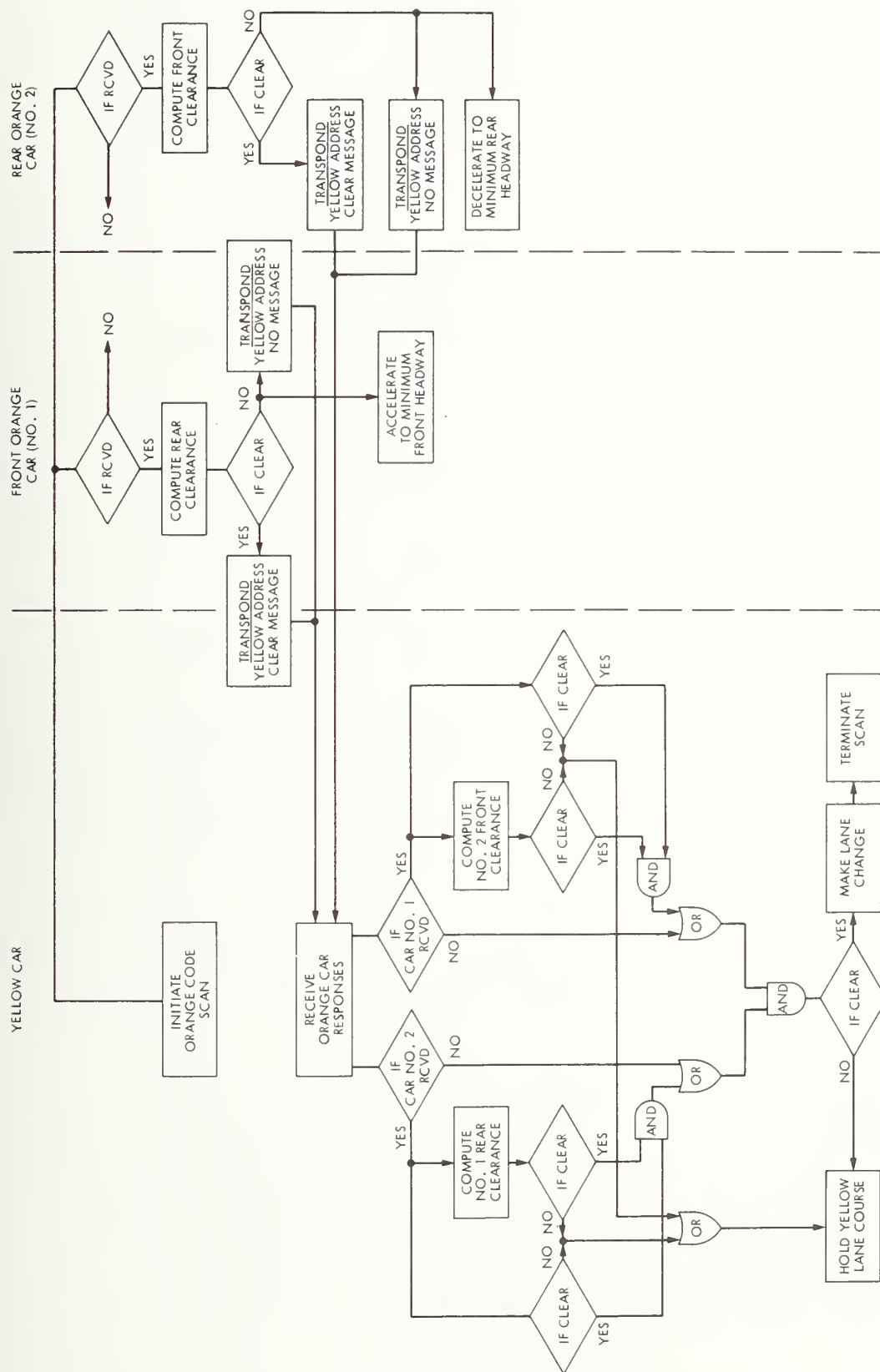

Figure B-5. Logic Diagram Showing Computational Process of Lane Change (See Figure B-4.)

interrogation transmission to signal its intent to merge with orange lane traffic and to determine its fore and aft clearance to cars staggered about it in the orange lane. (Rules of the road for the automatic guidance system prohibit cars from attempting to change more than one lane at a time, therefore the yellow lane car is internally inhibited from transmitting a red or blue code sweep interrogation.) On receipt of the orange code pencil beam sweep signal from the adjacent yellow car, each orange car in the swept zone immediately computes its fore and aft clearance to the interrogating car on the basis of the time of signal arrival relative to the RF scan synchronizing pulse received by all cars plus knowledge of the precise angular scan rate employed by all cars. The clearance computation involves first a determination of the angular direction to the interrogation source by means of the time delay between receipt of the scan synchronizing pulse and the peak amplitude of the interrogating signal, then the calculation of clearance based on standard car length and center-to-center lane spacing. The computations are performed instantaneously (relative to the scan rate) and a response carrying a yellow code address and a clear or no message (depending on the results of the clearance computations) is immediately sent by each orange car in the swept zone over its omnidirectional transmitter. In the event that the orange car clearance computations determine that there is insufficient fore and aft clearance to allow the yellow car to merge, both orange cars will determine on the basis of their own clearance computations whether they should move ahead or to the rear in order to accommodate the merging maneuver. Each orange car will then accelerate to reduce its front headway clearance to the orange car ahead or to reduce its rear headway clearance to the car behind by decelerating.

Receipt of the orange car responses enables the yellow car to make independent computations of its fore and aft clearance to adjacent orange lane cars. The clear (or not clear) orange car messages are then compared in the yellow car with the results of its own clearance computations whereupon it will negotiate the lane change maneuver, if, and only if, all inputs to the lane change decision are in concurrence. Otherwise, the yellow car must maintain its yellow lane course and continue to transmit an interrogation signal until clearance is guaranteed. Guidance during lane change maneuver is provided by the dead reckoning system in the yellow car, since in the course of the maneuver the yellow car receives no steering signals from the buried cables. Therefore, once the lane change decision is made, the scan and interrogation system is deactivated.

In the event that there are no orange cars within the sweep arc of the yellow car scanner, no responses will be received, and it will proceed to make the lane change maneuver on the assumption that the orange lane is completely clear. If, in the opposite case, the orange lane is so congested because of other yellow or red lane change maneuvers that space cannot be found for the yellow car, it must continue beyond its commanded turn point, if necessary, until space becomes available. In this case, the routing computer will not receive confirmation of the yellow car's lane change at the next intersection and will reprogram the yellow car to its destination by another route.



## TURN AND PARKING ENTRANCE MANEUVERS

### Implaced and On-board Equipment

Transition loops are placed at each intersection with the proper placement to permit turning cars to compute the correct deceleration profile and to complete the turn under wire guidance control. In general, modulation coding of the transition loops will be the same as that used for the new direction of travel such that as each car enters the transition region, it will receive the code of its present direction as well as the code of its new direction of travel.

No specific on-board equipment is dedicated to the turn and parking entrance maneuver function. Signals received through the guidance system are decoded and processed by the on-board processor to provide the necessary steering and braking control commands.

### Concept of Operation

Turn and parking entrance maneuver instructions will be issued to turning car by the central routing computer two blocks in advance of the maneuvers. The on-board processor must be able to store both a turn and a parking entrance maneuver command simultaneously since the parking entrance maneuver may be performed within one block of the final approach turn. Arrival of turning vehicles at the transition zone is signalled by the presence of both the present and new directional codes by a separate marker installed at a predetermined uniform distance from the turning intersection. On receipt of the transition zone entrance signal, the on-board processor will compute the correct slowdown profile to permit safe negotiation of the turn ahead and provide control signals to the accelerator and braking systems. At the same time, steering control will be switched to accept error signals from the transition loop which carries the code of the new direction and lane. On the basis of a distance computation by the on-board processor which is performed by integrating the speed-time profile after entry into the transition zone, an acceleration signal is given at the mid-point of the turn causing the vehicle to return to its speed prior to entry into the transition zone. In the case of a parking maneuver command, the car will continue to decelerate to a stop at the parking gate rather than accelerating at the mid-point of the maneuver as in a turn command.

If a turning car is unable to catch up with the retreating platoon in its new direction of travel and if it has not been commanded to make an immediate turn into a parking entrance, it will be forced to stop at the next intersection. In this case, the turning car will join the advancing platoon as the lead car rather than the retreating platoon as the trail car in its new direction of travel. In performing the intersection stop, the on-board processor will compute a deceleration profile



and provide commands to the service brakes based either on detection of entry into the next approach zone or on inputs from the front headway sensor. Because cars could back up at the next intersection, the headway system must be sensitized to initiate the stop at a headway clearance of approximately 150 feet rather than the normal 20 foot headway since there may otherwise be inadequate warning of the potential backup. The necessary sensitization logic will be incorporated as a part of the turn command execution routine in the on-board processor.

## PLATOON DISCIPLINE AND HEADWAY CONTROL

### On-Board Equipment

Headway sensor outputs and decoded signals from the dead reckoning system and intersection loops are used in the platoon discipline and headway control subsystem. These signals are processed in the on-board vehicle processor to provide commands to the vehicle accelerator and braking servo systems. An accurate speedometer having an electrical output (analog or digital) is the only added item of equipment unique to the platoon discipline and headway control subsystem.

### Lead Car Speed Control

The first car in each lane of each platoon receives and stores a "lead car" designation from the central routing computer on passage over the route guidance loops at each intersection. The designation holds for only one block of travel and must be renewed at each intersection. Since the trail car of the platoon ahead is normally out of range of the lead car's headway sensor, the lead car will usually respond only to the speed command received from the main or approach segment of the intersection loop in its lane. (Under all conditions, however, headway sensors will override the speed control command, even in a lead car). The speed command issued by the central routing computer is based on arrival of the lead car at the next intersection in a specific time interval to ensure adequate cross traffic clearance. Lead cars will be under integral speed control in response to the speed command, i.e., the error between the speed and the actual vehicle speed will be integrated on board the lead car and its processor will command a speed-time profile such that the error integral will reduce to zero well before arrival at the approach zone of the next intersection. The integrator is re-initialized to zero on passage over the route guidance loops at each intersection. Because of the use of integral control, lead cars will be allowed to exceed the speed command by 15 to 20 mph in order to make up for speed response lag.

The central routing computer will exercise "red light - green light" control over the intersection approach zone based on cross traffic clearance computations. Cars entering the approach segment with insufficient cross traffic clearance will receive a "zero" speed command modulation

code on the lateral guidance cable which corresponds to a "red light", and their on-board processor will compute and issue commands to the power braking unit and accelerator servos for a controlled stop trajectory. Cars already within the approach segment when a zero speed command is issued will ignore the "red light" and continue through the intersection at the same speed. A lead car which enters the approach zone under a "red light" will proceed to compute and execute a stop profile, but will resume speed at the instant the light turns "green". Because there is a possibility of backup at the next intersection due to on-turning cars from the previous cross-traffic platoon, lead car headway systems must be sensitized to initiate a stop at a headway clearance of approximately 150 feet since there may otherwise be inadequate warning of the potential backup. The necessary sensitization logic will be incorporated as a part of the lead car execution routine in the on-board processor.

#### Pack Car Speed Control

Vehicles other than lead cars will depend primarily on headway determinations for speed control. A nominal front headway of 20 feet will be maintained unless cars are yielding to an adjacent lane changing vehicle merging into their lane. In this case, the front car in the merging lane will reduce headway to 10 feet until its rear headway sensor detects the presence of the merging car 10 feet behind, at which time both it and the merging car will gradually adjust front headway clearances to the proper value. Similarly, the rear car in the merging lane will increase its front headway to 50 feet until its front headway sensor detects the presence of the merging car 20 feet ahead, after which it will continue to maintain its proper clearance. All cars to the rear will have yielded 40 feet to the incoming car. Should a car leave a lane, the car immediately behind will speed up to close the resulting gap. In such cases, pack cars will be allowed to exceed the commanded lane speed by 15 to 20 mph.

In the event a lead car is instructed to make a mid-block lane change, the car immediately to its rear will also be designated a lead car by the intersection computer. The successor will then operate under front headway sensor speed control until the front leader changes lanes, at which time the successor will operate under lead car rules. In this case, the successor will also be under integral speed control in response to the lane speed command, but will be inhibited by its headway sensor from reducing its speed error integral to zero until the front car has cleared its lane.



APPENDIX C

FIBER OPTIC ROTATION SENSOR  
FOR AUTOMATIC TRAFFIC CONTROL

## APPENDIX C

### FIBER OPTIC ROTATION SENSOR FOR AUTOMATIC TRAFFIC CONTROL

A new concept in rotation rate and position sensing has recently emerged which could be of significance to automatic traffic control. The new sensor has the potential of being a very low cost mass produced unit. Volume, weight and power requirements are minimal. The sensor is an optical interferometer, with the sensing element being a coil of optical fiber. Laser light is passed through the fiber in both directions, then recombined at a pair of detectors. A phase retardation of one beam relative to the other is developed in the fiber which is proportional to rotation rate component about the axis of the coil. This phase retardation alters the fringe displacement and intensity profiles at the detectors. Figure C-1 illustrates the basic concept. A practical unit would also be modulated to provide best possible signal to noise discrimination. The basic idea of sensing rotation through counter-travelling beams of light is quite old. Sagnac (Ref. 1), in 1913, set up four mirrors to enclose an area 30 cm on a side, and using a mercury emission line was able to measure fringe displacements when the apparatus was rotated at 2 revolutions per second. In 1925, Michaelson and Gale (Ref. 2), repeated the experiment with the mirrors separated by 400 meters, and were able to measure the earth's rotation rate,  $0.004^{\circ}$ /second.

Availability of very long single mode fibers and lasers present the possibility of using this effect in a practical instrument. Fibers are now available with losses of 2 dB/km. An optimum sensing fiber length is nearly 5 km long. Because of their small diameter the fibers can be packaged into a small space. For example, a 6" (15 cm) diameter coil containing 5 km of fiber would have a cross-section of about 3/8" (1 cm) on a side.

Although test work is proceeding using helium neon gas laser excitation, a practical unit would probably employ a solid state injection laser. Minimum detectable rotation rate, for the example given, would be less than  $10^{-2}$  degrees/hr for a bandwidth of 100 Hz, substantially lower than required.

Basic component development of low-loss, low-cost fibers and injection lasers suitable for coupling to fibers is proceeding rapidly under emphasis from the communications industry. Development of the rotation sensor for spacecraft applications is proceeding in a cooperative effort at the University of Utah Research Institute (Refs. 3 and 4), and at the Jet Propulsion Laboratory. There is no current work aimed at developing an instrument suitable for vehicle attitude sensing.



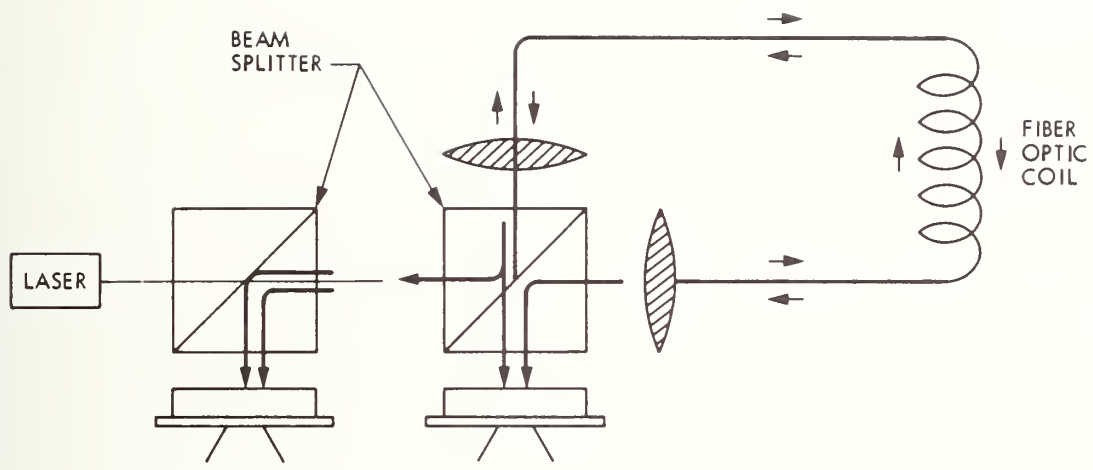
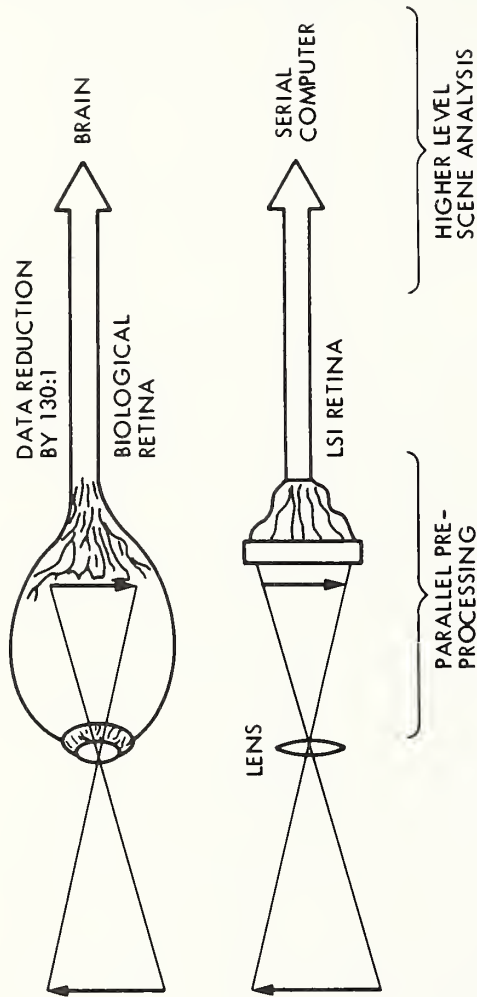

Figure C-1. Rotation Sensing Interferometer

## REFERENCES

1. Sagnac, G., Comptes Rendes, 157, p. 708 (1913).
2. Post, E. J., Rev. of Modern Physics, Vol. 39, No. 2, Apr 1967, p. 475.
3. Vali, V. and Shorthill, R. W., Appl. Opt., Vol 15, No. 5, May 1976, P. 1099.
4. Vali, V. and Shorthill, R. W., Appl. Opt., Vol 16, No. 2, Febr 1977, p. 290.

APPENDIX D  
ARTIFICIAL RETINA



- LSI RETINA
  - LOCAL DETECTORS AND LOGIC
  - INTERCONNECTING REGIONS
- LONG-RANGE GOALS
  - ANALYZE IMAGES IN 0.01 sec FOR REAL-TIME FEEDBACK
  - REDUCE SERIAL DATA HANDLING
  - EXPLORE PARALLEL PROCESSING ISSUES
  - ASSESS FEASIBILITY OF  $10^3 \times 10^3$  - ELEMENT LSI ARRAY
- FIRST EXPERIMENTAL SYSTEM
  - 8 x 8-ELEMENT ARRAY
  - ONE OR MORE ALGORITHMS
  - EDGE AND MOTION DETECTION, NOISE SUPPRESSION, STEREO CORRELATION
  - PROBLEM ASSESSMENT FOR NEXT STEP

Figure D-1. Artificial Retina

APPENDIX E

A MATHEMATICAL PROGRAM FOR GENERATION OF OPTIMAL  
ROUTE-ASSIGNMENT PATTERNS



## APPENDIX E

### A MATHEMATICAL PROGRAM FOR GENERATION OF OPTIMAL ROUTE-ASSIGNMENT PATTERNS

A good example of the mathematical formulation is given in Reference 5, Section IV. It deals with the following specific problem: given the constant demand rates associated with specified origin-destination (O/D) pairs of a road network, and travel cost functions for each link of the network, the traffic assignment problem is to determine the flow rates on each path, or route, of the network.

#### Network, Arc, Path, and Flow

The basic mathematical programming model is formulated in Reference 5 as follows: Given a directed network  $G = (N,A)$ , where  $N$  is the set of nodes and  $A$  is the set of directed arcs. A subset  $S$  of  $N \times N$ , where  $(i,j) \in S$  implies  $i \neq j$ , is designated as the set of O/D pairs. For each  $(i,j) \in S$  there is associated a positive real number  $d_{ij}$  called the demand for O/D pair  $(i,j)$ . Let  $Q_{ij}$  be the set of all simple paths directed from  $i$  to  $j$  and let  $F_p$  be the flow on path  $p \in Q_{ij}$ .

#### Feasible Flow Pattern

The condition that all demand must be satisfied is given by

$$\sum_{p \in Q_{ij}} F_p = d_{ij} \quad , \quad \text{for all } (i,j) \in S \quad (E.1)$$

The condition that flows must be non-negative is

$$F_p \geq 0 \quad , \quad \text{for all } p \in Q = \bigcup_{(i,j) \in S} Q_{ij} \quad (E.2)$$

Any set of flows  $\{F_p\}$ ,  $p \in Q$ , satisfying (E.1), (E.2) is called a feasible flow pattern. It is assumed that a feasible flow pattern exists.

#### Flow on an Arc

Let  $f_a$  be the flow on arc  $a \in A$  and  $(\delta_{ap})$  be the arc-arc incidence matrix for  $G$ ; i.e.,  $\delta_{ap} = 1$  if arc  $a$  is contained in path  $p$ , and  $\delta_{ap} = 0$  if otherwise. The arc flow can be computed from path flows by

$$f_a = \sum_{p \in Q} \delta_{ap} F_p \quad (E.3)$$

## Criteria for Optimal Assignment

Let  $t_a(f_a)$  be a real-valued, differentiable, nonnegative and non-decreasing function that specifies a per unit (per flow unit) travel cost on arc  $a$  as a function of the flow on arc  $a$  (congestion dependent). Let  $g_a(f_a) = t_a(f_a) \cdot f_a$  be the total travel cost on arc  $a$ , defined for all  $a \in A$ . A system-optimal flow pattern is defined to be a feasible one that minimizes total travel cost. Such an optimal pattern can be found by solving the mathematical program:

$$\min \sum_{a \in A} g_a(f_a) , \quad (E.4)$$

subject to (E.1), (E.2), and (E.3).

## Existence of, and the Kuhn-tucker Conditions for, an Optimal Solution

Since the set of feasible flow patterns is non-empty and is finite, the program (E.4) has an optimal solution. The well-known Kuhn-Tucker conditions for non-linear programming provide the necessary conditions for the optimal solution. Choosing convex functions to represent arc cost  $g_a$  for all arcs  $a \in A$ , further makes these conditions sufficient for an optimal solution.

## An Algorithm for Generating an Optimal Solution

Iterative procedures are usually used to generate an optimal solution. The authors of Reference 5 suggested one procedure which greatly reduces the computation and makes solutions of large networks tractable. The procedure starts with a reasonable subset of the set of all possible paths as the basis for optimization, performs the sub-optimization so defined, and gradually enlarges the subset until the Kuhn-Tucker conditions for the original problem are satisfied.

This procedure is particularly suitable for practical application since one can select a few promising paths for each O/D pair (doing this on all the O/D pairs), according to a good judgment, and then start the iteration. The suboptimal solution on the first iteration would already be a meaningful solution, and most likely a very practical one.

## Implementation of a Flow Pattern Using ERGS Routing System

If the vehicle does not remember its route, but only carries its destination code and follows turn instructions given to it at the intersections, as in the case of ERGS described in Section III-B-2, the optimal flow pattern must be transformed into destination-dependent

turn instructions at each intersection. In other words, given a system-optimal flow pattern chosen according to the mathematical program, one must generate the probability distribution of turn instructions at each intersection for each destination. For example, when a vehicle with a destination  $j$  comes to an intersection  $k$ , it will be told to turn left with probability 0.3, to turn right with probability 0, and to go straight with probability 0.7.

Such an intersection-resident,\* destination-dependent probability distribution of turn instructions can be obtained from the flow pattern as follows: Let  $f_{aj}$  be the flow on arc  $a$  with destination  $j$ , and let  $f_{ajk}$  be the portion of  $f_{aj}$  which has been assigned to the paths that turn to direction  $k$  at the end of arc  $a$ . Then, similar to equation (E.3), one can compute  $f_{ajk}$  by

$$f_{ajk} = \sum_{p \in R_{ajk}} F_p \quad (E.5)$$

where  $F_p$  denotes the flow on path  $p$ . The set  $R_{ajk}$  is defined to contain all directed paths that end at destination  $j$ , include arc  $a$  as a link, and turn to direction  $k$  at the end of arc  $a$ . It is obvious that

$$f_{aj} = \sum_{k \in K_a} f_{ajk} \quad (E.6)$$

where  $K_a$  is the set of possible turn directions at the end of arc  $a$ . Let  $h_{ajk}$  be the probability that, at the end of arc  $a$ , a vehicle heading for destination  $j$  is instructed to turn to direction  $k$ , then

$$h_{ajk} = f_{ajk} / f_{aj} \quad (E.7)$$

Equations (E.5), (E.6), (E.7) transform a traffic flow pattern  $\{F_p\}$  into a set of instructions  $\{h_{ajk} : a \in A, j \in N, k \in K_a\}$  which are executable by the road-side unit in the ERGS route guidance system.

---

\*The instructions are actually associated with an arc leading to the intersection (Section IV-B-2).

APPENDIX F

TRAFFIC MANAGEMENT SCHEMES DEVELOPED FOR EXCLUSIVE  
GUIDEWAY PERSONAL RAPID TRANSIT SYSTEMS

## APPENDIX F

### TRAFFIC MANAGEMENT SCHEMES DEVELOPED FOR EXCLUSIVE GUIDEWAY PERSONAL RAPID TRANSIT SYSTEMS

Some results in the traffic management studies conducted for fully automated exclusive guideway personal rapid transit (PRT) systems are also applicable to the automated road traffic system under study. The most applicable results have dealt with the merging of vehicle streams and the associated scheduling problems (See Refs. 1, 2 and 3). Merging techniques have also been the focus of network operation studies for PRT systems because such systems are mainly conceived for non-stop operation of high speed vehicles separated with close headways. Relatively less attention has yet been given to optimized routing algorithms. One exception is Ref. 4, where user-optimized routing algorithms were developed to minimize the total trip time for the user. System-optimized routing algorithms, to our knowledge, are not yet fully developed.

#### Synchronous and Quasisynchronous Network Operations

Two important examples of network operations for PRT systems are synchronous operation (See Refs. 1 and 2) and quasisynchronous operation (See Ref. 2). Both employ the concept of virtual slots that move in the network in some orderly fashion. Each automated vehicle is identified with one slot and moves with the slot, or guided by the slot, until it comes to an interchange where merging is to take place. The two operational schemes differ in whether they intend to allow completely uninterrupted travel from origin to destination. A comparison of the expected trip time delay associated with each policy was given by Kornhauser (See Ref. 3).

The synchronous system has virtual slots moving throughout the network. Each slot moves at the nominal speed defined for each line and is synchronized at each intersection. Departure by a vehicle from a station is not permitted until a whole sequence of synchronized slots can be reserved that will allow the vehicle to travel uninterrupted from origin to destination. Synchronized merging according to predetermined reservation string is illustrated in Figure F-1.

The quasisynchronous system relaxes the reservation constraints of the synchronous system by allowing vehicles to merge into the first available slot at the interchange. A vehicle can maneuver, or slip slots, to merge into the next gap or slot. The vehicle is allowed to hold back the vehicles behind it, up to a predetermined limit, to find an available merge slot. Over the limit, the vehicle passes straight ahead through the interchange, and receives new routing information. The quasisynchronous merging is illustrated in Figure F-2. Within a maneuver region near the interchange the vehicles operate within the virtual slots and are controlled by an interchange controller which surveys the main stream of traffic to find available merge slots.



Outside of these interchange maneuver regions, the vehicles can either be guided by the virtual slots or in an asynchronous vehicle-follower mode.

#### Comparison of Synchronous and Quasisynchronous Schemes

In the analytical comparison conducted by Kornhauser (See Ref. 27), the strict requirement of reserving synchronous merge slots for the whole trip before starting the journey was found to penalize the users in terms of longer average delays in trip time (including delays at stations and delays in making turns, if any). In Figure F-3 it is seen that, for line loadings heavier than 50% slot occupation, the average delay in the synchronous system is larger, and increases much faster, than the delay in the quasisynchronous system. It should be pointed out that certain modifications of the synchronous system, such as the cycle synchronous system\* mentioned in Reference 4, may conceivably reduce the excessive time delay indicated in Figure F-3.

#### Applicability to the Automated Road Traffic System

Future development of system-optimized routing algorithms for automated exclusive-guideway PRT systems may benefit vehicle routing in an automated road traffic system, particularly if such a system is to operate in a no-pedestrian, non-stop fashion similar to PRT operation. Possible contributions of the existing algorithms for PRT routing, to the automated road traffic system under study, appear to be quite limited.

However, the merging algorithms, particularly the handling of virtual slots and the formation of maneuver and non-maneuver regions as exemplified in the quasisynchronous system, can be a good alternative for the automated road traffic system to handle vehicle merging and turning in a typical street network of multiple-lane configuration.

---

\*Cycle synchronous system requires cycles of moving slots to be synchronized. The unit for synchronization is now a cycle, not a slot. The vehicles in each cycle can adjust their slots in a control section prior to each merge. The percent occupancy of the cycle can be controlled.

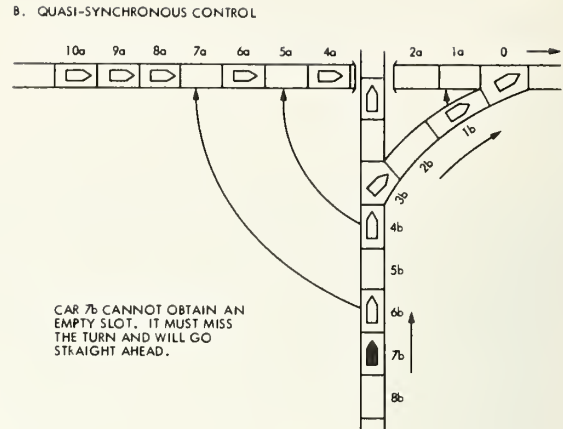
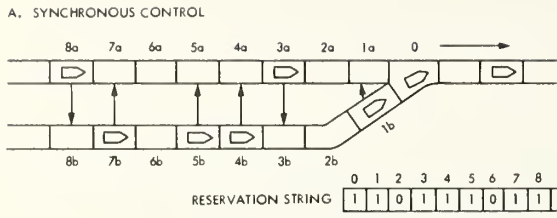

SOURCE: F. RUBIN  
(REF. 20)

Figure F-1. Synchronous Merge System

Figure F-2. Quasisynchronous Merge System

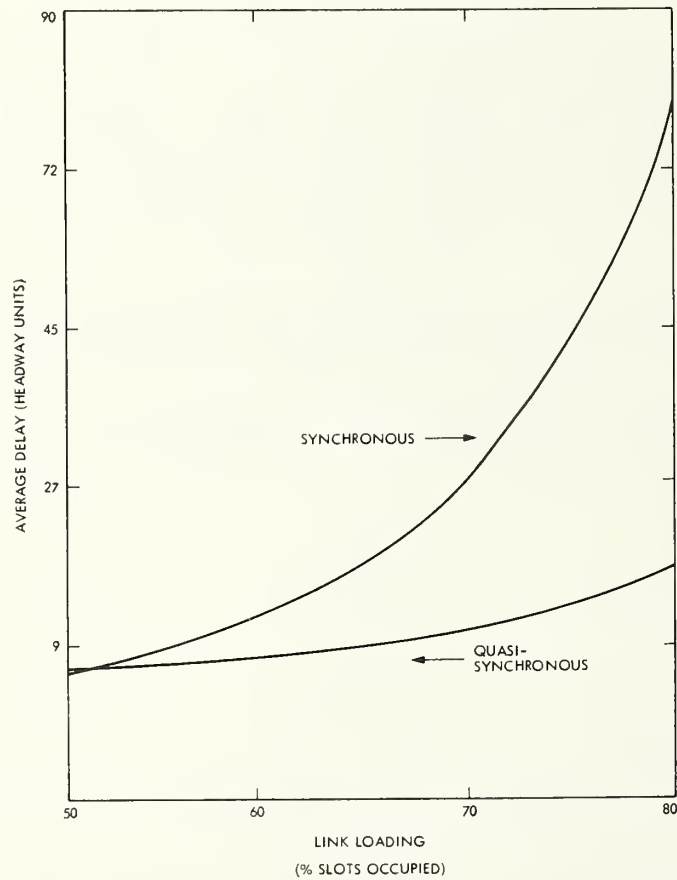

SOURCE: KORNHAUSER AND McEVADY  
(REF. 27)

Figure F-3. Comparison of Synchronous vs. Quasisynchronous Merge Systems

## REFERENCES

1. Godfrey, M. B., "Merging in Automated Transportation Systems," MIT Sc.D Thesis (unpublished), 1968.
2. Munson, A. V., "Quasi-Synchronous Control of High-Capacity PRT Network," pp. 325-350, Personal Rapid Transit (edited by Anderson et al.), University of Minnesota, 1972.
3. Kornhauser, A. L., and Mc Evaddy, P., "A Quantitative Analysis of Synchronous vs. Quasi-Synchronous Network Operations of Automated Transit Systems," Transportation Research, Vol. 9, pp. 241-248, 1975.
4. Rubin, F., "Routing Algorithms for Urban Rapid Transit," Transportation Research, Vol. 9, pp. 215-223, 1975.



HE 18.5

.A39

no. DOT-TST-

78-3

BORROWER

Form DOT F 17



DOT LIBRARY



00011672