



U.S. Department of Transportation
**Federal Highway
Administration**



MEDIAN U-TURN INTERSECTION

Informational Guide

August 2014

FOREWORD

The Federal Highway Administration (FHWA) Every Day Counts (EDC) initiative is designed to identify and deploy innovation aimed at reducing project delivery time, enhancing safety and protecting the environment. In 2012, FHWA chose Intersection & Interchange Geometrics (IIG) to feature as one of the innovative technologies in EDC-2. Specifically, IIG consists of a family of alternative intersection designs that improve intersection safety while also reducing delay, and at lower cost and with fewer impacts than comparable traditional solutions.

As part of the effort to mainstream these intersections, FHWA has produced a series of guides to help transportation professionals routinely consider and implement these designs. Concurrent with this Median U-turn (MUT) Informational Guide, FHWA developed and published guides for three other designs: Restricted Crossing U-turn (RCUT), Displaced Left Turn (DLT), and Diverging Diamond Interchange (DDI). These guides represent summaries of the current state of knowledge and practice, and are intended to inform project planning, scoping, design and implementation decisions.

An electronic version of this document is available on the Office of Safety website at <http://safety.fhwa.dot.gov/>. Additionally, limited quantities of hard copies are available from the Report Center; inquiries may be directed to report.center@dot.gov or 814-239-1160.



Michael S. Griffith
Director
Office of Safety Technologies

Notice

This document is disseminated under the sponsorship of the U.S. Department of Transportation in the interest of information exchange. The U.S. Government assumes no liability for the use of the information contained in this document. This report does not constitute a standard, specification, or regulation.

The U.S. Government does not endorse products or manufacturers. Trademarks or manufacturers' names appear in this report only because they are considered essential to the objective of the document.

Quality Assurance Statement

The Federal Highway Administration (FHWA) provides high-quality information to serve Government, industry, and the public in a manner that promotes public understanding. Standards and policies are used to ensure and maximize the quality, objectivity, utility, and integrity of its information. FHWA periodically reviews quality issues and adjusts its programs and processes to ensure continuous quality improvement.

Median U-Turn Informational Guide

Technical Report Documentation Page

| | | | |
|--|--|--|-----------|
| 1. Report No. FHWA-SA-14-069 | 2. Government Accession No. | 3. Recipient's Catalog No. | |
| 4. Title and Subtitle Median U-Turn Informational Guide | | 5. Report Date August 2014 | |
| | | 6. Performing Organization Code | |
| 7. Authors Jonathan Reid, Larry Sutherland, Parsons-Brinckerhoff; Brian Ray, Andy Daleiden, Pete Jenior, Julia Knudsen, Kittelson & Associates, Inc. | | 8. Performing Organization Report No. Project 13517 | |
| 9. Performing Organization Name and Address Kittelson & Associates, Inc. 610 SW Alder Street, Suite 700 Portland, OR 97205 | | 10. Work Unit No. (TRAVIS) | |
| | | 11. Contract or Grant No. TO DTFH61-00023-T-13002 | |
| 12. Sponsoring Agency Name and Address U.S. Department of Transportation Federal Highway Administration Office of Safety 1200 New Jersey Ave., SE Washington, DC 20590 | | 13. Type of Report and Period Technical Report Informational Report September 2013 to August 2014 | |
| | | 14. Sponsoring Agency Code FHWA | |
| 15. Supplementary Notes Jeffrey Shaw (jeffrey.shaw@dot.gov), Office of Safety Technologies (http://safety.fhwa.dot.gov/), served as the Technical Manager for the Federal Highway Administration (FHWA). The following FHWA staff contributed as technical working group members, reviewers and/or provided input or feedback to the project at various stages: Joe Bared, Mark Doctor, Brian Fouch, Elizabeth Hilton, Jim McCarthy, George Merritt, Will Stein, Jim Sturrock and Wei Zhang. | | | |
| 16. Abstract This document provides information and guidance on Median U-Turn (MUT) intersections, resulting in designs suitable for a variety of typical conditions commonly found in the United States. To the extent possible, the guide provides information on the wide array of potential users as it relates to the intersection form. This guide provides general information, planning techniques, evaluation procedures for assessing safety and operational performance, design guidelines, and principles to be considered for selecting and designing MUT intersections. | | | |
| 17. Key Words MUT, Median U-Turn, Indirect Left, Michigan Left, Alternative intersections, Alternative interchanges, Innovative Intersections | | 18. Distribution Statement No restrictions. | |
| 19. Security Classif. (of this report) Unclassified | 20. Security Classif. (of this page) Unclassified | 21. No. of Pages 148 | 22. Price |

Form DOT F 1700.7 (8-72)

Reproduction of completed pages authorized

| SI* (MODERN METRIC) CONVERSION FACTORS | | | | |
|--|-----------------------------|-----------------------------|-----------------------------|---------------------|
| APPROXIMATE CONVERSIONS TO SI UNITS | | | | |
| Symbol | When You Know | Multiply By | To Find | Symbol |
| LENGTH | | | | |
| in | inches | 25.4 | millimeters | mm |
| ft | feet | 0.305 | meters | m |
| yd | yards | 0.914 | meters | m |
| mi | miles | 1.61 | kilometers | km |
| AREA | | | | |
| in ² | square inches | 645.2 | square millimeters | mm ² |
| ft ² | square feet | 0.093 | square meters | m ² |
| yd ² | square yard | 0.836 | square meters | m ² |
| ac | acres | 0.405 | hectares | ha |
| mi ² | square miles | 2.59 | square kilometers | km ² |
| VOLUME | | | | |
| fl oz | fluid ounces | 29.57 | milliliters | mL |
| gal | gallons | 3.785 | liters | L |
| ft ³ | cubic feet | 0.028 | cubic meters | m ³ |
| yd ³ | cubic yards | 0.765 | cubic meters | m ³ |
| NOTE: volumes greater than 1000 L shall be shown in m ³ | | | | |
| MASS | | | | |
| oz | ounces | 28.35 | grams | g |
| lb | pounds | 0.454 | kilograms | kg |
| T | short tons (2000 lb) | 0.907 | megagrams (or "metric ton") | Mg (or "t") |
| TEMPERATURE (exact degrees) | | | | |
| °F | Fahrenheit | 5 (F-32)/9 or (F-32)/1.8 | Celsius | °C |
| ILLUMINATION | | | | |
| fc | foot-candles | 10.76 | lux | lx |
| fl | foot-Lamberts | 3.426 | candela/m ² | cd/m ² |
| FORCE and PRESSURE or STRESS | | | | |
| lbf | poundforce | 4.45 | newtons | N |
| lbf/in ² | poundforce per square inch | 6.89 | kilopascals | kPa |
| APPROXIMATE CONVERSIONS FROM SI UNITS | | | | |
| Symbol | When You Know | Multiply By | To Find | Symbol |
| LENGTH | | | | |
| mm | millimeters | 0.039 | inches | in |
| m | meters | 3.28 | feet | ft |
| m | meters | 1.09 | yards | yd |
| km | kilometers | 0.621 | miles | mi |
| AREA | | | | |
| mm ² | square millimeters | 0.0016 | square inches | in ² |
| m ² | square meters | 10.764 | square feet | ft ² |
| m ² | square meters | 1.195 | square yards | yd ² |
| ha | hectares | 2.47 | acres | ac |
| km ² | square kilometers | 0.386 | square miles | mi ² |
| VOLUME | | | | |
| mL | milliliters | 0.034 | fluid ounces | fl oz |
| L | liters | 0.264 | gallons | gal |
| m ³ | cubic meters | 35.314 | cubic feet | ft ³ |
| m ³ | cubic meters | 1.307 | cubic yards | yd ³ |
| MASS | | | | |
| g | grams | 0.035 | ounces | oz |
| kg | kilograms | 2.202 | pounds | lb |
| Mg (or "t") | megagrams (or "metric ton") | 1.103 | short tons (2000 lb) | T |
| TEMPERATURE (exact degrees) | | | | |
| °C | Celsius | 1.8C+32 | Fahrenheit | °F |
| ILLUMINATION | | | | |
| lx | lux | 0.0929 | foot-candles | fc |
| cd/m ² | candela/m ² | 0.2919 | foot-Lamberts | fl |
| FORCE and PRESSURE or STRESS | | | | |
| N | newtons | 0.225 | poundforce | lbf |
| kPa | kilopascals | 0.145 | poundforce per square inch | lbf/in ² |

*SI is the symbol for the International System of Units. Appropriate rounding should be made to comply with Section 4 of ASTM E380. (Revised March 2003)

TABLE OF CONTENTS

CHAPTER 1— INTRODUCTION..... 1
OVERVIEW OF ALTERNATIVE INTERSECTIONS AND INTERCHANGES 1
INTERSECTION CONTROL EVALUATIONS AND CONSIDERATIONS 1
ORGANIZATION OF THE GUIDELINES 2
SCOPE OF THE GUIDE..... 3
MUT INTERSECTION OVERVIEW 3
APPLICATION 7
RESOURCE DOCUMENTS..... 13

CHAPTER 2— POLICY AND PLANNING 15
PLANNING CONSIDERATIONS FOR ALTERNATIVE INTERSECTIONS AND
INTERCHANGES 15
STAKEHOLDER OUTREACH..... 18
POLICY CONSIDERATIONS 21
PLANNING CONSIDERATIONS 21
PLANNING CHALLENGES 22
PROJECT PERFORMANCE CONSIDERATIONS 23
PROJECT DEVELOPMENT PROCESS..... 24
SUMMARY OF MUT ADVANTAGES AND DISADVANTAGES 26

CHAPTER 3— MULTIMODAL CONSIDERATIONS..... 28
DESIGN PRINCIPLES AND APPROACH 29
PEDESTRIANS 29
BICYCLISTS..... 34
TRANSIT VEHICLE CONSIDERATION 36
HEAVY VEHICLE CONSIDERATIONS..... 38

CHAPTER 4— SAFETY 39
SAFETY PRINCIPLES 39
OBSERVED SAFETY PERFORMANCE..... 41
SAFETY CONSIDERATIONS..... 43
INCIDENT RESPONSE CONSIDERATIONS 46
SAFETY EVALUATION CONSIDERATIONS..... 47

CHAPTER 5— OPERATIONAL CHARACTERISTICS 49
OPERATIONAL PRINCIPLES 49
OPERATIONAL CONSIDERATIONS 55
COMPARATIVE LITERATURE AND PERFORMANCE STUDIES 56

| | |
|--|------------|
| CHAPTER 6— OPERATIONAL ANALYSIS | 59 |
| OPERATIONAL ANALYSIS TOOL OVERVIEW..... | 60 |
| PLANNING-LEVEL ANALYSIS | 61 |
| HIGHWAY CAPACITY ANALYSIS (HCM) ANALYSIS..... | 63 |
| MICROSIMULATION ANALYSIS..... | 67 |
| CHAPTER 7— GEOMETRIC DESIGN | 69 |
| DESIGN APPROACH..... | 69 |
| GEOMETRIC DESIGN PARAMETERS/PRINCIPLES..... | 71 |
| RANGE OF MUT CONFIGURATIONS..... | 71 |
| OPERATIONAL EFFECTS OF GEOMETRIC DESIGN..... | 76 |
| DESIGN GUIDANCE | 78 |
| CHAPTER 8— SIGNAL, MARKING, SIGNING, AND LIGHTING CONSIDERATIONS | 91 |
| DESIGN PRINCIPLES AND APPROACH | 91 |
| SIGNALIZED VERSUS UNSIGNALIZED U-TURN CROSSOVERS | 91 |
| SIGNALS..... | 92 |
| SIGNING | 96 |
| PAVEMENT MARKING..... | 99 |
| LIGHTING | 100 |
| CHAPTER 9— CONSTRUCTION AND MAINTENANCE | 103 |
| CONSTRUCTION..... | 103 |
| COSTS | 105 |
| MAINTENANCE | 106 |
| REFERENCES | 108 |
| Appendix A CATALOG OF ALL KNOWN INSTALLATIONS IN THE UNITED STATES | 111 |
| Appendix B SUPPLEMENTAL OPERATIONAL AND SAFETY DETAILS | 125 |
| Appendix C MARKETING AND OUTREACH MATERIALS | 127 |
| Appendix D SUPPLEMENTAL CONSTRUCTION AND DESIGN DETAILS | 137 |

LIST OF EXHIBITS

| | |
|--|----|
| Exhibit 1-1. Example of a MUT intersection..... | 4 |
| Exhibit 1-2. Example of a MUT intersection with one signal in main intersection. | 5 |
| Exhibit 1-3. Added stop-controlled U-turn crossover near intersection. ⁽¹⁾ | 6 |
| Exhibit 1-4. U-turn crossover on minor street. ⁽¹⁾ | 6 |
| Exhibit 1-5. Use of loons to reduce median width. ⁽²⁾ | 6 |
| Exhibit 1-6. U-turn crossovers on both streets. ⁽¹⁾ | 7 |
| Exhibit 1-7. Locations of MUT intersections. | 8 |
| Exhibit 1-8. Example of a U-Turn crossover intersection in Draper, Utah. ⁽³⁾ | 8 |
| Exhibit 1-9. View of upstream traffic approaching a MUT intersection in Draper, Utah. ⁽³⁾ | 9 |
| Exhibit 1-10. Advance signing at a MUT intersection in Draper, Utah. ⁽³⁾ | 9 |
| Exhibit 1-11. Example of a bicycle traveling through a MUT intersection in Draper, Utah. ⁽³⁾ ... | 10 |
| Exhibit 1-12. Pedestrian crossings at MUT main crossing intersection in Troy, Michigan. ⁽²⁾ | 10 |
| Exhibit 1-13. MUT crossover intersection in Southfield, Michigan. ⁽⁴⁾ | 11 |
| Exhibit 1-14. MUT crossover with direct access to adjacent land use in Southfield, Michigan. ⁽²⁾ | 11 |
| Exhibit 1-15. MUT intersection pedestrian connection and median landscaping in Birmingham, Michigan. ⁽²⁾ | 12 |
| Exhibit 1-16. MUT intersection with water retention ponds in median in New Orleans, Louisiana. ⁽²⁾ | 12 |
| Exhibit 1-17. MUT intersection with development in wide median in Silver Spring, Maryland. ⁽²⁾ | 13 |
| Exhibit 2-1. Relationship between traffic volume served and intersection type. | 17 |
| Exhibit 2-2. MUT intersection information page from UDOT. ⁽¹⁶⁾ | 18 |
| Exhibit 2-3. Thru-Turn Intersection video used by UDOT. ⁽¹⁷⁾ | 19 |
| Exhibit 2-4. Express left intersection graphic used by City of Tucson, AZ. ⁽¹⁸⁾ | 20 |
| Exhibit 2-5. Project development process. ⁽²²⁾ | 24 |
| Exhibit 2-6. Summary of MUT advantages and disadvantages..... | 27 |
| Exhibit 3-1. Pedestrian-vehicle conflict points at a conventional intersection. | 30 |
| Exhibit 3-2. Pedestrian-vehicle conflict points at MUT intersection. | 31 |
| Exhibit 3-3. Comparison of major street walk phases at conventional and MUT intersections... | 31 |
| Exhibit 3-4. Single- versus two-stage pedestrian crossings..... | 32 |
| Exhibit 3-5. Signalized mid-block crossing..... | 33 |
| Exhibit 3-6. Right-turn lane with bicycle lane..... | 35 |
| Exhibit 3-7. Left turn options for bicycles..... | 36 |
| Exhibit 3-8. Bus stop locations. | 37 |
| Exhibit 3-9. LRT or BRT accommodations in MUT corridor. ⁽²⁴⁾ | 38 |
| Exhibit 4-1. Conflict point comparison. | 39 |
| Exhibit 4-2. Vehicle-vehicle conflict points at conventional intersection. | 40 |
| Exhibit 4-3. Vehicle-vehicle conflict points at MUT intersection..... | 40 |
| Exhibit 4-4. Crash Rate comparison of MUT and conventional intersections. ⁽¹¹⁾ | 42 |
| Exhibit 4-5. Forecast crashes for MUT and conventional intersections for a 5-year period. ⁽¹¹⁾ ... | 42 |
| Exhibit 4-6. Example of U-turn/right-turn conflict. ⁽¹⁾ | 44 |
| Exhibit 4-7. MUT crossover detail. ⁽²⁷⁾ | 44 |
| Exhibit 4-8. MUT restrictive signing. ⁽⁴⁾ | 45 |
| Exhibit 4-9. Dual lane crossover design path overlap potential. | 46 |

| | |
|---|-----|
| Exhibit 5-1. Concurrent movements at a conventional intersection and at a MUT intersection. . | 50 |
| Exhibit 5-2. Typical MUT intersection signal locations..... | 51 |
| Exhibit 5-3. Comparison of intersection cycle lengths and phasing. ⁽⁴⁾ | 52 |
| Exhibit 5-4. MUT signal phase timing. | 53 |
| Exhibit 5-5. MUT intersection vehicle paths options. | 54 |
| Exhibit 5-6. Divided highway level of service and throughput comparison. ⁽¹²⁾ | 56 |
| Exhibit 5-7. Summary of comparison literature and performance studies. | 57 |
| Exhibit 6-1. MUT analysis techniques..... | 61 |
| Exhibit 6-2. CAP-X Planning Level Tool Screen Capture. ⁽³⁷⁾ | 62 |
| Exhibit 6-3. LOS criteria for signalized intersections (based on HCM Exhibit 18-5). ⁽⁶⁾ | 64 |
| Exhibit 6-4. HCM methodology for MUT intersection evaluation (adapted from HCM Exhibit 18-11). ⁽⁶⁾ | 65 |
| Exhibit 6-5. Input data for HCM evaluation of MUT intersections (based on HCM Exhibit 18-6). ⁽⁶⁾ | 66 |
| Exhibit 7-1. MUT characteristics..... | 70 |
| Exhibit 7-2. MUT intersection with one signal at the main intersection. | 70 |
| Exhibit 7-3. MUT intersection design variations – stop control crossover near intersection..... | 72 |
| Exhibit 7-4. MUT intersection design variations – U-turn crossover on minor street. | 73 |
| Exhibit 7-5. MUT intersection design variations – U-turn on both streets..... | 74 |
| Exhibit 7-6. RCUT intersection. | 75 |
| Exhibit 7-7. MUT intersection with narrow median, Tucson, AZ. ⁽¹⁾ | 76 |
| Exhibit 7-8. Loon at U-turn crossover in Wilmington, NC. ⁽⁹⁾ | 76 |
| Exhibit 7-9. Bicycle box for left turn..... | 78 |
| Exhibit 7-10. Typical right-turn lanes at MUT intersections. ⁽¹⁰⁾ | 79 |
| Exhibit 7-11. Directional crossover design on highway. ⁽²⁷⁾ | 80 |
| Exhibit 7-12. AASHTO- minimum median widths for U-Turn crossovers. ⁽⁵⁾ | 82 |
| Exhibit 7-13. Loon design serving a design vehicle. ⁽²⁷⁾ | 82 |
| Exhibit 7-14. Footprint comparison of a MUT intersection versus a conventional intersection. . | 84 |
| Exhibit 7-15. Spacing consideration for a major street left turn movement. | 86 |
| Exhibit 7-16. Spacing consideration for minor street left turn movement. | 87 |
| Exhibit 7-17. Spacing consideration for a right turn..... | 88 |
| Exhibit 8-1: Example of signalized (left) and unsignalized (right) U-turn crossover intersections. ⁽⁴⁾ | 92 |
| Exhibit 8-2. MUT intersection with multiple controllers. | 93 |
| Exhibit 8-3. MUT intersection with single controller..... | 94 |
| Exhibit 8-4: Signal pole placement for the U-turn crossover. | 95 |
| Exhibit 8-5. Detector placements..... | 96 |
| Exhibit 8-6. Example of MUT intersection signing plan..... | 98 |
| Exhibit 8-7. Alternate crossover guide sign..... | 98 |
| Exhibit 8-8. Alternate major street advance guide sign..... | 99 |
| Exhibit 8-9. Traditional fishhook (left), variation used in Michigan (center) and ThrU signage used in Utah (right). | 99 |
| Exhibit 8-10. Typical pavement marking at a directional crossover. ⁽²⁷⁾ | 100 |
| Exhibit 8-11. Pavement markings at a directional crossover with dual lanes. ⁽²⁷⁾ | 100 |
| Exhibit 9-1. Summary of costs associated with MUT intersections. | 106 |

CHAPTER 1— INTRODUCTION

OVERVIEW OF ALTERNATIVE INTERSECTIONS AND INTERCHANGES

Alternative intersections and interchanges offer the potential to improve safety and reduce delay at a lower cost and with fewer impacts than traditional solutions. However, transportation professionals are generally unfamiliar with many alternative intersection and interchange forms, partially because some forms have only a few installations in operation or because installations are concentrated in a few states. Furthermore, at the national level, well-documented and substantive resources needed for planning, analysis, design, and public outreach and education were limited.

Concurrent with this Median U-Turn (MUT) Informational Guide, the Federal Highway Administration (FHWA) developed and published informational guides for three other alternative intersection forms: Displaced Left Turn (DLT), Restricted Crossing U-Turn (RCUT), and Diverging Diamond Interchange (DDI). These guides are intended to increase awareness of these specific alternative intersections and interchanges and provide guidance on how to plan, design, construct, and operate them. These guidelines represent summaries of the current state of knowledge with the intent of supporting decisions when considering and potentially selecting alternative intersection and interchange forms for appropriate applications.

INTERSECTION CONTROL EVALUATIONS AND CONSIDERATIONS

The term “intersection” means the junction of two or more street facilities. In some cases, this may specifically mean an “at-grade” intersection form. In others, it may include the junction of two or more streets requiring partial or complete grade separation (“interchanges”). A number of state and city transportation agencies have or are implementing intersection control evaluation processes or policies as a means of integrating the widest range of intersection forms as project solutions. For example, California, Indiana, Minnesota, and Wisconsin have policies or processes to objectively consider and select the most appropriate intersection form for a given project context.

Many of the policies or processes include common objectives in selecting the optimal or preferred intersection control alternative for a given project context. The common elements generally include but not be limited to the following:

- Understanding the intended context, and how operations, safety, and geometry fit the that context for each intersection or corridor including intended users (pedestrians, bicyclists, passenger cars, transit vehicles, freight, emergency responders, and over size/over weight [OSOW] vehicles)
- Identifying and documenting the overall corridor or intersection context including the built, natural, and community environment and the intended performance outcomes of the intersection form
- Considering and assessing a wide range of traffic control strategies and other practical improvement concepts to identify worthy project-level technical evaluation

- Comparing engineering and economic analysis results of practical alternatives that consider implementation costs, performance benefits and impacts (safety, multimodal, operations, environment, etc.), and the estimated service life of alternatives

ORGANIZATION OF THE GUIDELINES

This guide is structured to address the needs of a variety of readers, including the general public, policy makers, transportation planners, operations and safety analysts, and conceptual and detailed designers. This chapter distinguishes MUT intersections from conventional intersections and provides an overview of each chapter in this guide. The remaining chapters in this guide increase in the level of detail provided.

Chapter 2: Policy and Planning—This chapter provides guidance on when to consider alternative intersections in general and MUT intersections in particular. Considerations related to policies, project challenges, performance measures, and the project development process throughout the duration of the project are presented.

Chapter 3: Multimodal Considerations—This chapter provides an overview of multimodal facilities at MUT intersections and how the needs of various users should inform decisions to produce a facility that optimally serves non-motorized and motorized traffic.

Chapter 4: Safety— This chapter summarizes documented safety performance and safety considerations at MUT intersections based on studies completed by state agencies and recent research efforts. Although the documented safety performance of MUT intersections is limited, information about conflict points and emergency services at these intersections are discussed.

Chapter 5: Operational Characteristics—This chapter provides information on the unique operational characteristics of MUT intersections and how they affect elements such as traffic signal phasing and coordination. The chapter also provides guidance for practitioners related to design elements such as driveways that may affect the operational performance of MUT intersections. It describes the unique operational characteristics of MUT intersections and prepares transportation professionals for conducting operational analysis as described in Chapter 6.

Chapter 6: Operational Analysis—This chapter presents an overview of the approach and tools available for conducting a traffic operations analysis of a MUT intersection.

Chapter 7: Geometric Design—This chapter describes the typical MUT intersection design approach and provides guidance for geometric features. Design of a MUT intersection will also require reviewing and integrating the intersection's multimodal considerations (Chapter 3), safety assessment (Chapter 4), and traffic operational analysis (Chapters 5 and 6).

Chapter 8: Signal, Signing, Marking, and Lighting—This chapter presents information relating to the design and placement of traffic control devices at MUT intersections, including traffic signals, signs, pavement markings, and intersection lighting.

Chapter 9: Construction and Maintenance—This chapter focuses on the constructability and maintenance of a MUT intersection.

An Appendix is included at the end of this guide for the purpose of providing more detailed information about many of the resources and best practices relating to MUT intersections. The Appendix contains the following information:

- A - Catalog of all known installations in the United States
- B - Supplemental operational and safety details
- C - Marketing and outreach materials
- D - Supplemental construction and design details

SCOPE OF THE GUIDE

This guide provides information and guidance on planning and designing for MUT intersections, resulting in designs suitable for a variety of typical conditions commonly found in the United States. To the extent possible, the guide provides information on how the intersection form can accommodate a wide variety of users. Developed from best practices and prior research, the scope of this guide is to provide general information, planning techniques, evaluation procedures for assessing safety and operational performance, design guidelines, and principles to be considered for selecting and designing MUT intersections. This guide does not include specific legal or policy requirements. However, Chapter 2 provides information on planning topics and considerations when investigating intersection control forms.

MUT INTERSECTION OVERVIEW

The Median U-Turn (MUT) Intersection is also known as the Median U-turn Crossover and sometimes referred to as a boulevard turnaround, a Michigan loon, or Thru-Turn Intersection. For the purposes of this informational guide, MUT refers to any intersection replacing direct left turns at an intersection with *indirect* left turns using a U-turn movement in a wide median. The MUT intersection eliminates left turns on both intersecting streets and thus reduces the number of traffic signal phases and conflict points at the main crossing intersection, resulting in improved intersection operations and safety.

At a MUT intersection, vehicles on the major street (the street with the wide median) that would typically turn left at a signalized intersection with the crossing street are directed through the main crossing intersection, make a U-turn movement at a downstream directional crossover (that is usually signalized), and proceed back to the main crossing intersection (in the opposite direction from which the motorist came). They then turn right onto the minor street. Directional crossovers are one-way median openings facilitating U-turns. Loons are paved areas on the outside edge of the travel lanes opposite directional crossovers that enable U-turns by large vehicles.

Similarly, vehicles on the minor street that would typically turn left at a signalized intersection with the major street are directed to turn right onto the major street, make a U-turn movement at the same directional crossover 500 to 600 feet downstream, and then proceed through the main crossing street. The signals at the main crossing intersection (that permit only through and right-turn movements from both streets) and the signals at the U-turn crossovers (that osculate between through traffic on the major street and U-turn movements) are coordinated to minimize stops and delays to both through and turning traffic. Exhibit 1-1 illustrates an example of a MUT intersection with two signals at the main intersection. Exhibit 1-2 illustrates an example of a MUT intersection with one signal at the main intersection.

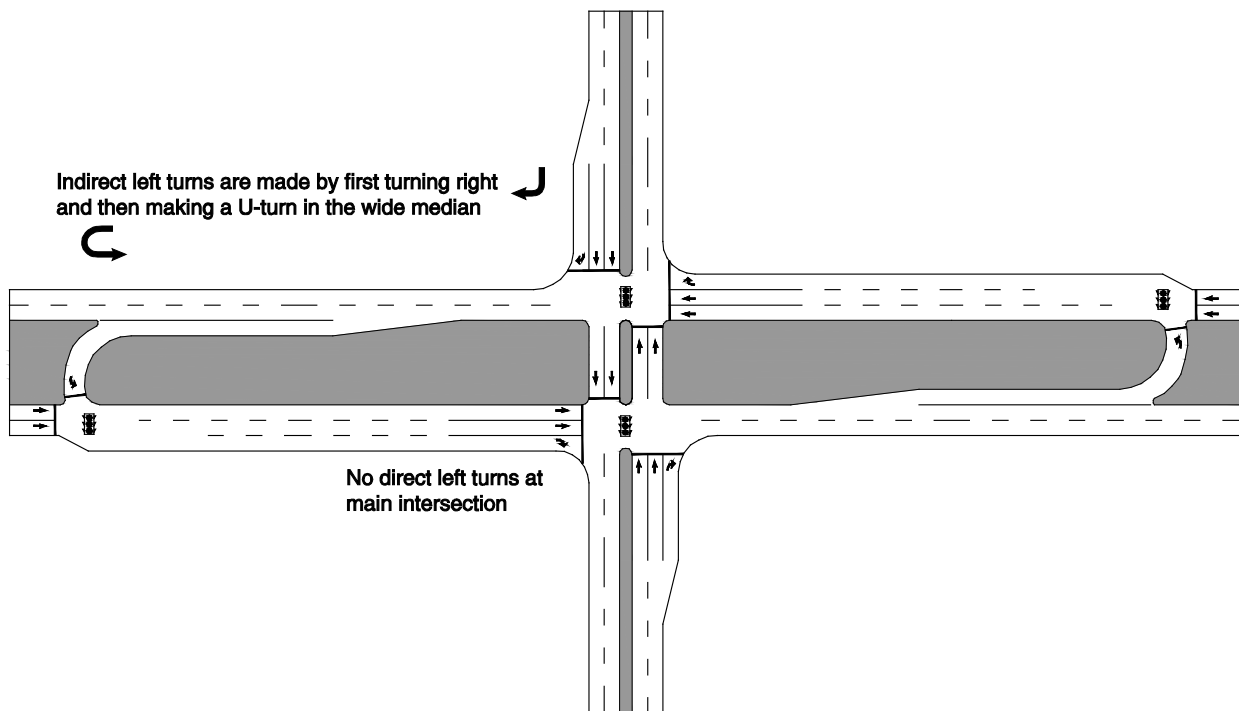

Exhibit 1-1. Example of a MUT intersection.

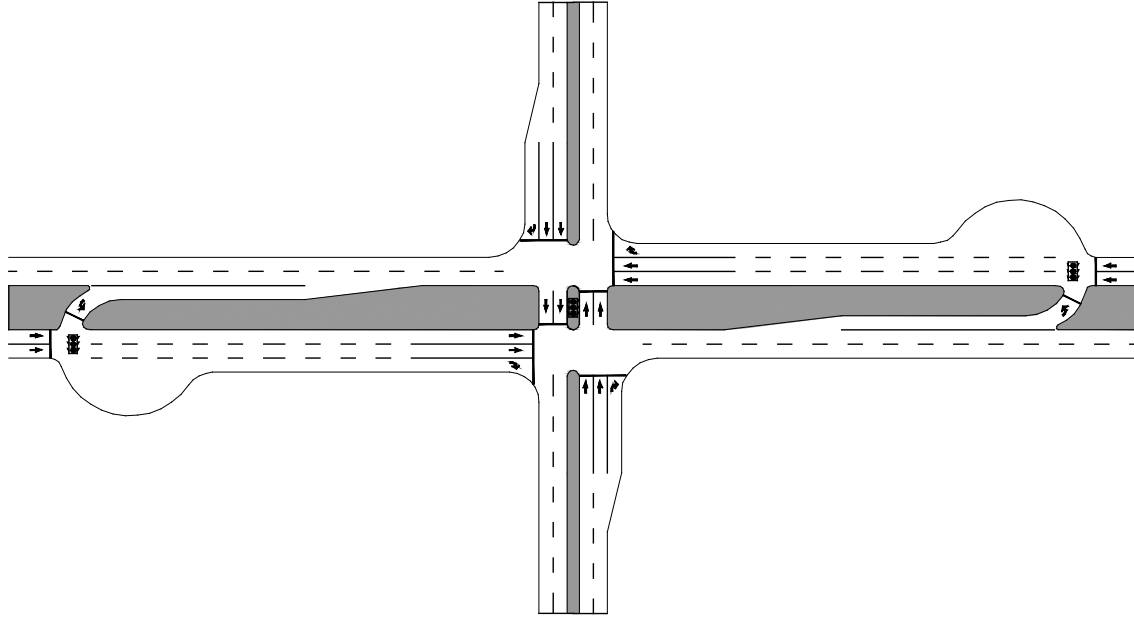

Exhibit 1-2. Example of a MUT intersection with one signal in main intersection.

There are unique design variations of the Median U-Turn intersections, which include:

- Placing a stop-controlled directional crossover immediately prior to the primary intersection
- Placing directional crossovers on the minor street to minimize major street median width and right-of-way requirements
- Using loons at crossover intersections to reduce median width requirements
- Placing directional crossovers on both the major and minor street

The selection of one of these variations is commonly influenced by right-of-way availability on the major and minor streets and the anticipated intersection and U-turn crossover volumes. MUT intersections can be used in multiple variations to accommodate specific locations. Crossover placement can be adjusted to minimize impacts to access, provide better access, or to work with right-of-way limitations. Exhibits 1-3 through 1-6 illustrate each design variation of the MUT intersection.

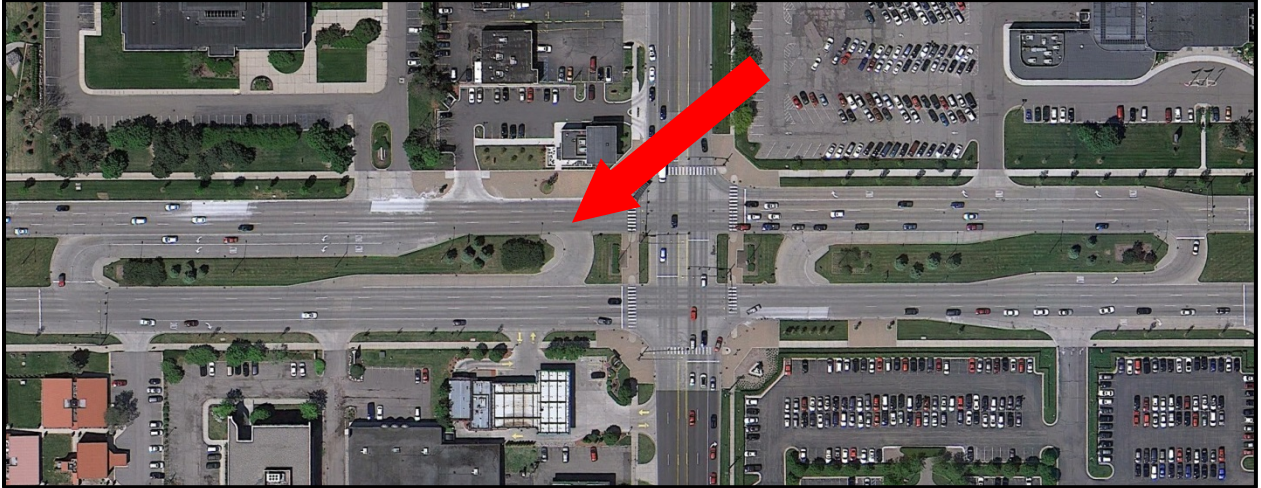

Exhibit 1-3. Added stop-controlled U-turn crossover near intersection.⁽¹⁾



Exhibit 1-4. U-turn crossover on minor street.⁽¹⁾



Exhibit 1-5. Use of loons to reduce median width.⁽²⁾



Exhibit 1-6. U-turn crossovers on both streets.⁽¹⁾

APPLICATION

Several MUT intersections have been installed throughout the United States and each location is documented in the Appendix. Exhibit 1-7 shows the location of known MUT intersections in the United States, as of the publication of this guide.

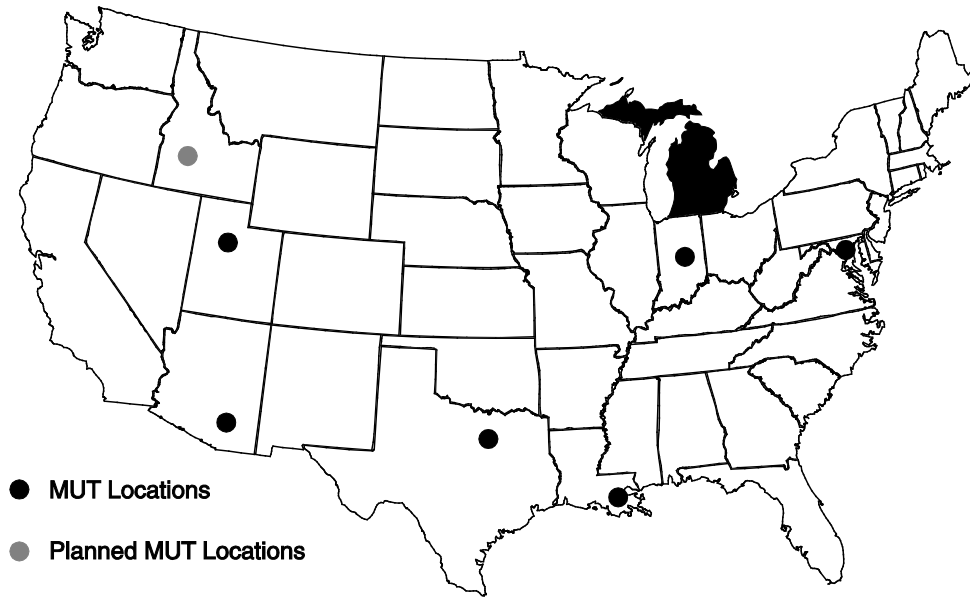

Exhibit 1-7. Locations of MUT intersections.

Exhibit 1-8 through Exhibit 1-17 feature photos of MUT intersections illustrating different contextual environments and a variety of design features.



Exhibit 1-8. Example of a U-Turn crossover intersection in Draper, Utah.⁽³⁾



Exhibit 1-9. View of upstream traffic approaching a MUT intersection in Draper, Utah.⁽³⁾



Exhibit 1-10. Advance signing at a MUT intersection in Draper, Utah.⁽³⁾



Exhibit 1-11. Example of a bicycle traveling through a MUT intersection in Draper, Utah.⁽³⁾



Exhibit 1-12. Pedestrian crossings at MUT main crossing intersection in Troy, Michigan.⁽²⁾



Exhibit 1-13. MUT crossover intersection in Southfield, Michigan.⁽⁴⁾

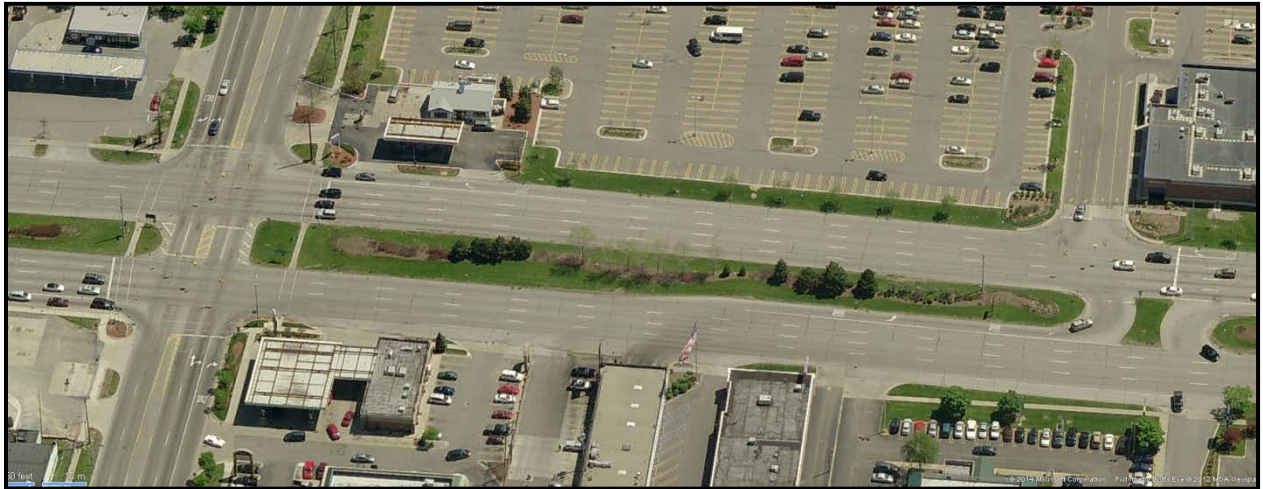

Exhibit 1-14. MUT crossover with direct access to adjacent land use in Southfield, Michigan.⁽²⁾



Exhibit 1-15. MUT intersection pedestrian connection and median landscaping in Birmingham, Michigan.⁽²⁾



Exhibit 1-16. MUT intersection with water retention ponds in median in New Orleans, Louisiana.⁽²⁾



Exhibit 1-17. MUT intersection with development in wide median in Silver Spring, Maryland.⁽²⁾

RESOURCE DOCUMENTS

This MUT intersection guide is supplemental to major resource documents including but not limited to:

- *A Policy on Geometric Design of Highways and Streets* (American Association of State Highway and Transportation Officials [AASHTO] Green Book)⁽⁵⁾
- *Highway Capacity Manual* (HCM)⁽⁶⁾
- *Manual of Uniform Traffic Control Devices* (MUTCD)⁽⁷⁾
- *Highway Safety Manual* (HSM)⁽⁸⁾
- Other referenced research documents that are more specialized to specific areas of the guide include various National Cooperative Highway Research Program (NCHRP) reports, Transportation Research Board (TRB) papers, and FHWA publications

The following are supplemental resource documents specific to MUT intersections:

- FHWA Alternative Intersections/Interchanges: Informational Report (AIIR), June 2010⁽⁹⁾
- FHWA Signalized Intersections: Informational Guide⁽¹⁰⁾
- FHWA Synthesis of the Median U-Turn Intersection Treatment⁽¹¹⁾
- “Directional Crossovers: Michigan’s Preferred Left Turn Strategy,” Michigan Department of Transportation Geometric Design Unit, December 1995⁽¹²⁾
- “Operational Aspects of Michigan Design for Divided Highways,” *Transportation Research Record 1579*⁽¹³⁾
- “A Preliminary Study in the Efficiency of Median U-Turn and Jughandle Arterial Left Turn Alternatives,” presented at the 72nd Annual Meeting of the TRB, Washington, DC, January 1993⁽¹⁴⁾
- “Analyzing System Travel Time in Arterial Corridors with Unconventional Designs Using Microscopic Simulation,” *Transportation Research Record 1678*⁽¹⁵⁾

CHAPTER 2— POLICY AND PLANNING

This chapter contains guidance on how to consider alternative intersections in general and MUT intersections in particular. This chapter summarizes policy and planning considerations related to MUT intersections. The remaining chapters of this guide will provide specific details of the multimodal, safety, operations, geometric design, and traffic control features of MUT intersections.

Alternative intersections are often initially considered for operational or safety needs, and other key factors may include spatial requirements and multimodal needs. This chapter provides approximate footprints for different types of MUT intersections to allow for planning-level screening and feasibility analysis.

PLANNING CONSIDERATIONS FOR ALTERNATIVE INTERSECTIONS AND INTERCHANGES

Alternative intersection evaluations may vary depending on the stage of the project development process. Each project stage can affect how the policy and technical considerations are assessed. While operation, design, safety, human factors, and signing controls should be considered at every stage of the development process, a planning-level design evaluation may not require the same level of analysis or detailed evaluation of each consideration as projects in later development stages. Evaluations should be as comprehensive as needed to answer key project questions for each unique project context.

Serving Pedestrians and Bicycles

When considering a MUT intersection, integrating pedestrian and bicycle needs at an early stage of the project planning process yields a higher quality solution. The unique characteristics of a MUT intersection require a wide median and reduced number of signal phases, which can introduce both benefits and challenges to pedestrians and bicyclists.

Pedestrians crossing at a MUT intersection encounter fewer conflicting traffic streams than at a conventional intersection. Crosswalks can be placed across all intersection legs and generally follow direct lines similar to conventional intersections. Pedestrians cross the major street during the minor street through and right-turn signal phase. Removing the left turns from the main crossing intersection creates a two-phase signal. This allows for a shorter signal cycle length while maintaining a similar green time for pedestrians and vehicles compared to a conventional intersection form. This benefits pedestrians by creating more pedestrian phases per hour and less “don’t walk” time between “walk” times (i.e. less wait time between walk signals).

A typical MUT intersection includes a wide center median on at least one or both streets, which may cause the total pedestrian crossing distance of the major street to be longer than a conventional intersection (though newer installations in Utah and Tucson, AZ are on streets without medians). Longer crossing distances must be accommodated in the signal phasing. The wide median allows for breaking the pedestrian crossing into two simplified crossings with each only opposed by one direction of traffic, and the lack of left-turn lanes generally reduces the number of lanes crossed by pedestrians compared to a conventional intersection.

Many MUT intersections have higher than average vehicle speeds because they are often built along principle or other high-volume streets designed to carry vehicles at higher speeds. Despite higher than average speeds, there are at least two older MUT corridors in Michigan that have more recently been retrofit with bicycle lanes, and the trend for newer and reconstructed streets in many communities is to integrate Complete Streets policies that include bicycle accommodations. Complete Streets is a transportation policy and design approach requiring a street to be planned, designed, operated, and maintained to enable safe, convenient, and comfortable travel and access for users of all ages and abilities regardless of their mode of transportation.

Through and right-turning bicyclists navigate MUT intersections in the same way as conventional intersections. Left-turning bicyclists have several options for navigating a MUT intersection, described in detail in Chapter 3. They can use the U-turn crossover, pass through the intersection on a multi-use path as a pedestrian would, or make two stage direct left turns and wait on the shoulder or in bicycle lanes or bicycle boxes.

Traffic Volume Relationships

Exhibit 2-1 conceptually depicts the relationship of conventional intersections, alternative intersections, and grade separations in their ability to serve increasing traffic volumes.

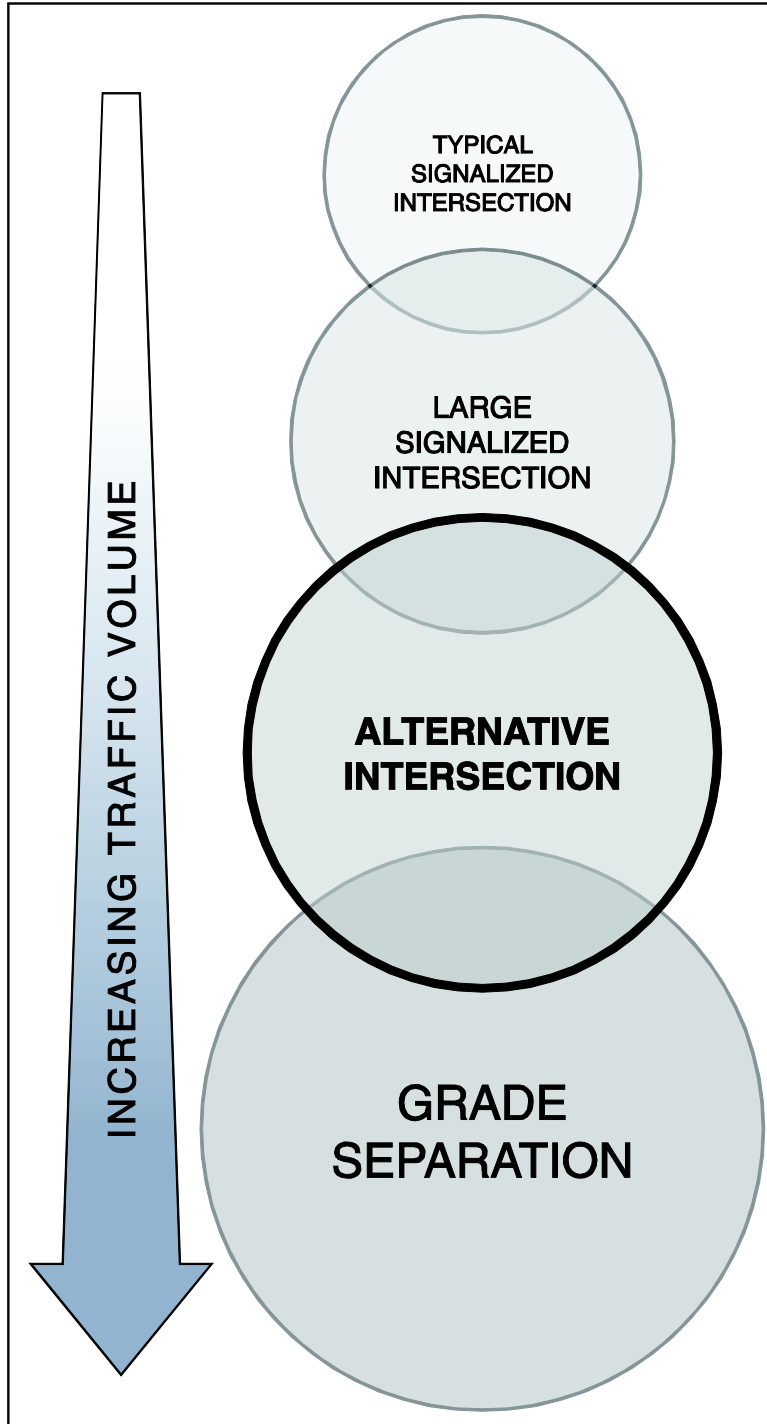

Exhibit 2-1. Relationship between traffic volume served and intersection type.

A MUT intersection generally has a larger footprint compared to conventional intersection because of the wide median and/or the loons. With right-of-way restrictions, it can be difficult to widen or add lanes; therefore, careful planning is required during the initial design of a MUT intersection. The right-of-way footprint may affect any agency’s decision on whether to construct this type of intersection.

STAKEHOLDER OUTREACH

Similar to other transportation projects, stakeholder outreach is a critical part of the overall planning process. Successfully implementing the first MUT intersection in a community may result from explicit and proactive outreach and education to affected stakeholders and the general public. This would create opportunities to familiarize others with how the intersections work while creating opportunities to hear of general project and MUT intersection specific issues and considerations.

Creating multiple forums to engage the public (including presentations at local council or board meetings, briefs at community organization functions, and project-specific open house meetings) results in opportunities to listen to community interests and share objective information about the intersection form. Media campaigns through local newspapers, television, and public meetings can be effective methods of keeping the community informed. Exhibit 2-2 is an example of an informational map used by the Utah Department of Transportation (UDOT) for explaining MUT intersections (Thru-Turn Intersections) to various users. Once the intersection is open to the public, monitoring driver behavior and using law enforcement as necessary to promote proper use of the new form can aid driver acclimation.



Exhibit 2-2. MUT intersection information page from UDOT.⁽¹⁶⁾

UDOT has also prepared videos for users to learn more about navigating this type of alternative intersection. Exhibit 2-3 shows multiple screen captures from the UDOT Thru-Turn Intersection video.



Exhibit 2-3. Thru-Turn Intersection video used by UDOT.⁽¹⁷⁾

In addition, some agencies have used different names to advertise and explain the MUT intersection during stakeholder outreach. The City of Tucson, AZ and Regional Transportation Authority use the term “express left” and “indirect left turn” intersection. Exhibit 2-4 shows a graphic for the “express left” intersection and provides information on how users may navigate the intersection.

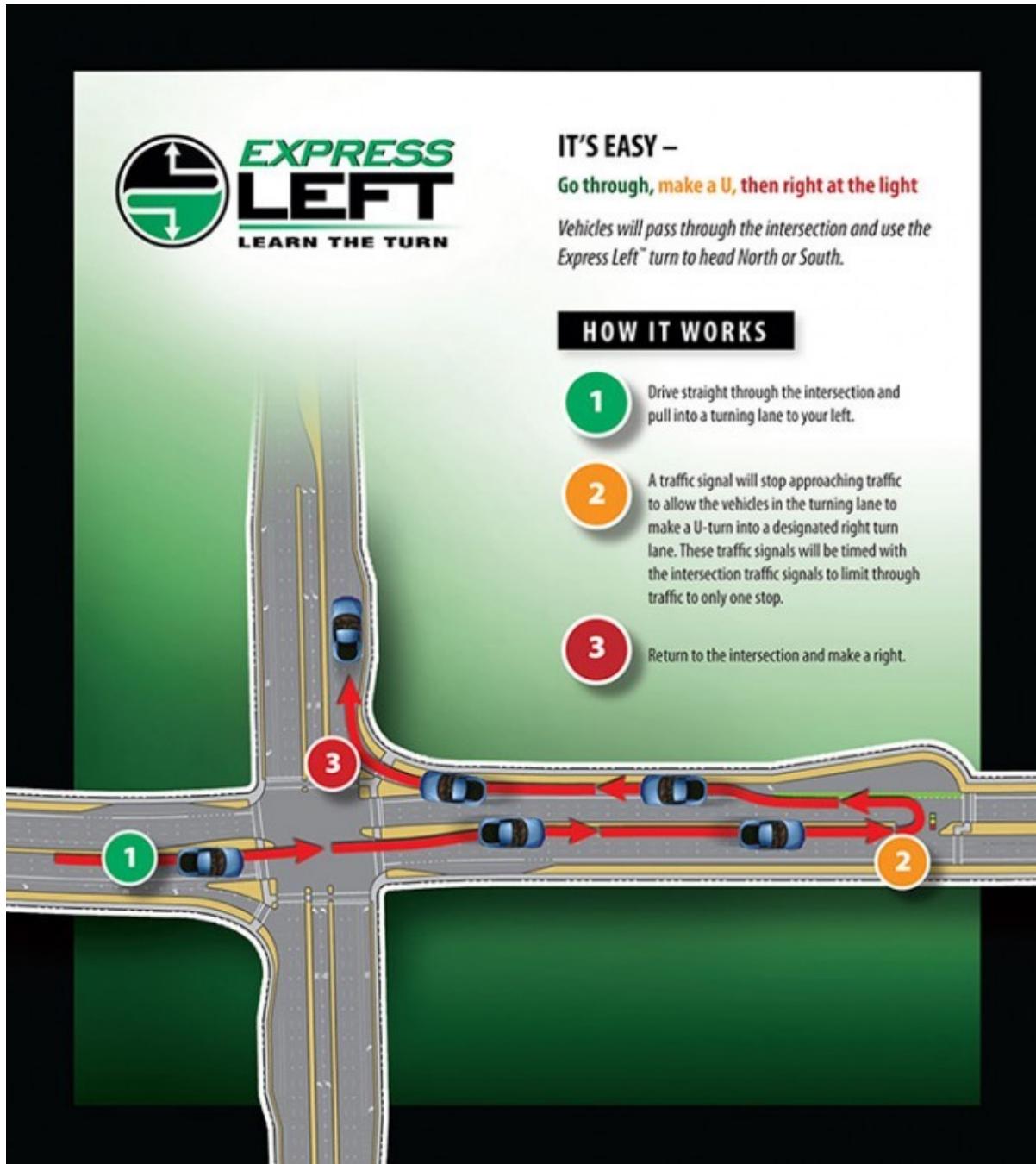

Exhibit 2-4. Express left intersection graphic used by City of Tucson, AZ.⁽¹⁸⁾

FHWA has created alternative intersection and interchange informational videos and video case studies, which can be viewed on the FHWA YouTube channel (<https://www.youtube.com/user/USDOTFHWA>).⁽¹⁹⁾ In addition, FHWA has developed alternative intersection brochures that can be found on the FHWA website (<http://safety.fhwa.dot.gov>).⁽²⁰⁾ Examples of this information are shown in the appendix.

POLICY CONSIDERATIONS

Designing, operating, and managing a street and its intersections should align with the appropriate jurisdictional policies associated with that facility. The facility location and type can often dictate the appropriateness of the right-of-way and access management needs associated with alternative intersections. The degree to which motor vehicle throughput should or should not be prioritized over other modes also plays a role in determining the appropriateness of alternative intersections at specific locations.

Some of the policy considerations of a MUT intersection include the following:

- Access management
 - U-turns
 - Driveway spacing or signal spacing criteria
- Operational Measures of Effectiveness (MOEs) criteria
- Pedestrian facilities with access and wayfinding for persons with disabilities, including the requirements of the Americans with Disabilities Act (ADA) and Section 504 (the Rehabilitation Act)⁽²¹⁾
- Providing safe and convenient bicycle facilities
- Design vehicle
- Snow removal and storage
- Incident management
- Emergency response needs
- Isolated versus corridor implementations
- Allowing or prohibiting left turn on red (LTOR). Several states currently do not permit LTOR between one-way streets. This has potential operational implications at U-turn crossover intersections.

PLANNING CONSIDERATIONS

The following are planning considerations for an alternative intersection design:

- **Community goals** – Outside formalized land use policies, cities and communities often have general goals that provide insights about the nature and character of their community. These goals can range from concepts that preserve a historic character or identified heritage to creating walkable communities or complete streets. Other goals can be to encourage economic development by preserving existing business or residential

areas while encouraging thoughtful development. Regardless of the specific goals or vision, these considerations may influence street and intersection design.

- **Surrounding land uses and zoning** – Consider the land uses along MUT intersections and possible design modifications that can be made to improve land use viability.
- **Project context** – Key questions that help to identify stakeholders for a particular project might include:
 - What is the purpose and function of the existing or planned road facilities?
 - What are the existing and planned land uses adjacent to and in the vicinity of the road facilities?
 - Who will likely desire to use the road facilities given the existing and planned land uses?
 - What are the existing and anticipated future socio-demographic characteristics of the populations adjacent to and in the vicinity of the existing or planned road facilities?
 - What are the perceived or actual shortcomings of the existing road facilities?
 - Who has jurisdiction over the facility?
 - Where is capital funding for the project originating (or expected to originate)?
 - Who will operate and maintain the facility?
- **Multimodal considerations** – Pedestrian, bicycle, and transit needs should play a role in selecting an intersection form and developing intersection design elements.
- **Access management** – On an intersection approach with a MUT, access may need to be restricted near crossovers.
- **Design vehicles** – The intersection geometry will need to accommodate transit, emergency vehicles, freight, and potentially oversize and overweight vehicles.

PLANNING CHALLENGES

The following are several challenges associated with planning MUT intersections:

- **Driver education** – Successful implementations of alternative intersections are often preceded by public outreach and education campaigns, which are typically not conducted for conventional intersection improvements. At MUT intersections, the prohibition of left turns at the main crossing intersection and the “turn-right-to-go-left” principle is communicated in the field but also can be communicated to the public prior to opening the intersection.

- **Driver expectation** – MUT intersections relocate left-turn movements from their conventional location. This is different from what most drivers would expect and must be accounted for in the intersection planning and design.
- **Multimodal accommodation** – As with any street segment or intersection, each configuration must consider and serve the various users who currently or may be expected to use the facilities. This should always include pedestrians and bicycles, understanding that the exact provisions may necessarily vary from site to site. However, pedestrian facilities must always be made accessible. MUT intersections are generally compatible with transit as well.
- **Sufficient corridor right-of-way** – The greatest challenge for the MUT intersection is the provision of sufficient right-of-way to accommodate wide medians.

PROJECT PERFORMANCE CONSIDERATIONS

Measuring the effectiveness of overall project performance depends on the nature or catalyst for the project. Understanding the intended specific operational, safety, and geometric performance context for each intersection or corridor including intended users can guide help determine project-specific performance measures. The project performance may be directly linked to the specific design choices and performance of the alternatives considered. The project performance categories described below can influence and are influenced by specific MUT intersection design elements and their characteristics.⁽²²⁾

Accessibility

Chapter 3 of this guide describes accessibility as it relates to special consideration given to pedestrians with disabilities including accommodating pedestrians with vision or mobility impairments. However, for the purposes of considering a project's general context and the performance considerations, the term "accessibility" goes beyond the conversation of policy related to ADA and Public Rights-of-Way Accessibility Guidelines (PROWAG) and is meant to be considered in broader terms.⁽²¹⁾ With respect to considering applicable intersection forms for a given project context, accessibility is defined broadly as the ability to approach a desired destination or potential opportunity for activity using highways and streets (including the sidewalks and/or bicycle lanes provided within those rights-of-way). This could include the ability for a large design vehicle to navigate an intersection as much as it might pertain to the application of snow mobiles or equestrian uses in some environments or conditions.

Mobility

Mobility is defined as the ability to move various users efficiently from one place to another using highways and streets. Mobility can sometimes be associated with motorized vehicular movement and capacity. For the purposes of this guide, mobility is meant to be independent of any particular travel mode.

Quality of Service

Quality of service is defined as the perceived quality of travel by a road user. It is used in the 2010 HCM to assess multimodal level of service (MMLoS) for motorists, pedestrians, bicyclists, and transit riders.⁽⁶⁾ Quality of service may also include the perceived quality of travel by design vehicle users such as truck or bus drivers.

Reliability

Reliability is defined as the consistency of performance over a series of time periods (e.g., hour-to-hour, day-to-day, year-to-year).

Safety

Safety is defined as the expected frequency and severity of crashes occurring on highways and streets. Expected crash frequencies and severities are often disaggregated by type, including whether or not a crash involves a non-motorized user or a specific vehicle type (e.g., heavy vehicle, transit vehicle, motorcycle). In cases where certain crash types or severities are small in number, as is often the case with pedestrian- or bicycle-involved, it may be necessary to review a longer period of time to gain a more accurate understanding.

PROJECT DEVELOPMENT PROCESS

For the purposes of this report, the project development process is defined as consisting of the stages described below. Federal, state, and local agencies may have different names or other nomenclature with the overall intent of advancing from planning to implementation. Exhibit 2-5 illustrates the overall project development process.⁽²²⁾

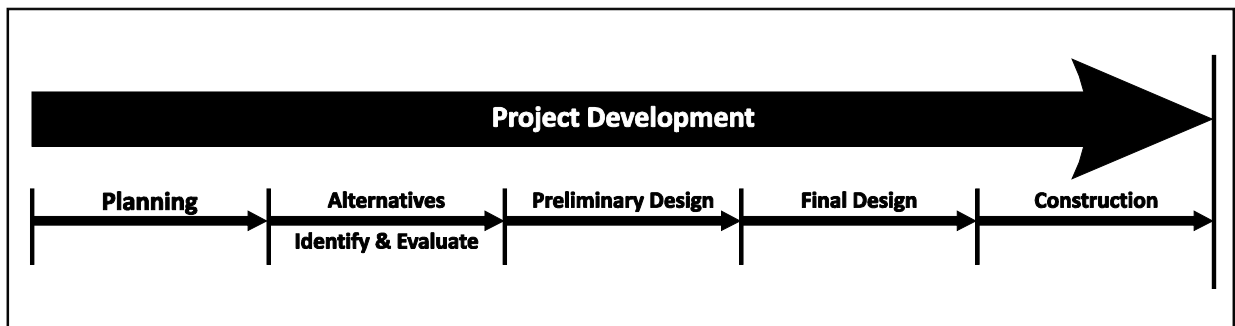

Exhibit 2-5. Project development process.⁽²²⁾

Planning Studies

Planning studies often include exercises such as problem identification and other similar steps to ensure there is a connection between the project purpose and need and the geometric concepts being considered. Planning studies could include limited geometric concepts on the general type or magnitude of project solutions to support programming.

Alternatives Identification and Evaluation

The project needs identified in prior planning studies inform concept identification, development, and evaluation. At this stage, it is critical to understand the project context and intended outcomes so potential solutions may be tailored to meet project needs within the opportunities and constraints of a given effort. FHWA describes context sensitive solutions as “... a collaborative, interdisciplinary approach that involves all stakeholders in providing a transportation facility that fits its setting.”⁽²³⁾ In considering the concept of “context sensitive design/solutions,” this stage calls for meaningful and continuous stakeholder engagement to progress through the project development process.

Preliminary Design

Concepts advancing from the previous stage are further refined and screened during preliminary design. For more complex, detailed, or impactful projects, the preliminary design (typically 30-percent design level plans) and subsequent documentation are used to support more complex state or federal environmental clearance activities. The corresponding increased geometric design detail allows for refined technical evaluations and analyses that inform environmental clearance activities. Preliminary design builds upon the geometric evaluations conducted as part of the previous stage (alternatives identification and evaluation). Some of the common components of preliminary design include:

- Horizontal and vertical alignment design
- Typical sections
- Grading plans
- Structures
- Traffic/intelligent transportation systems (ITS)
- Signing and pavement markings
- Illumination
- Utilities

Final Design

The design elements are advanced and refined in final design. Typical review periods include 60-percent, 90-percent, and 100-percent plans before completing the final set of PS&E. During this stage, there is relatively little variation in design decisions as the plan advances to 100-percent. Functionally, in this stage of the project development process, the targeted performance measures have a lesser degree of influence on the form of the project.

Construction

Construction activities could include geometric design decisions related to temporary streets, connections, or conditions that facilitate construction. Project performance measures may relate to project context elements.

SUMMARY OF MUT ADVANTAGES AND DISADVANTAGES

As described in Chapter 1 and the previous sections of this chapter, MUT intersections have unique features and characteristics related to multimodal considerations, safety performance, operations, geometric design, spatial requirements, constructability, and maintenance.

Exhibit 2-6 provides an overview of the primary advantages and disadvantages of MUT intersections for users, policy makers, designers, and planners to understand when considering this type of alternative intersection form.

Exhibit 2-6. Summary of MUT advantages and disadvantages.

| Advantages | Disadvantages |
|--|--|
| Non-Motorized Users | |
| <ul style="list-style-type: none"> • Pedestrians and bicyclists must cross only one direction of travel at a time • Pedestrians and bicyclists cross fewer lanes of travel (shorter distance, less exposure) • Because of the two-phase signal operations, greater service time can be given to pedestrians and bicyclists • Bicyclists have center refuge (room for bicycle box) in making two-stage left turns | <ul style="list-style-type: none"> • Pedestrians crossing the major street may have to cross in two stages, potentially increasing crossing time • Because all left turns must also turn right, greater right-turn/pedestrian exposure • Bicyclists turning left must use crosswalks as a pedestrian or mix with vehicle traffic to access MUT as a vehicle would |
| Safety | |
| <ul style="list-style-type: none"> • Fewer overall conflict points and no left-turn conflicts • Lower delay and fewer stops on major street could reduce rear-end crash rates | <ul style="list-style-type: none"> • Drivers may be less familiar with intersection • Potential for driver disregard of the left-turn prohibitions |
| Operations | |
| <ul style="list-style-type: none"> • Reduced delay and fewer stops for through movements on the major street • Shorter cycle lengths and increased green time for through movements decreases intersection delay, congestion, and queuing | <ul style="list-style-type: none"> • Potential increase in delay, travel distance, and stops for left-turning traffic • Slightly longer clearances phases needed to clear main crossing intersection |
| Access Management | |
| <ul style="list-style-type: none"> • Eliminates left turns out of driveways along corridor • Consolidates access to U-turn crossover intersections | <ul style="list-style-type: none"> • Some drivers must pass through intersections twice • Access may be restricted between main crossing and U-turn intersections |
| Right of Way | |
| <ul style="list-style-type: none"> • If planned properly, establishes final limits of ROW as future lanes can be added in the median without outside widening | <ul style="list-style-type: none"> • Requires substantially more ROW along major street • Required right of way not typically available in urban and suburban areas or at great cost |
| Aesthetics | |
| <ul style="list-style-type: none"> • Median provides opportunity for landscaping and other aesthetic treatments | <ul style="list-style-type: none"> • Wide distances between sides of road make urban feel difficult |

This page intentionally left blank.

CHAPTER 3— MULTIMODAL CONSIDERATIONS

This chapter provides an overview of multimodal facilities at MUT intersections and how provisions for pedestrians and bicycles should influence the overall planning and design of these intersections. Several of the guidelines presented here are based on elements of the AASHTO Green Book, but are applied within the unique context of a MUT intersection.⁽⁵⁾ The overall objective is to develop a design, regardless of the type of intersection, compatible with a Complete Street. A Complete Street is a facility that serves many types of users including freight, transit, and non-motorized users.

DESIGN PRINCIPLES AND APPROACH

MUT intersection planning and design should consider a variety of transportation modes. The following elements should be evaluated when considering a MUT intersection:

- Historically, MUT intersections were built on streets with wide medians; however, there are recent examples of MUT intersections with little or no median. Compared to streets without medians and streets with narrower medians, traditional MUT intersections have longer total pedestrian crossing distances within the main crossing intersection and increased time for bicyclists to ride across the major street.
- The prohibited left-turn movements at the main crossing intersection may create enforcement issues for automobiles and for bicycles when bicycle boxes, bicycle lanes, or other accommodations for direct left turns are not included in the design.
- Large vehicles require adequate space at the crossover intersections to accommodate swept paths. Geometrics may include wider turning lanes, paved shoulders within the crossover area, bump outs, and/or mountable or traversable features. The geometry of the intersection and all its associated movements need to accommodate the design vehicle for the facility.
- The unique geometrics that require a wide median or large loons, as well as the unique operations that reduce the number of signal phases at the median U-turn intersections, can introduce both benefits and challenges to pedestrians, bicyclists, transit vehicles, and users with disabilities.

This chapter describes the unique characteristics of the four primary non-auto modes (pedestrians, bicyclists, transit, and heavy vehicles) that should be considered when analyzing and designing MUT intersections.

PEDESTRIANS

Pedestrians crossing a MUT intersection encounter fewer conflicting traffic streams than at a conventional intersection. At a conventional intersection, pedestrians cross the street with one-stage or two-stage crossing during the vehicle phase of the adjacent street. Exhibit 3-1 shows traffic movements and conflict points that pedestrians experience at a conventional intersection.

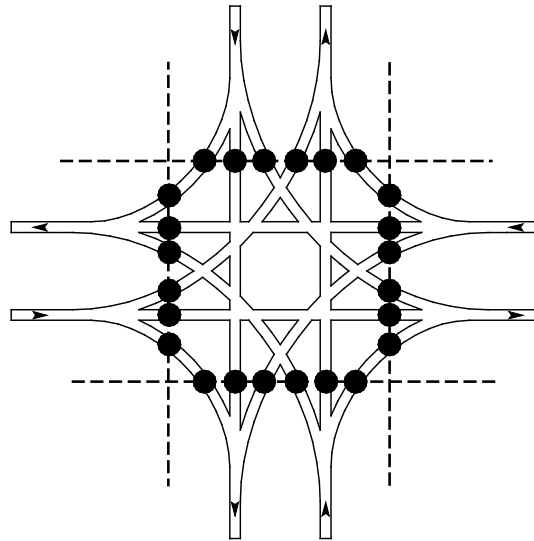

Exhibit 3-1. Pedestrian-vehicle conflict points at a conventional intersection.

At a MUT intersection, the left turns are removed from the main intersection and occur away from the intersection, thus removing potential pedestrian exposure to left-turning vehicles. Exhibit 3-2 shows the intersection movements with a MUT design. Crosswalks can be marked across all intersection legs, as at a conventional intersection. Pedestrians at a MUT intersection cross the major street during the minor street through and right-turn signal phase, when the only conflicts possible are with minor street right-turning vehicles or major street right-turning vehicles making a right turn on red (RTOR). As a result, the number of conflict points is reduced. However, the frequency of conflicts at each conflict point increases for a MUT intersection since left-turn movements are consolidated into right-turn movements, and the total number of vehicles crossing the crosswalk is the same. The net effect is expected to be positive for pedestrians since traffic patterns are simplified and easier for pedestrians to determine compared to a conventional intersection. There are no known studies or empirical data available to support or reject this assumption.

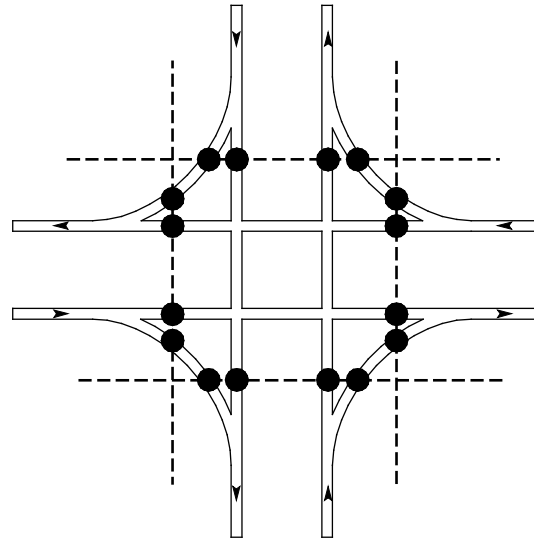

Exhibit 3-2. Pedestrian-vehicle conflict points at MUT intersection.

Removing the left turns from the main intersection allows for a two-phase signal. This results in a shorter signal cycle length, while producing similar green times for pedestrians and vehicles. This operation benefits pedestrians by creating more pedestrian phases per hour, compared to a conventional intersection, along with less “don’t walk” time between “walk” times (i.e., less wait time between walk signals). As shown in Exhibit 3-3, “walk”/flashing “don’t walk” time can increase even as the overall cycle length decreases, providing more pedestrian crossing time per hour.

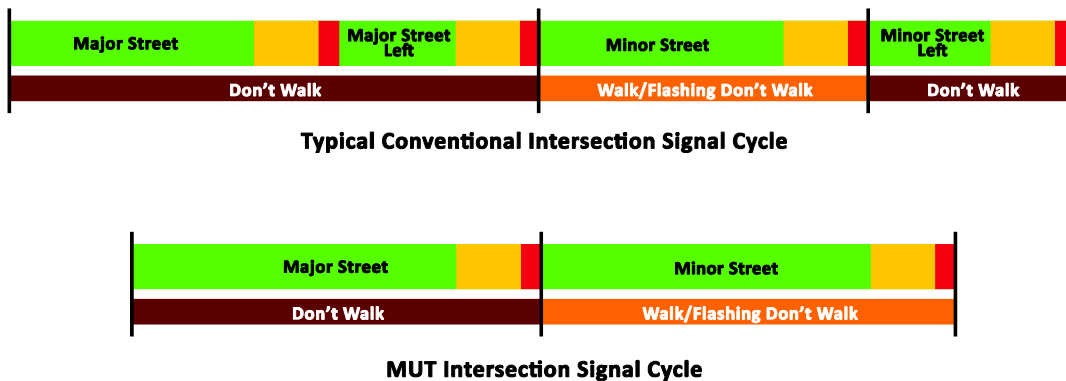

Exhibit 3-3. Comparison of major street walk phases at conventional and MUT intersections.

The typical MUT intersection includes a wide center median or refuge area on at least one of the two streets, which may cause the total pedestrian crossing distance to be longer compared to a conventional intersection. However, newer installations in Utah and Tucson, AZ are on streets with narrow medians approximately one lane wide. The crossing distance is mitigated at some intersections by removing the left-turn lanes, leaving fewer lanes to cross and less exposure of the pedestrian to vehicle traffic. Longer crossing distances must be accommodated in the signal

phasing. However, because of the two-phase signal operation, the minor street often receives a sufficient amount of green time to accommodate a single-stage major street pedestrian crossing time. If not, a balance must be struck between the required pedestrian time and the vehicle movement time, requiring pedestrians to cross the major street in two stages. A pedestrian pushbutton is required in the median to accommodate two-stage crossings.

Exhibit 3-4 compares a single-stage versus two-stage crossing of a MUT intersection. Single-stage crossings are always preferred so pedestrians are not unduly delayed and do not have to wait in the median between the streets. However, the width of the major street may result in pedestrian walk times longer than the green time required for vehicular movements from the minor street, which could otherwise be better allocated for major street traffic. In cases such as these, two-stage crossings can be used.

In a two-stage crossing, the pedestrian travels across one direction of the road to the median. The pedestrian then stops in the median in a refuge area—which is typically wide enough to accommodate pedestrians, wheelchairs, strollers, or bicycles—and waits for the “walk” display before crossing the other half of the street. Despite the overall shorter cycle length, the pedestrian crossing times for a MUT intersection under a two-stage crossing are typically greater than a single-stage crossing of a conventional intersection.

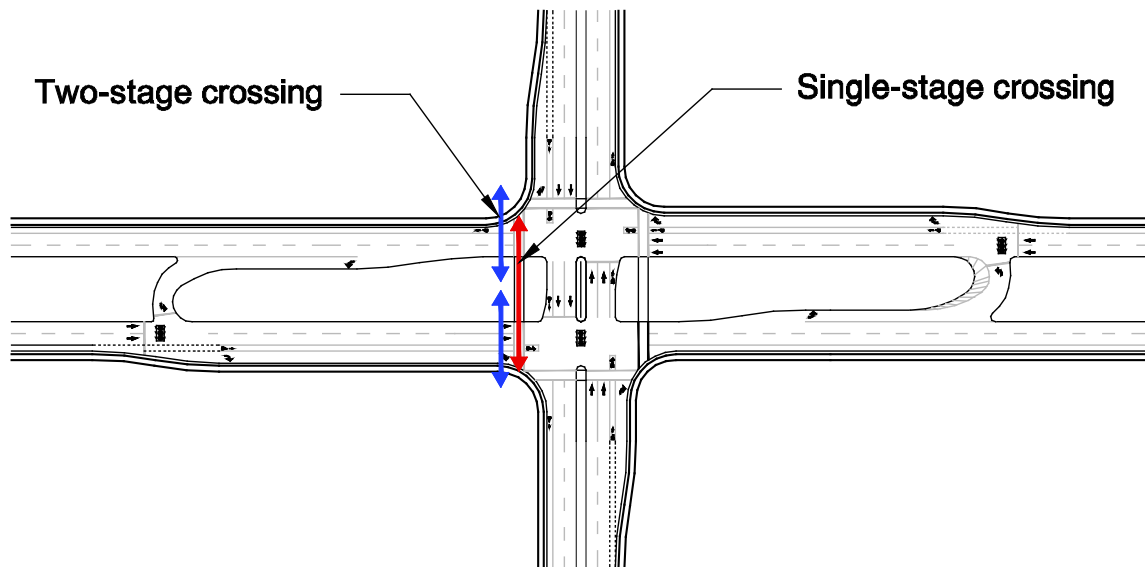

Exhibit 3-4. Single- versus two-stage pedestrian crossings.

U-Turn Crossovers

The U-turn crossover intersections create an opportunity for mid-block pedestrian crossings. If signalized, crossover intersections typically have signals that only control major street traffic approaching the main crossing intersection. However, signals controlling both directions of the major street could be installed to facilitate pedestrian crossings, as shown in Exhibit 3-5.

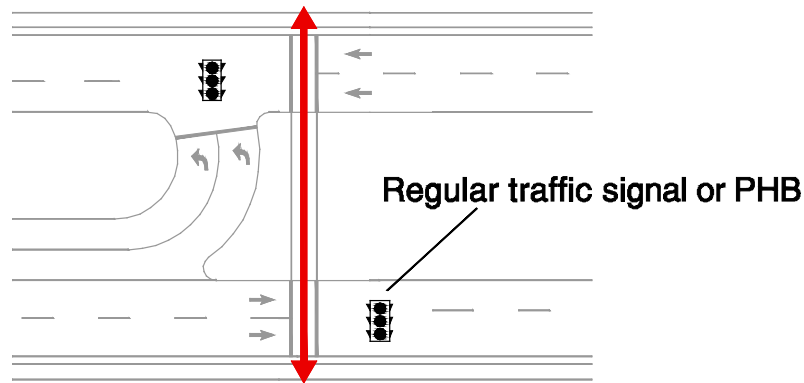

Exhibit 3-5. Signalized mid-block crossing.

ADA and PROWAG Accessibility Considerations

Accessibility was previously described in Chapter 2 in the broader contexts of considering a project's contextual environment and the ability for various users to approach a desired destination or potential opportunity for activity using highways and streets (including the sidewalks and/or bicycle lanes provided within those rights-of-way). In this section, accessibility is explicitly focused on the policies related to ADA and Public Rights-of-Way Accessibility Guidelines (PROWAG).⁽²¹⁾ Special consideration should be given to pedestrians with disabilities, including accommodating pedestrians with vision or mobility impairments. Being relatively new on a national level, specific guidance for "Accessible MUTs" is not yet available. However, general accessibility principles can be borrowed from other forms of intersections and applied here. The United States Access Board provides many additional resources on accessibility and specific requirements for Accessible Public Rights of Way, which the transportation professional should refer to and be familiar with.⁽²¹⁾

Pedestrians with vision, mobility, or cognitive impairments should find crossing a MUT intersection similar to crossing a conventional intersection. Either intersection form requires crossing multiple lanes and generates conflicts with right-turning vehicles. In general, intersection crossing conflicts can be accommodated with traditional design techniques. The cues that pedestrians with vision impairments rely on to cross intersections, such as the sound of traffic parallel to their crossing, are similar in the two intersection forms. The direct crossing path of a MUT intersection is relatively easy and convenient to use. All pedestrians will experience two-phase signal timing and a reduced number of conflicting traffic streams than at a conventional intersection. Auditory and sensory cues should be given in the median to indicate an additional street crossing is required, and to assist pedestrians choosing to make the crossing in two stages.

The basic principles for accessible design can be divided into the pedestrian walkway and the pedestrian crossing location. For the pedestrian walkways, the following considerations apply:

- Delineate the walkway through landscaping, curbing, or fencing to assist with wayfinding for blind pedestrians
- Provide sufficient space (length and width) and recommended slope rates for wheelchair users and other non-motorized users such as people pushing strollers, walking bicycles, and others
- Construct an appropriate landing with flat slope and sufficient size at crossing points

For pedestrian crossing locations, these additional considerations apply:

- Provide curb ramps and detectable warning surfaces at the transition to the street
- Provide accessible pedestrian signals with locator tone at signalized crossings
- Locate push-buttons to be accessible by wheelchairs and adjacent to the crossing at a minimum separation of 10 feet
- Use audible speech messages where spacing is less than 10 feet, or where additional narrative for the expected direction of traffic is needed
- Align the curb ramp landing to the intended crossing direction
- Crosswalk width through the intersection should be wide enough to permit pedestrians and wheelchairs to pass without delay from opposing directions, and the medians should provide sufficient storage for all non-motorized users to safely wait when two-stage crossing are required

All pedestrians—but especially those with vision, mobility, or cognitive impairments—may benefit from targeted outreach and additional informational material created with pedestrians in mind. These outreach materials include information on crosswalk placement and intended behavior, as well as answers to frequently asked questions. For blind pedestrians, materials need to be presented in an accessible format, with sufficient descriptions of all features of the MUT intersection.

BICYCLISTS

Traditionally, MUT intersections were built along suburban arterials or other high-volume streets where bicycle accommodations were less likely to be included. However, the current trend in many communities and State DOTs is to integrate Complete Streets policies that include bicycle accommodations on all types of streets. There are at least two older MUT corridors in Michigan with marked bicycle lanes added after the MUT intersections were established.

Through and right-turning bicyclists encounter relatively higher percentages of green time at MUT intersections compared to conventional intersections. At MUT intersections, there is a higher proportion of right-turning vehicles compared to a conventional intersection (as traffic that would turn left at a conventional intersection is required initially to turn right at a MUT

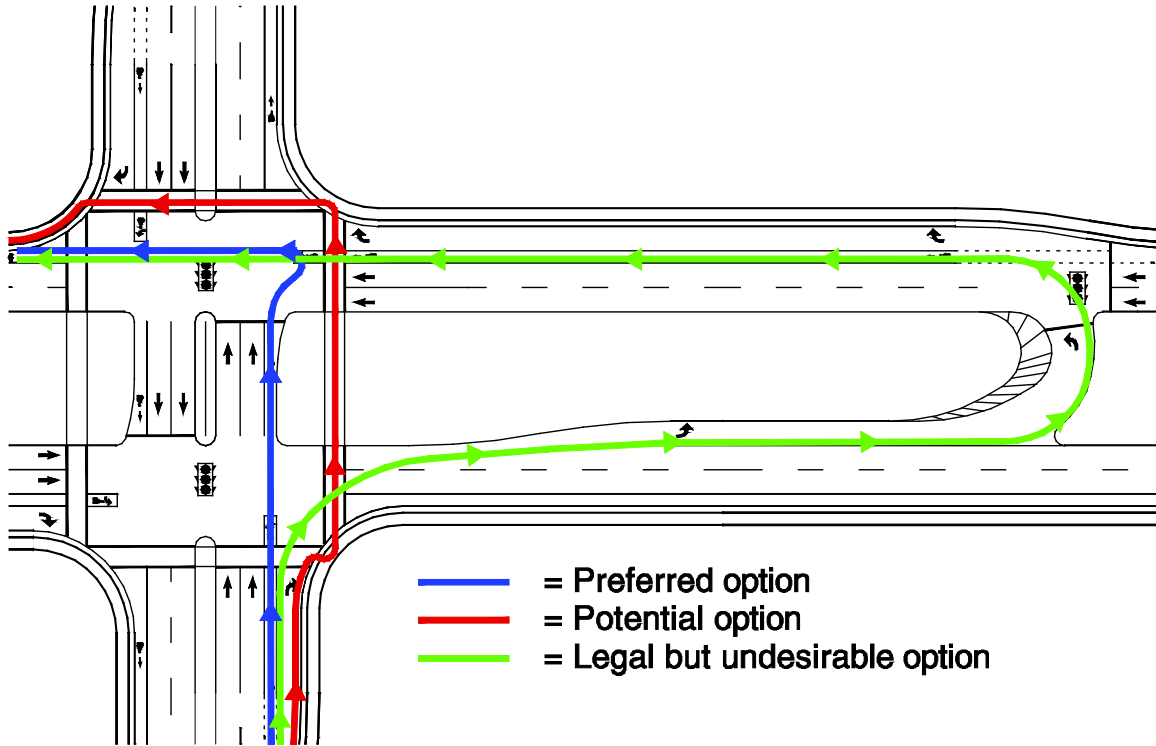

Exhibit 3-7. Left turn options for bicycles.

Of these options, the two-stage left turn is the most natural for bicyclists and the most likely to be obeyed. The “vehicle rules” option exposes bicyclists to significant out-of-direction travel and potential vehicle conflicts, while the “pedestrian rules” option generates potential pedestrian conflicts. However, the “pedestrian rules” option can be considered when upgrading sidewalks to multi-use paths, or when an otherwise off-street bicycle path crosses the street at the intersection.

TRANSIT VEHICLE CONSIDERATION

The MUT intersection does not introduce any unique movements for buses compared to a conventional intersection. Buses on the major street can operate using the right lane on both the major and minor streets and make stops before or after the main crossing intersection in the same manner as conventional intersections, while receiving more green time and less delay. Principle streets with MUT intersections provide the opportunity to develop curbside bus lanes, with the long auxiliary lane provided between a U-turn crossover and the intersection shared by buses and right-turning vehicles.

Transit stops can be developed at MUT intersections in much the same way as at a conventional intersection. If transit service is only provided along the major street, then providing a far-side bus stop is typically preferred to allow buses to take advantage of signal progression, support green-extension transit signal priority treatments, and avoid blocking right-turn movements. If transit service is provided on both streets, then transfer opportunities between bus lines should also be considered. This may involve a combination of a nearside stop on one street and a far-side stop on the other street, allowing the heavy transfer movement to be made by simply

walking around the corner. In that case, buses stopping at a nearside stop in a right-turn lane should be exempted from the right-turn requirement and possibly provided with a queue-jump phase to assist them in leaving the stop. Exhibit 3-8 illustrates potential locations for the near-side and far-side bus stop locations.

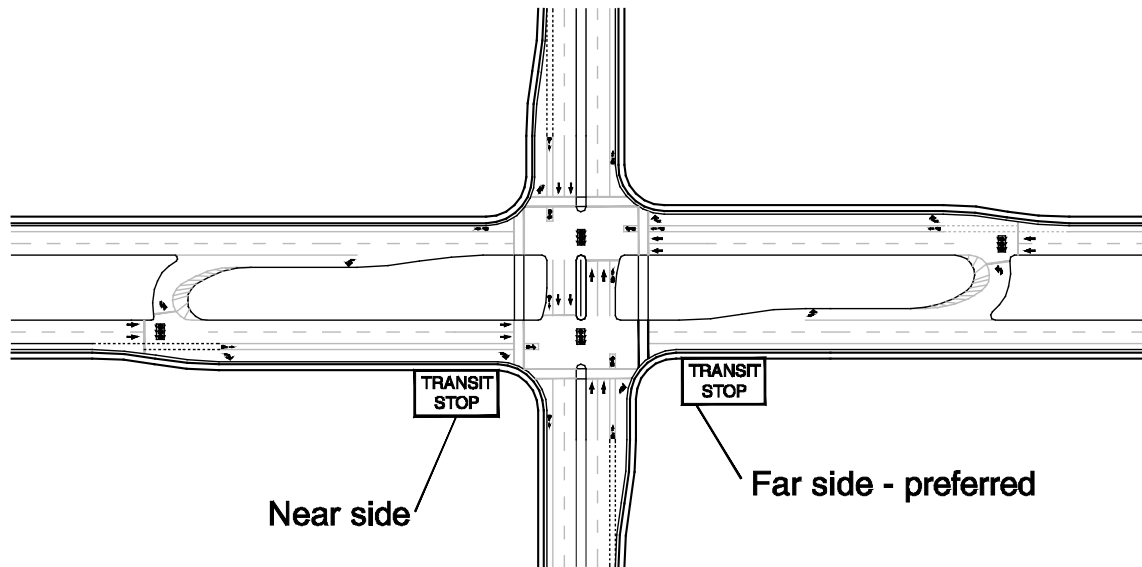

Exhibit 3-8. Bus stop locations.

Buses having to make left turns at the intersection will experience added delay from the out-of-direction travel, which could increase the transit provider's operating costs. Consideration could be given to exempting buses from the left-turn prohibition (particularly from the major street, when sufficient storage space is provided in the median), or to providing a special transit phase to facilitate bus left turns.

The MUT intersection may provide a unique opportunity for light-rail transit (LRT) and bus rapid transit (BRT) vehicles to use the wide median required for the U-turn movements. In a conventional highway corridor, the median width is typically insufficient to accommodate LRT or BRT operations, and median openings and/or two-way left-turn lanes (TWLTLs) are incompatible with the requirements to provide a semi-exclusive running way for transit vehicles. However, a MUT corridor typically has sufficient median width to accommodate LRT and BRT vehicles, and limits the number and direction of crossings across the transitway.

The transitway crossings would alter the location of where vehicles enter the crossover, but the crossovers could be kept clear and priority given to the transit vehicles with preemption phasing. The transit vehicles could also be given priority movement through the intersection during the same green phase as the major street without transit-vehicular conflicts. Station platforms could be moved toward the main crossing intersection, unlike at conventional intersections where left-turn lanes take up greater space in the median. Locations where streets cross the transitway would be controlled by traffic signals (BRT operation or LRT operations of 35 mph or slower) or by railroad-style gates and flashing lights (LRT operations above 35 mph).

At the time of this writing, there were no applications of LRT or BRT running in MUT corridors, but there is one corridor in New Orleans, LA (St. Charles Avenue) that features a trolley line running through the median parallel to a road with characteristics similar to a MUT intersection. The City of Detroit had selected LRT running in the median of Woodward Avenue as the locally preferred alternative for the Woodward Avenue LRT project. This project would retrofit transit into the median of one of the first MUT corridors in southeast Michigan. Concept plans for one intersection on the corridor are shown in Exhibit 3-10.

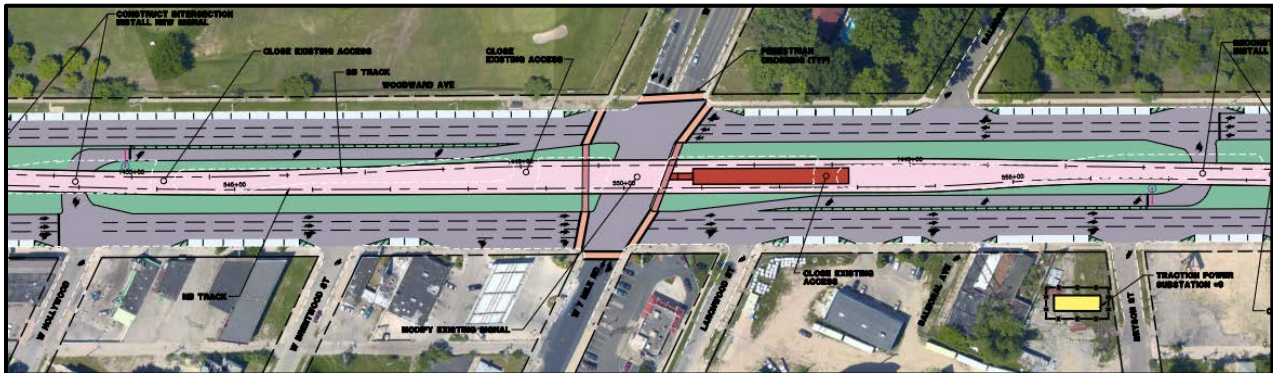

Exhibit 3-9. LRT or BRT accommodations in MUT corridor.⁽²⁴⁾

HEAVY VEHICLE CONSIDERATIONS

The typical MUT crossover can accommodate heavy vehicle U-turn movements given the wide median provided in a typical MUT corridor. The crossover design detail is further described in Chapter 7. A single-lane crossover is designed to provide adequate turning radii and tracking for both the front and rear ends of trucks. If the median width is less than adequate for larger vehicle U-turns, additional pavement can be added at the far side of the U-turn crossover in the form of “loons” (see Chapter 7).

CHAPTER 4— SAFETY

This chapter discusses safety principles and performance for MUT intersections, including geometric design and human factors that potentially impact safety. Safety performance and observations are presented, as well as discussions of specific safety issues or concerns not typical at conventional intersections.

SAFETY PRINCIPLES

An appropriate level of safety assessment corresponding to the stage of the project development process (planning, alternatives identification and evaluation, preliminary design, final design, and construction) supports decisions about MUT intersections. The analysis should be consistent with the available data, and the data should be consistent with the applied tools. Multimodal safety principles—including vehicle-pedestrian and vehicle-bicycle conflict points, accessibility, and crossing options—are discussed in Chapter 3.

Reduced Vehicle-Vehicle Conflict Points

While crash data are often used to develop models or other tools that can ultimately help professionals make safety decisions about transportation facilities, crash data are often limited or completely unavailable for some types of facilities. In lieu of crash data, one often-applied strategy is to examine the number of conflict points at an intersection. While no mathematical relationship between conflicts and collisions has been clearly documented, conflicts are correlated with collisions and are often used as a surrogate measure, particularly to compare different intersection forms. It is common to consider both lane-by-lane conflicts and an aggregated conflict analysis that treats each movement as one lane; the latter approach will be presented here for the sake of simplicity.

By restricting direct left turns at the main crossing intersection, MUT intersections reduce vehicular intersection conflict points from 32 to 16, including the conflict points introduced at the median U-turn crossovers, as shown in Exhibit 4-1. If another street is directly opposite the U-turn crossover, the number of conflict points is increased by four per instance. If more lanes than one in each direction are provided on either the major or minor cross street, the number of conflicts will increase. Exhibit 4-2 and 4-3 show the conflict points at a conventional intersection and at a MUT intersection, respectively.

Exhibit 4-1. Conflict point comparison.

| Conventional | MUT |
|--------------|-----|
| 32 | 16 |

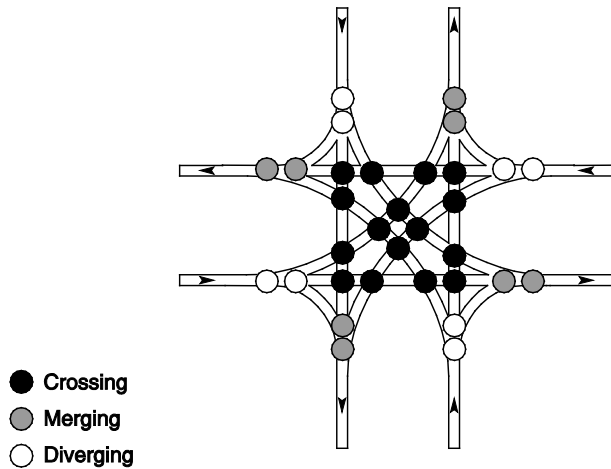

Exhibit 4-2. Vehicle-vehicle conflict points at conventional intersection.

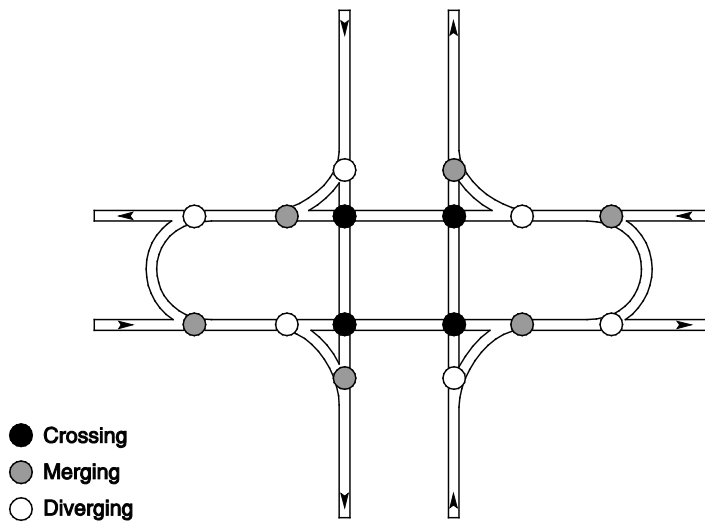

Exhibit 4-3. Vehicle-vehicle conflict points at MUT intersection.

Removing direct left turns also reduces some of the conflict points with the greatest crash type severity, namely left-through angle (“T-bone”) collisions. This type of collision ranks second behind head-on collisions for the chance of severe injury. In particular, the MUT intersection, compared to a conventional intersection, reduces crossing conflict points by 75-percent (from 16 to 4). Merging conflict points are reduced from 8 to 6, and diverging conflict points are reduced from 8 to 6. While reducing conflict points does not guarantee fewer or less severe crashes, it is often an indicator of crash reductions, particularly where crash types with the highest severity (including through and left-turn vehicle crashes) are reduced.

Human Factors Principles and Considerations

Human factors and driver expectancy suggest motorists typically accustomed to using conventional intersections position their vehicles to the left side of a directional street when approaching an intersection where they intend to make a left turn. Similarly, motorists position their vehicle to the right side of the directional street when approaching an intersection where they intend to make a right turn. MUT intersections prohibit direct left turns at the main intersections. Motorists may not expect this prohibition of direct left turns at MUT intersections.

The most common MUT intersection provides U-turn crossovers in the median downstream of the intersection on the major crossroad. As a result, motorists who are traveling on the major crossroad who desire to make a left turn at the approaching intersection will be naturally positioned within the street to use the U-turn after passing through the intersection.

Based on human factors and driver expectancy, motorists on the minor crossroad who are unfamiliar with an area and desiring to turn left at the approaching intersection (especially where more than one directional lane exists in the direction of travel) would also typically position their vehicle to the left side of the directional street. As a result, drivers desiring to make a left turn may not expect they must first make a right turn at the minor street. Clear, concise signing must be provided far enough in advance of the intersection to direct motorists desiring to make left turns to move to the right side of the street to make a right turn at the approaching intersection. Signage must also inform motorists on the minor crossroad, prior to turning right, where they must position themselves on the major crossroad to navigate the U-turn to complete a left turn.

OBSERVED SAFETY PERFORMANCE

Safety Performance Studies

There have been a number of research studies involving the safety performance of MUT intersections, and they generally show reductions in mean crash rates, especially injury-related crashes, when compared to conventional intersections. FHWA developed a Techbrief titled “Synthesis of the Median U-Turn Intersection Treatment.”⁽¹¹⁾ The synthesis reviewed 25 research studies published between 1974 and 2005. The studies considered the operational and safety performance of the MUT intersections. A subset of the studies compared crash rates between conventional and MUT intersections on both a corridor and isolated intersection basis (Exhibit 4-4), and a comparison of the forecast crashes by severity versus the type of crash (Exhibit 4-5). In general, the results indicate that MUT intersections show safety performance improvement compared to conventional intersections for most crash types and injury severities. In a few instances where the number of crashes for MUT intersections exceeded those for conventional intersections, the difference was marginal.

Median U-Turn Informational Guide

Exhibit 4-4. Crash Rate comparison of MUT and conventional intersections.⁽¹¹⁾

| Dataset | Rate Type | Group | Mean Crash Rates (Crashes/MVE) | Standard Deviation | Alpha ¹ | |
|----------------------|-----------|-----------------|--------------------------------|--------------------|--------------------|----|
| Corridor | All | MUT (Reduction) | 1.554 (14%) | 0.784 | 73 | |
| | | Conventional | 1.806 | 0.679 | | |
| Intersection Related | All | MUT (Reduction) | 1.388 (16%) | 0.593 | 80 | |
| | | Conventional | 1.644 | 0.643 | | |
| | PDO | MUT (Reduction) | 0.982 (9%) | 0.392 | 49 | |
| | | Conventional | 1.077 | 0.467 | | |
| | Injury | | MUT (Reduction) | 0.407 (30%) | 0.266 | 97 |
| | | | Conventional | 0.58 | 0.252 | |

¹"Alpha" denotes the confidence level that the two rates are statistically different.

Exhibit 4-5. Forecast crashes for MUT and conventional intersections for a 5-year period.⁽¹¹⁾

| Crash Type | Injury Crashes | | | | PDO Crashes | | | | All Crashes | | | |
|----------------|----------------|------------------|--------|------------------|--------------|------------------|--------|------------------|--------------|------------------|--------|------------------|
| | Conventional | | MUT | | Conventional | | MUT | | Conventional | | MUT | |
| | % | Forecast Crashes | % | Forecast Crashes | % | Forecast Crashes | % | Forecast Crashes | % | Forecast Crashes | % | Forecast Crashes |
| Overturn | 1.53 | 0.97 | 0.92 | 0.41 | 0.64 | 0.75 | 0.27 | 0.29 | 0.95 | 1.71 | 1.03 | 1.57 |
| Fixed Object | 3.56 | 2.26 | 4.25 | 1.89 | 4.77 | 5.62 | 6.97 | 7.5 | 4.36 | 7.85 | 6.13 | 9.38 |
| Head-On | 0.80 | 0.51 | 0.27 | 0.12 | 0.43 | 0.51 | 0.33 | 0.35 | 0.56 | 1.01 | 0.35 | 0.53 |
| Angle St | 36.87 | 23.4 | 19.77 | 8.8 | 18.35 | 21.63 | 9.06 | 9.75 | 24.73 | 44.53 | 12.12 | 18.54 |
| Rear End | 37.99 | 24.11 | 65.93 | 29.35 | 51.67 | 60.9 | 69.85 | 75.14 | 46.94 | 84.51 | 68.29 | 104.44 |
| Angle Turn | 3.56 | 2.26 | 4.76 | 2.12 | 6.71 | 7.91 | 7.74 | 8.33 | 5.62 | 10.12 | 6.84 | 10.46 |
| Rear End LT | 1.53 | 0.97 | 0.81 | 0.36 | 4.18 | 4.93 | 0.93 | 1 | 3.27 | 5.89 | 0.88 | 1.35 |
| Rear End RT | 0.20 | 0.13 | 0.65 | 0.29 | 1.45 | 1.71 | 1.43 | 1.54 | 1.02 | 1.84 | 1.19 | 1.82 |
| Sideswipe Opp | 0.20 | 0.13 | 0.13 | 0.06 | 0.27 | 0.32 | 0.22 | 0.24 | 0.25 | 0.45 | 0.20 | 0.3 |
| Head-On Lt | 13.75 | 8.73 | 2.52 | 1.12 | 10.89 | 12.84 | 2.75 | 2.96 | 11.87 | 21.37 | 2.66 | 4.07 |
| Sideswipe same | 0.00 | 0 | 0.00 | 0 | 0.64 | 0.75 | 0.44 | 0.47 | 0.42 | 0.76 | 0.31 | 0.47 |
| Σ | 100.00 | 63.47 | 100.00 | 44.52 | 100.00 | 117.87 | 100.00 | 107.57 | 100.00 | 180.04 | 100.00 | 152.93 |

Crash Observations

Since the publication of the FHWA MUT synthesis publication in 2007, there has been a number of new MUT intersections proposed and built throughout the United States, including in Metairie, LA; Plano, TX; Draper, UT; South Jordan, UT; Wilmington, NC; Tucson, AZ; and Springfield, MO.⁽¹¹⁾ Most of these locations have been constructed since 2010, and there has not been a sufficient period since their construction (typically three years at minimum) to acquire significant “after” crash data to use in before-and-after safety studies.

A new use for MUT intersections is emerging by combining the MUT intersection with access management techniques along a highway corridor. There are numerous locations in urbanized areas where businesses line the street with multiple driveways for ingress and egress. One practice in the past has been to provide two-way center left-turn lanes to accommodate left turns into and out of the businesses. Safety performance of TWLTLs has not always met agency interests. Some jurisdictions are removing the TWLTLs and installing raised medians, which only permit right turns by vehicles entering or exiting the driveways and have been shown to improve corridor safety.^(25, 26)

To accommodate vehicles required to cross the opposing lanes of traffic, signalized median U-turns are constructed through the median at mid-block locations. Often at the mid-block location, U-turns will be constructed directly opposite each other for the opposing directions of travel. With the median U-turns constructed, many jurisdictions believe it is a logical step to convert their multi-phased signals to two-phase signals by using the median U-turns to also accommodate left turns from the signalized intersections.

SAFETY CONSIDERATIONS

The MUT intersection introduces some unique operational qualities not present in a conventional intersection. These concerns are discussed in the following sections.

Right-Turn / U-Turn Conflicts

Where crossovers are aligned with streets or driveways that permit only right turns, U-turns from the crossover and right turns from the opposite street/driveway are potentially in conflict depending on driver lane choices. Where lower volumes exist on the crossover and/or the opposing street, and where the major street is sufficient to accommodate simultaneously turning vehicles (i.e. three or four lanes in each direction), U-turns and right-turn movements can be served under the same signal phase. However, at signalized intersections locations where the volumes of right-turn and U-turn movements increase the potential for crashes, separate signal phases can be provided for U-turn and right-turn phases. For a given site, a study would be required to determine if the additional signal phase impacts the main crossing intersection phasing and major street progression, and if an additional U-turn and/or an additional right-turn lane is needed to provide sufficient capacity and operations. U-turn movements also potentially conflict with buses on the major street, such as a bus stopped opposite or several vehicle lengths downstream from a crossover. A bus at such a stop would wait until a gap in major street and U-turning traffic was present before departing. Exhibit 4-6 shows an example of a U-turn/right-turn conflict.

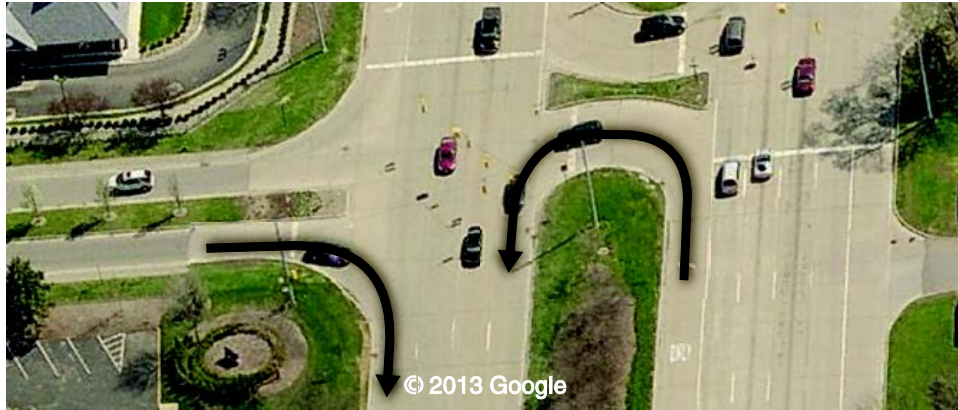

Exhibit 4-6. Example of U-turn/right-turn conflict.⁽¹⁾

Potential for Wrong-way Movements

MUT crossovers are directional, not two-way as in conventional divided highway corridors. This typically has no negative effects if crossovers are designed with channelization to prevent wrong-way movements. Exhibit 4-7 provides a detail of a Michigan Department of Transportation (MDOT) conventional U-turn crossover.⁽²⁷⁾

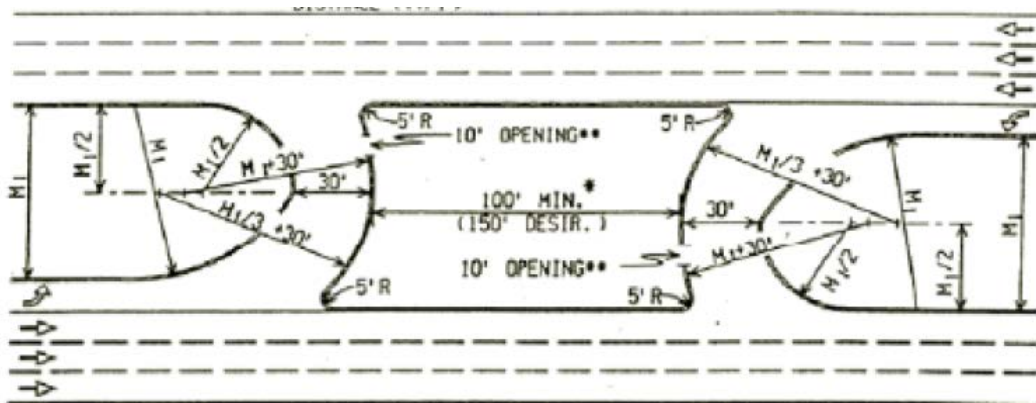

Exhibit 4-7. MUT crossover detail.⁽²⁷⁾

Weaving on the Major Street

The potential exists for some weaving movements to take place between through vehicles on the major street and vehicles turning right from the minor street and moving to the left lanes to reach the U-turn crossover. These movements have potential speed differentiations and can therefore be an operational and safety performance concern. In most cases, vehicles turning right from the minor street will wait for a gap suitable to move into the U-turn crossover lanes without weaving with or impeding through traffic. A simple remedy to eliminate this potential weaving conflict is to prohibit RTOR. Many MUT intersections in Michigan prohibit RTOR during certain (peak

period) portions of the day where adequate gaps in major street traffic would be difficult to safely obtain.

Potential for Violating Left Turn Prohibitions

While signing and geometrics can deter vehicles from making direct left turns at the main crossing intersection, there is no physical barrier to making illegal left turns. Proper overhead and ground-mount signing, marking, and geometric design that positively guide vehicles are all important factors in discouraging prohibited left turns at the main crossing intersection. Proper application of regulatory highway signs including “no left turn” (R3-2) and “one-way” (R6-1) aid in the guidance of movements through the MUT intersection and make prohibited movements illegal. Exhibit 4-8 illustrates best practices for signing restricted movements at the main crossing intersection, and Chapter 7 describes the intersection and crossover design details to discourage prohibited left-turn movements.



Exhibit 4-8. MUT restrictive signing.⁽⁴⁾

At the opening of some MUT intersections in recent years in areas where the MUT intersection design is new or not common, state or local police forces have been used during the first day of operations to reinforce the turning prohibitions and provide general guidance for proper intersection use.

Truck Navigation of Crossovers

When designing U-turn crossovers with multiple lanes, designing adequate crossovers for WB-50 or WB-67 trucks requires focused detail on truck turning paths. Large trucks should be signed to use the rightmost, or outermost, U-turn lanes. The design of the crossover must anticipate the vehicle tracking through the crossover to ensure that the WB-50 or WB-67 trucks path does not overlap with the path of a passenger car or single-unit truck in the leftmost of the dual lanes. Exhibit 4-9 illustrates the potential for path overlap, and design details for dual-lane crossovers are provided in Chapter 7.

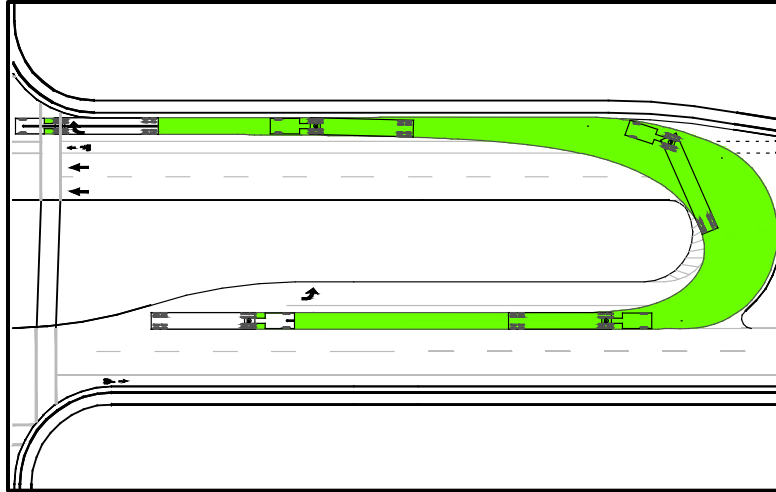

Exhibit 4-9. Dual lane crossover design path overlap potential.

Intersection Sight Distance

Providing adequate distance between consecutive U-turn crossovers allows drivers at one stop bar to see past a queue built up in the storage bay of the other crossover. Exhibit 4-7, from the MDOT, calls for a minimum separation of 100 feet and a desirable separation of 150 feet between U-turn crossovers.⁽²⁷⁾ If consecutive U-turn crossovers must be closer together, the designers can signalize them and prohibit LTOR. Designers should also ensure good intersection sight distances at MUT crossovers by making sure slopes and plantings in the median are cut back beyond the lines of sight.

INCIDENT RESPONSE CONSIDERATIONS

MUT intersections, while restricting direct left turns, do not install physical objects within the main intersection (intersection of major and minor crossroads) that would block emergency vehicles from making direct left turns. Direct left turns at MUT intersections are denied exclusively by signing, signal indications, and pavement markings. Emergency vehicles using sirens and flashing lights as they approach a MUT intersection and desiring to turn left can make a direct left turn after vehicles with conflicting movements have yielded the right-of-way. This practice is no different than an emergency vehicle making a direct left turn at a conventional intersection when approaching a red signal indication.

Emergency vehicles traveling through intersections must make sure all conflicting traffic movements have yielded the right-of-way before they proceed. As noted earlier, MUT intersections overall (Exhibit 4-4) have 16 fewer conflict points than the 32 noted for conventional intersections (Exhibit 4-3). As a result, emergency vehicles traveling through the MUT intersection have four fewer conflict points than conventional intersection, two fewer when making left turns, and one fewer when making right turns.

MUT intersections are generally located on divided streets with right-in, right-out driveway access. Access to these driveways may require out-of-direction travel compared to an undivided

street. Mountable portions of raised medians can reduce out-of-direction travel for emergency vehicles.

SAFETY EVALUATION CONSIDERATIONS

There are no CMFs specific to MUT intersections. The results of past safety studies presented earlier in this chapter indicate a trend of improved safety performance at MUT intersections versus conventional intersections.

If agencies wish to construct their own before-and-after safety evaluation of a set of MUT projects, there are several factors to keep in mind, including:

- The boundaries of the analysis area need to be large enough to include all crossovers. It would be unfair to compare a conventional intersection to just the main junction of a MUT intersection.
- Left-turn vehicles at a MUT intersection drive longer distances to negotiate the intersection than comparable conventional intersections. Thus, analyses using rates, such as crashes per vehicle-mile, should adjust for these “extra” distances driven.
- It is possible that some left-turning drivers may alter their routes to avoid the intersection. Thus, crash migration is a possible threat to the validity of a before-after analysis. Analysts should measure traffic demands during the before and after periods, and if crash migration is suspected should also widen the scope of the analysis to include new routes drivers are using.
- MUT intersections are sometimes installed in conjunction with developments that generate traffic. This reinforces the need to account for volume in an analysis since higher volumes result in lower crash rates for the same number of crashes.

General guidance on before/after safety studies and development of CMFs can be found in FHWA’s *A Guide to Developing Quality Crash Modification Factors*.⁽²⁸⁾

This page intentionally left blank.

CHAPTER 5— OPERATIONAL CHARACTERISTICS

This chapter provides information on the unique operational characteristics of MUT intersections and how they affect elements such as traffic signal phasing and coordination. The guidance presented here builds on existing MUT intersection studies, which include operational performance studies, comparative performance studies, and simulation analysis. The chapter also provides guidance relating to design elements that could affect the operational performance of MUT intersections. It is intended to help transportation professionals understand the unique operational characteristics of MUT intersections and prepare them for conducting operational analysis as described in Chapter 6.

OPERATIONAL PRINCIPLES

The MUT intersection provides traffic operational benefits, particularly for through movements on the major street, by reducing the number of intersection signal phases and shortening overall signal cycle lengths. Left-turn movements are made indirectly at MUT intersections. Minor street left turns are made by turning right at the main crossing intersection, left at a U-turn crossover, and proceeding back through the main crossing intersection. Major street left turns are made by proceeding through the main crossing intersection, turning left at a U-Turn crossover, and right at the main crossing intersection. Despite having to drive an additional distance compared to left turns at a conventional intersection, MUT intersection left turns usually have equal or improved delay and travel times compared to a conventional intersection.

Exhibit 5-1 illustrates concurrent movements at a conventional intersection and at a MUT intersection. Exhibit 5-2 shows the typical signal locations for a MUT intersection.

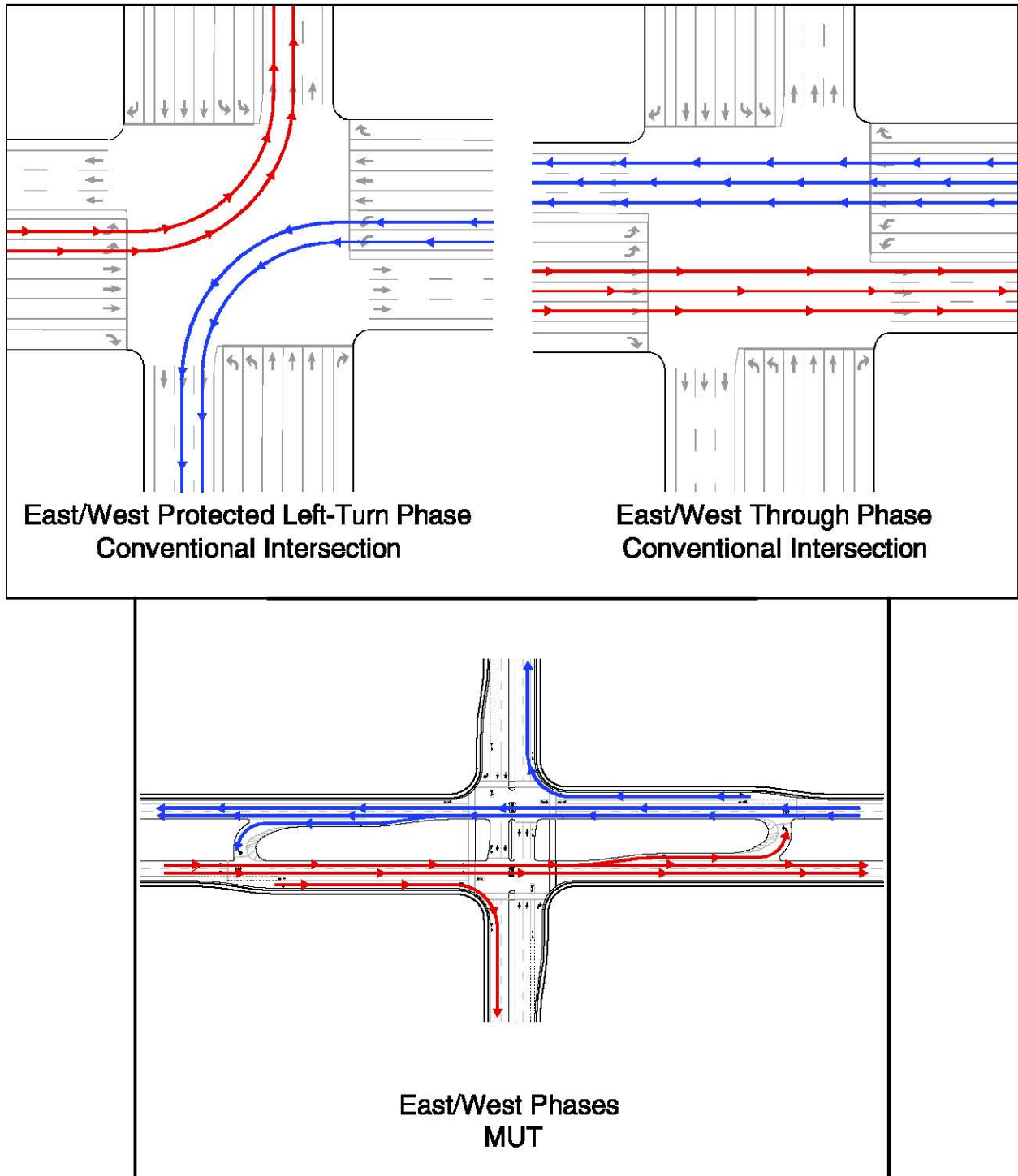

Exhibit 5-1. Concurrent movements at a conventional intersection and at a MUT intersection.

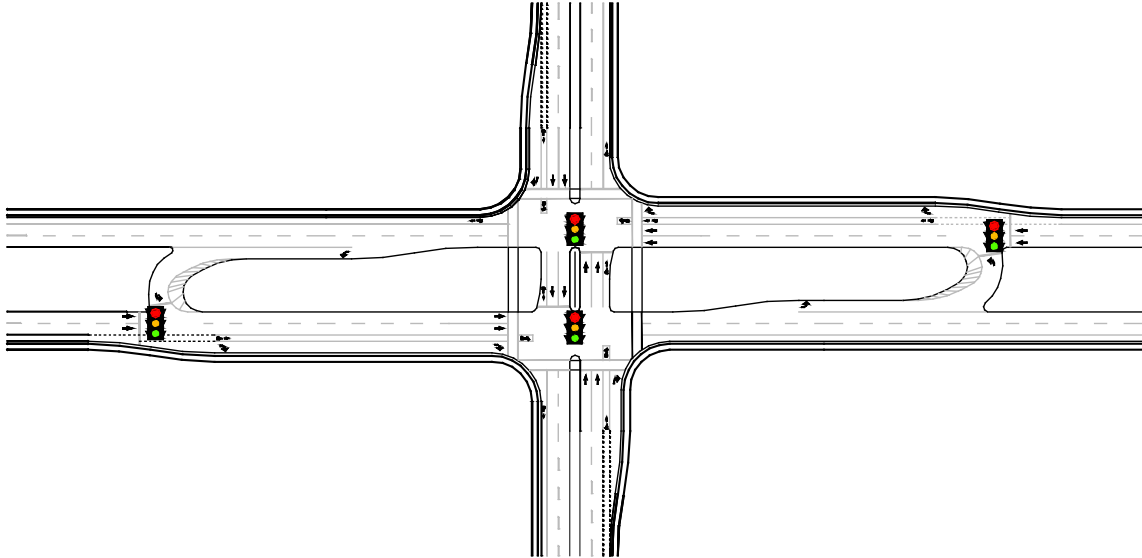

Exhibit 5-2. Typical MUT intersection signal locations.

Cycle Length

The MUT intersection, like many alternative intersections, removes left-turn phasing, which results in fewer clearance intervals in the intersection cycle (in this case, a reduction from four to two). The time formerly allocated for the eliminated clearance intervals can be allocated to other movements, thus improving intersection efficiency.

The MUT intersection provides similar green time per cycle for each through movement and more green time per cycle for left-turn movements. Each signalized intersection within the MUT will have the same cycle length, which typically ranges from 60 to 120 seconds. The cycle length is dependent on intersection traffic volumes, pedestrian crossing times, and the cycle lengths of conventional signals in the corridor that are coordinated with the MUT intersection.

In some cases, a MUT intersection will operate well with a shorter cycle length than is appropriate for one or more of the other signalized intersections along a corridor. If the cycle length for the MUT intersections is half of the cycle length for the surrounding signals, signal coordination and progression can remain along the corridor while also maintaining the benefits of MUT intersection. In other cases, the cycle length of the corridor signals must be decreased to match the MUT intersection cycle lengths or increased to be twice as long as the MUT intersection cycle length if the corridor is to remain coordinated. If the most congested intersection on a corridor is converted to a MUT intersection, decreasing the cycle length on the corridor is feasible.

Shorter cycle lengths allow more cycles to be served each hour, and vehicles have less time to “store” and form queues, thus shortening queues. Exhibit 5-3 illustrates a shorter cycle length at a high-volume MUT intersection compared to a conventional intersection. In this example, the green time allotted to the major street movement through is 56 seconds in the conventional intersection and 45 seconds in the MUT intersection. The pedestrian crossing on the major street

requires 33 seconds of “walk” and flash “don’t walk” time, which is the minimum green time for the minor street. The minor street green time is longer than this with the conventional intersection to serve vehicular demand. The conventional intersection’s 150-second cycle serves 24 full cycles each hour and allocates 1,344 seconds of green time to the major through movement. The MUT intersection’s 90-second cycle serves 40 full cycles each hour and allocates 1,800 seconds of green time to the major through movement. The comparative result is 33-percent more green time allocated under the MUT than the conventional intersection.

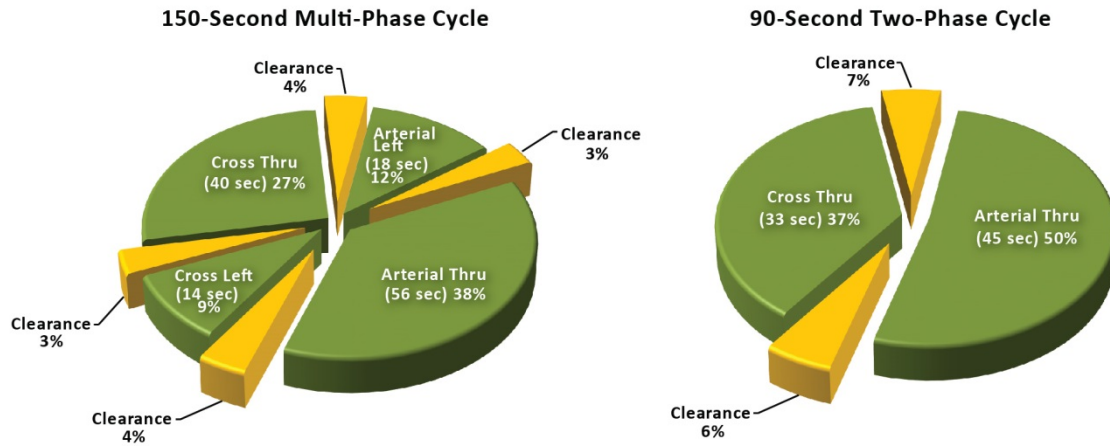

Exhibit 5-3. Comparison of intersection cycle lengths and phasing.⁽⁴⁾

The example above is most applicable to converting an isolated intersection to a MUT intersection. If a single intersection on a corridor was converted in a MUT intersection, it would be necessary to use a common cycle length (such as 120 seconds) or have the MUT intersection be half the cycle length of the other intersections on the corridor.

Signal Coordination

Left-turn phases are removed from the main intersection at MUT intersections. Therefore, the green time per phase increases, enabling better corridor progression and bandwidths. The shorter minimum cycle lengths typical at a MUT intersection can increase the likelihood the cycle length for the MUT intersection could be half the cycle length of the surrounding signals to allow coordination along the corridor. Providing progression in both directions simultaneously can be easier at MUT intersections compared to conventional forms.

Within the MUT intersection, traffic on the major street should either stop at the crossover signal prior to the main intersection (if the crossover is signalized), or travel through both intersections and progress through the main signal without stopping. This requires the crossover signal to turn red at the main intersection several seconds after the signal at the crossover displays red to clear vehicles through the dilemma zone for the main intersection signal; this minimizes queuing between the main intersection and the crossover and allows U-turning vehicles to complete their turn without queued vehicles blocking their path.

U-turn progression can be accomplished to minimize the travel time of the left-turning vehicles. Signals may be timed such that a vehicle traveling through the green light at the crossover has little to no wait for the green light at the main intersection before it turns green. Green time for the U-turn can nearly match the main intersection's minor street green time, while the major street green times (at the main intersection and crossover) will be nearly the same.

Signal phasing and timing for the U-turn crossovers match the main intersection (see Exhibit 5-4). To maintain progression along the corridor, upstream crossover signals change from green to red phases several seconds prior to the main intersection to allow through vehicles to pass through both intersections and reduce queuing between the main intersection and the crossover.



Exhibit 5-4. MUT signal phase timing.

Signal timing for an MUT intersection is simple given there are only two phase intervals. The minimum cycle length for low-volume periods is based on pedestrian crossings times. If longer green times are needed during a higher-volume period, minor street/U-turn split time should be set based on the minor street through movement or U-turn crossover demand (higher of the two). The major street through movement capacity should govern the minimum green time given to both major street movements simultaneously. If both capacities can be met, the major street movement should be favored slightly, as it typically serves a higher percentage of the traffic entering the intersection.

Crossover Saturation Flow Rates

There is no evidence saturation flow rates for major street through movements differ at a MUT intersection compared to a conventional intersection. However, the saturation flow rate for left turns at crossovers does differ from those of conventional left-turn movements. Crossover saturation flow rate is a measure of the capacity of the crossover. Major factors affecting the flow rate of these signalized crossovers include ratio of U-turns compared to left turns, radius of U-turns, and the number of lanes provided.

U-turns are a naturally slower movement than a left turn, so the saturation flow rate is lower for U-turns than left turns. Studies indicate U-turn saturation flow rates range from 1,300 to 1,400 vehicles per hour (veh/h).⁽²⁹⁾ Since conventional left-turn movements are more common and better understood, U-turn saturation flow rates are generally described as a factor of left-turn saturation flow rates. At conventional intersections locations with a high ratio of U-turns, studies suggest the U-turn saturation flow rate is reduced as much as 20-percent (factor of 0.80) over the left-turn saturation flow rate.⁽²⁹⁾ Since the crossovers at a MUT intersection are expected to have a high percentage of U-turn vehicles (100-percent in some cases), the radius of the U-turn likely has the greatest effect on the saturation flow rate. Small radii (less than 50 feet) slow vehicles, especially large vehicles, and reduce the saturation flow rate. Large radii (greater than 70 feet),

while increasing flow rates, require more right-of-way and wider medians, which can have implications on land use and other aspects of the MUT intersection design and operation.

The decision to use dual left-turn lanes is dependent on U-turn volumes as well as the design of the MUT system. Using the schematic in Exhibit 5-5, if U-turns only replace major street left turns (path A), the number of U-turn lanes are limited by the number of right-turn lanes from the major street to the minor street. However, if U-turns replace major and minor street left turns (paths A and B), then dual U-turn lanes can be accommodated regardless of the number of right-turn lanes from the major street to the minor street.

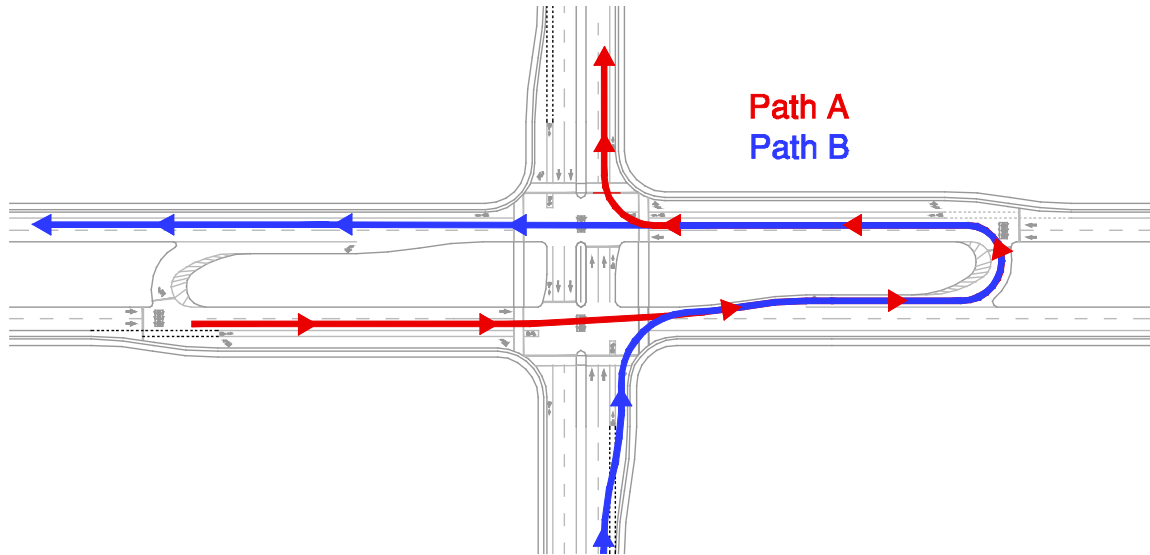

Exhibit 5-5. MUT intersection vehicle paths options.

When considering dual U-turn lanes, vehicle volumes expected from each path also affect lane utilization. Vehicles using path A will primarily (and almost exclusively) use the outer (rightmost) U-turn lane, and vehicles from path B will primarily (but not exclusively) use the inner (leftmost) lane. Generally, vehicles will queue equally in both lanes (drivers on path B are not bound to a particular lane choice and will likely choose the lane with the shorter queue), but if there is an imbalance in volumes using path A compared to path B, the rightmost U-turn lane may queue disproportionately. The design volumes for Path A and Path B should be applied when determining queue storage lengths and signal timing at the crossovers.

Weaving

Weaving areas are dependent on intersection lane numbers and arrangements and signal phasing. Weaving at a MUT intersection can typically be created in two scenarios:

1. When vehicles using paths A & B (see Exhibit 5-6) use the same dual U-turn crossover, any path A vehicles in the inner (leftmost) U-turn lane would have to weave with path B vehicles in the outer (rightmost) lane after the U-turn to complete their left turn.
2. Path B (see Exhibit 5-6) vehicles that turn right on red from the minor street must navigate across the major street through lanes to enter the U-turn crossover lanes. This

scenario also occurs when turning from an unsignalized intersection or property access between the main intersection and crossover. One way to eliminate this weaving movement is to prohibit RTOR movements from the minor street. The impact of delay due to prohibiting RTOR has some offset in that, in most cases, the right-turning vehicle delay will be less than a conventional signalized intersection, as the MUT intersection cycle length tends to be shorter and greater green time is given to the through and right-turn movements.

Both scenarios can be minimized through signing/markings or signal timing. For scenario 1, clear signage and pavement markings help drivers choose the appropriate U-turn lanes. If there is lane utilization imbalance, this becomes more difficult. For scenario 2, vehicles from the minor street have the opportunity to wait for their green time to turn instead of turning right on red. Spacing between the unsignalized intersection, main intersection, and crossover; number of lanes on major street; length of U-turn storage lane; and traffic volumes of conflicting movements all have an effect on the operation of the weave area.

Storage

Storage lengths for U-turn crossovers are determined using similar methods to other left-turn lanes. The storage should be sufficient to store queued vehicles without backing up onto the deceleration lanes, thus restricting through travel on the major street, or worse yet, back-up into the main intersection. This is a function of U-turn demand, capacity of crossover, and signal timing/coordination of the crossover. The storage length required based on these factors can be determined through Highway Capacity Manual analyses or microsimulation.

OPERATIONAL CONSIDERATIONS

Corridor Throughput

The combination of reduced clearance intervals, reduced cycle lengths, and improved corridor signal progression with MUT intersections enables greater corridor throughput compared to a conventional intersection corridor. As an illustration of this throughput benefit, the Michigan DOT, a leader in implementing MUT intersections and corridors, has performed studies at dozens of intersections comparing MUT versus conventional corridors. Exhibit 5-6 illustrates a compilation of the MDOT study results showing the MUT intersection design improves performance by a level of service (LOS) grade on average compared to a comparable intersection.⁽¹²⁾ Further, the maximum corridor throughput is approximately 20-percent greater with a MUT corridor (at LOS D) versus a conventional corridor.

Vehicle Progression

Vehicle progression is improved at MUT intersections compared to conventional intersections, especially if MUT intersections are implemented over a series of intersections in a corridor. Recalling the example in Exhibit 5-3, the major street through movement receives a greater portion of green time at a MUT intersection than at a conventional intersection. Therefore, the chances of a vehicle arriving during the green phase at a MUT intersection are greater than under a conventional intersection. In general, a MUT corridor provides a wider green band for progression and may more readily facilitate bidirectional coordination.

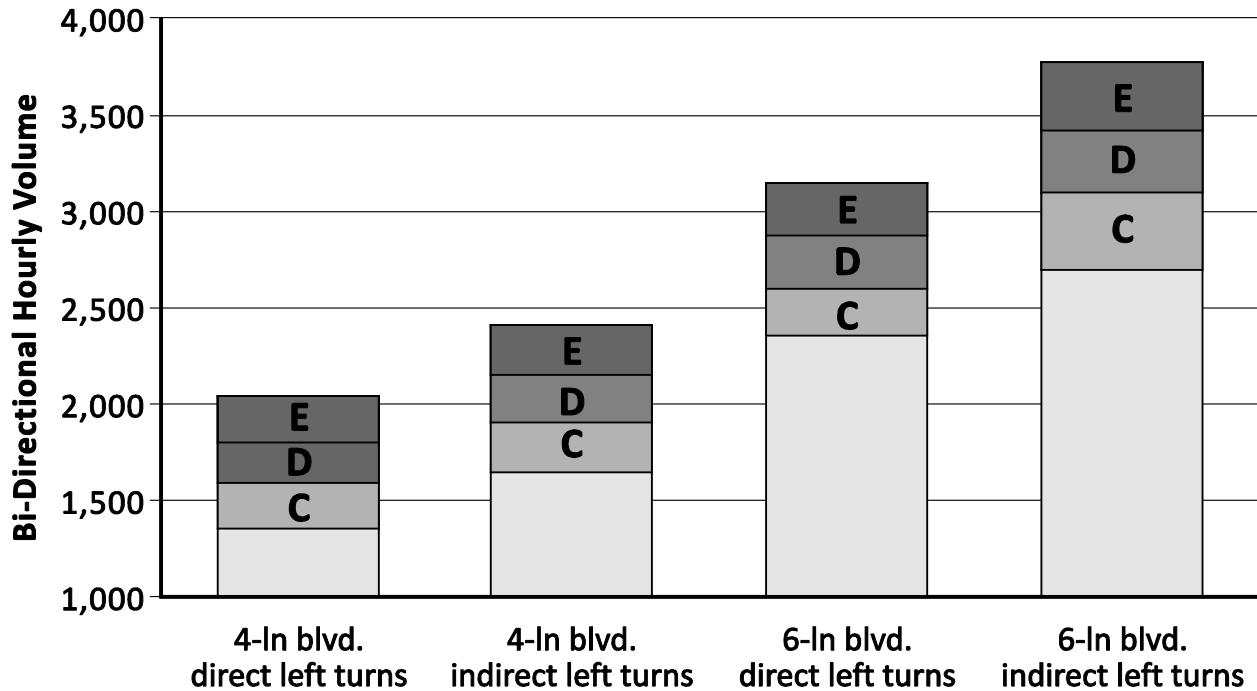

NOTE: Letters indicate Level of Service

Exhibit 5-6. Divided highway level of service and throughput comparison.⁽¹²⁾

COMPARATIVE LITERATURE AND PERFORMANCE STUDIES

Based on the comparative traffic operations and simulation studies, summarized in Exhibit 5-7, MUT intersections had the following operational advantages compared to conventional intersections:

- Added capacity of 14- to 18-percent
- Increase in total throughput increased from 15- to 40-percent
- Vehicles stopping in the network were 20- to 40-percent lower
- Critical lane volumes were reduced by 17-percent
- MUT corridors, compared to conventional corridors with TWLTLs, increased capacity by 20-to 50-percent, reduced travel times by 17-percent, and increased average speed by 25-percent

Exhibit 5-7. Summary of comparison literature and performance studies.

| Study Authors, Publication & Date | Type of Study | Key Finding |
|--|---------------|--|
| Reid & Hummer, TRR 2001 ⁽³⁰⁾ | Simulation | MUT intersections changed overall travel times (average for all movements) ranged from -21-percent to +6-percent compared to conventional intersections |
| Bared & Kaiser, ITE 2002 ⁽³¹⁾ | Simulation | Found considerable savings in travel time under MUT intersections compared to conventional intersections, especially where entering volumes exceeded 6,000 veh/h and left turns represented 10- to 20-percent of the entering volume |
| Hughes, Sengupta & Hummer, FHWA 2010 ⁽⁹⁾ | Field | MUT intersection increased throughput by 15- to 40-percent compared to a conventional intersection |
| Stover, Texas A&M 1990 ⁽³²⁾ | Field | MUT intersection reduced CLVs by 17-percent compared to a conventional intersection |
| Koepke & Levinson, TRR 1993 ⁽³³⁾ | Field | MUT intersections provide approximately 14- to 18-percent additional capacity compared to a conventional intersection |
| Savage, Journal of Traffic Engineering 1974 ⁽³⁴⁾ | Field | MUT intersections increased corridor capacity by 20- to 50-percent compared to a conventional corridor with TWLTL |
| Maki, MDOT 1992 ⁽³⁵⁾ | Field | Found a 20- to 50-percent increase when conventional intersections with TWLTL corridors were converted to boulevards with MUT intersections |
| Dorothy, Malek & Nolf, TRR 1997 ⁽¹³⁾ | Simulation | Found consistently lower network travel times when five-lane streets with TWLTL and conventional intersections were converted to four-lane streets with MUT intersections with signalized crossovers |
| Reid & Hummer, TRR 1999 ⁽¹⁵⁾ | Simulation | MUT corridor reduced total travel time by 17-percent compared to similar corridors with TWLTL and conventional intersections |

This page intentionally left blank.

CHAPTER 6— OPERATIONAL ANALYSIS

The previous chapter presented operational characteristics unique to MUT intersections. To support decisions regarding the choice and design of a MUT intersection, there needs to be an appropriate level of traffic operations analysis corresponding to the stage of the project development process. The level of analysis needs to be consistent with the available data, and that data needs to support the applied analysis tools. As vehicular traffic operations coincide with multimodal considerations, final intersection configurations and associated signal timing should be in balance with multimodal needs for each unique project context.

A MUT configuration is a system of multiple intersections. The main crossing intersection is broken into two separate signalized intersections on either side of a wide median that are coordinated to function as one intersection. At most MUT intersections, there are two additional signalized intersections, one at each intersection of the major street and the U-turn crossover. Therefore, operational analysis must consider the operations of each signalized intersection and the relationship among all signalized intersections.

Available data could include the following elements:

- Average daily traffic (ADT)
- Speed (posted, design, or 85th percentile)
- Weekday and weekend peak-hour turning movement counts
- Weekday and weekend off-peak turning movement counts
- Pedestrian volume at the intersection
- Bicycle volume at the intersection
- Proportion of the traffic stream composed of heavy vehicles
- Basic geometric data including distances between the U-turn and crossover intersections

Measures of effectiveness are used to evaluate the operational efficiency of a particular design like the MUT intersection. The FHWA Traffic Analysis Toolbox has identified the following seven basic measures of effectiveness for vehicles:⁽³⁶⁾

- Travel time: average time spent by vehicles traversing a facility, including control delay, in seconds or minutes per vehicle
- Speed: rate of motion (expressed in distance per unit of time)
- Delay: additional travel time experienced by travelers at speeds less than the free-flow (posted) speed (expressed in seconds or minutes)

- Queues: length of queued vehicles waiting to be served by the system (expressed in distance or number of vehicles)
- Stops: number of stops experienced by the section and/or corridor (based on a minimum travel speed threshold)
- Density: number of vehicles on a street segment averaged over space (usually expressed in vehicles per mile or vehicles per mile per lane)
- Travel time variance: a quantification of the unexpected non-recurring delay associated with excess travel demand (can be expressed in several ways)

The final two measures, density and travel time variance, are less applicable to an intersection treatment than an uninterrupted flow facility, but may still be considered during the operational analysis. While average speed and travel time apply to the MUT intersection much like they would to a conventional intersection (as long as the analysis area includes the entire configuration), the delay and stops performance measures must be carefully aggregated over the multiple intersections contained within intersection. Individual performance measures such as queues, stops, and delay across multiple intersections of a typical vehicle progressed through the intersection provides more meaningful comparisons versus simply adding or averaging the performance measures from each intersection.

OPERATIONAL ANALYSIS TOOL OVERVIEW

According to FHWA's Traffic Analysis Toolbox, several tools are available to analyze traffic operations at intersections, including the following:⁽³⁶⁾

- Planning-level analysis, such as critical lane volume and Capacity Analysis for Planning of Junctions (CAP-X)⁽³⁷⁾
- Highway Capacity Manual (HCM) Analysis
- Microsimulation analysis

One major factor distinguishing these three types of analysis is the amount of time required to evaluate each scenario. HCM analysis may take several times as long as planning analysis, and microsimulation is typically an order of magnitude greater than HCM analyses. Planning-level tools are useful in the initial feasibility analysis and to conduct a high-level comparison of the approximate number of lanes for a MUT intersection. An operational analysis using a deterministic method, such as the HCM, is useful to perform a more detailed peak-hour performance analysis and to estimate performance measures like delay, travel time, and queue lengths.⁽²⁾ The HCM analysis may provide insight on additional geometric design and signal timing details. Microsimulation is useful for alternative intersection forms containing multiple closely-spaced intersections for which an HCM procedure has not been explicitly developed.

Exhibit 6-1 provides a summary of available analysis techniques for MUT intersections.

Exhibit 6-1. MUT analysis techniques.

| Available Techniques | | |
|--|--|--|
| Planning | Highway Capacity Manual | Microscopic simulation |
| Available using critical lane analysis and CAP-X | Difficult to perform now for motor vehicles; can analyze crossing pedestrians and bicycles. MUT-specific HCM procedure under development | Can be performed for motor vehicles, pedestrians, and bicycles with most simulation packages |

PLANNING-LEVEL ANALYSIS

Planning-level tools and methods are useful in the early stages of a project when the MUT configuration is being considered as one of several options for an intersection improvement alternative. Planning-level tools and methods provide high-level analysis, typically providing no greater detail than volume-to-capacity (v/c) ratios and/or LOS computations. Travel time, delay, queue lengths, signal timings, and specific geometric data are typically not inputs nor outputs of planning-level tools. In general, planning-level analysis results are useful for feasibility and high-level design features but are not directly tied to actual operational performance or operational model results.

For planning-level evaluation of MUT intersections, the principle tool available is critical-movement analysis, as implemented in FHWA’s CAP-X tools.⁽³⁷⁾ CAP-X is a tool used to evaluate select types of innovative intersections, including the MUT intersection, requiring only peak volumes inputs. The tool, easily implemented in a spreadsheet workbook, is designed to work using simple inputs including:

- Turning movement counts at both the main crossing and U-turn crossover intersections
- Heavy vehicle percentages
- Number of lanes on each intersection approach
- Estimate of future growth in traffic

The outputs are the approximate v/c ratios at the main crossing intersection and each of the crossover points. Exhibit 6-2 is a screen capture from the spreadsheet that is downloadable from the Transportation Systems Institute website, *A Federal Highway Administration Project in partnership with the Transportation Systems Institute at the University of Central Florida.*⁽³⁷⁾ Note that when considering the result of the planning-level analysis, the worst intersection governs the operations of the entire MUT intersection. For example, if the main crossing intersection analysis results show a v/c of 0.7 and one of the crossover intersections has a v/c of 0.65 but the other crossover intersection has a v/c of 1.3, then the entire intersection would be considered unsatisfactory unless additional lanes can be added to the deficient crossover intersection to attain satisfactory operations.

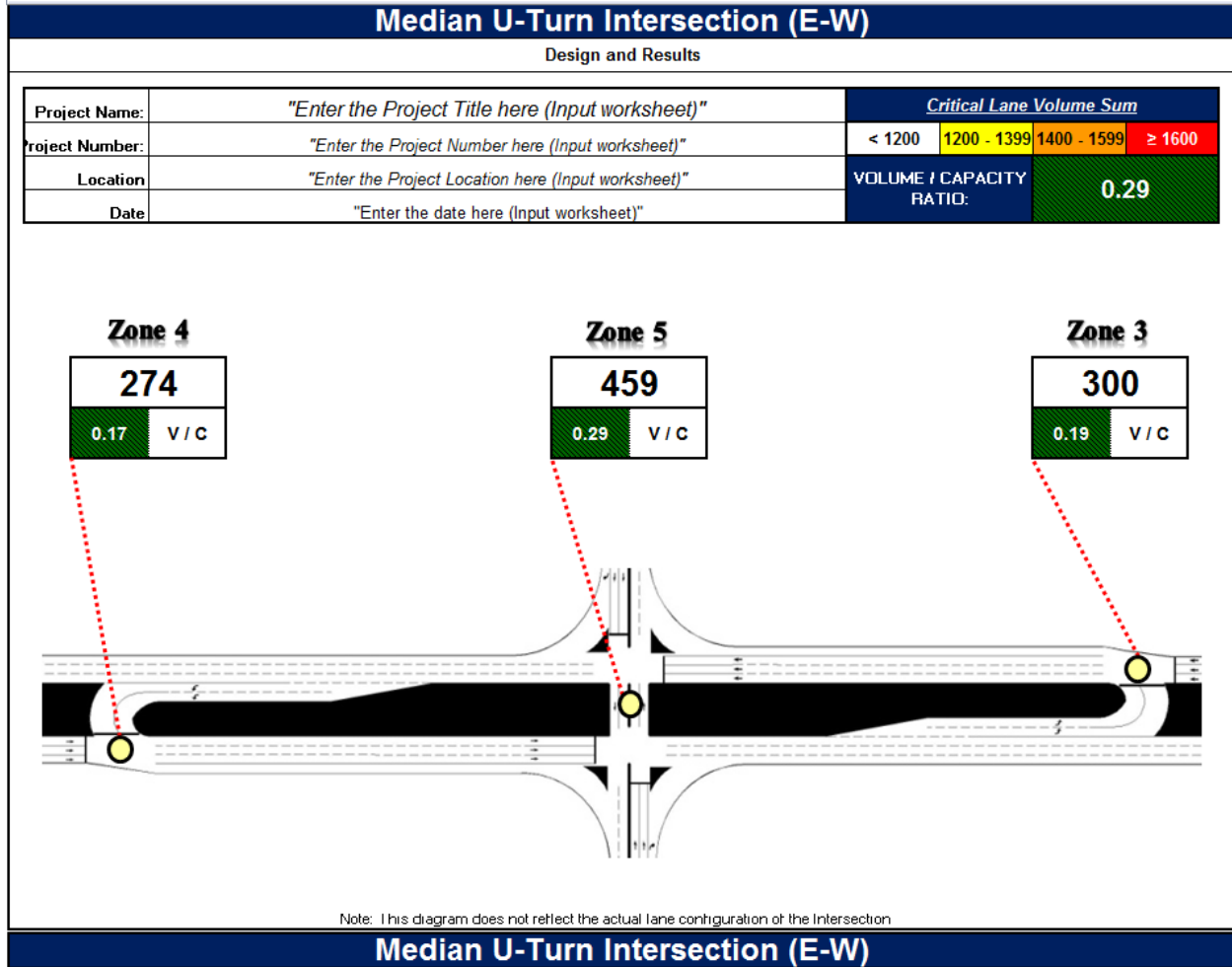

Exhibit 6-2. CAP-X Planning Level Tool Screen Capture.⁽³⁷⁾

The assumed per-lane capacity of each MUT intersection movement is a key parameter in the planning-level results. The capacity in an operational analysis is derived from the saturation flow rate and the green-to-cycle-length ratio. In a planning-level analysis, the combined capacity of two intersecting lanes is estimated through the critical lane volume at the crossing point. This value is reduced from a base, uninterrupted saturation flow rate of 1,800 to 1,900 vehicles-per-hour-per-lane (vphpl) to account for lost time in the signal cycle. The typical critical lane volume in a tool like CAP-X is 1,600 vphpl.

For the MUT intersection, research has shown the saturation flow rate at the U-turn crossover intersection may be lower than at a conventional intersection approach due to the slower speeds of the U-turning vehicles. The main crossing intersection saturation flow rate may also be reduced due to the longer signal clearance timing needed to safely clear vehicles through both intersections with the major street divided by the wide median. However, while these two MUT characteristics might suggest a reduction in the critical lane volume, the saturation flow rate is likely offset by a reduced lost time due to two-phase signal operations.

HIGHWAY CAPACITY ANALYSIS (HCM) ANALYSIS

Analytical methods and deterministic models to establish highway capacity, vehicular delay, and other performance measures are required for a more detailed analysis. The *Highway Capacity Manual*, as well as Highway Capacity Software and other types of software available from private vendors, can be used to perform this level of analysis.⁽⁶⁾ These tools use deterministic methods derived through analytical equations. An HCM procedure specifically for MUT intersections is under development by FHWA. The procedure will be included in an update of the 2010 HCM scheduled for completion in 2015.

The operational analysis methods provide further insight into the operational effects of geometric design and signal timing elements of an MUT compared to planning-level analysis methods. Advantages of the operational-level analysis approach in the HCM include the ability to balance operational detail with reasonable data input needs and analysis resource requirements. The HCM method provides more detailed output in the form of delays, travel time, and queue estimates than the planning-level method, while allowing for more customization and consideration of geometric variability and signal timing details. At the same time, its methods are typically applied more quickly than a more resource-intensive simulation analysis. Another key advantage of the HCM over simulation analysis is that the deterministic analysis framework offers consistency in performance estimation across analysts and interchange options. The HCM is generally regarded as the benchmark for operational performance estimation, and its equations and Level of Service (LOS) stratification form the basis of comparison with other tools.

Disadvantages of the current HCM include a limited scope of applicable geometry and lack of focus on network and system effects, including the interaction of the U-turn crossover intersections with the main crossing intersection. Other operational characteristics of MUT intersections not adequately handled by existing HCM methodologies include:

- The potential for queuing to spill back from the U-turn crossover intersection approaches back onto the major street
- The impact of weaving from the right turn from the minor street over to the U-turn crossover lanes with through traffic on the major street
- The arrival and departure of vehicles between the crossover and main intersection (signal coordination)
- The impact of weaving downstream of dual-lane U-turn crossovers
- The impact of transit stops within the boundary of the MUT intersection
- Estimation of pedestrian or bicycle level of service

The current HCM analysis models analyze each intersection independently. Weaving movements and lane imbalance in positioning for downstream movements are not factored into the results. It is also not possible to cumulatively analyze the travel time and delay associated with left-turning movements that are made through a series of intersections. Vehicles are not “tracked” through the series of intersections, and thus the net impact to left-turn delay and travel time is not readily comparable to conventional intersection operations. The MUT-specific procedure under

development for the update of the 2010 HCM will include “tracking” of vehicles and net impacts.

While the HCM has limitations, as discussed above, it does provide the consistency agencies need for evaluating alternatives. The HCM is an international reference manual overseen by an independent committee of experts in the field, and thus is often the basis for policy decisions and LOS thresholds for intersection selection.

Level of Service Definition

The LOS of an entire MUT intersection in the HCM can only be evaluated on an intersection-by-intersection basis. At present, there is no methodology for establishing an overall LOS grade for the MUT intersection; rather the intersection evaluation should be based on the “worst” operations of the multiple signalized intersections within the MUT footprint. Evaluation of the approach delay and LOS should be rated according to the thresholds established in Exhibit 6-3, which is reproduced from the HCM.⁽⁶⁾

Exhibit 6-3. LOS criteria for signalized intersections (based on HCM Exhibit 18-5).⁽⁶⁾

| Control Delay (s/veh) | LOS |
|----------------------------------|------------|
| ≤10 | A |
| >10–20 | B |
| >20–35 | C |
| >35–55 | D |
| >55–80 | E |
| >80 | F |

Computational Steps

The basic methodology for analyzing MUT intersection operations is shown in flowchart form in Exhibit 6-4. The MUT intersection methodology mirrors the HCM signalized intersection method (2010 HCM Exhibit 18-11), but with additional considerations.⁽⁶⁾ These include assigning conventional turning movements to the patterns permitted by the MUT intersection’s geometry, assuming optimal progression arriving at the main crossing intersection downstream of the U-turn crossover, and verifying the median U-turn queue does not exceed available storage length.

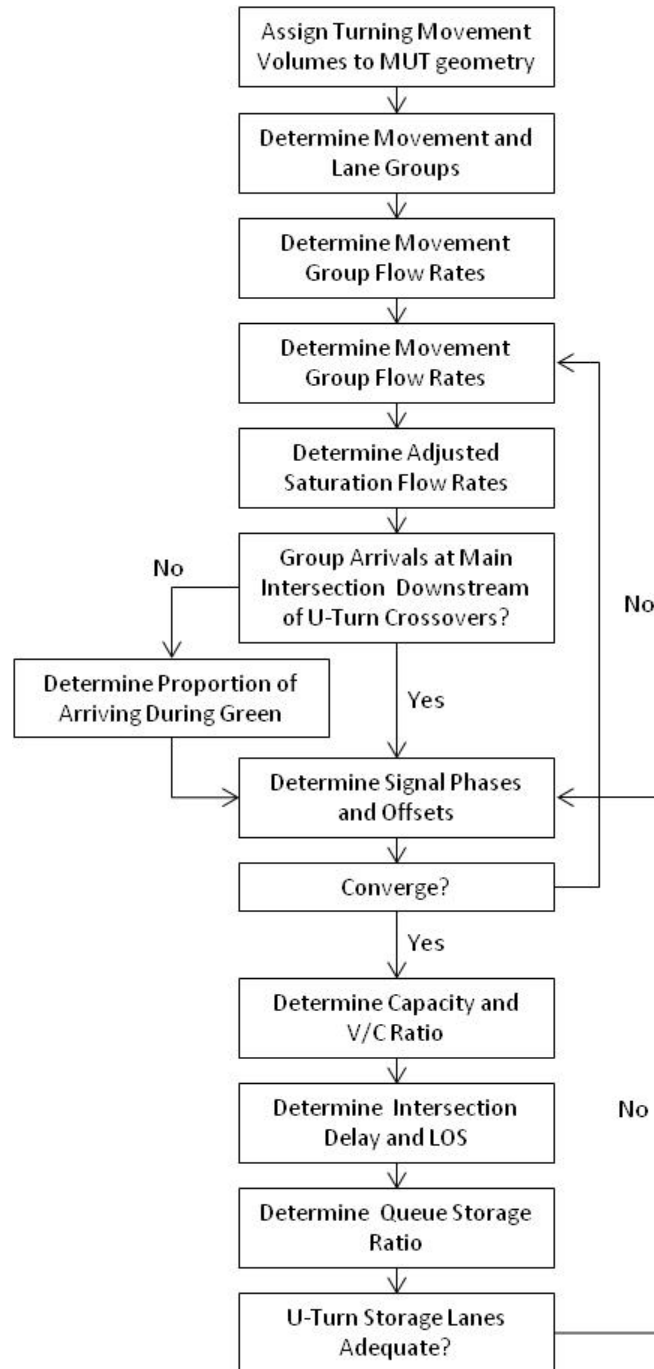

Exhibit 6-4. HCM methodology for MUT intersection evaluation (adapted from HCM Exhibit 18-11).⁽⁶⁾

A variety of input data are required to apply the HCM methodology to evaluate an MUT intersection. These generally fall into the three categories of geometric conditions, traffic conditions, and signalization conditions. Exhibit 6-5 shows input data needed for evaluating an MUT intersection using the HCM methodology.⁽⁶⁾

**Exhibit 6-5. Input data for HCM evaluation of MUT intersections
(based on HCM Exhibit 18-6).⁽⁶⁾**

| Type of Condition | Parameter |
|--------------------------------|--|
| Traffic Characteristics | Demand volume by O-D or turning movement |
| | Right turn on red flow rate |
| | Percent heavy vehicles |
| | Intersection peak hour factor |
| | Platoon ratios |
| | Upstream filtering adjustment factor |
| | Initial queue |
| | Base saturation flow rate |
| | Lane utilization adjustment factor |
| | Approach speed |
| | Pedestrian flow rate |
| | Bicycle flow rate |
| Local bus stopping rate | |
| Geometric Design | Number of lanes |
| | Average lane width |
| | Turn bay lengths |
| | Approach grades |
| | Turning radii for all turning movements |
| | Distance between main crossing and U-turn crossover intersections |
| | Existence of exclusive or shared left- or right-turn lanes |
| Signal Control | Type of signal control |
| | Phase sequence |
| | Cycle length |
| | Green times |
| | Yellow-plus-all-red change-and-clearance interval |
| | Offsets |
| | Maximum, minimum green, passage times, phase recall (for actuated control) |
| | Minimum pedestrian green |
| Phase plan | |
| Other | Analysis period |
| | 85th percentile, design, or posted speed |
| | Area type |

One of the key considerations in evaluating MUT intersections in an HCM context is traffic signal optimization. The HCM methodology does not include a methodology for optimizing MUT intersection traffic signals. Therefore, other tools are needed for optimizing MUT signal timing plans prior to implementation in the HCM or a simulation environment. To overcome this challenge, analysts often use off-the-shelf signal optimization tools to arrive at signal timing parameters for analysis of unbuilt MUT intersections.

When optimization tools are not available, some simplified optimization techniques can be applied. Since all MUT intersections operate as two-phase signals and the U-turn crossover intersections typically have lower volumes compared to the main crossing intersection, simple base signal timing assumptions can be developed by balancing the phasing split according to the proportional volumes on the major and minor streets. Once the main crossing intersection split is established, the U-turn crossover intersections are established to match the green time for the major street, and the offset is adjusted such that vehicles departing the U-turn crossover intersection on a green signal arrive at the downstream intersection at the beginning of the green phase (or stop on red with sufficient offset to clear the downstream intersection). The base signal phasing assumption can be tested and modified in the more detailed HCM process.

MICROSIMULATION ANALYSIS

Microsimulation analysis tools are capable of modeling the unique operational aspects of alternative intersections, including MUT intersections. Capacity is derived from car-following models rather than static assumptions, and all intersections within a MUT configuration can be included in a single network. Among the more critical features required to accurately model MUT intersections is the ability to replicate and track the turning movement patterns, including lane changing and lane assignment preferences. A list of calibration factors and validation parameters are described below. The selected tool must be able to include these. A discussion on the calibration process can be found in the FHWA's Traffic Analysis Tools website in Volumes III or Volume IV (specific to CORSIM) at <http://ops.fhwa.dot.gov/trafficanalysisitools/>.⁽³⁶⁾

Advantages of microsimulation models include flexible customization and configuration of geometry, signal timing, and other operational parameters. However, the greatest advantage is that microsimulation models can output "system" measures of effectiveness for MUT intersections, so that overall movement delay, travel times, and number of stops can be readily compared to conventional or other unconventional intersection designs. The MUT-specific procedure under development for the update of the 2010 HCM will provide some "system" measures of effectiveness.

Disadvantages of microsimulation models include the time, budget, data required for input and proper calibration, and the knowledge of how to properly choose, set-up, run, validate and obtain results. Another limitation of simulation is the need to calibrate and validate the effort, as well as the potential implications of failing to do so. The analyst needs to understand the many unique operational attributes of the MUT intersection including saturation flow rate, speed profiles, lost time and gap acceptance for U-turns (if U-turns are unsignalized), and know how to replicate those in simulation. There may also be variability in the results of MUT intersection evaluations performed by different analysts.

Calibration Factors

Key data needed to establish calibration factors input into MUT intersection simulation models include:

- Field-measured free-flow speeds through MUT crossover intersections. For calibration, speeds at MUT crossover approaches were observed to be below the free-flow speeds of through movement approaches as discussed in Chapter 5. Speed reduction zones can be

used to control free-flow speeds for vehicles using the U-turn crossovers. If the model does accurately reflect observed field conditions, an alternate or fall back approach is to observe free-flow speeds from other similar locations with similar driver behavior.

- Accurately modeling signalized control of MUT intersections requires exploring whether the main and U-turn crossover intersections should be modeled with one versus two controllers. The selected tool should employ signal control logic that is flexible enough to allow modeling of two-controller two-phase signal control, as well as four rings on a single controller. Details of MUT intersection signalization schemes are presented in Chapters 5 and 8.

Validation Factors

Several validation parameters are recommended for accurately modeling existing MUT intersections in simulation. Data should be collected in existing conditions to support these parameters and the testing of the base conditions model, including:

- Origin-destination (O-D) volumes collected beyond the area of influence of the MUT intersection footprint. A calibrated base model should be able to reflect similar volumes and travel patterns compared to existing field conditions. For MUT intersections, the O-D patterns are adjusted compared to the conventional intersection to match MUT intersection geometry and permitted movements.
- Route travel times, collected using GPS receivers, floating car, or other collection techniques. A calibrated model should be able to reflect similar travel times compared to existing field conditions.
- Average and 95th percentile queue lengths, particularly for through and left-turn movements. A calibrated model should be able to reflect reasonably similar queue lengths compared to existing field conditions.

CHAPTER 7— GEOMETRIC DESIGN

This chapter describes the typical MUT intersection design approach and provides guidance for geometric features. This chapter presents best practice design criteria developed by experienced state agencies, and also provides information regarding implementations in several states. It requires input from the multimodal considerations (Chapter 3), safety assessment (Chapter 4), and traffic operational analysis (Chapters 5 and 6). The guidance in this chapter is intended to supplement national resources on intersections that apply basic design principles.

DESIGN APPROACH

Developing the geometric layout for an intersection configuration requires considering the relationship and interaction of safety, operations, and design. In addition, it requires understanding the trade-offs of the physical, environmental, or right-of-way constraints for the proposed MUT intersection that may preclude ideal median width or crossover location. The overarching goal is to provide geometry that serves all users and meets their expectations. As with any intersection form under consideration, undesirable geometry cannot necessarily be mitigated by signing and pavement markings. The overarching goal is to provide geometry that serves various users and meets their expectations. This includes clear and defined channelization that is supplemented with signing and pavement markings. Exhibit 7-1 illustrates a MUT intersection with two signals at the main intersection and highlights the characteristic features of a MUT intersection. Exhibit 7-2 illustrates a MUT intersection with one signal at the main intersection.

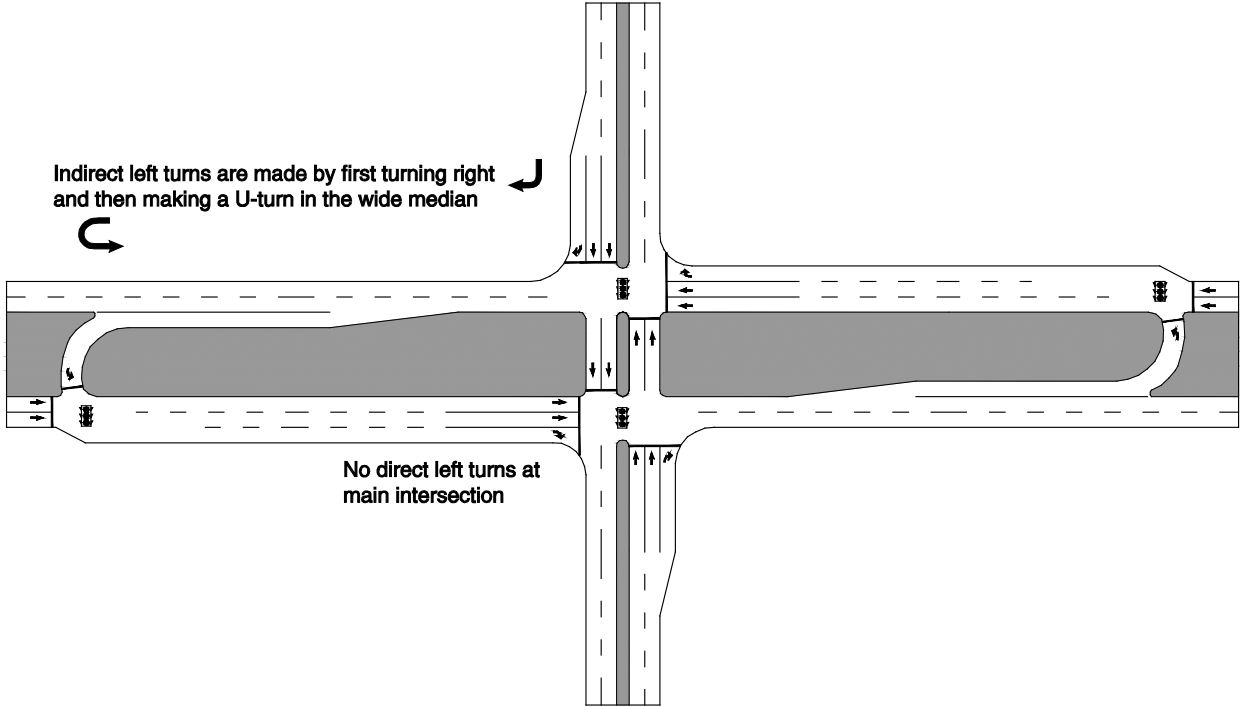

Exhibit 7-1. MUT characteristics.

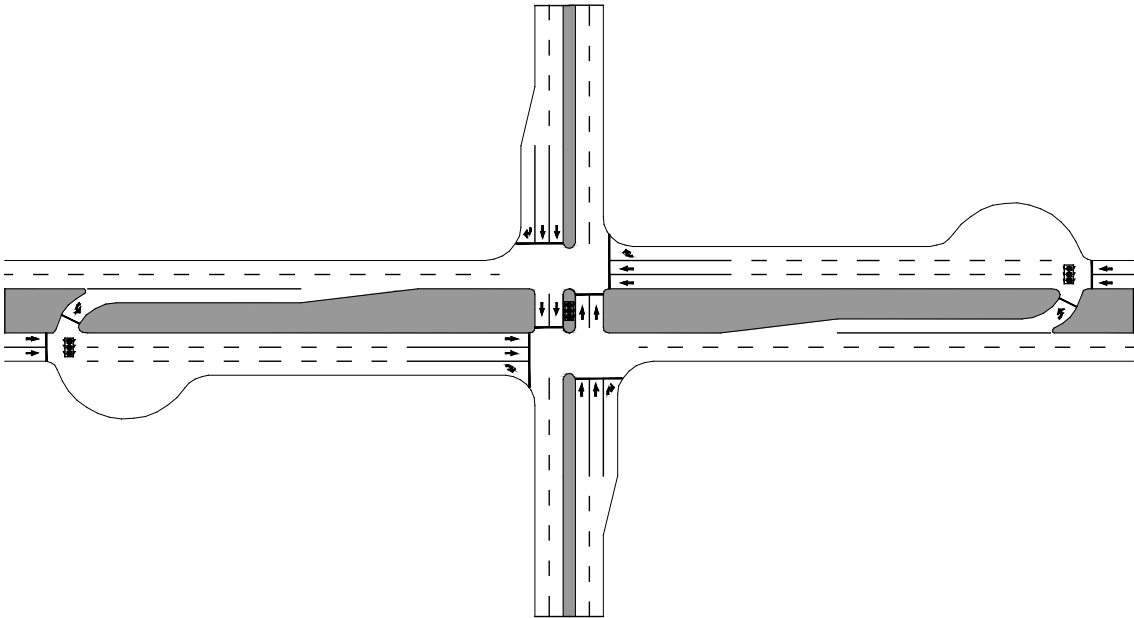

Exhibit 7-2. MUT intersection with one signal at the main intersection.

GEOMETRIC DESIGN PARAMETERS/PRINCIPLES

The geometric design of a MUT intersection introduces some unique design elements not typically present at a conventional intersection. These elements include:

- A wide median is often needed to facilitate the median U-turn movements. Typically this median is uniform through the intersection and main crossing street, but there are design variations reducing the length of the wide median or locate the median on the minor street.
- A large enough vehicle path at the U-turn crossover to accommodate trucks and allow for efficient movements through the U-turn by passenger vehicles.
- Design elements providing positive guidance using design elements and signage to reduce chances of driver error and discourage prohibited turns.
- Signing, marking, and geometric design promoting safe and efficient movements that would otherwise be unexpected or not familiar to motorists.
- Corridor-wide access strategies and management considerations to properties along the median street to promote safe and efficient access to these properties.

RANGE OF MUT CONFIGURATIONS

MUT intersections can be used in multiple variations to accommodate specific locations. Crossover placement can be adjusted to minimize impacts to access, provide better access, or to work with right-of-way limitations.

Median U-turn Locations

Examples of variations of U-turn locations (as illustrated in Exhibits 7-3 to 7-5) are:

- Placing a stop-controlled directional crossover immediately prior to the main intersection. This could improve adjacent land access by eliminating the need for some vehicles to travel through the intersection twice to access properties between the main intersection and the crossover. However, this places U-turns and right turns in greater conflict by sharing the same pavement area to make each respective movement.

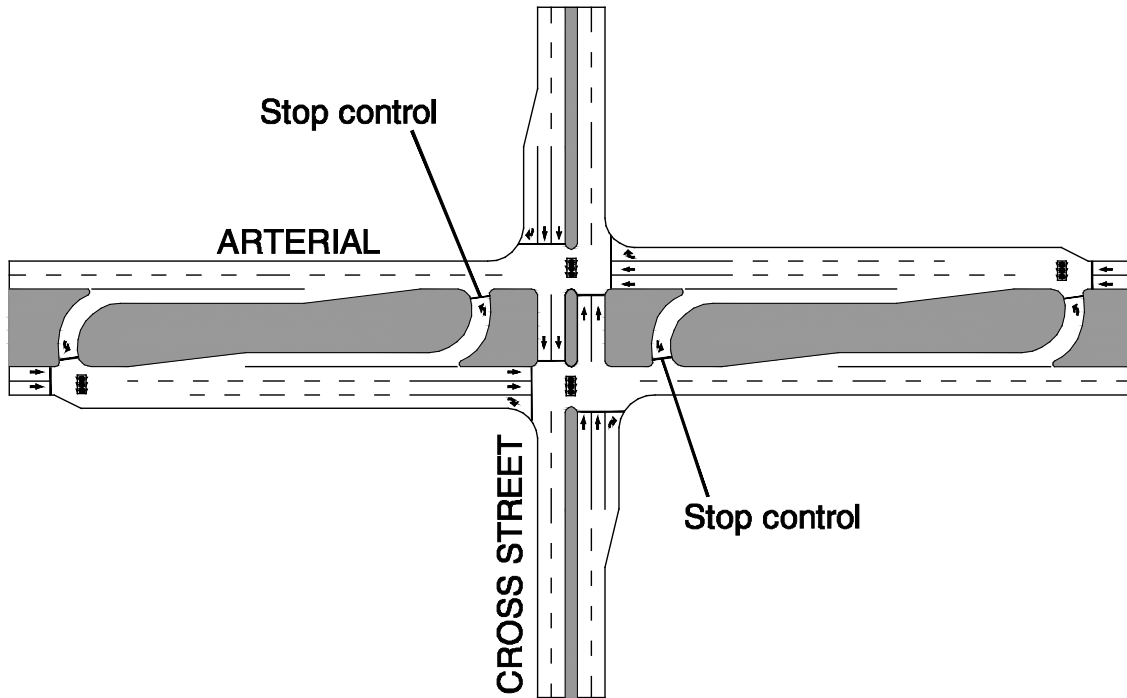

Exhibit 7-3. MUT intersection design variations – stop control crossover near intersection.

- Placing directional crossovers on the minor street to minimize major street median width and right-of-way requirements. This may be less intuitive to drivers in an “isolated” setting, but the operational and safety benefits of a MUT intersection are still achieved. Placing U-turn crossovers in the median over multiple intersections along a principle street corridor greatly improves route continuity and driver expectation, and provides greater access controls between major intersections.

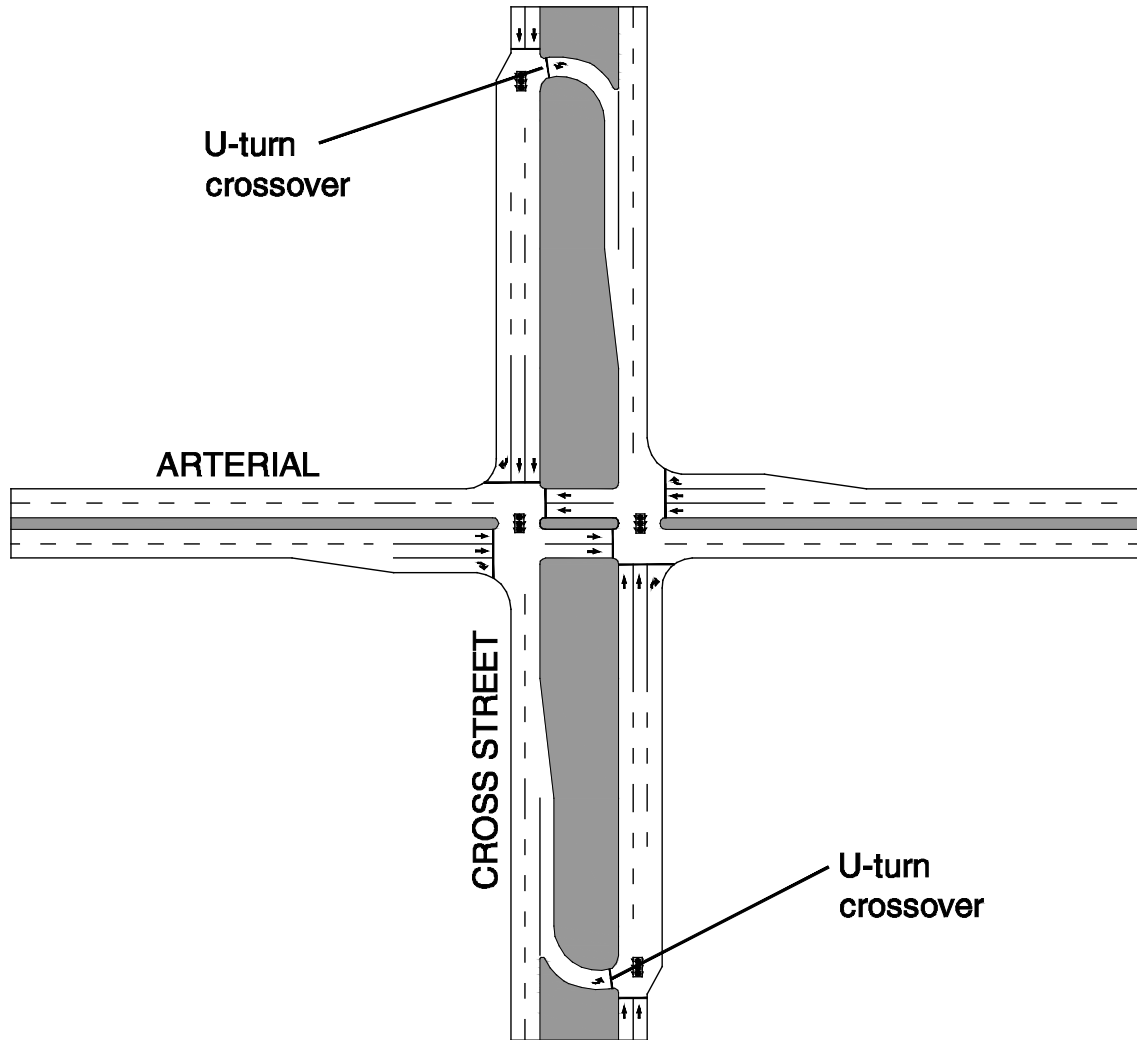

Exhibit 7-4. MUT intersection design variations – U-turn crossover on minor street.

- Placing directional crossovers on both the major and minor streets can increase left-turn capacity by dividing the turning movements into four crossovers instead of two. This is especially effective where two MUT streets intersect. It is also effective when the left-turn volumes displaced to the crossover are overburdening the crossover.

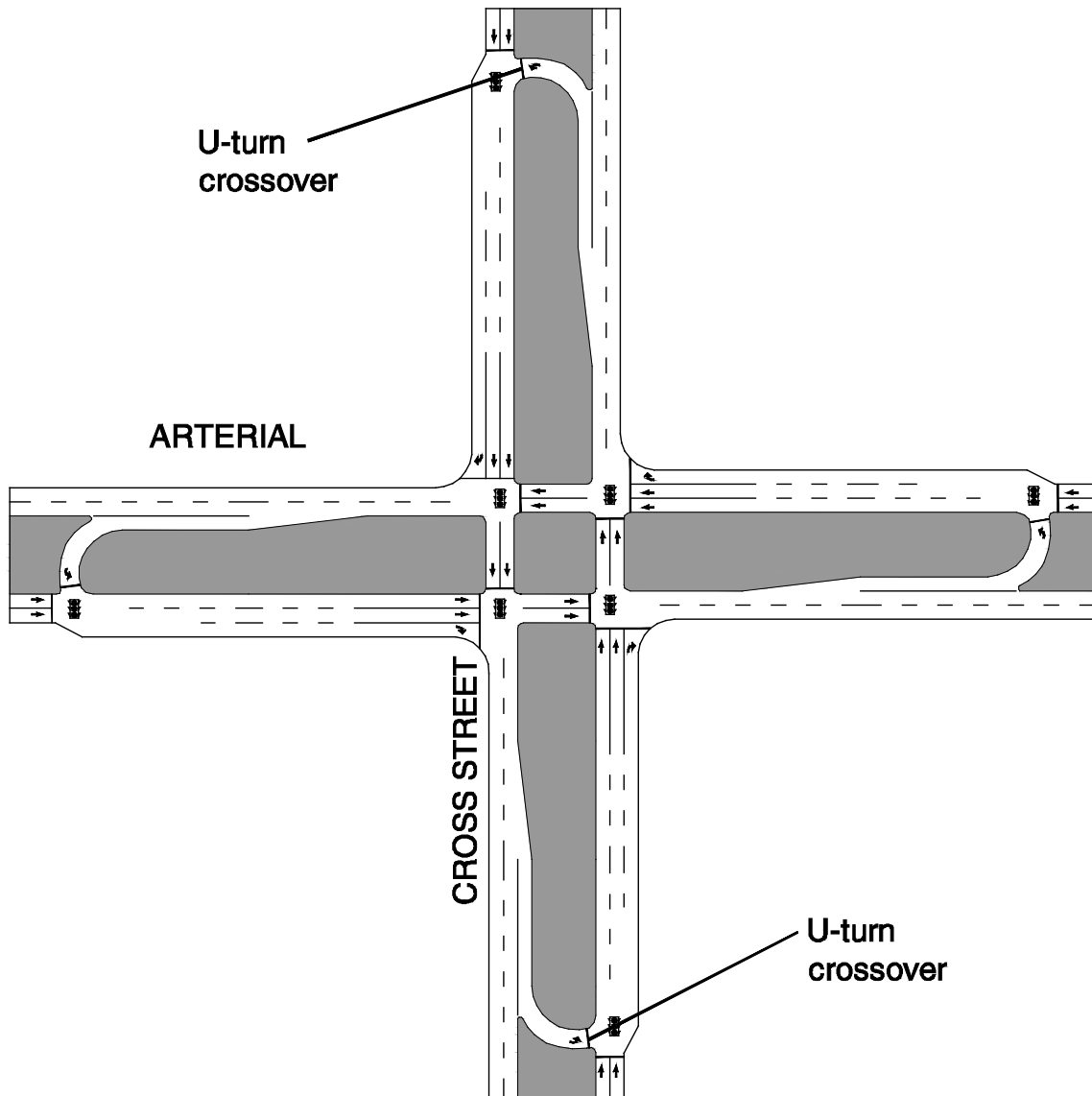

Exhibit 7-5. MUT intersection design variations – U-turn on both streets.

Restricted Crossing U-Turn (RCUT) Intersection

RCUT intersections are similar to MUT intersections and have the same median U-turn crossovers to redirect movements from a main intersection, as shown in Exhibit 7-6. The difference between MUT and RCUT intersections is seen with the movements allowed at the main intersection. For a RCUT intersection, major street through, rights turns, and left turns are allowed while only right turns are allowed from the minor street. The signals for RCUT intersections can operate independently with different cycle lengths in each direction on the major street. MUT and RCUT intersections are compatible with each other and can be combined

effectively along the same corridor. RCUT intersections are also known as superstreet intersections and j-turn intersections, and are discussed in detail in the companion FHWA RCUT Intersection Informational Guide.

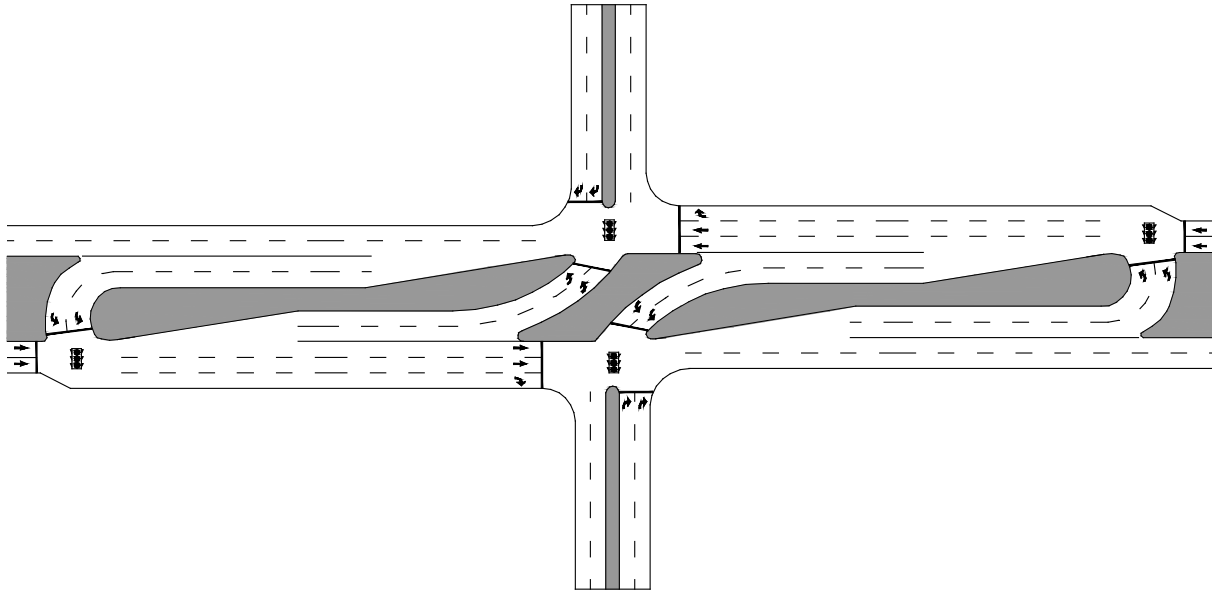

Exhibit 7-6. RCUT intersection.

Narrow Corridors

Many of the Michigan MUT intersections were designed and built in “super corridors” of reserved right-of-way that could accommodate wide medians. In other locations, it may be more difficult to find corridors of sufficient right-of-way, particularly in built-out urban and suburban areas. Therefore, some MUT intersections require different designs to provide the necessary width for intersections and crossover locations.

In Utah, two recent isolated MUT-style intersections were installed with wider right-of-way only at the U-turn crossover. These intersections, called “ThrU” intersections by local planners and designers, provide a wide loon at each crossover intersection and prohibit left turns at the main intersection. The U-turn loons eliminate the need for a wider median along the major street, minimizing right-of-way impacts. An example of a MUT design with narrow medians installed in 2013 by Arizona DOT in Tucson, AZ is shown in Exhibit 7-7.



Exhibit 7-7. MUT intersection with narrow median, Tucson, AZ.⁽¹⁾

Similar intersection designs were installed on MUT corridors in Grand Rapids, MI and Wilmington, NC, as shown in Exhibit 7-8. They use loons to provide the necessary turning radii at the U-turn crossovers where right-of-way at the main intersection is not available for a full median width. Loons generally require some right-of-way; however, they locate right-of-way acquisitions to the crossover locations only.



Exhibit 7-8. Loon at U-turn crossover in Wilmington, NC.⁽⁹⁾

OPERATIONAL EFFECTS OF GEOMETRIC DESIGN

This section addresses the operational effects of geometric design on safety performance, traffic operations, and quality of service for pedestrians and bicyclists. There are several geometric design features potentially affecting how the MUT intersection will operate once implemented.

Intersection Skew

U-turn intersections can be built with skewed intersections with minor streets. There are several lengthy MUT corridors in southeast Michigan (including Woodward, Grand River, and Gratiot avenues) built on radial routes that cause skews at most crossing street intersections. At skewed

intersections, the U-turn crossovers are unaffected as the U-turn geometry remains the same. The stop bars at the main intersection are adjusted or staggered on the skewed approaches similar to a conventional intersection design. Skewed left turns are eliminated at the main intersection. At conventional intersections, the acute skewed left turns have a detrimental impact on movement capacity. Therefore, the MUT has some operational and implementation advantages at skewed intersections.

U-turn Radii

At a MUT intersection U-turn crossover, the width of the median and the number of turn lanes together govern the radius of the U-turn movements and thus control the speed of the movement. Larger radii encourage U-turn vehicles to complete their movement at higher speeds, which in turn improves the capacity of the crossover. Loops can provide a wider turning radius for both cars and trucks. However, the speed and capacity benefit is slightly tempered by the fact that vehicles must turn more than 180-degrees to return to the through lanes of travel. While the number of lanes and median width are typically fixed for reasons other than operations, the turning radii should be maximized to the extent possible (acquiring as much right-of-way as possible) to establish efficient operational speeds and capacities at U-turns.

Pedestrians and Bicycles

Chapter 3 provides guidelines to accommodate pedestrians and bicyclists at MUT intersections. As for conventional intersection design, ADA guidelines provide guidance for designing crosswalks, pedestrian ramps, and sidewalks.⁽²¹⁾ As detailed in Chapter 3, pedestrians can be served using conventional pedestrian signals but are served with greater frequency (more cycles per hour) and longer walk time per cycle. Also detailed in Chapter 3, bicycle lanes can be constructed adjacent to the outside lanes and are given greater green time priority and face fewer conflicting movements at the main and U-turn intersections.

One unique feature for designing for bicyclists at a MUT intersection is providing a bicycle box to facilitate direct left turns. Exhibit 7-9 illustrates a layout for a modified pedestrian island to accommodate a bicycle box.

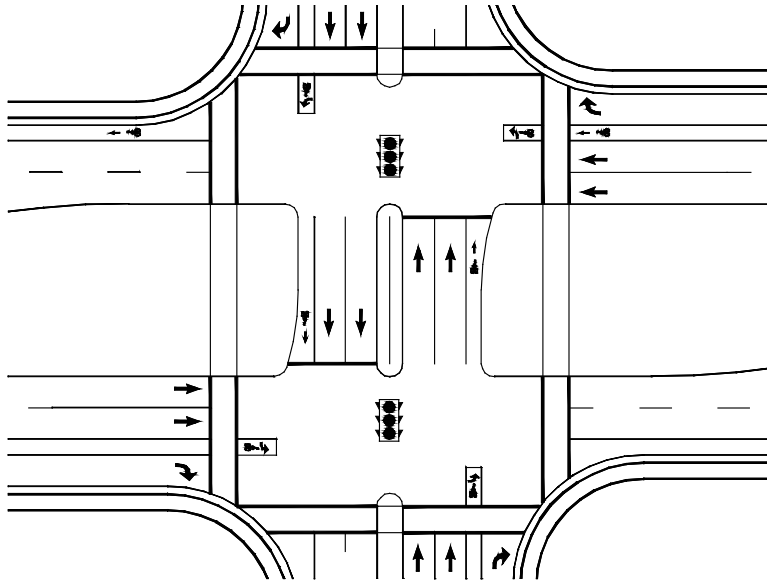

Exhibit 7-9. Bicycle box for left turn.

Transit

As discussed in Chapter 3, transit has similar operational impacts as a conventional intersection for most stop locations. Near-side stops on the major street can be placed in a location (in the long right-turn bay) such that bus stops would not impede through or U-turn traffic.

DESIGN GUIDANCE

MUT intersections may be used on divided streets or on undivided streets with special provisions for accommodating U-turns. The following sections will discuss the following geometric design guidance of MUT intersections:

- Main intersection turn lanes
- U-turn crossover with two-way crossovers or single-directional crossovers
- Median widths and loons
- Right-of-way requirements
- Design vehicle accommodations
- Spacing between the main intersection and U-turn crossovers
- Spacing between crossovers along a MUT corridor of intersections
- Pedestrians and bicycles
- Transit

Main Intersection Turn Lanes

At the main intersection of a MUT intersection, the geometric design is similar to a conventional intersection. However, direct left turns are not permitted from either the major or minor crossroads. As a result, the right-turn lanes on the major street must provide storage for the typical right-turn volume from the major street, plus the additional left-turn volume from the opposing direction that used the U-turn crossover and returned to the intersection as a right-turning vehicle.

Similarly, the right-turn lane on the minor street must provide storage for the typical right-turn volume from the minor street, plus the additional left-turn volume that will use the crossover in the major street median and pass back through the main intersection juncture to complete the indirect left-turn movement. As a result, approaches to the main MUT intersection juncture may have any combination of exclusive and shared through and right-turn lanes.

It is not uncommon to have multiple and shared through/right-turn lanes on the minor street approach to the MUT intersection. Multiple right-turn lanes allow the rightmost lane to be dedicated to right-turning vehicles and the leftmost lane to be dedicated to vehicles making U-turn movements at the downstream crossover in the median. On minor streets with at least two through lanes at the intersection, it is not uncommon to have a shared through/right-turn lane, as having two exclusive right-turn lanes would require additional right-of-way and additional pedestrian crossing distances; a shared through/right-turn lane often provides enough capacity for all approach movements.

It is not recommended, however, to have through/right-turn lanes on the major street, as vehicle speeds are typically higher and through vehicles would have to slow down for right-turning vehicles. Where right-of-way is available, a continuous right-turn lane on the major street from the U-turn crossover to the main intersection is recommended. This provides adequate right-turn lane storage (typically several hundred feet) and allows the vehicles using the U-turn crossover to move over immediately to the right-turn lane and out of the through lanes of travel.

Exhibit 7-10 provides examples of typical right-turn lanes at a MUT intersection.



Right-turn and shared through/right on minor street



Right-turn lane from U-turn to intersection on major street

Exhibit 7-10. Typical right-turn lanes at MUT intersections.⁽¹⁰⁾

Channelized right-turn lanes are seldom used at MUT intersections, since the channelizing would require additional street width for the cross-section, longer crossing widths for pedestrians, and additional right-of-way. Also, channelized right turns would induce undesirable weaving

conflicts that otherwise would not occur if vehicles were forced to stop before turning right on red.

The typical MUT intersection restricts direct left turns from both the major and minor crossroads and constructs the median U-turn on the major crossroad. However, variations to the typical design are sometimes made depending on traffic volumes for the various movements and availability of right-of-way. For example, direct left turns may be made permissible from either the major or minor crossroad, and/or median U-turns may be constructed on the minor crossroad.

U-turn Crossovers

MUT intersections require U-turn crossovers as secondary intersections. The U-turn crossover is typically located on the major crossroad to accommodate indirect left turns from the major and minor crossroads. U-turn crossovers should have directionally exclusive lanes in advance of the crossover to provide deceleration and storage for U-turning vehicles. Guidelines for directional median U-turn crossovers have been developed by various state agencies, such as MDOT and by the AASHTO Green Book.^(27,5) Exhibit 7-11, provided by the MDOT, illustrates the dimensions used for directional crossovers on a highway.

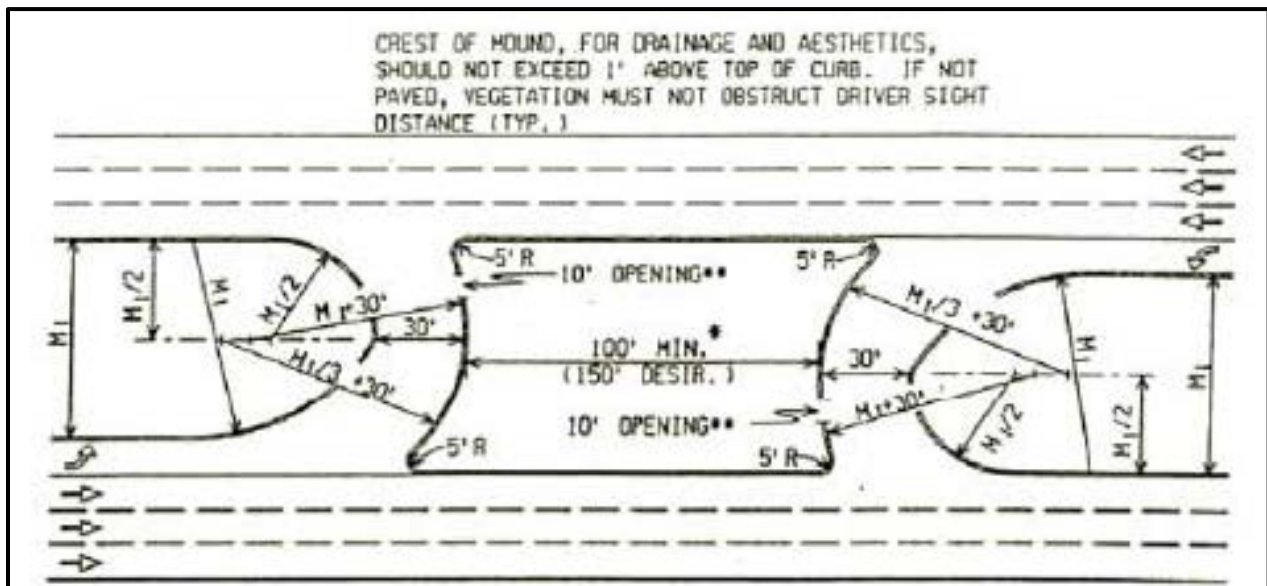

Exhibit 7-11. Directional crossover design on highway.⁽²⁷⁾

For the design used by MDOT, drivers in passenger cars typically queue side-by-side in the 30-foot-wide U-turn crossover and use it as a two-lane crossover. However, large trucks typically use the full 30-foot wide crossover when making U-turns. This is an understood practice in Michigan where drivers are familiar with this type of alternative intersection, although it is not a legal practice in some states.

Newer applications in other states with drivers who may be unfamiliar with this type of intersection may require additional signing, striping, or design modifications to restrict this practice. In particular, this practice may be restricted for unsignalized U-turn crossovers due to

the potential for vehicles on the outside to block the view of the vehicle on the inside from on-coming traffic. Similarly, vehicles should not be permitted to queue side-by-side in the crossover at signalized U-turn intersections where LTOR movements are allowed and to avoid the situation of each turning vehicle selecting the same lane. Where a two-lane crossover is designed as such, MDOT provides two exclusive U-turn lanes in advance of the crossover with the crossover width increased to 36 feet.

In addition to the design guidance from MDOT, the minimum design of crossovers can be customized for any design vehicle by using the minimum turning path for the design vehicle plus a 2-foot clearance from the vehicle's left and right sides as the lane width in the crossover.⁽²⁷⁾ The same technique can be used in designing dual turning lanes, which will result in a 4-foot clearance between vehicles and a 2-foot clearance to the outside edge of each lane. Minimum turning paths for design vehicles are readily available in Chapter 2 (Design Controls and Criteria) of the AASHTO Green Book, or can be obtained from computer-aided design (CAD) programs.⁽⁵⁾

Median Width and Loons

The AASHTO Green Book provides guidance on minimum median widths for various design vehicles when designing for U-turns.⁽⁵⁾ Exhibit 7-12 provides the minimum median width required for seven different types of design vehicles turning from the inside lane of a four-lane divided street to either (1) the inside lane in the opposing direction, (2) the outside lane in the opposing direction, or (3) the outside shoulder in the opposing direction.

Where an exclusive U-turn lane of 12 feet in width is provided in the median, an additional 12 feet should be added to the minimum median widths. Depending on the design vehicle and the resultant turning location when the U-turn is completed, median widths can range from a minimum of 8 feet (passenger car) to 69 feet (WB-67). Where the median width is not wide enough to accommodate the various design vehicles, loons can provide the additional width to complete the U-turn. Since most of the U-turning vehicles will make a right turn at the main crossing intersection after completing the U-turn, most of the U-turning traffic will need to be in the rightmost lane before the main crossing intersection. As a result, the optimal U-turn design will use the rightmost lane of the opposing through traffic as the receiving lane for U-turns where possible.

Right-of-Way Requirements

MDOT uses median widths between 47 and 71 feet to accommodate design vehicles at U-turn crossovers without encroaching on outside curbs or shoulders. If 12-foot lanes are assumed and an additional 10 feet is provided beyond the edge of the travelled street for drainage and utilities, the right-of-way for Michigan streets with MUT intersections can vary from 139 feet for four-lane streets to 163 feet for eight-lane streets. Similarly, using Exhibit 7-4 (from the AASHTO Green Book) for minimum median widths, when designing U-turns and using the same lane width assumptions described above, the right-of-way requirements would range from 139 feet for four-lane streets and 165 feet for eight-lane streets.⁽⁶⁾

If a MUT intersection is located on a street with a median wide enough to accommodate U-turns by design vehicles (47 to 69 feet for a WB-67), right-of-way requirements are essentially the same as a conventional intersection. For streets with no medians or narrow medians, right-of-way for loons is required. If a new street is built with a wide median specifically to accommodate MUT intersections, the MUT intersection will require additional right-of-way compared to a conventional intersection.

Exhibit 7-14 illustrates the estimated footprint for a MUT intersection compared to a conventional intersection.

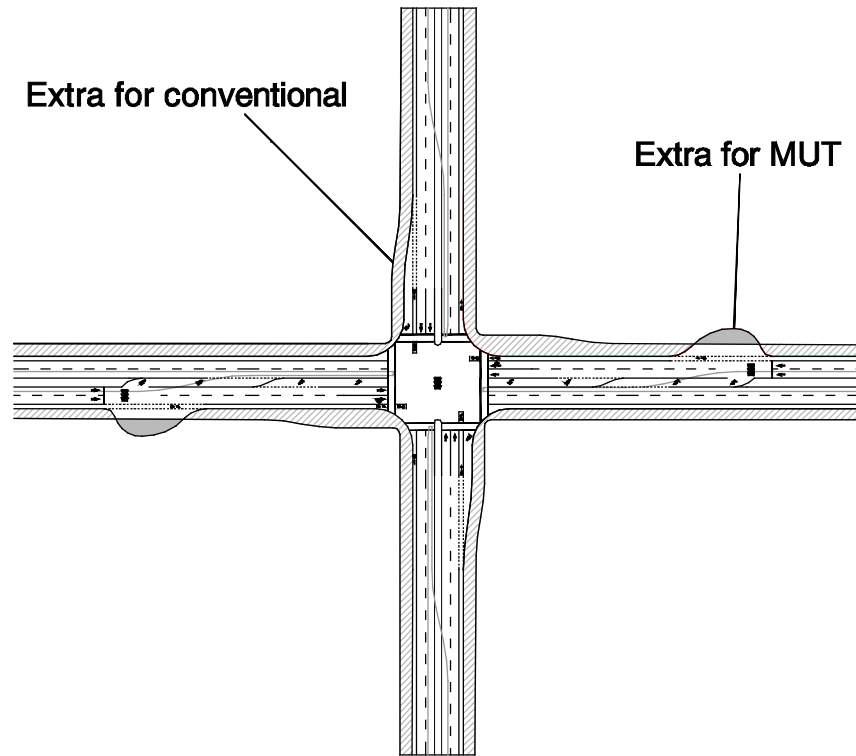
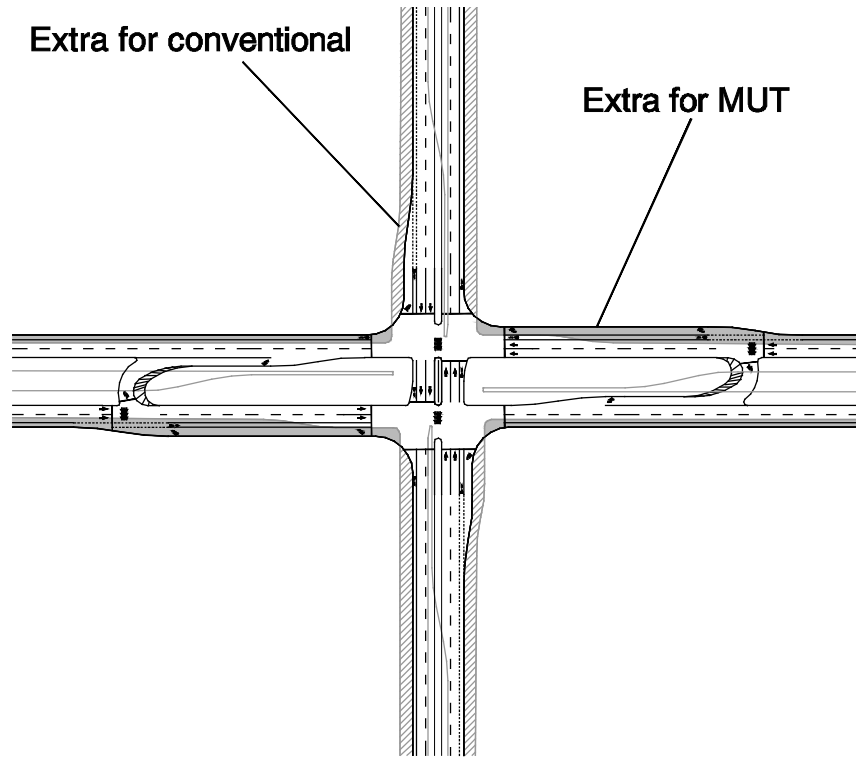

Exhibit 7-14. Footprint comparison of a MUT intersection versus a conventional intersection.

The right-of-way footprint may affect agency decisions on whether to construct this type of intersection. This may be of particular focus within an urban environment or other areas where right-of-way may be expensive or difficult to obtain.

Design Vehicles

The design vehicle's turning movements at the U-turn crossover and the additional time required for design vehicles to complete this movement are the primary differences between the design of a conventional intersection and a MUT intersection. Where loons are not used, the medians typically need to be 47 to 71 feet wide to accommodate the turning radius and the width of a design vehicle's turning path; medians at conventional intersections with dual-left turn lanes are typically 28 feet. Additionally, the lane width of the crossover must be increased to accommodate the turning path of the larger vehicles.

Dual U-turn lanes can be implemented if vehicle demand supports it. Dual U-turn lanes require more than twice the area of a single U-turn lane to accommodate large trucks and buses in both lanes side-by-side, simultaneously. The size of the U-turn crossover may be reduced if large vehicles were limited to one lane by signing and regulation, eliminating the possibility of two large vehicles using the crossover at the same time.

Additional signal time must also be provided for heavy vehicles at the U-turn crossover. Studies have shown U-turns at conventional intersections require up to 17-percent more time for passenger cars to complete than a right- or left-turn movement.⁽³⁸⁾ Heavy vehicles may require more time to complete U-turns than passenger cars.

Spacing Between Main Intersection and U-Turn Crossover

The distance between the main intersection and the U-turn crossover must be considered for both directions of travel on the major crossroad.

There is some variation between the AASHTO Green Book and state guidelines for the distance between the main intersection and the U-turn crossover.⁽⁵⁾ MDOT recommends a distance of 660 feet \pm 100 feet, which is based in part on the deceleration length required for the major street having a posted speed limit of 45 mph.⁽²⁷⁾ The AASHTO Green Book recommends a distance range of 400 to 600 feet.⁽⁵⁾ The AASHTO Green Book also suggests that at locations where the U-turn crossovers were designed specifically for eliminating direct left turns at a major intersection, the crossover should be located downstream of the intersection, preferably mid-block between adjacent crossroad intersections.

Where the minimum required distance to the U-turn crossover plus the distance required for the next downstream left-turn lane are greater than the distance between the two adjacent intersections, the AASHTO Green Book recommends the U-turn crossover should be located 50 to 100 feet in advance on the next downstream left-turn lane.⁽⁵⁾

The following describes each key distance that should be considered (see Exhibits 7-15 through 7-17):

- The distance for left turning vehicles passing through the main intersection to the U-turn crossover. This distance should include length for deceleration and storage for the left-turning vehicles for both the major crossroad and for those on the minor crossroads (those that were required to make a right turn onto the major crossroad).

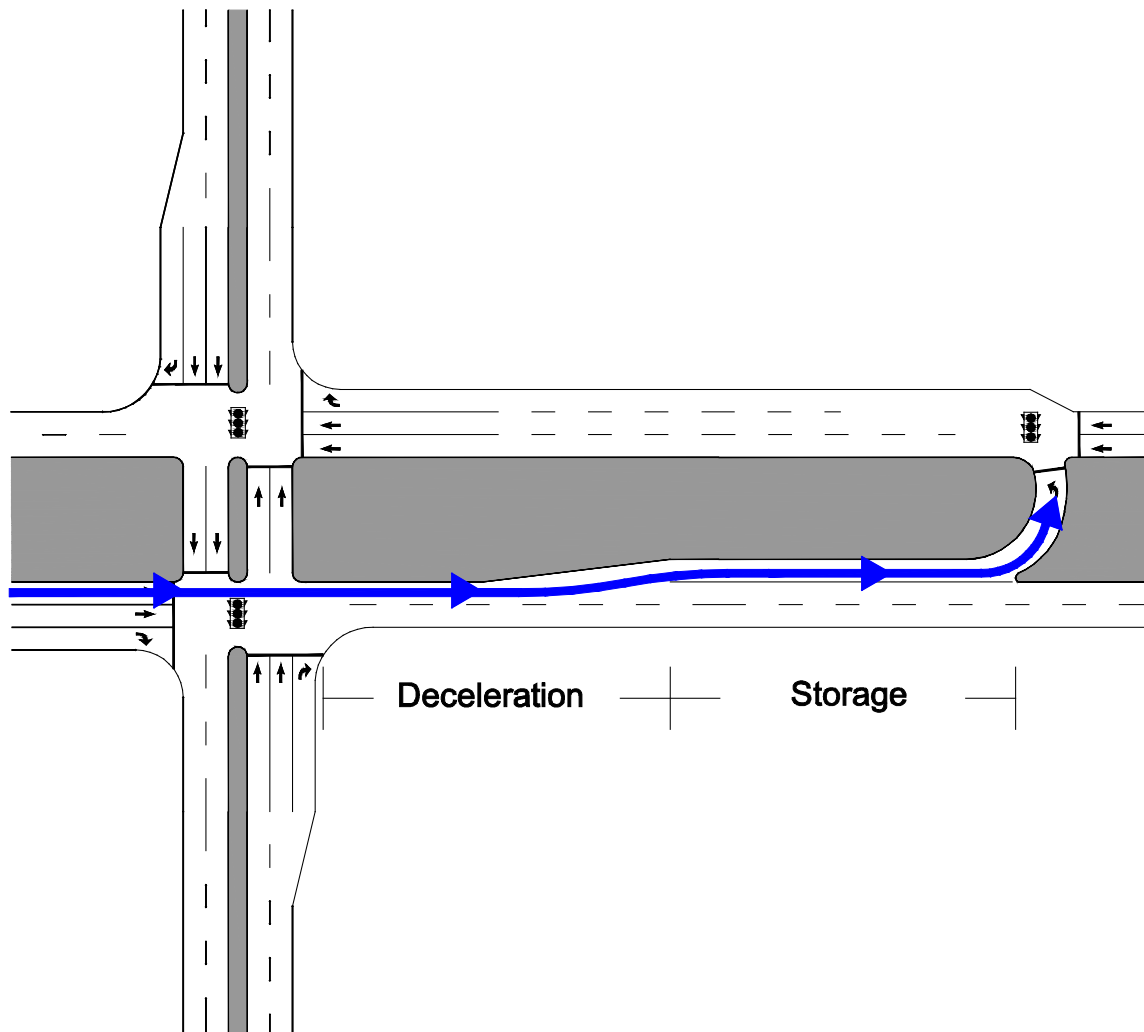

Exhibit 7-15. Spacing consideration for a major street left turn movement.

- The distance for right-turning vehicles (with a destination to the left on the major street) from the minor crossroad to move from the right side of the major crossroad after completing their right turn to the left side prior to the deceleration lane. While traffic laws vary among states, in some states right-turning vehicles are mandated to enter the rightmost lane available on the crossroad into which they are turning.

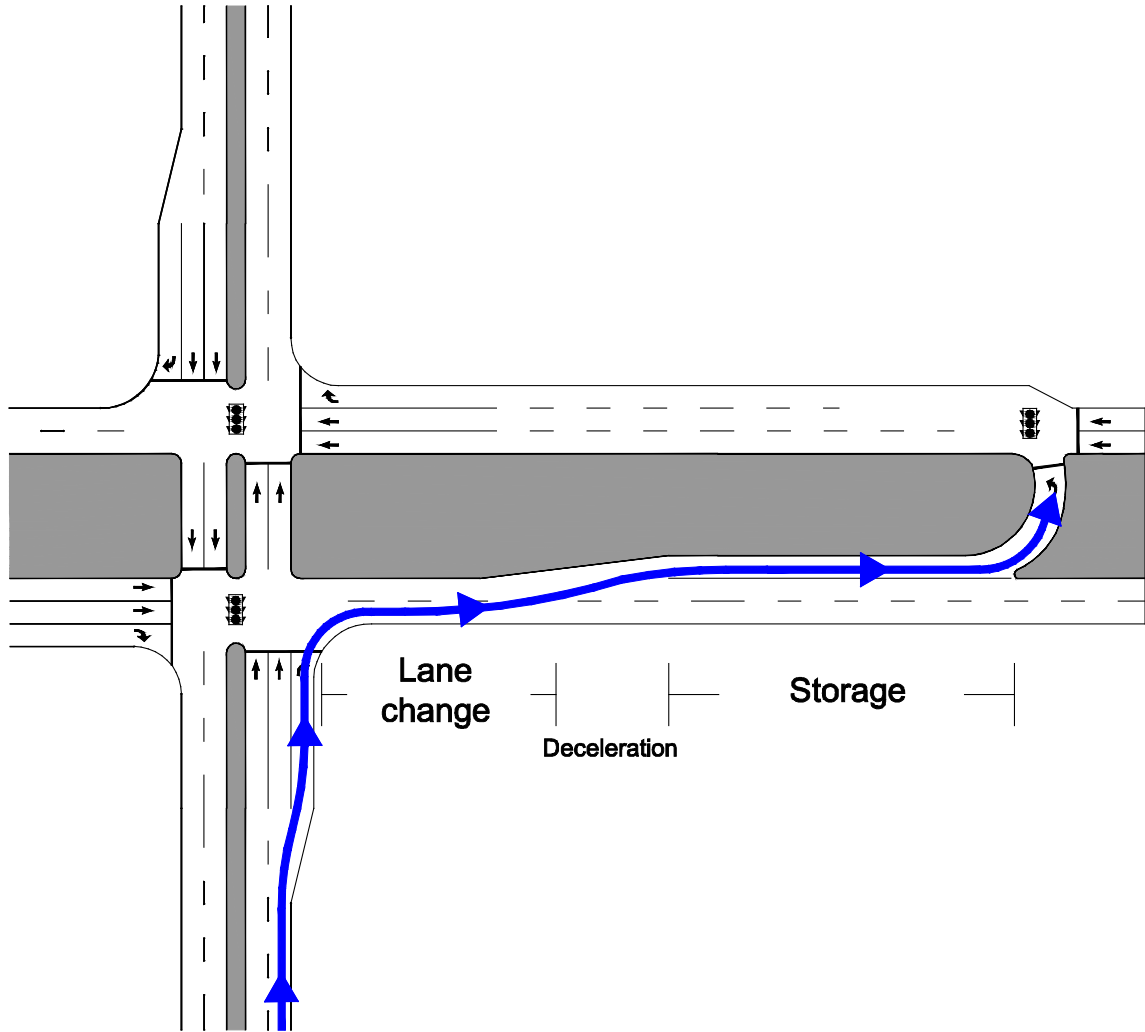

Exhibit 7-16. Spacing consideration for minor street left turn movement.

- The distance for vehicles to decelerate on the major crossroad plus storage for right-turning vehicles from the major crossroad and for those from the opposing left-turning vehicles on the major crossroad that used the U-turn crossover.

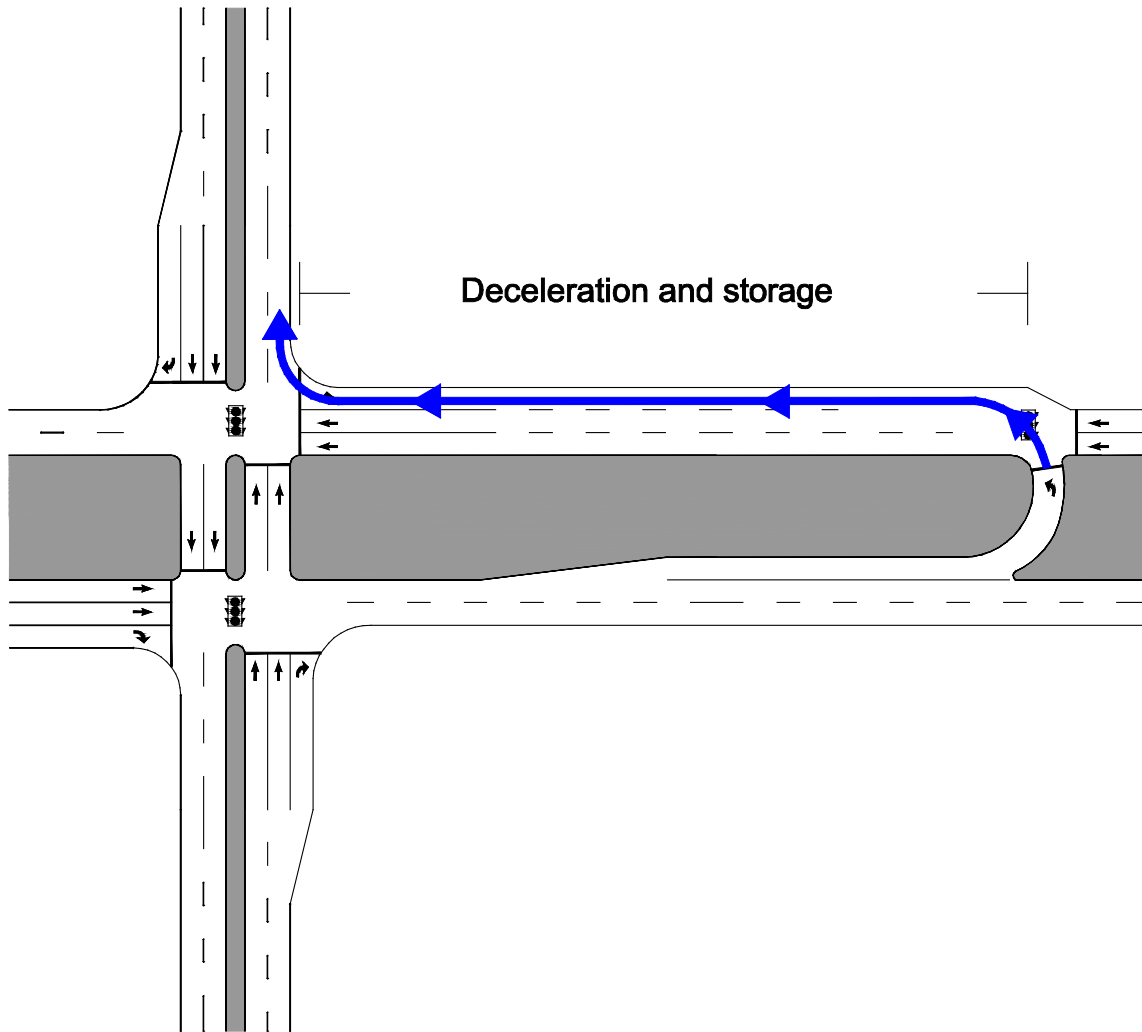

Exhibit 7-17. Spacing consideration for a right turn.

Spacing Between U-turn Crossovers

On a corridor with multiple MUT intersections, the spacing between opposing directional U-turn crossovers should be sufficient to prevent operational conflicts. MDOT guidance suggests a 100-foot minimum and 150-foot desirable distance.⁽²⁷⁾

Pedestrians and Bicycles

Chapter 3 provides guidelines to accommodate pedestrians and bicyclists at MUT intersections. As for conventional intersection design, ADA guidelines provide guidance for designing crosswalks, pedestrian ramps, and sidewalks, which applies to both pedestrian and shared-use pedestrian/bicycle paths.⁽²¹⁾ As discussed in Chapter 3, there are three basic ways a minor street

bicyclist could make a direct left-turn at a MUT intersection. The preferred option is to provide a bicycle box in front of far side, major street through lanes as shown in Exhibit 3-6.

Transit

As discussed in Chapter 3, transit bus stops are located no differently than at a conventional intersection. Many MUT corridors have wide medians that could accommodate LRT or BRT, and the City of Detroit has selected median-running LRT as the locally preferred alternative for transit service on a MUT corridor.

This page intentionally left blank.

CHAPTER 8— SIGNAL, MARKING, SIGNING, AND LIGHTING CONSIDERATIONS

This chapter discusses signal, signing, marking, and lighting design criteria and best practices for constructing and operating MUT intersections. The guidance in this chapter supplements the national resources on intersection design highlighted in previous chapters, including the MUTCD and local agency design criteria and policies.⁽⁷⁾

DESIGN PRINCIPLES AND APPROACH

Traffic signal design, signing, pavement marking, and lighting design at a MUT intersection can be different from a conventional intersection, particularly related to the left-turn prohibitions at the main crossing intersection. The following treatments need to be emphasized at MUT intersections:

- Provide signage and pavement markings to indicate the prohibition of left turns and alternative routing of left-turn movements
- Provide one-way and wrong-way signage to supplement the channelization of U-turn intersections
- Provide a means for direct or indirect bicycle left turns
- Provide appropriate lighting at conflict points (i.e., main crossing and U-turn crossover intersections) within the MUT configuration to emphasize the presence of various users

SIGNALIZED VERSUS UNSIGNALIZED U-TURN CROSSOVERS

Typically, the U-turn crossover upstream of the main crossing is signalized, allowing the U-turn and opposing major street through movements to alternate green phases in coordination with the main intersection signal. The U-turn volumes, which are a combination of left-turn volumes from both the main and minor streets, are typically high enough to warrant a signal. This is especially true at newer isolated MUT and “ThrU” intersections installed specifically to better serve high volumes compared to a conventional intersection. However, in a corridor of MUT intersections, there may be a lower volume minor street that meets warrants at the main intersection but not for the U-turn movement. The U-turn crossover intersection may operate as an unsignalized intersection if the volumes are low enough and sufficient gaps in the main street are available. In fact, most mid-block (between major crossing streets) U-turn crossovers operate as unsignalized intersections. The first U-turn crossover at the start of a corridor of MUT intersections is no different, but consideration should be given during design that this intersection may be upgraded to a signal in the future as volumes and safety history warrants.

Operating the U-turn crossover as unsignalized typically has no effect on pedestrians since pedestrian crossings occur at the main crossing intersection. However, for bicyclists it makes navigating the U-turn following vehicle rules more challenging. Since there is no signal, a bicyclist navigating the U-turn must wait for a gap in traffic big enough to cross all lanes of traffic to get to the right side of the road. Allowing bicyclists to use pedestrian facilities at the

main crossing intersection, as discussed in Chapter 3, would provide bicyclists an alternative to using the unsignalized U-turn.

Some signalized U-turn crossover intersections prohibit left turn on red (LTOR) to reduce U-turn/through movement conflicts. This can be done unilaterally or for certain peak periods of the day when traffic volumes are highest, which would reduce U-turn delay when opposing U-turn volumes are low. Also, while vehicle motor codes in most states allow LTOR from one one-way street onto another one-way street, there are several states that do not. In such states, the crossover U-turn movement would be prohibited on red unless special permission is granted and signing to permit this movement is enacted.



Exhibit 8-1: Example of signalized (left) and unsignalized (right) U-turn crossover intersections.⁽⁴⁾

SIGNALS

Chapter 5 provides operational characteristics for potential signal phasing, cycle length, timing, and progression. The main crossing at a MUT intersection is typically signalized, and U-turn intersections can be signalized or stop-controlled. Chapter 3 discussed pedestrian and bicycle elements at signals.

Controllers

If U-turns are signalized, MUT intersections include multiple signals operating as a system. The number of signalized intersections in this system can range from three to five. In many cases, the signal controller technology will allow all intersections to be operated with a single controller, although multiple controllers can be used as well. Use of a single controller can be accomplished by programming the controller with more than the typical two-ring cycle, maximizing the flexibility in timing each intersection.

The advantages of single- and multiple-controller signal systems are described below.

Advantages of multiple controllers include:

- If one controller fails, the other intersections of the MUT configuration can still function

- Programming phases and signal timing is simpler to install and maintain
- Installations require shorter wire lengths (signal conductor wire/detector wire runs to local controller only)
- Easier for signal maintenance in that each cabinet will likely be placed with visibility provided to the signal heads it controls

Advantages of a single controller include:

- System requires fewer cabinets and controllers to purchase, install, and maintain
- Interconnection is not required to keep signals coordinated
- Only one controller is required to program and maintain
- There is a single service point for power
- There are fewer components to fail
- Vehicle detection may be easier to configure

Exhibits 8-2 and 8-3 show a MUT intersection with multiple controllers and a MUT intersection with a single controller.

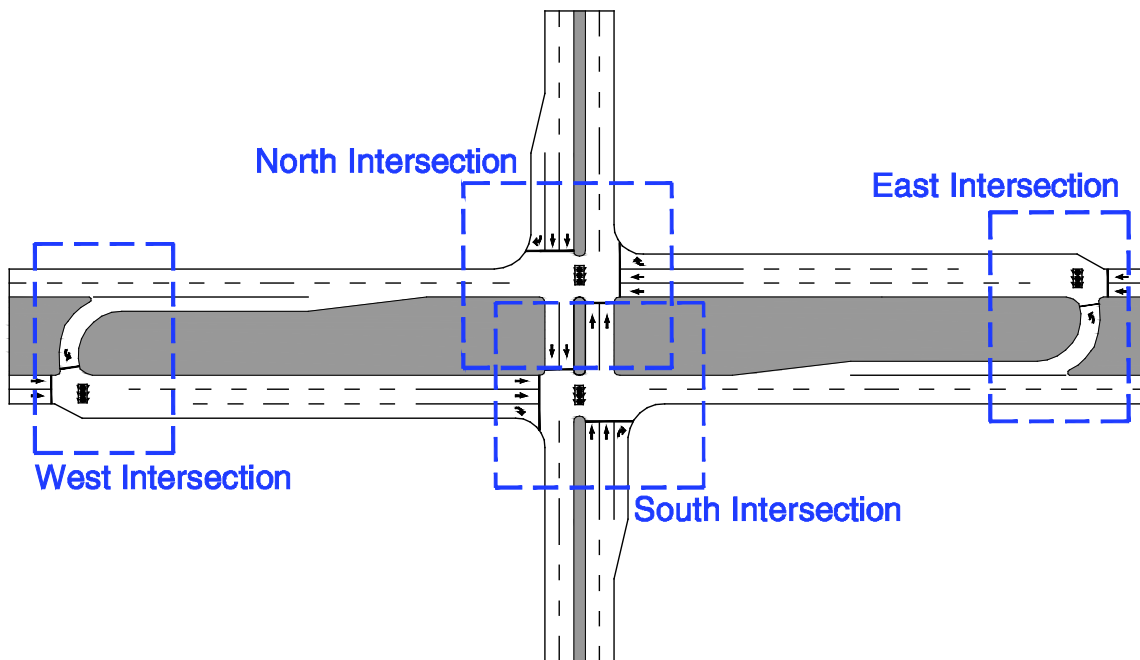

Exhibit 8-2. MUT intersection with multiple controllers.

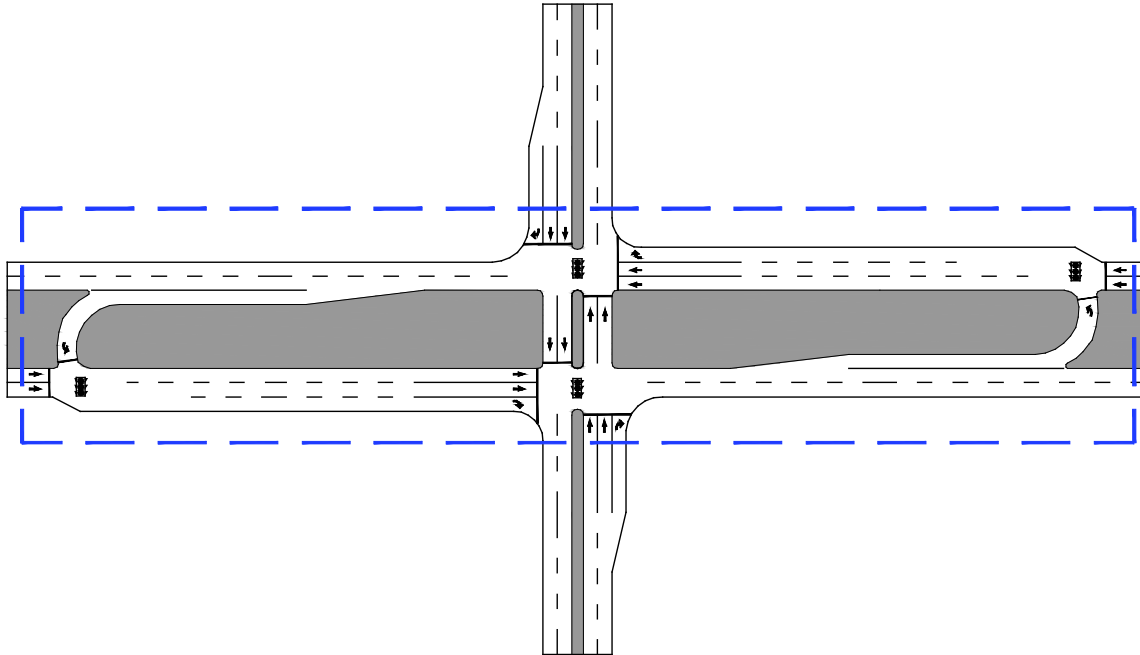

Exhibit 8-3. MUT intersection with single controller.

Signal Equipment Locations

The placement of signal poles and signal heads for the main intersection of a MUT intersection are identical to those for conventional intersections with or without a median except that no direct left-turn lanes are provided. The location of signal poles and signal heads follow the same MUTCD guidance as with a conventional intersection, and new MUT intersection installations should include pedestrian signals and Accessible Pedestrian Signals/pushbuttons.⁽⁷⁾

Currently, the MUTCD does not provide guidance for signal pole or signal head placement at the U-turn crossover of MUT intersections. Therefore, the same general guidance given in the MUTCD for conventional intersections should be applied to the U-turn crossover. The MUTCD requires signal heads to be placed no less than 40 feet beyond the stop bar, nor more than 180 feet, unless a supplemental nearside signal face is provided.⁽⁷⁾ Therefore, mast arm installations with signal heads will typically be located opposite the U-turn crossover on the outside of the opposing major street lanes. Where a span wire installation is used, the far-side strain pole will typically be located on the outside of the opposing major street lanes with the near-side strain pole located in the median. Two signal heads must be used for the “through” traffic in the crossover U-turn meeting the distances from the stop bar as required above. Exhibit 8-4 illustrates an example of signal pole placement for the U-turn crossover at a MUT intersection.

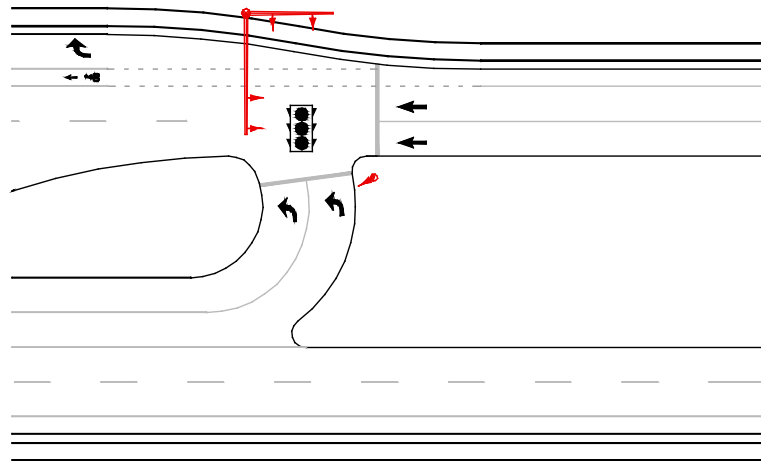

Exhibit 8-4: Signal pole placement for the U-turn crossover.

Detection

Vehicle, bicycle, and pedestrian detection can be implemented similar to a conventional intersection to “call-off” phases having extra green time and giving the excess time to other phases for additional green time. This technique is relatively simple in a MUT intersection since there are only two phases needing to be adjusted. This technique can be particularly effective in off-peak times by providing more efficient green time to the displaced left turns, mitigating the longer travel path. Exhibit 8-5 shows detector placements.

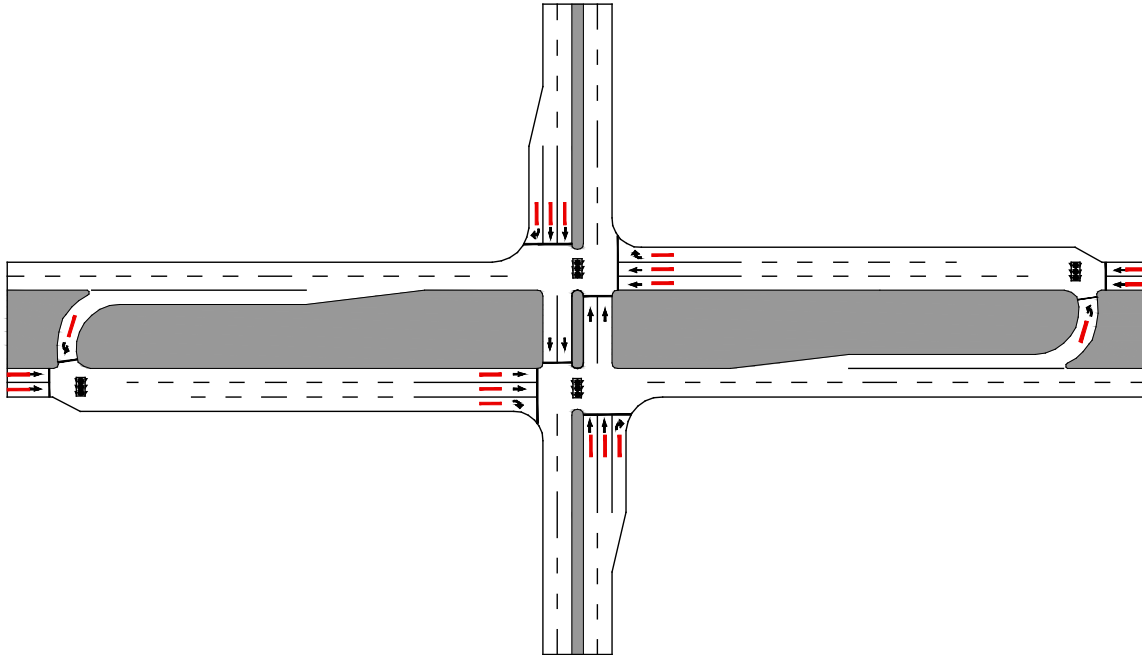

Exhibit 8-5. Detector placements.

Pedestrian Signals

Pedestrian signals at a MUT intersection should be installed to accommodate a two-stage crossing, even if it is possible to make a single-stage crossing. This means a set of pedestrian signal heads, push buttons, and accessible pedestrian signals would be provided in the median as well as on the roadside. Pedestrians who are slower or faster than the design value for walking speed may get caught in the median with a red signal.

Bicycle Signals

Minor street bicyclists making direct left turns by using bicycle boxes or the crosswalks of a shared-use path can be controlled with bicycle signals displaying green, yellow, and red bicycle indications. These signals could assist bicyclists who are unfamiliar with the intended bicycle travel pattern at a MUT intersection.

SIGNING

Signing for MUT intersections follows the same industry practice and MUTCD guidelines for vehicles, pedestrians, and bicyclists as for conventional intersections. However, MUT intersection signing needs to allow a motorist to make decisions at appropriate locations to complete movements through the intersection. Motorists on the minor street, particularly on approaches with two or more lanes, must be informed they need to turn right at the main crossing intersection to make a left-turn movement. At a MUT intersection, drivers may not expect the direct left turn to be prohibited at the main intersection on the major and minor crossroads.

Therefore, regulatory signing such as, “NO Left Turns” can be used to communicate this movement is prohibited. MUT intersections provide an alternate path serving as the equivalent of making a direct left turn. Therefore, signing in advance of the main intersection to guide left-turning vehicles to the U-turn crossovers is recommended. In addition, guide signs located between the main intersection and U-turn crossover direct users to the alternate turning routes, especially for motorists on the minor road.

The MUTCD does not provide standard MUT signing concepts. States with MUT intersections use the standard regulatory signs to indicate “no left turns;” standard lane-use signs; and standard “one-way,” “do not enter,” and “wrong-way” signs. The regulatory signs are located at typical locations where these signs would be recommended for conventional intersection forms. Guide signing can use route marking installations (cardinal direction, route number, and arrow guidance) where the major or minor crossroad is a numbered route, or by making special guide signs for streets that are not on numbered routes.

Since the overwhelming number of MUT intersections are in Michigan, other states and cities seeking to design and construct MUT intersections have looked to Michigan for practical experience and examples when developing guide signs. Typically, a minimum of two guide signs are used: an advance guide sign and a second guide sign located at the main crossing intersection, which confirms the message noted in the advance guide sign. While these signs may assumed to be experimental from a national perspective, the intent is to have them conform to the MUTCD with regard to color, letter size based on functional street type, amount of legend, type of destinations, and design of directional arrows.⁽⁷⁾

Sign placement is based on providing the motorist adequate time and distance to react to their message. This is particularly important for motorists on a multi-lane minor crossroad who may have to move from the left lane of the street to the right lane, since the left turn onto the major street is made indirectly and begins with a right turn. MUT intersection signs on the approach to the main intersection address the separate needs for users on the major and minor streets and for motorists using the U-turn crossover. Exhibit 8-6 is based on MDOT practice and provides an example of the combined regulatory and guide signs and their placement at Michigan MUT intersections.⁽²⁷⁾

In lieu of the “crossover” sign at the top of Exhibit 8-6, MDOT uses an alternate crossover sign shown in Exhibit 8-7. The alternate crossover sign provides specific information to motorists on the major and minor crossroads that they are not able to make direct left turns.

Additionally, MDOT uses the sign shown in Exhibit 8-8 as an advance guide sign on the major crossroad to the “¼ mile” sign shown at the top of Exhibit 8-6. Exhibit 8-9 illustrates the traditional “fishhook” sign to advise drivers on the minor street how to perform right and indirect left turns on the major street, and alternatives used in Michigan (on MUT intersections) and Utah (at “ThrU” intersections).

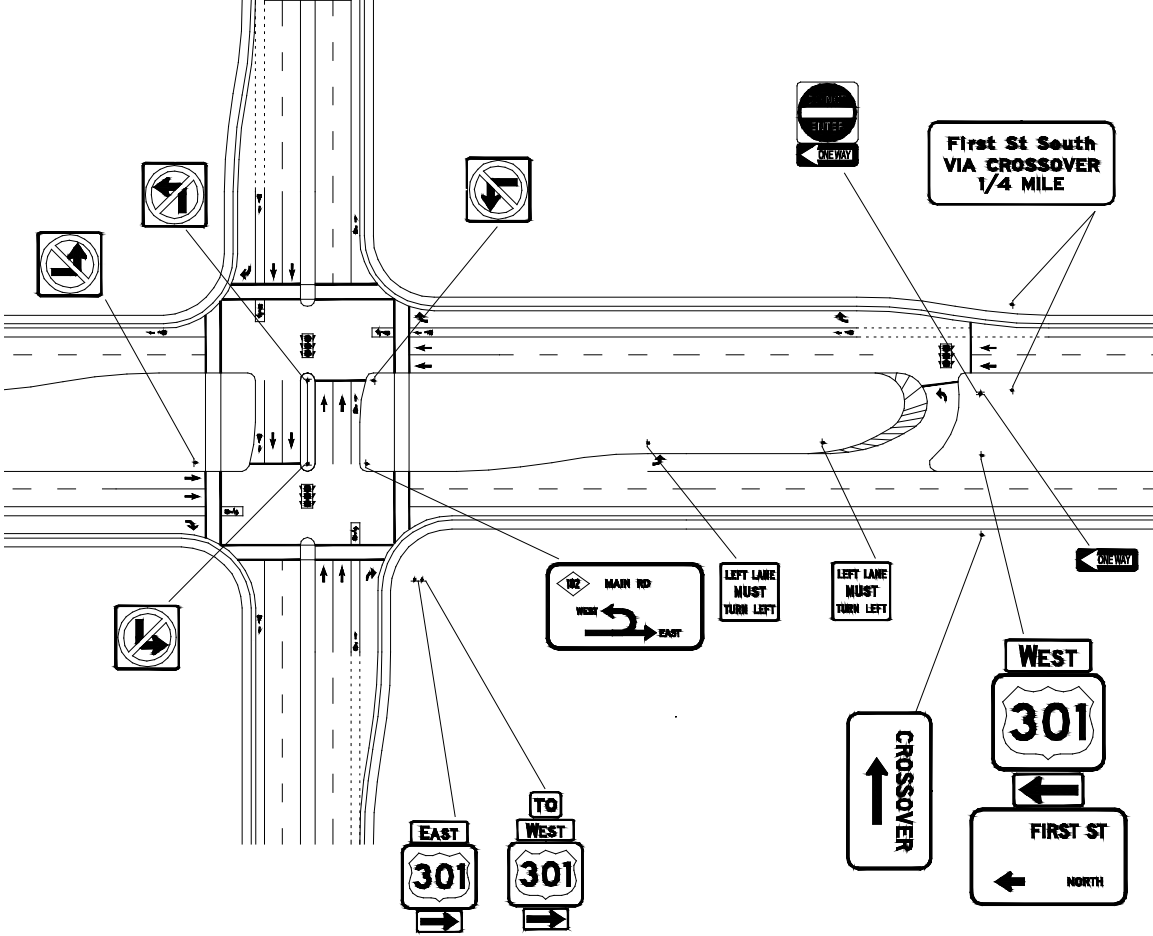

Exhibit 8-6. Example of MUT intersection signing plan.



Exhibit 8-7. Alternate crossover guide sign.



Exhibit 8-8. Alternate major street advance guide sign.

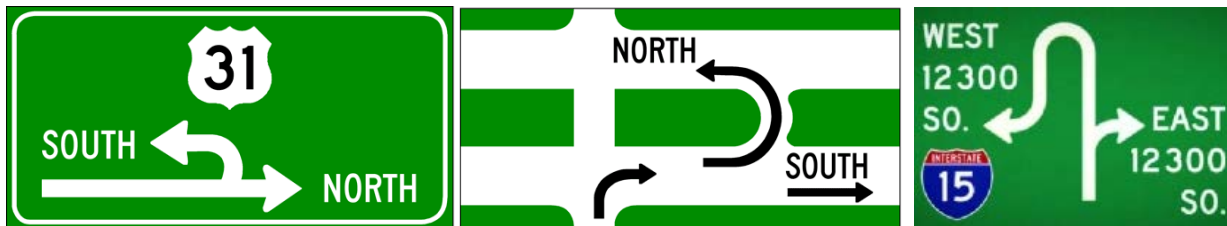

Exhibit 8-9. Traditional fishhook (left), variation used in Michigan (center) and ThrU signage used in Utah (right).

In addition to the signs shown in Exhibit 8-6, guide signs may be placed at or near the intersection on the major crossroad to inform motorists of an alternate path for making the equivalent left turn. Also, advance guide signs not shown in Exhibit 8-6 may be placed on the minor crossroad to inform motorists to:

- Make a right turn at the main intersection
- Move to the left lanes on major crossroad
- Use the U-turn crossover upstream

The signing concepts for pedestrian and bicycle accommodations follow industry practice for conventional signing that comply with the MUTCD and supplements pavement markings. Some concepts, such as bicycle turn queue boxes, accommodate two-stage turns at intersections. However, bicycle queue boxes are currently experimental for MUT intersections.

PAVEMENT MARKING

Pavement markings for the main intersection of a MUT intersection generally follow the same principles for those at conventional intersections (with or without medians), including markings for pedestrian and bicycle accommodations. However, no direct left-turn lanes are provided. The requirements within the MUTCD for edge lines, lane lines, pavement arrows, and words on the pavement are the same as with conventional intersection.⁽⁷⁾

The MUTCD does not provide guidance for pavement markings used at the U-turn crossovers for MUT intersections. However, MDOT has developed pavement marking standards for U-turn crossovers in Michigan.⁽²⁷⁾ Exhibits 8-10 and 8-11, developed by MDOT, provide typical pavement marking for U-turn crossovers with single and dual U-turn lanes, respectively.

The pavement marking concepts from the figures follow the general pavement marking concepts in the MUTCD. While not specifically shown in Exhibits 8-10 and 8-11, stop bars could be placed across the lane(s) of the U-turn crossover. The MUTCD requires stop bars to be placed no more than 30 feet or less than 4 feet from the nearest edge of the pavement.

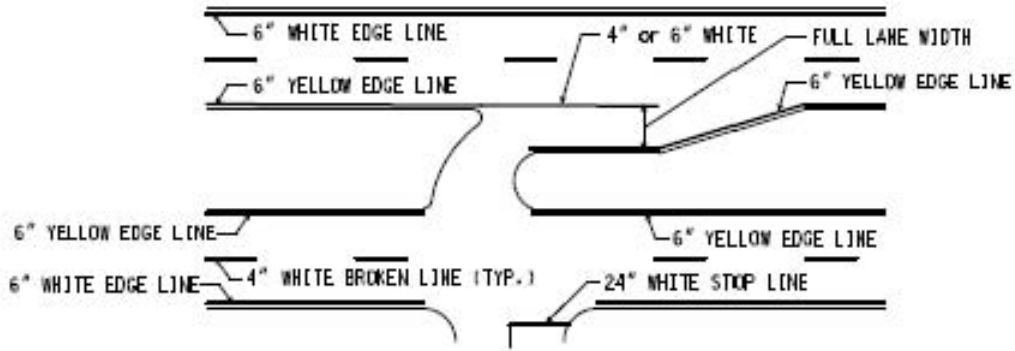

Exhibit 8-10. Typical pavement marking at a directional crossover.⁽²⁷⁾

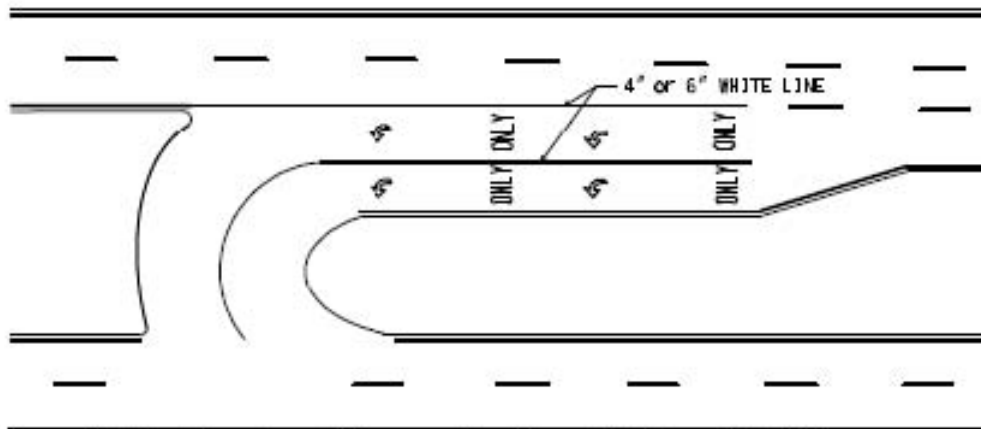

Exhibit 8-11. Pavement markings at a directional crossover with dual lanes.⁽²⁷⁾

LIGHTING

Lighting standards and specifications outlined in AASHTO's *Street Lighting Design Guide*, FHWA's *Lighting Handbook*, and the Illuminating Engineering Society of North America (IESNA) publications including *American National Standard Practice for Street Lighting* can be used to determine optimal lighting for MUT intersections.^(39,40,41)

Based on national lighting guidance, agencies establish street lighting design guidelines along their facilities based on national guidance documents, the road functional classification, and pedestrian conflict area classifications. Intersection lighting is typically 1.5 times the street lighting along the approaches, or the street lighting of the two crossing streets are added together to determine the lighting guidelines for the intersection.

Generally, MUT intersections are constructed on streets with high traffic volumes and, as a result, most street corridors that use MUT intersections probably already meet the corridor volume criteria for lighting. It is desirable to light the main crossing and U-turn crossover intersection according to the determined intersection light levels. Depending on the intersection spacing, the light levels for the road segments between the intersections may be reduced to the street segment light levels. If there is no lighting along the approaches, then transition coming from dark into light and vice versa may enhance the user experience and performance. Even with sufficient lighting provided for the overall intersection, additional supplemental lighting could be added in the median to illuminate the pedestrian refuge area.

This page intentionally left blank.

CHAPTER 9— CONSTRUCTION AND MAINTENANCE

Constructing a MUT intersection follows a pattern that might be similar as conventional intersections with the overall goal to maintain non-motorized and motorized traffic while providing a safe work environment. The context of the project location will inform the staging and sequencing of construction. MUT intersection construction costs may be higher compared to conventional intersections given the extents of the intersection and the need for increased traffic control devices (if U-turns are signalized). This is especially true in retrofit situations where an existing intersection on an existing street is converted to a MUT intersection. The guidance in this chapter supplements the national resources on construction and maintenance, including the MUTCD and local agency design standards and policies.⁽⁷⁾ MUT intersections have historically been built on roads with wide medians. These configurations may present fewer constraints for lane additions, temporary construction activities, and staging areas than streets without medians. However, some newer installations have included undivided streets.

CONSTRUCTION

Michigan, Utah, Arizona, Texas, Indiana, Virginia, and Maryland have constructed MUT intersections in recent years. These agencies could serve as resource for construction planning guidance. As with any new type of street construction, additional communication and coordination with construction contractors may streamline project implementation. Understanding lessons learned from agencies having developed MUT intersections may reduce construction delays.

One of the benefits of constructing MUT intersections, versus other alternative intersections, is their ability to be constructed relatively easily when being converted from a conventional intersection. This is especially true if a median widening does not occur at the same time. Conversion includes removing the exclusive left-turn lanes from the conventional intersection and constructing the new U-turn crossovers. Unlike other alternative intersections and interchanges that transpose traffic streams (such as diverging diamond interchanges and displaced left turn intersections), there is no coordination in moving traffic movements from the right side of the street to the left side of the street. Typically, MUT intersections do not require additional coordination in their construction phases than a conventional intersection.

Intersection and/or Corridor Widening

Developing new MUT intersections, much like conventional intersections, may require additional lanes to be added at the following locations:

- On the major crossroad in the center of the street for the exclusive U-turn movements
- To the right of the U-turn movements for through movements
- On the far right for right turning movements

Unlike a conventional intersection, which is primarily centered at the intersection of the two crossroads, MUT intersections extend approximately $\frac{1}{4}$ mile on the major crossroad from U-turn crossover to U-turn crossover. Depending on the width of the existing right-of-way throughout

the entire length of the intersection and where additional lanes are required, it may be more favorable to widen symmetrically on both sides of the street or perform all widening exclusively on one side. Each widening approach might be considered depending on project specific features. Decisions on each widening approach will primarily depend on the geometric design, project cost, maintenance of traffic, and overall impact to adjacent land owners and the community if additional right-of-way must be purchased.

Construction Staging

The sequencing of construction phases for a MUT intersection depends on the number of lanes and whether the street is divided or undivided for the existing street. While there are numerous variations to consider, three primary variations are provided below:

1. Two-Lane Existing Street Widened to Multilane Divided Street

- A. Maintain traffic through the existing intersection on the existing two-lane street while constructing a new directional multi-lane street with a median separation on new alignment. (Assume the new directional street is for eastbound traffic.)
- B. Shift the existing two lanes of traffic to the newly constructed multi-lane street for eastbound traffic and continue to operate the new intersection conventionally in the same manner as the existing intersection.
- C. Construct the U-turn crossovers and reconstruct the existing street, if required, to be used exclusively for westbound traffic.
- D. Shift westbound traffic currently operating as two-way traffic in the new eastbound lanes to the exclusive westbound lanes and restrict direct left turns at the new intersection by shifting left-turning traffic to U-turn crossovers.

2. Existing Conventional Intersection on Divided Street to MUT Intersection

- A. Construct U-turn crossovers, including exclusive U-turn lanes, while maintaining operation of the existing intersection.
- B. Add or lengthen right-turn lanes on divided street, if required.
- C. Restrict direct left turns at the existing intersection and shift them to the newly constructed U-turn crossover.
- D. Convert the conventional intersection to a MUT intersection. This may require removing exclusive left-turn lanes at the former intersection.

3. Existing Conventional Intersection Undivided Urban Street to ThrU MUT Intersection

- A. Clear and construct crossover loon(s) outside of existing pavement.
- B. Construct U-turn crossover lanes.
- C. Redirect traffic to use newly constructed ThrU intersection.
- D. Remove left turn lanes at main crossing intersection.

Work Zone Traffic Control

Part 6 of the MUTCD provides guidance regarding signing and marking needs during construction and temporary street and intersection configurations.⁽⁷⁾ MUTCD principles and applications for conventional intersections and streets would apply to constructing a MUT intersection.

Depending on the construction phasing and sequences, the work zone traffic control includes the following types of regulatory information:

- Signalization, signing, and pavement markings to inform motorists travelling through the construction zone when they have the right-of-way and appropriate lane assignment
- Guidance information to inform unfamiliar motorists in making decisions whether to turn right or left or continue through the intersection
- Guidance information to inform motorists of changes in the operation (e.g. lane changes) of the intersection due to construction activities

While there are numerous variations in constructing MUT intersections, the regulatory, guidance, and construction related functions must be provided throughout the construction phases and in accordance with MUTCD.⁽⁷⁾

COSTS

The cost of converting a conventional intersection to an MUT intersection varies depending on the specific project context. The general considerations and elements affecting costs of a MUT intersection are similar to those at a conventional form. It may include the following considerations:

- The number and length of additional lanes required
- Utility impacts
- Modifications to the existing signal system
- Amount of additional right-of-way
- Access modifications



The most significant cost factor is right-of-way, which can vary greatly by geographical location and by value and density of adjacent land uses.

Total project costs associated with developing a new MUT intersection may vary greatly depending on project specifics including right-of-way costs, displacements, and public outreach. While the cost to implement a MUT intersection is likely greater than the cost to construct a conventional intersection at the same project site, MUT intersections are considerably less expensive than a grade-separation alternatives.

Historically, MUT intersection construction costs were tempered by the availability of land in reserved “super corridors” in southeast Michigan (where right-of-way costs were negligible).

More recent MUT intersection applications at singular intersections have varied costs by right-of-way and access impacts. At the Draper, UT and Plano, TX locations, project costs varied from \$1.6M to \$2.3M. In both of these projects, the project costs included constructing crossovers but required little modification to the main intersection. Exhibit 9-1 presents cost estimates from three MUT intersection installations.

Exhibit 9-1. Summary of costs associated with MUT intersections.

| Location | Open to Traffic | Cost | Image |
|--|-----------------|---------------|--|
| Legacy Drive at Preston Parkway, Plano TX | Jul 27, 2010 | \$1.7 million |  |
| 12300 South and Minuteman, Draper, UT | Nov 2011 | \$5.1 million |  |
| Haggerty Connector, Novi MI¹ | Nov 1, 2002 | \$21 million |  |

¹ This project included a 2-mile, 8-lane boulevard on new alignment including two MUT intersections

MAINTENANCE

Maintaining a MUT intersection is similar to a conventional intersection. For through lanes at the main intersection and U-turn crossovers, maintenance requiring their closure may have reduced impacts as there is no adjacent left-turn lane, so there is less chance of vehicles traveling on both sides of the work zone simultaneously.

Maintaining pavement and striping of the U-turn crossover lanes is similar to left-turn lane maintenance at a conventional intersection, although it can be more challenging due to the confined nature of the channelized area. In both cases, maintenance of left-turn lanes requires temporarily closing the lane and detouring traffic. Like other conventional streets, conducting

maintenance activities during off-peak times can minimize traffic disruptions. In addition, this process generally follows the appropriate work zone guidelines as for all conventional intersections.

Where MUT intersections are part of a continuous corridor, maintenance can be done at one crossover while vehicles can use the next downstream crossover. Maintaining signals and lighting at MUT intersections is also similar to conventional intersection signal maintenance. In many cases, MUT intersections provide the advantage of being able to locate utility vehicles in the median to work on overhead signal and lighting fixtures, where utility vehicles at conventional intersections may have to block travel lanes or locate on private property to perform maintenance functions.

Snow Removal

Snow removal for a MUT intersection is accomplished similar to a conventional intersection. Through lanes are plowed as part of the corridor, and snow is systematically pushed to the outside of the street. Snow removal for the U-turn crossover is similar to a conventional left-turn lane. These are typically plowed after the through lanes and snow is pushed through the crossover to the opposite side of the street. The same technique is used for when a loon is part of the MUT intersection. Snow is pushed through the U-turn crossover to the opposite side of the loon.

LAW ENFORCEMENT

There are unique law enforcement needs at a MUT intersection. There is nothing to physically prohibit direct left turns at the main intersection. Wrong-way movements and red-light running sometimes occur at crossovers. Enforcement during the periods after the MUT intersections are initially opened to traffic could help drivers become familiar with intended operations and help reduce illegal maneuvers. As the novelty effect of the new intersection operations subside, the need for extra enforcement will likely diminish.

The area within a loon, if used, must be kept clear of parked or stopped vehicles. “No parking or standing” signs prominently displayed and the presence of law enforcement could reduce parked or stopped vehicles. Establishing a policy of towing vehicles parked in loons will be a unique enforcement need not found in conventional intersection forms.

REFERENCES

1. Google Inc. Google Earth. Accessed 2014.
2. Bing Maps. Accessed July 2014.
3. Rodegerdts, L. Photo Credit.
4. Reid, J. Photo Credit.
5. American Association of State Highway and Transportation Officials (AASHTO). *A Policy on the Geometric Design of Highways and Streets*. Washington, DC: AASHTO, 2011.
6. Transportation Research Board (TRB). *Highway Capacity Manual (HCM)*. Washington, DC: TRB, National Research Council (NRC), 2010.
7. Federal Highway Administration (FHWA). *Manual on Uniform Traffic Control Devices*. Washington, DC: U.S. Department of Transportation (USDOT), 2009.
8. AASHTO. *Highway Safety Manual (HSM)*. Washington, DC: AASHTO, 2010.
9. FHWA. *Alternative Intersection/Interchanges: Informational Report (AIIR)*, Report No. FHWA-HRT-09-060. Washington, DC: USDOT, 2010.
10. Federal Highway Administration (FHWA). *Signalized Intersections: Informational Guide*. USDOT: Washington, DC, 2013.
11. Federal Highway Administration (FHWA). *Synthesis of the Median U-Turn Intersection Treatment*. USDOT: Washington, DC, 2007.
12. Michigan Department of Transportation Geometric Design Unit. "Directional Crossovers: Michigan's Preferred Left Turn Strategy," December 1995.
13. Dorothy, P.W, T.L. Maleck, and S.E. Nolf, "Operational Aspects of Michigan Design for Divided Highways," *Transportation Research Record 1579*, TRB, National Research Council, Washington, DC, 1997, p.18-26
14. Thompson, T., and Hummer, J.E, "A Preliminary Study in the Efficiency of Median U-Turn and Jughandle Arterial Left Turn Alternatives," presented at the 72nd Annual Meeting of the TRB, Washington, DC, January 1993
15. Reid, J.D., and J.E. Hummer, "Analyzing System Travel Time in Arterial Corridors with Unconventional Designs Using Microscopic Simulation," In *Transportation Research Record 1678* (1999).
16. Utah Department of Transportation, "Thru-Turn Intersection" informational brochure webpage. <http://www.udot.utah.gov/5400south/dld/maps/Thru-Turn%20Map.pdf>
17. Utah Department of Transportation, "Thru-Turn Intersection" informational video webpage. <http://www.udot.utah.gov/5400south/dld/maps/Thru-Turn%20Map.pdf>
18. DeGrood, J. "Express left' will make intersections safer, more efficient." Inside Tucson Business. Guest opinion. <http://www.insidetucsonbusiness.com/opinion/columnists/>

guest_opinion/express-left-will-make-intersections-safer-more-efficient/article_3ab56aa2-3422-11e2-8077-0019bb2963f4.html?mode=story

19. FHWA, USDOT FHWA Information Videos, web page.

<https://www.youtube.com/user/USDOTFHWA>

20. FHWA, Safety Program Informational Brochures, web page. <http://safety.fhwa.dot.gov>.

21. The United States Access Board, Accessible Public Rights of Way webpage.

<http://www.access-board.gov/>

22. Ray, B., et al., *NCHRP 15-34A: Performance-Based Analysis of Geometric Design of Highways and Streets*, Contractor Final Report. Washington, DC: Transportation Research Board of the National Academies, 2014.

23. FHWA and AASHTO. Results of Joint AASHTO/FHWA Context Sensitive Solutions Strategic Planning Process, Summary Report. Raleigh, NC.: Center for Transportation and the Environment, North Carolina State University, 2007.

24. URS Corporation. Detroit Department of Transportation, Woodward Avenue Light Rail Alternative Analysis, Concept Plans.

25. Federal Highway Administration (FHWA). *Crash Modification Factors Clearinghouse*.

<http://www.cmfclearinghouse.org/>

26. Rodegerdts, L. A., Nevers, B., and Robinson, B., "Signalized Intersections: Informational Guide." FHWA-HRT-04-091, (2004)

27. Michigan Department of Transportation (MDOT). *Geometric Design Guide 670*, Lansing, MI: MDOT, 1993.

28. Federal Highway Administration (FHWA). *A Guide to Developing Quality Crash Modification Factors*. USDOT: Washington, DC, 2010.

29. Adams, J.C. and J.E. Hummer. "The Effects of U-turns on Left Turn Saturation Flow Rates," In Transportation Research Record 1398 (1993).

30. Reid, J.D., and Hummer, J. E, Travel Time Comparisons between Seven Unconventional Arterial Intersection Designs" In Transportation Research Record 1751 (2001).

31. Bared, J.G. and Kaiser, E.I. (2002). "Median U-Turn Design as an Alternative Treatment for Left Turns at Signalized Intersections," ITE Journal, 72(2), pp. 50-54.

32. Stover, V. (1990). City Street Design-Short Course Notes, Texas Transportation Institute, Texas A&M University, College Station, TX.

33. Koepke, F.J. and Levinson, H.S. (1993). Case Studies in access Management, Prepared for Transportation Research Board, National Research council, Washington, DC.

34. Savage, W F, Directional Median Crossovers, Journal of Traffic Engineering, Vol. 44, No. 11, 1974.

35. Maki, R.E. *Directional Crossovers: Michigan's Preferred Left-Turn Strategy*. Lansing, MI: Michigan Department of Transportation, 1992.
36. Federal Highway Administration (FHWA). *Traffic Analysis Toolbox*.
www.fhwa.dot.gov/publications/research/infrastructure/pavements/ltp/04038/index.cfm.
37. Transportation Systems Institute (TSI). *Capacity Analysis for Planning of Junctions*. Version 1.2. 2011. <http://tsi.cecs.ucf.edu/index.php/cap-x>
38. Carter, D; Hummer, JE; Foyle, RS, Phillips, S, *Operational and Safety Effects of U-Turns at Signalized Intersections*, TRB: Journal of the TRB No 1912, 2005.
39. AASHTO. *Roadway Lighting Design Guide*. Washington, DC: AASHTO, 2005.
40. FHWA. *Street Lighting Handbook*. Washington, DC: USDOT, 1978.
41. Illuminating Engineering Society of North America (IESNA). *Recommended Practices for Roadway Lighting*. New York, NY: IESNA, 2000.

Appendix A CATALOG OF ALL KNOWN INSTALLATIONS IN THE UNITED STATES

This appendix includes information on all known installations in the United States. Additionally, this appendix presents some background information on three MUT intersection projects.

Exhibit A-1 presents location information for all known installations of MUT intersections in the United States. Exhibit A-2 presents location information for all known installations of MUT corridors in the United States.

Median U-Turn Informational Guide

Exhibit A-1. Median U-turn intersections in the United States.

| Intersection | City, State | Description | Year Open | Location Coordinates |
|----------------------------------|----------------|---|-----------|----------------------------------|
| US 280 at Valleydale Road | Birmingham, AL | This MUT intersection, opened in November 2013 was one of the first portions of an overall \$15M improvement plan for 26 intersections on US 280. | 2013 | 33°25'12.37" N 86°41'40.91" W |
| West Ina at Oracle Road | Tucson AZ | The first ThrU-Turn intersection in Arizona opened in September 2013. Pima County DOT constructed the ThrU-Turn intersection to reduce congestion at this intersection that serves 96,000 cars/day; Project was a collaboration by Pima County, the RTA and Arizona DOT and cost \$5M to construct as a portion of improvements along Oracle Road. | 2013 | 32°20'13.77"N 110°58'39.02"W |
| W Grant Rd at N Oracle Rd | Tucson AZ | Tucson's second ThrU-Turn intersection (TTI) was opened in October, 2013 built to reduce both travel time and car accidents at this intersection that passes 70,000 cars/day. | 2013 | 32°15'0.72"N 110°58'41.06"W |
| 96th at Allisonville Road | Fishers, IN | First Michigan Left intersection in Indiana. After several public meetings, Town of Fishers collected the public's input and planned the intersection improvement to minimize disruption and significantly improve traffic along Allisonville Road at 96th St. Design and Construction costs were locally funded. Project opened in May 2013 and cost \$8.6M to design and construct. | 2013 | 39°55'37.19" N 86°03'57.79" W |
| W 4700 at S 4000 | Kerns, UT | Utah's second ThrU-Turn intersection (TTI) was opened in November 2012. The TTI was constructed to remove a bottleneck on W4700 and reduce crash rates (twice the statewide average). Because the TTI required less property and fewer business relocations, the \$1.5M project cost was considerably lower than a conventional intersection improvement alternative (\$5M). | 2012 | 40°40'3.23"N 111°59'11.87"W |

Median U-Turn Informational Guide

| Intersection | City, State | Description | Year Open | Location Coordinates |
|---|------------------|---|-----------|----------------------------------|
| 12300 South and State Street | Draper, UT | Utah's first ThrU-Turn (TTI) intersection was designed at this location because intersection is closely spaced with the I-15 interchange ramps and left turns from W12300 was backing up the interstate ramp. The project opened in November 2011 at a cost of \$5M. | 2011 | 40°31'36.34"N 111°53'19.23"W |
| Legacy Drive at Preston Parkway | Plano TX | In July 2010, the City of Plano converted this intersection to a Median Left-Turn to manage the 73,000 cars/day entering the intersection, and relieve traffic congestion, increase traffic flow and improve safety; was first intersection of this kind in Texas. | 2010 | 33° 4'14.74"N 96°47'46.31"W |
| US-29 at University Boulevard | Silver Spring MD | University Blvd has wide median at its intersection with US 29. Direct lefts from US-29 were eliminated and are made indirectly using crossovers on University. Direct lefts from University to US-29 are still permitted. Design is unique because businesses are located inside the median of the MUT intersection. | Unknown | 39° 1'13.12"N 77° 0'45.79"W |
| M-37 at 29th Street | Grand Rapids, MI | Unique design as this indirect-left intersection is not part of a MUT corridor as is typical in Michigan. Narrow median on 29th Street requires large loons for U-turn crossovers. The intersection does not accommodate high left turn volumes like typical Michigan MUT and large trucks are not accommodated. | Unknown | 42°54'32.82" N 85°34'59.40" W |
| I-196 Bus Loop at East Main Avenue | Zeeland, MI | At this MUT intersection, right turns from southbound East Main conflict with eastbound U-turn traffic, requiring separate phases (3-phase signal) at the crossover intersection, reducing intersection efficiency. | Unknown | 42°48'41.81" N 85°59'31.84" W |

Median U-Turn Informational Guide

Exhibit A-2. Median U-turn corridors in the United States.

| Primary Route | City, State | Description | Location Coordinates |
|---------------------------------|---|---|--------------------------------|
| Rochester Road | Troy, MI | 6-lane MUT blvd from 16 to 17 Mile Road (approx 1.5 miles and 2 MUT intersections); plans to extend MUT to M-59 (dist of 3.5 miles) | 42°34'9.21"N 83° 7'40.72"W |
| W. Esplanade Avenue | Metairie, LA | 4-lane MUT blvd from N Causeway Boulevard to Williams Boulevard (approx 5.5 mi and 5 MUT intersections); drainage canals in wide median along entire corridor | 30° 0'59.43"N 90°11'30.25"W |
| Woodward Avenue (M-1) | Detroit to Pontiac, MI | 8-lane MUT blvd from 6-Mile Road to South Blvd (approx 17 mi and 20 MUT intersections) including interchanges with I-696 and 8-mile Road | 42°32'48.46"N 83°12'35.36"W |
| Telegraph Road (US-24) | Taylor to Pontiac, MI | 6 & 8-lane MUT blvd from Eureka Road to Orchard Lake Road (approx 30 mi and 32 MUT intersections) inc interchanges with I-94, I-96 & I-696 | 42°25'27.97"N 83°16'39.36"W |
| Gratiot Avenue (M-3) | Detroit to Clinton Township, MI | 6-lane MUT blvd from 8 Mile Road to Metropolitan Parkway (approx 10 mi and 14 MUT intersections) including interchange with I-696 | 42°31'22.32"N 82°55'11.78"W |
| 8 Mile Road (M-102) | Farmington Hills to Gross Point Woods, MI | 8-lane MUT blvd from Grand River to Mack Road (approx 20 mi and 27 MUT intersections) including interchanges with I-94, I-75, M-37 & M-10 | 42°26'47.30"N 83° 7'42.16"W |
| Van Dyke Freeway (M-53) | Sterling Heights, MI | 4-lane MUT blvd from 15 Mile Road to M-53 Expressway (approx 4 mi and 5 MUT intersections) | 42°42'8.86"N 83° 1'31.73"W |
| Haggerty Connector (M-5) | Commerce Township to Detroit, MI | 8-lane MUT blvd from 13 Mile Road to North Pontiac Trail (approx 3.5 mi and 3 MUT intersections) | 42°27'44.53"N 83°24'43.91"W |
| Twelve Mile Road | Southfield to Novi, MI | 4-lane MUT blvd from Novi Road to Burke Hill Drive (approx 5 mi and 5 MUT intersections); narrow median w/loons throughout corridor | 42°29'51.67"N 83°25'00.58"W |
| Hall Road (M-59) | Utica, MI | 8-lane MUT blvd from I-94 to M-53 (approx 9 mi and 6 MUT intersections); very wide median for future expansion | 42°37'42.02"N 82°56'8.88"W |
| Ford Road (M-153) | Dearborn, MI | 8-lane MUT blvd from US-24 to Oakman Boulevard (approx 5.5 mi and 4 MUT intersections); includes several overpasses with crossing streets | 42°19'44.97"N 83°12'15.57"W |

Median U-Turn Informational Guide

| Primary Route | City, State | Description | Location Coordinates |
|----------------------------------|-------------------------------|---|--------------------------------|
| Big Beaver Rd/ Metro Pkwy | Troy to Harrison Township, MI | 6-lane MUT blvd from Coolidge Hwy to Jefferson Avenue (approx 20 mi and 20 MUT intersections); includes interchange with I-75 and several intersections with other MUT corridors | 42°34'0.09"N 83° 0'7.97"W |
| Mound Road | Shelby to Detroit, MI | 8-lane MUT from Caniff Street to E Auburn Avenue (approx 16 mi and 19 MUT intersections); interchanges with I-696 and M-53 and intersections 8-mile and Metropolitan Pkwy MUT corridors | 42°31'42.36"N 83° 2'51.71"W |
| M-44 East Beltline | Grand Rapids, MI | Good example of first MUT crossovers upstream or downstream of every minor street crossing NOT needing to be signalized | 42°58'42.17"N 85°35'26.94"W |
| US-41 | Marquette | 4-lane MUT from S McClellan Avenue to SR 492 (approx 3 mi and 5 MUT intersection); only MUT in Michigan's Upper Peninsula | 46°32'51.56"N 87°25'52.56"W |
| US-31 | Holland, MI | 4-lane MUT blvd (approx 23 mi and 20 MUT intersections); good example of loon application in narrow median to accommodate larger vehicles and unsignalized MUT intersections in mostly rural corridor | 42°55'10.70"N 86° 8'46.14"W |
| Michigan Ave (US-12) | Ypsilanti, MI | 4-lane MUT; concrete medians instead of landscaped or grass (approx ¾ mile and 5 MUT intersections) | 42°14'27.68"N 83°36'49.81"W |
| Grand River Avenue (M-5) | Redford Charter Township, MI | 8-lane MUT from I-96 to Six Mile Road (approx 3.5 mi and 8 MUT intersections) | 42°25'53.55"N 83°17'42.65"W |
| Northwestern Hwy (M-10) | Southfield, MI | 6-lane MUT from Orchard Lake Road to M-10 (approx 4 mi and 5 MUT intersections) | 42°30'46.91"N 83°19'48.95"W |
| Coolidge Highway | Troy, MI | 4-lane MUT from Square Lake Rd to Industrial Row Drive (approx 4.5 mi and 5 MUT intersections); intersection with Big Beaver MUT corridor | 42°34'16.38"N 83°11'14.55"W |
| Saginaw Hwy | Lansing | 4-lane MUT from I-69 to West Saginaw (approximately 3.5 mi and 5 MUT intersections); most U-turn crossovers are unsignalized | 42°45'41.97"N 84°26'11.13"W |
| M-45 thru Allendale | Allendale, MI | 4-lane MUT from 68 th Avenue to 24 th Avenue (approx 6 miles and 4 MUT intersections); most U-turn crossovers are unsignalized | 42°58'19.30"N 85°53'2.26"W |

MUT Intersection Profile: Rochester Road, Troy MI

Project Description



Exhibit A-3. Rochester Road corridor north of 16-Mile Road.

In November 2010, the City of Troy, Michigan finished construction of a Median U-Turn corridor on Rochester Road. The project extended from just north of 16-mile Road (which was already a Median U-Turn intersection with crossovers on all four approaches) north to Barclay Drive, a distance of 1.05 miles. Exhibit A-3 illustrates a segment of the MUT corridor. There is one major crossing street (Wattles Road) and that MUT intersection also has crossovers on all four intersection approaches. Rochester Road carries an average daily traffic (ADT) volume of 40,000 to 50,000, and Wattles Road carries an ADT of 20,000 to 25,000. The City has plans to extend the MUT corridor an additional 1.0 miles north in 2019 and a final 2.2-mile extension to M-59 is in the long range plan.

Project Design

The six-lane MUT replaced a five-lane roadway in a 150-ft ROW. This is less than the typical ROW desired by Michigan DOT in other MUT corridors (16-mile Road is built in a 204-ft ROW), so the median width was reduced from a desired 60 feet to 40 feet along Rochester Road. This 40-foot median width generally supports a WB-50 design vehicle with small bulbout (loons) at the signalized intersections, as the planting strip between the road and sidewalk is eliminated in these areas so no additional ROW is required. Also, permanent easements were acquired to reduce what would otherwise been prohibitive ROW costs, and the ROW was set at the back of sidewalk, with a minimum offset to the road.

The corridor runs through a predominant business area with small lots and numerous curb cuts. While driveway consolidations were made where possible, locations of the crossovers were difficult to accommodate access and ensure safety. While owners were familiar with the MUT concept being close to the 16-Mile MUT corridor and less public involvement was needed compared to other areas of the country where the MUT is a new concept, some education was needed on how customers would use the crossovers to gain access to individual properties.

During construction, some business owners complained of losses, but those losses were more likely attributed to the construction activities and the economic downturn in the late 2000's, as no businesses were lost and most business have returned stability during the economic upturn in the years that followed. Exhibit A-4 illustrates a major intersection on the MUT corridor. Exhibit A-5 illustrates pedestrian amenities implemented at this MUT intersection.



Exhibit A-5. Pedestrian amenities at Rocheter Road / 16-Mile Intersection.



Project Construction

The project was constructed by the City of Troy using state and federal funds totaling \$11.5M in construction costs (that included a new 78" storm sewer) and \$6M in right-of-way. The project

was completed in one year, which included handling a major issue of contamination at a service station in the corridor. The existing lanes were largely maintained during construction, while one side was widened, then shifted to the new lanes while the other side was constructed. The center median was the last portion to be constructed.

The MUT project followed on the heels of a 2008 project, sponsored by the Downtown Development Authority, that invested \$1.4M into a pedestrian improvement project at the intersection of 16 Mile Road and Rochester Road (see photos to right). This project provided textured crosswalks, vegetative plantings and a new park in the northeast quadrant of the intersection. The signal timings at the MUT intersection allow crossing of the roadways into a landscaped refuge median in the center of each roadway. The city of Troy is committed to provide complete street concepts that include mid-block crossings, and the MUT corridor fits into these plans.

Project Results

Although no definitive before-and-after study of traffic volumes and crashes was formally conducted, antidotal evidence and opinions point to a successful project, as businesses in the corridor continue to thrive, congestion on Rochester Road was substantially reduced and no crash concerns have arisen in the project corridor.

MUT Intersection Profile: 12300 South and State Street, Draper UT

Project Description

Utah's first-of-its kind ThrU-Turn intersection (adapted from the Median U-Turn intersections popular in Michigan) opened in November 2011 at the intersection of 12300 South and Minuteman Drive / State Street in Draper, Utah. The close proximity to the I-15 Interstate makes this an ideal solution to reduce existing queuing and turn lane storage deficiencies that can back up traffic onto the interstate during peak periods. UDOT engineers say that the ThrU Turns were selected for this intersection because they could relieve congestion while avoiding removing businesses at the crowded intersections for widening and could avoid even more expensive options such as building bridges

The ThrU Turn intersection design does not permit direct left turns at the main intersection. The intersection redirects all left turns through signalized U-turn crossovers located on three of the four intersection legs and provides additional green time for traffic traveling through the intersection on both roadways. Motorists wanting to turn left must go straight through the intersection and make a U-turn at a new, signalized U-turn intersection a few hundred feet down the road. Because there are U-turn intersections on three approaches, most left turn movements can also be accomplished by turning right, making the U-Turn downstream and passing through the main intersection.

Exhibit A-6 illustrates a conceptual layout of the MUT intersection used for project team and public meetings.



Exhibit A-6. Project description materials created for the project.

Extensive public involvement was undertaken before the project was designed. The public involvement process included the development of project informational materials (including the below project design schematic, simulation study results and preparation of a video detailing the project goals, simulation modeling results; and expected outcomes (posted on U-tube at <http://www.youtube.com/watch?v=jHojQLppEw>). A public meeting was held on November 3, 2010 for City and UDOT engineers to receive comments from the public about the project.

Exhibit A-7 illustrates the thru-turn maneuver location.



Exhibit A-7. Thru-turn crossover on State Street.

Studies and Findings

The general impact to traffic at the intersection has been positive. Severe traffic congestion has largely disappeared, and the traffic flows much more quickly through the intersection and traffic no longer backs up onto the I-15 ramps. A post-construction study for UDOT conducted by the consultant team says “the Thru Turn in Draper has helped to dramatically reduce congestion.” The study found that:

- The Thru-Turn reduces the average delay per vehicle at the intersection from 46 seconds to an average of 16 seconds. In other words, the intersection was improved from level of service (LOS) D to LOS B.

- The largest time savings are for cars that travel straight through the intersection. However, in some directions, cars making any combination of right and U-turns to go left generally have increased delay – up to 51 seconds longer – than before construction.
- Consumer savings in time and gasoline were estimated at \$1.25 million for the first year.
- Sales taxes collected by businesses in the area generally increased in the first six months after the ThrU Turn opened, so "there is no evidence that the ThrU Turn Interchange has reduced overall trips or that it has negatively impacted overall economic activity."
- Despite the overall gain in sales tax, one service station along State Street closed within one year of the project opening.

Anecdotally, the ThrU-Turn intersection appears to have decreased accidents as a result of reducing left-hand turns, but more statistically reliable data over time is needed to statistically verify any rate crash reductions attributable to the design.

Lessons Learned

Through extensive public involvement and public outreach, including educational materials and videos, Utah's first ThrU-Turn intersection was constructed with general support from the public. The operational improvements predicted were realized, and the success of this project enabled UDOT to construct a second ThrU-Turn intersection in neighboring Kerns in 2012, with several more planned to be implemented in the coming year.

MUT Corridor Profile: Preston Road (SH 289) at Legacy Drive, Plano TX

Project Description

In 2010, the City of Plano installed a variation of the median U-turn intersection at the intersection of Preston Road and Legacy Drive in lieu of building an overpass. Preston Road was originally designed for freeway expansion and already had an unusually wide median (approximately 300 feet) at its intersection with Legacy Parkway.

The intersection was converted to a Median U-Turn intersection, the first intersection of its kind in Texas, in July 2010. The purpose of the project was to relieve traffic congestion, increase traffic flow and improve safety at this intersection that serves approximately 73,000 vehicles per day. Left turns from Legacy Drive onto Preston Road were converted to indirect left turns using the newly constructed left U-turn crossovers in the median of Preston Road. Vehicles on Preston Road could also make "advance" U-turns prior to the intersection with Legacy Parkway. Left turns from Preston Road onto Legacy Parkway remained as direct left turns at the intersection. Both signalized intersections were converted to two-phase signal operations.

Exhibit A-8 provides an aerial view of the MUT intersection. Exhibit A-9 illustrates one of the locations for making the U-turn maneuver..



Exhibit A-8. Legacy Drive (east-west orientation) at Presto Road (north south orientation).



Exhibit A-9. View of Preston Road northbound U-turn crossover.

Studies and Findings

An initial study conducted by the Texas Transportation Institute¹ found that in the six months after the project opened:

- Total traffic-flow through the Legacy Drive and Preston Road intersection increased
- Vehicle queues longer than one signal phase were only found on the eastbound approach of Legacy Drive during the evening peak hour
- Peak hour travel time for vehicles using the median left-turn took up to 2-minutes 20-seconds
- Illegal U-turns from Preston Road to Legacy Drive were still occurring after several months
- A local Public Works study showed that new design provides increases in intersection capacity from 20 to 50 percent compared to the previous direct left turn intersection.

¹ TTI Technical Memorandum dated January 26, 2011

Project Performance

Despite the documented positive traffic operational benefits of the project, driver rejected the change. There was a lack of public acceptance from the start of the project and persistent public outcry from the public about the additional travel distance and confusion in making the indirect left turn movement. Many drivers found it confusing. Others simply began avoiding the intersection. It was estimated that 75 percent of people who would have turned left at the intersection simply found another route. The mayor of Plano admitted that “the public never accepted the concept” and said “it has been a very unfriendly thing for both the citizens of Plano and our visitors.”

In 2013, a study was conducted showed that the average morning wait time for a driver going south on Preston Road was less than 20 seconds and that going back to the old system, delay would increase to 51.6 second on average. However, despite supporting operational data, the public outcry led Plano City Council to return to the traditional intersection design in February 2014.

Lessons Learned

Though detailed pre-project studies correctly identified the MUT as having potential to reduce congestion and delay (that were indeed realized), there appears to be insufficient stakeholder and public involvement to identify (and perhaps mitigate) public acceptance and impacts to access that ultimately led to the unsuccessful outcome of this project. Because of the failure of this project, two other similar projects in Plano have been canceled.

Appendix B SUPPLEMENTAL OPERATIONAL AND SAFETY DETAILS

This appendix documents studies comparing the operational performance of MUT intersections versus conventional intersections. Studies comparing conventional intersections with the MUT intersection, in general, found the MUT intersection has several possible operational benefits.

Comparison of Travel Times between Conventional and MUT Intersections

Simulation studies have indicated that MUT intersections provided significantly lower than average travel times when compared to conventional intersections.

Reid and Hummer compared MUT intersections to conventional intersections on four-lane collector roads with the CORSIM microsimulation package.⁽²⁵⁾ Entering volumes ranged from 4,500 to 7,500 vehicles per hour. The change in overall travel times for all movements at the MUT intersections compared to the conventional intersections ranged from -21-percent to +6-percent during peak hours.

Bared and Kaiser compared MUT intersections to conventional intersections on a four-lane street intersecting a four-lane street with the CORSIM microsimulation package.⁽²⁶⁾ Total entering intersection volumes ranged from 2,000 to 7,000 vehicles per hour. Results indicate considerable savings in travel time for MUT intersections versus conventional intersections, especially where volumes entering the intersection exceeded 6,000 veh/h and left-turning vehicles were 10- to 20-percent of the entering intersection volume.

A simulation study by Dorothy et al. found consistently lower network travel times when five-lane streets with TWLTL and conventional intersections were converted to four-lane streets with MUT intersections with signalized crossovers.⁽⁹⁾ Specifically, the results indicated when the left-turning percentage was 10-percent, the reduction in left-turn total travel time for MUT intersections compared to conventional intersections was 20, 40, and 150 seconds per vehicle at 30-, 50-, and 70 percent of mainline saturation flow, respectively. Additionally, when the left-turning percentage was 25-percent, the reduction in left-turn total travel time for MUT intersections compared to conventional intersections was 20, 30, and 70 seconds per vehicle at 30-, 70-, and 90-percent mainline saturation, respectively.

Comparison of Stops between Conventional and MUT Intersections

Simulation studies have also shown MUT intersections had fewer stops when compared to conventional intersections. Bared and Kaiser's 2002 study also showed the proportion of vehicles stopping in the network, on average, was lower for the MUT intersection when compared to the conventional intersection.⁽²⁶⁾ Where 10-percent of the left-turning traffic was simulated, the MUT intersection had 20- to 40-percent fewer stops compared to the conventional intersection. At 20-percent left-turning vehicles, a reduction in the percentage of stops for MUT intersections became apparent when total entering intersection volumes reached 4,500 vehicles per hour.

Comparison of Throughput between Conventional and MUT Intersections

Simulation studies have also shown MUT intersections significantly increase throughput compared to similar conventional intersections. A simulation study by FHWA, with similarities to the study by Bared and Kaiser, provided two geometric design cases for MUT intersections and compared them to a conventional intersection with the VISSIM microsimulation package for six sets of traffic volumes representing low, medium, and high volumes.^(5,26) The results indicate the MUT intersection had an increase in throughput of 15- to 40-percent across the six sets of traffic volumes.

Comparison of Critical Lane Volumes between Conventional and MUT Intersections

Several studies have shown Critical Lane Volumes (CLVs) are improved by approximately 10- to 20-percent for MUT intersections compared to conventional intersections. Stover analyzed the intersection of two, six-lane principle streets by computing CLVs.⁽²⁷⁾ The study considered single left-turn lanes on all approaches versus dual left-turn lanes on all approaches for a conventional intersection. Using a MUT intersection reduced CLVs by 17-percent and permitted two signal phases. Koepke et al.'s study of CLVs indicated MUT intersections provide approximately 14- to 18-percent additional capacity over conventional intersections with dual left-turn lanes.⁽²⁸⁾ After accounting for overlapping traffic movements, the MUT intersection had a reduction of approximately 7- to 17-percent in CLVs compared to dual left-turn lanes for conventional intersections.

Comparisons of Corridor Capacity between Conventional Corridors (with TLWTLs) and MUT Corridors (w/Median Boulevards)

Studies have shown capacities of MUT corridors with median boulevards are 20- to 50-percent greater compared to conventional corridors with two-way center-turn lanes.

Through field studies, Savage found a 20- to 50-percent increase in corridor capacity when a five-lane street with a TWLTL with conventional intersections was converted to a four-lane street with MUT intersections.⁽²⁹⁾

Also through field studies, Maki found a 20- to 50-percent increase in capacity when five-lane and seven-lane boulevards with TWLTLs with conventional intersections were converted to four-lane and six-lane boulevards with MUT intersections.⁽³⁰⁾

Reid and Hummer compared streets with TWLTL and conventional intersections to principle streets with MUT intersections with the CORSIM microsimulation package.⁽¹¹⁾ The results indicated streets with MUT intersections resulted in a significant improvement in system travel times during peak hours without compromising system travel times during non-peak hours. Specifically, the corridor with MUT intersections had a 17-percent reduction in total travel time when compared to the corridor with TWLTL and conventional intersections. Average speeds in the corridor increased by 25-percent with the MUT intersections over the TWLTL with conventional intersections.

Appendix C MARKETING AND OUTREACH MATERIALS

This appendix provides some examples of MUT Public Outreach Materials.

FHWA has created alternative intersection and interchange informational videos and video case studies, which can be viewed on the FHWA YouTube channel (<https://www.youtube.com/user/USDOTFHWA>). Exhibit C-1 is an example of the type of information provided in the video for the Median U-Turn intersection.

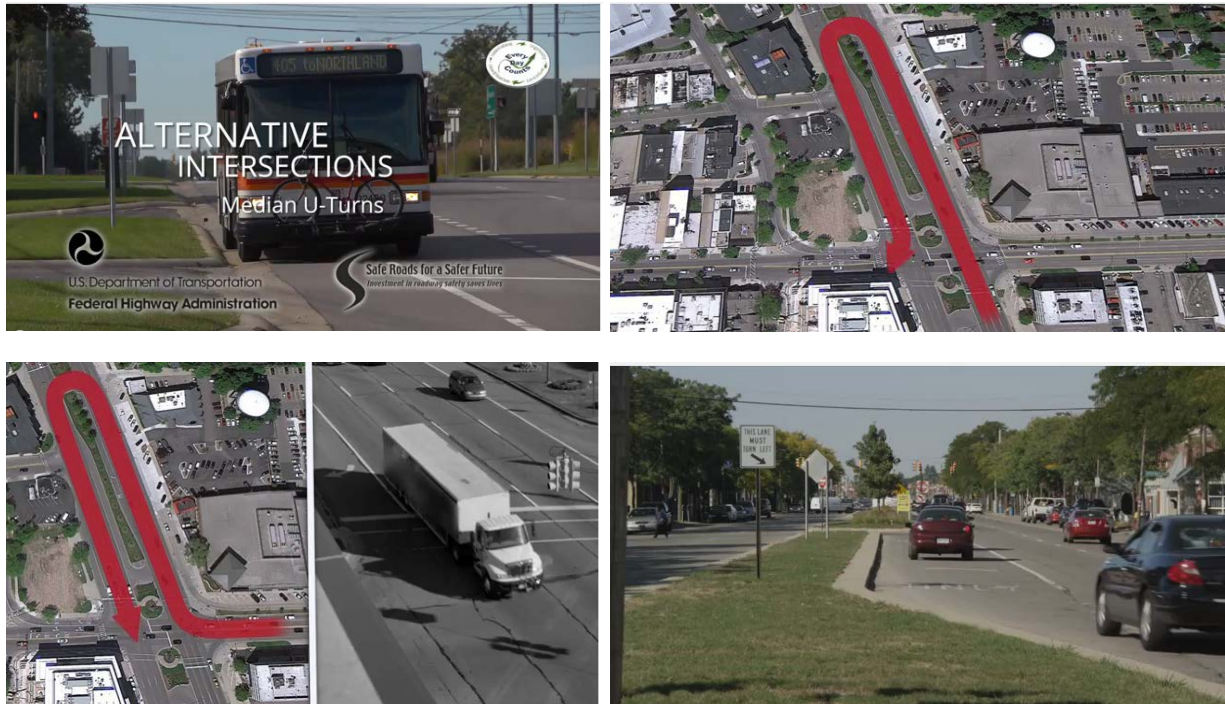

Exhibit C-1. FHWA Median U-Turn Intersection Informational Video.

In addition, FHWA has developed alternative intersection brochures that can be found on the FHWA website (<http://safety.fhwa.dot.gov>). An example of the Median U-Turn intersection brochure is shown in Exhibit C-2.



Exhibit C-2. FHWA Median U-Turn Intersection Brochure.

Several examples from state and local agencies are provided below, although various others are available online for additional information and guidance.

Educational Videos

Several agencies have developed educational videos as part their outreach with MUT intersections. Examples weblinks are provided below for access to these videos.

- Draper, UT ThrU intersection - http://www.youtube.com/watch?v=jHojQ_LppEw
- Fishers, IN Median U-turn - <http://www.youtube.com/watch?v=b-dDZoqv-Fc>
- Plano, TX MUT Intersection - <https://forms.plano.gov/engineering/NoLeftIntersections.wmv>
- Michigan DOT Information Page - http://www.michigan.gov/mdot/0,1607,7-151-9615_44557-161777--,00.html

Brochures and Fact Sheets

Several agencies have utilized brochures and fact sheets to help explain the MUT intersection. The following examples of outreach materials are provided on the next few pages:

- Exhibit C-3 illustrates an open house flyer used by the City Council for the MUT intersection in Draper, UT.
- Exhibit C-4 illustrates the concept of making a left-turn from the minor street via a right-turn and U-turn movement at the crossover.
- Exhibit C-5 illustrates the concept of making a left-turn from the major street via a through movement and U-turn movement at the crossover.
- Exhibit C-6 illustrates the first page of a two-page fact sheet on the use of the MUT intersection at several locations in the Tucson, AZ region.
- Exhibit C-7 illustrates the second page of a two-page fact sheet on the use of the MUT intersection at several locations in the Tucson, AZ region.
- Exhibit C-8 illustrates a learn the turn brochure used in Tucson, Arizona.
- Exhibit C-9 illustrates a thru-turn intersection information card with QR code from UDOT.
- Exhibit C-10 illustrates a thru-turn informational graphic from UDOT.

Open House

12300 South and Minute Man Drive ThrU Turn Intersection

Date: Wednesday, November 3, 2010
Time: 6:00 to 8:00 pm
Location: Draper City Hall Council Chambers,
1020 E. Pioneer Road (12400 South)

Questions? Call Draper City Engineering (801) 576-6546



The Draper City Council would like to invite you to attend an Open House on UDOT's proposed ThrUTurn Intersection at 12300 South and Minuteman Drive. Residents and business owners are encouraged to attend the meeting to find out about the proposed project and have your questions addressed by Draper City Council members, City Representatives and UDOT staff.

Project Overview: UDOT is in the design phase of a new intersection at 12300 South and Minute Man Drive in Draper, Utah. UDOT is coordinating with Draper City in the development of this new and innovative intersection. The intersection will be called a ThrU Turn Intersection (TTI).

The purpose of the TTI is to reduce the congestion and delay of this intersection and increase safety in the area. This will be accomplished by redirecting all the left turn movements away from the intersection and utilizing three signalized u-turns approximately 500-600 feet away from the main intersection. One u-turn will be on State Street, one on Minute Man Drive and one on 12300 South.

Traffic studies show that in the future, this intersection will be so congested during peak travel times that delays of up to seven minutes may be required to make some left hand turns. This congestion will also have an impact on I-15. By moving the left turns away from the intersection, more green time is dedicated to thru movements which will reduce the congestion at the intersection.

For more information visit www.udot.utah.gov/go/thrturn or contact the project team at 888-914-5454 or by email at thrUturn@utah.gov

Exhibit C-3. Open house flyer used by the City Council for the MUT intersection in Draper, UT.



Exhibit C-4. Concept of making a left-turn from the minor street via a right-turn and U-turn movement at the crossover.

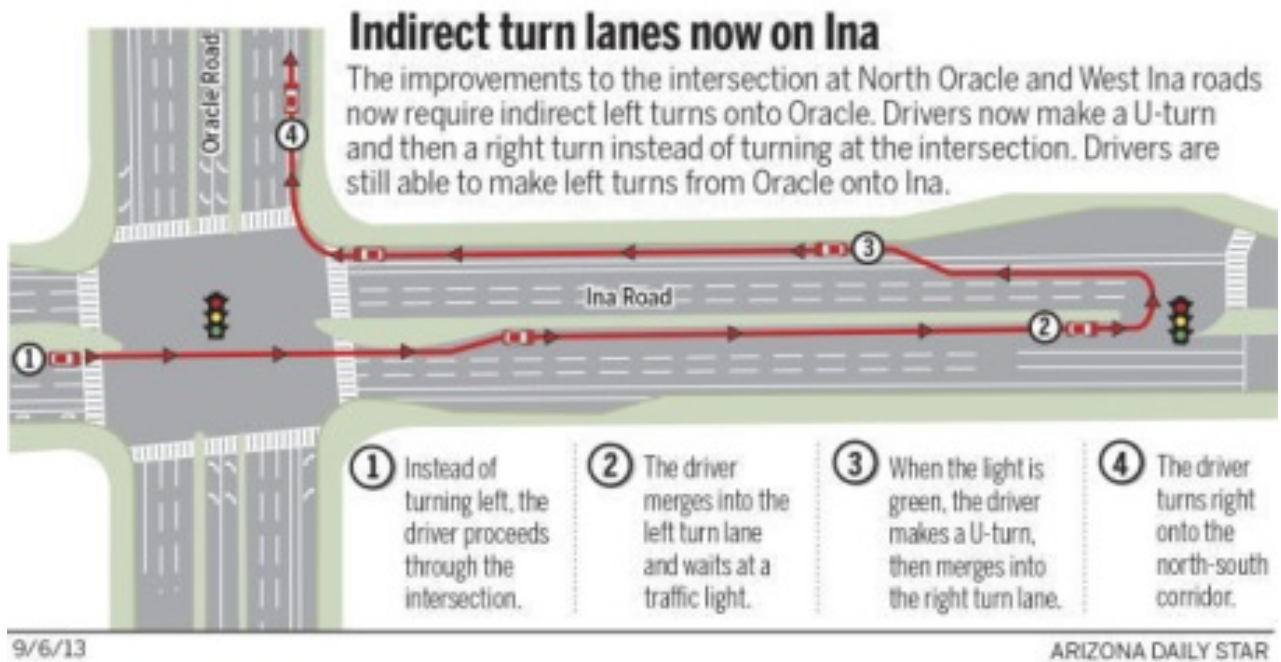

Exhibit C-5. Concept of making a left-turn from the major street via a through movement and U-turn movement at the crossover.



DESIGN INNOVATIONS –

Indirect Left Turn

FASTER • SAFER • GAS SAVING

HOW THE INDIRECT LEFT TURN BENEFITS YOU ...

A Shorter Wait at Light

- Reduces the amount of time vehicles are stopped at the intersection by 42%.

More Fuel Savings

- Reduces fuel consumption by approximately 9% for all vehicles using the intersection.

Safer

- Reduces total crashes at intersections by 16% and injury crashes by 30%.

Smaller Intersections

- Smaller intersection means less right-of-way needed, lower costs, and possibility of preserving existing businesses and reduces the distance pedestrians have to cross by 20 feet.

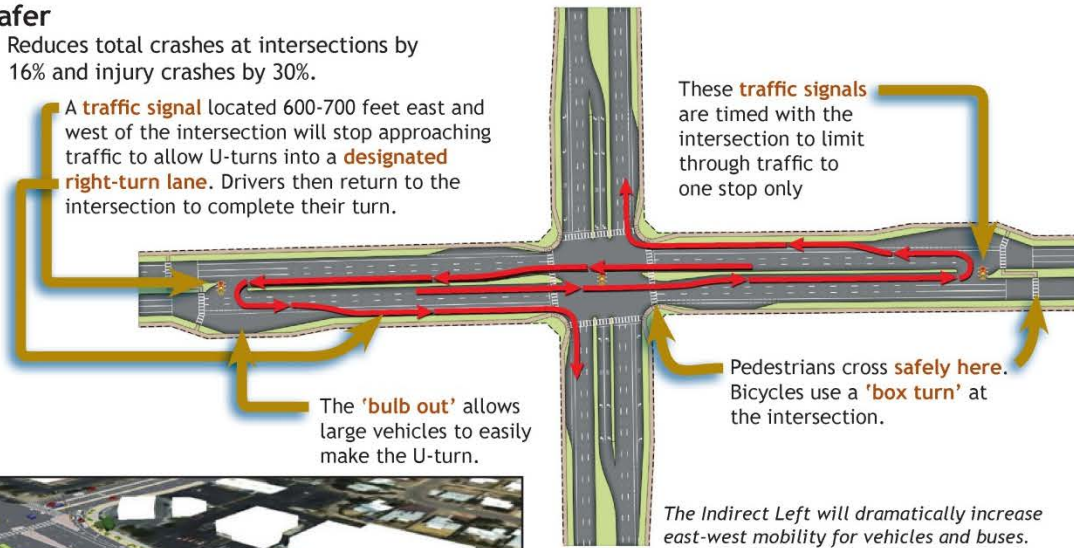

The 'bulb out' allows U-turns for larger vehicles such as buses and semi-trucks.

This is a project of the Regional Transportation Authority. The voter-approved, \$2.1 billion RTA plan will be implemented through 2026. Details about the full plan are available at www.RTAmobility.com. The Regional Transportation Authority has a nine-member board with representatives from local, state and tribal governments. This project will be managed by the City of Tucson.

Exhibit C-6. First page of a two-page fact sheet on the use of the MUT intersection at several locations in the Tucson, AZ region.



Improving East-West Travel

The Indirect Left Turn Intersection Design allows significantly more time to be given to traffic moving east-west along Grant Road.

Indirect Left Turn Traffic Signal Timing

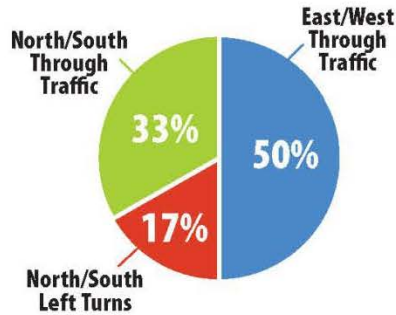

Traditional Traffic Signal Timing

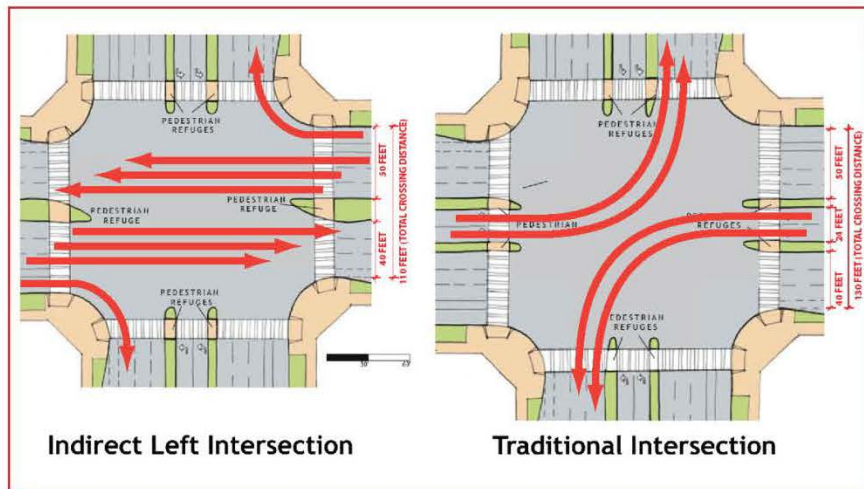
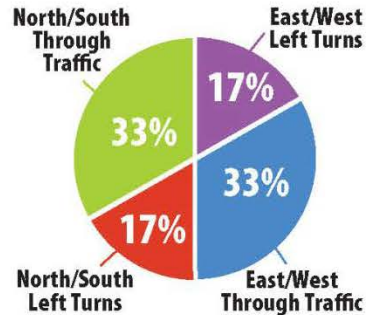

The Indirect Left Turn is recommended for seven major intersections along Grant Road:

- Swan Road
- Campbell Avenue
- Oracle Road
- Alvernon Way
- 1st Avenue
- Country Club Road
- Stone Avenue

Exhibit C-7. Second page of a two-page fact sheet on the use of the MUT intersection at several locations in the Tucson, AZ region.

RTA PROJECTS

Learn the Turn: Indirect Left

Oracle and Grant Intersection – Grant Indirect Left Turn
EFFECTIVE FALL 2013

Oracle and Ina Intersection – Ina Indirect Left Turn
EFFECTIVE FALL 2013

How do you make an indirect left turn?

- 1) As you approach the intersection, merge to the left through lane. At the intersection, proceed straight ahead through the intersection. (No left turn is allowed.)
Continue in the left through lane and merge into the left turn lane.
- 2) The left turn lane will be managed by a traffic signal. When the green arrow is illuminated, make a U-turn and enter the far right lane.
- 3) Stay in the right lane to turn right at the intersection.

Simply ...
Go through, make a U, then right at the light.

Remember: No left turns for eastbound/westbound vehicles allowed at the intersection. (Exception: Emergency vehicles.)

Indirect Left Benefits

SAFER

- reduces total car crashes and injury crashes
- shortens crossing distance for pedestrians
- provides “bike spots” for safer bicycle turns
- allows room for turns made by buses and semi-trucks

FASTER

- improves overall efficiency for all movements through the intersection

SAVES GAS

- reduces fuel consumption with vehicles idling less at the intersection

Project Management

The **Oracle and Grant Road** intersection is part of the Grant Road, Oracle to Swan, widening improvement project in the \$2.1 billion, 20-year Regional Transportation Authority Plan. The project is managed by the City of Tucson.

Details: www.grantroadinfo or call (520) 624-4727; www.RTAmobility.com

The **Oracle and Ina Road** intersection is part of the Safety Element of the RTA plan. The project is managed by Pima County.

Details: www.roadprojects.pima.gov/InaOracle; www.RTAmobility.com

Exhibit C-8. Learn the turn brochure used in Tucson, Arizona.

THE THRU-TURN INTERSECTION (TTI)

will reduce delay and improve safety by redirecting left turns from the main intersection to nearby U-turn locations.

The image consists of three main parts. On the left is a map showing the intersection of Sams Blvd and 4015 West. It highlights three locations with orange circles: the intersection of Sams Blvd and 4015 West, the intersection of Sams Blvd and 5415 S, and the intersection of Sams Blvd and 5540 S. Landmarks like Kearns Jr High School, Midas, Firestone, and a U.S. Post Office are also labeled. On the right is an aerial view of the intersection of Sams Blvd and 4015 West. A red dot indicates the traffic signal location at the intersection, and green dots indicate pedestrian signal locations. A legend below the aerial view identifies the red dot as 'TRAFFIC SIGNAL' and the green dot as 'PEDESTRIAN SIGNAL'. Below the legend is the text 'U-turn location at 4015 West and Sams Blvd.' At the bottom right is a smartphone displaying a QR code with the word 'SCAN' above it. To the left of the smartphone is the text 'SCAN THIS QR CODE WITH YOUR SMART PHONE TO SEE AN ANIMATION OF HOW THE TTI WILL WORK.' Below this text is the URL 'udot.utah.gov/5400south >>'.

● TRAFFIC SIGNAL
● PEDESTRIAN SIGNAL

U-turn location at 4015 West and Sams Blvd.

SCAN THIS QR CODE WITH YOUR SMART PHONE TO SEE AN ANIMATION OF HOW THE TTI WILL WORK.

udot.utah.gov/5400south >>

Exhibit C-9. Thru-turn intersection information card with QR code from UDOT.

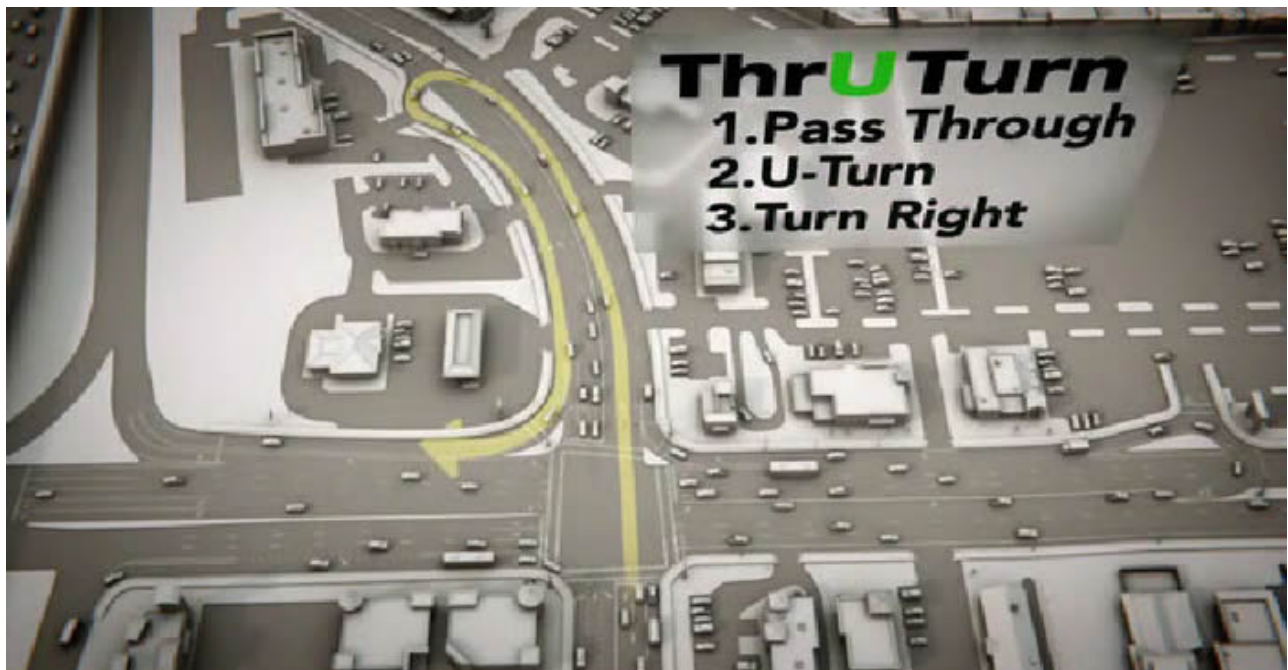

Exhibit C-10. Thru-turn informational graphic from UDOT.

This page intentionally left blank.

Appendix D SUPPLEMENTAL CONSTRUCTION AND DESIGN DETAILS

This appendix presents construction sequencing options for consideration during the construction of MUTs. A few plan sheets on construction and design details from recent MUT projects are provided below.

MDOT's crossover geometry (includes Loon design for narrow median):

http://mdotcf.state.mi.us/public/tands/Details_Web/mdot_geo670d.pdf

MDOT's Pavement Marking Details:

http://mdotcf.state.mi.us/public/tands/Details_Web/mdot_pave-985-b.pdf

MDOT's Signal layout details (pg 20-21):

http://mdotcf.state.mi.us/public/tands/Details_Web/mdot_signal_head_placement_box_span.pdf

MDOT's Signing Details (pg 87-90):

http://mdotcf.state.mi.us/public/tands/Details_Web/mdot_signing_%20design_placement_application_appendix.pdf

This page intentionally left blank.

This page intentionally left blank.



Safe Roads for a Safer Future
Investment in roadway safety saves lives

safety.fhwa.dot.gov
Publication Number FHWA-SA-14-069