

# FTA RESEARCH

FEDERAL TRANSIT ADMINISTRATION

## Rail Transit Shared Use and Control Systems Study

*Final Report*

MARCH 2014

FTA Report No. 0062  
Federal Transit Administration

**PREPARED BY**

Lawrence E. Light, P.E.

Stephen McEvoy

Jack Kanarek

SYSTRA Consulting, Inc.

Philadelphia, PA



U.S. Department of Transportation  
Federal Transit Administration

## COVER PHOTO

*Photo courtesy of Bob Vogel. Entitled “Southbound River LINE meets NS 39G and NS 65W at Cove Road” showing Locomotives: NJT 3501(LRV), BNSF 5181(C44-9W), and NS 8108(ES44AC).*

## DISCLAIMER

*This document is disseminated under the sponsorship of the U.S. Department of Transportation in the interest of information exchange. The United States Government assumes no liability for its contents or use thereof. The United States Government does not endorse products of manufacturers. Trade or manufacturers’ names appear herein solely because they are considered essential to the objective of this report.*

# Rail Transit Shared Use and Control Systems Study

Final Report

**MARCH 2014**

FTA Report No. 0062

**PREPARED BY**

Lawrence E. Light, P.E.  
Stephen McEvoy  
Jack Kanarek  
SYSTRA Consulting, Inc.  
1600 Market St, Suite 1310  
Philadelphia, PA 19103

**SPONSORED BY**

Federal Transit Administration  
Office of Budget and Policy  
U.S. Department of Transportation  
1200 New Jersey Avenue, SE  
Washington, DC 20590

**AVAILABLE ONLINE**

<http://www.fta.dot.gov/research>

## Metric Conversion Table

SYMBOL	WHEN YOU KNOW	MULTIPLY BY	TO FIND	SYMBOL
<b>LENGTH</b>				
<b>in</b>	inches	25.4	millimeters	mm
<b>ft</b>	feet	0.305	meters	m
<b>yd</b>	yards	0.914	meters	m
<b>mi</b>	miles	1.61	kilometers	km
<b>VOLUME</b>				
<b>fl oz</b>	fluid ounces	29.57	milliliters	mL
<b>gal</b>	gallons	3.785	liters	L
<b>ft<sup>3</sup></b>	cubic feet	0.028	cubic meters	m <sup>3</sup>
<b>yd<sup>3</sup></b>	cubic yards	0.765	cubic meters	m <sup>3</sup>
NOTE: volumes greater than 1000 L shall be shown in m <sup>3</sup>				
<b>MASS</b>				
<b>oz</b>	ounces	28.35	grams	g
<b>lb</b>	pounds	0.454	kilograms	kg
<b>T</b>	short tons (2000 lb)	0.907	megagrams (or "metric ton")	Mg (or "t")
<b>TEMPERATURE (exact degrees)</b>				
<b>°F</b>	Fahrenheit	5 (F-32)/9 or (F-32)/1.8	Celsius	°C

REPORT DOCUMENTATION PAGE		Form Approved OMB No. 0704-0188	
Public reporting burden for this collection of information is estimated to average 1 hour per response, including the time for reviewing instructions, searching existing data sources, gathering and maintaining the data needed, and completing and reviewing the collection of information. Send comments regarding this burden estimate or any other aspect of this collection of information, including suggestions for reducing this burden, to Washington Headquarters Services, Directorate for Information Operations and Reports, 1215 Jefferson Davis Highway, Suite 1204, Arlington, VA 22202-4302, and to the Office of Management and Budget, Paperwork Reduction Project (0704-0188), Washington, DC 20503.			
1. AGENCY USE ONLY	2. REPORT DATE March 2014	3. REPORT TYPE AND DATES COVERED September 2012 - March 2014	
4. TITLE AND SUBTITLE Rail Transit Signal and Control Systems Study, Final Report		5. FUNDING NUMBERS DTFT60-12-C-00008	
6. AUTHOR(S) Lawrence E. Light, P.E.; Stephen McEvoy; Jack Kanarek			
7. PERFORMING ORGANIZATION NAME(S) AND ADDRESSE(ES) SYSTRA Consulting, Inc. 1600 Market St, Suite 1301 Philadelphia, PA 19103		8. PERFORMING ORGANIZATION REPORT NUMBER FTA Report No. 0062	
9. SPONSORING/MONITORING AGENCY NAME(S) AND ADDRESS(ES) U.S. Department of Transportation Federal Transit Administration Office of Systems Planning East Building 1200 New Jersey Avenue, SE Washington, DC 20590		10. SPONSORING/MONITORING AGENCY REPORT NUMBER FTA Report No. 0062	
11. SUPPLEMENTARY NOTES [http://www.fta.dot.gov/research]			
12A. DISTRIBUTION/AVAILABILITY STATEMENT Available from: National Technical Information Service (NTIS), Springfield, VA 22161. Phone 703.605.6000, Fax 703.605.6900, email [orders@ntis.gov]		12B. DISTRIBUTION CODE TRI	
13. ABSTRACT Since the 1990s, there has been growing interest in shared use of general railway system railroad rights-of-way and tracks by transit vehicles (such as light rail vehicles) that do not fully comply with Federal Railroad Administration (FRA) regulations that govern the existing freight and commuter rail services on the system. This has prompted several research efforts and initiatives by transit operators. Since the Rail Safety Improvement Act of 2008 requires the implementation of Positive Train Control (PTC) on a significant portion of the general railway system to improve the safety of railroad operations, this research was undertaken with the goal of evaluating the potential to use PTC to facilitate the sharing of railroad rights-of-way and tracks that are under FRA oversight. The research reviewed currently-active transit services that have obtained temporal separation waivers from FRA; analyzed the functionality of existing PTC systems and identified the lessons learned in the development of these PTC systems; evaluated the feasibility, risk, and reliability of current PTC technologies for shared use operations; and identified the changes needed to PTC systems and underlying signal systems they enforce to enable shared use operations. In addition, the research prepared the outline for a scope of work for a potential demonstration project that would use Signal and PTC technologies to facilitate shared-use operations under a waiver from FRA.			
14. SUBJECT TERMS Shared use, rail transit, light rail, freight railroad, operations, engineering systems		15. NUMBER OF PAGES 204	
16. PRICE CODE			
17. SECURITY CLASSIFICATION OF REPORT Unclassified	18. SECURITY CLASSIFICATION OF THIS PAGE Unclassified	19. SECURITY CLASSIFICATION OF ABSTRACT Unclassified	20. LIMITATION OF ABSTRACT

# TABLE OF CONTENTS

1	Executive Summary
8	Introduction
8	Background
9	Research on Shared-Use Operations
12	Project Objectives
13	Review of Existing Temporal-Separation Waivers
13	Introduction
13	NJ TRANSIT's River LINE
16	NJ TRANSIT's Newark Light Rail
16	Tampa's TECO Streetcar Line (HART)
17	Oceanside-Escondido Sprinter (North County Transit District)
18	Santa Clara Valley Transportation Authority (VTA)
20	Lackawanna County Historic Trolley
21	Lessons Learned that May be Applicable When Using PTC for Enforcing Train Separations between Non-Compatible Train Types
25	Functionality of Existing PTC Systems
25	Background
27	What is PTC?
29	Advanced Civil Speed Enforcement System (ACSES)
38	Incremental Train Control System (ITCS)
49	Interoperable Electronic Train Management System (I-ETMS)
59	Lessons Learned During Development and Deployment of PTC Systems
59	Background
60	ACSES
64	ITCS
69	I-ETMS
74	Lessons Learned Common to All Applications Studied
77	Evaluation of Shared-Track Systems and Identification of Changes Needed
77	Background
78	Changes Needed to Existing Systems
82	Findings
85	Demonstration Project Using PTC for Shared Use of General Railway System
85	Background Information for Selection of Items to be Demonstrated
86	Observations on Shared-Track Options
88	Observations on Parallel-Track Options
91	Basic Considerations for Proposed Demonstration Project
92	Basic Outline of Demonstration Project

92	Demonstration Project: Use of PTC and Signal Systems to Mitigate Risk in a Shared Corridor – A Generic Template for a Pilot Program
108	Scope of Technical Work Required
109	Deliverables
109	Outline of Test Plan
111	Summary and Conclusions
115	Appendix A: Glossary
119	Appendix B: Review of Existing Temporal Separation Waivers
119	NJ TRANSIT'S River LINE
126	NJ TRANSIT's Newark Light Rail
129	Tampa's TECO Streetcar Line (HART)
131	Oceanside-Escondido Sprinter (North County Transit District)
133	Santa Clara Valley Transportation Authority (VTA)
135	Lackawanna County Historic Trolley
136	Existing Street-Running Trolleys Crossing FRA-Governed Railroad Tracks
137	Lessons Learned
140	Appendix C: PTC Options for Positively Separating Following-Move Non-Compatible Train Types on Same Track
140	PTC Base Case – Standard PTC System without Additional Mitigations
158	Appendix D: TC Options for Protecting Non-Compatible Train Types on Parallel Tracks of Same Rail Line
158	Single-Track Rail Line with Passing Sidings
160	Other Parallel-Track Rail Lines

## LIST OF FIGURES

14	Figure 2-1:	NJ TRANSIT River LINE train at Burlington Station
16	Figure 2-2:	Newark Light Rail train at Silver Lake Station
17	Figure 2-3:	TECO streetcar approaching green signal at CSX 14th Street automatic interlocking
18	Figure 2-4:	Sprinter train at Oceanside Station
19	Figure 2-5:	Map of Santa Clara VTA Light Rail System
20	Figure 2-6:	Union Pacific Railroad freight train operating over a track used at other times by VTA light rail trains
21	Figure 2-7:	Car 76 (J.G. Brill Co., 1926) exiting refurbished Crown Avenue Tunnel
23	Figure 2-8:	Amtrak train crossing in front of waiting TECO streetcar at CSX Tampa 14th Street automatic interlocking
24	Figure 2-9:	NJ TRANSIT's River LINE currently has the most sophisticated technological protections for enforcing On-Demand Spatial Separation between non-compatible train equipment
31	Figure 3-1:	Amtrak's on-board displays – speedometer and combined ACSES and cab-signal display
31	Figure 3-2:	Amtrak's ATC/ACSES display unit
35	Figure 3-3:	Open bridge – FRA concern and PTC requirement
36	Figure 3-4:	ACSES block diagram
42	Figure 3-5:	Amtrak's ITCS CLD, mounted to right of windshield in cab of a P-42 diesel locomotive
42	Figure 3-6:	Amtrak's ITCS CLD
44	Figure 3-7:	Hi-rail track car, one of many railroad safety exposures
51	Figure 3-8:	I-ETMS display unit in cab car
52	Figure 3-9:	I-ETMS display graphics for train with energy management option
95	Figure 6-1:	Typical double-track railroad mainline with bi-directional signaling
101	Figure 6-2:	Two transit trains operating at normal transit speeds ( $S=NT$ )
102	Figure 6-3:	Two conventional railroad trains (RP and RF) operating at their normal speeds ( $S=NP$ and $S=NF$ , respectively)
102	Figure 6-4:	Transit train operating at maximum speed has RP train "locked out"
103	Figure 6-5:	Mixed traffic – dispatcher elects to operate RP train with T train in shared segment
103	Figure 6-6:	Mixed traffic – RP train is cleared to enter A-B at reduced speed
104	Figure 6-7:	Mixed traffic – RP train resumes maximum speed upon passing T train
104	Figure 6-8:	RF train held to allow LRT to clear A-B at maximum speed



105	Figure 6-9:	T train held at B to permit RF train to continue at S=NF
105	Figure 6-10:	Dispatcher elects to permit T train to enter B-A with RF train still in Segment 3
106	Figure 6-11:	Required time delay has expired and T train is released to enter B-A with RF train still in Segment 4
106	Figure 6-12:	RF train has left Segments 4 and 5 and T train is cleared to operate at S=NT to A
119	Figure B-1:	NJ TRANSIT's River LINE route map
121	Figure B-2:	SITS implementation at River LINE CP 17 interlocked crossing
123	Figure B-3:	ETS provides on-demand spatial separation between lighter-weight passenger trains and freight trains
124	Figure B-4:	ETS implementation at and between River LINE CP 45 and CP Ross interlockings
127	Figure B-5:	View of retired freight track to right of Grove Street Station
128	Figure B-6:	SITS at Grove East interlocking
129	Figure B-7:	TECO streetcar approaching meet with opposite-direction streetcar in single-track non-signalized street-running territory
130	Figure B-8:	TECO streetcar approaching 14th Street automatic interlocking with CSX
130	Figure B-9:	Amtrak train crossing in front of waiting TECO streetcar at CSX Tampa 14th Street automatic interlocking
131	Figure B-10:	Sprinter train on viaduct approaching Cal State San Marcos Station
133	Figure B-11:	VTA light rail vehicle in Guadalupe Yard
135	Figure B-12:	Car 76 approaches the Steamtown National Historic Site Station in Scranton, PA
147	Figure C-1:	Illustration of ST Option 3
155	Figure C-2:	Illustration of ST Option 3D
158	Figure D-1:	Intrusion Detection System (IDS) at passing sidings
163	Figure D-2:	Typical double-track railroad mainline with bi-directional signaling
164	Figure D-3:	Two transit trains operating at maximum speeds
164	Figure D-4:	Two railroad trains operating at maximum speeds
165	Figure D-5:	Transit train operating at maximum speed has RP train "locked out"
165	Figure D-6:	Mixed traffic – dispatcher elects to operate RP train with LRT in shared segment
166	Figure D-7:	Mixed PSGR train is cleared to enter interlocking at reduced speed
166	Figure D-8:	Mixed traffic – RP train resumes maximum speed upon passing LRT

167	Figure D-9:	RF train held to allow LRT to clear A-B at maximum speed
167	Figure D-10:	RF train cleared to operate at maximum speeds
168	Figure D-11:	LRT train held at B to permit RF train to continue at maximum speed
168	Figure D-12:	Dispatcher elects to permit LRT to enter with RF train still in Segment 3
169	Figure D-13:	RF train has left Segment 4 and LRT is cleared en route to operate at NMAS to A

## LIST OF TABLES

22	Table 2-1:	Comparison of Existing Temporal-Separation Waivers Reviewed, with Respect to Technological Methods for Enforcing Separation of Non-Compatible Trains
83	Table 5-1:	Summary of ST Options for Positively Separating Following-Move Non-Compatible Train Types on Same Track
84	Table 5-2:	Summary of PT Options for Reducing Speeds of Non-Compatible Train Types on Parallel Adjacent Tracks
87	Table 6-1:	Summary of ST Options for Positively Separating Following-Move Non-Compatible Train Types on Same Track
89	Table 6-2:	Summary of PT Options for Reducing Speeds of Non-Compatible Train Types on Parallel Adjacent Tracks
98	Table 6-3:	OCSS Demonstration – Same Track – Block Entry Restrictions
139	Table B-1:	Comparison of Existing Temporal-Separation Waivers Reviewed, with Respect to Technological Methods for Enforcing Separation of Non-Compatible Trains
157	Table C-1:	Summary of ST Options for Positively Separating Following-Move Non-Compatible Train Types on Same Track
190	Table D-1:	Summary of PT Options for Reducing Speeds of Non-Compatible Train Types on Parallel Adjacent Tracks

## FOREWORD

The research completed under Federal Transit Administration Cooperative Agreement DTFT60-12-C-00008 has resulted in the preparation of a template for the development of a demonstration application of the use of Positive Train Control (PTC) to enforce Federal Railroad Administration requirements to facilitate improved shared use of the general railway system by compliant and non-compliant vehicles operating on the same and nearby rail tracks and rights-of-way. The research reviewed currently active temporal-separation waivers, analyzed the functionality of existing PTC systems, identified the lessons learned in the development of PTC systems, evaluated the feasibility, risk, and reliability of current PTC technologies for shared-use operations, and identified the changes needed to PTC systems to enable their use for shared-use operations.

## ACKNOWLEDGMENTS

The research team thanks the technical and safety staff and the Federal Transit Administration for their support and contributions—in particular, Patrick Centolanzi, P.E., Project Manager. Their insight, assistance, commentary, and commitment to advancing rail transit systems was especially helpful in the production of this research and corresponding documentation.

## ABSTRACT

Since the 1990s, there has been growing interest in shared use of the general railway system by compliant and non-compliant vehicles operating on the same and nearby rail tracks and rights-of-way. This has prompted several research efforts and initiatives by transit operators. Since the Rail Safety Improvement Act of 2008 requires the implementation of Positive Train Control (PTC) on a significant portion of the general railway system, this research was undertaken with the goal of evaluating the potential to use PTC to enforce Federal Railroad Administration modal separation requirements. The research prepared a template for the development of a demonstration application of the use of Positive Train Control (PTC) to enforce Federal Railroad Administration requirements to facilitate improved shared use of the general railway system by compliant and non-compliant vehicles operating on the same and nearby rail tracks and rights-of-way. The research reviewed the operating rules that govern shared-track operation and temporal separation, reviewed currently active temporal-separation waivers, analyzed the functionality of existing PTC systems and identified the lessons learned in the development of PTC systems, evaluated the feasibility, risk, and reliability of current PTC technologies for shared-use operations, and identified the changes needed to PTC systems to enable their use for shared-use operations.

## EXECUTIVE SUMMARY

The Federal Railroad Administration (FRA) of the United States Department of Transportation (USDOT) has jurisdiction over all railroads to provide for the safe operation of the nation's railroads. In recent years, as the need for public transit has grown, many urban areas have been seeking to use railroad rights-of-way or trackage for transit. The USDOT has been receptive and supportive of such increased use. However, it has recognized that such shared use poses some significant safety concerns; the two most significant issues are the enforced separation of trains and the standards for vehicle crashworthiness.

Separation of trains in most shared-use corridors is a function of the signal system. While the authorities for the movement of trains through the faithful observance of signal indications has been, and continues to be, a very safe and effective method for the daily movement of thousands of trains in the United States, an occasional lapse on the part of one crew member can cause catastrophic results. Following one of these lapses—in Chatsworth, California, on September 12, 2008, a line that had no system to enforce signal indications—there has been a very significant effort toward universal application of Positive Train Control (PTC) on all of the busiest rail corridors in the United States, including a number of shared-use corridors.

Crashworthiness is the other issue that is of paramount importance in the safe mix of diverse rail traffic in any corridor. This issue loomed large in the development of the high speed rail equipment used by Amtrak to operate the Acela Express service on the Northeast Corridor (NEC) between Washington, DC and Boston. As a result, the Acela Express equipment is the heaviest high speed train set used anywhere in the world. As the speeds for the Acela service were pushed upward to 150 mph, and now 160 mph, the existing train control system in the NEC was enhanced to the point that it is, today, a fully-compliant PTC system and received the first full certification in the nation by FRA, Type Approval FRA-TA-2010-001, on May 27, 2010.

The NEC Acela service is a case in which an improved train control system that met PTC standards was used to significantly mitigate the risk to passengers in a highly mixed-use, dense traffic corridor. This course was pursued when it was recognized that crashworthiness alone was not an adequate approach to safety.

Currently, the general railroad system tracks are limited to freight trains and passenger trains that meet FRA requirements, which include regulations pertaining to crashworthiness; which generally refers to structural strength, and is often referred to as buff strength, of the railroad vehicles. To date, most light rail vehicles in service in the United States are not compliant with FRA buff strength requirements for commingled operations with compliant passenger and freight trains.

Crashworthiness continues to be a factor as new passenger services at more moderate speeds are introduced in corridors that have seen freight only services in recent years. The resurgence of light rail passenger services has become a major concern with respect to the crashworthiness standards as many of the proposed light rail services - using rail passenger vehicles “not compliant” with FRA crashworthiness standards - would share rights of way with existing “compliant” freight services. Such proposed services may also include sharing corridors with rail passenger services operated with “compliant” rail passenger equipment.

As public transit operators have indicated a desire to use the newer types of non-compliant rail vehicles, primarily light rail vehicles, regulations have been established to separate compliant and non-compliant types. This usually separates the classes, generally a light rail passenger vehicle and a heavier freight vehicle temporally. Typically, the passenger services run during the day and the freight at night. This has provided for safe operation, but it limits the services each can provide.

Responding to the head-on collision in Chatsworth in September 2008 between a Metrolink (governed by the Southern California Regional Rail Authority) passenger train and a Union Pacific Rail Road (UPRR) freight train, the United States Congress incorporated in the Rail Safety Improvement Act of 2008 requirements for positive train control (PTC) systems. FRA has implemented in 49 CFR Part 236 new regulations as Subpart I for railroads to deploy PTC systems to prevent train-to-train collisions, derailments due to overspeed, routing of trains through misaligned switches, and protection of work zones. These capabilities of PTC have prompted interest in determining if these PTC systems could have the additional benefit of enabling concurrent shared use in places where shared use is procedurally enforced by temporal separation.

With the goal of evaluating the use of PTC to enforce FRA requirements to facilitate improved shared use of the general railway system by compliant and non-compliant vehicles operating on the same and nearby rail tracks and rights-of-way (generally referred to as “shared use” in this study), the objectives of this study were to:

- Review the operating rules that govern shared-track operation and temporal separation for currently-active temporal separation waivers issued to U.S. commuter and light rail transit systems operating on the general railway system.
- Analyze the functionality of PTC systems and software to automatically enforce the spatial separation and closing speed limitations of compliant and non-compliant trains in shared use operations.
- Document the lessons learned in the development of PTC.

- Evaluate the feasibility, risk, and reliability of current PTC technologies for shared-use operations.
- Identify the changes needed to PTC systems to enable their use for enforcement of certain restrictions designed to mitigate the risk of operating compliant and non-compliant trains in a shared corridor.
- Create a template for a demonstration project that would use a PTC system to improve the safety inherent in a shared-corridor operation.

### Review of Existing Temporal Separation Waivers

Existing transit operations with shared-use temporal-separation waivers were reviewed with the primary purpose of identifying, for the existing shared-use temporal-separation waivers, instances where train separation is enforced by technology, and where the temporal separation is not totally dependent on rules and human-based procedures. Such technological enforcements of temporal separation are being studied and documented so that they can be considered (and possibly incorporated) when determining how PTC systems can be used to implement and enforce On-Demand or On-Call Spatial Separation between railroad trains and lighter-weight passenger trains.

The review of currently-active transit services that have obtained temporal-separation waivers from FRA found that three of the shared-use operations surveyed use signal technology to implement temporal and spatial separation. NJ TRANSIT's River LINE and Newark Light Rail services, and Tampa's CSX/TECO-Streetcar at-grade crossing, demonstrate that conventional-interlocking and signal-system logic can be used to provide Localized On-Demand Spatial Separation and vitally separate non-compatible train types at and within a single interlocking. This capability is currently possible with the use of standard route-locking logic only when the two train types (typically lighter-weight passenger trains and railroad freight trains) have separate and different entry and exit points to and from the shared interlocking. In addition, NJ TRANSIT's River LINE contains a novel and more sophisticated interlocking and signal-system logic that can be used to provide a more global On-Demand Spatial Separation and vitally separate non-compatible train types at and between multiple successive interlockings. This capability is currently possible using vital communications between adjacent interlockings and route-locking logic only when the two train types have separate and different entry and exit points to and from the shared trackage.

These proven and vital (fail-safe) train-separation capabilities have eliminated the need for very inefficient time-based temporal-separation schemes requiring that the two train services be restricted to operate during different time periods. In addition, and as demonstrated on the River LINE and Newark Light Rail, the train separations can be implemented not just by vitally displaying red signal aspects, but they also can be enforced by such technologies as electromagnetic train

stops and cab-signal systems in concert with ATC speed enforcement and by the forced-positioning (using route locking) of interlocked turnouts and derails.

An additional finding of the research was that on the NJ TRANSIT River LINE, light rail passenger trains are allowed to operate at normal speeds with an adjacent freight-railroad track only 17 ft. away (center-to-center) without an Intrusion Detection System being required. However, on the VTA's Vasona shared corridor in California, the light rail and freight tracks are farther apart than 17 ft., but the light rail passenger trains are restricted to rather low speeds when passing a freight train. Fortunately, in this case, the freight trains are very infrequent.

### Functionality of Existing PTC Systems

This research prepared a review of the functionality of the existing North American PTC systems that are being investigated for the purpose of determining how they can be modified and/or enhanced to provide and enforce On-Call Spatial Separation between conventional railroad trains and lighter-weight passenger trains.

Per the Rail Safety Improvement Act of 2008 (RSIA08), “The term ‘positive train control system’ (PTC) means a system designed to prevent train-to-train collisions, over-speed derailments, incursions into established work zone limits, and the movement of a train through a switch left in the wrong position.” Per FRA Rule 236.1005 and subject to certain caveats, exceptions, and additions, the PTC requirements generally apply to railroad mainline trackage over which:

- Freight trains carry any quantity of material that is a Poison Inhalation Hazard (PIH) or Toxic Inhalation Hazard (TIH), and/or
- Intercity or commuter passenger trains regularly operate

RSIA08 (also known as the PTC law) and associated FRA regulations (also known as the PTC regulations) require that the affected railroad lines have fully-functioning and operational PTC systems for all trains and territories by December 31, 2015. The owner of the trackage is responsible for ensuring that all tenant-railroad trains operating over the owner's trackage have onboard systems that are compatible and interoperable with the host railroad's PTC system.

The ACSES (Advanced Civil Speed Enforcement System) PTC system was developed by Amtrak for the Northeast Corridor to support increasing train-operating speeds up to 150 mph, and now 160 mph. ACSES has been designed to be a vital overlay to enhance the automatic train control (ATC) system, a conventional wayside signal system that includes continuous cab signaling and onboard speed control. In fact, cab signaling and speed control are important components of the overall ATC/ACSES PTC system, as illustrated by the definition that  $ATC+ACSES = PTC$ . While the ATC's very fast response to



changing conditions ahead of the train make it ideal for higher-speed operation, ACSES was added to provide additional safety features for the higher-speed operation, features that are now also required by the PTC mandate.

ACSES is capable of enforcing stop signals and all speed restrictions and implementing the other PTC mandates. However, ACSES lacks (both in the central office and on the wayside) the fail-safe train ID and location data needed to implement On-Call Spatial Separation between non-compatible train types.

The Incremental Train Control System (ITCS) was developed to support increased train-operating speeds up to 110 mph in the Emerging Corridors such as Amtrak's Chicago–Detroit–Pontiac and Port Huron Corridor, where lack of some form of train control had held speeds to a maximum of 79 mph. ITCS is a distance-to-go (or speed-location profile-based) enforcement system similar to ACSES, but with different input sources. ITCS is entirely communications-based and it does not use transponders on the track.

In considering how ITCS can be used to provide and enforce Temporal Separation and On-Call Spatial Separation between conventional railroad trains and lighter-weight, non-compliant passenger trains, several issues must be considered. These issues all involve the same conceptual theme—i.e., ITCS has not been designed to vitally bring knowledge into a central computer about “what types of trains are where.” Whereas individual trains can and do know their “types” through on-board firmware, the existing ITCS designs do not cause this information to be transmitted (in useful formats) to the wayside interlockings or to the central office.

ITCS is capable of enforcing stop signals and speed restrictions and implementing the other PTC mandates, but it lacks (both in the central office and on the wayside) the fail-safe train-ID and location data needed to implement On-Call Spatial Separation between non-compatible train types.

The Interoperable Electronic Train Management System (I-ETMS) was conceived to support interoperability across railroads and to “apply consistent warning and enforcement of rules violations regardless of trackage ownership while maintaining some level of railroad specific rules and train handling policies.” The primary applications of I-ETMS include overlays on existing or modernized CTC traffic-control signaling and various forms of absolute block signaling (ABS). I-ETMS also is being designed to be implemented in “dark” non-signaled territories, on signaled trackage operated subject to mandatory-directive authorities, and on signaled trackage having continuous cab signaling that will continue in service with the I-ETMS enhancement.

I-ETMS is expected to be capable of enforcing stop signals and speed restrictions and implementing the other PTC mandates, but I-ETMS lacks (both in the central

office and on the wayside) the fail-safe train ID and location data needed to implement On-Call Spatial Separation.

### Lessons Learned During Development and Deployment of Three Current PTC Systems

The research identified lessons learned in the development of ACSES and ITCS, which are now in operation, and those that are being learned in the ongoing design, initial installation, and testing of I-ETMS. Among the lessons learned is the importance of a complete design, followed by a good pilot program for fine-tuning the finished product before major roll-out begins. In addition, full integration of the new system into the existing operating culture requires a broad multi-disciplinary approach to ensure that existing engineers/operators, dispatchers/train controllers, train rules specialists, and wayside and on-board maintenance technicians will all begin to view the “new” system as integral to their normal duties and responsibilities. This effort should include thorough training, well-documented manuals for each discipline, and a good pilot installation in revenue service to fully integrate the “new” PTC into the existing operation. This PTC system was developed by Amtrak for the Northeast Corridor to support increasing train-operating speeds up to 150 mph, and now 160 mph. ACSES has been designed to be a vital overlay to and on top of conventional wayside signal systems that include continuous cab signaling and onboard speed control. In fact, the cab signaling and speed control are important components of the overall ACSES PTC system, as illustrated by the definition that  $ATC+ACSES = PTC$ . ITCS and I-ETMS applications in the U.S. are overlays of existing wayside signal systems that take advantage of the vital logic already in the signal system.

### Evaluation of Feasibility, Risk, and Reliability of Current PTC Technologies for Shared-Track Operations, and Identification of Changes Needed to Prevent Train-to-Train Collisions Between Non-Compatible Train Types

In the review of track-sharing options, the research evaluated same and parallel track-sharing scenarios and concluded that certain current and planned functionalities of the three PTC systems can be used in Shared-Track Operations. This analysis included a high-level risk analysis that provided results supportive of the various track-sharing scenarios that were reviewed. However, to permit comingled Shared-Track Operations and mitigate the additional hazards that arise from such operation, enhancements will be needed over and above the basic features already incorporated in the current PTC system capabilities or in their underlying signal system capabilities. To ensure separation between compliant and non-compliant train types, these enhancements and/or some other form of mitigation will be required, regardless of which PTC system has been chosen for the corridor to be shared.

## Demonstration Project Using PTC for Shared Use of General Railway System

Based on the encouraging findings of this research, the study defined the essentials of a demonstration project to address the most pressing needs for mitigation of risk in developing safe shared corridors. The material prepared during this research can provide the basis for preparing a Statement of Work (SoW) for a technical specification for qualified suppliers to carry out a demonstration for a partnership consisting of a railroad carrier, an LRT carrier, FRA, and the Federal Transit Administration (FTA), leading to a practical installation in a specific shared corridor. The potential demonstration project would be focused on those particular safety concerns identified in this research, should seek to use cost-effective applications of existing technologies to create practical solutions designed to reduce the risk of commingling non-compatible equipment types to the maximum possible extent, and should seek (second only to safety considerations) to reduce the train delays associated with traditional methods of train separation.

The potential project should be designed so that the demonstration project, when fully vetted and enhanced in accordance with the experience gained during installation and testing, could remain in place for revenue service for the life of the equipment, both wayside and on-board. In this regard, the potential demonstration project would actually become a generic template for a pilot project for an actual installation in a specific shared corridor.

## Conclusion

The findings of this research project indicate that there is potential for expanded shared use of the general railway system by non-compatible vehicles, based on experience gained from existing shared corridor operations and with the initial deployments of PTC. However, for the use of any of the three existing PTC technologies for shared-use operations, creative application of the PTC system and changes to the underlying signal system it enforces will be needed. If there is continued interest in the development of shared-corridor operations, this research has resulted in the recommendation that a demonstration project should be advanced, drawing on the outline provided in this study.

# Introduction

## Background

The Federal Railroad Administration (FRA) of the United States Department of Transportation (USDOT) has jurisdiction over all railroads to provide for the safe operation of the nation's railroads. In recent years, as the need for public transit has been growing, many urban areas have been seeking to use railroad rights-of-way or trackage for transit. The USDOT has been receptive to and supportive of such increased use. However, it has recognized that such shared use poses some significant safety concerns. The two most significant issues are the enforced separation of trains and the standards for vehicle crashworthiness.

Separation of trains in most shared-use corridors is a function of the signal system. While the authorities for the movement of trains through the faithful observance of signal indications has been, and continues to be, a very safe and effective method for the daily movement of thousands of trains in the United States, an occasional lapse on the part of one crew member can cause catastrophic results. Following one of these lapses on September 12, 2008, in Chatsworth, California, on a line that had no system to enforce signal indications, there has been a very significant effort toward universal application of Positive Train Control (PTC) on all of the busiest rail corridors in the United States, including a number of shared-use corridors.

Crashworthiness is the other issue that is of paramount importance in the safe mix of diverse rail traffic in any corridor. This issue loomed large in the development of the high speed rail equipment used by Amtrak to operate the Acela Express service on the Northeast Corridor (NEC) between Washington, DC, and Boston. As a result, the Acela Express equipment is the heaviest high speed train set used anywhere in the world. As the speeds for the Acela service were pushed upward to 150 mph, the existing train control system in the NEC was enhanced to the point that it is today a fully-compliant PTC system, having received the first full certification in the nation by FRA, Type Approval FRA-TA-2010-001, on May 27, 2010.

The NEC Acela service is a case in which PTC was used to significantly mitigate the risk to passengers in a highly mixed-use, dense traffic corridor, when it was recognized that crashworthiness alone was not an adequate approach to safety.

Currently, the general railroad system tracks are limited to freight trains and passenger trains that meet FRA requirements, which include regulations pertaining to crashworthiness (which generally refers to structural strength and

often is referred to as buff strength) of the railroad vehicles. To date, all light-rail vehicles in service in the United States are not compliant with FRA buff strength requirements for commingled operations with compliant passenger and freight trains.

Crashworthiness continues to be a factor as new passenger services at more moderate speeds are introduced in corridors that have seen freight-only services in recent years. The resurgence of light-rail passenger services has become a major concern with respect to crashworthiness standards, as many of the proposed light rail services—using rail passenger vehicles “not compliant” with FRA crashworthiness standards—would share rights-of-way with existing “compliant” freight services. Such proposed services also may include sharing corridors with rail passenger services operated with “compliant” rail passenger equipment.

As public transit operators have indicated a desire to use the newer types of non-compliant rail vehicles, primarily light-rail vehicles, regulations have been established to separate compliant and non-compliant types. This usually separates the classes, generally a light-rail passenger vehicle and a heavier freight vehicle, temporally. Typically, passenger services run during the day and freight at night. This has provided for safe operation, but it limits the services each can provide.

Responding to the head-on collision in Chatsworth in September 2008 between a Metrolink (governed by the Southern California Regional Rail Authority) passenger train and a Union Pacific Rail Road (UPRR) freight train, the United States Congress incorporated in the Rail Safety Investment Act of 2008 requirements for PTC systems. FRA has implemented in 49 CFR Part 236 new regulations as Subpart I for railroads to deploy PTC systems to prevent train-to-train collisions, derailments due to overspeed, routing of trains through misaligned switches, and protection of work zones. These capabilities of PTC have prompted interest in determining if these PTC systems could have the additional benefit of enabling concurrent shared use in places where shared use is procedurally enforced by temporal separation.

This study builds on the work to date. It reviews current operations, regulations, conditions, and technology, including PTC.

## Research on Shared-Use Operations

FTA Report No. 0008, “Safe Transit in Shared Use,” (July 2011), provides an overview of recent research on shared use operations. The following is excerpted from that report:

Since the late 1990s, extensive analysis and documentation of shared-use operations has been provided by studies sponsored by the Transit Cooperative Research Program (TCRP):

- TCRP Report 52 – “Joint Operation of Light Rail Transit or Diesel Multiple Unit Vehicles with Railroads” (1999)
- *TCRP Research Results Digest* Number 43 – “Supplementing and Updating TCRP Report 52: Joint Operation of Light Rail Transit or Diesel Multiple Unit Vehicles with Railroads” (September 2001)
- *TCRP Research Results Digest* Number 47 – “International Transit Studies Program Report of the Spring 2000 Mission – Germany’s Track-Sharing Experience: Mixed Use of Rail Corridors” (March 2002)
- TCRP Report 130 – “Shared Use of Railroad Infrastructure with Non-compliant Public Transit Vehicles: A Practitioner’s Guide” (2009).

The initial research in TCRP Report 52 was undertaken as strong interest developed in shared use as the transit community in the United States observed the development and expansion of shared-track rail operations in Europe—and, in particular, in Karlsruhe, Germany. The report, published in 1999, provided a comprehensive analysis of regulations, institutions, historical context, operations, infrastructure, rolling stock, and risk assessment aspects. The report also included an extensive review of overseas experience with commingled, or simultaneous, train operation on shared track by railroad trains (freight, passenger, or both) and light-rail trains.

At the time of the research conducted for TCRP Report 52, the San Diego Trolley and the Baltimore Light Rail use of temporal separation represented the state of the art. In those operations, specific time periods of the day were allocated for the freight and passenger train operations, providing a clear separation of operations over significant segments of the rail line.

TCRP Report 52 included a number of potential concepts for shared-use operations. One of the concepts, referred to as Limited Track Sharing/Absolute Block Passing Tracks, may be viewed as an early version of Extended Temporal Separation (explained later in this report), which applies absolute blocking between modes over extended segments of track (but not entire lines) using conventional off-the-shelf signal technology with railroad operating practices.

Concurrent with the publication of Report 52 in 1999, FRA and the Federal Transit Administration (FTA) jointly introduced a draft policy statement on shared track. With consideration for public comments, in 2000 FRA and FTA distributed the final policy statement on shared use of track. At the same time, FRA published “Statement of Agency Policy Concerning Jurisdiction over Safety of Railroad Passenger Operations and Waivers Related to Shared Use of Tracks of the General Railroad System by Light Rail and Conventional Equipment.” In

this document, FRA explained its policies for regulating shared-track proposals and provided guidance for requesting waivers from FRA rules for implementation of such operations. The FRA policy statement specifically reviewed the overseas examples of joint use.

Subsequently, *TCRP Research Results Digest* Number 43 was published in September 2001 providing a supplement and update of Report 52 and incorporating the FRA and FTA policy statements. It also included additional information on overseas track sharing, which was further supplemented by material included in *TCRP Research Results Digest* Number 47.

These documents brought awareness of the potential for shared-use operations to the transit industry, the various safety regulatory and oversight organizations, and the research and professional community. As stated in the summary of TCRP Report 52: “The research team was urged by those interested in the study to produce ‘the last word’ on joint use. It has instead uttered ‘the first word’ by reintroducing the concept of genuine joint use in North America.” The summary concludes by saying, “To the extent that this report makes joint use of tracks a subject of productive debate and encourages and directs subsequent research into the topic, it might be considered useful.”

Following TCRP Report 52, research and development of the shared-track concept has continued, and implementation experience has been gained from the development of NJ TRANSIT’s Newark Light Rail and River LINE, San Diego’s Sprinter, and Austin’s Capital Metro Red Line. These projects were advanced with consideration for FRA’s July 10, 2000, policy statement and, as a result, they illustrate that the application of temporal separation techniques can result in successful petitions for waivers from FRA rules.

The follow-up TCRP research sponsored by FRA, as presented in TCRP Report 130, provides a comprehensive user guide for alternatives analysis and planning for shared-use operations. A portion of the report reviewed the temporal separation concepts that have been used on the NJ TRANSIT River LINE, which are the basis of the engineering analysis in this research project.

In 2010, the National Cooperative Highway Research Program (NCHRP) published Report 657, “Guidebook for Implementing Passenger Rail Service on shared Passenger and Freight Corridors.” The Guidebook was developed to aid states in developing public-private partnerships with private freight railroads to permit operation of passenger services over shared-use rail corridors. The Guidebook provides information on principles, processes, and methods to support agreements on access, allocation of operation and maintenance costs, capacity allocation, operational issues, future responsibilities for infrastructure improvements, and other fundamental issues that will affect the ultimate success

of shared-use passenger and freight agreements between public and private railroad stakeholders.

The FTA-sponsored “Safe Transit in Shared Use” research study developed concepts for temporal separation that could facilitate more frequent and more flexible operations of FRA-compliant and non-compliant services. The proposed operating concepts and technology were based on methods implemented on the NJ TRANSIT River LINE that were accepted by FRA and resulted in the granting of waivers. As part of the research, a design for operations and signal equipment was prepared for a specific segment of the River LINE that would facilitate the expansion of freight and passenger services during the non-peak periods of the light-rail operation while maintaining separation of modes.

## Project Objectives

With the goal of evaluating the use of PTC to enforce FRA requirements to facilitate improved shared use of the general railway system by compliant and non-compliant vehicles operating on the same and nearby rail tracks and rights-of-way (generally referred to as shared use in this study), the objectives of this study were to:

- Review the operating rules that govern shared-track operation and temporal separation for currently-active temporal-separation waivers issued to U.S. commuter and light-rail transit systems operating on the general railway system.
- Analyze the functionality of PTC systems and software to automatically enforce the spatial separation and closing speed limitations of compliant and non-compliant trains in shared-use operations.
- Document the lessons learned in the development of PTC.
- Evaluate the feasibility, risk, and reliability of current PTC technologies for shared-use operations.
- Identify the changes needed to PTC systems to enable their use for compliant and non-compliant trains in shared-use operations.
- Create a template for a demonstration project that would use a PTC system for shared-use operations.



SECTION  
2

# Review of Existing Temporal-Separation Waivers

## Introduction

Existing transit operations with shared-use temporal-separation waivers were reviewed with the primary purpose of identifying instances where train separation is enforced by technology and where the temporal separation is not totally dependent on rules and human-based procedures. Such technological enforcements of temporal separation are being studied and documented so that they can be considered (and possibly incorporated) when determining how PTC systems can be used to implement and enforce On-Demand Spatial Separation between railroad trains and lighter-weight passenger trains.

In addition, since the primary PTC systems in the U.S. (ACSES, ITCS, and I-ETMS) are all overlays to underlying conventional signal systems, and are not standalone systems, it is important to fully understand all concepts by which existing signal systems are being used to implement and enforce physical separation between non-compatible train types.

The SYSTRA team contacted all of the known temporal-separation waiver holders, and information was obtained and/or received from and for a number of these rail systems described below. Other rail systems are included where the temporal separation is solely dependent on human-based procedures. For each of the systems identified below, Appendix B provides a more detailed description of the investigative findings.

## NJ TRANSIT's River LINE

NJ TRANSIT's River LINE is an approximately 34-mile-long non-electrified light-rail transit (LRT) system extending from Camden, New Jersey, to Trenton, New Jersey, which began service in March 2004. Currently, freight-train operations are conducted over approximately 28.5 of the route miles.

The River LINE (Figure 2-1) has both single-track and double-track sections, along with numerous interlockings and non-interlocked sidetracks. This includes two interlocked railroad crossings at-grade, 21 passenger stations, and 72 rail-highway grade crossings. Bi-directional wayside automatic block signaling (ABS)

(without cab signals) is provided on all main tracks, and the entire line (including all interlockings) is centrally controlled by a CTC system.

**Figure 2-1**  
NJ TRANSIT River  
LINE train at  
Burlington Station



The LRT trains are “lighter-weight” diesel-multiple-unit (DMU) vehicles that do not meet FRA buff-strength requirements. Because of this, the FRA waiver requires that the two (passenger vs. freight) vehicle types (hereinafter also called the two modes) must be positively separated from each other.

The River LINE was found to have the most sophisticated technological enforcement for ensuring absolute physical separation between railroad trains and lighter-weight passenger trains. At two interlockings where freight-railroad routes cross the rail-transit tracks, protection is afforded by Short Interval Temporal Separation (SITS).

SITS was developed to permit freight-train movements to cross the River LINE at a single interlocking while normal passenger-train operations are being maintained on the remainder of the River LINE. SITS permits a very-localized form of temporal separation to be implemented between the two transportation modes and train types at one interlocking.

SITS protection is provided by the field-based vital interlocking circuits and is possible because the lighter-weight passenger trains and the freight trains have separate and different entry and exit points to and from the shared trackage. This operational feature of the River LINE permits the signal-system route locking of and for a passenger train entering the shared limits to lock out freight-train operations from those limits, and vice versa.

Under SITS, stop signals for passenger trains are enforced by electromagnetic train stops and stop signals for freight trains are enforced by interlocked derails.

The NJ TRANSIT River LINE also developed and implemented Extended Temporal Separation (ETS). ETS provides temporal separation over certain logical segments of the River LINE (including at and between multiple interlockings) rather than having to provide temporal separation uniformly over the entire River LINE. This permits freight-train operations within one line segment while passenger trains are operating in other line segments, and vice versa.

The words “temporal separation” in the terms SITS and ETS emanate from the practice of separating non-compliant from compliant operations by time of day (in which passenger services generally operate during the day and freight at night) to obtain a waiver for share-use operations from FRA. Instead, the River LINE technology and functionality provides on-demand or on-call “Spatial Separation,” which allows for more effective use of the railroad track and right-of-way.

Within such a logical shared-use segment of the River LINE, the train controller responsible for the territory may select one of three operating modes for the segment:

- Operating Mode 1 – passenger-only operations
- Operating Mode 2 – shared use with enforced separation between the two train types
- Operating Mode 3 – freight-only operations

Signal-system enforcement of ETS uses proven commercially-available components known as object controllers to vitally exchange pertinent information (technically, signal-system indications) including switch position and track-circuit occupancy between adjacent interlockings in the ETS territory. The object controllers and associated logic ensure the proper positioning of switches and derails at all affected interlockings and at all times, including before allowing the operating mode to be changed and while an operating mode is in effect.

The operating modes are selected by the train controller via the non-vital supervisory system. However, all safety logic, including the ETS links between interlockings, reside in vital wayside equipment.

Under Mode 2, multiple interlockings are effectively joined together into one large “pseudo” interlocking by the object controllers and associated logic.

Under ETS (and SITS), stop signals for passenger trains are enforced by electromagnetic train stops, and stop signals for freight trains are enforced by interlocked derails.

## NJ TRANSIT's Newark Light Rail

NJ TRANSIT's Newark Light Rail line from Newark to Grove Street has a double-track configuration (Figure 2-2) with intermediate interlockings. Bi-directional cab signaling with ATC speed control (without intermediate wayside signals) is provided on the main tracks, and the entire line (including all interlockings) is centrally-controlled by a CTC system.

**Figure 2-2**  
Newark Light Rail  
train at Silver Lake  
Station (freight  
operated on adjacent  
track on right)



The Newark Light Rail Line was extended to Grove Street in August 2002. The new segment of the line had an interlocking at which local CSX freight-train movements crossed and used a short portion of the transit line. Before these freight-railroad operations ceased in 2010, all components of the shared trackage were interlocked to vitally enforce the modal separation. As at NJ TRANSIT's River LINE, the interlocked protection is called SITS.

Under SITS, the vital signal-system circuits and the cab-signal ATC speed-control system forced passenger trains to stop short of any freight-train movement. Interlocked derails were strategically located to prevent freight trains from entering areas where passenger trains were operating.

## Tampa's TECO Streetcar Line (HART)

The HART historic-trolley TECO system, opened in October 2002, is a 2.7-mile-long non-signalized line with an at-grade interlocked crossing with the CSX Tampa Terminal Subdivision (Figure 2-3). Both rail lines have a single-track configuration at this automatic interlocking.

**Figure 2-3**

*TECO streetcar  
approaching Green  
Signal at CSX 14th  
Street automatic  
interlocking*



The CSX line is used by both Amtrak passenger trains and CSX freight trains. No railroad trains use the streetcar tracks, and no streetcars use the railroad tracks.

The automatic 14th Street interlocking uses conventional railroad signals to control movements of both railroad trains and streetcars and also uses conventional track circuits for train detection. At the interlocking, there are no derails and no form of train control on either the TECO Streetcar Line or on the CSX line. The automatic interlocking operation is based on first-come first-served logic activated by track-circuit occupancy of trains and streetcars approaching the interlocking.

There is no temporal separation between the railroad trains and the streetcars, and conflicting movements are separated solely by obedience to the operating rules and the interlocking signals.

## Oceanside-Escondido Sprinter (North County Transit District)

The NCTD Oceanside-Escondido Line is a 22-mile-long non-electrified LRT system extending from Oceanside to Escondido, California (Figure 2-4). The line began service in March 2008. The Sprinter line is shared with BNSF local freight-train operations under an FRA Temporal Separation waiver.

The Oceanside-Escondido Line has bi-directional ABS (without cab signals), and the entire line (including all interlockings) is centrally controlled by a CTC system.

**Figure 2-4***Sprinter Train at  
Oceanside Station*

photo provided by NCTD

The LRT trains are lighter-weight DMU vehicles and do not meet FRA buff-strength requirements. Because of this, the FRA waiver requires that the two (passenger vs. freight) vehicle types (the two modes) must be positively separated from each other.

The NCTD Sprinter FRA waiver requires temporal separation over the entire line (a complete shutdown of passenger-train operations to permit freight-train operations, and vice versa).

To provide modal separation, the Oceanside-Escondido Line was designed to include strategically-located interlocked derails to prevent freight trains from entering areas where passenger trains are operating, and vice versa.

The temporal separation on the Oceanside-Escondido Line is enforced only by operating rules and procedures. Once the human-based procedures are completed, the stop signals and derails provide the temporal separation. Aside for the foregoing, there is no technological enforcement of the modal separation.

## Santa Clara Valley Transportation Authority (VTA)

The Santa Clara Valley Transportation Authority (VTA) was issued an FRA shared-use waiver for the Winchester LRT line between San Jose Diridon Station and Campbell's Winchester Station. The Winchester LRT, which began service in October 2005, shares a corridor with the very-low-density Union Pacific Railroad (UPRR) Vasona Industrial Lead. The Vasona shared corridor is approximately 5.5 miles long, within which the VTA LRT line has a single-track

and double-track configuration and six stations. The UPRR Vasona Industrial Lead is single track within the shared corridor.

The VTA tracks within the shared corridor have bi-directional ABS, and the VTA mainline switches are all interlocked. The UPRR single-track Vasona Industrial Lead is non-signaled. This VTA line and the interlockings are controllable from the VTA's Operations Control Center (OCC) using a conventional CTC system. Figure 2-5 shows the general track configuration.

**Figure 2-5**  
Map of Santa Clara VTA Light Rail System  
(Winchester shared corridor shown in green)

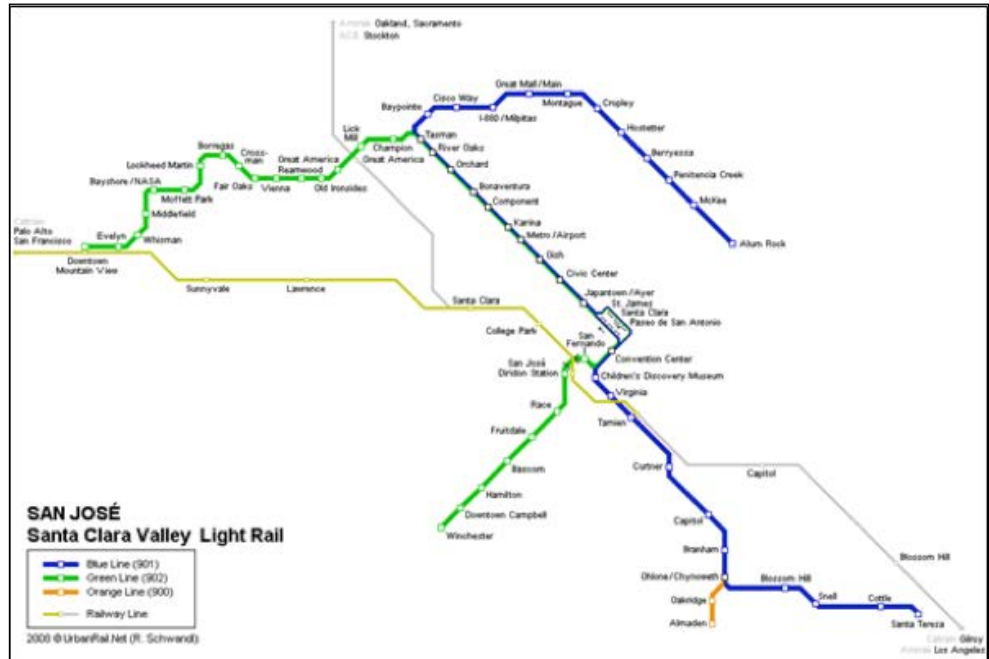

Graphic provided by Robert Schwandl and [www.urbanrail.net](http://www.urbanrail.net)

There are no connections between the LRT tracks and the freight track, but the track centers between the two rail lines within the shared corridor are generally less than 25 ft. Thus, there is a risk that a derailment of a freight train could foul an LRT passenger track.

The UPRR freight-train operations are very infrequent (Figure 2-6), typically one round-trip freight-train movement per week. The VTA LRT passenger trains operate from approximately 4:30 AM until 12:00 midnight, seven days a week.

**Figure 2-6**

*Union Pacific Railroad freight train operating over a track used at other times by VTA light rail trains*



Normally, when freight trains are not operating within the corridor, derails are installed on the freight track at each end of the shared corridor and secured in the derailing position. This permits VTA LRT trains to operate without any possible freight-train interference.

When the UPRR notifies the VTA OCC of an anticipated freight-train move through the shared corridor, VTA track personnel are dispatched to remove the freight-track derails. Coincidental with the process to remove the derails on the freight line, the VTA OCC notifies the VTA LRT trains of the anticipated freight-train movement and reminds the train operators of the special rules and speed restrictions governing LRT operations adjacent to a freight train. These risk-mitigation speed reductions are all based on human-based rules and procedures, for which there are no signal-system or other technological enforcements.

## Lackawanna County Historic Trolley

The Lackawanna County Historic Trolley Excursion (Figure 2-7) operates on an electrified single-track line segment from Scranton to Moosic, Pennsylvania, a distance of almost five miles. Now owned by Lackawanna County and operated by the short-line operator Delaware-Lackawanna Railroad (a subsidiary of Genesee Valley Transportation), the Historic Trolley Excursions share this single-track line with local freight-train operations.



There are no interlockings, signal systems, or control systems on this shared-use line. The Historic Trolley does not meet FRA buff-strength requirements. Because of this, the shared use is subject to an FRA shared-track waiver requiring that the two (trolley vs. freight) vehicle types must be temporally and positively separated from each other. This temporal separation is implemented using human-based rules and procedures as explained in Section 3 of this document. There are no technological enforcements of the temporal separation. The freight trains and trolley are scheduled and operated during defined and different time periods.

**Figure 2-7**

*Car 76 (J.G. Brill Co., 1926) exiting the refurbished Crown Avenue Tunnel*



Before permitting and during trolley operations, physical entry of conventional freight-train equipment to the shared trackage is prevented by the use of manually-applied special blocking devices at all access points along the route. These blocking devices ensure separation of the trolley and freight-train movements.

## Lessons Learned that May be Applicable When Using PTC for Enforcing Train Separations between Non-Compatible Train Types

Table 2-1 provides a comparison of the existing temporal separation waivers that were reviewed with respect to technological methods for enforcing the separation of non-compatible trains. The lessons learned from this comparison are provided below.

**Table 2-1**

*Comparison of Existing Temporal-Separation Waivers Reviewed, with Respect to Technological Methods for Enforcing Separation of Non-Compatible Trains*

<b>Rail-Line Attribute/ Rail-Line Waiver</b>	<b>NJ TRANSIT River LINE</b>	<b>NJ TRANSIT Newark Light Rail</b>	<b>Tampa TECO Streetcar</b>	<b>Oceanside-Escondido Sprinter</b>	<b>Santa Clara VTA</b>	<b>Lackawanna County Historic Trolley</b>
<b>Type Connection</b>	Two rail crossings, shared track at and between interlockings	Shared track within one interlocking (essentially a rail crossing with turnouts)	Rail crossing	Shared track	Shared corridor	Shared track
<b>Transit Trains</b>	Diesel LRT (DMU)	Electric LRT	Electric Historical Trolley	Diesel LRT (DMU)	Electric LRT	Electric Historical Trolley
<b>Railroad Trains</b>	Local freight	Local freight	Mainline passenger and mainline freight	Local freight	Local Freight	Local Freight
<b>Primary Method of Separating and/or Protecting Transit Trains from Railroad Trains</b>	Rail Crossings – Vital interlocking with some novel logic. // Shared Track – Vital interlockings, vital communications between interlockings, and novel route-locking logic involving multiple interlockings	Vital Interlocking	Vital Interlocking	Rules and Procedures	Rules and procedures	Rules and procedures
<b>Technological Enforcements for Separating Non-Compatible Trains</b>	Vital signal-system logic provides the following functionality: Electromagnetic-train-stop system enforces passenger-train compliance; interlocked derails enforce freight-train compliance	Vital signal-system logic provides the following functionality: Cab-signal ATC speed-control system enforces passenger-train compliance; interlocked derails enforce freight-train compliance	None – safety depends on train-operator obedience to signal-system aspects and indications	Interlocked derails are provided to enforce separation of non-compatible trains; however, proper positioning of derails depends on controller obedience to temporal-separation rules and procedures	None – safety depends on LRT train-operator obedience to rules and procedures, which require reducing speed when approaching and passing freight trains	None – safety depends on employee obedience to temporal-separation rules and procedures

As was found for NJ TRANSIT's River LINE and Newark Light Rail and for Tampa's CSX/TECO-Streetcar at-grade crossing (Figure 2-8), conventional-interlocking and signal-system logic can be used to provide Localized On-Demand Spatial Separation and vitally separate non-compatible train types at and within a single interlocking. This capability is currently possible using rather

standard route-locking logic when, and only when, the two train types (typically, lighter-weight passenger trains and railroad freight trains) have separate and different entry and exit points to and from the shared interlocking.

**Figure 2-8**

*Amtrak train crossing  
in front of waiting  
TECO streetcar at  
CSX Tampa 14th  
Street automatic  
interlocking*



Photo provided by Troy Nolen

As also was found for NJ TRANSIT's River LINE, novel and more sophisticated interlocking and signal-system logic can be used to provide a more global On-Demand Spatial Separation and vitally separate non-compatible train types at and between multiple successive interlockings. This capability is currently possible using vital communications between adjacent interlockings and route-locking logic when and only when the two train types have separate and different entry and exit points to and from the shared trackage.

These proven and vital (fail-safe) train-separation capabilities have eliminated the need for very inefficient time-based temporal-separation schemes requiring that the two train services be restricted to operate during different time periods. In addition, and as demonstrated on the River LINE and Newark Light Rail, the train separations can be implemented not just by vitally displaying red signal aspects, but the train separations also can be enforced by such technologies as electromagnetic train stops, cab-signal systems in concert with ATC speed enforcement, and by the forced-positioning (using route locking) of interlocked turnouts and derails.

Since the primary PTC systems in the U.S. (ACSES, I-ETMS, and ITCS) are all overlays on top of conventional railway signal systems, the signal-system enforcement techniques described herein should be considered for inclusion in PTC-based train-separation solutions, as and where appropriate. The data collected reminded the study team that each shared-use operation that is reviewed by FRA for a possible waiver is evaluated individually, and the approved safety requirements can be somewhat different from other approved-waiver scenarios.

For instance, at the CSX/TECO-Streetcar interlocked crossing in Tampa, no derails or form of train control are provided on either line. This is very much different than what was found on the NJ TRANSIT River LINE and the Newark Light Rail system, where the approved SITS schemes include both interlocked derails and a form of train control such as electromagnetic train stops or continuous cab signaling with ATC speed control.

Another example of diverse waiver scenarios is that on the NJ TRANSIT River LINE, passenger trains are allowed to operate at normal speeds when the track centers between an adjacent freight-railroad track are only 17 ft. apart (without an Intrusion Detection System being required), as shown in Figure 2-9. However, on the VTA's Vasona shared corridor, the passenger and freight tracks appear to be much further apart than 17 ft., but the passenger trains are restricted to rather low speeds when passing a freight-train.

**Figure 2-9**  
*NJ TRANSIT's River LINE currently has the most sophisticated technological protections for enforcing On-Demand Spatial Separation between non-compatible train equipment*



Photo provided by Bob Vogel

These observations indicate significant lack of consistency in regard to parallel-track operations on the same rail system involving lighter-weight passenger trains and conventional-railroad passenger and freight trains. Each case will need to be evaluated on its own merits in regard to protection required between trains on parallel tracks of the same rail system (shared track) as a function of the track-center distance between lighter-weight passenger trains and conventional railroad trains. In this context, lighter-weight passenger trains include typical LRT and DMU transit trains and also include modern railroad-type passenger trains designed to specific crashworthiness-performance levels. Any system that will mitigate or prevent same-track collisions such as PTC systems should reduce the need for drastic speed reductions on adjacent tracks. These parallel-track issues are evaluated in report Section 4.

## SECTION 3

# Functionality of Existing PTC Systems

This section describes the existing North American PTC systems that are being investigated in this study for the purpose of determining how they can be modified and/or enhanced to provide and enforce Temporal Separation and On-Demand Spatial Separation between conventional railroad trains and lighter-weight passenger trains.

## Background

The movement towards PTC essentially began in the mid-1980s with the Advanced Train Control Systems (ATCS) project. The Association of American Railroads (AAR), the Railway Association of Canada, many member railroads from both organizations, and a large number of railroad-industry system suppliers joined together in a monumental effort to identify the needs of and functions for new, modern, and future train control systems. The primary objective of that project was to establish a set of standards for new North American train-control systems. As originally envisioned, ATCS was to be so “robust” that it would eliminate the need for existing and conventional wayside signal systems, a very elusive goal that has not yet been achieved.

The early ATCS work established that there were a great many differing opinions within the railroad industry, primarily because of the wide range of existing operating conditions and functional needs. However, there was near unanimity in the 1980s that conventional ATC cab signaling with speed control should not be part of the new and modern ATCS systems, but that the ATCS systems should replace these well-established wayside-based signaling and train-control systems. Industry opinions have changed somewhat in recent years because of experience gained during a number of projects. It was subsequently determined that cab-signal systems can be valuable (but not necessary) components of modern PTC systems.

The then-existing railroad operating environments included a variety of archaic and contemporary up-to-date signaling and control systems:

- Non-signaled “dark” territories on which trains are “controlled” and separated by human-based procedures per railroad operating rules
- Basic ABS, including unidirectional ABS, bidirectional ABS with overlaps, and Absolute Permissive Block (APB)
- Controlled Manual Block signaling
- Traffic Control Systems (TCS) with Centralized Traffic Control (CTC)
- Intermittent inductive Automatic Train Stop (ATS) systems

- Continuous cab signaling, both with and without intermediate wayside signals, and both with and without ATC speed control and enforcement

TCS, CTC, ATS, cab signaling, and ATC are not standalone systems but are overlays and additional safeguards on top of traditional fixed-block track-circuit-based wayside signal systems. For instance, TCS, CTC, and continuous cab signaling with ATC have been installed on many rail lines that have basic and underlying ABS wayside signaling.

The types of railroad territories in North America are quite varied and include single-track and multiple-track lines, simple and complex interlockings, and traffic densities ranging from a few trains per day to very-high-density commuter-railroad networks and intercity corridors. Railroad operating environments include urban and suburban areas, rural plains, long tunnels, and rail lines in very remote and mountainous regions.

The ATCS project's technical progress was relatively slow. Varying levels of ATCS application and functionality were defined, and ATCS communication protocols were developed. However, there was a wide range of views as to what functions should be included under the ATCS umbrella and how (including whether vitally or non-vitally) the functions should be implemented. The original ATCS project led to a number of initiatives, tests, pilot programs, and demonstrations in the United States and Canada. It also became apparent that relatively inexpensive satellite-based technologies such as Global Positioning System (GPS) might become an important technological component for locating trains.

During 1994, the AAR and RAC abandoned their commitment to ATCS, with only a limited number of technical standards having been developed. However, this did not stop the industry's quest for new technologies to meet the operational and functional needs. The national emphasis on passenger high-speed intercity rail was a catalyst for continuing the development of new and cost-effective train-control systems, although at a much slower pace.

In 1996, FRA established the Railroad Safety Advisory Committee (RSAC) to develop new regulatory standards, through a collaborative (RSAC) process, with all segments of the rail community (rail carriers and the labor crafts in concert with FRA) working together to fashion mutually-satisfactory solutions on safety regulatory issues. Specifically, a primary purpose of RSAC was to "seek agreement on the facts and data underlying any real or perceived safety problems; identify cost-effective solutions based on the agreed-upon facts; and identify regulatory options where necessary to implement those solutions."

On September 12, 2008, a tragic head-on collision occurred in Chatsworth, California, between a Metrolink passenger train and a Union Pacific freight train. The passenger train passed a non-enforced stop signal at an interlocking, resulting in the head-on collision with 25 fatalities, 135 injuries, and significant

property damage. In response to this very serious and high-profile accident, Congress passed the Rail Safety Improvement Act of 2008 (RSIA08). Subsequently, FRA enacted regulations to implement the requirements and intent of RSIA08, and these FRA regulations are codified in 49CFR Subpart I (hereinafter called the FRA rules/regulations).

The first three of the basic functional requirements for PTCI included in RSIA08 were developed by the RSAC process. The fourth basic functional requirement was developed later because of the January 6, 2005, Norfolk Southern collision, derailment, and hazardous-materials release that occurred in Graniteville, South Carolina, due to a wrongly-positioned switch in non-signaled territory.

## What is PTC?

In 1994, FRA first introduced the term “Positive Train Control.” This term initially referred to technology that can intervene to prevent train collisions, control a train’s speed, and ensure that trains operate within authorized limits.

The latest PTC definition is from the Rail Safety Improvement Act of 2008 and Section 104 thereof—“The term ‘positive train control system’ means a system designed to prevent train-to-train collisions, over-speed derailments, incursions into established work zone limits, and the movement of a train through a switch left in the wrong position.”

Per FRA Rule 236.1005, and subject to certain caveats, exceptions, and additions, PTC requirements generally apply to railroad mainline trackage over which:

- freight trains carry any quantity of material that is a Poison Inhalation Hazard (PIH) or Toxic Inhalation Hazard (TIH), and/or
- intercity or commuter passenger trains regularly operate.

Most rail-transit systems are not subject to FRA regulations.

RSIA08 (also known as the PTC law) and associated FRA regulations (also known as the PTC regulations) require that the affected railroad lines have fully-functioning and operational PTC systems for all trains and territories by December 31, 2015. The owner of the trackage is responsible for ensuring that all tenant-railroad trains operating over the owner’s trackage have onboard systems that are compatible and/or interoperable with the host railroad’s PTC system.

The basic functional requirements for PTC systems were identified in the RSIA08 law and include preventing mainline train-to-train collisions, overspeed derailments, unauthorized incursions into work zones, and train operation over improperly positioned switch or derail.

### PTC Timeline

**1984** – Original ATCS project initiated by AAR and RAC. During the ensuing years, this project spurred several developments, prototypes, demonstrations, and pilot projects by both suppliers and railroads, few of which survived the original conception.

**1987** (January 4) – Fatal collision between Amtrak passenger train and Conrail locomotives at Gunpow Interlocking in Chase, Maryland.

**1993** – Amtrak begins discussions with FRA on the ACSES project to enhance the Northeast Corridor (NEC) ATC system for High Speed Rail (HSR) operation up to 150 mph.

**1994** – AAR and RAC significantly reduced their commitment to ATCS. FRA then introduced the term Positive Train Control (PTC) and announced creation of grant funding for a qualifying new-start demonstration project for PTC, inviting vendors, states, and railroad carriers to collaborate in competition for the grant. Amtrak, Michigan DOT, and Harmon Electronics won a significant portion of the grant, and the ITCS project was launched on the Amtrak-owned corridor in southwest Michigan in 1995.

**1996** (February 16) – Fatal side-collision between MARC commuter train and Amtrak intercity train at Silver Spring, Maryland. (February 20 and 29) – FRA issues Emergency Order No. 20, which included the Delay-in-Block rule. FRA established the Railroad Safety Advisory Committee (RSAC) to develop new regulatory standards, through a collaborative process of carriers, unions and FRA.

**1998** – FRA, IDOT, and AAR embarked on the North American Joint PTC (NAJPTC) project for the Chicago-St. Louis Corridor.

**2000** – Amtrak's ACSES system first deployed on the Northeast Corridor with Acela operating 150 mph.

**2002** – Amtrak's ITCS system in full revenue service in Michigan at 79 mph, eventually leading to full revenue service operation at 110 mph on February 7, 2012, after many improvements.

**2003** – BNSF awarded ETMS pilot project to Wabtec Railway Electronics.

**2005** (January 6) – Graniteville, South Carolina, collision, derailment, and hazardous-materials release due to wrongly-positioned switch in non-signalized territory.

**2006** – IDOT withdrew from NAJPTC project because no sure end in sight.

**2007** (January) – FRA approved BNSF's ETMS system.

**2008** (September 12) – Fatal head-on collision between Metrolink commuter train and UPRR freight train at Chatsworth, California.

**2008** (October 16) – Rail Safety Improvement Act of 2008 signed into law.

**2010** (April) – Deadline for railroads to submit their PTC Implementation Plan.

**2015** (December 31) – PTC must be fully operational on prescribed railroad lines.

*Note – This PTC timeline is brief and incomplete. Much significant information has been omitted in the interest of brevity and simplicity, including train accidents, technology developments, etc.*



## Advanced Civil Speed Enforcement System (ACSES)

The ACSES PTC system was developed by Amtrak for the Northeast Corridor and to support increasing train-operating speeds up to 150 mph. ACSES has been designed to be a vital overlay to and on top of conventional wayside signal systems that include continuous cab signaling and onboard speed control. In fact, the cab signaling and speed control are important components of the overall ACSES PTC system, as illustrated by the definition  $ATC + ACSES = PTC$ . ACSES, by itself, does not provide all of the required PTC functions.

ACSES can be characterized as being a distance-to-go or speed-location profile-based enforcement system. ACSES has been deployed by Amtrak and is operational on the Northeast Corridor, and additional enhancements are being developed. ACSES is also being adopted by many commuter host railroads in the Northeast U.S., including commuter carriers MBTA, Metro-North, LIRR, NJ TRANSIT and SEPTA. Additional tenant railroads and entities that have operated and/or will operate over ACSES trackage include ConnDOT's Shore Line East, freight carriers CSX and P&W, and commuter carrier MARC.

It is interesting to note that ACSES is already being used on the Northeast Corridor for operating speeds up to 150 mph, which is currently being upgraded to 160 mph. As of now, there are no known plans to use any of the other U.S. PTC systems for such high-speed operations.

### ACSES Functionality

ACSES implements the required PTC functions as described in the following subsections.

#### *Train-to-Train Collisions*

Preventing train-to-train collisions under ACSES is generally accomplished by enforcing trains to stop short of signals displaying (positive/absolute) stop. This, in concert with standard vital interlocking logic, prevents collisions at interlockings between trains on conflicting routes; because of typical vital traffic-direction locking associated with bidirectional signaling, stop-signal enforcement also prevents collisions between opposing trains.

ACSES does not prevent collisions with same-direction preceding trains, but the maximum speed of any such following-train collision (because of failure to obey signal rules) is limited by the cab-signal system and on-board speed-control functionality to a maximum speed of 15 or 20 mph (depending on the speed-control governor setting for Restricted Speed). This feature is permitted by FRA Rule 236.1005(f), which is applicable to all PTC systems. Having PTC systems

allow following close-in movements at Restricted Speed is a characteristic not only of ACSES, but is also a basic feature of I-ETMS and ITCS.

Under ACSES, a train's on-board computer (OBC) learns about signals on the route ahead by redundant transponders and redundant transponder messages. These transponders and messages identify each specific signal ahead in the train's route (that can display positive stop), and the distance and worst grade between the transponder and the specific signal. Using this information, the train's OBC establishes and enforces profiles for ensuring that the train will stop before passing any signal displaying stop.

ACSES does not provide any enforcement functionality for so-called intermediate signals whose most restrictive aspect is more favorable than stop. When these signals display an aspect such as Stop-and-Proceed or Restricting because the block is occupied, the cab-signal system and associated ATC speed-control functionality (which is part of the overall ACSES PTC solution) enforce trains to proceed at not exceeding 15 or 20 mph, as previously discussed. This is also true for occupied blocks when ACSES is used in cab-signal territory not having intermediate wayside signals. However, when ACSES is used without cab signaling, trains are enforced to stop for each and every intermediate signal when the signal's block is occupied.

Once the train's OBC learns about a specific signal ahead, the stop-enforcement profiles are immediately and automatically generated and placed into effect. The presence of a favorable cab-signal code rate in the rails and the successful on-board decoding of the cab-signal code rate (which vitally prove that the signal is not displaying stop) override the stop-signal enforcement. Thus, the normal technical mechanism by which a train is able to pass a cleared signal is the receipt of a proceed cab-signal code rate in the rails while approaching and operating up to the cleared signal's location. Under ACSES, code change points (CCPs) must be provided sufficiently in advance approaching each and every stop signal, so that the cab-signal aspect drops to Restricting before reaching a stop aspect.

For some cleared-signal scenarios, the cab-signal aspect drops to or is at Restricting before the train reaches the cleared signal. The transponders approaching an interlocked signal provide trains with the necessary radio-contact information for initiating data communications with the interlocking and determining the statuses of the specific signals being approached. In these relatively-few cases where there is no favorable cab-signal code rate in the rails approaching a cleared signal, the train must receive a data-radio release message that the specific signal is indeed displaying a proceed aspect before the train is able to pass the cleared signal. The data-radio release messages are always transmitted and provide a backup in case of the failure scenario when a favorable cab-signal code rate is not transmitted in the rails and/or is not decoded on-board the train.

Figure 3-1 shows the part of the train control panel with speedometer and combined ACSES and CAB signal display. This figure also shows that the train is approaching a 60-mph restriction and is being enforced down to that speed, as denoted by the red band. The train's instantaneous speed is 88 mph as it decelerates from a higher speed; hence, the overspeed indication (Figure 3-2). The red band and overspeed indication are not “official” ACSES indications. The “official” ACSES indications are also shown in Figure 3-2. These “unofficial” ACSES indications have been added by Amtrak to the non-vital speedometer display for the convenience of train engineers. In Figure 3-2, the cab signal is displaying Approach Medium with an ATC-enforced speed of 45 mph. The civil track speed limit per ACSES is 110 mph, but the 45-mph signal-system speed governs as indicated by the lighted orange square.

**Figure 3-1**

*Amtrak's on-board displays – speedometer (left of center) and combined ACSES and cab-signal display (on right)*



**Figure 3-2**

*Amtrak's ATC/ACSES display unit*



### *Overspeed Derailments*

ACSES protects against over-speed derailments by enforcing both permanent and temporary speed restrictions. This includes Maximum Authorized Speeds (MAS), Permanent Speed Restrictions (PSRs) (such as for curves), and Diverging

Speeds at interlockings. ACSES provides for up to five train types with each train type having different speeds and deceleration profiles.

Under ACSES, a train's OBC learns about MAS and PSR speeds on the route ahead by transponders and transponder messages. These transponders and messages identify each specific speed limitation ahead in the train's route and the distance and worst grade between the transponder and the point at which the speed becomes effective. Using this information, the train's OBC establishes and enforces profiles for ensuring that trains will be at or below the maximum permitted speeds before entering the restricted trackage.

Once the train's OBC learns about a specific lower-speed MAS or PSR restriction ahead, the deceleration-enforcement profiles are immediately and automatically generated and placed into effect. As already mentioned, different speeds and deceleration profiles can be specified for up to five different train types.

Diverging speeds at interlockings are transmitted to approaching trains via data radio along with the radio-release message that the signal is displaying a proceed aspect. More specifically, after the interlocking signal has been cleared, the data-radio message includes the maximum speed for the aligned route, any interlocking tracks that the lined route crosses, the exit track, and other pertinent information. When all train types do not have the same diverging speed (such as 45 mph for passenger trains but only 40 mph for freight trains), the lower speed is conveyed by transponders in the form of Route Dependent Speed Restrictions (RDSRs).

Temporary Speed Restrictions (TSRs) are entered into the Safety TSR Server by the Train dispatcher using a Select-Check-Execute scheme that requires the dispatcher to check his/her own work prior to executing it. The STS prepares vital files of all TSRs to be transmitted and delivered to the field via the data-radio network. As trains approach interlockings and other predefined locations, their OBCs (using data-radio contact information provided by transponders) request and receive the latest set of TSRs for the territories and interlockings immediately ahead of the train. TSRs typically include the affected track number, the speed(s) to be enforced, and the beginning and end of each restriction. The train's OBC computes deceleration-enforcement profiles for each TSR received by radio.

While the TSR functionality is highly reliable, there is no guarantee that a train will always receive the latest set of TSRs or receive a recently-issued TSR. ACSES, therefore, depends on TSRs also being issued to trains using conventional procedures such as voice radio, and that train engineers will obey these mandatory directives regardless of the very reliable ACSES enforcement.

TSRs have also been implemented under ACSES by placing two or more portable temporary transponders within the gauge between the rails. Trains receiving TSRs in this manner are immediately forced to decelerate to the target speed. Because of this functionality, the field personnel must place the portable temporary transponders sufficient safe-braking distance away from the track condition being protected. This implementation of TSRs also requires portable resume-speed transponders at the end of the restriction. The temporary transponders for a condition are typically installed at the advance and resume signs for the associated TSR. The practice of using portable transponders for implementing TSRs is not expected to continue once data radio is widely available for transmitting TSRs.

As implied in the above discussion, a train's OBC receives and simultaneously enforces MAS, PSR, TSR, and Diverging Speeds, each and every type, including determining and enforcing the most restrictive speed at each and every location.

### *Unauthorized Incursions into Work Zones*

ACSES does not currently have so-called Employee-in-Charge (EIC) capability such that a work zone can be established by the train dispatcher and that trains will then be enforced to stop short of the work zone unless and until the EIC in the field using a remote terminal releases individual trains to operate through the work zone at normal speed or at some specific lower speed.

Under ACSES, work zones are typically protected by the train dispatcher using track, signal and/or switch blocking. Once and while these blocks are in place, ACSES will enforce trains to stop at the prior signal so they cannot enter the protected trackage. This is excellent protection for roadway workers, especially in high-density multiple-track territory having many and closely-adjacent interlockings.

### *Train Operation over Improperly-Positioned Switch or Derail*

For interlocked switches and derails, this protection is afforded by enforcing trains to stop short of signals displaying (positive/absolute) stop in concert with the standard field-based vital route-locking logic.

For non-interlocked switches and derails, and because of the standard field-based vital circuits, the cab-signaling and ATC speed-control feature will enforce trains to not exceeding the 15- to 20-mph Restricted Speed, which functionality is permitted by FRA Rule 236.1005(e).

### *Improperly-Positioned Switch or Derail Not in Train's Route*

This additional PTC requirement does not apply to interlockings because all stop signals at interlockings will be enforced, and because standard vital interlocking logic ensures that all switches and derails (both on and off the route) are properly aligned for a cleared signal and route.

For non-interlocked switches and derails that are not in the train's route, but which could permit rolling equipment to foul the main track and the train's route if left in the wrong position, the wayside signal-system circuits will be arranged (if not already arranged) so that the main-track route will be effectively "shunted" by the improperly positioned switch or derail. This, in turn, will cause the cab-signaling and ATC speed-control feature to enforce trains to not exceeding the 15- to 20-mph Restricted Speed.

### *Mandatory Directive for Highway-Rail Grade-Crossing Warning-System Malfunction*

Under ACSES, TSRs will be implemented by the train dispatcher to enforce mandatory directives issued for highway-rail grade-crossing warning-system malfunctions. For one railroad employing ACSES, this will be accomplished as follows:

- For mandatory directives requiring Restricted Speed, a 15-mph TSR will be placed into effect for both directions from a point prior to the grade crossing, through and to a point past the grade crossing.
- For mandatory directives requiring stop-and-warn, a special "Stop & Release" TSR will be placed into effect for both directions. For the "Stop & Release" TSRs, ACSES will enforce a full stop prior to the grade crossing. ACSES will not allow the brakes to be released until after the train has stopped short of the crossing. After the enforced stop, trains will be enforced to not exceeding 15 mph until the train's headend reaches a point past/beyond the crossing.

### *Movable Bridge Not Properly Closed and Locked*

Movable bridges (Figure 3-3) are virtually always interlocked. Under ACSES, it is expected that all movable bridges (on tracks required to have PTC) will be interlocked. The standard vital interlocking logic will prevent signals governing movement over a movable bridge from being cleared unless the bridge is properly positioned and locked. If a movable bridge is not properly positioned and locked, ACSES will force trains to stop short of the interlocking signals protecting the bridge, as previously described.

**Figure 3-3**  
 Open bridge – FRA  
 concern and PTC  
 requirement



### *Special “C” Signal Functionality*

ACSES is being used by several railroads for territories and trackage not having intermediate wayside signals. Between interlockings and controlled signals on these lines, trains are governed solely by the cab-signal indications. Trains with operative cab signals need only receive a proceed cab signal or the basic data-radio release message to pass a cleared interlocking signal.

For trains with inoperative cab signals where signals govern the entrance to tracks without intermediate wayside signals, trains with cab-signal failures are forced to stop for cleared signals unless the data-radio release message also indicates that the signal is displaying an absolute-block aspect because the track is clear to the next interlocking. On Amtrak, the absolute-block aspect is conveyed by the auxiliary “C” light indicating Clear to Next Interlocking. On Metro-North and the LIRR, the absolute-block aspects are displayed on the regular signal head(s) using unique flashing aspects. (The data-radio release message for a cleared signal establishes whether the special C functionality applies to the route that is aligned, and if it does, whether or not the track is unoccupied to the next interlocking.)

### *ACSES Application without Cab Signaling*

LIRR is installing ACSES on two branches having ABS signaling without cab signaling. This is being accomplished by essentially treating each block between successive signals as an interlocking. Since there is no cab-signal code rate in this non-cab-signal territory approaching a cleared signal, a train can pass a cleared signal only if the data-radio release message for that signal is received. The data-radio release message is withheld for Stop-and-Proceed and Restricting wayside aspects, and is only transmitted when the signal displays the Approach or more favorable aspect indicating that the block is unoccupied.

Unless an approaching train receives the data-radio release message indicating an unoccupied block, the train is enforced by ACSES to stop short of the signal (even though it is displaying a Stop-and-Proceed or Restricting wayside aspect).

### *Stop Release Push Button*

The Stop Release Push Button (SRPB) is being provided to allow a train when necessary (such as because of signal-system or ACSES failures) to pass a stop signal, to pass a cleared signal without receiving a cab-signal code rate or data-radio release message, for a train without operative cab signals to pass a C signal without first receiving the special “clear to next interlocking” data-radio message, or to pass a Stop-and-Proceed or Restricting wayside aspect governing a block not having cab signaling. Once the SRPB is operated, ACSES restricts train speed through the interlocking to not exceeding the 15- to 20-mph Restricted Speed. It is expected that the SRPB will be sealed and used on rare occasions subject to obtaining permission of the train dispatcher.

### ACSES Pertinent Insights

An ACSES block diagram is provided in Figure 3-4. For convenience, this block diagram also shows the independent CTC control of interlockings by train dispatchers from the central office.

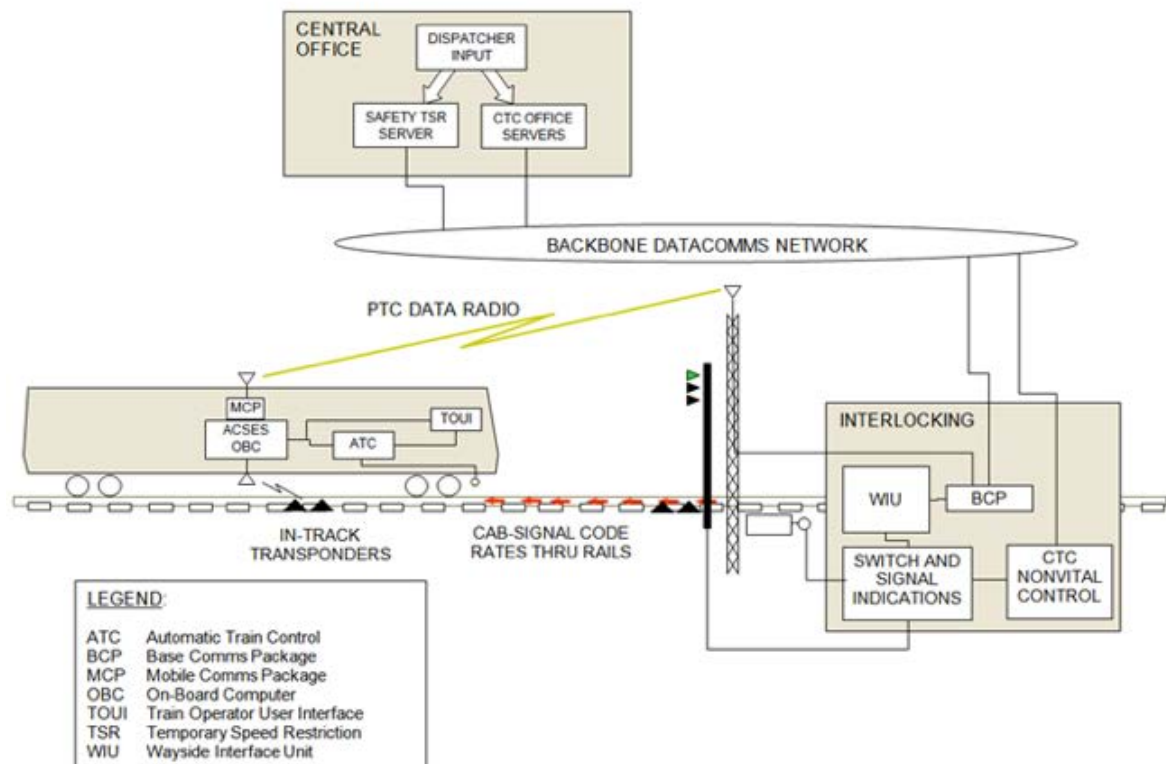

**Figure 3-4** ACSES block diagram



In considering how ACSES can be used to provide and enforce Temporal Separation and On-Demand Spatial Separation between conventional railroad trains and lighter-weight passenger trains, several issues must be considered. These issues all involve the same conceptual theme—currently, ACSES has not been designed to vitally bring knowledge into a central computer about “what types of trains are where.” While individual trains can and do know their “types” through on-board firmware, the existing ACSES designs do not cause this information to be transmitted (in useful formats) to the wayside interlockings or to the central office.

The ACSES central-office-based Safety TSR Server has been designed to accept (from the train dispatcher), implement and transmit TSRs to the field. This central-office-based ACSES equipment has no knowledge about what trains and types of trains are where.

While the office-based CTC equipment does receive and have available the non-vital signal, switch and track-circuit indications, this dynamic data does not include any useful train-ID information that can be used for safety applications. Additionally even though many modern CTC control facilities have office-based train-tracking capabilities, the train IDs are typically manually assigned. In virtually all cases where train IDs are displayed in the central office, train occupancies are “tagged” in the central office using human-based manual techniques, and the reliability of these office-based train-tracking IDs is not deemed reliable enough for use in providing separation between non-compatible train types.

While it is technically possible to automatically obtain train-ID data in the field for transmission to the central office, this field-based train-ID capability has not been widely provided in American railroading. The ACSES vital wayside logic and equipment at interlockings also does not have useful knowledge about what trains and train types are where. When a train is communicating with an interlocking via the data radio, the train does report its engine or controlling-unit number (not its train number) through the various radio base-station locations, and this information is logged non-vitally in network servers. This permits rudimentary tracking of trains from one radio base station to another. However, the ACSES wayside equipment has not been designed to request, receive, or maintain such dynamic data for safety-related purposes.

In summary, while ACSES is very capable of enforcing stop signals and speed restrictions, and implementing the other PTC mandates, ACSES currently lacks (both in the central office and on the wayside) highly-reliable train-ID and location data, which types of data are believed needed to implement On-Demand Spatial Separation between non-compatible train types. These issues will be further explored during later tasks as work is done to develop PTC prototype solutions for enforcing On-Demand Spatial Separation between non-compatible train types.

## Incremental Train Control System (ITCS)

ITCS was developed by Harmon Electronics [later taken over by General Electric Transportation Systems (GETS) and Amtrak to support increased train-operating speeds up to 110 mph in the Emerging Corridors such as Amtrak's Chicago–Detroit–Pontiac and Port Huron Corridor, where lack of some form of train control had held speeds to a maximum of 79 mph for more than six decades. This situation had resulted from a 1947 Interstate Commerce Commission (ICC) mandate requiring train control to support speeds 80 mph or greater. (The ICC, reporting to Congress, was responsible for rail safety until FRA inherited this function, placing this responsibility under the Secretary of Transportation.)

Prior to this mandate, streamlined trains had commonly served the Midwest at speeds of 100 and even 110 mph.

Amtrak's 97-mile Michigan Line (the AML) between Porter, Indiana, and Kalamazoo, Michigan, was owned by Amtrak, and the State of Michigan was seeking to upgrade the service to Chicago to reduce future congestion on I-94. Thus, the AML became the ideal laboratory to develop this vital overlay system for revenue service and bring it to maturity over a 17-year period.

ITCS can be characterized as being a distance-to-go (or speed-location profile-based) enforcement system similar to ACSES, but with different input sources. Deployed on Amtrak's AML since March 2000, ITCS has supported 110-mph operation over 80 miles of the first 97 miles, Porter to Kalamazoo, since February 7, 2012, and became certified as a valid PTC system on December 27, 2012.

Amtrak, MIDOT, and GETS are currently in the process of extending the ITCS operation and 110-mph operation another 135 miles to Dearborn, Michigan, with Amtrak assuming the operation and maintenance of this line segment. This will result in 232 route miles of ITCS as the PTC system of choice for the extended AML.

ITCS is also currently being used in the Chicago–St. Louis Corridor in Illinois to advance start the highway crossing warning systems in a special "partial" deployment of the ITCS capability, officially known in the Illinois operations as "X-ITCS." This was the most economical means to provide the extended highway crossing warning times for the initial 20-mile, 110-mph revenue High Speed Rail (HSR) operation between Dwight and Pontiac, Illinois, which began on November 22, 2012.

FRA proposed to award one or two grants in the early fall of 1994 to develop a then non-existing "cutting-edge" train control system. The driving force behind this offer was two-fold:

1. To re-kindle the industry's enthusiasm to pursue new forms of train control, just as the ATCS effort was dying.
2. To develop an affordable train control system to meet the needs of the "Emerging" Corridors outside the NEC, to "break the 79 mph barrier" where there were very few miles of line equipped with any form of train control or train stop.

These grants specifically were NOT to be awarded in the NEC, but were purposed to encourage improved technology and passenger services outside the NEC, as the NEC was already on its way to full HSR service up to 150 mph.

Amtrak and Harmon (later GETS) partnered with Michigan DOT in late 1994 and submitted their joint proposal in January 1995, and, winning a significant grant award, installation of ITCS began in late 1995. There was a 100-mph test demonstration in October 1996; the ITCS CLD (Compact Locomotive Display) was first implemented in regular revenue service in March 2000, and penalty brake enforcement was added at the existing 79 mph maximum speed in April 2001.

As Amtrak's and FRA's confidence in the new system increased, daily revenue train speeds were gradually raised to 90, then to 95, and finally to 110 mph on February 7, 2012. Full certification for the ITCS application on the AML as a compliant PTC system was received by Amtrak on December 27, 2012.

### ITCS Functionality

ITCS has been applied on the AML to be a vital overlay to enhance and enforce the existing wayside CTC signal system. The overall ITCS PTC system, as illustrated by the definition  $CTC + ITCS = PTC$ , provides all of the required PTC functions. All real-time signal inputs to a train's OBC in Amtrak's application come directly from the CTC wayside signal locations through WIUs (Wayside Interface Units) and forwarded to Wayside Controllers that concentrate and transmit data radio Status Update Messages (SUMs) at six second intervals.

Unlike ACSES, ITCS picks up its principal infrastructure database over data radio prior to departure at the train's initial terminal, and then verifies each 5–7 mile Wayside Controller section of the database over data radio as it approaches the corresponding section along the right of way. This is contrasted with ACSES, which picks up its entire static infrastructure database incrementally, a little bit at a time, in transponder set size "bites," to carry the OBC from one transponder set to the next. It is also contrasted with I-ETMS, which needs to have the entire static database updated periodically from the central office.

The ITCS data radio SUMs every six seconds provide the dynamic input to the OBC for the on-board display and enforcement of the underlying signal system speeds, closely resembling the similar functionality of the ATC in the NEC

PTC applications. However, these same SUMs also include the permanent and temporary speed restrictions and the GPS differential adjustment factor. This is contrasted with ACSES which uses a combination of transponder and data radio messages to perform these functions.

ITCS implements the required PTC functions as described in the following subsections.

### *Train-to-Train Collisions*

Preventing train-to-train collisions under ITCS is accomplished by enforcing trains to stop short of signals displaying (positive/absolute) stop. This, in concert with standard vital interlocking logic, prevents collisions at interlockings between trains on conflicting routes. Because of typical vital traffic-direction locking associated with bidirectional signaling, stop-signal enforcement Positive Train Stop (PTS) also prevents collisions between opposing trains.

ITCS does not prevent collisions with same-direction preceding trains, but the maximum speed of any such following-train is limited by ITCS on the AML to a maximum speed of 20 mph outside of interlockings and 15 mph within interlockings in accordance with the NORAC Rules definition of Restricted Speed. This is very similar to NEC PTC (ATC/ACSES).

This feature is also permitted by FRA Rule 236.1005(f), which is applicable to all PTC systems. Having PTC systems allow following close-in movements at Restricted Speed is a characteristic not only of ITCS, but is also a basic feature of I-ETMS and ACSES. This fundamentally derives from the universal U.S. practice of permitting following movements at Restricted Speed into occupied blocks in ABS territory and between Interlockings and Controlled Points in CTC territory.

Under ITCS, a train's OBC receives real time signal changes on the route ahead by SUMs every six seconds. These messages, which are created entirely by the Wayside Controller for each section, include all of the real-time PTC data required by trains approaching and passing through that section. These data include the identity of each specific signal ahead in the train's route and the distance and worst grade approaching that specific signal. Using this information, the train's OBC establishes and enforces profiles for ensuring that the train will stop before passing any signal displaying stop.

At intermediate signals whose most restrictive aspect is Stop-and-Proceed, ITCS releases the stop requirement after 20 seconds of no motion. The train is then restricted to not exceeding 20 mph while displaying the Restricted Speed requirement throughout the entire block to the next intermediate signal. The CLD (ITCS display) cannot be upgraded mid-block, as unlike ATC, ITCS has no capability to look at the rails to see when the last axle of the preceding train has

cleared the entire block once the following train has entered the same block with its leading axle.

When the SUM conveys a target location for a stop or beginning of a speed reduction, it is compared with the actual location of the train and the actual train speed, and at the required braking point the enforcement braking profiles are immediately and automatically generated and placed into effect. For passenger trains, 30-second advance warning is given with a TTP (Time to Penalty) countdown. Freight trains have much longer TTPs to provide the engineer with extra time for train handling. In ITCS, these warning times, once established for each train type, are essentially the same for all targets, whether signals requiring stop or reduced speed, or permanent or temporary speed restrictions.

ITCS also differs from ATC in that the calculated enforcement profiles require reduction to the speed required by the aspect of each signal prior to accepting (passing) that aspect, rather than immediately following the acceptance of the same aspect, as is the case in ATC territory. ITCS does not display signal aspects in the same way that Amtrak's ATC does, but, instead, displays the speeds required at the target, and an explanation of the nature of the target, e.g., "HOMESIG" for a home signal, "AUTOSIG" for an intermediate Automatic signal, "XING" for a highway crossing, "TMP SPD" for a temporary speed restriction, etc. These seven-character target display possibilities are all spelled out in the ITCS Rules for the edification of the engineers that operate in ITCS territories.

Further, ITCS differs from I-ETMS, as the ITCS OBC receives all real-time data concerning PTS, Speeds approaching signals other than Stop, PSR, and TSR restrictions in the SUM from the WIUs through the Wayside Controller for each section, but I-ETMS receives this information from two different sources. In I-ETMS, Signal Status is from the wayside WIU, and the other data come from the BOS (Back Office Server) commingled with the periodic static infrastructure database update, including both permanent and temporary speed restrictions.

### *Overspeed Derailments*

ITCS protects against over-speed derailments by enforcing MAS, PSRs, and TSRs. MAS and PSRs are part of the fixed database carried by the OBC from the initial terminal and verified through the Wayside Controller in each section of the line. TSRs for each section are conveyed from the dispatcher to each Wayside Controller section through the ITCS "OWL" (Office-Wayside Link) and delivered to each train as a portion of the SUM delivered every six seconds to each train approaching and traveling through the section.

Figure 3-5 is a photograph of Amtrak's ITCS CLD and the control panel in the cab of a P-42 diesel locomotive. Figure 3-6 shows a close-up image of the CLD.

The CLD shows the actual and authorized speeds with other digital information, when needed. Of note are the following aspects of the CLD:

- Green (left) and yellow (right) LED fields under “SPEED” are for maximum (left) and actual (right) speed display.
- The next two lines are red LEDs for “Target” display; upper left is the target speed and upper right is the TTP and the second line is the distance to the target in ft.
- The third (green) field under “TARGET” displays the ITCS type of target, e.g., “HOMESIG,” “AUTOSIG,” “TMP SPD” or “XING,” which are all defined in the ITCS Rules and displayed in this 7-character LED window.
- The bottom window is the LCD (liquid crystal display) and used for train type selection, departure test, and for other convenient en-route information, e.g., current mile post location.
- The buttons serve various purposes, e.g., initiate departure test and stop override.

**Figure 3-5**

*Amtrak’s ITCS CLD, mounted to right of windshield in cab of P-42 diesel locomotive*



**Figure 3-6**

*Amtrak’s ITCS CLD*



The current ITCS application on the AML provides for selection from a number of train type configurations prior to departure from the initial terminal. The selections include several passenger and several freight train engines, including light engines, and, like ACSES, the selection made is locked in by successful completion of the departure test. Unlike ACSES, the ITCS Train Type selection is made from a look-up table through an interactive LCD window near the bottom of the CLD.

ITCS speed restriction enforcement profiles calculated by the OBC for MAS, PSRs, and TSRs are initiated and provided in the same manner as the profiles created for signal enforcement, explained previously, and all input comes from the ongoing SUMs and the ongoing LDS (Location Determination System) position.

Unlike ACSES, the ITCS LDS position on the track is determined from input from GPS and a database conversion table from GPS latitude-longitude coordinates to the equivalent and more useful mile post and chaining values. These values are compared to the values received from axle or traction motor bearing tachometers as a check on the accuracy of the GPS location and to keep the location updated through brief periods of loss of GPS accuracy due to an insufficient array of GPS satellites in view. The GPS, in turn, continues to correct the tachometer to accommodate wheel wear.

Unlike most, if not all, other GPS-dependent PTC systems, ITCS has its own built in redundant safety check with its own internal GPS differential correction feature, secured by comparing two separately-mounted GPS receivers at each wayside controller station to ensure the correct correction factor is included in the SUM. In addition, two separate GPS receivers are included on each engine (and controlling cab cars) and compared to ensure that any unsafe failure of either receiver will be detected. As all GPS receivers are non-vital, with the possibility of any receiver failing unsafe, this is a significant safety check on-board, with a very low risk of both receivers failing in the same way at the same time.

While the TSR functionality is highly reliable, there is no guarantee that a train will always receive the latest set of TSRs or receive a recently-issued TSR. ITCS, therefore, depends on TSRs also being issued to trains using conventional procedures, including voice radio directives written down by a qualified crew member on paper forms and that train engineers will obey these mandatory directives regardless of ITCS enforcement.

As a safety feature, each SUM must have a TSR portion of the message, either with actual TSRs or the confirmation that there are no TSRs for the section. This feature is used to notify the engineer through the display, with an accompanying alarm that must be acknowledged, that the ITCS TSR information for this section

has not been verified and that ITCS cannot be relied upon to enforce TSRs in the section.

When this condition exists, 79 mph will be enforced, but the engineer is required by ITCS Rule to reduce to 40 mph approaching the section and further reduce to Restricted Speed within the section, until he has verbally checked TSRs in his possession with the dispatcher to ensure he has all of them. He is then permitted to resume 79 mph, observing all TSRs he has on paper.

This feature in ITCS is very similar to the “NO VALID TSR DATA” indication and alarm requiring acknowledgement when the same problem arises in ACSES due to a temporary failure of the data radio system. The advantage of this arrangement in both ITCS and ACSES is that all other protection features are retained to protect the train movement until a valid TSR file is received.

Hi-rail track cars pose a railroad safety exposure (Figure 3-7).

**Figure 3-7**

*Hi-rail track car, one of many railroad safety exposures*



### *Unauthorized Incursions into Work Zones*

ITCS does not currently have an EIC remote terminal capability such that a work zone can be established and released directly by the EIC in a smaller zone than the block between controlled signals. Under ITCS, work zones are typically protected by the train dispatcher using signal and/or exit blocking at the controlled points. When these blocks are in place, ITCS will enforce trains to stop at the entrance signal so they cannot enter the protected trackage. This practice in ITCS is the same as with ACSES and is excellent protection for roadway workers, especially in high-density multiple-track territory having many and closely-adjacent interlockings.



ITCS also is capable of placing “0 mph” TSRs for the work area, which will allow trains to approach stop signs placed by the EIC at other locations than stop signals. However, only the dispatcher has direct control of the “0 mph” TSRs, and the EIC must work through the dispatcher to place the “0 mph TSR” and to report the area clear for train movement so that the dispatcher may remove it.

### *Train Operation over Improperly-Positioned Switch or Derail*

For interlocked switches and derails, this protection is afforded by enforcing trains to stop short of signals displaying (positive/absolute) stop in concert with the standard field-based vital route-locking logic. This is the same in all PTC applications enforcing signal aspects as an overlay to the basic signal system.

For non-interlocked switches and derails, and because of the standard field-based vital circuits, the ITCS speed-control feature will enforce trains to not exceed the 15 to 20 mph cap for Restricted Speed, which is permitted by FRA Rule 236.1005(e). The ITCS application on the AML also includes WIUs at each non-interlocked hand-operated switch location to provide the same enforcement should the switch padlock and electric lock be compromised and the switch thrown after the approaching train has passed the last block signal. This was added by Amtrak as an additional safety feature in Higher Speed Rail (HrSR) territory, but it is not a requirement under 236.1005(e). ATC inherently provides the same switch protection, but it has to be added to ITCS.

### *Improperly-Positioned Switch or Derail Not in Train’s Route*

This additional PTC requirement does not apply to interlockings because all stop signals at interlockings will be enforced and because standard vital interlocking logic ensures that all switches and derails (both on and off the route) are properly aligned for a cleared signal and route.

For non-interlocked switches and derails that are not in the train’s route, but which could permit rolling equipment to foul the main track and the train’s route if left in the wrong position, the wayside signal-system circuits are arranged so that the main-track route will be effectively downgraded to Restricted Speed by the improperly positioned switch or derail. This, in turn, will cause the ITCS speed-control feature to enforce trains to not exceed the 20 mph cap for Restricted Speed outside interlockings. Such switches and derails are added in the WIUs described above in the ITCS AML installation to provide similar protection to that which is inherently part of all ATC installations.

### *Highway-Rail Grade-Crossing Warning-System Malfunctions*

Under ITCS, TSRs will be implemented by the train dispatcher to enforce mandatory directives issued for highway-rail grade-crossing warning-system credible report malfunctions. For mandatory directives requiring Restricted Speed, a 15-mph TSR will be placed into effect for both directions from a point prior to the grade crossing, through and to a point past the grade crossing. This will be the same as in all known PTC- certified systems.

Unlike I-ETMS or ACSES, ITCS also has certain automatic grade crossing warning system protection features built into the logic of the crossing WIUs as follows:

1. If the gates have been down for more than two minutes for any reason, it is assumed that drivers are beginning to think about possibly running around the gates, and HrSR operation is automatically suspended. The 110-mph display is automatically reduced to 79 mph, “XING” is displayed in the target window of the CLD, and 79 mph is enforced.
2. If the gates have been down for more than five minutes for any reason, it is assumed that drivers are actively running around the gates, the 79 mph display is further reduced to 15 mph, and 15 mph is enforced.
3. If the crossing is malfunctioning when the Signal Maintainer arrives at the crossing, he immediately throws a knife switch that will simultaneously suspend HrSR (causing 79 mph to be immediately enforced) and that will also temporarily remove the ITCS logic from the original “XR” control of the crossing. This act returns the crossing warning system to its pre-ITCS (totally XR-controlled) state and the Maintainer is then able to quickly determine which system is at fault. This feature normally shortens the overall restoration time of the warning system while allowing trains to proceed at a reduced speed consistent with the nature of the failure.

The above features have been made possible in ITCS due to its unique fail-safe crossing advance-start warning capability. This part of the original ITCS design provided constant warning times in the 80- to 110-mph range without adding to track-side equipment. This is a very cost effective tool in the implementation of HrSR up to 110 mph where there are many highway grade crossings, a feature currently provided only by ITCS. Without this fail-safe feature, traditional warning systems would have had to have been extended approximately 40 percent further on the rails at the higher speed to obtain the same warning times, essentially doubling the amount of traditional equipment needed for each individual crossing.

While the selection of the activation times of two and five minutes, respectively, as described above, may seem a bit arbitrary, these times have served very well

over the years and add a measure of safety where there are many highway grade crossings.

### *Movable Bridge Not Properly Closed and Locked*

Movable bridges are virtually always interlocked. In the ITCS application on the AML, there is one movable bridge, and it is interlocked. The standard vital interlocking logic will prevent signals governing movement over a movable bridge from being cleared unless the bridge is properly positioned, seated, and locked. If this movable bridge is not properly positioned, seated, and locked, the Interlocking signals will not be able to be cleared, and ITCS will force trains to stop short of the interlocking signals protecting the bridge as previously described.

### *Use of ITCS without Wayside Signals*

The current application of ITCS on the AML does not replace wayside signals. This is consistent with all known applications of I-ETMS in the U.S. where the system is being overlaid on an existing track circuit-based signal system. In these systems, trains that have failed en-route normally operate at reduced speed in accord with fixed signal indications. ITCS has some features that help to further mitigate delays under certain defined failure conditions.

There is no known reason why ITCS could not be overlaid upon an existing track-circuit-based signal system without the intermediate ABS between interlockings or controlled points. In this way, ITCS could function in a manner similar to ATC without intermediate wayside block signals.

In such an application, ITCS would govern movement into and through the blocks in roughly the same manner that ATC without wayside signals performs the same function on certain lines today. This approach assumes that all of the logic to prevent opposing moves and conflicts at interlockings and control points is resident in the signal system, and the “virtual” (but non-existent) intermediate automatic signals would still require a “signal” location with a WIU transmitting the same information derived from the track circuits “as if” the signal actually existed.

There is an application of ITCS in China on the recently-opened line from central China to Tibet, where ITCS has been applied as a stand-alone system without track circuits in a very harsh environment on frozen tundra on a plateau with elevations reaching 16,000 ft. This was specified by China Rail to avoid very difficult installation and maintenance issues with traditional wayside equipment and track connections. Sub-zero temperatures, high altitude, and lack of oxygen were very large issues on this line. The details of this application will not be explored at this point, except to say that there are also areas of dark territory in

the U.S. requiring some form of PTC, but which do not appear to be relevant to this immediate task.

### *Manual ITCS IN/OUT Switch*

The manual “IN/OUT” switch allows the engineer to temporarily suspend ITCS operation with enforced acknowledgement and reduced speed in a Wayside Controller section of 5–7 miles if the database up-loaded at the original terminal does not match the Wayside Controller section the train is approaching and travelling through. The advantage of this switch is that it permits the train to continue through a section that is experiencing difficulty, but keeps the system “on line” to resume normal ITCS operation at the end of the section when the next section is reached.

Without this switch, the failure of ITCS on the wayside over a single 5–7 mile section of the total route would likely cause the OBC to be cut out for the entire remainder of the train’s trip to its destination. This valuable tool keeps the ITCS OBC looking for the next point of ITCS support from the wayside when there is a wayside failure in one section of the line. This feature in ITCS is loosely analogous to resuming ATC after a brief cab signal “flip,” or in ACSES, after failing to read one transponder set but full operation resumes when the next set is reached.

### *Stop Override Button*

The Stop Override Button (SOB) is provided to allow a train to pass a stop signal in the event of a system (signal or ITCS) failure. Once the SOB is operated, ITCS restricts train speed through the interlocking to not exceed 15 mph and through the remainder of the block to 20 mph, the maximum speeds permitted under Restricted Speed.

### *ITCS Pertinent Insights*

In considering how ITCS can be used to provide and enforce Temporal Separation and On-Demand Spatial Separation between conventional railroad trains and lighter-weight passenger trains, several issues must be considered. These issues all involve the same conceptual theme—currently, ITCS has not been designed to vitally bring knowledge into a central computer about “what types of trains are where.” While individual trains can and do know their “types” through on-board firmware, the existing ITCS designs do not cause this information to be transmitted (in useful formats) to the wayside interlockings or to the central office.

The ITCS central-office-based OWL has been designed to transmit TSRs from the train dispatcher to the Wayside Controllers in the field, but the OWL has no knowledge about what trains and types of trains are where.

While the office-based CTC equipment does receive and has available the non-vital signal, switch, and track-circuit indications, these dynamic data do not include any useful train-ID information that can be used for safety applications. Even though many modern CTC control facilities have office-based train-tracking capabilities, the train IDs are typically manually assigned. In virtually all cases where train IDs are displayed in the central office, train occupancies are “tagged” in the central office using human-based manual techniques, and the reliability of these office-based train-tracking IDs is not deemed reliable enough for use in providing separation between non-compatible train types.

While it is technically possible to automatically obtain train-ID data in the field for transmission to the central office, this field-based train-ID capability has not been widely provided in American railroading. The ITCS vital wayside logic and equipment at interlockings also does not have useful knowledge about what trains and train types are where.

In summary, while ITCS is very capable of enforcing stop signals and speed restrictions and implementing the other PTC mandates, ITCS currently lacks (both in the central office and on the wayside) highly-reliable train-ID and location data, which are believed to be needed to implement On-Demand Spatial Separation between non-compatible train types. These issues will be further explored during later tasks as work is done to develop PTC prototype solutions for enforcing On-Demand Spatial Separation between non-compatible train types.

## Interoperable Electronic Train Management System (I-ETMS)

The I-ETMS PTC system is an evolutionary development of the BNSF ETMS system and was developed with the combined support of the CSX, Norfolk Southern (NS), and Union Pacific (UPRR) Railroads. I-ETMS is being designed primarily for freight railroads and is intended to be a vital overlay that runs on top of conventional wayside signal systems. The conventional signaling system may, or may not, include continuous cab signaling or any other form of train control.

The primary applications of I-ETMS include CTC traffic-control signaling and various forms of ABS. However, and as will be explained later, I-ETMS is also being designed to be implemented in “dark” non-signaled territories, on signaled trackage operated subject to mandatory-directive authorities, and on signaled

trackage having continuous cab signaling. A form of the latter is planned for the NS in certain parts of the NEC in concert with ATC, but with I-ETMS replacing ACSES for only NS freight trains.

I-ETMS was conceived to support interoperability across railroads and to “apply consistent warning and enforcement of rules violations regardless of trackage ownership while maintaining some level of railroad specific rules and train handling policies.” This has become especially important with the rail industry’s migration toward many more run-through freight trains from origin on one carrier to a destination on another carrier without changing engines and without incurring en-route delays.

I-ETMS has four distinct system segments: Office, Locomotive, Wayside, and Communications. The first three segments communicate with each other via the fourth, Communications. I-ETMS can be characterized as being a locomotive-centric PTC system that operates primarily based on the assimilation and processing of data on the locomotive within the Locomotive Segment. Required stops and lower speeds ahead are warned and enforced based on Predictive Braking Calculations made on-board the locomotive based upon near-real-time status of wayside conditions, actual train location, and other overriding authorities.

I-ETMS will be widely deployed throughout the BNSF, CSX, NS, and UPRR rail systems. It also is being adopted by many other host railroads throughout the United States, including the Kansas City Southern, Canadian Pacific, and Canadian National lines in the U.S. and many commuter lines outside the Northeast—Metrolink, New Mexico Rail Runner Express, and NCTD Coaster, to name a few.

Tenant railroads and entities that will operate over I-ETMS trackage include Amtrak, MARC, Metrolink, and Virginia Railway Express (VRE).

### I-ETMS Functionality

Being locomotive-centric, the lead locomotive must be initialized (Locomotive Segment Initialization) before beginning a trip. This initialization is heavily supported through communication with the BOS. The on-board system verifies that it is running the current version of the systems software, and that all of the in-effect infrastructure databases, including all track data (e.g., signal locations, maximum authorized speeds, permanent speeds and temporary speeds), mandatory directives (such as temporary speed restrictions, work zone limits, and crossing warning malfunction reports) are contained in the Train Management Computer (TMC, similar to the OBC). If any data are missing or not current, the correct data will be imparted from the BOS to the train as a part of the initialization process. In the event that conditions change after

initialization, there is provision for updating the operational restrictions used by the OBC while the train is on-route. This requirement and ability to update the database from the central office throughout the trip differs from ITCS and ACSES.

Initialization is invoked by the locomotive engineer while the locomotive is stopped and prior to departure. Locomotive Segment Initialization includes such things as entering and authenticating the engineer's employee credentials, selection by the engineer of the railroad(s) over which the train will be operated, verification and/or download of the track data from the Office Segments of each railroad over which the train will operate, checking that the latest Locomotive Segment software has been installed, train-ID and train-consist verification, Mandatory Directives have been downloaded and verified, and verification that an I-ETMS (PTC) departure test has been successfully completed when required.

Figure 3-8 illustrates the placement of the on-board I-ETMS display unit in a locomotive cab, and Figure 3-9 shows the I-ETMS display graphics for a train equipped with the energy management option.

**Figure 3-8**  
*I-ETMS display unit in  
cab car*



Photo provided by Wabtec Railway Electronics

**Figure 3-9**  
I-ETMS display  
graphics for train with  
energy management  
option

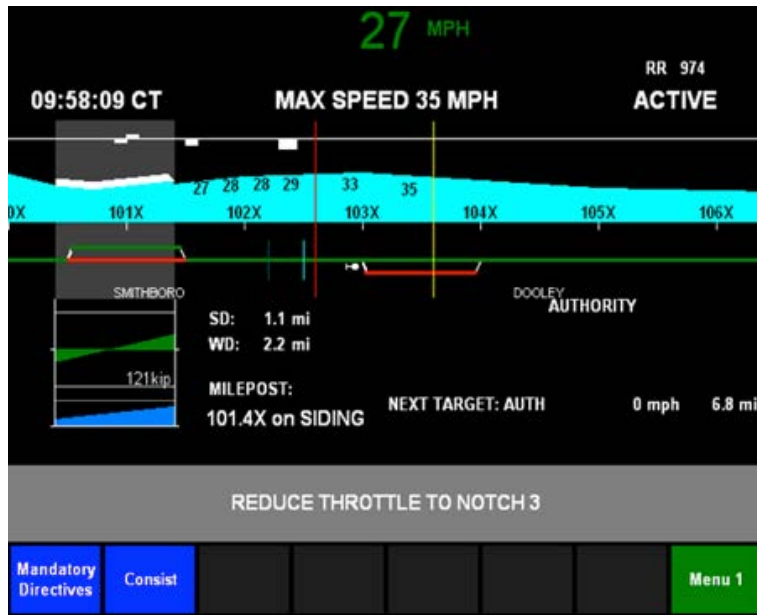

Photo provided by Wabtec Railway Electronics

Under I-ETMS, a train determines its location primarily based on GPS information in concert with the on-board geo-referenced track database (GPS location information applied to mapped track), supplemented by wheel-tachometer information for dead-reckoning during gaps in GPS reception. The I-ETMS track database for each track segment identifies the method of operation in effect (Traffic Control, Current of Traffic, Track Warrant Control, and Yard or Restricted Limits), as well as whether ABS, cab signaling, ATC, and/or Yard Limits are also in effect. I-ETMS is able to determine the proper enforcement rules and speed limits (both permanent and temporary) that are in effect on a track segment. During initialization in multiple-track territory, the train crew has to identify the specific track the train is on because of GPS discrimination limitations, and the lack of a vital track-circuit-sequence method to select the correct track automatically. Thereafter, the Locomotive Segment determines the specific track that the train is on through receipt of data-radio messages from the Wayside Segment conveying switch positions at interlockings, in concert with GPS information and the track database.

In a CTC signal-system environment, I-ETMS implements the required PTC functions, as described in the following subsections.

### *Train-to-Train Collisions*

Preventing train-to-train collisions under I-ETMS is generally accomplished by enforcing trains to stop short of signals displaying (positive/absolute) stop. This, in concert with standard vital interlocking logic, prevents collisions at



interlockings between trains on conflicting routes. Because of typical vital traffic-direction locking associated with bidirectional signaling, stop-signal enforcement also prevents collisions between opposing trains on tracks having bidirectional signaling.

I-ETMS will enforce a positive stop short of an intermediate signal displaying a Stop-and-Proceed aspect. However, after complying with the stop short of the signal, I-ETMS does not prevent collisions with same-direction preceding trains located beyond the signal, as it then allows the train to follow another train into the block. It should be noted that the maximum speed of the following-train is limited by I-ETMS functionality to display “Restricted Speed” and enforce the associated cap speed of 20 mph.

This feature is permitted by FRA Rule 236.1005(f), which is applicable to all PTC systems. Having PTC systems allow following close-in movements at Restricted Speed is a characteristic not only of I-ETMS, but is also a basic feature of ATC, ACSES, and ITCS. It follows from the nearly-universal practice of prescribing permissive block for following moves in ABS territories in the U.S., rather than the absolute block practice in the UK, for example.

Under I-ETMS, the Locomotive Segment learns about locations of signals on the route ahead from the track database that was downloaded from the Office Segment, but the actual signal status (stop or not stop) and switch position are received by the Locomotive Segment via the Communications Segment directly from the Wayside Segment (The peer-to-peer path). However, there is a back-up path via the BOS intended to supplement the peer-to-peer path if necessary.

Braking and warning profiles are calculated based upon train and track characteristics and locomotive control settings. This Locomotive Segment functionality ensures that trains will stop before passing any signal displaying stop, and that trains will slow to Restricted Speed before passing any signal requiring Restricted Speed. (For a signal requiring Restricted Speed, I-ETMS enforces a stop short of the signal. A positive stop is enforced until the train decelerates to the highest speed permitted under the Restricted Speed Rule, 20 mph under the General Code of Operating Rules (GCOR), at which time the stop requirement is cancelled.) Reduced speeds at interlockings for diverging routes, movable bridges, etc. are also enforced as described below.

### *Overspeed Derailments*

I-ETMS prevents over-speed derailments by enforcing both permanent and temporary speed restrictions. This includes MAS, PSRs (such as for curves and for diverging routes over switches), and TSRs (such as those issued under Mandatory Directives [MD]). I-ETMS provides for up to six train types (i.e., Ordinary Freight, Intermodal Freight, Intercity Passenger, High Speed Passenger,

Tilt Train, and Commuter), with each train type being able to have different speeds. Train-specific warning and braking profiles are dynamically generated by the Locomotive Segment for each and every individual train, and for each target.

Under I-ETMS, a train's Locomotive Segment learns about MAS and PSR speeds on the route ahead from the track database and TSR speeds from the MDs with GPS location information applied to mapped track to determine train location. The track database identifies each specific speed limitation ahead in the train's route, including the point at which the speed becomes effective. Using this information, the train's Locomotive Segment establishes and enforces a braking profile for the most restrictive condition ahead of the train, thereby ensuring that the train will be at or below the maximum permitted speed before entering the restricted trackage.

Diverging speeds at interlockings are determined by train type and by speed settings in the Subdivision file, and enforced based on switch positions that are transmitted to the approaching train via data radio directly from the WIU at the interlocking or control point. TSRs generated by the train dispatcher are imported into the BOS and then automatically transmitted at initialization and, periodically, to en-route trains that have already been initialized. TSRs typically include the affected track number, the speed(s) to be enforced, and the beginning and end of each restriction. The train's Locomotive Segment computes deceleration-enforcement profiles for each TSR in the same manner as for PSRs.

While the TSR functionality is expected to be reliable, there is no guarantee that a train will always receive the latest set of TSRs or receive a recently issued TSR. I-ETMS, therefore, depends on TSRs also being issued to trains using conventional procedures such as voice radio, and the assumption that train engineers will obey these mandatory directives regardless of whether I-ETMS displays and enforces them or not.

As implied in the above discussion, a train's Locomotive Segment simultaneously calculates MAS, PSR, TSR, and Diverging Speeds, each and every type, including determining and enforcing the most restrictive of these speeds at each and every location.

### *Unauthorized Incursions into Work Zones*

In addition to the enforcement provided at control points to block trains from entering work zones, similar to that previously described for ACSES and ITCS, I-ETMS has a feature that gives a measure of additional protection through a warning to the engineer when the train is within three miles in approach to the work zone. This allows the engineer adequate time to make his required contact with the EIC and obtain verbal permission to enter the work zone. If the engineer does not receive verbal permission, or he fails to follow the prescribed

steps in validating the permission, the on-board PTC system will automatically stop the train short of the work zone. The EIC is NOT warned directly by the PTC system that a train is approaching the work zone but can monitor his portable EIC unit to view train moves in his/her area through a slightly time delayed mimic of what is on the dispatcher's screen.

By rule, the engineer is required to contact the EIC over the road channel to request authorization to enter the work zone. Only after completion of the verbal authorization, read-back, and acknowledgement of the read-back protocol will the verbal authority by the EIC to an approaching train to enter a work zone be considered valid under the Rules. Soft keys on the CDU are provided for the engineer to manually acknowledge EIC's verbal authorization to enter the work zone and thereby release an enforced stop at the entrance to the zone. There currently is no provision for the EIC to directly release the stop order from his laptop. Work zone limits are established and removed by the dispatcher in accordance with the published MD and in coordination with the EIC. Work Zones are not removed for each train move, but stay in effect until canceled by the EIC through the dispatcher.

#### *Train Operation over Improperly-Positioned Switch or Derail*

For interlocked switches and derails, this protection is afforded by enforcing trains to stop short of signals displaying (positive/absolute) stop in concert with the standard field-based vital route-locking logic. This is the same in all PTC applications enforcing signal aspects as an overlay to the basic signal system.

For non-interlocked switches and derails, and because of the standard field-based vital circuits, the I-ETMS speed-control feature will enforce trains to not exceeding the 20-mph cap for Restricted Speed over any of these switches not in the normal position for the main track, which is permitted by FRA Rule 236.1005(e). The vital field-based circuits for signals governing movement over these switches must include their normal position in the control of each wayside signal under FRA Rule 236.202, thus relieving the carriers from providing separate WIUs at non-interlocked switch locations to comply with 236.1005(e). I-ETMS will overlay and enforce the existing signal system features.

#### *Improperly-Positioned Switch or Derail Not in Train's Route*

This additional PTC requirement normally would not apply to interlockings because all stop signals at interlockings will be enforced, and because standard vital interlocking logic ensures that all switches and derails (both on and off the route) are properly aligned for a cleared signal and route.

For non-interlocked switches and derails that are not in the train's route, but which, if left in the wrong position, could permit rolling equipment to foul the main track and the train's route, the wayside signal-system circuits are normally arranged so that the main-track route is treated as being occupied if the switch fouling circuit is occupied or if the switch or derail is improperly positioned. This, in turn, causes the I-ETMS speed-control feature to enforce trains to not exceeding the 20-mph cap for Restricted Speed, and also causes the governing signal to display an aspect no better than Stop and Proceed or Restricting. I-ETMS will enforce the features that have been included in the under-lying signal system.

### *Highway-Rail Grade-Crossing (HRGC) Warning-System Malfunctions*

Under I-ETMS, credible reports of HRGC Warning System "Activation Failures" (failures of the warning system to properly warn the public of an approaching train) will result in the dispatcher initiating a mandatory directive for trains approaching the reported failed warning system. Insofar as practical, I-ETMS will warn and/or enforce the provisions of FRA Rules 234.105, 106, and 107, through an interactive multi-tiered soft key arrangement involving the engineer when the train is within three miles of the impaired crossing. This arrangement is expected to meet the different requirements for the approaching train dependent upon the number and level of authority of flagmen located at the crossing at issue at the present time.

However, due to the complexity of these "234" Rules as a group and the current high level of human involvement required by the engineer in the current version of I-ETMS as he attempts to enforce them, it is apparent that this is "unfinished business" with FRA. Additional complications concerning I-ETMS enforcement of credible reports of various levels of crossing failures can be expected.

I-ETMS, as currently being fielded, does not provide direct mitigation features via a WIU at the crossing location to cover potential warning system failures. "800" phone numbers to control centers manned 24 hours 7 days per week are posted at all crossings, and various other technologies are being employed by different carriers to provide credible report information of warning system failures to the dispatcher as quickly as possible.

### *Movable Bridge Not Properly Closed and Locked*

Movable bridges are virtually always interlocked. The standard vital interlocking logic prevents signals governing movement over a movable bridge from being cleared unless the bridge is properly positioned, seated, and locked. If a movable bridge is not properly positioned, seated, and locked, the interlocking signals

will not be able to be cleared, and I-ETMS will force trains to stop short of the interlocking signals protecting the bridge.

### *Use of I-ETMS without Wayside Signals*

The current applications of I-ETMS do not replace wayside signals. When there is no underlying cab-signal system, there is a benefit in having intermediate wayside signals. In the case of a train having an en-route PTC failure, the train can be allowed to continue operating at a reduced speed in accordance with fixed wayside signal indications. This is the default way to permit the train to complete its trip to its destination after an en-route failure of ITCS, and, with an en-route failure of ACSES, the ATC continues to provide a significant measure of protection. Similarly, the rules for handling an I-ETMS failure en-route after December 31, 2015, will be covered by the applicable portions of FRA Rule §236.1029 and each individual carrier's approved PTCIP, PTCDP, and PTC Safety Plan.

Removing existing wayside signals would require some way to establish and enforce an absolute block all the way from one control point to the next in the event of an en-route failure. This has not been done in any ITCS application to date, and it is not recommended for I-ETMS applications where an en-route failure could cause serious traffic capacity constraints affecting the performance of trains other than the expected delay to the failed train.

The establishment of an absolute block between controlled signals has been provided to accommodate ATC en-route failures where there are no intermediate wayside signals between interlockings in dense-traffic multi-track environments as previously described for the Northeast Corridor. But this has only been done where the maturity, simplicity, and robustness of the ATC has resulted in extremely rare occurrences of en-route failures, and where the other traffic can be temporarily accommodated on other tracks in relatively short sections between interlockings until the failed train reaches its destination and is out of the way.

### *Stop Override Function*

This feature is still under development and may be implemented differently than this feature in ACSES and ITCS.

### *I-ETMS Pertinent Insights*

In considering how I-ETMS can be used to provide and enforce Temporal Separation and on-demand spatial separation between conventional railroad trains and lighter-weight passenger trains, several issues must be considered. These issues all involve the same conceptual theme—currently, I-ETMS has not been designed to vitally bring knowledge of train types and locations into a

central computer. While individual trains can and do know their types through on-board firmware, the existing I-ETMS designs do not cause this information to be transmitted (in useful formats) to the wayside interlockings or to the central office. The I-ETMS central-office BOS has been designed to process and transmit the Permanent Data Base, and the TSRs created in the train dispatcher's CAD system, to individual trains, but neither the BOS nor the CAD have vital, safety critical knowledge about train types and their locations.

While the office-based CTC equipment does receive and have available the non-vital signal, switch, and track-circuit indications, these dynamic data do not include any useful train-ID information that can be used for safety applications. Even though most modern CTC control facilities have office-based train-tracking capabilities (e.g., CAD), the train-IDs are typically manually assigned to each train by the dispatcher. In virtually all cases where train IDs are displayed in the central office, train occupancies are "tagged" in the central office using human-based manual techniques, and the reliability of these office/human-based train-tracking IDs is not adequate for use in providing a safety separation between non-compatible train types.

While it is technically possible to automatically obtain train-ID data in the field for transmission to the central office, this field-based train-ID capability has not been widely provided in American railroading. Neither do the I-ETMS WIUs at wayside locations have any useful knowledge about the locations of train types.

In summary, while I-ETMS is expected to be capable of enforcing stop signals and speed restrictions and implementing the other PTC mandates, I-ETMS currently lacks (both in the central office and on the wayside) the highly-reliable train-ID and location data, which are needed to implement On-Demand Spatial Separation.

# Lessons Learned During Development and Deployment of PTC Systems

This section lists and describes some of the lessons that have been learned from experience with the development and deployment of the three North American PTC Systems described in Section 3.

## Background

For this study, several individuals who have been key players in the development and implementation of one or more of these three PTC systems were asked to share the most important lessons they learned from their experience in these efforts. The following is a summary of the experiences, lessons learned that have been common to all three PTC systems during the early development and deployment phases, and a review of some of the differences between the systems that have impacted these efforts.

ATC/ACSES II began in 1993 and ITCS in 1994, 15 and 14 years (respectively) prior to the advent of the RSIA08 (Rail Safety Improvement Act of 2008) and the associated FRA PTC regulations. Both ACSES II and ITCS originally were designed to supplement existing signal systems to improve the safety of higher speed trains commingled with freight trains. These systems were designed to be in compliance with all FRA regulations regarding signal systems at that time, namely the original CFR49, Parts 234, 235, and 236, Subparts A through G. Then, following RSIA08 mandating PTC and the addition of Subparts H and I detailing the PTC requirements, ACSES II and ITCS were certified as PTC-compliant.

The primary requirements of the RSIA08 mandate for PTC and the last two Subparts, H and I, of CFR49, Part 236, were largely shaped by the RSAC (Rail Safety Advisory Committee) process. RSAC was a series of regular meetings called by FRA to help define the primary safety objectives of PTC during the 10+ year period prior to the 2008 Chatsworth crash that prompted the U.S. Congress to enact the RSIA08 mandate. The attendees were representatives of freight and passenger carriers, rail craft unions, and FRA. Much of the development of ACSES II and ITCS also occurred during this period, and there

was much useful interaction between the developers of these two train control systems and the RSAC process, with key players taking part in both roles.

Also during this period, the BNSF Railway began the development of the ETMS system, a non-vital forerunner of the I-ETMS system currently being developed by the Freight Class I carriers. This led to implementation of some early versions of their ETMS in pilot programs prior to RSIA08. Since then, ETMS has been applied primarily to BNSF freight-railroad mainlines and is not expected to support passenger train speeds exceeding 79 mph. ETMS is not considered fail-safe and is not part of this study.

As will be seen, some of the lessons learned reflect the various stages of maturity of these systems, which, in turn, is impacted by both the development time and the complexity of each system. We documented some of the lessons learned with each of the PTC systems studied elsewhere in this report.

## ACSES

ATC/ACSES was the only one of the three PTC systems studied that was able to take advantage of the prior development of two existing tried-and-proven train control systems. This enabled the system to achieve a level of operational maturity that permitted it to meet its original objective in a significantly shorter time frame than any other PTC system.

*Lesson Learned:* When the operational objectives can be met by a well-engineered blending of existing, well-proven sub-systems, very significant time and cost savings can result.

The ATC system was already in place, well-proven, very reliable, and train crews were well-trained in its use at the beginning of the ATC/ACSES program.

*Lesson Learned:* The continued use of existing systems currently in operation that continue to meet operational needs, when it is possible to do so, has huge operational benefits.

The existing ATC system had operational characteristics not available in the developing fully communications-based systems, and the technology used to deliver these ATC operational characteristics was the latest “state-of-the-art.”

*Lesson Learned:* If the current system fulfills all operating needs, and it is not obsolete, there is no reason to give it up for a supposedly “more modern” system that has a much longer road to maturity, with all of the additional costs associated with a long migration path.

The ACSES transponder technology had been well-proven in Europe, but the application of the technology in the U.S. was a new and unique application



which, when blended with Amtrak's existing ATC, met the needs of the North American PTC requirements.

*Lesson Learned:* If an existing technology is cost-effective, demonstrably reliable, and safe in its current application, and it can be made applicable to the required objectives of the train control system under development, much time and effort can be saved.

All operating, maintenance-of-equipment, and maintenance-of-way personnel in the Northeast Corridor were very familiar with the operational characteristics, the enforced speeds, and the real-time display of the cab signal aspects of the existing ATC system. However, the ACSES portion of the new PTC system required additions to the display and to the operating characteristics that were entirely new to all of these personnel.

*Lesson Learned:* Full integration of the new ACSES system into the existing operating culture required a broad multi-disciplinary approach to ensure that existing engineers/ operators, dispatcher/train controllers, train rules specialists, and wayside and on-board (including shop) maintenance technicians all begin to view the "new" system as integral to their current duties and responsibilities.

ACSES required new operating rules in the language of the operating culture, the addition of ACSES to the locomotive simulators used to train engineers, and extensive classroom training of all of the operating and maintenance disciplines in their individual and particular roles required for the successful roll-out of the ACSES portion of the new PTC system.

As ACSES was a new element introducing a new operating concept, it was recognized as important early in the program to get some "hands-on" feedback from those who would operate and maintain the system and ultimately accept it as part of their operating culture. This need led to the creation of specialized tools by the ACSES suppliers, such as "SimACSES," ACSESView," and the "WMT" (Wayside Maintenance Tool) to satisfy the need to study the new system's performance in real-time, from both the wayside and the on-board perspectives.

*Lesson Learned:* These tools then proved extremely valuable in bringing ACSES to maturity. They became the principal means provided for extensive testing prior to placing ACSES in service, as well as for on-going in-service diagnostic and maintenance needs.

As with any new system, it was recognized from the beginning, that to be successful, ACSES would require those who would operate it and maintain it to accept this "new thing" as part of their daily responsibilities.

*Lesson Learned:* A thorough training program with well-documented manuals for each of the disciplines involved with ACSES, followed by a well-conceived pilot installation in revenue service is very important to the process of fully integrating the “new and improved” PTC into the existing operation. The pilot installation in actual revenue service is the best possible training of a new cadre of employees accepting and teaching the new system, as follow-up to the classroom training.

Amtrak had been using the ACSES system successfully for eight years at the time of the PTC mandate, with 144 commuter vehicles operating for most of that time in the Boston area and more than 50 elsewhere on the NEC. However, certain applications in the densest commuter traffic areas in North America in the New York and northern New Jersey areas are requiring some relatively simple modifications to the FRA type-approved ACSES II being rolled out on Amtrak’s Northeastern lines.

*Lessons Learned:* While these changes are quite simple technical modifications, and they are being developed by following all prior signal safety criteria to ensure that each modification will be designed, tested, installed, operated, and maintained with continuation of the fail-safe approach at all times, the FRA regulatory requirements for rigorous “proof” that these changes will be safe have become very burdensome to the progression of these projects. While FRA has tried to expedite the approval process, there are a number of interacting factors causing this back-up in obtaining these approvals. Some are listed as follows:

- The dense-traffic, largely passenger-carrying railroads in the northeast U.S. had mature systems ready to deploy that have needed only relatively minor enhancements to roll it out on the seven commuter and two captive freight fleets operating in New England and the Mid-Atlantic regions. However, the rest of the country has had to await further development of a very complex and immature interoperable system to be fully developed, and this has impacted the rollout of ACSES in the Northeast as well, as will be seen in the following.
- The burden thrust upon the railroads outside the Northeast and on FRA by the failure of Congress to do sufficient research before passing RSIA08 has been enormous, bordering on the catastrophic. As FRA has attempted to “gear up” to handle this mandate to install an immature system in an insufficient time frame, they have had to devote too much time trying to follow the minute details of the PTC developments by the freight carriers and all other carriers outside the Northeast. However, in view of the required level of safety required for these systems, it has been quite necessary to do this, even bordering upon micro-managing these projects. This has placed FRA safety personnel in a role that they had not normally been called upon to perform prior to RSIA08.
- The magnitude of the huge burden thrust upon FRA to ensure the safe deployment of PTC on some 40+ different carriers, who have desperately

been trying to meet the deadline with systems interoperable with one another, has not been generally recognized. Congress and the media-saturated public have failed to grasp the magnitude of this burden, which, if left unsupervised by FRA, could very likely result in a less-safe PTC system attempting to enforce obedience to a very safe signal system. Unfortunately, human nature all too often ultimately will rely on the less-safe system to replace the human vigilance required while operating over the unenforced, but very safe, signal system. Realistic rail safety must consider this factor, which has been missed by many.

- Finally, because of the need for FRA to micro-manage the development of systems being deployed elsewhere, there has been a tendency also to micro-manage the minor enhancements to ACSES in the Northeast. This has largely become an educational process for new safety authorities following the retirement of those who were familiar with and had developed confidence in the ATC/ACSES system and the processes already in place to safely improve on it. This re-education process has resulted in some delay to the PTC rollout, which should, of course, have the priority in regard to further improving the safety of train operation in the New England and Mid-Atlantic regions.

A vital part of any PTC system is the LDS, as all of these systems must continually update the Safe Braking Distance (SBD) to the next most restrictive target, requiring a speed reduction or a positive stop. To do this safely, the leading end of the train must accurately know the train's position at any given second with respect to this target. ACSES is unique among the North American PTC systems in its use of in-track transponders to support the LDS functionality.

### ACSES Lessons Learned

- The use of in-track transponders in ACSES greatly simplifies the LDS requirement in regard to which track the train is on in multiple-track territories. (This difference between systems will be explored in greater depth in the next section on 100% Communications-Based [CB] systems.) Transponders also provide excellent precision in locating a train on its track in real-time relative to its next most restrictive target.
- Transponder-based LDS, in concert with the ATC, also significantly reduces the burden on the data radio system in a very dense-traffic, multi-track, multi-train environment, and there is no need to maintain GPS equipment on rolling stock or to engineer special GPS coverage for long tunnels or under extensive over-build structures typical in urban areas.
- In contrast to all communications-based PTC systems, for example, ATC/ACSES requires data radio coverage only within three miles of each interlocking to release the PTS and to “steer” the train through interlocking diverging moves at the proper speed. Transponders and the ATC meet all requirements between the interlockings and provide redundancy, with the

ATC and transponders backing-up the data radio in the three-mile-zone approaching interlockings.

- With this redundancy, the ATC/ACSES PTC system can actually operate safely at maximum authorized speed through interlockings without data radio, should it fail while all other sub-systems are fully functioning. This is not possible with any of the 100% CB PTC systems, including ITCS. This feature with ATC/ACSES places significantly less burden on the difficult-to-obtain and often very expensive spectrum required to support PTC. (Note: Under certain conditions, trains equipped with ITCS are permitted to proceed at 79 mph while observing fixed signals when data radio coverage is temporarily lost through one of the 5–7 mile coverage zones. This is an important feature in the operation of passenger trains.)

However, in spite of the operational advantages obtained through the use of in-track transponders, the freight carriers, particularly those in Class I, are apparently all in agreement that they want nothing to do with installation or maintenance of transponders on their tens of thousands of miles of track, nor do they want transponder readers on their thousands of engines. While this is understandable, it leads to additional operational challenges, particularly where the PTC is cut-in at locations where there are two or more main tracks.

## ITCS

ITCS was created by Harmon Electronics (later purchased by General Electric) in concert with Amtrak, to meet the need of the “emerging corridors.” These corridors are freight lines upon which there is an increasing desire by certain states to operate inter-city passenger trains at speeds up to 110 mph. Even though Amtrak owned and operated the line where ITCS was to be installed, it was decided at the outset that the LDS would be GPS-based in concert with on-board tachometers. Transponders were not to be included, due to the freight carrier aversion to using them on their own tracks outside the Northeast Corridor; ITCS also was viewed at that time as possibly being applied to other freight carrier-owned corridors for the purpose of raising passenger train speeds.

While ACSES took 7 years from its inception to reach its original goal of raising revenue service speeds from 125 to 150 mph, it took ITCS 16 years to reach its original objective of raising revenue service speeds from 79 to 110 mph. There were a number of reasons for this, which will be explained in more detail in the following:

- ITCS was developed as a totally communications-based system from the beginning, without any foundational “stand-alone” train control systems such as U.S. ATC or European off-the-shelf transponders to begin with. Harmon had the UltraCab On-Board Computer (OBC) platform which, until the

advent of the ITCS concept, had been developed solely for the purpose of equipping engines and cab cars to operate in ATC territories. Harmon also had developed the VHLC wayside processor to replace signal safety relays at interlocking and control point locations, and ElectroCode to replace relays with vital signal logic at intermediate automatic signal locations, including digital pulses on the rails to eliminate signal control wires on pole lines. These devices were a start, but the full development of ITCS from these very basic platforms required a significantly larger effort than just to blend two existing stand-alone train control systems together to achieve the desired functionality.

- ITCS requires 100% data radio coverage, which was a challenge for the original 900 MHz during changing weather patterns and foliage seasons. If radio coverage with ITCS is lost for 20 seconds, causing three status update messages to be missed, the on-board system will default to “Restricted Speed,” which will be displayed and enforced. For several years, there were marginal areas in this coverage that never quite achieved the level of reliability that was required for HrSR at 110 mph. It was not until there was a complete re-working of the radio coverage, with a change to 220 MHz supported by a fiber-optic backbone system and redundant coverage, that the level of reliability required to support a viable HrSR revenue operation was finally achieved.
- In contrast, as has been stated, ATC/ACSES requires data radio coverage only within three miles of each interlocking, with transponders and the ATC meeting all requirements between the interlockings. In ITCS, the redundancy is provided by 100% overlap of the data radio coverage instead of by transponders and ATC coded currents in the rails. However, any on-board data radio failure can cause complete loss of ITCS for the train affected for the remainder of its trip to its destination. Similarly, marginal loss of data radio signal in one of the 5–7 mile coverage zones along the wayside can cause loss of ITCS for all or most trains through the area affected.
- While the ITCS data-radio coverage was greatly improved in its performance with a switch to the 220 MHz redundant data radio network described above, the very nature of 100% reliance on the radio frequency spectrum is less robust and more subject to outside interference than coded currents in company-owned rails and “private” closely-coupled communications from company owned in-track transponders.
- Another issue was the maintenance of the ITCS on-board systems at the hub of Amtrak operations in Chicago. During the developmental years of ITCS, there were major turnovers of personnel and equipment, with engines equipped with ITCS designated to cover the Michigan service that ended in Los Angeles or Seattle. Technicians trained to install, test, and maintain the ITCS on-board equipment were re-assigned to different hours or moved to other assignments, causing the need to train still more technicians who had other duties that often became the priority. Radio technicians and locomotive technicians both were needed, and considerable effort went into

encouraging them to work more smoothly together, with each craft taking full responsibility for their own portion of the required work. The smaller plastic 900MHz antennas placed too close to the exhaust port on top of the engine would melt. The new 220 MHz antennas were larger and all metal resolving this problem.

Full integration of the new system into the existing operating culture required a broad multi-disciplinary approach to ensure that existing engineers/operators, dispatchers/train controllers, train rules specialists, and wayside and on-board maintenance technicians would all begin to view the “new” system as integral to their current duties and responsibilities.

### ITCS Lessons Learned

*Lesson Learned:* As previously noted, a system “started from a ‘scratch’,” such as ITCS (vs. the ATC/ACSES effort) has taken more than twice as long to achieve its original goal than the ATC/ACSES system that started with melding two excellent pre-proven safety signal systems to create the ultimate PTC system. None of the engineers in ITCS territories had ever operated trains in ATC territory before, but the first ones to operate in the ITCS test bed quickly recognized its value. The very user-friendly CLD with a TTP (Time To Penalty) feature was instrumental in helping new engineers quickly adapt to operating the train with the new system in service.

Basic functionality of ITCS from the beginning followed the model of existing ATC as far as it could practically be achieved. Then, the PTS at stop signals was added, as was the brake profile calculations for all speed restrictions, both “dynamic” (for signal enforcement) and “static” (for curve and other track restrictions).

*Lesson Learned:* Existing well-proven systems are good guides to follow in the development of the functionality of new train control systems based on a new technology. The operational functionality of any new train control system must be driven by the actual operational needs, not by the nature and promises of the new technology. Experienced signal engineers who have spent their lives meeting simple operational needs by practically and economically applying available technologies seem to be able to grasp this cardinal principle better than those brought up in the IT world without any signal experience.

Much emphasis was put on training of personnel in each of the affected disciplines during the ITCS development. However, during the very prolonged developmental period of ITCS, repetition of this training was sometimes necessary.

*Lesson Learned:* A thorough training program with well-documented manuals in each of the above disciplines, followed by a well-conceived pilot installation in

revenue service, is very important to the process of fully integrating the “new” PTC into the existing operation. Timing of the training relative to actually placing any portion of the new installation in general revenue service is important, but it can be very difficult in a developing system and more costly when it has to be repeated in all disciplines because of delays in placing the system in service.

Basic train separation for the ITCS application on the AML (Amtrak Michigan Line) is derived from the track-circuit-based CTC signal system already installed.

*Lessons Learned:* Building on a fail-safe existing system such as CTC, in the case of ITCS, significantly reduced the cost in terms of time and funding of fully implementing a PTC system. The ITCS application in the case of the AML consists simply of:

- Enforcing all existing signal aspects as they change with respect to the movement of other trains and as routes are cleared through the control points by the Train Director in Chicago
- Enforcing the permanent speed restrictions currently listed in the Employees Time Table Special Instructions (TT-SI)
- Enforcing all current TSRs as they are entered by the Train Director into ITCS through the OWL (Office to Wayside Link).

These were the basic minimum goals required for 110 mph operation and, as it has turned out, their satisfactory accomplishment has also qualified ITCS as the certified PTC system for the entire AML, including the extension to Dearborn, Michigan. The CTC system also serves as a fail-safe default for speeds up to 79 mph if the ITCS fails.

*Lesson Learned:* Keeping it as simple as possible, while still meeting all operating needs, is very beneficial in regard to developmental, training, and long-term maintenance costs. Even though ITCS was originally developed to safely raise passenger train speeds, it turned out to (quite simply) satisfy the PTC mandate as well.

ITCS was purposely developed without the use of in-track transponders to make the system more attractive to the freight railroads on which passenger trains are predominantly operated outside of the Amtrak-owned and operated Northeast Corridor. However, the lack of transponders complicates the LDS requirement and opens up an additional element of vulnerability to human failure if not properly addressed in the application engineering.

*Lesson Learned:* In the original pilot installation of ITCS in Michigan, the “cut-in” (entering ITCS) and “cut-out” (leaving ITCS) locations were purposely selected to be on single-track at both ends of the project. This avoided facing the issue that the GPS alone did not have the precision necessary to guarantee which

track the train was on. As long as there was only one track in the area where the system was cut-in, it was safe to assume that the train was on this track. This would have been a non-problem in any PTC system where in-track transponders safely guarantee to the OBC the track the train is on as part of its normal update message. (Note: Once the train is cut-in in ITCS territory, the train is furnished all facing point switch positions in the status-update messages and can determine the track it is on at all times through the database carried in the OBC.

However, in the current expansion of ITCS on Amtrak Midwest Lines, application engineers have been successful in developing special methods of safely arranging for initial ITCS cut-ins entering ITCS territories where there is more than one main track. This has avoided the need for human input to determine the right track without transponders and has provided a means to resolve this issue on future applications at other double-track locations. As far as we know, this is a first solution for this issue on any transponder-less communications-based PTC system in the U.S.

*Lesson Learned:* We can learn a great deal from previous signal systems, and it was previous knowledge of track-circuit-based ATC systems that led to this ITCS solution. An ATC issue has always been to ensure that the cab-signal track-code is turned on within interlockings only when the right train on the right track accepts the home signal displayed for it and that it will not turn on for a train that might enter the interlocking at another home signal that had not been displayed for movement within the interlocking. This logic, the basis for a “V” circuit in ATC design, which uses sequential occupation of track circuits and other events involved in the train’s movement to ensure that the right train gets the track-code intended for it, became a model that could be adapted to provide the ITCS double-track cut-in solution. Perseverance in finding this solution has kept ITCS from being compromised by having to rely on human intervention to provide the correct track number.

From its inception, the development of ITCS has included a fail-safe advance highway grade crossing warning system start feature that eliminates the need for additional hardware installations on the track when speeds are raised above 79 mph. This feature also provides redundancy in ensuring the operation of the crossing during approach speeds between 20 mph and 79 mph. ITCS is currently the only PTC system with this feature.

*Lesson Learned:* This feature has proven very valuable in PTC applications where speeds are being raised to 110 mph, saving millions where there are many grade crossings. This feature has paid off greatly in the HrSR corridors in both Michigan and Illinois. It can also be a valuable feature where very light traffic and excessive wheel/rail contamination result in marginal shunting on the approaches to grade crossings. Some new applications are being developed in commuter territories where busy highway grade crossings are located at the ends of station platforms.



Some enhancements of this feature are to be used to permit trains to safely make station stops with reduced disruption to highway traffic at these crossings.

## I-ETMS

I-ETMS is the natural outgrowth of a longstanding desire of many railroads to take full advantage of the very rapid advance of computer technologies since World War II. The original effort to attempt to apply this technology to control the movement of trains goes back more than three decades, and it was called ATCS (Advanced Train Control System). Several railroads that did not have ATC took the lead to attempt to define ATCS and develop operating specifications for such systems. At the beginning of this era, and for much of the period coincident with the following discussion, there had been, and which, to a certain extent, continues today, much hype about completely replacing current signal systems with “simpler, less-costly” systems, about creating “moving block” between freight trains to increase line capacity, and lots of other attractive features to “make a ‘business-case,’” etc.

### I-ETMS Lessons Learned

*Lesson Learned:* None of these goals have been achieved in current applications of I-ETMS in the “contiguous railroad system of the U.S.,” the nationwide system, all of which comes directly under the jurisdiction of FRA. It appears to be quite unlikely that any of them will be achieved in the immediate future. (Note: This statement does not apply to transit systems that are not a part of the contiguous rail system of the U.S., where a fail-safe train integrity check is practical and nationwide interoperability is not an issue.] There are several reasons for this, some of which are touched on below.

The above effort eventually led to the Burlington Northern Railroad, a predecessor of the BNSF Railway, installing a pilot installation called ARIES in northern Minnesota. Ultimately, the rest of the rail industry, through the AAR, decided not to adopt that system, but to move on with the original effort to a more sophisticated system that became known generically as PTC. Coincidentally, the AAR had ceased hosting regular meetings of the carriers’ signal engineers by this time, under the mistaken impression that PTC would replace the U.S. signal infrastructure. Signal engineers found a new home in AREMA, and the carriers’ representatives without this background that were left at the AAR to vote were apparently still trying to reach for the ultimate utopian system that would achieve all of the above goals listed above

*Lessons Learned:* The lesson described above had not yet been learned, and there were still years ahead for the industry that would have to learn it the hard way. ARIES never had a chance. Lessons learned by the signal engineers through

“blood, sweat, and tears” over the previous 100 years never entered into the vote.

During this period, amid much discussion among the railroads, prospective vendors, and FRA at monthly RSAC meetings, Amtrak began work on ACSES and ITCS, and the BNSF Railway began the effort known as ETMS. Also during this time, every time there was a new “PTC-preventable” rail accident, the National Transportation Safety Board (NTSB) would keep the pressure on all parties with a call for the ultimate “fix,” PTC. While Amtrak’s work on ACSES and ITCS was planned from the outset to be fully fail-safe at all levels, the BNSF was developing ETMS as an overlay non-vital system, following its success in a much more limited role of warning non-shunting on-track equipment, such as hi-rail vehicles, from straying out of their work limits and colliding with trains. The RSAC discussions included debates between the advocates of less expensive (initially) non-vital overlay system, and those who insisted that fully fail-safe systems built to the same standards as existing signal systems should be required when the system would be called upon to convey authority (or be perceived as conveying authority) for movement and to enforce speed reductions and stops when required.

*Lessons Learned:* Seasoned signal engineers normally were in the latter camp, and those with some operating or IT background were often in the former. Some of those in the former actually tended to be suspicious of signal engineers holding out for the latter as possibly being “turf-holding” efforts rather than as industry veterans genuinely concerned about their carrier’s liability when accidents occur. Industry veterans knew from experience what it cost the company if it could not prove “after the fact” that it had made its safety system as safe as could have reasonably and practically made it.

Likely, many of the advocates of a non-vital safety system are unaware of the 100+ year battle waged by traditional signal engineers to make the vital (fail-safe) signal system as safe as it is today. This effort started in earnest in 1907 to investigate and correct each and every one of the hundreds of false-proceed signal incidents in that year. It has continued through the years to reduce this number to a handful each year, most of which are either caused by human error or older systems not yet replaced by systems incorporating the latest improvements in signal technology.

*Lesson Learned:* This effort has much to teach the current generation in its quest for PTC. Those who do not know history are doomed to repeat it.

Then, at about the time of the Chatsworth accident, and the “PTC Mandate” with RSIA08 in the late fall of 2008, the Union Pacific Railroad came out with the plan for V-ETMS (Vital-ETMS) with two more freight Class I’s, Norfolk Southern and CSX, joining with the UP. Subsequently, the V-ETMS system shared by the

three Class I's was re-named I-ETMS (Interoperable-ETMS), and it is becoming the industry standard for PTC for all of the freight carriers, as well as for passenger carriers serving routes intertwined with freight lines outside the NEC and BNSF engines operating on lines other than their own.

*Lesson Learned?* Has the “I” become more important than the “V”?

The entire rail industry is now seeking relief from the ill-advised mandate's timing, but is the time being sought anywhere near enough?

*Lesson Still Being Learned:* A reliable new PTC system, which I-ETMS will need to become, will take time to bring to maturity and to fully integrate it into the existing operating culture. The time that it is likely to take for I-ETMS to become truly mature will certainly be considerably longer than politicians that voted for the mandate could have envisioned.

As the current I-ETMS effort is even more ambitious in concept than ITCS, past and current delays from original schedule estimates are not surprising. Past experience with ITCS would suggest that the time it will take to fully develop a solid, robust, safe, and reliable I-ETMS and then roll it out everywhere will take much longer than the relief the industry is currently seeking.

A decade-later start than the earlier ACSES and ITCS developments and the additional sophistication of this ambitious project are key factors in contributing to past and anticipated future delays in the rollout of I-ETMS throughout the U.S. The importance of a complete design, followed by a good pilot program for fine-tuning the finished product before major rollout begins, is particularly emphasized by their absence as the carriers struggle with an all-too-short time frame.

The Metrolink commuter system in Southern California, with strong support from the Class I's (BNSF and UPRR) in the region where the PTC mandate was triggered by the Chatsworth crash, has a significant head start on other passenger systems committed to I-ETMS. But these other commuter lines are handicapped in their working to implement their systems by the deadline as they continue to wait and watch for additional changes coming out of the Metrolink testing and the tests taking place on various lines of the Class I freight carriers.

In regard to the original hope that the ultimate PTC would include “moving block” to increase the capacity of existing lines by decreasing the distance between trains that could be run safely at the maximum authorized speed, I-ETMS, even with its added sophistication, comes no closer to providing this feature than the previous, less sophisticated PTC systems already described.

*Lesson Learned:* To do this safely, a typical freight train would need:

- A complete GPS/Tach/LDS system (the same as on a locomotive) on the rear end of the train to precisely locate its rear end relative to the head end of the following train in real time at all times. With the elimination of the caboose, where such a system could practically reside, this is not a practical solution (Note: Perhaps someday, when the interchange rules include requirements for electronic braking on freight cars with additional communications ability on freight train lines, freight trains could then conceivably have this feature in PTC.) OR
- A precise fail-safe method of measuring the exact length of a freight train, AND
- A vital integrity check of each train's length, ensuring that the rear end is always the same distance from the head end at all times once it is precisely measured. With all kinds of odd-length freight cars and no current means of providing a real-time train-length integrity-check with today's freight car train-lines, this also is not practical (see Note above). For those trains that still pick up and set out cars en route, this requirement would become an unenforceable nightmare.

In regard to ongoing hopes that PTC could be supported by making a “business case,” the current implementations of I-ETMS appear to be discovering that a so-called “business case” costs more than it is worth if it demands that the safety functionality be fully integrated on the same platform as all of the business features. The cost-effective approach to a good business case is to carefully limit the safety functions to only those that are absolutely necessary to operate the train safely and put them on a specially-designed “vital” safety platform. All other “business” features can be placed on a reliable but non-vital platform. This cardinal principle concerning signal and train control systems was discovered by signal engineers in 1928 when the first true CTC systems were invented. The interlocking of the signals and switches in the field required more costly “vital” fail-safe logic, but the controls from the central office to the field and the indications of the status of these devices coming back to the office could safely be accomplished through reliable but less costly non-vital logic. This principle is still valid today, and is still the basis for our large concentrated control centers.

*Lesson Learned:* The current signal infrastructure has much to teach the current generation in its quest for PTC. Once again, those who do not know history are doomed to repeat it.

Full integration of the new system into the existing operating culture requires a broad multi-disciplinary approach to ensure that existing engineers/operators, dispatchers/train controllers, train rules specialists, and wayside and on-board maintenance technicians will all begin to view the “new” system as integral to their normal duties and responsibilities.

*Lesson Learned:* As previously noted with ITCS, a system “started from a ‘scratch’” such as I-ETMS will be expected to take much longer to achieve its goals than the hybrid ATC/ACSES system previously described. Most engineers being asked to embrace I-ETMS have never operated trains in ATC territory before, except those who have operated on the UP under a two-speed ATC system (east of Omaha) and/or a four-aspect cab signal without speed control (west of Omaha). The concept of a train control screen display with a lot of real-time information is certainly a change from previous train control displays. It remains to be seen if the current screen display is able to optimally walk the fine line between showing truly useful information vs. becoming a distraction to the driver. Much thought, however, has gone into the integration of I-ETMS electronically into the current process of issuing paper authorities by dispatchers, so that both issuing and implementing employees should be well-schooled in the process that is used by I-ETMS to issue operating authorities other than those generated by signal aspects.

Training is continuing on Metrolink on a system that is not yet complete, and the manuals are still being written. Most other commuter lines committed to I-ETMS are waiting to begin this process. The additional sophistication and complexity of I-ETMS is expected to demand more training than has been required to operate and maintain ACSES and ITCS. Experience with the earlier systems points to a very long process with I-ETMS, and many employees must be thoroughly trained before revenue service is embraced system-wide. Many lessons with I-ETMS are yet to be learned.

*Lesson Learned:* Thorough training, well-documented manuals for each discipline, and a good pilot installation in revenue service are very important to fully integrate the “new” PTC into the existing operation. Trying to rush these things is not helpful.

Building on a valuable existing vital system such as CTC, in the case of I-ETMS, is expected to significantly reduce the cost in terms of developmental time and funding of fully implementing the chosen PTC system.

*Lesson Learned:* Again, the experience with ITCS suggests that the freight carriers applications of I-ETMS on busy CTC-equipped lines will help speed up the process of full implementation, but, for the most part, these lessons are still to be written in regard to I-ETMS.

I-ETMS was purposely developed without the use of in-track transponders by the freight railroads to eliminate the costs of these devices on locomotives and in the track structure. However, as in the ITCS effort, the lack of transponders complicates the LDS requirement and opens up an additional element of vulnerability to human failure if not properly addressed in the application engineering.

*Lesson Learned:* While application engineers have been successful in developing safe ITCS automatic cut-in points where there is more than one main track, it is our understanding that this has not been accomplished in any I-ETMS application to date. Thus, I-ETMS will differ from ATC/ACSES and ITCS in that it will require human input to initialize I-ETMS when the train will enter I-ETMS territory where there is more than one mapped main track. This significantly increases the risk of entering human error into the track selection process part of the LDS. Efforts should be made to mitigate this risk. If this type of risk mitigation can be accomplished in ITCS applications, these methods should also be explored for I-ETMS applications.

Train crew involvement in entering train consist data for train braking purposes introduces significant risk. While freight carriers may have their own reasons to insist on this approach, it is strongly questioned whether this approach should be extended to passenger trains.

*Lesson Learned:* In both ACSES and ITCS, this risk is mitigated by requiring only human input to select from a few simple “train types” that are easily-recognizable from simple consist descriptions and readily-verifiable as such in the Operating Employees’ Time Table (TT) Special Instructions (SI).

## Lessons Learned Common to All Applications Studied

- **General** – CBTC systems are normally highly-integrated systems including carborne, wayside, and central control systems. Upgrades required for any of the subsystems generally can be supplied only by the original manufacturer, locking the carrier into a sole-source supplier.
- **Design** – The design of a CBTC system normally incorporates the use of proprietary hardware and software components. Close attention should be paid as to how these hardware and software components will affect the operations and maintenance lifecycle.
- **Increased Equipment** – Even transit CBTC systems normally require a traditional back-up signaling system for failure recovery and broken rail detection. When applied to railroad carriers regulated by FRA, all applications of CBTC PTC to date have required retention of the existing signal system or a renewal of the existing signal system. The interface between the traditional signaling system and the CBTC system is not trivial and must be carefully managed. This practice also requires additional equipment to be maintained.
- **Hardware Availability** – The hardware components may be designed but not manufactured by the system vendor. Therefore, the need for additional spare parts could be affected by the long lead times required to justify the cost for limited manufacturing and startup expenses. Although

the specification typically calls for the availability of signal system hardware for 30 years, there is often no restriction on the cost of this requirement, which can become very expensive. A system using hardware components manufactured for other systems would be able to share these expenses and benefits of larger production runs.

- **Software Issues** – Vital system software is proprietary and often does not allow modification by the authority purchasing the system. This is a safety issue, and any liability associated with this and possible mitigations should be clearly understood by the designer and the carrier. Non-vital Operating Systems (OS) are primary interfaces with the computer hardware and application software. Therefore, the failure to update will eventually lead to an inability to use off-the-shelf hardware systems. Care should be taken to include contract requirements for operating system updates. The application software must be checked and possibly updated with OS updates. The update on the OS will eventually have some effect on the continued safety of the application software that will need to be resolved. The contract should include support for this requirement. If possible, it is recommended that application software be kept current with the latest versions.
- **Commissioning** – The initial startup of the PTC installation should be well-planned and comprehensive in nature. The process must be planned from the earliest stages of equipment procurement and construction. The commissioning of highly-integrated software and hardware systems requires the application of a good systems engineering and integration plan. Consideration must be given for the need to start testing of subsystems operation and integration requirements at the very basic levels of the installation. Conventional methods for testing of signal system must be revised for highly-integrated systems to assure comprehensive application and elimination of many reparative tasks that could otherwise result from failure to thoroughly test software subsystems up front. The more highly-integrated and complex the safety system, the more likely the possibility of unforeseen time and cost overruns involved in finally placing the system in revenue service.
- **Maintenance** – CBTC systems are more complicated and sophisticated than existing signal and train control systems, and maintenance personnel likely will need major training and their skills upgraded. Also, documentation of the as-built system including the need for software flow diagrams is important for the corrective and preventive maintenance process. Failure to procure such documentation for proprietary applications can lead to difficulties when troubleshooting. A comprehensive understanding of the FMEA analysis testing that identifies the indicators of potential safety failure is necessary for the System Safety Plans and the training of signal system staff to maintain the new PTC systems.
- **Operation** – These systems offer operating scenarios associated with design advantages that will be foreign to even the most skilled carrier operations management and line forces when installed for the first time. The

operations group needs to be well-trained in the operation management of the railroad system. Use of a simulator and comprehensive training prior to operation is critical. There should also be a consideration for on-the-job training for all employees working directly with the new systems. The development and implementation of a comprehensive system safety plan is critical to the safe operation of the new system.

- **Requirements Tracking/Limiting Custom Software Development** – All key stakeholders, including users and customers, should be part of the requirements phase to ensure a common understanding and agreement with what contractual requirements are to be included in the Final Design. Every effort must be made to identify the minimal requirements early in the program, to the end that everything that is needed is included in the initial contract up front. Each new requirement after the contract is signed requires custom software that must be developed, tested, safety analyzed, and verified. This effort concerning each new requirement is not trivial, and the actual need for each requirement should be thoroughly evaluated before adding it to the design.
- **Safety Certification** – Safety certification requires close cooperation between the supplier, the operating carrier, and the safety assessor throughout the design and installation of the system. These complex systems require education and understanding by all parties.
- **Test Facility and Test Track** – A local test track that is close to the installation site is invaluable in managing functional verification and training and the technical challenges that arise on all systems projects.
- **Training/Documentation** – These new systems are complex and require a significant amount of documentation and training. The carriers and the contractors need to collaborate to provide quality material when needed in a format that is useful (in most cases, in electronic format).
- **Submittals** – The submittal process needs to be tightly managed. A template or framework for submittals is required up front. Each submittal should be reviewed by only those that have a need to review it, and a limit needs to be set on the number of reviews.



# Evaluation of Shared-Track Systems and Identification of Changes Needed

This report section reviews the three primary North American PTC systems that are being investigated in this study for the purpose of determining how they can be applied, modified and/or enhanced to provide and enforce Temporal Separation and On-Demand Spatial Separation between conventional railroad trains that meet FRA crashworthy standards and lighter-weight passenger trains such as equipment often used in LRT. The three PTC systems under study in this regard are ATC/ACSES II, ITCS, and I-ETMS.

## Background

ATC/ACSES II and ITCS, having begun the long road to maturity in 1993 and 1994, respectively, have proven to be reliable and effective PTC systems for meeting the requirements of RSIA08 and the associated FRA PTC regulations.

ACSES overlaid on the existing ATC has been in operation since December 2000 on Amtrak's NEC between Washington, DC and Boston for operating speeds up to 150 mph, currently being upgraded to 160 mph. ITCS has been supporting Amtrak operation up to 110 mph on the AML since February 7, 2012, and on the UPRR in Illinois since November 22, 2012.

In addition, the BNSF ETMS system, a forerunner of the I-ETMS system, currently being developed by Freight Class I carriers, has been implemented on portions of the BNSF and has successfully demonstrated some PTC enforcements. ETMS has been applied primarily to freight-railroad mainlines and is not expected to support passenger train speeds exceeding 79 mph. ETMS is not considered "fail-safe" and is not part of this study.

ACSES II, ITCS, and I-ETMS are, or are planned to be, vital PTC overlays on top of conventional FRA-compliant, vital track-circuit-based signal systems. A version of ITCS has also been used in China in a "standalone" application.

## Changes Needed to Existing Systems

The review and analysis of the three primary PTC systems (ACSES II, ITCS, and I-ETMS) in Section 3 provided the background for determining the changes needed to prevent train-to-train collisions between non-compatible train types. The analysis concluded that certain current and planned functionalities of the three PTC systems can be used in Shared-Track Operations.

However, to permit comingled Shared-Track Operations and mitigate the additional hazards that arise from such operation, this research identified proposed enhancements that will be needed over and above the basic features already incorporated in the current PTC system capabilities or in their underlying signal system capabilities. To ensure separation between compliant and non-compliant train types, these enhancements and/or some other form of mitigation will be required regardless of which PTC system has been chosen for the corridor to be shared.

### Separation of Non-Compatible Train Types on Same Track

All three PTC systems provide or are expected to provide full protection at interlockings between trains on conflicting routes, and they also provide full protection between opposing trains on the same track, regardless of train type. However, all three PTC systems allow following close-in train movements on the same track and in the same block to be made at Restricted Speed enforced to 15 or 20 mph. By definition, the full measure of “Restricted Speed” can never be truly enforced, as it has two parts. The “cap” or maximum speed included in the Rule (i.e., 15 or 20 mph) can be enforced, but while the part of the Rule requiring the human driver to be vigilant and stop short of another train, obstruction, etc., can be aggressively displayed visually along with whistles, bells, or buzzers that must be initially or periodically acknowledged, the final stopping of the train short of a “hard-coupling” is left to the human driver.

Thus, in the case of a Restricted Speed operating-rules violation (e.g., failure to stop short of the preceding train), it would be possible for a railroad train to contact the rear of a preceding transit train at a maximum speed of 15 to 20 mph, and it would be similarly possible for a transit train to contact the rear of a preceding railroad train at 15 to 20 mph. This is a characteristic of all three PTC systems and is permitted by FRA Rule 236.1005(f), which is applicable to all train operations conducted anywhere on the “contiguous railroad system of the U.S.”

In the case of a rear-end collision between a railroad train and transit train, where one train is standing still and the following train is moving at 15 to 20 mph, regardless of which train is leading, the impact damage to the non-compliant

train is potentially more serious than that expected to occur during a similar incident involving two fully-compliant trains covered by FRA Rule 236.1005(f). An event that can be dismissed as a “hard-coupling” between compatible train types may result in actual damage to a non-compliant train with possible casualties, depending on the speed at the time of the collision and the magnitude of the difference in the buff strengths of the colliding vehicles.

The analysis presented in Appendix C, “PTC Options for Positively Separating Following-Move Non-Compatible Train Types on the Same Track,” describes how the three PTC systems and the underlying signal systems can be used, modified, and/or enhanced to provide positive separation between non-compatible train types operating on the same track and in the same direction. Mitigation of risk from rear-end collisions on the same track is significantly reduced with the required installation of PTC without any further enhancements, and this is presented as the “Base Case.” In addition, three possible options involving further enhancements to further protect non-compatible train types are explored.

### Protection between Non-Compatible Train Types on Parallel Tracks of Same Rail Line

On multiple-track rail lines, the simultaneous operation of mixed train types on closely-adjacent tracks creates the risk that any train on one track could derail, foul, and impact a transit train, whether compliant or non-compliant, on an adjacent track, and vice versa. Another exposure is that a “shifted load” on a freight train on one track can foul and impact a passenger train on an adjacent parallel track. Adding non-compliant trains to the above mixed-use scenario is likely to increase this type of risk to a certain extent, depending upon the crash-resistant qualities of the non-compliant trains.

To put this in the proper perspective, this is not a new risk problem created by commingling non-compliant trains with compliant trains, as history has recorded multiple train accidents on multiple track lines involving both passenger and freight trains in past years. While these accidents have been extremely rare in recent years, a few have caused serious to even catastrophic damage to passenger trains. While the overall risk to passengers from this type of event in more recent years has been very low, it continues as a low risk factor, normally mitigated by careful continued attention to and improvements in track structure, derailment counter measures, wheel-rail dynamics, and enforced standards involving the safe loading of freight cars. The Northeast Corridor is a good example of a dense-traffic, mixed-use environment where these mitigation measures must be vigorously pursued and practiced on a continuing daily basis.

For these scenarios, and the issue of Parallel-Track Protection (PTP) for tracks on the same rail line, the potential contribution of the PTC system would

be to prevent unacceptable simultaneous parallel-track operations between non-compatible train types. The question then arises as to what level of risk is unacceptable. While this threshold of risk is not readily quantifiable, and it would be beyond the scope of this study to attempt to quantify it, multiple-track systems, by their very nature, exist only because of the very high capacity required to carry large volumes of traffic. These multiple-track systems are considered very safe, and the level of risk per million train miles of collisions of any sort between trains on adjacent tracks is therefore expected to be lower than the risk of collision between trains on the same track.

Further, a study of multiple-track accidents over the years reveals that the most likely cause of catastrophic collisions between trains on adjacent tracks is as a secondary collision following a collision between two other trains on the adjacent track, followed by derailments on the adjacent track. Therefore, reduction of risk of collision between trains on the same track in multiple-track territory also results in a major reduction in the risk of potential collisions between trains on adjacent tracks. This report discusses some further possible mitigation enhancements concerning non-compatible train types on adjacent tracks Appendix D, but the need for such enhancements, or not, must be weighed carefully to avoid overly restricting the operation in multiple-track territory. Caution is urged here to avoid seeking the “perfect” risk-free environment that potentially could lead to a serious reduction in the very capacity for which the multiple-track infrastructure was designed, ultimately driving transit customers back to the highways to face a far more hazardous commute.

In looking at available enhancements to further reduce risk of parallel fouling of non-compatible train types, several enhancements will be considered. First, increased space between tracks, for example, will tend to decrease the risk of damage to trains on adjacent tracks by literally reducing the possibility of equipment on one track fouling equipment on the other track, regardless of the nature of the incident triggering the potential fouling. To support this concept, in cases where tracks are separated the typical legacy 12 ft. 2 in. track centers, or with more recent construction at typical 13 or 14 ft. track centers, if separation of main tracks is increased to 20 ft. or 25 ft., these increased track-center values have been used as a practical mitigation factor in reducing risk from traffic passing on an adjacent main track. An example would be to permit higher speeds on an active track when the separation is greater between the active track and a track out-of-service for maintenance work. This increased physical separation of parallel tracks has been recognized as a safety factor for roadway workers on the out-of-service track.

On former three- and four-track systems where an “inside” track has been removed due to changes in the nature of the traffic handled, the resulting

separation is approximately 24 ft. 4 in. or slightly less than 25 ft., and this has been used on these lines as a mitigation safety factor when planning and executing maintenance work. Another example is the former two-track UP line between Gibbon, and North Platte, Nebraska. A third main track was added to accommodate one of the heaviest concentrations of freight traffic in North America, and then the original tracks were completely rebuilt. As real estate was not an issue in this area, the three main tracks were purposely spread to 20 ft. track centers to ensure that traffic could continue to flow at full speed on any two tracks when a third track was out of service for maintenance.

While these are instances, and there are others, where increased separation is considered to be a parallel-track hazard mitigation factor, adequate data to actually quantify the acceptable level of additional risk, if any, and/or the level of mitigation provided by increased track separation is not currently available. Consistent with the lack of definition of the level of risk in adjacent-shared-track operation in the industry is the fact that the Federal Regulations are largely silent on this issue as well. FRA has not stipulated exactly what parallel-track protections are desired and/or required for such shared-use and shared-track operations. FRA's Shared Use Policy does not address these safety exposures, although FRA has required them to be addressed in temporal separation waiver applications.

Similar issues may arise when HSR Corridors involving some mixed traffic are involved, particularly when maximum speeds are planned to exceed the 160 mph maximum currently anticipated in the NEC. As a higher maximum speed than 160 mph elevates the operation into the next higher class of track, Class 9, with the attendant increased risk of damage accompanying still higher speeds should anything go wrong on an adjacent track, we may see additional mitigation requirements in regard to adjacent tracks attached to these ventures as well. While these issues are not in the scope of this study, the way they are addressed by FRA in HSR waivers could have some impact on the issues at hand.

For not-fully-FRA-compliant European-type railroad passenger trains, such as those being planned for Caltrain, FRA is expecting that these modern passenger trains will be authorized to operate commingled with conventional railroad trains. This certification is expected to be based on alternate methods of protecting the passengers (e.g., "crumple-zones") that will compensate for the lack of full compliance with FRA's current buff-strength standards. When the new broader crashworthy standards are met, this type of commingling is not expected to result in any requirement for special PTC protections over and above those enforcement functions already provided by the basic PTC systems.

However, FRA has had concerns about allowing LRT and other types of transit trains to operate on closely parallel tracks alongside opposite-direction, same-direction, and even stopped railroad freight trains, although FRA has never issued

a definitive set of general criteria, restrictions, or required protections. During informal discussions with FRA about this FTA study, FRA acknowledged that its Shared Use Policy does not address parallel-track operations between non-compatible train types on the same rail line.

The material in Appendix D, “PTC Options for Protecting Non-Compatible Train Types on Parallel Tracks of the Same Rail Line,” presents and analyzes a range of parallel-track conceptual PTC protections for shared-track operations between non-compatible train types.

This study does not address “parallel but separate” railroad and transit lines (with no physical connections between the two) within the same right-of-way (shared corridor). This is because transit lines normally are not equipped with railroad PTC systems. IDS can be a very practical alternative, or a crash-wall barrier, if the parallel exposure is not overly long. IDS applications can have an advantage of being solely under the control of the carrier needing the protection, and/or a physical barrier for short sections can be very effective with low maintenance. However, this parallel-but-separate rail lines scenario is not included within the scope of this study.

## Findings

For both same track and parallel-track scenarios for shared-track operations, the high level risk analysis presented in Appendices C and D provided results supportive of the various track-sharing scenarios that were reviewed. The following tables summarize the results the findings:

- Table 5-1 shows a summary of ST Options for positively separating following-move non-compatible train-types on the same track while
- Table 5-2 shows a summary of PT Options for reducing speeds of non-compatible train-types on parallel adjacent tracks.

**Table 5-1**  
*Summary of  
 ST Options for  
 Positively Separating  
 Following-Move Non-  
 Compatible Train  
 Types on Same Track*

Same-Track Following-Train Options	Estimated Accident Risk per IM Train Miles	Relative Incremental Cost	Comments
Pre-PTC and/or ATC Conditions	1.0(x)	NA	Unknown value of current risk without PTC, “x” likely “<<1”?
PTC Base Case	0.01(x) = 10 <sup>-2</sup> (x)	Zero	PTC System required regardless of shared use
ST Option 1 – Standard PTC System with additional rules for Absolute Automatic Block Signals (AABS)	0.001(x) = 10 <sup>-3</sup> (x)	Cost of preparing and distributing new rules only	PTC System unchanged but new Operating Rules and/or Special Instructions would be placed in effect
ST Option 2 – Standard PTC System with Enforced AABS	0.0001(x) = 10 <sup>-4</sup> (x)	Moderate	PTC Application Engineering but not system-design changes required; some underlying signal system modifications required
ST Option 3A – Field Logic added to signal system for selective enforcement of AABS	0.0001(x) = 10 <sup>-4</sup> (x)	Significant	Partially restores some capacity lost in ST Option 2; new vital signal field logic and exclusive entry points required
ST Option 3B – Local field logic added to signal system and Positive Train Identification (PTI) system for selective enforcement of AABS	0.0001(x) = 10 <sup>-4</sup> (x)	High	Partially restores some capacity lost in ST Option 2; new vital signal field logic required plus PTI
ST Option 3C – Same as 3B except local field logic is concentrated in Safety PTI Processors (SPTIPs)	0.0001(x) = 10 <sup>-4</sup> (x)	High	Partially restores some capacity lost in ST Option 2; new vital signal field logic required plus PTI
ST Option 3D – alternative to Options 3A, 3B, and 3C when one carrier is unable or unwilling to equip its fleet with IDs for PTI	0.0001(x) = 10 <sup>-4</sup> (x)	High	Partially restores some capacity lost in ST Option 2; new vital signal field logic required plus PTI for LRTs

**Table 5-2**  
*Summary of PT Options for Reducing Speeds of Non-Compatible Train Types on Parallel Adjacent Tracks*

Adjacent-Parallel-Track Options	Estimated Accident Risk per IM Train Miles	Relative Incremental Cost	Comments
Pre-PTC and/or ATC conditions on same track as “ST Benchmark”	1.0(x)	NA	Unknown value of current risk without PTC, “x” likely “<<1”?
Pre-PTC and/or ATC conditions on parallel track as “PT Benchmark”	10 <sup>-6</sup> (x)	Zero	PTC system is required regardless of shared use.
PT Option 1 – ATC/ ACSES PTC: Add PTP to signal system and adapt ATC portion of PTC to display and enforce PTP. PTP speeds to match ATC speeds.	10 <sup>-7</sup> (x)	Cost to add PTP to signal system + PTC application engineering	If ATC and PTP speeds can be matched, PT Option 1 expected to give best performance in multiple-track dense-traffic territories with least cost.
PT Option 2 – ACSES w/o ATC: Add to PTP to signal system and adapt ACSES to display and enforce PTP speeds as additional interlocking route speeds.	10 <sup>-7</sup> (x)	Cost to add PTP to signal system + PTC application engineering	PT Option 1 preferred with ATC; PT Option 2 not as fast as PT Option 1, but less need for speed in lighter traffic.
PT Option 3a – ITCS PTC Add PTP to WIUs and adapt ITCS “Signal Speeds” to display & enforce PTP	10 <sup>-7</sup> (x)	Cost to add PTP to WIUS + other PTC app. engineering	PT Option 3a expected to be least costly and easiest to implement of PT options outside NEC.
PT Option 3b – ITCS PTC: Add PTP to WIUs and adapt “temporary speeds” to display and enforce PTP.	10 <sup>-7</sup> (x)	Cost to add PTP to WIUS + other PTC application engineering	PT Option 3b expected to be slower in performance than 3a; ITCS most mature of CB PTC systems, but expected to be the least deployed.
PT Option 4a – I-ETMS: Add PTP to signal system and adapt I-ETMS “signal speeds” to display and enforce PTP.	10 <sup>-7</sup> (x)	Cost to add PTP to signal system + PTC application engineering	Implementation of PT Options 4a and 4b could be quite difficult in near term due to I-ETMS immaturity; however, outside NEC it is prevailing PTC.
PT Option 4b – I-ETMS: Add PTP to signal system and adapt I-ETMS “temporary speeds” to display and enforce PTP.	10 <sup>-7</sup> (x)	Cost to add PTP to signal system + PTC application engineering	PT Option 4b expected to be slower in performance than 4a; early implementation of I-ETMS expected to be high risk.



# Demonstration Project Using PTC for Shared Use of General Railway System

This report section outlines the essentials of a demonstration project to address the most pressing needs for mitigation of risk in developing safe shared corridors. The demonstration project will be focused on those particular safety concerns addressed in the report sections and will seek cost-effective applications of existing technologies to create practical solutions designed to reduce the risk of commingling non-compatible equipment types to the maximum possible extent.

The material presentation in this report section can provide the basis for preparing an SoW for a technical specification for selected suppliers to carry out a demonstration for a partnership consisting of a railroad carrier, an LRT carrier, FRA, and FTA, leading to a practical installation in a specific shared corridor.

The proposed demonstration should be designed so that the project, when fully vetted and enhanced in accordance with the experience gained during installation and testing, could remain in place for revenue service for the life of the equipment, both wayside and on-board. In this regard, the demonstration project could actually become a generic template for a pilot project for an actual installation in a specific shared corridor. Also, in this regard, the demonstration project can build on the experience of the authors of this research report in the development of the ACSES and ITCS projects, both of which began as demonstration/pilot projects in the same manner as will be described.

## Background Information for Selection of Items to be Demonstrated

The outline of the demonstration project draws on the very high-level risk assessments described in Section 5. While these risk assessments are arguably highly subjective without the availability of comprehensive data from historical records, the relative orders of magnitude represented in these risk assessments are of sufficient value to select the particular risk scenarios that are presented below.

Section 5 presented six options to address the risks associated with the operation of commingled non-compatible equipment on the Same Track (ST Options) and six options to address the risks associated with the operation of commingled non-compatible equipment on Parallel Tracks (PT Options), where stakeholders are concerned about the potential for adjacent track collisions following derailments, shifted lading, etc.

The comparison tables provided in Section 5 (Tables 5-1 and 5-2) are repeated as Tables 6-1 and 6-2 and include highlights and specific observations following each.

## Observations on Shared-Track Options

As noted in Table 6-1, ST Options 1 and 2 are not challenging technically nor adequate operationally. ST Option 1 can be accomplished through rules/instructions and lacks any form of enforcement. ST Option 2 restrains capacity with indiscriminate enforcement of all trains, which may not be acceptable in many cases. However, ST Options 3A, 3B, 3C, and 3D could prove useful to future developers of typical shared corridors, and all four of these options will require some additional work not currently “on the industry’s shelf” to safely achieve the desired functionality described in each option. These four options are shaded in Table 6-1.

**Table 6-1**  
*Summary of  
 ST Options for  
 Positively Separating  
 Following-Move Non-  
 Compatible Train  
 Types on Same Track*

Same-Track Following-Train Options	Estimated Accident Risk per IM Train Miles	Relative Incremental Cost	Comments
Pre-PTC and/or ATC Conditions	1.0(x)	NA	Unknown value of current risk without PTC, “x” likely “<<1”?
PTC Base Case	0.01(x) = $10^{-2}(x)$	Zero	PTC system required regardless of shared use.
ST Option 1 – Standard PTC system with additional rules for AABS	0.001(x) = $10^{-3}(x)$	Cost of preparing and distributing new rules only	PTC system unchanged but new operating rules and/or special instructions would be placed in effect.
ST Option 2 – Standard PTC system with enforced AABS	0.0001(x) = $10^{-4}(x)$	Moderate	PTC application engineering, but no system design changes required; some underlying signal system modifications required.
ST Option 3A – Field logic added to signal system for selective enforcement of AABS	0.0001(x) = $10^{-4}(x)$	Significant	Partially restores some capacity lost in ST Option 2.; new vital signal field logic and exclusive entry points required.
ST Option 3B – Local field logic added to signal system and PTI system for selective enforcement of AABS	0.0001(x) = $10^{-4}(x)$	High	Partially restores some capacity lost in ST Option 2; new vital signal field logic required plus PTI.
ST Option 3C – Same as 3B except local field logic concentrated in Safety PTI Processors (SPTIPs)	0.0001(x) = $10^{-4}(x)$	High	Partially restores some capacity lost in ST Option 2; new vital signal field logic required plus PTI.
ST Option 3D – Alternative to Options 3A, 3B, and 3C when one carrier is unable or unwilling to equip its fleet with IDs for PTI	0.0001(x) = $10^{-4}(x)$	High	Partially restores some capacity lost in ST Option 2; new vital signal field logic required plus PTI for LRTs.

It should also be noted that Options 3A, 3B, 3C, and 3D have five significant similarities:

- Each of these four options will require new fail-safe logic to safely carry each train’s positive identity as to its general category from block to block once it is positively identified. The basic categories are LRT, Railroad Passenger, and Railroad Freight, and the new system is called PTID (Positive Train ID).

- Each option is seeking new technology to safely and selectively achieve the AABS enforcement only on those train-type combinations that need it, thus restoring some capacity to lines that will not accept the solution presented in Option 2. This need arises from the capacity restraints with the indiscriminate enforcement of all trains in Option 2, which may not be acceptable in many cases.
- All four options are “generic” in regard to which PTC system would provide the actual enforcement. The selection of the enforcing PTC would be driven entirely by the greater region surrounding the shared corridor, as that selection is driven largely by the interoperability requirements of all the FRA-governed railroads in that region. Stakeholders in the development of the shared corridor likely will not have any input into the determination of which PTC system will apply.
- All four options are designed to mitigate the risk of collision involving incompatible equipment types on the same track.
- All four options fall in the same category as to their estimated order of magnitude of risk mitigation.

Note also that there are two significant differences among the four ST options:

- ST Option 3A differs from the other three in that it does not require costly labeling of train types and wayside readers to positively identify each train. This option relies totally on the exclusive nature of the original entry point of each train. This is the preferred arrangement, with no need to introduce costly PTID.
- ST Option 3D differs from the other three in that it attempts to deal with major railroad carriers that resist dedicating a captive fleet for operation in a relatively short shared corridor. Only LRTs could follow each other in any AABS block.

## Observations on Parallel-Track Options

As noted in Table 6-2, the six options shown, PT Options 1 through 4b, have three characteristics that set them apart from the ST Options listed in Table 6-1:

- All six PT options have estimated risk assessments three orders of magnitude less likely than the shared-track ST Options presented in Table 6-1.
- The PT options are about displaying and enforcing speed reductions, not about enforcing absolute block.
- Each PT option targets a specific PTC system, i.e., these options are NOT “generic” when it comes to each PT option.

**Table 6-2**  
*Summary of PT  
Options for Reducing  
Speeds of Non-  
Compatible Train  
Types on Parallel  
Adjacent Tracks*

Adjacent-Parallel Track Options	Estimated Accident Risk Per IM Train Miles	Relative Incremental Cost	Comments
Pre-PTC and/or ATC conditions on same-track as a “ST Benchmark”	1.0(x)	NA	Unknown value of current risk without PTC, “x” likely “<<1”?
Pre-PTC and/or ATC conditions on parallel-track as a “PT Benchmark”	10 <sup>-6</sup> (x)	Zero	PTC System required regardless of shared use.
PT Option 1 – ATC/ ACSES: Add PTP to signal system and adapt ATC portion of PTC to display and enforce PTP. PTP speeds to match ATC speeds.	10 <sup>-7</sup> (x)	Cost to add PTP to signal system + PTC application engineering	If ATC and PTP speeds can be matched, PT Option 1 expected to give best performance in multiple-track dense-traffic territories with least cost.
PT Option 2 – ACSES w/o ATC: Add to PTP to signal system and adapt ACSES to display and enforce PTP speeds as additional interlocking route speeds.	10 <sup>-7</sup> (x)	Cost to add PTP to signal system + PTC application engineering.	PT Option 1 preferred with ATC; PT Option 2 not as fast as PT Option 1, but less need for speed in lighter-traffic.
PT Option 3a – ITCS PTC: Add PTP to WIUs and adapt ITCS “signal speeds” to display and enforce PTP.	10 <sup>-7</sup> (x)	Cost to add PTP to WIUs + other PTC application engineering	PT Options 3a and 3b expected to be least costly and easiest to implement of PT options outside NEC.
PT Option 3b – ITCS PTC: Add PTP to WIUs and adapt “temporary speeds” to display and enforce PTP.	10 <sup>-7</sup> (x)	Cost to add PTP to WIUs + other PTC application engineering	PT Option 3b expected to be slower in performance than 3a; ITCS is most mature of CB PTC systems, but expected to be least deployed.
PT Option 4a – I-ETMS: Add PTP to signal system and adapt I-ETMS “signal speeds” to display and enforce PTP.	10 <sup>-7</sup> (x)	Cost to add PTP to signal system + PTC application engineering	Implementation of PT Options 4a and 4b could be quite difficult in near term due to I-ETMS immaturity; however, outside NEC is prevailing PTC.
PT Option 4b – I-ETMS: Add PTP to signal system and adapt I-ETMS “temporary speeds” to display and enforce PTP.	10 <sup>-7</sup> (x)	Cost to add PTP to signal system + PTC application engineering	PT Option 4b expected to be slower in performance than 4a; early implementation of I-ETMS expected to be high risk.

The basic reasons behind these three characteristics are as follows:

- In Section 5, these levels of risk on parallel tracks (vs. same track) were explored in more depth. Note particularly that these estimated orders of magnitude only take into account the probability that any kind of collision between equipment on adjacent tracks will ever happen. They do not account for the severity of collateral damage that may accompany such an accident in the rare case that it could happen. It is for this reason that stakeholders developing shared-track options may still need to consider PT options designed to mitigate the severity of an adjacent parallel-track collision should it ever take place.
- To mitigate the possible severity of an adjacent parallel track collision between non-compatible equipment, there is some history with FRA that speed reductions on trains at the time they are passing each other on adjacent tracks may provide an acceptable safety mitigation of the risk involved.
- In the case of the PT options, each PTC system is explored as the enforcement tool used to enforce the speed reductions that may result from the negotiations with FRA. As was seen in Section 5, the PT options presented take advantage of the individual characteristics of each PTC system.
- As these characteristics differ in each of the PTC systems reviewed, this requires that each PT option be treated individually, based upon the PTC system that will have already been selected by the regional stakeholders in the region within which the shared-track corridor is likely to be a much smaller part.

Also noted is that four of these six PT options, Options 1, 2, 3a, and 4a, have been highlighted in PT Table 6-2. These four PT options use the PTC system's own particular "signal speed" enforcing mechanism (different in each PTC system) to enforce speed reductions required when passing incompatible equipment on an adjacent track.

The other two PT options, Options 3b and 4b, are not highlighted as they use the temporary speed enforcement mechanism in ITCS and I-ETMS, respectively, and it would appear that the "signal speed" approach would provide superior performance. Use of the temporary speed feature, if it should become necessary, is expected to increase the latency, possibly to an unacceptable level, and would be investigated only as a last resort.

## Basic Considerations for Proposed Demonstration Project

In the development of the demonstration project, we propose concentrating on the two basic safety issues regarding operation of incompatible equipment in a shared corridor:

- Enforcement of absolute block on the same track
- Enforcement of reduced speeds when incompatible equipment is passing on closely adjacent parallel tracks without barriers or other adequate physical separation, as an option when the stakeholders determine that it will be required

Further considerations entering into the selection of the demonstration project are the following:

- The demonstration must be practical to the extent that it should be able to be accomplished through available technology applied through some additional creative engineering.
- It must address the basic issues presented above.
- It should be presented in sufficient detail that it can be used as a template for a SoW that can be included in a Request for Proposal (RFP) for an actual system designed to mitigate the risks associated with operation of incompatible equipment in a shared corridor.
- It should be flexible enough in description that it can be used with any one of the three PTC systems or enhanced versions of one of these three systems that may already be in place where any future shared corridor operation in North America may be planned.
- Referring again to Table 6-1 and Table 6-2, we will focus on the highlighted options as the bases for the Demonstration Project, namely
  - ST Options 3A, 3B, 3C, and 3D for enforcing absolute block on the same track in AABS territories, and
  - PT Options 1, 2, 3a, and 4a for enforcing speed reductions for incompatible equipment consists when included in trains passing one another on adjacent tracks. This will be included in the SoW template as an option.

## Basic Outline of Demonstration Project

The project to outlined below consists of an SoW that covers the following items:

- Need for Project – Brief Background
- Purpose of Project
- Operational Requirements
- Scope of Technical Work Required
- Deliverables
- Outline of Test Plan

## Demonstration Project: Use of PTC and Signal Systems to Mitigate Risk in a Shared Corridor – A Generic Template for a Pilot Program

The intent of the following is to describe a demonstration project in sufficient detail, but that also will be sufficiently generic to be used with any signal and PTC system in the U.S. and flexible enough to apply in any given shared corridor with its own unique physical and operational characteristics.

### Need for Project – Brief Background

As the populations of our urban areas continue to grow, traffic congestion is increasingly placing demands for new transit solutions. Where existing rail corridors exist, along with downtown passenger terminals and a more centrally-located subway and/or elevated distribution system, these systems can be enhanced to provide first-class regional-rail commuter systems supplemented by heavy-rail transit closer into the city center. These systems normally operate equipment that is fully compliant in regard to FRA crashworthy standards.

However, many rapidly-growing urban areas still have operating freight corridors, but no longer (or never did) have central passenger stations or heavy rail that can be enhanced to provide these services. Much of the former rail infrastructure that supported passenger services terminating in urban centers has been lost in the last five decades following the World War II.

In searching for affordable solutions for these urban areas, we turn to light rail to provide a one-seat ride from the suburbs to the central-city destinations



providing the jobs and services that are increasingly needing improved transportation. Some advantages of the LRT solution in these areas are the following:

- Downtown destinations can be reached by much-less-costly street operation than the preferred solutions requiring costly tunneling. Traffic signal coordination can be used to help mitigate some of the delay that occurs when the downtown distribution portion of the journey does not have the luxury of the private right-of-way that tunneling provides.
- The suburbs often can be reached by sharing rights-of-way with existing freight railroad operations, greatly reducing the cost of land acquisition.
- The train equipment of lighter construction can often be purchased “off-the-shelf” from a large number of competing firms potentially reducing the cost for procuring up-to-date trainsets.

However, the desired train equipment usually does not meet the FRA crashworthy standards required to operate in the shared corridors. The simplest solution, temporal separation, has been used in a few shared corridors to ensure that incompatible equipment is never operated in shared infrastructure at the same time.

While temporal separation has been used as a simple device to meet the real need for spatial separation, this is not a satisfactory solution where the operation of either or both the freight service and the LRT service requires a much more efficient use of the existing or enhanced capacity of the line being shared. This will require On-Call Spatial Separation (OCSS).

This demonstration will address the safety issues raised by these efforts to maximize the use of existing rail infrastructure through OCSS. The goals of the OCSS development will be to do this with minimum impact on the capacity of the shared facilities and to reduce potential delays to incompatible trains operating in close proximity to each other.

### Purpose of Project

The purpose of the OCSS project is to demonstrate the use of current “cutting-edge” signal and PTC technologies to mitigate the exposure that results when trains with consists of non-compatible equipment operate in a shared corridor. This demonstration project will address the following two areas of concern:

- The need to enforce spatial separation between trains with non-compatible equipment operating on the SAME TRACK without having to wait for a pre-selected block of time
- The need, in some cases, to enforce specified speed reductions when trains with consists of non-compatible equipment are passing each other on closely adjacent PARALLEL TRACKS, where adequate physical separation by

crashwalls, different elevations, or other structural protection is not available or practical

While the first issue has been addressed by manual temporal separation and the second by arbitrary speed reductions, these remedies will not be satisfactory for most new projects, due to inefficient use of existing track capacity in the case of temporal separation and due to unnecessary increases in trip running time in the case of arbitrary speed restrictions. Further, neither of these remedies have adequate provision for enforcement of these arbitrary restrictions.

The specific purpose of this project, then, is to find a technical solution, or a set of technical solutions, to provide a safe and affordable commingling of the non-compatible LRT trainsets (which do not meet FRA crashworthy standards) with heavy railroad freight equipment and/or passenger equipment that is designed to meet FRA standards. The demonstration will be designed to explore the practical possibilities of a typical application of OCSS to accommodate new shared corridors where anticipated levels of LRT traffic, freight traffic, and/or conventional passenger traffic are too great to consider sharing the corridor with current arbitrary methods of separation.

### Operational Requirements

On the same track (or tracks), OCSS will require positive identification of each train's compatibility type, enforcement of absolute blocks, and new fail-safe signal logic to process and carry forth the correct mode of each block in real time.

On closely-adjacent parallel tracks, where it is also deemed necessary to mitigate the risk of collision between non-compatible trainsets, this will be done by arranging for certain pre-specified speed reductions. This effort also will require some additional vital, fail-safe signal logic not currently available in the U.S. While this feature is not really "spatial" separation, it has been identified as a potential risk at normal passing speeds on adjacent tracks, and mitigation by On-Call Speed Reduction (OCSR) will be included in our OCSS model as an added OCSR Option.

The OCSS demonstration project, hereafter referred to as the OCSS Demo, will address these two major issues in very specific ways:

- Incompatible train equipment operating on the same track will require incompatible train types to be kept separate through PTS enforcement of Absolute-Block at all controlled block entry points. The OCSS Demo described here-in will be expected to use the PTC system already chosen by the owner and/or operator of the corridor to be shared. This local PTC system will be the agent of enforcement by means of its PTS feature.
- Provision for incompatible train equipment operating on parallel tracks at the same location at the same time also will be included as the OCSR Option to

enforce certain specified reduced speeds when the trains are passing each other on closely-adjacent tracks that cannot be adequately separated by barriers or other physical means. The local PTC system's speed enforcement feature will be used as the medium of enforcement.

The OCSS Demo (including the OCSR Option) also is expected to consider in its design the need to expedite the movement of all services to the maximum possible extent, both those that meet FRA's crashworthy standards, and those that do not, consistent with the safety restrictions required for safe operation. The Demo will accomplish this by positively identifying the category of each train approaching the shared trackage and vitally tracking each train with its category classification in a fail-safe manner, first to ensure that the restrictions will always be applied when the safety issue exists that the restriction is designed to mitigate, and then to release the restriction when it can be vitally proven that the safety issue is no longer present.

All failures in accomplishing the above primary task must default to the safe side, regardless of the source of the failure. This is the primary consideration. The Demo's second challenge will be to minimize the impact of these restrictions on each of the commingled services, by removing these restrictions as quickly as it can be positively determined that it is safe to do so.

### *Specific Operational Requirements – Concept of Operations (Con-Ops)*

The required operation to be demonstrated in OCSS Demo will be based on a typical section of double-track railroad between two "interlockings" or "controlled points," depending on which Operating Rules culture prevails in the area of the shared corridor. This is illustrated in Figure 6-1, showing a typical interlocking-to-interlocking section of double-track.

**Figure 6-1**  
*Typical double-track  
railroad mainline with  
bi-directional signaling*

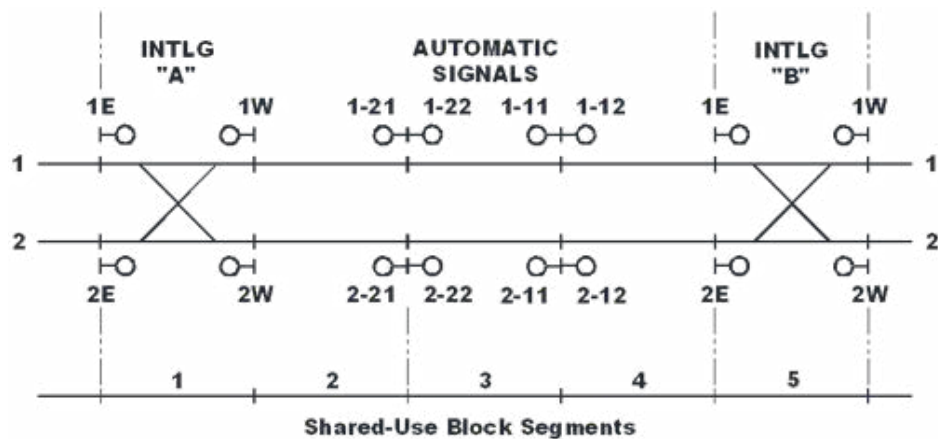

While the demo is to be designed so that it can be applied to any number of such double-track, multiple-track, or single-track contiguous sections to cover an entire shared corridor, a single section of double-track will be the simplest unit to work with in this generic description of the concept. Once the essentials of this double-track “template” application are fully described, with all of the requirements to be included in the OCSS Demo, the actual application on any desired track configuration in a future shared corridor should be a straightforward process.

Figure 6-1 shows a “generic” double-track section of railroad between two interlockings, “A” and “B,” respectively, with all signal numbers shown for easy reference. The track numbers at each end of the illustration and the numbers of the Block Segments also are shown for easy reference. The Block Segments are a new concept introduced for this demo.

Note that the Block Segments are congruent with the limits of the traditional signal blocks, as Figure 6-1 is used to illustrate the same track case. While the Block Segments are not needed for the same track case, they are defined to include the adjacent signal blocks on both tracks for the specific purpose of developing the parallel-tracks case. The need for this will be introduced later with the concept of Parallel Track Protection (PTP) and the Parallel-Track OCSR Option.

### *Requirements for Providing OCSS between Trains Having Incompatible Equipment on the Same Track*

The concept to be demonstrated to mitigate risk associated with non-compatible trains (in regard to crashworthy standards) following one another on the same track will require:

- Positive Identification (Pos ID or PID) of the correct train type of each train entering the shared corridor, i.e., T (LRTs), RP (RR-PSGR), RF (RR-FRT), or UNK. (Unknown). This initial PID can be assigned from the entry point of each train only when the different train types enter at exclusive entry points, where it is known that trains of other train types will never enter.
- If the shared corridor does not have exclusive entry points for each train type, a separate PID system will have to be developed and approved by the contracting railroad and/or authority.
- When the OCSS Demo will include only the Same Track option, only the RR (both PSGR and FRT) and the T (LRT) train types will need to enter at exclusive entry points to avoid the need to develop a separate PID system.
- However, if the Demo also includes the Parallel Track OCSR Option, the RP (RR-PSGR) and RF (RR-FRT) train types will be considered as separate train types, each needing its own exclusive entry point to avoid the need

for a separate PID system. In many (if not most) cases, the inclusion of the Parallel-Track OCSR Option will likely require a fail-safe PID system.

- The PID of each train type must be carried forward with the train from block to block, similar (in analogy only) to train IDs on modern dispatcher display screens. However, each PID must be forwarded vitally in the field with the train in a fail-safe manner in the fail-safe logic process. The PID must accompany the train congruent with the train's actual physical block occupancy and its vitally represented block location within the vital logic process. This specific vital logic is not known to be currently available in any existing fail-safe application anywhere in North America, but it is believed that it is now possible to develop it.
- Any failure to positively identify or properly carry the PID forward must default on the safe side, regardless of the source of the failure. Such failures might include, but not be limited to:
  - Failure to positively capture the PID initially with all necessary security code information. The proper default would be train type UNK.
  - Failure to positively carry the PID forward with the train for any reason, with all necessary security code information, including loss of normal progression from track circuit to track circuit. The proper default would be train type UNK.
  - While more sophisticated tracking methods to positively recover the correct PID in the event of a track circuit “bobble” is encouraged, such methods must be thoroughly vetted to ensure that an unsafe outcome is prevented. Any error detected in this process must default to UNK.
- The fail-safe logic process must have sufficient self-checking to ensure that this is the case at all levels of the process, including input from other sources, such as abnormal progression of track circuit inputs. Failure to meet the necessary self-checking requirements must default to UNK.
- The system must have the ability to enforce absolute block at each block-entry-point when the train type of the train seeking entry to that block on the same track is not compatible (in regard to crashworthy standards) with the train type of any train already in that block. For trains on the Same Track OCSS, Table 6-3 illustrates the concept, and will apply to each individual single track block in the illustration in Figure 6-1.

**Table 6-3**  
*OCSS Demonstration*  
*– Same Track – Block*  
*Entry Restrictions*

Train at Entrance to Block	Enforcement	Train in Block
T	*OK to FOLLOW*	T
T	STOP/STAY	RR (PSGR or FRT)
T	STOP/STAY	UNK
RR (PSGR or FRT)	STOP/STAY	T
RR (PSGR or FRT)	*OK to FOLLOW*	RR (PSGR or FRT)
RR (PSGR or FRT)	STOP/STAY	UNK
UNK	STOP/STAY	T
UNK	STOP/STAY	RR (PSGR or FRT)
UNK	STOP/STAY	UNK
T, RR or UNK	OK to ENTER	BLOCK UNOCCUPIED

[\*at Restricted Speed]

All enforcements in the above scenarios are to be implemented with the fail-safe PTS feature in the PTC system installed on the railroad(s) operating in the corridor shared with the LRT. The location of the shared corridor will largely determine which PTC system will already have been chosen for the region within which it is located, and it will likely be one of the following FRA type-approved systems, or an approved variance primarily based on one of these systems, as follows:

- ATC/ACSES, or
- ITCS, or
- I-ETMS

This approach would require the LRT system also to adopt the PTC system of the railroad(s) operating in the shared corridor. However, as this may not be in the best interest of the LRT system as a whole, which may already be committed to a different train control system on other lines, please see the following paragraph for a possible alternative.

- Enforcement of RR trains' PTS by the FRA-governed RR PTC system and enforcement of T (LRT) trains' PTS by an approved Train Control (TC) system with a vital PTS feature used elsewhere on the LRT system, may be an acceptable alternative arrangement when approved by all stakeholders, FRA, FTA, railroad(s) and LRT authority. The good news is that the location of the vital PID and Block Forwarding logic, once developed within the underlying signal system, will allow the required PTS to be enforced independently by two different enforcement systems interacting with a common signal system.
- Other alternative arrangements to enforce PTS on the same track will require full approval of all stakeholders listed above. In all cases, final approval by FRA and FTA will be required to successfully complete the work stated in this contract.

*OCSR Option for Enforcing Reduced Speeds when Trains Consisting of Incompatible Equipment Pass Each Other on Closely Adjacent Parallel Tracks, When Required*

The concept to be demonstrated is designed to mitigate risk associated with closely adjacent parallel tracks where adequate physical separation of the tracks is not possible or cost effective. It is to be used when it is determined that certain pre-defined speed reductions should be enforced to mitigate the possible damage resulting from a potential derailment of, or a lading shift on, an adjacent freight train.

Conceptually, there would be four operating modes and one “idle” MODE for each Block Segment of double track having less than adequate physical separation between closely adjacent parallel tracks. For the following, it will be useful to define the term Block Segment as the two single track blocks immediately adjacent to each other on closely adjacent parallel tracks. The limits of the two blocks must be at precisely the same location on each track, and the PTP logic will include both tracks in the process.

OCS Demonstration – Parallel Tracks with OCSR Option

- MODE RR – No T trains present; RP and RF trains may proceed at Normal Passenger speeds (S=NP) or Normal Freight (S=NF) speeds, respectively.
- MODE T – No RP or RF trains present; T trains may proceed at S=NT.
- MODE RRP-T – Both T and RP trains present; T trains enforced to lower speed S=TI and RP enforced to lower speed S=RPI. This scenario will not be permitted when there is a RF train present. See MODE RR-T.
- MODE RR-T – Both T and RF trains present; T trains enforced to lower speed S=T2 and RF trains enforced to lower speed S=RFI. Under this scenario, any RP trains present would be restricted to speed S=RPI. Normally, it would be expected that T speed S=T2 would be lower than S=TI, and RF speed S=RFI would be lower than RP speed S=RPI, due to heavier equipment operated in RF trains in North America.
- MODE NONE – The Block Segment is unoccupied and no MODE has been called for by the Vital PTP Logic or the Vital PTP Logic Forwarding system. This is the idle state, waiting for the next call to prepare the way for the next train type to enter the Block Segment

The actual speeds, TI, T2, RPI, and RFI, to be enforced in the above scenarios when this option is required will be those negotiated among all stakeholders and finally approved in a formal directive issued by FRA.

The implementation of speeds TI, T2, RPI, and RFI must never authorize a train to exceed the governing permanent and temporary speed restrictions or to violate signal-system prescribed speeds or stops. Thus, if Speed TI is 45 mph

(for example) and in effect, and the permanent MAS speed is 30 mph, and a TSR requires 15 mph, the 15 mph speed would be enforced.

The first essential principle is that the lower speed of all speed braking profiles being calculated at any given time is always to be displayed and enforced by the PTC.

This is not a new concept to PTC, but the new speeds, T1, T2, RPI, and RFI, are added to the mix of speeds that must be monitored and included in the real-time calculations of the master penalty braking profile. In the subsequent discussion, T1, T2, RPI, and RFI speeds are referred to as PTP (Parallel-Track Protection) Speeds.

The second essential principle to be demonstrated is that absolute-stop signals will be used to hold trains clear of all Block Segments until it can be positively determined that there are no non-compatible trains on the adjacent parallel track between the limits of the Block Segment or those non-compatible trains have been properly identified and have had time to reduce to the proper PTP speed for each positively identified trainset. This will require new external PTP control logic for the traditional intermediate automatic signals, and the interlocking and/or controlled-point home signals must be “jointly controlled” by the new PTP control logic as well as through the existing dispatcher controls. “Joint control” means that in order for any absolute-stop signal to change from displaying “STOP” to a more permissive aspect, the signal must receive a release from both the dispatcher and the fail-safe PTP logic.

A feature of this concept is that, depending on the scenario, the different PTP speeds will be defined and enforced under each scenario for each different train type. The enforced speeds in one shared corridor can be different than those in other shared corridors on other lines with different philosophies, factors and rulings from FRA.

*Operations Concept of OCSS Demonstration  
(to Demonstrate OCSR in a Practical Application)  
Combining Single Track OCSS with Parallel-Tracks  
OCSR Option on Double-Track Shared Corridor*

As illustrated in Figure 6-1, the double-track line is subdivided into Block Segments of parallel tracks congruent with the Automatic Blocks on each track between Interlockings A and B. These Automatic Blocks are spaced to meet the SBD requirements and the signal aspects displayed. Shorter blocks (made possible by multiple-aspect signals) and more of them in a given distance, will reduce train delays after non-compatible train types pass each other. All of the modes of the intermediate Block Segments will be set for the first train admitted to either double-track portion between two adjacent interlockings, prior to that



train's receiving the signal to enter the interlocking to interlocking portion of track containing the series of blocks and block segments.

Note that the shared-use block segments in Figure 6-1 have been matched to the signal blocks. All shared-use Block Segments include both tracks, and each segment will be set to one of the four modes, based upon "first come first served." This concept will require some pre-planning on the part of the dispatcher concerning the order in which signals are displayed for various train types, but the dispatcher will also have control over who goes first in order to give preference to the trains needing preference and to avoid disrupting the steady movement of a tonnage freight train (for example) through the shared trackage to mitigate the possibility of train-handling problems such a disruption might trigger.

Admission to the interlocking-to-interlocking portions of track at Interlockings "A" and "B" will be predicated upon:

- the Home Signal being cleared by the dispatcher, and
- the conditions spelled out in the matrix shown in Table 6-3 for the Same Track OCSS, and
- the requirements detailed in OCSS Demo for the Parallel-Tracks OCSR Option.

Figures 6-2 through 6-12 illustrate how the concept will function with several typical operating scenarios.

In Figure 6-2, all of the shared-use line segments are in MODE T due to positively-identified transit trains having been given the signal to enter the shared trackage, and the transit trains designated by T are permitted Normal Transit speeds, shown as "S=NT."

**Figure 6-2**  
Two transit trains operating at normal transit speeds (S=NT)

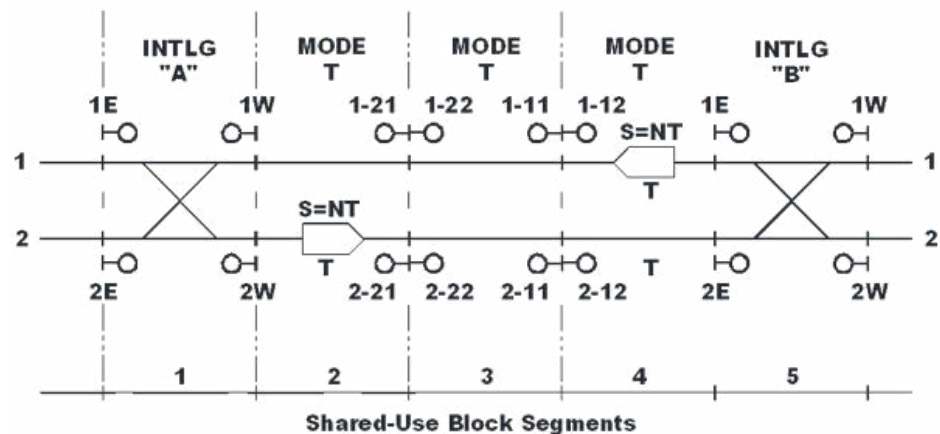

In Figure 6-3, all of the shared-use line segments are in MODE “RR” due to positively-identified railroad trains having been given the signal to enter the shared trackage, and the railroad trains (RF and RP) are permitted their respective Normal Speeds, S=NP for RP trains and S=NF for RF trains.

**Figure 6-3**

Two conventional railroad trains (RP and RF) operating at their normal speeds (S=NP and S=NF, respectively)

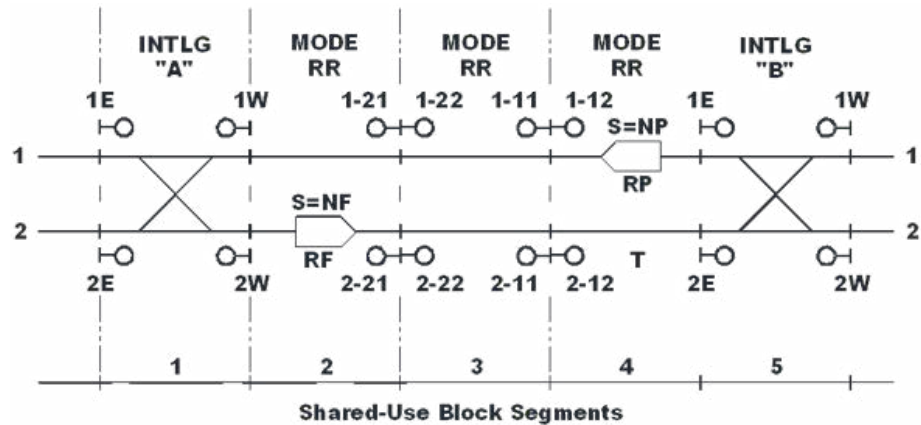

In Figure 6-4, a transit train has been admitted to the double-track segment between Interlocking (IXL) B and IXL A, which locks out the approaching opposing railroad passenger train, RP at IXL A, with all of the intermediate block segments set to MODE T. The dispatcher has to decide whether to operate the RP train before the T train clears IXL A, which would cause some delay to both trains, or to hold the RP train at A until the T train clears the IXL A to IXL B segment, after which the RP train could also operate at S=NP.

**Figure 6-4**

Transit train operating at maximum speed has RP train “locked out”

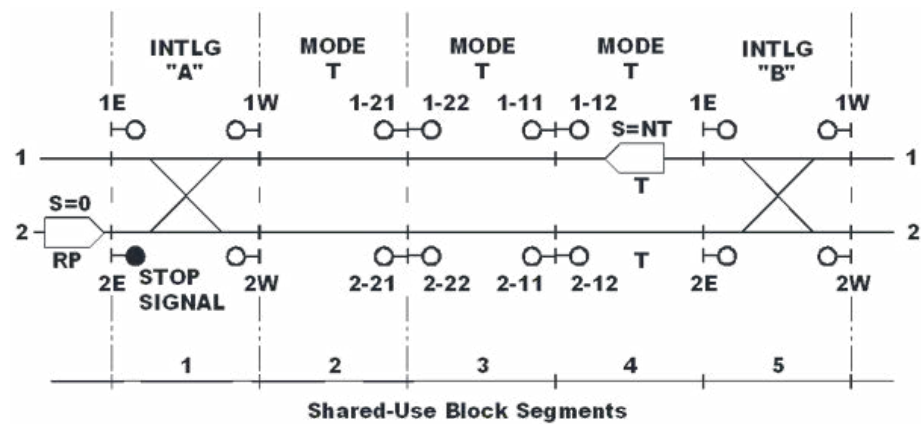

In Figure 6-5, the dispatcher has decided to allow the passenger RP train to proceed into the A-B segment and has called the signal at A, which causes all intermediate Block Segments which the T train has not yet cleared to tumble to MODE RRP-T, which, in turn, causes the opposing T train to receive a display to reduce speed to  $S=T1$ , the maximum transit speed permitted in MODE RRP-T. The T train is currently operating at a speed greater than  $T1$  (i.e.,  $S>T1$ ), but is in the process of reducing to  $S=T1$ .

**Figure 6-5**  
Mixed traffic – dispatcher elects to operate RP train with T train in shared segment

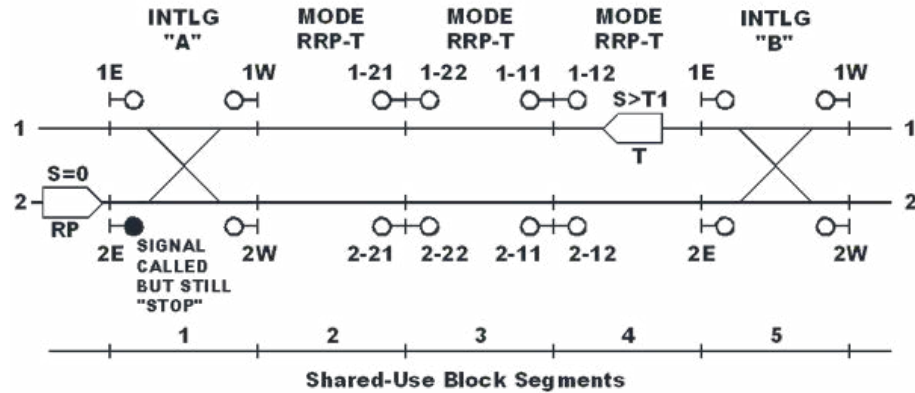

In Figure 6-6, the signal at A finally clears for the RP train after an appropriate time delay sufficient to ensure that all intermediate Block Segments have been set to MODE RRP-T and the opposing T train has been informed and then enforced to reduce speed to  $S=T1$ . The RP train is permitted to enter the A-B section limited to speed  $S=P1$ , the maximum speed permitted for passenger trains in MODE RRP-T. Note that when the T train clears intermediate Block Segment 4, the MODE changes to RR, which permits the RP train to resume  $S=NP$  when it reaches intermediate Block Segment 4.

**Figure 6-6**  
Mixed traffic – RP train cleared to enter A-B at reduced speed

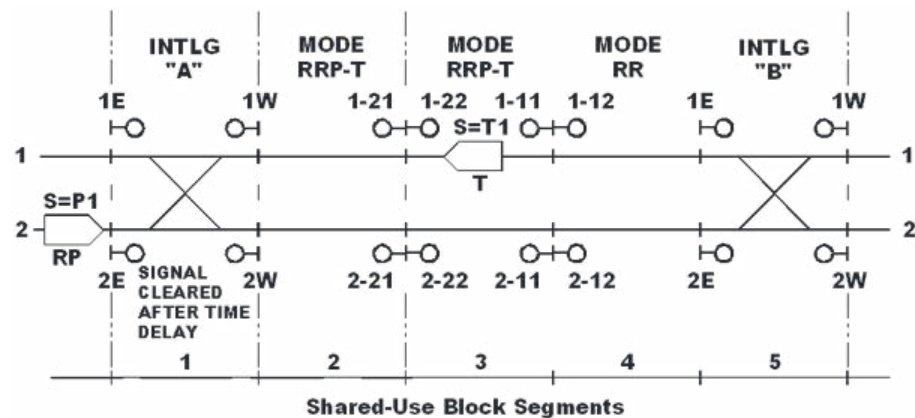

In Figure 6-7, the T train is now clear of both intermediate Block Segments 3 and 4, permitting the RP train to resume S=NP as soon as it enters block segment 3. Also, a RF train has followed the RP train and is now stopped at 2E Signal at IXL A until the T train clears Block Segments 2 and 1. Note that the T train is also now operating at S=NT in Block Segment 2, but will be slowing down to S=T2 prior to reaching the Block Segment to the left of IXL A, which is occupied by the RF train on the adjacent track. Block Segment 1 is still set to MODE T, but the PTC system is continually updating the Safe Braking Distance (SBD) profile, and braking for the T train will begin at a point which will bring it to S=T2 at the entry point to the next Block-Segment (not numbered in the diagram) now occupied by the RF train.

**Figure 6-7**  
Mixed traffic – RP train resumes maximum speed upon passing T train

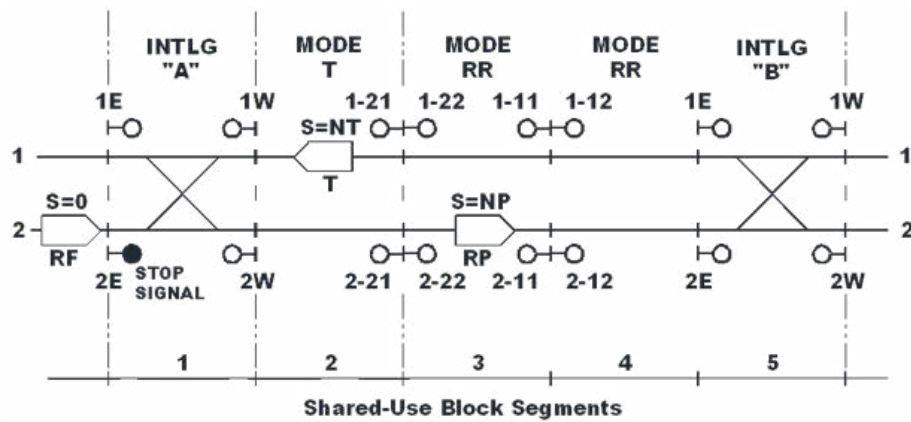

In Figure 6-8, the positively identified freight train RF at A was held at Signal 2E while the opposing T was still in intermediate Block Segments 2 and 1. The dispatcher has cleared Signal 2E at A for the RF train, which has no restrictions following the compatible RP train on the same track in the block of Automatic Signal 2-12 (Block Segment 4). The RF train is permitted S=NF, and it will operate in accordance with the aspects on the fixed signals, enforced by the PTC system, which will fully protect the normal movements of these compatible trains.

**Figure 6-8**  
RF train held to allow LRT to clear A-B at maximum speed

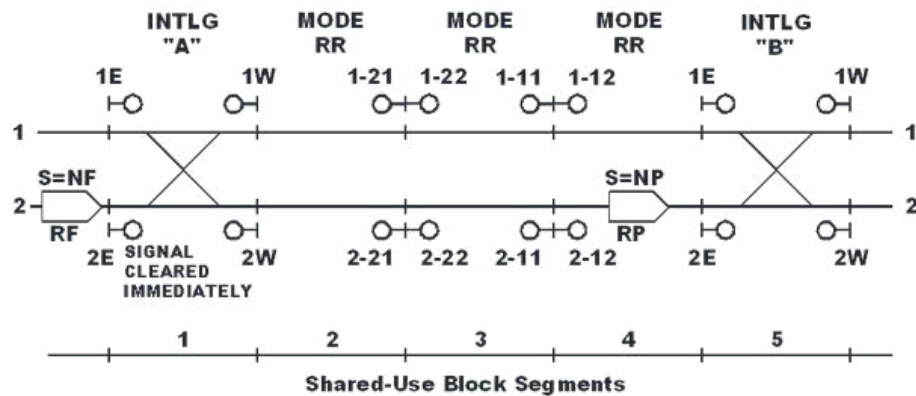

In this case, as illustrated in Figure 6-9, the RF freight train has advanced to intermediate Block Segment 3 at  $S=NF$  when another T train arrives at the stop signal at B. The dispatcher decides to hold the T at B briefly to allow the freight train to continue to advance at NF Speed without further restriction.

**Figure 6-9**

*T train held at B to permit R train to continue at  $S=NF$*

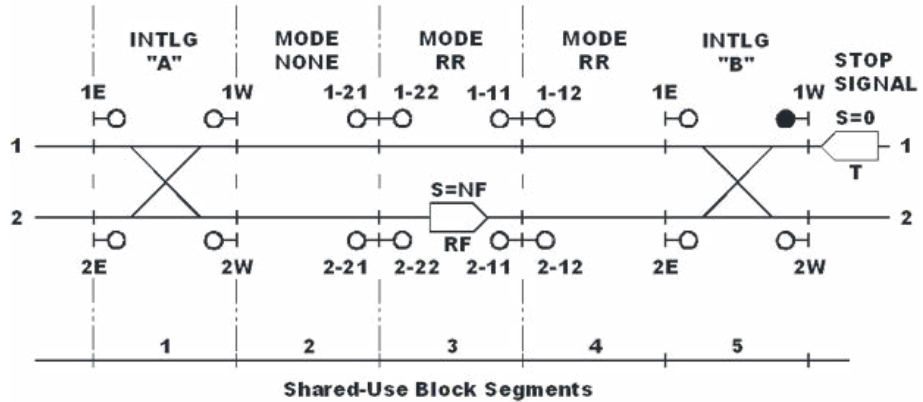

However, in Figure 6-10, the freight train has been delayed in intermediate Block Segment 3, and the dispatcher decides to clear the signal for the T train. Signal 1W at B is still displaying STOP to permit the required time delay to ensure the freight train reduces to  $S=F1$  (or less) for Block Segments 3, 4, and 5, which have now been set to MODE RR-T. The RF train has received the PTC display with the required enforcement to reduce to  $S=F1$ , and even though it may have stopped, it must still be assumed to be operating at a speed  $S>F1$  until the required time expires to ensure the PTC has had time to enforce  $S=F1$ .

**Figure 6-10**

*Dispatcher elects to permit T train to enter B-A with RF train still in Segment 3*

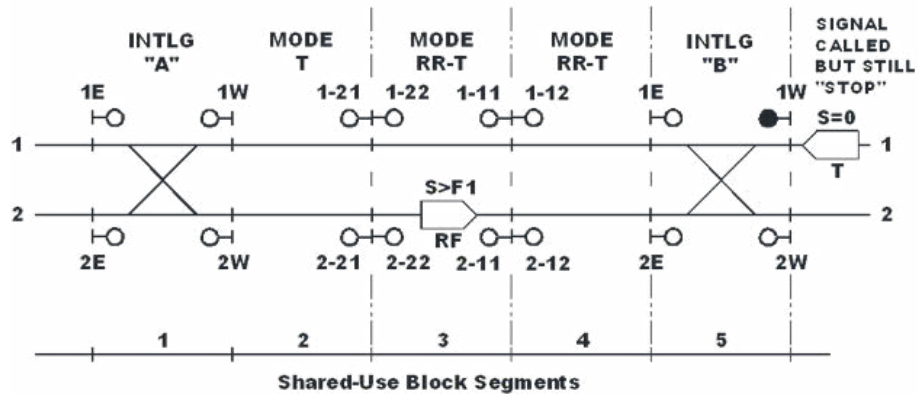

In Figure 6-11, after the required time delay to ensure the freight train has reduced to  $S=F1$  (or less) for MODE RR-T, the signal clears for the T train to operate at  $S=T2$  until it passes the RF freight train still in segment 4.

**Figure 6-11**  
 Required time delay has expired and T train is released to enter B-A with RF train still in Segment 4

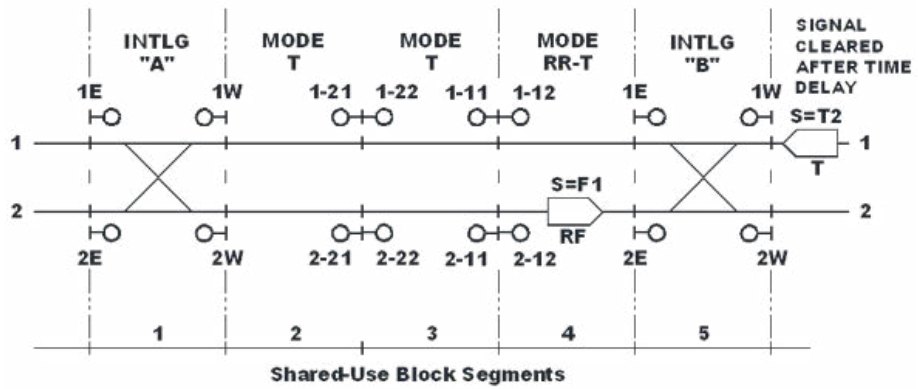

When the rear of the freight train clears intermediate Block Segments 4 and 5 at B, as illustrated in Figure 6-12, the T train is permitted to resume  $S=NT$  in Block Segments 4, 3, and 2, assuming the enforcing PTC is able to deliver a timely mid-block release to the T train.

**Figure 6-12**  
 RF train has left Segments 4 and 5 and T train is cleared to operate at  $S=NT$  to A

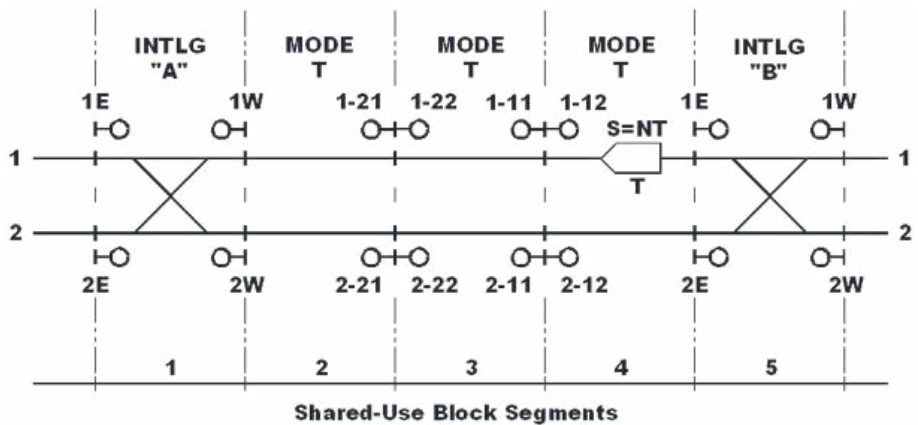

### *General Requirements for Providing PTP for Non-Compatible Train Types*

The approach taken above in the scenarios presented in the diagrams and discussions are dependent upon the following for practical implementation:

- PTI must be developed in each application for the underlying signal system, or for the PTC system, to ensure at all times that each train is positively identified and that this identity is verified as correct. This will probably be more readily accomplished for T trains and RP trains than it will be for RF trains, particularly if the RF trains are those operated by one of the large Class I freight carriers.
- PTI can be accomplished through applying transponders with vital codes on all vehicles that pass through the shared trackage, but this is a much more acceptable solution to carriers with relatively small captive fleets. Conceivably, temporary transponders could be applied to engines from large fleets at the last terminal prior to reaching the shared corridor and then removed at the next such terminal, but they would have to be “magnetic stick-ons” or some other very easily portable device.
- Portable transponders would have to be capable of being very simply applied and then removed and always placed within the area on the vehicle that would be well within the tolerance that ensures reliable reading by wayside readers. This could be difficult to police, and it is quite likely that it may not be acceptable to the large freight carriers.
- Conceivably, PTI might be accomplished through other means than transponders, such as using the original ATCS unique railroad carrier number with the carriers’ unique engine unit number. However, the manner in which these numbers are normally configured in the software upon installation of the on-board PTC equipment is not currently intended for a vital fail-safe application, nor do the message structures currently have the required check bits to be considered for a vital fail-safe application. This would have to be tightened up considerably from current PTC design and practices.
- Each controlling unit must have a PTC display that will enable the engineers/ drivers of trains to quickly and smoothly respond to en-route changes in the MODE in the Block Segment in which it is operating and the Block Segment it is approaching, particularly when a down-turn in speed is called for. This display must give the engineers ample time to respond to the changes and initiate any required braking before the train enters the penalty/enforcement phase. This is especially important for engineers of long freight trains who need more set-up time for proper train handling when pop-up speed reductions are called for at unexpected times and places.
- Vital logic will have to be developed that will enable these rapid changes in Block Segment MODES to be accomplished as the trains are cleared into MIXED MODE situations, and then to permit trains on one track to take advantage of the passing of the rear ends of non-compatible trains

on the adjacent track. This logic could possibly be either distributed or concentrated, but all safety features will need to be fail-safe (vital) in order to prevent wrong side failures that could lead operating employees into un-safe acts. Experience with such advanced systems over the years has been that some employees will tend to overly-depend upon a complex non-vital system which appears to work well, but which can fail and lead to disaster through a false sense of security, ultimately resulting in a lack of vigilance at the same time as the more-probable wrong-side failure of the non-vital system.

- A system design will need to carefully consider the block lengths, maximum speeds of the different train types, the braking characteristics of each of the train types, and the time delays chosen to enable and ensure a safe operation. The dispatchers' display will need to show adequate information on the train types in each block segment and up-to-date real-time information block occupancy in order to optimally dispatch the system described in these scenarios.
- Where there are three or more main tracks, adjacent tracks only would be considered for protection. Any non-adjacent main track would only be considered for protection from non-compatible equipment on a main track directly adjacent to it. In other words, where there are four main tracks, counting from south to north, 1, 2, 3, and 4, the following would be considered as double-track pairs:
  - 1 and 2
  - 2 and 3
  - 3 and 4

However, PTP for track-pairs 1 and 3, 1 and 4, and 2 and 4 would not be considered or required.

## Scope of Technical Work Required

The selected Supplier/Integrator (SI) will be required to design, build, install, test and commission a pilot project that will fully demonstrate the operating concepts outlined in this report section. The project is to be designed and installed in such a manner that it can be placed in revenue service for an extended period of time. The delivered system is to be designed and installed such that it can, as an option, ultimately remain in permanent revenue service to meet the needs of the shared corridor where it is to be installed.

The SI's designs must be based upon the detailed, up-to-date layouts of the full extent of the tracks, signals, and other supporting infrastructure to be shared by the non-compatible train types; documentation must be furnished by the customer. The customer also will furnish the required documentation for the adjacent tracks and signals necessary for the SI to provide SBDs for all train types approaching the limits of the shared trackage. Sufficient detailed documentation



of the PTC system and the underlying signal system(s) of the shared corridor will be furnished to the SI to enable efficient and robust designs.

To be considered as a potential SI, the Proposer will furnish a description of the detailed approach to meeting all of the operating requirements described herein. It is expected that the SI will be an established Supplier of Signal and PTC systems and will use its own products to the extent possible to meet the operating requirements of the specification. The use of these products, the necessary development of the additional hardware and software to meet these operating requirements, and/or the use of Signal and/or PTC products produced by others must be outlined in detail in the Proposer's bid documents.

All hardware and software components and the sub-systems to be provided to meet the overall operating requirements must be vital, and the resulting system delivered must be fully fail-safe in its operation. The SI must provide all documentation necessary to establish the safe operation of the final system delivered.

## Deliverables

The selected vendor/integrator will be required to furnish a "design-build-install" pilot system that can be fully tested and placed in revenue service as an enhancement to the existing Signal and PTC systems in place in the Shared Corridor. The delivered system must include the ability to fully perform the Same Track OCSS as described in Section 2, and also the Parallel Tracks OCSR Option.

The design of the OCSS/OCSR system must be furnished for 10%, 30%, 60%, 90%, and 100% reviews. Upon completion of all reviews and all factory acceptance testing, the complete system is to be delivered and installed, with the SI supplying all necessary components, all software upgrades, a comprehensive hardware and software configuration management plan, and all necessary installation, operation, and maintenance manuals and instructions, complete with training sessions for all classes of employees affected by the OCSS/OCSR system.

A full test plan will be provided by the SI, and the SI will take the lead in implementing the test plan, leading to the final placing of the OCSS/OCSR system in revenue service.

## Outline of Test Plan

Following acceptance of the SI's 90% design by the customer, the operation of the OCSS/OCSR system is to be fully vetted in the laboratory at the SI's factory site. Any anomalies uncovered in this initial factory testing will be thoroughly investigated, and the necessary changes resulting from these joint investigations

will be reflected in the 100% design. Final factory acceptance testing of the complete system will follow the review and acceptance of the 100% design by the customer.

There will be no deliveries to the field prior to the final factory acceptance of the complete system, unless it is jointly determined that one or more components or subsystems should be pre-tested in the field during the development phase of the project.

Following final factory acceptance of the OCSS/OCSR system, the SI will take the lead in installing the system in the field in accordance with the requirements of the railroad(s) and transit authority to ensure that any trains operating through the area during the installation will be guaranteed safe movement at all times. All work on the installation must be performed in such a manner that any existing Signal and/or PTC system is not in any way compromised.

When the installation has been completed, the SI will take the lead in working with all operating carriers affected by the OCSS/OCSR installation to fully test the installation prior to placing it in revenue service. The operating carriers will provide the necessary vehicles fully equipped with the required on-board PTC or Train Control equipment to fully field-test the system. This testing will be conducted in such a manner as to not in any way interfere with existing revenue service and will be conducted in full cooperation with and under the supervision of the authorized carrier representatives to ensure the safe conduct of the testing at all times.

When all stakeholders and the operating authorities are in agreement that the system is ready for revenue service, the system will be placed in service for all trains operating through the limits of the Shared Corridor.

## SECTION 7

# Summary and Conclusions

The growing interest in shared use of general railway system railroad rights-of-way and tracks by transit vehicles (typically, light rail vehicles) that do not fully comply with FRA regulations has prompted research into implementation methods and development of several shared-use projects in the United States. The enactment of RSIA08, which requires the implementation of PTC on a significant portion of the general railway system to improve the safety of railroad operations, led to this research project. PTC is intended to prevent:

- Train-to-train collisions
- Overspeed derailments
- Unauthorized incursions into work zones
- Train operation over improperly-positioned switch or derail

The research included the following:

- Review of currently-active transit services that have obtained temporal separation waivers from FRA with the primary purpose of identifying instances where train separation is enforced by technology and where the temporal separation is not totally dependent on rules and human-based procedures. The technologies enforcing temporal separation were studied and documented so that they can be considered (and possibly incorporated) when determining how PTC systems can be used to implement and enforce on-demand or on-call spatial separation between railroad trains and lighter-weight passenger trains.
- Analysis of the functionality of existing PTC systems (ACSES, ITCS, and I-ETMS) and identification of the lessons learned in the development of these PTC systems,
- Evaluation of the feasibility, risk, and reliability of current PTC technologies for shared-use operations.
- Identification of the changes needed to PTC systems and the underlying signal systems they enforce to enable shared-use operations.
- Preparation of an outline for a scope of work for a potential demonstration project that would use signal and PTC technologies to facilitate shared-use operations under a waiver from FRA.

The review of currently-active transit services that have obtained temporal separation waivers from FRA found that three of the shared-use operations

surveyed use signal technology to implement temporal and spatial separation. NJ TRANSIT's River LINE and Newark Light Rail services and Tampa's CSX/TECO-Streetcar at-grade crossing demonstrate that conventional-interlocking and signal-system logic can be used to provide Localized On-Demand Spatial Separation and vitally separate non-compatible train types at and within a single interlocking. This capability is currently possible using standard route-locking logic only when the two train types (typically lighter-weight LRT passenger trains and conventional railroad (both passenger and freight) trains) have separate and different entry and exit points to and from the shared interlocking. In addition, NJ TRANSIT's River LINE contains a novel and more sophisticated interlocking and signal-system logic that can be used to provide a more global OCSS and vitally separate non-compatible train types at and between multiple successive interlockings. This capability is currently possible using vital communications and signal technologies between adjacent interlockings, and route-locking logic only when the two train types have separate and different entry and exit points to and from the shared trackage.

These proven and vital (fail-safe) train-separation capabilities have eliminated the need for very inefficient time-based temporal-separation schemes requiring that the two train services be restricted to operate during different time periods. In addition, and as demonstrated on the River LINE and Newark Light Rail, the train separations can be implemented not just by vitally displaying red signal aspects, but also can be enforced by such technologies as electromagnetic train stops, cab-signal systems in concert with ATC speed enforcement, and by the forced-positioning (using route locking) of interlocked turnouts and derails.

An additional finding of the research was that on the NJ TRANSIT River LINE, light-rail passenger trains are allowed to operate at normal speeds when the track centers between the LRT track and the adjacent freight-railroad track is 17 ft. or greater without an Intrusion Detection System being required. However, on VTA's Vasona shared corridor in California, the LRT passenger and railroad freight tracks appear significantly greater than 17 ft., but the light-rail trains are restricted to rather low speeds when passing a freight-train.

The review of U.S. PTC systems provided the following:

- The ACSES PTC system was developed by Amtrak for the Northeast Corridor, which already had a modern ATC system, to support increasing train-operating speeds up to 150 mph. ACSES has been designed to be a vital overlay to enhance the vital ATC system. The ATC is a conventional train control system that includes continuous cab signaling and onboard speed control. The cab signaling and speed control features are important components of the overall ACSES PTC system, as illustrated by the definition  $ATC+ACSES = PTC$ . ATC, by itself, does not provide all of the required PTC functions, and ACSES supplies the remaining required features.

- ACSES is capable of enforcing stop signals and all fixed and temporary speed restrictions, and ATC supplies the display and enforcement of all wayside signal-related speeds. However, ACSES, like ITCS and I-ETMS, currently lacks (both in the central office and on the wayside) the fail-safe train ID and location data needed to implement OCSS between non-compatible train types.
- ITCS was developed to support increased train-operating speeds up to 110 mph in the Emerging Corridors, such as Amtrak’s Chicago–Detroit–Pontiac and Port Huron Corridor, where lack of some form of train control had held speeds to a maximum of 79 mph. ITCS is a distance-to-go or speed-location profile-based enforcement system similar to ACSES, but with different input sources.
- In considering how ITCS can be used to provide and enforce Temporal Separation and On-Demand Spatial Separation between conventional railroad trains and lighter-weight passenger trains, several issues must be considered. These issues all involve the same conceptual theme – currently, ITCS has not been designed to vitally bring knowledge into a central computer about “what types of trains are where.” While individual trains can and do know their “types” through on-board firmware, the existing ITCS designs do not cause this information to be transmitted (in useful formats) to the wayside interlockings or to the central office.
- ITCS is capable of enforcing stop signals and speed restrictions and implementing the other PTC mandates, but ITCS currently lacks (both in the central office and on the wayside) the fail-safe train-ID and location data needed to implement On-Call Spatial Separation between non-compatible train types. These issues were further explored in later sections of the report to develop PTC prototype solutions for enforcing On-Call Spatial Separation between non-compatible train types.
- I-ETMS was conceived to support interoperability across railroads and to “apply consistent warning and enforcement of rules violations regardless of trackage ownership while maintaining some level of railroad specific rules and train handling policies.” The primary applications of I-ETMS is as an overlay on CTC signaling and various forms of ABS signaling. However, I-ETMS also has being designed to be implemented in “dark” non-signaled territories, on signaled trackage operated subject to mandatory-directive authorities, and on signaled trackage having continuous cab signaling.
- I-ETMS is expected to be capable of enforcing stop signals and speed restrictions, and implementing the other PTC mandates. I-ETMS currently lacks (both in the central office and on the wayside) the fail-safe train-ID and location data needed to implement OCSS.
- The research identified lessons learned in the development of ACSES and ITCS, which are now in operation, and those that are being learned in the ongoing design, initial installation and testing of I-ETMS. Among the lessons learned is the importance of a complete design, followed by a good pilot program for fine-tuning the finished product before major roll-out begins.

In addition, full integration of the new system into the existing operating culture requires a broad multi-disciplinary approach to ensure that existing engineers/operators, dispatchers/train controllers, train rules specialists, and wayside and on-board maintenance technicians, will all begin to view the “new” system as integral to their normal duties and responsibilities. This effort should include thorough training, well-documented manuals for each discipline and a good pilot installation in revenue service to fully integrate the “new” PTC into the existing operation.

- In the review of track-sharing options, the research evaluated same and parallel track-sharing scenarios and concluded that certain current and planned functionalities of the three PTC systems can be used in Shared-Track Operations. This analysis included a high-level risk analysis that provided results supportive of the various track sharing scenarios that were reviewed. However, to permit comingled shared-track operations and mitigate the additional hazards that arise from such operation, enhancements will be needed over and above the basic features already incorporated in the current PTC system capabilities or in their underlying signal system capabilities. To ensure separation between compliant and non-compliant train types, these enhancements and/or some other form of mitigation will be required regardless of which PTC system has been chosen for the corridor to be shared.

Based on the encouraging findings of this research, the study defined the essentials of a demonstration project to address the most pressing needs for mitigation of risk in developing safe shared corridors. The material prepared during this research has provided the basis for preparing an SoW for a technical specification for selected suppliers to carry out a demonstration for a partnership consisting of a railroad carrier, an LRT carrier, FRA, and FTA, leading to a practical installation in a specific shared corridor. The demonstration project focuses on those particular safety concerns identified in this research and suggests the use of cost-effective applications of existing technologies to reduce the risk of commingling non-compatible equipment types, while also seeking to expedite the train movements involved when all restrictions to mitigate risk have been observed.

The demonstration project outlined, when fully vetted and enhanced in accordance with the experience gained during installation and testing, is intended to be capable of remaining in place for revenue service for the life of the equipment, both wayside and on-board. In this regard, the demonstration project is expected to pave the way as a generic template for a pilot project for an actual installation in a specific shared corridor when funding becomes available.

# Glossary

This glossary lists common terms and abbreviations used frequently in this research. An additional source of terms on shared use is in Appendix 2 of TCRP Report 130.

**AABS** – Absolute Automatic Block Signal System. An ABS system requiring trains to “stop and stay” clear of an occupied block.

**AAR** – Association of American Railroads

**ABS** – Automatic Block Signal System. Provides for movement of trains along a track in a single, pre-determined direction based on signal indication. While providing indication of train separation requirements to a train operator, ABS does not of itself positively enforce train separation or train routing requirement; appropriate action to conform with signal indications is required.

**ACSES** – Advanced Civil Speed Enforcement System. A vital, fail-safe transponder-based system designed to provide additional features to supplement traditional ATC, such as PTS (Positive Train Stop), PSR (Permanent Speed Restriction) and TSR (Temporary Speed Restriction) enforcements.

**ACSES II** – The particular level or version of ACSES at the time the system received the first Type Approval for a PTC system issued by FRA in the U.S. (Type Approval FRA-TA-2010-001 issued to Amtrak for ACSES II on May 27, 2010). This is the basic system serving as the template for the interoperable PTC system currently being installed throughout Amtrak’s Northeast Corridor and on six adjacent Commuter Rail systems in the Northeast.

**AML** – Amtrak Michigan Line. An Amtrak-owned line of railroad extending from Porter, Indiana to Dearborn, Michigan. The PTC system on this line is ITCS.

**ATC** – Automatic Train Control. A sub-system which provides some level of automated governance of a train’s compliance with signal indications. The ATC systems level of governance may vary from minimal control, e.g., with intermittent trip stops, to full continuous automatic control with enforced stop capabilities. In this report, ATC is used to indicate full continuous speed control, but without the enforced stop capability, of which the primary example is used throughout the Northeast Corridor and on most of the adjacent commuter railroads in the Northeast.

**CAD** – Computer-Aided Dispatching

**CBTC – Communications Based Train Control**

Compatible Trains or Equipment – Trains made up of equipment that is compliant with FRA crashworthy standards required on the contiguous railroad system of the U.S. or equipment that is non-compliant with FRA crashworthy standards but is being operated in a manner that keeps it isolated from potential exposure to heavier compliant equipment.

Compliant Trains or Equipment – Equipment that meets the FRA crashworthy standards required on the contiguous railroad system of the U.S.

CTC – Centralized Traffic Control. A system of control of switches, and signals, from a central office by non-vital communications with the vital (fail-safe) logic controlling the signals and switches in the field. Also, a system of operating rules in the “General Code of Operating Rules” (GCOR) used by main western railroads in the U.S.

ETS – Extended Temporal Separation. The application of the principles of Temporal Separation over segments of a given line, that is, on a line segment basis (for example, over a section of railway which includes two or three consecutive interlockings), rather than uniformly over the entire length of any given railway system. ETS involves the use of vital train control technology to assure absolute and fail-safe separation of modes over the design segment of trackage.

**FRA – Federal Railroad Administration**

HSR – High speed rail. HSR in the U.S. is intercity passenger rail service reaching speeds of 150 mph or more.

HrSR – Higher speed rail. HrSR in the United States is intercity passenger rail service over 79 mph to 110 mph and future 125 mph.

**I-ETMS – Interoperable Electronic Train Management System**

Incompatible or Non-Compatible Trains or Equipment – Trains made up of non-compliant equipment that does not meet the FRA crashworthy standards required on the contiguous railroad system of the U.S., typically light rail transit trains, when operated with exposure to the operation of heavier compliant equipment.

Interlocking – A series of railway devices and appurtenances connected in a manner to permit only certain configurations and/or to permit configurations to be operated only in a pre-determined sequence. The primary application of interlockings as used here applies to signals, turnouts, or derails and movable bridges.

**ITCS – Incremental Train Control System**



LRT – Light Rail Transit. LRT is a form of public transportation that is operated on fixed rails on either exclusive right of way or on public streets in mixed traffic. Light rail vehicles are typically driven electrically with power being drawn from an overhead electric line or are self-propelled by an on-board diesel engine.

Lightweight Equipment – Refers to passenger equipment, such as light rail vehicles, that does not satisfy FRA requirements pertaining to crashworthiness; which generally refers to structural strength, and is often referred to as buff strength. Such equipment is referred to as non-compliant.

MAS – Maximum authorized speed

NEC – Northeast Corridor Railroad Line (Boston–Washington DC)

Non-Compliant Trains or Equipment – Equipment that does not meet the FRA crashworthy standards required on the contiguous railroad system of the U.S.

NORAC – Northeast Operating Rules Advisory Committee. NORAC is a voluntary association of railroads that maintains a common set of operating rules for the northeastern United States. The main members include Amtrak, Conrail, NJ TRANSIT, Southeastern Pennsylvania Transportation Authority (SEPTA), Providence & Worcester, New York Susquehanna & Western, and a number of other railroads. CSX Transportation and Norfolk Southern incorporate elements of NORAC rules within their own rulebooks.

OBC – On-board computer

OCC – Operations Control Center

OCSR – On-Call Speed Reduction

OCSS – On-Call Spatial Separation. OCSS is the use of railroad signal technology (including PTC) and operating methodologies (including OCSR) to facilitate a safe and affordable commingling of non-compatible trainsets, which do not meet FRA crashworthiness standards, with heavy railroad freight equipment and/or passenger equipment that is designed to meet FRA standards.

Parallel Track Protection (PTP) – A form of “on-call” protection against collisions between compliant and non-compliant trains or equipment when they operate on closely adjacent parallel tracks in a shared corridor, to be developed in the proposed demonstration project.

PTC – Positive Train Control. PTC is the employment of technology and operating rules to provide for the protection of train movements. The Rail Safety Improvement Act of 2008 requires the implementation of PTC to automatically provide; enforcement of train separation; civil speed restrictions; temporary

speed restrictions; prevention of work zone incursion; and restriction of movement over a switch improperly aligned.

RAC – Railway Association of Canada

RSIA08 – Rail Safety Improvement Act of 2008

Railroad – A system or line which form part of the general railway system of North America and which is required, by law, to conform to the safety regulations of FRA.

Railroad Traffic Control – The function of a railroad signal system which controls the direction of allowed entry and movement on a single track; sometimes simply referred to as railroad traffic.

Railway Signal System – A system designed according to vital design principles whose primary purposes are to assure, through the combined use of equipment, automatic devices and the train's operator, the following functions:

- The safe separation of trains, traveling in the same direction on the same track
- Safe train routing, i.e., to prevent trains of opposite direction from entering the same section of track (without proper authorization)
- Broken rail protection and switch locking.
- Secondary purposes of railway signal systems include the reporting of train location, based on track occupancy.

Same Track Protection (STP) – A form of “on-call” protection against collisions between compliant and non-compliant trains or equipment when they operate on the same tracks in a shared corridor, to be developed in the proposed demonstration project.

Shared Corridor – Tracks shared by compliant and non-compliant trains or equipment.

SITS – Short Interval Temporal Separation. Refers to temporal separation in which the interval of modal separation is expressed in periods of one hour or less. This technique positively restricts the train movements as operating windows are shifted between freight and passenger while providing absolute separation of modes.

SPTIP – Safety Positive Train Identification Processor

Temporal Separation – A method of providing for separation of modes in shared use operations; which relies on assigning each mode a specific allowed period (time) of operation over common trackage.

TCS – Traffic Control Systems. A term that has been used interchangeably with CTC. See CTC.

# Review of Existing Temporal Separation Waivers

## NJ TRANSIT'S River LINE

The NJ TRANSIT River LINE (Figure B-1) started operations in March 2004 and is an approximately 34-mile-long non-electrified LRT system extending between the cities of Camden and Trenton, New Jersey. The River LINE includes in-street (a.k.a. street-running) operation and exclusive right-of-way (including rail-highway at-grade crossings), most of which trackage is shared with Conrail freight-train operations under an FRA waiver. Of the 34 route miles, 32 are considered part of the U.S. general railroad system. Currently, freight-train operations are conducted over approximately 28.5 of the route miles from CP 45 at Mile Post 4.5 to Trenton. The line includes 21 passenger stations and 72 rail-highway grade crossings. Passenger trains are operated at MAS of up to 65 mph and freight trains speeds range up to 30 mph.

**Figure B-1**  
NJ TRANSIT's River LINE route map



The River LINE is FRA-regulated and adheres to railroad operating, engineering, and maintenance practices. Mainline tracks are maintained to FRA Class 4 standards, and the mainline signaling and interlockings are designed and maintained per Part 236 of the FRA rules. The passenger trains and freight trains have common dispatching personnel and control systems and are subject to common operating rules. The River LINE is a “single-and-double” track configuration, having both single-track sections and double-track sections, along with numerous interlockings and non-interlocked sidetracks. This includes two interlocked railroad crossings at-grade. FRA-compliant bi-directional wayside ABS (without cab signals) is provided on all main tracks (except for the street-running territory where freight trains do not operate), and the entire line (including all interlockings) is centrally controlled by a CTC system. Electronic track circuits are used for train detection, which eliminates the need for line circuits.

The LRT trains (also known as light rail vehicles or LRVs) are lighter-weight DMU vehicles that do not meet FRA buff-strength requirements. Because of this, the FRA waiver requires that the two (passenger vs. freight) vehicle types (hereinafter also called the two modes) must be positively separated from each other. The River LINE initial FRA waiver required temporal separation over the entire line (a complete shutdown of passenger-train operations to permit freight-train operations, and vice versa), except for one interlocked railroad crossing at-grade.

There was a need to expand the passenger-train daytime operating period without impacting the freight-train operations. Providing total temporal separation over the entire line (except for the one interlocked crossing) was not a viable long-term option because of the high commercial importance and overlapping demands of both the passenger and freight transportation modes. To provide modal separation, the River LINE signaling was designed to include strategically-located interlocked derails to prevent freight trains from entering areas where passenger trains are operating. The signaling also was designed to include electromagnetic train stops at interlocking home signals on passenger-train routes, one purpose of which is to prevent passenger trains from entering areas where freight trains are operating.

The River LINE is unique in that the modal separation is not only enforced by operating rules and procedures, but that within certain geographical areas the modal separation is also and primarily enforced by the vital signal system. This signal-system enforcement on the River LINE is possible because the passenger trains and the freight trains have separate and different entry and exit points to and from the shared trackage. This operational feature of the River LINE permits signal-system route locking of and for a passenger train entering the shared-use limits to lock out freight-train operations from those limits, and vice versa.

## Types of Temporal Separation

### Short Interval Temporal Separation

Short Interval Temporal Separation (SITS) was developed to permit freight-train movements to cross the River LINE at a single interlocking while normal passenger-train operations are being maintained on the remainder of the River LINE. SITS permits a very localized form of temporal separation to be implemented between the two transportation modes and train types at one interlocking.

SITS is in operation at River LINE CP 17, as illustrated in Figure B-2.

**Figure B-2**  
SITS implementation  
at River LINE CP 17  
interlocked crossing

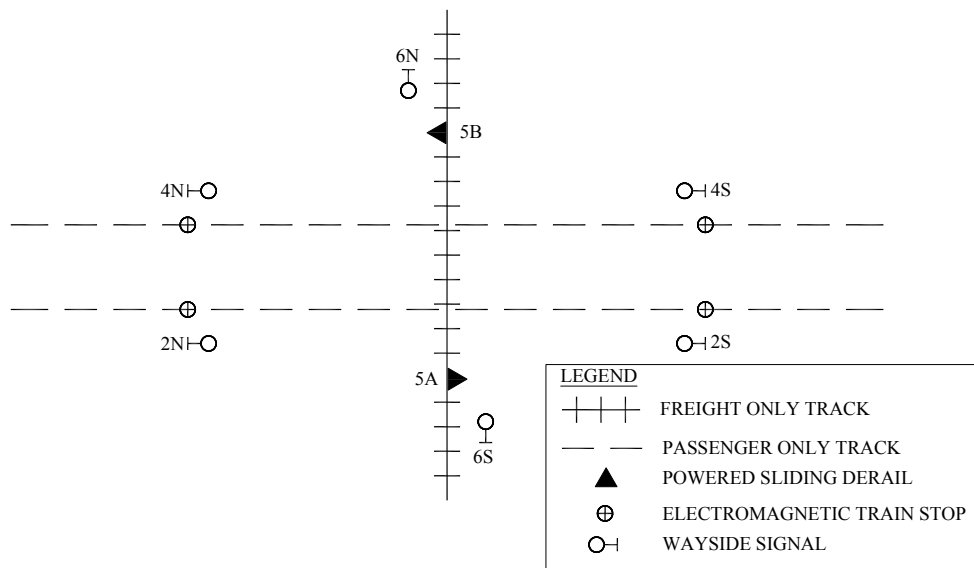

When passenger trains are operating over the interlocked crossing, the standard route locking of Signals 2N, 2S, 4N, and 4S force and lock Derails 5A and 5B to and in the normal/derailing position. This prevents Signals 6N and 6S from being cleared. The derails protect the passenger train(s) from freight-train interference.

Before Derails 5A and 5B can be reversed to the non-derailing (pass) position, the vital signal-system circuits require that traffic on both passenger-train tracks be set away from the interlocking, and (electronic-track-circuit) Code 2, 7, or 8 must be received inbound from both directions on both tracks at CP 17. This vitally ensures that no train can be approaching the interlocking on the passenger tracks from either direction before the derails are unlocked and reversed to allow a freight-train movement across the passenger tracks.

When Derails 5A and 5B are positioned in the normal/derailing position protecting the passenger trains, Signals 2N, 2S, 4N, and 4S when displaying the red/STOP aspect send back Code 2 so that the next signal to the rear (the

distant signal) can display the yellow/APPROACH aspect to the red/STOP aspect at CP 17 (as is normal in typical railroad signaling).

Once and when Derails 5A and 5B are reversed (thereby locking Signals 2N, 2S, 4N, and 4S at red/STOP), the vital circuits no longer allow Signals 2N, 2S, 4N, and 4S to send back Code 2. This, in turn, causes the next signal to the rear approaching CP 17 on each track from both directions to also display red/STOP, a so-called double-red aspect sequence.

The CP 17 design is very efficient in providing and enforcing the modal separation. All of the necessary vital signal-system indications for allowing Derails 5A and 5B to be reversed for the freight-train route are locally available at CP 17 in the form of inbound Codes 2, 7, and/or 8.

By controlling whether or not the CP 17 home signals on the passenger tracks send back Code 2 or not for a red/STOP aspect at CP 17 based on the position of Derails 5A and 5B, two successive red/STOP signals are provided to protect freight-train movements from passenger-train interference, but only one red/STOP signal is provided (as is the industry norm) behind following passenger-train movements. This novel signaling very effectively provides the SITS protection between the non-compatible modes.

### *Extended Temporal Separation*

The initial FRA waiver that required temporal separation over the entire line was subsequently modified to permit what is called Extended Temporal Separation (ETS). ETS provides temporal separation over certain logical segments of the River LINE rather than uniformly over the entire River LINE. This permits freight-train operations to be conducted within one line segment while passenger trains are operating in other line segments, and vice versa. ETS increased utilization of the existing infrastructure by allowing expansion of the passenger-train operating period and also by allowing Conrail new daytime freight-train operational capabilities. Figure B-3 is a photograph of the shared corridor operation of passenger and freight trains. Derails prevent freight trains from entering segments occupied by passenger trains, and electromagnetic train stops prevent passenger trains from entering segments occupied by freight trains.

**Figure B-3**

*ETS provides on-demand spatial separation between lighter-weight passenger trains and freight trains*



Within such a logical shared-use segment of the River LINE, the train controller responsible for the territory may select one of three operating modes for the segment:

- Operating Mode 1 – passenger-only operations
- Operating Mode 2 – shared use with enforced separation between the two train types
- Operating Mode 3 – freight-only operations

Signal-system enforcement of ETS uses proven commercially-available components known as object controllers to vitally exchange pertinent information (technically signal-system indications), including switch position and track-circuit occupancy between adjacent interlockings in the ETS territory. The object controllers and associated interlocking logic ensure the proper positioning of switches and derails at all affected interlockings and at all times, including before allowing the operating mode to be changed and while an operating mode is in effect.

The operating modes are selected by the train controller via the non-vital supervisory system. However, all safety logic including the ETS links between interlockings reside in vital wayside equipment.

Operating Mode 2 is intended for use during non-rush-hour periods when the passenger trains are operating on a 30-minute headway. ETS Mode 2 functionality allows freight-train movements to be made within designated geographical limits “in between” the passenger-train movements while maintaining the passenger-train 30-minute headway and while preventing possible contact between the two train types.

Under Mode 2, multiple interlockings are effectively joined together into one large pseudo interlocking by the object controllers and associated logic. Freight

trains are always physically separated from passenger trains (and vice versa) by the vital signal-system logic and by the derails and electromagnetic train stops as already described for SITS.

Figure B-4 depicts the line configuration that existed when ETS was first introduced. Referring to CP 45, the freight-train route between Signals 4N and 4S crosses the passenger-train-only route at grade. Freight-train movements can be made at any time between Signals 4N and 4S regardless of the ETS operational mode, as previously described for CP 17 and SITS. Freight trains and passenger trains are protected from each other by the vital CP 45 SITS logic, and by the derails and electromagnetic train stops.

**Figure B-4**  
ETS implementation  
at and between River  
LINE CP 45 and CP  
Ross interlockings

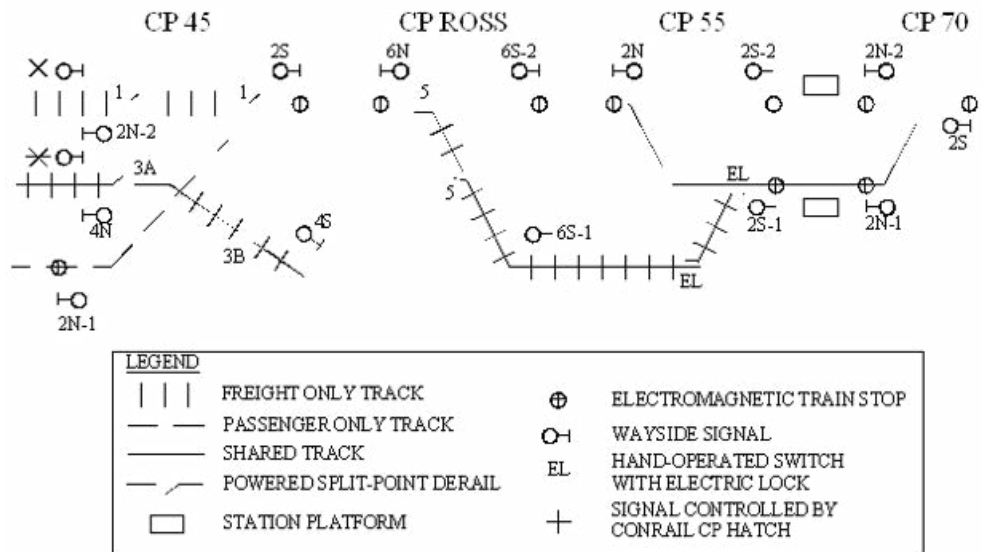

An illustration of ETS under Operational Mode 2 for shared use between two interlockings is as follows:

- For a freight-train movement to be made from the Conrail freight trackage left of CP 45 Signal 2N-2 to the River LINE freight trackage right of CP Ross Signal 6S-1, there must be no passenger trains within the affected area. If there were, CP 45 Switch and Derail I would be locked normal and CP Ross Switch and Derail 5 would also be locked normal. This would vitally prevent a freight-train route from being aligned.
- Once the freight-train route is aligned, Switch and Derail I and Switch and Derail 5 would be locked reverse until the freight-train movement was on the freight-only trackage to the right and clear of Signal 6S-1. Outside of this area, passenger-train operations would not be restricted.
- After the freight-train movement is on the freight trackage to the right and clear of Signal 6S-1, a passenger route can then be aligned between Signals 2N-1 and 6S-2. Before this can be done, Switch and Derail I and Switch



and Derail 5 all have to be in normal position. Simply put, Signal 2N-1 at CP 45 cannot be cleared until Switch and Derail 5 at CP Ross (the next interlocking) are lined and locked in the normal position. This is a hallmark feature of ETS—a switch and/or derail at one interlocking must be properly positioned and locked before a signal can be cleared for a route at another interlocking, and this locking at the second interlocking must remain in effect until no longer needed for the separation and protection between the two modes.

### Other Pertinent Information

Under the FRA waiver, passenger trains can operate past freight trains on adjacent tracks at normal speeds, and vice versa, as long as the tracks are 17 or more ft. apart. Where the tracks are less than 17 ft. apart (centerline to centerline), an FRA-required intrusion-detection system (IDS) is provided to identify potential fouling hazards within the zone of closely-adjacent tracks. Two detectors are provided for each IDS zone, one at each end—the two entry points. IDS Distant Indicator signals are located braking distance prior to the IDS zone to govern approaching trains in both directions. When an intrusion is detected, these special Distant Indicator signals protecting/governing that IDS zone are immediately “dropped” to display the Approach aspect. In addition, a radio message warning of the detected intrusion is automatically transmitted.

Because of the creative and positive signal-system enforcement of SITS and ETS, the River LINE was able to provide FRA with a very strong safety case in support of its waiver application.

River LINE CP 45 is immediately adjacent to Conrail CP Hatch on the freight-railroad trackage. Because of this, there are some required signal-system “handshakes” between the Conrail and River LINE signal systems. For instance, these handshakes require that the CP 45 signal entering or crossing the River LINE must be cleared first before a CP Hatch signal can be cleared towards that River LINE signal. This functionality prevents a freight train from being routed through CP Hatch but held at CP 45, thereby blocking CP Hatch. This functionality also provides two red/Stop signals to freight trains when they have not been cleared onto the River LINE.

### Credits and References

Much information about the River LINE, its signaling, SITS, and ETS was obtained from FTA Report No. 0008, “Safe Transit in Shared Use” (July 2011). Additional information and details about the River LINE and related issues may be found in that report.

## Summary

SITS protection has been well-proven at the River LINE and can be provided at a single interlocking, where railroad trains and lighter-weight passenger trains have crossing routes at grade, using standard and vital signal-system design concepts. SITS is also applicable where switches are used instead of crossing diamonds and the two modes share common trackage within the same interlocking. SITS, by its very nature, requires that the two train types enter and depart the interlocking on different tracks. Passenger trains are restricted by the interlocking logic to operate between specific entrance and exit tracks on a specific route or routes. Similarly, freight trains are restricted by the interlocking logic to operate between specific entrance and exit tracks on a specific route or routes. Passenger and freight trains cannot have any common entrance or exit points to the interlocking.

ETS protection also has been well proven at the River LINE and can be provided at multiple successive interlockings, where railroad trains and lighter-weight passenger trains share common trackage at and between interlockings, using standard and vital signal-system design concepts in concert with novel vital ETS communication and logic between the interlockings. ETS, by its very nature, also requires that the two train types enter and depart the shared trackage on different tracks (as described above for SITS).

The words “temporal separation” in the terms SITS and ETS emanates from the practice of separating non-compliant from compliant operations by time of day (where passenger services generally operate during the day and freight at night) to obtain a waiver for shared use operations from FRA. However, the River LINE technology and functionality instead provides on-demand or OCSS, which allows for more effective use of the railroad track and right of way.

## NJ TRANSIT’s Newark Light Rail

NJ TRANSIT’s Newark Light Rail (LRT) system has two lines, both of which are electrified. The primary trunk line extends from Newark Penn Station to Grove Street, a distance of 5.3 miles. A branch from the trunk line begins at a junction that is very close to Newark Penn Station and extends to Newark’s Broad Street Station, a distance of approximately 1 mile.

The primary line to Grove Street is entirely exclusive right-of-way (including rail-highway crossings at-grade). The LRT passenger trains are operated at MAS of up to 50 mph.

The Newark to Grove Street trunk line has a double-track configuration with intermediate interlockings. Bi-directional cab signaling with ATC speed control (without intermediate wayside block signals) is provided on the main tracks,

and the entire line (including all interlockings) is centrally controlled by a CTC system.

Near Grove Street at Grove East Interlocking, local CSX freight-train movements at one time crossed and used a short portion of the transit line. The freight-train route included turnouts and did not involve crossing diamonds. However, the shared use was limited to the confines of one single interlocking.

Because the LRT trains are lighter-weight DMU vehicles that do not meet the FRA buff-strength requirements, the FRA waiver required that the two (passenger vs. freight) vehicle types must be positively separated from each other.

Originally, these freight-train movements were made during the overnight hours when no passenger trains were operating. The protection between the two modes under the original FRA temporal-separation waiver was based solely on rules and procedures.

Subsequently, all components of the shared trackage were interlocked to vitally enforce the modal separation. As at NJ TRANSIT's River LINE, the interlocked protection is called Short Interval Temporal Separation (SITS). The term SITS is somewhat of a misnomer in that the Newark Light Rail technology and functionality provided Localized On-Demand Spatial Separation and not time-based separation.

Figure B-5 shows a retired freight track to adjacent to Grove Street Station. Figure B-6 depicts the track layout in the shared-use area under SITS.

### **Figure B-5**

*View of retired freight track to right of Grove Street Station*



**Figure B-6**  
SITS at Grove East  
interlocking

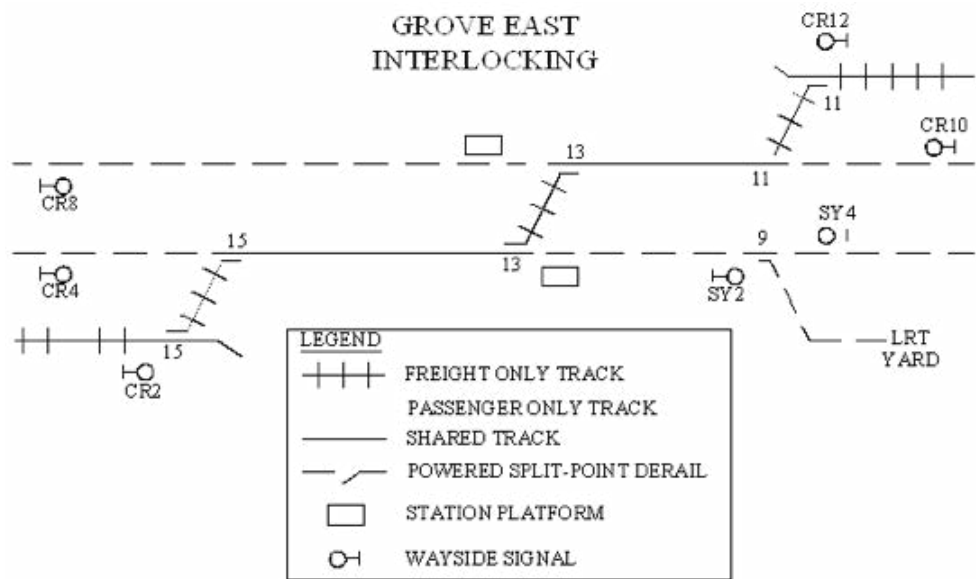

Instead of being restricted to the so-called midnight hours because of required temporal separation, SITS allowed the freight-train movements to be made at any time during the 24-hour day including during the “daytime” passenger-train operating period.

Under SITS, the vital signal-system circuits and the cab-signal ATC speed-control system forced passenger trains to stop short of any freight-train movement. Interlocked derails were strategically located, as shown in Figure B-6 to prevent freight trains from entering areas where passenger trains were operating.

Under the vital interlocking logic, freight trains could only be routed on the route between Signals CR2 and CR12, and passenger trains could only be routed on the routes between Signals CR4/CR8 and CR10/SY4/LRT Yard.

To initiate a freight-train movement in either direction between Signals CR2 and CR12, the freight-train crew provided early notification of the expected movement by contacting the Newark Light Rail control center by telephone prior to reaching the interlocking. Upon arriving at the interlocking, the freight-train crew notified the control center that they were ready to take control of the interlocking and (after the signal cleared) to make the movement across the interlocking. The Newark Light Rail controller then ensured that there were no LRT passenger trains approaching or within the affected shared-use trackage. The controller then granted the freight-train crew permission to take control of the interlocking and line the route by operating a pushbutton located in a local control box near the interlocking signal.

After the pushbutton was operated, and if the requested route was unoccupied and not locked, the freight-train route was automatically lined and locked. This

vitaly locked out all conflicting passenger-train routes. After the freight-train movement cleared the interlocking, the freight-train crew canceled the request using a local control box at the leaving end of the interlocking. If the interlocking route was unoccupied and not locked, this cancel request automatically reset the interlocking to again function for LRT passenger-train movements. The derails protecting entrance into the interlocking from the freight tracks were vitaly forced to the derailing position before signals could clear on and for passenger-train routes.

The shared-use freight-train operations ceased in 2010.

## Tampa's TECO Streetcar Line (HART)

The Hillsborough Area Regional Transit (HART) TECO historic trolley system is a 2.7-mile-long line extending from downtown Tampa to the Ybor City historic district near the city's downtown. The TECO Streetcar Line tracks are generally longitudinally separated from the motor-vehicle traffic, but there are many streetcar-highway grade crossings at which the streetcars are governed by highway-traffic-intersection bar signals.

The TECO system is primarily a single-track line with both short and long passing sidings (Figure B-7). Opposing streetcars meet at scheduled locations and/or as agreed between streetcar operators using radio communications. No signal-system protection is provided between same-direction or opposing streetcars. Except for the meeting of opposing streetcars as described, the streetcars are operated based on line-of-sight rules.

**Figure B-7**  
TECO streetcar  
approaching meet  
with opposite-  
direction streetcar in  
single-track non-  
signaled street-running  
territory



There is an interlocked crossing named 14th Street at which the TECO Streetcar Line crosses the CSX Tampa Terminal Subdivision at-grade (Figures B-8 and B-9). Both rail lines have a single-track configuration at this automatic interlocking.

**Figure B-8**

*TECO streetcar approaching 14th Street automatic interlocking with CSX (note signs for mandatory stop short of interlocking signal)*



**Figure B-9**

*Amtrak train crossing in front of waiting TECO streetcar at CSX Tampa 14th Street automatic interlocking*



Photo provided by Troy Nolen

The CSX line is used by both Amtrak passenger trains and CSX freight trains. No railroad trains use the streetcar tracks and no streetcars use the railroad tracks.

The automatic 14th Street Interlocking uses conventional railroad signals to control movements of both railroad trains and streetcars, and also uses conventional track circuits for train detection. At the interlocking, there are no derails and no form of train control on either the TECO Streetcar Line or on the CSX line. The operation of this automatic interlocking is based on first-come first-served logic, which is activated by track-circuit occupancy of trains and streetcars approaching the interlocking.

On the CSX line, the posted MAS over the crossing diamond is 25 mph.

On the TECO Streetcar Line, at the automatic interlocking, streetcars are authorized to operate up to a rather low speed of 10 mph. In addition, the streetcars are required to make two safety stops before being allowed to accept and pass a cleared interlocking signal.

There is no temporal separation between the railroad trains and the streetcars, and conflicting movements are separated solely by obedience to the operating rules and the aspects displayed by the interlocking signals.

## Oceanside-Escondido Sprinter (North County Transit District)

The NCTD Oceanside-Escondido Line is a 22-mile-long non-electrified LRT system extending from Oceanside to Escondido, California (Figure B-10). The Sprinter line is entirely exclusive right-of-way (including rail-highways crossings at-grade), and most trackage is shared with BNSF local freight-train operations under an FRA Temporal Separation waiver.

**Figure B-10**

*Sprinter train on viaduct approaching Cal State San Marcos Station*



Photo provided by NCTD

Passenger trains are operated at MAS of up to 50 mph, and freight trains MAS speeds extend up to 30 mph.

The Oceanside-Escondido Line is FRA-regulated and adheres to railroad operating, engineering and maintenance practices. The passenger trains and freight trains have common dispatching personnel and control systems and are subject to common operating rules.

The Oceanside-Escondido Line is a single-and-double track configuration, having both single-track sections and double-track sections, along with several non-

interlocked sidetracks. The passenger-train tracks diverge at CP Loop West from the original route to serve Cal State San Marcos Station before looping back and rejoining the original alignment and trackage at CP Loop East. The BNSF freight trains do not use the “new” passenger-train route between CP Loop West and CP Loop East, but, instead, operate on the original track bypassing the loop.

Bi-directional wayside ABS (without cab signals) is provided on all main tracks, and the entire line (including all interlockings) is centrally controlled by a CTC system. DC track circuits are used for train detection, and vital serial communication links are used for transmitting pertinent data and indications between signal-system locations.

The LRT trains are lighter-weight DMU vehicles and do not meet the FRA buff-strength requirements. Because of this, the FRA waiver requires that the two (passenger vs. freight) vehicle types must be positively separated from each other.

The NCTD Sprinter FRA waiver requires temporal separation over the entire line (a complete shutdown of passenger-train operations to permit freight-train operations, and vice versa).

The 24-hour day is split and allocated so that the passenger trains operate during specified daytime and evening hours and the local freight train operates overnight during the so-called midnight hours.

To provide modal separation, the Oceanside-Escondido Line was designed to include strategically-located interlocked derails to prevent freight trains from entering areas where passenger trains are operating, and vice versa.

The temporal separation on the Oceanside-Escondido Line is enforced only by operating rules and procedures. These procedures require that the dispatcher ensure that the joint trackage is clear of passenger trains and that the interlocked derails are properly positioned before allowing a freight train to enter the line. Similarly, these procedures require that the dispatcher ensure that the joint trackage is clear of freight trains and that the interlocked derails are properly positioned before allowing passenger trains to enter the line.

Once the human-based procedures are completed, the stop signals and derails provide the temporal separation. Aside for the foregoing, there is no technological enforcement of the modal separation.



## Santa Clara Valley Transportation Authority (VTA)

The Santa Clara Valley Transportation Authority (VTA) has a large light rail network serving the Greater San Jose (California) area, including San Jose, Mountain View, Sunnyvale, Santa Clara, Milpitas and Campbell. A VTA light rail vehicle is shown in Figure B-11. The VTA is also one of the governing agencies for the Caltrain commuter rail line that provides service between Gilroy, San Jose, and San Francisco.

**Figure B-11**

VTA light rail vehicle  
in Guadalupe Yard



The VTA was issued an FRA shared-use waiver for the Winchester LRT line between San Jose's Diridon Station on the east and Campbell's Winchester Station on the west, and the VTA line shares a corridor with the very-low-density Union Pacific Railroad (UPRR) Vasona Industrial Lead Track. The Vasona shared corridor is approximately 5.5 miles long, within which the VTA LRT line has a single-track and double-track configuration and six stations. The Vasona Industrial Lead has just a single track within the shared corridor, which continues on past VTA's Winchester end-of-line terminal station.

Within the shared corridor, the VTA tracks include 14 rail-highway grade crossings that are shared with the UPRR line, all of which have active warning devices consisting of flashing lights, gates, and audible alarms. In addition, there are a number of pedestrian grade crossings.

The VTA tracks within the shared corridor have bidirectional automatic block (ABS) signaling and the VTA mainline switches are all interlocked. The UPRR single-track Vasona Industrial Lead is non-signaled, and the freight-train operations are conducted subject to human-based manual-block procedures. While this VTA line and the interlockings are controllable from the VTA's Operations Control Center (OCC) using a conventional CTC system, the

interlockings are usually placed and kept in the Field Automatic mode of operation.

There are no connections between the LRT tracks and the freight track, and the track centers between the two rail lines within the shared corridor are generally less than 25 ft. Thus, the VTA LRT passenger trains and the UPRR freight trains are physically separated from each other because they do not share any common track. However, within the shared corridor, there is a risk that a derailment of a freight train could foul a LRT passenger track, and vice versa.

The infrequent UPRR freight-train operations are conducted primarily to serve one customer (a quarry) beyond the western end of the shared corridor. Typically, this involves one round-trip freight-train movement per week.

Hours of the VTA LRT revenue operations are from approximately 4:30 AM until 12:00 midnight, seven days a week. The frequency of VTA trains within the shared corridor ranges from every 15 minutes during the peak commutation periods to every 30 minutes during off-peak periods.

Normally, when freight trains are not operating within the corridor, derails are installed on the freight track at each end of the shared corridor and secured in the derailing position. This permits VTA LRT trains to operate without any possible freight-train interference.

The UPRR is required to notify the VTA OCC via radio a minimum of 30 minutes before a freight train arrives at the entrance to either end of the shared corridor. When the UPRR notifies the VTA OCC of an anticipated freight-train move thorough the shared corridor, VTA track personnel are dispatched to remove the freight-track derails. The VTA OCC advises the UPRR dispatcher about all installations and removals of the freight-track derails.

Coincidentally with the process to remove the derails on the freight line, the VTA OCC notifies the VTA LRT trains about the anticipated freight-train movement and reminds the train operators of the special rules governing LRT operations adjacent to a freight train.

UPRR trains are limited to a 10-mph maximum speed at all times within the shared corridor. VTA LRT trains must not exceed 25 mph when operating adjacent to and passing a same-direction moving freight train. VTA LRT trains must not exceed 10 mph when operating adjacent to and past a stopped freight train or a freight train moving in the opposite direction.

The above-described risk mitigations are all based on human-based rules and procedures, for which there are no signal-system or other technological enforcements.

## Lackawanna County Historic Trolley

The Lackawanna County Historic Trolley Excursion operates on an electrified single-track line segment from Scranton to Moosic, Pennsylvania, a distance of almost five miles. This scenic route follows a portion of the former Lackawanna and Wyoming Valley Railroad (aka the Laurel Line, an electrified interurban rail line) right-of-way. Included within this line segment is the 4,750-ft.-long Crown Avenue Tunnel, which is one of the longest streetcar tunnels ever constructed. Now owned by Lackawanna County and operated by the short-line operator Delaware-Lackawanna Railroad (a subsidiary of Genesee Valley Transportation), the Historic Trolley Excursions share this single-track line with local freight-train operations.

The Historic Trolley Excursion operates seasonal service six months each year and four days per week during those months using one electric-powered vintage trolley car (Figure B-12). The Delaware-Lackawanna Railroad operates year-round local freight-train service over four miles of the five-mile trolley route, approximately twice per week.

**Figure B-12**

*Car 76 approaches  
the Steamtown  
National Historic Site  
Station in  
Scranton, PA*



There are no interlockings, signal systems, or control systems on this shared-use line. Along the trolley route, there are two highway-rail grade crossings with passive warning devices that are flagged by train crews, and there is one highway-rail grade crossing with active warning devices.

The Historic Trolley does not meet the FRA buff-strength requirements. Because of this, the Delaware-Lackawanna Railroad requested and received an FRA shared-track waiver requiring that the two (trolley vs. freight) vehicle types must be temporarily and positively separated from each other. This temporal

separation is implemented using human-based rules and procedures as explained below.

The freight trains and trolley are operated during defined and different time periods. Freight-train track occupancy and movements are prohibited while the trolley has exclusive use of the shared track, and the trolley must not enter the shared-track limits while there are any freight-train occupancies or movements being conducted. No mixed operations are allowed.

There are 14 entrance and exit points to the shared trackage where conventional freight-train equipment can enter the joint trackage. These 14 points are all at hand-throw switches.

Before permitting and during trolley operations, physical entry of conventional freight-train equipment to the shared trackage is prevented by the use of manually-applied special blocking devices at all access points along the route. These blocking devices ensure separation of the trolley and freight-train movements.

During the “freight windows,” freight trains are governed by Dispatcher Control System (DCS) rules while on the main track, and, during the “trolley windows,” the trolley also is governed by the same DCS rules requiring Form D authority to enter and operate on the shared-use main track.

## Existing Street-Running Trolleys Crossing FRA-Governed Railroad Tracks

This report has not conducted an exhaustive search to determine how many places in the U.S. trolleys operating in streets cross FRA-governed railroad tracks in the same manner as buses, trucks, and automobiles with no waiver or additional protection of any kind. There is one known example of this in the greater Philadelphia area (Darby Borough), where SEPTA subway-surface trolleys run in the street under the Pennsylvania State Motor Vehicle Code in the same manner as buses, except that they are confined to rails within the paved area of the street. Potential conflict between the trolleys and CSX trains is mitigated by standard flashing light signals and short arm gates that activate upon the approach of trains, requiring all vehicles, including trolleys, to stop clear of the railroad track and wait until the crossing is clear before proceeding. This arrangement has existed for many years as a legacy from the Philadelphia Transit Co. and the Baltimore & Ohio Railroad, and it is unknown if any waiver has ever been required.

## Lessons Learned

As was found for NJT's River LINE, NJT's Newark Light Rail, and Tampa's CSX/TECO Streetcar at-grade crossing, conventional-interlocking and signal-system logic can be used to provide Localized On-Demand Spatial Separation and vitally separate non-compatible train types at and within a single interlocking. This capability is currently possible using rather-standard route-locking logic when and only when the two train types (typically lighter-weight passenger trains and railroad freight trains) have separate and different entry and exit points to and from the shared interlocking.

As was also found for NJT's River LINE that novel and more sophisticated interlocking and signal-system logic can be used to provide a more global On-Demand Spatial Separation and vitally separate non-compatible train types at and between multiple successive interlockings. This capability is currently possible using vital communications between adjacent interlockings and route-locking logic when and only when the two train types have separate and different entry and exit points to and from the shared trackage.

These proven and vital (fail-safe) train-separation capabilities have eliminated the need for very inefficient time-based temporal-separation schemes requiring that the two train services be restricted to operate during different time periods. In addition, and as demonstrated on the River LINE and Newark Light Rail, the train separations can be implemented not just by vitally displaying red signal aspects, but by such technologies as electromagnetic train stops, cab-signal systems in concert with ATC speed enforcement, and by the forced-positioning (using route locking) of interlocked turnouts and derails.

Since the primary PTC systems in the U.S. (ACSES, I-ETMS and ITCS) are all overlays on top of conventional railway signal systems, the signal-system enforcement techniques described herein should be considered for inclusion in PTC-based train-separation solutions, as and where appropriate.

The data collected reminded SYSTRA that each shared-use operation that is reviewed by FRA for a possible waiver is evaluated individually, and the approved safety requirements can be somewhat different from other approved-waiver scenarios.

For instance, at the CSX/TECO Streetcar interlocked crossing in Tampa, no derails or form of train control are provided on either line. This is very much different than found on the NJT River LINE and on the Newark Light Rail system, where the approved SITS schemes include both interlocked derails and a form of train control such as electromagnetic train stops or continuous cab signaling with ATC speed control.

Another example of diverse waiver scenarios is that on the NJT River LINE, passenger trains are allowed to operate at normal speeds when the track centers between the LRT track and an adjacent freight-railroad track are only 17 ft. apart (without an IDS being required). However, on the VTA's Vasona shared corridor, the passenger and freight tracks appear to be much further apart than 17 ft., but the passenger trains are restricted to rather low speeds when passing a freight-train.

These observations indicate that as follow-up to this study, we need to work closely with FRA in regard to parallel-track operations on the same rail system involving lighter-weight passenger trains and conventional-railroad passenger and freight trains. Normally, any PTP that may result from involving FRA would be an addition to the same track OCSS enforcements described elsewhere in this report. FRA likely will issue guidelines involving track center distances and possible speed reductions when non-compatible trains are passing on closely adjacent tracks.

**Table B-1**

*Comparison of Existing Temporal-Separation Waivers Reviewed, with Respect to Technological Methods for Enforcing Separation of Non-Compatible Trains*

<b>Rail-Line Attribute/Rail-Line Waiver</b>	<b>NJ TRANSIT River LINE</b>	<b>NJ TRANSIT Newark Light Rail</b>	<b>Tampa TECO Streetcar</b>	<b>Oceanside-Escondido Sprinter</b>	<b>Santa Clara VTA</b>	<b>Lackawanna County Historic Trolley</b>
<b>Type Connection</b>	Two rail crossings, shared track at and between interlockings	Shared track within one interlocking (essentially a rail crossing with turnouts).	Rail crossing	Shared track	Shared corridor	Shared track
<b>Transit Trains</b>	Diesel LRT (DMU)	Electric LRT	Electric historical trolley	Diesel LRT (DMU)	Electric LRT	Electric historical trolley
<b>Railroad Trains</b>	Local freight	Local Freight	Mainline passenger and mainline freight	Local freight	Local freight	Local freight
<b>Primary Method of Separating and/or Protecting Transit Trains from Railroad Trains</b>	Rail crossings – vital interlocking with some novel logic; shared track – vital interlockings, vital communications between interlockings, and novel route-locking logic involving multiple interlockings.	Vital interlocking	Vital interlocking	Rules and procedures	Rules and procedures	Rules and procedures
<b>Technological Enforcements for Separating Non-Compatible Trains</b>	Vital signal-system logic provides the following functionality: electromagnetic-train-stop system enforces passenger-train compliance; interlocked derails enforce freight-train compliance.	Vital signal-system logic provides the following functionality: cab-signal ATC speed-control system enforces passenger-train compliance; interlocked derails enforce freight-train compliance.	None – Safety depends on train-operator obedience to signal-system aspects and indications.	Interlocked derails are provided to enforce separation of non-compatible trains; however, proper positioning of these derails depends on controller obedience to temporal-separation rules and procedures.	None – Safety depends on LRT train-operator obedience to rules and procedures, which require reducing speed when approaching and passing freight trains.	None – Safety depends on employee obedience to temporal-separation rules and procedures.

# PTC Options for Positively Separating Following-Move Non-Compatible Train Types on Same Track

The analysis in this research has identified the following potential alternatives for consideration.

## PTC Base Case – Standard PTC System without Additional Mitigations

ACSES (with or without ATC), ITCS, and I-ETMS, at the very minimum, enforce a following train to decelerate to the 15 or 20 mph maximum permitted with Restricted Speed before entering an occupied block. Failure of a train's engineer to manually make the required speed reduction results in the PTC system bringing the train to a penalty stop short of the occupied block. This 15 or 20 mph maximum with Restricted Speed is then enforced throughout the occupied block. In the case of a train failing to obey the rule to stop short of a train, broken rail, or obstruction within the occupied block, PTC limits the maximum contact speed of any following-train with the preceding train to the 15 or 20 mph enforced speed. This enforced speed limiting, of course, is dependent on the following train having operative PTC equipment.

Prior to the advent of the ACSES, ITCS, and I-ETMS systems, this level of speed-limiting enforcement for following trains within occupied blocks existed only on railroads and rail lines having continuous-cab signal-based ATC speed control. Full ATC enforces trains to slow to 15 or 20 mph (dependent upon the carrier's own rule) while displaying the requirement to operate at Restricted Speed before reaching and while within an occupied block. For railroads and rail lines having only continuous cab-signaling without speed control, the potential collision speed with a preceding train was not limited to 15 or 20 mph, and serious violations of ABS indications could (and did) result in catastrophic situations at higher speeds.



Rear-end collisions between two compliant trains operating at 15 to 20 mph have been known to cause injuries, however slight. But a rear-end collision, even though limited to 15 to 20 mph, involving a compliant train and a non-compliant transit train is likely to have more serious results. The standard PTC functionality will greatly reduce this risk by stopping the train before reaching the occupied block if the engineer does not manually reduce speed to less than or equal to the maximum speed permitted for Restricted Speed before entering the occupied block. In this case, only if the engineer/driver then elects to proceed recklessly at the permitted 15 to 20 mph after the train has been stopped by the engineer or by a PTC penalty application of the brakes could a problem arise.

Prior to the implementation of full ATC, followed by the ACSES, ITCS, and I-ETMS PTC systems being studied, to attempt to illustrate the levels of mitigation of risk being considered, we will establish a bench-mark risk level of such a railroad Restricted Speed rear-end collision at “x” events per 1,000,000 train miles. The SYSTRA team was not able to obtain these historical data, so the value “x” is used to represent the historical pre-ATC/PTC risk. This will permit estimating future risk levels under potential improvement alternatives relatively as a function of “x,” the historical and pre-ATC/PTC risk level. The vast majority of these relatively-rare past accidents have occurred on rail lines not having any form of speed enforcement. It must also be recognized that while we do not know the value of “x” at this time, we expect that it is very likely less than “unity” (less than one per million train miles) and quite likely very much less than unity. This benchmark value will be represented mathematically as “1.0(x)” events per 1,000,000 train miles, where we believe “x” to be less than unity.

The risk of such a Restricted Speed rear-end collision under PTC and the PTC Base Case with operative PTC is very approximately estimated to be no more than  $0.01(x)$ , or  $10^{-2}(x)$ , events per 1,000,000 train miles, or no more than one-one-hundredth of the previous risk prior to ATC and PTC. Operative ATC or PTC precludes all of the more serious train collisions caused by higher speeds than 15 or 20 mph. These statistics are valid only when trains are actually moving with ATC or PTC cut in and fully functioning, and are suspended at all times that the system may be cut out for any reason. Therefore, the reliability of each PTC system will influence the final value of this risk factor, but as solid reliability levels are not yet well established with available data, the selection of the multiplier (“0.01” in this case) will be made based on subjective experience to represent an estimated order of magnitude.

For ACSES, when we use the term “operative PTC” in the previous sentence, this also includes operative ATC cab signaling with speed control, except for territories where ACSES is installed without ATC.

- Technical Feasibility of the Base Case – Feasible. No PTC changes are required.

- **Technical Risk of Implementation of the Base Case** – A direct function of the PTC system implementation, with the same risks as the implementation of the PTC system chosen.
- **Operational Risk of the Base Case** – When the PTC system is operative, there is a very slight risk of a rear-end Restricted Speed collision involving non-compatible train types because of engineer error. When the PTC system is not operative and is cut out, there are increased risks. While these failure-scenario risks cannot be calculated at this time because precise failure and cutout rates of the three PTC systems are not yet available, preliminary experience with these systems in revenue service during the first 10+ years does tend to confirm that the track-based systems dependent upon rail currents (ATC) and transponders (ACSES) currently do have a significant edge over the totally wireless systems in reliability. The industry is hopeful that the current heavy investment in the data radio systems and in solving comprehensive coverage issues may bring up the level of reliability of the 100% wireless systems to help close this preliminary gap in performance, but the fact remains that the rails and transponders are entirely under the control of the rail carrier, while the airwaves are not. The combined ATC/ACSES system has a further advantage in that either of the two subsystems can be cut out independently while the other continues to provide a level of protection, and even these incidents have been very few. These failure and cutout rates will directly affect the associated level of risk.
- **Reliability of the Base Case** – The same reliability as the PTC system’s reliability.

### Same-Track Option 1 – Standard PTC System with Additional Operating Rules and Procedures for AABS Operation

Under ST Option 1, the operating rules would be revised to mitigate the risk of a “railroad” train and a transit train coming into contact with each other. The revisions would prescribe special rules and procedures in territories where railroad trains operate comingled with transit trains.

Under such revised rules, railroad and transit trains would be required by rule to stop before entering an occupied block and report to the train dispatcher for permission to enter and proceed through the block. The dispatcher would authorize the following train to enter the block only after the dispatcher manually determines that no incompatible train was ahead in the occupied block. An exception to this withholding of authority in the event of an emergency would also be covered with special rules.

Besides having appropriate TTSIs define exactly where the new special rules and procedures were in effect, all signals within the territory could have an appropriate special “plate” attached to the signal mast designating and reinforcing

the fact that special rules and procedures apply before entering an occupied block.

For territories where PTC is used with continuous-cab-signaling and/or ATC speed control, but without intermediate block signals, the following train would be required by rule to stop immediately upon receiving a Restricting cab signal, or if block markers are installed at the entrance to each block, these would be the designated “absolute” stopping points when the Restricting cab signal is displayed on-board the train approaching them.

The risk of a Restricted Speed rear-end collision under ST Option 1 with operative standard PTC and rules enhancement only is very approximately estimated to be no more than 0.1 of the PTC-Base-Case risk (0.001 of the pre-ATC/PTC case risk) or  $0.001(x) = 10^{-3}(x)$  events per 1,000,000 train miles. This is one-one-thousandth of the pre-ATC/PTC exposure. The risk that the two trains would be non-compatible is less than this value, and would depend on the number of trains of each type that are operated.

For ACSES, when we use the term “operative PTC,” this also includes operative ATC cab signaling with speed control, except for ACSES without ATC territories.

- Technical Feasibility ST Option 1 – Feasible. No PTC changes are required.
- Technical Risk of Implementation of ST Option 1 – A direct function of the PTC system implementation, with the same risks as the implementation of the PTC system chosen.
- Operational Risk of ST Option 1 – When the PTC system is operative, the very slight risk of a rear-end Restricted Speed collision involving non-compatible train types because of a human error by both the train dispatcher and engineer, or by just the engineer. In the latter case, the engineer would have to make two major mistakes—not obtaining the dispatchers permission to enter the occupied block, and failing to properly control his or her train to stop short of the preceding train. When the PTC system is not operative and is cutout, there are increased risks. The failure and cutout rates will directly affect the increased level of risk of ST Option 1.
- Reliability of ST Option 1 – The same reliability as the PTC system’s reliability, but further affected by the effectiveness of the obedience to and the enforcement of the new rules.

### Same-Track Option 2 – Standard PTC System with Minimal PTC System Application Engineering Changes Only to Enforce AABS Operation

Under ST Option 2, the traditional application of the PTC system would be modified somewhat in and for territories where compliant railroad trains operate comingled with non-compliant transit trains. The modification would have the PTC system treat all permissive (non-absolute) signals as absolute signals and

enforce all trains to stop short of all occupied blocks. This special functionality should not require any PTC-system design modifications for any of the three PTC systems being studied. The modifications can be implemented in ACSES and ITCS by standard application engineering, using the existing configuration “tools,” without requiring any changes to the PTC system itself, and it is anticipated that this should also be the case with I-ETMS.

For absolute signals (such as at interlockings and control points) that display a proceed aspect (such as “Stop and Proceed” or “Restricting”) into an occupied block, either automatically or by manual call-on, the signal circuits would be modified to eliminate the automatic display of the close-in aspect, and possibly the call-on feature as well. If the call-on feature is maintained, the train dispatcher would not be permitted to use it unless it was first determined that the leading train and the following train were compatible.

The resulting modified PTC system would not only positively separate non-compatible trains, but would also positively separate each individual train from all other trains, regardless of whether they are compatible or not. Operationally, this would also eliminate the close-in capability (in the joint territory) between compatible railroad trains, a capability that has been inherent in historical and conventional U.S. railroad signaling, and which capability is provided in the standard ACSES, ITCS and I ETMS PTC system implementations.

This restrictive feature of ST Option 2, extending absolute block separation to compatible train operation may not be acceptable to either the established rail carrier in the corridor or the operator of the proposed light rail service, if the capacity required by either of these services is adversely impacted. Additional infrastructure may need to be offered to compensate.

Should a failed track circuit make it necessary for a train to enter a block falsely indicating “occupied,” or when the block is actually occupied, the train dispatcher will be required to first manually determine that any train in the block and the following train are compatible with each other, which means that they are either both compliant “railroad” trains or that they are both non-compliant transit trains. Only then will the dispatcher be permitted to authorize a train to override the PTC stop enforcement and enter an occupied block, unless an emergency requires special action.

If the Train ID on the dispatcher’s display is lost due to the false restrictive failure, which is sometimes the case, the dispatcher may have to actually talk with one or more trains in the area to positively establish their identities in order to determine their compatibility. The good news in regard to this type of failure is that track circuits on well-maintained track are normally very reliable. The bad news is that if it ever does happen, it puts a significant burden on the dispatcher to sort it out.

The risk of a Restricted Speed rear-end collision under ST Option 2 with operative standard PTC with minimum application engineering changes only, is very approximately estimated to be no more than 0.1 of ST Option 1, or  $0.0001(x) = 10^{-4}(x)$  events per 1,000,000 train miles. This is one-ten-thousandth of the pre-ATC/PTC case risk. The risk that the two trains would be non-compatible with each other and involve a transit train is less than this value, and would depend on the number of trains of each type that are operated. To compare ST Option 2 with other options, we will use the full value of  $0.0001(x)$  events, or  $10^{-4}(x)$ , per 1,000,000 train miles.

A slight risk is introduced in ST Option 2, should the dispatcher fail to identify the train in the block as in-compatible with the one following, authorizing entry of the following train into the block, and the following train engineer then overrides the PTS, but fails to operate “prepared to stop” per Restricted Speed. This would be a “two-contingency” failure; unlikely, but possible.

For ACSES, when we use the term “operative PTC,” this also includes operative ATC cab signaling with speed control, except for territories where ACSES is installed without cab signaling. If ST Option 2 is adopted in cab-without-wayside territories, adding distinctive reflectorized passive block markers at the block boundaries would help engineers find these locations, thus reducing the possibility of nuisance penalty brake applications.

- Technical Feasibility ST Option 2 – Feasible. No PTC system changes are required – only application-engineering changes.
- Technical Risk of Application of ST Option 2 – A direct function of the PTC system application, with the same risks as the application of the PTC system chosen.
- Operational Risk of ST Option 2 – When the PTC system is operative, the very slight risk of a rear-end Restricted Speed collision involving non-compatible train types because of a human error by both the train dispatcher and engineer. When the PTC system is not operative and is cutout, there are increased risks. The failure and cutout rates will directly affect the increased level of risk of ST Option 2.
- Reliability of ST Option 2 – The same reliability as the PTC system’s reliability and the reliability of the underlying signal system.

### Same-Track Option 3 – Standard PTC System with Significant Signal System Modifications for Selective Enforcement of AABS Operation

ST Option 3 would allow compatible trains to close-in on each other in the same block at Restricted Speed, while preventing non-compatible trains from doing so. This “smarter” functionality, with less dependency on operating rules, is significantly more complex and more costly than the much simpler ST Option

2, which prevents all trains “across the board” from entering all occupied blocks. The additional complexity in ST Option 3 is required to sort out the compatible trains from the non-compatible trains, and includes two costly additions to the underlying signal system:

- A vital, or fail-safe, Positive Train Identity (PTI) system to positively identify each train to entering the shared corridor. All entrances to the shared-corridor limits will need some type of PTI. ST Option 3A, for example, will require different entry points for Railroad trains vs. Transit trains as a positive means of identifying these trains. Other options will require some additional reliable and fail-safe system, such as transponders or labels on the rolling stock that can be reliably read by wayside readers.
- Additional vital signal functionality will be required that is currently not available, and its development will not be trivial. This additional vital signal functionality will be necessary to track the different train types once they have been positively identified, and positively carry each train’s identity through the entire shared corridor. This system will have to be very reliable, as the defaults, should failures occur in tracking one train, will adversely affect other trains in the area in a fail-safe design.

Figure C-1 depicts the intended functionality of ST Option 3. For the nine scenarios of leading-train/following-train combinations, Signal 2 displays Stop Signal when its block is occupied, except when the train approaching Signal 2 is compatible with the train in Signal 2’s block. Thus, when an LRT train is in Signal 2’s block, the only train that can pass Signal 2 and enter the occupied block is another LRT train. When a railroad train is in Signal 2’s block, the only train that can pass Signal 2 and enter the occupied block is another railroad train. The desired functionality is quite simple, but the technical implementation is more complex, as there is no known vital Signal or PTC application immediately available at this time to implement this functionality.

**Figure C-1**

*Illustration of ST  
Option 3*

Signal 2's Aspect and PTC Enforcement as a Function of Train Types under ST Option 3				
	Train in Block	Enforcement	Train in Block	
	LRT LRT LRT	** PASS ** STOP STOP	LRT RR UNK	
	RR RR RR	STOP ** PASS ** STOP	LRT RR UNK	
	UNK UNK UNK	STOP STOP STOP	LRT RR UNK	
	Any Train	Signal Aspect	Unoccupied	
<p>** PASS ** = Stop &amp; Proceed or Restricting Wayside Aspect, and Restricted Speed Enforcement            STOP = Stop Signal Wayside Aspect, and Enforced Stop Short of Signal</p> <p>LRT = Transit Train (Non-compliant)            RR = Railroad Train (FRA Crashworthy-certified-compliant)            UNK = Unknown Occupancy</p>				

All of the ST Option 3 alternatives discussed below include the following functionality:

- Signals protecting a block will display stop until a discreet vital control function is continuously received by that signal that will positively assure that both trains, the last train in the block governed by the signal and the first train approaching the signal, are compatible with each other.

**Same-Track Option 3 – Characteristics Common to Each Implementation Alternative that Follows**

As previously pointed out, the vital fail-safe signal logic required to safely implement ST Option 3 is not known to exist in the railroad industry today. For this option to work safely, the signal logic controlling each wayside signal has to positively (and vitally) identify each train in the block it governs as a compliant vehicle, or not, and also identify the first train approaching the same signal as a compliant vehicle, or not.

One of the challenges of the data collection for this option is to ensure that no unsafe condition could be caused by two or more trains occupying the same block, which can happen when any train is following a train of the same type. This option should not be implemented unless it can be made fail-safe. If it is

implemented and appears to the responsible operating employees over time to be reliable, at least some of these employees will tend to rely on it. It is when this reliance becomes imbedded into the prevailing culture over the course of time, that any wrong-side failure can have catastrophic results.

Once these two bits of logic are vitally established, and the assurance is provided that the trains represented in each block are truly adjacent to the block boundary directly between them, the logic of the truth table shown in Figure C-1 for Signal 2 (and at all other signals) should be relatively straightforward. However, the logic that will positively assure that this is the case under all conceivable scenarios must be very carefully thought-out and fully vetted.

The data needed by the special logic could be in the form of forwarding positive identification of the train types from block to block from their exclusive entry points (ST Option 3A) or providing a positive means of identification in each block with vital comparison of the train identities in adjacent blocks with the local vital signal logic performing the truth table shown in Figure C-1 (ST Option 3B), or the required vital data for each block could be collected at a centralized vital controller remote from the individual signal or block-point locations, where the vital truth table logic for all of the adjacent block combinations could be performed and then delivered to the individual locations (ST Option 3C). In the latter case, the communications between the central vital controller and all wayside locations will need to be encrypted in such a way as to ensure that all transmissions between the locations remain secure and entirely fail-safe. While there may be some economy in the central controller approach, this could also be off-set by increased vulnerability to false-restrictive failures due to communication failures. These failures should not be unsafe, but could negatively impact the overall reliability of the operation.

How this positive train identification would be transmitted to the wayside logic controllers is an issue that would need to be resolved. Vitally encrypted messages on the LRT equipment in the form of transducers or easily read labels should be a relatively straightforward solution for the non-compliant trains. However, equipping the railroad (compliant) trains may be a significant challenge if the freight railroad sharing the right of way is a large carrier with a large fleet of locomotives, and the carrier is understandably not interested in restricting their operation by equipping a “captive fleet” dedicated to the shared portion of track. This could result in a more restrictive “less-smart” ST Option 3D, where only LRT trains could be positively identified and all other trains would operate as UNK.

Note that the added functionality common to each of these options is introduced into the underlying signal systems, NOT into the enforcing PTC systems.

With either the local or remote approach to the implementation of ST Option 3 above, it is important to note that the vital logic that will need to be created to



perform the above functionality will likely be an enhancement to the underlying signal system, NOT to the enforcing PTC system. There are several very important reasons for this:

1. The additional vital data collection and truth table logic envisioned can be more cleanly added to the existing signal system as an additional logic module, than would be the case if an attempt were made to integrate it with the relatively immature PTC systems still in development. A case could possibly be made to attempt this with the most mature PTC systems, but the voice of experience suggests strongly that this would not be the cleanest, most economically-feasible route to success.
2. All of the PTC applications on the “contiguous railroad system of the U.S.” are currently focused on enforcement of the rules, authorities, and signal aspect authorities already resident on the various railroad lines being equipped. The full development and widespread deployment of I-ETMS, for example, is complicated enough with the rapidly approaching deadline (even if relief is granted) that any attempt to integrate new logic modules into the application standards at this point in that program will most assuredly and understandably be met with strong resistance. And this will likely be the case for many years to come.
3. Once the necessary data collection and logic is resident in the underlying signal system, the enforcement by the chosen PTC system will provide the required enforcement regardless of the PTC system chosen.
4. The Configuration Management of the rollout of the PTC system chosen, and the inevitable future functionality changes, both on the wayside and on-board the trains, will continue to be a very complex and intensive effort, even without the additional complication of a new module that would have a very small application in the country as a whole. Development of the module as an enhancement to the signal system will be entirely transparent to the PTC program and the PTC Configuration Management effort.

### Same-Track Option 3A – Exclusive Entry Points – Vital Logic in Signal System in Field for Selective Enforcement of AABS Operation

ST Option 3A can be applied only where the railroad (compliant) trains and the transit trains enter the shared trackage from different entry points, and when the length of the shared trackage is not overly excessive. ST Option 3A is somewhat similar to the NJ TRANSIT River LINE’s Extended Temporal Separation (ETS) logic. ST Option 3A requires no means of identifying each train type other than by its geographic entry point, and its ability to carry that identity with the train all the way through the system to the exit point. Its successful implementation relies entirely on this premise.

Under ST Option 3A, and using relay equivalents to illustrate the concept, there will be two special relays in the field for each block, one “picked” upon positive forwarding of a railroad (compliant) train identity from the previous block or entrance, and one “picked” upon positive identification of a LRT train in the same manner. When the block is unoccupied, both special relays will be de-energized and down. When the LRT relay is up, this indicates an LRT train in the block. When the railroad (compliant) relay is up, this indicates a railroad (RR) train in the block. When the block is occupied and both special relays are down, this indicates an unknown train or false occupancy in the block. By design, it will not be possible for both special relays to be energized at the same time, and/or comparison logic will be “exclusive-or,” i.e., if both relays are up the combination will be rejected as “not valid” and therefore “unknown.”

When a train enters a block from the previous block, the train-type data will be passed along from one block to the next. This and other data needs of ST Option 3A requires direct or indirect data communications between adjacent signal-system locations. While relays are used in the illustrations, this functionality would more likely be implemented by using vital microprocessor technology in lieu of safety relays. Fail-safety requires that if there is any “glitch” along the way whereby the “RR” or the “LRT” ID is lost, that train will continue to its destination as an UNK (unknown) train as the safe default condition.

Under ST Option 3A, a signal will only display a Stop & Proceed or Restricting wayside aspect into an occupied block if the approaching train and the train in the block are both RR trains, or both LRT trains. Without this data being available at the signal, the signal will display Stop whenever the block is occupied. The PTC enforcement of the signal will reflect the signal aspect that is displayed.

The above discussion only addresses the field-based logic. Most railroad and transit control centers have office-based non-vital train-tracking functionality. The design of ST Option 3A should consider any and all pre-existing office-based train-tracking capability, and any potential conflicts should be resolved as to the manner in which they are handled. While all pre-existing train-tracking ID systems are normally non-vital, they are (or should be) designed in such a way as to default to UNK as far as it is practical to do so. Assuming ST Option 3A to be a fail-safe system, it may in certain circumstances default to UNK when the pre-existing non-vital office system continues to retain a positive ID. Special Instructions will need to be written to safely deal with such issues.

In designing the special vital logic, decisions will have to be made about how the following and many other scenarios are to be handled:

- Two trains merging into one block when this can be discerned from the available indications. If the two trains are of the same type, we see no pressing issue. We also suggest keeping the type-train ID. If non-compatible

types somehow merge into the same block, it would be helpful if the logic can vitally retain the order in which one or more trains entered the block, but if not, the train type for the single occupancy must be changed to UNK.

- A single occupancy in the block splitting into two occupancies. With normal signal systems this can only be discerned after there is one unoccupied block between the two occupancies. Additional logic to vitally retain the order of the trains in each block with multiple occupancies would also help resolve this issue.
- Occupancy occurring when no train is positioned to enter the block would normally default to UNK.

There will need to be rules and procedures for handling UNK trains and occupancies at the exits from the shared trackage, and for emergencies when non-compatible train types must be admitted to the same block as a last resort.

The risk of Restricted Speed rear-end collisions between non-compatible trains in ST Option 3A is grossly estimated to be approximately the same as ST Option 2, i.e.,  $0.0001(x) = 10^{-4}(x)$  events per 1,000,000 train miles, or one-tenthousandth the risk of the pre-ATC/PTC case.

While ST Option 3A would not seem to be worth the additional cost of a significantly more sophisticated solution than ST Option 2, some carriers may see this option as worth pursuing to restore some of the capacity that would be inherently lost in an ST Option 2 solution. However, as ST Option 3A would appear to fit many of the shared corridor applications with exclusive entry points for railroad trains vs. transit trains, this could be a more attractive solution than Option 3B which, as we will see, requires the additional cost of a PTI system.

Under ST Option 3A, the slight risk of an incident occurring when the PTC system is operative could occur because of the human element when the train dispatcher is required to authorize a train to override the PTC enforcement and enter an occupied block when the train ahead is non-compatible, as a last resort in an emergency. This act would then have to be followed by the following train's engineer failing to operate the train prepared to stop short of the train ahead per the requirement of Restricted Speed.

- Technical Feasibility ST Option 3A – Feasible. The display of a Stop & Proceed or Restricting close-in aspect would require that the special-logic indicate that the two occupancies (in the block and approaching the block) are compatible. Without this indication of compatible trains, the special logic would keep the signal displaying Stop when the block is occupied, and the approaching train would be enforced to stop short of the signal.
- Technical Risk of ST Option 3A – No insurmountable technical risks, assuming the shared trackage is not overly excessive. There are precedents for the logic required to implement this, but in general more complex

systems often introduce greater risk of failure. All failure modes must be identified and covered with Special Instructions (SIs) that will be carefully crafted to ensure that failures of the system do not lead to safety exposures due to inadequate coverage by the Rules and SIs.

- Operational Risk of ST Option 3A – Low, when the PTC system is operative, and there are no abnormal track occupancy progressions. However, abnormal track occupancies can occur, and if they do, the risk of failure and train delay could be significant in a very dense traffic environment. When the PTC system is not operative and is cutout, there are also increased risks. The failure and cutout rates of the PTC system and the reliability of the track circuits will affect the level of risk.
- Reliability of ST Option 3A – Reliability of Option 3A will be a product of the PTC system reliability and the signal system reliability. On rare occasions, compatible trains may be unable to close-in on each other because of a failure or a train being tracked as UNK, and such possibilities must be covered by Special Instructions.

### Same-Track Option 3B – Logic in Signal System in Field with PTI and Train-Type Comparison in Field for Selective Enforcement of AABS Operation

ST Option 3B essentially functions the same as ST Option 3A once the train is positively identified, but ST Option 3B would require a supplemental field-based PTI system to be developed for the case where exclusive entry points to the shared trackage are not available for non-compatible trains. PTI detection may not be required for each block but must be located at strategic points along the rail line. At these points, train IDs could be verified and UNK train IDs could be re-identified and verified.

Generally, ST Option 3B would provide the same level of safety as ST Option 3A, but would introduce the additional cost of the PTI system. Depending upon the extent of the shared trackage, the number of points that would need PTI detection, and the number of vehicles that would need to be identified, this could become a complex and costly system, out-weighting the benefits that could be derived from implementing ST Option 3B.

The risk of a Restricted Speed rear-end collision between non-compatible trains under ST Option 3A with operative PTC is grossly estimated to be approximately the same order of magnitude as ST Options 2 and 3A, i.e.,  $0.0001(x) = 10^{-4}(x)$  events per 1,000,000 train miles, or one-ten-thousandth the risk of the pre-ATC/PTC case. While ST Option 3B would not seem to be worth the additional cost of a significantly more sophisticated solution than ST Option 2 or ST Option 3A, some carriers may see ST Option 3B as worth pursuing to restore some of the capacity that would be inherently lost in an ST Option 2 solution, and having non-exclusive entry points, be unable to implement ST Option 3A.

- **Technical Feasibility of ST Option 3B – Feasible.** The display of a Stop & Proceed or Restricting close-in aspect would require that the special-logic indicate that the two occupancies (the last train in the block and the first train approaching the block) are compatible. Without this assurance of compatible trains, the special logic would keep the signal displaying Stop when the block is occupied, and the approaching train would be enforced to stop short of the signal governing the block.
- **Technical Risk of ST Option 3B –** The introduction of a vital PTI detection system and the additional logic associated with Option 3B introduces significant complexity to the underlying signal system, and the more complex the system, the greater is the risk of failure. Vital field comparison of train types in adjacent blocks will need to be developed, and a safety case made for FRA. There are no precedents for the logic required to implement this, adding to the risk. All failure modes must be identified and covered with Special Instructions (SIs) that will be carefully crafted to ensure that failures of the system do not lead to safety exposures arising out of inadequate coverage by the Rules and SIs and the training of the employees that will have to implement them.
- **Operational Risk of ST Option 3B – Medium,** when the PTC system is operative, all PTI detectors work properly and there are no abnormal track occupancy progressions. However, abnormal track occupancies can occur, and PTI detectors can fail, and if they do, the risk of failure of Option 3B with resulting train delay could conceivably be significant, even to unacceptable, in a very dense traffic environment. When the PTC system is not operative and is cutout, there are also increased risks. The failure and cutout rates of the PTC system and the reliability of the track circuits will affect the level of risk. If a large railroad carrier is involved, the need for a captive fleet equipped with ID labels or on-board transponders for operation through the shared trackage could be a “deal killer.”
- **Reliability of ST Option 3B –** Reliability of Option 3B will be a product of the PTC system reliability, the signal system reliability and the PTI detection system reliability. On rare occasions, compatible trains may be unable to close-in on each other because of a failure or a train being tracked as UNK, and such possibilities will have to be covered by Special Instructions.

### Same-Track Option 3C – Vital Centralized SPTIP for Selective Enforcement of AABS Operation

ST Option 3C is functionally the same as ST Option 3B except that ST Option 3C concentrates the vital PTI processing and the vital signal release messaging to the individual signal locations at one point in a Safety PTI Processor (SPTIP), instead of distributing this functionality across the individual signal locations in their individual signal processors. This also requires very robust and redundant communications, preferably a fiber-optic system, between the SPTIP and the individual signal locations, i.e., the interlockings and block-point locations.

As in ST Options 3A and 3B, all signals governing an occupied block will display “Stop” until a special control or indication is transmitted from the SPTIP to the signal location and is vitally (and continuously) received at the signal indicating that both trains, the last train in the block governed by the signal and the first train approaching the signal, are compatible with each other. Only then will the appropriate close-in wayside signal aspect be displayed. The type of PTC enforcement will be based on the signal aspect being displayed.

There will need to be rules and procedures for handling anomaly conditions, including UNK trains and occupancies.

The risk of a Restricted Speed rear-end collision between non-compatible trains under ST Option 3C with operative PTC is very approximately estimated to be the same as for ST Options 2, 3A and 3B, i.e., less than  $0.0001(x) = 10^{-4}(x)$  events per 1,000,000 train miles, or one-ten-thousandth the risk of the pre-ATC/PTC case. ST Option 3C addresses the same operational needs as ST Option 3B, the only difference being in the concentration of the certain common vital processing of the PTI-Comparison/Signal-Releasing functionality for a number of individual signal locations in one centralized location.

ST Option 3C might be an attractive approach for a line that currently has a very modern processor-based signal system recently installed at all signal locations, and the addition of the SPTIP performing the PTI processing for the existing WCs would be the economic solution while causing less disruption to the WCs at the individual signal locations. Whereas, ST Option 3B would be more cost-effective where a new signal system was being concurrently installed, and the SPTIP functionality could be distributed in the individual local signal processors, with typical signal-type vital control lines between the locations, making a centralized processor unnecessary.

- Technical Feasibility ST Option 3C – Feasible. The display of a Stop & Proceed or Restricting close-in aspect would require that office-based logic continuously transmit a special control when it is known that the two occupancies (in the block and approaching the block) are compatible. Without this special control indicating compatible trains, the wayside logic would keep the signal displaying Stop while the block is occupied, and the approaching train would be enforced to stop short of the signal. This is a simple straightforward requirement.
- Technical Risk of ST Option 3C – The same risk levels as in ST Option 3B apply.
- Operational Risk of ST Option 3C – When the PTC system is not operative and is cut out, there are increased risks. The failure and cutout rates affect the increased level of risk. When the SPTIP-based train-tracking system is not operational, or the communications system is not available, the operation could be designed to revert to ST Option 2, and all trains would

be forced to stop short of all occupied blocks. As in ST Option 3B, if one of the carriers has a very large locomotive fleet and is not willing to equip a captive fleet for operation in the shared-track area, neither ST Option 3B nor ST Option 3C would be an acceptable solution.

- Reliability of ST Option 3C – Reliability of ST Option 3C would be a product of the PTC system reliability, the signal system reliability, the PTI detection system reliability and the communication system reliability. On rare occasions, compatible trains may be unable to close-in on each other because of a failure or a train being tracked as UNK, and such emergencies will have to be covered by Special Instructions.

### Same-Track Option 3D – When Only LRTs Can Be Identified and All Other Trains Must Operate as Unknown for Selective Enforcement of AABS Operation

ST Option 3D is a possible alternative when an operator of a large fleet of locomotives, such as a Class I Freight Carrier, would find it unattractive to equip the entire fleet, or even a small captive fleet, with ID labels or transponders. This would preclude ST Options 3B or 3C, and if the exclusive entry points required for ST Option 3A are not feasible, consider ST Option 3D.

Figure C-2 depicts the intended functionality of ST Option 3D. For the four scenarios of leading-train/following-train combinations, Signal 2 displays “Stop Signal” when its block is occupied, except when the train approaching Signal 2 is compatible with the train in Signal 2’s block. Thus, with an LRT train in Signal 2’s block, the only train that can pass Signal 2 to enter the occupied block is another LRT train. In all other cases, Signal 2 will display “Stop Signal.”

**Figure C-2**  
 Illustration of  
 ST Option 3D  
 (“truncated” version  
 of Figure C-1)

Signal 2’s Aspect and PTC Enforcement as a Function of Train Types under ST Option 3				
	<b>Train in Block</b>	<b>Enforcement</b>	<b>Train in Block</b>	
	LRT	** PASS **	LRT	
	LRT	STOP	UNK	
	UNK	STOP	LRT	
	UNK	STOP	UNK	
	Any Train	Signal Aspect	Unoccupied	
** PASS ** = Stop & Proceed or Restricting Wayside Aspect, and Restricted Speed Enforcement STOP = Stop Signal Wayside Aspect, and Enforced Stop Short of Signal LRT = Transit Train (Non-compliant) UNK = Unknown Occupancy				

The risk of a Restricted Speed rear-end collision between non-compatible trains under ST Option 3D with operative PTC is very approximately estimated to be the same as for ST Options 2, 3A, 3B and 3C, i.e., less than  $0.0001(x) = 10^{-4}(x)$  events per 1,000,000 train miles, or one-ten-thousandth the risk of the pre-ATC/PTC case.

- Technical Feasibility ST Option 3D – Feasible. Similar to ST Options 3B and 3C.
- Technical Risk of ST Option 3D – The same risk levels as in ST Option 3B and 3C also apply to ST Option 3D.
- Operational Risk of ST Option 3D – Similar to ST Options 3B and 3C except that it may be acceptable to a carrier with a large fleet of locomotives that would not find ST Options 3B or 3C acceptable.
- Reliability of ST Option 3D – Reliability of ST Option 3D will be a product of the PTC system reliability, the signal system reliability, the PTI detection system reliability and the communication system reliability. On rare occasions, compatible trains may be unable to close-in on each other because of a failure or a train being tracked as UNK, and such possibilities will have to be covered by Special Instructions.

### Summary of ST Options for Positively Separating Following-Move Non-Compatible Train-Types on Same Track

Table C-1 provides a comparison of ST Options 1, 2, 3A, 3B, 3C and 3D.



**Table C-1**

*Summary of ST Options for Positively Separating Following-Move Non-Compatible Train-Types on the Same Track*

Same-Track Following-Train Options	Estimated Accident Risk Per IM Train Miles	Relative Incremental Cost	Comments
Pre-PTC and/or ATC Conditions	1.0(x)	NA	Unknown value of current risk without PTC, “x” likely “<<1”?
PTC Base Case	0.01(x) = 10 <sup>-2</sup> (x)	Zero	PTC system required regardless of shared use.
ST Option 1 – Standard PTC system with additional rules for Absolute Automatic Block Signals (AABS)	0.001(x) = 10 <sup>-3</sup> (x)	Cost of preparing and distributing new rules only	PTC system unchanged but new operating rules and/or special instructions would be placed in effect.
ST Option 2 – Standard PTC system with enforced AABS	0.0001(x) = 10 <sup>-4</sup> (x)	Moderate.	PTC application engineering but not system design changes required; some underlying signal system modifications required.
ST Option 3A – Field logic added to signal system for selective enforcement of AABS	0.0001(x) = 10 <sup>-4</sup> (x)	Significant	Partially restores some capacity lost in ST Option 2; new vital signal field logic and exclusive entry points required.
ST Option 3B – Local field logic added to signal system and PTI system for selective enforcement of AABS	0.0001(x) = 10 <sup>-4</sup> (x)	High	Partially restores some capacity lost in ST Option 2; new vital signal field logic required plus PTI.
ST Option 3C – Same as 3B except local field logic concentrated in Safety PTI Processors (SPTIPs)	0.0001(x) = 10 <sup>-4</sup> (x)	High	Partially restores some capacity lost in ST Option 2; new vital signal field logic required plus PTI.
ST Option 3D –Alternative to Options 3A, 3B, and 3C when one carrier unable or unwilling to equip its fleet with IDs for PTI	0.0001(x) = 10 <sup>-4</sup> (x)	High	Partially restores some capacity lost in ST Option 2; new vital signal field logic required plus PTI for LRTs.

# TC Options for Protecting Non-Compatible Train Types on Parallel Tracks of Same Rail Line

## Single-Track Rail Line with Passing Sidings

The simple case of a single-track line with passing sidings and/or short sections of double track, also known as the Single-Track Concept, can easily be handled by providing an IDS between the tracks at the sidings and/or short double-track segments. This concept is illustrated in Figure D-1 and requires that the track centers be spaced wide enough to permit installation of the IDS.

The possibility of a well-designed crash wall, if it could be found cost-effective in this application, could reduce or eliminate the need for intrusion detection, but since it is outside of the scope of this study, it is mentioned only in passing to ensure that its consideration is not overlooked where it may provide a superior solution. A combination crashwall and a simpler crashwall-integrity-sensing system could also be considered as an alternative IDS.

**Figure D-1**  
*IDS at passing sidings*

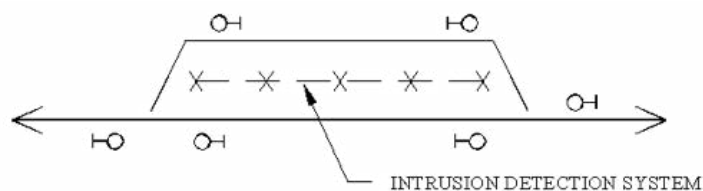

For a detected event, the vital field circuits would drop the signals to stop on both tracks and in both directions, and these stop signals would be enforced by the PTC system as for all other absolute signals.

The SYSTRA team considered other PTC-based options for providing protection on primarily single-track rail lines and concluded that, for passing sidings and short sections of double track, the IDS concept appears to be the simplest and most practical. If this concept is not acceptable in some applications, such as when the required track centers cannot be provided to accommodate the IDS equipment or because of the rail-line's management philosophies, the double-

track-line concepts are presented later for consideration instead of the Intrusion Detection Option.

The risk of a collision between derailed, or otherwise fouling, non-compatible train equipment on adjacent tracks without any intrusion protection or crashwall is highly dependent upon the quality and maintenance of the adjacent track structures and the wheel-rail dynamics of the equipment operated. Assuming a high level of attention to these basic items in safe railroad operation, the risk of any such collision on parallel tracks is very approximately estimated at less than  $0.000001(x)$ , or  $10^{-6}(x)$ , events per 1,000,000 train miles, or one-millionth the risk of the pre-ATC/PTC case for risk of collisions on the same track.

With the addition of continuous intrusion detection, this risk is very approximately estimated to be further reduced to  $0.0000001(x)$ , or  $10^{-7}(x)$  events per 1,000,000 train miles, or one-ten-millionth the risk of collision on the same track under pre-ATC/PTC conditions. With the addition of a well-designed effective crashwall and preferably with at least 20 ft. of separation between track centers, we estimate further reduction of the risk of collision of equipment operating on adjacent tracks to very approximately  $0.00000001(x) = 10^{-8}(x)$ , events per 1,000,000 train miles, or one-one-hundred-millionth the risk of the pre-ATC/PTC case for risk of collisions on the same track.

While these risks, as stated above, are estimated at two and three orders of magnitude less than the lowest risks estimated where non-compatible train types must actually share the same tracks at different times, this must be put into a proper perspective by reviewing the basic concept of a railroad track. A track is a “fixed guideway” which confines following and opposing trains to a common path. Safe operation requires that each train’s movement on any track be properly controlled in a manner that at all times it is able to stop short of collision with another train. If it is not, and it is on the same track with “the other” train, collision is inevitable. There will be no avoiding it. If “the other” train is on a different track, collision does not take place. Almost all collisions throughout the history of railroading from its very beginning have been on the same track.

With this basic premise as background, there are actually two basic reasons for adding a second (or more) main track(s) to the minimum of one track in the rail infrastructure. The first is obvious, i.e., to increase the capacity of the line, but we tend to overlook the second, which is to increase the safety of the line. Historically, at the beginning of the twentieth century, much multiple-track was being installed, and with rapidly expanding use of signal systems still in their infancy, doubling a single track and instituting dedicated directional running on each track was frequently cited as a safety improvement to eliminate the frequent head-on collisions that were occurring on single track when train orders were misread or overlooked and early versions of automatic block

signals were failing or violated for a number of reasons. On high density traffic lines, four tracks were installed to separate fast trains from slow trains in each direction, which reduced the risk of “catch-up” rear end collisions, as well as provide the obvious increase in capacity of the line.

Another three decades would pass before CTC operation under signal indication authority would begin to replace the previous 80+ years of TT-TO (Time Table & Train Order) operation. Another 80+ years would pass before the railroads of the U.S. would begin to install PTC to address the issue of a very occasional (but catastrophic when it happens) failure to stop for a “Stop Signal” where the double track ends. Therefore, as shown in Figure D-I, the risk of collision is historically\* (and this continues to be the case) much higher at the ends of the double-track shown than it is through the parallel-track area. Thus, the significantly lower risk values on parallel tracks throughout this section vs. the shared track risks dealt with in much detail in the previous section.

- Technical Feasibility of the Intrusion Detection Concept – Quite Feasible. Well-proven functionality, such as for slide fences. Also, IDS functionality is well-proven on NJ TRANSIT’s River LINE. Since standard PTC enforcement would be provided to stop trains short of detected hazards, the concept is quite feasible from a technical perspective.
- Technical Risk of the Intrusion Detection Concept – Very Low. No PTC changes or unique applications are required.
- Operational Risk of the Intrusion Detection Concept – Very Low. The very rare (with proper design) safe-side failure or false triggering of the IDS could cause some train delays.
- Reliability of the Single-Track Concept – The underlying signaling with the IDS functionality will be as reliable as any signaling with intrusion-detection functionality. Since no PTC changes or unique applications are required, the reliability will be the same as for typical and standard PTC applications.

## Other Parallel-Track Rail Lines

Once again, referring to the estimated risk discussed concerning parallel tracks in the previous section, we will build on the premise that the very essence of multiple track where safe operating practices concerning high standards for and continuing maintenance and inspection of the track structure and the rolling stock, plus careful attention to the loading of freight cars with enforcing inspections, lowers the risk of adjacent track collisions on multiple-track infrastructure quite significantly when compared to the risk of collisions between trains operating on the same track.

A review of the very rare collision of equipment on adjacent tracks will show that most of these (not all) are secondary collisions resulting from a primary collision on the adjacent track, and these secondary collisions constitute a

very small sub-set of the number of same-track collisions. Therefore, what is done to eliminate same-track collisions, rear-end or otherwise, will also serve to eliminate secondary collisions with trains on adjacent tracks. A further comparison leading to low risk factors per million train miles in multiple-track territories is that a very large percentage of the total train miles making up our calculations come from the dense traffic found in these multiple-track multiple-train environments, where very large numbers of trains are safely passing each other on adjacent tracks every day.

We have, therefore, very approximately estimated the comparative risk, prior to adding any PTC enhancements as  $10^{-6}(x)$  events per 1,000,000 train miles for the base case for non-enhanced multiple-track, when compared to the base case for pre-PTC/ATC risks for shared-track usage, which we had estimated at  $1.0(x)$  per 1,000,000 train miles, or a difference in order of magnitudes of approximately 6. We have also estimated the risk of multiple-track collisions between equipment on adjacent tracks with the enhancement of a well-designed continuously-monitored intrusion system with a minimum track separation of 20' between the tracks as  $10^{-7}(x)$  events per 1,000,000 train miles, or a difference in order of magnitude of approximately 7.

We have very approximately estimated the risk of adjacent-track collisions with an adequately designed crash-wall barrier, with a minimum separation between adjacent track centers of at least 20 ft., as very approximately  $0.00000001(x) = 10^{-8}(x)$  events per 1,000,000 train miles, or a difference in order of magnitude of approximately 8 when compared to the pre-ATC/PTC case for risk of collisions on the same track.

In reviewing FRA's involvement in setting standards for shared corridors involving non-compliant equipment on adjacent tracks, there are no general rules concerning this matter, and the few precedents have thus far given no clear definition of what protections and/or enforcements FRA would require to permit parallel-track operations on parallel rail alignments involving both railroad trains and transit trains. Based on the information obtained during Task I, it is believed that the FRA requirements would be based on track-center distances between the tracks and possibly based on other factors such as train operating speeds.

Because of this lack of clarity and based on the review of operations with existing temporal separation waivers, it is conceivable that FRA may allow parallel-track rail operations between non-compatible trains for prescribed track-center distances if the speeds of the involved trains when approaching and passing each other were PTC enforced to acceptable levels. What speeds might be acceptable is open to conjecture.

The above risk values, while highly subjective, and to be used only to compare orders of magnitude, one must always keep in mind that any application of

speed reductions can only serve to degrade the performance of the rail services involved. Any degrading of rail services will possibly spur customers to drive on highways where their risk of harm is far worse.

However, continuing with the primary purpose of this study, the basics of a possible general concept involving PTC protection (where intrusion protection or adequate barriers are not possible or cost effective) is presented as follows:

- Scenario 1 – No transit trains present – Railroad passenger and freight trains proceed at Normal MAS (NMA) speeds.
- Scenario 2 – No railroad trains present – Transit trains proceed at Normal MAS (NMA) speeds.
- Scenario 3 – Track centers 20 ft. or greater – All trains permitted to proceed at NMA.
- Scenario 4 – Transit and railroad passenger trains present and track centers less than 20 ft. – Transit trains enforced to lower speed T1 (e.g., 45 mph) and railroad passenger trains enforced to lower speed RPI (e.g., 50 mph).
- Scenario 5 – Transit and railroad freight trains present and track centers less than 20 ft. – Transit trains enforced to lower speed T2 (e.g., 35 mph) and railroad-freight trains enforced to lower speed RFI (e.g. 25 mph). Under this Scenario 4, railroad passenger trains would be restricted to speed RPI (e.g., 50 mph).

While hypothetical speeds are shown for the above scenarios, those hypothetical speeds are only provided to illustrate the concept, not to speak for FRA, and they would not be “hard-wired” into the system. The key feature of the concept is that depending on the scenario, different speeds would be defined and enforced under each scenario for each different train type. And the enforced speeds under one application can be different than other applications on other lines with different philosophies and risk factors.

The implementation of speeds T1, T2, RPI, and RFI never authorizes a train to exceed the governing permanent and temporary speed restrictions, or to violate signal-system prescribed speeds or stops. Thus, if speed T1 is 45 mph and in effect, and the permanent MAS speed is 30 mph, and a Temporary Speed Restriction (TSR) requires 15 mph, the 15-mph speed would be enforced. When in effect, speeds T1, T2, RPI and RFI never supersede or negate a lower permanent or temporary speed restriction. In the subsequent discussion, we will also refer to these speeds as PTP Speeds.

The actual values for the PTP Speeds, T1, T2, RPI, and RFI, would be individually defined and implemented for each FRA-approved application and installation. Conceptually, there would be four operating modes for each segment of double track with less than 20 ft. track centers:

- Mode Transit – Transit trains would be permitted NMAS. Railroad trains would be enforced to 0 mph MAS and to stop short of the line segment, and could not be present within the track segment as long as the transit train was permitted to operate at NMAS.
- Mode Railroad – Railroad trains would be permitted NMAS. Transit trains would be enforced to 0 mph MAS and to stop short of the line segment, and could not be present within the track segment while railroad trains are permitted NMAS.
- Mode Mixed Passenger – Railroad passenger trains would be enforced to RPI and transit trains would be enforced to TI. Freight trains would be enforced to 0 mph MAS and to stop short of the line segment and could not be present within the track segment until the transit train is actually enforced to not exceeding T2.
- Mode Mixed Freight (including Railroad Passenger) – Railroad passenger trains would be enforced to RPI, transit trains would be enforced to T2, and railroad freight trains would be enforced to RFI.

As illustrated in Figure D-2, the double-track line would be subdivided into segments of parallel tracks so that the line segments are not excessively long. This would minimize train delays after non-compatible train types pass each other, but unfortunately, due to practical implementation of the required functionality, all of the intermediate blocks will need to be set for the first train admitted to either double-track segment between two adjacent interlockings prior to receiving the signal to enter the combined Interlocking-to-Interlocking (ItI) block.

**Figure D-2**  
*Typical double-track  
 railroad mainline with  
 bi-directional signaling*

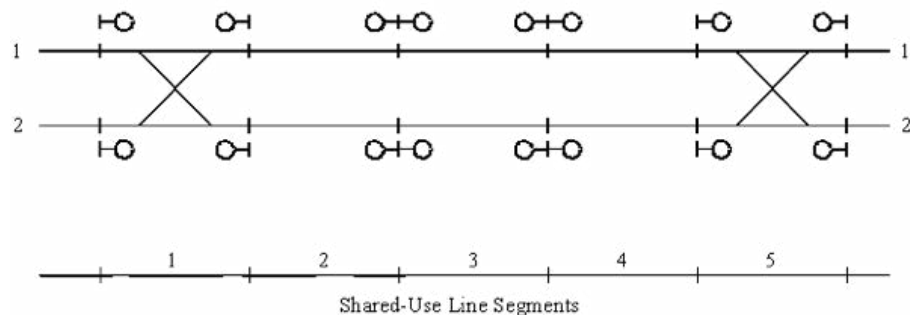

To simplify the illustration, the shared-use line segments in Figure D-2 have been matched to the signal blocks. Longer line-block segments will result in fewer blocks requiring less mode controls and indications but greater train delays after non-compatible trains pass each other.

Alternatively, shorter line segments will reduce train delays by permitting normal speeds to be resumed sooner after incompatible trains pass each other, but this will result in more mode controls and indications and higher cost.

All shared-use line segments include both tracks, and each segment would be set to one of the four modes, based upon “first come, first served.” This concept will require some pre-planning on the part of the dispatcher concerning the order in which signals are displayed for various train types, but the dispatcher will also have control over who goes first in order to give preference to the trains needing preference and to avoid disrupting the steady movement of a tonnage freight train through the shared trackage to mitigate the possibility of train-handling problems such a disruption might trigger.

The following graphics illustrate how the concept would function.

In Figure D-3, all of the shared-use line segments are in “Mode Transit” due to positively-identified transit trains having been given the signal to enter the shared trackage, and the transit trains designated by “LRT” are permitted NMAS speeds.

**Figure D-3**

*Two transit trains operating at maximum speeds*

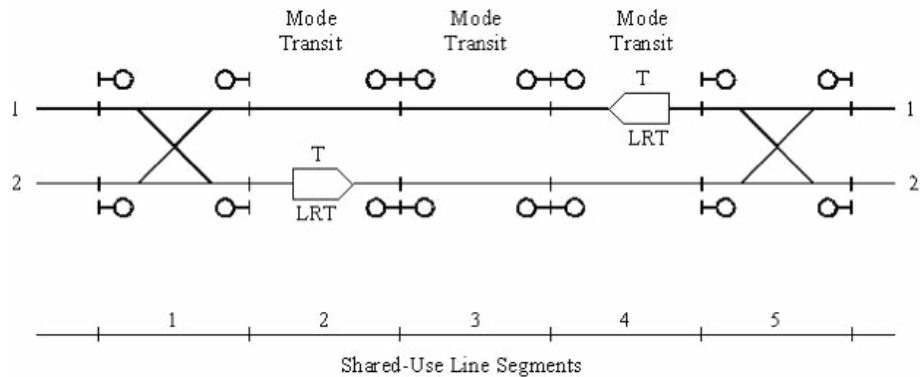

In Figure D-4, all of the shared-use line segments are in “Mode Railroad” due to positively identified railroad trains having been given the signal to enter the shared trackage, and the railroad trains (designated by RF and RP) are permitted NMAS speeds for their respective train types.

**Figure D-4**

*Two railroad trains operating at maximum speeds*

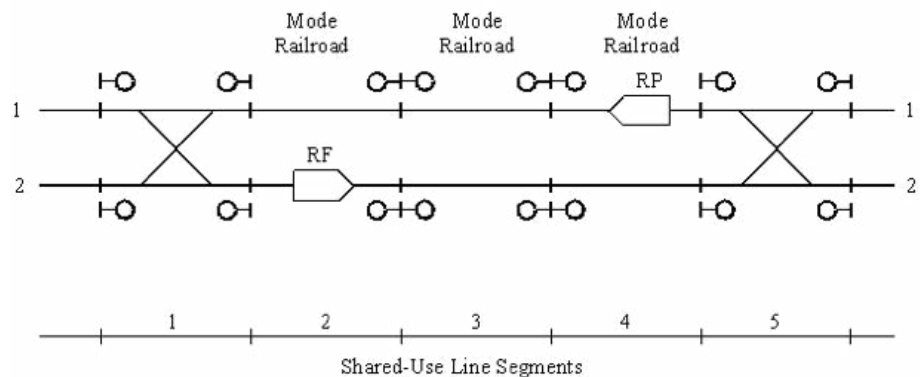



In Figure D-5, all of the shared-use line segments are in “Mode Transit” due to positively identified transit train having been given the signal to enter the shared trackage, and the railroad trains (designated by RP) are permitted NMAS speeds for their respective train types. An RP train is held by a stop signal on track 2 at interlocking A.

**Figure D-5**

*Transit train operating at maximum speed has RP train “locked out”*

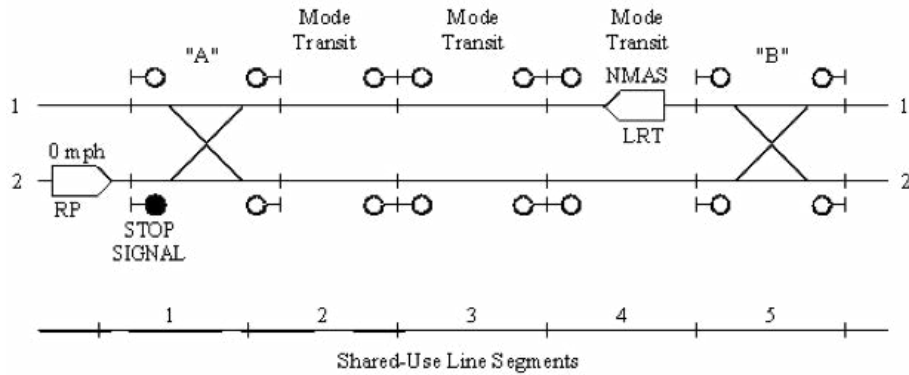

In Figure D-6, the dispatcher has decided to allow the railroad passenger train to proceed into the A-B segment, and has called the signal at A, which causes all intermediate block segments which the LRT has not yet cleared to “tumble” to “Mode Mixed PSGR,” which, in turn, causes the opposing LRT to receive a display to reduce speed to T1, the maximum speed permitted in “Mode Mixed PSGR.” The LRT is currently operating at a speed greater than T1 but is in the process of reducing to that speed.

**Figure D-6**

*Mixed traffic – dispatcher elects to operate RP train with LRT in shared segment*

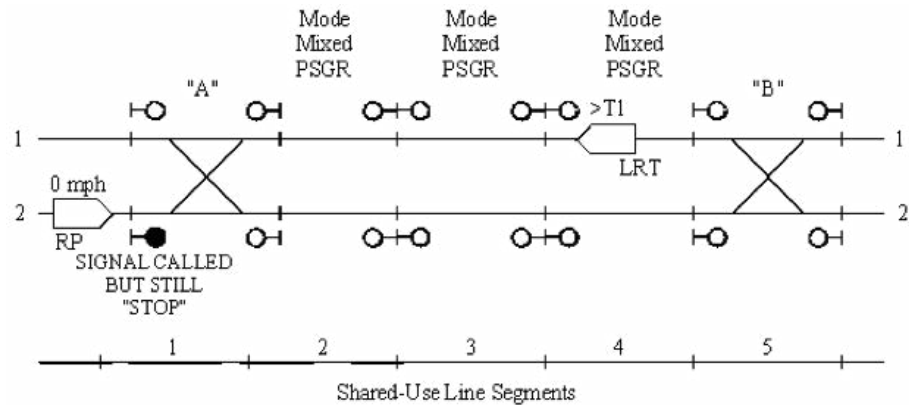

In Figure D-7, the signal at A finally clearing for the RP after an appropriate time delay sufficient to ensure that all intermediate block segments have been set to “Mode Mixed PSGR” and the opposing LRT has been informed and then enforced to reduce speed to T1. The railroad passenger train is permitted to enter the A-B section limited to RPI, the maximum speed permitted in “Mode Mixed PSGR.” Note that when the LRT clears intermediate segment 4, the Mode changes to “Mode Railroad,” which permits the railroad passenger train to resume NMAS when it reaches intermediate segment 4.

**Figure D-7**

*Mixed PSGR train is cleared to enter interlocking at reduced speed*

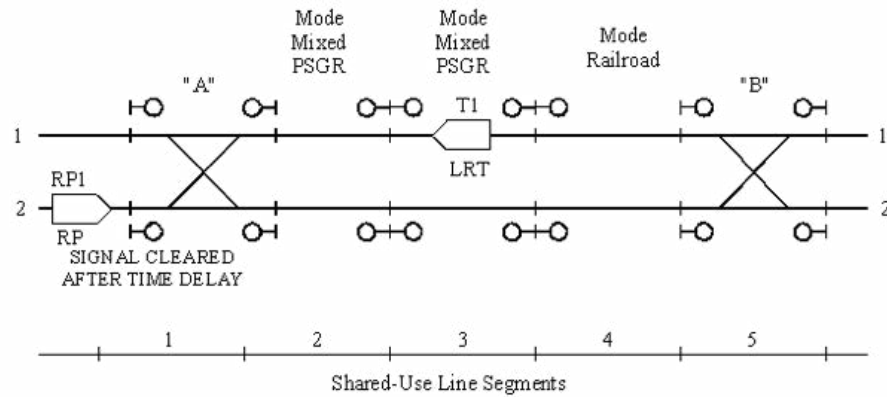

In Figure D-8, the LRT is now clear of both intermediate block segments 3 and 4, permitting the railroad passenger train to resume NMAS as soon as it enters block segment 3.

**Figure D-8**

*Mixed traffic – RP train resumes maximum speed upon passing LRT*

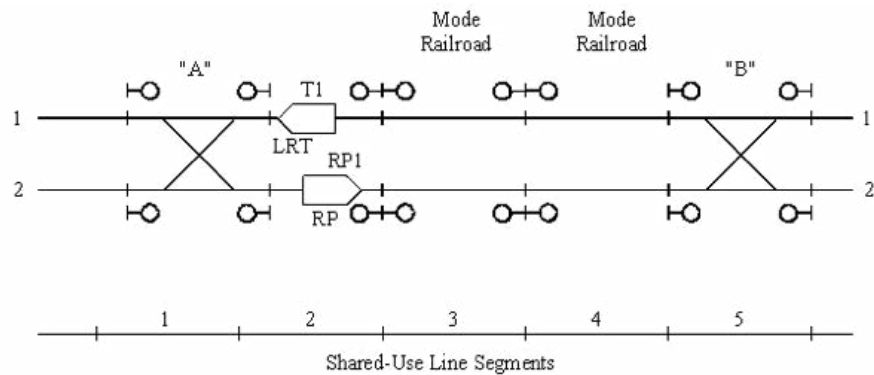

In Figure D-9, a positively identified freight train arrives at A while the opposing LRT is still in intermediate block segment 2, and is held at A for authority to enter the A-B segment until the LRT clears all intermediate block segments at A. LRT is now operating at maximum speed in segment 2 after RP has passed it.

**Figure D-9**  
RF train held to allow LRT to clear A-B at maximum speed

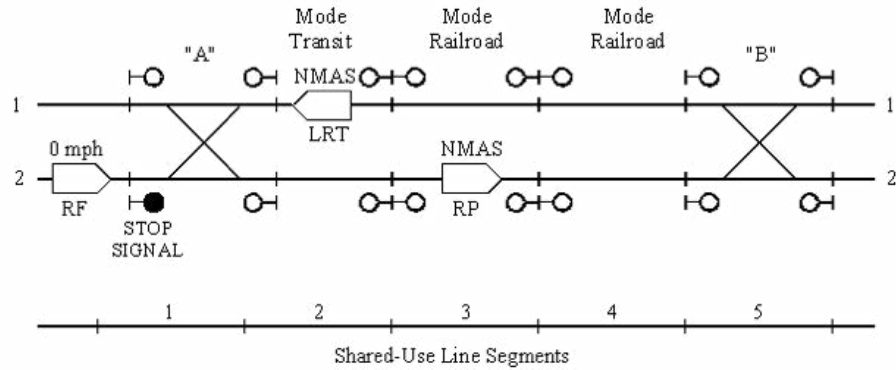

In this case, as illustrated in Figure D-10, the dispatcher waits until the LRT clears at A, and the signal for the freight train clears immediately when called, setting all intermediate block segments to “Mode Railroad.” The freight train is then released to operate at N.M.A.S. through the A-B segment without serious delay and also to accelerate into and through A-B Interlocking-to-interlocking segment at one steady speed, thus facilitating train-handling.

**Figure D-10**  
RF train cleared to operate at maximum speed

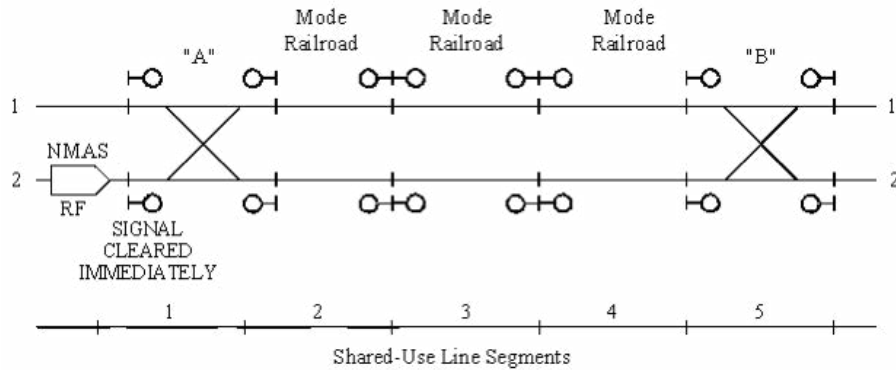

In Figure D-11, the freight train has advanced to intermediate block segment 3 at maximum speed when another LRT arrives at the stop signal at B. The dispatcher decides to hold the LRT at B to allow the freight train to continue to advance at NMAS without further restriction.

**Figure D-11**  
*LRT held at B to permit RF train to continue at maximum speed*

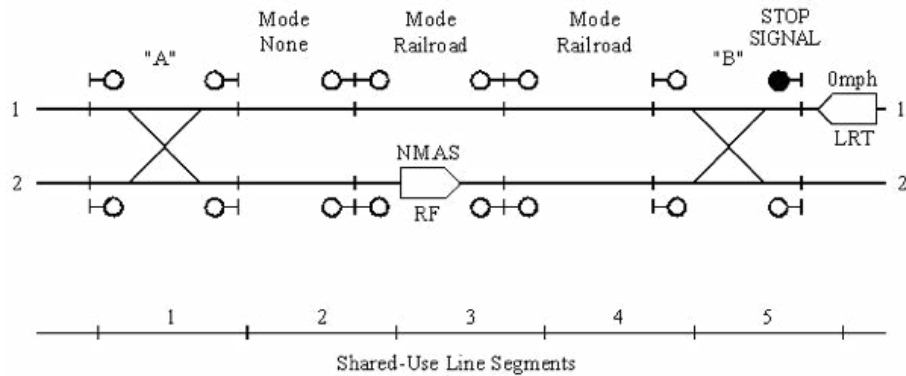

However, in Figure D-12, the freight train has been delayed in intermediate block segment 3, and the dispatcher decides to clear the signal for the LRT. After the required time delay to ensure the freight train has reduced to RFI (or less) for “Mode Mixed FRT,” the signal clears for the LRT and allows the LRT to operate at T2 until it passes the freight train in segment 3.

**Figure D-12**  
*Dispatcher elects to permit LRT to enter with RF train still in Segment 3*

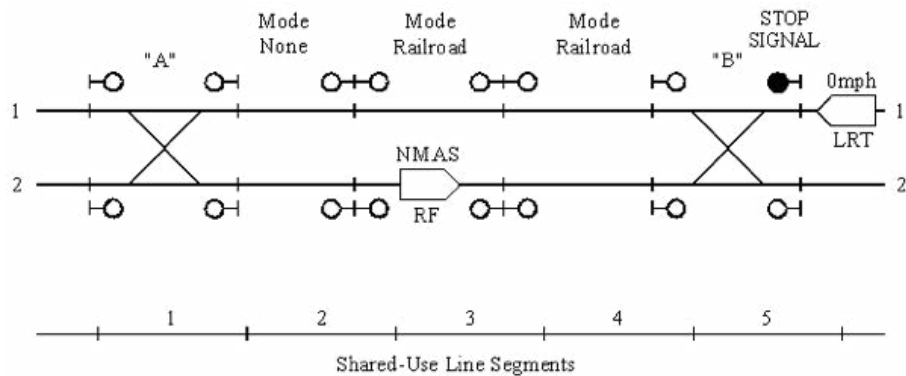

When the rear of the freight train clears intermediate block segment 4 at B, as illustrated in Figure D-13, the LRT is permitted to resume NMAS in segment 4, as well in segments 3 and 2, if the enforcing PTC is able to deliver a “mid-block release” to the LRT.

**Figure D-13**

*RF train has left Segment 4 and LRT is cleared en-route to operate at NMAS to A*

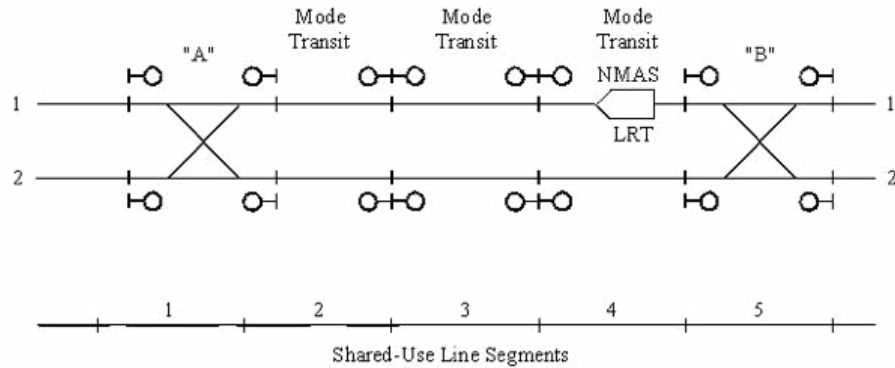

### *General Requirements for Providing PTP for Non-Compatible Train Types*

The approach taken above in the scenarios presented in the diagrams and discussions are dependent upon the following for practical implementation:

- PTI must be developed in each application for the underlying signal system, or for the PTC system, to ensure at all times that each train is positively identified and that this identity is verified as correct. This will probably be more readily accomplished for the transit (LRT) trains and RP trains than it will be for the RF trains, particularly if the RF trains are those operated by one of the large Class I freight carriers.
- PTI can be accomplished through applying transponders with vital codes on all vehicles that pass through the shared trackage, but this is a much more acceptable solution to carriers with relatively small captive fleets. Conceivably, temporary transponders could be applied to engines from large fleets at the last terminal prior to reaching the shared corridor, and then removed at the next such terminal, but they would have to be “magnetic stick-ons” or some other very easily portable device. They would have to be capable of being very simply applied and then removed, and always placed within the area on the vehicle that would be well within the tolerance that ensures reliable reading by wayside readers. This could be difficult to police and it is quite likely that it may not be acceptable to the large freight carriers.
- Conceivably, PTI might be accomplished through other means than transponders, such as using the original ATCS unique railroad carrier number with the carriers’ unique engine unit number. However, the manner in which these numbers are normally configured in the software upon installation of the on-board PTC equipment is not currently intended for a vital fail-safe application, nor do the message structures currently have the required check

bits to be considered for a vital fail-safe application. This would have to be tightened up considerably from current PTC design and practices.

- Each controlling unit must have a PTC display that will enable the engineers/drivers of trains to quickly and smoothly respond to en-route changes in the “Mode” in the block segment it is operating in, and the block segment it is approaching, particularly when a down-turn in speed is called for. This display must give the engineers ample time to respond to the changes and initiate any required braking before the train enters the penalty/enforcement phase. This is especially important for engineers of long freight trains who need more “set-up” time for proper train handling when “pop-up” speed reductions are called for at unexpected times and places.
- Vital logic will have to be developed that will enable these rapid changes in block segment modes to be accomplished as the trains are cleared into mixed mode situations, and then to permit trains on one track to take advantage of the passing by of non-compatible trains on the adjacent track. This logic could possibly be either distributed or concentrated, but all safety features will need to be fail-safe (vital) in order to prevent wrong side failures that could lead operating employees into un-safe acts. Experience with such advanced systems over the years has been that some employees will tend to overly-depend upon a complex non-vital system which appears to work well, but which can fail and lead to disaster through a false sense of security, ultimately resulting in a lack of vigilance at the same time as the more-probable failure of the non-vital system.
- A system design will need to carefully consider the block lengths, maximum speeds of the different train types, the braking characteristics of each of the train types and the time delays chosen to enable and ensure a safe operation. And the dispatchers’ display will need to show adequate information on the train types in each block segment and up-to-date real-time information block occupancy in order to optimally dispatch the system described in these scenarios.
- Where there are three or more main tracks, adjacent tracks only would be considered for protection. Any non-adjacent main track would only be considered for protection from non-compatible equipment on a main track directly adjacent to it. In other words, where there are four main tracks, counting from south to north, 1, 2, 3, and 4, the following would be considered double-track pairs:
  - 1 and 2
  - 2 and 3
  - 3 and 4

But PTP for track-pairs 1 and 3, 1 and 4, and 2 and 4 would NOT be considered or required.

## Potential PTC Options for Implementing PTP

In any multiple-track shared-trackage area equipped with PTC, where it is considered necessary to provide the additional protection previously outlined for parallel-track operation of non-compatible train equipment, the first goal of the PTC solution would be to display and enforce the required PTP speeds, T1, T2, RPI, or RFI, in real time at the required times when the exposures to non-compatible equipment is occurring.

The second goal, equally important, would be to stop non-compliant trains short of any block segment until the correct “compatibility” mode for that block is established and all non-compatible trains in that block segment can be assured to be operating at their respective required “compatibility” mode PTP speeds, T1, T2, RPI, or RFI.

The functionality to implement these two goals might be added directly to the underlying signal system. It might be an additional overlay to the existing signal system. It might be a new “creative” application of the existing PTC technology installed on the territory, or it might be a modification to the PTC system itself. As touched upon previously, the simplest solution that achieves the above goals will normally be the preferred solution, cost the least, and be the most reliable approach over the long-term.

The descriptions of possible ways PTP might be provided by the three PTC systems described in report Section 3 follows. Each of these descriptions will build on the scenarios described in the previous subsection, “Changes Needed to Existing PTC Systems or Their Underlying Signal System for Enforcing On-Demand Spatial Separation” (referred to as the former subsection in the following subsections below) and will follow the General Requirements for PTP outlined in the previous subsection entitled, “PTC Options for Positively Separating Following-Move Non-Compatible Train Types on the Same Track” (referred to as the latter subsection in the following subsections below). Frequent reference will be made to the narrative explanations in the former subsection and the illustrations shown in Figures D-3 through D-13, which illustrate the basic operation required, regardless of the PTC system installed in the territory where the shared corridor is to be established. While the desired operation in the former subsection is the same for each of the three PTC systems, the architectures of the three systems are quite different from one another. This will result in very significant differences in the suggested approaches to implementing the operation in the former subsection, to take advantage of architectural characteristics of each of the PTC systems. The suggested approaches to this implementation are provided below for ACSES, ITCS, and I-ETMS.

When working through these somewhat detailed proposals, it will be well to remember that the PTC system chosen for any territory involving a shared corridor will very likely be chosen to facilitate the interoperability of all trains that operate in the larger region, of which the shared corridor will be a small part. This means that the selection of which PTC system will be adapted to provide PTP in the shared corridor will not likely be driven by that application. Therefore, any perceived benefits of adopting any one of the PTC systems vs. the others that may arise from the following descriptions, may not enter into the choice of the PTC system.

### *PT Option 1: PTP in ATC/ACSES PTC Territories – Two Approaches using ATC*

Where ATC/ACSES is the PTC installed and where the PTP speeds, TI, T2, RPI, and RFI required for operation through the shared trackage actually match existing ATC speed commands for each of the train types, two potential Option 1 solutions show promise for consideration to implement the Double-Track PTP Concept. We will refer to the two sub-options as PT Option 1a and PT Option 1b, as follows:

- PT Option 1a would likely be favored where a modern signal system is already in service and the central SPTIP would make it unnecessary to make major changes to the existing wayside signal processors. The development of the vital software for the central SPTIP will not be a trivial effort.
- PT Option 1b would likely be favored when a new signal system is to be installed at the time the PTC is to be installed, as the PTP Safety PTI Processing functionality can be distributed over, and integrated into, the wayside signal processors at the interlockings and the intermediate locations, making the extra SPTIP unnecessary. However, as we will see in the detailed discussion, this distribution of the required functionality in the individual vital wayside signal processors will not be a trivial process either.

### *PT Option 1a: PTP in ATC/ACSES PTC Territories – Central SPTIP Concept*

On existing lines with a modern signal system, where ATC/ACSES is the PTC installed, and where the PTP speeds actually match the existing ATC speeds for each of the train types, the first solution to be considered uses a central processor, the SPTIP, to implement the Double-Track PTP Concept as follows:

- A separate vital SPTIP could receive the PTIs from strategic known locations in real time through vitally encrypted messages, which would include the known locations as part of the messages. If exclusive entry points for Railroad trains vs. Transit trains are available, the PTIs would be brought forward for processing by the SPTIP from those locations.



- This vital SPTIP would need to track each train vitally through each track block segment, and through vital processing functionality, select in real time one of the four modes: Mode Transit, Mode Railroad, Mode Mixed Passenger, or Mode Mixed Freight (which includes Railroad Passenger). When there are no trains between Interlockings or Controlled Points on a given double-track pair, and no trains are cleared to enter this section, all block segments would default to “Mode None.”
- Each Mode selected is transmitted back to the individual wayside locations controlling the ATC speeds. These individual locations (from these real-time Mode assignments) then select the correct ATC speed, i.e., T1, T2, RPI, or RFI, for the next approaching positively identified train on each track in the shared block segment.
- This additional functionality calling for speed reductions to T1, T2, RPI, or RFI can only supersede the existing ATC speed code selection when a lower speed is called for. If the existing ATC functionality is calling for a lower ATC speed than T1, T2, RPI, or RFI, the lower speed will prevail. If the existing ATC functionality is calling for a higher speed command than T1, T2, RPI, or RFI (depending on the train type) then the T1, T2, RPI, or RFI speed will prevail. The lower speed will always govern.
- The ATC speeds through the rails are precisely delivered to each approaching train in accordance with the Mode changes as described in the examples in the former subsection and the accompanying illustrations in Figures D-3 through D-13. In following these trains through these examples, as the selected Modes are changed, the ATC speeds are also changed accordingly. When all trains leave an interlocking-to-interlocking double-track segment and the Mode assignment of each block defaults to “Mode None,” the ATC code selections also default to zero code, or “no code,” while waiting for the next Mode assignments and the positively identified trains to follow.
- This approach requires no changes to the ACSES portion of the ATC/ACSES PTC system, and it requires no changes to the on-board ATC equipment. It does require changes to the wayside signal system to provide the additional functionality to change the cab signal ATC codes as described above.

### *PT Option 1b: PTP in ATC/ACSES PTC Territories – Distributed Processing Concept*

The second potential solution under PT Option I eliminates the central SPTIP and distributes the PTP functionality over traditional wayside signal processors. This approach could find favor where an older signal system is to be replaced by a new signal system when the ATC/ACSES PTC is installed, and where the PTP speeds required for operation through the shared trackage match the existing ATC speeds for each of the train types as follows:

- PT Option 1b would be very similar in overall functionality to PT Option 1a, but without a central SPTIP. The functionality assigned to the central SPTIP

in PT Option 1a would instead, in PT Option 1b, be distributed locally in the interlocking processors and in the individual intermediate signal processors. Instead of vital encrypted messages linking the SPTIP to individual locations as in PT Option 1a, one should visualize vital “signal data” links on the railroad-owned fiber-optic system in PT Option 1b. PTIs from strategic known PTI-scanning locations (or from exclusive entry points) would be picked up locally in real time at the nearest known wayside signal processor location, and entered into the distributed PTP functionality processing at these known locations.

- The dispatchers’ control and indication of the signals and power operated switches would continue to be controlled through reliable (but not vital) dispatch control systems in both PT Options 1a and 1b in the same manner that these systems continue to be used to dispatch signal system territories today. However, additional indications for RR and LRT will need to be provided for the dispatchers along with the traditional Train IDs.
- As in all traditional signal systems in the U.S., the “vital fail-safe” parts of the PT Option 1b system are “all in the field” at the signal, block-point and interlocking locations. Indications for the dispatchers, including the new ones to be added, may be non-vital.
- As implied above, the principal economy of PT Option 1b, when compared to PT Option 1a, would be derived from the elimination of the large and costly SPTIP. To create the same functionality that is described in PT Option 1a, significant additional non-traditional PTI processing functionality would be added to existing wayside signal and interlocking processors. However, once this is done for each type of processor, i.e., those for typical interlockings, intermediate signal and/or block-point locations, etc., the application is expected to be largely iterative over large shared territories and in new shared corridor projects.
- In PT Option 1b, the PTP functionality distributed in the wayside signal processors, and in conjunction with the duplex digital data streams between the wayside signal processors, would need to track each train vitally as it approaches the controlled signal at any interlocking. Once this train is positively identified as an LRT, RP, or RF, this PTI would be “tumbled-down” from block segment to block segment to the next interlocking through the digital data streams between the wayside signal locations. Visualize this PTP “tumble-down” as somewhat analogous to typical signal traffic locking tumble-down today, but with some more new logic superimposed on the existing signal logic.
- If the only other train (or trains) currently in the interlocking-to-interlocking segment of double-track is of a compatible type, the confirmation data stream will return to the originating interlocking, setting the NMAS for the train(s) involved in all of the intermediate block segments, and when this iterative task is confirmed as completed at all location in this “tumble-back” cascade of messages, the controlled signal will be allowed to clear to an aspect to proceed into the Interlocking-to-interlocking segment. The

train(s) involved will be permitted to operate through the interlocking-to-interlocking segment at NMAS. Referring to the former subsection, this scenario is illustrated in Figure D-3 for compatible LRTs moving through the interlocking-to-interlocking segment at NMAS, and in Figure D-4 for compatible railroad passenger and freight trains moving through the interlocking-to-interlocking segment at NMAS.

- In following through the examples in the former subsection, and illustrated in Figures D-5 through D-13, it can be readily seen that each wayside signal processor at each location must have the additional vital software to receive PTIs of approaching trains and select the most conservative Mode for the mix of trains approaching that location from each direction on each track.
- This real-time Mode selection for each Paired-Track section will require four real-time “geographical” ports (one for each track approaching in each direction) and four different “Mode” inputs possible through each “geographical” port. From these inputs each wayside signal location must select the correct ATC track codes for approaching trains on both tracks, downgrading them when necessary, based on real-time recognition of the most conservative Mode coming in simultaneously on the four different ports.
- Obviously, PT Option 1b will require the addition of significantly more complex functionality than the traditional control and locking of switches and opposing signals, interlocked with the control of signals displayed with the proper aspect sequences, and the simultaneous selection of the correct cab signal code for approaching trains on both tracks. However, it appears that it can be done in a similar manner to the current very structured and disciplined design of complex signal systems overlaid with enforcing ATC. And it appears that Option 1b can best be implemented in the vital wayside signal processors with vital data streams between adjacent locations that form the back-bone of the latest modern signal systems today. It must be emphasized, however, that this will not be a trivial effort.
- PT Option 1b, like Option 1a, requires no change to the ACSES portion of the ATC/ACSES PTC system, and no change to the on-board ATC equipment. However, very significant additions to the wayside signal system will be required.
- Except for the differences described above, the actual operation of compatible and non-compatible trains through shared trackage would be exactly the same in PT Options 1b as in PT Option 1a. Therefore, except for technical execution of the two different “sub-options,” the “look-and-feel” of the operation described in both PT Options 1a and 1b would be entirely transparent to the “user,” i.e., the engineers and the dispatchers.
- From a purely operational view, then, we can refer to the potential solutions using the ATC/ACSES PTC system described thus far as PT Option I.
- In PT Option I, the ATC speeds are precisely delivered through the rails to each approaching train in accordance with the Mode changes as described in

the examples in the former subsection and the accompanying illustrations in Figures D-2 through D-13. In following these trains through these examples, as the selected Modes are changed, the ATC speeds are also changed accordingly. When all trains leave an Interlocking to Interlocking double-track segment, and the Mode assignment of each block defaults to “Mode None,” the ATC code selections also default to zero code (actually “no code”) while waiting for the next Mode assignments.

- Significant strong points in implementing shared-track PTP solutions in PT Option 1 where the PTC system is ATC/ACSES are:
  - The precision and quick response to Mode upgrades that are inherent in the current ATC speed control systems, and
  - The precision with which each segment of track can be specifically defined in the over-all PTP functionality, and the resulting ability to more quickly clear the way for a train to accelerate once a non-compatible train type has been passed on the adjacent track, and
  - The fact that the more complex ACSES system currently being implemented throughout the Northeast U.S. does not need to be changed. This is important to those actively involved in this deployment, as they do not need the additional complication of another change to ACSES, either wayside or on-board, if it can be avoided, and the interoperability of ATC/ACSES will not be threatened.

*PT Option 2: PTP in ACSES Territories without ATC or Where Existing ATC Speeds Do Not Match Required PTP Speeds, T1, T2, RP1, and RF1*

PT Option 2 is not recommended where ATC/ACSES is in service. While PT Option 2 could be installed in ATC/ACSES territories, it will be more costly than either of the PT Option 1 solutions, as WIUs at all intervening intermediate signal locations would have to be added with extended data radio coverage not currently required or provided in typical ATC/ACSES applications. Also, the ACSES Option 2 solution loses the precision, rapid response and simplicity of the PT Option 1 ATC solutions, which are important characteristics for the PTP operation, particularly where dense traffic conditions are prevalent. Therefore, if there is an existing ATC system installed, every effort should be made to choose, and make the safety case for, the PTP speeds, T1, T2, RPI, and RFI, to match the existing ATC speeds, and avoid the need for PT Option 2. Using the ATC as described in PT Option 1 is strongly recommended wherever it is possible to do so.

*PT Option 2 where ACSES in Service without ATC*

If ACSES without ATC is the PTC system, PT Option 2 would be necessary. This concept uses the ACSES WIUs with Data Radio connectivity at all of the intermediate signal locations between interlockings. The good news is that

standalone ACSES without ATC has the required WIUs at all signal locations, with the radio connectivity and coverage to implement PT Option 2 as follows:

- A typical installation of ACSES w/o ATC treats each intermediate automatic signal block between interlockings as a simplified stand-alone “interlocking” with only one “long” route and no powered switches. The WIU at the entrance signal to each automatic block is currently used only to release a PTS for operation at 15 mph through an occupied block, or to permit a train to run at NMAS through the entire block to the next signal.
- The concept to implement PTP in ACSES stand-alone territory requires the PTI at strategic entry locations, the same as in PT Option 1. The PTP functionality processing this PTI information could be centralized as in PT Option 1a or distributed as in PT Option 1b. However, the selected PTP speed, TI, T2, RPI, or RFI, developed in the PTP functional processing would then be delivered to the WIU to be delivered over the ACSES data radio link as a “different ‘interlocking’ routing speed” for the next positively identified train’s operation through the block – instead of to the ATC cab code encoder for through-the-rails delivery as in PT Options 1a and 1b.
- The “look-and-feel” of the operation in PT Option 2 would be somewhat different than that of PT Option 1, as the PTP speeds will be enforced as an ACSES speed rather than as an ATC speed. At this point, an ACSES OBC change would be required, as the current ACSES II certification requires that the ACSES speed display be turned off when ATC is not available and is independently cut out on-board. This would also require new transponder messages to create two separate ACSES OBC “modes,” one for “IN ATC” territory, and one for “OUT OF ATC” (i.e., in ACSES without ATC) territory, as it would still be required to turn the ACSES speed display “OFF” when ATC is cut out when in ATC/ACSES Territory.
- The need for rapid digital data stream connectivity on a fiber system between all adjacent wayside signal system processors would be the same as that required by PT Option 1. However, the PTP operation under PT Option 2, implemented through ACSES rather than through ATC as in PT Option 1, will be expected to be slower than that of PT Option 1. This is primarily due to the slower data radio response than the much faster response of the ATC cab signal codes in the track.
- Additional delay in PT Option 2 will result from the fact that the blocks are longer in the few ACSES (only) applications; the WIU “routing” speeds cannot be up-graded mid-block as is possible with ATC, contributing to slower up-grades for trains that have passed a non-compatible train on an adjacent track; and there will be slower clearing times for trains to be permitted to enter interlocking-to-interlocking segments occupied by one or more non-compatible trains.
- The slower signal clearing times will be caused by longer times required for the WIU “routing” speeds to be confirmed and the additional time required for a non-compatible train to reach the next block signal where it

will be governed by the new WIU “routing” speed. However, as ACSES PTC without ATC applications are very few and currently only in less-dense traffic territory, slower operation may be acceptable.

- Other than the slower operation in PT Option 2 described above, the scenarios described in the former subsection for the general case and for PT Option 1, as illustrated by Figures D-3 through D-13, can be followed through to understand the application of this concept in a similar manner to that suggested in the descriptions of PT Option 1.

### *PT Option 3: PTP in ITCS Territories*

PT Option 3 describes a possible PTP solution for shared track for non-compatible train types where ITCS has been, or will be, installed as the PTC system for the territory involved. ITCS, as we have seen, is a totally communications-based train control system, with U.S. applications overlaid on existing CTC signal systems and certified as a qualified U.S. PTC system in that type of application. ITCS has also been certified for 110 mph HrSR operation.

- Typically, ITCS picks up its wayside permanent database prior to departure from its originating terminal. This database is then stored in the ITCS OBC in 5–7 mile segments we call “Wayside Controller (WC) zones.” Then, when an ITCS-equipped train approaches ITCS Territory, it communicates its presence to each ITCS WC over 220 MHz data radio. Once the ITCS OBC has verified from the WC SUM (Status Update Message) that the OBC-carried wayside database is correct for the next WC zone, the train is able to approach and travel through that zone under control of that zone’s WC.
- As the train receives the SUM, updated every six seconds, for all signal and switch statuses continuously gathered and updated by the WC in each WC zone, the train will receive the variable vital safety information the OBC will need from the WC, and along with its previously received on-board wayside “fixed” data-base, and its position on the track from its GPS/Tach LDS, the OBC will select the maximum speed permitted at each point along the line within the zone, with NMAS allowed when conditions permit. The GPS/Tach LDS in ITCS is not relied upon to discern which track the train is on in multiple-track segments. This normally requires ITCS to be cut-in initially on a single known track, and the track the train is on is then updated from facing point switch position information in the SUM as the train progresses through interlockings into and through multiple-track sections. (Note: Multiple-track cut-in is available with a special application using sequentially-occupied track circuits.)
- The spacing of the WC zones in typical ITCS applications is driven by continuous data radio coverage requirements and the ease of connectivity to a radio base immediately adjacent to each WC location. This places the WCs and the local radio bases at somewhat random locations relative to traditional signal layouts, but as the WCs are essentially the wayside “heart” of the local ITCS real-time train control functionality as trains move from

zone to zone, they are also the logical place for the new PTP PTI processing to reside. However, as the ITCS architecture is designed to implement the operation transparently without regard to the way the data radio coverage is configured, the PTP operation in PT Option 3 will be divided up into interlocking-to-interlocking segments and intermediate signal blocks in the same manner as previously described in PT Options 1 and 2.

- As the WCs are the “heart” of the wayside real-time activity in ITCS, the PTP functionality is expected to be resident in the WCs. An ITCS PTP model includes mini-SPTIPs at each WC location. The mini-SPTIPs take advantage of the unique-to-ITCS “semi-distributed” architecture, vs. the more centralized or fully-distributed SPTIP processing that appeared to be a “better fit” for PT Options 1 and 2.
- As all PTC/Signal System PTP applications will require PTI locations, our proposed model for ITCS will include PTI installations at strategically-placed WCs within the shared-track territory as well as at the entrances to shared territory. PTI installation at strategic locations also will include the case of Railroad and Transit train exclusive entry points, where wayside scanners for on-board transponders or labels are not necessary.
- Since the WCs are usually found at interlockings or intermediate signal locations in ITCS applications, each WC Zone geographically “surrounds” its WC with the WC in the center. Therefore, the interlocking-to-interlocking operational segment normally spans two WC zones. Thus, even though the mini-SPTIPs are ideally located to integrate the PTP functionality with the local ITCS functionality throughout each WC zone, there will need to be close vital “coupling” of the new PTP functionality between two adjacent WCs. Two possible methods for this vital coupling of the PTP functionality will be examined.
- This vital coupling of the new PTP functionality between two adjacent WC/mini-SPTIP locations will need additional spectrum space in the fiber-optic back-bone and it could take one of two basic forms. Visualize WC location A and adjacent WC location B, 5–7 miles apart. These two WCs typically share a common interlocking-to-interlocking block that resides partly under the ITCS control of A and partly under the ITCS control of B. Two potential sub-options follow:
  - PT Option 3x – Treat the mini-SPTIPs as “centralized” (similar to PT Option 1a), and forward all of the vital PTI/PTP data from the A portion of the interlocking-to-interlocking block to B through vital messaging. Then let B perform all real-time PTP functionality for the common interlocking-to-interlocking segment, and vitally forward the compatibility Mode selections back to A for the ultimate speed selection through the blocks in the WC A zone portion of the common interlocking-to-interlocking segment.
  - PT Option 3y – Treat the WCs as “distributed” (similar to PT Option 1b), where the PTP functionality for the common interlocking-to-interlocking segment is actually shared, A working with B, each performing the PTP

work for its own signal locations and relying on vital digital data streams on the fiber back-bone to stay in synch in regard to the operation of the joint interlocking-to-interlocking segment as a whole.

- Operationally, PT Options 3x and 3y are the same in their response times and their “look and feel,” and we will continue at this point to refer to this overall ITCS solution as PT Option 3, which then divides into two sub-options, PT Options 3a and 3b, based upon the method chosen for ITCS to display and enforce the new speeds. These two potential options are described more fully in the following sections.

### *PT Option 3a: PTP in ITCS Territory Adding PTP Speeds as “Signal Speeds”*

In the use of ITCS features to display and enforce the PTP speeds, TI, T2, RPI, and RFI, it will be desirable as far as it is possible to do so, to mimic the minimal response time of the ATC implementation described in Option 1. In comparison with ATC, the ITCS OBC response time is expected to be approximately 2 to 4 times longer than that of ATC, working out to 6 to 20 seconds vs. the 3 to 5 seconds benchmark response time of ATC. While this ITCS response time is unable to mimic the best train control response time available in the industry (i.e., ATC), it is believed to be on a par with other CB PTC systems.

- To take maximum advantage of the ITCS response time, the most attractive approach would be to create the four PTP speeds as new speeds available to be included in the controlling WC’s SUM in addition to the signal speeds stored in the ITCS signal aspect table. These new PTP speeds, of course, would be associated with the real-time compatibility Mode assignment in each
- It will have to be determined by the ITCS supplier whether the four new PTP speeds can be added to the SUM when it is called for by the PTP logic, without having to expand the signal aspect table to include them. Obviously, to be able to include these new speeds through simply adding the speeds to the database in the application engineering effort would be much preferred to having to expand the signal aspect table and potentially requiring a new version of ITCS.
- If PT Option 3a requires a significant retrofit of the existing ITCS territories in Michigan, Indiana, and Illinois with a new version of ITCS, this could lead to a large service disruption and/or field re-test effort that should be avoided if at all possible. Assuming the proposed shared-track would be relatively small (short) when compared to the current ITCS installations totaling several hundred miles on two routes out of the Chicago rail hub, this option may not be acceptable.
- Assuming the new PTP speeds can be added to the existing ITCS version through “creative application” engineering, these speeds would then be applied to each intermediate automatic signal block between interlockings



when called for by the PTP Mode selection process, and the reader interested in following a mix of compatible and non-compatible trains through the scenarios in the former subsection and the illustrations in Figures D-3 through D-13, should be able to visualize the ITCS implementation in the interlocking-to-interlocking Track Segment A-B in the same manner as was accomplished in PT Options 1 and 2.

- The above approach would seek to mimic in PT Option 3 the previous method described in PT Option 1 where it is proposed to include the new PTP speeds as ATC signal speeds. This proposed method in ITCS would also implement these new speeds as ITCS signal speeds. However, the mid-block clear-up readily available with the ATC track codes may be more of a challenge with ITCS, with the real possibility that trains can only have their speeds raised when their leading ends pass wayside signals and not mid-block, as is possible with ATC.

### *PT Option 3b: PTP in ITCS Territory Adding PTP Speeds as “Temporary Speeds”*

However, if PT Option 3a requires a new version of ITCS, it may not be an acceptable solution for the carriers seeking to develop a shared-track corridor for non-compatible train consists. In this case, the use of the ITCS TSR capability would be a possibility that could be examined.

- PT Option 3b differs significantly from previous options in the way the PTP speeds, T1, T2, RPI, and RFI, are displayed and enforced, due to differences in the way ITCS configures and delivers temporary speeds vs. permanent speeds. PT Option 3b would superimpose the PTP speeds on ITCS as temporary speeds, while PT Option 1 and PT Option 3a would superimpose the PTP speeds on the ATC and the ITCS, respectively, as signal speeds, and PT Option 2 would superimpose PTP speeds on ACSES II as pseudo interlocking route speeds.
- The proposed use of the temporary speed capability in PT Option 3b derives from the fact that in ITCS, once the permanent database is picked up on-board prior to the train’s departure from its originating terminal, that database, including all of the permanent speeds for the entire line to be travelled, is never changed. Temporary speeds, however, can be changed at any time in the local WCs, every 5–7 miles along the way.
- Currently, temporary speeds are input by the dispatcher into the OWL console in the dispatchers’ office. The OWL sends the temporary speeds to all (one or more) of the individual WCs that are required to incorporate the speed restriction in its SUM. The OWL, while currently non-vital, performs a critical function in its delivery of all TSRs to all the WCs needing it. It is imperative that no WC be missed in this delivery, to ensure that all train types in each direction have the required braking distance to approach, and operate through, the area between the specified limits, at the prescribed

speed. While not vital, a Select-Check-Execute process “hardens-up” this link between the human dispatcher and the individual WCs.

- Once the temporary speed is changed at a WC, this will be reflected in the next SUM for that WC zone. Receipt of these messages by the ITCS OBC would create the display and enforcement of the PTP speeds, T1, T2, RPI and RFI, as TSRs when the corresponding PTP Mode is selected for each intermediate block in the interlocking-to-interlocking segments. This is consistent with the current operation of ITCS, but SIs would be required to “legalize” the receipt of a TSR on the ITCS display as part of what can be expected within the shared-track zone while not holding a matching paper TSR, but a TSR that will be enforced nevertheless.
- A new link will be required between the new mini-SPTIP logic and the existing ITCS logic in each WC, to permit the PTP speeds, T1, T2, RPI, and RFI, to be input in parallel with the OWL as additional TSRs. The TSRs then become a part of the SUM. Certain functionality in the Office portion of the OWL may have to be repeated in the PTP functionality in the WCs to ensure that all WCs that need to incorporate a PTP speed as a new TSR will be included.
- To simplify this application of PT Option 3b, as well as the updates to the required configuration management plan, the limits of the TSRs selected to correspond to the PTP speeds, T1, T2, RPI, and RFI, will be the exact limits of the intermediate signal blocks in the ABS system between the CTC interlockings, the same as already described in all previous options. When this is done, readers interested in following a mix of compatible and non-compatible trains through the scenarios in the former subsection and the illustrations in Figures D-3 through D-13, should be able to visualize the ITCS implementation in the interlocking-to-interlocking Track Segment A-B in the same manner as was accomplished in PT Options 1, 2, and 3a.
- As previously mentioned in connection with PT Option 3a, while no 100% CB PTC system enjoys the rapid action and quick response times of traditional (through the rails) ATC action and responses, ITCS should perform at least as well, in this respect, as other 100% CB systems. As pointed out in PT Option 3a, the ITCS OBC latency of response is expected to be approximately 2 to 4 times longer than that of ATC. While this is anticipated to be approximately on a par with other 100% CB PTC systems, the other leading CB system is still in a stage of development wherein this latency value is currently unavailable for comparison.
- A slight additional time factor in PT Option 3b, more than in PT Option 3a, is expected for the PTP functionality to simulate the OWL in the select-check-execute input of the PTP TSRs. This process requires input first as Pending Enforce, followed by Enforcing. Upgrades will need the same over-all time to delete TSRs, first as Pending Delete, then as Delete. This need to automatically mimic the operation of the OWL as a security measure may add a few seconds to the over-all response time in the PT Option 3b implementation of PTP, making it slightly slower operationally than PT Option 3a.

### *PT Option 4: PTP in I-ETMS Territories*

PT Option 4 describes a possible PTP solution for shared track for non-compatible train types where I-ETMS is to be installed as the PTC system for the territory involved. I-ETMS, as we have seen, is a totally communications-based train control system, with most of the U.S. applications overlaid on existing signal systems such as CTC and ABS systems, based on track circuits for train detection.

I-ETMS has become the system of choice for all Class I freight carriers. Since passenger carriers outside of the Northeast Corridor, including Amtrak, operate largely in freight-owned corridors with their trains commingled with freight trains, this has forced the issue for these carriers to migrate to I-ETMS along with the Class Is. Therefore, there is a need to explore the possibilities of PTP scenarios in I-ETMS territories, where freight carriers, conventional passenger services and new light-rail services meet in the growing populated areas outside the Northeast. With the growth of urban and suburban regions in the Southeast, Midwest, and West, there is also an increasing demand for light rail, conventional rail passenger, HrSR (to 110 and 125 mph), and HSR (150 mph+) services. Coincident with this rising demand for a variety of passenger rail services is the increasing freight traffic on principal corridors.

All of this demand for rail service is leading to major investment in increased track capacity, resulting in a rise in multiple-track, dense-traffic corridors that are beginning to look more like the NEC. Applying I-ETMS (or PTC interoperable with I-ETMS) to the needs of all of these services in multiple-track dense-traffic territories may very well be the most challenging effort of all in meeting the PTC Mandate. Two of these areas of special concern are the full development of the very complex Back Office Servers (BOS) and the amount of Radio Frequency Spectrum available, especially in the dense-traffic multiple-line urban areas, such as Chicago, Kansas City, Dallas/Fort Worth, and Los Angeles.

The use of ATC/ACSES throughout the Northeast region of the U.S. could actually prove to be a significant blessing to the freight carriers as one contemplates the few thousand daily Amtrak and Commuter trains that will not be an added burden on the freight carriers' I-ETMS and BOSs in the highly-congested Boston to Washington, DC "mega-city" along the NEC "back-bone."

However, contrast this with Chicago, which has become particularly challenging. In the greater Chicago area all trains, including Amtrak, the very large Metra commuter operation, and a huge (growing) concentration of freight trains funneling through the Chicago hub will be vying for time, space and spectrum in I-ETMS and the BOSs. Every train, both passenger and freight, will be operating on at least one of the carrier's BOSs, and likely many trains will require handling

by at least two (or more), with hand-offs from one BOS to another at least once, if not multiple times, in passing through the greater Chicago region.

I-ETMS has suffered from a relatively late start, well over a decade behind ATC/ACSES and ITCS, and while it has had enormous resources applied to its development since late 2008, this system is more ambitious and therefore more complex than the earlier systems described. This additional complexity and later start have resulted in an I-ETMS that still is in development, even as it is being installed, and it is still far from being fully mature.

As I-ETMS is actually more of a “work-in-progress” than the systems described in PT Options 1, 2, and 3, the descriptions that follow and conclusions presented in PT Option 4 will be more “tentative” and in greater risk of being changed. Even more significantly, this risk is a factor in considering choices that will need to be made in implementing I-ETMS PTP applications outside the NEC. Wherever possible, such applications should avoid further changes in the basic system, which will understandably be strongly resisted by the I-ETMS developers. Instead, every effort should be made to provide the PTP features through modifications or additions to the underlying signal system and/or through “creative” application of I-ETMS. And where possible the tools that have already been provided (or which will be required by the freight carriers for themselves) should be used to do this.

I-ETMS, as 100 % communications-based, primarily relies on GPS, locomotive tachometers, and two levels of data radio. Upon initialization prior to leaving the initial terminal the controlling engine (or other controlling unit) receives a large data-base for the entire route of the train to its destination from the BOS, a key element in I-ETMS. The BOS monitors:

- The CAD (Computer Assisted Dispatch) system controls, which the dispatcher uses in dispatching trains, primarily through the control of CTC switches and signals, and also through the issuance of “paper authorities.” The paper authorities cover permanent and temporary speed restrictions, out of service tracks, and other notices and orders required to safely operate trains on each line.
- The CAD system indications fed back to the office from switches and signals out on the railroad (which are normally non-vital).
- Information continuously received from “other BOSs.” These are BOSs of other railroads that may dispatch other portions of the route to be travelled by one or more trains from “this” terminal to the train’s ultimate destination, possibly passing through several other BOS-controlled territories.
- Periodic data radio requests from all “Communicating Trains” under its jurisdiction.
- And other data that the carrier may choose to integrate into the overall PTC system.

This BOS then uses the above information to continuously update the data-base for delivery to each train initializing at its initial terminal, as well as to periodically update this information on each train as it moves out onto a main track and progresses along its intended route to its ultimate destination.

- When the train departs the terminal and enters a main track, it receives data radio messages with the signal aspect information of each wayside signal it encounters. These data radio messages are delivered locally from each signal location through a WIU and (normally) through a local radio base with, typically, a “low” antenna. The I-ETMS OBC receives the data radio messages and interprets the signal aspect in order to display and enforce the correct speeds or PTS as required by the signal aspects displayed.
- The train continues to monitor the BOS governing the portion of the line it is currently operating on. Throughout its journey. This is done through another data radio channel and strategic wider-area radio bases with “high” antennas connected directly to the BOS in the central office for the carrier whose tracks the train is operating on. This ongoing monitoring of the BOS as the train progresses, allows the I-ETMS OBC to periodically verify, or up-date, its database from data radio messages from the BOS. The latest TSRs also come from the BOS in this manner.

In reviewing the basic architecture of the I-ETMS system, and considering the tremendous pressure in the industry to “get on with it” in regard to installation, testing and commissioning a system that may have significant “issues” in accomplishing this roll-out, it is clear that it would be prudent to NOT make any more changes in the basic I-ETMS system for PTP.

- Following this reasoning, we propose that the underlying signal system be expanded along exactly the same lines as described in detail in PT Option 1a or in PT Option 1b.
- In PT Option 4x, PTP functionality would be centralized in a SPTIP that would collect the vital PTI data for each train from known locations, vitally track these trains, and vitally process their progress, creating the correct real-time Mode assignments for each intermediate automatic signal block between the interlockings (or control points), and return these assignments through vital messages to the local interlockings and intermediate signal locations, where the correct PTP speeds, TI, T2, RPI, or RFI, in each block are selected in accordance with the Mode level assigned by the SPTIP at any given time.
- In PT Option 4y, PTP functionality would be distributed over the wayside signal processors (or the WIUs at each signal location) with data-stream links between all WIUs working in concert to take the place of the SPTIP.
- For more detail on PT Options 4x and 4y, see the descriptions in the previous subsections of PT Options 1a and 1b, where these two concepts are more fully explored as alternate enhancements to the underlying signal

system to create the PTP functionality that the PTC system is expected to enforce. Since PT Option 4x and PT Option 4y should be operationally the same as far as performance, and on the PTP impact on the performance of I-ETMS, we will continue to refer to this proposed I-ETMS solution as PT Option 4.

- With the PTP functionality fully developed to the point of assigning the correct compatibility Modes and PTP speeds to each intermediate block in the underlying signal system, the I-ETMS, then, would provide the actual display and enforcement of these speeds when the movement of incompatible train types requires it.

#### *PT Option 4a: PTP in I-ETMS Territory Adding PTP Speeds as “Signal Speeds”*

I-ETMS, as in earlier options, could deliver the PTP speeds, TI, T2, RPI, and RFI two different ways. Ideally, these speed commands would be delivered locally from each WIU at the signal locations, and it would be hoped that four “virtual signal aspects” with the appropriate speed assignments to match the PTP speeds, could be added through “creative” application engineering. This would be PT Option 4a.

- Assuming the new PTP speeds can be added to the existing I-ETMS version through “creative application” engineering, these speeds would then be applied to each intermediate automatic signal block between interlockings when called for by the PTP Mode selection process, and the reader interested in following a mix of compatible and non-compatible trains through the scenarios in Section 4 should be able to visualize the I-ETMS implementation in the interlocking-to-interlocking Track Segment A-B in the same manner as was accomplished in PT Options 1, 2, and 3.
- The above approach would seek to mimic in PT Option 4a the previous methods described in PT Option 1, where it is proposed to include the new PTP speeds as ATC signal speeds, and PT Option 3a where it is proposed to include the new PTP speeds as ITCS signal speeds. This proposed method in I-ETMS would also implement these new speeds in Option 4a as I-ETMS signal speeds.
- As previously mentioned in connection with PT Option 3a, no 100% CB PTC system enjoys the rapid action and quick response times of traditional (through the rails) ATC action and responses. I-ETMS is expected to follow this same pattern. This pattern in the well-established CB PTC system described in PT Option 3a is 2 to 4 times longer than that of ATC, and the response time of I-ETMS under PT Option 4a is expected to be in the same range as in that proposed under PT Option 3a.

*PT Option 4b: PTP in I-ETMS Territory Adding PTP Speeds as “Temporary Speeds”*

PT Option 4a is based on the premise that four new speeds can be entered into the local WIUs as “spare signal aspects” from the new SPTIP logic functionality, and that it would be possible to use the existing level of development of I-ETMS in creative application engineering to display and enforce these new PTP speeds on board the compliant and non-compliant trains. If PT Option 4a requires a new version of I-ETMS to be developed, it quite likely would not be an acceptable solution for the carriers seeking to develop a shared-track corridor for non-compatible train consists. In this case, the use of the I-ETMS TSR capability would be a possibility that should be examined, thus PT Option 4b.

- PT Option 4b differs significantly from previous options in the way the PTP speeds, T1, T2, RPI, and RFI, are displayed and enforced, due to differences in the way I-ETMS configures and delivers temporary speeds vs. permanent speeds. PT Option 4b would superimpose the PTP speeds on I-ETMS as temporary speeds similar to that proposed for ITCS under PT Option 3b, while PT Options 1, 3a and 4a would superimpose the PTP speeds on the ATC, ITCS and I-ETMS, respectively, as signal speeds, and PT Option 2 would superimpose PTP speeds on ACSES w/o ATC as pseudo interlocking route speeds.
- The proposed use of the I-ETMS temporary speed capability in PT Option 4b derives from the fact that temporary speeds are subject to change, and as they can be changed in I-ETMS by the dispatcher as needed, it is assumed that a way could be provided to “automatically” add and delete the PTP speeds, T1, T2, RPI, and RFI, as needed. The significant unknown at this point in our research, is whether this can be accomplished regularly in a time frame that could be considered useful in providing the PTP speed changes quickly when needed.
- Currently, the plan is to input TSRs into the BOS from the dispatcher’s control console or work station when the dispatcher creates the restriction in the CAD system.
- CAD normally forms the heart of the dispatcher’s control of the field CTC signals and switches, and it also receives real time updates from the field of the status of signals, switches, track circuit and block occupancies, identities of trains, etc., displaying these statuses in real time on the dispatchers’ screens to enable them to follow the progress of the trains they are dispatching.
- Therefore, it would appear that for PT Option 4b, the new PTP functionality could reside in the BOS, or in a vital SPTIP in the office that would communicate directly with the I-ETMS BOS to permit the PTP speeds, T1, T2, RPI, and RFI, to be input to the BOS, and ultimately through the BOS to the trains in the area affected by the TSR. This would require the vital PTI data to be gathered from the field through the communications network, and

fed to the SPTIP to process the data for the BOS in the back room of the dispatchers' office.

- To simplify our description of PT Option 4b, as well as the required configuration management of the implementation of PT Option 4b, the limits of the TSRs selected to correspond to the PTP speeds, T1, T2, RPI, and RFI, will be the exact limits of the intermediate signal blocks in the automatic block system between the CTC interlockings, the same as already described in all previous options. When this is done, readers interested in following a mix of compatible and non-compatible trains through the scenarios in the former subsection and the illustrations in Figures D-3 through D-13 should be able to visualize the I-ETMS implementation in the interlocking-to-interlocking Track Segment A-B in the same manner as was accomplished in PT Options 1, 2, and 3a.
- However, the response time involved in PT Option 4b is expected to be greater than that expected in PT Option 4a, for the PTP functionality in the office to make the necessary PTP speed changes required in the field in real time. This could further slow the operation of the passing LRTs and the compliant "railroad" trains on adjacent tracks. The magnitude of these delays is not known at this time, nor is it known whether these response times would be acceptable to the carriers involved in providing service through these shared corridors. In fact, in one of the large commuter operations that is leading the effort to implement the I-ETMS system by the end of 2015, the CAD deployment is currently so far behind schedule that the CAD/PTC interface functionality does not yet exist, and thus there is no reliable way of determining the future timing of TSR release events.

### *Estimated Relative Risk Reduction Accomplished by Application of PTC PT Options for Implementing PTP*

In summary, the analysis very approximately estimated the comparative risk, prior to adding any PTC enhancements, as  $10^{-6}$  events per 1,000,000 train miles for the base case for non-enhanced multiple-track, when compared to the base case for pre-PTC/ATC risks for shared-track usage, which we had estimated at 1.0(x) per 1,000,000 train miles, or a reduction in risk on the order of magnitudes of approximately 6 simply by separating the trains on different tracks.

The analysis also estimated the risk of multiple-track collisions between equipment on adjacent tracks with the enhancement of a well-designed continuously-monitored intrusion system with a minimum track separation of 20 ft. between the tracks as  $10^{-7}$  events per 1,000,000 train miles, or a reduction in order of magnitude of approximately 7 from the risk of collision on shared track in the pre-PTC/ATC case. However, this is only a reduction of risk of collision on the order of magnitude of 1 from the risk of such a collision on un-enhanced multiple-track where the trains have been separated on different tracks.



In addition, the risk of multiple-track collisions was estimated between trains on adjacent tracks with the enhancement of a well-designed crash-wall barrier system, with a minimum track separation of 20 ft., as  $10^{-8}$  events per 1,000,000 train miles, or a reduction in order of magnitude of approximately 8 from the risk of collision on shared track in the pre-PTC/ATC case. However, this is only a reduction of risk of collision on the order of magnitude of 2 from the risk of such a collision on un-enhanced multiple-track where the trains have been separated on different tracks.

With the above as background perspective, we have reviewed the anticipated risk reduction for each of the six parallel-track options presented in some detail for potential applications of the three PTC systems. After a careful review of each of these options, the analysis very approximately estimated the risk in each case, assuming a successful application along the lines described in each option, of  $10^{-7}$  events per 1,000,000 train miles. This is a reduction in order of magnitude of approximately 7 from the original pre-PTC/ATC shared-track case, and a risk reduction on an order of magnitude of 1 when compared to the parallel track case with trains separated on adjacent tracks where no additional enhancements have been provided.

The above estimated risk values should be viewed as very approximate, and only for the purpose of comparing the various scenarios and options. Also, the levels of risk presented are primarily presented as relative probabilities of any sort of collision actually happening. The levels of risk cited in this report do not take into account any additional damage that could possibly occur to a non-compliant vehicle, if it should actually contact a compliant vehicle or its cargo on an adjacent track.

### Summary of PT Options for Reducing Speeds of Non-Compatible Train-Types on Parallel Adjacent Tracks

Table D-1 provides a comparison of PT Options 1, 2, 3a, 3b, 4a, and 4b.

**Table D-1**

*Summary of PT Options for Reducing Speeds of Non-Compatible Train-Types on Parallel Adjacent Tracks*

Adjacent-Parallel-Track Options	Estimated Accident Risk Per IM Train Miles	Relative Incremental Cost	Comments
Pre-PTC and/or ATC conditions on same-track as a “ST Benchmark”	1.0(x)	NA	Unknown value of current risk without PTC, “x” likely “<<1”?
Pre-PTC and/or ATC conditions on parallel-track as a “PT Benchmark”	10 <sup>-6</sup> (x)	Zero	PTC System required regardless of shared use.
PT Option 1 – ATC/ ACSES PTC: Add PTP to signal system and adapt ATC portion of PTC to display and enforce PTP; PTP speeds to match ATC speeds.	10 <sup>-7</sup> (x)	Cost to add PTP to signal system + PTC application engineering	If ATC and PTP speeds can be matched, PT Option 1 expected to give best performance in multiple-track dense-traffic territories with least cost.
PT Option 2 – ACSES w/o ATC: Add to PTP to signal system and adapt ACSES to display and enforce PTP speeds as additional interlocking route speeds.	10 <sup>-7</sup> (x)	Cost to add PTP to signal system + PTC application engineering	PT Option 1 preferred with ATC; PT Option 2 not as fast as PT Option 1, but less need for speed in lighter traffic.
PT Option 3a – ITCS PTC: Add PTP to WIUs and adapt ITCS “signal speeds” to display and enforce PTP.	10 <sup>-7</sup> (x)	Cost to add PTP to WIUs + other PTC application engineering	PT Options 3a and 3b expected to be least costly and easiest to implement of PT options outside NEC.
PT Option 3b – ITCS PTC: Add PTP to WIUs and adapt “temporary speeds” to display and enforce PTP.	10 <sup>-7</sup> (x)	Cost to add PTP to WIUs + other PTC application engineering	PT Option 3b expected to be slower in performance than 3a; ITCS most mature of CB PTC systems, but expected to be least deployed
PT Option 4a – I-ETMS: Add PTP to signal system and adapt I-ETMS “signal speeds” to display and enforce PTP.	10 <sup>-7</sup> (x)	Cost to add PTP to signal system + PTC application engineering	Implementation of PT Options 4a and 4b could be quite difficult in near term due to I-ETMS immaturity; however, outside NEC is prevailing PTC.
PT Option 4b – I-ETMS: Add PTP to signal system and adapt I-ETMS “temporary speeds” to display and enforce PTP.	10 <sup>-7</sup> (x)	Cost to add PTP to signal system + PTC application engineering	PT Option 4b expected to be slower in performance than 4a; early implementation of I-ETMS expected to be high risk.

## REFERENCES

- Bing, Alan J., Eric W. Beshers, Megan Chavez, David P. Simpson, Emmanuel S. “Bruce” Horowitz, and Walter E. Zullig, Jr. (2010). National Cooperative Highway Research Program (NCHRP) Report 657, Guidebook for implementing passenger rail service on shared passenger and freight corridors. TRB, National Research Council, Washington, DC.
- Booz | Allen | Hamilton, Jacobs Edwards & Kelcey, ICF Consulting, and New Jersey Institute of Technology. (2009). TCRP Report 130, Shared use of railroad infrastructure with non-compliant public transit rail vehicles: A practitioner’s guide. TRB, National Research Council, Washington, DC.
- Fazio, Alfred E., A. R. Troup, Bridget Hodgeson, and Jack Kanarek. (2011). FTA Report No. 0008: Safe transit in shared use. Washington, DC.
- Federal Railroad Administration. 49 Code of Federal Regulations (CFR) Part 236, Subpart H – Standards for Processor-Based Signal and Train Control Systems and Subpart I – Positive Train Control System.
- Federal Railroad Administration. (2000). Shared use of the tracks of the general railroad system by conventional railroads and light rail transit systems-notice and final rule. *Federal Register*, 65(132), 42529-42553.
- Federal Railroad Administration and Federal Transit Administration. (2000). Statement of agency policy concerning jurisdiction over the safety of railroad passenger operations and waivers related to shared use of the tracks of the general railroad system by light rail and conventional equipment. *Federal Register*, 65(132), 42525-42528.
- Phraner, D. (2001). Supplementing and updating TCRP report 52: Joint operation of light rail transit or diesel multiple unit vehicles with railroads issue. *TCRP Research Results Digest*, 43, TRB, National Research Council, Washington, DC.
- Phraner, D. (2002). Germany’s track sharing experience: Mixed use of rail corridor. *TCRP Research Results Digest*, 47, TRB, National Research Council, Washington, DC.
- Phraner, D., R. Roberts, P. Stangas, K. Korach, J. Shortreed, and G. Thompson. (1989). TCRP Report 52: Joint operation of light rail transit or diesel multiple unit vehicles with railroads. TRB, National Research Council, Washington, DC.



U.S. Department of Transportation  
**Federal Transit Administration**

---

U.S. Department of Transportation  
Federal Transit Administration  
East Building  
1200 New Jersey Avenue, SE  
Washington, DC 20590  
<http://www.fta.dot.gov/research>