

FTA RESEARCH

FEDERAL TRANSIT ADMINISTRATION

Dallas Integrated Corridor Management (ICM) Transit Vehicle Real-time Data Demonstration Final Report

JANUARY 2015

FTA Report No. 0082
Federal Transit Administration

PREPARED BY
Dallas Area Rapid Transit



U.S. Department of Transportation
Federal Transit Administration

COVER PHOTO

Courtesy of Dallas Area Rapid Transit

DISCLAIMER

This document is disseminated under the sponsorship of the U.S. Department of Transportation in the interest of information exchange. The United States Government assumes no liability for its contents or use thereof. The United States Government does not endorse products or manufacturers. Trade or manufacturers' names appear herein solely because they are considered essential to the objective of this report.



Dallas Integrated Corridor Management (ICM) Transit Vehicle Real-time Data Demonstration Final Report

JANUARY 2015

FTA Report No. 0082

PREPARED BY

Dallas Area Rapid Transit

SPONSORED BY

Federal Transit Administration
Office of Research, Demonstration and Innovation
U.S. Department of Transportation
1200 New Jersey Avenue, SE
Washington, DC 20590

AVAILABLE ONLINE

<http://www.fta.dot.gov/research>

Metric Conversion Table

SYMBOL	WHEN YOU KNOW	MULTIPLY BY	TO FIND	SYMBOL
LENGTH				
in	inches	25.4	millimeters	mm
ft	feet	0.305	meters	m
yd	yards	0.914	meters	m
mi	miles	1.61	kilometers	km
VOLUME				
fl oz	fluid ounces	29.57	milliliters	mL
gal	gallons	3.785	liter	L
ft³	cubic feet	0.028	cubic meters	m ³
yd³	cubic yards	0.765	cubic meters	m ³
NOTE: volumes greater than 1000 L shall be shown in m ³				
MASS				
oz	ounces	28.35	grams	g
lb	pounds	0.454	kilograms	kg
T	short tons (2000 lb)	0.907	megagrams (or "metric ton")	Mg (or "t")
TEMPERATURE (exact degrees)				
°F	Fahrenheit	5 (F-32)/9 or (F-32)/1.8	Celsius	°C

REPORT DOCUMENTATION PAGE		Form Approved OMB No. 0704-0188	
Public reporting burden for this collection of information is estimated to average 1 hour per response, including the time for reviewing instructions, searching existing data sources, gathering and maintaining the data needed, and completing and reviewing the collection of information. Send comments regarding this burden estimate or any other aspect of this collection of information, including suggestions for reducing this burden, to Washington Headquarters Services, Directorate for Information Operations and Reports, 1215 Jefferson Davis Highway, Suite 1204, Arlington, VA 22202-4302, and to the Office of Management and Budget, Paperwork Reduction Project (0704-0188), Washington, DC 20503.			
1. AGENCY USE ONLY	2. REPORT DATE January 2015	3. REPORT TYPE AND DATES COVERED July 2011 – January 2015	
4. TITLE AND SUBTITLE Dallas Integrated Corridor Management (ICM) – Transit Vehicle Real-time Data Demonstration, Final Report		5. FUNDING NUMBERS DTFH61-06-H-00040	
6. AUTHOR(S) Todd Plesko, Alan Gorman			
7. PERFORMING ORGANIZATION NAME(S) AND ADDRESS(ES) Dallas Area Rapid Transit 1401 Pacific Avenue Dallas, TX 75202		8. PERFORMING ORGANIZATION REPORT NUMBER FTA Report No. 0082	
9. SPONSORING/MONITORING AGENCY NAME(S) AND ADDRESS(ES) U.S. Department of Transportation Federal Transit Administration Office of Research, Demonstration and Innovation East Building 1200 New Jersey Avenue, SE Washington, DC 20590		10. SPONSORING/MONITORING AGENCY REPORT NUMBER FTA Report No. 0082	
11. SUPPLEMENTARY NOTES [http://www.fta.dot.gov/research]			
12A. DISTRIBUTION/AVAILABILITY STATEMENT Available from: National Technical Information Service (NTIS), Springfield, VA 22161. Phone 703.605.6000, Fax 703.605.6900, email [orders@ntis.gov]		12B. DISTRIBUTION CODE TRI-20	
13. ABSTRACT This project demonstrated and evaluated the ability to collect and transmit transit location and passenger loading data to a transit management center(s) and/or Integrated Corridor Management (ICM) system in real time. It also demonstrated and evaluated the ability to use the data in real time in a decision support subsystem, for example, to make informed operational decisions. Included in the project were the development, installation, testing, and demonstration of on-board automatic vehicle location (AVL) and automated passenger counter (APC) equipment and communications technologies to support real-time connectivity between transit vehicles and central facilities to support potential applications such as vehicle location, speed monitoring, and passenger load monitoring. The utility of real-time transit vehicle data was explored and assessed, and the issues, challenges, and feasibility of use were examined.			
14. SUBJECT TERMS Integrated Corridor Management, Automatic Vehicle Location, Automated Passenger Counter, SIRI		15. NUMBER OF PAGES 111	
16. PRICE CODE			
17. SECURITY CLASSIFICATION OF REPORT Unclassified	18. SECURITY CLASSIFICATION OF THIS PAGE Unclassified	19. SECURITY CLASSIFICATION OF ABSTRACT Unclassified	20. LIMITATION OF ABSTRACT

TABLE OF CONTENTS

1	Executive Summary
3	Section 1: Introduction
8	Section 2: Operational Concept Definition
9	Section 3: Requirements Development
12	Section 4: System Design
16	Section 5: Installation
17	Section 6: Testing
20	Section 7: Results and Conclusions
A-1	Appendix A: Operational Concept
B-1	Appendix B: System Requirements
C-1	Appendix C: Communications Assessment
D-1	Appendix D: System Design Document
E-1	Appendix E: Test Plan and Results
101	Glossary
102	References

LIST OF FIGURES

4	Figure 1-1:	US-75 Integrated Corridor
9	Figure 3-1:	Context diagram of real-time transit vehicle data system
10	Figure 3-2:	APC/AVL data flows
12	Figure 4-1:	Real-Time Transit Vehicle Data Demonstration System architecture
13	Figure 4-2:	High-level APC schematic
15	Figure 4-3:	APC data: SmartFusion Subsystem Interface
17	Figure 6-1:	Location of human counters at each doorway of an APC-equipped SLRV
17	Figure 6-2:	Location of APC equipment at each doorway of an APC-equipped SLRV

LIST OF TABLES

8	Table 2-1:	Dallas ICM User Needs Relating to Transit Vehicle Real-time Data
11	Table 3-1:	User Need to Subsystem Traceability
18	Table 6-1:	APC Installation Results

ACKNOWLEDGMENTS/FOREWORD

Dallas Area Rapid Transit (DART) would like to thank Steve Mortensen of the Federal Transit Administration (FTA) for his leadership and for assistance through the ICM and real-time data programs.

In addition, we would like to thank Schneider Electric, specifically Ahmad Sadegh, Kevin Miller, Fariel Bouattoura, and Joe Zingalli, for support in assisting DART with the integration and deployment of real-time transit data to the Dallas–Fort Worth region.

ABSTRACT

This project demonstrated and evaluated the ability to collect and transmit transit location and passenger loading data to a transit management center(s) and/or Integrated Corridor Management (ICM) system in real time. It also demonstrated and evaluated the ability to use the data in real time in a decision support subsystem, for example, to make informed operational decisions.

Included in the project were the development, installation, testing, and demonstration of on-board automatic vehicle location (AVL) and automated passenger counter (APC) equipment and communications technologies to support real-time connectivity between transit vehicles and central facilities to support potential applications such as vehicle location, speed monitoring, and passenger load monitoring. The utility of real-time transit vehicle data was explored and assessed, and the issues, challenges, and feasibility of use were examined.

EXECUTIVE SUMMARY

The Dallas Integrated Corridor Management System (ICMS) demonstration project is a multi-agency, de-centralized operation that uses a set of regional systems to integrate the operations of the corridor. The purpose of the Dallas ICM System is to implement a multi-modal operations decision support tool enabled by real-time data pertaining to the operation of freeways, arterials, and public transit. The system is shared among people involved in transportation operations and incident management in the US-75 Corridor. The Dallas ICM System is intended to provide improved integration of operation procedures, including procedures that take advantage of the data sharing capabilities of the system and facilitate improved incident management and traveler information.

Transit data are important to the successful implementation of an ICM system. Most transit agencies lack the capability to access transit vehicle data in a timely manner to support ICM operations, particularly dynamic mode shift to transit. The key real-time transit vehicle information needed to support ICM include vehicle location, time to arrival at next stop (derived from vehicle location and speed), and remaining capacity to carry additional passengers (derived from the current passenger count).

Most transit agencies do not have access to passenger load data in “real time.” Rather, these data typically are downloaded at the end of the day when the transit vehicle enters the bus/rail yard and are used for transit service planning, not operations. In addition, not all transit vehicles are equipped with automatic passenger counters (APCs), although APCs are becoming standard on new bus procurements.

During Stage I of the Dallas ICM project, the missing real-time capacity of light rail transit (LRT) fleets was identified as essential to the deployment of a multi-modal, multi-agency ICM concept. ICM depends on the acquisition of such data about current conditions in the corridor, the capability to implement various management strategies (which may include transit), and the modeling tools to support the evaluation and selection of strategies appropriate to current conditions.

The project team, headed by Dallas Area Rapid Transit (DART), developed several documents and used the systems engineering process in designing, deploying, testing, and operations and maintenance. This document discusses the steps of the process and the deliverables that were produced. The project has provided DART with many benefits, including added visibility into the operations of its light rail and bus fleets and more complete information provided to travelers within the region.

Prior to this project, DART lacked access to real-time LRT loading data. As a result, it was difficult to implement some ICM strategies that included transit, such as adding transit capacity in real time to accommodate dynamic mode shift

to transit (e.g., drivers shifting to transit as a result of a major incident on an adjacent freeway). This project demonstrated and evaluated the ability to collect and transmit transit location and passenger loading data to a transit management center(s) and/or ICM system in real time. The project also demonstrated and evaluated the ability to use the data in real time in a decision support subsystem, for example, to make informed operational decisions. The project included the development, installation, testing, and demonstration of on-board APC equipment and communications technologies to support real-time connectivity between transit vehicles and central facilities to support the following potential applications:

- Vehicle location and speed monitoring
- Passenger load monitoring

The project explored and assessed the utility of real-time transit vehicle data and examined the issues, challenges, and feasibility of use. For example, the project explored the scenarios for which DART could dynamically increase capacity (to accommodate dynamic mode shift to transit) based on LRT Red Line real-time passenger load information.

The Dallas ICM demonstration site was used as a test bed for this project. The project included the development of this operational concept to identify the appropriate transit vehicle real-time data applications that supports Dallas's proposed ICM strategies and operations. The applications selected for Dallas were demonstrated on DART's Red Line LRT system, which is located in the US-75 ICM corridor.

The project included a case study conducted by the Volpe Center (FTA Report No. 0077) that focuses on documenting the process of acquiring, integrating, and using real-time transit data for DART LRT vehicles, sharing lessons learned, and demonstrating qualitative evidence for changes in DART's Train Control Center due to real-time information.

Introduction

Background

The US-75 Integrated Corridor Management System (ICMS) is a component-based system that supports corridor management by sharing internal and external incident, construction, special event, transit, and traffic flow data and uses these data to provide operational planning and evaluation through decision support.

This US-75 Corridor contains the first major freeway in Dallas, completed around 1950. This section of freeway was totally reconstructed with cantilevered frontage roads over the depressed freeway section and re-opened in 1999 with a minimum of eight general-purpose lanes. The freeway main lanes carry more than 250,000 vehicles per day, with another 20,000–30,000 on the frontage roads. Concurrent flow, high-occupancy vehicle lanes are scheduled to open in 2016 in the freeway median in the northern section of the Corridor.

The corridor also contains the first light-rail line constructed in Dallas, part of the 20-mile DART starter system, opened in 1996. The Red Line now expands into the cities of Richardson and Plano and passes next to the cities of Highland Park and University Park. This facility operates partially at-grade and partially grade-separated through deep-bored tunnels under US-75. A map of the ICM corridor is shown in Figure I-1.

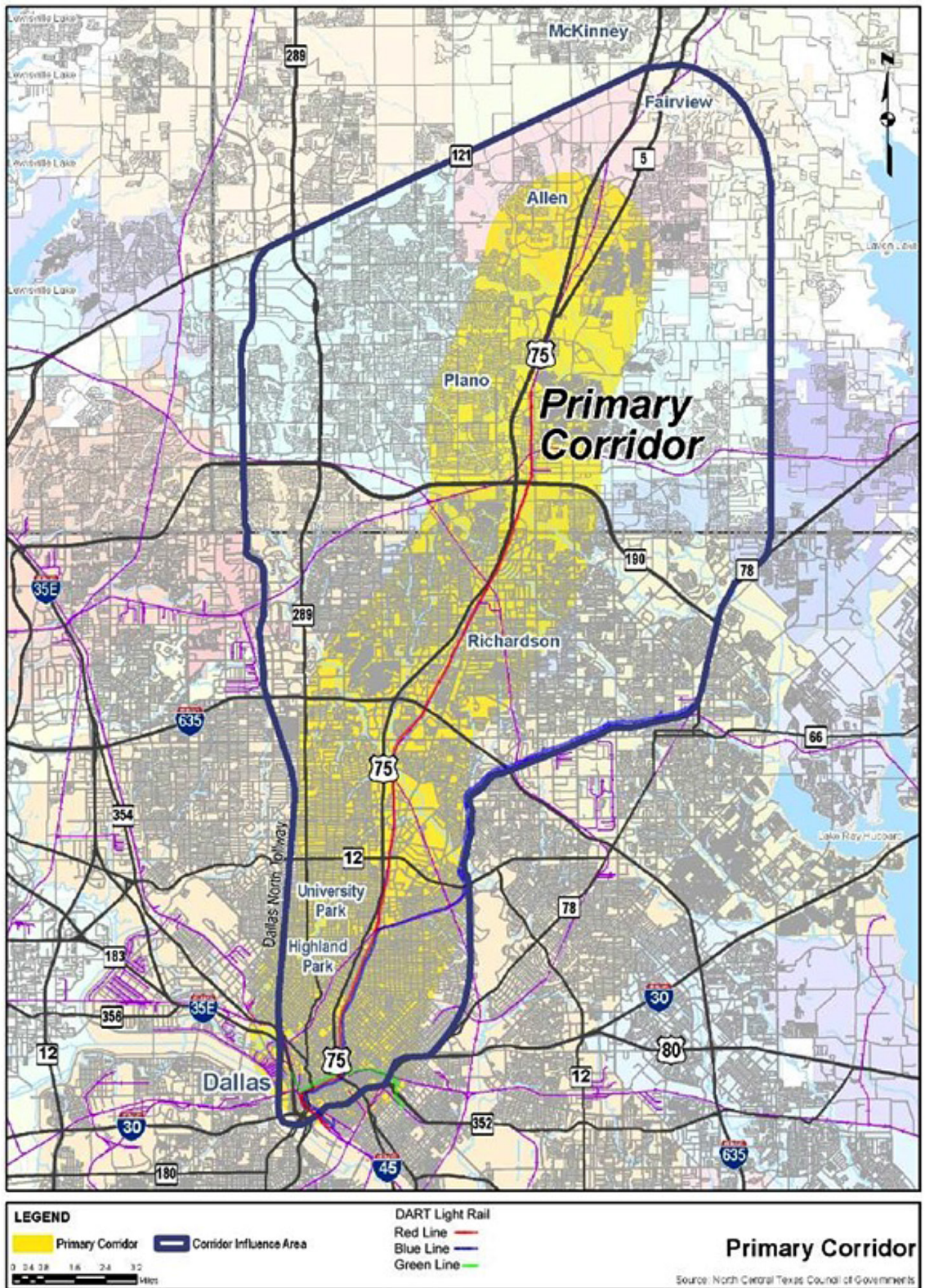

Figure 1-1
 US-75 Integrated Corridor

The ICM demonstration project has allowed the operating agencies along the corridor to manage the transportation network as an integrated asset and provide travelers with personalized, real-time information, enabling them to make better decisions about how to travel along the corridor. The effort is designed to collaboratively engage the planning, technology, and infrastructure resources of the various cities and government jurisdictions along the corridor from Dallas north to SH 121 in Plano, in improving mobility along the entire corridor instead of the traditional approach of managing individual assets to solve local mobility needs. By applying ICM, the operating agencies along this section of the corridor manage it as an integrated asset to improve travel time reliability and predictability by empowering travelers through better information and more transportation choices.

All operations among corridor networks and agencies (e.g., activation of specific ICM strategies) will be coordinated via the Decision Support Subsystem (DSS). Communications, systems, and system networks are integrated to support the virtual corridor command center. Voice, data, video, information, and control are provided to all agencies based on the adopted protocols and standards for the sharing of information and the distribution of responsibilities. The ICM supports the virtual nature of the corridor by connecting member agency staff on a real-time basis via communications and other ITS technologies. Although all the ICM operational strategies will be available for use, it is envisioned that only a subset of these strategies will be activated at any one time, depending on the operational conditions and events within the corridor.

To support the ICM project and provide real-time transit information to the stakeholders and systems supporting ICM, several technologies were researched, deployed, integrated, and operated, including automatic vehicle location (AVL), automatic passenger counters (APC), wireless communication to transit real-time data, software systems to aggregate and integrate the real-time data, and operational use of the data for transit operations, ICM operations, and traveler information.

The DSS is driven by the decision rules, expert system, and prediction modeling and evaluation components to recommend the plan of actions associated with specific events within the corridor. The involved agencies will be notified of the events along with the suggested recommendations for consideration and deployment.

In response to an incident, the process begins with the expert rules and model collecting information on corridor performance and incidents from the data fusion system. The model develops an assessment of the current roadway operations based on the data received from the data fusion system. In addition, the model periodically forecasts the current and predicted

performance of the network based on the current conditions and sends them to the expert rules system.

Given the information on the current conditions of the network and the predicted performance of the network, the expert rules develop candidate response plans that are delivered to the ICM coordinator via the DSS dialog. The ICM coordinator approves or rejects the candidate response plan from the recommendation of the expert rules.

For additional information on the Dallas ICM concept and vision, refer to the Dallas ICM Concept of Operations (FHWA-JPO-11-70).

Project Scope

Transit data are important to the successful implementation of an ICM system. Most transit agencies lack the capability to access transit vehicle data in a timely manner to support ICM operations, particularly dynamic mode shift to transit. Data acquisition issues for transit are mainly due to bandwidth limitations of transit vehicle communications systems (e.g., data radios) and on-board load counts (e.g., aggregated on-board loads). The key real-time transit vehicle information to support ICM include vehicle location, time to arrival at next stop (derived from vehicle location and speed), and the remaining capacity to carry additional passengers (derived from the current passenger count). Capacity of parking at transit stations also is a key component of providing travelers with the necessary information to decide to shift modes.

Prior to the ICM project, DART had limited information on the real-time location and on-board loads of its light rail transit vehicles (LRV) within the US-75 corridor. LRVs had AVL systems for tracking location, and a few had APC systems. However, on-board load information was not aggregated to the car level or transmitted in real-time and was downloaded and aggregated only once the train was brought into the rail yard, usually at the end of the day. This allowed DART to have sufficient data for planning purposes, but operational data were limited to current location and schedule adherence. Passenger loading information was not available, so recommending modal shift to transit was an ICM strategy that would be a challenge to implement.

For this project several technologies were selected, deployed, integrated, and operated for transit real-time information to support the US-75 Integrated Corridor Management Demonstration project.

The project applied the systems engineering process, including the development of an operational concept, requirements, and design, and installation, testing, and operations/demonstration. It should be noted that the systems engineering process was applied to and constrained by an existing

system, which was modified to add functionality of real-time transmission and use of APC data.

The following sections discuss the project steps and considerations for providing the real-time transit information system.

SECTION
2

Operational Concept Definition

The first step for the project was to develop an Operational Concept (see Appendix A), which answers the basic questions for this project of:

- What – the known elements and the high-level capabilities of the system.
- Where – the geographical and physical extents of the system.
- When – the time-sequence of activities that will be performed.
- How – resources needed to design, build, operate, and maintain the system.
- Who – the stakeholders involved with the system and their respective responsibilities.
- Why – justification for the system, identifying what the corridor currently lacks and what the system will provide.

Table 2-1 shows the identified needs of the Transit Vehicle Real-time Data Demonstration system as related to the existing user needs identified in the Dallas ICM Concept of Operations. Although DART has additional needs for operational improvements and efficiency, they are not included in Table 2-1 because they do not relate directly to ICM user needs and are for systems external to the Transit Vehicle Real-time Data Demonstration system.

Table 2-1

*Dallas ICM User Needs
Relating to Transit
Vehicle Real-time Data*

#	User Needs	Justification
1	Obtain current LRT capacity in corridor	Needed to make informed decisions on actions to be made to improve performance, including receiving passenger count information, determining vehicle loads, and processing data for further use.
2	Provide transit event information to travelers	Needed to provide transit capacity information to the public for planning trips and modifying trip plans en route to allow travelers to make informed decisions about their trips.
3	Obtain current location of LRTs in corridor	Needed to make informed decisions on actions to improve performance; includes receiving location information, determining arrival times, and processing data for further use.
4	Provide ICMS with current LRT location and capacity information	Needed to provide current location information and capacity of LRV network within corridor to ICMS for Decision Support and incident response plan selection.

SECTION
3

Requirements Development

Once the Operational Concept document was completed, a Requirements document was developed for the system and subsystems based on the user needs development in the Operational Concept. The Requirements document is attached in Appendix B.

Figure 3-1 shows a high-level framework on how the system will interface with external systems. The APC/AVL system uses standardized message formats for external users of the data.

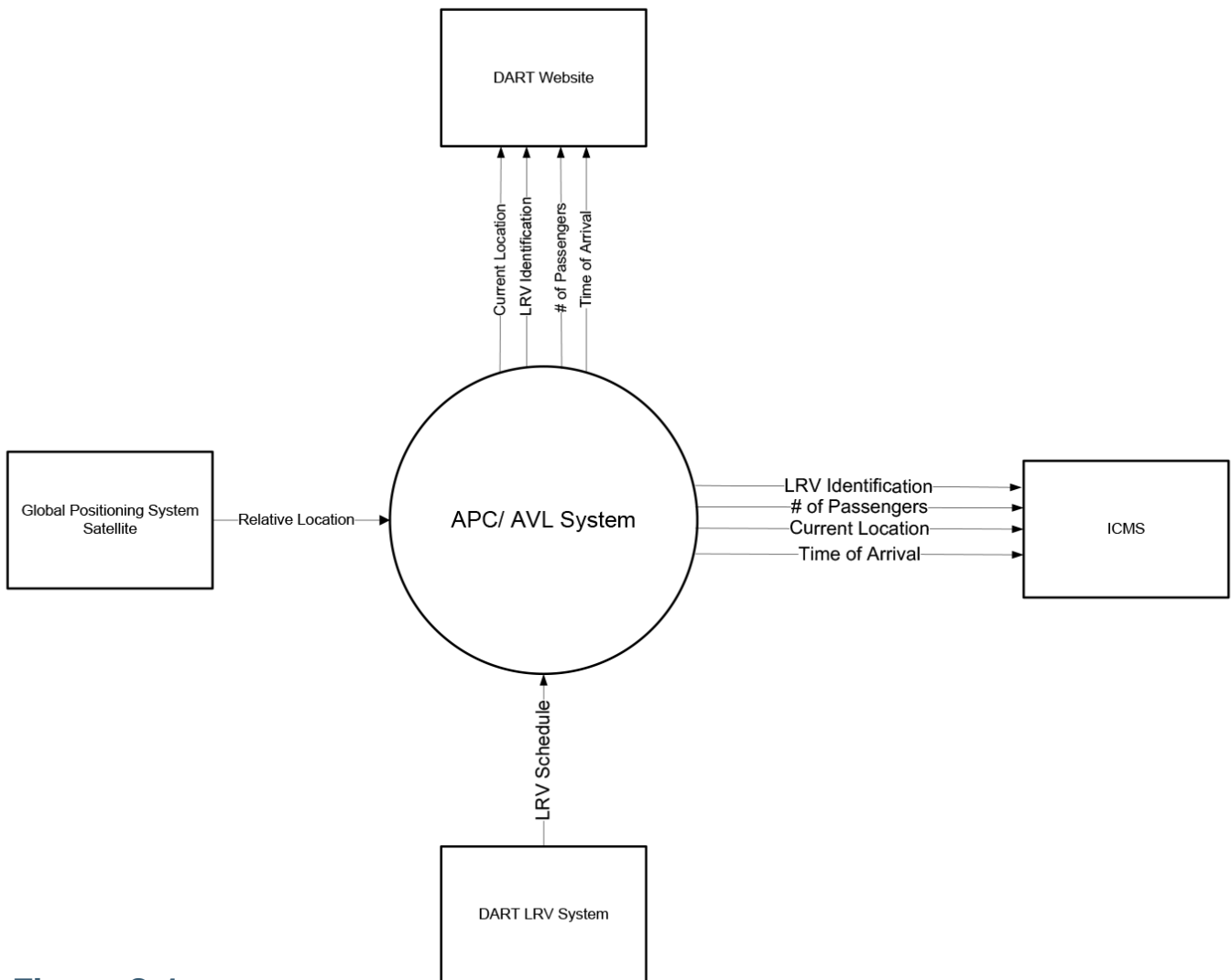
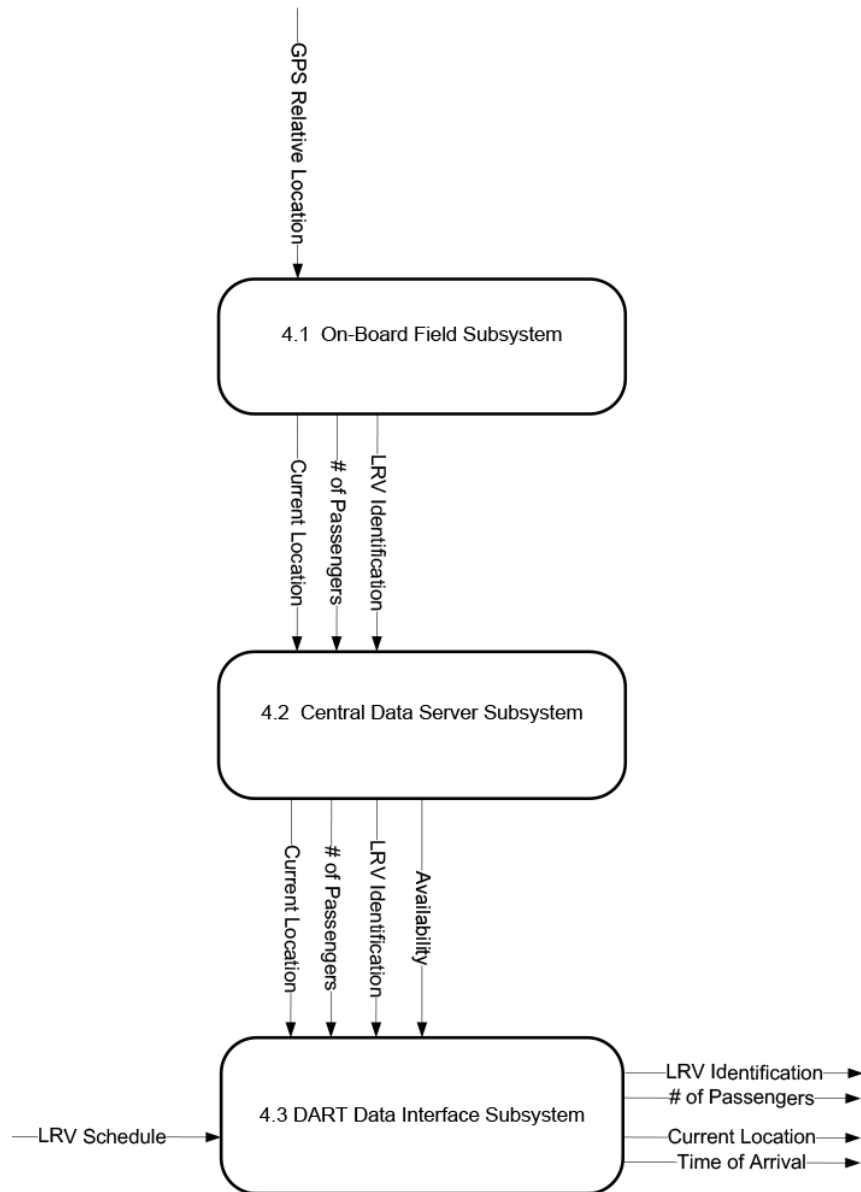

Figure 3-1
Context diagram of real-time transit vehicle data system

Figure 3-2 provides a context diagram of the APC/AVL System and its subsystems. The On-board Field Subsystem consists of hardware installed on an LRV, which is used to determine its location and current real-time loading. These data are processed on-board and sent via a wireless communication medium to a central server for processing.

Figure 3-2
APC/AVL data flows



The Central Data Server Subsystem consists of the central system, which processes the data received via a wireless communication medium from the on-board field hardware. The Central Data Server subsystem processes the data and sends specific location and vehicle loading data to the DART Data Interface Subsystem.

The DART Data Interface Subsystem consists of the data interface that receives specific location and vehicle loading data from the Central Data Server interface. The data are stored and published to DART websites and provided as an XML-based interface to the ICMS. In the future, the AVL/AVI Data Interface Subsystem also will potentially provide data to third parties.

To ensure that all functional requirements were identified from the user needs and use cases, a mapping of the user needs to the Transit Vehicle Real-time Data Demonstration systems and subsystems was completed, as shown in Table 3-1.

Table 3-1
*User Need
to Subsystem
Traceability*

Subsystems	User Needs	On-board Field Subsystem	Central Data Server Subsystem	DART Data Interface Subsystem
1	Need to obtain current status of LRT capacity in corridor	•	•	•
2	Need to provide transit event information to travelers			•
3	Need to obtain current location of LRTs in corridor	•	•	•
4	Need to provide ICMS with current LRT location and capacity information			•

Requirements were developed for the overall system and each subsystem, as provided in Appendix B. The requirements used the following numbering convention:

- System Requirements = 4.0.0.10 to 4.0.0.n
 - APC = 4.0.0.n
- Subsystem Requirements = 4.1.0.10 to 4.X.0.n
 - On-board Subsystem = 4.1.0.n
 - Central Data Server Subsystem = 4.2.0.n
 - DART Data Interface Subsystem = 4.3.0.n

System Design

The system design provides a description of the selected system and the detailed design for the system to be implemented for the Transit Vehicle Real-time Data Demonstration project.

The design is based on the in-vehicle and in-field requirements defined in the Requirements document. The architecture and design incorporates elements that must be used to provide a solution that fulfills the system and subsystem requirements and meets the existing needs of DART and the larger US-75 ICM Demonstration project.

The system architecture shown in Figure 4-1 provides a high-level diagram of the entire APC System, its subsystems, and the modules within the subsystem. The APC System consists of three subsystems: On-Board Field Hardware, DART Data Interface, and INIT Data Interface. The On-Board Field Hardware is the hardware added to the DART LRVs to provide the data needed to calculate the location and number of passengers on each LRV. The INIT Data Interface receives the data from the On-Board Field Hardware and calculates the location and passenger count information, which is then sent to the DART Data Interface. The DART Data Interface provides information on the LRVs to the ICMS and to DART for internal use.

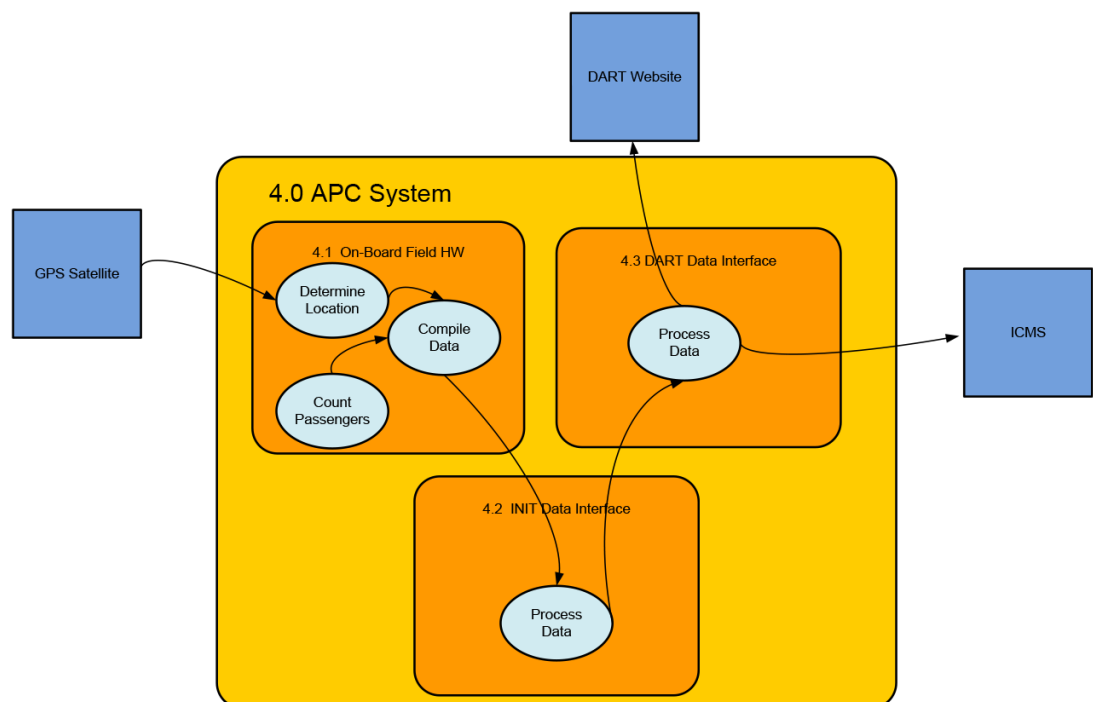

Figure 4-1

Real-Time Transit Vehicle Data Demonstration System architecture

Automated Vehicle Location

AVL is a means for determining the geographic location of a vehicle and transmitting this information to a point at which it can be stored and used with certain software and database applications. For DART, vehicle location is determined by using a Global Positioning System (GPS) device, and the transmission mechanism for the LRVs monitored as part of this project was 900 MHz radio and cellular connection. The system poll rate was 25 seconds for the trains.

Automatic Passenger Counters

APCs are installed in each LRV over each of the 10 doorways, which provides for detection of people entering and exiting the vehicle. Of the 163 LRVs in the DART fleet, 68 are APC-equipped; before the ICM project, DART had 48 APC-equipped cars. The APC sensor provides this information to the on-board computer for analyzing and packaging the data. As shown in Figure 4-2, the on-board computer sends the packaged data via cellular digital packet data (CDPD) radio to a central server for evaluation and analysis computer. The central server processes the data received from the on-board computer and provides the on-board loads to DART at 20-second intervals.

Figure 4-2

High-level APC schematic

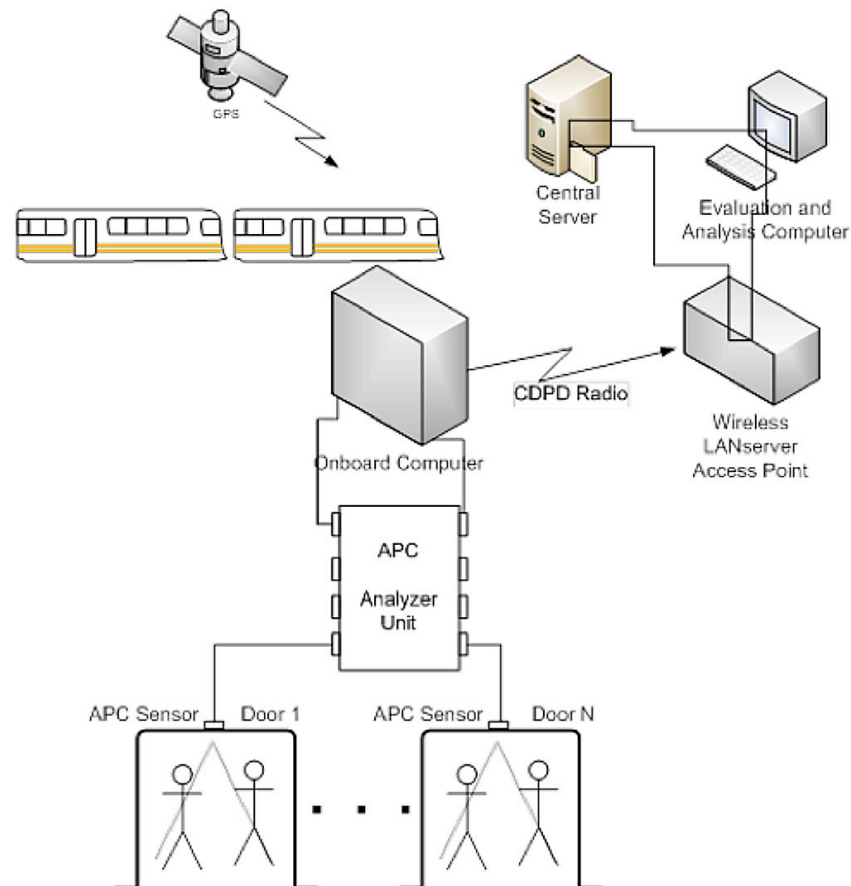

Source: DART

Communication Needs

Multiple communication media are involved in AVL and APC data collection, processing, and distribution. For the Transit Vehicle Real-time Data Demonstration project, the communication between the LRV on-board computer and the central servers was analyzed to ensure that the communication will be robust and sufficient for the amount of data. A cellular-based modem was selected to be consistent with other similar systems in DARTs fleet. The communication between the INIT servers and DART is an XML-based web service using a Service Information for Real-time Information (SIRI) standard XML message via the Internet.

For AVL location data, both GPS (for above ground) and odometer-inputted logical position (for tunnels) was used and provided to the ICMS via a web service using XML. The communications needs assessment for the project is attached in Appendix C.

Integration with ICMS

As previously mentioned, real-time capacities of LRT fleets were identified as essential to the deployment of a multi-modal, multi-agency ICM concept. ICM depends on the acquisition of such data about current conditions in the corridor, the capability to implement various management strategies, which may include transit, and the decision support tools to support the evaluation and selection of strategies appropriate to the current conditions.

As shown in Figure 4-3, the ICMS (SmartFusion subsystem) collects, fuses, stores, and disseminates various transportation-related data for the ICMS. The AVL and APC data will be provided to the SmartFusion subsystem via a web service using XML. The AVL and APC data are fused, stored, and provided to other systems within the ICMS, including the Decision Support subsystem and SmartNET subsystem. The Decision Support subsystem, via the ICMS XML web service, uses the AVL and APC data to evaluate response plans for events within the corridor (i.e., incidents) to determine if modal shift is recommended or if additional capacity for the LRT is needed and to evaluate if the current available capacity is sufficient.

The SmartNET subsystem will provide to the agency users within the corridor a layer on the map to show the current location and capacity of the LRVs within the corridor. This will provide the operators with a quick view of the impact of the decisions within their area of influence on the transit riders.

The design of the field hardware, software interfaces, and integration with the ICM system are provided in more detail in the Transit Vehicle Real-time Data Demonstration project System Design Document, Appendix D.

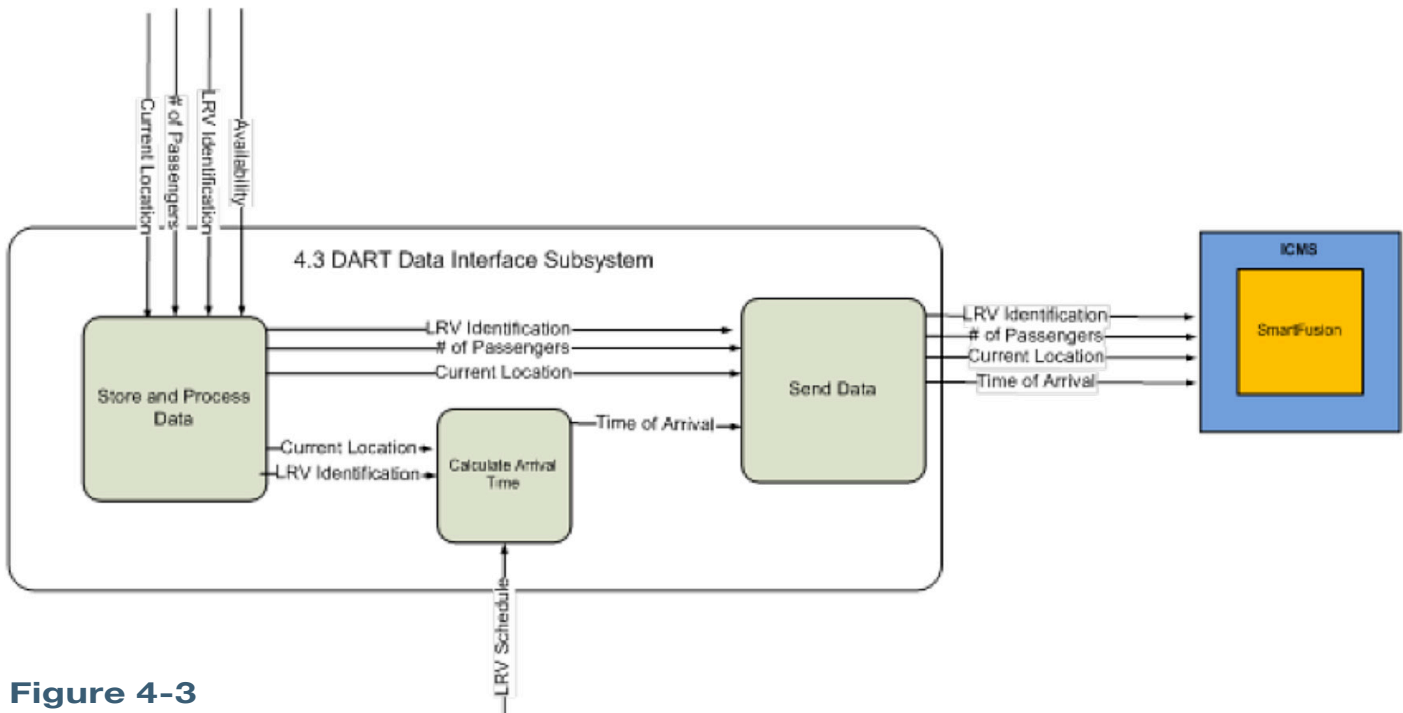

Figure 4-3

APC data: SmartFusion Subsystem interface

SECTION

5

Installation

DART conducted a procurement following FTA procedures to purchase, install, and test the equipment to outfit an additional 20 super LRVs (SLRVs) with APC equipment per the systems engineering process and documentation produced in the project. The contract was awarded to Kinkyshario (SLRV manufacturer) and INIT (APC equipment manufacturer). INIT provided the central server that received data from the SLRVs and provides the data to DART.

The equipment installed within each vehicle is described more fully in the System Design Document, Appendix D.

SECTION 6

Testing

After DART received the final APC software configuration from INIT, formal acceptance testing was conducted in February 2011 on two randomly-selected LRVs tested across six complete light rail in-service trips. DART provided human passenger counters at each SLRV doorway to conduct counts of boarding and alighting passengers. Additionally, DART's passenger count consultants were assigned to this same SLRV to allow the agency to compare its sampling-based approach to passenger counting to the APC counts. The door-by-door manual counts were then compared with APC boardings and alightings.

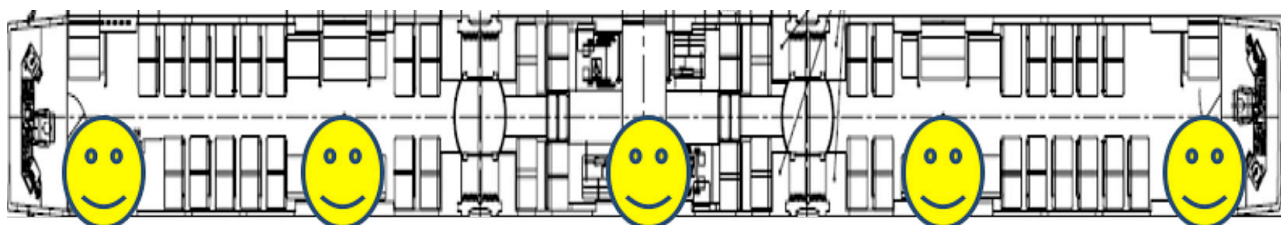

Source: DART

Figure 6-1

Location of human counters at each doorway of an APC-equipped SLRV



Source: DART

Figure 6-2

Location of APC equipment at each doorway of an APC-equipped SLRV

Following completion of the six in-service validation trips, the APC passenger boarding and alighting counts were within 3% of the passenger counts obtained by the human counters assigned to each LRV door. Based upon these initial results, the APC estimates were determined to be statistically equal to the manual counts.

Validation testing of the balance of the APC-equipped fleet was performed by DART Operations Technology staff responsible for APC maintenance and inspections before the vehicles were returned to service. APC-equipped cars are

required to provide APC counts within 3% of the manual test counts of boarding passengers before being used in revenue service. Results of the testing are shown in Table 6-1.

Table 6-1
*APC Installation
Results*

Count	SLRV #	Date Entered Program	Achieved 3% APC vs. Manual Validation Test	Date Returned to Service
1	201	2/19/2013	Yes	3/14/2013
2	204	3/11/2013	Yes	4/1/2013
3	209	4/1/2013	Yes	4/10/2013
4	202	4/8/2013	Yes	4/17/2013
5	200	4/15/2013	Yes	4/24/2013
6	197	4/22/2013	Yes	5/1/2013
7	205	4/29/2013	Yes	5/10/2013
8	203	5/6/2013	Yes	5/17/2013
9	208	5/13/2013	Yes	5/23/2013
10	214	5/20/2013	Yes	5/29/2013
11	206	5/24/2013	Yes	6/5/2013
12	212	6/3/2013	Yes	6/12/2013
13	210	6/10/2013	Yes	6/19/2013
14	213	6/17/2013	Yes	6/26/2013
15	199	6/24/2013	Yes	7/3/2013
16	198	7/1/2013	Yes	7/10/2013
17	211	7/8/2013	Yes	7/7/2013
18	215	7/15/2013	Yes	7/17/2013
19	196	7/17/2013	Yes	7/24/2013
20	207	7/29/2013	Yes	8/1/2013

As of August 1, 2013, all of the additional 20 APC-equipped cars have been assigned to the SLRV fleet for a total of 68 APC-equipped cars. The entire APC fleet is now included in the quarterly maintenance PMI program to ensure the accuracy of the equipment.

To meet the requirements of the US DOT ICMS real-time data program, INIT made modifications to the communication packets between the trains and the central system, allowing DART to receive the actual passenger load information on each car of the trains.

The APC load data, along with location, time, direction, and other VBS data, are sent over GPRS, the public cellular network. The trains communicate with the central server every 15–20 seconds or whenever an event occurs. Events include stop, start, door open, door close, load, etc. Therefore, the maximum delay is 20 seconds.

When a train departs a station, a communication packet is sent. However, that packet does not include the new load based on that station activity. The reason is that the onboard system does not gather and calculate the APC information until it confirms movement from the station. Therefore, the new load is not included until the second cycle of information is sent, typically 7–10 seconds later. This means that for a departing train, the time until the real-time data are available is approximately 30 seconds.

As part of the operational testing, DART conducted tests for each car to verify that the APC data were being collected by every equipped train car, transmitted to the DART central server, and transmitted to SmartNET for use by the DSS.

The test plan and results for the project are provided in the Test Plan & Results document, Appendix E.

Results and Conclusions

At the present time, the Red Line has the highest ridership and the highest maximum loads of all DART light rail lines. Over the years, it has been learned that ridership on this line can vary significantly based upon gasoline prices, the economy, and seasonal variation. However, ridership on particular days may vary as much as 100% based upon conventions, special regional cultural and sporting events, and road construction. Unfortunately, because DART was unable to measure real-time loading, the ability to add service, supplement with bus service, or modify times is limited to reviewing anecdotal accounts from customers and driver and supervisor reports after the fact.

Real-time data on loads has permitted DART to make same-day decisions to consider the following:

1. Addition of supplemental bus service if loads exceed capacity during the 2014 State Fair during the Texas-Oklahoma football game. Load information allowed the extra buses available to supplement train service on the US-75 Red Line Corridor to be deployed to the exact right stations to prevent overloading the corridor.
2. Dispatch of additional trains if real-time data show the inability to accommodate loads. Additional train capacity was added when information obtained from real-time APC counts allowed DART staff to assign the correct number of post-event trains following a review of pre-event train loads.
3. Advertising of train capacity (if available) in the event of traffic accidents or major construction-related delays. (This also requires parking lot monitoring technology as well as DMS signs on the highways to communicate with motorists.)
4. Reduction of train capacity (cars or extra trains) if real-time load data indicate that capacity is not needed. (Capacity often is added for special events when actual demand shows that the capacity was not needed.)
5. Deployment of supervisors, DART ambassadors, and DART fare enforcement and police to key stations when unplanned real-time loads are unusually high—for example, during the 2014 State Fair when DART's Special Event Control center managers were able to determine where additional supervisors were required to direct buses to skim off light rail ridership.

Secondary Benefits of Additional APCs

By increasing the number of APCs on weekdays to permit 100% real-time coverage of the Red Line, several unrelated benefits are possible:

1. The expanded fleet of APCs will permit 100% APC coverage on all light rail lines (Red, Blue, Orange, and Green) on Saturdays, Sundays, and holidays. This has particular benefit to help DART manage mass special events such as the State Fair of Texas, major conventions, and Dallas sporting events that have very large impacts on ridership loading.
2. The expanded fleet of APC-equipped cars would be large enough to permit DART to conduct special 100% deployments of the APC equipment on both the Red and Green lines on weekdays, if necessary. The Red and Green lines are the two highest ridership lines with potentially significant benefit as a diversion for parallel highways. The Red Line parallels US-75 in the Central Corridor; the Green Line parallels I-35E in northwest Dallas and US 178 in southeast Dallas. The ability to cover 100% of all trips on both lines for a special period of time would permit DART to make much quicker analysis of the impact of special events, highway construction, and serious accidents.
3. The larger sample size fleetwide allows for much more accurate factoring and estimating of full system ridership numbers.
4. The additional APC data obtained by expanding the DART APC-equipped vehicles provided extensive detailed justification for expanding the length of the Red and Blue line platforms as an interim solution to adding a second downtown alignment. Without the additional 20 APC-equipped vehicles installed as part of the ICM program, DART would not have been able to obtain the load-by-time-of-day precision necessary to determine a hybrid approach to deploying three-car SRLVs to the Red Line Corridor and avoid purchasing additional light rail vehicles.

APPENDIX

A

Operational Concept

Operational Concept

Dallas Integrated Corridor Management (ICM) – Transit Vehicle Real-time Data Demonstration

Final Report

October 5, 2012

Contents

- 1 Executive SummaryA-2
- 2 Scope and SummaryA-2
- 3 System Overview and Operational Description.....A-3
- 4 System Operational ConceptA-6
- 5 Operational Scenario A-10
- 6 References A-12
- 7 Acronyms A-13

List of Tables

- Table A-1 ICM Goals and Objectives related to APC..... A-7
- Table A-2 APC User Needs..... A-7
- Table A-3: APC Operations Agency Roles and ResponsibilitiesA-11
- Table A-4: Modal Shift Agency Roles and ResponsibilitiesA-13

List of Figures

- Figure A-1: DART Light Rail System Map (Source: DART)..... A-5
- Figure A-2: ICMS Logical Architecture (Source: DART)..... A-6
- Figure A-3: High-Level Automated Passenger Counter Schematic (Source: DART)..... A-8
- Figure A-4: APC Sensor and Analyzer Configuration (Source: Init) A-8
- Figure A-5: Communication Paths for AVL and APC data (Source: DART) A-9
- Figure A-6: APC Data: SmartFusion Subsystem Interface (Source: DART) A-10

I Executive Summary

This document provides the operational concept for the Dallas Area Rapid Transit (DART) Real-Time Transit Vehicle Data Demonstration project within the context of the larger ICM project. This document will include a statement defining how the envisioned system will meet the needs and expectations of the stakeholders. This operational concept will identify the proposed real-time data to be captured from DART light rail vehicles (LRV) and the proposed use of the data (i.e. applications), along with other available real-time data that will be used for more efficiently operating the light rail transit (LRT) system in support of the ICM demonstration project. The envisioned operation is defined from multiple viewpoints, with special attention to be paid to how the new infrastructure and services impact the overall ICM demonstration project and its strategies. This document identifies specific project stakeholders, goals and objectives and scenarios of operations that can be used to validate the final system designed and deployed.

2 Scope and Summary

Introduction

The Dallas Integrated Corridor Management System (ICMS) demonstration project is a multi-agency, de-centralized operation which will utilize a set of regional systems to integrate the operations of the corridor. The purpose of the Dallas ICM System is to implement a multi-modal operations decision support tool enabled by real-time data pertaining to the operation of freeways, arterials, and public transit. The system will be shared between information systems and people involved in transportation operations and emergency response in the US-75 Corridor. The Dallas ICM system is intended to provide improved integration of operation procedures, including procedures that take advantage of the data sharing capabilities of the Dallas ICM system and facilitate improved incident management, and traveler information.

A team headed by the Dallas Area Rapid Transit (DART) is providing technical and management services in support of the Dallas ICM demonstration project. DART currently lacks access to real time LRT passenger loading data. As a result, it will be difficult to implement some ICM strategies that include transit, such as adding transit capacity in real time to accommodate dynamic mode shift to transit (e.g., drivers may shift to transit as a result of a major incident on an adjacent freeway). This project will demonstrate and evaluate the ability to collect and transmit transit location and loading vehicle data to a transit management center(s) and/or ICM system in real time. The project will also demonstrate and evaluate the ability to use the data in real time, in a decision support subsystem, for example, to make informed operational decisions. The project will include the development, installation, testing, and demonstration of on-board automated passenger counter (APC) and automated vehicle location (AVL) equipment and communications technologies to support real-time connectivity between transit vehicles and central facilities to support the following potential applications:

- Vehicle location and speed monitoring
- Passenger load monitoring

The project will take advantage of the existing general packet radio system (GPRS) communications available on board. The project may also include the analysis of other communications technologies and methods, for example cellular, Wi-Fi, WiMAX, and Dedicated Short Range Communications technologies.

The project will explore and assess the utility of real-time transit vehicle data, and will examine the issues, challenges, and feasibility of its use. For example, the project will explore the scenarios for which the Dallas Area Rapid Transit (DART) could dynamically increase capacity (to accommodate dynamic mode shift to transit) based on the light-rail transit (LRT) red/ orange line real-time passenger load information.

The Dallas ICM demonstration site will be used as a test bed for this project. The project will include the development of this operational concept to identify the appropriate transit vehicle real-time data applications that supports Dallas' proposed ICM strategies and operations. The applications selected for Dallas will be demonstrated on DART's red line LRT system, which is located in the US-75 ICM corridor.

Last, the project will include an independent evaluation that will evaluate the performance of the on-board transit vehicle data collection and communications equipment, assess the utility of the real-time data/information, and determine the ability of DART and its ICM partners to make informed decisions and operational changes in real time. The evaluation will also document any lessons learned. The Volpe Center will conduct the independent evaluation via a separate grant.

3 System Overview and Operational Description

Project Scope

The following scope is the scope of work for the cooperative agreement between the Federal Transit Administration (FTA) and DART.

Overview

Transit data is important to the successful implementation of an ICM system. Most transit agencies lack the capability to access transit vehicle data in a timely manner to support ICM operations, particularly dynamic mode shift to transit. Data acquisition issues for transit are mainly due to bandwidth limitations of transit vehicle communications systems (e.g., data radios). The key real time transit vehicle information to support ICM include: vehicle location, time to arrival at next stop (derived from vehicle location and speed), and the remaining capacity to carry additional passengers (derived from the current passenger count).

During Stage I of the Dallas ICM project, the missing real time capacity of light rail transit (LRT) fleets were identified as essential to the deployment of a multi-modal, multi-agency ICM concept. ICM depends on the acquisition of such data about current conditions in the corridor; the capability to implement various management strategies which may include transit, and the modeling tools to support the evaluation and selection of strategies appropriate to the current conditions.

Most transit agencies do not have access to passenger load data in “real time.” Rather, these data are typically downloaded at the end of the day when the transit vehicle enters the bus/rail yard and are used for transit service planning and not operations. In addition, not all transit vehicles are equipped with automatic passenger counters (APCs), although APCs are becoming standard on new transit vehicle procurements.

The project includes the development, installation, testing, and demonstration of on-board APC and communications equipment to transmit AVL and loading data (e.g., passenger loads) in real time to a central facility (e.g., transit management center or ICM system) in order to support ICM operations at the Dallas ICM pioneer demonstration site.

Corridor Boundaries and Networks

The following descriptions of the US-75 ICM corridor boundaries were initially defined through the ICM project. Through stakeholder concurrence gained as part of developing the ICM ConOps, the corridor boundaries have been confirmed and remain unchanged. This concurrence took into account current and forecasted travel patterns; the travel market or markets that are served by the corridor; operational characteristics and typical scenarios/events within the corridor; availability of cross-network connections and spare capacity; as well as other conditions and deficiencies expressed by stakeholders within the corridor. In addition to a description of the corridor boundaries, travel networks that compose the corridor are also described in this section. For detailed information on the US-75 ICM corridor, including corridor stakeholder/users and characteristics, please refer to the document, *Concept of Operations for the US-75 Integrated Corridor in Dallas, Texas*

Transit Network – Light Rail

The primary light-rail line within the US-75 Corridor is the red/ orange line which runs north-south, as shown in Figure A-1. The portion of the red/ orange line within the corridor boundaries runs from the downtown Dallas station (Convention Center Station) to the northern-most station (Parker Road Station) in the City of Plano. Between these two endpoints, there are a total of 17 rail stations.

In addition, the blue line runs in the US-75 corridor influence area from downtown Dallas to the Mockingbird Lane station (approximately three miles). From the Mockingbird Lane station, the blue line runs into the City of Garland. The blue line is the eastern-most boundary of the larger corridor influence area and could serve as an alternate rail route into downtown if there were problems with the red/ orange line.

Recently, the green line has become operational within the US-75 corridor from downtown Dallas to the Market Center station on the western edge of the influence area.

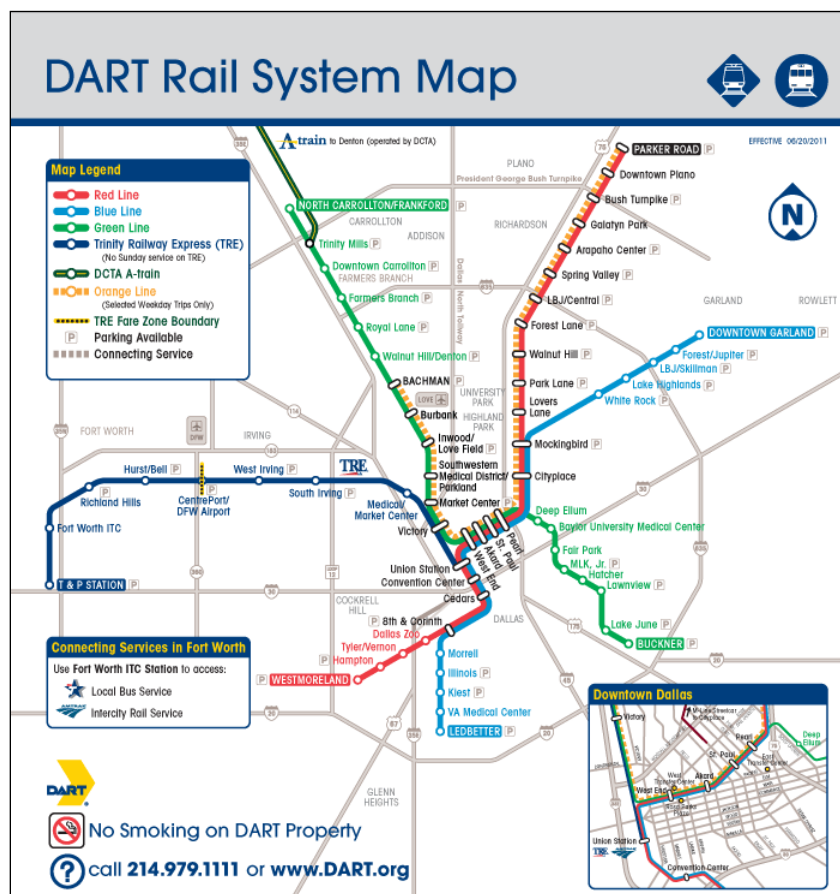

Figure A-1. DART Light Rail System Map (Source: DART)

Operational Conditions of the Light Rail Transit Line

The red/ orange line is the primary rail corridor near US-75. Light-rail lines within the downtown Dallas area operate at-grade. There are a total of 15 at-grade surface street intersection crossings. Implementation of transit signal priority in the City of Dallas downtown signal system, within the corridor boundary, is operational. From downtown to the Mockingbird Station, the rail lines operate in tunnels under the US-75 mainlanes and frontage roads. North of the Mockingbird Station, the rail line operates mostly at-grade with positive grade crossing control at each of the arterial crossings.

The typical light rail vehicle train (LRT) has two or three cars (LRVs), depending on time of day. Due to station configurations, trains cannot be longer than three LRVs. The rail lines operate on approximately five-minute headways in the peak periods.

Currently, 48 of the fleet of 163 Light Rail Vehicles (LRVs) have sensor equipment integrated into the onboard equipment of the LRT. Prior to this project, the number of passengers boarding and alighting at each rail station was stored onboard the vehicle and downloaded at the end of the day. When the LRV went back to the rail yard, all the operational data including passenger counts was offloaded via a wireless LAN at the rail yard. The data is

stored on the central server and each night all the data is processed and put into a database that DART Rail Operations and Service Planning personnel can access.

The 48 LRVs with APCs have sensors made by IRMA based on infrared laser pulse and Time-of-Flight (TOF) technology. There are ten doorways that passengers enter the LRV, six each with two physical doors that slide and four each with a single physical door that slides. The configuration of sensors is two sensors for each of the six wide doorways and one sensor for each of the narrow doorways; there are a total of sixteen sensors on each LRV. In the case of the wide doors, the sensors are configured and designed to count accurately even though they are monitoring the same doorway. The sensors in each section of the LRV are connected together with a device called an analyzer that collects the data about the laser pulses from the sensors. DART Rail Operations staff call each of the three sections of the SLRV the A-cab, the B-cab, and the C-unit. There are four sensors in the C-unit and six sensors in each of the A-cab and B-cab. Each of the three analyzers communicates its data to the onboard computer component of the LRT's CADAVAL system. The accuracy of the APC system as a whole when using the balancing process at the end of the day produces a greater than 95% accuracy and the vendor has experience resulting in greater than 98% for 500 passengers.

This project will add AVL/ APC equipment to 20 LRTs, all LRTs operating in the Red/ Orange line will be equipped with AVL and APC equipment for a total of 68 LRTs.

Light Rail Information Challenges and Needs

This section summarizes the problems, issues and needs of the current data provided by the light rail network. This section addresses operational, technical, and, institutional deficiencies and constraints, As such; it provides insight into the types of problems being faced by DART related to providing current light rail capacity information.

LRT Data Challenges

Currently, DART has limited information on the real-time location, and on-board loads of its light rail transit vehicles (LRV) within the US-75 corridor. Because of this lack of information, the use of transit for modal shift, and diversions during incidents could have a negative impact on the travelers within the corridor.

The location (i.e., AVL data) and the on-board loading (i.e., APC data) could be used by the ICM stakeholders to improve their decision making on modal shift strategies, and improve the operation and efficiency of the light rail transit (LRT) operations within DART.

LRT Data Needs

For the Transit Vehicle Real-time Data Demonstration project , APC data will be captured from DART LRVs by the use of the Init APC's and provided to DART once the data from the APC's has been processed by Init's central evaluation and analysis server.

For the ICM demonstration, three critical pieces of data are needed for the ICMS to evaluate the use of transit for potential diversions and strategies. These include:

- Number of vehicles connected to the LRV (to determine if additional vehicles could be added)
- Location and speed of the LRV
- On-board load of the LRV (to determine how much additional capacity is available)

LRT Data Usage

The proposed use of the data (i.e., applications) for the ICM demonstration includes providing the agency users with the current location and capacity of the light-rail transit vehicles within the corridor. In addition, the LRT data will be used to provide travelers with information via the 511 systems (IVR, My511, 511 website) on the current location of transit vehicles and schedule information. The ICMS logical architecture, shown in Figure A-2, provides an overview of the information sources and users for ICMS. As shown in the diagram, DART AVL & APC Data is a data source that feeds information into the SmartFusion subsystem, which then provides various ICM data to other subsystems within the ICMS and to external data users.

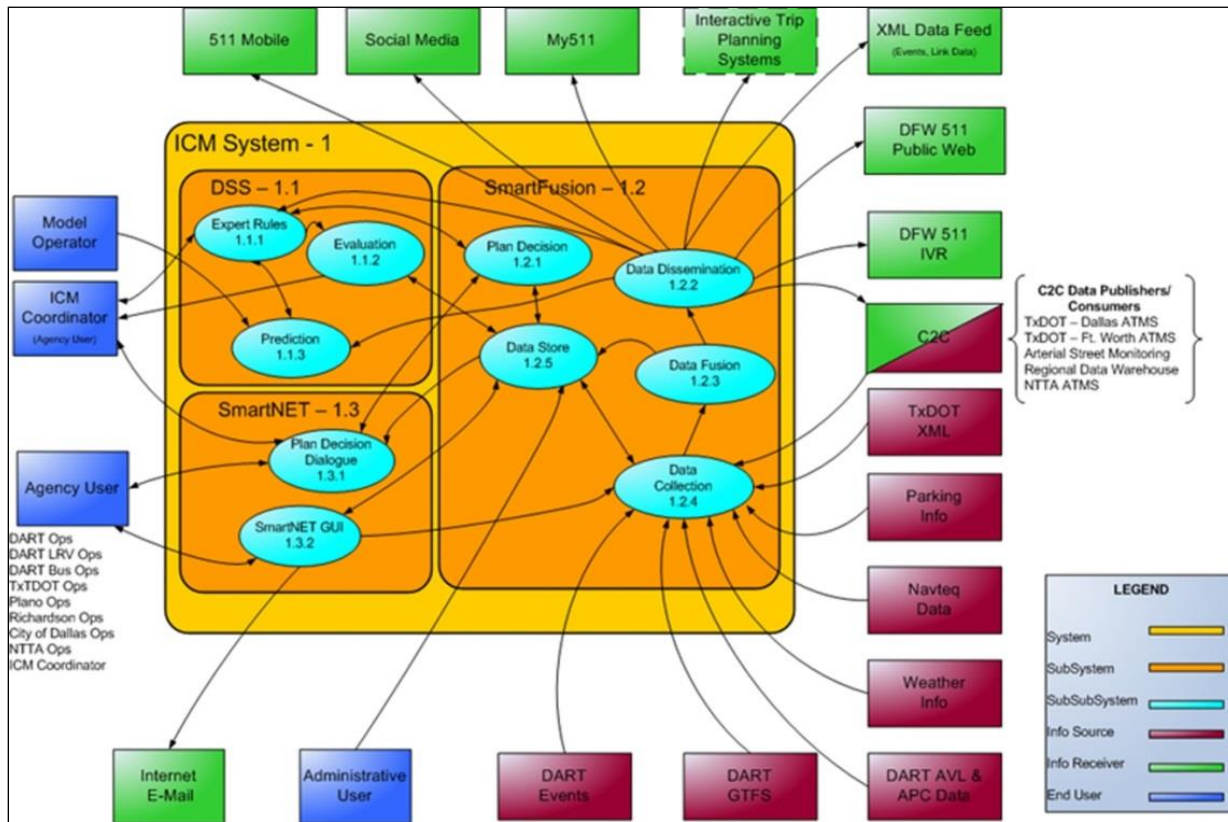

Figure A-2. ICMS Logical Architecture (Source: DART)

The decision support subsystem uses the AVL and APC data to evaluate response plans for events within the corridor (i.e., incidents) to determine if modal shift is recommended, if additional capacity for the LRT is needed, and to evaluate if the current available capacity is sufficient.

The prediction subsystem will use the current on-board loads, and location to help model the response plan options so that the use of transit is considered in the response plans selected for incidents. In addition, the evaluation subsystem will use the APC and AVL data to evaluate various measures of effectiveness for the US-75 corridor.

4 System Operational Concept

This section describes the operational concept for the Transit Vehicle Real-time Data Demonstration Project. The proposed concepts explain how things are expected to work once the Transit Vehicle Real-time Data Demonstration and the ICM demonstration project are in operation, and identify the responsibilities of the various stakeholders for making this happen. This section defines the goals and objectives; the user needs; and corridor operational description.

Goals and Objectives

Table A-1. ICM Goals and Objectives Related to APC

Goals	Objectives
<p>Increase corridor throughput – The agencies within the corridor have done much to increase the vehicle and passenger throughput of their individual networks both from a supply and operations point of view, and will continue to do so. The integrated corridor perspective builds on these network initiatives, managing delays on a corridor basis, utilizing any spare capacity within the corridor, and coordinating the junctions and interfaces between networks, in order to optimize the overall throughput of the corridor.</p>	<ul style="list-style-type: none"> • Increase the vehicle and person throughput of the US 75 corridor. • Increase transit ridership, with minimal increase in transit operating costs. • Facilitate intermodal transfers and route and mode shifts.
<p>Enable intermodal travel decisions – Travelers must be provided with a holistic view of the corridor and its operation through the delivery of timely, accurate and reliable multimodal information, which then allows travelers to make informed choices regarding departure time, mode and route of travel. In some instances, the information will recommend travelers to utilize a specific mode or network. Advertising and marketing to travelers over time will allow a greater understanding of the modes available to them.</p>	<ul style="list-style-type: none"> • Facilitate intermodal transfers and route and mode shifts • Increase transit ridership • Expand existing ATIS systems to include mode shifts as part of pre-planning • Obtain accurate real-time information on the current status of the LRV network

User Needs

User needs identify the high-level ICM system needs; these user needs are developed to focus on the operational aspects of the ICM, and defining the functional requirements of the proposed ICM system. These needs are based upon the system goals and objectives provided above, and the future operational conditions and scenarios defined in Section 5. The user needs will be utilized during the requirements development of the next phase of the systems engineering process to develop the high-level system requirements document.

User Needs Development

The following needs represent the identified needs of the APC system as related to the existing user needs identified in the ICM Concept of Operations. While DART does have some additional needs for operational improvements and efficiency, they are not included in Table A-2 since they do not relate directly to the ICM User Needs.

Table A-2. APC User Needs

#	User Needs	User Need Text
1	Need to obtain current status of LRT capacity in the corridor	DART needs to obtain current capacity information of its light rail vehicle network within the corridor in order to make informed decisions on actions to be made to improve performance.
2	Need to provide transit event information to travelers	DART needs to provide transit capacity information to the public for planning trips and modifying trip plans en route, in order to allow travelers to make informed decisions about their trips.

Corridor Concept Operational Description

Keeping in mind the vision of the ICM project, “Operate the US-75 Corridor in a true multimodal, integrated, efficient, and safe fashion where the focus is on the transportation customer,” the management and operations of the corridor and the ICM will be a joint effort involving all the stakeholders. The daily operation of the corridor will be coordinated through the existing arrangements and information will be exchanged through the center-to-center project and the SmartNET software. The central point of coordination for the corridor will be the ICM Coordinator, who will be located at the DalTrans facility.

Automatic Passenger Counter Schematic

The Automatic Passenger Counter (APC) is installed in each light-rail vehicle over the doorway, which provides for detection of people entering and exiting the light-rail vehicle. The APC sensor provides this information to the on-board computer for analysis, and packaging the data. As shown in Figure A-3, the on-board computer sends the packaged data via CDPD radio to a central server and evaluation and analysis computer. The central server processes the data received from the on-board computer and provides the on-board loads to DART at 20 second intervals.

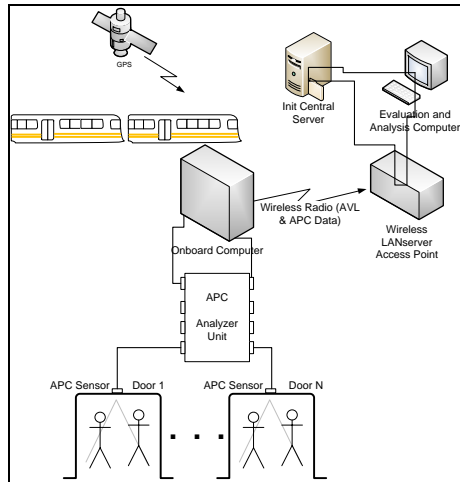

Figure A-3. High-Level Automated Passenger Counter Schematic (Source: DART)

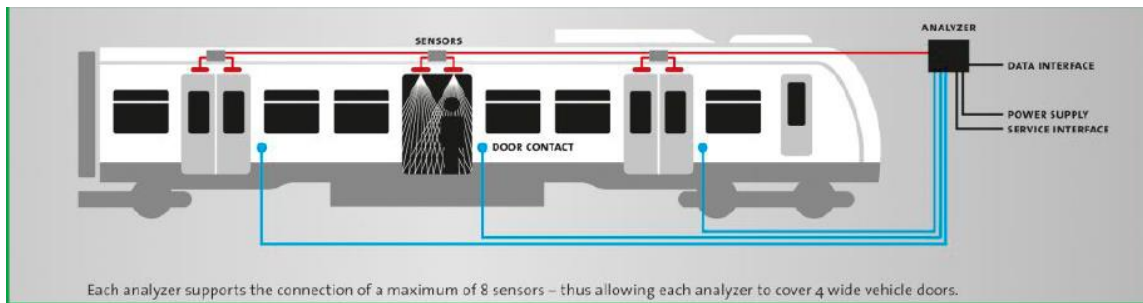

Figure A-4. APC Sensor and Analyzer Configuration (Source: Init)

Communication Needs

There are multiple communication mediums involved in the AVL and APC data collection, processing, and distribution. For the Transit Vehicle Real-time Data Demonstration Project, the communication between the LRV on-board computer and the central servers will be analyzed to ensure the communication will be robust and sufficient for the amount of data. The communication between the central servers and DART is planned to be a webservice utilizing XML via the internet.

For the AVL location data, both GPS (for above ground) and logical position (for tunnels) will be used and provided to the ICMS via a webservice utilizing XML. Figure A-5 shows how the data will be provided by DART to the SmartFusion subsystem for this project.

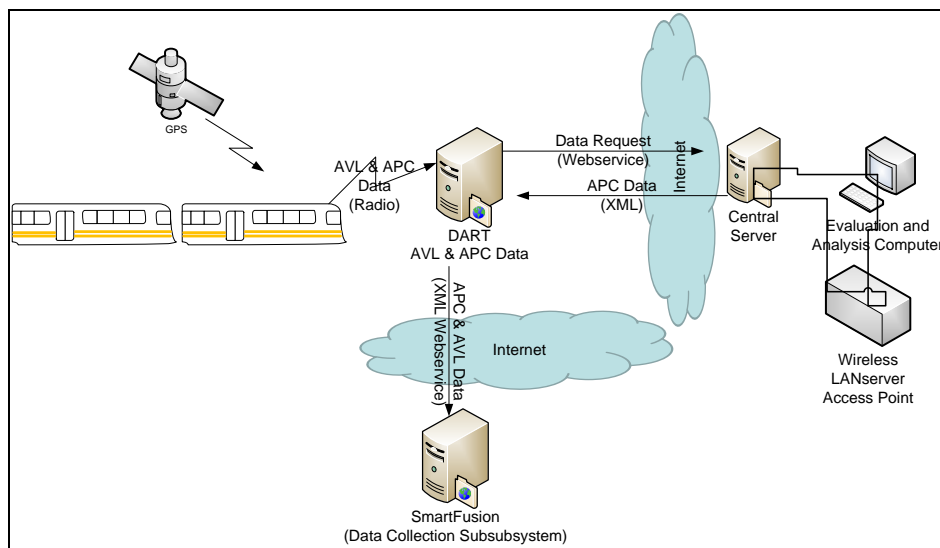

Figure A-5. Communication Paths for AVL and APC data (Source: DART)

Integration with ICMS

As previously mentioned, real time capacity of light rail transit (LRT) fleets were identified as essential to the deployment of a multi-modal, multi-agency ICM concept. ICM depends on the acquisition of such data about current conditions in the corridor, the capability to implement various management strategies which may include transit, and the decision support tools to support the evaluation and selection of strategies appropriate to the current conditions.

As shown in Figure A-6, the ICMS SmartFusion subsystem collects, fuses, stores, and disseminates various transportation related data for the ICMS. The DART AVL & APC data shown in the figure illustrates how the data from this project fits into the overall ICMS program. The AVL & APC data will be provided to the SmartFusion subsystem via a webservice utilizing XML. The AVL & APC data is fused, stored and provided to other subsystems within the ICMS, to include the decision support subsystem, and SmartNET subsystem. The decision support subsystem uses the AVL and APC data to evaluate response plans for events within the corridor (i.e., incidents) to determine if modal shift is recommended, if additional capacity for the LRT is needed, and to evaluate if the current available capacity is sufficient.

In addition, the evaluation subsystem will use the APC and AVL data to evaluate various measures of effectiveness for the US-75 corridor. The prediction subsystem will use the current on-board loads, and location to help model the response plan options so that the use of transit is considered in the predicted responses to incidents.

The SmartNET subsystem will provide the agency users within the corridor a layer on the map to show the current location and capacity of the light rail transit vehicles within the corridor. This will provide the operators with a quick view of what impact decisions within their area of influence may have on the transit riders.

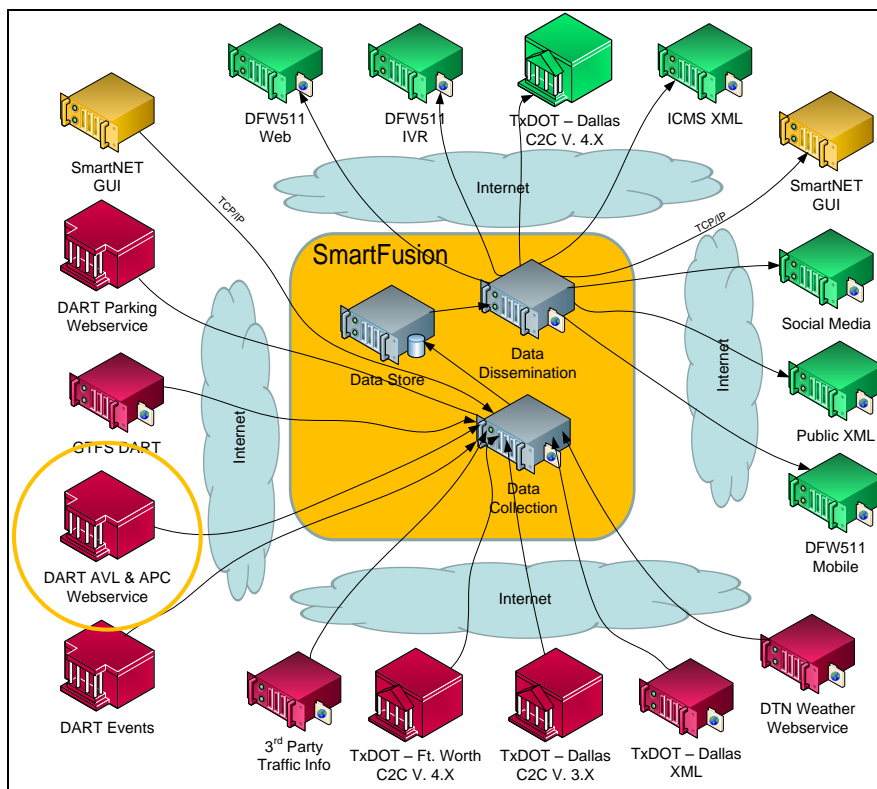

Figure A-6. APC Data: SmartFusion Subsystem Interface (Source: DART)

5 Operational Scenario

Future Operational Conditions

This section provides operational condition assumptions set forth by DART for use during scenario tabletop exercises carried out as part of developing this operational concept document. As such, these assumptions define a baseline operating environment that were needed for stakeholders to clearly identify operational roles and responsibilities, as well as needed data exchange and infrastructure improvements necessary for the DART APC Project. The baseline operational assumptions were developed using the needs and strategies identified in earlier stakeholder sessions, and in the development of the Dallas US-75 ICMS Concept of Operations.

Scenarios

The following scenarios provide the two main scenarios for utilizing the APC and AVL data within the US-75 ICM demonstration project. The first scenario is the normal operation of the corridor, which includes some minor incidents, and some minor schedule delays.

The second scenario is a major incident which requires modal shift as part of the response plan. This scenario is discussed in much more detail in the ICM ConOps, but the specific real-time transit data factors are discussed below.

Scenario 1: Normal Operations

Daily operation is defined as:

- Operations that are not related to a particular incident/event that causes response or management strategies to be carried out, however minor incidents are routine and a part of daily operations.
- Recurring congestion and peak ridership conditions

Table A-3 provides roles and responsibilities related to real-time transit vehicle data for DART who perform significant functions during Daily Operations within the US-75 ICM Corridor.

Table A-3. APC Operations Agency Roles and Responsibilities

Stakeholder	Roles and Responsibilities
DART	<p>Monitoring</p> <ul style="list-style-type: none"> • Monitor transit usage, provide additional vehicles (if needed) • Passenger counts <p>Coordination</p> <ul style="list-style-type: none"> • Inform other public agencies of available capacity on transit vehicle <p>Information Distribution</p> <ul style="list-style-type: none"> • Provide updated information on transit capacity as time goes by to the Dallas ICM system, which will update the 511 system. <p>Maintenance</p> <ul style="list-style-type: none"> • Perform routine maintenance • Repair APC system and communication failures • Repair / replace malfunctioning devices

Scenario 2: Modal Shift for Roadway Incident Response

Modal shift for roadway incidents will occur if the capacity of US-75 is reduced for an extended period of time and the capacity of the freeway and arterials cannot support the demand, such as a large multi-lane incident. As discussed in the ICM Concept of Operations, a modal shift will involve DART, TxDOT, and the cities within the corridor, depending on the location of the incident. Overflow parking may be needed for the additional riders, and shuttle buses may be needed to transport travelers from overflow parking facilities to the LRT stations.

Table A-4 provides roles and responsibilities related to real-time transit vehicle data for DART who perform significant functions during a modal shift within the US-75 ICM Corridor.

Table A-4. Modal Shift Agency Roles and Responsibilities

Stakeholder	Roles and Responsibilities
<p>DART</p>	<p>Monitoring</p> <ul style="list-style-type: none"> • Monitor transit usage, provide additional vehicles (if needed) • Provide shuttle bus service between rail stations and overflow parking • Passenger counts <p>Coordination</p> <ul style="list-style-type: none"> • Inform other public agencies of available capacity on transit vehicle • Inform cities when overflow parking is needed • Shuttle bus service to overflow parking <p>Information Distribution</p> <ul style="list-style-type: none"> • Provide updated information on transit capacity as time goes by to the Dallas ICM system, which will update the 511 system. <p>Maintenance</p> <ul style="list-style-type: none"> • Perform routine maintenance • Repair APC system and communication failures • Repair / replace malfunctioning devices
<p>TxDOT</p>	<p>Monitoring</p> <ul style="list-style-type: none"> • Monitor capacity of roadway <p>Coordination</p> <ul style="list-style-type: none"> • Inform DART of need for diversion of traffic • Communication with on-scene emergency response • Communicate any changes to pre-planned response <p>Information Distribution</p> <ul style="list-style-type: none"> • Provide traveler information, such as DMS messages to direct travelers to utilize transit.
<p>City of Dallas, Plano and Richardson</p>	<p>Monitoring</p> <ul style="list-style-type: none"> • On-going monitoring of response and flow on freeway system and impact to arterials • Monitor arterial traffic flow <p>Coordination</p> <ul style="list-style-type: none"> • Communication with on-scene emergency response • Communicate any changes to pre-planned response through decision support tool • Outreach to local business for overflow parking • Traffic control for re-directing traffic to overflow parking • Bus signal priority for overflow parking locations <p>Information Distribution</p> <ul style="list-style-type: none"> • Provide updated information on the incident as time goes by to the Dallas SmartNET system, which will update the 511 system.

6 References

Concept of Operations for the US-75 Integrated Corridor in Dallas, Texas, June 30, 2010.

Draft System Design Document, US-75 Integrated Corridor Management Demonstration Project, August 2012.

FHWA Rule 940, *Federal Register*/Vol. 66, No. 5/Monday, January 8, 2001/Rules and Regulations, Department of Transportation, Federal Highway Administration 23 CFR Parts 655 and 940, [FHWA Docket No. FHWA-99-5899] RIN 2125-AE65 Intelligent Transportation System Architecture and Standards.

Project Management Body of Knowledge (PMBOK), Third Edition, 2004, Project Management Institute, Four Campus Boulevard, Newtown Square, PA.

Real-Time Transit Vehicle Data Demonstration Final Statement of Work, May 2011.

System Engineering Handbook: A Guide for System Life Cycle Processes and Activities, version 3.2, January 2010, International Council on Systems Engineering.

Systems Requirements Specification for the US-75 Integrated Corridor in Dallas, Texas, May 2009.

7 Acronyms

AMS	Analysis, Modeling, and Simulation
APC	Automatic Passenger Counter
ASMS	Arterial Street Monitoring System
ATIS	Advanced Traveler Information Systems
AVI	Automatic Vehicle Identification
AVL	Automatic Vehicle Location
CCB	Configuration Control Board
CCTV	Closed Circuit Television
CDPD	Cellular Digital Packet Data
CDR	Critical Design Review
COTS	Commercial Off The Shelf
Daltrans	Dallas Transportation Management Center
DART	Dallas Area Rapid Transit
DMS	Dynamic Message Sign
DSS	Decision Support System
FHWA	Federal Highway Administration
FTA	Federal Transit Administration
GDP	Gross Domestic Product
GPS	Global Position System
HAR	Highway Advisory Radio
ICD	Interface Control Document
ICM	Integrated Corridor Management
ITS	Intelligent Transportation Systems
IVR	Interactive Voice Response
LRT	Light Rail Transit
LRV	Light Rail transit Vehicle
NCTCOG	North Central Texas Council of Governments
NTTA	North Texas Tollway Authority
PDR	Preliminary Design Review
RCU	Roadside Communications Units
RITA	Research and Innovative Technology Administration
RFP	Request for Proposals
RTM	Requirements Traceability Matrix
SDR	Software Development Review
SIRI	Service Interface for Real-time Information
SRR	System Readiness Review
TIS	Travel Information System
TMC	Traffic Management Center
TMDD	Traffic Management Data Dictionary
TSP	Transit Signal Priority
TxDOT	Texas Department of Transportation

APPENDIX

B

System Requirements

Requirements Document – In-Field and In Vehicle

Dallas Integrated Corridor Management (ICM) – Transit Vehicle Real-time Data Demonstration

Final Report

April 19, 2013

Contents

1	Introduction.....	B-2
2	Scope and Summary	B-2
3	System Description.....	B-3
4	User Needs.....	B-9
5	Requirements Process.....	B-10
6	Requirements	B-10
7	References.....	B-14
8	Acronyms	B-14
9	Action Verbs.....	B-14

List of Tables

Table B-1:	APC User Needs.....	B-10
Table B-2:	User Need to Subsystem Traceability.....	B-10
Table B-3:	APC System Requirements.....	B-12
Table B-4:	On-Board Subsystem Requirements.....	B-12
Table B-5:	Central Data Server Subsystem Requirements.....	B-13
Table B-6:	DART Data Interface Subsystem Requirements	B-13

List of Figures

Figure B-1:	APC Sensor and Analyzer Configuration (Source: INIT).....	B-4
Figure B-2:	High-Level Automated Passenger Counter Schematic (Source: DART).....	B-4
Figure B-3:	APC Data: SmartFusion Subsystem Interface (Source: DART).....	B-5
Figure B-4:	Context Diagram of Real-Time Transit Vehicle Data System (Source: DART).....	B-6
Figure B-5:	APC/AVL Data Flows (Source: DART).....	B-7
Figure B-6:	On-Board Subsystem Data Flow Diagram: (Source: DART).....	B-8
Figure B-7:	Central Data Server Subsystem Data Flow Diagram (Source: DART)	B-8
Figure B-8:	DART Data Interface Subsystem Data Flow Diagram.....	B-9

I Introduction

This document is intended as a listing and discussion of the requirements for the Dallas Area Rapid Transit (DART) Real-Time Transit Vehicle Data Demonstration project within the context of the larger ICM project. This document describes what the system is to do (the functional requirements), how well it is to perform (the performance requirements), and under what conditions (non-functional and performance requirements). This document does not define how the system is to be built, except where a solution is already in place and is being expanded; that is the province of the design document. This document pulls together requirements from a number of sources including but not limited to the Concept of Operations, and constraints identified by DART. This document sets the technical scope of the system to be built for the Real-Time Transit Vehicle Data Demonstration project. It is the basis for verifying the system and sub-systems when delivered via the Verification Plan.

2 Scope and Summary

Background

The Dallas Integrated Corridor Management (ICM) demonstration project is a multi-agency, decentralized operation which will utilize a set of regional systems to integrate the operations of the corridor. The purpose of the Dallas ICM System is to implement a multi-modal operations communications, decision support, and coordination tool enabled by real-time data pertaining to the operation of freeways, arterials, and public transit. The system will be shared between information systems and people involved in transportation operations and emergency response in the US-75 Corridor. The Dallas ICM system is intended to provide improved integration of operation procedures, including procedures that take advantage of the data sharing capabilities of the Dallas ICM system and facilitate improved emergency response, and traveler information.

A team headed by DART is providing technical and management services in support of the Dallas ICM demonstration project. DART currently lacks access to real time LRT passenger loading data. As a result, it will be difficult to implement some ICM strategies that include transit, such as adding transit capacity in real time to accommodate dynamic mode shift to transit (e.g., drivers may shift to transit as a result of a major incident on an adjacent freeway). This project will demonstrate and evaluate the ability to collect and transmit transit location and loading vehicle data to a transit management center(s) and/or ICM system in real time. The project will also demonstrate and evaluate the ability to use the data in real time, in a decision support subsystem, for example, to make informed operational decisions. The project will include the development, installation, testing, and demonstration of on-board automated passenger counter (APC) equipment and communications technologies to support real-time connectivity between transit vehicles and central facilities to support the following potential applications:

- Vehicle location and speed monitoring
- Passenger load monitoring

The project will explore and assess the utility of real-time transit vehicle data, and will examine the issues, challenges, and feasibility of its use. For example, the project will explore the scenarios for which the Dallas Area Rapid Transit (DART) could dynamically increase capacity (to accommodate dynamic mode shift to transit) based on the light-rail transit (LRT) red line real-time passenger load information.

The Dallas ICM demonstration site will be used as a test bed for this project. The project will include the development of this requirements document to identify the appropriate transit vehicle real-time data applications that supports Dallas' proposed ICM strategies and operations. The applications selected for Dallas will be demonstrated on DART's red line LRT system, which is located in the US-75 ICM corridor.

3 System Description

Project Scope

The following scope is the scope of work for the cooperative agreement between the Federal Transit Administration (FTA) and DART.

Overview

Transit data is important to the successful implementation of an ICM system. Most transit agencies lack the capability to access transit vehicle data in a timely manner to support ICM operations, particularly dynamic mode shift to transit. Data acquisition issues for transit are mainly due to bandwidth limitations of transit vehicle communications systems (e.g., data radios). The key real time transit vehicle information to support ICM include; vehicle location, time to arrival at next stop (derived from vehicle location and speed), and the remaining capacity to carry additional passengers (derived from the current passenger count).

During Stage I of the Dallas ICM project, the missing real time capacity of light rail transit (LRT) fleets were identified as essential to the deployment of a multi-modal, multi-agency ICM concept. ICM depends on the acquisition of such data about current conditions in the corridor, the capability to implement various management strategies which may include transit, and the modeling tools to support the evaluation and selection of strategies appropriate to the current conditions.

Most transit agencies do not have access to passenger load data in “real time.” Rather, these data are typically downloaded at the end of the day when the transit vehicle enters the bus/rail yard and are used for transit service planning and not operations. In addition, not all transit vehicles are equipped with automatic passenger counters (APCs), although APCs are becoming standard on new bus procurements.

The project includes the development, installation, testing, and demonstration of on-board APC and communications equipment to transmit AVL and loading data (e.g., passenger loads) in real time to a central facility (e.g., transit management center or ICM system) in order to support ICM operations at the Dallas ICM pioneer demonstration site.

Automatic Passenger Counter Schematic

The APC is installed in each light-rail vehicle over the doorway, which provides for detection of people entering and exiting the light-rail vehicle. The APC sensor provides this information to the on-board computer for analysis, and packaging the data. As shown in Figure B-1, the on-board computer sends the packaged data via CDPD radio to a central server and evaluation and analysis computer.

The central server processes the data received from the on-board computer and provides the on-board loads to DART at 20 second intervals.

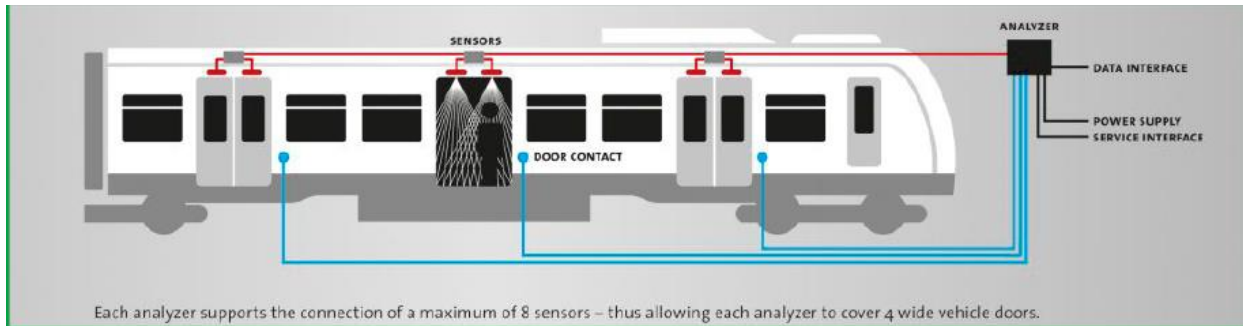

Figure B-1. APC Sensor and Analyzer Configuration (Source: INIT)

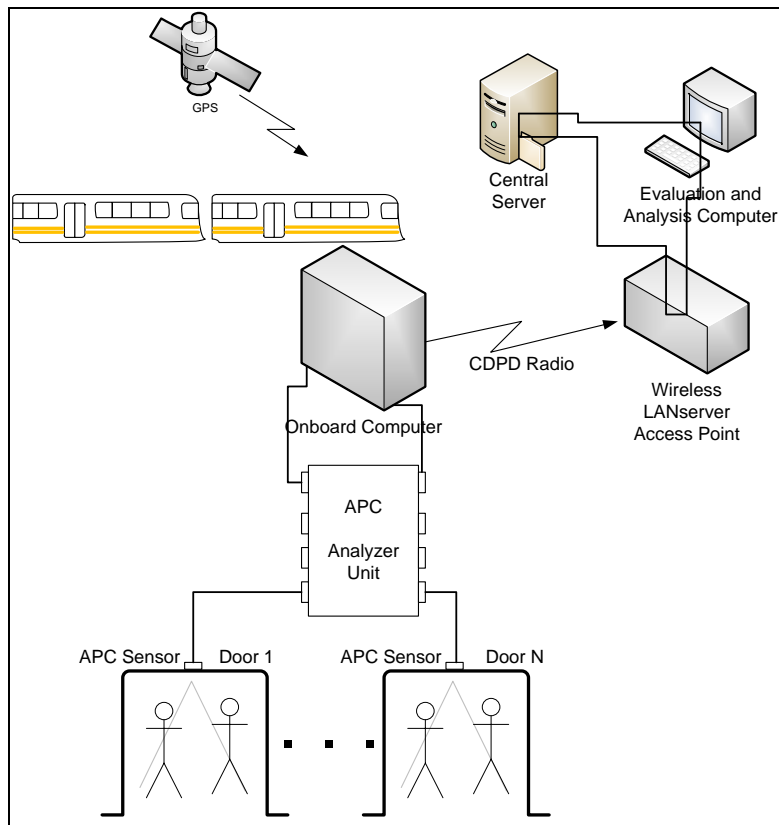

Figure B-2. High-Level Automated Passenger Counter Schematic (Source: DART)

Communication Needs

There are multiple communication mediums involved in the AVL and APC data collection, processing, and distribution. For the Transit Vehicle Real-time Data Demonstration Project, the communication between the LRV on-board computer and the central servers will be analyzed to ensure the communication will be robust and sufficient for the amount of data. The communication between the INIT servers and DART is planned to be a webservice utilizing a Service Information for Real-time Information (SIRI) standard XML message via the internet.

For the AVL location data, both GPS (for above ground) and odometer imputed logical position (for tunnels) will be used and provided to the ICMS via a webservice utilizing XML.

Integration with ICMS

As previously mentioned, real time capacity of LRT fleets were identified as essential to the deployment of a multi-modal, multi-agency ICM concept. ICM depends on the acquisition of such data about current conditions in the corridor, the capability to implement various management strategies which may include transit, and the decision support tools to support the evaluation and selection of strategies appropriate to the current conditions.

As shown in Figure B-3, the ICMS (SmartFusion subsystem) collects, fuses, stores, and disseminates various transportation related data for the ICMS. The AVL & APC data will be provided to the SmartFusion subsystem via a webservice utilizing XML. The AVL & APC data is fused, stored and provided to other systems within the ICMS, to include the decision support subsystem, and SmartNET subsystem. The decision support subsystem, via the ICMS XML webservice, uses the AVL and APC data to evaluate response plans for events within the corridor (i.e., incidents) to determine if modal shift is recommended, if additional capacity for the LRT is needed, and to evaluate if the current available capacity is sufficient.

In addition, the evaluation subsystem will use the APC and AVL data to evaluate various measures of effectiveness for the US-75 corridor. The prediction subsystem will use the current on-board loads, and location to help model the response plan options so that the use of transit is considered in the predicted responses to incidents.

The SmartNET subsystem will provide the agency users within the corridor a layer on the map to show the current location and capacity of the light rail transit vehicles within the corridor. This will provide the operators with a quick view of what impact decisions within their area of influence may have on the transit riders.

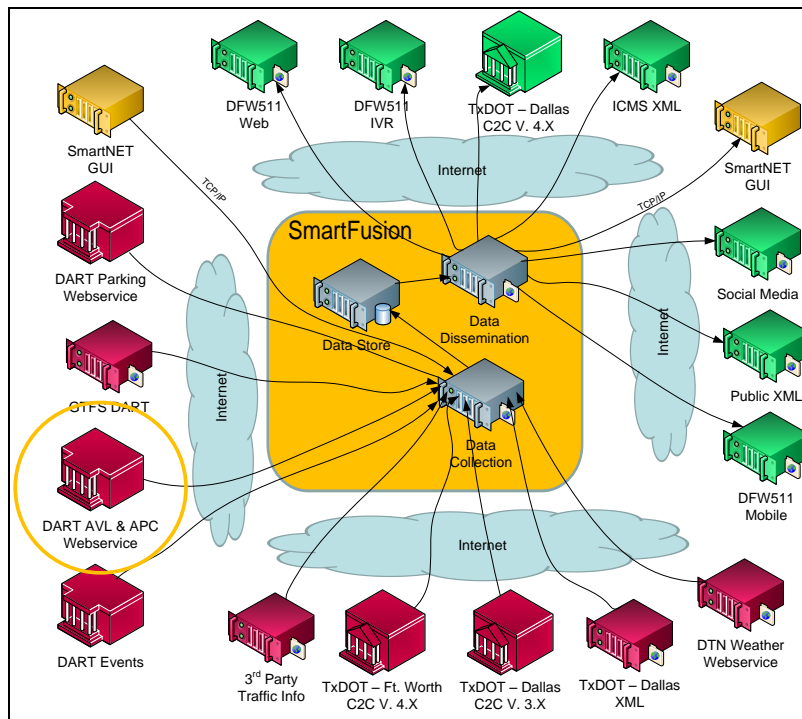

Figure B-3. APC Data: SmartFusion Subsystem Interface (Source: DART)

Context Diagram

Figure B-4 is a high-level framework on how the system will interface to the external systems. The APC system would utilize standardized message formats for external users of the data. Currently, DART has an agreement with the NextBus arrival Patent holder to use AVL data on its own web sites to provide arrival predictions. DART can provide the ICM Smart Fusion subsystem with location information and on-board loads without infringing on the patent. DART can provide arrival predictions or current schedule adherence offsets to Smart Fusion, since the ICMS is a DART owned system.

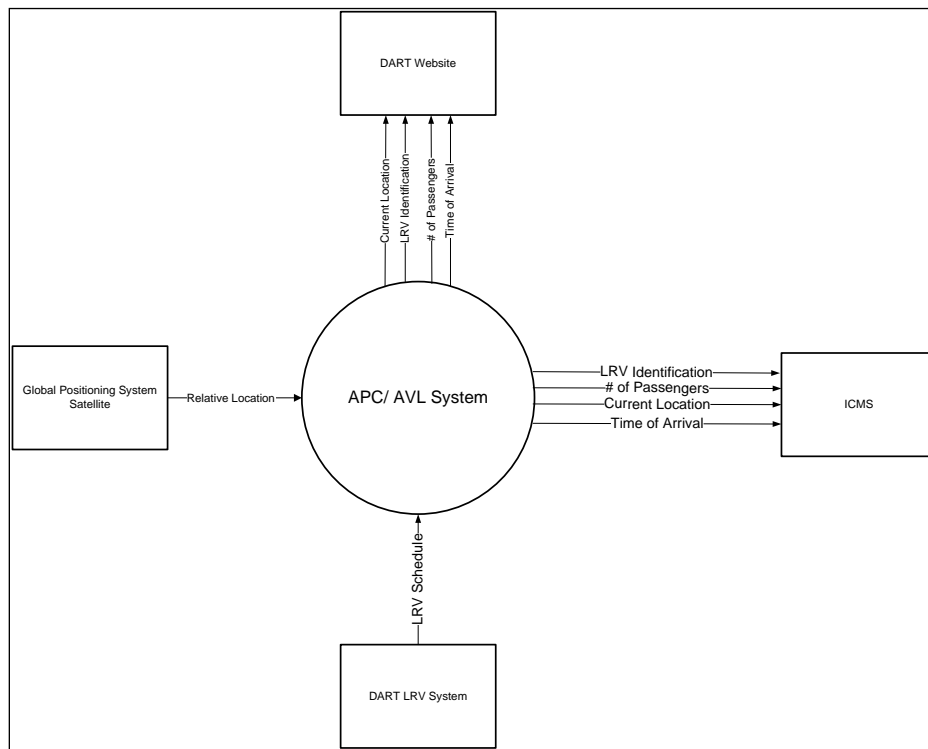

Figure B-4. Context Diagram of Real-Time Transit Vehicle Data System (Source: DART)

System Architecture

The following System Architecture provides an high-level context diagram of the “APC / AVL System” and its subsystems.

On-board Subsystem

The On-board Subsystem consists of the hardware installed on the Light Rail Vehicle (LRV) which is used to determine the location of the LRV, and current real-time loading of the LRV. This data is processed on-board and sent via a wireless communication medium to a central server for processing.

Central Data Server Subsystem

The Central Data Server Subsystem consists of the central system which processes the data received via a wireless communication medium from the on-board field hardware. The ICentral Data Server subsystem processes the data and sends specific location and vehicle loading data to the DART data interface subsystem.

DART Data Interface Subsystem

The DART Data Interface Subsystem consists of the data interface that receives specific location and vehicle loading data from the Central Data Server interface. The data is stored and published to DART websites and provided as an XML based interface to the ICMS. In the future, the AVL/AVI DI will also potentially provide data to third parties.

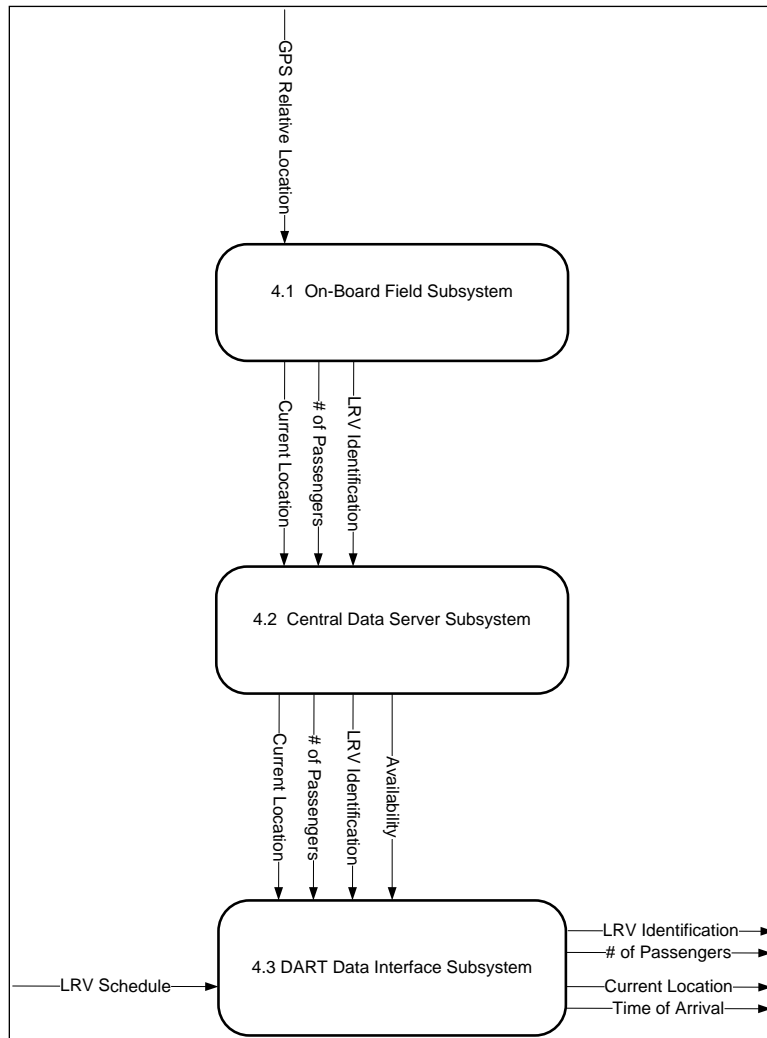

Figure B-5. APC/AVL Data Flows (Source: DART)

Data Flow Diagrams

In order to further understand the process flow and data formats of the Transit Vehicle Real Time Information Demonstration project, Figures B-6, B-7, and B-8 were created. The basic flow of information for the system is:

1. The On-Board Field Hardware collects AVL and APC data from the on-board hardware. The on-board processor calculates the location and passenger count information and combines this with information from the vehicle's on-board computer system (driver ID, train #, etc.) and sends this data via a wireless technology to a central system provided by the APC contractor, INIT.
2. The central data server subsystem receives the data from all of the light rail vehicles equipped with the AVL/ APC hardware, and sends a message to DART data interface subsystem which

includes train identification information (driver ID, train #, etc.), current location, and current on-board load information.

- The DART data interface subsystem receives the formatted message and stores the information into its data store. The data is provided to internal DART systems and external systems, such as ICMS. The DART web site uses this data to show schedule adherence, current location, and arrival times. The external systems can only receive the current location and on-board loading, due to patent issues with arrival time and schedule adherence data.

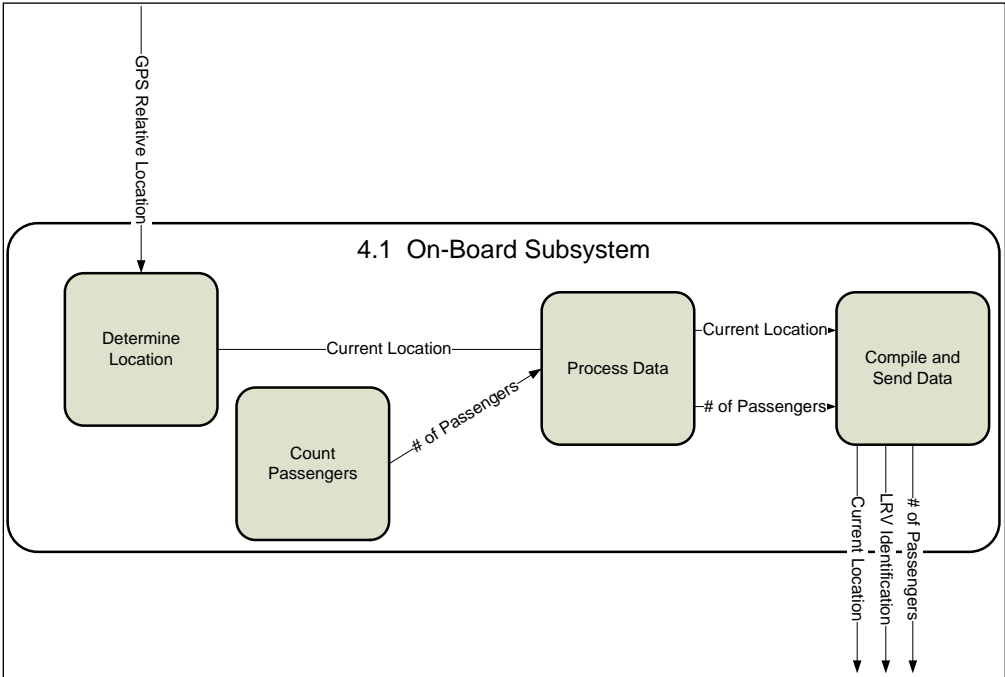

Figure B-6. On-Board Subsystem Data Flow Diagram: (Source: DART)

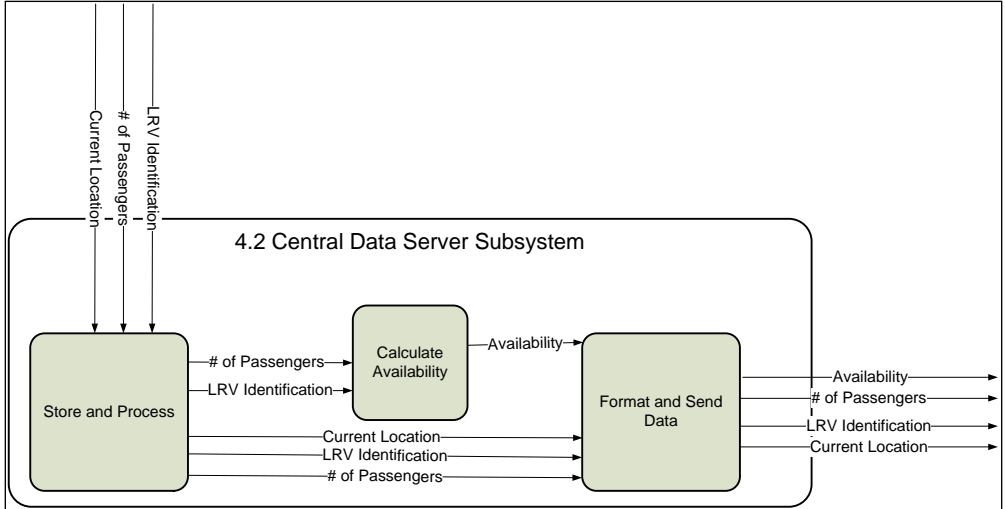

Figure B-7. Central Data Server Subsystem Data Flow Diagram (Source: DART)

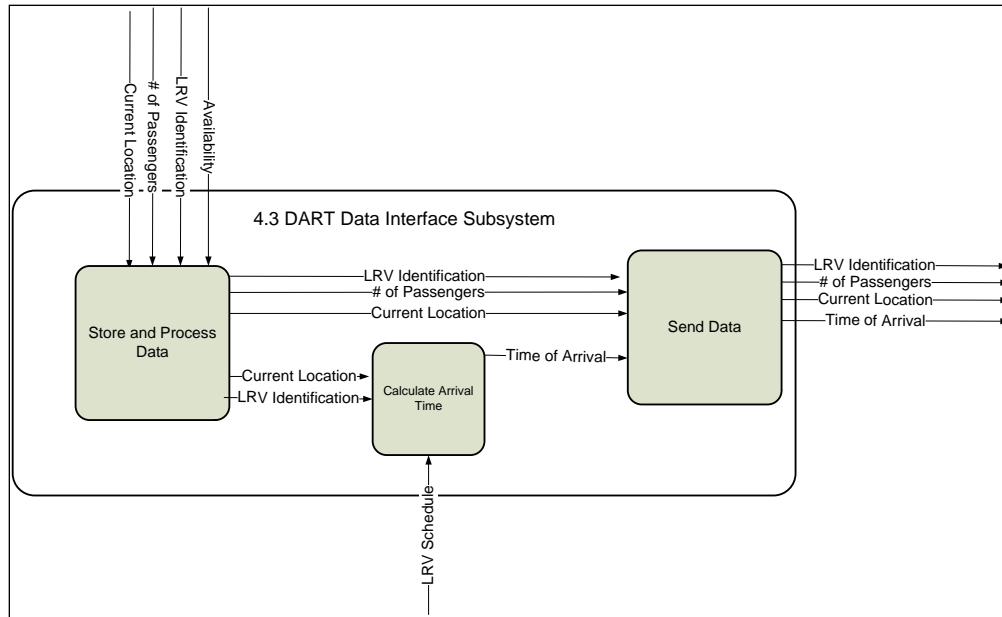

Figure B-8. DART Data Interface Subsystem Data Flow Diagram

Major System Constraints

The following assumptions were used in the development of the system requirements for the Real-Time Transit Vehicle Data Demonstration project.

System Assumptions for the Demonstration Project

Since DART currently has an INIT based AVL and APC system installed on a hand full of LRVs, it is assumed that this project will expand upon that system and include enhancements to the currently installed system

Technology Assumptions for the Demonstration Project

- Communication between the Central Data Server Subsystem and On-board subsystem will utilize the existing cellular modems installed by INIT
- INIT will provide an XML stream utilizing the SIRI standard

4 User Needs

The following needs represent the identified needs of the Transit Vehicle Real-time Data Demonstration System as related to the existing user needs identified in the ICM Concept of Operations. While DART does have some additional needs for operational improvements and efficiency, they are not included below since they do not relate directly to the ICM User Needs and are for external systems to the Transit Vehicle Real-time Data Demonstration System.

Table B-1: APC User Needs

#	User Needs	User Need Text
1	Need to obtain current LRT capacity in the corridor	DART needs to obtain current capacity information of its light rail vehicle network within the corridor in order to make informed decisions on actions to be made to improve performance. This would include receiving passenger count information, determining vehicle loads, and processing the data for further use.
2	Need to provide transit event information to travelers	ICMS needs to provide transit capacity information to the public for planning trips and modifying trip plans en route, in order to allow travelers to make informed decisions about their trips,
3	Need to obtain current location of LRTs in the corridor	DART needs to obtain current location information of its light rail vehicle network within the corridor in order to make informed decisions on actions to be made to improve performance. This would include receiving location information, determining arrival times, and processing the data for further use.
4	Need to provide ICMS with current LRT location and capacity information	DART needs to provide current location information, and capacity of its light rail vehicle network within the corridor to the ICMS for Decision Support and incident response plan selection.

5 Requirements Process

Map User Needs to Subsystems

To ensure that all functional requirements were identified from the user needs and use cases, a mapping of the user needs to the APC/AVL system and subsystems was completed, as shown in Table B-2.

Table B-2. User Need to Subsystem Traceability

User Needs		On-board Field Subsystem	Central Data Server Subsystem	DART Data Interface Subsystem
1	Need to obtain current status of LRT capacity in the corridor	X	X	X
2	Need to provide transit event information to travelers			X
3	Need to obtain current location of LRTs in the corridor	X	X	X
4	Need to provide ICMS with current LRT location and capacity information			X

6 Requirements

This section covers the functional, performance, interface, data, and hardware requirements. It also covers non-functional and enabling requirements, and constraints. For the requirements provided below, the requirement ID provides the level of requirement:

Level 1 – APC System – 4

Level 2 – APC Subsystem 4.X

Requirement Numbering Rules

- System Requirements are 4.0.0.10 to 4.0.0.n
 - APC is 4.0.0.n
- Subsystem Requirements are 4.1.0.10 to 4.X.0.n
 - On-board Subsystem is 4.1.0.n

- Central Data Server Subsystem is 4.2.0.n
- DART Data Subsystem is 4.3.0.n

Requirement Types

- F = Functional
- I = Interface (interface between APC and external systems)
- D = Data (internal storage, send and receive of data within the APC System)
- C = Constraint
- P = Performance

Verification Method

- Analysis = Analysis (Analysis is the use of established technical or mathematical models or simulations, algorithms, or other scientific principles and procedures to provide evidence that the item meets its stated requirements.)
- Inspect = Inspection (Inspection is observation using one or more of the five senses, simple physical manipulation, and mechanical and electrical gauging and measurement to verify that the item conforms to its specified requirements.)
- Demo = Demonstrate (Demonstration is the actual operation of an item to provide evidence that it accomplishes the required functions under specific scenarios.)
- Test = Test (Test is the application of scientific principles and procedures to determine the properties or functional capabilities of items.)

Requirement Criticality

- H = High
- M = Medium
- L = Low

Assumptions and Dependencies

- Existing INIT solution installed on Light Rail Vehicles within the DART fleet will be used

APC High-Level “Business” Requirements

The first step in the requirements process is the development of the overall ICMS “business” requirements. The ICM Steering Committee developed the User Needs, Goals, and Vision for the corridor. These were then translated into applicable use cases, and high-level requirements for the ICM System as a whole. These requirements are fulfilled by existing and new systems, and are the requirements for the stakeholders to operate the corridor in an integrated manner. Table B-3 provides high-level requirements which map directly to the user needs.

Table B-3. APC System Requirements

Req ID	Req Description	Type	User Needs	Criticality	Verification Method	Subsystem Allocation
4.0.0.10	APC/AVL System shall provide current capacity of light rail trains in the corridor	Functional	1	High	Demonstrate	On-Board Field Subsystem, Central Server Subsystem, DART Data Interface
4.0.0.20	APC/AVL System shall provide transit event information to travelers	Interface	2	High	Demonstrate	DART Data Interface
4.0.0.30	APC/AVL System shall provide current location of light rail trains in corridor	Functional	3	High	Demonstrate	On-Board Field Subsystem, Central Server Subsystem, DART Data Interface

Subsystem Technical Requirements

For each of the AVL/ APC subsystems, requirements were developed to provide high-level functions, data, interfaces, and performance requirements to complete the Transit Vehicle Real-time demonstration project. All of these subsystems are a part of the overall AVL/APC System.

On-Board Subsystem Requirements

Table B-4 provides a listing of the requirements related to the data and functions within the subsystem on the light rail vehicles.

Table B-4. On-Board Subsystem Requirements

Req No	Req Text	Type	Parent Req	User Needs	Criticality	Verification
4.1.0.10	On-Board Subsystem shall calculate the location of a Light Rail Vehicle using Global Positioning System technology	C	4.0.0.10	1	H	Demonstrate
4.1.0.20	On-Board Subsystem shall determine the number of passengers entering and exiting a Light Rail Vehicle with 90% accuracy	F, P	4.0.0.10	1	H	Demonstrate
4.1.0.30	On-Board Field Hardware Subsystem shall compute the on-board load of a Light Rail Vehicle within 20 seconds	F, P	4.0.0.10	1	H	Test
4.1.0.40	On-Board Field Hardware Subsystem shall send Light Rail Vehicle Loading Data within 20 seconds of calculation to the Central Data Server Subsystem	D, P	4.0.0.10	1	H	Demonstrate
4.1.0.50	On-Board Field Hardware Subsystem shall send Light Rail Vehicle Location Data within 20 seconds of determination to the Central Data Server Subsystem	D, P	4.0.0.30	3	H	Demonstrate

Central Data Server Subsystem Requirements

Table B-5 provides a listing of the requirements related to the INIT central software system used to analyze and process the AVL and APC data received from the light rail vehicles.

Table B-5. Central Data Server Subsystem Requirements

Req No	Req Text	Type	Parent Req	User Needs	Criticality	Verification
4.2.0.10	Central Data Server Subsystem shall receive LRV Loading Data from the On-Board Subsystem	D	4.0.0.10	1	H	Demonstrate
4.2.0.20	Central Data Server Subsystem shall receive from the On-Board Field Hardware Subsystem LRV Location Data	D	4.0.0.30	3	H	Demonstrate
4.2.0.30	Central Data Server Subsystem shall send to the DART Data Interface Subsystem LRV Loading Data	D	4.0.0.10	1	H	Demonstrate
4.2.0.40	Central Data Server Subsystem shall send to the DART Data Interface Subsystem LRV Location Data	D, C	4.0.0.30	3	H	Demonstrate
4.2.0.50	Central Data Server Subsystem shall compute the availability of passenger space on each LRV	F	4.0.0.10	1	H	Demonstrate

DART Data Interface Subsystem Requirements

Table B-6 provides a listing of the requirements related to the subsystem within DART that receives the AVL and APC data from the Central Data Server subsystem.

Table B-6. DART Data Interface Subsystem Requirements

Req No	Req Text	Type	Parent Req	User Needs	Criticality	Verification
4.3.0.10	DART Data Interface Subsystem shall receive from the Central Data Server Subsystem LRV Loading Data	D	4.0.0.10	1	H	Demonstrate
4.3.0.20	DART Data Interface Subsystem shall receive from the Central Data Server Subsystem, LRV Location Data	D, C	4.0.0.30	3	H	Demonstrate
4.3.0.30	DART Data Interface Subsystem shall publish LRV Loading Data in an XML format within 10 seconds of receipt from the Central Data Server subsystem	D, C, P	4.0.0.20	2, 4	H	Demonstrate
4.3.0.40	DART Data Interface Subsystem shall publish LRV Location Data in an XML format within 10 seconds of receipt from the Central Data Server subsystem	D, C, P	4.0.0.20	2, 4	H	Demonstrate
4.3.0.50	DART Data Interface Subsystem shall store LRV Loading Data	D	4.0.0.20	2	H	Demonstrate
4.3.0.60	DART Data Interface Subsystem shall store LRV Location Data	D	4.0.0.20	2	H	Demonstrate
4.3.0.70	DART Data Interface Subsystem shall compute the schedule adherence of each LRV within 10 seconds	F	4.0.0.20	2, 4	H	Demonstrate

7 References

Concept of Operations for the US-75 Integrated Corridor in Dallas, Texas, May 2009.

FHWA Rule 940, *Federal Register*/Vol. 66, No. 5/Monday, January 8, 2001/Rules and Regulations, Department of Transportation, Federal Highway Administration 23 CFR Parts 655 and 940, [FHWA Docket No. FHWA–99–5899] RIN 2125–AE65 Intelligent Transportation System Architecture and Standards.

Operational Concept, Dallas Real-Time Transit Vehicle Data Demonstration Project, August 2012.

Real-Time Transit Vehicle Data Demonstration Final Statement of Work, May 2011.

System Engineering Handbook: A Guide for System Life Cycle Processes and Activities, version 3.2, January 2010, International Council on Systems Engineering.

Systems Requirements Specification for the US-75 Integrated Corridor in Dallas, Texas, May 2009.

8 Acronyms

AMS	Analysis, Modeling, and Simulation	ICM	Integrated Corridor Management
APC	Automatic Passenger Counter	ITS	Intelligent Transportation Systems
ASMS	Arterial Street Monitoring System	IVR	Interactive Voice Response
ATIS	Advanced Traveler Information	LRT	Light Rail Transit
AVI	Automatic Vehicle Identification	LRV	Light Rail transit Vehicle
AVL	Automatic Vehicle Location	NCTCOG	North Central Texas Council of Governments
CCB	Configuration Control Board	NTTA	North Texas Tollway Authority
CCTV	Closed Circuit Television	PDR	Preliminary Design Review
CDPD	Cellular Digital Packet Data	RCU	Roadside Communications Devices
CDR	Critical Design Review	RITA	Research and Innovative Technologies Administration
COTS	Commercial Off The Shelf	RFP	Request for Proposals
Daltrans	Dallas Transportation Management Center	RTM	Requirements Traceability Matrix
DART	Dallas Area Rapid Transit	SDR	Software Development Review
DMS	Dynamic Message Sign	SIRI	Service Information for Real-time Information
DSS	Decision Support System	SRR	System Readiness Review
FHWA	Federal Highway Administration	TIS	Travel Information System
FTA	Federal Transit Administration	TMC	Traffic Management Center
GDP	Gross Domestic Product	TMDD	Traffic Management Data Dictionary
GPS	Global Position System	TSP	Transit Signal Priority
HAR	Highway Advisory Radio	TxDOT	Texas Department of Transportation
ICD	Interface Control Document	XML	eXtensible Message Library

9 Action Verbs

This section defines the action verb terms and definitions from the Dallas ICM project, including those used in this document.

Verb	Definition
Accept	To receive (e.g., data feed from another system)
Activate	To make active; cause to function or act (e.g., to make a planned event an active incident)
Add	To add (e.g., add a timestamp to a record)
Aggregate	To bring together; collect into one
Allow	To give permission to or for
Authorize	To give authority or official power to (associated with security authentication requirement)
Collect	To get from source; assemble

Compare	To examine (two or more objects, ideas, people, etc.) In order to note similarities and differences
Compute	To determine or ascertain by mathematical or logical means
Confirm	To make valid or binding by some formal or legal act; sanction; ratify
Determine	To settle or decide (a dispute, question, etc.) By an authoritative or conclusive decision
Display	To output (data) on a monitor or other screen
Evaluate	To judge or determine the significance, worth, or quality of; assess
Execute	To run (a program or routine) or to carry out (an instruction in a program)
Filter	To remove by the action of a filter
Generate	To bring into existence; cause to be; produce (e.g., generate a log file)
Import	To bring (documents, data, etc.) Into one software program from another, implies translate
Manage	To handle, direct, govern, or control in action or use (e.g., Manage the add, change, delete of an object)
Merge	To combine or blend
Monitor	To watch closely for purposes of control, surveillance, etc.; keep track of; check continually
Notify	To inform (someone) or give notice to
Parse	To analyze a string of characters to associate groups of characters with syntactic units of underlying grammar
Predict	To declare or tell in advance; prophesy; foretell
Provide	To make available (e.g., provide a function to a user)
Publish	To make generally known (e.g., Publish to c2c)
Receive	To get or be informed of
Recommend	To advise, as an alternative; suggest (a choice, course of action, etc.)
Refresh	To read and write (the contents of dynamic storage) at intervals in order to avoid loss of data
Remove	To get rid of; do away with (e.g., Remove from user interface display)
Reside	- Hardware constraint - e.g., Reside in a controller cabinet
Restore	To bring back to a former, original, or normal condition
Restrict	To confine or keep within limits, as of space, action, choice, intensity, or quantity
Retrieve	To locate and read (data) from storage, as for display on a monitor
Save	To copy (a file) from RAM onto a disk or other storage medium
Search	To examine (one or more files, as databases or texts) electronically, to locate specified items
Select	To make a choice; pick
Send	To cause to be transmitted to a destination
Simulate	To create a simulation, likeness, or model of (a situation, system, or the like)
Sort	To arrange according to sort, kind, or class; separate into sorts; classify
Start	To set in operation
Store	To put or retain (data) in a memory unit
Translate	To convert (a program, data, code, etc.) From one form to another
Update	To incorporate new or more accurate information in (a database, program, procedure, etc.)
Use	Constraint Only - to utilize a specific technology
Validate	To substantiate

APPENDIX

C

Communications Assessment

TECHNICAL MEMORANDUM

TO: Koorosh Olyai, Program Manager, ICM Program
FROM: Ahmad Sadegh, Project Manager, Telvent USA, LLC
SUBJECT: FINAL Communication Assessment – Transit Vehicle Real-time Data Demonstration Project
DATE: 5/9/2013

The purpose of this Technical Memorandum is to provide an overview of the communication options assessment for the Dallas Area Rapid Transit (DART) Real-Time Transit Vehicle Data Demonstration project within the context of the larger ICM project. This document will include a review and analysis of various wireless communication technologies which could be used for transmitting the real-time transit vehicle data from the light rail vehicles to a central computer system for processing and reporting the location and on-board loading of the light rail vehicles on the red/ orange line.

This project will explore and assess the utility of real-time transit vehicle data, and will examine the issues, challenges, and feasibility of its use. Transit data is important to the successful implementation of an ICM system. Most transit agencies lack the capability to access transit vehicle data in a timely manner to support ICM operations, particularly dynamic mode shift to transit. Data acquisition issues for transit are mainly due to bandwidth limitations of transit vehicle communications systems (e.g., data radios). The key real time transit vehicle information to support ICM includes: vehicle location, time to arrival at next stop (derived from vehicle location and speed), and the remaining capacity to carry additional passengers (derived from the current passenger count).

During Stage I of the Dallas ICM project, the missing real time capacity of light rail transit (LRT) fleets was identified as essential to the deployment of a multi-modal, multi-agency ICM concept. ICM depends on the acquisition of such data about current conditions in the corridor, the capability to implement various management strategies which may include transit, and the modeling tools to support the evaluation and selection of strategies appropriate to the current conditions.

Most transit agencies do not have access to passenger load data in “real time.” Rather, these data are typically downloaded at the end of the day when the transit vehicle enters the bus/rail yard and are used for transit service planning and not operations. In addition, not all transit vehicles are equipped with automatic passenger counters (APCs), although APCs are becoming standard on new transit vehicle procurements.

This project includes the development, installation, testing, and demonstration of on-board APC and communications equipment to transmit AVL and loading data (e.g., passenger loads) in real time to a central facility (e.g., transit management center or ICM system) in order to support ICM operations at the Dallas ICM pioneer demonstration site.

Transit Vehicle Data

This section summarizes the problems, issues and needs of the current data provided by the light rail network. This section addresses operational, technical, and, institutional deficiencies and constraints, as such; it provides insight into the types of problems being faced by DART related to providing current light rail capacity information.

LRT Data Challenges

Historically, DART has had limited information on the real-time location, and on-board loads of its light rail transit vehicles (LRV) within the US-75 corridor. Because of this lack of information, the use of transit for modal shift, and diversions during incidents could have a negative impact on the travelers within the corridor.

The location (i.e., AVL data) and the on-board loading (i.e., APC data) will be used by the ICM stakeholders to improve their decision making on modal shift strategies, and improve the operation and efficiency of the light rail transit (LRT) operations within DART.

LRT Data Needs

For the Transit Vehicle Real-time Data Demonstration project , APC data will be captured from DART LRVs by the use of the Init APC's and provided to DART once the data from the APC's has been processed by Init's central evaluation and analysis server.

For the ICM demonstration, three critical pieces of data are needed for the ICMS to evaluate the use of transit for potential diversions and strategies. These include:

- Number of vehicles connected to the LRV (to determine if additional vehicles could be added)
- Location and speed of the LRV
- On-board load of the LRV (to determine how much additional capacity is available)

LRT Data Usage

The proposed use of the data (i.e., applications) for the ICM demonstration includes providing the agency users with the current location and capacity of the light-rail transit vehicles within the corridor. In addition, the LRT data could be used to provide travelers with information via the 511 systems (IVR, My511, 511 website) on the current location of transit vehicles, the available capacity of the vehicles, and schedule information.

The decision support subsystem is planned to use the AVL and APC data to evaluate response plans for events within the corridor (i.e., incidents) to determine if modal shift is recommended, if additional capacity for the LRT is needed, and to evaluate if the current available capacity is sufficient.

The prediction sub subsystem is also planned to use the current on-board loads, and location to help model the response plan options so that the use of transit is considered in the response plans selected for incidents. In addition, the evaluation sub subsystem will use the APC and AVL data to evaluate various measures of effectiveness for the US-75 corridor.

Communications Requirements

There are multiple communication mediums involved in the AVL and APC data collection, processing, and distribution. For the Transit Vehicle Real-time Data Demonstration Project, the communication between the LRV on-board computer and the central servers will be analyzed to ensure the communication will be robust and sufficient for the amount of data. The communication between the INIT servers and DART is planned to be a web service utilizing XML via the internet.

Current AVL Data Transmission

Before this project, the number of passengers boarding and alighting at each rail station was stored onboard the vehicle and only downloaded at the end of the day. When the LRV went back to the rail yard, all the operational data including passenger counts was offloaded via a wireless LAN at the rail

yard. The data was then stored on the central server and each night all the data was processed in a balancing methodology and put into an Oracle database that DART’s Rail Operations and Service Planning personnel can access.

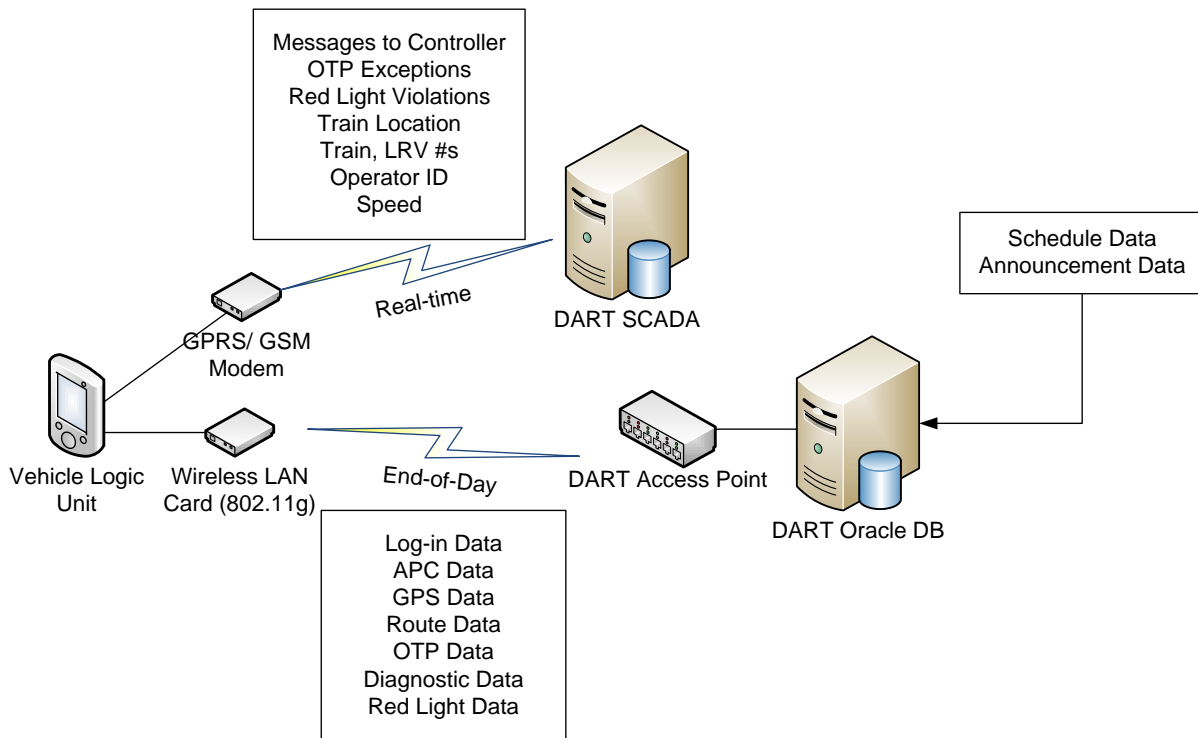

Figure C-1. Current DART Wireless Communication (Source: DART)

Proposed Modifications

With the implementation of this project, the AVL/APC vendor has been requested to make two major modifications to its solution. The first major modification is the software installed on the light rail vehicle (LRV) will be changed to not only store the information which is transmitted at the end of day but to also communicate the APC load values in real time to its central server. This provides a means for the load values to get off the vehicle in real-time.

The second modification is to add an interface from the central server application to provide operational data including APC loads to DART’s Oracle database. The operational data includes such pieces of information as LRV number, number of LRVs in the train, which piece of work (block) the train is performing, who is operating the vehicle (driver), how many people boarded and alighted at the rail stations, and its GPS coordinates.

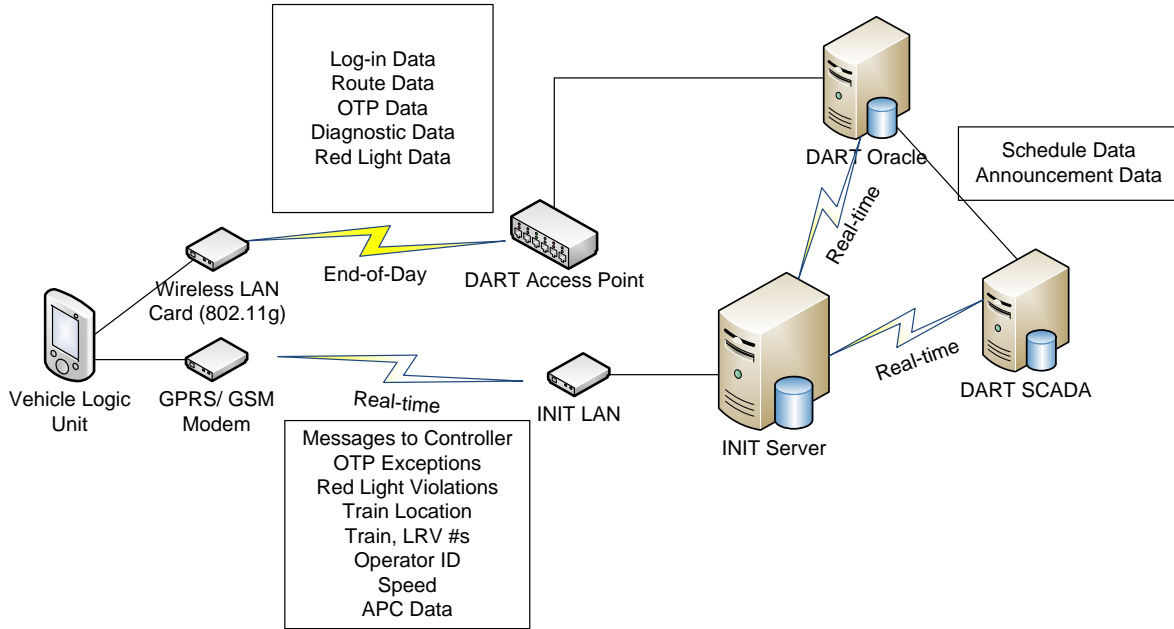

Figure C-2. Proposed Wireless Communication (Source: DART)

For the AVL location data, both GPS (for above ground) and logical position (for tunnels) is used.

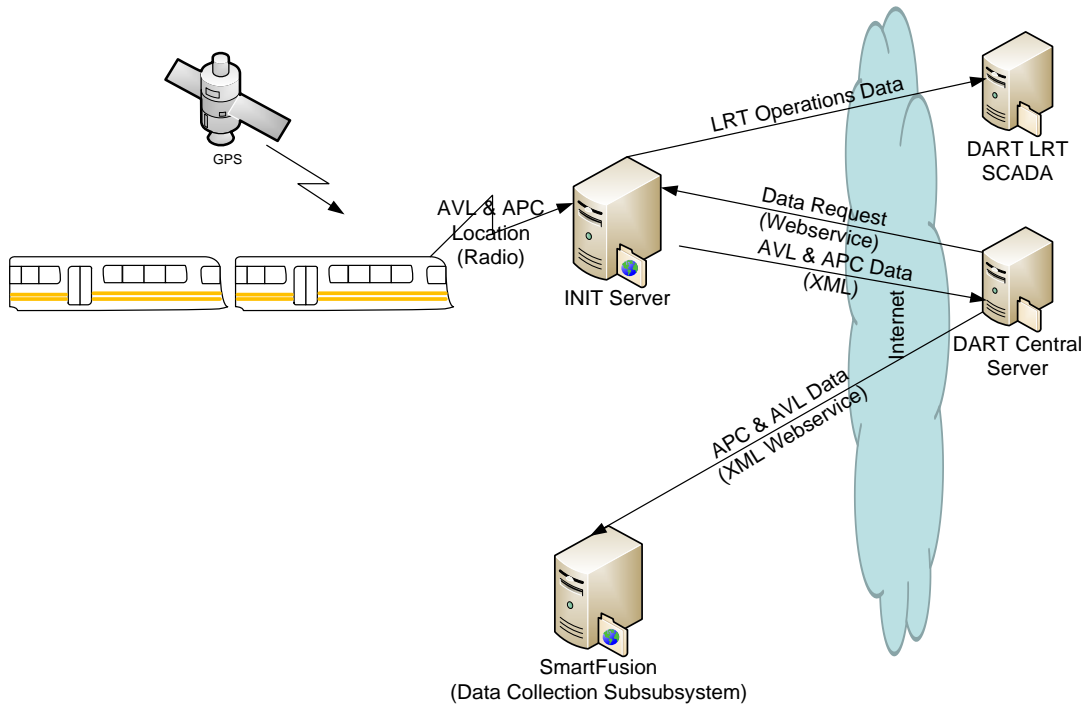

Figure C-3. Communication Paths for AVL and APC data (Source: DART)

DART Transit Application

The amount of bandwidth required for the transit vehicle real time demonstration project is relatively low. Since the LRV is only transmitting strings of data, it does not require a persistent connection, but could use a burst based communication technology. The amount of data is only a few kilobytes, so a low bandwidth connection is sufficient.

The estimation of the upload data bandwidth required for real time communications is around 128 kbps per vehicle. In future if live video or snapshot is required to be added the upload bandwidth shall be around 640 Kbps. Therefore in long term deployment a 4G cellular link per vehicle provides a very good quality of service for years. Due to DART operational goals, the system needs to transmit data every ~30 seconds. This requires that the communication method have good coverage in the US-75 corridor. Fortunately AT&T's has a very good coverage in Dallas compare to other cities, with an average 4G upload speed of 2 Mbps and download speed of 8 Mbps. The current technology installed on the LRV's already includes both WiFi and GPRS technologies. Other short range wireless technologies could be used; however an additional equipment cost would be required.

Communications Technologies

Several communication protocols and methods will be assessed for the communication between the LRT vehicles and the central systems. The sections below discuss each communication method and its abilities to meet the needs of the project.

Wi-Fi

Wi-Fi refers to interoperable implementations of the IEEE 802.11 Wireless LAN standards certified by the Wi-Fi Alliance. The IEEE 802.11 Wi-Fi / WLAN standards set the attributes for the different channels that may be used. These attributes enable different Wi-Fi modules to talk to each other and effectively set up a WLAN. To ensure that WLAN solutions operate satisfactorily, parameters such as the RF signal center frequencies, channel numbers and the bandwidths must all be set.

The 802.11g standard uses the 2.4 GHz and 802.11a standard uses the 5.8 GHz ISM frequency. This is a license free band for which individual users are not required to have a license.

The advantages of Wi-Fi are that the technology is very mature, and many products are available to use this family of standards.

The disadvantage is also because it is highly available; security for the WLAN must be configured such that outside entities cannot hack into the network. It is also an unlicensed frequency, which other entities could create a Wi-Fi network nearby with the same frequency and channel, which would potentially cause interference. Because of the vast popularity and large interference on 2.4 GHz frequency, the 802.11g standard is not recommended for any ITS applications. The 802.11a technology could be used for the real time component of the LRV data; however, access points would be needed along the rail route, so that the network was accessible. Due to environmental interference with the signal, this technology is not recommended for mobile uses without performing a radio spectrum analysis along the US-75 corridor.

Another potential Wi-Fi band that should be considered is the 4.9 GHz band. The 4.9 GHz band is a licensed band available for use by public safety agencies. Any agency qualified for a 700 MHz license qualifies for a 4.9 GHz license. Generally this covers all government entities, private companies sponsored by a government entity (such as private ambulance services) and any organization with critical infrastructure (power companies, pipelines, etc.).

The 4.9 GHz band may be used for any terrestrial based radio transmission including data, voice, and video. Point-to-point and multipoint operations are permitted. All multipoint and temporary (less than 1 year) point-to-point links are primary uses of the band. Permanent point-to-point links are secondary uses and require separate site licenses. Where interference cannot be eliminated by technical or operational modifications, primary users take precedence over secondary users.

Cellular

There are several cellular modem based technologies that can be used for transmitting/ receiving data. With the current cellular technology deployment in Dallas, a 4G based modem is recommended.

	AT&T Dwnld/Upld	T-Mobile Dwnld/Upld	Verizon Dwnld/Upld
3 G	2.6/0.8 Mbps	3.7/1.4 Mbps	1.02/0.75 Mbps
4G	8.12/4.2 Mbps	5.23/1.6 Mbps	7.35/5.1 Mbps

For the DART project, general packet radio service (GPRS) is not recommended in long term deployment. GPRS is not an efficient cellular link and it will go away in the next 5 years depending on the network. In the interim, carriers will stop deploying non-3G/4G-capable equipment, except in break-fix scenarios, and start devoting more and more spectrum to 4G. Combining that with some aggressive upgrade to 3G/4G will probably move the network carriers to the point that non-3G/4G services will cost more to continue running. This scenario has happened in Europe and Canada and Australia. For example there are already 3G only networks (TELUS/Bell in Canada has no GPRS/EDGE capable network at all and will only support 3G networks.)

The Cellular 4G technology could be used for the real time component of the LRV data. Its advantage is that the cellular coverage is good within the US-75 corridor, and the LRVs should be able to connect to the cellular network easily.

WiMAX

WiMAX refers to interoperable implementations of the IEEE 802.16 family of wireless-networks standards ratified by the WiMAX Forum. Although current 802.16 standards support the entire frequency range between 2 and 6 GHz, the WiMAX forum has focused WiMAX certification on the 2.5GHz, 3.5GHz and 5.8GHz bands. The IEEE 802.16e standard is an amendment to the 802.16d standard that allows supporting Mobile communications. Mobility will also enable operators to expand the range of services they offer their vertical customers within their coverage area, and to include applications that require, for instance, support for the mobile workforce or in-vehicle connectivity (e.g., for safety and security, government, utilities, and transportation applications). The ability of the WiMax technology to meet the ITS requirements, both from mobility perspective and from a performance one make it a very good option for mobile and fixed communications with the ITS devices. However, the cost of ownership for the WiMax network for the US-75 corridor is currently very high compare to the other solutions.

DSRC

The FCC allocated the 5.9 GHz band for Dedicated Short Range Communications (DSRC) in October 1999. DSRC allows high-speed communications between vehicles and the roadside, or between vehicles, for intelligent transportation system applications; it has a range of up to 1,000 meters.

DSRC communications take place over a dedicated 75 MHz spectrum band around 5.9 GHz, allocated by the US Federal Communications Commission (FCC) for vehicle safety applications.

The advantages of DSRC is that it is a licensed spectrum of communication, so there would be minimal devices in the area that could potentially interfere with the signal for the LRVs. DSRC is preferred over Wi-Fi because the proliferation of Wi-Fi hand-held and hands-free devices that occupy the 2.4 GHz and 5.8 GHz bands, along with the projected increase in Wi-Fi hot spots and wireless mesh extensions, could cause intolerable and uncontrollable levels of interference that could hamper the reliability and effectiveness of active applications. The bandwidth of each DSRC channel is 10 MHz, as opposed to the nominal 20 MHz IEEE 802.11 channel bandwidth. This brings better wireless channel propagation with respect to multi-path delay spread and Doppler effects caused by high mobility and roadway environments.

DSRC could not be used for the real time component. Therefore DSRC is not a good candidate for US-75 network but it could be a very good choice for the backup operations at the end of the day.

Conclusion

Since the current LRV system uses both Wi-Fi (802.11g) for transmitting end of day information, and GPRS/ GSM for transmitting and receiving real-time information, the existing technologies are sufficient for this demonstration project. Both WiMax and Cellular could be used for the real-time component, however, additional funding would be needed to deploy the hardware necessary to transmit the data on the LRV, and receive the data along the red/ orange line along the US-75 corridor.

It is therefore recommended that the current deployed technologies be used for a limited time. However, in the longer term it is recommended that other cellular technologies be considered as the cellular networks are upgraded. A combination of high speed cellular communications and DSRC (or 4.9 GHz public safety band Wi-Fi) will provide a solid and secure network for the Real-Time Transit Vehicle Data Demonstration project within the US-75 corridor.

References

A Case Study of DART Rail –Dallas, Texas, INIT, www.initag.com.

Dedicated Short Range Communication: Connected Vehicles Dedicated Short Range Communications Frequently Asked Questions, http://www.its.dot.gov/DSRC/dsrc_faq.htm, USDOT Website.

General Packet Radio Service, wikipedia.org.

Operational Concept – Transit Vehicle Real Time Demonstration Project, Dallas Area Rapid Transit, September 2012.

The Next Level of Real-Time Passenger Information, INIT, www.initag.com

What is a GPRS Modem? wisegeek.com.

What is the Frequency of GPRS, wiki.answers.com.

Wi-Fi / WLAN channels, frequencies and bandwidths, radio-electronics.com.

WiMAX IEEE 802.16 technology tutorial, radio-electronics.com.

APPENDIX

D

System Design Document

System Design Document

Dallas Integrated Corridor Management (ICM) – Transit Vehicle Real-time Data Demonstration

Final Report

August 23, 2013

Contents

1	Introduction	D-2
2	Scope and Summary.....	D-2
3	System Description	D-3
4	Design Considerations.....	D-7
5	Detailed System Design.....	D-13
6	Requirements Traceability	D-21
7	References.....	D-26
8	Acronyms.....	D-26

List of Tables

Table D-1:	XML Feed Use Case	D-18
Table D-2:	APC System Requirements	D-22
Table D-3:	On-Board Subsystem Requirements.....	D-23
Table D-4:	Central Data Server Subsystem Requirements.....	D-24
Table D-5:	DART Data Interface Subsystem Requirements	D-25

List of Figures

Figure D-1:	High-Level Automated Passenger Counter Schematic (Source: DART)	D-4
Figure D-2:	APC Data: SmartFusion Subsystem Interface (Source: DART)	D-5
Figure D-3:	Context Diagram of Real-Time Transit Vehicle Data System (Source: DART).....	D-6
Figure D-4:	Real-Time Transit Vehicle Data Demonstration System Architecture (Source: DART).....	D-7
Figure D-5:	Subsystem Data Flow Diagram (Source: DART)	D-9
Figure D-6:	On-Board Vehicle Hardware Components	D-10
Figure D-7:	Central Data Server Components.....	D-12
Figure D-8:	DART Data Interface Components	D-13
Figure D-9:	Vehicle Logic Unit Components	D-14
Figure D-10:	Power Conditioning Unit Components	D-15
Figure D-11:	Mobile Display ScreenComponents.....	D-15
Figure D-12:	Automatic Passenger Counters Components.....	D-16
Figure D-13:	GPS Components	D-17
Figure D-14:	Wireless LAN Components	D-18

I Introduction

This document contains the System Design for the Transit Vehicle Real-time Data Demonstration Project, further down called the APC/AVL Project.

The Automated Passenger Counter (APC)/ Automated Vehicle Location (AVL) system is a component based system that supports the ICM corridor management by sharing light rail vehicle transit location, capacity, and schedule adherence information, and utilizes this data to provide operational planning and evaluation for the ICM system through decision support.

2 Scope and Summary

Background

The Dallas Integrated Corridor Management System (ICMS) demonstration project is a multi-agency, decentralized operation, which will utilize a set of regional systems to integrate the operations of the corridor. The purpose of the Dallas ICM System is to implement a multi-modal operations decision support tool enabled by real-time data pertaining to the operation of freeways, arterials, and public transit. The system will be shared between information systems and people involved in transportation operations and incident management in the US-75 Corridor. The Dallas ICM system is intended to provide improved integration of operation procedures, including procedures that take advantage of the data sharing capabilities of the Dallas ICM system and facilitate improved incident management, and traveler information.

A team headed by the Dallas Area Rapid Transit (DART) is providing technical and management services in support of the Dallas ICM demonstration project. DART currently lacks access to real time LRT loading data. As a result, it will be difficult to implement some ICM strategies that include transit, such as adding transit capacity in real time to accommodate dynamic mode shift to transit (e.g., drivers may shift to transit as a result of a major incident on an adjacent freeway). This project will demonstrate and evaluate the ability to collect and transmit transit location and passenger loading data to a transit management center(s) and/or ICM system in real time. The project will also demonstrate and evaluate the ability to use the data in real time, in a decision support subsystem, for example, to make informed operational decisions. The project will include the development, installation, testing, and demonstration of on-board automated passenger counter (APC) equipment and communications technologies to support real-time connectivity between transit vehicles and central facilities to support the following potential applications:

- Vehicle location and speed monitoring
- Passenger load monitoring

The project will explore and assess the utility of real-time transit vehicle data, and will examine the issues, challenges, and feasibility of its use. For example, the project will explore the scenarios for which the Dallas Area Rapid Transit (DART) could dynamically increase capacity (to accommodate dynamic mode shift to transit) based on the light-rail transit (LRT) red line real-time passenger load information.

The Dallas ICM demonstration site will be used as a test bed for this project. The project will include the development of this concept of operations to identify the appropriate transit vehicle real-time data applications that supports Dallas' proposed ICM strategies and operations. The applications selected for Dallas will be demonstrated on DART's red line LRT system, which is located in the US-75 ICM corridor.

Lastly, the project will include a case study conducted by the Volpe Center. The case study will focus on documenting the process of acquiring, integrating, and using real-time transit data for DART LRT vehicles, sharing lessons learned, and demonstrating qualitative evidence for changes in DART's Train Control Center due to real-time information. To the degree available, the Volpe Center will also provide counts of any off-peak

operational changes made by DART due to real-time information as DART has indicated that peak operational changes are not possible.

Transit data is important to the successful implementation of an ICM system. Most transit agencies lack the capability to access transit vehicle data in a timely manner to support ICM operations, particularly dynamic mode shift to transit. Data acquisition issues for transit are mainly due to bandwidth limitations of transit vehicle communications systems (e.g., data radios). The key real time transit vehicle information to support ICM include; vehicle location, time to arrival at next stop (derived from vehicle location and speed), and the remaining capacity to carry additional passengers (derived from the current passenger count).

During Stage I of the Dallas ICM project, the missing real time capacity of light rail transit (LRT) fleets were identified as essential to the deployment of a multi-modal, multi-agency ICM concept. ICM depends on the acquisition of such data about current conditions in the corridor, the capability to implement various management strategies, which may include transit, and the modeling tools to support the evaluation and selection of strategies appropriate to the current conditions.

Most transit agencies do not have access to passenger load data in “real time.” Rather, these data are typically downloaded at the end of the day when the transit vehicle enters the bus/rail yard and are used for transit service planning and not operations. In addition, not all transit vehicles are equipped with automatic passenger counters (APCs), although APCs are becoming standard on new bus procurements.

The project includes the development, installation, testing, and demonstration of on-board APC and communications equipment to transmit AVL and loading data (e.g., passenger loads) in real time to a central facility (e.g., transit management center or ICM system) in order to support ICM operations at the Dallas ICM pioneer demonstration site.

Purpose

This document provides a detailed description of the selected system and the design for the systems to be implemented for the Transit Vehicle Real-time Data Demonstration Project.

This design document is based on the in-vehicle and in-field requirements defined in the Transit Vehicle Real-time Data Demonstration Project Requirements document. The architecture and design incorporates those elements that must be used to provide a solution that fulfills the system and subsystem requirements, and meets the existing needs of DART and the US-75 ICM Demonstration Project.

3 System Description

Project Scope

The following scope is the scope of work for the cooperative agreement between the Federal Transit Administration (FTA) and DART.

Automatic Passenger Counter Schematic

The Automatic Passenger Counter (APC) is installed in each light-rail vehicle over the doorway, which provides for detection of people entering and exiting the light-rail vehicle. The APC sensor provides this information to the on-board computer for analysis, and packaging the data. As shown in Figure D-1, the on-board computer sends the packaged data via CDPD radio to a central server and evaluation and analysis computer.

The central server processes the data received from the on-board computer and provides the on-board loads to DART at 20-second intervals.

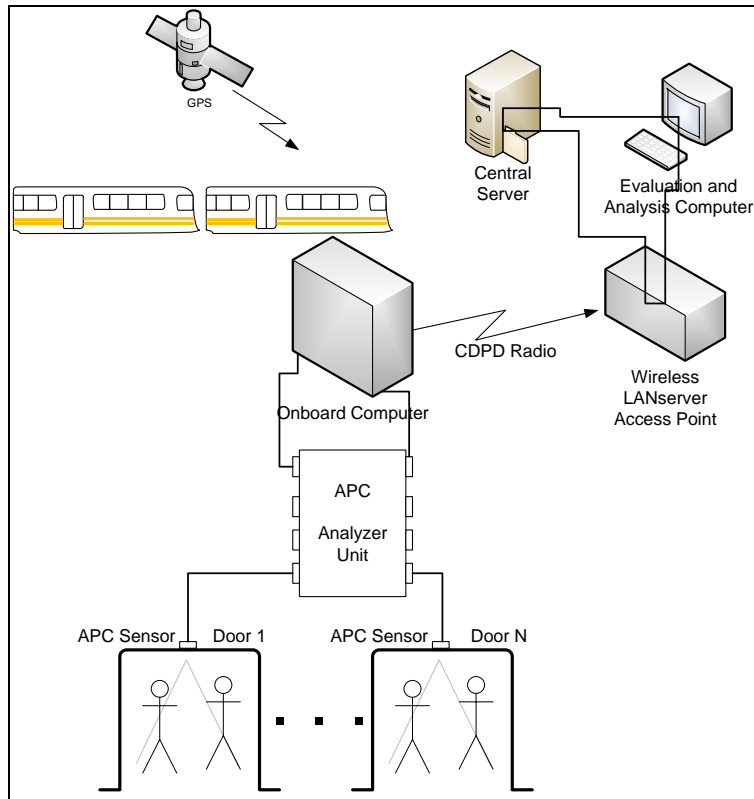

Figure D-1. High-Level Automated Passenger Counter Schematic (Source: DART)

Communication Needs

There are multiple communication mediums involved in the AVL and APC data collection, processing, and distribution. For the Transit Vehicle Real-time Data Demonstration Project (APC Project, for short), the communication between the LRV on-board computer and the central servers has been analyzed to ensure the communication will be robust and sufficient for the amount of data. The communication between the INIT servers and DART is planned to be a webservice utilizing a Service Information for Real-time Information (SIRI) standard XML message via the internet.

For the AVL location data, both GPS (for above ground) and odometer imputed logical position (for tunnels) will be used and provided to the ICMS via a webservice utilizing XML.

Integration with ICMS

As previously mentioned, real time capacity of light rail transit (LRT) fleets were identified as essential to the deployment of a multi-modal, multi-agency ICM concept. ICM depends on the acquisition of such data about current conditions in the corridor; the capability to implement various management strategies, which may include transit, and the decision support tools to support the evaluation and selection of strategies appropriate to the current conditions.

As shown in Figure D-2, the ICMS (SmartFusion subsystem) collects, fuses, stores, and disseminates various transportation related data for the ICMS. The AVL & APC data will be provided to the SmartFusion subsystem via a webservice utilizing XML. The AVL & APC data is fused, stored and provided to other systems within the ICMS, to include the decision support subsystem, and SmartNET subsystem. The decision support subsystem, via the ICMS XML webservice, uses the AVL and APC data to evaluate response plans for events within the

corridor (i.e. incidents) to determine if modal shift is recommended, if additional capacity for the LRT is needed, and to evaluate if the current available capacity is sufficient.

In addition, the evaluation subsystem will use the APC and AVL data to evaluate various measures of effectiveness for the US-75 corridor. The prediction subsystem will use the current on-board loads, and location to help model the response plan options so that the use of transit is considered in the predicted responses to incidents.

The SmartNET subsystem will provide the agency users within the corridor a layer on the map to show the current location and capacity of the light rail transit vehicles within the corridor. This will provide the operators with a quick view of what impact decisions within their area of influence may have on the transit riders.

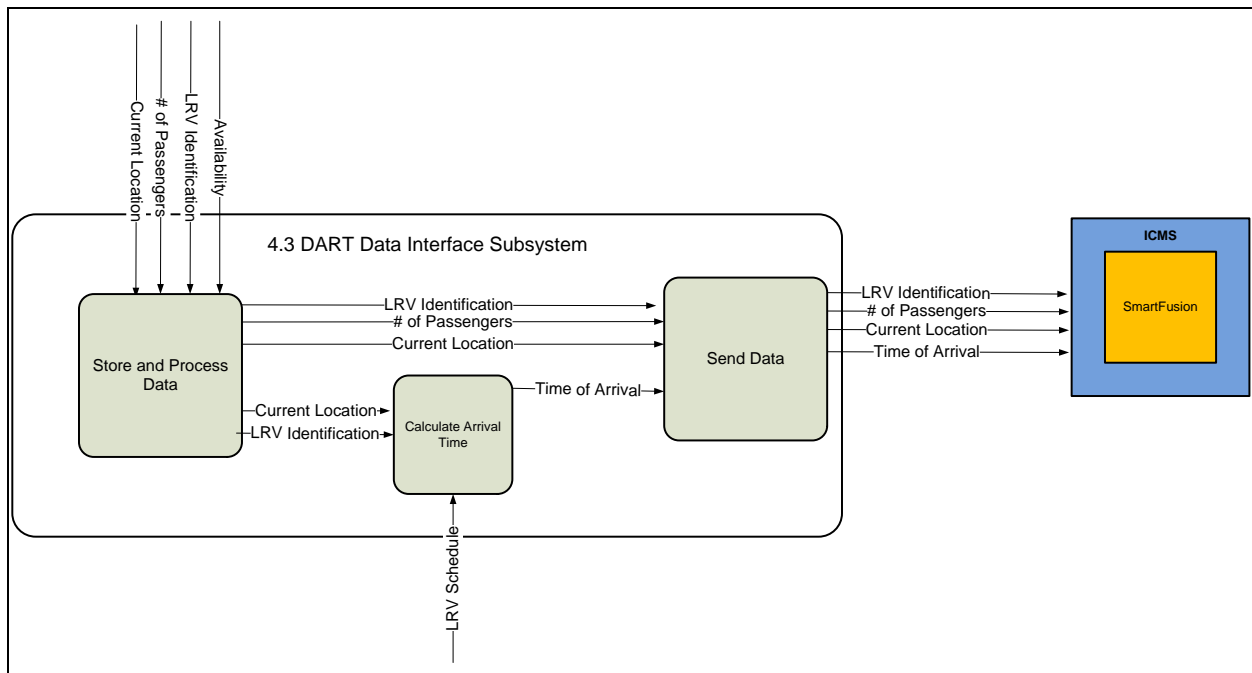

Figure D-2. APC Data: SmartFusion Subsystem Interface (Source: DART)

Context Diagram

Figure D-3 is a high-level framework on how the system will interface to the external systems. The APC system would utilize XML standards for external users of the data. Currently, DART has an agreement with the Patent holder to use AVL data on its own web sites to provide arrival predictions. DART can provide the ICM SmartFusion engine with location information and on-board loads without infringing on the patent. .

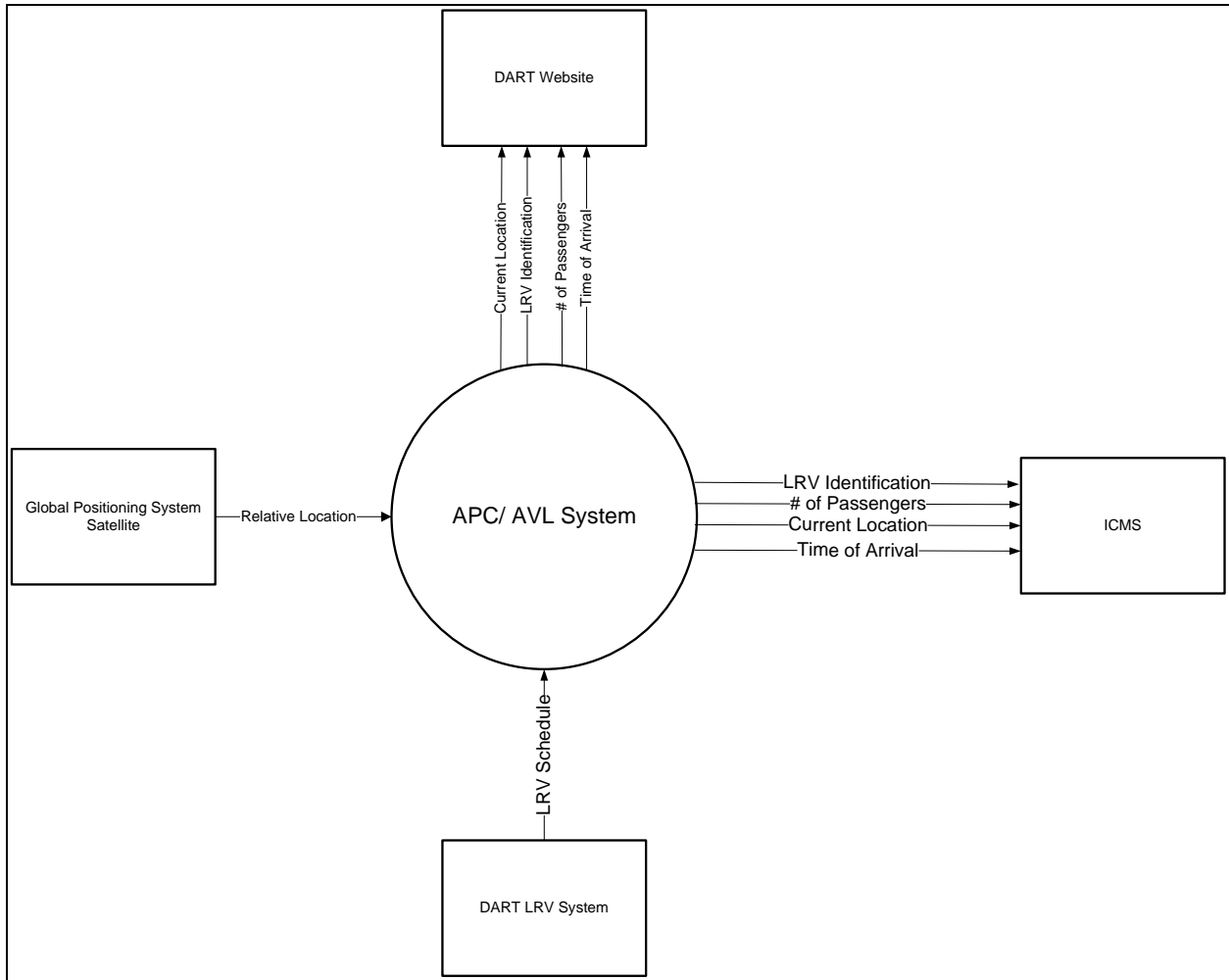

Figure D-3: Context Diagram of Real-Time Transit Vehicle Data System (Source: DART)

System Architecture

The following System Architecture provides a high-level diagram of the entire “APC System,” its subsystems, and the modules within the subsystem. The following is a discussion of and requirements for the system, subsystems, and modules.

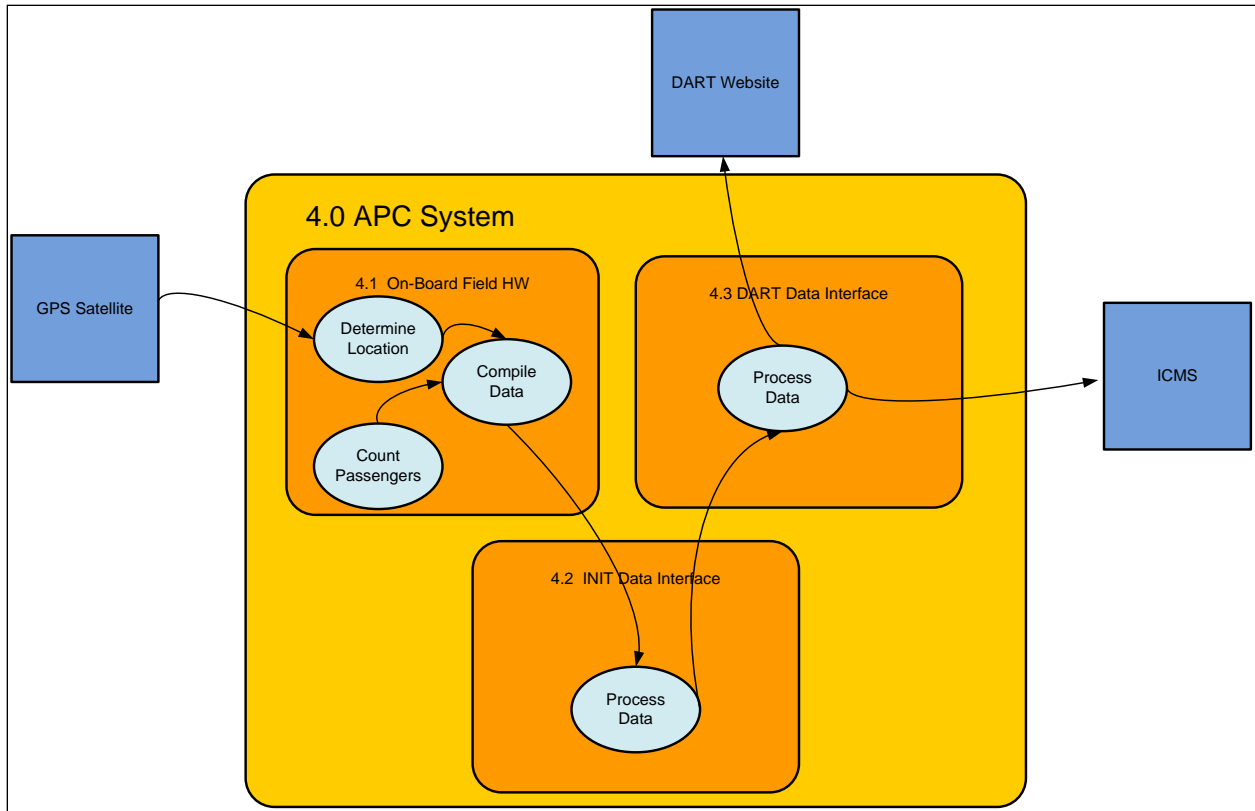

Figure D-4: Real-Time Transit Vehicle Data Demonstration System Architecture (Source: DART)

4 Design Considerations

Reusability of Components

All components (hardware, COTS software, custom code) have been analyzed for re-use.

Use of Standards

The ICMS will utilize information technology, Intelligent Transportation System, and transport protocol standards for publication of data to external subscribers as well as reception or request of data from external publishers and subscribers.

Major System Constraints

The following assumptions were used in the development of the system design for the Real-Time Transit Vehicle Data Demonstration project.

System Assumptions for the Demonstration Project

The following assumptions are overall system assumptions for this design:

- Since DART currently has an INIT based AVL and APC system installed on a hand full of LRVs, it is assumed that this project will expand upon that system and include enhancements to the currently installed system

Technology Assumptions for the Demonstration Project

The following assumptions are technology assumptions for this design:

- Communication between the INIT Data interface and On-board hardware will utilize the existing cellular modems installed by INIT
- INIT will provide an XML stream utilizing the SIRI standard

Data Flow Diagrams

In order to further understand the process flow and data formats of the Transit Vehicle Real Time Information Demonstration project, the following diagram was created. The basic flow of information for the system is:

1. The On-Board Field Hardware collects AVL and APC data from the on-board hardware. The on-board processor calculates the location and passenger count information and combines this with information from the vehicle's on-board computer system (driver ID, train #, etc.) and sends this data via a wireless technology to a central system provided by the APC contractor, INIT.
2. The INIT central system receives the data from all of the light rail vehicles equipped with the AVL/ APC hardware, and sends a SIRI formatted message to DART's system which includes train identification information (driver ID, train #, etc.), current location, and current on-board load information.
3. The DART system receives the SIRI formatted message and stores the information into its data store. The data is provided to internal DART systems and external systems, such as ICMS. The DART web site uses this data to show schedule adherence, current location, and arrival times. Any external system not owned by DART can currently only receive the current location and on-board loading, due to patent issues with arrival time and schedule adherence data. For external systems owned by DART, they will receive all available data shown in the diagram, including schedule adherence and arrival time.

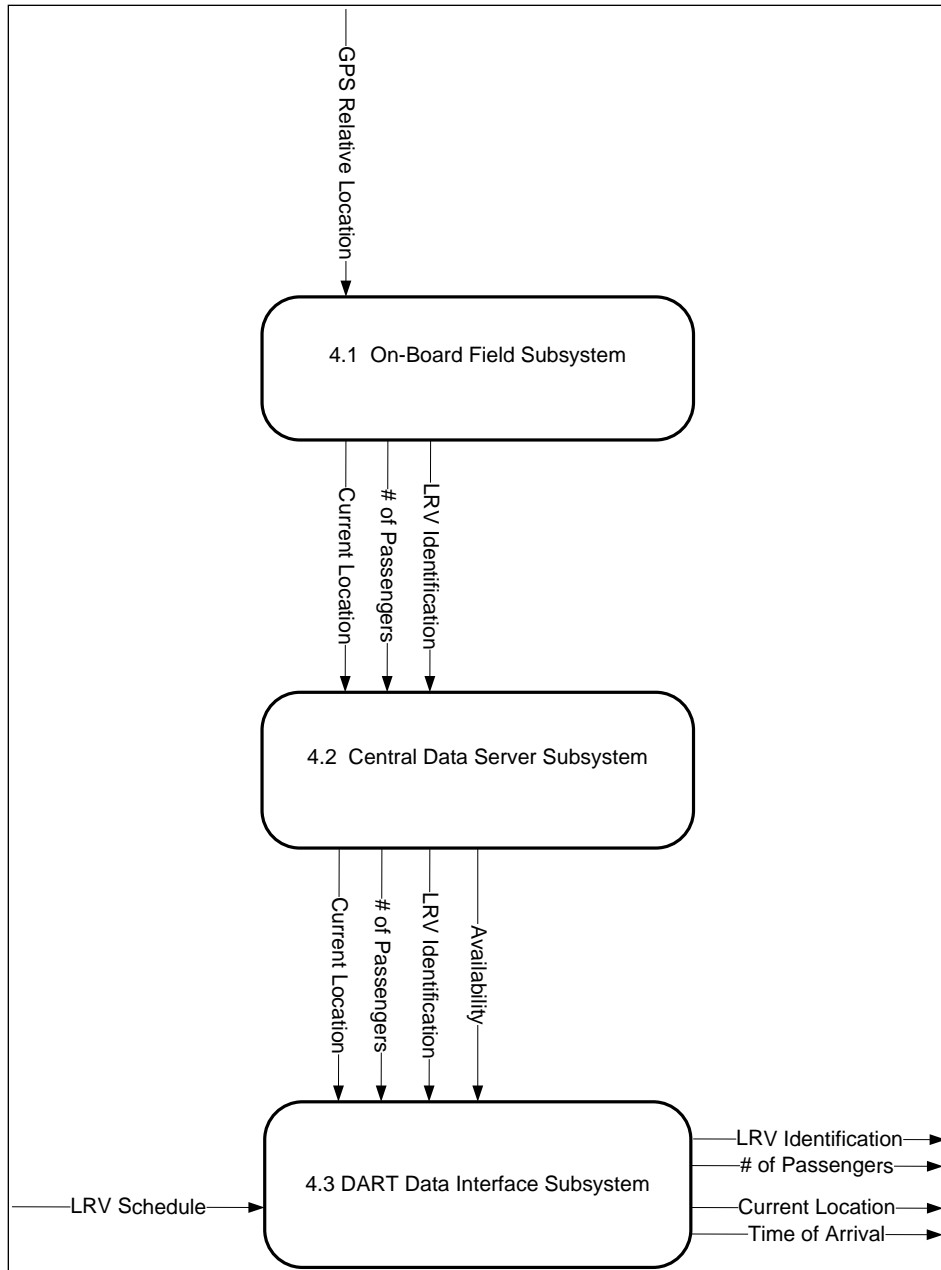

Figure D-5. Subsystem Data Flow Diagram (Source: DART)

External Interfaces

The external interfaces to the system include government provided systems for geo-location, and interfaces to data users once the system processes and provides information into standards based format.

Global Positioning System Interface to On-Board Field Hardware

Using the Global Positioning System signal from the geo-synchronous orbits of the GPS satellites, the APC/AVL system will calculate its location (latitude, longitude, elevation) for each equipped light rail vehicle.

DART Data Interface to Integrated Corridor Management System

DART will modify its existing XML feed to the ICMS to include AVL and APC data for the light rail vehicles in the corridor.

Internal Interfaces

Two main internal interfaces will be deployed for this project; between the Light Rail Vehicle Systems and the Central Servers provided by INIT and between the Central Servers and the DART Data Interface.

On-Vehicle System to Central Server

Once equipment has been installed on the light rail vehicles to provide location and capacity data, this data will be compiled and sent to the central server for processing and reporting to DART using a wireless communication technology.

Central Server to DART Data Interface

The Central Servers receive data from the on-board vehicles, and then fuses and processes this data for transmission to the DART systems. Utilizing a SIRI XML standard, the central server sends data to the DART Data Interface.

On-Board Subsystem

The On-board vehicle systems include the following primary components in support of the Transit Vehicle Real-time Data Demonstration Project:

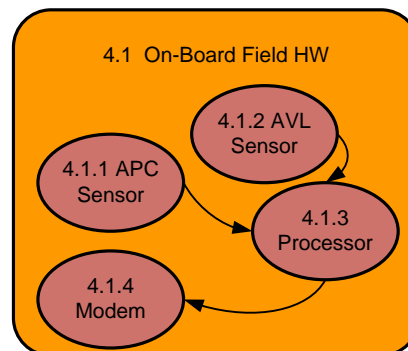

Figure D-6. On-Board Vehicle Hardware Components

The 48 Super Light Rail Vehicles (SLRV) with APCs will have sensors made by IRMA based on infrared laser pulse and Time-of-Flight (TOF) technology. There are ten doorways that passengers enter the SLRV, six each with two physical doors that slide and four each with a single physical door that slides. The configuration of sensors is two sensors for each of the six wide doorways and one sensor for each of the narrow doorways; there are sixteen sensors on each SLRV. In the case of the wide doors, the sensors are configured and designed to count accurately even though they are monitoring the same doorway. The sensors in each section of the SLRV are connected together with a device called an analyzer that collects the data about the laser pulses from the sensors. The three sections of the SLRV are the A-cab, the B-cab, and the C-unit. There are four sensors in the C-unit and six sensors in each of the A-cab and B-cab. Each of the three analyzers communicates its data to the onboard computer component of the CAD/AVL system.

APC Sensor Module

The APC Sensor Module is a hardware component that is installed over each door of the Light Rail Vehicle, and will meet the following specification:

- The APC Sensor shall collect passenger count data
- The APC Sensor shall send to the Processor Module loading data
- The APC Sensor shall utilize infrared laser pulse and Time-of-Flight (TOF) technology

AVL Sensor Module

The AVL Sensor module is a hardware component that is installed on the top of each Light Rail Vehicle, and will meet the following specification:

- The AVL Sensor Module shall be installed in the top middle of each Light Rail Vehicle
- The AVL Sensor Module shall calculate its latitude and longitude
- The AVL Sensor Module shall send to the Processor Module the LRV location data

Processor Module

The processor module is a hardware component that is installed in the on-board computer system, and will meet the following specification:

- The Processor Module shall receive from the AVL Sensor Module LRV location data
- The Processor Module shall receive from the APC Sensor Module LRV On-board loading data
- The Processor Module shall calculate LRV Location Data
- The Processor Module shall calculate LRV Loading Data
- The Processor Module shall use the Modem Module to send to the INIT Data Interface Subsystem LRV Location Data
- The Processor Module shall use the Modem Module to send to the INIT Data Interface Subsystem LRV Loading Data

Modem Module

The modem module is a hardware component that is installed as part of the on-board computer system for wireless communication with the central systems for the vendor and DART, and will meet the following specification:

- The Modem Module shall be installed in the top middle of each Light Rail Vehicle
- The Modem Module shall use Cellular wireless technology

Central Data Server Subsystem

The Central Data Server Subsystem consists of the central system that processes the data received via a wireless communication medium from the on-board field hardware. The Central Data Server subsystem processes the data and sends specific location and vehicle loading data to the DART data interface. The On-board vehicle systems include the following primary components in support of the Transit Vehicle Real-time Data Demonstration Project:

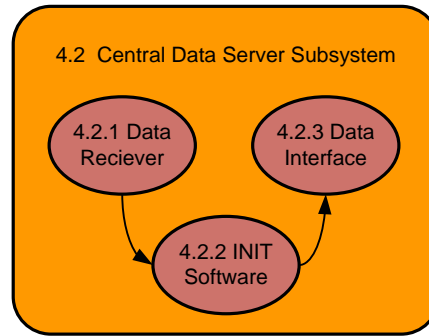

Figure D-7. Central Data Server Components

Data Receiver Module

The data receiver module is a system component that is installed in the central data server subsystem, and will meet the following specification:

- The Data Receiver Module shall receive from the On-Board Field Hardware Subsystem LRV Location Data
- The Data Receiver Module shall receive from the On-Board Field Hardware Subsystem LRV Loading Data
- The Data Receiver Module shall receive from the On-Board Field Hardware Subsystem LRV Loading Data using cellular wireless technology
- The Data Receiver Module shall receive from the On-Board Field Hardware Subsystem LRV Loading Data using cellular wireless technology
- The Data Receiver Module shall send to the INIT Software Module LRV Location Data
- The Data Receiver Module shall send to the INIT Software Module LRV Loading Data
- The Data Receiver Module shall receive data from the On-Board Field Hardware Subsystem on a system defined interval, initially around 25 seconds

INIT Software Module

The INIT Software module is a system component that is installed in the central data server subsystem, and will meet the following specification:

- The INIT Software Module shall receive from the Data Receiver Module LRV Location Data
- The INIT Software Module shall receive from the Data Receiver Module LRV Loading Data
- The INIT Software Module shall translate LRV Location Data and LRV Loading Data into a SIRI XML Format message
- The INIT Software Module shall publish LRV Location Data and LRV Loading Data when requested by the DART Data Interface Subsystem

Data Interface Module

The Data Interface module is a system component that is installed in the central data server subsystem for sending or publishing APC/ AVL data, and will meet the following specification:

- The Data Interface Module shall send to the DART Data Interface Subsystem LRV Location Data and LRV Loading Data in a SIRI XML format when requested by the DART Data Interface Subsystem
- The Data Interface Module shall send the DART Data Interface Subsystem LRV Loading Data using a SIRI XML format
- The Data Interface Module shall send the DART Data Interface Subsystem LRV Location Data using a SIRI XML format

DART Data Interface Subsystem

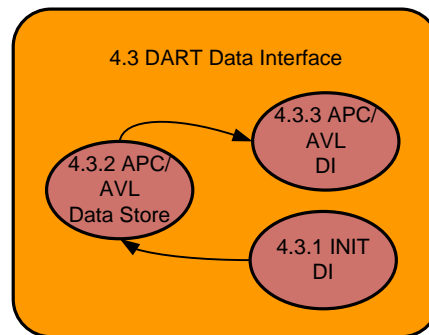

Figure D-8. DART Data Interface Components

Data Receiver Module

The Data Receiver Module is a software data interface that receives data from the Central Server subsystem, and includes the following specifications:

- The Data Receiver Module shall receive from the Data Interface Module LRV Location Data and LRV Loading Data in a SIRI XML format
- The Data Receiver Module shall request from the Data Interface Module LRV Location Data and LRV Loading Data
- The Data Receiver Module shall send the APC/AVL Data Store Module LRV Location Data and LRV Loading Data

APC/AVL Data Store Module

The APC/AVL Data Store Module is a database that receives data from the Central Server subsystem, and includes the following specifications:

- The APC/AVL Data Store Module shall receive from the Data Receiver Module LRV Location Data and LRV Loading Data
- The APC/AVL Data Store Module shall store LRV Location Data and LRV Loading Data
- The APC/AVL Data Store Module shall send to the APC/AVL Data Interface Module LRV Location Data and LRV Loading Data

APC/AVL Data Interface Module

The APC/AVL Data Interface Module is a software data interface that provides data to external systems in an XML format, and includes the following specifications:

- The APC/AVL Data Interface Module shall receive from the APC/AVL Data Store Module LRV Location Data and LRV Loading Data
- The APC/AVL Data Interface Module shall publish LRV Location Data and LRV Loading Data in an XML Format

5 Detailed System Design

Subsystem Components

The subsystem components as referenced in the High-Level Conceptual Diagram, Figure D-4, represent the highest-level processes in the APC/AVL System. For this design document, only the DART Data Interface is a

custom developed system. The other systems all consist of commercial products installed, and configured by the light rail vehicle vendor.

The following sections detail the components of each subsystem.

On-Vehicle Systems

Based on the contract between DART and the Light Rail Vendor, INIT – the following Hardware and Software components are installed on each of the 48 SLRV. Some of these items are outside the scope of this document, so will not be addressed. These are important to the operation of the LRV, but do not impact the real-time data systems for AVL and APC functions needed for the ICM program.

Hardware Components

- Processor - Vehicle Logic Unit (On-Board Computer)
- Power Conditioning Unit (PCU)
- Mobile Display Screen (MDS)
- Automatic Passenger Counter (APC)
- Modem
- Interface to On-Board Public Announcement System
- Interface to Trip Stop Counter

Processor

The Processor, component 4.1.3, is responsible for storing, receiving, and transmitting the APC and AVL data.

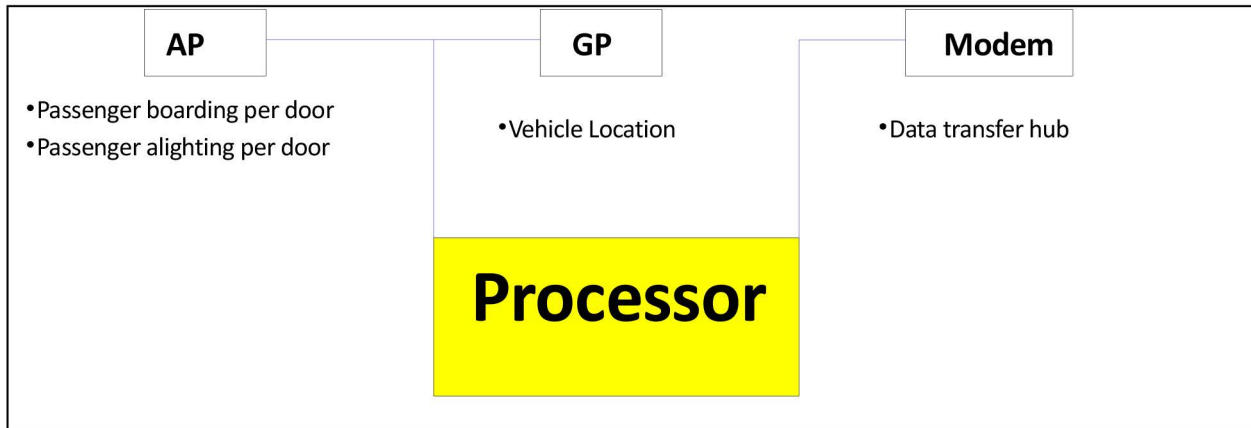

Figure D-9. Processor Components

Installation Locations

- 240V electrical cabinet in the low-floor cab or C-Car. (Preferred)
- 240V electrical cabinet in Cab A or B.

Automatic Passenger Counters

The APC units will be responsible for collecting passenger boarding and alighting activities while the train is in operation.

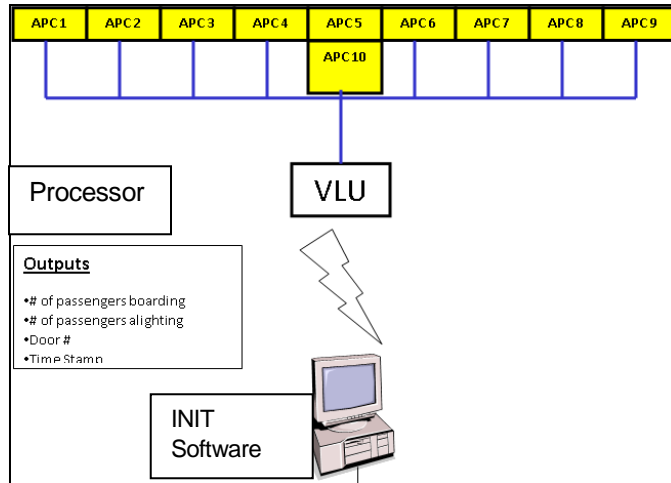

Figure D-10. Automatic Passenger Counters Components

Installation Location

The APC units will be installed above all 10 doors on the LRV (this includes the two C-Car doors).

AVL Sensor

The AVL Sensor, component 4.1.2, will provide location information to real-time systems.

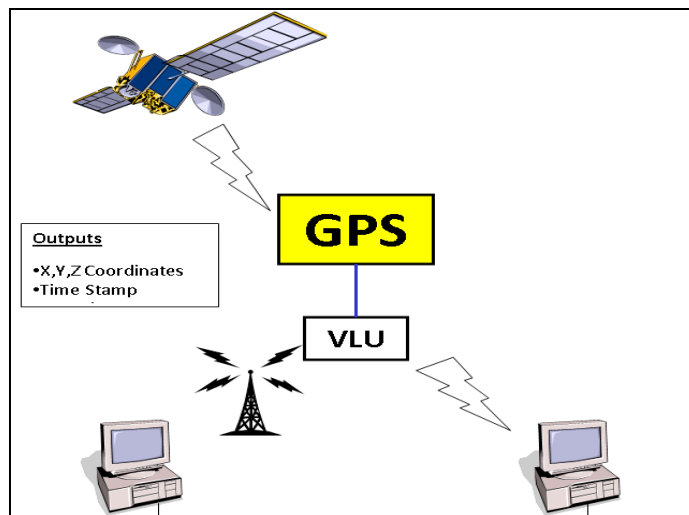

Figure D-11. AVL Sensor Components

Installation Location

The GPS antenna will be installed in the center of each Light Rail Vehicle.

Modem

The modem, component 4.1.4, will be used to download and upload information to and from the Processor. Real-Time communications will be used to transmit primary operations data to the control center, as well as, other back-end systems.

Installation Location: The Modem will be located inside the Processor using a PC card slot. The Modem antenna will be located in the center of each LRV.

Central Server Subsystem

Based on the contract between DART and the Light Rail Vendor, INIT – the following Software components are installed in the Central Server Subsystem. Some of these items are outside the scope of this document, so will not be addressed. These are important to the operation of the LRV, but do not impact the real-time data systems for AVL and APC functions needed for the ICM program.

Software/Interface Components

- Information Display System (IDS)
- Schedule Adherence Monitor (SAM)
- Central Data Server

Central Data Server Components

This system will be used to display rail operations information to the control center, non-operations stakeholders, and the DART customer. This system includes interfacing with the following existing DART systems:

- Supervisory Control and Data Acquisition (SCADA) System – GE
- Public Announcement/Visual Message Boards – PENTA Corporation
- DART intranet/internet

For this document the DART intranet/ internet systems will be the focus.

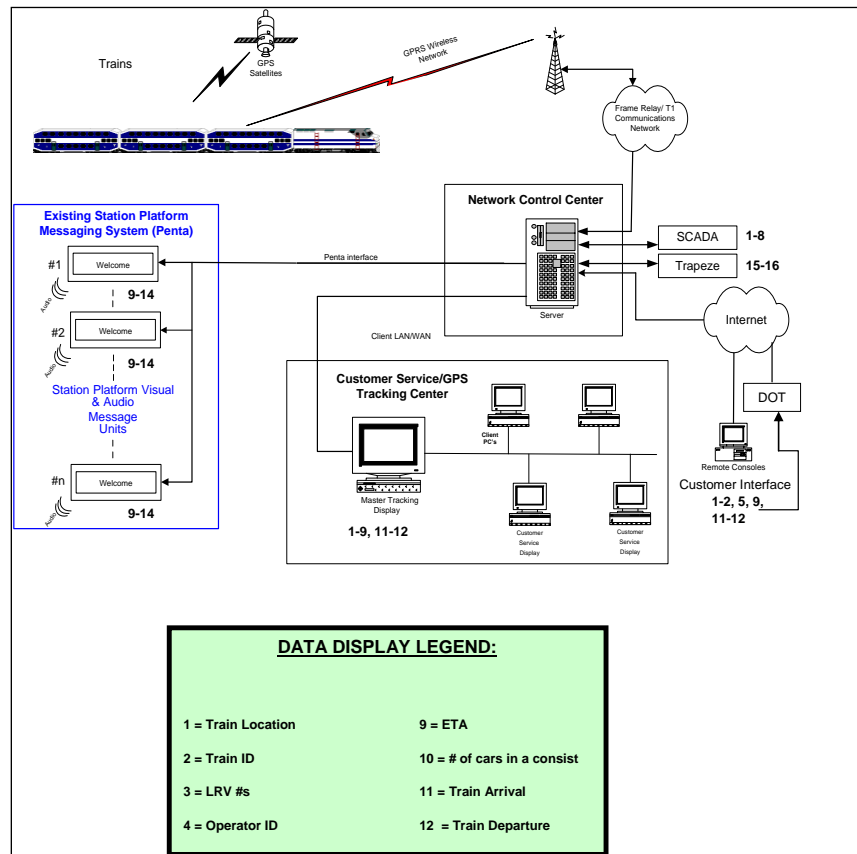

Figure D-12: Information Display System Components

Installation Location

The network control server will be located at the S&I facility.

Data Receiver Module

This software module will be used to transmit rail operations data to and from the Processor component on the LRV. The data transmitted from the Processor will be stored in an Oracle database for data and statistical analysis.

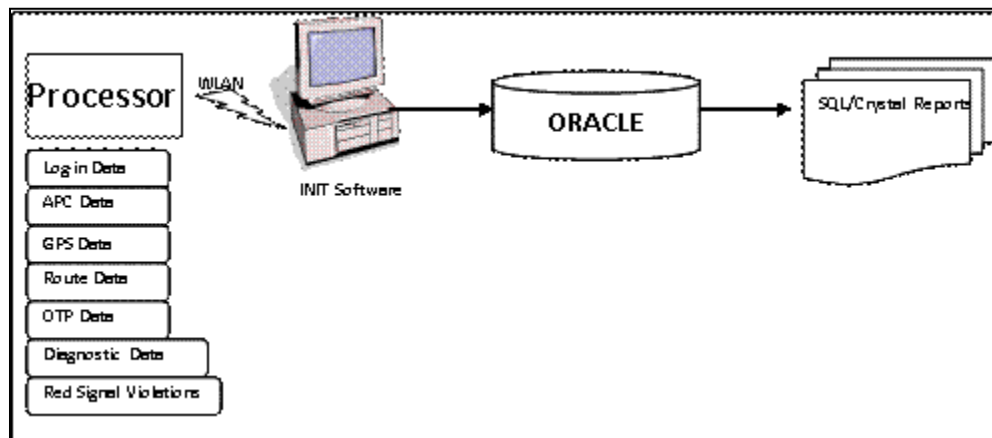

Figure D-13. Data Receiver Module Components

Installation Location: The INIT Software will be located at INIT. The access points for the wireless data transmission will be installed outside of the rail maintenance shop adjacent to the LRV cleaning tracks.

DART Data Interface Subsystem

Inputs/Outputs

The DART Data Interface Subsystem consists of both inputs and outputs of data, these are described below:

- Inputs – AVL and APC data in a SIRI XML message format.
- Outputs – AVL and APC data in a XML message format.

Data Stores

The DART Data Interface Subsystem consists of several data stores which store data received and provides it for output to other systems. These data stores include:

- AVL Data Store – Real-time Vehicle Location associated tables.
- APC Data Store – Real-time Vehicle Capacity associated Tables
- Vehicle ID Inventory – Vehicle identification tables

Dependencies/Constraints

The dependencies and constraints on the design of the DART Data Interface Subsystem include:

- The INIT Data Feed is provided in a SIRI XML based message format
- XML feed must be available to the DART Data Interface Subsystem

Use Case Diagram

The following use case diagram describes at a high level, the main activities performed by the DART Data Interface subsystem.

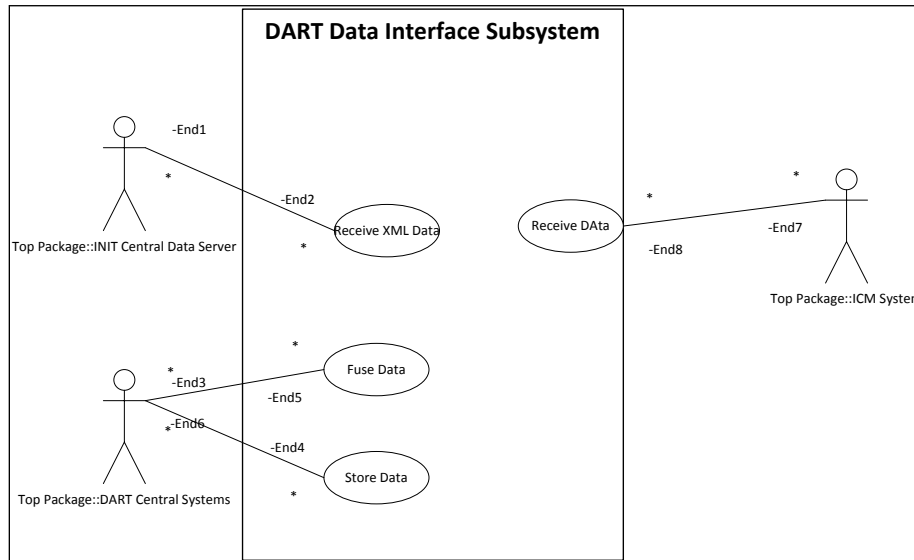

Figure D-14. DART Data Interface Subsystem Use Case Diagram

The DART data interface subsystem polls the central data server subsystem SIRI XML feed and fuses (creates or removes) AVL and APC data associated with each light rail vehicle.

- Poll XML Feed – The DART Data Interface Subsystem polls the Central Data Server SIRI XML Feed to get the current location and capacity of all equipped light rail vehicles in the corridor.
- Check Database – The XML feed checks the DART data interface subsystem database for changes to light rail vehicle location and capacity information.
- Populate APC/AVL XML – XML content is generated for location and capacity changes.
- Publish XML – XML data is published to each subscriber based on the type of access.

Table D-1. XML Feed Use Case

Use Case ID	
Description	XML Feed provides AVL_data and APC_data to subscribers
Actors	XMLFeed
Preconditions	db_AVL and db_APC are populated with new location and capacity or updated location and capacity data
Post Conditions	None
Normal Course of Events	<ol style="list-style-type: none"> 1. XML Feed checks db_AVL and db_APC databases 2. XML Feed populates AVL and APC data in which data has changed 3. XML Feed publishes the XML content based on user access list

XML Schema

The following XML Schema was developed by DART software staff to document the XML schema for the DART Data interface subsystem for publishing data to external systems, including the ICM System.

```

<?xml version="1.0" encoding="utf-8"?>
<xs:schema id="transitVehicleLocations" xmlns="" xmlns:xs="http://www.w3.org/2001/XMLSchema"
xmlns:msdata="urn:schemas-microsoft-com:xml-msdata">
<xs:element name="transitVehicleLocations" msdata:IsDataSet="true" msdata:UseCurrentLocale="true">
<xs:complexType>
<xs:choice minOccurs="0" maxOccurs="unbounded">
<xs:element name="transitVehicleLocation">
<xs:complexType>
<xs:sequence>
<xs:element name="vehicle_id" type="xs:integer" minOccurs="1" />
<xs:element name="route_type" type="xs:integer" minOccurs="0" />
<xs:element name="evt_date" type="xs:string" minOccurs="0" />
<xs:element name="latitude" type="xs:float" minOccurs="0" />
<xs:element name="longitude" type="xs:float" minOccurs="0" />
<xs:element name="location" type="xs:string" minOccurs="0" />
<xs:element name="prev_evt_date" type="xs:string" minOccurs="0" />
<xs:element name="prev_latitude" type="xs:float" minOccurs="0" />
<xs:element name="prev_longitude" type="xs:float" minOccurs="0" />
<xs:element name="blocknum" type="xs:integer" minOccurs="0" />
<xs:element name="line" type="xs:integer" minOccurs="0" />
<xs:element name="sched_adher" type="xs:integer" minOccurs="0" />
<xs:element name="pattern" type="xs:string" minOccurs="0" />
<xs:element name="last_timept" type="xs:string" minOccurs="0" />
<xs:element name="next_timept" type="xs:string" minOccurs="0" />
<xs:element name="occupancy" type="xs:integer" minOccurs="0" />
<xs:element name="num_block_parts" type="xs:integer" minOccurs="0" />
</xs:sequence>
</xs:complexType>
</xs:element>
</xs:choice>
</xs:complexType>
</xs:element>
</xs:schema>

```

SOAP 1.1

The following is a sample SOAP 1.1 request and response. The placeholders shown need to be replaced with actual values.

```

POST /webservice/VehicleLocations.asmx HTTP/1.1
Host: www.dartnet.org
Content-Type: text/xml; charset=utf-8
Content-Length: length
SOAPAction: "http://tempuri.org/GetVehicleLocations"
<?xml version="1.0" encoding="utf-8"?>
<soap:Envelope xmlns:xsi="http://www.w3.org/2001/XMLSchema-instance" xmlns:xsd="http://www.w3.org/2001/XMLSchema" xmlns:soap="http://schemas.xmlsoap.org/soap/envelope/">
<soap:Body>
<GetVehicleLocations xmlns="http://tempuri.org">
<line>string</line>

```

```

    <vehicleID>string</vehicleID>
    <blockNum>string</blockNum>
    <APIKey>string</APIKey>
  </GetVehicleLocations>
</soap:Body>
</soap:Envelope>
HTTP/1.1 200 OK
Content-Type: text/xml; charset=utf-8
Content-Length: length
<?xml version="1.0" encoding="utf-8"?>
<soap:Envelope xmlns:xsi="http://www.w3.org/2001/XMLSchema-
instance" xmlns:xsd="http://www.w3.org/2001/XMLSchema" xmlns:soap="http://schemas.xmlsoap.org/soap/e
nvelope/">
  <soap:Body>
    <GetVehicleLocationsResponse xmlns="http://tempuri.org/">
      <GetVehicleLocationsResult>xml</GetVehicleLocationsResult>
    </GetVehicleLocationsResponse>
  </soap:Body>
</soap:Envelope>

```

SOAP 1.2

The following is a sample SOAP 1.2 request and response. The placeholders shown need to be replaced with actual values.

```

POST /webservice/VehicleLocations.asmx HTTP/1.1
Host: www.dartnet.org
Content-Type: application/soap+xml; charset=utf-8
Content-Length: length
<?xml version="1.0" encoding="utf-8"?>
<soap12:Envelope xmlns:xsi="http://www.w3.org/2001/XMLSchema-
instance" xmlns:xsd="http://www.w3.org/2001/XMLSchema" xmlns:soap12="http://www.w3.org/2003/05/soap
-envelope">
  <soap12:Body>
    <GetVehicleLocations xmlns="http://tempuri.org/">
      <line>string</line>
      <vehicleID>string</vehicleID>
      <blockNum>string</blockNum>
      <APIKey>string</APIKey>
    </GetVehicleLocations>
  </soap12:Body>
</soap12:Envelope>
HTTP/1.1 200 OK
Content-Type: application/soap+xml; charset=utf-8
Content-Length: length
<?xml version="1.0" encoding="utf-8"?>
<soap12:Envelope xmlns:xsi="http://www.w3.org/2001/XMLSchema-
instance" xmlns:xsd="http://www.w3.org/2001/XMLSchema" xmlns:soap12="http://www.w3.org/2003/05/soap
-envelope">
  <soap12:Body>
    <GetVehicleLocationsResponse xmlns="http://tempuri.org/">

```



```

    <GetVehicleLocationsResult>xml</GetVehicleLocationsResult>
  </GetVehicleLocationsResponse>
</soap12:Body>
</soap12:Envelope>

```

HTTP GET

The following is a sample HTTP GET request and response. The placeholders shown need to be replaced with actual values.

```

GET
/webService/VehicleLocations.asmx/GetVehicleLocations?line=string&vehicleID=string&blockNum=string&API
Key=string HTTP/1.1
Host: www.dartnet.org
HTTP/1.1 200 OK
Content-Type: text/xml; charset=utf-8
Content-Length: length
<?xml version="1.0"?>
xml

```

HTTP POST

The following is a sample HTTP POST request and response. The placeholders shown need to be replaced with actual values.

```

POST /WebService/VehicleLocations.asmx/GetVehicleLocations HTTP/1.1
Host: www.dartnet.org
Content-Type: application/x-www-form-urlencoded
Content-Length: length
line=string&vehicleID=string&blockNum=string&APIKey=string
HTTP/1.1 200 OK
Content-Type: text/xml; charset=utf-8
Content-Length: length
<?xml version="1.0"?>
xml

```

6 Requirements Traceability

This section covers the functional, performance, interface, data, and hardware requirements. It also covers non-functional and enabling requirements, and constraints. For the requirements provided below, the requirement ID provides the level of requirement:

Level 1 – APC System – 4

Level 2 – APC Subsystem 4.X

Level 3 – APC Hardware or Software Module 4.X.Y.

Requirement Numbering Rules

- System Requirements are 4.0.0.10 to 4.0.0.n
 - APC is 4.0.0.n
- Subsystem Requirements are 4.1.0.10 to 4.X.0.n
 - On-board Hardware Subsystem is 4.1.0.n
 - INIT Data Subsystem is 4.2.0.n
 - DART Data Subsystem is 4.3.0.n

Requirement Types

- F = Functional
- I = Interface (interface between APC and external systems)
- D = Data (internal storage, send and receive of data within the APC System)
- C = Constraint
- P = Performance

Verification Method

- Analysis = Analysis (Analysis is the use of established technical or mathematical models or simulations, algorithms, or other scientific principles and procedures to provide evidence that the item meets its stated requirements.)
- Inspect = Inspection (Inspection is observation using one or more of the five senses, simple physical manipulation, and mechanical and electrical gauging and measurement to verify that the item conforms to its specified requirements.)
- Demo = Demonstrate (Demonstration is the actual operation of an item to provide evidence that it accomplishes the required functions under specific scenarios.)
- Test = Test (Test is the application of scientific principles and procedures to determine the properties or functional capabilities of items.)

Requirement Criticality

- H = High
- M = Medium
- L = Low

Assumptions and Dependencies

- Existing INIT solution installed on Light Rail Vehicles within the DART fleet will be used

APC High-Level “Business” Requirements

The first step in the requirements process is the development of the overall ICMS “business” requirements. The ICM Steering Committee developed the User Needs, Goals, and Vision for the corridor. These were then translated into applicable use cases, and high-level requirements for the ICM System as a whole. These requirements are fulfilled by existing and new systems, and are the requirements for the stakeholders to operate the corridor in an integrated manner. Table D-2 provides high-level requirements which map directly to the user needs.

Table D-2. APC System Requirements

Req ID	Req Description	Type	User Needs	Criticality	Verification Method	Subsystem Allocation
4.0.0.10	APC/AVL System shall provide current capacity of light rail trains in the corridor	Functional	1	High	Demonstrate	On-Board Field Subsystem, Central Server Subsystem, DART Data Interface
4.0.0.20	APC/AVL System shall provide transit event information to travelers	Interface	2	High	Demonstrate	DART Data Interface
4.0.0.30	APC/AVL System shall provide current location of light rail trains in the corridor	Functional	3	High	Demonstrate	On-Board Field Subsystem, Central Server Subsystem, DART Data Interface

Subsystem Technical Requirements

For each of the AVL/ APC subsystems, requirements were developed to provide high-level functions, data, interfaces, and performance requirements to complete the Transit Vehicle Real-time demonstration project. All of these subsystems are a part of the overall AVL/APC System.

On-Board Subsystem Requirements

Table D-3 provides a listing of the requirements related to the data and functions within the subsystem on the light rail vehicles.

Table D-3. On-Board Subsystem Requirements

Req No	Requirement Text	Type	Parent Req	User Needs	Criticality	Verification	Allocation
4.1.0.10	On-Board Subsystem shall calculate the location of a Light Rail Vehicle using Global Positioning System technology	C	4.0.0.10	I	H	Demonstrate	Section 0
4.1.0.20	On-Board Subsystem shall determine the number of passengers entering and exiting a Light Rail Vehicle with 90% accuracy	F,P	4.0.0.10	I	H	Demonstrate	Section 4.6
4.1.0.30	On-Board Field Hardware Subsystem shall compute the on-board load of a Light Rail Vehicle within 20 seconds	F,P	4.0.0.10	I	H	Demonstrate	Section 4.6
4.1.0.40	On-Board Field Hardware Subsystem shall send Light Rail Vehicle Loading Data within 20 seconds of calculation to the Central Data Server Subsystem	D,P	4.0.0.10	I	H	Demonstrate	Section 4.6
4.1.0.50	On-Board Field Hardware Subsystem shall send Light Rail Vehicle Location Data within 20 seconds of determination to the Central Data Server Subsystem	D,P	4.0.0.30	3	H	Demonstrate	Section 4.6

Central Data Server Subsystem Requirements

Table D-4 provides a listing of the requirements related to the INIT central software system used to analyze and process the AVL and APC data received from the light rail vehicles.

Table D-4. Central Data Server Subsystem Requirements

Req No	Requirement Text	Type	Parent Req	User Needs	Criticality	Verification	Allocation
4.2.0.10	Central Data Server Subsystem shall receive LRV Loading Data from the On-Board Subsystem	D	4.0.0.10	I	H	Demonstrate	Section 0
4.2.0.20	Central Data Server Subsystem shall receive from the On-Board Field Hardware Subsystem LRV Location Data	D	4.0.0.30	3	H	Demonstrate	Section 4.7
4.2.0.30	Central Data Server Subsystem shall send to the DART Data Interface Subsystem LRV Loading Data	D	4.0.0.10	I	H	Demonstrate	Section 4.7
4.2.0.40	Central Data Server Subsystem shall send to the DART Data Interface Subsystem LRV Location Data	D,C	4.0.0.30	3	H	Demonstrate	Section 4.7
4.2.0.50	Central Data Server Subsystem shall compute the availability of passenger space on each LRV	F	4.0.0.10	I	H	Demonstrate	Section 4.7

DART Data Interface Subsystem Requirements

Table D-5 provides a listing of the requirements related to the subsystem within DART that receives the AVL and APC data from the Central Data Server subsystem.

Table D-5. DART Data Interface Subsystem Requirements

Req No	Requirement Text	Type	Parent Req	User Needs	Criticality	Verification	Allocation
4.3.0.10	DART Data Interface Subsystem shall receive from the Central Data Server Subsystem LRV Loading Data	D	4.0.0.10	1	H	Demonstrate	Section 0
4.3.0.20	DART Data Interface Subsystem shall receive from the Central Data Server Subsystem, LRV Location Data	D, C	4.0.0.30	3	H	Demonstrate	Section 4.8
4.3.0.30	DART Data Interface Subsystem shall publish LRV Loading Data in an XML format within 10 seconds of receipt from the Central Data Server subsystem	D, C, P	4.0.0.20	2, 4	H	Demonstrate	Section 4.8
4.3.0.40	DART Data Interface Subsystem shall publish LRV Location Data in an XML format within 10 seconds of receipt from the Central Data Server subsystem	D, C, P	4.0.0.20	2, 4	H	Demonstrate	Section 4.8
4.3.0.50	DART Data Interface Subsystem shall store LRV Loading Data	D	4.0.0.20	2	H	Demonstrate	Section 4.8
4.3.0.60	DART Data Interface Subsystem shall store LRV Location Data	D	4.0.0.20	2	H	Demonstrate	Section 4.8
4.3.0.70	DART Data Interface Subsystem shall compute the schedule adherence of each LRV within 10 seconds	F	4.0.0.20	2, 4	H	Demonstrate	Section 4.8

7 References

Concept of Operations for the US-75 Integrated Corridor in Dallas, Texas, May 2009.

FHWA Rule 940, *Federal Register/Vol. 66, No. 5/Monday, January 8, 2001/Rules and Regulations, Department of Transportation, Federal Highway Administration 23 CFR Parts 655 and 940, [FHWA Docket No. FHWA–99–5899] RIN 2125–AE65 Intelligent Transportation System Architecture and Standards.*

Operational Concept, Dallas Real-Time Transit Vehicle Data Demonstration Project, August 2012.

Real-Time Transit Vehicle Data Demonstration Final Statement of Work, May 2011.

System Engineering Handbook: A Guide for System Life Cycle Processes and Activities, version 3.2, January 2010, International Council on Systems Engineering

System Requirements, Dallas Real-Time Transit Vehicle Data Demonstration Project, April 2013.

Systems Requirements Specification for the US-75 Integrated Corridor in Dallas, Texas, May 2009.

8 Acronyms

AMS	Analysis, Modeling, and Simulation	ICM	Integrated Corridor Management
APC	Automatic Passenger Counter	ITS	Intelligent Transportation Systems
ASMS	Arterial Street Monitoring System	IVR	Interactive Voice Response
ATIS	Advanced Traveler Information	LRT	Light Rail Transit
AVI	Automatic Vehicle Identification	LRV	Light Rail transit Vehicle
AVL	Automatic Vehicle Location	NCTCOG	North Central Texas Council of Govts.
CAD	Computer Aided Dispatch	NTTA	North Texas Tollway Authority
CCB	Configuration Control Board	PDR	Preliminary Design Review
CCTV	Closed Circuit Television	RCU	Roadside Communications Devices
CDPD	Cellular Digital Packet Data	RITA	Research & Innovative Technologies Administration
CDR	Critical Design Review	RFP	Request for Proposals
COTS	Commercial Off The Shelf	RTM	Requirements Traceability Matrix
Daltrans	Dallas Transportation Management Center	SDR	Software Development Review
DART	Dallas Area Rapid Transit	SIRI	Service Information for Real-time Information
DMS	Dynamic Message Sign	SRR	System Readiness Review
DSS	Decision Support System	TIS	Travel Information System
FHWA	Federal Highway Administration	TMC	Traffic Management Center
FTA	Federal Transit Administration	TMDD	Traffic Management Data Dictionary
GDP	Gross Domestic Product	TSP	Transit Signal Priority
GPS	Global Position System	TxDOT	Texas Department of Transportation
HAR	Highway Advisory Radio	XML	eXtensible Message Library
ICD	Interface Control Document		

APPENDIX

E

Test Plan and Results

Test Plan & Results

**Dallas Integrated Corridor Management (ICM) –
Transit Vehicle Real-time Data Demonstration**

Final Report

July 2, 2014

Contents

1 Introduction..... E-2

2 Scope and Summary E-2

3 Testing Overview and Results E-2

4 Acronyms E-8

Attachment A: LRTVBS and APC System Acceptance Test Plan..... E-9

List of Tables

Table E-1: APC Based Sampling Test Results..... E-5

Table E-2: APC Installation Results E-7

List of Figures

Figure E-1: APC Sensor and Analyzer Configuration E-4

Figure E-2: High-Level Automated Passenger Counter Schematic E-4

Figure E-3: Location of Human Counters at Each Doorway of an APC-equipped SLRV..... E-5

Figure E-4: Location of APC’s Equipment at Each Doorway of an APC-equipped SLRV..... E-5

1 Introduction

This document provides the testing plan and results for the Dallas Area Rapid Transit (DART) Real-Time Transit Vehicle Data Demonstration project within the context of the larger ICM project. This document includes a discussion of the testing approach for the installation of Automated Passenger Counting devices and the related systems for this project.

2 Scope and Summary

The Dallas Integrated Corridor Management (ICM) demonstration project is a multi-agency, decentralized operation which will utilize a set of regional systems to integrate the operations of the corridor. The ICM System, used by agency partners to manage the corridor in a collaborative and integrated manner, includes a multi-modal and operations decision support tool that is enabled by real-time data pertaining to the operation of freeways, arterials, and public transit. The system will be shared between information systems and people involved in transportation operations and emergency response in the US-75 Corridor. The Dallas ICM system is intended to provide improved integration of operation procedures, including procedures that take advantage of the data sharing capabilities of the Dallas ICM system and facilitate improved incident management, and traveler information.

A team headed by DART is providing technical and management services in support of the Dallas ICM demonstration project. DART currently lacks access to real time light rail transit (LRT) passenger loading data. As a result, it will be difficult to implement some ICM strategies that include transit, such as adding transit capacity in real time to accommodate dynamic mode shift to transit (e.g., drivers may shift to transit as a result of a major incident on an adjacent freeway). This project will demonstrate and evaluate the ability to collect and transmit transit location and loading vehicle data to a transit management center(s) and/or ICM system in real time. The project will also demonstrate and evaluate the ability to use the data in real time, in a decision support subsystem, for example, to make informed operational decisions. The project will include the development, installation, testing, and demonstration of on-board automated passenger counter (APC) and automated vehicle location (AVL) equipment and communications technologies to support real-time connectivity between transit vehicles and central facilities to support the following potential applications:

- Vehicle location and speed monitoring
- Passenger load monitoring

The Dallas ICM demonstration site will be used as a test bed for this project. The project will include the development of this operational concept to identify the appropriate transit vehicle real-time data applications that supports Dallas' proposed ICM strategies and operations. The applications selected for Dallas will be demonstrated on DART's red line LRT system, which is located in the US-75 ICM corridor.

3 Testing Overview and Results

Introduction

The Integrated Corridor Management System (ICMS) project will assess the utility of real-time transit vehicle data including light rail passenger loads, and will examine the issues, challenges, and feasibility of its use. For example, the project will explore the scenarios for which the Dallas Area Rapid Transit (DART) could dynamically encourage the shift of motorists traveling in the US-75 Corridor during a major traffic event disrupting highway capacity while monitoring transit parking lot capacity and train loads.

Before using the APC equipment, DART Operational Technology department and the Planning Research department conducted a series of tests to validate the accuracy of passenger count data and obtain FTA permission to use APC equipment to estimate National Transit Database passenger boardings and passenger miles traveled data. The testing procedure was used on DART's initial purchase of 48 APC-equipped SLRV cars and for the purchase of APC equipment for 20 SRLV cars required to meet the objectives of the ICMS program. The real time data test plan for verifying the accuracy and validity of APC data includes the following steps:

- Approval by FTA of DART's benchmark plan and APC maintenance plan before using automated passenger counting data for NTD reporting (September 14, 2012)
- Initial calibration of APC sensors and passenger counter compared to manual counts on the initial 48 SLRV cars. (February 22, 2011)
- Initial benchmarking and maintenance studies and submission of test results to FTA
- Initial benchmark validation of the accuracy of the new 20 APC-equipped cars to match the accuracy of the initial 48 SLRV cars and requirements for FTA reporting of NTD data. (Complete August 2013)
- Quarterly maintenance plan to insure validity and reliability of APC-equipped SLRV cars
- Annual APC maintenance to assure annual compliance with NTD reporting

It is important to note that the validation testing and maintenance procedures necessary for the ICMS program must be the same procedures used for the original 48 cars and the 20 additional cars purchased under the ICM grant. For that reason, the validation testing (including dates) and the ongoing maintenance plan will be described for both groups of SLRV cars.

Initial Calibration Tests on the Original 48 Cars

During December 2010 and January 2011, SLRV cars instrumented with APC equipment were operated in revenue service while DART and INIT staff collected manual passenger “on” and “off” counts at each door. The door by door manual counts were compared with the passenger counts collected by the APC equipment at the same doors. Because the raw APC counts included counts of strollers, bicycles, and large bags, the raw data along with the manual counts were sent to the sensor/analyzer manufacturer for detailed analysis. Based upon the differences between the manual and APC counts and the incorrect data like bikes, bags, and strollers, the sensor manufacturer made calibration modifications using the sensor software and delivered updated calibration factors to DART to load into the APC analyzer.

The calibration process of the APC consists of connecting a computer with the vendor's software to the vehicle business system (VBS). After each rail station stop, the software reads the APC counts and prompts for the manual counts. The collected data is sent to the vendor for analysis. The vendor then performs their calibration and supplies DART with updated software if needed. The process is repeated until the APC counts are within accepted range of the manual counts. This process incorporates an adjustment for data errors (non-human boardings like bikes, large bags, etc., or non-revenue passengers like the train operator, police, fare enforcement staff, etc.). Where the difference between actual counts of revenue passengers and APC door counts is greater than 9%, FTA will not approve for NTD counting purposes.

This calibration process required two (2) configuration software updates after the initial installation of the APC equipment before the APC counts matched the manual passenger counts.

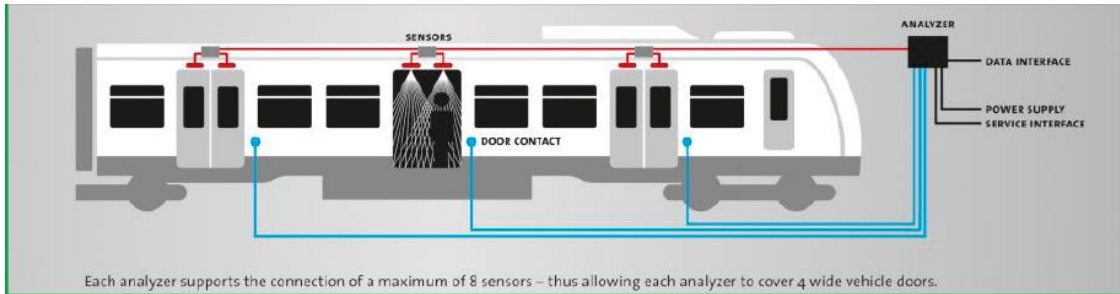

Figure E-1. APC Sensor and Analyzer Configuration (Source: INIT)

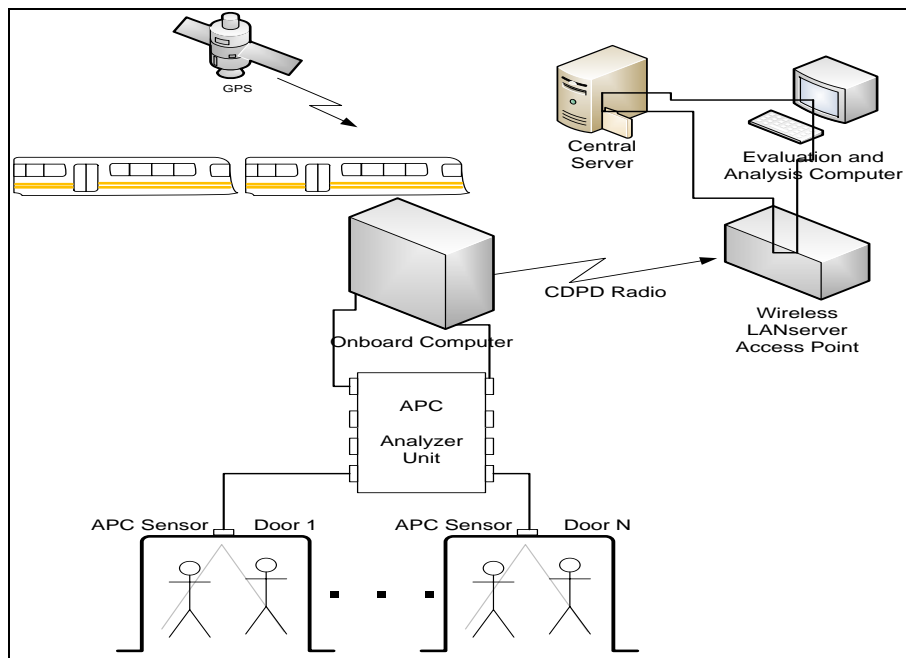

Figure E-2. High-Level Automated Passenger Counter Schematic (Source: DART)

FTA Requirements for Use of APC Equipment for NTD Reporting

Benchmarking Plan

FTA requires the use of a valid statistical sampling methodology which results in an estimate of unlinked passenger trips (UPT) totals and passenger miles traveled (PMT) at a 10% level of precision at the 95% level of confidence. This precision must be the same as the statistical sample using manual passenger counts or the sample using automated passenger counters (APC).

In the event that an agency elects to use APC technology to derive NTD data, the agency must receive written FTA approval of the APC benchmarking and maintenance plan prior to use of the APC sample. Additionally, the benchmarking plan requires concurrent manual and APC collection of NTD data on the same sample of trips over a full year. The results must show statistical equivalence between the APC sample and manual ride check sample.

Acceptance Testing of the Initial 48 Cars

After DART received the final APC software configuration from INIT, formal acceptance testing was conducted on February 22, 2011 on two randomly selected cars tested across six (6) complete light rail in-service trips. DART provided human passenger counters at each SLRV doorway to conduct counts of boarding and alighting passengers. Additionally, DART’s passenger count consultants were also assigned to this same SLRV to allow DART to compare its sampling based approach to passenger counting to the APC counts. The door by door manual counts were then compared with APC boardings and alightings.

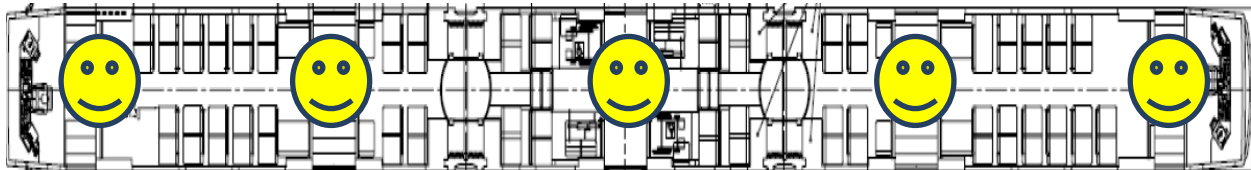

Figure E-3. Location of Human Counters at Each Doorway of an APC-equipped SLRV (Source: DART)

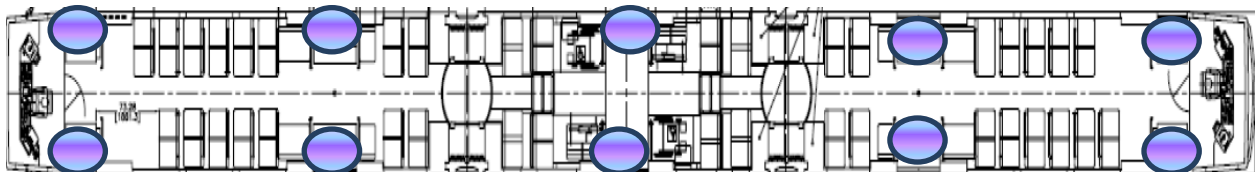

Figure E-4. Location of APC’s Equipment at Each Doorway of an APC-equipped SLRV (Source: DART)

Following the completion of the six in-service validation trips, the APC passenger boarding and alighting counts were within 3% of the passenger counts obtained by the human counters assigned to each light rail door. Based upon these initial results performed on February 22, 2011, the APC estimates were determined to be statistically equal to the manual counts.

FTA Approval of APC Based Sampling

From October 1, 2011 through September 30, 2012, DART conducted concurrent manual and APC counts of the NTD unlinked passenger trips and passenger miles traveled as required by FTA. The following results were submitted to FTA for the period of time October 1, 2011 through July 31, 2012. Based upon this data, DART received written approval from FTA on September 14 2012 via email to begin using APC based sampling of NTD data for FY12 and beyond.

Table E-1: APC Based Sampling Test Results

Description		Precision Based Upon Sample for UPT and PMT Estimates
Total Manual LRT Sampled Trips	158,255	10%
Total APC-equipped LRT Sampled Trips	1,685,091	3%
Manual Count – PMT (Trip Length) for FY11	8.15 miles	
APC Count Oct. 1, 2011 - July 2012 – PMT (Trip Length)	7.95 miles	Within 2.4% of FY11 Manual Count Est.

Maintenance Program

Annual Program

Following FTA approval of the initial one year benchmarking study of APC based sampling, FTA requires that DART perform a maintenance study at least annually and submit those results to FTA. The difference between the APC and Manual Counts must be statistically equivalent.

The minimum FTA requirement requires that DART select a sample of at least 100 vehicle trips using ride checkers to collect the unlinked passenger trips and passenger mile data each fiscal year. The estimates of UPT and PMT based upon this sample must be compared to the APC derived UPT and PMT estimates and the statistical variance must be calculated between the two data sets. These tests were performed in FY13 and will continue annually. The results are shared with FTA as part of the NTD annual reporting process.

Quarterly Maintenance Program

To ensure a high level of accuracy, DART maintenance staff performs a quarterly preventative maintenance inspection (PMI) on all APC doors and control units. Validity testing includes performing defined number of boardings and alightings repeatedly on each APC-equipped doorway and comparing the manual count results with the APC reported counts.

The PMI inspection program was originally performed monthly. However, due to the high accuracy of the results at the monthly PMI, DART shifted to quarterly PMI inspections. When the APC counts are within 3% of the manual counts, it is determined that the APC counts are equivalent and no maintenance is required. If there are performance problems, additional maintenance or vendor assistance is obtained.

Validation procedures for 20 APC-Equipped SLRVs Procured under ICMS Program

Following approval of FTA funding, DART conducted a procurement following FTA procedures to purchase, install and test the equipment to outfit an additional 20 SLRV's with APC equipment. The contract was awarded to Kinkyshario (SLRV manufacture) and INIT (APC equipment manufacturer). Table E-2 shows the cars and dates the APC installation began and ended. Validation testing was performed by DART Operations Technology staff responsible for APC maintenance and PMI inspections of the balance of the APC-equipped fleet before the vehicles were returned to service. APC-equipped cars are required to provide APC counts within 3% of the manual test counts of boarding passengers before being used in revenue service.

From August 1, 2013, all of the additional 20 APC-equipped cars have been assigned to the SLRV fleet making a total of 68 APC-equipped cars. The entire APC fleet is now included in the quarterly maintenance PMI program to insure the accuracy of the equipment.

Table E-2. APC Installation Results

Count	SLRV #	Date Entered Program	Achieved 3% APC vs. Manual Validation Test	Date Returned to Service
1	201	2/19/2013	Yes	3/14/2013
2	204	3/11/2013	Yes	4/1/2013
3	209	4/1/2013	Yes	4/10/2013
4	202	4/8/2013	Yes	4/17/2013
5	200	4/15/2013	Yes	4/24/2013
6	197	4/22/2013	Yes	5/1/2013
7	205	4/29/2013	Yes	5/10/2013
8	203	5/6/2013	Yes	5/17/2013
9	208	5/13/2013	Yes	5/23/2013
10	214	5/20/2013	Yes	5/29/2013
11	206	5/24/2013	Yes	6/5/2013
12	212	6/3/2013	Yes	6/12/2013
13	210	6/10/2013	Yes	6/19/2013
14	213	6/17/2013	Yes	6/26/2013
15	199	6/24/2013	Yes	7/3/2013
16	198	7/1/2013	Yes	7/10/2013
17	211	7/8/2013	Yes	7/7/2013
18	215	7/15/2013	Yes	7/17/2013
19	196	7/17/2013	Yes	7/24/2013
20	207	7/29/2013	Yes	8/1/2013

Assignment Plan for the ICMS program

On weekdays, DART assigns 102 SRLV's cars out of a fleet of 163 SLRV's. To assign 100% APC-equipped cars to the Red Line in the ICMS corridor requires 24 APC-equipped cars. This does not include the Orange Line trips which operate on the same corridor as the Red Line. To assign APC-equipped cars to the Red and Orange Line would require another 20 APC-equipped cars for a total of 44 cars. This is not possible to consistently assign 100% APC-equipped cars to the Orange Line while maintaining the required FTA NTD sampling program.

The Red Line assignment will be accomplished by assigning all of the 20 APC-equipped cars funded by USDOT as part of the ICMS grant. The additional 4 SLRV's will be assigned from the original group of 48 APC-equipped cars.

DART's NTD sampling program requires the assignment of at least 41 SRLV cars on a typical weekday. The sample includes the 100% assignment (24 cars) of the Red Line. On a typical day, approximately 50% of the Orange Line is APC-equipped.

Real Time Passenger Loads on the Red Line Corridor

To meet the requirements of the USDOT ICMS real time data program, INIT made modification to the communication packets between the trains and the central system allowing DART to receive the actual passenger load on each car of the trains in near real time.

To allow this on board data to be used to provide the "Real Time Passenger Load Information" to DART control staff in real time, two other modifications had to be completed by INIT. First, the Dispatch Application used by the Controllers and the Supervisor module had to be modified to configure the Vehicle List to add a column to display the "Load" information collected at the vehicle level. The second phase was implemented in the Service Interface for Real Time Information (SIRI) Vehicle Monitor (VM) Interface. The original SIRI VM interface provided information pertaining to the vehicle including location,

destination, previous stop, next stop and delay. It did not provide the load data. However, included in the SIRI VM configuration is a tag for client customization which INIT modified to include the “Load” for DART.

The APC load data, along with location, time, direction, and other VBS data is sent over the general packet radio system (GPRS), which is the public cellular network. The trains communicate with the central server every 15–20 seconds or whenever an event occurs. Events include stop, start, door open, door close, load, etc. Therefore, the maximum delay is 20 seconds.

When a train departs a station a communication packet is sent. However, that packet does not include the new load based on that station activity. The reason is that the onboard system does not gather and calculate the APC information until it confirms movement from the station. Therefore, the new load is not included until the second cycle of information is sent, typically 7–10 seconds later. This means that for a departing train, the time until the real time data is available is approximately 30 seconds.

As part of the operational testing, DART conducted tests for each car to verify that the APC data was being collected by every equipped train car, was transmitted to the DART central server, and was transmitted to Smartnet for use by the decision support system. The operational test was included observing that the data being collected on each car was being transmitted over the radio to the controllers without modification. Once this was completed for each car, the test was deemed to be a success and no further action was required.

4 Acronyms

AMS	Analysis, Modeling, and Simulation	ICD	Interface Control Document
APC	Automatic Passenger Counter	ICM	Integrated Corridor Management
ASMS	Arterial Street Monitoring System	ITS	Intelligent Transportation Systems
ATIS	Advanced Traveler Information Systems	IVR	Interactive Voice Response
AVI	Automatic Vehicle Identification	LRT	Light Rail Transit
AVL	Automatic Vehicle Location	LRV	Light Rail transit Vehicle
CCB	Configuration Control Board	NCTCOG	North Central Texas Council of Govts
CCTV	Closed Circuit Television	NTTA	North Texas Tollway Authority
CDPD	Cellular Digital Packet Data	PDR	Preliminary Design Review
CDR	Critical Design Review	RCU	Roadside Communications Units
COTS	Commercial Off The Shelf	RITA	Research & Innovative Technology Administration
Daltrans	Dallas Transportation Management Center	RFP	Request for Proposals
DART	Dallas Area Rapid Transit	RTM	Requirements Traceability Matrix
DMS	Dynamic Message Sign	SDR	Software Development Review
DSS	Decision Support System	SIRI	Service Interface for Real-time Information
FHWA	Federal Highway Administration	SRR	System Readiness Review
FTA	Federal Transit Administration	TIS	Travel Information System
GDP	Gross Domestic Product	TMC	Traffic Management Center
GPRS	General Packet Radio System	TMDD	Traffic Management Data Dictionary
GPS	Global Position System	TSP	Transit Signal Priority
HAR	Highway Advisory Radio	TxDOT	Texas Department of Transportation

Attachment A: LRTVBS and APC System Acceptance Test Plan

POST-TEST PLAN

LRTVBS and APC System Acceptance

DATE: _____

VEHICLE # _____

TESTERS: _____

ISSUES: _____

VER	DATE	AUTHOR	DESCRIPTION
1.0	3/15/08	D. Summey	Initial Release
1.1	5/30/08	D. Summey	Initial Draft
1.2	7/18/08	V. Brooks	Initial Draft
1.3	03/11/2013	Tin Nguyen	Revised

B. Script

#	Function	Activity	Description	Expected Results	Result	Comments
Card Swipe						
1	Card Swipe functionality	Verify Functionality	Swipe Card through readers on CAB-A Pressit slots	MDT will request Block log on.	Pass Fail	
2	Card Swipe functionality	Verify Functionality	Swipe Card through readers on CAB-B Pressit slots	MDT will request Block log on.	Pass Fail	
HW Input Testing						
3	CAB_A	MDT Display on/off	De-Activate the MDT CAB A	Pressit then goes dark then back on.	Pass Fail	
4	CAB_B	MDT Display on/off	De-Activate the MDT CAB B	Pressit then goes dark then back on.	Pass Fail	
5	Interior announcement	Interior audio	Select an interior announcement from the CA list.	The selected announcement is announced inside.	Pass Fail	
6	Exterior announcement	Exterior audio	Select an exterior announcement from the CA list	The selected announcement is announced outside. Check each of the six external speakers.	Pass Fail	
7	Interior and Exterior announcements	Interior & Exterior audio	Select an interior & exterior announcement from the CA list	The selected announcement is announced inside and outside. Check each of the six external speakers.	Pass Fail	
Data Provision for COPILOTpc. Using the vehicle simulator's MDT, set the vehicle into test mode (Menu, Test function, Password -4444)						
8	Show the current working application: COPILOTp	Data Verification	Test function to check the stored archives: 10103	Types to be displayed depending on the file extension: CopilotPc: 4.xx _____ Initexec: 1.24 _____ Xpe: COPpc_2.xx _____ MDTServer: 2.02 _____ Pressit-A: 1.3 _____ Pressit-B: 1.3 _____	Pass Fail	
9	Show the current working data archive:-Block data - Parameter -Mp3 Data	Data Verification	Test function to check the stored archives: 80102	WORKING DIRECTORY wc0: Analyzer parameter _____ pc0: Parameter _____ ic0: Block Data _____ gc0: Bitmaps, Buttons _____ BC _____ GSM_____, MDT_____ yc0: MP3 Data _____ xc0:Software _____ TRANSFER DIRECTORY wc0: Analyzer parameter _____ pc0: Parameter _____ ic0: Block Data _____ yc0: MP3 Data _____ xc0:Software _____ MDT Client _____	Pass Fail	

GPS						
10	GPS Time Synchronization	Time Synchronization by GPS	Use Test Function 10101 . Change the time with an incorrect value (11:11:11) Then Test Function 40101 Change parameter 300056 to 6 Exit parameter. Start test function 300002 – Check the Time received from the GPS Receiver.	The time is corrected by the GPS signal (with RMC). Enter test function 300002 again to erase text. Change back to 40 when complete.	Pass Fail	
WLAN						
11	WLAN Connection		Goto Test Function 110006 Select adapter 2 , hit enter 3 times to access WLAN IP address	Should show a valid DART IP address.	Pass Fail	
GPRS						
12	GPRS Communication	Start ITCS simulation	Goto Test Function 110006 Check the last adapter (usually a 6 digit ID) Hit enter 3 times to reveal the GPRS IP address	Should show a valid IP address IP Address.	Pass Fail	
TLI						
13	Communication with the TLI	TLI version	Activate test function 303301	Display Coupler A & B Status. Enter Test Function 303301 again to turn display off.	Pass Fail	
14	Vehicle ID setting	Set vehicle ID	Activate test function 10106 Set vehicle ID: 123 confirm mounting plate code: 0	<i>Vehicle code changed successfully.</i> Repeat and enter correct vehicle ID.	Pass Fail	
15	Door open	Door input check	Go to Test Function 500001 Select port 1 Enable Open & Close both left and right door	Acknowledge value change on MDT from 0 to 1 for each status change.	Pass Fail	
16	VBS fault	Check input for VBS fault	Goto Test Function 500005 and select output 12 , Press OK to toggle input. VBS fault light should illuminate. External blue light should be illuminated as well.	VBS fault light should illuminate. External blue light should be illuminated as well.	Pass Fail	

APC Test						
17	Clear Analyzer Data	Clear Analyzer Data	First utilize the door button to simulate all doors Closed on the vehicle Use Test function : 200610 to query the door status of all analyzers. Verify your response concludes all doors closed.	The query will be answered & a character response will be displayed for each analyzer: " - " indicates no answer " C " indicates door Closed, " O " indicates door opened.	Pass Fail	
18	Clear Analyzer Data	Clear Analyzer Data	Use Test function : 200611 to send the gathered way message	The summary is displayed and the characters are defined as " - " Telegram NOT acknowledged, " F " Telegram acknowledged. The numbers '0' and '15' describe the address range of the scan.	Pass Fail	
19	Clear Analyzer Data	Clear Analyzer Data	Use Test function : 200612 to initiate the retrieval of IRMA counts. Next the user has to specify all the IBIS address' of all the doors from which the APC results must be requested. (ie 1 ,2 ,3 ,4,.....10 and press the OK button to get the results) This is the final step to clear the analyzer data for accurate testing. Keep doors in the closed position	If there is an IRMA sensor installed with that address, the numbers of boarding and exiting passengers is displayed. Then the user can continue with another address or break by pressing the Cancel button.	Pass Fail	
20	Door Status Verification	Door Status Verification	Use Test function : 200610 To query the door status of all analyzers. Verify that they are CLOSED . Next open all doors and simulate that passengers are walkthrough the doors (keep note as to the exiting, or entering direction and at which doorways, from the Door Reference Table, that event takes place) Once all doors have been passed through, CLOSE ALL DOORS.	The query will be answered and a character response will be displayed for each analyzer: " - " indicates no answer, " C " indicates door closed, " O " indicates door opened.	Pass Fail	

21	Data Verification	Data Verification	Use Test function: 200611 to send the gathered way message. Verify message acknowledgment.	The summary is displayed and the characters are defined as “ – “ Telegram NOT acknowledged, “ F “ Telegram acknowledged. The numbers '0' and '15' describe the address range of the scan.	Pass Fail	
22	Data Verification	Data Verification	Use Test function : 200612 to initiate the retrieval of IRMA counts. Then the user has to specify the IBIS address of the door from which the APC results should be requested. (i.e. 1, 2, 3, 4,..10 and press the OK button to get the results) Verify accuracy counts and direction of doorway event by using the door reference table below.	If there is an IRMA sensor installed with that address, the numbers of boarding and exiting passengers is displayed. Then the user can continue with another address or break by pressing the Cancel button.	Pass Fail	

Door Reference Table

IBIS Address	DOOR	IN	OUT
IBIS Address 1	Door 1 R	1	2
IBIS Address 2	Door 2 R + 3 R	4	2
IBIS Address 3	Door 7 R + 8 R	1	2
IBIS Address 4	Door 4 R + 5 R	2	1
IBIS Address 5	Door 6 R	1	2
IBIS Address 6	Door 6 L	1	2
IBIS Address 7	Door 4 L + 5 L	2	1
IBIS Address 8	Door 7 L + 8 L	1	2
IBIS Address 9	Door 2 L + 3 L	4	2
IBIS Address 10	Door 1 L	1	2
TOTAL		18	18

GLOSSARY

AVL	Automated Vehicle Location
APC	Automatic Passenger Counter
CDPD	Cellular Digital Packet Data
DART	Dallas Area Rapid Transit
DSS	Decision Support Subsystem
FTA	Federal Transit Administration
ICM	Integrated Corridor Management
LRT	Light Rail Transit
LRV	Light Rail Vehicle
SIRI	Service Information for Real-time Information
SLRV	Super Light Rail Vehicle
USDOT	United States Department of Transportation
XML	eXtensible Markup Language

REFERENCES

Gorman, Alan, Kevin Miller, and Koorosh Olyai. (2012). Operational concept, transit vehicle real-time data demonstration project. October 5.

Gorman, Alan, Kevin Miller, and Koorosh Olyai. (2013) System design document, transit vehicle real-time data demonstration project. August.

Miller, Kevin, Fariel Bouattoura, Ed Seymour, Chris Poe, Marc Forgang, Roberto Macias, Joe Zingalli, and Bryan Miller. (2013). US-75 ICM system design document. FHWA-JPO-13-072, June.

Plesko, Todd, and Kevin Miller. (2014). Test plan & results, transit vehicle real-time data demonstration project. January.



U.S. Department of Transportation
Federal Transit Administration

U.S. Department of Transportation
Federal Transit Administration
East Building
1200 New Jersey Avenue, SE
Washington, DC 20590
<http://www.fta.dot.gov/research>