

Development, Field Testing, and Implementation of Improved Bridge Parapet Designs



Amy Kalabon, Lauren Hedges, Norbert Delatte

Prepared for:
The Ohio Department of Transportation,
Office of Statewide Planning & Research

State Job Number **134818**

March 2015

Final Report



Washkewicz College
of Engineering

TECHNICAL REPORT DOCUMENTATION PAGE

1. Report No.	2. Government Accession No.	3. Recipient's Catalog No.	
FHWA/OH-2015/5			
4. Title and Subtitle		5. Report Date	
Development, Field Testing, and Implementation of Improved Bridge Parapet Designs		March 2015	
		6. Performing Organization Code	
7. Author(s)		8. Performing Organization Report No.	
Amy Kalabon, Lauren Hedges, Norbert Delatte			
9. Performing Organization Name and Address		10. Work Unit No. (TRAIS)	
Cleveland State University Department of Civil and Environmental Engineering Fenn Hall Cleveland, Ohio 44115		11. Contract or Grant No.	
		SJN 134818	
12. Sponsoring Agency Name and Address		13. Type of Report and Period Covered	
Ohio Department of Transportation 1980 West Broad Street Columbus, Ohio 43223		Final Report	
		14. Sponsoring Agency Code	
15. Supplementary Notes			
16. Abstract			
<p>A total of 22 test parapets was constructed as part of this project to evaluate different approaches to address premature cracking. The experiments included the use of deeper saw cuts through glass fiber reinforced polymer (GFRP) reinforcement or field cut steel reinforcement, with the saw cut depth increased from 1 ½ inches (38 mm) to 3 ½ inches (89 mm). Another experimental modification was the use of polypropylene fibers in the mixture at two different dosage rates, 1 lb/yd³ (0.59 kg/m³) and 2 lb/yd³ (1.19 kg/m³). The research team monitored bridge parapets during and immediately after construction. This included instrumentation with embedded maturity sensors to capture temperature history of the parapets, using Command Center technology. Researchers also observed and documented parapet construction. It was important to note any constructability issues that may arise that may be related to the proposed solutions, since they would potentially impact the cost of implementation. Crack surveys were performed once formwork was removed and sawcutting had been completed. The stiffness gain of parapets and joint cracking were monitored using ultrasonic pulse velocity (UPV) technology. While all of the eight control bridges showed mid-panel cracking, only four of the twelve experimental bridges had mid-panel cracking. Both parapets with Vandal Protection Fence (VPF) posts showed cracks near the posts. The main purpose of using GFRP or field cut steel reinforcement with the 3.5 inch (89 mm) deep saw cut is to create a weakened plane at the control joint through the gap provided in the reinforcement, in order initiate cracking at the joints and reduce the risk of cracking elsewhere on the parapet. From the data gathered, this modification allowed more joints to crack at early stages, and prevented uncontrolled cracking. The parapets with fibers showed no measurable improvement over the parapets without fibers in regards to preventing shrinkage and temperature cracking. Reducing the joint spacing over negative tension areas was found to reduce uncontrolled bridge parapet cracking. However, since the experimental parapets with the reduced joint spacing were coupled with another modification of either the polypropylene fibers or the deeper saw cut, it was hard to determine if this alone would solve uncontrolled bridge parapet cracking.</p>			
17. Keywords		18. Distribution Statement	
Bridge parapets, concrete, cracking, improved parapet designs, joint details, deeper saw cuts, fibers, GFRP		No restrictions. This document is available to the public through the National Technical Information Service, Springfield, Virginia 22161	
19. Security Classification (of this report)	20. Security Classification (of this page)	21. No. of Pages	22. Price
Unclassified	Unclassified	126	\$40,000

Development, Field Testing, and Implementation of Improved Bridge Parapet Designs

State Job Number 134818

FINAL REPORT

Prepared in cooperation with the Ohio Department of
Transportation and the U.S. Department of Transportation,
Federal Highway Administration

By:
Cleveland State University
Department of Civil and Environmental Engineering
Fenn Hall, Cleveland, Ohio

March 2015

Research Team Amy Kalabon, Lauren Hedges, and Norbert Delatte

DISCLAIMER

The contents of this report reflect the views of the author(s) who is (are) responsible for the facts and the accuracy of the data presented herein. The contents do not necessarily reflect the official views or policies of the Ohio Department of Transportation or the Federal Highway Administration. This report does not constitute a standard, specification, or regulation.

ACKNOWLEDGEMENTS

This study was sponsored by the Ohio Department of Transportation (ODOT), under a research contract entitled “Development, Field Testing and Implementation of Improved Bridge Parapet Designs,” State Job No. 134818, Agreement No. 25969. The research was also supported by the Civil and Environmental Engineering Department, the Washkewicz College of Engineering, and the College of Graduate Studies at Cleveland State University.

Completion of this study was greatly aided by several key individuals from ODOT. The research team would like to acknowledge and thank the following individuals for their specific contributions: Jim Farrell, Mark Sakian, Tom Beutler, and Brian Negrea for their support, insight, assistance, and coordination to make site visits possible; technical liaisons Richard Walters, Randall Over, Dale Crowl, and Walter Gratz for their technical insight and suggestions; Richard Orient for his guidance and knowledge out in the field; and Jacob Bailosky for his assistance in obtaining construction plans and any other needed data.

The final work to complete the project, including final field observations, was carried out by Jennifer Woods and Larissa Susinskas. This included the final contributions to this report.

ABSTRACT

A total of 22 test parapets was constructed as part of this project to evaluate different approaches to address premature cracking. The experiments included the use of deeper saw cuts through glass fiber reinforced polymer (GFRP) reinforcement or field cut steel reinforcement, with the saw cut depth increased from 1 ½ inches (38 mm) to 3 ½ inches (89 mm). Another experimental modification was the use of polypropylene fibers in the mixture at two different dosage rates, 1 lb/yd³ (0.59 kg/m³) and 2 lb/yd³ (1.19 kg/m³). The research team monitored bridge parapets during and immediately after construction. This included instrumentation with embedded maturity sensors to capture temperature history of the parapets, using Command Center technology. Researchers also observed and documented parapet construction. It was important to note any constructability issues that may arise that may be related to the proposed solutions, since they would potentially impact the cost of implementation. Crack surveys were performed once formwork was removed and sawcutting had been completed. The stiffness gain of parapets and joint cracking were monitored using ultrasonic pulse velocity (UPV) technology. While all of the eight control bridges showed mid-panel cracking, only four of the twelve experimental bridges had mid-panel cracking. Both parapets with Vandal Protection Fence (VPF) posts showed cracks near the posts. The main purpose of using GFRP or field cut steel reinforcement with the 3.5 inch (89 mm) deep saw cut is to create a weakened plane at the control joint through the gap provided in the reinforcement, in order initiate cracking at the joints and reduce the risk of cracking elsewhere on the parapet. From the data gathered, this modification allowed more joints to crack at early stages, and prevented uncontrolled cracking. The parapets with fibers showed no measurable improvement over the parapets without fibers in regards to preventing shrinkage and temperature cracking. Reducing the joint spacing over negative tension areas was found to reduce uncontrolled bridge parapet cracking. However, since the experimental parapets with the reduced joint spacing were coupled with another modification of either the polypropylene fibers or the deeper saw cut, it was hard to determine if this alone would solve uncontrolled bridge parapet cracking.

EXECUTIVE SUMMARY

Project Background

A previous research project carried out by Cleveland State University (CSU) investigated the occurrence of widespread premature cracking of bridge concrete parapets. ODOT District 12 had identified several bridges exhibiting premature cracking of bridge concrete parapets to varying degrees. Bridge concrete parapets can be replaced without bridge deck replacement, and the decks on which these problem parapets were poured appeared to be performing as anticipated. A cursory review of District 12 parapets showed little correlation between deck characteristics; some were on short spans, while others were on longer spans and/or skews. Also, multiple contractors and concrete suppliers were involved. The District did replace one cracked parapet (without replacing the deck) and the cost was about \$140,000. Cracked parapets are a safety concern and the potential cost to the Department to remove and replace parapets could be significant. The overall objective of the study was to determine the reasons for uncontrolled bridge deck parapet cracking, and to provide recommendations to ODOT to prevent such cracking in the future.

This previous project identified the most likely causes of premature bridge parapet cracking. On the basis of the previous work, ODOT District 12 decided to investigate some of the alternatives suggested by the research by conducting field tests on construction projects. This project developed improved parapet designs to mitigate cracking, and monitored test sites constructed in the field during the summer of 2013 and/or 2014.

Study Objectives

The overall objective of this study was to develop improved concrete bridge parapet designs to mitigate cracking. Reasons for uncontrolled bridge parapet cracking were investigated in previous research. Prior to the start of this project, changes were implemented to the current bridge parapet design in an effort to reduce cracking, and these changes were included in the design of the control parapets. Additional design modifications were incorporated on thirteen bridge parapets. In order to fulfill the objective, the following goals were identified:

- Identify all relevant construction procedures potentially contributing to concrete parapet cracking.
- Determine which design modifications, if any, are most significant in preventing premature cracking on ODOT District 12 bridges.
- Provide results of which design modifications mitigate overall cracking of bridge parapets as well as recommendations for future research.

Description of Work

Twenty two test parapets in total were constructed as part of this project to evaluate different approaches to address premature cracking. The experiments included the use of deeper saw cuts through glass fiber reinforced polymer (GFRP) reinforcement or field cut steel reinforcement, with the saw cut depth increased from 1 ½ inches (38 mm) to 3 ½ inches (89 mm). Previous research had indicated that the 1 ½ inch (38 mm) saw cut depth was rarely achieved in the field, with most cuts much shallower. Another experimental modification was the use of polypropylene fibers in the mixture at two different dosage rates, 1 lb./yd³ (0.59 kg/m³) and 2 lb./yd³ (1.19 kg/m³). The higher dosage rate exceeded the manufacturer's maximum recommendation by 1/3, and led to high air content in the concrete mixture.

The research team monitored bridge parapets during and immediately after construction. This included instrumentation with embedded maturity sensors to capture temperature history of the parapets, using Command Center technology. This instrumentation was used to estimate thermal and shrinkage stresses and assess their potential role in parapet cracking. Researchers also observed and documented parapet construction. The steel reinforcement size and arrangement, fresh concrete properties, and construction processes were recorded through notes and photographs. It was important to note any constructability issues that arose that may be related to the proposed solutions, since they would potentially impact the cost of implementation. Crack surveys were performed once formwork was removed and sawcutting had been completed. The stiffness gain of parapets and joint cracking were monitored using ultrasonic pulse velocity (UPV) technology.

Research Findings and Conclusions

While all of the eight control bridge parapets showed mid-panel cracking, only four of the twelve experimental bridge parapets had mid-panel cracking. Both parapets with Vandal Protection Fence (VPF) posts showed cracks near the posts.

The main purpose of using GFRP or field cut steel reinforcement with the 3 ½ inch (89 mm) deep saw cut was to create a weakened plane at the control joint through the gap provided in the reinforcement, in order initiate cracking at the joints and reduce the risk of cracking elsewhere on the parapet. From the data gathered, this modification allowed more joints to crack at early stages, and prevented uncontrolled cracking. The 3 ½ inch (89 mm) deep saw cut allowed 15% more joints to crack within the first few weeks of placement than the 1 ½ inch (38 mm) deep cut. This modification is useful to control early age cracking.

The parapets with fibers showed no measurable improvement over the parapets without fiber in regards to preventing shrinkage and temperature cracking. The use of polypropylene fibers may be efficient in extending the service life and safety of parapets

as well as reducing life cycle costs. Fibers will enhance fatigue strength, and cracks caused by impact or freeze-thaw cycles will be better controlled. However, it is too early to tell if these long term benefits will be realized.

Reducing the joint spacing over negative tension areas is essential to reduce uncontrolled bridge parapet cracking. As shown by the results of the control parapets, parapets without enough control joints over the negative tension areas of the bridge tended to demonstrate uncontrolled cracking. However, since the experimental parapets with the reduced joint spacing were coupled with other modifications, either the polypropylene fibers or the deeper saw cut, it is hard to determine if this alone would solve uncontrolled bridge parapet cracking.

Cracking near the bolts on VPF post base plates occurred on both the north and south parapets of the South Marginal Bridge. This may be due to the shortened curing time the concrete experienced, but design details for the base plate anchorages, as well as when the base plates were anchored into the concrete may have caused the cracking. It is possible that drilling the bolt holes may have caused enough stress in the concrete to cause it to crack in these specific locations. Redesign of the post anchorage details or installations method may still be necessary to prevent cracking on parapets with vandal protection fences.

Costs of field cut reinforcement or GFRP reinforcement combined with 3 ½ inch (89 mm) deep sawcutting ranged from \$ 8.48 to \$ 15.81 per linear foot of parapet (\$ 26.27 to \$ 52.70 per linear meter) based on change orders for this project. The inclusion of fibers in the concrete mixtures was much less costly, at approximately \$ 1.35 per linear foot (\$ 4.50 per linear meter) for 1 lb./yd³ (0.59 kg/m³) and roughly double the cost for double the fiber dosage. However, the reinforcement alternatives combined with the deeper saw cuts were more effective at controlling cracking.

Benefits and Potential Application of Research Results

This research related to ODOT's mission of "Take care of what we have." It directly addressed the Strategic Focus Research Area of Transportation Asset Management. This represented an example of "Developing methods to better utilize resources and integrate advances in science, technology, and construction techniques." It also enhanced Transportation Safety because deteriorated parapet material could potentially pose a risk to the traveling public.

The significance of this work is that uncontrolled concrete bridge parapet cracking has been costly for ODOT, and this trend is expected to continue in the future unless a solution can be found. Bridge deck parapets are replaced when it is necessary to replace the bridge deck itself, as they sit on top of the deck and are constructed after the deck. District 12 had to replace the parapet on a bridge over I-271 in 2002 at a cost of approximately \$ 140,000 which did not include sealing, fence and expansion joint

repairs. So, if the parapet were to need replacement prior to the deck, that cost is wasted when the deck is ultimately replaced. Overall, the project is likely to result in higher durability, longer service life, reduced life cycle cost, and reduced disruption to the traveling public.

The benefits that are expected to be seen by implementing these recommendations are that the amount and severity of premature bridge parapet cracking will be reduced not only in Northeast Ohio, but throughout all of the ODOT districts. This will also reduce the number of premature bridge parapet repair and replacement projects that ODOT must conduct. The average cost to ODOT is \$188,175 per parapet replacement project, or \$283 per linear foot (\$86 per meter) of parapet. If the amount of premature bridge parapet repair and replacement projects is reduced, then ODOT is able to potentially save hundreds of thousands of dollar per year.

Limitations of this Study

Some potential factors of interest could not be addressed in this study. The use of slipforming to construct parapets has been controversial in Ohio and in other states. However, none of the parapets in the study were slipformed, so this possible effect could not be observed. In the previous CSU research project, cracks were observed propagating from VPF bases into parapets. Since 20 of the 22 parapets in the study did not have VPF, this effect could not be studied either. Finally, it has been suggested that longer bridges are at higher risk for parapet cracking due to their increased flexibility. Two of the bridges in the study had spans over twice as long as the others, but the study sample for bridge length is not sufficient to draw firm conclusions.

Implementation Recommendations

For effective implementation of the results of this research, several actions are recommended. The results and conclusions of this study should be disseminated among relevant industry professionals in order to increase their awareness of this problem.

The following changes are suggested for consideration:

1. Use a smaller spacing between parapet control joints over piers, in negative moment regions.
2. Use discontinuous lengths of steel reinforcement, with gaps at the control joints, to allow for 3 ½ inch (89 mm) saw cuts
3. Use GFRP reinforcement, to allow for 3 ½ inch (89 mm) saw cuts

Many of these recommendations have already been implemented in ODOT Standard Drawing ODOT BR-1-13 January 17, 2014 *New Jersey Shape Concrete Bridge Railing* (ODOT 2014b). These include positive moment joint spacing limited to 15 ft. (4.6 m) and negative moment joint spacing limited to between 5 and 7 ½ ft. (1.5 to 2.3 m). Six inch (150 mm) gaps are to be left in the steel reinforcement for joints. These gaps are crossed with 4 ½ ft. (1.4 m) lengths of ½ inch (13 mm) GFRP stiffening reinforcement.

The joint is to be cut into two stages, with an initial 1 ½ inch (38 mm) cut followed by a 4 inch (100 mm) cut.

Recommendations for Future Research

At this time, ODOT is planning to allow slipforming of bridge parapets for future construction. It would be useful to monitor the implementation of slipforming to ensure that it does not lead to new parapet cracking problems. It would also be useful to monitor the implementation of the new parapet standard drawing to ensure that it is performing as anticipated.

TABLE OF CONTENTS

TECHNICAL REPORT DOCUMENTATION PAGE	iii
DISCLAIMER	vi
ACKNOWLEDGEMENTS.....	vii
ABSTRACT	viii
EXECUTIVE SUMMARY.....	ix
LIST OF TABLES.....	xviii
LIST OF FIGURES	xix
INTRODUCTION AND RESEARCH OBJECTIVES	0
Background	0
Study Objectives	0
Research Methodology.....	1
Benefits and Potential Application of Research Results.....	1
Organization of this Report.....	1
BACKGROUND AND LITERATURE REVIEW	3
Observations from Other ODOT Districts	3
Observations from Other State DOTs.....	3
Published Research Studies from Other State DOTs	4
Causes and Cures for Cracking of Concrete Barriers (2004).....	4
Performance of Michigan’s Concrete Barriers (2007)	5
Wisconsin Department of Transportation (2008)	6
Virginia Department of Transportation (2013).....	7
Repair Projects and Costs	7
ODOT District 1	8
ODOT District 3	9
ODOT District 8	9
ODOT District 12	10
California DOT	11
EXPERIMENTAL DESIGN	12
Field Testing Plan	14
Concrete Mixture.....	14
Ultrasonic Pulse Velocity Meter	15

Concrete Maturity Sensors	16
Concrete Cylinder Samples	18
OVERVIEW OF BRIDGE CASE STUDIES	19
Eastbound Big Creek Bridge (LAK-90-16.41R).....	20
Project Information.....	20
Designed Bridge Dimensions	20
Eastbound Paine Creek Bridge (LAK – 90 – 20.03 R).....	21
Project Information.....	22
Designed Bridge Dimensions	22
Eastbound Paine Road Bridge (LAK – 90 – 21.10 R)	23
Project Information.....	23
Designed Bridge Dimensions	24
Eastbound Hermitage Road Bridge (LAK – 90 – 13.70 R)	25
Eastbound Hermitage Road Bridge (LAK – 90 – 13.70 R)	25
Project Information.....	25
Designed Bridge Dimensions	26
Eastbound Auburn Road Bridge (LAK – 90 – 14.87 R)	27
Project Information.....	27
Designed Bridge Dimensions	28
Westbound Paine Road Bridge (LAK – 90 – 21.10 L)	29
Project Information.....	29
Designed Bridge Dimensions	30
Westbound Paine Creek Bridge (LAK – 90 – 20.03 L)	31
Project Information.....	31
Designed Bridge Dimensions	32
South Marginal Road Bridge (CUY – 90 – 18.15)	33
Contractor and Project Information	33
Designed Bridge Dimensions	34
Westbound Big Creek Bridge (LAK – 90 – 16.41 L)	35
Project Information.....	35
Designed Bridge Dimensions	36
Westbound Auburn Road Bridge (LAK – 90 – 14.87 L)	37
Project Information.....	37

Designed Bridge Dimensions	38
Westbound Hermitage Road Bridge (LAK – 90 – 13.70 L)	39
Project Information.....	39
Designed Bridge Dimensions	39
FIELD OBSERVATIONS.....	42
Eastbound Big Creek Bridge (LAK-90-16.41R).....	42
North Parapet	42
South Parapet	43
Eastbound Paine Creek Bridge (LAK-90-20.03R).....	44
North Parapet	44
South Parapet	46
Eastbound Paine Road Bridge (LAK-90-21.10R).....	46
North Parapet	46
South Parapet	48
Eastbound Hermitage Road Bridge (LAK-90-13.70R)	49
North Parapet	49
South Parapet	52
Eastbound Auburn Road Bridge (LAK-90-14.87R)	55
North Parapet	55
South Parapet	57
Westbound Paine Road Bridge (LAK-90-21.10L)	58
North Parapet	58
South Parapet	61
Westbound Paine Creek (LAK-90-20.03L).....	65
North Parapet	65
South Parapet	69
South Marginal Road Bridge (CUY-90-18.15)	73
North Parapet	74
South Parapet	80
Westbound Big Creek Bridge (LAK-90-16.41L)	82
North Parapet	82
South Parapet	83
Westbound Auburn Road Bridge (LAK-90-14.87L)	84

North Parapet	84
South Parapet	85
Westbound Hermitage Road (LAK-90-13.70L).....	86
North Parapet	86
South Parapet	87
SUMMARY AND DISCUSSION OF OBSERVATIONS.....	89
General Observations	89
General Trends.....	90
ANALYSIS	92
Cost	92
Type of Reinforcement	93
Polypropylene Fibers	94
Joint Spacing	94
CONCLUSIONS AND RECOMMENDATIONS	98
Results of Implemented Modifications.....	98
Type of Reinforcement	98
Polypropylene Fibers	98
Joint Spacing	98
Recommendations	99
Design Recommendations	99
Construction Recommendations	99
Limitations of this Study	100
Potential Benefits.....	100
Implementation Recommendations	101
Recommendations for Further Research.....	101
REFERENCES.....	103

LIST OF TABLES

Table 1: Summary of Bridge Parapet Test Sites.....	13
Table 2: Concrete Mixture Proportions	14
Table 3: Summary of Bridges	19
Table 4: EB Big Creek south parapet UPV velocities.....	44
Table 5: EB Paine Creek south parapet UPV velocities.....	46
Table 6: EB Paine Road south parapet UPV velocities.....	49
Table 7: EB Hermitage north parapet UPV velocities.....	50
Table 8: EB Hermitage north parapet maturity sensor temperature data.....	52
Table 9: EB Hermitage south parapet UPV velocities.....	53
Table 10: EB Hermitage south parapet maturity sensor temperature data	54
Table 11: EB Auburn north parapet maturity sensor temperature data.....	56
Table 12: EB Auburn Road South parapet UPV velocities	57
Table 13: WB Paine Road North parapet UPV velocities.....	60
Table 14: WB Paine Road north parapet maturity sensor temperature data	60
Table 15: WB Paine Road south parapet UPV velocities	64
Table 16: WB Paine Road south parapet maturity sensor temperature data.....	65
Table 17: WB Paine Creek north parapet UPV velocities	66
Table 18: WB Paine Creek north parapet maturity sensor temperature data	68
Table 19: WB Paine Creek south parapet UPV velocities	71
Table 20: WB Paine Creek south parapet maturity sensor temperature data.....	73
Table 21: South Marginal north parapet maturity sensor temperature data	77
Table 22: South Marginal south parapet maturity sensor temperature data.....	81
Table 23: WB Big Creek south parapet UPV velocities	84
Table 24: WB Auburn Road north parapet UPV velocities	85
Table 25: WB Auburn Road south parapet UPV velocities	86
Table 26: WB Hermitage Road north parapet UPV velocities	87
Table 27: WB Hermitage Road south parapet UPV velocities	88
Table 28: Modification cost per linear foot (0.3 m).....	92
Table 29: Percentage of early age joint cracking with respect to joint depth.....	93
Table 30: Percentage of cracked joints with respect to fiber use	95
Table 31: Summary of Crack Inspections.....	96

LIST OF FIGURES

Figure 1: James Ultrasonic Pulse Velocity Meter.....	15
Figure 2: Maturity Sensor Attached to Reinforcement (Photograph by Amy Kalabon)...	17
Figure 3: Data Provided by Maturity Sensors	17
Figure 4: Eastbound Big Creek Bridge Construction Plans, Profile.....	21
Figure 5: Eastbound Big Creek Bridge Construction Plans, Parapet Cross Section	21
Figure 6: Eastbound Paine Creek Bridge Plans, Profile.....	22
Figure 7: Eastbound Paine Creek Bridge Plans, Parapet Cross Section	23
Figure 8: Eastbound Paine Road Bridge Plans, Profile.....	24
Figure 9: Eastbound Paine Road Bridge Plans, Parapet Cross Section	25
Figure 10: Eastbound Hermitage Road Bridge Plans, Profile.....	26
Figure 11: Eastbound Hermitage Road Bridge Plans, Parapet Cross Section	27
Figure 12: Eastbound Auburn Road Bridge Plans, Profile.....	28
Figure 13: Eastbound Auburn Road Bridge Plans, Parapet Cross Section	29
Figure 14: Westbound Paine Road Bridge Plans, Profile	30
Figure 15: Westbound Paine Road Bridge Plans, Parapet Cross Section	31
Figure 16: Westbound Paine Creek Bridge Plans, Profile.....	32
Figure 17: Westbound Paine Creek Bridge Plans, Parapet Cross Section	33
Figure 18: South Marginal Bridge Plans, Profile	34
Figure 19: South Marginal Bridge Plans, Parapet Cross Section.....	35
Figure 20: Westbound Big Creek Bridge Plans, Profile	36
Figure 21: Westbound Big Creek Bridge Plans, Parapet Cross Section	37
Figure 22: Westbound Auburn Road Bridge Plans, Profile.....	38
Figure 23: Westbound Auburn Road Bridge Plans, Parapet Cross Section	39
Figure 24: Westbound Hermitage Road Bridge Plans, Profile.....	40
Figure 25: Westbound Hermitage Road Bridge Plans, Parapet Cross Section	41
Figure 26: EB Big Creek Bridge North Parapet Crack (Photograph by Lauren Hedges)....	42
Figure 27: EB Big Creek south parapet crack (Photograph by Lauren Hedges).....	43
Figure 28: Crack along top of parapet (Photograph by Lauren Hedges)	43
Figure 29: EB Paine Creek north parapet crack near control joint (Photograph by Lauren Hedges)	45
Figure 30: Looking at EB Paine Creek north parapet crack from adjacent bridge (Photograph by Lauren Hedges)	45
Figure 31: EB Paine Road north parapet crack propagating out of control joint (Photograph by Lauren Hedges)	47
Figure 32: EB Paine Road 2 nd crack found between joints (Photograph by Lauren Hedges)	47
Figure 33: Spalling on EB Paine Road north parapet along location of horizontal reinforcement (Photograph by Lauren Hedges).....	48
Figure 34: EB Hermitage Road north parapet surface cracks (Photograph by Amy Kalabon)	50
Figure 35: EB Hermitage Road north parapet typical bug holes (Photograph by Amy Kalabon)	51

Figure 36: EB Hermitage south parapet condition (Photograph by Amy Kalabon).....	53
Figure 37: EB Hermitage south parapet winter temperature fluctuations	55
Figure 38: WB Paine Road north parapet performance of saw cuts (Photograph by Amy Kalabon)	59
Figure 39: Rubbing the WB Paine Road north parapet (Photograph by Amy Kalabon)...	59
Figure 40: WB Paine Road north parapet winter temperature fluctuations.....	61
Figure 41: Consolidation of the concrete on WB Paine Road south parapet (Photograph by Amy Kalabon)	62
Figure 42: WB Paine Road south parapet bug holes (Photograph by Amy Kalabon).....	63
Figure 43: Surface cracks found on WB Paine Road south parapet (Photograph by Amy Kalabon)	63
Figure 44: WB Paine Road rubbed south parapet (Photograph by Amy Kalabon).....	63
Figure 45: WB Paine Creek north parapet crack looking down from top of parapet (Photograph by Amy Kalabon).....	67
Figure 46: WB Paine Creek north parapet crack (Photograph by Amy Kalabon)	68
Figure 47: WB Paine Creek north parapet crack zoomed in view (Photograph by Amy Kalabon)	68
Figure 48: WB Paine Creek south parapet poor consolidation at the surface (Photograph by Amy Kalabon)	70
Figure 49: WB Paine Creek south parapet holes on the surface (Photograph by Amy Kalabon)	71
Figure 50: WB Paine Creek Bridge Profile.....	72
Figure 51: South Marginal Bridge with vandal protection fences (Photograph by Amy Kalabon)	74
Figure 52: Placement of maturity sensors (Photograph by Amy Kalabon)	74
Figure 53: South Marginal north parapet crack at VPF post base plate (Photograph by Amy Kalabon)	75
Figure 54: South Marginal north parapet cracks where control joint terminates (Photograph by Amy Kalabon).....	76
Figure 55: South Marginal north parapet mid-panel cracking (Photograph by Amy Kalabon)	77
Figure 56: South Marginal north parapet mid-panel cracking (Photograph by Amy Kalabon)	78
Figure 57: South Marginal north parapet mid-panel cracking (Photograph by Amy Kalabon)	78
Figure 58: South Marginal north parapet mid-panel cracking (Photograph by Amy Kalabon)	79
Figure 59: South Marginal north parapet small cracking (Photograph by Amy Kalabon)	79
Figure 60: South Marginal south parapet mid-panel crack (Photograph by Amy Kalabon)	81
Figure 61: South Marginal south parapet VPF post base plate crack (Photograph by Amy Kalabon)	82
Figure 62: New ODOT Parapet BR-1-13 January 17, 2014 (ODOT 2014b)	101

CHAPTER I INTRODUCTION AND RESEARCH OBJECTIVES

Background

A previous research project carried out by Cleveland State University investigated the occurrence of wide-spread premature cracking of bridge concrete parapets (Bazzo et al. 2013, Kalabon et al., 2014). ODOT District 12 had identified several bridges exhibiting premature cracking of bridge concrete parapets to varying degrees. Bridge concrete parapets can be replaced without bridge deck replacement, and the decks on which these problem parapets were poured appeared to be performing as anticipated. A cursory review of District 12 parapets showed little correlation between deck characteristics; some were on short spans, while others were on longer spans and/or skews. Also, multiple contractors and concrete suppliers were involved. The District had replaced one cracked parapet (without replacing the deck) and the cost was about \$140,000. Cracked parapets are a safety concern and the potential cost to the Department to remove and replace parapets could be significant. The overall objective of the study was to determine the reasons for uncontrolled bridge deck parapet cracking, and to provide recommendations to ODOT to prevent such cracking in the future.

This previous project identified the most likely causes of premature bridge parapet cracking. On the basis of the previous work, ODOT District 12 decided to investigate some of the alternatives suggested by the research by conducting field tests on construction projects. This project developed improved parapet designs to mitigate cracking, and monitored test sites constructed in the field during the summer of 2013 and 2014.

Study Objectives

The overall objective of this study was to develop improved concrete bridge parapet designs to mitigate cracking. Reasons for uncontrolled bridge parapet cracking were investigated in previous research. Prior to the start of this project, changes were implemented to the current bridge parapet design in an effort to reduce cracking, and these changes were included in the design of the control parapets. Additional design modifications were incorporated on thirteen bridge parapets. In order to fulfill the objective, the following goals were identified:

- Identify all relevant construction procedures potentially contributing to concrete parapet cracking.
- Determine which design modifications, if any, are most significant in preventing premature cracking on ODOT District 12 bridges.
- Provide results of which design modifications mitigate overall cracking of bridge parapets as well as recommendations for future research.

Research Methodology

ODOT developed a list of design modifications to incorporate on thirteen bridge parapets. The modifications included the addition of polypropylene microsynthetic fibers to the concrete mixture, the substitution of glass fiber reinforced polymer (GFRP) or field cut steel reinforcement instead of conventional continuous steel reinforcement along with the use of 3 ½ inch (89 millimeter) deep saw cut joints, and shortening the spacing of the control joints in tension zones. The 3 ½ inch (89 mm) deep control joints were assigned in combination with the GFRP or field cut steel reinforcement in order to perform the deeper cut. The performance of thirteen parapets incorporating one or more of these modifications will be monitored and compared to nine additional parapets acting as controls.

Benefits and Potential Application of Research Results

This research related to ODOT's mission of "Take care of what we have." It directly addressed the Strategic Focus Research Area of Transportation Asset Management. This represented an example of "Developing methods to better utilize resources and integrate advances in science, technology, and construction techniques." It also enhanced Transportation Safety because deteriorated parapet material could potentially represent a risk to the traveling public.

The significance of this work is that uncontrolled concrete bridge parapet cracking has cost ODOT significant expenditures, and this trend is expected to continue in the future unless a solution can be found. Bridge deck parapets are replaced when it is necessary to replace the bridge deck itself as they sit on top of the deck and are constructed after the deck. District 12 had to replace the parapet on a bridge over I-271 in 2002 at a cost of approximately \$ 140,000 which did not include sealing, fence and expansion joint repairs. So, if the parapet were to need replacement prior to the deck, that cost is wasted when the deck is ultimately replaced. Overall, the project is likely to result in higher durability, longer service life, reduced life cycle cost, and reduced disruption to the traveling public.

Organization of this Report

This report consists of eight chapters, beginning with this introduction. The second chapter is the Literature Review. The third chapter covers the Experimental Design, which explains the project in coordination with ODOT, procedures used in the field, and the key elements used in the experimental plan in order to identify which modifications were beneficial in reducing bridge parapet cracking. The fourth chapter gives the Overview of the Bridge Case Studies providing the basic information, contractor information, and important dimensions of the all the bridges included in this study. The fifth chapter, Field Observations, describes the field work carried out, including observations, crack surveys, concrete tests, non-destructive tests, and any additional data gathered. The sixth chapter provides the Summary and Discussion of Observations, providing review and analysis of the vast amount of data gathered in the field. The seventh chapter, Analysis, looks at costs and evaluates the effectiveness of the modifications implemented on the experimental parapets by comparing them to the control parapets. The eighth and final chapter, Conclusions and Recommendations, determines which

modifications were effective, ineffective, or inconclusive, and provides recommendations in design, construction, and future research. Additional details are provided in Kalabon (2014) and Hedges (2014).

CHAPTER II BACKGROUND AND LITERATURE REVIEW

This study is a continuation of research performed by Bazzo et al. (2013) on “Uncontrolled Concrete Bridge Parapet Cracking.” The bulk of the literature related to this topic was reviewed and documented in that report. This research determined the factors causing parapet cracking and provided implementation recommendations that were taken into consideration for this study. Additional information was gathered from other ODOT districts and state DOTs to determine how bridge parapets within those states are designed. Several references document ODOT practices (ODOT 2009, 2010, 2012, 2103, 2014a). Other DOTs were contacted to determine how concrete parapets in those areas perform in regards to cracking. Ohio districts and the state of California provided information about repair projects and costs.

Observations from Other ODOT Districts

Information regarding parapet cracking was collected from ODOT District 8, located in the Southwest portion of Ohio near Cincinnati. According to Brandon Collett, PE, the structures planning engineer, many bridge parapets located in their district also suffer from prominent vertical cracking. Many of the older bridges with these cracks were constructed with the use of slip forming. This practice is currently not used across all ODOT Districts, but was allowed starting in 2014. District 8 also had concerns that older bridges received a through joint, which allows for an air gap between parapets. With time these parapets were also subject to severe cracking near the joints. Finally, it has been observed that many of their bridges with a longer span length are subject to the worst cracking. Although parapet cracking is extensive in ODOT District 8, Collett argued that the vertical cracks were just an eyesore and not a maintenance issue. Instead, the cracking that really causes problems is horizontal cracking and cracking at the bases of vandal protection fences (VPFs).

Observations from Other State DOTs

A total of fourteen other state DOT bridge parapet specifications were reviewed. Of the fourteen other DOTs, four of them did not significantly differ from ODOT’s specifications. The ten remaining state DOT bridge parapet specifications were then reviewed to identify differences from ODOT specification. The three main differences found between these other state DOTs and ODOT’s specifications were the amount of concrete cover required, the amount of horizontal rebar required, and the spacing of deflection joints.

First, the amount of cover for vertical and horizontal rebar, as stated by the ODOT specification is a minimum of 2 inches (50 mm). From the other DOTs reviewed, five of them require a different amount of cover. Idaho (ITD 2010) and California (California 2010) only require 1 inch (25 mm) of cover, while Montana (MDT 2012) and Missouri (MODOT 2012) specify 1 ½ inches (38 mm) of cover. Michigan (MDOT 2013), however, requires the greatest amount of cover, 3 inches (76 mm).

ODOT and all of the other state DOTs use No. 5 (16 mm) reinforcement for their horizontal bars except for Maryland. Maryland's DOT specifies that eight pieces of horizontal rebar are to be used, but the top four pieces are to be No. 7 (22 mm) rebar and the bottom four pieces are to be No. 8 (25 mm) rebar (MDOT 2012). The amount of horizontal rebar used also varies among the state DOTs. ODOT specifies eight pieces of continuous No. 5 (16 mm) rebar. The DOTs for Idaho and Missouri specify seven continuous pieces of No. 5 (16 mm) rebar. Alabama's DOT also specifies seven continuous pieces, but placed in a zigzag type pattern within the parapet. Michigan's DOT requires the least amount of rebar, with only five continuous pieces.

There are also a few DOTs that require more reinforcement than specified by ODOT. Arkansas DOT specifies nine continuous pieces (AHTD 2003), and the Montana DOT specifies ten pieces. The DOT that requires the most horizontal rebar is California. Thirteen pieces of rebar are used in parapets in California. Five pieces are placed along the sloped side of the parapet and an additional five down the straight side, but the bottom three horizontal bars down the straight side are doubled.

Finally, only a few DOTs had control joint information readily available on their web sites. Missouri's DOT requires that joints be spaced every 12 feet (3.7 m). It is also specified that the joints are to be filled with ¼ inch (6 mm) of bituminous joint filler. The Arizona DOT requires that joint spacing does not exceed 10 feet (3 m). Arizona's DOT also specifies that ½ inch (13 mm) of bituminous joint filler be used (AZDOT 2012). Minnesota's DOT does not specify a minimum spacing for control joints, but notes that the maximum spacing is 20 feet (6.1 m).

In addition, many state DOTs allow slipforming of parapets, which has not been allowed in Northeast Ohio for several years. The Indiana DOT placed a moratorium on the use of slipforming parapets, which was later lifted (Anderson 2004; IDOT 2011). Transportation agencies in Michigan (Staton and Knauff 2007), Wisconsin (Battaglia et al.), and Connecticut (Georges 2005) also investigated bridge parapet performance. Additional information on state practices is provided by Hedges (2014).

Published Research Studies from Other State DOTs

A search of information regarding bridge parapet performance and cracking was conducted for other state DOTs. The search resulted in four separate studies, in which two were carried out by the Michigan DOT and one each from the Wisconsin DOT and the Virginia DOT.

Causes and Cures for Cracking of Concrete Barriers (2004)

In 2004, the Michigan Department of Transportation conducted a study to identify the causes and cures for prematurely deteriorating parapets in Michigan. Possible causes that were examined included freezing and thawing, alkali-silica reactions, ettringite, and carbonation effects. Then experimental equipment was used to conduct more research on sixteen cores from eight different locations (Van Dam et. al, 2004).

The parapets in Michigan were subjected to different types of cracking, such as “map cracking, vertical transverse cracking, horizontal cracking, delamination, pop-outs, scaling, and disintegration” (p.1, Van Dam et. al, 2004). The cores were collected from parapets constructed from 1983 until 2001. Cores were taken from parapets constructed using both cast-in-place and slip forming construction methods.

Sixteen cores were taken from various sites along the highway. The cores were then polished, examined, and prepared for petrographic study. Some of the methods of examination included the stereo optical microscopy, x-ray analytical microscopy, petrographic optical microscopy, and scanning electron microscopy. Finally, the cores were tested for carbonation through the use of phenolphthalein spray. The cores would turn pink with a pH higher than 8.3; if the concrete didn't change color it was carbonated (Van Dam et. al, 2004).

This study resulted in a few conclusions and recommendations (Van Dam et. al, 2004):

- Consolidation problems were seen on all of the cores, including many air voids.
- The air void system of protecting against freezing and thawing was negatively affected by the use of the slip form method.
- Ettringite was found in many of the cores' air voids.
- A study should be initiated of the alkali-silica reactivity that was present.
- Siltstones that were observed in some of the concrete cores were susceptible to frost.
- One of the sites had significant corrosion, which resulted in high carbonation.

Performance of Michigan's Concrete Barriers (2007)

In 2007, the Michigan Department of Transportation conducted a study on bridge barrier design. In this study, they wanted to review three main areas:

- Types of bridge barrier design configurations.
- Field performance of bridge barrier design.
- Potential factors that may contribute to premature deterioration.

Michigan DOT conducted this study due to frequent premature cracking of parapets, and the need to replace them multiple times throughout the lifespan of a bridge (Staton & Knauff, 2007).

This report begins with the discussion of how bridge barriers have changed, starting as concrete posts with metal lattice between them in the 1960's, up until today with the use of Jersey type concrete barrier. This Jersey type barrier was adopted in 1977, but has seen changes throughout the years, such as the approved use of slipforming in 1982 (Staton & Knauff, 2007).

To assess the performance of the bridge barriers, inspections of bridges began in 1997. Core samples were collected from twenty-six different bridge sites. These bridge construction dates ranged from 1973 until 1990 (Staton & Knauff, 2007).

Additionally, parapets made using cast-in-place methods and slip forming were both inspected and analyzed, and aggregate type such as natural gravel, slag and crushed limestone was investigated. Then, the cores were tested in a laboratory and rated either poor, fair, or good. Of the twenty-six cores taken, ten were rated poor, ten were rated fair, and six were rated good (Staton & Knauff, 2007).

The cores and other loose concrete collected at the sites was then investigated through petrography. This showed that alkali-silica gel had formed on many of the pieces. Petrography also concluded that near the surface on many of the slip formed parapets, the concrete was very porous, which easily allows for penetration of concrete by harmful materials (Staton & Knauff, 2007).

It was concluded that more parapets throughout Michigan should be examined and evaluated for replacement. Among the recommendations, some included (Staton & Knauff, 2007):

- No longer allow the use of low durability coarse aggregates for parapets.
- Slip forming should no longer be accepted for the construction of parapets.
- A minimum of seven day water cure should be used.
- Epoxy coated reinforcement should be used.
- Overall concrete quality improvement should be investigated.

Wisconsin Department of Transportation (2008)

In 2008, the Wisconsin Department of Transportation conducted a study to determine the effects of a shrinkage reducing admixture called Eclipse. The goal of the admixture was to reduce the number of shrinkage cracks that occurred in the parapets during the curing process (Battaglia, et. al, 2008).

Originally, the study began with the use of the admixture in the concrete for bridge decks in 2000. The project later investigated the admixture for the use in bridge parapets in 2003. The admixture was to be used in two separate sets of bridge parapets, but due to complications was only used in one (Battaglia, et. al, 2008).

The concrete used for both the test parapet and control parapet was evaluated in a laboratory setting, where cylinders were tested for compressive strength and shrinkage. At three days, the compressive strength of the experimental cylinder, control cylinder one, and control cylinder two were 3,150 psi (21.7 MPa), 2,790 psi (19.2 MPa), and 2,720 psi (18.8 MPa), respectively (Battaglia, et. al, 2008).

More cylinders were later tested at 7 days, 28 days, and 90 days. At the 90 day mark, the compressive strengths for the experimental cylinder, control cylinder number one, and control cylinder number two were 6,880 psi (47.4 MPa), 6,230 psi (43 MPa), and 6,290 psi (43.4 MPa), respectively (Battaglia, et. al, 2008).

To determine the amount of shrinkage, the change in length was measured for the three cylinders at 3, 7, 28, 56, and 90 days. At three days, the percentages of shrinkage for the experimental cylinder, control cylinder one and control cylinder two were 0.005 percent, 0.006 percent, and 0.007 percent, respectively. At the end of ninety days, the percentages of shrinkage were 0.021 percent, 0.024 percent and 0.024 percent for the experimental cylinder, control cylinder one, and control cylinder two, respectively (Battaglia, et. al, 2008).

The sites were visited twice to determine how the parapets in service were performing. The first site visit took place two months after construction. At that time, the experimental parapets showed three cracks in each parapet, while the control parapets revealed up to nine in each parapet. When the second site visit took place, four years later, the experimental parapet had no new cracking, while the control parapets had up to seven new cracks per parapet (Battaglia, et. al, 2008).

The Wisconsin Department of Transportation concluded that the Eclipse admixture helped to reduce shrinkage cracking for both short and long term periods. Ultimately, however, the Wisconsin DOT decided that it should not be used, because of how it affected the air content of the concrete (Battaglia, et. al, 2008).

Virginia Department of Transportation (2013)

The Virginia Department of Transportation (VDOT) conducted a study that looked at various bridges on I-95 Express Lanes in Virginia. VDOT examined cracking that occurred on both the bridge decks and parapets. On the bridge decks, both map cracking and transverse cracks were seen. Most of the cracks observed on the bridge deck were thought to be mainly due to plastic, thermal and drying shrinkage (Saraf, 2013).

The parapets were also subject to vertical cracks as wide as 0.05 inches (1 mm). Two core samples were taken at the location of where the cracks can be seen. For both cores, concrete voids were present around the vertical rebar. Because the parapets were constructed using the slipforming method, it was thought that the voids may have occurred due to the low slump and poor vibration methods not allowing the concrete to flow around to the underside of the vertical rebar (Saraf, 2013).

Repair Projects and Costs

One of the largest problems that premature bridge parapet cracking causes is the cost to replace them before the deck of the bridge needs to be replaced and the ensuring traffic disruption. If many early extensive parapet cracks occur, then the parapets must either be replaced or patched before the bridge deck has seen its lifespan worth of wear. Repair projects were identified in ODOT Districts 1, 3, 8, and 12. Complete details with photographs are provided by Hedges (2014).

ODOT District 1

ODOT District 1, located in the northwest portion of the state, identified four specific projects in which parapets have been replaced, or need to be replaced in the near future.

Bridge Number VAN-30-2041

This bridge is an overpass crossing US30, located in Van Wert County. The bridge was originally built in 1987 and had a total length of 462 feet (140 m). In 2009, the right side parapet of the bridge had extensive cracking that required the parapet to be replaced. The approximate total cost endured of replacing the parapet and deck edge was \$150,000, which is \$325 per linear foot of parapet (\$1,070/m).

Bridge Number ALL-75-1836

This bridge, located in Allen County, will need to have its parapets replaced. The bridge was originally built in 1965 and has a total length of 310 feet (94 m). It is estimated that this work will need to be done within the next five to ten years.

Although it is not considered premature, the replacement of the parapets will need to be done before the bridge deck needs to be repaired. An official estimate for this work has not yet been calculated, but Rod Maas, PE in District 1 has a rough estimate of \$225,000 (Rod Maas, personal communication, March 4, 2014). This is roughly \$363 per linear foot of parapet (\$1,190/m).

Bridge Number ALL-696-0086

This bridge is located in Allen County, and will need to have its parapets replaced. The bridge was originally built eight years ago in 2006, and has a total length of 175 feet (53 m). It is estimated that the parapets will need to be replaced within the next five to ten years.

An official estimate for the work needed has not yet been calculated, but Rod Maas, PE in District 1 has a rough estimate of \$150,000 (Rod Maas, personal communication, March 4, 2014). This is roughly \$428 per linear foot of parapet (\$1,400/m).

Bridge Number ALL-65-1322

This bridge is an overpass located in Allen County. It was originally built in 1969 and has a total length of 295 feet (90 m). Patches were done to the parapets and vandal protection fencing (VPF) was installed in 2009. The total cost of this work was \$599,417 for the whole structure. The approximate cost per linear foot of parapet is \$175 (\$574/m).

Since 2009, the parapets have begun to deteriorate again and will need more patching done. The patch work is planned for the spring construction season of 2014.

ODOT District 3

ODOT District 3, located in the central, northern part of Ohio, has identified one specific project in which a parapet has been repaired.

PID 81374

The bridge was originally built in 1995 and a total of approximately 1,200 feet (366 m) of parapet was repaired. The total cost of the repairs to the parapet was \$176,228, which is \$147 per linear foot of parapet (\$480/m).

ODOT District 8

ODOT District 8, located in the southwest corner of Ohio, was able to identify five specific projects in which parapets have been either repaired or replaced.

Bridge Number GRE-675-0895

This bridge parapet repair occurred in Greene County in 2012. The bridge is an overpass on Grange Hall Road that passes over I-675 and has a total length of 260 feet (79 m). Due to large cracks and damage caused by vandal protection fencing (VPF), the upper foot and a half of the parapet on both sides of the bridges needed to be repaired.

The total cost of repairs to the two parapets was \$218,852. This cost included the repair of the transition sections and purchase and installation of new VPF. The cost is approximately \$420 per linear foot of parapet (\$1,380/m).

Bridge Number HAM-74-1116L

This bridge parapet repair occurred in Hamilton County in 2013. The bridge is on I-74 and passes over Harrison Ave with a total length of 282 feet (86 m). Selected sections along one of the parapets needed to be replaced due to concrete deterioration.

The top foot and a half of the selected sections needed to be repaired. Other work that was performed at the same time included barrier replacement and zone painting. The total cost of these repairs was \$17,000, which is \$60 per linear foot of parapet (\$200/m).

Bridge Number GRE-675-1034

This bridge repair occurred in Greene County. The bridge is an overpass on North Fairfield Road that crosses over I-675 and has a total length of 277 feet (84 m). Due to extensive concrete deterioration and cracking caused by VPF, multiple patches were needed along the length of

the parapet. The total cost of these patches was \$13,600, which is \$50 per linear foot of parapet (\$910/m).

Bridge Number GRE-42-0789

This bridge parapet repair occurred in Greene County and has a total length of 244 feet (74 m). The cost of repairs included in this project included the removal of loose concrete from the parapets, various deep patches, and applying an epoxy sealer. The total cost of these patches was \$117,000, which is \$240 per linear foot of parapet (\$790/m).

Bridge Number GRE-380-0671

This bridge parapet repair will occur in Greene County with a total length of 277 feet (84 m). The repairs needed for this bridge not only include the replacement of the parapet, but also an overlay of the bridge deck and possible replacement of the VPF. The estimated total cost of these repairs is \$200,000, which is \$361 per linear foot of parapet (\$1,180/m).

ODOT District 12

ODOT District 12, located in northeast Ohio, has identified two specific projects in which parapets have been replaced in 2013.

Bridge Number CUY-71-0000

This bridge parapet replacement occurred in 2013, in Cuyahoga County. Both sides of the 618 feet (188 m) long bridge parapet needed to be replaced. Costs endured during the replacement of the parapet include \$120,000 for the removal of existing parapet, \$30,000 for new reinforcing steel, \$35,000 for dowel bars, \$34,000 for concrete, \$10,000 to seal the parapets, and \$40,000 for the purchase and installation of six foot tall VRP. The total cost of replacement for this bridge was \$269,000, which is \$435 per linear foot of parapet (\$1,425/m).

Bridge Number CUY-17-0449

The parapets for this bridge, also located in Cuyahoga County, were replaced in 2013. This bridge was a total length of 309 feet (94 m). There were also many costs endured for the replacement of this bridge, including \$65,000 for removal of the existing parapets, \$9,000 for new reinforcing steel, \$2,000 for dowel bars, \$17,000 for concrete, \$8,000 to seal the parapets, and \$21,000 for the purchase and installation of the six foot tall VPF. The total cost of replacement for the bridge was \$122,000, which is \$395 per linear foot of parapet (\$1,295/m).

California DOT

The California Department of Transportation, known as Caltrans, identified three specific projects in which parapets have been replaced in 2010.

Rancheria Creek Bridge

The Rancheria Creek Bridge crosses over the Rancheria Creek, located in Fresno County. This bridge was originally built in 1977, and has a total length of 229 feet (70 m). The total cost to repair both sides of the bridge's parapets due to freeze thaw damage was \$149,900, which is \$327 per linear foot of parapet (\$1,070/m).

Big Creek Bridge

The Big Creek Bridge crosses over Big Creek, and is also located in Fresno County. This bridge was originally built in 1977, and has a total length of 151 feet (46 m). The total cost to replace both sides of the bridge's parapets due to freeze thaw damage was \$98,600, which is \$326 per linear foot of parapet (\$1,070/m).

Tamarack Creek Bridge

The Tamarack Creek Bridge crosses over the Tamarack Creek in Fresno County. This bridge was originally built less than ten years ago in 2006. This bridge has a total length of 166 feet (51 m). The total cost to replace both sides of the bridge's parapet due to freeze thaw damage was \$109,600. This amounts to \$330 per linear foot of parapet (\$1,080/m).

CHAPTER III EXPERIMENTAL DESIGN

For this study, ODOT incorporated design modifications to thirteen parapets for eleven bridges within District 12. These bridges were undergoing deck and parapet replacement between 2012 and 2014. Of the field test sites, ten bridges were located in Lake County, east of downtown Cleveland, and the eleventh bridge was the South Marginal Road overpass over I-90 in downtown Cleveland. In 2012, three Lake County bridges, Big Creek, Paine Creek, and Paine Road, underwent deck and parapet replacement. In 2013, five bridges were constructed leaving three bridges to be completed in 2014. For each bridge, the north and south parapets provided different test conditions, which resulted in a total sample of 22 bridge parapets. All of the Lake County bridges were half width construction, built one side at a time with traffic maintained on the other side.

The six Lake County bridge parapets that were constructed in 2012 were built as controls following contract plans with no modifications. These were built before the start of this study. In 2013, the north parapet wall of South Marginal Road Bridge in Cleveland and two parapets constructed in 2014 served as controls. These nine parapets had standard 1 ½ inch (38 mm) deep saw cut joints spaced between 6 and 10 feet (1.8 and 3 m). The other thirteen parapet test sites had one or more of four modifications. The modifications ODOT incorporated into the parapet designs included the addition of synthetic polypropylene fibers to the concrete mix, the substitution of GFRP reinforcement instead of conventional steel reinforcement combined with the use of 3 ½ inch (89 mm) deep saw cuts, field cutting of the steel reinforcement with 3 ½ inch (89 mm) deep saw cuts to weaken the joints and promote control joint cracking, and reduced joint spacing over the negative moment tension regions of the bridge. The Lake County field test sites and their respective modifications are summarized in Table 1. Each bridge in Lake County was given a specific ODOT identification. The “R” or “L” assigned at the end of this identification represents the bridge’s location with respect to the right or left side of the center line. The “R” represents the bridges on the eastbound side of I-90 and the “L” represents bridges located on the westbound side of traffic.

For the addition of microsynthetic polypropylene fibers into the concrete mixture, seven out of eight test sites used a fiber dosage of 1 pound per cubic yard (0.59 kg/m³) of concrete. The final site, the south parapet wall of LAK-90-20.03L Paine Creek, used double the dosage at 2 pounds per cubic yard (1.19 kg/m³) of concrete.

Table 1: Summary of Bridge Parapet Test Sites

Bridge Number	Const. Year	Parapet	Experimental Treatment				
			Per Plans, Control	Poly Fibers	3 ½ in. Saw Cut	GFRP Rebar	Field Cut Steel
LAK-90-16.41R, Big Creek	2012	N	X				
		S	X				
LAK-90-20.03R, Paine Creek	2012	N	X				
		S	X				
LAK-90-21.10R, Paine Road	2012	N	X				
		S	X				
LAK-90-13.70R, Hermitage Road	2013	N			X	X	
		S		X			
LAK-90-14.87R, Auburn Road	2013	N			X	X	
		S		X	X	X	
LAK-90-21.10L, Paine Road	2013	N			X		X
		S		X			
LAK-90-20.03L, Paine Creek	2013	N		X			
		S		X			
CUY-90-18.15 (South Marginal Road over I90)	2013	N	X				
		S			X	X	
LAK-90-16.41L, Big Creek	2014	N			X	X	
		S		X	X	X	
LAK-90-14.87L, Auburn Road	2014	N	X				
		S		X	X		X
LAK-90-13.70L, Hermitage Road	2014	N	X				
		S		X	X		X

Five test sites include Aslan 100 GFRP Rebar manufactured by Aslan FRP. According to Hughes Brothers, the producers of Aslan FRP, the GFRP rebar has a tensile strength of at least 100 ksi (690 MPa) for No. 5 and No. 6 (16 and 19 mm) bars, and an elastic modulus of 6,700 ksi (46,200 MPa). Although the strength of the GFRP is thus nearly twice that of Grade 60 reinforcing steel, it lacks the ductility of steel. The elastic modulus is less than 25 % of that of reinforcing steel, therefore the GFRP will offer much less resistance to the development and opening of control joints. In other words, the GFRP may allow cracking to occur at the control joints more so than reinforcing steel. GFRP is also highly corrosion resistant.

Eight of the experimental sites included a 3 ½ inch (89 mm) deep saw cut with variable spacing. It is important to note that the 3 ½ inch (89 mm) deep saw cuts cannot be properly performed unless either GFRP rebar or field cut steel rebar are also used because steel reinforcing bars are usually too close to the concrete surface for a saw cut that deep without damaging the steel.

For the 3.5 inch (89 mm) deep saw cuts, the joint spacing was 5 to 6 feet (1.5 to 1.8 m) in the tension zones, over bridge piers, and 10 to 15 feet (3 to 4.6 m) at other locations. The tension zones are defined on the plans as extending between 10 and 40 feet (3 and 12 m) on either side of a pier.

Field Testing Plan

Visits to the sites constructed in 2013 took place before parapet construction, during concrete placement, during formwork removal and saw cutting operations, and periodically after construction. The main data of interest were cracks in the parapets, as well as whether joints functioned properly to control cracking.

Before parapet construction, site visits occurred to attach maturity sensors to the reinforcement as well as to check for proper installation of the rebar. During concrete placement, concrete cylinder samples were made, and documentation was gathered on the weather, the procedures used by the construction workers, and behavior of the concrete. As soon as the formwork was removed and control joints were cut, the parapet walls were analyzed for cracks, proper consolidation of the concrete, and accurate control joint depths and spacing. Ultrasonic pulse velocity (UPV) tests were also performed. After curing was completed, site visits were made to collect information from the maturity sensors, inspect the parapets for additional cracking, perform UPV tests, and determine whether the control joints were functioning properly and initiating cracking at the joints.

Concrete Mixture

The same concrete mixture was used for all of the bridges, with the exception of the addition of microsynthetic polypropylene fibers. The mixture proportions are shown in Table 2.

Table 2: Concrete Mixture Proportions

Constituent	Quantity lb/yd ³	Quantity kg/m ³
Cement (portland type I)	400	237
Slag cement	170	101
Silica fume	30	18
Total cementitious content	600	355
Coarse aggregate #57	1,300	771
Intermediate coarse aggregate # 8	350	207
Fine aggregate (natural sand)	1,280	759
Water	258	153

Slag cement was used as a cement replacement. Concrete produced using slag cement will set slower than concrete produced from only portland cement. The concrete may take longer to gain strength. However, the heat of hydration will be lower and the temperature of the concrete will be better controlled. Slag cement also provides higher resistance to attacks by sulfates and other chemicals. Microsilica, or silica fume, is used to create low permeability

concrete by filling the void space between cement particles. Like slag cement, silica fume increases the concrete's resistance to the ingress of chemicals.

The water to cementitious materials ratio (w/cm) was 0.43. The concrete mixtures used air entraining and superplasticizing admixtures, as well as retarders in hot weather. On the one hand, this concrete has a relatively high content of cementitious material of 600 lb/yd³ (355 kg/m³), which would tend to promote shrinkage. On the other hand, the concrete uses a blend of #57 coarse aggregate (1 inch or 25 mm maximum size) and #8 intermediate aggregate (3/8 inch or 9.5 mm maximum size) in order to optimize gradation to reduce paste requirements and shrinkage cracking.

ODOT is now implementing quality control, quality assurance (QC/QA) mix requirements. The new specifications replace Class C, Class S, and Class HP concrete with Classes QC1, QC2, QC3, and QC4 concrete (ODOT 2013). Concrete bridge parapets formerly used a Class HP concrete and will now use Class QC2 concrete. The new specification requires coarse aggregate absorption greater than 1% and adds well graded aggregate proportions, as previously stated, to help eliminate shrinkage cracking and lower the required amount of cementitious materials.

Ultrasonic Pulse Velocity Meter

The James Ultrasonic Pulse Velocity (UPV) V-Meter MK IV, shown in Figure 1, is a nondestructive testing instrument that was used during this study. The UPV method is based on the fact that the pulse velocity of compression waves in a concrete body is related to the elastic properties of the material. The UPV Meter is commonly used as a way to estimate strength; however for purposes of this study, the UPV was used as a quality control measure to study uniformity of the concrete and to determine the extent of cracking at the control joints.



Figure 1: James Ultrasonic Pulse Velocity Meter

The UPV has two transducers, a transmitter and a receiver. The transmitter sends an ultrasonic wave through the concrete. When the wave is received by the other transducer, a

velocity is calculated based on the amount of time it took to reach the receiver. The velocity of the wave depends on the consolidation of the concrete and the path the wave was forced to take to reach the other transducer. Therefore, if the transducers were placed over a cracked control joint, a very low apparent velocity would be observed, if any signal was received at all. A high velocity would represent a control joint that did not crack. The high velocity relates to good consolidation and consistency of the concrete as well as absence of internal cracks or defects. Using this concept, the UPV was used to estimate the quality and consistency of the concrete along the parapet and to determine the percentage of control joints that cracked along each parapet.

In order to establish the performance of the control joints, UPV tests were performed at each joint after the parapet was cured. If the velocity was found to be similar to the velocity over an area with no cracks, it was assumed that the control joint was not cracked and therefore was not functioning as designed. If the apparent velocity was measured to be considerably slower than the average velocity of the concrete, then the wave sent through the concrete had to find a way around a crack or void, suggesting that the joint had probably cracked.

Concrete Maturity Sensors

The rate of hydration of cement is greatly affected by both time and temperature, so the strength gain of concrete is also largely controlled by these two factors. These factors are likewise related to the quality of the concrete. Very high or low temperatures, including large changes in temperature, can severely affect the concrete's strength and can cause uneven temperature distributions. Large differences in temperature across a parapet can result in cracking and reduce its durability. Due to the significance of temperature, multiple maturity sensors were embedded within the concrete of each bridge parapet by attaching them to the reinforcement before the concrete was placed. This is shown in Figure 2. Using Command Center technology, the temperature history and maturity of the parapets were captured to assess their potential role in parapet cracking.

With the use of this technology, temperature data were collected during concrete placement, as the concrete cured, and after the parapet had been exposed to the environment. The highest temperature the concrete reached as well as any significant temperature changes were gathered from the sensors to look for unusual temperature effects that might be associated with cracking. The graph shown in Figure 3 is an example of the data that the sensors capture. The concrete for this parapet was placed on July 1st. During its seven day curing period, the concrete reaches its highest temperature of just under 110° F (43° C), and it then drops as the hydration process slows down. The parapet was then exposed to the environment on July 8th, when the curing materials were taken off. This can also be seen in the graph because at this point the temperatures begin to fluctuate more. In this case, the concrete should not experience any effects or cracking from temperature high because it did not experience any large temperature differentials nor did it hit an extreme high or low temperature.



Figure 2: Maturity Sensor Attached to Reinforcement (Photograph by Amy Kalabon)

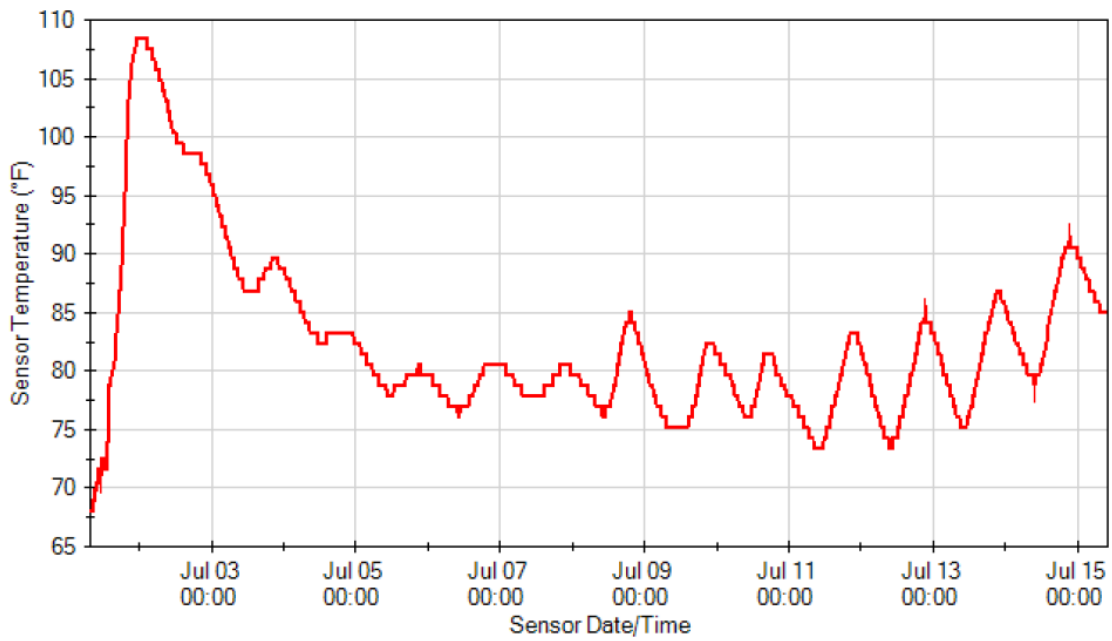

Figure 3: Data Provided by Maturity Sensors

Concrete Cylinder Samples

Concrete cylinder samples were collected in order to verify that the UPV values obtained out in the field were reasonable. UPV tests on the cylinders were performed on the same day the UPV was done on the parapets to make an accurate comparison. The cylinders were also used to find compressive strength values to compare to ODOT's compressive strength values. In the case that cylinder samples could not be obtained, compressive strength values were acquired from the District's cylinder tests.

**CHAPTER IV
OVERVIEW OF BRIDGE CASE STUDIES**

Between 2012 and 2014, eleven bridges in District 12 were planned for full deck and parapet replacements. ODOT selected these bridges to use as test sites for this study. Data for these eleven bridges have been collected, which include general structural information as well as designed bridge dimensions and characteristics. A brief summary of data related to these bridges is shown in Table 3.

Table 3: Summary of Bridges

Bridge	City	Bridge Limits (ft., m)	No. of Spans	Max. Span Length (ft., m)	No. of Traffic Lanes Carried	Year Built
LAK-90-16.41R, Big Creek	Painesville	344.5, 105.0	3	140.0, 42.67	2	1960
LAK-90-20.03R, Paine Creek	Painesville	496.10, 151.21	3	188.0, 57.30	2	1960
LAK-90-21.10R, Paine Road	Painesville	137.99, 42.06	3	58.17, 17.73	2	1960
LAK-90-13.70R, Hermitage Road	Painesville	160.58, 48.94	3	60.0, 18.29	2	1961
LAK-90-14.87R, Auburn Road	Painesville	148.82, 45.36	3	63.25, 19.28	3	1960
LAK-90-21.10L, Paine Road	Painesville	113.63, 34.63	3	46.0, 14.02	2	1960
LAK-90-20.03L, Paine Creek	Painesville	488.29, 148.83	3	188.5, 57.45	2	1960
CUY-90-18.15 (South Marginal Road over I90)	Cleveland	228.02, 69.5	4	68.0, 20.73	2	1959
LAK-90-16.41L, Big Creek	Painesville	344.5, 105.0	3	140.0, 42.67	2	1960
LAK-90-14.87L, Auburn Road	Painesville	159.28, 48.55	3	63.24, 19.28	3	1960
LAK-90-13.70L, Hermitage Road	Painesville	136.5, 41.61	3	60.0, 18.29	2	1961

All of the Lake County bridges were constructed as part of a joint venture between Allega, Inc. and the Great Lakes Construction Company. The bridges and parapets were all built by the Great Lakes Construction Company. The ready mix concrete supplier was Osborne, Inc. for all Lake County bridges. The South Marginal Road Bridge was constructed by Cuyahoga Bridge & Road and Tech Ready Mix was the concrete supplier.

Eastbound Big Creek Bridge (LAK-90-16.41R)

The Big Creek Bridge is an eastbound Interstate – 90 Highway bridge in Painesville, Ohio. It was originally built in 1960.

Inventory Number and Structural File Number

In the ODOT Bridge Inventory, the Eastbound Big Creek Bridge is identified as follows:

Bridge Inventory Number: LAK – 90 – 16.14 R

Structural File Number: 4304659 (R)

Structure Type

The bridge is a twin continuous steel plate girder bridge with a reinforced concrete deck and substructure with semi-integral abutments.

Project Information

The deck and superstructure rehabilitation took place in 2012. In addition to parapet replacement, a new widened non-composite reinforced concrete deck was constructed on the existing steel girders.

Designed Bridge Dimensions

Length

The total length of the bridge is 344.5 feet (105 m). It consists of three spans of the following lengths: 90' – 0", 140' – 0", and 110' – 0" (27.4 m, 42.7 m, 33.5 m). The bridge profile is shown in Figure 4.

Width

The total section width of the bridge is 47 feet (14.3 m), with a roadway width of 44 feet (13.4 m).

Parapet Dimensions

The height of each parapet is 3.5 feet (1.07 m). The top width of each parapet is 10 inches (254 mm) and reaches a width of 1.5 feet (457.2 mm) at the base of the parapet. The parapet detail is shown in Figure 5.

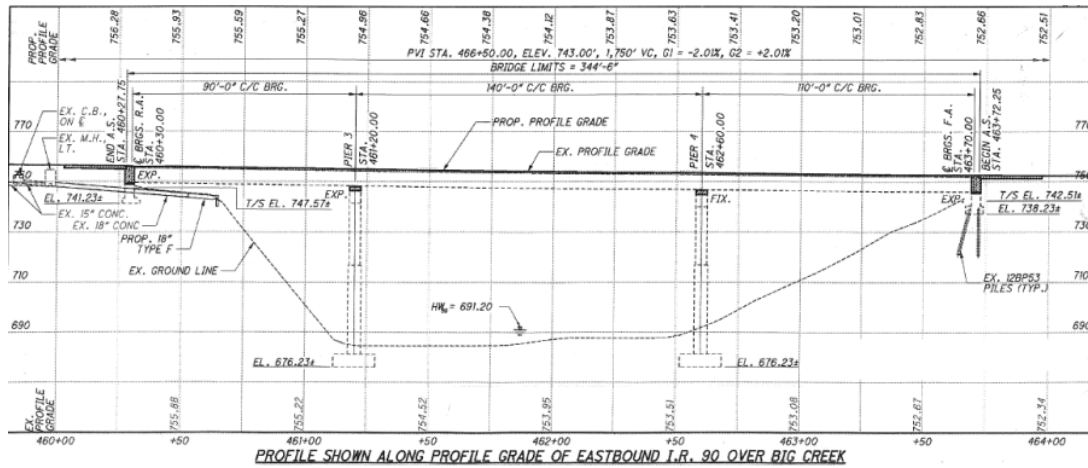

Figure 4: Eastbound Big Creek Bridge Construction Plans, Profile

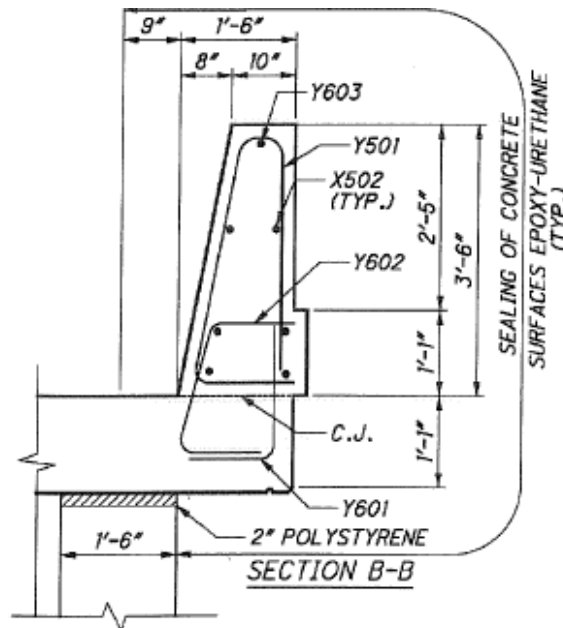

Figure 5: Eastbound Big Creek Bridge Construction Plans, Parapet Cross Section

Eastbound Paine Creek Bridge (LAK - 90 - 20.03 R)

The Paine Creek Bridge is an eastbound Interstate – 90 Highway bridge located in Painesville, Ohio. It was originally built in 1960.

Inventory Number and Structural File Number

In the ODOT Bridge Inventory, the Eastbound Paine Creek Bridge is identified as follows:

Bridge Inventory Number: LAK - 90 - 20.03 R

Structural File Number: 4304772 (R)

Structure Type

The bridge structure is a twin continuous steel plate girder bridge with reinforced concrete deck and substructure.

Project Information

The deck and superstructure rehabilitation took place in 2012. In addition to parapet replacement, a new widened non-composite reinforced concrete deck was constructed on the existing steel girders.

Designed Bridge Dimensions

Length

The total length of the bridge is 496.1 feet (151.2 m). It consists of three spans of the following lengths: 150' – 0", 188' – 0", 150' – 0" (45.72 m, 57.3 m, 45.72 m). A profile of the bridge is shown in Figure 6.

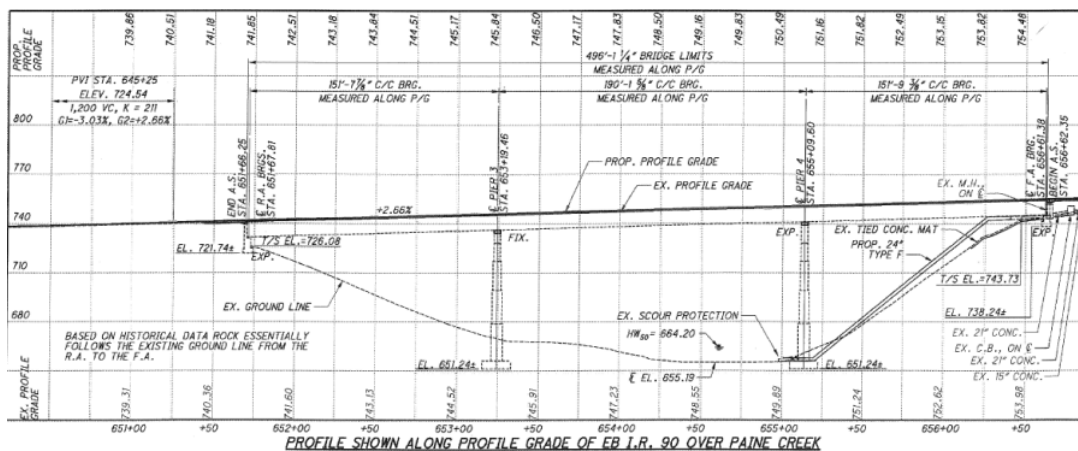

Figure 6: Eastbound Paine Creek Bridge Plans, Profile

Width

The total section width of the bridge is 47 feet (14.3 m), with a roadway width of 44 feet (13.4 m).

Parapet Dimensions

The height of each parapet is 3.5 feet (1.07 m). The top width of each parapet is 10 inches (254 mm) and reaches a width of 1.5 feet (457.2 mm) at the base of the parapet. The parapet detail is shown in Figure 7.

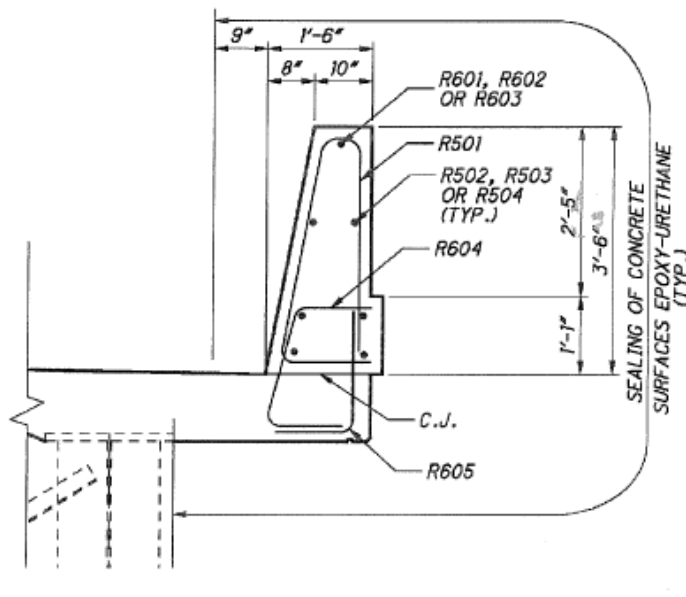

Figure 7: Eastbound Paine Creek Bridge Plans, Parapet Cross Section

Eastbound Paine Road Bridge (LAK – 90 – 21.10 R)

The Paine Road Bridge is an eastbound Interstate – 90 Highway bridge located in Painesville, Ohio. It was originally built in 1960.

Inventory Number and Structural File Number

In the ODOT Bridge Inventory, the Eastbound Paine Road Bridge is identified as follows:

Bridge Inventory Number: LAK – 90 – 21.10 R

Structural File Number: 4304802

Structure Type

The bridge structure consists of a three span continuous steel beam bridge with a reinforced concrete deck and substructure with semi-integral abutments.

Project Information

The deck and superstructure rehabilitation took place in 2012. In addition to deck and parapet replacement, the superstructure was raised and the approach slabs, deck expansion joints, and backwalls with semi-integral abutments were replaced.

Designed Bridge Dimensions

Length

The total length of the bridge is 137.99 feet (42.06 m). It consists of three spans of the following lengths: 37' – 7", 58' – 2", 37' – 7" (11.45 m, 17.73 m, 11.45 m). A profile of the bridge is shown in Figure 8.

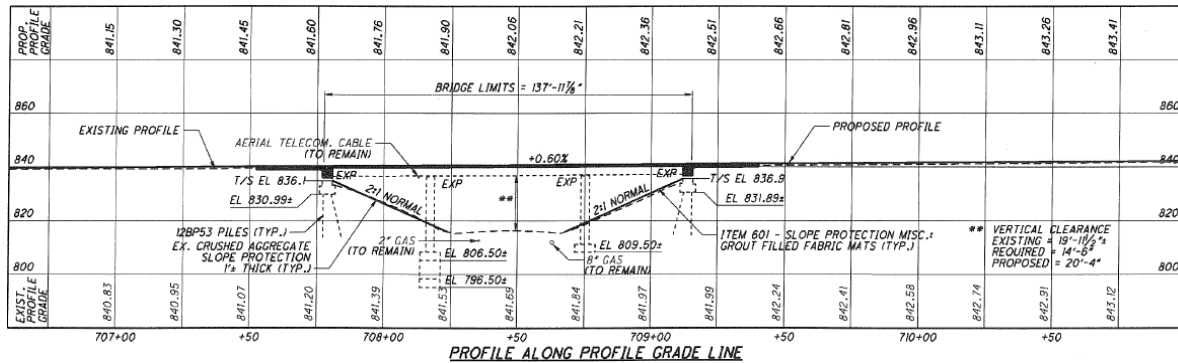

Figure 8: Eastbound Paine Road Bridge Plans, Profile

Width

The total section width of the bridge is 47 feet (14.3 m), with a roadway width of 44 feet (13.4 m).

Parapet Dimensions

The height of each parapet is 3.5 feet (1.07 m). The top width of each parapet is 10 inches (254 mm) and reaches a width of 1.5 feet (457.2 mm) at the base of the parapet. The parapet detail is shown in Figure 9.

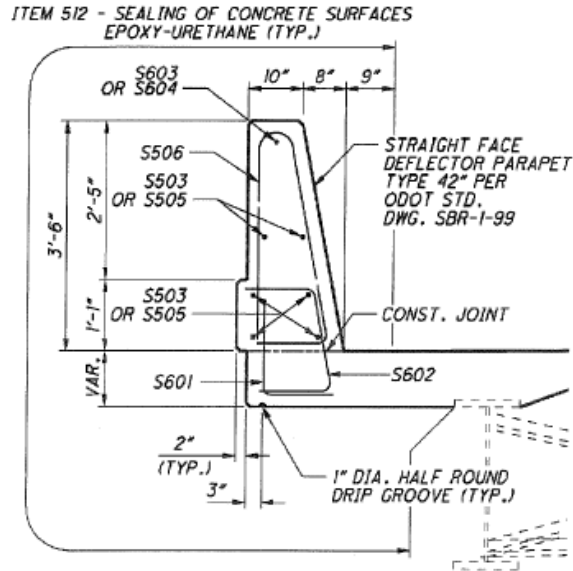

PARAPET DETAIL

Figure 9: Eastbound Paine Road Bridge Plans, Parapet Cross Section

Eastbound Hermitage Road Bridge (LAK - 90 - 13.70 R)

The Hermitage Road Bridge is an eastbound Interstate – 90 Highway bridge in Painesville, Ohio. It was originally built in 1961.

Inventory Number and Structural File Number

In the ODOT Bridge Inventory, the Eastbound Hermitage Road Bridge is identified as follows:
 Bridge Inventory Number: LAK – 90 – 13.70 R
 Structural File Number: 4304322

Eastbound Hermitage Road Bridge (LAK - 90 - 13.70 R)

Structure Type

The bridge structure consists of a three span continuous steel beam bridge with a reinforced concrete deck and substructure with semi-integral abutments.

Project Information

The deck and superstructure rehabilitation took place in 2013. In addition to deck and parapet replacement, the superstructure was raised and the approach slabs, deck expansion joints, and backwalls with semi-integral abutments were replaced.

Designed Bridge Dimensions

Length

The total length of the bridge is 160.58 feet (48.94 m). It consists of three spans of the following lengths: 47' – 4", 60' – 0", 47' – 10" (14.43 m, 18.29 m, 14.58 m). A profile of the bridge is shown in Figure 10.

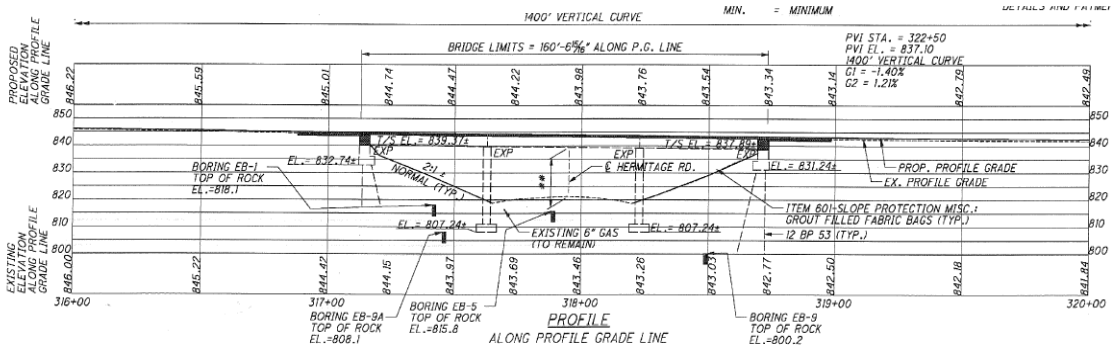

Figure 10: Eastbound Hermitage Road Bridge Plans, Profile

Width

The total section width of the bridge is 59 feet (18.0 m), with a roadway width of 56 feet (17.1 m).

Parapet Dimensions

The height of each parapet is 3.5 feet (1.07 m). The top width of each parapet is 10 inches (254 mm) and reaches a width of 1.5 feet (457.2 mm) at the base of the parapet. The parapet detail is shown in Figure 11.

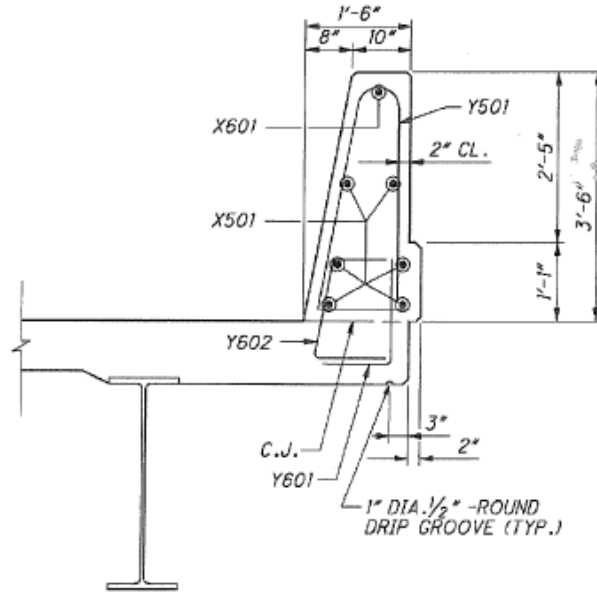

Figure 11: Eastbound Hermitage Road Bridge Plans, Parapet Cross Section

Eastbound Auburn Road Bridge (LAK – 90 – 14.87 R)

The Auburn Road Bridge is an eastbound Interstate – 90 Highway bridge in Painesville, Ohio. It was originally built in 1960.

Inventory Number and Structural File Number

In the ODOT Bridge Inventory, the Eastbound Auburn Road Bridge is identified as follows:

Bridge Inventory Number: LAK – 90 – 14.87 R

Structural File Number: 4304446

Structure Type

The bridge structure consists of a three span continuous steel beam bridge with reinforced concrete deck and substructure.

Project Information

The deck and superstructure rehabilitation took place in 2013. In addition to deck and parapet replacement, the superstructure was raised and the approach slabs, expansion joints, and backwalls were replaced.

Designed Bridge Dimensions

Length

The total length of the bridge is 160.58 feet (48.94 m). It consists of three spans of the following lengths: 41' – 7.25", 63' – 3.44", 41' – 7.5" (12.68 m, 19.29 m, 12.69 m). A profile of the bridge is shown in Figure 12.

Width

The total section width of the bridge varies and the roadway width varies between 74' – 1.13" and 84' – 9.88" (22.58 m and 84.82 m).

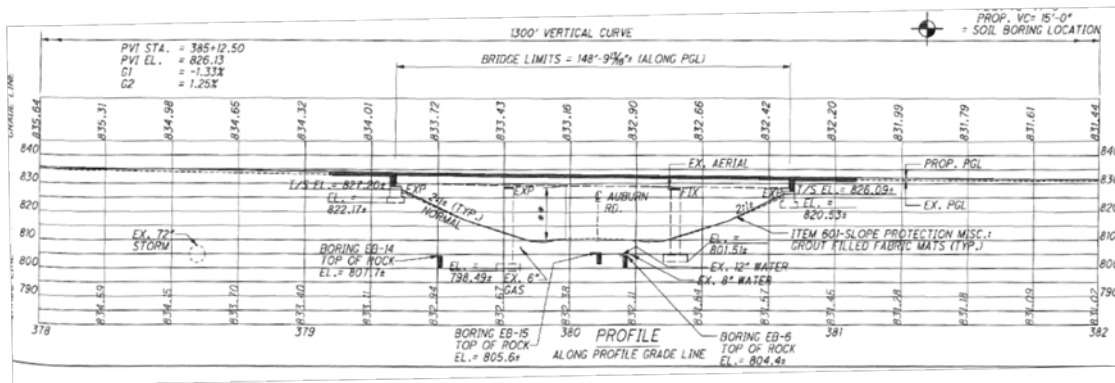

Figure 12: Eastbound Auburn Road Bridge Plans, Profile

Parapet Dimensions

The height of each parapet is 3.5 feet (1.07 m). The top width of each parapet is 10 inches (254 mm) and reaches a width of 1.5 feet (457.2 mm) at the base of the parapet. The parapet detail is shown in Figure 13.

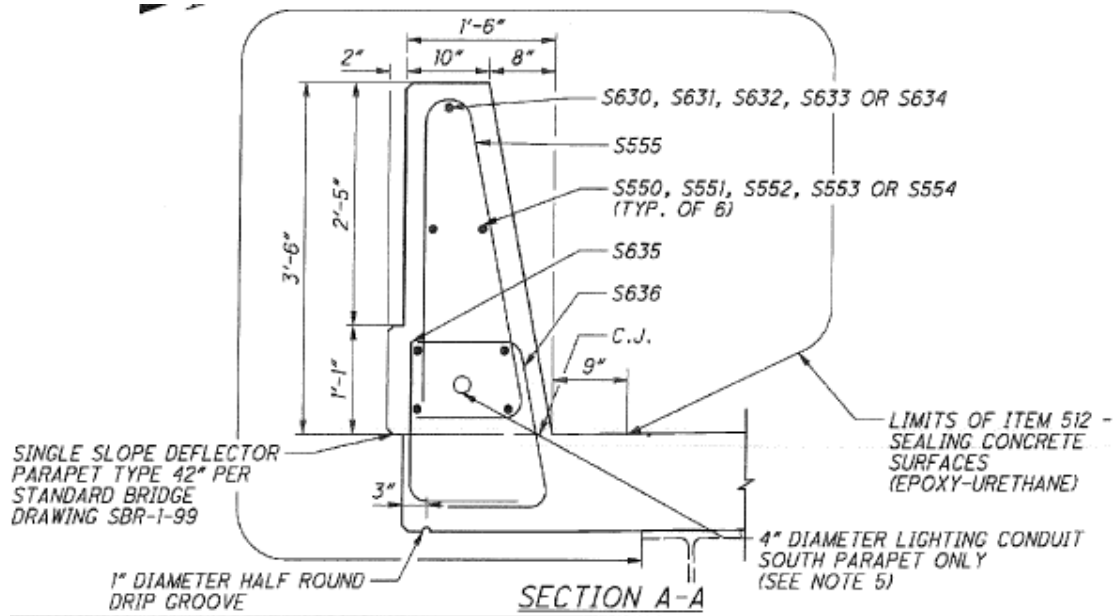

Figure 13: Eastbound Auburn Road Bridge Plans, Parapet Cross Section

Westbound Paine Road Bridge (LAK – 90 – 21.10 L)

The Paine Road Bridge is a westbound Interstate – 90 Highway bridge in Painesville, Ohio. It was originally built in 1960.

Inventory Number and Structural File Number

In the ODOT Bridge Inventory, the Eastbound Paine Road Bridge is identified as follows:

Bridge Inventory Number: LAK – 90 – 21.10 L

Structural File Number: 4304837

Structure Type

The bridge structure consists of a three span continuous steel beam bridge with reinforced concrete deck and substructure with semi-integral abutments.

Project Information

The deck and superstructure rehabilitation took place in 2013. In addition to deck and parapet replacement, the superstructure was raised and the approach slabs, deck expansion joints, and backwalls with semi-integral abutments were replaced.

Designed Bridge Dimensions

Length

The total length of the bridge is 113.63 feet (34.63 m). It consists of three spans of the following lengths: 31' – 3", 46' – 0", 31' – 3" (9.53 m, 14.02 m, 9.53 m). A profile of the bridge is shown in Figure 14.

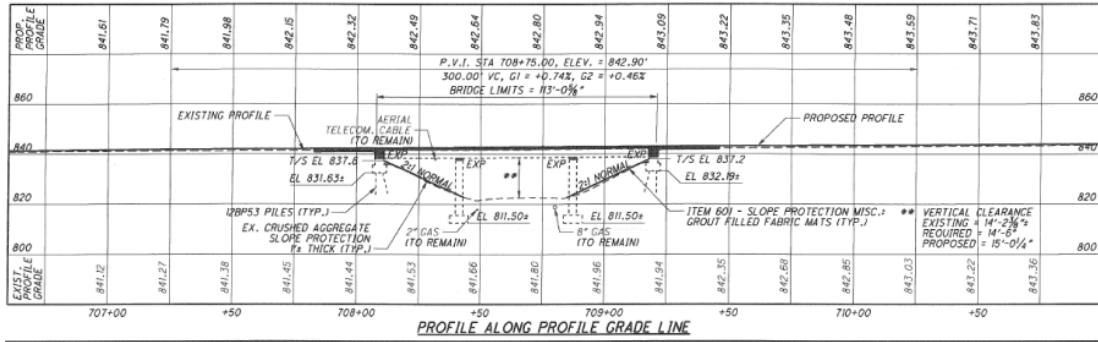

Figure 14: Westbound Paine Road Bridge Plans, Profile

Width

The total section width of the bridge is 47 feet (14.3 m), with a roadway width of 44 feet (13.4 m).

Parapet Dimensions

The height of each parapet is 3.5 feet (1.07 m). The top width of each parapet is 10 inches (254 mm) and reaches a width of 1.5 feet (457.2 mm) at the base of the parapet. The parapet detail is shown in Figure 15.

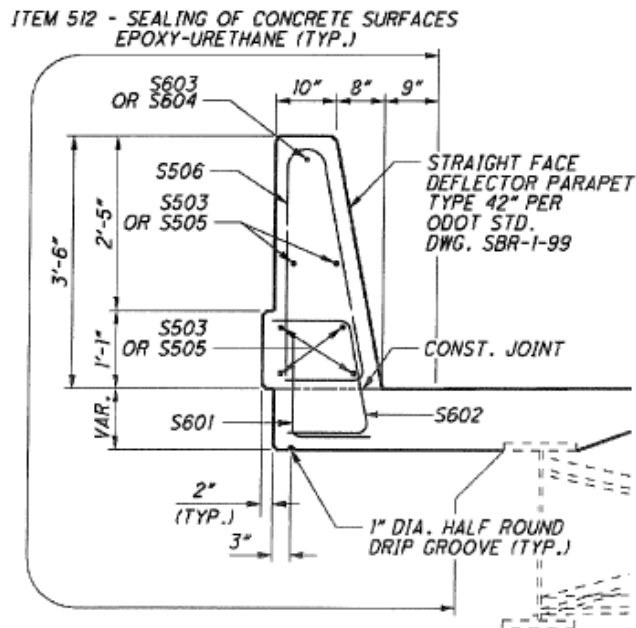

Figure 15: Westbound Paine Road Bridge Plans, Parapet Cross Section

Westbound Paine Creek Bridge (LAK – 90 – 20.03 L)

The Paine Creek Bridge is a westbound Interstate – 90 Highway bridge in Painesville, Ohio. It was originally built in 1960.

Inventory Number and Structural File Number

In the ODOT Bridge Inventory, the Westbound Paine Creek Bridge is identified as follows:

Bridge Inventory Number: LAK – 90 – 20.03 L

Structural File Number: 4304748 (L)

Structure Type

The bridge structure is a twin continuous steel plate girder bridge with reinforced concrete deck and substructure.

Project Information

The deck and superstructure rehabilitation took place in 2013. In addition to parapet replacement, work included a new widened non-composite reinforced concrete deck on existing steel girders.

Designed Bridge Dimensions

Length

The total length of the bridge is 488.29 feet (148.83 m). It consists of three spans of the following lengths: 150' – 9.88", 188' – 5.88", 149' – 2.75" (45.97 m, 57.45 m, 45.49 m). A profile of the bridge is shown in Figure 16.

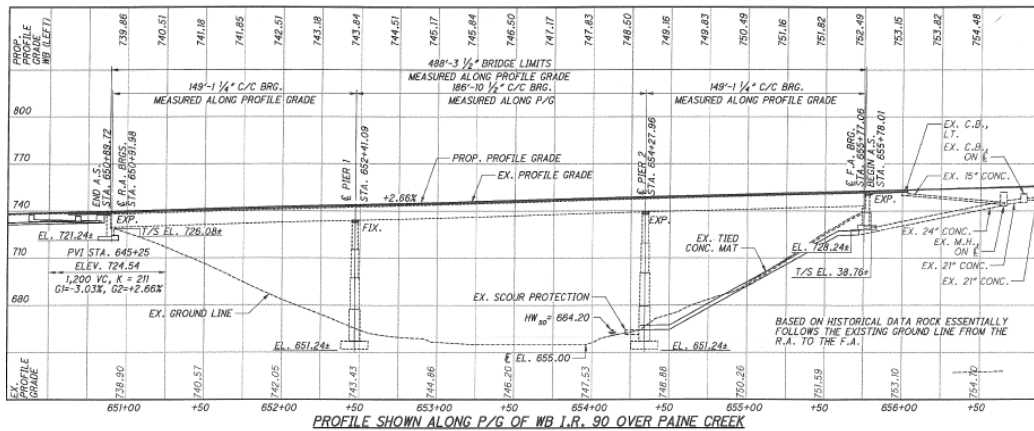

Figure 16: Westbound Paine Creek Bridge Plans, Profile

Width

The total section width of the bridge is 47 feet (14.3 m), with a roadway width of 44 feet (13.4 m).

Parapet Dimensions

The height of each parapet is 3.5 feet (1.07 m). The top width of each parapet is 10 inches (254 mm) and reaches a width of 1.5 feet (457.2 mm) at the base of the parapet. The parapet detail is shown in Figure 17.

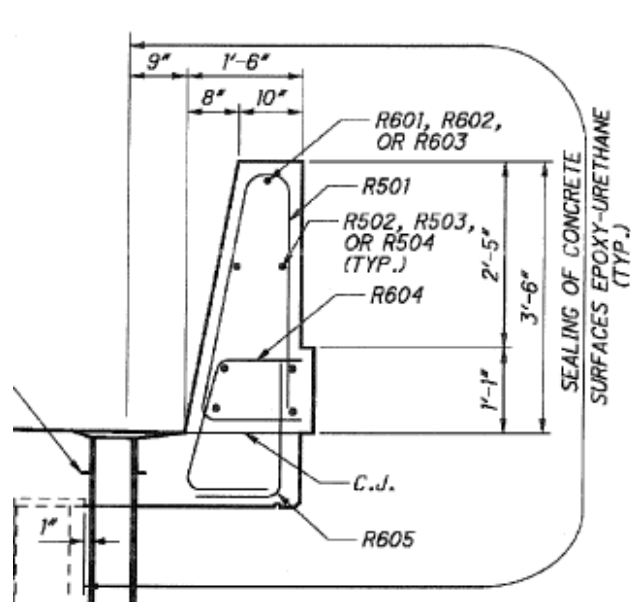

Figure 17: Westbound Paine Creek Bridge Plans, Parapet Cross Section

South Marginal Road Bridge (CUY – 90 – 18.15)

The South Marginal Bridge is an overpass bridge over I – 90 in downtown Cleveland. It was originally built in 1959.

Inventory Number and Structural File Number

In the ODOT Bridge Inventory, the South Marginal Bridge is identified as follows:

Bridge Inventory Number: CUY – 90 – 18.15

Structural File Number: 1808192

Structure Type

The bridge structure consists of continuous steel beams with composite reinforced concrete deck and reinforced concrete substructure.

Contractor and Project Information

The deck and superstructure rehabilitation took place in 2013. The contractor for the rehabilitation was Cuyahoga Bridge and Road, Inc., and the ready mix concrete supplier was Tech Ready Mix, Inc. In addition to parapet replacement, work included a new composite concrete deck on existing beams, refurbishment of pier bearings, and replacement of abutment bearings, end frames, abutment backwalls, and approach slabs, as well as patching and sealing of the substructure concrete.

Designed Bridge Dimensions

Length

The total length of the bridge is 228.02 feet (69.50 m). It consists of four spans of the following lengths: 45' – 0", 68' – 0", 68' – 0", 45' – 0" (13.72 m, 20.73 m, 20.73 m, 13.72 m). A profile of the bridge is shown in Figure 18.

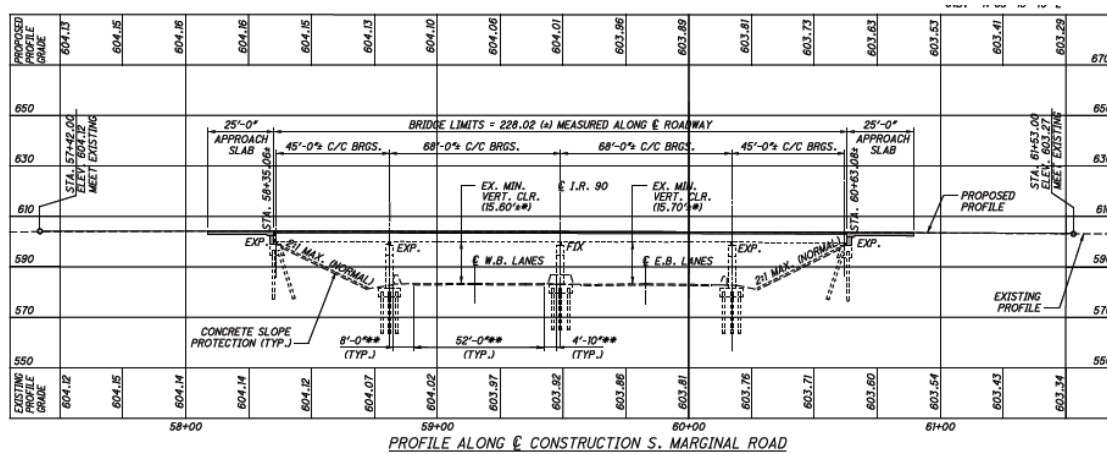

Figure 18: South Marginal Bridge Plans, Profile

Width

The total section width of the bridge is 31 feet (9.45 m), with a roadway width of 24 feet (7.32 m) and a safety curb width of 2 feet (0.61 m) on either side.

Parapet Dimensions

The height of each parapet is 3.5 feet (1.07 m). The top width of each parapet is 10 inches (254 mm) and reaches a width of 1.5 feet (457.2 mm) at the base of the parapet. The parapet detail is shown in Figure 19.

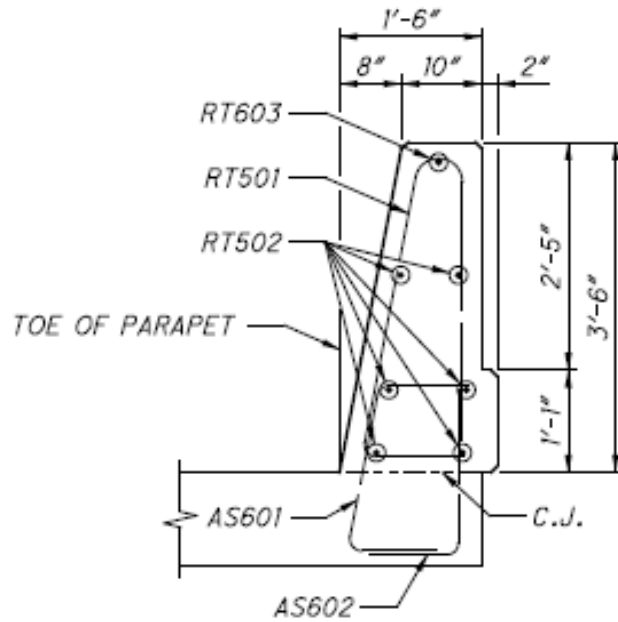

Figure 19: South Marginal Bridge Plans, Parapet Cross Section

Westbound Big Creek Bridge (LAK – 90 – 16.41 L)

The Big Creek Bridge is a westbound Interstate – 90 Highway bridge in Painesville, Ohio. It was originally built in 1960.

Inventory Number and Structural File Number

In the ODOT Bridge Inventory, the Westbound Paine Creek Bridge is identified as follows:

Bridge Inventory Number: LAK – 90 – 16.41 L

Structural File Number: 4304624 (L)

Structure Type

The bridge structure consists of a twin continuous steel plate girder bridge with reinforced concrete deck and substructure with semi-integral abutments.

Project Information

The deck and superstructure rehabilitation took place in 2014. In addition to parapet replacement, work included a new widened non-composite reinforced concrete deck on the existing steel girders.

Designed Bridge Dimensions

Length

The total length of the bridge is 344.5 feet (105.0 m). It consists of three spans of the following lengths: 90' – 0", 140' – 0", 110' – 0" (27.43 m, 42.67 m, 33.53 m). A profile of the bridge is shown in Figure 20.

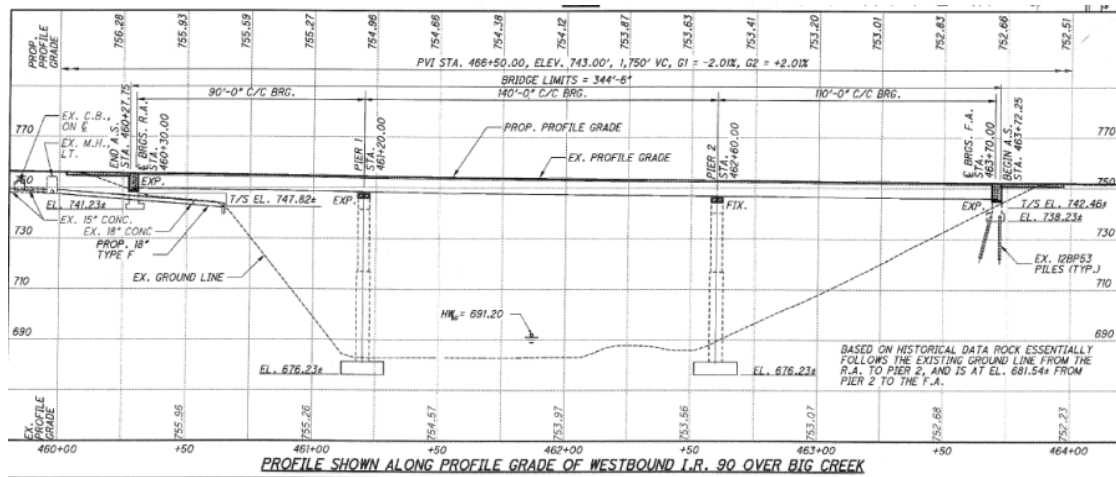

Figure 20: Westbound Big Creek Bridge Plans, Profile

Width

The total section width of the bridge is 47 feet (14.3 m), with a roadway width of 44 feet (13.4 m).

Parapet Dimensions

The height of each parapet is 3.5 feet (1.07 m). The top width of each parapet is 10 inches (254 mm) and reaches a width of 1.5 feet (457.2 mm) at the base of the parapet. The parapet detail is shown in Figure 21.

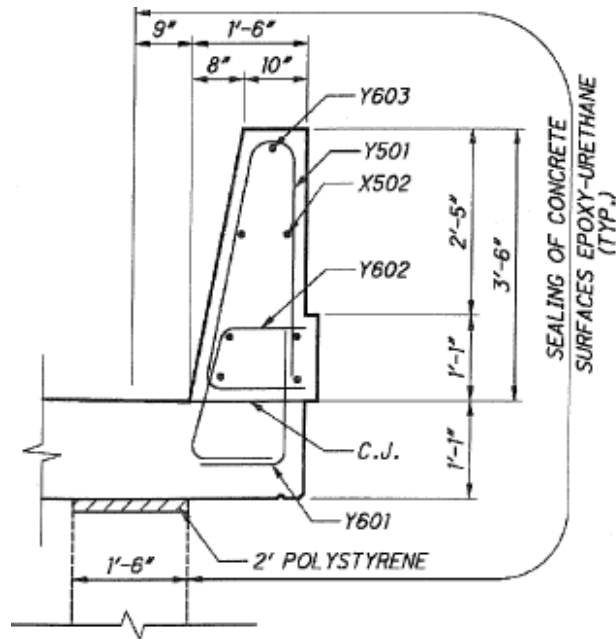

Figure 21: Westbound Big Creek Bridge Plans, Parapet Cross Section

Westbound Auburn Road Bridge (LAK - 90 - 14.87 L)

The Auburn Road Bridge is a westbound Interstate – 90 Highway bridge in Painesville, Ohio. It was originally built in 1960.

Inventory Number and Structural File Number

In the ODOT Bridge Inventory, the Auburn Road Bridge is identified as follows:

Bridge Inventory Number: LAK – 90 – 14.87 L

Structural File Number: 4304470

Structure Type

The bridge structure consists of a three span continuous steel beam bridge with reinforced concrete deck and substructure.

Project Information

The deck and superstructure rehabilitation took place in 2014. In addition to parapet replacement, work included raising the superstructure and replacing the approach slabs, deck, expansion joints, and backwalls.

Designed Bridge Dimensions

Length

The total length of the bridge is 159.28 feet (48.55 m). It consists of three spans of the following lengths: 46' – 8.13", 63' – 2.94", 46' – 9.25" (14.23 m, 19.28 m, 14.26 m). A profile of the bridge is shown in Figure 22.

Width

The total section width of the bridge varies, with a roadway width that varies between 54 feet (16.46 m) and 56.76 feet (17.3 m).

Parapet Dimensions

The height of each parapet is 3.5 feet (1.07 m). The top width of each parapet is 10 inches (254 mm) and reaches a width of 1.5 feet (457.2 mm) at the base of the parapet. The parapet detail is shown in Figure 23.

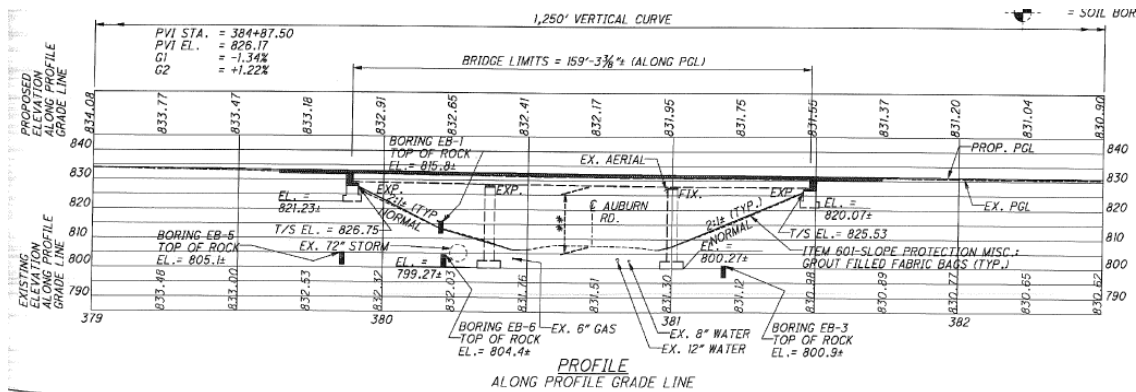

Figure 22: Westbound Auburn Road Bridge Plans, Profile

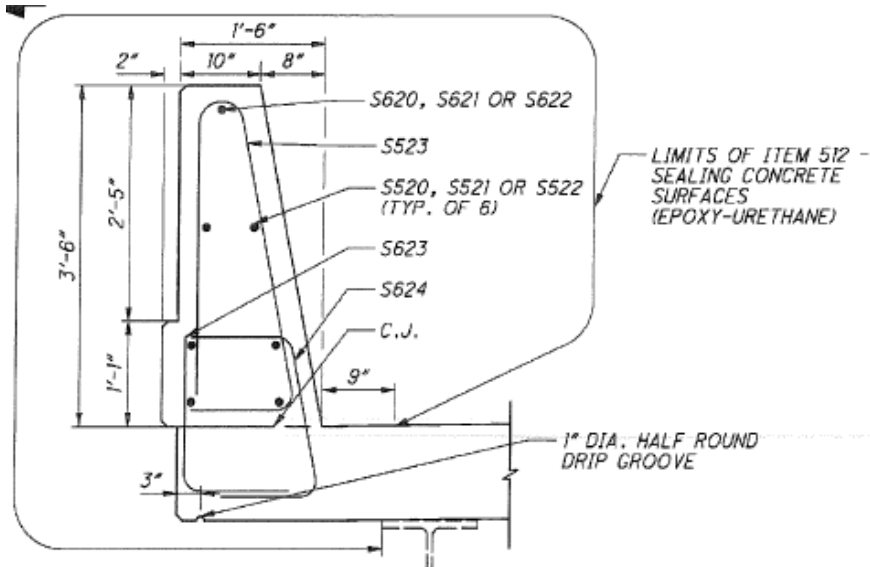

Figure 23: Westbound Auburn Road Bridge Plans, Parapet Cross Section

Westbound Hermitage Road Bridge (LAK - 90 - 13.70 L)

The Hermitage Road Bridge is a westbound Interstate – 90 Highway bridge in Painesville, Ohio. It was originally built in 1961.

Inventory Number and Structural File Number

In the ODOT Bridge Inventory, the Westbound Hermitage Road Bridge is identified as follows:

Bridge Inventory Number: LAK – 90 – 13.70 L

Structural File Number: 4304292

Structure Type

The bridge structure consists of a three span continuous steel beam bridge with a reinforced concrete deck and substructure with semi-integral abutments.

Project Information

The deck and superstructure rehabilitation took place in 2014. In addition to parapet replacement, work included raising the superstructure and replacing the approach slabs, deck, expansion joints, and backwalls with semi-integral abutments.

Designed Bridge Dimensions

Length

The total length of the bridge is 136.5 feet (41.61 m). It consists of three spans of the following lengths: 36' – 0", 60' – 0", 36' – 0" (10.97 m, 18.29 m, 10.97 m). A profile of the bridge is shown in Figure 24.

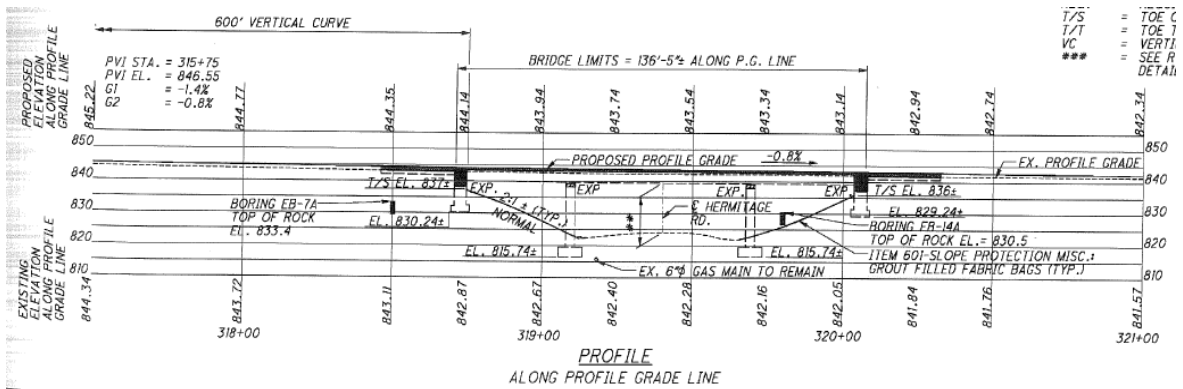

Figure 24: Westbound Hermitage Road Bridge Plans, Profile

Width

The total section width of the bridge is 59 feet (18.0 m), with a roadway width of 56 feet (17.1 m).

Parapet Dimensions

The height of each parapet is 3.5 feet (1.07 m). The top width of each parapet is 10 inches (254 mm) and reaches a width of 1.5 feet (457.2 mm) at the base of the parapet. The parapet detail is shown in Figure 25.

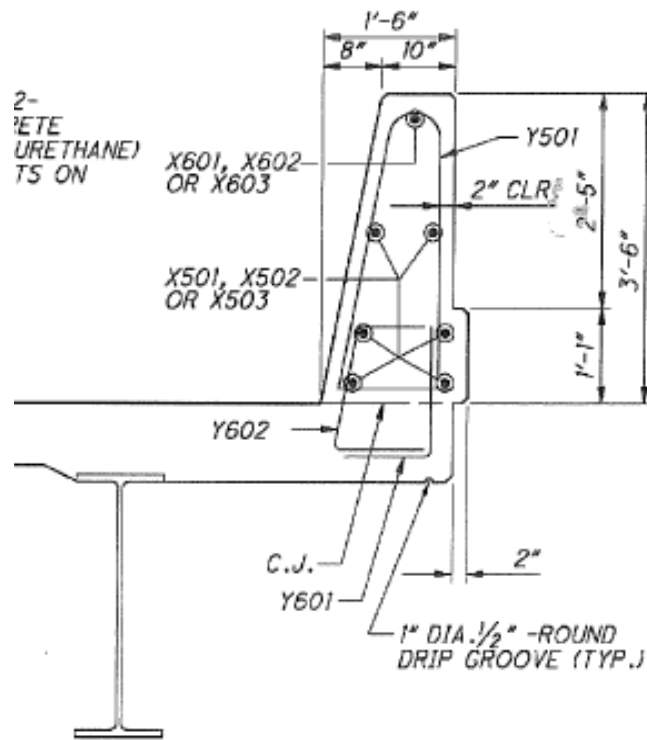

Figure 25: Westbound Hermitage Road Bridge Plans, Parapet Cross Section

CHAPTER V FIELD OBSERVATIONS

This chapter documents the field observations on completed bridge parapets, including data from UPV testing, cylinder sample testing, maturity results, and early age cracking.

Eastbound Big Creek Bridge (LAK-90-16.41R)

Both parapet walls on the eastbound Big Creek Bridge were constructed as experimental controls in 2012. Construction occurred before Cleveland State University was assigned the parapet study with ODOT, therefore site visits were not made during concrete placement or saw cutting operations. It is known that the parapets were constructed while traffic was using the other side of the bridge, and that the control joints were cut on the day of concrete placement while the concrete was still green. Visits were made in 2014, to perform a crack survey.

North Parapet

Due to the narrow shoulder on this side of the bridge, it was not possible to safely perform a crack survey of the north parapet. However, when looking from the side of the south parapet, a large crack could be seen that formed midway between the control joints. A picture from the other side of the bridge was taken. It is hard to make out the crack, but it is circled in Figure 26. It is unknown exactly when this crack formed; however, the crack was discovered on September 30, 2013. The control joints were spaced 10 feet (3.0 m) apart along the length of the wall.



Figure 26: EB Big Creek Bridge North Parapet Crack (Photograph by Lauren Hedges)

South Parapet

A crack survey was performed on the south parapet of the eastbound Big Creek Bridge. The control joints on this bridge were spaced 10 feet (3.0 m) apart along the length of the parapet. Again, a crack was found midway between the control joints as shown displayed in Figure 27. Figure 28 is a picture looking down at the top of the parapet showing that the crack continued all the way through the thickness of the wall. It also continued all the way down the back side of the parapet. This crack was not discovered until February 27, 2014, and it is unknown exactly when the crack formed.



Figure 27: EB Big Creek south parapet crack (Photograph by Lauren Hedges)



Figure 28: Crack along top of parapet (Photograph by Lauren Hedges)

Another site visit was made on October 9, 2014 to perform a visual inspection as well as UPV testing at each of the control joints. The crack survey found only one crack, pictured above. There were no new visible cracks to report. The UPV test velocities from the parapet are shown in Table 4.

Table 4: EB Big Creek south parapet UPV velocities

Time	Average UPV Velocities			
	Location			
	South Parapet		Concrete Cylinder Sample	
UPDATE	1,725 fps	525 mps	N/A	N/A

The velocities of the cylinder samples were used for comparison with the values collected in the field. Due to the curing conditions in the lab, the cylinder samples were expected to produce somewhat higher velocities than the parapet. Since the velocities of the parapet were in the appropriate range, average velocities over each control joint were recorded. These velocities were placed into three categories:

1. Cracked Joint
2. Partially Cracked Joint
3. Not Cracked Joint

A joint was labeled as cracked if the average velocity over that joint fell between “no signal” or 0 fps and 3,000 fps (915 mps). An average velocity from 3,000 to 7,000 fps (915 to 2,130 mps) represented a partially cracked joint and joints that were not cracked included velocities greater than 7,000 fps (2,130 mps). Approximately 85% of the joints cracked, 15% were partially cracked, and 0% were not cracked.

Eastbound Paine Creek Bridge (LAK-90-20.03R)

Both parapet walls on the eastbound Paine Creek Bridge were constructed as experimental controls in 2012. Construction occurred before Cleveland State University was assigned the parapet study with ODOT, therefore site visits were not made during concrete placement or saw cutting operations. It is known that the parapets were constructed while traffic was using the other side of the bridge, and the control joints were cut on the day of concrete placement while the concrete was still green. Visits were made in February of 2014 to perform a crack survey.

North Parapet

It was not practical to close a lane on the two lane highway, so the wall was scanned for cracks while slowly driving next to it in order to inspect the parapet safely. The control joints were spaced approximately 9.5 feet (2.9 m) along the parapet. A crack was found in between the control joints in a location near a pier. The crack was not discovered until February 27, 2014.

Figure 29 shows the crack from the front of the parapet, and Figure 30 was taken from the adjacent bridge showing the crack on the back side of the parapet.



Figure 29: EB Paine Creek north parapet crack near control joint (Photograph by Lauren Hedges)



Figure 30: Looking at EB Paine Creek north parapet crack from adjacent bridge (Photograph by Lauren Hedges)

South Parapet

A site visit to the south parapet of the eastbound Paine Creek Bridge was made on August 18, 2014. Four cracks were discovered on this parapet, each occurring between control joints. UPV tests were conducted along the entire length of the wall to include at each control joint and at the visible cracks. The UPV test velocities from the parapet are shown in Table 5.

Table 5: EB Paine Creek south parapet UPV velocities

Time	Average UPV Velocities			
	Location			
	South Parapet		Concrete Cylinder Sample	
UPDATE	2,846 fps	867 mps	N/A	N/A

The velocities of the cylinder samples were compared to the values collected in the field. Due to the curing conditions in the lab, the cylinder samples were expected to produce somewhat higher velocities than the parapet. Since the velocities of the parapet were in the appropriate range, average velocities over each control joint were recorded. These velocities were placed into three categories:

1. Cracked Joint
2. Partially Cracked Joint
3. Not Cracked Joint

A joint was labeled as cracked if the average velocity over that joint fell between “no signal” or 0 fps and 3,000 fps (915 mps). An average velocity from 3,000 to 7,000 fps (915 to 2,130 mps) represented a partially cracked joint and joints that were not cracked included velocities greater than 7,000 fps (2,130 mps). Approximately 61% of the joints cracked, 37% were partially cracked, and 2% were not cracked.

Eastbound Paine Road Bridge (LAK-90-21.10R)

Both parapet walls on the eastbound Paine Road Bridge were constructed as experimental controls in 2012. Construction occurred before Cleveland State University was assigned the parapet study with ODOT, therefore site visits were not made during concrete placement or saw cutting operations. It is known that the parapets were constructed while traffic was using the other side of the bridge, and the control joints were cut on the day of concrete placement while the concrete was still green. Visits were made in February of 2014 to perform a crack survey.

North Parapet

The north parapet had a wide shoulder allowing a close view and crack survey to be taken. The control joints were spaced every 7.25 feet (2.2 m) creating a total of 18 joints. Two cracks were discovered on this parapet on February 27, 2014. The first crack, in Figure 31, propagated out of the third control joint from the west end. The joint was located halfway between the edge

of the bridge and the pier. The second crack, in Figure 32, was found between the fourth and fifth control joints within the negative tension zone created by the pier.



Figure 31: EB Paine Road north parapet crack propagating out of control joint (Photograph by Lauren Hedges)



Figure 32: EB Paine Road 2nd crack found between joints (Photograph by Lauren Hedges)

This parapet showed a lot of spalling along the section of the parapet where the horizontal reinforcement is located. This may indicate there was not enough cover provided over the reinforcement. Figure 33 shows where the spalling began. As defined by the American Concrete Institute (ACI), spalling is “the development of a fragment, usually in the shape of a flake, detached from a larger mass by a blow, the action of weather, pressure, or expansion within the larger mass” (ACI Concrete Terminology 2014).



**Figure 33: Spalling on EB Paine Road north parapet along location of horizontal reinforcement
(Photograph by Lauren Hedges)**

UPV tests were performed on the parapet as well as over the control joints. The average velocity of the concrete was calculated as 9,493 fps (2,893 mps) or approximately 9,500 fps (2,900 mps). Using this information, the velocities found over the control joints were used to determine which joints fully cracked, showed signs of cracking, or did not crack at all. A joint was labeled as cracked if the average velocity fell between no signal, or 0 fps, and 4,500 fps (1,370 mps). A velocity between 4,500 fps and 8,500 fps (2,590 mps) represented a partially cracked joint. Joints that were not cracked included velocities 8,500 fps (2,590 mps) or greater that fell near the concrete’s average velocity of 9,500 fps (2,900 mps). Approximately 78% of the control joints fully cracked, 17% of the joints partially cracked, and 6% of the joints did not crack. One joint that did not crack was located near the west end of the bridge.

South Parapet

A site visit was made to perform UPV testing on August 12, 2014 on the south parapet of the Paine Road Bridge. An inspection for visual cracks along the parapet was also completed. The parapet was also inspected for early age cracking. No cracks were identified other than the flaws produced from poor consolidation at the surface and removal of the forms. The UPV test average velocity from the parapet is shown in Table 6.

Table 6: EB Paine Road south parapet UPV velocities

Time	Average UPV Velocities			
	Location			
	South Parapet		Concrete Cylinder Sample	
Update	3,942 fps	1,202 mps	N/A	N/A

The velocities of the cylinder samples were used as verification of the values collected out in the field. Due to the curing conditions in the lab, the cylinder samples were expected to produce somewhat higher velocities than the parapet. Since the velocities of the parapet were in the appropriate range, average velocities over each control joint were recorded. These velocities were placed into three categories:

1. Cracked Joint
2. Partially Cracked Joint
3. Not Cracked Joint

A joint was labeled as cracked if the average velocity over that joint fell between “no signal” or 0 fps and 3,000 fps (915 mps). An average velocity from 3,000 to 7,000 fps (915 to 2130 mps) represented a partially cracked joint and joints that were not cracked included velocities greater than 7,000 fps (2130 mps). Approximately 33% of the joints cracked, 50% were partially cracked, and 17% were not cracked.

Eastbound Hermitage Road Bridge (LAK-90-13.70R)

North Parapet

Three maturity sensors were attached to the reinforcement of the north parapet. The design of the reinforcement included both epoxy coated steel reinforcement and GFRP reinforcement. No. 5 (16 mm) steel bars were used as the vertical reinforcement, and No. 6 (19 mm) steel bars were used to connect the parapet to the deck. No. 5 (16 mm) GFRP bars were used for all the horizontal reinforcement except the single reinforcement at the top consisted of a No. 6 (19 mm) GFRP bar.

Concrete was placed on July 2, 2013, under cloud cover at 66° F (19° C) and 96% relative humidity. The first truck was tested at 5.8% air with a 6 inch (150 mm) slump and a concrete temperature of 77°F (25°C). Before placement, superplasticizer and a retarder were added to the concrete mixture onsite. The concrete mixture did not contain any fiber. Three cylinder samples were taken for UPV and compressive strength testing.

Removal of the formwork and saw cutting took place the next day, approximately 20 hours after concrete placement. The saw cuts went 3 ½ inches (889 mm) deep cutting through all of the GFRP reinforcement. The control joints were spaced between 5.83 and 6.08 feet (1.78 and 1.85 m) in negative tension zones and between 8.75 and 12.0 feet (2.67 and 3.66 m) in positive

moment areas. Unlike most of the other parapets, this parapet was kept continuously saturated during formwork removal and saw cutting.

When the forms were stripped, UPV was performed over the control joints and on the parapet before the wall was covered with wet burlap to cure for seven days. The parapet was also inspected for early age cracking. Other than flaws from formwork removal, no cracks were identified. Figures 34 and 35 show the bug holes and small surface cracks observed along the parapet.



Figure 34: EB Hermitage Road north parapet surface cracks (Photograph by Amy Kalabon)

Seven days later, after the wall cured, another site visit was made to take maturity sensor readings and complete UPV tests on the wall, over joints, and over any discovered cracks. No cracks were found during this site visit. The UPV velocities taken on the parapet and on the cylinder samples are shown in Table 7.

Table 7: EB Hermitage north parapet UPV velocities

Time	Average UPV Velocities			
	Location			
	North Parapet		Concrete Cylinder Sample	
Day 1	11462 fps	3494 mps	11967 fps	3648 mps
Day 7	12561 fps	3829 mps	13279 fps	4047 mps



Figure 35: EB Hermitage Road north parapet typical bug holes (Photograph by Amy Kalabon)

The velocities of the cylinder samples were compared to the values collected in the field. Due to the curing conditions in the lab, the cylinder samples were expected to produce higher velocities than the parapet.

Since the velocities of the parapet were in the appropriate range, average velocities over each control joint were recorded. These velocities were placed into three categories:

1. Cracked Joint
2. Partially Cracked Joint
3. Not Cracked Joint

A joint was labeled as cracked if the average velocity over that joint fell between “no signal” or 0 fps and 5,000 fps (1,500 mps). An average velocity from 5,000 fps to 10,000 fps (1,500 to 3,000 mps) represented a partially cracked joint. Joints that were not cracked included velocities greater than 10,000 fps (3,000 mps) that fell close to the average concrete velocity of 12,561 fps. Approximately, 18% of the joints cracked, 70% were partially cracked, and 12% were not cracked. It is expected that the partially cracked joints will fully crack in the future.

Three maturity sensors were placed on the bridge to determine temperatures of the concrete during placement and curing. One of the sensors was buried during concrete placement and another was damaged during construction. Table 8 shows the peak temperature and the initial

drop in the temperature the concrete reached during the hydration process from the surviving maturity sensor.

Table 8: EB Hermitage north parapet maturity sensor temperature data

Sensor	Peak Temperature (°F/°C)	Initial Low Temperature after Peak (°F/°C)	Temperature Differential (°F/°C)
Hermitage (n) #2	124.7/51.5	78.8/26.0	45.9/25.5

South Parapet

Three maturity sensors were attached to the reinforcement of the south parapet of the Hermitage Road Bridge. As per design, the type of reinforcement used was epoxy coated steel reinforcement with No. 5 (16 mm) longitudinal and vertical bars, a single No. 6 (19 mm) longitudinal bar at the top of the parapet, and No. 6 (19 mm) bars tying the parapet to the deck.

Placement of the concrete occurred on October 15, 2013, under cloudy and foggy conditions at 60°F (16°C) and 78% relative humidity. One of the ready mix trucks was tested to ensure the quality of the concrete. The truck that was tested had concrete with a temperature of 62°F (17°C), a 6 inch (150 mm) slump, and an air content of 8%. A factor contributing to the high air content of this concrete may have been the 1 lb/yd³ (0.59 kg/m³) of polypropylene fiber. Superplasticizer was added to the concrete before placement. Three concrete cylinder samples were collected for UPV and compressive strength testing.

The forms were removed the same day the concrete was placed, right after placement was complete. With the concrete in this green stage, UPV tests could not be performed before the wall was prepared and covered to cure. Form removal and saw cutting while the concrete is green may reduce the number of micro cracks that form during the first stages of hydration when the control joints have not yet been cut, and allows the wall to be easily rubbed before it is left to cure. The control joints cut in this parapet were the typical 1 ½ inch (38 mm) deep cuts, and were spaced from 5.25 to 6.42 feet (1.6 to 2 m) in negative tension areas and 11.83 to 12.33 feet (3.6 to 3.8 m) in positive moment areas.

After the parapet finished curing, a site visit was made to perform a crack survey and UPV tests. The parapet had no surface flaws such as holes or surface cracks. The condition of the parapet can be seen in Figure 36. No cracks were found; therefore UPV was only performed on the parapet and over the control joints. The average UPV velocities from both the parapet and the cylinder samples after curing are displayed in Table 9.



Figure 36: EB Hermitage south parapet condition (Photograph by Amy Kalabon)

Table 9: EB Hermitage south parapet UPV velocities

Time	Average UPV Velocities			
	Location			
	South Parapet		Concrete Cylinder Sample	
After Cure	8,797 fps	2,681 mps	13,609 fps	4,148 mps

The velocities of the cylinder samples were compared to the values collected in the field. Due to the curing conditions in the lab, the cylinder samples were expected to produce somewhat higher velocities than the parapet. However, the values of the cylinders in this case were much higher when compared to the parapet. Due to this, the ranges used to determine which category each control joint was placed into was adjusted. Again, the average velocities were placed into three separate categories:

1. Cracked Joint
2. Partially Cracked Joint
3. Not Cracked Joint

For this parapet, a joint was labeled as cracked if the average velocity over that joint fell between “no signal”, or 0 fps, and 3,000 fps (900 mps). An average velocity from 3,000 fps to 7,000 fps (2,100 mps) represented a partially cracked joint, and joints that were not cracked included velocities greater than 7,000 fps (2,100 mps) that fell close to the average concrete velocity of 8797 fps (2,681 mps). According to this adjusted system, only 6% of the joints cracked, 53% were partially cracked, and 41% did not crack.

The three maturity sensors placed on the bridge provided temperatures of the concrete during placement and curing. Table 10 shows the peak temperature and the initial drop in temperature the concrete reached during the hydration process.

Table 10: EB Hermitage south parapet maturity sensor temperature data

Sensor	Peak Temperature (°F/°C)	Initial Low Temperature after Peak (°F/°C)	Temperature Differential (°F/°C)
Hermitage (s) #1	99.5/37.5	70.7/21.5	28.8/16.0
Hermitage (s) #2	93.2/34.0	71.6/22.0	21.6/12.0
Hermitage (s) #3	95.0/35.0	72.5/22.5	22.5/12.5

On February 21, 2014, another site visit was made to the south parapet to perform UPV tests and a crack survey. Despite the very cold conditions, no cracks were found on the parapet.

UPV tests were performed on the parapet to see if the cold weather had initiated any additional cracking at the control joints. Before analyzing the velocities gathered from the control joints, the concrete’s average velocity was recalculated and found to have increased from 8,800 fps (2680 mps) to approximately 10,300 fps (3,140 mps). A joint was labeled as fully cracked if the velocity over the joint fell between 0 fps and 4,500 fps (1,370 mps), a partially cracked joint had a velocity between 4,500 fps and 8,500 fps (2,590 mps), and a joint was not cracked if it had a velocity of 8,500 fps (2,590 mps) or greater that fell near the average concrete velocity of 10,300 fps (3,140 mps). Since the fall, the majority of the control joints were fully cracked or showed signs of cracking. Approximately 47% of the joints fell in the fully cracked category, 47% were partially cracked, and only 6% of the joints did not crack at all. With more control joints due to the smaller spacing over the negative tension areas, not all of the control joints needed to completely crack in order to properly control cracking along the parapet. So even though not all of the joints fully cracked, they are still functioning as designed by preventing cracking elsewhere on the parapet.

The wires from the three maturity sensors placed on this bridge were still intact during the site visit; however, only one of the sensors was able to provide readings from January 9, 2014 to February 21, 2014. A graph of the temperature fluctuations the parapet experienced during this time is shown in Figure 37. Within this time, the parapet experienced a maximum temperature of 48.2°F (9°C) and a minimum temperature of 6.8°F (-14°C). Over the span of time since the parapet was placed in October, there was enough freeze-thaw action to cause the concrete to crack. With no cracks discovered along the length of the parapet, the parapet functioned as it was designed by limiting cracking to the joints.

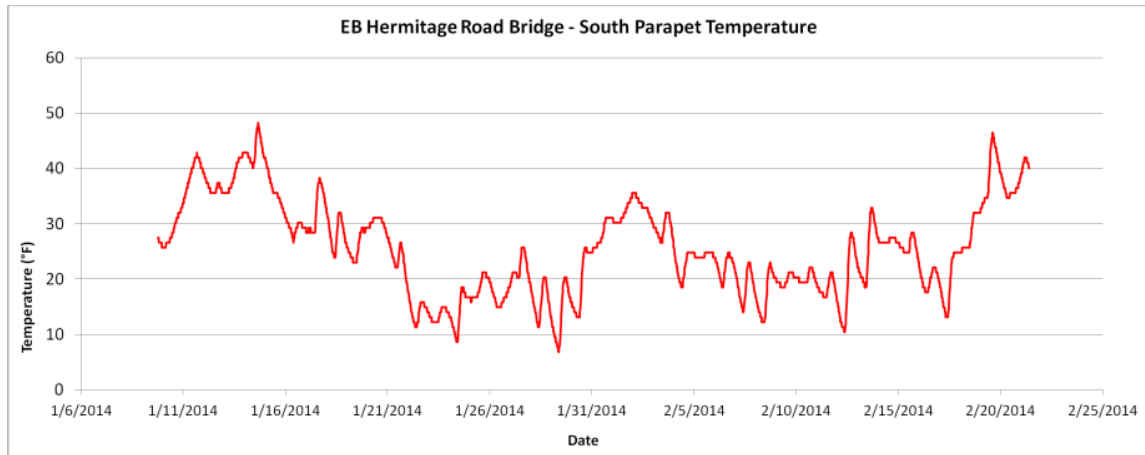

Figure 37: EB Hermitage south parapet winter temperature fluctuations

A final site survey was made on October 7, 2014 to the Hermitage Road south parapet. UPV tests were performed and a final crack survey was completed. No cracks were found on the wall but low readings recorded from the UPV suggest cracks occurring at the control joints as discussed above. Using the same conditions as before, the UPV data suggested that there was no change in the percentage of control joints that are cracked, partially cracked, or not cracked at all.

Eastbound Auburn Road Bridge (LAK-90-14.87R)

North Parapet

Three maturity sensors were attached to the reinforcement on the north parapet of Auburn Road Bridge. The design of the reinforcement included both epoxy coated steel reinforcement and GFRP reinforcement. No. 5 (16 mm) steel bars were used as the vertical reinforcement, and No. 6 (19 mm) steel bars were used to attach the parapet to the deck. No. 5 (16 mm) GFRP bars were used for all the horizontal reinforcement, except that the single reinforcement at the top consisted of a No. 6 (19 mm) GFRP bar.

Concrete was placed on July 1, 2013, with no cloud cover, at 70°F (21°C) and 89% relative humidity. The temperature of the concrete was 77°F (25°C) with 7% air and a 4 ¾ inch (120 mm) slump. The concrete mixture did not contain any fibers. During formwork removal, one day after placement, the saw cuts were made at 3 ½ inch (89 mm) depths cutting through all of the longitudinal GFRP reinforcement. The control joints were spaced at 3 ¼ to 6 feet (1.0 to 1.8 m) within negative tension zones, and 10 to 14 feet (3.0 to 4.3 m) along the rest of the parapet. No cracks were found; however there were small holes and many marks from the formwork.

A field visit was made after the seven-day curing period to perform UPV tests on the parapet where no flaws were present, over any identified cracks, and over each control joint. Again, no cracks were identified. Cylinder samples could not be collected for this parapet; however due

to similar conditions, the concrete tests on Auburn Road were compared to the north parapet concrete tests and cylinder samples on Hermitage Road for verification. The average UPV velocity of the concrete was determined to be approximately 12,460 fps (3,798 mps). After verifying this velocity, the average velocities over each control joint were recorded. These velocities were placed into three categories:

1. Cracked Joint
2. Partially Cracked Joint
3. Not Cracked Joint

A joint was labeled as cracked if the average velocity over that joint fell between “no signal” or 0 fps and 5,000 fps (1,500 mps). An average velocity from 5,000 fps to 10,000 fps (1,500 to 3,000 mps) represented a partially cracked joint and joints that were not cracked included velocities greater than 10,000 fps (3,000 mps) that fell close to the average concrete velocity of 12,460 fps (3800 mps). Approximately 28% of the joints cracked, 61% were partially cracked, and only 11% were not cracked.

The joints that did not crack were located on either side of the bridge at the edge of the negative tension zones, approximately 10 feet (3 m) away from the piers. The parapet length is about 149 feet (45.4 m), and within that length, due to the new spacing method, there are 18 control joints. The most common specification calls for control joints to be spaced between 6 feet and 10 feet (1.8 m and 3.0 m) throughout the length of the parapet. If the conventional spacing was used, the parapet would only have around 12 control joints. With the extra joints as well as the 3 ½ inch (89 mm) deep saw cuts through the GFRP bar, it appeared that the majority of the joints cracked.

The three maturity sensors placed on the bridge provided temperatures of the concrete during placement and curing. Table 11 shows the peak temperature and the initial drop in temperature the concrete reached during the hydration process.

Table 11: EB Auburn north parapet maturity sensor temperature data

Sensor	Peak Temperature (°F/°C)	Initial Low Temperature after Peak (°F/°C)	Temperature Differential (°F/°C)
Auburn (n) #1	108.5/42.5	86.9/30.5	21.6/12.0
Auburn (n) #2	108.5/42.5	88.7/31.5	19.8/11.0
Auburn (n) #3	108.5/42.5	87.8/31.0	20.7/11.5

The three maturity sensors were spaced evenly across the length of the parapet, and as shown in the table, they were consistent with each other. The parapet showed a small change in temperature during the initial phases of hydration, reducing the chances of any thermal cracking during this time.

A final site visit was made to the north parapet on July 16, 2014 to determine whether or not the cold winter had contributed to any cracking in the parapet. Four cracks were found, one at the middle of two control joints under tension, one located in the middle of two control joints under compression and two located at the east end of the parapet, one located close to the approach and the other located between the first and second control joint.

South Parapet

Three maturity sensors were placed deep in the center of the parapet on the steel reinforcement. The type of reinforcement used was GFRP with No. 5 (16 mm) longitudinal and vertical bars, a No. 6 (19 mm) longitudinal bar at the top of the parapet, and No. 6 (19 mm) bars tying the parapet to the deck. Concrete was placed on June 24, 2014, with partial cloud cover, at 73°F (23°C) and 88% relative humidity. Polypropylene fibers were added to the concrete mixture at 1 lb/yd³ (0.59 kg/m³). The formwork was removed the same day that the placement was completed and the saw cuts were made after curing. The saw cuts went 3 ½ inches (88.9 mm) deep cutting through all of the GFRP reinforcement. The control joints were spaced between 5.83 and 6.08 feet (1.78 and 1.85 m) in negative tension zones and between 8 ¾ and 12 feet (2.67 and 3.66 m) in positive moment areas. The UPV data that was taken at the control joints are shown in Table 12.

Table 12: EB Auburn Road South parapet UPV velocities

Time	Average UPV Velocities			
	Location			
	North Parapet		Concrete Cylinder Sample	
UPDATE	5,217 fps	1,590 mps	N/A	N/A

The velocities of the cylinder samples could not be used as verification of the values collected out in the field because cylinders were not available. Since the velocities of the parapet were in the appropriate range compared with other parapets with similar makeup, average velocities over each control joint were recorded. These velocities were placed into three categories:

1. Cracked Joint
2. Partially Cracked Joint
3. Not Cracked Joint

A joint was labeled as cracked if the average velocity over that joint fell between “no signal” or 0 fps and 3,000 fps (915 mps). An average velocity from 3,000 to 5,000 fps (915 to 1,524 mps) represented a partially cracked joint and joints that were not cracked included velocities greater than 5,000 fps (1,524 mps). Approximately 5% of the joints cracked, 74% were partially cracked, and 21% were not cracked.

Westbound Paine Road Bridge (LAK-90-21.10L)

North Parapet

Three maturity sensors were attached to the reinforcement of the north parapet to provide temperature data of the concrete. The reinforcement was epoxy coated field cut steel rebar with No. 5 (16 mm) longitudinal and vertical bars, a No. 6 (19 mm) longitudinal bar at the top of the parapet, and No. 6 (19 mm) rebar tying the parapet into the deck.

The north parapet was placed on September 23, 2013 under cloudy conditions at 53°F (12°C) and 73% humidity. The first truck was tested before placement began. The tested concrete was 69°F (20.6°C) with a 5 ¼ inch (133 mm) slump and 6.2% air content. Unfortunately, cylinder samples were not collected. Superplasticizer was added to the concrete onsite along with a retarder.

Once concrete placement was finished, formwork removal and saw cuts were performed while the concrete was still green as shown in Figure 38. The control joints were cut 3 ½ inches (88.9 mm) deep through the horizontal field cut steel rebar. The joints were spaced 4.5 to 5.7 feet (1.37 to 1.74 m) in negative moment areas, and 11.25 to 13.7 feet (3.43 to 4.18 m) in positive moment areas. Right before the wall was covered with burlap to cure for seven days, the wall was rubbed (Figure 39).

Due to the green state of the concrete, UPV tests could not be performed before curing started. A site visit was made after curing in order to collect data from the maturity sensors, survey for cracks, and perform UPV tests. Without having cylinder samples to verify the UPV velocities taken from the parapet, the average velocity of the concrete was compared to the velocities found for the other Lake County bridges. The average velocity was 9,178 fps (2,800 mps), which seems low compared to the other average parapet velocities. Taking this into account, the ranges used to determine which category the control joints fell into were readjusted for this parapet. A joint was labeled as cracked if the average velocity over that joint fell between “no signal,” or 0 fps, and 4,500 fps (1,370 mps). An average velocity from 4,500 fps (1,370 mps) to 9,000 fps (2,740 mps) represented a partially cracked joint, and joints that were not cracked included velocities greater than 9,000 fps (2,740 mps) that fell close to the average concrete velocity of 9,178 fps (2,800 mps). Approximately, 31% of the control joints cracked, 54% were partially cracked, and 15% of the joints did not crack. The joints that did not show any signs of cracking were located at the ends of the bridge.

Another site visit was performed in order to conduct UPV testing as well as a visual crack survey on August 15, 2014. This was conducted to see if the freeze-thaw cycle changed the previous results. The average UPV velocity is shown in Table 13.



Figure 38: WB Paine Road north parapet performance of saw cuts (Photograph by Amy Kalabon)



Figure 39: Rubbing the WB Paine Road north parapet (Photograph by Amy Kalabon)

Table 13: WB Paine Road North parapet UPV velocities

Time	Average UPV Velocities			
	Location			
	North Parapet		Concrete Cylinder Sample	
UPDATE	5,605 fps	1,708 mps	N/A	N/A

The velocities of the cylinder samples were compared to the values collected in the field. Due to the curing conditions in the lab, the cylinder samples were expected to produce somewhat higher velocities than the parapet. Since the velocities of the parapet were in the appropriate range, average velocities over each control joint were recorded. These velocities were placed into three categories:

4. Cracked Joint
5. Partially Cracked Joint
6. Not Cracked Joint

A joint was labeled as cracked if the average velocity over that joint fell between “no signal,” or 0 fps, and 4,500 fps (1,370 mps). An average velocity from 4,500 fps to 9,000 fps (2,740 mps) represented a partially cracked joint, and joints that were not cracked included velocities greater than 9,000 fps (2,740 mps) that fell close to the average concrete velocity of 9,178 fps (2,800 mps). Approximately 50% of the joints cracked, 44% were partially cracked, and 6% were not cracked.

The three maturity sensors placed in the parapet provided the peak temperatures and the initial drop in temperature the concrete reached during curing as shown in Table 14.

Table 14: WB Paine Road north parapet maturity sensor temperature data

Sensor	Peak Temperature (°F/°C)	Initial Low Temperature after Peak (°F/°C)	Temperature Differential (°F/°C)
Paine Road (n) #1	94.1/34.5	85.1/29.5	9.0/5.0
Paine Road (n) #2	95.9/35.5	85.1/29.5	10.8/6.0
Paine Road (n) #3	95.9/35.5	83.3/28.5	12.6/7.0

On February 21, 2014, a site visit was made to check the parapet for cracks. No cracks were found, and one of the maturity sensors was in good condition. It provided temperature readings from January 9, 2014 to February 21, 2014. During this time, the parapet experienced a maximum temperature of 44.6°F (7°C) and a minimum temperature of 5°F (-15°C). Figure 40 shows the temperature changes the concrete experienced. Since the parapet was placed in September, it has been through a lot of freeze-thaw cycles that might induce cracking. Just like the south parapet of the eastbound Hermitage Road Bridge, the design of this parapet functioned properly by limiting cracking to the control joints.

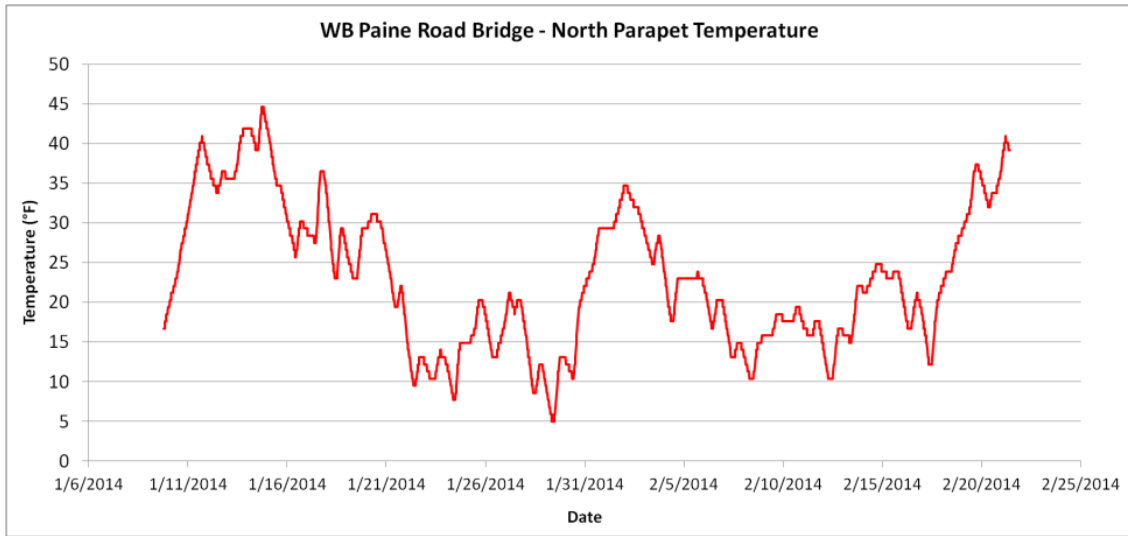

Figure 40: WB Paine Road north parapet winter temperature fluctuations

South Parapet

Prior to concrete placement, three maturity sensors were attached to the reinforcement of the south parapet. The type of reinforcement used was epoxy coated steel rebar with No. 5 (16 mm) longitudinal and vertical bars, a No. 6 (19 mm) longitudinal bar at the top of the parapet, and No. 6 (19 mm) bars tying the parapet into the deck.

Concrete was placed on June 17, 2013, with no cloud cover at 79°F (26.1°C) and 64% relative humidity. The first truck was tested before placement for the proper air content. At 5.8% air, the truck was approved and three cylinder samples were taken for UPV and compressive strength testing. The temperature of the concrete was 76°F (24°C), and it had a slump of 3 ½ inches (89 mm). The concrete mixture included 1 lb./yd³ (0.59 kg/m³) of polypropylene fibers. Therefore, a superplasticizer was added onsite to assist in proper consolidation around the rebar and at the top of the parapet without adding water to the mixture. Figure 41 is looking down in between the formwork showing how the concrete was consolidating around the reinforcement with the assistance of the added superplasticizer.



Figure 41: Consolidation of the concrete on WB Paine Road south parapet (Photograph by Amy Kalabon)

One vibrator was used during placement. It could not be used close to the surface of the wall without hitting the reinforcement. With a low slump of 3 ½ inches (89 mm), the concrete consolidated poorly along the surface of the wall. This became more apparent once the forms were pulled. A way to address this is to rub the wall immediately after stripping the forms to make a continuous surface, removing any holes or pits. Stripping of the forms and saw cutting of the 1.5 inch (38 mm) deep control joints occurred 24 hours after concrete placement. Figures 42 and 43 show the holes and surface cracks that were found after stripping the forms. The pits were found all the way across the wall ranging from ¼ to ¾ inches (6 to 19 mm) in diameter and ½ inches (13 mm) deep. These holes, as well as the flaws created by the formwork, were not rubbed out by the construction workers before placing the burlap on the wall. Typically, the wall is rubbed immediately after form removal before allowing the wall to cure for seven days. In this case, the parapet was “rubbed” sometime after the seven day cure. Since the concrete hardened by this point, paste was added to the wall to cover up the holes and flaws. Figure 44 shows how the parapet looked when the parapet is rubbed after the concrete has hardened.

The control joints cut in this parapet were the typical 1 ½ inch (38 mm) deep cuts, but spaced 3.5 to 4.7 feet (1.1 to 1.4 m) in negative moment areas and 8 feet (2.4 m) in positive moment areas.



Figure 42: WB Paine Road south parapet bug holes (Photograph by Amy Kalabon)



Figure 43: Surface cracks found on WB Paine Road south parapet (Photograph by Amy Kalabon)



Figure 44: WB Paine Road rubbed south parapet (Photograph by Amy Kalabon)

When the forms were stripped, UPV tests were performed on several areas of the parapet before it was covered with wet burlap to cure for seven days. The parapet was also inspected for early age cracking. No cracks were identified other than the flaws produced from poor

consolidation at the surface and removal of the forms. Another field visit was made after curing was complete to perform UPV tests on the parapet where no flaws were present, over any identified cracks, and over each control joint. Two additional cracks were found, similar to the crack in Figure 43. The three cracks were determined to be insignificant surface cracks that initiated from holes that were not rubbed out or from flaws created during removal of the formwork. The UPV test velocities from both the parapet and the cylinder samples before and after curing are displayed in Table 15.

Table 15: WB Paine Road south parapet UPV velocities

Time	Average UPV Velocities			
	Location			
	South Parapet		Concrete Cylinder Sample	
Day 1	11,410 fps	3,478 mps	11,763 fps	3,585 mps
Day 7	11,863 fps	3,616 mps	13,261 fps	4,042 mps

The velocities of the cylinder samples were compared to the values collected in the field. Due to the curing conditions in the lab, the cylinder samples were expected to produce somewhat higher velocities than the parapet. Since the velocities of the parapet were in the appropriate range, average velocities over each control joint were recorded. These velocities were placed into three categories:

1. Cracked Joint
2. Partially Cracked Joint
3. Not Cracked Joint

A joint was labeled as cracked if the average velocity over that joint fell between “no signal” or 0 fps and 5,000 fps (1,500 meter per second). An average velocity from 5,000 to 10,000 fps (1,500 to 3,000 mps) represented a partially cracked joint and joints that were not cracked included velocities greater than 10,000 fps (3,000 mps) that fell close to the average concrete velocity of 11,863 fps. Approximately 10% of the joints cracked, 20% were partially cracked, and 70% were not cracked. It is possible that the use of polypropylene fiber in the concrete mixture and 1 ½ inch (38 mm) deep saw cuts kept the control joints from cracking at early stages. It is expected that the partially cracked joints will crack completely in the future, but it is not known whether the joints that did not crack will crack and prevent cracking elsewhere on the parapet.

The control joints that showed signs of cracking were located directly over and in between the bridge piers. The joints that did not crack were located at the ends of the bridge, between the pier and the end expansion joints. A correlation between the condition of the control joints and the negative tension region could not be made. The negative tension region fell between 10 to 14 feet (3.05 to 4.27 m) on either side of the piers. Possibly due to the short length of the parapet, 113 feet (34.4 m), the negative tension region at the ends of the bridge may not have had a large impact on the parapet enough to cause all the control joints to crack. Also, using the smaller spacing method, there were 20 control joints cut in this parapet instead of 11 joints

by the conventional spacing method. With the availability of additional control joints, it is possible that fewer of the joints needed to crack. Despite the number of control joints that cracked, the parapet functioned as designed up to this point by preventing any early age cracks from forming outside of a control joint.

The three maturity sensors embedded in the bridge provided temperatures of the concrete during placement and curing. Table 16 shows the peak temperature and the initial drop in temperature the concrete reached during the hydration process.

Table 16: WB Paine Road south parapet maturity sensor temperature data

Sensor	Peak Temperature (°F/°C)	Initial Low Temperature after Peak (°F/°C)	Temperature Differential (°F/°C)
Paine Road (s) #1	130.1/54.5	83.3/28.5	46.8/26.0
Paine Road (s) #2	125.6/52.0	81.5/27.5	44.1/24.5
Paine Road (s) #3	125.6/52.0	76.1/24.5	49.5/27.5

During placement and curing of the south parapet, the concrete reached high temperatures, due to summer conditions. All three sensors were consistent with each other showing a large change in temperature. This large temperature differential could possibly be the cause of potential future cracking.

Westbound Paine Creek (LAK-90-20.03L)

North Parapet

Five maturity sensors were attached to the reinforcement of the north parapet. No. 5 (16 mm) epoxy coated steel bars provided the longitudinal and vertical reinforcement with a single No. 6 (19 mm) rebar at the top of the parapet. No. 6 (19 mm) reinforcement was also used to tie the parapet to the deck.

Concrete for the north parapet was placed on September 30, 2013. When placement started, it was cloudy and rainy at 63°F (17°C) and 91% humidity. The first ready mix truck was tested before placing any concrete. The truck was approved with a 7% air content and 4 ¾ inch (120.7 mm) slump at a temperature of 70°F (21°C). Three cylinder samples were collected from this batch of concrete. The concrete mixture included 1 lb/yd³ (0.59 kg/m³) of polypropylene fibers, and so to assist with proper consolidation, superplasticizer was added onsite to the mix.

Formwork was removed once concrete placement was complete. As the forms were removed, saw cutting was performed in order to get the curing on as quickly as possible. The depth of the control joints were between 1 ½ to 2 inches (38 to 50 mm) deep. The joints were spaced 4.67 to 8.5 feet (1.42 to 2.60 m) in negative tension areas and 10.67 to 16.08 feet (3.25 to 4.90 m) in positive moment areas. Before leaving the parapet to cure, the flaws from pulling off the

formwork were rubbed out. Due to the green state of the concrete, UPV tests could not be performed.

After the parapet was cured, a site visit was made on October 16, 2013, to collect maturity data, look for cracks, and perform UPV tests. The UPV test velocities from both the parapet and the cylinder samples after curing are shown in Table 17.

Table 17: WB Paine Creek north parapet UPV velocities

Time	Average UPV Velocities			
	Location			
	North Parapet		Concrete Cylinder Sample	
After Cure	9,876 fps	3,010 mps	10,365 fps	3,159 mps

The velocities of the cylinder samples were used as verification of the values collected out in the field. Due to the curing conditions in the lab, the cylinder samples were expected to produce somewhat higher velocities than the parapet.

Since the velocities of the parapet were in the appropriate range, average velocities over each control joint were recorded. These velocities were placed into three categories:

1. Cracked Joint
2. Partially Cracked Joint
3. Not Cracked Joint

A joint was labeled as cracked if the average velocity over that joint fell between “no signal” or 0 fps and 3,000 fps (900 mps). An average velocity from 3,000 fps to 7,000 fps (900 to 2,100 mps) represented a partially cracked joint and joints that were not cracked included velocities greater than 7,000 fps (2,100 mps) that fell close to the average concrete velocity of 9,876 fps (3,010 mps). Following this adjusted system, approximately 27% of the joints cracked, 63% were partially cracked, and 11% of the joints did not crack at all.

A crack was found on October 16, 2013, immediately after the parapet finished curing. It is shown in Figures 45, 46, and 47. The crack initiates from the control joint on the top of the parapet and follows the control joint down the side of the parapet until about a foot from the ground where it moves back into the joint. The crack does not appear on the outer side of the parapet. The crack width ranged from 0.004 to 0.007 inches (0.1 to 0.2 mm). With the depth of the control joints at approximately 1 ½ inches (38 mm), it is possible that the control joint was not fully activated. The 1 ½ inch deep (38 mm) saw cut may not have been accurate all the way through the joint, so where the cut was shallow, the crack was not able to continue through the joint. This crack may also represent a plane of weakness within the parapet, where a piece of vertical reinforcement may be located relatively close to the control joint or even right beneath the location of the crack. The amount of concrete cover on the reinforcement may not have been enough to prevent the crack from leaving the control joint by providing a path of least resistance. The UPV tests over the control joint and over the crack indicate that the control joint cracked and that the crack itself was deep. The concrete contained 1 lb/yd³ (0.59 kg/m³) of

polypropylene fibers. Despite the use of shallow 1 ½ inch (38 mm) deep saw cuts, only about 11% of the control joints failed to crack. This, as well as the crack found, could be a result of the half-width construction. The amount of extra vibration and bouncing from traffic still using the bridge might result in additional cracking.



**Figure 45: WB Paine Creek north parapet crack looking down from top of parapet
(Photograph by Amy Kalabon)**



Figure 46: WB Paine Creek north parapet crack (Photograph by Amy Kalabon)



Figure 47: WB Paine Creek north parapet crack zoomed in view (Photograph by Amy Kalabon)

The five maturity sensors embedded in the bridge provided temperatures of the concrete during placement and curing. Table 18 shows the peak temperatures and the initial drops in temperature the concrete reached during the hydration process.

Table 18: WB Paine Creek north parapet maturity sensor temperature data

Sensor	Peak Temperature (°F/°C)	Initial Low Temperature after Peak (°F/°C)	Temperature Differential (°F/°C)
Paine Creek (n) #1	112.1/44.5	81.5/27.5	30.6/17.0
Paine Creek (n) #2	110.3/43.5	80.6/27.0	29.7/16.5
Paine Creek (n) #3	102.2/39.0	78.8/26.0	23.4/13.0
Paine Creek (n) #4	104.9/40.5	77.0/25.0	27.9/15.5
Paine Creek (n) #5	104.9/40.5	95.9/35.5	9.0/5.0

On February 21, 2014, a site visit was made to Paine Creek to inspect the parapet for any additional cracking. Due to the length of the bridge and the restriction to the shoulder between the parapet and oncoming traffic, the wall was inspected from inside an ODOT vehicle for safety. No additional cracks were found along the parapet, showing good performance of the parapet’s design in response to the dramatic temperature changes over the winter.

A final site visit was made to the parapet on August 19, 2014 to inspect for any further cracking. UPV testing was also conducted. In total, there were two cracks found along the length of the

parapet. The crack discussed above now ranges from a width of 0.016 – 0.02 inches (0.41 – 0.51 mm). The second crack found has a width of 0.004 – 0.009 inches (0.10 – 0.23 mm) and begins at the outer side of the parapet and travels towards the pop out. Two cracks running parallel on top of the outer side join together and one crack continues to the bottom of the parapet.

South Parapet

Due to the length of this bridge, five maturity sensors were attached to the reinforcement of the south parapet. The type of reinforcement used was epoxy coated steel rebar with No. 5 (16 mm) longitudinal and vertical bars, a No. 6 (19 mm) longitudinal bar at the top of the parapet, and No. 6 (19 mm) bars tying the parapet into the deck.

The length of this parapet required concrete to be placed on two separate days, due to the lack of forms available. The first half of the parapet was placed on June 19, 2013 and the second half on June 24, 2013. During the first placement, the temperature was 67°F (19°C) with no cloud cover and 62% humidity. The first and third trucks were tested for proper air percentage. The first truck had 5.6% air, a concrete temperature of 74°F (23°C), and slump of 3 ½ inches (89 mm). At 8.8% air content, the third truck was almost rejected due to high air content. Also, the concrete for the entire first half of the parapet was poured downhill. This proved to be inefficient because as construction workers finished the top of the parapet and moved down, the concrete kept flowing down the forms, requiring additional work. The first half was finished at a bulkhead approximately 288 feet (88 m) from the east expansion joint.

The second half of the parapet was placed with an outside temperature of 79°F (26°C), no cloud cover, and 61% relative humidity. The first truck had a high air content of 7.8%, a 6 ¾ inch (170 mm) slump, and a temperature of 79°F (26°C). For both halves of the bridge, the forms were removed 24 hours after concrete placement and 1 ½ inch (38 mm) deep control joints were cut, spaced 4 feet (1.2 m) in negative tension areas and 8 feet (2.4 m) in positive moment areas.

The concrete mixture used on the Paine Creek parapets contained 2 lb/yd³ (1.19 kg/m³) of polypropylene fibers. The product sold by BASF, MasterFiber F70, is a fibrillated polypropylene microsynthetic fiber manufactured from 100% virgin homopolymer polypropylene resins. The recommended dosage of MasterFiber F70 product provided by BASF (2010), as well as other producers of similar fibrillated microfiber products, is 1.5 lb/yd³ (0.89 kg/m³). The south parapet of Paine Creek exceeded the recommended dosage of fiber. This may have led to the high air contents. Typically, microfibers are coated in a surfactant in order to stop them from sticking together and collecting a charge in the machines during the drawing process. The surfactant coating can cause increased air entrainment, and therefore the increased dosage of fiber increased the amount of surfactant in the concrete.

One vibrator was used during placement. It could not be used close enough to the surface of the wall without hitting the reinforcement. With a low slump of 3 ½ inches (89 mm), the concrete consolidated poorly along the surface of the first half of the wall, this became more apparent once the forms were pulled. A way to fix this is to rub the wall immediately after

stripping the forms to make a continuous surface removing any holes or pits. This poor consolidation not only causes holes, like the ones on the Paine Road parapet, but it also causes a weak bond within the matrix of the concrete. It allows large pieces to fall off the surface, as shown in Figures 48 and 49. The parapet had many flaws that looked like this, as well as numerous holes up to $\frac{1}{4}$ inches (6 mm) in diameter and $\frac{1}{4}$ to $\frac{3}{4}$ inches (6 to 19 mm) deep across the entirety of the parapet. The parapet was not rubbed, except for a few severely flawed areas where paste was added after the concrete had already hardened.



Figure 48: WB Paine Creek south parapet poor consolidation at the surface (Photograph by Amy Kalabon)

On both halves of the parapet, the forms were stripped the next day, and UPV tests were performed on several areas of the parapet before it was covered with wet burlap to cure for seven days. The parapet was also inspected for early age cracking. Despite the many bug holes and flaws on the parapet, no cracks were found. Another field visit was made after the seven-day curing period to perform UPV tests on the parapet where no flaws were present, over any identified cracks, and over each control joint. Again, no cracks were identified. The UPV test velocities from both the parapet and the cylinder samples before and after curing are displayed in Table 19.



Figure 49: WB Paine Creek south parapet holes on the surface (Photograph by Amy Kalabon)

Table 19: WB Paine Creek south parapet UPV velocities

Time	Average UPV Velocities			
	Location			
	South Parapet		Concrete Cylinder Sample	
Day 1	11,617 fps	3,541 mps	11,925 fps	3,635 mps
Day 7	12,365 fps	3,769 mps	12,955 fps	3,949 mps

The velocities of the cylinder samples were compared to the values collected in the field. Due to the curing conditions in the lab, the cylinder samples were expected to produce somewhat higher velocities than the parapet. Since the velocities of the parapet were in the appropriate range, average velocities over each control joint were recorded. These velocities were placed into three categories:

1. Cracked Joint
2. Partially Cracked Joint
3. Not Cracked Joint

A joint was labeled as cracked if the average velocity over that joint fell between “no signal” or 0 fps and 5,000 fps (1,500 mps). An average velocity from 5,000 fps to 10,000 fps (1,500 to 3,000 mps) represented a partially cracked joint and joints that were not cracked included velocities greater than 10,000 fps (3,000 mps) that fell close to the average concrete velocity of 11,620 fps. Approximately 12% of the joints cracked, 41% were partially cracked, and 47% were not cracked. It is possible that the high dosage of polypropylene fibers in the concrete mixture and shallow 1 ½ inch (38 mm) deep saw cuts kept the control joints from cracking at early

stages. It is expected that the partially cracked joints will fully crack in the future, but it is not known whether the joints that did not crack will crack and thus prevent cracking elsewhere on the parapet. Since Paine Creek is such a long bridge and was also exposed to the vibrations of traffic on the adjacent side throughout its construction, it is surprising that more of the joints did not crack.

Looking more closely, the majority of the joints that did not crack were located at the west end of the bridge, including the joints located over the west end pier or pier 1 shown in Figure 50. About 40% of the joints located in between the piers, pier 1 and pier 2, did not crack. Between the east end of the bridge and pier 2, only 16% of the joints did not crack. With this significant difference between the sides of the bridge, the joints were analyzed again, but in two sections in regards to the two pours that took place. Fewer of the joints, about 26%, did not crack within the first 288 feet (88 m), from the east end of the bridge to the bulkhead, shown in Figure 50, where the first pour was finished. The second half of the parapet was poured on June 24, 2013. The second half was between the bulkhead and the west end of the bridge, and 72% of joints that did not crack within this section.

West

East

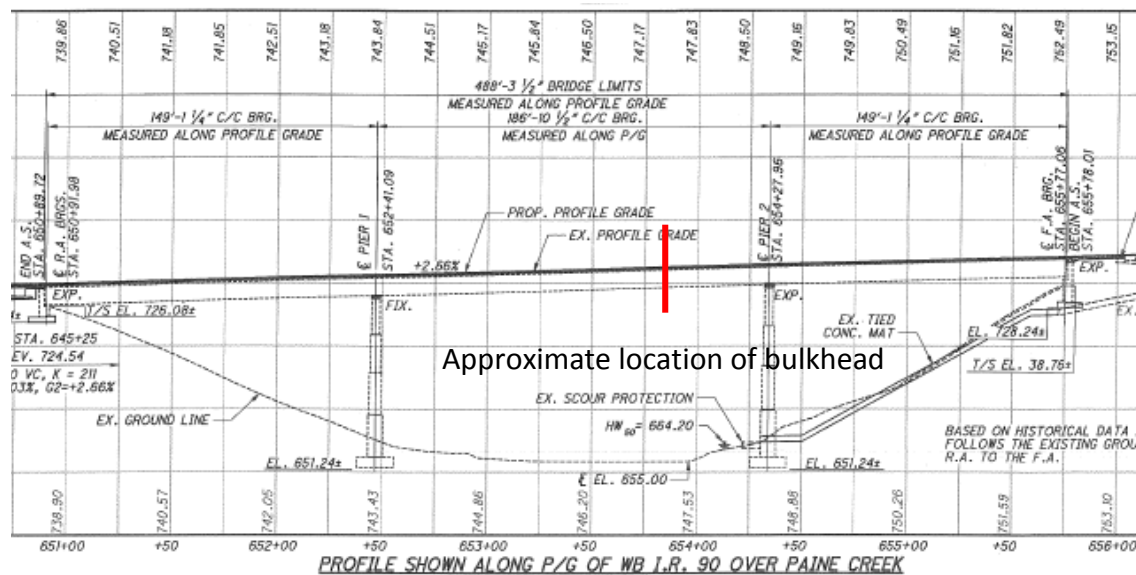

Figure 50: WB Paine Creek Bridge Profile

The control joint spacing on this bridge was 4 feet (1.2 m) over negative tension areas, and 8 feet (2.4 m) over the rest of the bridge. The 4 foot (1.2 m) spacing was extended out from each of the piers between 32 and 44 feet (9.8 and 13.4 m). The total parapet length is approximately 490 feet (150 m) long with 81 control joints. If conventional spacing was used, only 49 joints would have been cut. However, despite the number of control joints that were cut on this bridge, nearly 50% of them did not crack. It is not known whether this is due to the high amount of fibers used in the concrete mix, the shallow saw cut, the use of many closely spaced

joints, or a combination of these factors. The design was effective at preventing early age cracking.

Five maturity sensors were installed on the Paine Creek parapet. The first three sensors were located within the first half of the parapet, providing temperatures during the first placement. The other two sensors were placed on the second half of the parapet. Unfortunately, the wires for the fifth sensor were buried during construction leaving only the fourth sensor to provide temperature readings for the second placement. Table 20 shows the peak temperatures and the initial drops in temperature the concrete reached at these four locations during the hydration process.

Table 20: WB Paine Creek south parapet maturity sensor temperature data

Sensor	Peak Temperature (°F/°C)	Initial Low Temperature after Peak (°F/°C)	Temperature Differential Peak (°F/°C)
Paine Creek (s) #1	115.7/46.5	86.0/30	29.7/16.5
Paine Creek (s) #2	107.6/42	86.0/30	21.6/12.0
Paine Creek (s) #3	109.4/43	88.7/31.5	20.7/11.5
Paine Creek (s) #4	132.8/56	91.4/33	41.4/23.0

The three sensors on the first half of the parapet were closely related, showing a slightly smaller change in temperature when compared to the second half. At sensor #4, during placement and curing of the second half of the parapet, the concrete reached a high peak temperature of 132.8°F (56°C). As a result, the concrete developed a large temperature differential, which is associated with a high risk of cracking. The high temperatures may also be the reason why the majority of the control joints did not crack on this section of the parapet. During and after curing of the parapet, about 21 days after placement, the temperature of the concrete remained high with an average of 80°F (26.7°C). Since the concrete did not fall to a lower temperature, the parapet did not experience an increase of stress due to contraction and therefore, the joints did not need to crack.

South Marginal Road Bridge (CUY-90-18.15)

The South Marginal Road overpass bridge is located in downtown Cleveland, crossing over Interstate 90. On the South Marginal Bridge, the north parapet was a control following the typical ODOT design standards, and the south parapet included GFRP bars for vertical reinforcement to allow for a 3 ½ inch (89 mm) deep saw cut joint. Unlike the Lake County bridges, both parapets have vandal protection fences (VPFs) on top of the parapets, as shown in Figure 51. The anchor bolts for the VPF were not cast in place, but were drilled into the concrete while it was still fairly green.

The South Marginal Road overpass is the main access to the tailgating parking lot for the Cleveland Browns' football fans. A lot of pressure was placed on the construction schedule by the City of Cleveland to complete this bridge before the start of the football season.



Figure 51: South Marginal Bridge with vandal protection fences (Photograph by Amy Kalabon)

North Parapet

Three maturity sensors were placed deep in the center of the parapet on the steel reinforcement, as shown in Figure 52. The type of reinforcement used was epoxy coated steel rebar with No. 5 (16 mm) longitudinal and vertical bars, a No. 6 (19 mm) longitudinal bar at the top of the parapet, and No. 6 (19 mm) bars tying the parapet to the deck.



Figure 52: Placement of maturity sensors (Photograph by Amy Kalabon)

Concrete was placed on August 13, 2013 at 68°F (20°C) and 82% humidity under cloudy conditions. The first ready mix truck was tested with 5.1% air and a 4 inch (100 mm) slump. Three cylinder samples were taken from this truck. Before placing the concrete, superplasticizer was added to the mixture onsite. During placement, the workers started having trouble with the forms lifting up off the ground due to the pressure from the concrete. They were able to fix the forms before the second truck arrived. The second truck was tested for air content before placement, and it was rejected due to a low air content of 4.4%. As the concrete was poured into the forms, one vibrator was used to aid in proper consolidation of the concrete.

Due to the fast pace of the project, the front forms of the parapet were removed right after the concrete was placed. With the concrete still in its green state, the front of the wall could be rubbed out nicely giving the wall a proper finish. Unfortunately, the concrete was too green to perform any UPV tests on the wall. The back forms were left on until the following day when the saw cutting was performed. With the work under such a fast pace, it was not possible to gather UPV velocities before the wall was set to cure. Unlike the front of the parapet, the back was not rubbed when the formwork was removed the following day because the concrete already hardened by this point and the project was being rushed. Due to this, small pits and holes were found, similar to the ones found on the Lake County bridges that were not rubbed.

The north parapet wall was cured for only two days when the burlap was removed in order to put the cure on the south parapet. The wall was inspected for cracks and UPV velocities were taken. A large crack was found beneath one of the vandal protection fence (VPF) post base plates. The crack, which was most likely caused during installation, is shown in Figure 53. Another crack was also found on the back side of the north parapet, near the third fence post base plate looking from the east. Since the crack was on the back of the parapet, a photo and UPV could not be taken of the crack.



Figure 53: South Marginal north parapet crack at VPF post base plate (Photograph by Amy Kalabon)

The UPV test velocities from both the parapet and the cylinder samples after cure were 6,700 fps (2,040 mps) and 13,292 fps (4,050 mps), respectively. Since the parapet only cured for 2 days, a large difference between the wall and the cylinders was expected. With such a low concrete velocity, the ranges used to determine which category a control joint fell in were adjusted. A joint was labeled as cracked if the average velocity over that joint fell between “no signal,” or 0 fps, and 3,000 fps (900 mps). An average velocity from 3,000 to 5,000 fps (900 to 1,500 mps) represented a partially cracked joint, and joints that were not cracked had velocities greater than 5,000 fps that fell close to the average concrete velocity of 6,700 fps (2,040 mps). The control joints were cut 1 ½ to 2 inches (38 to 51 mm) deep and were spaced approximately 10 feet (3 m) along the parapet. Using the adjusted ranges, about 36% of the joints fully cracked, 45% were partially cracked, and 18% did not crack. Of the four joints that did not crack, one of them showed surface crack found where the joint terminated about 2 inches (51 mm) above the bottom of the parapet. This is shown in Figure 54. Also, all of the control joints that were labeled as cracked or partially cracked showed cracking at the bottom of the parapet as in Figure 54.



Figure 54: South Marginal north parapet cracks where control joint terminates (Photograph by Amy Kalabon)

Of the three maturity sensors embedded in the bridge, the wires for one of them were buried during construction, so only two of the sensors provided temperatures of the concrete during placement and curing. Table 21 shows the peak temperatures and the initial drops in temperature the concrete experienced during the hydration process.

The sensors were consistent with each other, showing similar temperature readings. During the weeks after the curing was taken off of the concrete, the parapet remained at a high temperature around 77°F (25°C). This could be because the parapet was not cured for the full 7 day span. It was also exposed to the environment a few times during its shortened curing time, without being watered down to lower temperatures. After the concrete was placed, without watering it down, the front forms were removed and the burlap was placed on the wall. The next day the burlap was removed entirely to take off the back forms and saw cut the control joints. Then the burlap was put back on the wall for one more day of curing.

Table 21: South Marginal north parapet maturity sensor temperature data

Sensor	Peak Temperature (°F/°C)	Initial Low Temperature after Peak (°F/°C)	Temperature Differential (°F/°C)
S.M. #1	104/40.0	85.1/29.5	18.9/10.5
S.M. #3	104/40.0	87.8/31.0	16.2/9.0

A field visit took place on February 21, 2014 to check the parapet for cracking. Approximately 12 large cracks were found for the first time along the north parapet located midway between the joints and sometimes extending from the VPF post base plates. Examples of these types of cracks are shown in Figures 55 through 58.



Figure 55: South Marginal north parapet mid-panel cracking (Photograph by Amy Kalabon)



Figure 56: South Marginal north parapet mid-panel cracking (Photograph by Amy Kalabon)



Figure 57: South Marginal north parapet mid-panel cracking (Photograph by Amy Kalabon)



Figure 58: South Marginal north parapet mid-panel cracking (Photograph by Amy Kalabon)

There were many additional fine cracks elsewhere along the parapet, as shown in Figure 59, but most were too small to photograph.



Figure 59: South Marginal north parapet small cracking (Photograph by Amy Kalabon)

South Parapet

Three maturity sensors were attached to the reinforcement of the south parapet. The reinforcement followed typical design plans using No. 5 (16 mm) GFRP bar as the longitudinal reinforcement, No. 5 (16mm) epoxy coated steel bars as the vertical reinforcement, a No. 6 (19 mm) GFRP bar at the top of the parapet, and No. 6 (19 mm) steel bars tying the parapet into the deck.

Concrete for the south parapet was placed on August 15, 2013 at 59°F (15°C) and 70% humidity under partly cloudy conditions. The second ready mix truck was tested with 6.7% air at 75°F (24°C). Three concrete cylinder samples were taken from this truck. Prior to placement, superplasticizer was added to the mixture to aid in consolidation of the concrete. As soon as concrete placement was complete, the front forms were removed, the wall was rubbed, and then the wall was covered with burlap. The next day, the burlap was removed in order to take off the back forms and saw cut the control joints. The control joints were spaced between 4.8 and 5.17 feet (1.5 and 1.6 m) in negative moment areas and 8.25 to 10 feet (2.5 to 3.1 m) in positive moment areas. During saw cutting, the saw hit a piece of the vertical reinforcement in one of the control joints. This control joint was sealed extra carefully to avoid corrosion and accelerated cracking within the joint. The control joints were cut between 2 ½ to 3 ½ inches (64 to 89 mm) deep cutting through the GFRP bar. The wall was covered back up with the burlap to cure for two days.

After curing, the wall was inspected for cracks and UPV was performed. No cracks were identified. Due to the shortened curing of the parapet, it was expected that the UPV velocities of the cylinder samples would be higher than the velocities of the parapet. The average velocity of the cylinder was found to be 12,822 fps (3,900 mps) and the average velocity of the parapet was 7,101 fps (2,160 mps). With such a low concrete velocity, the ranges used to determine which category a control joint fell in were adjusted. A joint was labeled as cracked if the average velocity over that joint fell between “no signal,” or 0 fps, and 3,000 fps (900 mps). An average velocity from 3,000 fps to 5,000 fps (900 to 1,500 mps) represented a partially cracked joint and joints that were not cracked included velocities greater than 5,000 fps (1,500 mps) that fell close to the average concrete velocity of 7,101 fps (2,160 mps). A majority of the control joints had a crack that continued from where the saw cut terminated down to the bottom of the parapet. About 11% of the joints cracked, 38% were partially cracked, and 51% of the joints did not crack. On this parapet, the saw cuts terminated between 5 and 6 inches (127 and 152 mm) above the bridge deck surpassing the typical 2 inches (51 mm). The shortened saw cuts in combination with poor curing may have made it harder for the control joints to fully crack.

Three maturity sensors embedded in the concrete provided temperatures of the concrete during placement and curing. Table 22 shows the peak temperatures and the initial drops in temperature the concrete reached during the hydration process.

Table 22: South Marginal south parapet maturity sensor temperature data

Sensor	Peak Temperature (°F/°C)	Initial Low Temperature after Peak (°F/°C)	Temperature Differential (°F/°C)
S.M. #4	107.6/42.0	87.8/31.0	19.8/11.0
S.M. #5	107.6/42.0	86.9/30.5	20.7/11.5
S.M. #6	109.4/43.0	86.9/30.5	22.5/12.5

On February 21, 2014, a field visit was made to inspect the parapet for cracks. Due to the quality of curing on this bridge, it is not a surprise that cracks were discovered even with the modifications that were implemented on the design of this parapet. However, the south parapet exhibited far less cracking than the north parapet. The south parapet used the GFRP reinforcement and the 3 ½ inch (89 mm) deep saw cut. Two prominent cracks were found, among a few others that were too small to capture. One of the cracks, shown in Figure 60, was a full depth crack located midway between the control joints. The other crack, in Figure 61, extended downward from one of the VPF post base plates.



Figure 60: South Marginal south parapet mid-panel crack (Photograph by Amy Kalabon)

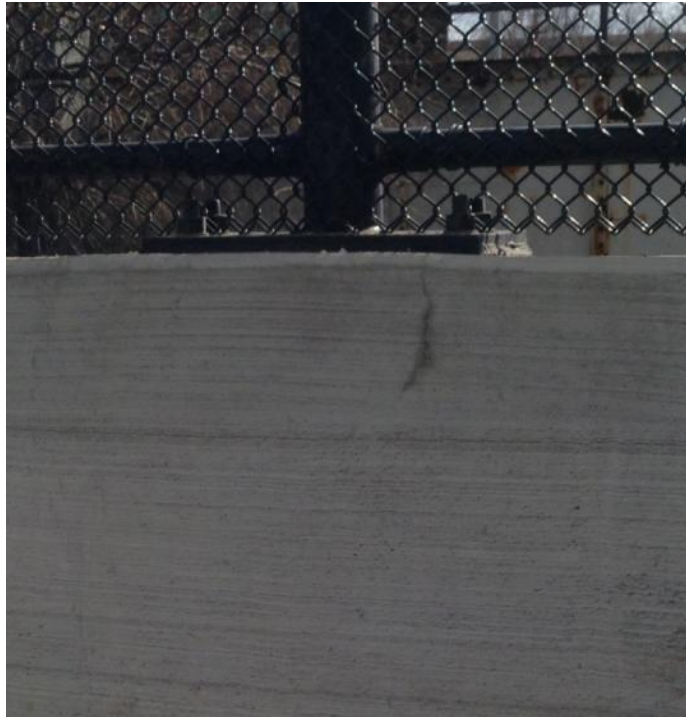

Figure 61: South Marginal south parapet VPF post base plate crack (Photograph by Amy Kalabon)

Westbound Big Creek Bridge (LAK-90-16.41L)

North Parapet

Four maturity sensors were attached to the reinforcement of the north parapet. Design of the reinforcement included both epoxy coated steel reinforcement and GFRP reinforcement with 2 ½ inches (63.5 mm) of concrete cover. No. 5 (16 mm) steel bars were used as the vertical reinforcement, and No. 6 (19 mm) steel bars were used to connect the parapet to the deck. No. 5 (16 mm) GFRP bars were used for all the horizontal reinforcement except the single reinforcement at the top consisted of a No. 6 (19 mm) GFRP bar.

The concrete was placed in two phases, the first on September 4, 2014, under partial cloud cover at 70°F (21°C) and 61% relative humidity. The first truck was tested at 6.8% air with a 6 ¼ inch (160 mm) slump and a concrete temperature of 74°F (23°C). The second placement took place on September 5, 2014, at 76°F (24°C) and 63% relative humidity. The first truck was tested at 5.2% air with a 3 inch (76 mm) slump and a concrete temperature of 75°F (24°C). Before placement, superplasticizer was added to the concrete mix onsite. Three cylinder samples were taken for UPV and compressive strength testing.

The formwork was removed the same day that the placement was completed and the saw cuts were made after curing. The saw cuts went 3 ½ inches (89 mm) deep cutting through all of the GFRP reinforcement. The control joints were spaced between 5.83 and 6.08 feet (1.78 and 1.85 m) in negative tension zones and between 8.75 and 12.0 feet (2.67 and 3.66 m) in positive moment areas.

After the forms were stripped, the parapet was inspected for early age cracking. Other than flaws from formwork removal, no cracks were identified.

On October 30, 2014, a field visit was made to further inspect the parapet for cracks. Sealing of the parapet was in progress. Four prominent cracks were found, ranging from 0.006 in to 0.01 in. (0.15 to 0.25 mm). Three of the four cracks propagated up and over the parapet. Several micro cracks were observed as well throughout the parapet, mostly occurring between the control joints.

South Parapet

Four maturity sensors were attached to the reinforcement of the south parapet. The design of the reinforcement included both epoxy coated steel reinforcement and GFRP reinforcement. No. 5 (16 mm) steel bars were used as the vertical reinforcement, and No. 6 (19 mm) steel bars were used to connect the parapet to the deck. No. 5 (16 mm) GFRP bars were used for all the horizontal reinforcement except the single reinforcement at the top consisted of a No. 6 (19 mm) GFRP bar.

Concrete was placed on June 17, 2013, under clear skies at 75°F (23.9°C) and 76% relative humidity. The first truck was tested at 7% air with a 7 ½ inch (190 mm) slump and a concrete temperature of 74°F (23°C). Before placement, superplasticizer was added to the concrete mix onsite. Polypropylene fiber was added to the mix at 1 lb./yd³ (0.59 kg/m³). Three cylinder samples were taken for UPV and compressive strength testing.

The formwork was removed the same day that the placement was completed and the saw cuts were made after cure. The saw cuts went 3 ½ inches (89 mm) deep cutting through all of the GFRP reinforcement. The control joints were spaced between 5.83 and 6.08 feet (1.78 and 1.85 m) in negative tension zones and between 8.75 and 12.0 feet (2.67 and 3.66 m) in positive moment areas.

UPV was performed over the control joints and on the parapet wall the following day by temporarily removing the saturated burlap and replacing once complete. The parapet was also inspected for early age cracking. Upon inspection, the concrete felt very hot and dry to the touch due to the saturation hose not working in all locations along the parapet.

When the forms were stripped, UPV tests were performed on several areas of the parapet after it was covered with wet burlap to cure for seven days. The parapet was also inspected for early age cracking. No cracks were identified other than the flaws produced from poor consolidation

at the surface and removal of the forms. The UPV test velocities from both the parapet and the cylinder samples after curing are shown in Table 23.

Table 23: WB Big Creek south parapet UPV velocities

Time	Average UPV Velocities			
	Location			
	South Parapet		Concrete Cylinder Sample	
Day 7	5,120 fps	1,561 mps	5,483 fps	1,671 mps

The velocities of the cylinder samples were compared to the values collected in the field. Due to the curing conditions in the lab, the cylinder samples were expected to produce somewhat higher velocities than the parapet. Since the velocities of the parapet were in the appropriate range, average velocities over each control joint were recorded. These velocities were placed into three categories:

1. Cracked Joint
2. Partially Cracked Joint
3. Not Cracked Joint

A joint was labeled as cracked if the average velocity over that joint fell between “no signal” or 0 fps and 3,000 fps (915 mps). An average velocity from 3,000 to 5,000 fps (915 to 1,524 mps) represented a partially cracked joint and joints that were not cracked included velocities greater than 5,000 fps (1,524 mps). Approximately 7% of the joints cracked, 52% were partially cracked, and 41% were not cracked.

Westbound Auburn Road Bridge (LAK-90-14.87L)

North Parapet

The north parapet wall on the westbound Auburn Road Bridge was constructed as experimental control on October 10, 2014. Three maturity sensors were attached to the reinforcement of the parapet. The first truck was tested at 5% air with a 5 ½ inch (140 mm) slump and a concrete temperature of 58°F (14°C). Superplasticizer and an accelerator were added to the concrete mix before it reached the site.

A site visit was made to perform a crack survey and UPV tests on October 30, 2014. At this time, no cracks were identified. The parapet was in good condition. However, readings at some of the control joints were low suggesting cracks at the joints. The UPV test velocities from both the parapet and the cylinder samples before and after curing are shown in Table 24.

Table 24: WB Auburn Road north parapet UPV velocities

Time	Average UPV Velocities			
	Location			
	North Parapet		Concrete Cylinder Sample	
Day 28	3,354 fps	1,022 mps	6,882 fps	2,098 mps

The velocities of the cylinder samples were compared to the values collected in the field. Due to the curing conditions in the lab, the cylinder samples were expected to produce somewhat higher velocities than the parapet. Since the velocities of the parapet were in the appropriate range, average velocities over each control joint were recorded. These velocities were placed into three categories:

1. Cracked Joint
2. Partially Cracked Joint
3. Not Cracked Joint

A joint was labeled as cracked if the average velocity over that joint fell between “no signal” or 0 fps and 3,000 fps (915 mps). An average velocity from 3,000 to 7,000 fps (915 to 2,130 mps) represented a partially cracked joint and joints that were not cracked included velocities greater than 7,000 fps (2,130 mps). Approximately 44% of the joints cracked, 50% were partially cracked, and 6% were not cracked.

South Parapet

The south parapet wall was constructed as one of two parapets containing polypropylene fibers, a 3 ½ inch (89 mm) saw cut as well as field cut steel. Maturity sensors were not attached to the reinforcement due to the concrete placement being made early. The design of the reinforcement included both epoxy coated steel reinforcement and GFRP reinforcement. No. 5 (16 mm) steel bars were used as the vertical reinforcement, and No. 6 (19 mm) steel bars were used to connect the parapet to the deck. No. 5 (16 mm) GFRP bars were used for all the horizontal reinforcement except the single reinforcement at the top consisted of a No. 6 (19 mm) GFRP bar.

The concrete was placed on June 23, 2014. The first truck was tested at 7.2% air with a 4 inch (100 mm) slump and a concrete temperature of 75°F (24°C). Polypropylene fiber was added to the mix at 1 lb./yd³ (0.59 kg/m³). Three cylinder samples were taken for UPV and compressive strength testing.

The formwork was removed the same day that the placement was completed and the saw cuts were made after cure. The saw cuts went 3 ½ inches (89 mm) deep cutting through all of the GFRP reinforcement. The control joints were spaced between 5.83 and 6.08 feet (1.78 and 1.85 m) in negative tension zones and between 8.75 and 12.0 feet (2.67 and 3.66 m) in positive moment areas.

When the forms were stripped, UPV tests were performed on several areas of the parapet before it was covered with wet burlap to cure for seven days. The parapet was also inspected for early age cracking. No cracks were identified other than the flaws produced from poor consolidation at the surface and removal of the forms. Another field visit was made after curing was complete to perform UPV tests on the parapet where no flaws were present, over any identified cracks, and over each control joint. The UPV test velocities from both the parapet and the cylinder samples before curing are displayed in Table 25.

Table 25: WB Auburn Road south parapet UPV velocities

Time	Average UPV Velocities			
	Location			
	South Parapet		Concrete Cylinder Sample	
Day 1	4,892 fps	1,491 mps	6,133 fps	1,869 mps

The velocities of the cylinder samples were compared to the values collected in the field. Due to the curing conditions in the lab, the cylinder samples were expected to produce somewhat higher velocities than the parapet. Since the velocities of the parapet were in the appropriate range, average velocities over each control joint were recorded. These velocities were placed into three categories:

1. Cracked Joint
2. Partially Cracked Joint
3. Not Cracked Joint

A joint was labeled as cracked if the average velocity over that joint fell between “no signal” or 0 fps and 3,000 fps (915 mps). An average velocity from 3,000 to 5,000 fps (915 to 1,524 mps) represented a partially cracked joint and joints that were not cracked included velocities greater than 5,000 fps (1,524 mps). Approximately 0% of the joints cracked, 56% were partially cracked, and 44% were not cracked.

Westbound Hermitage Road (LAK-90-13.70L)

North Parapet

The north parapet wall on westbound Hermitage Road was constructed as experimental control on September 19, 2014. Three maturity sensors were attached to the reinforcement of the parapet. The first truck was tested at 6% air with a 3 ½ inch (89 mm) slump and a concrete temperature of 67°F (19°C). Superplasticizer was added to the concrete mix before it reached the site.

A site visit was made to perform a crack survey and UPV tests on October 28, 2014. At this time, no cracks were identified. The parapet was in good condition, however, readings at some control joints were low suggesting cracks at certain joints. The UPV test velocities from the parapet are displayed in Table 26.

Table 26: WB Hermitage Road north parapet UPV velocities

Time	Average UPV Velocities			
	Location			
	North Parapet		Concrete Cylinder Sample	
Day 28	2,536 fps	772 mps	7,012 fps	2,137 mps

The velocities of the cylinder samples were compared to the values collected in the field. Due to the curing conditions in the lab, the cylinder samples were expected to produce somewhat higher velocities than the parapet. Since the velocities of the parapet were in the appropriate range, average velocities over each control joint were recorded. These velocities were placed into three categories:

1. Cracked Joint
2. Partially Cracked Joint
3. Not Cracked Joint

A joint was labeled as cracked if the average velocity over that joint fell between “no signal” or 0 fps and 3,000 fps (915 mps). An average velocity from 3,000 to 7,000 fps (915 to 2,130 mps) represented a partially cracked joint and joints that were not cracked included velocities greater than 7,000 fps (2,130 mps). Approximately 82% of the joints cracked, 18% were partially cracked, and 0% were not cracked.

South Parapet

The south parapet wall was constructed as one of two parapets containing polypropylene fibers, a 3 ½ inch (89 mm) saw cut as well as field cut steel. Three maturity sensors were attached to the reinforcement of the south parapet of the Hermitage Road Bridge. As per design, the type of reinforcement used was epoxy coated steel reinforcement with No. 5 (16 mm) longitudinal and vertical bars, a single No. 6 (19 mm) longitudinal bar at the top of the parapet, and No. 6 (19 mm) bars tying the parapet to the deck.

Placement of the concrete occurred on June 27, 2014, under clear skies at 65°F (18°C) and 81% relative humidity. One of the ready mix trucks was tested to ensure the quality of the concrete. The truck that was tested had concrete with a temperature of 75°F (24°C), an 8 ¼ inch (210 mm) slump, and an air content of 7%. If the air content had been above 8%, the truck would have been turned away. A factor contributing to the high air content of this concrete is the 1 lb/yd³ (0.59 kg/m³) of polypropylene fiber. Superplasticizer was added to the concrete before placement. Three concrete cylinder samples were collected for UPV and compressive strength testing.

Once concrete placement was finished, formwork was removed and saw cuts were performed while the concrete was still green. The control joints were cut 3 ½ inches (89 mm) deep through the horizontal field cut steel rebar. The joints were spaced 4.5 to 5.7 feet (1.37 to 1.74

m) in negative moment areas, and 11.25 to 13.7 feet (3.43 to 4.18 m) in positive moment areas. Right before the wall was covered with burlap to cure for seven days, the wall was rubbed.

Due to the green state of the concrete, UPV tests could not be performed before curing took place. A site visit was made after curing in order to collect data from the maturity sensors, survey for cracks, and perform UPV tests on August 12, 2014. At that time, the parapet had been recently sealed, so no cracks were visible.

The UPV test velocities from both the parapet and the cylinder samples are displayed in Table 27.

Table 27: WB Hermitage Road south parapet UPV velocities

Time	Average UPV Velocities			
	Location			
	South Parapet		Concrete Cylinder Sample	
Update	4,867 fps	1,484 mps	5,345 fps	1,629 mps

The velocities of the cylinder samples were used as verification of the values collected out in the field. Due to the curing conditions in the lab, the cylinder samples were expected to produce somewhat higher velocities than the parapet. Since the velocities of the parapet were in the appropriate range, average velocities over each control joint were recorded. These velocities were placed into three categories:

1. Cracked Joint
2. Partially Cracked Joint
3. Not Cracked Joint

A joint was labeled as cracked if the average velocity over that joint fell between “no signal” or 0 fps and 3,000 fps (915 mps). An average velocity from 3,000 to 7,000 fps (915 to 2,130 mps) represented a partially cracked joint and joints that were not cracked included velocities greater than 7,000 fps (2,130 mps). Approximately 16% of the joints cracked, 79% were partially cracked, and 5% were not cracked.

CHAPTER VI SUMMARY AND DISCUSSION OF OBSERVATIONS

This section summarizes the field observations made over the course of this project, as well as the trends that emerged among all of the parapets that were inspected.

General Observations

The Lake County bridges were all cured for the proper seven day length. The South Marginal Bridge parapets were only cured for two days. As stated by Kosmatka et al. (2011), "Curing is the process in which the concrete is protected from loss of moisture and kept within a reasonable temperature range. This process results in concrete with increased strength and decreased permeability. Curing is also a key player in mitigating cracks, which can severely affect durability."

The process of curing results in decreased permeability, and because the South Marginal Bridge did not have proper curing procedures there may be voids and internal microcracking within the concrete. The concrete cylinder samples provided an average compressive strength of 6,400 psi (44 MPa), but because the cylinders had optimal curing conditions, the parapets may not have reached this strength while exposed to the conditions in the field. This assumption was supported by the results from the UPV meter. The UPV velocities found on both parapets of the South Marginal Bridge were extremely low, when compared to the velocities of the concrete cylinder samples as well as the velocities gathered from the Lake County bridge parapets. The average UPV of the concrete was around 6,900 fps (2,100 mps). The Lake County bridges had an average velocity between 9,000 to 13,000 fps (2,740 to 3,960 mps). The low velocity is generally related to low strength, which may be why the parapet cracked so easily during the installation of the vandal protection fence post base plate. These anchors were drilled in the field. Several cracks were found on the north parapet midway between control joints and extending from the VPF post base plates. Fewer cracks were found on the south parapet, but these were similar. It is important to note that this bridge is not a highway bridge like the Lake County bridges. It will not be subjected to the type of interstate highway traffic the Lake County bridges experience every day, therefore it will not undergo large amounts of vibrations and deflections. Even without significant traffic, the South Marginal Bridge parapets showed the most cracking out of all the inspected parapets.

The durability of the parapets may be increased when the parapet surface is rubbed. As shown by the parapets whose forms were removed one day after placement, there were many holes and voids along the surface of the parapet. Holes are also more likely to form along the surface if the concrete had a low slump, such as the 3 ½ inch (89 mm) slump of the concrete for both the south parapets of WB Paine Road Bridge and WB Paine Creek Bridge. If these holes cannot be rubbed out, they may be a reason for early deterioration of the concrete as deicing salt and other chemicals get into them and begin breaking down the concrete. Also, as the concrete experiences temperature changes, these areas on the surface will be the first to crack since the surface of the concrete has already been weakened. Removing the forms when the concrete is

still green seems to be more effective. It is easier to rub the wall, faster to cut the control joints, and the entire wall can be left to cure. In addition, cutting the control joints while the concrete is still green allows the construction workers to get ahead of the formation of any cracks as the concrete hydrates.

The location of the vertical reinforcement with respect to the control joints is important during saw cutting procedures. This may be impractical as well as too time consuming for construction workers to keep track of; however, this was demonstrated on the south parapet of the South Marginal Bridge when the saw hit part of the vertical reinforcement. Other than possibly exposing the reinforcement, the relation of the control joint to the vertical rebar can possibly cause cracking to occur. This may have been the case on the north parapet of the Paine Creek Bridge. It seemed that there was a plane of weakness created where the vertical reinforcement was located, making it easier for the concrete to crack along the reinforcement instead of at the control joint. If the location of the vertical rebar cannot be followed, the proper amount of cover must be provided.

Not enough water was used during the removal of the formwork and saw cutting procedures. A few of the parapets dried out and turned white before the burlap was placed on the wall. It is important to keep the concrete cool and moist to allow proper curing, especially when the curing cannot be put on right away. Curing is the key to mitigating cracking.

In regards to cracking, all of the control parapets that could be inspected displayed uncontrolled cracking. The majority of the cracks found were discovered after being exposed to the harsh winter conditions of 2013-2014, with the exception of the north parapet on the WB Paine Creek Bridge. Two control parapets, the south parapets of the EB Paine Creek Bridge and the EB Paine Road Bridge, could not be safely inspected. Typically, the control parapets displayed mid-panel cracking, with a few cracks near a control joint or initiating from the control joint. Of the crack surveys that were performed, only two of the experimental parapets showed cracking, the north parapet of the WB Paine Creek Bridge and the south parapet of the South Marginal Bridge. The north parapet of the WB Paine Creek Bridge had a crack that initiated out of a control joint. This was a very early aged crack, and no other cracks were found along the length of the parapet after enduring the winter. The south parapet of the South Marginal Bridge had two large cracks, among some fine cracks. One crack initiated out from the VPF post base plate near the side where the bolts were installed to keep it in place. The other crack was a mid-panel crack. This cracking may not be due to the design, but due to the fact that the concrete did not receive proper curing. Since the bridge does not see heavy traffic, a combination of the poor curing and stresses put on the parapet from the VPF most likely caused the cracking to occur. The drilling of the anchors for the VPF bases into green concrete may well have initiated the cracking.

General Trends

The design of the reinforcement remained the same for all of the parapets. No. 6 (19 mm) epoxy coated steel reinforcement was used to tie the parapet into the deck, as well as provide

reinforcement at the top of the parapet as a single horizontal bar. A single No. 6 (19 mm) GFRP bar was also used at the top of the parapet when GFRP replaced steel in the design. Whether the design of the parapet included No. 5 (16 mm) epoxy coated steel or GFRP bars for the horizontal reinforcement, the sizes remained equivalent to provide the proper amount of reinforcement. No. 5 (16 mm) epoxy coated steel rebar was also used as the vertical reinforcement in the parapets.

The concrete mixture used on all the parapets was the same, with the exception of adding polypropylene fibers for some parapets. When fibers were added to the concrete mixture, it proved difficult to keep the air content within allowable limits when compared to the mixes with no fiber. The slump of the concrete fell anywhere between 3 ½ to 6 inches (89 to 152 mm) for all of the parapets, and the compressive strengths of the cylinder samples ranged from 4,860 psi to 6,700 psi (33.5 to 46.2 MPa). The cylinder samples were also very useful in providing a basis to verify the UPV velocities taken in the field.

The average UPV was a good indicator of the uniformity and quality of the concrete as in the instance of the South Marginal Road Bridge parapets. The low velocities gathered were not surprising, due to the shortened curing procedures used in order to complete construction on time. The UPV was also a great way to assess behavior of the control joints. It was easy to tell the difference between a cracked joint and a joint with no signs of cracking at all. However, the velocity fell between the two extremes several times, making it difficult to define the joint as one or the other, so a third category of partially cracked joints was added.

The maturity sensors embedded in each parapet were consistent with each other, displaying even temperature distributions along the length of the parapets. The sensors showed the highest temperature the concrete reached during placement. The concrete of the two bridges that did not exhibit any cracking, the south parapets of the EB Hermitage Road Bridge and the WB Paine Road Bridge, never reached a temperature higher than 96°F (36°C). All of the other parapets easily exceeded 105°F (41°C) during the curing stages. The data from the sensors were also used to see if the concrete had any unusual behavior or experienced any large temperature differentials. The consistent temperatures among all the parapets helped to rule out temperature changes as a direct cause of any uncontrolled cracking. Months after placement, the sensors remained in good condition to gather additional data and document how the concrete responded to the winter. It was easy to see the parapets had endured the effects of freeze-thaw cycles. With the concrete undergoing volume changes due to the fluctuating temperatures, the parapets that did not show any uncontrolled cracking proved to have an effective design.

CHAPTER VII ANALYSIS

The field observations and data gathered over the course of this project show a significant difference between the control and experimental parapets. This difference implies that one or some of the modifications included in the experimental parapet designs accomplished the goal to reduce parapet cracking. Since all of the modifications add cost, it is important to analyze what performed well and what proved to be ineffective.

Cost

The costs referred to represent the costs for this project only. Since the prices are a result of change orders, the amounts may be higher than normal; however these values were used as a reference in order to compare the implemented modifications. The costs per linear foot (0.3 m) for the modifications added to the bridges are shown in Table 28.

Table 28: Modification cost per linear foot (0.3 m)

Modification	Bridges Included	Parapet	Cost of Change Order	Parapet Length (ft)	Cost per Linear Foot
GFRP	EB Hermitage Road	North	\$2,250.36	160.41	\$14.03/ft
	EB Auburn Road	North	\$1,726.53	147.74	\$11.69/ft
	WB Big Creek	North	\$4,020.77	344.50	\$11.67/ft
	South Marginal	South	\$1,922.25	226.60	\$8.48/ft
GFRP + 1 lb/yd ³ Fiber	EB Auburn Road	South	\$2,443.46	154.52	\$15.81/ft
	WB Big Creek	South	\$4,487.67	344.50	\$13.03/ft
Field Cut Steel	WB Paine Road	North	\$1,329.09	113.13	\$11.75/ft
Field Cut Steel + 1 lb/yd ³ Fiber	WB Auburn Road	South	\$2,044.85	158.23	\$12.92/ft
	WB Hermitage Road	South	\$1,763.45	136.78	\$12.89/ft
1 lb/yd ³ Fiber	EB Hermitage Road	South	\$217.35	160.72	\$1.35/ft
	WB Paine Road	South	\$152.95	113.08	\$1.35/ft
	WB Paine Creek	North	\$652.05	488.27	\$1.34/ft
2 lb/yd ³ Fiber	WB Paine Creek	South	\$1,210.95	488.27	\$2.48/ft

The prices include the cost of the material, shipping, labor, and the contractor's markup for the change order. Looking at the table, the cost to add polypropylene fiber is insignificant compared to the addition of GFRP or field cut steel reinforcement. Since fiber does not have additional costs for labor or shipping, its price lies solely in the material itself. The price for the GFRP reinforcement changes for each parapet, but averages out to be around the same cost for field cut steel.

Type of Reinforcement

The type of reinforcement was used in correlation with the depth of the control joints. If the typical epoxy coated steel reinforcement was used, the control joints were cut 1 ½ inches (38 mm) deep, and the use of GFRP or field cut steel reinforcement allowed a 3 ½ inch (89 mm) deep cut.

When comparing the parapets with the reinforcement modification, there does not seem to be a significant difference between the use of field cut steel reinforcement and the GFRP reinforcement. Only one of the parapets had field cut steel reinforcement, therefore it is hard to properly analyze its effect. However, from the number of joints that cracked at early stages between the GFRP and field cut steel reinforcement, the field cut steel produced approximately 10%, or about one or two more cracked joints. Both modifications seem to cost about the same, averaging between \$11.00 and \$13.00 per linear foot (0.3 m). For this project, GFRP bar cost \$3.74 per pound (0.45 kg), which includes the markups for the change order as well as shipping, and there is also a cost for labor, which is \$57.70 per hour. For the field cut steel, the steel cost \$0.62 per pound (0.45 kg), and labor cost \$57.70 per hour plus the additional cost for an ironworker to cut through the steel at \$78.26 per hour. If used more often, the cost of the GFRP bar may go down, and since it is less labor intensive, it might be a more economical choice over the field cut steel reinforcement.

The use of the 3 ½ inch (89 mm) deep saw cuts with either the field cut steel or GFRP reinforcement increases the likelihood of joint cracking. The percentages of control joints that cracked during these early stages of the parapets are displayed in Table 29.

Table 29: Percentage of early age joint cracking with respect to joint depth

Depth of Cut	Parapets Included				Average % of All Cracked Joints	Average % of Not Cracked Joints
	Bridge	Name	Parapet	Reinforcement		
1 ½ inches (38 mm)	-	South Marginal	North	Steel	62.6	37.4
	EB	Hermitage	South	Steel		
	WB	Paine Creek	North	Steel		
	WB	Paine Creek	South	Steel		
	WB	Paine Road	South	Steel		
3 ½ inches (89 mm)	WB	Paine Road	North	Field Cut Steel	77.8	22.3
	EB	Auburn	North	GFRP		
	EB	Hermitage	North	GFRP		
	-	South Marginal	South	GFRP		

As shown, about 15% more of the control joints that used the 3 ½ inch (89 mm) deep saw cuts cracked within the first few weeks of placement. However, there is not a significant variation between the two saw cut depths to conclude that the 3 ½ inch (89 mm) deep cut along with the field cut steel or GFRP reinforcement is a cost-effective choice. The parapets including the 3 ½ inch (89 mm) deep saw cuts may not have displayed any uncontrolled cracking, but the experimental parapets with a 1 ½ inch (38 mm) deep saw cut and closer joint spacing also did not display any cracking. Since the parapets including the 3 ½ inch deep (89 mm) saw cuts also had the reduced joint spacing, it is not clear what specific impact the deeper saw cut has on a parapet to control cracking.

Polypropylene Fibers

The purpose for adding polypropylene fibers in the concrete mixture was to prevent temperature and shrinkage cracking. On the north parapet of the WB Paine Creek Bridge, a crack was found despite the use of 1 lb./yd³ (0.59 kg/m³) of fibers in the concrete. It was hypothesized that the concrete cracked due to a combination of the control joint not being fully activated, with only a 1 ½ inch (38 mm) deep saw cut. Also, there was not enough cover over the vertical reinforcement that was located close to the joint. It is likely that the crack did not have to do with temperature or shrinkage cracking, therefore, the fibers served as expected. However, the parapets with no fibers in the concrete mixture also did not show any signs of temperature or shrinkage cracking. From the data in Table 30, it seems that the use of fibers kept the control joints from cracking. As a result, the use of polypropylene fiber may not be worth the added cost of \$8.05 per cubic yard when adding 1 lb/yd³ (0.59 kg/m³) of fibers or \$14.95 per cubic yard when adding 2 lb/yd³ (1.19 kg/m³) of fibers. For example, the south parapet of the WB Paine Creek Bridge was estimated as a total of 81 cubic yards (62 cubic meters) of concrete and with the addition of 2 lb/yd³ (1.19 kg/m³) of polypropylene fibers, the cost of the fibers alone was approximately \$1,210.95. Fibers may not be the most economical choice with the concrete mixture used in regards to early age cracking, but the use of fibers may prove to be a contributing factor to extend the service life and safety of bridge parapets.

Joint Spacing

Changing the joint spacing had a major effect on the performance of a parapet. Due to composite structural action, it is expected that a continuous parapet would experience significant tensile bending stresses in the negative moment regions of the bridge spans. This is supported by the results gathered from the control and experimental parapets. The control parapets had joints spaced evenly along the bridge and did not increase the number of joints over the negative moment areas. With this spacing, all the control parapets showed uncontrolled mid-panel cracking. Little or no cracking was found on the experimental parapets, because there were more joints spaced closely together in the negative moment areas over the piers. The additional control joints in this region give the parapet the ability to flex or bend without cracking.

Most of the experimental parapets could not be examined for a second time after the winter due to safety concerns. However, the last time these parapets were inspected, no cracks had

been found. The north parapet of the WB Paine Creek Bridge and the south parapet of the South Marginal Bridge were the two experimental parapets that showed uncontrolled cracking, but seemed to have cracked for reasons other than the joint spacing, as stated in the general observations. A summary of which parapets observed uncontrolled cracking is shown in Table 31.

Table 30: Percentage of cracked joints with respect to fiber use

Amount of Polypropylene Fibers	Parapets Included			Average % of All Cracked Joints	Average % of Not Cracked Joints
	Bridge	Name	Parapet		
No Fibers	-	South Marginal	North	81.2	18.8
	EB	Paine Road	North		
	WB	Paine Road	North		
	EB	Auburn Road	North		
	EB	Hermitage Road	North		
-	South Marginal	South			
1 lb/yd ³ (0.59 kg/m ³)	EB	Hermitage Road	South	71.3	29.0
	WB	Paine Creek	North		
	WB	Paine Road	South		
2 lb/yd ³ (1.19 kg/m ³)	WB	Paine Creek	South	53.0	47.0

Only two of the experimental parapets that could be examined after the winter were free of cracking. The south parapet of the EB Hermitage Road Bridge and the north parapet of the WB Paine Road Bridge did not have many factors in common. The south parapet of the EB Hermitage Road Bridge had 1 ½ inch (38 mm) deep saw cuts, epoxy coated steel reinforcement, and 1 lb/yd³ (0.59 kg/m³) of polypropylene fiber in the mixture. The north parapet of the WB Paine Road Bridge had 3 ½ inch (89 mm) deep saw cuts, field cut steel reinforcement, and no fiber in the mixture. The two similarities between these parapets were the shorter spacing of the control joints, and performing the saw cuts for the control joints while the concrete was still in a green state. The Hermitage parapet had control joints that were spaced 5.25 to 6.42 feet (1.6 to 1.9 m) in negative moment areas and 11.83 to 12.33 feet (3.6 to 3.8 m) in positive moment areas. The Paine Road parapet had control joints that were spaced 4.5 to 5.7 feet (1.4 to 1.7 m) in the negative moment areas and 11.25 to 13.7 feet (3.4 to 4.2 m) in positive moment areas. As shown by the close correlation of the spacing between these bridges, joint spacing is an important factor in crack control.

Table 31: Summary of Crack Inspections

Bridge Number	Const Year	Parapet	Experimental Treatment					Last Visit	Type of Cracking
			Per Plans, Control	Poly Fibers	3 ½ in. Saw Cut	GFRP Rebar	Field Cut Steel		
LAK-90-16.41R, Big Creek	2012	N	X					February 21, 2014	Mid-Panel
		S	X					October 9, 2014	Mid-Panel
LAK-90-20.03R, Paine Creek	2012	N	X					February 21, 2014	Mid-Panel
		S	X					August 15, 2014	Mid-Panel
LAK-90-21.10R, Paine Road	2012	N	X					February 21, 2014	Mid-Panel /Joint
		S	X					July 1, 2014	Mid-Panel
LAK-90-13.70R, Hermitage Road	2013	N			X	X		August 12, 2014	None
		S		X				February 21, 2014	None
LAK-90-14.87R, Auburn Road	2013	N			X	X		July 16, 2014	Mid-Panel /Joint
		S		X	X	X		July 1, 2014	Mid-Panel /Joint
LAK-90-21.10L, Paine Road	2013	N			X		X	February 21, 2014	None
		S		X				October 15, 2013	None
LAK-90-20.03L, Paine Creek	2013	N		X				August 15, 2014	Mid-Panel /Joint
		S		X				October 15, 2013	None
CUY-90-18.15 (South Marginal Road over I90)	2013	N	X					February 21, 2014	About 12 large cracks
		S			X	X		February 21, 2014	Some mid panel, less than control

Bridge Number	Const Year	Parapet	Per Plans, Control	Poly Fibers	3 ½ in. Saw Cut	GFRP Rebar	Field Cut Steel	Last Visit	Type of Cracking
LAK-90-16.41L, Big Creek	2014	N			X	X		October 30, 2014	Mid-Panel
		S		X	X	X		Nov 4, 2014	None
LAK-90-14.87L, Auburn Road	2014	N	X					Nov 4, 2014	None
		S		X	X		X	Nov 4, 2014	None
LAK-90-13.70L, Hermitage Road	2014	N	X					Nov 4, 2014	None
		S		X	X		X	August 12, 2014	None

CHAPTER VIII CONCLUSIONS AND RECOMMENDATIONS

Results of Implemented Modifications

The modifications to the experimental bridge parapets were implemented to reduce uncontrolled cracking. Analysis of the available information suggests that all of the modifications were effective to some degree. As shown in Table 31, while all of the eight control bridges showed mid-panel cracking, only four of the twelve experimental bridges had mid-panel cracking. Both parapets with VPF posts showed cracks near the posts.

Type of Reinforcement

The main purpose of using GFRP or field cut steel reinforcement with the 3 ½ inch (89 mm) deep saw cut is to create a weakened plane at the control joint through the gap provided in the reinforcement, in order initiate cracking at the joints and reduce cracking elsewhere on the parapet. From the data gathered, this modification allowed more joints to crack at early stages, and prevented uncontrolled cracking. The 3 ½ inch (89 mm) deep saw cut allowed 15% more joints to crack within the first few weeks of placement than the 1 ½ inch (38 mm) deep cut. This modification is useful to control early age cracking, but this alone is not enough information to determine whether a 3 ½ inch (89 mm) deep saw cut is an economical and cost-effective choice when parapets with closer joint spacing produced similar results.

Polypropylene Fibers

The parapets with fibers showed no measurable improvement over the parapets without fiber in regards to preventing shrinkage and temperature cracking. From the temperatures provided by the maturity sensors, the concrete in the parapets did not experience significant enough temperature variations at early stages to cause thermal cracking. The absence of temperature and shrinkage cracking on the parapets without fibers may be due to the concrete mixtures used on all the parapets. For the parapets using this concrete mixture, the fibers proved to be ineffective. For a different concrete mixture, the addition of fibers may be more beneficial. The use of polypropylene fibers may be efficient in extending the service life and safety of parapets as well as reduce life cycle costs. Fibers will enhance fatigue strength, and cracks caused by impact or freeze-thaw cycles will be better controlled.

Joint Spacing

Reducing the joint spacing over negative tension areas is essential to reduce uncontrolled bridge parapet cracking. This seems to be an important modification to include in the design of continuous bridge parapets. As shown by the results of the control parapets, parapets without enough control joints over the negative tension areas of the bridge tended to demonstrate uncontrolled cracking. However, since the experimental parapets with the reduced joint

spacing were coupled with another modification of either the polypropylene fibers or the deeper saw cut, it is hard to determine if this alone will solve uncontrolled bridge parapet cracking.

Recommendations

Based off of the data gathered, recommendations for the design as well as construction of concrete bridge parapets have been developed.

Design Recommendations

The most optimal design of a bridge parapet, researched thus far, should include reducing the spacing of the control joints over negative tension regions of the bridge. Maximum spacing of 15 feet (4.6 m) should be reduced to 10 feet (3 m). The control parapets without this modification displayed uncontrolled cracking between control joints, while the experimental parapets did not. The concrete mixture design used throughout this study also proved to be robust by preventing temperature and shrinkage cracking without the use of polypropylene fibers.

It is uncertain if the use of GFRP or field cut steel reinforcement with a deeper saw cut is essential for providing crack control. There is no doubt that the modification will aid the parapet to crack at the control joints and reduce cracking elsewhere; however, it is inconclusive whether this modification is the most cost-effective.

The parapets including the addition of polypropylene fibers in the mixture did not perform any differently than the parapets without fibers in terms of early age cracking. The addition of fibers proved unnecessary with the concrete mixture used. However, the use of fibers may prove to be beneficial in the future by extending the service life of the parapet through its enhanced fatigue strength, and reducing life cycle costs by improving control of cracks caused by impact or freeze-thaw cycles. If polypropylene fiber is used in the concrete mixture, the recommended dosage of 1.5 lb/yd³ (0.89 kg/m³) should not be exceeded to avoid any issues with the air content.

Cracking near the bolts on VPF post base plates occurred on both the north and south parapets of the South Marginal Bridge. This may be due to the shortened curing time the concrete experienced, but design details for the base plate anchorages, as well as when the base plates were anchored into the concrete may have caused the cracking. It is possible that drilling the bolt holes may have caused enough stress in the concrete to cause it to crack in these specific locations. Redesign of the post anchorage details or installations method may still be necessary to prevent cracking on parapets with vandal protection fences.

Construction Recommendations

It is important to pay attention to the workability of the concrete during placement. A low slump can cause poor consolidation, especially near the surface of the parapet. A

superplasticizer should be added, if necessary, and vibrators should be used thoroughly to aid in consolidation of the concrete. On the other hand, high workability can be a problem if the bridge parapet has a significant slope along the centerline.

During removal of the formwork and saw cutting, the parapet should be watered to keep the concrete cool and prevent the occurrence of any shrinkage or temperature cracking. Also, saturated burlap must be placed on the parapet immediately to keep as much moisture as possible from evaporating. Getting the curing on quickly is an important step.

Performing saw cuts for the control joints while the concrete is still in a green state seems more effective than waiting one day after placement. This allows the construction workers to intercept the formation of any cracks by providing a location for the concrete to crack as it cures and hardens. It is also easier to rub the wall, faster to cut the control joints, and the entire wall can be left to cure. While the new specification requires two cuts (ODOT 2014b), only single cuts were made in the field.

Once the formwork is removed and saw cuts are made, if the wall can be kept saturated, rubbing should occur before allowing the concrete to cure. This way paste does not need to be added to already hardened concrete, and it reduces the chance that cracking will not initiate from any pits, holes, or flaws in existence on the parapet surface. Rubbing the wall immediately will also make the parapet more aesthetically pleasing.

Curing is the key to mitigating cracking. Therefore, allowing the parapet to cure in saturated conditions for 7 days is vital to the outcome of the parapet, which was proven by the South Marginal Road Bridge parapets.

Limitations of this Study

Some potential factors of interest could not be addressed in this study. The use of slipforming to construct parapets has been controversial in Ohio and in other states. However, none of the parapets in the study were slipformed, so this possible effect could not be observed. In the previous CSU research project, cracks were observed propagating from VPF bases into parapets. Since 20 of the 22 parapets in the study did not have VPF, this effect could not be studied either. Finally, it has been suggested that longer bridges are at higher risk for parapet cracking due to their increased flexibility. Two of the bridges in the study had spans over twice as long as the others, but the study sample for bridge length is not sufficient to draw firm conclusions.

Potential Benefits

The benefits that are expected to be seen by implementing these recommendations are that the amount and severity of premature bridge parapet cracking will reduce not only in Northeast Ohio, but throughout all of the ODOT districts. This will also number the amount of premature bridge parapet repair and replacement projects that ODOT must conduct. The average cost to ODOT is \$188,175 per parapet replacement project, or \$283 per linear foot (\$86 per meter) of

parapet. If the amount of premature bridge parapet repair and replacement projects is reduced, then ODOT is able to potentially save hundreds of thousands of dollars per year.

Implementation Recommendations

For effective implementation of the results of this research, several actions are recommended. The results and conclusions of this study should be disseminated among relevant industry professionals in order to increase their awareness of this problem. The following changes are suggested for consideration:

1. Use a smaller spacing between parapet control joints over piers, in negative moment regions.
2. Use discontinuous lengths of steel reinforcement, with gaps at the control joints, to allow for 3 ½ inch (89 mm) saw cuts
3. Use GFRP reinforcement, to allow for 3 ½ inch (89 mm) saw cuts

Many of these recommendations have already been implemented in ODOT Standard Drawing ODOT BR-1-13 January 17, 2014 New Jersey Shape Concrete Bridge Railing (ODOT 2014b). These include positive moment joint spacing limited to 15 ft. (4.6 m) and negative moment joint spacing limited to between 5 and 7 ½ ft. (1.5 to 2.3 m). Six inch (150 mm) gaps are to be left in the steel reinforcement for joints. These gaps are crossed with 4 ½ ft. (1.4 m) lengths of ½ inch (13 mm) GFRP stiffening reinforcement. The joint is to be cut into two stages, with an initial 1 ½ inch (38 mm) cut followed by a 4 inch (100 mm) cut. These details are shown in Figure 62.

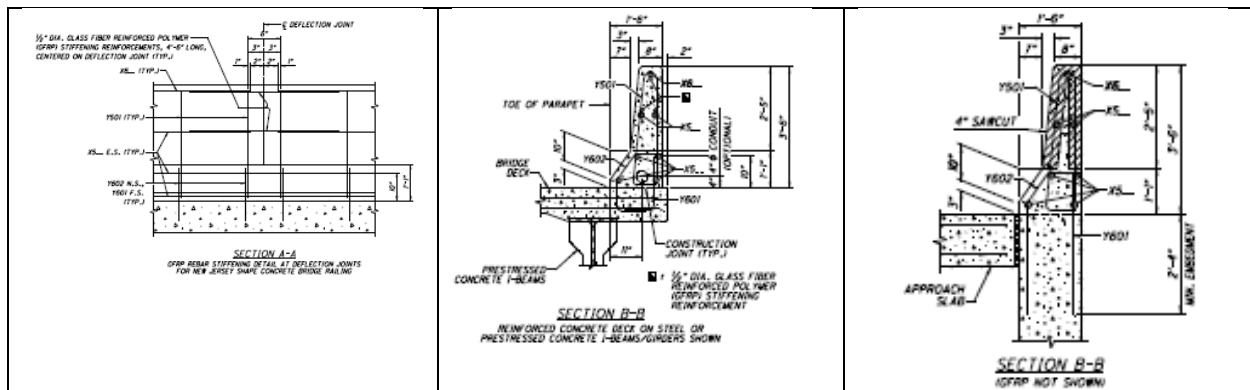

Figure 62: New ODOT Parapet BR-1-13 January 17, 2014 (ODOT 2014b)

Recommendations for Further Research

The findings up until this point have been based on only one or two years of performance observation. It would be useful to return to these test parapets in five years to investigate how they perform over time and after exposure to multiple winters.

One issue that had been raised in conjunction with this research was whether or not the cracking was related to slipforming. As documented by Bazzo et al. (2013), Illinois had imposed a moratorium on parapet slipforming and later lifted it. None of the parapets in this study were

slipformed. If ODOT allows slipforming for future parapet construction, it would be useful to monitor those parapets to determine whether they are prone to increased cracking.

Finally, another issue is whether longer bridges are more prone to parapet cracking than shorter bridges due to increased vibration. Because most of the bridges in this study were approximately the same length, it was not possible to investigate this issue. Whereas the Big Creek and Paine Creek bridges did have longer spans, this was a relatively small part of the test population and no significant differences were observed. These two bridges were control bridges and did not use any of the experimental treatments.

REFERENCES

- American Concrete Institute. (2013). *ACI CT-13 Concrete Terminology*. <http://www.concrete.org/portals/0/files/pdf/ACI_Concrete_Terminology.pdf>. (Feb. 17, 2014).
- AHTD. (2003). *Bridge Division Standards*. Little Rock: Arkansas Highway and Transportation Department.
- Alabama DOT bridge parapet detail. (2011). <[http://www.dot.state.al.us/brweb/doc/standards/I-131%20\(Sheet%203%20of%208\).pdf](http://www.dot.state.al.us/brweb/doc/standards/I-131%20(Sheet%203%20of%208).pdf)>.
- Anderson, R. E. (2004). *Bridge Parapet Joint Details*. Springfield: Illinois Department of Transportation.
- Anderson, R. E. (2004). *Slipform Bridge Parapet Construction*. Springfield: Illinois Department of Transportation.
- ASTM C597-09 (2009) *Standard Test Method for Pulse Velocity Through Concrete*, ASTM International, West Conshohocken, PA
- AZDOT. (2012). *Bridge Highway Details*. Arizona Department of Transportation.
- BASF (2010) BASF The Chemical Company. *MasterFiber F70*. N.p. Print.
- Battaglia, I., Whited, G., and Swank, R. (2008). *Eclipse Shrinkage Reducing Admixture Product Evaluation*. Madison: Wisconsin Department of Transportation.
- Bazzo, J., Delatte, N., and Kalabon, A. (2013), *Uncontrolled Concrete Bridge Parapet Cracking*, final report, Ohio Department of Transportation, State Job Number 134602, May 2013
- California. (2010). *Project Plans*. California Department of Transportation.
- Collett, B., "Parapet Cracking." Message to Norbert Delatte. 19 June 2013. E-mail.
- "Curing." *Portland Cement Association*. (2014). <<http://www.cement.org/cement-concrete-basics/working-with-concrete/curing>> (Feb. 20, 2014).
- "GFRP Rebar – Aslan 100 Series." *Aslan FRP, Hughes Brothers, Inc.* (2011). <<http://aslanfrp.com/Aslan100/Aslan100fiberglassrebar.html>> (Aug. 12, 2013).
- Georges, J. F. (2005). *New Bridge Design Standard Practice*. Connecticut Department of Transportation.

Hedges, L., (2014), *Developing Improved Bridge Parapet Designs*, Master's Thesis. Cleveland State University.

IDOT. (2011). *Guide Bridge Special Provision Number 61*. Springfield: Illinois Department of Transportation.

ITD. (2010). *Standard Drawings*. Boise: Idaho Transportation Department.

Kalabon, A. (2014), *Implementation and Field Testing of Improved Bridge Parapet Designs*, Master's Thesis. Cleveland State University.

Kalabon, A., Hedges, L., and Delatte, N. (2014), *Development, Field Testing, and Implementation of Improved Bridge Parapet Designs*, Concrete Materials 2014, TRR 2441, *Transportation Research Record: Journal of the Transportation Research Board*, pp. 46 – 52

Kosmatka, S. H., Wilson, M. L. (2011). *Design and Control of Concrete Mixtures*, 15th Edition, Portland Cement Association. Skokie, Illinois.

Maggenti, R., Knapp, C., and Fereira, S. (2013). "Controlling Shrinkage Cracking." *Concrete International Magazine*, 36-41.

Maas, R., personal communication, March 4, 2014

MDOT. (2012). *Bridge Standards*. Hanover: Maryland Department of Transportation.

MDOT. (2013). *Standard Plan Book*. Lansing: Michigan Department of Transportation.

MDT. (2012). *Bridge Standard Drawings*. Helena: Montana Department of Transportation.

MNDOT. (2006). *Bridge Manual*. St. Paul: Minnesota Department of Transportation.

MODOT. (2012). *Standard Drawings*. Jefferson City: Missouri Department of Transportation.

ODOT. (2009). *Construction Inspection Manual of Procedures*. Columbus: Ohio Department of Transportation.

ODOT. (2010). *Construction and Material Specifications*. Columbus: Ohio Department of Transportation.

ODOT (2012). *Bridge Design Manual*. Columbus: Ohio Department of Transportation.

ODOT (2013). *Construction and Material Specifications*. Columbus: Ohio Department of Transportation.

ODOT (2014a). *Bridge Design Manual*. Columbus: Ohio Department of Transportation.

ODOT (2014b). *New Jersey Shape Concrete Bridge, Standard Drawings*, Columbus: Ohio Department of Transportation.

Railing <http://www.dot.state.oh.us/Divisions/Engineering/Structures/standard/Bridges/Pages/StandardBridgeDrawings.aspx>

Saraf, F. K. P.E. (2013). "I-95 Express Lanes Project". *Virginia Department of Transportation*.

Staton, J. F., and Knauff, J. (2007). *Performance of Michigan's Concrete Barrier*. Lansing: Michigan Department of Transportation.

Van Dam, T., Delem, L., Peterson, K. R., & Sutter, L. L. (2004). "Causes and Cures for Cracking of Concrete Barriers". *Transportation Materials Research Center*.