

Maine Department of  
Transportation  
**Transportation Research  
Division**



**Technical Report 00-19**  
*Comparison of “Saw and Seal” Procedure and  
Performance Grade Binder to Minimize Thermal  
Cracking*

*First Interim Report June 2002*

# Transportation Research Division

## *Comparison of “Saw and Seal” Procedure and Performance Grade Binder to Minimize Thermal Cracking*

### Introduction

In an effort to compare performance and cost effectiveness of the “Saw and Seal” procedure and Performance Grade (PG) binders, the Maine Department of Transportation (MDOT) constructed an experimental project in Weston, Maine during the fall of 2000. Both the Saw and Seal method and PG binder are designed to minimize thermal cracking.

### Procedure/Product Description

#### Saw and Seal

Saw and Seal is the process of introducing uniformly spaced sawed joints to a bituminous overlay in an attempt to eliminate or retard the formation of thermal and/or reflective cracking. Several states, including Minnesota, New York and Massachusetts have successfully used the saw and seal process. MDOT is currently evaluating two saw and seal projects to determine the effectiveness of this process in minimizing thermal cracking.

#### Performance Grade Binder (58-34)

Performance Grade binder is a modified asphalt binder designed for use in harsh temperature conditions. Its application is intended to minimize thermal cracking. PG binder 58-34 is designed for a maximum pavement design temperature of 58 °C and a minimum temperature of -34 °C.

### Project Location/Description

This project is located on a section of Route 1 in the town of Weston in Aroostook County. The project is a highway improvement with full depth reclamation. It begins at the Danforth town line and extends northerly 5.09 km (3.14 miles). The designed pavement thickness is a base course of 60 mm of 19.0 mm superpave and 40 mm of 12.5 mm superpave wearing surface.

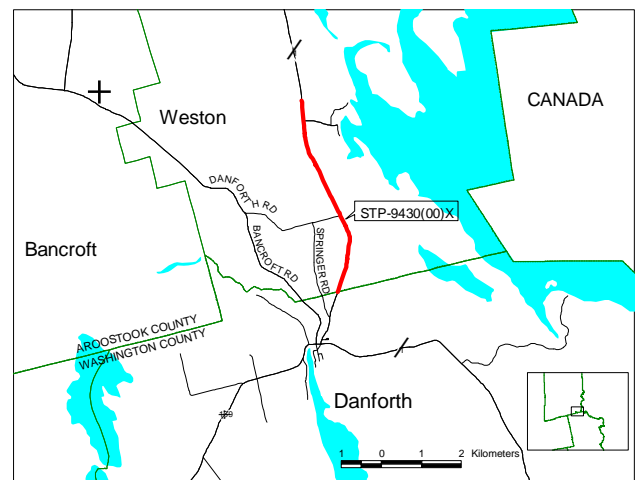

The experimental feature of this project consists of three sections. The saw and seal portion begins at station 20+200 and extends to station 20+500. The control section begins at station 20+500 and ends at station 20+778. The full depth PG binder section begins at station 20+800 and ends at station 21+088.

## Construction Procedures

### Saw and Seal

Paving of the base coarse in the saw and seal section was completed on September 5 and 6, 2000. The surface material was applied on October 2, 2000. Both the base and wearing surface materials were superpave design with MDOT's standard 64-28 asphalt.

The saw and seal process was completed on October 13, 2000. Full width joints, 7.2 meters (23.6 feet) in length were introduced to the surface using two passes of the pavement saw. The first pass completed the 15.75 mm (5/8 inch) reservoir; the second and final pass completed the approximate 50 mm (2 inch) depth of joint as recommended.

Contrary to the work plan, full width and two-pass cutting of the joints was accepted, and traffic was allowed to travel on the cut joints. Unsealed joints were exposed to traffic for approximately two hours, during which time they were closely monitored and no detrimental effects were reported. The project resident deemed this deviation of the work plan necessary because of equipment availability, the remote project location and the impending winter weather season. After sawing, joints were blown clean and sealed with Crafco Roadsaver 222 sealing material. Thirty-four joints were introduced to the 300-meter section at a spacing interval of 9.15 meters (30 feet). The saw and seal process took approximately ten man-hours to complete. Overall cost of this process was \$4,896.00.

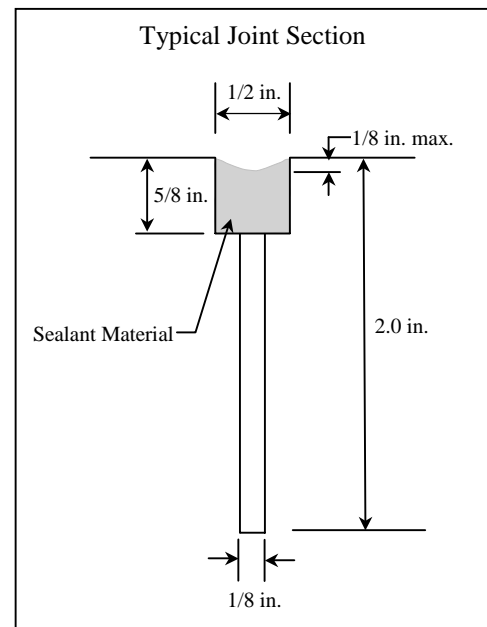

The following Special Provision was included in the work plan.

---

***SPECIAL PROVISION***  
***SECTION 419***  
***SAWING AND SEALING JOINTS IN BITUMINOUS PAVEMENT***

***Description:*** This work shall consist of sawing a cut transversely across the newly finished bituminous concrete pavement as shown on the plans or as directed, and in accordance with this Special Provision. Upon the satisfactory completion of each cut, it shall be sealed with hot rubber asphalt joint sealer. The work is to establish a weakened plane joint to control thermal cracking in the newly placed bituminous concrete pavement.

## **MATERIALS**

Joint Sealer. Joint sealer shall be an asphalt rubber compound of the hot poured type conforming to AASHTO M301 and ASTM D3405.

## **CONSTRUCTION REQUIREMENTS**

Weather. Joint sealer shall not be applied when weather conditions are unfavorable for proper construction procedures. Specifically; when atmospheric temperature is below 10 °C (50 °F) at the work site, when pavement surface is wet. Joint sealer shall not be applied before sunrise and after sunset.

Equipment. Equipment used in the performance of the work shall be subject to the Engineers approval and shall be maintained in a satisfactory working condition at all times.

a) Air Compressor: Air compressors shall be portable and capable of furnishing not less than 3.0 m<sup>3</sup> (100 cu.ft.) of air per minute at not less than 600 kPa (90 psi) pressure at the nozzle. The compressor shall be equipped with traps that will maintain the compressed air free of oil and water.

b) Hand Tools: Shall consist of brooms, shovels, metal bars with chisel shaped ends and any other tools which may be satisfactorily used to accomplish this work.

c) Melting Kettle: The unit used to melt the joint sealing compound shall be a double boiler, indirect fired type. The space between inner and outer shells shall be filled with a suitable heat transfer oil or substitute having a flash point of not less than 315 °C (600 °F). The kettle shall be equipped with a satisfactory means of agitating and mixing the joint sealer at all times. The kettle must be equipped with thermostatic control calibrated between 90 °C and 290 °C (200 °F and 550 °F).

Sawing Joints. The bituminous concrete shall be in place a minimum of 48 hours prior to sawing to allow a clean cut to be made, and to withstand the eroding effects of the saw or other cutting device.

The joint shall be cut with an abrasive blade or blades of such size and configuration that the resulting depth and reservoir shape are in accordance with the plans. Sawed joints will be made with a single pass. Either dry or wet cutting will be allowed.

Joints shall be sawed using a 9.15 mm (30 foot) spacing interval.

The completed cut shall extend in a straight line transversely across the travel way and shall extend 300 mm (12 inches) into the paved shoulder.

Sealing Joints. The sawed joints shall be sealed immediately after the cut has been made. Traffic shall not be allowed to knead together or damage the sawed joint. Each joint shall be clean and dry prior to the placement of sealing compound by blowing out all dirt, dust and deleterious matter that may have accumulated in the saw joints. Sufficient air pressure shall be provided to insure thorough cleaning and drying.

The joint seal shall be applied with a mobile carriage and rubber shoe and have a flow control valve which allows all joints to be filled to refusal, so as to eliminate all voids or entrapped air, and not leave surplus sealer on the pavement surface. Any depression in the sealer greater than 3 mm (1/8 inch) below

*the pavement surface shall be brought up flush to the pavement by the further addition of hot sealer. The recommended melting temperature of the sealer shall be furnished to the Contractor by the manufacturer and the actual temperature of the material in the melter shall not fluctuate from this recommended temperature by more than 5.5 °C (10 °F).*

*Workmanship. All workmanship shall be of the highest quality. Excess of spilled sealer shall be removed from the pavement by approved methods and discarded. Any workmanship determined to be below normal acceptable standards will not be accepted and will be corrected and/or replaced as directed by the Engineer.*

*Method of Measurement. This work shall be measured for payment by the number of linear feet of joint sawed and sealed in the bituminous concrete surface, measured in place and accepted.*

*Basis of Payment. Payment for this work shall be at the contract unit price per linear foot for sawing and sealing joints in bituminous concrete pavement, complete in place.*

*Payment will be made under:*

<i>Pay Item</i>	<i>Pay Unit</i>
<i>419.20 Sawing, Sealing Joints in Bituminous Concrete Surface</i>	<i>Meter (Linear Foot)</i>

---

### **Control Section**

Paving of the base coarse and wearing surface was completed on the same dates as the saw and seal section. Identical paving materials and standard paving practices were used.

### **Performance Grade Binder (58-34)**

The 19.0 mm base coarse treated with the PG binder 58-34 was completed on September 8, 2000. The 12.5 mm wearing surface was placed on September 26, 2000. Standard paving practices were followed and only minimal problems were encountered at the bituminous plant when the asphalt type was changed to accommodate the experimental feature of this section.

Use of the PG binder 58-34 added an approximate total of \$3800.00 to the completion cost of this section.

Monitoring of the project will consist of annual visual evaluations with a focus on the formation of transverse cracks. Sawed joints will also be monitored for deterioration.

### **Visual Evaluation**

The project was evaluated on October 11, 2001. There was no cracking or deformation in the roadway. The sawed joints had no raveling or cracks. The sealant was pliable and there were no signs of separation from the sidewall of the joint.

## Summary

After exposure to traffic and weather for one year, the project has performed as expected. Future evaluations will determine if Saw and Seal or PG Binder can eliminate or reduce transverse cracking.

Prepared by:

Brian Marquis  
Transportation Planning Analyst

Reviewed By:

Dale Peabody  
Transportation Research Engineer

For more information contact:

Brian Marquis  
Maine Department of Transportation  
P.O. Box 1208  
Bangor, Maine 04402 - 1208  
207-941-4067  
E-mail: [brian.marquis@state.me.us](mailto:brian.marquis@state.me.us)