



FINAL REPORT  
FHWA-WY-13/002F

# Update to: A Guide to Standardized Highway Lighting Pole Hardware

---

**Final Report**  
**Transportation Pooled Fund Program**  
**Project TPF-5(002)**



By:  
Roadsafe LLC  
P.O. Box 312  
Canton ME 04221

March 2013

## **DISCLAIMER**

### **Notice**

This document is disseminated under the sponsorship of the U.S. Department of Transportation in the interest of information exchange. The U.S. Government assumes no liability for the user of the information contained in this document.

The contents of this report reflect the views of the author(s) who are responsible for the facts and accuracy of the data presented herein. The contents do not necessarily reflect the official views or policies of the Wyoming Department of Transportation or the Federal Highway Administration. This report does not constitute a standard, specification or regulation.

The United States Government and the State of Wyoming do not endorse products or manufacturers. Trademarks or manufacturer's names appear in this report only because they are considered essential to the objectives of the document.

### **Quality Assurance Statement**

The Federal Highway Administration (FHWA) provides high-quality information to serve Government, industry, and the public in a manner that promotes public understanding. Standards and policies are used to ensure and maximize the quality, objectivity, utility, and integrity of its information. FHWA periodically reviews quality issues and adjusts its programs and processes to ensure continuous improvement.

<b>1. Report No.</b> FHWA-WY-05/002F		<b>2. Government Accession No.</b>		<b>3. Recipient Catalog No.</b>	
<b>4 Title and Subtitle</b> UPDATE TO A GUIDE TO STANDARDIZED HIGHWAY LIGHTING POLE HARDWARE				<b>5 Report Date</b> 13 March 2013	
				<b>6 Performing Organization Code</b>	
<b>7. Author(s)</b> Malcolm H. Ray and Chuck A. Plaxico				<b>8 Performing Organization Report No.</b>	
<b>9 Performing Organization Name and Address</b> Roadsafe LLC P.O. Box 312 Canton ME 04221				<b>10 Work Unit No. (TRAIS)</b>	
				<b>11 Contract or Grant No.</b> TPF-5(002)	
<b>12 Sponsoring Organization Name and Address</b> The Wyoming Department of Transportation 5300 Bishop Blvd. Cheyenne, WY 82009  Transportation Pooled Fund Program Federal Highway Administration Office of Corporate Research, Technology and Innovation Management				<b>13 Type of Report and Period Covered</b> Draft Final: 2001- 2012	
				<b>14 Sponsoring Agency Code</b>	
<b>15 Supplementary Notes</b> WYDOT Technical Contacts: Keith Fulton, P.E., State Bridge Engineer; Greg Fredrick, P.E., Assistant Chief Engineer; Pat Collins, P.E., former Assistant Chief Engineer.					
<b>16 Abstract</b> This report describes the development of an updated Online Guide to Luminaire Supports. The Guide is a web-based content management system for luminaire support systems that allows full viewing, submission, management, and reporting services to its users (e.g., State DOT personnel, construction contractors, etc.). The Online Guide to Luminaire Supports is one of six online guides maintained by the AASHTO-AGC-ARTBA Joint Committee on New Highway Materials Task Force 13 (TF13). The homepage for the Online Guides can be found online at <a href="http://guides.roadsafellc.com/">http://guides.roadsafellc.com/</a> .  The luminaire support systems included in the Online Guide to Luminaire Supports have been successfully crash tested according to NCHRP Report 350 or the Manual for Assessing Safety Hardware (MASH) and comply with the AASHTO Standard Specification for Structural Supports for Highway Signs, Luminaires and Traffic Signals. A link to the appropriate FHWA Eligibility Letter, is included in the index listing for each system.					
<b>17 Key Words</b> Roadside safety, luminaire, luminaire support, lighting hardware, crash test			<b>18 Distribution Statement</b> No restrictions. This document is available to the public through the National Technical Information Service, Springfield, Virginia 22161		
<b>19 Security Classification (of this report)</b> Unclassified		<b>20 Security Classification (of this page)</b> Unclassified		<b>21 No. of pages</b> 79	<b>22 Price</b>

# SI\* (Modern Metric) Conversion Factors

## Approximate Conversions from SI Units

Symbol	When You Know	Multiply By	To Find	Symbol
<b>Length</b>				
mm	millimeters	0.039	inches	in
m	meters	3.28	feet	ft
m	meters	1.09	yards	yd
km	kilometers	0.621	miles	mi
<b>Area</b>				
mm <sup>2</sup>	square millimeters	0.0016	square inches	in <sup>2</sup>
m <sup>2</sup>	square meters	10.764	square feet	ft <sup>2</sup>
m <sup>2</sup>	square meters	1.195	square yards	yd <sup>2</sup>
ha	hectares	2.47	acres	ac
km <sup>2</sup>	square kilometers	0.386	square miles	mi <sup>2</sup>
<b>Volume</b>				
ml	milliliters	0.034	fluid ounces	fl oz
l	liters	0.264	gallons	gal
m <sup>3</sup>	cubic meters	35.71	cubic feet	ft <sup>3</sup>
m <sup>3</sup>	cubic meters	1.307	cubic yards	yd <sup>3</sup>
<b>Mass</b>				
g	grams	0.035	ounces	oz
kg	kilograms	2.202	pounds	lb
Mg	megagrams	1.103	short tons (2000 lbs)	T
<b>Temperature (exact)</b>				
°C	Centigrade temperature	1.8 C + 32	Fahrenheit temperature	°F
<b>Illumination</b>				
lx	lux	0.0929	foot-candles	fc
cd/m <sup>2</sup>	candela/m <sup>2</sup>	0.2919	foot-Lamberts	fl
<b>Force and Pressure or Stress</b>				
N	newtons	0.225	poundforce	lbf
kPa	kilopascals	0.145	pound-force per square inch	psi

## Approximate Conversions to SI Units

Symbol	When You Know	Multiply By	To Find	Symbol
<b>Length</b>				
in	inches	25.4	millimeters	Mm
ft	feet	0.305	meters	M
yd	yards	0.914	meters	M
mi	miles	1.61	kilometers	Km
<b>Area</b>				
in <sup>2</sup>	square inches	645.2	square millimeters	mm <sup>2</sup>
ft <sup>2</sup>	square feet	0.093	square meters	m <sup>2</sup>
yd <sup>2</sup>	square yards	0.836	square meters	m <sup>2</sup>
ac	acres	0.405	hectares	Ha
mi <sup>2</sup>	square miles	2.59	square kilometers	km <sup>2</sup>
<b>Volume</b>				
fl oz	fluid ounces	29.57	milliliters	ml
gal	gallons	3.785	liters	L
ft <sup>3</sup>	cubic feet	0.028	cubic meters	m <sup>3</sup>
yd <sup>3</sup>	cubic yards	0.765	cubic meters	m <sup>3</sup>
<b>Mass</b>				
oz	ounces	28.35	grams	G
lb	pounds	0.454	kilograms	Kg
T	short tons (2000 lbs)	0.907	megagrams	Mg
<b>Temperature (exact)</b>				
°F	Fahrenheit temperature	5(F-32)/9 or (F-32)/1.8	Celsius temperature	°C
<b>Illumination</b>				
fc	foot-candles	10.76	lux	Lx
fl	foot-Lamberts	3.426	candela/m <sup>2</sup>	cd/m <sup>2</sup>
<b>Force and Pressure or Stress</b>				
lbf	pound-force	4.45	newtons	N
psi	pound-force per square inch	6.89	kilopascals	kPa

## **Acknowledgements**

The authors wish to acknowledge several persons and organizations that contributed to the success of this research project: the Federal Highway Administration, the Departments of Transportation of the States of Alabama, California, Connecticut, Georgia, Iowa, Illinois, Kansas, Missouri, North Dakota, Nebraska, New Jersey, New York, South Carolina, Texas, Washington and Wyoming. In particular the State of Wyoming was the lead State and the authors would particularly like to thank Mr. Keith Fulton and Mr. Patrick Collins who coordinated the project for Wyoming Department of Transportation. The AASHTO-ARTBA-AGC Task Force 13 Subcommittee on Supports was a vital collaborator in this project, providing comments, input and data to the on-line guide.

## Executive Summary

The first Guide to Standardized Highway Lighting Pole Hardware was published in 1980 to provide a resource for field engineers and designers in selecting standardized lighting pole hardware components. A great deal of research work was done on luminaire and sign supports in the 1980s: AASHTO published its “Standard Specifications for Structural Supports for Highway Signs, Luminaires and Traffic Signals” in 1985, several NCHRP projects up-date the AASHTO Guide and there have been extensive crash testing programs performed by the FHWA and several States on luminaire support hardware. The information in the 1980 TF13 Lighting Pole Guide is, therefore, long out of date and does not conform to the latest research and specifications on lighting pole hardware. Much of the information in the 1980 Guide is obsolete and a great deal of material needed to be added or modified to conform to the latest research.

This report describes the development, use and maintenance of an updated *Online Guide to Luminaire Supports*. This document serves both as a User’s Guide and a Guide for Maintenance of the guide’s content. The Guide is a web-based content management system for luminaire support systems that allows full viewing, submission, management, and reporting services to its users (e.g., State DOT personnel, construction contractors, etc.). The *Online Guide to Luminaire Supports* is one of six online guides maintained by the AASHTO-AGC-ARTBA Joint Committee on New Highway Materials Task Force 13 (TF13). The homepage for the Online Guides is shown in Figure 1 and can be found online at <http://guides.roadsafellc.com>.

# Table of Contents

Introduction.....	1
Background.....	2
Objectives .....	3
Content of the Luminaire Support Guide.....	4
FHWA Eligibility.....	4
AASHTO Certification .....	5
Summary.....	9
User’s Guide .....	10
Nomenclature.....	10
Components .....	10
Systems .....	11
Methods for Searching for Luminaire Support Systems.....	13
Browse Luminaire Supports .....	14
Search Luminaire Supports.....	20
Search Based on Associated Components .....	23
Procedures for Data Submission.....	30
Basic Process .....	30
Data Entry Form .....	31
Procedure for Submitting Component Drawings and Photos.....	32
Component Drawings .....	33
Component Photos.....	44
Procedure for Submitting Luminaire Support System Drawings and Photos .....	44
System Drawings .....	44
System Photos.....	44
Online Guide Administration Procedures.....	48
Updating and Editing Luminaire Support Systems Data.....	49
Luminaires Administration Page .....	49
Bulk Import Administration Page.....	52
Bulk Export Administration Page.....	55
Bulk Edit Administration Page.....	55
Updating and Editing Supporting Databases .....	60

Test Specifications Administration Page .....	60
Materials Administration Page .....	61
Base Types Administration Page .....	61
Arm Types Administration Page .....	62
Contacts Administration Page.....	62
Approvals Administration Page .....	64
Components Administration Page .....	65
Summary and Conclusions .....	67
References.....	68

### List of Tables

Table 1. EPA for HAPCO pole RTA20B6B4 using 3-second gust wind speed.....	6
Table 2. Poll results of webinar participants regarding EPA values.....	9
Table 3. Nomenclature used for naming luminaire components. ....	11
Table 4. Nomenclature used for <i>General System</i> names for Luminaires. ....	12
Table 5. Drawing margins.....	33
Table 6. Acceptable abbreviations in drawings. ....	33

### List of Figures

Figure 1. Homepage for the AASHTO-AGC-ARTBA Task Force 13 Online Guides to Highway Hardware Systems.....	1
Figure 2. Basic wind speed from AASHTO Specifications.[AASHTO09] .....	6
Figure 3. Basic wind speed from AASHTO Specifications (continued).[AASHTO09].....	7
Figure 4. Naming convention for <i>Specific Systems</i> in the Luminaire Guide. ....	13
Figure 5. <i>Online Guide to Luminaire Supports</i> home page. ....	14
Figure 6. Example of luminaire system information displayed when the <i>Browse Luminaire Support</i> option is selected. ....	15
Figure 7. General System Page for SLH01. ....	17
Figure 8. Example results from a search of the SLH01 systems that have a maximum mounting height of 20 ft and two mast arms. ....	18
Figure 9. Webpage displaying details for luminaire support configuration SL20/H01/A01-7-4-5/M01b2. ....	19
Figure 10. <i>Search Luminaire Systems</i> page.....	20
Figure 11. Partial results using <i>Search Luminaire Supports</i> option to find systems with 20-ft mounting height and two mast arms. ....	21
Figure 12. Example of using the <i>Advanced Search Options</i> on the <i>Search Luminaire Supports</i> page.....	22
Figure 13. Component webpage.....	24
Figure 14. <i>Online Guide to Components</i> home page. ....	25
Figure 15. <i>Browse Components</i> Page.....	26



Figure 16. Search Components page.....	27
Figure 17. Search option example for finding luminaire transformer bases components.....	28
Figure 18. Partial results from search for luminaire transformer base components using the Search Components option. ....	29
Figure 19. Data-Entry-Form.xlsx – columns A through F. ....	31
Figure 20. Data-Entry-Form.xlsx – Columns G through O. ....	32
Figure 21. Data-Entry-Form.xlsx – Columns P through U. ....	32
Figure 22. Example of a component web page in the Online Guide.....	35
Figure 23. Example drawing of luminaire shaft component (page 1 of 4). ....	36
Figure 24. Example drawing of luminaire shaft component (page 2 of 4). ....	37
Figure 25. Example drawing of luminaire shaft component (page 3 of 4). ....	38
Figure 26. Example drawing of luminaire shaft component (page 4 of 4). ....	39
Figure 27. Example drawing of luminaire base component (page 1 of 4). ....	40
Figure 28. Example drawing of luminaire base component (page 2 of 4). ....	41
Figure 29. Example drawing of luminaire base component (page 3 of 4). ....	42
Figure 30. Example drawing of luminaire base component (page 4 of 4). ....	43
Figure 31. Example of a luminaire support system web page in the <i>Online Guide</i> .....	45
Figure 32. Example drawing of luminaire support system (page 1 of 2). ....	46
Figure 33. Example drawing of luminaire support system (page 2 of 2). ....	47
Figure 34. Administration page for Luminaire support systems.....	50
Figure 35. Administration tool for adding/editing entries for specific luminaire system configurations (abridged view). ....	51
Figure 36. Procedure for “un-hiding” the database worksheet on the Data Entry Form .....	52
Figure 37. System designator for each new general system is assigned in column D of the Data Entry Form on the Database worksheet. ....	53
Figure 38. Procedure for exporting the database.....	55
Figure 39. Administration page for the “bulk edit” feature (abridged view).....	56
Figure 40. Example 1 of using the search criteria to identify all configurations of the general system SLH01 .....	57
Figure 41. Example 2 of using the search criteria to identify all configurations of the general system SLH01 .....	58
Figure 42. Search results from Example 1 or Example 2 in Figure 40 and Figure 41, respectively (abridged view).....	58
Figure 43. Administration page for modifying selected systems from the “bulk edit” option (abridged view).....	59
Figure 44. Administration page for luminaire test specifications. ....	60
Figure 45. Administration tool for adding/editing entries for “test specifications” .....	61
Figure 46. Administration page for luminaire materials .....	61
Figure 47. Administration page for luminaire base types. ....	62
Figure 48. Administration page for luminaire arm types .....	62
Figure 49. Administration page for adding/editing contact information.....	63
Figure 50. Administration tool for adding/editing entries for contacts.....	64
Figure 51. Administration tools for approval status.....	65
Figure 52. Administration tools for components.....	66



# Chapter 1

## Introduction

This report describes the development of an updated *Online Guide to Luminaire Supports*. The Guide is a web-based content management system for luminaire support systems that allows full viewing, submission, management, and reporting services to its users (e.g., State DOT personnel, construction contractors, etc.). The *Online Guide to Luminaire Supports* is one of six online guides maintained by the AASHTO-AGC-ARTBA Joint Committee on New Highway Materials Task Force 13 (TF13). The homepage for the Online Guides is shown in Figure 1 and can be found online at <http://guides.roadsafellc.com/>.

**AASHTO-AGC-ARTBA Joint Committee  
Subcommittee on New Highway Materials  
Task Force 13 Report**

<p><b>Guides</b></p> <p><b>On-Line Guides</b></p> <p><b>Bridge Rail Systems</b></p> <p><b>Transition Systems</b></p> <p><b>Sign Support Systems</b></p> <p><b>Luminaire Support Systems</b></p> <p><b>Hardware Systems</b></p> <p><b>Components</b></p>	<p>Task Force 13 of the AASHTO-AGC-ARTBA Joint Committee maintains several on-line guides to a variety of highway products. The on-line guides that are available from the Task Force are listed at the left. The links at the left will take you to the particular guides where you can search for particular systems, view system details, download photographs and drawings, and see components. The "system" guides provide information about complete systems such as particular bridge rail systems, sign support systems and luminaire support systems. The component guide provides details about the parts used in the non-proprietary systems like bolts, posts, brackets, guardrail sections, etc.</p>
---	---

**Figure 1. Homepage for the AASHTO-AGC-ARTBA Task Force 13 Online Guides to Highway Hardware Systems.**

The luminaire support systems included in the *Online Guide to Luminaire Supports* have been successfully crash tested according to *NCHRP Report 350* or the Manual for Assessing Safety Hardware (*MASH*) and comply with the AASHTO Standard Specification for Structural Supports for Highway Signs, Luminaires and Traffic Signals. [Ross03; AASHTO09; AASHTO85] A link to the appropriate FHWA Eligibility Letter, sometimes referred to as an Acceptance Letter or Approval Letter, is included in the index listing for each system.

Chapter 1 discusses the background and objectives of the project. Chapter 2 discusses the content of the Guide, as well as some critical issues that had to be resolved regarding the scope and functionality of the Guide. Chapter 3 discusses the general layout of the *Online Guide to Luminaire Supports*, the nomenclature for naming luminaire support systems and their components, and guidance on how to use the Guide for finding luminaire systems. This information is important for a user of the Guide. Chapter 4 discusses the basic procedure for gathering and submitting data for inclusion into the *Guide*, including a checklist for the submittal process; guidance for using the *Data Entry Form* to gather data; guidance for submitting data, drawings and photos for components; and guidance for creating and submitting drawings and photos for luminaire support systems. Chapter 5 discusses the basic procedures necessary to

maintain the Guide, including how to use the various administration tools to add new data or to edit existing data to the Guide. The report also includes two Appendices. Appendix A is a stand-alone User's Guide and Appendix B is a stand-alone Data Submission Guide. Both of these documents will be posted on the home page of the *Online Guide to Luminaire Supports* to serve as tutorials for users of the *Guide* and for those wishing to submit luminaire support data for inclusion into the *Guide*.

## ***Background***

AASHTO-ARTBA-AGC Task Force 13 (TF13) has been a strong force in the roadside safety industry for over 30 years. TF13 has accomplished its mission primarily by developing and publishing Guides that essentially serve as catalogs for all types of roadside hardware including guardrails, guardrail terminals, crash cushions, small sign supports, luminaire supports, bridge railings and transitions. These guides have helped to standardize the roadside hardware industry with respect to dimensions and details of common roadside devices. The popular Guide to Standardized Barrier Rail Hardware, the first of the TF13 Guides, was published in 1971 and then updated in 1973 and 1979. [TF13-72; TF13-73; TF13-79] TF13 has also developed Guides for small sign supports, work zone channeling devices, drainage products, bridge railings, general hardware components, transitions and luminaire supports. [TF13-80; TF13-83; TF13-90; TF13-96]

Unfortunately, it became increasingly difficult for the all-volunteer TF13 to manage the publications such that by the late 1980s the TF13 Guides were largely out-of-date. In addition, the States had been directed to switch to SI units and, of course, all the Guides were in United States Customary Units (USCU). New crash testing guidelines appeared in the early 1980s spawning a great deal of innovation and change in the roadside safety hardware industry. All these changes made it imperative for TF13 to update their Guides and find more effective update and distribution procedures. An NCHRP Project was initiated in 1991 to update both the Hardware Guide and the Small Sign Support Guide. [TF13-95] The principal objectives were to survey the states for design details, present materials in SI units and develop an update process to allow for continuous updating. By the end of the project new technology was becoming available to allow for distribution of documents on CDs and also making materials available on the world-wide-web.

While the Task Force attempted to switch from an all-paper guide to digital media, AASHTO was not quite ready for the change in 1996 when project NCHRP 22-10 was completed. At the time there was a great deal of interest in updating both the Sign Guide and the Luminaire Support Guide but neither project proceed due to lack of funding. As an interim informal measure, Ray put both the Hardware Guide and the Sign Guide on the web by simply posting the PDF documents on a webpage. Many TF13 members liked the accessibility of the material on the web and after working with AASHTO and NCHRP over a number of years were able to obtain funding to update the Hardware Guide and put it on the web. In 2005, Ray put the Hardware Guide online as a part of NCHRP 20-7 (196). As a result, the content of the Hardware Guide was greatly expanded to include drawings, photographs, links to manufacturer web pages and FHWA eligibility letters. Also, the whole process of submitting, updating and approving drawings was made an online process including commenting and draft web pages that are visible to all members of the roadside safety community.

Once the power and effectiveness of the web as a distribution and update tool were realized, additional funding was provided by NCHRP for updating and developing an online version of the Bridge Rail Guide, Transition Guide and Small Sign Support Guide. The TF-13 Guides have evolved to include dynamic searchable databases that allow users to search for systems based on the type, material, testing procedures and other features of the system. In addition, the procedure for submitting, reviewing, commenting on and revising the drawings has become much more formalized and takes place almost entirely digitally.

TF13 first published its A Guide to Standardized Highway Lighting Pole Hardware in 1980. A great deal of work was done on luminaire and sign supports in the 1980s: AASHTO published its “Standard Specifications for Structural Supports for Highway Signs, Luminaires and Traffic Signals” in 1985, several NCHRP projects have been performed to up-date the AASHTO Guide and there have been extensive crash testing programs performed by the FHWA and several States.[AASHTO85] The information in the 1980 TF13 Lighting Pole Guide is, therefore long out of date. Much of the information in the 1980 Guide is obsolete and a great deal of material needs to be added or modified to conform to the latest research. In addition, most of the Guides are being presented in dual units whereas the 1980 Lighting Pole Guide is exclusively in USCU.

### ***Objectives***

The objective of this project was to develop an updated, fully-digital, searchable, online Standardized Guide to Lighting Pole Hardware. The experience of TF13 in putting the Hardware, Bridge, Transition and Sign Guides online also demonstrated that a new updated Lighting Pole Hardware Guide should take advantage of the latest advances in technology. It was, therefore, decided that the new Guide should use the same format, procedures and features that the latest TF13 documents were using. Such an online searchable fully-digital Guide would make the information easier to distribute to those who need it and also make it much easier to update and maintain.

## Chapter 2

### Content of the Luminaire Support Guide

To date, the database includes more than 8,000 luminaire configurations, all of which meet the AASHTO “Standard Specification for Structural Supports for Highway Signs, Luminaires and Traffic Signals” and the FHWA eligible requirements for use on federally funded projects. The information page for each luminaire support system configuration provides the system manufacturer, luminaire base manufacturer, FHWA eligibility letter number, material type, base type, test specification, crash test level, mounting height, type of arm, arm length, bolt-circle diameter, and pole dimensions. Also included on the information page are the system drawings, photographs, and links to the detailed component pages for each individual component of the system.

The content of the *Online Guide to Luminaire Supports* was largely driven by the comments and directives of the AASHTO-ARTBA-AGC Task Force 13 Sign and Luminaire Subcommittee. This group, which meets bi-annually, is composed largely of State and Federal DOT personnel and manufactures of sign and luminaire systems. The progress of the Guide’s development was presented to this group at its bi-annual meetings. Some of the relevant issues discussed by this group include:

- Guide content.
- Guide functionality.
- Automated AASHTO Certification within the Guide.

#### ***FHWA Eligibility***

All roadside safety devices, including luminaire supports, installed on Federal-Aid Projects are required to meet the current crash test requirements adopted by the FHWA. In some States, breakaway supports are required to meet FHWA crash-worthy requirements when luminaire structures are located within the “clear zone” for roadways with traffic speed exceeding 40 mph regardless of Federal-Aid status. [MnDOT03]

The first test procedures for testing the crash-worthiness of luminaire support structures were documented in the 1985 AASHTO Standard Specifications for Structural Supports for Highway Signs, Luminaires, and Traffic Signals. [AASHTO85] The test criteria for luminaire supports were essentially unchanged in the 1993 NCHRP Report 350 crash test procedures [Ross03] and thus all luminaire testing done between 1985 and 1993 was considered acceptable under NCHRP Report 350. The current crash test guidelines were published in the AASHTO 2009 *Manual for Assessing Safety Hardware (MASH)*. [AASHTO09]

Until the acceptance of *MASH*, the test criteria were based on “stub height” and occupant impact velocity (i.e., computed based on vehicle velocity change), both of which could be determined via simple pendulum testing without the need for full-scale crash tests. The new procedures maintain these same evaluation criteria for the small car, which have been unchanged since the 1985 testing guidelines; however, new criteria regarding windshield damage and roof-crush have been added in *MASH* which cannot readily be evaluated via simple pendulum tests.

Thus, at-least one full-scale test must be conducted with the test vehicles mandated in *MASH* (i.e., the small car, pickup truck or both) in order to qualify for FHWA eligibility.[AASHTO09]

Traditionally, Task Force 13 Guides have been limited to hardware that has been crash tested and accepted for use on the national highway system by FHWA. This is the policy for the Hardware Guide, the Sign Guide and the Bridge Rail/Transition Guides. Several members of the subcommittee, however, felt that the luminaire guide should also include non-crashworthy items like high-mast poles, ornamental poles, etc. Although it was clear that the group wanted to indicate the acceptance status of any luminaire hardware in the guide, there was some question whether non-accepted hardware should be included. It was later decided that the standard TF13 policy of only including crash tested items or items with FHWA eligibility letters would be followed and that is the policy used in developing the current online guide.

The FHWA eligibility letters are available on the FHWA website at ([http://safety.fhwa.dot.gov/roadway\\_dept/policy\\_guide/road\\_hardware/listing.cfm?code=lumin](http://safety.fhwa.dot.gov/roadway_dept/policy_guide/road_hardware/listing.cfm?code=lumin)). Seventy-two letters have been written since 1988 and are available online. Each system in the online guide has a direct hyperlink to the FHWA eligibility letters.

### ***AASHTO Certification***

The AASHTO Standard has detailed procedures for assessing the service loads of luminaire supports based on the dead loadings, wind loadings, service loads, fatigue, fracture and other aspects of structural design. The AASHTO specifications for signs and luminaire supports were reviewed and several specific pole designs were discussed with manufacturers. It was determined that it was not feasible to incorporate an internal code-check to verify that a particular luminaire configuration conforms to the Standard because essentially all luminaire support systems available today are proprietary and only the manufacturer has the necessary information (e.g., geometry, welding, materials specifications, etc.) to assess a particular product design with respect to the AASHTO specification. However, since manufacturers must certify to States that their designs meet the Standard, it is recommended that manufacturers provide copies of their certification statements to be included in the Guide. The AASHTO Structural Standard is then handled much like the FHWA acceptance letters, in that the material will be available and cataloged in the online guide but the responsibility for doing the certification falls to the manufacturer.

A primary concern in the design of luminaire support system is wind loading (e.g., wind induced shear, bending, torsion and vibrations). The AASHTO standards provide formulas for computing wind pressure loading on luminaire supports and attachments for a specified design wind speed ( $V$ ) based on a 50-year mean recurrence interval, with adjustment factors for different mean recurrence intervals ( $I_r$ ), height and wind exposure effects ( $k_z$ ), wind gust effects ( $G$ ), and wind drag effects (i.e., for various geometric shapes) ( $C_d$ ). Thus, a key parameter in the structural design of a luminaire support system is the Effective Projected Area (EPA) of the luminaire system components that the wind acts upon.

The wind speed map from Figure 3.2 of AASHTO's *Standard Specifications for Structural Supports for Highway Signs, Luminaires and Traffic Signals* (2006) is shown in Figure 2 and Figure 3. This map is based on peak gust data collected at 485 weather stations and from predictions of hurricane speeds on the US Gulf and Atlantic coasts. The map represents the variation of the 3-second gust wind speed over open terrain at a height of 10 m (32.8 ft) for a 50-

year mean recurrence interval. Table 1 shows the EPA ratings for a HAPCO luminaire system (HAPCO catalog number RTA20B6B4) based on the 3-second wind gust speed.

**Table 1. EPA calculations for HAPCO pole RTA20B6B4 using 3-second gust wind speed.**

Max 3-second Wind Gust	70	80	90	100	110	120	130	140	150
Maximum EPA			8.1	6.0	4.7	3.8	3	2.5	2

*Standard Specifications for Structural Supports for Highway Signs, Luminaires and Traffic Signals*

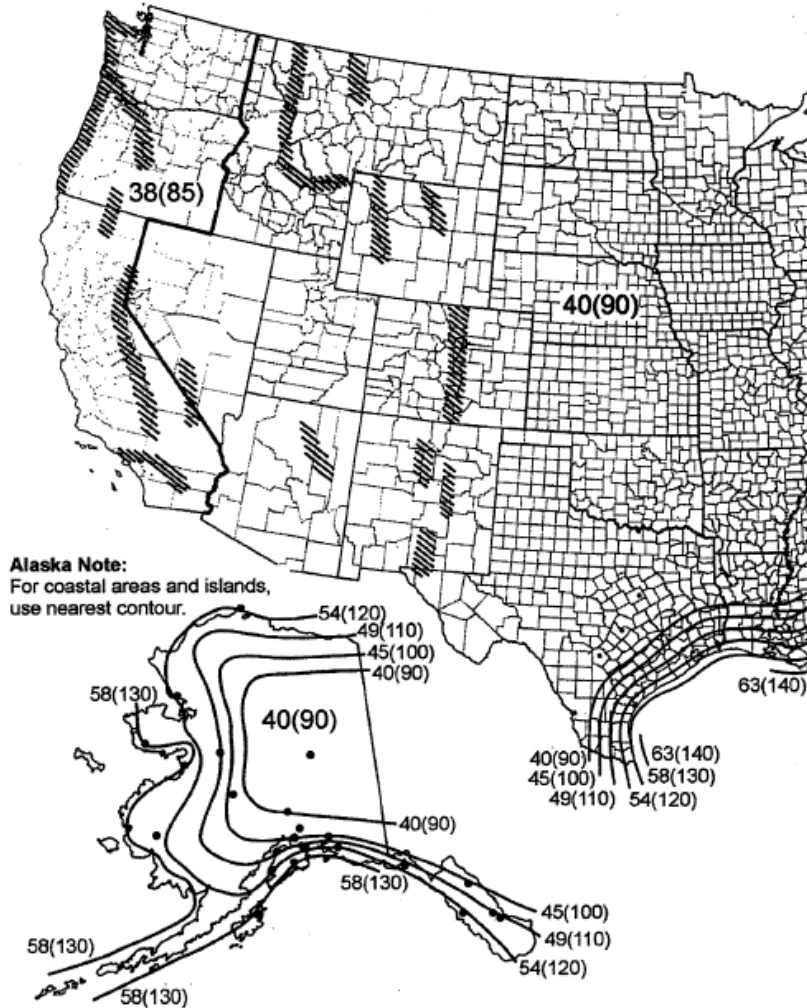
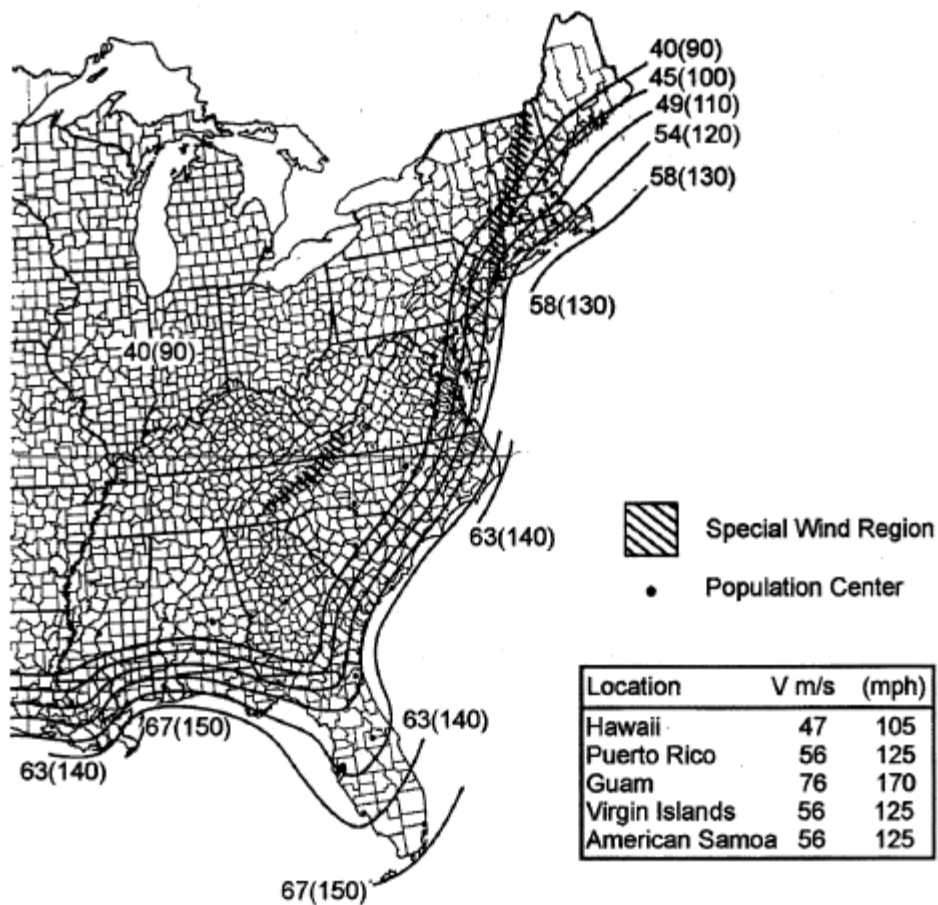

Figure 3-2. Basic Wind Speed, m/s (mph)

Figure 2. Basic wind speed from AASHTO Specifications.[AASHTO09]





Notes:

1. Values are 3-second gust speeds in m/s (mph) at 10 m (32.8 ft) above ground for Exposure C category and are associated with an annual probability of 0.02 (50-year mean recurrence interval).
2. Linear interpolation between wind speed contours is permitted.
3. Islands and coastal areas shall use wind speed contour of coastal area.
4. Mountainous terrain, gorges, ocean promontories, and special wind regions shall be examined for unusual wind conditions

Figure 3-2. Basic Wind Speed, m/s (mph) (continued)

Figure 3. Basic wind speed from AASHTO Specifications (continued).[AASHTO09]

The TF13 subcommittee liked the idea of a designer indicating the design parameters (i.e., the designers specifies things like the pole height, fixture weight, fixture EPA, number and type of arms, bolt circle diameter, and design wind speed) and then having the system search for all combinations of luminaire supports from all manufacturers that satisfy the criteria. For example, In order to accomplish this, the maximum allowable fixture EPA and fixture weight would need to be provided by the manufacturers for each luminaire support configuration.

It was of concern, however, that not all manufacturers compute EPA in exactly the same way; that is, some use may more conservative estimates for the design parameters. For example, the AASHTO standards provide two methods to account for second order bending moment effects caused by axial compressive loading on structural components of the system -- a simplified method and a detailed method. Luminaire systems designed using the simplified method are more conservative than those designed using the detailed method.[AASHTO09]<sup>1</sup> Therefore, if two or more manufacturers offer the exact luminaire system configuration, the one that lists higher EPA values may give a competitive advantage to one manufacturer over another. It is understandable that manufacturers would want to provide conservative EPA values since they must stand behind their own designs, but it is also understandable that they do not want to be penalized for it.

Another issue is that the calculation of maximum fixture EPA for a particular system configuration is dependent on the weight and center of gravity (c.g.) location of the fixture, which is not known prior to discussions with the lighting designers. Unfortunately, there is no standard value for fixture weight (e.g., fixtures may range from 20 lb to 300 lb) or fixture dimensions. For example, maximum fixture EPA computed using a fixture weight of 100 lb will be greater than those computed using a fixture weight of 300 lb.

Therefore, an important issue in the development of the *Guide* was how to achieve consistency in calculating the maximum allowable fixture EPA for each luminaire support configuration based on design wind speed and luminaire fixture weight. As previously mentioned, the research team considered developing an automated procedure within the *Guide* for making such calculations; the basic idea being that if all EPA values in the *Guide* were computed using the same calculation procedures and with the same basic assumptions then a direct comparison of the systems could be made. It was determined, however, that the development of such an automated procedure was not possible since the required information (e.g., geometry, welding, materials specifications, etc.) for the proprietary components of these systems is not readily available. Discussions with manufacturers confirmed that they would rather compute the EPA results themselves than to have a third party make those calculations; however, they also indicated that making such calculations for all eligible luminaire configurations would require significant effort.

On August 24, 2011 a webinar meeting was conducted to demonstrate the functionality of the *Online Guide* to members of the pooled-fund State sponsors. Representatives of five sponsoring State DOTs were in attendance. The objectives of the webinar were to identify problems and general concerns with the *Guide* and to finalize the *Guide*'s content.

---

<sup>1</sup> See commentary for article 4.8 in the AASHTO *Standard Specifications for Structural Supports for Highway Signs, Luminaires and Traffic Signals* (2009)

Of particular importance in the webinar meeting was the issue of whether or not to include the maximum fixture EPA values for each luminaire pole configuration, given the resistance of manufacturers to provide such information. Further, several variables and parameters involved in the calculations for EPA would require standardization to ensure consistency, including:

- Recurrence Interval, which will affect,
  - Wind Importance Factor,  $I_r$ ,
  - Velocity Conversion Factor,  $C_v$ .
- Fixture weight.
- Fixture attachment point and c.g location.

A poll was taken among the participants regarding whether or not to keep the EPA values in the Guide. It was agreed that EPA values based on a standardized parameters would be helpful in getting the designer closer to a final design; however, given that actual design parameters are site specific and that the largest group of users (e.g., city or county lighting designers) are not likely to be knowledgeable of EPA, a decision was made to exclude EPA from the Guide (see poll results in Table 2). This decision was consistent with the consensus of the manufacturers polled at the Spring 2011 TF13 meeting.

**Table 2. Poll results of webinar participants regarding inclusion of EPA values in the Guide**

Poll Question: Keep EPA values in the Guide	
<u>Answers:</u>	<u>Votes</u>
Yes	1
No	3

### **Summary**

The information provided in the *Online Guide to Luminaire Supports* includes system manufacturer, luminaire base manufacturer, FHWA approval letter number, material type, base type, test specification, crash test level, mounting height, type of arm, arm length, bolt-circle diameter, and pole dimensions. Also included are system drawings, photographs, and links to the detailed component pages for each individual component of the system. All systems included in the *Online Guide* meet AASHTO standards and FHWA crashworthiness requirements for eligibility for installation on federally funded projects.

## Chapter 3

### User's Guide

Consistent with the other online guides being developed for Task Force 13 by the project team, the *Online Guide to Luminaire Supports* was developed using the interactive web programming language PHP and the web-based database program MySQL. The *Online Guide to Luminaire Supports* website is also structured similarly to the other online guides such that all the TF13 online guides have the same “look and feel” and present the same type and level of functionality (i.e., search, browsing, contact information, etc.). This chapter is a tutorial on how to use the *On-Line Guide to Luminaire Supports*. It discusses the general layout of the Guide, the nomenclature for naming luminaire support systems and their components, and guidance on how to use the Guide for finding luminaire systems. A stand-alone User's Guide is also included as Appendix A of this report.

#### ***Nomenclature***

The naming convention used in the *Online Guide* is designed to establish a unique name for each luminaire support system and its associated components. The nomenclature is determined according to the category, function, type of the component or system and, indirectly, according to the manufacturer. In some cases additional nomenclature will be used to denote specific variations of a system or component, such as the length, diameter and thickness of a particular luminaire pole. The nomenclature system used for the luminaire guide is similar in structure to that used in all the other TF13 online guides.

#### **Components**

Valid designators for luminaire components are shown in Table 3. The nomenclature consists of three uppercase letters (e.g., LAC01de), two digits ((e.g., LAC01de), and optional alphanumeric characters to further describe the component (e.g., LAC01de). This nomenclature is consistent with style used in the other Guides and easily integrates into the *Online Guide to Components*.

The first letter in the component name identifies the category of the component (i.e., Fastener, Post, Rail, or Luminaire), the next letter denotes the function of the component, (e.g., Pole, Base or Arm) and the third letter provides another level of detail about the component. The next two digits in the nomenclature further identify the component by indicating the order in which the component was entered into the Guide. For example, LAC01de, is the first entry of an aluminum cross arm into the Guide. These designators also serve to indirectly associate the component with a specific manufacturer, and/or a specific make and model of the component. For example, LPA01 and LPA02, are both aluminum poles and, in this case, both made by the same manufacturer; however, LPA01 is a smooth, round, tapered pole whereas LPA02 is a fluted, straight, decorative pole.

The first five characters (e.g., LAC01), therefore, denote the general component name. Additional nomenclature may be used to more clearly define variations of the component, such as variations in dimensions or decorative styles. There is not, however, a separate component

drawing for each variation. Rather, all components with the same prefix (e.g., LAC01) are included on the same drawing.

**Table 3. Nomenclature used for naming luminaire components.**

Category	Function	Type	Sequence No.
<b><u>L</u>uminaire (L)</b>	<b><u>P</u>ole (P)</b>	<b><u>A</u>luminum (A)</b>	01-99
		<b><u>S</u>teel (S)</b>	01-99
		<b><u>P</u>lastic (P)</b>	01-99
		<b><u>C</u>omposite(C )</b>	01-99
		<b><u>O</u>ther (O)</b>	01-99
	<b><u>B</u>ase (B)</b>	Breakaway <b><u>J</u>oint (J)</b>	01-99
		<b><u>S</u>hoebase (S)</b>	01-99
		<b><u>T</u>ransformer (T)</b>	01-99
		Direct <b><u>B</u>uried (B)</b>	01-99
		<b><u>C</u>oupling (C )</b>	01-99
	<b><u>A</u>rm (A)</b>	<b><u>D</u>avitt (D)</b>	01-99
		<b><u>M</u>ast (M)</b>	01-99
		<b><u>T</u>russ (T)</b>	01-99
		<b><u>C</u>ross (C )</b>	01-99
		Teno <b><u>N</u></b> (N)	01-99

### Systems

There are two basic naming conventions for luminaire systems in the Guide: one that denotes the *general system name* and another that denotes the *specific system name*. A specific system refers to a specific luminaire base, pole and arm configuration of a general system that meets FHWA eligibility for use on federally funded projects.

## General Systems Nomenclature

The nomenclature for *general systems* includes five alphanumeric characters, as defined in Table 4. All *system* designators in the TF13 Guides begin with the letter *S*. The second letter identifies the type of system, where *L* denotes a luminaire system. For all luminaire systems, the third letter indicates the type of base that is used, while the last two numeric digits denote the sequence in which a luminaire system with this general base type was entered into the Guide. For example, the general system name SLH01 represents the first entry (**01**) of a Luminaire sHoebase system into the Guide. The information provided on the *general systems* webpages include a summary of the *full range* of system configurations encompassed within the FHWA eligibility letter. More details on the *General Systems* pages will be discussed in section 3.2.

**Table 4. Nomenclature used for General System names for Luminaires.**

Category	Type	Frangible Base	Sequence No.
<u>S</u> ystem (S)	<u>L</u> uminaire (L)	<u>S</u> lip (S)	01-99
		<u>S</u> Hoe (H)	01-99
		<u>T</u> ransformer (T)	01-99
		<u>C</u> oupling (C)	01-99
		Direct <u>B</u> uried (B)	01-99
		Breakaway <u>J</u> oint (J)	01-99
		<u>O</u> ther (O)	01-99

## Specific Systems Nomenclature

The nomenclature for the *specific systems*, on the other hand, is intended to provide key information that sufficiently and uniquely defines each configuration of the parent *general system*. The system nomenclature includes mounting height, base component, pole component with specific dimensions, arm component with additional descriptors, and number of arms, where, for example:

- The first letter denotes that the name corresponds to a System and the second identifies the type of system, such as Luminaire (**SL20/H01/A01-7-4-5/M01b2**).
- The following two numbers define the mounting height of the system (feet) (**SL20/H01/A01-7-4-5/M01b2**).
- The next three alphanumeric characters specify the base component name (**SL20/H01/A01-7-4-5/M01b2**).
- The next three alphanumeric characters specify the general pole component name (**SL20/H01/A01-7-4-5/M01b2**).
- The following three numbers define the pole's base diameter (inches), top diameter (inches), and wall thickness (32<sup>nd</sup> of an inch) (**SL20/H01/A01-7-4-5/M01b2**).
- The next four alphanumeric characters define the arm component name (**SL20/H01/A01-7-4-5/M01b2**).
- The last number defines the number of arms (**SL20/H01/A01-7-4-5/M01b2**).

Figure 4 provides a more detailed annotation of the nomenclature for *Specific Systems* in the Luminaire Support Guide. More details on the *Specific Systems* pages will be discussed in section 3.2.

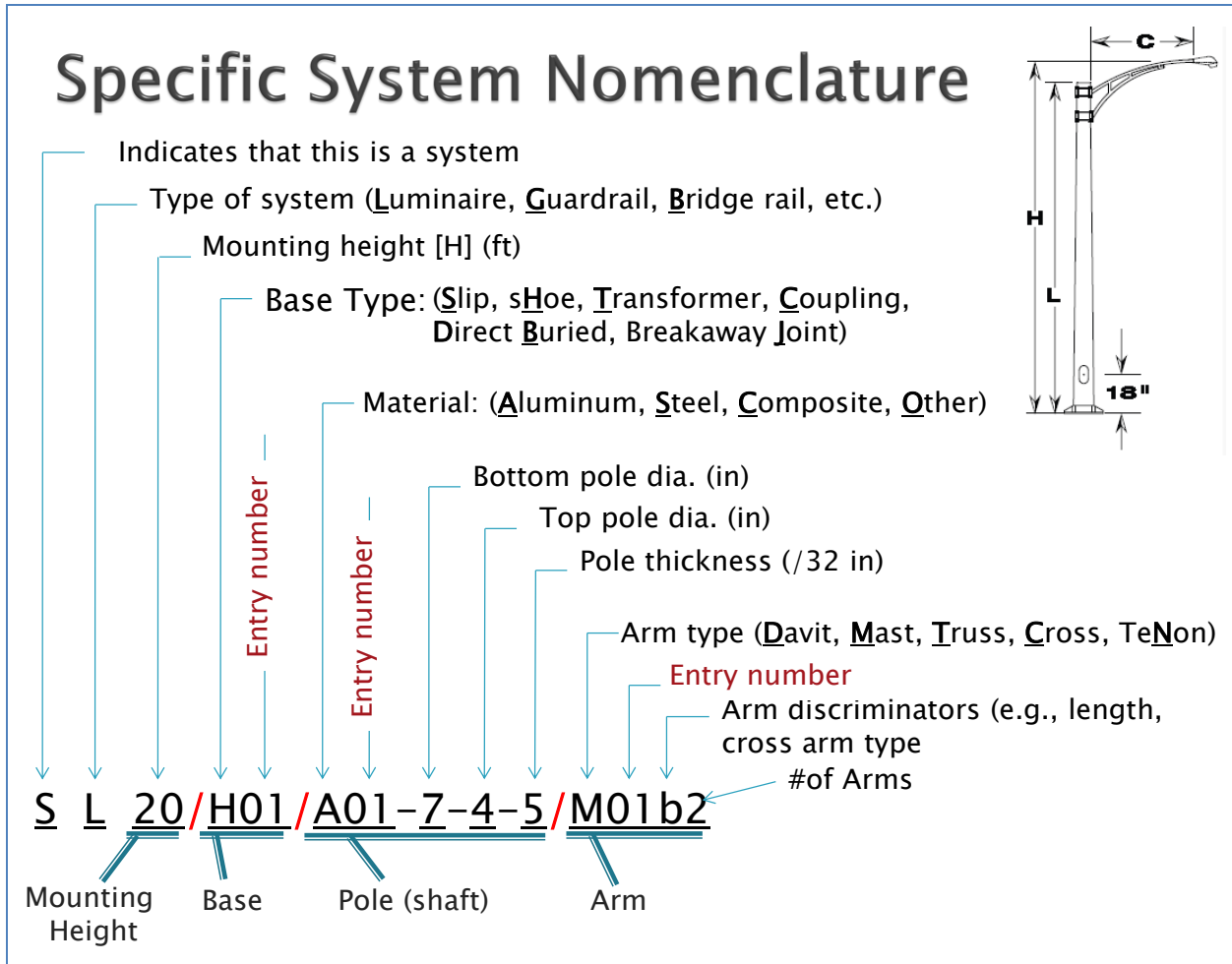
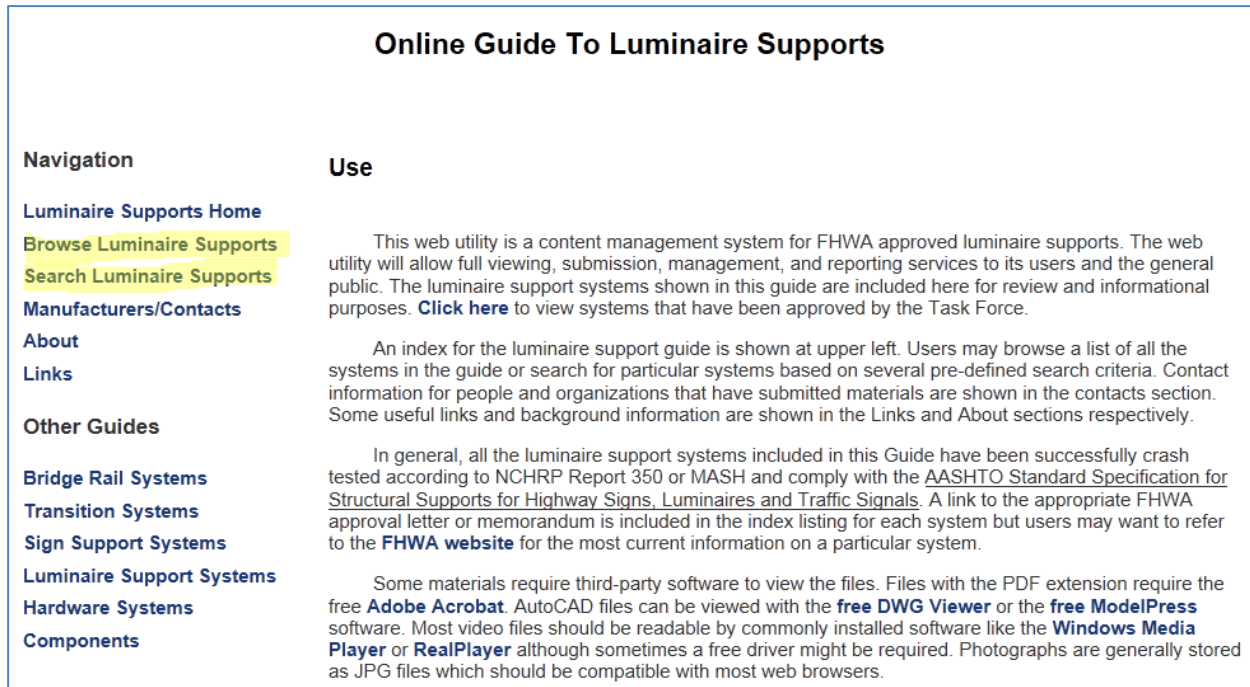

Figure 4. Naming convention for *Specific Systems* in the Luminaire Guide.

### Methods for Searching for Luminaire Support Systems

A portion of the home page for the *Online Guide to Luminaire Supports* is shown in Figure 5. A navigation menu is provided on the left side of the page, as well as links to the other AASHTO Online Guides. There are two ways to search for luminaire systems from the Navigation menu: (1) [Browse Luminaire Supports](#) and (2) [Search Luminaire Supports](#), which are both highlighted in Figure 5. An alternative option for finding luminaire supports is by their [associated components](#).



**Figure 5. Online Guide to Luminaire Supports home page.**

The *Browse Luminaire Supports* option directs the user to a page which contains a list of all luminaire support systems contained in the Guides, denoted by their general system name. The browse option provides a photo of each *general system*, along with other basic information, and thus provides a convenient means for a user to browse the various luminaire support designs in order to narrow their selection. Once a general system has been selected, the *Guide* will provide additional search criteria for identifying all available configurations of the system that meet user-specific design criteria, such as mounting height, bolt-circle diameter, arm type, etc. The *Search Luminaire Supports* option searches all systems in the database to find those that meet user-specified design criteria. This option does not provide thumbnail images; however, it does include all systems corresponding to specified design criteria in a single list. Alternatively, a user can search for luminaire systems directly from a component's webpage. Each of these methods is discussed in detail in the following sections.

### **Browse Luminaire Supports**

When the *Browse Luminaire Supports* option is selected, the user will be directed to a webpage with basic information about the systems, including the *general system* name, number of system configurations, a photograph of the system, the system manufacturer, the base component and manufacture, type of material the system is made from, and the FHWA eligibility letter number, as illustrated in Figure 6. For example, the first system listed on the Browse Luminaire Supports page is SLC01, which is an aluminum luminaire support system manufactured by HAPCO that uses the Precision Form LBC01 coupling base. The SLC01 has 601 different configurations of poles dimensions and arm types that correspond to the system accepted under FHWA eligibility letter LS-23.

The systems listed on the *Browse Page* can be resorted in ascending or descending order with respect to any of the table headings to facilitate the search process. For example, clicking on the



heading “Base Component” will sort the systems in descending alphabetical order with respect to that heading; clicking on the same heading a second time will resort the systems in ascending alphabetical order with respect to that heading. The information in the table also includes links to other pages within the Guide that provide additional information about that particular aspect of the system. For example, clicking on the link for LBC01 directs the user to the LBC01 component page, or clicking on the link for SLC01 directs the user to the general system page for the SLC01 systems.



### Online Guide To Luminaire Supports

#### Navigation

- [Luminaire Supports Home](#)
- [Browse Luminaire Supports](#)
- [Search Luminaire Supports](#)
- [Manufacturers/Contacts](#)
- [About](#)
- [Links](#)
- Other Guides**
- [Bridge Rail Systems](#)
- [Transition Systems](#)
- [Sign Support Systems](#)
- [Luminaire Support Systems](#)
- [Hardware Systems](#)
- [Components](#)

#### Browse Generalized Luminaire Supports

Click on a column heading to arrange the list in order of that luminaire support characteristic.

Name	Photo	BaseComponent	Base Manufacturer	System Manufacturer	Material	FHWAAcceptanceLetter
SLC01 601 configuration (s).		LBC01 Coupling (C)	Precision Form	HAPCO	Aluminum	LS-23.pdf
SLC02 34 configuration (s).	No photo.	LBC02 Coupling (C)	Transpo Industries Inc.	Valmont Industries	Aluminum	LS-45.pdf
SLH01 95 configuration (s).		LBH01 Shoe (H)	HAPCO	HAPCO	Aluminum	LS-27.pdf
SLJ01 77 configuration (s).		LBJ01 Breakaway Joint (J)	HAPCO	HAPCO	Aluminum	LS-65.pdf

**Figure 6. Example of luminaire system information displayed when the *Browse Luminaire Support* option is selected.**

### General System Page

When the link to a particular system name is selected from the Browse Luminaire Supports page, the user will be directed to a General System page that lists all the options for that system. The General System page provides a summary of the complete range of system variables that are encompassed by the FHWA eligibility letter. For example, Figure 7 shows the General System SLH01. The information on the SLH01 webpage shows that there are 95 different configurations of this shoe base system that meet the safety criteria of NCHRP Report 350 according to FHWA letter LS-27. The page lists the manufacturers of the luminaire support system and provides links to supplemental pages with contact information and a list of other systems developed by the manufacture. The General System page also includes photographs, drawings and other associated documents and images related to the luminaire support system.

Another important feature of the General System page is a search option that allows the user to search for configurations of that system that meet specific search criteria, including pole dimensions, bolt circle diameter, arm type, number of arms, and arm length, as shown in Figure

7. For example, in Figure 8 the SLH01 systems are searched to find luminaire support configurations with a 20 foot mounting height and two mast arms. In this case, four configurations were identified and additional descriptive information about each configuration is provided in table format.

### **Specific System Page**

Selecting a system from the search results page (i.e., clicking on the system name) will direct the user to a page which provides a detailed description of the system, as shown in Figure 9; this page also echoes the search criteria. The information on this page includes test specifications, manufacturer catalog number, manufacturer name, system dimensions, a photo of each system component, link to each component page and system drawings.

## SLH01: General System

This page provides only general information about this system. To view the specific configurations of this system, use the search criteria at the bottom of this page. To search through specific configurations of all systems, please use the [Search Luminaires Supports](#) page.

<b>Specific Configurations:</b>	95 specific systems
<b>Acceptance:</b>	Submitted
<b>FHWA Acceptance Letters:</b>	LS-27.pdf
<b>Test Specification:</b>	Report 350
<b>System Manufacturer:</b>	HAPCO
<b>Base Manufacturer:</b>	HAPCO
<b>Base Type:</b>	Shoe (H)
<b>Base Component:</b>	LBH01
<b>Arm Type:</b>	Davit (D) Tenon (N) Cross (C) Mast (M) Truss (T)
<b>Num. of Arms:</b>	0, 1, 2, 3, 4 (arms)
<b>Mounting Height:</b>	20, 25, 30 (feet)
<b>Base Diameter Range:</b>	7.00 to 7.00 (inches)
<b>Top Diameter Range:</b>	4.50 to 7.00 (inches)
<b>Wall Thickness of Pole:</b>	0.156 to 0.188 (inches)
<b>Contact:</b>	<a href="#">Mr. Joe Bowman</a> (Click for details)



Drawings	Other Documents	Images
<ul style="list-style-type: none"> <li>• SLH01.pdf</li> <li>• SLH01.dwg</li> </ul>	<ul style="list-style-type: none"> <li>• Test Report 72785 July 1 1992.pdf</li> <li>• 3-Second Gust Wind Map.pdf</li> <li>• FHWA-Acceptance-Letter_LS-27.pdf</li> </ul>	<ul style="list-style-type: none"> <li>• Thumbnail Gallery</li> </ul>

### Search Specific Configurations of SLH01

Pole/Mounting Height  to  ft  
 Pole Base Diameter  to  in  
 Pole Top Diameter  to  in  
 Pole Thickness  to  in  
 Bolt Circle Diameter   
 Arm Type  ▾  
 Number of Arms   
 Arm Length  to  in

**Figure 7. General System Page for SLH01.**

## Search Specific Configurations of SLH01

Pole/Mounting Height  to  ft

Pole Base Diameter  to  in

Pole Top Diameter  to  in

Pole Thickness  to  in

Bolt Circle Diameter

Arm Type

Number of Arms

Arm Length  to  in

*Click on a column heading to arrange the list in order of that luminaire characteristic.*

Name/Designator	Mounting Height (ft)	Base Type	Material	Pole Base Dia. (in)	Pole Thickness (in)	Num. Arms	Arm Type	Arm Length (ft)
SL20/H01/A01-7-4.5-5/M01b2	20	Shoe (H)	Aluminum	7.00	0.156	2	Mast (M)	6' 0"
SL20/H01/A01-7-4.5-5/M01c2	20	Shoe (H)	Aluminum	7.00	0.156	2	Mast (M)	8' 0"
SL20/H01/A01-7-4.5-6/M01b2	20	Shoe (H)	Aluminum	7.00	0.188	2	Mast (M)	6' 0"
SL20/H01/A01-7-4.5-6/M01c2	20	Shoe (H)	Aluminum	7.00	0.188	2	Mast (M)	8' 0"

**Figure 8. Example results from a search of the SLH01 systems that have a maximum mounting height of 20 ft and two mast arms.**

## Online Guide To Luminaire Supports

### Navigation

- [Luminaire Supports Home](#)
- [Browse Luminaire Supports](#)
- [Search Luminaire Supports](#)
- [Manufacturers/Contacts](#)
- [About](#)
- [Links](#)





### Other Guides

- [Bridge Rail Systems](#)
- [Transition Systems](#)
- [Sign Support Systems](#)
- [Luminaire Support Systems](#)
- [Hardware Systems](#)
- [Components](#)

### SL20/H01/A01-7-4.5-6/M01b2 (SLH01)

Aluminum Shoe Base with 20 ft Mtg. Ht. and 2 Mast Arms

Acceptance:	Submitted	
Test Level:	TL-3	
Test Specification:	Report 350	
Manufacturer's Catalog #:	Not Provided	
System Manufacturer:	<a href="#">HAPCO</a>	
Base Manufacturer:	<a href="#">HAPCO</a>	
Base Type:	Shoe (H)	
Arm Type:	Mast (M)	
Arm Length:	6' 0" (feet)	
Num. of Arms:	2 (arms)	
Material:	Aluminum	
Mounting Height:	20 (feet)	
Bolt Circle Diameter:	10.00 to 11.00 (inches)	
Pole Length:	N/A	<i>Not searchable.</i>
Pole Base Diameter:	7.00 (inches)	
Pole Top Diameter:	4.50 (inches)	
Wall Thickness of Pole:	0.188 (inches)	<i>Not searchable.</i>
Contact:	<a href="#">Mr. Joe Bowman</a>	<i>Not searchable.</i>
Last Updated:	September 5, 2012	<i>Not searchable.</i>
FHWA Acceptance Letters:	<a href="#">Letter LS27</a>	<i>Not searchable.</i>

General System	Base Component	Pole Component	Arm Component
<a href="#">SLH01</a> 	<a href="#">LBH01</a> 	<a href="#">LPA01-x-7-4.5-6</a> 	<a href="#">LAM01b</a> 
<b>Drawings</b> <ul style="list-style-type: none"> <li>• <a href="#">SLH01.pdf</a></li> <li>• <a href="#">SLH01.dwg</a></li> </ul>		<b>Other Documents</b> <ul style="list-style-type: none"> <li>• <a href="#">Test Report 72785 July 1 1992.pdf</a></li> <li>• <a href="#">3-Second Gust Wind Map.pdf</a></li> <li>• <a href="#">FHWA-Acceptance-Letter_LS-27.pdf</a></li> </ul>	

**Figure 9. Webpage displaying details for luminaire support configuration SL20/H01/A01-7-4-5/M01b2.**

## Search Luminaire Supports

The *Search Luminaire Supports* Option, located on the left hand side of the webpage in the Navigation List, allows the user to search through the entire database for luminaire support system configurations that meet specific search criteria. The search options included with this feature are shown in Figure 10, which include the search options shown previously on the *General System* page (refer to Figure 7), plus several additional search options including test specification, manufacture, material type, and base type. Using *Search Luminaire Supports* Option to search for systems based on the same search criteria specified in the previous example (refer to Figure 8) results in over 30 luminaire support configurations, as shown in Figure 11 (note that results are abridged). Included in this list is the subset of SLH01 systems that were identified in the previous search via the SLH01 General System page illustrated in Figure 8.

### Online Guide To Luminaire Supports

**Navigation**

- [Luminaire Supports Home](#)
- [Browse Luminaire Supports](#)
- [Search Luminaire Supports](#)
- [Manufacturers/Contacts](#)
- [About](#)
- [Links](#)
- Other Guides**
- [Bridge Rail Systems](#)
- [Transition Systems](#)
- [Sign Support Systems](#)
- [Luminaire Support Systems](#)
- [Hardware Systems](#)
- [Components](#)

### Search Luminaire Supports

Acceptance	<input type="text" value="Any Type"/>	<input type="button" value="v"/>
Test Specification	<input type="text" value="Any Type"/>	<input type="button" value="v"/>
System Manufacturer	<input type="text" value="Any Manufacturer"/>	<input type="button" value="v"/>
Base Manufacturer	<input type="text" value="Any Manufacturer"/>	<input type="button" value="v"/>
Material	<input type="text" value="Any Material"/>	<input type="button" value="v"/>
Base Type	<input type="text" value="Any Base Type"/>	<input type="button" value="v"/>
Pole/Mounting Height	<input type="text" value="Minimum"/> to <input type="text" value="20"/>	ft
Pole Base Diameter	<input type="text" value="Minimum"/> to <input type="text" value="Maximum"/>	in
Pole Top Diameter	<input type="text" value="Minimum"/> to <input type="text" value="Maximum"/>	in
Pole Thickness	<input type="text" value="Minimum"/> to <input type="text" value="Maximum"/>	in
Bolt Circle Diameter	<input type="text" value="Any"/>	in
Arm Type	<input type="text" value="Mast (M)"/>	<input type="button" value="v"/>
Number of Arms	<input type="text" value="2"/>	<input type="button" value="v"/>
Arm Length	<input type="text" value="Minimum"/> to <input type="text" value="Maximum"/>	<input type="text" value="Feet"/> <input type="button" value="v"/>

[Show advanced search options](#)

Figure 10. Search Luminaire Systems page.

## Online Guide To Luminaire Supports

### Navigation

- Luminaire Supports Home
- Browse Luminaire Supports
- Search Luminaire Supports
- Manufacturers/Contacts
- About
- Links
- Other Guides
  - Bridge Rail Systems
  - Transition Systems
  - Sign Support Systems
  - Luminaire Support Systems
  - Hardware Systems
  - Components

### Search Luminaire Supports

Acceptance:    
 Test Specification:    
 System Manufacturer:    
 Base Manufacturer:    
 Material:    
 Base Type:    
 Pole/Mounting Height: Minimum  to  ft   
 Pole Base Diameter: Minimum  to Maximum  in   
 Pole Top Diameter: Minimum  to Maximum  in   
 Pole Thickness: Minimum  to Maximum  in   
 Bolt Circle Diameter:  in   
 Arm Type:    
 Number of Arms:    
 Arm Length: Minimum  to Maximum  Feet

Show advanced search options

Click on a column heading to arrange the list in order of that luminaire support characteristic.

Subset of systems identified in previous example

Name/Designator	System Manufacturer	Mounting Height (ft)	Base Type	Material	Pole Base Dia. (in)	Pole Thickness (in)	Num. Arms	Arm Type	Arm Length (ft)
SL20/T07/A03-7-4-6/M02b2	Valmont Industries	20	Transformer (T)	Aluminum	7.00	0.188	2	Mast (M)	8' 0"
SL20/T07/A03-7-4-5/M02c2	Valmont Industries	20	Transformer (T)	Aluminum	7.00	0.156	2	Mast (M)	8' 0"
SL20/T07/A03-7-4-6/M02c2	Valmont Industries	20	Transformer (T)	Aluminum	7.00	0.188	2	Mast (M)	8' 0"
SL20/T07/A03-7-4-6/M02b2	Valmont Industries	20	Transformer (T)	Aluminum	7.00	0.188	2	Mast (M)	8' 0"
SL20/T07/A03-7-4-6/M02c2	Valmont Industries	20	Transformer (T)	Aluminum	7.00	0.188	2	Mast (M)	8' 0"
SL20/T07/A03-7-4-5/M02b2	Valmont Industries	20	Transformer (T)	Aluminum	7.00	0.156	2	Mast (M)	8' 0"
SL20/T07/A03-7-4-5/M02c2	Valmont Industries	20	Transformer (T)	Aluminum	7.00	0.156	2	Mast (M)	8' 0"
SL20/T07/A03-7-4-5/M02b2	Valmont Industries	20	Transformer (T)	Aluminum	7.00	0.156	2	Mast (M)	8' 0"
SL20/H01/A01-7-4.5-6/M01b2	HAPCO	20	Shoe (H)	Aluminum	7.00	0.188	2	Mast (M)	8' 0"
SL20/H01/A01-7-4.5-6/M01c2	HAPCO	20	Shoe (H)	Aluminum	7.00	0.188	2	Mast (M)	8' 0"
SL20/H01/A01-7-4.5-5/M01b2	HAPCO	20	Shoe (H)	Aluminum	7.00	0.156	2	Mast (M)	8' 0"
SL20/H01/A01-7-4.5-5/M01c2	HAPCO	20	Shoe (H)	Aluminum	7.00	0.156	2	Mast (M)	8' 0"
SL20/C01/A01-6-4.5-5/M01c2	HAPCO	20	Coupling (C)	Aluminum	6.00	0.156	2	Mast (M)	8' 0"
SL20/C02/A03-7-4-5/M02c2	Valmont Industries	20	Coupling (C)	Aluminum	7.00	0.156	2	Mast (M)	8' 0"
SL20/C01/A01-6-4.5-6/M01c2	HAPCO	20	Coupling (C)	Aluminum	6.00	0.188	2	Mast (M)	8' 0"
SL20/C01/A01-7-4.5-5/M01b2	HAPCO	20	Coupling (C)	Aluminum	7.00	0.156	2	Mast (M)	8' 0"
SL20/C02/A03-7-4-6/M02b2	Valmont Industries	20	Coupling (C)	Aluminum	7.00	0.188	2	Mast (M)	8' 0"
SL20/C01/A01-7-4.5-6/M01b2	HAPCO	20	Coupling (C)	Aluminum	7.00	0.188	2	Mast (M)	8' 0"
SL20/C01/A01-7-4.5-5/M01c2	HAPCO	20	Coupling (C)	Aluminum	7.00	0.156	2	Mast (M)	8' 0"
SL20/C02/A03-7-4-6/M02c2	Valmont Industries	20	Coupling (C)	Aluminum	7.00	0.188	2	Mast (M)	8' 0"

**Figure 11. Partial results using *Search Luminaire Supports* option to find systems with 20-ft mounting height and two mast arms.**

## Advanced Search Criteria

Also included on the *Search Luminaire Supports* page is an *Advanced Search Option* which allows users to search for systems that include a specific base component, pole component, arm component, or any combination thereof. For example, a search for systems with a double cross-arm, a mounting height of 12-ft, and a bolt-circle diameter of 7 inches results in a relatively large number of configurations. However, if after reviewing the configurations, it is determined that a particular base type, arm type, and/or pole type is of interest, the search can be further refined to include only systems with those particular components. Figure 12 shows the results of using the advanced options to restrict the search to systems with base component LBT01, pole component LPA02 and arm component LAC02.

Online Guide To Luminaire Supports

**Navigation**

[Luminaire Supports Home](#)  
[Browse Luminaire Supports](#)  
[Search Luminaire Supports](#)  
[Manufacturers/Contacts](#)  
[About](#)  
[Links](#)

**Other Guides**

[Bridge Rail Systems](#)  
[Transition Systems](#)  
[Sign Support Systems](#)  
[Luminaire Support Systems](#)  
[Hardware Systems](#)  
[Components](#)

**Search Luminaire Supports**

Acceptance:    
 Test Specification:    
 System Manufacturer:    
 Base Manufacturer:    
 Material:    
 Base Type:    
 Pole/Mounting Height:  to  ft  
 Pole Base Diameter:  to  in  
 Pole Top Diameter:  to  in  
 Pole Thickness:  to  in  
 Bolt Circle Diameter:  in  
 Arm Type:    
 Number of Arms:   
 Arm Length:  to  Feet

Base Component Name:  (e.g., LBS99)  
 Pole Component Name:  (e.g., LPA99)  
 Arm Component Name:  (e.g., LAT99)

**LPA02**



**LBT01**



**LAC02**

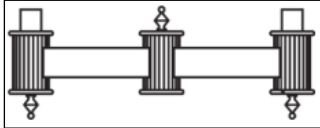

Click on a column heading to arrange the list in order of that luminaire support characteristic.

Name/Designator	System Manufacturer	Mounting Height (ft)	Base Type	Material	Pole Base Dia. (in)	Pole Thickness (in)	Num. Arms	Arm Type	Arm Length (ft)
SL12/T01/A02-4-4-4/C02d	HAPCO	12	Transformer (T)	Aluminum	4.00	0.125	2	Cross (C)	3' 0"
SL12/T01/A02-5-4.1-4/C02d	HAPCO	12	Transformer (T)	Aluminum	5.00	0.125	2	Cross (C)	3' 0"
SL12/T01/A02-5-4.1-6/C02d	HAPCO	12	Transformer (T)	Aluminum	5.00	0.188	2	Cross (C)	3' 0"
SL12/T01/A02-5-5-4/C02d	HAPCO	12	Transformer (T)	Aluminum	5.00	0.125	2	Cross (C)	3' 0"
SL12/T01/A02-5-5-6/C02d	HAPCO	12	Transformer (T)	Aluminum	5.00	0.188	2	Cross (C)	3' 0"

**Figure 12. Example of using the *Advanced Search Options* on the *Search Luminaire Supports* page.**

22



## Search Based on Associated Components

As mentioned previously, detailed information pertaining to any component of a luminaire support system can be viewed by clicking on the component name on the luminaire system webpage (refer to Figure 9). The user is then directed to the component webpage which provides the manufacturer's name and contact information, a photo of the component, drawing files, other documents related to the component (e.g., brochures, FHWA eligibility letter, etc.), a link to the photo gallery, and a list of all the systems that utilize the component. For example, Figure 13 shows the information provided on the component webpage for component LBT07 (i.e., the Modified TB1-17 transformer base manufactured by Akron Foundry). Currently, no drawing files have been submitted for this component, but other documents are available, as well as photos of the component. At the lower, right-side of the page is a list of systems that use this component; in this case, luminaire support system SLT07. Clicking on the system name (e.g., SLT07) will direct the user to the webpage for the *general system*.

Alternatively, a user can search for components directly from the *Online Guide to Components* webpage by selecting "Components" under the "Other Guides" menu list shown on the lower-left-side of any webpage in the Guide (e.g., refer to Figure 13). This link directs the user to the home page for the components guide, as shown in Figure 14.

The options and procedures for searching luminaire components are analogous to those for search luminaire support systems discussed earlier, that is via the *Browse Components* and *Search Components* links under the *Navigation* menu. The *Browse Components* option directs the user to a page which contains a list of all components contained in the Guides, as shown in Figure 15, and provides basic information about each one including the component name, a general description, a photo, and the Category/Function/Type designators (e.g., refer to the [Nomenclature](#) section of this tutorial).

The *Search Components* page provides four search options, as shown in Figure 16. The first three options are "relational" and thus must be entered in order. In other words, a component's *function* will depend on the *category* that is selected; likewise, the component *type* will depend on its *category* and *function* (refer to A simple example illustrating the search for luminaire transformer bases is shown in Figure 17 and Figure 18. When the search is executed, the Guide will display all the components that meet the search criteria, using the same format as was shown in Figure 15 from the *Browse Component* results.

## Online Guide To Components

### Navigation

[Components Home](#)  
[Browse Components](#)  
[Search Components](#)  
[Contacts](#)  
[About](#)  
[Links](#)

### Other Guides

[Bridge Rail Systems](#)  
[Transition Systems](#)  
[Sign Support Systems](#)  
[Luminaire Support Systems](#)  
[Hardware Systems](#)  
[Components](#)

### Akron Foundry Modified TB1-17 Transformer Base (LBT07)

Category:	Luminaire (L)
Function:	Frangible Base (B)
Type:	Transformer (T)
Manufacturer:	Akron Foundry Company
Contact:	<a href="#">Robert A. Sik (Click for details)</a>
Last Updated:	August 26, 2010



Drawings	Other Documents	Images	Systems
No files found.	<ul style="list-style-type: none"><li><a href="#">Break_Trns_Brochure [1].pdf</a></li><li><a href="#">ls58.pdf</a></li></ul>	<ul style="list-style-type: none"><li><a href="#">Thumbnail Gallery</a></li></ul>	<b>Luminaire Systems</b> <ul style="list-style-type: none"><li>SLT07</li></ul> <b>Sign Systems</b> <ul style="list-style-type: none"><li>None</li></ul> <b>Transitions</b> <ul style="list-style-type: none"><li>None</li></ul>

### Existing Comments

Click [here](#) to post a new comment.

There are no comments for this system yet.

Figure 13. Component webpage.

# Online Guide To Components

## Navigation

- Components Home
- Browse Components
- Search Components
- Contacts
- About
- Links

## Other Guides

- Bridge Rail Systems
- Transition Systems
- Sign Support Systems
- Luminaire Support Systems
- Hardware Systems
- Components

## Welcome to the Online Guide to Components!

This page will eventually have some content and serve as the home page for the components guide.

Figure 14. *Online Guide to Components* home page.

## Online Guide To Components

### Navigation

[Components Home](#)  
[Browse Components](#)  
[Search Components](#)  
[Contacts](#)  
[About](#)  
[Links](#)

### Other Guides

[Bridge Rail Systems](#)  
[Transition Systems](#)  
[Sign Support Systems](#)  
[Luminaire Support Systems](#)  
[Hardware Systems](#)  
[Components](#)

### Browse Components

*Click on a column heading to arrange the list in order of that component characteristic.*

Name/Designator	Photo	Category	Function	Type	Manufacturer
<b>FBB01-05</b> Guardrail Bolt and Recessed Nut		Fastener (F)	Bolt (B)		
<b>FBX06a-24</b> Class 4.6 Hex Bolt and Nut		Fastener (F)	Bolt (B)	Hex (X)	
<b>FLS01</b> Dent Universal Base System		Fastener (F)	Plate (L)	Slipbase (S)	<b>Dent Breakaway Industries</b>
<b>FMA01</b> TRANSPO Anchor		Fastener (F)	Misc Fastener (M)	Anchor (A)	<b>TRANSPO Industries, Inc.</b>
<b>FMC01</b> SNAP'n SAFE Round Post Ground-Mount Coupler		Fastener (F)	Misc Fastener (M)	Coupling (C)	<b>Designovations</b>
<b>FMC02</b> SNAP'n SAFE Round Post Surface Mounted Coupler		Fastener (F)	Misc Fastener (M)	Coupling (C)	<b>Designovations</b>
<b>FMC03</b> SNAP'n SAFE U		Fastener (F)	Misc Fastener	Coupling (C)	<b>Designovations</b>

**Figure 15. Browse Components Page.**

<b>Navigation</b>	<b>Search Components</b>
<a href="#">Components Home</a>	Category <input type="text" value="Any Category"/>
<a href="#">Browse Components</a>	Function <input type="text" value="Any Function"/>
<a href="#">Search Components</a>	Type <input type="text" value="Any Type"/>
<a href="#">Contacts</a>	Manufacturer <input type="text" value="Any Manufacturer"/>
<a href="#">About</a>	<input type="button" value="Search"/>
<a href="#">Links</a>	
<b>Other Guides</b>	
<a href="#">Bridge Rail Systems</a>	
<a href="#">Transition Systems</a>	
<a href="#">Sign Support Systems</a>	
<a href="#">Luminaire Support Systems</a>	
<a href="#">Hardware Systems</a>	
<a href="#">Components</a>	

**Figure 16. Search Components page.**

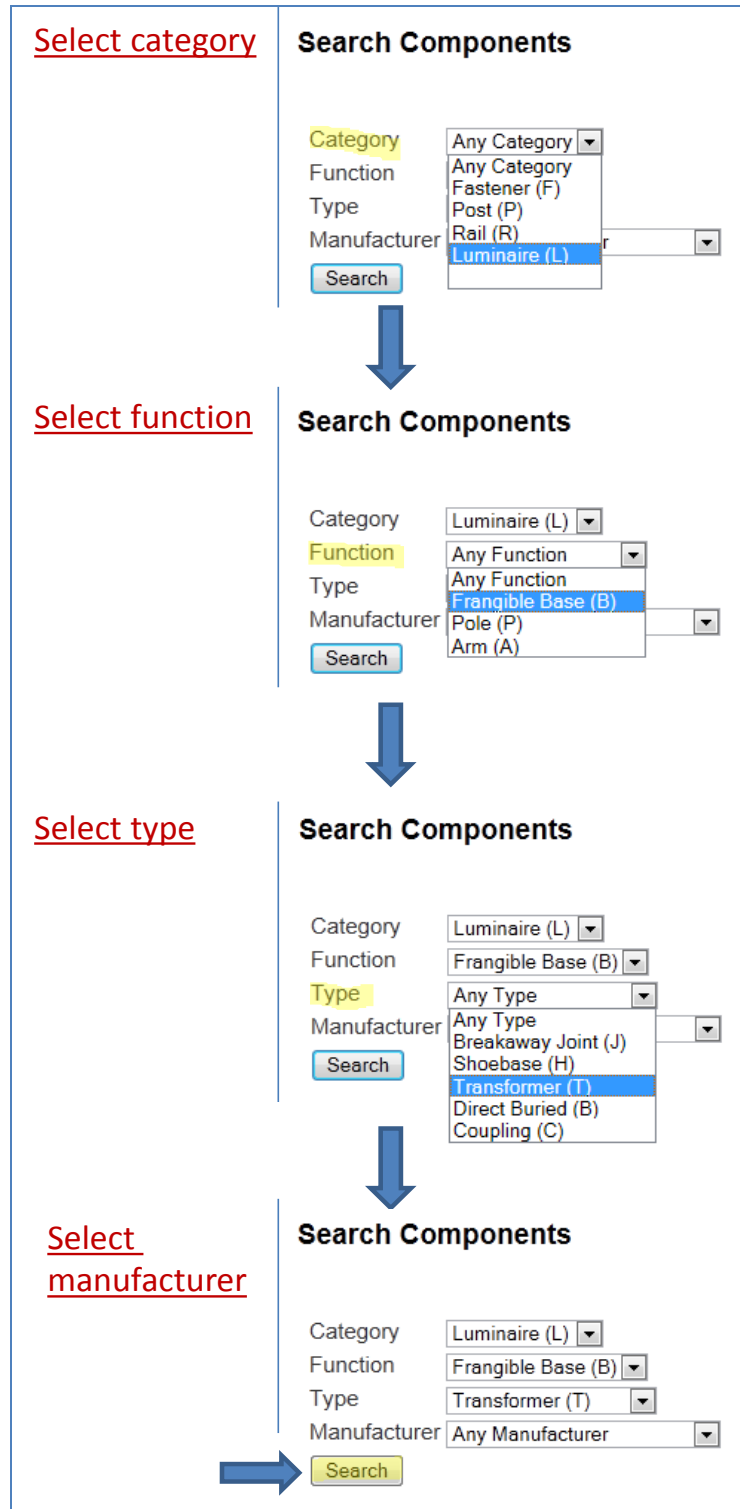

**Figure 17. Search option example for finding luminaire transformer bases components.**

NameDesignator	Photo	Category	Function	Type	Manufacturer
LBT01 HAPCO Decorative GEORGETOWN Transformer Base [GES]		Luminaire (L)	Frangible Base (B)	Transformer (T)	HAPCO
LBT03 HAPCO Decorative ARLEN Transformer Base		Luminaire (L)	Frangible Base (B)	Transformer (T)	HAPCO
LBT04 HAPCO Decorative YORK Transformer Base [Y7S]		Luminaire (L)	Frangible Base (B)	Transformer (T)	HAPCO
LBT05 HAPCO Decorative GRAND Transformer Base [GR5]		Luminaire (L)	Frangible Base (B)	Transformer (T)	HAPCO
LBT06 HAPCO Decorative WINCHESTER Transformer base [W5S]		Luminaire (L)	Frangible Base (B)	Transformer (T)	HAPCO
LBT07 Akron Foundry Modified TB1-17 Transformer Base		Luminaire (L)	Frangible Base (B)	Transformer (T)	Akron Foundry Company
LBT08 Akron Foundry TB1-17 Transformer Base		Luminaire (L)	Frangible Base (B)	Transformer (T)	Akron Foundry Company
LBT09 Akron Foundry TB2-17 Transformer Base		Luminaire (L)	Frangible Base (B)	Transformer (T)	Akron Foundry Company
LBT10 Akron Foundry TB3-17 Transformer Base		Luminaire (L)	Frangible Base (B)	Transformer (T)	Akron Foundry Company

**Figure 18. Partial results from search for luminaire transformer base components using the Search Components option.**

## Chapter 4

### Procedures for Data Submission

The following sections discuss the basic procedure for gathering and submitting data for inclusion into the *Online Guide*, including a checklist for the submittal process; guidance for entering data into the *Data Entry Form*; guidance for submitting data, drawings and photos for components; and guidance for creating and submitting drawings and photos for luminaire support systems. A stand-alone Data Submission Guide is also included in Appendix B of this report.

A key contact in submitting the data is the administrator for the guide. Using the usual Task Force 13 procedures, the administrator is one of the co-chairs of the subcommittee in charge of each guide; in this case the luminaire guide is managed by subcommittee #5, Support Hardware. The contact information for the current co-chairs can be found on the Task Force 13 website, <http://www.aashtotf13.org>.

#### *Basic Process*

- Verify that your company's contact information is listed in the *Online Guide's* [Manufacturers/Contacts](#) page.
  - If the contact information is not listed, then submit the following information to the administrator of the *Online Guide*:
    - Organization
    - Contact name
    - E-Mail address.
    - Business address.
    - Phone number.
    - Company website.
- Verify that each component (i.e., base, shaft, and arm) of the luminaire support system being submitted is listed in the [Online Guide to Components](#).
  - If a component is not listed: Submit component information to the Guide's administrator and obtain AASHTO-AGC-ARTBA designator for the component, including:
    - Component manufacturer.
    - Contact Information for manufacturer.
    - Component drawings.
    - Component photos.
    - Any additional information you wish to be included (e.g., test reports, manufacturer's drawings, brochure, etc.).
- Download and complete the Data-Entry-Form at <http://guides.roadsafellc.com/luminaireGuide/DataEntryForm.xlsx> and submit the file to the administrator of the *Online Guide*.



- Submit drawings and photos of the overall luminaire support system to the administrator of the *Online Guide*.

### **Data Entry Form**

The data in the *Online Guide* includes: luminaire system manufacturer, luminaire base manufacturer, FHWA approval letter number, crash test specification, crash test level, material type, TF13 base component, base type, TF13 pole component, mounting height, pole dimensions, TF13 arm component, arm type, arm length, number of arms, and bolt-circle diameter. This data must be provided by the manufacturer and must be in the correct format. To aid in the data collection and submission effort, an Excel Workbook, named Data-Entry-Form.xlsx, can be downloaded from the following link: <http://guides.roadsafellc.com/luminaireGuide/DataEntryForm.xlsx>. The workbook serves as a template for data entry and contains some example content, which corresponds to a Valmont Industries luminaire support system. The data in the template file should be deleted (or overwritten) and replaced with the new luminaire system data. Figure 19 through Figure 21 show the types of data that are to be provided in each column of the Data-Entry-Form.

Each row in the data file corresponds to a specific luminaire support configuration (i.e., pole, base and arm). For many data columns, only certain values are permissible for data entry. In those cases, a pull-down menu is provided for convenience and, more importantly, to ensure that the data entry is valid. These columns are denoted in the data entry template by rose-colored cells, as shown in Figure 19 through Figure 21. Each of the data entries are discussed in more detail in the Data Submission Guide (i.e., Chapter 4).

	A	B	C	D	E	F
1					<b>OPTIONS</b>	<b>OPTIONS</b>
2					Report 230	1 (e.g., TL1)
3					Report 350	2 (e.g., TL2)
4					MASH	3 (e.g., TL3)
5						
6						
7						
8						
9		<b>Per Manufacturers Catalog</b>		<b>FHWA Qualification Letter</b>		
10	<b>System Manufacturer</b>	<b>Manufacturer's Base Component Name</b>	<b>Manufacturer's Catalog Number for System</b>	<b>FHWA Letter No.</b>	<b>Test Specs</b>	<b>Crash Test Level</b>
11	Valmont Industries	TB1-17 Modified	190840705T4	LS15	Report 350	3
12	Valmont Industries	TB1-17 Modified	170840705T4	LS15	Report 350	3
13	Valmont Industries	TB1-17 Modified	170840705T4	LS15	Report 350	3
14	Valmont Industries	TB1-17 Modified	20007520D4	LS15	Report 350	3

**Figure 19. Data-Entry-Form.xlsx – columns A through F.**

	G	H	I	J	K	L	M	N	O
1	<b>OPTIONS</b>	<b>OPTIONS</b>	<b>OPTIONS</b>	<b>OPTIONS</b>	<b>OPTIONS</b>				<b>OPTIONS</b>
2	Aluminum	- Existing name	Slip	- Existing name	12,13,14,15				1 (e.g., 1/32)
3	Steel	(e.g., LBT99)	Transformer	(e.g., LBT99)	16,18,20,25				2 (e.g., 2/32)
4	Composite	- New	Shoe	- New	30,35,40,45				3 (e.g., 3/32)
5	Other		Coupling		50, ...				4 (e.g., 4/32)
6			Direct Buried						...
7			Breakaway Joint						16 (e.g., 1/2)
8			Other						
9	<b>Frangible Base</b>			<b>Pole/Shaft</b>					
10	<b>Material</b>	<a href="#">AASHTO General Component Name</a>	<b>Luminaire Base Type</b>	<a href="#">AASHTO General Component Name</a>	<b>Mounting Height (ft)</b>	<b>(Optional) Shaft Length (ft)</b>	<b>Butt Diameter (in)</b>	<b>Top Diameter (in)</b>	<b>Wall Thickness (* /32 in)</b>
11	Aluminum	LBT07	Transformer	LPA03	20	19.67	7	4.5	5.000
12	Aluminum	LBT07	Transformer	LPA03	20	17.67	7	4	5.000
13	Aluminum	LBT07	Transformer	LPA03	20	17.67	7	4	5.000
14	Aluminum	LBT07	Transformer	LPA03	20	13.5	7	4	5.000

Figure 20. Data-Entry-Form.xlsx – Columns G through O.

	P	Q	R	S	T	U
1	<b>OPTIONS</b>	<b>OPTIONS</b>				
2	- Existing name	None				
3	(e.g., LBT99)	Mast				
4	- New	Truss				
5		Davit				
6		Cross				
7		Tenon				
8		Other				
9	<b>Arm</b>			<b>Bolt Circle Diameter</b>		
10	<a href="#">AASHTO General Component Name</a>	<b>Arm Type</b>	<b>Arm Length (in)</b>	<b>Num. of Arms</b>	<b>min (in)</b>	<b>max (in)</b>
11		None		0	10	12.5
12	LAM02	Mast	72	2	10	12.5
13	LAM02	Mast	96	2	10	12.5
14	LAD02	Davit	48	2	10	12.5

Figure 21. Data-Entry-Form.xlsx – Columns P through U.

### *Procedure for Submitting Component Drawings and Photos*

In order for a component to be included in the *Online Guide to Components*, it must be associated with one or more of the highway hardware systems listed in the Online Guides (i.e., bridge rail, transition, sign support, luminaire support, or hardware systems). To request inclusion of a component, please submit the following information to the administrator of the Guides:

- Component manufacturer.
- Contact Information for manufacturer.

- Component drawings.
- Component photos.
- Any additional information you wish to be included (e.g., test reports, manufacturer’s drawings, brochure, etc.).

A web-page for the component will be created and the component will be assigned a name based on AASHTO-AGC-ARTBA nomenclature. An example of a component web-page is shown in Figure 22. The component designator must be included on the Data-Entry-Form where specified.

### Component Drawings

Drawings for the component must be submitted in AASHTO-AGC-ARTBA Task Force 13 format, and must be submitted as a PDF file type. The dimensions in the drawings must be provided in both inches and millimeters, with the millimeter measurement in brackets. For example, a height of 30 inches (762 millimeters) is labeled as 30 [760]. Unit conversions and rounding conform to the recommendations in the “Guide to Metric Conversions” [AASHTO93].

All text, with the exception of the title block text, should be 3/32 inch (2.4 mm) high and in a Roman font. Borders should be drawn around the drawing pages as shown in Table 5.

**Table 5. Drawing margins**

Left	3/64"-thick black line 1" from the left edge.
Right	3/64"-thick black line 1/2" from the right edge.
Top	3/64"-thick black line 1/2" from the top edge.
Bottom	3/64"-thick black line 1/2" from the bottom edge.

Table 6 lists the acceptable abbreviations that may be used in the drawings. The abbreviations shall be stand-alone without any period.

**Table 6. Acceptable abbreviations in drawings.**

CLR	clear distance
D	Diameter
EA	Each
OC	on-center
LONGIT	longitudinal reinforcement
LNG	Long
MAX	Maximum

R	Radius
TOL	Tolerance
TYP	Typical

A title block shall be located at the bottom of the drawing page. This title block is approximately 6-1/2 inches wide (the entire width of the drawing) and 1-1/4 inches high. It is divided into three sections, each with a 3/64-inch border:

- The top box, which is 6-1/2 inches wide and 3/8 inches high, contains a descriptive name for the component (e.g., Decorative Fluted Pole) in a 3/8-inch Roman font.
- The lower left box, which is 1-11/16 inches wide and 15/16 inches high, may contain a manufacturer's logo if desired.
- The lower right box, which is 1-7/8 inches wide and 15/16 inches high, contains the component designator, a sheet number and total number of sheets (both drawing and specification pages), and the date of the latest revision of the drawing. The designator should be in a 1/4-inch Roman font, and the other items should be in a 3/32-inch Roman font.

In the lower left corner of the drawing, above the title block, the year that the component first entered the Guide should also be placed in a 3/32-inch Roman font.

For proprietary systems, the drawings are generally “generic” but must provide sufficient information to describe the component. Content for components and systems in the Online Guides consists of drawings on the facing sheets (i.e., the odd-numbered pages) and design specifications, intended use of the component/product and manufacturer contact information listed on the back sheets (i.e., the even-numbered pages). Generally, content for components consists of a one-page drawing and a one-page specification; in exceptional cases it may be acceptable to have multiple sheets for a single component. For systems, often all the material cannot be contained on a single front-and-back sheet so multiple sheets may be used. For both components and systems, if multiple sheets are needed, drawing content should always be on the facing sheets and specification text should always be on the back. Blank sheets may be inserted to facilitate this arrangement.

An example drawing for a luminaire shaft component is provided in Figure 23, Figure 24, Figure 25 and Figure 26; and an example drawing for a luminaire base component is provided in Figure 27, Figure 28, Figure 29 and Figure 30. For components such as luminaire shafts and arms, which may have varying dimensions, the corresponding variables (e.g., diameter of shaft) may be labeled with a letter designator, as shown in Figure 23; the optional values for the variable dimension would then be provided in a table included on the drawing file, as shown in Figure 25.

## Online Guide To Components

### Navigation

- [Components Home](#)
- [Browse Components](#)
- [Search Components](#)
- [Contacts](#)
- [About](#)
- [Links](#)

### Other Guides

- [Bridge Rail Systems](#)
- [Transition Systems](#)
- [Sign Support Systems](#)
- [Luminaire Support Systems](#)
- [Hardware Systems](#)
- [Components](#)

### Decorative - Hapco Fluted Pole (LPA02)

Category:	Luminaire (L)
Function:	Pole (P)
Type:	Aluminum (A)
Manufacturer:	HAPCO
Contact:	<a href="#">Mr. Joe Bowman (Click for details)</a>
Last Updated:	August 31, 2010



Drawings	Other Documents	Images	Systems
<ul style="list-style-type: none"> <li>• <a href="#">LPA02.pdf</a></li> </ul>	No files found.	<ul style="list-style-type: none"> <li>• <a href="#">Thumbnail Gallery</a></li> </ul>	<b>Luminaire Systems</b> <ul style="list-style-type: none"> <li>• SLT03</li> <li>• SLT05</li> <li>• SLT06</li> <li>• SLT04</li> <li>• SLT01</li> </ul> <b>Sign Systems</b> <ul style="list-style-type: none"> <li>• None</li> </ul> <b>Transitions</b> <ul style="list-style-type: none"> <li>• None</li> </ul>

**Figure 22. Example of a component web page in the Online Guide.**

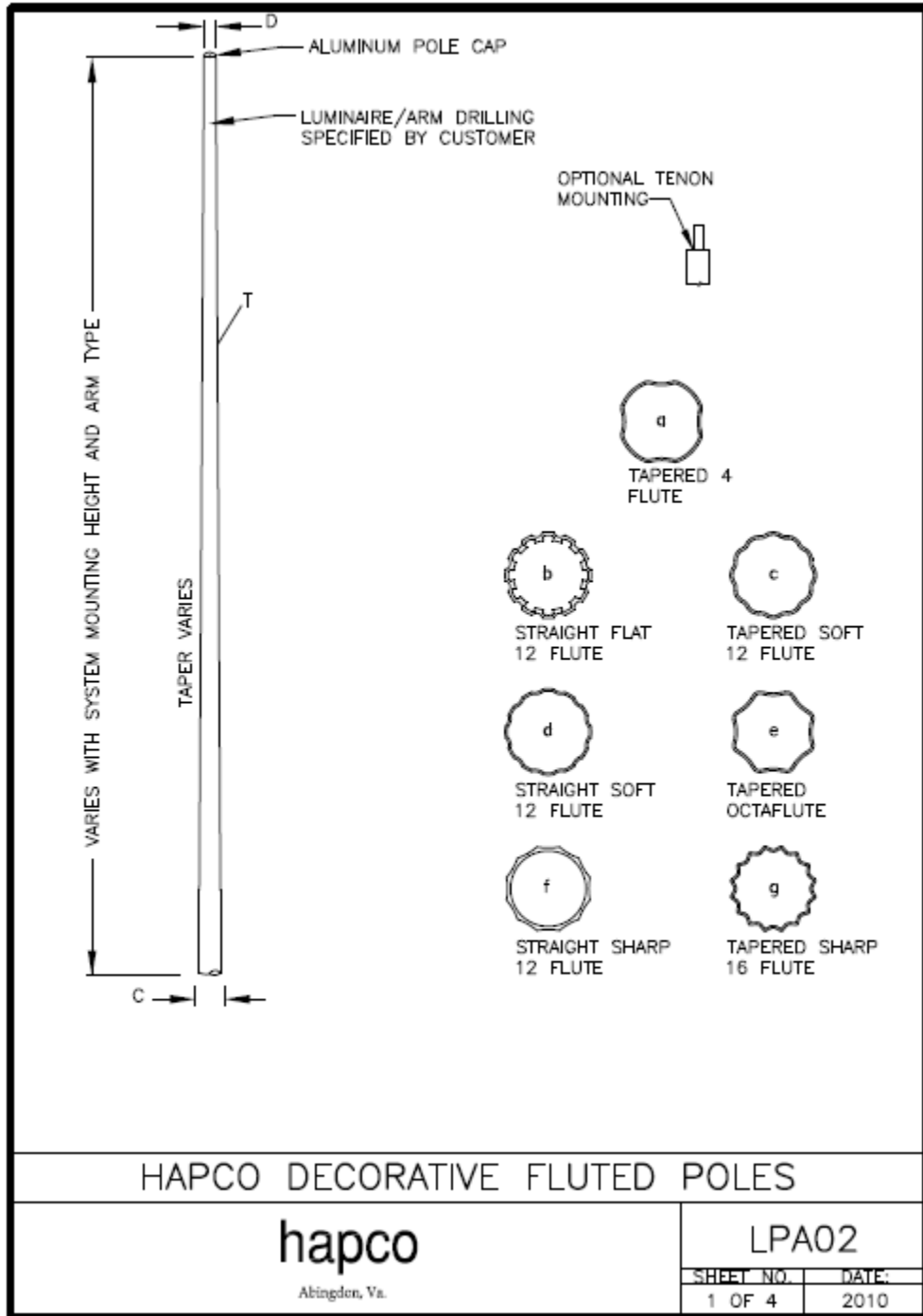

Figure 23. Example drawing of luminaire shaft component (page 1 of 4).

### SPECIFICATIONS

The shaft shall be a one piece round tapered or straight fluted tube of 6063 aluminum alloy and shall be full-length heat-treated to T6 temper after welding on the base. Shaft shall be free of longitudinal welds. Pole shaft cap, when required, shall be of cast aluminum of 443 or 356F aluminum alloy and attached utilizing stainless steel hardware. The pole shall be designed for a minimum design life of 50 years in accordance with "Standard Specifications for Structural Supports for Highway Signs, Luminaires and Traffic Signals "AASHTO 2001", 4th Edition.

Dimensional tolerances not shown or implied are intended to be those consistent with the proper functioning of the part, including its appearance and accepted manufacturing practices.

### INTENDED USE

This pole is designed for use with HAPCO luminaire support systems SLT01, SLT03, SLT04, SLT05, and SLT06.

### CONTACT INFORMATION

Hapco Aluminum Pole Products  
26252 Hillman Highway  
Abingdon, VA 24210  
Phone: 1-800-368-7171  
Email: [joe.bowman@hapco.com](mailto:joe.bowman@hapco.com)  
Website: [www.hapco.com](http://www.hapco.com)

### HAPCO DECORATIVE FLUTED POLES

**LPA02**

SHEET NO.	DATE
2 of 4	2010



Figure 24. Example drawing of luminaire shaft component (page 2 of 4).

DESIGNATOR	X-SECTION TYPE	C	D	T
LPA02--4-4-4	d	4 [104]	4 [102]	$\frac{1}{2}$ [3]
LPA02--4-4-6	d	4 [104]	4 [102]	$\frac{3}{8}$ [5]
LPA02--5-3-4	a,c,e,g	5 [127]	3.5-3.96 [89-101]	$\frac{1}{2}$ [3]
LPA02--5-3-6	a,c,e,g	5 [127]	3.5-3.96 [89-101]	$\frac{3}{8}$ [5]
LPA02--5-4-4	a,c,e,g	5 [127]	4.01-4.31 [102-109]	$\frac{1}{2}$ [3]
LPA02--5-4-6	a,c,e,g	5 [127]	4.01-4.31 [102-109]	$\frac{3}{8}$ [5]
LPA02--5-5-4	b,d,f	5 [127]	5 [127]	$\frac{1}{2}$ [3]
LPA02--5-5-6	b,d,f	5 [127]	5 [127]	$\frac{3}{8}$ [5]
LPA02--6-4-4	a,c,e,g	6 [152]	4.08-4.52 [104-115]	$\frac{1}{2}$ [3]
LPA02--6-4-6	a,c,e,g	6 [152]	4.08-4.52 [104-115]	$\frac{3}{8}$ [5]
LPA02--6-6-4	d	6 [152]	6 [152]	$\frac{1}{2}$ [3]

HAPCO DECORATIVE FLUTED POLES

hapco

Abingdon, Va.

LPA02

SHEET NO.	DATE:
3 OF 4	2010

Figure 25. Example drawing of luminaire shaft component (page 3 of 4).



Page intentionally left blank

<b>HAPCO DECORATIVE FLUTED POLES</b>	
<b>LPA02</b>	
SHEET NO.	DATE
4 of 4	2010
	

Figure 26. Example drawing of luminaire shaft component (page 4 of 4).

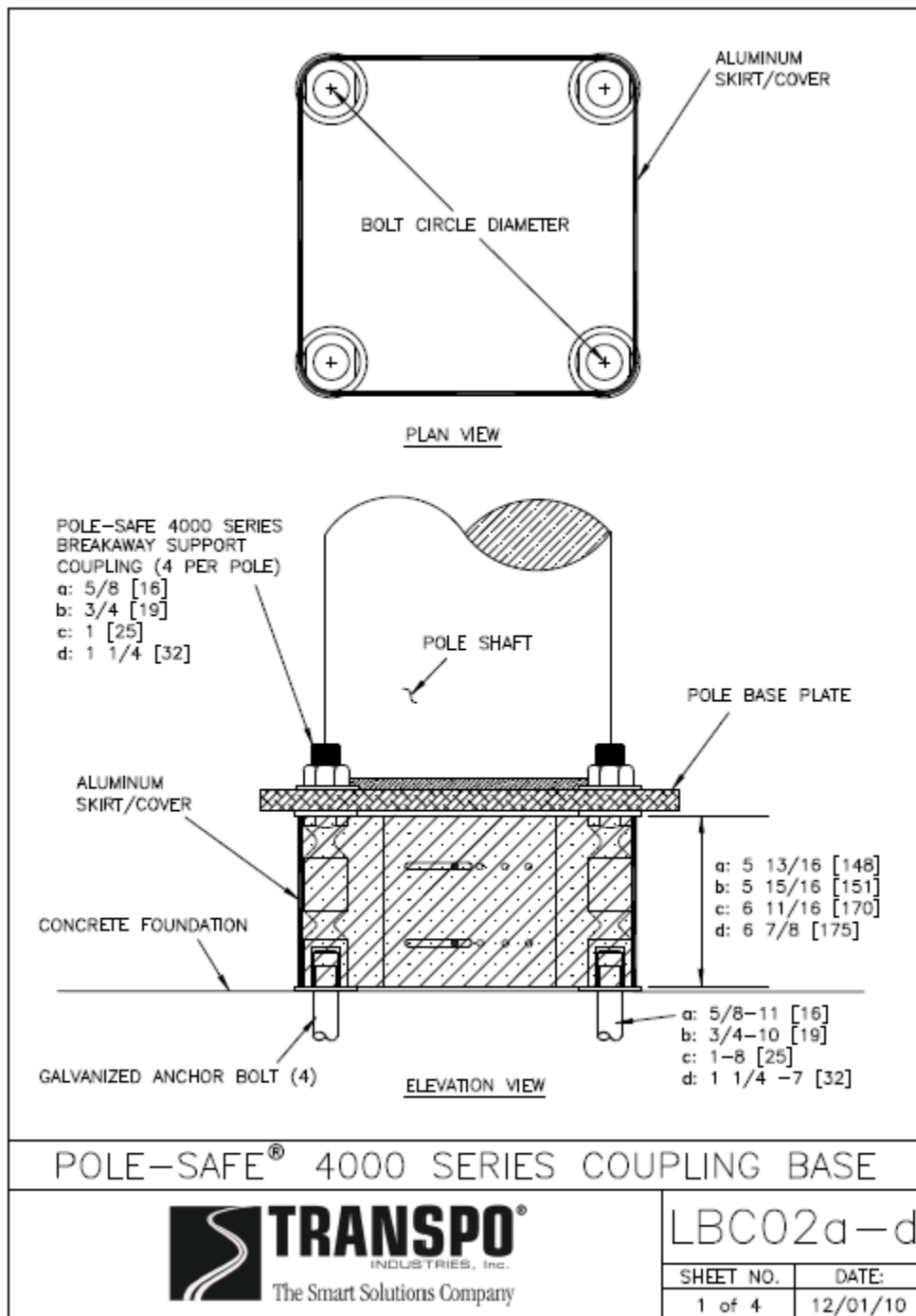

Figure 27. Example drawing of luminaire base component (page 1 of 4).

**INTENDED USE**

Transpo's Pole-Safe® 4000 Series coupling base is an omni-directional breakaway support system for a wide variety of light poles and other elements located within roadside clear zones or other locations vulnerable to vehicular impacts. The primary component of the system is a high-strength coupling, designed to break away quickly and cleanly upon impact, thus saving lives and reducing property damage costs. Pole-Safe® has been vehicle crash-tested in accordance with NCHRP Report 350 Test Level 3, and is approved for use on all FHWA-funded projects.

In addition to superior safety performance, Pole-Safe® provides high structural load-carrying capacity. Extensive finite-element analysis and simulated wind-load testing has been used to optimize the system for maximum loading conditions.

The Pole-Safe® 4000 Series consists of four (4) models of different coupling sizes to cover a wide range of pole sizes and configurations, up to and including the heaviest pole mass allowed (992 lbs [450 kg]) in the AASHTO Standard Specifications for Structural Supports for Highway Signs, Luminaires and Traffic Signals.

Below are the Pole-Safe® 4000 Series Models with corresponding standard anchor bolt size:

- Pole-Safe® Model 4062 for use with 5/8" [16] Anchor Bolts.
- Pole-Safe® Model 4075 for use with 3/4" [19] Anchor Bolts.
- Pole-Safe® Model 4100 for use with 1" [25] Anchor Bolts.
- Pole-Safe® Model 4125 for use with 1 1/4" [32] Anchor Bolts.

Each model is a complete base system that contains four (4) Pole-Safe® breakaway couplings, and all related hardware shown. The reinforced concrete foundation, pole, and base plate are not included.

**REFERENCES**

Dwight A. Horne, "Breakaway Luminaire Supports, Geometric and Roadside Design Acceptance Letter Number LS-45B, Federal Highway Administration, January 16, 1997.

**CONTACT INFORMATION**

Transpo Industries, Inc.  
 20 Jones Street, New Rochelle, NY 10801  
 Phone: (914) 636-1000  
 Fax: (914) 636-1282  
 Email: info@transpo.com  
 Web: www.transpo.com

**POLE-SAFE® 4000 SERIES COUPLING BASE**

<b>LBC02a-d</b>		
SHEET NO.	DATE	
2 of 4	12/01/10	

**Figure 28. Example drawing of luminaire base component (page 2 of 4).**

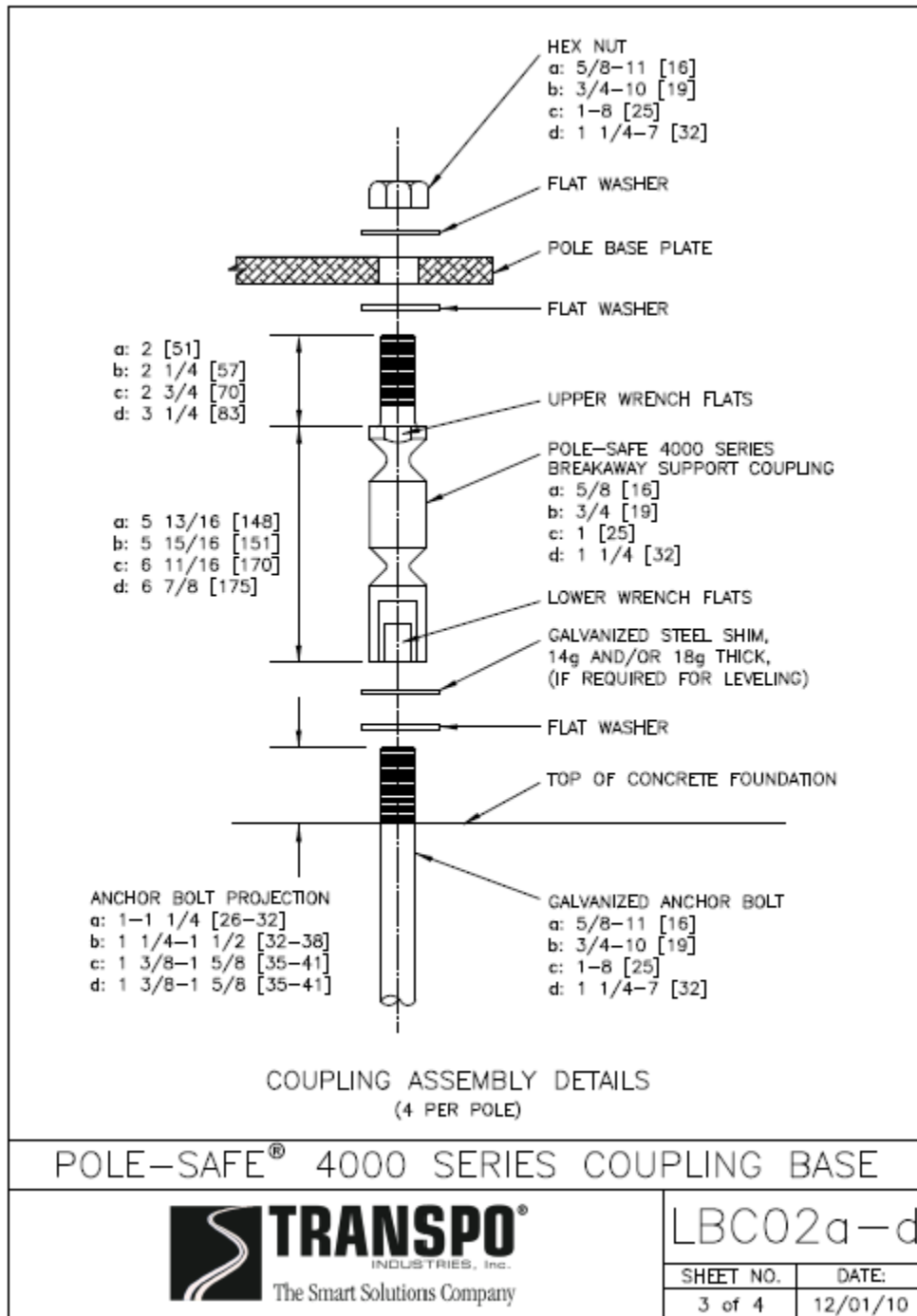

Figure 29. Example drawing of luminaire base component (page 3 of 4).

**INTENDED USE**

Transpo's Pole-Safe® 4000 Series coupling base is an omni-directional breakaway support system for a wide variety of light poles and other elements located within roadside clear zones or other locations vulnerable to vehicular impacts. The primary component of the system is a high-strength coupling, designed to break away quickly and cleanly upon impact, thus saving lives and reducing property damage costs. Pole-Safe® has been vehicle crash-tested in accordance with NCHRP Report 350 Test Level 3, and is approved for use on all FHWA-funded projects.

In addition to superior safety performance, Pole-Safe® provides high structural load-carrying capacity. Extensive finite-element analysis and simulated wind-load testing has been used to optimize the system for maximum loading conditions.

The Pole-Safe® 4000 Series consists of four (4) models of different coupling sizes to cover a wide range of pole sizes and configurations, up to and including the heaviest pole mass allowed (992 lbs [450 kg]) in the AASHTO Standard Specifications for Structural Supports for Highway Signs, Luminaires and Traffic Signals.

Below are the Pole-Safe® 4000 Series Models with corresponding standard anchor bolt size:

- Pole-Safe® Model 4062 for use with 5/8" [16] Anchor Bolts.
- Pole-Safe® Model 4075 for use with 3/4" [19] Anchor Bolts.
- Pole-Safe® Model 4100 for use with 1" [25] Anchor Bolts.
- Pole-Safe® Model 4125 for use with 1 1/4" [32] Anchor Bolts.

Each model is a complete base system that contains four (4) Pole-Safe® breakaway couplings, and all related hardware shown. The reinforced concrete foundation, pole, and base plate are not included.

**REFERENCES**

Dwight A. Horne, "Breakaway Luminaire Supports, Geometric and Roadside Design Acceptance Letter Number LS-45B, Federal Highway Administration, January 16, 1997.

**CONTACT INFORMATION**

Transpo Industries, Inc.  
 20 Jones Street, New Rochelle, NY 10801  
 Phone: (914) 636-1000  
 Fax: (914) 636-1282  
 Email: info@transpo.com  
 Web: www.transpo.com

**POLE-SAFE® 4000 SERIES COUPLING BASE**

<b>LBC02a-d</b>		
SHEET NO.	DATE	
4 of 4	12/01/10	

**Figure 30. Example drawing of luminaire base component (page 4 of 4).**

## **Component Photos**

Photos of each component should be submitted as part of the data submission process. One photo may be selected for display on the component web-page, as shown in Figure 22. This photo must be named “Photo-01.jpg,” as the *Online Guide* automatically displays the photo with that name on the component web-page. Additional photos may also be submitted, which will be included on a separate web-page accessed by clicking the link for “Thumbnail Gallery” as shown in Figure 22.

## ***Procedure for Submitting Luminaire Support System Drawings and Photos***

The format and procedures for submitting drawings and photos for luminaire support systems are the same as those for luminaire components, described in the previous section. A web-page for the luminaire support system will be created and the system will be assigned a name based on AASHTO-AGC-ARTBA nomenclature. An example of a luminaire support system web-page is shown in Figure 31. The component designator must be included on the Data-Entry-Form where specified.

## **System Drawings**

A single drawing file shall be submitted for each *general system*. The drawing should include all variations of base, pole and arm component configurations corresponding to that general system. An example drawing file for a luminaire support is provided in Figure 32 and Figure 33.

## **System Photos**

Photos of the general system should also be provided as part of the data submission process. One photo may be selected for display on the luminaire support system web-page, as shown in Figure 31. The photo to be displayed on the luminaire support system web-page must be named “Photo-01.jpg” and located in the appropriate system subdirectory as the *Online Guide* automatically displays the photo with that name on all relevant luminaire system web-pages. It is suggested that multiple system configurations be included in Photo-01.jpg, as illustrated in Figure 31, as it will provide a more descriptive indication of the various configurations available for the system. Additional photos may also be submitted, which will be included in on a separate web-page accessed by clicking the link for “Thumbnail Gallery” as shown in Figure 31.

## Online Guide To Luminaire Supports

### Navigation

- [Luminaire Supports Home](#)
- [Browse Luminaire Supports](#)
- [Search Luminaire Supports](#)
- [Manufacturers/Contacts](#)
- [About](#)
- [Links](#)

### Other Guides

- [Bridge Rail Systems](#)
- [Transition Systems](#)
- [Sign Support Systems](#)
- [Luminaire Support Systems](#)
- [Hardware Systems](#)
- [Components](#)

### SLH01: General System

This page provides only general information about this system. To view the specific configurations of this system, use the search criteria at the bottom of this page. To search through specific configurations of all systems, please use the [Search Luminaires Supports](#) page.

Specific Configurations:	95 specific systems
Acceptance:	Submitted
FHWA Acceptance Letters:	LS27.pdf
Test Level:	TL-3
Test Specification:	Report 350
System Manufacturer:	HAPCO
Base Manufacturer:	HAPCO
Base Type:	Shoe (H)
Base Component:	LBH01
Arm Type:	Davit (D) Tenon (N) Cross (C) Mast (M) Truss (T)
Num. of Arms:	0, 1, 2, 3, 4 (arms)
Mounting Height:	20, 25, 30 (feet)
Base Diameter Range:	7.00 to 7.00 (inches)
Top Diameter Range:	4.50 to 7.00 (inches)
Wall Thickness of Pole:	0.156 to 0.188 (inches)
Contact:	<a href="#">Mr. Joe Bowman</a> (Click for details)



Drawings	Other Documents	Images
<ul style="list-style-type: none"> <li>• SLH01.pdf</li> <li>• SLH01.dwg</li> </ul>	<ul style="list-style-type: none"> <li>• Test Report 72785 July 1 1992.pdf</li> <li>• 3-Second Gust Wind Map.pdf</li> <li>• FHWA-Acceptance-Letter_LS-27.pdf</li> </ul>	<ul style="list-style-type: none"> <li>• <a href="#">Thumbnail Gallery</a></li> </ul>

**Figure 31. Example of a luminaire support system web page in the *Online Guide*.**

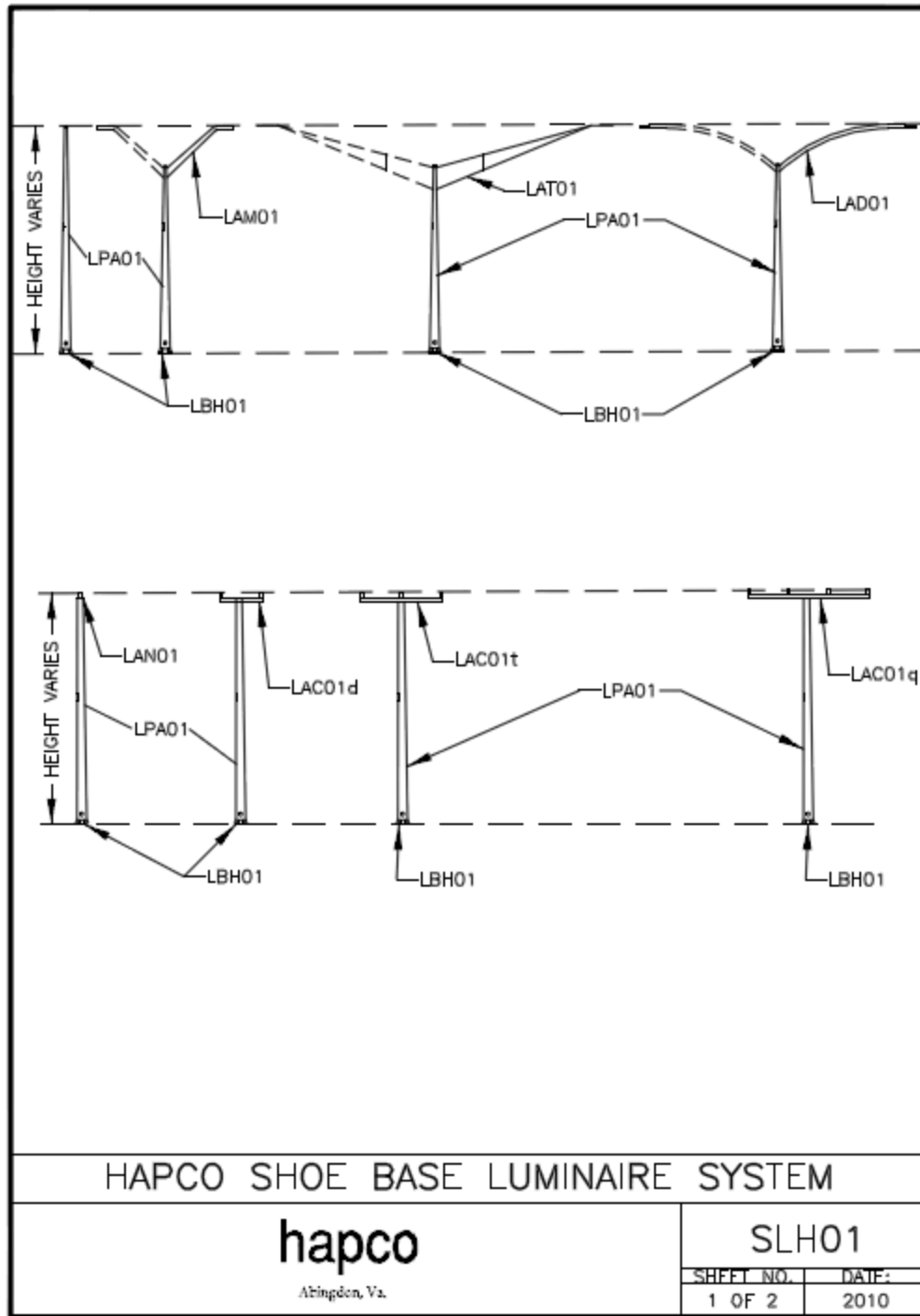

**Figure 32. Example drawing of luminaire support system (page 1 of 2).**



## SPECIFICATIONS

This system is available in mounting heights [A] of 20, 25 and 30 ft. It is qualified for use on the National Highway System via FHWA Acceptance Letter LS-27. Pole (shaft) dimensions vary depending on system mounting height, type of arm, fixture weight, and desired EPA values. The system is available with the following finishes: Satin ground or powder coat: black, white, dark bronze, green, and grey

Dimensional tolerances not shown or implied are intended to be those consistent with the proper functioning of the part, including its appearance and accepted manufacturing practices.

Warning: Do not install system without luminaire.

### INTENDED USE

This aluminum luminaire support system has been crash-tested and satisfies the criteria for NCHRP Report 350 test level 3. This is a proprietary product and its use on Federal-aid projects must adhere to the regulations contained in Title 23, Code of Federal Regulations, Section 635.411.

### CONTACT INFORMATION

#### Hapco Aluminum Pole Products

26252 Hillman Highway  
Abingdon, VA 24210

Phone: 800-368-7171

e-mail: [joe.bowman@hapco.com](mailto:joe.bowman@hapco.com)

## HAPCO SHOE BASE LUMINAIRE SUPPORT SYSTEM

**SLH01**

SHEET

DATE

2 of 2

2010



Figure 33. Example drawing of luminaire support system (page 2 of 2).

## Chapter 5

### Online Guide Administration Procedures

The general procedure for entering new information into the *Online Guide to Luminaire Supports* is listed below:

#### Component Data

1. Assign designator to the new component(s) (e.g., LBS99) and create a folder with that name in the ...\*Documents* directory of the Online Guides.
2. Create three sub-folders in the new component folder:

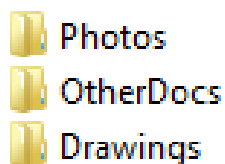

3. Copy all photographs into the sub-folder “Photos.”
4. Copy drawing files into the sub-folder “Drawings.”
5. Copy any other files (e.g., test reports, brochures, etc.) into the sub-folder “OtherDocs.”
6. Use the Administration Tool to create the component page in the *Online Guide* (refer to section 5.7).

#### Luminaire Support System Data

7. Upload the data from the Data Entry Form prepared by the submitter into the *Online Guide to Luminaires* database.
  - Open the DataEntryFile.xlsx prepared by the submitter,
  - Select the worksheet within the DataEntryForm.xlsx named “Database” (refer to section 5.9 for instructions) and assign a designator to each general system in column D.
  - Export the “Database” sheet to a CSV file and upload the file to the *Online Guide* database using the “Bulk Upload” feature on the administration home page.
8. Create a folder with the same name as the General System designator (e.g., SLS99) in the ...\*Documents* directory of the Online Guides.
9. Create three sub-folders in the system directory:

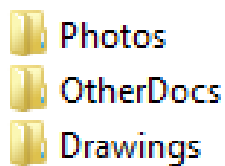

10. Copy all photographs into the sub-folder “Photos.”

## 11. Copy drawing files into the sub-folder “Drawings.”

- Copy any other files (e.g., test reports, brochures, etc.) into the sub-folder “OtherDocs.”

The administration of the *Online Guide* is performed using a set of web-based tools on the administration website, located at <http://guides.roadsafellc.com/admin>. This website serves as the administration page (administration home page) for all the TF13 Guides. The web-tools for administering the *Online Guide to Luminaire Supports* can be found by scrolling to the bottom of the admin-page. The primary administration pages for updating and editing luminaire support system data are listed on the administration home page under the heading “Luminaire Guide” as:

- Luminaire
- Bulk Import
- Bulk Export
- Bulk Edit

Additional links are also provided that are used to update and edit the supporting databases. The databases that are exclusively related to the Luminaire Guide are listed on the administration home page under the heading “Luminaire Guide” as:

- Test Specifications
- Materials
- Base Types
- Arm Types
- Approvals
- Comments

There are two additional supporting databases which are located under other headings on the administration home page; these databases are common to all Task Force 13 Online Hardware Guides and are therefore listed under separate headings. These include:

- Contacts – located under the heading “Global”
- Components – located under the heading “Component Guide”

Guidance on the use of each of the admin-tools is discussed in the following sections.

## *Updating and Editing Luminaire Support Systems Data*

### **Luminaires Administration Page**

The “luminaires” administration page, shown in Figure 34, is used to create or edit data that define specific configurations for luminaire support systems. The information on this page includes the numeric **ID**, the name, a brief **description**, the **sub-directory** used to store the files associated with the system entry, a designator indicating if the entry is active or not (i.e., **deleted**), the date that the entry was last **modified** and the date that the entry was **created**. There are currently over 8,000 luminaire system configuration entries listed in the database. Additional luminaire support configurations can be added to the database or existing entries can be edited by clicking the on the links provided.

The administration tool for adding/editing test specifications is shown in Figure 35. There are many data entry fields to be filled out on this form, including several that require numeric ID entries from other databases (e.g., iArmComponent, iPoleComponent, etc.). All fields that begin

with an “i” followed by a file name (e.g., iPoleComponent) are related to data entry information from another database and require the associated numeric ID as input. Those databases are discussed in later sections of this report. For example, the material ID for the system shown in Figure 35 is “1”, which refers to aluminum (refer to Figure 46); the base type ID for the system is “4”, which refers to a coupling base (refer to Figure 47); the approval status ID for the system is “1”, which refers to “submitted”; etc. When an entry is created or edited, the remaining fields are internally updated automatically and cannot be changed by the administrator. This ensures that no two entries are mistakenly assigned the same ID and that the creation and modification dates are entered correctly.

**LULUMINAIRES**

Create [here](#) to insert a new LULuminaire.

Click on an ID to edit an entry.

< Previous 1000 items | Next 1000 items >

ID	name	description	subdir	Deleted	Modified	Created
1	SL16/C01/A01-6-4.5-6/	Aluminum Coupling Base with 16 ft Mtg. Ht. and No Arms	SLC01		2012-09-05 08:46:28	2012-09-05 08:46:28
2	SL18/C01/A01-6-4.5-5/	Aluminum Coupling Base with 18 ft Mtg. Ht. and No Arms	SLC01		2012-09-05 08:46:28	2012-09-05 08:46:28
3	SL18/C01/A01-7-4.5-5/	Aluminum Coupling Base with 18 ft Mtg. Ht. and No Arms	SLC01		2012-09-05 08:46:28	2012-09-05 08:46:28
4	SL18/C01/A01-6-4.5-6/	Aluminum Coupling Base with 18 ft Mtg. Ht. and No Arms	SLC01		2012-09-05 08:46:28	2012-09-05 08:46:28
5	SL20/C01/A01-6-4.5-4/	Aluminum Coupling Base with 20 ft Mtg. Ht. and No Arms	SLC01		2012-09-05 08:46:28	2012-09-05 08:46:28
6	SL20/C01/A01-6-4.5-5/	Aluminum Coupling Base with 20 ft Mtg. Ht. and No Arms	SLC01		2012-09-05 08:46:28	2012-09-05 08:46:28
7	SL20/C01/A01-7-4.5-5/	Aluminum Coupling Base with 20 ft Mtg. Ht. and No Arms	SLC01		2012-09-05 08:46:28	2012-09-05 08:46:28
8	SL20/C01/A01-8-4.5-5/	Aluminum Coupling Base with 20 ft Mtg. Ht. and No Arms	SLC01		2012-09-05 08:46:28	2012-09-05 08:46:28
9	SL20/C01/A01-6-4.5-6/	Aluminum Coupling Base with 20 ft Mtg. Ht. and No Arms	SLC01		2012-09-05 08:46:28	2012-09-05 08:46:28
10	SL20/C01/A01-7-4.5-6/	Aluminum Coupling Base with 20 ft Mtg. Ht. and No Arms	SLC01		2012-09-05 08:46:28	2012-09-05 08:46:28
11	SL20/C01/A01-8-4.5-6/	Aluminum Coupling Base with 20 ft Mtg. Ht. and No Arms	SLC01		2012-09-05 08:46:28	2012-09-05 08:46:28
12	SL25/C01/A01-6-4.5-5/	Aluminum Coupling Base with 25 ft Mtg. Ht. and No Arms	SLC01		2012-09-05 08:46:28	2012-09-05 08:46:28
13	SL 25/C01/A01-7-4.5-5/	Aluminum Coupling Base with 25	SL C01		2012-09-05	2012-09-05

**Figure 34. Administration page for Luminaire support systems**

### Update LULUMINAIRE ID# 1

Field	Value	Hint
id	1	(read-only)
name	SL16/C01/A01-6-4.5-6/	
manufacturerCatalog	RTA16D6B4	
description	Aluminum Coupling Bas	
subdir	SLC01	
iArmComponent	0	
iPoleComponent	27	
iBaseComponent	608	
specificArmComponentName		
specificPoleComponentName	LPA01-x-6-4.5-6	
specificBaseComponentName	LBC01	
numArms	0	
iContact	71	
FHWAAcceptanceLetter	LS23	
iMaterial	1	
iBaseType	4	
iApproval	2	
testLevel	3	
iTestSpecification	1	
mountingHeight	16	
poleLength	0	
iArmType	0	
armLength	0	
boltCircleMin	9.00	
boltCircleMax	10.00	
baseDiameter	6.00	
topDiameter	4.50	
wallThickness	0.188	

...

dCreated	2012-09-05 08:46:28	(read-only)
dModified	2012-09-05 08:46:28	(read-only)
bDeleted		(1 for TRUE, 0 for FALSE)

**Figure 35. Administration tool for adding/editing entries for specific luminaire system configurations (abridged view).**

Note that there is no mechanism for removing an entry from the database once it has been entered; however, an entry can be effectively deleted by putting a value of “1” in the “bdeleted” field. Leaving the field blank or entering a zero indicates that the entry is active.

### Bulk Import Administration Page

It is often necessary to input multiple configurations corresponding to a general luminaire support system. For example, as shown in Figure 6, there are 601 configurations of the general luminaire system SLC01. The default administration tool for creating and editing luminaire support configuration data can quickly become a tedious and time consuming effort when dealing with such large data sets; therefore a special administration tool was developed to facilitate the data entry process. The Luminaire Bulk Import tool, located on the administration panel of the *Online Guide*, is designed to allow a non-technical user to upload a CSV (Comma Separated Value) file with large numbers of Luminaires into the *Online Guide*'s database.

Anyone submitting luminaire support data for inclusion into the online Guide must fill out the Data Entry Form – the Microsoft Excel workbook which serves as a template for data submission (refer to section 4.2 for more details). The Data Entry Form includes two hidden worksheets: one named “Database” and another named “Pulldown Menu Items”. Each row of the Database worksheet contains all the data required to create a luminaire support entry into the *Online Guide*. To unhide the database worksheet:

1. Right-click on any worksheet tab and select “unhide” from the menu options, as shown in Figure 36;
2. A pop-up window will be displayed that lists the hidden sheets;
3. Select the “Database” worksheet and click “OK”.

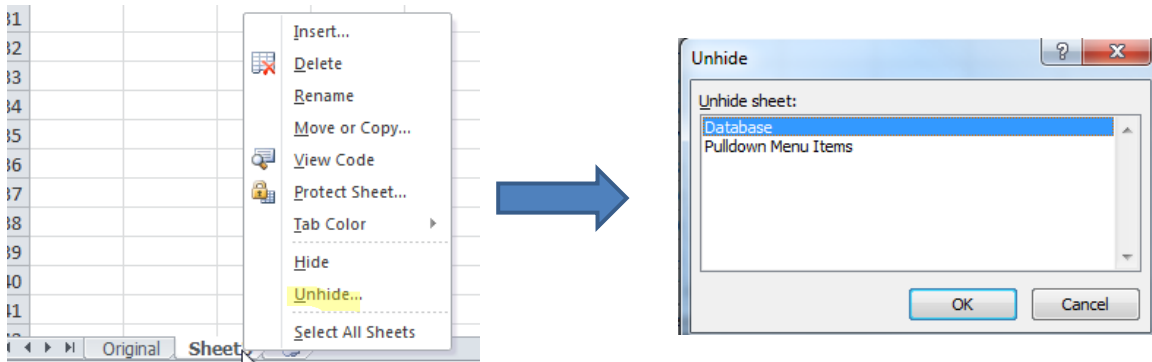

**Figure 36. Procedure for “un-hiding” the database worksheet on the Data Entry Form**

Once the worksheet is visible, the administrator must assign a general system designator in column D of the worksheet for each system, as illustrated in Figure 37.

	A	B	C	D	E	F
1	Description	Specific System Name	Manufacturer's Catalog No.	Basic System	Base	Pole
2	Aluminum Transformer Base	SL20/T07/A03-7-4-5/	190840705T4	SLT07	LBT07	LPA03-19.67-7-4-5
3	Aluminum Transformer Base	SL20/T07/A03-7-4-5/M02b2	170840705T4	SLT07	LBT07	LPA03-17.67-7-4-5
4	Aluminum Transformer Base	SL20/T07/A03-7-4-5/M02c2	170840705T4	SLT07	LBT07	LPA03-17.67-7-4-5
5	Aluminum Transformer Base	SL20/T07/A03-7-4-5/D02a2	20007520D4	SLT07	LBT07	LPA03-13.5-7-4-5
6	Aluminum Transformer Base	SL20/T07/A03-7-4-5/D02b2	20007520D4	SLT07	LBT07	LPA03-13.5-7-4-5
7	Aluminum Transformer Base	SL20/T07/A03-7-4-5/D02c2	20007520D4	SLT07	LBT07	LPA03-13.5-7-4-5
8	Aluminum Transformer Base	SL20/T07/A03-7-4-5/N020	190840705T4	SLT07	LBT07	LPA03-19.67-7-4-5
9	Aluminum Transformer Base	SL20/T07/A03-7-4-5/C08d	190840705T4	SLT07	LBT07	LPA03-19.67-7-4-5
10	Aluminum Transformer Base	SL20/T07/A03-7-4-5/C08t	190840705T4	SLT07	LBT07	LPA03-19.67-7-4-5
11	Aluminum Transformer Base	SL20/T07/A03-7-4-5/C08q	190840705T4	SLT07	LBT07	LPA03-19.67-7-4-5

**Figure 37. System designator for each new general system is assigned in column D of the Data Entry Form on the Database worksheet.**

The worksheet can then be saved in CSV format and directly uploaded into the *Online Guide* database using the “Bulk Import” option on the administration home page.

The Bulk Import tool can be used in two modes: “Overwrite” and “Append.” By default, the tool operates in “Append” mode, which allows new systems to be appended to the existing database. Alternatively, the tool can be used in “Overwrite” mode, in which all existing luminaire systems in the *Online Guide* will be deleted and replaced with the new data being uploaded. **Misuse of the mode can lead to lost data!**

### Cautionary Warnings

Please use caution when uploading files with the Bulk Import tool. Mistakes can lead to thousands of corrupted or even destroyed database records. It is recommended that a database backup be performed using the “Bulk Export” option on the administration home-page before importing any particularly large, novel, or quirky datasets (refer to section 5.10 for more details on “Bulk Export”).

Be careful about refreshing pages and using the web-browser's back button. Refreshing the import tool's web page after an import, including navigating back to the page, may cause the import to take place a second time, which may lead to lost or duplicated data!

### Instructions

1. In a program such as Microsoft Excel, export the dataset to CSV format.
2. Navigate to <http://guides.roadsafellc.com/admin/luminaireimport.php>
  - Alternatively, a link to “Bulk Import” can be found in the Luminaire navigation section of the Online Guides administration tool at <http://guides.roadsafellc.com/admin/>.
3. Click on the “Choose File” button. Find the CSV file on your local computer.
4. If you wish to operate the Bulk Import tool in “Overwrite mode”, mark the checkbox labeled “Overwrite existing database?”
5. Click Submit.
6. Expect to wait to as long as thirty seconds.
7. Read the import tool's resulting output to determine whether the operation succeeded or

failed.

- If the final line of the tool's output says “Done! Import Completed Successfully,” then the import was successful.
- If the final line of the tool's output says something else, the import failed. Read the tool's output and use the Troubleshooting section below to determine the exact error.

## Converting the Database Worksheet to CSV format

Exact instructions for exporting to CSV vary from one version of Excel to another, but the general procedure is to:

1. Select the worksheet “Database” to make it the active worksheet. Only a single “sheet” of an Excel (.xls) file can be exported to CSV at a time, so make sure to select the correct sheet during export.
2. Select “File” → “Save As”, and select “.csv” as the new file type.
3. The Bulk Import tool expects CSV files that use:
  - Commas (“,”) as field delimiters/terminators.
  - New lines (“\n”) as row delimiters/terminators. (Not carriage returns!)
  - Quotation marks to enclose fields.
  - Quotation marks within fields are not expected, but will be handled if escaped with a backslash (“\”).
  - Quotation marks are expected to be neutral Unicode quotation marks, not left/right specific quotation marks, etc.

## Troubleshooting

### Numeric ID Translation Errors

If an error is received stating, “*ERROR: \_\_ rows contained invalid \_\_\_\_\_s that could not be converted to numeric Ids. The invalid values are:*” followed by a list of values, then search the dataset **and** the existing Online Guides for typos corresponding to the values listed in the error message. If no typos are found, then the values listed in the error message do not yet exist in the Online Guides and must be added manually via the admin-page.

During import, many properties of Luminaires must be looked up in other, secondary databases and converted into unique identifiers. For example, the luminaire material database currently includes four materials: (1) Aluminum, (2) Steel, (3) Composite and (4) Wood. If a luminaire system made from another material is being imported into the Guide, then the new material must first be added to the materials database, shown in Figure 46, where it will be assigned a numeric ID.

It's also common to encounter spelling variations/typos and abbreviations for Materials, Base Types, and Arm Types. The value in the dataset being imported must **exactly** match the value being referenced in the Online Guides. This includes spacing, capitalization, and punctuation. For example, aluminum luminaire supports must list the material exactly as “Aluminum” - not “aluminum”, “aluminium”, “aluminum\*”, etc. Although the Data Entry Form includes data verification checks to guard against spelling errors and typos, these types of errors may sometimes occur. If discrepancies exist due to typos in the dataset being imported, then the dataset must be corrected before importing. If discrepancies occur due to existing errors in the



*Online Guide* databases, then the corrections must be made using the *Online Guide*'s administration tool.

## Caching Errors

Sometimes an import may complete successfully, but the new luminaire data may not appear in the Luminaire Guide. This is most likely due to the web-browser caching old versions of webpages from the Luminaire Guide. Try refreshing any stale pages multiple times, and possibly even clearing the browser's cache.

## Environment Errors & Bugs

These are configuration eccentricities or errors in the *Online Guide*'s third-party hosting environment, as well as actual bugs in the Bulk Import tool's source code. Although these sorts of errors are unlikely to be serious issues, they should be examined by a programmer.

Please e-mail the exact output of the Import Tool and a copy of the CSV file being imported to the administrator of the *Online Guide*.

## Bulk Export Administration Page

The "Bulk Export" on the administration home page is used to export the luminaire systems' database to a CSV file. The CSV file is a common-separated-variable ASCII text file and can be edited with many different programs, including Microsoft Excel. It is suggested that the database be exported and saved prior to using the "bulk edit" or "bulk upload" tools, in case the upload results in a corrupt database. If there is a problem with the upload or edit procedure, the original database can be restored by simply re-uploading it using "bulk upload" (see section 5.1.2).

To export the database, select the "Bulk Export" from the administration home page. A window will appear, as shown in Figure 38. It may take several minutes for the window to appear depending on the size of the database and the internet connection speed. Select "save" to save the file. A file will be created which includes the date (year-month-day) that it was created in the name, such as "luminaire-export-2012-10-18.csv", which indicates that the file was created on October 18, 2012.

## Luminaire Guide

Bulk Import

**Bulk Export**

Bulk Edit

Approvals

Comments



Figure 38. Procedure for exporting the database.

## Bulk Edit Administration Page

The "Bulk Edit" feature on the administration panel of the Online Guides was developed to facilitate the process of editing multiple systems at once. For example, it may sometimes be

necessary to make corrections to a number of systems in the database in which each of the systems has the same error, such as system manufacturer, material type, FHWA eligibility letter, etc. The “bulk edit” feature can be used to quickly and easily make the necessary changes to a sub-set of selected systems. The “bulk edit” tool is also useful for updating the “status” for a group of systems, for example, changing the status from “In-Review” to “TF13 Approved.”

The administration page for the “bulk edit” feature is shown in Figure 39. Initially, all systems in the database are listed when the page is initially loaded. Any subset of the systems listed can be selected by checking the box on the left of the system name. Another important feature of the “bulk edit” page is a search option that allows the administrator to search for systems that meet specific search criteria, including criteria based on system naming nomenclature using “wildcards”.

**Search Luminaire Supports to Bulk Edit**

Full Descriptor   
*(Use \* as wildcard, e.g. 'SL2\*/C')*

Deleted

Acceptance

Test Level

Test Specification

System Manufacturer

Base Manufacturer

Material

Base Type

Pole/Mounting Height  to  ft

Pole Base Diameter  to  in

Pole Top Diameter  to  in

Pole Thickness  to  in

Bolt Circle Diameter  in

Arm Type

Number of Arms

Arm Length  to

**Show advanced search options**

*Click on a column heading to arrange the list in order of that luminaire support characteristic.*

<input type="checkbox"/>	ID	Name/Designator	Deleted	System Manufacturer	Mounting Height (ft)	Base Type	Material	Pole Base Dia. (in)	Pole Thickness (in)	Num. Arms	Arm Type	Arm Length (ft)
<input type="checkbox"/>	1	SL16/C01/A01-6-4.5-6/	No	HAPCO	16	Coupling (C)	Aluminum	6.00	0.188	0	N/A	0' 0"

**Figure 39. Administration page for the “bulk edit” feature (abridged view)**

There are two convenient ways to use the search criteria to change the status of all luminaire support configurations associated with a particular general system:

1. The “Full Descriptor” field can be used to find all configurations of the general system SLH01 by simply entering “\*/H01/\*” and then selecting “Search”, as shown in Figure 40.

- Alternatively, the criteria for “System Manufacturer” can be set to “HAPCO” and the “Base Component Name” (under the Advanced Search Options) can be set to LBH01, as shown in Figure 41.

The entire group of systems can then be selected for editing by “checking” the top check box located in the first column in the search results, as illustrated in Figure 42.

### Search Luminaire Supports to Bulk Edit

Full Descriptor <i>(Use * as wildcard, e.g. 'SL2*/C*')</i>	<input type="text" value="*/H01/*"/>		
Deleted	<input type="text" value="Show All Systems"/>		
Acceptance	<input type="text" value="Any Type"/>		
Test Level	<input type="text" value="TL-3"/>		
Test Specification	<input type="text" value="Any Type"/>		
System Manufacturer	<input type="text" value="HAPCO"/>		
Base Manufacturer	<input type="text" value="Any Manufacturer"/>		
Material	<input type="text" value="Any Material"/>		
Base Type	<input type="text" value="Any Base Type"/>		
Pole/Mounting Height	<input type="text" value="Minimum"/>	to	<input type="text" value="Maximum"/> ft
Pole Base Diameter	<input type="text" value="Minimum"/>	to	<input type="text" value="Maximum"/> in
Pole Top Diameter	<input type="text" value="Minimum"/>	to	<input type="text" value="Maximum"/> in
Pole Thickness	<input type="text" value="Minimum"/>	to	<input type="text" value="Maximum"/> in
Bolt Circle Diameter	<input type="text" value="Any"/>	in	
Arm Type	<input type="text" value="Any ArmType"/>		
Number of Arms	<input type="text" value="Any"/>		
Arm Length	<input type="text" value="Minimum"/>	to	<input type="text" value="Maximum"/> <input type="text" value="Feet"/>

[Show advanced search options](#)

**Figure 40. Example 1 of using the search criteria to identify all configurations of the general system SLH01.**

### Search Luminaire Supports to Bulk Edit

Full Descriptor   
*(Use \* as wildcard, e.g. 'SL2\*/C')*

Deleted

Acceptance

Test Level

Test Specification

System Manufacturer

Base Manufacturer

Material

Base Type

Pole/Mounting Height  to  ft

Pole Base Diameter  to  in

Pole Top Diameter  to  in

Pole Thickness  to  in

Bolt Circle Diameter  in

Arm Type

Number of Arms

Arm Length  to

[Hide advanced search options](#)

Base Component Name  (e.g., LBS99)

Pole Component Name  (e.g., LPA99)

Arm Component Name  (e.g., LAT99)

**Figure 41. Example 2 of using the search criteria to identify all configurations of the general system SLH01**

Modify Selected Systems												
<input checked="" type="checkbox"/>	ID	Name/Designator	Deleted	System Manufacturer	Mounting Height (ft)	Base Type	Material	Pole Base Dia. (in)	Pole Thickness (in)	Num. Arms	Arm Type	Arm Length (ft)
<input checked="" type="checkbox"/>	602	SL20/H01/A01-7-4.5-5/	No	HAPCO	20	Shoe (H)	Aluminum	7.00	0.156	0	N/A	0' 0"
<input checked="" type="checkbox"/>	603	SL20/H01/A01-7-4.5-5/M01b2	No	HAPCO	20	Shoe (H)	Aluminum	7.00	0.156	2	Mast (M)	6' 0"
<input checked="" type="checkbox"/>	604	SL20/H01/A01-7-4.5-5/M01c2	No	HAPCO	20	Shoe (H)	Aluminum	7.00	0.156	2	Mast (M)	8' 0"
<input checked="" type="checkbox"/>	605	SL20/H01/A01-7-4.5-5/D01a2	No	HAPCO	20	Shoe (H)	Aluminum	7.00	0.156	2	Davit (D)	4' 0"
<input checked="" type="checkbox"/>	606	SL20/H01/A01-7-4.5-5/D01b2	No	HAPCO	20	Shoe (H)	Aluminum	7.00	0.156	2	Davit (D)	6' 0"
<input checked="" type="checkbox"/>	607	SL20/H01/A01-7-4.5-5/D01c2	No	HAPCO	20	Shoe (H)	Aluminum	7.00	0.156	2	Davit (D)	8' 0"
<input checked="" type="checkbox"/>	608	SL20/H01/A01-7-4.5-5/N011	No	HAPCO	20	Shoe (H)	Aluminum	7.00	0.156	1	Tenon (N)	0' 0"
<input checked="" type="checkbox"/>	609	SL20/H01/A01-7-4.5-5/C01d	No	HAPCO	20	Shoe (H)	Aluminum	7.00	0.156	2	Cross (C)	2' 9"
<input checked="" type="checkbox"/>	610	SL20/H01/A01-7-4.5-5/C01t	No	HAPCO	20	Shoe (H)	Aluminum	7.00	0.156	3	Cross (C)	3' 5"
<input checked="" type="checkbox"/>	611	SL20/H01/A01-7-4.5-5/C01q	No	HAPCO	20	Shoe (H)	Aluminum	7.00	0.156	4	Cross (C)	4' 0"
<input checked="" type="checkbox"/>	612	SL20/H01/A01-7-4.5-5/	No	HAPCO	20	Shoe (H)	Aluminum	7.00	0.156	0	N/A	0' 0"

**Figure 42. Search results from Example 1 or Example 2 in Figure 40 and Figure 41, respectively (abridged view).**

Then, clicking on the button “Modify Selected Systems” will invoke the administration page, shown in Figure 43, which permits simultaneous changes to the selected systems. Only enter data

into the fields that require modification! To change the status of the selected systems to “TF13 Approved”, enter a “3” into the “iApproval” field and select “Modify All 95 Systems” at the bottom of the page. Note that a “blank” field on this page means that no change will be made to that data field.

### Luminaire Bulk Edit: Modifying 95 Systems

Field	Value	Type of Value
description	<input type="text"/>	Text
subdir (base system name)	<input type="text"/>	e.g. "SLC01"
iArmComponent	<input type="text"/>	Integer ID of Arm Component
iPoleComponent	<input type="text"/>	Integer ID of Pole Component
iBaseComponent	<input type="text"/>	Integer ID of Base Component
specificArmComponentName	<input type="text"/>	e.g. "LAM01a"
specificPoleComponentName	<input type="text"/>	e.g. "LPA01-x-6-4.5-6"
specificBaseComponentName	<input type="text"/>	e.g. "LBC01"
numArms	<input type="text"/>	Integer (0 for none)
iContact	<input type="text"/>	Integer ID of Contact Person
FHWAAcceptanceLetter	<input type="text"/>	e.g. "LS23"
iMaterial	<input type="text"/>	Integer ID of Material
iBaseType	<input type="text"/>	Integer ID of Base Type
iApproval	3	Integer ID of Approval Type
testLevel	<input type="text"/>	Integer ID of Test Level
iTestSpecification	<input type="text"/>	Integer ID of Test Spec
mountingHeight	<input type="text"/>	Integer (inches)
poleLength	<input type="text"/>	Integer (inches) or "NULL"
iArmType	<input type="text"/>	Integer ID of Arm Type
armLength	<input type="text"/>	Integer (inches) (zero if no arm)
boltCircleMin	<input type="text"/>	Decimal or NULL
boltCircleMax	<input type="text"/>	Decimal or NULL
baseDiameter	<input type="text"/>	Decimal
topDiameter	<input type="text"/>	Decimal

*Warning: This will modify all systems that were selected on the previous stage. Double check your modifications before saving them, and consider making a database backup/export first.*

[Modify All 95 Systems](#)

↖

**Figure 43. Administration page for modifying selected systems from the “bulk edit” option (abridged view).**

## Updating and Editing Supporting Databases

### Test Specifications Administration Page

“Test Specifications” refers to the test procedures and criteria used to evaluate the crashworthiness of the luminaire support system for determining FHWA eligibility for use on the national highway system. Refer to Section 2.1 for more discussion on FHWA eligibility requirements.

The administration page for appending and editing the test specification options is accessed by clicking the appropriate link from the administration home page, as illustrated in Figure 44. The information on this page includes the unique numeric **ID** for each entry, the **name** of each entry, designator indicating if the entry is active or not (i.e., **deleted**), the date that the entry was last **modified** and the date that the entry was **created**.

Luminaire Guide      LUTESTSPECIFICATIONS

Bulk Import      Create [here](#) to insert a new LUtestSpecification.

Bulk Export

Bulk Edit      Click on an ID to edit an entry.

Approvals      < Previous 1000 items | Next 1000 items >

Comments

Arm Types

Base Types

→ Test Specifications

Luminaires

Materials

ID	name	Deleted	Modified	Created
1	Report 350	0	2009-02-18 14:02:27	2009-02-18 14:02:27
2	MASH	0	2011-09-07 12:01:16	2011-09-07 12:01:16

**Figure 44. Administration page for luminaire test specifications.**

There are currently two test specification options listed in the database: Report 350 and MASH, as shown in Figure 44. Additional test specifications can be added to the database or existing entries can be edited by clicking the on the links provided. The administration tool for adding/editing test specifications is shown in Figure 45. Only two fields can be created or edited on this page; these are “name” and “bDeleted”. When an entry is created or edited, the remaining fields are internally updated automatically. This ensures that no two entries are mistakenly assigned the same ID and that the creation and modification dates are entered correctly.

**Create a new LUTESTSPECIFICATION**

Field	Value	Hint
id	<input type="text" value="0"/>	(read-only)
name	<input type="text"/>	
dCreated	<input type="text" value="0"/>	(read-only)
bDeleted	<input type="text"/>	(1 for TRUE, 0 for FALSE)
dModified	<input type="text" value="0"/>	(read-only)

**Figure 45. Administration tool for adding/editing entries for “test specifications”**

**Materials Administration Page**

“Materials” refers to the type of material that the luminaire support is constructed from. Figure 46 shows the current list of materials in the database and their associated IDs. Additional materials can be added to the database or existing entries can be edited using the procedures described in Section 5.2.1.

**LUMATERIALS**

Create [here](#) to insert a new LUMaterial.

Click on an ID to edit an entry.

[< Previous 1000 items](#) | [Next 1000 items >](#)

ID	name	Deleted	Modified	Created
<a href="#">1</a>	<a href="#">Aluminum</a>	0	2009-05-27 19:51:21	2009-05-27 19:51:21
<a href="#">2</a>	<a href="#">Steel</a>	0	2009-11-05 06:26:55	2009-11-05 06:25:50
<a href="#">3</a>	<a href="#">Composite</a>	0	2011-09-07 12:02:11	2011-09-07 12:02:11
<a href="#">4</a>	<a href="#">Wood</a>	0	2012-10-17 07:35:53	2012-10-17 07:35:53

**Figure 46. Administration page for luminaire materials**

**Base Types Administration Page**

“Base Types” refers to the various types of breakaway bases that are used on luminaire support systems. Figure 47 shows the current list of base types in the database and their associated IDs. Additional luminaire bases can be added or existing entries can be edited using the procedures described in Section 5.2.1.

## LUBASETYPES

Create [here](#) to insert a new LUBaseType.

Click on an ID to edit an entry.

< [Previous 1000 items](#) | [Next 1000 items](#) >

ID	name	Deleted	Modified	Created
1	<a href="#">Slip (S)</a>	0	2010-07-26 12:06:16	2009-02-18 14:02:06
2	<a href="#">Transformer (T)</a>	0	2009-12-11 08:38:45	2009-11-30 13:17:28
3	<a href="#">Shoe (H)</a>	0	2010-07-26 12:06:27	2009-11-30 13:18:17
4	<a href="#">Coupling (C)</a>	0	2009-12-11 08:39:13	2009-11-30 13:18:32
5	<a href="#">Direct Buried (B)</a>	0	2010-01-28 15:38:04	2009-11-30 13:18:43
6	<a href="#">Breakaway Joint (J)</a>	0	2010-01-28 15:38:33	0000-00-00 00:00:00

Figure 47. Administration page for luminaire base types.

## Arm Types Administration Page

“Arm Types” refers to the various types of arms that are used on luminaire support systems. Figure 48 shows the current list of arm types in the database and their associated IDs. Additional luminaire arms can be added or existing entries can be edited using the procedures described in Section 5.2.1.

## LUARMTYPES

Create [here](#) to insert a new LUArmType.

Click on an ID to edit an entry.

< [Previous 1000 items](#) | [Next 1000 items](#) >

ID	name	Deleted	Modified	Created
1	<a href="#">Mast (M)</a>	0	2009-12-11 08:37:44	2009-02-18 14:00:33
2	<a href="#">Truss (T)</a>	0	2009-12-11 08:37:37	2009-02-18 14:00:38
3	<a href="#">Davit (D)</a>	0	2010-07-26 11:56:51	2009-02-18 15:14:38
4	<a href="#">Cross (C)</a>	0	2009-12-11 08:37:17	2009-12-01 05:53:38
5	<a href="#">Tenon (N)</a>	0	2010-08-10 17:47:55	2009-12-11 08:36:13

Figure 48. Administration page for luminaire arm types

## Contacts Administration Page

“Contacts” refers to the contact person for a given luminaire support system or component. The contacts for a system in one of the Online Guides is often the same contact listed in one or more of the other Guides (i.e., bridge rail, transition, sign support, luminaire support, hardware systems, or components); therefore the link to administration page for “contacts” is listed under the heading “Global” on the administration home page, as shown in Figure 49. The information



on this page includes the same type of information that is included on the administration pages previously shown, plus one additional field for “Company Name.”

The administration tool for adding/editing contacts is shown in Figure 50. As with the other administration pages, the ID, the creation date and the modification date are created automatically by the Guide and cannot be changed by the administrator. This is done to ensure that no two entries are mistakenly assigned the same ID and that the creation and modification dates are entered correctly.

### Guides Administration

Global

**Contacts**

Bridge Rail Guide

Approvals

Comments

Deck Types

Materials

Mounting Types

Perm-Temp Statuses

Railings

Test Specifications

Sign Support Guide

Approvals

Comments

Manufacturer

Signs

Test Specifications

Type

**CONTACTS**

Create [here](#) to insert a new Contact.

Click on an ID to edit an entry.

< Previous 1000 items | Next 1000 items >

ID	name	companyName	Deleted	Modified	Created
1	Malcolm H. Ray	Roadsafe LLC	0	2011-05-19 13:44:26	2007-11-11 23:48:48
2	Malcolm H. Ray, MDS LLC	MDS LLC	0	2011-05-19 13:43:19	2008-04-04 13:48:33
3	Mr. David Hubbell	Composite Structural Design L.L.C.	1	2011-10-06 13:37:34	2008-04-10 08:52:18
4	Ronald K. Faller, P.E., Ph.D.	Midwest Roadside Safety Facility	0	2011-05-20 05:40:25	2008-04-11 08:17:39
5	Heath E. Valentine	Valentine & Company	0	2009-09-27 11:56:16	2008-04-11 08:23:39
6	William P. Longstreet	Federal Highway Administration	0	2011-10-18 05:58:00	2008-04-11 08:23:44
7	Roger Bligh, Ph.D.	Texas Transportation Institute	0	2008-04-11 08:29:40	2008-04-11 08:29:40
8	Mr. Steve Beck	Michigan Department of Transportation	0	2008-05-04 12:28:33	2008-04-16 07:40:14
9	Clamp Crete	Clamp Crete Corporation	0	2008-04-24 11:49:40	2008-04-16 14:39:37
10	Transpo	Transpo Industries Inc	0	2008-04-24	2008-04-16

**Figure 49. Administration page for adding/editing contact information.**

## Update CONTACT ID# 1

Field	Value	Hint
id	<input type="text" value="1"/>	(read-only)
name	<input type="text" value="Malcolm H. Ray"/>	
companyName	<input type="text" value="Roadsafe LLC"/>	
email	<input type="text" value="mac@roadsafellc.com"/>	
address	<input type="text" value="P.O. Box 312&lt;br/&gt;12 Main Street&lt;br/&gt;Canton, Maine 04221"/>	Backslashes will be inserted before quotation marks.
phone	<input type="text" value="207-514-5474"/>	
URL	<input type="text" value="http://www.roadsafellc.com"/>	
logoURL	<input type="text" value="http://guides.roadsafellc.com/logos/roa"/>	
bDeleted	<input type="text" value="0"/>	(1 for TRUE, 0 for FALSE)
dModified	<input type="text" value="2011-05-19 13:44:26"/>	(read-only)
dCreated	<input type="text" value="2007-11-11 23:48:48"/>	(read-only)

**Figure 50. Administration tool for adding/editing entries for contacts.**

## Approvals Administration Page

“Approvals” refers to the approval status of the luminaire system or component. Figure 51 shows the current list of options for approval status and their associated IDs. Additional approval status entries can be added or existing entries can be edited using the procedures described in Section 5.2.1.

When an agency or individual submits luminaire component or system data for inclusion in the Online Guide, the following steps must be followed:

1. The administrator enters the information into the Guide and the approval status is set to “Submitted”
2. The submitter reviews the data that has been uploaded using the Online Guide, and confirms that the information is correct.
3. The administrator creates a forum for the component or system on the Guides discussion board and the approval status is set to “In Review”
4. The Task Force 13 members review the submissions and comments and vote on approving additions to the Guide.
5. If Task Force 13 approves a submission, it is added to the online Guide and the comments prior to approval are archived. Approval Status is set to “TF13 Approved”
6. If Task Force 13 votes not to add a submission to the Guide, the submitted material and comments are also archived. The Approval Status can be set to “In Review”

if the original submitter wishes to continue working on the materials or the system can be completely removed.

## LUAPPROVALS

Create [here](#) to insert a new LUApproval.

Click on an ID to edit an entry.

< [Previous 1000 items](#) | [Next 1000 items](#) >

ID	name	Deleted	Modified	Created
<a href="#">1</a>	<a href="#">In Review</a>	0	<a href="#">2009-02-18 13:59:44</a>	<a href="#">2009-02-18 13:59:44</a>
<a href="#">2</a>	<a href="#">Submitted</a>	0	<a href="#">2009-02-18 14:01:35</a>	<a href="#">2009-02-18 14:01:35</a>
<a href="#">3</a>	<a href="#">TF13 Approved</a>	0	<a href="#">2009-12-11 08:43:51</a>	<a href="#">2009-12-11 08:43:51</a>
<a href="#">4</a>		1	<a href="#">2012-10-17 09:40:05</a>	<a href="#">2009-12-11 08:43:59</a>
<a href="#">5</a>		1	<a href="#">2011-09-07 11:59:48</a>	<a href="#">2009-12-11 08:44:32</a>

**Figure 51. Administration tools for approval status.**

## Components Administration Page

The “Components” administration page, shown in Figure 52 (figure shows abridged data), is used to create or edit information for components. The information on this page includes the numeric **ID**, the **name**, the **sub-directory** used to store the files associated with the component entry, the numeric ID designating the **general type** of the component (e.g., a “4” indicates that it is a luminaire component), a designator indicating if the entry is active or not (i.e., **deleted**), the date that the entry was last **modified** and the date that the entry was **created**. Additional luminaire components can be added to the database or existing entries can be edited by clicking the on the links provided.

## COCOMPONENTS

Create [here](#) to insert a new COComponent.

Click on an ID to edit an entry.

< [Previous 1000 items](#) | [Next 1000 items](#) >

ID	subdir	name	iGeneralType	Deleted	Modified	Created
1	LAM02	Valmont Mast Arm	4	0	2012-08-16 11:53:04	2008-07-30 14:18:22
2	LAN02	Valmont Tenon	4	0	2012-08-16 11:54:17	2008-07-30 14:19:55
3	LAD02	Valmont Davit Arm	4	0	2012-08-16 11:54:48	2008-07-30 14:30:20
4	LAC05t	HAPCO Decorative Triple Cross Arm [ARM41300]	4	1	2010-08-10 13:30:40	2008-07-30 15:11:30
5	LAC05d	HAPCO Decorative Quad Cross Arm [ARM41300]	4	1	2010-08-10 13:32:24	2008-09-17 08:58:10
6	LAC06	HAPCO Decorative Cross Arm [ARM41400]	4	0	2010-08-10 13:32:39	2008-09-19 14:25:23
7	LAC06t	HAPCO Decorative Triple Cross Arm [ARM41400]	4	1	2010-08-10 13:32:44	2008-09-19 14:25:49
8	LAC06q	HAPCO Decorative Quad Cross Arm [ARM41400]	4	1	2010-08-10 13:32:48	2008-09-19 14:26:07
9	LAC07	HAPCO Decorative Cross Arm [ARM41500]	4	0	2010-08-10 13:33:14	2008-09-19 14:26:26
10	LAC07t	HAPCO Decorative Triple Cross Arm [ARM41500]	4	1	2010-08-10 13:33:19	2008-09-19 14:26:45
11	LAC01	HAPCO Cross Arm	4	0	2010-09-02 12:51:00	2008-09-19 14:27:06
12	LAT01	HAPCO Truss Arm	4	0	2009-12-31 12:19:15	2008-09-19 14:27:17

**Figure 52. Administration tools for components**

## Chapter 6

### Summary and Conclusions

This report describes the development of the updated *Guide to Standardized Highway Lighting Pole Hardware*. The updated Guide is fully digital, searchable, and online and uses the same format, procedures and features of the other Task Force 13 online guides. The online format facilitates distribution of information and makes the Guide simple to update and maintain. Chapters 3, 4 and 5 provide detailed instructions on how to use the Guide, how to submit data for inclusion into the Guide, and how to update and maintain the Guide, respectively. The updated Guide will serve as an effective tool for State and local agencies to quickly identify luminaire support structures for their projects. All luminaire support systems included in the Guide meet both the AASHTO “Standard Specification for Structural Supports for Highway Signs, Luminaires and Traffic Signals” and the FHWA eligible requirements for use on federally funded projects.

## References

- AASHTO85 AASHTO, Standard Specification for Structural Supports for Highway Signs, Luminaires and Traffic Signals, American Association of State Highway and Transportation Officials (AASHTO), Subcommittee on Bridges and Structures, Washington, D.C., 1985.
- AASHTO09 AASHTO, Standard Specifications for Structural Supports for Highway Signs, Luminaires and Traffic Signals, 5<sup>th</sup> Edition, American Association of State and Highway Transportation Officials, Subcommittee on Bridges and Structures, Washington, D.C., 2009
- MnDOT03 MnDOT, Roadway Lighting Design Manual, Minnesota Department of Transportation, St. Paul, Minnesota, 2003.
- Ross03 Ross, H.E., D.L. Sicking, and H.S. Perrara, "Recommended Procedures for the Safety Performance Evaluation of Highway Appurtenances," *National Cooperative Highway Research Program Report No. 350*, National Academy of Sciences, Washington, D.C., 1993.
- TF13-72 AASHTO-ARTBA-AGC, A Guide to Standardized Highway Barrier Rail Hardware, American Association of State Highway and Transportation Officials (AASHTO), Subcommittee on New Materials, Task Force 13, Washington, D.C., 1972.
- TF13-73 AASHTO-ARTBA-AGC, A Supplement to a Guide to Standardized Highway Barrier Rail Hardware, American Association of State Highway and Transportation Officials (AASHTO), Subcommittee on New Materials, Task Force 13, Washington, D.C., 1973.
- TF13-79 AASHTO-ARTBA-AGC, A Guide to Standardized Highway Barrier Rail Hardware, American Association of State Highway and Transportation Officials (AASHTO), Subcommittee on New Materials, Task Force 13, Washington, D.C., 1979.
- TF13-80 AASHTO-ARTBA-AGC, A Guide to Standardized Highway Lighting Pole Hardware, American Association of State Highway and Transportation Officials (AASHTO), Subcommittee on New Materials, Task Force 13, Washington, D.C., 1980.
- TF13-83 AASHTO-ARTBA-AGC, A Guide to Standardized Small Highway Sign Support Hardware, American Association of State Highway and Transportation Officials (AASHTO), Subcommittee on New Materials, Task Force 13, Washington, D.C., 1983.
- TF13-90 AASHTO-ARTBA-AGC, Work Zone Barrier Supplement to A Guide to Standardized Highway Barrier Rail Hardware, American Association of State

Highway and Transportation Officials (AASHTO), Subcommittee on New Materials, Task Force 13, Washington, D.C., 1990.

- TF13-95 AASHTO-ARTBA-AGC, A Guide to Standardized Highway Barrier Hardware, American Association of State Highway and Transportation Officials (AASHTO), Subcommittee on New Materials, Task Force 13, Washington, D.C., 1995.
- TF13-96 AASHTO-ARTBA-AGC, A Guide to Standardized Highway Drainage Products, American Association of State Highway and Transportation Officials (AASHTO), Subcommittee on New Materials, Task Force 13, Washington, D.C., 1996.
- TF13-05 AASHTO-ARTBA-AGC, Online Guide to Standardized Highway Barrier Hardware, American Association of State Highway and Transportation Officials (AASHTO), Subcommittee on New Materials, Task Force 13, Washington, D.C., 2005. <http://aashtotf13.tamu.edu/OldGuide/index.html>