



TESTING CERT # 2937.01

*Midwest States Regional Pooled Fund Research Program  
Fiscal Year 2011 (Year 21)  
Research Project Number TPF-5(193) Supplement #32  
NDOR Sponsoring Agency Code RFP-11-MGS-2*

# **SAFETY PERFORMANCE EVALUATION OF WEAK-POST, W-BEAM GUARDRAIL ATTACHED TO CULVERT**

Submitted by

Allison J. Schneider  
Undergraduate Research Assistant

Scott Rosenbaugh M.S.C.E., E.I.T.  
Research Associate Engineer

Ronald K. Faller, Ph.D., P.E.  
Research Associate Professor  
MwRSF Director

Dean L. Sicking, Ph.D., P.E.  
Emeritus Professor

Karla A. Lechtenberg, M.S.M.E., E.I.T.  
Research Associate Engineer

John D. Reid, Ph.D.  
Professor

## **MIDWEST ROADSIDE SAFETY FACILITY**

Nebraska Transportation Center  
University of Nebraska-Lincoln  
130 Whittier Research Center  
2200 Vine Street  
Lincoln, Nebraska 68583-0853  
(402) 472-0965

Submitted to

## **MIDWEST STATES REGIONAL POOLED FUND PROGRAM**

Nebraska Department of Roads  
1500 Nebraska Highway 2  
Lincoln, Nebraska 68502

MwRSF Research Report No. TRP-03-277-14

February 12, 2014

## TECHNICAL REPORT DOCUMENTATION PAGE

1. Report No. <b>TRP-03-277-14</b>	2.	3. Recipient's Accession No.	
4. Title and Subtitle <b>Safety Performance Evaluation of Weak-Post, W-Beam Guardrail Attached to Culvert</b>		5. Report Date <b>February 12, 2014</b>	
7. Author(s) <b>Schneider, A.J., Rosenbaugh, S.K., Faller, R.K., Sicking, D.L., Lechtenberg, K.A., and Reid, J.D.</b>		8. Performing Organization Report No. <b>TRP-03-277-14</b>	
9. Performing Organization Name and Address <b>Midwest Roadside Safety Facility (MwRSF) Nebraska Transportation Center University of Nebraska-Lincoln 130 Whittier Research Center 2200 Vine Street Lincoln, Nebraska 68583-0853</b>		10. Project/Task/Work Unit No.	
12. Sponsoring Organization Name and Address <b>Midwest States Regional Pooled Fund Program Nebraska Department of Roads 1500 Nebraska Highway 2 Lincoln, Nebraska 68502</b>		11. Contract © or Grant (G) No. <b>TPF-5(193) Supplement #32</b>	
13. Type of Report and Period Covered <b>Final Report: 2011-2014</b>		14. Sponsoring Agency Code <b>RPPF-11-MGS-2</b>	
15. Supplementary Notes <b>Prepared in cooperation with U.S. Department of Transportation, Federal Highway Administration.</b>			
16. Abstract (Limit: 200 words) <p>A new W-beam guardrail system for use on low-fill culverts was developed and evaluated. The system was adapted from the MGS bridge railing for attachment to the outside face of culvert headwalls. Four attachment concepts were developed and evaluated through dynamic component testing. Both lateral and longitudinal impacts were conducted on the design concepts while mounted to a simulated concrete culvert headwall. The resulting damage from each test was confined to post bending only. Although all four designs prevented damage to the socket assembly and culvert headwall, the top-mounted, single-anchor design and the side-mounted design were recommended for use based on ease of fabrication and installation.</p> <p>The new weak-post, W-beam guardrail system for attachment to low-fill culverts was designed with multiple advantages over current culvert treatments. The guardrail system is mounted to the outside face of the headwall, thereby minimizing intrusion over the culvert and maximizing the traversable roadway width. The barrier has an unrestricted system length and does not require a transition when attached to standard MGS. Additionally, the attachment configurations were designed utilizing epoxy anchors, enabling the system to be installed on new or existing culverts. Finally, implementation guidance was provided for new system installations.</p>			
17. Document Analysis/Descriptors <b>Roadside Safety, W-beam, Guardrail, Culverts, Weak-Post, Non-Blocked, MASH, MGS, and Component Testing</b>		18. Availability Statement <b>No restrictions. Document available from: National Technical Information Services, Springfield, Virginia 22161</b>	
19. Security Class (this report) <b>Unclassified</b>	20. Security Class (this page) <b>Unclassified</b>	21. No. of Pages <b>169</b>	22. Price

## **DISCLAIMER STATEMENT**

This report was completed with funding from the Federal Highway Administration, U.S. Department of Transportation. The contents of this report reflect the views and opinions of the authors who are responsible for the facts and the accuracy of the data presented herein. The contents do not necessarily reflect the official views or policies of the state highway departments participating in the Midwest States Regional Pooled Fund Program nor the Federal Highway Administration, U.S. Department of Transportation. This report does not constitute a standard, specification, regulation, product endorsement, or an endorsement of manufacturers.

## **UNCERTAINTY OF MEASUREMENT STATEMENT**

The Midwest Roadside Safety Facility (MwRSF) has determined the uncertainty of measurements for several parameters involved in standard full-scale crash testing and non-standard testing of roadside safety features. Information regarding the uncertainty of measurements for critical parameters is available upon request by the sponsor and the Federal Highway Administration.

## **INDEPENDENT APPROVING AUTHORITY**

The Independent Approving Authority (IAA) for the data contained herein was Dr. Jennifer Schmidt, P.E., Post-Doctoral Research Associate.

## **ACKNOWLEDGEMENTS**

The authors wish to acknowledge several sources that made a contribution to this project:

(1) the Midwest States Regional Pooled Fund Program funded by the Illinois Department of Transportation, Iowa Department of Transportation, Kansas Department of Transportation, Minnesota Department of Transportation, Missouri Department of Transportation, Nebraska Department of Roads, Ohio Department of Transportation, South Dakota Department of Transportation, Wisconsin Department of Transportation, and Wyoming Department of Transportation for sponsoring this project; and (2) MwRSF personnel for constructing the barriers and conducting the crash tests.

Acknowledgement is also given to the following individuals who made a contribution to the completion of this research project.

### **Midwest Roadside Safety Facility**

J.C. Holloway, M.S.C.E., E.I.T., Test Site Manager  
R.W. Bielenberg, M.S.M.E., E.I.T., Research Associate Engineer  
A.T. Russell, B.S.B.A., Shop Manager  
K.L. Krenk, B.S.M.A., Maintenance Mechanic  
D.S. Charroin, Laboratory Mechanic  
S.M. Tighe, Laboratory Mechanic  
Undergraduate and Graduate Research Assistants

### **Illinois Department of Transportation**

Priscilla A Tobias, P.E., State Safety Engineer / Bureau Chief  
Timothy J Sheehan, P.E., Safety Design Unit Chief  
Paul L. Lorton, P.E., Safety Programs Unit Chief

### **Iowa Department of Transportation**

David Little, P.E., Assistant District Engineer  
Deanna Maifield, P.E., Methods Engineer  
Chris Poole, P.E., Roadside Safety Engineer



**Kansas Department of Transportation**

Ron Seitz, P.E., Bureau Chief  
Rod Lacy, P.E., Metro Engineer  
Scott King, P.E., Road Design Leader

**Minnesota Department of Transportation**

Michael Elle, P.E., Design Standard Engineer

**Missouri Department of Transportation**

Joseph G. Jones, P.E., Engineering Policy Administrator

**Nebraska Department of Roads**

Phil TenHulzen, P.E., Design Standards Engineer  
Jodi Gibson, Research Coordinator

**Ohio Department of Transportation**

Michael Bline, P.E., Standards and Geometrics Engineer  
Maria Ruppe, P.E., Roadway Standards Engineer

**South Dakota Department of Transportation**

David Huft, Research Engineer  
Bernie Clocksin, Lead Project Engineer

**Wisconsin Department of Transportation**

Jerry Zogg, P.E., Chief Roadway Standards Engineer  
John Bridwell, P.E., Standards Development Engineer  
Erik Emerson, P.E., Standards Development Engineer

**Wyoming Department of Transportation**

William Wilson, P.E., Architectural and Highway Standards Engineer

**Federal Highway Administration**

John Perry, P.E., Nebraska Division Office  
Danny Briggs, Nebraska Division Office

## TABLE OF CONTENTS

TECHNICAL REPORT DOCUMENTATION PAGE .....	i
DISCLAIMER STATEMENT .....	ii
UNCERTAINTY OF MEASUREMENT STATEMENT .....	ii
INDEPENDENT APPROVING AUTHORITY.....	ii
ACKNOWLEDGEMENTS .....	iii
TABLE OF CONTENTS.....	v
LIST OF FIGURES .....	vii
LIST OF TABLES .....	x
1 INTRODUCTION .....	1
1.1 Background.....	1
1.2 Objective .....	7
1.3 Scope.....	8
2 SIMULATED CULVERT DESIGN .....	9
3 BARRIER ATTACHMENT DESIGNS .....	18
3.1 Design Criteria .....	18
3.2 Design Concepts .....	19
3.2.1 Concept A: Top-Mounted, Single-Anchor .....	19
3.2.2 Concept B: Top-Mounted, Double-Anchor .....	28
3.2.3 Concept C: Wrap-Around .....	36
3.2.4 Concept D: Side-Mounted, Through-Bolted.....	44
3.2.5 Concept D2: Side-Mounted, Epoxy-Anchored.....	52
4 EVALUATION CRITERIA AND TEST CONDITIONS .....	60
4.1 Testing Criteria .....	60
4.2 Critical Impact Conditions .....	60
4.3 Scope.....	61
4.4 Test Facility .....	61
4.5 Equipment and Instrumentation .....	63
4.5.1 Bogie .....	63
4.5.2 Accelerometers .....	65
4.5.3 Retroreflective Optic Speed Trap .....	65
4.5.4 Digital Photography .....	66
4.6 End of Test Determination.....	66
4.7 Data Processing.....	67
5 COMPONENT TESTING RESULTS AND DISCUSSION .....	68
5.1 Lateral Impact Testing Results .....	68

5.1.1 Test No. CP-1C..... 68  
5.1.2 Test No. CP-2A..... 73  
5.1.3 Test No. CP-3D..... 78  
5.1.4 Test No. CP-4B..... 83  
5.1.5 Test No. CP-5D2..... 88  
5.2 Lateral Impact Testing Discussion..... 93  
5.3 Longitudinal Impact Testing Results ..... 96  
    5.3.1 Test No. CP-6D2..... 96  
    5.3.2 Test No. CP-7A..... 100  
5.4 Longitudinal Impact Testing Discussion ..... 104  
  
6 SUMMARY, CONCLUSIONS, AND RECOMMENDATIONS..... 106  
  
7 REFERENCES ..... 125  
  
8 APPENDICES ..... 127  
    Appendix A. Material Specifications ..... 128  
    Appendix B. Bogie Test Results ..... 154

## LIST OF FIGURES

Figure 1. W-beam System Attached to Low-Fill Culverts Developed at MwRSF [2-4] .....	3
Figure 2. W-beam System Attached to Low-Fill Culverts Developed at TTI [7] .....	4
Figure 3. NCHRP Report No. 350-Compliant Long-Span Guardrail System [8-10].....	5
Figure 4. MASH-Compliant, MGS Long-Span Guardrail System [11-12].....	5
Figure 5. Weak-Post, MGS Bridge Rail attached to Concrete Deck [13-14].....	7
Figure 6. Simulated Culvert, System Layout.....	12
Figure 7. Simulated Culvert, Elevation View .....	13
Figure 8. Simulated Culvert, Headwall Reinforcement Details .....	14
Figure 9. Simulated Culvert, Rebar Details .....	15
Figure 10. Simulated Culvert, Bill of Materials .....	16
Figure 11. Simulated Culvert Photographs .....	17
Figure 12. Design Concept A: Top-Mounted, Single-Anchor Attachment .....	21
Figure 13. Design Concept A, Socket Assembly Details .....	22
Figure 14. Design Concept A, Tube and Bottom Mounting Plate Details .....	23
Figure 15. Design Concept A, Top Mounting Plate Details .....	24
Figure 16. Design Concept A, Post Assembly.....	25
Figure 17. Design Concept A, Bill of Materials .....	26
Figure 18. Design Concept A, Installation Photographs.....	27
Figure 19. Design Concept B: Top-Mounted, Double-Anchor Attachment.....	29
Figure 20. Design Concept B, Socket Assembly Details.....	30
Figure 21. Design Concept B, Tube and Bottom Mounting Plate Details.....	31
Figure 22. Design Concept B, Top Mounting Plate Details .....	32
Figure 23. Design Concept B, Post Assembly .....	33
Figure 24. Design Concept B, Bill of Materials .....	34
Figure 25. Design Concept B, Installation Photographs.....	35
Figure 26. Design Concept C: Wrap-Around Attachment.....	37
Figure 27. Design Concept C, Socket Assembly Details.....	38
Figure 28. Design Concept C, Tube and Bottom Mounting Plate Details.....	39
Figure 29. Design Concept C, Top Mounting Plate Details .....	40
Figure 30. Design Concept C, Post Assembly .....	41
Figure 31. Design Concept C, Bill of Materials .....	42
Figure 32. Design Concept C, Installation Photographs.....	43
Figure 33. Design Concept D: Side-Mounted, Through-Bolted Attachment .....	45
Figure 34. Design Concept D, Socket Assembly Details .....	46
Figure 35. Design Concept D, Tube and Bottom Mounting Plate Details .....	47
Figure 36. Design Concept D, Top Mounting Plate Details .....	48
Figure 37. Design Concept D, Post Assembly.....	49
Figure 38. Design Concept D, Bill of Materials .....	50
Figure 39. Design Concept D, Installation Photographs.....	51
Figure 40. Design Concept D2: Side-Mounted, Epoxy-Anchored Attachment .....	53
Figure 41. Design Concept D2, Socket Assembly Details .....	54
Figure 42. Design Concept D2, Tube and Bottom Mounting Plate Details .....	55
Figure 43. Design Concept D2, Top Mounting Plate Details .....	56
Figure 44. Design Concept D2, Post Assembly.....	57
Figure 45. Design Concept D2, Bill of Materials .....	58

Figure 46. Design Concept D2, Installation Photographs.....	59
Figure 47. Locations of Test Articles on Simulated Culvert .....	62
Figure 48. Rigid-Frame Bogie Equipped with Lateral and Longitudinal Impact Heads.....	64
Figure 49. Force vs. Deflection and Energy vs. Deflection, Test No. CP-1C .....	69
Figure 50. Time-Sequential Photographs, Test No. CP-1C.....	70
Figure 51. Additional Time-Sequential Photographs, Test No. CP-1C.....	71
Figure 52. Post-Impact Photographs, Test No. CP-1C .....	72
Figure 53. Force vs. Deflection and Energy vs. Deflection, Test No. CP-2A .....	74
Figure 54. Time-Sequential Photographs, Test No. CP-2A.....	75
Figure 55. Additional Time-Sequential Photographs, Test No. CP-2A .....	76
Figure 56. Post-Impact Photographs, Test No. CP-2A.....	77
Figure 57. Force vs. Deflection and Energy vs. Deflection, Test No. CP-3D.....	79
Figure 58. Time-Sequential Photographs, Test No. CP-3D.....	80
Figure 59. Additional Time-Sequential Photographs, Test No. CP-3D .....	81
Figure 60. Post-Impact Photographs, Test No. CP-3D.....	82
Figure 61. Force vs. Deflection and Energy vs. Deflection, Test No. CP-4B .....	84
Figure 62. Time-Sequential Photographs, Test No. CP-4B.....	85
Figure 63. Additional Time-Sequential Photographs, Test No. CP-4B.....	86
Figure 64. Post-Impact Photographs, Test No. CP-4B .....	87
Figure 65. Force vs. Deflection and Energy vs. Deflection, Test No. CP-5D2.....	89
Figure 66. Time-Sequential Photographs, Test No. CP-5D2.....	90
Figure 67. Additional Time-Sequential Photographs, Test No. CP-5D2 .....	91
Figure 68. Post-Impact Photographs, Test No. CP-5D2 .....	92
Figure 69. Force vs. Deflection Plots from Lateral Impact Tests.....	95
Figure 70. Energy vs. Deflection Plots from Lateral Impact Tests .....	95
Figure 71. Force vs. Deflection and Energy vs. Deflection, Test No. CP-6D2.....	97
Figure 72. Time Sequential Photographs, Test No. CP-6D2.....	98
Figure 73. Post-Impact Photographs, Test No. CP-6D2.....	99
Figure 74. Force vs. Deflection and Energy vs. Deflection, Test No. CP-7A.....	101
Figure 75. Time-Sequential Photographs, Test No. CP-7A.....	102
Figure 76. Post-Impact Photographs, Test No. CP-7A.....	103
Figure 77. Force vs. Deflection Plots from Longitudinal Impact Tests.....	105
Figure 78. Energy vs. Deflection Plots from Longitudinal Impact Tests .....	105
Figure 79. Weak-Post, W-beam Guardrail System on Culverts, System Layout.....	111
Figure 80. Post Spacing and Rail-to-Post Attachment Details .....	112
Figure 81. Post Assembly Details.....	113
Figure 82. W-beam Rail, Backup Plate, and Attachment Hardware Details.....	114
Figure 83. Top-Mounted Configuration Details .....	115
Figure 84. Top-Mounted Configuration, Socket Assembly Details .....	116
Figure 85. Top-Mounted Configuration, Socket Assembly Components .....	117
Figure 86. Top-Mounted Configuration, Attachment Hardware Details.....	118
Figure 87. Top-Mounted Configuration, Bill of Materials .....	119
Figure 88. Side-Mounted Configuration Details .....	120
Figure 89. Side-Mounted Configuration, Socket Assembly Details.....	121
Figure 90. Side-Mounted Configuration, Socket Assembly Components.....	122
Figure 91. Side-Mounted Configuration, Attachment Hardware Details .....	123
Figure 92. Side-Mounted Configuration, Bill of Materials .....	124

Figure A-1. Culvert Support Wall Concrete, Mix Details .....	135
Figure A-2. Culvert Support Wall Concrete, Strength Test.....	136
Figure A-3. Culvert Deck Slab Concrete, Mix Details .....	137
Figure A-4. Culvert Deck Slab Concrete, Strength Test .....	138
Figure A-5. Culvert Headwall Concrete, Mix Details .....	139
Figure A-6. Culvert Headwall Concrete, Strength Test.....	140
Figure A-7. Culvert Reinforcement, No. 5 Bars .....	141
Figure A-8. Culvert Reinforcement, No. 4 Bars .....	142
Figure A-9. 4x4x $\frac{3}{8}$ -in. Steel Socket Tubes, Test Nos. CP-1 through CP-7.....	143
Figure A-10. Post Standoffs (Test Nos. CP-1 through 7), Gusset Plates (CP-3, 5, and 6), and Washer Plates (CP-3).....	144
Figure A-11. Top and Bottom Mounting Plates (Test Nos. CP-1 through 7) and Gusset Plates (CP-1, 2, 4, and 7) .....	145
Figure A-12. $\frac{1}{2}$ -in. Dia. Hardened Round Washer, Test Nos. CP-1 through 7 .....	146
Figure A-13. $\frac{5}{8}$ -in. Dia. Hardened Round Washer, Test No. CP-1 .....	146
Figure A-14. $1\frac{1}{8}$ -in. Dia. UNC Threaded Rod and Washer, Test Nos. CP-2 and 7 .....	147
Figure A-15. $1\frac{1}{8}$ -in. Dia. UNC Heavy Hex Nut, Test Nos. CP-2 and 7.....	147
Figure A-16. $\frac{1}{2}$ -in. Dia. UNC Heavy Hex Nut, Test Nos. Test Nos. CP-1 through 7.....	148
Figure A-17. $\frac{3}{4}$ -in. Dia. UNC Heavy Hex Nut, Test Nos. CP-3 through 6 .....	148
Figure A-18. $\frac{5}{8}$ -in. Dia. UNC Heavy Hex Nut, Test No. CP-1 .....	149
Figure A-19. $\frac{5}{8}$ -in. 11x5 A325 Heavy Hex Bolt with Nut, Test Nos. CP-1 through 7 .....	149
Figure A-20. $\frac{1}{2}$ -in. Dia UNC Threaded Rod (Test Nos. CP-1 through 7), $\frac{5}{8}$ -in. Dia UNC Threaded Rod (CP-1), and $\frac{3}{4}$ -in. Dia UNC Threaded Rod (CP-3 through 6) .....	150
Figure A-21. $\frac{3}{4}$ -in. Dia. Hardened Round Washer, Test Nos. CP-4 through 6 .....	151
Figure A-22. S3x5.7 Steel Post, Test Nos. CP-1 through 4.....	152
Figure A-23. S3x5.7 Steel Post, Test Nos. CP-5 through 7 .....	153
Figure B-1. Test No. CP-1C Results (EDR-3).....	155
Figure B-2. Test No. CP-1C Results (SLICE).....	156
Figure B-3. Test No. CP-2A Results (EDR-3) .....	157
Figure B-4. Test No. CP-2A Results (SLICE).....	158
Figure B-5. Test No. CP-3D Results (EDR-3) .....	159
Figure B-6. Test No. CP-3D Results (SLICE).....	160
Figure B-7. Test No. CP-4B Results (EDR-3).....	161
Figure B-8. Test No. CP-4B Results (SLICE).....	162
Figure B-9. Test No. CP-5D2 Results (EDR-3) .....	163
Figure B-10. Test No. CP-5D2 Results (SLICE).....	164
Figure B-11. Test No. CP-6D2 Results (EDR-3) .....	165
Figure B-12. Test No. CP-6D2 Results (SLICE).....	166
Figure B-13. Test No. CP-7A Results (EDR-3) .....	167
Figure B-14. Test No. CP-7A Results (SLICE).....	168

**LIST OF TABLES**

Table 1. Survey Results of State DOT Standard Culvert Plans .....11  
Table 2. Bogie Testing Matrix .....63  
Table 3. Weather and Atmospheric Conditions, Lateral Impact Testing .....68  
Table 4. Summary of Lateral Impact Testing .....93  
Table 5. Weather and Atmospheric Conditions .....96  
Table 6. Summary of Lateral Impact Testing .....104  
Table A-1. Material Certification List, Simulated Concrete Culvert.....129  
Table A-2. Material Certification List, Design Concept A, Test Nos. CP-2A and CP-7A .....130  
Table A-3. Material Certification List, Design Concept B, Test No. CP-4B .....131  
Table A-4. Material Certification List, Design Concept C, Test No. CP-1C .....132  
Table A-5. Material Certification List, Design Concept D, Test No. CP-3D.....133  
Table A-6. Material Certification List, Design Concept D2, Test Nos. CP-5D2 and CP-6D2 ...134

## 1 INTRODUCTION

### 1.1 Background

Concrete box culverts are routinely installed under roadways in order to allow water drainage without affecting the motoring public. Unfortunately, these box culverts can also represent a hazard on the roadside when they do not extend outside of the clear zone and often require safety treatments in the form of roadside barriers. The most common safety barriers utilized to shield these areas are W-beam guardrail systems. However, low-fill culverts with less than 40 in. (1,016 mm) of soil fill prevent the proper installation of standard guardrail posts due to a lack of available embedment depth. Previous crash testing has shown that W-beam installations with shallow post embedment do not perform adequately and are prone to vehicle override [1]. Therefore, low-fill culverts require specialized guardrail systems to safely treat the hazard.

Currently, two different types of guardrail systems are being used to treat cross-drainage, box culverts: 1) guardrail systems anchored to the top slab of the culvert and 2) long-span guardrail systems. Top-mounted guardrail systems typically consist of steel posts welded to base plates which are bolted to the top slab of the culvert. Anchoring the guardrail posts to the culvert's top slab ensures that the post will provide the lateral stiffness necessary for the barrier to contain and safely redirect errant vehicles. One such system developed at the Midwest Roadside Safety Facility (MwRSF) incorporated W6x9 (W152x13.4) steel posts spaced 37½ in. (953 mm) on center, a 27¾-in. (705-mm) top rail height, a deformable ½-in. (13-mm) base plate, and four 1-in. (25-mm) diameter threaded anchors [2-4], as shown in Figure 1. The system was successfully tested to the safety performance criteria of National Cooperative Highway Research Program (NCHRP) Report No. 350 [5].



A similar system developed by the Texas Transportation Institute (TTI) was configured to satisfy the more demanding safety performance criteria from the American Association of State Highway and Transportation Officials (AASHTO) *Manual for Assessing Safety Hardware* (MASH) [6]. The system utilized W6x9 (W152x13.4) steel posts spaced 75 in. (1,905 mm) on center, a thicker,  $\frac{7}{8}$ -in. (22-mm) base plate, and a 31-in. (787-mm) top rail height [7], as shown in Figure 2. Both top-mounted guardrail systems described herein were designed for use with a minimum fill depth of 9 in. (229 mm) on the culverts.

Although top-mounted guardrail designs provide a crashworthy treatment for culvert openings, they have disadvantages. Both of the crashworthy systems were crash tested with an 18-in. (457-mm) lateral offset between the back of the post and the inside of the culvert headwall. MwRSF later recommended a 10-in. (254-mm) minimum offset following an analysis of the crash test's high-speed video. This offset is necessary to allow the post to rotate back freely without contacting the headwall. If rotation is restricted by placing the post too close to the headwall, the posts can become snag points or climbing ramps and may result in vehicle instabilities [2]. However, this 10-in. (254-mm) lateral offset, coupled with the footprint of the system itself, results in the loss of over 4.5 ft (1.4 m) of traversable roadway width. Extending the culvert length another 4.5 ft (1.4 m) to gain back this loss in roadway width can drastically increase costs. Additionally, when these systems are impacted, the damaged posts must be replaced, similar to standard guardrail installations. However, the fill soil must be removed around damaged top-mounted posts to gain access to the anchor bolts. This soil removal and replacement after the new post is installed adds to repair time and labor costs.

Long-span guardrail systems contain unsupported lengths of W-beam rail that span over the top of culverts. These barrier systems do not require attachment to the culvert, thus allowing the culvert and the barrier system to operate independently. One crashworthy system consists of

W152x13.4 steel posts, 946-mm long with 152x203x356 routed wood blockouts

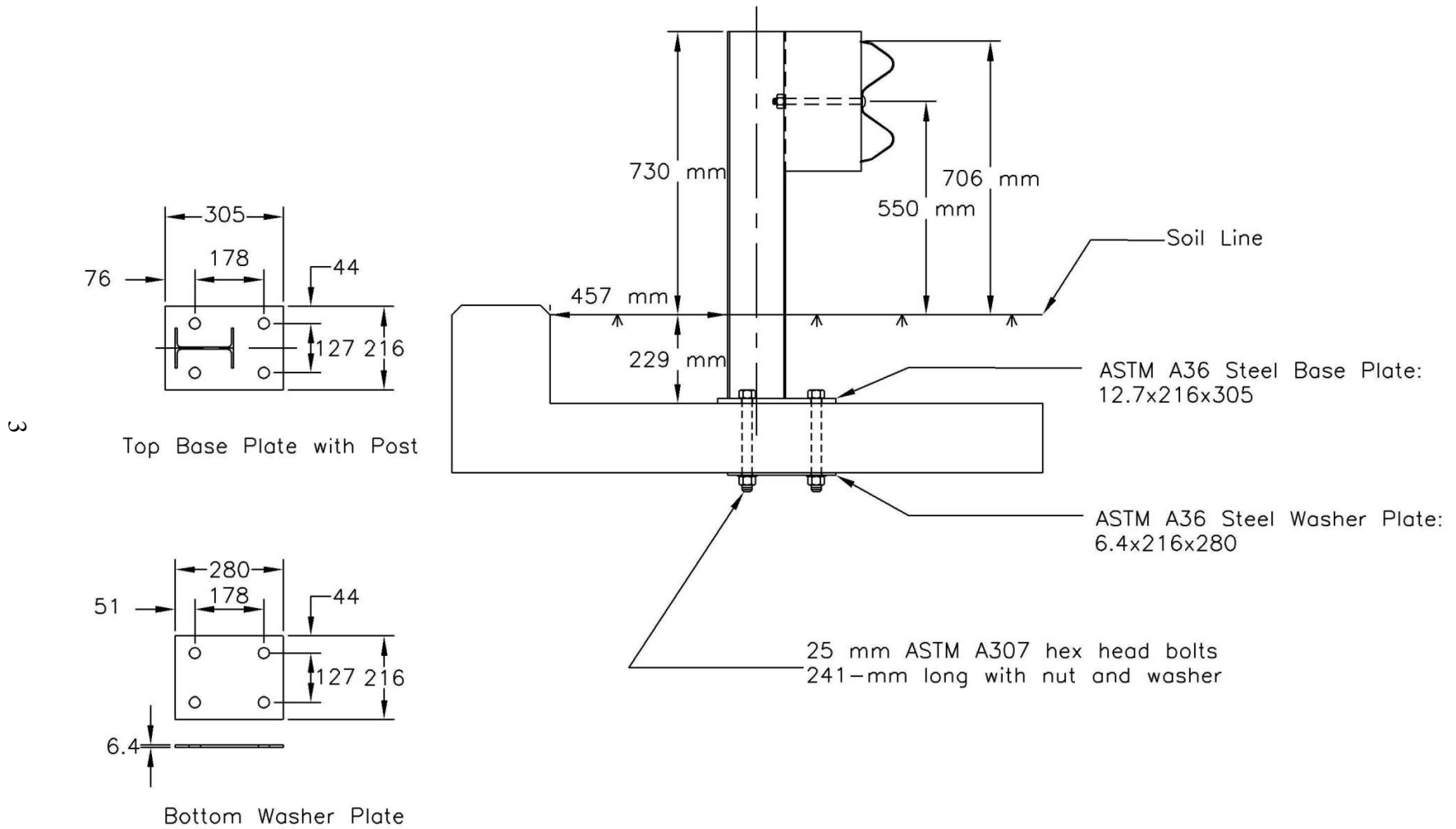

Figure 1. W-beam System Attached to Low-Fill Culverts Developed at MwRSF [2-4]

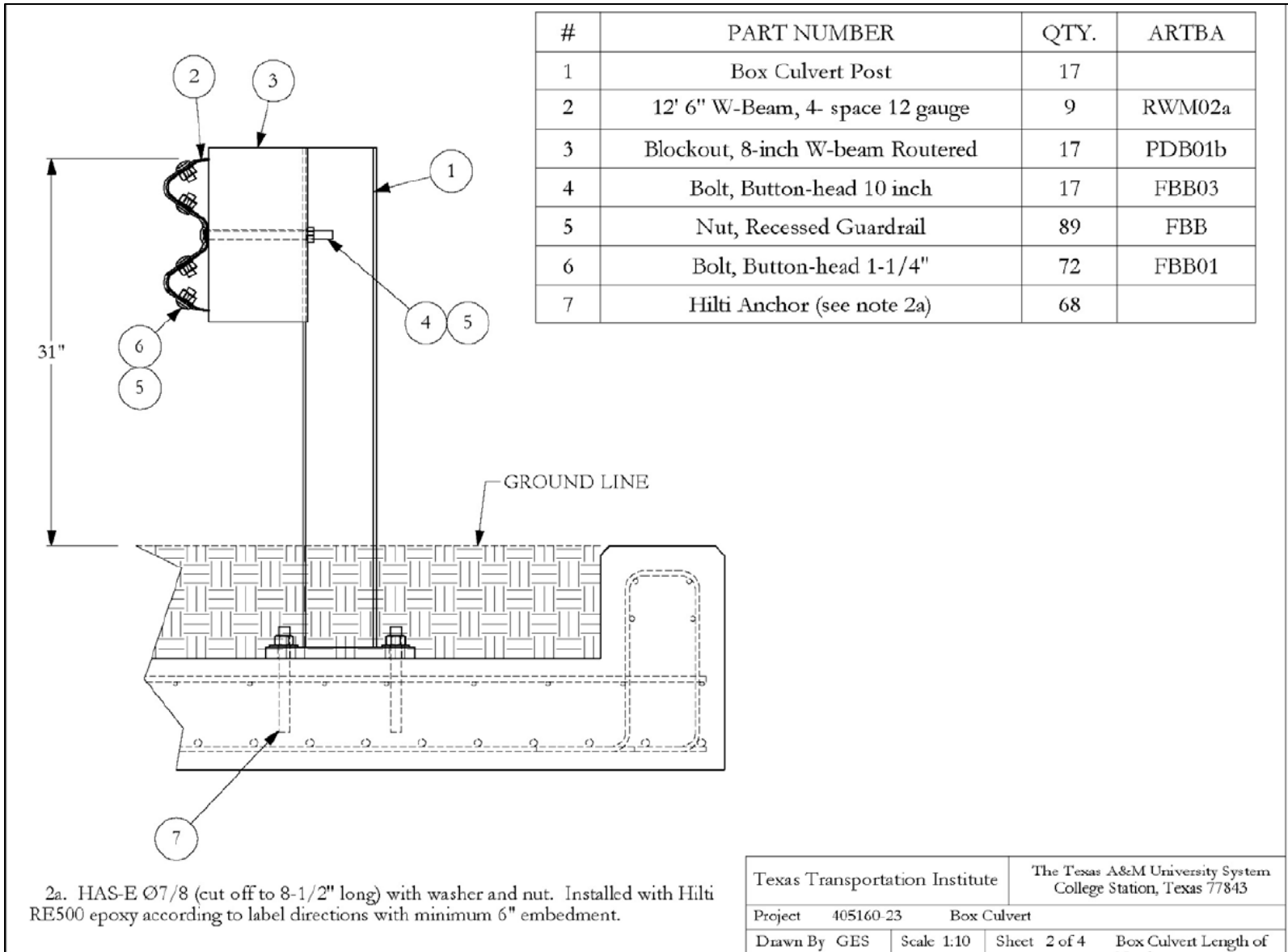

Figure 2. W-beam System Attached to Low-Fill Culverts Developed at TTI [7]

100 ft (30.5 m) of nested, 12-gauge (2.66-mm thick) W-beam guardrail centered over a 25-ft (7.6-m) unsupported span length [8-10], as shown in Figure 3. A 27¾-in. (705-mm) top rail height was utilized for the entire system. Three wooden CRT posts were placed adjacent to and on both sides of the unsupported span length in order to prevent vehicle pocketing and snagging. This system was designed and successfully crash tested to NCHRP No. Report 350 safety performance criteria.

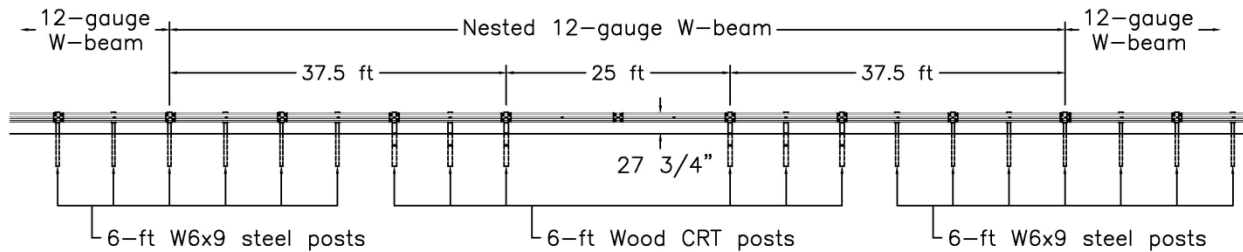

Figure 3. NCHRP Report No. 350-Compliant Long-Span Guardrail System [8-10]

The Midwest Guardrail System (MGS) long-span system is an updated version of the original system and was designed to satisfy MASH safety standards. The MGS long-span system maintained the 25-ft (7.6-m) unsupported span length and the use of six CRT posts, as shown in Figure 4. However, only a single layer of 12-gauge (2.66-mm thick) W-beam was utilized, the rail height was increased to 31 in. (787 mm), and the rail splices were moved to post mid-spans [11-12].

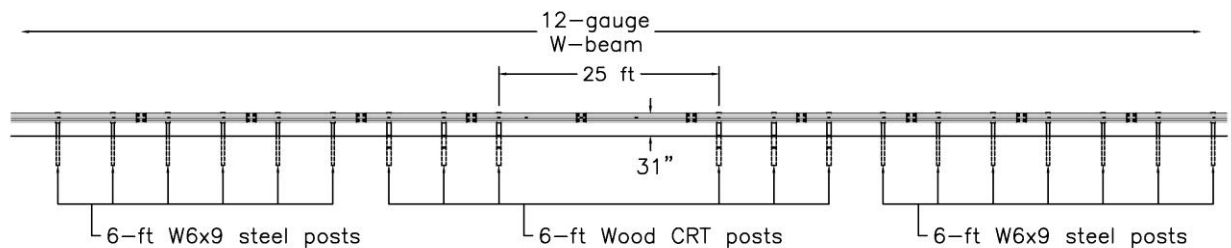

Figure 4. MASH-Compliant, MGS Long-Span Guardrail System [11-12]

Long-span guardrail systems do not require additional components for attachment to the culvert and provide a cost-effective method for shielding culverts. Further, long-span systems do not require an offset from the culvert and can be installed with the back of the post even with the interior face of the culvert headwall. Thus, long-span systems do not intrude into the roadway width as much as top-mounted systems. However, the NCHRP Report No. 350 long-span system utilizes double blockouts for a 16-in. (406-mm) total depth, while the MGS long-span system utilizes 12-in. (305-mm) deep blockouts. These blockout depths, in addition to the 8-in. (203-mm) deep post, still result in a loss of nearly 4 ft (1.2 m) of traversable roadway width. Finally, long-span systems are limited to a maximum unsupported span length of 25 ft (7.6 m). Thus, box culverts with a width, or roadway length, greater than 25 ft (7.6 m) cannot be treated with current long-span W-beam systems.

Although the weak-post, MGS bridge rail was not designed for use on culverts, it has some similarities to culvert-mounted barrier systems. The weak-post, MGS bridge rail incorporates 31-in. (787-mm) tall W-beam guardrail and attaches to concrete bridge decks (similar to concrete box culverts). The use of weak, S3x5.7 (S76x8.5) posts and the method of post attachment to the bridge deck make this system unique. The posts are installed into HSS4x4x $\frac{3}{8}$  (HSS 102 mm x 102 mm x 10 mm) steel sockets placed along the outside edge of the bridge deck. Each socket is attached to the bridge deck with a 1-in. (25-mm) diameter ASTM A307 vertical through-bolt and a bottom steel angle, as shown in Figure 5. The placement of the posts and sockets off the edge of the bridge deck, coupled with the use of 6-in. (152-mm) long, W-beam backup plates instead of blockouts, allows for minimal intrusion into the roadway and maximizes the traversable width [13-14].

The use of weak S3x5.7 (S76x8.5) posts limits the load transferred to the bridge deck and prevents deck damage. During the successful MASH test level 3 (TL-3) crash testing program,

the posts were bent over while only minor cracking was observed in the bridge deck. Without significant damage to the deck or attachment sockets, repairs to an impacted system require only the removal of the damaged posts and rail segments, insertion of new posts, and attachment of new W-beam segments. Thus, repair to the system should be relatively quick and easy. Finally, the posts were spaced at half-post spacing, or 37½ in. (953 mm) on center. The combination of a weaker post and reduced post spacing makes the lateral stiffness and dynamic deflection of the weak-post, MGS bridge rail very similar to that observed for the standard MGS. Therefore, a stiffness transition is not required between the bridge rail and the adjacent MGS installations.

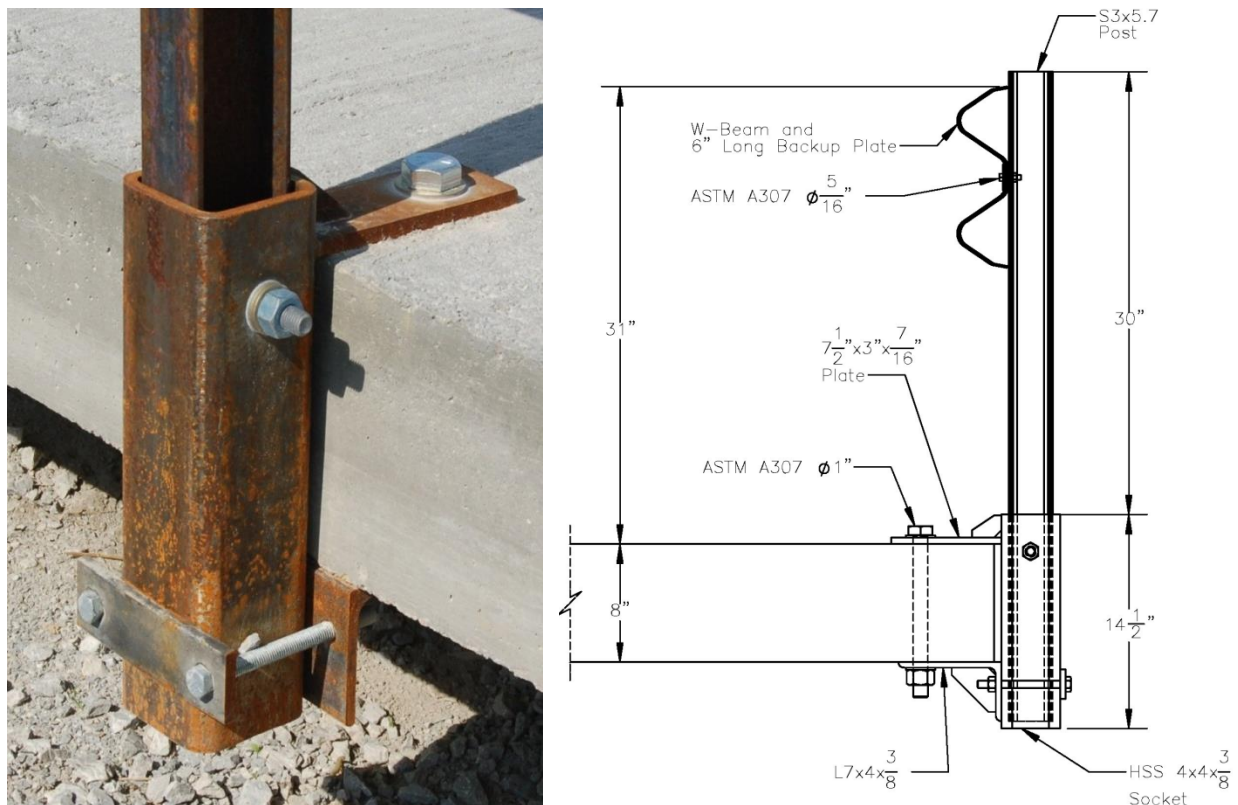

Figure 5. Weak-Post, MGS Bridge Rail attached to Concrete Deck [13-14].

## 1.2 Objective

The objective of this research effort was to develop a new W-beam guardrail system for use on low-fill culverts that satisfied the safety performance criteria of MASH TL-3. The new

guardrail system was to address the disadvantages of current culvert treatments by maximizing the traversable roadway width, providing an unrestricted system length, minimizing repair time and effort, and maintaining the ability to be utilized without a stiffness transition between upstream and downstream guardrails. Since the weak-post, MGS bridge rail provides these characteristics for concrete bridge decks, this study was focused on adapting the weak-post, MGS bridge rail for attachment to the outside face of culvert headwalls.

### **1.3 Scope**

The first step in the research effort was to conduct a survey of the standard culvert headwall designs used throughout the states participating in the Midwest States Regional Pooled Fund Research Program in order to identify the critical culvert design based on structural capacity. A simulated critical culvert was then constructed at the MwRSF testing grounds. Next, the MGS bridge rail post-to-deck attachment was redesigned in order to accommodate anchorage to the exterior face of existing culvert headwalls. Four design options were fabricated, installed on the simulated culvert, and subjected to dynamic component testing. Testing was conducted in both the lateral and longitudinal directions to evaluate the performance of each design option under both critical loading scenarios. Finally, the results from the component tests were utilized to guide the selection of the final designs and make appropriate recommendations for future use.

## 2 SIMULATED CULVERT DESIGN

In order to design a barrier attachment that would be applicable to a wide range of culverts, a critical culvert configuration needed to be identified. Thus, a survey was conducted to gather the current culvert standards and system drawings from the state departments of transportation (DOTs) within the Midwest States Regional Pooled Fund Program. The survey sought to obtain design details such as top slab thickness, headwall width, headwall height, and steel reinforcement configurations for both the top slab of the culvert and the headwall. Only the critical configurations (identified as the structurally weakest) were recorded from each state. The survey results are shown in Table 1.

The critical dimensions and reinforcement configurations vary depending on the height and width of the culvert as well as the fill depth on top of the culvert. However, only box culvert details with a cell width greater than 9 ft (2.7 m) and fill depths less than 2 ft (0.6 m) were considered. The minimum cell width was based on culverts that would exceed the 25 ft (7.6 m) maximum unsupported guardrail length of the MGS long-span system [11] and would, therefore, require an anchored post system. For the common triple box style culvert installation, an 8 ft (2.4 m) cell width results in a total length of only 24 ft (7.3 m). Thus, 9 ft (2.7 m) was set as the minimum cell width. The fill depth limitation was necessary to prevent large elevation differentials between the roadway and the top of the headwall, where the system was to be mounted. Thus, only minimal fill depths were desired, and most state DOTs list a minimum fill depth as less than 2 ft (0.6 m).

For each of the component characteristics listed in the columns of Table 1, a weak configuration was selected for the final design. All of the selected dimensions and reinforcement patterns were common to at least three different states and were often the weakest of all the survey results. However, a few of the component characteristics contained a single weakest



configuration. In these instances, the outlier was ignored, and the next weakest of the configurations was selected for use in the final simulated culvert design.

A simulated culvert was built at the MwRSF testing facility as per the selected critical design characteristics. The simulated culvert was configured with three adjacent cells, each with a width (or span) of 9 ft (2.7 m) and a total installation length of 28 ft (8.5 m). The simulated culvert was positioned such that the top of the headwall was level with the top of the existing tarmac. A 9-in. (229-mm) deep soil fill was used to create a level ground surface for testing. To anchor the system, the lateral steel reinforcement in the top slab of the simulated culverts was extended and epoxied into the tarmac, as shown in Figure 6.

The top slab was 9 in. (229 mm) thick, and both a top and bottom layer of steel reinforcement was used. The longitudinal reinforcement (relative to the roadway) consisted of #5 bars spaced 12 in. (305 mm) on center, while the lateral reinforcement consisted of #4 bars spaced 18 in. (457 mm) on center. The culvert headwall was 12 in. (305 mm) wide and extended 9 in. (229 mm) above the slab for a total height of 18 in. (457 mm). The headwall contained four #4 longitudinal reinforcing bars and #4 transverse stirrups spaced on 12 in. (305 mm) centers. Detailed drawings and installation photographs of the simulated critical culvert are shown in Figures 6 through 10, and Figure 11, respectively.

Table 1. Survey Results of State DOT Standard Culvert Plans

STATE	CULVERT TOP SLAB			CULVERT HEADWALL			
	Thickness	Longitudinal Reinforcement	Transverse Reinforcement	Height	Width	Longitudinal Reinforcement	Transverse Reinforcement
Wyoming	9"	Top Mat: #4 @ 6" Bot. Mat: #4 @ 6"	Top Mat: #4 @ 12" Bot. Mat: #4 @ 18"	9" + slab	12"	4 # 6 bars	#4 stirrup @ 6"
South Dakota	NA	NA	Top Mat: #4 @ 12" Bot. Mat: #4 @ 12"	9" + slab	12"	4 # 5 bars	#4 stirrup @ 12"
Nebraska	12"	Top Mat: #5 @ 10.5" Bot. Mat: #5 @ 10.5"	Top Mat: #4 @ 18" Bot. Mat: #4 @ 12"	9" + slab	12"	4 #4 bars	#4 stirrup @ 18"
Kansas	9"	Top Mat: #5 @ 6" Bot. Mat: #7 @ 6"	Top Mat: #5 @ 6" Bot. Mat: #4 @ 6"	18"		4 # 5 bars	#4 stirrup @ 12"
Missouri	11"	Top Mat: #5 @ 14.5" Bot. Mat: #5 @ 6"	Top Mat: #4 @ 24" Bot. Mat: #4 @ 24"	9" + slab	20"	4 #8 bars	#5 stirrup @ 12"
Iowa	9"	Top Mat: #5 @ 12" Bot. Mat: #5 @ 12"	Top: #4 @ 18" Bot. Mat: #5 @ 12"	24"	12"	4 #7 bars	#4 stirrup @ 6"
Minnesota	9"	Top Mat: #4 @ 10" Bot. Mat: #5 @ 6"	Top Mat: #4 @ 12" Bot. Mat: #4 @ 12"	12" + slab	12"	4 #4 bars	#4 stirrup @ 12"
Wisconsin	Varies >7"	Top Mat: #4 @ 12" Bot. Mat: #4 @ 12"	Top Mat: #4 @ 18" Bot. Mat: #4 @ 18"	6" + slab	15"	4 #4 bars	#3 stirrup @ 9"
Illinois	9"	Top Mat: #5 @ 18" Bot. Mat: #8 @ 6"	Top Mat: #4 @ 12" Bot. Mat: #6 @ 12"	9" + slab	12"	4 #6 bars	#4 stirrup @ 6"
Ohio	12"	NA	NA	9" + slab	12"	4 #6 bars	#5 stirrup @ 12"

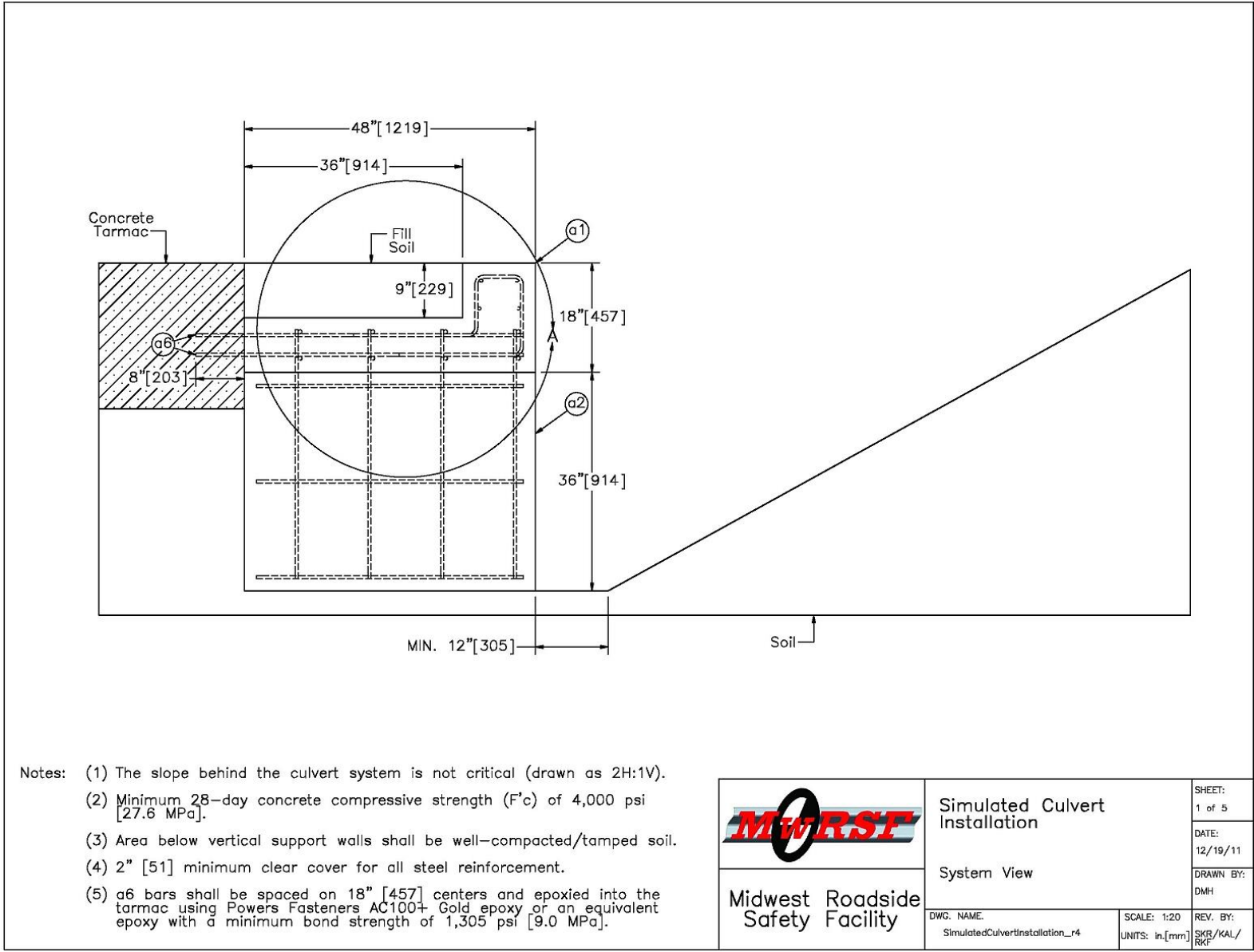

Figure 6. Simulated Culvert, System Layout

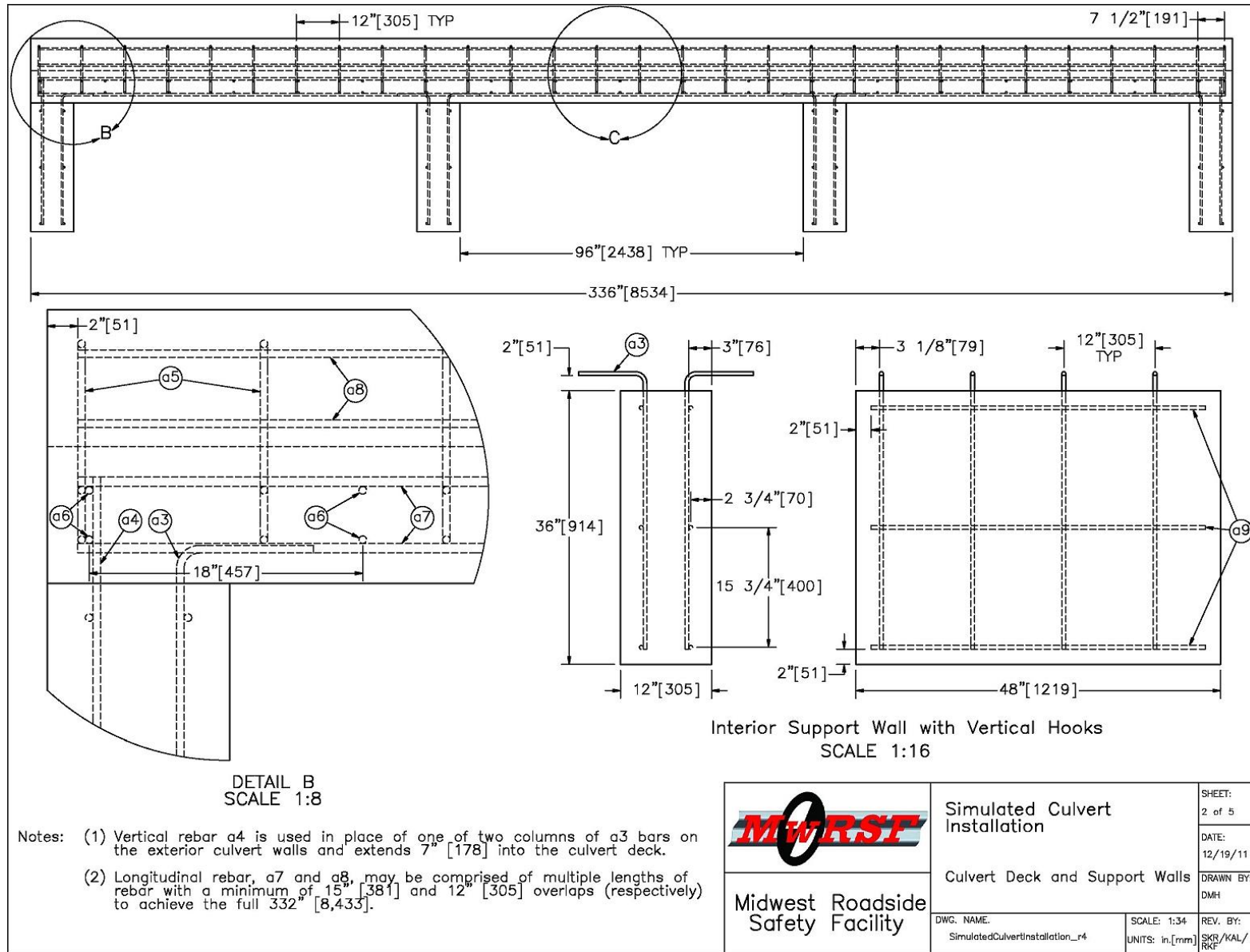

Figure 7. Simulated Culvert, Elevation View

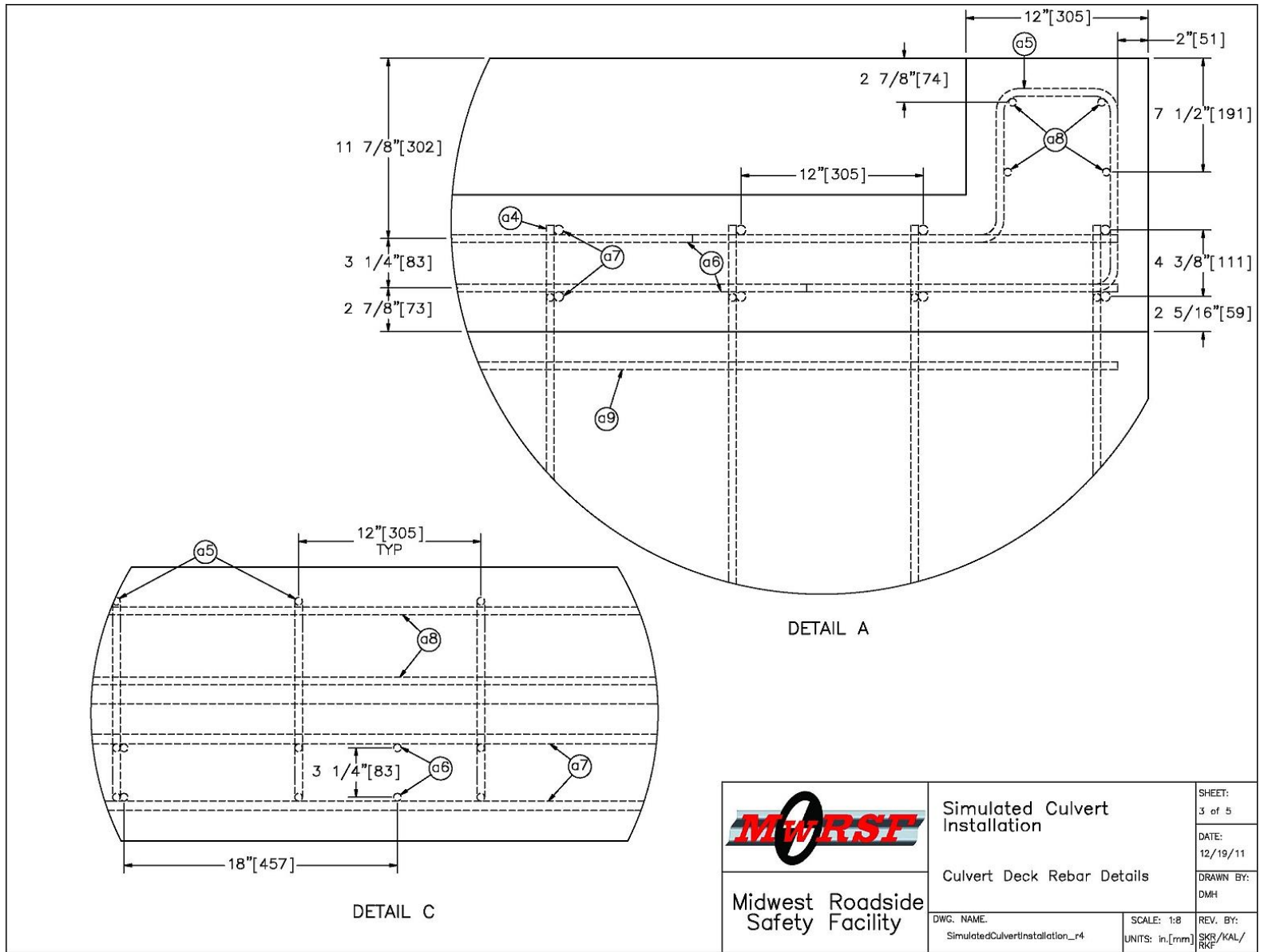

Figure 8. Simulated Culvert, Headwall Reinforcement Details

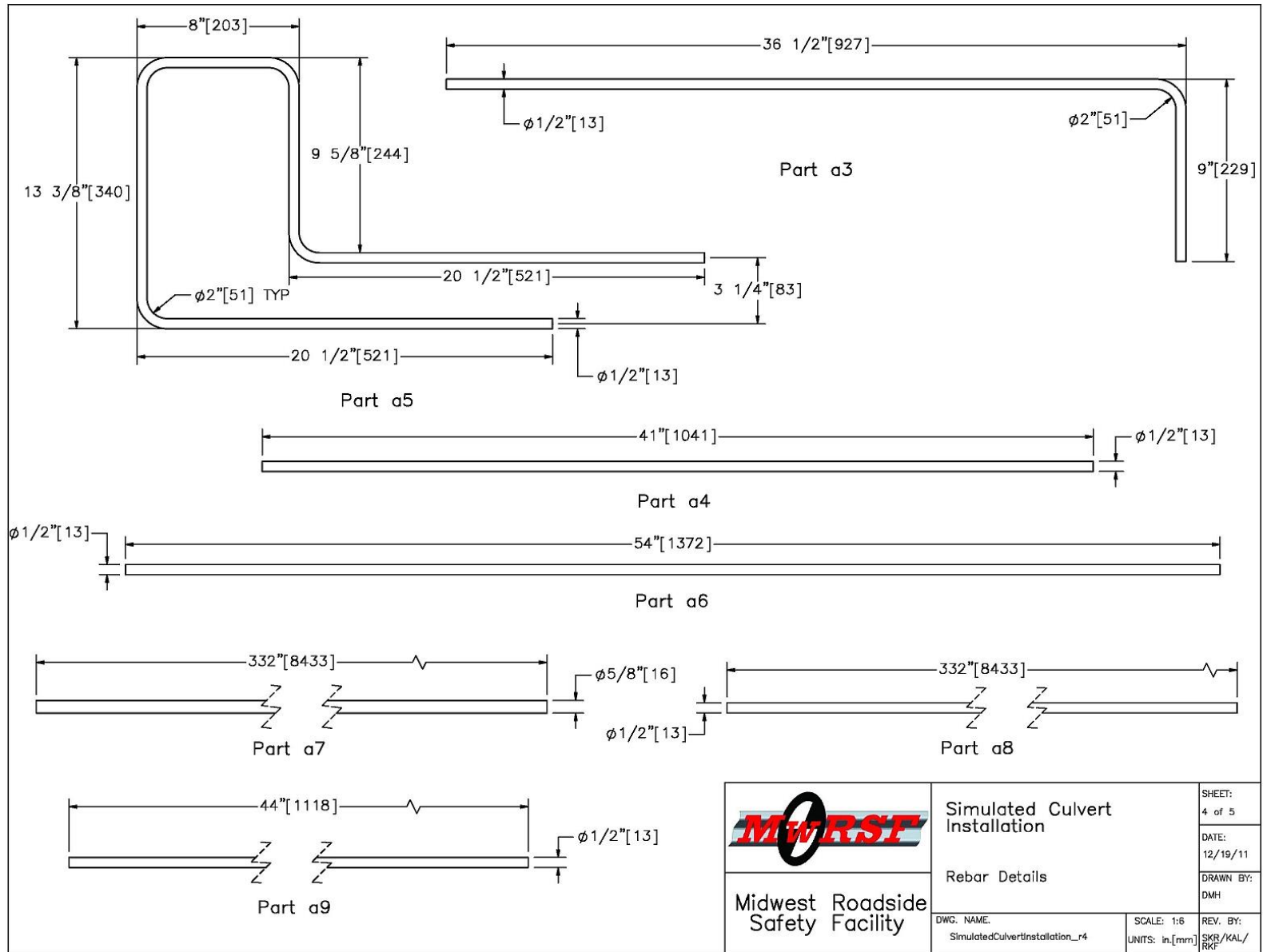



Figure 9. Simulated Culvert, Rebar Details

 <b>Midwest Roadside Safety Facility</b>	<b>Simulated Culvert Installation</b> Rebar Details		SHEET: 4 of 5
	DWG. NAME: SimulatedCulvertInstallation_r4		DATE: 12/19/11
		SCALE: 1:6 UNITS: in.[mm]	DRAWN BY: DMH
			REV. BY: SKR/KAL/RKF

Item No.	QTY	Description	Material Specifications	Hardware Guide
a1	1	332"x18"x48" [8,433x457x1219] Reinforced Concrete Culvert Deck/Headwall	Min. F'c = 4,000 psi	—
a2	4	12"x36"x48" [305x914x1219] Reinforced Concrete Support Wall	Min. F'c = 4,000 psi	—
a3	24	#4 Bent Rebar, Support Wall Hook, 44 1/2" [1,130] Total Length Unbent	Grade 60	—
a4	8	#4 Straight Rebar, 41" [1,041] Long	Grade 60	—
a5	29	#4 Bent Rebar, Vertical Hoop, 68 1/4" [1,734] Total Length Unbent	Grade 60	—
a6	38	#4 Straight Rebar, 54" [1,372] Long	Grade 60	—
a7	8	#5 Straight Rebar, 27'-8" [8.4 m] Long	Grade 60	—
a8	4	#4 Straight Rebar, 27'-8" [8.4 m] Long	Grade 60	—
a9	24	#4 Straight Rebar, 44" [1,118] Long	Grade 60	—

 Midwest Roadside Safety Facility	Simulated Culvert Installation	SHEET: 5 of 5
	Bill of Materials	DATE: 12/19/11
DWG. NAME: SimulatedCulvertInstallation_r4	SCALE: None UNITS: in.[mm]	DRAWN BY: DMH
		REV. BY: SKR/KAL/ RKE

Figure 10. Simulated Culvert, Bill of Materials





Figure 11. Simulated Culvert Photographs



### 3 BARRIER ATTACHMENT DESIGNS

#### 3.1 Design Criteria

In order to avoid confusion between similar systems and allow State DOTs to stock a single component instead of two, the same post assembly from the weak-post, MGS bridge rail was to be used for the new guardrail-to-culvert attachment system. Thus, the same 44-in. (1,118-mm) long S3x5.7 (S76x8.5) steel post equipped with ¼-in. (6-mm) thick standoff shim plates was utilized. Since all post dimensions remained the same, the same 4-in. x 4-in. x ⅜-in. (102-mm x 102-mm x 10-mm) steel tube was utilized as the post socket, and the same ⅝-in. (16-mm) diameter bolt was utilized to hold the post in the socket.

Due to the location of the bolt hole and shims on the post, the top of the socket had to remain at a distance of 30 in. (762 mm) from the top of the post. Thus, the top of the socket needed to extend 2 in. (51 mm) above the top of the culvert headwall just as the original socket design extended 2 in. (51 mm) above the bridge deck. Keeping the original socket height ensured the post would bend at the same point during impacts, thus providing the same resistance forces demonstrated during the successful MASH testing of the MGS bridge rail system.

Recognizing that the barrier (i.e., post) resistance forces would be identical to the original system, the performance criteria for the new attachment design was very straightforward: transfer the plastic bending loads of the post to the culvert headwall without sustaining significant damage to the attachment hardware or the culvert. Significant damage would include large deformations in the socket assembly, steel tearing, weld failure, anchor pullout, and/or concrete cracking. This performance specification applied to impact loads in both the lateral (strong-axis bending) and longitudinal (weak-axis bending) directions.

As stated in the objectives of this study, it was desired to maximize the traversable roadway width over the culvert. Thus, similar to the original bridge rail system, the sockets were

to be placed along the outside face of the culvert headwall. The attachment hardware could utilize the top, bottom, or inside surfaces of the headwall, but the socket and post had to remain adjacent to the outside face. Additionally, it was desired to have an attachment design that could be applied to both new and existing culverts. Thus, components could not be designed as cast into the culvert slab or headwall. Subsequently, all anchors had to be epoxied into the culvert, threaded into the culvert, or through bolted.

### **3.2 Design Concepts**

Through brainstorming and preliminary design calculations, four socket-to-culvert attachment concepts were developed and subjected to dynamic testing and evaluation. These concepts were: 1) a top-mounted, single-anchor concept; 2) a top-mounted, double-anchor concept; 3) a wrap-around concept; and 4) two versions of a side-mounted concept. Each concept had a unique way of transferring impact loads to the culvert headwall in hopes of minimizing attachment and culvert damage. The design concepts are described in the following sections.

#### **3.2.1 Concept A: Top-Mounted, Single-Anchor**

Design Concept A was developed to be as similar as possible to the original MGS bridge rail attachment by utilizing a top mounting plate, gusset, and a single vertical anchor, as shown in Figures 12 through 18. Impact loads would be transferred into the culvert as a tensile force through the top mounting plate (or shear force through the vertical anchor) and a compression force at the bottom of the socket as it bears against the face of the headwall. However, small changes were implemented to minimize the risk of damaging the culvert or socket assembly. The top mounting plate was extended 2 in. (51 mm) to a length of 9½ in. (241 mm) in order reduce potential concrete cracking by moving the threaded anchor farther away from the edge of the headwall. Additionally, the plate thickness was increased from  $\frac{7}{16}$  in. (11 mm) to ½ in. (13 mm) to prevent plate tearing, and the anchor rod diameter was increased to 1⅛ in. (29 mm) to reduce

concerns for bearing failure. Finally, the length of the socket tube was extended 2 in. (51 mm) to 16½ in. (419 mm) in order to increase the moment arm distance from the top mounting plate to the bottom attachment plate, thus resulting in reduced tension and compression forces under a constant bending moment.

The original MGS bridge rail system utilized a through-bolt to anchor the top mounting plate to the bridge deck. In an effort to make the new system attachment applicable to existing structures, the bolt was replaced with a 1⅛-in. (29-mm) diameter, ASTM A307 Grade C threaded rod embedded 10 in. (254 mm) into the top of the culvert headwall using an epoxy with a minimum bond strength of 1,300 psi (9.0 MPa). During installation, the socket assembly would be lowered into position over the threaded rod.

A ½-in. (13-mm) thick bottom mounting plate was welded to the lower-front face of the socket. Two ½-in. (13-mm) diameter, ASTM A307 Grade C threaded rods, one on each side of the socket tube, were utilized to attach the bottom mounting plate to the outside face of the headwall. The rods were embedded 4½ in. (114 mm) into the headwall using 1,300 psi (9.0 MPa) minimum bond strength epoxy adhesive. Two ⅝-in. (16-mm) wide slots were cut into the bottom mounting plate so that the socket assembly could be lowered into place over the threaded rods. Washers and nuts were used on each threaded rod to attach the socket to the headwall. The socket, mounting plates, and gusset plate were all fabricated from 50-ksi (345-MPa) steel.

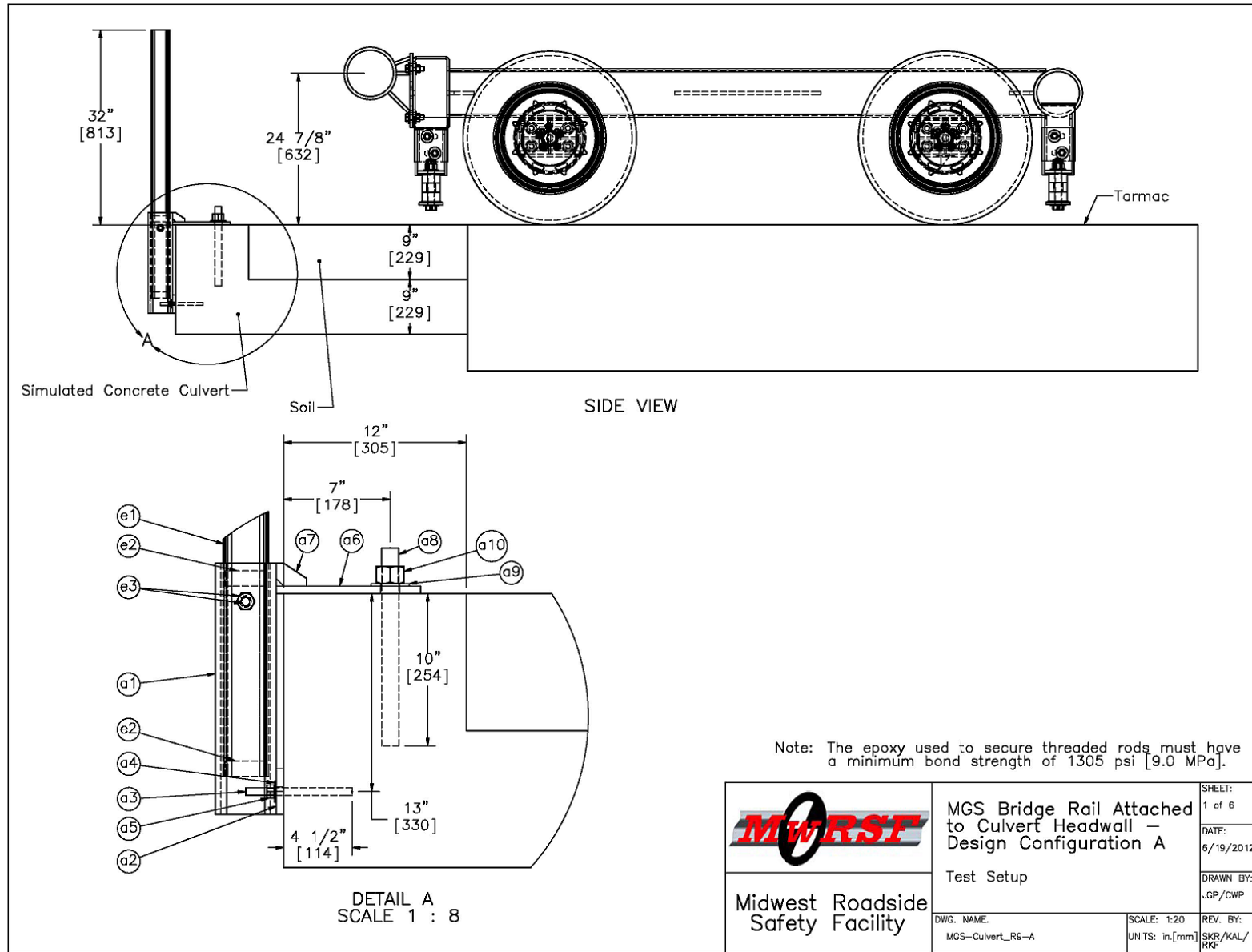

Figure 12. Design Concept A: Top-Mounted, Single-Anchor Attachment

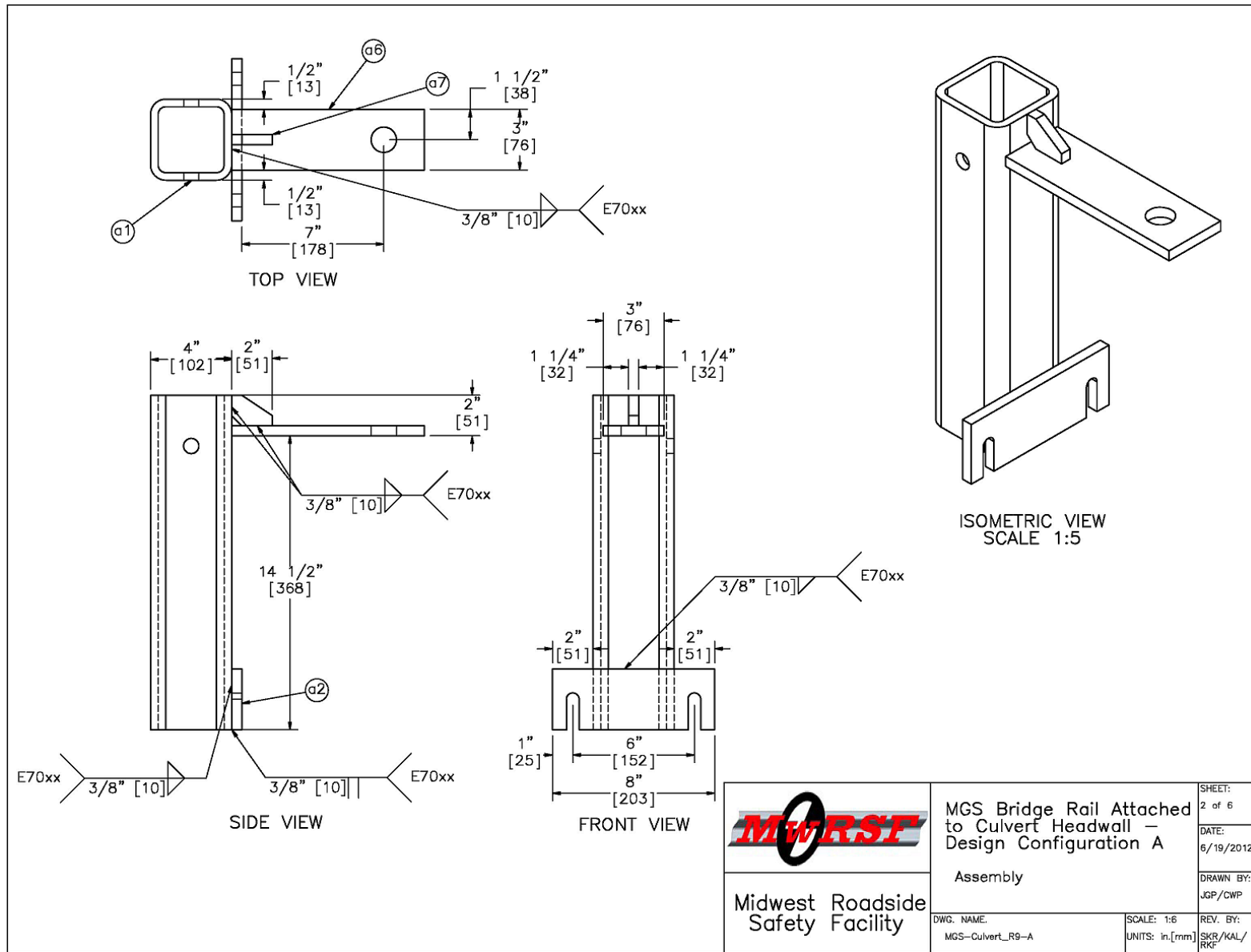

Figure 13. Design Concept A, Socket Assembly Details

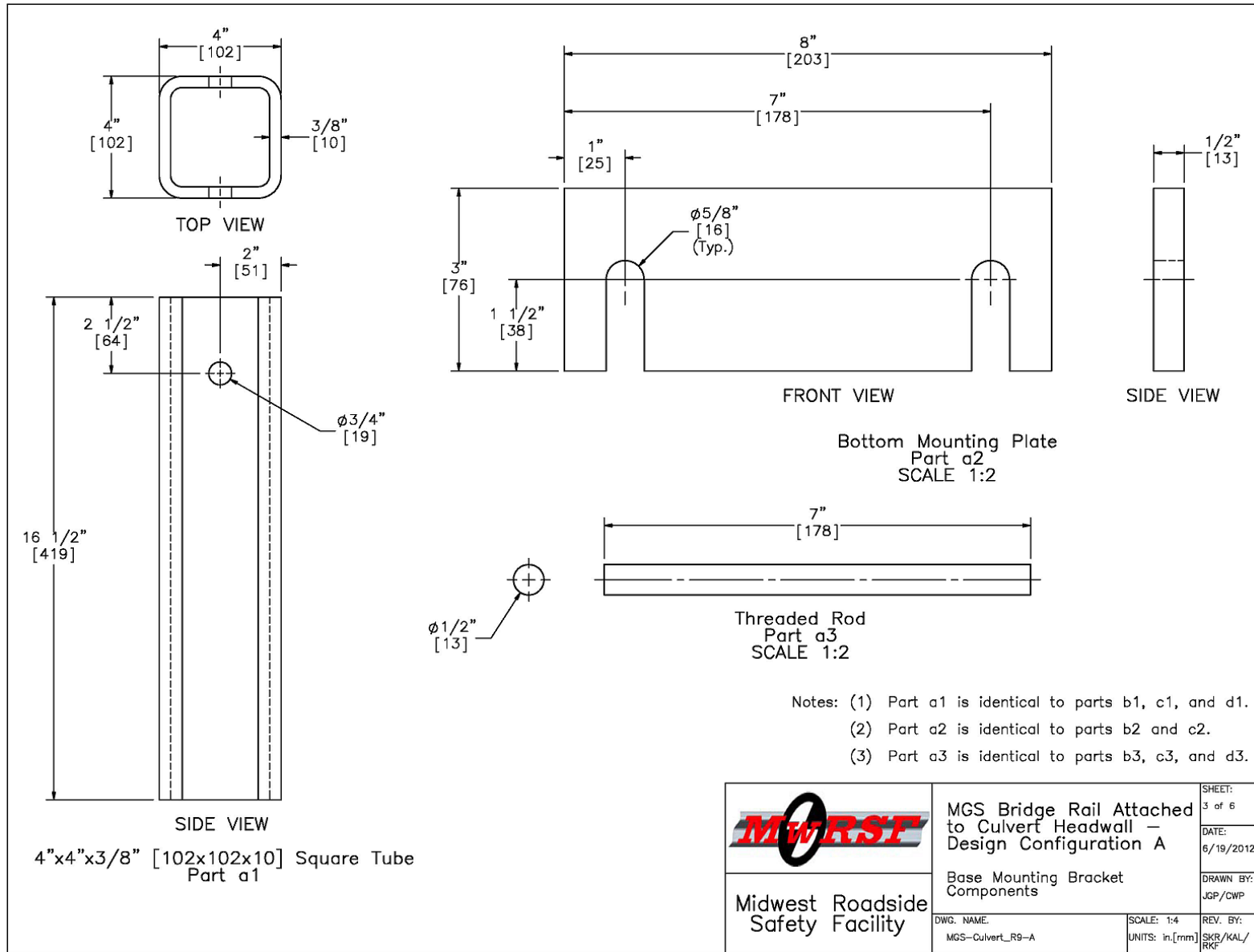

Figure 14. Design Concept A, Tube and Bottom Mounting Plate Details

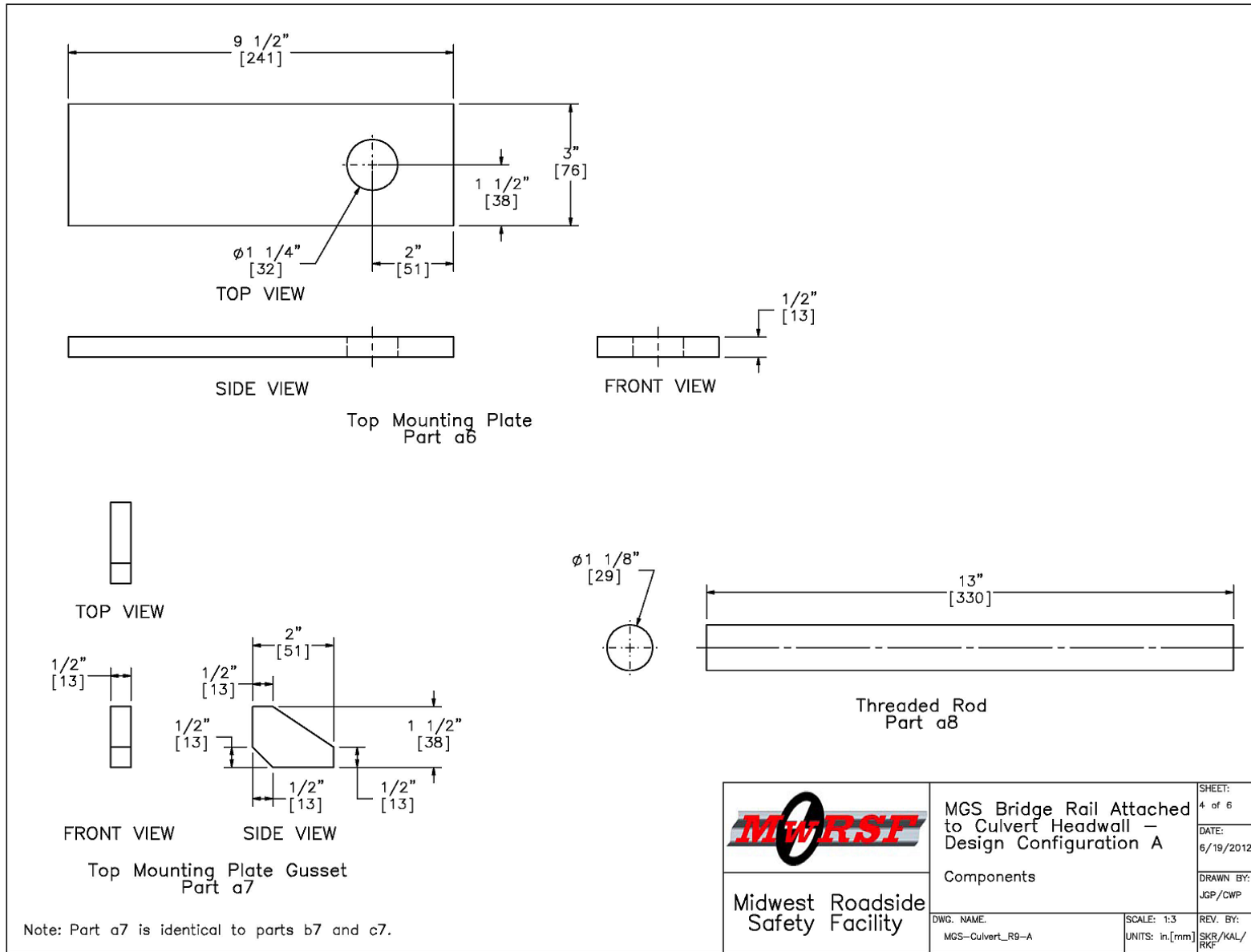

Figure 15. Design Concept A, Top Mounting Plate Details

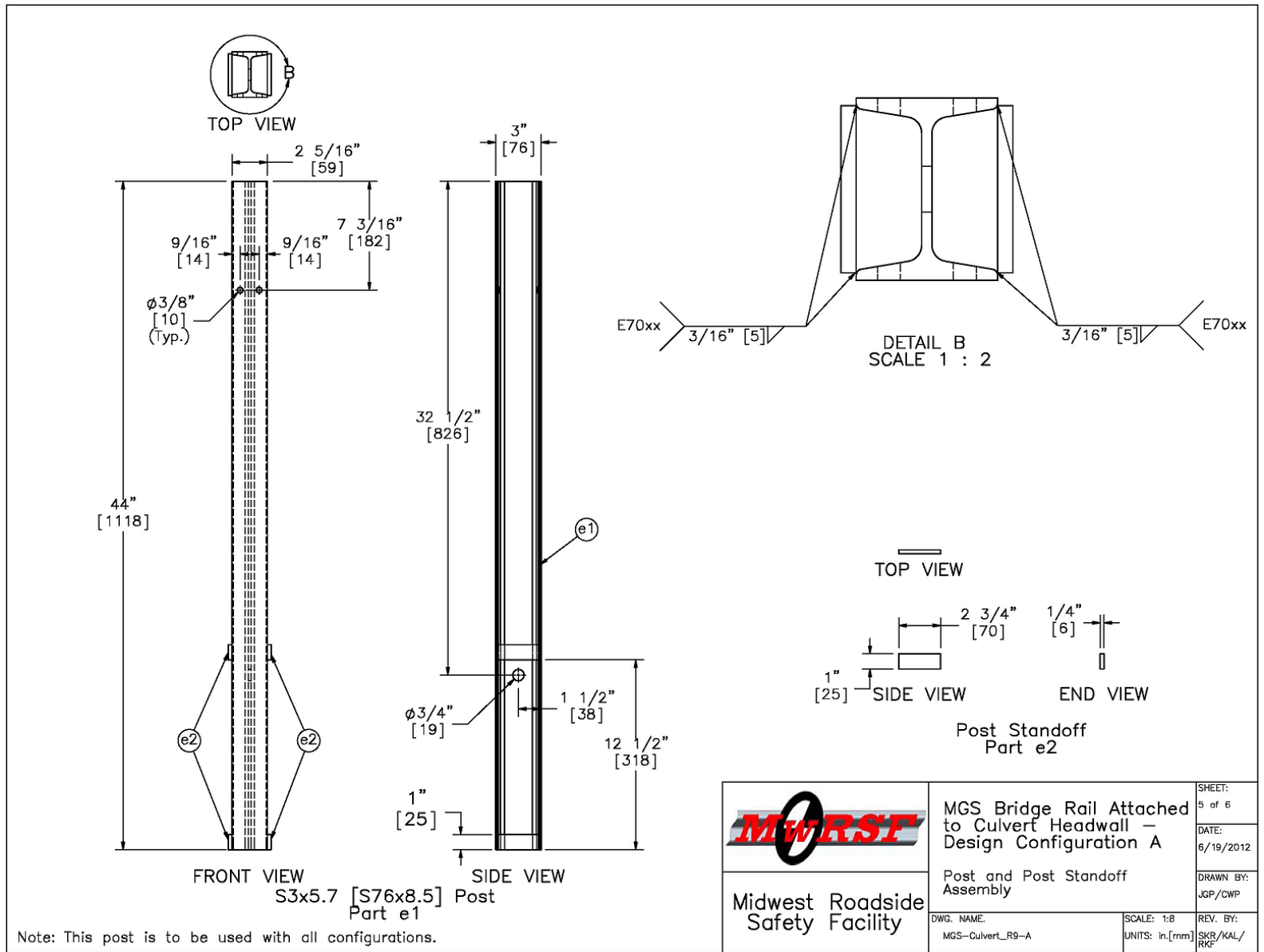

Figure 16. Design Concept A, Post Assembly



Configuration A			
Item No.	QTY.	Description	Material Specification
a1	1	4"x4"x3/8" [102x102x10] Square Steel Tube	ASTM A500 Grade B Steel Galvanized
a2	1	8"x3"x1/2" [203x76x13] Bottom Mounting Plate	ASTM A572 Grade 50 Steel Galvanized
a3	2	1/2" [13] Dia. UNC, 7" [178] Long Threaded Rod	ASTM A307 Grade C Galvanized/ASTM F1554 Grade 36 Galvanized/SAE J429 Grade 2 Galvanized
a4	2	1/2" [13] Dia. Hardened Round Washer	ASTM F436 Galvanized
a5	2	1/2" [13] Dia. UNC Heavy Hex Nut	ASTM A563A Galvanized
a6	1	9 1/2"x3"x1/2" [241x76x13] Top Mounting Plate	ASTM A572 Grade 50 Steel Galvanized
a7	1	2"x1 1/2"x1/2" [51x38x13] Top Mounting Plate Gusset	ASTM A572 Grade 50 Steel Galvanized
a8	1	1 1/8" [29] Dia. UNC, 13" [330] Long Threaded Rod	ASTM A307 Grade C Galvanized/ASTM F1554 Grade 36 Galvanized/SAE J429 Grade 2 Galvanized
a9	1	1 1/8" [29] Dia. Hardened Round Washer	ASTM F436 Galvanized
a10	1	1 1/8" [29] Dia. UNC Heavy Hex Nut	ASTM A563A Galvanized
e1	1	S3x5.7 [S76x8.5] by 44" [1118] Long Steel Post	ASTM A992 Grade 50 Steel Galvanized
e2	4	2 3/4"x1"x1/4" [70x25x6] Post Standoff	ASTM A36 Steel Galvanized
e3	1	5/8" [16] Dia. UNC, 5" [127] Long Heavy Hex Bolt and Nut	Bolt ASTM A325 Type 1 Galvanized, Nut ASTM A563A Galvanized
f1	-	Epoxy	Powers Fasteners AC Gold 100+ or equivalent epoxy with minimum 1305 psi [9.0 MPa] bond strength

 Midwest Roadside Safety Facility	MGS Bridge Rail Attached to Culvert Headwall – Design Configuration A		SHEET: 6 of 6
	Bill of Materials		DATE: 6/19/2012
DWG. NAME: MGS-Culvert_R9-A	SCALE: NONE UNITS: in.[mm]	REV. BY: SKR/KAL/ RKF	DRAWN BY: JGP/CWP

Figure 17. Design Concept A, Bill of Materials



Figure 18. Design Concept A, Installation Photographs

### **3.2.2 Concept B: Top-Mounted, Double-Anchor**

Due to the design similarities with the original weak-post, MGS bridge rail, concerns arose that a single-anchor design would result in the same concrete cracking that occurred during full-scale crash testing of the MGS bridge rail. Therefore, the top-mounted, double-anchor concept was developed to better distribute the tensile force from the top mounting plate to the headwall and prevent shear concrete cracking.

The only differences between the top-mounted, double-anchor design and the top-mounted, single-anchor design are the top mounting plate dimensions and the use of a second top anchor rod, as shown in Figures 19 through 25. Two ¾-in. (19-mm) diameter, ASTM A307 Grade C threaded rods spaced 6 in. (152 mm) apart were used to anchor the top mounting plate to the headwall. The top anchor rods were embedded 4½ in. (114 mm) into the headwall using an epoxy adhesive with a minimum bond strength of 1,300 psi (9.0 MPa), similar to the bottom anchor rods. Thus, both the diameter and the embedment depth of the top anchors were reduced by more than 50 percent from the single anchor attachment of Design Concept A. To accommodate the double anchors, the top mounting plate was flared from a 3 in. (76 mm) width adjacent to the socket to a 9 in. (229 mm) width around the anchors.

Similar to Design Concept A, the top-mounted, double-anchor concept was installed by lowering the socket assembly over the epoxy-embedded, threaded rods. Washers and nuts were used on all four threaded rods to attach the socket to the headwall. The socket, mounting plates, and gusset plate were all fabricated with 50-ksi (345-MPa) steel.



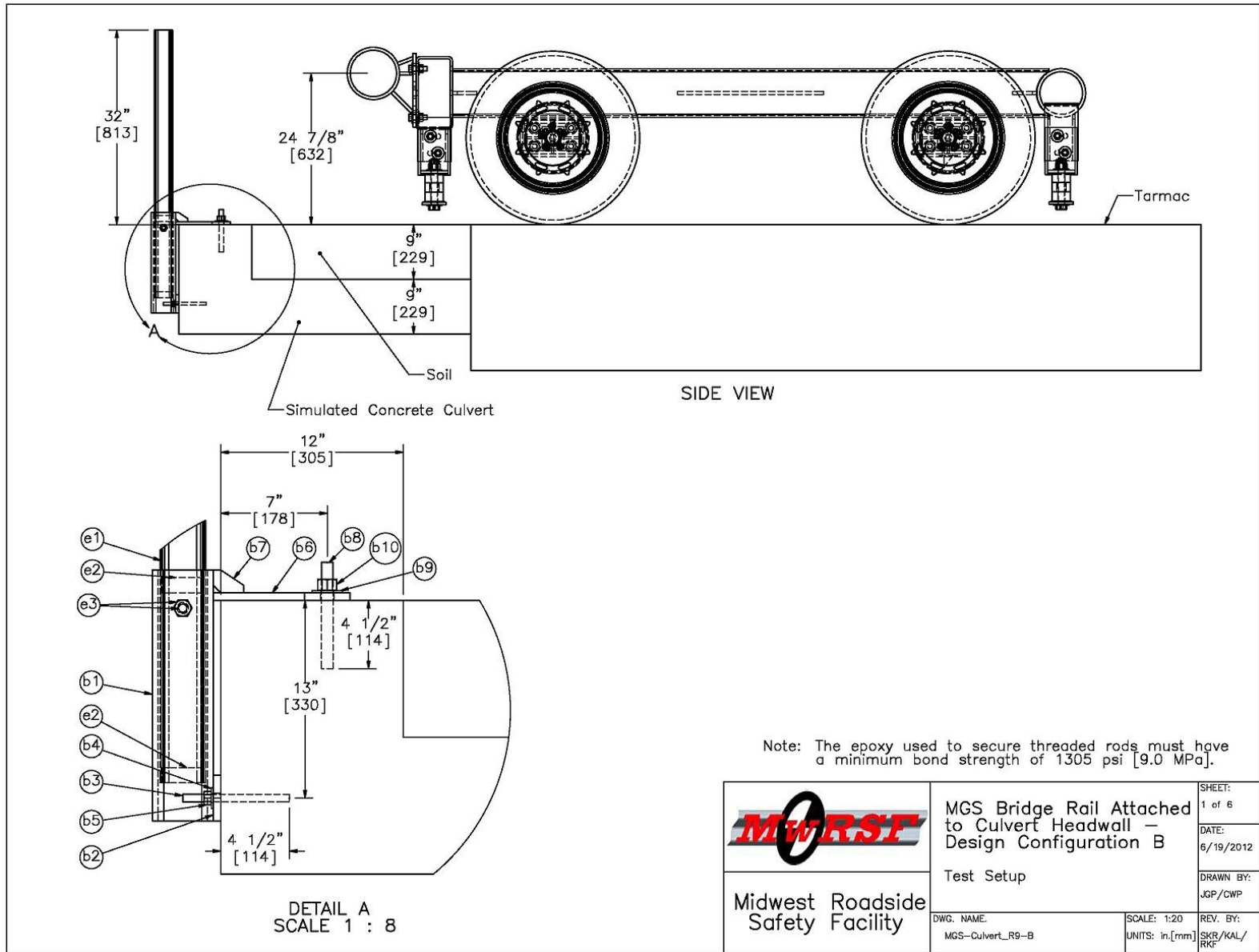

Figure 19. Design Concept B: Top-Mounted, Double-Anchor Attachment

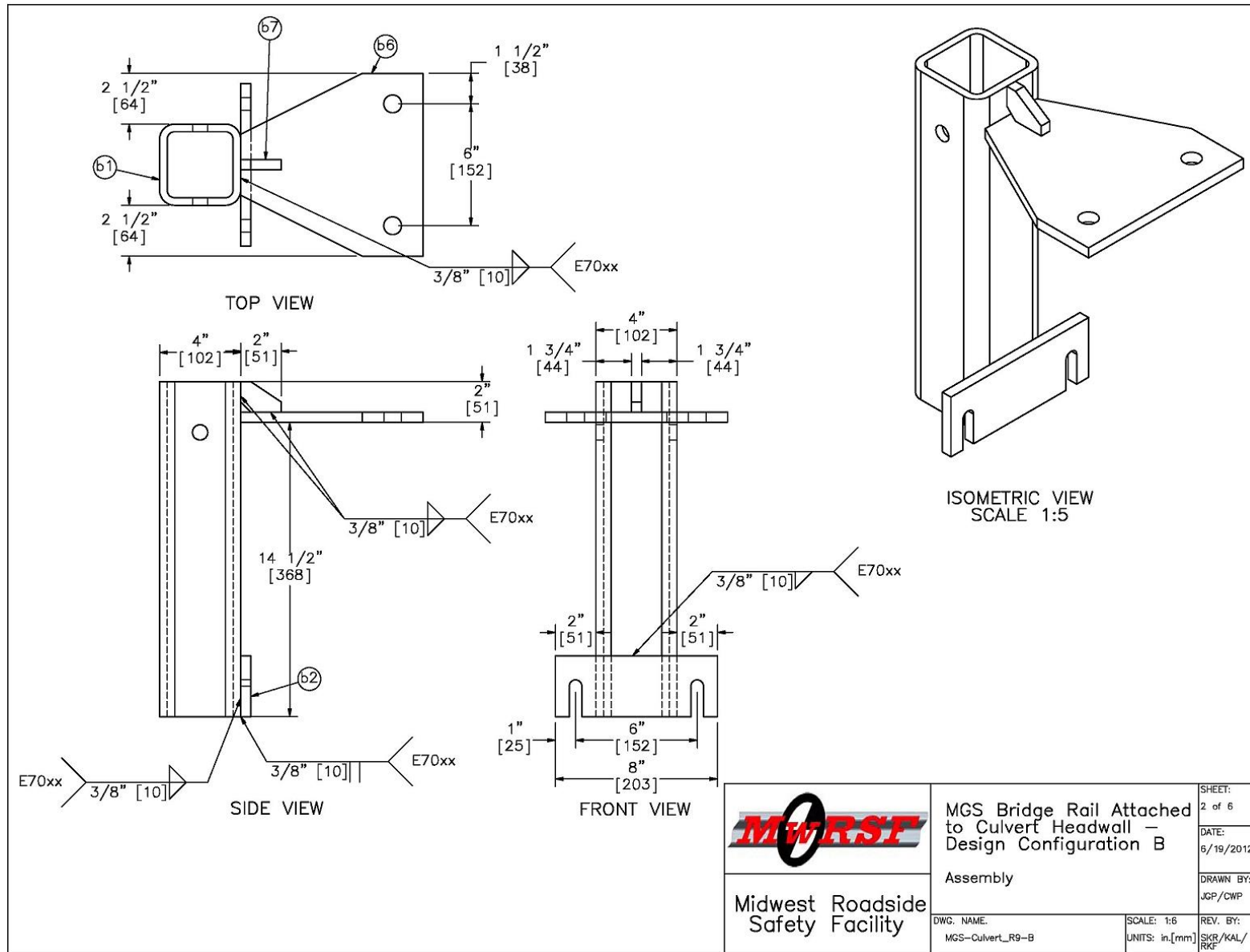

Figure 20. Design Concept B, Socket Assembly Details

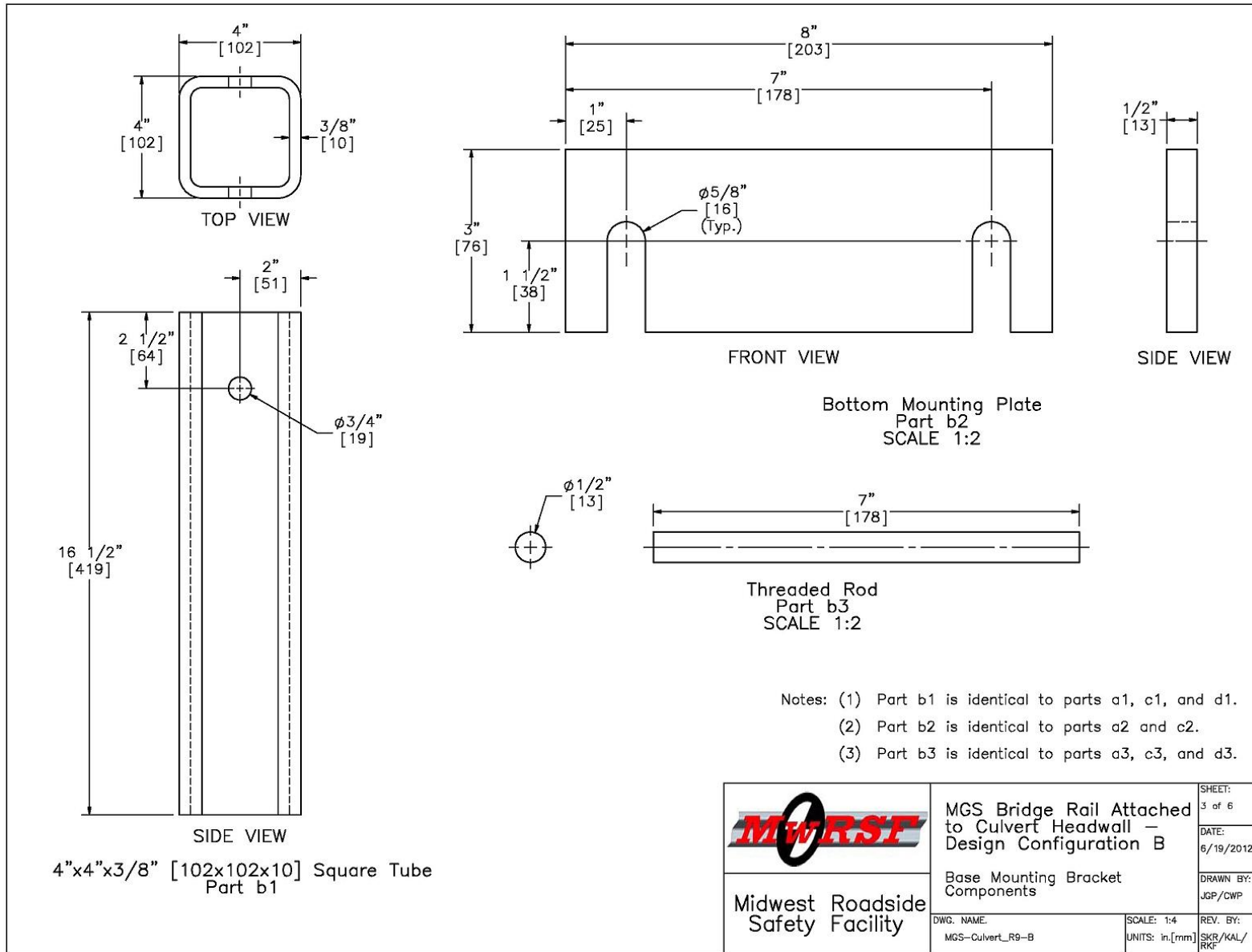

Figure 21. Design Concept B, Tube and Bottom Mounting Plate Details

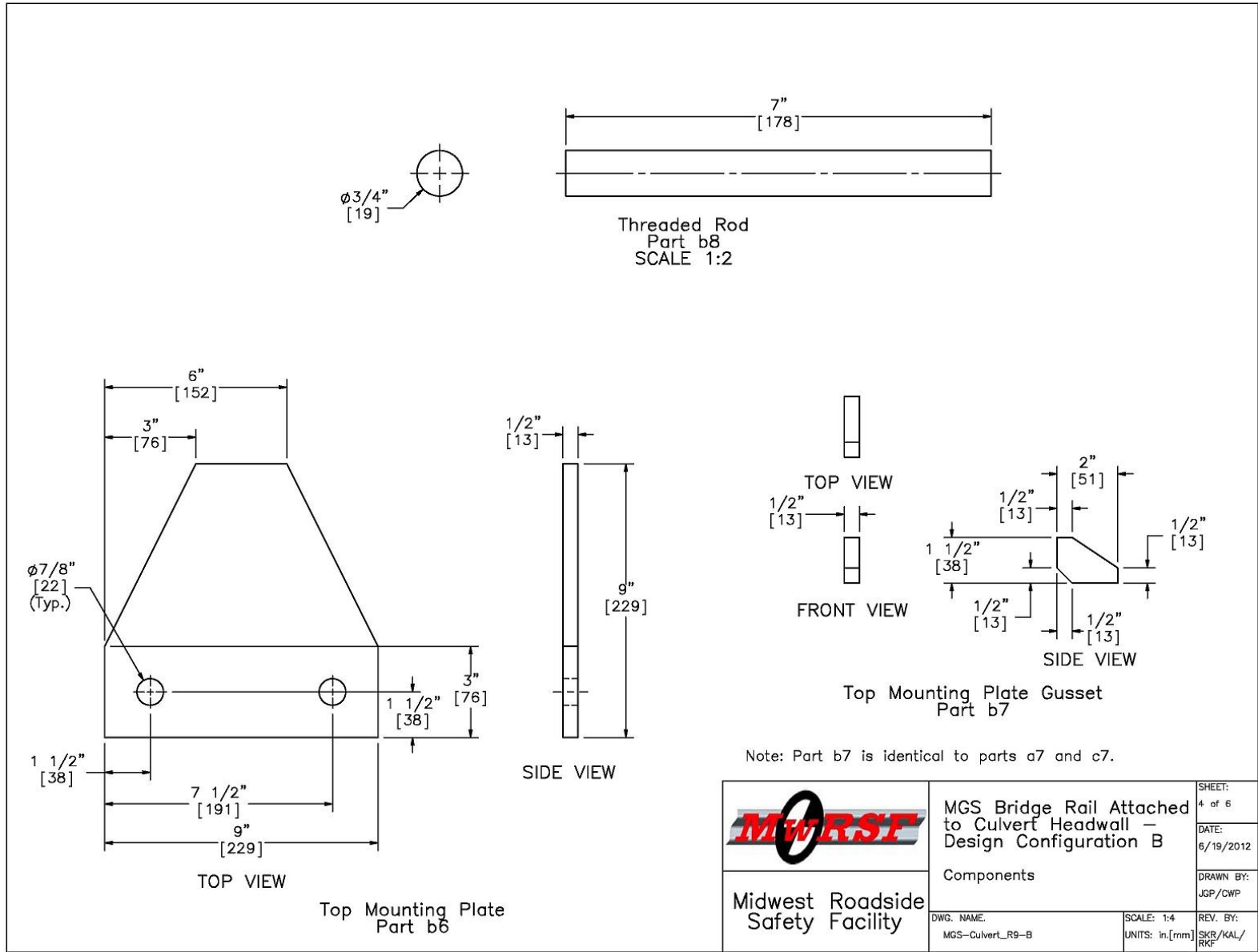

Figure 22. Design Concept B, Top Mounting Plate Details

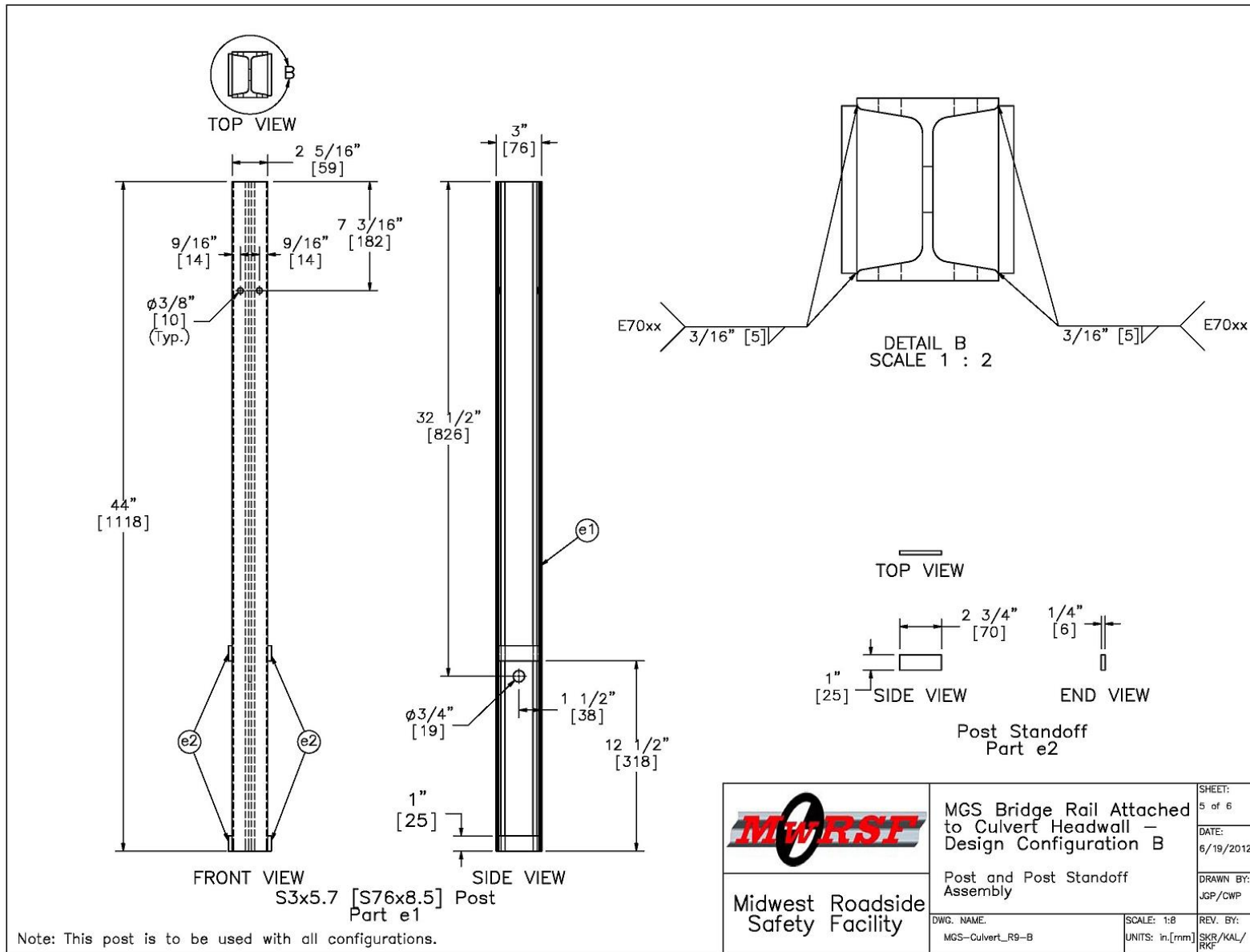

Figure 23. Design Concept B, Post Assembly



Configuration B			
Item No.	QTY.	Description	Material Specification
b1	1	4"x4"x3/8" [102x102x10] Square Steel Tube	ASTM A500 Grade B Steel Galvanized
b2	1	8"x3"x1/2" [203x76x13] Bottom Mounting Plate	ASTM A572 Grade 50 Steel Galvanized
b3	2	1/2" [13] Dia. UNC, 7" [178] Long Threaded Rod	ASTM A307 Grade C Galvanized/ASTM F1554 Grade 36 Galvanized/SAE J429 Grade 2 Galvanized
b4	2	1/2" [13] Dia. Hardened Round Washer	ASTM F436 Galvanized
b5	2	1/2" [13] Dia. UNC Heavy Hex Nut	ASTM A563A Galvanized
b6	1	9"x9"x1/2" [229x229x13] Top Mounting Plate	ASTM A572 Grade 50 Steel Galvanized
b7	1	2"x1 1/2"x1/2" [51x38x13] Top Mounting Plate Gusset	ASTM A572 Grade 50 Steel Galvanized
b8	2	3/4" [19] Dia. UNC, 7" [178] Long Threaded Rod	ASTM A307 Grade C Galvanized/ASTM F1554 Grade 36 Galvanized/SAE J429 Grade 2 Galvanized
b9	2	3/4" [19] Dia. Hardened Round Washer	ASTM F436 Galvanized
b10	2	3/4" [19] Dia. UNC Heavy Hex Nut	ASTM A563A Galvanized
e1	1	S3x5.7 [S76x8.5] by 44" [1118] Long Steel Post	ASTM A992 Grade 50 Steel Galvanized
e2	4	2 3/4"x1"x1/4" [70x25x6] Post Standoff	ASTM A36 Steel Galvanized
e3	1	5/8" [16] Dia. UNC, 5" [127] Long Heavy Hex Bolt and Nut	Bolt ASTM A325 Type 1 Galvanized, Nut ASTM A563A Galvanized
f1	-	Epoxy	Powers Fasteners AC Gold 100+ or equivalent epoxy with minimum 1305 psi [9.0 MPa] bond strength

	MGS Bridge Rail Attached to Culvert Headwall – Design Configuration B		SHEET: 6 of 6
	Bill of Materials		DATE: 6/19/2012
Midwest Roadside Safety Facility	DWG. NAME: MGS-Culvert_R9-B	SCALE: NONE UNITS: in.[mm]	DRAWN BY: JGP/CWP
			REV. BY: SKR/KAL/RKF

Figure 24. Design Concept B, Bill of Materials

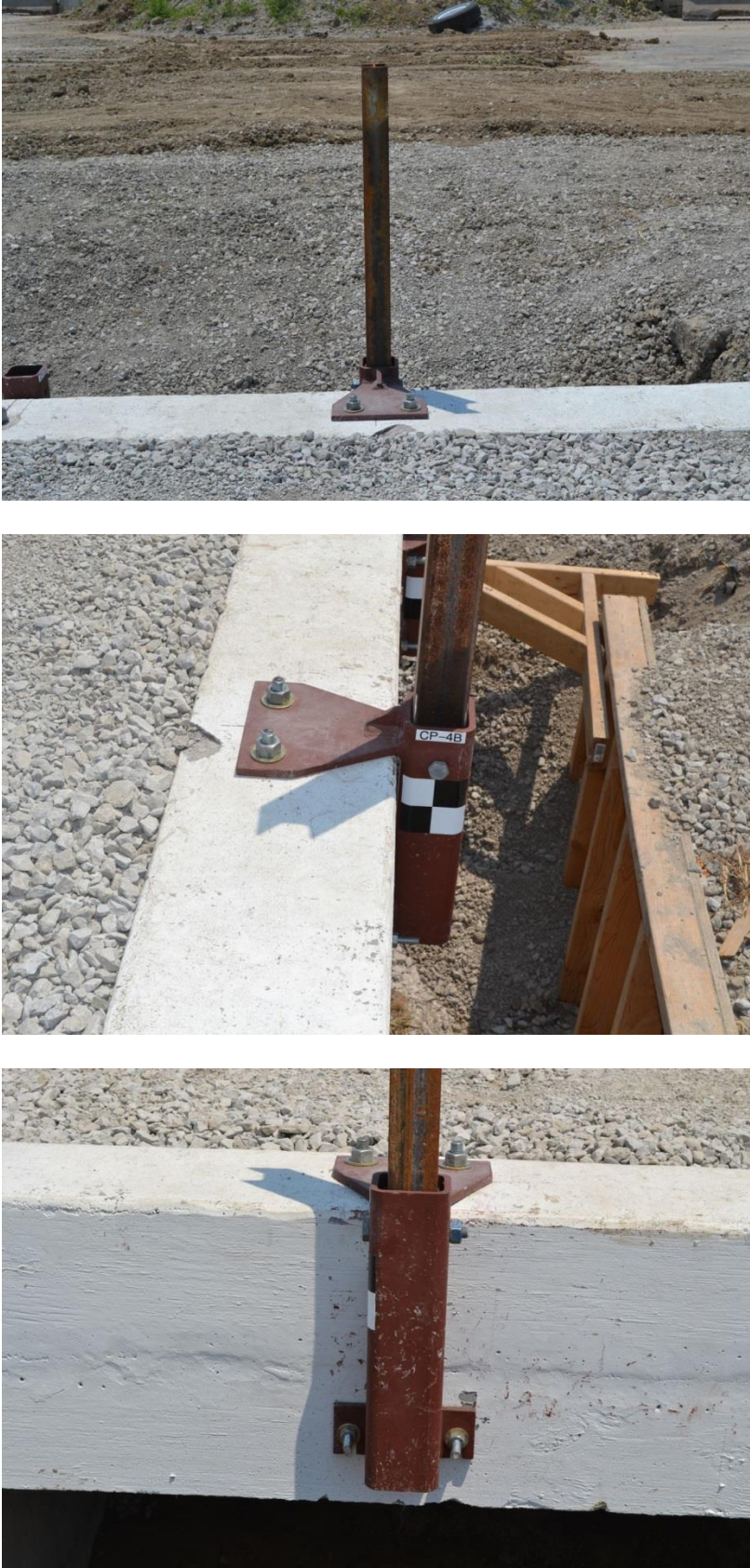

Figure 25. Design Concept B, Installation Photographs

### 3.2.3 Concept C: Wrap-Around

The wrap-around design concept was developed to further reduce the risk of concrete cracking and failure of the culvert headwall. The wrap-around concept incorporated an elongated top mounting plate that extended over the top of the headwall and continued down the inside face, as shown in Figures 26 through 32. This concept also removed all anchor hardware from the top of the culvert headwall. Although not prevalent during full-scale crash testing of the original MGS bridge rail system, preventing possible interactions between vehicle tires and the attachment hardware was considered a positive design aspect.

The ½-in. (13-mm) thick top mounting plate maintained a 3-in. (76-mm) width throughout its length and was attached to the inside face of the headwall utilizing a ⅝-in. (16-mm) diameter ASTM A307 Grade C threaded rod. The threaded anchor was necessary to keep the top plate in tension and prevent it from unfolding and releasing from the headwall. The bottom plate, bottom anchor rods, and socket tube configurations remained the same as used in the top-mounted designs. Washers and nuts were used on threaded anchors and the socket, mounting plates, and gusset plate were all fabricated with 50-ksi (345-MPa) steel.

For the test installation, the top anchor rod was embedded 4½ in. (114 mm) into the headwall using an epoxy adhesive with a minimum bond strength of 1,300 psi (9.0 MPa). Consequently, the socket assembly had to be lowered into place before the top anchor was epoxied into the headwall. However, either a mechanical anchor or an epoxy-anchored threaded insert could have been used to make the installation of the socket assembly easier. Finally, Design Concept C required soil work to expose the inside face of the culvert headwall during installation, similar to the existing guardrail designs that mount to the culvert top slab. This additional soil movement may significantly add to installation costs as compared to the other concepts.

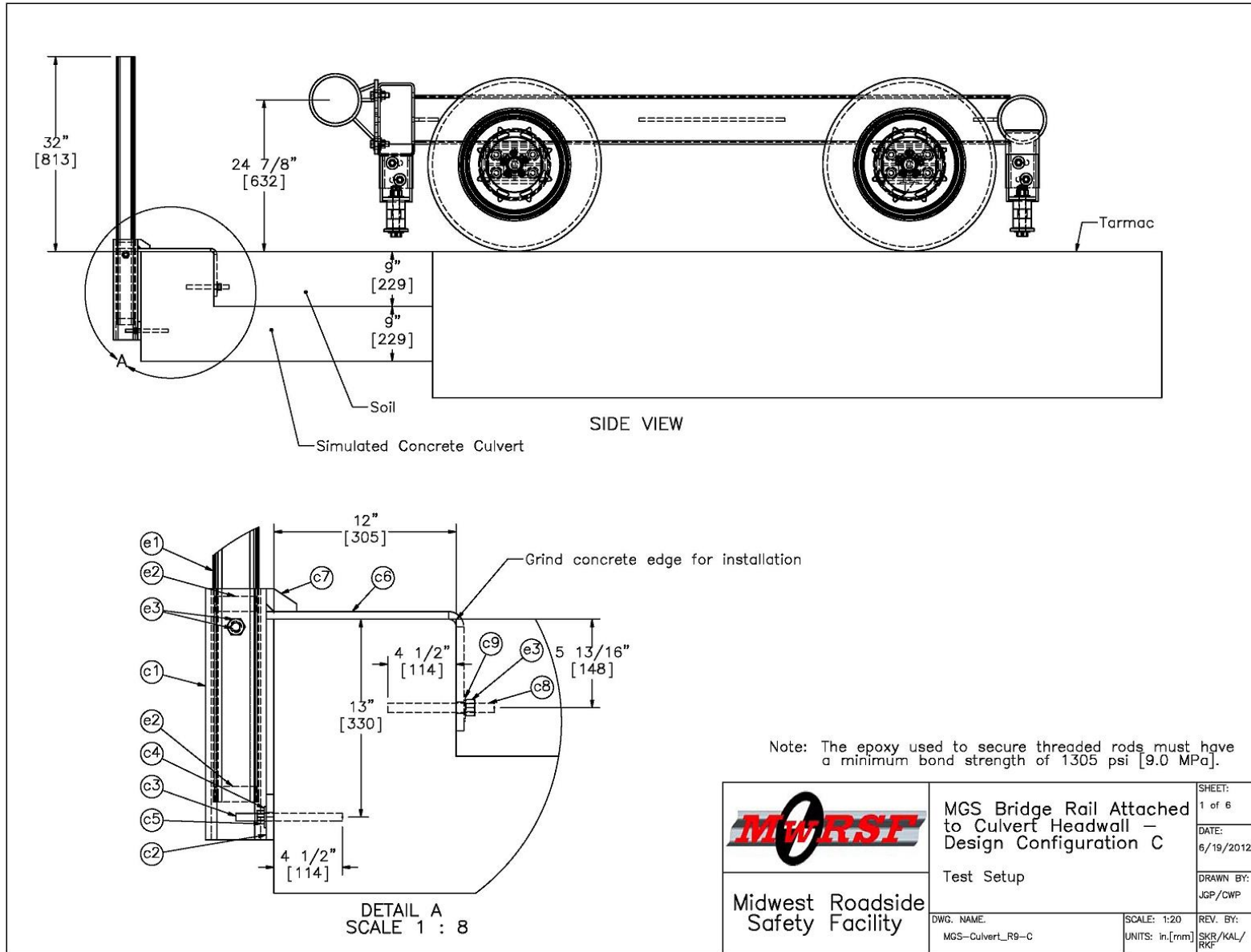

Figure 26. Design Concept C: Wrap-Around Attachment

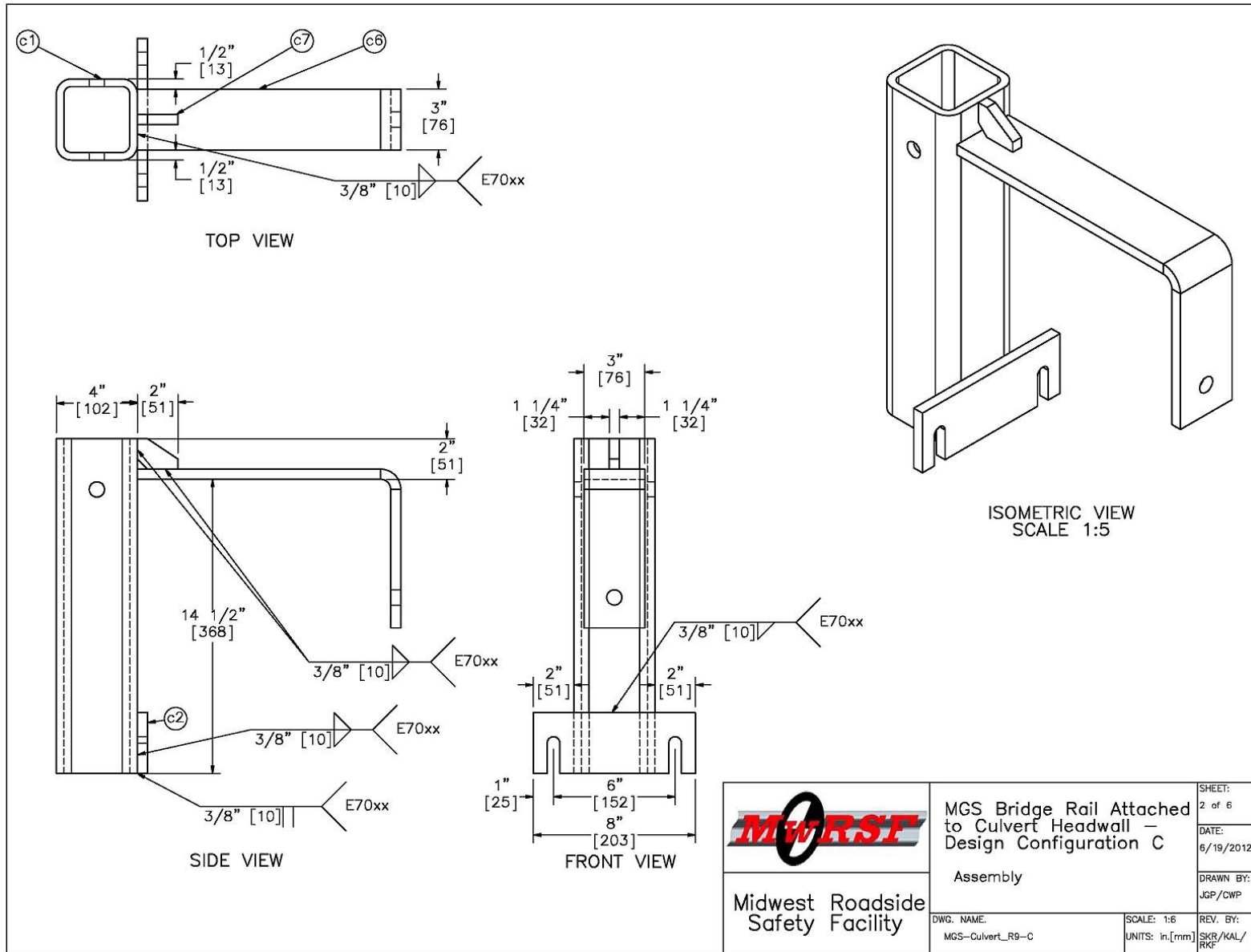

Figure 27. Design Concept C, Socket Assembly Details



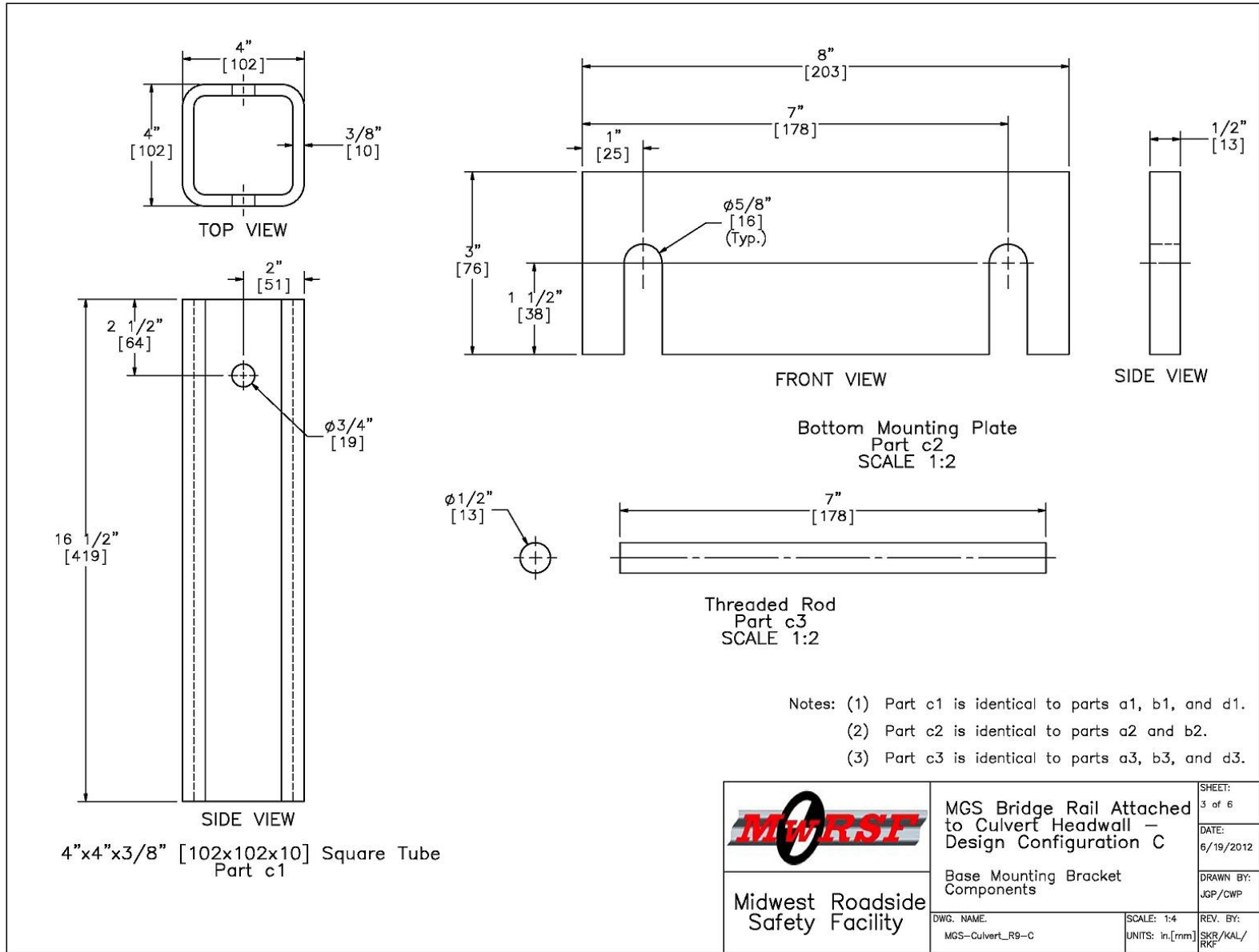

Figure 28. Design Concept C, Tube and Bottom Mounting Plate Details

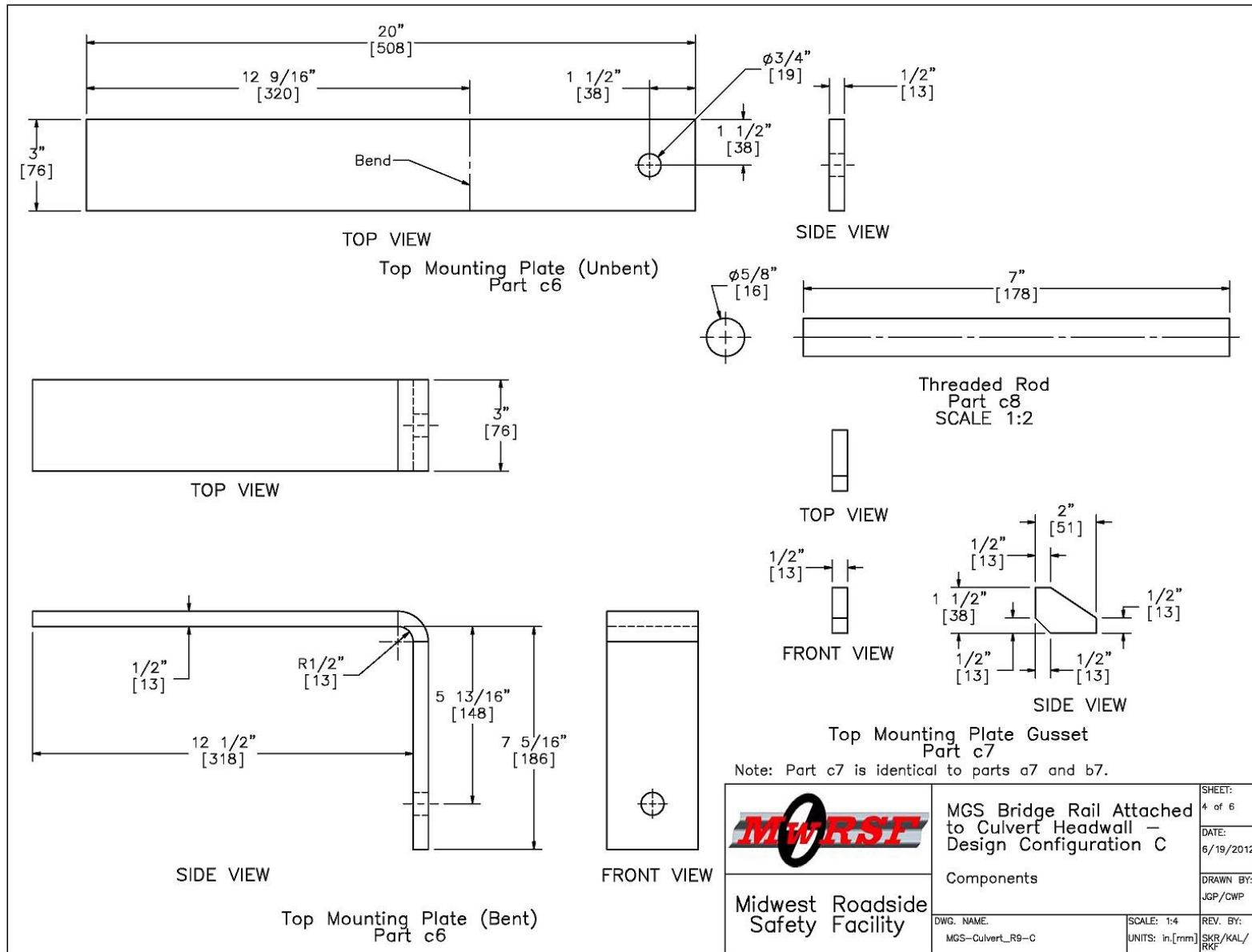

Figure 29. Design Concept C, Top Mounting Plate Details

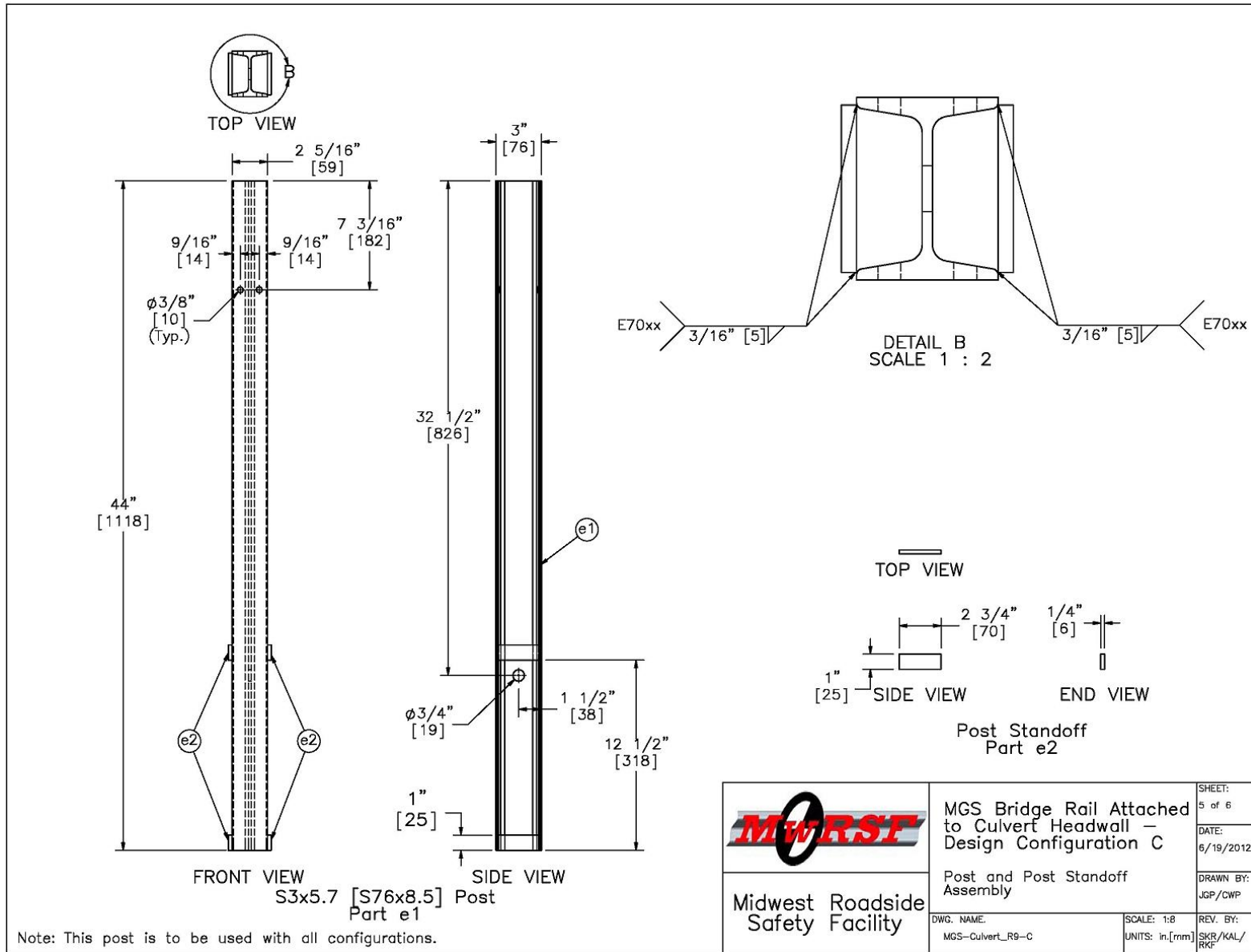

Figure 30. Design Concept C, Post Assembly



Configuration C			
Item No.	QTY.	Description	Material Specification
c1	1	4"x4"x3/8" [102x102x10] Square Steel Tube	ASTM A500 Grade B Steel Galvanized
c2	1	8"x3"x1/2" [203x76x13] Bottom Mounting Plate	ASTM A572 Grade 50 Steel Galvanized
c3	2	1/2" [13] Dia. UNC, 7" [178] Long Threaded Rod	ASTM A307 Grade C Galvanized/ASTM F1554 Grade 36 Galvanized/SAE J429 Grade 2 Galvanized
c4	2	1/2" [13] Dia. Hardened Round Washer	ASTM F436 Galvanized
c5	2	1/2" [13] Dia. UNC Heavy Hex Nut	ASTM A563A Galvanized
c6	1	20"x3"x1/2" [508x76x13] Top Mounting Plate	ASTM A572 Grade 50 Steel Galvanized
c7	1	2"x1 1/2"x1/2" [51x38x13] Top Mounting Plate Gusset	ASTM A572 Grade 50 Steel Galvanized
c8	1	5/8" [16] Dia. UNC, 7" [178] Long Threaded Rod	ASTM A307 Grade C Galvanized/ASTM F1554 Grade 36 Galvanized/SAE J429 Grade 2 Galvanized
c9	1	5/8" [16] Dia. Hardened Round Washer	ASTM F436 Galvanized
e1	1	S3x5.7 [S76x8.5] by 44" [1118] Long Steel Post	ASTM A992 Grade 50 Steel Galvanized
e2	4	2 3/4"x1"x1/4" [70x25x6] Post Standoff	ASTM A36 Steel Galvanized
e3	1	5/8" [16] Dia. UNC, 5" [127] Long Heavy Hex Bolt and Nut	Bolt ASTM A325 Type 1 Galvanized, Nut ASTM A563A Galvanized
f1	-	Epoxy	Powers Fasteners AC Gold 100+ or equivalent epoxy with minimum 1305 psi [9.0 MPa] bond strength

 Midwest Roadside Safety Facility	MGS Bridge Rail Attached to Culvert Headwall – Design Configuration C	SHEET: 6 of 6
	Bill of Materials	DATE: 6/19/2012
DWG. NAME: MGS-Culvert_R9-C	SCALE: NONE UNITS: in.[mm]	DRAWN BY: JGP/CWP
		REV. BY: SKR/KAL/ RKF

Figure 31. Design Concept C, Bill of Materials



Figure 32. Design Concept C, Installation Photographs



### **3.2.4 Concept D: Side-Mounted, Through-Bolted**

Design Concept D was developed to keep all attachment hardware on the outside face of the culvert headwall and prevent interactions between vehicle components and attachment hardware. The side-mounted design concept utilized a ½-in. (13-mm) thick top mounting plate, two ¼-in. (6-mm) thick gusset plates, and two ¾-in. (19-mm) diameter ASTM A307 threaded rods to anchor the top of the socket assembly, as shown in Figures 33 through 39. Gusset plates were added between the socket and the top mounting plate to prevent the plate from bending outward when the socket is subjected to high lateral loads. The top threaded rods were centered 4½ in. (114 mm) from the top of the headwall to avoid interference with internal steel reinforcing bars that are typically placed near the top of the headwall. Finally, ¼-in. (6-mm) thick plate washers and nuts were used to anchor the top threaded rods on the inside face of the headwall for this through-bolted configuration.

The bottom mounting plate and threaded rods remained largely unchanged from the previous design concepts. However, since the socket assembly was installed laterally instead of dropped in vertically, slotting the bottom mounting plate was unnecessary. Therefore, only ⅝-in. (16-mm) diameter holes were drilled into the bottom plate.

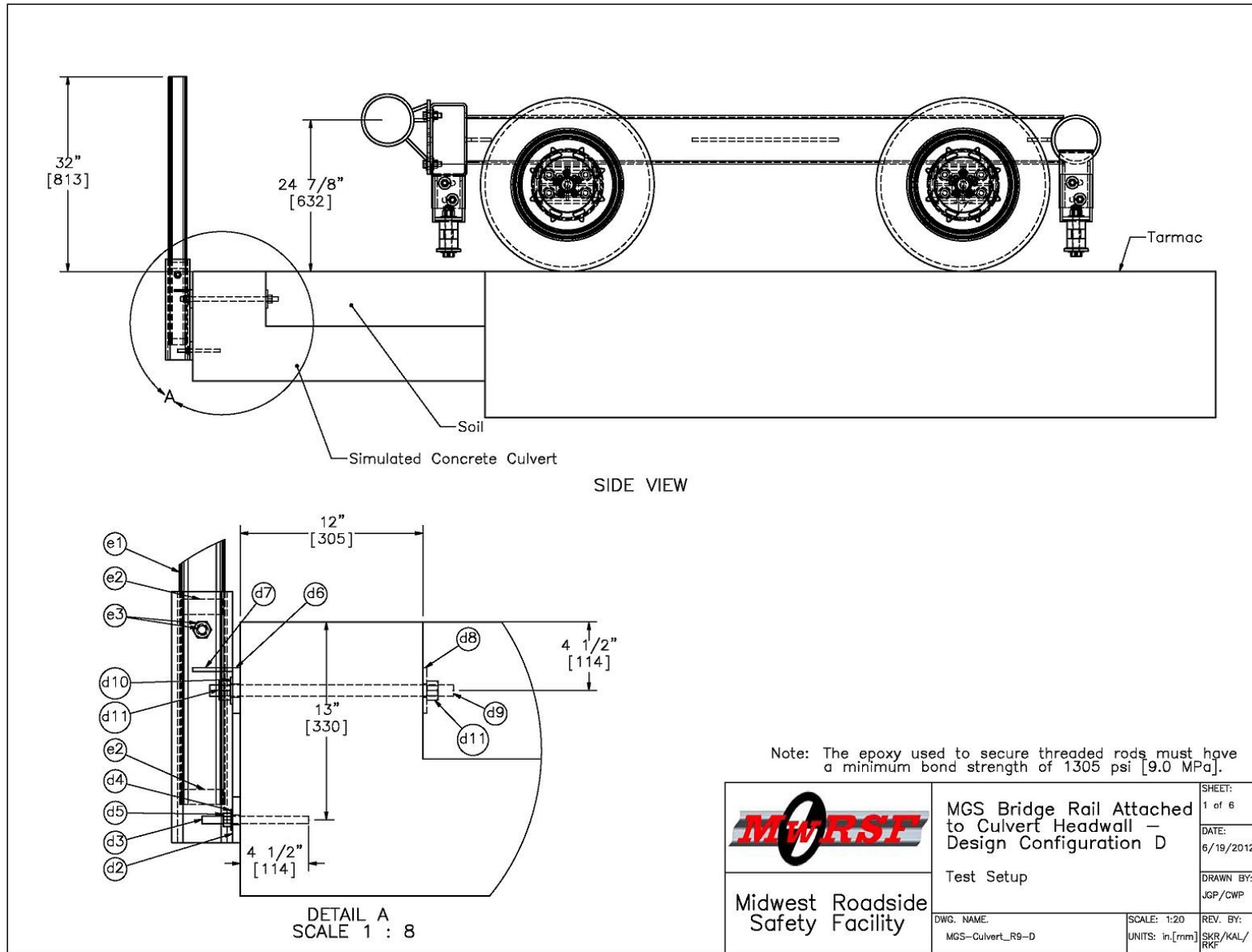

Figure 33. Design Concept D: Side-Mounted, Through-Bolted Attachment

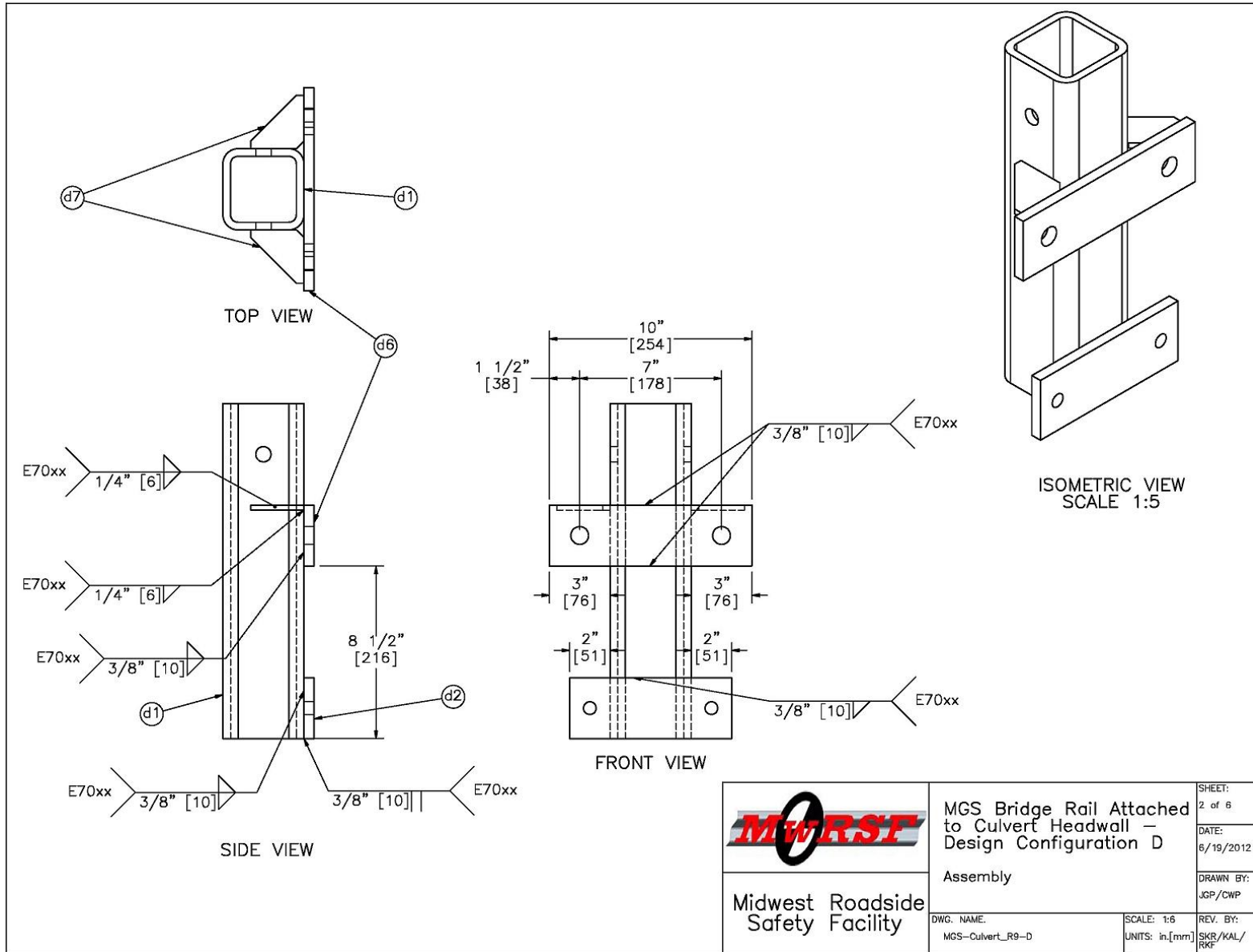

Figure 34. Design Concept D, Socket Assembly Details

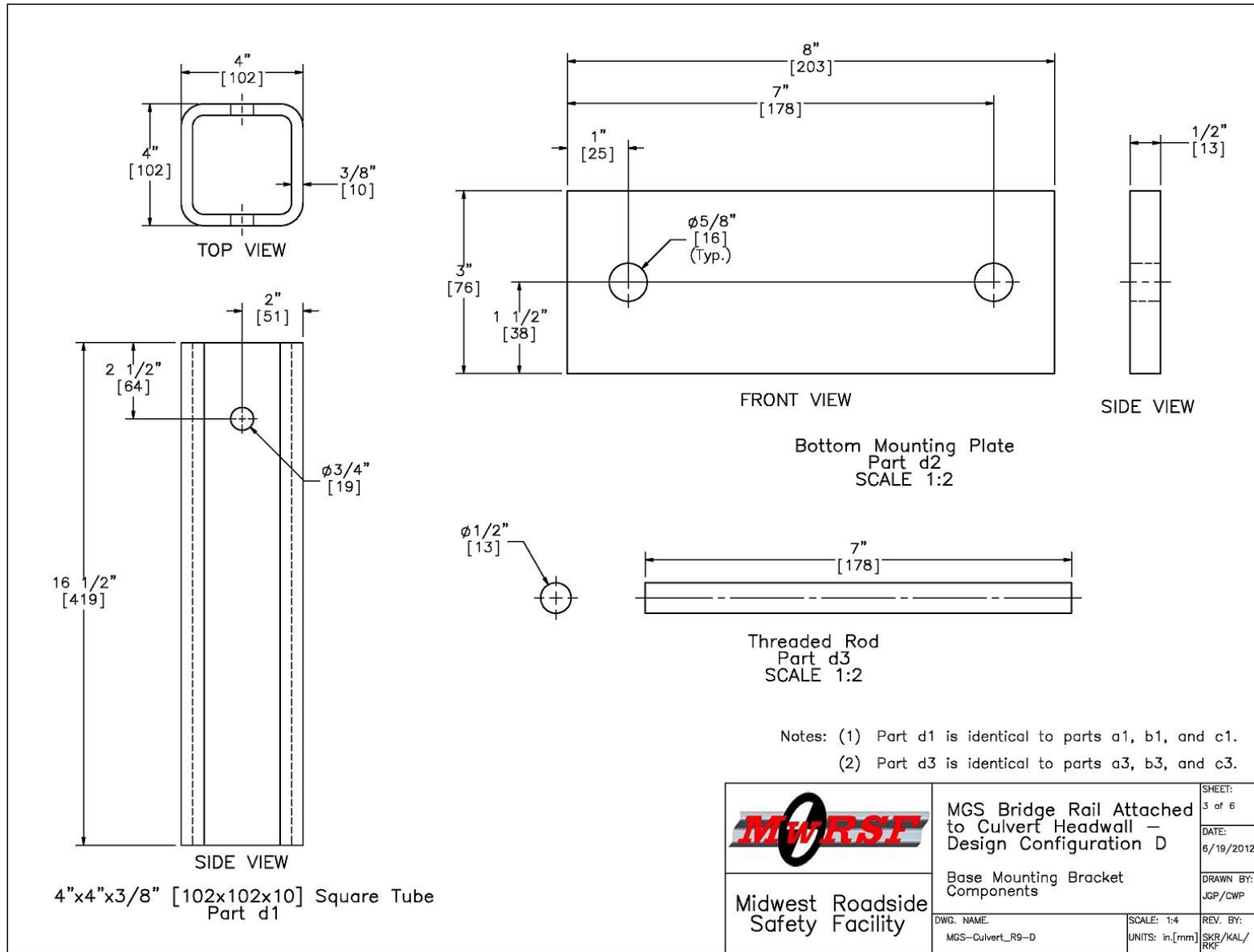

Figure 35. Design Concept D, Tube and Bottom Mounting Plate Details

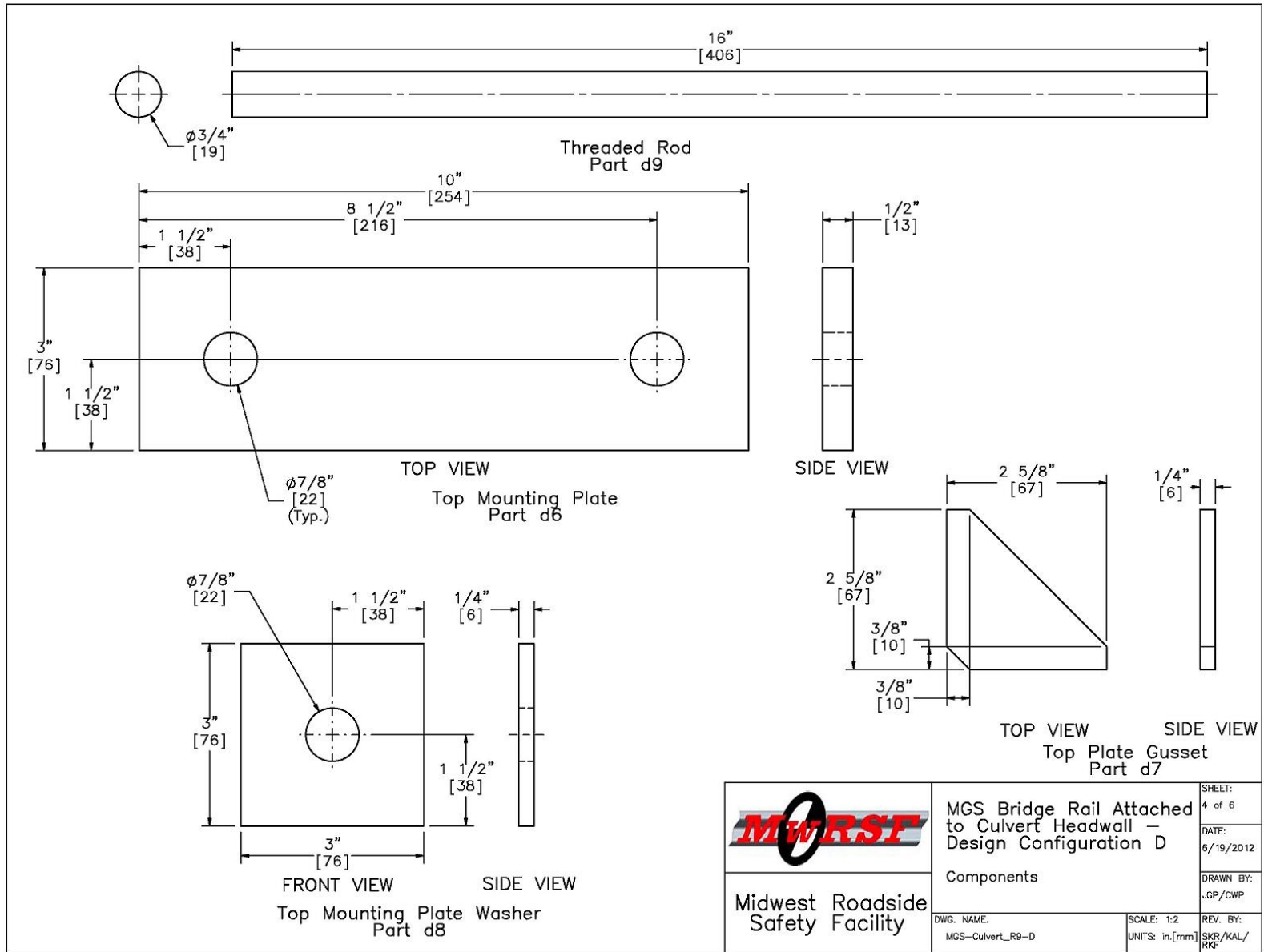

Figure 36. Design Concept D, Top Mounting Plate Details

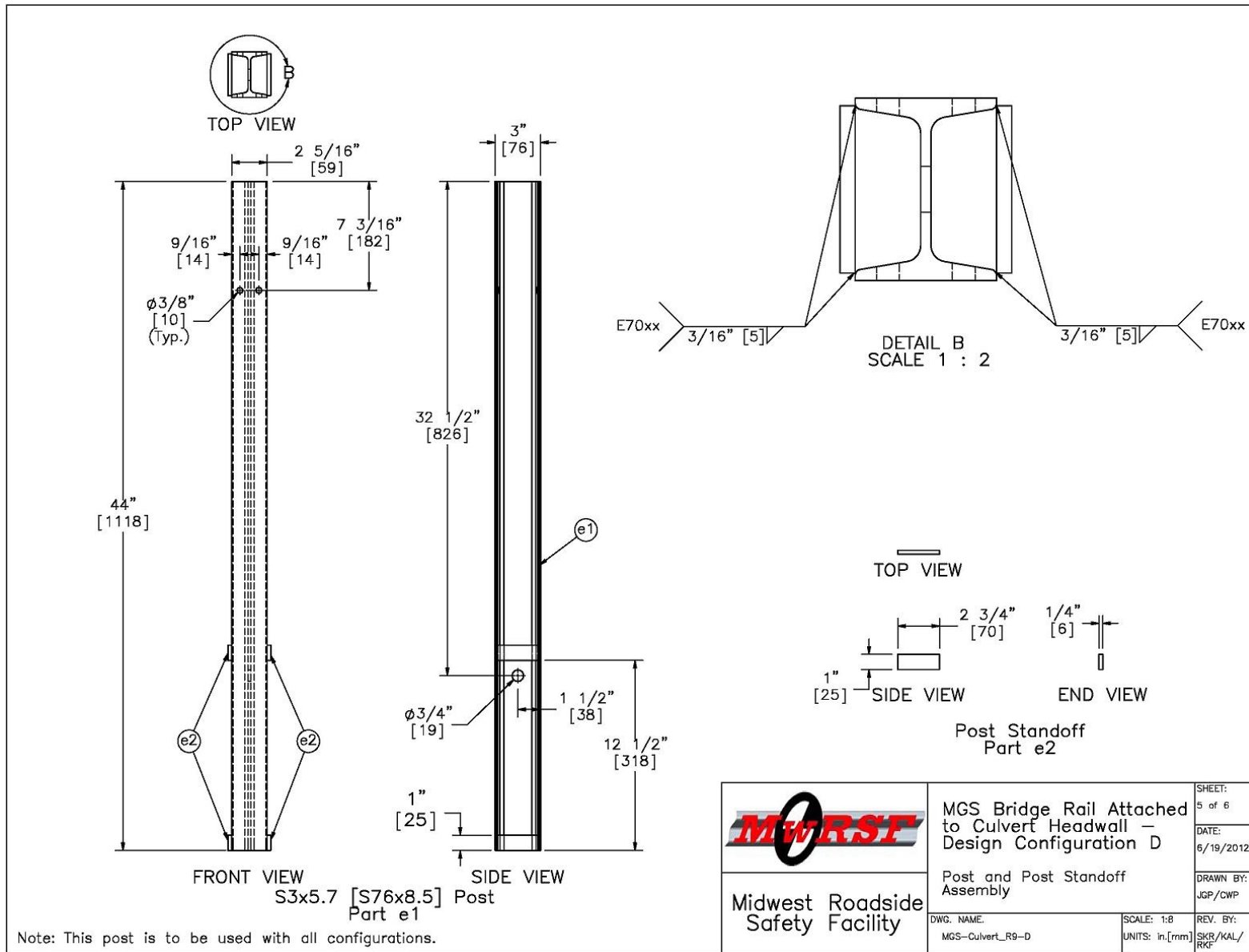

Figure 37. Design Concept D, Post Assembly



Configuration D			
Item No.	QTY.	Description	Material Specifications
d1	1	4"x4"x3/8" [102x102x10] Square Steel Tube	ASTM A500 Grade B Steel Galvanized
d2	1	8"x3"x1/2" [203x76x13] Bottom Mounting Plate	ASTM A572 Grade 50 Steel Galvanized
d3	2	1/2" [13] Dia. UNC, 7" [178] Long Threaded Rod	ASTM A307 Grade C Galvanized/ASTM F1554 Grade 36 Galvanized/SAE J429 Grade 2 Galvanized
d4	2	1/2" [13] Dia. Hardened Round Washer	ASTM F436 Galvanized
d5	2	1/2" [13] Dia. UNC Heavy Hex Nut	ASTM A563A Galvanized
d6	1	10"x3"x1/2" [254x76x13] Top Mounting Plate	ASTM A572 Grade 50 Steel Galvanized
d7	2	3"x3"x1/4" [76x76x6] Top Plate Gusset	ASTM A572 Grade 50 Steel Galvanized
d8	2	3"x3"x1/4" [76x76x6] Top Mounting Plate Washer	ASTM A572 Grade 50 Steel Galvanized
d9	2	3/4" [19] Dia. UNC, 16" [406] Long Threaded Rod	ASTM A307 Grade C Galvanized/ASTM F1554 Grade 36 Galvanized/SAE J429 Grade 2 Galvanized
d10	2	3/4" [19] Dia. Hardened Round Narrow Washer	ASTM F436 Galvanized
d11	4	3/4" [19] Dia. UNC Heavy Hex Nut	ASTM A563A Galvanized
e1	1	S3x5.7 [S76x8.5] by 44" [1118] Long Steel Post	ASTM A992 Grade 50 Steel Galvanized
e2	4	2 3/4"x1"x1/4" [70x25x6] Post Standoff	ASTM A36 Steel Galvanized
e3	1	5/8" [16] Dia. UNC, 5" [127] Long Heavy Hex Bolt and Nut	Bolt ASTM A325 Type 1 Galvanized, Nut ASTM A563A Galvanized
f1	-	Epoxy	Powers Fasteners AC Gold 100+ or equivalent epoxy with minimum 1305 psi [9.0 MPa] bond strength

 Midwest Roadside Safety Facility	MGS Bridge Rail Attached to Culvert Headwall – Design Configuration D Bill of Materials	SHEET: 6 of 6 DATE: 6/19/2012 DRAWN BY: JGP/CWP
	DWG. NAME: MGS-Culvert_R9-D	SCALE: NONE UNITS: in.[mm]

Figure 38. Design Concept D, Bill of Materials

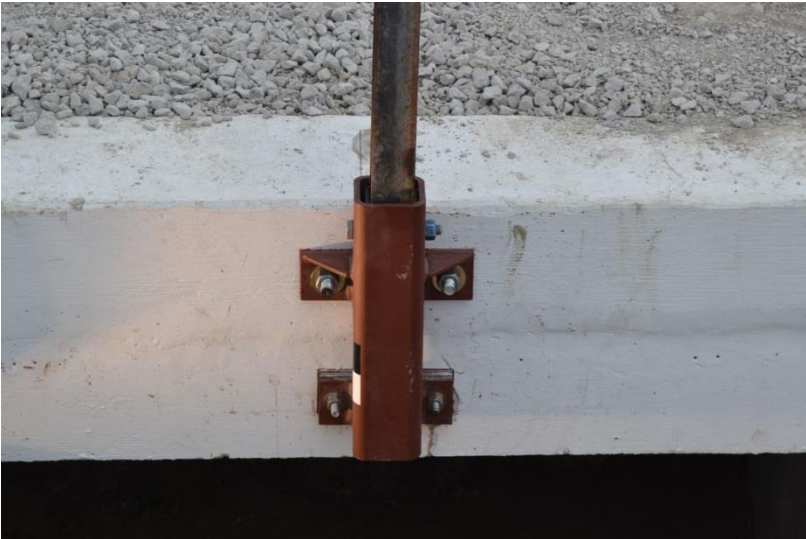

Figure 39. Design Concept D, Installation Photographs

### **3.2.5 Concept D2: Side-Mounted, Epoxy-Anchored**

Design Concept D2 was identical to Design Concept D except that the top anchor rods were epoxied into the headwall instead of passing through and being fastened to the inside face of the headwall. An epoxy with minimum bond strength of 1,300 psi (9.0 MPa) was used to embed the anchor rods 9 in. (229 mm) into the headwall, as shown in Figures 40 through 46. Thus, the anchor rods were shortened and the interior washer plates and nuts were eliminated from the through-bolted configuration. Further, the soil fill on the culvert did not have to be disturbed during installation.

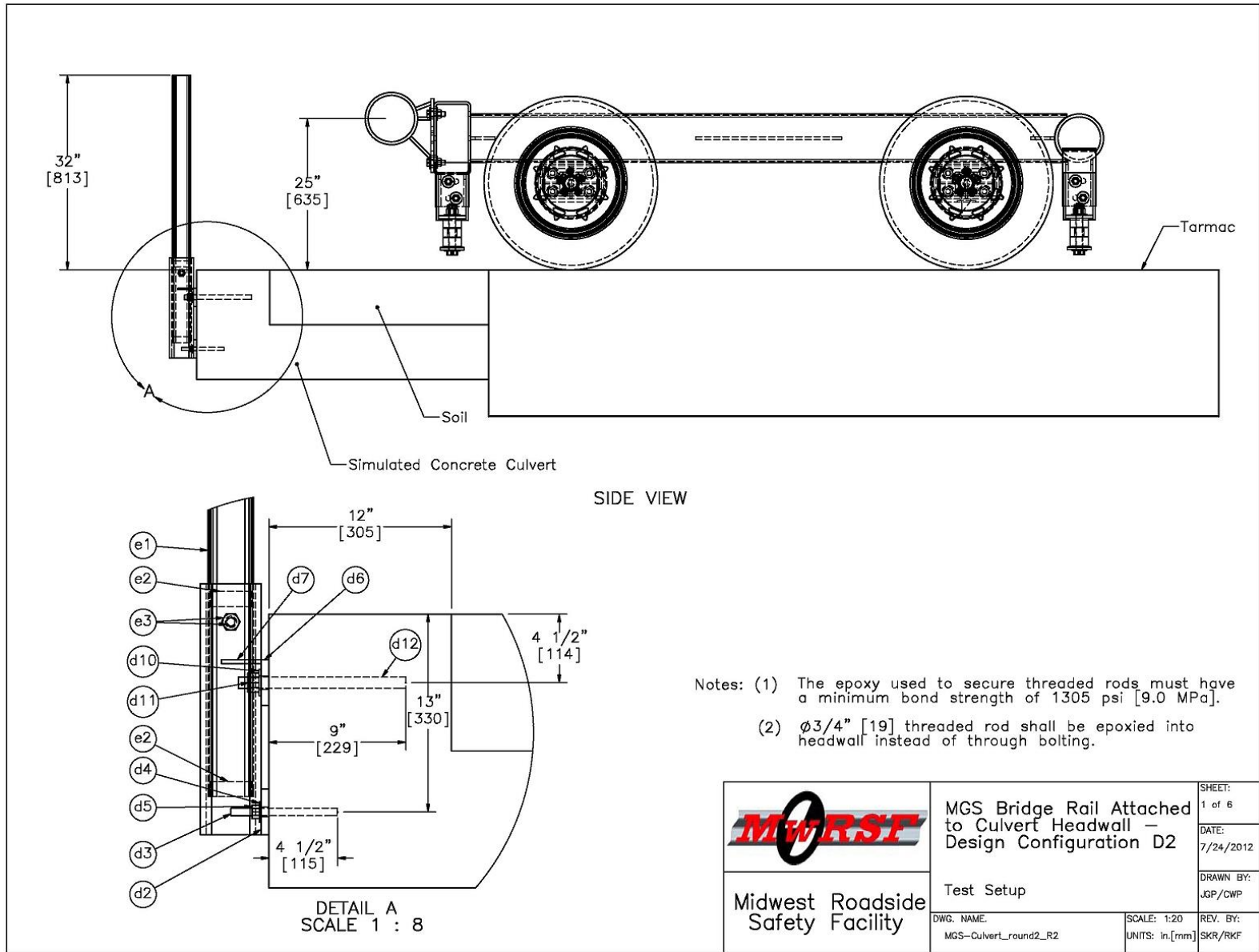

Figure 40. Design Concept D2: Side-Mounted, Epoxy-Anchored Attachment

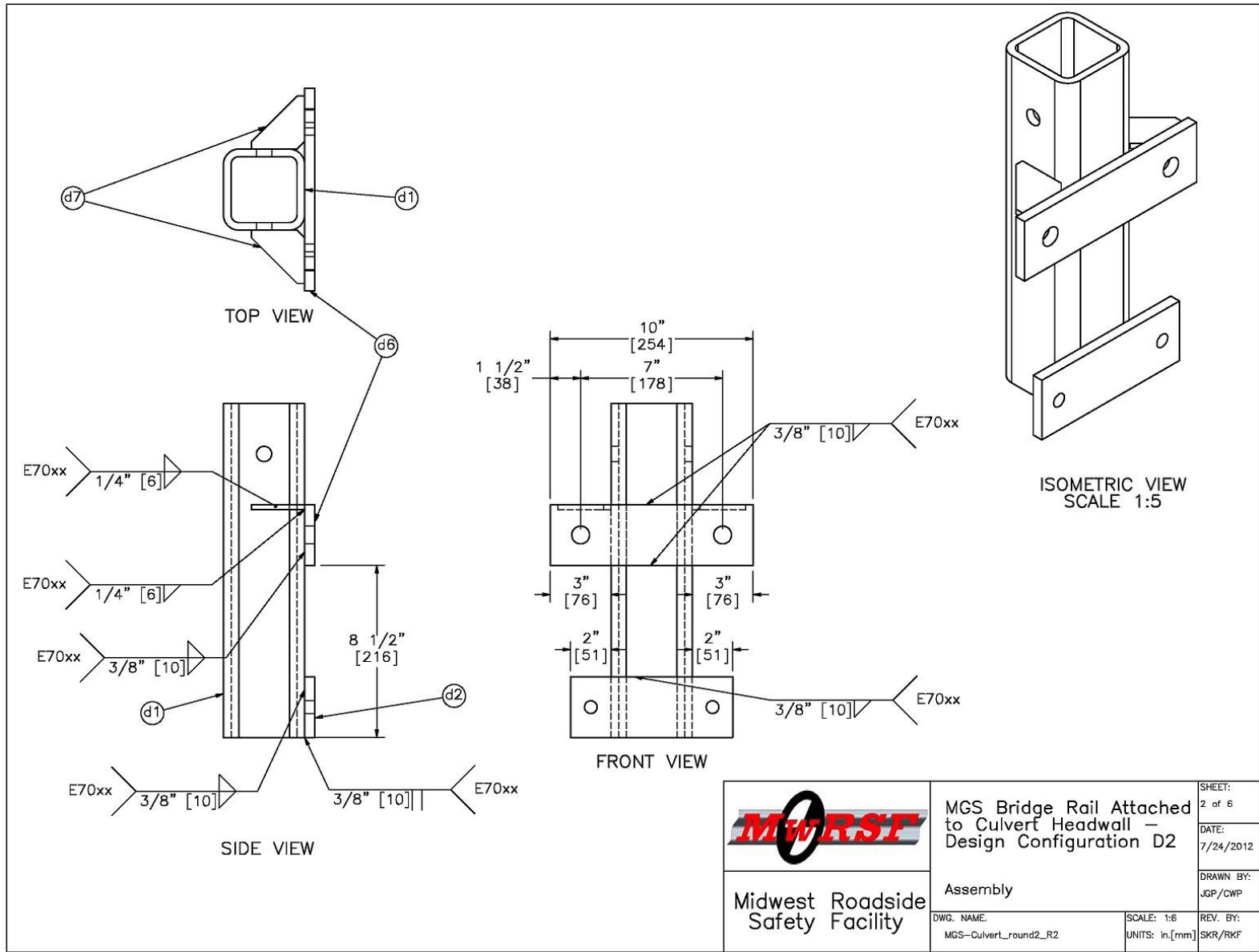

Figure 41. Design Concept D2, Socket Assembly Details

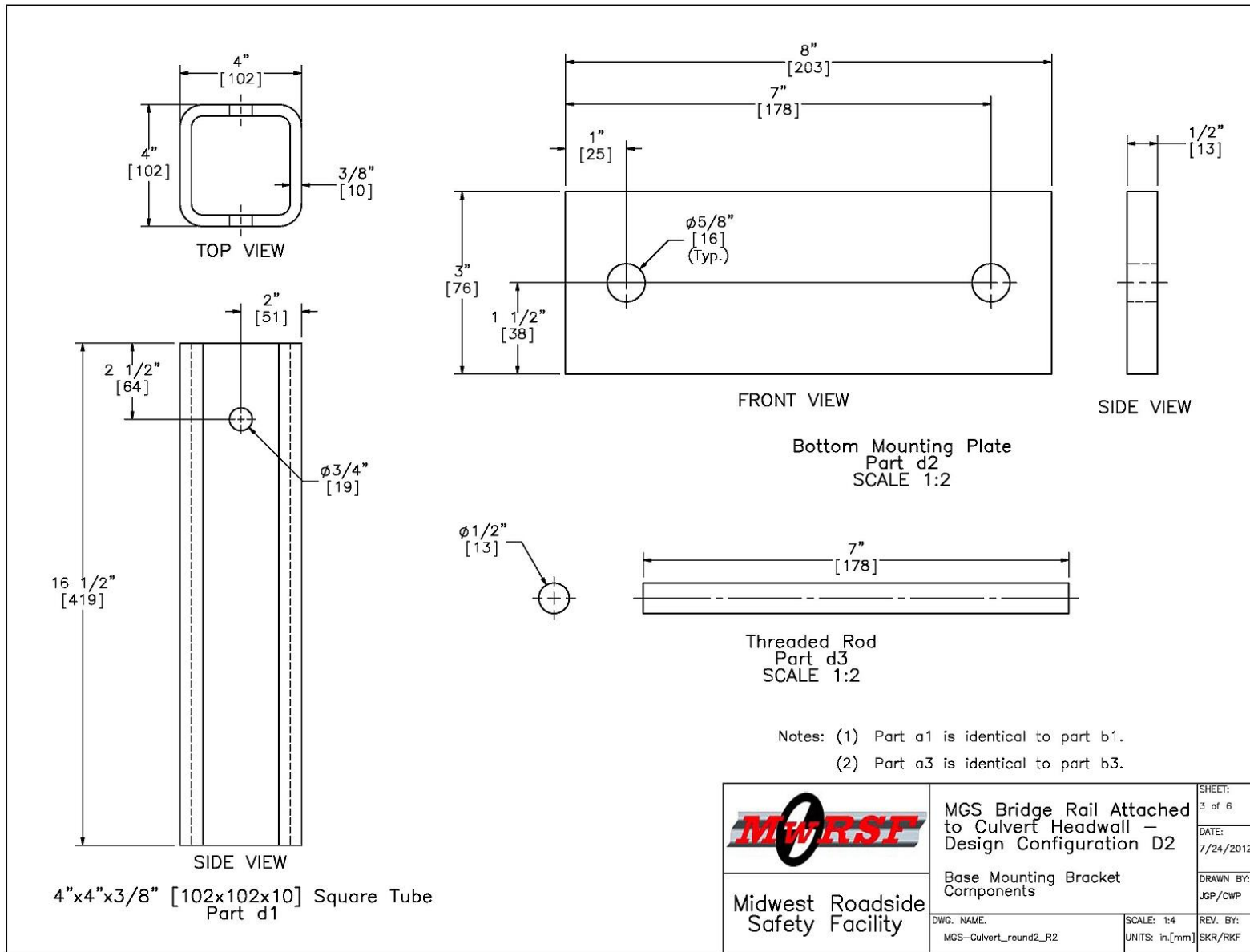
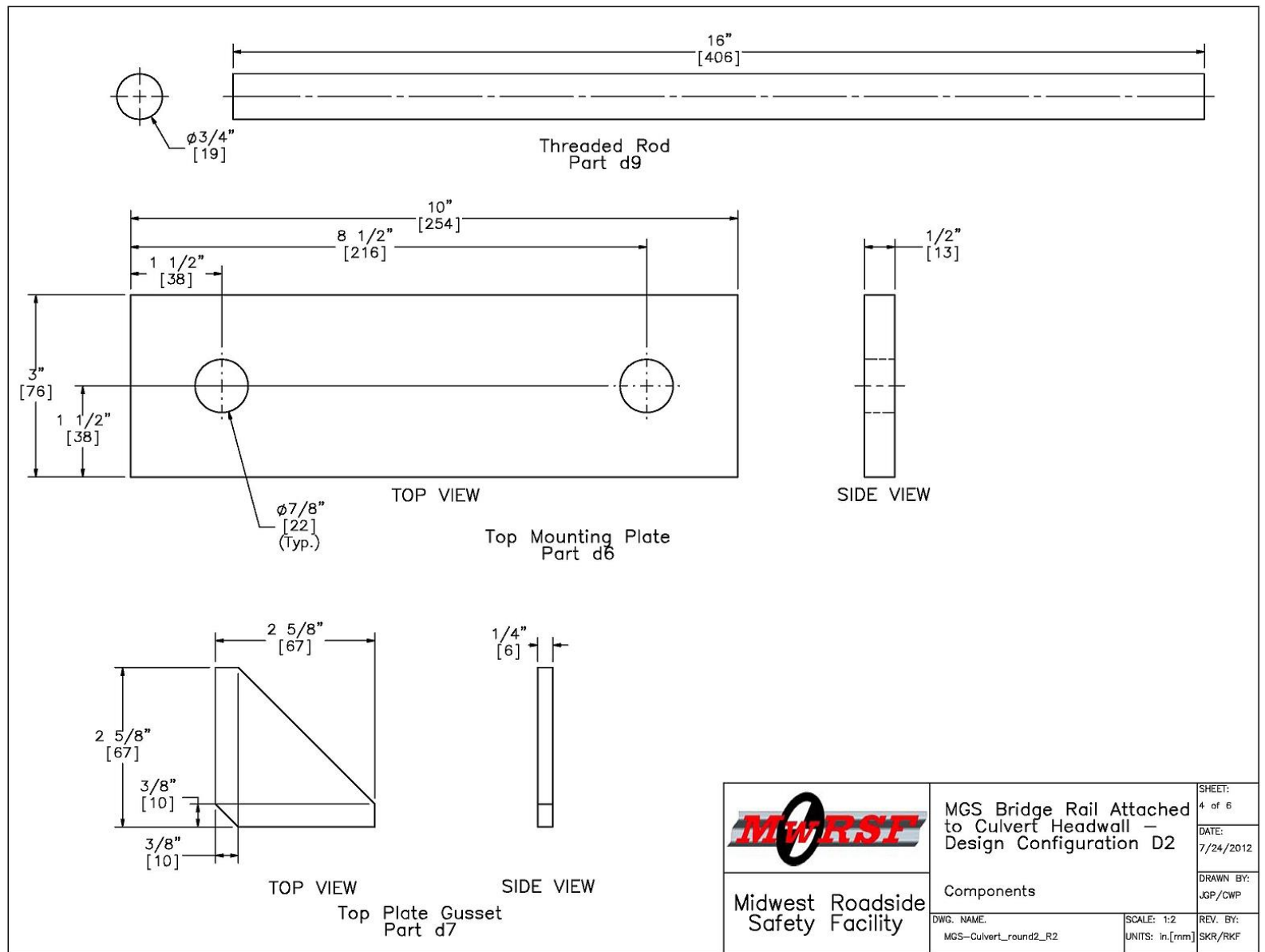

Figure 42. Design Concept D2, Tube and Bottom Mounting Plate Details





 <b>Midwest Roadside Safety Facility</b>	<b>MGS Bridge Rail Attached to Culvert Headwall – Design Configuration D2</b>		SHEET: 4 of 6
	Components		DATE: 7/24/2012
DWG. NAME: MGS-Culvert_round2_R2	SCALE: 1:2 UNITS: in.[mm]	REV. BY: SKR/RKF	DRAWN BY: JGP/CWP

Figure 43. Design Concept D2, Top Mounting Plate Details

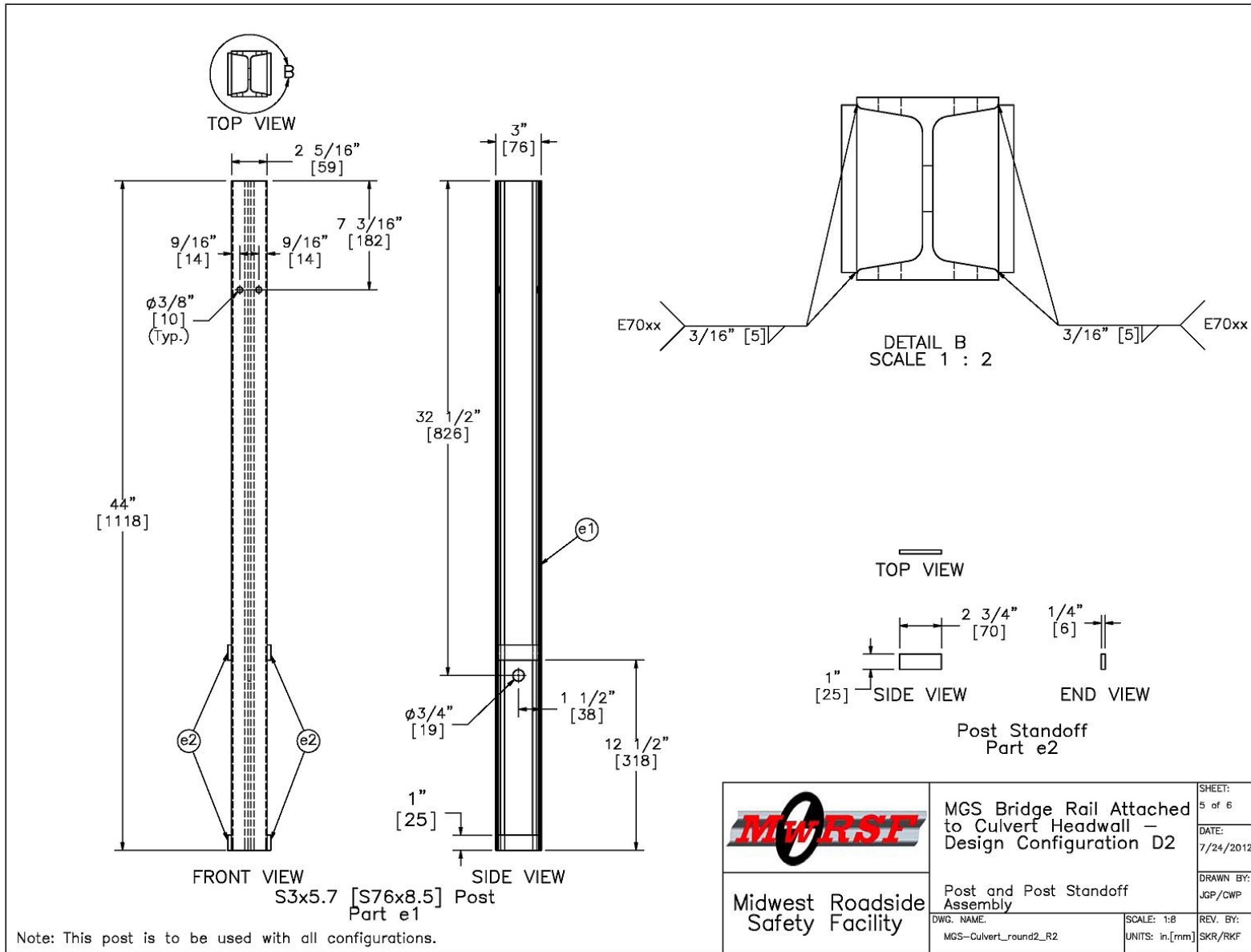

Figure 44. Design Concept D2, Post Assembly



Configuration D2				
Item No.	QTY.	Description	Material Specification	Hardware
d1	1	4"x4"x3/8" [102x102x10] Square Steel Tube	ASTM A500 Grade B Steel Galvanized	—
d2	1	8"x3"x1/2" [203x76x13] Bottom Mounting Plate	ASTM A572 Grade 50 Steel Galvanized	—
d3	2	1/2" [13] Dia. UNC, 7" [178] Long Threaded Rod	ASTM A307 Grade C Galvanized/ASTM F1554 Grade 36 Galvanized/SAE J429 Grade 2 Galvanized	—
d4	2	1/2" [13] Dia. Hardened Round Washer	ASTM F436 Galvanized	—
d5	2	1/2" [13] Dia. UNC Heavy Hex Nut	ASTM A563A Galvanized	—
d6	1	10"x3"x1/2" [254x76x13] Top Mounting Plate	ASTM A572 Grade 50 Steel Galvanized	—
d7	2	3"x3"x1/4" [76x76x6] Top Plate Gusset	ASTM A572 Grade 50 Steel Galvanized	—
d10	2	3/4" [19] Dia. Hardened Round Narrow Washer	ASTM F436 Galvanized	FWC20b
d11	2	3/4" [19] Dia. UNC Heavy Hex Nut	ASTM A563A Galvanized	FNX20a
d12	2	3/4" [19] Dia. UNC, 11" [406] Long Threaded Rod	ASTM A307 Grade C Galvanized/ASTM F1554 Grade 36 Galvanized/SAE J429 Grade 2 Galvanized	—
e1	1	S3x5.7 [S76x8.5] by 44" [1118] Long Steel Post	ASTM A992 Grade 50 Steel Galvanized	—
e2	4	2 3/4"x1"x1/4" [70x25x6] Post Standoff	ASTM A36 Steel Galvanized	—
e3	1	5/8" [16] Dia. UNC, 5" [127] Long Heavy Hex Bolt and Nut	Bolt ASTM A325 Type 1 Galvanized, Nut ASTM A563A Galvanized	FBX16a
f1	—	Epoxy	Powers Fasteners AC Gold 100+ or equivalent epoxy with minimum 1305 psi [9.0 MPa] bond strength	—

	MGS Bridge Rail Attached to Culvert Headwall – Design Configuration D2		SHEET: 6 of 6
	Bill of Materials		DATE: 7/24/2012
Midwest Roadside Safety Facility	DWG. NAME: MGS-Culvert_round2_R2	SCALE: NONE UNITS: in.[mm]	DRAWN BY: JGP/CWP
			REV. BY: SKR/RKF

Figure 45. Design Concept D2, Bill of Materials

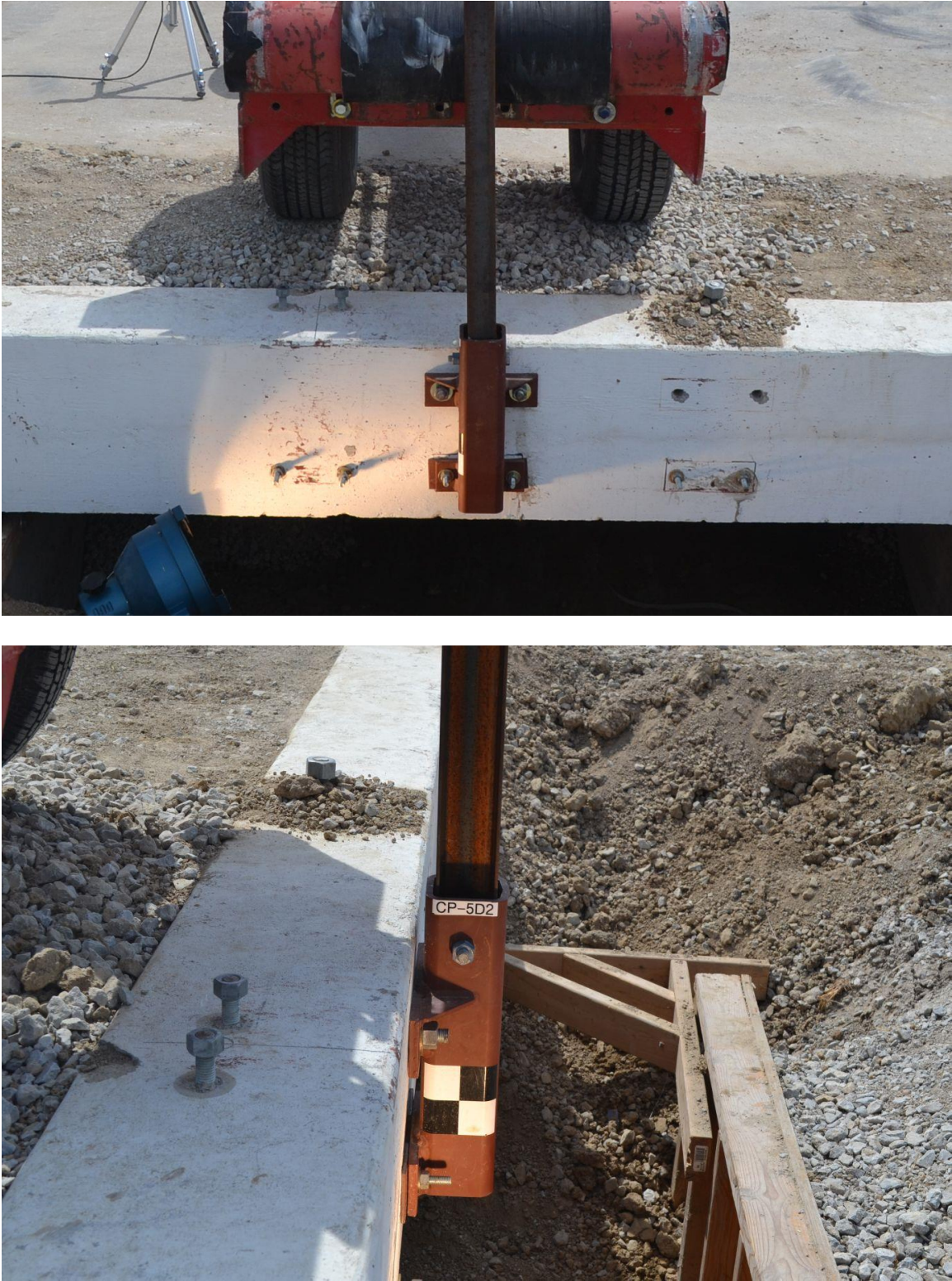

Figure 46. Design Concept D2, Installation Photographs

## **4 EVALUATION CRITERIA AND TEST CONDITIONS**

### **4.1 Testing Criteria**

New highway barriers must typically be subjected to full-scale crash testing and satisfy the MASH safety performance criteria in order to be deemed crashworthy. However, the original weak-post, MGS bridge rail had already satisfied the MASH TL-3 criteria, and this study focused only on adapting the original system for use on culvert headwalls. In fact, the W-beam rail, rail-to-post attachment hardware, mounting height, post assembly, and socket tube all remained unchanged from the original bridge rail. The only new components in these concepts were the attachment hardware utilized to mount the socket flush with the outside face of the culvert headwall. Further, the new attachments and anchorage pieces were designed to withstand impact loads and remain undamaged, while the post and rail components deform and absorb energy. If these new components were shown to withstand extreme loading conditions without damage to the socket assembly or the culvert headwall, the new weak-post guardrail attached to concrete box culvert systems would perform similarly to the original weak-post bridge rail. Thus, full-scale testing was deemed unnecessary, and the evaluation of the new design concepts was limited to dynamic component testing.

### **4.2 Critical Impact Conditions**

During dynamic component testing, the design concepts were subjected to two critical loading conditions. The first involved a lateral impact (90-degree impact angle) on the post at a height of 24<sup>7</sup>/<sub>8</sub> in. (632 mm), subjecting it to strong-axis bending. These impact conditions were selected to match the height to the center of the W-beam rail and represent maximum lateral loading into the guardrail system. Similar impact conditions are routinely used to observe the performance of guardrail posts installed in soil. The second critical test condition involved a longitudinal impact (0-degree impact angle) where a post was subjected to weak-axis bending.

The longitudinal impacts were conducted with a load height of 12 in. (305 mm) to simulate a small car bumper impacting posts during a redirection. This second impact was deemed critical because it induces high shear loads into the socket and may cause the socket to rotate.

The location of the test articles on the culvert headwall was also critical as these impact tests were evaluating the propensity for damage to the both the socket and the culvert. Both the top slab and the culvert headwall are strengthened and stiffened at locations above the vertical support walls (both interior and end walls). Impact tests conducted over a support wall may not produce the same magnitude of damage that would occur elsewhere on the culvert. Therefore, all test articles were attached to the headwall at 1/3-span locations resulting in a 3-ft (0.9 m) offset between each post and the adjacent support wall, as shown in Figure 47.

### **4.3 Scope**

Seven dynamic component tests were conducted on the various post and socket attachment configurations mounted to the simulated critical culvert described in Chapter 2. Each of the five design concepts was impacted laterally (causing strong-axis bending) with an impact height of 24<sup>7</sup>/<sub>8</sub> in. (632 mm). Additionally, Design Concepts A and D2 were subjected to longitudinal impacts (weak-axis) with an impact height of 12 in. (305 mm). The target impact velocity was 20 mph (32 km/h) for all seven tests. The bogie testing matrix, which describes details for each test, is shown in Table 2. Material specifications for all construction materials used in the culvert and railing components are shown in Appendix A.

### **4.4 Test Facility**

Physical testing of the post and socket assemblies mounted to a simulated culvert was conducted at the MwRSF testing facility, which is located at the Lincoln Air Park on the northwest side of the Lincoln Municipal Airport. The facility is approximately 5 miles (8 km) northwest from the University of Nebraska-Lincoln's city campus.

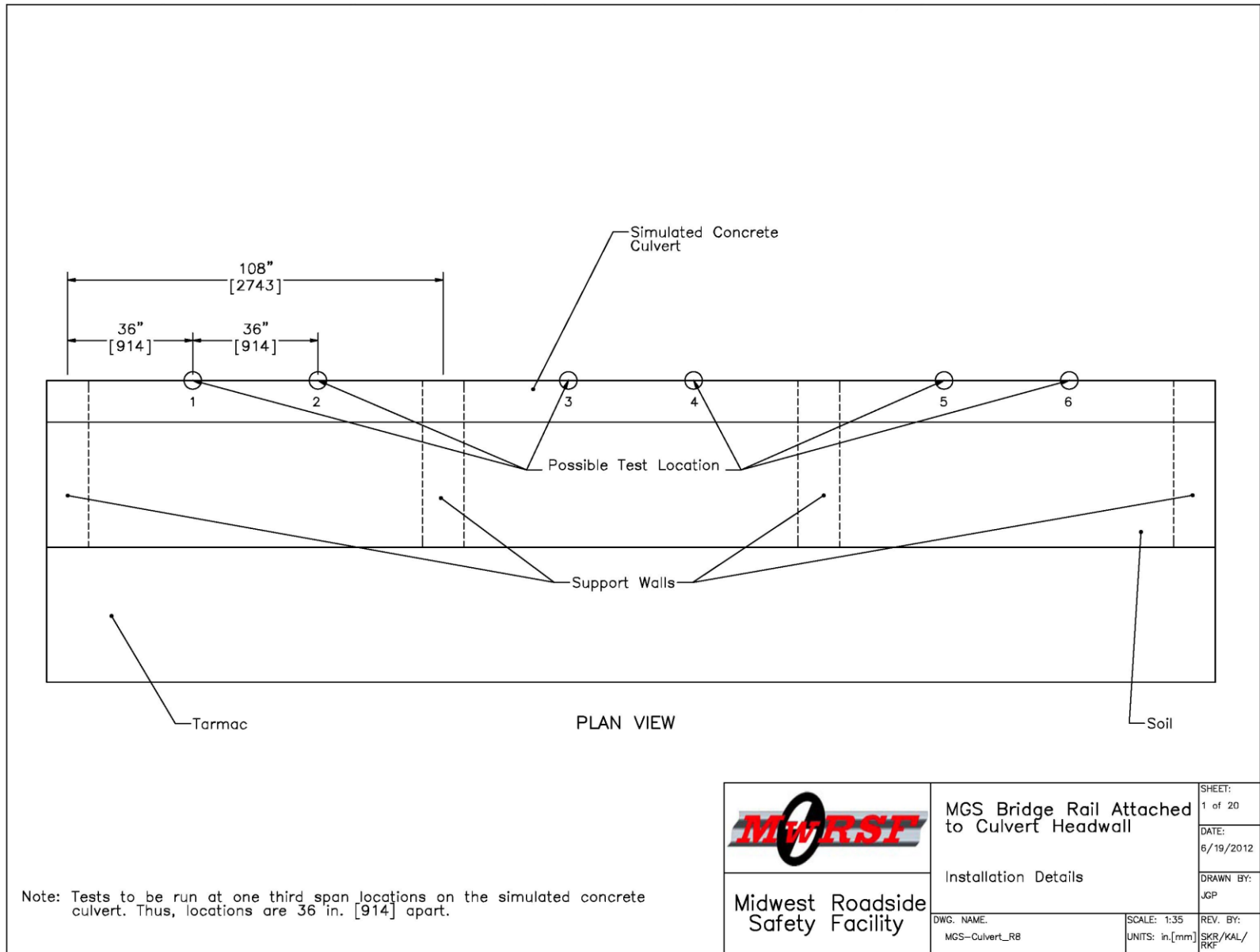

Figure 47. Locations of Test Articles on Simulated Culvert



Table 2. Bogie Testing Matrix

Test No.	Design Concept	Description	Target Impact Velocity (mph)	Impact Angle	Impact Height
CP-1C	C	Wrap-Around	20 mph (32 km/h)	90° (lateral)	24 <sup>7</sup> / <sub>8</sub> in. (632 mm)
CP-2A	A	Top-Mounted, Single-Anchor	20 mph (32 km/h)	90° (lateral)	24 <sup>7</sup> / <sub>8</sub> in. (632 mm)
CP-3D	D	Side-Mounted, Through-Bolted	20 mph (32 km/h)	90° (lateral)	(24 <sup>7</sup> / <sub>8</sub> in. (632 mm)
CP-4B	B	Top-Mounted, Double-Anchor	20 mph (32 km/h)	90° (lateral)	24 <sup>7</sup> / <sub>8</sub> in. (632 mm)
CP-5D2	D2	Side-Mounted, Epoxy-Anchored	20 mph (32 km/h)	90° (lateral)	24 <sup>7</sup> / <sub>8</sub> in. (632 mm)
CP-6D2	D2	Side-Mounted, Epoxy-Anchored	20 mph (32 km/h)	0° (longitudinal)	12 in. (305 mm)
CP-7A	A	Top-Mounted, Single-Anchor	20 mph (32 km/h)	0° (longitudinal)	12 in. (305 mm)

#### 4.5 Equipment and Instrumentation

Equipment and instrumentation utilized to collect and record data during the dynamic component tests included a bogie vehicle, accelerometers, a retroreflective optical speed trap, high-speed and standard-speed digital video, and still cameras.

##### 4.5.1 Bogie

A rigid-frame bogie vehicle was used to impact the post and socket assemblies. Two different impact heads were used in the testing. For the lateral impacts, the bogie head was constructed of 8-in. (203-mm) diameter, ½-in. (13-mm) thick standard steel pipe, with ¾-in. (19-mm) neoprene belting wrapped around the pipe. This impact head was bolted to the bogie vehicle, creating a rigid frame with an impact height of 24<sup>7</sup>/<sub>8</sub> in. (632 mm). For the longitudinal

impacts, the bogie head consisted of a 2½-in. x 2½-in. x 5/16-in. (64-mm x 64-mm x 8-mm) square tube mounted on the outside flange of a W6x25 (W152x37.2) steel beam with reinforcing gussets. The impact head was bolted to the bogie vehicle, creating a rigid frame with an impact height of 12 in. (305 mm). Photographs of the bogie with both impact heads are shown in Figure 48. The weight of the bogie with the addition of the mountable impact heads varied between tests, but was approximately 1,800 lb (815 kg). The bogie vehicle weight for each test is shown on the individual test summaries provided in Appendix B.

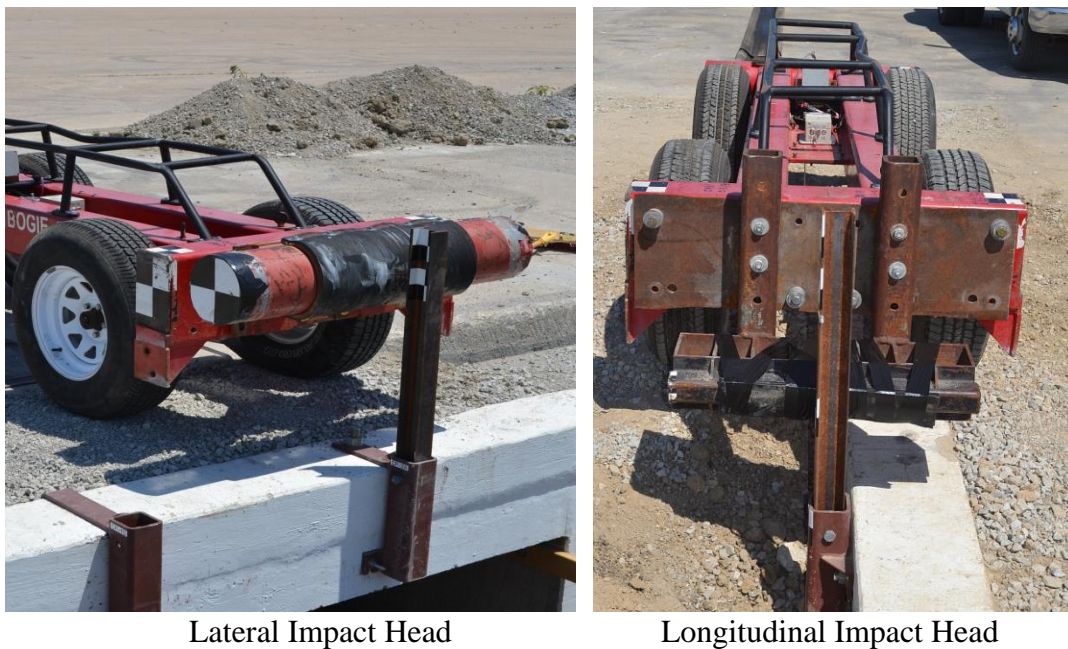

Figure 48. Rigid-Frame Bogie Equipped with Lateral and Longitudinal Impact Heads

The tests were conducted using a steel, corrugated-beam guardrail to guide the tire of the bogie vehicle as shown in Figure 48. A pickup truck was used to push the bogie vehicle to the targeted impact velocity of 20 mph (32 km/h). After reaching the target velocity, the push vehicle braked, allowing the bogie to be free rolling as it came off the track. A remote braking system was installed on the bogie, allowing it to be brought safely to rest after the test.



#### **4.5.2 Accelerometers**

Two environmental shock and vibration sensor/recorder systems were used to measure the accelerations along the longitudinal axis of the bogie vehicle. Both accelerometers were mounted near the center of gravity of the test vehicles. The electronic accelerometer data obtained in dynamic testing was filtered using the SAE Class 60 Butterworth filter conforming to the SAE J211/1 specifications [15].

The first system, SLICE 6DX, was a modular data acquisition system manufactured by DTS of Seal Beach, California. The acceleration sensors were mounted inside the body of the custom built SLICE 6DX event data recorder and recorded data at 10,000 Hz to the onboard microprocessor. The SLICE 6DX was configured with 7 GB of non-volatile flash memory, a range of  $\pm 500$  g's, a sample rate of 10,000 Hz, and a 1,650 Hz (CFC 1000) anti-aliasing filter. The "SLICEWare" computer software programs and a customized Microsoft Excel worksheet were used to analyze and plot the accelerometer data.

The second system, Model EDR-3, was a triaxial piezoresistive accelerometer system manufactured by IST of Okemos, Michigan. The EDR-3 was configured with 256 kB of RAM, a range of  $\pm 200$  g's, a sample rate of 3,200 Hz, and a 1,120 Hz low-pass filter. The "DynaMax 1 (DM-1)" computer software program and a customized Microsoft Excel worksheet were used to analyze and plot the accelerometer data.

#### **4.5.3 Retroreflective Optic Speed Trap**

The retroreflective optic speed trap was used to determine the speed of the bogie vehicle before impact. Three retroreflective targets, spaced at approximately 18-in. (457-mm) intervals, were applied to the side of the bogie vehicle, and a light beam Emitter/Receiver was placed perpendicular to the path of bogie vehicle. When the emitted beam of light was reflected by the targets and returned to the Emitter/Receiver, a signal was sent to the Optic Control Box, which in

turn sent a signal to the data computer as well as activated the External LED box. The computer recorded the signals and the time each occurred. The speed was then calculated using the spacing between the retroreflective targets and the time between the signals. LED lights and high-speed digital video analysis are only used as a backup in the event that vehicle speeds cannot be determined from the electronic data.

#### **4.5.4 Digital Photography**

Two AOS X-PRI high-speed digital video cameras and two JVC digital video cameras were used to document each test. The AOS high-speed cameras each had a frame rate of 500 frames per second and the JVC digital video cameras each had a frame rate of 29.97 frames per second. Both high-speed cameras were placed laterally from the post, with a view perpendicular to the bogie's direction of travel. A Nikon D50 digital still camera was also used to document pre- and post-test conditions for all tests.

#### **4.6 End of Test Determination**

When the impact head initially contacts the test article, the force exerted by the surrogate test vehicle is directly perpendicular. However, as the post rotates, the surrogate test vehicle's orientation and path moves further from perpendicular. This introduces two sources of error: (1) the contact force between the impact head and the post has a vertical component and (2) the impact head slides upward along the test article. Therefore, only the initial portion of the accelerometer trace may be used since variations in the data become significant as the system rotates and the surrogate test vehicle overrides the system. Additionally, guidelines were established to define the end of test time using the high-speed video of the impact. The first occurrence of either of the following events was used to determine the end of the test: (1) the test article fractures or (2) the surrogate vehicle overrides/loses contact with the test article.

#### **4.7 Data Processing**

The electronic accelerometer data obtained in dynamic testing was filtered using the SAE Class 60 Butterworth filter conforming to the SAE J211/1 specifications [15]. The pertinent acceleration signal was extracted from the bulk of the data signals. The processed acceleration data was then multiplied by the mass of the bogie to get the impact force using Newton's Second Law. Next, the acceleration trace was integrated to find the change in velocity versus time. Initial velocity of the bogie, calculated from the speed trap, was then used to determine the bogie velocity, and the calculated velocity trace was integrated to find the bogie's displacement, which is also the displacement of the post. Combining the previous results, a force vs. deflection curve was plotted for each test. Finally, integration of the force vs. deflection curve provided the energy vs. deflection curve for each test.

## 5 COMPONENT TESTING RESULTS AND DISCUSSION

### 5.1 Lateral Impact Testing Results

One lateral impact test was conducted on each of the five attachment design concepts described in Chapter 3. The accelerometer data for each test was processed in order to obtain force vs. deflection and energy vs. deflection curves. Although both transducers produced similar results, the values described herein were calculated from the SLICE accelerometer. Weather conditions for each test as recorded by the National Oceanic and Atmospheric Administration (station 14939/LNK) are shown in Table 3. A summary of the testing results is shown in Table 4. Test results from each individual transducer are provided in Appendix B.

Table 3. Weather and Atmospheric Conditions, Lateral Impact Testing

Test No.	Test Date	Temp. (°F)	Hum. (%)	Wind Speed (mph)	Sky Conditions	Pavement Surface	Previous 3-Day Precip. (in.)	Previous 7-Day Precip. (in.)
CP-1C	6/27/2012	96	43	15	Clear	Dry	0	0.84
CP-2A	6/27/2012	99	39	14	Clear	Dry	0	0.84
CP-3D	6/29/2012	82	62	5	Overcast	Dry	0	0.69
CP-4B	6/29/2012	85	70	14	Clear	Dry	0	0.69
CP-5D2	7/31/2012	93	36	3	Clear	Dry	0.02	0.33

#### 5.1.1 Test No. CP-1C

During test no. CP-1C, the bogie impacted the post at a speed of 22.5 mph (36.2 km/h) and an angle of 90 degrees, causing strong-axis bending in the post. At 0.004 sec after impact, the top of the socket shifted backward about 1/8 in. (3 mm) as the top mounting plate was pulled tight against the inside face of the headwall. By 0.010 sec, a plastic hinge had formed in the post adjacent to the top-back edge of the socket. The post continued to bend over until the bogie overrode the post at 0.088 sec after impact.

Upon post-test examination, the socket and attachment hardware were found to be intact and free of plastic deformations. The slight lateral movement of the socket was not significant enough to require repairs if a new post was to be installed in the socket. Additionally, the culvert headwall was free of concrete cracking and spalling.

Force vs. deflection and energy vs. deflection curves were created from the accelerometer data, as shown in Figure 49. The post and socket assembly provided a peak resistance of 8.4 kips (37.4 kN) and maintained a relatively constant force around 6 kips (27 kN) over the first 15 in. (381 mm) of deflection. The resistance then steadily decreased through the remainder of the test. The post and socket assembly absorbed 113.9 k-in. (12.9 kJ) of energy before the bogie overrode the post at a deflection of 31.5 in. (800 mm). Time-sequential photographs are shown in Figures 50 and 51, while post-impact photographs are shown in Figure 52.

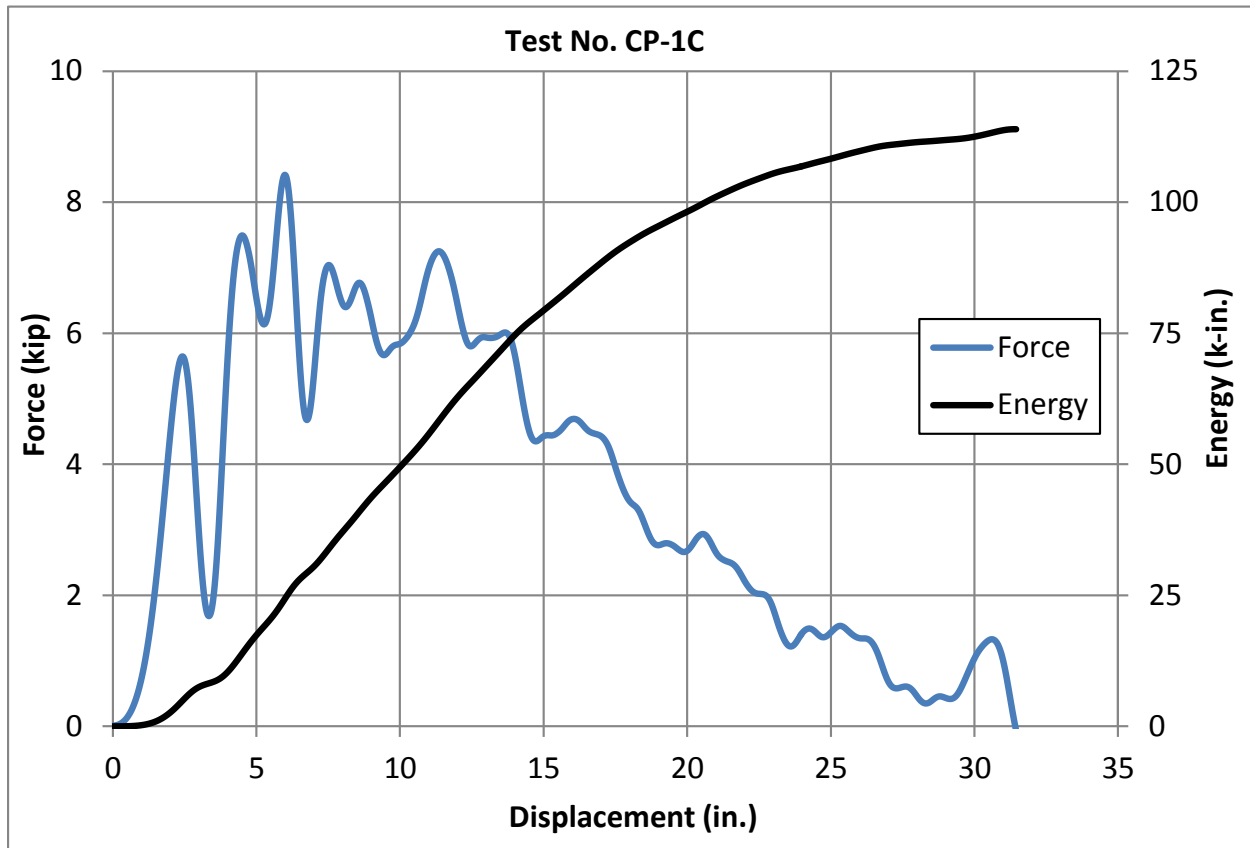

Figure 49. Force vs. Deflection and Energy vs. Deflection, Test No. CP-1C



IMPACT



0.090 sec



0.030 sec



0.120 sec



0.060 sec



0.150 sec

Figure 50. Time-Sequential Photographs, Test No. CP-1C





IMPACT



0.090 sec



0.030 sec



0.120 sec



0.060 sec



0.150 sec

Figure 51. Additional Time-Sequential Photographs, Test No. CP-1C





Figure 52. Post-Impact Photographs, Test No. CP-1C

### 5.1.2 Test No. CP-2A

During test no. CP-2A, the bogie impacted the post at a speed of 22.3 mph (35.9 km/h) and an angle of 90 degrees, causing strong-axis bending in the post. At 0.004 sec after impact, the top of the socket shifted backward about  $\frac{1}{8}$  in. (3 mm). This slight movement was attributed to construction tolerances as the hole in the top mounting plate had a slightly larger diameter than the anchor rod. By 0.008 sec, a plastic hinge had formed in the post adjacent to the top-back edge of the socket. The post continued to bend over until the bogie overrode the post at 0.084 sec after impact.

Upon post-test examination, the socket and attachment hardware were found to be intact and free of plastic deformations. The slight lateral movement of the socket was not significant enough to require repairs if a new post was to be installed in the socket. Additionally, the culvert headwall was free of concrete cracking and spalling.

Force vs. deflection and energy vs. deflection curves were created from the accelerometer data, as shown in Figure 53. The post and socket assembly provided a peak resistance of 8.3 kips (37.0 kN) and maintained a relatively constant force around 6 kips (27 kN) over the first 13 in. (330 mm) of deflection. The resistance then steadily decreased through the remainder of the test. The post and socket assembly absorbed 117.6 k-in. (13.3 kJ) of energy before the bogie overrode the post at a deflection of 29.4 in. (747 mm). Time-sequential photographs are shown in Figures 54 and 55, while post-impact photographs are shown in Figure 56.

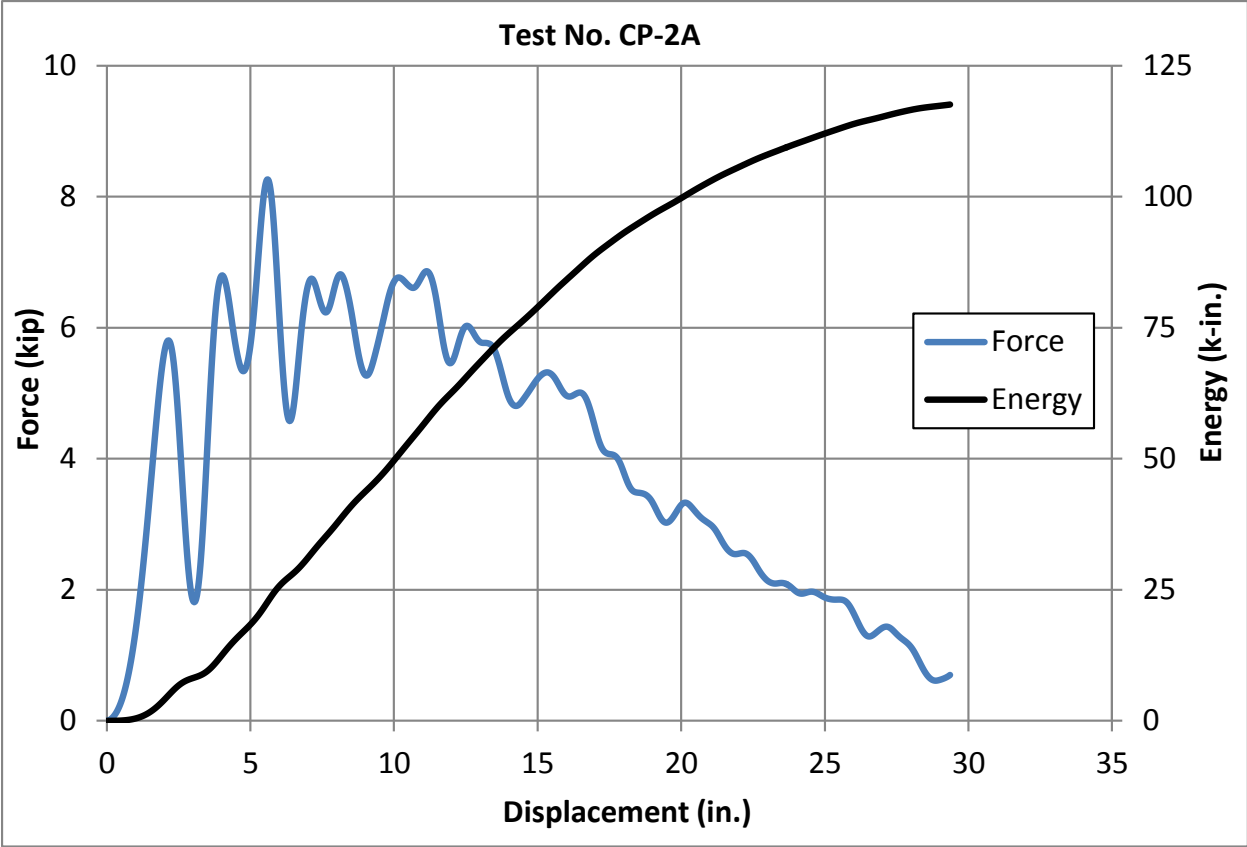
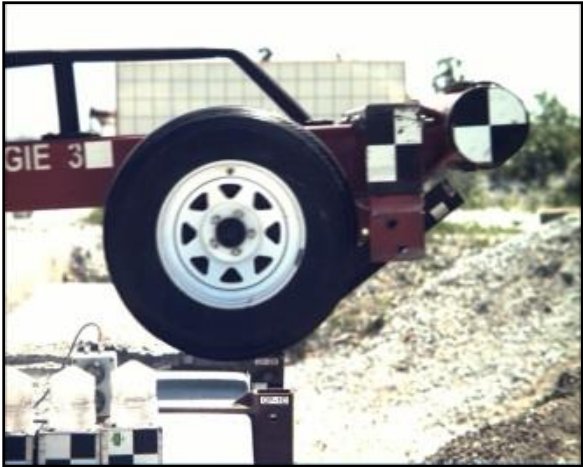

Figure 53. Force vs. Deflection and Energy vs. Deflection, Test No. CP-2A





IMPACT



0.090 sec

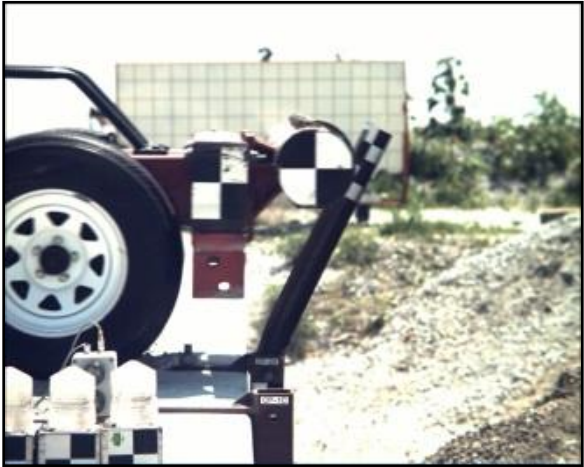

0.030 sec

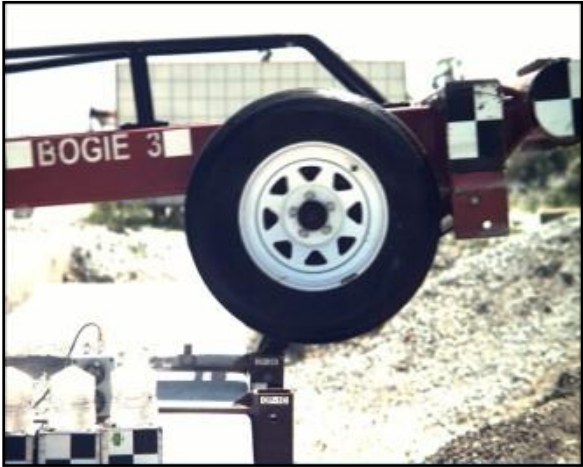

0.120 sec



0.060 sec



0.150 sec

Figure 54. Time-Sequential Photographs, Test No. CP-2A



IMPACT



0.090 sec



0.030 sec



0.120 sec



0.060 sec



0.150 sec

Figure 55. Additional Time-Sequential Photographs, Test No. CP-2A





77

Figure 56. Post-Impact Photographs, Test No. CP-2A

### **5.1.3 Test No. CP-3D**

During test no. CP-3D, the bogie impacted the post at a speed of 22.0 mph (35.4 km/h) and an angle of 90 degrees, causing strong-axis bending in the post. By 0.008 sec, a plastic hinge had formed in the post adjacent to the top-back edge of the socket. The post continued to bend over until the bogie overrode the post at 0.084 sec after impact.

Upon post-test examination, the socket and attachment hardware were found to be intact and free of plastic deformations. The socket did not appear to have translated, thus a new post could be installed in the socket without repairs. The through bolts and washer plates on the inside face of the headwall showed no signs of plastic deformation and the socket remained rigidly attached to the culvert. Additionally, the culvert headwall was free of concrete cracking and spalling.

Force vs. deflection and energy vs. deflection curves were created from the accelerometer data, as shown in Figure 57. The post and socket assembly provided a peak resistance of 7.1 kips (31.6 kN) and maintained a relatively constant force around 6 kips (27 kN) over the first 12 in. (305 mm) of deflection. The resistance then steadily decreased through the remainder of the test. The post and socket assembly absorbed 113.8 k-in. (12.6 kJ) of energy before the bogie overrode the post at a deflection of 29.1 in. (739 mm). Time-sequential photographs are shown in Figures 58 and 59, while post-impact photographs are shown in Figure 60.



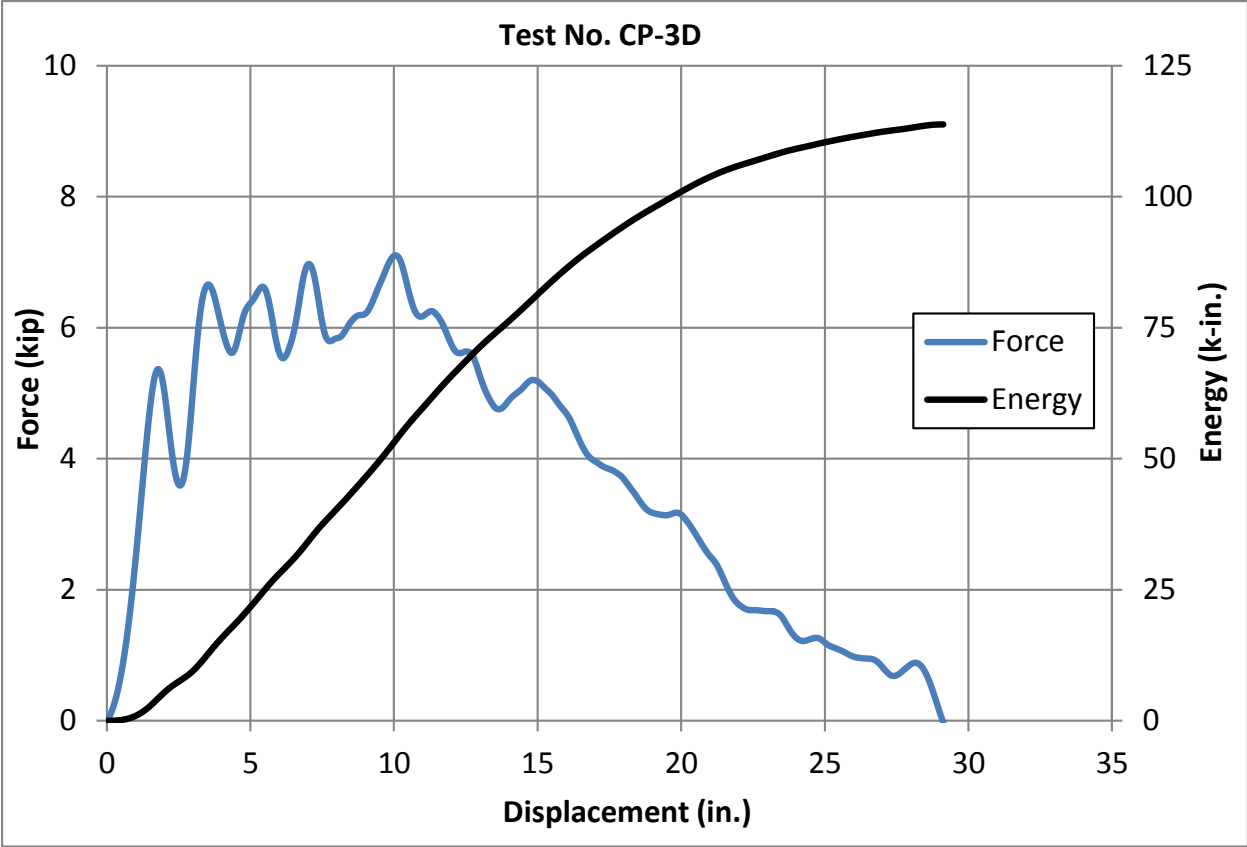

Figure 57. Force vs. Deflection and Energy vs. Deflection, Test No. CP-3D



IMPACT



0.090 sec



0.030 sec



0.120 sec



0.060 sec



0.150 sec

Figure 58. Time-Sequential Photographs, Test No. CP-3D



IMPACT

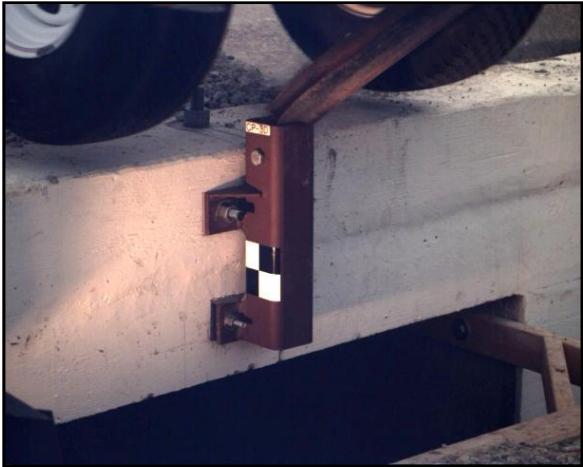

0.090 sec

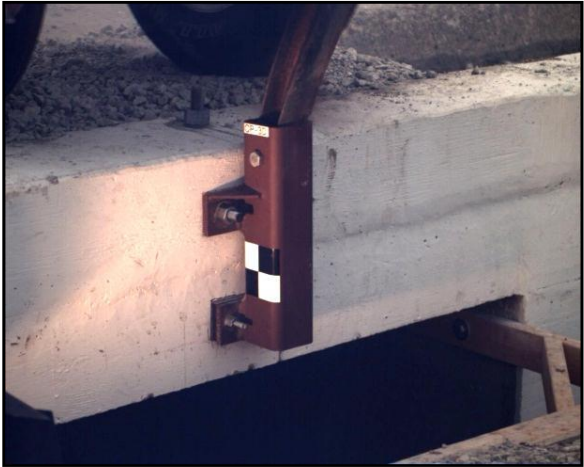

0.030 sec

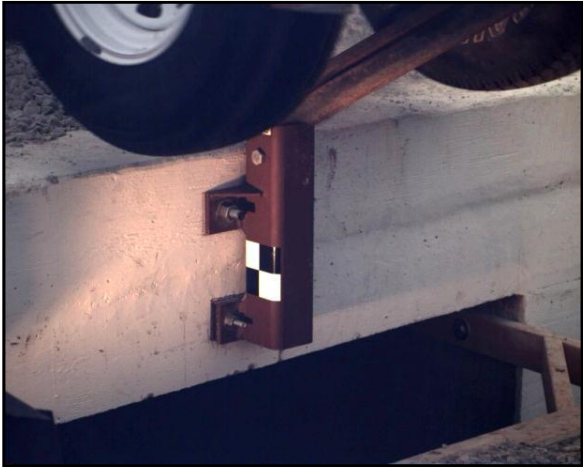

0.120 sec

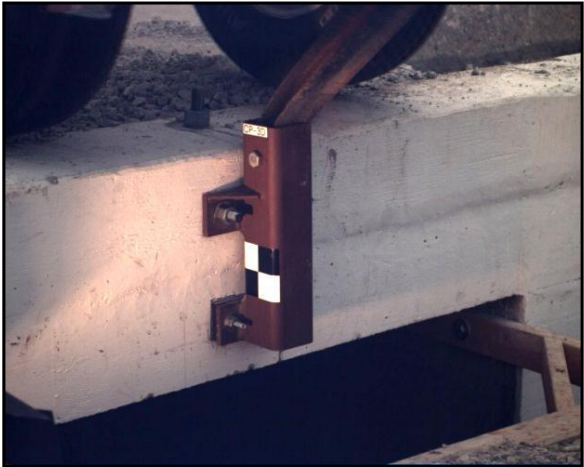

0.060 sec

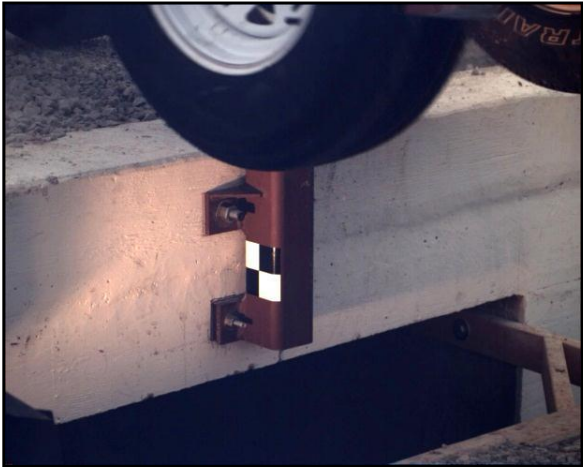

0.150 sec

Figure 59. Additional Time-Sequential Photographs, Test No. CP-3D



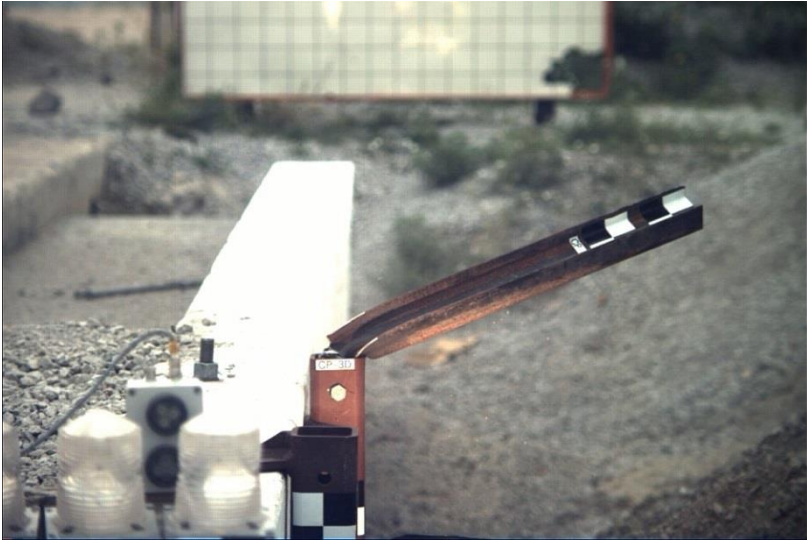

Figure 60. Post-Impact Photographs, Test No. CP-3D

#### **5.1.4 Test No. CP-4B**

During test no. CP-4B, the bogie impacted the post at a speed of 21.8 mph (35.1 km/h) and an angle of 90 degrees, causing strong-axis bending in the post. At 0.004 sec after impact, the top of the socket shifted backward about  $\frac{1}{8}$  in. (3 mm). This slight movement was attributed to construction tolerances as the holes in the top mounting plate had slightly larger diameters than the anchor rods. By 0.010 sec, a plastic hinge had formed in the post adjacent to the top-back edge of the socket. The post continued to bend over until the bogie overrode the post at 0.088 sec after impact.

Upon post-test examination, the socket and attachment hardware were found to be intact and free of plastic deformations. The slight lateral movement of the socket was not significant enough to require repairs if a new post was to be installed in the socket. Additionally, the culvert headwall was free of concrete cracking and spalling.

Force vs. deflection and energy vs. deflection curves were created from the accelerometer data, as shown in Figure 61. The post and socket assembly provided a peak resistance of 7.1 kips (31.6 kN) and maintained a relatively constant force around 6 kips (27 kN) over the first 15 in. (381 mm) of deflection. The resistance then steadily decreased through the remainder of the test. The post and socket assembly absorbed 122.4 k-in. (13.8 kJ) of energy before the bogie overrode the post at a deflection of 30.3 in. (770 mm). Time-sequential photographs are shown in Figures 62 and 63, while post-impact photographs are shown in Figure 64.

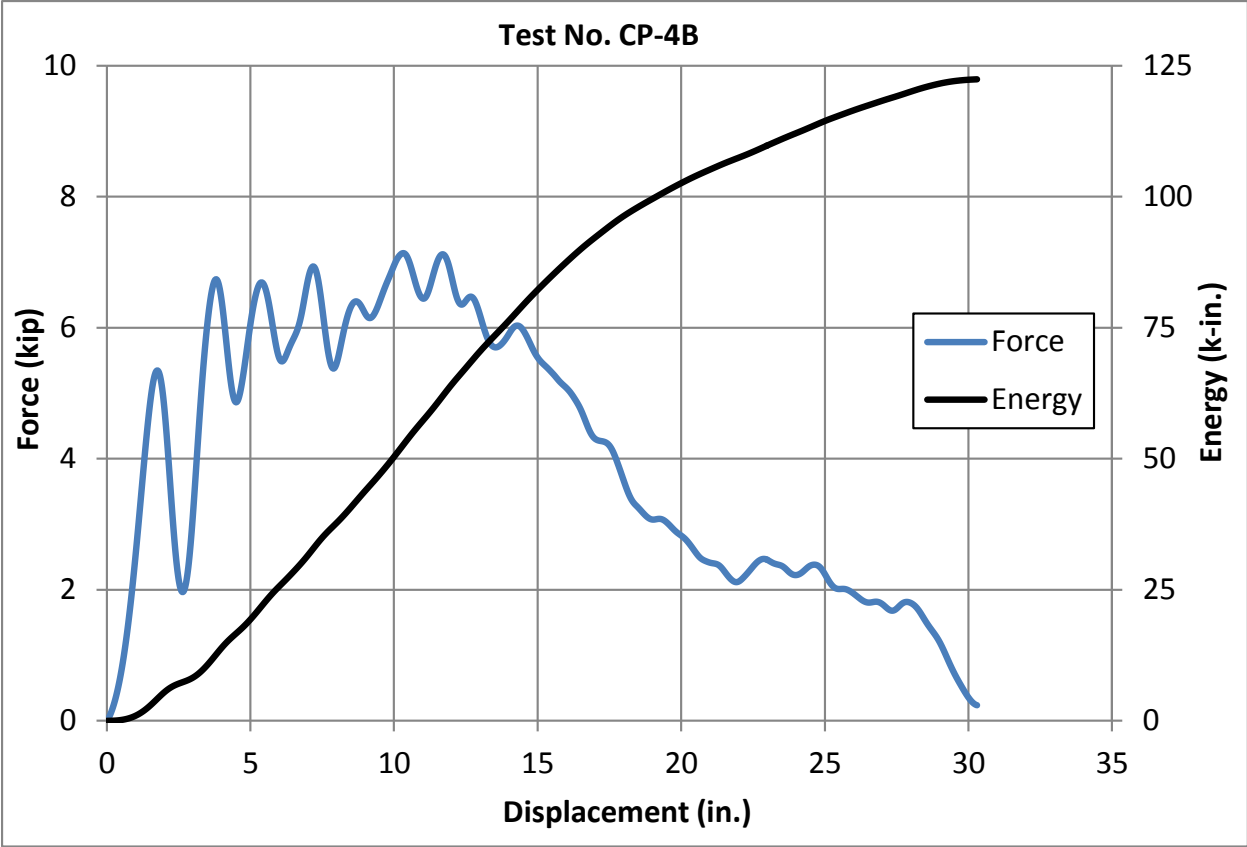

Figure 61. Force vs. Deflection and Energy vs. Deflection, Test No. CP-4B





IMPACT



0.090 sec

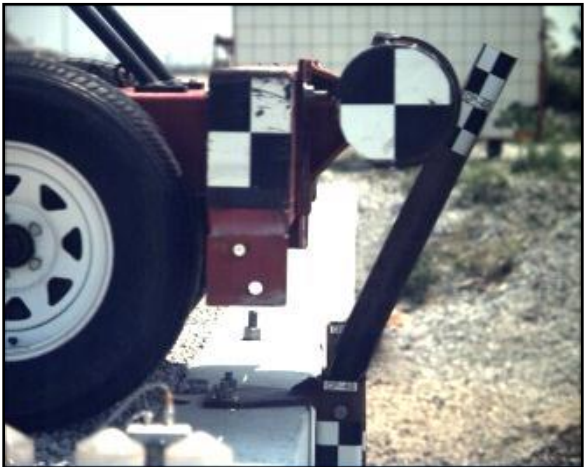

0.030 sec



0.120 sec

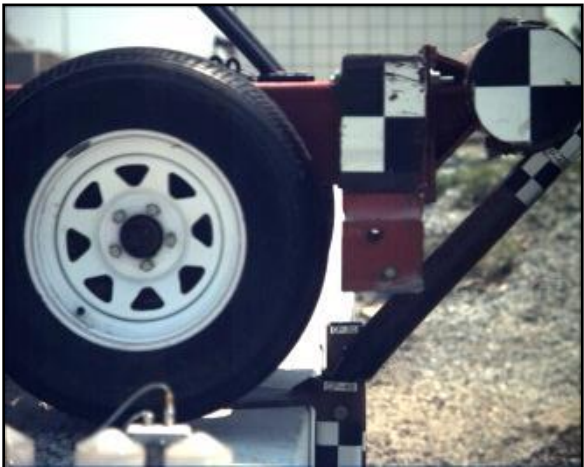

0.060 sec



0.150 sec

Figure 62. Time-Sequential Photographs, Test No. CP-4B





IMPACT



0.090 sec



0.030 sec



0.120 sec



0.060 sec



0.150 sec

Figure 63. Additional Time-Sequential Photographs, Test No. CP-4B



Figure 64. Post-Impact Photographs, Test No. CP-4B



### **5.1.5 Test No. CP-5D2**

During test no. CP-5D2, the bogie impacted the post at a speed of 20.5 mph (33.0 km/h) and an angle of 90 degrees, causing strong-axis bending in the post. By 0.008 sec, a plastic hinge had formed in the post adjacent to the top-back edge of the socket. The post continued to bend over until the bogie overrode the post at 0.092 sec after impact.

Upon post-test examination, the socket and attachment hardware were found to be intact and free of plastic deformations. The socket did not appear to have translated, thus a new post could be installed in the socket without repairs. The epoxied anchors held and showed no signs of slippage or pullout. Additionally, the culvert headwall was free of concrete cracking and spalling.

Force vs. deflection and energy vs. deflection curves were created from the accelerometer data, as shown in Figure 65. The post and socket assembly provided a peak resistance of 7.9 kips (35.2 kN) and maintained a relatively constant force around 6 kips (27 kN) over the first 13 in. (330 mm) of deflection. The resistance then steadily decreased through the remainder of the test. The post and socket assembly absorbed 122.0 k-in. (14.6 kJ) of energy before the bogie overrode the post at a deflection of 28.7 in. (729 mm). Time-sequential photographs are shown in Figures 66 and 67, while post-impact photographs are shown in Figure 68.

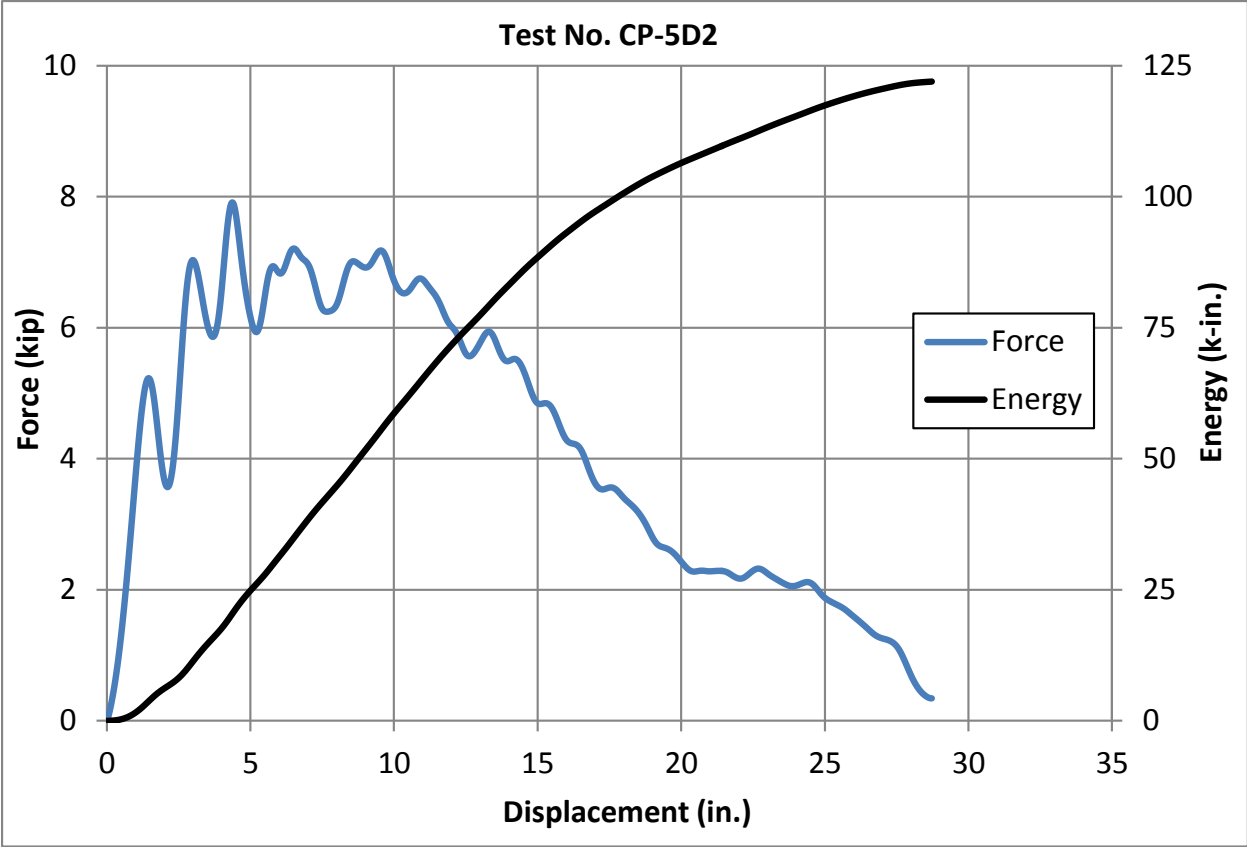
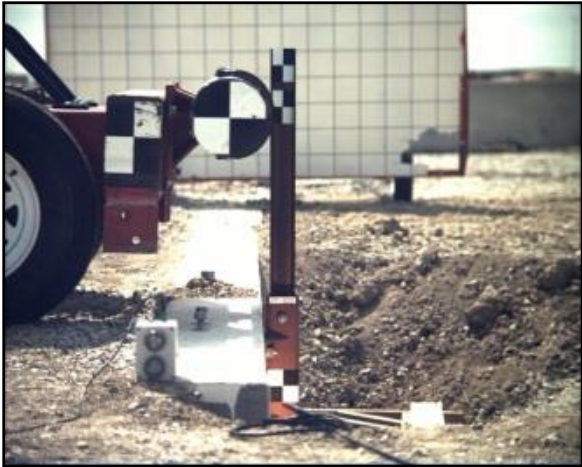

Figure 65. Force vs. Deflection and Energy vs. Deflection, Test No. CP-5D2



IMPACT



0.090 sec



0.030 sec



0.120 sec



0.060 sec



0.150 sec

Figure 66. Time-Sequential Photographs, Test No. CP-5D2





IMPACT



0.090 sec



0.030 sec



0.120 sec



0.060 sec



0.150 sec

Figure 67. Additional Time-Sequential Photographs, Test No. CP-5D2





Figure 68. Post-Impact Photographs, Test No. CP-5D2



## 5.2 Lateral Impact Testing Discussion

All five of the lateral impact tests resulted in the posts bending about the strong axis at a location adjacent to the top-back edge of the socket. Plastic bending of the post continued until the bogie vehicle eventually overrode the post. None of the socket assemblies sustained significant damage in the form of plastic deformations, weld failures, or anchor pullouts. Additionally, the culvert and headwall remained free of concrete cracks and spalling during all of the tests. A summary of the lateral testing is shown in Table 4.

Table 4. Summary of Lateral Impact Testing

Test No.	Impact Velocity mph (km/h)	Peak Force kips (kN)	Average Force kips (kN)			Maximum Deflection <sup>1</sup> in. (mm)	Total Energy k-in. (kJ)	Failure Mechanism
			@5"	@10"	@15"			
CP-1C	22.5 (36.2)	8.4 (37.4)	3.5 (15.6)	4.9 (21.8)	5.3 (23.6)	31.5 (800)	113.9 (12.9)	Post Bending
CP-2A	22.3 (35.9)	8.3 (36.9)	3.6 (16.0)	4.9 (21.8)	5.3 (23.6)	29.4 (747)	117.6 (13.3)	Post Bending
CP-3D	21.97 (35.4)	7.1 (31.6)	4.3 (19.1)	5.3 (23.6)	5.4 (24.0)	29.1 (739)	113.8 (12.9)	Post Bending
CP-4B	21.8 (35.1)	7.1 (31.6)	3.9 (17.4)	5.0 (22.3)	5.5 (24.5)	30.3 (770)	122.4 (13.8)	Post Bending
CP-5D2	20.5 (33.0)	7.9 (35.2)	4.9 (21.8)	5.9 (26.3)	5.9 (26.3)	28.7 (729)	122.0 (13.8)	Post Bending

<sup>1</sup> Maximum deflection measured when bogie overrode the post

From the high-speed video analysis of the impacts, only slight lateral movements of the socket were documented for the two top-mounted concepts and the wrap-around concept (Design Concepts A, B, and C). These translations at the top of the sockets were attributed to the construction tolerances given to the attachment hardware (i.e., holes in the top mounting plates were slightly oversized and the wrap-around plate was slightly longer than the width of the headwall). None of the sockets shifted enough to affect the installment of a replacement post.

The recorded data from the onboard accelerometers was processed and analyzed to calculate force and displacement data as a function of time. Force vs. deflection and energy vs. deflection plots for the lateral impacts are shown in Figures 69 and 70, respectively. All force curves were very similar, which was expected given the same post bending occurred during each test. In fact, the average forces through 15 in. (381 mm) of deflection varied from one another by 10 percent or less, and the total absorbed energies varied by less than 7 percent. Interestingly, the two top-mounted concepts and the wrap-around concept each had a large dip in resistance at about 3 in. (76 mm) of deflection. This drop coincides with the slight shifting of the top mounting plates described previously and explains why the results from the two side-mounted concepts showed much smaller force dips.

After the completion of the lateral impact testing, it was clear that the weak-post system would not generate enough load to cause significant damage to the culvert headwall or any of the socket attachment configuration. Recall, the top-mounted, double-anchor concept and the wrap-around concept (Design Concepts B and C) were developed due to concerns for possible damage to the culvert headwall. With these concerns alleviated, testing of these two design concepts was not continued. Further, the epoxy-anchor variation of the side-mounted concept proved easier to install than the through-bolted concept because it did not require removal of soil. Since both variations of the side-mounted design provided similar test results, testing of the through-bolt variation (Design Concept D) was also discontinued. Thus, only the top-mounted, single-anchor and the side-mounted, epoxy-anchored concepts (Design Concepts A and D2) were recommended for testing in the longitudinal direction.

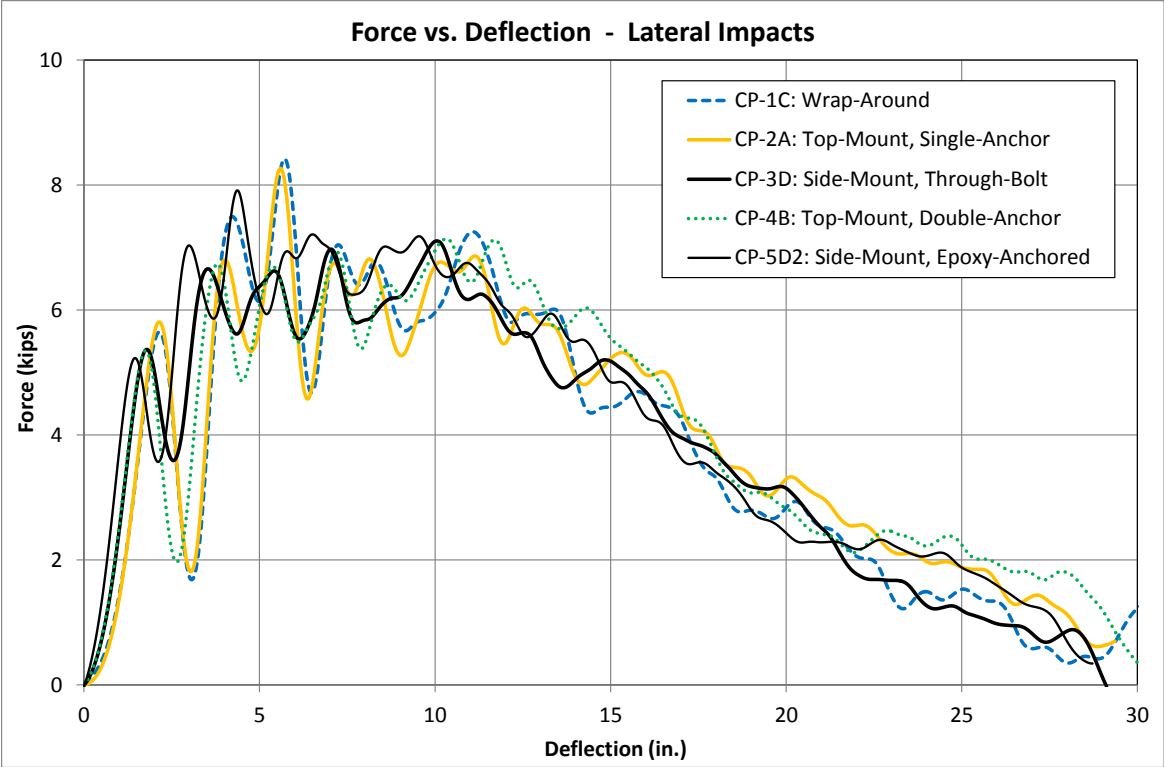

Figure 69. Force vs. Deflection Plots from Lateral Impact Tests

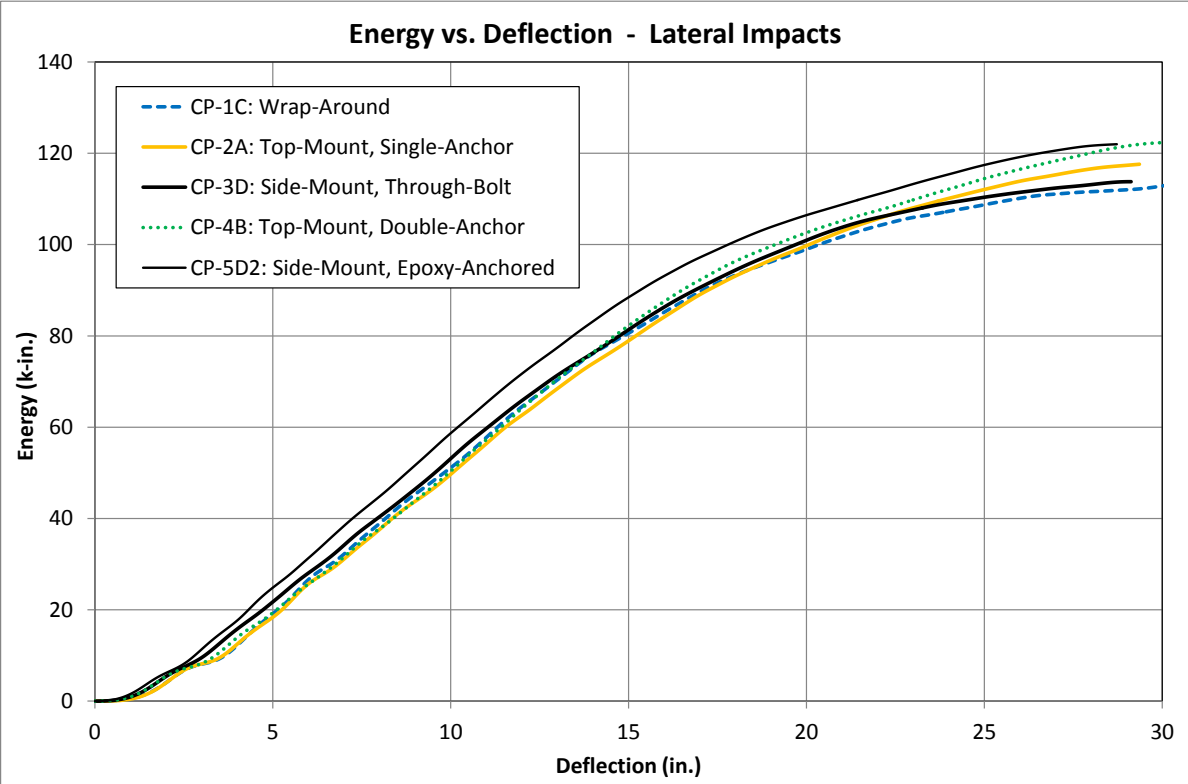

Figure 70. Energy vs. Deflection Plots from Lateral Impact Tests

### 5.3 Longitudinal Impact Testing Results

Longitudinal impact tests were conducted on both Design Concepts A and D2. The assemblies previously tested in the lateral direction were reused for the longitudinal tests since they had not sustained any significant damage. The accelerometer data for each test was processed in order to obtain force vs. deflection and energy vs. deflection curves. Although both transducers that were utilized during testing produced similar results, the values described herein were calculated from the SLICE accelerometer. Weather conditions for each test as recorded by the National Oceanic and Atmospheric Administration (station 14939/LNK) are shown in Table 5. A summary of the testing results is shown in Table 6. Test results from each individual transducer are provided in Appendix B.

Table 5. Weather and Atmospheric Conditions

Test No.	Test Date	Temp. (°F)	Hum. (%)	Wind Speed (mph)	Sky Conditions	Pavement Surface	Previous 3-Day Precip. (in.)	Previous 7-Day Precip. (in.)
CP-6D2	8/1/2012	92	41	6	Clear	Dry	0.02	0.33
CP-7A	8/2/2012	91	39	17	Clear	Dry	0.02	0.27

#### 5.3.1 Test No. CP-6D2

During test no. CP-6D2, the bogie impacted the post at a speed of 21.0 mph (33.8 km/h) and at an angle of 0 degrees, causing weak-axis bending in the post. At 0.004 sec after impact, the top of the socket shifted downstream about 1/8 in. (3 mm). This movement was attributed to construction tolerances as the holes in the mounting plates were slightly larger than the threaded rods anchoring the socket to the headwall. By 0.006 sec, a plastic hinge had formed in the post adjacent to the top-downstream edge of the socket. The post continued to bend over until the bogie overrode the post at 0.086 sec after impact.

Upon post-test examination, the socket and attachment hardware were found to be intact with only minimal plastic deformations at the top of the socket. The slight downstream movement of the socket was not significant enough to require repairs if a new post was to be installed in the socket. The epoxied anchors held and showed no signs of slippage or pullout. Additionally, the culvert headwall was free of concrete cracking and spalling.

Force vs. deflection and energy vs. deflection curves were created from the accelerometer data, as shown in Figure 71. The low impact height of the longitudinal test caused significant vibrations in the bogie frame. However, the average forces recorded during the test were still accurate. The post and socket assembly provided an average resistance of 3.1 kips (13.8 kN) over the first 15 in. (381 mm) of deflection. The post and socket assembly absorbed 64.4 k-in. (7.3 kJ) of energy before the bogie overrode the post at 30.0 in. (762 mm) of deflection. Time-sequential photographs are shown in Figure 72, and post-impact photographs are shown in Figure 73.

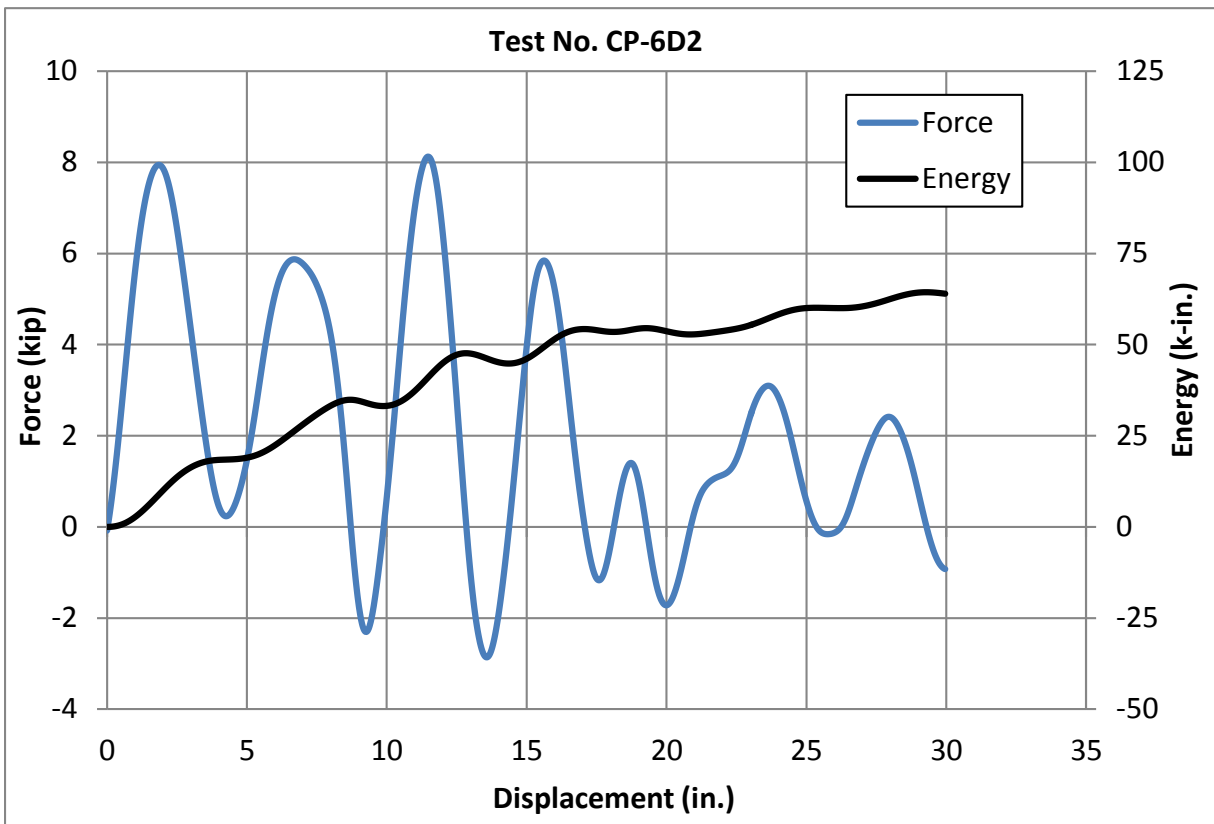
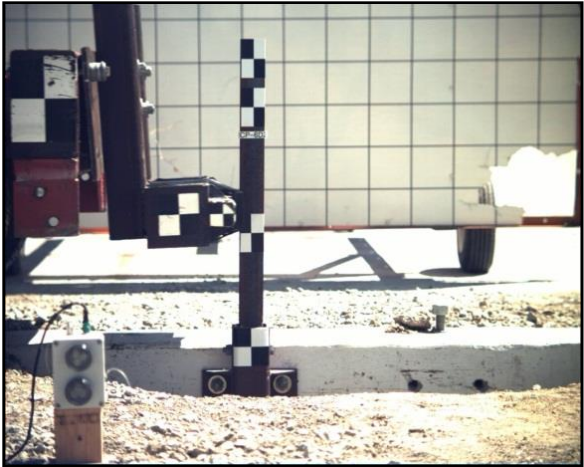

Figure 71. Force vs. Deflection and Energy vs. Deflection, Test No. CP-6D2



IMPACT



0.090 sec

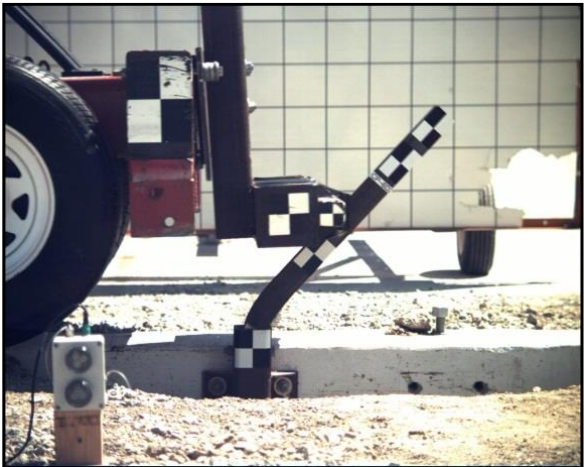

0.030 sec



0.120 sec

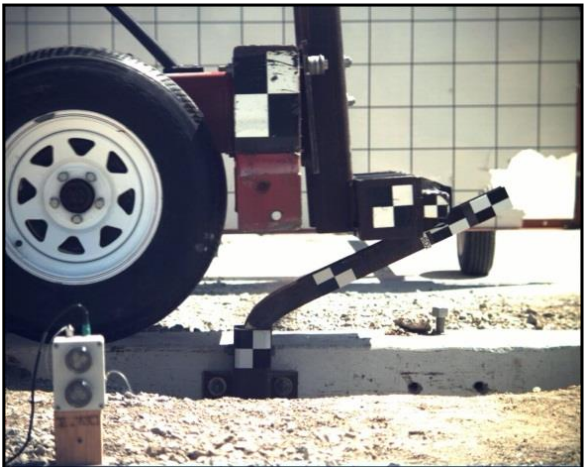

0.060 sec



0.150 sec

Figure 72. Time Sequential Photographs, Test No. CP-6D2





Figure 73. Post-Impact Photographs, Test No. CP-6D2



### 5.3.2 Test No. CP-7A

During test no. CP-7A, the bogie impacted the post at a speed of 21.3 mph (34.3 km/h) and at an angle of 0 degrees, causing weak-axis bending in the post. At 0.004 sec after impact, the top of the socket shifted downstream about ¼ in. (6 mm). This movement was attributed to both construction tolerances and the 7½-in. (191-mm) distance between the socket and the top anchor which allowed some socket rotation prior to loading. By 0.008 sec, a plastic hinge had formed in the post adjacent to the top-downstream edge of the socket. The post continued to bend over until the bogie overrode the post at 0.090 sec after impact.

Upon post-test examination, the socket and attachment hardware were found to be intact and free of plastic deformations. The slight downstream rotation of the top of the socket was not significant enough to require repairs if a new post was to be installed in the socket. The epoxied anchors held and showed no signs of slippage or pullout. Additionally, the culvert headwall was free of concrete cracking and spalling.

Force vs. deflection and energy vs. deflection curves were created from the accelerometer data, as shown in Figure 74. The low impact height of the longitudinal test caused significant vibrations in the bogie frame. However, the average forces recorded during the test were still accurate. The post and socket assembly provided an average resistance of 3.8 kips (16.9 kN) over the first 15 in. (381 mm) of deflection. The post and socket assembly absorbed 85.6 k-in. (9.7 kJ) of energy before the bogie overrode the post at 31.6 in. (803 mm) of deflection. Time-sequential photographs are shown in Figure 75, and post-impact photographs are shown in Figure 76.

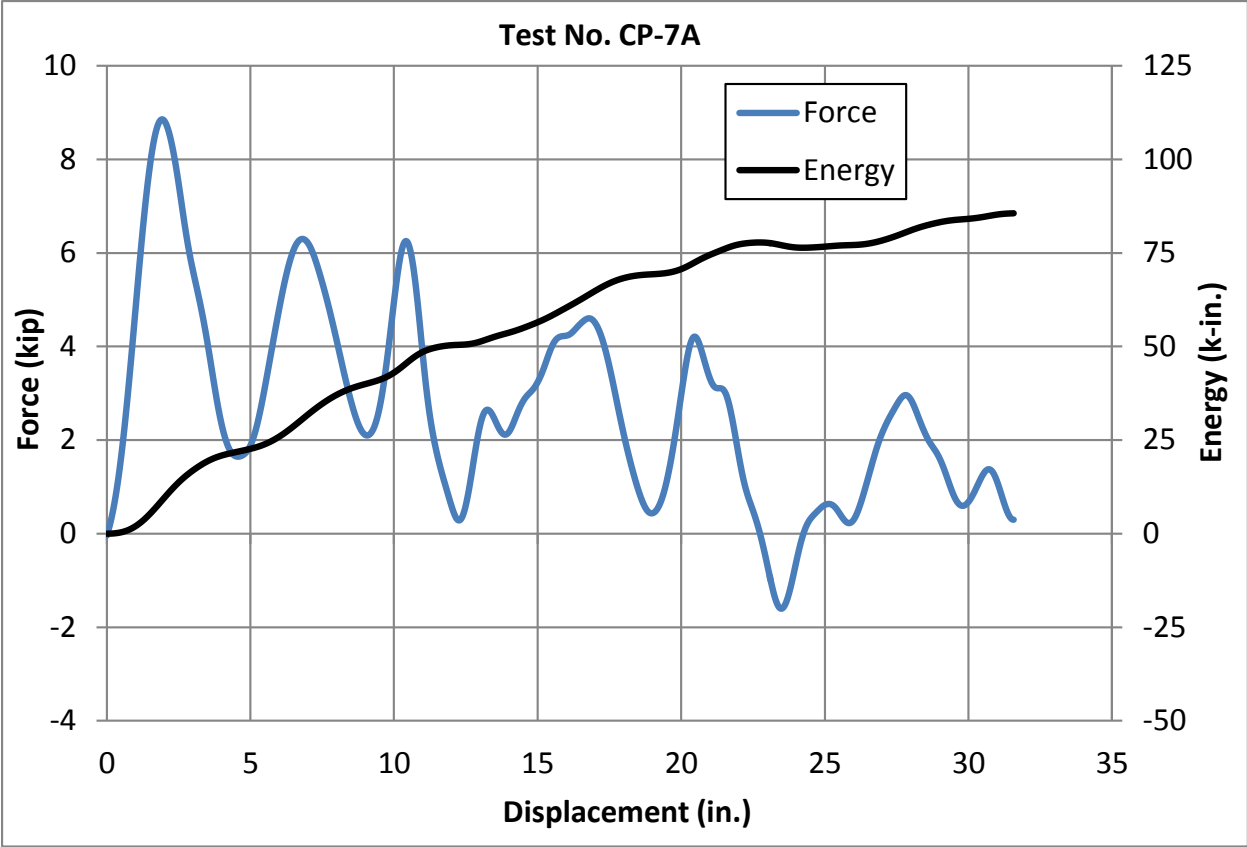
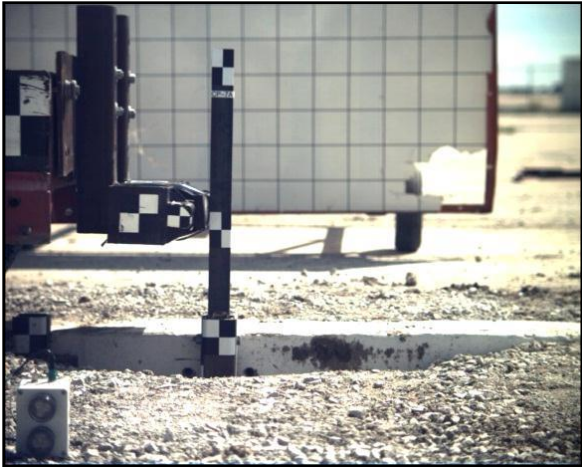

Figure 74. Force vs. Deflection and Energy vs. Deflection, Test No. CP-7A



IMPACT



0.090 sec



0.030 sec



0.120 sec



0.060 sec



0.150 sec

Figure 75. Time-Sequential Photographs, Test No. CP-7A





Figure 76. Post-Impact Photographs, Test No. CP-7A

## 5.4 Longitudinal Impact Testing Discussion

The longitudinal impacts resulted in very similar results to those of the lateral tests. Both of the longitudinal impact tests resulted in the posts bending about the weak axis at a location adjacent to the top-downstream edge of the socket. Plastic bending of the post continued until the bogie vehicle eventually overrode the post. None of the socket assemblies sustained significant damage in the form of plastic deformations, weld failures, or anchor pullouts. Additionally, the culvert and headwall remained free of concrete cracks and spalling during all of the tests. A summary of the lateral testing is shown in Table 6.

Table 6. Summary of Lateral Impact Testing

Test No.	Impact Velocity mph (km/h)	Peak Force kips (kN)	Average Force kips (kN)			Maximum Deflection <sup>1</sup> in. (mm)	Total Energy k-in. (kJ)	Failure Mechanism
			@5"	@10"	@15"			
CP-6D2	21.0 (33.8)	8.1 (36.0)	3.8 (16.9)	3.3 (14.7)	3.1 (13.8)	30.0 (762)	64.4 (7.3)	Post Bending
CP-7A	21.3 (34.3)	8.9 (39.6)	4.5 (20.0)	4.3 (19.1)	3.8 (16.9)	31.6 (803)	85.6 (9.7)	Post Bending

<sup>1</sup> Maximum deflection measured when bogie overrode post.

Both tests resulted in small downstream displacements at the top of the sockets. However, these displacements were limited to ¼ in. (6 mm) or less and did not affect the removal of the damaged post nor the installation of a new post. Thus, these displacements were deemed insignificant.

The recorded data from the onboard accelerometers was processed and analyzed to calculate force and displacement data as a function of time. Force vs. deflection and energy vs. deflection plots for the longitudinal impacts are shown in Figures 77 and 78, respectively. The force curves are similar in magnitude and duration. However, ringing vibrations in the bogie



prevented the curves from matching up directly and caused the absorbed energies to deviate toward the end of the impact event.

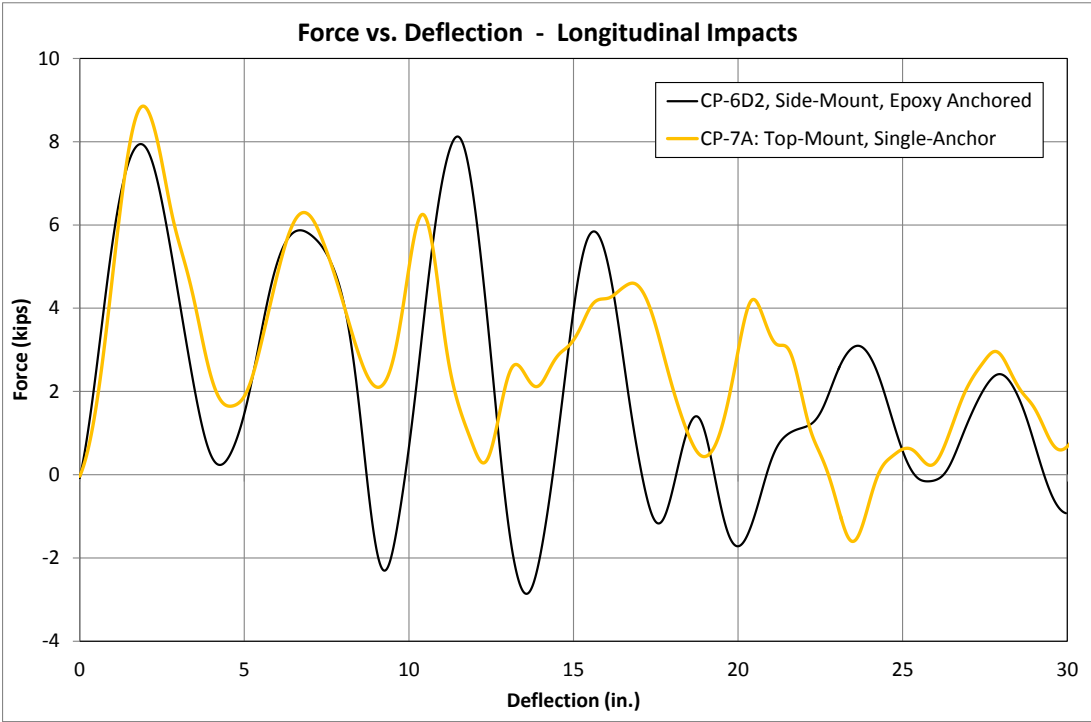

Figure 77. Force vs. Deflection Plots from Longitudinal Impact Tests

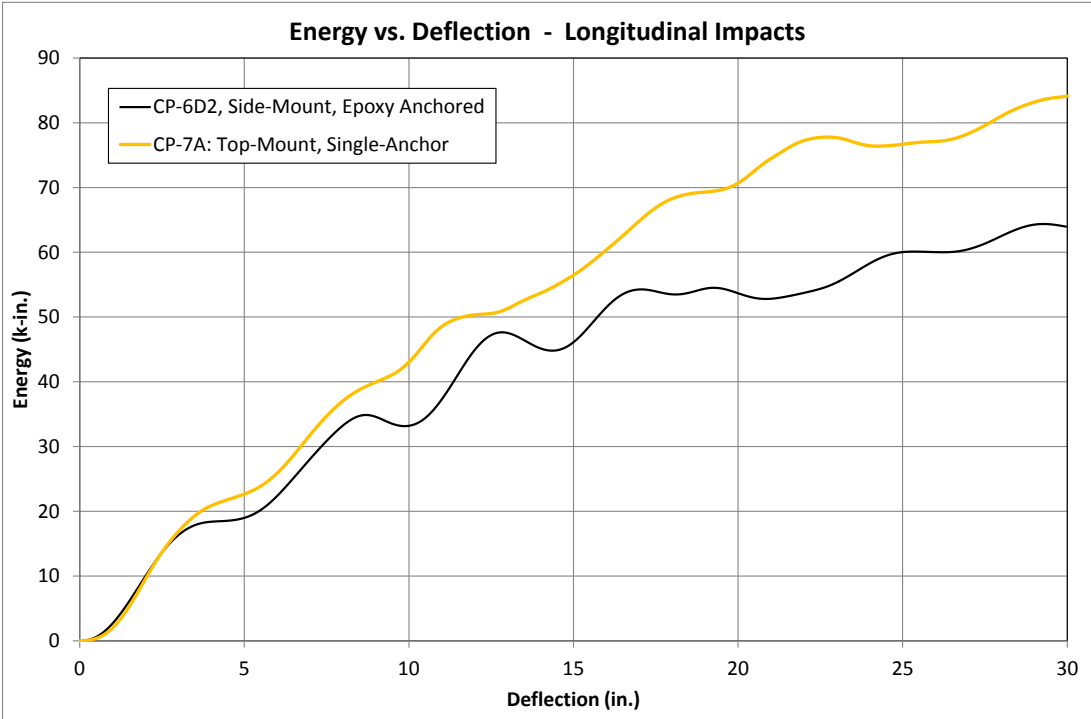

Figure 78. Energy vs. Deflection Plots from Longitudinal Impact Tests

## 6 SUMMARY, CONCLUSIONS, AND RECOMMENDATIONS

The objective of this project was to develop a new weak-post, W-beam guardrail system for attachment to culvert headwalls. This new system was developed by adapting the weak-post, MGS bridge rail system for attachment to culvert headwalls. Thus, the system was to utilize weak, S3x5.7 (S76x8.5) posts spaced 37½ in. (953 mm) on center and positioned within HSS4x4x¾ (102-mm x102-mm x10-mm) steel socket tubes. However, the socket assembly and attachment hardware had to be modified in order for the system to be mounted to the outside face of culvert headwalls.

Five attachment design concepts were explored through dynamic bogie testing: 1) a top-mounted, single-anchor concept; 2) a top-mounted, double-anchor concept; 3) a wrap-around concept; 4) a side-mounted, through-bolt concept; and 5) a side-mounted, epoxy-anchored concept. During the first round of testing, all five concepts were subjected to a lateral impact (causing strong-axis bending in the post) at a height of 24⅞ in. (632 mm). The results from the lateral tests were very similar as all of the posts bent over just above the top of the sockets, all of the tests had similar force vs. deflection plots, and the socket assemblies, anchor rods, and concrete culvert were undamaged.

After the completion of the lateral impact testing, it was clear that the weak-post system would not generate enough load to cause significant damage to the culvert headwall or any of the socket attachment design concepts. However, instead of continuing with testing of all five of the attachment variations, only the two design concepts that proved to be the easiest to install were recommended for longitudinal testing. These concepts were the top-mounted, single-anchor concept and the side-mounted, epoxy-anchored concept.

Two longitudinal tests were then conducted with an impact height of 12 in. (305 mm) to represent small car bumpers impacting a post during redirection. The longitudinal tests exhibited

results similar to the lateral impact tests. The weak posts bent over adjacent to the top-downstream edge of the sockets, while the socket assemblies, threaded anchors, and culvert headwall sustained no significant damage. Therefore, both the top-mounted, single-anchor concept and the side-mounted, epoxy-anchored concept (Design Concepts A and D2) were recommended for use in the new weak-post, guardrail attached to culvert system. Complete drawings for the system are shown in Figures 79 through 92.

Both attachment configurations mount the socket to the outside face of the culvert headwall. The S3x5.7 (S76x8.5) posts positioned off the edge of the culvert coupled with the system not requiring blockouts results in minimal barrier intrusion over the culvert and onto the roadway. Therefore, the traversable roadway width is maximized, while the culvert length is minimized.

Unlike long-span guardrail systems [8-12], the new W-beam guardrail system attached to culverts is unrestricted in terms of system length and can be used to treat culverts over 25 ft (7.6 m) in length. Additionally, the sockets are attached to the headwall using epoxy anchors, so the system can be installed on new or existing culvert structures. Since the socket assembly hardware and the culvert itself remained undamaged during the critical impact tests, repair to a damaged system would consist of simply removing damaged rail segments and posts, dropping replacement posts into the undamaged sockets, and bolting on new rail segments.

Although the final drawing set illustrates only two of the original five attachment concepts, MwRSF has confidence in the ability of the other three design concepts to perform adequately in a system installation as well. Recall all concepts performed similarly during lateral testing, but the top-mounted, single-anchor concept and the side-mounted, epoxy-anchored concept were selected due to ease of installation and lowest amount of material costs. However, situations may arise with the side-mounted concept when bolting through a narrow headwall is

desired over the epoxy-anchored version. Although the socket may rotate slightly more downstream during longitudinal impacts due to the construction tolerances between the drilled hole and the threaded anchor, it should not affect the overall system performance nor prevent easy replacement of a damaged post. Additionally, situations may arise when the top-mounted, double-bolt or wrap-around concepts are desired to avoid interference with internal steel reinforcing bars. Depending on the width tolerance of the wrap-around concept, both of these may actually reduce the amount of socket displacement during longitudinal impacts compared to the top-mounted, single-bolt attachment. Therefore, under unusual situations, the roadside designer may utilize any of the attachment concepts.

The test installations evaluated during this study utilized an epoxy adhesive with a specified minimum bond strength of 1,300 psi (9.0 MPa). Therefore, the W-beam, guardrail system attached to culverts can be installed using a wide variety of epoxy adhesives as long as the specified bond strength is at least 1,300 psi (9.0 MPa). Additionally, the design details and recommendations provided in this report are applicable for culverts with a minimum compressive concrete strength of  $f'_c = 4$  ksi (27.6 MPa). Culverts built with a weaker concrete strength may require increased embedment depths for the anchor rods. For these installations, the proper embedment depth can be calculated utilizing Appendix D of ACI-318, the concrete strength of the weaker culvert, and increasing the anchor embedment depth until the anchor strength matches the strength of the recommended design with  $f'_c = 4$  ksi (27.6 MPa).

This barrier system was designed as part of a family of non-proprietary, 31-in. (787-mm) high, W-beam guardrail systems commonly referred to as the MGS. This new guardrail system attached to culverts was designed with a similar lateral stiffness and overall system performance to that observed for the original MGS. Therefore, a stiffness transition between the new guardrail attached to culvert system and adjacent standard MGS installations is unnecessary. A 75-in. (1.9-

m) spacing is recommended between the last S3x5.7 (S76x8.5) culvert post and the first standard guardrail post of the adjacent MGS installation. The adjacent MGS may be either blocked or non-blocked.

Guardrail post should not be placed too close to the upstream or downstream ends of a culvert. If a socket is placed near the end of a headwall, the attachment anchors may not have enough concrete cover to develop the required shear and/or tension loads. Thus, a minimum of 4 in. (102 mm) should be used between a free end of a culvert headwall and the center of any attachment anchor. Additionally, to prevent interference with post rotation, the first standard guardrail post adjacent to the culvert should be placed a minimum of 12 in. (305 mm) from the culvert and any wingwalls that may be present. The 12 in. (305 mm) should be measured from the center of the post to the nearest edge of the headwall/wingwall.

Although a critical culvert headwall was selected for use in the dynamic impact tests, care should be taken not to install this W-beam guardrail system attached to culverts on headwalls of significantly smaller size or reduced internal reinforcement. Installations on weaker structures may result in unwanted damage to the headwall in the form of concrete cracking and spalling. Additionally, the system was designed and evaluated for use on low-fill culverts with relatively flat grading. It is recommended that the system only be used with approach slopes of 10H:1V or flatter.

Finally, installations should be installed with the guardrail terminals (or end anchorages) located a sufficient distance from the culvert to prevent the two systems from interfering with the proper performance of one another. As such, the following implementation guidelines should be considered in addition to guardrail length of need requirements:



1. A recommended minimum length of 12 ft – 6 in. (3.81 m) of standard MGS between the first S3x5.7 (S76x8.5) weak post and the interior end of an acceptable TL-3 guardrail end terminal.
2. A recommended minimum barrier length of 50 ft (15.2 m) before the first S3x5.7 (S76x8.5) weak post, which includes standard MGS and a crashworthy guardrail end terminal. This guidance applies to the downstream end as well.
3. For flared guardrail applications, a recommended minimum length of 25 ft (7.6 m) between the first S3x5.7 (S76x8.5) weak post and the start of the flared section (i.e. bend between flared and tangent sections).

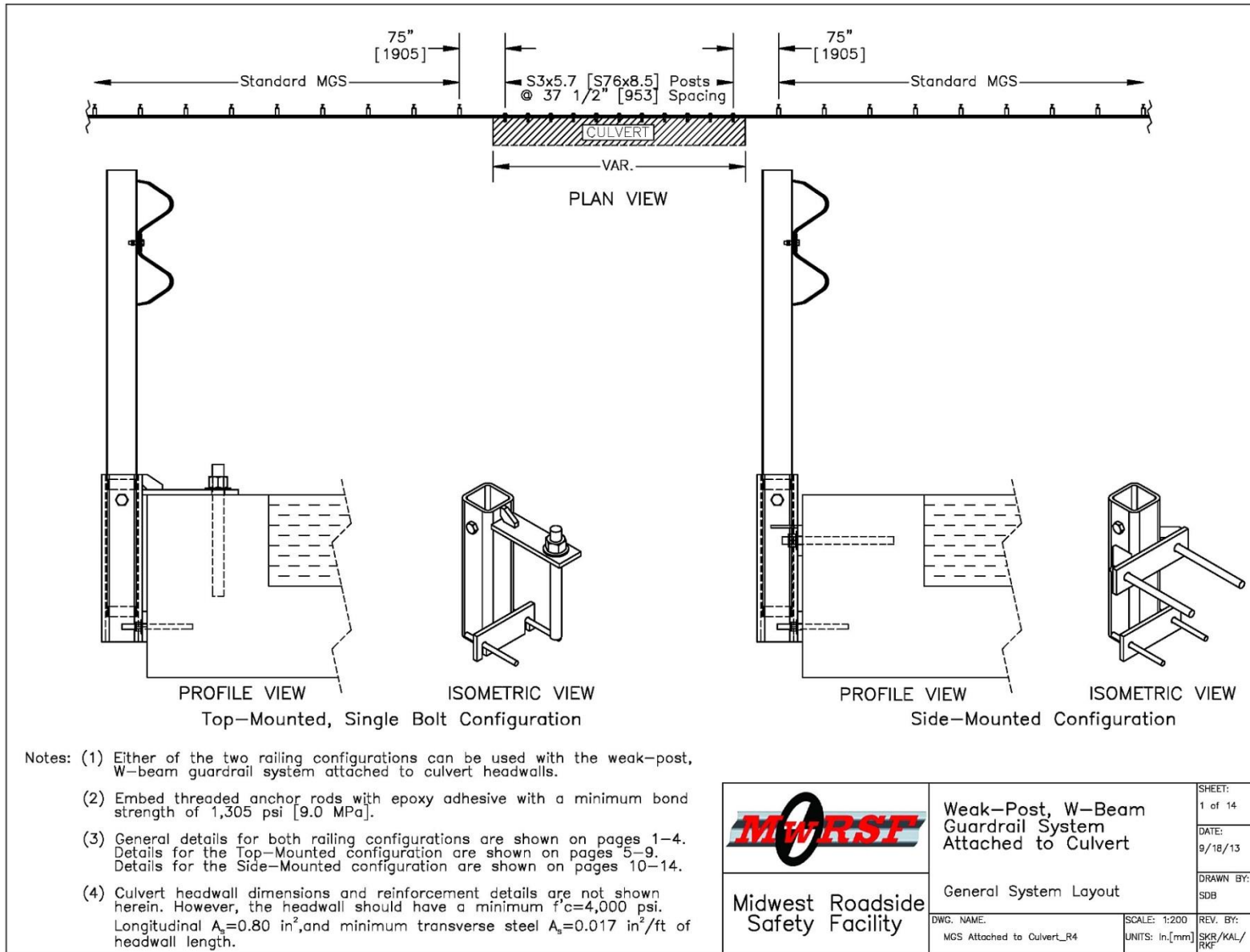

Figure 79. Weak-Post, W-beam Guardrail System on Culverts, System Layout

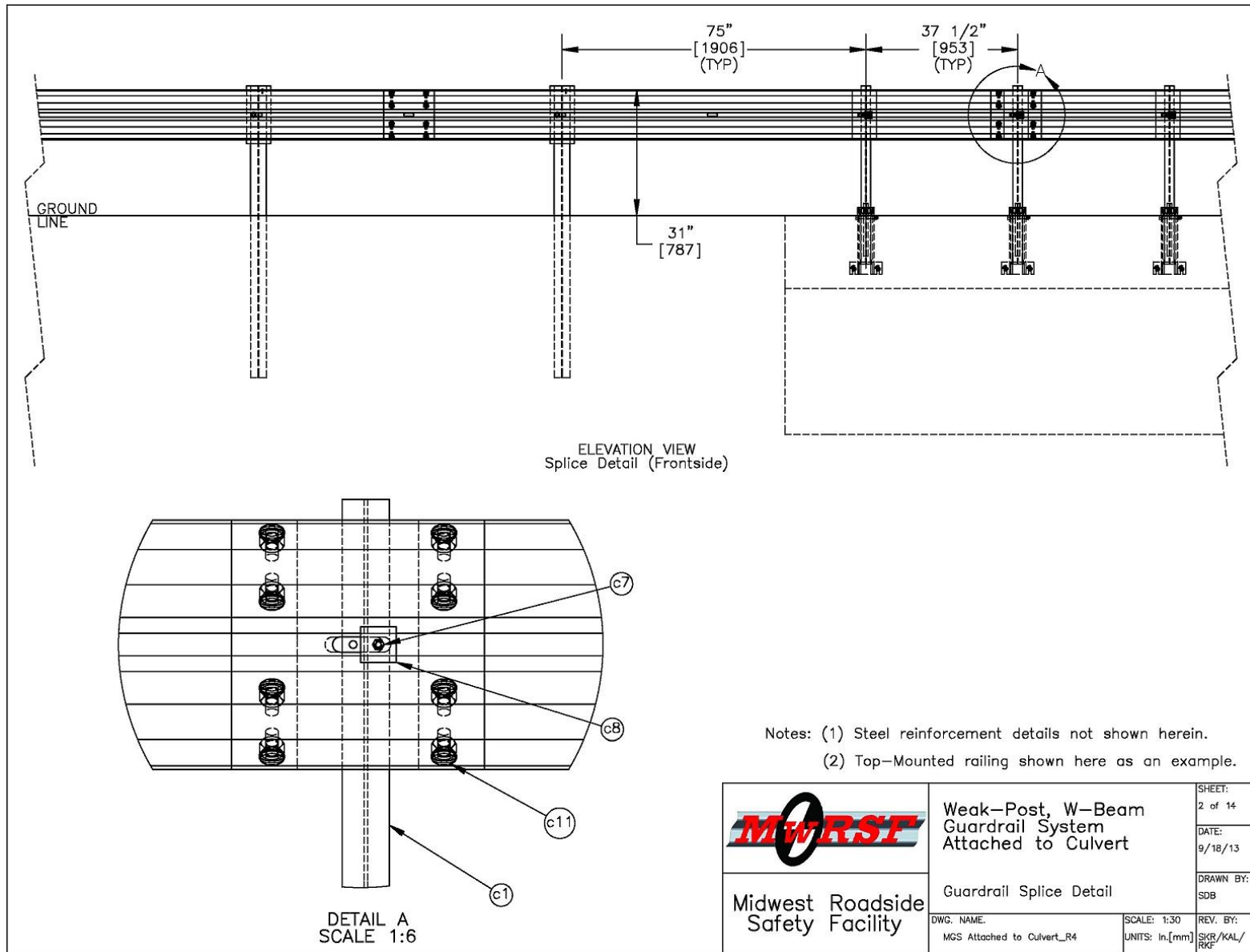

Figure 80. Post Spacing and Rail-to-Post Attachment Details

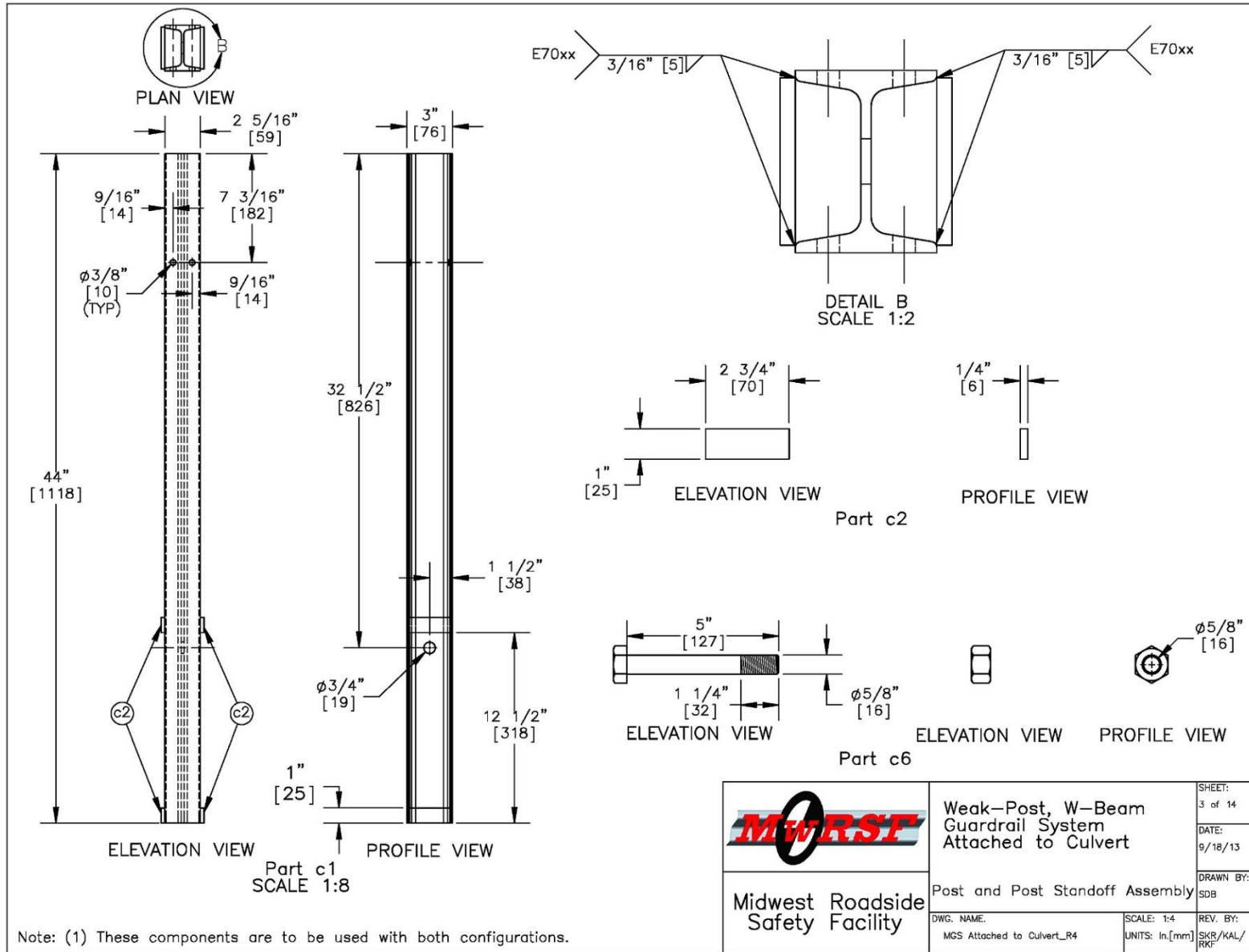

Figure 81. Post Assembly Details

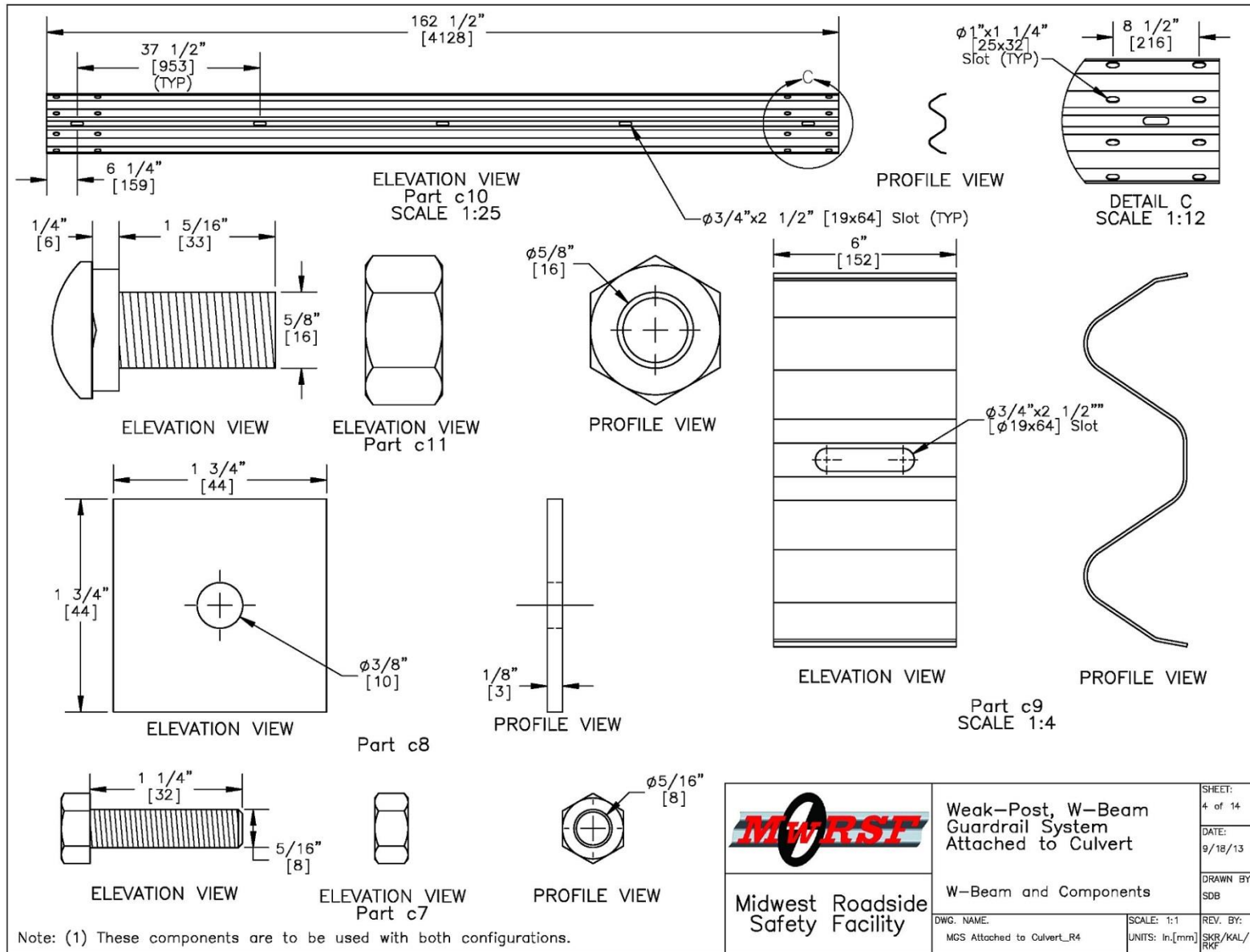



Figure 82. W-beam Rail, Backup Plate, and Attachment Hardware Details

 <b>Midwest Roadside Safety Facility</b>	<b>Weak-Post, W-Beam Guardrail System Attached to Culvert</b>	SHEET: 4 of 14 DATE: 9/18/13 DRAWN BY: SDB
	<b>W-Beam and Components</b>	REV. BY: SKR/KAL/RKF
DWG. NAME: MGS Attached to Culvert_R4	SCALE: 1:1 UNITS: In.,[mm]	



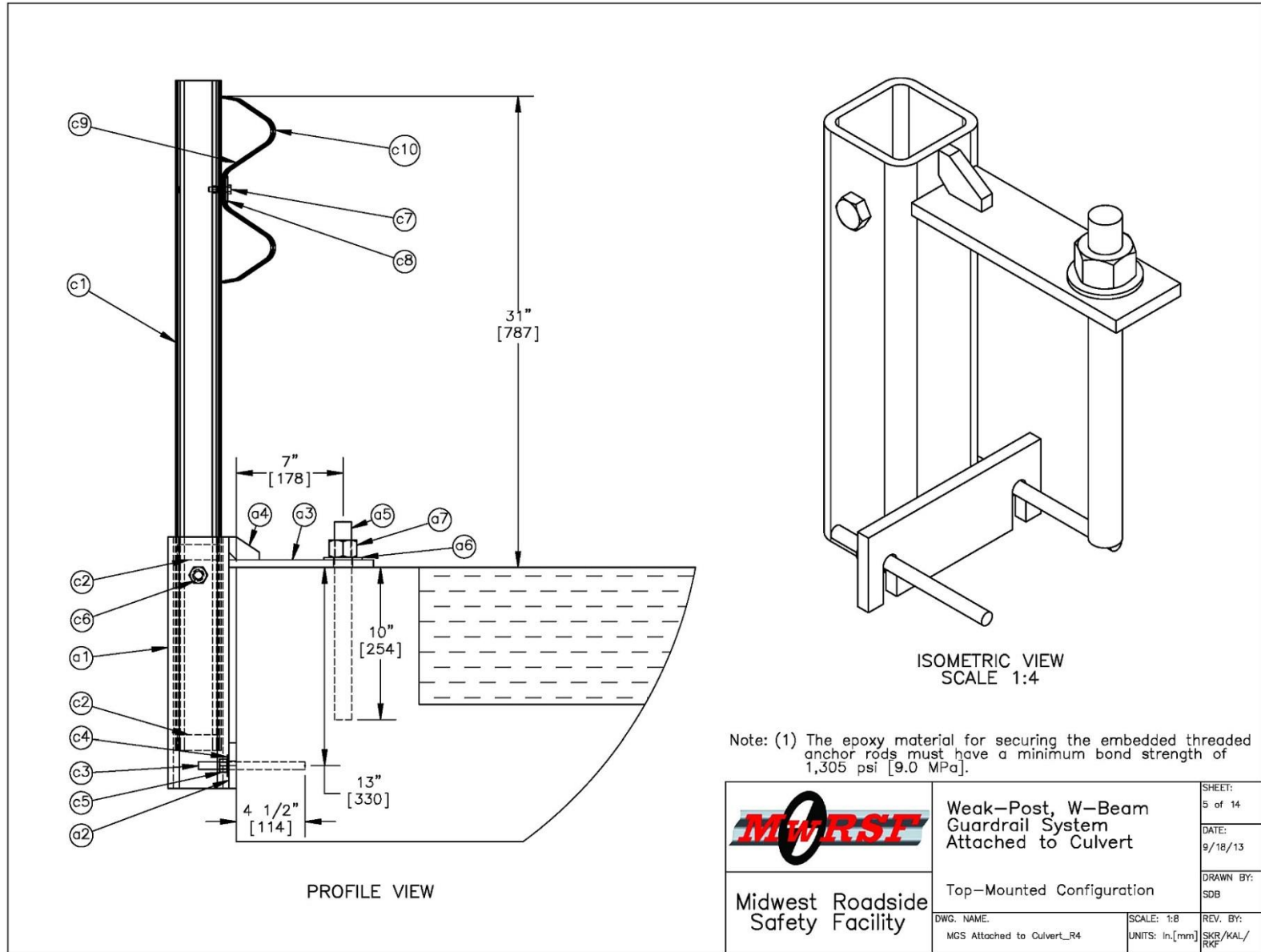



Figure 83. Top-Mounted Configuration Details

Note: (1) The epoxy material for securing the embedded threaded anchor rods must have a minimum bond strength of 1,305 psi [9.0 MPa].

 <b>Midwest Roadside Safety Facility</b>	<b>Weak-Post, W-Beam Guardrail System Attached to Culvert</b> Top-Mounted Configuration	SHEET: 5 of 14 DATE: 9/18/13 DRAWN BY: SDB
	DWG. NAME: MGS Attached to Culvert_R4	SCALE: 1:8 UNITS: In.,[mm]

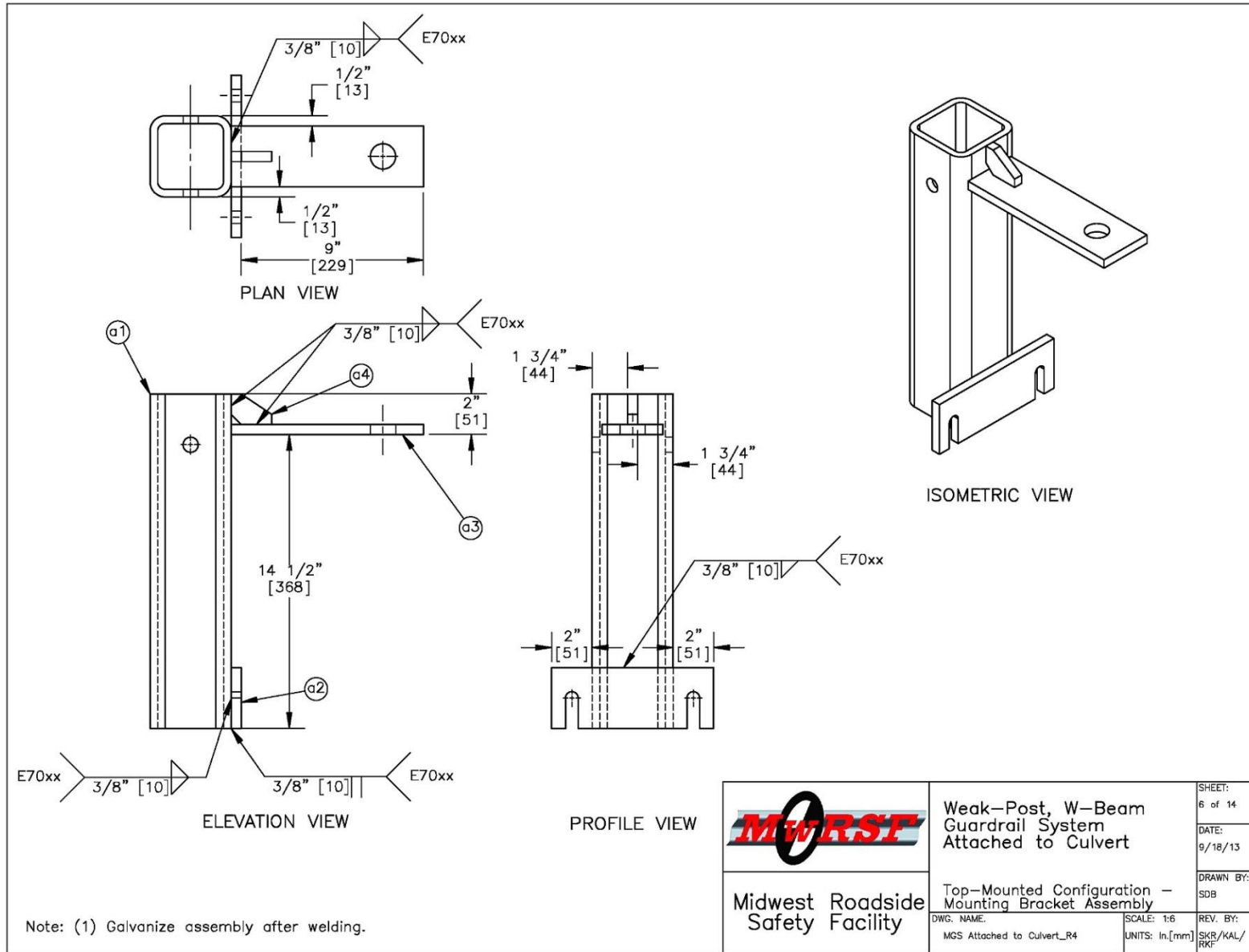

Figure 84. Top-Mounted Configuration, Socket Assembly Details

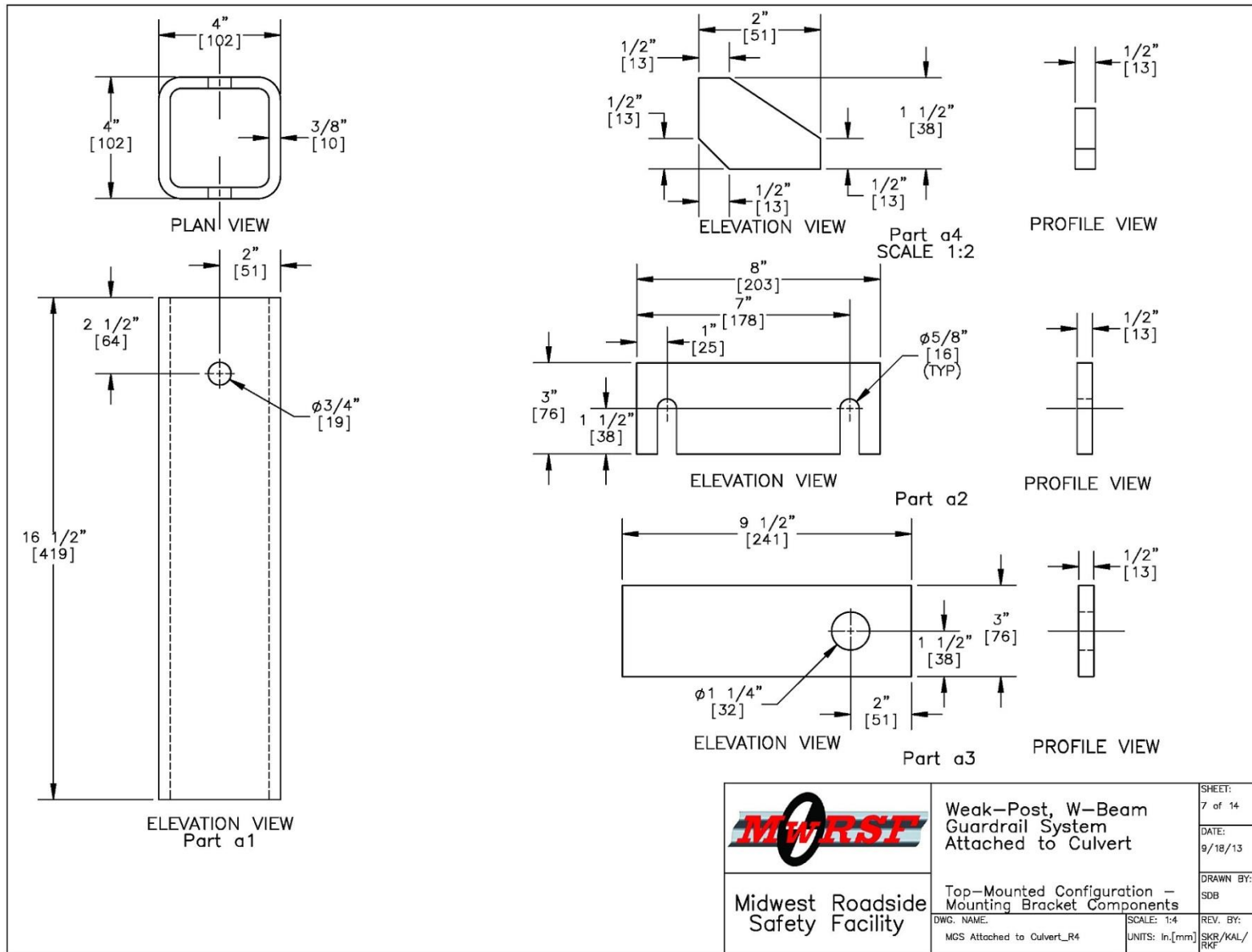

Figure 85. Top-Mounted Configuration, Socket Assembly Components

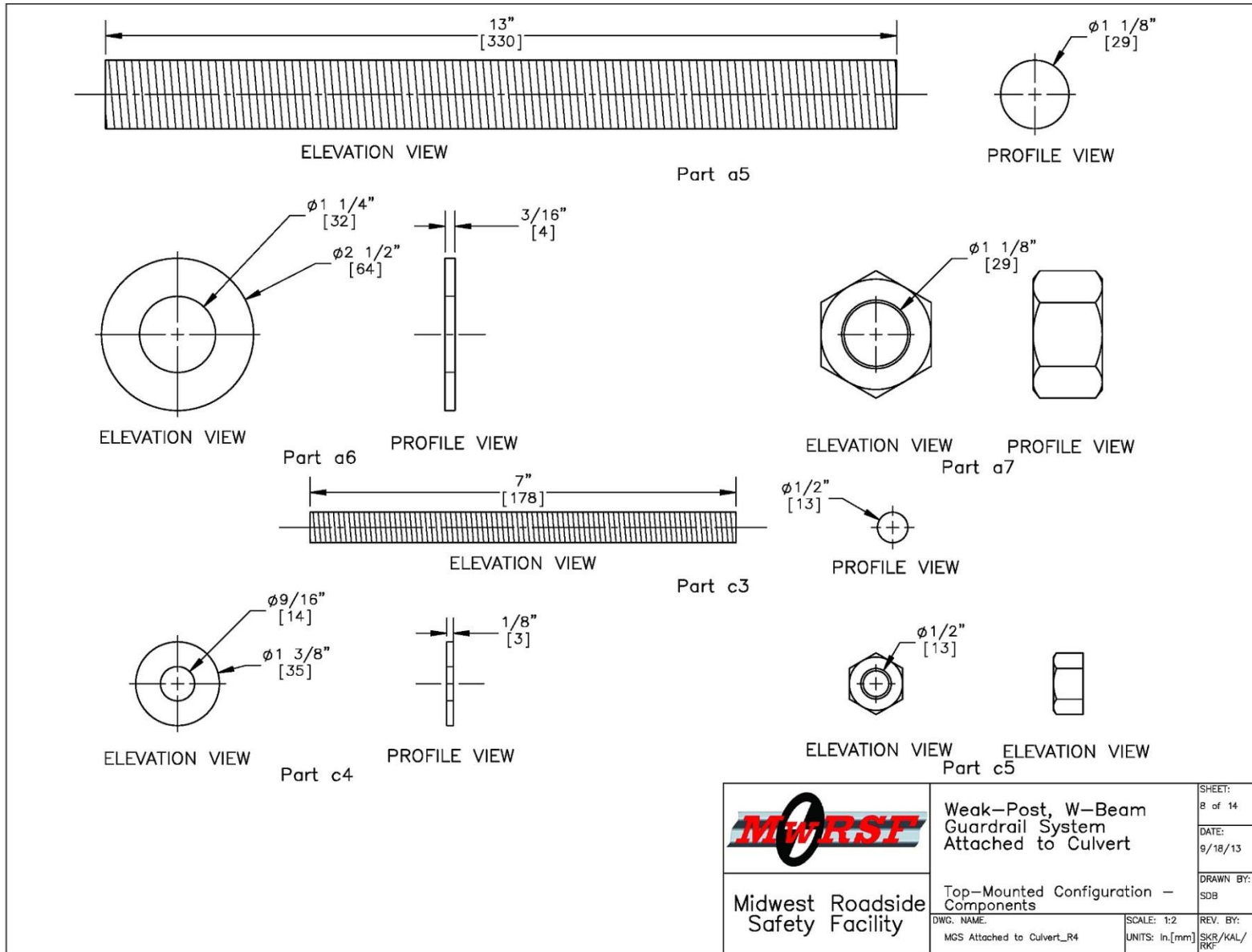



Figure 86. Top-Mounted Configuration, Attachment Hardware Details

Top-Mounted Configuration				
Item No.	QTY. (Per Post Location)	Description	Material Specification	Hardware Guide
a1	1	4"x4"x3/8" [102x102x10] Square Socket	ASTM A500 Grade B Steel Galvanized	—
a2	1	8"x3"x1/2" [203x76x13] Bottom Mounting Plate	ASTM A572 Grade 50 Steel Galvanized	—
a3	1	9 1/2"x3"x1/2" [241x76x13] Top Mounting Plate	ASTM A572 Grade 50 Steel Galvanized	—
a4	1	2"x1 1/2"x1/2" [51x38x13] Top Mounting Plate Gusset	ASTM A572 Grade 50 Steel Galvanized	—
a5	1	1 1/8" [29] Dia. UNC, 13" [330] Long Threaded Rod	ASTM A307 Grade C Galvanized/ASTM F1554 Grade 36 Galvanized/SAE J429 Grade 2 Galvanized	—
a6	1	1 1/8" [29] Dia. Hardened Round Washer	ASTM F436 Galvanized	—
a7	1	1 1/8" [29] Dia. UNC Heavy Hex Nut	ASTM A563A Galvanized	—
c1	1	S3x5.7 [S76x8.5] by 44" [1118] Long Steel Post	ASTM A992 Grade 50 Steel Galvanized	—
c2	4	2 3/4"x1"x1/4" [70x25x6] Post Standoff	ASTM A36 Steel Galvanized	—
c3	2	1/2" [13] Dia. UNC, 7" [178] Long Threaded Rod	ASTM A307 Grade C Galvanized/ASTM F1554 Grade 36 Galvanized/SAE J429 Grade 2 Galvanized	—
c4	2	1/2" [13] Dia. Hardened Round Washer	ASTM F436 Galvanized	—
c5	2	1/2" [13] Dia. UNC Heavy Hex Nut	ASTM A563A Galvanized	—
c6	1	5/8" [16] Dia. UNC, 5" [127] Long Heavy Hex Bolt and Nut	Bolt ASTM A325 Type 1 Galvanized, Nut ASTM A563A Galvanized	FBX16a
c7	1	5/16" [8] Dia. UNC, 1 1/4" [32] Long Hex Bolt and Nut	ASTM A307 Galvanized	FBX08a
c8	1	1 3/4"x1 3/4"x1/8" [44x44x3] Square A36 Steel Washer	ASTM A36 Galvanized	RWR01
c9	1	6" [152] W-Beam Backup Plate	12 gauge [2.7] AASHTO M180	—
c10	Var.	12'-6" [3810] W-Beam MGS Section 1/2 Post Spacing	12 gauge [2.7] AASHTO M180	RWM04a
c11	Var.	5/8" [16] Dia., 1 1/2" [38] Guardrail Bolt and Nut	ASTM A307 Galvanized	FBB01
c12	—	Epoxy	Minimum bond strength = 1305 psi [9.0 MPa]	—

	Weak-Post, W-Beam Guardrail System Attached to Culvert	SHEET: 9 of 14
	Top-Mounted Configuration - Bill of Materials	DATE: 9/18/13
Midwest Roadside Safety Facility	DWG. NAME: MCS Attached to Culvert_R4	DRAWN BY: SDB
	SCALE: NONE UNITS: In.,[mm]	REV. BY: SKB/KAL/ RKF

Note: (1) W-Beam and Guardrail Bolt and Nut (Parts c10 and c11) quantities vary by width of culvert or length of system.

Figure 87. Top-Mounted Configuration, Bill of Materials



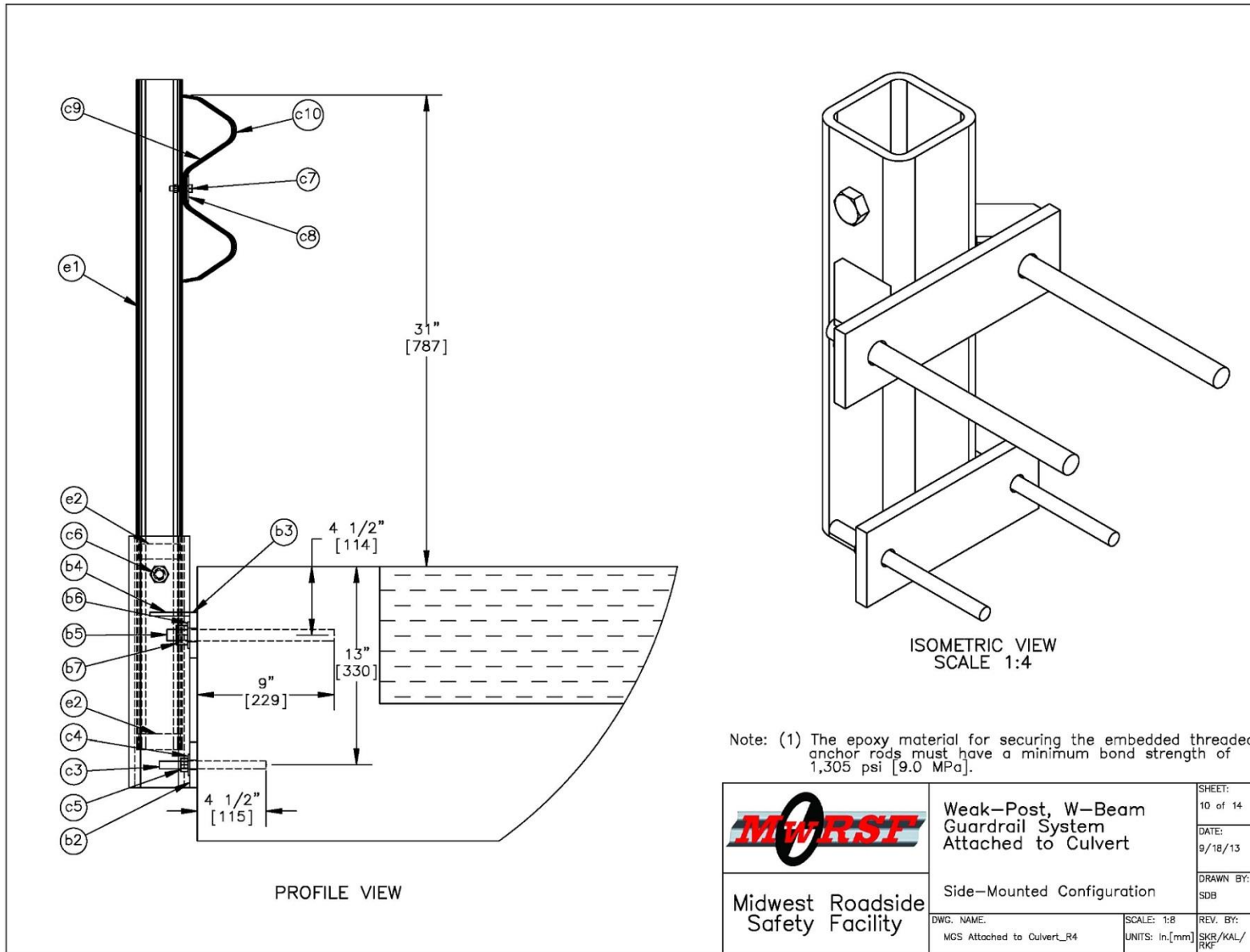

Figure 88. Side-Mounted Configuration Details

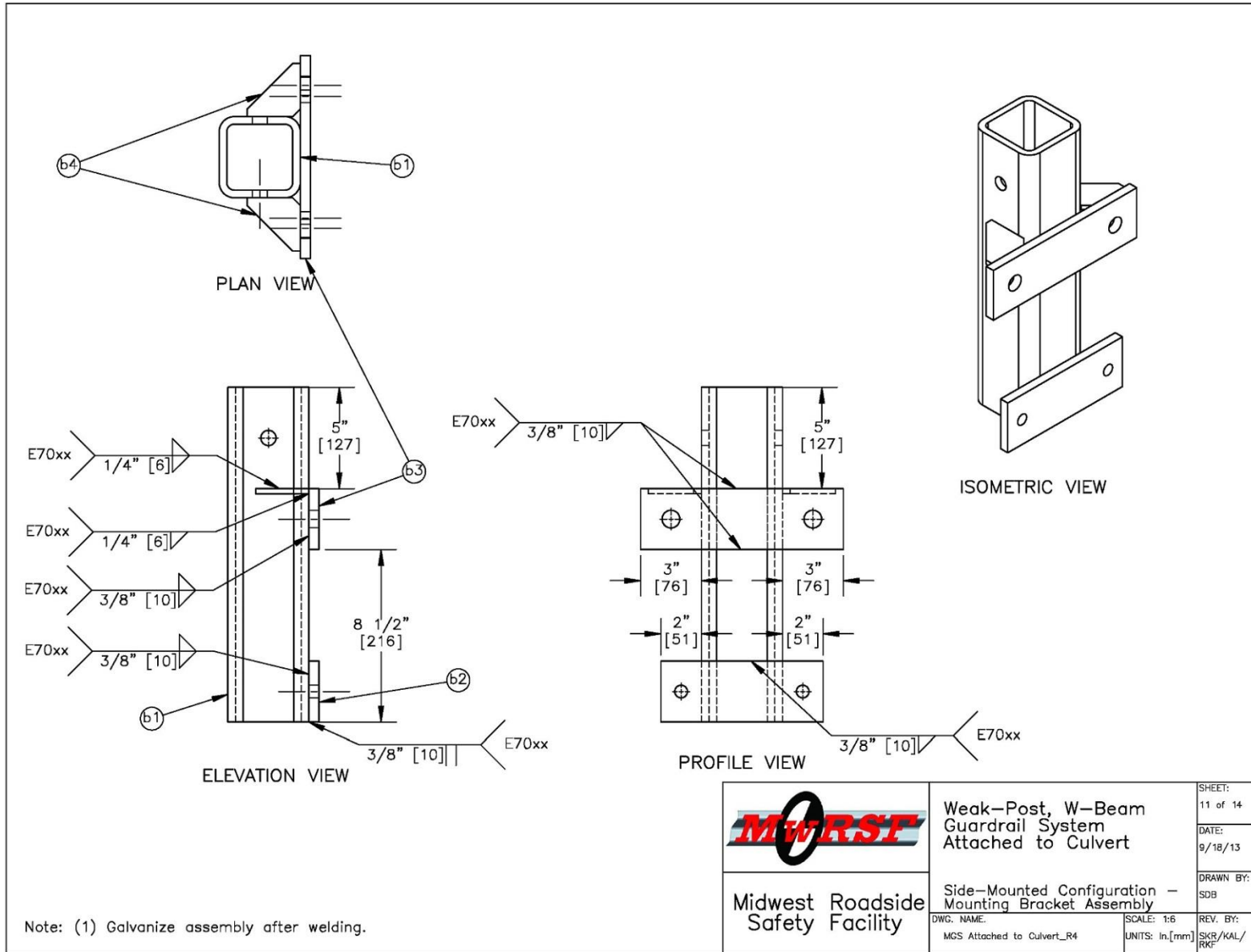

Figure 89. Side-Mounted Configuration, Socket Assembly Details

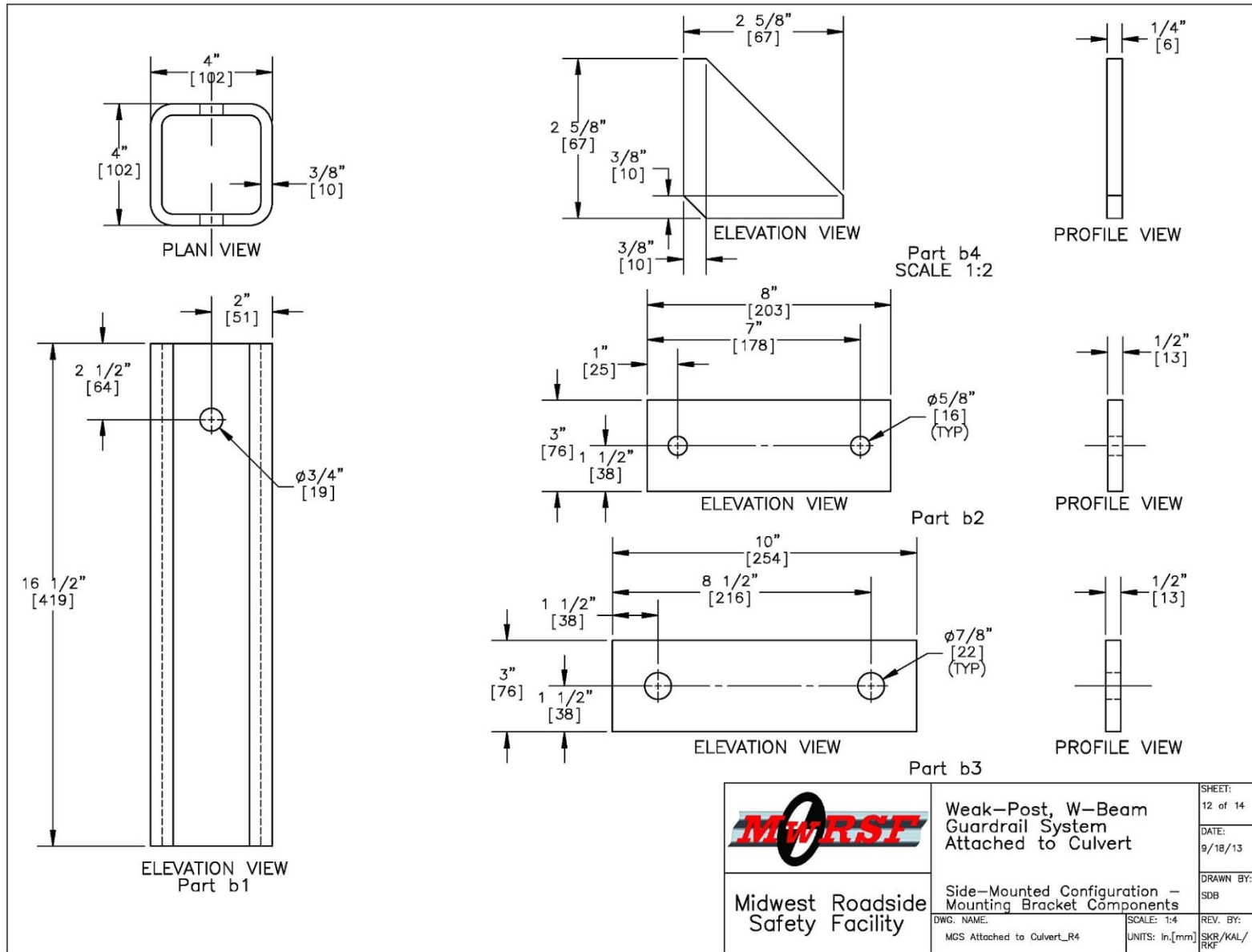

Figure 90. Side-Mounted Configuration, Socket Assembly Components

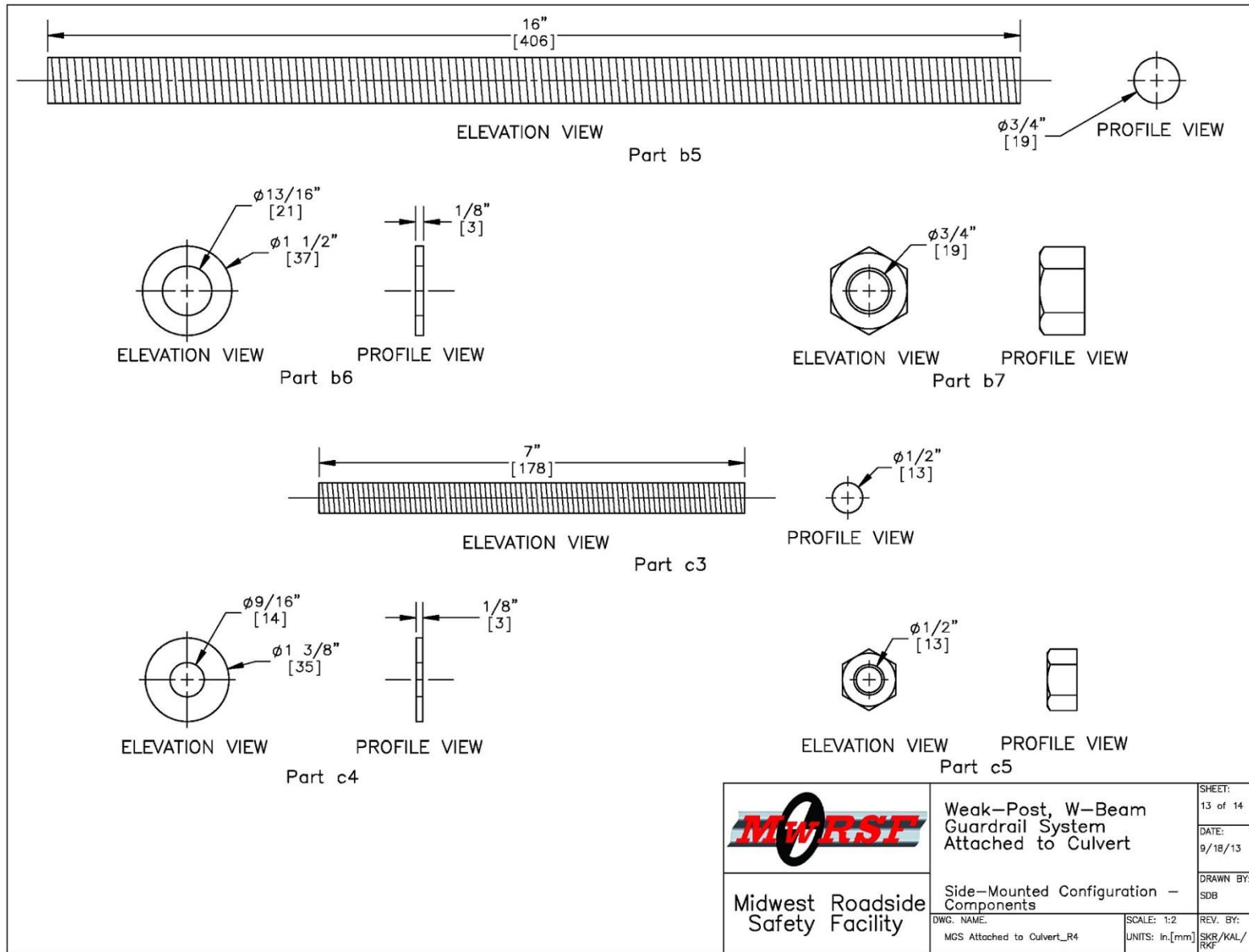

Figure 91. Side-Mounted Configuration, Attachment Hardware Details

Side-Mounted Configuration				
Item No.	QTY. (Per Post Location)	Description	Material Specification	Hardware Guide
b1	1	4"x4"x3/8" [102x102x10] Square Socket	ASTM A500 Grade B Steel Galvanized	—
b2	1	8"x3"x1/2" [203x76x13] Bottom Mounting Plate	ASTM A572 Grade 50 Steel Galvanized	—
b3	1	10"x3"x1/2" [254x76x13] Top Mounting Plate	ASTM A572 Grade 50 Steel Galvanized	—
b4	2	3"x3"x1/4" [76x76x6] Top Plate Gusset	ASTM A572 Grade 50 Steel Galvanized	—
b5	2	3/4" [19] Dia. UNC, 11" [279] Long Threaded Rod	ASTM A307 Grade C Galvanized/ASTM F1554 Grade 36 Galvanized/SAE J429 Grade 2 Galvanized	—
b6	2	3/4" [19] Dia. Hardened Round Narrow Washer	ASTM F436 Galvanized	FWC20b
b7	2	3/4" [19] Dia. UNC Heavy Hex Nut	ASTM A563A Galvanized	FNX20a
c1	1	S3x5.7 [S76x8.5] by 44" [1118] Long Steel Post	ASTM A992 Grade 50 Steel Galvanized	—
c2	4	2 3/4"x1"x1/4" [70x25x6] Post Standoff	ASTM A36 Steel Galvanized	—
c3	2	1/2" [13] Dia. UNC, 7" [178] Long Threaded Rod	ASTM A307 Grade C Galvanized/ASTM F1554 Grade 36 Galvanized/SAE J429 Grade 2 Galvanized	—
c4	2	1/2" [13] Dia. Hardened Round Washer	ASTM F436 Galvanized	—
c5	2	1/2" [13] Dia. UNC Heavy Hex Nut	ASTM A563A Galvanized	—
c6	1	5/8" [16] Dia. UNC, 5" [127] Long Heavy Hex Bolt and Nut	Bolt ASTM A325 Type 1 Galvanized, Nut ASTM A563A Galvanized	FBX16a
c7	1	5/16" [8] Dia. UNC, 1 1/4" [32] Long Hex Bolt and Nut	ASTM A307 Galvanized	FBX08a
c8	1	1 3/4"x1 3/4"x1/8" [44x44x3] Square A36 Steel Washer	ASTM A36 Galvanized	RWR01
c9	1	6" [152] W-Beam Backup Plate	12 gauge [2.7] AASHTO M180	—
c10	Var.	12'-6" [3810] W-Beam MGS Section 1/2 Post Spacing	12 gauge [2.7] AASHTO M180	RWM04a
c11	Var.	5/8" [16] Dia., 1 1/2" [38] Guardrail Bolt and Nut	ASTM A307 Galvanized	FBB01
c12	—	Epoxy	Minimum bond strength = 1305 psi [9.0 MPa]	—

Note: (1) W-Beam and Guardrail Bolt and Nut (Parts c10 and c11) quantities vary by width of culvert or length of system.		Weak-Post, W-Beam Guardrail System Attached to Culvert		SHEET: 14 of 14
		Side-Mounted Configuration - Bill of Materials		DATE: 9/18/13
Midwest Roadside Safety Facility		DWG. NAME: MGS Attached to Culvert_R4		DRAWN BY: SDB
		SCALE: NONE UNITS: in,[mm]	REV. BY: SKR/KAL/RKF	

Figure 92. Side-Mounted Configuration, Bill of Materials



## 7 REFERENCES

1. Hirsch, T.J., and Beggs, D., *Use of Guardrails on Low Fill Bridge Length Culverts*, Transportation Research Record No. 1198, Transportation Research Board, National Research Council, Washington D.C., 1988.
2. Polivka, K.A., Faller, R.K., Sicking, D.L., Rohde, J.R., Reid, J.D., and Holloway, J.C., *NCHRP 350 Development and Testing of a Guardrail Connection to Low-Fill Culverts*, Research Report No. TRP-03-114-02, Midwest Roadside Safety Facility, University of Nebraska-Lincoln, Lincoln, Nebraska, November 2002.
3. Polivka, K.A., Faller, R.K., and Rohde, J.R., *Guardrail Connection to Low-Fill Culverts*, Transportation Research Record No. 1851, Transportation Research Board, National Research Council, Washington D.C., 2003.
4. Price, C.W., Rosenbaugh, S.K., Faller, R.K., Sicking, D.L., Reid, J.D., and Bielenberg, R.W., *Post Weld and Epoxy Anchorage Variations for W-Beam Guardrail Attached to Low-Fill Culverts*, Research Report No. TRP-03-278-13, Midwest Roadside Safety Facility, University of Nebraska-Lincoln, Lincoln, Nebraska, August 12, 2013.
5. Ross, H.E., Sicking, D.L., Zimmer, R.A., and Michie, J.D., *Recommended Procedures for the Safety Performance Evaluation of Highway Features*, National Cooperative Research Program (NCHRP) Report No. 350, Transportation Research Board, Washington, D.C., 1993.
6. *Manual for Assessing Safety Hardware (MASH)*, American Association of State Highway and Transportation Officials (AASHTO), Washington, D.C., 2009.
7. Williams, W.F., and Menges, W.L., *MASH Test 3-11 of the W-beam Guardrail on Low-Fill Box Culvert*, Test Report No. 405160-23-2, Texas Transportation Institute, Texas A&M University, College Station, Texas, February 2012.
8. Polivka, K.A., Bielenberg, B.W., Sicking, D.L., Faller, R.K., and Rohde, J.R., *Development of a 7.62-m Long Span Guardrail System*, Research Report No. TRP-03-72-99, Midwest Roadside Safety Facility, University of Nebraska-Lincoln, Lincoln, Nebraska, April 6, 1999.
9. Polivka, K.A., Bielenberg, B.W., Sicking, D.L., Faller, R.K., Rohde, J.R., and Keller, E.A., *Development of a 7.62-m Long Span Guardrail System - Phase II*, Research Report No. TRP-03-88-99, Midwest Roadside Safety Facility, University of Nebraska-Lincoln, Lincoln, Nebraska, August 13, 1999.
10. Faller, R.K., Sicking, D.L., Polivka, K.A., Rohde, J.R., and Bielenberg, R.W., *A Long-Span Guardrail System for Culvert Applications*, Paper No. 00-0598, Transportation Research Record No. 1720, Transportation Research Board, National Research Council, Washington, D.C., 2000.

11. Bielenberg, B.W., Faller, R.K., Rohde, J.R., Reid, J.D., Sicking, D.L., Holloway, J.C., Allison, E.M., and Polivka, K.A., *Midwest Guardrail System for Long-Span Culvert Applications*, Research Report No. TRP-03-187-07, Midwest Roadside Safety Facility, University of Nebraska-Lincoln, Lincoln, Nebraska, November 16, 2007.
12. Bielenberg, R.W., Faller, R.K., Sicking, D.L., Rhode, J.R., and Reid, J.D., *Midwest Guardrail System for Long-Span Culvert Applications*, Transportation Research Record No. 2025, Transportation Research Board, National Research Council, Washington D.C., 2007.
13. Thiele, J.C., Sicking, D.L., Faller, R.K., Bielenberg, R.W., Lechtenberg, K.A., Reid, J.D., and Rosenbaugh, S.K., *Development of a Low-Cost, Energy-Absorbing Bridge Rail*, Research Report No. TRP-03-226-10, Midwest Roadside Safety Facility, University of Nebraska-Lincoln, Lincoln, Nebraska, August 2010.
14. Thiele, J.C., Sicking, D.L., Lechtenberg, K.A., Reid, J.D., Faller, R.K., Bielenberg, R.W., and Rosenbaugh, S.K., *Development of a Low-Cost, Energy-Absorbing Bridge Rail*, Transportation Research Record No. 2262, Transportation Research Board, National Research Council, Washington D.C., 2011.
15. Society of Automotive Engineers (SAE), *Instrumentation for Impact Test – Part 1 – Electronic Instrumentation*, SAE J211/1 MAR95, New York City, New York, July, 2007.

## **8 APPENDICES**

## **Appendix A. Material Specifications**

Table A-1. Material Certification List, Simulated Concrete Culvert

Part Description	Material Specifications	Material Reference
Concrete Support Walls, 12"x36"x48"	L4000 Type 3 mix, f'c ≥ 4,000 psi	Ticket No. 1147496 Test Report No. 2147362885
Concrete Culvert Deck Slab, 332"x48"x9"	L4000 Type 3 mix, f'c ≥ 4,000 psi	Ticket No. 4132597 Test Report No. 2147362886
Concrete Culvert Headwall, 332"x12"x9"	L4000 Type 3 mix, f'c ≥ 4,000 psi	Ticket No. 1151056 Test Report No. 2147362888
#4 Bent Rebar, Support Wall Hook, 44½" Total Length Unbent	Grade 60	Heat No.: M668699
#4 Straight Rebar, 41" Long	Grade 60	Heat No.: M668699
#4 Bent Rebar, Vertical Hoop, 68¼" Total Length Unbent	Grade 60	Heat No.: M668699
#4 Straight Rebar, 54" Long	Grade 60	Heat No.: M668699
#5 Straight Rebar, 27'-8" Long	Grade 60	Heat No.: K112473
#4 Straight Rebar, 27'-8" Long	Grade 60	Heat No.: M668699
#4 Straight Rebar, 44" Long	Grade 60	Heat No.: M668699
Epoxy	Min. Bond Strength 1,300 psi	AC100+Gold C222 / April 2013



Table A-2. Material Certification List, Design Concept A, Test Nos. CP-2A and CP-7A

Part Description	Material Specifications	Material Reference
4"x4"x $\frac{3}{8}$ " Steel Socket Tube	ASTM A500 Grade B	Heat No.: Y45608
8"x3"x $\frac{1}{2}$ " Bottom Mounting Plate	ASTM A572 Grade 50	Heat No.: B1R6601
$\frac{1}{2}$ " Dia. UNC, 7" Long Threaded Rod	SAE J429 Grade 2 Galvanized	Grainger CoC Aug 3, 2012
$\frac{1}{2}$ " Dia. Hardened Round Washer	ASTM F436 Galvanized	Lot# 52386-01
$\frac{1}{2}$ " Dia. UNC Heavy Hex Nut	ASTM A563A Galvanized	Lot# 123792C
9 $\frac{1}{2}$ "x3"x $\frac{7}{16}$ " Top Mounting Plate	ASTM A572 Grade 50	Heat No.: B1R6601
2"x1 $\frac{1}{2}$ "x $\frac{7}{16}$ " Top Mounting Plate Gusset	ASTM A572 Grade 50	Heat No.: B1R6601
1 $\frac{1}{8}$ " Dia. UNC, 13" Long Threaded Rod	SAE J429 Grade 2 Galvanized	Lot# 1012-143289-001-01-
1 $\frac{1}{8}$ " Dia. Hardened Round Washer	ASTM F436 Galvanized	n/a
1 $\frac{1}{8}$ " Dia. UNC Heavy Hex Nut	ASTM A563A Galvanized	Lot#156334
S3x5.7 by 44" Long Steel Post	ASTM A36	Heat No.: G106836 and Heat No.:G104598/99
2 $\frac{3}{4}$ "x1"x $\frac{1}{4}$ " Post Standoff	ASTM A36	Heat No.: B0X8426
$\frac{5}{8}$ " Dia. UNC, 5" Long Heavy Hex Bolt	ASTM A325 Type 1 Galvanized	Lot#142823
$\frac{5}{8}$ " Dia. UNC Heavy Hex Nut	ASTM A563A Galvanized	Lot#142823
Epoxy	Min. Bond Strength 1,300 psi	AC100+Gold C293/May13

Table A-3. Material Certification List, Design Concept B, Test No. CP-4B

Part Description	Material Specifications	Material Reference
4"x4"x $\frac{3}{8}$ " Steel Socket Tube	ASTM A500 Grade B	Heat No.: Y45608
8"x3"x $\frac{1}{2}$ " Bottom Mounting Plate	ASTM A572 Grade 50	Heat No.: B1R6601
$\frac{1}{2}$ " Dia. UNC, 7" Long Threaded Rod	SAE J429 Grade 2 Galvanized	Grainger CoC Aug 3, 2012
$\frac{1}{2}$ " Dia. Hardened Round Washer	ASTM F436 Galvanized	Lot# 52386-01
$\frac{1}{2}$ " Dia. UNC Heavy Hex Nut	ASTM A563A Galvanized	Lot# 123792C
9"x9"x $\frac{7}{16}$ " Top Mounting Plate	ASTM A572 Grade 50	Heat No.: B1R6601
2"x1 $\frac{1}{2}$ "x $\frac{7}{16}$ " Top Mounting Plate Gusset	ASTM A572 Grade 50	Heat No.: B1R6601
$\frac{3}{4}$ " Dia. UNC, 7" Long Threaded Rod	SAE J429 Grade 2 Galvanized	Grainger CoC Aug 3, 2012
$\frac{3}{4}$ " Dia. Hardened Round Washer	ASTM F436 Galvanized	Lot#52389-01
$\frac{3}{4}$ " Dia. UNC Heavy Hex Nut	ASTM A563A Galvanized	Lot#170277
S3x5.7 by 44" Long Steel Post	ASTM A36	Heat No.: G106836
2 $\frac{3}{4}$ "x1"x $\frac{1}{4}$ " Post Standoff	ASTM A36	Heat No.: B0X8426
$\frac{5}{8}$ " Dia. UNC, 5" Long Heavy Hex Bolt	ASTM A325 Type 1 Galvanized	Lot#142823
$\frac{5}{8}$ " Dia. UNC Heavy Hex Nut	ASTM A563A Galvanized	Lot#142823
Epoxy	Min. Bond Strength 1300 psi	AC100+Gold C020/August13

Table A-4. Material Certification List, Design Concept C, Test No. CP-1C

Part Description	Material Specifications	Material Reference
4"x4"x $\frac{3}{8}$ " Steel Socket Tube	ASTM A500 Grade B	Heat No.: Y45608
8"x3"x $\frac{1}{2}$ " Bottom Mounting Plate	ASTM A572 Grade 50	Heat No.: B1R6601
$\frac{1}{2}$ " Dia. UNC, 7" Long Threaded Rod	SAE J429 Grade 2 Galvanized	Grainger CoC Aug 3, 2012
$\frac{1}{2}$ " Dia. Hardened Round Washer	ASTM F436 Galvanized	Lot# 52386-01
$\frac{1}{2}$ " Dia. UNC Heavy Hex Nut	ASTM A563A Galvanized	Lot# 123792C
20"x3"x $\frac{7}{16}$ " Top Mounting Plate	ASTM A572 Grade 50	Heat No.: B1R6601
2"x1 $\frac{1}{2}$ "x $\frac{7}{16}$ " Top Mounting Plate Gusset	ASTM A572 Grade 50	Heat No.: B1R6601
$\frac{5}{8}$ " Dia. UNC, 7" Long Threaded Rod	SAE J429 Grade 2 Galvanized	Grainger CoC Aug 3, 2012
$\frac{5}{8}$ " Dia. Hardened Round Washer	ASTM F436 Galvanized	Lot#51614-01
S3x5.7 by 44" Long Steel Post	ASTM A36	Heat No.: G106836
2 $\frac{3}{4}$ "x1"x $\frac{1}{4}$ " Post Standoff	ASTM A36	Heat No.: B0X8426
$\frac{5}{8}$ " Dia. UNC, 5" Long Heavy Hex Bolt	ASTM A325 Type 1 Galvanized	Lot#142823
$\frac{5}{8}$ " Dia. UNC Heavy Hex Nut	ASTM A563A Galvanized	Lot#142823, and Lot# 124738C
Epoxy	Min. Bond Strength 1300 psi	AC100+Gold C293/May13

Table A-5. Material Certification List, Design Concept D, Test No. CP-3D

Part Description	Material Specifications	Material Reference
4"x4"x $\frac{3}{8}$ " Steel Socket Tube	ASTM A500 Grade B	Heat No.: Y45608
8"x3"x $\frac{1}{2}$ " Bottom Mounting Plate	ASTM A572 Grade 50	Heat No.: B1R6601
$\frac{1}{2}$ " Dia. UNC, 7" Long Threaded Rod	SAE J429 Grade 2 Galvanized	Grainger CoC Aug 3, 2012
$\frac{1}{2}$ " Dia. Hardened Round Washer	ASTM F436 Galvanized	Lot# 52386-01
$\frac{1}{2}$ " Dia. UNC Heavy Hex Nut	ASTM A563A Galvanized	Lot# 123792C
10"x3"x $\frac{1}{2}$ " Top Mounting Plate	ASTM A572 Grade 50	Heat No.: B1R6601
3"x3"x $\frac{1}{4}$ " Top Plate Gusset	ASTM A572 Grade 50	Heat No.: B0X8426
3"x3"x $\frac{1}{4}$ " Top Mounting Plate Washer	ASTM A572 Grade 50	Heat No.: B0X8426
$\frac{3}{4}$ " Dia. UNC, 16" Long Threaded Rod	SAE J429 Grade 2 Galvanized	Grainger CoC Aug 3, 2012
$\frac{3}{4}$ " Dia. Hardened Round Narrow Washer	ASTM F436 Galvanized	Lot#52389-01
$\frac{3}{4}$ " Dia. UNC Heavy Hex Nut	ASTM A563A Galvanized	Lot#170277
S3x5.7 by 44" Long Steel Post	ASTM A36	Heat No.: G106836
$2\frac{3}{4}$ "x1"x $\frac{1}{4}$ " Post Standoff	ASTM A36	Heat No.: B0X8426
$\frac{5}{8}$ " Dia. UNC, 5" Long Heavy Hex Bolt	ASTM A325 Type 1 Galvanized	Lot#142823
$\frac{5}{8}$ " Dia. UNC Heavy Hex Nut	ASTM A563A Galvanized	Lot#142823
Epoxy	Min. Bond Strength 1300 psi	AC100+Gold C020/August13

133

Table A-6. Material Certification List, Design Concept D2, Test Nos. CP-5D2 and CP-6D2

Part Description	Material Specifications	Material Reference
4"x4"x $\frac{3}{8}$ " Steel Socket Tube	ASTM A500 Grade B	Heat No.: Y45608
8"x3"x $\frac{1}{2}$ " Bottom Mounting Plate	ASTM A572 Grade 50	Heat No.: B1R6601
$\frac{1}{2}$ " Dia. UNC, 7" Long Threaded Rod	SAE J429 Grade 2 Galvanized	Grainger CoC Aug 3, 2012
$\frac{1}{2}$ " Dia. Hardened Round Washer	ASTM F436 Galvanized	Lot# 52386-01
$\frac{1}{2}$ " Dia. UNC Heavy Hex Nut	ASTM A563A Galvanized	Lot# 123792C
10"x3"x $\frac{1}{2}$ " Top Mounting Plate	ASTM A572 Grade 50	Heat No.: B1R6601
3"x3"x $\frac{1}{4}$ " Top Plate Gusset	ASTM A572 Grade 50	Heat No.: B0X8426
$\frac{3}{4}$ " Dia. UNC, 11" Long Threaded Rod	SAE J429 Grade 2 Galvanized	Grainger CoC Aug 3, 2012
$\frac{3}{4}$ " Dia. Hardened Round Narrow Washer	ASTM F436 Galvanized	Lot#52389-01
$\frac{3}{4}$ " Dia. UNC Heavy Hex Nut	ASTM A563A Galvanized	Lot#170277
S3x5.7 by 44" Long Steel Post	ASTM A992 Grade 50	Heat No.: G104598/99
$2\frac{3}{4}$ "x1"x $\frac{1}{4}$ " Post Standoff	ASTM A36	Heat No.: B0X8426
$\frac{5}{8}$ " Dia. UNC, 5" Long Heavy Hex Bolt	Bolt ASTM A325 Type 1 Galvanized	Lot#142823
$\frac{5}{8}$ " Dia. UNC Heavy Hex Nut	ASTM A563A Galvanized	Lot#142823
Epoxy	Min. Bond Strength 1300 psi	AC100+Gold C020/August13

134





**CAUTION  
FRESH CONCRETE**

Body and or eye contact with fresh (moist) concrete should be avoided because it contains alkali and is caustic.

**Ready Mixed  
Concrete Company**  
6200 Cornhusker Highway, P.O. Box 29288  
Lincoln, Nebraska 68529  
Telephone 402-434-1844

PLANT	MIX CODE	YARDS	TRUCK	DRIVER	DESTINATION	CLASS	TIME	DATE	TICKET
01	24033000	2.25	0108		NTE		01:21	03/02/2012	1147496
CUSTOMER	JOB	CUSTOMER NAME		TAX CODE	PARTIAL	NIGHT R.	LOADS		
00003		CIA---UNIVERSITY OF NE					1		
DELIVERY ADDRESS				SPECIAL INSTRUCTIONS			P.O. NUMBER		
4800 NW 35TH				NORTH OF MOST NORTH GOODYEAR HAN GER			4506250 JIM		
LOAD QUANTITY	CUMULATIVE QUANTITY	ORDERED QUANTITY	PRODUCT CODE	PRODUCT DESCRIPTION		UNIT PRICE	AMOUNT		
2.25	2.25	2.25	24033000	L4000 TYPE 3 MINIMUM HAUL WINTER SERVICE		98.89	222.50 47.50 9.00		
WATER ADDED ON JOB AT CUSTOMER'S REQUEST _____ GAL.							SUBTOTAL		279.00
RECEIVED BY							TAX		279.00
							TOTAL		279.00

TRUCK	USER LOGIN	DISP	TICKET NUM	TICKET NUM	TICKET ID	TIME	DATE
0108	USER		1147496	168937	19780	13:21	03/02/2012
LOAD SIZE	MIX CODE					SEQ	LOAD ID
2.25 yd	24033000					W	19824
MATERIAL	DESIGN QTY	REQUIRED	BATCHED	VAR	% VAR	%MOISTURE	ACTUAL WAT
G47B	2090 lb	4821 lb	4800	-21	-.44%	2.53 A	14.18 g/l
L47B	909 lb	2068 lb	2060	-8	-.39%	1.10 M	2.69 g/l
CEM3	611 lb	1375 lb	1515	+	140		
PROT	1.20 oz	2.70 oz	4.00	+	1.30		
WATER	34.0 GL	52.5 GL	52.7		0.2		52.73 g/l
WATER2	15.0 %	9.3 g/l	9.6		0.3		9.59 g/l
NON-SIMULATED		NUM BATCHES: 1					
LOAD TOTAL: 8895 lb		DESIGN W/C: 0.464		WATER/CEMENT: 0.436A		DESIGN WATER: 76.5 g/l	
SLUMP: 4.00		# WATER IN TRUCK: 0.0 g/l		ADJUST WATER: 0.0 g/l/load		TRIM WATER: 0.0 g/l/yd	
				ACTUAL WATER: 79.2 g/l		TO ADD: 0.0 g/l	

ORIGINAL

Figure A-1. Culvert Support Wall Concrete, Mix Details



LINCOLN OFFICE  
825 "J" Street  
Lincoln, NE 68508  
Phone: (402) 479-2200  
Fax: (402) 479-2276

COMPRESSION TEST OF CYLINDRICAL CONCRETE  
SPECIMENS - 6x12

ASTM Designation: C 39

Client Name: Midwest Roadside Safety Facility  
Project Name: Miscellaneous Concrete Testing  
Placement Location: Culvert Support

Date 06-Jun-12

Mix Designation:

Required Strength:

Laboratory Test Data

Laboratory Identification	Field Identification	Date Cast	Date Received	Date Tested	Days Cured in Field	Days Cured in Laboratory	Age of Test, Days	Length of Specimen, in.	Diameter of Specimen, in.	Cross-Sectional Area, sq.in.	Maximum Load, lbf	Compressive Strength, psi.	Required Strength, psi.	Type of Fracture	ASTM Practice for Capping Specimen
URR- 1	A	3/2/2012	6/5/2012	6/5/2012	95	0	95	12	6.01	28.37	201,200	7,090		5	C 1231

1 cc: Ms. Karla Lechtenberg  
Midwest Roadside Safety Facility

Remarks: No Field Data provided to lab by contractor.

Concrete test specimens along with documentation and test data were submitted by Midwest Roadside Safety Facility.

Test results presented relate only to the concrete specimens as received from Midwest Roadside Safety

This report shall not be reproduced except in full, without the written approval of Alfred Benesch & Company.

Report Number 2147362885  
Page 1

Sketches of Types of Fractures

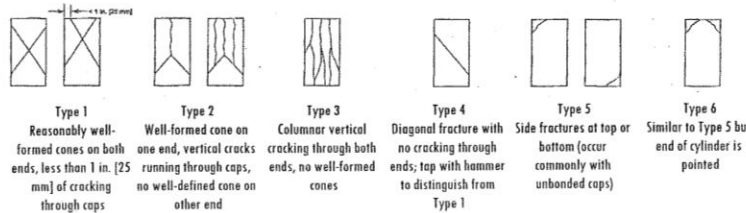

ALFRED BENESCH & COMPANY  
CONSTRUCTION MATERIALS LABORATORY

By Tim Watson  
Tim Watson, Coordinator

Figure A-2. Culvert Support Wall Concrete, Strength Test



**CAUTION  
FRESH CONCRETE**

Body and or eye contact with fresh (moist) concrete should be avoided because it contains alkali and is caustic.

**Ready Mixed  
Concrete Company**  
6200 Cornhusker Highway, P.O. Box 29288  
Lincoln, Nebraska 68529  
Telephone 402-434-1844

PLANT 4	MIX CODE 24013000	YARDS 4.50	TRUCK 0203	DRIVER 010	DESTINATION NTE	CLASS	TIME 09:04AM	DATE 05/14/12	TICKET 4132597
CUSTOMER 00003	JOB	CUSTOMER NAME CIA---UNL / MWRSF		TAX CODE	PARTIAL	NIGHT R.	LOADS 1		
DELIVERY ADDRESS 4800 NW 35TH			SPECIAL INSTRUCTIONS NORTH OF GOODYEAR HANGERS				P.O. NUMBER 450-6250 JIM		

LOAD QUANTITY	CUMULATIVE QUANTITY	ORDERED QUANTITY	PRODUCT CODE	PRODUCT DESCRIPTION	UNIT PRICE	AMOUNT
4.50	4.50	4.50	24013000	L4000 MINIMUM HAUL	94.75	426.38 25.00

WATER ADDED ON JOB AT CUSTOMER'S REQUEST	10	RECEIVED BY	SA		SUBTOTAL TAX TOTAL 451.38 451.38 451.38
---	----	-------------	----	--	--

TRUCK	USER LOGIN	DISP	TICKET NUM	TICKET NUM	TICKET ID	TIME	DATE
0203	USER		4132597	152638	164933	09:04	05/14/2012
LOAD SIZE	MIX CODE	SEQ	LOAD ID				
4.50 yd	24013000	W	166617				
MATERIAL	DESIGN QTY	REQUIRED	BATCHED	VAR	% VAR	%MOISTURE	ACTUAL WAT
G47B	2113.0 lb	9737.7 lb	9700.0	-37.7	-39%	2.41 A	27.36 gl
L47B	919.0 lb	4197.5 lb	4180.0	-17.5	-42%	1.50 M	7.40 gl
CEM1	611.0 lb	2749.5 lb	2785.0	+ 35.5	1.29%		
PROT	5.7 oz	25.6 oz	26.0	0.4	1.56%		
WATER	31.5 gl	111.4 gl	111.4	0.0	0.00%		111.44 gl
WATER2	0.0 gl #	0.0 gl	0.0	0.0	0.00%		
NON-SIMULATED NUM BATCHES: 1							
LOAD TOTAL: 17597 lb DESIGN W/C: 0.430 WATER/CEMENT: 0.438A DESIGN WATER: 141.7 gl ACTUAL WATER: 146.2 gl							
SLUMP: 4.00 "% WATER IN TRUCK: 0.0 gl							

ORIGINAL

Figure A-3. Culvert Deck Slab Concrete, Mix Details



LINCOLN OFFICE  
825 "J" Street  
Lincoln, NE 68508  
Phone: (402) 479-2200  
Fax: (402) 479-2276

COMPRESSION TEST OF CYLINDRICAL CONCRETE  
SPECIMENS - 6x12

ASTM Designation: C 39

Client Name: Midwest Roadside Safety Facility  
Project Name: Miscellaneous Concrete Testing  
Placement Location: Culvert Deck

Date 06-Jun-12

Mix Designation:

Required Strength:

Laboratory Test Data

Laboratory Identification	Field Identification	Date Cast	Date Received	Date Tested	Days Cured in Field	Days Cured in Laboratory	Age of Test, Days	Length of Specimen, in.	Diameter of Specimen, in.	Cross-Sectional Area, sq.in.	Maximum Load, lbf	Compressive Strength, psi.	Required Strength, psi.	Type of Fracture	ASTM Practice for Capping Specimen
URR- 2	B	5/14/2012	6/5/2012	6/5/2012	22	0	22	12	6.01	28.37	120,950	4,260		5	C 1231

1 cc: Ms. Karla Lechtenberg  
Midwest Roadside Safety Facility

138

Remarks: No Field Data provided to lab by contractor.

Concrete test specimens along with documentation and test data were submitted by Midwest Roadside Safety Facility.

Test results presented relate only to the concrete specimens as received from Midwest Roadside Safety

This report shall not be reproduced except in full, without the written approval of Alfred Benesch & Company.

Report Number 2147362886  
Page 1

Sketches of Types of Fractures

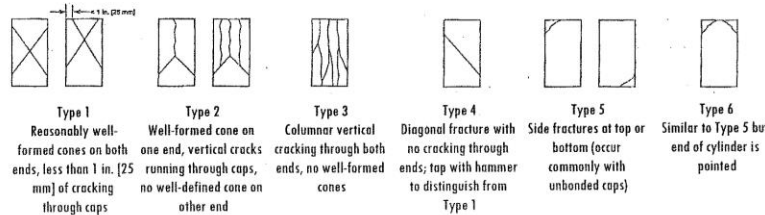

ALFRED BENESCH & COMPANY  
CONSTRUCTION MATERIALS LABORATORY

By *Tim Watson*  
Tim Watson, Coordinator

Figure A-4. Culvert Deck Slab Concrete, Strength Test



**CAUTION  
FRESH CONCRETE**

Body and or eye contact with fresh (moist) concrete should be avoided because it contains alkali and is caustic.

**Ready Mixed  
Concrete Company**

6200 Cornhusker Highway, P.O. Box 29288  
Lincoln, Nebraska 68529  
Telephone 402-434-1844

PLANT	MIX CODE	YARDS	TRUCK	DRIVER	DESTINATION	CLASS	TIME	DATE	TICKET
01	24033000	1.00	0110		NTE		11:48AM	05/29/12	1151056
CUSTOMER	JOB	CUSTOMER NAME			TAX CODE	PARTIAL	NIGHT R	LOADS	
00003		CIA---MwRS						1	
DELIVERY ADDRESS				SPECIAL INSTRUCTIONS			P.O. NUMBER		
4800 NW 35TH				NORTH OF GOODYEAR HANGERS			450-6250 JIM		
LOAD QUANTITY	CUMULATIVE QUANTITY	ORDERED QUANTITY	PRODUCT CODE	PRODUCT DESCRIPTION		UNIT PRICE	AMOUNT		
1.00	1.00	1.00	24033000	L4000 TYPE 3 MINIMUM HAUL		102.39	102.39 60.00		
							SUBTOTAL	162.39	
WATER ADDED ON JOB							TAX	162.39	
AT CUSTOMER'S REQUEST							TOTAL	162.39	

TRUCK	USER LOGIN	DISP	TICKET NUM	TICKET NUM	TICKET ID	TIME	DATE
0110	USER		1151056	172467	23364	11:48	05/29/2012
LOAD SIZE	MIX CODE					SEQ	LOAD ID
1.00 yd	24033000					W	23414
MATERIAL	DESIGN QTY	REQUIRED	BATCHED	VAR	% VAR	%MOISTURE	ACTUAL WAT
S47B	2090 lb	2126 lb	2120	-6	-0.28%	1.70 M	4.25 gl
L47B	909 lb	927 lb	1080	+	153	2.00 M	2.54 gl
CEM3	611 lb	611 lb	620		9		
PROT	1.20 oz	1.20 oz	1.00	-0.20	-16.67%		
WATER	34.0 GL	28.6 GL	28.3	-0.3	-1.05%		28.28 gl
WATER2	0.0 gl #	0.0 gl	0.0	0.0	0.00%		
NON-SIMULATED NUM BATCHES: 1							
LOAD TOTAL: 4056 lb DESIGN W/C: 0.464 WATER/CEMENT: 0.472A DESIGN WATER: 34.0 gl ACTUAL WATER: 35.1 gl TO ADD: 0.0 gl							
SLUMP: 4.00 % WATER IN TRUCK: 0.0 gl ADJUST WATER: 0.0 gl /load TRIM WATER: 0.0 gl /yd							

REQ #  
12-0369  
Box CURVERT  
Deck/curb

ORIGINAL

Figure A-5. Culvert Headwall Concrete, Mix Details





LINCOLN OFFICE  
825 "J" Street  
Lincoln, NE 68508  
Phone: (402) 479-2200  
Fax: (402) 479-2276

COMPRESSION TEST OF CYLINDRICAL CONCRETE  
SPECIMENS - 6x12

ASTM Designation: C 39

Client Name: Midwest Roadside Safety Facility  
Project Name: Miscellaneous Concrete Testing  
Placement Location: Culvert Curb

Date 06-Jun-12

Mix Designation:

Required Strength:

Laboratory Test Data

Laboratory Identification	Field Identification	Date Cast	Date Received	Date Tested	Days Cured in Field	Days Cured in Laboratory	Age of Test, Days	Length of Specimen, in.	Diameter of Specimen, in.	Cross-Sectional Area, sq.in.	Maximum Load, lbf	Compressive Strength, psi.	Required Strength, psi.	Type of Fracture	ASTM Practice for Capping Specimen
URR- 4	D	5/29/2012	6/5/2012	6/5/2012	7	0	7	12	6.01	28.37	137,450	4,850		5	C 1231

1 cc: Ms. Karla Lechtenberg  
Midwest Roadside Safety Facility

140

Remarks: No Field Data provided to lab by contractor.

Concrete test specimens along with documentation and test data were submitted by Midwest Roadside Safety Facility.

Test results presented relate only to the concrete specimens as received from Midwest Roadside Safety

This report shall not be reproduced except in full, without the written approval of Alfred Benesch & Company.

Report Number 2147362888  
Page 1

Sketches of Types of Fractures

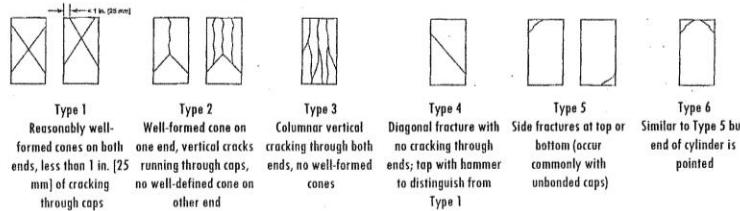

ALFRED BENESCH & COMPANY  
CONSTRUCTION MATERIALS LABORATORY

By *Tim Watson*  
Tim Watson, Coordinator

Figure A-6. Culvert Headwall Concrete, Strength Test



KNOXVILLE STEEL MILL  
 1919 TENNESSEE AVE  
 KNOXVILLE TN 37921 USA

Chemical and Physical Test Report

MADE IN UNITED STATES

CUSTOMER: CONCRETE INDUSTRIES INC

SHAPE + SIZE		GRADE		SPECIFICATION											SALES ORDER		CUST P.O. NUMBER	
X16MM REBAR (# 5)		420 (60)		ASTM A615/A615M-09B THERMEX TREATED														
HEAT I.D.	C	Mn	P	S	Si	Cu	Ni	Cr	Mo	V	Nb	Sn	C Eqv					
K112473	.31	.48	.017	.073	.16	.38	.20	.05	.021	.003	.001	.004	.414					

Mechanical Test: Yield 85420 PSI, 588.95 MPA Tensile: 103180 PSI, 711.4 MPA %El: 12.5/8in, 12.5/200MM Bend: OK Def HT: .045, 1.14MM Def Gap: .137, 3.48MM Def SP: .386, 9.8MM %l/h 3.9L

Customer Requirements CASTING: STRAND CAST

141

This material, including the billets, was melted and manufactured in the United States of America

Bhaskar Yalamanchili  
 Quality Director  
 Gerdau

THE ABOVE FIGURES ARE CERTIFIED CHEMICAL AND PHYSICAL TEST RECORDS AS CONTAINED IN THE PERMANENT RECORDS OF COMPANY.

Metallurgical Services Manager  
 KNOXVILLE STEEL MILL

Seller warrants that all material furnished shall comply with specifications subject to standard published manufacturing variations. NO OTHER WARRANTIES, EXPRESSED OR IMPLIED, ARE MADE BY THE SELLER, AND SPECIFICALLY EXCLUDED ARE WARRANTIES OF MERCHANTABILITY AND FITNESS FOR A PARTICULAR PURPOSE. In no event shall seller be liable for indirect, consequential or punitive damages arising out of or related to the materials furnished by seller. Any claim for damages for materials that do not conform to specifications must be made from buyer to seller immediately after delivery of same in order to allow the seller the opportunity to inspect the material in question.

Figure A-7. Culvert Reinforcement, No. 5 Bars



ST PAUL STEEL MILL  
1678 RED ROCK ROAD  
ST PAUL MN 55119 USA

Chemical and Physical Test Report

CUSTOMER: CONCRETE INDUSTRIES INC

SHAPE + SIZE	GRADE		SPECIFICATION										SALES ORDER	CUST P.O. NUMBER	
X13MM REBAR (# 4)	420 (60)		ASTM A6/A6M-10A A615/A615M-09 GR 60/420												
HEAT I.D.	C	Mn	P	S	Si	Cu	Ni	Cr	Mo	Sn	C Eqv				
M668699	.43	1.11	.014	.020	.21	.31	.14	.11	.032	.012	.642				

Mechanical Test: Yield 68500 PSI, 472.29 MPA Tensile: 110000 PSI, 758.42 MPA %El: 16.0/8in, 16.0/203.2mm Bend: OK Def HT: .038, .97MM Def Gap: .117, 2.97MM Def SP: .332, 8.43MM %l/h 1h Red R 132.55 Idl Diam: 0 Corrosion Index: 5.75

Customer Requirements SOURCE: GA-Beaumont, TX CASTING: STRAND CAST

Comment: melted and MFG in the USA  
melt shop heat 20032T1, melt dtd 8/26/2011 Beaumont, TX, roll lot M668699 roll dtd 9/5/2011

142

Bhaskar Yalamanchilli  
Quality Director  
Gerdaul

THE ABOVE FIGURES ARE CERTIFIED CHEMICAL AND PHYSICAL TEST RECORDS AS CONTAINED IN THE PERMANENT RECORDS OF COMPANY.

Metallurgical Services Manager  
ST PAUL STEEL MILL

Seller warrants that all material furnished shall comply with specifications subject to standard published manufacturing variations. NO OTHER WARRANTIES, EXPRESSED OR IMPLIED, ARE MADE BY THE SELLER, AND SPECIFICALLY EXCLUDED ARE WARRANTIES OF MERCHANTABILITY AND FITNESS FOR A PARTICULAR PURPOSE. In no event shall seller be liable for indirect, consequential or punitive damages arising out of or related to the materials furnished by seller. Any claim for damages for materials that do not conform to specifications must be made from buyer to seller immediately after delivery of same in order to allow the seller the opportunity to inspect the material in question.

Figure A-8. Culvert Reinforcement, No. 4 Bars

03May12 16: 9 TEST CERTIFICATE No: MAR 880168

INDEPENDENCE TUBE CORPORATION F/O No 4500176711  
6226 W. 74TH STREET Rel  
CHICAGO, IL 60638 S/O No MAR 209345-007  
Tel: 708-496-0380 Fax: 708-563-1950 E/L No MAR 124226-003 Shp 27Apr12  
Inv No Inv

Sold To: ( 5017) Ship To: ( 1)  
STEEL & PIPE SUPPLY STEEL & PIPE SUPPLY  
401 NEW CENTURY PARKWAY 401 NEW CENTURY PKWY  
KANSAS CITY, MO. NEW CENTURY, KS 66031  
NEW CENTURY, KS 66031

Tel: 913-768-4333 Fax: 913 768-6683

---

CERTIFICATE of ANALYSIS and TESTS, Cert. No: MAR 880168  
27Apr12

Part No		Fcs	Wgt
TUBING A500 GRADE B(C)		24	16,580
4" SQ X 3/8" X 40'			
Heat Number	Tag No	Fcs	Wgt
Y45608	349620	12	8,290
	YLD=66840/TEN=78050/ELG=28.6		
Y45608	349621	12	8,290

Heat Number Y45608 \*\*\* Chemical Analysis \*\*\*  
C=0.1800 Mn=0.7500 P=0.0150 S=0.0070 Si=0.0190 Al=0.0480  
Cu=0.0400 Cr=0.0400 V=0.0010 Ni=0.0100

WE PROUDLY MANUFACTURE ALL OF OUR HSS IN THE USA.  
INDEPENDENCE TUBE PRODUCT IS MANUFACTURED, TESTED,  
AND INSPECTED IN ACCORDANCE WITH ASTM STANDARDS.  
\*\*\*\*\*  
CURRENT STANDARDS:  
..... A500/A500M-10a  
..... A513-07  
..... A252-98 (2002)

Page: 1 .... Last

Figure A-9. 4x4x3/8-in. Steel Socket Tubes, Test Nos. CP-1 through CP-7

SPS Coil Processing Tulsa  
 5275 Bird Creek Ave.  
 Port of Catoosa, OK 74015



# METALLURGICAL TEST REPORT

PAGE 1 of 1  
 DATE 05/06/2011  
 TIME 08:42:33  
 USER GIANGRER

S  
O  
L  
D  
T  
O

S  
H  
I  
P  
T  
O

13713  
 Warehouse 0020  
 1050 Fort Gibson Rd  
 CATOOSA OK 74015

Order	Material No.	Description	Quantity	Weight	Customer Part	Customer PO	Ship Date
40161829-0190	72896240A2	1/4 96 X 240 A572GR50 MILL PLATE	1	1,633.600			05/06/2011

### Chemical Analysis

Heat No.	Vendor	MELTED AND MANUFACTURED IN THE USA													
BOX8426	NUCOR STEEL TUSCALOOSA INC	DOMESTIC MILL NUCOR STEEL TUSCALOOSA INC													
Batch 0000943411	1 EA	1,633.600 LB													
Carbon	Manganese	Phosphorus	Sulphur	Silicon	Nickel	Chromium	Molybdenum	Boron	Copper	Aluminum	Titanium	Vanadium	Columbium	Nitrogen	Tin
0.0700	1.3100	0.0110	0.0030	0.0300	0.0700	0.0700	0.0180	0.0002	0.2800	0.0290	0.0010	0.0010	0.0300	0.0110	0.0090

### Mechanical/ Physical Properties

Mill Coil No.	Tensile	Yield	Elong	Rckwl	Grain	Charpy	Charpy Dr	Charpy Sz	Olsen
OK1582	70000.000	60000.000	29.50	0	0.000	0	NA		
	70000.000	58900.000	39.00	0	0.000	0	NA		
	71200.000	59400.000	31.20	0	0.000	0	NA		
	72700.000	63400.000	39.10	0	0.000	0	NA		

THE CHEMICAL, PHYSICAL, OR MECHANICAL TESTS REPORTED ABOVE ACCURATELY REFLECT INFORMATION AS CONTAINED IN THE RECORDS OF THE CORPORATION.

144

Figure A-10. Post Standoffs (Test Nos. CP-1 through7), Gusset Plates (CP-3, 5, and 6), and Washer Plates (CP-3)



1700 HOLT RD N.E.  
Tuscaloosa, AL 35404-1000  
800-827-8872

Load Number	Tally	Mill Order Number	P.O. Number	Part Number	Certificate Number	Date														
386513	00000000410154	N-105963-007	4500156614		L325787-1	05/19/2013														
Grade				Customer:																
Order Description: A572/A709, 0.5000 IN x 96.000 IN x 240.000 IN				Sold TO: STEEL & PIPE SUPPLY CO., INC. MANHATTAN KS																
Quality Plan Description: A57250/A70950: ASTM A572-07 GR 50/A709-08 GR 50				Ship TO: Kansas City Warehouse New Century KS																
Shipped Item	Heat/Slab Number	Certified By	C	Mn	P	S	Si	Cu	Ni	Cr	Mo	Cb	V	Al	Ti	N2	B	Ca	S	
1E0881C	B1R6601-01 ***	B1R6601	0.06	1.18	0.007	0.005	0.06	0.27	0.08	0.06	0.019	0.000	0.047	0.033	0.001	0.009	0.0001	0.0029	0.00	
Shipped Item	Certified By	Heat Number	Yield ksi	Tensile ksi	Y/T %	ELONGATION %		Bend OK?	Hard HB	Charpy Impacts (ft-lbf)				Shear %						
						2"	8"			Size mm	1	2	3	Avg	1	2	3	Avg		
1E0881C	S1E0881FTT	B1R6601 ***	54.8	68.6	79.9	38.8														
1E0881C	S1E0881MTT	B1R6601 ***	65.6	74.8	87.7	31.5														

145

Items: 1 PCS: 8 Weight: 26137 LBS

Mercury has not come in contact with this product during the manufacturing process not has any mercury been used by the manufacturing process. Certified in accordance with EN 10204 3.1. No weld repair has been performed on this material. Manufactured to a fully killed fine grain practice. \*\* Produced from Coil \*\* ISO 9001:2008 Registered, PED Certified

We hereby certify that the product described above passed all of the tests by the specifications.

*April Pitts*  
April Pitts - QA Engineer

\*\*\* indicates Heats melted and Manufactured in the U.S.A.

Figure A-11. Top and Bottom Mounting Plates (Test Nos. CP-1 through 7) and Gusset Plates (CP-1, 2, 4, and 7)



Figure A-12. 1/2-in. Dia. Hardened Round Washer, Test Nos. CP-1 through 7



Figure A-13. 5/8-in. Dia. Hardened Round Washer, Test No. CP-1

PICK TICKET PRINT

NEBRASKA BCLN  
5501 N. 57TH STREET  
LINCOLN, NEBRASKA 68503-3154  
402-466-8488

NO. 508474  
PAGE 1  
05/31/11

Ship-to: STENP  
MIDWEST ROAD SIDE SAFETY  
LINCOLN, NE 68508

Bill-to: 420701  
UNIVERSITY OF NE/LINCOLN  
401 ADMINISTRATION BLDG  
LINCOLN, NE 68508

IST P.C. #	ORDERED	REQUESTED	ISLSP	TERMS	LN	IFREIGHT	SHIP VIA
N	05/31/11	05/31/11	LN2	112	10	NET 30	100 (PREPAID)
SM	DESCRIPTION	ORDERED	SHIP	EACH	WT	WEIGHT	LG
81102EA	11-1/8-7 A563 DH HVY HX NUT H. D.GALV Lot# 1001-190874-001-01-1 Available: 80	4	0	0	2.1	0.084	011
872ATRZ	11-1/8-7X3 ALL THRD ROD Z1 Lot# 1012-143239-001-01-1	9	0	0	100	0.000	011
81102EA	11-1/8 002-3/4X3 USS FL W/ 1EA	2	0	0	13	0.010	011

Figure A-14. 1 1/8-in. Dia. UNC Threaded Rod and Washer, Test Nos. CP-2 and 7

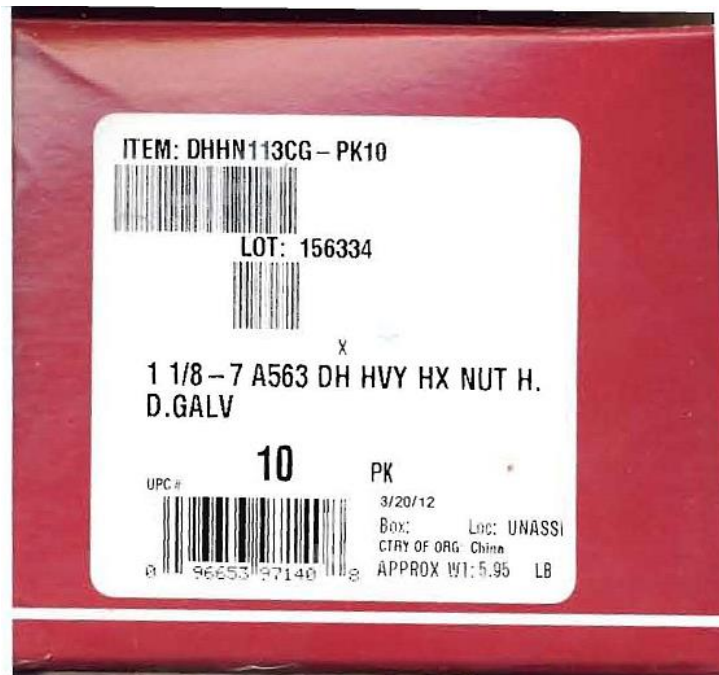

Figure A-15. 1 1/8-in. Dia. UNC Heavy Hex Nut, Test Nos. CP-2 and 7

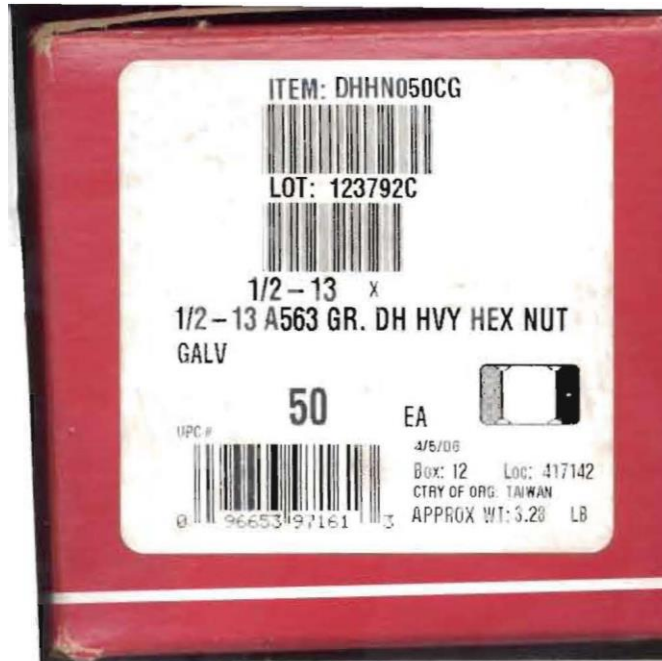

Figure A-16. 1/2-in. Dia. UNC Heavy Hex Nut, Test Nos. CP-1 through 7

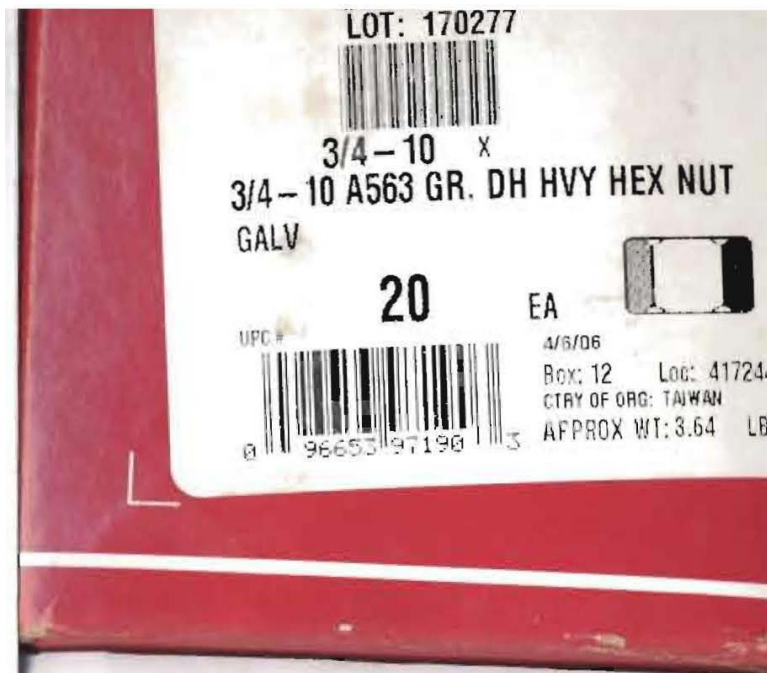

Figure A-17. 3/4-in. Dia. UNC Heavy Hex Nut, Test Nos. CP-3 through 6



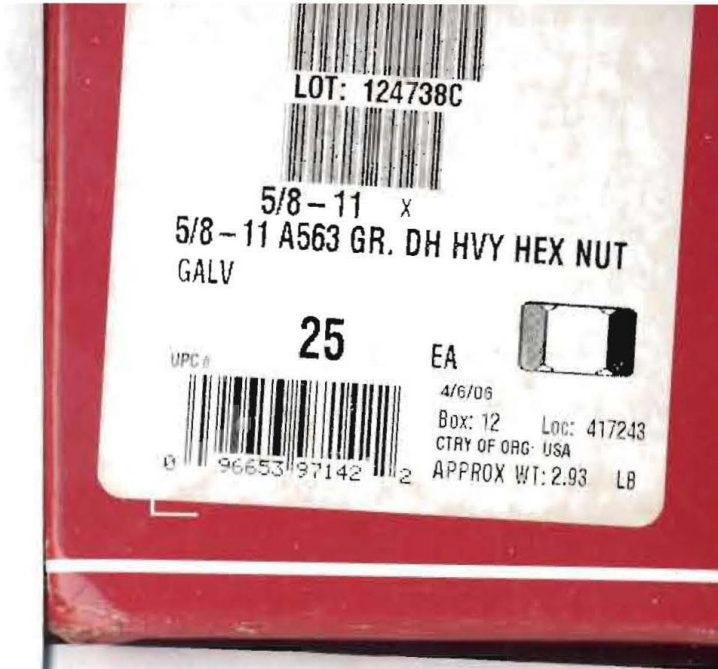

Figure A-18. 5/8-in. Dia. UNC Heavy Hex Nut, Test No. CP-1



Figure A-19. 5/8-in. 11x5 A325 Heavy Hex Bolt with Nut, Test Nos. CP-1 through 7



**W.W. Grainger, Inc.**  
100 Grainger Parkway  
Lake Forest, IL. 60045-5201

August 03 2012

**Attn:** KEN KRENK  
UNIVERSITY HEALTH CENTER  
1500 U STREET  
LINCOLN, NE, 68503-0000

**Fax #**

**Grainger Sales Order #:** 1157926749  
**Customer PO #:** 045545430

Dear KEN KRENK  
As you requested, we are providing you with the following information. We certify that, to the best of Grainger's actual knowledge, the products described below conform to the respective manufacturer's specifications as described and approved by the manufacturer.

Item #	Description	Vendor Part #	Catalog Page #
4FGL2	Threaded Rod,Gr 2,Zinc,3/4-10x3Ft,RH,UNC	4FGL2	3060
4FGH8	Threaded Rod,Gr 2,Zinc,1/2-13x2Ft,RH,UNC	4FGH8	3060
1RU96	Structural Bolt,5/8-11,5 L,Pk 10	1RU96	2915
1AY84	Hex Nut,Heavy,3/4-10,1 1/8 In,PK20	1AY84	2931
1AY95	Hex Nut,1 1/8-7,1 13/16 In,PK 10	1AY95	2931
6PE84	Flat Washer,Ylw Zinc,Fits 1/2 In,Pk 25	HU-0500USSHZYBAGGR	2957
6PE88	Flat Washer,Ylw Zinc,Fits 5/8 In,Pk 25	HU-0625USSHZYBAGGR	2957
6PE90	Flat Washer,Ylw Zinc,Fits 3/4 In,Pk 20	HU-0750USSHZYBAGGR	2957
4FGJ3	Threaded Rod,Gr 2,Zinc,3/4-10x2Ft,RH,UNC	4FGJ3	3060
1AY80	Hex Nut,Heavy,5/8-11,1 1/16In,PK25	1AY80	2931
1AY76	Hex Nut,Heavy,1/2-13,7/8 In,PK 50	1AY76	2931

If you need any additional information, please contact our Compliance Team at 847-647-4649 or [prod\\_mgmt\\_support@grainger.com](mailto:prod_mgmt_support@grainger.com).

**Gary Figiel**  
Engineering Technician  
Compliance Team  
Grainger Industrial Supply

Figure A-20. 1/2-in. Dia UNC Threaded Rod (Test Nos. CP-1 through 7), 5/8-in. Dia UNC Threaded Rod (CP-1), and 3/4-in. Dia UNC Threaded Rod (CP-3 through 6)





Figure A-21. 3/4-in. Dia. Hardened Round Washer, Test Nos.CP-4 through 6



CARTERSVILLE STEEL MILL  
 384 OLD GRASSDALE RD NE  
 CARTERSVILLE GA 30121 USA  
 (770) 387-3300

Chemical and Physical Test Report  
 Made and Melted In USA

G-164172

<b>SHIP TO</b> STEEL AND PIPE SUPPLY CO INC 401 NEW CENTURY PARKWAY 785-587-5185 NEW CENTURY, KS 66031	<b>INVOICE TO</b> STEEL AND PIPE SUPPLY CO. INC. PO BOX 1688  MANHATTAN, KS 66505-1688	<b>SHIP DATE</b> 11/15/10  <b>CUST. ACCOUNT NO</b> 40130833
--	--	---

**PRODUCED IN: CARTERSVILLE**

SHAPE + SIZE	GRADE		SPECIFICATION														SALES ORDER		CUST P.O. NUMBER						
WB X 18#	A57250/992		ASTM A572 GR50-07, ASTM A992 -06A, ASTM A709 GR50-09A														0125902-01		4500149794-01						
HEAT I.D.	C	Mn	P	S	SI	Cu	Ni	Cr	Mo	V	Nb	B	N	Sn	Al	Ti	Ca	Zn	C Eqv						
G106480	.18	1.00	.010	.014	.21	.28	.10	.05	.025	.017	.002	.0003	.0090	.010	.003	.00200	.00330	.00560	.42						

Mechanical Test: Yield 55200 PSI, 380.59 MPA Tensile: 76600 PSI, 528.14 MPA %El: 26.2/8in, 26.2/200MM  
 Customer Requirements CASTING: STRAND CAST  
 Comment: NO WELD REPAIRMENT PERFORMED. STEEL NOT EXPOSED TO MERCURY.  
 Mechanical Test: Yield 54000 PSI, 372.32 MPA Tensile: 76300 PSI, 526.07 MPA %El: 20.9/8in, 20.9/200MM  
 Customer Requirements CASTING: STRAND CAST  
 Comment: NO WELD REPAIRMENT PERFORMED. STEEL NOT EXPOSED TO MERCURY.

**PRODUCED IN: CARTERSVILLE**

SHAPE + SIZE	GRADE		SPECIFICATION														SALES ORDER		CUST P.O. NUMBER						
W3 X 5.7# S-BEAM	A57250/992		ASTM A572 GR50-07, ASTM A992 -06A, ASTM A709 GR50-09A														0124791-02		4500149612-02						
HEAT I.D.	C	Mn	P	S	SI	Cu	Ni	Cr	Mo	V	Nb	B	N	Sn	Al	Ti	Ca	Zn	C Eqv						
G106936	.14	.90	.013	.028	.20	.33	.10	.05	.023	.016	.000	.0003	.0107	.013	.001	.00100	.00000	.00380	.37						

Mechanical Test: Yield 54100 PSI, 373.01 MPA Tensile: 75700 PSI, 521.93 MPA %El: 22.3/8in, 22.3/200MM  
 Customer Requirements CASTING: STRAND CAST  
 Comment: NO WELD REPAIRMENT PERFORMED. STEEL NOT EXPOSED TO MERCURY.  
 Mechanical Test: Yield 54500 PSI, 375.76 MPA Tensile: 74800 PSI, 515.73 MPA %El: 21.2/8in, 21.2/200MM  
 Customer Requirements CASTING: STRAND CAST  
 Comment: NO WELD REPAIRMENT PERFORMED. STEEL NOT EXPOSED TO MERCURY.

**Customer Notes**

NO WELD REPAIRMENT PERFORMED. STEEL NOT EXPOSED TO MERCURY.  
 All manufacturing processes including melt and cast, occurred in USA. MTR complies with EN10204 3.1B

*Bhaskar Yalamanchili*  
 Bhaskar Yalamanchili  
 Quality Director  
 Gerdau Ameristeel

THE ABOVE FIGURES ARE CERTIFIED EXTRACTS FROM THE ORIGINAL CHEMICAL AND PHYSICAL TEST RECORDS AS CONTAINED IN THE PERMANENT RECORDS OF COMPANY.

*Zhang*  
 Metallurgical Services Manager  
 CARTERSVILLE STEEL MILL

Seller warrants that all material furnished shall comply with specifications subject to standard published manufacturing variations. NO OTHER WARRANTIES, EXPRESSED OR IMPLIED, ARE MADE BY THE SELLER, AND SPECIFICALLY EXCLUDED ARE WARRANTIES OF MERCHANTABILITY AND FITNESS FOR A PARTICULAR PURPOSE. In no event shall seller be liable for indirect, consequential or punitive damages arising out of or related to the materials furnished by seller. Any claim for damages for materials that do not conform to specifications must be made from buyer to seller immediately after delivery of same in order to allow the seller the opportunity to inspect the material in question.

152

Figure A-22. S3x5.7 Steel Post, Test Nos. CP-1 through 4

48 hr Glass - 4-30-2011

Chemical and Physical Test Report  
Made and Melted In USA

G-163740

<b>SHIP TO</b> SIOUX CITY FOUNDRY INC 801 DIVISION STREET 800-831-0874 SIOUX CITY, IA 51102	<b>INVOICE TO</b> SIOUX CITY FOUNDRY INC ACCTS PAYABLE PO BOX 3067 SIOUX CITY, IA 51102	<b>SHIP DATE</b> 11/08/10  <b>CUST. ACCOUNT NO</b> 60044062
---	---	---

**PRODUCED IN: CARTERSVILLE**

SHAPE + SIZE	GRADE	SPECIFICATION																	SALES ORDER	CUST P.O. NUMBER							
W3 X 5.7# S-BEAM	A57250/992	ASTM A572 GR50-07, ASTM A992 -06A, ASTM A709 GR50-09A																	0123380-05	129309W-05							
HEAT I.D.	C	Mn	P	S	Si	Cu	Ni	Cr	Mo	V	Nb	B	N	Sn	Al	Ti	Ca	Zn	C Eqv								
G104598	14	.91	.012	.020	.22	.30	.09	.05	.022	.016	.002	.0003	.0100	.010	.002	.00100	.00030	.00710	.374								

Mechanical Test: Yield 53300 PSI, 367.49 MPA Tensile: 74200 PSI, 511.59 MPA %El: 19.2/8in, 19.2/200MM

Customer Requirements CASTING: STRAND CAST

Comment NO WELD REPAIRMENT PERFORMED. STEEL NOT EXPOSED TO MERCURY.

Mechanical Test: Yield 53900 PSI, 371.63 MPA Tensile: 73300 PSI, 505.39 MPA %El: 20.0/8in, 20.0/200MM

Customer Requirements CASTING: STRAND CAST

Comment NO WELD REPAIRMENT PERFORMED. STEEL NOT EXPOSED TO MERCURY.

**PRODUCED IN: CARTERSVILLE**

SHAPE + SIZE	GRADE	SPECIFICATION																	SALES ORDER	CUST P.O. NUMBER							
W3 X 5.7# S-BEAM	A57250/992	ASTM A572 GR50-07, ASTM A992 -06A, ASTM A709 GR50-09A																	0123380-05	129309W-05							
HEAT I.D.	C	Mn	P	S	Si	Cu	Ni	Cr	Mo	V	Nb	B	N	Sn	Al	Ti	Ca	Zn	C Eqv								
G104599	14	.92	.014	.023	.22	.28	.09	.05	.025	.016	.002	.0003	.0095	.010	.002	.00100	.00050	.00740	.373								

Mechanical Test: Yield 54800 PSI, 377.83 MPA Tensile: 74700 PSI, 515.04 MPA %El: 19.5/8in, 19.5/200MM

Customer Requirements CASTING: STRAND CAST

Comment NO WELD REPAIRMENT PERFORMED. STEEL NOT EXPOSED TO MERCURY.

Mechanical Test: Yield 53800 PSI, 370.94 MPA Tensile: 73700 PSI, 508.14 MPA %El: 21.3/8in, 21.3/200MM

Customer Requirements CASTING: STRAND CAST

Comment NO WELD REPAIRMENT PERFORMED. STEEL NOT EXPOSED TO MERCURY.

**Customer Notes**

NO WELD REPAIRMENT PERFORMED. STEEL NOT EXPOSED TO MERCURY.

All manufacturing processes including melt and cast, occurred in USA. MTR complies with EN10204 3.1B

THE ABOVE FIGURES ARE CERTIFIED EXTRACTS FROM THE ORIGINAL CHEMICAL AND PHYSICAL TEST RECORDS AS CONTAINED IN THE PERMANENT RECORDS OF COMPANY.

*Bhaskar*

Bhaskar Yalamanchili  
Quality Director  
Gerdau Ameristeel

*Zhang*

Metallurgical Services Manager  
CARTERSVILLE STEEL MILL

Seller warrants that all material furnished shall comply with specifications subject to standard published manufacturing variations. NO OTHER WARRANTIES, EXPRESSED OR IMPLIED, ARE MADE BY THE SELLER, AND SPECIFICALLY EXCLUDED ARE WARRANTIES OF MERCHANTABILITY AND FITNESS FOR A PARTICULAR PURPOSE.

In no event shall seller be liable for indirect, consequential or punitive damages arising out of or related to the materials furnished by seller.

Any claim for damages for materials that do not conform to specifications must be made from buyer to seller immediately after delivery of same in order to allow the seller the opportunity to inspect the material in question

Figure A-23. S3x5.7 Steel Post, Test Nos. CP-5 through 7

153

## **Appendix B. Bogie Test Results**

The results of the recorded data from each accelerometer for every dynamic bogie test are provided in the summary sheets found in this appendix. Summary sheets include acceleration, velocity, and deflection vs. time plots as well as force vs. deflection and energy vs. deflection plots.

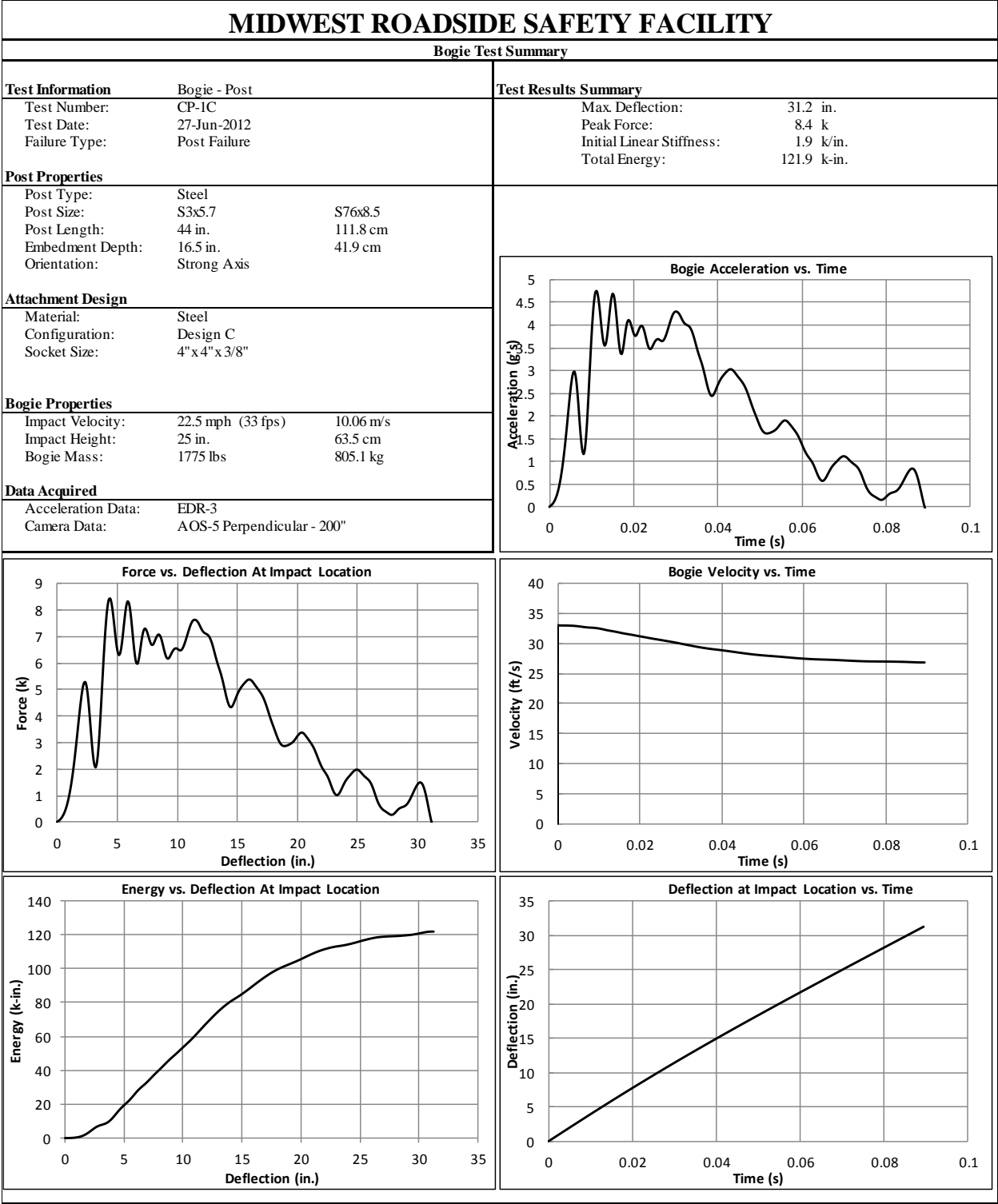

Figure B-1. Test No. CP-1C Results (EDR-3)



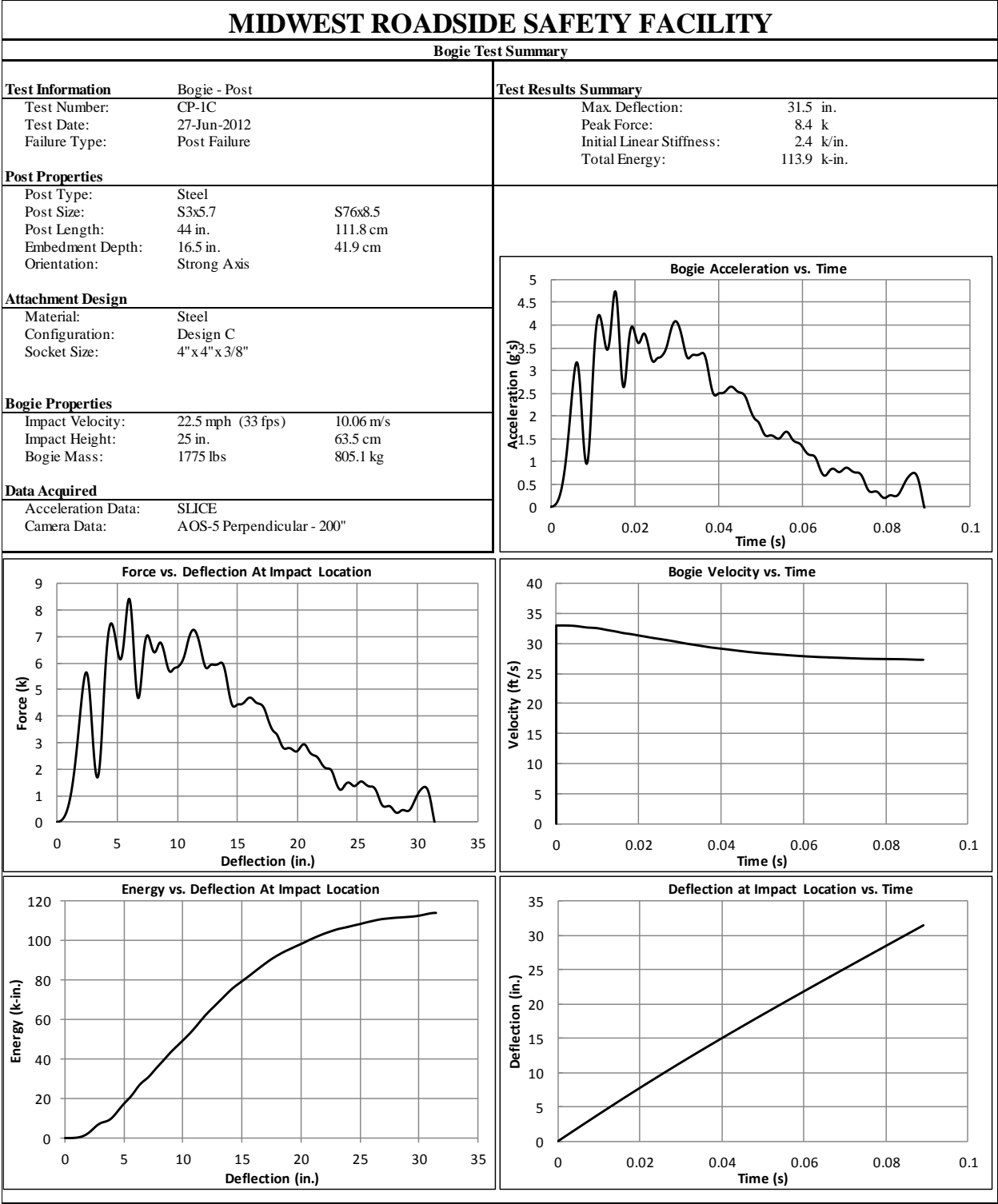

Figure B-2. Test No. CP-1C Results (SLICE)

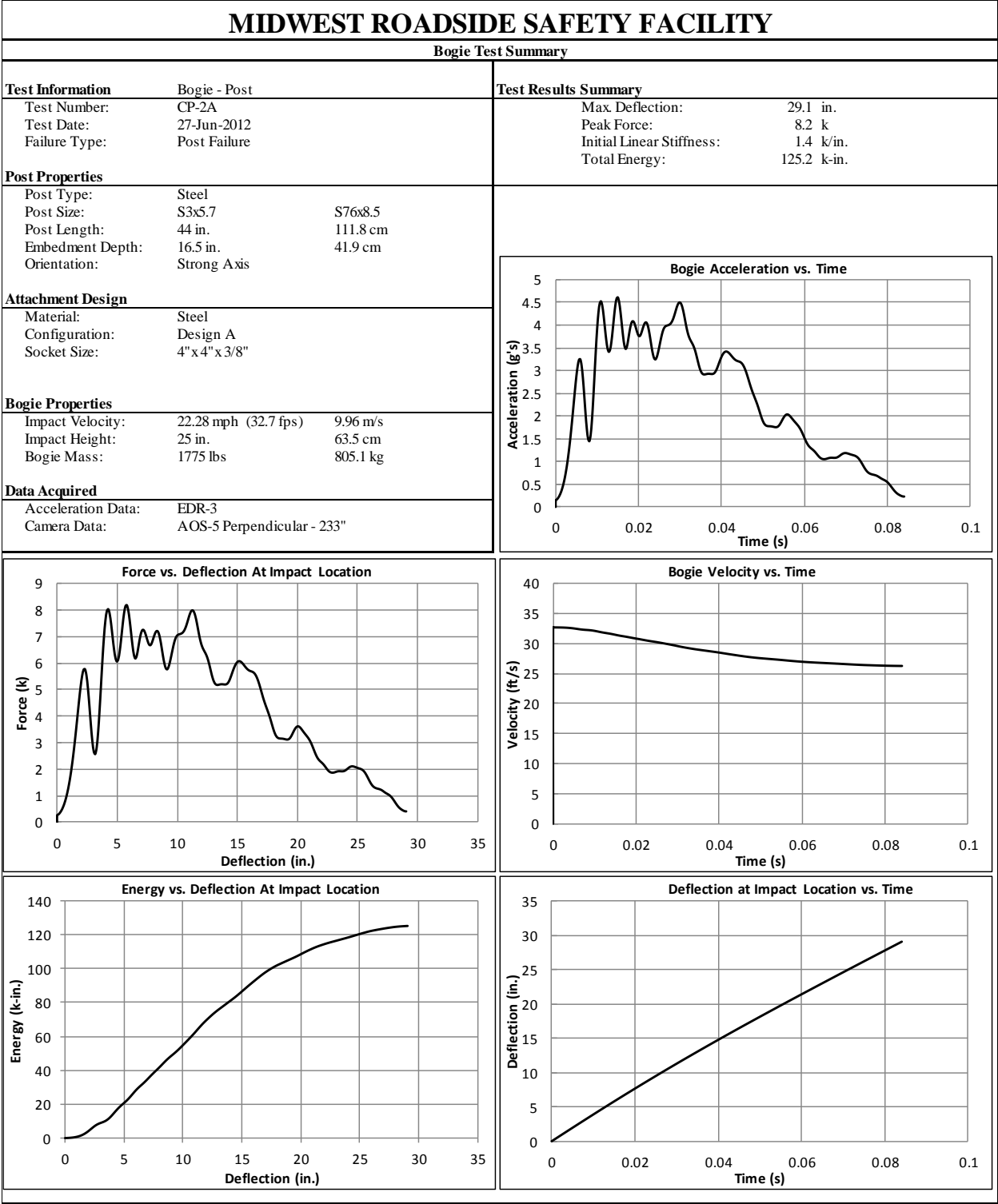

Figure B-3. Test No. CP-2A Results (EDR-3)

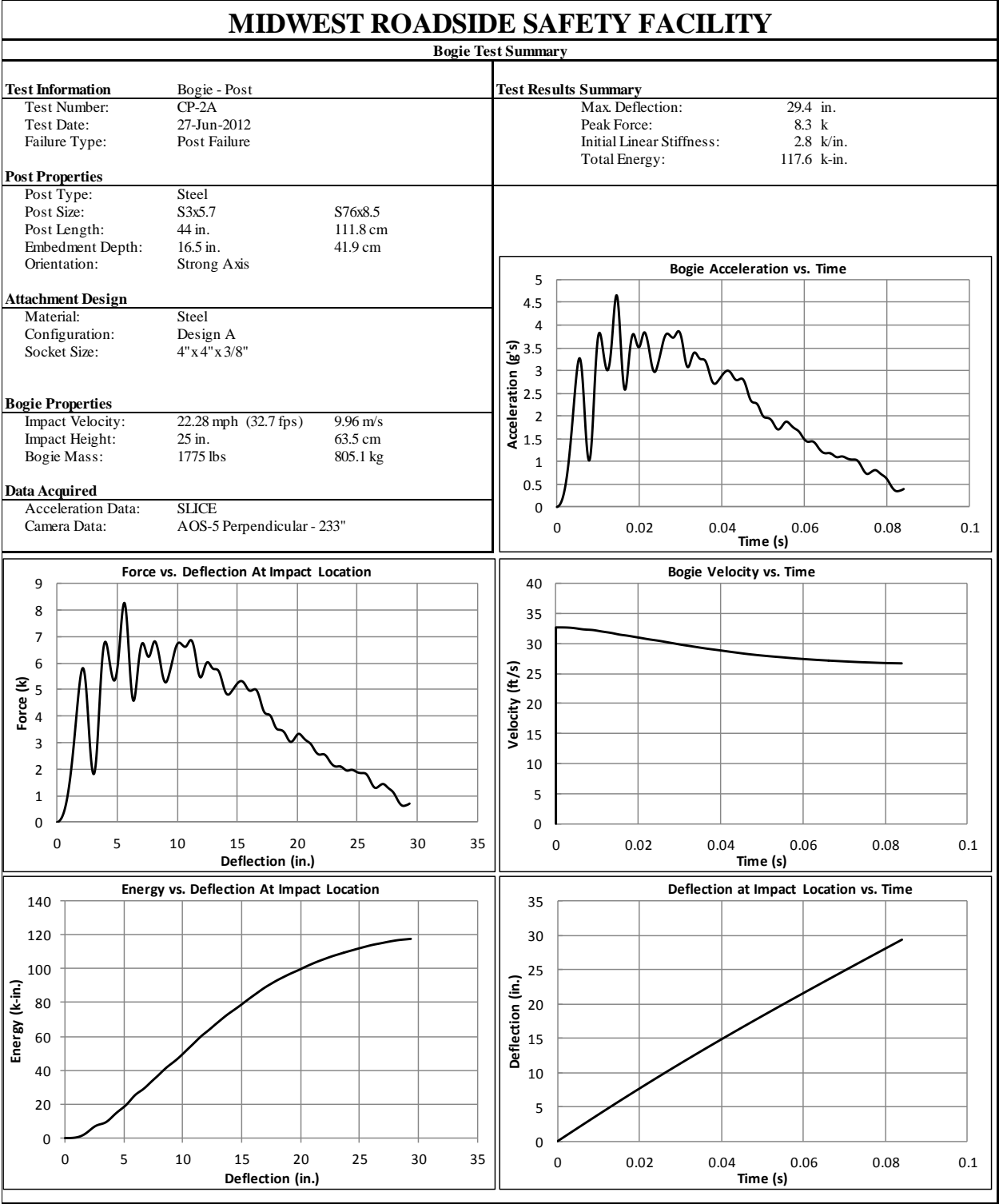

Figure B-4. Test No. CP-2A Results (SLICE)

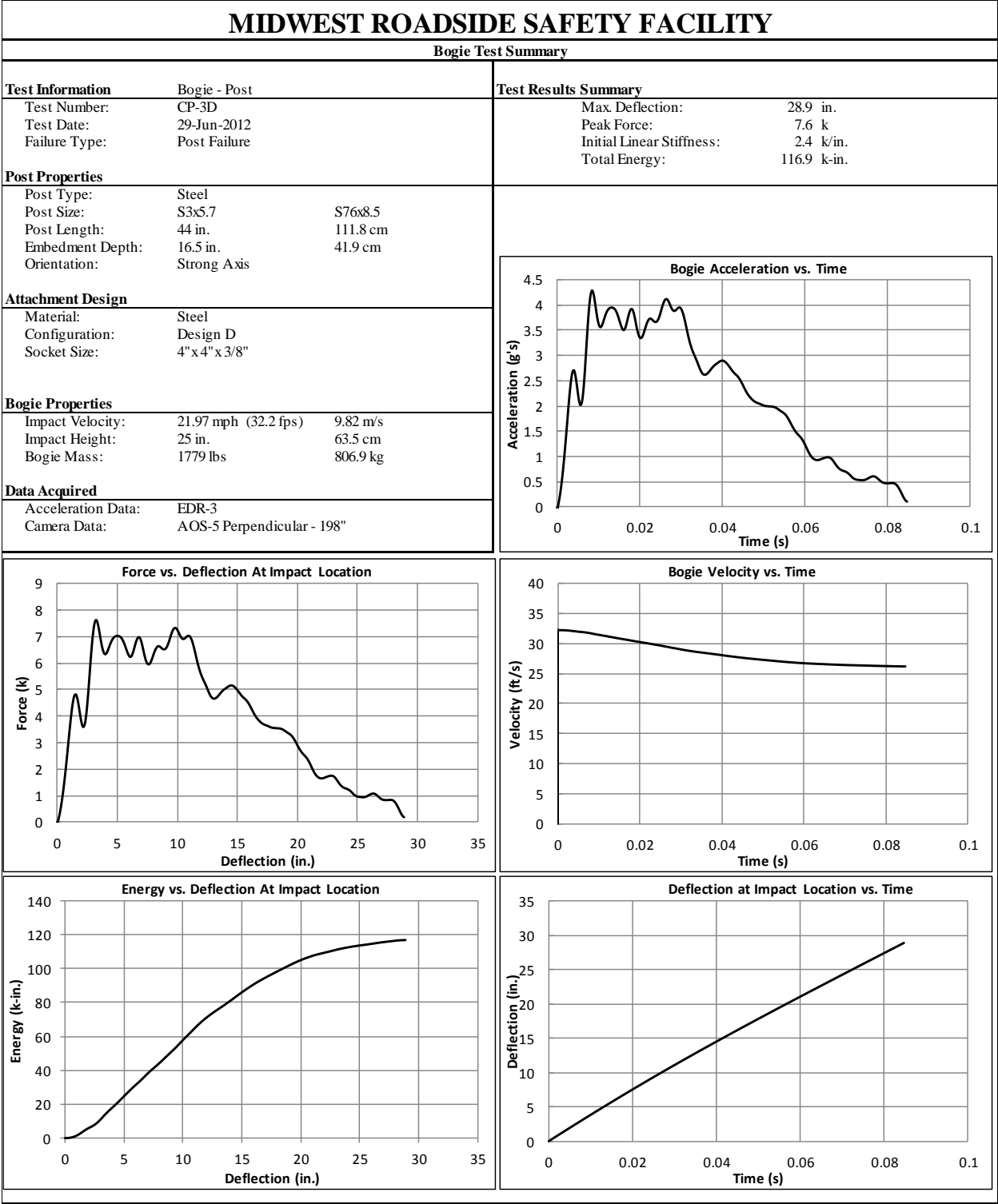

Figure B-5. Test No. CP-3D Results (EDR-3)

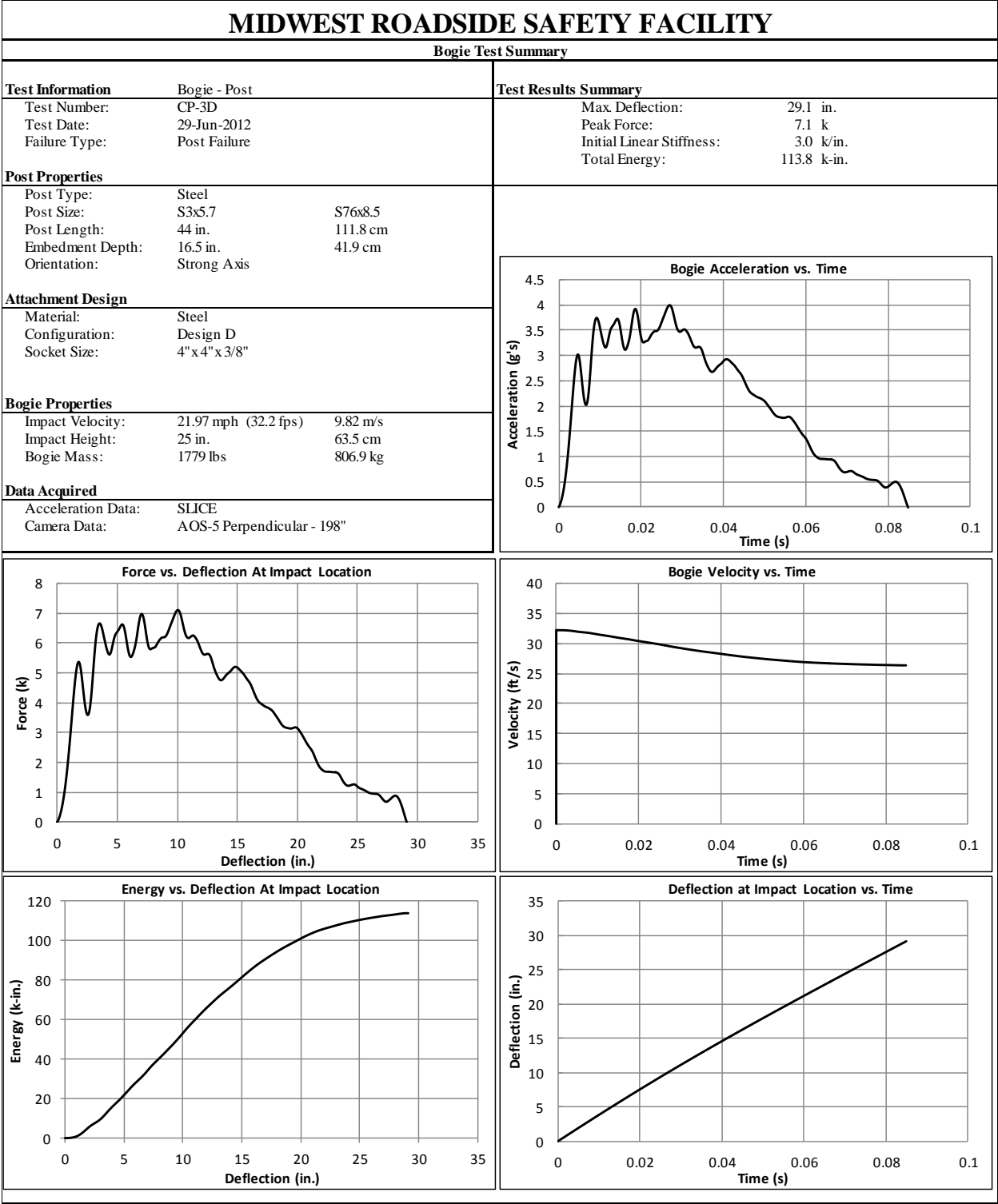

Figure B-6. Test No. CP-3D Results (SLICE)

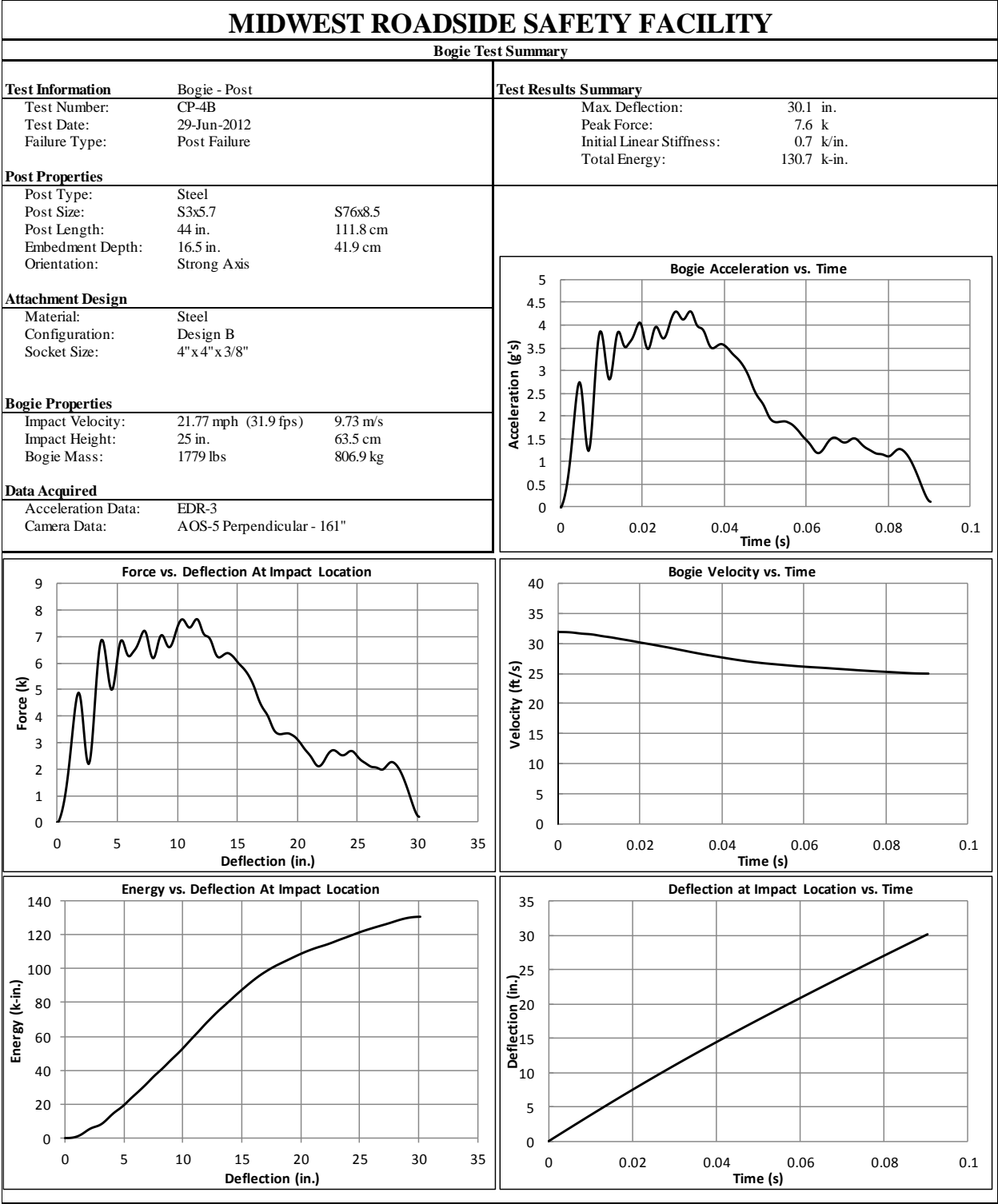

Figure B-7. Test No. CP-4B Results (EDR-3)



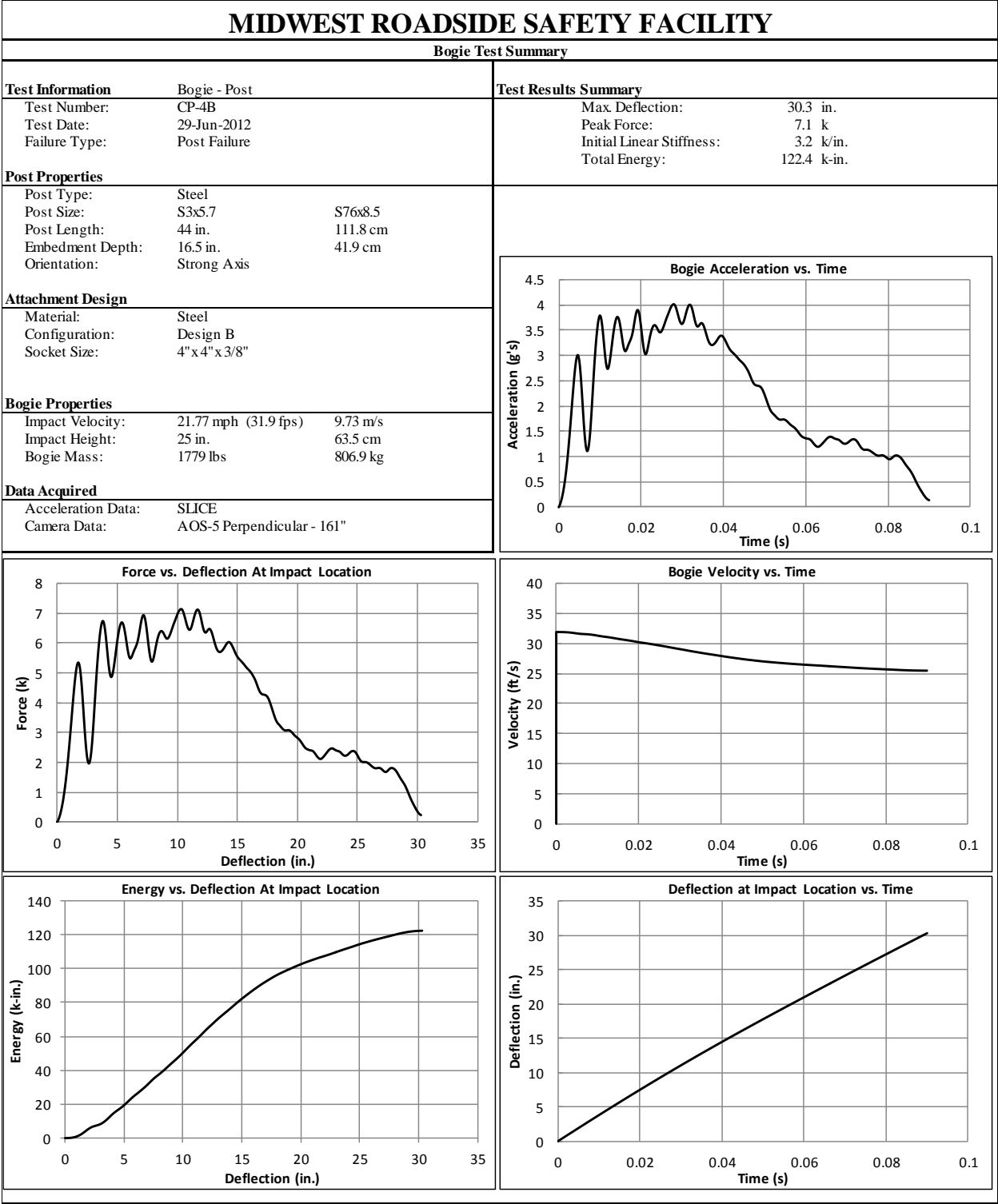

Figure B-8. Test No. CP-4B Results (SLICE)

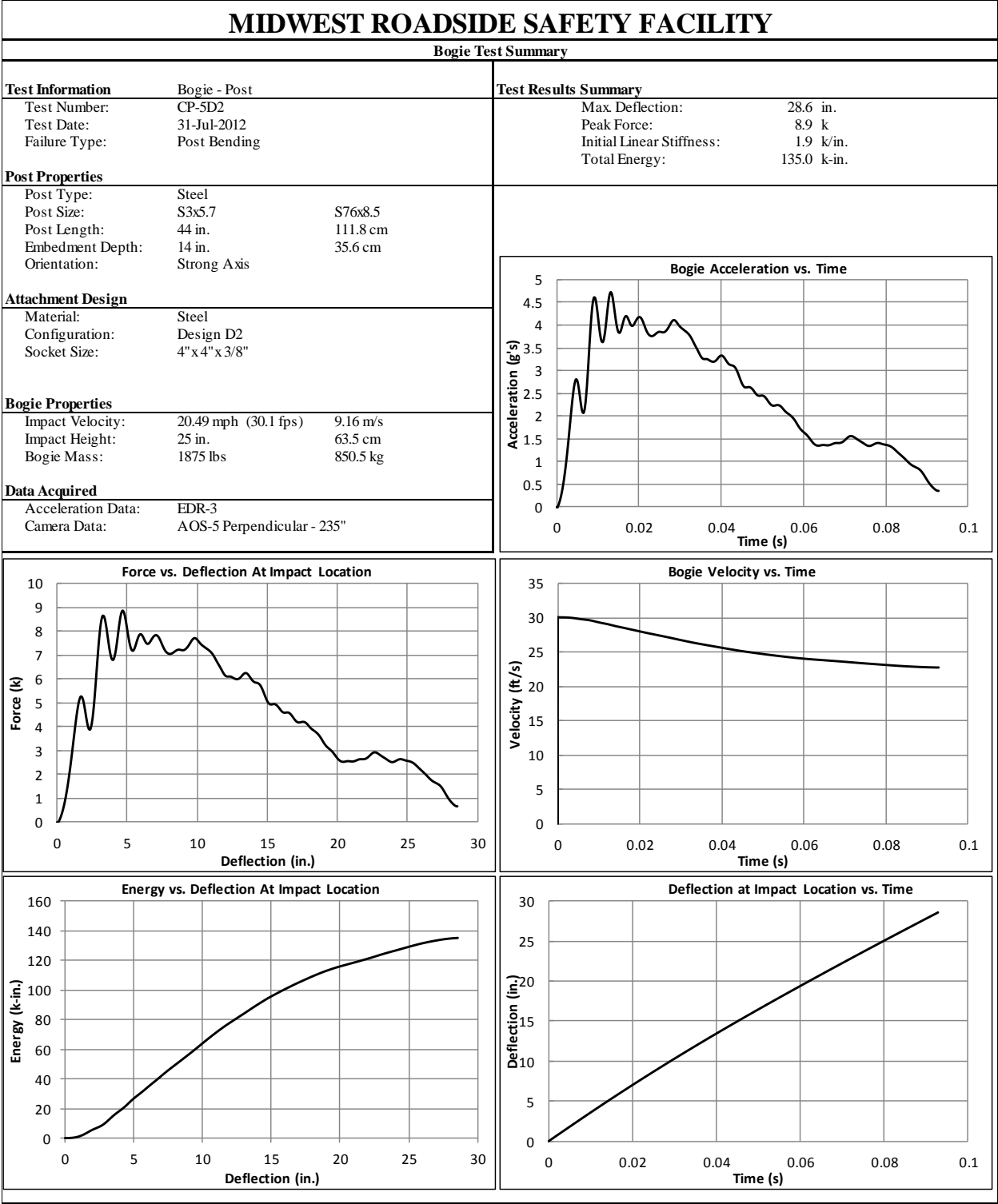

Figure B-9. Test No. CP-5D2 Results (EDR-3)

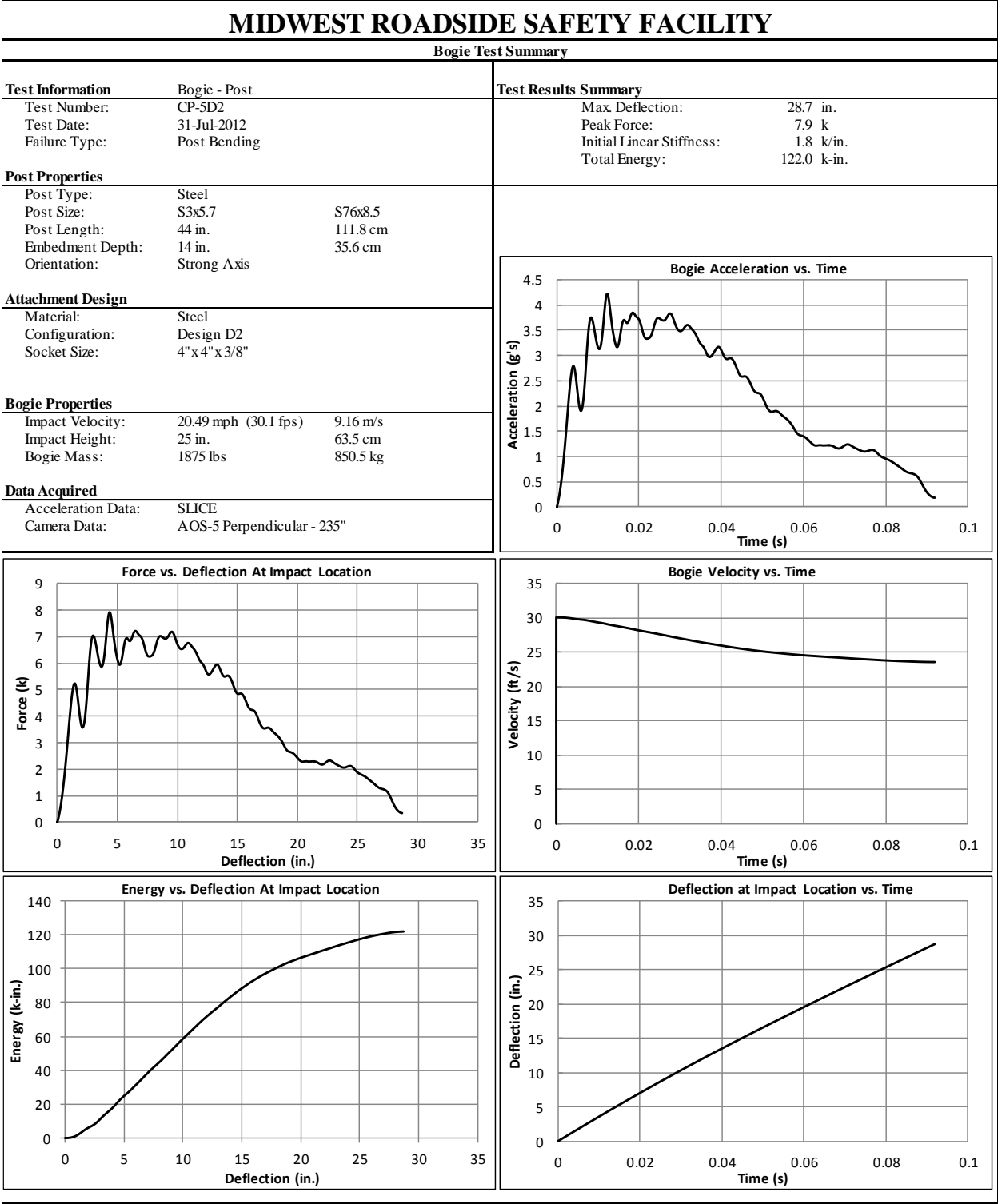

Figure B-10. Test No. CP-5D2 Results (SLICE)

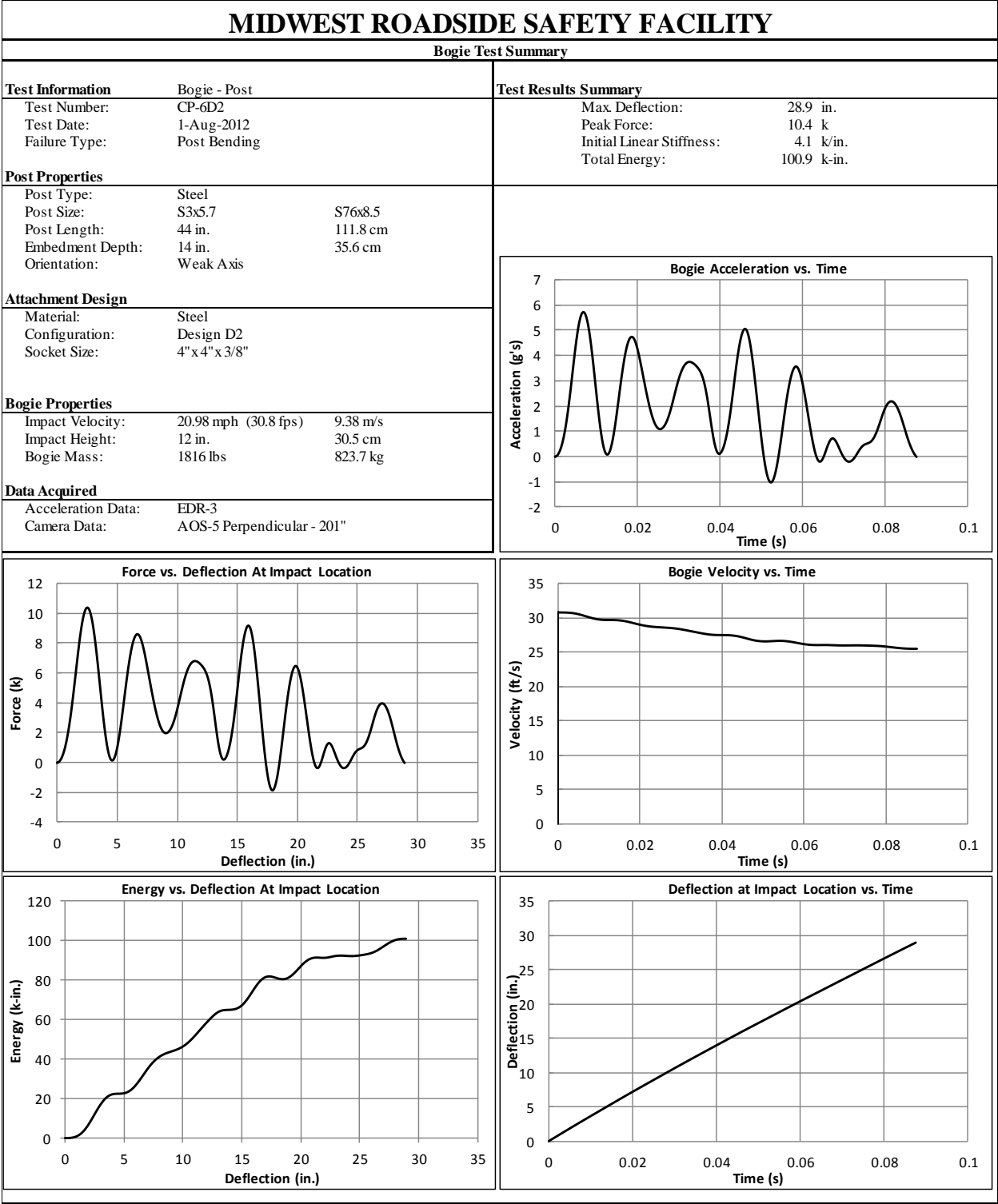

Figure B-11. Test No. CP-6D2 Results (EDR-3)

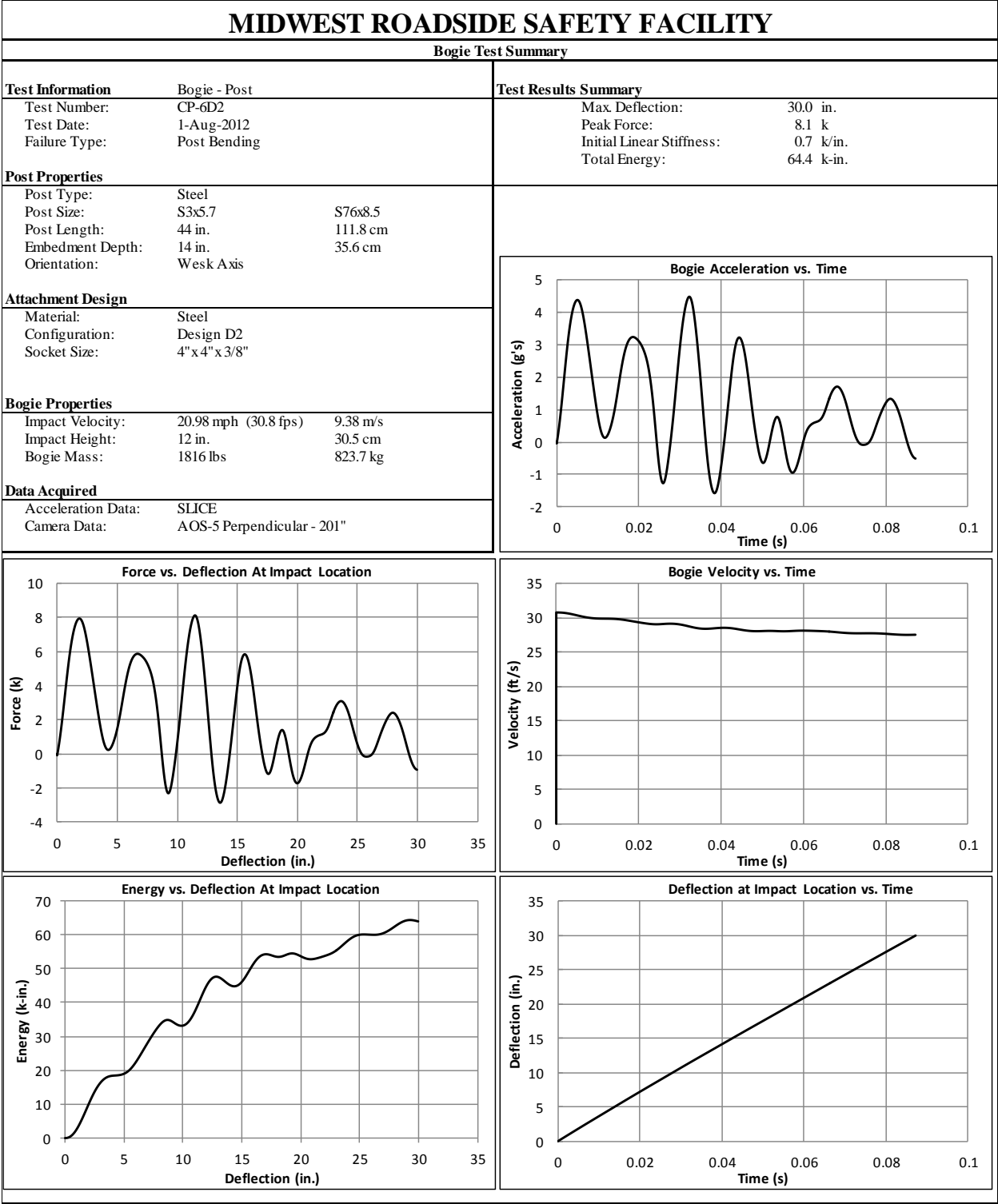

Figure B-12. Test No. CP-6D2 Results (SLICE)

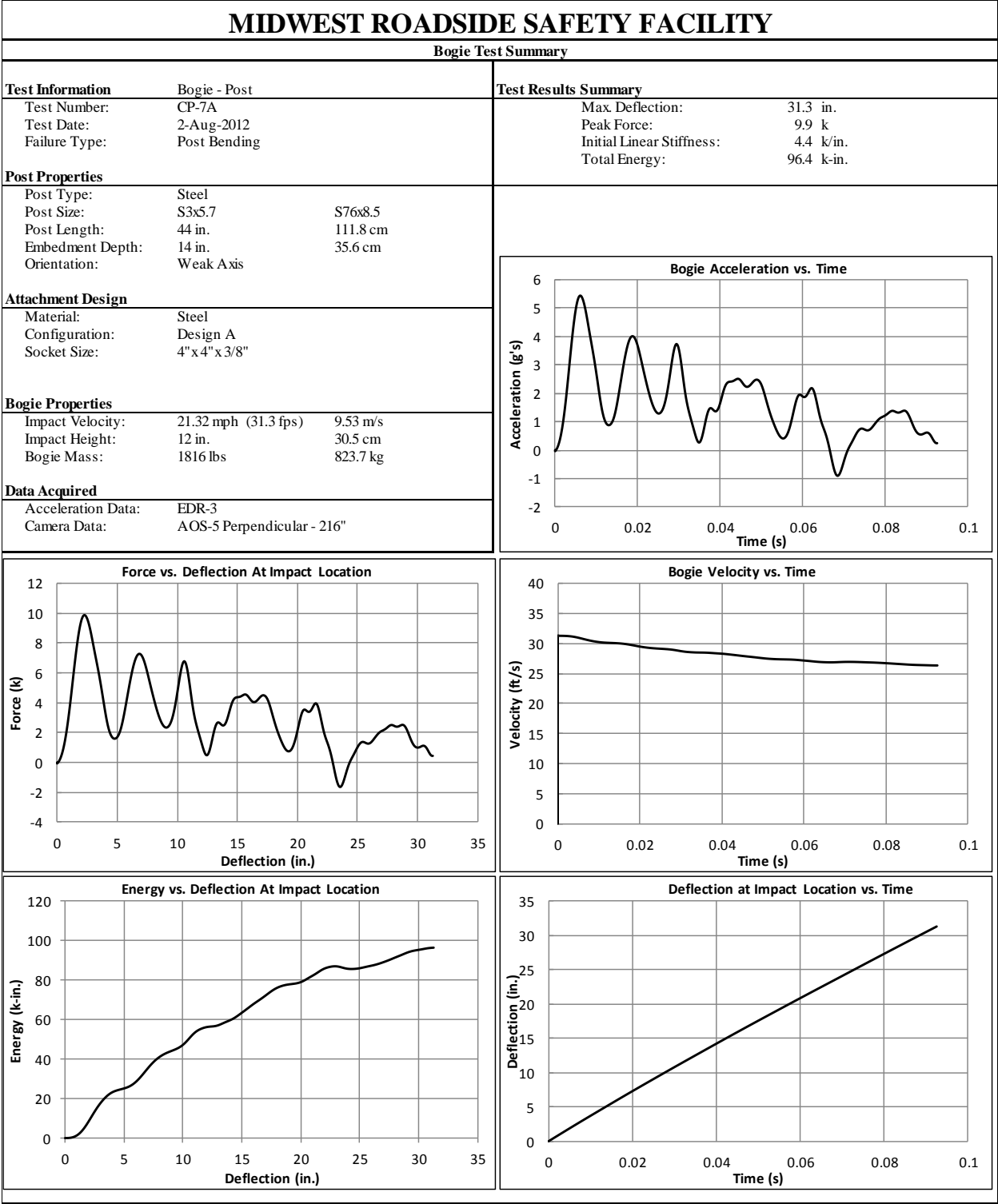

Figure B-13. Test No. CP-7A Results (EDR-3)



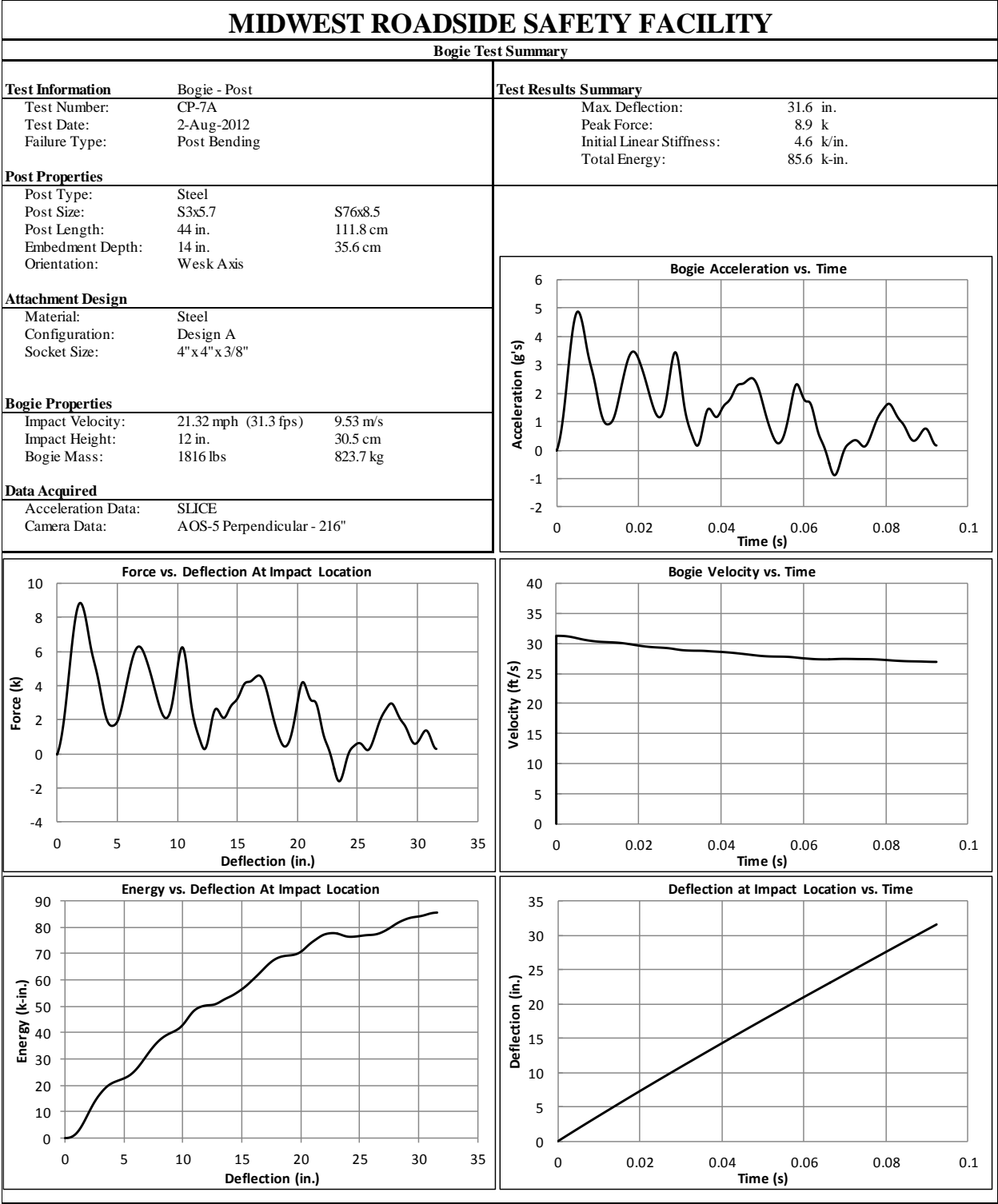

Figure B-14. Test No. CP-7A Results (SLICE)

**END OF DOCUMENT**