

# Performance Analysis of Centerline and Shoulder Rumble Strips Installed in Combination in Washington State

WA-RD 799.1

Dave Olson  
Mark Sujka  
Brad Manchias

April 2013





**RESEARCH REPORT**

WA-RD 799.1

**PERFORMANCE ANALYSIS OF CENTERLINE AND SHOULDER RUMBLE STRIPS  
INSTALLED IN COMBINATION IN WASHINGTON STATE**

by

Dave Olson

Design Policy, Standards, and Research Manager

360-705-7952

[olsonda@wsdot.wa.gov](mailto:olsonda@wsdot.wa.gov)

Mark Sujka

Safety Research Analyst

360-705-7239

[sujkam@wsdot.wa.gov](mailto:sujkam@wsdot.wa.gov)

Brad Manchab

Design Research Analyst

360-704-6309

[manchab@wsdot.wa.gov](mailto:manchab@wsdot.wa.gov)

Washington State Department of Transportation

Environmental and Engineering Programs

Development Division, Design Office

Design Policy Research

MS 47329 – PO Box 47329

310 Maple Park Ave SE

Olympia, WA 98504

February 2013

1. REPORT NO.  WA-RD 799.1	2. GOVERNMENT ACCESSION NO.	3. RECIPIENT'S CATALOG NO.	
4. TITLE AND SUBTITLE Performance Analysis of Centerline and Shoulder Rumble Strips Installed in Combination in Washington State		5. REPORT DATE April 2013	
7. AUTHOR(S) Washington State Department of Transportation Design Policy Research Mark Sujka, Brad Manchas, Research Analysts Dave Olson, Manager		6. PERFORMING ORGANIZATION CODE	
9. PERFORMING ORGANIZATION NAME AND ADDRESS Washington State Department of Transportation (WSDOT) Design Policy Research MS 47329 Olympia, WA 98504		8. PERFORMING ORGANIZATION REPORT NO.	
		10. WORK UNIT NO.	
		11. CONTRACT OR GRANT NO.	
		13. TYPE OF REPORT AND PERIOD COVERED Technical Report	
		14. SPONSORING AGENCY CODE	
15. SUPPLEMENTARY NOTES			
16. ABSTRACT WSDOT began installing rumble strips on undivided highways in 1999 as a countermeasure for roadway departure crashes. Installations on the shoulders were intended to reduce run-off-the-road crashes, while centerline rumble strips targeted reductions in cross-centerline crashes. A March 2011 report detailed the performance of centerline rumble strips on Washington State highways. This study: <ul style="list-style-type: none"> <li>• Examines the combined effects of centerline and shoulder rumble strips.</li> <li>• Details the performance of rumble strips on undivided highways in Washington State under a variety of conditions.</li> <li>• Explores various traffic volumes, geometric conditions, lane and shoulder widths, and driver contributing circumstances.</li> <li>• Compares various installation scenarios with shoulder and centerline rumble strip installation at different times, as well as simultaneous installation.</li> </ul>			
17. KEY WORDS WSDOT, rumble strips, shoulder rumble strips, centerline rumble strips, crash rate, lane departure, run-off-the-road collision, crossover crash, contributing circumstances		18. DISTRIBUTION STATEMENT No restrictions. This document is available to the public through the National Technical Information Service, Springfield, VA 22616	
19. SECURITY CLASSIF. (of this report)  None	20. SECURITY CLASSIF. (of this page)  None	21. NO. OF PAGES  104 pages	22. PRICE

## DISCLAIMER

The contents of this report reflect the views of the authors, who are responsible for the facts and the accuracy of the data presented herein. The contents do not necessarily reflect the official views or policies of the Washington State Transportation Commission, the Washington State Department of Transportation (WSDOT), or the Federal Highway Administration (FHWA). This report does not constitute a standard, specification, or regulation.

UNDER 23 UNITED STATES CODE (USC), SECTION 409, THESE DATA CANNOT BE USED IN DISCOVERY OR AS EVIDENCE AT TRIAL IN ANY ACTION FOR DAMAGES AGAINST WSDOT OR ANY JURISDICTIONS INVOLVED IN THE DATA.

Federal law 23 USC 409 governs the use of these data. Under this law, data maintained for purposes of evaluating potential highway safety enhancements:

*".....shall not be subject to discovery or admitted into evidence in a federal or state court proceeding or considered for other purposes in any action for damages arising from any occurrence at a location mentioned or addressed in such reports, surveys, schedules, lists, or data."* [Emphasis added.]

# CONTENTS

DISCLAIMER .....	ii
EXECUTIVE SUMMARY.....	1
SECTION 1: OBJECTIVE .....	5
Background .....	5
What are Rumble Strips and How Are They Used? .....	5
SECTION 2: METHODS .....	7
History.....	7
Analysis Scenarios.....	7
Study Location Data.....	8
Collision Data.....	9
Roadway Geometry .....	11
Crash Rates.....	13
SECTION 3: DATA ANALYSIS AND FINDINGS .....	14
SRS .....	14
CLRS&SRS .....	14
SRS+CLRS.....	15
CLRS+SRS.....	15
Composite.....	16
SECTION 4: SRS.....	17
SECTION 5: CLRS&SRS.....	18
CLRS&SRS: Contributing Category .....	18
CLRS&SRS: Posted Speed .....	23
CLRS&SRS: Lane Width .....	26
CLRS&SRS: SRS Recovery Width .....	29
CLRS&SRS: AADT.....	31
CLRS&SRS: Horizontal Alignment .....	34
CLRS&SRS: Percent/Length Curve .....	39
CLRS&SRS Summary.....	43
SECTION 6: SRS+CLRS .....	45
SRS+CLRS: Contributing Category.....	45
SRS+CLRS: Posted Speed.....	47
SRS+CLRS: Lane Width .....	48

SRS+CLRS: SRS Recovery Width.....	49
SRS+ CLRS: AADT .....	50
SRS+CLRS: Horizontal Alignment .....	52
SRS+CLRS: Percent/Length Curve .....	53
SRS+CLRS Summary .....	55
SECTION 7: CLRS+SRS .....	57
CLRS+SRS: Contributing Category.....	57
CLRS+SRS: Posted Speed .....	59
CLRS+SRS: Lane Width .....	60
CLRS+SRS: SRS Recovery Width.....	62
CLRS+SRS: AADT .....	63
CLRS+SRS: Horizontal Alignment .....	64
CLRS+SRS: Percent/Length Curve .....	66
CLRS+SRS Summary .....	67
SECTION 8: COMPOSITE.....	69
Composite: Contributing Category.....	70
Composite: Posted Speed .....	72
Composite: Lane Width .....	74
Composite: SRS Recovery Width .....	75
Composite: AADT.....	76
Composite: Horizontal Alignment .....	79
Composite: Percent/Length Curve .....	81
Composite Summary.....	83
SECTION 9: CONCLUSIONS.....	84
GLOSSARY .....	87
BIBLIOGRAPHY.....	90
APPENDIX A: LIST OF STUDY SEGMENTS .....	92
APPENDIX B: MAP OF STUDY SITES .....	95
APPENDIX C: CONTRIBUTING CATEGORY TRANSLATION TABLE.....	96
APPENDIX D: ALL EXPOSURE VARIABLES – PERCENT CHANGE IN RATE.....	97
APPENDIX E: SHOULDER RUMBLE STRIP STANDARD PLAN .....	101
APPENDIX F: CENTERLINE RUMBLE STRIP STANDARD PLAN .....	103

## TABLES

Table 3.1	SRS Study .....	14
Table 3.2	CLRS&SRS Study .....	15
Table 3.3	SRS+CLRS Study .....	15
Table 3.4	CLRS+SRS Study .....	16
Table 3.5	Composite Study .....	16
Table 4.1	SRS: Overall Performance .....	17
Table 5.1	CLRS&SRS: Overall Performance .....	18
Table 5.2	CLRS&SRS: Lane Departure Rates by Contributing Category .....	19
Table 5.3	CLRS&SRS: Crossover Rates by Contributing Category .....	20
Table 5.4	CLRS&SRS: ROTRR Rates by Contributing Category .....	22
Table 5.5	CLRS&SRS: Lane Departure Rates by Posted Speed .....	24
Table 5.6	CLRS&SRS: Crossover Rates by Posted Speed .....	24
Table 5.7	CLRS&SRS: ROTRR Rates by Posted Speed .....	26
Table 5.8	CLRS&SRS: Lane Departure Rates by Lane Width .....	26
Table 5.9	CLRS&SRS: Crossover Rates by Lane Width .....	27
Table 5.10	CLRS&SRS: ROTRR Rates by Lane Width .....	28
Table 5.11	CLRS&SRS: Lane Departure Rates by SRS Recovery Width .....	30
Table 5.12	CLRS&SRS: ROTRR Rates by SRS Recovery Width .....	31
Table 5.13	CLRS&SRS: Lane Departure Rates by AADT .....	32
Table 5.14	CLRS&SRS: Crossover Rates by AADT .....	32
Table 5.15	CLRS&SRS: ROTRR Rates by AADT .....	33
Table 5.16	CLRS&SRS: Lane Departure Rates by Horizontal Alignment .....	35
Table 5.17	CLRS&SRS: Crossover Rates by Horizontal Alignment .....	37
Table 5.18	CLRS&SRS: ROTRR Rates by Horizontal Alignment .....	38
Table 5.19	CLRS&SRS: Lane Departure Rates by Percent/Length Curve .....	40
Table 5.20	CLRS&SRS: Crossover Rates by Percent/Length Curve .....	41
Table 5.21	CLRS&SRS: ROTRR Rates by Percent/Length Curve .....	42
Table 6.1	SRS+CLRS: Overall Performance .....	45
Table 6.2	SRS+CLRS: Lane Departure Rates by Contributing Category .....	46
Table 6.3	SRS+CLRS: Crossover Rates by Contributing Category .....	46
Table 6.4	SRS+CLRS: ROTRR Rates by Contributing Category .....	47
Table 6.5	SRS+CLRS: Lane Departure Rates by Posted Speed .....	47



Table 6.6	SRS+CLRS: Crossover Rates by Posted Speed .....	47
Table 6.7	SRS+CLRS: ROTRR Rates by Posted Speed.....	48
Table 6.8	SRS+CLRS: Lane Departure Rates by Lane Width.....	48
Table 6.9	SRS+CLRS: Crossover Rates by Lane Width .....	48
Table 6.10	SRS+CLRS: ROTRR Rates by Lane Width .....	49
Table 6.11	SRS+CLRS: Lane Departure Collision Rates by SRS Recovery Width .....	49
Table 6.12	SRS+CLRS: ROTRR Collision Rates by SRS Recovery Width.....	50
Table 6.13	SRS+CLRS: Lane Departure Rates by AADT.....	50
Table 6.14	SRS+CLRS: Crossover Rates by AADT .....	51
Table 6.15	SRS+CLRS: ROTRR Rates by AADT .....	51
Table 6.16	SRS+CLRS: Lane Departure Rates by Horizontal Alignment .....	52
Table 6.17	SRS+CLRS: Crossover Rates by Horizontal Alignment .....	52
Table 6.18	SRS+CLRS: ROTRR Rates by Horizontal Alignment.....	53
Table 6.19	SRS+CLRS: Lane Departure Rates by Percent/Length Curve .....	53
Table 6.20	SRS+CLRS: Crossover Rates by Percent/Length Curve .....	54
Table 6.21	SRS+CLRS: ROTRR Rates by Percent/Length Curve .....	55
Table 7.1	CLRS+SRS: Overall Performance .....	57
Table 7.2	CLRS+SRS: Lane Departure Rates by Contributing Category.....	57
Table 7.3	CLRS+SRS: Crossover Rates by Contributing Category.....	58
Table 7.4	CLRS+SRS: ROTRR Rates by Contributing Category.....	58
Table 7.5	CLRS+SRS: Lane Departure Rates by Posted Speed .....	59
Table 7.6	CLRS+SRS: Crossover Rates by Posted Speed .....	59
Table 7.7	CLRS+SRS: ROTRR Rates by Posted Speed.....	60
Table 7.8	CLRS+SRS: Lane Departure Rates by Lane Width.....	60
Table 7.9	CLRS+SRS: Crossover Rates by Lane Width .....	61
Table 7.10	CLRS+SRS: ROTRR Rates by Lane Width .....	61
Table 7.11	CLRS+SRS: Lane Departure Rates by SRS Recovery Width .....	62
Table 7.12	CLRS+SRS: ROTRR Rates by SRS Recovery Width.....	62
Table 7.13	CLRS+SRS: Lane Departure Rates by AADT.....	63
Table 7.14	CLRS+SRS: Crossover Rates by AADT .....	63
Table 7.15	CLRS+SRS: ROTRR Rates by AADT .....	64
Table 7.16	CLRS+SRS: Lane Departure Rates by Horizontal Alignment .....	65
Table 7.17	CLRS+SRS: Crossover Rates by Horizontal Alignment .....	65

Table 7.18	CLRS+SRS: ROTRR Rates by Horizontal Alignment.....	65
Table 7.19	CLRS+SRS: Lane Departure Rates by Percent/Length Curve .....	66
Table 7.20	CLRS+SRS: Crossover Rates by Percent/Length Curve .....	66
Table 7.21	CLRS+SRS: ROTRR Rates by Percent/Length Curve .....	67
Table 8.1	Composite: Overall Performance.....	69
Table 8.2	Composite: Lane Departure Rates by Contributing Category .....	70
Table 8.3	Composite: Crossover Rates by Contributing Category .....	70
Table 8.4	Composite: ROTRR Rates by Contributing Category.....	71
Table 8.5	Composite: Lane Departure Rates by Posted Speed.....	72
Table 8.6	Composite: Crossover Rates by Posted Speed .....	73
Table 8.7	Composite: ROTRR Rates by Posted Speed .....	73
Table 8.8	Composite: Lane Departure Rates by Lane Width.....	74
Table 8.9	Composite: Crossover Rates by Lane Width.....	74
Table 8.10	Composite: ROTRR Rates by Lane Width .....	74
Table 8.11	Composite: Lane Departure Rates by SRS Recovery Width .....	75
Table 8.12	Composite: ROTRR Rates by SRS Recovery Width .....	76
Table 8.13	Composite: Lane Departure Rates by AADT .....	77
Table 8.14	Composite: Crossover Rates by AADT.....	78
Table 8.15	Composite: ROTRR Rates by AADT.....	79
Table 8.16	Composite: Lane Departure Rates by Horizontal Alignment.....	80
Table 8.17	Composite: Crossover Rates by Horizontal Alignment .....	80
Table 8.18	Composite: ROTRR Rates by Horizontal Alignment .....	81
Table 8.19	Composite: Lane Departure Rates by Percent/Length Curve.....	81
Table 8.20	Composite: Crossover Rates by Percent/Length Curve .....	82
Table 8.21	Composite: ROTRR Rates by Percent/Length Curve .....	82

## FIGURES

Figure 5.1	CLRS&SRS: Lane Departure Rates by Contributing Category – All Injury Severities .....	19
Figure 5.2	CLRS&SRS: Crossover Rates by Contributing Category – All Injury Severities.....	21
Figure 5.3	CLRS&SRS: ROTRR Rates by Contributing Category – All Injury Severities.....	22
Figure 5.4	CLRS&SRS: Crossover Rates by Posted Speed – All Injury Severities.....	25
Figure 5.5	CLRS&SRS: Crossover Rates by Posted Speed – Fatal & Serious Injury.....	25
Figure 5.6	CLRS&SRS: Lane Departure Rates by Lane Width – Fatal & Serious Injury .....	27
Figure 5.7	CLRS&SRS: Crossover Rates by Lane Width – Fatal & Serious Injury.....	28
Figure 5.8	CLRS&SRS: ROTRR Rates by Lane Width – All Injury Severities .....	29
Figure 5.9	CLRS&SRS: Lane Departure Rates by SRS Recovery Width – All Injury Severities .....	30
Figure 5.10	CLRS&SRS: ROTRR Rates by SRS Recovery Width – All Injury Severities.....	31
Figure 5.11	CLRS&SRS: Crossover Rates by AADT – All Injury Severities .....	33
Figure 5.12	CLRS&SRS: ROTRR Rates by AADT – All injury Severities .....	34
Figure 5.13	Inside vs. Outside Curve Crash Illustration.....	35
Figure 5.14	CLRS&SRS: Lane Departure Rates by Horizontal Alignment – All Injury Severities .....	36
Figure 5.15	CLRS&SRS: Lane Departure Rates by Horizontal Alignment – Fatal & Serious Injury.....	36
Figure 5.16	CLRS&SRS: Crossover Rates by Horizontal Alignment – All Injury Severities .....	37
Figure 5.17	CLRS&SRS: Crossover Rates by Horizontal Alignment – Fatal & Serious Injury.....	38
Figure 5.18	CLRS&SRS: ROTRR Rates by Horizontal Alignment – All Injury Severities.....	38
Figure 5.19	CLRS&SRS: ROTRR Rates by Horizontal Alignment – Fatal & Serious Injury .....	39
Figure 5.20	CLRS&SRS: Lane Departure Rates by Percent/Length Curve – All Injury Severities .....	40
Figure 5.21	CLRS&SRS: Crossover Rates by Percent/Length Curve – All Injury Severities .....	41
Figure 5.22	CLRS&SRS: Crossover Rates by Percent/Length Curve – Fatal & Serious Injury.....	42
Figure 5.23	CLRS&SRS: ROTRR Rates by Percent/Length Curve – All Injury Severities.....	43
Figure 5.24	CLRS&SRS: ROTRR Rates by Percent/Length Curve – Fatal & Serious Injury.....	43
Figure 6.1	SRS+CLRS: Crossover Rates by Percent/Length Curve – All Injury Severities.....	54
Figure 6.2	SRS+CLRS: ROTRR Rates by Percent/Length Curve – All Injury Severities.....	55
Figure 8.1	Composite: Crossover Rates by Contributing Category – All Injury Severities.....	71
Figure 8.2	Composite: ROTRR Rates by Contributing Category – All Injury Severities.....	72
Figure 8.3	Composite: ROTRR Rates by SRS Recovery Width – All Injury Severities.....	76
Figure 8.4	Composite: Lane Departure Rates by AADT – All Injury Severities.....	77
Figure 8.5	Composite: Crossover Rates by AADT – All Injury Severities .....	78
Figure 8.6	Composite: ROTRR Rates by AADT – All Injury Severities .....	79

## EXECUTIVE SUMMARY

In March 2011, the Washington State Department of Transportation's (WSDOT's) Design Policy Research Office published the report "Performance Analysis of Centerline Rumble Strips in Washington State." The [2011 CLRS Report](#) stated the authors' intentions to follow up the centerline rumble strip study with a report focused on shoulder rumble strip performance on Washington State highways. As the researchers set out to conduct the shoulder rumble strip study, they recognized that there were fewer than 20 miles of highway where only shoulder rumble strips were installed. Most of Washington's undivided highways with shoulder rumble strips also had centerline rumble strips installed. Consequently, this research shifted to focus on the combined performance of shoulder and centerline rumble strips. The timing of these installations resulted in simultaneous installations: centerline rumble strip installations followed by shoulder rumble strip installations, and shoulder rumble strip installations followed by centerline rumble strip installations. Each of these scenarios was analyzed individually to evaluate performance differences. The studies in this report evaluated crash history before and after rumble strips were installed.

The research team identified locations and installation dates where shoulder rumble strips (SRS) had been installed on the state highway system. For each of these locations, they also determined whether centerline rumble strips (CLRS) had been installed, and how the timing of those installations compared with the SRS installation. The installations were then grouped into studies that evaluated the performance of different installation scenarios. Crash history was compiled and evaluated for installations that had at least one full year of collision history available *prior to* rumble strip installation and at least one full year of collision history *following* rumble strip installation. Locations that did not meet the minimum crash history requirements were excluded. Installations where SRS and CLRS were installed at the same time were compared with existing installations of SRS where CLRS were added at a later date and existing installations of CLRS where SRS were added at a later date. In addition to these scenarios, the researchers reviewed phased installations where the two types of rumble strips were installed at different times, to determine whether sufficient crash experience existed to allow a performance comparison of no rumble strips versus both SRS and CLRS. Locations that met minimum crash data requirements of at least one year with no rumble strips and one year with both SRS and CLRS were aggregated with simultaneous installations of SRS and CLRS, resulting in a larger dataset for analysis.

The researchers explored the influences of driver contributing circumstances, posted speed, lane width, shoulder recovery width, annual average daily traffic, and roadway geometry. The influence of these factors was evaluated for cross-centerline crashes, run-off-the-road-to-the-right (ROTRR) crashes, and jointly as lane departure crashes.

The above study parameters and conditions resulted in the data being reported in the following five specific analyses:

**SRS: Locations where only SRS were installed.**

Shoulder rumble strip performance on the two-lane rural highway system was the original focus of this study. While a considerable number of miles of SRS have been installed, most of the exposure has since had CLRS added to the segments, leaving little mileage of solely SRS available for analysis. The SRS dataset has the least amount of miles of exposure (18.74 miles), the lowest vehicle miles traveled (VMT), and the fewest number of collision events. There were only 5 crashes available prior to SRS installation and 12 after.

For those SRS segments examined, a 12.3% increase in lane departure collisions was recorded for All Injury Severities events. For All Injury Severities collisions, increases of 5.3% in the rate of crossover collisions and 40.4% in ROTRR collisions were recorded. For Fatal and Serious Injury collisions, both crossover and ROTRR recorded a 100% increase in the rate of these collisions. The researchers believe this performance is not indicative of the actual performance seen in Washington State for SRS; rather, is a reflection of the limited data available.

**CLRS&SRS: Locations where CLR &SRS were installed at the same point in time.**

The expectation with CLRS&SRS was that both crossover and ROTRR lane departure collisions would be reduced. The CLRS&SRS segments span 77.44 miles with 312 lane departure events, of which 260 were in the before period and 52 were in the after period. The before period VMT reached 952.160 million miles and the after period VMT totaled 518.629 million miles.

For all lane departure crashes, there was a 63.3% reduction in collision rates and a 43.0% reduction in Fatal and Serious Injury collision rates. Crossovers were reduced by 65.4% for All Injury Severities, and Fatal and Serious Injury crash rates were reduced by 28.6%. The ROTRR crashes were reduced by 61.4% and the Fatal and Serious Injury ROTRR crashes were reduced by 66.6%. A more detailed review of the performance of the CLRS&SRS installations by specific geometric or roadway attributes is available in [Section 5](#) of this report. The data suggest that this pattern of installing both CLRS and SRS while following WSDOT's design limitations is a significantly effective and low-cost method of reducing lane departure crashes on two-lane rural highways.

**SRS+CLRS: Locations where SRS had been initially installed and CLRS were added at a later point in time.**

The data available for SRS+CLRS encompasses 38.93 miles, with 40 collisions in the before period and 39 collisions in the after period. The before period VMT was 242.675 million miles and the after period VMT totaled 426.911 million miles. These installations were expected to reduce the crossover collisions with the installation of CLRS, and the ROTRR experience was expected to remain roughly the same in both periods.

For all lane departures, the SRS+CLRS installations recorded a 44.6% reduction in the crash rate and a 24.2% reduction in the Fatal and Serious Injury collision rate. The crossover component saw a reduction of 64.7% for All Injury Severities and a 24.2% reduction in the Fatal and Serious Injury rate. The ROTRR collision rate increased slightly for All Injury Severities, with an 8.5% increase, while the Fatal and Serious Injury crash rate remained the same at 0.00, with no events in either period.

The SRS+CLRS detailed analysis is found in [Section 6](#). The addition of CLRS to the previously installed SRS performed as expected within this limited dataset. There was a marked reduction in cross-centerline collisions and little change to the ROTRR experience.

**CLRS+SRS: Locations where CLRS had initially been installed and SRS were added at a later point in time.**

The CLRS+SRS dataset consists of 40.77 miles for evaluation, with 42 collisions in the before period and 31 collisions in the after period. The before period VMT had 196.567 million miles and the after period VMT had 232.005 million miles. These installations were expected to reduce ROTRR collisions with little impact to the crossover collision experience.

Overall, the CLRS+SRS installations recorded a 37.5% reduction in all lane departure collisions and a 32.2% reduction in Fatal and Serious Injury collisions. The crossover experience saw a 6.8% reduction in All Injury Severities events and a 100% reduction in Fatal and Serious Injury collisions (a single event in the before period). The ROTRR collision rates were reduced by 47.0% for All Injury Severities collisions, with a 15.3% reduction in the Fatal and Serious Injury collision rate.

Within the limited data available, the expectation of decreased ROTRR collisions was realized with the addition of the SRS to the previous installation of CLRS. [Section 7](#) provides a detailed examination of the CLRS+SRS installations.

**Composite: Locations where there were no rumble strips in the before period and both CLRS and SRS in the after period.**

The Composite group consists of 135.88 miles for evaluation, with a before period VMT of 1,343.426 million miles and an after period VMT of 763.045 million miles. The collision events consist of 373 crashes in the before period and 72 crashes in the after period. The Composite group consists of data previously reviewed for the CLRS&SRS, SRS+CLRS, and CLRS+SRS installations. The data is organized to compare a before period where no rumble strips are installed to an after period where both CLRS and SRS are in place. The Composite view ignores crash experience for any time period where a single type of rumble strip (CLRS or SRS) is installed. This manner of analysis allowed the researchers to increase the size of the dataset for evaluation.

The overall performance of the Composite set revealed a 66% reduction in the rate of lane departure collisions and a 56% decrease in the rate of Fatal and Serious Injury collisions. The crossover experience saw a 71.0% reduction for All Injury Severities and a 57.5% reduction in rates of Fatal and Serious Injury collisions. The ROTRR experience also saw significant reductions in the rate of collisions: a 61.6% reduction for All Injury Severities and a 53.7% reduction in the Fatal and Serious Injury collision rate.

The Composite group analysis shows significant reductions in the rate of collisions in almost all cases and types of detailed views, as seen in [Section 8](#).

[Appendix A](#) is a list of the state route milepost beginning and ending points of each segment and the specific lane departure performance for the individual segment. [Appendix B](#) is a map of those same study locations.

Rumble strips of either CLRS or SRS are effective, low-cost tools in reducing the rate of lane departure collisions. This study validates that rumble strips are effective in reducing lane departure collisions when installed in accordance with WSDOT's design standards.

## SECTION 1: OBJECTIVE

### Background

In March 2011, the Washington State Department of Transportation's (WSDOT's) Design Policy Research Office published the report, "Performance Analysis of Centerline Rumble Strips in Washington State" (<http://www.wsdot.wa.gov/Research/Reports/700/768.1.htm>). This report focused on cross-centerline collisions and also examined the effects of run-off-the-road-to-the-right (ROTRR) collisions where centerline rumble strips (CLRS) had been installed. Centerline rumble strip installations were not expected to reduce these ROTRR events; however, there was a 6.9% reduction in crashes for All Injury Severities and a 19.5% reduction in Fatal & Serious Injury crashes. This information can be found in Table 5.7 of the 2011 CLRS Report.

The [2011 CLRS Report](#) stated the authors' intentions to follow up the centerline rumble strip study with a report focused on shoulder rumble strip performance on Washington State highways. The purpose of this report is to fulfill that intention. However, a number of factors led to a shift in the shoulder rumble strip study as compared to the 2011 CLRS Report. While the first installations of shoulder rumble strips on undivided highways date back to 1999, the crash data for earlier years is limited to electronic data only. Record retention schedules resulted in the destruction of the Police Traffic Collision Reports prior to 2002. The absence of those records precluded the possibility of a more in-depth review of those crashes, which is required in order to extract additional information about driver actions and the influence of rumble strips. For a similar level of crash data and subsequent analysis as that used in the 2011 CLRS Report, the crash data is limited to a time frame starting in January 1, 2002, which reflects the availability of Police Traffic Collision Reports.

An additional factor limiting the scope of a shoulder rumble strip performance study is the number of miles of shoulder rumble strips that are available for review. Although WSDOT has placed over 260 miles of shoulder rumble strips on Washington's undivided highway network, there are less than 20 miles of highway with only shoulder rumble strips installed. The rest of those highway miles also have centerline rumble strips installed. For this reason, much of this report focuses on the combined performance of centerline and shoulder rumble strips. With noted restrictions, the examination of shoulder rumble strip performance is very limited in scope and detail. As a result, the scope of this research was modified to include the combined performance of shoulder rumble strip and centerline rumble strip installations on the Washington State highway system.

### What Are Rumble Strips and How Are They Used?

Rumble strips are a pattern of depressions installed on the highway centerline or shoulder where an errant vehicle is expected to travel over them. Rumble strips are intended to alert drowsy or inattentive drivers that they have veered from their intended travel path. When a vehicle's tires roll over the depressions, rumble strips transmit noise and vibration through the vehicle, thereby alerting the driver that the vehicle is departing from the travel lane.



In Washington State, rumble strips are usually milled into the roadway surface. They are installed on the centerline, on the shoulder outside the edge stripe (fog line), or in both locations. The installation of centerline and/or shoulder rumble strips is dependent upon roadway geometrics, lane and shoulder widths, and rural versus urban locations, with particular consideration given to expected roadway users. Because they are designed to generate vibration through the vehicle, rumble strips impact the comfort and control of bicycles when traversed. Therefore, shoulder usage is a major factor in the consideration of shoulder rumble strips.

The major points of Washington State's design policy for the placement and installation of shoulder rumble strips are as follows:

- Use on rural roads only.
- Use where posted speed is 45 mph or higher.
- Provide for at least 4 feet of usable shoulder between the rumble strip and the outside edge of shoulder. If guardrail or barrier is present, increase the dimension to 5 feet of usable shoulder. Field verify these dimensions.
- Ensure shoulder pavement is structurally adequate to support milled rumble strips.
- Do not place shoulder rumble strips on downhill grades exceeding 4% for more than 500 feet in length along routes where bicyclists are frequently present.
- Consult the region and Headquarters Bicycle and Pedestrian Coordinators to determine bicycle usage along a route, and involve them in the decision-making process when considering rumble strips along bike touring routes or other routes where bicycle events are regularly held.

## SECTION 2: METHODS

### History

WSDOT first used rumble strips on the shoulders of the rural Interstate System to reduce run-off-the-road (ROTR) collisions. Those rumble strip installations provided significant reductions in ROTR collisions. Similar trends were reported in other states. Those successes led WSDOT to investigate the possibility that rumble strips installed on undivided highways may reduce ROTR and cross-centerline collisions. Ultimately, those investigations led to WSDOT's decisions to install shoulder rumble strips and/or centerline rumble strips on undivided highways.

Rumble strips generally target specific circumstances contributing to crashes involving cross-centerline and ROTRR events. Targeted contributing circumstances are primarily those where a driver is inattentive, distracted, fatigued, or asleep. It is in these specific circumstances that rumble strips are considered to be the most effective in reducing the severity and frequency of collisions.

WSDOT's first combined installation of centerline and shoulder rumble strips was completed in September 2000 on State Route (SR) 522 in Snohomish County near the City of Monroe. From September 2000 through mid-2011, WSDOT installed over 260 miles of both centerline and shoulder rumble strips on Washington highways.

These miles are a mix of new installations where both centerline and shoulder rumble strips were installed simultaneously, locations where shoulder rumble strips were added to a segment where centerline rumble strips had previously been installed, and locations where centerline rumble strips had previously been installed and shoulder rumble strips were added later. These various installation scenarios present challenges in a before and after study, as the *before* condition may reflect no rumble strips, only centerline rumble strips, or only shoulder rumble strips. In each of these three scenarios, the *after* period has similar treatment conditions. In some of the instances where shoulder rumble strips and centerline rumble strips were installed in different time periods, the researchers were able to review crash history at points in time where no rumble strips existed at those locations. In other instances, the time periods did not allow for evaluation of crash experience when there were no rumble strips.

### Analysis Scenarios

This report provides performance information for the following installation scenarios:

- **CLRS** (centerline rumble strips) – CLRS are not evaluated in this study, except as a before condition for their influence on lane departure crashes.
- **SRS** (shoulder rumble strips) – SRS are evaluated for their influence on run off the road crashes. There are no rumble strips in the before period. The after period has only SRS installed.
- **CLRS&SRS** – CLRS and SRS were installed at the same time. There are no rumble strips in the before period. The after period has both CLRS and SRS installed.

- **SRS+CLRS** – The before period has only SRS installed. CLRS were added later, resulting in both CLRS and SRS in the after period.
- **CLRS+SRS** – The before period has only CLRS installed. SRS were added later, resulting in both CLRS and SRS in the after period.
- **COMPOSITE** – This is similar to the CLRS&SRS analysis, as there are no rumble strips in the before period, and the after period has both CLRS and SRS installed. In addition to the CLRS&SRS mileage, this dataset includes another 58.44 miles representing some locations from the CLRS+SRS and SRS+CLRS datasets. The additional 58.44 miles represent locations where sufficient data is available to allow for analysis of a before period where no rumble strips existed. **Note:** The time period where only CLRS or only SRS existed is excluded from this analysis. This was done to provide a larger dataset than the CLRS&SRS study.

Within these groupings, it is possible that a particular segment may be evaluated in multiple portions of the study. For example, a SRS segment may offer a reasonable period in both the before and after period for an analysis, and also may have had CLRS installed at a later point to be reviewed as a SRS+CLRS segment. This same location may also provide an opportunity to analyze crash experience before any rumble strips were installed, and be part of the Composite dataset. In such a scenario, crashes that were analyzed in the after period for one analysis may be included in the before period for another analysis.

### **Study Location Data**

For this study, the WSDOT research team reviewed the Construction Contract Information System (CCIS) application to determine where rumble strips have been placed on Washington’s highways. The researchers determined which construction projects included bid items for shoulder rumble strips and centerline rumble strips. They then reviewed individual contract plans to determine milepost limits where the rumble strips were installed.

WSDOT’s SR-View tool (highway video log) was used as necessary to resolve questions arising from plan reviews and in collision-matching with rumble strip locations. This tool was also vital in identifying locations where rumble strips were discontinued, such as limited shoulder width on one side of the roadway that prevented shoulder rumble strips from being installed. In some cases, this resulted in a roadway segment being defined as a CLRS&SRS segment in a single direction of travel and a CLRS-only segment in the other travel direction. In these instances, the analysis was conducted as if it were a single travel direction; for example, the average annual daily traffic for vehicle miles traveled was halved to represent directional travel.

The CCIS application also provided contract progress dates that allowed the researchers to determine the before and after time periods for evaluation of each location where rumble strips were installed. The performance evaluation compared collision experience in the period before rumble strips were installed against the collision experience after rumble strips were installed. The project’s “work started” date was used as the closing date for the before evaluation period. The project’s “physically complete” date was used as the beginning date of the after evaluation period.

The researchers excluded collisions that occurred between those two dates to ensure traffic patterns influenced by construction activities did not skew the performance results. Locations that did not provide for at least one year of crash data in either the before or after period were not included in the analysis. The researchers conducted all analyses using whole years (365 days from installation date) of crash data; no partial years were included.

The research team assembled these data elements in a rumble strip locations list. The resultant list was used to determine which collisions to focus on during the evaluation. This list provided route milepost locations and dates to guide the team's review of the collision history for each highway segment analyzed in the study.

The mileage identified for all elements of the study was defined at 190.53 miles, which encompassed 45 segments covering all geographic areas of the state. The longest segment evaluated exceeded 18 miles in length and the shortest was 0.08 miles in length, with the average length just over 5 miles.

## **Collision Data**

The research team retrieved the collision data records from the Collision Branch of WSDOT's Statewide Travel and Collision Data Office (STCDO). The collision data used for the analysis covers the period from January 1, 2002, through December 31, 2010. Collisions in this dataset are those Police Traffic Collision Report records that are stored electronically and offer opportunities for a detailed review by analysts.

The 2002–2010 collision records retrieved from the STCDO are an electronic coded summary of the circumstances of each Police Traffic Collision Report completed by the investigating law enforcement officer. These records contain detailed information on the circumstances and conditions of the collision. Examples of the data fields collected are: weather conditions; roadway type or character; contributing circumstances; injuries; and collision location. In addition to these data fields, the Police Traffic Collision Report contains additional information primarily found in the narrative and collision diagram that is not available in the electronic coded summary of the collision records.

Collision records were filtered to exclude collisions that were not located within the limits of the segments defined for the study. This filtered set of collisions was further reduced to roadway departure collisions consisting of cross-centerline and ROTRR collisions. These are the types of collisions that are expected to be influenced by rumble strips.

Once the locations and the desired collision types were isolated, they were further scrutinized to *exclude* collisions that fit at least one of the following conditions or circumstances: intentional acts; medically caused; law enforcement activities; avoidance maneuvers; defective equipment; and intersection or driveway junction-related collisions. The specific conditions and circumstances were: passing another vehicle (passing defined as crossing the centerline to overtake); avoiding an object, animal, or another vehicle in the roadway; fleeing from law enforcement; a medical condition-caused collision; or operating defective equipment. In each of these situations, the installation of

rumble strips was not expected to influence the frequency or severity of those collision types. Junction-related collisions were also excluded from the dataset. These collisions are a result of a vehicle making a turning movement onto or from a state highway, a circumstance that rumble strips would not be expected to influence.

In each Police Traffic Collision Report, the information found in the investigating officer's narrative and scene drawing provided a significant amount of detail about the circumstances and location in which the collision took place. In order to collect and analyze this additional information, it was necessary for the researchers to review each report. During the course of this study, multiple reviewers examined approximately 8,000 collision reports. They did so by electronically retrieving the record and recording the additional information in the analysis. Although this required a large investment in time, it significantly enhanced the strength of the data and the resulting analysis. This effort yielded additional information in four primary areas (data elements): driver overcorrection, weather related, curve relationship, and/or additional impact location(s).

The researchers anticipated that a physical review of the Police Traffic Collision Reports would provide a means to evaluate whether rumble strips may have influenced driver overcorrection that contributed to lane departure crashes. In analyzing driver overcorrection, the research team looked for two general situations. Both situations involved vehicles departing from their lane of travel prior to overcorrecting back across the lane, which ultimately resulted in a collision on the opposite side of the lane from the original departure direction. One situation is an event where the driver first left the roadway to the right and then overcorrected back to the left, resulting in a collision across the centerline. The second situation is an event where the driver crossed the centerline and overcorrected back to the right, resulting in a collision off the roadway to the right.

The research team identified driver overcorrection collisions primarily from the collision diagram on the Police Traffic Collision Report. If the diagram illustrated a vehicle leaving its lane of travel as described for either of the overcorrection conditions, the record was coded with an overcorrection crash code. While this approach does provide some insight, those driver overcorrection collisions identified are not believed to represent the entirety of the overcorrection collisions. There are instances where the officer did not adequately describe the event or was not able to determine whether the vehicle left its lane of travel. Collisions identified as driver overcorrection were collected with the expectation that they would provide data from which to draw some conclusions regarding those overcorrection experiences after the installation of rumble strips. The number of overcorrection events identified throughout the dataset totaled 51; these crashes occurred roughly equally in the before period (26 crashes) and after period (25 crashes) and occurred across the rumble strip types evaluated. A cursory review of these data did not reveal any distinct trends.

To assess the overall effectiveness of rumble strips, the researchers *excluded* weather-related collisions in the analysis. They defined weather-related collisions as those that included one or more of the following conditions: roadway surface conditions at the time of the collision were noted to be snow, slush, ice, or standing water; or weather conditions at the time of the collision were found to be snow, sleet, hail, or freezing rain.

Rumble strips are used to target certain contributing circumstances associated with lane departure crashes. Targeted contributing circumstances are primarily those where a driver is inattentive, distracted, fatigued, or asleep. It is in these specific circumstances that rumble strips are thought to be the most effective in reducing the frequency of collisions. The researchers' approach was to evaluate the effect of rumble strips on these behaviors, without the influence of weather-related crashes.

An investigating officer has the option to select from a list of 44 contributing circumstances and may identify up to 3 circumstances believed to have contributed to the crash. Within this study, the researchers aggregated these 44 choices into 7 categories (see [Appendix C](#)):

- Asleep/Fatigued (A/F)
- Inattentive/Distracted (I/D)
- Under the Influence of Alcohol or Drugs (UI)
- Speed
- Over Centerline (OCL)
- Other
- None

Because a single collision report may identify as many as three contributing circumstances, the count of contributing circumstances studied usually exceeds the number of collisions evaluated.

The contributing category "Other" merits some explanation. An officer selecting this category is directed to describe the specific circumstances in the collision report's narrative. Driver actions prompting an officer to select "Other" are not easily categorized and require a textual description. For this analysis, 19 separate contributing circumstances (see [Appendix C](#)) are combined to report results for the "Other" category. Of these 19, many crashes have been excluded from the data for reasons previously described. For example, if the officer identified "improper passing," that collision would be excluded from the dataset, because all intentional crossings of the centerline (passing) have been excluded. In some cases, the contributing circumstance (such as "improper backing") is not a collision type that would be associated with a targeted lane departure crash and as such was previously screened from the analysis dataset.

## **Roadway Geometry**

The influence of roadway geometry on rumble strip performance was also an area of interest to the researchers. In particular, they had an interest in comparing performance on horizontal curves with tangent segments of highway. Comparing the effectiveness of the rumble strips between curve and tangent portions of the roadway required the research team to identify those collisions where a horizontal curve may have influenced the collisions. They matched the collision dataset to the geometric database to identify those crashes that occurred within the physical limits of a horizontal curve. Although this approach identified those collisions that actually occurred within the limits of a horizontal curve, it did not identify those collisions where a curve may have had an influence on the drivers' actions or control in staying within their lane. During the review of the Police Traffic Collision Reports, the research team identified instances where the collision occurred just prior to

or just following a horizontal curve. This allowed the team to further analyze those collisions for factors such as traveling too fast through a curve, losing control and crashing just beyond the curve, or “straightening out” in a curve and driving off the roadway.

During the data review process, collision data records were flagged with a “curve location key” identification code for use in later analysis. This key was used to extract additional information regarding the geometrics of any curve, such as length or radii. It also allowed the researchers to identify curves along a route that may have experienced unusual numbers of lane departure collisions. Any collision record linked to a curve identifier indicates that the crash may have been influenced by that curve.

The researchers had an interest in evaluating whether curve direction had a significant influence on vehicles crossing the centerline or running off the road to the right during the evaluation of lane departure collision experience on curves. However, the direction of vehicle travel and the direction of a curve listed in the collision record led to confusion in making this determination.

In the geometric data, curve direction is normally described as to the left or to the right, based on the increasing milepost direction of the state route. From a driver’s perspective, a curve to the right in one direction is a curve to the left in the opposite direction. Consequently, using the curve direction as recorded in the Highway Log geometric dataset may contradict a driver’s perspective. Using the descriptors of inside or outside a curve, coupled with the direction of the errant vehicle, offers a more meaningful perspective. This approach associates curvature to the perspective of the driver, regardless of whether the vehicle is traveling in the increasing or decreasing milepost direction. For a curve to the right, a departure to the left is classified as outside the curve and a departure to the right is classified as inside the curve. It is this inside and outside perspective that is used in this analysis.

In addition to an analysis of performance related to specific curves, the research team also evaluated whether more curvilinear alignments exhibited performance that differed from straighter alignments. To do this, they identified the percentage of curvature by computing the total length of curves within a segment and dividing that total by the overall length of the segment. (This approach does not have a relationship to the radius or degree of curvature.) A segment with a series of long, gentle curves through the segment had a greater curve percentage over another segment that had a number of short-length, tight-radii curves. Missing curve information prevented the research team from analyzing the influence of specific curve radii.

The STCDO’s Roadway Branch reported the roadway and shoulder width data elements used in the study. Using this data, the researchers encountered some limitations in defining lengths of roadway and shoulder widths. It was rare that the entire length of any specific roadway segment used in the study was of consistent widths in the travel lanes and shoulders. These dimensions may have changed for a number of reasons. Roadway and shoulder width values are available every 1/100 of a mile in the WSDOT Roadway Data Mart, and these specific values were used in this analysis.

## Crash Rates

To develop a uniform comparison of collision experience between highway segments across the state, crash experience is expressed as a crash rate per vehicle miles traveled (VMT). The VMT is calculated by multiplying the number of days studied for each segment by the annual average daily traffic (AADT) volume for each 1/100 of a mile (0.01) within each segment. This calculation differs from the method used in the March 2011 report, "[Performance Analysis of Centerline Rumble Strips in Washington State](#)," which used a weighted average for each segment. Calculating VMT for each 0.01 of a mile allows for a more accurate reflection of the AADT values for each collision event and the other analyses performed in this study. The VMT for individual segments does account for changes in traffic volume over time, spanning the period from 2002 to 2010. In some analyses, such as the inside/outside of curves analysis, the AADT was halved to generate the directional VMT. This approach was also used in some unique circumstances where study segments may have had SRS omitted on one side of the roadway. Individual 0.01-mile segment VMTs were then aggregated to provide the totals for each study segment.

Crash rates are calculated for All Injury Severities and for Fatal & Serious Injury crashes. All Injury Severities includes non-injury, possible injury, evident injury, serious injury, and fatal crashes. As the name suggests, Fatal & Serious Injury crashes include only those that resulted in a serious or fatal injury. The reader is cautioned to look at how many crashes are represented when looking at the crash rates, particularly for Fatal & Serious Injury crashes. In many instances, the structure of the analysis results in crash rates that are calculated from very small crash numbers. The addition or subtraction of even a single crash could result in significant changes in crash rates.

Crash rates for All Injury Severities are presented as a rate per one million VMT. Because of the small count of collisions, a rate per 100 million VMT is used with Fatal & Serious Injury collisions. When Fatal & Serious Injury crash rates are presented in tabular data, they are shown within parentheses and follow the crash rate for All Injury Severities. This approach also accounts for changes in crash experience that may be associated with traffic growth (or reduction). When comparing the before and after periods for individual segments, performance increases or decreases are reported as a change in rate; that is, the after period value is subtracted from the before period value. Positive values represent a reduction in crash rates, while negative values represent an increase in crash rates. In most cases, percentage differences between the collision rates are reported. A negative value here indicates reduced crash rates, while increased crash rate percentages are indicated by positive values.



## SECTION 3: DATA ANALYSIS AND FINDINGS

The research team initially looked at the influence of rumble strips on lane departure crashes. This global analysis looked at overall performance based on collision type: cross-centerline (crossover) and run-off-the-road-to-the-right (ROTRR). The influence of more specific factors follows in each configuration-specific analysis. These studies examined crash experience before and after rumble strips were installed.

### SRS

The “SRS” study evaluated locations where only shoulder rumble strips (SRS) were installed. There are no centerline rumble strips (CLRS) in these study segments. For all lane departure crashes, a 12.3% increase was observed following installation. This includes a 5.3% increase in the rate of centerline crossover crashes and a 40.4% increase for ROTRR crashes. For Fatal & Serious Injury crossover crashes, a 100% increase was observed, which reflects a single fatal event in the after period. Although the results show an increase in the collision types examined, the analysis is based on a SRS dataset that is small compared to the other datasets examined in this study. The SRS dataset had the least number of miles installed of any of the datasets examined, the lowest VMT, and the fewest number of collision events.

**Table 3.1 SRS Study**

Collision Type	Miles	Before Crash Count	After Crash Count	Before Crash Rate	After Crash Rate	Difference in Rate	% Change in Rate
Lane Departure	18.74	5 (0)	12 (1)	0.185 (0.000)	0.208 (1.732)	-0.023 (-1.732)	12.3% (100%)
Crossover	18.74	4 (0)	9 (1)	0.148 (0.000)	0.156 (1.732)	-0.008 (-1.732)	5.3% (100%)
ROTRR	18.74	1 (0)	3 (0)	0.037 (0.000)	0.052 (0.000)	-0.015 (0.000)	40.4% (0%)

Fatal & Serious Injury results are in ( ) with rate per 100 mVMT

### CLRS&SRS

The “CLRS&SRS” study evaluated locations where centerline rumble strips and shoulder rumble strips were installed at the same point in time. The before condition had no rumble strips installed, and the after condition included both CLRS and SRS. For all lane departure crashes, a 63.3% reduction was observed for All Injury Severities following installation. A 43.0% reduction in Fatal & Serious Injury collisions was observed for lane departure crashes. A 65.4% reduction was observed in crossover crashes for All Injury Severities, with a 28.6% reduction in Fatal & Serious Injury crossover crashes. For ROTRR crashes, a 61.4% reduction was observed for All Injury Severities, with a 66.6% reduction in Fatal & Serious Injury crashes.

**Table 3.2 CLRS&SRS Study**

Collision Type	Miles	Before Crash Count	After Crash Count	Before Crash Rate	After Crash Rate	Difference in Rate	% Change in Rate
Lane Departure	77.44	260 (29)	52 (9)	0.273 (3.046)	0.100 (1.735)	0.173 (1.310)	-63.3% (-43.0%)
Crossover	77.44	122 (18)	23 (7)	0.128 (1.890)	0.044 (1.350)	0.084 (0.541)	-65.4% (-28.6%)
ROTRR	77.44	138 (11)	29 (2)	0.145 (1.155)	0.056 (0.386)	0.089 (0.770)	-61.4% (-66.6%)

Fatal & Serious Injury results are in ( ) with rate per 100 mVMT

### SRS+CLRS

The “SRS+CLRS” study evaluated locations where shoulder rumble strips were installed initially and centerline rumble strips were added later. The before condition had SRS in place and the after condition includes both SRS and CLRS. For all lane departure crashes following the installation of CLRS, a 44.6% reduction was observed for All Injury Severities, with a 24.2% reduction in Fatal & Serious Injury collisions. A 64.7% reduction was observed in crossover crashes for All Injury Severities, with a 24.2% reduction in Fatal & Serious Injury crashes. For ROTRR crashes, an 8.5% increase was observed for All Injury Severities, with no Fatal & Serious Injury crashes occurring in either the before or after periods.

**Table 3.3 SRS+CLRS Study**

Collision Type	Miles	Before Crash Count	After Crash Count	Before Crash Rate	After Crash Rate	Difference in Rate	% Change in Rate
Lane Departure	38.93	40 (3)	39 (4)	0.165 (1.236)	0.091 (0.937)	0.073 (0.299)	-44.6% (-24.2%)
Crossover	38.93	29 (3)	18 (4)	0.120 (1.236)	0.042 (0.937)	0.077 (0.299)	-64.7% (-24.2%)
ROTRR	38.93	11 (0)	21 (0)	0.045 (0.000)	0.049 (0.000)	-0.004 (0.000)	8.5% (0%)

Fatal & Serious Injury results are in ( ) with rate per 100 mVMT

### CLRS+SRS

The “CLRS+SRS” study evaluated locations where centerline rumble strips were installed initially and shoulder rumble strips were added later. The before condition had CLRS in place, and the after condition includes both CLRS and SRS. For all lane departure crashes following the installation of SRS, a 37.5% reduction was observed for All Injury Severities, with a 32.2% reduction in Fatal & Serious Injury collisions. A 6.8% reduction was observed in crossover crashes for All Injury Severities, with a 100% reduction in Fatal & Serious Injury crashes. For ROTRR crashes, a 47.0% reduction was observed for All Injury Severities, with a 15.3% reduction in Fatal & Serious Injury crashes.

**Table 3.4 CLRS+SRS Study**

Collision Type	Miles	Before Crash Count	After Crash Count	Before Crash Rate	After Crash Rate	Difference in Rate	% Change in Rate
Lane Departure	40.77	42 (5)	31 (4)	0.214 (2.544)	0.134 (1.724)	0.080 (0.820)	-37.5% (-32.2%)
Crossover	40.77	10 (1)	11 (0)	0.051 (0.509)	0.047 (0.000)	0.003 (0.509)	-6.8% (-100%)
ROTRR	40.77	32 (4)	20 (4)	0.163 (2.035)	0.086 (1.724)	0.077 (0.311)	-47.0% (-15.3%)

Fatal & Serious Injury results are in ( ) with rate per 100 mVMT

## Composite

The “Composite” study is similar to the “CLRS&SRS” study. The before condition had no rumble strips installed, and the after condition includes both CLRS and SRS. Where data availability permits, segments from the “SRS+CLRS” and “CLRS+SRS” studies were included in the Composite study. For sample segments that offered sufficient crash experience, the “no rumble strip” condition was compared to a time period when both CLRS and SRS were installed. The interim time period where only one type of rumble strip was in place was not evaluated in the Composite study. This approach yielded a larger dataset for analysis. For all lane departure crashes, a 66.0% reduction was observed for All Injury Severities following installation of both SRS and CLRS, with a 56.0% reduction in Fatal & Serious Injury collisions. A 71.0% reduction was observed in crossover crashes for All Injury Severities, with a 57.5% reduction in Fatal & Serious Injury crashes. A 61.6% reduction was observed in ROTRR crashes for All Injury Severities, with a 53.7% reduction in Fatal & Serious Injury crashes.

**Table 3.5 Composite Study**

Collision Type	Miles	Before Crash Count	After Crash Count	Before Crash Rate	After Crash Rate	Difference in Rate	% Change in Rate
Lane Departure	135.88	373 (48)	72 (12)	0.278 (3.573)	0.094 (1.573)	0.183 (2.000)	-66.0% (-56.0%)
Crossover	135.88	176 (29)	29 (7)	0.131 (2.159)	0.038 (0.917)	0.093 (1.241)	-71.0% (-57.5%)
ROTRR	135.88	197 (19)	43 (5)	0.147 (1.414)	0.056 (0.655)	0.090 (0.759)	-61.6% (-53.7%)

Fatal & Serious Injury results are in ( ) with rate per 100 mVMT

## SECTION 4: SRS

Shoulder rumble strips (SRS) have been shown to be an effective tool in reducing lane departure collisions on the limited access Interstate System in Washington State. Milled shoulder rumble strips were first installed on a 44-mile section of I-82 on a test basis in 1992. An evaluation of this installation found a reduction of 40% in run-off-the-road (ROTR) crashes. These collision reductions led to the statewide installation of SRS on the rural Interstate System. An additional study of shoulder rumble strip performance incorporating several other locations on varying interstate routes also reported a significant reduction (35%) in ROTR collisions.

These significant reductions in ROTR collisions on the Interstate System led to the consideration of using these low-cost safety features on the undivided rural highway system. Because of the differences in these types of highways, it was anticipated that the collision reduction experience for undivided rural highways might be different from the limited access interstate experience. The interstate routes were much more likely to have greater clear zones with flatter side slopes, fewer fixed objects such as trees or utility poles adjacent to the traveled way, and wider paved shoulders offering more opportunity for an errant vehicle to recover.

Just over 14 miles of shoulder rumble strips were first installed in 1998 on SR 17 near Othello, with an additional 6.5 miles installed on an adjoining segment the following year. To date, more than 260 miles of shoulder rumble strips have been installed on the two-lane rural highway system in Washington State. However, most of these miles have since had centerline rumble strips (CLRS) installed in conjunction with the SRS. The addition of CLRS renders it nearly impossible to isolate the performance of SRS. Many of these miles are included in the SRS+CLRS study.

In this study, a total of 18.74 miles of shoulder rumble strip installations were found to meet the conditions of a minimum of one year of crash data before and after rumble strip installation between the periods of 01/01/02 to 12/31/10. Of this total mileage, 18.41 (98%) miles was comprised of a single highway segment. Only 17 lane departure events were recorded over the study period. Of these 17 events, four were run-off-the-road-to-the-right (ROTRR) collisions, with one collision prior to rumble strip installation and three after. [Table 4.1](#) details this collision experience. With the limitations imposed by such a small sample size, the research team elected to forgo a more detailed analysis of shoulder rumble strip performance.

**Table 4.1 SRS: Overall Performance**

Collision Type	Miles	Before Crash Count	After Crash Count	Before Crash Rate	After Crash Rate	Difference in Rate	% Change in Rate
Lane Departure	18.74	5 (0)	12 (1)	0.185 (0.000)	0.208 (1.732)	-0.023 (-1.732)	12.3% (100%)
Crossover	18.74	4 (0)	9 (1)	0.148 (0.000)	0.156 (1.732)	-0.008 (-1.732)	5.3% (100%)
ROTRR	18.74	1 (0)	3 (0)	0.037 (0.000)	0.052 (0.000)	-0.015 (0.000)	40.4% (0%)

Fatal & Serious Injury results are in ( ) with rate per 100 mVMT

## SECTION 5: CLRS&SRS

For the purpose of this study, the installation of centerline rumble strips (CLRS) and shoulder rumble strips (SRS) in the same highway project is labeled as CLRS&SRS. From September 2000 through 2010, just over 125 miles of CLRS&SRS were installed. Some of the later installations had been in place less than one year, and they were not included in this analysis. The data available for analysis spans 77.44 miles and accounts for a total of 312 lane departure collisions. Of these collision events, 260 occurred before rumble strips were installed, with 52 following rumble strip placement. The VMT for the before period had 952.160 million miles, and the VMT for the after period had 518.629 million miles.

It was expected that CLRS&SRS installations would reduce all lane departure events, both cross-centerline and ROTRR. The overall performance of these installations was examined, followed by the cross-centerline events and then the ROTRR events.

Table 5.1 shows the overall performance of CLRS&SRS for the 77.44 miles included in the dataset. For all lane departure crashes, there is a 63.3% reduction in crash rates and a 43.0% reduction in Fatal & Serious Injury crash rates. For All Injury Severities, the reductions are similar for crossover crashes (65.4%) and ROTRR crashes (61.4%). Reductions in Fatal & Serious Injury crash rates are more substantial for the ROTRR crashes than for crossover crashes.

**Table 5.1 CLRS&SRS: Overall Performance**

Collision Type	Miles	Before Crash Count	After Crash Count	Before Crash Rate	After Crash Rate	Difference in Rate	% Change in Rate
Lane Departure	77.44	260 (29)	52 (9)	0.273 (3.046)	0.100 (1.735)	0.173 (1.310)	-63.3% (-43.0%)
Crossover	77.44	122 (18)	23 (7)	0.128 (1.890)	0.044 (1.350)	0.084 (0.541)	-65.4% (-28.6%)
ROTRR	77.44	138 (11)	29 (2)	0.145 (1.155)	0.056 (0.386)	0.089 (0.770)	-61.4% (-66.6%)

Fatal & Serious Injury results are in ( ) with rate per 100 mVMT

### CLRS&SRS: Contributing Category

#### ■ Lane Departure Crashes

Table 5.2 provides a summary of the performance of CLRS&SRS segments and focuses on contributing circumstances associated with lane departure crashes.

The contributing categories are:

- Asleep/Fatigued (A/F)
- Inattentive/Distracted (I/D)
- Under the Influence of Alcohol or Drugs (UI)
- Speed
- Over Centerline (OCL)
- Other
- None

**Table 5.2 CLRS&SRS: Lane Departure Rates by Contributing Category**

Contributing Category*	Miles	Before Count	After Count	Before Rate	After Rate	Difference in Rate	% Change in Rate
A/F	77.44	89 (8)	10 (0)	0.093 (0.840)	0.019 (0.000)	0.074 (0.840)	-79.4% (-100%)
I/D	77.44	47 (5)	9 (3)	0.049 (0.525)	0.017 (0.578)	0.032 (-0.053)	-64.8% (10.2%)
UI	77.44	61 (7)	17 (4)	0.064 (0.735)	0.033 (0.771)	0.031 (-0.036)	-48.8% (4.9%)
Speed	77.44	36 (2)	11 (1)	0.038 (0.210)	0.021 (0.193)	0.017 (0.017)	-43.9% (-8.2%)
OCL	77.44	46 (14)	12 (5)	0.048 (1.470)	0.023 (0.964)	0.025 (0.506)	-52.1% (-34.4%)
Other	77.44	32 (3)	8 (1)	0.034 (0.315)	0.015 (0.193)	0.018 (0.122)	-54.1% (-38.8%)
None	77.44	1 (0)	0 (0)	0.001 (0.000)	0.000 (0.000)	0.001 (0.000)	-100% (0%)

\*See [Appendix C](#)

Fatal & Serious Injury results are in ( ) with rate per 100 mVMT

For all lane departure injury collisions, there are reductions in the collision rates in each of the contributing categories. Of particular interest are the A/F and I/D categories, which are specifically targeted by rumble strips.

**A/F:** For those collisions where an investigating officer noted that A/F was a contributing circumstance, a 79.4% reduction in crash rates was observed. In the A/F category for Fatal & Serious Injury collisions, the performance was a 100% reduction, with eight crashes prior to rumble strip installation and none after.

**I/D:** In the I/D category, a reduction of 64.8% in the crash rate was found for All Injury Severities collisions. For Fatal & Serious Injury collisions, a 10.2% increase was noted. Prior to rumble strip installation, there were five of these events. After rumble strips were installed, there were three Fatal & Serious Injury crashes.

[Figure 5.1](#) is a graphic representation of the data in [Table 5.2](#) and may better illustrate the level of performance observed in this study.

**Figure 5.1 CLRS&SRS: Lane Departure Rates by Contributing Category – All Injury Severities**

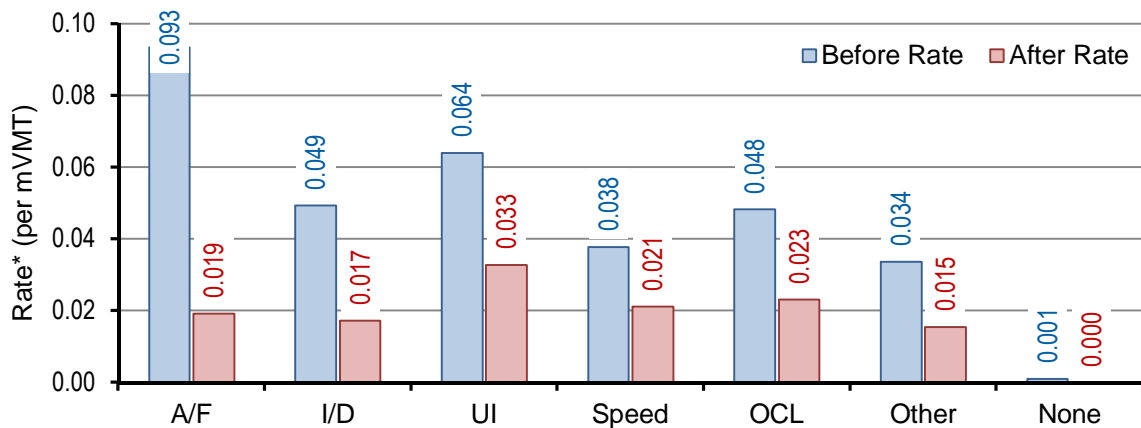

\*Rate of collisions with Contributing Circumstance Category

Total Crash Record Counts: 260 Before, 52 After

Total Contributing Circumstances Evaluated: 312 Before, 67 After

A few of the contributing categories deserve further comment before moving on to the specific collision types.

**None:** The “None” category reflects collision events where the investigating officer either found no contributing cause or did not complete the appropriate fields on the collision report. Consequently, a 100% reduction in All Injury Severities collisions in this category may very well be an anomaly.

**OCL:** Although the “OCL” category is a valid code that the investigating officer may select, it offers little clarity as a contributing circumstance in a crash event. It does identify the position of the vehicle, but offers no insight about the driver’s actions. The use of this contributing category is overused and has been problematic for this type of research as officers seem to use it as a descriptive condition instead of a causal factor.

**Other:** The “Other” category can also be problematic. When officers select this circumstance, they are instructed to explain the conditions in the narrative portion of the report form, as the contributing cause does not align with the other 43 choices they have available. In many cases, this contributing circumstance is used when the officer comes upon an abandoned vehicle at the collision location. With no driver or witness available to describe the circumstances leading to the collision, this code of “Other” is commonly applied to the collision report.

**UI:** Rumble strips are not expected to significantly impact the “UI” contributing category; however, the data suggest that there was a 48.8% reduction in All Injury Severities. Driving under the influence is a behavioral issue best addressed through enforcement activities, with a goal of getting UI drivers off the road. While rumble strips are not intended to promote or encourage such poor driver choices, reducing lane departures for these users does result in a reduced crash experience.

**Speed:** “Speed” is another contributing category that rumble strips are not expected to significantly influence; however, a 43.9% reduction in the All Injury Severities collision rate was noted, as well as an 8.2% reduction in the Fatal & Serious Injury rate, as seen in [Table 5.2](#).

■ Crossover Crashes

[Table 5.3](#) depicts how CLRS&SRS applied in combination influence crossover collisions by contributing category. The same data is presented in a graphical format in [Figure 5.2](#).

**Table 5.3 CLRS&SRS: Crossover Rates by Contributing Category**

Contributing Category*	Miles	Before Count	After Count	Before Rate	After Rate	Difference in Rate	% Change in Rate
A/F	77.44	44 (3)	5 (0)	0.046 (0.315)	0.010 (0.000)	0.037 (0.315)	-79.1% (-100%)
I/D	77.44	14 (2)	4 (3)	0.015 (0.210)	0.008 (0.578)	0.007 (-0.368)	-47.5% (175.4%)
UI	77.44	30 (3)	6 (2)	0.032 (0.315)	0.012 (0.386)	0.020 (-0.071)	-63.3% (22.4%)
Speed	77.44	16 (1)	5 (1)	0.017 (0.105)	0.010 (0.193)	0.007 (-0.088)	-42.6% (83.6%)
OCL	77.44	46 (14)	12 (5)	0.048 (1.470)	0.023 (0.964)	0.025 (0.506)	-52.1% (-34.4%)
Other	77.44	11 (2)	1 (1)	0.012 (0.210)	0.002 (0.193)	0.010 (0.017)	-83.3% (-8.2%)
None	77.44	0 (0)	0 (0)	0.000 (0.000)	0.000 (0.000)	0.000 (0.000)	0% (0%)

\*See [Appendix C](#)

Fatal & Serious Injury results are in ( ) with rate per 100 mVMT

**Figure 5.2 CLRS&SRS: Crossover Rates by Contributing Category – All Injury Severities**

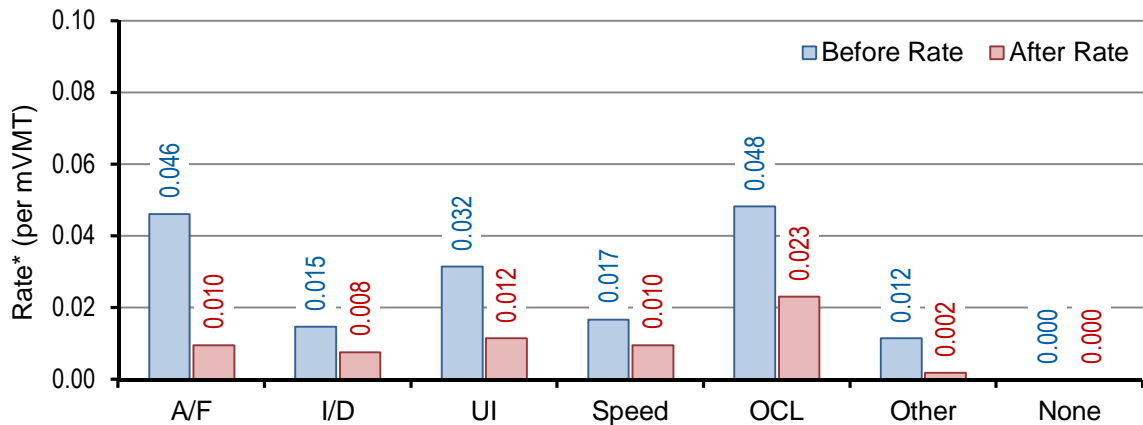

\*Rate of collisions with Contributing Circumstance Category

Total Crash Record Counts: 122 Before, 23 After

Total Contributing Circumstances Evaluated: 161 Before, 33 After

The performance trend for all contributing categories indicates reduced collision rates for All Injury Severities. It is particularly noteworthy that there is a 79.1% decline in A/F and a 47.5% decline in the rate for I/D. However, with Fatal & Serious Injury collisions, there are some categories that indicate significant increases, although they are based on a small number of events.

The A/F category had a 100% decrease in Fatal & Serious Injury crashes, with three crashes prior to rumble strip installation and none after. The I/D category had two Fatal & Serious Injury collisions before rumble strip installation and three after, for a 175.4% increase in the crash rate. The UI category showed an increase in the Fatal & Serious Injury crash rate of 22.4%; three of those collisions were reported before rumble strip placement and two occurred after. The Speed category had two Fatal & Serious Injury collisions, with one in the before period and one in the after period, resulting in an 83.6% increase in the collision rate. The categories of OCL and Other both showed crash reductions, with decreases in the Fatal & Serious Injury rate of 34.4% and 8.2%, respectively.

#### ■ ROTRR Crashes

In examining the performance of CLRS&SRS installations on the rate of ROTRR collisions, the researchers saw reduced crash rates across all contributing categories except for OCL (see [Table 5.4](#)). For the contributing category of A/F, there was a 79.6% reduction in crash rates for All Injury Severities and a 100.00% reduction in Fatal & Serious Injury crash rates. Five Fatal & Serious Injury events were recorded before rumble strips were installed, and there were none after. This data is presented in graphic form in [Figure 5.3](#).



**Table 5.4 CLRS&SRS: ROTRR Rates by Contributing Category**

Contributing Category*	Miles	Before Count	After Count	Before Rate	After Rate	Difference in Rate	% Change in Rate
A/F	77.44	45 (5)	5 (0)	0.047 (0.525)	0.010 (0.000)	0.038 (0.525)	-79.6% (-100%)
I/D	77.44	33 (3)	5 (0)	0.035 (0.315)	0.010 (0.000)	0.025 (0.315)	-72.2% (-100%)
UI	77.44	31 (4)	11 (2)	0.033 (0.420)	0.021 (0.386)	0.011 (0.034)	-34.9% (-8.2%)
Speed	77.44	20 (1)	6 (0)	0.021 (0.105)	0.012 (0.000)	0.009 (0.105)	-44.9% (-100%)
OCL	77.44	0 (0)	0 (0)	0.000 (0.000)	0.000 (0.000)	0.000 (0.000)	0% (0%)
Other	77.44	21 (1)	7 (0)	0.022 (0.105)	0.013 (0.000)	0.009 (0.105)	-38.8% (-100%)
None	77.44	1 (0)	0 (0)	0.001 (0.000)	0.000 (0.000)	0.001 (0.000)	-100% (0%)

\*See Appendix C

Fatal & Serious Injury results are in ( ) with rate per 100 mVMT

**Figure 5.3 CLRS&SRS: ROTRR Rates by Contributing Category – All Injury Severities**

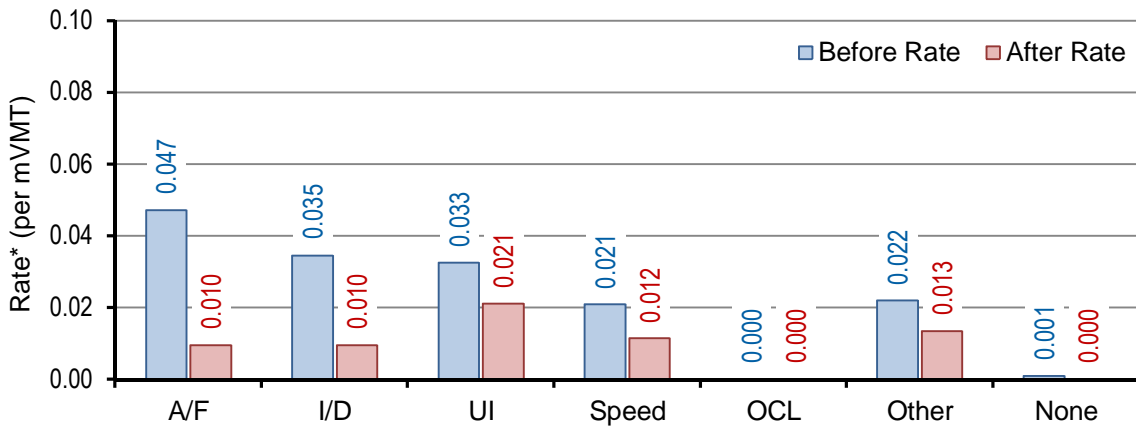

\*Rate of collisions with Contributing Circumstance Category

Total Crash Record Counts: 138 Before, 29 After

Total Contributing Circumstances Evaluated: 151 Before, 34 After

**I/D:** For the contributing category of I/D, there was a 72.2% reduction in the rate of All Injury Severities ROTRR collisions, and a 100% reduction in the rate of Fatal & Serious Injury collisions. Three Fatal & Serious Injury events were recorded in the evaluation period before rumble strips were installed, with none reported in the after period.

**OCL:** While the OCL category had no records in the collision datasets for either period, this is not unusual for ROTRR crashes. Although the researchers looked for instances where a vehicle first crossed the centerline and then overcorrected back to the right, no such collisions were identified. In the [2011 CLRS Report](#) (pp. 58–60), 50 collisions were found in the before period and another 45 occurred in the after period that were determined to be overcorrection events.

**Speed:** For the Speed category, the numbers are similar to the findings with crossover crashes. There was a 44.9% reduction in the rate of All Injury Severities collisions, and a 100% reduction in the rate of Fatal & Serious Injury events. There was one Fatal & Serious Injury event in the before period and none in the after period.

**UI:** In the UI category, there was a 34.9% reduction in the rate of All Injury Severities collisions, and an 8.2% reduction in the rate of Fatal & Serious Injury events. There were four Fatal & Serious Injury events in the evaluation period before rumble strips and two in the after period.

**Other:** The Other category also recorded a reduction in the collision rates for ROTRR events. There was a 38.8% reduction in the rate of All Injury Severities collisions, and a 100% reduction in Fatal & Serious Injury events. There was a single Fatal & Serious Injury event, which occurred before rumble strips were installed.

### **CLRS&SRS: Posted Speed**

The researchers examined the effect that the posted speed limits had on the performance of the CLRS&SRS pattern of rumble strips.

WSDOT design guidance for the installation of CLRS and SRS recommends that they be used where the posted speed limit is 45 mph or greater. This guidance also states that the effectiveness of rumble strips is reduced where speeds are below 35 mph. As a result of this guidance, the number of miles where CLRS&SRS are installed and the speed limit is less than 45 mph is limited; at 40 mph or less, only 2.35 miles (or 3.0%) of the total mileage is available for study. The number of miles below 50 mph makes up 4.6% of the miles examined, and the collision set is 2.5 % of the total crashes. Prior to rumble strip installation, there were eight crashes associated with these lower speeds, one of which was a Fatal & Serious Injury event. After rumble strip installation, there was one crash, which was a Fatal & Serious Injury event. This limited data doesn't offer much significance in the analysis of these locations. However, despite the limited data available, this information is presented herein.

For the posted speed limits of 50 mph or higher, there were 73.84 miles examined, with a total of 252 collisions prior to rumble strip installation, of which 28 were Fatal & Serious Injury events. After rumble strips were installed, 51 collisions occurred, of which eight were Fatal & Serious Injury events.

#### ■ Lane Departure Crashes

[Table 5.5](#) shows that the installation of CLRS&SRS was effective in reducing the number of lane departure collisions through the full range of posted speed limits analyzed. For the higher speeds, the trend indicates that the percentage of reduction for all injuries increased as the posted speed increased. A 49.2% reduction was noted at 50 mph, a 58.4% reduction at 55 mph, and a 64.8% reduction at 60 mph.

**Table 5.5 CLRS&SRS: Lane Departure Rates by Posted Speed**

Posted Speed Limit	Miles	Before Crash Count	After Crash Count	Before Crash Rate	After Crash Rate	Difference in Rate	% Change in Rate
35	2.17	6 (1)	1 (1)	0.197 (3.285)	0.096 (9.571)	0.101 (-6.285)	-51.4% (191.3%)
40	0.18	0 (0)	0 (0)	0.000 (0.000)	0.000 (0.000)	0.000 (0.000)	0% (0%)
45	1.25	2 (0)	0 (0)	0.150 (0.000)	0.000 (0.000)	0.150 (0.000)	-100% (0%)
50	8.57	47 (7)	8 (0)	0.468 (6.969)	0.238 (0.000)	0.230 (6.969)	-49.2% (-100%)
55	36.15	150 (18)	28 (6)	0.313 (3.756)	0.130 (2.791)	0.183 (0.964)	-58.4% (-25.7%)
60	29.12	55 (3)	15 (2)	0.169 (0.920)	0.059 (0.790)	0.109 (0.129)	-64.8% (-14.1%)

Fatal & Serious Injury results are in ( ) with rate per 100 mVMT

For the Fatal & Serious Injury events in the posted speed ranges of 50 mph or greater, the reduction in the collision rates continued. There was a 100% reduction at 50 mph, a 25.7% reduction at 55 mph, and a 14.1% reduction at 60 mph.

■ Crossover Crashes

Table 5.6 and Figure 5.4 illustrate the performance of the CLRS&SRS treatment in crossover collisions by posted speeds. For crossover collisions with the CLRS&SRS installations, a speed-focused evaluation generally indicates reduced crash rates.

**Table 5.6 CLRS&SRS: Crossover Rates by Posted Speed**

Posted Speed Limit	Miles	Before Crash Count	After Crash Count	Before Crash Rate	After Crash Rate	Difference in Rate	% Change in Rate
35	2.17	3 (1)	1 (1)	0.099 (3.285)	0.096 (9.571)	0.003 (-6.285)	-2.9% (191.3%)
40	0.18	0 (0)	0 (0)	0.000 (0.000)	0.000 (0.000)	0.000 (0.000)	0% (0%)
45	1.25	1 (0)	0 (0)	0.075 (0.000)	0.000 (0.000)	0.075 (0.000)	-100% (0%)
50	8.57	23 (2)	2 (0)	0.229 (1.991)	0.059 (0.000)	0.170 (1.991)	-74.1% (-100%)
55	36.15	72 (14)	13 (4)	0.150 (2.921)	0.060 (1.861)	0.090 (1.060)	-59.7% (-36.3%)
60	29.12	23 (1)	7 (2)	0.071 (0.307)	0.028 (0.790)	0.043 (-0.484)	-60.8% (157.8%)

Fatal & Serious Injury results are in ( ) with rate per 100 mVMT

For all injury crossover collisions in CLRS&SRS pattern areas, the results for speeds below 50 mph indicate a reduction in crash rates, with the caveat that there were very few miles and collision events to evaluate. At 35 mph, there was a negligible change, at 40 mph, there were no crashes to evaluate, and at 45 mph, there was a single collision prior to rumble strip installation and none after.

For speeds of 50 mph or greater, there were substantial reductions in All Injury Severities crashes. There was a 74.1% reduction at the 50 mph posted speed, a 59.7% reduction at 55 mph, and a 60.8% reduction at 60 mph.

**Figure 5.4 CLRS&SRS: Crossover Rates by Posted Speed – All Injury Severities**

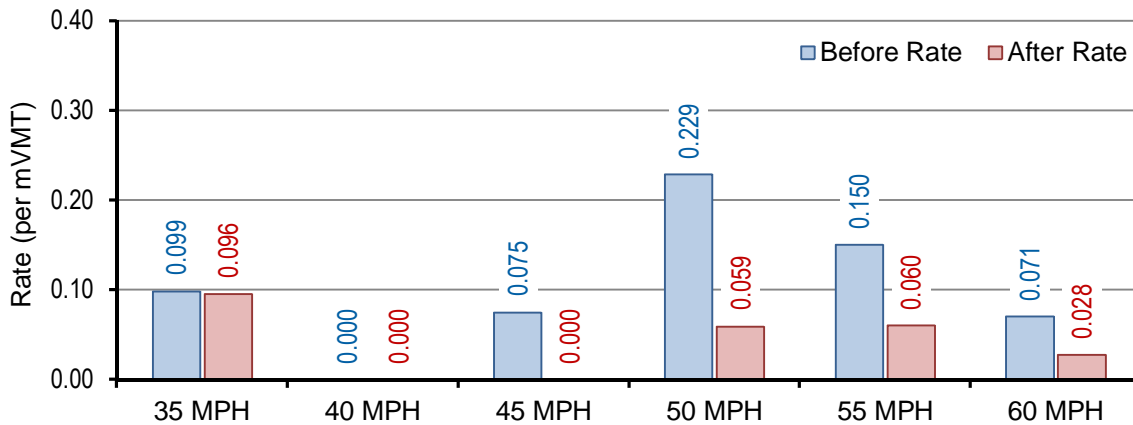
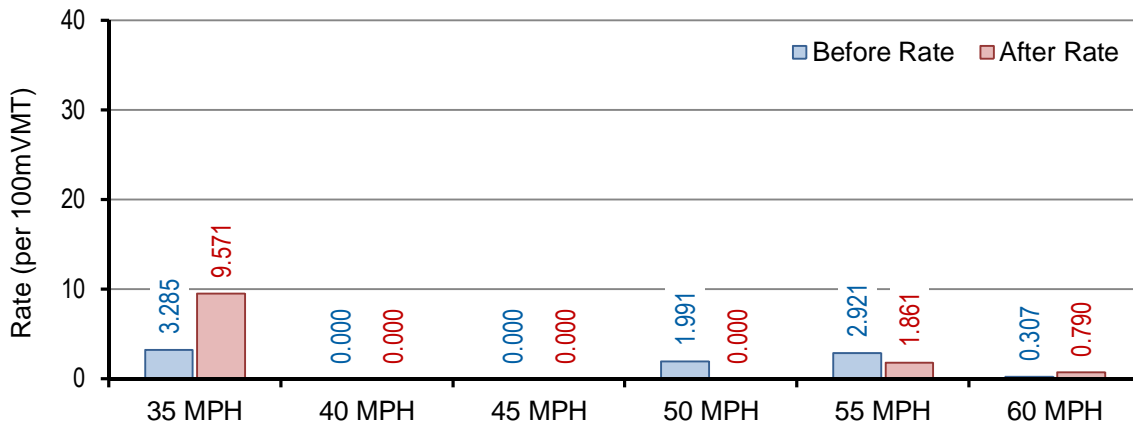

Figure 5.5 illustrates the Fatal & Serious Injury centerline crossover collision experience of the CLRS&SRS installation by posted speed. At the 35 mph posted speed, one Fatal & Serious Injury collision occurred prior to rumble strip installation and one after, which resulted in a 191.3% increase in the collision rate. The 40 and 45 mph posted speeds had no Fatal & Serious Injury events recorded in either period. The 50 mph speed range had two events prior to rumble strip installation and none after, for a 100% reduction. The 55 mph posted speed range had 14 Fatal & Serious Injury events before rumble strips, and four after, resulting in a 36.3% reduction. The 60 mph range had an increase in the Fatal & Serious Injury rate of 157.8%, reflecting one event before rumble strips and two after.

**Figure 5.5 CLRS&SRS: Crossover Rates by Posted Speed – Fatal & Serious Injury**



■ ROTRR Crashes

The examination of ROTRR collisions for the CLRS&SRS installations by posted speeds is shown in Table 5.7. These results show reductions in collision rates for All Injury Severities and similar reductions for Fatal & Serious Injury events, with a single exception. The 55 mph posted speed range shows a moderate increase of 11.5% for Fatal & Serious Injury events, with four prior to rumble strip installation and two after.

**Table 5.7 CLRS&SRS: ROTRR Rates by Posted Speed**

Posted Speed Limit	Miles	Before Crash Count	After Crash Count	Before Crash Rate	After Crash Rate	Difference in Rate	% Change in Rate
35	2.17	3 (0)	0 (0)	0.099 (0.000)	0.000 (0.000)	0.099 (0.000)	-100% (0%)
40	0.18	0 (0)	0 (0)	0.000 (0.000)	0.000 (0.000)	0.000 (0.000)	0% (0%)
45	1.25	1 (0)	0 (0)	0.075 (0.000)	0.000 (0.000)	0.075 (0.000)	-100% (0%)
50	8.57	24 (5)	6 (0)	0.239 (4.978)	0.178 (0.000)	0.061 (4.978)	-25.4% (-100%)
55	36.15	78 (4)	15 (2)	0.163 (0.835)	0.070 (0.930)	0.093 (-0.096)	-57.1% (11.5%)
60	29.12	32 (2)	8 (0)	0.098 (0.613)	0.032 (0.000)	0.066 (0.613)	-67.8% (-100%)

Fatal & Serious Injury results are in ( ) with rate per 100 mVMT

For highways with a posted speed of 50 mph or greater, the ROTRR crash reductions demonstrate a similar pattern to the overall lane departure experience, with reduction rates increasing as the posted speed increases. The reduction in the ROTRR collisions was 25.4% at 50 mph, 57.1% at 55 mph, and 67.8% at 60 mph. With this data, it appears that regardless of the lane departure collision type, installing both CLRS and SRS reduces crash rates across all posted speed ranges analyzed.

### CLRS&SRS: Lane Width

The researchers explored differing roadway geometrics, such as lane width, shoulder width, and SRS recovery width on the shoulder, to try to identify any performance differences in the CLRS&SRS installations.

#### ■ Lane Departure Crashes

The team examined 77.44 miles with 312 total collision events in the analysis periods. Lane widths examined in this portion of the study were defined as 11', 12', and > 12'. Performance findings are tabulated in [Table 5.8](#).

**Table 5.8 CLRS&SRS: Lane Departure Rates by Lane Width**

Lane Width	Miles	Before Crash Count	After Crash Count	Before Crash Rate	After Crash Rate	Difference in Rate	% Change in Rate
11'	43.24	136 (15)	21 (3)	0.280 (3.087)	0.089 (1.271)	0.191 (1.816)	-68.2% (-58.8%)
12'	34.05	123 (13)	31 (6)	0.266 (2.816)	0.110 (2.137)	0.156 (0.679)	-58.6% (-24.1%)
> 12'	0.15	1 (1)	0 (0)	0.219 (21.907)	0.000 (0.000)	0.219 (21.907)	-100% (-100%)
All	77.44	260 (29)	52 (9)	0.273 (3.046)	0.100 (1.735)	0.173 (1.310)	-63.3% (-43.0%)

Fatal & Serious Injury results are in ( ) with rate per 100 mVMT

Highway segments with a > 12' lane width represent only 0.15 of a mile. Within this short length, there is a single collision event prior to CLRS&SRS installation and none after. This category offers no meaningful comparison of rumble strip performance.

Considerably more crash data exists for the 11' and 12' lane widths, allowing for a more robust comparison. For lane departure collisions, the 11' and 12' widths yield similar crash rates prior to CLRS&SRS installation for All Injury Severities. Although one may expect that a narrower lane offers less room to maneuver and might result in a higher rate of lane departure collisions, the data suggest that the differences are minimal. After CLRS&SRS were installed, there were substantial reductions in crash rates for 11' and 12' lanes. The results indicate a greater reduction in crash rates for roadways with 11' lanes.

Evaluating Fatal & Serious Injury events and the relationship to the lane widths reveals significant reductions in lane departure collisions realized by CLRS&SRS installation, ranging from 24.1% to 58.8%. [Figure 5.6](#) illustrates the change in the Fatal & Serious Injury rates. The > 12' data is not shown, as it reflects only a single crash in the before period (the > 12' data is shown in [Table 5.8](#)).

**Figure 5.6 CLRS&SRS: Lane Departure Rates by Lane Width – Fatal & Serious Injury**

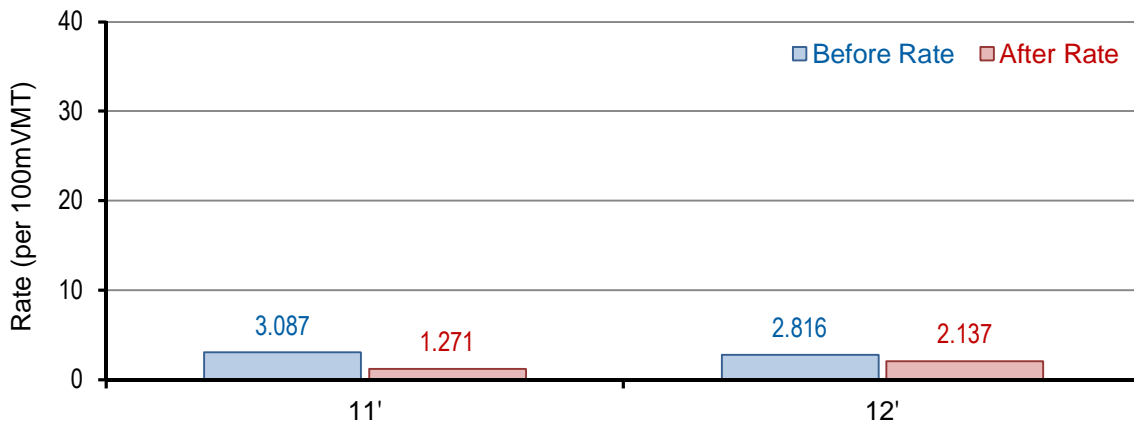

### ■ Crossover Crashes

Crossover collision performance by lane width for the CLRS&SRS is presented in [Table 5.9](#) and [Figure 5.7](#). Examining the All Injury Severities experience before CLRS&SRS were installed suggests a moderately higher rate of crossover crashes with 11' lanes compared to 12' lanes.

The data indicates that wider lanes have lower crossover collision rates before and after CLRS&SRS installation, although the margin of difference is smaller following CLRS&SRS installation. For All Injury Severities events, there were fairly consistent reductions in crash rates after CLRS&SRS were installed.

**Table 5.9 CLRS&SRS: Crossover Rates by Lane Width**

Lane Width	Miles	Before Crash Count	After Crash Count	Before Crash Rate	After Crash Rate	Difference in Rate	% Change in Rate
11'	43.24	68 (11)	11 (2)	0.140 (2.264)	0.047 (0.847)	0.093 (1.416)	-66.7% (-62.6%)
12'	34.05	53 (6)	12 (5)	0.115 (1.300)	0.043 (1.781)	0.072 (-0.481)	-62.8% (37.0%)
> 12'	0.15	1 (1)	0 (0)	0.219 (21.907)	0.000 (0.000)	0.219 (21.907)	-100% (-100%)
All	77.44	122 (18)	23 (7)	0.128 (1.890)	0.044 (1.350)	0.084 (0.541)	-65.4% (-28.6%)

Fatal & Serious Injury results are in ( ) with rate per 100 mVMT

**Figure 5.7 CLRS&SRS: Crossover Rates by Lane Width – Fatal & Serious Injury**

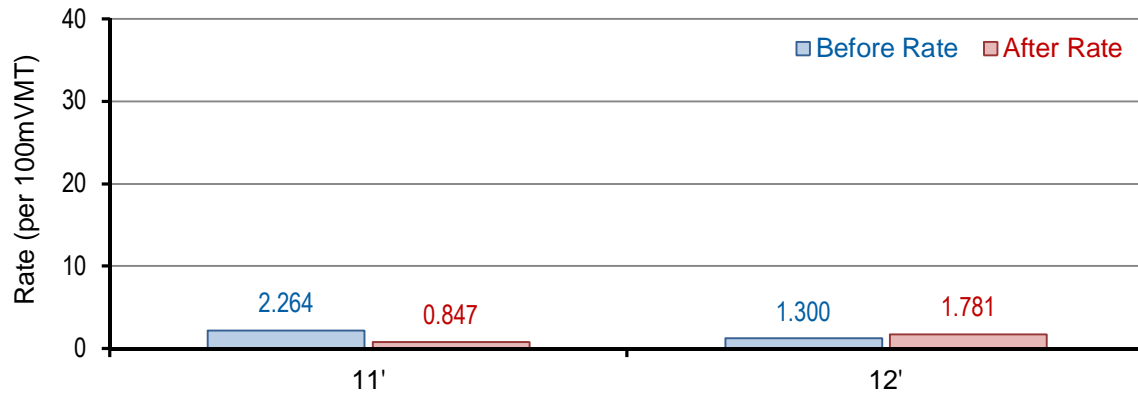

The results are mixed for the Fatal & Serious Injury analysis of crossover collisions. A 62.6% reduction in the Fatal & Serious Injury crash rate was observed for 11' lanes, and a 37.0% increase was found for roadways with 12' lanes. The reason for the increase in the rate of crossover Fatal & Serious Injury collisions with 12' lanes is unclear. An examination of the five separate crash events in the after period revealed that all of them occurred on the same route with AADTs of 17,000 or greater and a posted speed of 60 mph. Four of five of these events occurred within the influence of a curve: three to the outside and a single event to the inside of a curve. This commonality is linked to the limited number of routes examined in this view.

■ **ROTRR Crashes**

Table 5.10 outlines the performance of CLRS&SRS for lane widths. There are substantial reductions in crash rates for All Injury Severities collisions with 11' and 12' lane widths. This trend is also reflected with Fatal & Serious Injury crash rates.

**Table 5.10 CLRS&SRS: ROTRR Rates by Lane Width**

Lane Width	Miles	Before Crash Count	After Crash Count	Before Crash Rate	After Crash Rate	Difference in Rate	% Change in Rate
11'	43.24	68 (4)	10 (1)	0.140 (0.823)	0.042 (0.424)	0.098 (0.399)	-69.7% (-48.5%)
12'	34.05	70 (7)	19 (1)	0.152 (1.516)	0.068 (0.356)	0.084 (1.160)	-55.4% (-76.5%)
> 12'	0.15	0 (0)	0 (0)	0.000 (0.000)	0.000 (0.000)	0.000 (0.000)	0% (0%)
All	77.44	138 (11)	29 (2)	0.145 (1.155)	0.056 (0.386)	0.089 (0.770)	-61.4% (-66.6%)

Fatal & Serious Injury results are in ( ) with rate per 100 mVMT

Figure 5.8 provides a graphical depiction of the All Injury Severities data from Table 5.10.

**Figure 5.8 CLRS&SRS: ROTRR Rates by Lane Width – All Injury Severities**

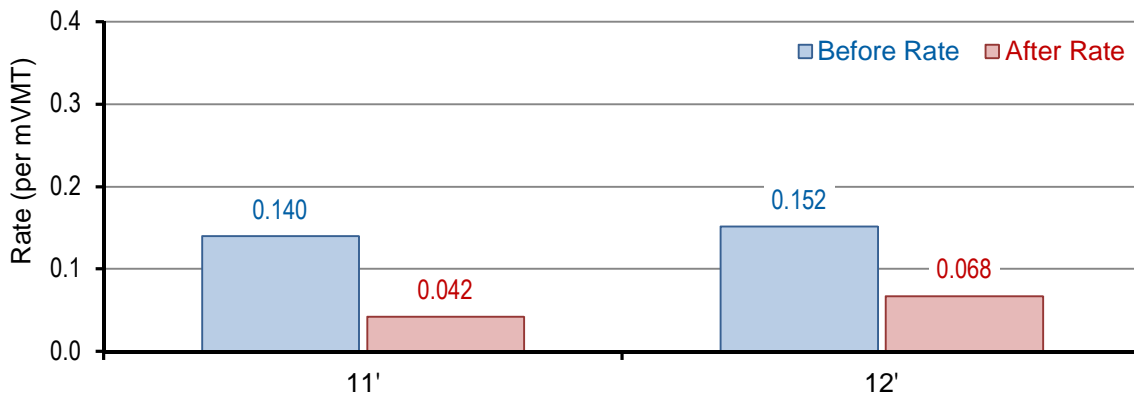

### CLRS&SRS: SRS Recovery Width

The research team wanted to take a closer look at the how much shoulder area was available for recovery after the vehicle had crossed the rumble strip. Subtracting the offset width from the edge line, plus the width of the rumble, leaves the balance of the paved shoulder area available for a corrective maneuver. This concept of SRS recovery width was explored to determine if the findings offered more clarity on performance than the overall shoulder width. The researchers segregated the SRS recovery width into ranges of a single foot, starting with < 1' and increasing by 1' increments to the maximum range of ≥ 8'. The cross-centerline crashes are not specifically explored in the SRS recovery width analysis.

#### ■ Lane Departure Crashes

Table 5.11 shows the results of the SRS recovery widths for all lane departures. These data show a modest reduction for locations with 3' to 4' of recovery width and substantial reductions for locations with 4' or more of recovery width when examining All Injury Severities events. The numbers for Fatal & Serious Injury crash rates exhibit more variability in the results, presumably because of the low count numbers. The remainder of the ranges all show a reduction in the collision rates for All Injury Severities, with the exception of the 2 to < 3' range, which indicates a very modest increase of 1.6%. Low count numbers for Fatal & Serious Injury crashes yield highly inconsistent results, reflecting substantial increases and decreases in collision rates.



**Table 5.11 CLRS&SRS: Lane Departure Rates by SRS Recovery Width**

Range	Miles	Before Crash Count	After Crash Count	Before Crash Rate	After Crash Rate	Difference in Rate	% Change in Rate
< 1'	0.01	0 (0)	0 (0)	0.000 (0.000)	0.000 (0.000)	0.000 (0.000)	0% (0%)
1 to < 2'	0.00	0 (0)	0 (0)	NX (NX)	NX (NX)	NX (NX)	NX (NX)
2 to < 3'	2.98	13 (1)	4 (1)	0.704 (5.416)	0.715 (17.874)	-0.011 (-12.459)	1.6% (230.0%)
3 to < 4'	3.49	20 (4)	4 (0)	0.732 (14.633)	0.525 (0.000)	0.207 (14.633)	-28.2% (-100%)
4 to < 5'	8.77	47 (2)	7 (1)	0.283 (1.203)	0.114 (1.632)	0.169 (-0.429)	-59.6% (35.6%)
5 to < 6'	10.25	36 (2)	5 (2)	0.304 (1.687)	0.078 (3.130)	0.225 (-1.443)	-74.2% (85.6%)
6 to < 7'	24.47	77 (8)	17 (1)	0.221 (2.299)	0.079 (0.462)	0.143 (1.837)	-64.5% (-79.9%)
7 to < 8'	20.21	48 (4)	10 (3)	0.225 (1.877)	0.115 (3.436)	0.111 (-1.560)	-49.1% (83.1%)
≥ 8'	7.27	19 (8)	5 (1)	0.315 (13.272)	0.065 (1.309)	0.250 (11.963)	-79.2% (-90.1%)
All	77.44	260 (29)	52 (9)	0.273 (3.046)	0.100 (1.735)	0.173 (1.310)	-63.3% (-43.0%)

NX = No Exposure Fatal & Serious Injury results are in ( ) with rate per 100 mVMT

Figure 5.9 illustrates the performance of the SRS recovery width for All Injury Severities, with the same data as shown in Table 5.11. The data illustrates a significant change in the collision rate for locations with a SRS recovery width of < 4' when compared to locations with a SRS recovery width of > 4'. Crash rates are substantially higher for the narrower SRS recovery widths, before and after CLRS&SRS were installed, suggesting that SRS recovery width is closely linked to lane departure experience.

**Figure 5.9 CLRS&SRS: Lane Departure Rates by SRS Recovery Width – All Injury Severities**

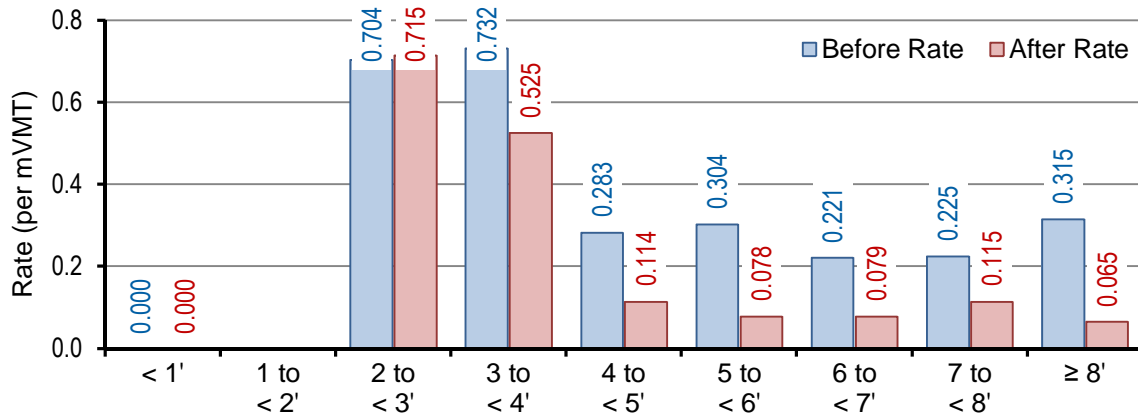

■ ROTRR Crashes

Table 5.12 and Figure 5.10 illustrate ROTRR collisions and the SRS recovery widths. This dataset displays similar performance characteristics as the SRS recovery width lane departure collision data. There are significant performance differences in crash rates for recover widths of < 4' when compared to wider widths. This holds true before and after CLRS&SRS were installed. It appears that increased SRS recovery widths result in reduced ROTRR crashes, and that further reductions were realized through the placement of CLRS&SRS.

**Table 5.12 CLRS&SRS: ROTRR Rates by SRS Recovery Width**

Range	Miles	Before Crash Count	After Crash Count	Before Crash Rate	After Crash Rate	Difference in Rate	% Change in Rate
< 1'	0.01	0 (0)	0 (0)	0.000 (0.000)	0.000 (0.000)	0.000 (0.000)	0% (0%)
1 to < 2'	0.00	0 (0)	0 (0)	NX (NX)	NX (NX)	NX (NX)	NX (NX)
2 to < 3'	2.98	7 (0)	4 (1)	0.379 (0.000)	0.715 (17.874)	-0.336 (-17.874)	88.6% (100%)
3 to < 4'	3.49	11 (3)	2 (0)	0.402 (10.975)	0.263 (0.000)	0.140 (10.975)	-34.7% (-100%)
4 to < 5'	8.77	29 (0)	4 (0)	0.174 (0.000)	0.065 (0.000)	0.109 (0.000)	-62.6% (0%)
5 to < 6'	10.25	19 (1)	1 (0)	0.160 (0.843)	0.016 (0.000)	0.145 (0.843)	-90.2% (-100%)
6 to < 7'	24.47	43 (4)	10 (0)	0.124 (1.149)	0.046 (0.000)	0.077 (1.149)	-62.6% (-100%)
7 to < 8'	20.21	25 (1)	6 (1)	0.117 (0.469)	0.069 (1.145)	0.049 (-0.676)	-41.4% (144.1%)
≥ 8'	7.27	4 (2)	2 (0)	0.066 (3.318)	0.026 (0.000)	0.040 (3.318)	-60.5% (-100%)
All	77.44	138 (11)	29 (2)	0.145 (1.155)	0.056 (0.386)	0.089 (0.770)	-61.4% (-66.6%)

NX = No Exposure Fatal & Serious Injury results are in ( ) with rate per 100 mVMT

**Figure 5.10 CLRS&SRS: ROTRR Rates by SRS Recovery Width – All Injury Severities**

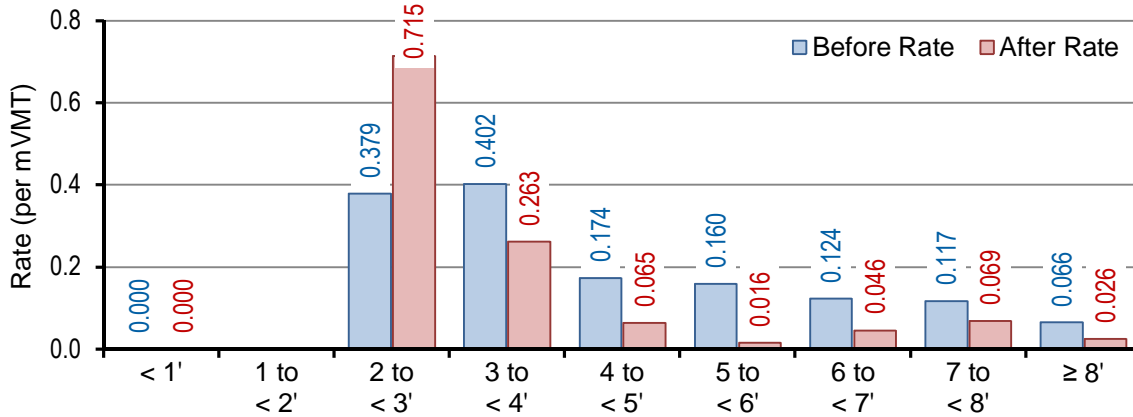

**CLRS&SRS: AADT**

The researchers also explored the performance of CLRS&SRS for various traffic volumes on the roadway segments, in an attempt to determine whether traffic volumes influenced crash experience. In this study, the average annual daily traffic (AADT) for each collision location was assigned an AADT value for that 1/100 of a mile where the collision occurred. The AADT values for each 1/100 of a mile location within this study were supplied by the SCTDO Highway Usage Branch and calculated by the Miletraf algorithm. These values were then grouped into the defined ranges listed in [Table 5.13](#). This provided a more accurate depiction of the traffic volumes where individual collisions occurred than a weighted average applied over the entire study segment length. The researchers chose to examine the data by bands segmented by 2000 vehicles, from < 2000 up to the 14,000 AADT. The next higher range spanned 3000 vehicles, and then the largest volume band was defined as > 17,000 vehicles. This same set of ranges was used in the 2011 CLRS study.

## ■ Lane Departure Crashes

Table 5.13 displays the performance of CLRS&SRS locations broken down by AADT values. The majority of the exposure for the CLRS&SRS installations is on highways with AADT levels below 8000. There were reductions in the collision rates of all lane departure events except for the 10,000 to 11,999 range. This AADT range represents the shortest length of exposure in the analysis.

**Table 5.13 CLRS&SRS: Lane Departure Rates by AADT**

Range	Miles	Before Crash Count	After Crash Count	Before Crash Rate	After Crash Rate	Difference in Rate	% Change in Rate
< 2000	0.00	0 (0)	0 (0)	NX (NX)	NX (NX)	NX (NX)	NX (NX)
2000 to 3999	12.08	35 (4)	7 (0)	0.445 (5.084)	0.400 (0.000)	0.045 (5.084)	-10.2% (-100%)
4000 to 5999	27.17	78 (10)	8 (3)	0.371 (4.758)	0.103 (3.855)	0.268 (0.903)	-72.3% (-19.0%)
6000 to 7999	15.36	34 (2)	13 (0)	0.169 (0.993)	0.091 (0.000)	0.077 (0.993)	-45.9% (-100%)
8000 to 9999	4.34	19 (1)	0 (0)	0.297 (1.562)	0.000 (0.000)	0.297 (1.562)	-100% (-100%)
10,000 to 11,999	0.63	3 (2)	2 (1)	0.219 (14.579)	0.338 (16.889)	-0.119 (-2.309)	54.5% (15.8%)
12,000 to 13,999	7.19	29 (2)	4 (1)	0.239 (1.652)	0.046 (1.158)	0.193 (0.494)	-80.7% (-29.9%)
14,000 to 16,999	6.46	31 (3)	8 (2)	0.232 (2.249)	0.072 (1.793)	0.161 (0.456)	-69.1% (-20.3%)
≥ 17,000	4.22	31 (5)	10 (2)	0.239 (3.857)	0.158 (3.163)	0.081 (0.694)	-33.9% (-18.0%)
All	77.44	260 (29)	52 (9)	0.273 (3.046)	0.100 (1.735)	0.173 (1.310)	-63.3% (-43.0%)

NX = No Exposure

Fatal & Serious Injury results are in ( ) with rate per 100 mVMT

## ■ Crossover Crashes

Table 5.14 and Figure 5.11 illustrate the observed performance of the cross-centerline component and the AADT values. Reduced crash rates were found across most of the ranges, with a few exceptions at the 10,000 to 11,999 and 12,000 to 13,999 bands. The 2011 CLRS study found that cross-centerline collisions occurred more frequently at lower AADT volumes. The CLRS&SRS data here does not seem to indicate the same trend; however, that may be influenced by the crash counts. The 2011 CLRS Report had more miles under study above the 8000 AADT band than this study has in its entirety. What appears to be clear is that, with minor exceptions, CLRS&SRS are reducing cross-centerline events across the AADT bands examined.

**Table 5.14 CLRS&SRS: Crossover Rates by AADT**

Range	Miles	Before Crash Count	After Crash Count	Before Crash Rate	After Crash Rate	Difference in Rate	% Change in Rate
< 2000	0.00	0 (0)	0 (0)	NX (NX)	NX (NX)	NX (NX)	NX (NX)
2000 to 3999	12.08	17 (1)	2 (0)	0.216 (1.271)	0.114 (0.000)	0.102 (1.271)	-47.2% (-100%)
4000 to 5999	27.17	36 (6)	3 (2)	0.171 (2.855)	0.039 (2.570)	0.133 (0.285)	-77.5% (-10.0%)
6000 to 7999	15.36	13 (0)	6 (0)	0.065 (0.000)	0.042 (0.000)	0.022 (0.000)	-34.7% (0%)
8000 to 9999	4.34	10 (1)	0 (0)	0.156 (1.562)	0.000 (0.000)	0.156 (1.562)	-100% (-100%)
10,000 to 11,999	0.63	2 (2)	1 (1)	0.146 (14.579)	0.169 (16.889)	-0.023 (-2.309)	15.8% (15.8%)
12,000 to 13,999	7.19	16 (1)	2 (1)	0.132 (0.826)	0.023 (1.158)	0.109 (-0.332)	-82.5% (40.2%)
14,000 to 16,999	6.46	17 (2)	4 (1)	0.127 (1.499)	0.036 (0.896)	0.092 (0.603)	-71.9% (-40.2%)
≥ 17,000	4.22	11 (5)	5 (2)	0.085 (3.857)	0.079 (3.163)	0.006 (0.694)	-6.8% (-18.0%)
All	77.44	122 (18)	23 (7)	0.128 (1.890)	0.044 (1.350)	0.084 (0.541)	-65.4% (-28.6%)

NX = No Exposure

Fatal & Serious Injury results are in ( ) with rate per 100 mVMT

**Figure 5.11 CLRS&SRS: Crossover Rates by AADT – All Injury Severities**

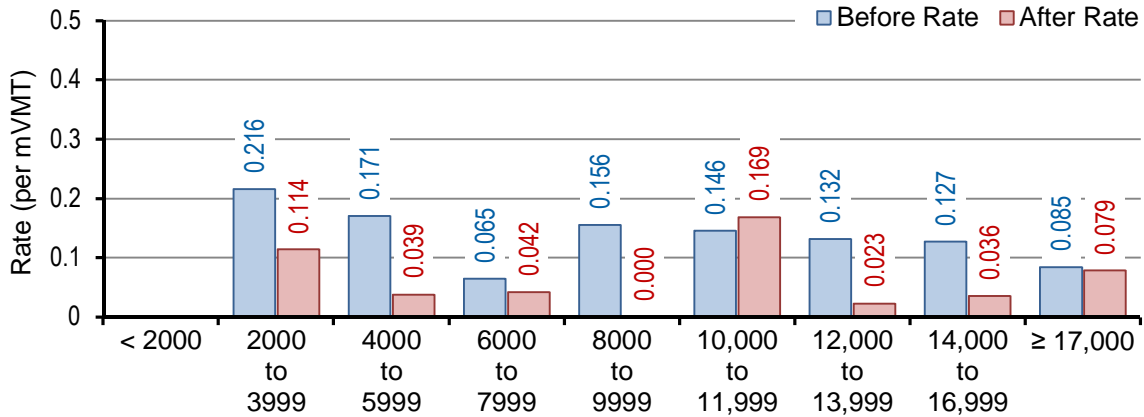

■ ROTRR Crashes

Table 5.15 and Figure 5.12 illustrate the effect of the CLRS&SRS installations with ROTRR experience and the relationship with AADT. The ROTRR experience across the AADT bands exhibits some variability. In most cases, the reduction in collision rates is substantial. Overall, CLRS&SRS are reducing ROTRR crashes at AADT levels above 4000. The 10,000 to 11,999 range indicates an increased collision rate; however, the limited mileage and small crash counts do not generate much confidence in the crash rates for this range.

**Table 5.15 CLRS&SRS: ROTRR Rates by AADT**

Range	Miles	Before Crash Count	After Crash Count	Before Crash Rate	After Crash Rate	Difference in Rate	% Change in Rate
< 2000	0.00	0 (0)	0 (0)	NX (NX)	NX (NX)	NX (NX)	NX (NX)
2000 to 3999	12.08	18 (3)	5 (0)	0.229 (3.813)	0.285 (0.000)	-0.057 (3.813)	24.8% (-100%)
4000 to 5999	27.17	42 (4)	5 (1)	0.200 (1.903)	0.064 (1.285)	0.136 (0.618)	-67.8% (-32.5%)
6000 to 7999	15.36	21 (2)	7 (0)	0.104 (0.993)	0.049 (0.000)	0.055 (0.993)	-52.8% (-100%)
8000 to 9999	4.34	9 (0)	0 (0)	0.141 (0.000)	0.000 (0.000)	0.141 (0.000)	-100% (0%)
10,000 to 11,999	0.63	1 (0)	1 (0)	0.073 (0.000)	0.169 (0.000)	-0.096 (0.000)	131.7% (0%)
12,000 to 13,999	7.19	13 (1)	2 (0)	0.107 (0.826)	0.023 (0.000)	0.084 (0.826)	-78.4% (-100%)
14,000 to 16,999	6.46	14 (1)	4 (1)	0.105 (0.750)	0.036 (0.896)	0.069 (-0.147)	-65.8% (19.6%)
≥ 17,000	4.22	20 (0)	5 (0)	0.154 (0.000)	0.079 (0.000)	0.075 (0.000)	-48.7% (0%)
All	77.44	138 (11)	29 (2)	0.145 (1.155)	0.056 (0.386)	0.089 (0.770)	-61.4% (-66.6%)

NX = No Exposure

Fatal & Serious Injury results are in ( ) with rate per 100 mVMT

**Figure 5.12 CLRS&SRS: ROTRR Rates by AADT – All injury Severities**

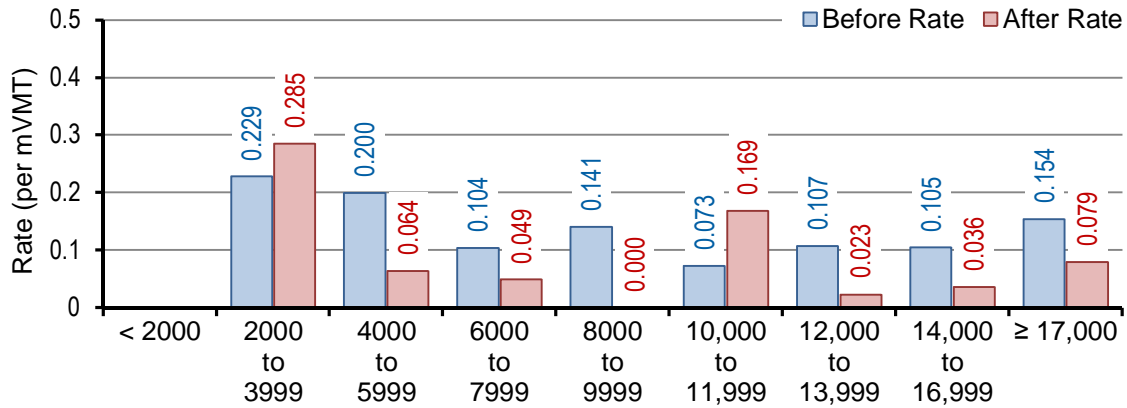

### CLRS&SRS: Horizontal Alignment

The researchers evaluated roadway geometry in this study to determine whether the performance of CLRS&SRS pattern rumble strips was influenced by the horizontal alignment of the roadway, comparing crashes on curves with crashes on tangent (straight) sections of the roadway.

Individual crashes were evaluated to determine whether they occurred on a tangent or were related to a curve in the roadway. A curve relationship was based on either of two conditions: the crash occurred within the physical limits of a horizontal curve per the State Horizontal Alignment dataset or, based on review of the collision report, the research team concluded that a horizontal curve influenced the collision. For example, the team may have identified a collision where the driver straightened out a curve or overcorrected entering or exiting a horizontal curve in the roadway.

#### ■ Lane Departure Crashes

In evaluating lane departure collision experience on curves, the researchers had an interest in evaluating whether curve direction had a significant influence on vehicles crossing the centerline or running off the road to the right. However, the direction of vehicle travel and the direction of a curve listed in the collision record contributed to confusion in making this determination.

In the geometric data, curve direction is normally described as to the left or to the right, based on the increasing milepost direction of the state route. From a driver’s perspective, a curve to the right in one direction is a curve to the left in the opposite direction. Consequently, relating to the curve direction as recorded in the Highway Log geometric dataset may contradict a driver’s perspective. Using the descriptors of inside or outside a curve, coupled with the direction of the errant vehicle, offers a more meaningful perspective. This approach associates curvature to the perspective of the driver, regardless of whether the vehicle is traveling in the increasing or decreasing milepost direction. For a curve to the right, a departure to the left is classified as outside the curve and a departure to the right is classified as inside the curve. It is this inside and outside perspective that is used in this analysis. For calculating collision rates for the inside or outside of a curve, the VMT was halved as the roadway was evaluated, as if it were a single direction of travel for each of the evaluated portions.

Figure 5.13 illustrates the inside or outside of a curve lane departure collisions.

**Figure 5.13 Inside vs. Outside Curve Crash Illustration**

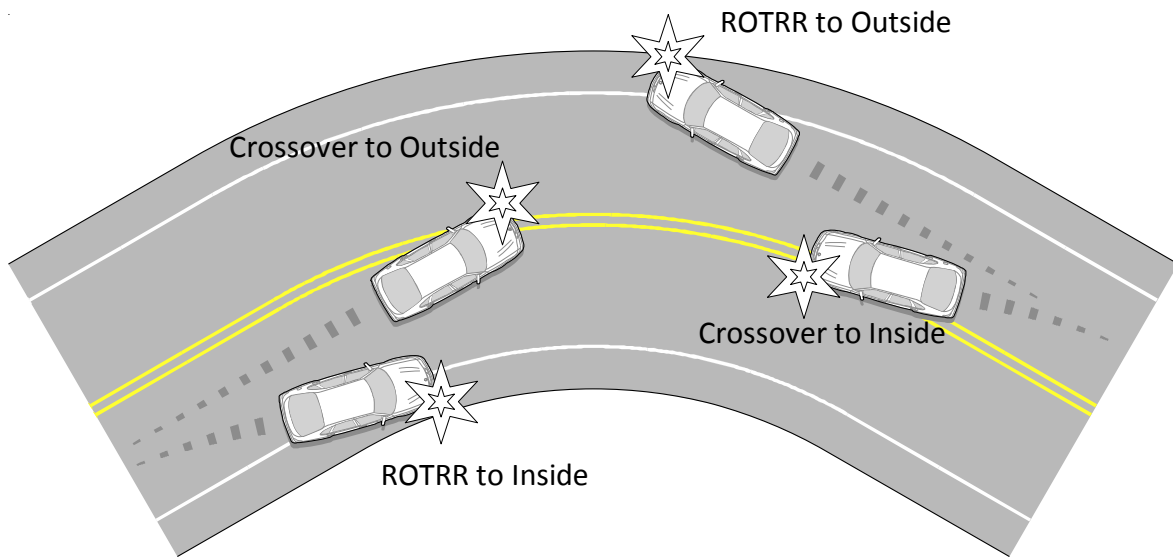

Table 5.16 illustrates the performance findings of the CLRS&SRS installations in relation to the horizontal alignment of tangents and curves for all lane departure collisions. A comparison of crash rates before and after CLRS&SRS were installed indicates a substantial reduction, regardless of whether the crashes occurred on a tangent or a curvilinear roadway. For All Injury Severities events, a 67.9% reduction in the collision rate was recorded for the tangent sections. For the curve-related collisions, a 52.9% reduction was noted. Substantial reductions were found in Fatal & Serious Injury collision rates as well, with a 50.1% reduction on tangent sections and a 28.4% reduction in curve-related crashes.

**Table 5.16 CLRS&SRS: Lane Departure Rates by Horizontal Alignment**

Horizontal Alignment	Miles	Before Crash Count	After Crash Count	Before Crash Rate	After Crash Rate	Difference in Rate	% Change in Rate
Tangent	58.70	168 (18)	30 (5)	0.232 (2.482)	0.074 (1.240)	0.157 (1.242)	-67.9% (-50.1%)
Curve	18.74	92 (11)	22 (4)	0.405 (4.846)	0.191 (3.468)	0.215 (1.378)	-52.9% (-28.4%)
Inside*		31 (1)	10 (2)	0.273 (0.881)	0.173 (3.468)	0.100 (-2.587)	-36.5% (293.7%)
Outside*		61 (10)	12 (2)	0.537 (8.811)	0.208 (3.468)	0.329 (5.343)	-61.3% (-60.6%)

\*Rates based on half of the curve VMT.

Fatal & Serious Injury results are in ( ) with rate per 100 mVMT

As they began evaluating collision experience to the inside or the outside of a curve, the researchers anticipated an increased collision rate to the outside of a curve, consistent with the 2011 CLRS study. Table 5.16 validates this expectation, as the collision rate for departures to the outside of a curve is greater than that to the inside. This holds true whether looking at the period before or after CLRS&SRS installation. More driver influence is necessary with steering and/or acceleration/braking to result in a collision on the inside of a curve. However, a drowsy or distracted driver can easily miss the curve and run off the road to the outside of the curve with little driver input.

Figure 5.14 illustrates the difference in lane departure crash rates for tangents versus horizontal curves. The collision rate for curves is almost twice that of tangent roadway segments when looking at All Injury Severities collisions. The comparison in crash rates between the inside and outside of a curve yields similar findings. Before CLRS&SRS were installed, the crash rates for lane departures to the outside of the curve were roughly double the rate of lane departure crashes to the inside of the curve. The collision rates are more similar following the installation of CLRS&SRS; however, the rate for the outside of the curve is still roughly 20% higher.

**Figure 5.14 CLRS&SRS: Lane Departure Rates by Horizontal Alignment – All Injury Severities**

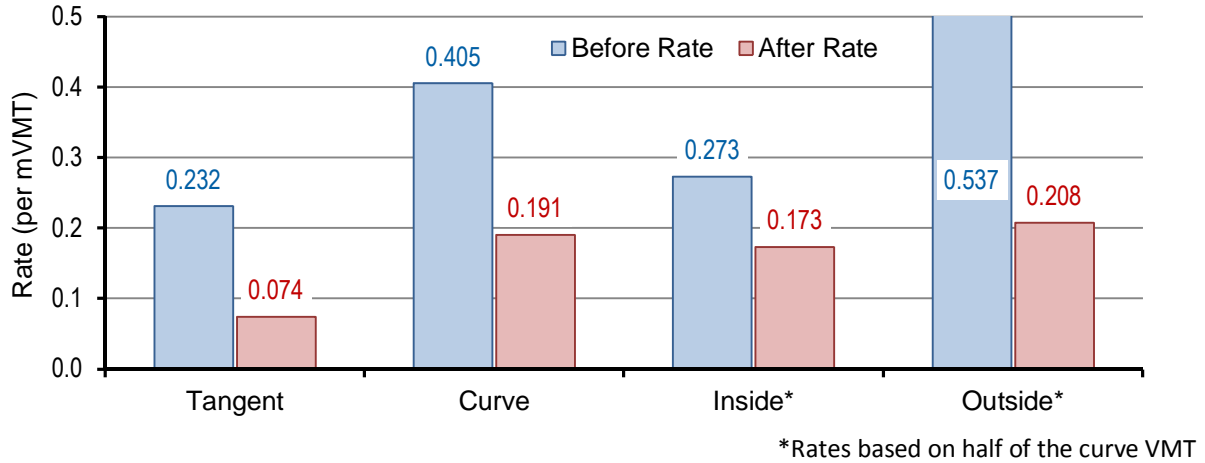
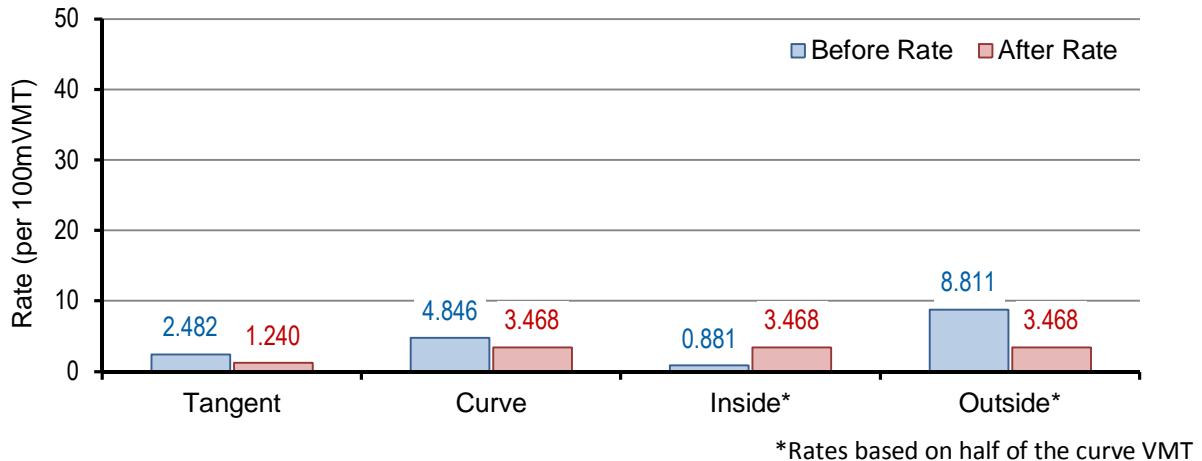

Figure 5.15 illustrates the Fatal & Serious Injury collision rates for horizontal curves and tangents. The rate for Fatal & Serious Injury crashes on curves is again nearly double the rate for tangent roadways prior to CLRS&SRS installation. Prior to CLRS&SRS installation, the Fatal & Serious Injury crash rates for lane departures to the outside of a curve are ten times higher than for crashes to the inside of a curve. CLRS&SRS installation is associated with moderate reductions in Fatal & Serious Injury crash rates for tangents and curves in general. However, the rate of Fatal & Serious Injury crashes went way up for crashes to the inside of a curve. This change in rates reflects one Fatal & Serious Injury crash on the inside of a curve prior to CLRS&SRS installation and two after installation.

**Figure 5.15 CLRS&SRS: Lane Departure Rates by Horizontal Alignment – Fatal & Serious Injury**



■ Crossover Crashes

Collision rates for cross-centerline collisions are provided in Table 5.17. Similar to findings with lane departure crashes, crossover crashes occurred at higher rates on curves than on tangents, and to the outside of a curve more frequently than to the inside of a curve. The lone exception to this trend is an observation that the rate for Fatal & Serious Injury crashes to the inside of a curve is higher than to the outside of a curve after the installation of CLRS&SRS.

**Table 5.17 CLRS&SRS: Crossover Rates by Horizontal Alignment**

Horizontal Alignment	Miles	Before Crash Count	After Crash Count	Before Crash Rate	After Crash Rate	Difference in Rate	% Change in Rate
Tangent	58.70	74 (13)	12 (4)	0.102 (1.793)	0.030 (0.992)	0.072 (0.801)	-70.8% (-44.7%)
Curve	18.74	48 (5)	11 (3)	0.211 (2.203)	0.095 (2.601)	0.116 (-0.399)	-54.9% (18.1%)
Inside*		16 (0)	5 (2)	0.141 (0.000)	0.087 (3.468)	0.054 (-3.468)	-38.5% (100%)
Outside*		32 (5)	6 (1)	0.282 (4.406)	0.104 (1.734)	0.178 (2.671)	-63.1% (-60.6%)

\*Rates based on half of the curve VMT.

Fatal & Serious Injury results are in ( ) with rate per 100 mVMT

Figure 5.16 illustrates the difference in cross-centerline crash rates for tangents versus horizontal curves. The collision rate for curves is generally double that of tangent roadway segments when looking at All Injury Severities collisions. Prior to the installation of CLRS&SRS, the comparison in crash rates between the inside and outside of a curve yields similar findings. After CLRS&SRS were installed, the crash rates for lane departures to the outside of the curve were approximately 20% higher than the rate of lane departure crashes to the inside of the curve.

**Figure 5.16 CLRS&SRS: Crossover Rates by Horizontal Alignment – All Injury Severities**

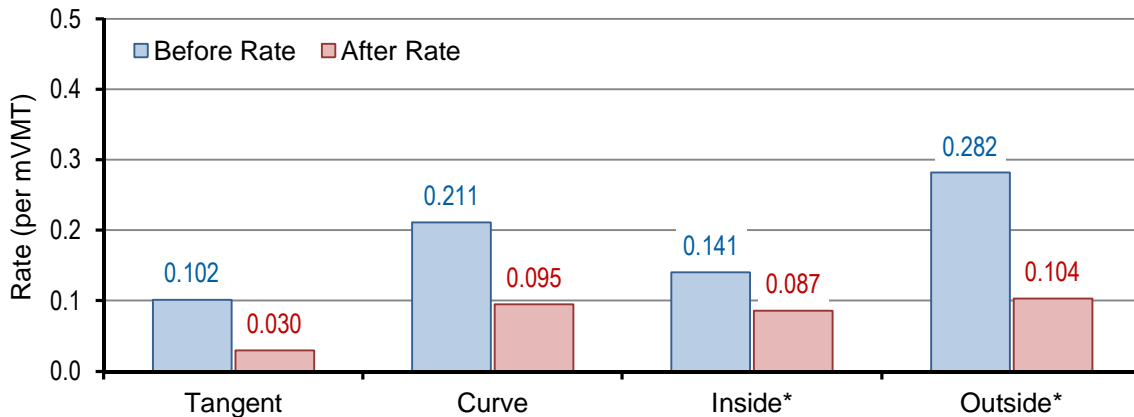

\*Rates based on half of the curve VMT

Figure 5.17 shows the Fatal & Serious Injury collision rates, which were reduced 44.7% on tangent segments. The curve segments saw an increase in the Fatal & Serious Injury collision rate of 18.1%. The Fatal & Serious Injury rate increased to the inside of curves as a result of no fatal or serious injuries in the before period and two in the after period. The outside of curves data reflects a 60.6% decrease in Fatal & Serious Injury events.



**Figure 5.17 CLRS&SRS: Crossover Rates by Horizontal Alignment – Fatal & Serious Injury**

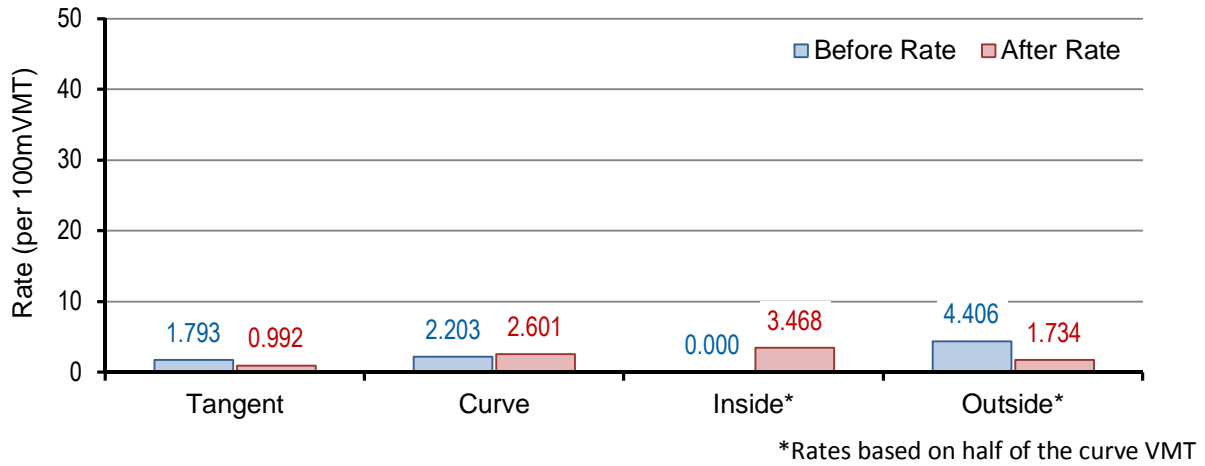

■ ROTRR Crashes

Table 5.18 shows the experience recorded for the ROTRR collision events for CLRS&SRS installations. Figures 5.18 and 5.19 display the rates by All Injury Severities and Fatal & Serious Injury, respectively. As in the crossover experience, curve-related collisions occur at a higher rate than those on tangents. This trend is the same before and after installation of CLRS&SRS.

**Table 5.18 CLRS&SRS: ROTRR Rates by Horizontal Alignment**

Horizontal Alignment	Miles	Before Crash Count	After Crash Count	Before Crash Rate	After Crash Rate	Difference in Rate	% Change in Rate
Tangent	58.70	94 (5)	18 (1)	0.130 (0.689)	0.045 (0.248)	0.085 (0.442)	-65.6% (-64.0%)
Curve	18.74	44 (6)	11 (1)	0.194 (2.643)	0.095 (0.867)	0.098 (1.776)	-50.8% (-67.2%)
Inside*		15 (1)	5 (0)	0.132 (0.881)	0.087 (0.000)	0.045 (0.881)	-34.4% (-100%)
Outside*		29 (5)	6 (1)	0.256 (4.406)	0.104 (1.734)	0.151 (2.671)	-59.3% (-60.6%)

\*Rates based on half of the curve VMT.

Fatal & Serious Injury results are in ( ) with rate per 100 mVMT

**Figure 5.18 CLRS&SRS: ROTRR Rates by Horizontal Alignment – All Injury Severities**

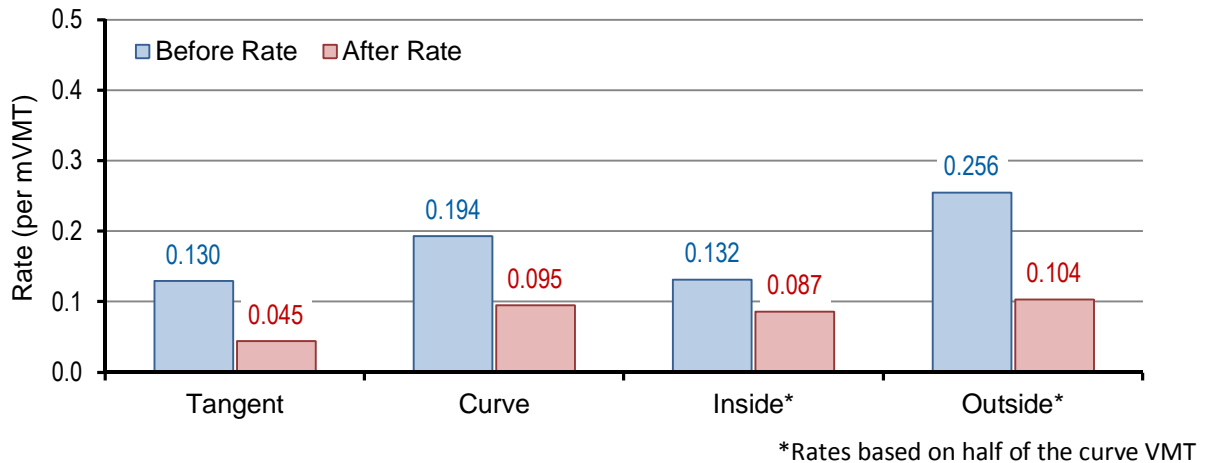

**Figure 5.19 CLRS&SRS: ROTRR Rates by Horizontal Alignment – Fatal & Serious Injury**

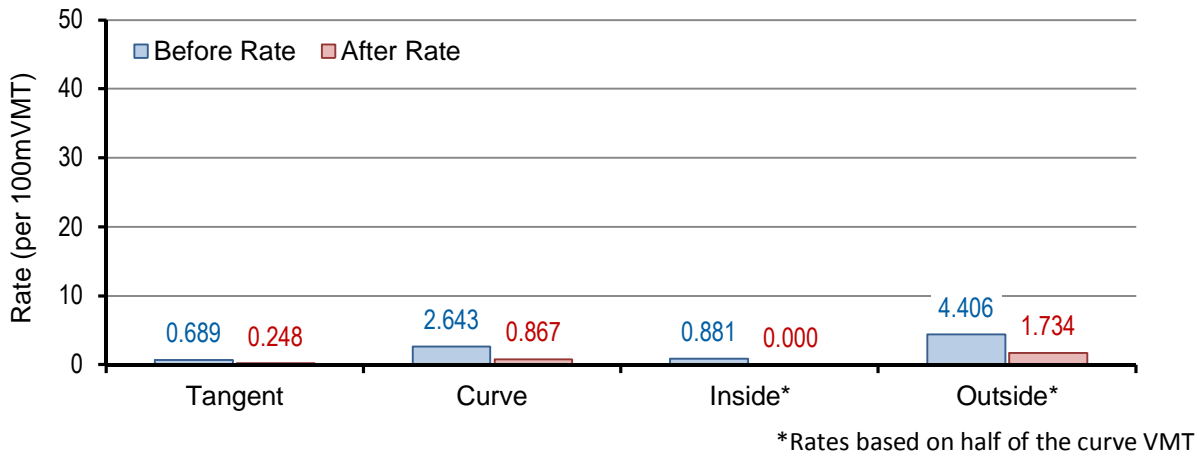

The installation of rumble strips reduced the rate of ROTRR collisions for tangents and curves, and for all types of injury severities. CLRS&SRS appear to be more effective in reducing collision events on the tangent sections than on the curve portions. A 65.6% reduction in All Injury Severities collisions was recorded for the tangents, where a 50.8% reduction was noted in the curve portions of the roadway segments. Rumble strips were more effective in reducing collisions to the outside of curves than to the inside, as shown in [Table 5.18](#) and [Figures 5.18](#) and [5.19](#). A 59.3% reduction in collisions to the outside of curves in comparison to a 34.4% reduction to the inside of curves was recorded.

**CLRS&SRS: Percent/Length Curve**

As noted previously, the researchers found that the lane departure collision frequency is greater within (or when influenced by) horizontal curves. An attempt to quantify the degree of curvature was made, but the horizontal curve dataset was incomplete. Instead, the researchers identified and defined the length of the curves in a segment and used this length to calculate the horizontal curves as a percentage of the overall segment’s length. This approach did not allow for an investigation of the degree of curvature; it did, however, offer another view of the performance of the rumble strip combinations against curves or tangent sections of the roadway.

■ Lane Departure Crashes

[Table 5.19](#) shows that the performance for All Injury Severities events, with a single exception, is positive. The 50 to < 60% range, which had only 0.32 of a mile of exposure, had no collisions in the before period and one in the after. In all other percent length bands, the rate of collision events was reduced. For the Fatal & Serious Injury events, there were reductions in the collision rates for all but two ranges. The 20 to < 30% range saw a modest increase in the collision rate of 2.7%, and the 50 < 60% range had no change.

**Table 5.19 CLRS&SRS: Lane Departure Rates by Percent/Length Curve**

Range*	Miles	Before Crash Count	After Crash Count	Before Crash Rate	After Crash Rate	Difference in Rate	% Change in Rate
0 to < 10%	5.74	14 (0)	2 (0)	0.261 (0.000)	0.108 (0.000)	0.152 (0.000)	-58.4% (0%)
10 to < 20%	31.18	91 (8)	27 (4)	0.195 (1.717)	0.082 (1.208)	0.114 (0.508)	-58.2% (-29.6%)
20 to < 30%	16.39	76 (6)	8 (2)	0.315 (2.484)	0.102 (2.552)	0.213 (-0.068)	-67.6% (2.7%)
30 to < 40%	22.03	62 (10)	8 (2)	0.422 (6.806)	0.136 (3.391)	0.286 (3.415)	-67.9% (-50.2%)
40 to < 50%	0.00	0 (0)	0 (0)	NX (NX)	NX (NX)	NX (NX)	NX (NX)
50 to < 60%	0.32	0 (0)	1 (0)	0.000 (0.000)	0.075 (0.000)	-0.075 (0.000)	100% (0%)
60 to < 70%	1.78	17 (5)	6 (1)	0.436 (12.825)	0.324 (5.406)	0.112 (7.419)	-25.6% (-57.9%)
≥ 80%	0.00	0 (0)	0 (0)	NX (NX)	NX (NX)	NX (NX)	NX (NX)
All	77.44	260 (29)	52 (9)	0.273 (3.046)	0.100 (1.735)	0.173 (1.310)	-63.3% (-43.0%)

\*Determined per segment, then grouped NX = No Exposure Fatal & Serious Injury results are in ( ) with rate per 100 mVMT

Figure 5.20 diagrams the data in Table 5.19. The general trend is that the crash rates increase as the alignment gets more curvilinear. The range of 10 to < 20% is an exception to this trend.

**Figure 5.20 CLRS&SRS: Lane Departure Rates by Percent/Length Curve – All Injury Severities**

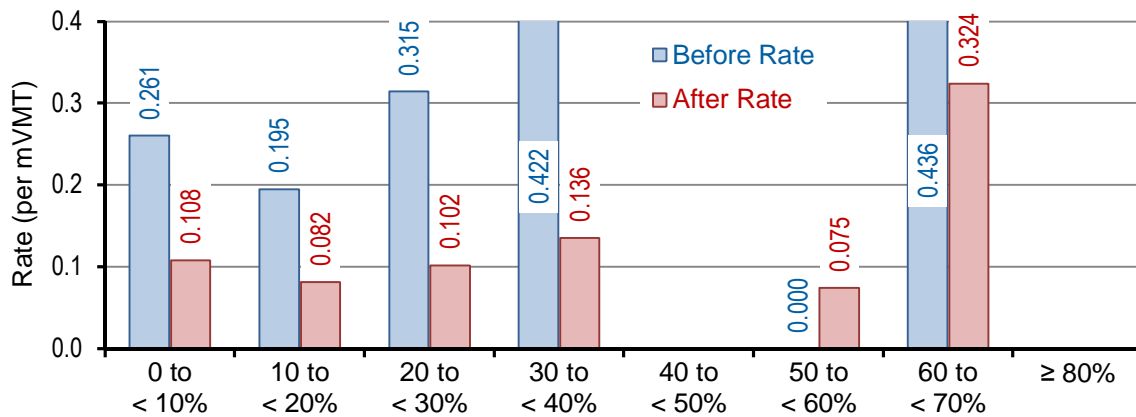

■ Crossover Crashes

For the crossover collision dataset, the results were again positive in nearly all cases and injury classes, as shown in Table 5.20. The 50 to < 60% range lists no crashes prior to rumble strips, and a single incident after rumble strips were installed, yielding a 100% increase in the rates. The small sample represented in this range allows a single event to result in large percentage changes in the crash rates. For the rest of the ranges, in the All Injury Severities category, the collision rate reductions were significant.

**Table 5.20 CLRS&SRS: Crossover Rates by Percent/Length Curve**

Range*	Miles	Before Crash Count	After Crash Count	Before Crash Rate	After Crash Rate	Difference in Rate	% Change in Rate
0 to < 10%	5.74	6 (0)	0 (0)	0.112 (0.000)	0.000 (0.000)	0.112 (0.000)	-100% (0%)
10 to < 20%	31.18	36 (5)	11 (3)	0.077 (1.073)	0.033 (0.906)	0.044 (0.166)	-57.0% (-15.5%)
20 to < 30%	16.39	38 (4)	4 (1)	0.157 (1.656)	0.051 (1.276)	0.106 (0.380)	-67.6% (-22.9%)
30 to < 40%	22.03	32 (5)	5 (2)	0.218 (3.403)	0.085 (3.391)	0.133 (0.012)	-61.1% (-0.4%)
40 to < 50%	0.00	0 (0)	0 (0)	NX (NX)	NX (NX)	NX (NX)	NX (NX)
50 to < 60%	0.32	0 (0)	1 (0)	0.000 (0.000)	0.075 (0.000)	-0.075 (0.000)	100% (0%)
60 to < 70%	1.78	10 (4)	2 (1)	0.256 (10.260)	0.108 (5.406)	0.148 (4.854)	-57.9% (-47.3%)
≥ 80%	0.00	0 (0)	0 (0)	NX (NX)	NX (NX)	NX (NX)	NX (NX)
All	77.44	122 (18)	23 (7)	0.128 (1.890)	0.044 (1.350)	0.084 (0.541)	-65.4% (-28.6%)

\*Determined per segment, then grouped NX = No Exposure Fatal & Serious Injury results are in ( ) with rate per 100 mVMT

Figure 5.21 reflects the All Injury Severities events from Table 5.20. This figure illustrates the same trend as Figure 5.20, where the collision rates increase as the percentage of curvature increases. The data indicates that the reductions in the collision rates are relatively consistent across the ranges, with crash rate reductions of roughly 60% across all ranges that have any substantial crash counts.

**Figure 5.21 CLRS&SRS: Crossover Rates by Percent/Length Curve – All Injury Severities**

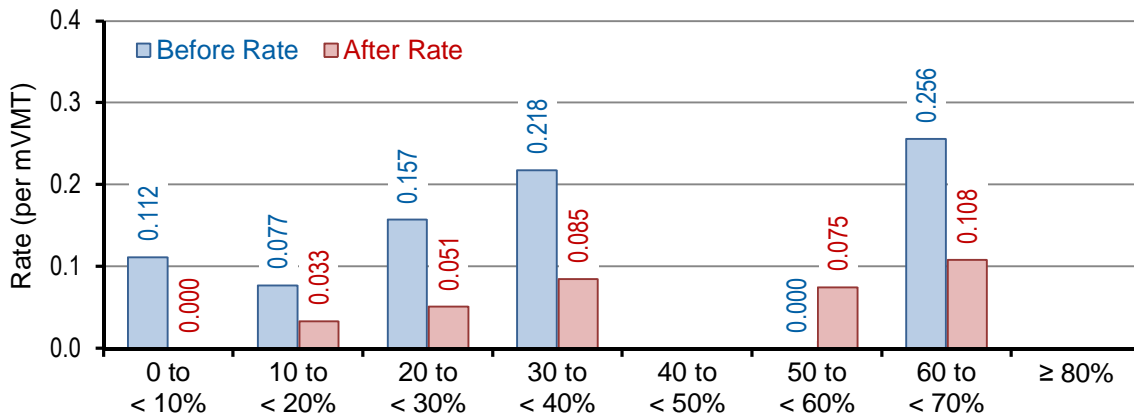

For the Fatal & Serious Injury crossover collisions, stratified by percent/length curve, the results continue to be positive, although much more modest in the reductions. In Figure 5.22, the greatest reduction in the Fatal & Serious Injury component was observed in the 60 to < 70% range, where a 47.3% drop in the rate was recorded. Double-digit reductions were also noted in the 10 to < 20% and 20 to < 30% ranges, where 15.5% and 22.9% reductions were recorded.

A clear trend is obvious in all of these views of the percent/length curve data: the greater the percentage of a curvilinear alignment, the greater the collision rate.

**Figure 5.22 CLRS&SRS: Crossover Rates by Percent/Length Curve – Fatal & Serious Injury**

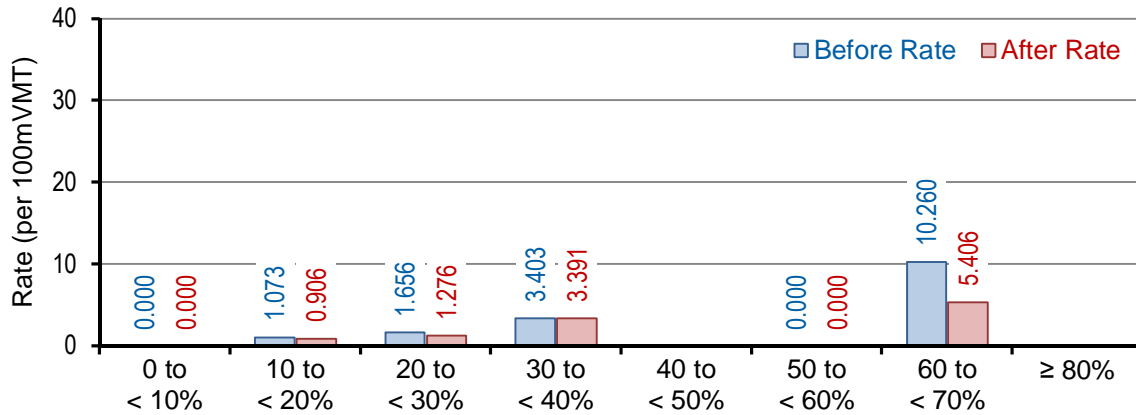

■ ROTRR Crashes

Table 5.21 and Figures 5.23 and 5.24 depict the impact of CLRS&SRS installations on ROTRR collisions when examined by the percent/length curve.

An increase in the collision rate was observed in only the 60 to < 70% range. This range had 1.78 miles of exposure, with seven collisions before the CLRS&SRS installation and four after. Similar results were observed in the Fatal & Serious Injury ROTRR data, with reductions across all ranges except the 20 to < 30% range. In this range, two Fatal & Serious Injury events prior to rumble strips and a single event after resulted in a 54.1% increase in the crash rate.

**Table 5.21 CLRS&SRS: ROTRR Rates by Percent/Length Curve**

Range*	Miles	Before Crash Count	After Crash Count	Before Crash Rate	After Crash Rate	Difference in Rate	% Change in Rate
0 to < 10%	5.74	8 (0)	2 (0)	0.149 (0.000)	0.108 (0.000)	0.041 (0.000)	-27.2% (0%)
10 to < 20%	31.18	55 (3)	16 (1)	0.118 (0.644)	0.048 (0.302)	0.070 (0.342)	-59.0% (-53.1%)
20 to < 30%	16.39	38 (2)	4 (1)	0.157 (0.828)	0.051 (1.276)	0.106 (-0.448)	-67.6% (54.1%)
30 to < 40%	22.03	30 (5)	3 (0)	0.204 (3.403)	0.051 (0.000)	0.153 (3.403)	-75.1% (-100%)
40 to < 50%	0.00	0 (0)	0 (0)	NX (NX)	NX (NX)	NX (NX)	NX (NX)
50 to < 60%	0.32	0 (0)	0 (0)	0.000 (0.000)	0.000 (0.000)	0.000 (0.000)	0% (0%)
60 to < 70%	1.78	7 (1)	4 (0)	0.180 (2.565)	0.216 (0.000)	-0.037 (2.565)	20.4% (-100%)
≥ 80%	0.00	0 (0)	0 (0)	NX (NX)	NX (NX)	NX (NX)	NX (NX)
All	77.44	138 (11)	29 (2)	0.145 (1.155)	0.056 (0.386)	0.089 (0.770)	-61.4% (-66.6%)

\*Determined per segment, then grouped      NX = No Exposure      Fatal & Serious Injury results are in ( ) with rate per 100 mVMT

**Figure 5.23 CLRS&SRS: ROTRR Rates by Percent/Length Curve – All Injury Severities**

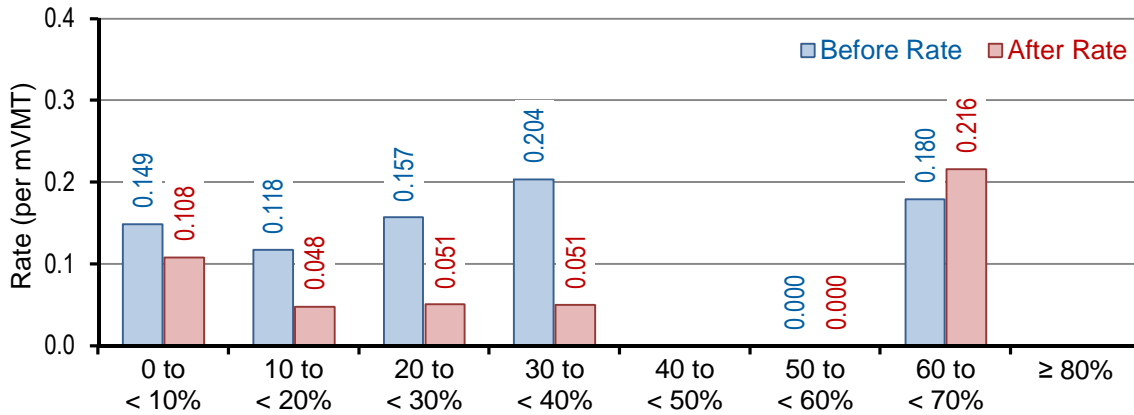

**Figure 5.24 CLRS&SRS: ROTRR Rates by Percent/Length Curve – Fatal & Serious Injury**

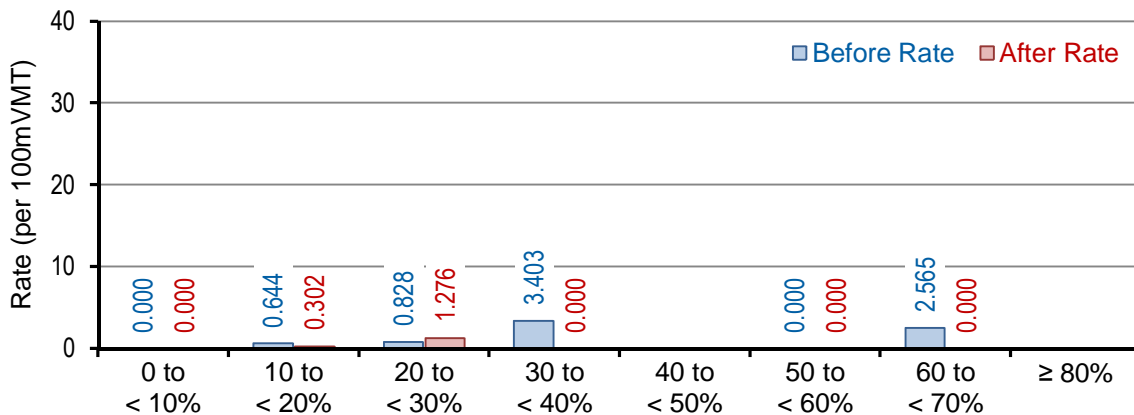

### CLRS&SRS Summary

The combination installation of CLRS&SRS on 77.44 miles of Washington State highways resulted in a 63.3% reduction in lane departure crashes. A 65.4% reduction was observed for crossover crash rates, and a 61.4% reduction in ROTRR crash rates was found. Lane departure crash rates where drivers were Asleep or Fatigued (A/F) were reduced by 79.4%, and Inattentive or Distracted (I/D) crash rates declined by 64.8%. Reductions from 44% to 54% were observed for all other contributing circumstances analyzed. Reductions in A/F crash rates were nearly identical for crossover crashes and ROTRR crashes. For I/D crashes, the reduction in ROTRR crash rates (72.2%) was more substantial than the 47.5% reduction in crossover crash rates.

CLRS&SRS installations appear to be more effective at higher speeds, although the sample data is too limited at lower speeds for conclusive results. A 49.2% reduction was noted for locations with posted speeds of 50 mph. For speeds of 55 and 60 mph, crash rates were reduced 58.4% and 64.8%, respectively.

Reduced crash rates for ROTRR crashes appear to be linked to shoulder width, with greater reductions associated with wider shoulders. When the shoulder width is 6 feet or greater, the reductions in crash rates were found to be approximately 60% or more. A similar look at remaining shoulder width beyond the SRS evaluated “SRS recovery width.” Lane departure crash rates were reduced by 49% to 79% for SRS recovery widths greater than 4 feet.

Crash rates may be influenced by traffic volume. Prior to rumble strip installation, locations below 6000 AADT had the highest rates of lane departure, crossover, and ROTRR crashes. It isn't clear whether this is actually influenced by the traffic volume, or whether there are more curves and narrower shoulders/SRS recovery widths on these lower-volume highways. Interestingly, the greatest influence of CLRS&SRS on crash rates seems to be with higher AADT levels, with the highest reductions in crash rates occurring at AADT levels from 12,000 to 13,999 AADT.

Crash rates for lane departure collisions are notably higher for highway segments within horizontal curves compared to crash rates on tangents. This holds true before CLRS&SRS installation and after. Although the reduction for curves was substantial, the greatest crash rate reductions were observed for tangent roadways. Reductions in crossover crash rates were several percentage points better than ROTRR reductions. As expected, crash rates for lane departures to the outside of a curve are much higher than lane departures to the inside of a curve.

The researchers explored what percentage of a highway segment's length is within the limits of a horizontal curve. This analysis revealed that the vast majority of the segments sampled range from 10% to 40% of the alignment within the boundaries of horizontal curves. 55% or greater reductions in lane departure, crossover, and ROTRR crash rates were found for these alignments.

## SECTION 6: SRS+CLRS

SRS+CLRS is defined as an installation of CLRS on a segment of roadway where SRS have previously been installed. The rumble strip dimensions for SRS+SRS are the same as the CLRS&SRS evaluation. This study evaluated what changes in crash experience resulted from the addition of CLRS to existing SRS installations. It was expected that the significant changes would be reflected in cross-centerline crash experience.

The data available for analysis of SRS+CLRS encompassed 38.93 miles and had 40 collisions in the period before CLRS were installed and 39 collisions after. The vehicle miles traveled (VMT) for the period prior to CLRS installation was 242.675 million and there were 426.911 million VMT after.

There were 38.93 miles of SRS+CLRS included in this study. These miles were studied to evaluate whether the addition of CLRS to existing SRS installations would decrease the rate of cross-centerline collisions while not adversely impacting the rate of ROTRR events. Much of the focus of this study was on the cross-centerline performance, with limited analysis of the ROTRR experience.

Table 6.1 illustrates the overall performance of the SRS+CLRS installations. These data indicate a significant reduction in the All Injury Severities collision rate at 64.7%, and a 24.2% reduction in the Fatal & Serious Injury rate. There was a modest change in the after rate for ROTRR collisions, with an 8.5% increase in All Injury Severities rate and no change in the Fatal & Serious Injury rate.

**Table 6.1 SRS+CLRS: Overall Performance**

Collision Type	Miles	Before Crash Count	After Crash Count	Before Crash Rate	After Crash Rate	Difference in Rate	% Change in Rate
Lane Departure	38.93	40 (3)	39 (4)	0.165 (1.236)	0.091 (0.937)	0.073 (0.299)	-44.6% (-24.2%)
Crossover	38.93	29 (3)	18 (4)	0.120 (1.236)	0.042 (0.937)	0.077 (0.299)	-64.7% (-24.2%)
ROTRR	38.93	11 (0)	21 (0)	0.045 (0.000)	0.049 (0.000)	-0.004 (0.000)	8.5% (0%)

Fatal & Serious Injury results are in ( ) with rate per 100 mVMT

### SRS+CLRS: Contributing Category

#### ■ Lane Departure Crashes

When examining contributing categories for All Injury Severities events in lane departure crashes associated with SRS+CLRS installations, reduced crash rates were observed following the addition of CLRS (see Table 6.2). This was true for all but one of the contributing categories. The category of “None” tallied one crash after adding the CLRS, while there weren’t any when just the SRS were in place. An officer would select this category when the circumstances that led to the collision were no fault of the driver. In reviewing this particular event, it was apparent that the reporting officer was unable to contact the vehicle driver. Consequently, it was not possible to reconstruct events contributing to the collision. There were substantial reductions in crash rates for the targeted behaviors of Asleep/Fatigued and Inattentive/Distracted. Results are mixed for Fatal & Serious Injury crashes, as might be expected with the small number of crashes available for analysis.



**Table 6.2 SRS+CLRS: Lane Departure Rates by Contributing Category**

Contributing Category*	Miles	Before Count	After Count	Before Rate	After Rate	Difference in Rate	% Change in Rate
A/F	38.93	9 (1)	8 (0)	0.037 (0.412)	0.019 (0.000)	0.018 (0.412)	-49.5% (-100%)
I/D	38.93	9 (0)	9 (0)	0.037 (0.000)	0.021 (0.000)	0.016 (0.000)	-43.2% (0%)
UI	38.93	5 (1)	4 (2)	0.021 (0.412)	0.009 (0.468)	0.011 (-0.056)	-54.5% (13.7%)
Speed	38.93	7 (0)	10 (0)	0.029 (0.000)	0.023 (0.000)	0.005 (0.000)	-18.8% (0%)
OCL	38.93	10 (1)	12 (3)	0.041 (0.412)	0.028 (0.703)	0.013 (-0.291)	-31.8% (70.5%)
Other	38.93	8 (0)	4 (0)	0.033 (0.000)	0.009 (0.000)	0.024 (0.000)	-71.6% (0%)
None	38.93	0 (0)	1 (0)	0.000 (0.000)	0.002 (0.000)	-0.002 (0.000)	100% (0%)

\*See [Appendix C](#)

Fatal &amp; Serious Injury results are in ( ) with rate per 100 mVMT

As mentioned previously, the SRS+CLRS study was expected to exhibit a greater influence on cross-centerline collisions than in the ROTRR events. [Table 6.3](#) illustrates the performance observed for the crossover collisions and their contributing categories. There were very large reductions in crash rates recorded in those contributing categories where a CLRS installation was expected to have the greatest effect. The Asleep/Fatigued category saw a 91.9% reduction in the collision rate after adding CLRS to the SRS locations. For the Inattentive/Distracted category, a 75.6% reduction was observed.

#### ■ Crossover Crashes

**Table 6.3 SRS+CLRS: Crossover Rates by Contributing Category**

Contributing Category*	Miles	Before Count	After Count	Before Rate	After Rate	Difference in Rate	% Change in Rate
A/F	38.93	7 (1)	1 (0)	0.029 (0.412)	0.002 (0.000)	0.027 (0.412)	-91.9% (-100%)
I/D	38.93	7 (0)	3 (0)	0.029 (0.000)	0.007 (0.000)	0.022 (0.000)	-75.6% (0%)
UI	38.93	3 (1)	4 (2)	0.012 (0.412)	0.009 (0.468)	0.003 (-0.056)	-24.2% (13.7%)
Speed	38.93	3 (0)	4 (0)	0.012 (0.000)	0.009 (0.000)	0.003 (0.000)	-24.2% (0%)
OCL	38.93	10 (1)	12 (3)	0.041 (0.412)	0.028 (0.703)	0.013 (-0.291)	-31.8% (70.5%)
Other	38.93	6 (0)	0 (0)	0.025 (0.000)	0.000 (0.000)	0.025 (0.000)	-100% (0%)
None	38.93	0 (0)	1 (0)	0.000 (0.000)	0.002 (0.000)	-0.002 (0.000)	100% (0%)

\*See [Appendix C](#)

Fatal &amp; Serious Injury results are in ( ) with rate per 100 mVMT

#### ■ ROTRR Crashes

[Table 6.4](#) tallies the results for ROTRR crashes. The crash counts available for analysis are small numbers, but do suggest a trend of increased ROTRR crashes when CLRS were added to SRS installations, particularly for targeted categories of A/F and I/D.

**Table 6.4 SRS+CLRS: ROTRR Rates by Contributing Category**

Contributing Category*	Miles	Before Count	After Count	Before Rate	After Rate	Difference in Rate	% Change in Rate
A/F	38.93	2 (0)	7 (0)	0.008 (0.000)	0.016 (0.000)	-0.008 (0.000)	99.0% (0%)
I/D	38.93	2 (0)	6 (0)	0.008 (0.000)	0.014 (0.000)	-0.006 (0.000)	70.5% (0%)
UI	38.93	2 (0)	0 (0)	0.008 (0.000)	0.000 (0.000)	0.008 (0.000)	-100% (0%)
Speed	38.93	4 (0)	6 (0)	0.016 (0.000)	0.014 (0.000)	0.002 (0.000)	-14.7% (0%)
OCL	38.93	0 (0)	0 (0)	0.000 (0.000)	0.000 (0.000)	0.000 (0.000)	0% (0%)
Other	38.93	2 (0)	4 (0)	0.008 (0.000)	0.009 (0.000)	-0.001 (0.000)	13.7% (0%)
None	38.93	0 (0)	0 (0)	0.000 (0.000)	0.000 (0.000)	0.000 (0.000)	0% (0%)

\*See [Appendix C](#)

Fatal & Serious Injury results are in ( ) with rate per 100 mVMT

**SRS+CLRS: Posted Speed**

While examining the performance of the SRS+CLRS by posted speed limits, the researchers found that 98% of the mileage analyzed was for a single posted speed of 60 mph (see [Table 6.5](#)). This offered little opportunity for a comparison by posted speed.

**Table 6.5 SRS+CLRS: Lane Departure Rates by Posted Speed**

Posted Speed Limit	Miles	Before Crash Count	After Crash Count	Before Crash Rate	After Crash Rate	Difference in Rate	% Change in Rate
35	0.00	0 (0)	0 (0)	NX (NX)	NX (NX)	NX (NX)	NX (NX)
40	0.00	0 (0)	0 (0)	NX (NX)	NX (NX)	NX (NX)	NX (NX)
45	0.00	0 (0)	0 (0)	NX (NX)	NX (NX)	NX (NX)	NX (NX)
50	0.00	0 (0)	0 (0)	NX (NX)	NX (NX)	NX (NX)	NX (NX)
55	0.74	5 (0)	5 (0)	0.444 (0.000)	0.166 (0.000)	0.279 (0.000)	-62.7% (0%)
60	38.19	35 (3)	34 (4)	0.151 (1.296)	0.086 (1.008)	0.066 (0.288)	-43.3% (-22.2%)

NX = No Exposure

Fatal & Serious Injury results are in ( ) with rate per 100 mVMT

[Table 6.6](#) reflects the crossover collision experience for the SRS+CLRS installations by posted speed. At 55 mph, with only 0.74 of a mile to evaluate, the results were favorable, with a 62.7% reduction in all injuries. The Fatal and Serious Injury rates were unchanged, with no crashes fitting these injury classes. At 60 mph, the All Injury Severities rate was reduced by 65.4% and the Fatal & Serious Injury rate decreased by 22%.

**Table 6.6 SRS+CLRS: Crossover Rates by Posted Speed**

Posted Speed Limit	Miles	Before Crash Count	After Crash Count	Before Crash Rate	After Crash Rate	Difference in Rate	% Change in Rate
35	0.00	0 (0)	0 (0)	NX (NX)	NX (NX)	NX (NX)	NX (NX)
40	0.00	0 (0)	0 (0)	NX (NX)	NX (NX)	NX (NX)	NX (NX)
45	0.00	0 (0)	0 (0)	NX (NX)	NX (NX)	NX (NX)	NX (NX)
50	0.00	0 (0)	0 (0)	NX (NX)	NX (NX)	NX (NX)	NX (NX)
55	0.74	2 (0)	2 (0)	0.178 (0.000)	0.066 (0.000)	0.111 (0.000)	-62.7% (0%)
60	38.19	27 (3)	16 (4)	0.117 (1.296)	0.040 (1.008)	0.076 (0.288)	-65.4% (-22.2%)

NX = No Exposure

Fatal & Serious Injury results are in ( ) with rate per 100 mVMT

Table 6.7 examines the ROTRR experience by posted speed. In this view, the 55 mph range showed a decrease in the All Injury Severities rate by 62.7%, with no Fatal & Serious Injury collisions recorded in either period for no change in the rate. At 60 mph, the ROTRR experience indicates a 31.3% increase in the rate of All Injury Severities collisions.

**Table 6.7 SRS+CLRS: ROTRR Rates by Posted Speed**

Posted Speed Limit	Miles	Before Crash Count	After Crash Count	Before Crash Rate	After Crash Rate	Difference in Rate	% Change in Rate
35	0.00	0 (0)	0 (0)	NX (NX)	NX (NX)	NX (NX)	NX (NX)
40	0.00	0 (0)	0 (0)	NX (NX)	NX (NX)	NX (NX)	NX (NX)
45	0.00	0 (0)	0 (0)	NX (NX)	NX (NX)	NX (NX)	NX (NX)
50	0.00	0 (0)	0 (0)	NX (NX)	NX (NX)	NX (NX)	NX (NX)
55	0.74	3 (0)	3 (0)	0.267 (0.000)	0.099 (0.000)	0.167 (0.000)	-62.7% (0%)
60	38.19	8 (0)	18 (0)	0.035 (0.000)	0.045 (0.000)	-0.011 (0.000)	31.3% (0%)

NX = No Exposure

Fatal & Serious Injury results are in ( ) with rate per 100 mVMT

## SRS+CLRS: Lane Width

### ■ Lane Departure Crashes

An analysis of SRS+CLRS by lane width wasn't possible as the data was limited to only the 12' lane width (see Table 6.8). Lane departures were reduced by 44.6% for All Injury Severities and 24.2% for Fatal & Serious Injury collisions.

**Table 6.8 SRS+CLRS: Lane Departure Rates by Lane Width**

Lane Width	Miles	Before Crash Count	After Crash Count	Before Crash Rate	After Crash Rate	Difference in Rate	% Change in Rate
11'	0.00	0 (0)	0 (0)	NX (NX)	NX (NX)	NX (NX)	NX (NX)
12'	38.93	40 (3)	39 (4)	0.165 (1.236)	0.091 (0.937)	0.073 (0.299)	-44.6% (-24.2%)
> 12'	0.00	0 (0)	0 (0)	NX (NX)	NX (NX)	NX (NX)	NX (NX)
All	38.93	40 (3)	39 (4)	0.165 (1.236)	0.091 (0.937)	0.073 (0.299)	-44.6% (-24.2%)

Fatal & Serious Injury results are in ( ) with rate per 100 mVMT

### ■ Crossover Crashes

For the crossover collision set in Table 6.9, reductions were found in both categories: the All Injury Severities rate was 64.7% and the Fatal & Serious Injury rate was 24.2%.

**Table 6.9 SRS+CLRS: Crossover Rates by Lane Width**

Lane Width	Miles	Before Crash Count	After Crash Count	Before Crash Rate	After Crash Rate	Difference in Rate	% Change in Rate
11'	0.00	0 (0)	0 (0)	NX (NX)	NX (NX)	NX (NX)	NX (NX)
12'	38.93	29 (3)	18 (4)	0.120 (1.236)	0.042 (0.937)	0.077 (0.299)	-64.7% (-24.2%)
> 12'	0.00	0 (0)	0 (0)	NX (NX)	NX (NX)	NX (NX)	NX (NX)
All	38.93	29 (3)	18 (4)	0.120 (1.236)	0.042 (0.937)	0.077 (0.299)	-64.7% (-24.2%)

Fatal & Serious Injury results are in ( ) with rate per 100 mVMT

■ ROTRR Crashes

In Table 6.10, the ROTRR collision set experienced a slight increase in the rate of All Injury Severities collisions, with an 8.5% increase over the before period. There were no Fatal & Serious Injury events recorded in the ROTRR before or after period with this rumble type.

**Table 6.10 SRS+CLRS: ROTRR Rates by Lane Width**

Lane Width	Miles	Before Crash Count	After Crash Count	Before Crash Rate	After Crash Rate	Difference in Rate	% Change in Rate
11'	0.00	0 (0)	0 (0)	NX (NX)	NX (NX)	NX (NX)	NX (NX)
12'	38.93	11 (0)	21 (0)	0.045 (0.000)	0.049 (0.000)	-0.004 (0.000)	8.5% (0%)
> 12'	0.00	0 (0)	0 (0)	NX (NX)	NX (NX)	NX (NX)	NX (NX)
All	38.93	11 (0)	21 (0)	0.045 (0.000)	0.049 (0.000)	-0.004 (0.000)	8.5% (0%)

Fatal & Serious Injury results are in ( ) with rate per 100 mVMT

**SRS+CLRS: SRS Recovery Width**

As stated in the CLRS&SRS study, the SRS recovery width is a calculated field, where the values represent the width of the paved shoulder area beyond the outer edge of the rumble strips. Table 6.11 summarizes the crash trends for lane departure collisions in SRS+CLRS installations. Exposure and crash data limitations preclude a broad spectrum study of various SRS recovery widths. There are only three width ranges with exposure and crash data, and the majority of the data represents two width ranges. Although limited, the data does indicate reduced crash rates for All Injury Severities for both of these width ranges. A small increase was noted for Fatal & Serious Injury crash rates where SRS recovery widths are 6' to 7'; however, the crash numbers are small.

**Table 6.11 SRS+CLRS: Lane Departure Collision Rates by SRS Recovery Width**

Range	Miles	Before Crash Count	After Crash Count	Before Crash Rate	After Crash Rate	Difference in Rate	% Change in Rate
< 1'	2.27	0 (0)	0 (0)	0.000 (0.000)	0.000 (0.000)	0.000 (0.000)	0% (0%)
1 to < 2'	0.20	0 (0)	0 (0)	0.000 (0.000)	0.000 (0.000)	0.000 (0.000)	0% (0%)
2 to < 3'	2.31	1 (0)	1 (0)	0.147 (0.000)	0.148 (0.000)	-0.001 (0.000)	0.7% (0%)
3 to < 4'	0.00	0 (0)	0 (0)	NX (NX)	NX (NX)	NX (NX)	NX (NX)
4 to < 5'	26.40	24 (2)	6 (1)	0.209 (1.739)	0.054 (0.906)	0.154 (0.833)	-73.9% (-47.9%)
5 to < 6'	0.00	0 (0)	0 (0)	NX (NX)	NX (NX)	NX (NX)	NX (NX)
6 to < 7'	7.49	15 (1)	32 (3)	0.134 (0.891)	0.106 (0.994)	0.028 (-0.103)	-20.6% (11.6%)
7 to < 8'	0.00	0 (0)	0 (0)	NX (NX)	NX (NX)	NX (NX)	NX (NX)
≥ 8'	0.25	0 (0)	0 (0)	0.000 (0.000)	0.000 (0.000)	0.000 (0.000)	0% (0%)
All	38.93	40 (3)	39 (4)	0.165 (1.236)	0.091 (0.937)	0.073 (0.299)	-44.6% (-24.2%)

NX = No Exposure Fatal & Serious Injury results are in ( ) with rate per 100 mVMT

Table 6.12 shows a 26.5% increase in the collision rate for the SRS recovery widths from 6' to < 7' and a 30.5% reduction for the SR recovery widths between 4' and < 5'. That was unexpected, as wider recovery areas typically yield lower crash rates. There were no Fatal & Serious Injury events in either period for the ROTRR collision set.

**Table 6.12 SRS+CLRS: ROTRR Collision Rates by SRS Recovery Width**

Range	Miles	Before Crash Count	After Crash Count	Before Crash Rate	After Crash Rate	Difference in Rate	% Change in Rate
< 1'	2.27	0 (0)	0 (0)	0.000 (0.000)	0.000 (0.000)	0.000 (0.000)	0% (0%)
1 to < 2'	0.20	0 (0)	0 (0)	0.000 (0.000)	0.000 (0.000)	0.000 (0.000)	0% (0%)
2 to < 3'	2.31	0 (0)	0 (0)	0.000 (0.000)	0.000 (0.000)	0.000 (0.000)	0% (0%)
3 to < 4'	0.00	0 (0)	0 (0)	NX (NX)	NX (NX)	NX (NX)	NX (NX)
4 to < 5'	26.40	6 (0)	4 (0)	0.052 (0.000)	0.036 (0.000)	0.016 (0.000)	-30.5% (0%)
5 to < 6'	0.00	0 (0)	0 (0)	NX (NX)	NX (NX)	NX (NX)	NX (NX)
6 to < 7'	7.49	5 (0)	17 (0)	0.045 (0.000)	0.056 (0.000)	-0.012 (0.000)	26.5% (0%)
7 to < 8'	0.00	0 (0)	0 (0)	NX (NX)	NX (NX)	NX (NX)	NX (NX)
≥ 8'	0.25	0 (0)	0 (0)	0.000 (0.000)	0.000 (0.000)	0.000 (0.000)	0% (0%)
All	38.93	11 (0)	21 (0)	0.045 (0.000)	0.049 (0.000)	-0.004 (0.000)	8.5% (0%)

NX = No Exposure Fatal & Serious Injury results are in ( ) with rate per 100 mVMT

## SRS+ CLRS: AADT

### ■ Lane Departure Crashes

Table 6.13 examines the SRS+CLRS installations by AADT. The ranges available for comparison are limited by the 38.93 miles of exposure. Of these miles, roughly 62% is found in the 2000 to 3999 range, almost 20% is in the maximum AADT range of ≥ 17,000, and 15% is found in the < 2000 range. These three ranges total 97% of the exposure available, limiting the possible analysis. Exploring the performance by lane departure events revealed that collision rate reductions were found in all ranges and injury classes, except for the ≥ 17,000 range for Fatal & Serious Injury events, where an 11.6% increase was noted.

**Table 6.13 SRS+CLRS: Lane Departure Rates by AADT**

Range	Miles	Before Crash Count	After Crash Count	Before Crash Rate	After Crash Rate	Difference in Rate	% Change in Rate
< 2000	5.97	3 (0)	1 (0)	0.171 (0.000)	0.057 (0.000)	0.114 (0.000)	-66.5% (0%)
2000 to 3999	24.17	20 (2)	4 (1)	0.197 (1.972)	0.051 (1.264)	0.147 (0.708)	-74.4% (-35.9%)
4000 to 5999	0.55	1 (0)	1 (0)	0.620 (0.000)	0.623 (0.000)	-0.003 (0.000)	0.4% (0%)
6000 to 7999	0.00	0 (0)	0 (0)	NX (NX)	NX (NX)	NX (NX)	NX (NX)
8000 to 9999	0.00	0 (0)	0 (0)	NX (NX)	NX (NX)	NX (NX)	NX (NX)
10,000 to 11,999	0.00	0 (0)	0 (0)	NX (NX)	NX (NX)	NX (NX)	NX (NX)
12,000 to 13,999	0.00	0 (0)	0 (0)	NX (NX)	NX (NX)	NX (NX)	NX (NX)
14,000 to 16,999	0.55	1 (0)	1 (0)	0.140 (0.000)	0.051 (0.000)	0.089 (0.000)	-63.4% (0%)
≥ 17,000	7.69	15 (1)	32 (3)	0.130 (0.870)	0.104 (0.970)	0.027 (-0.101)	-20.7% (11.6%)
All	38.93	40 (3)	39 (4)	0.165 (1.236)	0.091 (0.937)	0.073 (0.299)	-44.6% (-24.2%)

NX = No Exposure Fatal & Serious Injury results are in ( ) with rate per 100 mVMT

## ■ Crossover Crashes

For crossover collisions (see [Table 6.14](#)), the same trend was found, with reductions in all ranges and injury types where data was recorded, except for the AADT range of  $\geq 17,000$ , where an increase of 11.6% was found in the Fatal & Serious Injury rates.

**Table 6.14 SRS+CLRS: Crossover Rates by AADT**

Range	Miles	Before Crash Count	After Crash Count	Before Crash Rate	After Crash Rate	Difference in Rate	% Change in Rate
< 2000	5.97	3 (0)	1 (0)	0.171 (0.000)	0.057 (0.000)	0.114 (0.000)	-66.5% (0%)
2000 to 3999	24.17	14 (2)	1 (1)	0.138 (1.972)	0.013 (1.264)	0.125 (0.708)	-90.8% (-35.9%)
4000 to 5999	0.55	1 (0)	0 (0)	0.620 (0.000)	0.000 (0.000)	0.620 (0.000)	-100% (0%)
6000 to 7999	0.00	0 (0)	0 (0)	NX (NX)	NX (NX)	NX (NX)	NX (NX)
8000 to 9999	0.00	0 (0)	0 (0)	NX (NX)	NX (NX)	NX (NX)	NX (NX)
10,000 to 11,999	0.00	0 (0)	0 (0)	NX (NX)	NX (NX)	NX (NX)	NX (NX)
12,000 to 13,999	0.00	0 (0)	0 (0)	NX (NX)	NX (NX)	NX (NX)	NX (NX)
14,000 to 16,999	0.55	1 (0)	0 (0)	0.140 (0.000)	0.000 (0.000)	0.140 (0.000)	-100% (0%)
$\geq 17,000$	7.69	10 (1)	16 (3)	0.087 (0.870)	0.052 (0.970)	0.035 (-0.101)	-40.5% (11.6%)
All	38.93	29 (3)	18 (4)	0.120 (1.236)	0.042 (0.937)	0.077 (0.299)	-64.7% (-24.2%)

NX = No Exposure Fatal & Serious Injury results are in ( ) with rate per 100 mVMT

## ■ ROTRR Crashes

The ROTRR collision set had no fatal or serious injury events recorded in any of the AADT ranges (see [Table 6.15](#)). The All Injury Severities rates in the 2000 to 3999 range saw a 35.9% decrease in the collision rate. Both the 4000 to 5999 range and the 14,000 to 16,999 range saw an increase of 100% in the after period. In both cases, this was the result of a single collision in each respective range. The miles of exposure for both of these ranges combined are 1.10 miles, or less than 3% of the total exposure under review.

**Table 6.15 SRS+CLRS: ROTRR Rates by AADT**

Range	Miles	Before Crash Count	After Crash Count	Before Crash Rate	After Crash Rate	Difference in Rate	% Change in Rate
< 2000	5.97	0 (0)	0 (0)	0.000 (0.000)	0.000 (0.000)	0.000 (0.000)	0% (0%)
2000 to 3999	24.17	6 (0)	3 (0)	0.059 (0.000)	0.038 (0.000)	0.021 (0.000)	-35.9% (0%)
4000 to 5999	0.55	0 (0)	1 (0)	0.000 (0.000)	0.623 (0.000)	-0.623 (0.000)	100% (0%)
6000 to 7999	0.00	0 (0)	0 (0)	NX (NX)	NX (NX)	NX (NX)	NX (NX)
8000 to 9999	0.00	0 (0)	0 (0)	NX (NX)	NX (NX)	NX (NX)	NX (NX)
10,000 to 11,999	0.00	0 (0)	0 (0)	NX (NX)	NX (NX)	NX (NX)	NX (NX)
12,000 to 13,999	0.00	0 (0)	0 (0)	NX (NX)	NX (NX)	NX (NX)	NX (NX)
14,000 to 16,999	0.55	0 (0)	1 (0)	0.000 (0.000)	0.051 (0.000)	-0.051 (0.000)	100% (0%)
$\geq 17,000$	7.69	5 (0)	16 (0)	0.043 (0.000)	0.052 (0.000)	-0.008 (0.000)	19.0% (0%)
All	38.93	11 (0)	21 (0)	0.045 (0.000)	0.049 (0.000)	-0.004 (0.000)	8.5% (0%)

NX = No Exposure Fatal & Serious Injury results are in ( ) with rate per 100 mVMT

## SRS+CLRS: Horizontal Alignment

### ■ Lane Departure Crashes

Table 6.16 shows the lane departure results of the performance of the SRS+CLRS installations in an analysis of the horizontal alignment features.

**Table 6.16 SRS+CLRS: Lane Departure Rates by Horizontal Alignment**

Horizontal Alignment	Miles	Before Crash Count	After Crash Count	Before Crash Rate	After Crash Rate	Difference in Rate	% Change in Rate
Tangent	32.20	23 (2)	18 (1)	0.125 (1.086)	0.062 (0.345)	0.063 (0.741)	-50.2% (-68.2%)
Curve	6.73	17 (1)	21 (3)	0.290 (1.708)	0.153 (2.186)	0.137 (-0.478)	-47.3% (28.0%)
Inside*		7 (0)	5 (1)	0.239 (0.000)	0.073 (1.457)	0.166 (-1.457)	-69.5% (100%)
Outside*		10 (1)	16 (2)	0.342 (3.416)	0.233 (2.914)	0.108 (0.502)	-31.8% (-14.7%)

\*Rates based on half of the curve VMT.

Fatal & Serious Injury results are in ( ) with rate per 100 mVMT

Examining All Injury Severities for lane departure collisions suggests that the results were favorable for tangent and curve portions of the roadway, with significant reductions in crash rates. When examining the inside and outside of curves, reduced crash rates were observed for All Injury Severities. The inside of the curve exhibited greater reductions in the collision rate than the outside, a trend similar to the findings in the CLRS&SRS study. When examining Fatal & Serious Injury collisions, increased crash rates were observed on curves.

### ■ Crossover Crashes

Cross-centerline collision experience for SRS+CLRS is reflected in Table 6.17. Reductions in crash rates were noted in the All Injury Severities category for tangents and curves. In the Fatal & Serious Injury events on curves, increased collision rates were noted following the addition of CLRS.

**Table 6.17 SRS+CLRS: Crossover Rates by Horizontal Alignment**

Horizontal Alignment	Miles	Before Crash Count	After Crash Count	Before Crash Rate	After Crash Rate	Difference in Rate	% Change in Rate
Tangent	32.20	17 (2)	6 (1)	0.092 (1.086)	0.021 (0.345)	0.072 (0.741)	-77.6% (-68.2%)
Curve	6.73	12 (1)	12 (3)	0.205 (1.708)	0.087 (2.186)	0.118 (-0.478)	-57.3% (28.0%)
Inside*		5 (0)	4 (1)	0.171 (0.000)	0.058 (1.457)	0.113 (-1.457)	-65.9% (100%)
Outside*		7 (1)	8 (2)	0.239 (3.416)	0.117 (2.914)	0.123 (0.502)	-51.3% (-14.7%)

\*Rates based on half of the curve VMT.

Fatal & Serious Injury results are in ( ) with rate per 100 mVMT

## ■ ROTRR Crashes

Table 6.18 depicts the crash trends for the ROTRR collisions associated with SRS+CLRS and horizontal alignment. Although these crash trends are based on small numbers of crashes, a 27.1% increase in the ROTRR collision rate was noted on tangents, and a 23.2% reduction was noted on horizontal curves. The overall reduction in crash rates on curves reflects the reduction in crashes to the inside of the curve. Crash rates actually increased slightly on the outside of curves. There were no Fatal & Serious Injury events in this data.

**Table 6.18 SRS+CLRS: ROTRR Rates by Horizontal Alignment**

Horizontal Alignment	Miles	Before Crash Count	After Crash Count	Before Crash Rate	After Crash Rate	Difference in Rate	% Change in Rate
Tangent	32.20	6 (0)	12 (0)	0.033 (0.000)	0.041 (0.000)	-0.009 (0.000)	27.1% (0%)
Curve	6.73	5 (0)	9 (0)	0.085 (0.000)	0.066 (0.000)	0.020 (0.000)	-23.2% (0%)
Inside*		2 (0)	1 (0)	0.068 (0.000)	0.015 (0.000)	0.054 (0.000)	-78.7% (0%)
Outside*		3 (0)	8 (0)	0.102 (0.000)	0.117 (0.000)	-0.014 (0.000)	13.7% (0%)

\*Rates based on half of the curve VMT.

Fatal & Serious Injury results are in ( ) with rate per 100 mVMT

## SRS+CLRS: Percent/Length Curve

### ■ Lane Departure Crashes

Table 6.19 displays the results of all lane departure collisions for SRS+CLRS installations as a percentage of the length of curves within the corridors studied. As this data was stratified, there were a number of ranges depicted that have no exposure. In general, the alignments within this dataset were not highly curvilinear. Reduced crash rates were noted for All Injury Severities for all segments studied. In the 30 to < 40% range, Fatal & Serious Injury crash rates increased following the addition of CLRS to SRS locations.

**Table 6.19 SRS+CLRS: Lane Departure Rates by Percent/Length Curve**

Range*	Miles	Before Crash Count	After Crash Count	Before Crash Rate	After Crash Rate	Difference in Rate	% Change in Rate
0 to < 10%	12.28	14 (2)	4 (1)	0.210 (3.006)	0.090 (2.254)	0.120 (0.752)	-57.2% (-25.0%)
10 to < 20%	18.41	10 (0)	2 (0)	0.185 (0.000)	0.037 (0.000)	0.148 (0.000)	-79.9% (0%)
20 to < 30%	0.00	0 (0)	0 (0)	NX (NX)	NX (NX)	NX (NX)	NX (NX)
30 to < 40%	6.65	12 (0)	28 (3)	0.118 (0.000)	0.103 (1.104)	0.015 (-1.104)	-13.0% (100%)
40 to < 50%	0.00	0 (0)	0 (0)	NX (NX)	NX (NX)	NX (NX)	NX (NX)
50 to < 60%	0.00	0 (0)	0 (0)	NX (NX)	NX (NX)	NX (NX)	NX (NX)
60 to < 70%	1.59	4 (1)	5 (0)	0.192 (4.798)	0.088 (0.000)	0.104 (4.798)	-54.3% (-100%)
≥ 80%	0.00	0 (0)	0 (0)	NX (NX)	NX (NX)	NX (NX)	NX (NX)
All	38.93	40 (3)	39 (4)	0.165 (1.236)	0.091 (0.937)	0.073 (0.299)	-44.6% (-24.2%)

\*Determined per segment, then grouped

NX = No Exposure

Fatal & Serious Injury results are in ( ) with rate per 100 mVMT



■ Crossover Crashes

Table 6.20 and Figure 6.1 depict the crash rates for crossover collisions. Although the available data is limited, it suggests that the installation of the SRS+CLRS has performed as expected and markedly reduced crossover collision rates.

For All Injury Severities events: the 0 to < 10% range shows an 83.3% reduction; the 10 to < 20% range shows an 88.8% reduction; the 30 to < 40% range shows a 25.4% reduction; and the 60 to < 70% range shows an 81.7% reduction.

**Table 6.20 SRS+CLRS: Crossover Rates by Percent/Length Curve**

Range*	Miles	Before Crash Count	After Crash Count	Before Crash Rate	After Crash Rate	Difference in Rate	% Change in Rate
0 to < 10%	12.28	9 (2)	1 (1)	0.135 (3.006)	0.023 (2.254)	0.113 (0.752)	-83.3% (-25.0%)
10 to < 20%	18.41	9 (0)	1 (0)	0.167 (0.000)	0.019 (0.000)	0.148 (0.000)	-88.8% (0%)
20 to < 30%	0.00	0 (0)	0 (0)	NX (NX)	NX (NX)	NX (NX)	NX (NX)
30 to < 40%	6.65	7 (0)	14 (3)	0.069 (0.000)	0.052 (1.104)	0.018 (-1.104)	-25.4% (100%)
40 to < 50%	0.00	0 (0)	0 (0)	NX (NX)	NX (NX)	NX (NX)	NX (NX)
50 to < 60%	0.00	0 (0)	0 (0)	NX (NX)	NX (NX)	NX (NX)	NX (NX)
60 to < 70%	1.59	4 (1)	2 (0)	0.192 (4.798)	0.035 (0.000)	0.157 (4.798)	-81.7% (-100%)
≥ 80%	0.00	0 (0)	0 (0)	NX (NX)	NX (NX)	NX (NX)	NX (NX)
All	38.93	29 (3)	18 (4)	0.120 (1.236)	0.042 (0.937)	0.077 (0.299)	-64.7% (-24.2%)

\*Determined per segment, then grouped      NX = No Exposure      Fatal & Serious Injury results are in ( ) with rate per 100 mVMT

**Figure 6.1 SRS+CLRS: Crossover Rates by Percent/Length Curve – All Injury Severities**

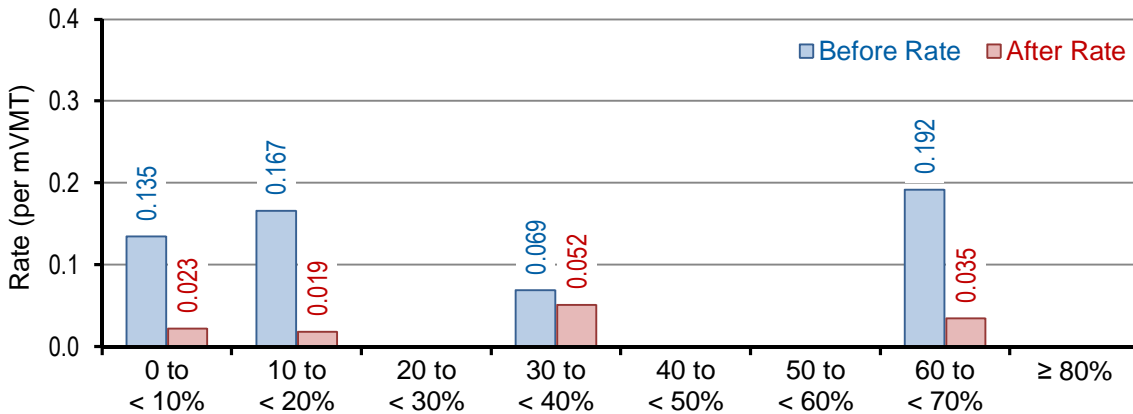

■ ROTRR Crashes

Table 6.21 outlines the ROTRR crash experience as a percentage of the alignment in curvature.

Figure 6.2 graphs the crash experience for ROTRR events. In contrast to the crossover crashes, this analysis illustrates very minor changes in crash rates, except for the increase in the 60 to < 70% range, where three crashes occurred after CLRS were added. There were no ROTRR crashes for this range when only SRS existed on those highway segments.

**Table 6.21 SRS+CLRS: ROTRR Rates by Percent/Length Curve**

Range*	Miles	Before Crash Count	After Crash Count	Before Crash Rate	After Crash Rate	Difference in Rate	% Change in Rate
0 to < 10%	12.28	5 (0)	3 (0)	0.075 (0.000)	0.068 (0.000)	0.008 (0.000)	-10.0% (0%)
10 to < 20%	18.41	1 (0)	1 (0)	0.019 (0.000)	0.019 (0.000)	0.000 (0.000)	0.4% (0%)
20 to < 30%	0.00	0 (0)	0 (0)	NX (NX)	NX (NX)	NX (NX)	NX (NX)
30 to < 40%	6.65	5 (0)	14 (0)	0.049 (0.000)	0.052 (0.000)	-0.002 (0.000)	4.4% (0%)
40 to < 50%	0.00	0 (0)	0 (0)	NX (NX)	NX (NX)	NX (NX)	NX (NX)
50 to < 60%	0.00	0 (0)	0 (0)	NX (NX)	NX (NX)	NX (NX)	NX (NX)
60 to < 70%	1.59	0 (0)	3 (0)	0.000 (0.000)	0.053 (0.000)	-0.053 (0.000)	100% (0%)
≥ 80%	0.00	0 (0)	0 (0)	NX (NX)	NX (NX)	NX (NX)	NX (NX)
All	38.93	11 (0)	21 (0)	0.045 (0.000)	0.049 (0.000)	-0.004 (0.000)	8.5% (0%)

\*Determined per segment, then grouped NX = No Exposure Fatal & Serious Injury results are in ( ) with rate per 100 mVMT

**Figure 6.2 SRS+CLRS: ROTRR Rates by Percent/Length Curve – All Injury Severities**

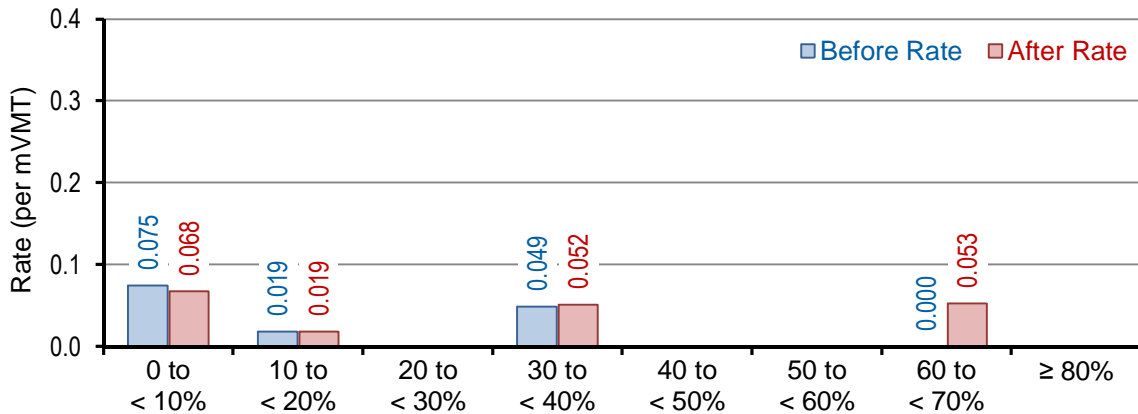

### SRS+CLRS Summary

Although the data available for analysis of the SRS+CLRS installations is limited, it seems to validate that CLRS can be added to SRS installations without a substantial increase in ROTRR events. The overall crash reductions overshadow the minor increases in crossover crash experience. The lane departure crash rate declined by 44.6%, and the targeted crossover crash rate declined by 64.7%. There was an 8.5% increase in All Injury Severities ROTRR crashes; however, the Fatal & Serious Injury crash rate was unchanged.

When exploring the contributing circumstances associated with crashes, the researchers noted an interesting trend in the targeted circumstances of A/F and I/D. Crossover crash rates were reduced by 91.9% for collisions associated with A/F drivers. There was a 99% increase in the rate of ROTRR crashes associated with A/F drivers. A similar trend occurred for I/D crashes, with a 75.6% reduction in crossover crash rates and a 70.5% increase in ROTRR crash rates. Overall, the reductions in the crossover crashes overshadowed the increase in ROTRR crashes, yielding a 49.5% reduction in A/F crash rates and a 43.2% reduction in I/D crash rates. A larger dataset would offer more confidence in such an analysis.

The SRS recovery width analysis offered limited insight into ROTRR crash performance, as much of the exposure mileage and all of the crash data were grouped within two width ranges. SRS recovery widths of 4 to < 5' showed a 30.5% decrease in crash rates, and the 6 to < 7' width range showed a 26.5% increase in ROTRR crash rates. This is counterintuitive, as more recovery area would be expected to be associated with reduced ROTRR crashes. Overall, ROTRR crash rates were up 8.5% after adding CLRS to existing SRS locations. There were no Fatal or Serious Injury crashes in the ROTRR dataset.

Lane departure crash rates were reduced by 50.2% on tangent alignments and 47.3% on curved roadways. These results are heavily influenced by the reduction in crossover crashes, with a 77.6% reduction on tangents and a 57.3% reduction on curves. ROTRR crash rates were reduced 23.2% on curves, but were up 27.1% for tangent segments.

## SECTION 7: CLRS+SRS

The CLRS+SRS study evaluated locations where CLRS were already in place and SRS were added at a later date. The expectation for this phased installation was that the crossover collision events would remain at a similar performance level before and after SRS were added. Any significant difference in performance was expected to be with ROTRR crashes. [Table 7.1](#) suggests that this is the case, with a modest 6.8% reduction in the crossover collision rate and a more significant 47.0% reduction in the ROTRR collision rate. Overall, the reduction in All Injury Severities crash rates was 37.5%, while Fatal & Serious Injury crash rates declined by 32.2%.

The dataset for these locations presents similar limitations as the sample size found in the SRS+CLRS study. The CLRS+SRS dataset consists of 40.77 miles of exposure, with 42 collisions in the before period, five of which were Fatal & Serious Injury events, and 31 collisions in the after period, four of which were Fatal & Serious Injury events. There were 196.567 million vehicle miles traveled (mVMT) prior to adding the SRS and 232.005 mVMT after.

**Table 7.1 CLRS+SRS: Overall Performance**

Collision Type	Miles	Before Crash Count	After Crash Count	Before Crash Rate	After Crash Rate	Difference in Rate	% Change in Rate
Lane Departure	40.77	42 (5)	31 (4)	0.214 (2.544)	0.134 (1.724)	0.080 (0.820)	-37.5% (-32.2%)
Crossover	40.77	10 (1)	11 (0)	0.051 (0.509)	0.047 (0.000)	0.003 (0.509)	-6.8% (-100%)
ROTRR	40.77	32 (4)	20 (4)	0.163 (2.035)	0.086 (1.724)	0.077 (0.311)	-47.0% (-15.3%)

Fatal & Serious Injury results are in ( ) with rate per 100 mVMT

### CLRS+SRS: Contributing Category

#### ■ Lane Departure Crashes

Lane departure and contributing categories are summarized in [Table 7.2](#). The results are mixed, showing reduced crash rates in the A/F, UI, and Other categories for All Injury Severities. The remainder of the contributing categories reflect increased crash rates for All Injury Severities. The increases in the I/D and the Speed categories are noteworthy, with increases of 57.3 % and 210.7%, respectively.

**Table 7.2 CLRS+SRS: Lane Departure Rates by Contributing Category**

Contributing Category*	Miles	Before Count	After Count	Before Rate	After Rate	Difference in Rate	% Change in Rate
A/F	40.77	17 (3)	5 (0)	0.086 (1.526)	0.022 (0.000)	0.065 (1.526)	-75.1% (-100%)
I/D	40.77	7 (0)	13 (1)	0.036 (0.000)	0.056 (0.431)	-0.020 (-0.431)	57.3% (100%)
UI	40.77	10 (1)	11 (3)	0.051 (0.509)	0.047 (1.293)	0.003 (-0.784)	-6.8% (154.2%)
Speed	40.77	3 (0)	11 (3)	0.015 (0.000)	0.047 (1.293)	-0.032 (-1.293)	210.7% (100%)
OCL	40.77	4 (1)	6 (0)	0.020 (0.509)	0.026 (0.000)	-0.006 (0.509)	27.1% (-100%)
Other	40.77	5 (1)	1 (0)	0.025 (0.509)	0.004 (0.000)	0.021 (0.509)	-83.1% (-100%)
None	40.77	0 (0)	0 (0)	0.000 (0.000)	0.000 (0.000)	0.000 (0.000)	0% (0%)

\*See [Appendix C](#)

Fatal & Serious Injury results are in ( ) with rate per 100 mVMT

■ Crossover Crashes

Table 7.3 shows the crossover crash performance by contributing category. The results are mixed, with reduced crash rates in some categories and increased collision rates in others.

**Table 7.3 CLRS+SRS: Crossover Rates by Contributing Category**

Contributing Category*	Miles	Before Count	After Count	Before Rate	After Rate	Difference in Rate	% Change in Rate
A/F	40.77	1 (0)	1 (0)	0.005 (0.000)	0.004 (0.000)	0.001 (0.000)	-15.3% (0%)
I/D	40.77	0 (0)	4 (0)	0.000 (0.000)	0.017 (0.000)	-0.017 (0.000)	100% (0%)
UI	40.77	3 (0)	5 (0)	0.015 (0.000)	0.022 (0.000)	-0.006 (0.000)	41.2% (0%)
Speed	40.77	1 (0)	5 (0)	0.005 (0.000)	0.022 (0.000)	-0.016 (0.000)	323.6% (0%)
OCL	40.77	4 (1)	6 (0)	0.020 (0.509)	0.026 (0.000)	-0.006 (0.509)	27.1% (-100%)
Other	40.77	1 (0)	0 (0)	0.005 (0.000)	0.000 (0.000)	0.005 (0.000)	-100% (0%)
None	40.77	0 (0)	0 (0)	0.000 (0.000)	0.000 (0.000)	0.000 (0.000)	0% (0%)

\*See Appendix C

Fatal & Serious Injury results are in ( ) with rate per 100 mVMT

■ ROTRR Crashes

**Table 7.4 CLRS+SRS: ROTRR Rates by Contributing Category**

Contributing Category*	Miles	Before Count	After Count	Before Rate	After Rate	Difference in Rate	% Change in Rate
A/F	40.77	16 (3)	4 (0)	0.081 (1.526)	0.017 (0.000)	0.064 (1.526)	-78.8% (-100%)
I/D	40.77	7 (0)	9 (1)	0.036 (0.000)	0.039 (0.431)	-0.003 (-0.431)	8.9% (100%)
UI	40.77	7 (1)	6 (3)	0.036 (0.509)	0.026 (1.293)	0.010 (-0.784)	-27.4% (154.2%)
Speed	40.77	2 (0)	6 (3)	0.010 (0.000)	0.026 (1.293)	-0.016 (-1.293)	154.2% (100%)
OCL	40.77	0 (0)	0 (0)	0.000 (0.000)	0.000 (0.000)	0.000 (0.000)	0% (0%)
Other	40.77	4 (1)	1 (0)	0.020 (0.509)	0.004 (0.000)	0.016 (0.509)	-78.8% (-100%)
None	40.77	0 (0)	0 (0)	0.000 (0.000)	0.000 (0.000)	0.000 (0.000)	0% (0%)

\*See Appendix C

Fatal & Serious Injury results are in ( ) with rate per 100 mVMT

Comparing the crossover crash performance from Table 7.3 with the ROTRR experience depicted in Table 7.4 shows a mixed outcome. The categories most likely to be affected by the installation of the rumble strips, A/F, I/D and OCL, do not demonstrate any consistent trends in this analysis.

## CLRS+SRS: Posted Speed

### ■ Lane Departure Crashes

Table 7.5 presents the performance of the CLRS+SRS installations by the posted speed for all lane departure collisions. The table shows that the majority of the miles of exposure are clustered in the speed ranges from 50 to 60 mph. The small portion of the mileage in the 35 mph range did not have any corresponding collision experience for analysis. The distribution of collision data was heavily skewed within a single posted speed. 90% of crashes available for analysis in this study occurred on highways with a posted speed of 55 mph. The ability to compare performance at various speeds was compromised by the distribution of the data.

**Table 7.5 CLRS+SRS: Lane Departure Rates by Posted Speed**

Posted Speed Limit	Miles	Before Crash Count	After Crash Count	Before Crash Rate	After Crash Rate	Difference in Rate	% Change in Rate
35	0.23	0 (0)	0 (0)	0.000 (0.000)	0.000 (0.000)	0.000 (0.000)	0% (0%)
40	0.00	0 (0)	0 (0)	NX (NX)	NX (NX)	NX (NX)	NX (NX)
45	0.00	0 (0)	0 (0)	NX (NX)	NX (NX)	NX (NX)	NX (NX)
50	5.17	3 (0)	2 (0)	0.179 (0.000)	0.107 (0.000)	0.072 (0.000)	-40.2% (0%)
55	25.04	38 (5)	28 (4)	0.230 (3.030)	0.142 (2.025)	0.089 (1.005)	-38.5% (-33.2%)
60	10.33	1 (0)	1 (0)	0.068 (0.000)	0.065 (0.000)	0.004 (0.000)	-5.2% (0%)

NX = No Exposure Fatal & Serious Injury results are in ( ) with rate per 100 mVMT

### ■ Crossover Crashes

Cross-centerline crash experience is presented in Table 7.6. The only speed that had sufficient crash experience for evaluation of effectiveness was 55 mph, which had an increase of 14.9% in the All Injury Severities category after SRS were added.

**Table 7.6 CLRS+SRS: Crossover Rates by Posted Speed**

Posted Speed Limit	Miles	Before Crash Count	After Crash Count	Before Crash Rate	After Crash Rate	Difference in Rate	% Change in Rate
35	0.23	0 (0)	0 (0)	0.000 (0.000)	0.000 (0.000)	0.000 (0.000)	0% (0%)
40	0.00	0 (0)	0 (0)	NX (NX)	NX (NX)	NX (NX)	NX (NX)
45	0.00	0 (0)	0 (0)	NX (NX)	NX (NX)	NX (NX)	NX (NX)
50	5.17	1 (0)	0 (0)	0.060 (0.000)	0.000 (0.000)	0.060 (0.000)	-100% (0%)
55	25.04	8 (1)	11 (0)	0.048 (0.606)	0.056 (0.000)	-0.007 (0.606)	14.9% (-100%)
60	10.33	1 (0)	0 (0)	0.068 (0.000)	0.000 (0.000)	0.068 (0.000)	-100% (0%)

NX = No Exposure Fatal & Serious Injury results are in ( ) with rate per 100 mVMT

■ ROTRR Crashes

Table 7.7 shows that nearly all the ROTRR crash experience is represented by posted speeds of 50 and 55 mph. A 10.3% reduction in crash rates was observed for the All Injury Severities collision rate at 50 mph, with a 52.7% reduction in the All Injury Severities rate at 55 mph.

**Table 7.7 CLRS+SRS: ROTRR Rates by Posted Speed**

Posted Speed Limit	Miles	Before Crash Count	After Crash Count	Before Crash Rate	After Crash Rate	Difference in Rate	% Change in Rate
35	0.23	0 (0)	0 (0)	0.000 (0.000)	0.000 (0.000)	0.000 (0.000)	0% (0%)
40	0.00	0 (0)	0 (0)	NX (NX)	NX (NX)	NX (NX)	NX (NX)
45	0.00	0 (0)	0 (0)	NX (NX)	NX (NX)	NX (NX)	NX (NX)
50	5.17	2 (0)	2 (0)	0.119 (0.000)	0.107 (0.000)	0.012 (0.000)	-10.3% (0%)
55	25.04	30 (4)	17 (4)	0.182 (2.424)	0.086 (2.025)	0.096 (0.399)	-52.7% (-16.5%)
60	10.33	0 (0)	1 (0)	0.000 (0.000)	0.065 (0.000)	-0.065 (0.000)	100% (0%)

NX = No Exposure Fatal & Serious Injury results are in ( ) with rate per 100 mVMT

**CLRS+SRS: Lane Width**

In examining the performance of the CLRS+SRS installations by lane width, the researchers expected that wider lanes would have a reduced rate of collisions prior to and after the installation of rumble strips. This expectation was based on a presumption that a wider lane allows more time and area for an errant driver to recover and avoid a lane departure collision.

■ Lane Departure Crashes

Table 7.8 displays the results of the CLRS+SRS installations by lane width for lane departure collisions. The data is limited to just 11' and 12' lane widths, with the great majority of the exposure in the 12' range. Reduced crash rates were found in both of the lane widths and in all injury categories. At the 11' width, there was a reduction of 78.3% for All Injury Severities and a 100% reduction in Fatal & Serious Injury collision rates. There was single Fatal & Serious Injury event in the before period and none in the after. At the 12' width, the All Injury Severities collision rate was decreased by 31.2%, and there was a 14% decline in the Fatal & Serious Injury collision rate.

**Table 7.8 CLRS+SRS: Lane Departure Rates by Lane Width**

Lane Width	Miles	Before Crash Count	After Crash Count	Before Crash Rate	After Crash Rate	Difference in Rate	% Change in Rate
11'	4.77	7 (1)	3 (0)	1.668 (23.834)	0.361 (0.000)	1.307 (23.834)	-78.3% (-100%)
12'	35.99	35 (4)	28 (4)	0.182 (2.079)	0.125 (1.788)	0.057 (0.291)	-31.2% (-14.0%)
> 12'	0.00	0 (0)	0 (0)	NX (NX)	NX (NX)	NX (NX)	NX (NX)
All	40.77	42 (5)	31 (4)	0.214 (2.544)	0.134 (1.724)	0.080 (0.820)	-37.5% (-32.2%)

Fatal & Serious Injury results are in ( ) with rate per 100 mVMT

## ■ Crossover Crashes

The distribution of crossover crashes resulted in no valid opportunity to explore lane width for the CLRS+SRS installations. The 11' lane width had no before period collisions and a single after period collision. This is reflected by the 100% increase in the All Injury Severities rate found in [Table 7.9](#). The 12' lane width had ten collisions in the before period, one of which was a serious or fatal injury. The after period for the 12' width had ten collisions as well, with no fatal or serious injury events recorded. The 12' width recorded a 14% reduction in the collision rate of All Injury Severities and a 100% reduction in the Fatal & Serious Injury rate.

**Table 7.9 CLRS+SRS: Crossover Rates by Lane Width**

Lane Width	Miles	Before Crash Count	After Crash Count	Before Crash Rate	After Crash Rate	Difference in Rate	% Change in Rate
11'	4.77	0 (0)	1 (0)	0.000 (0.000)	0.120 (0.000)	-0.120 (0.000)	100% (0%)
12'	35.99	10 (1)	10 (0)	0.052 (0.520)	0.045 (0.000)	0.007 (0.520)	-14.0% (-100%)
> 12'	0.00	0 (0)	0 (0)	NX (NX)	NX (NX)	NX (NX)	NX (NX)
All	40.77	10 (1)	11 (0)	0.051 (0.509)	0.047 (0.000)	0.003 (0.509)	-6.8% (-100%)

Fatal & Serious Injury results are in ( ) with rate per 100 mVMT

## ■ ROTRR Crashes

[Table 7.10](#) displays the ROTRR performance found with the installation of the CLRS+SRS. Both lane widths saw decreases in the All Injury Severities collision rates: an 85.6% reduction in ROTRR at the 11' width and a 38.1% reduction at the 12' width. For the Fatal & Serious Injury category, the 11' width had a 100% decrease, with a single event in the before period and no events in the after period. At the 12' width, there was a 14.7% increase noted; the before period had three fatal or serious injury collisions and there were four in the after period.

**Table 7.10 CLRS+SRS: ROTRR Rates by Lane Width**

Lane Width	Miles	Before Crash Count	After Crash Count	Before Crash Rate	After Crash Rate	Difference in Rate	% Change in Rate
11'	4.77	7 (1)	2 (0)	1.668 (23.834)	0.241 (0.000)	1.427 (23.834)	-85.6% (-100%)
12'	35.99	25 (3)	18 (4)	0.130 (1.559)	0.080 (1.788)	0.049 (-0.229)	-38.1% (14.7%)
> 12'	0.00	0 (0)	0 (0)	NX (NX)	NX (NX)	NX (NX)	NX (NX)
All	40.77	32 (4)	20 (4)	0.163 (2.035)	0.086 (1.724)	0.077 (0.311)	-47.0% (-15.3%)

Fatal & Serious Injury results are in ( ) with rate per 100 mVMT

An examination of the CLRS+SRS installations by lane width reveals reduced crash rates. The after period's All Injury Severities collision rate, regardless of collision type (ROTRR or crossover), was roughly three times higher for the narrower lane width. This is likely a reflection of limited data, but it does suggest the expected result that wider lanes equate to lower lane departure crash rates.



## CLRS+SRS: SRS Recovery Width

### ■ Lane Departure Crashes

Table 7.11 provides an analysis of CLRS+SRS installations and the SRS recovery width. For those SRS recovery width bands that have two or more crashes for calculation of crash rates, reductions for All Injury Severities collisions are in the range of 42.4% to 45.7%.

**Table 7.11 CLRS+SRS: Lane Departure Rates by SRS Recovery Width**

Range	Miles	Before Crash Count	After Crash Count	Before Crash Rate	After Crash Rate	Difference in Rate	% Change in Rate
< 1'	0.00	0 (0)	0 (0)	NX (NX)	NX (NX)	NX (NX)	NX (NX)
1 to < 2'	0.09	0 (0)	0 (0)	0.000 (0.000)	0.000 (0.000)	0.000 (0.000)	0% (0%)
2 to < 3'	1.35	3 (0)	2 (0)	0.720 (0.000)	0.405 (0.000)	0.315 (0.000)	-43.8% (0%)
3 to < 4'	7.26	9 (0)	14 (2)	0.470 (0.000)	0.271 (3.867)	0.199 (-3.867)	-42.4% (100%)
4 to < 5'	10.74	1 (0)	2 (0)	0.068 (0.000)	0.122 (0.000)	-0.054 (0.000)	79.2% (0%)
5 to < 6'	1.61	1 (1)	0 (0)	0.527 (52.652)	0.000 (0.000)	0.527 (52.652)	-100% (-100%)
6 to < 7'	12.87	24 (4)	13 (2)	0.220 (3.673)	0.120 (1.842)	0.101 (1.831)	-45.7% (-49.8%)
7 to < 8'	0.93	0 (0)	0 (0)	0.000 (0.000)	0.000 (0.000)	0.000 (0.000)	0% (0%)
≥ 8'	5.92	4 (0)	0 (0)	0.085 (0.000)	0.000 (0.000)	0.085 (0.000)	-100% (0%)
All	40.77	42 (5)	31 (4)	0.214 (2.544)	0.134 (1.724)	0.080 (0.820)	-37.5% (-32.2%)

NX = No Exposure Fatal & Serious Injury results are in ( ) with rate per 100 mVMT

Table 7.12 reflects the ROTRR performance of the CLRS+SRS installations by SRS recovery width. Note that the data is limited in some ranges. These limitations resulted in some 100% increases or decreases, reflecting a single event in the before or after period. There were some decreases in the rates of ROTRR collisions, ranging from 43.8% to 57.7%, in those ranges where data was available. An analysis of the after All Injury Severities rates suggests that increased width is linked to reduced crash rates.

**Table 7.12 CLRS+SRS: ROTRR Rates by SRS Recovery Width**

Range	Miles	Before Crash Count	After Crash Count	Before Crash Rate	After Crash Rate	Difference in Rate	% Change in Rate
< 1'	0.00	0 (0)	0 (0)	NX (NX)	NX (NX)	NX (NX)	NX (NX)
1 to < 2'	0.09	0 (0)	0 (0)	0.000 (0.000)	0.000 (0.000)	0.000 (0.000)	0% (0%)
2 to < 3'	1.35	3 (0)	2 (0)	0.720 (0.000)	0.405 (0.000)	0.315 (0.000)	-43.8% (0%)
3 to < 4'	7.26	7 (0)	8 (2)	0.366 (0.000)	0.155 (3.867)	0.211 (-3.867)	-57.7% (100%)
4 to < 5'	10.74	0 (0)	1 (0)	0.000 (0.000)	0.061 (0.000)	-0.061 (0.000)	100% (0%)
5 to < 6'	1.61	1 (1)	0 (0)	0.527 (52.652)	0.000 (0.000)	0.527 (52.652)	-100% (-100%)
6 to < 7'	12.87	17 (3)	9 (2)	0.156 (2.755)	0.083 (1.842)	0.073 (0.912)	-46.9% (-33.1%)
7 to < 8'	0.93	0 (0)	0 (0)	0.000 (0.000)	0.000 (0.000)	0.000 (0.000)	0% (0%)
≥ 8'	5.92	4 (0)	0 (0)	0.085 (0.000)	0.000 (0.000)	0.085 (0.000)	-100% (0%)
All	40.77	32 (4)	20 (4)	0.163 (2.035)	0.086 (1.724)	0.077 (0.311)	-47.0% (-15.3%)

NX = No Exposure Fatal & Serious Injury results are in ( ) with rate per 100 mVMT

## CLRS+SRS: AADT

### ■ Lane Departure Crashes

The analysis of the CLRS+SRS pattern by AADT is presented in [Table 7.13](#). Limited exposure and crash counts restricted the analysis. No Fatal or Serious Injury collisions were recorded in any AADT range below 10,000. In those ranges where data was available, only one All Injury Severities rate increased in the after period: the 12,000 to 13,999 collision rate increased by 21.9%. All other ranges reported decreases in the All Injury Severities rate, a reduction from 1% to 89.0% in the rate of lane departure collisions.

**Table 7.13 CLRS+SRS: Lane Departure Rates by AADT**

Range	Miles	Before Crash Count	After Crash Count	Before Crash Rate	After Crash Rate	Difference in Rate	% Change in Rate
< 2000	4.87	0 (0)	0 (0)	0.000 (0.000)	0.000 (0.000)	0.000 (0.000)	0% (0%)
2000 to 3999	12.11	8 (1)	4 (0)	0.546 (6.828)	0.207 (0.000)	0.339 (6.828)	-62.0% (-100%)
4000 to 5999	3.96	0 (0)	0 (0)	0.000 (0.000)	0.000 (0.000)	0.000 (0.000)	0% (0%)
6000 to 7999	0.00	0 (0)	0 (0)	NX (NX)	NX (NX)	NX (NX)	NX (NX)
8000 to 9999	0.00	0 (0)	0 (0)	NX (NX)	NX (NX)	NX (NX)	NX (NX)
10,000 to 11,999	9.64	10 (0)	13 (2)	0.142 (0.000)	0.141 (2.163)	0.001 (-2.163)	-1.0% (100%)
12,000 to 13,999	5.88	9 (0)	12 (1)	0.180 (0.000)	0.220 (1.833)	-0.040 (-1.833)	21.9% (100%)
14,000 to 16,999	1.69	6 (3)	1 (1)	0.338 (16.917)	0.055 (5.505)	0.283 (11.412)	-83.7% (-67.5%)
≥ 17,000	2.61	9 (1)	1 (0)	0.256 (2.848)	0.028 (0.000)	0.228 (2.848)	-89.0% (-100%)
All	40.77	42 (5)	31 (4)	0.214 (2.544)	0.134 (1.724)	0.080 (0.820)	-37.5% (-32.2%)

NX = No Exposure Fatal & Serious Injury results are in ( ) with rate per 100 mVMT

### ■ Crossover Crashes

[Table 7.14](#) summarizes the crossover collisions by AADT. In this analysis, the All Injury Severities collision rates dropped in all ranges reporting except for the 10,000 to 11,999 AADT band, where an increase of 90.4% was seen. There were no fatal or serious injury events in either period for these rumble installations.

**Table 7.14 CLRS+SRS: Crossover Rates by AADT**

Range	Miles	Before Crash Count	After Crash Count	Before Crash Rate	After Crash Rate	Difference in Rate	% Change in Rate
< 2000	4.87	0 (0)	0 (0)	0.000 (0.000)	0.000 (0.000)	0.000 (0.000)	0% (0%)
2000 to 3999	12.11	1 (0)	1 (0)	0.068 (0.000)	0.052 (0.000)	0.016 (0.000)	-24.1% (0%)
4000 to 5999	3.96	0 (0)	0 (0)	0.000 (0.000)	0.000 (0.000)	0.000 (0.000)	0% (0%)
6000 to 7999	0.00	0 (0)	0 (0)	NX (NX)	NX (NX)	NX (NX)	NX (NX)
8000 to 9999	0.00	0 (0)	0 (0)	NX (NX)	NX (NX)	NX (NX)	NX (NX)
10,000 to 11,999	9.64	2 (0)	5 (0)	0.028 (0.000)	0.054 (0.000)	-0.026 (0.000)	90.4% (0%)
12,000 to 13,999	5.88	4 (0)	4 (0)	0.080 (0.000)	0.073 (0.000)	0.007 (0.000)	-8.6% (0%)
14,000 to 16,999	1.69	1 (0)	0 (0)	0.056 (0.000)	0.000 (0.000)	0.056 (0.000)	-100% (0%)
≥ 17,000	2.61	2 (1)	1 (0)	0.057 (2.848)	0.028 (0.000)	0.029 (2.848)	-50.4% (-100%)
All	40.77	10 (1)	11 (0)	0.051 (0.509)	0.047 (0.000)	0.003 (0.509)	-6.8% (-100%)

NX = No Exposure Fatal & Serious Injury results are in ( ) with rate per 100 mVMT

## ■ ROTRR Crashes

The ROTRR collisions by AADT analysis is presented in [Table 7.15](#). Several of the AADT ranges have no exposure or no collision events in either period, which prevented any analysis. For those ranges where data was available, all but one in the All Injury Severities category showed a reduction in the rate of collisions. The 12,000 to 13,999 range had a 46.3% increase in the collision rate for All Injury Severities. Reductions were seen in the All Injury Severities collision rates of 67.5% at the 2000 to 3999 range, 23.8% at the 10,000 to 11,999 range, and 80.5% at the 14,000 to 16,999 range. Also declining was the top range at > 17,000, with a 100% reduction in the All Injury Severities rate. Analyses of the Fatal & Serious Injury rates were hampered by the low crash counts.

**Table 7.15 CLRS+SRS: ROTRR Rates by AADT**

Range	Miles	Before Crash Count	After Crash Count	Before Crash Rate	After Crash Rate	Difference in Rate	% Change in Rate
< 2000	4.87	0 (0)	0 (0)	0.000 (0.000)	0.000 (0.000)	0.000 (0.000)	0% (0%)
2000 to 3999	12.11	7 (1)	3 (0)	0.478 (6.828)	0.156 (0.000)	0.322 (6.828)	-67.5% (-100%)
4000 to 5999	3.96	0 (0)	0 (0)	0.000 (0.000)	0.000 (0.000)	0.000 (0.000)	0% (0%)
6000 to 7999	0.00	0 (0)	0 (0)	NX (NX)	NX (NX)	NX (NX)	NX (NX)
8000 to 9999	0.00	0 (0)	0 (0)	NX (NX)	NX (NX)	NX (NX)	NX (NX)
10,000 to 11,999	9.64	8 (0)	8 (2)	0.114 (0.000)	0.087 (2.163)	0.027 (-2.163)	-23.8% (100%)
12,000 to 13,999	5.88	5 (0)	8 (1)	0.100 (0.000)	0.147 (1.833)	-0.046 (-1.833)	46.3% (100%)
14,000 to 16,999	1.69	5 (3)	1 (1)	0.282 (16.917)	0.055 (5.505)	0.227 (11.412)	-80.5% (-67.5%)
≥ 17,000	2.61	7 (0)	0 (0)	0.199 (0.000)	0.000 (0.000)	0.199 (0.000)	-100% (0%)
All	40.77	32 (4)	20 (4)	0.163 (2.035)	0.086 (1.724)	0.077 (0.311)	-47.0% (-15.3%)

NX = No Exposure Fatal & Serious Injury results are in ( ) with rate per 100 mVMT

## CLRS+SRS: Horizontal Alignment

### ■ Lane Departure Crashes

[Table 7.16](#) shows the performance of the horizontal alignment components of the CLRS+SRS treatment for all lane departures. The tangent segments were found to have substantial reductions in crash rates for All Injury Severities, with a 59.4% reduction in the lane departure collision rate.

A more focused look at the curve data reveals a reduction in All Injury Severities lane departure crash rates for the outside of the curve, and a minor increase for the inside of the curve.

The researchers have verified that the rate of collisions on the outside of curves is almost always greater than the rate for the inside, for all conditions of injury or lane departure collision types.

**Table 7.16 CLRS+SRS: Lane Departure Rates by Horizontal Alignment**

Horizontal Alignment	Miles	Before Crash Count	After Crash Count	Before Crash Rate	After Crash Rate	Difference in Rate	% Change in Rate
Tangent	31.88	25 (3)	12 (4)	0.158 (1.901)	0.064 (2.142)	0.094 (-0.241)	-59.4% (12.7%)
Curve	8.89	17 (2)	19 (0)	0.439 (5.160)	0.420 (0.000)	0.019 (5.160)	-4.3% (-100%)
Inside*		8 (2)	10 (0)	0.413 (10.321)	0.442 (0.000)	-0.029 (10.321)	7.0% (-100%)
Outside*		9 (0)	9 (0)	0.464 (0.000)	0.398 (0.000)	0.067 (0.000)	-14.4% (0%)

\*Rates based on half of the curve VMT

Fatal & Serious Injury results are in ( ) with rate per 100 mVMT

### ■ Crossover Crashes

Table 7.17 summarizes the cross-centerline collision experience for tangents and curves. There were some substantial differences noted here, with a 57.7% reduction in the rate of crossover crashes on tangents, while the collision rate on curves increased by 71.3%. Interestingly, the crossover crash experience for the inside and outside of curves in this dataset appears to be identical, with 71.3% increases in both cases.

**Table 7.17 CLRS+SRS: Crossover Rates by Horizontal Alignment**

Horizontal Alignment	Miles	Before Crash Count	After Crash Count	Before Crash Rate	After Crash Rate	Difference in Rate	% Change in Rate
Tangent	31.88	6 (1)	3 (0)	0.038 (0.634)	0.016 (0.000)	0.022 (0.634)	-57.7% (-100%)
Curve	8.89	4 (0)	8 (0)	0.103 (0.000)	0.177 (0.000)	-0.074 (0.000)	71.3% (0%)
Inside*		2 (0)	4 (0)	0.103 (0.000)	0.177 (0.000)	-0.074 (0.000)	71.3% (0%)
Outside*		2 (0)	4 (0)	0.103 (0.000)	0.177 (0.000)	-0.074 (0.000)	71.3% (0%)

\*Rates based on half of the curve VMT

Fatal & Serious Injury results are in ( ) with rate per 100 mVMT

### ■ ROTRR Crashes

Table 7.18 indicates that there were reductions in the collision rates for All Injury Severities events for tangents, curves, inside, and outside. The only increase noted was in the Fatal & Serious Injury events on the tangent segments, with a 69.0% increase in the collision rate.

**Table 7.18 CLRS+SRS: ROTRR Rates by Horizontal Alignment**

Horizontal Alignment	Miles	Before Crash Count	After Crash Count	Before Crash Rate	After Crash Rate	Difference in Rate	% Change in Rate
Tangent	31.88	19 (2)	9 (4)	0.120 (1.267)	0.048 (2.142)	0.072 (-0.875)	-60.0% (69.0%)
Curve	8.89	13 (2)	11 (0)	0.335 (5.160)	0.243 (0.000)	0.092 (5.160)	-27.5% (-100%)
Inside*		6 (2)	6 (0)	0.310 (10.321)	0.265 (0.000)	0.044 (10.321)	-14.4% (-100%)
Outside*		7 (0)	5 (0)	0.361 (0.000)	0.221 (0.000)	0.140 (0.000)	-38.8% (0%)

\*Rates based on half of the curve VMT

Fatal & Serious Injury results are in ( ) with rate per 100 mVMT

## CLRS+SRS: Percent/Length Curve

### ■ Lane Departure Crashes

Table 7.19 displays the results of all lane departure collisions for CLRS+SRS installations as a percentage of the length of curves to the overall length of the corridors studied. For locations with 10 to 20% of the alignment in curves, there was little change in All Injury Severities crash rates, and there was a 100% increase in Fatal & Serious Injury crash rates. This sample range had the largest crash counts and the most miles represented of all the ranges analyzed. Substantial reductions in All Injury Severities crash rates were observed in the 0 to < 10%, 20 to < 30%, and 30 to < 40% ranges.

**Table 7.19 CLRS+SRS: Lane Departure Rates by Percent/Length Curve**

Range*	Miles	Before Crash Count	After Crash Count	Before Crash Rate	After Crash Rate	Difference in Rate	% Change in Rate
0 to < 10%	3.69	10 (1)	1 (0)	0.236 (2.359)	0.025 (0.000)	0.211 (2.359)	-89.3% (-100%)
10 to < 20%	23.49	16 (0)	21 (3)	0.155 (0.000)	0.156 (2.235)	-0.002 (-2.235)	1.3% (100%)
20 to < 30%	3.75	5 (1)	2 (0)	1.447 (28.937)	0.293 (0.000)	1.154 (28.937)	-79.8% (-100%)
30 to < 40%	7.03	7 (3)	3 (1)	0.272 (11.636)	0.102 (3.401)	0.169 (8.235)	-62.4% (-70.8%)
40 to < 50%	2.58	4 (0)	4 (0)	0.188 (0.000)	0.184 (0.000)	0.004 (0.000)	-2.2% (0%)
50 to < 60%	0.00	0 (0)	0 (0)	NX (NX)	NX (NX)	NX (NX)	NX (NX)
60 to < 70%	0.23	0 (0)	0 (0)	0.000 (0.000)	0.000 (0.000)	0.000 (0.000)	0% (0%)
≥ 80%	0.00	0 (0)	0 (0)	NX (NX)	NX (NX)	NX (NX)	NX (NX)
All	40.77	42 (5)	31 (4)	0.214 (2.544)	0.134 (1.724)	0.080 (0.820)	-37.5% (-32.2%)

\*Determined per segment, then grouped NX = No Exposure Fatal & Serious Injury results are in ( ) with rate per 100 mVMT

Table 7.20 examines the crossover performance by percent/length curve. There is no exposure and no collisions for this rumble type recorded for any ranges greater than the 40 to < 50% range. For those ranges where data was reported, the results were mixed in performance.

**Table 7.20 CLRS+SRS: Crossover Rates by Percent/Length Curve**

Range*	Miles	Before Crash Count	After Crash Count	Before Crash Rate	After Crash Rate	Difference in Rate	% Change in Rate
0 to < 10%	3.69	10 (1)	1 (0)	0.047 (2.359)	0.025 (0.000)	0.022 (2.359)	-46.4% (-100%)
10 to < 20%	23.49	16 (0)	21 (3)	0.048 (0.000)	0.060 (0.000)	-0.011 (0.000)	23.4% (0%)
20 to < 30%	3.75	5 (1)	2 (0)	0.000 (0.000)	0.146 (0.000)	-0.146 (0.000)	100% (0%)
30 to < 40%	7.03	7 (3)	3 (1)	0.078 (0.000)	0.034 (0.000)	0.044 (0.000)	-56.2% (0%)
40 to < 50%	2.58	4 (0)	4 (0)	0.047 (0.000)	0.000 (0.000)	0.047 (0.000)	-100% (0%)
50 to < 60%	0.00	0 (0)	0 (0)	NX (NX)	NX (NX)	NX (NX)	NX (NX)
60 to < 70%	0.23	0 (0)	0 (0)	0.000 (0.000)	0.000 (0.000)	0.000 (0.000)	0% (0%)
≥ 80%	0.00	0 (0)	0 (0)	NX (NX)	NX (NX)	NX (NX)	NX (NX)
All	40.77	10 (1)	11 (0)	0.051 (0.509)	0.047 (0.000)	0.003 (0.509)	-6.8% (-100%)

\*Determined per segment, then grouped NX = No Exposure Fatal & Serious Injury results are in ( ) with rate per 100 mVMT

Table 7.21 shows the ROTRR analysis associated with percent/length curve. With a single exception for All Injury Severities rates, the ROTRR events were decreased after the installation of the SRS pattern. The exception was the 40 to < 50% range, which has the only increase in the rate of All Injury Severities. The 40 to < 50% range recorded a 30.4% increase in the collision rate, with three collisions in the before period and four in the after.

**Table 7.21 CLRS+SRS: ROTRR Rates by Percent/Length Curve**

Range*	Miles	Before Crash Count	After Crash Count	Before Crash Rate	After Crash Rate	Difference in Rate	% Change in Rate
0 to < 10%	3.69	8 (0)	0 (0)	0.189 (0.000)	0.000 (0.000)	0.189 (0.000)	-100% (0%)
10 to < 20%	23.49	11 (0)	13 (3)	0.106 (0.000)	0.097 (2.235)	0.009 (-2.235)	-8.8% (100%)
20 to < 30%	3.75	5 (1)	1 (0)	1.447 (28.937)	0.146 (0.000)	1.300 (28.937)	-89.9% (-100%)
30 to < 40%	7.03	5 (3)	2 (1)	0.194 (11.636)	0.068 (3.401)	0.126 (8.235)	-64.9% (-70.8%)
40 to < 50%	2.58	3 (0)	4 (0)	0.141 (0.000)	0.184 (0.000)	-0.043 (0.000)	30.4% (0%)
50 to < 60%	0.00	0 (0)	0 (0)	NX (NX)	NX (NX)	NX (NX)	NX (NX)
60 to < 70%	0.23	0 (0)	0 (0)	0.000 (0.000)	0.000 (0.000)	0.000 (0.000)	0% (0%)
≥ 80%	0.00	0 (0)	0 (0)	NX (NX)	NX (NX)	NX (NX)	NX (NX)
All	40.77	32 (4)	20 (4)	0.163 (2.035)	0.086 (1.724)	0.077 (0.311)	-47.0% (-15.3%)

\*Determined per segment, then grouped      NX = No Exposure      Fatal & Serious Injury results are in ( ) with rate per 100 mVMT

### CLRS+SRS Summary

The addition of SRS to existing CLRS installations was expected to have the most influence on ROTRR crashes. This study indicated a reduction in All Injury Severities crash rates of 47% for ROTRR crashes and 6.8% for crossover crashes. These numbers suggest that adding SRS to existing CLRS installations has reduced crash rates. Overall, lane departure crash rates declined by 37.5% for All Injury Severities and 32.2% for Fatal & Serious Injury crashes.

The contributing categories of A/F and Other saw the greatest decreases in crash rates for lane departure collisions, with reductions of 75.18% and 83.1%, respectively. Lane departure crash rates associated with I/D drivers saw an increase of 57.3%. Speed-related crash rates also saw a substantial increase of 210.7%.

The overwhelming majority of the crash data for this analysis was confined to installations with posted speeds of 55 mph. Consequently, the researchers were unable to conduct a meaningful comparison of performance by posted speed.

An analysis of SRS recovery width didn't offer a lot of clarity about CLRS+SRS performance. For widths where there were more than five crashes in the sample, crash rates were reduced by 40% to 45%.

Lane departure crash reductions were generally attributed to tangent roadways, with a 59.4% reduction compared to a 4.3% reduction for segments in a curve. ROTRR crash rates went down in both tangents and curves, with reductions of 60% and 27.5%, respectively. However, crossover crash rates were adversely affected on curves, with a 71.3% increase in All Injury Severities crashes. This increase was equally distributed between crashes to the inside and the outside of the curve.

Results were mixed when analyzing the performance based on the percent/length curve. Substantial reductions in All Injury Severities crash rates were observed for the 0 to < 10%, 20 to < 30%, and 30 to < 40% ranges. However, there was little change in All Injury Severities crash rates for locations with 10 to 20% of the alignment in curves. A 100% increase in Fatal & Serious Injury crash rates was observed for locations with 10 to 20% of the alignment in curves.

## SECTION 8: COMPOSITE

The Composite study is similar to the CLRS&SRS study, but adds miles from some of the locations in the SRS+CLRS and the CLRS+SRS studies, where the crash experience from the “no rumble strip” condition can be compared with the period where both CLRS and SRS are installed. This allowed for a larger dataset for analysis. Each of the installations previously discussed had differences in the manner of installation. One installation may have had SRS installed and at a later date CLRS installed, another had both CLRS and SRS installed in conjunction, and a third may have had CLRS installed first, followed by SRS. Each of these cases complicated a comparison of the before and after periods, as each variant had a differing rumble strip exposure prior to the final configuration.

The Composite view ignored crash experience for any time period where a single type of rumble strip (CLRS or SRS) was installed. In order to expand the sample size, the researchers were able to “reach” back in time and define the before period of each segment as that where no rumble strips were installed in the roadway. The after period was defined as that where the combination of both CLRS and SRS were in place.

The data included in this Composite examination were on segments already reviewed in one of the other portions of this study. All segments of the CLRS&SRS study were included in this examination. An additional 58.44 miles of exposure were added, bringing the total to 135.88 miles available for review and analysis. Not all segments of the SRS+CLRS or CLRS+SRS were included. Segments that did not have at least one complete anniversary year in either the before or after period were eliminated from this analysis. This approach netted 373 crashes for analysis in the before period and 72 following rumble strip installation.

The average length of the analysis period prior to rumble strip application was in excess of four years. After rumble strips were installed, the average length exceeded three years. The VMT for the before period equaled 1,343.426 million miles, and for the after period, 763.045 million miles.

Table 8.1 shows the overall performance of these installations. These results are similar to the results found in the CLRS&SRS study, although the reductions found for Fatal & Serious Injury crashes are superior with this larger dataset. Significant reductions in all collision types and injury classifications are recorded: 66.0% for all lane departure collisions; 56.0% for all Fatal & Serious Injury lane departure collisions; 71.0% for crossover collisions; 57.5% for Fatal & Serious Injury crossover collisions; 61.6% for ROTRR collisions; and 53.7% for All Injury Severities and Fatal & Serious Injury ROTRR rates.

**Table 8.1 Composite: Overall Performance**

Collision Type	Miles	Before Crash Count	After Crash Count	Before Crash Rate	After Crash Rate	Difference in Rate	% Change in Rate
Lane Departure	135.88	373 (48)	72 (12)	0.278 (3.573)	0.094 (1.573)	0.183 (2.000)	-66.0% (-56.0%)
Crossover	135.88	176 (29)	29 (7)	0.131 (2.159)	0.038 (0.917)	0.093 (1.241)	-71.0% (-57.5%)
ROTRR	135.88	197 (19)	43 (5)	0.147 (1.414)	0.056 (0.655)	0.090 (0.759)	-61.6% (-53.7%)

Fatal & Serious Injury results are in ( ) with rate per 100 mVMT



## Composite: Contributing Category

### ■ Lane Departure Crashes

Table 8.2 shows the results for the lane departure collisions in the Composite analysis segments. Substantial reductions were observed in collision rates for all contributing circumstance categories for All Injury Severities. Those categories of A/F and I/D that were expected to be most influenced by the installation of rumble strips showed positive results. For A/F, there was an 84.0% decrease in the collision rate for All Injury Severities and a 100% reduction in the Fatal & Serious Injury collision rate. In the I/D category, there was a 43.2% reduction recorded for the All Injury Severities collision rate and a stable 0.6% change in the Fatal & Serious Injury collision rate. Other driver behaviors also exhibited substantial reductions in crash rates for All Injury Severities. With Fatal & Serious Injury crashes, the results were mixed, with reduced rates in the U/I and Other category, and increased rates in Speed.

**Table 8.2 Composite: Lane Departure Rates by Contributing Category**

Contributing Category*	Miles	Before Count	After Count	Before Rate	After Rate	Difference in Rate	% Change in Rate
A/F	135.88	143 (15)	13 (0)	0.106 (1.117)	0.017 (0.000)	0.089 (1.117)	-84.0% (-100%)
I/D	135.88	62 (7)	20 (4)	0.046 (0.521)	0.026 (0.524)	0.020 (-0.003)	-43.2% (0.6%)
UI	135.88	79 (11)	22 (6)	0.059 (0.819)	0.029 (0.786)	0.030 (0.032)	-51.0% (-4.0%)
Speed	135.88	51 (4)	17 (3)	0.038 (0.298)	0.022 (0.393)	0.016 (-0.095)	-41.3% (32.0%)
OCL	135.88	69 (22)	16 (5)	0.051 (1.638)	0.021 (0.655)	0.030 (0.982)	-59.2% (-60.0%)
Other	135.88	39 (3)	8 (1)	0.029 (0.223)	0.010 (0.131)	0.019 (0.092)	-63.9% (-41.3%)
None	135.88	2 (0)	0 (0)	0.001 (0.000)	0.000 (0.000)	0.001 (0.000)	-100% (0%)

\*See Appendix C

Fatal & Serious Injury results are in ( ) with rate per 100 mVMT

### ■ Crossover Crashes

Table 8.3 shows the results of the crossover collision experience and performance of the CLRS and SRS. Collision rates for all of the contributing categories were reduced significantly, with a single exception. The Fatal & Serious Injury crash rate in the I/D category saw a 76.1% increase. The targeted circumstances of A/F and I/D exhibited crash rate reductions of 87.2% and 28%, respectively. While rumble strips are not intended to encourage behaviors such as speeding or alcohol usage, reduced crash rates in these categories are viewed as positive results.

**Table 8.3 Composite: Crossover Rates by Contributing Category**

Contributing Category*	Miles	Before Count	After Count	Before Rate	After Rate	Difference in Rate	% Change in Rate
A/F	135.88	69 (5)	5 (0)	0.051 (0.372)	0.007 (0.000)	0.045 (0.372)	-87.2% (-100%)
I/D	135.88	22 (3)	9 (3)	0.016 (0.223)	0.012 (0.393)	0.005 (-0.170)	-28.0% (76.1%)
UI	135.88	39 (6)	8 (2)	0.029 (0.447)	0.010 (0.262)	0.019 (0.185)	-63.9% (-41.3%)
Speed	135.88	25 (3)	7 (1)	0.019 (0.223)	0.009 (0.131)	0.009 (0.092)	-50.7% (-41.3%)
OCL	135.88	68 (21)	16 (5)	0.051 (1.563)	0.021 (0.655)	0.030 (0.908)	-58.6% (-58.1%)
Other	135.88	12 (2)	1 (1)	0.009 (0.149)	0.001 (0.131)	0.008 (0.018)	-85.3% (-12.0%)
None	135.88	0 (0)	0 (0)	0.000 (0.000)	0.000 (0.000)	0.000 (0.000)	0% (0%)

\*See Appendix C

Fatal & Serious Injury results are in ( ) with rate per 100 mVMT

The scale of the changes in crash rates detailed in Table 8.3 becomes clearer when presented in Figure 8.1, which shows the crossover results for All Injury Severities.

**Figure 8.1 Composite: Crossover Rates by Contributing Category – All Injury Severities**

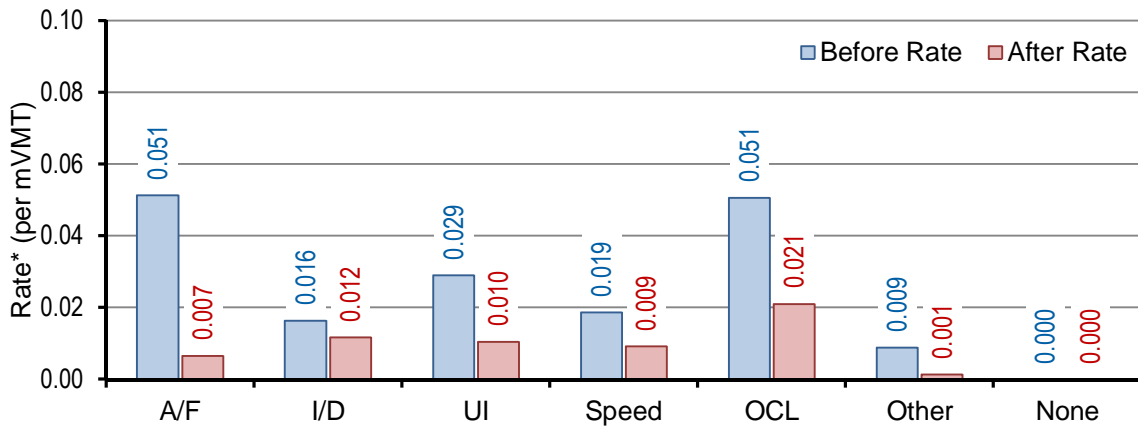

\*Rate of collisions with Contributing Circumstance Category

Total Crash Record Counts: 176 Before, 29 After

Total Contributing Circumstances Evaluated: 235 Before, 46 After

■ ROTRR Crashes

Table 8.4 shows the performance of ROTRR crashes by contributing categories. Substantially reduced crash rates were noted in all categories for All Injury Severities. For Fatal & Serious Injury crashes, the only increases noted were those human factor-related categories of UI and Speed.

**Table 8.4 Composite: ROTRR Rates by Contributing Category**

Contributing Category	Miles	Before Count	After Count	Before Rate	After Rate	Difference in Rate	% Change in Rate
A/F	135.88	74 (10)	8 (0)	0.055 (0.744)	0.010 (0.000)	0.045 (0.744)	-81.0% (-100%)
I/D	135.88	40 (4)	11 (1)	0.030 (0.298)	0.014 (0.131)	0.015 (0.167)	-51.6% (-56.0%)
UI	135.88	40 (5)	14 (4)	0.030 (0.372)	0.018 (0.524)	0.011 (-0.152)	-38.4% (40.8%)
Speed	135.88	26 (1)	10 (2)	0.019 (0.074)	0.013 (0.262)	0.006 (-0.188)	-32.3% (252.1%)
OCL	135.88	1 (1)	0 (0)	0.001 (0.074)	0.000 (0.000)	0.001 (0.074)	-100% (-100%)
Other	135.88	27 (1)	7 (0)	0.020 (0.074)	0.009 (0.000)	0.011 (0.074)	-54.4% (-100%)
None	135.88	2 (0)	0 (0)	0.001 (0.000)	0.000 (0.000)	0.001 (0.000)	-100% (0%)

See Appendix C

Fatal & Serious Injury results are in ( ) with rate per 100 mVMT

Figure 8.2 presents data from Table 8.4, showing the All Injury Severities crash rates by contributing category.

**Figure 8.2 Composite: ROTRR Rates by Contributing Category – All Injury Severities**

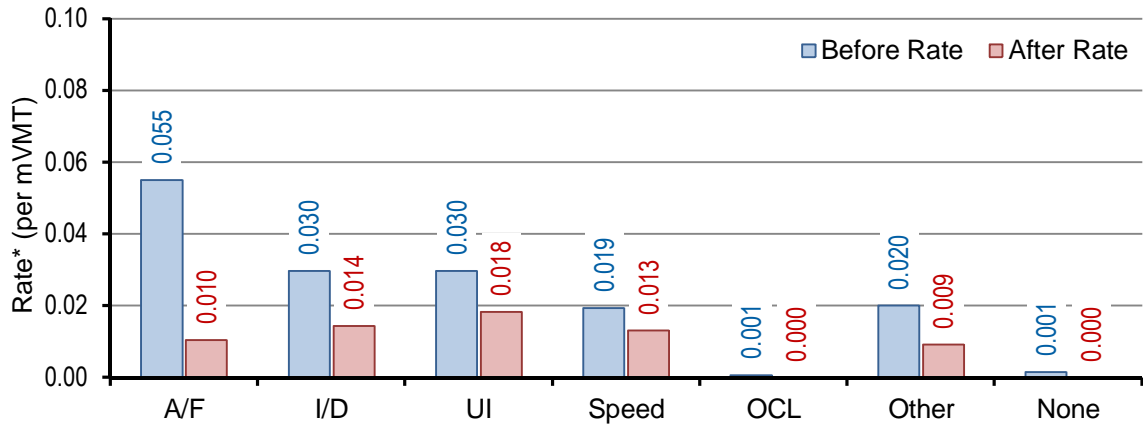

\*Rate of collisions with Contributing Circumstance Category

Total Crash Record Counts: 197 Before, 43 After

Total Contributing Circumstances Evaluated: 210 Before, 50 After

### Composite: Posted Speed

#### ■ Lane Departure Crashes

Table 8.5 shows the collision experience of the combination rumble strip installations by posted speed limits. The majority of the miles of exposure available for analysis were found in the top three posted speed limit bands of 50, 55, and 60 mph. Fewer than 4 miles of exposure represented the lower speeds, with only nine collisions prior to rumble strip installation and a single event after installation.

**Table 8.5 Composite: Lane Departure Rates by Posted Speed**

Posted Speed Limit	Miles	Before Crash Count	After Crash Count	Before Crash Rate	After Crash Rate	Difference in Rate	% Change in Rate
35	2.39	7 (2)	1 (1)	0.224 (6.400)	0.094 (9.425)	0.130 (-3.025)	-57.9% (47.3%)
40	0.18	0 (0)	0 (0)	0.000 (0.000)	0.000 (0.000)	0.000 (0.000)	0% (0%)
45	1.25	2 (0)	0 (0)	0.150 (0.000)	0.000 (0.000)	0.150 (0.000)	-100% (0%)
50	13.74	60 (8)	10 (0)	0.448 (5.970)	0.197 (0.000)	0.250 (5.970)	-55.9% (-100%)
55	60.45	224 (32)	43 (9)	0.298 (4.259)	0.115 (2.413)	0.183 (1.846)	-61.3% (-43.3%)
60	57.87	80 (6)	18 (2)	0.195 (1.460)	0.056 (0.621)	0.139 (0.839)	-71.3% (-57.5%)

Fatal & Serious Injury results are in ( ) with rate per 100 mVMT

For posted speeds of 50 through 60 mph, crash rate reductions from 55.9% to 71.3% were observed for All Injury Severities. Favorable results were also observed for Fatal & Serious Injury crashes in these speed ranges, where reductions from 43.3% to 100% were found.

■ Crossover Crashes

Table 8.6 shows the recorded results for crossover crashes by the posted speed ranges. As previously noted in the lane departure analysis, the number of miles and crashes for speeds below 50 mph did not offer much data for analysis. In the 50 through 60 mph posted speed ranges, the All Injury Severities analysis resulted in crash reductions ranging from 64.8% to 81.8%. Reductions of 36.2% to 100% were found for Fatal & Serious Injury crashes.

**Table 8.6 Composite: Crossover Rates by Posted Speed**

Posted Speed Limit	Miles	Before Crash Count	After Crash Count	Before Crash Rate	After Crash Rate	Difference in Rate	% Change in Rate
35	2.39	4 (2)	1 (1)	0.128 (6.400)	0.094 (9.425)	0.034 (-3.025)	-26.4% (47.3%)
40	0.18	0 (0)	0 (0)	0.000 (0.000)	0.000 (0.000)	0.000 (0.000)	0% (0%)
45	1.25	1 (0)	0 (0)	0.075 (0.000)	0.000 (0.000)	0.075 (0.000)	-100% (0%)
50	13.74	29 (3)	2 (0)	0.216 (2.239)	0.039 (0.000)	0.177 (2.239)	-81.8% (-100%)
55	60.45	103 (20)	18 (4)	0.137 (2.662)	0.048 (1.072)	0.089 (1.589)	-64.8% (-59.7%)
60	57.87	39 (4)	8 (2)	0.095 (0.973)	0.025 (0.621)	0.070 (0.353)	-73.8% (-36.2%)

Fatal & Serious Injury results are in ( ) with rate per 100 mVMT

■ ROTRR Crashes

The ROTRR crash experience is detailed in Table 8.7. Once again, the high-speed ranges demonstrated substantial reductions in crash rates.

**Table 8.7 Composite: ROTRR Rates by Posted Speed**

Posted Speed Limit	Miles	Before Crash Count	After Crash Count	Before Crash Rate	After Crash Rate	Difference in Rate	% Change in Rate
35	2.39	3 (0)	0 (0)	0.096 (0.000)	0.000 (0.000)	0.096 (0.000)	-100% (0%)
40	0.18	0 (0)	0 (0)	0.000 (0.000)	0.000 (0.000)	0.000 (0.000)	0% (0%)
45	1.25	1 (0)	0 (0)	0.075 (0.000)	0.000 (0.000)	0.075 (0.000)	-100% (0%)
50	13.74	31 (5)	8 (0)	0.231 (3.731)	0.158 (0.000)	0.073 (3.731)	-31.7% (-100%)
55	60.45	121 (12)	25 (5)	0.161 (1.597)	0.067 (1.340)	0.094 (0.257)	-58.4% (-16.1%)
60	57.87	41 (2)	10 (0)	0.100 (0.487)	0.031 (0.000)	0.069 (0.487)	-68.9% (-100%)

Fatal & Serious Injury results are in ( ) with rate per 100 mVMT

## Composite: Lane Width

### ■ Lane Departure Crashes

Table 8.8 shows the analysis for lane departure crashes, segregated by lane width. Note that the lane width > 12' had very little exposure, at only 0.15 of a mile. Significant reductions in the collision rates were observed in the All Injury Severities and Fatal & Serious Injury categories.

**Table 8.8 Composite: Lane Departure Rates by Lane Width**

Lane Width	Miles	Before Crash Count	After Crash Count	Before Crash Rate	After Crash Rate	Difference in Rate	% Change in Rate
11'	48.02	159 (20)	21 (3)	0.314 (3.947)	0.087 (1.249)	0.226 (2.698)	-72.1% (-68.3%)
12'	87.71	213 (27)	51 (9)	0.256 (3.245)	0.098 (1.727)	0.158 (1.518)	-61.8% (-46.8%)
> 12'	0.15	1 (1)	0 (0)	0.219 (21.907)	0.000 (0.000)	0.219 (21.907)	-100% (-100%)
All	135.88	373 (48)	72 (12)	0.278 (3.573)	0.094 (1.573)	0.183 (2.000)	-66.0% (-56.0%)

Fatal & Serious Injury results are in ( ) with rate per 100 mVMT

### ■ Crossover Crashes

Table 8.9 shows the crossover collision rates by lane width. The reductions in crash rates for crossover collisions are similar to all lane departure collisions shown in Table 8.8.

**Table 8.9 Composite: Crossover Rates by Lane Width**

Lane Width	Miles	Before Crash Count	After Crash Count	Before Crash Rate	After Crash Rate	Difference in Rate	% Change in Rate
11'	48.02	76 (14)	11 (2)	0.150 (2.763)	0.046 (0.833)	0.104 (1.930)	-69.5% (-69.9%)
12'	87.71	99 (14)	18 (5)	0.119 (1.682)	0.035 (0.959)	0.084 (0.723)	-71.0% (-43.0%)
> 12'	0.15	1 (1)	0 (0)	0.219 (21.907)	0.000 (0.000)	0.219 (21.907)	-100% (-100%)
All	135.88	176 (29)	29 (7)	0.131 (2.159)	0.038 (0.917)	0.093 (1.241)	-71.0% (-57.5%)

Fatal & Serious Injury results are in ( ) with rate per 100 mVMT

### ■ ROTRR Crashes

The ROTRR experience is shown in Table 8.10. Again, substantial reductions in collision rates were noted for all situations analyzed.

**Table 8.10 Composite: ROTRR Rates by Lane Width**

Lane Width	Miles	Before Crash Count	After Crash Count	Before Crash Rate	After Crash Rate	Difference in Rate	% Change in Rate
11'	48.02	83 (6)	10 (1)	0.164 (1.184)	0.042 (0.416)	0.122 (0.768)	-74.6% (-64.8%)
12'	87.71	114 (13)	33 (4)	0.137 (1.562)	0.063 (0.768)	0.074 (0.795)	-53.8% (-50.9%)
> 12'	0.15	0 (0)	0 (0)	0.000 (0.000)	0.000 (0.000)	0.000 (0.000)	0% (0%)
All	135.88	197 (19)	43 (5)	0.147 (1.414)	0.056 (0.655)	0.090 (0.759)	-61.6% (-53.7%)

Fatal & Serious Injury results are in ( ) with rate per 100 mVMT

The examination of Composite treatment performance by lane width shows reduced crash rates for all scenarios evaluated.

## Composite: SRS Recovery Width

### ■ Lane Departure Crashes

In examining the SRS recovery width and the performance of the Composite dataset, the primary focus of the researchers was the ROTRR performance, although lane departure experience was also evaluated. [Table 8.11](#) shows the lane departure results by the SRS recovery width. There are no crashes and limited mileage represented for SRS recovery widths < 2'. For the remaining widths, the results were mostly favorable, with reduced crash rates. The only increased rate was observed for the Fatal & Serious Injury crashes in the 5 to < 6' and 7 to < 8' ranges. With this larger dataset, the range from 2 to <3' shows significantly different results than this same range in the CLRS&SRS analysis, where a 1.6% increase in crash rates was observed.

**Table 8.11 Composite: Lane Departure Rates by SRS Recovery Width**

Range	Miles	Before Crash Count	After Crash Count	Before Crash Rate	After Crash Rate	Difference in Rate	% Change in Rate
< 1'	2.28	0 (0)	0 (0)	0.000 (0.000)	0.000 (0.000)	0.000 (0.000)	0% (0%)
1 to < 2'	0.29	0 (0)	0 (0)	0.000 (0.000)	0.000 (0.000)	0.000 (0.000)	0% (0%)
2 to < 3'	6.63	22 (3)	6 (1)	0.750 (10.229)	0.365 (6.076)	0.386 (4.153)	-51.4% (-40.6%)
3 to < 4'	10.75	31 (4)	7 (1)	0.366 (4.728)	0.265 (3.782)	0.102 (0.945)	-27.7% (-20.0%)
4 to < 5'	33.14	77 (7)	9 (1)	0.312 (2.833)	0.077 (0.859)	0.234 (1.975)	-75.2% (-69.7%)
5 to < 6'	11.85	42 (3)	5 (2)	0.329 (2.349)	0.076 (3.036)	0.253 (-0.687)	-76.9% (29.2%)
6 to < 7'	36.79	118 (14)	30 (3)	0.233 (2.763)	0.093 (0.934)	0.139 (1.829)	-59.9% (-66.2%)
7 to < 8'	21.14	48 (4)	10 (3)	0.221 (1.844)	0.114 (3.406)	0.108 (-1.562)	-48.7% (84.7%)
≥ 8'	12.99	35 (13)	5 (1)	0.272 (10.112)	0.041 (0.825)	0.231 (9.287)	-84.9% (-91.8%)
All	135.88	373 (48)	72 (12)	0.278 (3.573)	0.094 (1.573)	0.183 (2.000)	-66.0% (-56.0%)

Fatal & Serious Injury results are in ( ) with rate per 100 mVMT

### ■ ROTRR Crashes

ROTRR crash performance is reflected in [Table 8.12](#). Reduced crash rates were noted for the All Injury Severities category, for every range where data was available. For Fatal & Serious Injury crashes, the results were mixed, with reductions in four of the SRS recovery widths analyzed and increased crash rates in three others. The data suggest that reduced crash rates were most significant for SRS recovery widths > 4'. The benefits offered by wider SRS recovery widths were also apparent when looking at the crash rates. Higher crash rates were observed for SRS recovery widths < 4', before rumble strips were installed as well as after installation.

**Table 8.12 Composite: ROTRR Rates by SRS Recovery Width**

Range	Miles	Before Crash Count	After Crash Count	Before Crash Rate	After Crash Rate	Difference in Rate	% Change in Rate
< 1'	2.28	0 (0)	0 (0)	0.000 (0.000)	0.000 (0.000)	0.000 (0.000)	0% (0%)
1 to < 2'	0.29	0 (0)	0 (0)	0.000 (0.000)	0.000 (0.000)	0.000 (0.000)	0% (0%)
2 to < 3'	6.63	13 (1)	5 (1)	0.443 (3.410)	0.304 (6.076)	0.139 (-2.666)	-31.5% (78.2%)
3 to < 4'	10.75	19 (3)	4 (1)	0.225 (3.546)	0.151 (3.782)	0.073 (-0.236)	-32.6% (6.7%)
4 to < 5'	33.14	43 (1)	6 (0)	0.174 (0.405)	0.052 (0.000)	0.123 (0.405)	-70.4% (-100%)
5 to < 6'	11.85	22 (1)	1 (0)	0.172 (0.783)	0.015 (0.000)	0.157 (0.783)	-91.2% (-100%)
6 to < 7'	36.79	64 (7)	19 (2)	0.126 (1.382)	0.059 (0.623)	0.067 (0.759)	-53.2% (-54.9%)
7 to < 8'	21.14	25 (1)	6 (1)	0.115 (0.461)	0.068 (1.135)	0.047 (-0.674)	-40.9% (146.2%)
≥ 8'	12.99	11 (5)	2 (0)	0.086 (3.889)	0.016 (0.000)	0.069 (3.889)	-80.7% (-100%)
All	135.88	197 (19)	43 (5)	0.147 (1.414)	0.056 (0.655)	0.090 (0.759)	-61.6% (-53.7%)

Fatal & Serious Injury results are in ( ) with rate per 100 mVMT

Figure 8.3 illustrates the ROTRR crash experience for All Injury Severities, as noted in Table 8.12.

**Figure 8.3 Composite: ROTRR Rates by SRS Recovery Width – All Injury Severities**

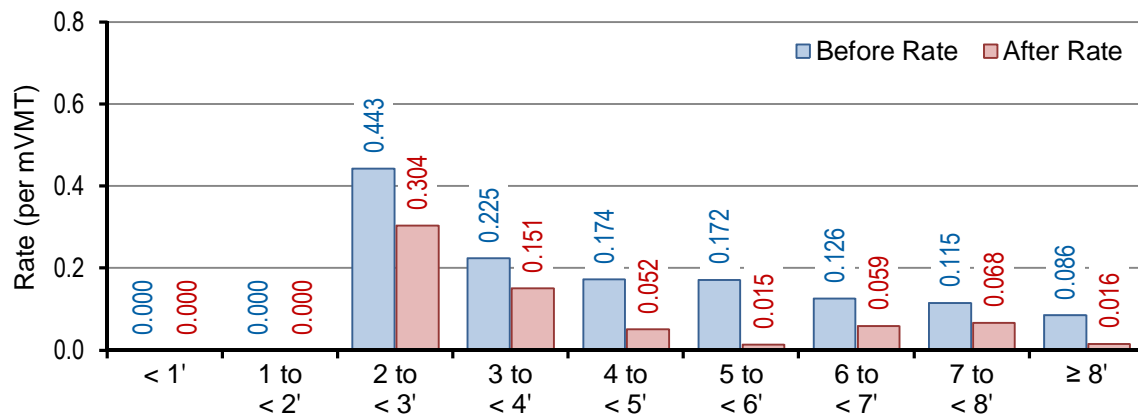

**Composite: AADT**

■ Lane Departure Crashes

The researchers explored whether traffic volumes seemed to be linked to rumble strip performance. Table 8.13 shows the results of the lane departure collision study. The performance was positive across all of the bands for All Injury Severities, with reduced crash rates for all AADT ranges. The only increase in crash rates was observed for the Fatal & Serious Injury collisions in the 14,000 to 16,999 AADT range, where a 22.4% increase was noted for 8.15 miles of exposure.

As shown in Table 8.13, the collision rates for All Injury Severities dropped significantly across all of the AADT ranges, with the lowest reduction at 45.9%. The greatest reduction for All Injury Severities was noted in the AADT range of < 2000, with an 87.8% reduction in the rate of lane departure crashes. Substantial improvement in Fatal & Serious Injury crash rates was noted for nearly all of the AADT ranges where Composite rumble strips were installed.

**Table 8.13 Composite: Lane Departure Rates by AADT**

Range	Miles	Before Crash Count	After Crash Count	Before Crash Rate	After Crash Rate	Difference in Rate	% Change in Rate
< 2000	10.83	7 (0)	1 (0)	0.400 (0.000)	0.049 (0.000)	0.351 (0.000)	-87.8% (0%)
2000 to 3999	36.08	72 (10)	8 (0)	0.453 (6.290)	0.119 (0.000)	0.334 (6.290)	-73.8% (-100%)
4000 to 5999	31.67	90 (12)	9 (3)	0.380 (5.061)	0.105 (3.515)	0.274 (1.546)	-72.2% (-30.5%)
6000 to 7999	15.36	34 (2)	13 (0)	0.169 (0.993)	0.091 (0.000)	0.077 (0.993)	-45.9% (-100%)
8000 to 9999	4.34	19 (1)	0 (0)	0.297 (1.562)	0.000 (0.000)	0.297 (1.562)	-100% (-100%)
10,000 to 11,999	10.27	27 (9)	7 (2)	0.201 (6.691)	0.092 (2.637)	0.108 (4.054)	-54.0% (-60.6%)
12,000 to 13,999	12.33	48 (4)	14 (2)	0.254 (2.113)	0.108 (1.546)	0.145 (0.568)	-57.3% (-26.9%)
14,000 to 16,999	8.15	37 (3)	9 (3)	0.233 (1.890)	0.069 (2.313)	0.164 (-0.423)	-70.2% (22.4%)
≥ 17,000	6.83	39 (7)	11 (2)	0.214 (3.848)	0.112 (2.028)	0.103 (1.820)	-48.0% (-47.3%)
All	135.88	373 (48)	72 (12)	0.278 (3.573)	0.094 (1.573)	0.183 (2.000)	-66.0% (-56.0%)

Fatal & Serious Injury results are in ( ) with rate per 100 mVMT

Figure 8.4 illustrates the All Injury Severities lane departure data in Table 8.13 in graphical form. The data seems to indicate that prior to rumble strip installation, the rate of lane departure events decreased as AADT volumes increased. That trend is not evident following rumble strip installation, with a fairly consistent result across all of the traffic volumes examined.

**Figure 8.4 Composite: Lane Departure Rates by AADT – All Injury Severities**

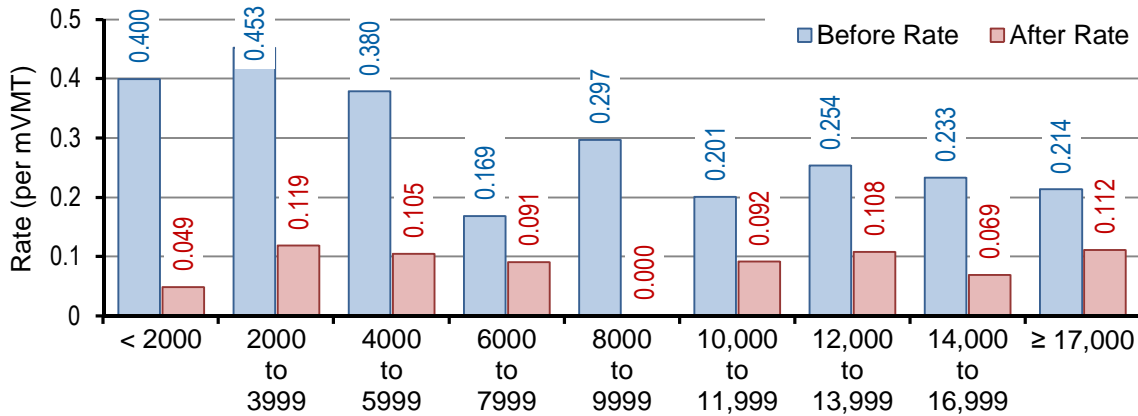

■ Crossover Crashes

Table 8.14 shows the performance of the crossover collision set stratified by AADT range. The data indicates a reduction in the collision rates across all traffic volume ranges and injury severities.



**Table 8.14 Composite: Crossover Rates by AADT**

Range	Miles	Before Crash Count	After Crash Count	Before Crash Rate	After Crash Rate	Difference in Rate	% Change in Rate
< 2000	10.83	2 (0)	1 (0)	0.114 (0.000)	0.049 (0.000)	0.066 (0.000)	-57.3% (0%)
2000 to 3999	36.08	33 (5)	2 (0)	0.208 (3.145)	0.030 (0.000)	0.178 (3.145)	-85.7% (-100%)
4000 to 5999	31.67	44 (8)	3 (2)	0.186 (3.374)	0.035 (2.343)	0.150 (1.030)	-81.1% (-30.5%)
6000 to 7999	15.36	13 (0)	6 (0)	0.065 (0.000)	0.042 (0.000)	0.022 (0.000)	-34.7% (0%)
8000 to 9999	4.34	10 (1)	0 (0)	0.156 (1.562)	0.000 (0.000)	0.156 (1.562)	-100% (-100%)
10,000 to 11,999	10.27	12 (4)	3 (1)	0.089 (2.974)	0.040 (1.319)	0.050 (1.655)	-55.7% (-55.7%)
12,000 to 13,999	12.33	29 (3)	4 (1)	0.153 (1.585)	0.031 (0.773)	0.122 (0.812)	-79.8% (-51.2%)
14,000 to 16,999	8.15	19 (2)	4 (1)	0.120 (1.260)	0.031 (0.771)	0.089 (0.489)	-74.2% (-38.8%)
≥ 17,000	6.83	14 (6)	6 (2)	0.077 (3.298)	0.061 (2.028)	0.016 (1.271)	-21.0% (-38.5%)
All	135.88	176 (29)	29 (7)	0.131 (2.159)	0.038 (0.917)	0.093 (1.241)	-71.0% (-57.5%)

Fatal & Serious Injury results are in ( ) with rate per 100 mVMT

Figure 8.5 displays the All Injury Severities data from Table 8.14. The data exhibits a similar trend to what was observed for all lane departure collisions, where prior to rumble strip installation, the crash rates decreased as AADT volumes increased. Also, similar to the lane departure data, that trend seems to break down following rumble strip installation, with more consistent rates across all of the traffic volumes examined.

**Figure 8.5 Composite: Crossover Rates by AADT – All Injury Severities**

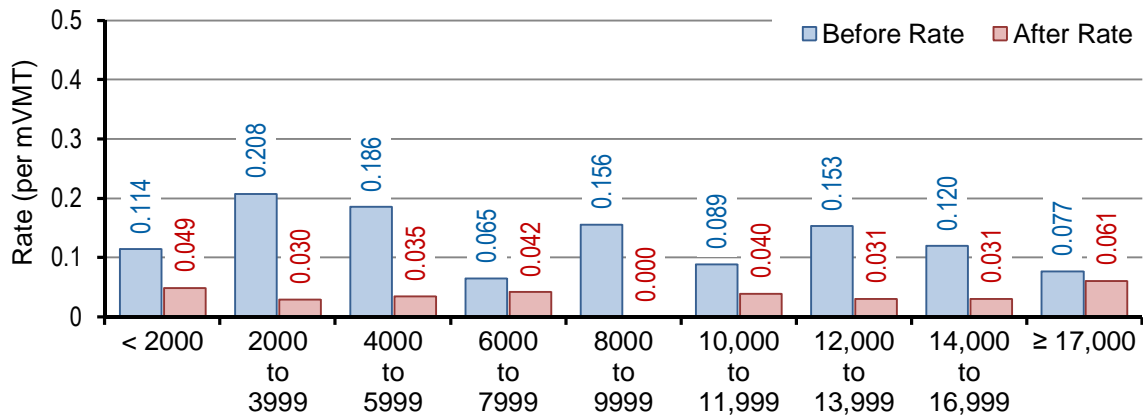

■ ROTRR Crashes

Table 8.15 shows the ROTRR collision experience component when examined by AADT. For the All Injury Severities category, significant reductions in the collision rates were found for all ranges examined. The lowest of the reductions seen was a 23.0% drop in the rate at the 12,000 to 13,999 range. All other ranges exceeded this rate of reduction. However, the Fatal & Serious Injury category had two ranges where increases in the rate were recorded. The 12,000 to 13,999 range recorded a 46.3% increase and the 14,000 to 16,999 range recorded a 144.7% increase.

**Table 8.15 Composite: ROTRR Rates by AADT**

Range	Miles	Before Crash Count	After Crash Count	Before Crash Rate	After Crash Rate	Difference in Rate	% Change in Rate
< 2000	10.83	5 (0)	0 (0)	0.286 (0.000)	0.000 (0.000)	0.286 (0.000)	-100% (0%)
2000 to 3999	36.08	39 (5)	6 (0)	0.245 (3.145)	0.089 (0.000)	0.156 (3.145)	-63.7% (-100%)
4000 to 5999	31.67	46 (4)	6 (1)	0.194 (1.687)	0.070 (1.172)	0.124 (0.515)	-63.8% (-30.5%)
6000 to 7999	15.36	21 (2)	7 (0)	0.104 (0.993)	0.049 (0.000)	0.055 (0.993)	-52.8% (-100%)
8000 to 9999	4.34	9 (0)	0 (0)	0.141 (0.000)	0.000 (0.000)	0.141 (0.000)	-100% (0%)
10,000 to 11,999	10.27	15 (5)	4 (1)	0.112 (3.717)	0.053 (1.319)	0.059 (2.399)	-52.7% (-64.5%)
12,000 to 13,999	12.33	19 (1)	10 (1)	0.100 (0.528)	0.077 (0.773)	0.023 (-0.244)	-23.0% (46.3%)
14,000 to 16,999	8.15	18 (1)	5 (2)	0.113 (0.630)	0.039 (1.542)	0.075 (-0.912)	-66.0% (144.7%)
≥ 17,000	6.83	25 (1)	5 (0)	0.137 (0.550)	0.051 (0.000)	0.087 (0.550)	-63.1% (-100%)
All	135.88	197 (19)	43 (5)	0.147 (1.414)	0.056 (0.655)	0.090 (0.759)	-61.6% (-53.7%)

Fatal & Serious Injury results are in ( ) with rate per 100 mVMT

Figure 8.6 displays the All Injury Severities data from Table 8.15. Note that the collision rates prior to rumble strip installation do show a trend of lower traffic volumes having higher ROTRR collision rates. The rates in the after period display more variability than the crossover dataset. In this dataset, the crash rates appear to follow a trend line more similar to the before period, with the lower volumes experiencing a higher rate of ROTRR events. Although there is a higher rate for the 12,000 to 13,999 AADT range, the remainder of the ranges suggest a tendency toward lower crash rates as the AADT increases after rumble strips were installed.

**Figure 8.6 Composite: ROTRR Rates by AADT – All Injury Severities**

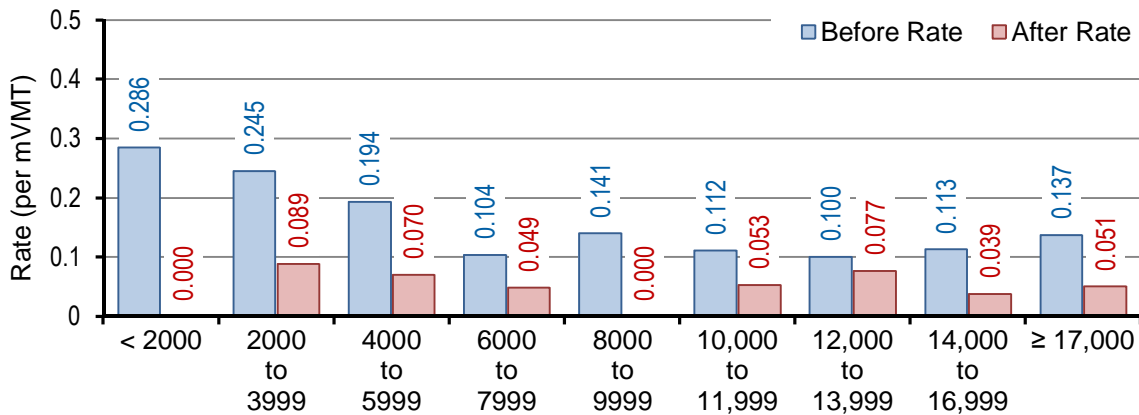

**Composite: Horizontal Alignment**

■ Lane Departure Crashes

Table 8.16 displays the lane departure experience by horizontal alignment for the Composite view. Significant reductions were made in the All Injury Severities category. There was a 71.5% reduction in the rate of collisions on tangent segments, and a 55.1% reduction for curve segments for All Injury Severities. A 43.4% reduction in crash rates was observed for crashes on the inside of the curve, with a 62.1% decrease in crash rates for the outside of the curve.

Both tangent and curve segments saw reductions in the Fatal & Serious Injury collision rate, with a 53.9% reduction on tangents and a 58.4% reduction on curves. The Fatal & Serious Injury collision rate to the inside of the curve increased by 87.3%, while to the outside of the curve, the Fatal & Serious Injury rate was reduced by 76.6%. This increase in the Fatal & Serious Injury rate was due to two crossover collision events that occurred in the after period; none occurred in the before period.

**Table 8.16 Composite: Lane Departure Rates by Horizontal Alignment**

Horizontal Alignment	Miles	Before Crash Count	After Crash Count	Before Crash Rate	After Crash Rate	Difference in Rate	% Change in Rate
Tangent	105.28	231 (30)	38 (8)	0.223 (2.890)	0.063 (1.333)	0.159 (1.557)	-71.5% (-53.9%)
Curve	30.59	142 (18)	34 (4)	0.465 (5.893)	0.209 (2.453)	0.256 (3.440)	-55.1% (-58.4%)
Inside*		53 (2)	16 (2)	0.347 (1.310)	0.196 (2.453)	0.151 (-1.144)	-43.4% (87.3%)
Outside*		89 (16)	18 (2)	0.583 (10.476)	0.221 (2.453)	0.362 (8.023)	-62.1% (-76.6%)

\*Rates based on half of the curve VMT

Fatal & Serious Injury results are in ( ) with rate per 100 mVMT

■ Crossover Crashes

Table 8.17 shows the crossover rate by horizontal alignment. Significant reductions in the All Injury Severities collision rates were found in all instances. The Fatal & Serious Injury rate was reduced in all but one analysis. There was a 100% increase in Fatal & Serious Injury rates, with two crossover collisions occurring to the inside of curves in the after period, with none in the before period.

**Table 8.17 Composite: Crossover Rates by Horizontal Alignment**

Horizontal Alignment	Miles	Before Crash Count	After Crash Count	Before Crash Rate	After Crash Rate	Difference in Rate	% Change in Rate
Tangent	105.28	103 (20)	14 (4)	0.099 (1.927)	0.023 (0.667)	0.076 (1.260)	-76.5% (-65.4%)
Curve	30.59	73 (9)	15 (3)	0.239 (2.947)	0.092 (1.840)	0.147 (1.107)	-61.5% (-37.6%)
Inside*		28 (0)	6 (2)	0.183 (0.000)	0.074 (2.453)	0.110 (-2.453)	-59.9% (100%)
Outside*		45 (9)	9 (1)	0.295 (5.893)	0.110 (1.227)	0.184 (4.666)	-62.5% (-79.2%)

\*Rates based on half of the curve VMT

Fatal & Serious Injury results are in ( ) with rate per 100 mVMT

■ ROTRR Crashes

Table 8.18 shows the ROTRR rates by horizontal alignment. Significant reductions were found in all collision rates in this view. All Injury Severities and Fatal & Serious Injury collisions were reduced on tangents and curves and within the inside or outside of a curve.

**Table 8.18 Composite: ROTRR Rates by Horizontal Alignment**

Horizontal Alignment	Miles	Before Crash Count	After Crash Count	Before Crash Rate	After Crash Rate	Difference in Rate	% Change in Rate
Tangent	105.28	128 (10)	24 (4)	0.123 (0.963)	0.040 (0.667)	0.083 (0.297)	-67.6% (-30.8%)
Curve	30.59	69 (9)	19 (1)	0.226 (2.947)	0.117 (0.613)	0.109 (2.333)	-48.4% (-79.2%)
Inside*		25 (2)	10 (0)	0.164 (1.310)	0.123 (0.000)	0.041 (1.310)	-25.1% (-100%)
Outside*		44 (7)	9 (1)	0.288 (4.583)	0.110 (1.227)	0.178 (3.357)	-61.7% (-73.2%)

\*Rates based on half of the curve VMT

Fatal &amp; Serious Injury results are in ( ) with rate per 100 mVMT

**Composite: Percent/Length Curve**

## ■ Lane Departure Crashes

Table 8.19 summarizes the analysis for the Composite set by percent/length curve. Significant reductions were recorded in all but one range. The 50 to < 60% range had a 100% increase in the All Injury Severities rate. This range consisted of 0.32 of a mile and had a single event in the after period. It is interesting to note that the after collision rate of both the All Injury Severities and the Fatal & Serious Injury categories increased as the percent/length curve percentage increased.

**Table 8.19 Composite: Lane Departure Rates by Percent/Length Curve**

Range*	Miles	Before Crash Count	After Crash Count	Before Crash Rate	After Crash Rate	Difference in Rate	% Change in Rate
0 to < 10%	8.69	25 (4)	3 (0)	0.233 (3.731)	0.055 (0.000)	0.178 (3.731)	-76.2% (-100%)
10 to < 20%	73.08	147 (19)	40 (6)	0.207 (2.678)	0.082 (1.228)	0.125 (1.450)	-60.5% (-54.1%)
20 to < 30%	20.14	93 (8)	8 (2)	0.359 (3.091)	0.098 (2.446)	0.262 (0.645)	-72.8% (-20.9%)
30 to < 40%	29.06	79 (10)	11 (3)	0.412 (5.217)	0.129 (3.519)	0.283 (1.698)	-68.7% (-32.5%)
40 to < 50%	2.58	11 (1)	3 (0)	0.348 (3.161)	0.140 (0.000)	0.208 (3.161)	-59.7% (-100%)
50 to < 60%	0.32	0 (0)	1 (0)	0.000 (0.000)	0.075 (0.000)	-0.075 (0.000)	100% (0%)
60 to < 70%	2.01	18 (6)	6 (1)	0.452 (15.075)	0.322 (5.359)	0.131 (9.716)	-28.9% (-64.5%)
≥ 80%	0.00	0 (0)	0 (0)	NX (NX)	NX (NX)	NX (NX)	NX (NX)
All	135.88	373 (48)	72 (12)	0.278 (3.573)	0.094 (1.573)	0.183 (2.000)	-66.0% (-56.0%)

\*Determined per segment, then grouped

NX = No Exposure

Fatal &amp; Serious Injury results are in ( ) with rate per 100 mVMT

## ■ Crossover Crashes

Table 8.20 shows the crossover rates by percent/length curve. As in the lane departure section, only the 50 to < 60% range failed to show significant improvement. A single event in the after period of this 0.32 of mile section resulted in a 100% increase in the All Injury Severities collision rate. In all other ranges, the All Injury Severities and Fatal & Serious Injury collision rates decreased. Again, there seems to be a trend for increased crash rates as the percentage of curvature to the roadway increased for both injury categories in the after period.

**Table 8.20 Composite: Crossover Rates by Percent/Length Curve**

Range*	Miles	Before Crash Count	After Crash Count	Before Crash Rate	After Crash Rate	Difference in Rate	% Change in Rate
0 to < 10%	8.69	10 (2)	1 (0)	0.093 (1.866)	0.018 (0.000)	0.075 (1.866)	-80.2% (-100%)
10 to < 20%	73.08	65 (11)	15 (3)	0.092 (1.551)	0.031 (0.614)	0.061 (0.936)	-66.5% (-60.4%)
20 to < 30%	20.14	44 (5)	4 (1)	0.170 (1.932)	0.049 (1.223)	0.121 (0.709)	-71.2% (-36.7%)
30 to < 40%	29.06	40 (5)	6 (2)	0.209 (2.609)	0.070 (2.346)	0.138 (0.262)	-66.3% (-10.1%)
40 to < 50%	2.58	6 (1)	0 (0)	0.190 (3.161)	0.000 (0.000)	0.190 (3.161)	-100% (-100%)
50 to < 60%	0.32	0 (0)	1 (0)	0.000 (0.000)	0.075 (0.000)	-0.075 (0.000)	100% (0%)
60 to < 70%	2.01	11 (5)	2 (1)	0.276 (12.563)	0.107 (5.359)	0.169 (7.204)	-61.2% (-57.3%)
≥ 80%	0.00	0 (0)	0 (0)	NX (NX)	NX (NX)	NX (NX)	NX (NX)
All	135.88	176 (29)	29 (7)	0.131 (2.159)	0.038 (0.917)	0.093 (1.241)	-71.0% (-57.5%)

\*Determined per segment, then grouped      NX = No Exposure      Fatal & Serious Injury results are in ( ) with rate per 100 mVMT

### ■ ROTRR Crashes

The ROTRR dataset is shown in [Table 8.21](#). There were significant reductions in the rate of collisions observed in most all categories and injury classes. Only two ranges indicated increases in the collision rates. The 20 to < 30% range recorded a 5.5% increase in Fatal & Serious Injury collision rates, and the 60 to < 70% range had a 21.9% increase in the All Injury Severities rate.

The trend of increasing collision rates with the increase in the percent of curvilinear roadway noted in the crossover and lane departure collision sets was less apparent in this class of collisions. For the All Injury Severities rates, this trend seemed to continue; however, it did not for the Fatal & Serious Injury events for those ranges where data was available.

**Table 8.21 Composite: ROTRR Rates by Percent/Length Curve**

Range*	Miles	Before Crash Count	After Crash Count	Before Crash Rate	After Crash Rate	Difference in Rate	% Change in Rate
0 to < 10%	8.69	15 (2)	2 (0)	0.140 (1.866)	0.037 (0.000)	0.103 (1.866)	-73.6% (-100%)
10 to < 20%	73.08	82 (8)	25 (3)	0.116 (1.128)	0.051 (0.614)	0.064 (0.514)	-55.7% (-45.5%)
20 to < 30%	20.14	49 (3)	4 (1)	0.189 (1.159)	0.049 (1.223)	0.140 (-0.064)	-74.2% (5.5%)
30 to < 40%	29.06	39 (5)	5 (1)	0.203 (2.609)	0.059 (1.173)	0.145 (1.435)	-71.2% (-55.0%)
40 to < 50%	2.58	5 (0)	3 (0)	0.158 (0.000)	0.140 (0.000)	0.018 (0.000)	-11.4% (0%)
50 to < 60%	0.32	0 (0)	0 (0)	0.000 (0.000)	0.000 (0.000)	0.000 (0.000)	0% (0%)
60 to < 70%	2.01	7 (1)	4 (0)	0.176 (2.513)	0.214 (0.000)	-0.038 (2.513)	21.9% (-100%)
≥ 80%	0.00	0 (0)	0 (0)	NX (NX)	NX (NX)	NX (NX)	NX (NX)
All	135.88	197 (19)	43 (5)	0.147 (1.414)	0.056 (0.655)	0.090 (0.759)	-61.6% (-53.7%)

\*Determined per segment, then grouped      NX = No Exposure      Fatal & Serious Injury results are in ( ) with rate per 100 mVMT

## Composite Summary

Comparing the time period where no rumble strips were installed with a condition where both CLRS and SRS were installed revealed a 66% reduction in lane departure crash rates in the All Injury Severities category. A 56% reduction was observed in Fatal & Serious Injury crash rates.

The analysis of contributing circumstances indicated significant reductions in All Injury Severities crash rates for all categories evaluated. For lane departure crashes, the crash rate reductions ranged from 41% to 84%. The targeted circumstances of A/F and I/D were reduced 84% and 43.2%, respectively, for All Injury Severities crash rates. The Fatal & Serious Injury crash rate for the A/F category was reduced 100%, while the I/D Fatal & Serious Injury crash rate was essentially unchanged.

Reflecting WSDOT's design guidance stating that rumble strips are appropriate for highways with speeds of 45 mph or higher, 97% of the exposure mileage and crash experience represented in this analysis came from highways with posted speeds of 50 to 60 mph. The All Injury Severities lane departure crash rates were reduced from 55.9% to 71.3% within these speed ranges. Reductions in crossover crash rates were greater than reductions in ROTRR crash rates, although they were substantial in both instances.

The 11' wide lanes appeared to benefit slightly more than 12' wide lanes from combinations of CLRS and SRS. All Injury Severities lane departure crash rates were reduced by 72.1% where lane widths were 11'. All Injury Severities lane departure crash rates for 12' wide lanes were reduced by 61.8%. A similar trend was observed for Fatal & Serious Injury crash rates, with crash rate reductions of 68.3% for 11' lanes and 46.8% for 12' lanes.

Although the results indicated substantial reductions in All Injury Severities crash rates for SRS recovery width, the results were variable. Generally, the All Injury Severities crash rate reductions were greater for locations with 4 feet or more of recovery area. The results for Fatal & Serious Injury collisions were mixed, with increased crash rates for 5 to < 6' and 7 to < 8' widths, and 20% to 91.8% reductions in crash rates for the remaining widths studied.

An evaluation of AADT levels and composite rumble strip performance reveals that lane departure crash rates were higher for lower-volume highways prior to rumble strip installation. Installations of CLRS and SRS on these highways resulted in reduced crash rates for all AADT groupings. The greatest reductions were noted for the lower AADT bands. Greater reductions were found for crossover crash rates than for ROTRR crash rates.

## SECTION 9: CONCLUSIONS

### SRS

As stated early in this report, the original goal was to examine the effectiveness of shoulder rumble strips (SRS) on Washington State undivided roadways. Limited SRS installations did not provide sufficient data for analysis. Ninety-eight percent of the SRS miles available for study represented a single segment. There was only one run-off-the-road-to-the-right (ROTRR) crash prior to installation of SRS and three following installation. The research team elected to focus on the performance of combinations of shoulder and centerline rumble strips.

### CLRS&SRS

The combination of centerline rumble strips (CLRS) installed at the same time as SRS (CLRS&SRS) resulted in a 63.3% reduction in lane departure crashes. Data was analyzed for 77.44 miles of Washington highways. Crossover crash rates were reduced 65.4% and ROTRR crash rates were reduced 61.4%. Asleep or Fatigued (A/F) driver-related crash rates were reduced by 79.4% and Inattentive or Distracted (I/D) crash rates declined by 64.8%. All other contributing circumstances analyzed produced substantially reduced crash rates as well, ranging from 44% to 54% reductions. Reductions in A/F crash rates were nearly identical for crossover crashes and ROTRR crashes. For I/D crashes, the reduction in ROTRR crash rates (72.2%) was more substantial than the 47.5% reduction in crossover crash rates.

Although the sample data is rather limited at lower speeds, CLRS&SRS installations appear to be more effective at higher speeds. A 49.2% reduction was noted for locations with posted speeds of 50 mph. For speeds of 55 and 60 mph, crash rates were reduced 58.4% and 64.8%, respectively. Reduced crash rates for ROTRR crashes appear to be linked to the “recovery width” beyond the SRS. Lane departure crash rates were reduced by 49% to 79% for SRS recovery widths greater than 4 feet.

Crash rates appear to be influenced by traffic volume. When examining AADT and crash experience, the researchers noted that, prior to rumble strip installation, locations below 6000 AADT had the highest rates of lane departure, crossover, and ROTRR crashes. It is unclear whether this is related to traffic volume, or whether these lower-volume highways may be designed with more curvature, narrower shoulders/SRS recovery widths, etc. Interestingly, the greatest influence of CLRS&SRS on crash rates seems to be at higher average annual daily traffic (AADT) levels, with the highest reductions in crash rates occurring at levels from 12,000 to 13,999 AADT.

Lane departure crash rates are notably higher for highway segments within horizontal curves compared to tangents. This holds true before and after CLRS&SRS installation. The greatest crash rate reductions were observed for tangent roadways, although the reductions for curves were substantial. Reductions in crossover crash rates were several percentage points better than ROTRR reductions.

Exploring what percentage of a highway segment's length is within the limits of a horizontal curve revealed that the vast majority of the segments sampled range from 10% to 40% of the alignment within the boundaries of horizontal curves. The researchers found 55% or greater reductions in lane departure, crossover, and ROTRR crash rates for these alignments.

### **SRS+CLRS**

This analysis seems to validate that CLRS can be added to SRS installations without a substantial increase in ROTRR events. Crossover crash rates declined by 64.7%, while ROTRR crashes increased by 8.5% for All Injury Severities. The Fatal and Serious Injury crash rate declined for crossover crashes and was unchanged for ROTRR crashes. The crash reductions overshadow the increased crash experience for ROTRR crashes, with an aggregate 44.6% reduction in lane departure crash rates.

Results were mixed for the targeted circumstances of A/F and I/D. A 92.9% reduction in A/F crashes was observed with crossover crash rates, and a 99% increase was found for ROTRR crash rates for All Injury Severities crashes. A similar trend occurred for I/D collisions, with a 75.6% reduction in crossover crash rates and a 70.5% increase in ROTRR crash rates. Overall, the reductions in the crossover crashes overshadowed the increases in ROTRR crashes, yielding a 49.5% reduction in A/F crash rates and a 43.2% reduction in I/D crash rates.

An analysis of ROTRR crash experience based on SRS recovery width was impacted by limitations in the available data, as much of the exposure mileage and all of the crash data were grouped within two width ranges. SRS recovery widths of 4 to < 5' showed a 30.5% reduction in crash rates, and the 6 to < 7' width range showed a 26.5% increase in ROTRR crash rates. This was not anticipated, as more recovery area would be expected to be associated with reduced ROTRR crashes. There were no Fatal or Serious Injury crashes in the ROTRR dataset.

Lane departure crash rates were reduced by 50.2% on tangent alignments and 47.3% on curved roadways for All Injury Severities crashes. Reductions in crossover crash rates were found to be 77.6% on tangents and 57.3% on curves. ROTRR crash rates were reduced 23.2% on curves, but were up 27.1% on tangent segments.

### **CLRS+SRS**

The addition of SRS to existing CLRS installations was expected to reduce ROTRR crashes. Those expectations were met, with a 47% reduction in All Injury Severities crash rates for ROTRR collisions. A 6.8% reduction in crossover crash rates for All Injury Severities was observed. Overall, lane departure crash rates declined by 37.5% for All Injury Severities and 32.2% for Fatal and Serious Injury crashes.

The greatest reductions in crash rates for lane departure collisions was noted for the contributing categories of A/F and Other for All Injury Severities collisions, with reductions of 75.1% and 83.1%, respectively. Lane departure crash rates associated with I/D drivers saw an increase of 57.3%. A 210.7% increase in speed-related crash rates was observed for All Injury Severities events, along with a 100% increase in Fatal and Serious Injury crash rates.



Lane departure crash reductions were generally attributed to tangent roadways, with a 59.4% reduction compared to a 4.3% reduction for segments on a curve. ROTRR crash rates went down on both tangents and curves, with reductions of 60% and 27.5%, respectively. However, a 71.3% increase was found for the All Injury Severities rates for crossover crashes on curves. This increase was equally distributed between crashes to the inside and the outside of the curve.

An analysis of crash experience based on the percent/length curve produced mixed results. Substantial reductions were observed in All Injury Severities crash rates for the 0 to < 10%, 20 to < 30%, and 30 to < 40% ranges. However, there was little change in All Injury Severities crash rates for locations with 10 to 20% of the alignment in curves. A 100% increase in Fatal and Serious Injury crash rates was observed for locations with 10 to 20% of the alignment in curves.

### **Composite**

A 66% reduction in lane departure crash rates for All Injury Severities was found after a combination of CLRS and SRS was installed. A 56% reduction in Fatal and Serious Injury crash rates was noted.

The analysis of contributing circumstances related to lane departure crashes indicates reduced crash rates ranging from 41% to 84% for All Injury Severities. The targeted circumstances of A/F and I/D were reduced 84% and 43.2%, respectively, for All Injury Severities collisions. A 100% reduction in Fatal and Serious Injury crash rates was found for A/F crashes, while I/D Fatal and Serious Injury crash rates were unaffected.

Nearly all of the exposure mileage and crash experience represented in an analysis of posted speed comes from highways with posted speeds of 50 to 60 mph. All Injury Severities lane departure crash rates were reduced from 55.9% to 71.3% within these speed ranges. Reductions in crossover crash rates were greater than the reduction in ROTRR crash rates.

For combinations of CLRS and SRS, 11' wide lanes appear to benefit slightly more than 12' wide lanes. All Injury Severities lane departure crash rates were reduced by 72.1% where lane widths were 11'. For 12' wide lanes, that reduction was 61.8%. A similar trend was observed for Fatal and Serious Injury crash rates, with crash rate reductions of 68.3% for 11' lanes and 46.8% for 12' lanes.

Generally, the All Injury Severities reductions were greater when the SRS recovery width was 4 feet or greater. The results for Fatal and Serious Injury collisions were mixed, with increased crash rates for 5 to < 6' and 7 to < 8' widths, and 20% to 91.8% reductions in crash rates for the remaining widths evaluated.

Lane departure crash rates were found to be higher for lower-volume highways prior to rumble strip installation. Installation of CLRS and SRS resulted in reduced lane departure crash rates for all AADT groupings. The greatest reductions were noted for the lower AADT bands. Greater reductions were found with crossover crash rates than with ROTRR crash rates.

The performance of each segment is detailed by the specific areas of analysis in [Appendix D](#). These results are specific to those locations only. [Appendices E](#) and [F](#) are the WSDOT Standards Plans for SRS and CLRS, respectively.

## GLOSSARY

AADT	Annual average daily traffic: The estimated average daily traffic over a period of one year.
All Injury Severities	Includes all reported crashes, regardless of injury severity. Injury severities include property damage only (non-injury) crashes, possible injury crashes, evident injury crashes, serious injury crashes, and fatal injury crashes.
Asleep/Fatigued	A combination of the contributing circumstances of “Asleep” and “Fatigued” as noted by the investigating officer of a reported collision. The officer may have noted either or both circumstances.
CLRS	Centerline rumble strips: Rumble strips installed on the centerline of roadway.
CLRS&SRS	Centerline rumble strips and shoulder rumble strips were installed under the same contract. This provides for a performance comparison where a time period with no rumble strips is compared with a time period where both types are installed on the same highway segment.
CLRS+SRS	Centerline rumble strips existed along a highway segment and shoulder rumble strips were installed later. This provides for a performance comparison where a time period with only centerline rumble strips is compared with a time period where both types are installed on the same highway segment.
Collision (also Crash)	An unintended event that causes a death, injury, or property damage and involves at least one motor vehicle on a public roadway. There is no requirement to report collisions resulting in property damage valued at less than \$700.
Collision Rate	Number of reportable collisions for a specified segment of public roadway per one million vehicle miles of travel, unless otherwise stated.
Composite	Centerline rumble strips and shoulder rumble strips were installed under different contracts (at different times). There is no collision data representing the time period where only one type of rumble strips existed. The time period prior to installation of any rumble strips is represented in the data. This provides for a performance comparison where a time period with no rumble strips is compared with a time period where both types are installed on the same highway segment.
Contributing Circumstances	A driving action that in the investigating officer’s opinion best describes the primary factors associated with the collision. If available, first, second, and third contributing circumstances are collected for each motor vehicle driver, pedalcyclist, and pedestrian involved in the collision. In this study, multiple circumstances are grouped into categories (see <a href="#">Appendix C</a> ).
Curve	A nontangential portion of the roadway. A curve-related collision within this study may not have actually occurred within the physical limits of the horizontal curve (begin and end of the curve); however, the curve was believed to have had an influence on the collision.
Fatal Collision	Any collision that results in the death of one or more persons due to injuries sustained in the collision. Injuries resulting in death within 30 days of the collision are included in this category.
Fatal & Serious Injury Collision Rate	Number of reportable fatal and serious injury collisions for a specified segment of public roadway per 100 million vehicle miles of travel.

## GLOSSARY

FHWA	Federal Highway Administration
Inattentive/ Distracted	An aggregation of a number of contributing circumstances noted by the investigating officer. There are a number of specific choices the officer may select that would be included in this category: Inattention, Driver Operating Handheld Telecommunications Device, Driver Operating Hands-free Wireless Telecommunications Device, Driver Operating Other Electronic Devices, Driver Adjusting an Audio or Entertainment System, Driver Smoking, Driver Eating or Drinking, Driver Reading or Writing, Driver Grooming, Driver Interacting with Passengers, Animals or Objects in the vehicle, Other Driver Distractions Inside the Vehicle, Driver Distractions Outside the Vehicle, and Unknown Driver Distraction.
Initial Action	A study-defined circumstance where a vehicle driver initially leaves the lane of travel to the left or to the right and subsequently overcorrects, resulting in a collision.
Inside	The interior radius of a curve; for example, a driver who travels in a curve to the left and crosses the centerline has left the lane of travel to the inside.
Intentional Acts	A collision where the vehicle operator intentionally collides with another vehicle or fixed object. Drivers of vehicles fleeing law enforcement who are involved in a collision while being pursued are also considered to have committed intentional acts.
Medical	A collision where the investigating officer states the collision was a result of a medical condition or circumstance.
No Injury	No reported or observed bodily injury due to the collision.
None	A contributing circumstance category where the investigating officer found no contributing circumstance by the vehicle operator (see <a href="#">Appendix C</a> ).
Other	A contributing circumstance category where the investigating officer found a contributing circumstance by the vehicle operator that did not meet the choices offered by the Police Collision Traffic Report (see <a href="#">Appendix C</a> ).
Outside	The exterior radius of a curve; for example, a driver who travels in a curve to the left and leaves the roadway to the right departs the roadway to the outside.
Over Centerline	The circumstance where a vehicle crosses into an opposing traffic lane.
Passing	For this analysis, defined as an intentional crossing of the centerline to overtake another vehicle; the legality of the maneuver is not relevant.
PCTR	Police Collision Traffic Report
ROTR	Run-off-the-road: A lane departure collision.
ROTRR	Run-off-the-road-to-the-right: A lane departure collision off the right side of the roadway.
Rumble Strips	A series of milled/formed depressions or raised thermo-plastic devices installed on a roadway to alert a driver by means of vibration and/or noise generated from tires rolling over the rumble strips. Normally positioned for travel when the driver leaves the designated travel way. (See <a href="#">Appendix D</a> for WSDOT Standard Plans for rumble strips.)
SCTDO	Statewide Collision and Traffic Data Office: The WSDOT office formerly known as TDO.
Segment	A specific length of roadway defined for analysis.

## GLOSSARY

Serious Injury	Any injury that prevents the injured person from walking, driving, or continuing normal activities at the time of the collision.
Speed	A contributing category or narrative description noted by the investigating officer. This includes the contributing circumstances of “exceeding stated speed limit” and “exceeding reasonable safe speed” (see <a href="#">Appendix C</a> ).
SRS	Shoulder rumble strips: Rumble strips installed on the right shoulder of the roadway outside the fog line.
SRS+CLRS	Shoulder rumble strips existed along a highway segment and centerline rumble strips were installed later. This provides for a performance comparison where a time period with only shoulder rumble strips is compared with a time period where both types are installed on the same highway segment.
Tangent	A straight stretch of roadway.
Under the Influence	Contributory circumstance noted by an investigating officer; this includes alcohol and/or drugs (illegal drugs, legal drugs, or prescription or over-the-counter medications or drugs).
VMT	Vehicle miles traveled: A calculation of the number of miles traveled by all vehicles over a specified length of roadway and period of time. Calculated by the number of vehicles per day (ADT) multiplied by the length of the segment of roadway multiplied by the number of days in the evaluation period.
Weather related	Relates to a collision report where the investigating officer noted the roadway or weather conditions of snow/slush, ice, or standing water.
WSDOT	Washington State Department of Transportation

## BIBLIOGRAPHY

Dulaski, D. M. and D. A. Noyce, 2006. "Development and Evaluation of an Unique Centerline Rumble Strip Pattern to Improve Driver Comprehension," Prepared for the 85th Annual meeting of the Transportation Research Board, Washington, D.C., January, 2006.

☞ [http://www.topslab.wisc.edu/publications/David/noyce\\_2006\\_2442.pdf](http://www.topslab.wisc.edu/publications/David/noyce_2006_2442.pdf)

Enders, M., 2004. "Highway Safety: Quarterly Update," in the June 30, 2004, *Measures, Markers and Mileposts* (the *Gray Notebook*), WSDOT's quarterly report to the Washington State Transportation Commission on transportation programs and department management: p39.

☞ <http://www.wsdot.wa.gov/NR/rdonlyres/C051285A-8FCE-4B6C-AAEB-AD1994CF2B6C/0/GrayNotebookJun04.pdf#page=42>

FHWA, 2001. "Synthesis of Shoulder Rumble Strip Practices and Policies," FHWA-RD-01-072. FHWA, U.S. Department of Transportation, 2001.

☞ [http://safety.fhwa.dot.gov/roadway\\_dept/research/exec\\_summary.htm](http://safety.fhwa.dot.gov/roadway_dept/research/exec_summary.htm)

Finley, Melissa, Funkhouser, Dillon S. & Brewer, Marcus A. 2008. "Studies to Determine Operational Effects of Shoulder & Centerline Rumble Strips on Two-Lane Undivided Roadways," Report 0-5577-1. Texas Transportation Institute, August 2009. ☞ <http://tti.tamu.edu/documents/0-5577-1.pdf>

Miles, J. D. and M. D. Finley. "Factors That Influence the Effectiveness of Rumble Strip Design," Transportation Research Record: Journal of the Transportation Research Board, Issue 2030, 2007.

☞ <http://pubsindex.trb.org/view/2007/C/802346>

Miles, J.D., et al., 2005. "Traffic Operational Impacts Of Transverse, Centerline, And Edgeline Rumble Strips," Report No. FHWA/TX-05/0-4472-2, Texas Transportation Institute, The Texas A&M University System, College Station, Texas 77843-3135, March 2005.

☞ <http://tti.tamu.edu/documents/0-4472-2.pdf>

Neuman, T. R., R. Pfefer, K. L. Slack, K. K. Hardy, H. McGee, L. Prothe, K. Eccles, and F. Council, 2003. "NCHRP Report 500: Guidance for Implementation of the AASHTO Strategic Highway Safety Plan. Volume 4: A Guide for Addressing Head-On Collisions," National Cooperative Highway Research Program, Transportation Research Board, Washington, D.C., 2003.

☞ <http://pubsindex.trb.org/view/2003/M/661882>

Noyce, D. A. and V. V. Elango, 2004. "Safety Evaluation of Centerline Rumble Strips: Crash and Driver Behavior Analysis," Transportation Research Record, No. 1862, TRB, National Research Council, Washington, D.C., 2004. ☞ <http://trb.metapress.com/content/e423g23070724n1u/fulltext.pdf>

Outcalt, W., 2001. "Centerline Rumble Strips," Report No. CDOT-DTDR-2001-8, Colorado Department of Transportation, 4201 East Arkansas Avenue, Denver, Colorado 80222, August 2001.

☞ <http://www.dot.state.co.us/Publications/PDFFiles/centerline.pdf>

Patel, R. B., F. M. Council, and M. S. Griffith, 2007. "Estimating Safety Benefits of Shoulder Rumble Strips on Two-Lane Rural Highways in Minnesota: Empirical Bayes Observational Before-and-After Study," Transportation Research Record: Journal of the Transportation Research Board, Issue 2019, 2007. ☞ <http://pubsindex.trb.org/view/2007/C/801951>

- Persaud, B. N., R. A. Retting, and C. Lyon, 2003. "Crash Reduction Following Installation of Centerline Rumble Strips on Rural Two-Lane Roads," Insurance Institute for Highway Safety, 1005 North Glebe Road, Arlington, VA 22201, September (2003). Websites:  
 ☞ <http://www.highwaysafety.org>  
 ☞ [http://www.dot.state.mn.us/trafficeng/safety/rumble/IIHS\\_report.pdf](http://www.dot.state.mn.us/trafficeng/safety/rumble/IIHS_report.pdf)
- Porter, R. J., E. T. Donnell, and K. M. Mahoney, 2004. "Evaluation of Effects of Centerline Rumble Strips on Lateral Vehicle Placement and Speed," Transportation Research Record, No. 1862, TRB, National Research Council, Washington, D.C., 2004.  
 ☞ <http://trb.metapress.com/content/vu2287867n3g2382/fulltext.pdf>
- Räsänen, M., 2005. "Effects of a Rumble Strip Barrier Line on Lane Keeping in a Curve," Accident Analysis and Prevention, Vol. 37, No. 3, May 2005.  
 ☞ <http://www.psychology.nottingham.ac.uk/IAAPdiv13/ICTTP2004papers2/Performance/Rasanen.pdf>
- Russell, E. R., M. J. Rys, and T. S. Brin, 2003. "US Experience with Centerline Rumble Strips on Two-Lane Roads: Pattern Research and North American Usage," Mid-continent Transportation Research Symposium, Ames, IA, 2003. ☞ <http://www.ctre.iastate.edu/pubs/midcon2003/RussellRumble.pdf>
- Russell, E. R., and M. J. Rys, 2005. "NCHRP Synthesis 339: Centerline Rumble Strips," National Cooperative Highway Research Program, Transportation Research Board, National Research Council, Washington, D.C., 2005. ☞ <http://pubsindex.trb.org/view/2005/M/753956>
- Taylor, William C., Abu-Lebdeh, Ghassen, & Rai, Sachin, 2005. "Effect of Continuous Shoulder Rumble Strips & Pavement Marking on Lateral Placement of Vehicles," Transportation Research Record: Journal of the Transportation Research Board, No. 1911, Transportation Research Board of the National Academies, Washington, D.C., 2005, pp. 105–112.
- Thompson, H. T., and D. D. Perkins. 1983. "Surrogate Measures for Accident Experience at Rural Isolated Horizontal Curves," Transportation Research Record, No. 905, TRB, National Research Council, Washington, D.C., 1983, pp. 142–147.
- Torbic, D.J., et al., 2009. "NCHRP Report 641: Guidance for the Design and Application of Shoulder and Centerline Rumble Strips," National Cooperative Highway Research Program, Transportation Research Board, Washington D. C., 2009. ☞ <http://pubsindex.trb.org/view/2009/M/905351>
- van Schalkwyk, I. and S. P. Washington, 2008. "Cost Effective Safety Improvements on Two-Lane Rural State Roads in Washington State," WA-RD 695.1, Washington State Department of Transportation, Olympia, Washington, April 2008.  
 ☞ <http://www.wsdot.wa.gov/research/reports/fullreports/695.1.pdf>
- Washington State Department of Transportation, 02/2007. "Washington State's Strategic Highway Safety Plan: Target Zero."  
 ☞ [http://www.sos.wa.gov/library/docs/DOT/TargetZero/shsp\\_2007\\_001442.pdf](http://www.sos.wa.gov/library/docs/DOT/TargetZero/shsp_2007_001442.pdf)

## APPENDIX A: LIST OF STUDY SEGMENTS

SRS Treatment/Study			Lane Departures					
			All Injury Severities			Fatal & Serious Injury		
State Route	Begin Milepost	End Milepost	Before Rate	After Rate	Change in Rate	Before Rate	After Rate	Change in Rate
003	53.21	53.46	0.0906	0.0000	0.0906	0.0000	0.0000	0.0000
026	0.47	18.88	0.1281	0.1892	-0.0611	0.0000	0.0000	0.0000
507	16.75	16.83	0.0000	0.0000	0.0000	0.0000	0.0000	0.0000
507	16.84	16.92	10.9447	7.2730	3.6717	0.0000	363.649	-363.649

CLRS&SRS Treatment/Study			Lane Departures					
			All Injury Severities			Fatal & Serious Injury		
State Route	Begin Milepost	End Milepost	Before Rate	After Rate	Change in Rate	Before Rate	After Rate	Change in Rate
002	3.87	4.19	0.0000	0.0750	-0.0750	0.0000	0.0000	0.0000
002	15.39	16.12	0.3922	0.2953	0.0969	11.7671	9.8445	1.9225
002	21.36	21.46	0.2991	0.0000	0.2991	0.0000	0.0000	0.0000
002	103.27	103.51	0.4004	0.6770	-0.2766	40.0398	0.0000	40.0398
002	321.78	324.88	0.3803	0.6251	-0.2448	0.0000	0.0000	0.0000
002	326.47	332.62	0.2279	0.0000	0.2279	3.5059	0.0000	3.5059
002	22.95	23.46	0.1468	0.0000	0.1468	0.0000	0.0000	0.0000
002	24.35	25.38	0.5313	0.0000	0.5313	4.0872	0.0000	4.0872
002	26.24	27.82	0.3226	0.0740	0.2485	2.9324	7.4040	-4.4716
003	53.47	59.73	0.2582	0.1081	0.1500	2.6891	1.3518	1.3373
011	2.19	6.87	0.5041	0.3498	0.1543	0.0000	0.0000	0.0000
012	8.42	9.10	0.0000	0.0000	0.0000	0.0000	0.0000	0.0000
017	21.80	21.96	0.0000	0.0000	0.0000	0.0000	0.0000	0.0000
017	22.21	27.24	0.4712	0.0295	0.4418	0.0000	2.9478	-2.9478
017	27.52	27.66	0.0000	0.0000	0.0000	0.0000	0.0000	0.0000
020	66.94	74.15	0.2745	0.1305	0.1440	0.9465	0.0000	0.9465
020	74.16	80.38	0.3295	0.1489	0.1805	4.7070	3.7237	0.9833
020	80.39	97.65	0.4106	0.2794	0.1312	8.3795	3.9914	4.3881
028	43.63	44.57	0.5457	0.2914	0.2544	9.0956	0.0000	9.0956
104	0.41	13.75	0.0982	0.0563	0.0419	0.5454	0.5626	-0.0172
904	12.75	15.25	0.1489	0.0941	0.0548	0.0000	3.1365	-3.1365

SRS+ CLRS Treatment/Study			Lane Departures					
			All Injury Severities			Fatal & Serious Injury		
State Route	Begin Milepost	End Milepost	Before Rate	After Rate	Change in Rate	Before Rate	After Rate	Change in Rate
002	4.20	5.82	0.1919	0.0877	0.1042	4.7985	0.0000	4.7985
002	5.83	12.73	0.1185	0.1030	0.0154	0.0000	1.1039	-1.1039
026	0.47	18.88	0.1852	0.0372	0.1480	0.0000	0.0000	0.0000
026	18.89	31.17	0.2104	0.0902	0.1203	3.0064	2.2541	0.7522

CLRS+SRS Treatment/Study			Lane Departures					
			All Injury Severities			Fatal & Serious Injury		
State Route	Begin Milepost	End Milepost	Before Rate	After Rate	Change in Rate	Before Rate	After Rate	Change in Rate
026	31.18	42.67	0.0621	0.0589	0.0033	0.0000	0.0000	0.0000
101	257.24	259.90	0.2563	0.0283	0.2280	2.8477	0.0000	2.8477
101	267.51	269.67	0.3092	0.1294	0.1799	13.2531	4.3130	8.9402
101	270.11	272.33	0.1433	0.1419	0.0014	0.0000	0.0000	0.0000
101	272.34	273.08	0.0000	0.0000	0.0000	0.0000	0.0000	0.0000
101	273.09	281.40	0.1272	0.0995	0.0277	0.0000	1.4217	-1.4217
410	26.00	31.04	1.4468	0.2928	1.1540	28.9365	0.0000	28.9365
410	38.00	38.60	3.5721	1.8068	1.7654	0.0000	0.0000	0.0000
410	42.17	42.49	0.0000	0.0000	0.0000	0.0000	0.0000	0.0000
410	44.47	45.15	4.0584	0.0000	4.0584	0.0000	0.0000	0.0000
410	47.53	51.53	0.0000	0.0000	0.0000	0.0000	0.0000	0.0000
410	51.81	53.48	0.0000	0.0000	0.0000	0.0000	0.0000	0.0000
410	55.85	57.17	0.0000	0.0000	0.0000	0.0000	0.0000	0.0000
507	39.60	43.41	0.3592	0.2772	0.0820	0.0000	4.2650	-4.2650



Composite Treatment/Study			Lane Departures					
			All Injury Severities			Fatal & Serious Injury		
State Route	Begin Milepost	End Milepost	Before Rate	After Rate	Change in Rate	Before Rate	After Rate	Change in Rate
002	3.87	4.19	0.0000	0.0750	-0.0750	0.0000	0.0000	0.0000
002	15.39	16.12	0.3922	0.2953	0.0969	11.7671	9.8445	1.9225
002	21.36	21.46	0.2991	0.0000	0.2991	0.0000	0.0000	0.0000
002	103.27	103.51	0.4004	0.6770	-0.2766	40.0398	0.0000	40.0398
002	321.78	324.88	0.3803	0.6251	-0.2448	0.0000	0.0000	0.0000
002	326.47	332.62	0.2279	0.0000	0.2279	3.5059	0.0000	3.5059
002	22.95	23.46	0.1468	0.0000	0.1468	0.0000	0.0000	0.0000
002	24.35	25.38	0.5313	0.0000	0.5313	4.0872	0.0000	4.0872
002	26.24	27.82	0.3226	0.0740	0.2485	2.9324	7.4040	-4.4716
003	53.47	59.73	0.2582	0.1081	0.1500	2.6891	1.3518	1.3373
011	2.19	6.87	0.5041	0.3498	0.1543	0.0000	0.0000	0.0000
012	8.42	9.10	0.0000	0.0000	0.0000	0.0000	0.0000	0.0000
017	21.80	21.96	0.0000	0.0000	0.0000	0.0000	0.0000	0.0000
017	22.21	27.24	0.4712	0.0295	0.4418	0.0000	2.9478	-2.9478
017	27.52	27.66	0.0000	0.0000	0.0000	0.0000	0.0000	0.0000
020	66.94	74.15	0.2745	0.1305	0.1440	0.9465	0.0000	0.9465
020	74.16	80.38	0.3295	0.1489	0.1805	4.7070	3.7237	0.9833
020	80.39	97.65	0.4106	0.2794	0.1312	8.3795	3.9914	4.3881
026	0.47	18.88	0.1281	0.0372	0.0909	0.0000	0.0000	0.0000
026	31.18	42.67	0.3154	0.0589	0.2566	3.9428	0.0000	3.9428
028	43.63	44.57	0.5457	0.2914	0.2544	9.0956	0.0000	9.0956
101	257.24	259.9	0.1531	0.0283	0.1248	3.8267	0.0000	3.8267
101	267.51	269.67	0.3095	0.1294	0.1801	0.0000	4.3130	-4.3130
101	270.11	272.33	0.2974	0.1419	0.1555	3.3040	0.0000	3.3040
101	273.09	281.40	0.2476	0.0995	0.1480	7.6172	1.4217	6.1955
104	0.41	13.75	0.0982	0.0563	0.0419	0.5454	0.5626	-0.0172
410	26.00	31.04	0.9885	0.0000	0.9885	11.6300	0.0000	11.6300
410	38.00	38.60	1.4585	0.0000	1.4585	0.0000	0.0000	0.0000
410	42.17	42.49	1.2287	0.0000	1.2287	122.874	0.0000	122.874
410	44.47	45.15	2.4682	0.0000	2.4682	164.548	0.0000	164.548
410	47.53	51.53	0.6907	0.0000	0.6907	0.0000	0.0000	0.0000
410	51.81	53.48	0.4738	0.0000	0.4738	0.0000	0.0000	0.0000
410	55.85	57.17	0.0000	0.0000	0.0000	0.0000	0.0000	0.0000
507	39.60	43.41	0.0857	0.1826	-0.0968	0.0000	6.0854	-6.0854
904	12.75	15.25	0.1489	0.0941	0.0548	0.0000	3.1365	-3.1365

# APPENDIX B: MAP OF STUDY SITES

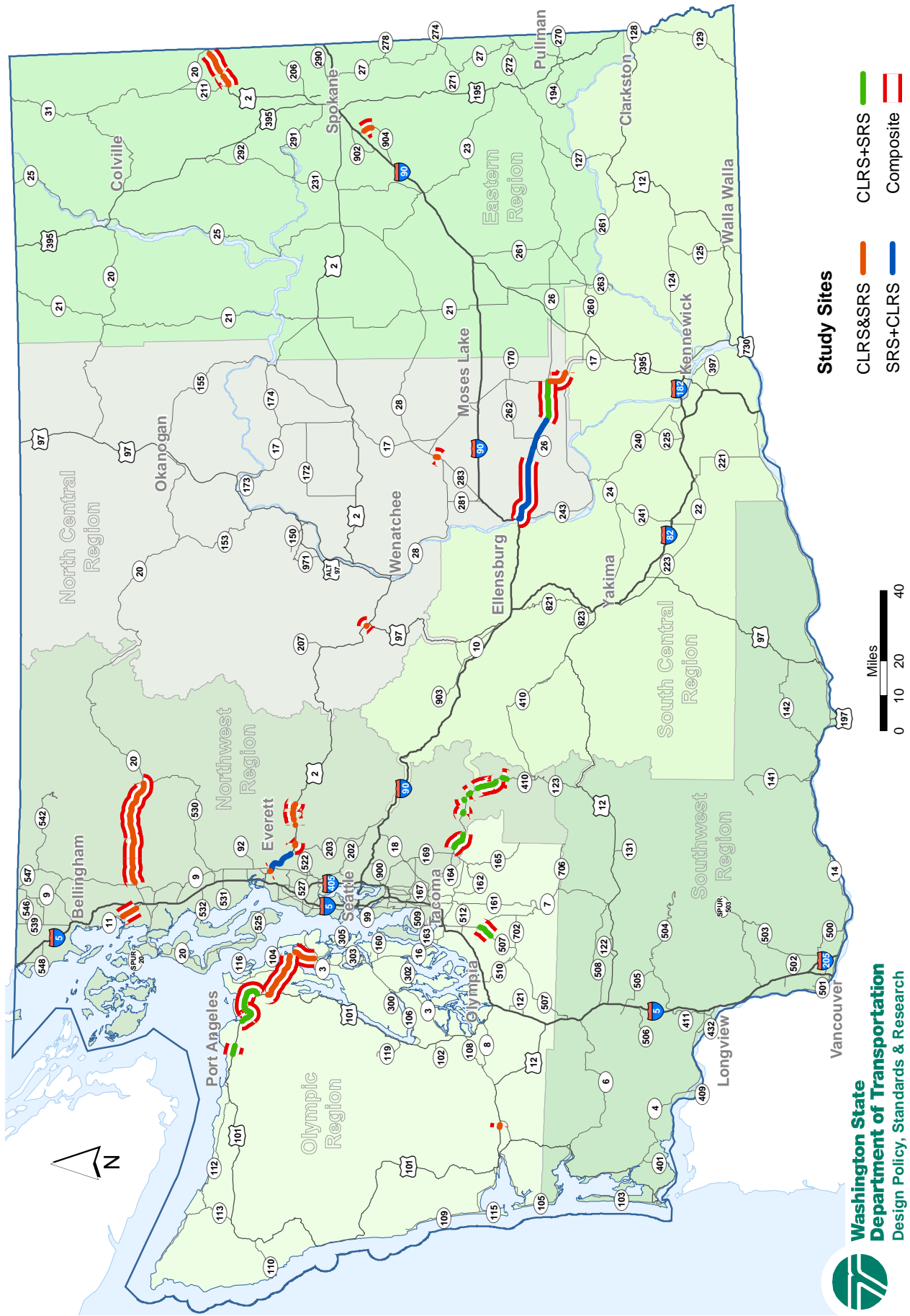

### APPENDIX C: CONTRIBUTING CATEGORY TRANSLATION TABLE

Contributing Category	Contributing Circumstance
<b>Asleep/Fatigued (A/F)</b>	Apparently Asleep
	Apparently Fatigued
	Apparently Ill
<b>Inattentive/Distracted (I/D)</b>	Inattention
	Driver Adjusting an Audio or Entertainment System
	Driver Grooming
	Driver Eating or Drinking
	Driver Interacting with Passengers, Animals, or Objects in the Vehicle
	Driver Operating Other Electronic Devices
	Driver Operating Handheld Telecommunication Device
	Driver Operating Hands-free Wireless Telecommunication Device
	Driver Reading or Writing
	Driver Smoking
	Other Driver Distractions Inside the Vehicle
	Driver Distractions Outside the Vehicle
	Unknown Driver Distraction
<b>Under Influence (UI)</b>	Under Influence of Alcohol
	Under Influence of Drugs
	Had Taken Medication
<b>Speed</b>	Exceeding Reas. Safe Speed
	Exceeding Stated Speed Limit
<b>Over Centerline (OCL)</b>	Over Centerline
	On Wrong Side of Road
<b>Other</b>	Other
	Did Not Grant RW to Vehicle
	Disregard Stop and Go Light
	Disregard Stop Sign – Flashing Red
	Disregard Yield Sign – Flashing Yellow
	Disregard Flagger – Officer
	Fail to Yield Row to Pedestrian
	Failing to Signal
	Failure to Use Xwalk
	Following Too Closely
	Headlight Violation
	Improper Backing
	Improper Parking Location
	Improper Signal
	Improper Passing
	Improper Turn
	Improper U-Turn
Operating Defective Equipment	
Driver Not Distracted	
<b>None</b>	None
	(Blank)

## APPENDIX D: ALL EXPOSURE VARIABLES – PERCENT CHANGE IN RATE

		SRS	CLRS&SRS	SRS+CLRS	CLRS+SRS	Composite
Miles		18.74	77.44	38.93	40.77	135.88
<b>Overall</b>						
Lane Dep. = Lane Departure		12.3% (100%)	-63.3% (-43.0%)	-44.6% (-24.2%)	-37.5% (-32.2%)	-66.0% (-56.0%)
Crossover		5.3% (100%)	-65.4% (-28.6%)	-64.7% (-24.2%)	-6.8% (-100%)	-71.0% (-57.5%)
ROTRR		40.4% (0%)	-61.4% (-66.6%)	8.5% (0%)	-47.0% (-15.3%)	-61.6% (-53.7%)
<b>Contributing Category</b>		See Appendix A	Fatal & Serious Injury results are in ( )			
Lane Dep.	A/F	40.4% (0%)	-79.4% (-100%)	-49.5% (-100%)	-75.1% (-100%)	-84.0% (-100%)
	I/D	100% (0%)	-64.8% (10.2%)	-43.2% (0%)	57.3% (100%)	-43.2% (0.6%)
	UI	-6.4% (0%)	-48.8% (4.9%)	-54.5% (13.7%)	-6.8% (154.2%)	-51.0% (-4.0%)
	Speed	-68.8% (0%)	-43.9% (-8.2%)	-18.8% (0%)	210.7% (100%)	-41.3% (32.0%)
	OCL	-6.4% (100%)	-52.1% (-34.4%)	-31.8% (70.5%)	27.1% (-100%)	-59.2% (-60.0%)
	Other	100% (0%)	-54.1% (-38.8%)	-71.6% (0%)	-83.1% (-100%)	-63.9% (-41.3%)
	None	0% (0%)	-100% (0%)	100% (0%)	0% (0%)	-100% (0%)
Crossover	A/F	100% (0%)	-79.1% (-100%)	-91.9% (-100%)	-15.3% (0%)	-87.2% (-100%)
	I/D	100% (0%)	-47.5% (175.4%)	-75.6% (0%)	100% (0%)	-28.0% (76.1%)
	UI	-100% (0%)	-63.3% (22.4%)	-24.2% (13.7%)	41.2% (0%)	-63.9% (-41.3%)
	Speed	-100% (0%)	-42.6% (83.6%)	-24.2% (0%)	323.6% (0%)	-50.7% (-41.3%)
	OCL	-6.4% (100%)	-52.1% (-34.4%)	-31.8% (70.5%)	27.1% (-100%)	-58.6% (-58.1%)
	Other	100% (0%)	-83.3% (-8.2%)	-100% (0%)	-100% (0%)	-85.3% (-12.0%)
	None	0% (0%)	0% (0%)	100% (0%)	0% (0%)	0% (0%)
ROTRR	A/F	-100% (0%)	-79.6% (-100%)	99.0% (0%)	-78.8% (-100%)	-81.0% (-100%)
	I/D	0% (0%)	-72.2% (-100%)	70.5% (0%)	8.9% (100%)	-51.6% (-56.0%)
	UI	100% (0%)	-34.9% (-8.2%)	-100% (0%)	-27.4% (154.2%)	-38.4% (40.8%)
	Speed	100% (0%)	-44.9% (-100%)	-14.7% (0%)	154.2% (100%)	-32.3% (252.1%)
	OCL	0% (0%)	0% (0%)	0% (0%)	0% (0%)	-100% (-100%)
	Other	0% (0%)	-38.8% (-100%)	13.7% (0%)	-78.8% (-100%)	-54.4% (-100%)
	None	0% (0%)	-100% (0%)	0% (0%)	0% (0%)	-100% (0%)
<b>Posted Speed</b>		NX = No Exposure				
Lane Dep.	35 mph	NX (NX)	-51.4% (191.3%)	NX (NX)	0% (0%)	-57.9% (47.3%)
	40 mph	NX (NX)	0% (0%)	NX (NX)	NX (NX)	0% (0%)
	45 mph	NX (NX)	-100% (0%)	NX (NX)	NX (NX)	-100% (0%)
	50 mph	NX (NX)	-49.2% (-100%)	NX (NX)	-40.2% (0%)	-55.9% (-100%)
	55 mph	55.9% (100%)	-58.4% (-25.7%)	-62.7% (0%)	-38.5% (-33.2%)	-61.3% (-43.3%)
	60 mph	47.7% (0%)	-64.8% (-14.1%)	-43.3% (-22.2%)	-5.2% (0%)	-71.3% (-57.5%)
Crossover	35 mph	NX (NX)	-2.9% (191.3%)	NX (NX)	0% (0%)	-26.4% (47.3%)
	40 mph	NX (NX)	0% (0%)	NX (NX)	NX (NX)	0% (0%)
	45 mph	NX (NX)	-100% (0%)	NX (NX)	NX (NX)	-100% (0%)
	50 mph	NX (NX)	-74.1% (-100%)	NX (NX)	-100% (0%)	-81.8% (-100%)
	55 mph	16.9% (100%)	-59.7% (-36.3%)	-62.7% (0%)	14.9% (-100%)	-64.8% (-59.7%)
	60 mph	18.1% (0%)	-60.8% (157.8%)	-65.4% (-22.2%)	-100% (0%)	-73.8% (-36.2%)

		SRS	CLRS&SRS	SRS+CLRS	CLRS+SRS	Composite
<b>Posted Speed</b>						
ROTRR	35 mph	NX (NX)	-100% (0%)	NX (NX)	0% (0%)	-100% (0%)
	40 mph	NX (NX)	0% (0%)	NX (NX)	NX (NX)	0% (0%)
	45 mph	NX (NX)	-100% (0%)	NX (NX)	NX (NX)	-100% (0%)
	50 mph	NX (NX)	-25.4% (-100%)	NX (NX)	-10.3% (0%)	-31.7% (-100%)
	55 mph	133.9% (0%)	-57.1% (11.5%)	-62.7% (0%)	-52.7% (-16.5%)	-58.4% (-16.1%)
	60 mph	100% (0%)	-67.8% (-100%)	31.3% (0%)	100% (0%)	-68.9% (-100%)
<b>Lane Width</b>						
Lane Dep.	11'	-33.7% (100%)	-68.2% (-58.8%)	NX (NX)	-78.3% (-100%)	-72.1% (-68.3%)
	12'	55.3% (0%)	-58.6% (-24.1%)	-44.6% (-24.2%)	-31.2% (-14.0%)	-61.8% (-46.8%)
	> 12'	NX (NX)	-100% (-100%)	NX (NX)	NX (NX)	-100% (-100%)
Crossover	11'	-66.9% (100%)	-66.7% (-62.6%)	NX (NX)	100% (0%)	-69.5% (-69.9%)
	12'	86.4% (0%)	-62.8% (37.0%)	-64.7% (-24.2%)	-14.0% (-100%)	-71.0% (-43.0%)
	> 12'	NX (NX)	-100% (-100%)	NX (NX)	NX (NX)	-100% (-100%)
ROTRR	11'	100% (0%)	-69.7% (-48.5%)	NX (NX)	-85.6% (-100%)	-74.6% (-64.8%)
	12'	-6.8% (0%)	-55.4% (-76.5%)	8.5% (0%)	-38.1% (14.7%)	-53.8% (-50.9%)
	> 12'	NX (NX)	0% (0%)	NX (NX)	NX (NX)	0% (0%)
<b>Shoulder Width</b>						
Lane Dep.	2 to < 3'	NX (NX)	0% (0%)	NX (NX)	NX (NX)	0% (0%)
	3 to < 4'	NX (NX)	-24.8% (0%)	NX (NX)	-74.7% (0%)	-49.4% (-100%)
	4 to < 6'	0% (0%)	-18.6% (-26.8%)	0% (0%)	-33.9% (100%)	-42.3% (-20.9%)
	6 to < 8'	100% (0%)	-66.3% (62.1%)	-50.6% (0%)	-54.1% (-100%)	-68.5% (-12.2%)
	≥ 8'	14.6% (100%)	-63.7% (-59.1%)	-44.8% (-24.4%)	-53.5% (-49.9%)	-65.7% (-65.8%)
Crossover	2 to < 3'	NX (NX)	0% (0%)	NX (NX)	NX (NX)	0% (0%)
	3 to < 4'	NX (NX)	-100% (0%)	NX (NX)	0% (0%)	-100% (-100%)
	4 to < 6'	0% (0%)	-43.7% (-100%)	0% (0%)	44.7% (0%)	-56.3% (-100%)
	6 to < 8'	100% (0%)	-52.7% (116.1%)	-50.6% (0%)	-100% (0%)	-60.1% (0.4%)
	≥ 8'	4.1% (100%)	-68.2% (-49.7%)	-66.4% (-24.4%)	-42.7% (-100%)	-73.5% (-66.3%)
ROTRR	2 to < 3'	NX (NX)	0% (0%)	NX (NX)	NX (NX)	0% (0%)
	3 to < 4'	NX (NX)	28.9% (0%)	NX (NX)	-74.7% (0%)	-17.3% (-100%)
	4 to < 6'	0% (0%)	4.6% (22.1%)	0% (0%)	-53.5% (100%)	-33.2% (38.4%)
	6 to < 8'	0% (0%)	-76.0% (-100%)	0% (0%)	-8.2% (-100%)	-75.4% (-100%)
	≥ 8'	56.2% (0%)	-59.1% (-76.6%)	8.2% (0%)	-57.1% (-33.2%)	-57.6% (-65.1%)
<b>SRS Recovery Width</b>						
Lane Dep.	< 1'	0% (0%)	0% (0%)	0% (0%)	NX (NX)	0% (0%)
	1 to < 2'	0% (0%)	NX (NX)	0% (0%)	0% (0%)	0% (0%)
	2 to < 3'	100% (0%)	1.6% (230.0%)	0.7% (0%)	-43.8% (0%)	-51.4% (-40.6%)
	3 to < 4'	0% (0%)	-28.2% (-100%)	NX (NX)	-42.4% (100%)	-27.7% (-20.0%)
	4 to < 5'	32.9% (0%)	-59.6% (35.6%)	-73.9% (-47.9%)	79.2% (0%)	-75.2% (-69.7%)
	5 to < 6'	NX (NX)	-74.2% (85.6%)	NX (NX)	-100% (-100%)	-76.9% (29.2%)
	6 to < 7'	42.9% (100%)	-64.5% (-79.9%)	-20.6% (11.6%)	-45.7% (-49.8%)	-59.9% (-66.2%)
	7 to < 8'	NX (NX)	-49.1% (83.1%)	NX (NX)	0% (0%)	-48.7% (84.7%)
	≥ 8'	-100% (0%)	-79.2% (-90.1%)	0% (0%)	-100% (0%)	-84.9% (-91.8%)

		SRS	CLRS&SRS	SRS+CLRS	CLRS+SRS	Composite
<b>SRS Recovery Width</b>						
Crossover	< 1'	0% (0%)	0% (0%)	0% (0%)	NX (NX)	0% (0%)
	1 to < 2'	0% (0%)	NX (NX)	0% (0%)	0% (0%)	0% (0%)
	2 to < 3'	100% (0%)	-100% (-100%)	0.7% (0%)	0% (0%)	-80.2% (-100%)
	3 to < 4'	0% (0%)	-20.2% (-100%)	NX (NX)	11.0% (0%)	-20.0% (-100%)
	4 to < 5'	3.4% (0%)	-54.8% (35.6%)	-88.4% (-47.9%)	-10.4% (0%)	-81.3% (-64.6%)
	5 to < 6'	NX (NX)	-56.3% (271.1%)	NX (NX)	0% (0%)	-61.2% (93.9%)
	6 to < 7'	-28.5% (100%)	-66.9% (-59.8%)	-44.2% (11.6%)	-42.7% (-100%)	-67.9% (-77.5%)
	7 to < 8'	NX (NX)	-57.5% (62.8%)	NX (NX)	0% (0%)	-57.2% (64.2%)
	≥ 8'	0% (0%)	-84.2% (-86.8%)	0% (0%)	0% (0%)	-86.7% (-86.7%)
ROTRR	< 1'	0% (0%)	0% (0%)	0% (0%)	NX (NX)	0% (0%)
	1 to < 2'	0% (0%)	NX (NX)	0% (0%)	0% (0%)	0% (0%)
	2 to < 3'	0% (0%)	88.6% (100%)	0% (0%)	-43.8% (0%)	-31.5% (78.2%)
	3 to < 4'	0% (0%)	-34.7% (-100%)	NX (NX)	-57.7% (100%)	-32.6% (6.7%)
	4 to < 5'	100% (0%)	-62.6% (0%)	-30.5% (0%)	100% (0%)	-70.4% (-100%)
	5 to < 6'	NX (NX)	-90.2% (-100%)	NX (NX)	-100% (-100%)	-91.2% (-100%)
	6 to < 7'	100% (0%)	-62.6% (-100%)	26.5% (0%)	-46.9% (-33.1%)	-53.2% (-54.9%)
	7 to < 8'	NX (NX)	-41.4% (144.1%)	NX (NX)	0% (0%)	-40.9% (146.2%)
	≥ 8'	-100% (0%)	-60.5% (-100%)	0% (0%)	-100% (0%)	-80.7% (-100%)
<b>AADT Range</b>						
Lane Dep.	< 2000	100% (0%)	NX (NX)	-66.5% (0%)	0% (0%)	-87.8% (0%)
	2000 to 3999	-11.4% (0%)	-10.2% (-100%)	-74.4% (-35.9%)	-62.0% (-100%)	-73.8% (-100%)
	4000 to 5999	-41.4% (100%)	-72.3% (-19.0%)	0.4% (0%)	0% (0%)	-72.2% (-30.5%)
	6000 to 7999	NX (NX)	-45.9% (-100%)	NX (NX)	NX (NX)	-45.9% (-100%)
	8000 to 9999	NX (NX)	-100% (-100%)	NX (NX)	NX (NX)	-100% (-100%)
	10,000 to 11,999	NX (NX)	54.5% (15.8%)	NX (NX)	-1.0% (100%)	-54.0% (-60.6%)
	12,000 to 13,999	NX (NX)	-80.7% (-29.9%)	NX (NX)	21.9% (100%)	-57.3% (-26.9%)
	14,000 to 16,999	NX (NX)	-69.1% (-20.3%)	-63.4% (0%)	-83.7% (-67.5%)	-70.2% (22.4%)
	≥ 17,000	-100% (0%)	-33.9% (-18.0%)	-20.7% (11.6%)	-89.0% (-100%)	-48.0% (-47.3%)
Crossover	< 2000	100% (0%)	NX (NX)	-66.5% (0%)	0% (0%)	-57.3% (0%)
	2000 to 3999	-40.9% (0%)	-47.2% (-100%)	-90.8% (-35.9%)	-24.1% (0%)	-85.7% (-100%)
	4000 to 5999	-60.9% (100%)	-77.5% (-10.0%)	-100% (0%)	0% (0%)	-81.1% (-30.5%)
	6000 to 7999	NX (NX)	-34.7% (0%)	NX (NX)	NX (NX)	-34.7% (0%)
	8000 to 9999	NX (NX)	-100% (-100%)	NX (NX)	NX (NX)	-100% (-100%)
	10,000 to 11,999	NX (NX)	15.8% (15.8%)	NX (NX)	90.4% (0%)	-55.7% (-55.7%)
	12,000 to 13,999	NX (NX)	-82.5% (40.2%)	NX (NX)	-8.6% (0%)	-79.8% (-51.2%)
	14,000 to 16,999	NX (NX)	-71.9% (-40.2%)	-100% (0%)	-100% (0%)	-74.2% (-38.8%)
	≥ 17,000	0% (0%)	-6.8% (-18.0%)	-40.5% (11.6%)	-50.4% (-100%)	-21.0% (-38.5%)
ROTRR	< 2000	0% (0%)	NX (NX)	0% (0%)	0% (0%)	-100% (0%)
	2000 to 3999	100% (0%)	24.8% (-100%)	-35.9% (0%)	-67.5% (-100%)	-63.7% (-100%)
	4000 to 5999	100% (0%)	-67.8% (-32.5%)	100% (0%)	0% (0%)	-63.8% (-30.5%)
	6000 to 7999	NX (NX)	-52.8% (-100%)	NX (NX)	NX (NX)	-52.8% (-100%)
	8000 to 9999	NX (NX)	-100% (0%)	NX (NX)	NX (NX)	-100% (0%)
	10,000 to 11,999	NX (NX)	131.7% (0%)	NX (NX)	-23.8% (100%)	-52.7% (-64.5%)
	12,000 to 13,999	NX (NX)	-78.4% (-100%)	NX (NX)	46.3% (100%)	-23.0% (46.3%)
	14,000 to 16,999	NX (NX)	-65.8% (19.6%)	100% (0%)	-80.5% (-67.5%)	-66.0% (144.7%)
	≥ 17,000	-100% (0%)	-48.7% (0%)	19.0% (0%)	-100% (0%)	-63.1% (-100%)

		SRS	CLRS&SRS	SRS+CLRS	CLRS+SRS	Composite
<b>Horizontal Alignment</b>		*From rates based on half of the curve VMT				
Lane Dep.	Tangent	-3.4% (0%)	-67.9% (-50.1%)	-50.2% (-68.2%)	-59.4% (12.7%)	-71.5% (-53.9%)
	Curve	97.5% (100%)	-52.9% (-28.4%)	-47.3% (28.0%)	-4.3% (-100%)	-55.1% (-58.4%)
	Inside*	100% (0%)	-36.5% (293.7%)	-69.5% (100%)	7.0% (-100%)	-43.4% (87.3%)
	Outside*	-1.3% (100%)	-61.3% (-60.6%)	-31.8% (-14.7%)	-14.4% (0%)	-62.1% (-76.6%)
Crossover	Tangent	-3.4% (0%)	-70.8% (-44.7%)	-77.6% (-68.2%)	-57.7% (-100%)	-76.5% (-65.4%)
	Curve	48.1% (100%)	-54.9% (18.1%)	-57.3% (28.0%)	71.3% (0%)	-61.5% (-37.6%)
	Inside*	100% (0%)	-38.5% (100%)	-65.9% (100%)	71.3% (0%)	-59.9% (100%)
	Outside*	-1.3% (100%)	-63.1% (-60.6%)	-51.3% (-14.7%)	71.3% (0%)	-62.5% (-79.2%)
ROTRR	Tangent	0% (0%)	-65.6% (-64.0%)	27.1% (0%)	-60.0% (69.0%)	-67.6% (-30.8%)
	Curve	196.2% (0%)	-50.8% (-67.2%)	-23.2% (0%)	-27.5% (-100%)	-48.4% (-79.2%)
	Inside*	100% (0%)	-34.4% (-100%)	-78.7% (0%)	-14.4% (-100%)	-25.1% (-100%)
	Outside*	-1.3% (0%)	-59.3% (-60.6%)	13.7% (0%)	-38.8% (0%)	-61.7% (-73.2%)
<b>Percent Length Curve</b>						
Lane Dep.	0 to < 10%	NX (NX)	-58.4% (0%)	-57.2% (-25.0%)	-89.3% (-100%)	-76.2% (-100%)
	10 to < 20%	47.7% (0%)	-58.2% (-29.6%)	-79.9% (0%)	1.3% (100%)	-60.5% (-54.1%)
	20 to < 30%	NX (NX)	-67.6% (2.7%)	NX (NX)	-79.8% (-100%)	-72.8% (-20.9%)
	30 to < 40%	NX (NX)	-67.9% (-50.2%)	-13.0% (100%)	-62.4% (-70.8%)	-68.7% (-32.5%)
	40 to < 50%	NX (NX)	NX (NX)	NX (NX)	-2.2% (0%)	-59.7% (-100%)
	50 to < 60%	-33.5% (100%)	100% (0%)	NX (NX)	NX (NX)	100% (0%)
	60 to < 70%	0% (0%)	-25.6% (-57.9%)	-54.3% (-100%)	0% (0%)	-28.9% (-64.5%)
	≥ 80%	-100% (0%)	NX (NX)	NX (NX)	NX (NX)	NX (NX)
Crossover	0 to < 10%	NX (NX)	-100% (0%)	-83.3% (-25.0%)	-46.4% (-100%)	-80.2% (-100%)
	10 to < 20%	18.1% (0%)	-57.0% (-15.5%)	-88.8% (0%)	23.4% (0%)	-66.5% (-60.4%)
	20 to < 30%	NX (NX)	-67.6% (-22.9%)	NX (NX)	100% (0%)	-71.2% (-36.7%)
	30 to < 40%	NX (NX)	-61.1% (-0.4%)	-25.4% (100%)	-56.2% (0%)	-66.3% (-10.1%)
	40 to < 50%	NX (NX)	NX (NX)	NX (NX)	-100% (0%)	-100% (-100%)
	50 to < 60%	-66.8% (100%)	100% (0%)	NX (NX)	NX (NX)	100% (0%)
	60 to < 70%	0% (0%)	-57.9% (-47.3%)	-81.7% (-100%)	0% (0%)	-61.2% (-57.3%)
	≥ 80%	0% (0%)	NX (NX)	NX (NX)	NX (NX)	NX (NX)
ROTRR	0 to < 10%	NX (NX)	-27.2% (0%)	-10.0% (0%)	-100% (0%)	-73.6% (-100%)
	10 to < 20%	100% (0%)	-59.0% (-53.1%)	0.4% (0%)	-8.8% (100%)	-55.7% (-45.5%)
	20 to < 30%	NX (NX)	-67.6% (54.1%)	NX (NX)	-89.9% (-100%)	-74.2% (5.5%)
	30 to < 40%	NX (NX)	-75.1% (-100%)	4.4% (0%)	-64.9% (-70.8%)	-71.2% (-55.0%)
	40 to < 50%	NX (NX)	NX (NX)	NX (NX)	30.4% (0%)	-11.4% (0%)
	50 to < 60%	100% (0%)	0% (0%)	NX (NX)	NX (NX)	0% (0%)
	60 to < 70%	0% (0%)	20.4% (-100%)	100% (0%)	0% (0%)	21.9% (-100%)
	≥ 80%	-100% (0%)	NX (NX)	NX (NX)	NX (NX)	NX (NX)

# APPENDIX E: SHOULDER RUMBLE STRIP STANDARD PLAN

DRAWN BY: FERN LIDDELL

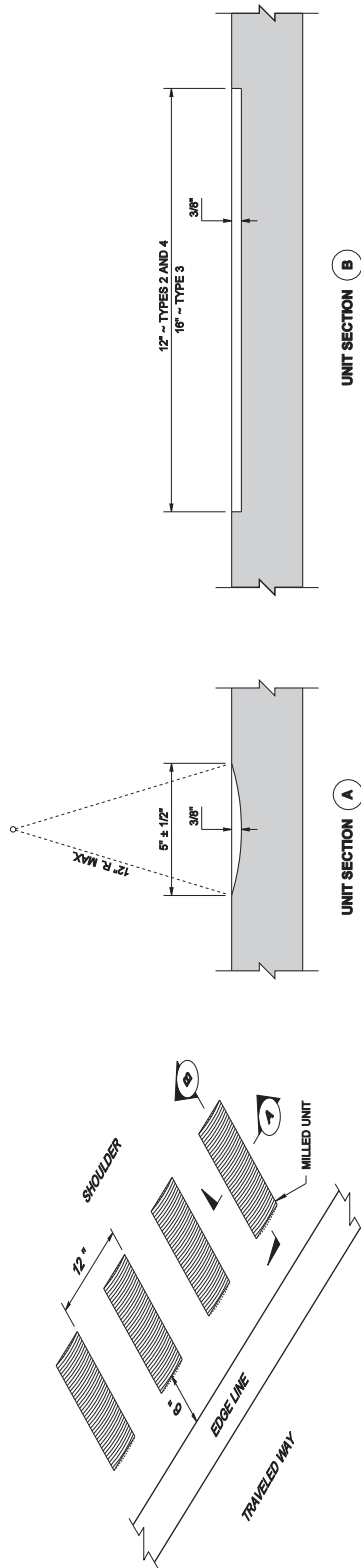

ISOMETRIC VIEW  
TYPICAL SHOULDER INSTALLATION

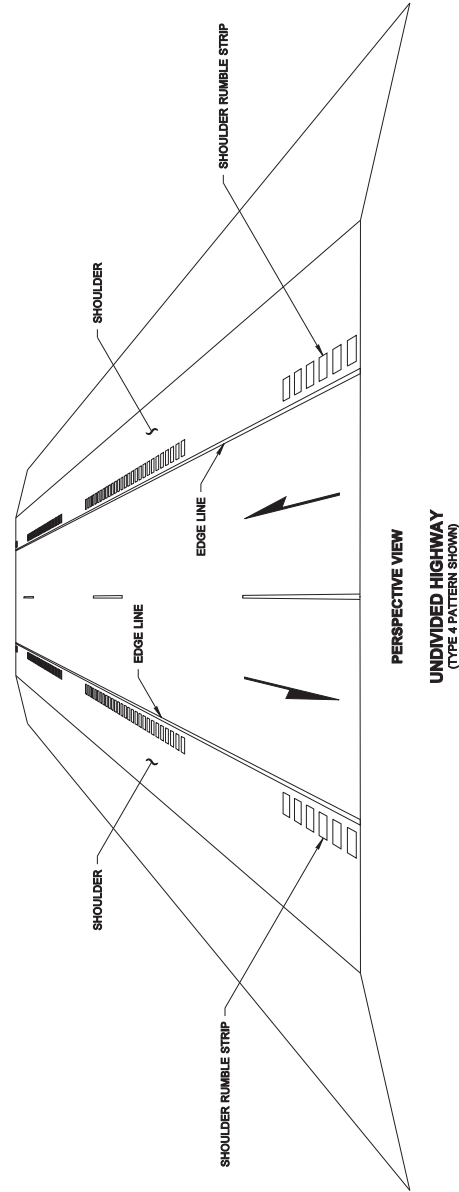

PERSPECTIVE VIEW  
UNDIVIDED HIGHWAY  
(TYPE 4 PATTERN SHOWN)

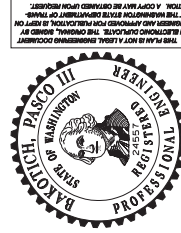

SHOULDER RUMBLE STRIP  
TYPES 2, 3, AND 4  
FOR UNDIVIDED HIGHWAYS  
STANDARD PLAN M-60.20-02

SHEET 1 OF 2 SHEETS  
APPROVED FOR PUBLICATION  
Pasco Bakofich III  
DATE 06-27-11  
DATE 06-27-11  
Washington State Department of Transportation







DRAWN BY: FERN LIDDELL

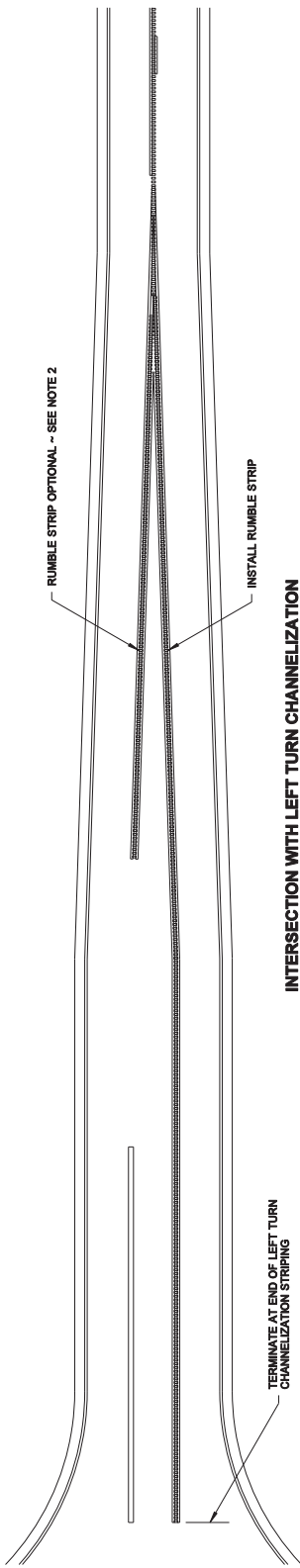

**INTERSECTION WITH LEFT TURN CHANNELIZATION**

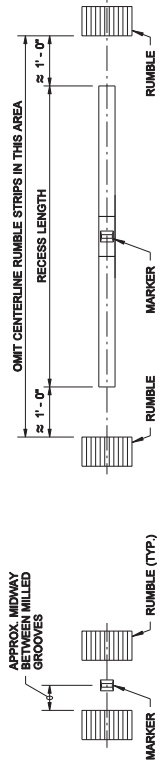
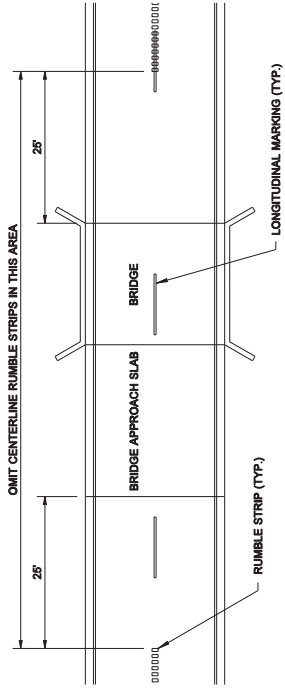

REFER TO STANDARD PLAN M-65.10-38 FOR RECESSED PAVEMENT MARKER DETAIL WHEN SPECIFIED IN CONTRACT



**CENTERLINE RUMBLE STRIP**  
STANDARD PLAN M-65.10-20  
SHEET 2 OF 2 SHEETS

APPROVED FOR PUBLICATION  
**Pasco Bakofch III**  
STATE DESIGN ENGINEER  
05-11-11 DATE  
Washington State Department of Transportation

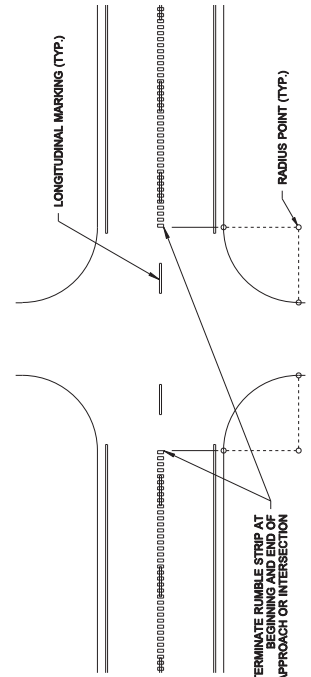

**UNCHANNELIZED INTERSECTIONS AND COMMERCIAL ROAD APPROACHES**

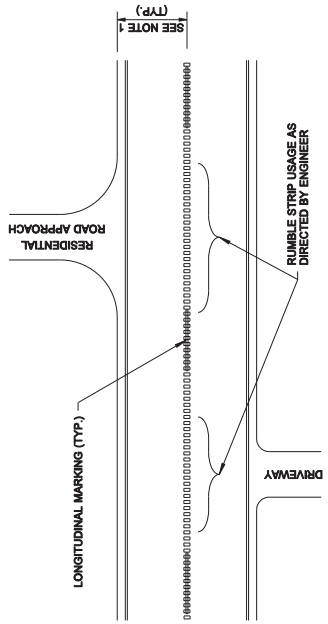

**NON-COMMERCIAL ROAD APPROACHES AND DRIVEWAYS**