

# BOTTOM FLANGE REINFORCEMENT IN NU I-GIRDERS

Nebraska Department of Roads (NDOR)

Project Number: P331



August 2010

# **BOTTOM FLANGE REINFORCEMENT IN NU I-GIRDERS**

Nebraska Department of Roads (NDOR)

Project Number: P331

## **FINAL REPORT**

### **PRINCIPAL INVESTIGATORS**

George Morcous, Kromel Hanna, and Maher K. Tadros

### **SPONSORED BY**

Nebraska Department of Roads  
University of Nebraska - Lincoln

August 2010

Technical Report Documentation Page

Report No.	Government Accession No.	Recipient's Catalog No.	
1. Title and Subtitle Bottom Flange Reinforcement in NU I-Girders		2. Report Date August 2010	3. Performing Organization Code
4. Author(s) George Morcouc, Kromel Hanna, and Maher K. Tadros		5. Performing Organization Report No.	
6. Performing Organization Name and Address College of Engineering University of Nebraska-Lincoln Omaha, Nebraska 68182-0178		7. Work Unit No.	8. Contract or Grant No.
9. Sponsoring Agency Name and Address Nebraska Department of Roads Bridge Division P. O. Box 94759 Lincoln, NE 68509-4759		10. Type of Report and Period Covered Final Report	11. Sponsoring Agency Code
12. Supplementary Notes			
13. Abstract <p>The 1996 edition of AASHTO Standard Specifications for Highway Bridges stated that nominal confinement reinforcement be placed to enclose prestressing steel in the bottom flange of bridge girder from girder ends to at least distance equal to the girder's height. The 2004 edition of AASHTO LRFD Bridge Design Specifications changed the distance over which the confinement reinforcement was to be distributed from 1.0h to 1.5h, and gave minimum requirements for the amount of steel to be used, No.3 bars, and their maximum spacing, not to exceed 6".</p> <p>Research was undertaken to study what impact, if any, confinement reinforcement has on the performance of prestressed concrete bridge girders. Of particular interest was the effect confinement had on the transfer length, development length, and vertical shear capacity of the fore mentioned members. First, an analytical investigation was carried out, and then an experimental investigation followed which consisted of designing, fabricating, and testing eight 24" tee-girders and three NU1100 girders. These girders had different amount and distribution of confinement reinforcement at girder ends and were tested for transfer length, development length, and shear capacity. The results of the study indicated that: 1) neither the amount or distribution of confinement reinforcement had a significant effect on the initial or final transfer length of the prestressing strands; 2) at the AASHTO predicted development length, no significant change was found on the nominal flexural capacity of the tested girders regardless of the amount and distribution of confinement reinforcement; and 3) despite the improved anchorage of prestressing strands at the girder ends when higher levels of confinement reinforcement are used, the ultimate shear capacity of tested girder was found to be considerably higher than nominal capacity even when low levels of confinement reinforcement are used.</p>			
14. Keywords: AASHTO Specification, Confinement, I-girders, transfer length, development length, shear capacity		15. Distribution Statement	
16. Security Classification (of this report) Unclassified	17. Security Classification (of this page) Unclassified	18. No. of Pages: 67	22. Price

## **DISCLAIMER**

The contents of this report reflect the views of the authors who are responsible for the facts and the accuracy of the data presented herein. The contents do not necessarily reflect the official views or policies of the Nebraska Department of Roads, nor of the University of Nebraska-Lincoln. This report does not constitute a standard, specification, or regulation. Trade or manufacturers' names, which may appear in this report, are cited only because they are considered essential to the objectives of the report. The United States (U.S.) government and the State of Nebraska do not endorse products or manufacturers.

## **ACKNOWLEDGEMENTS**

This project was sponsored by the Nebraska Department of Roads (NDOR) and the University of Nebraska-Lincoln. The support of the technical advisory committee (TAC) members is gratefully acknowledged. The design team at NDOR Bridge Division is also acknowledged; they spent considerable time and effort in coordinating this project, discussing its technical direction, and inspiring the university researchers. Special thanks to Quinton Patzlaff, the graduate student participating in this project, as well as Kelvin Lein, the technician at the PKI structural lab.

## ABSTRACT

The 1996 edition of AASHTO Standard Specifications for Highway Bridges stated that nominal confinement reinforcement be placed to enclose prestressing steel in the bottom flange of bridge girder from girder ends to at least distance equal to the girder's height. The 2004 edition of AASHTO LRFD Bridge Design Specifications changed the distance over which the confinement reinforcement was to be distributed from  $1.0h$  to  $1.5h$ , and gave minimum requirements for the amount of steel to be used, No.3 bars, and their maximum spacing, not to exceed 6".

Research was undertaken to study what impact, if any, confinement reinforcement has on the performance of prestressed concrete bridge girders. Of particular interest was the effect confinement had on the transfer length, development length, and vertical shear capacity of the fore mentioned members. First, an analytical investigation was carried out, and then an experimental investigation followed which consisted of designing, fabricating, and testing eight 24" tee-girders and three NU1100 girders. These girders had different amount and distribution of confinement reinforcement at girder ends and were tested for transfer length, development length, and shear capacity.

The results of the study indicated that: 1) neither the amount or distribution of confinement reinforcement had a significant effect on the initial or final transfer length of the prestressing strands; 2) at the AASHTO predicted development length, no significant change was found on the nominal flexural capacity of the tested girders regardless of the amount and distribution of confinement reinforcement; and 3) despite the improved anchorage of prestressing strands at the girder ends when higher levels of confinement reinforcement are used, the ultimate shear capacity of tested girder was found to be considerably higher than nominal capacity even when low levels of confinement reinforcement are used.

## TABLE OF CONTENTS

<b>1 INTRODUCTION .....</b>	<b>1</b>
1.1 PROBLEM STATEMENT .....	1
1.2 OBJECTIVE .....	5
1.3 ORGANIZATION .....	5
<b>2 TRANSFER LENGTH.....</b>	<b>6</b>
2.1 DEFINITION .....	6
2.2 ANALYTICAL INVESTIGATION .....	6
<i>An Analysis of Transfer and Development Lengths for Pretensioned Concrete Structures (1994).....</i>	<i>6</i>
<i>Measured Transfer Lengths of 0.5 and 0.6 in. Strands in Pretensioned Concrete (1996)7</i>	<i>7</i>
2.2 EXPERIMENTAL INVESTIGATION .....	10
<i>Mono-strand Prism Tests – University of Nebraska (2009) .....</i>	<i>10</i>
<i>T24 Girders – University of Nebraska (2009) .....</i>	<i>12</i>
<b>3 DEVELOPMENT LENGTH.....</b>	<b>17</b>
3.1 DEFINITION .....	17
3.2 ANALYTICAL INVESTIGATION .....	17
<i>Strength and Ductility of Confined Concrete (1992).....</i>	<i>17</i>
<i>A Critical Evaluation of the AASHTO Provisions for Strand Development Length of Prestressed Concrete Members (2001).....</i>	<i>22</i>
3.3 EXPERIMENTAL INVESTIGATION .....	24
<i>Pull out Tests – University of Nebraska (2009).....</i>	<i>24</i>
<i>T24 Girders – University of Nebraska (2009) .....</i>	<i>27</i>
<i>NU1100 Girders – University of Nebraska (2010).....</i>	<i>30</i>
<b>4 SHEAR CAPACITY.....</b>	<b>36</b>
4.1 ANALYTICAL INVESTIGATION .....	36
<i>A Shear Moment Model for Prestressed Concrete Beams (1991) .....</i>	<i>36</i>
<i>An Investigation of Shear Strength of Prestressed Concrete AASHTO Type II Girders (1993).....</i>	<i>39</i>
<i>Experimental Evaluation of Confinement Effect in Pretensioned Concrete Girders (2010).....</i>	<i>42</i>
4.2 EXPERIMENTAL INVESTIGATION .....	45
<i>T24 Girders – University of Nebraska (2010) .....</i>	<i>45</i>
<i>NU1100 Girders – University of Nebraska (2010).....</i>	<i>50</i>
<b>5 SUMMARY, CONCLUSIONS, AND RECOMMENDATIONS .....</b>	<b>54</b>
5.1 SUMMARY .....	54
5.2 CONCLUSIONS.....	54
5.3 RECCOMENDATIONS .....	57
<b>IMPLEMENTATION .....</b>	<b>59</b>
<b>REFERENCES.....</b>	<b>60</b>

# 1 INTRODUCTION

## 1.1 PROBLEM STATEMENT

Section 9.22.2 of the 1996 AASHTO Standard Specifications for Highway Bridges states that “For at least the distance  $d$  from the end of the girder, where  $d$  is the depth of the girder, nominal reinforcement shall be placed to enclose the prestressing steel in the bottom flange” (AASHTO 1996). This requirement does not specify either the size or spacing of the bottom flange reinforcement. Therefore, several bridge girders developed in the mid 1990’s, such as NU I-girders, were detailed conservatively using welded wire reinforcement D4 @ 4 in. spacing (equivalent to #3 @ 12 in. spacing) along the full length of the girder regardless of the girder depth. Refer to Figure 1.

Section 5.10.10.2 of the 2004 AASHTO LRFD Bridge Design Specifications states that “For the distance of  $1.5d$  from the end of the girders other than box girders, where  $d$  is the depth of the girder, reinforcement shall be placed to confine the prestressing steel in the bottom flange. The reinforcement shall not be less than No. 3 deformed bars, with spacing not exceeding 6.0 in. and shaped to enclose the strands” (AASHTO 2004).

The 2004 AASHTO specified reinforcement defined as “confinement reinforcement” is significantly higher than NDOR’s standard bottom flange reinforcement shown in Figure 1 and specified in the Bridge Operations, Policies, and Procedures (BOPP) manual (NDOR 2008). Although NDOR has adopted AASHTO LRFD specifications for superstructure design since 2004, the bottom flange reinforcement detail developed in the mid 1990’s has not been updated to satisfy the latest AASHTO LRFD specifications.

Although the AASHTO LRFD Section 5.10.10.2 on confinement reinforcement does not refer to the origin of this provision, it is believed that it was based on the research sponsored by Florida Department of Transportation (FDOT) in the late 1980’s to investigate the effect of confinement reinforcement on the shear capacity of prestressed/precast bridge girders (Shahawy, et al. 1993; and Csagoly, 1991).



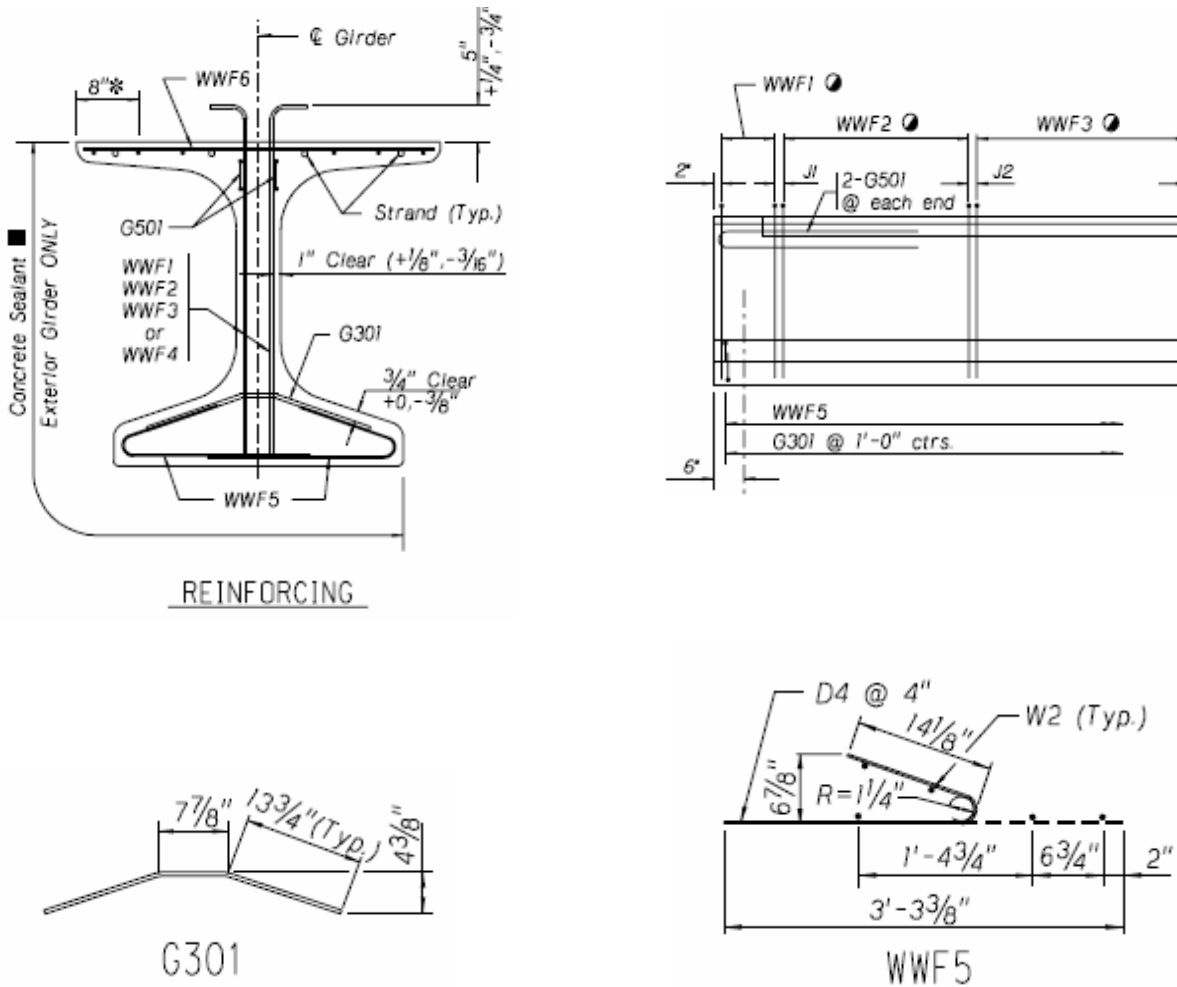

Figure 1 Standard Bottom Flange Reinforcement Detail in NU I-Girders (BOPP 2008)

In order to demonstrate the difference between the bottom flange reinforcement required by the 2004 AASHTO LRFD and that provided by NDOR, Table 1 lists the total area of steel reinforcement required versus provided within the specified 1.5 times the girder depth for each of the six NU I-girders. Table 1 indicates that the current NDOR standard detail does not provide the amount of reinforcement required by the AASHTO specification within the specified length for any of the six NU I-girders. Table 1 also indicates that the current NDOR standard detail provides approximately 55% of the AASHTO required confinement reinforcement. Although the percentage of confinement steel provided versus required is constant for all of the NU girders, the difference of required minus provided increases proportional to the depth of the girder.

Table 1 Required vs. Provided Bottom Flange Reinforcement in NU I-Girders

Girder Designation	Depth (d) (in.)	1.5 Depth (in.)	AASHTO 5.10.10.2 $A_{s_{required}} (1.5d)$ (in. <sup>2</sup> )	NDOR BOPP $A_{s_{provided}} (1.5d)$ (in. <sup>2</sup> )	AASHTO-NDOR $A_{s_{provided}} (1.5d)$ (in. <sup>2</sup> )	NDOR/AASHTO $A_{s_{provided}} (1.5d)$ (%)
NU900	35.4	53.1	1.95	1.06	0.89	54.5
NU1100	43.3	65.0	2.38	1.30	1.08	54.5
NU1350	53.1	79.7	2.92	1.59	1.33	54.5
NU1600	63.0	94.5	3.47	1.89	1.58	54.5
NU1800	70.9	106.4	3.90	2.13	1.77	54.5
NU2000	78.7	118.1	4.33	2.36	1.97	54.5

Figure 2 presents the actual confinement steel provided for all six NU girders along with the required amount by AASHTO 5.10.10.2. It is clearly shown that although the percent provided is constant for all of the girders, the difference between the provided to required increases as the girder depth increases.

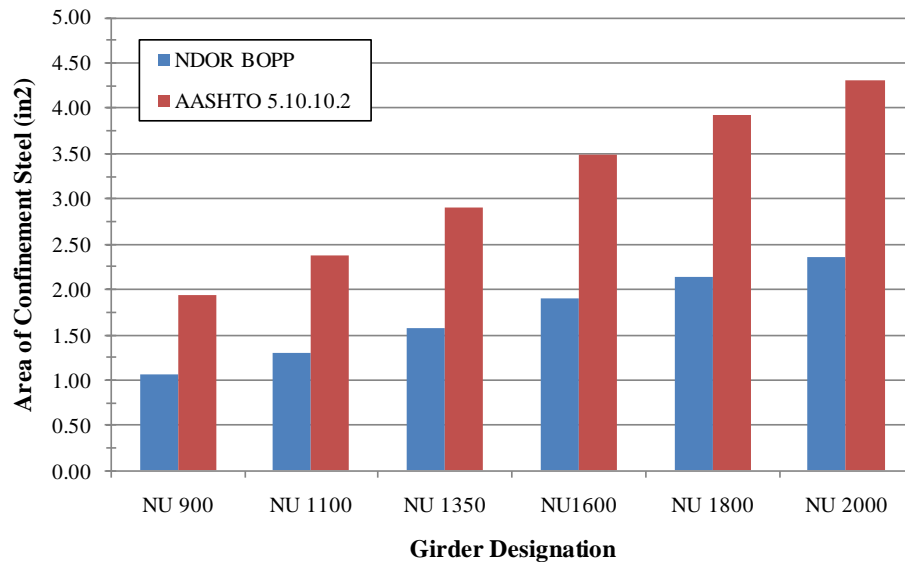

Figure 2 Total area of confinement steel using AASHTO and NDOR BOPP Manual

Figure 3 and Figure 4 clearly demonstrate these conclusions for the NU 900 and NU 2000 respectively as they plot the cumulative area of confinement reinforcement along the distance of the girder from each end.

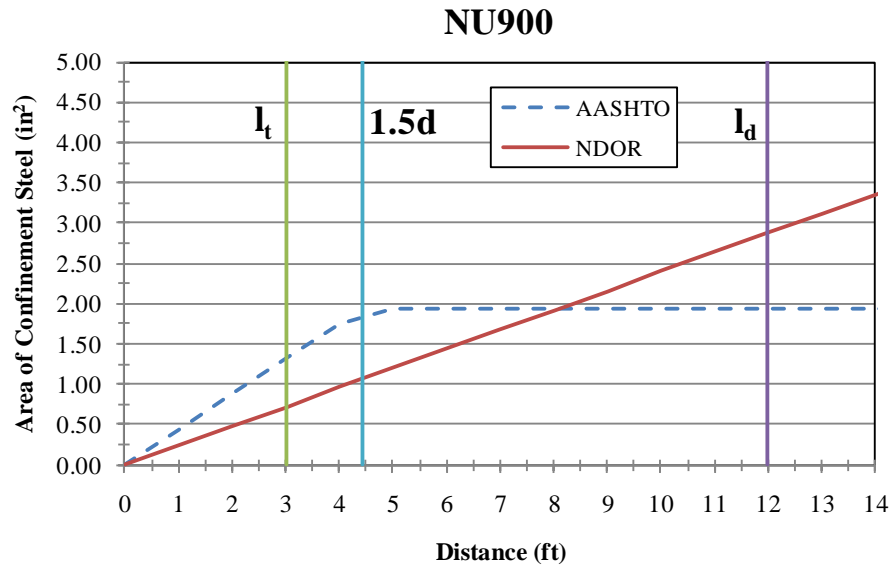

Figure 3 Total area of confinement steel using AASHTO and NDOR specs for NU 900

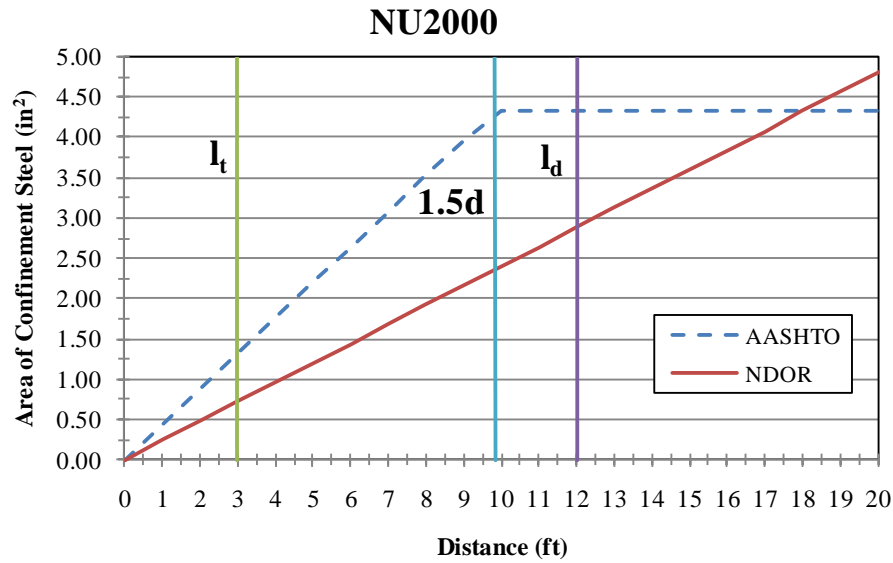

Figure 4 Total area of confinement steel using AASHTO and NDOR specs for NU 2000

The difference between the bottom flange reinforcement required by the 2004 AASHTO LRFD specifications and that provided by NDOR in NU I-girders might affect the transfer and development of the prestressing strands and, consequently, the shear capacity of the

girder. Due to this, the effects of confinement steel on prestressing strand properties needs to be investigated and evaluated.

## 1.2 OBJECTIVE

The objectives of this study is to investigate analytically and experimentally presents the effect of confinement reinforcement, in general, and NDOR standard detail, in particular, on the transfer and development length of prestressing strands in NU I-girders. Data obtained from the analytical investigation, a thorough literature review, as well as the experimental investigation with laboratory testing, will be used as validation for the research team's assessments.

## 1.3 ORGANIZATION

The report is organized as follows; Section 2 presents the results from an analytical investigation, an experimental investigation, and the research team's assessment related to the effect confinement has on a prestressing strand's transfer length. Section 3 provides the research analysis relating the development length of confined prestressed strand identical to Section 2. Section 4 reports the results from investigation and an assessment of NDOR's NU I-girder's pertaining to their shear capacity with relation to strand confinement. Section 5, the conclusion, presents a summary from the research and proposed recommendations for modifications, optional and required, to existing and future NDOR NU I-girder designs. The end of the report provides a list of references utilized in the analytical investigation as validation for the provided assessments.

## 2 TRANSFER LENGTH

### 2.1 DEFINITION

Transfer length is the length of the strand measured from the end of the prestressed member over which the effective prestress is transferred to the concrete. The transferred force along the transfer length is assumed to increase linearly from zero at the end of the member to the effective prestress at the end of the transfer length. According to the 2004 AASHTO LRFD Bridge Design Specifications Section 5.11.4.1, transfer length ( $l_t$  in.) for fully bonded prestressing strands is equal to  $60d_p$ , where  $d_p$  is the nominal diameter of strand in inches.

$$l_t = 60d_b \quad (\text{AASHTO 5.11.4.1})$$

$l_t$  = transfer length (in)

$d_b$  = nominal strand diameter (in)

Transfer length is important for the shear design and calculations of release stresses at the girder ends. An over-estimated transfer length results in conservative shear design and higher top and bottom stresses at release. An under-estimated transfer length results in inadequate shear design and lower top and bottom stresses at release.

### 2.2 ANALYTICAL INVESTIGATION

*An Analysis of Transfer and Development Lengths for Pretensioned Concrete Structures (1994)*

In 1988 the Federal Highway Administration (FHWA) issued a memorandum, restricting the use of seven-wire strands for pretensioned members in bridge applications. In an attempt to reconcile some of the differences in the design recommendations, the FHWA requested an independent review of the recently conducted research on transfer and development lengths of pretensioned strands. The author, Dale Buckner, fulfills the administration's objectives by reporting findings and presenting recommendations and equations for determining strand transfer and development lengths.

The author reviews the research performed with respect to confinement steel and commented. Intuitively the effect of closed hoops or spirals around prestressing strands should constrict lateral expansion of concrete, therefore improving frictional resistance and improving the transfer length. However, experimental evidence, performed at the University of Texas-Austin, shows the effects from confinement reinforcement to be negligible for members which do not split at release. With regards to a prestress strands development length, the author mentions the testing done previously by the FDOT. The tests performed indicated the effectiveness of the steel against longitudinal splitting in the bottom flanges of end bearing members. The report also mentions that the steel is beneficial in maintaining the integrity of girders that develop splitting cracks at transfer.

*Measured Transfer Lengths of 0.5 and 0.6 in. Strands in Pretensioned Concrete (1996)*

For this study, transfer lengths were measured on a wide variety of variables and on different sizes and types of cross sections. The variables included number of strands, size of strand (0.5 and 0.6), debonding, confinement reinforcement, and size and shape of the cross section.

The number of specimens and the variables included in the testing represent one of the largest bodies of transfer length data taken from a single research project. Altogether, transfer lengths were measured on each end of 44 specimens. Of these specimens, 32 were constructed with concentric prestressing in rectangular transfer length prisms. The remaining 12 specimens were built as scale model AASHTO type beams with four, five, or eight strands. Primarily, transfer lengths were determined by measuring concrete surface strains along the length of each specimen. By measuring the concrete strains and plotting the strains with respect to length, transfer length can be determined from the resulting strain profile. The strain profiles taken were then plotted versus the length of the specimen. The method used, which was conceived by personnel from the research project, was labeled the “95 Percent Average Maximum Strain” method. The method gives a transfer length value that is free from arbitrary interpretation because the “Average Maximum Strain” will not change significantly if one or two data points are either included or excluded from the average. Its “inherent objectivity” is the major advantage derived by using the “95% AMS” method.

The results show that for both 0.5” and 0.6” strands, the transfer lengths for AASHTO type beams were remarkably shorter than the transfer lengths of the other test specimens. The data indicated that test specimens with larger cross sections and multiple strands possess significantly shorter transfer lengths. Those results indicate that transfer lengths measured on relatively small, single strand specimens may not simulate transfer lengths of real pretensioned concrete members. Typical pretensioned beams, with larger cross sections and multiple strands, could be expected to register shorter transfer lengths when compared to many of the typical research specimens.

Confining reinforcement is analogous to hoop ties in a column. Presumably, confining reinforcement surrounding the concrete and pretensioned strand would improve strand anchorage and shorten the transfer length. However, the data from this study did not support this theory. Transfer length measurements on specimens containing confining reinforcement are presented in Table 2.

Table 2 Effects of Confining Reinforcement on Measured Transfer Lengths  
(Russell and Burns 1996)

Specimen	Measured transfer length (in.)			
	0.5 in. strands		0.6 in. strands	
	North end	South end	North end	South end
FCT350-3	30.5	30.0	—	—
FCT350-4	29.0	32.0	—	—
FCT550-2	36.0	39.5	—	—
FCT360-3	—	—	39.5	45.5
FCT360-4	—	—	50.5	42.0
FCT362-12	—	—	44.0	42.0
FCT560-2	—	—	48.0	51.5
Average transfer lengths: Strands confined by hoops	32.8 (Standard deviation = 4.1 in.)		45.4 (Standard deviation = 4.3 in.)	
Average transfer lengths: All test specimens	29.5 (Standard deviation = 6.9 in.)		40.0 (Standard deviation = 6.8 in.)	

Note: 1 in. = 25.4 mm.

The average transfer lengths for specimens made with confining reinforcement are 32.8 in. for 0.5” strands and 45.4 in. for 0.6” strands. In comparison, specimens containing confining reinforcement possessed about 12% longer transfer lengths than those with the confinement reinforcing omitted.

It is postulated that the confining reinforcement remained largely ineffective because the concrete remained relatively free from cracking throughout the transfer zone. Even though confining reinforcement necessarily must increase each member’s elastic stiffness in the circumferential direction, the effect is apparently small compared to the elastic stiffness of concrete. Fundamental mechanics prove that small radial cracking must occur locally at the interface of strand and concrete. However, these cracks do not usually become large enough to activate confining forces in the reinforcement hoops.

Therefore, the confining reinforcement exerts little or no influence on the prestress transfer. Conversely, for the general design case, pretensioned concrete members must be detailed to prevent propagation of splitting cracks that can occur at transfer and transverse reinforcement should not be eliminated from standard detailing.

In the early and mid 1980’s, many testing programs focused on developing reliable design guidelines for the shear design of pretensioned concrete. Tests performed in those research programs consistently demonstrated a direct interaction between shear failures and bond failures. The failure modes from the research were difficult to distinguish and failures were labeled shear/bond failures. Of significance, those shear/bond failures were sudden, violent and would represent catastrophic failures in real structures. From the development length testing, it is imperative to recognize that the transfer length can adversely affect the strength and ductility of a pretensioned member. Those failures highlight the need for the industry to collectively acknowledge the importance of transfer length in the safe design of pretensioned beams.



## 2.2 EXPERIMENTAL INVESTIGATION

### *Mono-strand Prism Tests – University of Nebraska (2009)*

To experimentally evaluate the transfer length of prestressing strands, four 8 ft long specimen were made as shown in Figure 5. Each specimen had a 7 in. x 7 in. cross section and only one 0.7” diameter, Grade 270, low-relaxation strand at the center. Confinement loops of 3/8” diameter, Grade 60 steel were used at different spacing in each specimen to apply different levels of confinement. These loops are 5 in. x 5 in. in size and spaced as follows: 3 in., 6 in., 9 in., and 12 in..

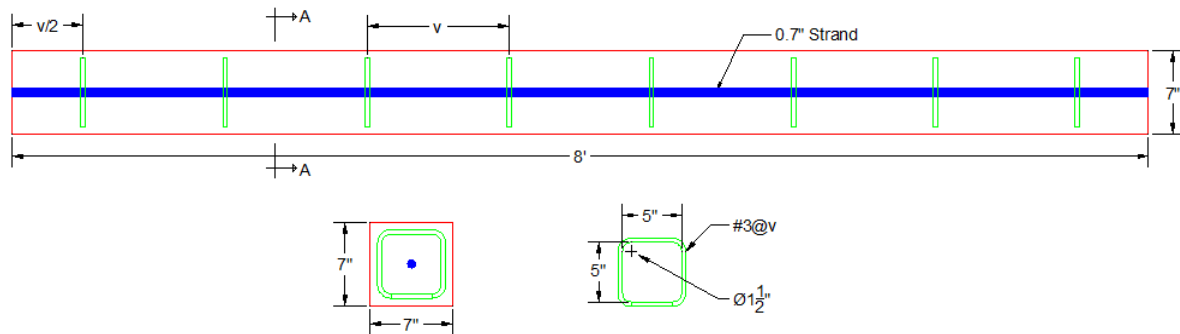

Figure 5 Transfer Length Test Specimen

To measure the transfer length, a series of Detachable Mechanical gauges (DEMEC gauges) were placed along the two sides of each specimen at 4 in. spacing, starting 2 in. from the end of the concrete specimen, at the same elevation of the prestressing strand before prestress release. These gauges were manufactured by Hayes Manufacturing Company in the United Kingdom. DEMEC readings were taken at release (1-day) and at 7, 14, 21, and 28 days using a W.H. Mayes & Son caliper gauge. The change in the measured distance between DEMEC gauges was used to calculate the strain in the concrete at different ages. Figure 6 and Figure 7 plot the 1-day and 28-day strains averaged from the readings of the two sides of each specimen. The predicted transfer length for the 0.7” diameter strand is 42 in. according to the AASHTO LRFD. The measured transfer length was calculated using the 95 percent average maximum strain (AMS) method, which was found to be approximately 31 in.. This indicates that transfer length of 0.7” diameter strand can be better predicted using the American Concrete Institute (ACI) 318-08 expression  $50d_p$ , 35 in., than the 2007 AASHTO LRFD expression  $60d_p$ , 42 in., which is significantly conservative.

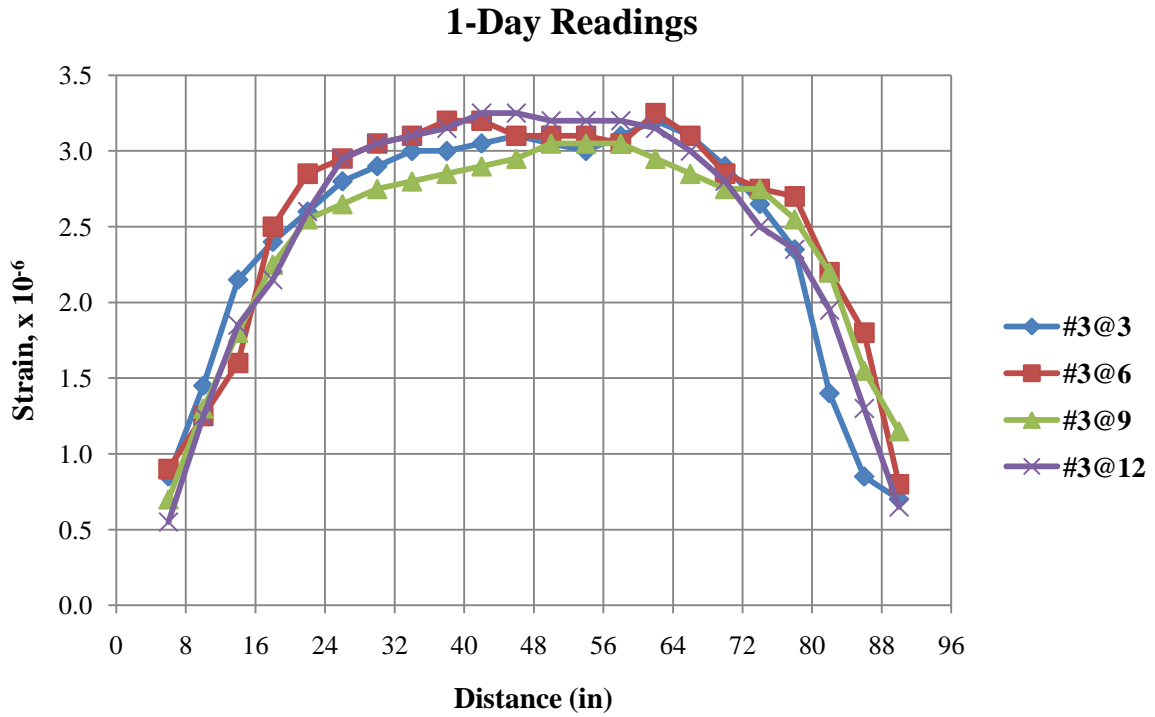

Figure 6 1-day Transfer Length Measurements at Different Levels of Confinement

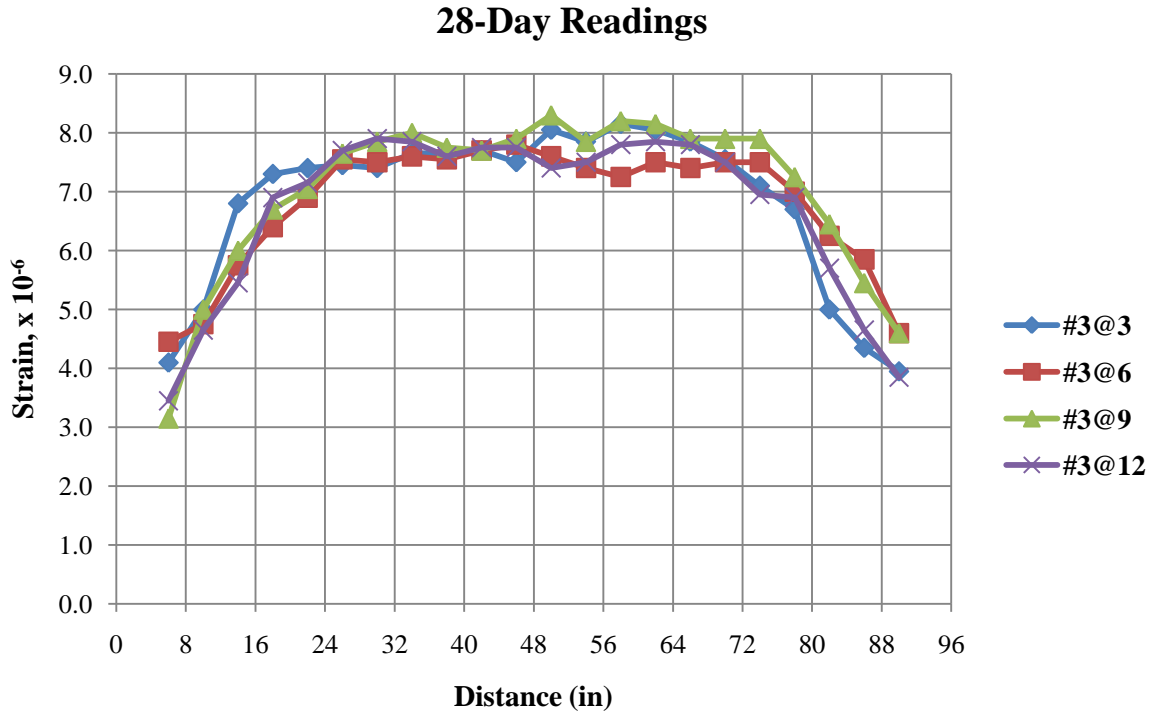

Figure 7 28-day Transfer Length Measurements at Different Levels of Confinement

Figure 6 and Figure 7 also indicate that there is no clear difference between the strain profiles in the specimens with different confinement reinforcement. This means that there is no significant effect from the level of confinement on the transfer length of 0.7" diameter strand. This is in agreement with the previously mentioned conclusion of investigation carried out on 0.5" and 0.6" strand by Russell and Burns.

*T24 Girders – University of Nebraska (2009)*

Eight twenty eight foot long tee-girders were designed and fabricated for transfer length testing using different confinement patterns and concrete strength. Each girder was pretensioned using six 0.7" diameter, Grade 270, low-relaxation strands distributed in two rows (3 strands each) with 2 in. horizontal and vertical spacing as shown in Figure 8. Strands were tensioned up to  $0.75 f_{pu}$  (59.5 kips). The overall depth of each girder was 24 in. with 8 in. wide web and 32 in. wide top flange. Four 0.6" diameter strands, stressed to  $.075 f_{pu}$ , were used in the top flange to control cracking at release. Shear reinforcement of two D20@12 in. was determined to ensure that the girders reach their ultimate flexural capacity prior to their shear capacity. End zone reinforcement of two 0.5 in. coil rods were welded to the 0.5 in. bearing plate at each girder end to control cracking due to bursting force. Figure 8 (a) and (b) show the typical dimensions and reinforcing details of test specimens.

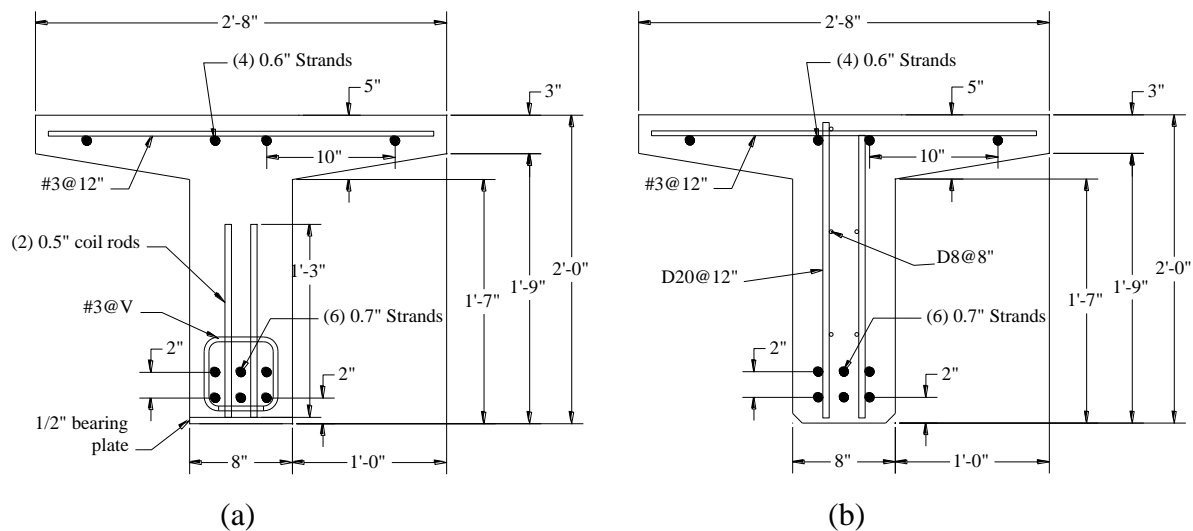

Figure 8 (a) Specimen End-span Section; (b) Specimen Mid-span Section

To evaluate the effect of confinement reinforcement, No. 3, Grade 60, 5 in. x 5 in. square confinement ties were used in all specimens at q spacing (V), and along a distance (L). Figure 9 shows these parameters on the side view of the specimen, while Table 3 lists the values of these parameters in the eight specimens. It should be noted that the AASHTO LRFD confinement reinforcement was used as the base confinement in all comparisons. Table 3 also presents the girder designation used, which was set up as follows: Girder shape-Confinement spacing-Confinement distribution distance-Concrete strength designation (A for 13,500 psi, B for 11,900 psi, C for 9,000 psi, and D for 11,200 psi).

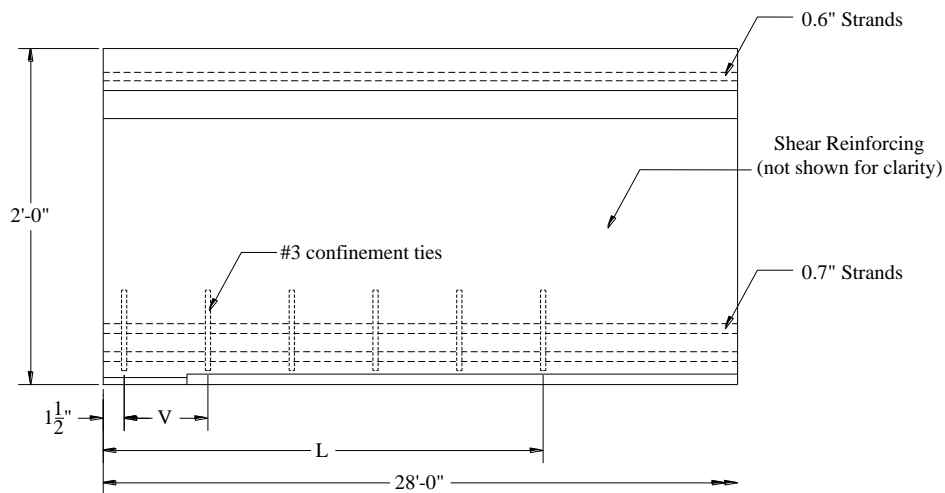

Figure 9 Confinement Reinforcement Distribution

Table 3 Girder Designation and Confinement Reinforcement

Test		Confinement			
Number	Girder Designation	Size	No. per end	Spacing-V (in)	Distribution-L (in)
1	T-6-1.5h-A	#3	6	6.0	36.0
2	T-6-0.5l-A	#3	28	6.0	168.0
3	T-6-1.5h-B	#3	6	6.0	36.0
4	T-4-1.0h-B	#3	6	4.0	24.0
5	T-6-1.5h-C	#3	6	6.0	36.0
6	T-4-1.0h-C	#3	6	4.0	24.0
7	T-12-0.5l-D	#3	14	12.0	168.0
8	T-4/6-1/1.5h-D	#3	6	4.0 / 6.0	24.0 / 36.0

To measure the transfer length from the prestressing steel in the tee-girders, a series of Detachable Mechanical gauges (DEMEC gauges) were placed starting 1 in. from each end at an elevation equal to the centroid of the prestressing force. The DEMEC gauges were spaced at approximately 2 inches, over a distance of 44 inches, and then spaced at approximately 4 inches for another 32 inches. Those measurements were based on the expected AASHTO transfer length of 42 inches and a maximum possible transfer length of  $100d_b$  or 70 inches. Figure 10 provides a drawing of the DEMEC gauge layout. DEMEC readings were taken before release, immediately after release (1-day), three days after release, and 14 days after release using a W.H. Mayes & Son caliper gauge as shown in Figure 11. The change in the measured distance between DEMEC gauges was used to calculate the strain in the concrete at different ages.

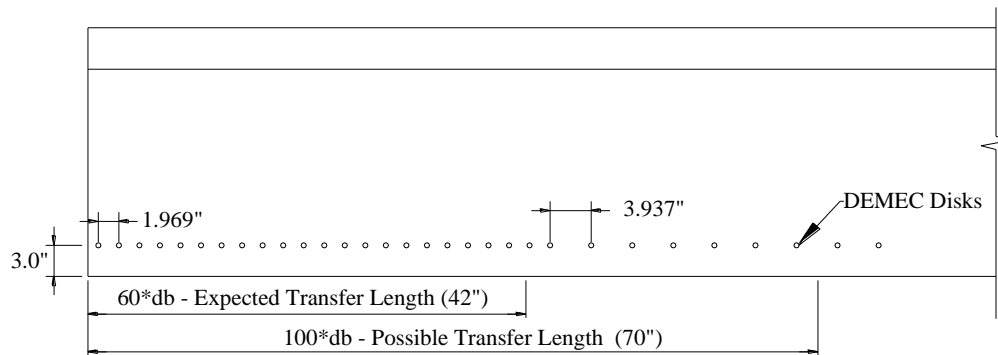

Figure 10 DEMEC Gauge Layout



Figure 11 Measuring Strain in Concrete for Transfer Length Estimation

To evaluate the effect of amount of confinement on transfer lengths, the results of testing the two specimens T-6-1.5h-A and T-6-0.5l-A were compared. Girder T-6-1.5h-A had confinement ties spaced at the AASHTO minimum of 6 in. for a distance of 1.5 times the depth of the girder, (36 in.), while girder T-6-0.5l-A had the same confinement ties spaced at 6 inches, but over the entire length of the girder. Figure 12 shows that increasing the amount of confinement for the prestressing strands above the AASHTO minimum requirement has insignificant impact on both initial (at release) and final (at 14 days) transfer lengths of prestressing strands. Also, Figure 12 indicates that measured transfer lengths are well below the values predicted by AASHTO LRFD 5.11.4.1.

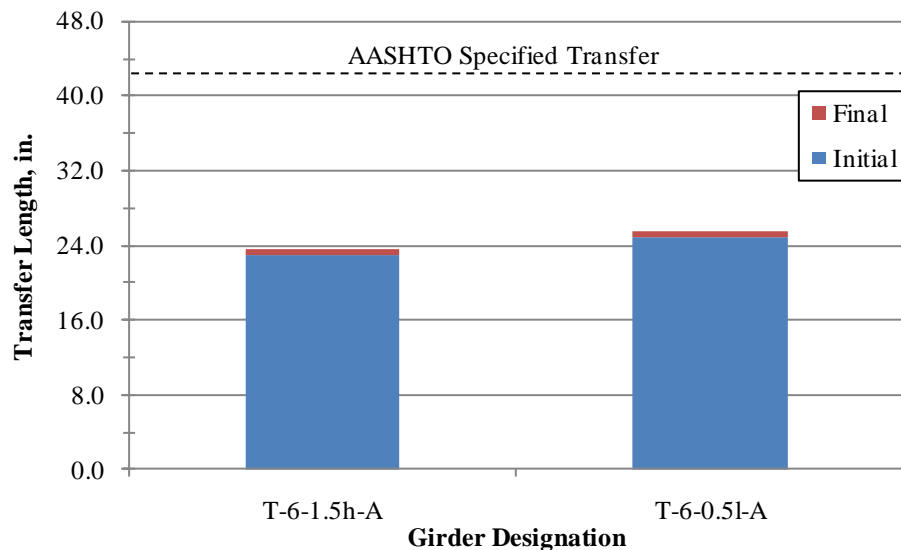

Figure 12 Effect of Amount of Confinement on Transfer Length

To evaluate the effect of confinement distribution on transfer lengths, the results of testing the two specimens T-6-1.5h-B and T-6-1.5h-C were compared versus those of specimens T-1-1.0h-B and T-4-1.0h-C. Girders T-6-1.5h-B and T-6-1.5h-C had confinement ties spaced at the AASHTO minimum of 6 inches for a distance of 1.5 times the depth of the girder, (36 in.), while girders T-1-1.0h-B and T-4-1.0h-C had the same confinement ties spaced at 4 inches over a distance of 1.0 times the depth of the girder (24 in.). Figure 13 shows that increasing the intensity of confinement ties for prestressing strands above the AASHTO minimum requirement slightly decreases the initial (at release) transfer length, but it has

insignificant impact of the final (at 14 days) transfer length of prestressing strands. Also, Figure 13 indicates that measured transfer lengths are well below the values predicted by AASHTO LRFD 5.11.4.1.

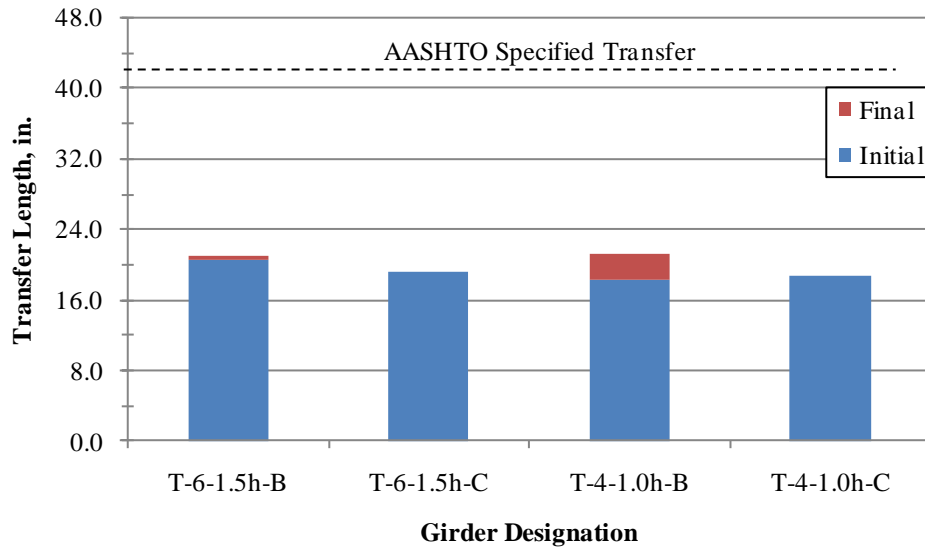

Figure 13 Effect of Confinement Distribution on Transfer Length

The conclusion is that confinement reinforcement does not contribute significantly to prestress transfer because the confinement reinforcement remains inactive until concrete cracking occurs, which is usually controlled by end zone reinforcement. Also, transfer length is mainly a function of the stiffness of the uncracked concrete section, which is hardly affected by the amount of confinement reinforcement.

### 3 DEVELOPMENT LENGTH

#### 3.1 DEFINITION

The development length of prestressing strands is defined as the minimum embedment needed to reach the section ultimate capacity without strand slippage. Thus, at the point of strand development, the strand stress could reach a maximum tensile stress without strand-concrete bond failure. The development length is measured from the member end to the point of maximum stress. According to the 2004 AASHTO LRFD Bridge Design Specifications Section 5.11.4, development length provision for fully bonded prestressing strands is as follows:

$$l_d \geq k \left[ f_{ps} - \frac{2}{3} f_{pe} \right] d_b \quad (\text{AASHTO 5.11.4.2-1})$$

$l_d$  = development length (in)

$d_b$  = nominal strand diameter (in)

$f_{ps}$  = average stress in prestressing steel (ksi)

$f_{pe}$  = effective stress in prestressing steel (ksi)

$k$  = factor equal to 1.0 for pre-tensioned panels, piling, and other pre-tensioned members with a depth of less than or equal to 24.0 in.; and 1.6 otherwise.

The relationship of development length, as well as transfer, is necessary for identifying the critical sections in flexure and shear and calculating the capacities of the girder. Accurate estimate of the development length is important for the flexure design of girders. While an under-estimated development length might result in a lower girder capacity at the sections within the development length, an over-estimated development length result in an uneconomical design with unnecessarily excessive reinforcement.

#### 3.2 ANALYTICAL INVESTIGATION

*Strength and Ductility of Confined Concrete (1992)*



The effects of confinement on the compressive strength of concrete has been observed and documented by many researchers. It makes logical sense that if you confine Material A with another stronger material, Material B, and then measure the axial force required to yield Material A, that force should be higher than the same test performed on Material A without the benefit of any confinement. By resisting the lateral displacement of the confined material, an increase in its overall strength can be achieved. Figure 14 presents a stress-strain diagram for confined and unconfined concrete.

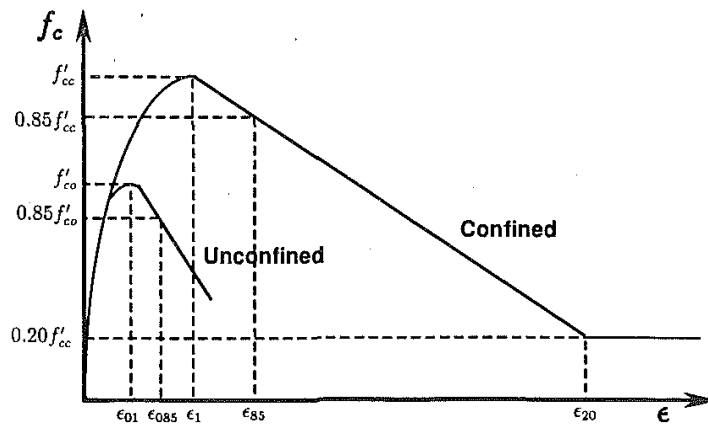

Figure 14 Proposed Stress-Strain Relationship (Saatcioglu and Razvi 1992)

Research was done in the early 1990's by Saatcioglu and Razvi on the subject of concrete confinement and its effects on the overall compressive strength of concrete. They tested ninety-seven specimens, with varying cross-sections, and derived an equation to calculate the concrete strength of a confined specimen. Their research found the general equation for confined concrete to be:

$$f'_{cc} = f'_{co} + k_1 f_{le}$$

The term  $f'_{co}$  is taken as:

$$f'_{co} = f'_c MF$$

The unconfined concrete strength may be different than that obtained from standard cylinder testing. A modification factor, MF, may need to be applied to adjust the cylinder results to a

better approximation of  $f'_{co}$ . Modification factors from 0.85 to 1.00 have been documented in literature. All sample calculations for the research will use an MF of 1.00, therefore standard cylinder test results can be used directly. Where the coefficient  $k_1$  was calculated as:

$$k_1 = 6.7(f_{le})^{-0.17}$$

The term  $f_{le}$ , which represents the uniform confining pressure, for a square section is:

$$f_{le} = \frac{\sum A_s f_{yt} \sin \alpha}{s b_c} k_2$$

Whereas for a rectangular section, the  $f_{le}$  term is calculated as:

$$f_{le} = \frac{f_{lex} b_{cx} + f_{ley} b_{cy}}{b_{cx} + b_{cy}} k_2$$

The  $k_2$  term is used to reduce the average lateral pressure for concrete which has large spacing between lateral reinforcement. For cases with closely spaced lateral reinforcement  $k_2$  is equal to 1.0. For our calculations the strands, which are spaced at two inches horizontally and vertically, will be considered the longitudinal reinforcement and  $k_2$  will be set at 1.0, which is the most conservative case. Figure 15 presents the distribution of lateral pressure from the confined concrete to the reinforcement. It also explains the calculation of  $f_l$  for the steel.

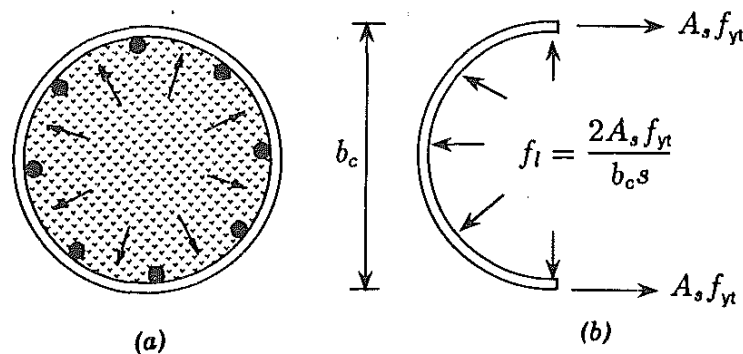

Figure 15 Computation of Lateral Pressure from Hoop Tension (Saatcioglu and Razvi 1992)

Figure 16 presents the lateral distribution between the ties of a rectangular member. From the figure, it can be seen that the pressure is dependent on the longitudinal reinforcement. This is where the  $k_2$  term becomes relevant.

The actual calculation of  $k_2$  is:

$$k_2 = 0.26 \sqrt{\frac{b_c b_c}{s s_l f_l}}$$

In the  $k_2$  equation,  $s_l$  is the spacing between the lateral reinforcement. As the lateral spacing increases, the term  $k_2$  decreases.

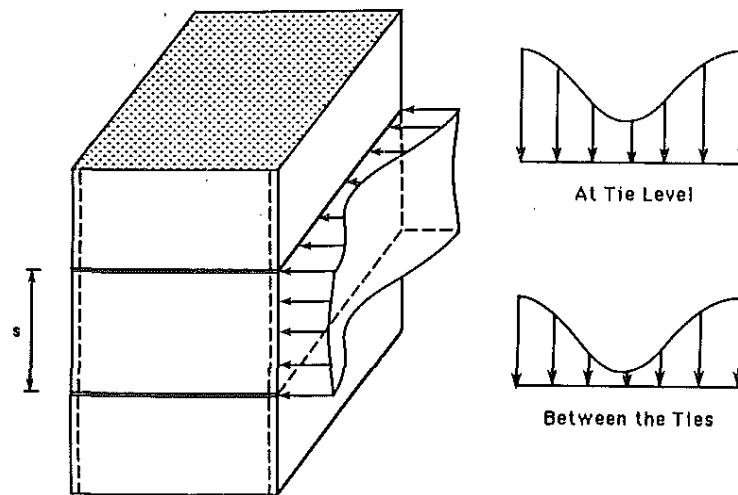

Figure 16 Distribution of Lateral Pressures (Saatcioglu and Razvi 1992)

Knowing of the phenomena introduced by confinement, the researchers looked into what effect the bottom flange confinement reinforcement had on the actual strength of the concrete surrounding the prestressing steel of bridge girders. The two types of girders that were looked at were the shapes to be utilized for the experimental work. The first is a tee girder and the second is an NU I-girder. Figure 8 and Figure 28 present those two cross-sections. Using the equations derived by Saatcioglu and Razvi along with confinement specifications prescribed in AASHTO 5.10.10.2, Table 4 presents the results from confinement on both girder sections.

Table 4 Confined Concrete Strength

T24			NU1100		
$f'_{co}$	8,000	psi	$f'_{co}$	10,000	psi
$k_1$	2.12		$k_1$	2.84	
$k_2$	1.00		$k_2$	1.00	
$f_1$	880	psi	$f_{lex}$	157	psi
$A_s$	0.22	in <sup>2</sup>	$A_s$	0.22	in <sup>2</sup>
$f_{yt}$	60,000	psi	$f_{yt}$	75,000	psi
$b_c$	5.00	in	$b_{cx}$	35.00	in
$s$	6.0	in	$s$	6.0	in
			$f_{ley}$	917	psi
			$A_s$	0.22	in <sup>2</sup>
			$f_{yt}$	75,000	psi
			$b_{cy}$	6.00	in
			$s$	6.0	in
			$f_{le}$	268	psi
$f'_{cc}$	9,862	psi	$f'_{cc}$	10,446	psi
$f'_{cc} / f'_{co}$	<b>1.23</b>		$f'_{cc} / f'_{co}$	<b>1.04</b>	

The T24 concrete strength was calculated using confinement for a square section, while the NU1100 was calculated with a rectangular section. There is quite a difference in the effects from confinement on the two different sections. Initially the effects from confinement on the T24 section look good, but the final ratio presents a maximum case, which may never exist in the life of the girder as it takes into account three assumptions. The first assumption for both girders is that the confinement reinforcement has reached yielding. The second assumption is that the  $k_2$  factor is indeed 1.0. The third is that the MF factor for  $f'_{co}$  is 1.0. With all three assumptions, then the concrete strength could possibly reach a confined strength presented in Table 4.

Also, the overall effects from confinement are drastically reduced for larger I-girder or box cross-sections. Taking into account the assumptions and standard deviation between specimens, the equations presented show there is no significant increase in the confined concrete strength of those members. From these results, the researchers concluded that there is no conclusive evidence supporting a significant effect from confinement on the concrete strength around the prestressing strands. This is mainly due to the relatively small amount of

confinement around a very large area, without the presence of any longitudinal reinforcement.

*A Critical Evaluation of the AASHTO Provisions for Strand Development Length of Prestressed Concrete Members (2001)*

Part of the overall study presented by Shahawy in 2001 involved testing twelve forty-one foot long AASHTO Type II girders designed in accordance by the AASHTO 1991 Interim Specification with approximately the same ultimate flexural strength (2100 k-ft) for their individual development lengths. Figure 17 presents a cross-section of one type of girder tested.

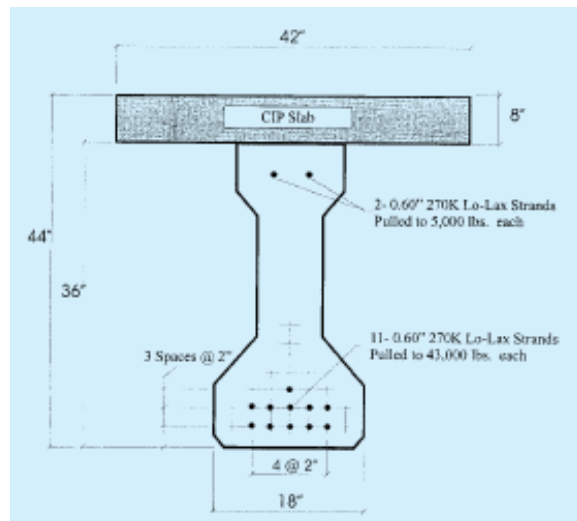

Figure 17 Section Details of Type C Test Girders (M. Shahawy 2001)

Three different size 270 ksi, LRS prestressing strands were used in the investigation; namely, 1/2", 1/2" Special, and 0.6". The main variables in the test program were the nominal strand diameter, available embedment length as a result of varying the distance of the applied loading, and the presence of confinement reinforcement in the tension flange. After the precast beams were produced a top flange, 42 inches wide and 8 inches thick, was cast on all the specimens.

The effects of confinement steel were seen by comparing the results for those girders provided with confinement steel, beams A0-00R, A1-00R, C0-00R, and C1-00R, against those not provided with such reinforcement, beams A0-00RD, A1-00RD, C0-00RD, and C1-00RD. Each girder end was tested using a single concentrated load. The location of the load varied and the test span was shortened after the first end of the girder was tested to eliminate the opposite failed zone. According to AASHTO, the presence or lack of confinement steel does not affect the predicted development length. During testing all of the strands were continuously monitored by linear voltage differential transducers (LVDTs). The strains and deflections were also monitored. An important observation was the value of the applied moment at which initial strand slippage occurred. The author reports that although the initial strand slippage occurred shortly after the appearance of the first shear crack, all of the girders continued to carry increasing load until complete bond slip of all strands occurred. Figure 18 presents the results of development testing the AASHTO girders. The green circles encompass the eight points on the graph which represent the tests done on the four girders without any confinement steel. The other points are tests performed on specimen with confinement reinforcement consisting of No. 3 D-bars placed six inches apart for a distance of 1.0h. The lines presented on Figure 18 represent a best fit approximation of the data for reference purposes only. The circles and lines were not a part of the original figure; they were placed by the researchers for visual assistance and understanding to the reader.

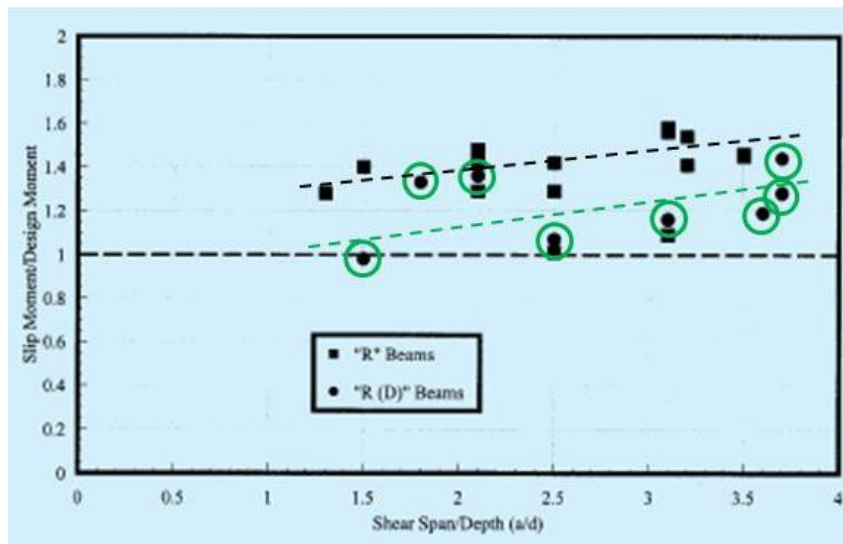

Figure 18 Effects of Shear Span to Depth Ratio on Strand Slip (M. Shahawy 2001)

From Figure 18 the effects of confinement, as the loading gets closer to the end of the girder, are more pronounced. Intuitively this makes sense. As the bond length of the strand increases, the contribution from confinement reinforcement proportionally decreases. The author concludes, with respect to the effect of confinement, it was determined that higher strength and higher ductility can be expected with the use of confinement reinforcement in the tension flange. The strength ratios,  $M_{\text{applied}}/M_{\text{nominal}}$ , were also compared for girders with and girders without confinement. There was high variability in the strength ratio results, but seven of the eight cases showed that the presence of confinement increased the capacity of the tested girders. Overall, on average the actual capacity of girders with confinement steel increased by 23%.

### 3.3 EXPERIMENTAL INVESTIGATION

#### *Pull out Tests – University of Nebraska (2009)*

Pullout tests were performed to evaluate the bond between concrete and 0.7” diameter strand. Three parameters were considered in this testing: embedded length, level of confinement, and stress state of the strand. A total of thirty-nine specimen were poured and tested in the Structural Lab at the Peter Kiewit Institute at the University of Nebraska: twelve 4 ft, fifteen 5 ft, and twelve 6 ft. The specimens had the same cross section as the transfer length specimens shown in Figure 5. Due to the capacity limitations of the prestressing bed, the specimens were fabricated in two phases. Phase I include 21 specimens, which were tested and reported by Akhnoukh in 2008. Phase II include 18 additional specimen that were needed to study the effect of the identified parameters. Figure 19 shows the forms set up in the prestressing bed, Figure 20 shows the placement of the #3 confinement reinforcing around the 0.7” strand, and Figure 21 shows the test setup. This setup was designed to apply clamping force on the strand while testing to prevent strand slippage and ensure that the ultimate stress is applied. A potentiometer was attached to the strand on the other end of each specimen during testing to monitor the bond failure of the strand, which is defined as any relative movement that is greater than 0.01 inch. This value was determined based on the precision of the used potentiometer.



Figure 19 Forms of the Pullout Specimens



Figure 20 Specimen Strand Confinement



Figure 21 Pull-out Testing Setup



Table 5 gives the pullout testing results of all thirty-nine specimens. Two types of failure were observed: strand rupture and strand slippage. Specimen that failed above the ultimate strength of 270 ksi had strand rupture, while those which failed below 270 ksi had strand slippage except those marked with an asterisk. The rupture of those strands at a stress level below the ASTM A416-06 and AASHTO M203-07 specified 270 ksi might be attributed to lower strand quality and/or stress concentration due to improper alignment of the inset and chuck. These specimens were still considered in the study as they resulted in stress levels very close to 270 ksi without slippage.

Table 5 Results from Pull-out Testing

Specimen No.	3 # 3 - Pre-tensioned			5 # 3 - Pre-tensioned			5 # 3 - Non-tensioned		
	4 ft	5 ft	6 ft	4 ft	5 ft	6 ft	4 ft	5 ft	6 ft
1	277	269*	278	279	278	295	249	264*	264
2	255	283	285	279	294	273	233	269	270
3	247	283	277	268*	295	286	248	255	241
4	249	280	277	278	269*	299	230	272	273
5		275			268*			269	
<b>Average (ksi)</b>	<b>257</b>	<b>280</b>	<b>280</b>	<b>278</b>	<b>289</b>	<b>288</b>	<b>240</b>	<b>266</b>	<b>262</b>
<b>Std. Dev.</b>	<b>14.0</b>	<b>3.7</b>	<b>3.9</b>	<b>0.4</b>	<b>9.5</b>	<b>11.7</b>	<b>9.8</b>	<b>7.5</b>	<b>14.4</b>

\* indicates strand rupture below the ASTM A 416 – 06 & AASHTO M203-07 Standard of 270 ksi

To evaluate the effect of level of confinement on the bond between the concrete and 0.7” diameter strand, thirteen specimens were made using five #3, Grade 60 confinement loops (i.e. stirrups) and another thirteen specimens were made using three #3 stirrups (low confinement). Each group consisted of four 4 ft long specimens, five 5 ft long specimens, and four 6 ft long specimens. Stirrups were distributed at equal spacing as shown in Figure 5. All twenty-six specimens were pre-tensioned at 59.5 kip, which is 75% the ultimate strand strength. Figure 22 presents the results from the pull-out testing of the two groups of specimens.

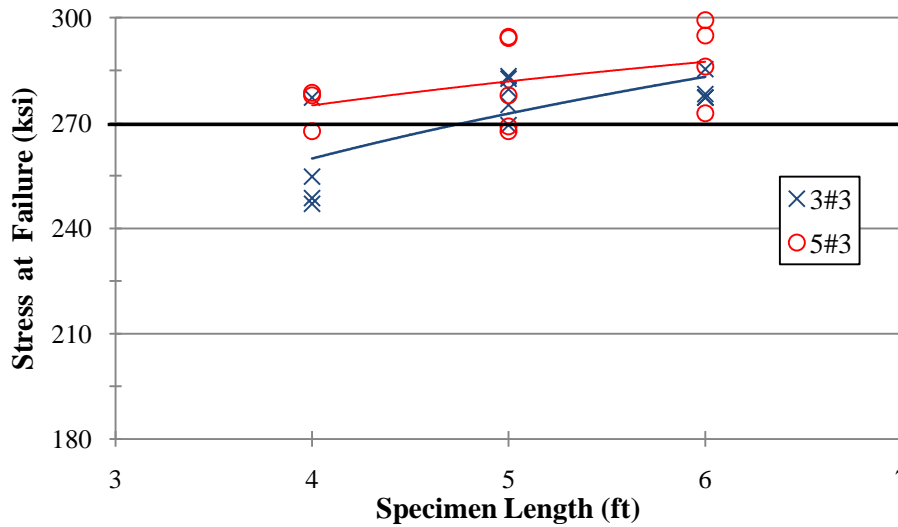

Figure 22 Effect of Level of Confinement on Pull-out Testing Results

Figure 22 indicates that the required amount of confinement to develop the 0.7” strand varies with the embedment length of the strand. Although five #3 stirrups were needed for the strand to reach an ultimate strength of 270 ksi in the 4 ft long specimens, only three #3 stirrups were needed for the same strand to reach the stress level in the 5 ft and 6 ft long specimens. Therefore, it can be concluded that level of confinement has a significant effect on the development of 0.7” strand.

*T24 Girders – University of Nebraska (2009)*

Eight 28ft long tee-girders were designed and fabricated for development length testing using different confinement patterns and concrete strength. Figure 8 (a) and (b) show the typical dimensions and reinforcing details of test specimens. Figure 9 shows the parameters on the side view of the specimen, while Table 3 lists the values of the parameters in the eight specimens. To determine the effects on the development length of the specimen, a single point load was applied on the top flange at mid span of the fabricated tee girders as shown in Figure 23 and Figure 24. The applied load and corresponding mid-span vertical deflection were recorded as the load increased up to failure. While testing, each girder was visually inspected and cracks were periodically marked to identify the failure mode. Also, bottom strand slippage was monitored using 6 potentiometers (3 at each end), as shown in Figure 25.

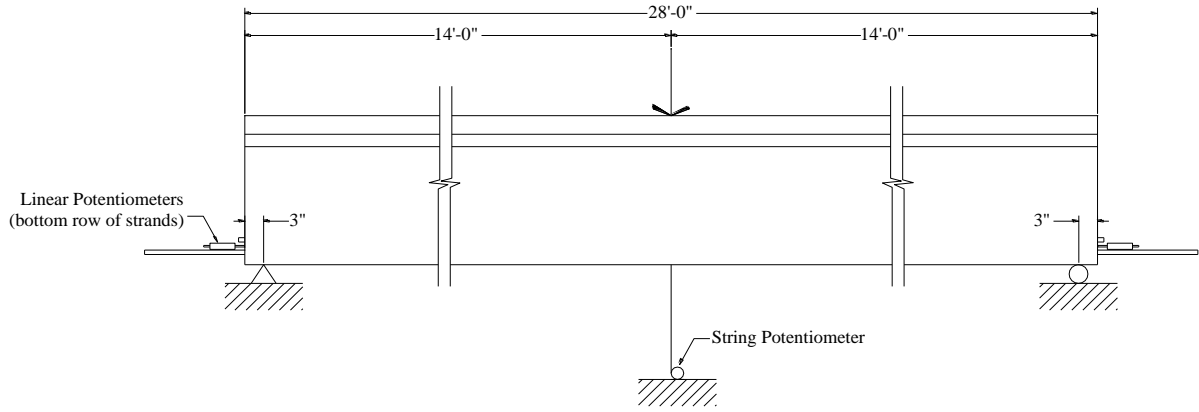

Figure 23 Development Length Test Setup

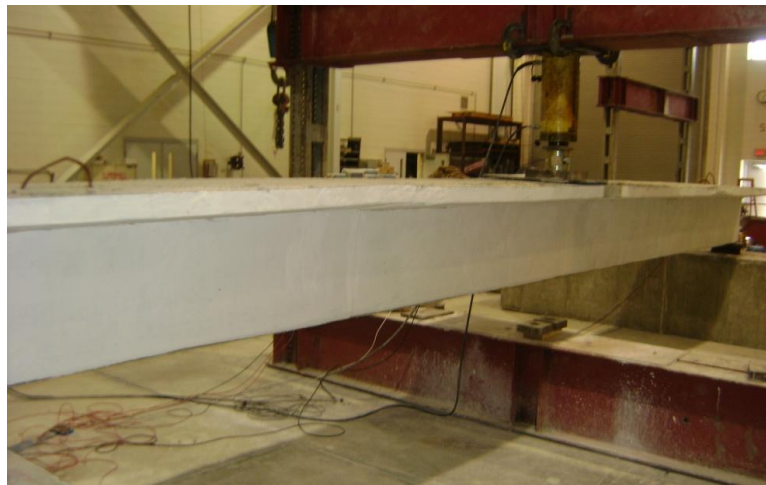

Figure 24 Development Length Testing Setup

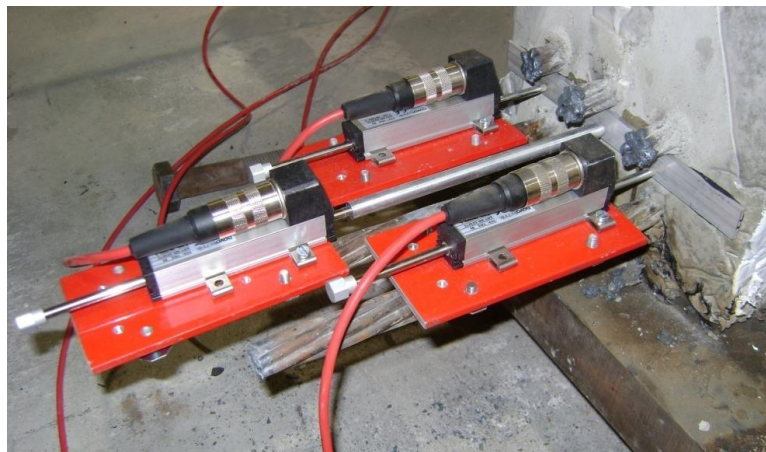

Figure 25 Potentiometers Attached to the Bottom Row of Strands

To evaluate the effect of amount of confinement on development lengths, the results of testing the two specimens T-6-1.5h-A and T-6-0.5l-A were compared. Girder T-6-1.5h-A had confinement ties spaced at the AASHTO minimum of 6 in. for a distance of 1.5 times the depth of the girder, (36 in.), while girder T-6-0.5l-A had the same confinement ties spaced at 6 inches, but over the entire length of the girder.

Figure 26 shows the load-deflection relationships for the development length testing of the two girders. These relationships are almost identical, which indicates that increasing the amount of confinement reinforcement above the AASHTO minimum confinement does not increase the flexural capacity of the girder. AASHTO specified development length and confinement reinforcement resulted in fully developed strands up to the failure load. Also, the two girders had the same failure mode, which is crushing of the top flange concrete.

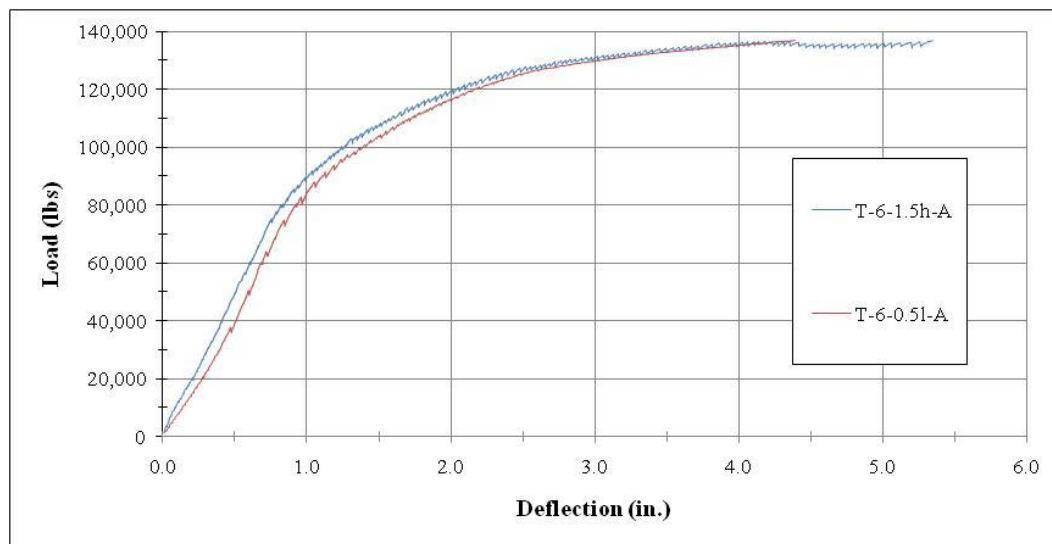

Figure 26 Effect of Amount of Confinement on Development Length

To evaluate the effect of confinement distribution on development lengths, the results of testing the two specimens T-6-1.5h-B and T-6-1.5h-C are compared versus those of specimens T-4-1.0h-B and T-4-1.0h-C. Girders T-6-1.5h-B and T-6-1.5h-C had confinement ties spaced at the AASHTO minimum of 6 inches for a distance of 1.5 times the depth of the girder, (36 in.), while girders T-1-1.0h-B and T-4-1.0h-C had the same confinement ties

spaced at 4 inches over a distance of 1.0 times the depth of the girder (24 in.). Figure 27 shows the load-deflection relationships for the development length testing of the four girders.

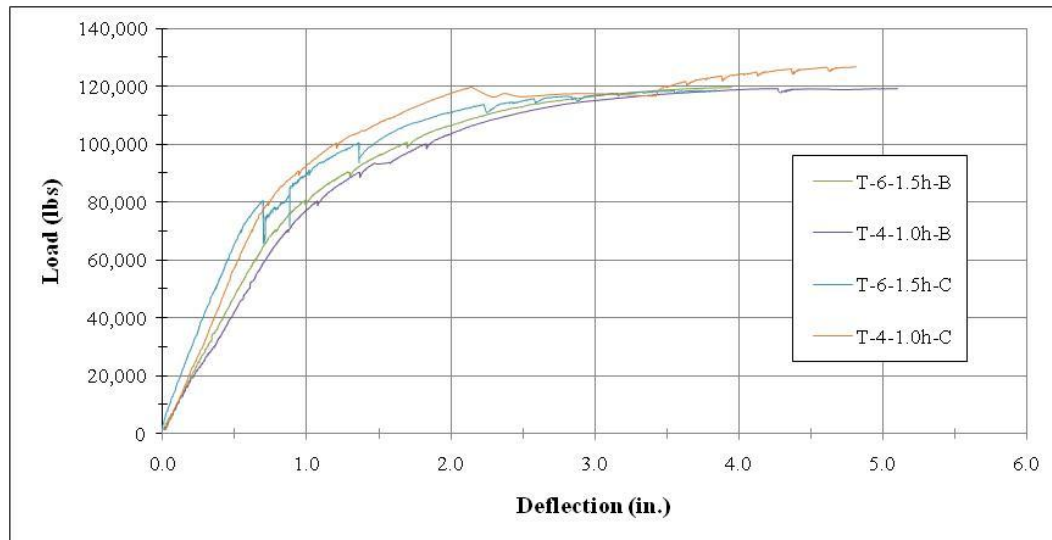

Figure 27 Effect of Confinement Distribution on Development Length

The relationships of the girders with the same concrete strength are almost identical, which indicates that increasing the intensity of confinement reinforcement above the AASHTO minimum requirement has negligible effect on the flexural capacity of the girders. AASHTO specified development length and confinement reinforcement resulted in fully developed strands up to the failure load. Also, all girders had the same failure mode, which is crushing of the top flange concrete.

#### *NU1100 Girders – University of Nebraska (2010)*

Three forty foot long NU1100 girders were designed for testing the effects of confinement reinforcement on the transfer length, development length, and shear capacity of commonly specified bridge girders in the state of Nebraska. The depth of the NU1100 girder is 43.3”; they have a 5.9” wide web, a 38.4” wide bottom flange and a 48.2” wide top flange. Each girder was pretensioned with thirty-four 0.7” diameter Grade 270 low-relaxation strands, stressed to 75%  $f_{pu}$  (59.5 kips), distributed in three rows with eighteen in the bottom, fourteen in the middle, and two strands in the top row at 2” horizontal and vertical spacing as shown

in Figure 28. Four 0.5” diameter strands were placed and fully stressed to 75%  $f_{pu}$  (30.9 kips), in the top flange of the girders to control cracking upon release of the prestress force. As designed for all three NU specimens, one end of the girders had eight strands debonded. The end designated with the debonded strands was to be used during the shear testing of the girders. There were four debonded strands in the bottom row for a distance of 3.5 feet, and four strands debonded in the middle row for a distance of 7 feet. The concrete specified for girder design and fabrication was a SCC mix with a minimum strength at release of 7.8 ksi, and an  $f'_c$  at twenty-eight days of 10 ksi.

The design of the NU1100 specimen incorporated the addition of a concrete deck to be placed prior to any testing. The deck was designed to be 7.5” thick, the full width of the girders’ top flange. The deck concrete was specified to have a final strength of 8 ksi, which was done to simulate a 7.5” deck comprised of 4 ksi concrete for a girder with eight foot spacing. Welded wire mesh was used for reinforcing the deck as two rows of D20@12” transverse and D20@6” longitudinal steel sheets were placed the length of the girder.

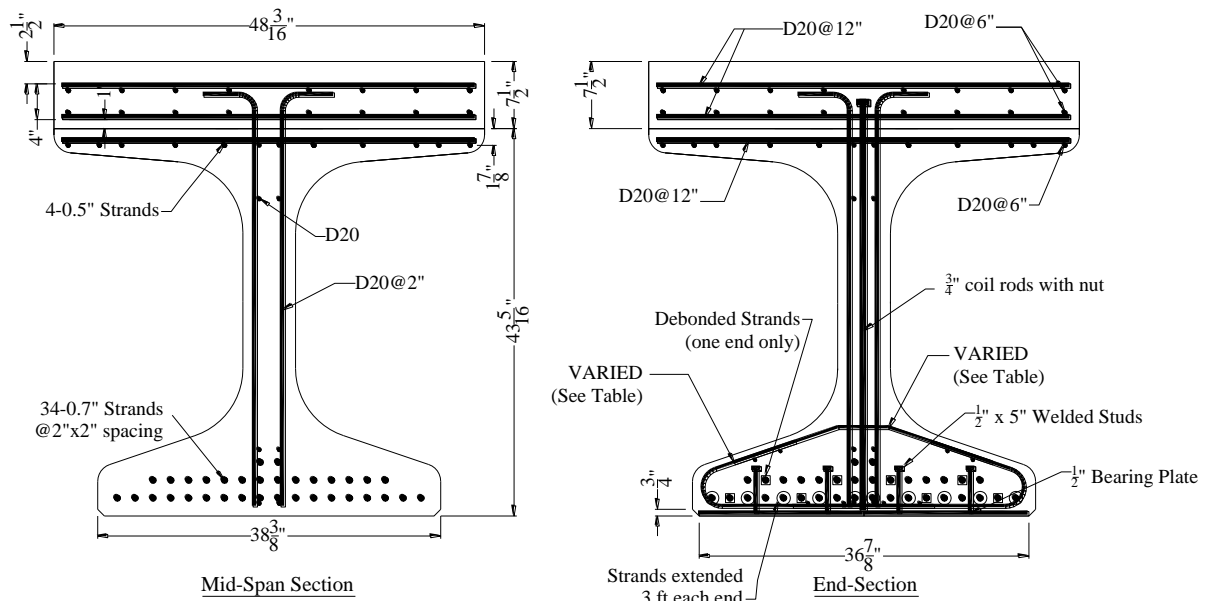

Figure 28 Cross Section of NU1100 Test Specimen

Figure 29 provides the detail used by the researchers for comparison on the project. The bottom pieces of the confinement were made up of either D4 or D11 Grade 75 mesh, while the cap bar always consisted of a #3 Grade 60 bent bar. One detail provided to the fabricator for incorporation into the girders was specified by the 2008 NDOR BOPP, one came from AASHTO LRFD Section 5.10.10.2, and the third was a combination of the first two.

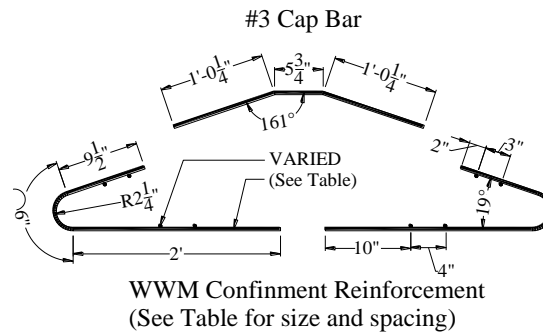

Figure 29 Confinement Detail

Although both ends of each girder were provided the same confinement reinforcement detail, to evaluate the effect of confinement reinforcement each NU1100 was designed with a different amount and distribution of confinement. Table 6 presents the confinement reinforcement and cap bar placement specific to each girder.

Table 6 NU1100 End Confinement

Beam Designation	Confinement Reinforcement	
	WWM	Cap Bar
1	D4@4" entire length	#3@12" entire length
2	D11@6" for 72" each end	#3@6" for 72" each end
3	D11@6" for 72" each end; D4@4" middle	#3@6" for 72" each end; #3@12" middle

To determine the effects from confinement on the development length of the NU1100 specimen, a point load was applied to the deck at a distance of fourteen feet as shown in Figure 30 and Figure 31. Bearing was located six inches in from each end producing an overall unsupported span of the girder for the development test of thirty-nine feet. The

loading location for testing was chosen to satisfy current AASHTO specifications for required length to fully develop prestress strand. The applied load and corresponding vertical deflection was monitored and recorded as the load increased up to the calculated nominal flexural capacity of the section. The load was stopped just above the calculated value in order to validate the strands full development and corresponding girders capacity, while preserving the structural integrity of the girder for moving and future testing.

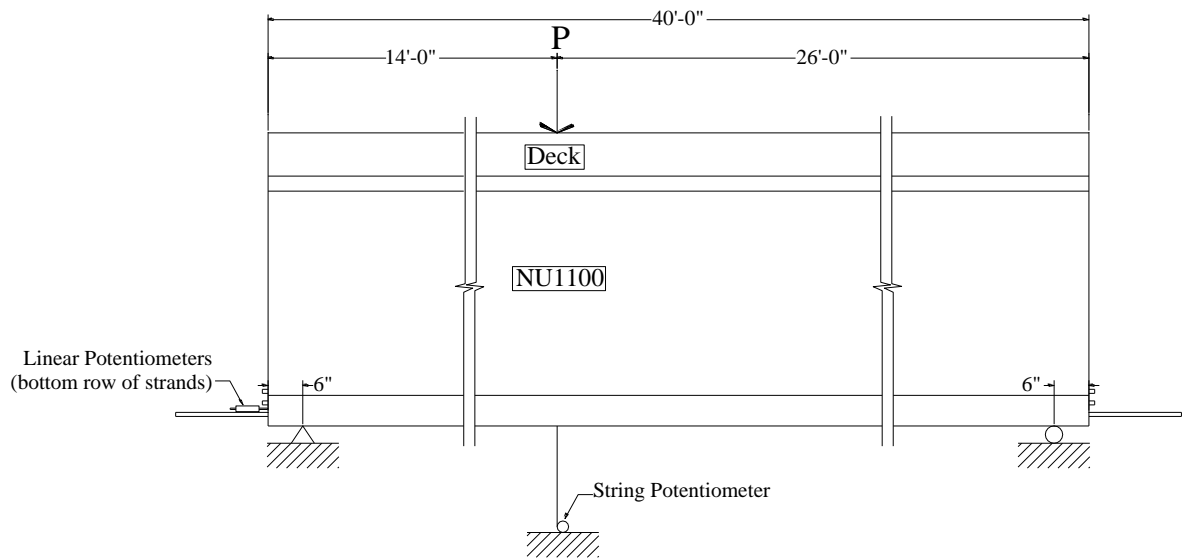

Figure 30 Development Length Test Setup



Figure 31 NU1100 Development Length Test Setup



While testing, each girder was visually inspected and cracks were periodically marked to identify the failure mode. Bottom strand slippage was monitored using ten potentiometers as shown in Figure 32, while the two top strands were monitored via a mechanical gauge and a string potentiometer.



Figure 32 Development Length Test Strand Instrumentation

The development length of the prestress strand was tested on one end of all three NU1100 girders. Table 7 presents the results from the flexural tests performed on the specimen. The calculated column presents the section values with the actual material properties inserted in the design calculations. The tested column in Table 7 is data from the actual test performed on the NU1100 girders.

Table 7 NU1100 Girder Flexural Capacity

Nominal Flexural Capacity [ $M_n$ ]			
Girder No.	Calculated	Tested	Tested/Calculated
	(kip-ft)	(kip-ft)	(%)
1	9697	9649	99.5
2	9634	9648	100.1
3	9653	9647	99.9

Figure 33 provides a graphical presentation of the girders behavior while testing. The line indicating AASHTO  $M_n$  represents the required applied load, at the designated test distance which corresponds to the nominal capacity of the section incorporating the specified materials properties and with a resistance factor,  $\phi$ , of 1.0. All three NU1100 girders were tested to approximately their specified nominal flexural capacity in order to validate the strands full development and corresponding girders capacity and yet preserve the structural integrity of the girder for subsequent shear testing.

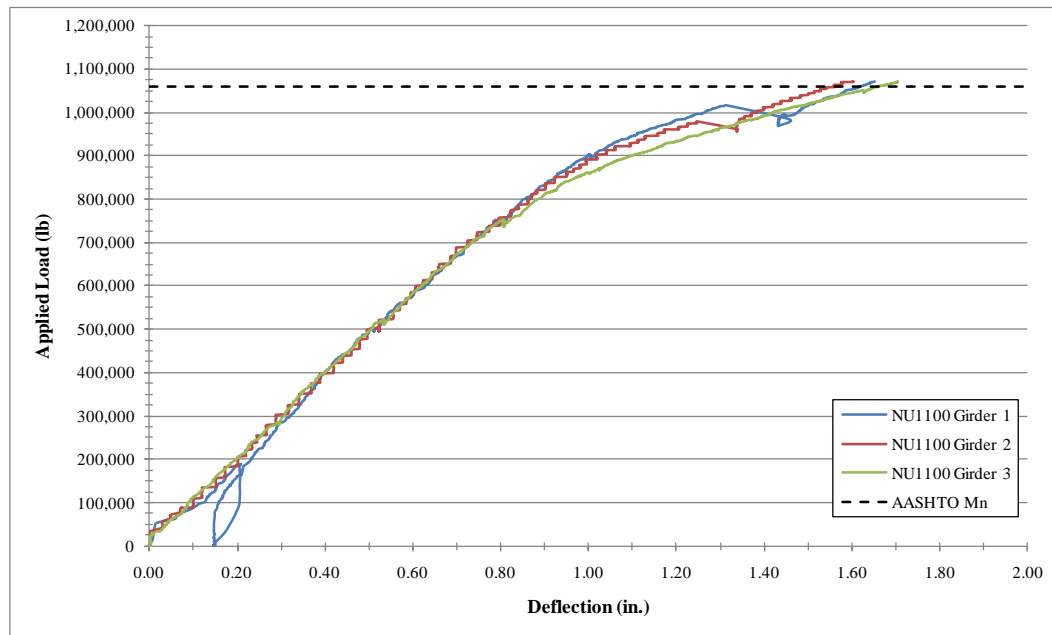

Figure 33 NU1100 Load v. Deflection Comparison

Table 7 along with Figure 33 shows the calculated load and observed deflection for the development length testing on the NU1100 girders. The relationships between all three girders were almost identical, indicating that an increase in the amount of confinement reinforcement above the specified AASHTO minimum, Girders 1 and 3 versus Girder 2, does not significantly increase the flexural capacity of the girder. Comparing Girder 1 with Girder 2, a decrease in the intensity of confinement over a distance equal to  $1.5h$ , but with an overall increase in total confinement again provides no significant increase in a girders' flexural capacity.

## 4 SHEAR CAPACITY

### 4.1 ANALYTICAL INVESTIGATION

#### *A Shear Moment Model for Prestressed Concrete Beams (1991)*

In excess of 1,300 AASHTO IV beams were prefabricated for the approaches of the Florida Sunshine Skyway Bridge over the Tampa Bay entrance. The endzones of some of these prestressed concrete beams showed honey-combing and cracking, indicating the possibility of reduced shear resistance. Pilot tests which were carried out on two such beams confirmed that possibility. Under the aegis of the Florida Department of Transportation, the author performed 16 shear tests on eight AASHTO IV beams, specially fabricated, in order to determine the cause(s) of the substandard performance observed. The three independent variables involved for review in this study were, a) 50% shielding or no shielding of the strands, b) confinement or no confinement cage in the end zone, and c) coated or uncoated web steel.

The shear span for all 16 tests was 75 inches, or about 1.21 times the structural height of the specimen, including the 54 inch AASHTO beam with an 8 inch deep concrete slab. Regardless of the combination of variables, the failure pattern was observed to be remarkably identical and in all cases, several diagonal web cracks developed, one of which - not necessarily the first or last that had appeared - dilated out-of proportion to the others. That crack, was referred to as the “significant” or "S" crack, completely separated the bottom chord, the web, and bottom part of the top chord (the slab) and was confined by what appeared to be a compression zone.

The "S" crack invariably intercepted the development length, even at times the transfer length of the AASHTO beams. The failure was always precipitated by the slip of strands, after which a considerable resistance had been retained, but the peak value was never regained. An earlier study performed by Maruyama and Rizkalla at the University of Manitoba, also brought attention to the significance of the "S" crack intercepting the strands within the development length.

Where the “S” crack intercepts the development length of the prestressing strands, the bonded or anchored strength of the strands should be calculated on the basis of bond stress distribution between the crack and the end of the beam. Both the 1996 AASHTO Standard Specifications for Highway Bridges and the 2004 AASHTO LRFD Bridge Design Specifications provide only for the transfer and development lengths, and therefore cannot directly be used in conjunction with a mechanical shear model.

Over the years several jurisdictions abandoned the confinement steel, as well as the end block, in order to reduce cost of pre-cast, pre-stressed concrete beams. This change was supported by several tests, either carried out or sponsored by PCA. The majority of these tests, both static and dynamic, included third-point loading, in which the environment leading to serious inelastic straining of and subsequent shear failure in the end zone may not easily be attained, as the beam tends to fail in flexure.

In an appropriate shear test, the shear span should not normally exceed 2.0 to 2.5 times the structural height ( $h$ ) of the beam. The Florida DOT tests with a shear span of  $1.21h$  were therefore valid shear tests as all beams exhibited pronounced longitudinal cracking at the level of strand rows, as well as at the center line of the bottom of the lower flange. Obviously the cracks observed at the level of strands must have been caused by the wedging or Hoyer effect of the strands.

The author concludes that a plausible explanation for the crack in the bottom is exhibited in Figure 34, a strut-and-tie model which can be drawn to approximate the magnitude of the transverse splitting force ( $T$ ), resulting from the spreading of the reaction force ( $R$ ) above the bearing.

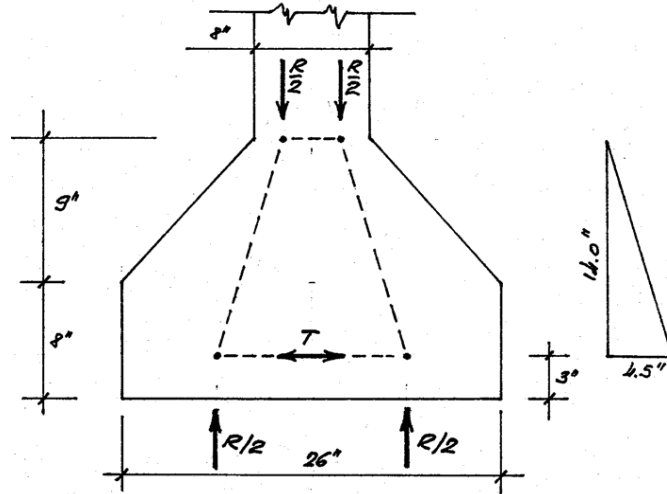

Figure 34 Splitting Force in Bearing Area (Csagoly 1991)

By this calculation an AASHTO IV beam would experience a splitting force of  $T = 0.161 R$ , which translates to 56.3k for a 350k reaction force. This T-force, depending on other factors such as the lateral bearing resistance, resistance by the horizontal stirrup legs and the longitudinal distribution of the T-force, may conceivably cause cracking. If the significant crack penetrates the end zone, where confinement steel is present, such steel is incorporated in the calculated force  $V_s$ . Unfortunately; there is no way by which the enhancement of bond due to confinement may be assessed with complete confidence. Consequently only the direct shear effect of this steel was considered by the author.

Testing found that on average the beams with confinement steel possessed 13.2% more shear resistance than those without any confinement. It is of interest to note that neither the ACI nor AASHTO directly incorporates the effects of confinement steel in the shear design of prestressed concrete beams.

It is often difficult to determine whether failure is precipitated by shear or by the slip of strands. The model assumes that all active strands slip simultaneously. In reality the slip is gradual, one or two strands at a time, always starting at the top row. As the shear resistance depends to a large degree on the compression force, which in turn is being limited by the

anchored strand force, a gradual deterioration by slip may lead to what appears to be a genuine shear failure. It is therefore quite conceivable that the two modes do closely interact.

*An Investigation of Shear Strength of Prestressed Concrete AASHTO Type II Girders (1993)*

The main objectives of this study was to determine experimentally the actual values of transfer and development lengths of prestressing strands, effect of strand shielding (debonding) on development length, shear and fatigue behavior, and the shear strength as it compares to existing and proposed code provisions. This shear capacity study was particularly significant in light of the then proposed changes to the AASHTO code for the design of members subject to shear and torsion. This report presented and compared the test results with predictions based on the 1989 AASHTO Standard Specifications for Design of Highway Bridges, the 1990 and 1991(current) Interim Specifications of that code, and the proposed revisions of the code based on the Modified Compression Field Theory (MCFT).

The test program consisted of thirty-three 41 feet long AASHTO Type II prestressed concrete girders, designed in accordance by the AASHTO 1991 Interim Specification with approximately the same ultimate flexural strength (2100 k-ft). Three different size 270 ksi, LRS prestressing strands were used in the investigation; namely, 1/2", 1/2" Special, and 0.6". In addition, the amount of shear reinforcement was varied by changing the area and spacing of stirrups. Shear reinforcement ranged from the minimum (M) steel permitted by AASHTO, to three times (3R) the amount required for the design dead and live loads.

The main variables in the test program were the percentage of shielded strands (25 and 50%), the web shear reinforcement ratio and beam end details, and the size of the prestressing strands. After the precast beams were produced a top flange, 42 inches wide and 8 inches thick, was cast on all the specimens as shown in Figure 35.

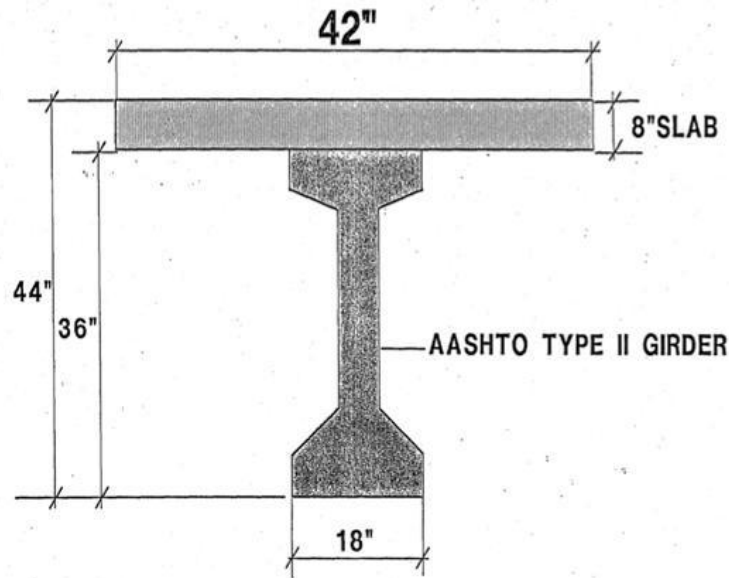

Figure 35 AASHTO Beam Cross Section (Shahawy et al. 1993)

The effects of confinement steel were seen by comparing the results for those girders provided with confinement steel against those not provided with such reinforcement. According to AASHTO, the presence or lack of confinement steel does not affect the predicted shear capacities. However, the test results clearly show that test shear strength was reduced when confinement steel was not present.

Five beams were designed, fabricated, and tested for comparison as beams A0-00R, A1-00R, A2-003R, C0-00R, and C1-00R included confinement, while the corresponding beams A0-00RD, A1-00RD, A2-003RD, C0-00RD, and C1-00RD did not contain any confinement.

The values for the tests shears at both ends of A0-00-R were much greater than the predicted capacities, the ratio of the test values to the AASHTO Code values being 1.41 and 1.25 for the TEST NORTH and TEST SOUTH values, respectively. Comparatively the test shears of beam A0-00-RD were greatly reduced in comparison to A0-00-R. The test shears in the former specimen are approximately equal to the current AASHTO predicted values, the ratios of test capacity to current AASHTO capacity being 1.06 and 1.03 for TEST NORTH and TEST SOUTH, respectively.

The results for specimens A1-00-R and A1-00-RD also show a similar reduction in shear capacity when confinement steel is not present. The shear capacity for A1-00-R with confinement steel is greater than the capacity predicted by the current AASHTO Code, the test to AASHTO ratios being 1.09 and 1.31 for the TEST NORTH and TEST SOUTH, respectively. However, the shear capacity is reduced in beam A1-00-RD, for which, the ratios of the test capacity to AASHTO capacities were 0.93 and 1.19, respectively for the TEST NORTH and TEST SOUTH values. For girders A2-00-3R and A2-00-3RD, as well as C0-00R and C1-00R, the failure mode was that of flexure, and therefore was not able to be compared in shear. Figure 36 graphically presents the results from testing of the A-series girders.

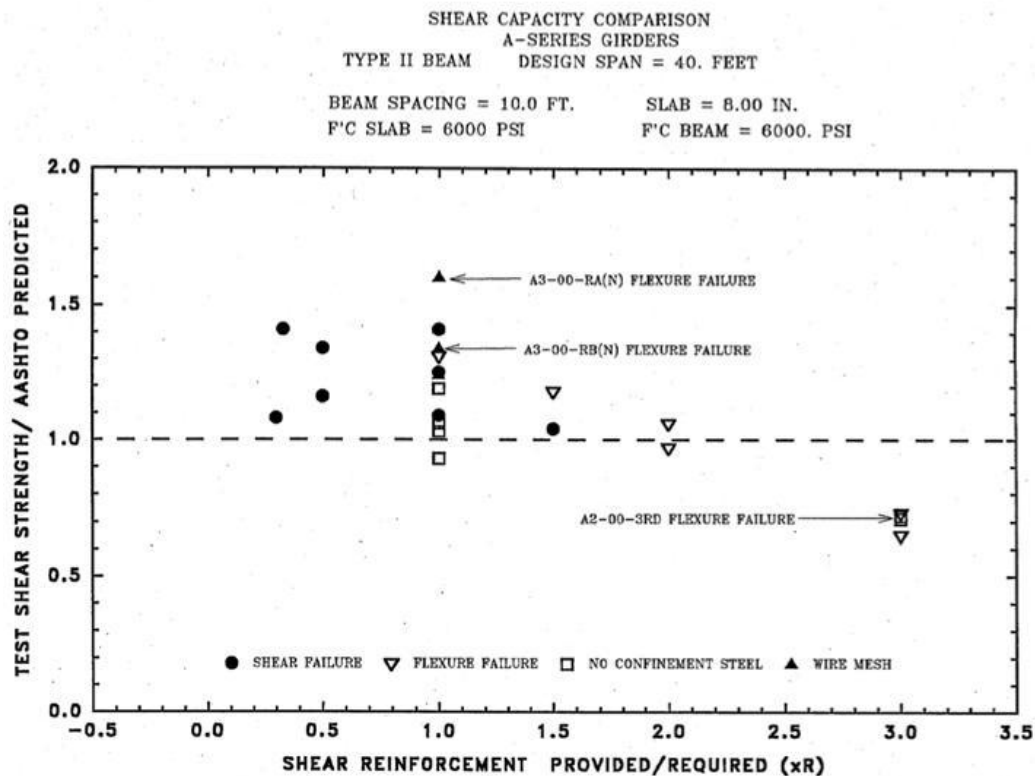

Figure 36 Shear Comparison (Shahawy et al. 1993)

From testing, the presence of confinement steel increased the shear capacity for the TEST SOUTH values by 10% from 189k to 208k. Similarly, for the TEST NORTH values, the presence of confinement steel increased the shear capacity by 17% from 179k to 210k.



Another test of note in the study involved girder BI-00-0R, which contained no shear reinforcement. The predicted shear capacities for this beam were 90k for TEST NORTH and 88k TEST SOUTH while the actual shear capacities found for this beam were 166k for TEST NORTH and 155k TEST SOUTH. These figures indicate that the codes greatly under-predict the shear contribution of the concrete,  $V_c$ , to the overall shear strength. The then current AASHTO code gave its best approximation, but even that value was an average of only 54% of the test value. Notable conclusions from this report were, 1) the provision of confinement steel for the prestressing strands at the end regions of a girder increases their shear capacity, 2) the 1991 AASHTO code predicts shear capacities which are adequate for girders with or without confinement steel, 3) both the current AASHTO code and the proposed code greatly under-estimate the shear strength provided by concrete with the current AASHTO code the less conservative of the two. This study demonstrated the beneficial effect of confinement steel in delaying bond failure of prestressing strands, and in enhancing shear capacity.

*Experimental Evaluation of Confinement Effect in Pretensioned Concrete Girders (2010)*

Work has begun at the University of Florida to experimentally evaluate confinement reinforcement in pretensioned concrete girders. The test program is performing full-scale tests on specimen with variable 0.5" and 0.6" strand patterns with and without confinement. Figure 37 presents the test specimen.

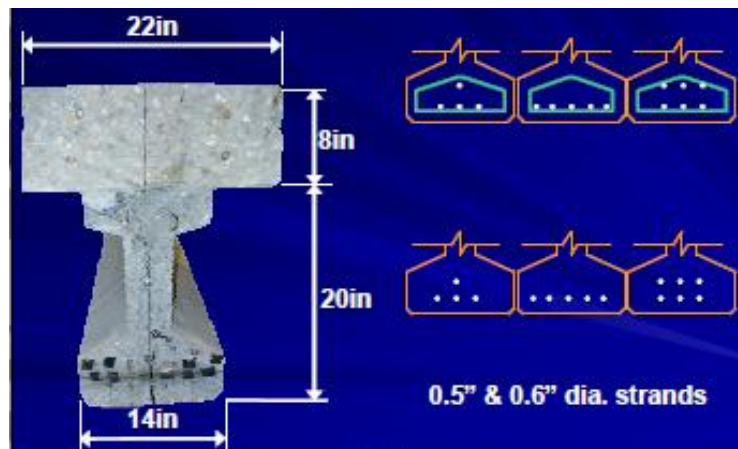

Figure 37 Specimen Details (Ross 2010)

In order to test an unconfined section versus confined the end of a pretensioned bridge girder was removed as shown in Figure 38 and both ends were tested independently from each other. The supports were placed at 5.5 inches from one end and 11 feet 2 inches from the end support. A single point load was placed at a distance of 2 feet 10 inches from the end of the girder, 2 feet 4.5 inches from the support, for a tested shear span of almost exactly 1.0h.

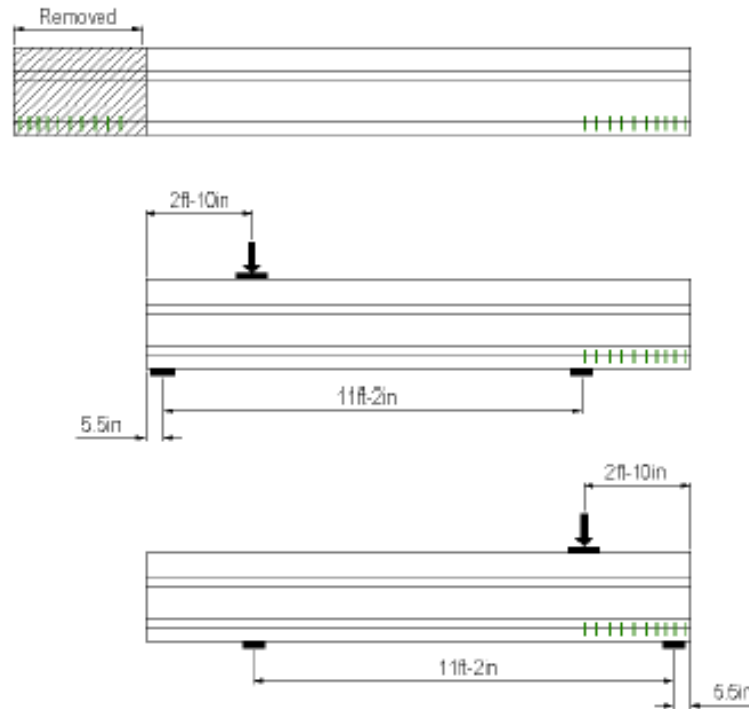

Figure 38 Specimen Fabrication and Test Setup (Ross 2010)

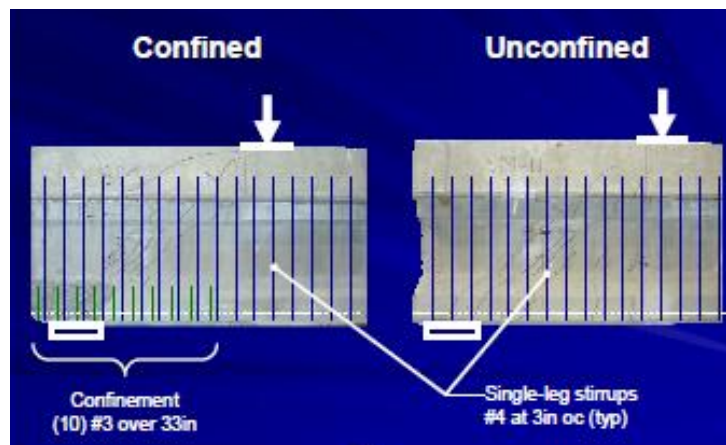

Figure 39 Specimen Reinforcement (Ross 2010)

The results from testing are presented in Figure 40 and Figure 41. One preliminary conclusion was that the addition of confinement has negligible effect on the elastic behavior of the test girders. Another conclusion was that the confinement reinforcement has negligible effect on the initial strand slip, but does aid in maintaining the strand capacity after the initial slippage.

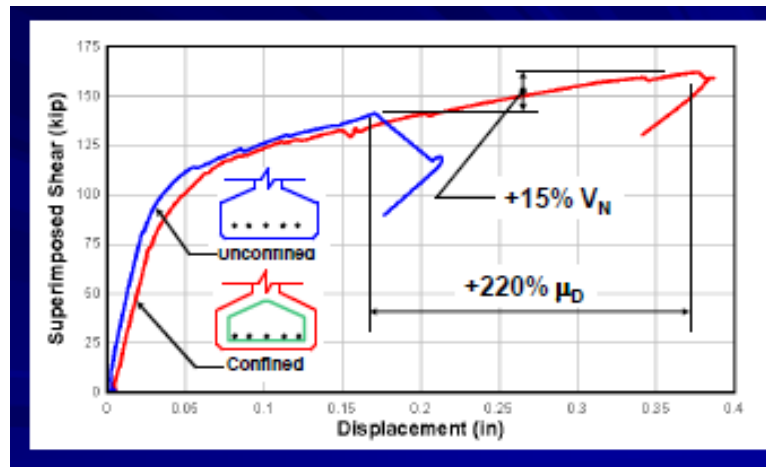

Figure 40 Shear vs. Displacement (Ross 2010)

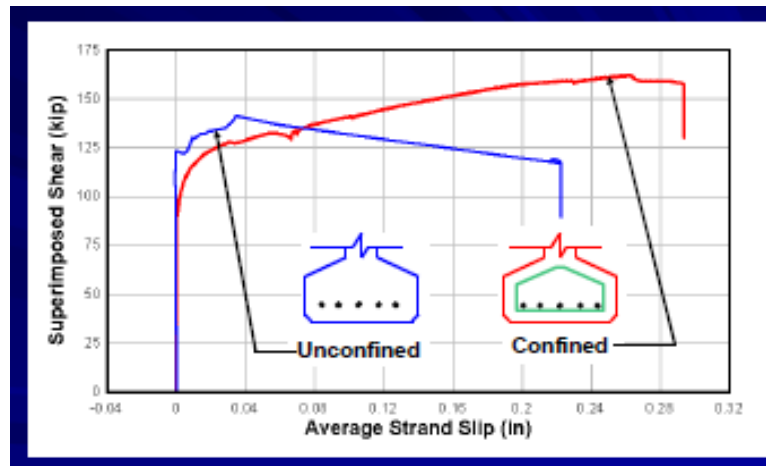

Figure 41 Shear vs. Strand Slip (Ross 2010)

Two notable conclusions from the initial test results at the University of Florida are: 1) the incorporation of confinement steel as prescribed by AASHTO LRFD Section 5.10.10.2

increases the shear capacity of the given girder by approximately 15% and 2) the overall ductility of the structure significantly increases, with the confined beam experiencing a deflection of 200% to that of the unconfined. Future work at the university will include full-scale testing of more girders as well as an analytical investigation incorporating FE modeling for comparison and justification of the test data.

## 4.2 EXPERIMENTAL INVESTIGATION

### *T24 Girders – University of Nebraska (2010)*

Two of the T24 girders, T-4/6-1/1.5h-D and T-12-0.51-D, were subjected to shear testing at both ends post their development testing. The girders were loaded at a distance of  $2.08h$  from the end support.

Figure 42 presents the CAD drawing for setup of the tests, while Figure 43 presents an image of the setup prior to one of the tests. The overall span of the girders for the shear tests was reduced to 13'-6". This was done in order to perform two tests, one on each end, of the two T24 girders. Also, these girders were first tested for development; consequently the mid section of the tee girders was damaged from the previous test. By moving the support near the mid-span of the girder, the damaged portion at the new support location would see no moment and roughly one third of the shear from the applied loading.

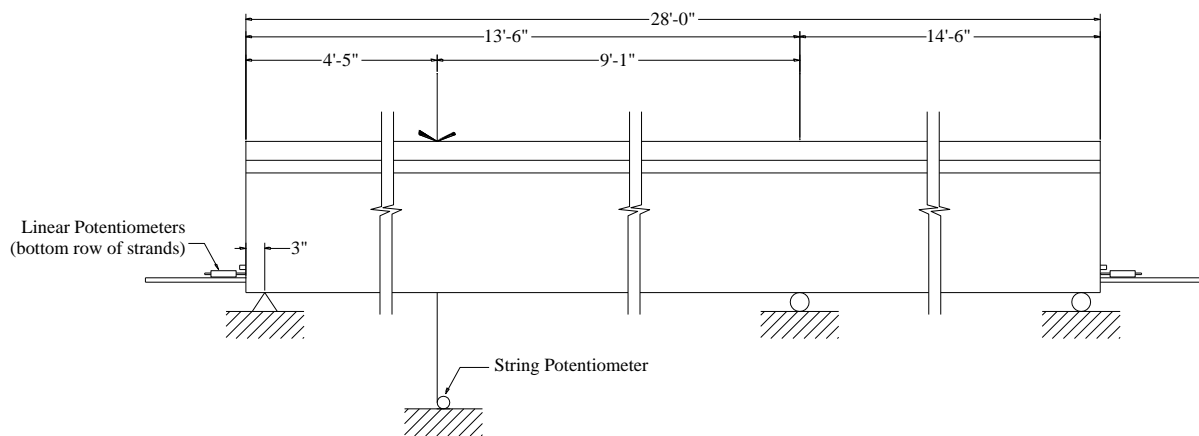

Figure 42 Vertical Shear Test Setup (CAD)



Figure 43 Vertical Shear Test Setup

While testing, each girder was visually inspected and cracks were periodically marked to identify the failure mode. Also, bottom strand slippage was monitored using three potentiometers on the tested end as shown in Figure 44.



Figure 44 Shear Test Strand Instrumentation

Table 8 T24 Girder Shear Capacity

Nominal Shear Capacity [ $V_n$ ]			
Girder No.	Calculated	Tested	Tested/Calculated
	(lb)	(lb)	(%)
T-6-1.5h-D	82,000	109,000	132.9
T-4-1.0h-D	82,000	102,000	124.4
T-12-0.5l-D	82,000	102,000	124.4
T-12-0.5l-D	82,000	62,000	-

The calculated column presents the section values with the actual material properties inserted in the design calculations. The tested column of Table 8 is obtained data from the actual test performed on the two T24 girders.

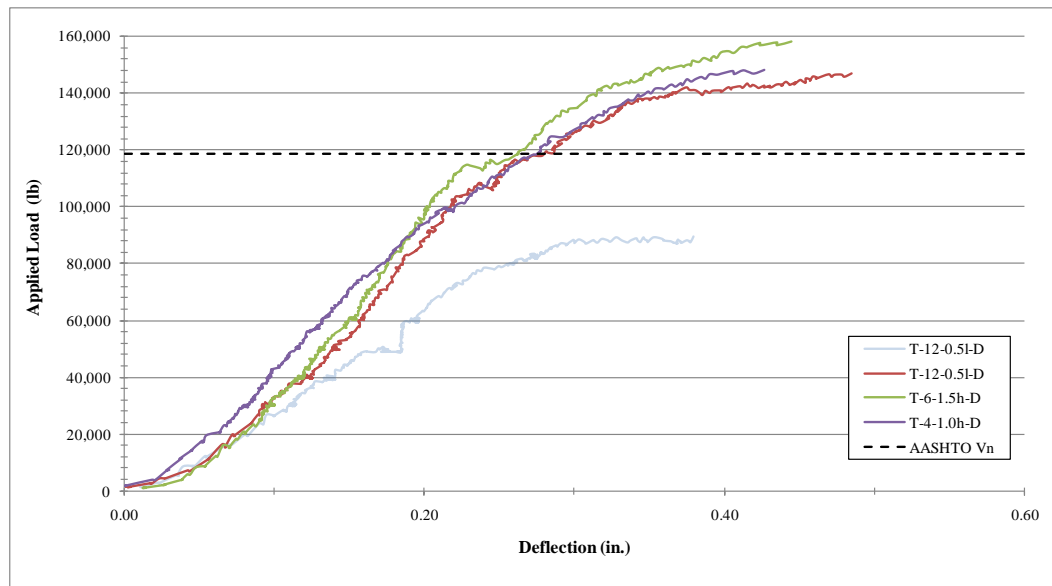

Figure 45 T24 Load v. Deflection Comparison

Figure 45 graphically presents the applied load versus girder deflection for the tests performed. The line indicating AASHTO  $V_n$  represents the required applied load, at the designated test distance which corresponds to the nominal shear resistance of the section incorporating the specified materials properties and with a resistance factor,  $\phi$ , of 1.0.

Upon completion of shear testing the T24 girders one result was drastically different from the other three. One end of the T-12-0.51-D reached an actual shear capacity of 109,000 pounds, similar to the T-4/6-1/1.5h-D results, while the opposite end only obtained an ultimate capacity of 62,000 pounds. Further investigation of previously recorded data revealed the cause of the premature failure at one end of the girder.

Figure 46 presents the strand slip data from the development test for the T-12-0.51-D girder. The girders south end strands saw a permanent movement at or around 0.002” however; the north end of girder T-12-0.51-D had an outer strand with permanent slip above 0.006”. This strand movement confirms that the bond of that outer strand was compromised in the previous test which could have led to a greatly reduced capacity of the tee section on that end. For this reason, the data obtained from the low shear test is only provided for information. The results from that test will not be included in the researchers’ evaluation on the shear performance of the T24 girders.

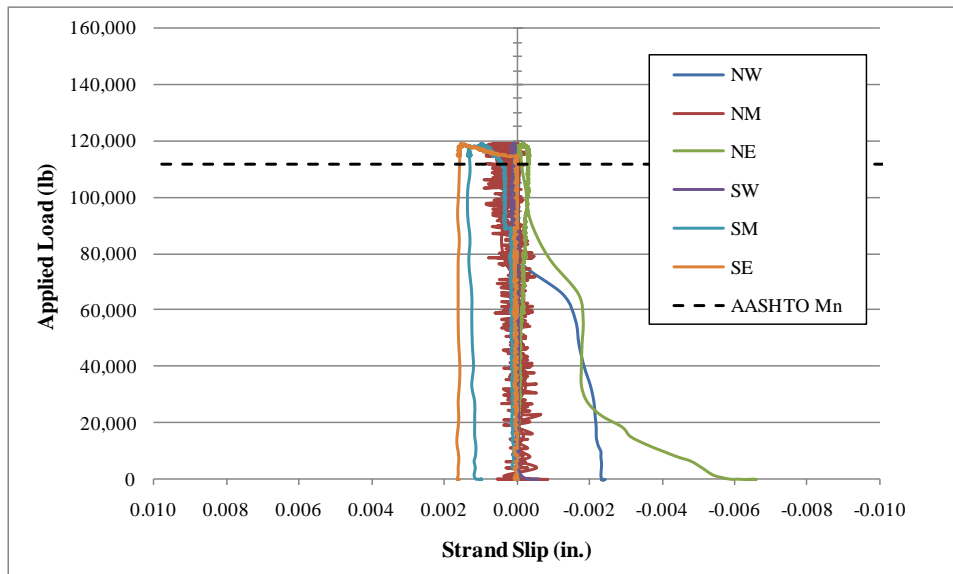

Figure 46 T-12-0.51-D Development Length Test Slippage

Figure 47 graphically presents the applied load versus the average strand slippage during testing. The average slippage was calculated incorporating movement from all three monitored bottom strands.

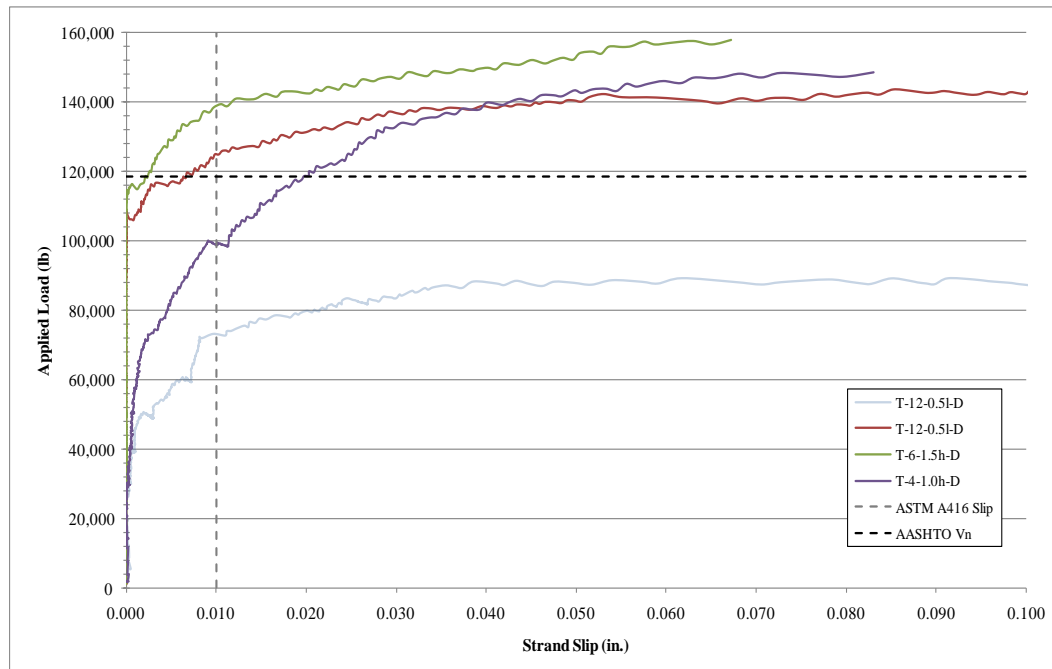

Figure 47 T24 Load v. Avg. Strand Slip Comparison

In the maximum strand slip case, the end with the confinement spaced at four inches for a distance equal to the height of the girder saw bond failure before the section reached its nominal capacity. This was not the case for either of the other two comparable cases. For the T-4-1.0h-D all of the confinement was located within the first 1.0h, twenty-four inches. The transfer length previously found on similar specimen was between twenty and twenty-five inches, and the shear cracking is clearly within the transfer region of the tested T24 girders. For this test setup, the distribution of confinement presented an effect on the bond capacity of the strands. However, even though the strands did slip on the T-4-1.0h-D section beyond the ASTM A416 limit of 0.01", the ultimate shear capacity of the section was not compromised.

Overall the T24 girders shear tests provide negligible results with regard to the effects from the amount of confinement reinforcement on the capacity of the section. In both the AASHTO specified amount, T-4/6-1/1.5h-D, and for above the minimum amount, T-12-0.5l-D, the overall capacity was shown to be around 24% above the calculated values. Something



of note again with the shear test; the girder with the confinement dispersed throughout its entire length saw slightly more deflection during loading. This result was previously seen during the development length testing of the T24 girders. The data seems to show that one benefit to providing confinement throughout a girders' entire length is in an increase in ductility of that member.

*NU1100 Girders – University of Nebraska (2010)*

A shear test was performed on one end of each of the three NU1100 girders. The girders were loaded at a distance of 1.77h from the end support, eight feet from the end of the girder. The overall span for the test was thirty-nine feet with each end bearing located in six inches from the end of the girder. Figure 48 and Figure 49 present the setup utilized for testing the NU1100 girders in shear.

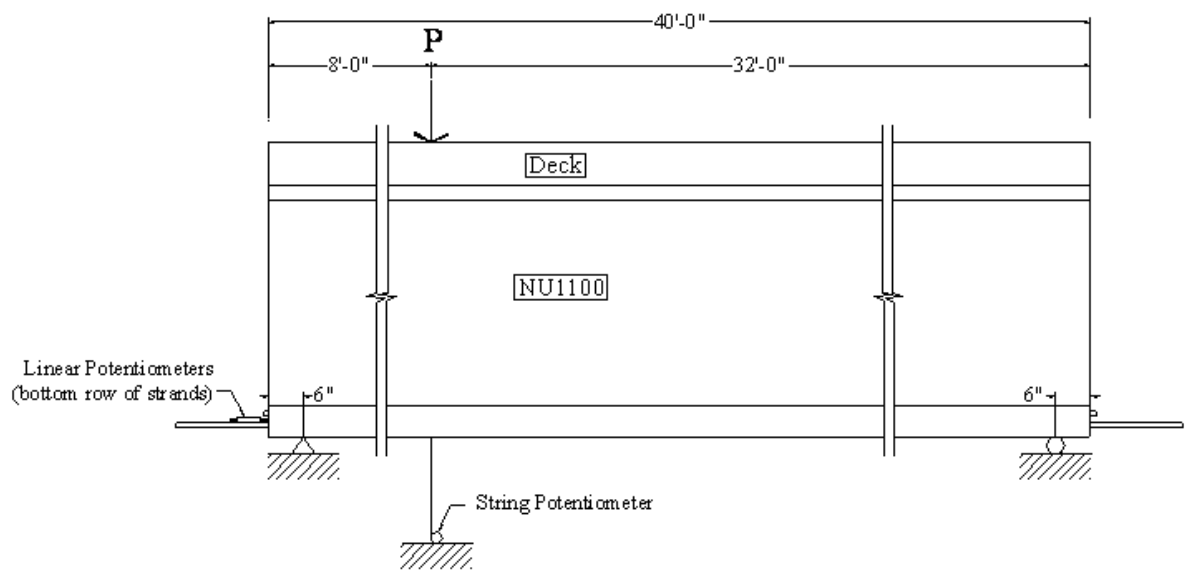

Figure 48 NU1100 Vertical Shear Test Setup (CAD)



Figure 49 NU1100 Vertical Shear Test Setup

While testing, each girder was visually inspected and cracks were periodically marked to identify the failure mode. Bottom strand slippage was monitored using ten potentiometers as shown in Figure 50, while the two top strands were monitored via a mechanical gauge and a string potentiometer.

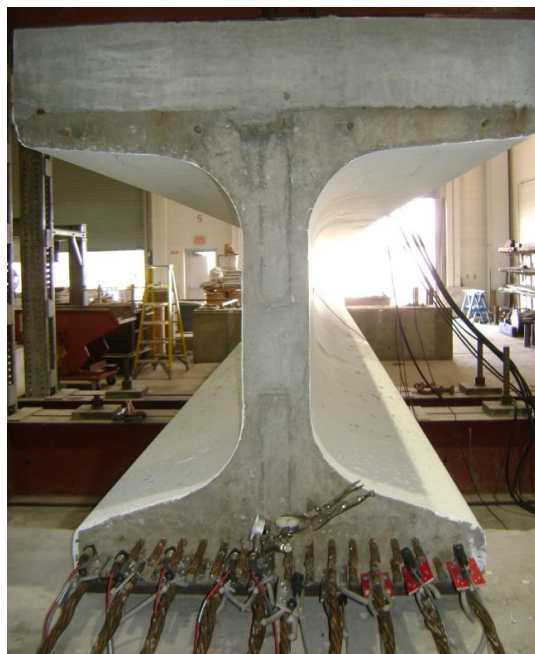

Figure 50 Shear Test Strand Instrumentation

Table 9 provides the test data from the three shear tests on the NU1100 girders. The calculated column presents the section values with the actual material properties inserted in the design calculations. The tested column in Table 9 is data from the actual test performed.

Table 9 NU1100 Girder Shear Capacity

Nominal Shear Capacity [ $V_n$ ]			
Girder No.	Calculated	Tested	Tested/Calculated
	(lb)	(lb)	(%)
1	659,000	795,000	120.6
2	659,000	796,000	120.8
3	659,000	766,000	116.2

Figure 51 presents the behavior of the three girders while testing. The line indicating AASHTO  $V_n$  represents the required applied load, at the designated test distance which corresponds to the nominal shear resistance of the section incorporating the specified materials properties and with a resistance factor,  $\phi$ , of 1.0.

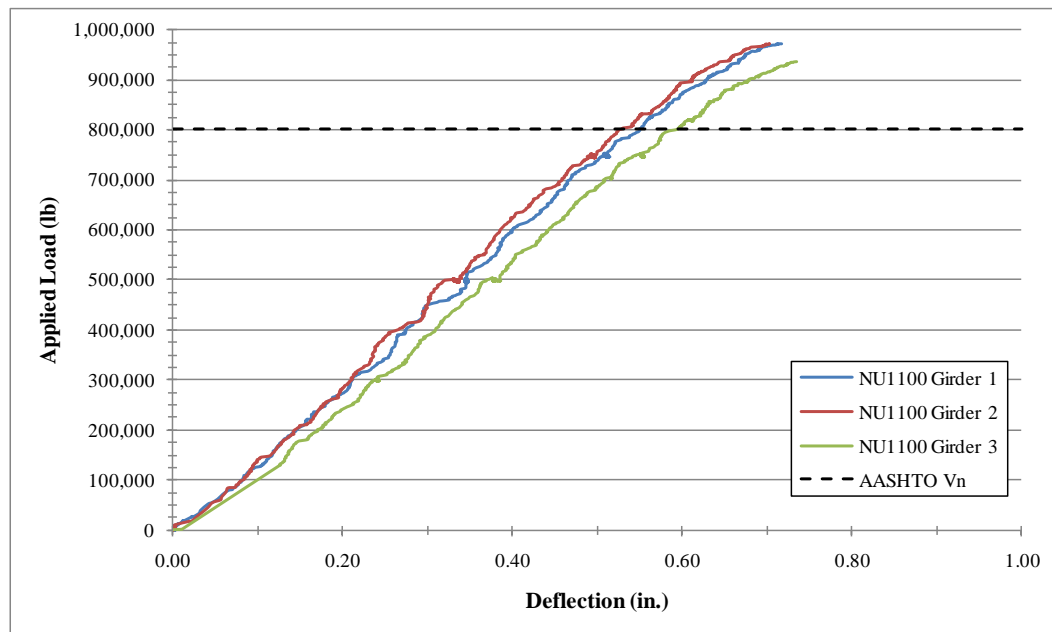

Figure 51 NU1100 Load v. Deflection Comparison

Figure 52 provides the applied load versus the maximum strand slippage for each shear test. The maximum strand slippage plot is of the one strand with greatest relative movement throughout the shear testing. For all three NU girders, Strand 4 experienced the most relative movement during testing but only Girder 1 had one strand which reached the ASTM defined level of slippage prior to meeting the nominal shear resistance of the section. Monitoring the two top strands during the shear tests was done with both a mechanical gauge and a rotary potentiometer. In none of the three tests, for either of the top strands, was any slippage detected by either means of observation and documentation.

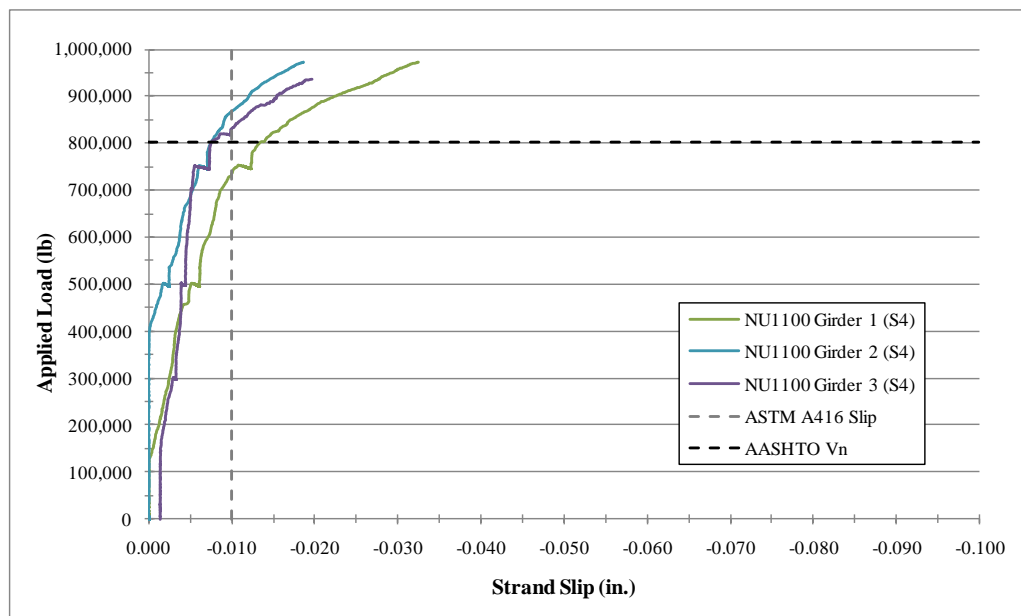

Figure 52 NU1100 Load v. Max. Strand Slip Comparison

The slippage results from shear testing indicated that Girder 1, with a reduced amount of confinement at the end of the girder had more slipping strands than the other two girders with the AASHTO specified confinement reinforcement. An association may be made that the intensity of confinement at girder ends improves strand-concrete bond with respect to a shear loading condition. The overall load-deflection results show no evidence that favors one confinement condition over another. Table 9 provides results which indicate that actual shear capacity of the three NU1100 girders are 16 % - 20% higher than nominal capacities.

## 5 SUMMARY, CONCLUSIONS, AND RECOMMENDATIONS

### 5.1 SUMMARY

The main objective of this study was to determine what impact, if any, confinement reinforcement has on the performance of prestressed concrete bridge girders. Of particular interest was the effect confinement had on the transfer length, development length, and vertical shear capacity of the fore mentioned members. This was accomplished through extensive analytical and experimental investigations performed on first a twenty-four inch tee girder section and later a NU1100 girder section.

The T24 girders designed, fabricated, and tested by the researchers were subjected to transfer length tests, flexural tests for development length, and shear testing. The NU1100 girders were designed and tested by the researchers, but fabrication was provided by a local precaster. The specimens were later shipped to the PKI structures lab for testing in flexure (one end), and finally shear (opposite end).

Transfer length data was obtained by means of the concrete surface strain and calculated using the 95% AMS Method. DEMEC readings were taken just prior to release of the prestressing force to the girder and immediately after to establish the initial transfer. After a period of fourteen days the readings were again taken and compared to the pre-release data to constitute the final transfer data.

Development length testing for both sets of specimen was performed by placing an applied load to the top of the section at a distance equal to the 2004 AASHTO specified development length, which for both sections was approximately fourteen feet. The ultimate capacity of the sections were then calculated and used to gauge the performance of each specimen. An actual ultimate capacity greater than that calculated by AASHTO specifications provided evidence that the section was fully developed and met AASHTO design criteria.

Shear tests were also performed on a number of specimens. A load was applied to the top of the section at a specified distance of approximately two times the height of the section. The nominal resistance was then calculated and used to gauge the performance of each specimen. The ultimate capacity data recorded from each test, for each section, was then compared to one another.

## 5.2 CONCLUSIONS

The following sections present conclusions made, from the study, with respect to the impact of confinement reinforcement on performance of prestressed concrete bridge girders.

### **Transfer Length**

- 1) The amount of confinement reinforcement had an insignificant effect on the initial or final prestress strand transfer length.
- 2) The distribution of confinement reinforcement had an insignificant effect on the initial or final prestress strand transfer length.

The aforementioned conclusions occur because confinement reinforcement remains inactive until concrete cracks, which does not usually occur at time of prestress transfer. This result is in agreement with conclusions made by others studying 0.5” and 0.6” diameter strands.

### **Development Length**

At the 2004 AASHTO LRFD calculated development length; the following conclusions can be made.

- 1) The amount of confinement reinforcement:
  - a) Had insignificant effect on the flexural capacity of the tested girders.
  - b) Produced insignificant evidence that it effects bond capacity or prevents premature slippage of the prestressed strands.
  - c) Provided a slight increase in the girders’ overall ductility when placed along the entire length.
- 2) The distribution of confinement reinforcement:
  - a) Had insignificant effect on the flexural capacity of the tested girders.

- b) Produced insignificant evidence that it effects bond capacity or prevents premature slippage of the prestressed strands.
- c) Reduced cracking and spalling of concrete around the strands at ultimate loading.

Overall, the impact of varied confinement reinforcement on the ultimate flexural capacity of bridge girders at their development length was negligible. This determination is viewed as a product of a conservative AASHTO LRFD development length equation by incorporating a k factor of 1.6. In all tested cases, regardless of confinement variability, the sections' nominal moment capacity was reached or exceeded. The tests performed show that current AASHTO LRFD specifications pertaining to nominal moment values of bridge girder sections, as well as, strand development length are adequate.

### **Vertical Shear**

From testing, the following results can be made for girders which include some amount of bottom flange confinement reinforcement.

- 1) The amount of confinement reinforcement:
  - a) Had an insignificant effect on the shear resistance of the tested girders.
  - b) Provided a slight increase in the girders' overall ductility when placed along the entire length.
- 2) The distribution of confinement reinforcement:
  - a) Had an insignificant effect on the shear resistance of the tested girders.
  - b) Produced conclusive evidence that it improves bond capacity or prevents premature slippage of the prestressed strands.

Overall, the impact of varied confinement reinforcement on the shear resistance of bridge girders was negligible. In all tested cases, regardless of confinement variability, the ultimate shear capacity was found to be 17% - 25% greater than the AASHTO LRFD calculated nominal resistance for each section.

## 5.2 RECOMMENDATIONS

Based on the research findings, the authors made three recommendations with regard to NU I-girders.

- First, no modifications are deemed necessary to any NU I-girders designed and fabricated with D4@4" confinement reinforcement. This recommendation is based on the experimental research which indicates insignificant effects on the prestress transfer, AASHTO specified development of prestress strands, and shear capacities of girders.
- Second, it is recommended that the level of bottom flange confinement reinforcement increased to at least the level specified by AASHTO LRFD Section 5.10.10.2. Although the results from testing specimen with older confinement details show no significant effects on the ultimate flexure or shear section capacities, the current AASHTO detail did provide higher bond capacity for the strands at extreme loading conditions. It should also be noted that bond between strands and concrete is significantly enhanced when some of bottom strands are extended and bent into a concrete diaphragm. The diaphragm would help increase the bond capacity of those strands even with limited confinement reinforcement is used.
- Third, additional confinement reinforcement should be placed throughout the entire length of bridge girders. Both the analytical and experimental research revealed that those girders with reinforcement placed over their entire length possessed higher ductility and reduced cracking and spalling under extreme loading. In addition to the improved structural performance of the girders, another benefit of extending some confinement throughout the entire girder is to reduce impact damage, most likely to occur at midspan. The confinement protects the concrete surrounding the prestressing steel and in the event of impact from an over-height vehicle, the confined concrete is less likely to isolate from the strands, thereby exposing them to rupture.

Based on these recommendations, the proposed confinement detail shown in Figures 53 and 54 includes D7@4" Grade 75, WWM with #3 cap bars placed at 4" on center for the entire length of NU I-girders.



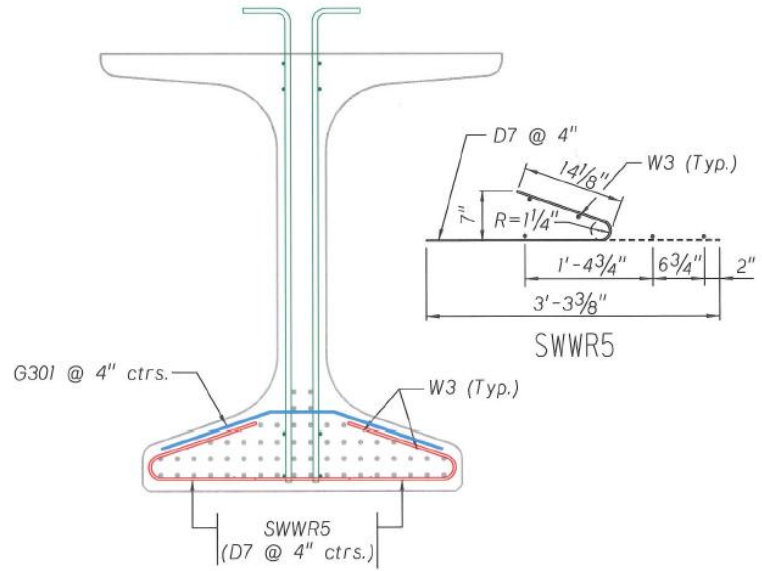

Figure 53 Recommended Confinement Detail

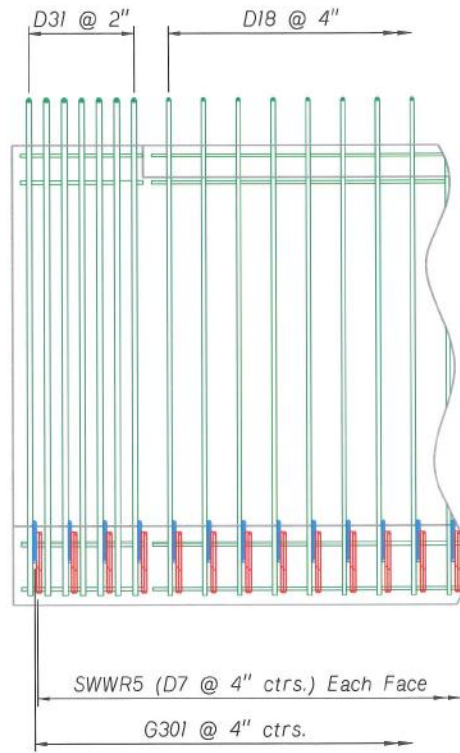

Figure 54 Recommended Confinement Placement

## **IMPLEMENTATION**

The outcome of this project is ready for immediate implementation with no need for additional investigation. The project addressed the impact of bottom flange confinement reinforcement on transfer length and development length of prestressing strands in NU-I girders as well as its impact on the girder shear capacity. Test results had shown that the amount and distribution of the confinement reinforcement adopted by NDOR in existing NU I-girder are satisfactory and do not result in any significant reduction of the girder flexural and/or shear capacities. However, it was recommended to use AASHTO LRFD specified bottom flange confinement for the entire length of the girder as it improves the girder ductility and resistance to impact loads from over-height vehicles. Based on these findings and recommendations, NDOR bridge office has already changed their standard sheet to reflect the recommended bottom flange confinement detail. It should be also noted that large 0.7 in. diameter strands spaced 2 in. in the horizontal and vertical directions were used in all experimental investigations to allow the implementation of test results to future girders with 0.7 in. diameter strands, which is conservative for 0.5 in. and 0.6 in. diameter strands.

## REFERENCES

- Akhnoukh, A. (2008) "Development of High Performance Precast/Prestressed Bridge Girders", Ph.D. Dissertation, University of Nebraska-Lincoln, NE.
- American Association of State Highway and Transportation Officials (AASHTO) (1996) "Standard Specifications for Highway Bridges", 16th Edition, Washington, DC.
- American Association of State Highway and Transportation Officials (AASHTO) (2004) "AASHTO LRFD Bridge Design Specifications", 3<sup>th</sup> Edition.
- Csagoly, P. (1991) "A Shear Moment Model for Prestressed Concrete Beams", FDOT.
- Federal Highway Administration. "An Analysis of Transfer and Development Lengths for Pretensioned Concrete Structures." 1994.
- Maguire, Marc. "Impact of 0.7 Inch Diameter Prestressing Strands in Bridge Girders." Lincoln, NE, 2009.
- Nebraska Department of Roads (NDOR) (2008), "Bridge Operations, Policies & Procedures (BOPP), Lincoln, NE.
- Patzlaff, Q., Morcous, G., Hanna, K., Tadros, M. K. (2009) "Transfer and Development of 0.7 inch Strand in Precast/Prestressed Bridge Girders", PCI National Bridge Conference, Sept. San Antonio, TX.
- Ross, B. (2010) "Experimental Evaluation of Confinement Reinforcement in Pretensioned Concrete Girders", ACI Convention, March, Chicago.
- Russell, B. W., and Burns, N. H. (1996) "Measured Transfer Lengths of 0.5 and 0.6 in. Strands in Pretensioned Concrete", PCI Journal, Sept.-Oct.
- Saatcioglu, Murat, and Razvi, Salim. "Strength and Ductility of Confined Concrete." Journal of Structural Engineering, June 1992: 1590-1607.
- Shahawy, M. (2001) "A Critical Evaluation of the AASHTO Provisions for Strand Development Length of Prestressed Concrete Members", PCI Journal, July-August.
- Shahawy, M., Robinson, B., deV. Batchelor, B. (1993) "An Investigation of Shear Strength of Prestressed Concrete AASHTO Type II Girders", FDOT.