

Development of a Bridge Construction Live Load Analysis Guide

Mike Garlich, P.E., S.E.
Steve Miller, P.E.

Collins Engineers, Incorporated
Milwaukee, Wisconsin

WisDOT ID no. 0092-10-13
December 2011



RESEARCH & LIBRARY UNIT



WISCONSIN HIGHWAY RESEARCH PROGRAM

WISCONSIN DOT
PUTTING RESEARCH TO WORK

Disclaimer

This research was funded through the Wisconsin Highway Research Program by the Wisconsin Department of Transportation and the Federal Highway Administration under Project 0092-10-13. The contents of this report reflect the views of the authors who are responsible for the facts and accuracy of the data presented herein. The contents do not necessarily reflect the official views of the Wisconsin Department of Transportation or the Federal Highway Administration at the time of publication.

This document is disseminated under the sponsorship of the Department of Transportation in the interest of information exchange. The United States Government assumes no liability for its contents or use thereof. This report does not constitute a standard, specification or regulation.

The United States Government does not endorse products or manufacturers. Trade and manufacturers' names appear in this report only because they are considered essential to the object of the document.

Technical Report Documentation Page

1. Report No. WisDOT 0092-10-13	2. Government Accession No	3. Recipient's Catalog No	
4. Title and Subtitle Development of a Bridge Construction Live Load Analysis Guide		5. Report Date December 2011	
		6. Performing Organization Code	
7. Authors Mike Garlich, P.E., S.E. and Steve Miller, P.E.		8. Performing Organization Report No.	
9. Performing Organization Name and Address Collins Engineers, Incorporated 2033 W Howard Avenue Milwaukee, WI 53221		10. Work Unit No. (TRAIS)	
		11. Contract or Grant No. WisDOT 0092-10-13	
12. Sponsoring Agency Name and Address Wisconsin Department of Transportation Research & Library Unit PO Box 7915 Madison, WI 53707		13. Type of Report and Period Covered Final report, 2009-2011	
		14. Sponsoring Agency Code	
15. Supplementary Notes			
<p>16. Abstract</p> <p>This project was sponsored through the Wisconsin Highway Research Program and its Structure Technical Oversight Committee. The objective of this research was to develop a guide for the analysis of construction loads with and without traffic live loads on permanent bridge structures, including construction of new bridges and rehabilitation of existing bridges. The research also developed specification language indicating the responsibilities of all parties involved to address loads and ensure that structures are not overstressed.</p>			
17. Key Words Wisconsin, transportation, research, WHRP, bridge, construction loads, live loads, load model study		18. Distribution Statement No restriction. This document is available to the public through the National Technical Information Service 5285 Port Royal Road Springfield VA 22161	
18. Security Classif.(of this report) Unclassified	19. Security Classif. (of this page) Unclassified	20. No. of Pages	21. Price



Wisconsin Highway Research Program (WHRP) Bridge Construction Live Load Analysis Guide



Executive Summary

This research project has been prepared under the Wisconsin Highway Research Program. The objective of this research is to develop a guide for the analysis of construction loads with and without traffic live loads on permanent bridge structures, including construction of new bridges and rehabilitation of existing bridges. The following general tasks were performed under this research:

1) Literature Review

The literature review included surveys of Present Practices being used by state agencies and contractors, as well as a search of other studies or information currently available. The review generally included an attempt to discover:

- How heavy or potentially damaging construction loads are treated by agencies during bridge construction. As an example, does the agency delegate the responsibility of the analysis of heavy construction loads to the contractor, or does the agency perform these analyses within the agency.
- If/when the contractor is responsible for performing the analyses what tools or guidance is the agency providing to the contractor.
- The differences in the treatment of construction live loads vs. typical AASHTO design vehicles, including the distribution of loads from construction vehicles (i.e. what distribution factor should be used?).
- Current practices and treatments with respect to the stockpiling of materials on bridges under construction.

2) Load Model Studies

Significant research has been performed by AASHTO and others to determine load distribution for standard AASHTO design vehicles, however little data is available as to how heavy construction loads, such as cranes and heavy haul dump trucks, distribute their loads across a bridge. This research used finite element analysis, utilizing CSiBridge version 15, to analyze the distribution of heavy loads across different types of bridges.

Three bridges were selected for analysis to determine typical distribution factors under various loading conditions. The bridges are local to the state of Wisconsin and represent three common types of bridge structures. The bridges included a one-span simply supported concrete slab type bridge, a two-span composite steel plate girder bridge, and a three-span composite pre-stressed girder bridge.

Three types of heavy construction loads were examined including local concentrated loads representative of crane outriggers, crawler tracks representative of tracked cranes and excavators, and heavy haul dump trucks characterized by large wheel loads and short axle spacing. The loads were placed as uniform pressures on finite element deck elements. On all three structures, loads for the three different types of equipment were moved to different locations both along the length of the spans



Wisconsin Highway Research Program (WHRP) Bridge Construction Live Load Analysis Guide



and transversely across the bridge to gain a better understanding of the behavior of the load distribution.

The analysis of the three structures with three different types of common construction load provides data which can be correlated into guidelines for load distribution factors.

Loads placed at midspan

For loads placed between girders on the steel or concrete beam bridges, the type and size of load has only a minor impact on the load distribution. A very concentrated outrigger load distributes about 32% to each of the adjacent girders, while crane tracks distribute approximately 28%, and the heavy haul truck is 27%. Based on this analysis, it was conservatively assumed that 40% of the total load of a piece of heavy equipment is transferred to each adjacent girder. If one of the adjacent girders is an exterior girder however, then 50% was assumed.

A load placed at or near midspan and directly over a girder, transferred 30% to 40% of the load to the girder below. 15% to 25% of the load then distributes to the two adjacent girders. These numbers were adjusted if an exterior girder was involved since the distribution was limited by the bridge width. Based on this analysis, it was conservatively assumed that for a construction load located near midspan and directly over a girder, that 50% of the load would be distributed to the girder below.

Loads placed near substructures

Less distribution between girders occurs as the load is placed in proximity to a pier or abutment support. Loads centered between girders and within a few feet of a support distribute 60% to 70% of the load to the girder below. These same loads distribute 35% to 45% to the adjacent girders. Based on this analysis, distribution factors were conservatively assumed to be 80% for a girder directly below the load and 50% distribution to adjacent girders for a load centered between girders. This same distribution could also be used for loads within a quarter-span length from the support.

The use of timber mats has little effect on the distribution amounts to each girder on a bridge. A timber mat can be utilized to reduce the total moment caused by a load by distributing the load over the length of the bridge. Therefore, the same percentage of moment would still be taken by each girder, however the moment would be slightly less because of the load distribution of the timber mat.

3) Construction Live Load Design Guide Handbook

The guide is intended to provide guidance for assessing the effects of construction loads in typical bridge structures under construction. Construction loads are often very heavy and applied to localized areas as compared to standard highway design loads. The guide provides descriptions of typical construction loads including equipment and material loads. The behavior and important loading criteria for such equipment as cranes, loaders and excavators, trucks, paving equipment and specialized equipment are discussed. Bridge analysis and bridge assessment factors are also discussed in the guide.



Wisconsin Highway Research Program (WHRP) Bridge Construction Live Load Analysis Guide



Project Overview

This research project has been prepared under the Wisconsin Highway Research Program. The objective of this research is to develop a guide for the analysis of construction loads with and without traffic live loads on permanent bridge structures, including construction of new bridges and rehabilitation of existing bridges. The following general tasks were performed under this research:

1) Literature Review

A review of literature was performed in an effort to collect available information for this research. The review in general included the following:

- Reference Material Searches
- Present Practices Surveys
 - Agency Survey
 - Contractor Survey

2) Load Model Studies

Significant research has been performed by AASHTO and others to determine load distribution for standard AASHTO design vehicles, however little data is available as to how heavy construction loads, such as cranes and heavy haul dump trucks, distribute their loads across a bridge. This research used finite element analysis, utilizing CSiBridge version 15, to analyze the distribution of heavy loads across different types of bridges. This research can be used to present general guidelines as to the expected load distributions from certain types of construction loads on different types of structures.

3) Construction Live Load Design Guide Handbook



**Wisconsin Highway Research Program (WHRP)
Bridge Construction Live Load Analysis Guide**



SECTION 1- LITERATURE REVIEW



Wisconsin Highway Research Program (WHRP) Bridge Construction Live Load Analysis Guide



1) Literature Review

The Literature Review included surveys of Present Practices being used by state agencies and contractors, as well as a search of other studies or information currently available. The review generally included an attempt to discover:

- How heavy or potentially damaging construction loads are treated by agencies during bridge construction. As an example, does the agency delegate the responsibility of the analysis of heavy construction loads to the contractor, or does the agency perform these analyses within the agency.
- If/when the contractor is responsible for performing the analyses what tools or guidance is the agency providing to the contractor.
- The differences in the treatment of construction live loads vs. typical AASHTO design vehicles, including the distribution of loads from construction vehicles (i.e. what distribution factor should be used?).
- Current practices and treatments with respect to the stockpiling of materials on bridges under construction.

A) Agency Survey

A survey was sent to all state DOT's and other agencies in February 2010. 24 of 50 states responded to the survey, as well the USFS-Region 4 and the Ontario Ministry of Transportation. The survey was comprised of seven questions related to bridge construction specifications and loadings. A copy of the survey sent to the agencies is provided in Appendix A to this report.

The purpose of the survey was to solicit information related to the standard practices, procedures and methods which agencies utilize to account for construction loads. This information was used to provide background information and general best practice information for the development of the Construction Live Load Design Guidebook.

The survey questions focused in the following general areas:

- Contractor responsibilities to the agency related to construction loading
- Agency requirements and/or guidance provided to contractors related to limiting load criteria, distribution of loads and other information
- Specification Requirements

A summary and consolidation of the answers and comments provided by the respondents is provided on the pages that follow.



Wisconsin Highway Research Program (WHRP) Bridge Construction Live Load Analysis Guide



Agency Survey Question 1 – Contractor Proof

WisDOT recently implemented specification changes to Section 108.7 Methods and Equipment of its specifications, which requires that contractors perform structural analysis on bridges to assure that loadings during construction do not exceed allowable limits. The purpose of Question 1 was to determine other agencies current practices with respect to whether contractors are held responsible during the construction process to assure the integrity of bridges.

Question 1a- *Does your state currently have specifications in place requiring contractors submit proof that a bridge structure is not overloaded during construction?*

Question 1B- *If you don't currently have specifications; are you currently in the process of developing them?*

Question 1C- Please attach any requirements/policy contained in your Bridge Manual and /or construction specifications.

Twelve (12) of the twenty-six (26) respondents indicated that their agency did have specifications in place requiring contractors provide proof that the structure was not overloaded during construction. Proofs required by the agencies generally fell into the following categories:

- Submittal of load rating calculations / drawings / diagrams for loads in excess of Legal Loads (e.g. MDOT, SCDOT).
- Submittal of proof that contractor does not exceed certain load or stress limitations (e.g. Caltrans, Hawaii DOT, NJDOT)
- Submittal of approved methods of load distribution or bridging (e.g. MnDOT)
- Submittal of Falsework Calculations and Drawings (e.g. Hawaii DOT , KDOT)
- Preparation of a Structural Assessment Report (IDOT)

Fourteen (14) of the twenty-six (26) respondents indicated that their agency did not have specifications in place requiring contractors provide proof that the structure was not overloaded during construction.

Three agencies indicated they were currently in the process of developing specifications to require contractors submit proof that a bridge structure was not overloaded during construction?

- InDOT indicated they have a research proposal being considered that will provide direction for future specifications/guidelines and what Construction Load analysis will be required of the Design Consultant and/or Contractor.
- MoDOT provided recent specification and Engineering Policy Guide clarifications promulgated by the I-35 collapse, with regard to construction stockpiling on their bridges during construction.
- WyDOT specification revisions are pending and related to the storage of materials or equipment not directly involved with bridge work will not be allowed on the bridge. “Do not stockpile, place, or store debris, rubble, or aggregate on bridges”.



Wisconsin Highway Research Program (WHRP) Bridge Construction Live Load Analysis Guide



Eighteen (18) of the twenty-six (26) agencies provided information on the requirements / policies contained in their Bridge Manual and / or specifications. A summary of the agency requirements / policies is provided in Table 1-1 below.

TABLE 1-1	
State or Agency	Remarks
Alaska DOT	Alaska DOT only has generic language that the contractor is “responsible for implementing all preventative measures necessary to protect, prevent damage, and repair damage to the work from all causes at no additional cost to the Department”.
Caltrans	Caltrans Standard Specifications 5-1.08 ‘Inspection’ establishes the right of the engineer to require proof of all the contract requirements. Caltrans Standard Specifications -7.02 ‘Load Limitations’ establishes construction load criteria. Caltrans requires contractors furnish to the engineer the dimensions and maximum axle loadings of equipment proposed for use on bridge structures. The specifications provide the maximum limits of axle loadings for various vehicles based on the center to center spacing of girders. Caltrans also allows the contractor to propose strengthening of a bridge (at its own expense) under certain conditions.
Delaware DOT	None Provided
Hawaii DOT	Hawaii DOT design requires the contractor submit calculations for false-work and centering, as a complete package, stamped and signed by a Hawaii Licensed Structural Engineer. Additionally, live loads are not allowed on completed portions of structure when such live loads will produce more than allowable stresses permitted by AASHTO LRFD Bridge Design Specifications”.
Illinois DOT	IDOT Specifications require contractor to submit Structural Assessment Report(s) (SARs) to the engineer for approval. The SARs must demonstrate that the structural demands of the applied loads due to the contractor’s means and methods will not exceed the available capacity of the structure at the time the loads are applied.
Indiana DOT	InDOT has a research proposal being considered that will provide direction for future specifications/guidelines and what Construction Load analysis will be required of the Design Consultant and/or Contractor.
Kansas DOT	The contractor is responsible for designing and constructing safe and adequate false-work. KDOT specifications require that false-work plans and details be prepared and sealed by a registered Professional Engineer. KDOT or consultants review false-work for any inadequacies or revisions required, and grants approval of false-work. Load Limits for false-work design are provided in Chapter 5.0 of the Bridge Design Manual.
Kentucky DOT	None Provided
Michigan DOT	Except for the requirement that the contractor submit proof for non-legal loads, Michigan does not require proof that structure is not overloaded during construction. MDOT may however, request this information on a case by case basis (such as for false-work).



**Wisconsin Highway Research Program (WHRP)
Bridge Construction Live Load Analysis Guide**



TABLE 1-1	
State or Agency	Remarks
Minnesota DOT	<p>The Contractor must comply with legal load restrictions, and with any special restrictions imposed by the Contract, in hauling or storing materials, moving or storing equipment on structures, completed subgrades, base courses, and pavements within the Project that are under construction, or have been completed but have not been accepted and opened for use by traffic.</p> <p>Should construction operations necessitate the crossing of an existing pavement, bridges or completed portions of the pavement structure with equipment or loads that would otherwise be prohibited, approved methods of load distribution or bridging shall be provided by the Contractor at no expense to the Department.</p>
Mississippi DOT	None Provided
Missouri DOT	<p>None provided, however review of MoDOT Specifications revealed the following criteria: If the contractor requests to move overweight/over dimension equipment across an existing MoDOT structure (i.e. a bridge) open to traffic. The contractor must inform the resident engineer who then forwards the request to the Bridge Division for review and analysis. The request must include:</p> <ul style="list-style-type: none"> • Longitudinal and transverse dimension of the item to be moved • Axle weights and • The length and width of the vehicle's tracks (if it has tracks). <p>The Bridge Division will review this material to determine if there are any structural issues associated with moving the vehicle across the structure.</p>
New Hampshire DOT	None Provided
New Jersey DOT	No specific proof required except for newly constructed decks where contractor desires after a minimum of 28 days to load deck with more than 80,000 pound load. To obtain approval contractor must submit stress analysis calculations for the load and the location of the load on the deck. The Department will not approve stresses that exceed the design allowable by more than 20 percent.
New Mexico DOT	NMDOT puts a General Note in their plans stating the contractor shall not place any heavy construction loads or heavy equipment on the bridge without prior approval from the NMDOT. An analysis needs to be done by a Professional Engineer hired by the Contractor proving the bridge can handle these loads.
Ohio DOT	Per ODOT Specification Section 5.01- Contractor must prepare and provide working drawings for excavation bracing, structure demolition, false-work, the erection of steel or precast concrete structural members, the jacking and support of existing structures, the placing or moving of equipment having a gross weight in excess of 60,000 pounds on or across a structure, and for structures maintaining traffic. Working drawings must be prepared, signed and sealed by two separate/different Ohio Registered Engineers.
Oklahoma DOT	None Provided
South Carolina DOT	SCDOT Specification Section 105.12 requires contractor seek the Department's authorization for loads which exceed the legal load limit. Loads are not allowed on concrete pavement, base course or structure prior to the expiration of the curing period.
South Dakota DOT	None Provided



Wisconsin Highway Research Program (WHRP) Bridge Construction Live Load Analysis Guide



TABLE 1-1	
State or Agency	Remarks
Tennessee DOT	TDOT Specification Section 107.02 requires the contractor be responsible for submitting to the Engineer all analysis and supplementary support details required to effect construction load distribution. Additionally TDOT requires that “When the area occupied by construction loads in any span exceeds 25% of the area of that span the Contractor shall be required to submit a diagram detailing the location, character, sequence and weight of construction loads...” to the Department for approval.
Texas DOT	Construction traffic on roadways, bridges and culverts within the limits of the work, including any structures under construction are subject to legal size and weight limitations. For construction loads which exceed legal load limits the contractor must submit for approval a structural analysis by a licensed professional engineer indicating that the excessive loads should be allowed. Manufacturer’s certificate of weight including the distribution of that weight for equipment used is additional information required to be submitted.
Virginia DOT	None Provided
Washington DOT	Bridges under construction shall remain closed to all traffic, including construction equipment, until the Substructure and the Superstructure, through the roadway deck, are complete for the entire Structure, except as provided elsewhere. Completion includes release of all false-work, removal of all forms, and attainment of the minimum design concrete strength and specified age of the concrete in accordance with Specifications. Once the Structure is complete, Section 1-07.7 governs all traffic loading, including construction traffic (equipment). If necessary and safe to do so, and if the Contractor requests it in writing, the Engineer may approve traffic on a bridge prior to completion. The maximum distributed load at each construction equipment support shall not exceed the design load by more than 33-percent.
Wyoming DOT	<p>Section 105.13 Load Restrictions- requires contractor comply with legal load restrictions when moving equipment or hauling materials on public roads that remain in service. A permit from the department to operate an overweight, oversized, or over-width vehicle does not relieve the contractor of liability for damage to public roads due to the moving of equipment or materials.</p> <p>Without damaging structures, roadways, or other work, the contractor may operate empty, overweight, or oversize equipment on roadways within the construction limits as required to perform the work. Such operation does not require an overweight, oversized, or over-width permit but is subject to approval by the engineer.</p>
USFS- Region 4	The bridges on USFS roads are not typically big enough for this to be a consideration. USFS normally install 1 or 2 lane bridges that are closed to all traffic until the bridge is re-opened. They do require overload permits when other construction activities require heavy equipment to cross existing bridges. They calculate inventory and operating ratings and permit non-divisible loads up to the operating rating level.
Ontario Ministry of Transportation	<p>Relevant construction specifications include:</p> <ul style="list-style-type: none"> • SP100S60 (e.g. refers to construction equipment and unlicensed vehicles), • OPSS 510 (e.g. limits milling equipment weight) • SP109S49 (e.g. limits scarifiers and other equipment used in rehabilitation) • OPSS 919 (e.g. gives some construction loading requirements for falsework/formwork) <p>Other specifications may also have some specific limitations</p>



Wisconsin Highway Research Program (WHRP) Bridge Construction Live Load Analysis Guide



Agency Survey Question 2- Construction Load Guidance

The purpose of Question 2 was to solicit what practices other agencies use for the analysis of construction loads. It was anticipated that the answers would provide a list of best practices which would be documented in the Construction Live Load Manual.

Question 2a- *Do you issue any specific guidance to contractors for the analysis of construction loads?*

Question 2b- *Please attach any guidance you provide.*

7 of the 26 responding agencies indicated that they provide specific guidance to contractors for the analysis of construction loads. Table 2 provides a summary of the specific guidance provided by agencies related to the analysis of construction loads. Some states (e.g. Alaska, Minnesota) perform the analysis of constructions loads in-house, other states just refer contractors to meet AASHTO Specifications. Delaware DOT is currently working with the Delaware Contractor's Association to develop acceptable guidance.

The answers provided fell into the following general categories:

- IDOT Structure Assessment Report (SAR)- The following information is provided to the contractor to the extent possible by IDOT to assist the contractor with the preparation of the SAR.
 - Existing Structure Information Package- which includes the As-built plans and the latest NBIS Inspection Report
 - Specific notes on the Contract Plans regarding bridge condition.
 - Current load rating information (Inventory & Operating) including any Live Load Restrictions.
- InDOT Guidance with respect to allowable uniform loads is a live load allowance of 50 psf on the horizontal projections of surfaces. InDOT Structural Concrete Specification Section 702.13, paragraph 570.
- Limits on gross vehicle weights
- Guidance with respect to the analysis and loading of falsework.

A summary of the responses to question 2 is provided in Table 1-2.



**Wisconsin Highway Research Program (WHRP)
Bridge Construction Live Load Analysis Guide**



TABLE 1-2	
State or Agency	Remarks
Illinois DOT	Illinois DOT provides guidance through the requirement that the contractor prepare a Structural Assessment Report.
Indiana DOT	There are minimal guidelines in the form of uniform loads to be considered over the area of the structure.
Kansas DOT	Chapter 5.0 of the Kansas DOT Specifications provides guidance to contractors related to the loading and analysis of false-work.
Kentucky DOT	<p>Kentucky DOT Guidance Manual, Article 10.38.1.7 provides the following:</p> <p>“Add 10% of the concrete dead load to allow for weight of forms when computing steel dead load stress. Do not assume that the concrete slab supports the steel flange when computing the allowable steel compressive dead load stress. For most cases a concentrated load of 5000 pounds is sufficient to account for the effects of screed machines and live loads during the pouring operation. Note that pouring procedures can cause girder stresses due to wet concrete on portions of the structure to be significantly greater than girder stresses due to wet concrete on the entire structure.”</p>
New Hampshire DOT	<p>Section 105.13.B.2 of the specification states, “Gross loads in excess of the legal gross loads will not be allowed unless authorized in writing by the Engineer. Requests for such authorization shall be in writing and shall indicate the length of the vehicle, the type and amount of gross load with the location and the load distribution to each axle.</p> <p>Authorization will specify the maximum speed and location of loads relative to the centerline of the bridge. New concrete bridge decks shall be closed to traffic, including the Contractor's trucks and equipment, for a period of time as specified in 520.3.11.2.1 with the following exception:</p> <p>Lightweight vehicular loads weighing less than 6,000 lb (2720 kg) GVW will be allowed after the concrete test cylinders have attained 80 percent of the minimum compressive strength of the specified deck concrete. Heavier loads may be permitted upon written request and authorization in the same manner as for gross loads in excess of the legal gross loads.”</p> <p>The next section of the specification states, “The Contractor shall not operate equipment of such type, weight or so loaded as to cause any damage to structures, to the roadway, or to any other work.”</p>
Washington DOT	See answer in Table 1-1 above.

Maine DOT- did not respond to the agency survey, however the following guidelines from Maine DOT were found during our information search:

“The construction live load to be used for constructability checks is 50 psf applied over the entire deck area. Considerations should be given to slab placement sequence for calculation of maximum force effects”.



Wisconsin Highway Research Program (WHRP) Bridge Construction Live Load Analysis Guide



Agency Survey Question 3- Agency Specification Requirements

Bridge owners are placing an increased emphasis on the evaluation of the effects of construction loads upon bridge structures. Construction loads, whether from materials stockpiles or equipment loads, can be of substantial magnitude and can produce load effects that differ from those for which a bridge was designed. Structure evaluation can be performed in a simplified or sophisticated manner. The AASHTO Specifications are primarily a design oriented specification with limited direction or guidance with respect construction loads.

AASHTO Standard Specification (17th Edition) Requirements

Construction Loads are covered in Division II-Construction of the Standard Specifications, Section 8.15.3. This section of the specification provides guidance on the timing and/or extent of construction loading on bridges. Table 1-3C provides a summary of guidance provided.

Table 1-3C

Criteria	Vehicle or Material Limits
Within the first 24 hours after completion of the deck pour (providing curing is not interrupted and surface is not damaged)	Light materials and equipment (assumed less than 1000 lbs) are allowed.
Deck Compressive Strength greater than or equal to 2400 psi.	Construction Vehicles (and comparable materials) weighing between 1,000 and 4,000 lbs. are allowed.
Deck concrete greater than or equal to the specified design strength.	Loads in excess of 4000 lbs. are allowed.
Loading on post tensioned structures	Loads in excess of 4500 lbs. (and comparable materials and equipment) are <u>not</u> allowed until pre-stressing steel has been pre-tensioned for the span being considered.
For substructure concrete which has not attained at least 70% of its strength?	Steel or precast concrete girders cannot be placed.
Loads greater than the load carrying capacity of the structure using Load Factor Design, Load Group 1B.	Loads (except as provided above) on existing, new or partially completed portions of structures due to construction operations are <u>not</u> allowed.

AASHTO LRFD / LRFR Specification, 4th Edition Requirements

With the exception of segmental concrete bridges, the AASHTO LRFD / LRFR Specifications **do not provide construction load information and instead refer the designer to obtain information from contractors.** Section 3.4.2 of the specifications, however, provides the Load Factors to be considered for construction loads. These load factors are provided in Table 1-3B.



**Wisconsin Highway Research Program (WHRP)
Bridge Construction Live Load Analysis Guide**



Table 1-3B

Item Description	Load Factor
Weight of structure and appurtenances	1.25
Equipment and Dynamic Effects	1.50
Wind	1.25
All other load factors	1.00

The purpose of Question 3 was to determine if agencies had specifications in place which provide information to contractors above and beyond what AASHTO specifications currently provide.

Question 3- When analyzing bridges for construction loads what specifications do you require be used.

The majority of agencies surveyed require contractors to use either the AASHTO LRFD/LRFR or AASHTO Standard Specifications in the analysis of bridges for construction loads. 5 of the 26 agencies specify that the contractor must analyze the structure using the specifications of the original bridge design (e.g. either AASHTO LRFD or AASHTO Standard Specifications). Table 1-3A, below provides the breakdown of the respondents requirements.

Table 1-3A

AASHTO LRFD/LRFR	AASHTO STD. Specifications	Agency / Dept. Procedures	Other	Multiple Specifications
9	7	2	2	5

Two (2) of the twenty-six (26) agencies (CalTrans and Delaware DOT) have specific Agency Procedures other than AASHTO.

CALTRANS Specification Section 7-1.02 Load Limitations provides contractors with maximum loads for pneumatic-tired truck and trailer combinations and pneumatic-tired earthmoving equipment based on axle numbers, type (i.e. single, tandem etc.) and spacing.

Delaware DOT Specification Section 105.12 Load Restrictions provides customary loading values for dump trucks and tractor-trailer combinations.

The Ontario Ministry of Transportation Specifications also provides guidance with respect to the maximum weight of scarifying and milling equipment, the maximum allowable energy and dynamic load allowance factor to be used for rig-mounted breakers and concrete crushers, and construction loading for false-work criteria. Specifications sections are provided in the appendix to this report.



Wisconsin Highway Research Program (WHRP) Bridge Construction Live Load Analysis Guide



Agency Survey Question 4- Construction Vehicle Load Limits

Construction vehicles and equipment come in a wide array of configurations, weights and axle arrangements and therefore construction loads, can be of substantial magnitude and can produce load effects that differ greatly from those for which the bridge was designed. While the effects on a bridge of many, if not most, pieces of construction equipment will not exceed those of a standard AASHTO vehicle, either the gross weight or load distribution for some equipment can be well in excess of the effects of an AASHTO vehicle.

Federal Bridge Formula (FBF)

If a vehicle conforms to the FBF, then it most likely will not cause bridge structure stresses, strains or deflections to exceed those critical values calculated using the standard HS20-44 design vehicle. In effect the formula helps to ensure bridges are not “overstressed” due to the almost infinite number of truck-axle configurations and weights. The FBF reflects the fact that loads concentrated over a short distance are generally more damaging to bridges than loads spread over a longer distance. It provides for additional gross weight as the wheel base lengthens and the number of axles increases.

The FBF calculates the maximum allowable load (the total gross weight in pounds) that legally can be imposed on a bridge by any group of two or more consecutive axles on a vehicle or combination of vehicles. The FBF is given as follows:

- Federal Bridge Formula (FBF) $W = 500 [LN / (N - 1) + 12N + 36]$
 - W = maximum weight in pounds that can be carried on a group of two or more axles to the nearest 500 lbs.
 - L = the distance in feet between the outer axles of any two or more consecutive axles
 - N = the number of axles being considered.

Maximum Weight Allowed under FBF in Kips			
Wheelbase (ft)	3-Axles	4-Axles	5-Axles
20	51.0	55.5	60.5
24	54.0	58.0	63.5
28	57.0	60.5	65.5
32	60.0	63.5	68.0
36	63K > 20 K/Axle Limit	66.0	70.5
40	66K > 20 K/Axle Limit	68.5	73.0



Wisconsin Highway Research Program (WHRP) Bridge Construction Live Load Analysis Guide



Basic Federal Weight Limits

- 20,000 lbs for Single Axles (total weight allowed on one or more axles whose centers are 40 inches or less apart)
- 34,000 lbs for tandem axles (total weight allowed on two or more consecutive axles spaced greater than 40 inches, but not more than 96 inches apart)
- Maximum GVW of 80,000 lbs (Truck + Payload)
- Application of FBF for each axle group up to the maximum GVW.

State Legal Loads and Weight Limits

Legal loads vary widely from one agency to another. Truck loads are considered legal in a given state if the gross load, axle load, axle configuration, length and width are within the current weight and size laws or rules. Although the federal weight limits generally apply both on and off the Interstate system, only seven states apply the federal limits without modification or “grandfather right adjustment”. When the Interstate System axle and gross weight limits were adopted in the 1950’s states were allowed to keep (grandfather) those vehicles which were higher. State rating and posting loads include a wide variety of vehicle configurations intended to meet the commercial and transportation needs of a particular state. These trucks include:

- Trucks which meet Federal Formula B for gross and axle group weights
- Short multi-axle trucks that meet Formula B for gross and axle weights, but have configurations that differ significantly from AASHTO vehicles.
- Trucks that meet Formula B for gross vehicle weight but exceed axle group weight limits.
- Trucks that do not meet Formula B for gross or axle weight (grandfathered).

Wisconsin Legal Loads and Weight Limits

Section 108.7.2 and 108.7.3 of the Wisconsin Standard Specifications require contractors obtain written permission to exceed state Legal Loads. Chapter 45 of the Wisconsin Bridge Manual provides information on Wisconsin Legal Loads. Wisconsin Legal Loads include any of the AASHTO Legal Loads (Type 3, 3S2, and 3-3), AASHTO Specialized Hauling Vehicles (Type SU4, SU5, SU6 and SU7), and WisDOT’s Specialized Annual Permit Vehicle Vehicles)

Wisconsin Statutes

Wisconsin Statute 348 provides information for legal loads in Wisconsin. The limitations on size, weight and load imposed by this statute however do not apply to construction vehicles or equipment actually engaged in construction or maintenance of a highway within the limits of the project. These statutes can be used however as a beginning step to provide contractors and WisDOT with a viable method to determine if contractor equipment can be used or traverse an existing bridge.

Wisconsin Statute 348 provides maximum limits for the width, height and loads for vehicles using the states roadways. Vehicles which exceed these limits must obtain a permit to use the roadways



Wisconsin Highway Research Program (WHRP) Bridge Construction Live Load Analysis Guide

or be subject to fine or other sanctions. This research will focus only on the load limits imposed by the statutes. The statutes provide a few definitions which are relevant to this section of the research. The definitions are as follows:

Axle -An axle includes all wheels of a vehicle imposing weight on the highway, the centers of which are included between 2 parallel transverse vertical planes less than 42 inches apart, and extending across the full width of vehicle and load.

Tandem Axle- Means any 2 or more consecutive axles whose centers are 42 or more inches apart and which are individually attached to or articulated from, or both, a common attachment to the vehicle including a connecting mechanism designed to equalize the load between axles.

Gross Weight -Means the weight of a vehicle or combination of vehicles equipped for service plus the weight of any load which the vehicle or combination of vehicles may be carrying.

Class 'A' Highway-Includes all state trunk highways and connecting highways and those county trunk highways, town highways and city and village streets, or portions thereof, that have not been designated as class "B" highways pursuant to s. 349.15.

Class 'B' Highway -includes those county trunk highways, town highways and city and village streets, or portions thereof, which have been designated as class "B" highways by the local authorities pursuant to s. 349.15.



Wisconsin Highway Research Program (WHRP) Bridge Construction Live Load Analysis Guide



The purpose of Question 4 was to determine what vehicle types the agency requires the contractor use in order to determine construction loading.

Question 4a- Does your state have specific limits on construction vehicle loads?

Question 4b- If the answer to Question 4 A is yes, what limiting loading criteria do you require?

5 of the 26 respondents stated they have no specific restrictions for construction vehicles.

15 of the 26 respondents stated that construction vehicle loads are limited to that agencies legal load or permit load requirements.

3 of 26 use other criteria vehicles

1 of the 26 respondents use HL 93

1 of the 26 respondents use maximum axle loads



Wisconsin Highway Research Program (WHRP) Bridge Construction Live Load Analysis Guide



Agency Survey Question 5- Load Distribution

In designing a new bridge, the appropriate distribution of the truck loads to the bridge members is given in the *AASHTO Standard or LRFD Specifications*. For construction loads from equipment, such as crane outrigger loads, distribution to bridge members must be evaluated for the specific load pattern. Section 2-“Load Model Studies”, of this research provides an analysis of the distribution of loads for representative construction vehicles/equipment. Lateral live load distribution is dependent on many factors including beam spacing, diaphragms, bridge skew and other factors, and may not be best represented by the AASHTO distribution factor equations. AASHTO Specifications include the Standards Specification and the LRFD Specification methods as follows:

AASHTO Standard Specifications

Moment & Shear (except as described below) Distribution Factor= S/D where S is the Girder Spacing and D is a variable constant which depends on the deck and stringer materials used.

The Shear Distribution Factor at the ends of beams is calculated assuming the flooring acts as a simple span between girders (i.e. the lever rule). The shear distribution factors for the remaining portions of the beams are calculated similar to the Moment Distribution Factors.

AASHTO LRFD Specifications

LRFD Specifications have limited range of applicability, and when ranges of applicability are exceeded a more refined analysis is required. The LRFD Specifications for Distribution Factors are as follows:

For One Lane Loaded for Moment or Multiple Lanes Loaded for Shear

$$Mg = m\gamma_s[a(g_{\text{lever rule}}) + b] \geq m\{N_{\text{lanes}}/N_g\}$$

Where:

a and b = calibration constants

γ_s = live load distribution simplification factor (DSF)

M= multiple presence factor

N_g = number of girders

N_{lanes} = number of design lanes considered in the analysis (in this case using the lever rule)

$g_{\text{lever rule}}$ = distribution factor computed by lever rule

g = distribution factor

For Multiple Lanes Loaded for Moment

$$Mg_m = m\gamma_s[a_m(W_c/10N_g) + b_m] \geq m\{N_L/N_g\}$$

a and b = calibration constants

γ_s = live load distribution simplification factor (DSF)

N_L = maximum number of design lanes for the bridges, and design lane width = 10 feet



Wisconsin Highway Research Program (WHRP) Bridge Construction Live Load Analysis Guide



The purpose of Question 5 was to determine what guidance agencies provide with respect to load distribution for construction loads.

Question 5a- For analysis of construction loads, do you issue guidance to contractors or require specific criteria with respect to load distribution.

Question 5b- If the answer to Question 5 a is yes, what load distribution criteria is specified

17 of the 26 agencies who responded stated that they do not specifically issue guidance with respect to the distribution of construction loads. 8 of the 26 agencies require the contractor to use the AASHTO Specifications to calculate the distribution effects. The Ontario, Ministry of Transportation uses a modified S-over D method for the calculation of Live Load Distribution Factors. Table 1-5 below provides a summary of responses provided by the surveyed agencies. The

Table 1-5

Agency	Remarks
Alaska DOT	None
Caltrans	Caltrans specifies the use of AASHTO Distribution Factors.
Delaware DOT	Delaware DOT specifies the use of AASHTO Distribution Factors.
Hawaii DOT	Hawaii DOT specifies the use of AASHTO Distribution Factors, and specifically the distribution factors in accordance with AASHTO LRFD Specifications.
Illinois DOT	None
Indiana DOT	Indiana DOT does not specifically issue guidance to contractors for load distribution, however makes the assumption that contractors understand that AASHTO Distribution Factors would be used.
Kansas DOT	Kansas DOT expects contractors to use AASHTO Distribution Factors unless a more elaborate analysis of load distribution is required.
Kentucky DOT	None
Michigan DOT	Load distribution with respect to live load distribution factors is not explicitly covered. MDOT does limit equipment traveling on pavements to loads less than 850 pounds per inch of nominal tire width. MDOT also requires the use of planks and timbers on pavement, but these methods are used to prevent surface damage to pavements, as opposed to distribution of loads for overload.
Minnesota DOT	Guidance is not provided to contractors, since analysis is done by MnDOT. MnDOT uses AASHTO distribution factors as applicable.
Mississippi DOT	None
Missouri DOT	None
New Hampshire DOT	None
New Jersey DOT	AASHTO LRFD Specifications are used for load distribution.
New Mexico DOT	New Mexico DOT specifies the use of AASHTO Distribution Factors.
Ohio DOT	None
Oklahoma DOT	None
South Carolina DOT	SCDOT requires construction wheel loads to be maintained directly over the girder line, and uses AASHTO Distribution Factors as the method to calculate distribution factors.
South Dakota DOT	None
Tennessee DOT	None
Texas DOT	None
Virginia DOT	None
Washington DOT	Washington DOT specifies the use of AASHTO Distribution Factors.
Wyoming DOT	None



Wisconsin Highway Research Program (WHRP) Bridge Construction Live Load Analysis Guide

USFS Region 4	None
Ontario Ministry of Transportation	The Ontario Highway Bridge Design Codes follow a modified S-over D method, in which a “ D_d ” factor is determined by considering several parameters. The Canadian Highway Bridge Design Code follows the concept of equal distribution as a “baseline”, but applies modification factors in order to improve accuracy.



Wisconsin Highway Research Program (WHRP) Bridge Construction Live Load Analysis Guide



Agency Survey Question 6- Stock Piling

The National Transportation Safety Board determined that the probable cause of the Aug. 1, 2007 collapse of the Interstate 35W bridge in Minneapolis was the inadequate load capacity of the gusset plates at the structure's U10 nodes due to a design error. The gusset plates failed under a combination of (1) substantial increases in the weight of the structure from previous bridge modifications, and (2) traffic and concentrated construction loads on the bridge on the day of the collapse.

As a result of its investigation, the NTSB made several recommendations to the Federal Highway Administration. Included in those recommendations were specific provisions related to the stock piling of materials on bridges. NTSB's recommendation was to *"develop specifications and guidelines for use by bridge owners to ensure that construction loads and stockpiled raw materials placed on a structure during construction or maintenance projects do not overload the bridge's structural members or their connections"*.

As a result of those recommendations, MnDOT revised its construction specifications to limit construction loads from stockpiles on bridges and include a process for engineering review of construction loads that exceed typical traffic loads. Per MnDOT's response to the agency survey (see summary below), *"Stockpiled materials are limited to 65 psf. Individual material stockpiles (including pallets of products, reinforcing bar bundles, aggregate piles) are limited to a maximum weight of 250 psf. Combinations of vehicles, materials, and other equipment are limited to a maximum weight of 200,000 lbs per span providing span lengths are over 40 feet long"*.

The August 2007 collapse of the I35W bridge in Minnesota brought to light the severe loading effect that materials and equipment can produce on structures. The purpose of Question 6 was to determine what policies/procedures agencies apply with respect to the stockpiling of materials on bridges, and to assist in developing a list of best practices related to the stockpiling of materials when allowed.

Question 6A- Does your state allow stockpiling of construction materials on bridges under construction?

Question 6B- If the answer to Question 6A is yes, what limiting criteria do you require?

14 of 26 agencies who responded do not allow stockpiling of materials on their bridges. The remaining 12 agencies do allow the stockpiling of materials on their bridges. Where allowed the limiting criteria generally fell into the following categories:

- Area Loads
 - MnDOT- 65 psf to 250 psf (individual pallets)
 - TnDOT- 50 psf
 - Ontario Ministry of Transportation- 40 psf (pedestrian bridges) to 100 psf (vehicular bridges)
- Gross Loads
 - KDOT- Posted Limit or 20,000 lbs. (10 Tons)
 - ODOT- Posted Limit or 60,000 lbs. (30 Tons)



Wisconsin Highway Research Program (WHRP) Bridge Construction Live Load Analysis Guide



Table 1-6 below provides a summary of the agencies response to question 6.

Table 1-6

Agency	Remarks
Alaska DOT	Alaska DOT allows stockpiling of construction materials on bridges and uses an Area Load as the allowable load. Exact load limits were not provided.
Caltrans	Caltrans does not allow stockpiling of materials on bridges.
Delaware DOT	Delaware DOT does not allow stockpiling of materials on bridges.
Hawaii DOT	Hawaii DOT does not have provisions which prohibit stockpiling of materials. If contractor makes requests to stockpile materials, the Department would request structural calculations be provided to justify their use.
Illinois DOT	IDOT allows stockpiling of materials, but requires contractor verification that stockpiling will not overload the structure. No specific load type was provided.
Indiana DOT	Indiana DOT does not allow stockpiling except under unusual conditions, and then Department approval would be required.
Kansas DOT	Kansas DOT Special Provisions for Bridge Demolition, provide some guidance to contractors with respect to stockpiling of materials. These provisions limit stock pile construction materials, debris, or rubble to the lesser of the posted limit, or 10 tons. Additionally, equipment on the structure must not exceed the lesser of the posted limit, or the operating load rating for the structure. Contractor must provide KDOT plans showing the location, quantity and weight of the proposed materials, debris and/or equipment exceeding the stated limits.
Kentucky DOT	Kentucky DOT allows stock piling of materials on bridges. Allowable values were not provided.
Michigan DOT	Stockpiling not allowed.
Minnesota DOT	Stockpiled materials are limited to 65 psf. Individual material stockpiles (including pallets of products, reinforcing bar bundles, aggregate piles) are limited to a maximum weight of 250 psf. Combinations of vehicles, materials, and other equipment are limited to a maximum weight of 200,000 lbs per span providing span lengths are over 40 feet long.
Mississippi DOT	Stockpiling not allowed.
Missouri DOT	Traditionally, MoDOT has not allowed construction stockpiling on their bridges during construction. This was enforced by construction inspectors and somewhat understood by Contractors. As a result of the I-35 collapse, proposed specification and Engineering Policy Guide changes are under development that will help clarify requirements to Contractors.
New Hampshire DOT	Stockpiling of materials is allowed, however materials which exceed the legal gross load would require analysis and by the contractor.
New Jersey DOT	Specification Section 108.04 Work Site and Storage- "The Department will not allow the decks of bridges or the area under bridges, including the slopes, to be used as work sites or storage areas."
New Mexico DOT	Stockpiling not allowed.
Ohio DOT	Stockpiling of materials is allowed up to 60,000 pounds or the posted weight limits. Locations of stockpiles required department approval.
Oklahoma DOT	Stockpiling not allowed.
South Carolina DOT	Stockpiling of materials on bridges is allowed. No specific criteria were provided or could be found.
South Dakota DOT	Except for minor quantities of materials and equipment, South Dakota DOT does not allow stockpiling of materials.
Tennessee DOT	Stockpiling of materials is allowed and must be less than 50 psf uniform load. Non-uniform loads must be reconciled to an effective uniform load or provisions made by the contractor to



Wisconsin Highway Research Program (WHRP) Bridge Construction Live Load Analysis Guide



	use timbers or other means to distribute the construction loads.
Texas DOT	Texas DOT allows the stockpiling of materials with written permission from the Department. The Department also reserves the right to request the submission of a structural analysis. The use of temporary matting or other protective measures may be directed by the Department. No specific limits for stockpile loading are provided.
Virginia DOT	Virginia DOT does not allow stockpiling of construction materials on their bridges.
Washington DOT.	Washington DOT does not allow the stockpiling of construction materials on their bridges.
Wyoming DOT.	Wyoming DOT does not allow the stockpiling of construction materials on their bridges.
USFS Region 4	USFS Region 4 does not allow the stockpiling of construction materials on their bridges.
Ministry of Transportation, Ontario	Special Provision No. 100S60 of the Ontario Ministry of Transportation Specifications allows the stockpiling of materials on bridge decks except as follows: <ul style="list-style-type: none"> • No material shall be stockpiled on spans of bridges in which concrete removal has commenced for rehabilitation. • 100 psf (5 kPa) on decks of highway bridges, unless otherwise specified • 40 psf (2 kPa) on decks of pedestrian bridges, unless otherwise specified • Vehicular traffic and other construction equipment shall not be permitted over areas where material is stockpiled.

Connecticut DOT- did not respond to the agency survey, however in our search for information we found the following guidance from Connecticut DOT:

As a result of FHWA’s 2007 advisory, Connecticut DOT’s Load Restriction Specifications, Article 1.07.05 was revised. *“Designers are being directed to add notes to their structure plans to indicate the allowable load for existing and proposed structures. When a structure is not posted, the contractors will be allowed to stockpile material and store construction equipment, when the maximum weight of equipment or material stored in each 12 foot wide travel lane of any given span shall be limited to 750 plf combined with a 20,000 pound concentrated load located anywhere within the subject lane”.*



Wisconsin Highway Research Program (WHRP) Bridge Construction Live Load Analysis Guide



Agency Survey Question 7

The evaluation of the effects of construction loads on bridges must consider several factors. These factors should include but not be limited to the actual configuration and condition of the bridge, redundancy, the load rating and/or capacity of the bridge, magnitude and location of the construction loading, and other factors.

The purpose of Question 7 was to determine if agencies applied specific criteria related to the types of bridges which they would require analysis for construction loads.

Question 7 – How does your agency determine what structures are analyzed for construction loads?

Table 1-7 provides a summary of the agency responses. The answers for this question were generally categorized as follows:

- Bridge Condition
- Existing Load Rating Capacity and/or Posting of the Bridge
- Intensity of the proposed loads (i.e. limits exceeding legal loads or other limiting criteria).
- Agency qualitative/quantitative analysis of contractors proposed construction methods.
- Structure type and/or complexity

Table 1-7

Agency	Remarks
Alaska DOT	The Department bases its determination on the proposed type of construction load, the condition of the bridge, and the current load rating of the bridge.
Cal Trans	The Structure Construction Engineer administering the contract will require the contractor to submit documentation for any non-standard construction loads.
Delaware DOT	Delaware DOT bases its decision on low ratings (i.e. < HS20) and Delaware Legal Loads.
Illinois DOT	The Structure Analysis Report is used for all bridges under construction
Indiana DOT	It is left to the designer to determine if the structure is unique and needs specific construction loading checked. <i>“It is noted that InDOT stated that when/if AASHTO specifications address construction loading items in a more specific way, InDOT will provide design consultants and contractors additional guidance.”</i>
Kansas DOT	Specific notes are provided on the plans if analysis for construction loads is required. If the plan contains no notes to this effect, then the Special Provision for “Controlled Demolition” will determine the extent of analysis required.
Kentucky DOT	Kentucky DOT decides if analysis is warranted / required based on the Contractor’s Proposed Construction Methods.
Michigan DOT	Unusual situations would require analysis <i>“MDOT stated that this is not normally a concern”</i> .
Minnesota DOT	Structures are analyzed by MnDOT when the proposed construction loads exceed the limits specified in the answer to Question 6 above.
Mississippi DOT	Structures deemed as complicated or otherwise unusual will typically merit a detailed analysis.
Missouri DOT	See Note 1 below
New Hampshire DOT	See Note 1 below
New Jersey DOT	New structure decks with loads which exceed the 80,000 lb. limit will require an analysis.



Wisconsin Highway Research Program (WHRP) Bridge Construction Live Load Analysis Guide



New Mexico DOT	See Note 1 below
Ohio DOT	Ohio DOT requires an analysis when construction loads exceed allowable gross vehicle weights.
Oklahoma DOT	Bridges are not typically analyzed for construction loading except for falsework loads.
South Carolina DOT	Analysis is required when/if contractor proposes to place loads on any bridge over the legal limit. The resident construction engineer is the point of contact for the contractor.
South Dakota DOT	When non-legal loads are requested to track across the structure or by request of the project engineer if more than minor temporary materials / equipment may be allowed.
Tennessee DOT	Construction equipment is not allowed on bridges without prior approval. When allowed, the Department will either analyze the structure or request contractor to analyze.
Texas DOT	All loads in excess of legal loads will require analysis of the structure
Virginia DOT	No answer provided
Washington DOT	The load restrictions in Section 6-01.6 of the specifications apply to all bridges under construction.
Wyoming DOT	Structures are analyzed on a case by case basis depending on bridge condition, load rating and structure type.
USFS Region 4	No answer provided.
Ministry of Transportation, Ontario	The Ministry's Regional Structural Section makes the determination of when a structure is analyzed.
Note 1	The answers provided by the agency appear to be related to Question 6 on "Stockpiling". The intent of the question was to solicit analysis practices in general as opposed to analysis practices as they relate to stockpiling.



Wisconsin Highway Research Program (WHRP) Bridge Construction Live Load Analysis Guide



B) Contractor Survey

In March 2010 a meeting was held with Wisconsin based contractors to discuss the research being conducted, as well as to solicit contractor input related to this research. As one of the action items from that meeting it was decided that a survey would be sent to contractors to solicit additional input related to contractor practices, as well as to gather information related to representative contractor equipment being used during construction projects. A copy of the survey sent to contractors is provided in Appendix B to this report.

In April 2010 a survey was sent to Wisconsin Based Contractors. The survey was sent to a total of 30 contractors, was comprised of five (5) questions and focused in the following general areas:

- The reference material and/or specifications used by contractors to perform load ratings,
- Information that a contractor would find helpful to be included in the Construction Live Load Handbook,
- Procedure or methods used to distribute heavy concentrated loads placed on structures,
- Procedure or methods in place to limit the stockpiling of materials on bridges,
- And a list of construction equipment used by contractors including the types (crawlers, wheel loaders etc.), the Manufacturer and model or serial numbers.

Of the 30 surveys sent out only three (3) surveys were completed and sent back and a fourth survey provided only a general comment concerning bridge deck construction. A follow up request to complete the surveys was sent in October 2010, however no additional responses were received. The contractors who completed the survey or provided a comment included:

- Lunda Construction Company
- Hoffmann Construction
- Zenith Tech, Inc.
- Zignego (General comment only stating that Zignego stays off bridges completely until the bridge deck has completely cured to avoid damage to the deck)



Wisconsin Highway Research Program (WHRP) Bridge Construction Live Load Analysis Guide



Contractor Survey Question 1 – Specification Use

AASHTO Specifications are generally more design oriented and cover design vehicles (e.g. HS 25, HL 93) as opposed to construction vehicles. Although the AASHTO specifications do provide some guidance with respect to construction vehicles, the guidance provided is rather limited. The purpose of Question 1 was to determine whether the AASHTO Specifications provide sufficient guidance to contractors to perform their load rating work, and if not what other reference materials contractors might use.

Question 1- *What specifications or reference materials does your company use if required to perform a bridge load rating for a vehicle which exceeds the standard permit vehicle (e.g. different axle spacing or loads) or for which analysis is otherwise required?*

- AASHTO Specifications
- Other Specifications (Please Specify)
- Unknown or Load Rating is Outsourced

TABLE 2-1	
Contractor	Remarks
Lunda Construction	Lunda Construction uses the AASHTO and WisDOT Specifications to perform bridge load ratings.
Hoffman Construction	Hoffman Construction typically outsources their load rating work.
Zenith Tech, Inc.	Zenith Tech, Inc. typically outsources their load rating work.



Wisconsin Highway Research Program (WHRP) Bridge Construction Live Load Analysis Guide



Contractor Survey Question 2 – Helpful Information

The goal of this research is provide additional information and guidance to contractors with respect to the loading of bridges. The purpose of Question 2 was to solicit contractor input as to what sorts of information would be useful to them in this handbook.

Question 2- *What information might be helpful to your company which should be included in the Construction Live Load Handbook?*

TABLE 2-2	
Contractor	Remarks
Lunda Construction	Lunda Construction thought that it would be helpful to provide typical distribution factors for different equipment based on different structure types or lengths, or to provide potential modification factors to the AASHTO distribution factors.
Hoffman Construction	Hoffman Construction thought that it would be helpful to provide a standard acceptable overload for certain bridges. As an example “a bridge designed for xxxxx can withstand a loaded off truck weighing no more that 140,0000 pounds traveling 5 mph”.
Zenith Tech, Inc.	Zenith Tech, Inc. thought that it would be helpful to provide guidance on the loading behavior of tracked vehicles as well as clarification as to when equipment loads exceed the standard permit vehicle load. As an example a large tire loader may exceed the maximum axle load when placed directly on a deck, however when that same loader is placed on a trailer the axle loads do not exceed the permissible axle loads.



Wisconsin Highway Research Program (WHRP) Bridge Construction Live Load Analysis Guide



Contractor Question 3- *Load Distribution*

The purpose of Question 3 was to solicit information on the methods used to distribute heavy loads to bridge structures, and to assist in developing a list of best practices for bridge construction.

Question 3- *What procedures or methods does your company use to distribute or minimize heavy concentrated loads (wheel loads, outriggers etc.) placed on structures?*

TABLE 2-3	
Contractor	Remarks
Lunda Construction	Lunda Construction uses one foot thick timber mats for outriggers and/or maintain concentrated loads over girder lines.
Hoffman Construction	Hoffman Construction Company is a roadway contractor and therefore typically hauls loads across structures. During hauling, heavier loads are typically located along girder lines and at lower speeds. Structures are also shored at mid-span in some cases.
Zenith Tech, Inc.	Zenith Tech, Inc. stated that large loads (wheel, outrigger, or track) are typically laid out directly over girder lines. Outriggers are placed on OSHA approved out rigger pans and additional cribbing/matting is used as needed.



**Wisconsin Highway Research Program (WHRP)
Bridge Construction Live Load Analysis Guide**



Contractor Question 4- Stockpiling

As previously noted in the agency survey, the I35W bridge in Minnesota brought to light the severe loading effect that materials and equipment can produce on structures. The purpose of Question 4 was to determine what procedures contractors apply with respect to the stockpiling of materials on bridges. Table 2-4 below provides a summary of the contractor’s response to question 4.

Question 4- Does your company have specified procedures or methods in place to limit the stockpiling of materials or equipment on bridges?

TABLE 2-4	
Contractor	Remarks
Lunda Construction	Lunda Construction answered this question as follows: <ul style="list-style-type: none"> • Demo plans review equipment and material loads • Typically new structures with cranes over 50 tons on deck consider material loads • Analysis for heavy or multiple pieces of equipment on deck, however no analysis for small equipment or ready mix trucks. • Typically material (decking) is less than future wearing surface so analysis is not completed • Aggregate materials are not stored on bridge decks
Hoffman Construction	Hoffman Construction Company is a roadway contractor and therefore does not stockpile materials on bridges.
Zenith Tech, Inc.	Zenith Tech Inc. answered this question as follows: <ul style="list-style-type: none"> • Aggregate materials are not stored on bridge decks • Parapet steel, parapet formwork, decking that is stripped from under the deck is stored on the deck to be bundled and loaded onto trucks. • Any equipment that is under the maximum allowable permit weight is used on a bridge deck without consideration- Overweight equipment is looked at on a one-one basis. Stripping platforms on bridge decks without too much consideration to access the underside of a bridge deck for formwork stripping requirements.



Wisconsin Highway Research Program (WHRP) Bridge Construction Live Load Analysis Guide



Contractor Question 5- *Equipment*

Determination of construction loads requires input from the contractor. Different contractors may approach a project in varying manners, as well as have particular equipment preferences. While the effects on a bridge of many, if not most, pieces of construction equipment will not exceed those of a standard AASHTO vehicle, either the gross weight or load distribution for some equipment can be well in excess of the effects of an AASHTO vehicle.

As an example, demolition activities as well as new construction may require cranes to work atop an existing bridge. Examples include pile driving from the bridge deck to extend an existing pier, or removal of girders for a multi-span demolition. Crawler (or track mounted) cranes as well as truck mounted cranes are often used. During lifting operations, truck mounted—including so-called rough terrain cranes—are supported on outriggers and not on their tires. The load transferred to the bridge comprises not only the crane weight, but also the lifted load, which includes the weight of rigging and lifting beams.

The purpose of question 5 was to determine the typical equipment being used by contractors during construction, and to determine a general representation of equipment loads on Wisconsin Structures.

Question 5- In the table below please list representative equipment that your company owns or otherwise uses during construction which might cause significant loading on a bridge structure?

TABLE 2-5				
Equipment Type	Manufacturer	Model / Serial Number	Comments/Attachments/ Uses/ Other Information	Contractor
Crawler Dozers	Caterpillar	D9L		Hoffman
	Caterpillar	D3 or D5		Zenith Tech
Crawler Loaders	None	None		None
Wheel Loaders	Samsung	120 / 150		Lunda
	Volvo	L90 / L110		Lunda
	Case	821 E		Hoffman
	Caterpillar	936, 950, 966, 980	Forks for removing deck slabs	Zenith Tech
Wheel Scrapers	Caterpillar	631G		Hoffmann
Dump Trucks	Various	Quad Axle	Hauling Demo Material / limited use	Zenith Tech
Haulers (Lowboy etc.)	Trail Kings	TK 25FA-051	8 axles with & without stinger	Lunda
	Various	Triaxle	Moving cranes or loaders across bridges	Zenith Tech



Wisconsin Highway Research Program (WHRP) Bridge Construction Live Load Analysis Guide



Cranes (Truck / Track Mounted etc.)	American	5299	Track Mounted 50 Ton	Lunda
Equipment Type	Manufacturer	Model / Serial Number	Comments/Attachments/ Uses/ Other Information	Contractor
	Terex	HC110 / HC 165		Lunda
	Link Belt	LS 138		Lunda
	Liebherr	LR-1160	Track Mounted 150 Ton	Zenith Tech
	Terex	HC110	Track Mounted 110 Ton	Zenith Tech
	American	5310	Track Mounted 75 Ton	Zenith Tech
	American	5299	Track Mounted 50 Ton	Zenith Tech
	American	7450	Truck Crane 80 Ton	Zenith Tech
	American	5530	Truck Crane 55 Ton	Zenith Tech
Concrete Mixer	Cemen Tech	MCD10-130	Mobile Mixer on Freightliner Chassis	Zenith Tech
Paving Equipment	None	None	None	None
Crawler Excavator	Volvo	EC290/EC360/ EC460		Lunda
	Caterpillar	330B		Zenith Tech
Wheeled Excavator	Liebherr	922		Lunda
	Liebherr	A904		Zenith Tech
Off Road Truck	Caterpillar	740		Hoffman
	Zenith Tech		Suspended Stripping Platform	Zenith Tech



**Wisconsin Highway Research Program (WHRP)
Bridge Construction Live Load Analysis Guide**



SECTION 2- LOAD MODEL STUDY



Wisconsin Highway Research Program (WHRP) Bridge Construction Live Load Analysis Guide



2) LOAD MODEL STUDY

Construction of new bridges, or rehabilitation and widening of existing bridges may require operating heavy equipment on the bridge. As work areas become congested, and adjacent construction staging areas are reduced, the need to place loads on bridges increases. In addition, with loads concentrated over small areas, construction equipment may be much heavier than are the design trucks. For these reasons, it is important to determine how construction loads behave on bridge structures.

Significant research has been performed to determine load distribution for standard AASHTO vehicles, however little data is available as to how heavy construction loads, such as cranes and heavy haul dump trucks, distribute their loads across a bridge. This project was initiated to gain a better understanding of the distribution of heavy construction loads, and to develop load distribution guidance. This research uses finite element analysis, utilizing CSiBridge version 15, to analyze how heavy loads distribute across different types of bridges. For this research, three bridges were selected which are representative of general bridge types. This research can be used to present general guidelines as to the expected load distributions from certain types of construction loads on different types of structures.

AASHTO Standard Specifications utilizing LFD design, AASHTO LRFD design, and lever rule all provide methods to determine load distribution. The AASHTO equations were developed for truck or lane loads involving standard trucks and the lever rule is a conservative approach which may not yield accurate load distributions. This analysis was undertaken to provide accurate load distribution analysis on several as-built structures which can form a basis for load distribution guidelines and equations. The results from the finite element analysis are compared with load distribution equations presented by AASHTO to determine the validity of those equations in terms of heavy construction loads. Guidelines as to expected load distributions are presented based on this analysis with the idea that further examination will yield equations which might be used to accurately predict load distribution for construction loadings.

BRIDGES

The three bridges selected by WISDOT are analyzed utilizing CSiBridge version 15. The bridges are local to the state of Wisconsin and represent three common types of bridge structures. The first bridge, 30th Avenue over Pike River in Kenosha County (B30-0005), is a one-span simply supported concrete slab. The second bridge analyzed, CTH KE over STH 16 (B67-173), is a two-span composite steel plate girder bridge. The third bridge analyzed, STH 27 over the Holcombe Flowage (B09-273), is a three-span composite prestressed girder bridge.

The bridges are modeled with linear analysis in CSiBridge version 15. Frame elements are used to model the girders and plate elements for the decks. The deck discretization is taken at one foot increments for the slab bridge, and approximately four to five foot elements for the two larger steel girder and precast girder bridges. On the girder bridges, localized areas of finer discretization are manually adjusted to account for the effects of locally applied areas of loading. The element size was selected to provide meaningful data while maintaining efficient computer use.



Wisconsin Highway Research Program (WHRP) Bridge Construction Live Load Analysis Guide



LOADS

Three types of heavy construction loads are examined: local concentrated loads representative of crane outriggers, crawler tracks representative of tracked cranes and excavators, and heavy haul dump trucks characterized by large wheel loads and short axle spacing. The loads are placed as uniform pressures on the finite element deck elements. As noted above, the deck element sizes are adjusted to match the equipment loading at a specific location on the bridge. On all three structures, loads for the three different types of equipment are moved to different locations both along the length of the spans and transversely across the bridge to gain a better understanding of the behavior of the load distribution.

Outrigger Loads

The outrigger load examined in the finite element models is 104,000 lbs taken over a 2'x2' base. This represents typical operational loads from a 70 ton crane operating with a 40 foot radius. Additional analysis included the impact of placing outriggers on varying sizes of timber mats.

Track Loads

The crane track load represents typical operational loads for a 200 ton crane, such as a Link Belt 248, with the load concentrated over one track. The load used for analysis is 240,000 pounds spread over a 24 foot long by 4 foot wide track. This represents the crane while executing a lift over the side. Lifts over the corner, which are generally the governing condition for the crane, are similar to the more concentrated effects of the outrigger loads.

Wheel Loads

The heavy haul dump truck load used for analysis is 156,000 lbs with two-thirds of the load acting on the rear axle. The double wide rear tires have a four foot wide by one foot long contact area and the single front tires have a two foot wide by one foot long contact area. The wheel base is 13 feet, the rear wheel gage is 8 feet, the front wheel gage is 10 feet. This is based on a CAT770 Off-Highway Truck, a commonly used heavy haul truck.

RESULTS

Variations of load types, locations and combinations are analyzed in CSiBridge for the three different bridges. The results given in this section are based on the output from the finite element analysis as to how the loads distribute along and across the structure. Selected data, which is meant to provide an understanding of the behavior of the load distribution across the bridge, is included in graphs in the results. Since actual force or stress values are difficult to understand and compare, the values are presented as a percentage of the total load. These percentages can then be correlated to distribution ratios.

Bridge B30-005 – 30th Avenue over Pike River

30th Avenue over Pike River in Kenosha County, Bridge Number B30-005, is a one-span simply supported concrete slab with a span length of 45'-11", an out to out width of 41'-4", and a slab depth of 24.8". Both abutments have a skew of 20 degrees and are designed as fixed bearings. The superstructure slab consists of 4000 psi concrete with 60 ksi yield strength mild reinforcement. The roadway is a two-lane bridge with 8 foot wide shoulders at each side. Figures 1 and 2 are taken from the original design drawings of the plan and cross section views for the structure (note the dimensions are in metric units).

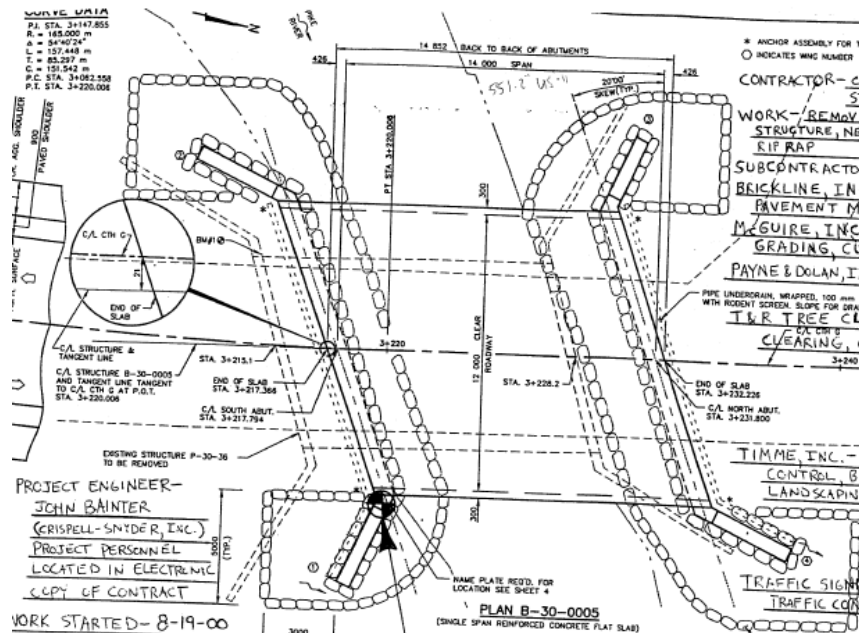

FIG. 1 - Plan View - 30th Avenue over Pike River from Design Drawings

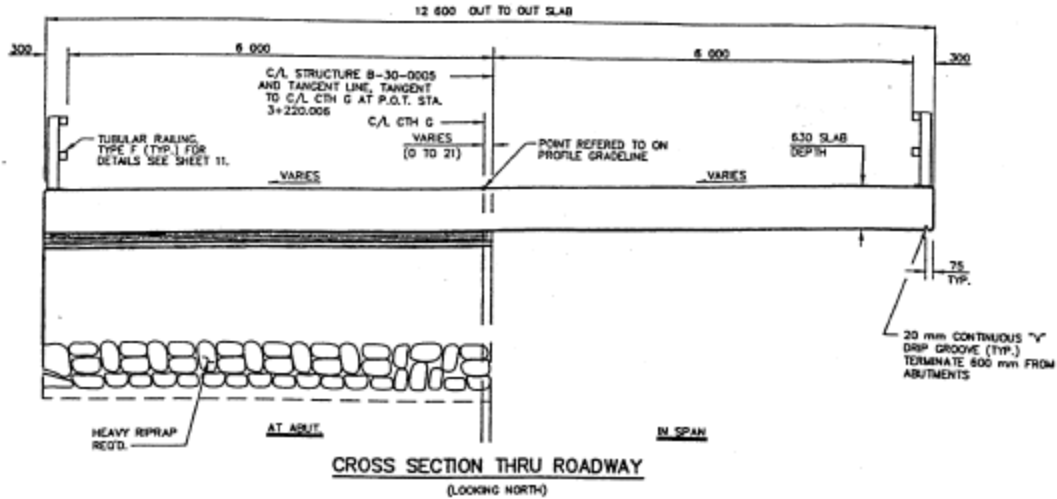
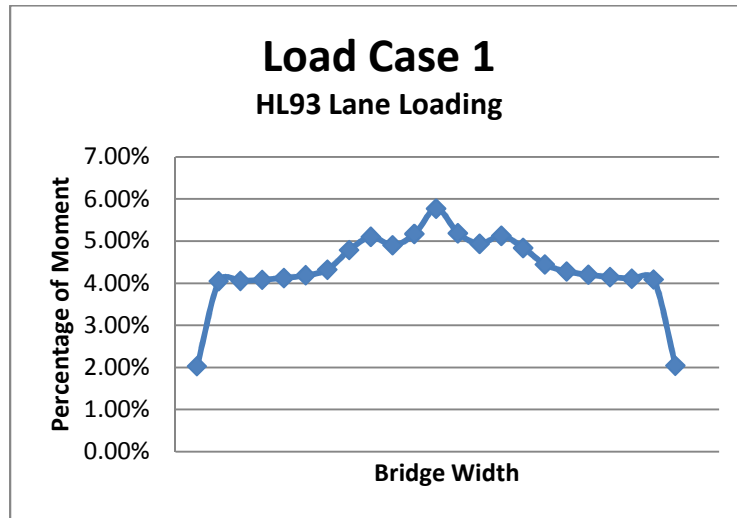

FIG. 2 - Cross Section - 30th Avenue over Pike River from Design Drawings

Bridge B30-005 – Load Case 1

As a comparison for construction loads, a standard 12 foot wide lane located along the centerline of the bridge and loaded with the HL-93 design load was examined. The distribution of the positive bending moment across the width of the bridge from the lane loading is shown in Figure 3. The plot points are spaced at approximately two foot intervals across the width of the bridge. The lane loading peaks along the center of the bridge at almost 6% of the total moment, levels down to 5% over the 12 foot width of the lane and then spreads out quite uniformly down to 4% near the edges. The edge plot points represent an approximately one foot width, and therefore are expected to carry half as much load.



Load Type	HL 93 (Lane + Concentrated)
Transverse Location	Transverse Center Point
Longitudinal Location	Midspan

FIG. 3 - Bridge B-30-005 – Load Case 1

Bridge B30-005 – Load Case 2

A two foot by two foot 104,000 lb. outrigger load placed on the centerline of the bridge at mid-span has a positive bending moment distribution as shown in Figure 4. The plot points are at 2 foot intervals. The section of bridge width located directly at the outrigger peaks near 8%. This decreases to below 6% at less than four feet from the centerline of the load, and then distributes to slightly below 4% near the edges of the bridge.

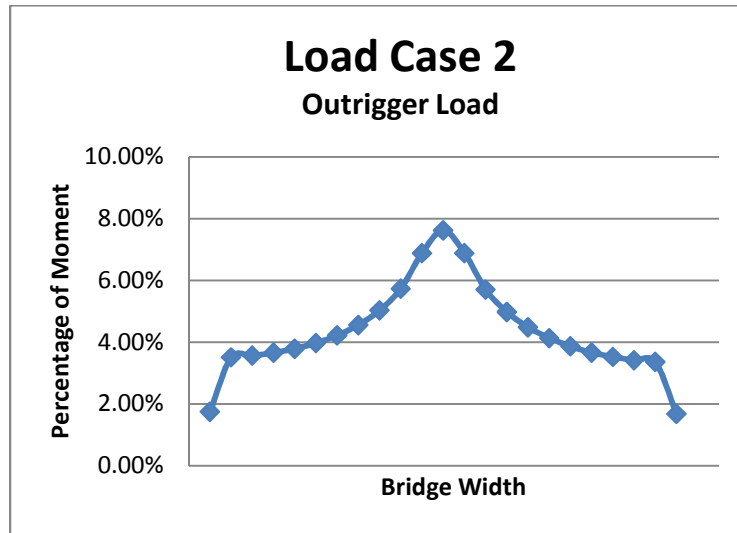

Load Type	104,000 lb. Outrigger Load
Transverse Location	Transverse Center Point
Longitudinal Location	Midspan

FIG. 4 - Bridge B-30-005 - Load Case 2

Bridge B30-005 - Load Case 3A & 3B

The 104,000 lb. outrigger load was examined in the same location as for Load Case 2, but spread out uniformly over a 4'x4' area representing a timber mat placed under the outrigger (Load Case 3A). The peak load at the center of the bridge is reduced to approximately 6.5%, while the percentages near the edges of the bridge remain similar to the outrigger load without timber mats.

The same loading scenario was also examined with the outrigger uniformly distributed over a 6'x6' timber mat (Load Case 3B). The load is spread out more evenly across the center of the bridge with a maximum percentage of approximately 6.1%, though the loads towards the edge remain essentially unchanged.

The comparison of Load Cases 3A and 3B are shown in Figure 4.

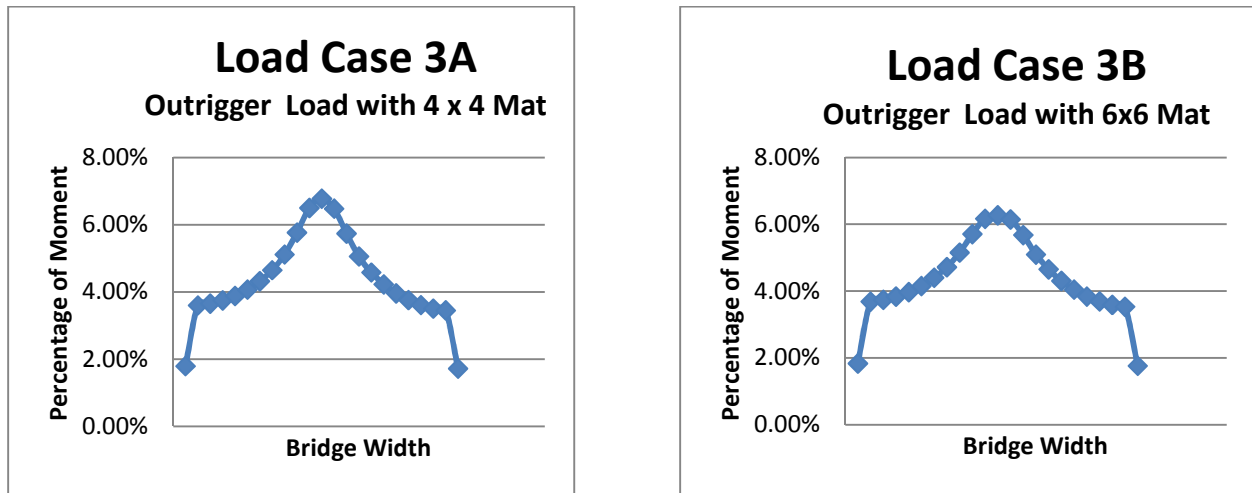

Load Type	104,000 lb. Outrigger Load on 4'x4' Mat (Load Case 3A) 104,000 lb. Outrigger Load on 6x6 Mat (Load Case 3B)
Transverse Location	Transverse Center Point
Longitudinal Location	Midspan

FIG. 4 - Bridge B-30-005 – Load Case 3A and 3B

Bridge B30-005 – Load Case 4

A 2'x2' foot 104,000 lb. outrigger load acting at the quarter-point of the span has a bending moment distribution, as shown in Figure 5. The distribution is very similar to when the outrigger acts at mid-span. Although the bending moment is reduced due to the location of the load along the span,

the load is distributed transversely across the bridge with similar ratios as the outrigger at midspan (Load Case 1). The maximum percentage of moment increases slightly to approximately 8.2% due to the reduced length along the bridge for the load to spread out. The difference, however, is negligible.

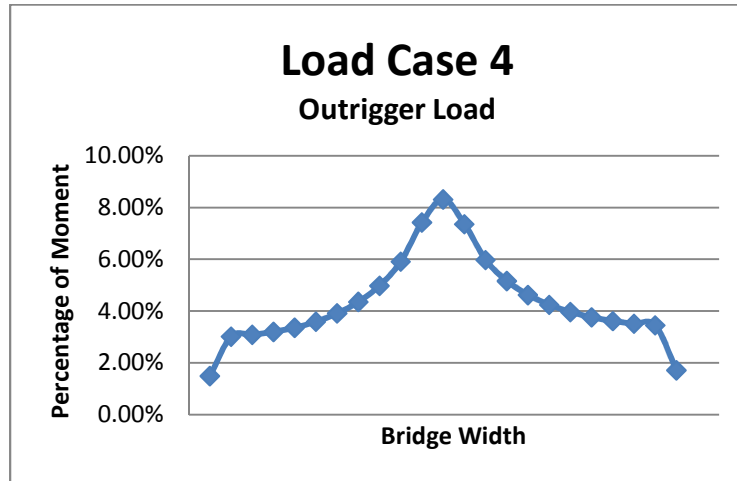

Load Type	104,000 lb. Outrigger Load
Transverse Location	Transverse Center Point
Longitudinal Location	1/4 Point of Span

FIG. 5 - Bridge B-30-005 - Load Case 4

Bridge B30-005 - Load Case 5

The 104,000 lb. outrigger load placed at mid-span and at the quarter-point transversely across the bridge width produces a peak percentage of load of 8%, as shown in Figure 6. This is consistent with the outrigger placed along the centerline of the bridge. The load distributes toward the edge of the bridge closest to the offset outrigger with values around 6%. The load dissipates to approximately 2.5% toward the opposite edge of the bridge which is furthest from the offset outrigger.

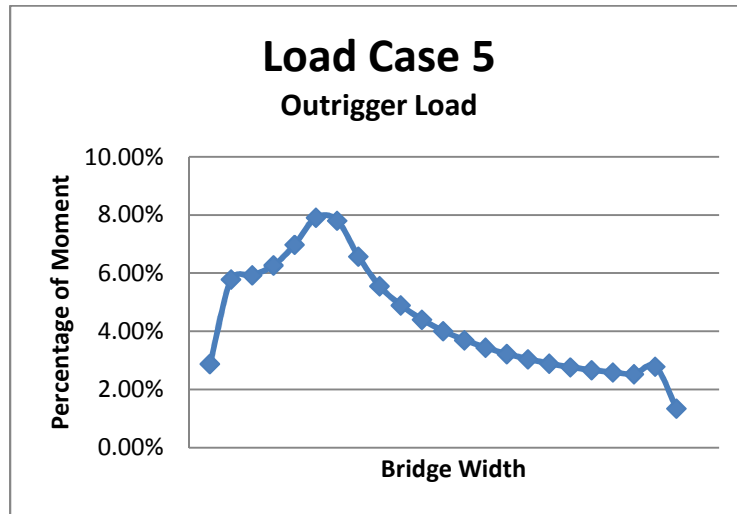

Load Type	104,000 lb. Outrigger Load
Transverse Location	Transverse ¼ Point
Longitudinal Location	Midspan

FIG. 6 - Bridge B-30-005 - Load Case 5



Wisconsin Highway Research Program (WHRP) Bridge Construction Live Load Analysis Guide



Bridge B30-005 – Load Case 6

Four different load cases are analyzed which examine the CAT770 heavy haul dump truck as well as three HS20 truck loadings in the form of a single axle, a three axle truck with a 14 foot long trailer, and a three axle truck with a 26 foot long trailer. The positive bending moment distribution across the width of the structure is shown in Figure 7.

The CAT770 heavy haul dump truck with two axles distributes load across the width of the bridge very similarly to a three axle HS20 truck with a 26 foot long trailer. The maximum moments both peak around 5.5% at the location of the wheels and level off to 4% near the bridge edges. The CAT770 load length is less than the 26 foot long trailer; however the wheel spacing is wider. These factors combine to result in a very similar load distribution across the bridge.

A single HS20 axle load consisting of two 16 kip wheel loads has a more concentrated distribution with maximum moments peaking at 6.5%. The multiple axles of the HS20 truck spread out the load and allow for slightly more distribution laterally.

A comparison of the three HS20 load from a single axle, to a fourteen foot long trailer to a twenty-six long trailer shows that the load distributions spreads out with more length in the truck. The peak percentage of load decreases from 6.6% with a single axle to 5.6% with a 26' long trailer and three axles. This correlates to approximately a 15% reduction in the load.

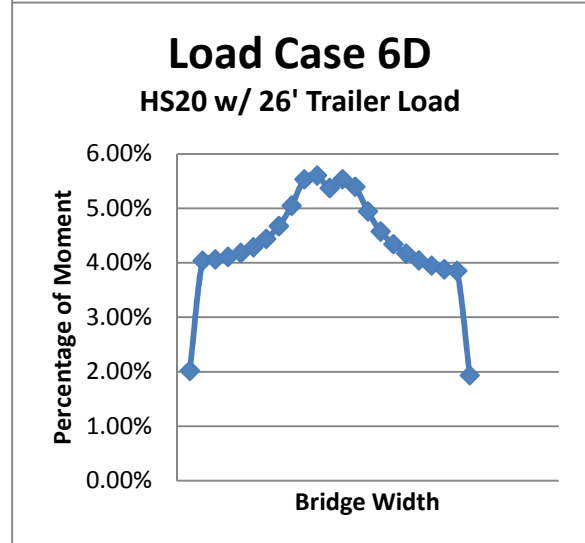
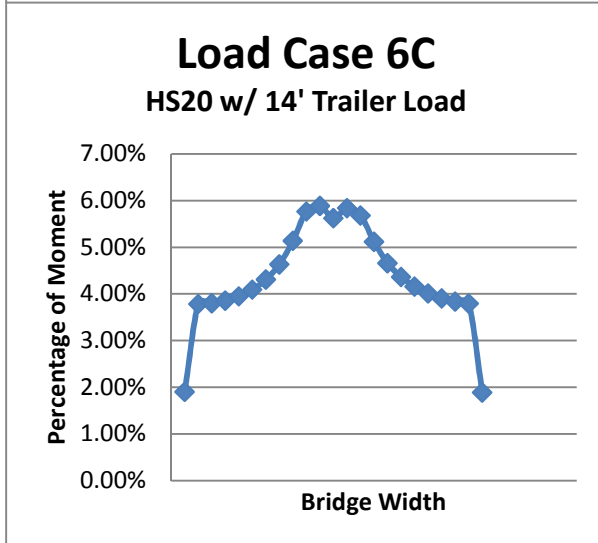
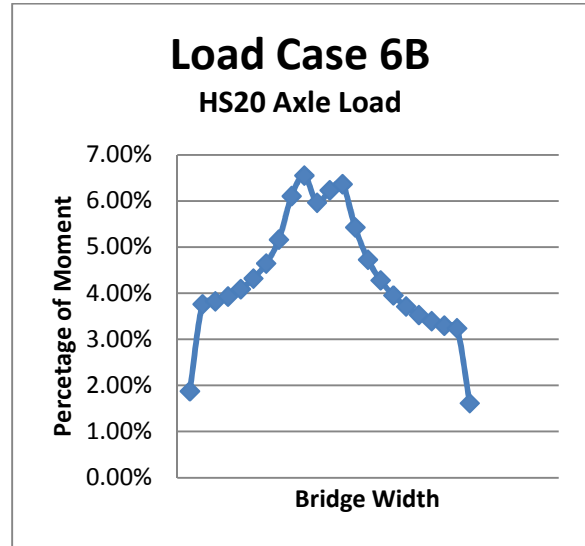
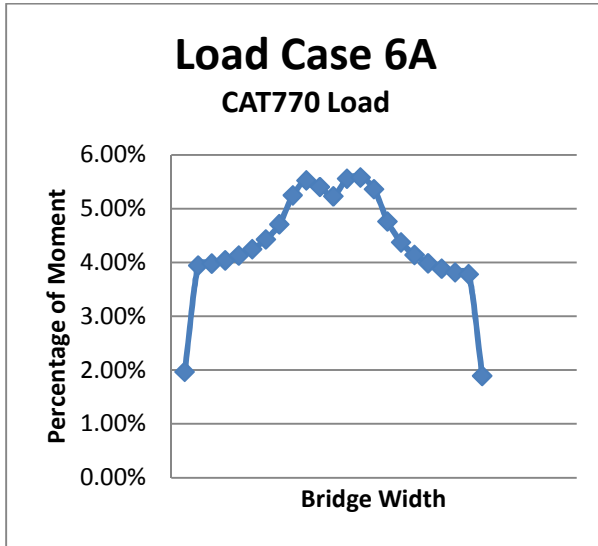

Load Type	CAT770 Truck Load (Load Case 6A) Single HS20 Axle (Load Case 6B) HS20 Truck with 14' Trailer (Load Case 6C), HS20 Truck with 26' Trailer (Load Case 6D),
Transverse Location	Transverse Center Point
Longitudinal Location	Midspan

FIG. 7 - Bridge B-30-005 – Load Case 6A, 6B, 6C, 6D

Bridge B30-005 – Load Case 7

Load case 7 examines the single crane track loaded along the centerline of the bridge at midspan. As shown in Figure 8, the crane track load distributes a greater percentage of the load transversely towards the edges of the bridge compared to the outrigger load. The wider load width and longer load length allows for a more uniform distribution over the full width of the bridge.

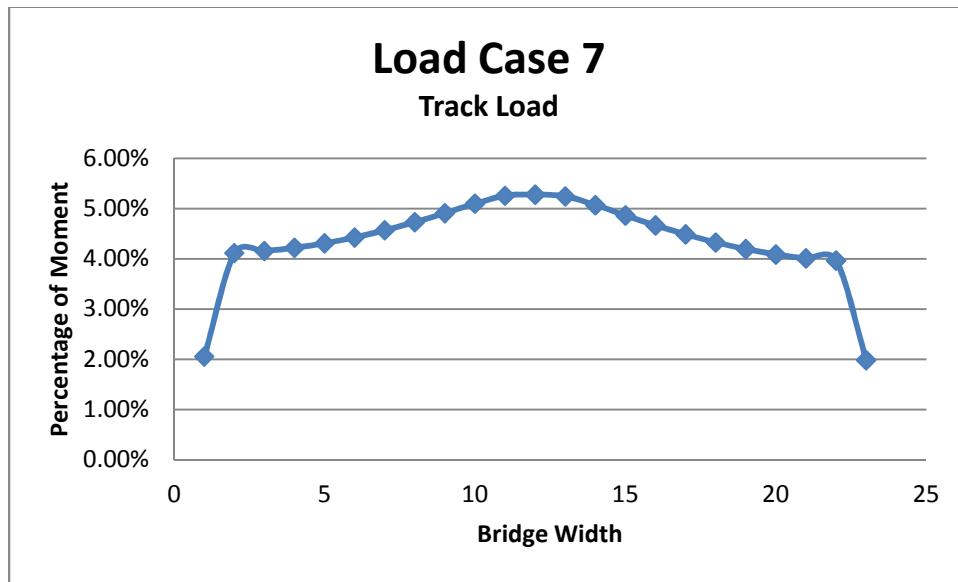

Load Type	240,000 lb Track Load (24 ft. x 4 ft. Track)
Transverse Location	Transverse Center Point
Longitudinal Location	Midspan

FIG. 8 - Bridge B-30-005 – Load Case 7

Bridge B30-005 – Load Comparison

Figure 9 is a comparison of positive bending moment distribution of the three pieces of equipment previously discussed and the HL93 AASHTO design lane load. The outrigger load, which is more concentrated, has more concentrated distribution at the centerline of the bridge than the track, heavy haul truck loading, or the design lane load. The crawler track and the CAT770 truck distribution is very similar to the AASHTO design lane load because of their wider and longer load layout compared to the localized outrigger force.

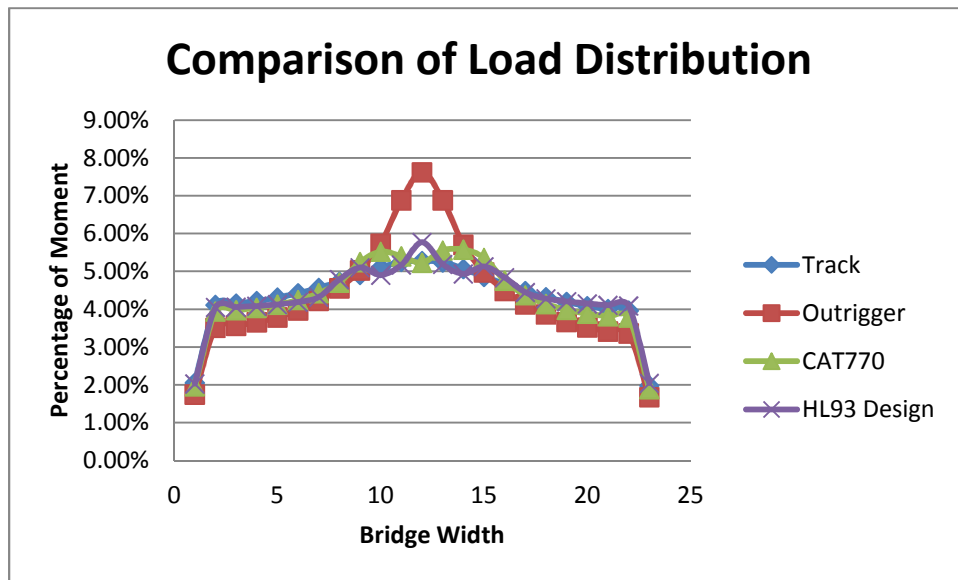

FIG. 9 - Bridge B-30-005 – Load Comparison

Bridge B67-173 – CTH KE over STH 16

CTH KE over STH 16 in Waukesha County, Bridge Number B67-173, is a two-span continuous composite steel plate girder bridge with a total span of 327'-6" and an out to out width of 71'-10". The bridge superstructure consists of seven 6'-0" deep plate girders spaced at 10'-7 1/2" which haunch to 9'-0" deep at the center pier with an 8.5 inch thick deck. The plate girders are 36 ksi steel with a 3000 psi concrete deck and 40 ksi yield strength mild reinforcement. The abutments and pier have a skew of 34.4 degrees with respect to the centerline of the roadway. The two abutments are designed as expansion bearings while the center pier support acts as a fixed bearing. The roadway is designed as a two-lane bridge with a 20 foot wide median in the center and 10 foot wide shoulders at each edge. Figures 10 and 11 were developed from the original design drawings and show the plan and cross section views for the structure.

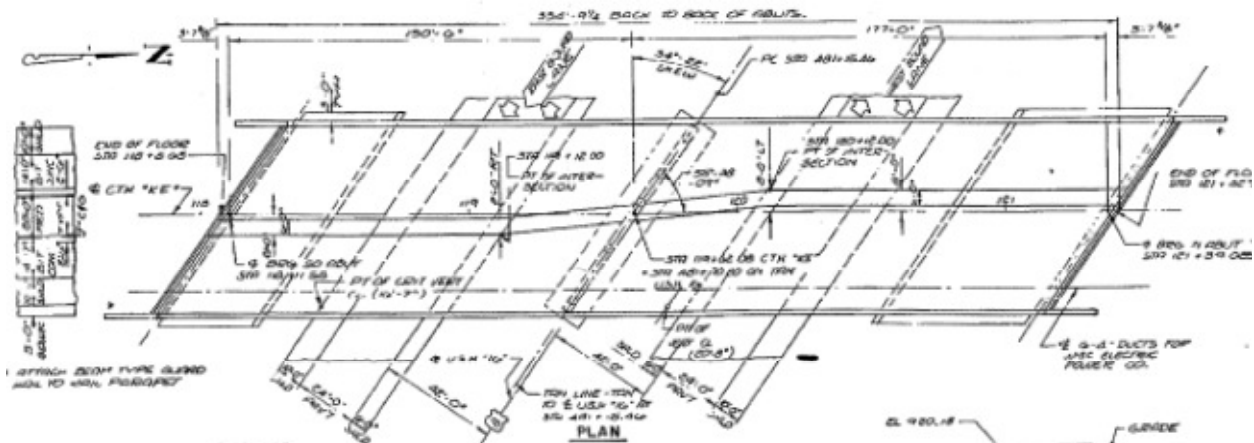

FIG. 10 - Plan View - CTH KE over STH 16 from Design Drawings

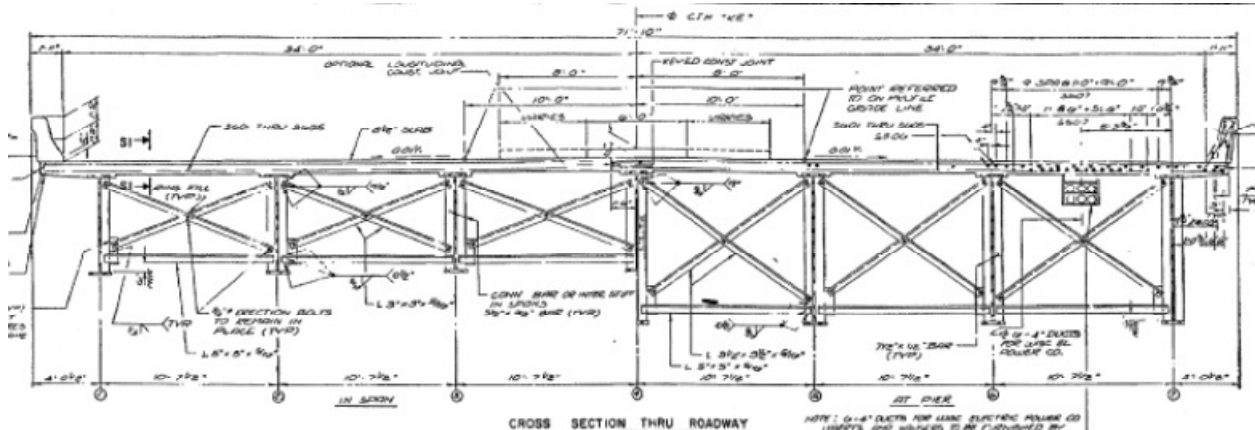
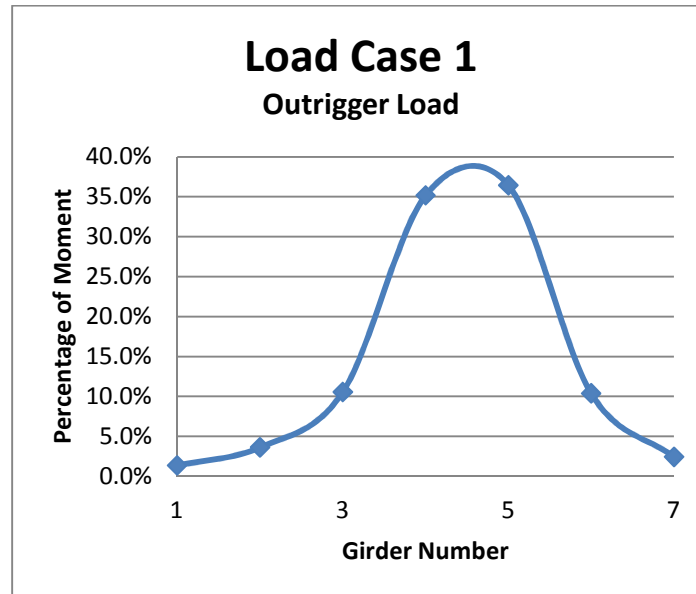

FIG. 11 - Cross Section - CTH KE over STH 16 from Design Drawings

Bridge B67-173 – Load Case 1

Figure 12 shows the positive bending moment distribution of the 104,000 lb outrigger load placed between Girders G4 and G5. The load is examined at this location to represent a possible construction staging scenario in which traffic would remain open over Girders G1, G2 and G3, and the opposite side of the bridge would contain construction loads.

The outrigger load is laterally distributed across the bridge with approximately 36% of the load going to each Girder G4 and Girder G5. Approximately 11% is distributed to Girders G3 and G6 with small amounts also going to girders G1, G2, and G7.



Load Type	104,000 lb. Outrigger Load
Transverse Location	Centered between G4 & G5
Longitudinal Location	Midspan

FIG. 12 - Bridge B67-173 – Load Case 1

Bridge B67-173 – Load Case 2

As shown in Figure 13, the outrigger placed directly above Girder G4 in the mid-span of the bridge distributes approximately 48% of the total load to Girder G4. The same load distributes 19% to girders G3 and G5 and approximately 7% to Girders G2 and G6 respectively.

**Wisconsin Highway Research Program (WHRP)
Bridge Construction Live Load Analysis Guide**

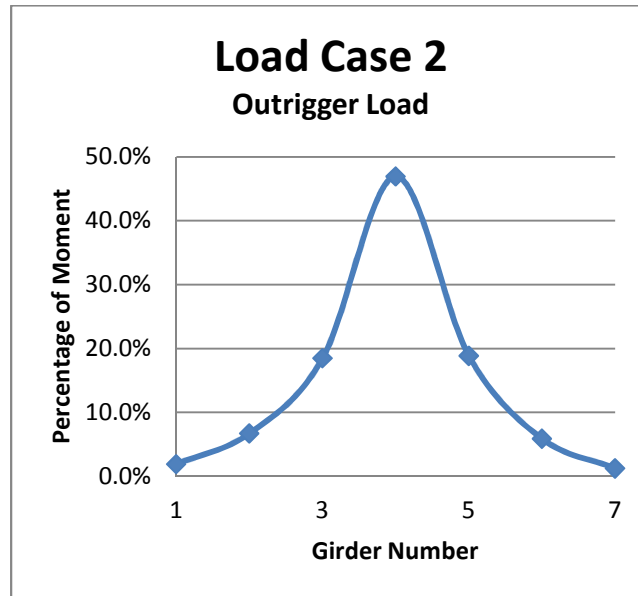

Load Type	104 K Outrigger Load
Transverse Location	Centered over G4
Longitudinal Location	Midspan

FIG. 13 - Bridge B-67-173 - Load Case 2

Bridge B67-173 - Load Case 3

In continuous bridges, the negative moment over a pier should be investigated as well as the positive moment in the center of a span. The negative moment of the pier resulting from placing the

outrigger between girders G4 and G5 and at midspan is shown in Figure 14. The distribution of moment is slightly more to the outer girders (in comparison to Load Case 1) as the load progresses towards the pier. It is therefore concluded that the load does not distribute laterally as much at the pier as it does near midspan.

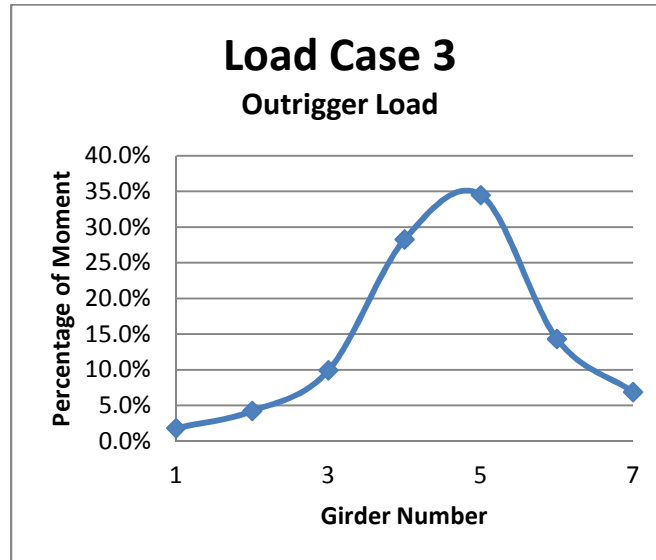

Load Type	104 K Outrigger Load
Transverse Location	Centered between G4 & G5
Longitudinal Location	Midspan

FIG. 14 - Bridge B67-173 – Load Case 3

Load cases 4A and 4B examine placing the outrigger in between girders G4 and G5 on a 4'x4' and 6'x6' timber mat. As shown in Figure 15, the 4 foot square timber mat has very little effect on the load distribution to the girders,. The total moment and percentages of load distribution change by less than one percent.

The change in bending moment distribution is also insignificant with a 6'x6' timber mat. The total moment is reduced by spreading the load out along the length of the bridge, however the distribution percentage of the moment does not significantly change.

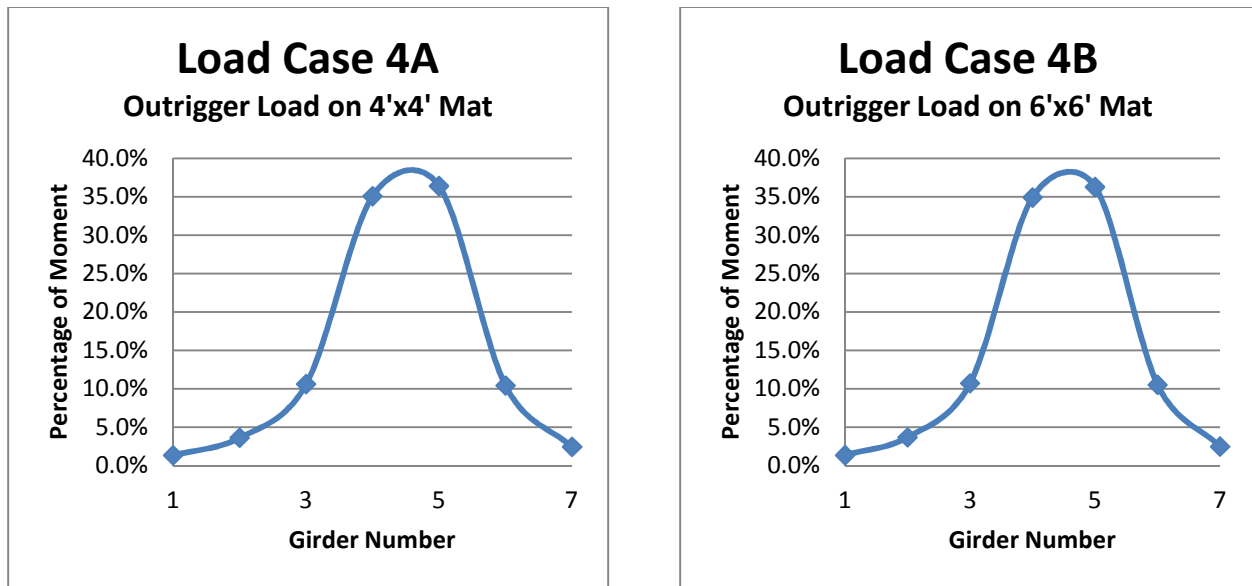

Load Type	104 K Outrigger Load on 4x4 Mat (Load Case 4A) 104 K Outrigger Load on 6x6 Mat (Load Case 4B)
Transverse Location	Centered between G4 & G5
Longitudinal Location	Midspan

FIG. 15 - Bridge B67-173 – Load Case 4A and 4B

Bridge B 67-173 – Load Case 5A & 5B

Load cases 5A and 5B examine the same timber mats as Load cases 4A and 4B except the outrigger load is centered over Girder 5. The outrigger load placed on a 4'x4' timber mat directly above a girder has a 1% reduction (compared with Load Case 2) in the load distributing to the girder below, as shown in Figure 16. A 6'x6' mat decreases the loading an additional 2% (compared with Load Case 2) which correlates to approximately a 5% - 10% reduction in loading taken by the girder from the outrigger alone to a six by six mat.

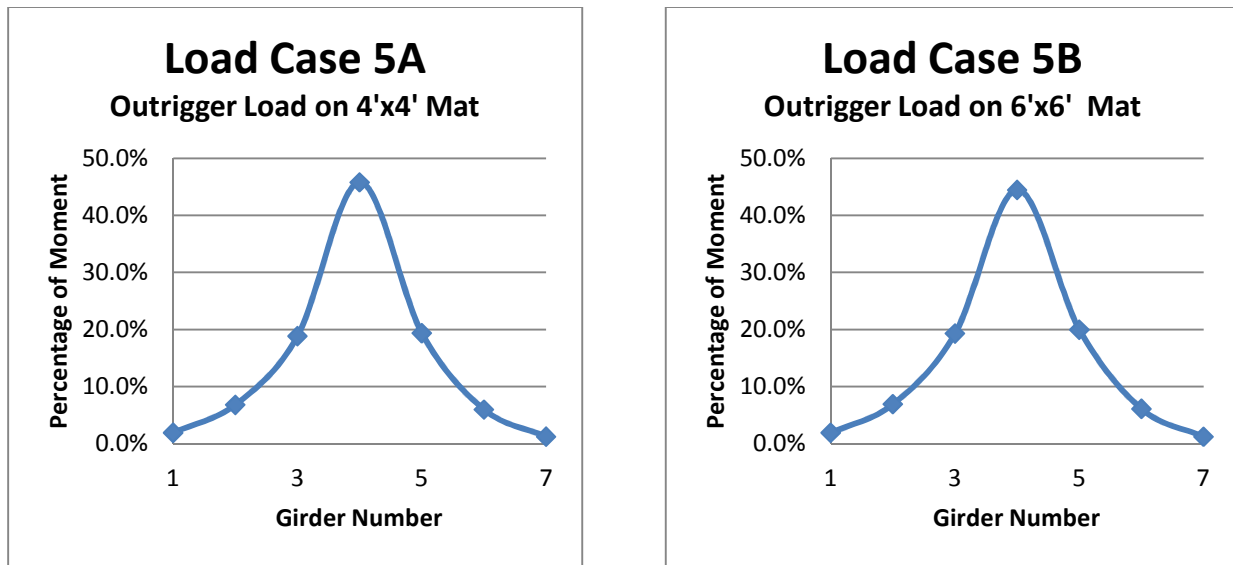

Load Type	104 K Outrigger Load on 4x4 Mat (Load Case 5A) 104 K Outrigger Load on 6x6 Mat (Load Case 5B)
Transverse Location	Centered over G4
Longitudinal Location	Midspan

FIG. 16 - Bridge B-67-173 – Load Case 5A and 5B

Bridge B67-173 – Load Case 6

The CAT770 dump truck load is examined acting at mid-span of the bridge with the wheel loads placed approximately between girders 3 and 4 and between girders 4 and 5. as shown in Figure 17, Girder 4, with the two wheel lines straddling it, receives 33% of the load, and Girders 3 and 5 receive about 24% each, and Girders 1 and 7 receive about 2% each.

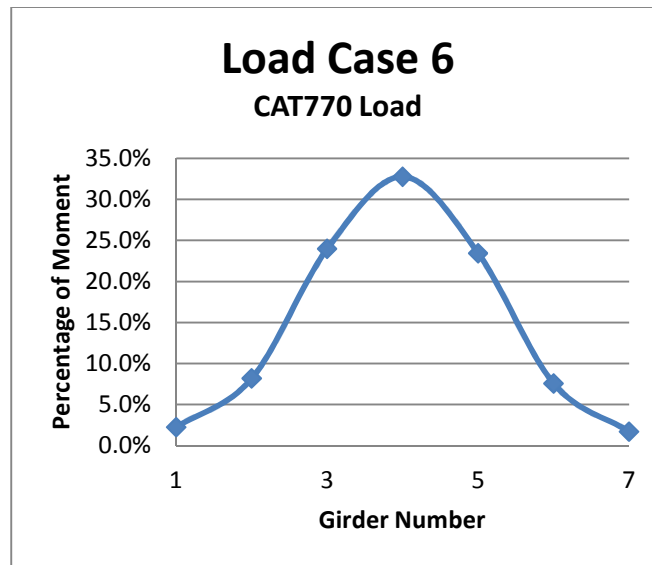

Load Type	CAT770 Truck Load
Transverse Location	Centered between G3 & G4
Longitudinal Location	Midspan

FIG. 17 - Bridge B-67-173 – Load Case 6

Bridge B67-173 – Load Case 7

Load Case 7 has the CAT770 located at midspan with the wheel lines placed directly above Girders 4 and 5. as shown in Figure 18, the loads are distributed with Girders 4 and 5 each receiving 32% of the load, and Girders 3 and 6 each receiving 12% to 14% of the load.

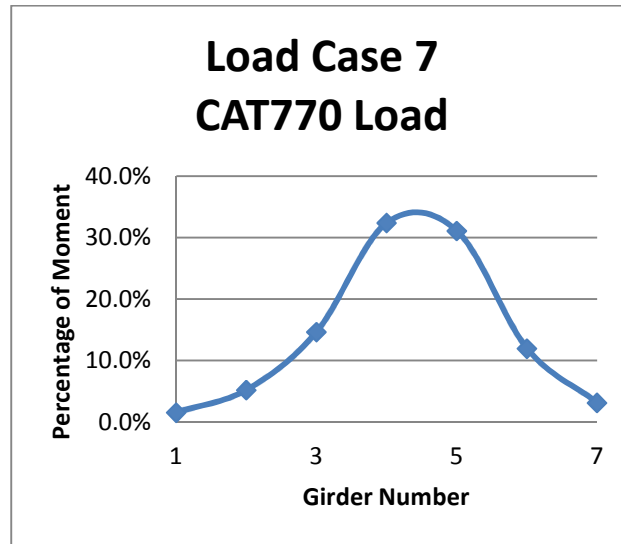

Load Type	CAT770 Truck Load
Transverse Location	Centered over G4 & G5
Longitudinal Location	Midspan

FIG. 18 - Bridge B67-173 – Load Case 7

Bridge B67-173 – Load Case 8

Load Case 8 represents a possible construction stage in which two traffic lanes are open over girders 1, 2, and 3. Figure 19 shows the bending moment distribution between girders for the two traffic lanes. Most of the load is distributed to the three girders below the lanes. The remainder of the load distributes about 8% to Girder 4 and less than 3% to the remaining three girders. This information can be superimposed with analysis for the heavy construction working on the other side of the bridge to determine total live load to each girder.

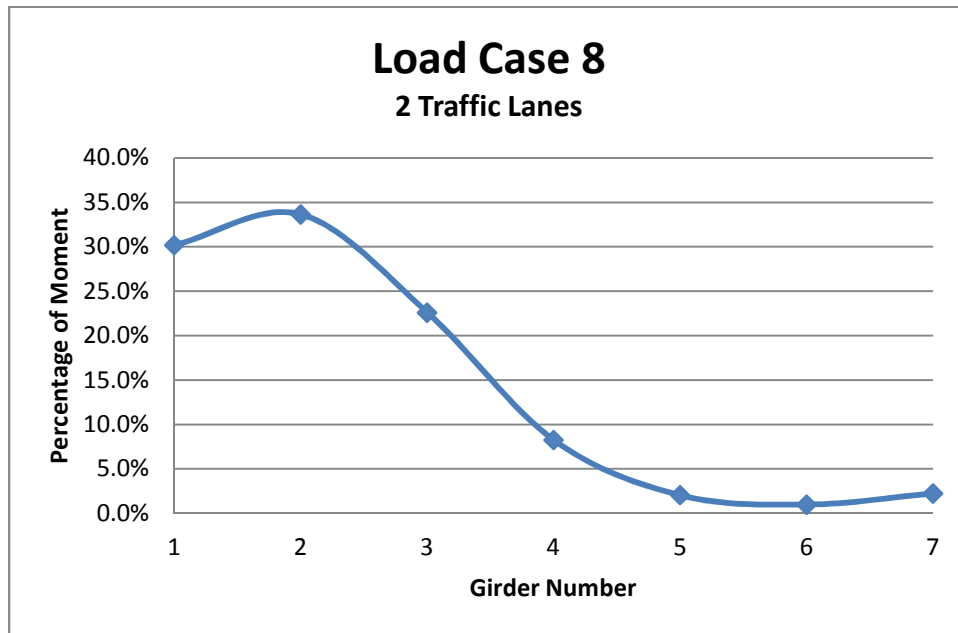

Load Type	HL 93 (Lane + Concentrated)
Transverse Location	Uniformly from G1 to G3
Longitudinal Location	Midspan

FIG. 19 - Bridge B67-173 – Load Case 8

Bridge B09-273 – STH 27 over the Holcombe Flowage

STH 27 over the Holcombe Flowage in Chippewa County, Bridge Number B09-273, is a three-span composite prestressed girder bridge with a total span of 425'-0" and an out to out width of 46'-11". The superstructure consists of six 6'-0" deep prestressed bulb tee girders spaced at 8'-0" and an 8" thick deck. The girders are 8,000 psi concrete with 0.6 inch diameter grade 270 low relaxation strands. The deck is 4,000 psi concrete with 60 ksi mild reinforcement. The two abutments are designed as expansion bearings while the two center piers act as fixed bearings. The structure was built with a slight curvature having a radius of 12,000 feet, which was included in the finite element of the bridge. The roadway is a two-lane bridge with 10 foot wide shoulders at each edge. Figures 20 and 21 were developed from the original design drawings and show the plan and cross section views for the structure.

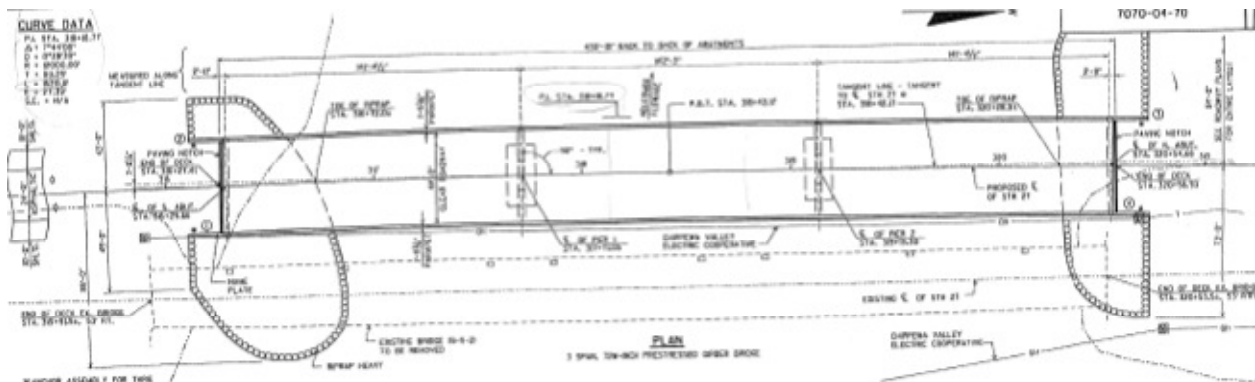

FIG. 20 - Plan View - STH 27 over the Holcombe Flowage from Design Drawings

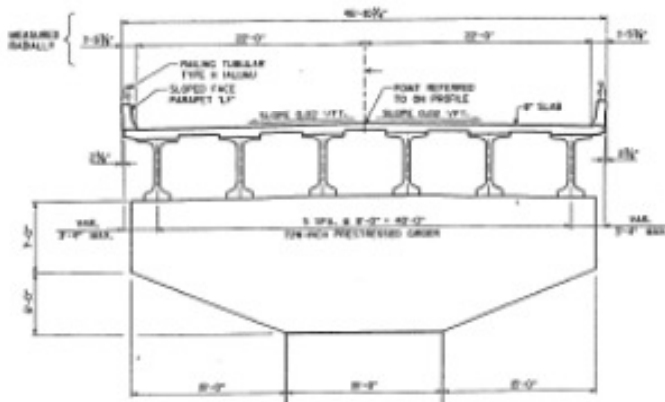
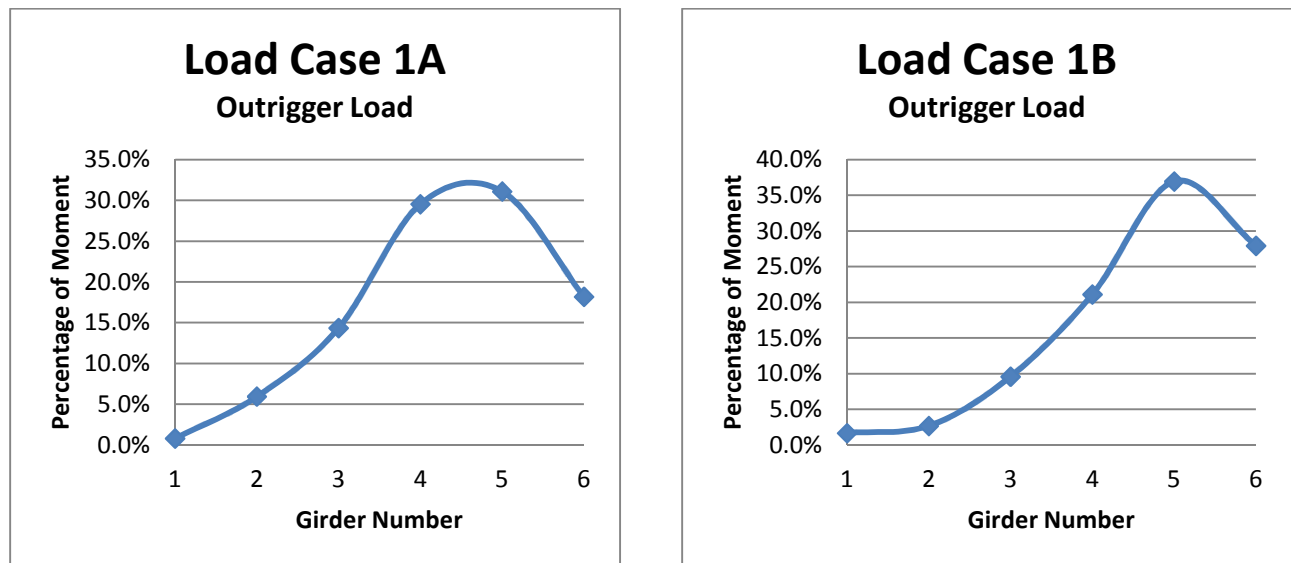

FIG. 21 - Cross Section - STH 27 over the Holcombe Flowage from Design Drawings

Bridge B09-273 – Load Case 1A & 1B

Load Case 1A examines the 104,000 lb. crane outrigger load placed between Girders G4 & G5 at midspan and Load Case 1B places the outrigger directly above girder G5 also at midspan. This transverse location was selected to determine the effects of loading the bridge near an exterior girder and also to simulate construction loads on one side of the bridge while traffic could be open on the other side. The outrigger load placed between girders distributes approximately 30% of the load to each of the nearest girders, as shown in Figure 22. The girder load percentage is increased to approximately 37% when the outrigger load is centered above the girder. For Load Case 1B, the adjacent interior girder, G4, receives about 22% of the load, while the exterior girder, G6, receives 28% of the load.



Load Type	104 K Outrigger Load
Transverse Location	Between Girders G4 & G5 (Load Case 1A) Centered over G5 (Load Case 1B)
Longitudinal Location	Midspan

FIG. 22 - Bridge B09-273 – Load Case 1A and 1B

Bridge B09-273 – Load Case 2A & 2B

Load Cases 2A and 2B examine the same 104,000 lb outrigger force in the same transverse locations as Load Cases 1A and 1B, except the outriggers are placed a few feet from a pier instead of at midspan. The outrigger force being placed a few feet from the pier shows an increase in load applied to the nearest girders compared to Load Case 1. The outrigger placed between Girders G4 & G5 results in approximately 38% percent of the load distributed to each adjacent girder, up from 32% at midspan loading (Load Case 1A). The outrigger placed directly on girder G5 near the pier distributes 60% of the load to G5, as shown in Figure 23.

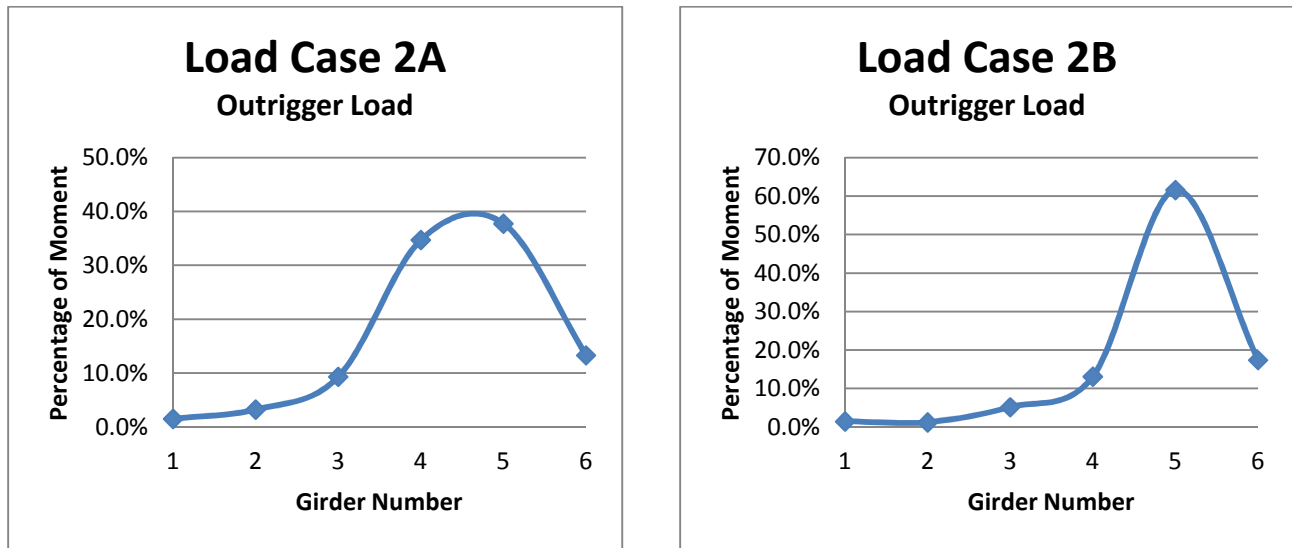

Load Type	104 K Outrigger Load
Transverse Location	Between girders G4 & G5 (Load Case 2A) Centered over G5 (Load Case 2B)
Longitudinal Location	Close to Pier

FIG. 23 - Bridge B-09-273 – Load Case 2A and 1B

Bridge B09-273 – Load Case 3A & 3B

Load Case 3A examine the CAT770 wheels loads both between Girders G3 and G4 and between G4 and G5. Load Case 3B examines wheel loads directly above Girders G4 and G5. As shown in Figure 24, the wheels centered between girders distribute 27% to the straddled girder and 21% to 23% to the adjacent two girders. The wheels located above the girders distribute 27% to girders G4 & G5, 23% to Girder G6 and 16% to Girder G3.

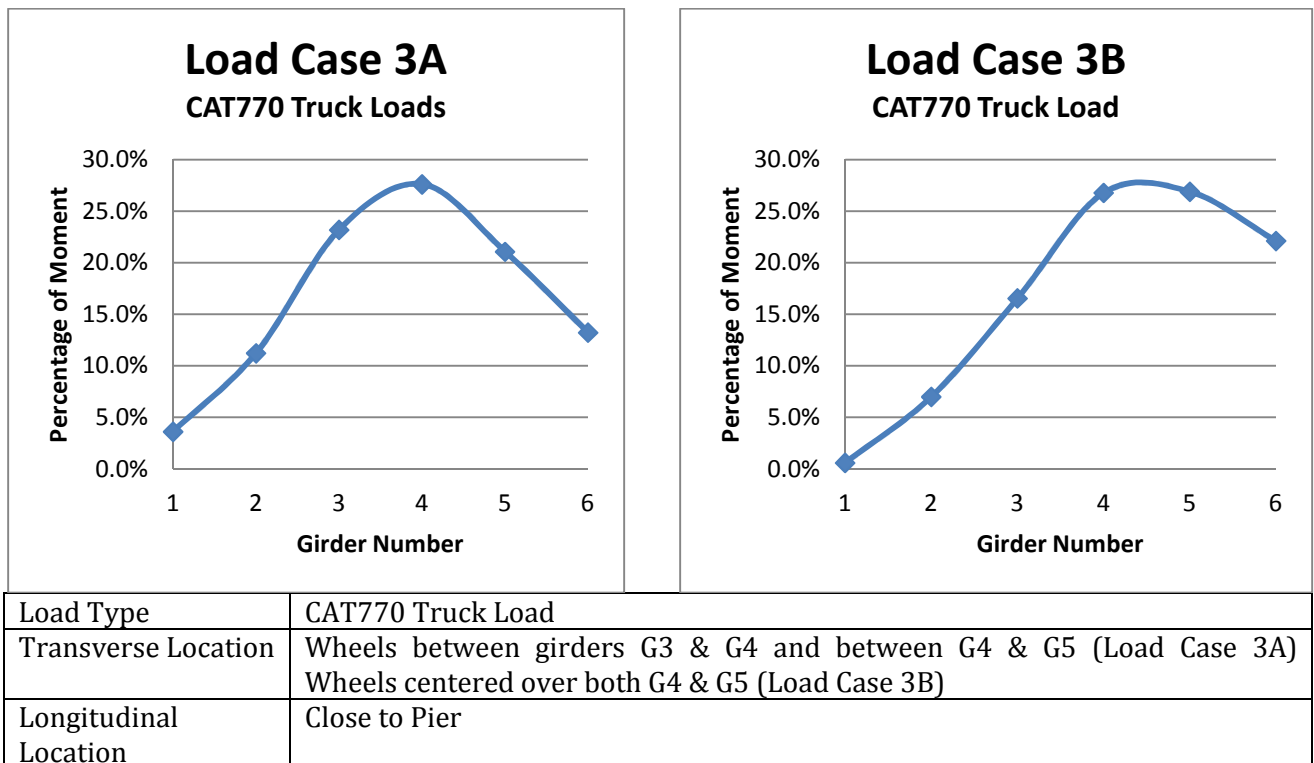
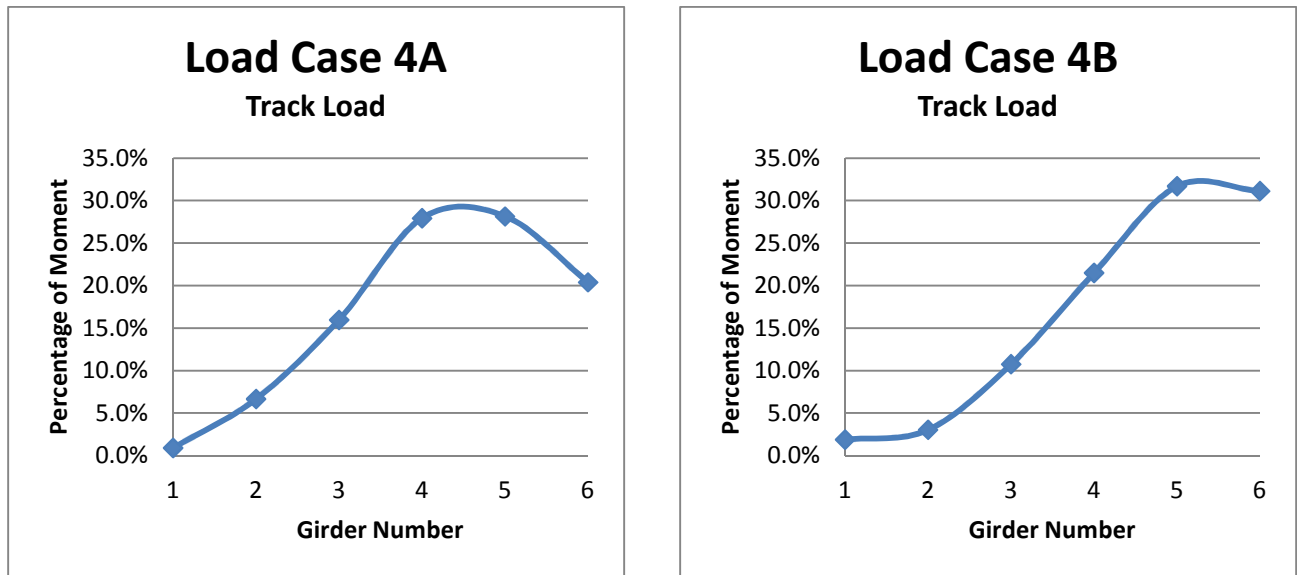

FIG. 24 - Bridge B-09-273 – Load Case 3A and 3B

Bridge B09-273 – Load Case 4A & 4B

The track load placed between Girders G4 & G5 (Load Case 4A) distributes approximately 29% to each adjacent girder. The track load directly above Girder G5 (Load Case 4B) distributes 32% to the girder below the track and 21% Girder G4. The adjacent Girder G6 receives 31% of the load because it is the exterior girder, and because the load cannot distribute any further.



Load Type	240 K Track Load (24 ft. x 4 ft. Track)
Transverse Location	Track located between girders G4 & G5 (Load Case 4A) Track centered over girder G5 (Load Case 4B)
Longitudinal Location	Close to Pier

Bridge B09273 - Comparison Summary

A comparison of the three pieces of equipment acting in similar locations on the bridge show very similar load distribution to the girders.

Slight differences occur due to the more concentrated force of the outrigger loads distributing the nearest girders with a higher percentage load vs. the more uniformly distributed forces of the crane track or the CAT770 truck.

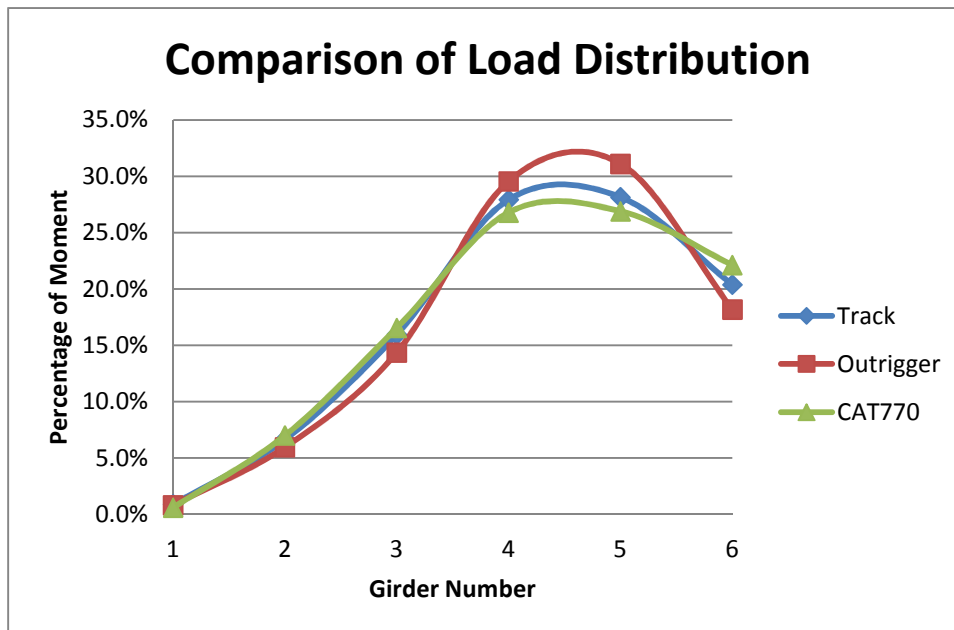



**Wisconsin Highway Research Program (WHRP)
Bridge Construction Live Load Analysis Guide**



Distribution Factors based on AASHTO Equations

Three methods were used to determine theoretical distribution factors for the different structures. As expected, the lever rule results in a conservative figure compared to the AASHTO equations. The AASHTO Standard Specification 17th Edition provides factors slightly higher than the newer AASHTO LRFD factors. This is the result of more specialized equations in the LRFD code which allows for less conservative assumptions.

Computed Distribution Factors										
Bridge	Type	Standard	LRFD				Lever Rule		Lever Rule CAT 770	
			Int. Mom.	Int. Shear	Ext. Mom.	Ext. Shear	Interior	Exterior	Interior	Exterior
B-09-0273	Prestressed Girders	0.725	0.523	0.814	0.523	0.658	0.875	0.762	0.6	0.606
B-30-0005	Slab	0.149	0.083				-	-	-	-
B-67-0173	Steel Girders	0.965	0.553	0.993	0.554	0.807	1.059	0.876	0.92	0.744

The AASHTO distribution equations must take many unknowns into account such as overloaded trucks and lane width changes during construction phases. These unknowns force the AASHTO distribution factors to be conservative for design of the bridge. Specific construction loads can be more closely controlled for both weight and location, significantly reducing the uncertainty in the loading. Therefore, more accurate load distribution factors can be utilized when the risk of load variation is minimal.

The lever rule check for the CAT770 truck shows a decrease in the distribution factors because of the larger transverse wheel spacing. It would be expected that the AASHTO distribution factors could also be reduced based on the spacing of the wheels, tracks, outriggers, etc. For example, the AASHTO Standard Specification distribution factor for Bridge B09-0273 is 0.725. The CAT770 maximum load to anyone girder at midspan is under 30%. Therefore, using the AASHTO Standard Specification load distribution factor to determine the CAT770 load distribution to each girder would result in a value more than double than provided by the finite element analysis.

The AASHTO LRFD distribution factor of 0.523 is closer to the distribution found for the CAT770, but is almost double the distribution found in the computer analysis. The fact that the AASHTO equations are designed for typical vehicle traffic means that they cannot be easily correlated to larger construction equipment and unique load cases such as a single outrigger or crane track. Therefore, equations and factors pertaining to these specific types of construction loads should be provided as a guide for engineers and contractors to follow.



Wisconsin Highway Research Program (WHRP) Bridge Construction Live Load Analysis Guide



Punching Shear

Punching shear was examined for a typical 8" thick deck slab, as well as the slab on the 30th Ave over Pike River Bridge. The outrigger loads control over heavy haul truck wheel loads and crane track loads. The computations for the punching shear capacities are included in the appendices.

For the 30th Ave bridge deck, an outrigger distribution of 2'x2' has an allowable outrigger load of 489 kips. The allowable load increases to 743 kips for a 4 foot square distribution and to 997 kips for a 6'x6' foot mat. These capacities would be adequate for most construction activities.

Punching shear is more critical to examine on a typical deck of a girder bridge. On an 8" thick deck, the punching shear capacities for a 2 foot square, 4 foot square, and 6 foot square load layout are 94 kips, 134 kips, and 171 kips respectively. These values could be surpassed by crane outrigger loads in some cases, and therefore, it is usually best to place outriggers directly above the girders, and/or use grillage systems to distribute load to the girders.

Conclusion

The analysis of the three structures with three different types of common construction load provides data which can be correlated into guidelines for load distribution factors. For loads placed between girders on a steel or concrete bridge, the type and size of load has minor impact on the load distribution. A very concentrated outrigger load distributes about 32% to each of the adjacent girders, while crane tracks distribute approximately 28%, and the heavy haul truck is 27%. Based on this analysis, it would be reasonable to conservatively assume 40% of the total load of a piece of heavy equipment is transferred to each adjacent girder. If one of the adjacent girders is an exterior girder, then 50% would be distributed to it.

A load placed at or near midspan and directly over a girder, transfers 30% to 40% of the load to the girder below. 15% to 25% of the load then distributes to the two adjacent girders. These numbers should be adjusted if an exterior girder is involved and the distribution is limited by the bridge width. It seems reasonably conservative to therefore assume that for a construction load located near midspan and directly over a girder, that 50% of the load would be distributed to the girder below.

Less distribution between girders occurs as the load is placed in proximity to a pier or abutment support. Loads centered between girders and within a few feet of a support distribute 60% to 70% of the load to the girder below. These same loads distribute 35% to 45% to the adjacent girders. It would be therefore be conservative to assume 80% distribution to a girder directly below the load, and 50% distribution to adjacent girders for a load centered between girders. This same distribution could also be used for loads within a quarter-span length from the support. In that area of the span, the moment is significantly less than midspan loading, and therefore the larger distribution factor will most likely not control. The shear values to the girders at these locations would become the critical item to check.



Wisconsin Highway Research Program (WHRP) Bridge Construction Live Load Analysis Guide

The use of timber mats has little effect on the distribution amounts to each girder on a bridge. A timber mat can be utilized to reduce the total moment caused by a load by distributing the load over the length of the bridge. Therefore, the same percentage of moment would still be taken by each girder, however the moment would be slightly less because of the load distribution of the timber mat. Timber mats are however useful to reduce the effects of punching shear on an outrigger load which cannot be placed directly over a girder.



**Wisconsin Highway Research Program (WHRP)
Bridge Construction Live Load Analysis Guide**



SECTION 3- Bridge Construction Live Load Guide



Wisconsin Highway Research Program (WHRP) Bridge Construction Live Load Analysis Guide



3) Bridge Construction Live Load Guide

Introduction

Construction of new bridges, bridge rehabilitation and replacement projects may require placing materials or operating equipment on the bridge during construction. This requirement increases as construction sites become congested and limited staging areas are available.

This Guide is intended to provide guidance for assessing the effects of construction loads in typical bridge structures under construction. Construction loads are often very heavy and applied to localized areas as compared to standard highway design loads. Both overall and local load effects need to be addressed. In addition, the bridge may be in a deteriorated condition, or the construction activities may themselves alter the bridge behavior.

Construction Loads

Construction loads on bridges include materials loads and equipment loads. Materials loads include stockpiled materials prior to placement into the structure as well as construction debris resulting from removal and demolition activities. Equipment loads include relatively static loads, such as a pile driving rig operating from a bridge deck or moving loads such as trucks or hydro-demolition equipment.

Materials Loads

Both the magnitude and location of materials loads dictate the effects of the loads on the bridge. Estimates of the weights of materials should be based on calculated weights that accurately account for compaction, bulking, moisture content, angle of repose and specific material unit weights. Load effects of materials should also account for impact where materials may be dumped or dropped. Load placement and magnitude should be controlled during construction to assure overloads do not occur.

Equipment Loads

Equipment loads may be static loads or moving loads. However, even with static loads the equipment must normally travel over portions of the structure to reach its static or operating location. In some cases the equipment moves across the bridge, perhaps only once, while in other cases it operates and travels about the bridge deck. The effects of the equipment must be based on the actual equipment and configuration to be used, and must be developed through close coordination with the contractor. Various models and configurations are often available for a given piece of equipment, each of which may differ in weight, track width, wheel loads, etc., so it is critical that full data be available. Equipment loads often vary dramatically from standard AASHTO truck loads in both magnitude and distribution. Equipment data is often available on manufacturer's websites, although contractors may use older equipment whose data is not available and must be obtained through the contractor.



Wisconsin Highway Research Program (WHRP) Bridge Construction Live Load Analysis Guide



Crane Loads

Crane loads may be due to a crane moving over the bridge to be relocated, or the result of the crane operating from a specific position. Determination of crane loads must address the following factors:

- Make and model of the crane, including amount and distribution of counterweights
- Maximum lift, including rigging weights
- Swing limits
- Maximum radius of lift
- New construction vs. demolition activities

Transfer of loads from the crane into the bridge structure is through the tracks (for crawler cranes) or outriggers for wheel or truck mounted cranes. Crane selection is made by the contractor based on the specific task to be performed, access to the job site, availability and cost. Crane loads depend upon the type and model of crane as well as the specific configuration of the crane. For instance, depending upon the specific job requirements, a base crane model may be configured with differing counterweights, track widths or track center-to-center spacing, all of which affect loads, and load distribution.

As the load is lifted and moved laterally (swung) the load distribution to the tracks or outriggers changes. The structure must be evaluated for the worst case load distribution. Load distributions can be calculated using statics if sufficient weight and geometric data is available for the crane; however, in most cases the loads are provided by the crane supplier/manufacturer. Figures 3.1, 3.2 and 3.3 show typical printouts of crane track pressures while Figure 3.4 shows a load diagram for a crane on outriggers. Track pressures provided by manufacturers or calculated using manufacturer computer programs are computed for either soft support, Figure 3.1, such as earth, beneath the track or hard support, Figure 3.2. Track pressures to bridges should be based on a hard surface (concrete deck) support under the tracks, even if timber mats are used. Track pressures are based on the contact area of the track and are frequently reported as pounds per square foot (Figures 3.1 and 3.2) or pounds per square inch, Figure 3.3. The crane dimensional data for the tracks is then used to compute the applied loads. The track contact width is generally less on a hard surface than on a soft surface as can be seen by comparing the tread contact width shown in Figures 3.1 and 3.2. For tracked equipment, the length of track available to contact the deck or ground is approximately equal to the distance between the centerline of the sprockets as opposed to the overall track length.

An impact factor is not normally applied to crane loads. Crane movements are performed at a slow speed and the lifting operations are also performed in a controlled manner. A 10 percent increase in the lifted load – not crane weight – may be applied for normal operations and a factor of 20 percent on the lifted load is recommended when performing demolition to account for any “hang up” as members are removed. This is added to the lifted load value used to calculate the resulting track or outrigger loads.

When cranes operate from the structure, a lateral load due to wind should also be accounted for in the load calculations. Design wind pressures should be calculated in accordance with ASCE/SEI 7-10 “Minimum Design Loads for Buildings and Other Structures” with appropriate wind velocity reductions for the exposure time. An option is to remove the crane during high winds. Cranes only operate in low winds, and the booms can be lowered to reduce loads when not in use.

Wisconsin Highway Research Program (WHRP) Bridge Construction Live Load Analysis Guide

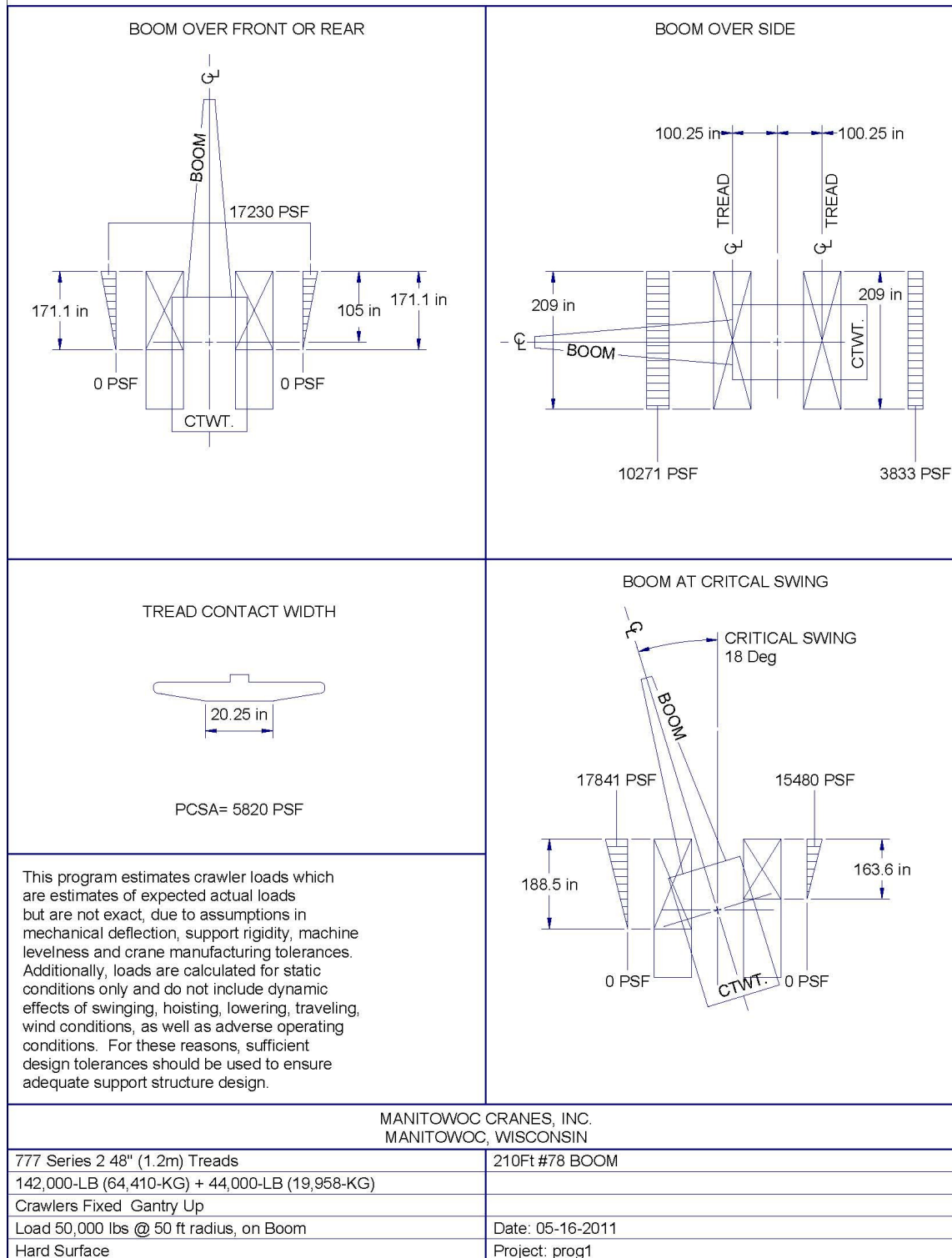

Figure 3.1 Crane Track Pressures, Hard Surface, Manitowoc 777

Wisconsin Highway Research Program (WHRP) Bridge Construction Live Load Analysis Guide

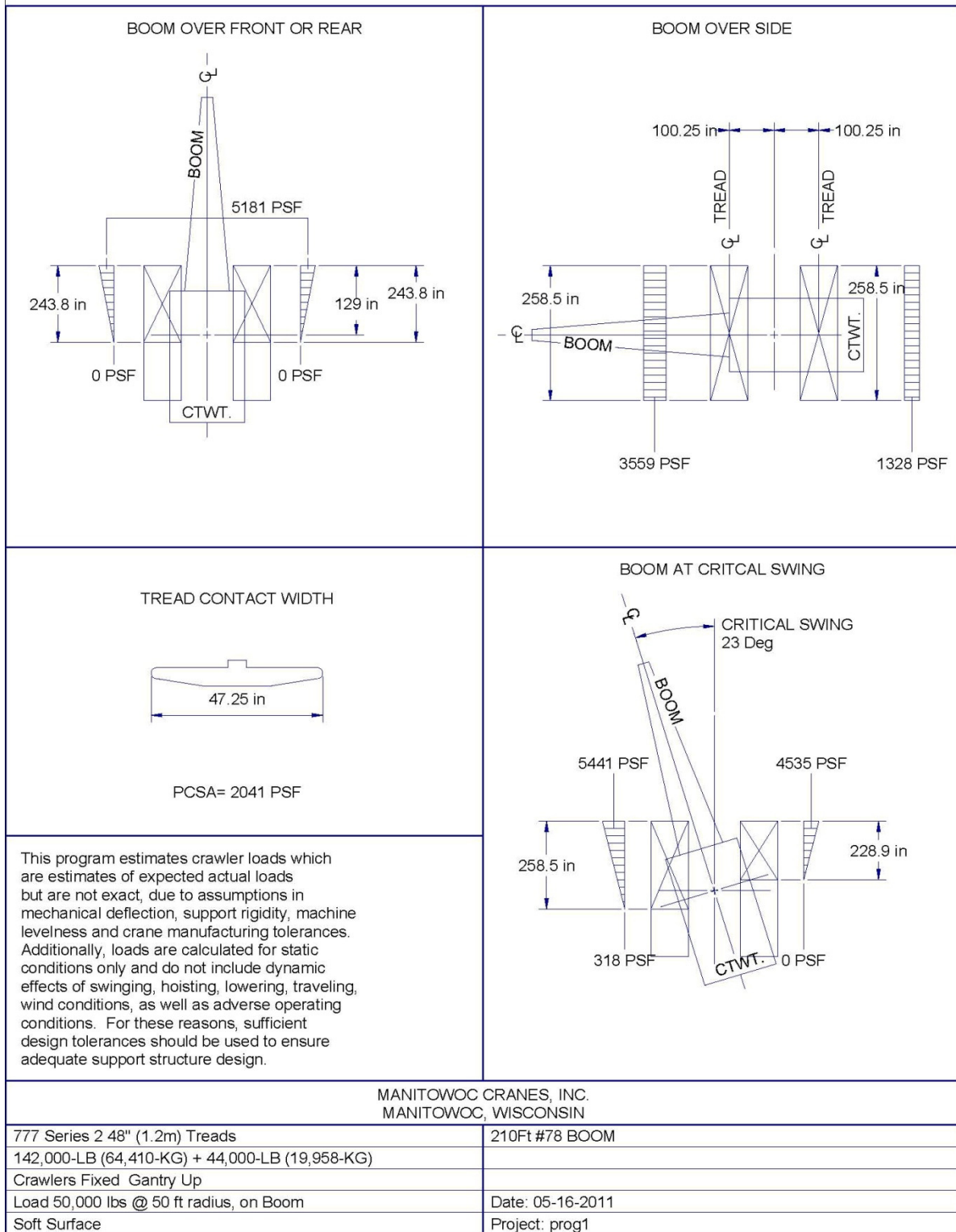
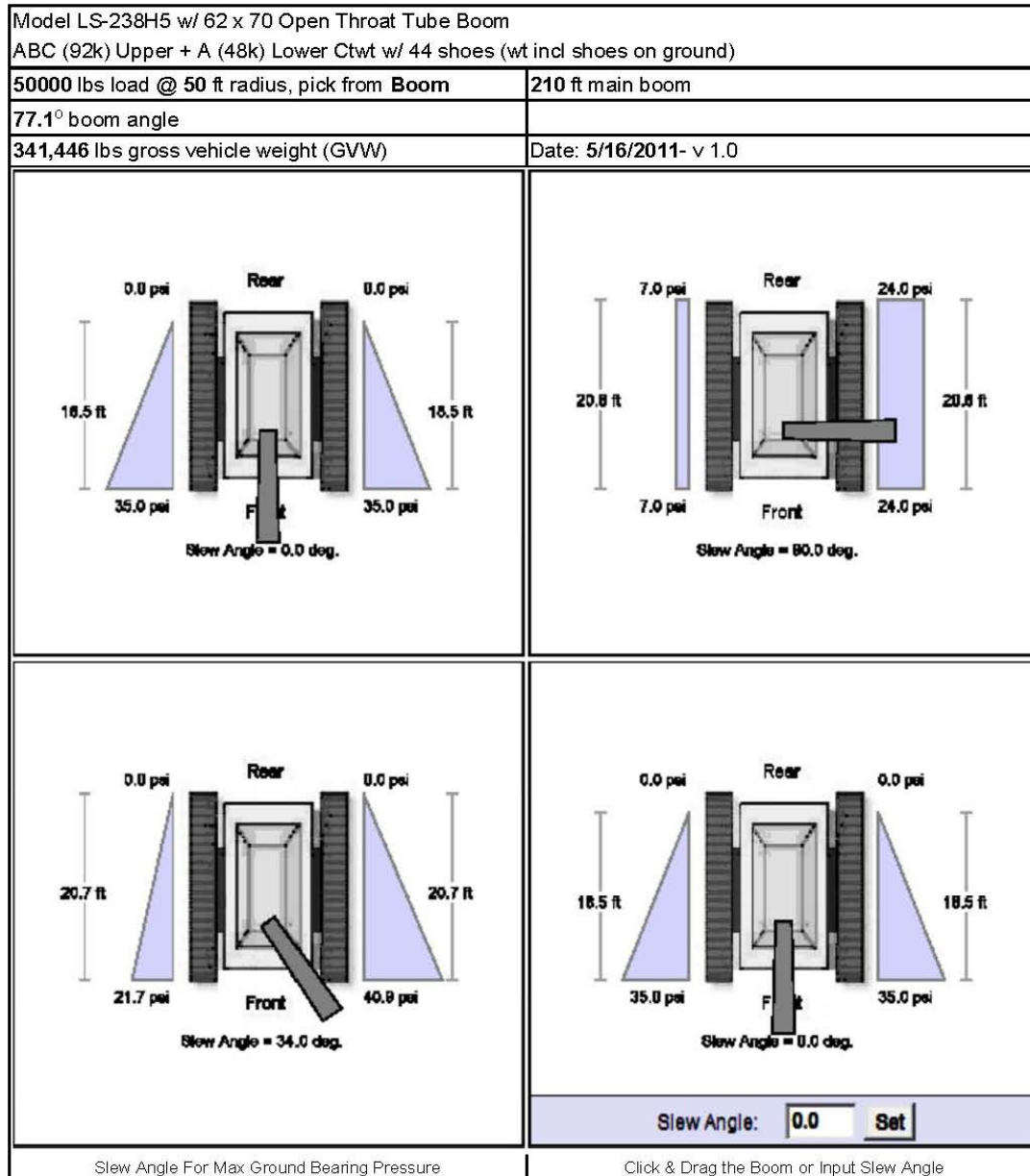

Figure 3.2 Crane Track Pressures, Soft Surface, Manitowoc 777

Link-Belt Constructon Equipment Co., Lexington, Kentucky - 238 HYLAB 5



CAUTION: DO NOT USE FOR CAPACITIES!

User to consult the crane rating manual or capacity plate supplied with the machine for input values used in these ground bearing reaction calculations. Do not exceed allowable lifting capacities for configured machine setup.

Figure 3.3 Crane Track Pressures, Link-Belt 238 HYLVB5

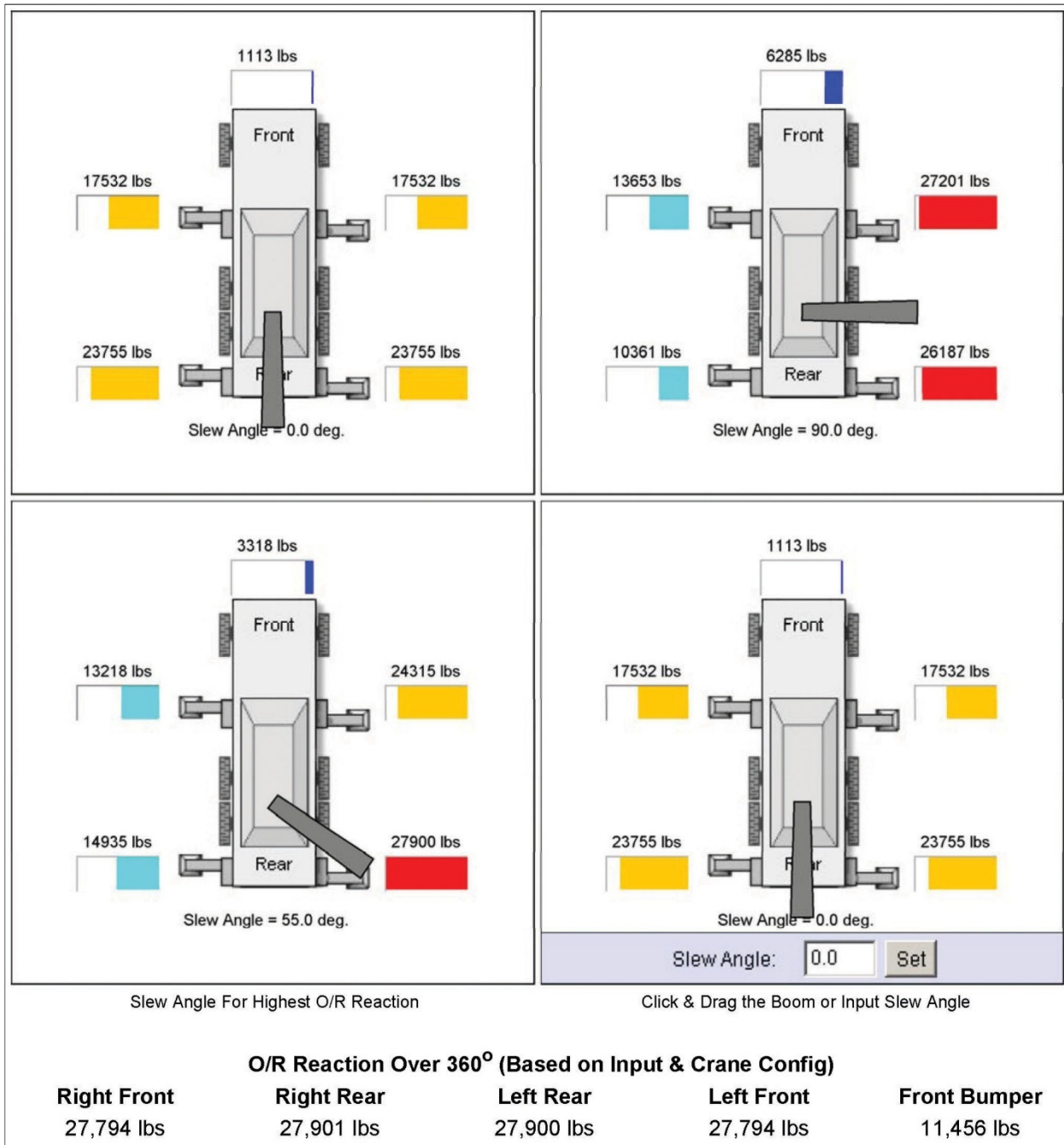

Figure 3.4 Representative Outrigger Loads

Loaders and Excavators

Loaders and excavators may be mounted on tracks or wheels. Track and wheel load data should be obtained from the manufacturer’s data for the specific piece of equipment to be used. The total load as well as load distribution to axles or tracks will depend on specific attachments (bucket size and capacity,



Wisconsin Highway Research Program (WHRP) Bridge Construction Live Load Analysis Guide



hydraulic breaker weight, etc.). Since equipment usage may change over the course of a project, it is recommended that the design account for maximum potential loads so that no added design checks, which could cause project delays, are required for these cases. While many pieces of equipment will produce loads less than the standard AASHTO design loads, other pieces can exceed these loads.

When tracked equipment turns, one track is stopped in place and the equipment is pivoted about this track. Design loads should include a lateral load factor of ten percent of the equipment weight to account for turning operations, as well as starting and stopping. This load should be applied longitudinally as well as laterally.

Trucks

Many trucks utilized by contractors fall within normal AASHTO live load provisions. However, heavy haul trucks or earthmovers are often utilized, particularly where extensive earthwork is part of the project and these do not meet standard AASHTO load criteria. These vehicles are characterized by short wheel bases and heavy axle weights. Figure 3.5 shows the wheel loads for some representative heavy haul equipment, along with the HS20-44 truck load as a comparison.

Design loads should be based on equipment load data provided by the manufacturers for the specific equipment to be used. The wheel contact area should also be provided. When not provided, wheel contact area can be calculated by dividing the wheel load by the tire pressure. Heavy haul vehicle impact effects may be reduced below standard AASHTO values since travel speeds are normally slow; however this reduction in impact factor should be based on bridge deck conditions and speed constraints and control. A minimum impact factor of 10 percent should be included, even for very slow speeds.

Pump Trucks

Pump trucks may be supported on outriggers during operations similar to cranes. Load data should be obtained from the manufacturer. While pump trucks are legal loads during travel, outrigger loads may be quite high during pump operations, with the maximum loads occurring with the boom approximately over the outrigger.

Paving Equipment

Loads from paving equipment include bridge deck pavers and finishing machines for new deck construction, as well as pavers for placing deck overlays. Bridge deck pavers and finishing machines are supported by rails that run atop the (outside) bridge girders. Paving machines used for overlays run on wheels or tracks atop the deck. Specific load data to include weights and distributions should be obtained from equipment manufacturers.

Volvo A400

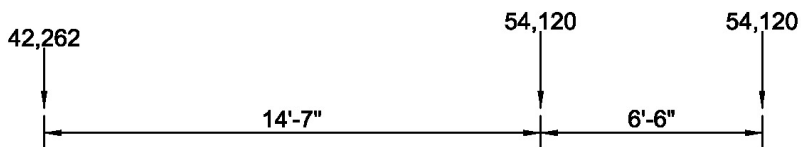

CAT 740

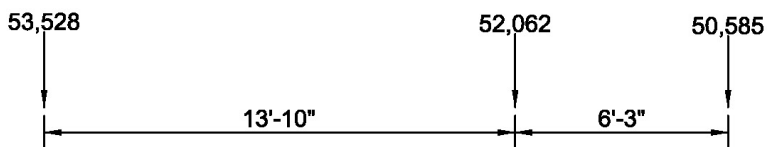

CAT 621G (Scraper)

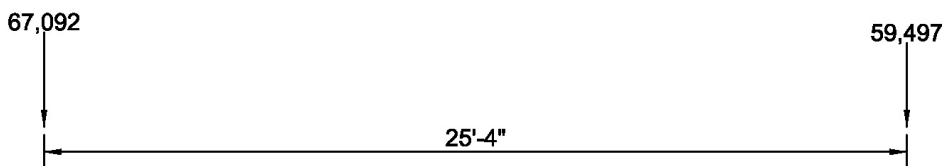

AASHTO HS 20-44

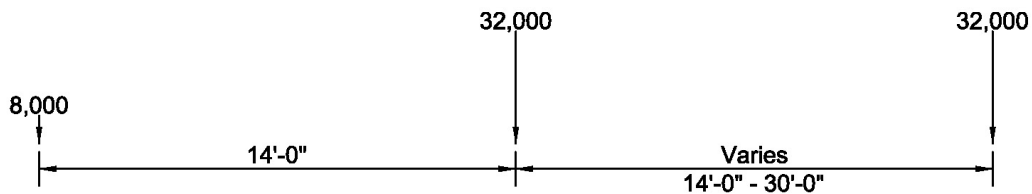

Figure 3.5 Representative Wheel Loads for Heavy Haul Trucks vs. AASHTO HS20-44 Truck



Wisconsin Highway Research Program (WHRP) Bridge Construction Live Load Analysis Guide



Specialized Equipment

Various types of equipment may be used or adapted by contractors for use in bridge construction projects. As an example, straddle lifts have been used to place girders. Equipment loads should be obtained from manufacturers when available. If not available, loads can be calculated based on statics, or determined by actual loads tests.

Construction Loads General

Some times during construction, the size, weight and load of construction vehicles or equipment may come into question by the projects' engineer or construction inspector. The contractor may propose to use a certain piece of equipment or vehicle on the bridge. In many of those cases the on-site engineer will ask the contractor to provide proof that the structure is not overloaded prior to allowing the work to be done. This scenario may cause delays to the project schedule since the contractor has to stop work and provide the proof. This section of the research seeks to provide contractors and on-site engineers with guidance to help minimize the occurrences of these types of problems.

Weight Limitations on Class "A" Highways

No person, without a permit, may operate on a class "A" highway any vehicle or combination of vehicles unless the vehicle or combination of vehicles complies with the following weight limitations:

- (a) The gross weight imposed on the highway by any one wheel or multiple wheels supporting one end of an axle may not exceed 11,000 pounds.
- (b) The gross weight imposed on the highway by the wheels of any one axle may not exceed 20,000 pounds.
- (c) The gross weight imposed on the highway by any group of 2 or more consecutive axles of a vehicle or combination of vehicles may not exceed the maximum gross weights in the statutes (See Appendix D) for each of the respective distances between axles and the respective numbers of axles of a group.

Weight Limitations on Class "B" Highways

No person, without a permit may operate on a class "B" highway any vehicle or combination of vehicles imposing wheel, axle, group of axles, or gross weight on the highway exceeding 60 percent of the weights authorized for Class A Highways.

Contractor Provided Information

As an effective first step, the contractor should provide the on-site engineer with relevant vehicle and equipment information from which to make a more informed decision. This Information at a minimum should include:

- Manufacturers Equipment Sheet
- GVW- Empty + Payload
- Number of Axles
- Maximum Actual Axle Weight (Single or Tandem)
- Distance Front to Back Axles

This information could be provided in a table format similar to as shown below for all vehicles prior to arriving site. A comparison of the proposed vehicle weights to the statutes would provide the on-site engineer with a document which shows that the proposed equipment does or does not meet the statute requirements. Table 3.1 below shows an example of typical equipment and the relevant information that could be provided.

TABLE 3.1

Vehicle Type	Manufacturer	Model Number	Actual GVW (LBS)	# of Axles	Max Single Axle Weight (LBS)	Max Tandem Axle Weight	Distance Front to Back Axle (FT.)	Allowable GVW from Statute Tables
Self Propelled Scraper	Caterpillar	631G	193,567	2	97,870	N/A	28.75	40,000
Wheel Loader	Samsung	120	22,707	2	18,300	N/A	9.40	39,940
Wheel Loader	Volvo	L90 w/QC	33,830	2	16,310	N/A	9.83	39,983
Wheel Loader	Volvo	L120	42,340	2	33,025	N/A	10.50	40,000
Wheel Loader	Caterpillar	980	67,138	2	47,000	N/A	12.17	40,000
Wheeled Excavator	Liebherr	A904	46,500	2	25,420	N/A	9.00	39,000

Please note the values in Table 3.1 above are only assumed values, and the actual values should be obtained from the equipment manufacturers. Allowable GVW's were determined by interpolation where actual axle distances are between table values.

In the example table above the Caterpillar 980 Wheel Loader Vehicle has a Gross Vehicle Weight (GVW) of 67,138lbs which exceeds the Allowable 40,000 lbs of GVW provided by the statutes for the vehicle

wheel base. Additionally, the maximum single axle weight of 47,000 lbs for the Caterpillar 980 exceeds the allowable axle weight of 20,000 lbs by statute. This vehicle therefore does not meet statutes. Using similar information for the Samsung 120 and the Volvo L90 loader shows that both the GVW and axle weights are less than the allowable statute loads.

Another Less Conservative Approach

The Wisconsin Statutes do not apply to construction vehicles within the limits of a project. As such, it seems realistic to provide a less conservative approach to be used during construction. Currently bridges are designed for vehicles with GVW's and single axle values that exceed the values allowed by Wisconsin Statutes. The following vehicles and loads are typical of design vehicles for most of the bridges currently designed in Wisconsin:

- HS20 Truck- (GVW=72,000 lbs), maximum axle load = 32K (Minimum axle spacing of 14 feet)
- HS25 Truck – (GVW=90,000 lbs) maximum axle load = 40K (Minimum axle spacing of 14 feet)
- HL93 Load- (GVW=72,000 lbs+ lane load) maximum axle load of 32K + Lane Load of 0.64k/ft.

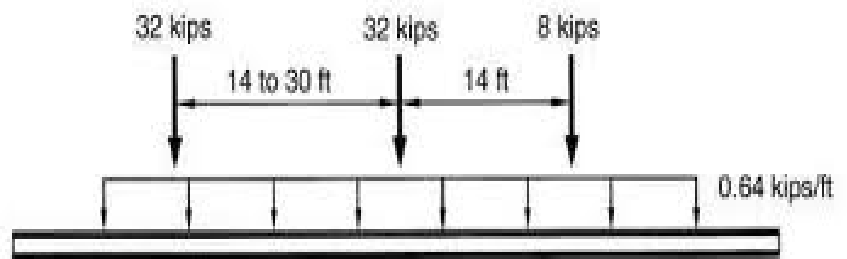

HL 93 Design

Given that the original design vehicle can be determined for many of the bridges in Wisconsin it seems reasonable that the maximum GVW's and/or axle weights of the design vehicles could be used as an upper limit of what could be allowed to be used on the bridge. These values however should be considered as upper limits, and could be lowered due to other factors including but not limited to:

- Unsafe bridge conditions
- Changes to bridge condition or configuration that may have an effect on the structures capacity
- Loads which exceed a bridges posted value shall not be allowed
- Loads which exceed a bridges operating rating shall not be allowed
- Redundancy, allowable loads may be reduced for non-redundant bridges
- Other conditions as determined by WisDOT

The contractor should provide similar but more expanded information as before. Some of this information is available from the inspection report for the bridge under consideration. This Information at a minimum should include:

- Manufacturers Equipment Sheet
- GVW- Empty + Payload



Wisconsin Highway Research Program (WHRP) Bridge Construction Live Load Analysis Guide



- Number of Axles
- Maximum Actual Axle Weight (Single or Tandem)
- Distance Front to Back Axles
- Original Design Vehicle
- Existing Inventory Load Rating
- Existing Operating Load Rating
- Existing Posted Load
- Bridge Redundancy

The information noted above should be provided in tables similar to those shown below for all vehicles prior to arriving site. It is noted that redundancy is an important factor when considering the allowable load to pass over a structure. Failure of one of the girders in a non-redundant bridge could cause complete collapse of the bridge.

Table 3.2

Bridge	Bxxxxxx
Redundancy	Redundant
Design Vehicle Type	HS20 etc.
GVW	72,000
Max Axle Weight	32,000
Bridge Inventory Rating	57,600
Bridge Operating Rating	79,200
Bridge Posting Load	32,000

Table 3.3

Vehicle Type	Manufacturer	Model Number	Actual GVW (LBS)	Max Axle Weight Loaded (LBS)	Exceeds Design Vehicle GVW ?	Exceeds Design Vehicle Axle Weight?	GVW Exceeds Bridge Operating Rating?	GVW Exceeds Bridge Posting?
Self Propelled Scraper	Caterpillar	631G	193,567	97,870	Yes	Yes	Yes	Yes
Wheel Loader	Samsung	120	22,707	18,300	No	No	No	No
Wheel Loader	Volvo	L90 w/QC	33,830	16,310	No	No	No	No
Wheel Loader	Volvo	L120	42,340	33,025	No	Yes	No	Yes
Wheel Loader	Caterpillar	980	67,138	47,000	No	Yes	No	Yes
Wheeled Excavator	Liebherr	A904	46,500	25,420	No	No	No	Yes



Wisconsin Highway Research Program (WHRP) Bridge Construction Live Load Analysis Guide



A comparison of the proposed GVW and axle weights to the information provided would provide the on-site engineer with a document which shows that the proposed equipment does or does not meet the requirements. Any vehicle or equipment, for which an answer of “yes” is given in the table, would be prohibited from using the bridge, unless a more detailed analysis proves the bridge is safe to carry that load. Said another way, only those vehicles or equipment for which all answers are “no” in the table would be considered for crossing the bridge. The final determination however, of whether a vehicle is allowed to cross the bridge would be left to the discretion of WisDOT.

Detailed Analysis

For conditions where the preliminary study shows that the allowable limits have been exceeded (as an example the allowable GVW or axle load exceeds the GVW or axle weight of the design vehicle) a more detailed analysis would be required. Sample detailed rating calculations are provided in the Appendices E & F for informational purposes. Additionally, Appendix G provides a checklist that can be used by contractors to assist in the bridge analysis for construction loads. Appendix H provides a checklist that can be used by a project engineers to assist in the bridge analysis for construction loads.

Bridge Assessment

Assessment of the ability of a bridge to sustain construction loads should be based on as-built bridge plans and current bridge conditions. The very fact that the bridge is undergoing rehabilitation suggests that the existing structural capacity has probably been reduced. Bridge load posting and rating information should be reviewed, and whenever possible, a site visit to verify available documentation should be made. If recent inspection data is not available, then a field inspection may be needed. This inspection can be limited to those areas of the bridge affected by the construction loads.

Load capacity calculations must account for member section loss or reinforcing steel losses due to corrosion as well as cracked or damaged members and connections. For older bridges, specific information on the bridge dimensions and materials properties may be unavailable. Field measurements can be made to obtain dimensional data. Unknown material properties can be based on information in the AASHTO “Manual for Bridge Evaluation” for typical bridge materials found in bridges of differing ages. When calculations based on such data show marginal or insufficient bridge capacity, the use of nondestructive or partially destructive (i.e., coring) testing may be able to be used to determine actual material properties for use in analysis. Materials properties obtained from testing are often found to be stronger than those assumed simply from the “typical” construction materials of a given age. Where major reconstruction or rehabilitation is being undertaken, it may even be possible to extract samples from steel members which are to be replaced later.

Structure capacity computations must be based on bridge conditions at the particular stage of construction when the loads are applied. As an example, for a bridge widening project, the contractor may wish to place a pile driving crane on the bridge deck over an existing pier in order to drive piles for the foundation widening. If the existing bridge is to receive a new deck as part of the project, then local damage to the existing deck may be acceptable, where it is not acceptable if the deck is to remain.



Wisconsin Highway Research Program (WHRP) Bridge Construction Live Load Analysis Guide



Deck removal operations generally utilize equipment located on the bridge deck for breaking or cutting slabs for removal. In evaluating member capacity, the effect of losing composite action from areas where the deck has been removed should be considered for bridges designed as composite structures. Girder stability may also be adversely affected by deck or lateral bracing removal. This may be a particular problem if loads exceeding the original construction loads are present in adjacent spans or members.

Partial deck removal, patching, and milling operations remove deck concrete, sometimes extending to below the top mat of the existing reinforcing steel. Hydro-demolition equipment, for example, operates directly atop deck sections that have the upper concrete removed. The capacity of the remaining deck should be evaluated accounting for the reduced deck thickness as it affects both moment and shear capacities. Should deck repair include an increased deck thickness to improve top reinforcing bar cover, or addition of a wearing surface, the effects of the added concrete weight during placement must be considered.

Calculation of the structure capacity must account for the specific location of construction loads. For equipment such as cranes or excavators, the load effects to the bridge during travel may differ from that resulting from equipment operation at a specific location. Where normal traffic will continue in operation in lanes adjoining those subject to construction operations, the associated vehicle traffic load effects on the girders that support construction loads must be included, as well as the load transfer of construction loads to the traffic lanes.

The effects of the applied loads during construction therefore shall not exceed the available capacity for any portion of the bridge as delineated below:

- For redundant bridges, capacity may be based on operating stresses for materials and equipment loads, except heavy haul trucks.
- For non-redundant bridges, capacity shall be based on inventory stresses unless otherwise approved by the WisDOT Chief Structures Development Engineer.
- For heavy haul trucks with Gross Vehicle Weights exceeding 90,000 pounds, capacity shall be based on inventory stresses.

Bridge capacity shall be determined in accordance with the procedures contained in “The Manual for Bridge Evaluation.”

It is recommended that the distribution of the construction loads to the bridge be determined using a three-dimensional grillage analysis or other computer models which account for the contribution of deck stiffness and diaphragms/cross frames in lateral load distribution. In lieu of such an analysis, a lateral load distribution may be made utilizing the distribution factors in Figure 3.6, and applying superposition principles. The distribution factors in Figure 3.6 were developed from analysis of non-curved girder bridges considered representative of typical Wisconsin bridges and should be used recognizing this basis. Where distribution factors to a beam are not shown, the computed distribution factor was less than 0.05, and considered small enough to be neglected.



Wisconsin Highway Research Program (WHRP) Bridge Construction Live Load Analysis Guide



Where the construction area adjoins lanes carrying traffic, the effects of this must be accounted for in both the construction and traveled areas. Unless a more refined analysis is performed, for girder bridges these effects should be computed as follows:

- For traffic loads transferred to the construction area, the beam nearest the traffic lane should be designed for a traffic live load moment and shear of 0.15 times the design loads from the girder under traffic.
- The distribution of construction loads to the girders under traffic should conform to the distribution factors shown in Figure 3.6.

These lateral distribution factors are based on the bridge deck and diaphragms/cross bracing being in place.

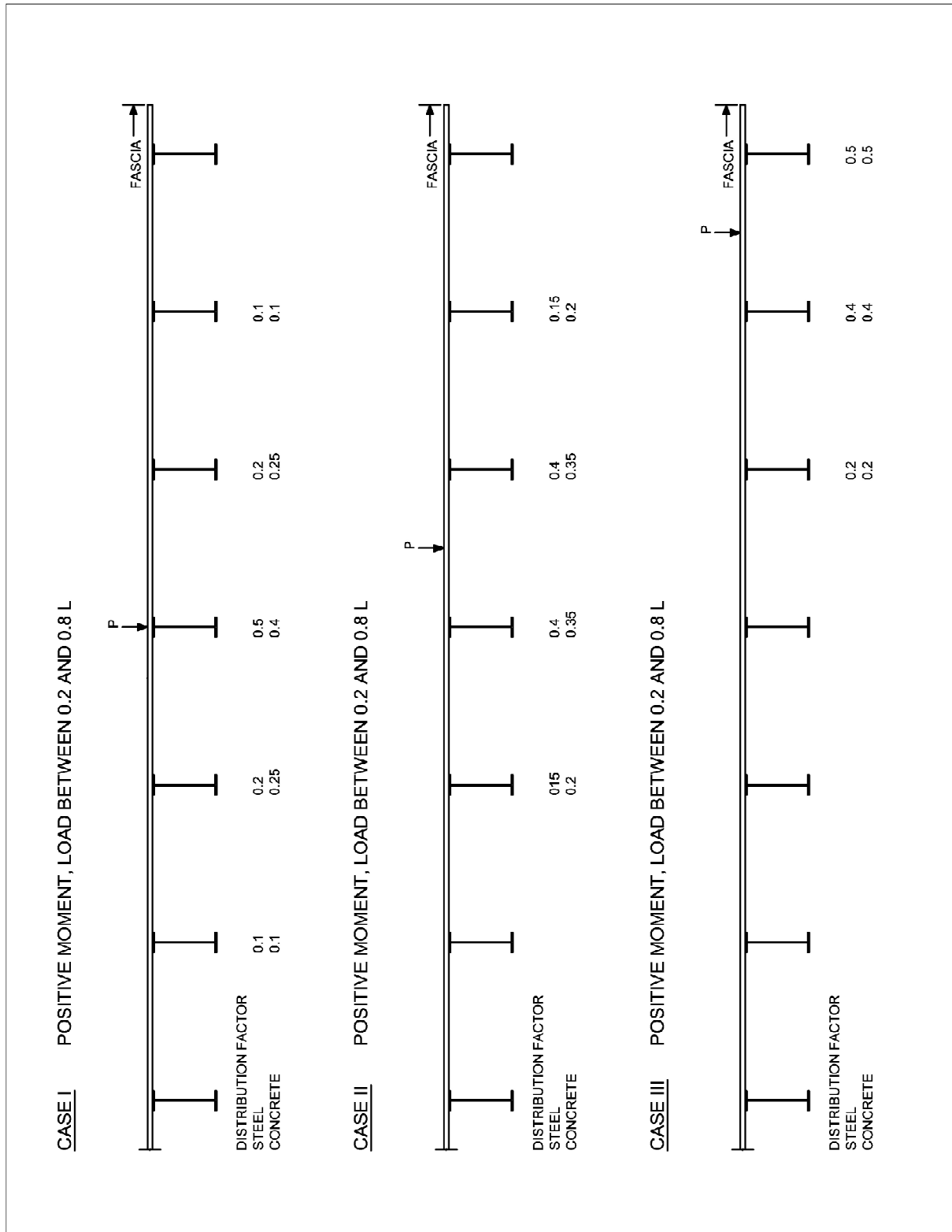

Figure 3.6 Lateral Load Distribution Factors

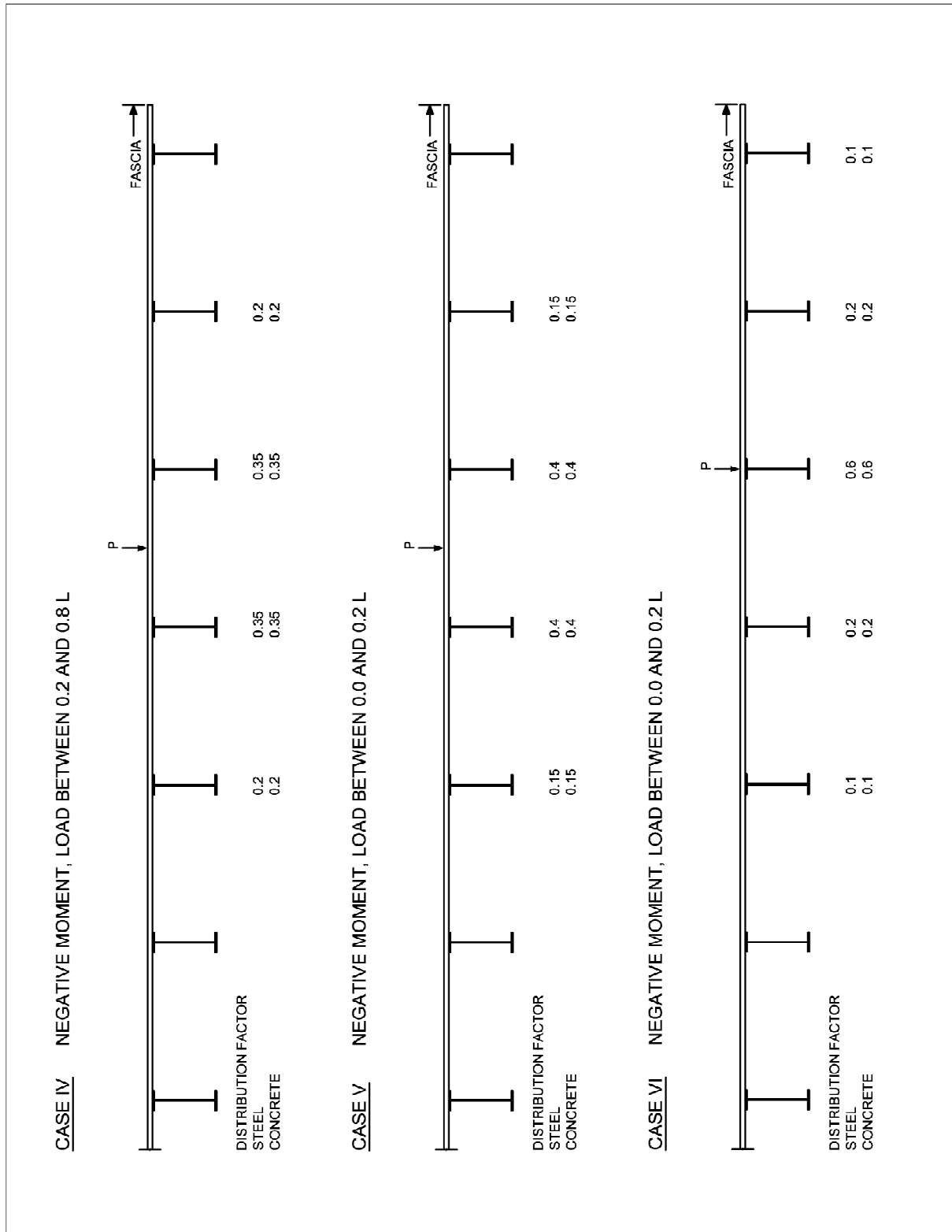

Figure 3.6 (Continued)

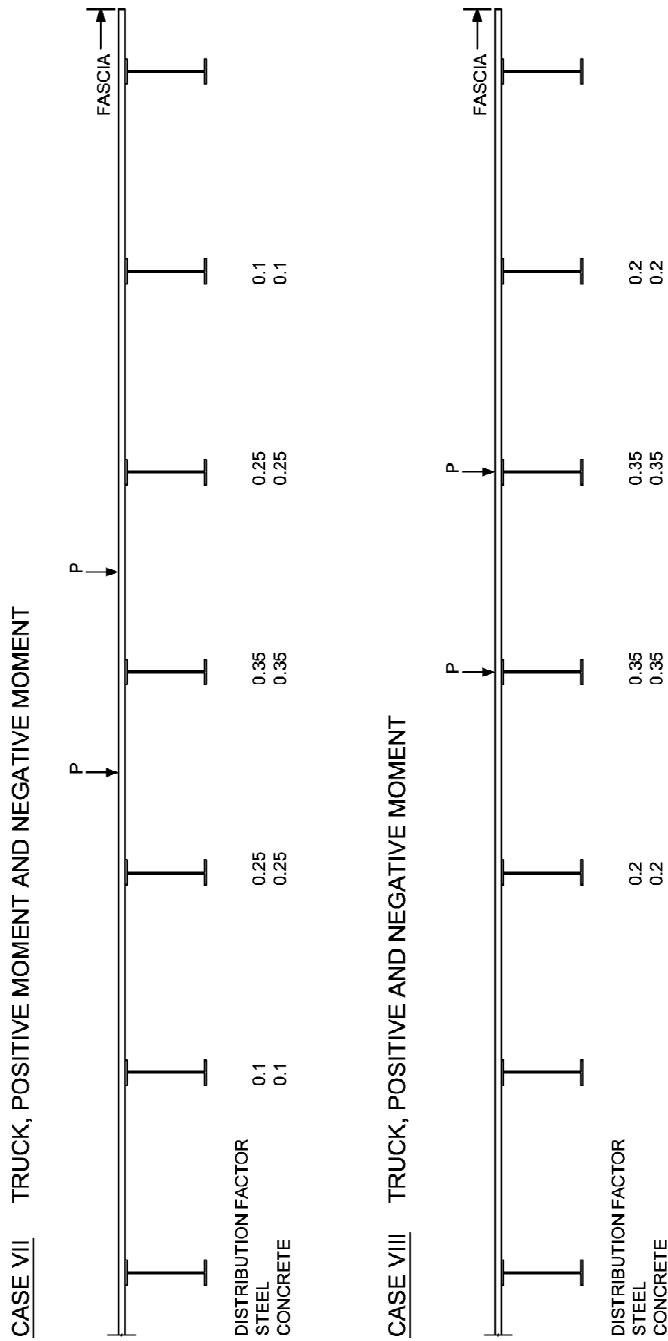

Figure 3.6 (Continued)



Wisconsin Highway Research Program (WHRP) Bridge Construction Live Load Analysis Guide



Construction loads are typically applied only a few times over the duration of a construction project. As a result, fatigue effects are not normally considered in evaluating their effects. A possible exception to this might include multiple passages of heavy haul trucks or excavators over a bridge, in which case the expected number of load cycles should be determined, and the bridge owner consulted to determine whether fatigue should be investigated.

Distribution Factors for Slab Type Bridges

The AASHTO Standard Specifications for Bridges utilize an effective width (E) to determine the live load distribution factors for use in determining the live load moment to be applied to the bridge. The effective width is limited to a maximum of 7 feet. The specifications provide for the calculation of a wheel load distribution factor (DF) as well as a lane load distribution factor.

For Wheel Loads the $DF = 1/E$ and therefore the minimum DF is 14.3% using the maximum effective width of 7 feet. For Lane Loads the $DF = 1/2E$ and therefore the minimum DF is 7.1% using the maximum effective width of 7 feet.

The effective width (E) is determined from the AASHTO Equation $E = 4 + 0.06L$ where L = span length of the bridge. Using this equation and the maximum effective width of 7 feet, the minimum distribution factors would apply for all slab type bridges over 50 feet in length. Given that slab type bridges are not typically an economical choice for spans much greater than 50 feet, the actual distribution factors calculated using AASHTO Standard Specifications will typically be greater than the minimum values shown above.

Grillage analysis shows that the distribution factors for lane type loading predicted by the AASHTO Equations correspond relatively well to those predicted by the grillage analysis. The distribution factors for concentrated loads or wheel loads predicted by AASHTO appear to be more conservative than those predicted by grillage analysis.

The AASHTO LRFD Bridge Design Specifications use an effective width (E) to determine the distribution factors for live load moment. The LRFD Specifications use a single or multiple lane load scenario for the calculation of distribution factors, and do not use a wheel load type distribution factor. Grillage analysis shows that the distribution factors for lane type loading predicted by the AASHTO LRFD Equations also correspond relatively well to those predicted by the grillage analysis.

WisDOT typically uses a lane load type analysis for determining the strip width for slab type structures and therefore it is recommended that the calculation of distribution factors for construction loads follow the WisDOT Bridge Manual. As options, the AASHTO distribution factors or a more refined computer analysis may be used to account for concentrated load distribution.

Deck Considerations

Bridge decks should be evaluated to assure adequate capacity in flexure and shear resulting from construction loads, recognizing that these loads may be both large and distributed over limited areas.



Wisconsin Highway Research Program (WHRP) Bridge Construction Live Load Analysis Guide



Flexure and shear capacity checks should conform to the provisions of the “AASHTO LRFD Bridge Design Specification,” with load factors consistent with “The Manual for Bridge Evaluation.” The existing deck conditions and the effect of any deck removal shall be accounted for in the analysis.

Substructure

The capacity of substructure components should be verified using the provisions in the “AASHTO LRFD Bridge Design Specifications,” and appropriate load factors. Pier caps should be evaluated for any increases to bearing loads and the potential of unbalanced live load moments in piers and shafts should be investigated, as these areas may have deterioration.

Connections

Connections should be investigated to assure that they are adequate for loads from construction materials and equipment. Local concentrated loads may produce connection loads that exceed capacity. Bearings and bearing stiffeners should also be investigated, particularly where loads are applied over girders and near the supports. The condition of pier caps at bearings should also be investigated.

Connection strength should be assessed in accordance with the “AASHTO LRFD Bridge Design Specifications.” Evaluation of gusset plate capacity should be in accordance with FHWA Publication No. FHWA-1F-09-014, “Load Rating Guidance and Examples for Bolted and Riveted Gusset Plates in Truss Bridges.”

Load Control

While much construction equipment can safely be supported on a bridge during construction, there are cases requiring measures to be taken to limit those effects, or provide supplementary support. Various techniques may be used to control the effects of construction loads. Commonly used methods include the following:

- Adjust load position
- Control equipment speeds
- Limit equipment capacity
- Assemble equipment in place
- Provide load distribution systems
- Provide temporary shoring
- Strengthen members

The simplest method to control effects of a load is to limit the position or magnitude of the load. This may be more difficult to achieve with equipment loads than for materials loads. Use of alternate types or sizes of equipment may result in reduced loads, though it generally also reduces the contractor’s efficiency. When load positioning is used, the area to be loaded should be physically demarcated with barricades or painted lines on the bridge deck. Load limits, such as equipment configuration, maximum

crane lift, or type and maximum height of stored materials should be conspicuously posted at the location. Similar means can be used to control loading locations for travel over the bridge. It is critical that all load or operating restrictions be rigidly enforced.

Impact loads are reduced as speeds are reduced. It is common for cranes to move at a walking speed when moving over a bridge, producing minimal impact. This will be more difficult for trucks and similar equipment; however, speed limits can be imposed. Restricting trucks to one vehicle on the bridge at a time will also limit loads. Another advantage of slow operating speeds is the opportunity to monitor bridge behavior under the load by visual observations, survey data, or other means.

Loads may be controlled by limiting the carried or lifted loads. The volume (weight) of material carried by a truck or in the bucket with an end loader or excavator bucket can be limited to a certain value, although this results in a drop in productivity. The allowable lifted load for a crane can also be limited to control the maximum outrigger or track pressures. Any such operating restrictions must be clearly explained to operating personnel and posted in equipment cabs, at loading points, etc., Figure 3.7.



Figure 3.7 Sign Posting Construction Load Restrictions

Cranes and equipment for drilled shaft installation, pile driving, or other activities may be too heavy to cross a bridge span, but may be able to safely operate when located over a pier. In such cases it may be possible to assemble the crane in place if individual components can be safely moved over the span(s). Installation of counterweights is often performed with the crane in its final position, and some cranes are specifically designed to place their counterweights unassisted. When a separate crane is needed, its load effects also need to be evaluated with the combination of both cranes in place.

Load distribution systems or grillages may sometimes be used to shift loads to locations with higher capacity or reduce overall applied load effects. In these cases a supplemental support structure, essentially a small bridge, is built to redirect loads to locations that can safely support them. The equipment may be assembled on the grillage or the grillage might only be required for operating conditions. The dead load of the grillage becomes an additional dead load on the bridge.



Wisconsin Highway Research Program (WHRP) Bridge Construction Live Load Analysis Guide

Cranes and excavators are often placed on timber mats that rest on the bridge deck. For track mounted equipment, the mats normally extend the width and length of the equipment. Outrigger supported equipment utilizes individual mats placed under each outrigger. Timber mats provide protection to the deck from track movement, and also improve load distribution. Timber mats used beneath tracked equipment are generally known as “crane mats,” and commonly consist of 12 inch by 12 inch timbers that are through bolted to create approximately four foot wide assemblies. Outrigger pads are typically square, ranging from four feet to eight feet square, constructed of 6 inch by 6 inch or 8 inch by 8 inch timbers (though sizes may vary). The lateral distribution of the vertical load through the timber mats placed on a concrete deck may be taken to occur on a 1V:1H plane through the mat thickness. Mats can be stacked to distribute the loads over a larger deck area. A uniform load distribution over the effective area is normally used for design. Mats must be designed for the resulting bending, shear and bearing stresses. Steel plates may be used under equipment to protect the bridge deck. However, due to their flexibility, they should not be counted on to provide load distribution.

Where construction loads cannot otherwise be accommodated, strengthening of individual members or installation of temporary shoring may be used. Design strengthening should conform to the “AASHTO LRFD Bridge Design Specifications,” and WisDOT requirements. Strengthening, temporary attachments or other modifications that are not removed upon completion of construction must be detailed so as not to adversely affect permanent load distribution, bridge fatigue performance or promote deterioration. The required extent of reinforcing is often limited to local areas or a few individual members. Design of strengthening must account for existing stresses and strain compatibility in determining the size and connection of supplemental members.

Temporary shoring should be designed in accordance with the AASHTO “Guide Design Specifications for Bridge Temporary Works.” The design should include installation sequencing that may be needed as well as any preload requirements to control load distribution or deformations. Temporary shoring which will also support traffic loads should be designed in accordance with the “AASHTO LRFD Bridge Design Specifications.”

Installation of strengthening should use bolted connections to the existing structure unless welding is specifically approved by WisDOT. Should welding be performed, it must be designed and executed using procedures that account for specific member steel chemistry. Whenever possible, connections of temporary shoring to the existing bridge should be made by use of clamps and bracket assemblies in lieu of bolts or welds. When temporary strengthening is removed, or for removal of shoring, any resulting bolt holes should be filled with properly tensioned high strength bolts. Any weld areas should be ground smooth and inspected by use of magnetic particle testing. Any damaged coatings must be repaired in accordance with the Standard Specifications.



Wisconsin Highway Research Program (WHRP) Bridge Construction Live Load Analysis Guide



Submittals

Prior to placing construction loads upon a bridge, an evaluation of its capacity should be made and the results submitted to the Department for review. As a minimum the submittal should include:

- Existing bridge condition overview
- Description and sequence of construction activities as they affect construction loading
- Data on materials loads to be placed on the bridge to include location and magnitude
- Data on equipment loads to be placed on the bridge to include locations and magnitudes
- A comparison of proposed construction loads to Statute Load, Design Vehicles, Posting's etc.
- Calculations demonstrating existing bridge members are not over stressed
- Description of any load control measures to be employed
- Design and drawings for any temporary supports
- Proposed monitoring program (if any)
- Final bridge condition inspection report upon completion of construction

The submittal should be prepared under direction of a Wisconsin Licensed Professional Engineer who should seal the submittal.

Inspection

Where structures are to be loaded during construction, an inspection should be made prior to start of work to document existing conditions. Special attention should be given to any cracks, distorted members, or physical damage and such damage should be documented with photographs and sketches. A similar inspection should be made upon completion of construction and the two inspections compared to assure no damage occurred during construction. For long duration projects, or where numerous passes of heavy haul vehicles is anticipated, periodic inspection may be required. Copies of all inspection reports should be provided to the bridge owner.

WisDOT Specifications related to Bridge Loading During Construction

The current WisDOT Specifications related to loading on bridges is provided in Sections 108.7.2 "Moving Heavy Loads" and 108.7.3 "Load on Structures". These sections are included as an excerpt in Appendix I. Based on this research, suggested revisions to the WisDOT Specifications are provided in Appendix J.



Wisconsin Highway Research Program (WHRP) Bridge Construction Live Load Analysis Guide



References

1. **Technical Advisory 5140.28 – Construction Loads on Bridges.** U.S. Department of Transportation, Federal Highway Administration, August 8, 2007.
2. **Standard Specifications for Highway Bridges, 17th Edition with Interims.** American Association of State Highway and Transportation Officials, AASHTO.
3. **LRFD Bridge Design Specifications.** American Association of State Highway and Transportation Officials, AASHTO.
4. **The Manual for Bridge Evaluation.** American Association of State Highway and Transportation Officials, AASHTO.
5. **Guide Design Specifications for Bridge Temporary Works.** American Association of State Highway and Transportation Officials, AASHTO.
6. **Load Rating Guidance and Examples for Bolted and Riveted Gusset Plates in Truss Bridges.** FHWA-1F-09-014. U.S. Department of Transportation, Federal Highway Administration.
7. **Minimum Design Loads for Buildings and Other Structures. ASCE/SEI 7-10,** American Society of Civil Engineers, 2010.



**Wisconsin Highway Research Program (WHRP)
Bridge Construction Live Load Analysis Guide**



**APPENDIX A
AGENCY SURVEY**



Division of Transportation
System Development
Bureau of Structures
PO Box 7916
Madison, WI 53707-7916

Jim Doyle, Governor
Frank J. Busalacchi, Secretary
Internet: www.dot.wisconsin.gov

Telephone: Area Code-Tel. #: 608-266-8489
Facsimile (FAX): 608-261-6277
E-mail: william.dreher@dot.wi.gov

Dear Survey Participant,

The Wisconsin Highway Research Program (WHRP), in partnership with the Wisconsin Department of Transportation, is conducting research related to the development of a Bridge Construction Live Load Analysis Guide. The research includes among other things, the development of a Construction Live Load Analysis Guide/ Handbook.

As part of this research, we would like to request your participation in a brief survey related to bridge construction. As a token of our appreciation for completing this survey we will provide you with a copy of the final completed Construction Live Load Analysis Guide / Handbook, as well as a copy the results of this survey.

The survey information you provide will be used in the development of our research as well as the completed handbook. It is anticipated that this handbook may be a valuable resource to contractors and others on the analysis of bridge structures subjected to construction equipment and material loads, recommended load distribution factors, guidance on ways to control or minimize loads/load effects and other information.

If you or another person in your agency is interested in completing this survey, please email your response to this survey to Mr. Bill Dreher at William.Dreher@dot.wi.gov by April 1st, 2010. Thank you in advance for your participation in this survey.

Sincerely,

William C. Dreher, P.E.
Chief Structures Design Engineer
WisDOT
Division of Transportation System Development
Bureau of Structures



Division of Transportation
System Development
 Bureau of Structures
 PO Box 7916
 Madison, WI 53707-7916

Jim Doyle, Governor
 Frank J. Busalacchi, Secretary
 Internet: www.dot.wisconsin.gov

Telephone: Area Code-Tel. #: 608-266-8489
 Facsimile (FAX): 608-261-6277
 E-mail: william.dreher@dot.wi.gov

SURVEY OF PRESENT PRACTICES RELATED TO BRIDGE CONSTRUCTION LOADING

Please Identify your Agency/Department _____

1a	Does your state currently have specifications in place requiring contractors submit proof that a bridge structure is not overloaded during construction?	Yes <input type="checkbox"/>
		No <input type="checkbox"/>
1b	If you don't currently have specifications, are you in the process of developing them?	Yes <input type="checkbox"/>
		No <input type="checkbox"/>
		N/A <input type="checkbox"/>
1c	Please attach any requirements/policy contained in your Bridge Manual and/or construction specifications.	
Remarks:		

2a	Do you issue any specific guidance to contractors for the analysis of bridges for construction loads?	Yes <input type="checkbox"/>
		No <input type="checkbox"/>
2b	Please attach any guidance that you provide.	
Remarks:		

3	When analyzing bridges for construction loads what specifications do you require be used?		
<input type="checkbox"/>	<input type="checkbox"/>	<input type="checkbox"/>	<input type="checkbox"/>
AASHTO LRFD/LRFR	AASHTO Standard Specs.	Agency/Depart. Procedures	Other
Remarks:			



Division of Transportation
 System Development
 Bureau of Structures
 PO Box 7916
 Madison, WI 53707-7916

Jim Doyle, Governor
 Frank J. Busalacchi, Secretary
 Internet: www.dot.wisconsin.gov

Telephone: Area Code-Tel. #: 608-266-8489
 Facsimile (FAX): 608-261-6277
 E-mail: william.dreher@dot.wi.gov

SURVEY OF PRESENT PRACTICES RELATED TO BRIDGE CONSTRUCTION LOADING

4a	Does your state have specific limits on construction vehicle loads?	Yes <input type="checkbox"/>
		No <input type="checkbox"/>
4b	If the answer to Question 4a is yes, what limiting loading criteria do you require?	
<input type="checkbox"/>	Permit Load	<input type="checkbox"/> HS20
<input type="checkbox"/>	Max. Axle Load	<input type="checkbox"/> Other
		<input type="checkbox"/> HS25
		<input type="checkbox"/> HL93
Remarks:		

5a	For the analysis of construction loads, do you issue guidance to contractors or require specific criteria with respect to load distribution?	Yes <input type="checkbox"/>
		No <input type="checkbox"/>
5b	If the answer to Question 5a is yes, what load distribution criteria is specified?	
<input type="checkbox"/>	AASHTO Distribution Factors	<input type="checkbox"/> Other
Remarks:		



Division of Transportation
 System Development
 Bureau of Structures
 PO Box 7916
 Madison, WI 53707-7916

Jim Doyle, Governor
 Frank J. Busalacchi, Secretary
 Internet: www.dot.wisconsin.gov

Telephone: Area Code-Tel. #: 608-266-8489
 Facsimile (FAX): 608-261-6277
 E-mail: william.dreher@dot.wi.gov

SURVEY OF PRESENT PRACTICES RELATED TO BRIDGE CONSTRUCTION LOADING

6a	Does your state allow stockpiling of construction materials on bridges under construction?	Yes <input type="checkbox"/>					
		No <input type="checkbox"/>					
6b	If the answer to Question 6a is yes, what limiting loading criteria do you require?						
<input type="checkbox"/>	Area Load (example ksf)	<input type="checkbox"/>	Point Load (example kips)	<input type="checkbox"/>	Linear Load (example klf)	<input type="checkbox"/>	Other
Remarks:							

7	How does your agency determine what structures are analyzed for construction loads?
Remarks:	



Wisconsin Highway Research Program (WHRP)
Bridge Construction Live Load Analysis Guide



APPENDIX B
CONTRACTOR SURVEY



Division of Transportation
System Development
Bureau of Structures
PO Box 7916
Madison, WI 53707-7916

Jim Doyle, Governor
Frank J. Busalacchi, Secretary
Internet: www.dot.wisconsin.gov

Telephone: Area Code-Tel. #: 608-266-8489
Facsimile (FAX): 608-261-6277
E-mail: william.dreher@dot.wi.gov

Dear Participant,

The Wisconsin Highway Research Program (WHRP) is in the process of conducting research related to the development of a Bridge Construction Live Load Analysis Guide. As part of this research, we met with Wisconsin based contractors on March 12th, 2010 to discuss the research being conducted, as well as to solicit contractor input related to the research.

As one of the action items from that meeting it was decided that a survey would be sent to contractors to solicit additional input related to your practices, as well as to gather information related to representative equipment your company uses during construction projects. This information will be used by the research team to conduct analyses of typical bridge loads by construction equipment and materials. It is noted that responses received from individual contractors will be kept confidential as to the source of responses.

Your assistance in filling out this survey would be very much appreciated. As you fill out the survey, please remember that the more comprehensive the information that you can provide, the more useful the research will be to your company in the end.

Please forward your completed survey to Mr. Steve Miller of Collins Engineers, at 414-282-6905, ext. 2323 or via email at smiller@collinsengr.com. Additionally if you have any additional comments or input you would like to share please feel free to contact Steve.

Sincerely,

William C. Dreher, P.E.
Chief Structures Design Engineer
WisDOT
Division of Transportation System Development
Bureau of Structures



Division of Transportation
 System Development
 Bureau of Structures
 PO Box 7916
 Madison, WI 53707-7916

Jim Doyle, Governor
 Frank J. Busalacchi, Secretary
 Internet: www.dot.wisconsin.gov

Telephone: Area Code-Tel. #: 608-266-8489
 Facsimile (FAX): 608-261-6277
 E-mail: william.dreher@dot.wi.gov

Please Identify Your Company _____

1)	What specifications or reference materials does your company use if required to perform a bridge load rating for a vehicle which exceeds the standard permit vehicle (e.g. different axle spacing or loads) or for which analysis is otherwise required?
<input type="checkbox"/> AASHTO Specifications <input type="checkbox"/> Other Specifications (Please Specify) <input type="checkbox"/> Unknown or Load Rating is Outsourced Comments:	
2)	What information might be helpful to your company which should be included in the Construction Live Load Handbook?
Comments:	
3)	What procedures or methods does your company use to distribute or minimize heavy concentrated loads (wheel loads, outriggers etc.) placed on structures?
Comments:	
4)	Does your company have specified procedures or methods in place to limit the stockpiling of materials or equipment on bridges?
<input type="checkbox"/> Yes <input type="checkbox"/> No Comments:	



Division of Transportation
 System Development
 Bureau of Structures
 PO Box 7916
 Madison, WI 53707-7916

Jim Doyle, Governor
 Frank J. Busalacchi, Secretary
 Internet: www.dot.wisconsin.gov

Telephone: Area Code-Tel. #: 608-266-8489
 Facsimile (FAX): 608-261-6277
 E-mail: william.dreher@dot.wi.gov

5) In the table below please list representative equipment that your company owns or otherwise uses during construction which might cause significant loading on a bridge structure.

Equipment Type	Manufacturer	Model /Serial Number	Comments/Attachments/Uses Other Information
Crawler Dozers			
Crawler Loaders			
Wheel Loaders			
Wheel Scrapers			
Dump Trucks			
Haulers (Lowboy etc.)			
Cranes (Truck/Track Mounted etc.)			
Concrete Mixer			
Paving Equipment (pavers, rollers etc.)			
Other			



Wisconsin Highway Research Program (WHRP)
Bridge Construction Live Load Analysis Guide



APPENDIX C

PUNCHING SHEAR CALCULATIONS

PUNCHING SHEAR CHECK - 30TH AVE. OVER PIKE RIVER

CONSTANTS

$$\text{psf} := \frac{\text{lb}}{\text{ft}^2} \quad \text{pcf} := \frac{\text{lb}}{\text{ft}^3} \quad k := 1000 \cdot \text{lb} \quad \text{ksi} := \frac{k}{\text{in}^2} \quad \text{psi} := \frac{\text{lb}}{\text{in}^2} \quad \text{ksf} := \frac{k}{\text{ft}^2}$$

MATERIAL PROPERTIES

$$f_c := 4000 \cdot \text{psi} \quad \text{-Concrete Strength}$$

SLAB PROPERTIES

$$t_s := 24.8 \text{ in} \quad d := 22.3 \text{ in}$$

Outrigger Mat Size

$$b_c := 2 \text{ ft} \quad w_c := 2 \text{ ft}$$

CHECK CAPACITY OF SLAB IN PUNCHING SHEAR

$$\phi_s := 0.75$$

- Area resisting punching shear:

$$b_1 := b_c + d \quad b_1 = 46.3 \text{ in} \quad b_2 := w_c + d \quad b_2 = 46.3 \text{ in}$$

Perimeter resisting punching shear:

$$b_o := 2 \cdot (b_1 + b_2) \quad b_o = 185.2 \text{ in}$$

Ratio of long side of column to short side of column:

$$\beta_c := \frac{b_c}{w_c} \quad \beta_c = 1$$

The Punching Shear capacity of the slab is the minimum of:

$$\phi V_{n1} := \phi_s \cdot \left(0.063 + \frac{0.126}{\beta_c} \right) \cdot \sqrt{f_c \cdot \text{ksi}} \cdot b_o \cdot d \quad \phi V_{n1} = 1171 \text{ k}$$

$$\phi V_{n2} := \phi_s \cdot (0.126) \cdot \sqrt{f_c \cdot \text{ksi}} \cdot b_o \cdot d \quad \phi V_{n2} = 780.6 \text{ k}$$

$$\phi V_{n2 \times 2} := \min(\phi V_{n1}, \phi V_{n2}) \quad \phi V_{n2 \times 2} = 780.6 \text{ k}$$

Outrigger Mat Size

$$b_c := 4 \text{ ft}$$

$$w_c := 4 \text{ ft}$$

CHECK CAPACITY OF SLAB IN PUNCHING SHEAR

$$\phi_s := 0.75$$

- Area resisting punching shear:

$$b_1 := b_c + d \quad b_1 = 70.3 \text{ in}$$

$$b_2 := w_c + d \quad b_2 = 70.3 \text{ in}$$

Perimeter resisting punching shear:

$$b_o := 2 \cdot (b_1 + b_2)$$

$$b_o = 281.2 \text{ in}$$

Ratio of long side of column to short side of column:

$$\beta_c := \frac{b_c}{w_c}$$

$$\beta_c = 1$$

The Punching Shear capacity of the slab is the minimum of:

The Punching Shear capacity of the slab is the minimum of:

$$\phi V_{n1} := \phi_s \cdot \left(0.063 + \frac{0.126}{\beta_c} \right) \cdot \sqrt{f_c \cdot \text{ksi}} \cdot b_o \cdot d$$

$$\phi V_{n1} = 1778 \text{ k}$$

$$\phi V_{n2} := \phi_s \cdot (0.126) \cdot \sqrt{f_c \cdot \text{ksi}} \cdot b_o \cdot d$$

$$\phi V_{n2} = 1185.2 \text{ k}$$

$$\phi V_{n4 \times 4} := \min(\phi V_{n1}, \phi V_{n2})$$

$$\phi V_{n4 \times 4} = 1185.2 \text{ k}$$

Outrigger Mat Size

$$b_c := 6\text{ft}$$

$$w_c := 6\text{ft}$$

CHECK CAPACITY OF SLAB IN PUNCHING SHEAR

$$\phi_s := 0.75$$

- Area resisting punching shear:

$$b_1 := b_c + d \quad b_1 = 94.3\text{ in}$$

$$b_2 := w_c + d \quad b_2 = 94.3\text{ in}$$

Perimeter resisting punching shear:

$$b_o := 2 \cdot (b_1 + b_2)$$

$$b_o = 377.2\text{ in}$$

Ratio of long side of column to short side of column:

$$\beta_c := \frac{b_c}{w_c}$$

$$\beta_c = 1$$

The Punching Shear capacity of the slab is the minimum of:

The Punching Shear capacity of the slab is the minimum of:

$$\phi V_{n1} := \phi_s \cdot \left(0.063 + \frac{0.126}{\beta_c} \right) \cdot \sqrt{f_c \cdot \text{ksi}} \cdot b_o \cdot d$$

$$\phi V_{n1} = 2385\text{ k}$$

$$\phi V_{n2} := \phi_s \cdot (0.126) \cdot \sqrt{f_c \cdot \text{ksi}} \cdot b_o \cdot d$$

$$\phi V_{n2} = 1589.8\text{ k}$$

$$\phi V_{n6x6} := \min(\phi V_{n1}, \phi V_{n2})$$

$$\phi V_{n6x6} = 1589.8\text{ k}$$

Allowable Outrigger Forces

Mat Size - 2x2

$$P_{\text{all}2x2} := \frac{\phi V_{n2x2}}{1.6}$$

$$P_{\text{all}2x2} = 487.9\text{ k}$$

Mat Size - 4x4

$$P_{\text{all}4x4} := \frac{\phi V_{n4x4}}{1.6}$$

$$P_{\text{all}4x4} = 740.7\text{ k}$$

Mat Size - 6x6

$$P_{\text{all}6x6} := \frac{\phi V_{n6x6}}{1.6}$$

$$P_{\text{all}6x6} = 993.6\text{ k}$$

PUNCHING SHEAR CHECK - 8 INCH THICK DECK

CONSTANTS

$$\text{psf} := \frac{\text{lb}}{\text{ft}^2} \quad \text{pcf} := \frac{\text{lb}}{\text{ft}^3} \quad k := 1000 \cdot \text{lb} \quad \text{ksi} := \frac{k}{\text{in}^2} \quad \text{psi} := \frac{\text{lb}}{\text{in}^2} \quad \text{ksf} := \frac{k}{\text{ft}^2}$$

MATERIAL PROPERTIES

$$f_c := 4000 \cdot \text{psi} \quad \text{-Concrete Strength}$$

SLAB PROPERTIES

$$t_s := 8 \text{ in} \quad d := 6.5 \text{ in}$$

Outrigger Mat Size

$$b_c := 2 \text{ ft} \quad w_c := 2 \text{ ft}$$

CHECK CAPACITY OF SLAB IN PUNCHING SHEAR

$$\phi_s := 0.75$$

- Area resisting punching shear:

$$b_1 := b_c + d \quad b_1 = 30.5 \text{ in} \quad b_2 := w_c + d \quad b_2 = 30.5 \text{ in}$$

Perimeter resisting punching shear:

$$b_o := 2 \cdot (b_1 + b_2) \quad b_o = 122 \text{ in}$$

Ratio of long side of column to short side of column:

$$\beta_c := \frac{b_c}{w_c} \quad \beta_c = 1$$

The Punching Shear capacity of the slab is the minimum of:

$$\phi V_{n1} := \phi_s \cdot \left(0.063 + \frac{0.126}{\beta_c} \right) \cdot \sqrt{f_c \cdot \text{ksi}} \cdot b_o \cdot d \quad \phi V_{n1} = 225 \text{ k}$$

$$\phi V_{n2} := \phi_s \cdot (0.126) \cdot \sqrt{f_c \cdot \text{ksi}} \cdot b_o \cdot d \quad \phi V_{n2} = 149.9 \text{ k}$$

$$\phi V_{n2 \times 2} := \min(\phi V_{n1}, \phi V_{n2}) \quad \phi V_{n2 \times 2} = 149.9 \text{ k}$$

Outrigger Mat Size

$$b_c := 4\text{ft}$$

$$w_c := 4\text{ft}$$

CHECK CAPACITY OF SLAB IN PUNCHING SHEAR

$$\phi_s := 0.75$$

- Area resisting punching shear:

$$b_1 := b_c + d \quad b_1 = 54.5\text{ in}$$

$$b_2 := w_c + d \quad b_2 = 54.5\text{ in}$$

Perimeter resisting punching shear:

$$b_o := 2 \cdot (b_1 + b_2)$$

$$b_o = 218\text{ in}$$

Ratio of long side of column to short side of column:

$$\beta_c := \frac{b_c}{w_c}$$

$$\beta_c = 1$$

The Punching Shear capacity of the slab is the minimum of:

The Punching Shear capacity of the slab is the minimum of:

$$\phi V_{n1} := \phi_s \cdot \left(0.063 + \frac{0.126}{\beta_c} \right) \cdot \sqrt{f_c \cdot \text{ksi}} \cdot b_o \cdot d \quad \phi V_{n1} = 402\text{ k}$$

$$\phi V_{n2} := \phi_s \cdot (0.126) \cdot \sqrt{f_c \cdot \text{ksi}} \cdot b_o \cdot d \quad \phi V_{n2} = 267.8\text{ k}$$

$$\phi V_{n4x4} := \min(\phi V_{n1}, \phi V_{n2}) \quad \phi V_{n4x4} = 267.8\text{ k}$$

Outrigger Mat Size

$$b_c := 6 \text{ ft}$$

$$w_c := 6 \text{ ft}$$

CHECK CAPACITY OF SLAB IN PUNCHING SHEAR

$$\phi_s := 0.75$$

- Area resisting punching shear:

$$b_1 := b_c + d \quad b_1 = 78.5 \text{ in}$$

$$b_2 := w_c + d \quad b_2 = 78.5 \text{ in}$$

Perimeter resisting punching shear:

$$b_o := 2 \cdot (b_1 + b_2)$$

$$b_o = 314 \text{ in}$$

Ratio of long side of column to short side of column:

$$\beta_c := \frac{b_c}{w_c}$$

$$\beta_c = 1$$

The Punching Shear capacity of the slab is the minimum of:

The Punching Shear capacity of the slab is the minimum of:

$$\phi V_{n1} := \phi_s \cdot \left(0.063 + \frac{0.126}{\beta_c} \right) \cdot \sqrt{f_c \cdot \text{ksi}} \cdot b_o \cdot d$$

$$\phi V_{n1} = 579 \text{ k}$$

$$\phi V_{n2} := \phi_s \cdot (0.126) \cdot \sqrt{f_c \cdot \text{ksi}} \cdot b_o \cdot d$$

$$\phi V_{n2} = 385.7 \text{ k}$$

$$\phi V_{n6x6} := \min(\phi V_{n1}, \phi V_{n2})$$

$$\phi V_{n6x6} = 385.7 \text{ k}$$

Allowable Outrigger Forces

$$\text{Mat Size - 2x2} \quad P_{\text{all}2x2} := \frac{\phi V_{n2x2}}{1.6}$$

$$P_{\text{all}2x2} = 93.7 \text{ k}$$

$$\text{Mat Size - 4x4} \quad P_{\text{all}4x4} := \frac{\phi V_{n4x4}}{1.6}$$

$$P_{\text{all}4x4} = 167.4 \text{ k}$$

$$\text{Mat Size - 6x6} \quad P_{\text{all}6x6} := \frac{\phi V_{n6x6}}{1.6}$$

$$P_{\text{all}6x6} = 241.1 \text{ k}$$



**Wisconsin Highway Research Program (WHRP)
Bridge Construction Live Load Analysis Guide**



**APPENDIX D
WISCONSIN STATUTE 348**

CHAPTER 348

VEHICLES — SIZE, WEIGHT AND LOAD

	SUBCHAPTER I		
	GENERAL PROVISIONS		
348.01	Words and phrases defined.	348.16	Weight limitations on class "B" highways.
348.02	Applicability of chapter.	348.17	Special or seasonal weight limitations.
	SUBCHAPTER II	348.175	Seasonal operation of vehicles hauling peeled or unpeeled forest products cut crosswise or abrasives or salt for highway winter maintenance.
	SIZE AND LOAD	348.18	Weight limitations apply to publicly-owned vehicles; exceptions.
348.05	Width of vehicles.	348.19	Traffic officers may weigh vehicles and require removal of excess load.
348.06	Height of vehicles.	348.195	Weight records of raw forest products purchasers.
348.07	Length of vehicles.	348.20	Policy in prosecuting weight violations.
348.08	Vehicle trains.	348.21	Penalty for violating weight limitations.
348.09	Projecting loads on side of vehicles.	348.22	Courts to report weight violation convictions.
348.10	Special limitations on load.		SUBCHAPTER IV
348.11	Penalty for violating size and load limitations.		PERMITS
	SUBCHAPTER III	348.25	General provisions relating to permits for vehicles and loads of excessive size and weight.
	WEIGHT	348.26	Single trip permits.
348.15	Weight limitations on class "A" highways.	348.27	Annual, consecutive month or multiple trip permits.
		348.28	Permits to be carried.

SUBCHAPTER I

GENERAL PROVISIONS

348.01 Words and phrases defined. (1) Words and phrases defined in s. 340.01 are used in the same sense in this chapter unless a different definition is specifically provided.

(2) In this chapter the following terms have the designated meanings:

(a) "Axle" includes all wheels of a vehicle imposing weight on the highway, the centers of which are included between 2 parallel transverse vertical planes less than 42 inches apart, extending across the full width of vehicle and load.

(am) "Certified stationary scale" means a stationary scale which is tested and inspected annually for accuracy by the department of agriculture, trade and consumer protection or other authorized testing agency in accordance with specifications, tolerances, standards and procedures established by the national institute of standards and technology and the department of agriculture, trade and consumer protection for the testing and examination of scales.

(ar) "Consecutive month permit" means a permit issued for a minimum of 3 consecutive months.

(at) "Double-decked bus" means a motor bus designed to carry passengers on an upper level throughout the length of the bus over passengers on a lower level throughout the length of the bus and the roof of which is permanently enclosed with rigid construction and extends throughout the length of the bus.

(av) "Fender line", in the case of motor trucks, means the outermost limits of the rear fenders, flare boards or floor of the body, whichever projects outward the farthest.

(ax) "Forestry biomass" means byproducts and waste generated by the practice of forestry on forestry lands.

(b) "Gross weight" means the weight of a vehicle or combination of vehicles equipped for service plus the weight of any load which the vehicle or combination of vehicles may be carrying.

(bm) "Personal watercraft" has the meaning given in s. 30.50 (9d).

(bt) "Raw forest products" means logs, pilings, posts, poles, cordwood products, wood chips, sawdust, pulpwood, intermediary lumber, fuel wood and Christmas trees not altered by a manufacturing process off the land, sawmill or factory from which they are taken.

(c) "Tandem axle" means any 2 or more consecutive axles whose centers are 42 or more inches apart and which are individually attached to or articulated from, or both, a common attachment

to the vehicle including a connecting mechanism designed to equalize the load between axles.

History: 1981 c. 312 ss. 1, 2, 4; 1985 a. 202, 212, 332; 1989 a. 165; 1993 a. 62, 439; 1999 a. 85; 2005 a. 11, 167; 2007 a. 16; 2009 a. 180.

348.02 Applicability of chapter. (1) The provisions of this chapter restricting the size, weight and load of vehicles apply also to vehicles owned by or operated by or for a governmental agency, subject to such exceptions in this chapter.

(2) The provisions of this chapter restricting the size and weight of vehicles apply to the vehicle and any load which it is carrying except as otherwise provided in this chapter.

(3) Any owner of a vehicle who causes or permits such vehicle to be operated on a highway in violation of this chapter is guilty of the violation the same as if the owner had actually operated the vehicle.

(4) The limitations on size, weight and load imposed by this chapter do not apply to road machinery actually engaged in construction or maintenance of a highway within the limits of the project.

(5) The limitations on weight, length and number of vehicles in combination imposed by this chapter shall not apply to a combination of vehicles in an emergency towing operation in which the towing vehicle is being used to remove a stalled or disabled vehicle or combination of vehicles from the highway to the nearest adequate place for repairs, or in which the towing vehicle is an emergency truck tractor temporarily substituted for a stalled or disabled truck tractor. The vehicle owner or the owner's agent shall designate the nearest adequate place for repairs for vehicles or combinations of vehicles exceeding the statutory length limits or limits on the number of vehicles in combination.

History: 1977 c. 197; 1979 c. 348; 1981 c. 268, 312, 390; 1989 a. 134; 1991 a. 316.

SUBCHAPTER II

SIZE AND LOAD

348.05 Width of vehicles. (1) No person without a permit therefor shall operate on a highway any vehicle having a total width in excess of 8 feet 6 inches, except as otherwise provided in this section.

(2) The following vehicles may be operated without a permit for excessive width if the total outside width does not exceed the indicated limitations:

(a) No limitation for implements of husbandry temporarily operated upon a highway in the course of performance of its work.

348.05 VEHICLES — SIZE, WEIGHT AND LOAD

Updated 09–10 Wis. Stats. Database 2

(b) No limitation for snowplows operated by or for a governmental agency.

(c) Twelve feet for farm tractors, except that the total outside width of a farm tractor shall not exceed 9 feet when operated on any Wisconsin highway, other than that portion of USH 51 between Wausau and STH 78 and that portion of STH 78 between USH 51 and the I 90/94 interchange near Portage upon their federal designation as I 39, that is a part of the national system of interstate and defense highways.

(d) Ten feet 6 inches for snowplows attached to motor vehicles normally used for the transportation of milk.

(f) Eight feet 8 inches for urban passenger buses.

(i) A realistic body width of 8 feet 6 inches for mobile homes, including recreational vehicles, and motor homes, and, for motor homes and for recreational vehicles used only as temporary or recreational dwellings, up to an additional 4 inches on the left side and 6 inches on the right side of such vehicles for appurtenances provided that, if any appurtenance extends the maximum 4 inches on the left side or 6 inches on the right side, the appurtenance is located at a height of not less than 8 feet from the ground. In this paragraph, "appurtenance" means any mechanical or other device, including retracted awning assemblies, vent grates, electrical outlet covers, and door handles, that is related to the structure of the vehicle and is installed upon the vehicle by a manufacturer or dealer.

(k) Nine feet for loads of tie logs, tie slabs and veneer logs, provided that no part of the load shall extend more than 6 inches beyond the fender line on the left side of the vehicle or extend more than 10 inches beyond the fender line on the right side of the vehicle. This paragraph does not apply to transport on highways designated as parts of the national system of interstate and defense highways under s. 84.29.

(L) Twelve feet for loads of hay in bales and, from September 15 to December 15 of each year, for loads of Christmas trees from the point of harvesting or staging to a Christmas tree yard or point of commercial shipment, if the total outside width of the loads do not exceed the width of a single traffic lane of any highway over which the loads are carried. This paragraph does not apply to vehicles on highways designated as parts of the national system of interstate and defense highways under s. 84.29.

(2m) The secretary, by rule, shall designate safety devices which may not be included in the calculation of width under subs. (1) and (2). The designation of safety devices under this subsection may not be inconsistent with the safety devices designated by the U.S. secretary of transportation under P.L. 97–369, section 321.

(3) Farm tractors exceeding 12 feet in width and all other farm machinery and implements of husbandry exceeding 8 feet 6 inches in width not being operated in the course of performance of its work may be moved, towed or hauled over the highways without a special permit issued under s. 348.27 (14) between one-half hour before sunrise and sunset on Mondays to Thursdays and from one-half hour before sunrise to 2 p.m. on Fridays. Such overwidth machinery shall not be moved, towed or hauled on any Wisconsin highway, other than any overwidth machinery that is not a commercial motor vehicle on that portion of USH 51 between Wausau and STH 78 and that portion of STH 78 between USH 51 and the I 90/94 interchange near Portage upon their federal designation as I 39, which is part of the national system of interstate and defense highways without a special permit issued under s. 348.27 (14).

(4) Notwithstanding sub. (1), the secretary may restrict vehicles to a width of less than 8 feet 6 inches on any portion of any state or local highway if he or she deems such restriction necessary to protect the public safety. Any such restriction shall be indicated by official signs. If the secretary restricts vehicles to a width of less than 8 feet 6 inches on any local highway, the local

authority in charge of maintenance shall be responsible for erecting the appropriate signs on the local highway.

History: 1975 c. 50; 1977 c. 26; 1977 c. 29 s. 1654 (9) (b); 1981 c. 22; 1983 a. 78, 508; 1985 a. 187; 1993 a. 353, 404; 1995 a. 7, 225, 348; 1999 a. 85; 2003 a. 213.
Cross-reference: See also s. Trans 276.04, Wis. adm. code.

348.06 Height of vehicles. (1) Except as provided in subs. (2) and (2m), no person, without a permit therefor, may operate on a highway any motor vehicle, mobile home, recreational vehicle, trailer, or semitrailer having an overall height in excess of 13 1/2 feet.

(2) Implements of husbandry of any height may be temporarily operated upon a highway without a permit for excessive height.

(2m) (a) Double-decked buses having an overall height not exceeding 14 feet 5 inches may be operated without a permit for excessive height upon a highway, other than a state trunk highway, that has a speed limit of 45 miles per hour or less if the vehicle owner or operator has, prior to the vehicle's operation, obtained written approval for such operation and for the vehicle's route from the local authority with jurisdiction over the highway on any highway on which the vehicle will be operated. A local authority may not approve the operation of a vehicle under this subsection on a highway under its jurisdiction unless all of the following apply:

1. The local authority has received a copy of the vehicle's proposed route, inspected the route, and verified that there is at least 6 inches of height clearance between the vehicle and any overhead structure or obstruction, including any utility line, on all parts of the route.

2. The vehicle owner has agreed, in writing, to assume liability for any personal injury or property damage resulting from the vehicle's striking of any overhead structure or obstruction, including any utility line, regardless of whether the personal injury or property damage occurs on an approved route.

3. The local authority has inspected the vehicle and verified that the sign required under par. (b) is displayed.

(b) A vehicle specified in par. (a) shall conspicuously display, in the operator's area of the vehicle, a sign informing the operator that operation of the vehicle on any highway that is not part of a route approved under par. (a) is unlawful.

(c) A local authority may, for any reason, deny approval for the operation of a vehicle under this subsection, or deny approval of any route regardless of whether the requirements under par. (a) are satisfied, on any highway under the local authority's jurisdiction.

(d) A local authority that has approved operation of a vehicle under this subsection shall, with respect to any route approved for every such vehicle, inspect the approved route at least once each year. If the inspection reveals that the clearance requirements specified in par. (a) 1. are no longer satisfied, the local authority shall revoke the route approval, but may approve an alternative route that complies with the clearance requirements specified in par. (a) 1.

(e) A local authority may delegate to any department, division, official, or employee of the local authority the responsibility for issuing approvals, conducting inspections, or carrying out any other duty specified under this subsection.

(3) The limitations on total height stated in this section shall not be construed as requiring a clearance of such height or as relieving the owners of vehicles not exceeding such total height from liability for any damage.

History: 1999 a. 85; 2005 a. 11; 2007 a. 11.

348.07 Length of vehicles. (1) No person, without a permit therefor, may operate on a highway any single vehicle with an overall length in excess of 40 feet or any combination of 2 vehicles with an overall length in excess of 65 feet, except as otherwise provided in subs. (2) and (2a).

(2) The following vehicles may be operated without a permit for excessive length if the overall length does not exceed the indicated limitations:

(c) Forty five feet for recreational vehicles, motor homes, and motor buses.

(e) No limitation for implements of husbandry temporarily operated upon a highway.

(f) No overall length limitation for a tractor–semitrailer combination, a double bottom or an automobile haulaway when such tractor–semitrailer combination, double bottom or automobile haulaway is operated on a highway designated under sub. (4).

(fm) No length limitation for a truck tractor or road tractor when such truck tractor or road tractor is operated in a tractor–semitrailer combination or as part of a double bottom or an automobile haulaway on a highway designated under sub. (4).

(fs) 75 feet for a tractor–semitrailer combination that is operated on any part of the state trunk highway system, except as provided in par. (f) or sub. (4m).

(g) 48 feet for a semitrailer or trailer operated as part of a 2–vehicle combination, except as provided in par. (gr) or (gv).

(gm) 28 feet 6 inches for a semitrailer or trailer operated as part of a double bottom on a highway designated under sub. (4).

(gr) 53 feet for a semitrailer whose length from kingpin to axle does not exceed 43 feet and which is operated as part of a 2–vehicle combination on a highway designated under sub. (4). The length limits in this paragraph do not apply to a trailer or a semitrailer that is authorized to operate under par. (im).

(gv) 53 feet for a semitrailer whose length from kingpin to axle does not exceed 43 feet and which is operated as part of a 2–vehicle combination on any part of the state trunk highway system, except as provided in par. (gr) or sub. (4m).

(h) 65 feet for articulated buses operated in urban areas.

(i) 58 feet for a vehicle combination consisting of a motor bus and trailer owned and operated by, and for the exclusive use of a nonprofit organization. This paragraph does not apply to trailers used for transporting recreational vehicles. As used in this paragraph, “nonprofit organization” means any organization described in section 501 (c) (3) of the internal revenue code which is exempt from federal income tax under section 501 (a) of the internal revenue code.

(im) Seventy-five total feet for a 2–vehicle combination designed and primarily used for transporting livestock, if the trailer or semitrailer, measured as required by sub. (3) (b), is not longer than 53 feet, the trailer or semitrailer is equipped with at least 2 axles, and the towing vehicle is not a motor truck, truck tractor, road tractor, or combination vehicle with a gross vehicle weight rating or actual gross weight of 10,000 pounds or less.

(j) 66 feet for an automobile haulaway plus an additional overhang of 4 feet to the front of the vehicle and 5 feet to the rear of the vehicle.

(2a) Tour trains consisting of 4 vehicles including the propelling motor vehicle may be operated as provided in s. 348.08 (1) (c).

(3) (a) The overall length of a mobile home or recreational vehicle shall be measured from the rear thereof to the rear of the vehicle to which it is attached.

(b) 1. Except as provided in subd. 2., the length of a semitrailer or trailer shall be measured from the front thereof to the rear of the semitrailer or trailer or cargo, whichever is longer, excluding bumpers, stake pockets, air deflectors and refrigeration units.

2. The length of a semitrailer operated as the first trailing unit in a double bottom consisting of a truck tractor and 2 semitrailers does not include a frame extension bearing a fifth–wheel connection by which the 2nd trailing unit is drawn unless the frame extension is more than 8 feet in length. This subdivision does not affect the measurement of length from the front of the semitrailer to the rear of the cargo.

(c) The distance between a kingpin and semitrailer axle shall be measured as follows:

1. On a semitrailer having a tandem axle, from the kingpin to a point midway between the first and last axles of the tandem axle.

2. On a semitrailer not having a tandem axle, from the kingpin to the center of the rearmost axle.

(4) The secretary shall, by rule, designate the highways to which sub. (2) (f), (fm), (gm), and (gr) and s. 348.08 (1) (e) apply. The designation of highways under this subsection may not be inconsistent with the designation of highways made by the U.S. secretary of transportation under P.L. 97–424, section 411. The secretary may also designate additional highways by rule. In adopting a rule designating other highways, which may include 2–lane highways, the secretary shall specify the factors which resulted in the determination to designate the highways. These factors shall include, but are not limited to, safety, economics, energy savings, industry productivity and competition. Vehicles to which sub. (2) (f), (fm), (gm), and (gr) and s. 348.08 (1) (e) apply may also operate on highways not designated under this subsection for a distance of 15 miles or less in order to obtain access to a highway designated under this subsection or to reach fuel, food, maintenance, repair, rest, staging, terminal or vehicle assembly facilities or points of loading or unloading. The secretary may, by rule, designate an access route of more than 15 miles from a highway designated under this subsection when the longer route provides safer and better access to a location which is within the 15–mile limit. Household goods carriers may operate between highways designated under this subsection and points of loading and unloading.

(4m) The secretary shall, by rule, designate those parts of the state trunk highway system to which sub. (2) (fs) and (gv) do not apply. For each part of the state trunk highway system designated under this subsection, the secretary shall specify the factors that resulted in the determination to designate the part as not suitable to accommodate vehicle lengths as specified in sub. (2) (fs) and (gv).

(5) As often as it deems necessary, the department shall publish maps required for its own use and for free distribution showing the highways designated under subs. (4) and (4m), those parts of the state trunk highway system not designated under sub. (4m), and such other main highways and other features as the department deems desirable.

History: 1975 c. 279; 1977 c. 29 ss. 1487g to 1487m, 1654 (9) (b); 1977 c. 418; 1979 c. 255; 1981 c. 159, 176; 1983 a. 20, 78, 192; 1985 a. 165, 187; 1987 a. 30; 1991 a. 39, 72; 1995 a. 193; 1997 a. 27; 1999 a. 85, 186; 2003 a. 213, 234; 2005 a. 363, 365; 2007 a. 11, 93.

Cross-reference: See also ch. Trans 276, Wis. adm. code.

The state may not prohibit 65–foot double–bottom trailers. *Raymond Motor Transportation, Inc. v. Rice*, 434 U.S. 429 (1978).

348.08 Vehicle trains. (1) No person, without a permit therefor shall operate on a highway any motor vehicle drawing or having attached thereto more than one vehicle, except that:

(a) Two or 3 vehicles may, without such permit, be drawn or attached when such vehicles are being transported by the drive–away method in saddlemount combination and the overall length of such combination of vehicles does not exceed 65 feet.

(b) Two trailers used primarily as implements of husbandry in connection with seasonal agricultural activities or one such trailer and any other implement of husbandry may, without such permit, be drawn by a farm tractor if the operation of such combination of vehicles is exclusively a farming operation and not for the transportation of property for hire and if the overall length of such combination of vehicles does not exceed 60 feet.

(c) “Tour trains,” as defined in s. 340.01 (67m), may, without such permit, be drawn by a motor vehicle upon and along county and municipal roads and streets and across state trunk highways, and upon and along state trunk highways where there are no alternate municipal or county routes or streets for such operation. The

348.08 VEHICLES — SIZE, WEIGHT AND LOAD

Updated 09–10 Wis. Stats. Database 4

following requirements and restrictions shall apply to “tour train” operations:

1. Tour trains shall operate within a radius of 10 miles from the situs of the beginning and ending of the excursion.

2. Tour trains shall operate only along those portions of the state trunk highway system approved by the department.

3. The towing vehicle shall be of such design and construction that it will safely tow the unit at speeds up to 35 m.p.h. and the towing vehicle shall in no case be a farm-type tractor, but shall be a motor vehicle originally designed and manufactured expressly for operation upon public highways.

4. Each unit of a “tour train”, regardless of weight, shall be equipped with brakes as provided in s. 347.35 (3) (a).

5. Tour trains shall be equipped with head lamps, tail lamps, stop lamps, directional signal lamps and reflectors as provided in ch. 347 and in compliance with these provisions as if the train were a single motor vehicle.

6. All hitches, couplings, safety chains or cables shall be in compliance with s. 347.47.

(d) Two trailers transporting empty pressurized or nonpressurized tanks used for hauling or storing liquid agricultural fertilizer or 2 implements of husbandry, including 2 empty trailers used primarily as implements of husbandry in connection with seasonal agricultural activities, may, without such permit, be drawn by a motor truck or truck tractor if the overall length of such combination of vehicles and load does not exceed 60 feet. For purposes of this paragraph, “empty” means less than 20% full.

(e) A double bottom may be operated on highways designated by the secretary under s. 348.07 (4).

(f) A double bottom transporting dairy products from the point of production to the first point of processing may operate on any highway not designated under s. 348.07 (4) if the overall length of such double bottom does not exceed 60 feet. If the double bottom operates on a highway designated under s. 348.07 (4), s. 348.07 (2) (f), (fm) and (gm) applies.

(g) Three trailers containing only warning signs used exclusively for highway maintenance or construction purposes may, without a permit, be drawn by a motor truck if the overall length of the combination of vehicles does not exceed 60 feet.

(h) Two new trailers or semitrailers to be used for transporting farm products or livestock may, without such permit, be drawn by a motor truck not exceeding 25 feet in length if each trailer or semitrailer is 28 feet 6 inches or less in length and the trailers or semitrailers are being transported directly from a manufacturer to a dealer or directly from a dealer to another dealer. The length of the first trailing unit does not include a frame extension by which the 2nd trailing unit is drawn.

(2) Whenever any train of agricultural vehicles is being operated under sub. (1) (b), the train shall be equipped as provided in s. 347.21 (1m) and (2). Whenever any train of agricultural vehicles is being operated under sub. (1) (d), the train shall be equipped as provided in s. 347.21 (1) and (2). The trailer hitches of a train of agricultural vehicles shall be of a positive nature so as to prevent accidental release.

History: 1977 c. 29 s. 1654 (8) (a); 1981 c. 276, 277; 1983 a. 78; 1985 a. 202, 209; 1987 a. 164; 1991 a. 14, 39, 72.

The state may not prohibit 65-foot double-bottom trailers. *Raymond Motor Transportation, Inc. v. Rice*, 434 U.S. 429 (1978).

348.09 Projecting loads on side of vehicles. (1) No person, without a permit therefor, may operate on a highway any motor vehicle, trailer or semitrailer carrying any load extending beyond the fender line on the left side or extending more than 6 inches beyond the fender line on the right side of the vehicle.

(2) This section applies even though the total width of the vehicle and load does not exceed the maximum permitted under s. 348.05.

History: 1999 a. 85.

348.10 Special limitations on load. (1) No person, without a permit therefor, may operate on a highway any vehicle or combination of vehicles with any load thereon extending more than 3 feet beyond the front of the foremost vehicle, except as provided in s. 348.07 (2) (j), and except that a vehicle carrying another vehicle equipped with a crane or boom which extends more than 3 feet beyond the front of the foremost vehicle may be operated without permit if the total length of the vehicle or combination of vehicles, measuring from the end of the foremost projection of the load to the rear of the rearmost vehicle, does not exceed statutory length limitations.

(2) No person shall operate a vehicle on a highway unless such vehicle is so constructed and loaded as to prevent its contents from dropping, sifting, leaking or otherwise escaping therefrom.

(3) No person may operate on a highway any motor vehicle, trailer or semitrailer carrying logs unless the logs are transported within a cargo body or are securely fastened to the vehicle by chains, steel cables or other attachment devices of equivalent strength whose safety is approved by the department.

(3m) No person may operate on a highway any motor vehicle, trailer or semitrailer carrying junk or scrapped vehicles unless one of the following conditions is satisfied:

(a) Each junk or scrapped vehicle is securely fastened to the vehicle carrying the load by chains, steel cables or other attachment devices of equivalent strength whose safety is approved by the department. In this paragraph, “securely fastened” means that each tier of junk or scrapped vehicles is secured by at least 2 chains, steel cables or other attachment devices across the axis of its width.

(b) The vehicle carrying the load is equipped with stakes which are securely fastened by chains, steel cables or other attachment devices of equivalent strength whose safety is approved by the department and the top of the load is lower than the top of the stakes.

(c) The vehicle carrying the load is equipped with sides, sideboards or side stakes and with a rear endgate, endboard or rear stakes. These devices shall be of sufficient strength and height to prevent the cargo from shifting upon or falling from the vehicle. No device may have any aperture large enough to permit cargo in contact with one or more of the devices to pass through the aperture.

(4) All other provisions notwithstanding, no person shall operate on a highway any trailer or semitrailer when the gross weight of the trailer or semitrailer exceeds the empty weight of the towing vehicle, unless the trailer or semitrailer is equipped with brakes as provided in s. 347.35 (3) (a) and (b).

(5) The load imposed upon trailers, semitrailers, recreational vehicles, or mobile homes shall be distributed in a manner that will prevent side sway under all conditions of operation:

(a) All items of load carried by any trailer, semitrailer, recreational vehicle, or mobile home, except bulk material such as sand, gravel, dirt not in containers, shall be secured to, on or in the trailer, semitrailer, recreational vehicle, or mobile home in such manner as to prevent shifting of the load while the trailer, semitrailer, recreational vehicle, or mobile home is being drawn by a towing vehicle.

(b) Boats of any type transported on a trailer or semitrailer being drawn by a towing vehicle shall be secured in position at bow and stern by attachments of such strength and design as to prevent the boat from shifting its position on the trailer or becoming separated from the trailer while being transported thereon.

(c) The load carried by any trailer, semitrailer, recreational vehicle, or mobile home shall be so positioned that a weight of not less than 35 pounds is imposed at the center of the point of attachment to the towing vehicle when parked on a level surface.

History: 1983 a. 78; 1983 a. 192 s. 304; 1985 a. 161; 1991 a. 249; 1993 a. 401; 2007 a. 11.

Cross-reference: See also ch. Trans 307, Wis. adm. code.

348.11 Penalty for violating size and load limitations.

(1) Any person violating s. 348.09 or 348.10 may be required to forfeit not less than \$10 nor more than \$200.

(2) Any person violating ss. 348.05 to 348.08 may be required to forfeit not less than \$50 nor more than \$100 for the first offense and may be required to forfeit not less than \$100 nor more than \$200 for the 2nd and each subsequent conviction within one year.

History: 1971 c. 278.

SUBCHAPTER III

WEIGHT

Cross-reference: See also ch. Trans 312, Wis. adm. code.

348.15 Weight limitations on class “A” highways.

(1) In this section “class ‘A’ highway” includes all state trunk highways and connecting highways and those county trunk highways, town highways and city and village streets, or portions thereof, that have not been designated as class “B” highways pursuant to s. 349.15.

(3) Subject to any modifications made by a 1st class city under s. 349.15 (3) and except as provided in s. 348.17 (5), no person, without a permit, may operate on a class “A” highway any vehicle or combination of vehicles unless the vehicle or combination of vehicles complies with the following weight limitations:

(a) The gross weight imposed on the highway by any one wheel or multiple wheels supporting one end of an axle may not exceed 11,000 pounds.

(b) The gross weight imposed on the highway by the wheels of any one axle may not exceed 20,000 pounds. In addition, the gross weight imposed on the highway by the wheels of the steering axle of a truck tractor may not exceed 13,000 pounds unless the manufacturer’s rated capacity of the axle and the tires is sufficient to carry the weight, but not to exceed 20,000 pounds.

(bg) In the case of a vehicle or combination of vehicles transporting exclusively milk from the point of production to the primary market and the return of dairy supplies and dairy products from such primary market to the farm, the gross weight imposed on the highway by the wheels of any one axle may not exceed 21,000 pounds or, for 2 axles 8 or less feet apart, 37,000 pounds or, for groups of 3 or more consecutive axles more than 9 feet

apart, a weight of 2,000 pounds more than is shown in par. (c), but not to exceed 80,000 pounds. This paragraph does not apply to the national system of interstate and defense highways, except for that portion of USH 51 between Wausau and STH 78 and that portion of STH 78 between USH 51 and the I 90/94 interchange near Portage upon their federal designation as I 39.

(br) In the case of a vehicle or combination of vehicles transporting exclusively peeled or unpeeled forest products cut crosswise or in the case of a vehicle or combination of vehicles transporting exclusively scrap metal, the gross weight imposed on the highway by the wheels of any one axle may not exceed 21,500 pounds or, for 2 axles 8 or less feet apart, 37,000 pounds or, for groups of 3 or more consecutive axles more than 9 feet apart, a weight of 4,000 pounds more than is shown in par. (c), but not to exceed 80,000 pounds. This paragraph does not apply to the national system of interstate and defense highways, except for that portion of USH 51 between Wausau and STH 78 and that portion of STH 78 between USH 51 and the I 90/94 interchange near Portage upon their federal designation as I 39.

(bv) In the case of a vehicle or combination of vehicles used primarily for the transportation of septage, as defined in s. 281.49 (1) (m), the gross weight imposed on the highway by the wheels of any one axle may not exceed 21,500 pounds or, for 2 axles 8 or less feet apart, 37,000 pounds or, for groups of 3 or more consecutive axles more than 9 feet apart, a weight of 4,000 pounds more than is shown in par. (c) or, for groups of 4 or more consecutive axles more than 10 feet apart, a weight of 6,000 pounds more than is shown in par. (c) or, for groups of 5 or more consecutive axles more than 14 feet apart, a weight of 7,000 pounds more than is shown in par. (c), but not to exceed 80,000 pounds. This paragraph does not apply to the national system of interstate and defense highways, except for that portion of USH 51 between Wausau and STH 78 and that portion of STH 78 between USH 51 and the I 90/94 interchange near Portage upon their federal designation as I 39.

(c) The gross weight imposed on the highway by any group of 2 or more consecutive axles of a vehicle or combination of vehicles may not exceed the maximum gross weights in the following table for each of the respective distances between axles and the respective numbers of axles of a group: [See Figure 348.15 (3) (c) following]

Figure 348.15 (3) (c):

Distances in feet between foremost and rear-most axles of a group	Maximum gross weight in pounds on a group of—									
	2 consecutive axles of a 2-axle vehicle or any vehicle or combination of vehicles having a total of 3 or more axles	3 consecutive axles of a 3-axle vehicle or of any vehicle or combination of vehicles having a total of 4 or more axles	4 consecutive axles of any combination of vehicles having a total of 5 or more axles	4 consecutive axles of a 4-axle vehicle or of any vehicle having a total of 5 or more axles	5 consecutive axles of any combination of vehicles having a total of 5 or more axles	5 consecutive axles of a 5-axle vehicle or of any vehicle having a total of 6 or more axles	6 consecutive axles of any combination of vehicles having a total of 6 or more axles	6 consecutive axles of any vehicle having a total of 6 or more axles	7 consecutive axles of a 7-axle vehicle or of any vehicle or combination of vehicles having a total of 7 or more axles	8 consecutive axles of a 8-axle vehicle or of any vehicle or combination of vehicles having a total of 8 or more axles
4	34,000									
5	34,000									
6	34,000									
7	34,000	37,000								
7.5 to 8 more than 8 but less than 8.5	35,000	38,500								
8	38,000	42,000								
9	39,000	43,000								
10	40,000	43,500	48,500							
11		44,500	49,500							
12		45,000	50,000	55,500						
13		46,000	50,500	60,000	62,500					
14		46,500	51,500	60,500	62,500					
15		47,500	52,000	61,500	62,500					
16		48,000	52,500	62,000	62,500	64,200				
17		49,000	53,500	63,000	63,200	71,700	64,000			
18		49,500	54,100	63,500	64,400	72,200	65,000			
19		50,500	55,100	64,500	65,000	73,000	65,500			
20		51,500	56,000	65,000	65,700	73,000	66,000	73,000		
21		52,200	56,800	66,000	66,900	73,000	66,900	73,000	73,000	
22		52,900	57,600	66,500	67,700	73,000	67,700	73,000	73,000	
23		53,600	58,400	67,500	68,900	73,000	68,900	73,000	73,500	
24		54,300	59,200	68,500	70,000	73,000	70,000	73,000	74,000	
25		55,000	60,000	69,000	71,000	73,000	71,000	73,000	74,500	80,000
26		55,700	60,800	69,500	72,000	73,000	72,000	73,000	75,000	80,000
27		56,500	61,600	70,500	72,800	73,000	72,800	73,000	76,000	80,000
28		57,100	62,400	71,300	73,000	73,000	73,000	73,000	76,500	80,000
29		58,000	63,200	72,000	73,000	73,000	73,000	73,000	77,000	80,000
30		58,500	64,000	72,700	73,000	73,000	73,000	73,000	77,500	80,000
31		59,500	64,000	73,000	73,000	73,000	73,000	73,000	78,000	80,000
32		60,000**	64,000	73,000**	73,000	73,000**	73,000	73,000**	78,500	80,000**
33			64,000		73,000		74,000		79,500	
34			64,500		73,000		74,500		80,000***	
35			65,500		73,000		75,000			
36			66,000		73,000		75,500			
37			66,500		73,000		76,000			
38			67,500		73,000		77,000			
39			68,000		73,000		77,500			
40			68,500		73,000		78,000			
41			69,500		73,500		78,500			
42			70,000		74,500		79,000			
43			70,500		75,000		80,000			
44			71,500		75,500		80,000			
45			72,000		76,000		80,000			
46			72,500		77,000		80,000			
47			73,500		77,500		80,000			
48			74,000		78,000		80,000			
49			74,500		78,500		80,000			
50			75,500		79,500		80,000			
51			76,000****		80,000****		80,000****			

*Maximum at 10 or more feet between axles.
 **Maximum at 32 or more feet between axles.
 ***Maximum at 34 or more feet between axles.
 ****Maximum at 51 or more feet between axles.

(d) Notwithstanding par. (c), 2 consecutive sets of tandem axles may impose on the highway a gross load of 34,000 pounds each if the overall distance between the first and last axles of such consecutive sets of tandem axles is 36 feet or more.

(e) Notwithstanding pars. (a), (b) and (c), in the case of a vehicle or combination of vehicles transporting exclusively livestock, the gross weight imposed on the highway by the wheels of any one axle or axle group may exceed the applicable weight limit

specified in pars. (a), (b) and (c) by 15% if the gross weight of the vehicle or combination of vehicles does not exceed the maximum gross weight specified for that vehicle or combination of vehicles under par. (c). This paragraph does not apply to the national system of interstate and defense highways, except for that portion of USH 51 between Wausau and STH 78 and that portion of STH 78 between USH 51 and the I 90/94 interchange near Portage upon their federal designation as I 39.

(f) 1. In this paragraph:

a. “Heavy-duty vehicle” has the meaning given in 42 USC 16104 (a) (4).

b. “Idle reduction technology” has the meaning given in 42 USC 16104 (a) (5).

2. Notwithstanding pars. (a) to (c), sub. (4), and ss. 348.17 and 349.16, and subject to subd. 3., in the case of a heavy-duty vehicle equipped with idle reduction technology, the gross weight of the vehicle, and the gross weight imposed on the highway by the wheels of any one axle or axle group of the vehicle, may exceed the applicable weight limitation specified in pars. (a) to (c) or posted as provided in s. 348.17 (1) by not more than 400 pounds or the weight of the idle reduction technology, whichever is less.

3. This paragraph applies only if the heavy-duty vehicle operator, upon request, proves, by written certification, the weight of the idle reduction technology and, by demonstration or certification, that the idle reduction technology is fully functional at all times.

(4) Notwithstanding the possibility of increased weight on a particular wheel or axle or group of axles due to practical operating problems, including, but not limited to, accumulation of snow, ice, mud or dirt, the use of tire chains or minor shifting of load, the maximum weights set forth in sub. (3) include absolutely all weights allowable.

(5) For enforcement of weight limitations specified by this chapter the gross weight, measured in pounds, imposed on the highway by any wheel or any one axle or by any group of 2 or more axles shall be determined by weighing the vehicles and load, either by single draft or multiple draft weighing on certified stationary scales or on portable scales in good working order which are tested in comparison to certified stationary scales within 180 days immediately prior to any weighing operation by the department of agriculture, trade and consumer protection or other authorized testing agencies for accuracy to within standard accepted tolerances. The weighing operation shall be performed in accordance with and under conditions accepted as good weighing technique and practice. In multiple draft weighing the sum of the weight of respective components shall be used to establish the weight of a combination of the components. It is recognized that the weight, determined in accordance with methods prescribed in this chapter, includes all statutory weights and represents the momentary load force or reaction imposed on the scale at the time of weighing. Such weights include any variation due to the following factors:

(a) Positioning or tilt of the vehicle on the scale platform and adjacent bearing surface;

(b) Momentary position of axle centers with respect to wheel bearings and vehicle body;

(c) Temporary distribution of loading on the wheel or axle; and

(d) Miscellaneous variable factors of spring flexure, shackle friction, clutch engagement, brake pressure, tire compression and other variable factors.

(5m) The distances between axles and between the foremost and rearmost of a group of axles shall be measured between axle centers to the nearest even foot, and when a fraction is exactly one-half foot, the nearest larger whole number shall be used.

(5r) Irrespective of sub. (5), in determining overweight under sub. (3) the results of weighing by means of either portable scales or certified stationary scales shall be admissible as evidence. In all cases where a vehicle is weighed on a certified stationary scale, axles less than 6 feet apart shall be weighed as one unit.

(6) At any state weighing scale where a vehicle is found overloaded, the driver may request its reweighing at the same scale. Upon reweighing the state officials shall supply the tabulated weight ticket to the driver. All weight tickets for any vehicle shall be supplied to the court in case the matter goes to trial.

(8) Unless the department provides otherwise by rule, any axle of a vehicle or combination of vehicles which does not

impose on the highway at least 8% of the gross weight of the vehicle or combination of vehicles may not be counted as an axle for the purposes of sub. (3) (c).

History: 1977 c. 29 ss. 1487p to 1487s, 1650m (4), 1654 (3); 1977 c. 418; 1979 c. 326; 1981 c. 312; 1983 a. 27, 345, 486; 1985 a. 202, 332; 1987 a. 174; 1989 a. 56, 70; 1995 a. 113, 227; 1999 a. 85; 2005 a. 347, 364; 2007 a. 20; 2009 a. 156.

If a tractor-trailer combination is too long and too wide for a scale, multiple weighing of the separate wheel groups is permissible. An overload permit is to be disregarded if the total weight exceeds that specified in the permit. *State v. Trailer Service, Inc.* 61 Wis. 2d 400, 212 N.W.2d 683 (1973).

Subs. (3) (b) 2, 1979 stats. [now (3) (br)] and (5r) are discussed. 62 Atty. Gen. 100.

348.16 Weight limitations on class “B” highways.

(1) In this section:

(b) “Class ‘B’ highway” includes those county trunk highways, town highways and city and village streets, or portions thereof, which have been designated as class “B” highways by the local authorities pursuant to s. 349.15.

(2) Except as provided in sub. (3) and s. 348.175 and subject to any modifications made by a city of the first class pursuant to s. 349.15 (3), no person, without a permit therefor, shall operate on a class “B” highway any vehicle or combination of vehicles imposing wheel, axle, group of axles, or gross weight on the highway exceeding 60 percent of the weights authorized in s. 348.15 (3).

(3) Any motor vehicle whose operation is pickup or delivery, including operation for the purpose of moving or delivering supplies or commodities to or from any place of business or residence that has an entrance on a class “B” highway, may pick up or deliver on a class “B” highway without complying with the gross vehicle weight limitations imposed by sub. (2).

History: 1981 c. 312; 2001 a. 16; 2009 a. 177.

348.17 Special or seasonal weight limitations. (1) No

person, whether operating under a permit or otherwise, shall operate a vehicle in violation of special weight limitations imposed by state or local authorities on particular highways, highway structures or portions of highways when signs have been erected as required by s. 349.16 (2) giving notice of such weight limitations, except when the vehicle is being operated under a permit expressly authorizing such weight limitations to be exceeded.

(2) Whenever the operator of a vehicle is ordered by the officer or agency in charge of maintenance or by a traffic officer to suspend operation of such vehicle because of the damage such vehicle is causing or likely to cause to the highway or the public investment therein, the operator shall forthwith comply with such order.

(3) During an energy emergency, after consultation with the department of administration, the department may waive the divisible load limitation of s. 348.25 (4) and authorize for a period not to exceed 30 days the operation of overweight vehicles having a registered gross weight of 50,000 pounds or more and carrying energy resources or fuel or milk commodities designated by the governor or a designee, regardless of the highways involved, to conserve energy. Such authorization may only allow weights not more than 10% greater than the gross axle and axle combination weight limitations, and not more than 15% greater than the gross vehicle weight limitations under ss. 348.15 and 348.16. Nothing in this subsection shall be construed to permit the department to waive the requirements of ss. 348.05 to 348.07. This subsection does not apply to vehicles on highways designated as parts of the national system of interstate and defense highways, except for that portion of USH 51 between Wausau and STH 78 and that portion of STH 78 between USH 51 and the I 90/94 interchange near Portage upon their federal designation as I 39.

(5) From September 1 to November 30 of each year, no permit shall be required for the transportation of corn, soybeans, potatoes, vegetables, or cranberries from the field to storage on the grower’s owned or leased land, from the field to initial storage at a location not owned or leased by the grower, or from the field to initial processing in a vehicle or combination of vehicles having a registered gross weight of 50,000 pounds or more or described

348.17 VEHICLES — SIZE, WEIGHT AND LOAD

in s. 340.01 (24) (b) that exceeds the weight limitations under s. 348.15 by not more than 15 percent. This subsection does not apply to the national system of interstate and defense highways, except for that portion of I 39 between USH 51 and I 90/94.

History: 1991 a. 316; 1995 a. 348 ss. 11, 13 to 15, 17; 2005 a. 364.

348.175 Seasonal operation of vehicles hauling peeled or unpeeled forest products cut crosswise or abrasives or salt for highway winter maintenance. The transportation of peeled or unpeeled forest products cut crosswise or of abrasives or salt for highway winter maintenance in excess of gross weight limitations under s. 348.15 shall be permitted during the winter months when the highways are so frozen that no damage may result thereto by reason of such transportation. If at any time any person is so transporting such products or abrasives or salt upon a class “A” highway in such frozen condition then that person may likewise use a class “B” highway without other limitation, except that chains and other traction devices are prohibited on class “A” highways but such chains and devices may be used in cases of necessity. On the first day that conditions warrant their determination of such frozen condition and freedom of damage to such highways by transportation, the officers or agencies in charge of maintenance of highways shall declare particular highways, or highways within areas of the state, as eligible for increased weight limitations, and each declaration shall be effective as of 12:01 a.m. on the 2nd day following the declaration. Such declaration shall include the maximum weight on each axle, combination of axles and the gross weight allowed. Any person transporting any such product over any highway of this state under this section is liable to the maintaining authority for any damage caused to such highway. This section does not apply to the national system of interstate and defense highways, except for that portion of I 39 between USH 51 and I 90/94.

History: 1983 a. 531; 1991 a. 316; 1995 a. 113; 2005 a. 167; 2009 a. 28.
The phrase “peeled or unpeeled forest products cut crosswise” does not encompass wood chips. The phrase instead invokes images of logs, posts, poles, or similar pieces of timber, with or without bark, and cut to length. *State v. T. P. Trucking*, 2006 WI App 98, 293 Wis. 2d 273, 715 N.W.2d 736, 05–2496.

348.18 Weight limitations apply to publicly-owned vehicles; exceptions. Sections 348.15 to 348.17 and the penalties for violations thereof also apply to vehicles owned by the state, a county or municipality, except when such vehicles are being used for the removal, treatment or sanding of snow or ice or when such vehicles are authorized emergency vehicles.

348.19 Traffic officers may weigh vehicles and require removal of excess load. (1) (a) Any traffic officer having reason to believe that the gross weight of a vehicle is unlawful or in excess of the gross weight for which the vehicle is registered may require the operator of such vehicle to stop and submit the vehicle and any load it may be carrying to a weighing by means of either portable or certified stationary scales and may require that such vehicle be driven to the nearest usable portable or certified stationary scale except as provided in par. (b).

(b) Any other provision of the statutes notwithstanding, a vehicle transporting peeled or unpeeled forest products cut crosswise shall not be required to proceed to a scale more than one mile from the point of apprehension if the estimated gross weight of the vehicle does not exceed the lawful limit. The gross weight of the vehicle shall be estimated by multiplying the average length of the load by the average height of the load in feet and then multiplying by the average weight per square foot of load measurement and adding this computed weight to the empty weight of the vehicle. The average weights per square foot of load measurement to be used in computing the estimated load weight are given in the following table: [See Figure 348.19 (1) (b) following]

Figure: 348.19 (1) (b)

Softwood and Poplar	Green	Seasoned
Peeled	325 lbs.	200 lbs.

Unpeeled	300 lbs.	250 lbs.
Other Hardwoods		
Peeled	350 lbs.	225 lbs.
Unpeeled	325 lbs.	275 lbs.

(Pulpwood which has been cut 6 months prior to hauling is considered seasoned.)

(2) (a) Except as provided in par. (b), whenever after a weighing of a vehicle and load as provided in sub. (1) a traffic officer determines that the weight exceeds the limitations imposed by s. 348.15, 348.16 or 348.17 (3) or (5) or any limitations posted as provided in s. 348.17 (1), the operator of such vehicle shall not proceed (except to drive to such place as directed by the traffic officer for the purpose of reloading or unloading) until such portion of the load has been reloaded or unloaded as may be necessary to reduce the weight of the vehicle and load to comply with the limitations imposed by s. 348.15, 348.16 or 348.17 (3) or (5) and any limitations posted as provided in s. 348.17 (1). All material so reloaded or unloaded shall be reloaded or unloaded and cared for by and at the risk of the owner or operator of the vehicle.

(b) If upon weighing a vehicle transporting livestock a traffic officer determines that the gross weight of the vehicle exceeds the limitations imposed by s. 348.15, 348.16 or 348.17 (3) or a limitation posted as provided in s. 348.17 (1), and if the point of apprehension is 15 miles or less from the destination of the vehicle, the traffic officer shall permit the operator of the vehicle to proceed to such destination without requiring the vehicle to be reloaded or unloaded as provided in par. (a). This paragraph does not apply to vehicles transporting livestock on the national system of interstate and defense highways, except for that portion of I 39 between USH 51 and I 90/94.

(3) No operator of a vehicle shall fail or refuse to stop and submit the vehicle and load to a weighing or to drive the vehicle to a scale when directed to do so by a traffic officer except that a dual purpose motor home is not required to stop at weighing stations when it is being used as a motor home. No operator of a vehicle shall fail or refuse after a weighing to reload or unload as provided in this section or to comply with the directions of a traffic officer relative to such reloading or unloading.

(4) Subsection (1) (b) shall not apply to vehicles transporting peeled or unpeeled forest products on the national, interstate or defense highway systems, except for that portion of USH 51 between Wausau and STH 78 and that portion of STH 78 between USH 51 and the I 90/94 interchange near Portage upon their federal designation as I 39.

History: 1975 c. 136; 1985 a. 202; 1987 a. 116; 1995 a. 113, 348; 2005 a. 364.

348.195 Weight records of raw forest products purchasers. (1) Any purchaser of raw forest products transported by a vehicle or vehicle combination subject to the requirements of this subchapter that generates a weight scale record identifying the gross weight of the vehicle or vehicle combination or the weight of the load transported by the vehicle or vehicle combination shall retain the weight scale record for not less than 30 days from the date that the weight scale record is generated.

(2) Upon demand by any traffic officer in this state within the 30-day period specified in sub. (1), any person required to retain records under sub. (1) shall promptly provide such records to the requesting officer.

(3) For purposes of this section, a true, accurate, and legible copy of any weight scale record may be substituted for, and shall be given the effect of, an original.

(4) Any person required to retain records under sub. (1) or to produce records under sub. (2) who fails to retain or produce such records shall forfeit \$1,000. Each violation constitutes a separate offense.

(5) In any prosecution of a person for transporting raw forest products in violation of the requirements of this subchapter, the records required to be retained under sub. (1) and produced under

sub. (2) may be relevant evidence under s. 904.01 and admissible under s. 904.06.

History: 2005 a. 167.

348.20 Policy in prosecuting weight violations. (1) It is declared to be the public policy of the state that prosecutions for overweight violations shall in every instance where practicable be instituted against the person holding the authority, certificates, licenses or permits evidencing operating privileges from the department which may be the proper object of cancellation or revocation proceedings. In instances where a combination of tractor and trailer or semitrailer is used, the person standing in the relationship of principal or employer to the driver of the tractor portion of the vehicle combination is liable for violation of ss. 348.15 to 348.17 along with the owner holding authority, certificates, licenses or permits from the state. It is a violation of ss. 348.15 to 348.17 for the owner or any other person employing or otherwise directing the operator of the vehicle to require or permit the operation of such vehicle upon a highway contrary to ss. 348.15 to 348.17. This section shall not apply to individuals, partnerships, limited liability companies or corporations whose principal business is leasing, for compensation, vehicles including trailers and semitrailers, but such prosecutions shall be instituted against the lessee of the vehicle.

(2) The operator of a vehicle, as agent of the person holding authority, certificate, license or permit from the state or as agent of the owner of the tractor portion of a vehicle combination of tractor and trailer or semitrailer, shall accept service of a summons on behalf of such person or owner.

History: 1977 c. 29 ss. 1487t, 1654 (9) (d); 1981 c. 347 s. 80 (2); 1987 a. 369; 1993 a. 16, 112, 490.

348.21 Penalty for violating weight limitations. (2) (a) Any person who violates s. 348.17 (2) or 348.19 (3) may be required to forfeit not less than \$50 nor more than \$100 upon the first conviction and, upon the 2nd or each subsequent conviction within a 12-month period, may be required to forfeit not less than \$100 nor more than \$200.

(b) If the load on any wheel, axle, or group of axles does not exceed the weight prescribed in s. 348.15 (3) or 348.16 or in a declaration issued under s. 348.175, or prescribed in an overweight permit issued under s. 348.27 (9m) (a) 4. with respect to a vehicle combination being operated under such a permit, by more than 2,000 pounds and if such excess can be reloaded within the normal load carrying areas, on any other wheel, axle, or axles, so that all wheels and axles are then within the statutory limits, the operator may reload as provided in this paragraph. A total of 2,000 pounds per vehicle or combination of vehicles may be reloaded under this paragraph. If reloading is accomplished and all axles or group of axles are within the legal limits, including the limits of the permit for a vehicle combination operated under a permit issued under s. 348.27 (9m) (a) 4., no forfeiture may be imposed. A vehicle or combination of vehicles under this paragraph that is not reloaded may continue to be operated upon the highway, but a forfeiture of \$50 shall be imposed for failure to reload. This forfeiture shall be paid upon the basis of the citation issued by the official to the court named in the citation. Failure to pay shall subject the operator to the penalty in par. (a) or sub. (3) (a) or (3g). Violations under this paragraph shall not be considered as violations or prior convictions under par. (a) or sub. (3) to (3r).

(3) Except as provided in sub. (3g), any person violating s. 348.15 or 348.16 or any weight limitation posted as provided in s. 348.17 (1) or in a declaration issued under s. 348.175 or authorized under s. 348.17 (3) or (5) or in an overweight permit issued under s. 348.26 or 348.27 may be penalized as follows:

(a) If the weight exceeds by 1,000 pounds or less the maximum set forth in s. 348.15 (3) or 348.16 or posted as provided in s. 348.17 (1) or in a declaration issued under s. 348.175 or authorized under s. 348.17 (3) or (5) or in an overweight permit issued under s. 348.26 or 348.27, a forfeiture of not less than \$50 nor

more than \$100 upon the first conviction and, upon the 2nd and each subsequent conviction within a 12-month period, a forfeiture of not less than \$100 nor more than \$200.

(b) If the weight exceeds by more than 1,000 pounds the maximum set forth in s. 348.15 (3) or 348.16 or posted as provided in s. 348.17 (1) or in a declaration issued under s. 348.175 or authorized under s. 348.17 (3) or (5) or in an overweight permit issued under s. 348.26 or 348.27, the forfeiture shall be computed according to the following schedule and in the case of violation of s. 348.15 (3) (bg) or (br) shall be computed on the basis of the weights stated in s. 348.15 (3) (bg) or (br):

1. For the first conviction, a forfeiture of not less than \$50 nor more than \$200 plus an amount equal to whichever of the following applies:

a. One cent for each pound of total excess load when the total excess is not over 2,000 pounds.

b. Two cents for each pound of total excess load if the excess is over 2,000 pounds and not over 3,000 pounds.

c. Three cents for each pound of total excess load if the excess is over 3,000 pounds and not over 4,000 pounds.

d. Five cents for each pound of total excess load if the excess is over 4,000 pounds and not over 5,000 pounds.

e. Seven cents for each pound of total excess load if the excess is over 5,000 pounds.

2. For the 2nd and each subsequent conviction within a 12-month period, a forfeiture of not less than \$100 nor more than \$300, plus an amount equal to whichever of the following applies:

a. Two cents for each pound of total excess load when the total excess is not over 2,000 pounds.

b. Four cents for each pound of total excess load if the excess is over 2,000 pounds and not over 3,000 pounds.

c. Six cents for each pound of total excess load if the excess is over 3,000 and not over 4,000 pounds.

d. Eight cents for each pound of total excess load if the excess is over 4,000 pounds and not over 5,000 pounds.

e. Ten cents for each pound of total excess load if the excess is over 5,000 pounds.

(3g) Any person who, while operating a vehicle combination that is transporting raw forest products, violates s. 348.15 or 348.16 or any weight limitation posted as provided in s. 348.17 (1) or in a declaration issued under s. 348.175 or authorized in an overweight permit issued under s. 348.26 or 348.27 may be penalized as follows:

(a) For a first conviction or a 2nd conviction within a 12-month period, a forfeiture of not less than \$150 nor more than \$250 plus an amount equal to whichever of the following applies:

1. Six cents for each pound of total excess load when the total excess is less than 2,000 pounds.

2. Eight cents for each pound of total excess load if the excess is 2,000 pounds or more and not over 3,000 pounds.

3. Nine cents for each pound of total excess load if the excess is over 3,000 pounds and not over 4,000 pounds.

4. Ten cents for each pound of total excess load if the excess is over 4,000 pounds and not over 5,000 pounds.

5. Eleven cents for each pound of total excess load if the excess is over 5,000 pounds.

(b) For the 3rd and each subsequent conviction within a 12-month period, a forfeiture of not less than \$500 nor more than \$550, plus an amount equal to whichever of the following applies:

1. Twenty cents for each pound of total excess load when the total excess is 3,000 pounds or less.

2. Twenty-one cents for each pound of total excess load if the excess is over 3,000 pounds and not over 4,000 pounds.

3. Twenty-two cents for each pound of total excess load if the excess is over 4,000 pounds and not over 5,000 pounds.

4. Twenty–three cents for each pound of total excess load if the excess is over 5,000 pounds.

(3r) In determining the number of prior convictions for purposes of subs. (3) and (3g), the court shall include convictions under both subsections.

(4) For the purpose of determining a repetitious violator, receipt of a certificate of conviction by the department is prima facie evidence of conviction. In determining whether a 2nd or subsequent conviction has occurred within a given 12–month period, either the original judgment of conviction in a circuit court or a municipal court or the affirmance of the judgment by an appellate court, if the judgment has been affirmed, may be counted. This method of counting is authorized to effectively reach the repetitious violator and to prevent misuse of the right of appeal for the purpose of forestalling imposition of the penalties provided by this section. Forfeiture of deposit or payment of a forfeiture is a conviction within the meaning of this section.

History: 1971 c. 164 s. 83; 1971 c. 278, 307; 1975 c. 297; 1977 c. 29 s. 1654 (7) (a); 1981 c. 312; 1985 a. 201, 332; 1995 a. 348; 1997 a. 27; 2005 a. 167, 364; 2007 a. 20, 97; 2009 a. 28, 180, 222, 241.

Penalty provisions for weight and size violations are discussed. *East Troy v. Town & Country Waste Service*, 159 Wis. 2d 694, 465 N.W.2d 510 (Ct. App. 1990).

348.22 Courts to report weight violation convictions.

Whenever any owner or operator is convicted of violating ss. 348.15 to 348.17 or any local ordinance in conformity with ss. 348.15 to 348.17 or any ordinance enacted under s. 349.15 (3), the clerk of the court in which the conviction occurred, or the judge or municipal judge, if the court has no clerk, shall, within 48 hours after the conviction, forward a record of conviction to the department. Forfeiture of bail or appearance money or payment of a fine is a conviction within the meaning of this section.

History: 1971 c. 164 s. 83; 1977 c. 29 s. 1654 (7) (a); 1985 a. 332; 1989 a. 31; 2005 a. 167.

SUBCHAPTER IV

PERMITS

348.25 General provisions relating to permits for vehicles and loads of excessive size and weight. (1)

person shall operate a vehicle on or transport an article over a highway without first obtaining a permit therefor as provided in s. 348.26 or 348.27 if such vehicle or article exceeds the maximum limitations on size, weight or projection of load imposed by this chapter.

(2) (a) Vehicles or articles transported under permit are exempt from the restrictions and limitations imposed by this chapter on size, weight and load to the extent stated in the permit. Except as provided in par. (b), any person who violates a condition of a permit under which that person is operating is subject to the same penalties as would be applicable if that person were operating without a permit.

(b) If an overweight permit has been obtained under s. 348.26 or 348.27, and the vehicle exceeds the weight stated in the permit, any overweight violation shall be computed on the basis of the weight authorized in the permit. The amount of the forfeiture for overweight violations determined under this paragraph shall be calculated as provided in s. 348.21 (3) to (3r). This paragraph does not apply if any other conditions of an overweight permit are violated.

(3) The department shall prescribe forms for applications for all single trip permits the granting of which is authorized by s. 348.26 and for those annual, consecutive month or multiple trip permits the granting of which is authorized by s. 348.27 (2) and (4) to (15). The department may impose such reasonable conditions prerequisite to the granting of any permit authorized by s. 348.26 or 348.27 and adopt such reasonable rules for the operation of a permittee thereunder as it deems necessary for the safety of travel and protection of the highways. The department may limit use of the highways under any permit issued to specified hours of

the day or days of the week. Local officials granting permits may impose such additional reasonable conditions as they deem necessary in view of local conditions.

(4) Except as provided under s. 348.26 (5), (6), or (7) or 348.27 (3m), (4m), (9), (9m), (9r), (9t), (10), (12), (13), or (15) permits shall be issued only for the transporting of a single article or vehicle which exceeds statutory size, weight or load limitations and which cannot reasonably be divided or reduced to comply with statutory size, weight or load limitations, except that:

(a) A permit may be issued for the transportation of property consisting of more than one article, some or all of which exceeds statutory size limitations, provided statutory gross weight limitations are not thereby exceeded and provided the additional articles transported do not cause the vehicle and load to exceed statutory size limitations in any way in which such limitations would not be exceeded by the single article.

(b) A single trip permit may be issued for the transportation of a load of implements of husbandry, consisting of not more than 2 articles, when the load does not exceed the length requirement in s. 348.07 by more than 5 feet.

(5) The officer or agency authorized by s. 348.26 or 348.27 to issue permits may require the permittee to file a bond, certificate of insurance or certified check which, to the satisfaction of such officer or agency, saves the state and any county, city, village or town through which the vehicle or article will be operated or transported harmless from any claim, loss or damage that may result from the granting of such permit or that may arise from or on account of any act done pursuant thereto and conditioned to require the permittee to pay for restoration to a condition satisfactory to the officer in charge of the maintenance of any such highway any pavement, bridge, culvert, sewer pipe or other improvement that may be injured by reason of the use of the highways by the permittee. If a permittee refuses to pay for damage caused, the officer or agency who required the filing of a bond may maintain an action upon such bond.

(6) The officer or agency authorized by s. 348.26 or 348.27 to issue permits may require the permittee to file proof satisfactory to such officer or agency that personal injury and property damage insurance in an amount considered sufficient by such officer or agency will be in force to cover any claim for bodily injury or property damage which may occur in connection with operation under the permit and for which the permittee is legally responsible.

(7) Subject to s. 348.27 (9m) (d), the officer or agency which issued a permit may, for good cause, suspend or revoke such permit or may decline to issue additional permits or may decline to authorize the use of a telephone call–in procedure for any applicant after having given the permittee or applicant reasonable opportunity for a hearing.

(8) (a) Except as provided under par. (dm), the department shall charge the following fees for each permit issued under s. 348.26:

1. For a vehicle or combination of vehicles which exceeds length limitations, \$15, except that if the application for a permit for a vehicle described in this subdivision is submitted to the department after December 31, 1999, and before July 1, 2005, the fee is \$17.

2. For a vehicle or combination of vehicles which exceeds either width limitations or height limitations, \$20, except that if the application for a permit for a vehicle described in this subdivision is submitted to the department after December 31, 1999, and before July 1, 2005, the fee is \$22.

2m. For a vehicle or combination of vehicles which exceeds both width and height limitations, \$25, except that if the application for a permit for a vehicle described in this subdivision is submitted to the department after December 31, 1999, and before July 1, 2005, the fee is \$28.

3. For a vehicle or combination of vehicles, the weight of which exceeds any of the provisions of s. 348.15 (3), 10% of the

fee specified in par. (b) 3. for an annual permit for the comparable gross weight, rounded to the nearest whole dollar.

(b) Unless a different fee is specifically provided, the department shall charge the following fees for the first permit and each subsequent or revalidated annual or multiple trip permit issued under s. 348.27 except that no fee may be charged for the amendment of a permit under s. 348.27 (3m):

1. For a vehicle or combination of vehicles which exceeds length limitations, \$60, except that if the application for a permit for a vehicle described in this subdivision is submitted to the department after December 31, 1999, and before July 1, 2005, the fee is \$66.

2. For a vehicle or combination of vehicles which exceeds width limitations or height limitations or both, \$90, except that if the application for a permit for a vehicle described in this subdivision is submitted to the department after December 31, 1999, and before July 1, 2005, the fee is \$99.

3. For a vehicle or combination of vehicles, the weight of which exceeds any of the provisions of s. 348.15 (3):

a. If the gross weight is 90,000 pounds or less, \$200, except that if the application for a permit for a vehicle described in this subd. 3. a. is submitted to the department after December 31, 1999, and before July 1, 2005, the fee is \$220.

b. If the gross weight is more than 90,000 pounds but not more than 100,000 pounds, \$350, except that if the application for a permit for a vehicle described in this subd. 3. b. is submitted to the department after December 31, 1999, and before July 1, 2005, the fee is \$385.

c. If the gross weight is greater than 100,000 pounds, \$350 plus \$100 for each 10,000-pound increment or fraction thereof by which the gross weight exceeds 100,000 pounds, except that if the application for a permit for a vehicle described in this subd. 3. c. is submitted to the department after December 31, 1999, and before July 1, 2005, the fee is \$385 plus \$110 for each 10,000-pound increment or fraction thereof by which the gross weight exceeds 100,000 pounds.

(bm) 1. Unless a different fee is specifically provided, the fee for a consecutive month permit is one-twelfth of the fee under par. (b) for an annual permit times the number of months for which the permit is desired, plus \$15 for each permit issued. This subdivision does not apply to applications for permits submitted after December 31, 1999, and before July 1, 2005.

2. Unless a different fee is specifically provided, the fee for a consecutive month permit is one-twelfth of the fee under par. (b) for an annual permit times the number of months for which the permit is desired, plus \$16.50 for each permit issued, rounded to the nearest whole dollar. This subdivision does not apply to applications submitted before January 1, 2000, or submitted after June 30, 2005.

(c) For the purpose of computing the fees under this subsection, if the vehicle or combination of vehicles exceeds width limitations or height limitations or both, no fee in addition to the fee under par. (a) 2., or 2m., (b) 2. or (bm) shall be charged if the vehicle or combination of vehicles also exceeds length limitations.

(d) For the purpose of computing the fees under this subsection, if the vehicle or combination of vehicles exceeds weight limitations, no fee in addition to the fee under par. (a) 3., (b) 3. or (bm) shall be charged if the vehicle also exceeds length, width or height limitations or any combination thereof.

(de) For the purpose of computing the fee under par. (a) for the issuance of a single trip permit for a vehicle or combination of vehicles for which an annual permit has been obtained under s. 348.27:

1. For size or weight authorized by the annual permit, the fee for a single trip permit is \$5.

2. For gross weight in excess of that authorized by the annual permit, the fee is \$15 for each 10,000-pound increment or fraction

thereof by which the gross weight authorized by the single trip permit exceeds the gross weight authorized by the annual permit.

(dm) If the annual permit for a vehicle or combination of vehicles is suspended for the purpose of protecting the highways and a single trip permit is issued for the vehicle or combination of vehicles, the fee for the single trip permit is \$5.

(e) The officer or agency authorized to issue a permit under s. 348.26 or 348.27 may require any applicant for a permit under s. 348.26 or 348.27 to pay the cost of any special investigation undertaken to determine whether a permit should be approved or denied.

(f) Any local officer or agency authorized to issue a permit under s. 348.26 or 348.27 may charge a permit issuance fee for each permit issued under s. 348.26 and for the first and each subsequent or revalidated permit issued under s. 348.27. This paragraph does not apply to the amendment of a permit under s. 348.27 (3m).

(9) If a permit under s. 348.26 or 348.27 is denied, suspended or revoked, the permit applicant or holder may petition the division of hearings and appeals for a hearing on the matter within 30 days after the denial, suspension or revocation.

(10) Notwithstanding any other provision of this section or ss. 348.26 to 348.28, the department may enter into a reciprocal agreement with another jurisdiction for the issuance or recognition of permits for oversize or overweight vehicles or loads if that jurisdiction's laws or rules on oversize or overweight permits are substantially similar to those imposed by this chapter. Any permit recognized by this state under a reciprocal agreement shall be considered a permit issued under this section for purposes of this chapter or s. 347.26 (10).

(11) The department shall develop and implement an automated system for designating the route to be traveled by a vehicle for which a permit is issued under s. 348.26 or 348.27.

History: 1973 c. 316, 333, 336; 1975 c. 66; 1977 c. 29 ss. 1488, 1654 (8) (a); 1979 c. 34, 221; 1981 c. 20, 69, 215, 312; 1981 c. 347 s. 80 (2), 1981 c. 391; 1983 a. 78 s. 37; 1985 a. 212; 1987 a. 27; 1989 a. 35, 130; 1991 a. 39, 316; 1993 a. 16; 1995 a. 163, 348; 1999 a. 9, 80; 2001 a. 78; 2003 a. 33; 2005 a. 167; 2007 a. 171; 2009 a. 28, 222.

Cross-reference: See also chs. Trans 230, 250, and 252, Wis. adm. code.

Penalty provisions for weight and size violations are discussed. East Troy v. Town & Country Waste Service, 159 Wis. 2d 694, 465 N.W.2d 510 (Ct. App. 1990).

Compliance with state rules promulgated under this section, and incorporating federal guidelines, is a condition of overweight permits under this section. Violations of overweight permits do not constitute registration violations under ch. 341. Town of East Troy v. A-1 Service Co., Inc. 196 Wis. 2d 120, 537 N.W.2d 126 (Ct. App. 1995), 94-0610.

348.26 Single trip permits. (1) APPLICATIONS. All applications for single trip permits for the movement of oversize or overweight vehicles or loads shall be made upon the form prescribed by the department and shall be made to the officer or agency designated by this section as having authority to issue the particular permit desired for use of the particular highway in question.

(1m) **TELEPHONE CALL-IN PROCEDURE.** The department shall develop and implement a telephone call-in procedure for permits issued under this section. The telephone call-in procedure for permits may not be utilized until permit information is computerized to ensure inquiry capability into the database for enforcement purposes.

Cross-reference: See also ch. Trans 275, Wis. adm. code.

(2) **PERMITS FOR OVERSIZE OR OVERWEIGHT VEHICLES OR LOADS.** Except as provided in sub. (4), single trip permits for oversize or overweight vehicles or loads may be issued by the department for use of the state trunk highways and by the officer in charge of maintenance of the highway to be used in the case of other highways. Such local officials also may issue such single trip permits for use of state trunk highways within the county or municipality which they represent. Every single trip permit shall designate the route to be used by the permittee. Whenever the officer or agency issuing such permit deems it necessary to have a traffic officer escort the vehicle through the municipality or county, a reasonable fee for such traffic officer's services shall be paid by the permittee. All moneys received from fees imposed by

the department under this subsection shall be deposited in the general fund and credited to the appropriation account under s. 20.395 (5) (dg).

Cross-reference: See also ch. Trans 254, Wis. adm. code.

(3) TRAILER TRAIN PERMITS. The department and those local officials who are authorized to issue permits pursuant to sub. (2) also are authorized to issue single trip permits for the operation of trains consisting of truck tractors, tractors, trailers, semitrailers or wagons on highways under their jurisdiction, except that no trailer train permit issued by a local official for use of a highway outside the corporate limits of a city or village is valid until approved by the department. No permit shall be issued for any train exceeding 100 feet in total length. Every permit issued pursuant to this subsection shall designate the route to be used by the permittee.

Cross-reference: See also ch. Trans 256, Wis. adm. code.

(4) MOBILE HOME, MANUFACTURED HOME, AND MODULAR HOME PERMITS. Single trip permits for the movement of oversize mobile homes, manufactured homes, or modular homes may be issued only by the department, regardless of the highways to be used. Every such permit shall designate the route to be used by the permittee. No permit may be issued under this subsection for operation of a vehicle combination exceeding 110 feet in overall length or for movement of a mobile home, manufactured home, or modular home exceeding 80 feet in length.

(4m) PERMITS FOR VEHICLES TRANSPORTING CERTAIN BUILDINGS. (a) In this subsection:

1. “Building” has the meaning given in s. 348.27 (12m) (a) 1.

2. “Vehicle” has the meaning given in s. 348.27 (12m) (a) 2.

(b) The requirements for issuance of a permit under s. 348.27 (12m) (c) shall also apply to issuance of a permit under sub. (2) for a vehicle transporting a building on the highways, and the department and those local officials who are authorized to issue permits under sub. (2) may not issue a permit under sub. (2) for a vehicle transporting a building unless these requirements are satisfied. The department and those local officials who are authorized to issue permits under sub. (2) may deny a permit under sub. (2) for a vehicle transporting a building if the department or local official finds that any of the circumstances specified in s. 348.27 (12m) (d) applies. The provisions of this subsection apply in addition to any other requirement imposed under this chapter, chs. 194, 343, 346, and 347, and federal law.

(5) VEHICLE TRAIN PERMITS. The department and those local officials who are authorized to issue permits under sub. (2) may issue a single trip permit for not more than 3 vehicles being drawn or attached if the vehicles are being transported by the drive-away method in saddle-mount combination. No vehicle train permit issued by a local official for use of a highway outside the corporate limits of a city or village is valid until approved by the department. No permit may be issued for any train exceeding 65 feet in total length. Every permit issued pursuant to this subsection shall designate the route to be used by the permittee.

(6) BACKHAUL PERMITS. If an oversize permit has been issued for an oversize vehicle or combination of oversize vehicles under this section or s. 348.27, the authority issuing the permit may also issue a backhaul permit to enable such vehicle or combination to transport a load which does not exceed statutory size and weight limits. A backhaul permit may be issued only when an oversize load is transported on the return trip or outgoing trip. The fee for the backhaul permit is \$3.

Cross-reference: See also ch. Trans 262, Wis. adm. code.

(7) SPECIALIZED HAULING RIG PERMITS. (a) In this subsection, “specialized hauling rig” means a vehicle, or combination of vehicles, that exceeds 100 feet in length and that is designed to transport nondivisible cargo that is exceptionally heavy. A specialized hauling rig is a nondivisible vehicle within the meaning of 23 CFR 658.5.

(b) The department and those local officials who are authorized to issue permits under sub. (2) may issue single trip permits for the operation of overweight or oversize specialized hauling

rigs whose unladen cargo-bearing component units are loaded or stacked on one or more of the specialized hauling rig’s cargo-bearing component units. A permit issued under this paragraph is valid only while the specialized hauling rig is in transit to the site where the cargo to be transported will be loaded onto the specialized hauling rig, and while in transit from the site where the specialized hauling rig delivered its cargo. Every permit issued under this paragraph shall designate the route to be used by the permittee. No permit issued under this paragraph may authorize the operation of a specialized hauling rig that exceeds 120 feet in length or that exceeds the height limitations under s. 348.06.

History: 1977 c. 29 s. 1654 (8) (a); 1977 c. 273; 1981 c. 20, 215, 312, 391; 1983 a. 78; 1997 a. 27; 1999 a. 185; 2001 a. 78; 2005 a. 170, 250; 2007 a. 11.

Cross-reference: See also chs. Trans 230 and 250, Wis. adm. code.

348.27 Annual, consecutive month or multiple trip permits. **(1) APPLICATIONS.** All applications for annual, consecutive month or multiple trip permits for the movement of oversize or overweight vehicles or loads shall be made to the officer or agency designated by this section as having authority to issue the particular permit desired for use of the particular highway in question. All applications under subs. (2) and (4) to (15) shall be made upon forms prescribed by the department.

(2) ANNUAL AND CONSECUTIVE MONTH PERMITS. Except as otherwise restricted in this section, annual and consecutive month permits for oversize or overweight vehicles or loads may be issued by the department, regardless of the highways involved.

Cross-reference: See also chs. Trans 251 and 255, Wis. adm. code.

(3) GENERAL PERMITS. For good cause in specified instances for specified construction or maintenance operations or for a specified period, the officer or agency in charge of maintenance of a highway may allow loads exceeding the size or weight limitations imposed by this chapter to be hauled on such highway. No such officer or agency shall issue such permits for use of a highway the cost of maintenance of which is paid by a unit of government other than the unit of government which such officer or agency represents.

(3m) PERMIT AMENDMENTS FOR REPLACEMENT VEHICLES. If a vehicle for which a permit has been issued under this section is removed from service or sold, the permittee may operate a replacement vehicle of the same type and weight class for the remainder of the period for which the permit was issued or validated under an amendment of the permit. The permittee shall apply to the officer or agency that issued the permit for the amendment. The terms of the permit, including any requirements imposed by the officer or agency for issuance of the permit, shall apply to the permittee’s operation of the replacement vehicle under the amendment of the permit. No fee shall be charged for the amendment of a permit under this subsection.

(4) INDUSTRIAL INTERPLANT PERMITS. The department may issue, to industries and to their agent motor carriers owning and operating oversize vehicles in connection with interplant, and from plant to state line, operations in this state, annual or consecutive month permits for the operation of such vehicles over designated routes, provided that such permit shall not be issued under this section to agent motor carriers or, except for that portion of USH 51 between Wausau and STH 78 and that portion of STH 78 between USH 51 and the I 90/94 interchange near Portage upon their federal designation as I 39, from plant to state line for vehicles or loads of width exceeding 102 inches upon routes of the national system of interstate and defense highways. If the routes desired to be used by the applicant involve city or village streets or county or town highways, the application shall be accompanied by a written statement of route approval by the officer in charge of maintenance of the highway in question.

(4m) PERMITS FOR THE TRANSPORTATION OF LOADS ON STH 31 AMONG MANUFACTURING PLANTS, DISTRIBUTION CENTERS, AND WAREHOUSES. (a) Subject to pars. (b) and (c), the department may issue annual or consecutive month permits for the transportation of loads in vehicle combinations that exceed the maximum gross weight limitations under s. 348.15 (3) (c) by not more than 18,000

pounds if the vehicle combination has 6 or more axles and the gross weight imposed on the highway by the wheels of any one axle of the vehicle combination does not exceed 18,000 pounds, except that the gross weight imposed on the highway by the wheels of any steering axle on the power unit may not exceed the greater of 13,000 pounds or the manufacturer's rated capacity, but not to exceed 18,000 pounds. Notwithstanding s. 348.15 (8), any axle of a vehicle combination that does not impose on the highway at least 8 percent of the gross weight of the vehicle combination may not be counted as an axle for the purposes of this paragraph. A permit issued under this subsection does not authorize the operation of any vehicle combination at a maximum gross weight in excess of 98,000 pounds.

(b) A permit under this subsection is valid only for the transportation of loads between or among any of the following:

1. A manufacturing plant located in Racine County.
2. A distribution center located in Kenosha County.
3. A warehouse located in Kenosha County.
4. A warehouse located in Racine County.

(c) 1. Except as provided in subs. 2. and 3., and subject to par.

(d), a permit under this subsection is valid only on STH 31 and on local highways designated in the permit that provide access to STH 31.

2. A permit under this subsection is not valid on any interstate highway designated under s. 84.29 (2) or on any highway or bridge with a posted weight limitation that is less than the vehicle combination's gross weight.

3. Except as provided in subd. 2., if any portion of STH 31 in Kenosha County or Racine County is closed, a permit under this subsection is valid on any highway providing a detour around this closed portion of STH 31.

(d) If the routes desired to be used by the applicant involve highways under the jurisdiction of local authorities, the department shall, prior to issuing the permit, submit the permit application to the officers in charge of maintenance of the local highways to be used, for their approval. The department may issue the permit, notwithstanding the objections of these officers, if, after consulting with these officers, the department determines that their objections lack merit.

(5) **POLE AND PIPE PERMITS.** Except as further provided in this subsection, the department may issue an annual or consecutive month permit to pipeline companies or operators or public service corporations for transportation of poles, pipe, girders and similar materials and to companies and individuals hauling peeled or unpeeled pole-length forest products used in its business. Such permits issued to companies and individuals hauling peeled or unpeeled pole-length forest products shall limit the length of vehicle and load to a maximum of 10 feet in excess of the limitations in s. 348.07 (1) and shall be valid only on a class "A" highway as defined in s. 348.15 (1). Permits issued to companies or individuals hauling pole-length forest products may not exempt such companies or individuals from the maximum limitations on vehicle load imposed by this chapter.

Cross-reference: See also ch. Trans 257, Wis. adm. code.

(7) **MOBILE HOME, MANUFACTURED HOME, AND MODULAR HOME PERMITS.** The department may issue annual or consecutive month statewide permits to licensed mobile home, manufactured home, or modular home transport companies and to licensed mobile home, manufactured home, or modular home manufacturers and dealers authorizing them to transport oversize mobile homes, manufactured homes, or modular homes over any of the highways of the state in the ordinary course of their business.

(7m) The department may issue an annual or consecutive month permit for the movement of a 3-vehicle combination consisting of a towing vehicle and, in order by weight, with the lighter of the towed vehicles as the 3rd vehicle in the 3-vehicle combination unless not structurally possible, a recreational vehicle or camping trailer, and a trailer for a personal recreational vehicle,

if the overall length of the combination of vehicles does not exceed 60 feet or, if the 2nd vehicle in the 3-vehicle combination is equipped with brakes adequate to control the movement of and to stop and hold it, does not exceed 65 feet, and the towed vehicles are for the use of the operator of the towing vehicle. A permit under this subsection may be issued only by the department, regardless of the highways to be used. The department may designate the routes that may be used by the permittee. The fee for an annual permit under this subsection is \$40. The fee for a consecutive month permit under this subsection shall be determined in the manner provided in s. 348.25 (8) (bm), except that the \$40 fee for an annual permit under this subsection shall be used in the computation. No 3-vehicle combination may operate under this paragraph if highway or weather conditions include heavy snow, freezing rain, icy roads, high winds, limited visibility, or upon a highway that is closed or partially closed by the department due to highway conditions.

(9) **TRANSPORTATION OF LOADS NEAR THE MICHIGAN-WISCONSIN STATE LINE.** (a) 1. The department may issue annual or consecutive month permits, for the transportation on a vehicle or combination of vehicles of loads exceeding statutory length or weight limitations, that authorize all of the following:

a. The transportation of loads over any class of highway for a distance not to exceed 11 miles from the Michigan-Wisconsin state line.

b. The transportation of exclusively peeled or unpeeled forest products cut crosswise, wood chips, or forestry biomass anywhere upon USH 2 in Iron County or Ashland County or upon USH 2 in Bayfield County from the Ashland County line through Hart Lake Road if the vehicle or combination of vehicles is traveling between this state and Michigan and does not violate length or weight limitations established, as of April 28, 2004, under Michigan law.

c. The transportation of exclusively peeled or unpeeled forest products cut crosswise, wood chips, or forestry biomass upon USH 2 from STH 13 in the city of Ashland through Hart Lake Road in Bayfield County.

2. If the roads desired to be used by an applicant for a permit under this paragraph involve streets or highways other than those within the state trunk highway system, the application shall be accompanied by a written statement of route approval by the officer in charge of maintenance of the other highway.

(b) For a vehicle or combination of vehicles the weight of which exceeds any of the provisions of s. 348.15 (3), the fee for an annual permit under this subsection shall be one of the following:

1. If the gross weight is 90,000 pounds or less, \$100.
2. If the gross weight is more than 90,000 pounds but not more than 100,000 pounds, \$175.
3. If the gross weight is greater than 100,000 pounds, \$175 plus \$50 for each 10,000-pound increment or fraction thereof by which the gross weight exceeds 100,000 pounds.

(c) The fee for a consecutive month permit under this subsection for a vehicle or combination of vehicles the weight of which exceeds any of the provisions of s. 348.15 (3) shall be determined in the manner provided in s. 348.25 (8) (bm), except that the applicable fee for an annual permit under par. (b) shall be used in the computation.

Cross-reference: See also ch. Trans 253, Wis. adm. code.

(9m) **TRANSPORTATION OF RAW FOREST AND AGRICULTURAL PRODUCTS.** (a) The department may issue annual or consecutive month permits for the transportation of any of the following:

1. Raw forest products or of fruits or vegetables from field to storage or processing facilities in vehicles or vehicle combinations that exceed the maximum gross weight limitations under s. 348.15 (3) (c) by not more than 10,000 pounds. A permit under this subdivision is not valid on highways designated as part of the national system of interstate and defense highways, except on I 39

between STH 29 south of Wausau and the I 90/94 interchange near Portage in Marathon, Portage, Waushara, Marquette and Columbia counties.

2. Bulk potatoes from storage facilities to rail loading facilities in vehicle combinations that exceed the maximum gross weight limitations under s. 348.15 (3) (c) by not more than 10,000 pounds. A permit under this subdivision shall be valid only on USH 51 between CTH “V” and CTH “B” in Waushara and Portage counties, and for a distance not to exceed 15 miles from that portion of USH 51 in order to obtain access to USH 51 or to reach fuel, food, maintenance, repair, rest, staging, terminal facilities or points of loading or unloading.

3. Bulk potatoes from storage facilities to food processing facilities in vehicles or vehicle combinations that exceed the maximum gross weight limitations under s. 348.15 (3) (c) by not more than 10,000 pounds. A permit under this subdivision is not valid on highways designated as part of the national system of interstate and defense highways, except to the extent permitted by federal law without any loss or reduction of federal aid or other sanction.

4. Raw forest products in vehicle combinations that exceed the maximum gross weight limitations under s. 348.15 (3) (c) by not more than 18,000 pounds if the vehicle combination has 6 or more axles and the gross weight imposed on the highway by the wheels of any one axle of the vehicle combination does not exceed 18,000 pounds, except that the gross weight imposed on the highway by the wheels of any steering axle on the power unit may not exceed the greater of 13,000 pounds or the manufacturer’s rated capacity, but not to exceed 18,000 pounds. Notwithstanding s. 348.15 (8), any axle of a vehicle combination that does not impose on the highway at least 8 percent of the gross weight of the vehicle combination may not be counted as an axle for the purposes of this subdivision. Subject to par. (c), a permit under this subdivision is not valid on any interstate highway designated under s. 84.29 (2), any highway or bridge with a posted weight limitation that is less than the vehicle combination’s gross weight, and any part of the state trunk highway system that the department has designated by rule as a route on which a permit issued under this subsection is not valid.

(b) A permit issued under par. (a) 1. to 3. does not authorize the operation of any vehicle or vehicle combination at a maximum gross weight in excess of 90,000 pounds. A permit issued under par. (a) 4. does not authorize the operation of any vehicle combination at a maximum gross weight in excess of 98,000 pounds.

(c) A permit issued under par. (a) 4. shall expressly authorize the vehicle combination to exceed, on state trunk highways and connecting highways, any special weight limitation imposed under ss. 348.17 (1) and 349.16 (1) (a) and (2) in connection with the thawing of frozen highways and to be operated at the full weight allowable under par. (a) on state trunk highways and connecting highways.

(d) 1. The department shall suspend a permit issued under par. (a) 4. if the person operating under the permit does any of the following:

a. Violates any weight limitation specified in the permit more than 2 times during the valid period of the permit.

b. Violates any weight limitation specified in the permit by exceeding the weight limitation by 10,000 or more pounds.

2. The suspension under subd. 1. shall be for a period of 6 months. If the remaining valid period of the permit at the time of the suspension is less than 6 months, the person may not apply for, or operate under, any other permit issued under par. (a) 4. for a period of 6 months from the suspension.

Cross-reference: See also ch. Trans 259, Wis. adm. code.

(9r) TRANSPORTATION OF SCRAP. The department may issue an annual or consecutive month permit for the transportation of metallic or nonmetallic scrap for the purpose of recycling or processing on a vehicle or combination of vehicles which exceeds statutory weight or length limitations and for the return of the vehicle or combination of vehicles when empty. This subsection

does not apply to the transportation of scrap on highways designated as part of the national system of interstate and defense highways, except for that portion of USH 51 between Wausau and STH 78 and that portion of STH 78 between USH 51 and the I 90/94 interchange near Portage upon their federal designation as I 39.

Cross-reference: See also ch. Trans 269, Wis. adm. code.

(9t) TRANSPORTATION OF POTATOES. The department may issue annual or consecutive month permits for the transportation of potatoes intended for use as seed in specially configured vehicle combinations that exceed the maximum gross weight limitations under s. 348.15 (3) (c) by not more than 10,000 pounds. A permit issued under this subsection does not authorize the operation of any vehicle combination at a maximum gross weight in excess of 90,000 pounds. A permit under this subsection may authorize operation during a spring thaw and shall be valid only on STH 64 between CTH “H” and USH 41 in Langlade, Oconto and Marinette counties; USH 41 between STH 64 and the Wisconsin-Michigan border; and any highway for a distance not to exceed 15 miles from any portion of STH 64 or USH 41 specified in this subsection in order to obtain access to STH 64 or USH 41 or to reach fuel, food, maintenance, repair, rest, staging, terminal facilities or points of loading or unloading. The department shall establish by rule configuration requirements for vehicle combinations under this subsection and such requirements may permit vehicle combinations to exceed the length requirements of s. 348.07. The department may establish by rule an alternative route for any portion of a highway specified in this subsection.

Cross-reference: See also ch. Trans 258, Wis. adm. code.

(10) TRANSPORTATION OF GRAIN OR COAL OR IRON. The department may issue annual or consecutive month permits for the transportation of loads of grain, as defined in s. 126.01 (13), coal, iron ore concentrates or alloyed iron on a vehicle or a combination of 2 or more vehicles that exceeds statutory weight or length limitations and for the return of the empty vehicle or combination of vehicles over any class of highway for a distance not to exceed 5 miles from the Wisconsin state line. If the roads desired to be used by the applicant involve streets or highways other than those within the state trunk highway system, the application shall be accompanied by a written statement of route approval by the officer in charge of maintenance of the other highway. This subsection does not apply to highways designated as part of the national system of interstate and defense highways.

(11m) AGRICULTURAL EMERGENCY PERMITS. (a) If the secretary of agriculture, trade and consumer protection determines that an agricultural emergency exists, the secretary of transportation may authorize the issuance of permits to allow vehicles that are transporting loads of hay in bales and, from September 15 to December 15 of each year, loads of Christmas trees from the point of harvesting or staging to a Christmas tree yard or point of commercial shipment to exceed the width limitation under s. 348.05 (1) if the total outside width does not exceed 12 feet. This authorization is limited to the operation of commercial motor vehicles upon routes of the national system of interstate and defense highways.

(b) In authorizing the issuance of permits under this subsection, the secretary of transportation shall specify in writing the factors which resulted in the determination to issue permits under this subsection. The factors shall include the effect of the increased width limits on highway safety.

(c) Nothing in this subsection shall be construed to permit the department to waive the requirements of s. 348.07.

(d) The secretary of transportation may limit the application of permits issued under this subsection to specific areas of the state or to specific highways. A permit authorized under this subsection takes effect upon the mailing of a complete application and the required fee to the department. A permit authorized under this subsection is valid for up to 90 days, as determined by the secretary of transportation.

(12) **TRANSPORTATION OF GARBAGE OR REFUSE.** The department may issue an annual or consecutive month permit for the transportation of garbage, as defined in s. 289.01 (9), or refuse, in a self-compactor equipped vehicle which exceeds statutory weight and length limitations and for the return of the vehicle when empty. A permit under this subsection may be issued for use on any highway within this state. In this subsection, “refuse” means combustible and noncombustible rubbish, including paper, wood, metal, glass, cloth and products thereof, litter and street rubbish, ashes, and lumber, concrete and other debris resulting from the construction or demolition of structures.

Cross-reference: See also ch. Trans 269, Wis. adm. code.

(12m) **PERMITS FOR VEHICLES TRANSPORTING CERTAIN BUILDINGS.** (a) In this subsection:

1. a. “Building” means a dwelling or other structure or portion of a dwelling or other structure that, when measured as provided in subd. 1. b., is more than 12 feet wide, more than 14 feet 3 inches in height, or more than 100 feet long; that is transportable as a whole or in sections; and that is raised and supported from an existing foundation to be moved and placed on a permanent foundation at a new location where the dwelling or other structure is to be delivered. “Building” does not include a modular housing unit, a manufactured building as defined in s. 101.71 (6), or a manufactured home as defined in s. 101.91 (2).

b. For purposes of subd. 1. a., width shall be measured from the farthest extremity of the vehicle and load on each side, height shall be measured from the ground to the highest point of the vehicle and load, and length shall be measured from the rearmost point of the vehicle and load to the frontmost point of the vehicle.

2. “Vehicle” includes a combination of vehicles.

(b) The department may issue annual or consecutive month permits for vehicles transporting buildings on the highways. A permit under this subsection may be issued only by the department, regardless of the highways to be used.

(c) The department may not issue a permit under this subsection unless the department determines that all of the following requirements are met:

1. The applicant identifies each potential operator of a vehicle under the permit and provides proof that each such operator holds a valid commercial driver license, with any endorsement required under ch. 343 for operation of the class and type of vehicle to be used to transport a building under the permit.

2. The applicant provides proof of a valid motor carrier certificate or license of authority issued under ch. 194 or under federal law applicable for each vehicle to be used to transport a building under the permit.

3. The applicant provides proof, by a certificate of insurance filed with the department, that the applicant, in addition to satisfying the insurance requirements described in s. 346.924 (2), maintains a policy of comprehensive general liability insurance, issued by an insurer authorized to transact business in this state, that provides bodily injury liability coverage and property damage liability coverage, including for underground property damage, with a total limit of not less than \$500,000 for each occurrence.

(d) The department may deny any application for a permit under this subsection if the department finds any of the following:

1. That the applicant, or any potential operator identified in par. (c) 1., has been convicted, within 3 years immediately preceding the date of application, of a violation of s. 346.924.

2. That the applicant, or any potential operator identified in par. (c) 1., has engaged in conduct endangering the safety of persons using the highways.

3. That the applicant has failed to provide reimbursement for damage, which is not paid for by the applicant’s insurer, to a highway caused while transporting a building under a permit under this subsection.

4. That the applicant, or any potential operator identified in par. (c) 1., has abandoned a building on a highway or on public or private property without permission of the property owner.

(e) The provisions of this subsection apply in addition to any other requirement imposed under this chapter, chs. 194, 343, 346, and 347, and federal law.

(13) **VEHICLE TRAIN PERMITS.** The department for the state trunk highways or the officer in charge of maintenance in the case of other highways may issue an annual or consecutive month permit for not more than 3 vehicles being drawn or attached if the vehicles are being transported by the drive-away method in saddle-mount combination. No vehicle train permit issued by a local official for use of a highway outside the corporate limits of a city or village is valid until approved by the department. No permit may be issued for any train exceeding 65 feet in total length.

(14) **FARM MACHINERY PERMITS.** The department may issue annual or consecutive month permits for the movement, towing or hauling of farm tractors exceeding 12 feet in width and all other farm machinery and implements of husbandry exceeding 8 feet 6 inches in width not being operated in the course of performance of its work on highways designated as part of the national system of interstate and defense highways. A permit under this subsection is not required for the movement, towing or hauling of any overwidth machinery that is not a commercial motor vehicle and which is authorized by s. 348.05 (3) on that portion of USH 51 between Wausau and STH 78 and that portion of STH 78 between USH 51 and the I 90/94 interchange near Portage upon their federal designation as I 39.

(15) **MULTIPLE TRIP PERMITS.** (a) The department shall issue to qualifying applicants multiple trip permits for the transportation of granular roofing material in vehicles or vehicle combinations that exceed the maximum gross weight limitations under s. 348.15 (3) (c) by not more than 10,000 pounds. A permit issued under this subsection does not authorize the operation of any vehicle or vehicle combination at a maximum gross weight in excess of 90,000 pounds. A permit under this subsection may be issued only by the department, regardless of the highways to be used. A permit under this subsection is not valid on highways designated as part of the national system of interstate and defense highways except that a permit may be issued that is valid on not more than 2.5 miles of any state trunk highway if such issuance of the permit is consistent with federal law.

(b) 1. An application for a permit under this subsection shall include all of the following information:

a. The motor carrier on behalf of which the load is to be transported.

b. The location from which the transportation of the load is to originate and the load’s destination, along with the designated route over which the load will be transported.

2. A permit issued under this subsection shall include as conditions of the permit the information specified in subd. 1. a. and b.

(c) If the designated route under par. (b) 1. b. includes streets or highways other than those within the state trunk highway system, no permit may be issued under this subsection unless the governing body of each municipality or county having jurisdiction over such streets or highways adopts a resolution approving the transportation of the load over that portion of the designated route that is on streets or highways under the jurisdiction of the municipality or county. An applicant for a permit under this subsection shall include a copy of each such resolution with the permit application.

(d) The department shall promulgate rules to implement and administer this subsection.

Cross-reference: See also ch. Trans 263, Wis. adm. code.

History: 1973 c. 157, 316; 1973 c. 333 s. 190m; 1973 c. 336; 1975 c. 25, 285; 1977 c. 29 ss. 1488m, 1654 (8) (a); 1977 c. 30 s. 5; 1977 c. 191, 197, 272, 273, 418; 1979

348.27 VEHICLES — SIZE, WEIGHT AND LOAD

Updated 09–10 Wis. Stats. Database 16

c. 34, 315, 326; 1981 c. 20, 69, 163, 215, 391; 1983 a. 78 ss. 32 to 35, 37; 1983 a. 529; 1985 a. 29 s. 3202 (3); 1985 a. 202, 212; 1987 a. 27; 1989 a. 31, 35, 130, 305; 1991 a. 258; 1993 a. 62, 439; 1995 a. 113, 163, 227, 347, 348; 1997 a. 27, 35, 237; 1999 a. 85; 2001 a. 16; 2003 a. 210, 241; 2005 a. 119, 167, 250; 2007 a. 11, 16, 171; 2009 a. 28, 222, 229; 2011 a. 20.

Cross-reference: See also chs. Trans 230 and 250, Wis. adm. code.

That the department of transportation issues, denies, suspends, and revokes permits under this section, does not deny a sheriff deputy's authority to issue a citation for a violation of this section. *County of Milwaukee v. Superior of Wisconsin*, 2000 WI App 75, 234 Wis. 2d 218, 610 N.W.2d 484, 98–2851.

348.28 Permits to be carried. (1) Permits issued under ss. 348.25, 348.26 and 348.27 (1) to (10), (12) to (13), and (15) shall be carried on the vehicle during operations so permitted.

(2) Any person violating this section may be required to forfeit not less than \$10 nor more than \$20 for the first offense and not less than \$25 nor more than \$50 for the 2nd and each subsequent conviction within one year.

History: 1971 c. 278; 1985 a. 202 s. 37; 2005 a. 250; 2007 a. 171.



**Wisconsin Highway Research Program (WHRP)
Bridge Construction Live Load Analysis Guide**



**APPENDIX E
AASHTO CAPACITY ANALYSIS**

AASHTO Capacity Analysis

Structure is 360 feet long, consisting of three continuous 120 feet long spans.
The bridge was designed for HS-20 loading.

Will check structure adequacy to allow Manitowoc 999 crane configured to weigh 275 kips to travel over structure.

This calculation assumes the bridge has not been reduced in rating below its design criteria. The live load from the crane will be compared to the design live load for the bridge.

This calculation follows AASHTO Standard Specifications for Highway Bridges - 17th Edition.

Bridge Details

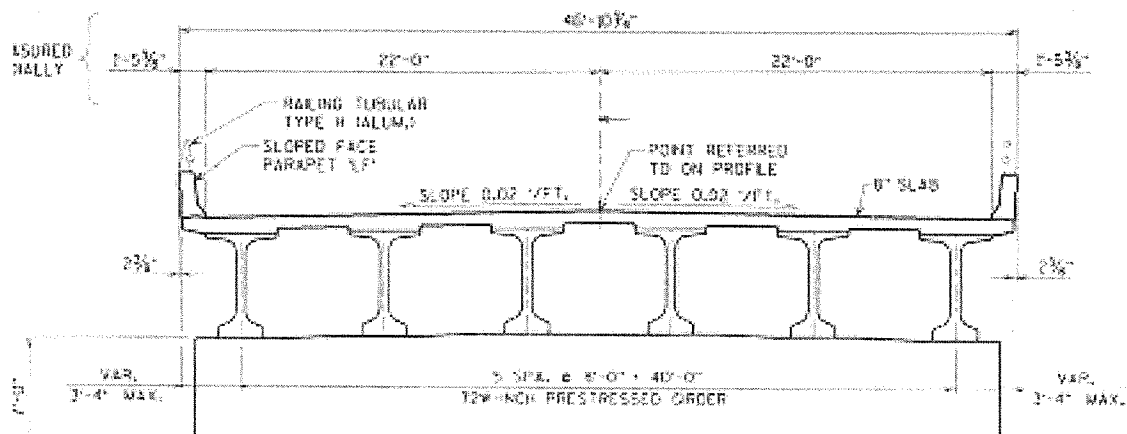
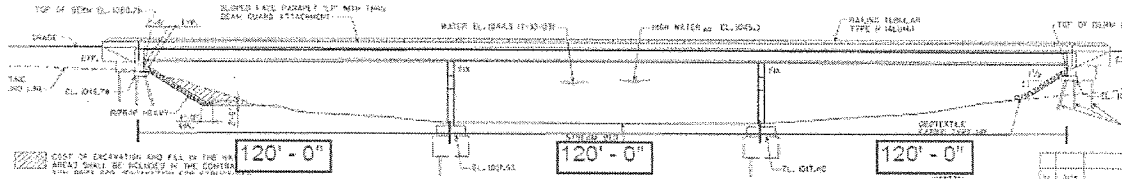

**Forces per Lane**

Live load forces can be determined by hand using influence lines, however in this case the design forces are provided in AISC "Moments, Shears and Reactions for Continuous Highway Bridges." See Attachment A.

Maximum Moments:

$$M_{AB} := 1509.2\text{k}\cdot\text{ft} \quad \text{Positive Moment in First/Third Span}$$

$$M_B := 1469.9\text{k}\cdot\text{ft} \quad \text{Negative Moment in Middle Span}$$

$$M_{BC} := 1252.8\text{k}\cdot\text{ft} \quad \text{Positive Moment in Middle Span}$$

Maximum Shears:

$$V_{AB} := 73.4\text{k} \quad \text{Maximum Shear in First/Third Span}$$

$$V_{BC} := 70.8\text{k} \quad \text{Maximum Shear in Middle Span}$$

Will determine live load design forces to each beam

Bridge Data

$$L_S := 120\text{ft} \quad \text{Length of Spans}$$

$$\text{spacing} := 8\text{ft} \quad \text{Beam Spacing}$$

Load Fraction (AASHTO 3.23.2 & Table 3.23.1)

$$S := \text{spacing} \cdot \frac{1}{\text{ft}} \quad S = 8$$

$$LF := \frac{S}{5.5} \quad \text{Concrete Deck on Prestressed Concrete Girders}$$

$$LF = 1.455 \quad \text{Distribution of Wheel Loads}$$

**Impact Factor (AASHTO 3.8.2)**

$$IF := \frac{50}{L_S \cdot \frac{1}{ft} + 125} \quad \text{AASHTO (3-1)}$$

$$IF = 0.204 \quad \text{Impact Factor}$$

Wheel Load Factor (AASHTO 3.23.2.2)

$$WLF := 0.5 \quad \text{2 Wheels per Lane}$$

Reduction in Load Intensity Factor (AASHTO 3.12)

$$RiLi := 1.0 \quad \text{2 Lane Bridge}$$

Live Load Factors (AASHTO Table 3.22.1A)

$$\gamma := 1.3 \quad \text{Load Factor Design for Live Load}$$

$$\beta := 1.67$$

Factored Live Load Design Forces on Each Beam

$$M_{\max AB} := \gamma \cdot \beta M_{AB} \cdot RiLi \cdot WLF \cdot (1 + IF) \cdot LF$$

$$M_{\max AB} = 2869 \text{ k}\cdot\text{ft} \quad \text{Positive Beam Design Moment in First/Third Span}$$

$$M_{\max B} := \gamma \cdot \beta M_B \cdot RiLi \cdot WLF \cdot (1 + IF) \cdot LF$$

$$M_{\max B} = 2794 \text{ k}\cdot\text{ft} \quad \text{Negative Beam Design Moment in Middle Span}$$

$$M_{\max BC} := \gamma \cdot \beta M_{BC} \cdot RiLi \cdot WLF \cdot (1 + IF) \cdot LF$$

$$M_{\max BC} = 2382 \text{ k}\cdot\text{ft} \quad \text{Positive Beam Design Moment in Middle Span}$$



$$V_{\max AB} := \gamma \cdot \beta V_{AB} \cdot RiLi \cdot WLF \cdot (1 + IF) \cdot LF$$

$$V_{\max AB} = 139.5 \text{ k}$$

Maximum Beam Design Shear in First/Third Span

$$V_{\max BC} := \gamma \cdot \beta V_{BC} \cdot RiLi \cdot WLF \cdot (1 + IF) \cdot LF$$

$$V_{\max BC} = 134.6 \text{ k}$$

Maximum Beam Design Shear in Middle Span

Forces from Equipment on Bridge

Manitowoc 999 traveling across structure with an overall weight of 275 kips.

Full load of Manitowoc 999 was analyzed as a moving load across the structure in a finite element program. See Attachment B.

Full Crane Forces

Maximum Moments:

$$M_{999AB} := 5523 \text{ k} \cdot \text{ft}$$

Positive Moment in First/Third Span

$$M_{999B} := 3095 \text{ k} \cdot \text{ft}$$

Negative Moment in Middle Span

$$M_{999BC} := 4614 \text{ k} \cdot \text{ft}$$

Positive Moment in Middle Span

Maximum Shears:

$$V_{999AB} := 239 \text{ k}$$

Maximum Shear in First/Third Span

$$V_{999BC} := 233 \text{ k}$$

Maximum Shear in Middle Span

**Track Forces**

Conservatively assume 55% of load to one track for crane rolling across bridge. Load distribution analysis of crane would be required for crane operating on structure. No Impact Factor for cranes moved slow and steady over bridge.

Maximum Moments:

$$M_{T999AB} := 0.55 \cdot M_{999AB}$$

$$M_{T999AB} = 3038 \text{ k}\cdot\text{ft} \quad \text{Positive Track Moment in First/Third Span}$$

$$M_{T999B} := 0.55 \cdot M_{999B}$$

$$M_{T999B} = 1702 \text{ k}\cdot\text{ft} \quad \text{Negative Track Moment in Middle Span}$$

$$M_{T999BC} := 0.55 \cdot M_{999BC}$$

$$M_{T999BC} = 2538 \text{ k}\cdot\text{ft} \quad \text{Positive Track Moment in Middle Span}$$

Maximum Shears:

$$V_{T999AB} := 0.55 \cdot V_{999AB}$$

$$V_{T999AB} = 131.45 \text{ k} \quad \text{Maximum Track Shear in First/Third Span}$$

$$V_{T999BC} := 0.55 \cdot V_{999BC}$$

$$V_{T999BC} = 128.15 \text{ k} \quad \text{Maximum Track Shear in Middle Span}$$



Load Distribution Between Beams

Refer to Figure 3.6 of the WHRP Bridge Construction Live Load Guide. See Attachment C. Maximum positive and negative moments occur while the load is at or near midspan.

The beams are spaced at 8 feet on centers while the center to center of tracks is spaced at 19 feet for this crane. Therefore, begin with a worst case assumption of the track centered over a girder.

For a concrete girder bridge, with the load centered over a girder, the distribution factor for the moment is 0.4. A 0.25 factor is distributed to the adjacent beam, in this case the beam in between the two tracks. A 0.1 factor is distributed to the next beam, which in this case would be the beam under the other track. Therefore, the 0.4 and 0.1 factors will be added and a 0.5 track load distribution factor will be used for this crane on this bridge.

For the loads near the supports, which causes maximum shear, a 0.6 distribution factor will be added to a 0.1 factor from the other track. Therefore, the shear load distribution factor to one beam from one track will be 0.7 for this particular setup.

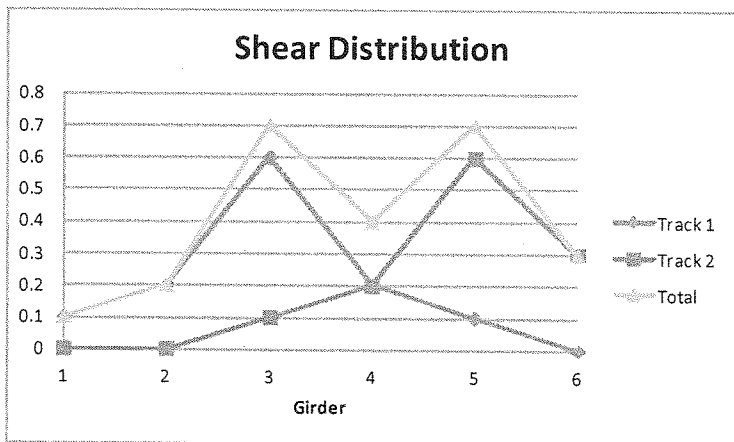
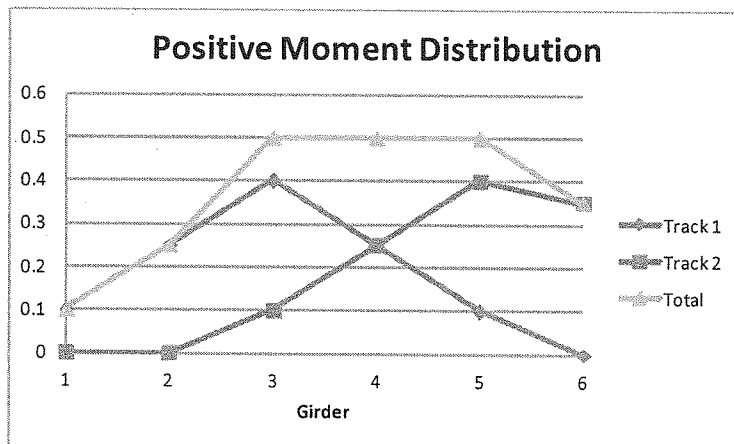

**Beam Unfactored Forces**

Moment Distribution Factor $DF_M := 0.5$ Figure 3.6

Shear Distribution Factor $DF_S := 0.7$ Figure 3.6

Maximum Moments:

$$M_{B999AB} := DF_M \cdot M_{T999AB}$$

$$M_{B999AB} = 1519 \text{ k}\cdot\text{ft} \quad \text{Positive Beam Moment in First/Third Span}$$

$$M_{B999B} := DF_M \cdot M_{T999B}$$

$$M_{B999B} = 851 \text{ k}\cdot\text{ft} \quad \text{Negative Beam Moment in Middle Span}$$

$$M_{B999BC} := DF_M \cdot M_{T999BC}$$

$$M_{B999BC} = 1269 \text{ k}\cdot\text{ft} \quad \text{Positive Beam Moment in Middle Span}$$

Maximum Shears:

$$V_{B999AB} := DF_S \cdot V_{T999AB}$$

$$V_{B999AB} = 92 \text{ k} \quad \text{Maximum Beam Shear in First/Third Span}$$

$$V_{B999BC} := DF_S \cdot V_{T999BC}$$

$$V_{B999BC} = 89.7 \text{ k} \quad \text{Maximum Beam Shear in Middle Span}$$

**Beam Factored Forces**

Since the bridge is a multi-beam redundant structure, operating stresses may be used for capacity check.

$$\gamma := 1.3$$

Load Factor Design for Operating Live Load

$$\beta := 1.0$$

$$M_{FB999AB} := \gamma \cdot \beta \cdot M_{B999AB}$$

$$M_{FB999AB} = 1974 \text{ k}\cdot\text{ft}$$

Positive Factored Beam Moment in First/Third Span

$$M_{FB999B} := \gamma \cdot \beta \cdot M_{B999B}$$

$$M_{FB999B} = 1106 \text{ k}\cdot\text{ft}$$

Negative Factored Beam Moment in Middle Span

$$M_{FB999BC} := \gamma \cdot \beta \cdot M_{B999BC}$$

$$M_{FB999BC} = 1650 \text{ k}\cdot\text{ft}$$

Positive Factored Beam Moment in Middle Span

$$V_{FB999AB} := \gamma \cdot \beta \cdot V_{B999AB}$$

$$V_{FB999AB} = 119.6 \text{ k}$$

Maximum Beam Shear in First/Third Span

$$V_{FB999BC} := \gamma \cdot \beta \cdot V_{B999BC}$$

$$V_{FB999BC} = 116.6 \text{ k}$$

Maximum Beam Shear in Middle Span



Recall Beam Factored Design Forces

$M_{\max AB} = 2869 \text{ k}\cdot\text{ft}$	Positive Beam Design Moment in First/Third Span
$M_{\max B} = 2794 \text{ k}\cdot\text{ft}$	Negative Beam Design Moment in Middle Span
$M_{\max BC} = 2382 \text{ k}\cdot\text{ft}$	Positive Beam Design Moment in Middle Span
$V_{\max AB} = 139.5 \text{ k}$	Maximum Beam Design Shear in First/Third Span
$V_{\max BC} = 134.6 \text{ k}$	Maximum Beam Design Shear in Middle Span

Check Beam Adequacy

$M_{AB} := \begin{cases} \text{"OK"} & \text{if } M_{FB999AB} < M_{\max AB} \\ \text{"No Good"} & \text{otherwise} \end{cases}$	$M_{AB} = \text{"OK"}$
$M_B := \begin{cases} \text{"OK"} & \text{if } M_{FB999B} < M_{\max B} \\ \text{"No Good"} & \text{otherwise} \end{cases}$	$M_B = \text{"OK"}$
$M_{BC} := \begin{cases} \text{"OK"} & \text{if } M_{FB999BC} < M_{\max BC} \\ \text{"No Good"} & \text{otherwise} \end{cases}$	$M_{BC} = \text{"OK"}$
$V_{AB} := \begin{cases} \text{"OK"} & \text{if } V_{FB999AB} < V_{\max AB} \\ \text{"No Good"} & \text{otherwise} \end{cases}$	$V_{AB} = \text{"OK"}$
$V_{BC} := \begin{cases} \text{"OK"} & \text{if } V_{FB999BC} < V_{\max BC} \\ \text{"No Good"} & \text{otherwise} \end{cases}$	$V_{BC} = \text{"OK"}$

The beams are adequate to support the crane load moving over the bridge.
Need to check the deck locally under the crane tracks.

Deck Design Forces

Effective Span Length between Beams:

$t_f := 4\text{ ft}$ Top Flange Width of Beams

$SL := \text{spacing} - \frac{1}{2} \cdot t_f$ Effective Span Length (AASHTO 3.24.1.2)

$SL = 6\text{ ft}$

Live Load Moment

$P_{20} := 16\text{ k}$ Wheel Load for HS20

$c := 0.8$ Continuity Factor for Three or More Beams

$M_{LL} := \left(\frac{SL + 2\text{ ft}}{32} \right) \cdot P_{20} \cdot c$ AASHTO 3-15

$M_{LL} = 3.2\text{ k}\cdot\text{ft}$ Live Load Moment

Impact Factor (AASHTO 3.8.2)

$IF := \frac{50}{L_S \cdot \frac{1}{\text{ft}} + 125}$ AASHTO (3-1)

$IF = 0.204$ Impact Factor

Live Load Factors (AASHTO Table 3.22.1A)

$\gamma := 1.3$

$\beta := 1.67$ Load Factor Design for Live Load

Factored Design Live Load Moment

$M_{FLL} := \gamma \cdot \beta \cdot (1 + IF) \cdot M_{LL}$

$M_{FLL} = 8.365\text{ k}\cdot\text{ft}$

**Local Deck Forces from Tracks**

$$W := 275 \text{ k}$$

Weight of Crane

$$P_T := 0.55 \cdot W \quad P_T = 151.25 \text{ k}$$

Load to One Track

$$L_T := 24 \text{ ft}$$

Track Length

$$W_T := 4 \text{ ft}$$

Track Width

$$q_t := \frac{P_T}{L_T \cdot W_T} \cdot 1 \text{ ft} \quad q_t = 1.576 \frac{\text{k}}{\text{ft}}$$

Distributed Track Load per Foot of Deck

$$R_t := q_t \cdot \frac{W_T}{2} \quad R_t = 3.151 \text{ k}$$

Reaction to One Girder per foot of Track

$$M_t := R_t \cdot \left[\left(\frac{SL - W_T}{2} \right) + \frac{R_t}{2 \cdot q_t} \right]$$

Moment Assuming Track centered between girders

$$M_t = 6.302 \text{ k} \cdot \text{ft}$$

Unfactored Lateral Deck Moment

Factored Local Deck Forces from Tracks

$$\gamma := 1.3 \quad \beta := 1.0 \quad \text{Load Factor Design for Operating Live Load}$$

$$M_{ft} := \gamma \cdot \beta \cdot M_t \quad M_{ft} = 8.193 \text{ k} \cdot \text{ft}$$

Check Deck Adequacy

$$M_D := \begin{cases} \text{"OK"} & \text{if } M_{ft} < M_{FLL} \\ \text{"No Good"} & \text{otherwise} \end{cases}$$

$$M_D = \text{"OK"}$$

The deck is adequate to support the crane tracks assuming the worst case scenario of the tracks being centered between girders. Therefore, the crane can operate without timber mats.



Check Bearing on Deck

$$P_{20} := 16k$$

Wheel Load for HS20

Design Bearing

$$BR_D := \frac{P_{20}}{10in \cdot 20in}$$

$$BR_D = 0.08 \text{ ksi}$$

AASHTO 3.30

Track Bearing

$$BR_T := \frac{P_T}{W_T \cdot L_T}$$

$$BR_T = 0.01 \text{ ksi}$$

$$BR := \begin{cases} \text{"OK"} & \text{if } BR_T < BR_D \\ \text{"No Good"} & \text{otherwise} \end{cases}$$

BR = "OK"

The deck is adequate in bearing, timber mats are not needed.

MOMENTS SHEARS and REACTIONS

FOR CONTINUOUS HIGHWAY BRIDGES

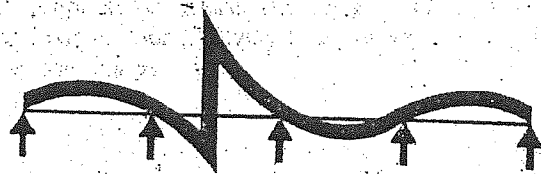

AMERICAN INSTITUTE OF STEEL CONSTRUCTION, INC.

TABLE 3.0

Symmetrical three-span continuous beam.

Constant moment of inertia.

AASHTO HS20-44 loading.

N=1.0

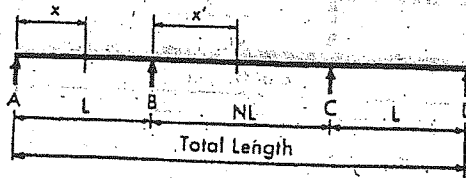

Total Length Ft.	Exter. Span Length "L"	Max. Reaction Kips.		Max. Shear Kips.		Max. Moment Kip-ft.			Impact Coefficient				Dist.-Ft.	
		at A	at B	in AB at B	in BC at B or C	in AB at X	at B	in BC at X'	I	II	III	IV	X	X'
90	30.0	46.2	62.3	-53.0	49.6	228.1	-184.4	179.6	.300	.300	.300	.270	10.6	14.0
105	35.0	49.3	64.7	-56.5	53.1	286.6	-219.5	231.6	.300	.300	.300	.256	12.6	16.0
120	40.0	51.8	66.4	-59.0	55.7	352.4	-254.2	285.9	.300	.300	.300	.244	16.0	18.5
135	45.0	53.9	67.5	-60.8	57.8	422.2	-299.2	342.1	.294	.294	.294	.233	18.0	21.0
150	50.0	55.5	68.4	-62.3	59.4	492.8	-351.1	399.7	.286	.286	.286	.222	20.1	23.5
165	55.0	56.9	69.1	-63.4	60.8	564.0	-406.8	458.2	.278	.278	.278	.213	22.2	26.0
180	60.0	58.1	72.1	-64.3	61.9	635.7	-466.2	517.5	.270	.270	.270	.204	24.2	28.5
195	65.0	59.2	75.9	-65.1	62.8	707.6	-529.3	577.3	.263	.263	.263	.196	26.3	31.0
210	70.0	60.0	79.8	-65.7	63.6	779.9	-596.1	637.6	.256	.256	.256	.189	28.4	33.5
225	75.0	60.8	83.6	-66.2	64.2	852.3	-666.7	698.2	.250	.250	.250	.182	30.5	36.0
240	80.0	61.5	87.4	-66.6	64.8	924.9	-741.0	759.2	.244	.244	.244	.175	32.6	38.5
255	85.0	62.1	91.3	-67.0	65.3	997.6	-819.1	820.3	.238	.238	.238	.169	34.8	41.0
270	90.0	62.6	95.1	-67.4	65.7	1070.5	-900.9	881.7	.233	.233	.233	.164	36.9	43.5
285	95.0	63.1	99.0	-67.7	66.1	1143.4	-986.4	943.2	.227	.227	.227	.159	39.0	46.0
300	100.0	63.6	102.8	-67.9	66.4	1216.5	-1075.6	1004.9	.222	.222	.222	.154	41.1	48.5
315	105.0	64.0	106.6	-68.2	66.7	1289.6	-1168.6	1066.8	.217	.217	.217	.149	43.3	51.0
330	110.0	64.3	110.5	-69.4	67.1	1362.7	-1265.3	1128.7	.213	.213	.213	.145	45.4	53.5
345	115.0	64.6	114.3	-71.4	68.9	1436.0	-1365.8	1190.7	.208	.208	.208	.141	47.5	56.0
360	120.0	64.9	118.2	-73.4	70.8	1509.2	-1469.9	1252.8	.204	.204	.204	.137	49.6	58.5
Impact		I	IV	I	III	I	II	III						
Dead Load		.4000 x WL	1.1000 x WL	-.6000 x WL	.5000 x WL	.0800 x WL	-.1000 x WL ²	.0250 x WL ²					.4000 x L	.5000 x L



Software licensed to

Job No

Sheet No

1

Rev

Part

Job Title AASHTO Capacity Analysis

Ref

By

Date 02-Aug-11

Chd

Client WHRP

File AASHTO Capacity Analys

Date/Time 03-Aug-2011 10:11

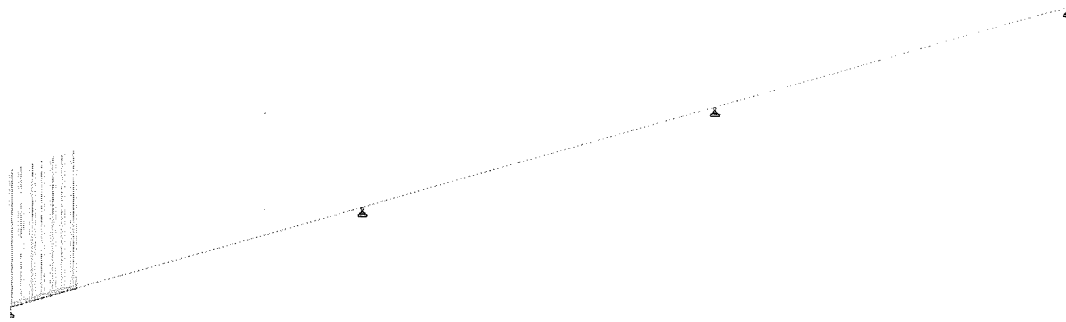

```

*****
*
*          STAAD.Pro V8i SELECTseries1          *
*          Version  20.07.06.23                *
*          Proprietary Program of              *
*          Bentley Systems, Inc.               *
*          Date=    AUG  3, 2011               *
*          Time=    14:20:10                   *
*
*          USER ID:                            *
*****

```

```

1. STAAD PLANE
INPUT FILE: AASHTO Capacity Analysis.STD
2. START JOB INFORMATION
3. ENGINEER DATE 02-AUG-11
4. JOB NAME AASHTO CAPACITY ANALYSIS
5. JOB CLIENT WHRP
6. END JOB INFORMATION
7. INPUT WIDTH 79
8. UNIT FEET KIP
9. JOINT COORDINATES
10. 1 0 0 0; 2 120 0 0; 3 240 0 0; 4 360 0 0
11. MEMBER INCIDENCES
12. 1 1 2; 2 2 3; 3 3 4
13. DEFINE MATERIAL START
14. ISOTROPIC STEEL
15. E 4.176E+006
16. POISSON 0.3
17. DENSITY 0.489024
18. ALPHA 6E-006
19. DAMP 0.03
20. END DEFINE MATERIAL
21. MEMBER PROPERTY AMERICAN
22. 1 TO 3 TABLE ST W6X25
23. CONSTANTS
24. MATERIAL STEEL ALL
25. SUPPORTS
26. 1 TO 4 PINNED
27. DEFINE MOVING LOAD
28. TYPE 1 LOAD 10.63 10.63 10.63 10.63 10.63 10.63 10.63 10.63 10.63 10.63 10.63 10.63 -
29. 10.63 10.63 10.63 10.63 10.63 10.63 10.63 10.63 10.63 10.63 10.63 10.63
30. DIST 1 1 1 1 1 1 1 1 1 1 1 1 1 1 1 1 1 1 1 1 1 1 1 1
31. LOAD GENERATION 61
32. TYPE 1 0 0 0 XINC 5
33. PERFORM ANALYSIS

```

P R O B L E M S T A T I S T I C S

NUMBER OF JOINTS/MEMBER+ELEMENTS/SUPPORTS = 4/ 3/ 4

SOLVER USED IS THE OUT-OF-CORE BASIC SOLVER

ORIGINAL/FINAL BAND-WIDTH= 1/ 1/ 2 DOF
TOTAL PRIMARY LOAD CASES = 61, TOTAL DEGREES OF FREEDOM = 4
SIZE OF STIFFNESS MATRIX = 0 DOUBLE KILO-WORDS
REQRD/AVAIL. DISK SPACE = 12.0/ 380273.1 MB

34. PRINT MAXFORCE ENVELOPE NSECTION 50 LIST 1 TO 3

MEMBER FORCE ENVELOPE

 ALL UNITS ARE KIP FEET

MAX AND MIN FORCE VALUES AMONGST ALL SECTION LOCATIONS

MEMB	FY/ FZ	DIST DIST	LD LD	MZ/ MY	DIST DIST	LD LD	FX	DIST	LD
1 MAX	224.28	0.00	1	3089.22	120.00	12			
	0.00	0.00	1	0.00	0.00	1	0.00	0.00	1
MIN	-238.64	120.00	20	-5522.76	50.40	9			
	0.00	120.00	61	0.00	120.00	61	0.00	120.00	61
2 MAX	226.74	0.00	26	3094.77	120.00	57			
	0.00	0.00	1	0.00	0.00	1	0.00	0.00	1
MIN	-232.34	120.00	44	-4613.62	60.00	35			
	0.00	120.00	61	0.00	120.00	61	0.00	120.00	61
3 MAX	234.48	0.00	50	3094.77	0.00	57			
	0.00	0.00	1	0.00	0.00	1	0.00	0.00	1
MIN	-129.28	117.60	61	-5519.64	67.20	60			
	0.00	120.00	61	0.00	120.00	61	0.00	120.00	61

***** END OF FORCE ENVELOPE FROM INTERNAL STORAGE *****

35. FINISH

***** END OF THE STAAD.Pro RUN *****

**** DATE= AUG 3,2011 TIME= 14:20:11 ****

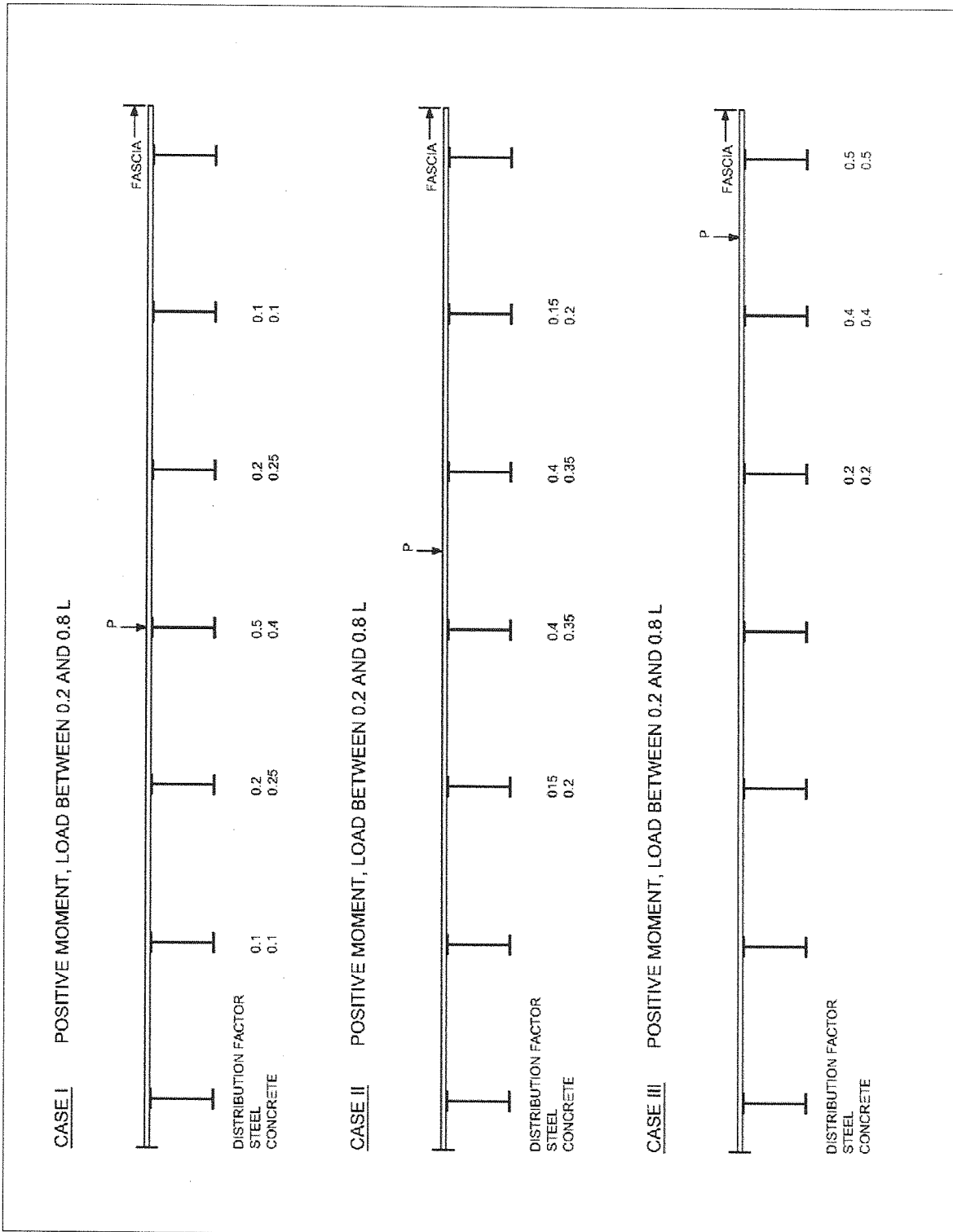

Figure 3.6 Lateral Load Distribution Factors

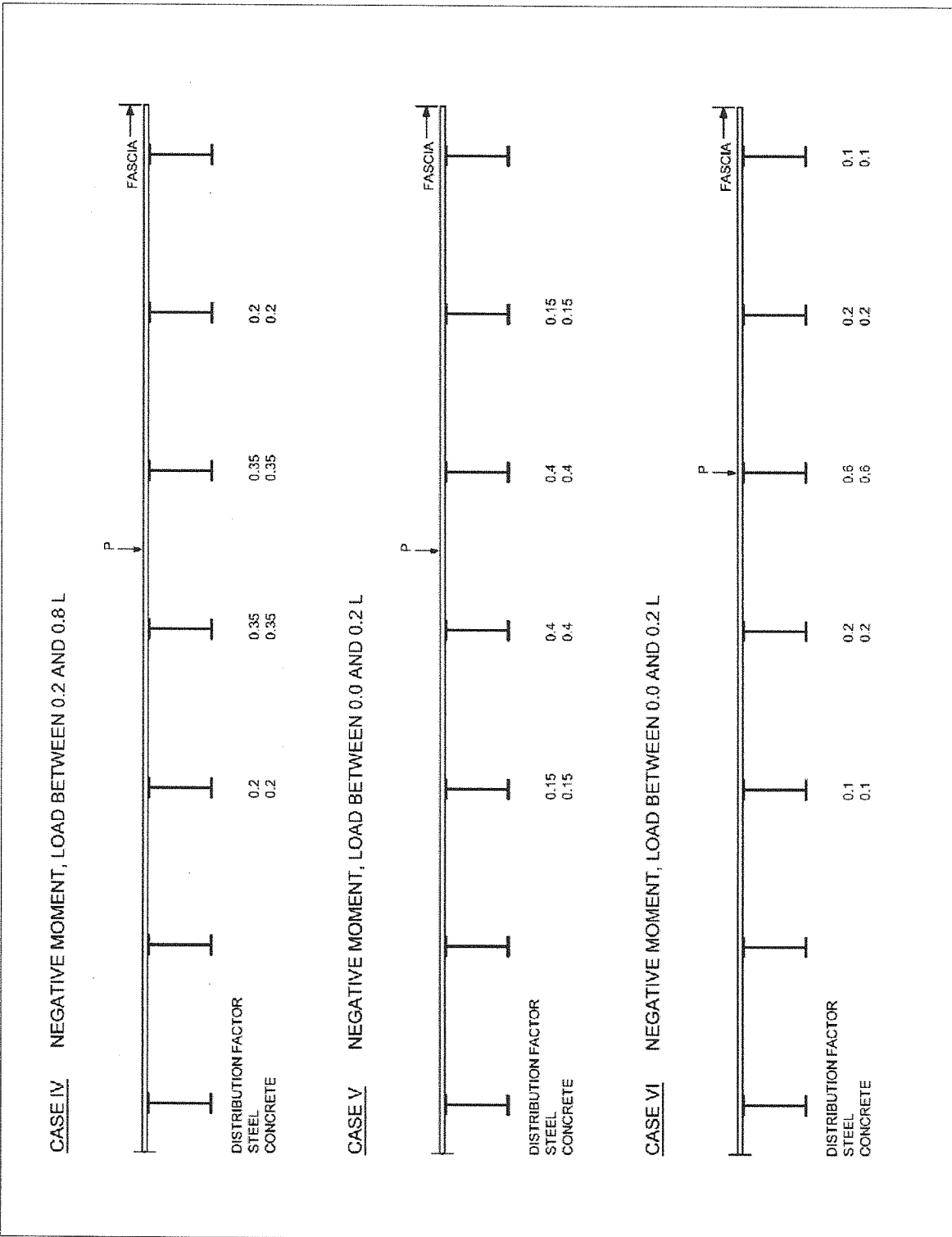

Figure 3.6 (Continued)

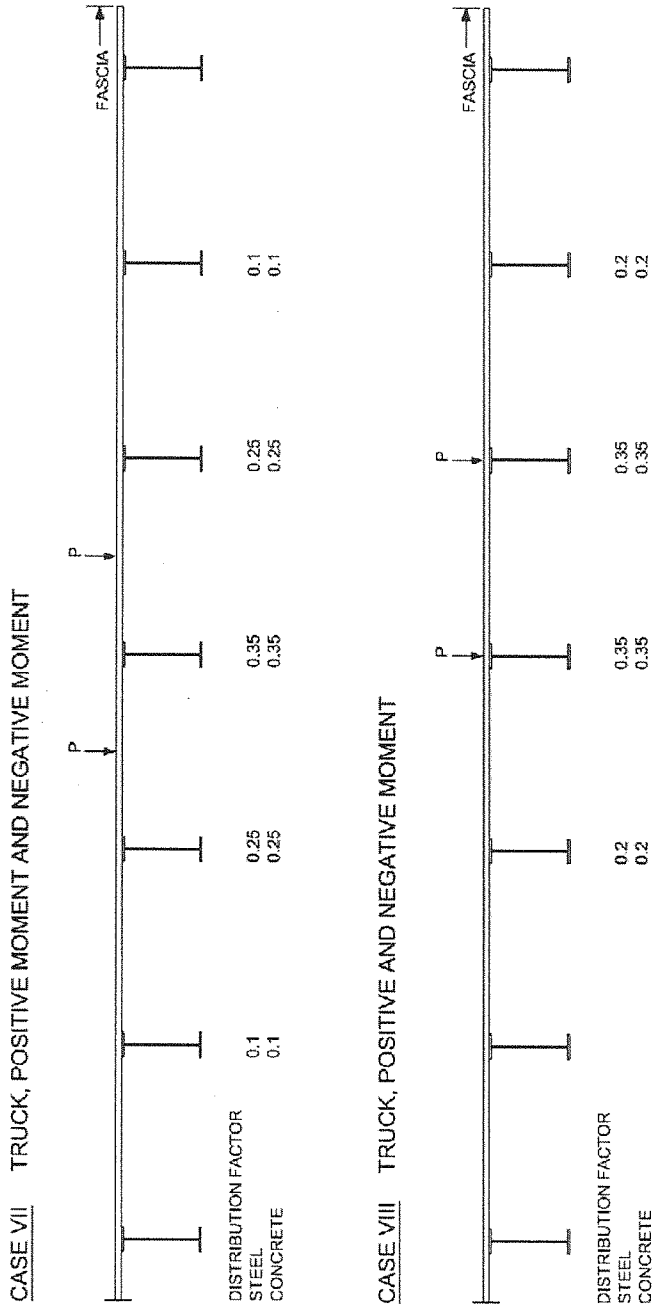

Figure 3.6 (Continued)



Wisconsin Highway Research Program (WHRP)
Bridge Construction Live Load Analysis Guide



APPENDIX F
ASSHTO DECK REMOVAL ANALYSIS

AASHTO Capacity Analysis for Deck Removal

Structure is 56 feet 10 inch simple span, designed for composite action with an 8 inch thick concrete deck.

Will check structure adequacy to allow Link Belt 1600 Excavator configured to weigh 16.6 kips to work backwards along the bridge removing the deck.

This calculation assumes the bridge beams have not been reduced in rating below its design criteria.

This calculation follows AASHTO Standard Specifications for Highway Bridges - 17th Edition.

Bridge Plan

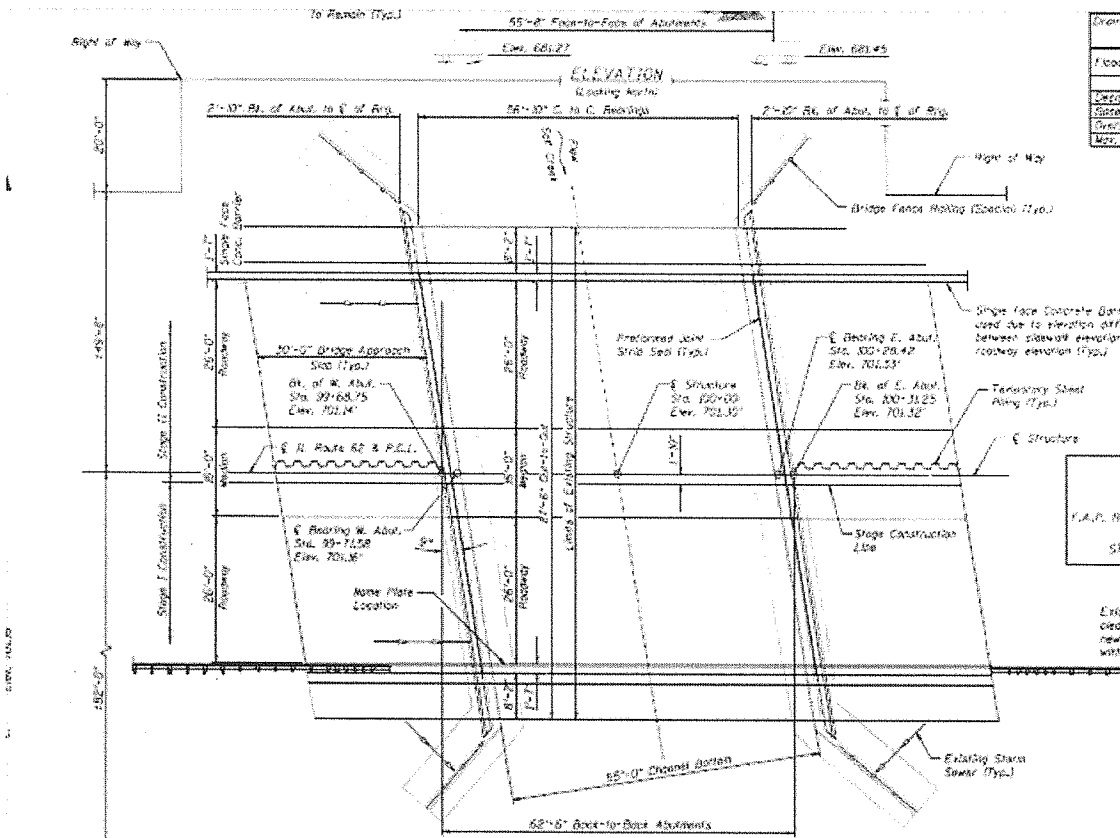

Bridge Cross Section

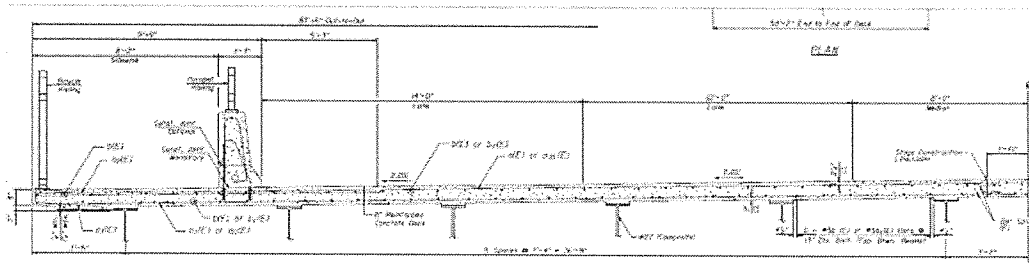

Bridge Details

Span := 56.83 ft

W27x161 Beams at 7 feet 4 inch spacing $F_{wy} := 50\text{ksi}$

8 inch thick Concrete Deck

Diaphragm Spacing of 11 feet 6 inches

W27x161 Beams

$t_{tf} := 1.08\text{in}$ $b_{tf} := 14.02\text{in}$ $S_{bx} := 455\text{in}^3$
 $t_{bf} := 1.08\text{in}$ $b_{bf} := 14.02\text{in}$ $S_{tx} := 455\text{in}^3$
 $t_w := 0.66\text{in}$ $h := 24\text{in}$ $d := 27.59\text{in}$

Unbraced Length: $l_w := 11.5\text{ft}$ Diaphragm Spacing

Equipment Details - Link Belt 1600

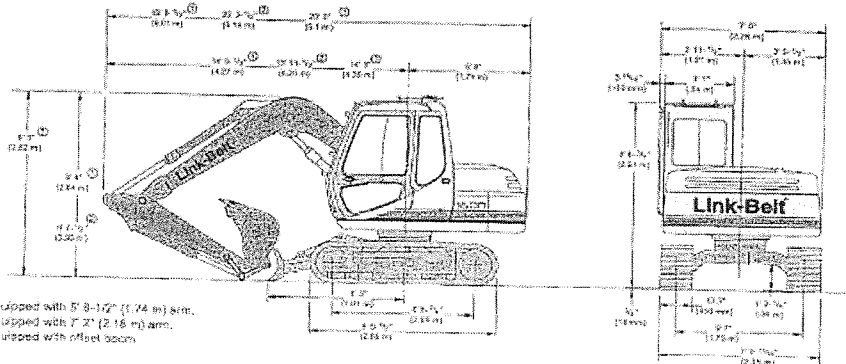



$\frac{W}{n} := 16.6k$ Operating Load See Appendix A
 $w := 3k$ Max Pick Weight
 $P := W + w$ $P = 19.6k$ Maximum Load

STAAD Analysis

Will analyze worst case scenerio with excavator at midspan and deck up to the point of the excavator removed. Parapets removed completely prior to deck removal. Will conservatively take entire load of excavator as a point load over one beam at midspan.

Maximum Moments: $M_{maxp} := 567k \cdot ft$ See Appendix B

Check Compression Flange

Partially Supported Girders - AASHTO Table 10.32.1A

$$F_{bt} = \frac{50000 \cdot C_b}{S_{xc}} \left(\frac{I_{yc}}{l} \right) \cdot \sqrt{0.772 \cdot \left(\frac{J_1}{I_{yc}} \right) + 9.87 \cdot \left(\frac{d}{l} \right)^2}$$

Where $F_{bt} \leq 0.55F_y = 19.8ksi$

$$C_b := 1.0$$

$$S_{xc} := S_{tx} \quad S_{xc} = 455 \text{ in}^3$$

$$I_{yc} := \frac{1}{12} \cdot t_{tf} \cdot b_{tf}^3$$

$$I_{yc} = 248 \text{ in}^4$$

$$J_1 := \frac{b_{tf} \cdot t_{tf}^3 + b_{bf} \cdot t_{bf}^3 + h \cdot t_w^3}{3}$$

$$J_1 = 14.1 \text{ in}^4$$

$$F_{b1} := \frac{50000 \cdot C_b}{S_{xc}} \left(\frac{I_{yc}}{l} \right) \cdot \sqrt{0.772 \cdot \left(\frac{J_1}{I_{yc}} \right) + 9.87 \cdot \left(\frac{d}{l} \right)^2} \cdot ksi$$

$$F_{b1} = 130.8 \text{ ksi}$$

$$F_{b2} := 19.8ksi$$

$$F_b := \min(F_{b1}, F_{b2}) \quad F_b = 19.8 \text{ ksi}$$

$$f_b := \frac{M_{maxp}}{S_{tx}} \quad f_b = 15 \text{ ksi}$$

$$FbCHECK := \text{if}(F_b > f_b, \text{"OK"}, \text{"NG"})$$

$$FbCHECK = \text{"OK"}$$

Beam is adequate with conservative load analysis.

**Check Bearing on Deck**

$$P_{20} := 16k$$

Wheel Load for HS20

Design Bearing

$$BR_D := \frac{P_{20}}{10in \cdot 20in}$$

$$BR_D = 0.08 \text{ ksi}$$

AASHTO 3.30

Track Bearing

$$L_T := 6.7ft$$

Length of Track

$$L_t := \frac{L_T}{3}$$

$$L_t = 2.233 \text{ ft}$$

Assume full load to front 1/3 of track during operation.

$$W_T := 17in$$

Width of Track

$$BR_T := \frac{P}{W_T \cdot L_t}$$

$$BR_T = 0.04 \text{ ksi}$$

$$BR := \begin{cases} \text{"OK"} & \text{if } BR_T < BR_D \\ \text{"No Good"} & \text{otherwise} \end{cases}$$

$$BR = \text{"OK"}$$

The deck is adequate in bearing, timber mats are not needed.

Deck Bending

By inspection, the conservative 20 kip load is spread out along the bridge 2.2 feet which is greater than the 10 inches for a 16 kip HS20 tire. Therefore, the deck is adequate in bending.

LINK-BELT 1600 QUANTUM MIDI EXCAVATOR

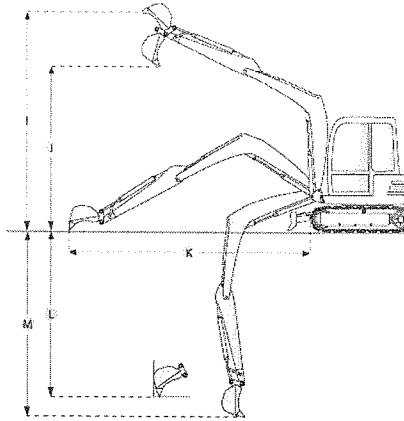
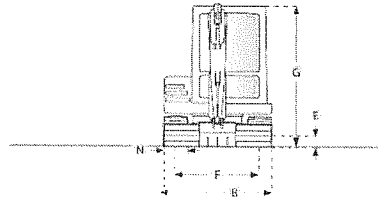
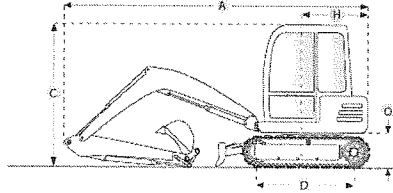

Boom/Stick Option	Boom/Stick Option (HEX) 1	
A. SHIPPING LENGTH OF UNIT	19.7 ft in	6010 mm
C. SHIPPING HEIGHT OF UNIT	8.7 ft in	2640 mm
I. MAX CUTTING HEIGHT	23.7 ft in	7230 mm
J. MAX LOADING HEIGHT	16.9 ft in	5150 mm
K. MAX REACH ALONG GROUND	20.4 ft in	6220 mm
L. MAX VERTICAL WALL DIGGING DEPTH	11.5 ft in	3490 mm
M. MAX DIGGING DEPTH	13.6 ft in	4150 mm
Dimensions		
B. WIDTH TO OUTSIDE OF TRACKS	7.1 ft in	2150 mm
D. LENGTH OF TRACK ON GROUND	6.7 ft in	2050 mm
E. GROUND CLEARANCE	1.2 ft in	360 mm
G. HEIGHT TO TOP OF CAB	8.6 ft in	2610 mm
H. TAIL SWING RADIUS	5.7 ft in	1740 mm
Undercarriage		
F. TRACK GAUGE	5.6 ft in	1700 mm
N. SHOE SIZE	17.7 in	450 mm

RITCHIE Specs Everything about Equipment

LINK-BELT 1600 QUANTUM MIDI EXCAVATOR

Specification

Engine

MAKE	Isuzu	
MODEL	4JB1	
NET POWER	54 hp	40.3 kw
POWER MEASURED @	2100 rpm	
DISPLACEMENT	169 cu in	2.8 L
TORQUE MEASURED @	1600 rpm	
MAX TORQUE	139 lb ft	188.5 Nm
ASPIRATION	Natural	
NUMBER OF CYLINDERS	4	

Operational

OPERATING WEIGHT	15432 lb	6999.8 kg
FUEL CAPACITY	37 gal	140 L
COOLING SYSTEM FLUID CAPACITY	2.6 gal	10 L
HYDRAULIC SYSTEM FLUID CAPACITY	25.1 gal	95 L
ENGINE OIL CAPACITY	1.8 gal	6.8 L
OPERATIONAL VOLTAGE	24 V	
ALTERNATOR SUPPLIED AMPERAGE	40 amps	
HYDRAULIC SYSTEM RELIEF VALVE PRESSURE	4409 psi	30399 kPa
HYDRAULIC PUMP FLOW CAPACITY	40 gal/min	151.4 L/min

Swing Mechanism

SWING SPEED	13.5 rpm	
SWING TORQUE	13057 lb ft	17702.9 Nm

Undercarriage

NUMBER OF SHOES PER SIDE	42	
SHOE SIZE	17.7 in	450 mm
NUMBER OF CARRIER ROLLERS PER SIDE	1	
NUMBER OF TRACK ROLLERS PER SIDE	5	
GROUND PRESSURE	4.7 psi	32.3 kPa
MAX TRAVEL SPEED	3.1 mph	5 km/h
TRACK GAUGE	5.6 ft in	1700 mm

Buckets

REFERENCE BUCKET CAPACITY	0.24 yd ³	0.18 m ³
MINIMUM BUCKET CAPACITY	0.24 yd ³	0.18 m ³
MAXIMUM BUCKET CAPACITY	0.45 yd ³	0.34 m ³

Boom/Stick Option (HEX) 1

BOOM/STICK OPTION (HEX) 1	Boom 12'2" (3700mm) / Stick 5'8" (1740mm)	
SHIPPING HEIGHT OF UNIT	8.7 ft in	2640 mm
SHIPPING LENGTH OF UNIT	19.7 ft in	6010 mm
MAX DIGGING DEPTH	13.6 ft in	4150 mm
MAX REACH ALONG GROUND	20.4 ft in	6220 mm
MAX CUTTING HEIGHT	23.7 ft in	7230 mm
MAX LOADING HEIGHT	16.9 ft in	5150 mm
MAX VERTICAL WALL DIGGING DEPTH	11.5 ft in	3490 mm

Boom/Stick Option (HEX) 2

BOOM/STICK OPTION (HEX) 2	Boom 12'2" (3700mm) / Stick 7'2" (2180mm)	
SHIPPING HEIGHT OF UNIT	9.6 ft in	2930 mm
SHIPPING LENGTH OF UNIT	20.2 ft in	6160 mm
MAX DIGGING DEPTH	15 ft in	4580 mm
MAX REACH ALONG GROUND	21.9 ft in	6680 mm
MAX CUTTING HEIGHT	25.1 ft in	7660 mm
MAX LOADING HEIGHT	18.2 ft in	5560 mm
MAX VERTICAL WALL DIGGING DEPTH	13.3 ft in	4060 mm

Boom/Stick Option (HEX) 3

BOOM/STICK OPTION (HEX) 3	Offset Boom 12'6" (3800mm) / Stick 5'8" (1740mm)	
---------------------------	--	--

SHIPPING HEIGHT OF UNIT	9.3 ft in	2820 mm
SHIPPING LENGTH OF UNIT	20 ft in	6100 mm
MAX DIGGING DEPTH	13.5 ft in	4130 mm
MAX REACH ALONG GROUND	20.5 ft in	6240 mm
MAX CUTTING HEIGHT	23.7 ft in	7220 mm
MAX LOADING HEIGHT	16.9 ft in	5160 mm
MAX VERTICAL WALL DIGGING DEPTH	10.5 ft in	3190 mm

Appendix A

Dimensions

WIDTH TO OUTSIDE OF TRACKS	7.1 ft in	2150 mm
HEIGHT TO TOP OF CAB	8.6 ft in	2610 mm
GROUND CLEARANCE	1.2 ft in	360 mm
TAIL SWING RADIUS	5.7 ft in	1740 mm
LENGTH OF TRACK ON GROUND	6.7 ft in	2050 mm



Software licensed to

Job No

Sheet No

1

Rev

Part

Job Title AASHTO Deck Removal

Ref

By

Date 08-Aug-11

Chd

Client WHRP

File AASHTO Deck Removal .

Date/Time 08-Aug-2011 09:37

Appendix B

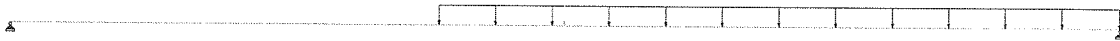

Y
Z-X

Appendix B

```

*****
*
*          STAAD.Pro V8i SELECTseries1          *
*          Version  20.07.06.23                 *
*          Proprietary Program of              *
*          Bentley Systems, Inc.               *
*          Date=    AUG  8, 2011               *
*          Time=    9:38:41                   *
*
*          USER ID:                           *
*****

```

1. STAAD PLANE
- INPUT FILE: AASHTO Deck Removal .STD
2. START JOB INFORMATION
3. ENGINEER DATE 08-AUG-11
4. JOB NAME AASHTO DECK REMOVAL
5. JOB CLIENT WHRP
6. END JOB INFORMATION
7. INPUT WIDTH 79
8. UNIT FEET KIP
9. JOINT COORDINATES
10. 1 0 0 0; 2 56.83 0 0
11. MEMBER INCIDENCES
12. 1 1 2
13. DEFINE MATERIAL START
14. ISOTROPIC STEEL
15. E 4.176E+006
16. POISSON 0.3
17. DENSITY 0.489024
18. ALPHA 6E-006
19. DAMP 0.03
20. END DEFINE MATERIAL
21. MEMBER PROPERTY AMERICAN
22. 1 TABLE ST W27X161
23. CONSTANTS
24. MATERIAL STEEL ALL
25. SUPPORTS
26. 1 2 PINNED
27. LOAD 1 LOADTYPE NONE TITLE LOAD CASE 1
28. SELFWEIGHT Y -1.15 LIST 1
29. MEMBER LOAD
30. 1 UNI GY -0.733 22 56.83
31. 1 CON GY -20 28.42
32. PERFORM ANALYSIS

Appendix B

PROBLEM STATISTICS

NUMBER OF JOINTS/MEMBER+ELEMENTS/SUPPORTS = 2/ 1/ 2

SOLVER USED IS THE OUT-OF-CORE BASIC SOLVER

ORIGINAL/FINAL BAND-WIDTH= 1/ 1/ 2 DOF
TOTAL PRIMARY LOAD CASES = 1, TOTAL DEGREES OF FREEDOM = 2
SIZE OF STIFFNESS MATRIX = 0 DOUBLE KILO-WORDS
REQRD/AVAIL. DISK SPACE = 12.0/ 384076.5 MB

33. PRINT MAXFORCE ENVELOPE NSECTION 50 LIST 1

STAAD PLANE

-- PAGE NO. 3

Appendix B

MEMBER FORCE ENVELOPE

ALL UNITS ARE KIP FEET

MAX AND MIN FORCE VALUES AMONGST ALL SECTION LOCATIONS

MEMB	FY/ FZ	DIST DIST	LD LD	MZ/ MY	DIST DIST	LD LD	FX	DIST	LD
1 MAX	23.08	0.00	1	0.00	0.00	1			
	0.00	0.00	1	0.00	0.00	1	0.00	0.00	1
MIN	-32.97	56.83	1	-566.06	28.42	1			
	0.00	56.83	1	0.00	56.83	1	0.00	56.83	1

***** END OF FORCE ENVELOPE FROM INTERNAL STORAGE *****

34. FINISH

***** END OF THE STAAD.Pro RUN *****

*** DATE= AUG 8,2011 TIME= 9:38:41 ***

Appendix B

```
*****
*           For questions on STAAD.Pro, please contact           *
*   Bentley Systems Offices at the following locations           *
*                                                                 *
*           Telephone                Web / Email                *
*                                                                 *
*   USA:           +1 (714)974-2500                               *
*   CANADA        +1 (905)632-4771    detech@odandetech.com    *
*   UK            +44(1454)207-000                               *
*   SINGAPORE     +65 6225-6158                                   *
*   EUROPE        +31 23 5560560                                 *
*   INDIA         +91(033)4006-2021                              *
*   JAPAN         +81(03)5952-6500    http://www.ctc-g.co.jp    *
*   CHINA         +86 10 5929 7000                               *
*   THAILAND      +66(0)2645-1018/19 partha.p@reisoftwareth.com *
*                                                                 *
*   Worldwide     http://selectservices.bentley.com/en-US/     *
*                                                                 *
*****
```



**Wisconsin Highway Research Program (WHRP)
Bridge Construction Live Load Analysis Guide**



**APPENDIX G
CONTRACTOR CHECKLIST**



**Wisconsin Highway Research Program (WHRP)
Bridge Construction Live Load Analysis Guide**



Bridge Load Analysis Contractor Checklist

It is important for contractors to obtain as much information as possible about the structure and the loads that will be operating on the structure. The greater the information collected, the greater the accuracy and efficiency of the analysis. Some of this information is critical to the analysis while other information is not as critical. It is noted however, that more limited information often results in the use of more conservative assumptions, and over conservatism might ultimately prohibit a piece of equipment from passing the adequacy check. The following questions or information should be obtained by the contractor prior to conducting a detailed structural analysis.

CONTRACTOR CHECKLIST- BRIDGE LOAD ANALYSIS	
<input type="checkbox"/>	Have the Structure As-Built Drawings (which typically include design criteria) been reviewed?
<input type="checkbox"/>	Has the bridge condition information (Inspection Report, Inspection Records, Load Rating Reports/Calculations, etc.) been reviewed?
<input type="checkbox"/>	Has a site visit been made to verify bridge arrangement and condition?
<input type="checkbox"/>	Have the equipment specifications and details on the specific configuration of the equipment (Types of counterweights, tracks, jibs and booms on a crane, e.g.) been determined?
<input type="checkbox"/>	For cranes or equipment operating on structure: have lift loads, lift radius, rigging weight, etc. been determined? Some manufacturers supply computer outputs of track, outrigger, or wheel pressure for specific lifting scenarios or have a computer program available for download for the engineers to determine pressures. Is this information included in the submittal?
<input type="checkbox"/>	Are the loads within legal limits for the bridge?
<input type="checkbox"/>	Are there specific areas where equipment will operate on or pass over the structure?
<input type="checkbox"/>	Has a range of areas been considered to determine the most ideal location for the equipment to be placed? Are these areas shown on the submittal?
<input type="checkbox"/>	Will loads be placed on the bridge due to material stock piles or equipment storage? If so, what are their magnitudes and locations?
<input type="checkbox"/>	Will regular traffic be operating in adjacent lanes? Are any traffic restrictions in place or needed?
<input type="checkbox"/>	If restrictions on equipment operation or material storage on a bridge are part of the plan, how will they be controlled during construction?
<input type="checkbox"/>	Is any strengthening or temporary support required? If so, are designs provided in the submittal and do they comply with AASHTO Specifications?
<input type="checkbox"/>	Have local effects of loads (i.e. decks, connections) been checked?
<input type="checkbox"/>	Are timber mats or grillage systems required? If so, are sizes, locations and design calculations included in the submittal?
<input type="checkbox"/>	Are pre or post construction inspections required?
<input type="checkbox"/>	Are periodic inspections during construction required? If so, what is the frequency and for how long?
<input type="checkbox"/>	Does the submitted plan include the required check calculations and support data?



**Wisconsin Highway Research Program (WHRP)
Bridge Construction Live Load Analysis Guide**



**APPENDIX H
PROJECT ENGINEER CHECKLIST**



Wisconsin Highway Research Program (WHRP)
Bridge Construction Live Load Analysis Guide



Bridge Load Analysis Project Engineer Checklist

When the contractor plans to place live loads on a bridge under construction, whether from equipment or materials storage, the contractor must demonstrate that these loads can be safely carried by the structure. The contractor must comply with the provisions of Section 108.7.3, Loads on Structures, of the Standard Specifications.

PROJECT ENGINEER CHECKLIST - BRIDGE LOAD ANALYSIS	
<input type="checkbox"/>	Has the contractor submitted procedures and calculations (as may be required) to support the placement of any live loads on the bridge during construction?
<input type="checkbox"/>	Have contractor's submittals (if any) been reviewed and returned?
<input type="checkbox"/>	Have all required resubmissions been made?
<input type="checkbox"/>	Are there restrictions on regular traffic in adjacent lanes? If so, have they been implemented?
<input type="checkbox"/>	Are any restrictions on bridge loads clearly posted at bridge access points?
<input type="checkbox"/>	Where bridge loads can be placed only in specific areas of the bridge, are these clearly delineated with paint lines, barricades, etc.?
<input type="checkbox"/>	Is any required temporary shoring, timber mats, etc., in place and per design?
<input type="checkbox"/>	Are any required (periodic) structure inspections completed as scheduled and documented?
<input type="checkbox"/>	Has any damage been caused by construction live loads? If so, have repair plans been provided and repairs performed?
<input type="checkbox"/>	Has the contractor submitted a post construction letter signed by a Wisconsin P.E. stating that no damage was done to the structure or that any damage found has been repaired to the satisfaction of WisDot?



**Wisconsin Highway Research Program (WHRP)
Bridge Construction Live Load Analysis Guide**



**APPENDIX I
BEST PRACTICES FOR CONTROLLING
CONSTRUCTION LOAD EFFECTS**



Wisconsin Highway Research Program (WHRP) Bridge Construction Live Load Analysis Guide



Best Practices for Controlling or Minimizing Construction Loads

General

- Obtain existing bridge plan and most recent bridge inspection report from the Department
- Consider whether the condition of the existing structure will result in restrictions to the proposed work.
- Determine available capacity at the controlling locations
- Determine the intended means and methods of construction. Consider multiple alternatives of means and methods if they exist. As an example, the contractor may want to remove a superstructure from the banks of the stream below. If the stream floods the contractor might decide instead to remove the superstructure from an adjacent bridge deck.
- Develop maximum load effect envelopes
- Verify that the structural demands of the applied loads due to means and methods will not exceed the available capacity of the structure at the time the loads are applied.
- List the allowable construction activities and/or acceptable loadings at various stages covered by the envelope. List any restrictions to means and methods

Load Position

- Use of barricades or painted areas to control where loads can or cannot be placed on a bridge. For example will loads only be allowed to travel or be placed directly over beam lines?
- Place temporary guides on the bridge floor, as directed by the engineer, in order to position the wheel loads as nearly as possible directly over the bridge girders.
- Assemble equipment in place. As an example a heavy crane could be assembled in place over a pier instead of driven to the pier location.
- Use of load distribution systems, timber mats. Distribution through matting is typically assumed as 1V to 1H.

Load Limits

- Conspicuously post the maximum allowable permitted equipment to cross the bridge.
- Conspicuously post equipment load limits for equipment operators.
- Limit equipment capacity. As an example if the maximum allowable structure load is 20 tons, then a proposed truck with an empty weight of 16 tons and maximum payload of 6 tons could be prohibited from using the bridge.
- Limit the allowable lifted load for a crane to control the maximum outrigger or track pressures.
- Limit equipment configurations
- Limit impact effects by reducing allowable speed limits for equipment traversing the bridges. Limit speed to less than 10 mph (Kentucky), 15 mph (Tennessee)



Wisconsin Highway Research Program (WHRP) Bridge Construction Live Load Analysis Guide

Providing Additional Capacity

- If strengthening existing structural members. Avoid using welded connections which may have fatigue sensitive details.
- Provide temporary shoring which does not support traffic live loads designed in accordance with the “AASHTO Guide Design Specifications for Bridge Temporary Works”
- Provide temporary shoring which supports traffic live loads designed in accordance with the “AASHTO LRFD Bridge Design Specifications ”

Bridge Demolition

- The design assumptions for structural design and evaluation must accurately represent the condition of the structure during construction, including but not limited to the effect of concrete removals on load distribution and member resistance, support location and restraints, construction loads and construction staging.
- A dynamic load allowance for rig mounted breakers, concrete crushers and other equipment should be used since this equipment will induce higher load effects on a structure than normal traffic. A dynamic load allowance factor of 0.4 has been suggested in some literature.
- Prepare calculations to substantiate structural adequacy and stability for each stage of demolition, accounting for the structure’s lack of completeness, various stages of partial connections, or complex structural geometry.
- Prepare calculations indicating structural redundancy of the incomplete structure at intermediate stages of demolition.

Crane Loads

General

- Location of each crane for each primary member pick, showing radius and crane support (barges, mats etc.)
- Capacity chart for each crane configuration and boom length used in the work.
- Center of gravity locations for primary member
- Rigging weights, capacity and arrangement for primary member picks
- Lifting weight of primary picks, including all rigging and pre-attached elements.

Wind Loads - lateral loads in accordance with ASCE/SEI 7-10 “Minimum Design Loads for Buildings and Other Structures”

Impact

Normal Operations I=10% of lifted load
Deck Demolition I=20% of lifted load



Wisconsin Highway Research Program (WHRP)
Bridge Construction Live Load Analysis Guide



APPENDIX J
SUGGESTED REVISIONS TO
WisDOT SPECIFICATIONS



Wisconsin Highway Research Program (WHRP) Bridge Construction Live Load Analysis Guide



Proposed Revisions to WisDOT Standard Specifications

108.7.2 Moving Heavy Loads

(1) For all vehicles operated on completed subgrade, base, or pavement that will remain a permanent part of the project, do not exceed the legal loading defined in Wisconsin statutes for Class A highways without the engineer's written permission. For structures, do not exceed that legal loading without written permission whether or not the structure will remain a permanent part of the project. Adhering to these requirements, or allowed variations, does not relieve the contractor of liability for damage caused by those operations.

(2) *At its discretion, the Engineer may provide written authorization to allow specific vehicles or equipment to move across a structure. The Contractor shall prove that the vehicle or equipment does not exceed the structures posted load limit.*

The following information shall be submitted to the engineer in a table format to assist in making this determination:

- *Manufacturers Equipment Sheet*
- *Gross Vehicle Weight- Empty + Payload*
- *Maximum Axle Weight (Single or Tandem)*
- *Number of Axles*
- *Distance Front to Back Axles*
- *Allowable Gross Vehicle Weight by Statutes*
- *Allowable Axle Weight by Statutes*
- *Original Design Vehicle*
- *Design Vehicle Gross Vehicle Weight*
- *Design Vehicle Axle Loads*
- *Existing Inventory and Operating Load Rating*
- *Existing Posted Load*
- *Bridge Redundancy*
- *At what speed will the Vehicle be crossing the bridge?*
- *What other contractor loads will be on the bridge at the time the vehicle crosses?*
- *Is this project staged? Can WisSPV vehicles be on other portions of the structure simultaneously?*

Adhering to these requirements, or allowed variations, does not relieve the contractor of liability for damage caused by those operations.



Wisconsin Highway Research Program (WHRP) Bridge Construction Live Load Analysis Guide



108.7.3 Loads on Structures

(1) Demonstrate that all loads on structures within the project limits throughout the duration of the contract do not exceed the structural capacity of the structure. If the engineer directs, submit stamped and signed copies of analyses and associated calculations performed by a professional engineer (PE) registered in the state of Wisconsin to the engineer and to the department's bureau of structures. Do not begin construction operations or move a heavy load across a structure without the engineer's written authorization.

(2) If a PE's analysis is required, determine capacity at the operating load level using the same AASHTO specification the structure was rated under. Include materials, equipment, and other construction or vehicular loads in the analyses.

- A. *If under public traffic, also include the Wisconsin standard permit vehicle (Wis-SPV) as shown in chapter 45 of the department's bridge manual.*
 - i. *The structure must be capable of carrying a Wis-SPV load equal to or greater than 170,000 pounds in addition to construction loads, and*
 - ii. *The structure must be capable of carrying a Wis-SPV load equal to or greater than the legal load.*
 - iii. *For structures where the allowable SPV weight is greater than 170,000 pounds but less than a legal load, the engineer/contractor shall report the allowable Wis-SPV load to the Bureau of Structures Load Rating Engineer, along with the dates that the bridge will be subject to that restriction.*
- B. *The effects of the applied loads during construction shall not exceed the available capacity for any portion of the bridge as delineated below:*
 - i. *For redundant bridges, capacity may be based on operating stresses for materials and equipment loads, except heavy haul trucks.*
 - ii. *For non-redundant bridges, capacity shall be based on inventory stresses unless otherwise approved by the WisDOT Chief Structures Development Engineer.*
 - iii. *For heavy haul trucks with Gross Vehicle Weights exceeding 90,000 pounds, capacity shall be based on inventory stresses.*
- C. *The engineer's written authorization must be accompanied by a copy of the analysis stamped accepted by department's bureau of structures before proceeding.*

(3) Except as required to accommodate public traffic or to complete the deck pour, do not operate heavy equipment or impose vehicular live loads on lanes adjacent to freshly placed concrete decks until it develops sufficient strength to open it to service under 502.3.10.1.