



Florida Department of Transportation Research

Pendulum Impact Testing of an Impact-Breakaway, Wind-Resistant Base Connection for Multi-Post Ground Signs

BDK75 977-40

Roadside signs are critical to traffic control. However, if not properly designed to yield upon vehicle impact, these signs become life-threatening hazards. Yet, the signs must be able to withstand wind loading, in Florida, up to hurricane force winds. In a disaster, a collapsed sign poses two dangers: drivers no longer receive the sign's information, and it can obstruct traffic lanes. Current sign supports meet these challenges, but their breakaway mechanism is undesirably sensitive to the accuracy of the torque that is imposed on the bolts during installation and maintenance.

In this study, University of Florida researchers developed a new breakaway sign post base connection – a shear-controlled moment collar – with: (1) resistance to hurricane winds; (2) breakaway behavior under vehicle impact; (3) relative insensitivity to installation and maintenance procedures; and (4) applicability to ground signs with large panels. A special challenge for the design was that, as panel area and clearance height increase, it becomes more difficult to satisfy the conflicting requirements for breaking away during a collision and not breaking away under wind loading. For this study, sign panel dimensions of 12 feet by 20 feet were selected. The breakaway system was designed to withstand winds up to 150 mph but break upon impact of compact cars and full-size pickup trucks.

The project began by using structural impact modeling and analysis techniques to develop and evaluate a new system that would fulfill

connection requirements. The design concept was refined by iterating through structural calculations, equivalent-static wind load and impact analyses, practical fabrication issues, and installation and maintenance issues. Data from this process also aided in planning physical tests.

The researchers then proceeded to static testing of the newly proposed breakaway connection and post. They evaluated the structural capacity of full-scale test articles under equivalent-static design hurricane wind loading and frangibility under static shear loading. Static tension tests on connector bolts aided numerical simulation and facilitated connection development.

Dynamic testing of the newly developed connection was also conducted. For this major subtask, an impact pendulum test facility was designed and constructed: a structure of three 50-foot-tall pylons capable of swinging up to 9,020 lb (4,090 kg; equivalent to two full-size pickup trucks) dropped through a vertical swing height of 35 ft. Breakaway post and connection test articles were tested with an 1100-kg impactor, striking both head-on and obliquely at a speed of 30 kph. Test data were processed and compared to corresponding finite element simulation results.

A thorough design and testing program led to the creation of a shear-controlled moment collar breakaway system that met all requirements. Improved breakaway connections will lead to lower maintenance costs, greater integrity of the highway system, and safer roadways for the traveling public.

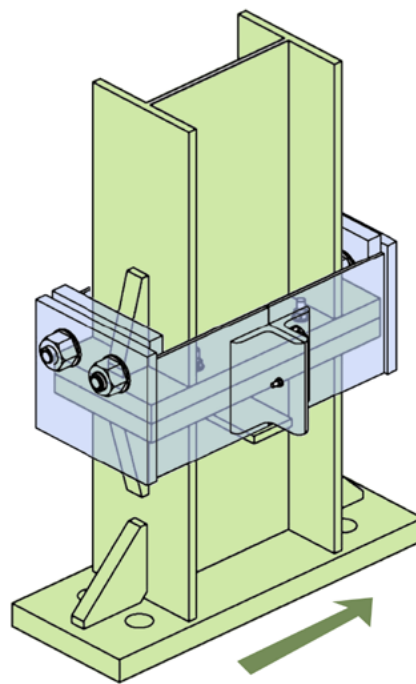

The moment collar system. The collar (blue) is semitransparent to show the slip plates that allow breakaway upon vehicle impact. The arrow shows traffic direction.