



*Midwest States Regional Pooled Fund Research Program  
Fiscal Years 2005-2006 (Year 16)  
Research Project Number SPR-3(017) Supplement 35  
NDOR Sponsoring Agency Code RFPF-06-08*

# **EVALUATION OF THE IN-SERVICE SAFETY PERFORMANCE OF SAFETY- SHAPE AND VERTICAL CONCRETE BARRIERS**

Submitted by

Francisco Daniel B. de Albuquerque, Ph.D  
Post-Doctoral Research Associate

Dean L. Sicking, Ph.D, P.E  
Professor and MwRSF Director

## **MIDWEST ROADSIDE SAFETY FACILITY**

Nebraska Transportation Center  
University of Nebraska-Lincoln  
130 Whittier Research Center  
2200 Vine Street  
Lincoln, Nebraska 68583-0853  
(402) 472-0965

Submitted to

## **MIDWEST STATES REGIONAL POOLED FUND PROGRAM**

Nebraska Department of Roads  
1500 Nebraska Highway 2  
Lincoln, Nebraska 68502

MwRSF Research Report No. TRP-03-259-11

December 16, 2011

**TECHNICAL REPORT DOCUMENTATION PAGE**

1. Report No. TRP-03-259-11	2.	3. Recipient's Accession No.	
4. Title and Subtitle Evaluation of The In-Service Safety Performance of Safety-Shape and Vertical Concrete Barriers		5. Report Date December 16, 2011	
		6.	
7. Author(s) Albuquerque, F.D.B. and Sicking, D.L.		8. Performing Organization Report No. TRP-03-259-11	
9. Performing Organization Name and Address Midwest Roadside Safety Facility (MwRSF) Nebraska Transportation Center University of Nebraska-Lincoln 130 Whittier Research Center 2200 Vine Street Lincoln, Nebraska 68583-0853		10. Project/Task/Work Unit No.	
		11. Contract © or Grant (G) No. SPR-3(017) Supplement 35	
12. Sponsoring Organization Name and Address Midwest States Regional Pooled Fund Program Nebraska Department of Roads 1500 Nebraska Highway 2 Lincoln, Nebraska 68502		13. Type of Report and Period Covered Final Report: 2005 – 2011	
		14. Sponsoring Agency Code RPFPP-06-08	
15. Supplementary Notes Prepared in cooperation with U.S. Department of Transportation, Federal Highway Administration.			
16. Abstract (Limit: 200 words) <p>Roadside concrete barriers have been widely used to protect errant motorists from hitting roadside hazards or obstacles. Two concrete barrier profiles, vertical and safety-shape, have been used for this purpose. The safety-shape profile has been shown to produce excessive vehicle climbing which tends to increase rollover propensity. On the other hand, the vertical profile does not cause vehicle climbing, but it does produce higher lateral forces which may produce higher injury levels.</p> <p>The objective of this research is to investigate which barrier profile is the safest based on real-world vehicle crash data. The safest barrier profile is defined as the one that produces lower injury levels. Rollover propensity was also used as a second indicator of barrier performance since rollovers may also affect injury severity.</p> <p>Bridge-related crash data was collected from State maintained highways in the State of Iowa. It was found that rollovers are twice more likely to occur in crashes involving safety-shape barriers as compared to vertical barriers. It was also found that crashes that involved safety-shape barriers resulted in higher injury levels as compared to crashes that involved the vertical barriers. Therefore, it is believed that the expanded use of vertical barriers would improve overall highway safety.</p>			
17. Document Analysis/Descriptors Highway Safety, Roadside Appurtenances, Roadside Safety, Concrete Barriers, Accidents, Rollover, Injury Severity		18. Availability Statement No restrictions. Document available from: National Technical Information Services, Springfield, Virginia 22161	
19. Security Class (this report) Unclassified	20. Security Class (this page) Unclassified	21. No. of Pages 156	22. Price

## **DISCLAIMER STATEMENT**

This report was completed with funding from the Federal Highway Administration, U.S. Department of Transportation. The contents of this report reflect the views and opinions of the authors who are responsible for the facts and the accuracy of the data presented herein. The contents do not necessarily reflect the official views or policies of the state highway departments participating in the Midwest States Regional Pooled Fund Program nor the Federal Highway Administration, U.S. Department of Transportation. This report does not constitute a standard, specification, regulation, product endorsement, or an endorsement of manufacturers.

## **ACKNOWLEDGEMENTS**

The authors wish to acknowledge several sources that made a contribution to this project:

(1) the Midwest States Regional Pooled Fund Program funded by the Illinois Department of Transportation, Iowa Department of Transportation, Kansas Department of Transportation, Minnesota Department of Transportation, Missouri Department of Transportation, Nebraska Department of Roads, Ohio Department of Transportation, South Dakota Department of Transportation, Wisconsin Department of Transportation, Wyoming Department of Transportation, and New Jersey Department of Transportation for sponsoring this project.

Acknowledgement is also given to the following individuals who made a contribution to the completion of this research project.

### **Midwest Roadside Safety Facility**

R.K. Faller, Ph.D., P.E., Research Assistant Professor  
K.A. Lechtenberg, M.S.M.E., E.I.T., Research Associate Engineer

### **Illinois Department of Transportation**

David Piper, P.E., Safety Implementation Engineer

### **Iowa Department of Transportation**

David Little, P.E., Assistant District Engineer  
Deanna Maifield, P.E., Methods Engineer  
Chris Poole, P.E., Roadside Safety Engineer

### **Kansas Department of Transportation**

Ron Seitz, P.E., Bureau Chief  
Rod Lacy, P.E., Metro Engineer  
Scott King, P.E., Road Design Leader

### **Minnesota Department of Transportation**

Michael Elle, P.E., Design Standard Engineer

**Missouri Department of Transportation**

Joseph G. Jones, P.E., Engineering Policy Administrator

**Nebraska Department of Roads**

Amy Starr, P.E., Research Engineer  
Phil TenHulzen, P.E., Design Standards Engineer  
Jodi Gibson, Research Coordinator

**Ohio Department of Transportation**

Dean Focke, P.E., Road Safety Engineer (Retired)  
Michael Blin, P.E., Standards and Geometrics Engineer

**South Dakota Department of Transportation**

David Huft, Research Engineer  
Bernie Clocksin, Lead Project Engineer

**Wisconsin Department of Transportation**

Jerry Zogg, P.E., Chief Roadway Standards Engineer  
John Bridwell, P.E., Standards Development Engineer  
Erik Emerson, P.E., Standards Development Engineer

**Wyoming Department of Transportation**

William Wilson, P.E., Architectural and Highway Standards Engineer

**Federal Highway Administration**

John Perry, P.E., Nebraska Division Office  
Danny Briggs, Nebraska Division Office

## TABLE OF CONTENTS

TECHNICAL REPORT DOCUMENTATION PAGE .....	i
DISCLAIMER STATEMENT .....	ii
ACKNOWLEDGEMENTS .....	iii
TABLE OF CONTENTS.....	v
LIST OF FIGURES .....	vii
LIST OF TABLES.....	viii
1 INTRODUCTION .....	1
1.1 Problem Statement.....	1
1.2 Objective.....	6
1.3 Scope.....	6
2 LITERATURE REVIEW .....	8
2.1 Concrete Barrier.....	8
2.2 Rollover.....	11
2.3 Occupant Safety .....	13
2.4 Vehicle Safety.....	16
2.5 Run-off-the-road and bridge related crashes.....	16
3 DATA COLLECTION .....	19
4 MODELING APPROACH.....	27
4.1 Statistical Model .....	27
4.2 Model Building.....	37
4.3 Goodness-Of-Fit Test.....	39
5 DATA DESCRIPTION, SUMMARY, AND CODING.....	43
5.1 Variable Description .....	43
5.1.1 Data Summary .....	51
6 ROLLOVER ANALYSIS .....	80
6.1 Univariate Analysis.....	80
6.2 Multivariate Analysis and Model Building.....	87
6.2.1 Multivariate Analysis and Model Building Using All Data .....	88
6.2.2 Multivariate analysis using the restricted data.....	94
6.3 Model fit assessment.....	95
7 INJURY ANALYSIS.....	97
7.1 Univariate Analysis.....	98
7.2 Multivariate Analysis and Model Building.....	104

7.2.1 Multivariate Analysis and Model Building Using All Data ..... 104  
7.2.2 Multivariate Analysis Using Restricted Data ..... 109  
7.3 Injury As a Binary Response ..... 110  
7.4 Proportional Versus Non-Proportional Odds Assumption ..... 111  
7.5 Model Fit Assessment..... 112

8 SUMMARY AND CONCLUSIONS ..... 114  
8.1 Data and Methods ..... 114  
8.2 Rollover Analysis..... 115  
8.3 Injury Analysis..... 116  
8.4 Safety Performance of the Concrete Rails ..... 117

9 RECOMMENDATIONS AND LIMITATIONS ..... 119

10 REFERENCES ..... 121

11 APPENDICES ..... 127

## LIST OF FIGURES

Figure 1. Concrete Median Barrier on a Narrow Median Suburban Highway with High Traffic Volume.....	2
Figure 2. General Motor, New Jersey and F-Shaped Concrete Median Barrier Profiles (From the Left to the Right Side)[2].....	4
Figure 3. (1) Vertical Profile and (2) New-Jersey Profile .....	5
Figure 4. Driver Lost Control and Hit Bridge.....	24
Figure 5. Vehicle Lost Control and Went Into the Median Striking the Bridge Guardrail .....	24
Figure 6. The Trailer was Too High and Struck the Bridge .....	25
Figure 7. Vehicle Started Drifting Off the Roadway Until it Struck the Blunt End.....	25
Figure 8. Driver Lost Control on Snow Covered Road, The Left Rear Bumper and Corner Panel Struck the Cement Bridge Railing and Vehicle Went Into the Median South of the Bridge .....	26
Figure 9. Three-Level Hierarchical or Multilevel Structure.....	29
Figure 10. Potential Hierarchical or Multilevel Structure to be Used With the Bridge Crash Data .....	30
Figure 11. Logit and Probit Curves.....	32
Figure 12. Crash Frequency Distribution By Year By Rail Type.....	51
Figure 13. Crash Frequency Distribution by Annual Average Daily Traffic By Rail Type.....	52
Figure 14. Crash Distribution by Facility by Rail Type .....	53
Figure 15. Crash Frequency Distribution By Bridge Construction Year By Rail Type .....	54
Figure 16. Crash Frequency Distribution By Bridge Length By Rail Type .....	55
Figure 17. Crash Frequency Distribution By Bridge Width By Rail Type .....	56
Figure 18. Crash Frequency Distribution By Speed Limit and Rail Type.....	56
Figure 19. Crash Frequency Distribution By Approach Roadway Width By Rail Type .....	57
Figure 20. Crash Frequency Distribution By Number of Traffic Lanes.....	59
Figure 21. Crash Frequency Distribution By Road Location By Rail Type.....	60
Figure 22. Crash Frequency Distribution By Traffic Flow By Rail Type.....	60
Figure 23. Crash Frequency Distribution By Surface Type By Rail Type.....	61
Figure 24. Crash Frequency Distribution By Rail Type By Flared Structure .....	61
Figure 25. Crash Frequency Distribution By Horizontal Alignment By Rail Type .....	62
Figure 26. Crash Frequency Distribution By Vertical Alignment By Rail Type .....	62
Figure 27. Crash Frequency Distribution By Crash Day By Rail Type .....	64
Figure 28. Crash Frequency Distribution By Month By Rail Type.....	64
Figure 29. Crash Frequency Distribution By Surface Condition By Rail Type .....	65
Figure 30. Crash Frequency Distribution By Light Condition By Rail Type.....	66
Figure 31. Crash Frequency Distribution By Surface Condition By Rail Type .....	67
Figure 32. Crash Frequency Distribution By Vehicle Information By Rail Type.....	68
Figure 33. Crash Frequency Distribution By Number of Occupants Involved By Rail Type.....	68
Figure 34. Crash Frequency Distribution By Vehicle Initial Impact Point By Rail Type.....	69
Figure 35. Crash Frequency Distribution By Collision Type By Rail Type .....	69
Figure 36. Crash Frequency Distribution By Driver Age By Rail Type .....	72
Figure 37. Crash Frequency Distribution By Driver Gender By Rail Type .....	73
Figure 38. Crash Frequency Distribution By Driver Physical Condition By Rail Type .....	73
Figure 40. Crash Frequency Distribution By Airbag Deployment Status By Rail Type.....	76
Figure 41. Conceptualization of Relevant Factors to Rollover Occurrence .....	81



## LIST OF TABLES

Table 1. Stability for High-Speed, High-Angle Tracking Impacts with Concrete Safety-Shape Barriers [8].....	12
Table 2. Restraint System Use Versus Ejection.....	14
Table 3. Fatalities Versus Ejection.....	14
Table 4. Information Extracted From Narratives and Diagrams .....	21
Table 5. Accident Frequency Distribution By Year .....	22
Table 6. Distribution of Number of Accidents Per Bridge.....	31
Table 7. Partition for the Hosmer-Lemeshow Test.....	40
Table 8. Confusion Matrix.....	42
Table 9. Variable Description.....	44
Table 10. Crash Distribution By Rail Type .....	51
Table 11. Results From the T-Tests.....	53
Table 12. Narrow Bridge Distribution By Rail Type .....	58
Table 13. Crash Distribution By Traffic Control Device By Rail Type.....	63
Table 14. Crash Frequency Distribution By Vision Condition By Rail Type.....	66
Table 15. Crash Frequency Distribution By Vehicle Defect By Rail Type.....	70
Table 16. Crash Frequency Distribution By Fire/Explosion Occurrence By Rail Type .....	70
Table 17. Crash Frequency Distribution By Maneuver Type By Rail Type .....	71
Table 18. Descriptive Statistics For Vehicle Year.....	71
Table 19. Crash Frequency Distribution By Vehicle Attachment By Rail Type.....	71
Table 20. Descriptive Statistics for Driver Age.....	72
Table 21. Crash Frequency Distribution By Alcohol Consumption By Rail Type .....	74
Table 22. Crash Frequency Distribution By Rollover Occurrence By Rail Type .....	74
Table 23. Crash Frequency Distribution By Seat Belt Use By Rail Type.....	75
Table 24. Crash Frequency Distribution By Ejection Status By Rail Type.....	75
Table 25. Crash Frequency Distribution By Rail Type .....	76
Table 27. Univariate Analysis Output for All Data .....	83
Table 28. Variables Included in the Initial Multivariate Model .....	89
Table 29. Model Without the Variable Gender .....	90
Table 30. Model Without the Variable Driver Condition.....	91
Table 31. Model Without the Variable Vehicle Attachment.....	91
Table 32. Model Without the Variable Speed Limit.....	91
Table 33. Model Without the Variable Bridge Length.....	92
Table 34. Model Without the Variable BAC .....	92
Table 35. Final Model.....	93
Table 36. Odds Estimates for the Final Model .....	94
Table 38. Goodness-of-Fit Results for the models Used in the Rollover Analysis if Terms of Quality if Fit.....	96
Table 39. Injury Scale.....	97
Table 41. Four-Level Driver Injury Severity Distribution.....	98
Table 42. Results of the Univariate Analysis for Injury Analysis Using All Data.....	100
Table 43. Variables Included in the Initial Model .....	105
Table 44. Model Without the Variable BAC.....	106
Table 45. Model Without the Variable Vehicle Type.....	106

Table 46. Model Without the Variable Number of Occupants ..... 107  
Table 47. Model with Variable Facility Back in and Without the Variable Month ..... 108  
Table 48. Final Model ..... 108  
Table 50. Odds Estimates for the Model Using the Restricted Data ..... 109  
Table 51. Univariate Results With All Data ..... 110  
Table 52. Univariate Results With Restricted Data ..... 110  
Table 53. Multivariate Model With All Data ..... 110

## **1 INTRODUCTION**

### **1.1 Problem Statement**

Motor vehicle crashes are a major cause of fatalities and serious injuries along U.S highways. According to the National Highway Traffic Safety Administration (NHTSA), there were 33,808 fatalities and 2,217,000 injuries in motor vehicle crashes in the United States in 2009 only. Approximately one-third of all these fatalities occurred on the roadside. In other words, approximately 11,000 fatalities resulted from a vehicle run-off-the-road crash into a roadside safety structure or some other hazardous feature, such as trees or shrubs, embankments, fences, and other fixed objects [1]. Some of these fatalities are caused by the lack of or improper use of roadside safety hardware. As a consequence, intensive efforts have been devoted to the development of improved roadside safety practices, such as the implementation of efficient clear zones, breakaway devices, roadside and median barriers, etc.

The American Association of State Highway and Transportation Officials (ASSHTO) Roadside Design Guide (RDG) [2] provides guidance, best practices, and procedures to improve roadside safety. The safety treatment options recommended in the RDG, in order of preference, are: (1) remove the obstacle or hazard; (2) redesign it; (3) relocate it; (4) reduce the impact severity by using appropriate devices; (5) shield the obstacle; and (6) delineate it, if nothing else can be done. More than one of these alternatives may be appropriate depending on the specific combination of roadway, roadside, and traffic characteristics.

The most desirable safety measure is to remove the obstacle or hazard. However, this is not always possible. Shielding the obstacle has traditionally been the safety measure of choice for many engineers. This practice usually involves utilizing a barrier to prevent errant motorists from striking roadside obstacles that cannot be removed or treated by any other safety measure.

Roadside concrete barriers have been used for this purpose, especially on roadways with narrow medians as well as on high volume traffic and/or high speed highways, as shown in Figure 1.



Figure 1. Concrete Median Barrier on a Narrow Median Suburban Highway with High Traffic Volume

However, the rigidity of concrete barriers may also produce serious injuries and fatalities. Different concrete barrier profiles have gained widespread acceptance over the last 50 years. In the early 1960's, engineers introduced concrete safety-shape barriers on few highway miles as one of the biggest improvements in roadside safety. The original concrete safety-shape barrier was developed by General Motors (GM) [3]. There have been different concrete barrier profiles used nationwide. These devices would have to be structurally able to contain and redirect errant vehicles, safe to provide acceptable vehicle occupant risks, and lead vehicles through a

reasonable exit trajectory. As an initial model, the General Motors (GM) Concrete Safety-Shape barrier had two sets of slope faces. The lower slope one had started at a height of 15 in. (381 mm) from the ground, as shown in Figure 2. This high height caused excessive lifting of small cars of the 1970s, thus resulting in increased vehicular instabilities and rollovers. As a result, the use of the GM shape was discontinued [2].

As an attempt to solve this problem, the New Jersey Department of Transportation began to build concrete median barriers (CMB) which had their slope break point 13 in. (330 mm) above the ground, as shown in Figure 2 [3]. These New Jersey (NJ) shape concrete barriers were placed on medians to prevent head-on collisions between cars traveling in opposing lanes of divided highways. However, the NJ barriers with a lower slope of 13 in. (330 mm) still resulted in considerable wheel/barrier climb, thus causing certain vehicle instability during vehicle redirection.

In order to overcome this problem, a parametric study with six barrier profile configurations was performed, and the F-Shape barrier profile was developed [2]. This F-shape profile had a slope break point of 10 in. (254 mm), which was 3 in. (76 mm) lower than that provided by the NJ safety-shape concrete barrier, as shown in Figure 2. The lower slope break point decreased the lifting and climbing effects. With these successful findings, the F-Shape profile has been widely used along U.S. highways. The GM, NJ, and the F-shape profiles are all shown in Figure 2.

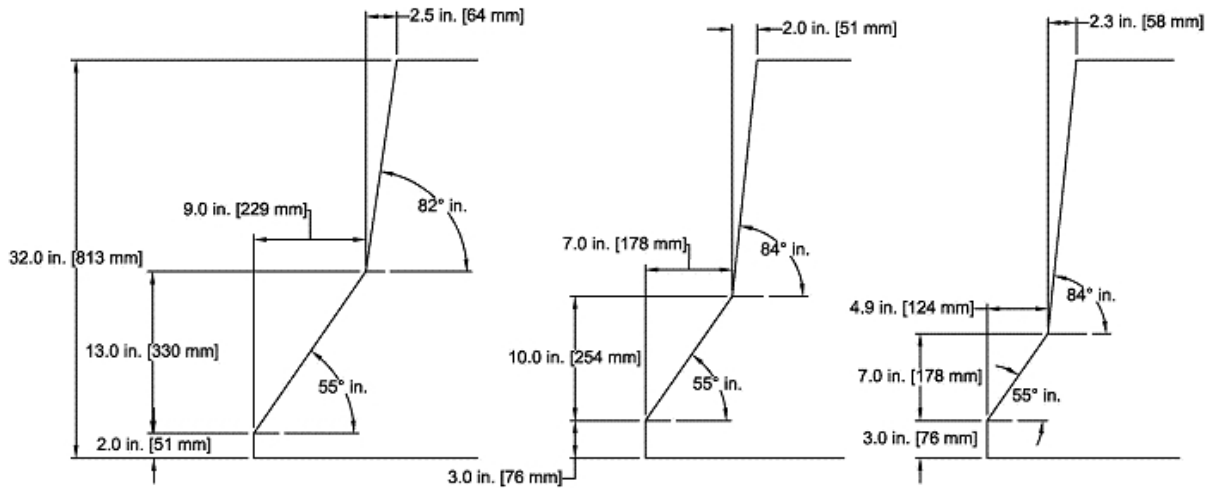

Figure 2. General Motor, New Jersey and F-Shaped Concrete Median Barrier Profiles (From the Left to the Right Side)[2]

Besides the safety-shape concrete barrier profiles discussed previously, the vertical concrete barrier has also been widely used. As the name suggests, the vertical concrete barrier does not have a sloped face but instead is totally vertical. Figure 3 shows a vertical profile and a New-Jersey profile. If the bottom of the bumper of a small car has a height of approximately equal to 9 in. (229 mm) from the ground and it impacts these barrier profiles, an impact force  $F_1$  generates a lateral redirective force  $F_1'$  for the vertical barrier profile. However, for a safety-shape barrier profile, a vehicle impact force  $F_2$  produces a tangent force  $R_t$  and a normal force  $R_n$  on the sloped surface, as shown in Figure 3. The impulses resulting from the reaction forces from both barriers should be the same. However, the elapsed time corresponding to the contact between vehicle and barrier for the safety-shape profile should be larger than the elapsed time corresponding to the contact between vehicle and barrier for the vertical barrier. Since impulse is equal to the area under the force versus time curve, the reaction force produced by the vertical barrier should be larger than the reaction force produced by the safety-shape barrier in order to

generate the same impulse. As a result, vehicle and occupant loading is expected to be higher for impacts with the vertical barrier profile.

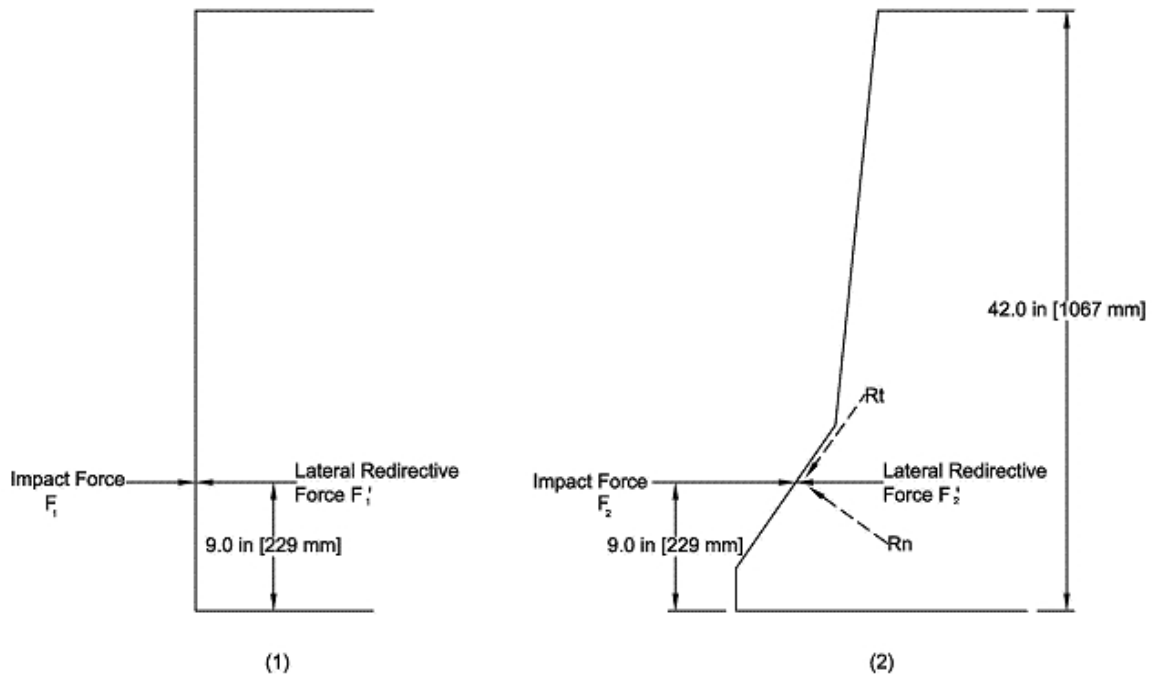

Figure 3. (1) Vertical Profile and (2) New-Jersey Profile

On the other hand, since the vertical concrete barrier does not have a sloped face, vehicles are less prone to instabilities upon impact, and rollover propensity is potentially decreased. Past research studies have shown that:

- Rollovers tend to increase the risks of severe injuries [4],
- Rollovers are responsible for almost 10,000 deaths annually in the U.S.A [4],
- Concrete safety-shape barriers are able to mitigate the magnitude of lateral forces on occupants while climbing on the lower slope [5],
- Excessive vehicle climbing on the face of safety-shape barriers may cause rollovers [2,5,6],
- Vertical concrete barriers are able to significantly decrease rollover propensity, but they may tend to provoke more serious occupant injuries due to higher lateral forces [2,7].

Because of these conflicting findings, it has been very controversial as to whether vertical or safety-shape concrete barriers provide the best option for reducing the risks of occupant injuries and fatalities. Vertical concrete barrier may lead to greater vehicle occupant injuries. On the other hand, safety-shape concrete barriers may increase rollover propensity which may consequently lead to an increased number of serious injuries and fatalities.

In addition, the conclusions regarding the safety performance of these different barrier profiles have been based on results obtained from full-scale vehicle crash testing. Therefore, there is a need to further investigate the relative safety benefits for using these different barrier profiles based on real-world crashes. In other words, the safety benefits would be based on an in-service safety performance evaluation.

## **1.2 Objective**

The objective of this research study is to evaluate the in-service safety performance of vertical and safety-shape concrete barriers. For the purpose of the study, the safest barrier will be defined as the profile that produces the lowest injury levels. Rollover propensity has also been used as a secondary indicator of the safety performance of these concrete barriers. The findings of this study should help highway designers identify which barrier type is safer to be utilized nationwide.

## **1.3 Scope**

The present study includes major tasks, which are described in the following chapters. Chapter 2 describes a literature review which includes findings from past research studies related to concrete barrier safety performance, rollovers, vehicle safety, occupant safety, run-off-the-road crashes, and bridge-related crashes. Chapter 3 describes the vehicle crash data collection process. Chapter 4 describes the statistical modeling approach used in this study. Chapter 5



presents the description, summary, and coding for each variable included in the present study. Chapter 6 presents the rollover analysis which was conducted to evaluate which concrete barrier profile tends to increase rollover propensity. Chapter 7 presents the injury analysis which was conducted to evaluate the safety performance of each concrete barrier profile based on injury severity level. Finally, chapter 8 presents the findings from the study.

## **2 LITERATURE REVIEW**

An extensive, computerized literature search was conducted through the Transportation Research Information Service (TRIS), the National Technical Information Service (NTIS), the Federal Highway Administration home page (FHWA), and the Engineering Village. The following key words were used in the search: concrete barrier, bridge rail, crash test, rollover, overturn, accident, severity, and injury.

The literature review contains information on concrete barrier, rollover, occupant safety, vehicle safety, run-off-the-road crashes, and bridge-related vehicle accidents. Each one of these topics is described in the following sub-sections. Also, fifteen research studies were summarized and critiqued. These summaries from each of these studies are included in the Appendix.

### **2.1 Concrete Barrier**

Rigid barriers have been used nationwide to prevent errant vehicles from striking roadside hazards, especially when smaller deflections and lower maintenance costs are required. Concrete barriers may also be required on roads carrying a large number of heavy vehicles. Full-scale crash tests have shown that rigid barriers are able to contain and redirect heavy vehicles within acceptable deflections and without large maintenance costs. The NJ shape median barrier demonstrated an ability to safely contain and smoothly redirect a 40,000-lb (18,144-kg) intercity bus in three crash tests at increasing severities. Concrete barriers were penetrated by heavy vehicles in only 2 out of 49 accidents [6]. In another study, the Iowa concrete barrier rail demonstrated an ability to meet the required AASHTO evaluation criteria for two full-scale crash tests that were conducted with an 18,000-lb (8,165-kg) single-unit truck. The truck impacted the barrier rail at 45 mph (72.4 km/h) and 15 degrees as well as at 50 mph (80.5 km/h) and 15 degrees [8]. A Ford F 600 box truck with a gross static weight of 17,454 lb (7,917 kg) was

successfully contained and redirected by impacted a tall, F-shape, precast concrete barrier when impacting at 47.3 mph (76.1 km/h) and 15 degrees [9]. Summary 4 reinforces the capability of rigid barriers to contain and redirect heavy vehicles.

Rigid barriers have also demonstrated an ability to contain and redirect passenger vehicles, as described in Summaries 1, 4 and 5. Summary 5 indicates that vehicles weighing 4,000 lb (1,814 kg) were safely contained and redirected by the barrier when impacting at 40 mph (64.4 km/h) and 25 degrees. However, for small cars, the experience of crashing against a concrete barrier may be very dramatic, especially at severe impact conditions (i.e., high impact speed and angle). For small cars, safety criteria pertaining to occupant injury and vehicle trajectory may not be met. Summaries 4 and 7 provide further details on the safety performance of concrete barriers regarding small cars.

For lighter vehicles, past research studies have shown that guardrails may be safer than concrete barriers. Summary 5 shows that lower impact forces were produced when passenger cars impacted the standard guardrail compared to rigid barriers. Summary 8 indicates that guardrails produce reduced accident severity as compared to concrete barriers.

However, accident severity levels may also be affected by concrete barrier profile. Summary 3 discusses about the rigid barrier profiles that have been used throughout the years. Summaries 1 and 2 show evidence that the F-shape concrete barrier produces smaller roll angles compared to the NJ profile which may be translated into a lower rollover propensity. However, when compared to the vertical concrete barrier, the F-shape barrier profile seemed to increase rollover propensity as vehicles were more prone to climb the face of the barrier and lose stability. Summary 6 also provides relevant findings concerning rollover propensity generated by the impact against each of these barrier profiles. Concrete barrier safety performance has also

been measured by collecting data (i.e., occupant impact velocity, occupant ridedown deceleration, and maximum roll angle) from a series of crash tests using different barrier profiles (i.e., New Jersey, F-shape, Single slope, vertical, and open concrete rail) that were subjected to crashes at different impact conditions (i.e., impact speed and angle) and with different vehicle classes (i.e., small car, sedan, and pick-up) [11]. The impact speed and angle used for the tests with a small car were 62.1 mph (100 km/h) and 20 degrees, respectively. The impact speed and angle used for the tests with a sedan were 62.1 mph (100 km/h) and 25 degrees, respectively. The impact speed and angle used for the tests with a pickup were 62.1 mph (100 km/h) and 20 degrees as well as 62.1 mph (100 km/h) and 25 degrees, respectively. The vertical concrete barrier presented a maximum roll angle of 6.3 degrees while the NJ and F-shape concrete barriers presented maximum roll angles of 29.6 and 10.0 degrees, for the full-scale crash test using a small car. The vertical concrete barrier presented a maximum roll angle of 5.0 degrees while the NJ and F-shape concrete barriers presented maximum roll angles of 46.0 and 52.0 degrees, for the full-scale crash test using a sedan. The tests using a pick-up revealed that the vertical concrete barrier presented a maximum roll angle of 5.8 degrees while the NJ and F-shape concrete barriers presented maximum roll angles of 6.0 and 7.0 degrees. Based on the results from these full-scale crash tests, the vertical shape has proven to be the best barrier for limiting both vehicular roll and wheel climb. On the other hand, the safety-shape barriers (i.e., NJ and F-shape) have proven to be the best shapes for lowering impact velocities and ridedown decelerations.

Therefore, even though safety shapes perform poorly for vehicle stability, safety-shapes have been found to produce the lowest impact forces compared to the vertical barrier profile. The difference in the magnitude of these redirective forces may be attributed to the fact that the

reaction force produced by the vertical barrier should be larger than the reaction force produced by the safety-shape barrier in order to generate the same impulse.

## **2.2 Rollover**

In the U.S., rollover crashes occur least often of all crashes, but serious and fatal injuries occur relatively often in rollovers. Almost 10,000 people are killed annually in rollover crashes. The fatality rate for rollover crashes is second only to frontal crashes [4]. The distribution of injury severity for rollovers was comparable to that for all other crash types. However, eight percent of the rollovers, resulted in occupant ejection [11].

The severity of rollover crashes may be influenced by several factors. Pre-roll travel speed, for example, has been found to be associated with the severity of rollover crashes [12]. Rollovers have also been found to significantly affect the propensity for occupant ejection. Researchers found that the risk of serious injuries and ejection were much higher in rollovers than for non-rollovers. The most frequent serious injuries occurred to the head and neck, and crash severity was related to the number of quarter turns and distance traveled [11].

Vehicle type has also been found to be a relevant factor in rollover propensity and vehicle stability. Past research has shown that vehicles with higher centers of gravity, such as vans and pickup trucks, presented the highest rollover rates [4]. However, when passenger cars impacted concrete barriers, rollover propensity was found to be lower for heavier vehicles. Table 1 shows results from computer simulations to verify the stability for high-speed, high-angle impacts against concrete safety-shape barriers under tracking conditions [7].

Table 1. Stability for High-Speed, High-Angle Tracking Impacts with Concrete Safety-Shape Barriers [8]

Vehicle Type lb (kg)	Angle (Degree)	Speed – mph (km/h)		
		18.6 (30)	28.0 (45)	37.3 (60)
Fiat Uno-45 1,560 (708)	35	Stable	Stable	Stable
	45	Stable	Marginal	Overturn
	60	Overturn	Overturn	Overturn
Daihatsu Domino 1,280 (581)	35	Stable	Stable	Stable
	45	Spinout	Spinout	Marginal
	60	Overturn	Overturn	Overturn
Chevrolet Sprint 1,530 (694)	35	Stable	Stable	Stable
	45	Sideslip	Marginal	Overturn
	60	Overturn	Overturn	Overturn
Honda Civic 1,800 (816)	35	Stable	Stable	Stable
	45	Marginal	Overturn	Overturn
	60	Overturn	Overturn	Overturn
Plymouth Fury 4,500 (2,041)	35	Stable	Stable	Stable
	45	Sideslip	Sideslip	Sideslip
	60	Sideslip	Sideslip	Sideslip

The Plymouth Fury weighing 4,500 lb (2,041 kg) demonstrated increased stability as compared to the Daihatsu Domino weighing 1,280 lb (581 kg). Huelke et al. showed that smaller cars were involved more frequently in rollovers than larger cars [11]. Smaller cars appeared to have a greater tendency to rollover upon an impact against concrete barriers because of their shorter wheel track widths and much lower roll-moment-of-inertia [13].

Research findings have shown that most fatal rollover crashes were found to be single-vehicle crashes. Alcohol consumption has also been associated with fatal rollovers. Rollovers were found to be more likely to produce fatal injuries than any other type of crash. Males, 40 years old or younger, were more likely to be the driver of vehicles involved in rollovers. Speed was also found to be a significant factor for rollover occurrence. Most rollover crashes occurred on roads with speed limits of 55 mph (88.5 km/h) or higher [14]. Collisions with fixed vertical objects, such as trees and walls, during rollover events may increase the risks of severe or fatal

injuries. Collisions with other vehicles prior to the rollover also increase the risks of serious injuries [15]. A study conducted in Georgia found that rollovers were more likely to occur on curved road sections and steep gradients [16]. Summaries 9, 11, 12, and 13 provide additional research findings on rollover events and their causation.

### **2.3 Occupant Safety**

According to the National Highway Traffic Safety Administration (NHTSA), there were 33,808 people killed and 2,217,000 people injured in traffic crashes in 2009 only. The majority of these people (i.e., almost 70 percent or 23,382 people) were killed while traveling in passenger vehicles. Alcohol was found to have a significant impact on fatalities since almost 30 percent of all crashes involved alcohol-impaired drivers. Among those who were killed in passenger vehicle crashes, approximately 53 percent were unrestrained occupants [1].

Restraint system use has been shown to have a significant impact on occupant safety. Huelke et al. showed that 30 percent of non-restrained occupants were ejected, while no restrained occupants were ejected [17]. Therefore, seat-belt usage seems to be an outstanding measure for significantly avoiding or at least minimizing the propensity of ejection which may be a probable event when rollover occurs. However, restrained occupants, however, are still likely to sustain at least low level injuries, generally on the chest and thorax due to the seat belt pressure during the crash impact [18]. These findings were confirmed in a full-scale crash test to demonstrate the seat belt efficacy during a large-angle, moderate-speed impact into a concrete median barrier [19]. The unrestrained occupant would have been highly probable to suffer fatal injuries while the restrained occupant would have suffered injuries that would likely not be life threatening.

As can be seen in Table 2, the restraint system demonstrated very good results if the observed values are compared to the expected values. That is, note that the number of restrained occupants that were ejected (i.e., 3) was much lower than the expected (i.e., 13.2). Only 2 percent of restrained occupants were ejected, while 25 percent of unrestrained occupants were ejected. This data shows the efficacy and importance of the seat-belt usage for the prevention of ejections and, consequently, of fatalities, as shown in Table 3 [18].

Table 2. Restraint System Use Versus Ejection.

Ejection	Restrained	Unrestrained	Total
Yes	3 (13.2)	16 (5.8)	19
No	140 (129.8)	47 (57.2)	187
Total	143	63	206

Note: Number in parentheses are expected values.

Table 3. Fatalities Versus Ejection.

Ejection	Fatal	Non-fatal	Total
Yes	10 (1.4)	9 (17.6)	19
No	11 (19.6)	252 (243.4)	263
Total	21	261	282

Note: Numbers in parentheses represent expected values.

As shown in Table 3, the results show that the number of fatalities for ejected occupants was much higher (i.e., 10) than the expected (i.e., 1.4). More than one-half of ejected occupants suffered fatal injuries, while only 4 percent of non-ejected occupants died. Note that the expected values shown in Tables 2 and 3 were calculated based on a chi-square test to investigate the association between the two variables contained in each table.

A past research study has shown that ejections usually cause serious abdominal injuries which were often found to be life threatening injuries. In addition, vehicle accidents usually cause injuries in the upper and lower extremities. Even though these injuries may not be life threatening, they may cause disabling injuries which may justify the need to limit vehicle's occupant compartment deformations [20]. Head, chest and extremities were seriously injured



more often than were neck, back and abdomen. Further, the head was the most frequent body part injured in rollovers, but most of those injuries were classified as low severity level. The injuries classified as high severity level occurred with ejected occupants [21]. In general, the most frequent injured body parts were found to be abdomen, neck, head, both upper and lower extremities, and chest. Even though head and neck were the most frequent parts affected by vehicle accidents, they were not found to suffer the most serious injuries [20]. Also, the injuries were found to vary when the vehicle rolled right or left. That is, the most frequent injuries were in the spine, thorax, and head when the vehicle rolled right; while head, lower and upper extremities, and thorax were the body parts more affected when the vehicle rolled left [22].

Factors such as occupant age, gender, physical condition, and seating position may also have an effect on vehicle occupant safety. Bedard et al. investigated driver characteristics that have an impact on the fatality risk of drivers involved in single-vehicle crashes with fixed objects. It was found that the risk of fatality increased for older female drivers [23]. Hanrahan et al. also showed that older drivers are more prone to dying or experiencing severe injuries when involved in motor vehicle crashes [24]. Even seating position may have a significant impact on vehicle occupant safety. It was found that the center rear seat was the safest position. Fatality risk to passenger in the back seat was found to be lower than the fatality risk to occupants in the front seat [25]. Driver physical condition (e.g., normal condition, under influence of alcohol and/or drugs, under influence of prescription medications, sleepy, fatigued) also may have a significant effect on safety. It was found that drivers under the influence of alcohol presented a higher fatality risk [23, 26]. It has also been found that sleepy drivers are at higher risks of fatal single-vehicle run-off-the-road crashes [26].

Summaries 11, 12, and 13 provide more detailed information on occupant safety from past research studies.

## **2.4 Vehicle Safety**

An accident study conducted in Washington collected traffic accident data from 1973 to 1979. Results showed that subcompact vehicle presented the highest accident severity index [27]. Past studies have shown that different vehicle categories have a diverse effect on injury propensity of vehicle occupants. These studies have suggested that occupants of lighter vehicles tend to sustain more severe injuries than occupants of heavier vehicles [27-30].

Summary 14 indicates that car mass is also a factor that may have a significant effect on vehicle safety while summary 15 indicates that different vehicle categories may have different rollover rates.

## **2.5 Run-off-the-road and bridge related crashes**

A literature review on run-off-the-road and bridge related crashes may also provide important inputs to the present study since most of the crash data collected include run-off-the-road crashes (e.g., vehicle leaving the road and hitting a bridge rail, guardrail, or entering the roadside slope/ditch), and all the crash data used in this study involved bridge related accidents.

According to NHTSA, there were 18,087 people involved in fatal roadway departure crashes in 2009 [1]. This finding is staggering since it corresponds to more than one-half of all fatalities in 2009. There are a number of factors that may have a significant impact on run-off-the-road crash occurrence. It has been found that driver sleep, alcohol consumption, horizontal curvature, speeding, rural road location, adverse weather, and high speed limit road are all contributing factors to higher risks of fatal single-vehicle run-off-the-road crashes [31]. Another study revealed that the existence of curve or grade, rural crash locations, alcohol consumption or

drug use, traveling speed, and point of impact did contribute to increasing the probability for having a more severe run-off-the-road crash involving young drivers [32]. Run-off-the-road crashes were also found to be more frequent under low-visibility and low-friction conditions than in clear and dry conditions. A research study found that the most frequently identified contributing factor among the run-off-the-road crashes was distraction [33]. Male drivers have also been found to have higher run-off-the-road crash rates than females [34].

The severity of run-off-the-road crashes may also be significantly affected by the roadway departure conditions (i.e., departure speed and angle), which may have a significant influence on the impact conditions. That is, high road departure speeds and angles will very likely result in high impact speeds and angles, which may result in higher injury severity. In a study on impact conditions of errant vehicles conducted by Albuquerque et al., it was found that the 90<sup>th</sup> percentile impact speed for Interstates was higher (i.e., 66 mph (106 km/h)) than for U.S. and State highways (i.e., 60.28 and 57.47 mph (97.01 and 92.49 km/h), respectively). This difference in impact speed was found to be statistically significant, while there was no significant statistical difference in impact angle for these road classes [35].

Bridge related crashes have also been found to be critical casualties in the highway system. Kaiser found that bridge related crashes accounted for 3 percent of all traffic accidents in Ohio [36], while Hilton found that bridge crashes accounted for 3.4 percent of all fatalities on Interstate highways [37]. In a study conducted by the NHTSA, severity of bridge-related accidents was found to be higher than that of non-bridge-related accidents [38]. Narrow bridges have been identified as a highway safety problem. The AASHTO defines a narrow bridge as a structure which has its width less than the approaching roadway width [39]. Mak and Calcote have recommended that focus should be turned to bridges located on two-lane undivided roads

because these structures presented the highest accident rates and severity [40]. According to Michie, many accidents can be attributed to narrow bridges, obsolete approach guardrails, and inadequate bridge rail installations [41]. Raff and Jorgensen also showed that narrow bridges tend to increase crash frequency and severity [42]. A study conducted by Agent found that a large proportion of the bridge accidents occurred at night time [43]. This was further confirmed by a study conducted in North Carolina [44]. Curved horizontal alignment also presented to have a significant impact on the number of fatal accidents on bridge structures [45, 46]. Bridge width, annual average daily traffic, and bridge length were also factors found to affect bridge safety [47]. More recently, a study of crashes at bridges in Kansas revealed that bridge accidents accounted for 3 percent of all traffic crashes, while they accounted for 7 percent of all fatalities in Kansas in 2005 [48].

### 3 DATA COLLECTION

The present study used eleven years (i.e., from 1998 to 2008) of vehicle crash data involving bridge-related accidents from the State of Iowa. The accident data was obtained with the Iowa Department of Transportation and it was limited to bridge-related accidents since State of Iowa utilized both safety-shape (i.e., New-Jersey and F-shape profiles) and vertical bridge rails throughout the State.

Not all accidents were found to be useful for the present study. For example, many accidents, involved a truck hitting the bottom of the bridge, while other accidents involved a vehicle hitting a guardrail or any other fixed object other than a concrete barrier. Since the objective of this study was to investigate the safety performance of safety-shape and vertical rails, if an accident did not involve a concrete barrier collision, this accident was eliminated from the study.

The data was limited to State maintained highways. Therefore, accidents that occurred on County maintained highways were not included in this study. This restriction of the data was due to the fact that only State maintained highways had information on bridge rail type. Bridge rail type was either safety-shape rail or vertical rail.

Significant data, including accident, road, bridge, occupant, and vehicle information, were obtained. Information from multiple databases was merged together, to form a single major database. Narratives and diagrams for all bridge-related accidents that occurred on State maintained highways between 1998 and 2008 were collected and reviewed. The information extracted from these narratives and diagrams (i.e., sequence of events as well as rollover occurrence, cause, and location) were added to the major database. Narrative and diagram information were crucial for a better accuracy of the data because accident database coding may

not contain details that are essential for a better understanding of accident injury causation. For example, there may be a single code for bridge rail/bridge/overpass in the database which makes it difficult to identify the type of object struck. However, the narratives and diagrams may describe the accident in more details, allowing a more accurate identification of the object struck. Identification of rollover location and cause may also provide an additional illustration on how useful the narratives and diagrams were. For example, the database may indicate that the crash involved a rollover, but it does not indicate where the rollover occurred and what the cause was. The narratives and diagrams allowed the identification of whether the rollover occurred on the road or on the roadside, and most importantly, whether the rollover was caused by a concrete barrier impact. Without such detailed information, the accuracy of the findings from this study could be compromised. Table 4 shows information extracted from the narratives and diagrams for a few accident cases.

Table 4. Information Extracted From Narratives and Diagrams

<b>Case Number</b>	<b>Rollover</b>	<b>Rollover Location</b>	<b>First Impact</b>	<b>Second Impact</b>	<b>Third Impact</b>	<b>Fourth Impact</b>	<b>Other Description</b>
1998013503	Yes	On the roadside	Concrete Barrier	NA	NA	NA	Vehicle rolled over as it entered the median.
1998011246	Yes	On the road	Concrete Barrier	NA	NA	NA	Vehicle rolled over due to barrier impact.
1998067294	Yes	On the roadside	Concrete Barrier	Power Pole	Fence	NA	Vehicle rolled over as it entered the ditch.
2005265990	No	NA	Guardrail	Concrete Barrier	Concrete Barrier	NA	None.
2006255083	No	NA	Vehicle	Concrete Barrier	NA	NA	Vehicle was rear-end hit and then struck barrier.

The 1998-2000 databases were different from databases that contained information from years 2001 and on. That is, there were some variables that were contained in the older databases (i.e., databases from years 1998 to 2000) that were not in the newer databases (i.e., databases from years 2001 to 2008) and vice-versa. All the variables, however, were included in the major database, and they are described in Table 9 shown in chapter 5.

There were 6,303 reported bridge-related crashes from years 1998 to 2008. Table 5 shows the accident frequency distribution by year. Less than half of these accidents occurred on State maintained highways (i.e., 2,781 accidents). The remaining accidents occurred on Local or County roads which did not have information on rail type.

Table 5. Accident Frequency Distribution By Year

<b>Year</b>	<b>Total number of accidents</b>	<b>Accidents on State maintained highways</b>	<b>Accidents that involved bridge rail</b>
1998	637	265	150
1999	617	233	131
2000	651	316	202
2001	500	225	110
2002	531	231	116
2003	565	243	114
2004	548	241	114
2005	599	285	134
2006	553	159	159
2007	576	292	150
2008	526	291	155
<b>Total</b>	<b>6303</b>	<b>2781</b>	<b>1535</b>

Not all of these crashes involved the concrete barrier. As a result, the number of accidents was further reduced to 1,535 cases. Narratives and diagrams were used to verify whether the vehicle hit a concrete barrier. Only those accidents which the narrative and diagram indicated that vehicle hit the concrete wall were used in the study.

In many instances, however, narratives and diagrams did not provide certainty whether the vehicle hit concrete barrier wall. These cases were classified in two groups. Group 1 was



formed by those accidents which there was no certainty whether vehicle hit the concrete barrier. After examining hundreds of narratives, it was observed that there was no consistency on the words used to describe struck objects. A struck object could have been named as bridge, but it was not possible to determine whether “bridge” was the approaching or downstream guardrail, or the bridge rail. In many of these cases, the diagrams were not helpful due to their lack of details and/or clarity. A guardrail could also have been named as bridge rail and vice-versa. In other instances, the officer indicated that the vehicle hit the barrier and this barrier could have been the approaching guardrail or the concrete barrier. Therefore, group 1 was formed by all accidents that did not provide clear evidence that the vehicle hit a bridge rail. Figure 4 shows an example of one of these accident cases. As can be seen, Figure 4 indicates that the vehicle lost control and hit bridge. However, there is no clear evidence, by looking at the diagram only, whether the vehicle hit the bridge rail or the downstream guardrail.

Group 2 was formed by all accidents which there was no impact against the bridge rail. Figures 5, 6 and 7 show examples of accidents that fell in the group 2 category. Figure 5 clearly shows that the vehicle hit an approaching guardrail in the median. Figure 6 shows an accident which involves a truck hitting the bottom of an overpass. Figure 7 shows a vehicle hitting a blunt end. Therefore, none of these accidents involved a bridge rail impact which makes them useless for the present study.

Figure 8 shows an example of an accident that was appropriate to be used in this study. As can be seen, the vehicle hit the bridge rail and left the road. There were 1,535 accidents involving a bridge rail impact. Out of these 1,535 accidents, there were 1,234 accidents that had the bridge rail as the first impact. The remaining of the accidents (i.e., 301 accidents) that involved the bridge rail hit the bridge rail in the second, third or even fourth impacts.

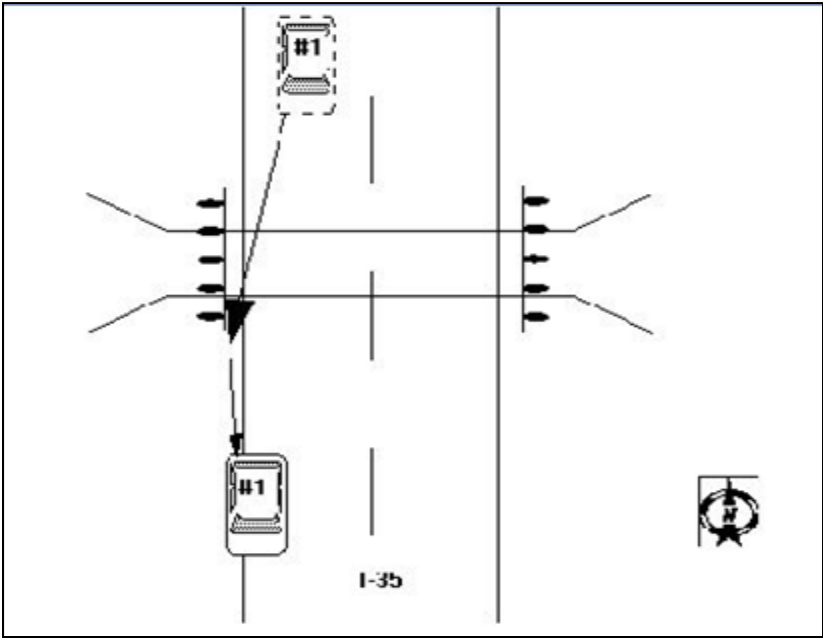

Figure 4. Driver Lost Control and Hit Bridge

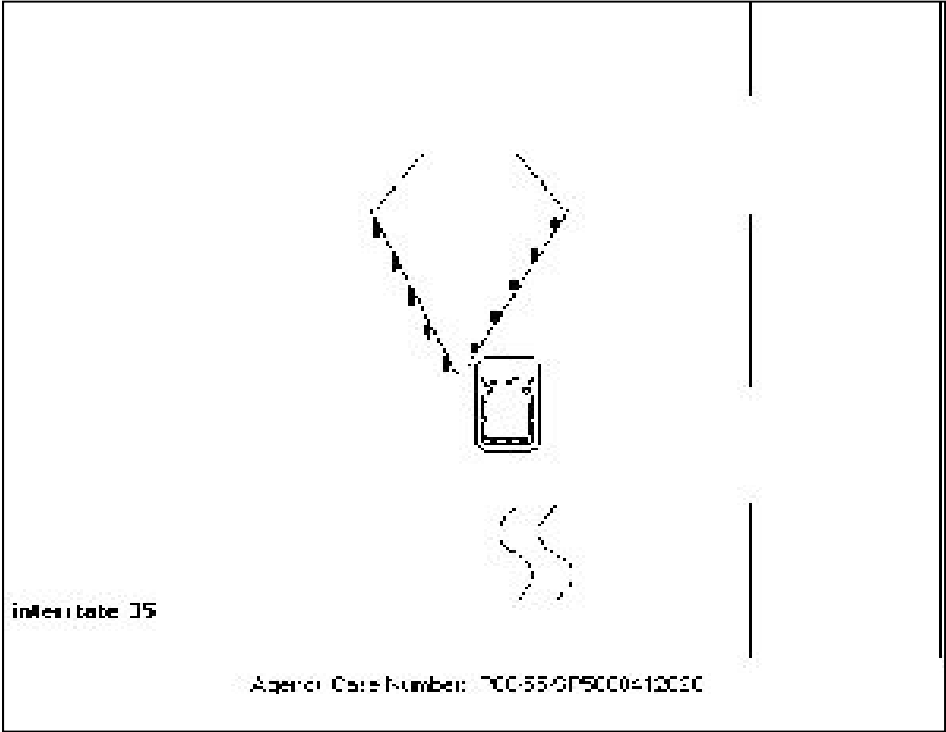

Figure 5. Vehicle Lost Control and Went Into the Median Striking the Bridge Guardrail

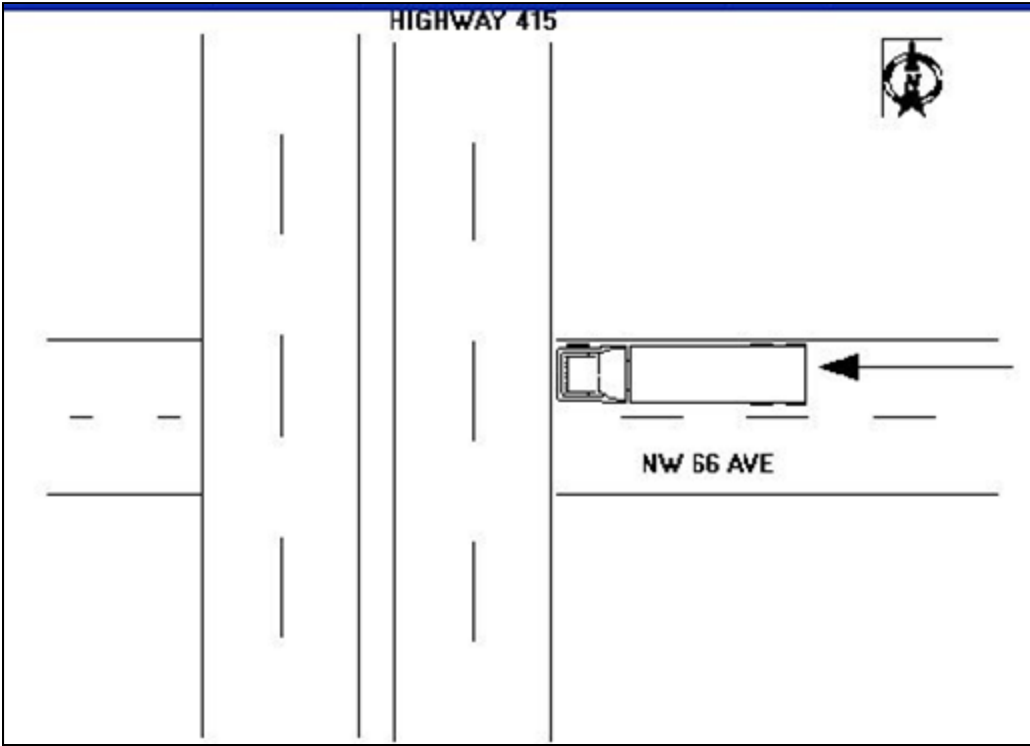

Figure 6. The Trailer was Too High and Struck the Bridge

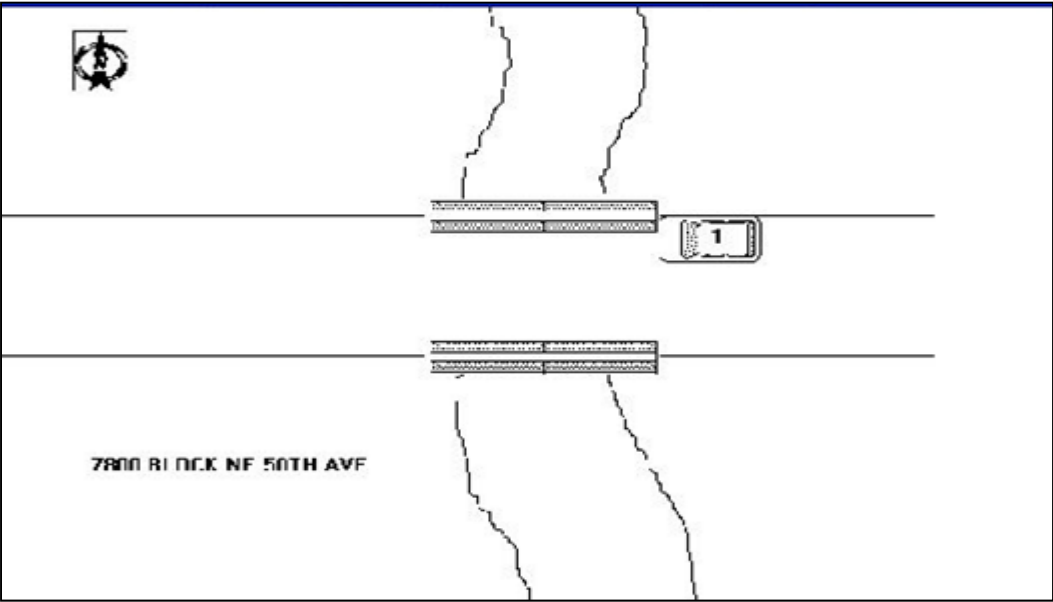

Figure 7. Vehicle Started Drifting Off the Roadway Until it Struck the Blunt End

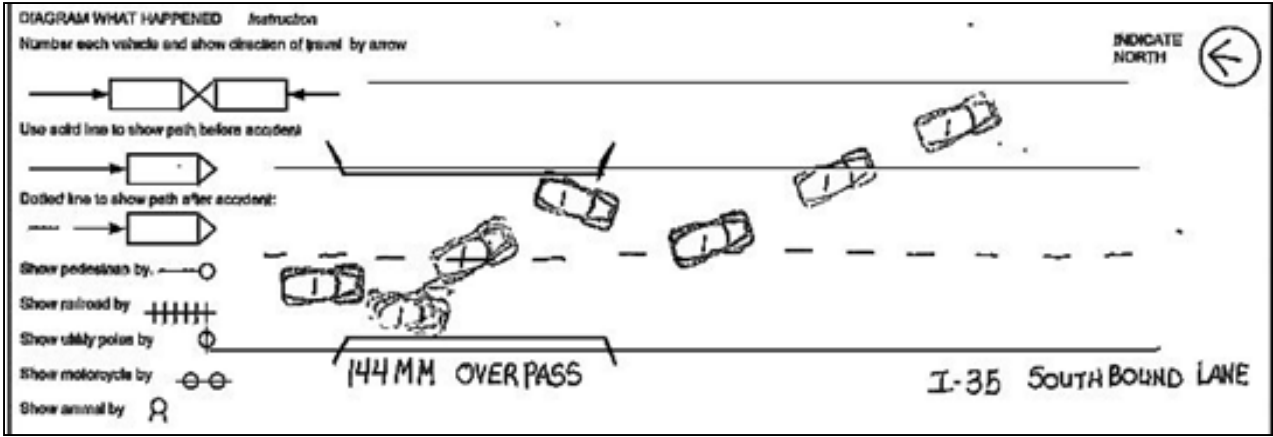

Figure 8. Driver Lost Control on Snow Covered Road, The Left Rear Bumper and Corner Panel Struck the Cement Bridge Railing and Vehicle Went Into the Median South of the Bridge

## 4 MODELING APPROACH

### 4.1 Statistical Model

The objective of the present research study was to evaluate the safety performance of two types (i.e., safety-shape and vertical barrier profiles) of concrete bridge rails located on State maintained highways in the State of Iowa. Statistical methods were used to analyze vehicle crash data. The safety performance was evaluated based on injury severity levels. The safest barrier would present lower injury levels. Rollover propensity was also used as a secondary indicator of the safety performance of the bridge rail since past research has shown that rollovers tend to affect injury severity. Therefore, the analysis was divided in two major tasks: rollover analysis and injury analysis. For these analyses, the response variables were rollover (i.e., yes and no) and injury level (i.e., uninjured, minor/possible, non-incapacitating, incapacitating, and fatal).

Regression analysis has been widely used in research to investigate the relationship between variables (i.e., a dependent variable and one or more explanatory variables) as well as to predict an outcome of the dependent variable based on a sample of observed values of one or more predictor variables. The Ordinary Least Squares (OLS) and the Non-linear Least Squares methods are often used to estimate linear and non-linear regression models [49].

However, regression models that are estimated using the OLS methods have limitations. One of their major limitations is that they cannot be used for binary or multinomial response variables. In such cases, models that are able to analyze categorical response variables are needed. Contingency tables may be used to identify relationships between categorical variables. However, statistical models may handle more complex analyses with several predictors. In this case, models from the family of Generalized Linear Models (GLMs) are the most appropriate tools to be used [50]. GLMs constitute a broad family of models which includes: probit, log-

linear, hierarchical, and logit models. Road safety researchers have used these models in the past to analyze categorical vehicle crash data. Duncan et al. (1998), Lui et al. (1988), Abdel et al. (1998), and Jones et al. (2003) have used ordered probit models, ordered logit models, loglinear models, and hierarchical models in road safety studies, respectively [51-54].

Log-linear models are more appropriate for use in studying the association between response variables rather than modeling the effect of one or more predictor variables on a response variable. Log-linear models make no distinction between a dependent and an independent response variable [55]. Because this study evaluates the impact of two bridge rail types on injury levels and on rollover propensity, log-linear models were not considered in this study.

On the other hand, hierarchical, logit, and probit models may be considered appropriate for this study. Hierarchical or multilevel structures are models that contain a set of levels within the data. For example, consider the case that one is interested in the performance of a student in science. In order to evaluate the student's performance, the researcher must consider that students are clustered in classrooms that might have different professors. Also, classrooms may be clustered within different schools. Therefore, this data is clearly a multilevel or clustered data. In this specific example, the data may be defined as a three-level hierarchical structure, as shown in the Figure 9.

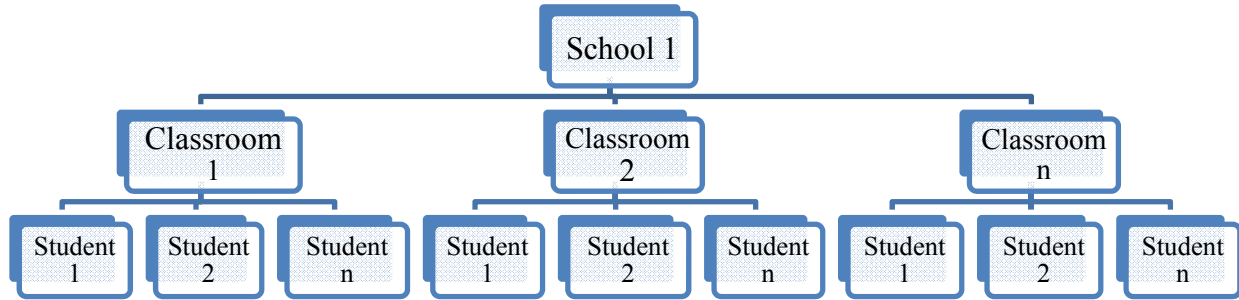

Figure 9. Three-Level Hierarchical or Multilevel Structure

In this case, level one is the student level, level two is the classroom level, and level three is the school level. The performance of the student may be impacted due to this clustered structure. A student may present a higher performance than another student because they are grouped in different classrooms, which may have different professors. Some professors may be more gifted than others which may impact the students' interest for the subject being taught. Also, different classrooms may be grouped in different schools. Not all schools are equally good and this may also have an effect on the students' performance.

In this study, vehicle accidents occurred on different bridges. Therefore, bridges may be considered as clusters. Serious injuries may be caused by bridge and crash characteristics that are not being taken in consideration by the current database. Hierarchical modeling would capture some of these characteristics that are not being taken in account by the used database.

If the data used in this study be considered as a multilevel structure, a three-level hierarchical structure, as shown in the Figure 10, may be appropriate.

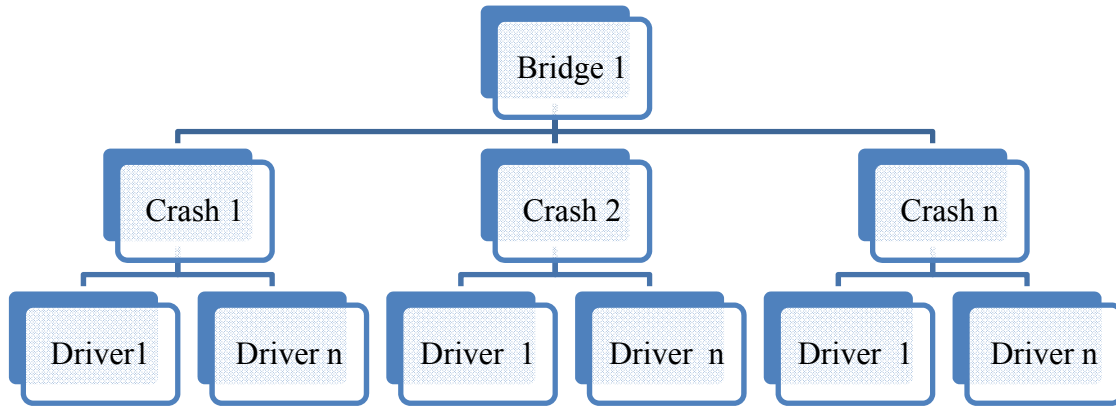

Figure 10. Potential Hierarchical or Multilevel Structure to be Used With the Bridge Crash Data

Hierarchical models require enough number of replications within each cluster to make statistical analyses possible (i.e., meaningful). Therefore, hierarchical models could not be used in this study since a large number of bridges had a very low number of accidents. Table 6 shows that more than one-half (i.e., 58.47%) of the bridges had only one accident. Even though hierarchical structures would be an appropriate methodology to be used in this study, it was not possible to be applied because of the nature of the data (i.e., too many bridges with very few accidents).



Table 6. Distribution of Number of Accidents Per Bridge

<b>Number of accidents per bridge</b>	<b># bridges</b>	<b>% relative to the # of bridges</b>	<b>Cumulative % relative to the # of bridges</b>
1	452	58.47	58.47
2	171	22.12	80.60
3	62	8.02	88.62
4	28	3.62	92.24
5	18	2.33	94.57
6	14	1.81	96.38
7	8	1.03	97.41
8	5	0.65	98.06
9	4	0.52	98.58
10	3	0.39	98.97
11	1	0.13	99.09
12	4	0.52	99.61
14	1	0.13	99.74
15	1	0.13	99.87
19	1	0.13	100.00

Equation 1 shows the structural form of probit and logit models, where  $x_i$  is the row vector representing the predictor variable,  $\beta$  is the column vector of coefficients, and  $\varepsilon$  is the error term.

$$y_i = x_i\beta + \varepsilon_i \quad \text{Eq. (1)}$$

There is little difference between the parameter estimates between the probit and the logit models. The major difference between these models is the random term  $\varepsilon$  shown in Equation 1. The random term  $\varepsilon$  for the probit model is assumed to be normally distributed with mean 0 and variance 1, while the random term  $\varepsilon$  for the logit model is assumed to be logistically distributed with a mean of 0 and variance of  $\pi^2/3$ . Figure 11 shows that the distributions for these two models appear to be S-shaped. As can be seen in Figure 11, logit models have slightly flatter tails which means that the probit curve approaches the axes more quickly than the logistic. This

indicates that it would be needed to have a significant amount of data in the tails to see a significant difference between the curves fitted with these two models.

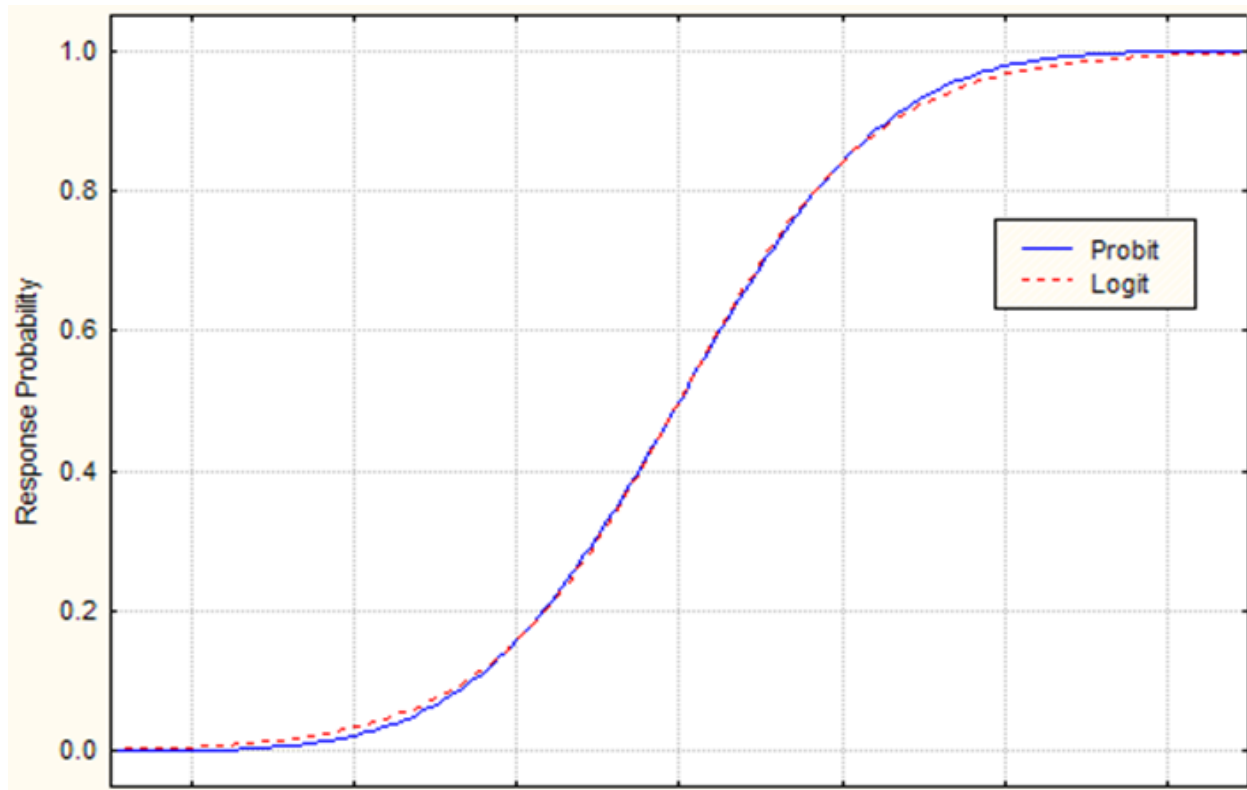

Figure 11. Logit and Probit Curves

The choice between the logit and probit models is largely one of convenience and convention, since the results are generally indistinguishable. Therefore, the choice between the logit and the probit model is usually based on factors such as software availability, on researcher familiarity with the chosen model, and on the research area since some subjects tend to use more often either one of these two models. However, even though probit and logit models tend to give very similar results, the estimates of parameters of the two models are not directly comparable [57].

The logit model was selected for this study. This model has been found to be popular among road safety peers [52,56,57] and the fact that its outputs may be easily interpreted in

terms of odds ratio was a deciding factor for using this model in the present study. The Statistical Analysis Software (SAS) was used to fit the logit models applied in this study [58]. With odd estimates, the effects of variables on rollover propensity and injury levels may be easily quantified and interpreted. For example, Table 27 shows that the odd estimate for rail type was found to be 3.45, which means that safety-shape rails are 3.45 times more likely to produce rollovers as compared to vertical rails.

The probability density function for the logit model may be described by Equation 2. Equation 3 describes the cumulative probability function. The parameters  $\mu$  and  $\sigma$  represent the mean and the standard deviation, respectively.

$$f(x) = \frac{e^{-(x-\mu)/\sigma}}{\sigma(1+e^{-(x-\mu)/\sigma})^2} \quad \text{Eq. (2)}$$

$$F(x) = \frac{1}{1+e^{-(x-\mu)/\sigma}} \quad \text{Eq. (3)}$$

A univariate (i.e., with only one predictor variable) logit model may be mathematically expressed by Equation 4, where  $x$  is the predictor variable,  $\pi(x)$  is the success probability at the value  $x$ ,  $\beta_0$  is the intercept, and  $\beta$  represents the effect of the variable  $x$  on the response variable.

$$\text{Logit}[\pi(x)] = \beta_0 + \beta x \quad \text{Eq. (4)}$$

The effect of the variable  $x$  on the response variable increases as the absolute value of  $\beta$  increases. The positive sign in Equation 4 indicates that the logit curve ascends as the curve shown in Figure 11. A negative sign in Equation 4 would indicate that the logit curve descends. This result would indicate that the success probability at value  $x$  would tend to decrease as value  $x$  increases. A logit model with  $n$  predictor variables may be expressed by Equation 5. In order to calculate the odd estimate, the exponential of the logit is determined by Equation 6. The odd estimate may also be translated into probabilities, as given by Equation 7.

$$\text{Logit}[\pi(x)] = \beta_0 + \beta_1 x_1 + \beta_2 x_2 + \beta_n x_n \quad \text{Eq. (5)}$$

$$\text{Odds} = e^{\beta_0 + \beta x} \quad \text{Eq. (6)}$$

$$\pi(x) = \frac{e^{\beta_0 + \beta x}}{1 + e^{\beta_0 + \beta x}} \quad \text{Eq. (7)}$$

If the response variable was binary (i.e.,  $y = 0$  or  $1$ ), a binary logit model was used. If the response variable was polytomous (i.e., response variable  $y$  has more than 2 levels), a cumulative logit model was used. The binary logit model was used in the rollover analysis described in chapter 6 since rollover was coded as “yes” or “no”. The cumulative logit model was used in the injury analysis described in chapter 7 since injury was coded in the KABCO scale (i.e., K = fatal, A = incapacitating injury, B = non-incapacitating injury, C = possible/minor injury, and O = uninjured). The binary logit model calculates the probability that the response is equal to 1 (e.g.,  $\pi[y = \text{rollover}]$ ), while the cumulative logit model calculates the probability that the response variable assumes values equal or lower than level  $j$  (i.e.,  $\pi[y \leq j]$ ), as given by Equation 8.

$$\text{logit}[P(y \leq j)] = \alpha_j + \beta x \quad \text{Eq. (8)}$$

For example, if the number of injury levels is 5, this model describes four relationships. First, the effect of  $x$  on the odds that  $y \leq 1$  instead of  $y > 1$ . Second, the effect of  $x$  on the odds that  $y \leq 2$  instead of  $y > 2$ . Third, the effect of  $x$  on the odds that  $y \leq 3$  instead of  $y > 3$ . Lastly, the effect of  $x$  on the odds that  $y \leq 4$  instead of  $y > 4$ . The model requires a separate intercept parameter for each cumulative probability. Because the cumulative probability increases as  $j$  increases, the value of the intercept parameter increases as well.

In order to fit the logistic regression model, the coefficient(s) beta(s) need to be determined. The statistical method used to determine the model’s parameters is the maximum likelihood estimation. A likelihood function must first be developed in order to use the maximum likelihood method. The values of the parameters that maximize the likelihood function are chosen and called as the maximum likelihood estimators [59]. In other words, the maximum

likelihood method will produce the values for the unknown parameters which maximize the probability to replicate the observed set of data. Hosmer and Lemeshow provides explanations on how the parameter values that maximize the likelihood function, in the case of a logistic regression model, are determined [60]. Hosmer and Lemeshow describes that if a binary response variable  $y$  is coded as zero or one, the probability that  $y$  will be one given a specific  $x$  is  $P(y=1/x) = \pi(x)$ . On the other hand, the probability that  $y$  is equal to zero given  $x$  is  $P(y=0/x) = 1 - \pi(x)$ . More specifically, the contribution to the likelihood function for a pair of observation  $(x_i, y_i)$  may be expressed by Equation 9, which is the representation of a Bernoulli distribution since the binary logit model has only two possible outcomes.

$$\zeta(x_i) = \pi(x_i)^{y_i} [1 - \pi(x_i)]^{(1-y_i)} \quad \text{Eq. (9)}$$

The likelihood function may be calculated as  $l(\beta) = \prod_{i=1}^n \zeta(x_i)$ . Because the observations are assumed to be independent, the contribution of  $n$  observations to the likelihood function may be expressed as the product of all  $\zeta(x)$ , from observation 1 to  $n$ . The likelihood function may also be expressed in terms of summation by taking the log of  $\prod_{i=1}^n \zeta(x_i)$  as given by Equation 10, which is the log likelihood. The maximum likelihood method will find coefficients for the logit model that maximizes Equation 10. That is, the value of  $\beta$  that maximizes  $\ln[l(\beta)]$  is determined. In order to determine  $\beta$ ,  $\ln[l(\beta)]$  is differentiated with respect to  $\beta_0$  and  $\beta_1$  and set the resulting expressions equal to zero. The resulting expressions are given by Equations 11 and 12 and they are the likelihood equations. Iterative methods programmed into statistical software are used to solve Equations 11 and 12 using a generalized weighted least squares procedure [60]. The solution of Equations 11 and 12 will find a value of  $\beta$  which is the maximum likelihood estimate.

$$\ln[l(\beta)] = \sum_{i=1}^n \{y_i \ln[\pi(x_i)] + (1 - y_i) \ln[1 - \pi(x_i)]\} \quad \text{Eq. (10)}$$

$$\sum_{i=1}^n [y_i - \pi(x_i)] = 0 \quad \text{Eq. (11)}$$

$$\sum_{i=1}^n x_i [y_i - \pi(x_i)] = 0 \quad \text{Eq. (12)}$$

In the case of the polytomous logit model, the estimation of the parameters may be explained as an extension of the binary logit model. Suppose the parameters to be estimated is from a model that has the outcome variable with three categories. Assume that the categories of the outcome variable  $Y$  are coded as 0, 1, or 2. In this case, there are two logit functions. One logit function for  $Y = 0$  versus  $Y = 1$ . Another logit function for  $Y = 0$  versus  $Y = 2$ . Note that  $Y = 0$  serves as the reference outcome value. If the logit for comparing  $Y = 2$  versus  $Y = 1$  is desired, it may be obtained as the difference between the logit of  $Y = 2$  versus  $Y = 0$  and the logit of  $Y = 1$  versus  $Y = 0$ . The two logit functions may be denoted as:

$$g_1(x) = \ln \left[ \frac{P(Y=1/x)}{P(Y=0/x)} \right] \quad \text{Eq. (13)}$$

$$g_2(x) = \ln \left[ \frac{P(Y=2/x)}{P(Y=0/x)} \right] \quad \text{Eq. (14)}$$

The conditional probabilities of each outcome category may be given as:

$$P(Y = 0/x) = \frac{1}{1 + e^{g_1(x)} + e^{g_2(x)}} \quad \text{Eq. (15)}$$

$$P(Y = 1/x) = \frac{e^{g_1(x)}}{1 + e^{g_1(x)} + e^{g_2(x)}} \quad \text{Eq. (16)}$$

$$P(Y = 2/x) = \frac{e^{g_2(x)}}{1 + e^{g_1(x)} + e^{g_2(x)}} \quad \text{Eq. (17)}$$

In order to construct the likelihood function, it is convenient to formulate three binary variables coded as zero or one to indicate group membership of an observation. These variables would be used only to clarify the likelihood function and they are not actually used in the polytomous logistic regression model. The variables would be coded as: if  $y = 0$  then  $y_0 = 1$ ,  $y_1 = 0$ , and  $y_2 = 0$ ; if  $y = 1$  then  $y_0 = 0$ ,  $y_1 = 1$ , and  $y_2 = 0$ ; and if  $y = 2$  then  $y_0 = 0$ ,  $y_1 = 0$ , and  $y_2 = 1$ . If  $P(Y = j/x) = \pi_j(x)$ , the conditional likelihood function for a polytomous model and a

sample of  $n$  independent observations may be expressed as the product given by Equation 18. Equation 19 gives the log-likelihood function, which is the log of Equation 18.

$$l(\beta) = \prod_{i=1}^n [\pi_0(x_i)^{y_{0i}} \pi_1(x_i)^{y_{1i}} \pi_2(x_i)^{y_{2i}}] \quad \text{Eq. (18)}$$

$$\ln[l(\beta)] = \sum_{i=1}^n y_{1i} g_1(x_i) + y_{2i} g_2(x_i) - \ln(1 + e^{g_1(x_i)} + e^{g_2(x_i)}) \quad \text{Eq. (19)}$$

The likelihood equations are determined by taking the first partial derivatives of Equation 19 with respect to each of the  $2(p+1)$  unknown parameters. The general form of these equations is given by Equation 20. For each subject,  $x_{0i} = 1$ ,  $j = 1, 2$  and  $k = 0, 1, 2, \dots, p$ . Iterative methods should be used to solve the likelihood equations and obtain the maximum likelihood estimator  $\hat{\beta}$ .

$$\frac{\delta \ln[l(\beta)]}{\delta \beta_{jk}} = \sum_{i=1}^n x_{ki} (y_{ji} - \pi_{ji}) \quad \text{Eq. (20)}$$

## 4.2 Model Building

The objective of the present study consisted on comparing the safety performance of two types of bridge rails (i.e., safety-shape and vertical rails). The safety performance was evaluated based on the injury levels resulted from the crashes involving each type of bridge rail. Rollover propensity was used as a second indicator of the safety performance. Chapter 6 describes the rollover analysis, while chapter 7 describes the injury analysis. For each one of these analyses, the effect of each independent variable on the response variable (i.e., either rollover or injury) was first examined, which consisted in the univariate analysis. All the variables that presented a p-value up to 0.25 were included in the multivariate analysis which consisted on evaluating the effect of multiple predictors simultaneously on the response variable. The p-value of 0.25 was chosen as an indicator of which variable should be included in the multivariate analysis was based on recommendations made by Hosmer and Lemeshow [60] which mention the work by Bendel and Afifi on linear regression [62] and the work by Mickey and Greenland on logistic

regression [64]. Hosmer and Lemeshow mention that these authors do not recommend to use the traditional  $p$ -value = 0.05 since it may fail to identify variables that may be relevant to the study and the univariate analysis may ignore that an isolated variable which presents a  $p$ -value larger than 0.05 may become relevant (i.e., statistically significant) when it is taken together along with other variables).

As multiple variables are taken together, some of them are going to become non-significant and each one of these might be removed from the model if they are found not to be relevant to the model once all other variables are included in the model. This stage is called the model building stage. Backward regression techniques and the likelihood ratio test were used in this stage in order to find a final model that is as parsimonious as possible and that contain variables that are relevant to the outcome (i.e., either rollover occurrence or injury level) in analysis.

Backward regression involves starting with a model that contains all variables (i.e., full model) and testing them one by one for statistical significance. That is, the initial model is fit and the variable that presents the lowest statistical significance (i.e., the highest  $p$ -value) is tested to check its influence on the model once all other variables are in the model. If the variable is not found to be relevant to the model, it is dropped from the model and a simpler model is considered.

The likelihood ratio test may be used to test the variable for significance in the backward regression process. The likelihood ratio test compares the fit of two models by evaluating the statistical significance of the least significant variable to the model. If this variable is found not to be relevant, the simpler model is considered. The test is based on the ratio that expresses how many times more likely the data are under one model than the other. In other words, both models



are fitted and the ratio of their log-likelihood is calculated as shown in Equation 21. The likelihood of the model is the probability that the model would be observed given the coefficient estimates.

$$D = -2\ln\left(\frac{\text{likelihood for full model}}{\text{likelihood for simpler model}}\right) \quad \text{Eq. (21)}$$

If the ratio is significant, then the variable being evaluated should be kept in the model since it significantly contributes to the model. On the other hand, if the ratio is not significant, then the variable may be dropped from the model. The statistical significance of the ratio is evaluated by using the ratio as a chi-square value and comparing it to a critical chi-square value. If the ratio is greater than the critical chi-square value, then the variable is significant. If the ratio is not greater than critical chi-square value, then the variable is not significant and, therefore, it may be dropped from the model. The critical chi-square value adopted in this study was 3.84 which is based on a chi-square distribution with 1 degree of freedom and a 5 percent confidence level.

### **4.3 Goodness-Of-Fit Test**

After a model has been selected, it is important to assess how well this model fits the data. In the present study, the fit of models for two different analyses has to be assessed. The first analysis conducted was the rollover analysis. The main objectives of this analysis was to identify variables that significantly contributed to rollover propensity as well as identify which rail type tended to decrease rollover likelihood. In this case, a binary logit model was used. The second analysis conducted was the injury analysis. The main objectives of this analysis was to identify variables that significantly affected injury severity levels as well as identify which bridge rail type tended to produce lower injury levels (i.e., which bridge rail is safer). In this case, a polytomous logit model was used.

The Hosmer-Lemeshow test was used to assess the goodness-of-fit of the binary logit model used developed in the rollover analysis. This test consists of creating 10 ordered groups of subjects and then comparing the number of actual observations in each group to the number of observations predicted by the logistic regression model as shown in an example illustrated by Table 7. A chi-square statistic is used to evaluate whether the predicted probabilities developed by the logit model are statistically different from the observed probabilities calculated from the actual data. The 10 groups that divide the observations are created based on their estimated probabilities. That is, those observations with probability up to 0.1 should fall into group 1, those with probabilities higher than 0.1 up to 0.2 should fall into group 2, and so on until the group 10 that includes those observations with probabilities between 0.9 and 1.0. Each one of these groups is further divided into two groups based on whether the outcome is “success” or “failure” [60].

Table 7. Partition for the Hosmer-Lemeshow Test

Group	Total	Rollover = 0		Rollover = 1	
		Observed	Expected	Observed	Expected
1	139	3	1.32	136	137.68
2	150	3	2.35	147	147.65
3	134	1	2.79	133	131.21
4	137	4	3.44	133	133.56
5	134	5	4.43	129	129.57
6	137	6	5.15	131	131.85
7	136	5	6.54	131	129.46
8	127	8	7.8	119	119.2
9	147	8	11.89	139	135.11
10	115	18	15.28	97	99.72

The Hosmer-Lemeshow goodness-of-fit statistic may be computed as shown in Equation 22.

$$H = \sum_{g=1}^n \frac{(O_g - E_g)^2}{N_g \pi_g (1 - \pi_g)} \quad \text{Eq.(22)}$$

The parameters  $O_g$ ,  $E_g$ ,  $N_g$ , and  $\pi_g$  denote the observed events, expected events, observations and predicted probability for the  $g^{th}$  risk decile group. The computed value is compared to a critical value based on a chi-square distribution (n-2) degrees of freedom, where n is the number of decile groups. If the computed Hosmer-Lemeshow goodness-of-fit statistic is found to be lower than the critical value, then the model fits the data well.

Because the Hosmer-Lemeshow test is essentially a goodness-of-fit test used for binary logit models, other goodness-of-fit statistics had to be adopted in order to assess the fit of the polytomous model developed in the injury analysis. Other goodness-of-fit statistics such as the Pearson's chi-square as well as Deviance may be used to assess the fit of polytomous logistic regression models. However, because of the sparseness problem, assessing goodness-of-fit is often difficult with categorical models. A model with multiple categorical variables may experience too much sparseness and, therefore, these methods would not be the most appropriate methods since they require a minimum number of replications (i.e., usually at least 5) within each subpopulation group.

A likelihood ratio test of the model of interest versus the saturated model may give one type of a goodness-of-fit test. The model of interest would be the model with the predictor variables that were selected from the model building stage. This model could include only main effects, but it also could include interactions. The saturated model would be the model that would include all main effects and possible interactions. The saturated model is the model that perfectly reproduces the data and, therefore, it has a perfect fit to the data. The results of the likelihood ratio test would indicate if the lack-of-fit generated by the reduction of the saturated model to a much simpler model is significant. If the test is significant, it means the reduced model does not fit the data well when compared to the saturated model. If the test is not

statistically significant, it means that the lack-of-fit generated by the adoption of the reduced model instead of the saturated model is acceptable and, therefore, the reduced model is an acceptable model in terms of goodness-of-fit.

A confusion matrix may also be used to assess how well the model performs. The model used in the injury analysis has four possible outcomes. In this case, the confusion matrix should be a 4x4 matrix as shown below. The letters in red would represent the outcomes that were correctly predicted. In order to determine how well the model performs, the percent of the outcomes that were correctly predicted may be calculated as  $(a + f + l + q) / (a + b + c + d + e + f + g + h + l + j + l + m + n + o + p + q)$ . If the model predicts at least 80 percent of the outcomes correctly, it may be said that the model performs well.

Table 8. Confusion Matrix

		Predicted outcome			
		1	2	3	4
Actual outcome	1	<b>a</b>	b	c	d
	2	e	<b>f</b>	g	h
	3	i	j	<b>l</b>	m
	4	n	o	p	<b>q</b>

## **5 DATA DESCRIPTION, SUMMARY, AND CODING**

In this chapter, section 5.1 describes the variables used in the study (i.e., variables that were included in all datasets received from the Iowa DOT) while section 5.2 summarizes these variables. This chapter also presents how variables were coded. The coding scheme is presented in section 5.3.

### **5.1 Variable Description**

The data used for this study included 11 years (i.e., from 1998 to 2008) of bridge-related crash data that occurred on State maintained highways in the State of Iowa. Datasets included accident, road, bridge, occupant, and vehicle information. Accident reports from years 1998 to 2000 are different from those used after year 2000. As a result, some of the variables that are contained in the datasets referring to the years from 1998 to 2000 are not contained in the datasets referring to the years after 2000, and vice-versa. Table 9 shows all variables contained in all datasets from year 1998 to year 2008. Note that Table 9 also indicates if a variable is contained only in the datasets before 2001, if a variable is contained only in the datasets after 2000, or if a variable is contained in both datasets. It is also indicated in Table 9 whether a variable was included in the rollover analysis, in the injury analysis, or in both analyses. The present study conducts two major analyses (i.e., rollover and injury analysis) which will be discussed in chapters 6 and 7, respectively. Note that there is a column in Table 9 which gives the description of the variable. In some instances, there is no description for the variable's name itself describes the variable.

Table 9. Variable Description

<b>Variable</b>	<b>Description</b>	<b>1998-2000 Dataset</b>	<b>2001-2008 Dataset</b>	<b>Rollover Analysis</b>	<b>Injury Analysis</b>
Airbag deployment	*		X		X
Airbag switch status	ON or OFF		X		
Annual average daily traffic	*	X	X	X	X
Approach roadway width to the bridge	*	X	X		
Facility	Indicates the road classification	X	X	X	X
Bridge - feature crossed	Indicates which feature bridge crossed (e.g., river, road)	X	X		
Bridge - FHWA Number	This is the bridge identification number	X	X		
Bridge - type of service	Indicates service under and on the bridge (e.g., highway, waterway, railroad)	X	X		
Bridge construction year	*	X	X	X	X
Bridge Deck width	*	X	X	X	X
Bridge length	*	X	X	X	X
Bridge location	Locates the bridge based on a reference point such as a junction or interchange	X	X		
Bridge skew angle	The angle between the centerline of piers and the roadway centerline.	X	X		
Bridge width	*	X	X	X	X
Cloth color	Pedestrian clothing darkness	X			
County	*	X	X		

<b>Variable</b>	<b>Description</b>	<b>1998-2000 Dataset</b>	<b>2001-2008 Dataset</b>	<b>Rollover Analysis</b>	<b>Injury Analysis</b>
Date	*	x			
Contributing circumstances - Non-motorist	Circumstances that contributed to an accident involving a person that was not in a vehicle		x		
Collision type	It may be head-on, sideswipe, rear-end, right or left turn, right angle, and broadside	x		x	x
Day of the month	*	x			
Day of the week	*	x	x	x	x
Driver age	*	x	x	x	x
Driver charged	Indicates whether the driver received a fine or not		x		
Driver contributing circumstances	Circumstances that contributed to the driver to be involved in the accident		x		
Driver gender	*	x	x	x	x
Driver license state	*		x		
Driver physical condition	Whether driver was under normal physical condition or not	x	x	x	x
Driver's license class	*		x		
Driver's license endorsements	*		x		
Drug/alcohol use	*		x		
Ejection	Whether vehicle occupant was ejected or not	x	x		x
Ejection path	*		x		
Environmental contributing circumstances	*		x		

<b>Variable</b>	<b>Description</b>	<b>1998-2000 Dataset</b>	<b>2001-2008 Dataset</b>	<b>Rollover Analysis</b>	<b>Injury Analysis</b>
Fire/explosion	Whether vehicle got on fire or exploded	x			x
First harmful event	Indicates which event was the first harmful in a sequence of events		x		
First impact	Description of what the vehicle hit in the first impact in a sequence of events	x	x	x	x
Fixed struck object location	Indicates whether the struck object was on the roadside or on the roadway	x			
Fourth impact	Description of what the vehicle hit in the fourth impact in a sequence of events	x	x		
Hazardous material released	*		x		
Injured occupant age	*	x	x		
Injured occupant gender	*	x	x		
Injury body area	*	x			
Intersection classification	*	x			
License plate state	*		x		
Light Condition	*	x	x	x	x
Location of first harmful event	Indicates whether the first harmful event occurred on the roadside or on the roadway		x		
Median type	*	x	x		
Major cause	Indicates what the major cause for the accident was (e.g., failure to have control)	x	x		



<b>Variable</b>	<b>Description</b>	<b>1998-2000 Dataset</b>	<b>2001-2008 Dataset</b>	<b>Rollover Analysis</b>	<b>Injury Analysis</b>
Military time	*	X	X		
Month	*	X	X	X	X
Most damaged vehicle area	*		X		
Most harmful event	Indicates which event was the most harmful in a sequence of events		X		
Non-motorist action	Variable related to a non-vehicle occupant involved in the accident		X		
Non-motorist condition	Variable related to a non-vehicle occupant involved in the accident		X		
Non-motorist location	Variable related to a non-vehicle occupant involved in the accident		X		
Non-motorist safety equipment	Variable related to a non-vehicle occupant involved in the accident		X		
Non-motorist type	Variable related to a non-vehicle occupant involved in the accident		X		
# fatalities in the accident	*	X	X		
# injuries in the accident	*	X	X		
# lanes on bridge structure	*	X	X	X	X
# lanes under bridge structure	*	X	X		
# occupants involved in the accident	*	X	X		
# vehicle occupants	*	X	X	X	X
Number of vehicles involved in the accident	*	X	X	X	X
Occupant Injury severity	*	X	X		X

<b>Variable</b>	<b>Description</b>	<b>1998-2000 Dataset</b>	<b>2001-2008 Dataset</b>	<b>Rollover Analysis</b>	<b>Injury Analysis</b>
Other accident description	This variable was used to add additional relevant information from the accident narratives and/or diagrams	x	x		
Pedestrian action	Variable used when a pedestrian was involved	x			
Percent alcohol in the blood	*	x	x	x	x
Property damage cost	*	x	x		
Rail condition rating	*	x	x		
Rail type	Safety-shape or vertical	x	x	x	x
Vehicle repair cost	*				
Road class	*	x		x	x
Road contributing circumstances	Circumstances such as road surface condition and debris		x		
Roadway/environmental contributing circumstances	Circumstances such as weather conditions and roadway defect	x			
Road geometry	Information on horizontal and vertical alignment	x		x	x
Road surface condition	*	x	x	x	x
Road surface type	*	x		x	x
Rollover occurrence	Yes or no	x	x	x	x
Rollover Location	Whether rollover occurred on the roadway or on the roadside	x	x	x	
Route	*	x	x		
Route direction	*	x			
Road location	Rural or urban location	x		x	x

<b>Variable</b>	<b>Description</b>	<b>1998-2000 Dataset</b>	<b>2001-2008 Dataset</b>	<b>Rollover Analysis</b>	<b>Injury Analysis</b>
Second impact	Description of what the vehicle hit in the second impact in a sequence of events	x	x		
Side walk left (ft)	*	x	x		
Side walk right (ft)	*	x	x		
Sobriety Test	Indicates what test was used to verify alcohol consumption	x	x		
Speed limit	*	x	x	x	x
Structure flared	Indicates variation in bridge width	x	x	x	x
Third impact	Description of what the vehicle hit in the third impact in a sequence of events	x	x		
Traffic control	Present or not present	x	x	x	x
Traffic flow	One-way or two-way traffic flow	x		x	x
Traffic type	Indicates the number of lanes of the traffic way	x			
Trapped	Whether a vehicle occupant was trapped or not		x		x
Vehicle action	Indicates whether vehicle was going straight or making a maneuver	x	x	x	x
Vehicle damage severity	*	x	x		
Vehicle attachment	Describes the type of cargo body, if any, is attached to the vehicle (e.g., trailer).	x	x	x	x
Vehicle defect	Describes the vehicle defect, if any, that contributed to the accident (e.g., brakes, suspension, or steering)	x	x	x	x

<b>Variable</b>	<b>Description</b>	<b>1998-2000 Dataset</b>	<b>2001-2008 Dataset</b>	<b>Rollover Analysis</b>	<b>Injury Analysis</b>
Vehicle initial impact	Vehicle area that was first impacted (e.g., front, top, or rear)	x	x	x	x
Vehicle occupant protective device	*	x	x		x
Vehicle occupant seating position	*	x	x		
Vehicle special use	Police, Taxi, Fire, Ambulance, etc.	x			
Vehicle type	*	x	x	x	x
Vehicle travel direction	North, Northeast, Northwest, South, Southeast, Southwest, West, or East	x	x		
Vehicle year	*	x	x	x	x
Vision obscured	Indicates if driver's vision was obscured due to an obstacle	x	x	x	x
Weather Condition	*	x	x	x	x
Year of the accident	*	x	x		

### 5.1.1 Data Summary

In this section, all the variables listed in Table 9, which were used either in the rollover or in the injury analysis, have been summarized. Figure 12 shows the crash frequency distribution by year by rail type. The average annual number of crashes was found to be approximately 128 with the highest number of crashes occurring in year 2000 (i.e., 192) and the lowest number of crashes in years 2002, 2003, and 2004 (i.e., 114). There seems to be no trend of annual crash frequency by rail type except that there were a much larger number of crashes involving safety-shape rails in years 2006, 2007, and 2008. However, when all years are combined, the number of crashes by rail type appears to be almost even as shown in Table 10.

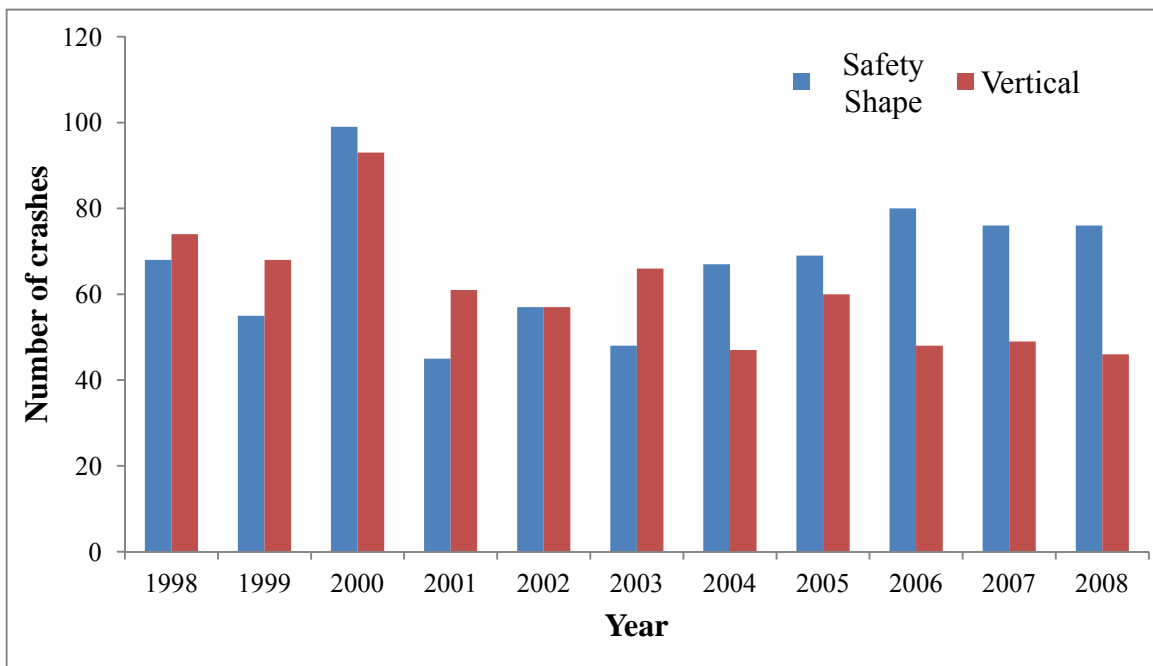

Figure 12. Crash Frequency Distribution By Year By Rail Type

Table 10. Crash Distribution By Rail Type

Rail Type	Number of Crashes	% of Total Crashes
Safety-shape	755	49.18
Vertical	780	50.81

Figure 13 shows the crash frequency distribution by annual average daily traffic by rail type. As can be seen, most crashes occurred on facilities with traffic volumes ranging from 1,000 to 30,000 vehicles per day. The figure shows that more crashes with safety-shape rail occurred on facilities with traffic volumes up to 10,000 vehicles per day and on facilities with very high traffic volumes (i.e., more than 50,000 vehicles per day).

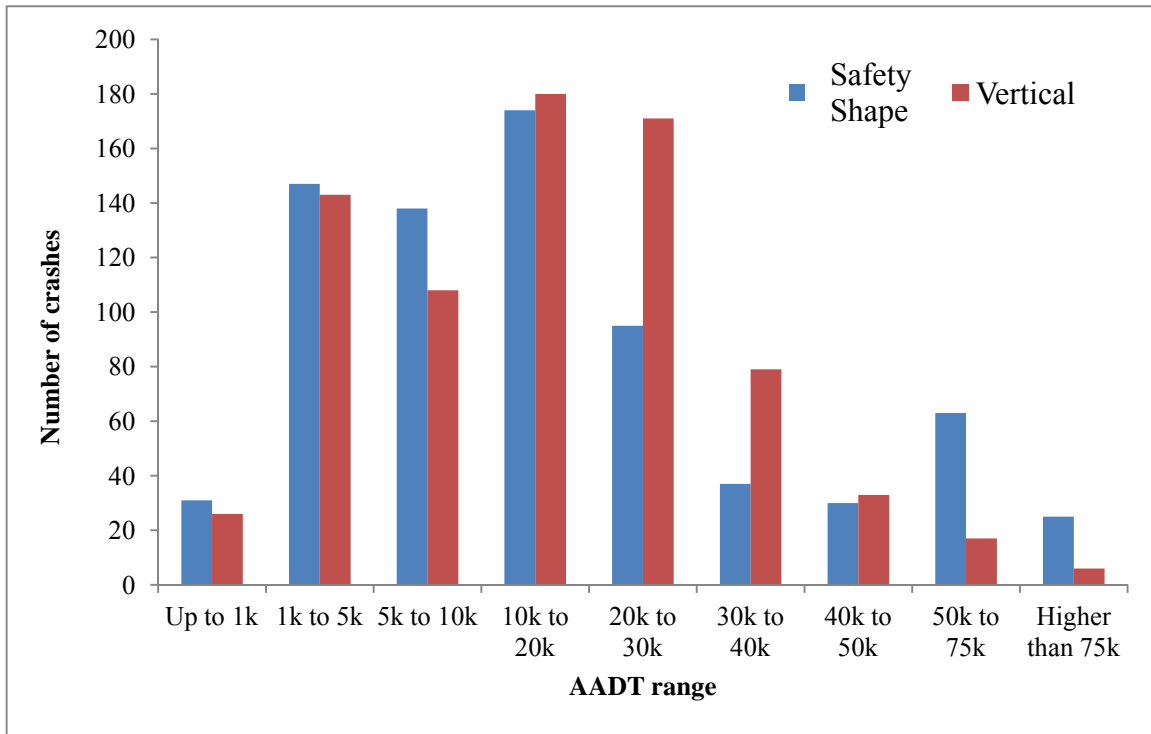

Figure 13. Crash Frequency Distribution by Annual Average Daily Traffic By Rail Type

Figure 14 shows that most crashes occurred on US and Interstate highways. Note that there were a much larger number of crashes involving vertical rails on Interstate highways. T-tests were used to investigate the speed limit differences among the three highway classes (i.e., State highways, US highways, Interstate highways, and Other) as shown in Table 11. Table 11 shows that all classes presented speed limits statistically different from each other, which mean that the highway classes present different characteristics. It was found that speed limits for Interstates are 5.43 mph (8.74 km/h) higher (i.e., p-value < 0.0001) than those for US highways

in average, speed limits for US highways are 4.67 mph (7.52 km/h) higher (i.e., p-value <0.0001) than those for IA highways in average, and speed limits for IA highways are 2.55 mph (4.10 km/h) higher (i.e., p-value = 0.04) than those for Other facilities (i.e., street, avenues, and ramps) in average.

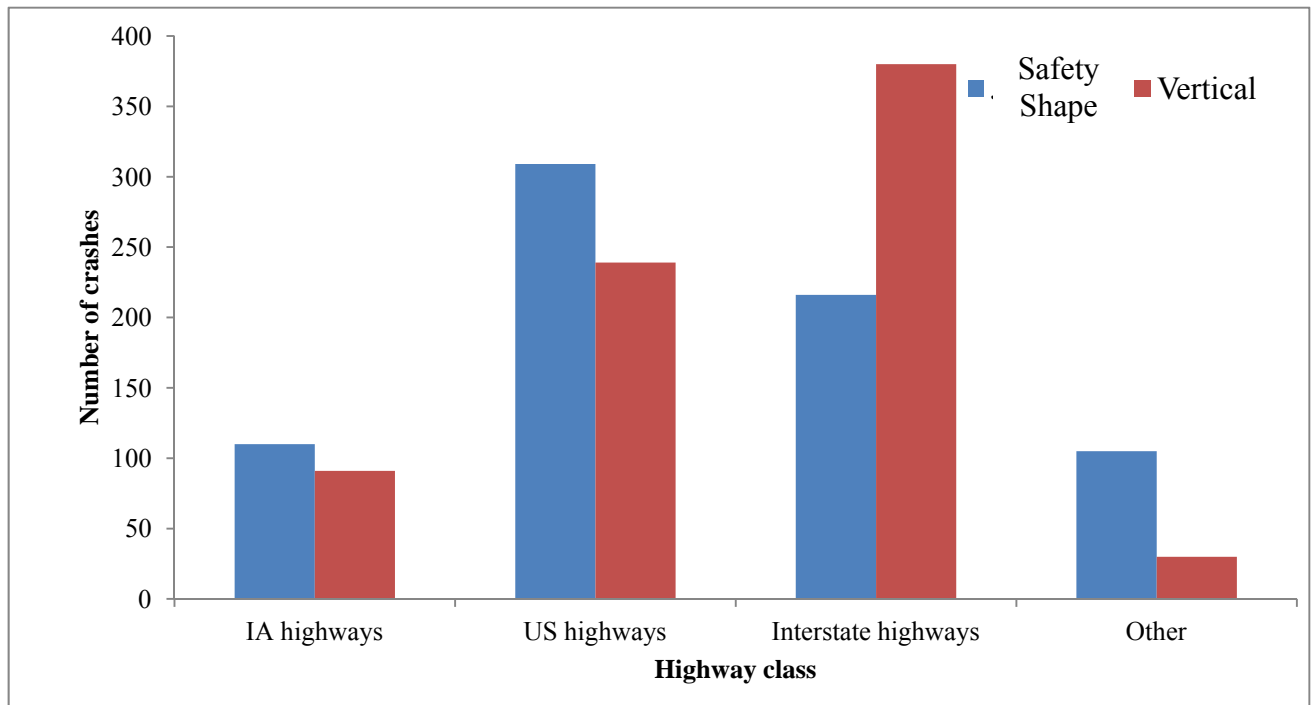

Figure 14. Crash Distribution by Facility by Rail Type

Table 11. Results From the T-Tests

GROUP 1	GROUP 2	P-value	Mean difference
Interstate	US	<0.0001	5.43
US	IA	<0.0001	4.67
IA	Other	0.04	2.55

Figure 15 shows the crash frequency distribution by bridge construction year by rail type. As can be seen, very few bridges included in this study were built before 1950, and the number of safety-shape rails on bridges built after 1980 is overwhelmingly higher than the number of vertical rails. This indicates that the use of vertical rails was discontinued after 1980s. Vertical rails were a retrofit design that was used to replace a box-aluminum bridge rail design. This

previous design was found to be inadequate based on two full-scale crash tests that were conducted to evaluate its safety performance. The rail caused a 1982 Honda Civic weighing 1,800 lb (816 kg) to rollover, and too much snagging occurred with a 1982 Cadillac Coupe Deville weighing 4,310 lb (1955 kg) [62].

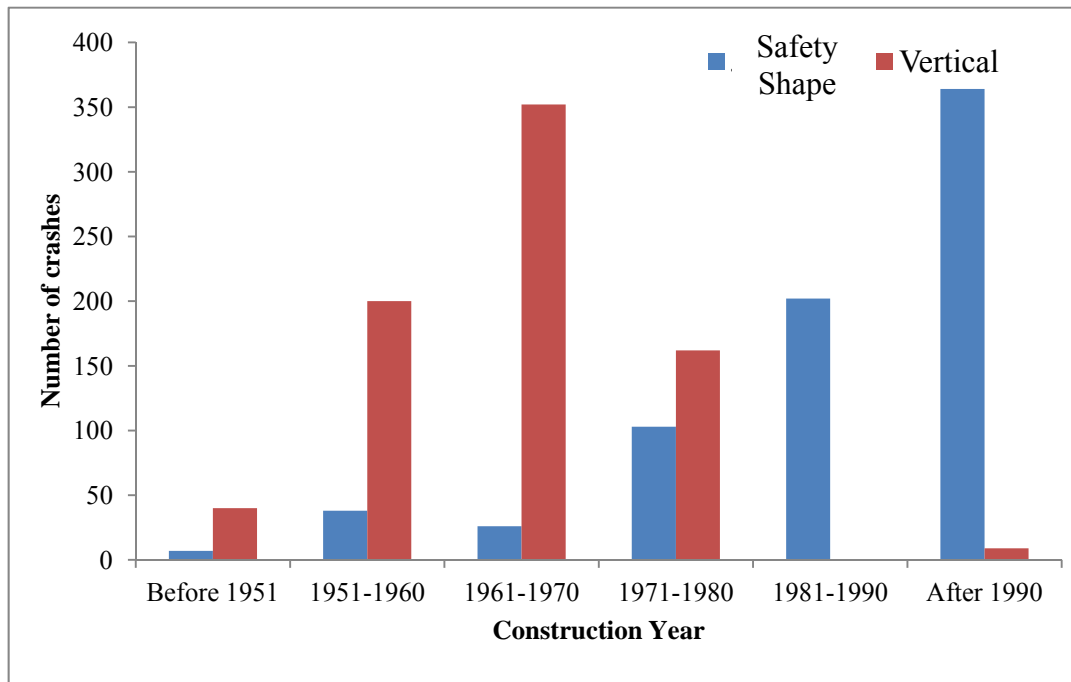

Figure 15. Crash Frequency Distribution By Bridge Construction Year By Rail Type

Figure 16 shows the crash frequency distribution by bridge length, in feet, by rail type. As can be seen, the majority of the bridges presented a length between 101 and 300 ft (30.8 and 91.4 m). Figure 16 also indicates that bridges longer than 400 ft (121.9 m) tended to have more safety-shape rails while bridges up to 200 ft (61.0 m) tended to have more vertical rails which mean that longer bridges appear to have safety-shape rails more often.



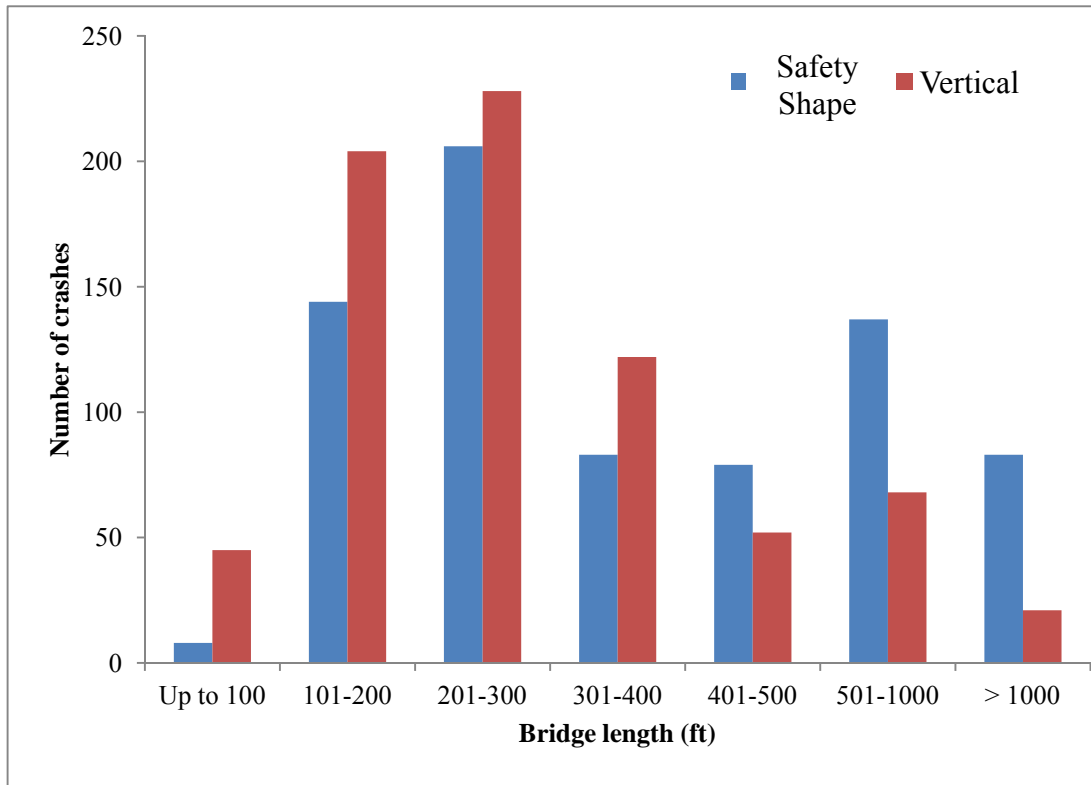

Figure 16. Crash Frequency Distribution By Bridge Length By Rail Type

Figure 17 shows the crash frequency distribution by bridge width, in feet, by rail type. As can be seen, the large majority of the bridges presented width between 30 and 50 ft (9.1 and 15.2 m). Figure 17 also indicates that bridges with safety-shape rails appeared to be wider than bridges with vertical rails.

Figure 18 shows the crash frequency distribution by speed limit and rail type. As can be seen, the majority of the crashes occurred on 60-70 mph (96.6-112.7 km/h) speed limit roads. The speed limit distribution for crashes involving safety-shape rails is very similar to the speed limit distribution for crashes involving vertical rails.

Figure 19 shows the crash frequency distribution by approach roadway width to the bridge by rail type. As can be seen, most approach roadway widths are between 31 and 50 ft (9.4 and 15.2 m) which match well with the bridge width distribution shown in Figure 17.

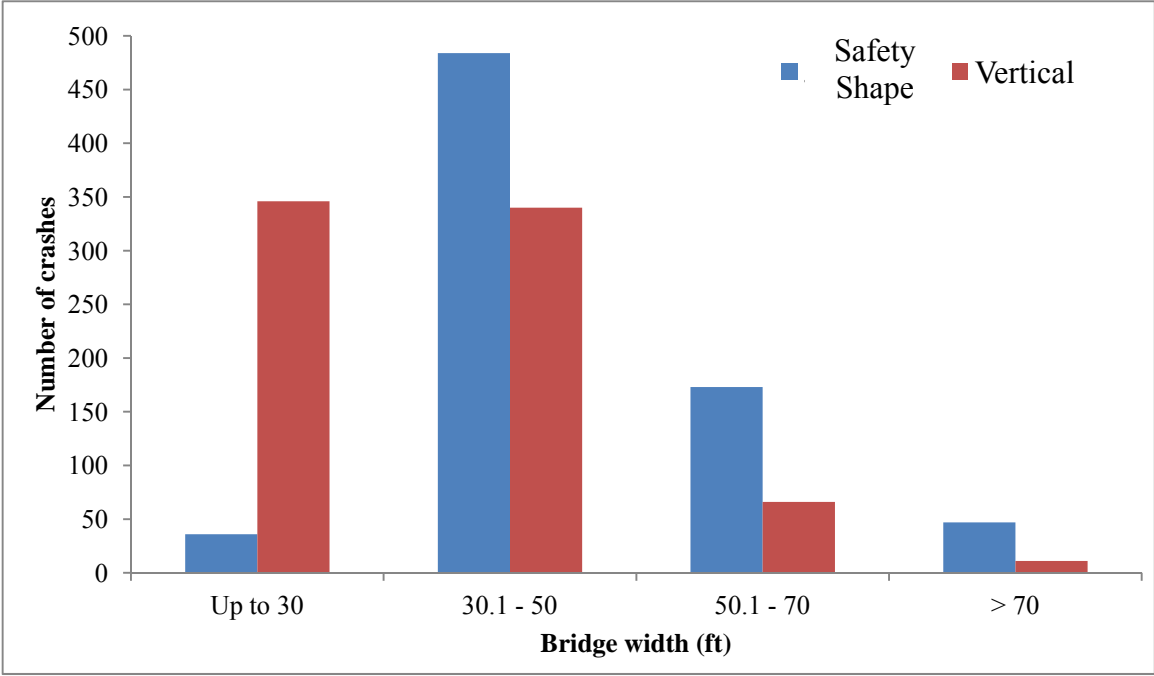

Figure 17. Crash Frequency Distribution By Bridge Width By Rail Type

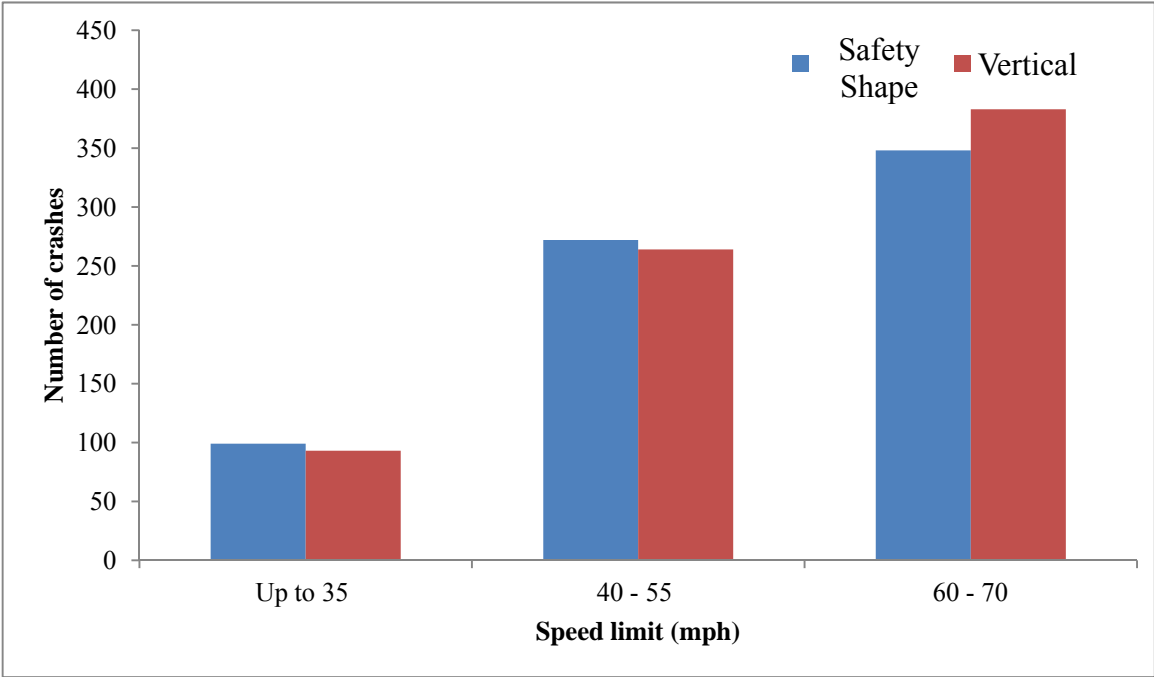

Figure 18. Crash Frequency Distribution By Speed Limit and Rail Type

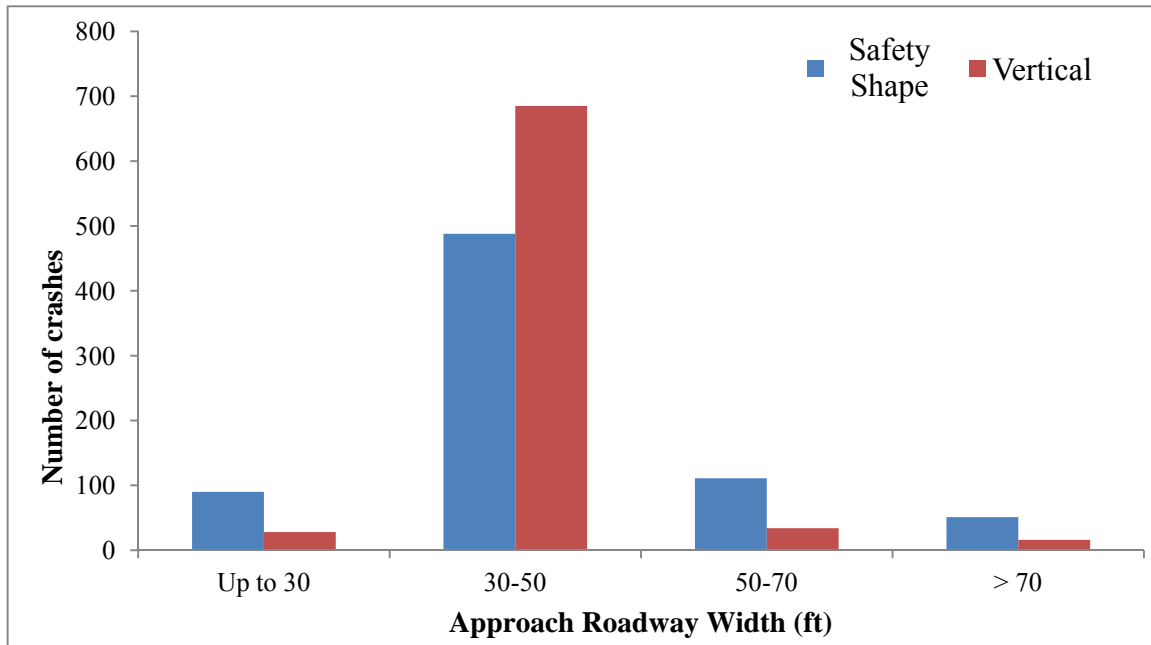

Figure 19. Crash Frequency Distribution By Approach Roadway Width By Rail Type

Table 12 shows that more than half (i.e., 65.27 percent) of the bridges containing a vertical concrete bridge rail are narrow bridges while less than half (i.e., 37.16 percent) of the bridges containing a safety-shape concrete bridge rail are narrow bridges. The American Association of State Highway and Transportation Officials has defined a narrow bridge as a bridge that has its width narrower than its approaching roadway width [39]. This difference between the number of narrow bridges containing these two rail types must be taken in consideration when evaluating the safety performance of these two rails since past research studies have shown that narrow bridges tend to increase both severity and frequency of bridge-related crashes [40,41].

Table 12. Narrow Bridge Distribution By Rail Type

	<b>Difference Between Bridge Width and Roadway Approach Width – ft (m)</b>	<b>#</b>	<b>% of Sub-total</b>	<b>% of Rail Type Total</b>
Safety-shape rail	<b>Negative (Bridge is a narrow bridge) Sub-total</b>	275		37.16
	0.1 – 2 (0.03 – 0.61)	121	44.00	
	2.1 – 4 (0.62 – 1.22)	72	26.18	
	4.1 – 10 (1.23 – 3.05)	54	19.64	
	> 10 (3.05)	28	10.18	
	<b>Positive (Bridge is not a narrow bridge) Sub-total</b>	240		32.43
	0.1 – 2 (0.03 – 0.61)	84	35.00	
	2.1 – 4 (0.62 – 1.22)	22	9.17	
	4.1 – 10 (1.23 – 3.05)	40	16.67	
	> 10 (3.05)	94	39.17	
	<b>Null (Bridge&amp; Roadway have same width)</b>	225		30.41
	Vertical rail	<b>Negative (Bridge is a narrow bridge) Sub-total</b>	498	
0.1 – 2 (0.03 – 0.61)		70	14.06	
2.1 – 4 (0.62 -1.22)		15	3.01	
4.1 – 10 (1.23 – 3.05)		188	37.75	
> 10 (3.05)		225	45.18	
<b>Positive (Bridge is not a narrow bridge) Sub-total</b>		122		15.99
0.1 – 2 (0.03 – 0.61)		63	51.64	
2.1 – 4 (0.62 – 1.22)		7	5.74	
4.1 – 10 (1.23 – 3.05)		28	22.95	
> 10 (3.05)		24	19.67	
<b>Null (Bridge&amp; Roadway have same width)</b>		143		28.65

Figure 20 shows the crash frequency distribution by number of traffic lanes by rail type. As can be seen, the large majority of crashes occurred on bridges with 2 traffic lanes.

Figure 21 shows the crash frequency distribution by road location by rail type. As can be seen, more crashes occurred on rural roads. This variable contains a reduced number of crashes because only the older datasets (i.e., from 1998 to 2000) contain this variable.

Figure 22 shows the crash frequency distribution by traffic flow by rail type. This variable also contains a reduced number of crashes because it is contained only in the older datasets. Figure 23 shows the crash frequency distribution by surface type by rail type. As can be seen, the large majority of the crashes occurred on roads with cement pavement. Surface type is

probably correlated to highway class and/or location. Rural interstates usually are cement paved and Figure 14 shows that most of the crashes occurred on Interstate highways. Figure 24 shows the crash frequency distribution by rail type and by whether the bridge is a flared structure or not. A flared structure is defined as the bridge that has varied width along its length. Figure 24 shows that most of the bridges are not flared.

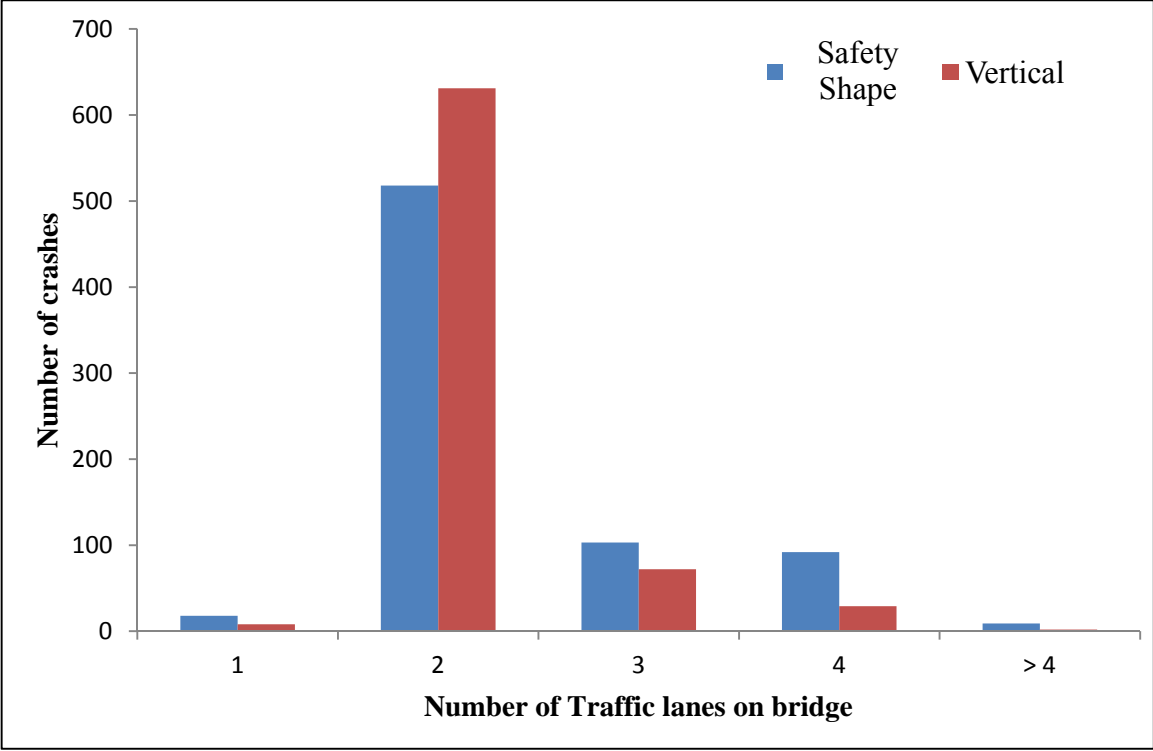

Figure 20. Crash Frequency Distribution By Number of Traffic Lanes

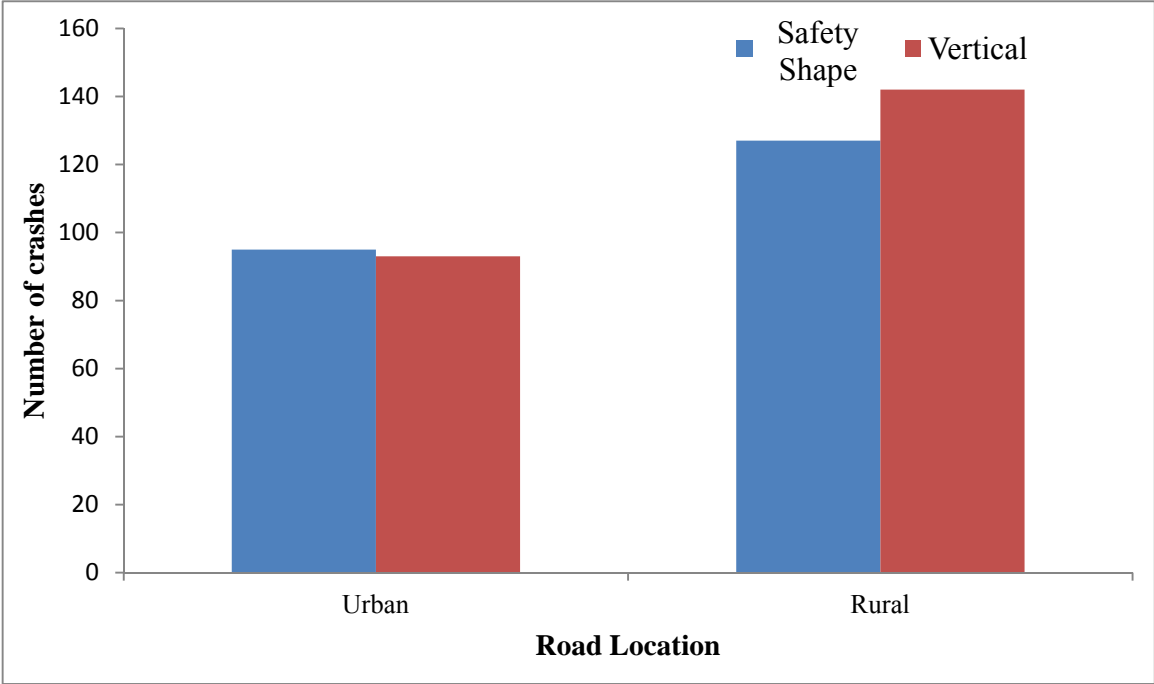

Figure 21. Crash Frequency Distribution By Road Location By Rail Type

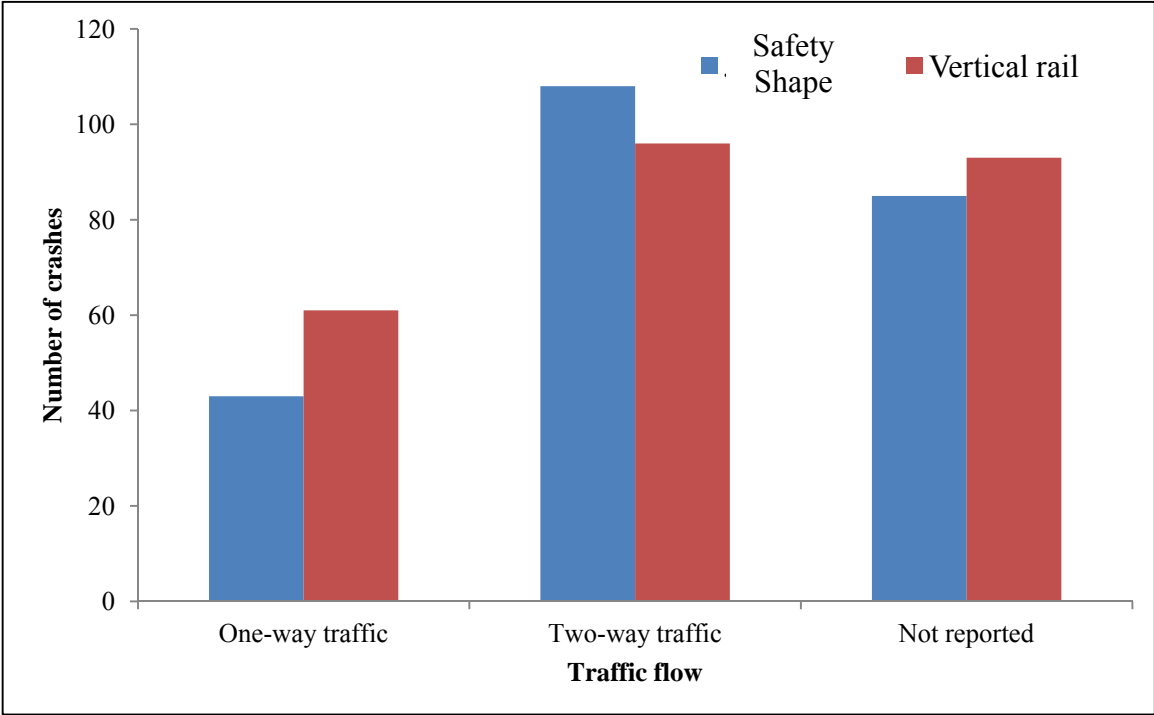

Figure 22. Crash Frequency Distribution By Traffic Flow By Rail Type

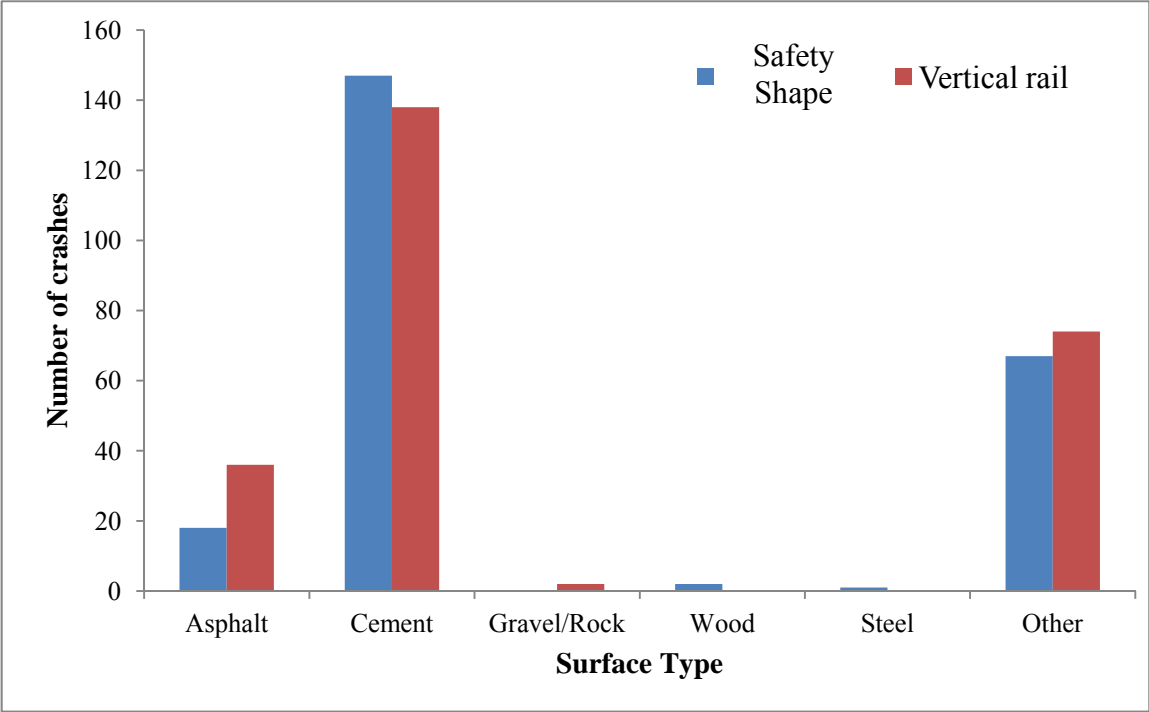

Figure 23. Crash Frequency Distribution By Surface Type By Rail Type

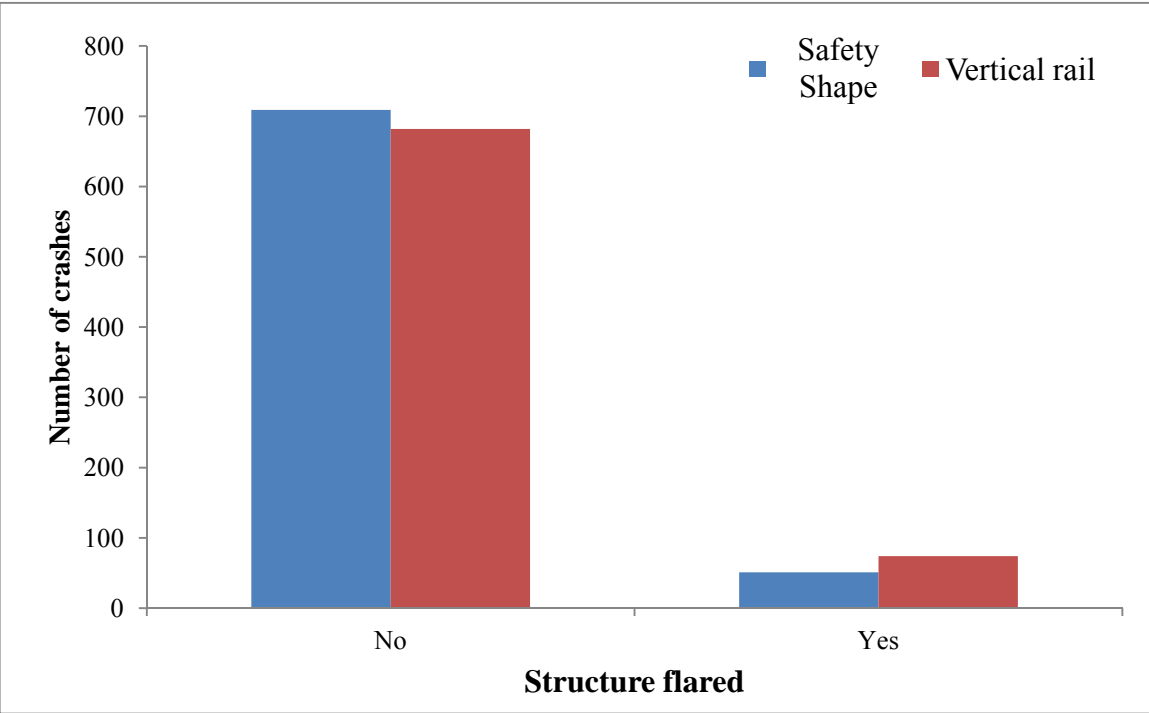

Figure 24. Crash Frequency Distribution By Rail Type By Flared Structure

Figures 25 and 26 show the crash frequency distribution by horizontal alignment by rail type and by vertical alignment by rail type, respectively. As can be seen, most crashes occurred on straight and level roads segments. These variables were included in the older datasets only.

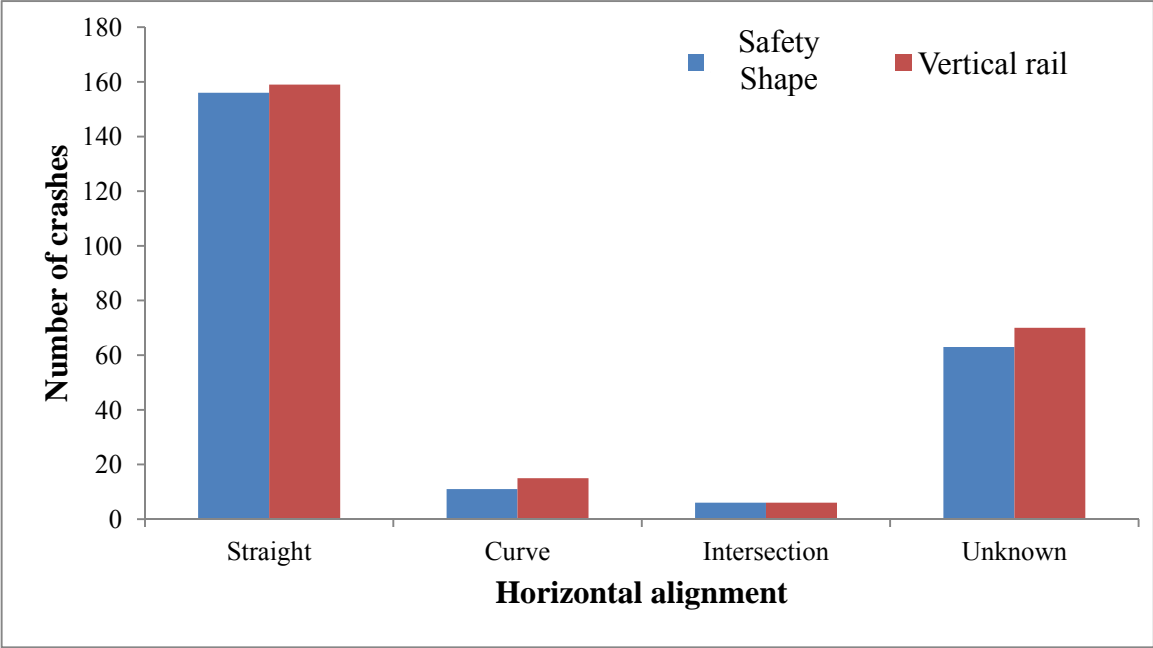

Figure 25. Crash Frequency Distribution By Horizontal Alignment By Rail Type

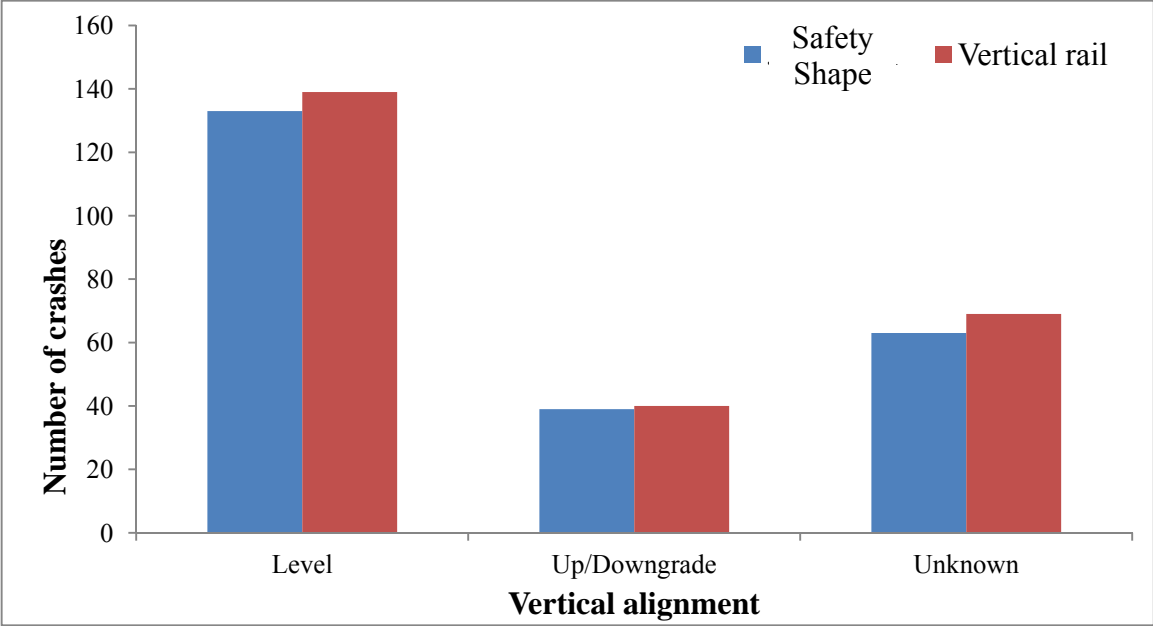

Figure 26. Crash Frequency Distribution By Vertical Alignment By Rail Type



Table 13 shows the crash frequency distribution by traffic control device by rail type.

Note that at least 90 percent of all crashes occurred on locations with no traffic control.

Table 13. Crash Distribution By Traffic Control Device By Rail Type

	<b>TRAFFIC CONTROL</b>	<b>#</b>	<b>% of Rail Type Total</b>
Safety-shape rail	No controls present	680	91.03
	Traffic signal	18	2.41
	Stop sign	2	0.27
	Yield sign	2	0.27
	No passing zone (marked)	10	1.34
	Warning sign	17	2.28
	Traffic director	1	0.13
	Workzone signs	2	0.27
	Other control	2	0.27
	Unknown/Not reported	13	1.74
Vertical rail	No controls present	713	94.19
	Traffic signal	3	0.40
	Stop sign	3	0.40
	Yield sign	5	0.66
	No passing zone (marked)	10	1.32
	Warning sign	8	1.06
	Traffic director	0	0.00
	Workzone signs	4	0.53
	Other control	1	0.13
	Unknown/Not reported	10	1.32

The past figures and tables have referred to highway and/or bridge elements. The next five figures and Table 14 refer to temporal and environmental related variables. Figure 27 shows the crash frequency distribution by crash day by rail type. As can be seen, there appears to be no trends, except that the number of crashes on either Saturday or Sunday (i.e., weekends) seemed to be higher than the number of crashes on week days. Figure 28 shows the crash frequency distribution by month by rail type. The figure appears to be a U-shaped plot with the number of crashes being higher in November, December, January, and February which are months that may present winter conditions (i.e., snow and ice). The fact that the number of crashes appears to be higher in winter months may be attributed to adverse driving conditions.

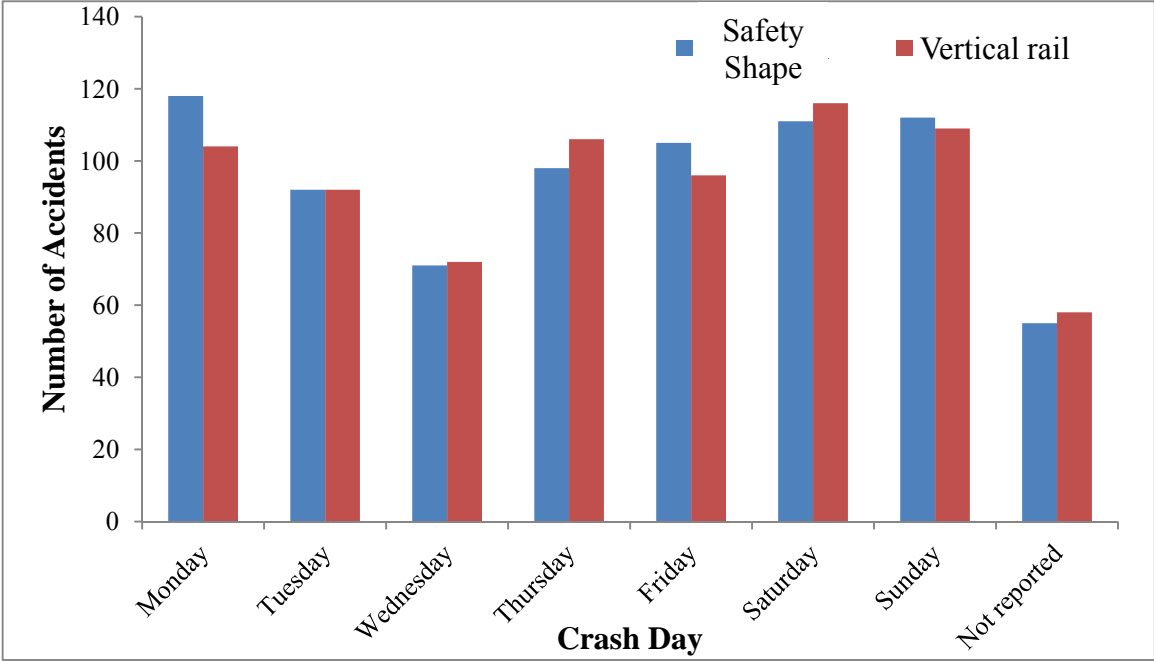

Figure 27. Crash Frequency Distribution By Crash Day By Rail Type

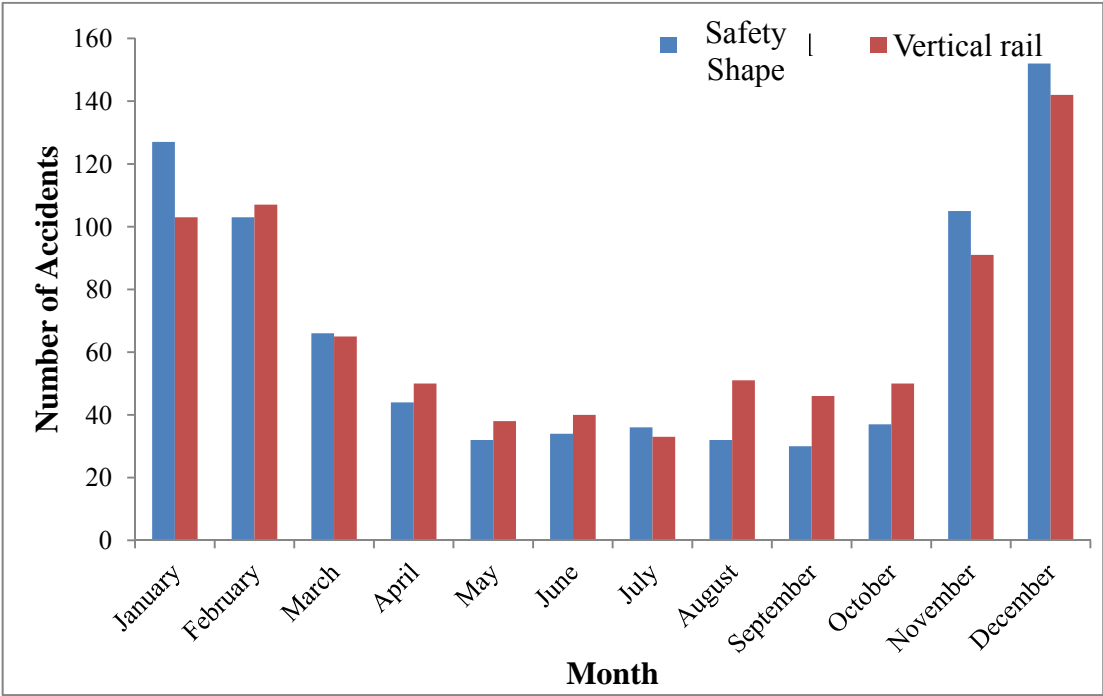

Figure 28. Crash Frequency Distribution By Month By Rail Type

Figure 29 shows the crash frequency distribution by weather condition by rail type. As can be seen, most crashes occurred on clear weather conditions followed by cloudy and snowy weather conditions.

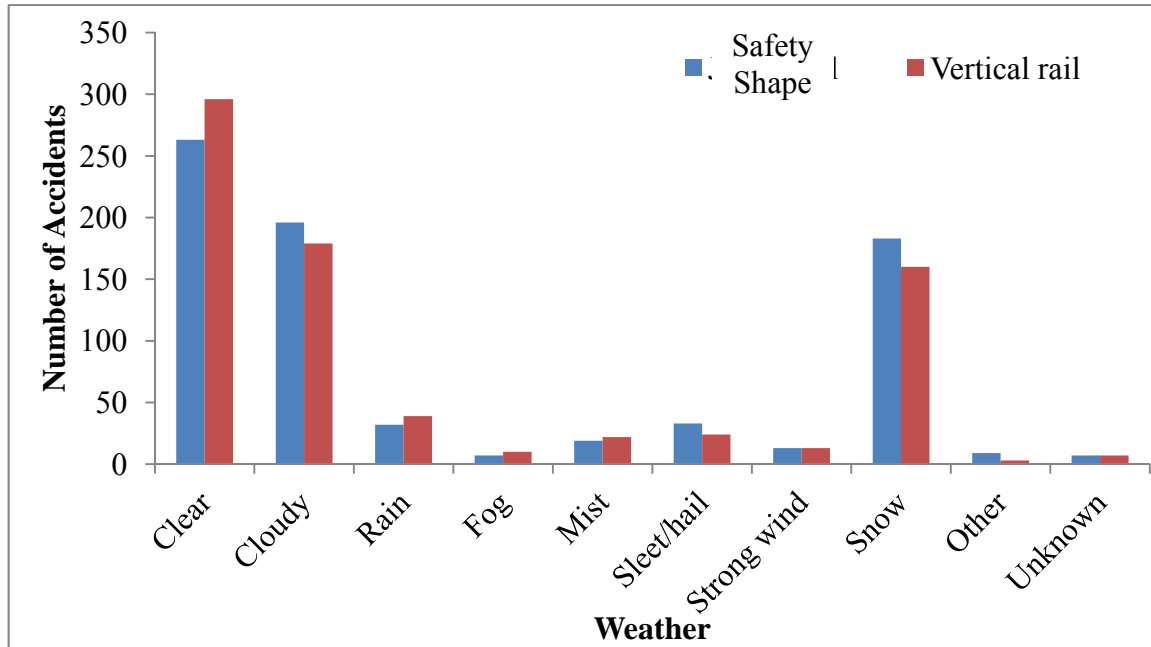

Figure 29. Crash Frequency Distribution By Surface Condition By Rail Type

Figure 30 shows the crash frequency distribution by light condition by rail type. As can be seen, most crashes occurred on daylight conditions. The dark-roadway not lighted conditions also presented a large number of crashes which may be indicative of crashes that occurred on rural locations. Table 14 indicates that at least 90 percent of the drivers involved in the crashes did not have their vision obscured which may also indicate the large number of crashes that occurred under clear weather condition as shown in Figure 29.

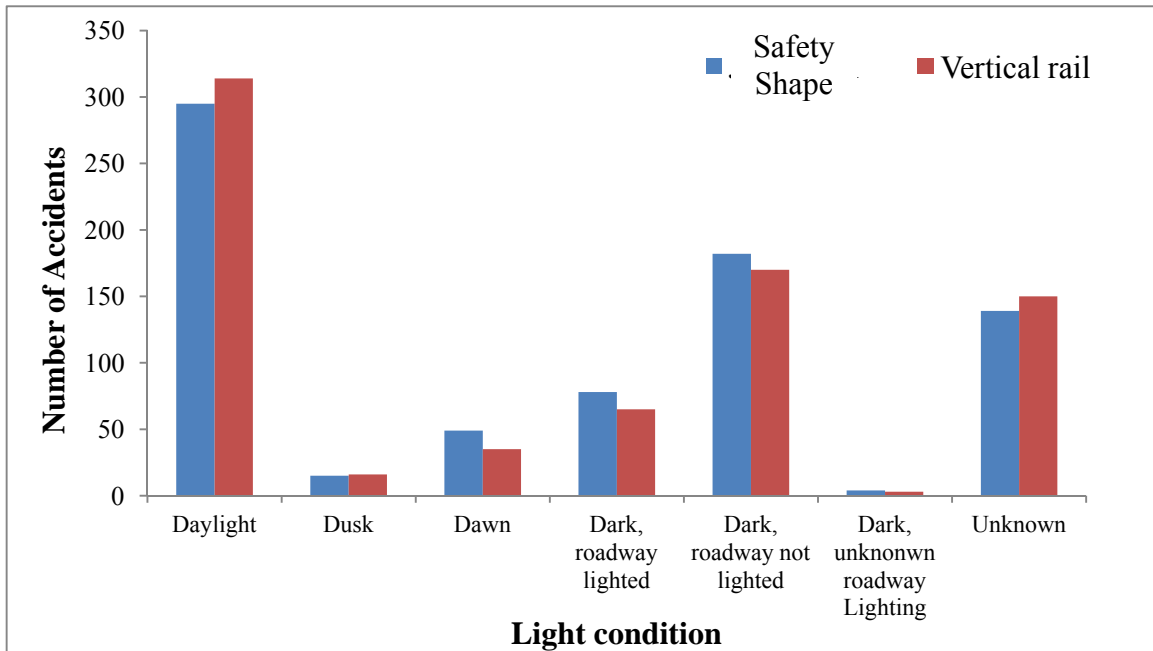

Figure 30. Crash Frequency Distribution By Light Condition By Rail Type

Table 14. Crash Frequency Distribution By Vision Condition By Rail Type

	Vision	#	% of Rail Type Total
Safety-shape rail	Not obscured	685	92.07
	Obscured	23	3.09
	Blowing snow	6	0.81
	Fog	1	0.13
	Other/Not reported	29	3.90
Vertical rail	Not obscured	691	90.92
	Obscured	22	2.89
	Blowing snow	11	1.45
	Fog	1	0.13
	Other/Not reported	35	4.61

Figure 31 shows the crash frequency distribution by surface condition by rail type. As can be seen, most crashes occurred on dry surface conditions followed by icy and snowy conditions. A greater number of crashes that occurred on dry surface conditions involved vertical rails. Safety-shape rails had a larger representation on crashes that occurred on icy surface conditions which may be due to the fact that there were more crashes with safety-shape rails during the months of November, December and January as shown in Figure 28.

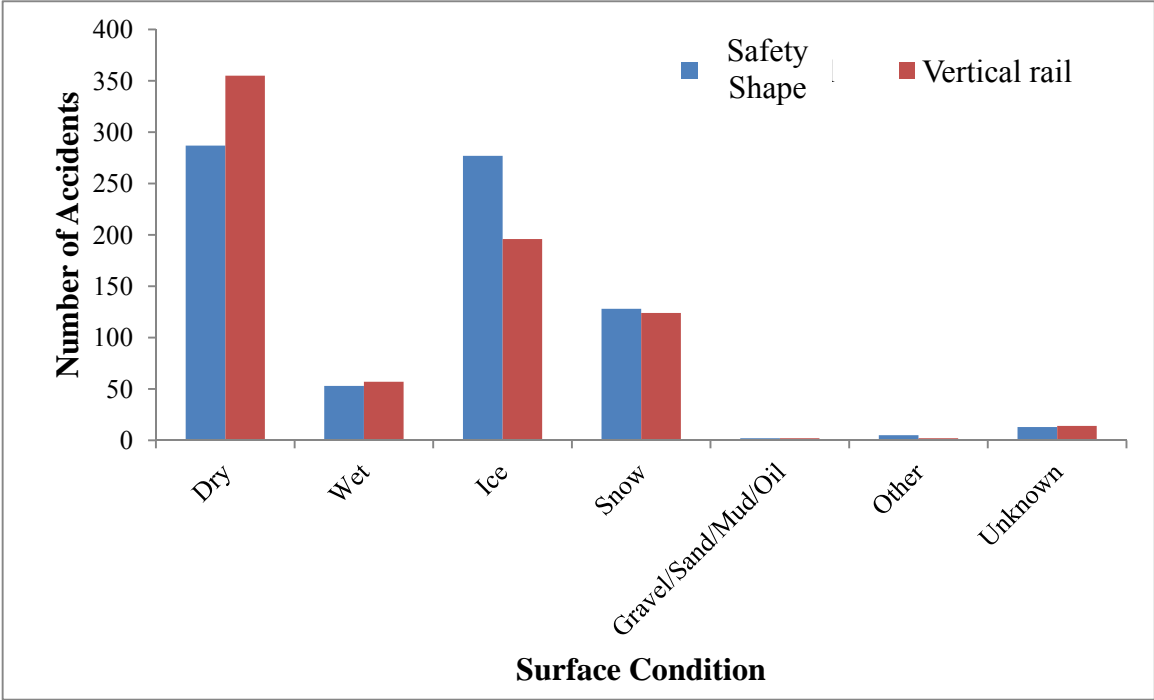

Figure 31. Crash Frequency Distribution By Surface Condition By Rail Type

Figures 32 through 35 show crash frequency distribution by vehicle related characteristics and by rail type. These figures show that most vehicles involved were passenger cars and had either one or two occupants. Figure 34 shows that most vehicles had their initial impact on the front. Figure 35 shows that the large majority of the crashes were single-vehicle collisions.

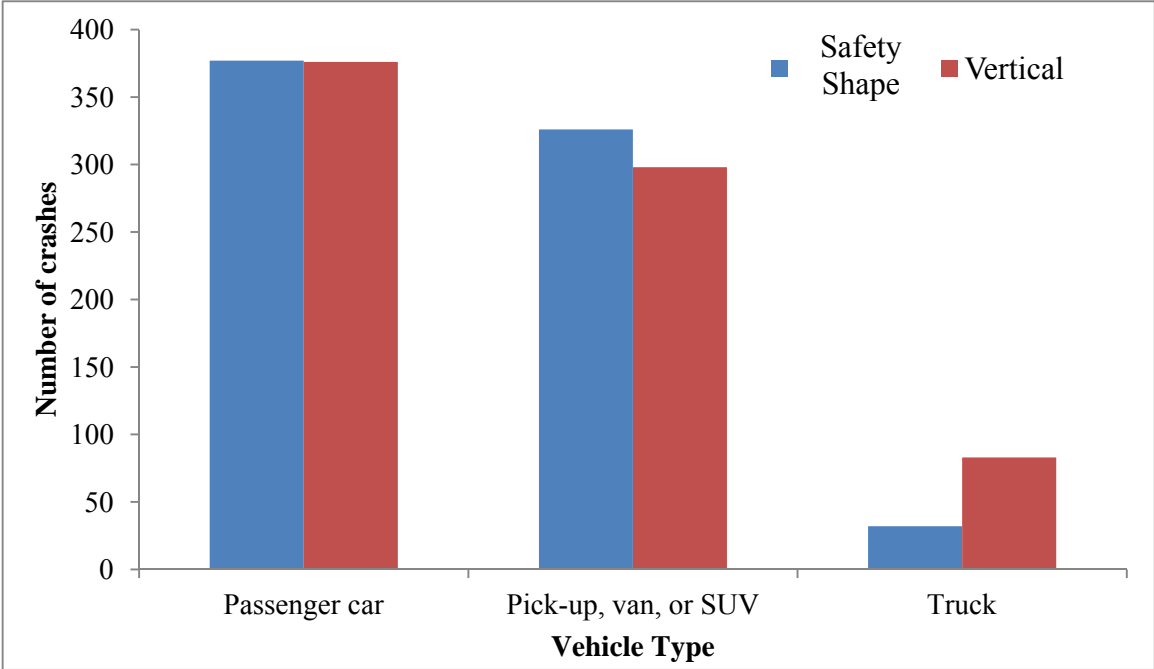

Figure 32. Crash Frequency Distribution By Vehicle Information By Rail Type

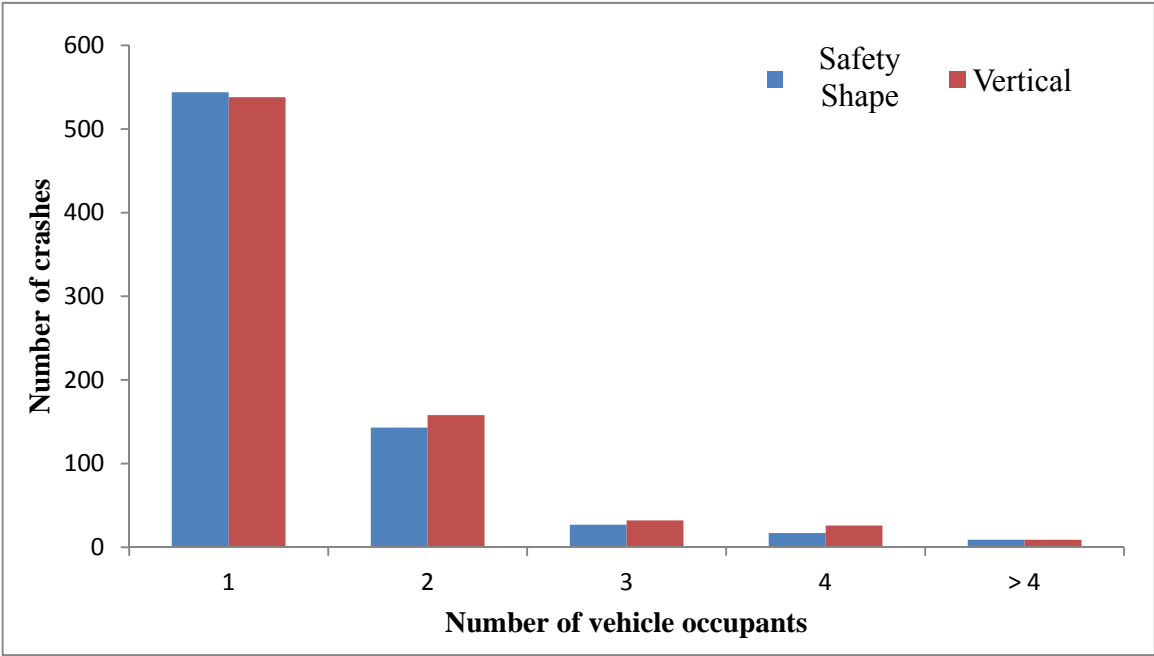

Figure 33. Crash Frequency Distribution By Number of Occupants Involved By Rail Type

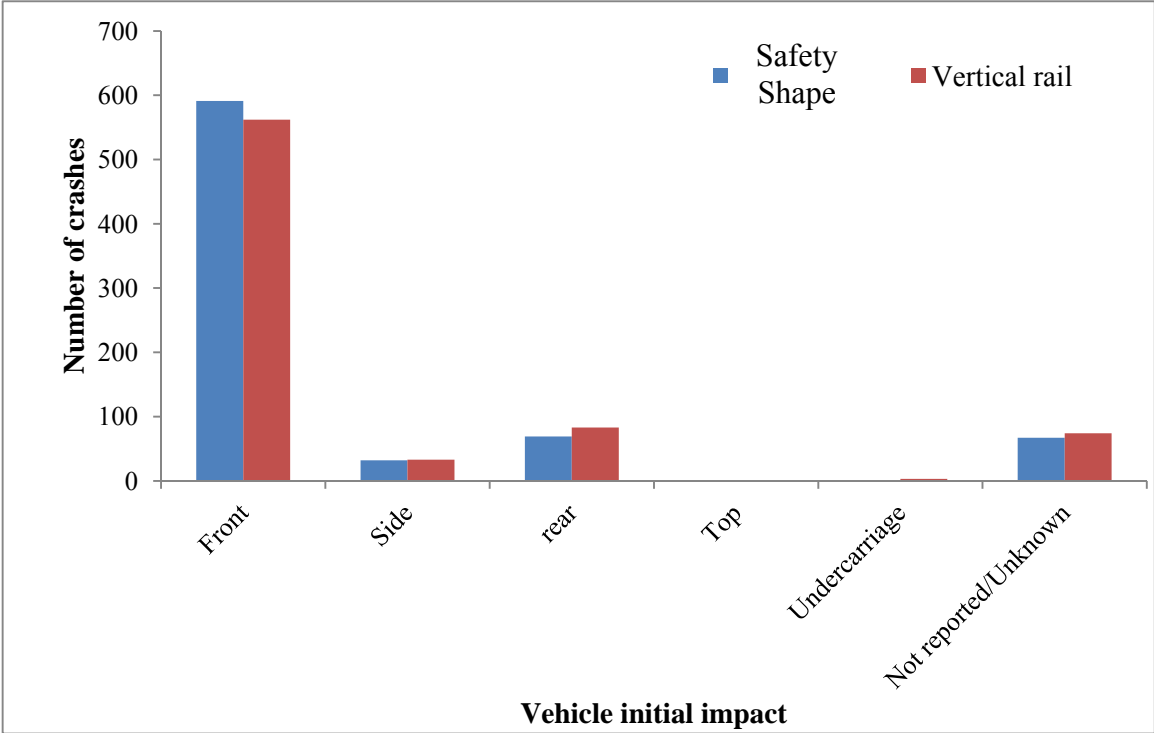

Figure 34. Crash Frequency Distribution By Vehicle Initial Impact Point By Rail Type

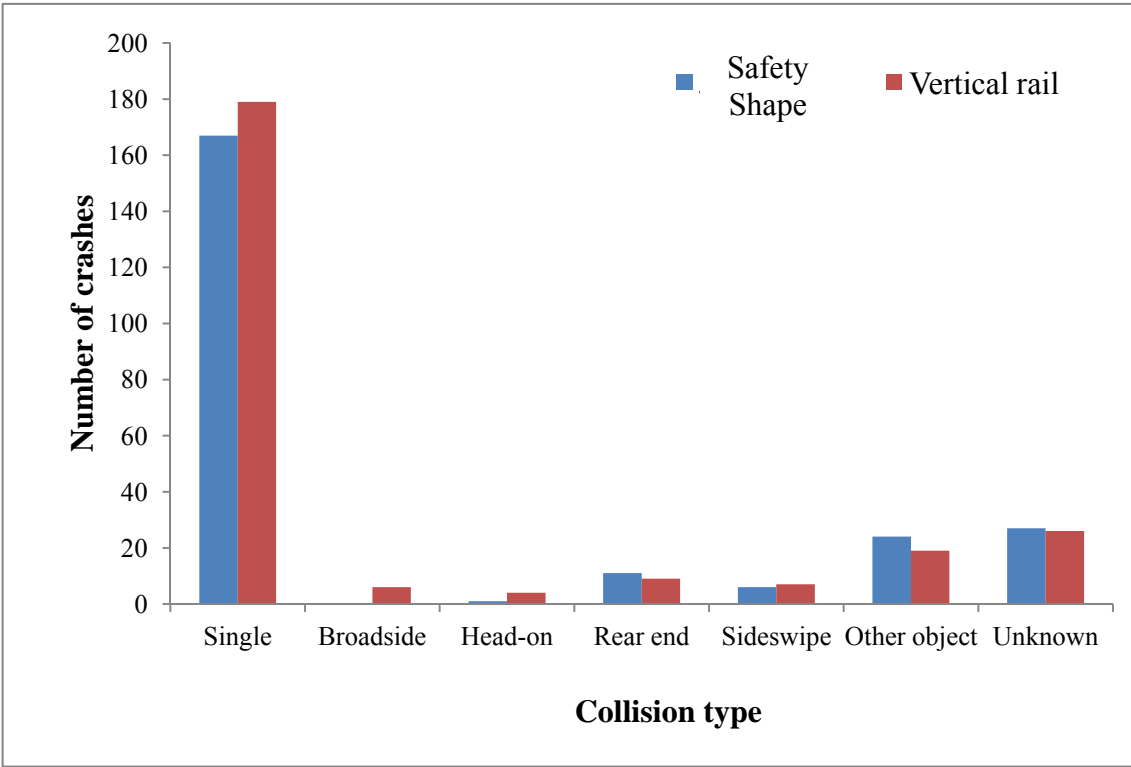

Figure 35. Crash Frequency Distribution By Collision Type By Rail Type

Tables 15 through 19 show the crash frequency distribution by vehicle defect, fire/explosion occurrence, vehicle maneuver, vehicle year, and vehicle attachment, respectively. Table 15 shows that almost 80 percent of the crashes were not caused by any vehicle defect. Tire blowout was the most common vehicle defect reported. Table 16 shows that there were 4 vehicles involved in fire and/or explosion between years 1998 and 2000. Table 17 shows that almost 90 percent of the vehicles were going straight when they were involved in a crash. Table 18 shows descriptive statistics for vehicle year while Table 19 shows that the majority (i.e., more than 80 percent) of the vehicles involved had no attachment to them.

Table 15. Crash Frequency Distribution By Vehicle Defect By Rail Type

	<b>Vehicle Defect</b>	<b>#</b>	<b>% of Rail Type Total</b>
Safety-shape rail	None	582	78.65
	Blowout	14	1.89
	Brakes	5	0.68
	Exhaust	1	0.14
	Steering	2	0.27
	Not reported	136	18.38
Vertical rail	None	622	78.24
	Blowout	31	3.90
	Brakes	2	0.25
	Exhaust	1	0.13
	Not reported	139	17.48

Table 16. Crash Frequency Distribution By Fire/Explosion Occurrence By Rail Type

	<b>Fire/Explosion</b>	<b>#</b>
Safety-shape rail	Yes	2
	No	192
Vertical rail	Yes	2
	No	204



Table 17. Crash Frequency Distribution By Maneuver Type By Rail Type

	<b>Maneuver</b>	<b>#</b>	<b>% of Rail Type Total</b>
Safety-shape rail	Backing	3	0.45
	Changing lanes	10	1.49
	Entering traffic lanes	8	1.19
	Going straight	599	89.14
	Making U-turning	5	0.74
	Overtaking/passing	9	1.34
	Slowing/stopping	9	1.34
	Turning left	7	1.04
	Turning right	3	0.45
	Other/Not reported	19	2.83
Vertical rail	Backing	2	0.24
	Changing lanes	22	2.64
	Entering traffic lanes	7	0.84
	Going straight	725	87.14
	Making U-turning	5	0.60
	Overtaking/passing	15	1.80
	Slowing/stopping	9	1.08
	Turning left	12	1.44
	Turning right	5	0.60
	Other/Not reported	30	3.61

Table 18. Descriptive Statistics For Vehicle Year

Safety-shape rail	<b>Minimum</b>	<b>Maximum</b>	<b>Average</b>	<b>Mode</b>	<b>90th Percentile</b>
	1903	2008	1996	1999	2002
Vertical rail	<b>Minimum</b>	<b>Maximum</b>	<b>Average</b>	<b>Mode</b>	<b>90th Percentile</b>
	1903	2008	1996	1999	2003

Table 19. Crash Frequency Distribution By Vehicle Attachment By Rail Type

	<b>Vehicle Attachment</b>	<b>#</b>	<b>% of Rail Type Total</b>
Safety-shape rail	None	657	88.78
	Trailer-type	14	1.89
	Truck-type	17	2.30
	Not reported/Unknown	52	7.03
Vertical rail	None	622	81.41
	Trailer-type	20	2.62
	Truck-type	61	7.98
	Not reported/Unknown	61	7.98

Table 20 and Figure 36 contain driver age information. As shown in Table 20, the mean driver age was found to be 36 years old. Figure 36 shows that most drivers were between 26 and 65 years old.

Table 20. Descriptive Statistics for Driver Age

Minimum	Maximum	Mean	Mode	90th Percentile
13	94	36	20	59

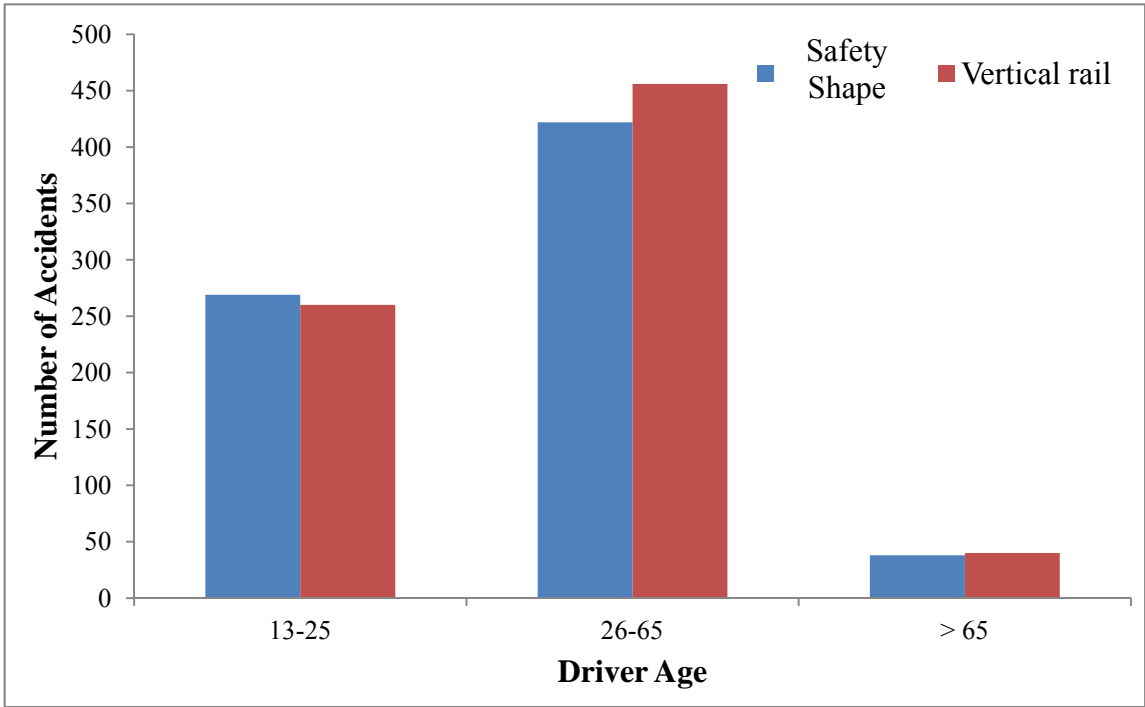

Figure 36. Crash Frequency Distribution By Driver Age By Rail Type

Figure 37 shows that there were more male than female drivers. More female drivers were involved in crashes with safety-shape rails while more male drivers were involved in crashes with vertical rails. Figure 38 shows that the large majority of the drivers were under normal condition.

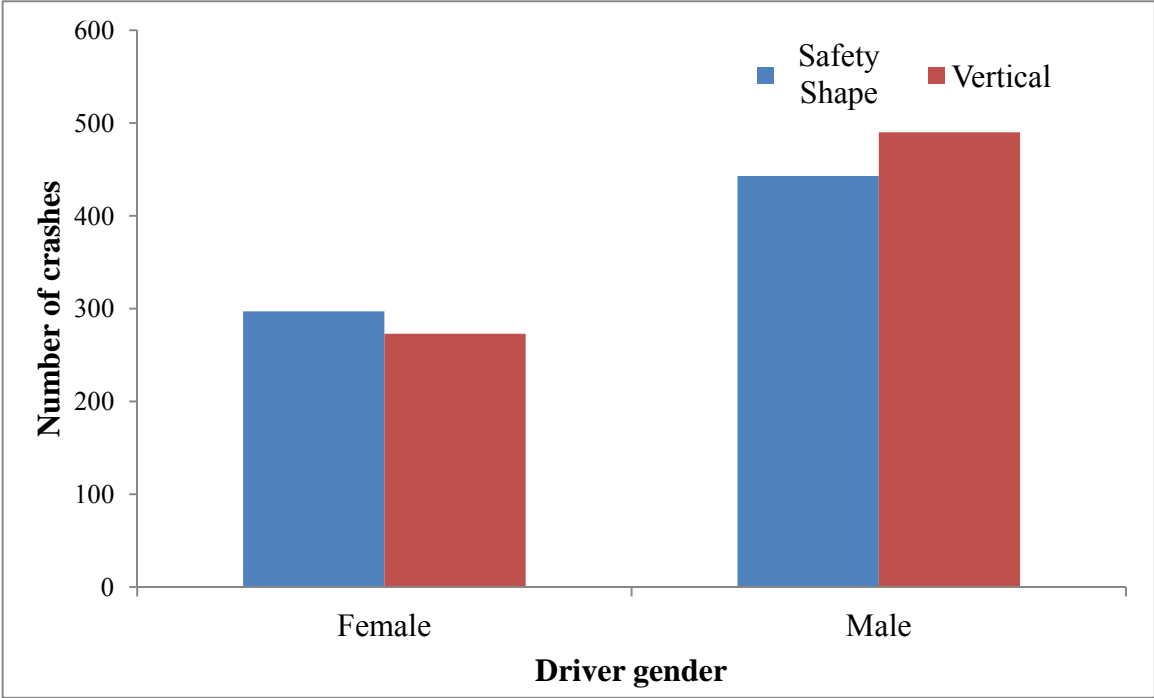

Figure 37. Crash Frequency Distribution By Driver Gender By Rail Type

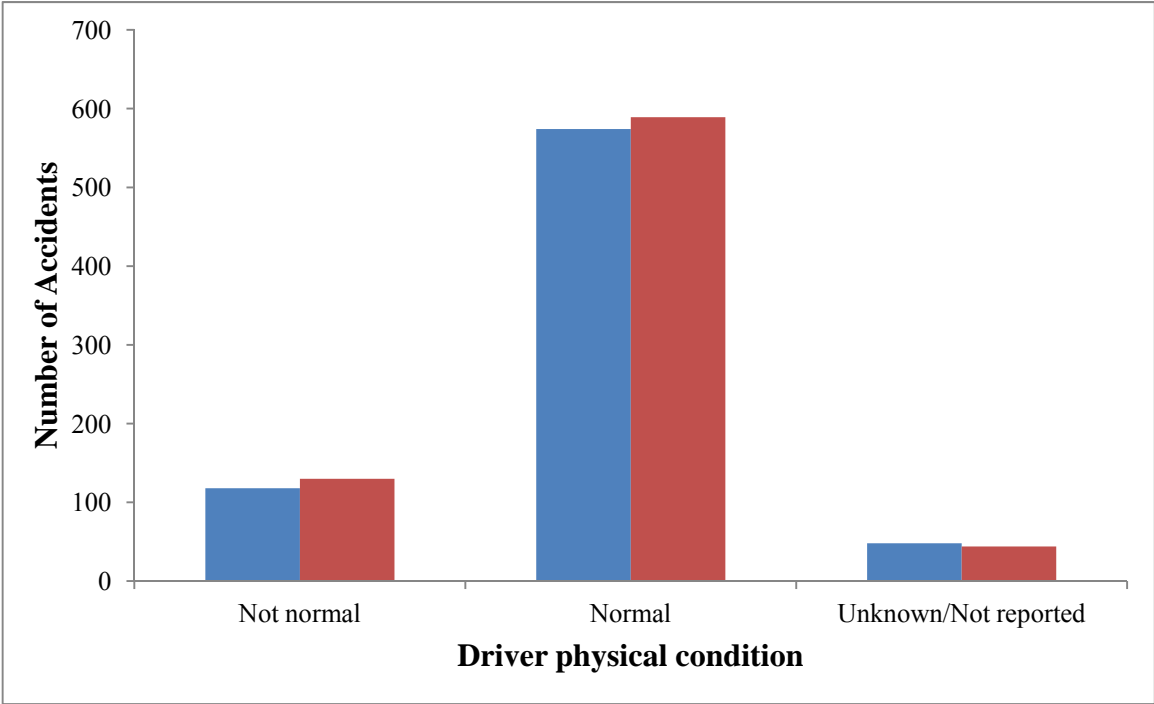

Figure 38. Crash Frequency Distribution By Driver Physical Condition By Rail Type

Table 21 shows that 55 drivers (i.e., 3.65 percent) were found to have consumed more alcohol than the legal tolerance which is 0.08 percent of alcohol in the blood stream.

Table 21. Crash Frequency Distribution By Alcohol Consumption By Rail Type

	Blood Alcohol Content (BAC)	#	% of Rail Type Total
Safety-shape rail	Up to 0.08%	717	96.76
	Greater than 0.08%	24	3.24
Vertical rail	Up to 0.08%	732	95.94
	Greater than 0.08%	31	4.06

Figure 39 shows the injury severity distribution by rail type. As can be seen, most crashes involved no injury.

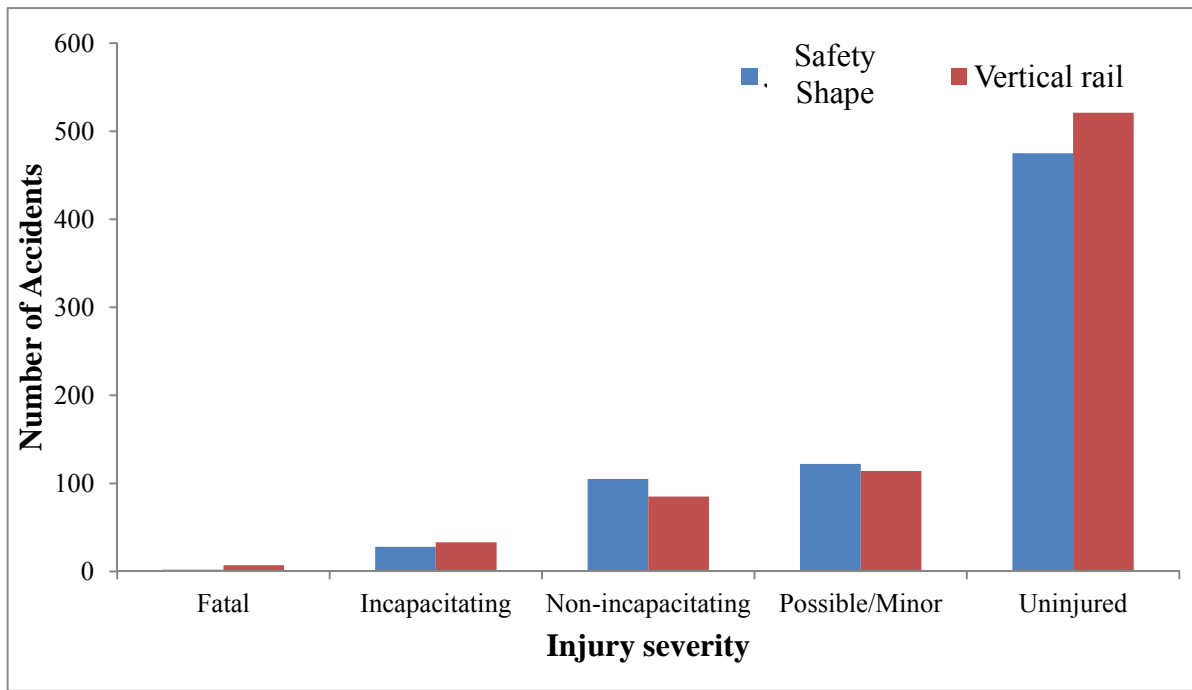

Figure 39. Crash Frequency Distribution By Injury Severity By Rail Type

Table 22 shows the distribution of rollover crashes by rail type. As can be seen, rollovers were involved more often (i.e., 5.70 versus 4.75 percent) with safety-shape rails.

Table 22. Crash Frequency Distribution By Rollover Occurrence By Rail Type

	Rollover	#	% of Rail Type Total
Safety-shape rail	Yes	43	5.70
	No	712	94.30
Vertical rail	Yes	37	4.75
	No	743	95.25

Table 23 shows the seat belt distribution by rail type. As can be seen, the distributions are similar which means that there appears to be no significant difference in seat belt use between crashes involving safety-shape rails and crashes involving vertical rails. Table 24 shows the crash frequency distribution by ejection by rail type. As can be seen, a higher percent of the drivers were ejected in crashes involving safety-shape rails. Table 25 shows the crash frequency distribution by rail type and by whether driver was trapped. As can be seen, the percent of drivers that were trapped when the crash involved a safety-shape rail (i.e., 3.17 percent) was almost the double of the percent of drivers that were trapped when the crash involved a vertical rail (i.e., 1.88 percent).

Table 23. Crash Frequency Distribution By Seat Belt Use By Rail Type

	<b>Seat belt use</b>	<b>#</b>	<b>% of Rail Type Total</b>
Safety-shape rail	None	27	4.75
	Lap and shoulder belt	339	59.68
	Shoulder belt only	46	8.10
	Lap belt only	2	0.35
	Not reported/Unknown	154	27.11
Vertical rail	None	33	5.77
	Lap and shoulder belt	339	59.26
	Shoulder belt only	46	8.04
	Lap belt only	3	0.52
	Not reported/Unknown	151	26.41

Table 24. Crash Frequency Distribution By Ejection Status By Rail Type

	<b>Ejection</b>	<b>#</b>	<b>% of Rail Type Total</b>
Safety-shape rail	Not ejected	659	84.49
	Partially ejected	2	0.26
	Totally ejected	5	0.64
	Not reported/Unknown	114	14.61
Vertical rail	Not ejected	642	85.03
	Partially ejected	1	0.13
	Totally ejected	1	0.13
	Not reported/Unknown	111	14.71

Table 25. Crash Frequency Distribution By Rail Type

	<b>Trapped</b>	<b>#</b>	<b>% of Rail Type Total</b>
Safety-shape rail	Not trapped	532	84.44
	Trapped	20	3.17
	Not reported	78	12.38
Vertical rail	Not trapped	530	83.33
	Trapped	12	1.88
	Not reported	94	14.79

Figure 40 shows the crash frequency distribution by airbag deployment status by rail type. As can be seen, the number of crashes that caused the airbag to deploy was fewer than the number of crashes that did not cause airbag deployment. This can be attributed to the fact that airbag deployment occurs more often when the crash is more severe. However, as shown in Figure 39, the number of severe crashes is much smaller than the number of non-severe crashes.

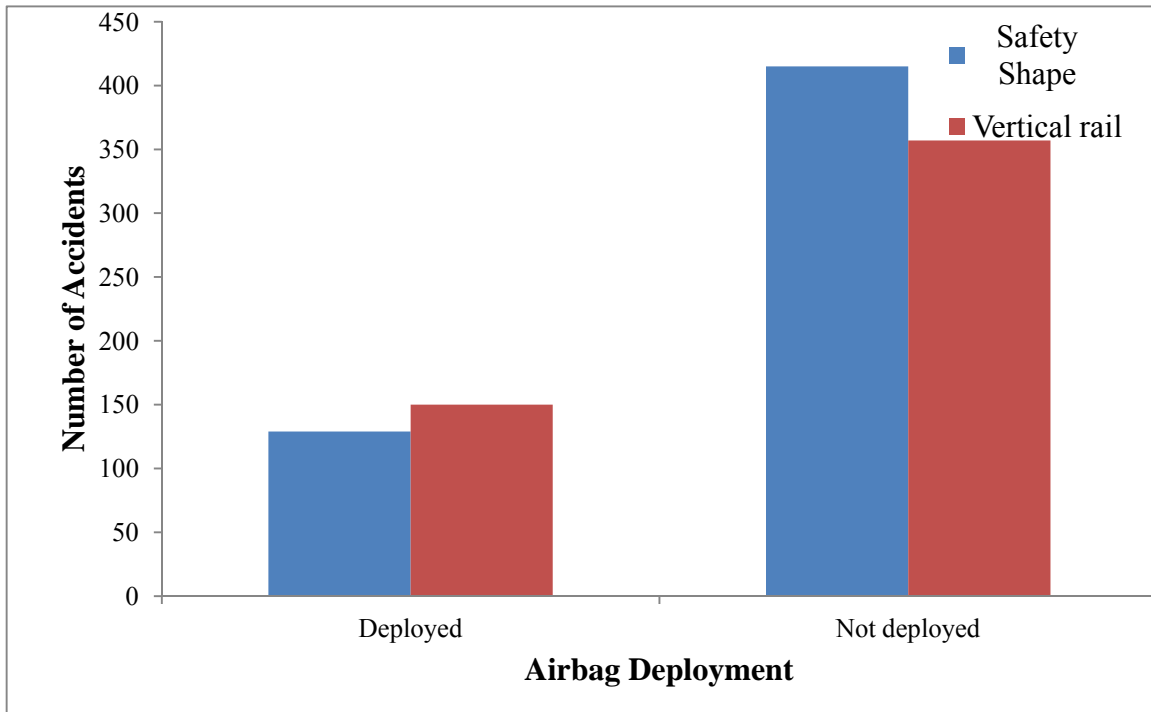

Figure 40. Crash Frequency Distribution By Airbag Deployment Status By Rail Type

### 5.3 Data Coding

This section provides the coding scheme used in the statistical analyses (i.e., rollover analysis and injury analysis) described in the next two chapters. As mentioned in the previous chapter (i.e., Modeling Approach), logistic regression has been used in both rollover and injury analyses. In the rollover analysis, logit models are used to identify variables that significantly contribute to rollover occurrence as well as to identify which concrete bridge rail (i.e., whether vertical or safety-shape rail) tends to increase rollover propensity. Many predictor variables used are nominal or ordinal variables, while few of them are continuous variables. Nominal variables are variables that do not have ordered categories. These variables were coded as binary variables. Even though reducing nominal variables with more than 2 categories to binary variables may lead to information loss, this is needed if these variables may not be coded as ordinal variables. Logistic regression can work with ordinal and continuous variables, and if nominal variables with more than two categories are to be used, they must be reduced to binary variables.

Table 26 shows how the variables were coded. If the variable was a continuous variable, no change was needed. However, if the variable was a nominal variable, the variable was coded as a binary variable. Also, note that only variables that were considered to be relevant to the objectives of this study were listed below. That is, not all variables listed in Table 9 are included in Table 26. In addition, if the total number of records shown in Table 26 for each variable does not match the total number of accidents used (i.e., 1,535), the lacking number of records were either coded as not reported or unknown. There are also variables that were included either in the older dataset only or in the newer dataset only which may cause the number of records to be reduced.

Table 26. List of Variables Included in the Analyses

Variable	Coding	#	%
Airbag deployment	Not Deployed = 0	544	48.75
	Deployed = 1	572	51.25
Annual average daily traffic	Continuous	*	*
Bridge construction year	Continuous	*	*
Bridge length (ft)	Continuous	*	*
Bridge width (ft)	Continuous	*	*
Collision type	Single-vehicle collision = 0	329	90.38
	Multiple-vehicle collision = 1	35	9.62
Day	Daylight = 0	1045	69.53
	Otherwise = 1	458	30.47
Driver age	Continuous	*	*
Driver gender	Female = 0	570	38.70
	Male = 1	903	61.30
Driver physical condition	Normal = 0	1163	79.28
	Not normal = 1	304	20.72
Ejection	Not ejected = 0	922	98.82
	Ejected = 1	11	1.18
Fire/explosion	No fire and/or explosion = 0	396	99.00
	Fire and/or explosion = 1	4	1.00
Facility	IA highways = 0	202	13.43
	US highways = 1	548	36.44
	Interstate highways = 2	596	39.63
	Other = 3	158	10.51
Injury severity	Uninjured = 1	996	66.80
	Minor/Possible = 2	236	15.83
	Non-incapacitating = 3	190	12.74
	Incapacitating = 4	61	4.09
	Fatal = 5	8	0.54
Intersection/Interchange	No = 0	360	79.65
	Yes = 1	92	20.35
Light	Daylight = 0	702	51.20
	Otherwise = 1	669	48.80
Month	Non-winter month = 0	702	46.71
	Winter Month (December through March) = 1	801	53.29
# of traffic lanes on bridge	Continuous variable	*	*
# vehicle occupants	Continuous variable	*	*
BAC	Up to 0.08%	1448	96.34
	Greater than 0.08%	55	3.66



<b>Variable</b>	<b>Coding</b>	<b>#</b>	<b>%</b>
Rail type	Safety-shape rail = 0	740	49.23
	Vertical Rail = 1	763	50.77
Horizontal alignment	Straight = 0	296	92.50
	Not straight = 1	24	7.50
Vertical alignment	Level = 0	253	76.20
	Not level = 1	79	23.80
Rollover occurrence	No = 0	1455	94.78
	Yes = 1	80	5.22
Rural or urban location	Urban = 0	188	41.22
	Rural = 1	268	58.78
Speed limit	5 - 35 mph = 0	192	13.16
	40 - 55 mph = 1	536	36.74
	60 - 70 mph = 2	731	50.10
Structure flared	No = 0	1379	91.74
	Yes = 1	124	8.26
Surface condition	Dry = 0	706	47.61
	Otherwise = 1	777	52.39
Surface type	Asphalt = 0	266	83.91
	Concrete = 1	51	16.09
Traffic control	No traffic control present = 0	1393	94.44
	Traffic control present = 1	82	5.56
Traffic flow	One-way traffic = 0	96	33.45
	Two-way traffic = 1	191	66.55
Trapped	Not trapped = 0	1062	96.45
	Trapped = 1	39	3.55
Vehicle action	Going straight = 0	1190	98.92
	Not going straight = 1	13	1.08
Vehicle attachment	No attachment = 0	1276	91.67
	Attachment = 1	116	8.33
Vehicle defect	No defect = 0	1204	95.33
	defect = 1	59	4.67
Vehicle initial impact	Not at front = 0	179	13.09
	At front = 1	1188	86.91
Seat belt use	No = 0	60	7.17
	Yes = 1	777	92.83
Vehicle type	Passenger car = 0	753	50.47
	Pick-up, Van, or Sport Utility Vehicle = 1	624	41.82
	Truck = 2	115	7.71
Vehicle year	Continuous variable	*	*
Vision obscured	Not obscured = 0	1371	96.28
	Obscured = 1	53	3.72
Weather	Clear = 0	539	36.17
	Not clear = 1	951	63.83

## **6 ROLLOVER ANALYSIS**

The objective of this research was to evaluate the in-service safety performance of two types of concrete bridge rails (i.e., safety-shape and vertical rails). Rollover propensity was also used as an indicator of the safety performance of these barrier profiles since rollover may affect injury levels. A rollover analysis of the two bridge rail types is described in the present chapter. Section 6.1 describes a univariate analysis used to identify the variables that are statistically significant to rollover propensity. Section 6.2 describes a multivariate analysis which includes the model building process used to find an adequate model that determines the rollover propensity for the two barriers. Section 6.3 describes model checking techniques used to assess the fit of the model selected in section 6.2. All analyses contained in this chapter as well as in chapter 7 were performed using the statistical software package SAS version 9.2.

The following analyses were performed with two datasets. The first dataset had all the data (i.e., 1,535 accidents). The second dataset had only those accidents (i.e., 1,234 accidents) in which striking the barrier was the first harmful event. Therefore, the second dataset is a subset of the larger dataset. The intention in analyzing these datasets separately was to control for sequence of events. Controlling for sequence of events is important since the severity of the first impact is probably different from the severity of subsequent impacts.

### **6.1 Univariate Analysis**

The first step in the rollover analysis was to conduct a univariate analysis to identify the significance of each independent variable with respect to rollover occurrence. A few different factors may affect the propensity of rollover in a crash. A number of variables may be contained within a factor and they may be grouped as shown in Figure 41. Note that Figure 41 is only an

illustration of how some of the variables affecting rollover occurrence may be grouped. Thus, Figure 41 does not contain all possible variables that may be relevant to rollover occurrence.

The factors may be roadway-related factors that include variables such as speed limit and vertical/horizontal alignment, driver-related factors that include variables such as age and gender, vehicle-related factors that include variables such as vehicle type and vehicle year, or environmental and temporal-related factors that include variables such as weather condition and day of week. Ideally, all these variables would be considered in the rollover analysis. However, some of these variables (e.g., pavement condition) were not contained in the bridge crash data.

Table 9 in section 5.1 shows the variables that were included in the rollover analysis. It may be noted that all of these factors shown in Figure 41 were represented by variables included in Table 9.

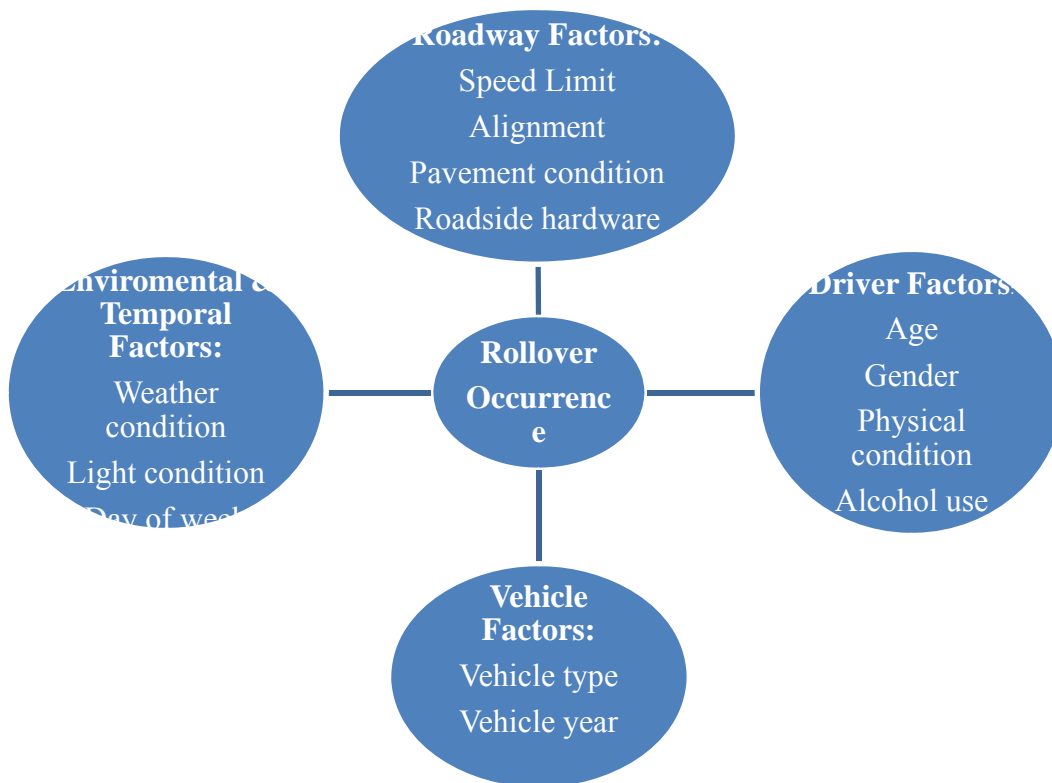

Figure 41. Conceptualization of Relevant Factors to Rollover Occurrence

As described in chapter 4, a multiple logistic regression model with n variables may be described as  $\text{Logit}(x) = \alpha + \beta_1x + \beta_2x + \beta_3x + \beta_nx$ , where each  $\beta$  coefficient represents the effect of each of the n predictors included in the model on the response variable x. However, in a univariate analysis, the effect of a single variable on the dependent variable is investigated. Therefore, the logistic regression model becomes a simple model as  $\text{Logit}(x) = \alpha + \beta x$ . Thus,  $\beta$  is the primary measure of the importance of a given variable, x, on rollover propensity. The greater the  $\beta$  is, the greater the effect of a given variable on rollover propensity.

Table 27 shows the results of the univariate analysis for rollover. Note that Table 27 shows from left to right the variable name, the reference to which the odd estimates are referring to (e.g., if the reference is safety-shape rail, the odd estimate refers to this rail type instead of vertical rail), the corresponding p-values, the odd estimates, the lower and the upper Wald confidence intervals for the odd estimates. In order to determine the logit, the natural logarithm of the odds should be calculated. For example, the first row of Table 27 shows that the odds are 1.28 which results in a logit estimate equal to 0.24 which corresponds to  $\text{LN}(1.28)$ . Since the odd estimate, in this case, is greater than 1, it may be concluded that crashes involving safety-shape rails are 1.28 times more likely to result in rollovers than crashes involving vertical rails. This finding is not statistically significant though (i.e., see p-value = 0.28). The 95% Wald confidence interval indicates that the odd estimate may range from 0.81 to 2.02. Since 1.0 is within the interval, this reinforces that there should exist no difference between rollover propensity between crashes involving jersey rails and crashes involving vertical rails. The Wald confidence intervals may be calculated as  $\hat{\theta} \pm z_{1-\alpha/2} \frac{\hat{\theta}}{2*SE}$ ; where  $\hat{\theta}$  is the odds of success, where success is defined as rollover. SE is the estimated standard error and Z equals to 1.96 considering that the confidence interval was calculated based on a 95% confidence level.

Table 27. Univariate Analysis Output for All Data

Variable	Reference	P-value	Estimate	Standard Error	Odds	Lower 95% CL	Upper 95% CL	Conclusion
Rail type – Safety-shape versus vertical	Jersey	0.28	0.24	0.23	1.28	0.81	2.02	Not significant
Rail type - Counting only rollovers that occurred on the road due to barrier impact	Jersey	0.07	0.30	0.28	1.81	0.95	3.45	Rollovers are more likely as crash involves a Jersey rail
Vehicle type - Passenger Car versus Pickup, van, SUV	Passenger car	0.05	-0.53	0.26	0.59	0.35	0.99	Pick-ups, vans, and SUVs are more likely to rollover than passenger cars
Vehicle type - Passenger car versus Truck	Passenger car	<0.0001	-1.70	0.33	0.18	0.10	0.35	Trucks are more likely to rollover than passenger cars
Vehicle type - Pickup, van, SUV versus truck	Pick-up, van, or SUV	<0.0001	-1.17	0.31	0.31	0.17	0.57	Trucks are more likely to rollover than pick-ups, vans, and SUVs.
Vehicle year	*	0.68	0.00	0.00	1.00	1.00	1.00	Not significant
Vehicle Defect - Yes versus no	No	0.57	-0.30	0.53	0.74	0.26	2.11	Not significant
Attachment - yes versus no	No	<0.0001	-1.33	0.29	0.27	0.15	0.47	Rollovers are more likely with vehicles that have a trailer attached
Number of occupants	*	0.05	0.19	0.10	1.21	1.00	1.47	The more occupants, the higher the rollover propensity
Initial impact point - Front versus other	Front	0.42	-0.26	0.32	0.77	0.42	1.44	Not significant

<b>Variable</b>	<b>Reference</b>	<b>P-value</b>	<b>Estimate</b>	<b>Standard Error</b>	<b>Odds</b>	<b>Lower 95% CL</b>	<b>Upper 95% CL</b>	<b>Conclusion</b>
Vehicle Action - Going straight versus other	Going straight	0.81	-0.10	0.44	0.90	0.38	2.12	Not significant
Speed limit (5-35mph versus 40-55mph)	5-35 mph	0.25	0.44	0.38	1.55	0.73	3.30	Not significant
Speed limit (5-35mph versus 60-70mph)	5-35 mph	0.65	-0.15	0.34	0.86	0.44	1.68	Not significant
Speed limit (40-55mph versus 60-70mph)	40-55 mph	0.03	-0.59	0.27	0.55	0.33	0.94	Rollovers are more likely on 60-70mph speed limit roads
Surface condition - Dry versus other	Dry	0.80	0.06	0.23	1.06	0.67	1.67	Not significant
Driver age	*	0.13	-0.01	0.01	0.99	0.97	1.00	Younger drivers are more prone to be involved in rollovers
Driver gender	Female	0.18	-0.33	0.25	0.72	0.44	1.17	Not significant
Driver Condition	Normal	0.19	-0.34	0.26	0.71	0.42	1.19	Not significant
Blood Alcohol Content (BAC)	Up to 0.08%	0.19	-0.63	0.48	0.53	0.21	1.37	Not significant
Vision Obscured - Yes versus no	No	0.64	-0.34	0.73	0.71	0.17	2.99	Not significant
Month – Winter versus Non-winter months	Winter months	0.05	0.46	0.23	1.59	1.01	2.51	Rollovers are more prone to occur during the winter
Light - Daylight versus other	Daylight	0.30	0.54	0.52	1.72	0.62	4.79	Not significant

Variable	Reference	P-value	Estimate	Standard Error	Odds	Lower 95% CL	Upper 95% CL	Conclusion
Weather - Clear versus other	Clear	0.63	0.12	0.24	1.12	0.71	1.78	Not significant
Day - weekday versus weekend	Weekday	0.28	0.30	0.28	0.77	0.48	1.24	Not significant
Bridge width (ft)	*	0.27	-0.01	0.01	0.99	0.97	1.01	Not significant
Bridge Length (ft)	*	0.08	0.00	0.00	1.00	1.00	1.00	Rollovers are more likely on shorter bridges
Construction year	*	0.90	0.00	0.01	1.00	0.99	1.01	Not significant
AADT	*	0.97	0.00	0.00	1.00	1.00	1.00	Not significant
Narrow Bridge - Not narrow versus narrow	Not narrow	0.53	0.24	0.38	1.27	0.60	2.70	Not significant
Number of lanes on structure	*	0.73	-0.06	0.17	0.94	0.68	1.31	Not significant
Facility Carried (IA versus US highways).	IA highways	0.77	0.13	0.46	1.14	0.47	2.80	Not significant
Facility Carried (IA versus Interstate highways).	IA highways	0.07	-0.75	0.42	0.47	0.21	1.06	Rollovers are less likely on IA highways.
Facility Carried (US versus Interstate highways).	US highways	0.002	-0.89	0.29	0.41	0.23	0.73	Rollovers are less likely on US highways.
Structure flared - Yes versus no	No	0.30	0.54	0.52	1.72	0.62	4.79	Not significant
Traffic control - Present versus not present	Not present	0.36	-0.40	0.44	0.67	0.28	1.59	Not significant
Road Location - Rural versus urban	Rural	0.04	-3.40	0.56	3.10	1.02	9.34	Rollovers are more likely on rural areas.
Traffic flow - One-way versus two-way traffic	One-way traffic	0.61	0.25	0.50	1.29	0.48	3.43	Not significant
Surface Type - Asphalt versus concrete	Concrete	0.47	0.43	0.59	1.53	0.48	4.86	Not significant

<b>Variable</b>	<b>Reference</b>	<b>P-value</b>	<b>Estimate</b>	<b>Standard Error</b>	<b>Odds</b>	<b>Lower 95% CL</b>	<b>Upper 95% CL</b>	<b>Conclusion</b>
Number of vehicles involved	*	0.93	-0.07	0.81	0.94	0.19	4.54	Not significant
Collision Type - Single versus multiple-vehicle crash	Single-vehicle crash	0.36	-0.61	0.66	0.55	0.15	1.97	Not significant
Intersection/Interchange - Non-intersection/Non-interchange versus intersection/interchange	Non-intersection/Non-interchange	0.48	0.45	0.63	1.56	0.45	5.42	Not significant
Road geometry - straight versus curve	Straight	0.75	0.34	1.05	1.40	0.18	10.99	Not significant
Road geometry - level versus grade	Level	0.47	0.47	0.65	1.60	0.45	5.66	Not significant



As shown in Table 27, it was found that rollover propensity was not significantly affected by rail type (i.e., p-value = 0.28). However, some of the rollovers occurred on the roadside or were caused by an impact other than the bridge rail. The data was then restricted to those accidents which the rollover was actually caused due to the impact against the bridge rail and it was found that the safety-shape rail tends to increase rollover propensity (i.e., p-value = 0.07). The analysis indicated that rollovers were 1.81 times more likely to occur when the crash involves an impact against a jersey rail.

Using a 10% confidence level, Table 27 also shows that rollover propensity was found to significantly increase when vehicle type was a van, sport utility vehicle, pickup, or truck compared to passenger car. This probably can be attributed to the fact that vans, sport utility vehicles, pick-ups and trucks all have a higher center of gravity compared to passenger cars which makes them more prone to rollovers. Trucks were also found to be more likely to be involved in a rollover than pickups, vans, or SUVs. Rollover propensity also tended to increase as the number of vehicle occupants increased, as the vehicle had an attachment (e.g., trailer), as driver age decreased, during non-winter months (i.e., from December to March), on 60-70 mph (96.6-112.7 km/h) speed limit roads compared to 40-55 mph (64.4-88.5 km/h) speed limit roads, as the bridge length increased, on IA highways when compared to Interstate highways, on US highways compared to Interstate highways, and in rural areas.

## **6.2 Multivariate Analysis and Model Building**

The next step for the rollover analysis was to conduct a multivariate analysis. While the univariate analysis investigated the effect of a single predictor on the dependent variable (i.e., rollover), the multivariate analysis investigated the effect of multiple predictors simultaneously. As discussed in section 4.2, any variable that presented a p-value equal or lower than 0.25 was

included in the multivariate analysis. The only exception for this rule would be the case when a variable was considered to be critical to the study, and the univariate analysis showed that this variable presented a p-value greater than 0.25. In this case, engineering judgment should be used.

### **6.2.1 Multivariate Analysis and Model Building Using All Data**

Based on the p-values shown in Table 27, the following variables were included in the multivariate model: rail type, vehicle type, vehicle attachment, number of vehicle occupants, speed limit, driver age, driver gender, driver physical condition, BAC, month, bridge length, and facility. Even though road location was found to be significant, it was not included in the multivariate analysis because this variable was contained in the older dataset (i.e., from years 1998 to 2000) only which means that more than half of all data would have to be deleted from the multivariate analysis if this variable was to be included in the multivariate model.

Table 28 shows the p-values of each variable as the multivariate model was fitted. As can be seen, only five variables (i.e., number of vehicle occupants, driver age, vehicle type, rail type, and facility) were found to be significant at the 10% level. The model has too many variables and a much simpler model would be more desirable since parsimony is highly recommended for any statistical model. Also, there may be variables that are sufficiently correlated to produce multicollinearity. Multicollinearity is a phenomenon that occurs with a multiple regression model when one or more variables are correlated to each other. When this occurs, a variable A, that is highly correlated with a variable B, may not be needed in the model since there is much overlap (i.e., they indicate and/or measure the same factor) between each other. In this case, some of these correlated variables could be deleted from the model since they may not be significantly contributing to the model. Therefore, it is better to build a model that contains only variables that

make significant contribution to the model. In this section, the model building process is described while the model fit checking process is described in section 6.3.

Table 28. Variables Included in the Initial Multivariate Model

<b>VARIABLE</b>	<b>P-VALUE</b>
Vehicle type	0.02
Driver age	0.02
Rail type	0.02
Number of occupants	0.04
Facility	0.08
Month	0.23
Bridge length	0.23
BAC	0.37
Speed limit	0.43
Vehicle attachment	0.43
Driver condition	0.58
Driver gender	0.92

Backward selection was the technique used in the model building process. In backward selection, the analysis is started fitting a model with all variables of interest and the least significant variable (i.e., variable that presents the highest p-value) is dropped from the model. This process continues until all the remaining variables in the model are significant to the level chosen and/or are considered to be relevant to the study. In other words, backward selection starts with the full model (i.e., with all variables). The variable that presents the highest p-value is dropped and the model becomes a simpler model. The contribution of the variable that was removed is then assessed to evaluate whether that variable should be utilized in the final analysis. If the variable that was removed from the full model shows not to significantly contribute to the model, then it means that it could be left out and that the simpler model is acceptable and even more desirable for parsimony purposes. The Likelihood ratio (LR) test was used to assess the contribution of each variable assessed in the backward selection process.

As shown in Table 28, the variable driver gender presented the highest p-value (i.e., p-value = 0.92) in the initial multivariate model. Therefore, this variable was taken out of the

model and the LR test was used to assess whether the variable driver gender should remain in the model or not (i.e., whether a simpler model is appropriate or not). A p-value = 0.91 was found for this test and it means that the variable gender could be thrown out of the model and that the simpler model is adequate. In other words, the variable gender adds little to the model once the other variables are included in the model. Table 29 shows that the variable driver condition becomes the variable with the highest p-value. The LR test indicated that this variable also does not significantly contribute to the model once all other variables are in the model since a p-value = 0.58 was found.

Table 29. Model Without the Variable Gender

<b>VARIABLE</b>	<b>P-VALUE</b>
Rail type	0.01
Vehicle type	0.02
Driver age	0.02
Number of occupants	0.04
Facility	0.09
Bridge length	0.21
Month	0.22
BAC	0.37
Speed limit	0.43
Vehicle attachment	0.43
Driver condition	0.58

Table 30 shows the results from the model without the variable driver condition and it shows that the variable vehicle attachment becomes the variable with the highest p-value. The LR test indicated that the variable vehicle attachment may also be removed (i.e., based on a p-value = 0.44) since it does not significantly contribute to the model when all other variables are included in the model.

Table 31 shows the results from the model without the variable vehicle attachment and it also shows that the variable speed limit becomes the variable with the highest p-value. The LR test indicates a p-value = 0.20 which suggests that the variable speed limit may also be removed.

Table 30. Model Without the Variable Driver Condition

<b>VARIABLE</b>	<b>P-VALUE</b>
Vehicle type	<.0001
Rail type	0.02
Driver age	0.02
Number of occupants	0.04
Facility	0.08
Month	0.17
Bridge length	0.2
BAC	0.21
Speed limit	0.43
Vehicle attachment	0.44

Table 31. Model Without the Variable Vehicle Attachment

<b>VARIABLE</b>	<b>P-VALUE</b>
Vehicle type	<.0001
Number of occupants	0.04
Rail	0.01
Driver age	0.03
Facility	0.04
Month	0.16
BAC	0.18
Bridge length	0.20
Speed limit	0.43

Table 32 shows the model without speed limit and it shows that the variable bridge length becomes the next variable to be considered for removal. The LR test indicates that the variable bridge length may also be removed since p-value for the test equals to 0.14.

Table 32. Model Without the Variable Speed Limit

<b>VARIABLE</b>	<b>P-VALUE</b>
Vehicle type	<0.0001
Rail	0.01
Driver age	0.03
Number of occupants	0.04
Facility	0.04
Month	0.16
BAC	0.18
Bridge length	0.20

After the variable bridge length is removed, the variable BAC becomes candidate for removal as shown in Table 33. The LR test indicates that the variable BAC does not significantly

contribute to the model since the p-value for the test was found to be equal to 0.21. A simpler model is fit and it is shown in Table 34.

Table 33. Model Without the Variable Bridge Length

<b>VARIABLE</b>	<b>P-VALUE</b>
Vehicle type	< 0.0001
Facility	0.02
Number of occupants	0.03
Rail	0.03
Driver age	0.03
Month	0.14
BAC	0.17

Table 34. Model Without the Variable BAC

<b>VARIABLE</b>	<b>P-VALUE</b>
Vehicle type	< 0.0001
Facility	0.02
Number of occupants	0.03
Rail	0.03
Driver age	0.03
Month	0.10

As shown in Table 34, all variables are statistically significant at the 10% level and all the variables seem to be relevant to rollover causation, except Number of occupants. Rollovers may be influenced by different factors such as vehicle, driver, environmental, and road factors. Vehicle type may capture vehicle-related characteristics such as vehicle weight, facility may capture road-related characteristics such as speed limit and geometric design, driver age may capture driver-related characteristics such as driving behavior, and month may capture environment-related characteristics such as snow and ice causing drivers to slow down in the winter. However, the variable number of occupants does not seem to be relevant to rollover causation. That is, rollovers should not be more or less likely to occur based on the number of occupants are in a vehicle. A vehicle class may be able to carry more occupants than another (e.g., buses tend to carry more occupants than passenger cars) and this may be the reason why number of occupants appears to affect rollover likelihood. Vehicle class is already being taken

into account by the variable Vehicle Type and, therefore, the Number of Occupants was removed and the final model is shown in Table 35.

Table 35. Final Model

<b>VARIABLE</b>	<b>P-VALUE</b>
Vehicle type	<0.0001
Facility	0.02
Driver age	0.02
Rail	0.03
Month	0.08

Table 36 shows the estimated odds for the variables presented in Table 35. As can be seen, rollovers are 7.7 (i.e., 1 divided by 0.13) times more likely to occur when the vehicle is a truck compared to a passenger car as well as 4 times (i.e., 1 divided by 0.25) more likely to occur when the vehicle is a truck compared to a pick-up truck, van, or SUV. Rollovers were also found to be about 1.5 times more likely to occur as during non-winter months compared to winter months (i.e., December, January, February, and March). Rollovers were also found to be about twice (i.e., 1 divided by 0.47) more likely to occur on US highways than on streets, avenues, and ramps. The estimated odds for rail type indicated that rollovers were 1.7 times more likely to occur when a crash involved a jersey rail compared to a crash that involved a vertical rail. Finally, rollovers were found to be more likely as the driver was younger (i.e., odd estimate for older drivers is lower than 1 which indicates that older drivers are less likely to be involved in rollovers).

Note that Table 35 indicates that the variable Facility presented a p-value equals to 0.02. This is the result of the Type 3 Analysis of Effects which shows that Facility has a significant effect on the response variable Rollover. However, the results shown in Table 36 are from the analysis of Maximum Likelihood Estimation and it shows more specifically that rollovers are more likely to occur on US highways than on Other (i.e., ramps, streets and avenues). The

likelihood of rollovers between IA highways and Other as well as between Interstate highways and Other do not differ significantly.

Table 36. Odds Estimates for the Final Model

Variable	Reference	Odds	Lower 95% CL for Odds	Upper 95% CL for Odds	P-value
Vehicle type (Passenger car versus truck)	Passenger car	0.13	0.06	0.27	<.0001
Vehicle type (Pick-up, van, and SUV versus truck).	Pickup, van, or SUV	0.25	0.13	0.49	<.0001
Driver age	Older	0.98	0.96	0.99	0.03
Month	Non-winter months	1.55	0.94	2.54	0.08
Facility (IA highways versus Other)	IA highways	0.52	0.19	1.4	0.21
Facility (US highways versus Other)	US highways	0.47	0.21	1.07	0.07
Facility (Interstate highways versus Other)	Interstate highways	1.09	0.52	2.29	0.81
Rail type (Safety-shape versus Vertical)	Safety-shape	1.70	1.03	2.82	0.03

### 6.2.2 Multivariate analysis using the restricted data

The multivariate analysis was carried further with the restricted data (i.e., data that had a vehicle striking a bridge rail as the first harmful event). Table 37 shows the results for the final model shown in Table 35 using the restricted data. As can be seen, the results seem to be similar to those shown in Table 36. The odds estimate for rail type increased from 1.7 to 2.1 as the data was restricted, which means that rollovers became even more likely for crashes that involved



bridge rails with a safety-shape profile when striking the barrier was the first harmful event.

Table 37. Odds Estimates for the Final Model Using the Restricted Data

Variable	Reference	Odds	Lower 95% CL for Odds	Upper 95% CL for Odds	P-value
Vehicle type (Passenger car versus truck)	Passenger car	0.18	0.07	0.47	0.0004
Vehicle type (Pick-up, van, and SUV versus truck).	Pickup, van, or SUV	0.38	0.16	0.92	0.03
Driver age	Older	0.98	0.96	0.99	0.04
Month	Non-winter months	1.60	0.91	2.81	0.09
Facility (IA highways versus Other)	IA highways	0.59	0.18	1.93	0.38
Facility (US highways versus Other)	US highways	0.61	0.24	1.56	0.30
Facility (Interstate highways versus Other)	Interstate highways	1.54	0.64	3.68	0.33
Rail type (Safety-shape versus Vertical)	Safety-shape	2.10	1.18	3.75	0.01

### 6.3 Model fit assessment

Once the model is selected, it is necessary to check how well the model fits the data. This may be referred as goodness-of-fit analysis. The Hosmer-Lemeshow Test [60] was used as the technique to check the goodness-of-fit of the models described in Tables 36 and 37. Even though there may be other techniques such as Pearson Chi-Square and Deviance, these techniques were found not to be suitable for this specific set of data. These techniques require sufficient replication within subpopulations to make the goodness-of-fit tests valid. When there is one or

more continuous predictors in the model, the data are often too sparse to use these statistics. This would be the case for the models shown in Tables 36 and 37 since driver age is included.

Table 38 shows the results of the Hosmer-Lemeshow Test for the analysis using all data as well as for the analysis using the restricted dataset. This goodness-of-fit test is testing two hypotheses. The null hypothesis is testing whether the model fits the data well while the alternative hypothesis is testing whether the model does not fit the data well. As can be seen, the P-values for the models developed using both datasets (i.e., full and restricted datasets) are all much higher than 0.05 (i.e., if a critical p-value equal to 0.05 is used) which means that the models shown in Tables 35 and 36 fit the data reasonably well. Even though the null hypothesis is accepted, which means that the model fits the data well, this does not mean that the model perfectly fits the data. Instead, the high P-values found from the Hosmer-Lemeshow test indicates that these are acceptable models.

Table 38. Goodness-of-Fit Results for the models Used in the Rollover Analysis if Terms of Quality if Fit

	<b>Chi-Square</b>	<b>Degrees-of-Freedom</b>	<b>P-value</b>
<b>All Data</b>	4.95	8	0.76
<b>Restricted Data</b>	8.83	8	0.36

## 7 INJURY ANALYSIS

The analysis presented in this chapter uses logit models to identify variables that significantly affect injury level as well as to identify which concrete bridge rail tends to produce lower injury levels. Section 7.1 describes the univariate analysis, section 7.2 describes the multivariate analysis which includes the model building process, and section 7.3 describes the model fit assessment.

As with the rollover analysis described in the previous chapter, the injury analysis was conducted based on two datasets. The first dataset included had all the data while the second dataset had fewer accidents which included only those crashes that the vehicle hit the barrier first in a sequence of events.

The injury severity levels used in the injury analysis refer to driver injury severity. It is very important to carry an injury analysis based on driver injury levels only since seating position has been found to affect injury severity level [25] and, therefore, it was important to control for the effects of seating position on injury level.

The injury scale used was the KABCO scale which is shown in Table 39 and the injury severity distribution is shown in Table 40. Note that there were very few fatal injuries. This injury class was then grouped with incapacitating injuries forming only one group of injury (i.e., A+K injuries) as shown in Table 41.

Table 39. Injury Scale

<b>Injury</b>	<b>Coding</b>
K= Fatal	5
A = Incapacitating	4
B = Non-incapacitating	3
C = Minor/Possible	2
O = Uninjured	1

Table 40. Five-Level Driver Injury Severity Distribution

<b>Outcome</b>	<b>Safety-shape</b>	<b>Vertical</b>
Fatal	2 (0.27%)	6 (0.79%)
Incapacitating	28 (3.83%)	33 (4.35%)
Non-incapacitating	105 (14.34%)	85 (11.20%)
Possible/Minor	122 (16.67%)	114 (15.02%)
Uninjured	475 (64.89%)	521 (68.64%)

Table 41. Four-Level Driver Injury Severity Distribution

<b>Outcome</b>	<b>Safety-shape</b>	<b>Vertical</b>
Fatal + Incapacitating	30 (4.10%)	39 (5.14%)
Non-incapacitating	105 (14.34%)	85 (11.20%)
Possible/Minor	122 (16.67%)	114 (15.02%)
Uninjured	475 (64.89%)	521 (68.64%)

## 7.1 Univariate Analysis

The first step in the injury analysis was to conduct a univariate analysis to identify whether the effect of each independent variable was significant to injury severity. As shown in Figure 41 for rollover, a number of different variables may be relevant to the injury analysis. Table 9 shows the variables that were included in the injury analysis. Table 42 shows the results of the univariate analysis for injury.

Results contained in Table 42 indicates that rail type did not significantly affect injury severity (i.e., p-value = 0.15) when all crashes were considered as well as when the restricted data (i.e., only crashes that had the bridge rail as the first harmful object struck) was used (i.e., p-value = 0.55). Note that these are the results of a univariate analysis and, therefore, there may be other variables that mask the importance of bridge rail type in the analysis. Thus, the multivariate analysis is needed to explore the true effect of bridge rail type on injury severity.

Table 42 also indicates that injury severity tended to increase as rollover occurred (i.e., p-value < 0.0001), as ejection occurred (i.e., p-value < 0.0001), as seat belt was not used (i.e., p-value < 0.0001), as vehicle was a truck compared to as vehicle was a pickup, van, or SUV (i.e., p-value = 0.03), as the number of vehicle occupants increased (i.e., p-value = 0.04), as driver was

not under normal physical condition compared to as the driver was under normal conditions (i.e., p-value < 0.0001), as the driver's content of alcohol in the blood was greater than 0.08% (i.e., p-value = 0.005), as the driver's vision was obscured (i.e., p-value = 0.06), as crash occurred during non-winter months (i.e., p-value < 0.0001), as the driver was trapped (i.e., p-value 0.04), as the road was level (i.e., p-value = 0.08), as crash resulted in fire and/or explosion (i.e., p-value 0.01), and as traffic control devices were not present (i.e., p-value 0.0004).

Table 42. Results of the Univariate Analysis for Injury Analysis Using All Data

Variable	Reference	P-value	Estimate	Std. Error	Odds	Lower 95% CL	Upper 95% CL	Conclusion
Rail type – Safety-shape versus vertical	Jersey	0.15	0.15	0.11	1.16	0.94	1.43	Not significant
Rail type – using restricted data.	Jersey	0.55	0.07	0.13	1.07	0.84	1.37	Not significant
Rollover - yes versus no	Yes	<0.0001	1.54	0.21	4.68	3.09	7.10	Injuries are higher as rollover occurs.
Ejection - Yes versus no	No	<0.0001	-2.50	0.56	0.08	0.03	0.24	Injuries are higher as ejection occurs.
Seat belt - Use versus no use	Use	<0.0001	-2.21	0.26	-2.72	-1.71	0.11	Injuries are higher as driver is not wearing seat belt.
Vehicle type - Passenger car versus Pick-up, van, or SUV	Passenger car	0.94	-0.44	0.11	0.65	0.43	0.97	Not significant
Vehicle type - Passenger car versus Truck	Passenger car	0.68	-0.08	0.20	0.92	0.62	1.39	Not significant
Vehicle type - Pick-up, van, or SUV versus truck	Pick-up, van, or SUV	0.03	-0.44	0.21	0.64	0.43	0.98	Injuries are higher with trucks.
Vehicle year	*	0.70	0.00004	0.0001	1.00	1.00	0.97	Not significant
Vehicle Defect - Yes versus no	No	0.16	0.42	0.30	1.5	0.85	2.70	Not significant
Attachment - yes versus no	No	0.54	-0.12	0.20	0.88	0.60	1.30	Not significant

Variable	Reference	P-value	Estimate	Std. Error	Odds	Lower 95% CL	Upper 95% CL	Conclusion
Initial impact point - Front versus other	Front	0.17	0.22	0.16	1.25	0.91	1.7	Not significant
Number of occupants	*	0.04	0.07	0.03	1.07	1.00	1.15	Injuries are higher as the number of occupants increases.
Vehicle Action - Going straight versus other	Going straight	0.42	-0.22	0.29	0.79	0.45	1.40	Not significant
Speed limit (Up to 35mph versus 40-60 mph)	Up to 35 mph	0.36	-0.16	0.178	0.85	0.60	1.20	Not significant
Speed limit (Up to 35mph versus 65-70 mph)	Up to 35 mph	0.44	-0.13	0.17	0.88	0.63	1.20	Not significant
Speed limit (40-60 mph versus 65-70 mph)	40-60 mph	0.79	0.03	0.12	1.03	0.82	1.30	Not significant
Surface condition - Dry versus other	Dry	<.0001	0.77	0.11	2.16	1.73	2.67	Injuries are higher as surface is dry
Driver age	*	0.63	-0.0016	0.003	0.99	0.99	1.00	Not significant
Driver gender	Female	0.12	0.17	0.11	1.19	0.96	1.50	Injuries are higher as the driver is female.
Driver Physical Condition - Normal versus other	Normal	<0.0001	-1.01	0.13	0.36	0.28	0.50	Injuries are higher as the driver is under normal condition.

Variable	Reference	P-value	Estimate	Std. Error	Odds	Lower 95% CL	Upper 95% CL	Conclusion
BAC (Up to 0.08% versus higher than 0.08%)	Up to 0.08%	0.005	-0.72	0.26	0.49	0.29	0.80	Injuries are higher as BAC > 0.08%.
Vision Obscured - Yes versus no	No	0.06	-0.22	0.12	0.80	0.64	1.01	Injuries are higher as vision is not obscured.
Month - Winter versus non-winter months	Winter months	<0.0001	0.55	0.11	1.73	1.40	2.14	Injuries are higher on winter months
Light - Daylight versus other	Daylight	0.60	-0.06	0.11	0.94	0.76	1.18	Not significant
Weather - Clear versus other	Clear	0.61	-0.06	0.11	0.94	0.76	1.18	Not significant
Day - Weekday versus weekend	Weekday	0.96	0.006	0.12	1.01	0.80	1.27	Not significant
Bridge width	*	0.54	0.002	0.003	1.002	0.99	1	Not significant
Bridge Length	*	0.51	0.00006	0.0001	1.00	1.00	1.00	Not significant
Construction year	*	0.78	0.0009	0.003	1.00	1.00	1.00	Not significant
AADT	*	0.30	2.8E-6	2.7E-6	1.00	1.00	1.00	Not significant
Narrow Bridge	Not narrow	0.29	0.15	2.7E-6	1.17	0.94	1.46	Not significant
Number of lanes on structure	*	0.43	0.06	0.07	1.06	0.92	1.23	Not significant
Facility Carried (IA versus US highways).	IA highways	0.61	0.11	0.23	1.12	0.71	1.75	Not significant
Facility Carried (IA versus Interstate highways).	IA highways	0.27	0.21	0.19	1.23	0.84	1.80	Not significant
Facility Carried (US versus Interstate highways).	US highways	0.17	0.26	0.19	1.29	0.89	1.89	Not significant
Structure flared - Yes versus no	No	0.42	-0.15	0.19	0.86	0.59	1.25	Not significant
Trapped - Yes versus no	No	0.04	-0.61	0.29	0.54	0.31	0.96	Injuries are higher as driver is trapped



Variable	Reference	P-value	Estimate	Std. Error	Odds	Lower 95% CL	Upper 95% CL	Conclusion
Airbag deployment - Yes versus no	No	0.71	0.0	0.14	1.05	0.8	1.38	Not significant
Road Location - Urban versus rural	Rural	0.15	0.28	0.20	1.32	0.90	1.94	Not significant
Traffic flow - One-way versus two-way traffic	One-way traffic	0.25	0.18	0.49	1.19	0.73	1.96	Not significant
Surface Type - Asphalt versus concrete	Concrete	0.51	-0.21	0.33	0.81	0.42	1.54	Not significant
Intersection/Interchange - Non-intersection/Non-interchange versus intersection/interchange	Non-intersection/Non-interchange	0.27	0.28	0.25	1.32	0.82	2.18	Not significant
Horizontal alignment - straight versus curve	Straight	0.83	0.09	0.44	1.10	0.46	2.61	Not significant
Vertical alignment - level versus grade	Level	0.08	-0.43	0.25	0.65	0.40	1.05	Not significant
Fire/explosion - Yes versus no	Yes	0.01	2.58	0.94	13.23	2.10	83.23	Injuries are higher as fire/ explosion occur.
Traffic control - Present versus not present	No traffic control	0.0004	-0.77	0.22	0.46	0.30	0.71	Injuries are higher as there is no traffic control

## **7.2 Multivariate Analysis and Model Building**

The next step in the injury analysis was to conduct a multivariate analysis and find a model that may answer the research questions imposed by this study. As in the rollover analysis, all variables that presented a p-value  $< 0.25$  in the univariate analysis were considered in the multivariate analysis.

### **7.2.1 Multivariate Analysis and Model Building Using All Data**

Based on the p-values shown in Table 43, the following variables presented a p-value lower than 0.25: rail type, rollover, ejection, vehicle type, vehicle defect, number of occupants, surface condition, initial impact point, driver gender, seat belt, driver physical condition, BAC, facility, vision obscured, month, trapped, traffic control, road location, vertical alignment, and fire/explosion. However, some of these variables were not included in the multivariate model. Road location, vertical alignment, and fire/explosion were contained in the older (i.e., from 1998 to 2000) datasets only which means that if these variables were to be considered, more than half of the data could not be included. The variable seat belt was also not included in the multivariate analysis because it presented too many missing values. Also, in order to minimize the number of cases removed from the analysis (i.e., since the more variables, the greater the number of cases deleted because of the missing values in each variable), the variables vehicle defect, trapped, vision obscured, and traffic control were not included in the modeling effort. Variables trapped, vehicle defect, and vision obscured presented 402, 240 and 79 missing cases, respectively. The variable traffic control was also removed from the analysis since the indication of control (i.e., outcome = "1") would not provide much insight since there is a wide variety of sub-categories under the major category "presence of control". That is, the presence of control could be just a

no passing zone marking or even a traffic signal. The number of cases left in the multivariate analysis was 1,040 cases.

Table 43 shows the initial multivariate model. As can be seen in Table 42, the variable BAC presented the highest p-value. As in the rollover analysis described in the previous chapter, backward selection was used to find an adequate model to be used in the injury analysis. Therefore, BAC was removed from the analysis and a new model was fit as shown in Table 44. The Likelihood ratio test showed that BAC does not significantly add to the model based on a p-value = 0.49.

Table 43. Variables Included in the Initial Model

<b>VARIABLE</b>	<b>P-value</b>
Rollover	<.0001
Ejection	<.0001
Driver physical condition	<.0001
Driver gender	0.003
Surface condition	0.004
Rail Type	0.006
Initial point of impact	0.11
Month	0.37
Facility	0.36
Number of Occupants	0.55
Vehicle Type	0.73
BAC	0.81

Table 44 shows that vehicle type becomes the variable with the highest p-value and, therefore, it is the candidate to be considered for removal. The LR test shows that a p-value = 0.64 indicates that vehicle type may be removed. Table 45 shows the model without the variable vehicle type. The variable number of occupants becomes the variable with the highest p-value which indicates that this variable becomes the next candidate for removal. The LR test indicates that number of occupants may be removed based on a p-value = 0.60.

Table 44. Model Without the Variable BAC

<b>VARIABLE</b>	<b>P-value</b>
Rollover	<.0001
Ejection	<.0001
Driver physical condition	<.0001
Driver gender	0.003
Surface condition	0.004
Rail Type	0.006
Initial point of impact	0.11
Month	0.36
Facility	0.36
Number of Occupants	0.54
Vehicle Type	0.73

Table 45. Model Without the Variable Vehicle Type

<b>VARIABLE</b>	<b>P-value</b>
Rollover	< 0.0001
Ejection	< 0.0001
Driver physical condition	< 0.0001
Driver gender	0.002
Surface condition	0.003
Rail Type	0.006
Initial point of impact	0.13
Month	0.30
Facility	0.36
Number of Occupants	0.57

Table 46 shows the model without the variable number of occupants. The variable facility becomes the next candidate for removal but the LR test indicates that this variable has a significant contribution to the model since the LR test presented a p-value = 0.06. The variable facility was left in the model and the variable with the second highest p-value (i.e., month) was tested.

Table 46. Model Without the Variable Number of Occupants

<b>VARIABLE</b>	<b>P-value</b>
Rollover	< 0.0001
Ejection	< 0.0001
Driver physical condition	< 0.0001
Driver gender	0.002
Surface condition	0.002
Rail Type	0.006
Initial point of impact	0.13
Month	0.29
Facility	0.36

Table 47 shows the model without the variable month. The LR test indicated that this variable does not have a significant contribution to the model (i.e., p-value = 0.29). The variable facility becomes the next candidate for removal again. However, the variable facility has been found to have a significant contribution to the model before. The variable initial impact point is then tested since it presented the highest p-value after the variable facility. The LR test indicated that initial impact point does not have a significant contribution to the model based on a p-value = 0.12. Table 48 shows the final model. The model has seven variables (i.e., rollover, ejection, driver condition, driver gender, rail type, facility, and surface condition). All the variables are statistically significant at a confidence level lower than 0.01, except facility which presented a p-value = 0.39. The variable facility was left in the model because it was found that this variable had a significant contribution to the model when all other variables were in the model, based on the LR test. Also, this variable may be relevant to injury causation since it captures road-related characteristics which may have an impact on accident characteristics such as impact speed and angle.

Table 47. Model with Variable Facility Back in and Without the Variable Month

<b>VARIABLE</b>	<b>P-value</b>
Rollover	< 0.0001
Ejection	< 0.0001
Driver physical condition	< 0.0001
Surface condition	0.0005
Driver gender	0.002
Rail Type	0.008
Initial point of impact	0.13
Facility	0.39

Table 48. Final Model

<b>VARIABLE</b>	<b>P-value</b>
Rollover	<0.0001
Ejection	< 0.0001
Driver physical condition	< 0.0001
Surface condition	0.0004
Driver gender	0.002
Rail Type	0.007
Facility	0.39

Table 49 shows the odd estimates for the variables included in the model shown in Table 48. The results shown in Table 49 mean that, for any given injury level, the estimated odds that a injury caused by a safety-shape rail is in the direction of more severe injuries rather than to less severe injuries equals 1.44 times the estimated odds that a injury caused by a vertical rail is in the direction of more severe injuries rather than to less severe injuries. Also, injuries are more likely to be in the direction of more severe injuries rather than in the direction of less severe injuries as the driver is male and is not under normal condition, as rollover occurs, as ejection occurs, on dry surface condition, on US and Interstate highways compared to the “Other” category (i.e., streets, avenues, and ramps).

Table 49. Odds Estimates for the Model Shown in Table 48

VARIABLE	Reference	Odds	Lower 95% CL	Upper 95% CL	P-value
Rollover	Yes	5.68	3.41	9.43	< 0.0001
Ejection	Yes	12.82	3.74	43.47	< 0.0001
Driver condition	Not normal	2.79	2.05	3.80	<0.0001
Driver gender	Male	1.52	1.17	1.97	0.001
Surface condition	Dry	1.62	1.24	2.12	0.01
Rail Type	Safety-shape	1.44	1.11	1.87	0.05
Facility	US highways	1.47	0.93	2.34	0.09
Facility	Interstate highways	1.46	0.92	2.33	0.10
Facility	IA highways	1.37	0.79	2.38	0.25

### 7.2.2 Multivariate Analysis Using Restricted Data

The injury analysis was carried out further with the restricted data which involves only accidents that had striking a bridge rail as the first harmful event. The model shown in Table 48 was used with the restricted data and the odd estimates for each variable are shown in Table 50. The odd estimate for rail type was found to have almost the same value as that shown in Table 50. The other estimates shown in Table 51 are all toward the same direction as those shown in Table 50. A fewer number of accident cases (i.e., 937) were used in the analysis with the restricted data.

Table 50. Odds Estimates for the Model Using the Restricted Data

VARIABLE	Reference	Odds	Upper 95% CL	Lower 95% CL	P-value
Driver condition	Not normal	3.03	2.08	4.35	<.0001
Rollover	Yes	6.57	3.58	12.05	<.0001
Driver gender	Male	1.63	1.21	2.21	0.001
Ejection	Yes	10.31	2.57	41.67	0.001
Surface condition	Dry	1.38	1.01	1.91	0.05
Rail Type	Safety-shape	1.33	0.98	1.81	0.07
Facility	US highways	1.22	0.73	2.03	0.44
Facility	Interstate highways	1.15	0.69	1.94	0.59
Facility	IA highways	1.18	0.63	2.18	0.61

### 7.3 Injury As a Binary Response

Injury was further coded as a binary variable. That is, injury was coded as: serious injury (i.e., fatal or incapacitating injury) = 1 and other = 0. The objective of this analysis was to detect whether a rail type tended to be more likely to cause severe injuries than the other. As can be seen in Tables 51 and 52, the results of the univariate analysis, when all data as well as when the restricted data was used, shows that rail type was not statistically significant to injury which means that one rail type did not tend to be more likely to cause severe injuries than the other.

The model shown in Table 48 was used as a binary logit model. The results of the type 3 analysis of effects are shown in Tables 53 and 54. As can be seen, the results for rail type were not statistically significant in any case.

Table 51. Univariate Results With All Data

Variable	Reference	P-value	Odds	Lower 95% CL	Upper 95% CL
Rail Type	Safety-shape	0.34	0.78	0.48	1.28

Table 52. Univariate Results With Restricted Data

Variable	Reference	P-value	Odds	Lower 95% CL	Upper 95% CL
Rail Type	Safety-shape	0.24	0.63	0.28	1.56

Table 53. Multivariate Model With All Data

VARIABLE	P-VALUE
Ejection	<.0001
Driver condition	<.0001
Rollover	<.0001
Month	0.17
Driver gender	0.54
Vehicle Type	0.78
Rail Type	0.92



**Table 54. Multivariate Model With the Restricted Data**

VARIABLE	P-VALUE
Driver condition	<.0001
Rollover	<0.0001
Month	0.61
Ejection	0.004
Rail Type	0.73
Driver gender	0.80
Vehicle Type	0.94

#### 7.4 Proportional Versus Non-Proportional Odds Assumption

As shown in Table 49, a single odd estimate was calculated for each predictor variable independently of the outcome of the response variable. For example, note that the odd estimate for the variable Rollover was found to be 5.68 which mean that this odd estimate was constrained to be the same across all of the outcome levels. This is due to the fact that PROC LOGISTIC (i.e., SAS command used to fit a logistic regression model) automatically fits the proportional odds model by default when the response variable is ordinal and the default logit link is used [58]. The proportional odds model constrains each predictor’s parameter estimates to be the same across all of the logits. In this case, the constant term (i.e., intercept) would be the only thing that would change. However, in order to verify that proportionality holds for a specific set of data, a Chi-Square Score Test for the Proportional Odds assumption should be conducted. This test essentially examines whether a proportional odds model is adequate or not. In this case, the null hypothesis should be that the proportional odds model is not adequate while the alternate hypothesis should be that the proportional odds model is adequate. If the null hypothesis is rejected, it could be concluded that ordered logit coefficients are not equal across the levels of the outcome and, therefore, a non-proportional odds model should be the most appropriate model. On the other hand, if the null hypothesis is not rejected, the proportional odds

assumption appears to be valid and the ordered logit coefficients are equal across the levels of the outcome.

The p-value for the Chi-Square Score Test for the Proportional Odds assumption was found to be equal to 0.15 which means that the null hypothesis is accepted and, therefore, the proportional odds model assumption holds which means that the assumption of a single logit across all outcome levels as shown in Table 50 is valid.

### **7.5 Model Fit Assessment**

Similarly with the rollover analysis, the third step in the injury analysis is to evaluate the fit of models selected. The Hosmer-Lemeshow test used in the rollover analysis is appropriate for binary logit models only and, therefore, should not be used for the polytomous logit model developed in this chapter. The Pearson's chi-square test presented a p-value equals to 0.18 which would indicate that the model fit is acceptable based on a critical p-value of 0.05. This method, however, is not indicated when the data table is too sparsely populated. The model shown in Table 48 has seven predictor variables. Six of them have 2 levels while one has 4 levels. Tabulation of this data would need a contingency table with 256 (i.e.,  $2*2*2*2*2*2*4$ ) cells. Such a contingency table was prepared and several cells had no observation.

A confusion matrix as shown in Table 8 may be used as an alternative to assess how well a model performs. For the model shown in Table 48, 64.4 percent of the all predicted outcomes were in the diagonal of the confusion matrix.

A likelihood ratio test of the model of interest versus the saturated model was used to assess how well the model of interest in comparison to a model that perfectly fits the data (i.e., the saturated model). The model of interest, in this case, is the model shown in Table 49 which has seven predictor variables which are the main effects. The saturated model contained all main

affects (i.e., 7) as well as all possible interactions (i.e., 120). Therefore, the saturated model contained a total of 127 terms. The saturated model contained 21 terms with a two-term interaction which result from a  $\binom{2}{7}$  combination, 35 terms with a three-term interaction which result from a  $\binom{3}{7}$  combination, 35 terms with a four-term interaction which result from a  $\binom{4}{7}$  combination, 21 terms with a five-term interaction which result from a  $\binom{5}{7}$  combination, 7 terms with a six-term interaction which result from a  $\binom{6}{7}$  combination, one term with a seven-term interaction which result from a  $\binom{7}{7}$  combination, and the seven main effects. The two hypotheses to be tested are:

*Null hypothesis  $H_0$ : Simpler model is acceptable compared to the saturated model.*

*Alternate hypothesis  $H_a$ : Simpler model is not acceptable compared to the saturated model.*

The likelihood ratio test presented a p-value equals to 0.27 which indicates that the null hypothesis is accepted and it may be concluded there is not statistical evidence that the model shown in Table 49 performs poorly compared to the saturated model.

## 8 SUMMARY AND CONCLUSIONS

### 8.1 Data and Methods

The present study used vehicle crash data to evaluate the in-service safety performance of two types of concrete bridge rails (i.e., safety-shape and vertical rail). The safety performance was evaluated based on the driver injury level (i.e., the safest barrier would present lower driver injury levels). Rollover propensity was also used as an indicator of the safety performance of these concrete rails since past research has shown that rollovers tend to affect injury severity.

Eleven years (i.e., from 1998 to 2008) of accident data was collected from the Iowa Department of Transportation involving bridge-related crashes. There were 6,303 reported bridge-related crashes from years 1998 to 2008. Only accidents that occurred on State maintained highways had rail type information available. Because less than one-half of the accidents had information on rail type, the data was reduced to 2,781 accidents. Further, not all of the 2,781 accidents involved bridge rail crashes, which further reduced the database to 1,535 accidents. Thus, 1,535 accidents were used to compare the rollover propensity for the two barrier types.

Logistic regression models were used to evaluate the safety performance of the two bridge rails as well as to identify variables that significantly affect rollover propensity and injury severity. The analysis was divided in two major tasks: rollover analysis presented in chapter 6 and injury analysis presented in chapter 7. In each of these chapters, the analyses were conducted in three major steps. First, univariate logit models were used to investigate the impact of each independent variable on both rollover propensity and injury severity. Second, all of the variables that presented a p-value lower than 0.25 in the univariate analysis were included in a multivariate model. However, some of the variables were not found to be significant when all of them were

included in the model. A simpler model was then found based on model building strategies. Finally, the third step consisted of assessing the fit of the models.

## **8.2 Rollover Analysis**

The rollover analysis used a binary logistic regression model since the response variable (i.e., rollover) had only two possible outcomes (i.e., “yes” or “no”).

The univariate logistic regression analysis revealed that rollover propensity tended to increase (i.e., conclusions based on a 10 percent confidence level) as concrete barrier was a safety-shape rail, as vehicle type was a passenger car compared to a pickup, van, SUV, or truck, as vehicle type was a pickup, van or SUV compared to a truck, as the vehicle had an attachment (e.g., trailer), as the number of vehicle occupants increased, on 60 to 70 mph (96.6 to 112.7 km/h) speed limit roads compared to 40 to 55 mph (64.4 to 88.5 km/h) speed limit roads, during non-winter (i.e., from April to November) months, on shorter bridges, on IA highways compared to Interstate highways, on US highways compared to Interstate highways, and on rural locations.

The multivariate analysis started with all variables that presented a p-value lower than 0.25 in the univariate analysis. Model building strategies were used to find a more parsimonious model. The final model revealed that safety-shape rails are (1) 1.70 times more likely to cause rollover as compared to vertical rails when all data was used and (2) 2.10 times more likely to cause rollover when the restricted data was considered. The final multivariate model also indicated that passenger cars, vans, SUVs, and pickups were all less prone to rollover when compared to trucks. Rollovers were also found to be more likely during non-winter months, as the driver was younger, and on U.S. highways as compared to the “Other” category (i.e., ramps, avenues, and streets).

### **8.3 Injury Analysis**

Logistic regression was also utilized for injury severity analysis. The objective of the injury analysis was to identify variables that significantly affect driver injury severity levels as well as to identify which rail type tends to produce lower injury levels. Injury severity was coded as a variable with 5 levels (i.e., uninjured, minor/possible, non-incapacitating, incapacitating, and fatal).

The univariate analysis for injury showed that injuries tended to be higher as rollover occurred, as the driver was ejected, as the driver was not wearing the seat belt, as the vehicle was a truck compared to pickup, van, or SUV, as the number of vehicle occupants increased, as the surface condition was dry, as the driver was not under normal physical condition, as the content of alcohol in the blood was higher than 0.08 percent, as driver's vision was obscured, during non-winter months, as the driver was trapped, as the road segment was level, as fire and/or explosion occurred, and as there were not traffic control devices present. All of these findings were statistically significant at a confidence level less than or equal to 10 percent.

When all significant variables were taken together, the multivariate analysis revealed that seven variables (i.e., driver physical condition, driver gender, rollover, ejection, rail type, surface condition, and facility) were left in the model. It was found that for any given injury level, an injury was more likely to be in the direction of more severe injuries rather than in the direction of less severe injuries when driver was not under normal physical condition (i.e., 2.7 times more likely), as rollover occurred (i.e., 5.68 times more likely), as surface condition was dry (i.e., 1.6 times more likely), as driver was male (i.e., 1.5 times more likely), as bridge rail was safety-shape (i.e., 1.4 times more likely), as ejection occurred (i.e., 16 times more likely), and on Interstate and U.S. highways compared to Other (i.e., 1.4 times more likely). Similar findings

were found when the data was restricted to only those accidents that had the bridge rail as the first harmful object struck (i.e., see Table 50).

Injury was further coded as a binary variable (i.e., serious injuries versus other). The variable rail type was not found to be statistically significant to injury level neither on a univariate nor on multivariate model, as shown in Tables 51 through 54.

#### **8.4 Safety Performance of the Concrete Rails**

The main purpose of this study was to evaluate the in-service safety performance of two bridge rail profiles (i.e., safety-shape and vertical rails). The main measure of the safety performance was defined as injury level. However, rollover propensity was used as a secondary indicator since rollovers tend to affect injuries.

It was found that rollovers are more likely to occur when crashes involved safety-shape rails. The multivariate models indicated that rollovers are about twice (i.e., 1.70 times more likely for all data and 2.10 times more likely for the restricted data) more likely to occur as the rail was a safety-shape profile.

It was also found that safety-shape rails tend to present higher injury levels as compared to vertical rails. The final multivariate model used in the injury analysis indicated that, for any fixed injury level, the estimated odds that an injury caused by a safety-shape rail is in the direction of more severe injuries rather than to less severe injuries equals 1.33 times the estimated odds that an injury caused by a vertical rail is in the direction of more severe injuries rather than to less severe injuries. In other words, the injury analysis suggested that there is statistical evidence to state that the chances of safety-shape rail crashes to produce higher injury levels as compared to vertical rail crashes is higher than the chances of vertical rail crashes to produce higher injury levels as compared to safety-shape rail crashes. However, the injury distribution shown in Table

41 indicates that there were more (A+K) injuries for the vertical rail than for the safety-shape rail. The difference for these two categories was very small though. That is, safety-shape barrier crashes produced 30 (A+K) injuries while vertical barrier crashes produced 39 (A+K) injuries. Obviously, these small sample sizes cannot make any statistical analysis meaningful. On the other hand, the vertical rail was found to be safer for the other three injury categories (i.e., uninjured, possible/minor, and non-incapacitating). That is, Table 41 shows the injury distribution and it indicates that the vertical rail profile produced fewer non-incapacitating and possible/minor injuries while it produced more uninjured crashes which indicate a higher safety performance. Injury severity was then coded as a binary variable (i.e., A+K versus other), and a binary logit model was used in order to investigate whether injury levels between the two barriers were statistically different. It was found that there was no significant finding in this case. Therefore, even though there was no statistical evidence that one bridge rail profile produces more (A+K) injuries than the other, the polytomous logit model used in the analysis suggested that there is statistical evidence that the safety-shape barrier tends to produce lower injury levels as compared to the vertical barrier when the other injury levels (i.e., uninjured, possible/minor, and non-incapacitating) are considered. Therefore, it may be stated that, overall, the vertical rail profile tends to produce lower injury levels as compared to the safety-shape rail profile. However, the data does not support the hypothesis that vertical rails produce fewer serious and fatal injuries.

In sum, it may be stated that, overall, the statistical analyses suggested that the vertical rail profile is less likely to produce rollovers and it tends to produce lower injury levels as compared to the safety-shape rail profile and, therefore, it is expected that the expanded use of concrete barriers with the vertical profile would tend to improve overall highway safety.



## **9 RECOMMENDATIONS AND LIMITATIONS**

In the present research study, an evaluation of the safety performance of safety-shape and vertical concrete barriers was performed. This evaluation was based on vehicle crash data collected from State maintained highways in the State of Iowa. Even though the vertical concrete barrier was found to be safer as compared to the safety-shape concrete barrier, it was not possible to evaluate the safety performance of the vertical barrier as compared to other safety-shape barriers such as to the single-slope concrete barrier. Although, other barrier types have been used on U.S highways for a number of years, only safety-shape and vertical concrete barriers have been widely used in Iowa. Therefore, no data with single-slope profiles, or with any other concrete barrier profile, was obtained.

In this study, safety-shape concrete barrier has been defined as both New-Jersey and F-shape concrete barriers. Even though these two safety-shape profiles may have different safety performances, it was not possible to distinguish them since the database coding was the same for both of these barrier profiles. As a result, it is recommended that researchers evaluate the safety performance of vertical concrete barriers as compared to each one of these shaped configurations separately. It is also recommended that the safety performance of vertical and single-slope concrete barriers be compared in order to determine the safest shape for concrete barriers.

Even though a large dataset was used, there was no statistical evidence that one rail produced more serious injuries (i.e., fatal and incapacitating injuries) than the other rail. However, the statistical model suggested that the chances of vertical rail crashes to produce lower injury levels as compared to injury levels caused by safety-shape rail crashes are higher than the chances of safety-shape rail crashes to produce lower injury levels as compared to injury levels caused by vertical rail crashes. Therefore, it is recommended that future research may

consider a dataset with a larger sample of serious injuries so that results may be significant regarding which barrier profile tends to cause more serious injuries.

The analyses contained in this study were based on data collected from State maintained highways in the State of Iowa. Thus, it is not possible to assume that the same conclusions drawn from this study would be applicable to other highway classes and/or to other parts of the U.S. Therefore, it is recommended that analysis of more a comprehensive dataset with wider geographic coverage be conducted.

## 10 REFERENCES

1. National Highway Traffic Safety Administration [NHTSA]. Traffic Safety Facts, 2009.
2. American Association of State Highway and Transportation Officials (AASHTO), "Roadside Design Guide", Washington, D.C., 2002.
3. McDevitt, C.F. "Basics of Concrete Barriers", Journal Title: Public Roads, Federal Highway Administration, Washington D.C, March 2000.
4. "Concrete Barriers Save Lives", Journal Title: Better Roads, Vol. 39, No. 6, pp. 31-32, June, 1969.
5. Henty, M., El-Gindy, M., and Kulakowski, B.T. "Physical and Virtual passenger vehicle rollover crash tests: A literature review", Heavy Vehicle systems Intl Journal of Vehicle Design. Inderscience Enterprises Limited World Trade center Building, 29 Route de Pre-Bois, CP 896 CH-1215 Geneve 15, Switzerland, 2002.
6. Mak, K.K. and Sicking, D.L., "Rollover Caused by Concrete Safety Shaped Barrier", Report No. FHWA-RD-88-219 and FHWA-RD-88-220, Texas Transportation Institute and Federal Highway Administration, January 1989.
7. Bronstad, M.E., Calcote, L.R, and Kimball, Jr., C.E, "Concrete Median Barrier Research," Report No. FHWA-RD-77-3 and 77-4, Federal Highway Administration, Washington, D.C., March 1976.
8. Perera, H. S. and Ross, H.E. Jr., "Prediction of Rollovers Caused by Concrete Safety-Shape Barriers", Transportation Research Record, No. 1233, pp. 124-131, 1989.
9. Pfeifer, B.G., Holloway, J.C., Faller, R.K., and Post, E.R., "Full-Scale 18,000 LB Vehicle Crash Test on the Iowa Retrofit Concrete Barrier Rail", Report No. TRP-03-19-90, University of Nebraska-Lincoln, January 1990.
10. McDonald, D.J. and Kirk, A.R., "Precast Concrete Barrier Crash Testing", Report No. FHWA-OR-RD-02-07, Oregon Department of Transportation and Federal Highway Administration, December 2001.
11. Rosenbaugh, S.K., Sicking, D.L., and Faller, R.K., "Development of a TL-5 Vertical Faced Concrete Median Barrier Incorporating Head Ejection Criteria", Final Report to the Nebraska Department of Roads, Midwest Research Report No. TRP-03-194-07 (Final), Project No.: SPR-3(017)-Year 15, Supplement 33, Midwest Roadside Safety Facility, University of Nebraska-Lincoln, December 2007.
12. Huelke, D.F. and Compton, C.P., "Injury Frequency and Severity in Rollover Car Crashes Related to Occupant Ejection, Contacts and Roof Damage", Report No. PT-101, Society of Automotive Engineers, January 2004.

13. Malliaris, A. and DeBlois, H., "Pivotal Characterization of Rollover", Proceedings of the 13<sup>th</sup> ESV Conference, 1991a.
14. Briglia, P. M., Benac, J. D., Geno, D. E., and McDonald, K. A. "An Evaluation of Concrete Median Barrier in Michigan", Report No. TSD.531-83, Michigan Department of Transportation, Michigan, June 1983.
15. Deuterman, W., "Characteristics of Fatal Rollover Crashes", Report No. DOT HS 809438, 2002 NHTSA, Washington, D.C., 2001.
16. Digges, K., H. and Eigen, A. M., "Crash Attributes that Influence the Severity of Rollover Crashes", Paper 231, Proceedings of the ESV Conference, May 2003.
17. Wright, P.H. and Zador, P., "Study of Fatal Rollover Crashes in Georgia", Journal of the Transportation Research Board, Transportation Research Record No. 819, Washington D.C., 1981.
18. Huelke, D.F., Marsh, J.C., and Sherman, H.W., "Analysis of Rollover Accident Factors and Injury Causation", American Association for Automotive Medicine Conf Proc; Issue 16; pagination 62-79, American Association for Automotive Medicine, 1973.
19. Mackay, G.M., Parkin, S., Morris, A.P., and Brown, R.N. , "The Urban Rollover: Characteristics, Injuries, Seat-Belts, and Ejection", Report No. PT-101, Society of Automotive Engineers, January 2004.
20. Folsom, J., Stoughton, R., and Glauz, D., "A Seat Belt Efficacy Demonstration: a Large Angle Moderate Speed Impact into a Concrete Median Barrier". Report No: CA/TL-87/06 Final Report. California Department of Transportation; April 1987.
21. Melvin, J.W., Mohan, D., and Stalnaker, R.L., "Human Injury Mechanisms and Impact Tolerance", Transportation Research Record No. 586, pp. 11-21, Transportation Research Board, 1976.
22. Huelke, D.F. and Compton, C.P., "Injury Frequency and Severity in Rollover Car Crashes Related to Occupant Ejection, Contacts and Roof Damage", Report No. PT-101, Society of Automotive Engineers, January 2004.
23. Bedard, M., Guyatt, G.H., Stones, M.J., and Hirdes, J.P. "The independent contribution of driver, crash, and vehicle characteristics to driver fatalities", Accident Analysis and Prevention 34(6), pp. 717-727, 2002.
24. Hanrahan, R.B., Layde, P.M., Zhu, S., Guse, C.E., and Hargarten, S.W., "The Association of Driver Age with Traffic Injury Severity in Wisconsin", Traffic Injury Prevention, Vol. 10, Issue 4, pp. 361-367, 2009.
25. Evans, L. and Frick, M., "Seating Position in Cars and Fatality Risk". American Journal Public Health, 78, 1456-1458, 1988.

26. Mclaughlin, S.B., Hankey, J.M., Klauer, S.G., and Dingus, T.A., “Contributing Factors to Run-Off-Road Crashes and Near-Crashes”, U.S Department of Transportation, National Highway Traffic Safety Administration, Report No: DOT HS 811 079, January, 2009.
27. R.S. Nielsen, Washington State Department of Transportation, “Small Car Accident Experience in Washington State”, Report No. HS-037 797, January, 1983.
28. Kahane. C. J., “Vehicle Weight, Fatality Risk, and Crash Compatibility of Model Year 1991-99 Passenger Cars and Light Trucks”, <http://www.nhtsa.dot.gov/cars/rules/regrev/evaluate/pdf/809662.pdf>. Accessed July 1, 2004.
29. Farmer, C. M., Braver, E. R., and Milter, E.L., “Two-vehicle side impact crashes: The relationship of vehicle and crash characteristics to injury severity”, *Accident Analysis and Prevention* 29(3), pp.399-406, 1997.
30. Toy, E.L. and Hammit, J.K., “Safety Impacts of SUVs, Vans, and Pickup Trucks in Two-vehicle Crashes”, *Risk Analysis* 23(4), pp. 641-650, 2003.
31. Liu, C. and Subramanian, R., “Factors Related to Fatal Single-Vehicle Run-off-Road Crashes”, U.S. Department of Transportation, National Highway Traffic Safety Administration, Report No. DOT HS 811 232, November 2005.
32. Dissanayake, S., “Young Drivers and Run-off--the-Road Crashes”, *Proceedings of the 2003 Mid-Continent Transportation Research Symposium*, Iowa, August 2003.
33. Mclaughlin, S.B., Hankey, J.M., Klauer, S.G., and Dingus, T.A., “Contributing Factors to Run-Off-Road Crashes and Near-Crashes”, U.S. Department of Transportation, National Highway Traffic Safety Administration, Report No. DOT HS 811 079, January 2009.
34. McGinnis, R.G., Davis, M.J., and Hathaway, E.A., “Longitudinal Analysis of Fatal Run-Off-Road Crashes”, *Journal of the Transportation Research Board*, Transportation Research Record No. 1746, Washington D.C., 2001.
35. Albuquerque, F.D.B., Sicking, D.L., and Stolle, C.S. “Roadway Departure and Impact Conditions”, *Journal of the Transportation Research Board*, Transportation Research Record No. 2195, Washington, D.C., 2010.
36. Kaiser, H., “Traffic Accidents on Highway Bridges on Rural State Highways in Ohio”, *Proceedings of 10<sup>th</sup> Annual Ohio Engineering Conference*, Ohio State University, 1956.
37. Hilton, M.H., “Some Case Studies of Highway Bridges Involved in Accidents,” paper presented at TRB Meeting, January 1973.
38. National Highway Traffic Safety Administration [NHTSA], *Compilation of Annual Accident Reports of 43 States*, 1978.

39. “Highway Design and Operational Practices Related to Highway Safety”, American Association of Highway and Transportation Officials [AASHTO], Second Edition, 1974.
40. Mak, K.K. and Calcote, L.R., “Accident Analysis of Highway Narrow Bridge Sites”, Volume II – Technical Documentation, Federal Highway Administration, February 1983.
41. Michie, J.D., “Strategy for Selection of Bridges for Safety Improvement,” Transportation Research Record No. 757, Washington, D.C., 1980.
42. Raff, M.S. and Jorgensen, S.H., “Interstate Highway – Accident Study,” Highway Research Board Bulletin No. 74, pp. 18-45, 1953.
43. Agent, K.R., “Accident Associated with Highway Bridges”, Division of Department of Transportation, Federal Highway Administration, January 1980.
44. Council, F.M. and Reinfurt, D.W., Accident Research Manual, U.S. Department of Transportation, Federal Highway Administration, Report No. FHWA-RD-76-25, August 1975.
45. Agent, K.R. and Deen, R.C., “Highway Accidents at Bridges”, Journal of the Transportation Research Board, Transportation Research Record No. 601, 1976.
46. Ogden, K.W., “Crashes at Bridges and Culverts”, Monash University Accident Research Centre, Melbourne, Australia, April 1989.
47. Turner, D. S., “Prediction of Bridge Accident Rates”, Journal of Transportation Engineering, American Society of Civil Engineering (ASCE), Volume 110, No. 1, pp. 45-54, January/February 1984.
48. Hurt, M., Schrock, S. D., and Rescot, R., “Review of crashes at bridges in Kansas”, Proceedings of the 2009 Mid-Continent Transportation Research Symposium, Iowa, August 2009.
49. Draper, N.R., and Smith, H., Applied Regression Analysis, third edition. New York: Wiley.
50. Agresti, A., (2002). Categorical Data Analysis, 2<sup>nd</sup> Edition. New York: Wiley.
51. Duncan, C., Khattak, A., and Council, F., “Applying the Ordered Probit Model to Injury Severity in Truck-Passenger Car Rear-end Collisions”. Proceedings of 77<sup>th</sup> Annual Meeting of the Transportation Research Board, Transportation Research Board, Washington, D.C, 1998.
52. Lui, K.J., Mc Gee, D., Rhodes, P., and Pollock, D., “An Application of Conditional Logistic Regression to Study the Effects of Safety Belts, Principal Impact Points, and Car Weights on Driver’s Fatalities”, Journal of Safety Research 19, 197-203, 1988.

53. Abdel-aty, M.A., Chen, C., and Schott, J.R., “An Assessment of the Effect of Driver Age on Traffic Accident Involvement Using Log-Linear Models”, *Accident Analysis and Prevention*, 30(6), 851-861, 1998.
54. Jones, A.P. and Jorgensen, S.H., “The Use of Multilevel Models for the Prediction of Road Accident Outcomes”, *Accident Analysis and Prevention*, 35, 59-70, 2003.
55. Long, J.S., *Regression Models for Categorical and Limited Dependent Variables*, Advanced Quantitative Techniques in the Social Sciences Series, 1997.
56. Ye, F., and Lord, D., “Investigating the Effects of Underreporting of Crash Data on Three Commonly Used Traffic Crash Severity Models: Multinomial Logit, Ordered Probit and Mixed Logit Models”, Paper to be presented at the 90<sup>th</sup> Transportation Research Board Meeting.
57. Quddus, M., Wang, C., and Ison, S.G., “Road Traffic Congestion and Crash Severity: Econometric Analysis Using Ordered Response Models”, *Journal of Transportation Engineering*, American Society of Civil Engineering (ASCE), Volume 136, No. 5, pp. 424-435, May 2010.
58. Stokes, M.E., Davis, C.S., and Koch, G.G., “Categorical Data Analysis Using the SAS System”, 2<sup>nd</sup> Edition, SAS.
59. Eliason, S.R., “Maximum Likelihood Estimation Logic and Practice”, Series: Quantitative Applications in the Social Sciences.
60. Hosmer, D.W. and Lemeshow, S., “Applied Logistic Regression, 2<sup>nd</sup> Edition, New York: Wiley.
61. McCullagh, P. and Nelder, J.A., “Generalized Linear Models”, London: Chapman & Hall.
62. Bendel, R.B. and Afifi, A.A., “Comparison of Stopping Rules in Forward ‘Stepwise’ Regression”, *Journal of the American Statistical Association*, Volume 72, pp. 46-53, 1977.
63. Faller, R.K., Magdaleno, J., A., and Post, E., R., “Full-Scale Vehicle Crash Tests on the Iowa Box-Aluminum Bridge Rail”, Final Report to Iowa Department of Transportation, Midwest Research Report No. TRP-03-013-88, Civil Engineering Department, University of Nebraska-Lincoln, December 1988.
64. Mickey, R.M. and Greenland, S., “The impact of confounder selection criteria on effect estimation”, *American Journal of Epidemiology*, 129, pp. 125-137, 1989.
65. Parenteau, C.S. and Shah, M., “Driver Injuries in US Single-Event Rollovers”, Report No. PT-101, Society of Automotive Engineers, January 2004.

66. Jehu, V.J. and Pearson, L.C., “Impacts of European Cars and a Passenger Coach Against Shaped Concrete Barriers”, Transport and Road Research Laboratory Report, 1977.
67. Qunicy, R. and Vulin, D., “Concrete Median Barriers Crash Tests and Accident Investigations”, Transportation Research Circular, Issue 341, pp. 17-23, Transportation Research Record, December 1988.
68. Grzebieta, R.H., Zou, R. and Jiang, T., “Roadside hazard and barrier crashworthiness issues confronting vehicle and barrier manufactures and government regulators”, Proceedings - 19th International Technical Conference on the Enhanced Safety of Vehicles, Washington, D.C., June 2005.
69. Evans, L., “Driver fatalities versus car mass using a new exposure approach”, Transportation Research Department, 1977.
70. Viner, J.G., Council, F.M., and Stewart, J.R., “Frequency and Severity of Crashes Involving Roadside Safety Hardware by Vehicle Type”. Report No. 940894, Transportation Research Board, January 1994.



## **11 APPENDICES**

## **Appendix A. Summary of Literature Reviews**

**Summary 1:**

Bronstad, M.E., Calcote, L.R., and Kimball, Jr., C.E., “Concrete Median Barrier Research,” Report No. FHWA-RD-77-3 and 77-4, Federal Highway Administration, Washington D.C., March 1976.

**Study Purpose:**

Evaluate the safety performance of concrete safety-shape barriers.

**Scope:**

Baseline crash tests were conducted to provide comparison between New Jersey and General Motors shapes when impacted by standard and subcompact sedans. In addition, baseline crash tests with a new shape (i.e., configuration F), identified during parametric evaluations using the Calspan HVOSM crash simulation program, were also conducted for comparison to the two other shapes (i.e., New Jersey and General Motors).

Impact conditions of 60 mph (95 km/h) and angles of 7 and 15 degrees were selected to compare the shapes. Vehicles weighting 4370 lb (1980 kg) and 2250 lb (1020 kg) were used for the crash tests.

**Findings:**

It was verified that the F-shape barrier reduced the tendency of vehicle rollover in relation to the other two concrete shapes. Roll angles decreased considerably in most of the tests for the standard and subcompact vehicles.

**Critique and important background provided to current research:**

The results of the accident data were collected from more than thirty years ago. Thus, the car population that is in use today is different from the car sample used for accident studies. Thus, these results might not reflect the reality in nowadays.



**Summary 2:**

Ray, M.H., “Summary Report on Selected Bridge Railings”, Report No. FHWA-SA-91-049, Federal Highway Administration, Washington D.C., June 1992.

**Study Purpose:**

Summarize the development, testing and field performance of three bridge railing design: the F-shape concrete bridge railing, the vertical wall bridge railing, and the Illinois 2399-1 steel tube bridge railing.

**Scope:**

Descriptions of the appurtenances and an explanation of the design principals are included along with estimates of the construction costs. All information on this summary is based on the study performed to determine which shape was the safest barrier profile to use. This study was conducted in the early 1970’s with the participation of 36 states that used a safety-shape concrete barrier. The F-shape was included on the 1986 list of crash tested bridge railings acceptable to the FHWA since it had been tested in the 1970’s. The FHWA and a number of states sponsored crash tests to develop PL-2 and PL-3 versions of the F-shape bridge railing and of the vertical bridge railing so that the classification of these rails could be based on performance levels. Two versions of the F-shape concrete barrier and vertical concrete barrier were presented: 32-in. (813-mm) tall and 42-in. (1,067-mm) tall.

**Findings:**

While safety-shape barriers are characterized by lower occupant risk value as compared to vertical barriers, the occupant risk value for vertical barriers is still within the currently accepted guidelines of 1989 AASHTO guide specifications.

The author concludes that both vertical concrete barrier and F-shape concrete barrier can be considered options with maintenance free and only exceptionally severe collisions will take these barriers out of service.

Based on the crash tests, the 42-in. (1,067-mm) tall F-shape concrete barrier has been recommended for impacts with large vehicles like a 50,000 lb (22,680 kg) tractor trailer trucks.

**Critique and important background provided to current research:**

It was found that the lower break point (10 in. (254 mm) from the pavement) is instrumental in the improved stability characteristics of the F-shape as compared to the New-Jersey shape when rollover propensity is a concern.

Even though occupant risk values were acceptable, higher occupant responses and increased vehicle damage are undesirable trades-offs of the vertical wall. The author also appoints the vertical concrete barrier as a better choice than F-shape where minimizing the chance of a rollover is a priority because vehicles were very stable in all tests with the vertical wall.

The summary does not present crash test or in-service evaluations on the F-shape and on the vertical concrete barriers.

**Summary 3:**

McDevitt, C.F., “Basics of Concrete Barriers”, Journal Title: Public Roads, Federal Highway Administration, Washington D.C., March 2000.

**Study Purpose:**

Document the main kinds of concrete barriers in use today and their particularities.

**Scope:**

This journal describes the main kinds of concrete barriers in use today such as concrete safety shape (high-performance, F-shape, GM-shape and NJ-shape), vertical concrete parapet, constant-slope concrete barrier, low-profile concrete barrier, and portable concrete barrier. The journal also discusses the differences among the different shapes of these barrier profiles and the effects of these shapes on vehicle redirection and stability.

**Findings:**

The author discusses that the key design parameter for a safety shape profile is the distance from the ground to the slope break point because this determines how much the suspension will be compressed. The GM-shape was discontinued because its higher distance from the slope break point to the ground (15 in. (381 mm)) caused excessive lifting of the small cars from 1970s.

A parametric study, using computer simulations, of several barrier profiles was performed and barrier configurations were labeled A through F. The F profile performed distinctly better than the New-Jersey shape. The results of these computer simulations were confirmed by a series of full-scale crash tests. Configuration F became known as the F-shape.

The major difference between the F-shape and the New-Jersey concrete barrier is the distance from the ground to the slope break point which is 10 in. (254 mm), 3 in. (75 mm) lower

than for the New-Jersey shape. It is expected that this lower break point may reduce the lifting of the vehicle and greatly improve the performance of the concrete barrier regarding vehicle stability.

Based on full-scale crash tests, vertical parapets can perform acceptably as traffic barriers. Although they tend to cause greater damage on the vehicles and higher occupant responses, these barriers are able to decrease the propensity of vehicle rollover because bumpers usually do not slide up vertical concrete walls and lift the vehicle. Trajectories of passenger cars after crashing into vertical concrete barriers have been pointed as a problem due to the uncertainty to predict them because of the wheel damage that can occur.

**Critique and important background provided to current research:**

The higher the slope-break point, the higher the rollover propensity due to vehicle climbing/lifting. Vertical barriers tend to cause higher occupant responses.



**Summary 4:**

Jehu, V.J. and Pearson, L.C., “Impacts of European Cars and a Passenger Coach against Shaped Concrete Barriers”, Transport and Road Research Laboratory Report 801, 1977.

**Study Purpose:**

Investigate the safety adequacy of safety-shape concrete barriers when impacted by passenger cars and a passenger coach under different crash conditions.

**Scope:**

Several crash tests were conducted to verify the containment capability of the fences and bridge parapets, and their capability to properly redirect vehicles.

Barriers were labeled from shape 1 to 5 corresponding to General Motors barrier, New Jersey barrier raised 3 in. (75 mm), New Jersey barrier with a layer of concrete 2 ½ in. (63 mm) thick added to the lower slope of shape 2, New Jersey parapet (59 in. (1500 mm) height), and New Jersey parapet lowered 3 in. (75 mm).

**Findings:**

Even though acceptable when impacted by a Leyland 1800 car, shapes 1 and 2 were not recommended to be used for dual three-lane carriageway roads because the Leyland Mini severely rolled over when impacting at 70.8 mph (114 km/h) at an relative shallow angle (i.e., 20 degrees). However, when impact speed was reduced to 52.8 mph (85 km/h), rollovers were avoided with the mini car. No benefit was observed upstanding the shape 1 to reach the shape 2.

Shapes 3 and 4 showed no success when being impacted by the mini car at 62.8 mph (101 km/h) and 59.0 mph (95 km/h), respectively. The vehicle rolled over for these conditions.

Shape 5 showed important results in determining the importance of the slope break point height. The mini car did not roll over when impacted against this parapet.

The shape 4 showed to be efficient in redirecting the passenger coach at 44.7 mph (72 km/h) with the vehicle remaining upright the parapet and suffering a small roll angle.

**Critique and important background provided to current research:**

Rigid barriers are able to contain and redirect even heavy vehicles at severe impact conditions.

**Summary 5:**

Qunicy, R. and Vulin, D., “Concrete Median Barriers Crash Tests and Accident Investigations”. Transportation Research Circular, Issue 341, pp. 17-23, Transportation Research Record, December 1988.

**Study Purpose:**

Present the safety performance results of concrete barriers placed either on medians or on the roadside.

**Scope:**

Crash tests with a truck, buses and passenger cars were conducted. In-service data was also collected to investigate the safety performance of concrete barriers.

**Findings:**

Tests with passenger cars impacting standard guardrail resulted in less severe impact forces compared to concrete barriers. When impacted by a truck and three buses, the standard concrete barrier presented fair results. These vehicles were redirected and the deformation as well as decelerations was within acceptable limits. The barrier did suffer only minimal cracks.

In-service data from accidents in a suburban highway was collected and better safety levels were found for concrete barriers when compared to the standard guardrail. This was attributed mainly to the fact that, since barriers were placed in the median, smaller deflections would increase safety.

**Critique and important background provided to current research:**

Full-scale crash tests showed that guardrail crashes seemed to produce lower forces compared to concrete barrier crashes, but concrete barrier results were within acceptable limits.

However, when in-service data from suburban highways were taken in consideration, concrete barriers presented better safety levels mainly because of their smaller deflections.

The information is not well detailed and the analyses presented in the paper are cursory in nature.

**Summary 6:**

Perera, H.S. and Ross, H.E.Jr., “Prediction of Rollovers Caused by Concrete Safety-Shape Barriers”, Transportation Research Record, no. 1233, pp. 124-131, Washington, D.C., 1989.

**Study Purpose:**

Evaluate the safety performance of different concrete barrier designs such as the concrete safety-shape barrier (CSSB) and the New Jersey profile. The performance was evaluated under tracking and non-tracking impact conditions using computer simulation model.

**Scope:**

The study first shows findings from extensive literature review. It was found from the literature that Council, in “Safe Geometric Design for Minicars”, found that small cars have an increased propensity to overturn in almost all types of accidents, including impacts with the CSSB. On the other hand, Ross, in “Roadside Safety Design for Small Vehicles”, found different results from Council.

The study proceeded with computer simulation using HVOSM to investigate not only the divergent findings found from the literature, but also the behavior of large vehicle impacts with CSSB, nontracking impacts, and the tracking impacts at lower speeds and higher impact angles than those recommended in NCHRP Report No. 230. The constant slope concrete wall, the modified CSSB and the vertical concrete wall were used as other potential new barrier designs being impacted by small and large cars.

The HVOSM was submitted to several modifications as calibration efforts to capture the propensity of overturns.

**Findings:**

For cars crashing into a CSSB with high impact speed and angle, small cars presented greater propensity to overturn than larger cars did under tracking and non-tracking conditions.

Even though it is not noted whether the vertical concrete wall and the constant slope wall barrier would provoke more serious injuries to vehicle's occupants than the CSSB, they presented the smallest roll angle which can mean that they have a lower propensity to cause rollovers.

**Critique and important background provided to current research:**

Vertical concrete barriers presented smaller roll angles compared to CSSB.

**Summary 7:**

Grzebieta, R.H., Zou, R., Jiang, T. and Carey, A., “Roadside hazard and barrier crashworthiness issues confronting vehicle and barrier manufactures and government regulators”, Monash University, Dept. of Civil Engineering, Australia, Report number: 05-0149.

**Study Purpose:**

Provide knowledge on the safety performance of concrete barriers, steel guardrail barriers, wire rope barriers, and temporary plastic barriers through available literature and full-scale crash tests.

**Scope:**

The study provides background indicating that 40% of the road fatalities in Australia are due to run-off-the-road crashes which involved a vehicle leaving the road and hitting a roadside hazard and/or rolling-over.

A series of crash tests provided insight into outcomes of vehicle-barrier crashes, vehicle damage, occupant and vehicle kinematics, and desirable occupant protection systems related to existing barrier profiles. A Toyota Echo was used to impact the rigid concrete barrier at 49.7 mph (80 km/h) and 45 degrees as well as at 68.4 mph (110 km/h) and 20 degrees, the guardrail barrier at 68.4 mph (110 km/h) and 20 degrees as well as at 49.7 mph (80 km/h) and 45 degrees, and the wirerope barrier at 68.4 mph (110 km/h) and 20 degrees.

**Findings:**

It was found that airbags are very likely to deploy when the vehicle strikes rigid concrete barriers when the impact speed exceeds 37.3 mph (60 km/h) and when impact angle exceeds 20 degrees. Significant damage to vehicle steering was observed for these impacts.

When the Toyota Echo was submitted to an impact against rigid concrete barriers (F-shape and New Jersey) with a speed of 49.7 mph (80 km/h) and an impact angle of 45 degrees, the behavior of the vehicle was totally inadequate to ensure the safety of occupants. Under these conditions, the small car was launched meters above the ground followed by rollovers causing serious external and internal damages to the car, including roof damage. The Toyota Echo was also launched in the air when submitted to a crash test at impact speed of 68.4 mph (110 km/h) and impact angle of 20 degrees. The dummy's head was thrown towards the side window and the passenger's head stroke the shoulder of the driver. Airbags were immediately deployed in both tests.

On the other hand, when struck against a guardrail barrier, the Toyota Echo was brought safely to rest in a controlled manner when it impacted the guardrail system at 62.1 mph (100 km/h) and a 20-degree angle. The vehicle was "pocketed" into the barrier rather than being redirected when it impacted the system at 49.7 mph (80 km/h) and 45-degree angle.

**Critique and important background provided to current research:**

The study indicates that small cars have a high propensity to roll over as they are involved in severe concrete barrier crashes. This propensity seemed to be similar independently of concrete barrier type (i.e., F-shape or New Jersey). As vehicles roll over, there is a significant chance of disabling or even fatal injuries to occur. These injuries may happen even with proper use of occupant restraint systems since extensive roof damage was observed which may cause head and neck injuries.

Steel guardrail systems seemed to work better for severe crashes even though vehicle may have undergone too high deceleration at a 45-degree angle.



It is important to note that impact conditions used in this study are not frequently seen in real-world crashes. A recent study conducted by Albuquerque et al. showed that the 90<sup>th</sup> percentile of impact angle is well below 45 degrees used for the crash tests.

**Summary 8:**

Briglia, P.M., Benac, J.D., Geno, D.E. and McDonald, K. A., “An Evaluation of Concrete Median Barrier in Michigan”, Michigan Department of Transportation, Report no. TSD.531-83, Michigan, June 1983.

**Study Purpose:**

Investigate accident experience before and after concrete median barrier installations on Michigan roadways in terms of accidents/mile, percentage of total accidents, severity ratio, single as well as multivehicle accidents, and fatal accidents. The study also intended to investigate the effects of various vehicle and roadway characteristics (i.e. alignment, shoulder slope, glare screen, curb/shoulder type, ADT, and number of lanes) on the number of injury and fatal concrete median barrier accidents.

**Scope:**

Accident data from 1971 to 1981 related to concrete median barriers was collected and divided into three categories according to the earlier conditions at the median sites where concrete median barriers were placed.

Statistical techniques were used to investigate the effects of several variables on accidents related to median barriers.

**Findings:**

Small cars represented a large percentage of vehicles involved in injury and fatal rollover accidents. Severity ratio of concrete median barrier accidents was greater than that for left-side guardrail accidents.

**Critique and important background provided to current research:**

Accident severity was found to be higher for concrete barrier than for guardrails.

**Summary 9:**

Huelke, D.F., Marsh, J.C., and Sherman, H.W., “Analysis of Rollover Accident Factors and Injury Causation”, American Association for Automedicine, Conference Proceedings, Issue 16, pp. 62-79, 1973.

**Study Purpose:**

Analyze characteristics of rollovers such as frequency, vehicle damage and occupant injury severity.

**Scope:**

Statistical analysis was developed to study data from the Highway Safety Research Institute at the University of Michigan.

**Findings:**

The percentage of rollovers significantly increased as crashes were single-vehicle type crashes, as vehicle was a small car, as speed limit was above 40 mph (64 km/h), on rural areas, on curved sections, under low visibility conditions, and with impaired drivers.

The percentage of ejections exponentially increased when rollovers happened which was accompanied by increase in the number of deaths. Side windows were the most common way through which occupants were ejected.

**Critique and important background provided to current research:**

Rollovers are more likely to occur with single-vehicle crashes occurring on rural roads with high speed limits. Ejection tends to increase the risk of fatalities greatly.

**Summary 10:**

Folsom, J., Stoughton, R., and Glauz, D. “A Seat Belt Efficacy Demonstration: a Large Angle Moderate Speed Impact into a Concrete Median Barrier”. Final Report no. CA/TL-87/06, California Department of Transportation, April 1987.

**Study Purpose:**

Demonstrate the importance of seat belts on vehicle occupant safety as well as determine vehicle behavior during and after impact with a safety-shape barrier at a large angle and moderate speed.

**Scope:**

One full-scale crash test was conducted at the Caltrans Dynamic Test Facility in Bryte, California. A 1975 Ford Granada weighing 3,575 lb (1,622 kg) impacted an immovable New Jersey concrete median barrier at 40.3 mph (25 km/h) and 45 degrees. Two anthropomorphic dummies were used to study the seat belt efficacy. One of the dummies was not wearing seat belt.

**Findings:**

While the restrained dummy was not hit at the head, knee or torso, the unrestrained occupant would have had serious knee and head injuries. The unrestrained dummy's head went forward and fractured the windshield, while his knees fractured the plastic in the area left side of the glove compartment. This accident was considered as highly probable to be a fatal accident for an unrestrained occupant.

The vehicle was contained and redirected in an acceptable manner and no structural damage was observed on the concrete barrier.

**Critique and important background provided to current research:**

This research shows the importance of seat belt usage, more specifically in cases when crashes occur at moderate to severe crash conditions against rigid barriers. The unrestrained occupant would probably have suffered fatal injuries if a real accident happened under these crash and safety constraint conditions. Also, even though the impact conditions were relatively intense, especially because of the 45-degree impact angle, the vehicle was contained and acceptably redirected as it crashed against the safety-shape barrier.

**Summary 11:**

Parenteau, C.S. and Shah, M., “Driver Injuries in US Single-Event Rollovers”, Society of Automotive Engineers, Report No. PT-101, January 2004.

**Study Purpose:**

Investigate the driver’s injuries caused by rollovers.

**Scope:**

Investigation of injuries caused by rollovers was accomplished using data obtained from the Weighted National Automotive Sampling System/Crashworthiness Data System (NASS-CDS). The influences of roll direction, ejection, seat-belt usage, and number of rollover turns on driver’s injuries were all studied. Trip-overs were the type of rollovers included in this study.

**Findings:**

Even though there were three times more belted than unbelted drivers, the percentage of ejections was immensely greater for unbelted drivers (i.e., 27 percent of unbelted drivers versus only 1 percent of belted drivers). Further, the percent of drivers that were seriously injured was higher for those that were partially or completely ejected. The probability of a driver to be seriously injured with no ejection due to a rollover crash was twice higher for unbelted as compared to belted drivers. Therefore, seat-belt usage seems to be an effective measure to avoid or at least minimize rollover injuries.

The study also indicates that when the vehicle rolled right, the most frequent injuries were in the spine, thorax and head. When the vehicle rolled left, the most affected body areas were head, extremities, and thorax.

The left-side window was the most common area through which ejections occurred.

**Critique and important background provided to current research:**

Seat-belt usage was found to be an effective safety measure to decrease driver injuries caused by rollover crashes. Rollover crashes cause injuries mainly in the head, spine, thorax, and limbs. Ejections occurred more often with unbelted drivers and they tended to increase injury severity.

**Summary 12:**

Huelke, D.F. and Compton, C.P., “Injury Frequency and Severity in Rollover Car Crashes Related to Occupant Ejection, Contacts and Roof Damage”, Society of Automotive Engineers, Report No. PT-101, January 2004.

**Study Purpose:**

Investigate the effects of occupant ejection, occupant contact, and roof damage on injury frequency and severity in rollover car crashes.

**Scope:**

Based on data from the National Highway Traffic Safety Administration (NHTSA), a national crash severity study was developed. The accidents were sampled at several rates according to the worst injury in a vehicle case.

Rollovers were defined as accidents that involved vehicles with primary roof damage due to ground contact. Almost 500 (4.1 percent) accidents were found to be involved in rollovers from 12,050 analyzed accidents.

The study included investigations about the rollover crash frequency, injury severity in various types of crashes, relationship between rollover frequency and ejection, objects contacted and injury severity, injury severity related to roof deformation, and body region injury severity related to ejection.

**Findings:**

The distribution of injury severity for rollovers was comparable to that for all other crash types such as rear-end, frontal and side.



Eight percent of the rollovers resulted in occupant ejections. The chance of an ejected occupant to be seriously injured was found to be seventeen times greater than a non-ejected occupant.

Smaller cars were involved more frequently in rollovers but ejection was less likely for those cars as compared to larger cars.

The head was the most frequent body's part injured in rollovers but more than ninety percent of these injuries were not serious injuries while the injuries classified as high severity level occurred on ejected occupants. Further, head, chest and extremities were seriously injured more often than were neck, back and abdomen.

It was not found a significant evidence to establish relationship between roof deformation and injury severity.

**Critique and important background provided to current research:**

Rollovers are relatively frequent considering that they accounted for eight percent of all crashes. Higher injury severity is expected when ejection occurs.

There is no description about the relationship between seat-belt usage and ejections, which makes difficult to determine whether the frequency and severity of injuries could simply be decreased and/or mitigated by seat-belt usage.

**Summary 13:**

Mackay, G.M., Parkin, S., Morris, A.P., and Brown, R.N. "The Urban Rollover: Characteristics, Injuries, Seat-Belts and Ejection". Society of Automotive Engineers, Report No. PT-101, January 2004.

**Study Purpose:**

Analyze the rollover crash characteristics and the injury consequences.

**Scope:**

Data was collected from vehicle accidents that occurred in an urban environment, in and around the West Midlands conurbation. A total of 158 vehicles and 282 occupants were registered. In addition, data from local hospitals were collected in relation to occupant injuries. Important information such as accident types, occupant age and sex, impact type, first object struck, seat belt use, ejection, and body's parts injured were collected.

Rollovers were defined as at least 90 degrees of vehicular rotation about any horizontal axis.

**Findings:**

Posts and other cars were the most common objects struck responsible for rollover initiation, representing more than 50 percent of them. Over 70 percent of the rollover events involved one single vehicle only. Most the rollovers had at most one turn, being 63 percent of them a maximum of one-half revolution. The percentage of those that exceeded one revolution decreased exponentially. Over 60 percent of the vehicles rolled over after a major impact which evidently shows the urban environment influence.

It was also found that non-restrained occupants were immensely more likely to be ejected which was directly related to serious or fatal injuries. Injury severity rate was much lower to

non-ejected restrained occupants who received more serious injuries on the thorax and neck which may have reflected the seat-belt effect. On the other hand, almost all unrestrained occupants received head injuries.

It was shown that, in general, males have a higher propensity to be involved in rollover accidents than females. Further, more than 50 percent of the people involved in rollover were between 16 and 25 years old.

This study shows no significant correlation between occupant injury and roof deformation. The paper also mentions another study by Plastiras et al., 1985, in which similar conclusion, regarding no association between occupant injury and roof deformation, was found.

**Critique and important background provided to current research:**

In general, seat-belts were not able to spare occupants from suffering at least low level injuries. Urban rollovers were not considered as a mortal event since 85 percent of them caused low level injuries. In general, rollovers were not a too dramatic event. Young males were more prone to be involved in rollovers.

Study does not indicate any relationship between vehicle type and rollover. Such correlation could also be crucial to better understand factors affecting rollover occurrence.

**Summary 14:**

Evans, L., "Driver fatalities versus car mass using a new exposure approach", *Accident Analysis & Prevention*, Volume 16, Issue 1, pp. 19-36, 1984.

**Study Purpose:**

Investigate a relationship between car mass and driver fatality rates.

**Scope:**

Investigation of a relationship between car mass and driver fatality is based on accident data.

**Findings:**

Car mass is a crucial factor able to affect directly the probability of a driver to survive a car crash. That is, increasing the car mass, the survival probability will also increase greatly.

**Critique and important background provided to current research:**

Occupants of heavier vehicles have higher survival chances than occupants of lighter vehicles.

**Summary 15:**

Viner, J.G., Council, F.M., Stewart, J.R., “Frequency and Severity of Crashes Involving Roadside Safety Hardware by Vehicle Type”, Journal of Transportation Research Board, Transportation Research Record, No. 1468, Washington, D.C., January 1994.

**Study Purpose:**

Investigate whether the frequency and severity of crashes involving roadside safety hardware can be aggravated due to vehicle type.

**Scope:**

State (Michigan and North Carolina) and national (FARS and GES) Crash data was collected and analyzed. The investigation considered differences in driver injuries by vehicle body type and different roadside safety hardware. Statistical analyses were done and syntheses are displayed on tables.

**Findings:**

The FARS data shows that 42 percent of the cases of deaths were caused by rollovers which 31 percent involved bridge rails.

Passenger cars presented smaller rollover rates as compared to those from pickup trucks, utility vehicles and vans combined.

**Critique and important background provided to current research:**

Vehicles with higher center of gravity (e.g., pickups and vans) appear to be more prone to rollover compared to vehicles with lower center of gravity (e.g., passenger cars). A large portion of the fatal injuries were caused by accidents that involved bridge rail impacts resulting in rollovers.

**END OF DOCUMENT**