



DEVELOPMENT GUIDANCE FOR SIGN DESIGN STANDARDS

Test Report 0-6363-1

Cooperative Research Program

TEXAS TRANSPORTATION INSTITUTE
THE TEXAS A&M UNIVERSITY SYSTEM
COLLEGE STATION, TEXAS

TEXAS DEPARTMENT OF TRANSPORTATION

in cooperation with the
Federal Highway Administration and the
Texas Department of Transportation
<http://tti.tamu.edu/documents/0-6363-1.pdf>

| | | | |
|---|-----------------------------|--|-----------|
| 1. Report No. FHWA/TX-12/0-6363-1 | 2. Government Accession No. | 3. Recipient's Catalog No. | |
| 4. Title and Subtitle DEVELOPMENT GUIDANCE FOR SIGN DESIGN STANDARDS | | 5. Report Date November 2011 Published: February 2012 | |
| 7. Author(s) Chiara Silvestri, Dusty R. Arrington, Roger P. Bligh, and Wanda L. Menges | | 6. Performing Organization Code | |
| 9. Performing Organization Name and Address Texas Transportation Institute Proving Ground The Texas A&M University System College Station, Texas 77843-3135 | | 8. Performing Organization Report No. Test Report 0-6363-1 | |
| 12. Sponsoring Agency Name and Address Texas Department of Transportation Research and Technology Implementation Office P.O. Box 5080 Austin, Texas 78763-5080 | | 10. Work Unit No. (TRAIS) | |
| 15. Supplementary Notes Project performed in cooperation with the Texas Department of Transportation and the Federal Highway Administration. Project Title: Improvements to Large and Small Roadside Sign Hardware and Design URL: http://tti.tamu.edu/documents/0-6363-1.pdf | | 11. Contract or Grant No. Project 0-6363 | |
| 16. Abstract Many of the design practices that Texas Department of Transportation (TxDOT) uses for large and small sign mounting were established many years ago. These mounting details may no longer be appropriate, given changes in sign materials, fabrication methods, and installation practices. Further, the vehicle fleet and operating conditions on our highways have changed considerably, and there is a need to assess the compliance of some existing sign support systems with current vehicle testing criteria, and to evaluate new technologies that offer to enhance performance and maintenance. This two-year research project was designed to provide TxDOT with comprehensive review and update of mounting details and standards for large and small sign supports, and to provide a mechanism for TxDOT to quickly and effectively evaluate and address high priority needs related to sign support systems. The information provided through the project will be used to update standard Sign Mounting Detail (SMD) sheets, revise or set policies and standards, and evaluate new products and technologies. The issues researched under this are formulated on an annual basis, with the ability to modify priorities as needed. | | 13. Type of Report and Period Covered Test Report: September 2009–July 2011 | |
| 17. Key Words Signs, Sign Supports, Slipbase, Fuse Plates, Crash Testing, Roadside Safety | | 14. Sponsoring Agency Code | |
| 19. Security Classif. (of this report) Unclassified | | 18. Distribution Statement No restrictions. This document is available to the public through NTIS: National Technical Information Service Alexandria, Virginia 22312 http://www.ntis.gov | |
| 20. Security Classif. (of this page) Unclassified | | 21. No. of Pages 382 | 22. Price |

DEVELOPMENT GUIDANCE FOR SIGN DESIGN STANDARDS

by

Chiara Silvestri
Post Doctoral Research Associate
Texas Transportation Institute

Dusty R. Arrington
Engineering Research Associate
Texas Transportation Institute

Roger P. Bligh, P.E.
Research Engineer
Texas Transportation Institute

and

Wanda L. Menges
Research Specialist
Texas Transportation Institute

Report 0-6363-1

Project 0-6363

Project Title: Improvements to Large and Small Roadside Sign Hardware and Design

Performed in cooperation with the
Texas Department of Transportation
and the
Federal Highway Administration

November 2011

Published: February 2012

TEXAS TRANSPORTATION INSTITUTE
The Texas A&M University System
College Station, Texas 77843-3135

DISCLAIMER

This research was performed in cooperation with the Texas Department of Transportation (TxDOT) and the Federal Highway Administration (FHWA). The contents of this report reflect the views of the authors, who are responsible for the facts and the accuracy of the data presented herein. The contents do not necessarily reflect the official view or policies of the FHWA or TxDOT. This report does not constitute a standard, specification, or regulation, and its contents are not intended for construction, bidding, or permit purposes. In addition, the above listed agencies assume no liability for its contents or use thereof. The United States Government and the State of Texas do not endorse products or manufacturers. Trade or manufacturers' names appear herein solely because they are considered essential to the object of this report. The engineer in charge of the project was Roger P. Bligh, P.E. (Texas, #78550).

TTI PROVING GROUND DISCLAIMER

The full-scale crash test reported herein was performed at Texas Transportation Institute (TTI) Proving Ground. TTI Proving Ground is an International Standards Organization (ISO) 17025 accredited laboratory with American Association for Laboratory Accreditation (A2LA) Mechanical Testing certificate 2821.01. The full-scale crash test was performed according to TTI Proving Ground quality procedures and according to the *MASH* guidelines and standards. The results of the crash testing reported herein apply only to the article being tested. TTI Proving Ground is accredited to perform and evaluate the crash tests reported herein. However, accreditation does not apply to the engineering analyses also reported in this document.



Wanda L. Menges, Research Specialist
Deputy Quality Manager

Richard A. Zimmer, Senior Research Specialist
Test Facility Manager
Quality Manager
Technical Manager

ACKNOWLEDGMENTS

This research project was conducted under a cooperative program between the Texas Transportation Institute, the Texas Department of Transportation, and the Federal Highway Administration. The TxDOT project director for this research was Mr. Doug Skowronek. The TxDOT research engineer for this project was Mr. Wade Odell. The authors acknowledge and appreciate their guidance and assistance. The authors also acknowledge the assistance of the project monitoring committee members: Larry Colclasure (WAC), Christina Gutierrez (CST), Carlos Ibarra (ATL), Karl Janak (CST), Armen Miskarov (BRG), and Charlie Wicker (TRF).

TABLE OF CONTENTS

| | |
|--|-----|
| LIST OF FIGURES | xii |
| LIST OF TABLES | xix |
| CHAPTER 1. INTRODUCTION | 1 |
| 1.1 INTRODUCTION | 1 |
| 1.2 BACKGROUND | 1 |
| 1.3 OBJECTIVES/SCOPE OF RESEARCH | 4 |
| 1.3.1 Objective 1. Select and Prioritize Sign Support Issues..... | 4 |
| 1.3.2 Objective 2. Execute Approved Work Plan for Selected Sign Mounting Issues..... | 5 |
| 1.4 RESEARCH STRUCTURE | 5 |
| CHAPTER 2. COMPARISON OF WIND LOAD PRESSURE CALCULATION METHODS | 9 |
| 2.1 INTRODUCTION | 9 |
| 2.2 METHODS COMPARISON | 9 |
| 2.2.1 Current Wind Load Pressure Calculation Method..... | 9 |
| 2.2.2 Appendix C: Method for Wind Load Pressure Calculation (Legacy Method)..... | 10 |
| 2.2.3 Summary..... | 11 |
| CHAPTER 3. SIGN AREA ON SCHEDULE 80 PIPE SUPPORTS | 13 |
| CHAPTER 4. ANALYSIS OF SCHEDULE 40 PIPE SUPPORTS..... | 19 |
| CHAPTER 5. REVIEW OF CURRENT STANDARDS FOR LARGE GUIDE SIGNS..... | 21 |
| 5.1 INTRODUCTION | 21 |
| 5.2 TASK 3A: REVIEW OF CURRENT LARGE GUIDE SIGN WIND LOAD CHARTS..... | 21 |
| 5.3 TASK 3B: REVIEW OF FUSE PLATE FAILURES | 29 |
| 5.4 TASK 3C. REVIEW CAPABILITY OF W8×18 AND W8×21 SLIPBASE CONNECTIONS | 36 |
| CHAPTER 6. EVALUATION OF NEED/PLACEMENT OF STIFFENERS ON LARGE GUIDE SIGNS..... | 41 |
| CHAPTER 7. OPTIMIZATION OF FUSE PLATE CAPACITIES FOR LARGE GUIDE SIGNS..... | 45 |
| 7.1 INTRODUCTION | 45 |
| 7.2 FULL-SCALE CRASH TESTS | 62 |
| 7.2.1 Crash Test Matrix | 62 |
| 7.2.2 Evaluation Criteria..... | 64 |
| 7.2.3 Crash Test No. 463630-1 (MASH Test 3-61) W6×9 – 4-ft × 10-ft Large Sign Support Test Installation..... | 64 |
| 7.2.3.1 Test Installation Description..... | 64 |
| 7.2.3.2 Test Designation and Actual Impact Conditions | 68 |
| 7.2.3.3 Test Vehicle | 68 |
| 7.2.3.4 Weather Conditions | 68 |
| 7.2.3.5 Test Description..... | 68 |
| 7.2.3.6 Damage to Test Installation | 71 |
| 7.2.3.7 Vehicle Damage..... | 71 |
| 7.2.3.8 Occupant Risk Factors | 71 |

| | | |
|--|---|-----|
| 7.2.3.9 | Assessment of Test Results..... | 71 |
| 7.2.4 | Crash Test No. 463630-2 (<i>MASH</i> Test 3-61) on W8×18 – 16-ft × 10-ft Large Sign Support Test Installation..... | 76 |
| 7.2.4.1 | Test Installation Description..... | 76 |
| 7.2.4.2 | Test Designation and Actual Impact Conditions..... | 77 |
| 7.2.4.3 | Test Vehicle..... | 77 |
| 7.2.4.4 | Weather Conditions..... | 77 |
| 7.2.4.6 | Damage to Test Installation..... | 81 |
| 7.2.4.7 | Vehicle Damage..... | 82 |
| 7.2.4.8 | Occupant Risk Factors..... | 82 |
| 7.2.4.9 | Assessment of Test Results..... | 87 |
| 7.3 | SUMMARY OF TEST RESULTS..... | 88 |
| 7.3.1 | <i>MASH</i> Test 3-61 on the TxDOT Large Sign Support (W6×9 – 4-ft × 10-ft)..... | 88 |
| 7.3.2 | <i>MASH</i> Test 3-61 on the TxDOT Large Sign Support (W8×18 – 16-ft × 10-ft)..... | 88 |
| 7.4 | CONCLUSIONS..... | 89 |
| CHAPTER 8. DEVELOPMENT OF UPDATED LARGE GUIDE SIGN WIND LOAD CHARTS..... | | 93 |
| CHAPTER 9. DEVELOP GUIDANCE FOR MINIMUM SIGN AREA FOR SLIPBASE SUPPORTS..... | | 101 |
| 9.1 | INTRODUCTION..... | 101 |
| 9.2 | FINITE ELEMENT SIMULATION..... | 103 |
| 9.2.1 | Validation of Slipbase Model..... | 103 |
| 9.2.2 | Finite Element Model of the Slipbase..... | 103 |
| 9.2.3 | Finite Element Models of the Vehicles Used for FE Simulations..... | 104 |
| 9.2.4 | Analysis with Small Passenger Car..... | 104 |
| 9.2.4.1 | Simulation Burn Ban Test No. 452108-2..... | 104 |
| 9.2.4.2 | Simulation Burn Ban Test No. 452108-3..... | 107 |
| 9.2.4.3 | Simulation Burn Ban Test No. 452108-4..... | 110 |
| 9.2.5 | Analysis with Pickup Truck..... | 113 |
| 9.2.5.1 | Simulation NTTA Test No. 405872-1..... | 114 |
| 9.2.5.2 | Simulation TxDOT Test No. 455266-2..... | 116 |
| 9.2.6 | Conclusions..... | 119 |
| 9.3 | FINITE ELEMENT PREDICTION..... | 120 |
| 9.3.1 | FE Simulations..... | 120 |
| 9.3.2 | Discussion on Finite Element Prediction and Validation Results..... | 132 |
| 9.4 | FULL-SCALE CRASH TESTING ON 12 FT ² SIGN PANEL..... | 133 |
| 9.4.1 | Crash Test 463631-1 (<i>MASH</i> Test No. 3-62) on 10 BWG Steel Slipbase Support with 12 ft ² Sign Panel..... | 133 |
| 9.4.1.1 | Test Installation Description..... | 133 |
| 9.4.1.2 | Test Designation and Actual Impact Conditions..... | 134 |
| 9.4.1.3 | Weather Conditions..... | 139 |
| 9.4.1.4 | Test Description..... | 139 |
| 9.4.1.5 | Test Article and Component Damage..... | 139 |
| 9.4.1.6 | Test Vehicle Damage..... | 143 |
| 9.4.1.7 | Occupant Risk Values..... | 143 |
| 9.4.1.8 | Assessment of Test Results..... | 143 |

| | | |
|---|---|-----|
| 9.4.1.8.1 | Structural Adequacy | 143 |
| 9.4.1.8.2 | Occupant Risk | 147 |
| 9.4.1.8.3 | Vehicle Trajectory | 148 |
| 9.4.2 | Test 463631-2 (<i>MASH</i> Test No. 3-61) on 10 BWG Steel Slipbase Support with 12 Ft ² Sign Panel | 148 |
| 9.4.2.1 | Test Designation and Actual Impact Conditions | 148 |
| 9.4.2.2 | Test Vehicle | 148 |
| 9.4.2.3 | Weather Conditions | 148 |
| 9.4.2.4 | Test Description | 148 |
| 9.4.2.5 | Test Article and Component Damage | 151 |
| 9.4.2.6 | Test Vehicle Damage | 151 |
| 9.4.2.7 | Occupant Risk Values | 151 |
| 9.4.2.8 | Assessment of Test Results | 158 |
| 9.4.2.8.1 | Structural Adequacy | 158 |
| 9.4.2.8.2 | Occupant Risk | 158 |
| 9.4.2.8.3 | Vehicle Trajectory | 159 |
| 9.5 | COMMENTS | 159 |
| 9.6 | FULL-SCALE CRASH TESTING ON 14-FT ² SIGN PANEL | 163 |
| 9.6.1 | Design Modifications for Test No. 463631-3 | 163 |
| 9.6.2 | Test 463631-3 (<i>MASH</i> Test No. 3-61) on 10 BWG Steel Slipbase Support with 14 Ft ² Sign Panel | 167 |
| 9.6.2.1 | Test Designation and Actual Impact Conditions | 167 |
| 9.6.2.2 | Test Vehicle | 167 |
| 9.6.2.3 | Weather Conditions | 167 |
| 9.6.2.4 | Test Description | 167 |
| 9.6.2.5 | Test Article and Component Damage | 170 |
| 9.6.2.6 | Test Vehicle Damage | 170 |
| 9.6.2.7 | Occupant Risk Values | 170 |
| 9.6.2.8 | Assessment of Test Results | 177 |
| 9.6.2.8.1 | Structural Adequacy | 177 |
| 9.6.2.8.2 | Occupant Risk | 177 |
| 9.2.6.8.3 | Vehicle Trajectory | 178 |
| 9.7 | SUMMARY OF TEST RESULTS | 178 |
| 9.7.1 | Test 463631-1 (<i>MASH</i> Test No. 3-62) on 10 BWG Steel Slipbase Support with 12 Ft ² Sign Panel | 178 |
| 9.7.2 | Test 463631-2 (<i>MASH</i> Test No. 3-61) on 10 BWG Steel Slipbase Support with 12 Ft ² Sign Panel | 178 |
| 9.7.3 | Test 463631-3 (<i>MASH</i> Test No. 3-61) on 10 BWG Steel Slipbase Support with 14 Ft ² Sign Panel | 179 |
| 9.8 | CONCLUSIONS | 179 |
| CHAPTER 10. DEVELOP MOUNTING STANDARDS FOR CHEVRONS AND MILE MARKERS | | 185 |
| 10.1 | BACKGROUND | 185 |
| 10.2 | OBJECTIVE | 185 |
| 10.3 | LITERATURE REVIEW | 186 |

| | | |
|-------------|---|-----|
| 10.4 | EVALUATION OF POLE EFFECTIVE HEIGHT FOR CHEVRON SIGNS INSTALLATION PRACTICE IN DITCHES | 190 |
| 10.5 | ENGINEERING ANALYSIS..... | 191 |
| 10.5.1 | Trajectory Analysis of an Errant Vehicle Entering a 6:1 Slope Ditch..... | 191 |
| 10.5.2 | Recommendation | 193 |
| 10.6. | PROPOSED MODIFICATION FOR CURRENT D&OM TXDOT STANDARD SHEETS..... | 193 |
| 10.6.1 | Revision of Current D&OM TxDOT Standard Sheets..... | 193 |
| 10.6.2 | Proposed Layout Alternatives for D&OM(1) and (2)..... | 195 |
| 10.7 | CONCLUSIONS..... | 195 |
| CHAPTER 11. | ANALYSIS OF “U-BRACKETS” ON SCHEDULE 80 PIPE SUPPORTS ... | 209 |
| 11.1 | OBJECTIVES..... | 209 |
| 11.2 | PROBLEMS IN THE FIELD | 209 |
| 11.3 | ENGINEERING ANALYSIS..... | 211 |
| 11.4 | FINITE ELEMENT SIMULATION RESULTS | 212 |
| 11.5 | STATIC TESTING..... | 216 |
| 11.6 | RECOMMENDATIONS..... | 227 |
| CHAPTER 12. | IMPLEMENTATION..... | 229 |
| REFERENCES | | 231 |
| APPENDIX A. | STATIC TESTS ON SCHEDULE 80 CANTILEVER (S6-S8)..... | 233 |
| | TEST ARTICLE DESCRIPTION | 233 |
| | TEST RESULTS..... | 234 |
| APPENDIX B. | STATIC TESTS ON FUSE PLATE (S12-S14, S16)..... | 237 |
| | TEST ARTICLE DESCRIPTION | 237 |
| | S12-S14: Ungalvanized Standard W8×18 Fuse Plates | 237 |
| | S16: Ungalvanized Standard W8×21 Fuse Plates..... | 237 |
| | TENSION TEST SETUP..... | 239 |
| | TEST RESULTS..... | 239 |
| APPENDIX C. | STATIC TESTS ON W8×18 (S3, S20-S27)..... | 243 |
| | TEST ARTICLE DESCRIPTION | 243 |
| | TxDOT W8×18 Standard Slip Base Connection..... | 243 |
| | Test S3: W8×18 Post Assembly with Standard Fuse Plates Installed ($\frac{3}{8}$ -inch Hole Offset to Create $\frac{3}{8}$ -inch Gap at the Fuse Plate). | 243 |
| | S20-S23: W8×18 Slip Base Connection..... | 245 |
| | S24-S25: W8×18 with Standard Fuse Plate Splice..... | 245 |
| | S26-S27: W8×18 with Standard Fuse Plate Splice with Gap..... | 246 |
| | TEST RESULTS:..... | 246 |
| APPENDIX D. | TEST CONDITIONS..... | 251 |
| | TEST FACILITY..... | 251 |
| | VEHICLE TOW AND GUIDANCE SYSTEM..... | 251 |
| | DATA ACQUISITION SYSTEMS..... | 251 |
| | Vehicle Instrumentation and Data Processing..... | 251 |
| | Anthropomorphic Dummy Instrumentation | 252 |
| | Photographic Instrumentation and Data Processing..... | 252 |
| APPENDIX E. | CRASH TEST No. 463630-1 | 253 |
| APPENDIX F. | CRASH TEST No. 463630-2 | 275 |

| | |
|---|-----|
| APPENDIX G. REPRESENTATIVE PROOF CALCULATIONS..... | 295 |
| G1. S4×7.7, 8 FT TALL SIGN AT 7-FT MOUNTING HEIGHT..... | 295 |
| G2. W8×18, 8 FT TALL SIGN AT 14-FT MOUNTING HEIGHT..... | 298 |
| APPENDIX H. CRASH TEST NO. 463631-1..... | 301 |
| APPENDIX I. CRASH TEST NO. 463631-2..... | 321 |
| APPENDIX J. CRASH TEST NO. 463631-3..... | 333 |
| APPENDIX K. PROPOSED MOUNTING STANDARDS FOR CHEVRONS AND MILE MARKERS..... | 353 |

LIST OF FIGURES

| | |
|--|----|
| Figure 2.1. Texas Isotachs Wind Load Chart. | 10 |
| Figure 2.2. Appendix C: 10-Year Recurrence Interval Wind Load Chart..... | 11 |
| Figure 3.1. Schedule 80 Support Static Testing Setup..... | 14 |
| Figure 3.2. Schedule 80 Support Static Testing Setup before Load Application. | 15 |
| Figure 3.3. Schedule 80 Support at Maximum Load. | 15 |
| Figure 3.4. Updated Schedule 80 Wind Load Chart (Current Pressure Method). | 17 |
| Figure 4.1. 2.5-Inch Pipe Support Wind Load Chart Comparison (Current Pressure Method). . | 20 |
| Figure 5.1. Current TxDOT Large Guide Sign Wind Load Charts. | 22 |
| Figure 5.2. Current TxDOT Large Guide Sign Zone 1 Wind Load Charts. | 23 |
| Figure 5.3. Wind Capacities of Current Large Guide Sign Supports (Legacy Method). | 24 |
| Figure 5.4. Current TxDOT Large Guide Sign Supports Slipbase and Fuse Plate Details. | 25 |
| Figure 5.5. Current Perforated Fuse Plate Fabrication Detail..... | 26 |
| Figure 5.6. Large Guide Sign Support Force Diagram for Wind Load Condition. | 27 |
| Figure 5.7. Typical Fuse Plate Failure Mode Reported by Districts. | 30 |
| Figure 5.8. Test Sample Dimensional Analysis..... | 31 |
| Figure 5.9. Fuse Plate Tensile Test (S12–S14)..... | 32 |
| Figure 5.10. W8×18 Fuse Plate Fuse Plate Connection Capacity Verification (S24–S27). | 34 |
| Figure 5.11. W8×18 Support Assembly Capacity Verification (S3). | 35 |
| Figure 5.12. W8×18 Support Ready for Load Application (S3). | 35 |
| Figure 5.13. W8×18 Support at Maximum Load (S3)..... | 36 |
| Figure 5.14. Comparison of W8×18 and W8×21 Slipbase Connection Details. | 38 |
| Figure 5.15. W8×18 Slipbase Connection Capacity Static Test Setup..... | 39 |
| Figure 5.16. W8×18 Slipbase Capacity Verification Test Images. | 40 |
| Figure 6.1. Current TxDOT Vertical Stiffener Detail Sheet..... | 42 |
| Figure 6.2. 10 ft × 6 ft Sign Panel Torsional Stiffness Relationship Comparison..... | 43 |
| Figure 6.3. Predicted Maximum Sign Panel Assembly Torsional Capacity..... | 44 |
| Figure 7.1. Predicted OIV Analysis. | 47 |
| Figure 7.2. Wind Load Condition. | 48 |
| Figure 7.3. Impact Load Condition..... | 49 |
| Figure 7.4. Minimum Fuse Plate Capacity for Wind Load Condition..... | 50 |
| Figure 7.5. Predicted Maximum Sign Panel Assembly Torsional Capacity..... | 52 |
| Figure 7.6. Simplified LSDYNA Impact Simulation Setup. | 53 |
| Figure 7.7. Simulated Force Times Histories. | 54 |
| Figure 7.8. Static Test of HSS3×3×1/8 with Through Bolt Connection..... | 56 |
| Figure 7.9. Static Test of HSS3×3×1/8 with Bracket Connection..... | 56 |
| Figure 7.10. Measured Force Times Histories of Torsional Stiffeners..... | 57 |
| Figure 7.11. Sign Panel and Torsional Stiffener Force Time History Comparison..... | 58 |
| Figure 7.12. 90 mph Selection Chart for Optimized Fuse Plate Hbs = 7 ft (Current Method).... | 60 |
| Figure 7.13. 90 mph Selection Chart for Optimized Fuse Plate Hbs = 12 ft (Current Method).. | 61 |
| Figure 7.14. 90 mph Selection Chart for Current Fuse Plate Hbs = 7 ft (Current Method). | 63 |
| Figure 7.15. Details of the TxDOT W6×9 – 4-ft × 10-ft Large Sign Support Test Installation.. | 66 |
| Figure 7.16. TxDOT W6×9 – 4-ft × 10-ft Large Sign Support before Test No. 463630-1..... | 67 |
| Figure 7.17. Vehicle/Installation Geometrics for Test No. 463630-1. | 69 |

| | |
|---|-----|
| Figure 7.18. Vehicle before Test No. 463630-1. | 70 |
| Figure 7.19. Installation/Vehicle Positions after Test No. 463630-1. | 70 |
| Figure 7.20. Installation after Test No. 463630-1. | 72 |
| Figure 7.21. Vehicle after Test No. 463630-1. | 73 |
| Figure 7.22. Interior of Vehicle for Test No. 463630-1. | 73 |
| Figure 7.23. Summary of Results for <i>MASH</i> Test 3-61 on the TxDOT Large Sign Support (W6×9 – 4-ft × 10-ft). | 74 |
| Figure 7.24. Details of the TxDOT W8×18 – 16-ft × 10-ft Large Sign Support Test Installation. | 78 |
| Figure 7.25. TxDOT W8×18 – 16-ft × 10-ft Large Sign Support before Test No. 463630-2. | 79 |
| Figure 7.26. Vehicle/Installation Geometrics for Test No. 463630-2. | 80 |
| Figure 7.27. Vehicle before Test No. 463630-2. | 81 |
| Figure 7.28. Installation/Vehicle Positions after Test No. 463630-2. | 83 |
| Figure 7.29. Installation after Test No. 463630-2. | 84 |
| Figure 7.30. Vehicle after Test No. 463630-2. | 85 |
| Figure 7.31. Interior of Vehicle for Test No. 463630-2. | 85 |
| Figure 7.32. Summary of Results for <i>MASH</i> Test 3-61 on the TxDOT W8×18 – 16-ft × 10-ft Large Sign Support. | 86 |
| Figure 8.1. TxDOT Wind Zone Chart for Large Guide Signs (Legacy Method). | 94 |
| Figure 8.2. Wind Load Condition. | 95 |
| Figure 8.3. 90 mph Raw Support Selection Chart. | 95 |
| Figure 9.1. Finite Element Model of Slipbase Sign Support System. | 104 |
| Figure 9.2. Vehicles Finite Element Models Employed in the Computer Simulations. | 105 |
| Figure 9.3. Comparison between Burn Ban Test No. 452108-2 and FE Model Sign Support Slipbase System Configurations. | 106 |
| Figure 9.4. Comparison between Burn Ban Test No. 452108-2 and FE Model Impact Conditions. | 107 |
| Figure 9.5. Comparison between Burn Ban Test No. 452108-2 and FE Model Impact Results. | 108 |
| Figure 9.6. Comparison between Burn Ban Test No. 452108-3 and FE Model Sign Support Slipbase System Configurations. | 109 |
| Figure 9.7. Comparison between Burn Ban Test No. 452108-3 and FE Model Impact Conditions. | 110 |
| Figure 9.8. Comparison between Burn Ban Test No. 452108-3 and FE Model Impact Results. | 111 |
| Figure 9.9. Comparison between Burn Ban Test No. 452108-4 and FE Model Sign Support Slipbase System Configurations. | 112 |
| Figure 9.10. Comparison between Burn Ban Test No. 452108-4 and FE Model Impact Conditions. | 113 |
| Figure 9.11. Comparison between Burn Ban Test No. 452108-4 and FE Model Results. | 114 |
| Figure 9.12. Comparison between NTTA Test No. 405870-1 and FE Model Sign Support Slipbase System Configurations. | 115 |
| Figure 9.13. Comparison between NTTA Test No. 405870-1 and FE Model Impact Conditions. | 115 |
| Figure 9.14. Comparison between NTTA Test No. 405870-1 and FE Model Impact Results.. | 116 |

| | |
|--|-----|
| Figure 9.15. Comparison between TxDOT Test No. 455266-2 and FE Model Sign Support Slipbase System Configurations. | 117 |
| Figure 9.16. Comparison between TxDOT Test No. 455266-2 and FE Model Impact Conditions. | 118 |
| Figure 9.17. Comparison between TxDOT Test No. 455266-2 and FE Model Impact Results. | 118 |
| Figure 9.18. Thickness Comparison of Size 2.5-Inch Pipe Supports for Use on Slipbase Systems. | 120 |
| Figure 9.19. Single Sign Support Configurations Used for FE Simulations. | 123 |
| Figure 9.20. Prefabricated “T” Bracket-Texas Universal Triangular Slipbase System (9). | 124 |
| Figure 9.21. Center of Gravity for Pole System with Varying Sign Areas. | 126 |
| Figure 9.22. Summary of FE Simulation Impact Predictions with Small Passenger Car, 1100C Vehicle. | 127 |
| Figure 9.23. Summary of FE Simulation Impact Predictions with Pickup Truck, 2270P Vehicle. | 128 |
| Figure 9.24. Roof Crush Results with Varying Sign Areas and Pole Systems for Both 1100C and 2270P Vehicles. | 129 |
| Figure 9.25. Roof Crush Results with Varying Sign Areas and Pole Systems for 1100C Vehicle. | 130 |
| Figure 9.26. Roof Crush Results with Varying Sign Areas and Pole Systems for 2270P Vehicle. | 131 |
| Figure 9.27. Details of the Sign Support System Used for Test Nos. 463631-1 and 463631-2. | 135 |
| Figure 9.28. Details of the Sign Panel Used in Test Nos. 463631-1 and 463631-2. | 136 |
| Figure 9.29. Details of the Triangular Slipbase System. | 137 |
| Figure 9.30. Sign Support System prior to Test Nos. 463631-1 and 2. | 138 |
| Figure 9.31. Vehicle/Installation Geometrics for Test No. 463631-1. | 140 |
| Figure 9.32. Vehicle before Test No. 463631-1. | 141 |
| Figure 9.33. Installation after Test No. 463631-1. | 142 |
| Figure 9.34. Vehicle after Test No. 463631-1. | 144 |
| Figure 9.35. Interior of Vehicle for Test No. 463631-1. | 145 |
| Figure 9.36. Summary of Results for <i>MASH</i> Test 3-62 on the 10 BWG Steel Pipe Slipbase Support with 12 ft ² Sign Panel (Test No. 463631-1). | 146 |
| Figure 9.37. Vehicle/Installation Geometrics for Test No. 463631-2. | 149 |
| Figure 9.38. Vehicle before Test No. 463631-2. | 150 |
| Figure 9.39. Position of Sign Support/Vehicle after Impact for Test No. 463631-2. | 152 |
| Figure 9.40. Installation after Test No. 463631-2. | 153 |
| Figure 9.41. Vehicle after Test No. 463631-2. | 154 |
| Figure 9.42. Vehicle Roof Deformation after Test No. 463631-2. | 155 |
| Figure 9.43. Interior of Vehicle after Test No. 463631-2. | 156 |
| Figure 9.44. Summary of Results for <i>MASH</i> Test 3-61 on the 10 BWG Steel Pipe Slipbase Support with 12 ft ² Sign Panel (Test No. 463631-2). | 157 |
| Figure 9.45. Distance of Sign Impact Location to the Roof Edge for Test No. 463631-2. | 160 |
| Figure 9.46. Comparison of FE Predicted Sign Impact Locations with Different Sign Areas. | 160 |
| Figure 9.47. Reinforced Structure at the Small Passenger Vehicle’s Roof Edge. | 161 |

| | |
|--|-----|
| Figure 9.48. Reinforced Structure at the Small Passenger Vehicle’s Roof Edge..... | 162 |
| Figure 9.49. 90-mph Wind Load Chart for Single Sign Post with 7-ft Mounting Height..... | 162 |
| Figure 9.50. Details of the Sign Support System Used for Test No. 463631-3..... | 164 |
| Figure 9.51. Details of the Sign Panel Used for Test No. 463631-3..... | 165 |
| Figure 9.52. Sign Support System prior to Test No. 463631-3..... | 166 |
| Figure 9.53. Vehicle/Installation Geometrics for Test No. 463631-3..... | 168 |
| Figure 9.54. Vehicle before Test No. 463631-3..... | 169 |
| Figure 9.55. Position of Sign Support/Vehicle after Impact for Test No. 463631-3..... | 171 |
| Figure 9.56. Installation after Test No. 463631-3..... | 172 |
| Figure 9.57. Vehicle after Test No. 463631-3..... | 173 |
| Figure 9.58. Vehicle Roof Deformation after Test No. 463631-3..... | 174 |
| Figure 9.59. Interior of Vehicle after Test No. 463631-3..... | 175 |
| Figure 9.60. Summary of Results for <i>MASH</i> Test 3-61 on the 10 BWG Steel Pipe Slipbase Support with 14 ft ² Sign Panel (Test No. 463631-3)..... | 176 |
| Figure 10.1. Dual Chevron Support Test No. 417929-3..... | 187 |
| Figure 10.2. Thin-Walled Aluminum Sign Support Tests Nos. 405231-7 and 405231-9..... | 188 |
| Figure 10.3. Support System’s Effective Height and Post-Impact Pole System Behavior..... | 189 |
| Figure 10.4. Effective Pole Height Variation for Chevron Installation in a Ditch..... | 190 |
| Figure 10.5. Relative Bumper Impact Height for Chevron Installation in a 6H:1V Ditch..... | 191 |
| Figure 10.6. Relative Distance between Bumper Impact Location and Bottom Edge of Chevron in a 6H:1V Ditch..... | 192 |
| Figure 10.7. Effective Pole Height for a 30-Inch-High Chevron Sign Installation on 4-Ft Mounting Height, at 8-Ft Lateral Offset in a 6H:1V Ditch..... | 193 |
| Figure 10.8. “Object Marker” Section in the Proposed New Layout TxDOT D&OM(1)- 11, Option #1..... | 201 |
| Figure 10.9. “Chevrons” Section in the Proposed New Layout TxDOT D&OM(1)-11, Option #1..... | 202 |
| Figure 10.10. “Barrier Reflectors” Section in the Proposed New Layout TxDOT D&OM(1)-11, Option #1..... | 203 |
| Figure 10.11. “Delineators” Section in the Proposed New Layout TxDOT D&OM(1)-11, Option #1..... | 204 |
| Figure 10.12. “Reflector Unit Sizes” Section in the Proposed New Layout TxDOT D&OM(1)-11, Option #1..... | 205 |
| Figure 10.13. “Support Foundation Details” Section in the Proposed New Layout TxDOT D&OM(1)-11, Options #1 and #2..... | 206 |
| Figure 10.14. “Type of Delineator Mounts” Section in the Proposed New Layout TxDOT D&OM(1)-11, Options #1 and #2..... | 207 |
| Figure 10.15. “Typical Installation Examples” Section in the Proposed New Layout TxDOT D&OM(1)-11, Options #1 and #2..... | 208 |
| Figure 11.1. Example of U-Bracket Failure..... | 210 |
| Figure 11.2. U-Bracket Weld Failure..... | 210 |
| Figure 11.3. Improper Installation of U-Bracket Extension Tube..... | 211 |
| Figure 11.4. U-Bracket Installation Configuration for Engineering Analysis..... | 212 |
| Figure 11.5. Simulation of Current TxDOT Design..... | 213 |
| Figure 11.6. Simulation of Schedule 80 U-Pipe..... | 214 |
| Figure 11.7. Simulation of Modified Nipple Design..... | 215 |

| | |
|--|-----|
| Figure 11.8. U-Bracket Design Comparison..... | 215 |
| Figure 11.9. U-Bracket Installation Static Test Setup Drawings..... | 217 |
| Figure 11.10. Image of U-Bracket Installation Static Test Setup prior to Loading..... | 217 |
| Figure 11.11. Image of U-Bracket Load Application..... | 218 |
| Figure 11.12(a). Image of U-Bracket Installation Static Test Setup at Maximum Load..... | 219 |
| Figure 11.12(b). Image of Deformation to Schedule 80 Pipe Support..... | 219 |
| Figure 11.12(c). Load versus Deflection Curves for Tests S1-S3..... | 220 |
| Figure 11.13. Schedule 80 Pipe Support Static Test Setup Drawings..... | 221 |
| Figure 11.14. Schedule 80 Pipe Support Static Test Setup prior to Loading..... | 221 |
| Figure 11.15. Schedule 80 Pipe Support Static Test Setup at Maximum Load..... | 222 |
| Figure 11.16. Deformation to Schedule 80 Pipe Support..... | 222 |
| Figure 11.17. Load versus Deflection Curves for Tests S4-S6..... | 223 |
| Figure 11.18. U-Bracket Support Static Test Setup Drawings..... | 224 |
| Figure 11.19. U-Bracket Static Test Setup prior to Loading..... | 225 |
| Figure 11.20. U-Bracket Static Test Setup at Maximum Load..... | 225 |
| Figure 11.21. Deformation and Failure of U-Bracket Support..... | 226 |
| Figure 11.22. Load versus Deflection Curves for Tests S7-S8..... | 227 |
| Figure A1. Test Setup for S6–S8..... | 233 |
| Figure A2. Load for Tests on the Schedule 80 Cantilever Support..... | 234 |
| Figure B1. TxDOT Standard Fuse Plate Detail..... | 237 |
| Figure B2. TxDOT Large Sign Support Splicing Standards..... | 238 |
| Figure B3. Test Setup for S12–S19..... | 239 |
| Figure B4. Load for Tests on Fuse Plates..... | 240 |
| Figure C1. TxDOT Standard Slipbase Detail..... | 243 |
| Figure C2. Test Setup for S3..... | 244 |
| Figure C3. Test Setup for S20-23..... | 245 |
| Figure C4. Test Setup for S24 and 25..... | 246 |
| Figure C5. Test Setup for S26 and 27 (with 3/8-inch gap)..... | 247 |
| Figure C6. Test Sample S3 at Maximum Load..... | 247 |
| Figure C7. Test Sample S20 after Slip Bolt Failure..... | 248 |
| Figure C8. Slip Bolts after Test S20..... | 248 |
| Figure C9. Test Sample S26 after Fuse Plate Rupture..... | 249 |
| Figure C10. Load for Tests on W8×18 Sign Support..... | 250 |
| Figure E1. Details of the W6×9 with 4-ft × 10-ft Sign..... | 253 |
| Figure E2. Sequential Photographs for Test No. 463630-1 (Perpendicular and Frontal Oblique Views)..... | 265 |
| Figure E3. Vehicle Angular Displacements for Test No. 463630-1..... | 267 |
| Figure E4. Vehicle Longitudinal Accelerometer Trace for Test No. 463630-1 (Accelerometer Located at Center of Gravity)..... | 268 |
| Figure E5. Vehicle Lateral Accelerometer Trace for Test No. 463630-1 (Accelerometer Located at Center of Gravity)..... | 269 |
| Figure E6. Vehicle Vertical Accelerometer Trace for Test No. 463630-1 (Accelerometer Located at Center of Gravity)..... | 270 |
| Figure E7. Vehicle Longitudinal Accelerometer Trace for Test No. 463630-1 (Accelerometer Located over Rear Axle)..... | 271 |

| | |
|---|-----|
| Figure E8. Vehicle Lateral Accelerometer Trace for Test No. 463630-1 (Accelerometer Located over Rear Axle)..... | 272 |
| Figure E9. Vehicle Vertical Accelerometer Trace for Test No. 463630-1 (Accelerometer Located over Rear Axle)..... | 273 |
| Figure F1. Details of the W8×18 with 16-ft × 10-ft Sign..... | 275 |
| Figure F2. Sequential Photographs for Test No. 463630-2 (Perpendicular and Frontal Oblique Views)..... | 285 |
| Figure F3. Vehicle Angular Displacements for Test No. 463630-2..... | 287 |
| Figure F4. Vehicle Longitudinal Accelerometer Trace for Test No. 463630-2 (Accelerometer Located at Center of Gravity)..... | 288 |
| Figure F5. Vehicle Lateral Accelerometer Trace for Test No. 463630-2 (Accelerometer Located at Center of Gravity)..... | 289 |
| Figure F6. Vehicle Vertical Accelerometer Trace for Test No. 463630-2 (Accelerometer Located at Center of Gravity)..... | 290 |
| Figure F7. Vehicle Longitudinal Accelerometer Trace for Test No. 463630-2 (Accelerometer Located over Rear Axle)..... | 291 |
| Figure F8. Vehicle Lateral Accelerometer Trace for Test No. 463630-2 (Accelerometer Located over Rear Axle)..... | 292 |
| Figure F9. Vehicle Vertical Accelerometer Trace for Test No. 463630-2 (Accelerometer Located over Rear Axle)..... | 293 |
| Figure H1. Details of the 10 BWG Steel Pipe Support with 12 ft ² Sign..... | 301 |
| Figure H2. Sequential Photographs for Test No. 463631-1..... | 312 |
| (Oblique Views)..... | 312 |
| Figure H3. Vehicle Angular Displacements for Test No. 463631-1..... | 314 |
| Figure H4. Vehicle Longitudinal Accelerometer Trace for Test No. 463631-1 (Accelerometer Located at Center of Gravity)..... | 315 |
| Figure H5. Vehicle Lateral Accelerometer Trace for Test No. 463631-1 (Accelerometer Located at Center of Gravity)..... | 316 |
| Figure H6. Vehicle Vertical Accelerometer Trace for Test No. 463631-1 (Accelerometer Located at Center of Gravity)..... | 317 |
| Figure H7. Vehicle Longitudinal Accelerometer Trace for Test No. 463631-1 (Accelerometer Located over Rear Axle)..... | 318 |
| Figure H8. Vehicle Lateral Accelerometer Trace for Test No. 463631-1 (Accelerometer Located over Rear Axle)..... | 319 |
| Figure H9. Vehicle Vertical Accelerometer Trace for Test No. 463631-1 (Accelerometer Located over Rear Axle)..... | 320 |
| Figure I1. Sequential Photographs for Test No. 463631-2 (Perpendicular and Oblique Views)..... | 324 |
| Figure I1. Sequential Photographs for Test No. 463631-2 (Perpendicular and Oblique Views) (continued)..... | 325 |
| Figure I2. Vehicle Angular Displacements for Test No. 463631-2..... | 326 |
| Figure I3. Vehicle Longitudinal Accelerometer Trace for Test No. 463631-2 (Accelerometer Located at Center of Gravity)..... | 327 |
| Figure I4. Vehicle Lateral Accelerometer Trace for Test No. 463631-2 (Accelerometer Located at Center of Gravity)..... | 328 |

| | |
|---|-----|
| Figure I5. Vehicle Vertical Accelerometer Trace for Test No. 463631-2 (Accelerometer Located at Center of Gravity)..... | 329 |
| Figure I6. Vehicle Longitudinal Accelerometer Trace for Test No. 463631-2 (Accelerometer Located over Rear Axle)..... | 330 |
| Figure I7. Vehicle Lateral Accelerometer Trace for Test No. 463631-2 (Accelerometer Located over Rear Axle)..... | 331 |
| Figure I8. Vehicle Vertical Accelerometer Trace for Test No. 463631-2 (Accelerometer Located over Rear Axle)..... | 332 |
| Figure J1. Details of the 10 BWG Steel Support with 14 ft ² Sign..... | 333 |
| Figure J2. Sequential Photographs for Test No. 463631-3 (Perpendicular and Oblique Views)..... | 343 |
| Figure J3. Vehicle Angular Displacements for Test No. 463631-3..... | 345 |
| Figure J4. Vehicle Longitudinal Accelerometer Trace for Test No. 463631-3 (Accelerometer Located at Center of Gravity)..... | 346 |
| Figure J5. Vehicle Lateral Accelerometer Trace for Test No. 463631-3 (Accelerometer Located at Center of Gravity)..... | 347 |
| Figure J6. Vehicle Vertical Accelerometer Trace for Test No. 463631-3 (Accelerometer Located at Center of Gravity)..... | 348 |
| Figure J7. Vehicle Longitudinal Accelerometer Trace for Test No. 463631-3 (Accelerometer Located over Rear Axle)..... | 349 |
| Figure J8. Vehicle Lateral Accelerometer Trace for Test No. 463631-3 (Accelerometer Located over Rear Axle)..... | 350 |
| Figure J9. Vehicle Vertical Accelerometer Trace for Test No. 463631-3 (Accelerometer Located over Rear Axle)..... | 351 |
| Figure K1. Proposed TxDOT D&OM(1)-11, Option #1..... | 355 |
| Figure K2. Proposed TxDOT D&OM(1)-11, Option #2..... | 357 |
| Figure K3. Proposed TxDOT D&OM(2)-11..... | 359 |
| Figure K4. Proposed TxDOT D&OM(3)-11..... | 361 |

LIST OF TABLES

| | |
|---|-----|
| Table 3.1. Schedule 80 Support Summary of Maximum Loads..... | 15 |
| Table 4.1. Comparison of 2.5-Inch Pipe Support Section Properties..... | 19 |
| Table 5.1. Current Table of Slipbase and Fuse Plate Dimensions and Details..... | 26 |
| Table 5.2. Large Guide Sign Support Component Capacity Comparison (Hbs = 10 ft). | 28 |
| Table 5.3. TxDOT Slipbase Connection Details. | 37 |
| Table 5.4. TxDOT Slipbase and Post Factored Capacity Comparison..... | 37 |
| Table 6.1. Sign Panel Configurations Tested..... | 43 |
| Table 7.1. Maximum Fuse Plate Capacity for Impact Load Condition. | 51 |
| Table 7.2. Optimized Fuse Plate Capacities. | 51 |
| Table 7.3. Design Table of Static Sign Panel Torsional Capacities. | 55 |
| Table 7.4. Design Table of Static Fuse Plate Connection Capacities..... | 55 |
| Table 7.5. Design Table of Torsional Stiffeners and Capacities. | 58 |
| Table 9.1. Roof Crush Comparison between Tests and FE Simulations. | 119 |
| Table 9.2. Performance Evaluation Summary for <i>MASH</i> Test 3-62 on the 10 BWG Steel Pipe Support with 12 ft ² Sign Panel..... | 180 |
| Table 9.3. Performance Evaluation Summary for <i>MASH</i> Test 3-61 on the 10 BWG Steel Pipe Support with 12 ft ² Sign Panel..... | 181 |
| Table 9.4. Performance Evaluation Summary for <i>MASH</i> Test 3-61 on the 10 BWG Steel Pipe Support with 14 ft ² Sign Panel..... | 182 |
| Table 9.5. Recommendation of Support System and Pole Type for Use with Different Sign Areas..... | 183 |
| Table 10.1. Chevron Alignment Sign Sizes..... | 185 |
| Table 10.2. Thin-Walled Aluminum Sign Support Tests Nos. 405231-7 and 405231-9. | 188 |
| Table 10.3. Suggested Modifications to the Current TxDOT D&OM(1) and (2) Standard Sheets..... | 197 |
| Table 11.1. Calculated Capacities of U-Bracket Installation Components. | 212 |

CHAPTER 1. INTRODUCTION

1.1 INTRODUCTION

Many of the design practices that the Texas Department of Transportation (TxDOT) uses for large and small sign mounting were established many years ago. These mounting details may no longer be appropriate, given changes in sign materials, fabrication methods, and installation practices. Further, the vehicle fleet and operating conditions on our highways have changed considerably, and there is a need to assess the compliance of some existing sign support systems with current vehicle testing criteria, and to evaluate new technologies that offer to enhance performance and maintenance.

This two-year research project was designed to provide TxDOT with comprehensive review and update of mounting details and standards for large and small sign supports, and to provide a mechanism for TxDOT to quickly and effectively evaluate and address high-priority needs related to sign support systems. The information provided through the project will be used to update standard Sign Mounting Detail (SMD) sheets, revise or set policies and standards, and evaluate new products and technologies. The issues researched under this are formulated on an annual basis, with the ability to modify priorities as needed.

1.2 BACKGROUND

Roadside signs perform the important function of relaying needed information to motorists. Because the supports for these signs are typically placed within the roadside clear zone, it is important that they be designed to safely break away to minimize the potential for injury to the occupants of vehicles that might errantly impact them.

Current guidance regarding the testing and evaluation of sign supports is contained in National Cooperative Highway Research Program (NCHRP) *Report 350*, “Recommended Procedures for the Safety Performance Evaluation of Highway Features,” which was published in 1993 (1). This document provides a basis on which the impact performance of roadside safety features can be assessed and compared. The crash testing guidelines present matrices for vehicular tests that are defined in terms of vehicle type, impact conditions (i.e., speed and angle), and impact location. *NCHRP Report 350* requires two tests with an 1800-lb car to evaluate breakaway support structures; one low-speed test at 21.7 mph and one high-speed test at 62.2 mph.

NCHRP Report 350 further prescribes how to evaluate performance of a safety feature in terms of occupant risk, structural adequacy, exposure to workers and pedestrians who may be in the debris path resulting from the impact, and post-impact behavior of the vehicle. Of most significance in the evaluation of sign supports is occupant compartment deformation. Evaluation Criterion D of *NCHRP Report 350* states that “Deformation of, or intrusion into, the occupant compartment that could cause serious injuries should not be permitted.” To reduce the level of

subjectivity associated with evaluating this criterion, the Federal Highway Administration (FHWA) established a 6-inch threshold for occupant compartment deformation or intrusion.

Through various research projects, TxDOT brought its sign mounting standards into compliance with *NCHRP Report 350*. However, the highway environment is continually changing and evolving. Consequently, the guidelines for testing and evaluating the impact performance of roadside safety features must be periodically updated to keep pace with advancement in technology, the changing vehicle fleet, and changes in impact conditions.

Research to update *NCHRP Report 350* and take the next step in the continued advancement and evaluation of roadside safety testing and evaluation was recently completed under NCHRP Project 22-14. The result of this research effort, which was conducted at the University of Nebraska, was a new document that the American Association of State Highway and Transportation Officials (AASHTO) had published and, as of January 2009, supersedes *NCHRP Report 350*. This document, which is entitled *Manual for Assessing Safety Hardware (MASH)*, was approved through the AASHTO balloting process through the Subcommittee on Design and the Subcommittee on Bridges and Structures (2). Changes in the new guidelines include new design test vehicles, revised test matrices, and revised impact conditions.

The test matrix in *MASH* for evaluating breakaway support structures recommends three tests. The low-speed test (Test 60) utilizes a 2420-lb passenger car (denoted 1100C) impacting the support structure at a speed of 18.6 mph. When combined with the increased weight of the new 2420-lb passenger car, the reduction in speed maintains the kinetic energy used in *NCHRP Report 350* to evaluate activation of breakaway supports. This test evaluates the activation of the breakaway, fracture, or yielding mechanism of the support. Of concern for this test are the potential for excessive velocity change and penetration of structural components into the occupant compartment of the impacting vehicle.

Two tests are recommended to evaluate the behavior of the breakaway support during high-speed impacts: test 61 with the 1100C vehicle, and test 62 with a 5000-lb pickup truck (denoted 2270P), both impacting the support structure at a speed of 62.2 mph. These two tests evaluate the potential for penetration of structural components into the vehicle windshield, excessive occupant compartment intrusion, and vehicle instability, as well as occupant risk.

MASH adopted more quantitative and stringent evaluation criteria for occupant compartment deformation than *NCHRP Report 350*. The limited extent of deformation varies by area of the vehicle damaged. Those most relevant to the evaluation of sign supports include:

- Roof crush ≤ 3.9 inches.
- Windshield deformation ≤ 3.0 inches.
- No holes or tears in safety lining of the windshield.

Little evaluation of sign supports has been performed with larger vehicles such as the pickup. Systems that have been demonstrated to be crashworthy for passenger cars may not be geometrically compatible with pickup trucks. There exists a need to assess the compliance of

some existing sign support systems with *MASH*, and to evaluate new technologies that offer to enhance performance and maintenance.

In addition to being crashworthy, a sign support should have the ability to withstand anticipated service loads and be cost-effective in terms of installation, maintenance, and repair. Of particular importance is consideration of wind loads. The vertical supports of sign systems should be designed to have sufficient structural capacity to accommodate the flexural stresses induced by a prescribed design wind pressure.

The wind loads on a structure are determined when the appropriate design wind pressure is applied to the exposed areas of the vertical supports and sign panels. Once the loads have been applied, the stresses in the support members can be computed and compared to the allowable stresses.

The maximum sign area that a support can accommodate is based on various factors including:

- Design wind pressure.
- Sign panel area.
- Sign panel aspect ratio.
- Sign panel mounting height.
- Capacity of the support.

One of the needs that could be addressed under this project is the development of wind load charts and/or tables to assist with the economical selection of a support post for a given sign panel dimensions and design wind speed. Charts can be included in standard SMD sheets for the design engineers' use, and appropriately formatted tables could be incorporated into the Sign Crew Field Book for the maintenance personnel's use.

Flexure or bending of the sign substrate is another wind-related issue that deserves attention. A sign substrate must have sufficient strength and stiffness to accommodate handling, erection, and service loads. An improperly stiffened substrate can bend and be damaged. Stiffeners are specified in TxDOT standard details, but some districts are not following this practice, claiming they are unnecessary and that most other states do not use them. Further, the stiffening practices that were developed and used for plywood substrates are not necessarily appropriate for aluminum substrates. The optimization of sign stiffening practices could lead to considerable cost savings for TxDOT.

Additionally, the original TxDOT standard for large sign supports is to saw cut the beam below the sign substrate and attach fuse plates that provide moment capacity for resisting wind loads, but activate as a hinge during impact, allowing the impacting vehicle to travel beneath the sign panel. This method has been replaced. The new method includes splicing two post sections at the hinge location using two fuse plates attached to the front and rear flanges, respectively. This design has never been statically tested to determine if it provides the required service load capacity. At least one other state does not require either type of treatment.

In summary, there is a need to conduct a thorough review of large and small sign mounting details and practices. Such a review should consider all factors that might impact the design, installation, maintenance, and repair of sign support systems. This includes assessing the impact performance of some existing sign support systems and determining if improvements are necessary and appropriate, and evaluating new products and technologies for use in Texas. The findings and results of the project will be used to update standard SMD sheets, and revise or set policies and standards related to sign mounts. Additionally, the project provides a mechanism for TxDOT to quickly and effectively evaluate and address high priority needs that may arise related to sign support systems.

1.3 OBJECTIVES/SCOPE OF RESEARCH

Issues associated with large and small sign support systems were identified, prioritized, and addressed under this project in conjunction with TxDOT personnel. Factors such as impact performance, maintenance, and cost were considered. Depending on the issue being investigated, statewide implementation of research results may be achieved in the form of new or revised standard SMD sheets. Any new or improved sign support hardware found to be in compliance with *MASH* guidelines will be available for implementation on the state highway system. Drawings of recommended design details developed under the project will be submitted to TxDOT for use by personnel in the Traffic Operations Division.

There are millions of signs on the state highway systems. Therefore, even a small improvement or cost savings in the design of sign structures can result in significant cost savings to TxDOT. Such economy could be realized through simplified design, improved installation procedures, reduction in materials used, interchangeability, or other factors. This project is expected to result in new or revised guidelines, procedures, and policies for the design, installation, maintenance, and repair of sign support systems. The research results and recommendations will be provided in a format suitable for incorporation into standard detail sheets, design manuals, and/or the Sign Crew Field Book as appropriate.

The work plan for the project was comprised of two basic objectives. A prioritized list of topics was established and specific details of the research approach were determined. The Texas Transportation Institute (TTI) researchers worked closely with the TxDOT project director and project monitoring committee to ensure that the work conducted under this project was responsive to TxDOT's needs. Details of the objectives are provided below.

1.3.1 Objective 1. Select and Prioritize Sign Support Issues

A critical, in-depth review of the SMD sheets was conducted. District input was sought regarding field problems that have been encountered regarding the selection, installation, maintenance, or repair of sign support systems. Following the review, the TTI researchers met with the project director, project monitoring committee, and other interested TxDOT personnel to discuss, prioritize, and select the sign mounting issues that were studied. The project monitoring committee and TTI research team worked jointly to identify the work plan.

1.3.2 Objective 2. Execute Approved Work Plan for Selected Sign Mounting Issues

After the project panel approved the research plan, the TTI research/testing needed to address the assigned issues was conducted under this task. The nature of the analyses performed to investigate a particular sign mounting issue varies from topic to topic and included review of practice in other states, engineering analyses, computer simulation, static load testing, dynamic pendulum testing, and full-scale crash testing.

Structural issues associated with the sign support systems are typically addressed through static load testing and engineering analysis. Such issues include the development of guidelines for stiffening sign substrates, wind load analysis, and evaluation of mechanisms for resisting the rotation of single supports.

A key objective of this project was to assess the compliance of current sign mounting practices with *MASH* impact performance criteria. For certain hardware features, computer simulation techniques are used to support analysis efforts. When necessary, full-scale vehicle crash tests are performed to evaluate the impact performance of existing, modified, or new sign support configurations.

The selected sign support system was crash tested according to the guidelines and procedures set forth in *MASH*, as the project director and project monitoring committee had determined. This report details the sign support system, the details of the crash tests performed, and the evaluation and assessment of the results of the tests.

1.4 RESEARCH STRUCTURE

Multiple tasks are included in this three-year research project. In this report, each task is addressed separately in a chapter. Literature review, engineering analysis, computer simulations, and full-scale crash testing will be performed according to the nature and the needs of each task. Tasks and their objectives are listed below:

Task #1. Comparison of Wind Load Pressure Calculation Methods.

This task reviewed the differences in the new AASHTO's method for calculating wind pressures to the legacy method used previously. Task 1 evaluated the differences in the methods and what effects updating the wind load charts to the new method has on calculated capacities of TxDOT sign supports.

Task #2. Sign Area on Schedule 80 Pipe Supports.

This task evaluated the ability of a standard TxDOT schedule 80 pipe support to uphold a 42-square ft sign. This is in excess of the current maximum 32 square ft; however, there is a need for a single support configuration to support these larger signs in some locations. Static tests have shown that the capacity of single sign supports usually exceed what is calculated. This added

capacity may make supporting sign panels larger than 32 square ft a viable option on a limited basis.

Task #3. Analysis of Schedule 40 Pipe Support.

This task evaluated the viability of adding a schedule 40 pipe support to the current list of standard pipe supports. The evaluation focused on the cost-effectiveness of adding a schedule 40 pipe support as an intermediate size between a BWG10 and schedule 80 pipe support.

Task #4. Review of Current Standards for Large Guide Signs.

This task evaluated reported failures of large guide sign supports from district offices. Preliminary evaluation indicated that failures were related to failures of fuse plate connections.

Task #5. Evaluation of Need/Placement of Stiffeners on Large Guide Signs.

This task evaluated the need for vertical sign panel stiffeners on large guide signs. Vertical stiffeners were highly labor-intensive to install and TxDOT may save a significant amount of resources by not installing them.

Task #6. Optimization of Fuse Plate Capacities for Large Guide Signs.

This task developed an optimized fuse plate design that provided for a more efficient utilization of current large guide sign supports. Previous research under Task 4 has shown that fuse plates are generally the controlling factor in determining the wind load capacity of a large guide sign support. By optimizing the fuse plate design, the capacity of most large guide sign supports could be increased, possibly leading to reduced large guide sign support installation costs.

Task #7. Development of Updated Large Guide Sign Wind Load Charts.

This task developed new wind load charts to better represent current large guide sign support wind load capacities. By updating wind load design charts to account for previously unrepresented fuse plate failures, many failures of large guide sign supports can be prevented, leading to maintenance cost savings.

Task #8. Develop Guidance for Minimum Sign Area for Slipbase Supports.

This task established a minimum sign area for slipbase support to reduce severity of the roof crush and improve safety according to the safety-performance evaluation guidelines included in *MASH*. *MASH* has reduced the maximum roof deflection from 6 inches in *NCHRP Report 350* to just 4 inches. Previous burn ban sign testing passed *NCHRP Report 350*; however, the measured crush values would not meet the new *MASH* criteria. By defining a minimum sign area according to the new testing requirements, the severity of a sign impact would be reduced.

Task #9. Develop Mounting Standards for Chevrons and Mile Markers.

Currently, chevrons can be installed on either slip base or on wedge and socket support systems. Research in Task 8 showed that chevrons may not meet the minimum sign area requirements for slip base support systems. For this reason, a full evaluation of the installation methods for chevrons was reevaluated. As part of this evaluation, researchers were also asked to investigate the appropriateness of allowing 30-inch × 36-inch and 36-inch × 48-inch chevron sign sizes on a 4-ft mounting height, from a crashworthiness point of view. Also as part of this evaluation, current TxDOT D&OM sheets were reviewed for completeness and effectiveness in presenting required information.

Task #10. Analysis of U-Brackets on Schedule 80 Pipe Supports.

The objective was to review reported instances of failures. As part of this task, the current design for U-brackets was evaluated for perceivable weakness that may be causing reported failures.

CHAPTER 2. COMPARISON OF WIND LOAD PRESSURE CALCULATION METHODS

2.1 INTRODUCTION

There are currently two acceptable methods of calculating wind pressures, both of which are described in *AASHTO Standard Specifications for Structural Supports for Highway Signs, Luminaires and Traffic Signals* (3). The current method is described under section 3 of the design manual. This method is an attempt to unify wind load design with that of other structures. However, the legacy method is still considered an acceptable method for determining wind load values and is included in Appendix C of the design standard. Both methods should result in similar wind pressures; however, one method may generate pressures in excess of the other, depending on the geographic location. One is not considered more conservative than the other.

2.2 METHODS COMPARISON

2.2.1 Current Wind Load Pressure Calculation Method

The design wind pressure is based on the basic wind speed and the anticipated design life of the structure. The basic wind speed is associated with the annual probability of 0.02 (or a 50 year mean recurrence interval), and is prescribed by isotachs contained in the *AASHTO Standard Specifications for Structural Supports for Highway Signs, Luminaires and Traffic Signals*. Figure 2.1 shows that the basic wind speed varies with geographical location across Texas and ranges from 90 mph to 130 mph near the coast. The current basic wind speed is modified by an importance factor based on the recommended minimum design life of a structure. The recommended minimum design life for roadside sign structures is 10 years.

Wind Pressure Equation

$$P_z = 0.00256 K_z G (V * C_v)^2 I_r C_d \text{ (psf)}$$

Variables

P_z = Design Wind Pressure (psf)

I_r = Wind Importance Factor

C_v = Velocity Conversion Factor

K_z = Height and Exposure Factor

G = Gust Effect Factor

C_d = Wind Drag Coefficients

V = Basic Wind Speed (mph), from Wind Chart

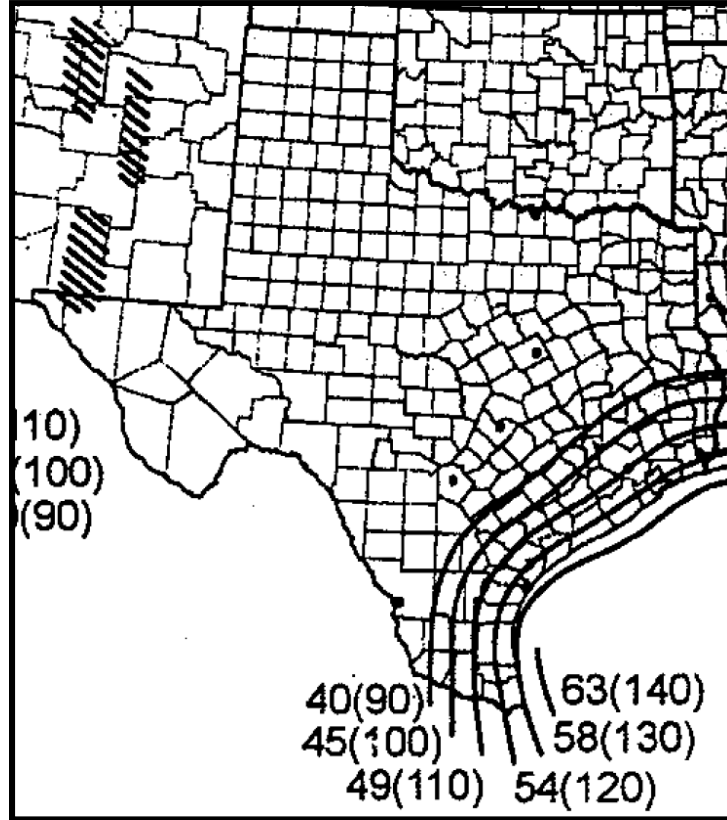


Figure 2.1. Texas Isotachs Wind Load Chart.

2.2.2 Appendix C: Method for Wind Load Pressure Calculation (Legacy Method)

The design wind pressure is based on the 10 year recurrence (based on design life) interval wind speed. The 10-year recurrence wind speed is prescribed by isotachs contained in Appendix C of the AASHTO *Standard Specifications for Structural Supports for Highway Signs, Luminaires and Traffic Signals*. Figure 2.2 shows the basic wind speed varies with geographical location across Texas and ranges from 60 mph to 80 mph near the coast. Again, the recommended minimum design life for roadside sign structures is 10 years.

Wind Pressure Equation:

$$P_z = 0.00256 (1.3 V_{fm})^2 C_d C_h \text{ (psf)}$$

Variables:

P_z = Wind Pressure (psf)

C_h = Coefficient of Height (0.80 for 14ft or less)

C_d = Wind Drag Coefficients (Varies from 1.12 to 1.30 depending on L/W)

V_{fm} = Wind Speed from Wind Load Charts

1.3 V_{fm} = 30 percent Increase in wind velocity for gust

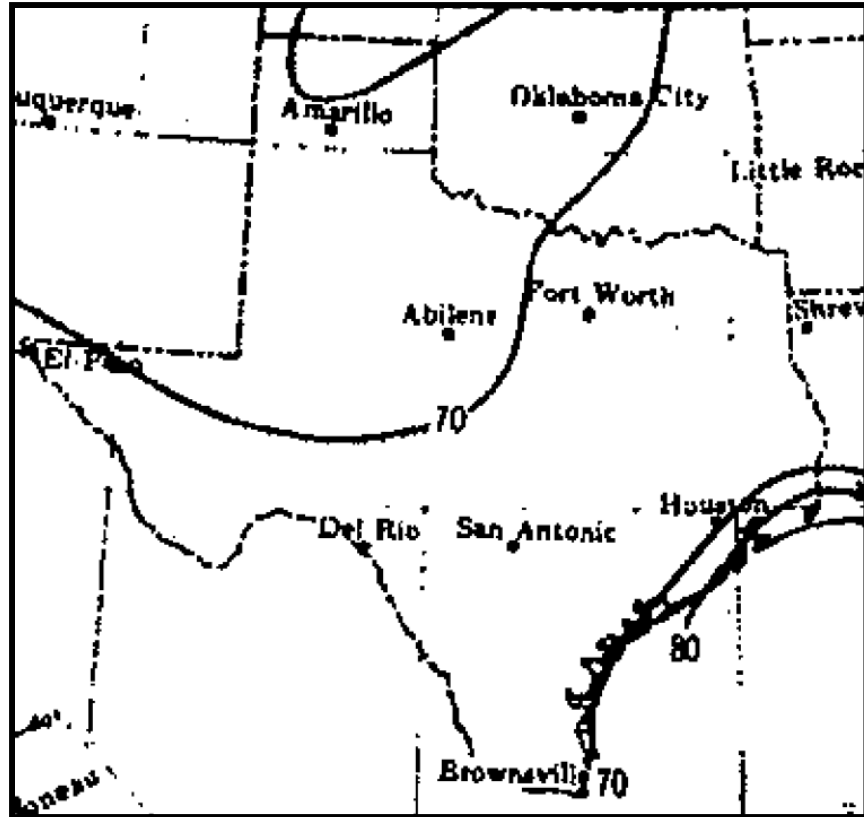


Figure 2.2. Appendix C: 10-Year Recurrence Interval Wind Load Chart.

2.2.3 Summary

AASHTO's *Standard Specifications for Structural Supports for Highway Signs, Luminaires and Traffic Signals* states that for a given location, either method may be greater than the other, depending on associated factors. From our research on sign supports, it appears that the legacy method generally results in a higher calculated wind load. Therefore, if the support's capacity is reevaluated using the new method, it is expected that it will have a higher calculated capacity. If the new method is utilized, it may require the update of TxDOT wind zone charts that other supports and luminaires also used, which are not being evaluated under this project.

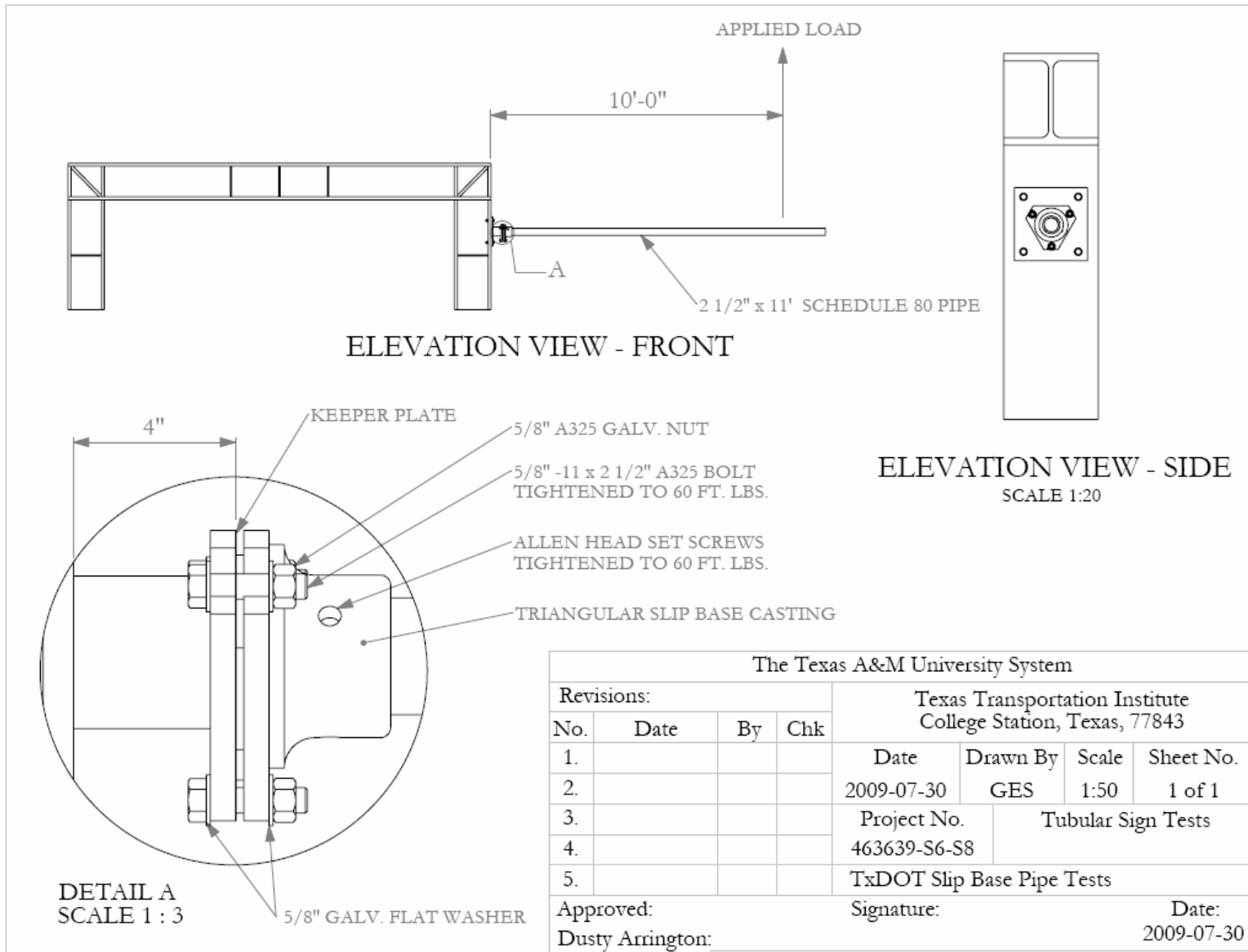
CHAPTER 3. SIGN AREA ON SCHEDULE 80 PIPE SUPPORTS

According to AASHTO *Standard Specifications for Structural Supports for Highway Signs, Luminaires and Traffic Signals*, the minimum material specifications for the support must be used when calculating the maximum sign area with respect to wind loads. TxDOT standard sheets require supports to be constructed to ASTM 500 grade C specifications. TxDOT standard sheets specify that the yield stress meets or exceeds 46 ksi, and the ultimate stress meets or exceeds 62 ksi. Historically, most schedule 80 sign support posts that steel suppliers provide have exceeded this specification by a large margin. TxDOT standard sheets mandate a maximum of 32 ft² sign area to be supported by a single schedule 80 support. This value is again based on minimum material specifications.

TxDOT has several sign configurations that require the mounting of signs between 32 ft² and 42 ft² on dual supports. Since historically the actual material properties of the supports supplied to TxDOT are significantly greater than the minimums they had set, it was suggested that a study should be conducted to see if a 42 ft² sign panel could be supported on a single schedule 80 sign support. AASHTO Section 12.4 states that static testing can be performed in place of standard analysis procedures. Furthermore, Section 12.4 states that if three static tests are performed and each test varies less than 10 percent from the average value, the resulting average force can be used to determine maximum sign areas. As part of this process, the resulting average is divided by 1.5 to determine the resulting allowable total wind force.

To determine the maximum allowable force, three static tests (S6-S8 as described in Appendix A) on schedule 80 support posts were performed utilizing standard slipbase connections. Each static test consisted of a cantilevered slipbase connection attached to a rigid load frame. An 11-ft, 2.5-inch schedule 80 sign support was then inserted into each slipbase, which was installed with standard hardware. Each test article was then loaded perpendicular to the support post at an effective height of 10 ft. Deflection was also recorded at the point of load application. Each test sample was then loaded until the article failed or the load reached a maximum and then began trending downwards. Figure 3.1 shows the test setup of this series of testing.

Figure 3.2 shows the test setup before load application, and Figure 3.3 shows the test setup at the point of maximum loading. Table 3.1 presents a summary of recorded loads. The testing resulted in an average failure load of 1022 lb. All three tests yielded the post support plastically at the slipbase interface. Notice that all the recorded failure loads are within 10 percent of the average failure load meeting the AASHTO requirement of a maximum allowable 681-lb wind load.



T:\2008-2009\463639-TxDOT\Single Tubular Sign Supports\SolidWorks\Tubular Sign Support tests

Figure 3.1. Schedule 80 Support Static Testing Setup.



Figure 3.2. Schedule 80 Support Static Testing Setup before Load Application.

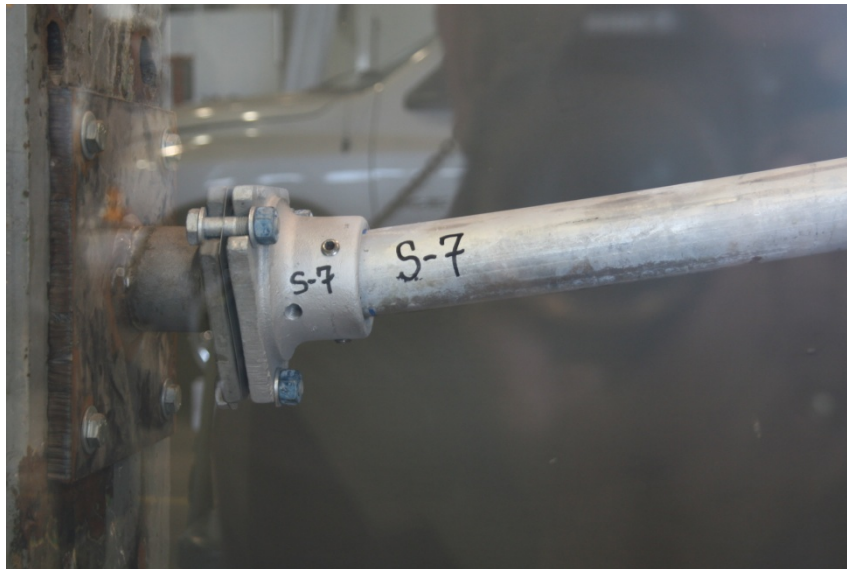


Figure 3.3. Schedule 80 Support at Maximum Load.

Table 3.1. Schedule 80 Support Summary of Maximum Loads.

| Support Tested | Test No. | Maximum Load (lb) | Displacement (inches) |
|--------------------------------|-----------------|--------------------------|------------------------------|
| Schedule 80 Cantilever Support | S6 | 1047 | 25.5 |
| | S7 | 1047 | 25.5 |
| | S8 | 971 | 20.4 |

All three test samples received from Northwest Pipe had mill certifications that far exceeded the minimum A500 grade C requirements. Again, TxDOT sets the requirement that the yield stress shall not be less than 46 ksi and the ultimate stress shall exceed 58 ksi. The mill certification sheets sent with the samples stated the yield stress was 66 ksi and the ultimate stress was approximately 72 ksi, which is 43 percent greater than the TxDOT minimum requirement. A 42 square ft sign is 31 percent larger than the TxDOT mandated maximum of 32 ft². This gives merit to the idea that a 2.5-inch schedule 80 sign support could support a 42 ft² sign.

Figure 3.4 is a wind load generated using two basic yield stresses. This wind load chart was generated using the current method of calculating wind pressures, not the legacy method described in Appendix C of the current AASHTO *Standard*. All calculations represented in this chart assume a 7 ft mounting height of the sign. The calculations also assume a 10-year recurrence interval (standard practices for roadside sign supports). The blue line represents the capacity of a 2.5-inch schedule 80 support post assuming a yield stress equal to 46 ksi (TxDOT's minimum requirement). The red line represents the 2.5-inch schedule 80 support post assuming a yield stress equal to 66 ksi (actual test sample values).

As expected, the blue line aligns with the 32 ft² maximum allowable sign area. Also, note that the red line falls above the 42 ft² sign area. This shows that the test samples analytically have sufficient capacity to support a 42 ft² sign area for a 90 mph wind region (Again, this is based on the current wind method, not the legacy method). This region covers most of the state of Texas.

Using the maximum allowable design wind load force (681 lb) from the static testing above and an assumed sign area of 42 ft², the support can sustain a wind pressure of 16.2 lb/ft². A 90 mph wind speed, assuming again a 6 ft tall sign mounted at 7 ft height, results in a wind pressure of 16.4 lb/ft² (total wind force of 689 lb). This again leads to the conclusion that the test samples would be capable of sustaining a 42 ft² sign.

That being said, if a pipe support was supplied with a yield stress less than 66 ksi and greater than the 46 ksi minimum, it would not be able to sustain the 42 ft² sign. To ensure that the sign support can support the larger sign area, TxDOT could require a minimum yield stress of 66 ksi. Another option would be to leave the minimum as it is and expect some risk that some supports may yield during extreme loading events. A study of manufacturer-supplied material specifications should be conducted to give better insight into what TxDOT is actually being supplied.

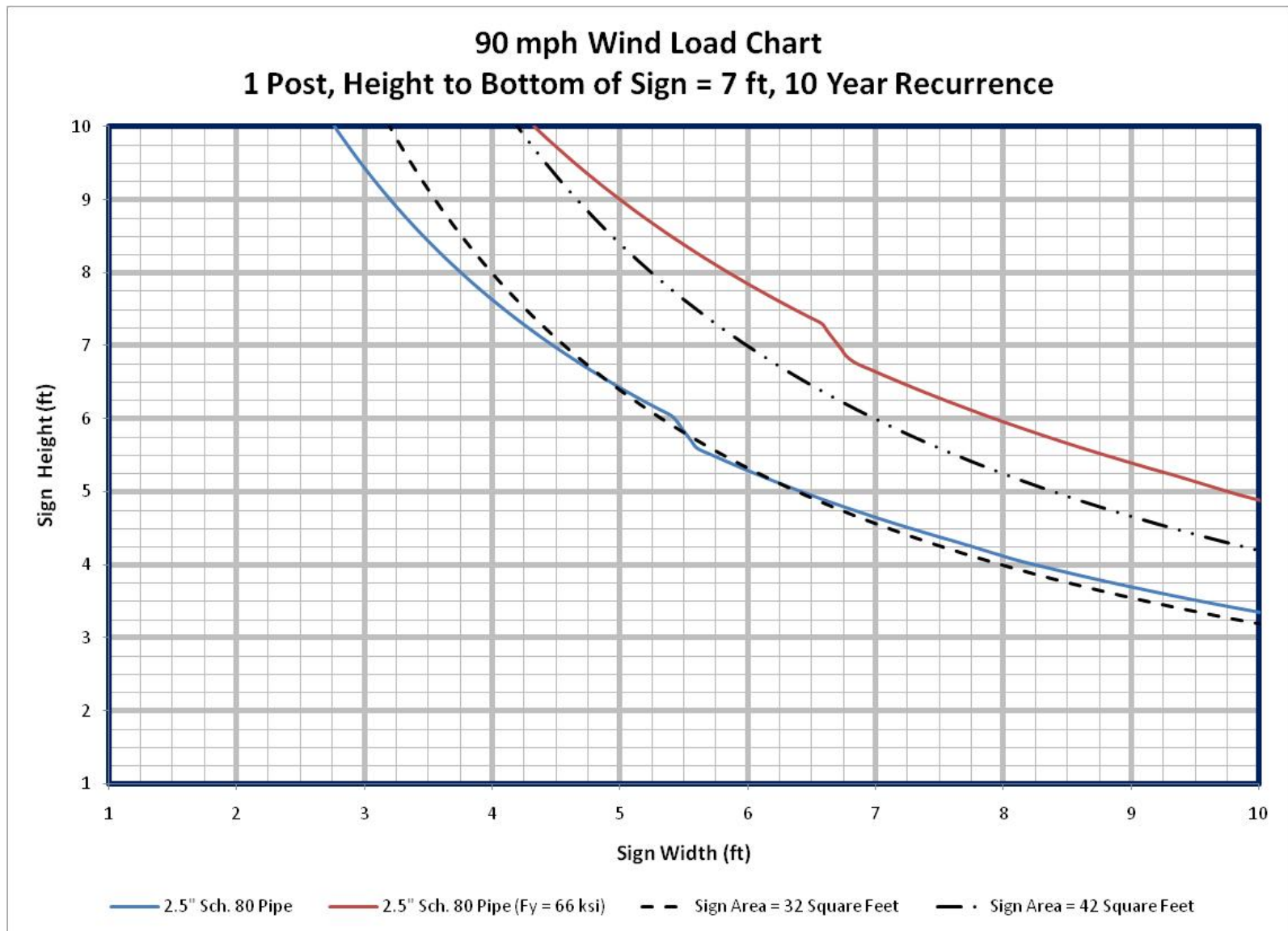


Figure 3.4. Updated Schedule 80 Wind Load Chart (Current Pressure Method).

CHAPTER 4. ANALYSIS OF SCHEDULE 40 PIPE SUPPORTS

TxDOT historically has inventoried two 2.5-inch nominal pipe sign support thickness (10 British Wire Gage [BWG] and schedule 80). Both pipe supports have the same outer diameter to allow them to both be used interchangeably with a triangular slipbase. The 10 BWG is lighter/cheaper than the schedule 80 pipe support; however, its thinner wall reduces its maximum sign area rating significantly. This difference in capacity has led to the question: Is there a section that falls between these two that could provide some cost savings for some of the intermediate sign sizes?

TxDOT has asked TTI to analyze a schedule 40 sign support to determine its maximum sign area, and to compare the calculated capacity to the two current section capacities. Table 4.1 is a summary table of the key sections properties of all three pipe support sections.

Table 4.1. Comparison of 2.5-Inch Pipe Support Section Properties.

| Post Size | Outer ϕ (OD) | Inside ϕ (ID) | Thk | Zx | Fy | Fu |
|-------------------|-------------------|--------------------|-------|-----------------|-----|-----|
| | in | in | in | in ³ | ksi | ksi |
| 2.5" 10 BWG Pipe | 2.875 | 2.607 | 0.134 | 1.008 | 55 | 70 |
| 2.5" Sch. 40 Pipe | 2.875 | 2.469 | 0.203 | 1.452 | 42 | 62 |
| 2.5" Sch. 80 Pipe | 2.875 | 2.323 | 0.276 | 1.871 | 42 | 62 |

Using the section properties detailed in Table 4.1 and the current wind pressure method described in AASHTO, the research team generated wind load charts (see Figure 4.1) for all three 2.5-inch pipe sections (10 BWG, schedule 40, and schedule 80) to demonstrate their relative capacities. Furthermore, Figure 4.1 shows that the schedule 40 pipe support does fall between the 10 BWG and the schedule 80 sections. However, the capacity is fairly close to that of the 10 BWG, showing that there will be only a few instances where a schedule 40 could be used instead of a schedule 80 support.

Cost per foot values were collected for each of the three sections for a cost comparison. The schedule 80, schedule 40, and 10 BWG cost \$9/ft, \$5/ft, and \$3/ft, respectively. Therefore, a schedule 40 support costs 67 percent more than a BWG 10 and is only 8 percent stronger. The minor increase in strength is due to the wide variance in minimum yield stress values between the two materials used to fabricate the supports. Schedule 40 sections have a minimum yield stress value of 42 ksi, whereas a 10 BWG has a minimum stress value of 55 ksi. Again, if TxDOT required the minimum yield stress values for the schedule 40 sections to exceed 55 ksi, the gap between the wind load chart lines would increase substantially, making the option of inventorying the schedule 40 section more palatable to local districts.

As the sections are currently defined, it does not appear that the cost savings of adding the schedule 40 pipe section to current inventories would outweigh the additional inventory costs. Should the minimum yield stress requirement for the schedule 40 be increased, the option for adding this section to the current inventory may need to be revisited.

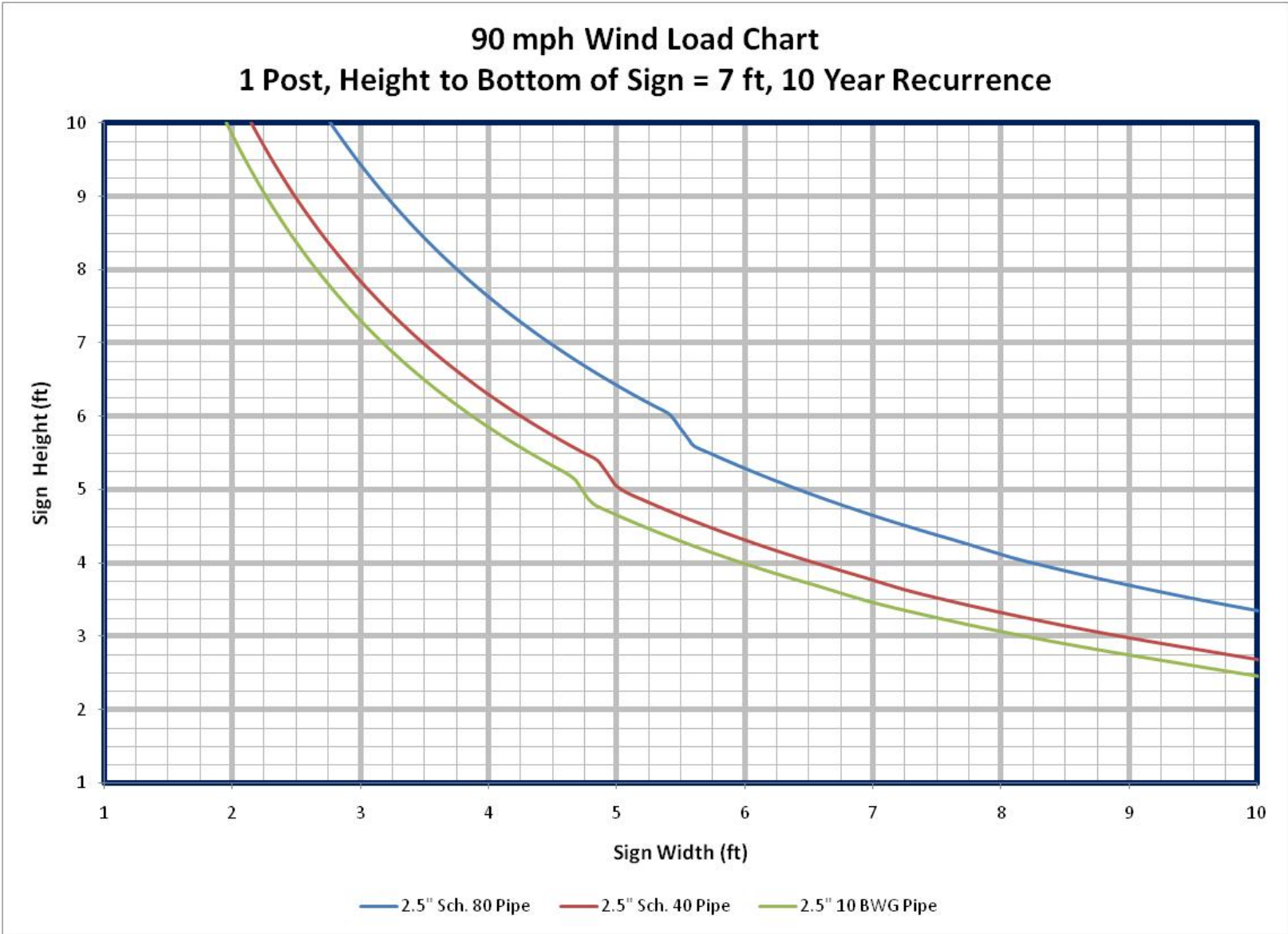


Figure 4.1. 2.5-Inch Pipe Support Wind Load Chart Comparison (Current Pressure Method).

CHAPTER 5. REVIEW OF CURRENT STANDARDS FOR LARGE GUIDE SIGNS

5.1 INTRODUCTION

As the origins of the current wind load charts TxDOT used are unknown, a thorough review was required to verify that they meet current codes and specifications. Also, many reports of fuse plate failures have been reported. A thorough analysis to determine the cause of the failures was required. Many questions have been raised about the major differences between the W8×18 and W8×21 slipbase connection details. TxDOT requested that TTI analyze the connections to determine if the connections could be unified.

5.2 TASK 3A: REVIEW OF CURRENT LARGE GUIDE SIGN WIND LOAD CHARTS

Current large guide sign support selection charts were obtained from TxDOT's standards website for review. Figure 5.1 is an image of the current standard obtained. Figure 5.2 is an enlarged image of Zone 1 of the current selection chart. This chart was developed many years ago, and there is no record of who developed it or how it was developed. Therefore, to evaluate this chart's accuracy, new wind load charts were generated using the current support specifications according to the legacy wind pressure method detailed in Appendix C of AASHTO *Standard*. Figure 5.3 shows the resulting chart, which assumes the same conditions defined by Zone 1 (90 mph wind speed) of the TxDOT support selection chart. Also, Figure 5.3 assumes a 7-ft mounting height and that the sign is mounted on two support posts.

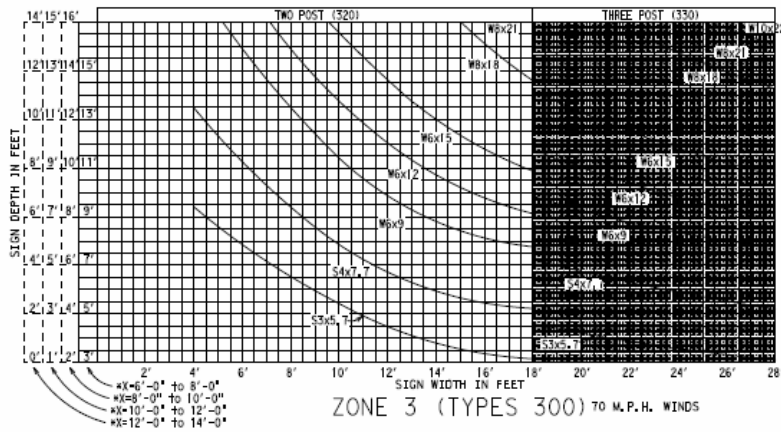
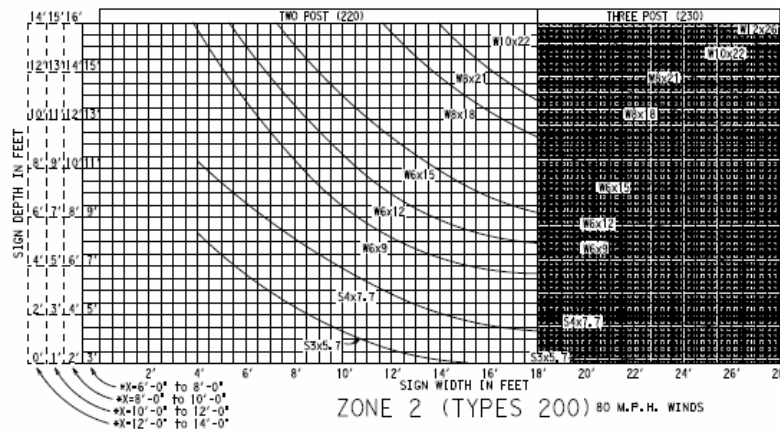
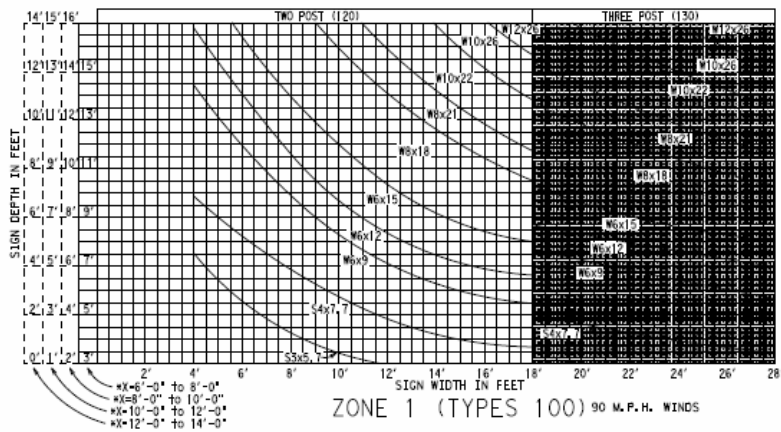
Several inconsistencies are immediately evident. First, the current selection chart generally over predicts the wind load capacity of the support assemblies. Currently, this inconsistency cannot be explained.

Second, several of the support assemblies wind load capacities fall directly on atop one another. This is counterintuitive. One would expect that if the strength of the beam was increased, it would result in an increase in the wind load capacity. This, however, is not the case.

The answer lies in the fuse plate capacity. Figure 5.4 is an image of the current TxDOT standard detailing the slipbase and fuse plate connections. Table 5.1 is an enlarged image of the design table detailing the sizes of each of the components corresponding to each support section's size. Also, Figure 5.4 is the current generic fabrication diagram for all fuse plate designs; the sections that have equivalent wind load capacities share the same fuse plate details. Researchers conducted further investigation into the cause of the phenomena.

The use of this standard is governed by the "Texas Engineering Practice Act". No warranty of any kind is made by TxDOT for any purpose whatsoever. TxDOT makes no representation for the fitness or suitability of this standard for other purposes or for other post designs or designs postloading from its use.

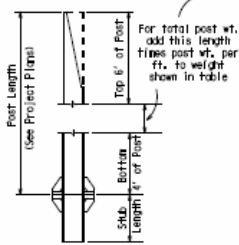
DATE FILE:



* NOTE: "X" EQUALS THE AVERAGE HEIGHT FROM THE GROUND LINE TO THE BOTTOM EDGE OF THE SIGN.

SHADED AREA DENOTES 3 POST SUPPORTS

Notes: Footings for S3x5.7 and S4x7.7 post sizes shall be non-reinforced with Class A concrete, while footing for all other post sizes shall be reinforced with Class C concrete.

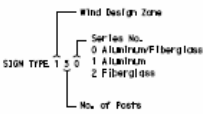


| POST WEIGHT DATA | | | |
|------------------|------------------------|-------------------------|---------------------------|
| POST SIZE | WEIGHT OF ONE POST LB. | WEIGHT OF TWO POSTS LB. | WEIGHT OF THREE POSTS LB. |
| W6x9* | 123.2 | 246.4 | 369.6 |
| W6x12* | 160.3 | 320.6 | 480.9 |
| W6x15* | 167.8 | 335.6 | 503.4 |
| W6x18* | 201.8 | 403.6 | 605.4 |
| W6x21* | 254.7 | 509.4 | 764.1 |
| W10x22* | 266.0 | 532.0 | 798.0 |
| W10x26* | 308.0 | 616.0 | 924.0 |
| W12x26* | 308.6 | 617.2 | 925.8 |
| S3x5.7* | 85.9 | 171.8 | 257.7 |
| S4x7.7* | 112.2 | 224.4 | 336.6 |

*LAST FIGURES=POST WT. PER FT.

Weight Data is the weight of items shown for one, two or three posts - includes top 6' of post, bottom 4' of post, post foundation stub, related base connection plates and stiffeners, friction fuse plate and all high strength bolts, nuts and washers.

SIGN TYPE



Texas Department of Transportation
Traffic Operations Division

**LARGE ROADSIDE SIGN SUPPORTS
POST SELECTION
WORKSHEET**
SMD (8W1) -08

| DATE | BY | CHKD | APP | DATE |
|------|--------|------|-----|------|
| 1-82 | RS/D/S | | | |
| 5-01 | | | | |
| 9-08 | | | | |

Figure 5.1. Current TxDOT Large Guide Sign Wind Load Charts.

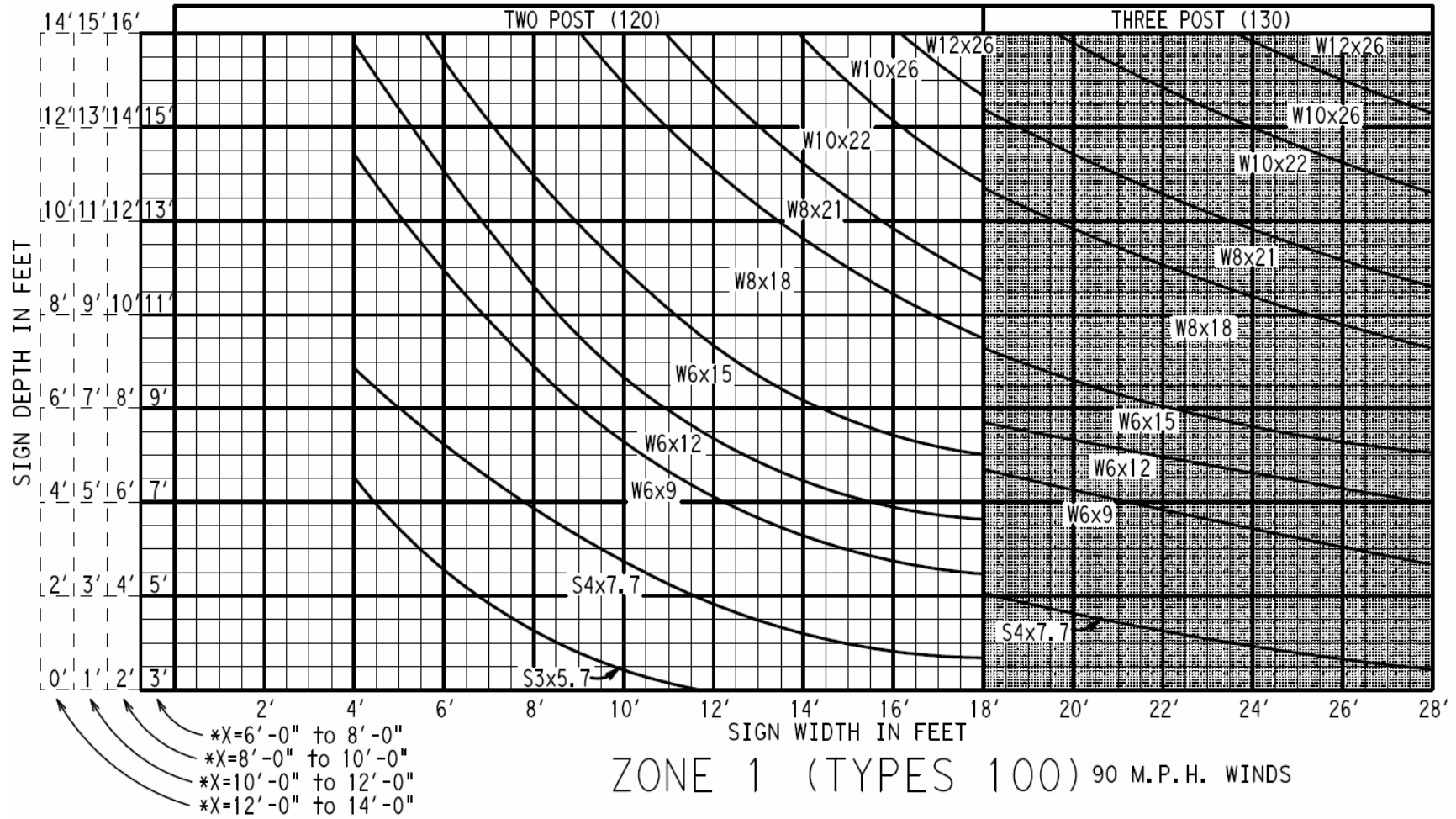


Figure 5.2. Current TxDOT Large Guide Sign Zone 1 Wind Load Charts.

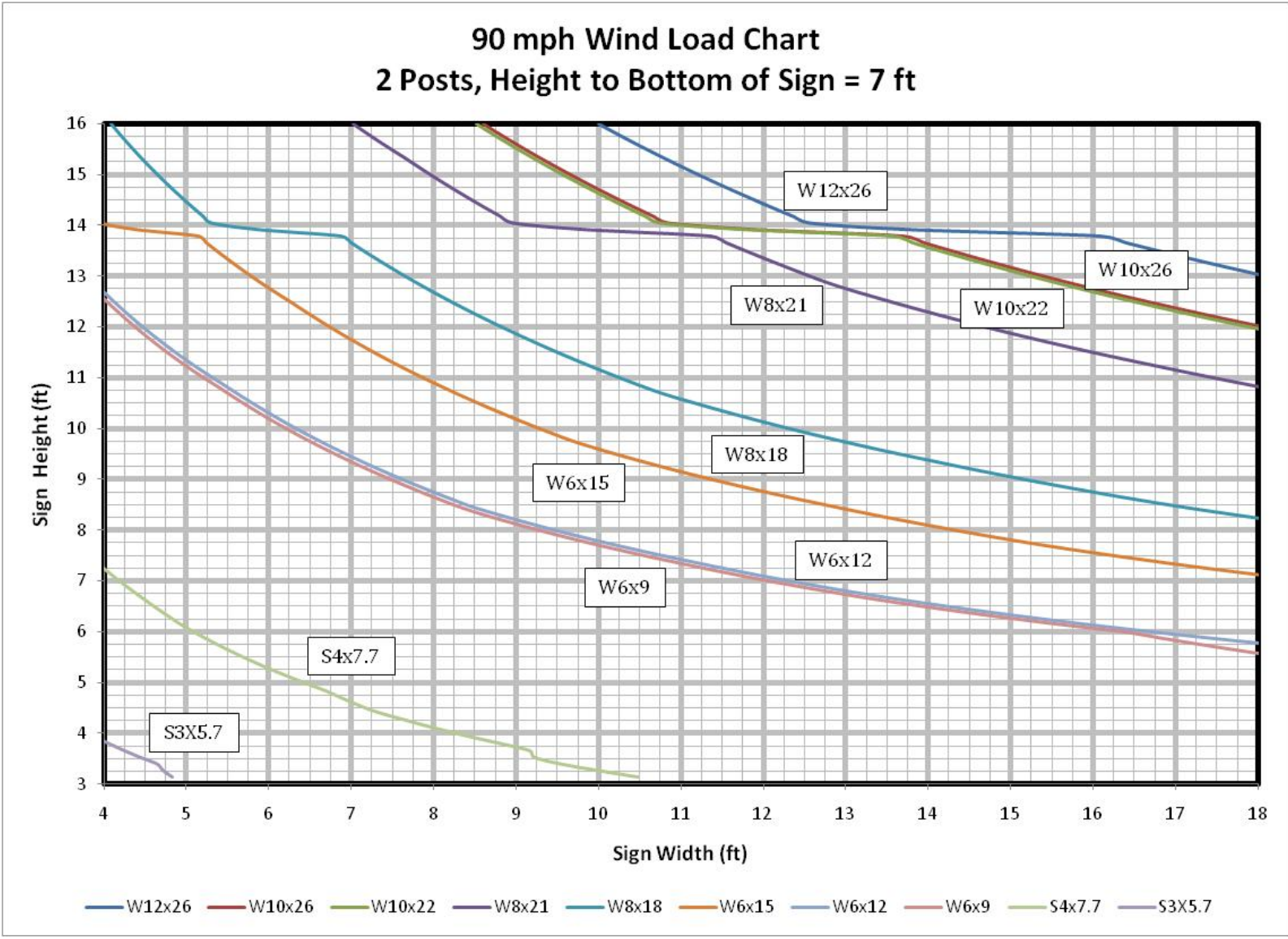
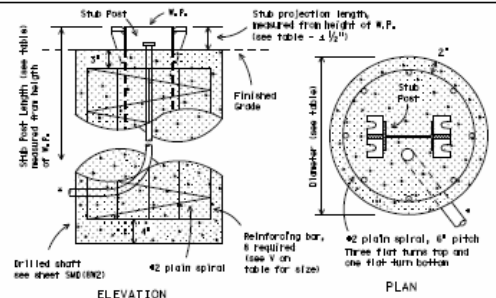
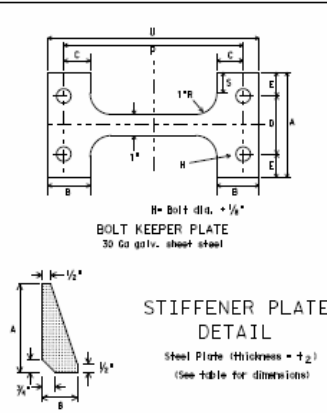
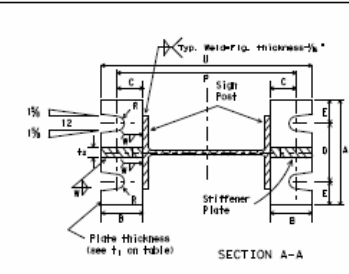
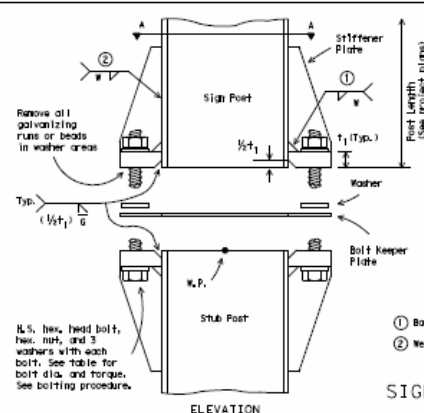


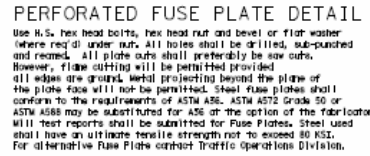
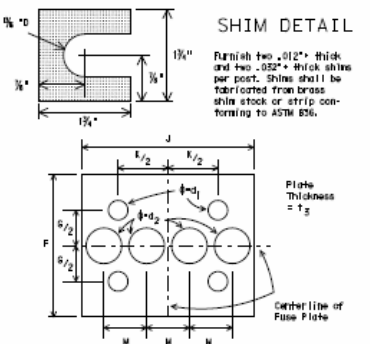
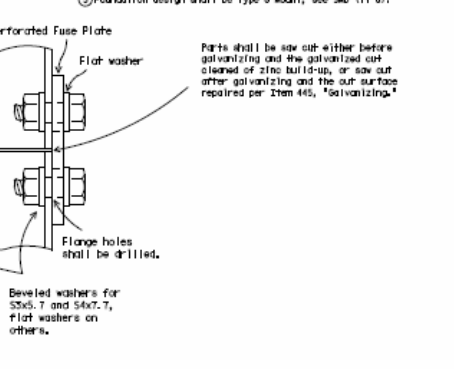
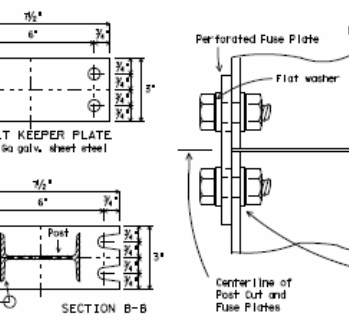
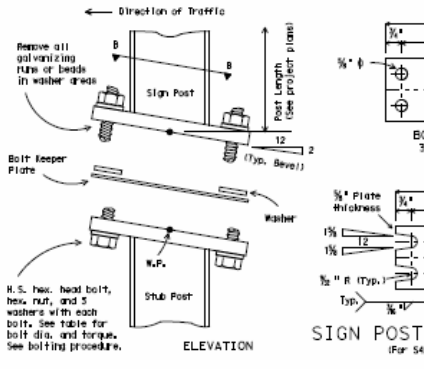
Figure 5.3. Wind Capacities of Current Large Guide Sign Supports (Legacy Method).

The use of this standard is governed by the "Texas Engineering Practice Act". No warranty of any kind is made by TxDOT for any purpose whatsoever. TxDOT makes no representation for the fitness of any article or material for other purposes or for installation outside of those specified herein. The user of this standard is advised to consult the manufacturer's literature for proper installation and use.



- BOLTING PROCEDURE FOR ASSEMBLY OF BASE CONNECTION**
1. Assemble sign post, BOLT KEEPER PLATE and stub post with bolts and three flat washers per bolt as shown.
 2. Shim as required to stub post.
 3. Tighten all bolts the maximum possible with a 12 to 15 inch wrench to clean bolt threads and to bed washers and shims.
 4. Loosen each bolt in sequence and retighten bolts in a systematic order to the prescribed torque. Do not over-tighten.
 5. To prevent nut loosening, bury threads of bolt at junction with nut using a center punch.

| Dimensions Post Size | Base Connection Data Table | | | | | | | | | | Perforated Fuse Plate Data Table | | | | | | | | | | Bolt Keeper Data | | | Foundation Data | | | |
|-------------------------|----------------------------|------------------|--------|--------|--------|--------|----------------|----------------|------|---|----------------------------------|--------|--------|--------|--------|----------------|----------------|----------------|-------------------|---------------------|------------------|--------|---------|-----------------|-----------------|--------------------|----------------|
| | Bolt Size & Torque | A | B | C | D | E | t ₁ | t ₂ | W | R | F | G | J | K | M | d ₁ | d ₂ | t ₃ | Bolt Dia. (Inch.) | Bolt length (Inch.) | P | S | U | Stub length | Stub projection | Dr. Shaft diameter | Bar Size |
| W6x9 | 3/8" φ x 2 3/4" | | | | | | | | | | 4/4" | 2" | 4" | 2 1/4" | 1" | 3/4" | 1/4" | 1/2" | 1.01 | 1 1/2" | 8 1/2" | | 9 3/8" | 2'-0" | 3" | | #5 |
| W6x12 | 440-450 (inch pounds) | | | | | | | | | | 5" | 2 1/2" | 6" | 3 1/2" | 1 1/2" | 1 1/4" | 3/8" | 3/8" | 2.51 | 2 1/4" | 8 1/2" | 1" | 10" | 2'-0" | 3" | | #5 |
| W6x15 | 36-38 foot pounds | 5' | 2" | 1 1/4" | 2 1/4" | 1 1/2" | 3/4" | 1/2" | 1/4" | | 5" | 2 1/2" | 6" | 3 1/2" | 1 1/2" | 1 1/4" | 3/8" | 3/8" | 2.28 | 2 1/4" | 10 3/4" | | 12 1/2" | 2'-6" | 3" | | #6 |
| W8x18 | | | | | | | | | | | 6" | 3" | 5 3/4" | 2 3/4" | 1 3/8" | 1 1/8" | 1/2" | 3/4" | 3.35 | 2 1/4" | 11" | 1 1/2" | 12 3/4" | 3'-0" | 2 1/2" | 24" | #8 |
| W8x21 | 3/4" φ x 3 1/2" | | | | | | | | | | 6" | 3" | 5 3/4" | 2 3/4" | 1 3/8" | 1 1/8" | 1/2" | 3/4" | 4.03 | 2 1/4" | 12 3/8" | | 14 3/8" | 3'-0" | 2 1/2" | | #9 |
| W10x22 | 740-750 (inch pounds) | 6' | 2 1/4" | 1 3/8" | 3 1/2" | 1 1/4" | 1" | 3/4" | 1/2" | | 6" | 3" | 6 1/2" | 3 1/2" | 1 3/8" | 1 1/8" | 1 1/2" | 3/4" | 4.47 | 2 1/4" | 13 3/8" | 1 1/2" | 16 1/4" | 3'-0" | 2 1/2" | | #10 |
| W10x26 | 52-65 foot pounds | | | | | | | | | | 6" | 3" | 6 1/2" | 3 1/2" | 1 3/8" | 1 1/8" | 1 1/2" | 3/4" | 4.47 | 2 1/4" | 15" | | 16 1/4" | 3'-0" | 2 1/2" | | #11 |
| W12x26 | | | | | | | | | | | 6" | 3" | 6 1/2" | 3 1/2" | 1 3/8" | 1 1/8" | 1 1/2" | 3/4" | 4.47 | 2 1/4" | 15" | | 16 1/4" | 3'-0" | 2 1/2" | | #11 |
| S3x5.7 | 1/2" φ x 2 1/4" | See Detail Below | | | | | | | | | 3 3/4" | 1 1/2" | 2 5/8" | 1 1/2" | 3/8" | 3/8" | 1/4" | 1/2" | 0.60 | 1 1/2" | See Detail Below | | | 3'-3 1/2" | 3/4" | 12" | Not referenced |
| S4x7.7 | 1 1/4" φ x 2 1/4" | See Detail Below | | | | | | | | | 3 3/4" | 1 1/2" | 2 5/8" | 1 1/2" | 3/8" | 3/8" | 1/4" | 1/2" | 0.60 | 1 1/2" | See Detail Below | | | 3'-3 1/2" | 3/4" | 12" | Not referenced |



Use U.S. hex head bolts, hex head nut and bevel or flat washer where required under nut. All holes shall be drilled, sub-punched and reamed. All plate cuts shall preferably be saw cuts. However, flame cutting will be permitted provided all edges are ground, metal projecting beyond the plane of the plate face will not be permitted. Steel fuse plates shall conform to the requirements of ASTM A56. ASTM A572 Grade 50 or ASTM A588 may be substituted for A56 at the option of the fabricator. Mill test reports shall be submitted for Fuse Plates. Steel used shall have an ultimate tensile strength not to exceed 80 KSI. For alternative Fuse Plate contact Traffic Operations Division.

**SIGN MOUNTING DETAILS-
 LARGE ROADSIDE SIGNS
 FOUNDATION & STUB**

 SMD (2-2)-08

| REV | DATE | BY | CHK | APP | DESCRIPTION |
|-----|----------|----|-----|-----|-------------|
| 01 | 08/19/95 | | | | ISSUED |
| 02 | 09/08/95 | | | | REVISED |

Figure 5.4. Current TxDOT Large Guide Sign Supports Slipbase and Fuse Plate Details.

Table 5.1. Current Table of Slipbase and Fuse Plate Dimensions and Details.

| Dimensions Post Size | Base Connection Data Table | | | | | | | | | | Perforated Fuse Plate Data Table | | | | | | | | | | |
|-------------------------|--|------------------|--------|--------|--------|--------|----------------|----------------|-------|--------|----------------------------------|--------|--------|--------|--------|----------------|----------------|----------------|-----------|------------------|-------------|
| | Bolt Size & Torque | A | B | C | D | E | t ₁ | t ₂ | W | R | F | G | J | K | M | d ₁ | d ₂ | t ₃ | Bolt Dia. | Wt. (ea.) (lbs.) | Bolt length |
| W6x9 | 5/8" φ x 2 3/4" | | | | | | | | | | 4 1/4" | 2" | 4" | 2 1/4" | 1" | 9/16" | 3/4" | 1/4" | 1/2" | 1.01 | 1 1/2" |
| W6x12 | 440-450 inch pounds 36-38 foot pounds | 5" | 2" | 1 1/4" | 2 3/4" | 1 1/8" | 3/4" | 1/2" | 1/4" | 11/32" | 5" | 2 1/2" | 6" | 3 1/2" | 1 1/2" | 11/16" | 1 1/4" | 3/8" | 5/8" | 2.51 | 2 1/4" |
| W6x15 | | | | | | | | | | | 5" | 2 1/2" | 5 1/4" | 2 3/4" | 1 1/4" | 11/16" | 1 1/16" | 3/8" | 5/8" | 2.26 | 2 1/4" |
| W8x18 | | | | | | | | | | | 5 1/2" | 2 1/2" | 5 1/4" | 2 3/4" | 1 1/4" | 13/16" | 1" | 1/2" | 3/4" | 3.35 | 2 1/4" |
| W8x21 | 3/4" φ x 3 1/2" | | | | | | | | | | 5 1/2" | 2 1/2" | 5 1/4" | 2 3/4" | 1 1/4" | 13/16" | 1" | 1/2" | 3/4" | 3.35 | 2 1/4" |
| W10x22 | 740-750 inch pounds 62-63 foot pounds | 6" | 2 1/4" | 1 3/8" | 3 1/2" | 1 1/4" | 1" | 3/4" | 5/16" | 13/32" | 6" | 3" | 5 3/4" | 2 3/4" | 1 3/8" | 13/16" | 1 1/8" | 1/2" | 3/4" | 4.03 | 2 1/4" |
| W10x26 | | | | | | | | | | | 6" | 3" | 6 1/2" | 3 1/2" | 1 5/8" | 13/16" | 1 5/16" | 1/2" | 3/4" | 4.47 | 2 1/4" |
| W12x26 | | | | | | | | | | | 6" | 3" | 6 1/2" | 3 1/2" | 1 5/8" | 13/16" | 1 5/16" | 1/2" | 3/4" | 4.47 | 2 1/4" |
| S3x5.7 | 1/2" φ x 2 1/2" | See Detail Below | | | | | | | | | 3 3/4" | 1 1/2" | 2 5/8" | 1 1/2" | 5/8" | 9/16" | 3/8" | 1/4" | 1/2" | 0.60 | 1 1/2" |
| S4x7.7 | 440-450 inch pounds 36-38 foot pounds | | | | | | | | | | | | | | | | | | | | |

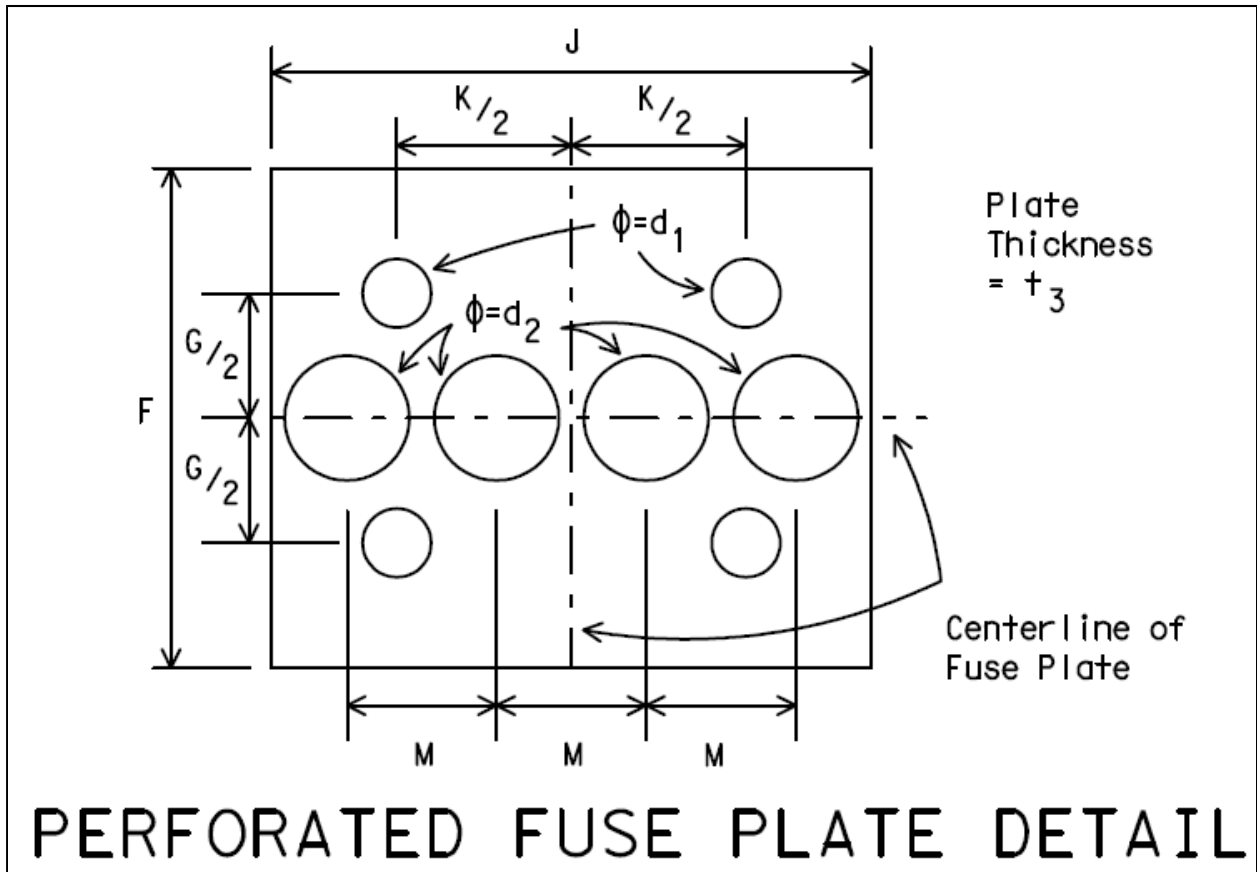


Figure 5.5. Current Perforated Fuse Plate Fabrication Detail.

Figure 5.6 is a diagram showing the forces resisted by the support section under a wind loading event. The shear force is constant across the length of the support. However, the moment increases linearly until it reaches a maximum value at ground level. This diagram details the forces that must be resisted to support the sign during the wind load event. Three important locations that need to be investigated are the height of the fuse plate, the height of the slipbase, and, finally, the forces at ground level. The first location equates to the minimum moment capacity of the fuse plate connection to support. The second corresponds to the minimum capacity of the slipbase connection. Finally, the final location corresponds to the minimum capacity of the support post. If any of the calculated capacities exceed those of the support components, then the support system will not be able to support that sign configuration.

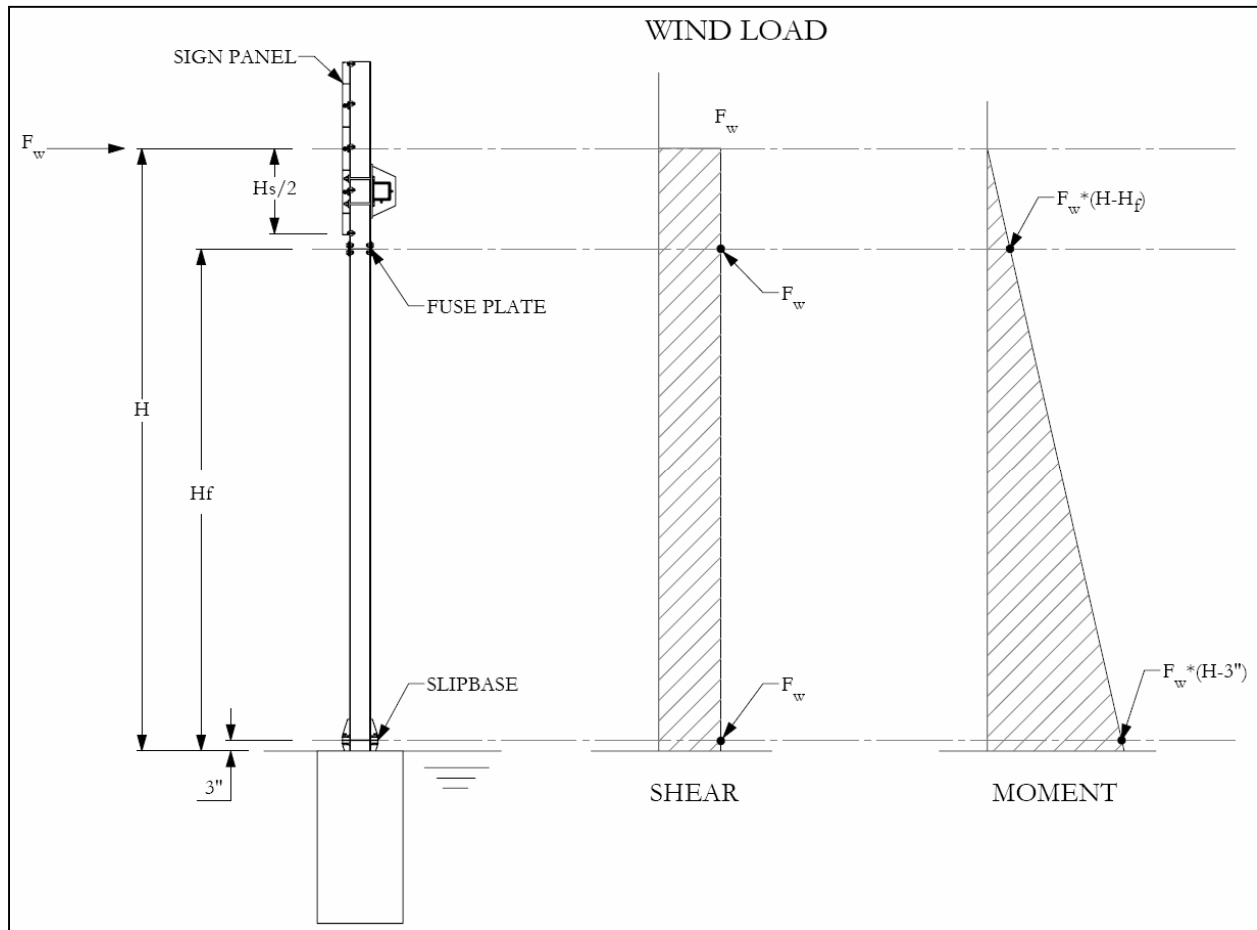


Figure 5.6. Large Guide Sign Support Force Diagram for Wind Load Condition.

When the calculated capacities are substituted into this analysis, it was determined (for the typical mounting height of 10 ft) the fuse plate was primarily the limiting factor in many cases. To visualize this, Table 5.2 shows the equivalent moment capacity of all three components (fuse plate, slipbase, and post section) at the same location (height of slipbase). This allows for a direct comparison of the capacities of the components. In Table 5.2, the cells that are highlighted in red are instances where the fuse plate controls; those in green are instances where the post controls.

Table 5.2. Large Guide Sign Support Component Capacity Comparison (Hbs = 10 ft).

| Post Size | Fuse Plate Capacity | Max Vertical Sign Dimension (From TxDOT Design Charts) | Fuse Plate Capacity Max Vert. Dim. Meq (@ Slipbase) | Fuse Plate Capacity 4ft Vert. Dim. Meq (@ Slipbase) | Slip Base Capacity | Post Capacity |
|-----------|---------------------|---|---|---|--------------------|---------------|
| | kip*ft | ft | kip*ft | kip*ft | kip*ft | kip*ft |
| W12x26 | 19.18 | 16 | 43.16 | 86.32 | 80.31 | 75.38 |
| W10x26 | 16.31 | 16 | 36.70 | 73.41 | 70.11 | 59.45 |
| W10x22 | 16.16 | 16 | 36.36 | 72.73 | 69.57 | 49.23 |
| W8x21 | 13.26 | 16 | 29.84 | 59.68 | 59.25 | 36.50 |
| W8x18 | 7.72 | 16 | 17.36 | 34.73 | 38.76 | 30.31 |
| W6x15 | 5.77 | 16 | 12.98 | 25.96 | 30.74 | 21.20 |
| W6x12 | 3.79 | 16 | 8.54 | 17.07 | 30.89 | 10.69 |
| W6x9 | 3.72 | 14.5 | 8.84 | 16.72 | 30.40 | 7.92 |
| S4x7.7 | 2.89 | 10 | 8.67 | 13.00 | 14.33 | 2.02 |
| S3X5.7 | 2.21 | 7.5 | 8.10 | 9.94 | 14.33 | 0.86 |

The fact that the fuse plates control the capacity of the system does not fully explain why the capacities of multiple supports fall on top of each other. To explain this, we must refer back to Table 5.1, which details the dimensions and details of the fuse plates for each post section. Table 5.1 shows that the W6×9, W6×12, W6×15, and W8×18 all share the same fuse plate design, while the W8×21, W10×22, W10×26, and W12×26 all share another different fuse plate design. The new chart (Table 5.2) shows the calculated wind load capacities of a W6×9 to be equal to that of a W6×12, and a W10×22 to be equal to that of a W10×26. This can be explained by the fact that each pair of support posts utilizes the same fuse plate and has essentially the same section depth. Therefore, both pairs have the same fuse plate connection capacity. Since at a 7-ft mounting height the fuse plate connection is typically the controlling factor, each pair results in the same wind load capacity. This situation illuminates an inherent inefficiency in the current fuse plate design, and a critical issue in the current wind load charts.

After analyzing the current large guide sign support charts, the research team determined that the charts include inherent flaws and need to be updated. During the process of analyzing the charts, an inherent inefficiency in the fuse plate design was discovered. Several courses of action can be taken, given these circumstances.

- First, the wind load charts can simply be updated to reflect the current support system designs.
- Second, redundant post assemblies could be removed from the inventory, simplifying the wind load charts. New wind load charts would need to be generated to reflect the calculated capacities of the remaining support assemblies.
- Finally, the fuse plates can be redesigned in an attempt to make the system more efficient. New wind load charts would need to be generated once the new design was finalized.

TxDOT chose to proceed with the second and third options parallel with the intention of selecting one of the options for implementation at the end of the project.

5.3 TASK 3B: REVIEW OF FUSE PLATE FAILURES

Many districts, including Atlanta, Lubbock, and Waco Districts, have reported similar failures, (see Figures 5.7 (a) and (b)). The Atlanta district was contacted specifically because of the abnormally high number of instances of fuse plate failure in recent history. The district representatives conveyed the following field maintenance problems during the conversation with TTI.

- Localized high wind events causing fuse plate failure (high winds typically not in excess of design wind load conditions)
- Fuse plate connecting bolts were becoming loose over time (varied between a few days to a few months)
- Some sign locations were failing between two and three times a year.
- Dual fuse plate and single fuse plate designs were equally represented in failures.
- After further investigation, the W8×18 sign supports made up an abnormally large percentage of the sign installations failing under high wind loading events.



Figure 5.7. Typical Fuse Plate Failure Mode Reported by Districts.

After meetings with the Atlanta district, TTI contacted the Lubbock District to see what problems were being reported. Lubbock District representatives stated that they were no longer having problems with the sign supports after taking steps to alleviate the problems. Below is a list of actions that the Lubbock District took to reduce the number of instances of blown down sign supports:

- Stated W8×18 was overrepresented in the instances of fuse plate connection failures.
- Opted to design supports according to Zone 1 (90 mph wind speed) about 7–8 years ago.
- Added third leg to existing signs with recurring instances of blow downs.
- No longer utilizes the W8×18 support (uses W8×21 instead.).
- Noted problems with bolts loosening over time.

One major pattern that was noticed immediately was the overrepresentation of the W8×18 post assembly in fuse plate failures. The previous review of the current sign support selection chart showed that the support post capacities are being overestimated. Some posts, such as the W8×18, may be more overestimated than others, leading to more failures. It also may be due to the fact that the W8×18 makes up the majority of the support sections installed in the field. However, it is not surprising that the fuse plates are failing before the post yields; the analysis of the support selection charts showed this failure. For many mounting heights, the fuse plate connection is the limiting factor for wind load capacity, so if an extreme wind event occurs, it is expected that the fuse plate connection will fail.

To be thorough and to verify that the current design does not provide a capacity lower than what is calculated, researchers obtained a series of samples for static testing. They performed a total of eight static tests to verify the capacities of the test samples. Three tensile tests (S12–S14) were performed using W8×18 standard fuse plates. Two tests (S24 and S25) were done to verify the moment capacity of the fuse plate connection when fabricated and assembled as detailed in TxDOT specifications. Two tests (S26 and S27) were performed to

verify the moment capacity of the fuse plate connection when fabricated and assembled improperly ($\frac{3}{8}$ -inch gap between spliced beam sections). Finally, a full W8×18 post assembly (S3) was statically loaded to verify the calculated capacities. Appendix B of this report gives details of all of this testing.

Fuse plate tensile testing was performed to verify the calculated capacity of the machined fuse plate; a local supplier sent four test samples. TTI requested that the supplier send ungalvanized samples to allow for verification of primary dimensions. Figure 5.8 details the measured dimensions of each of the test samples, and lists the intended design measurements.

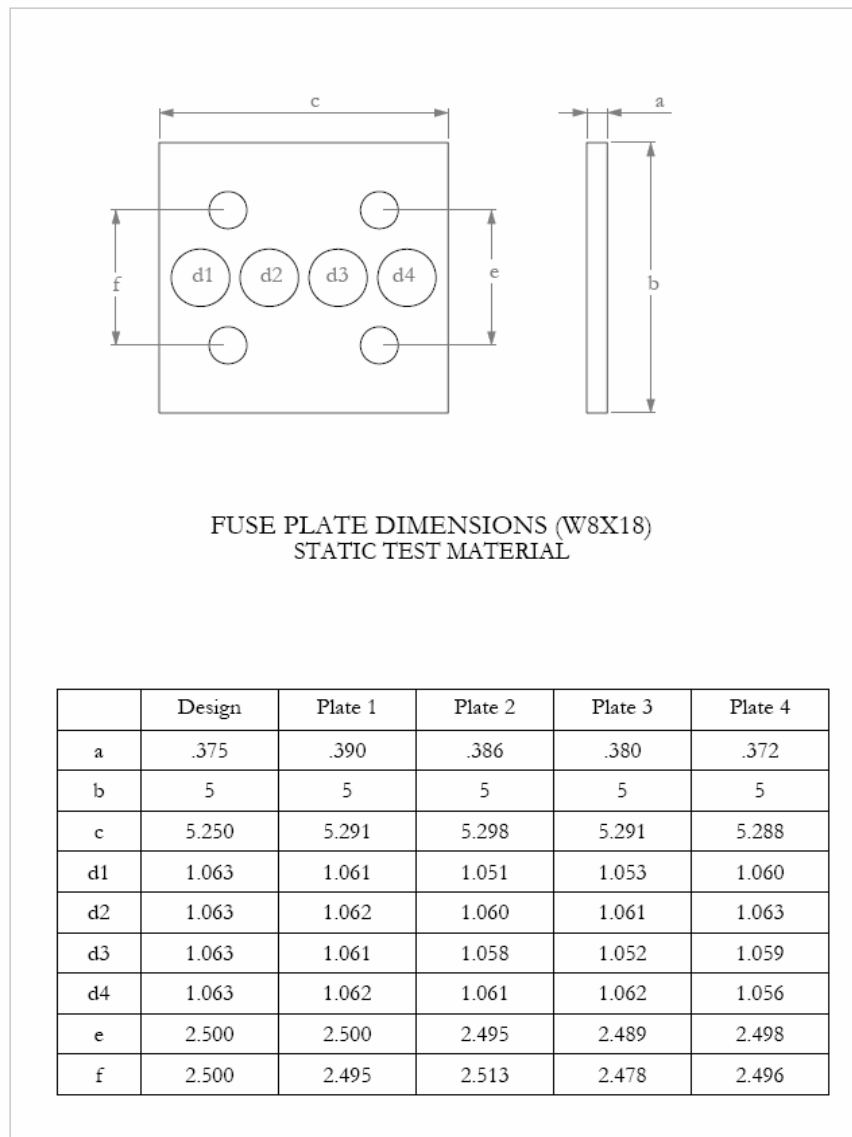


Figure 5.8. Test Sample Dimensional Analysis.

Three of the samples were then chosen at random for testing (S12–S14). Loading was applied using a hydraulic cylinder. Care was taken to ensure bending stresses were not induced into the fuse plate during loading. This ensures that failure loads are not artificially reduced by combined stresses due to bending. Appendix B gives a recorded force-time history of the load event. Figure 5.9 (a-c) details the test setup and typical failure witnessed during the testing.

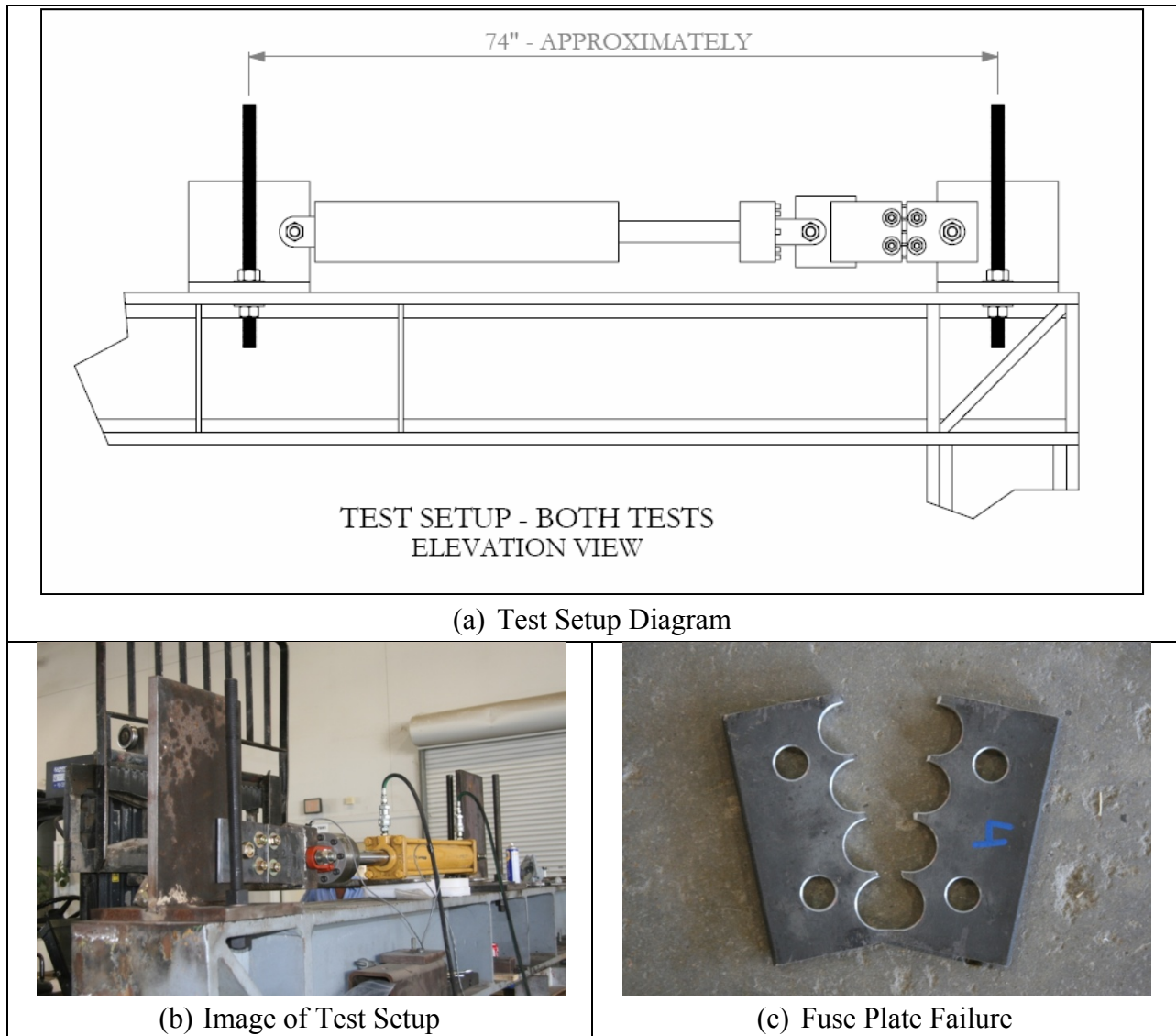


Figure 5.9. Fuse Plate Tensile Test (S12–S14).

A total net area of cross sections through the fuse plate along the axis of perforations was calculated to be equal to 0.375 inches². A36 steel has a minimum ultimate stress of 58 ksi. This equates to a predicted failure load of 21.8 kips. The three static tests resulted in the following failure forces: 34.3 kips (S12), 33.3 kips (S13), and 32.0 kips (S14). Each test failure capacity was significantly higher than the calculated capacity. S12 was 57 percent above the minimum, S13 was 53 percent above the minimum, and S14 was 47 percent above the minimum. This testing has ensured that fuse plates are being fabricated according to TxDOT requirements and

are providing capacities in excess of those required by A36 specifications. One thing to note: TxDOT specifications state that yield stress shall not exceed 80 ksi (30 kips). The test samples failed slightly above this failure threshold.

A total of four tests were performed to prove that fuse plate connections are providing capacities in excess of those calculated. Two tests were performed where no gap existed between the spliced beam sections (S24 and S25). Another set of two tests was performed where a $\frac{3}{8}$ -inch gap existed between the spliced beam sections (S26 and S27). This gap was included after noticing multiple field installations where large gaps existed between spliced beam sections.

Figure 5.10 (a) details the basic test setup. The spliced beam was clamped to the rigid load frame, and then a vertical load was applied approximately 75 inches from the fuse plate connection. Appendix C gives further details of the test installation. Photos b and d in Figure 5.10 show the gapless fuse plate connection (S24 and S25) before and after failure of the fuse plate connection. Meanwhile, photos c and e in Figure 5.10 are images of the fuse plate connections with a $\frac{3}{8}$ -inch gap (S26 and S27) before and after failure of the fuse plate connection.

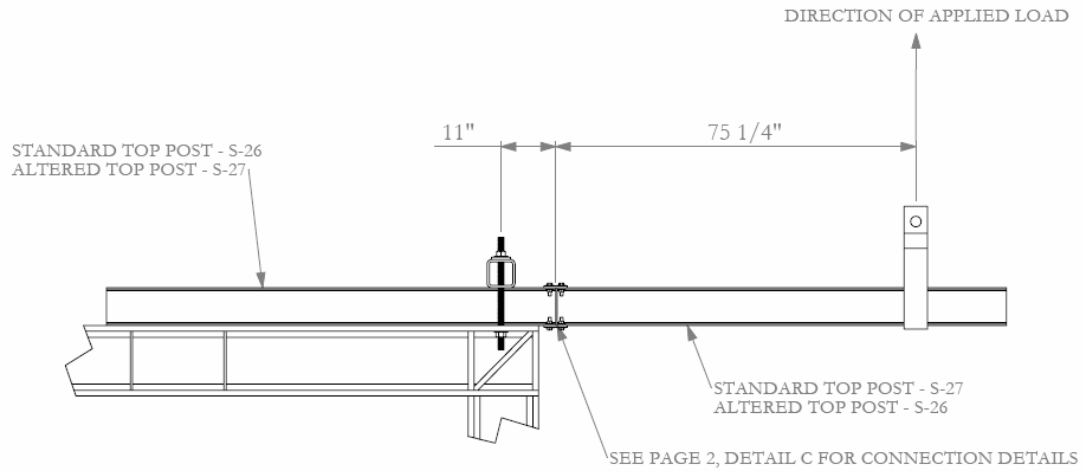
After analyzing the W8×18 fuse plate connection, the research team calculated that the connection has a predicted moment capacity of 15.4 kip*ft. This capacity equates to a vertically applied load of 2.5 kips.

- Test S24 tension fuse plate failed at a vertical load of 3.2 kips. This equates to a 19.2 kip*ft fuse plate connection moment capacity.
- Test S25 tension fuse plate failed at a vertical load of 4.3 kips. This equates to a 26.6 kip*ft fuse plate connection moment capacity.
- Test S26 tension fuse plate failed at a vertical load of 3.9 kips. This equates to a 24.7 kip*ft fuse plate connection moment capacity.
- Test S27 tension fuse plate failed at a vertical load of 3.0 kips. This equates to a 18.7 kip*ft fuse plate connection moment capacity.

After reviewing the results of the testing, it was determined that fuse plate connections with gaps between spliced beam sections up to $\frac{3}{8}$ -inch will provide capacities in excess of those calculated.

A single static test was performed to and verify that a full W8×18 support system will provide capacities in excess of those calculated. Figure 5.11 details the setup for this test, and Appendix C gives further details. This test consisted of the testing of W8×18 post section, W8×18 slipbase, and W8×18 fuse plate connection all assembled into a single support. The ground stub was clamped to the rigid load frame to simulate a rigid foundation. Then, a vertical load was applied 16 ft 3 inches from the clamp location. Figure 5.12 shows the test setup before load application, and Figure 5.13 shows the test article under maximum load.

FUSE PLATE TESTS 463639-S26, 27



(a) Generic Static Test Setup



(b) Fuse Plate Connection Before Loading
(No Gap)



(c) Fuse Plate Connection Before Loading
($\frac{3}{8}$ -inch Gap)

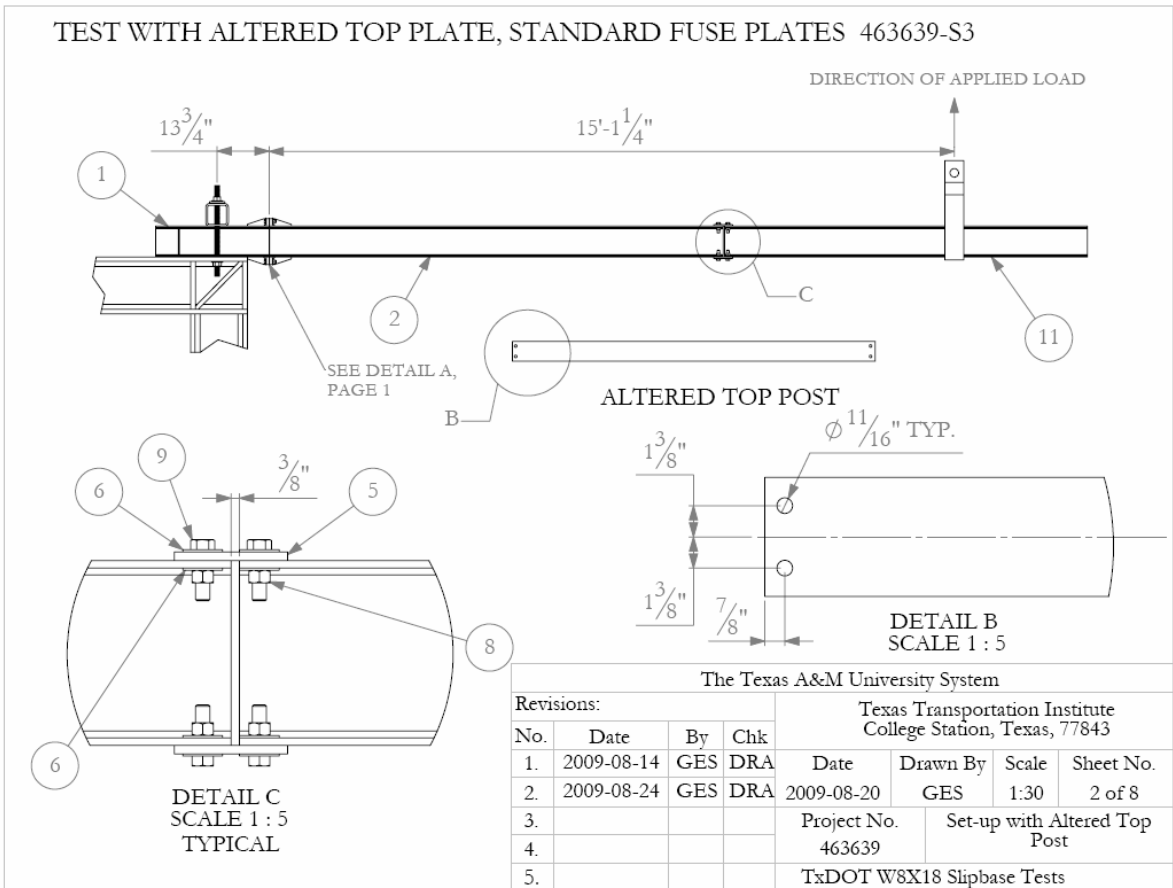


(d) Fuse Plate Connection after Failure
(No Gap)



(e) Fuse Plate Connection after Failure
($\frac{3}{8}$ -inch Gap)

Figure 5.10. W8×18 Fuse Plate Fuse Plate Connection Capacity Verification (S24–S27).



T:\2008-2009\463639-TxDOT\Review of large sign support slipbase standards (SolidWorks \W8X18 Static Tests \Drawings \Prints, as tested

Figure 5.11. W8×18 Support Assembly Capacity Verification (S3).



Figure 5.12. W8×18 Support Ready for Load Application (S3).



Figure 5.13. W8×18 Support at Maximum Load (S3).

Test S3 reached a maximum load of 3.5 kips. The calculated equivalent capacity of the fuse plate connection is 3.0 kips, and that of the base post section with an unbraced length of 16 ft 3 inches is 0.1 kips. This calculation includes reductions according to lateral torsional buckling (LTB) effects. Figure 5.13 shows that the beam did, in fact, fail due to LTB. The results of the static testing show the post assemblies provide capacities in excess of those calculated.

5.4 TASK 3C. REVIEW CAPABILITY OF W8×18 AND W8×21 SLIPBASE CONNECTIONS

When looking at the design chart shown in Table 5.3, one will notice that W6×9 through W8×18 utilize the same foot attachment and the same size bolt in the slipbase connection. Likewise, W8×21 through W12×26 utilize the same foot attachment and the same size bolt in the slipbase connection. This break point is counterintuitive. One would think that the capacity differences would not be great enough between W8×18 and W8×21 sections to allow for this breakpoint to occur. TxDOT has asked TTI to investigate this detail to determine if it is consistent with the capacity of the base sections. Also, several districts have asked about design of an adapter to allow the installation of a W8×18 post on a W8×21 base section, and vice versa.

To begin the analysis, the research team calculated the capacities of each of the slipbase connections, and then compared these to the calculated maximum capacities of the support posts. Table 5.4 was generated to compare the calculated capacities. Notice that all slipbase connections are equal to, or in excess of, the capacities of the base post sections. Also, note that the W8×18 capacity of the slipbase connection is only slightly higher than the post section capacity. Since the slipbase connection capacity is primarily dependent on the capacity of the bolts and their distance apart, a W8×21 post with the smaller W8×18 foot will have approximately the same capacity as the W8×18 slipbase connection. And since the W8×18

slipbase connection has a capacity far lower than the W8×21 post section, it would become the limiting factor. For this reason, the slipbase design is changed between the W8×18 and W8×21 post sections. This change maintains maximum efficiency, but it also raises questions about its design.

Table 5.3. TxDOT Slipbase Connection Details.

| Dimensions Post Size | Base Connection Data Table | | | | | | | | | |
|-------------------------|---|------------------|--------|--------|--------|--------|----------------|----------------|-------|--------|
| | Bolt Size & Torque | A | B | C | D | E | t ₁ | t ₂ | W | R |
| W6x9 | 5/8" φ x 2 3/4" 440-450 inch pounds 36-38 foot pounds | 5" | 2" | 1 1/4" | 2 3/4" | 1 1/8" | 3/4" | 1/2" | 1/4" | 1/32" |
| W6x12 | | | | | | | | | | |
| W6x15 | | | | | | | | | | |
| W8x18 | | | | | | | | | | |
| W8x21 | 3/4" φ x 3 1/2" 740-750 inch pounds 62-63 foot pounds | 6" | 2 1/4" | 1 3/8" | 3 1/2" | 1 1/4" | 1" | 3/4" | 5/16" | 13/32" |
| W10x22 | | | | | | | | | | |
| W10x26 | | | | | | | | | | |
| W12x26 | | | | | | | | | | |
| S3x5.7 | 1/2" φ x 2 1/2" 440-450 inch pounds 36-38 foot pounds | See Detail Below | | | | | | | | |
| S4x7.7 | | | | | | | | | | |

Table 5.4. TxDOT Slipbase and Post Factored Capacity Comparison.

| Post Size | Slip Base Capacity | Post Capacity |
|-----------|--------------------|---------------|
| | kip*ft | kip*ft |
| W12x26 | 80.31 | 80.31 |
| W10x26 | 70.11 | 68.65 |
| W10x22 | 69.57 | 56.99 |
| W8x21 | 59.25 | 43.67 |
| W8x18 | 38.76 | 36.39 |
| W6x15 | 30.74 | 24.23 |
| W6x12 | 30.89 | 15.60 |
| W6x9 | 30.40 | 11.76 |
| S4x7.7 | 14.33 | 3.84 |
| S3x5.7 | 14.33 | 1.74 |

One option to make the connection more consistent across these two sections is to utilize the stronger W8×21 slipbase connection details on the weaker W8×18 post section. As this connection detail will be stronger than the original configuration, it will not affect the structural capacity of the system. Figure 5.14 shows diagrams of each of the configurations. The addition

of the W8×21 feet on the W8×18 section may allow for the attachment of a W8×18 post on a W8×21 base, and vice versa. The sections appear to be compatible; however, it is not recommended to mix sections like this due to possible maintenance and structural capacity issues. TTI recommends that fuse plate details for these sections should be left as is due to unknown effects on impact performance.

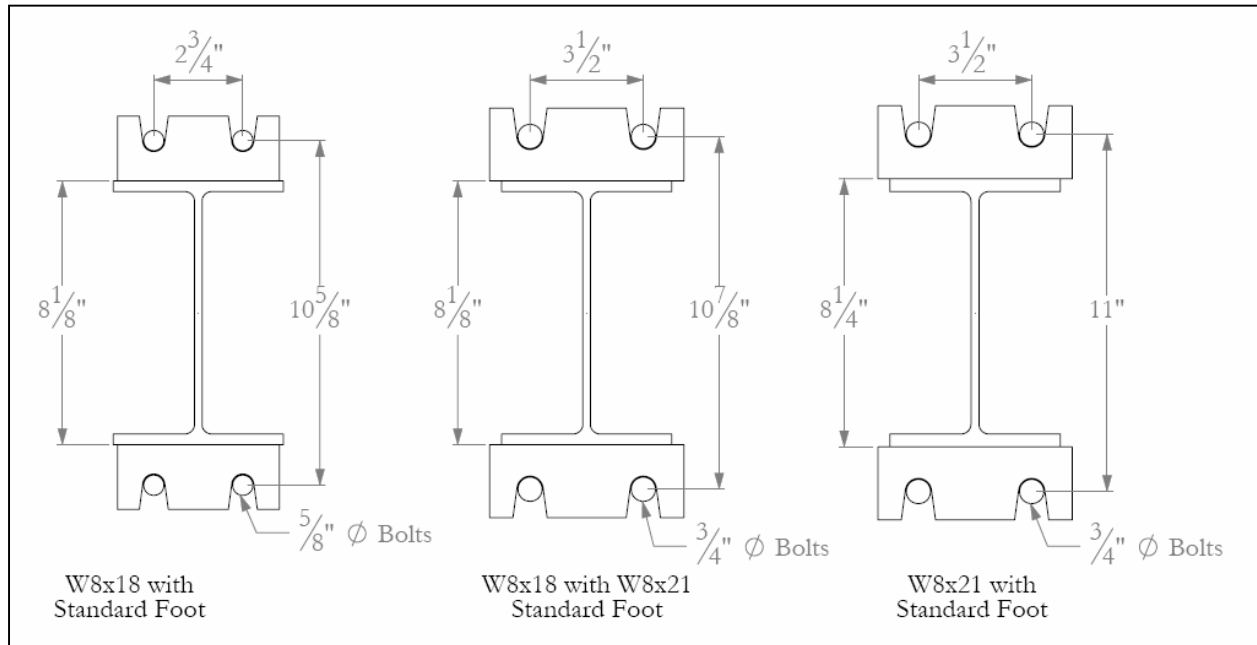


Figure 5.14. Comparison of W8×18 and W8×21 Slipbase Connection Details.

To further investigate the slipbase compatibility issues and to verify that slipbase designs are providing capacities in excess of calculated values, TTI conducted four static tests (S20–S23) to verify the structural capacity of the W8×18 slipbase connection. Appendix C discusses these tests in detail.

Figure 5.15 details the test setup. First, a W8×18 foundation stub is clamped to the rigid load frame. A short section of W8×18 support post is then fastened to the foundation stub using the current W8×18 slipbase connection details. A vertical load is then applied 9 ft 2 inches from the clamp location, until it reaches a maximum.

An unfactored equivalent vertical load capacity of the W8×18 post section and A325 bolted connection were calculated to be 7.9 and 6.4 kips, respectively. Therefore, it is expected that the system will fail due to bolt rupture in the slipbase connection. S20 reached a vertical load capacity of 6.4 kips, S21 reached a vertical load capacity of 6.3 kips, S22 reached a vertical load capacity of 6.4 kips, and S23 reached a vertical load capacity of 6.5 kips. These values correspond exactly with the calculated values. This also shows that the W8×18 post section may benefit in some situations from using the stronger W8×21 slipbase configuration. Photos a–d in Figure 5.16 are representative images from the static load tests.

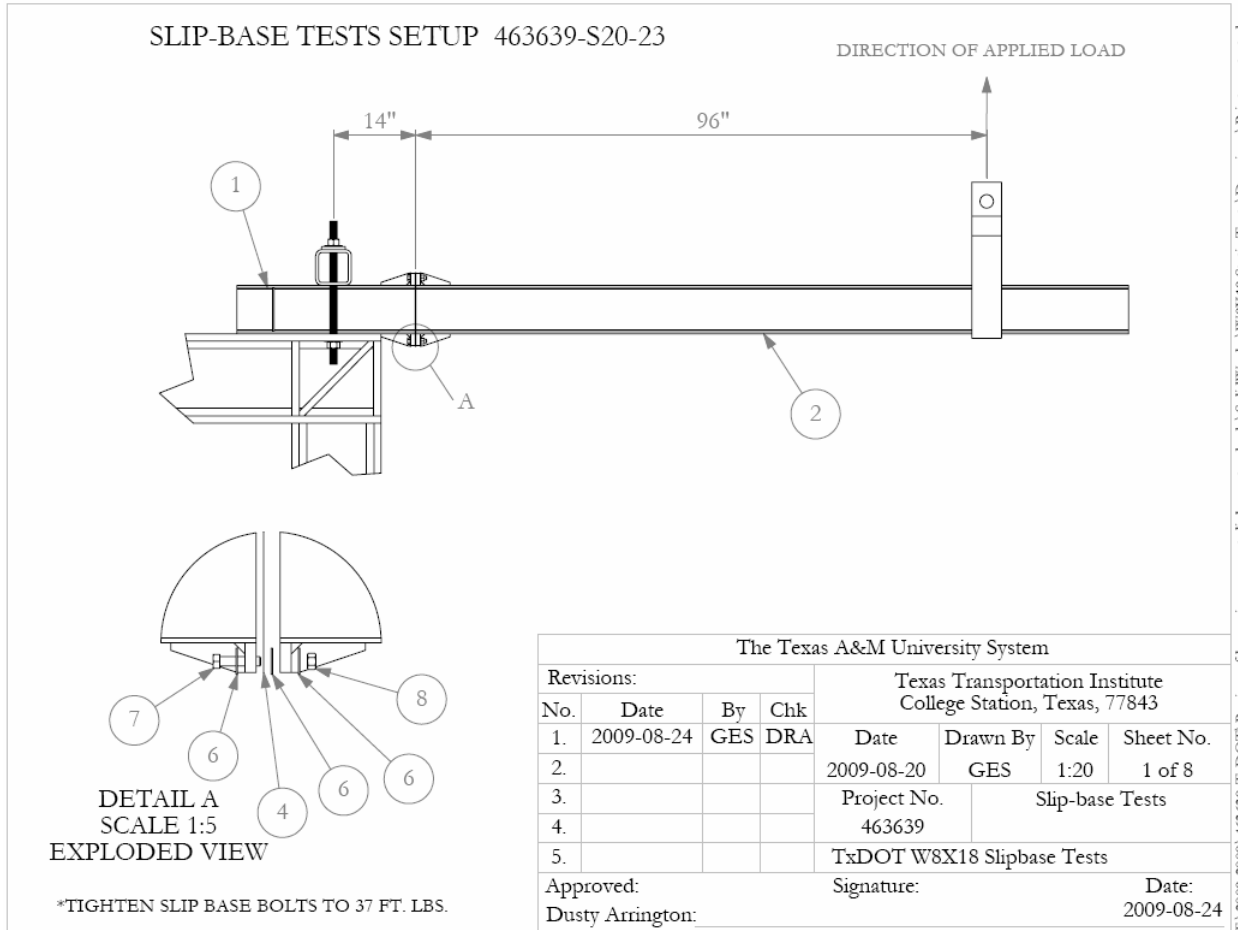


Figure 5.15. W8×18 Slipbase Connection Capacity Static Test Setup.

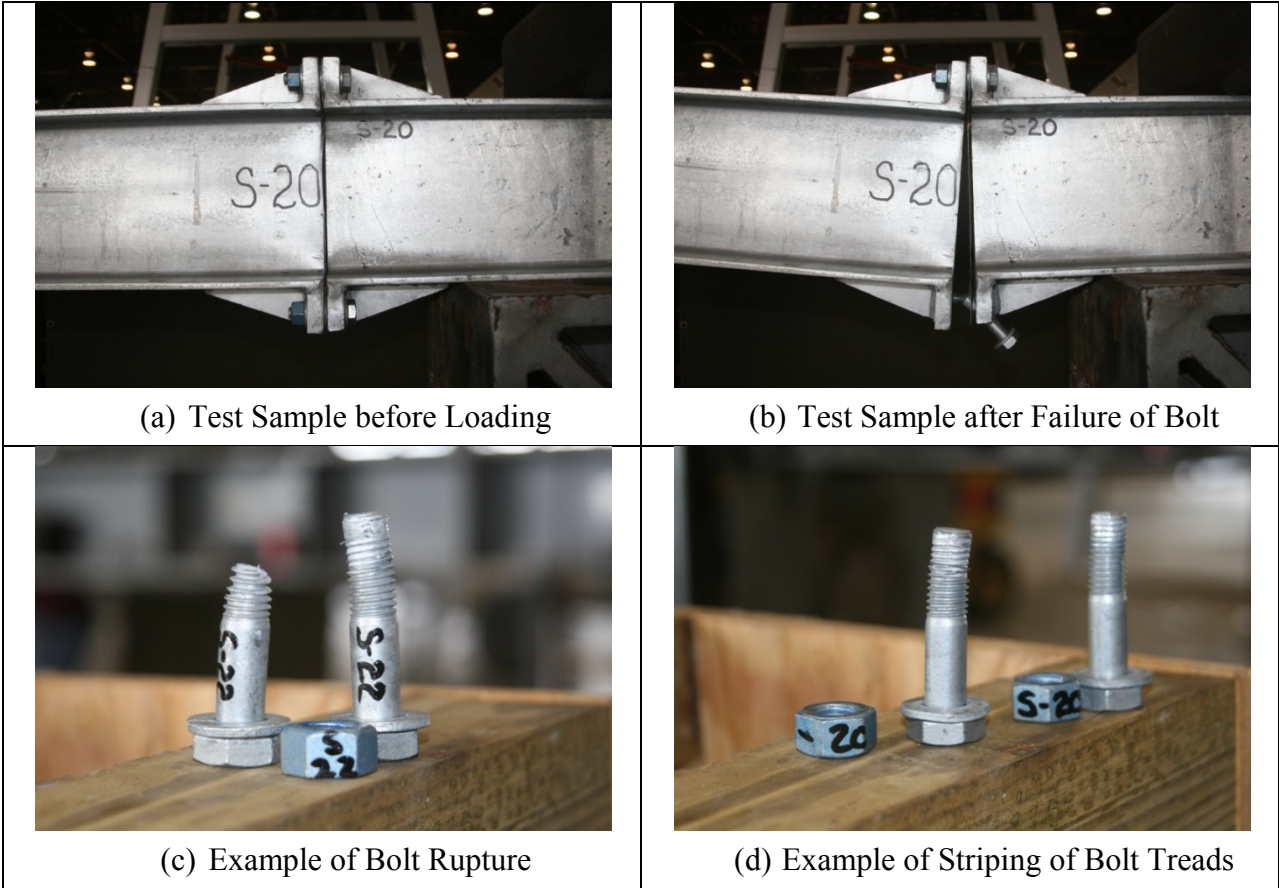


Figure 5.16. W8×18 Slipbase Capacity Verification Test Images.

CHAPTER 6. EVALUATION OF NEED/PLACEMENT OF STIFFENERS ON LARGE GUIDE SIGNS

Many states have stopped the use of stiffeners on large guide signs. This decision does not appear to be based on a structural analysis. A study needs to be performed to determine if stiffeners are, in fact, required. Very little information is available on how stiffeners were first designed and what their original design intent was. Another complicating factor is the sign substrate. Originally, wood signs were used; now, TxDOT uses extruded aluminum sign panels exclusively.

Many benefits unrelated to the structural capacity were identified after the current stiffener standards were reviewed. First, if the stiffeners are placed near the end of sign panels, these can help reduce damage to the sign if it hits the ground in the event of a vehicle impact. Second, since some of these signs are substantial in size, they can give added stiffness to the panels, making installation on sign supports easier.

However, there are some problems noted regarding the installation of stiffeners on the back of the sign panels. Stiffeners make up a substantial additional cost to the sign installation. Many sign clips are required to secure the stiffeners to the back of the panels. There was one instance of a stiffener sliding free of the securing sign clips and striking a worker during the erection of a sign support. The cause of this instance is still under investigation.

As the true design intent of the vertical stiffeners is unknown, TTI researchers have theorized the intent is to increase the torsional stiffness of the sign panel. This facilitates the activation of the fuse plate connections in the event of an errant vehicle striking the panel. To verify this assumption and to develop torsional stiffness relationships, static tests were performed with two main objectives. The first was to determine the torsional capacity relationship for sign panels without vertical stiffeners. The second objective was to determine how much additional torsional stiffness is gained by adding the standard vertical stiffeners. Figure 6.1 shows an image of current TxDOT vertical stiffener details for large guide signs.

Because of the complex sign panel assembly, the torsional stiffness cannot be easily determined analytically. For this reason, a static test was developed to experimentally measure the torsional stiffness of sign panels. The test was set up to measure the force deflection relationship of the sign panel when loaded torsionally. Multiple sign sizes and aspect ratios were tested to determine their effect on the torsional stiffness. Some configurations were tested with and without vertical stiffeners installed. Figures 6.1 and 6.2 show a 10 ft × 6 ft sign panel being loaded to 20 degrees of rotation with and without stiffeners installed. Figure 6.2 shows the recorded force deflection relationship overlaid on a single graph. Notice that there is not a significant increase in stiffness for deflections less than 14 degrees. Sign clips began to pull out of extruded panels at approximately 14 degrees of rotation. Through experimentation, researchers have determined that sign panel assembly remains elastic until sign clip failure occurs. Table 6.1 contains a complete list of the sign panel sizes and aspect ratios tested without stiffeners installed.

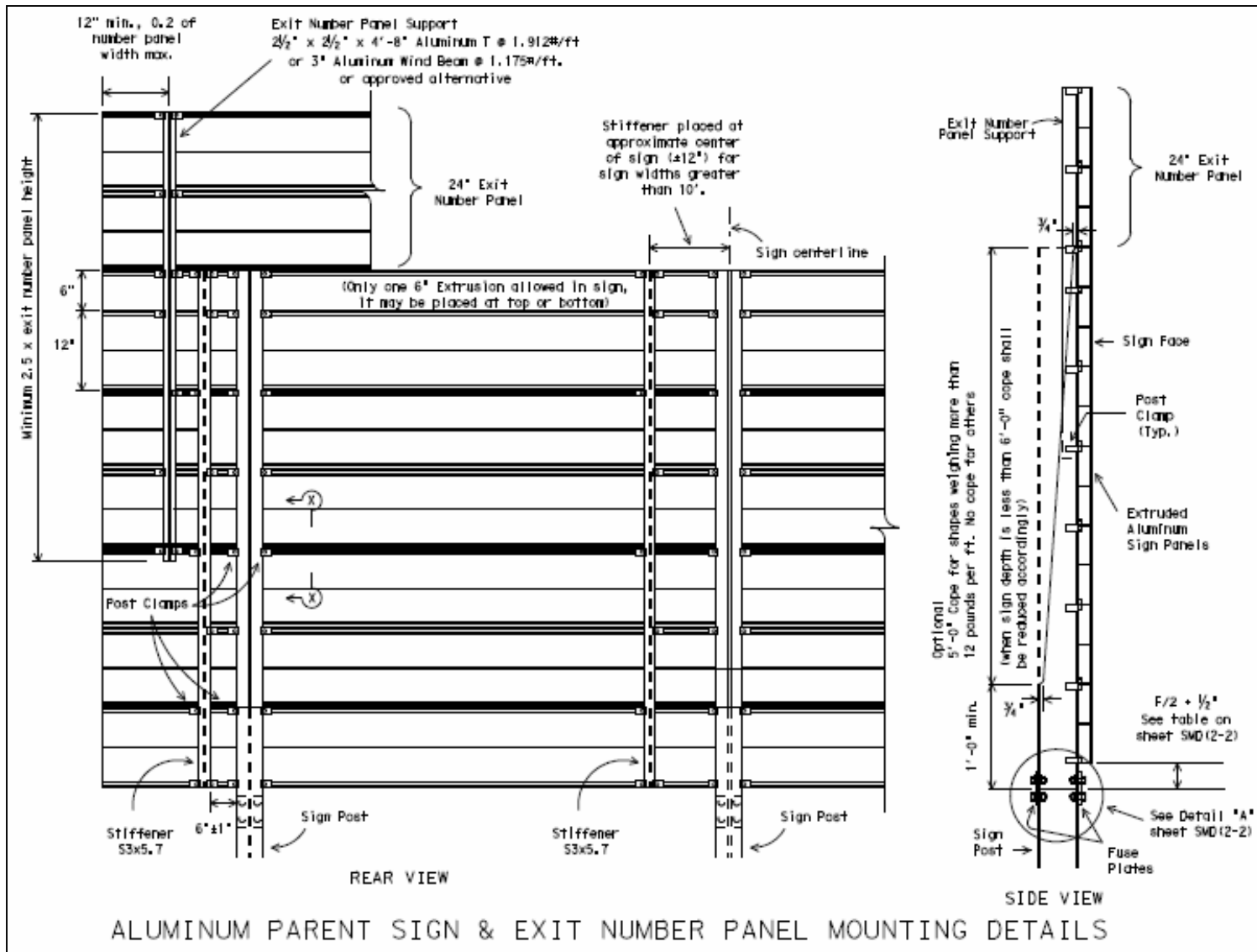


Figure 6.1. Current TxDOT Vertical Stiffener Detail Sheet.

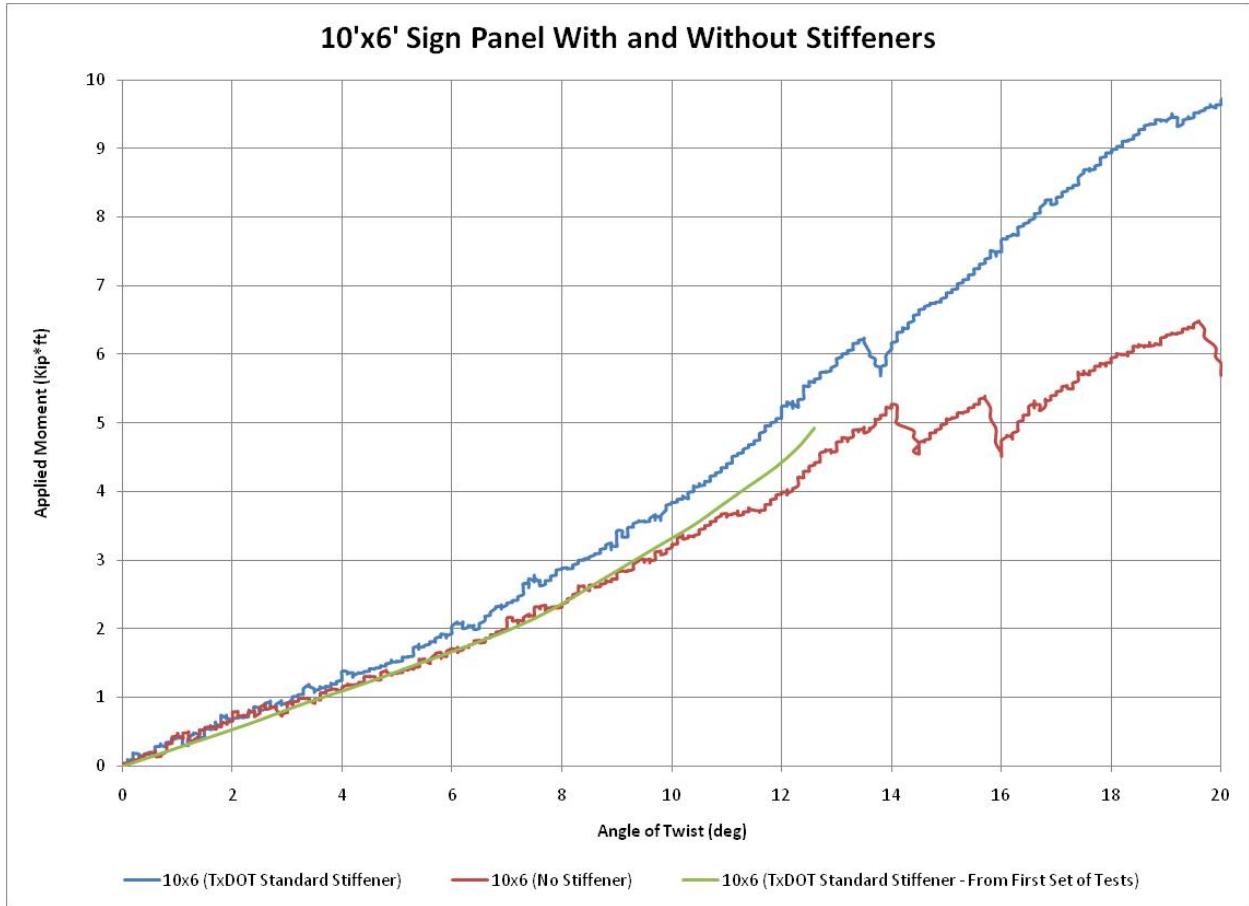


Figure 6.2. 10 ft × 6 ft Sign Panel Torsional Stiffness Relationship Comparison.

Table 6.1. Sign Panel Configurations Tested.

| Sign Width (ft) | Sign Height (ft) | Aspect Ratio |
|-----------------|------------------|--------------|
| 6 | 6 | 1.00 |
| 14 | 6 | 0.43 |
| 10 | 4 | 0.40 |
| 10 | 6 | 0.60 |
| 10 | 8 | 0.80 |

All experimental data were analyzed and used to extrapolate the torsional capacity for all sign panel configurations. From testing, it was determined that sign clips have an increased chance of failing if sign panel twist exceeds 10 degrees. Figure 6.3 shows a graphical representation of the stiffness extrapolation of all sign panel configurations at a 10-degree twist angle. This would equate to the predicted maximum static torsional capacity of each sign configuration.

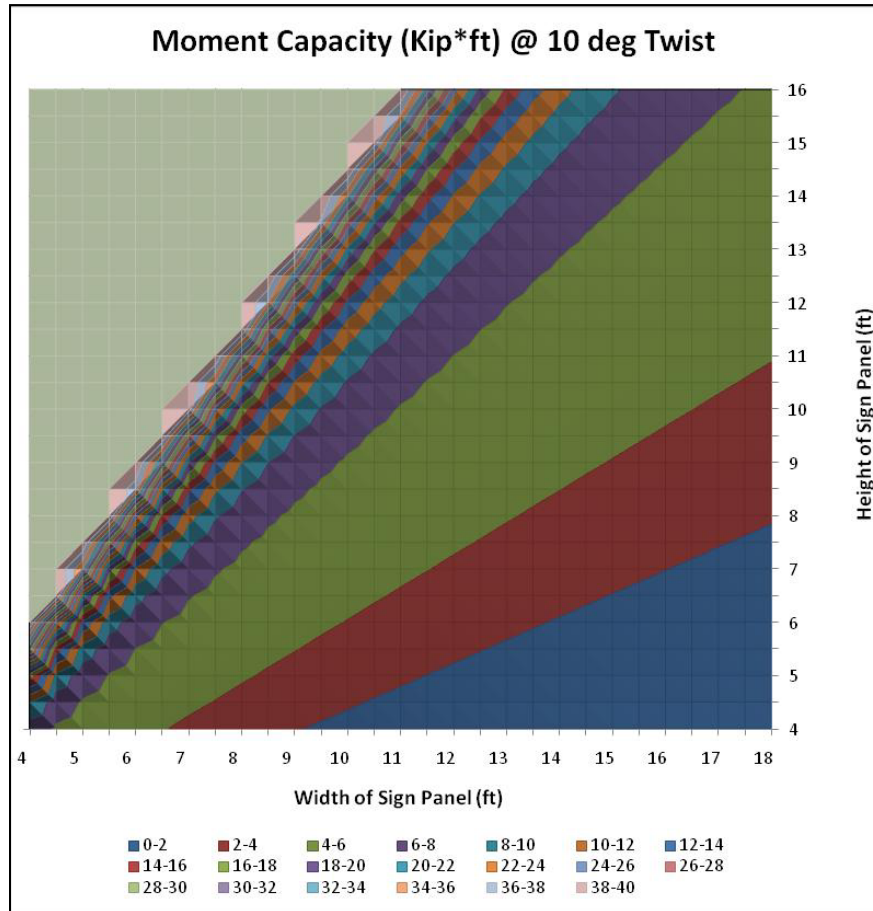


Figure 6.3. Predicted Maximum Sign Panel Assembly Torsional Capacity.

This analysis has resulted in the conclusion that the vertical stiffeners provide little to no increased torsional capacity to the extruded aluminum sign panels. For this reason, it has been concluded that the stiffeners are not required for impact loading conditions; however, some stiffeners may still need to be installed to take advantage of the abovementioned benefits. The researchers suggest that if stiffeners are installed, they should be moved to within 6 inches of each end of the sign panel. This will help prevent damage to the sign panel corners when the sign strikes the ground after an errant vehicle hits the support system.

CHAPTER 7. OPTIMIZATION OF FUSE PLATE CAPACITIES FOR LARGE GUIDE SIGNS

7.1 INTRODUCTION

After reviewing the previous research, the team suggested that fuse plate designs may be optimized to allow for a more efficient usage of standard support sections. Current fuse plate designs are limiting maximum sign areas in many standard sign configurations. This leads to redundant sections, as shown in previously in this report. If fuse plate connections could be strengthened, they will no longer be the limiting factor and larger signs could be installed on smaller sections, leading to possible cost savings. There is a downside: as the fuse plate connection is strengthened, the system runs the risk of adversely affecting impact performance.

There are three possible worst-case outcomes for over-strengthening the fuse plate connection.

- First, the connection may not fail in an impact event, possibly causing severe damage to the vehicle, causing failure of the test.
- Second, the stiffness of the system could be increased to the point that the vehicle may sustain increased Occupant Impact Velocity (OIV) values beyond maximum allowable values.
- Third, the capacity of the fuse plate connection may exceed the capacity of the sign panel causing it to be irreversibly damaged.

To address the condition of increasing the stiffness beyond OIV limits, simulation was performed according to the method described in NCHRP Synthesis 318 (4). This analysis allows the prediction of OIV values when impacting a dual support system with fuse plate connections. The method predicts the OIV values given certain system properties, such as weight per foot of the beam and rupture strength of the fuse plate connection. A simulation was then performed for each post assembly configuration. Each simulation was then utilized to predict the maximum allowable rupture fuse plate force which predicts a OIV value less than or equal to 10 ft/sec (maximum value set by *MASH*). The analysis predicts the activation force of the slipbase given the tensile force in each bolt. This force can be determined from the applied torque given a specified conversion factor (K). This factor varies with bolt construction; however, upper and lower limits on K are described in the conversion method. Instead of determining the K value for each bolt experimentally, the analysis was performed with both the maximum and minimum values, giving a range of solutions. Figure 7.1 is a plot of the results of the simulation. As seen in Figure 7.1, the fuse plate tensile force have to be increased beyond realistic values to cause OIV values to exceed mandated limits.

Ideally, the design of the fuse plate connection capacity should be a balance between maximizing wind load capacity and minimizing impact loading. A truly efficient design will match the wind load capacity of the support post at a minimum sign mounting height and maximum sign height dimension. This design will also verify that the fuse plate connection will always be weaker than the post at the maximum sign mounting height for an impact loading

event. Diagrams of wind loading (Figure 7.2) and impact loading (Figure 7.3) can be found below. This is not always possible; however, to ensure impact performance, the impact loading condition should be the overriding controlling factor. If both conditions can be achieved, the minimum fuse plate connection strength should be used.

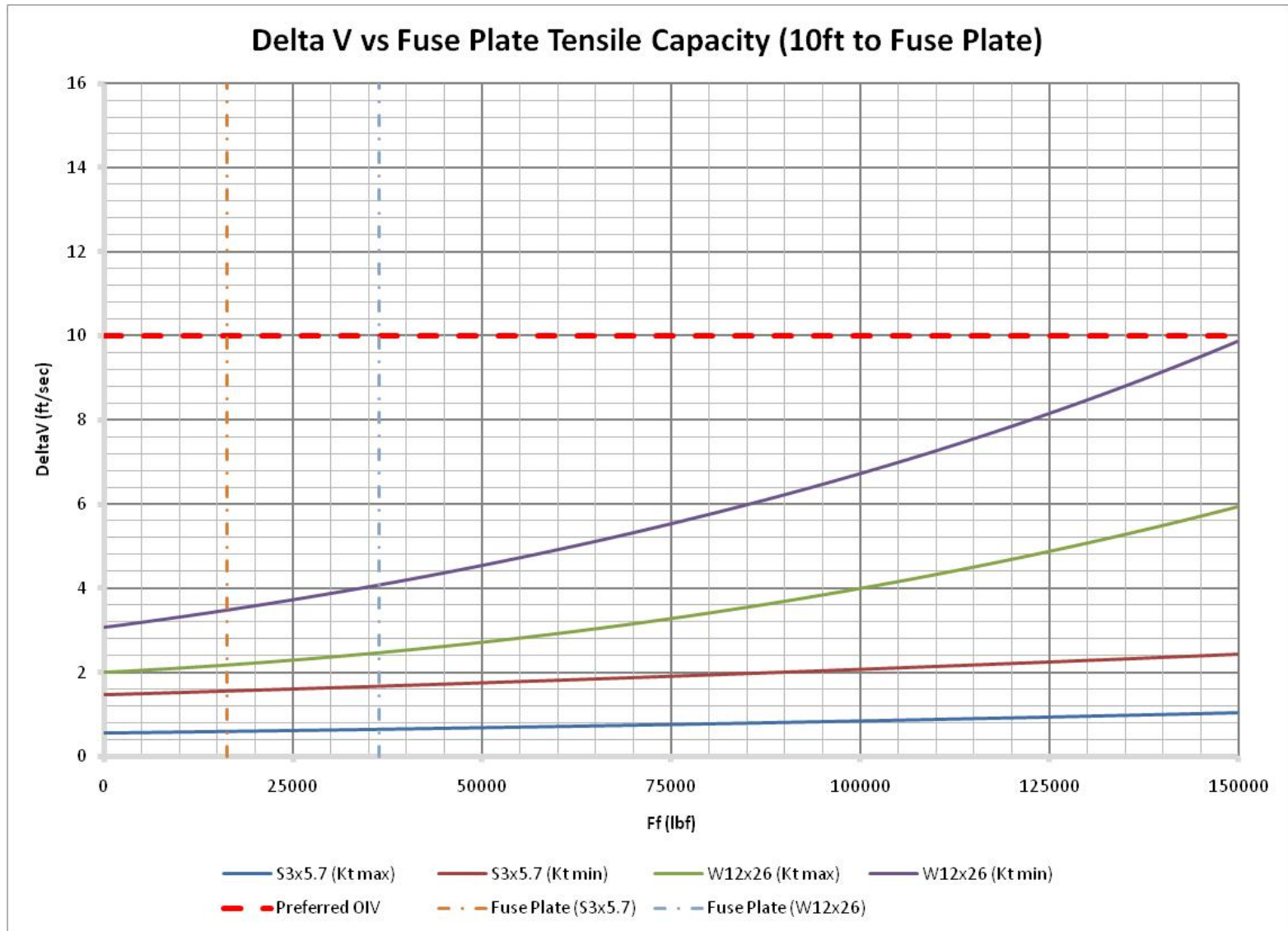


Figure 7.1. Predicted OIV Analysis.

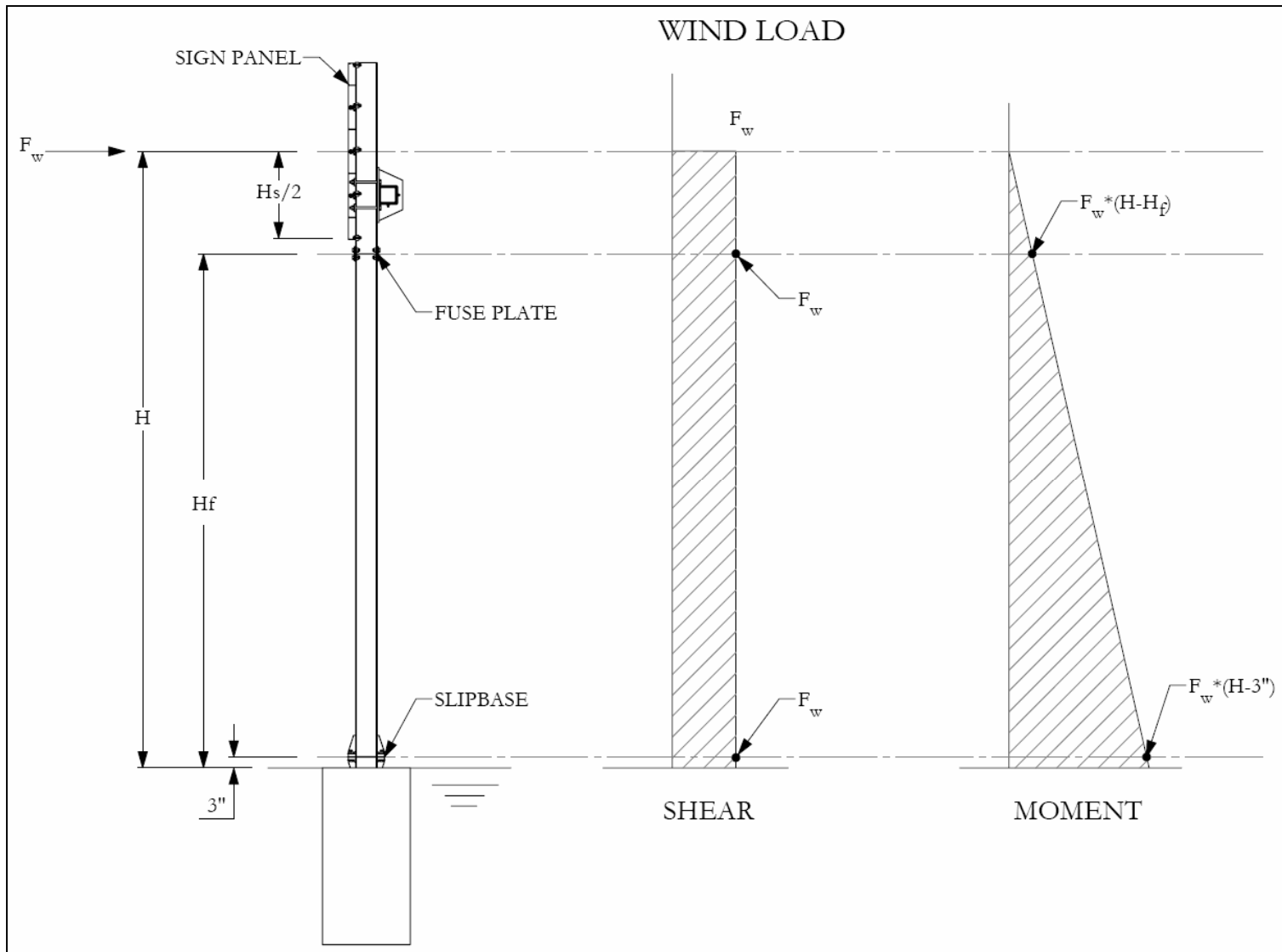


Figure 7.2. Wind Load Condition.

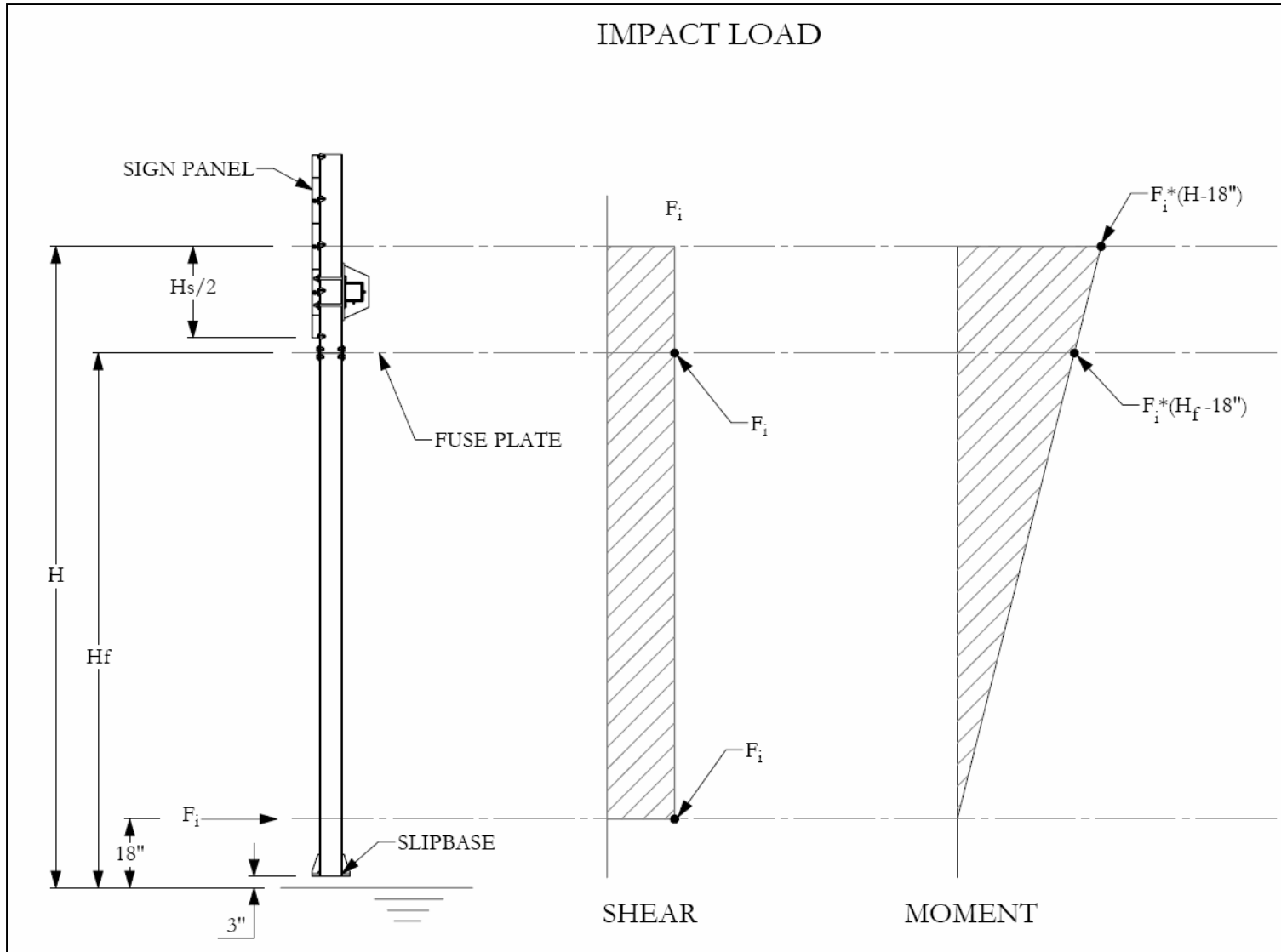


Figure 7.3. Impact Load Condition.

To facilitate this analysis, a chart of minimum fuse plate capacities for wind loading is plotted in Figure 7.4 for a minimum mounting height of 7 ft for each post section. If the fuse plate capacity falls below the plotted line in Figure 7.4, the fuse plate will control the maximum sign area instead of the post section, leading to inefficiencies in the system design. Table 7.1 is a list of maximum fuse plate tensile capacities that will ensure that the fuse plate connection will fail before the post will yield or buckle. Notice all maximum tensile capacities are in excess of the minimum required in Figure 7.4, except for the W6×9 support condition. Figure 7.4 shows that a minimum capacity of approximately 22 kips is required to ensure that the post will control in a wind load condition. However, the maximum tensile capacity for impact loading is only 17 kips. For this reason, it is not possible to ensure that the fuse plate will not control in all wind load conditions. This special situation is primarily due to the fact that a W6×9 is a “non-compact section.” This means that the bending capacity of this section will drop off more rapidly than a “compact section” allowing this condition to occur.

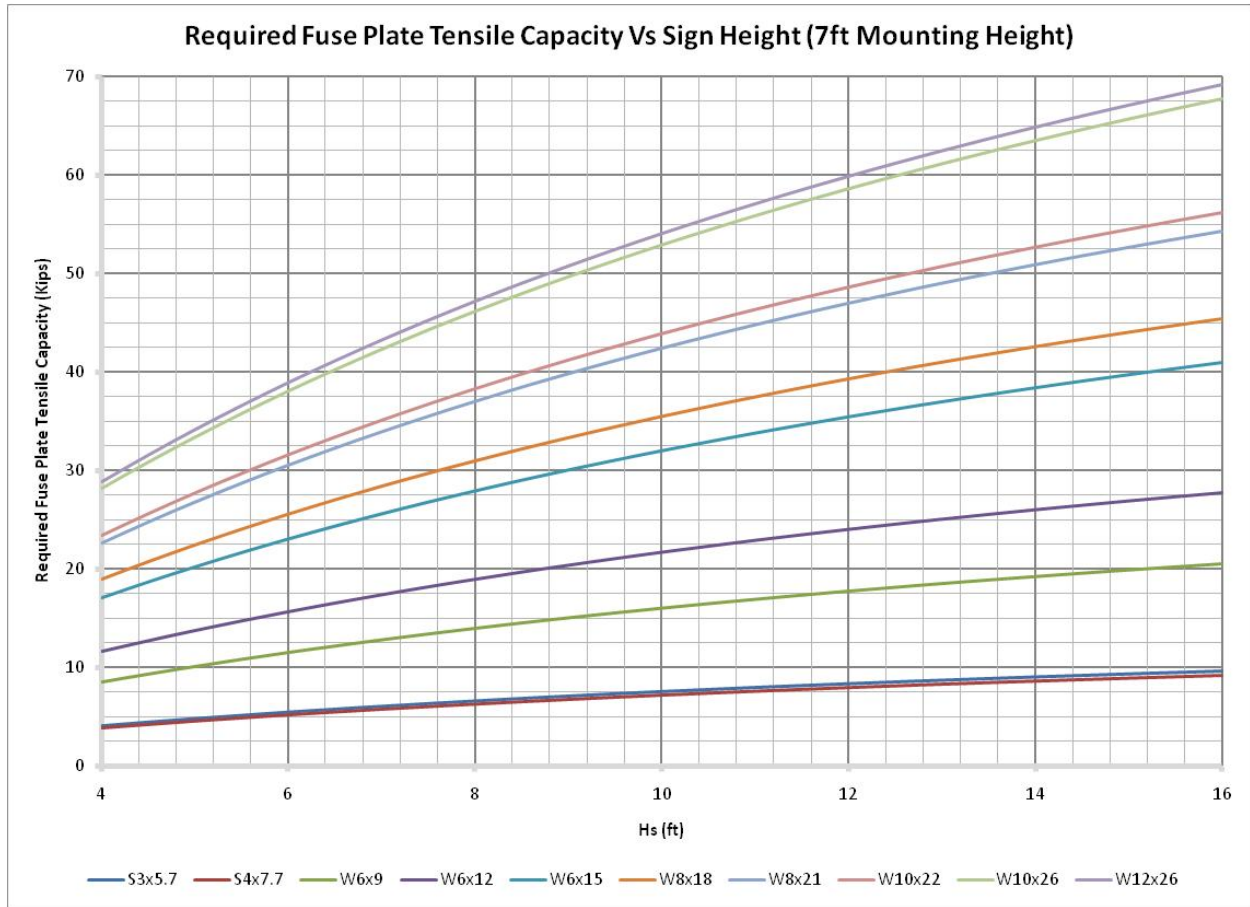


Figure 7.4. Minimum Fuse Plate Capacity for Wind Load Condition.

Table 7.1. Maximum Fuse Plate Capacity for Impact Load Condition.

| Post Section | Fuse Plate Max Tensile Capacity (kips) |
|--------------|--|
| S3×5.7 | 13 |
| S4×7.7 | 13 |
| W6×9 | 17 |
| W6×12 | 27 |
| W6×15 | 55 |
| W8×18 | 55 |
| W8×21 | 70 |
| W10×22 | 70 |
| W10×26 | 90 |
| W12×26 | 90 |

After compiling these results, the optimized tensile capacities of the fuse plates were selected. Table 7.2 summarizes the current and optimized fuse plate tensile capacities, as well as the equivalent fuse plate moment capacities. All of these capacities are using unfactored methods.

Table 7.2. Optimized Fuse Plate Capacities.

| | | Current Fuse Plates | | Proposed Fuse Plates | |
|---------------------------------|---------|---------------------|--|----------------------|-------------|
| Post Section | Db (in) | Ff (kips) | Mn (kip*ft) | Ff (kips) | Mn (kip*ft) |
| S3x5.7 | 3 | 16.3 | 4.08 | 13 | 3.25 |
| S4x7.7 | 4 | 16.3 | 5.43 | 13 | 4.33 |
| W6x9 * and ** | 5.9 | 14.5 | 7.13 | 17 | 8.36 |
| W6x12 ** | 6.03 | 14.5 | 7.29 | 27 | 13.57 |
| W6x15 * | 5.99 | 21.75 | 10.86 | 55 | 27.45 |
| W8x18 | 8.14 | 21.75 | 14.75 | 55 | 37.31 |
| W8x21 | 8.28 | 36.25 | 25.01 | 70 | 48.30 |
| W10x22 | 10.2 | 36.25 | 30.81 | 70 | 59.50 |
| W10x26 | 10.3 | 36.25 | 31.11 | 90 | 77.25 |
| W12x26 | 12.2 | 36.25 | 36.85 | 90 | 91.50 |
| * This is a non compact section | | | ** Fuse Plate Controls Some Wind Load Conditions | | |

Note that all fuse plate capacities (with exception of the S3×5.7 and S4×7.7) are greater than the current fuse plate designs. This led to the question: Will the sign panel be able to have the torsional capacity to activate the fuse plate connections? Further analysis is required to answer this question.

Again, Figure 7.4 is a graphical representation of the extrapolated torsional capacity of varying sign configurations at a rotation of 10 degrees. When comparing the values in Table 7.2 to the chart in Figure 7.5, it is quickly evident that for a majority of the sign configurations, the static capacity of the sign panels are far less than the static capacities of the fuse plate

connections. It is evident that the capacities of the current fuse plates still exceed the static capacities of the sign configurations; however, they still perform properly in the field. It is suggested that dynamic amplification of the impact loading may be greater for the sign panel assembly than the fuse plate connection. The sign panel has a large inertial component in a dynamic impact that could account for this increase.

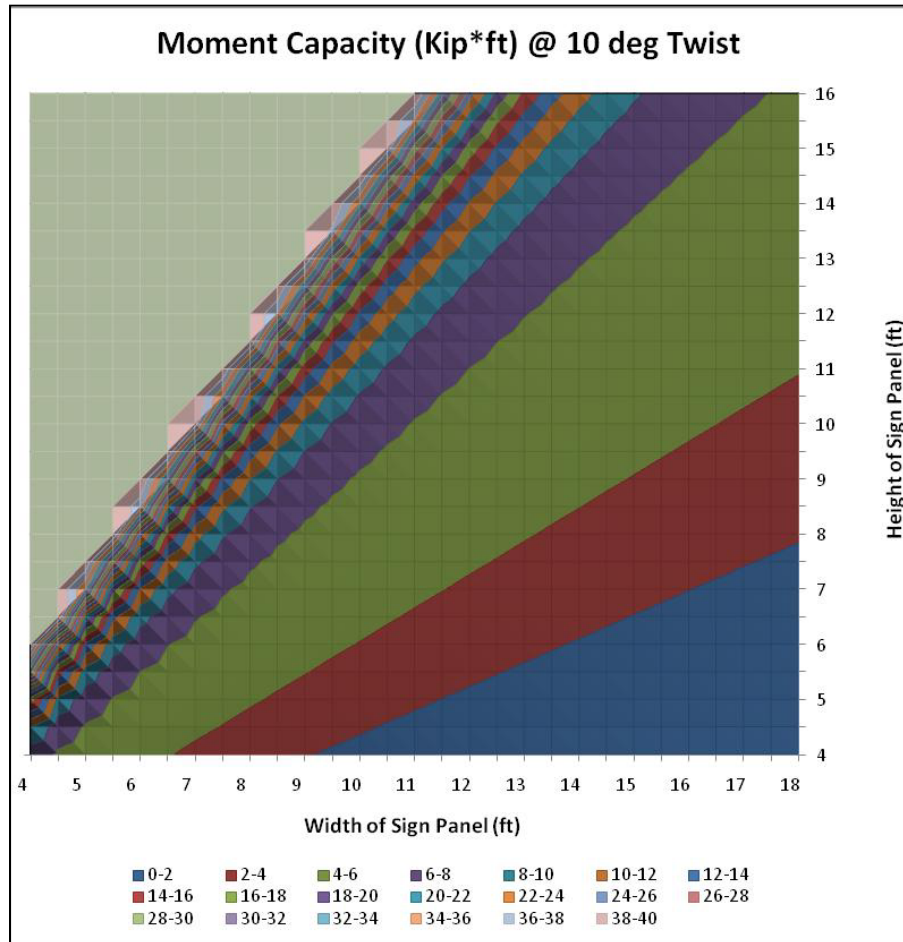


Figure 7.5. Predicted Maximum Sign Panel Assembly Torsional Capacity.

To verify, the research team performed a simplified series of LS-DYNA simulations. This simulation was constructed to represent a 10 ft × 8 ft sign panel mounted on a W8×18 post continuous post section with a 7-ft sign mounting height; the slipbase and fuse plate connections were not incorporated into this model. The model was then impacted using a simulated 1800 kg vehicle surrogate modeled after TTI’s pendulum impact vehicle. Due to the simplifications of this model, validation against static testing was not performed. Since the researchers were looking for a capacity amplification factor, the validation of the model was not required. Figure 7.6 is an image of the simplified simulation setup.

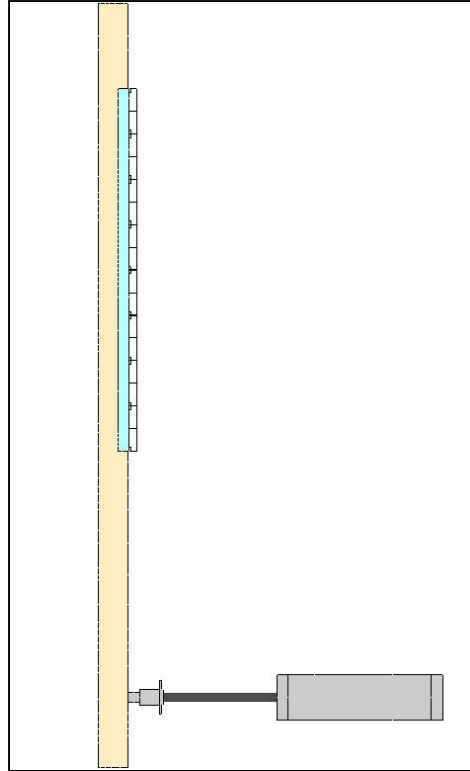


Figure 7.6. Simplified LSDYNA Impact Simulation Setup.

The impact force-time history induced by the impacting surrogate vehicle was recorded for four different loading rates: quasi-static (QS), 18.6 mph, 31.1 mph, and 62.1 mph. Figure 7.7 shows all four force-time histories plotted on a single chart. The resultant maximum forces were then recorded: QS = 1.1 kips, 18.6 mph = 7.0 kips, 31.1 mph = 11.6 kips, and 62.1 mph = 29.3 kips. These forces resulted in the following amplification factors: 18.6 mph = 6, 31.1 mph = 10, and 62.1 mph = 25.

As *MASH* TL-3 specification requires testing at 18.6 mph and 62.1 mph, the worst case need to be applied when designing the system to verify that the system will provide the capacity to fail the fuse plate connection. Past research has shown that lower impact velocities induce the highest force on the vehicle for activation of the slipbase connection. Therefore, future design calculations will assume a multiplication factor of 6, corresponding to a impact velocity of 18.6 mph.

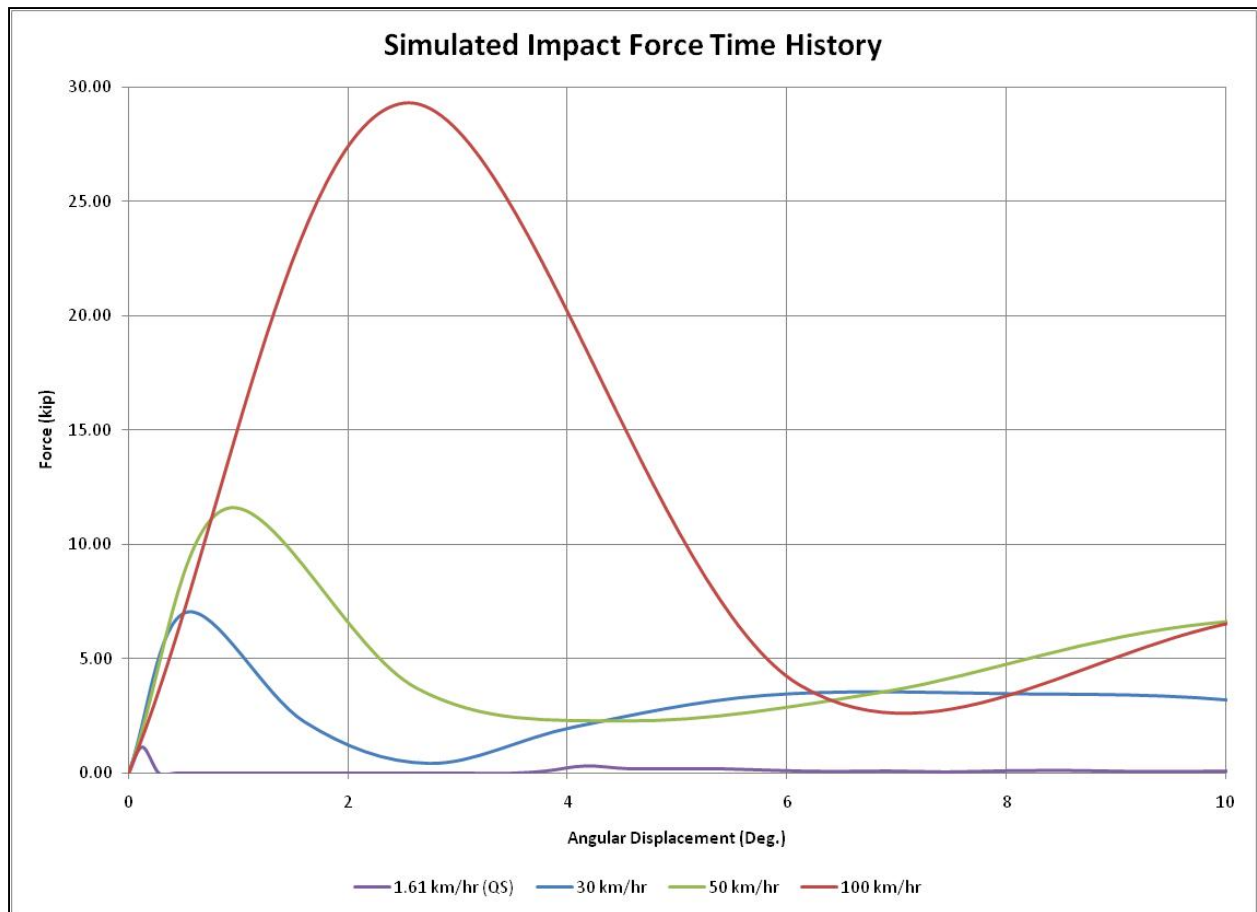


Figure 7.7. Simulated Force Times Histories.

To aid with the design of sign support systems, Table 7.3 was generated to make looking up predicted torsional capacities easier. As a design example, take an 8 ft × 12 ft sign panel. Assume that a W8×21 support will hold up the sign. First, look up the capacity of the sign panel in Table 7.3: this size has a capacity of 4.5 kip*ft. A dynamic multiplier of 6 will then be applied to the capacity to determine the predicted dynamic torsional capacity of the sign panel. Therefore, the dynamic capacity of the sign panel is predicted to be 27 kip*ft. Next, look up the capacity of the fuse plate connection in Table 7.4, which is a design table listing all the bending capacities of all fuse plate connections. From the same Table 7.4, note that the W8×21 fuse plate connection has a capacity of 48.3 kip*ft, which exceeds the calculated dynamic capacity of the sign panel. Some other form of stiffening will be required to activate the fuse plate for this condition. This being said, there are several conditions where the sign panel will provide the required stiffness without the benefit of extra stiffening.

Table 7.3. Design Table of Static Sign Panel Torsional Capacities.

| | | $M_s = \text{Estimated Static Moment Capacity of Sign Panel (kip*ft)}$ | | | | | | | | | | | | | | | | | | | | |
|-------------|------------|--|-----|-----|-----|-----|------|------|-----------|------|------|------|-----|-----|-----|------------|-----|-----|-----|-----|-----|-----|
| Height (ft) | 16 | | | | | | | 81.1 | 43.8 | 25.2 | 15.7 | 10.8 | 8.2 | 6.9 | 6.2 | 5.8 | | | | | | |
| | 15.5 | | | | | | | 66.1 | 35.7 | 20.7 | 13.2 | 9.4 | 7.5 | 6.5 | 6.0 | 5.6 | | | | | | |
| | 15 | | | | | | | 53.5 | 29.0 | 17.1 | 11.3 | 8.4 | 6.9 | 6.2 | 5.8 | 5.5 | | | | | | |
| | 14.5 | | | | | | 84.8 | 43.0 | 23.5 | 14.2 | 9.7 | 7.5 | 6.5 | 5.9 | 5.6 | 5.4 | | | | | | |
| | 14 | | | | | | | 67.7 | 34.3 | 19.0 | 11.9 | 8.5 | 6.9 | 6.1 | 5.7 | 5.4 | 5.2 | | | | | |
| | 13.5 | | | | | | | | 53.5 | 27.2 | 15.4 | 10.1 | 7.6 | 6.4 | 5.9 | 5.5 | 5.3 | 5.1 | | | | |
| | 13 | | | | | | | 89.6 | 41.9 | 21.5 | 12.6 | 8.7 | 6.9 | 6.1 | 5.7 | 5.4 | 5.2 | 4.9 | | | | |
| | 12.5 | | | | | | | | 69.6 | 32.6 | 17.1 | 10.5 | 7.7 | 6.4 | 5.8 | 5.5 | 5.2 | 5.0 | 4.7 | | | |
| | 12 | | | | | | | | 53.5 | 25.2 | 13.7 | 8.9 | 6.9 | 6.0 | 5.6 | 5.3 | 5.1 | 4.8 | 4.5 | | | |
| | 11.5 | | | | | | | 96.1 | 40.6 | 19.4 | 11.1 | 7.7 | 6.4 | 5.8 | 5.4 | 5.2 | 4.9 | 4.6 | 4.3 | | | |
| | 11 | | | | | | | | 72.3 | 30.6 | 15.1 | 9.2 | 6.9 | 6.0 | 5.5 | 5.3 | 5.0 | 4.7 | 4.4 | 4.1 | | |
| | 10.5 | | | | | | | | 53.5 | 22.8 | 11.9 | 7.8 | 6.3 | 5.7 | 5.4 | 5.1 | 4.8 | 4.5 | 4.1 | 3.8 | | |
| | 10 | | | | | | | | 39.0 | 17.1 | 9.6 | 6.9 | 5.9 | 5.5 | 5.2 | 4.9 | 4.5 | 4.2 | 3.8 | 3.5 | | |
| | 9.5 | | | | | | | | 75.8 | 28.1 | 12.9 | 8.0 | 6.3 | 5.6 | 5.3 | 5.0 | 4.6 | 4.3 | 3.9 | 3.5 | 3.2 | |
| | 9 | | | | | | | | 53.5 | 20.2 | 10.1 | 6.9 | 5.9 | 5.4 | 5.1 | 4.7 | 4.3 | 4.0 | 3.6 | 3.2 | 2.8 | |
| | 8.5 | | | | | | | | 37.0 | 14.6 | 8.1 | 6.2 | 5.6 | 5.2 | 4.8 | 4.4 | 4.0 | 3.6 | 3.2 | 2.8 | 2.5 | |
| | 8 | | | | | | | | 81.1 | 25.2 | 10.8 | 6.9 | 5.8 | 5.3 | 4.9 | 4.5 | 4.1 | 3.7 | 3.2 | 2.8 | 2.4 | 2.1 |
| | 7.5 | | | | | | | | 53.5 | 17.1 | 8.4 | 6.2 | 5.5 | 5.1 | 4.7 | 4.2 | 3.7 | 3.3 | 2.8 | 2.4 | 2.1 | 1.8 |
| 7 | | | | | | | | 34.3 | 11.9 | 6.9 | 5.7 | 5.2 | 4.8 | 4.3 | 3.8 | 3.3 | 2.8 | 2.4 | 2.0 | 1.7 | 1.4 | |
| 6.5 | 89.6 | 21.5 | 8.7 | 6.1 | 5.4 | 4.9 | 4.4 | 3.9 | 3.3 | 2.8 | 2.4 | 2.0 | 1.6 | 1.4 | 1.1 | 0.9 | 0.7 | 0.6 | 0.5 | 0.4 | 0.3 | |
| 6 | 53.5 | 13.7 | 6.9 | 5.6 | 5.1 | 4.5 | 4.0 | 3.4 | 2.8 | 2.3 | 1.9 | 1.6 | 1.3 | 1.0 | 0.9 | 0.7 | 0.6 | 0.5 | 0.4 | 0.3 | 0.2 | |
| 5.5 | 30.6 | 9.2 | 6.0 | 5.3 | 4.7 | 4.1 | 3.4 | 2.8 | 2.3 | 1.8 | 1.5 | 1.2 | 0.9 | 0.8 | 0.6 | 0.5 | 0.4 | 0.3 | 0.2 | 0.1 | 0.1 | |
| 5 | 17.1 | 6.9 | 5.5 | 4.9 | 4.2 | 3.5 | 2.8 | 2.2 | 1.8 | 1.4 | 1.1 | 0.9 | 0.7 | 0.6 | 0.5 | 0.4 | 0.3 | 0.2 | 0.1 | 0.1 | 0.0 | |
| 4.5 | 10.1 | 5.9 | 5.1 | 4.3 | 3.6 | 2.8 | 2.2 | 1.7 | 1.3 | 1.0 | 0.8 | 0.6 | 0.5 | 0.4 | 0.3 | 0.2 | 0.1 | 0.1 | 0.0 | 0.0 | 0.0 | |
| 4 | 6.9 | 5.3 | 4.5 | 3.7 | 2.8 | 2.1 | 1.6 | 1.1 | 0.9 | 0.7 | 0.5 | 0.4 | 0.3 | 0.2 | 0.1 | 0.1 | 0.0 | 0.0 | 0.0 | 0.0 | 0.0 | |
| | 4 | 5 | 6 | 7 | 8 | 9 | 10 | 11 | 12 | 13 | 14 | 15 | 16 | 17 | 18 | | | | | | | |
| | Width (ft) | | | | | | | | | | | | | | | | | | | | | |

Table 7.4. Design Table of Static Fuse Plate Connection Capacities.

| Mf= Max Moment Capacity of Fuse Plate Connection | |
|--|--------------|
| Post Section | Mn (kip*ft) |
| S3x5.7 | 3.25 |
| S4x7.7 | 4.33 |
| W6x9 | 8.36 |
| W6x12 | 13.57 |
| W6x15 | 27.45 |
| W8x18 | 37.31 |
| W8x21 | 48.30 |
| W10x22 | 59.50 |
| W10x26 | 77.25 |
| W12x26 | 91.50 |

In an attempt to provide added stiffness, the researchers began testing torsional stiffeners as a option for adding more torsional stiffness. The researchers also began looking into methods of connecting the stiffeners to the support posts. Two different strength torsional stiffeners were

selected for testing. These included an HSS3×3×1/8 and an HSS4×4×1/8 sections. Two different methods of attaching the torsional stiffeners were also tested, including through bolting the stiffener to the post (see Figure 7.8), and attaching a sleeve bracket (see Figure 7.9). The sleeve bracket was considered the best option; however, it would be far more expensive than through bolting the stiffener. To add to this, two tests were performed with a 10 ft × 4 ft sign panel installed adjacent to the torsional stiffener.



Figure 7.8. Static Test of HSS3×3×1/8 with Through Bolt Connection.



Figure 7.9. Static Test of HSS3×3×1/8 with Bracket Connection.

Figures 7.10 and 7.11 have the test results. Figure 7.10 compares the capacities of various torsional stiffeners, while Figure 7.11 compares those of torsional stiffeners with and without sign panels. Figures 7.10 and 7.11 show that the attachment method makes a significant difference in the stiffness of the torsional stiffener. The HSS3×3×1/8-inch stiffener actually yielded after the maximum load was reached when installed using the sleeve bracket. Figure 7.11 shows that the summation of the individual stiffness approximates the combined stiffness.

With the additional capacity of torsional stiffeners, a final design procedure can be proposed. To accomplish this, a final design chart was generated. Care was taken to select a family of torsional stiffeners that would fit all situations. Since this system of stiffening will require the fabrication of a sleeve bracket, it is desirable that all stiffeners fit that single bracket design. After reviewing the structural tube sections, the researchers settled on an HSS4.5×4.5 family of stiffeners because of its wide range of torsional stiffness and its minimalist size. This size minimizes the required sleeve bracket size and cost, while maximizing torsional capacity. Table 7.5 lists the torsional stiffeners in this family and their corresponding torsional capacity.

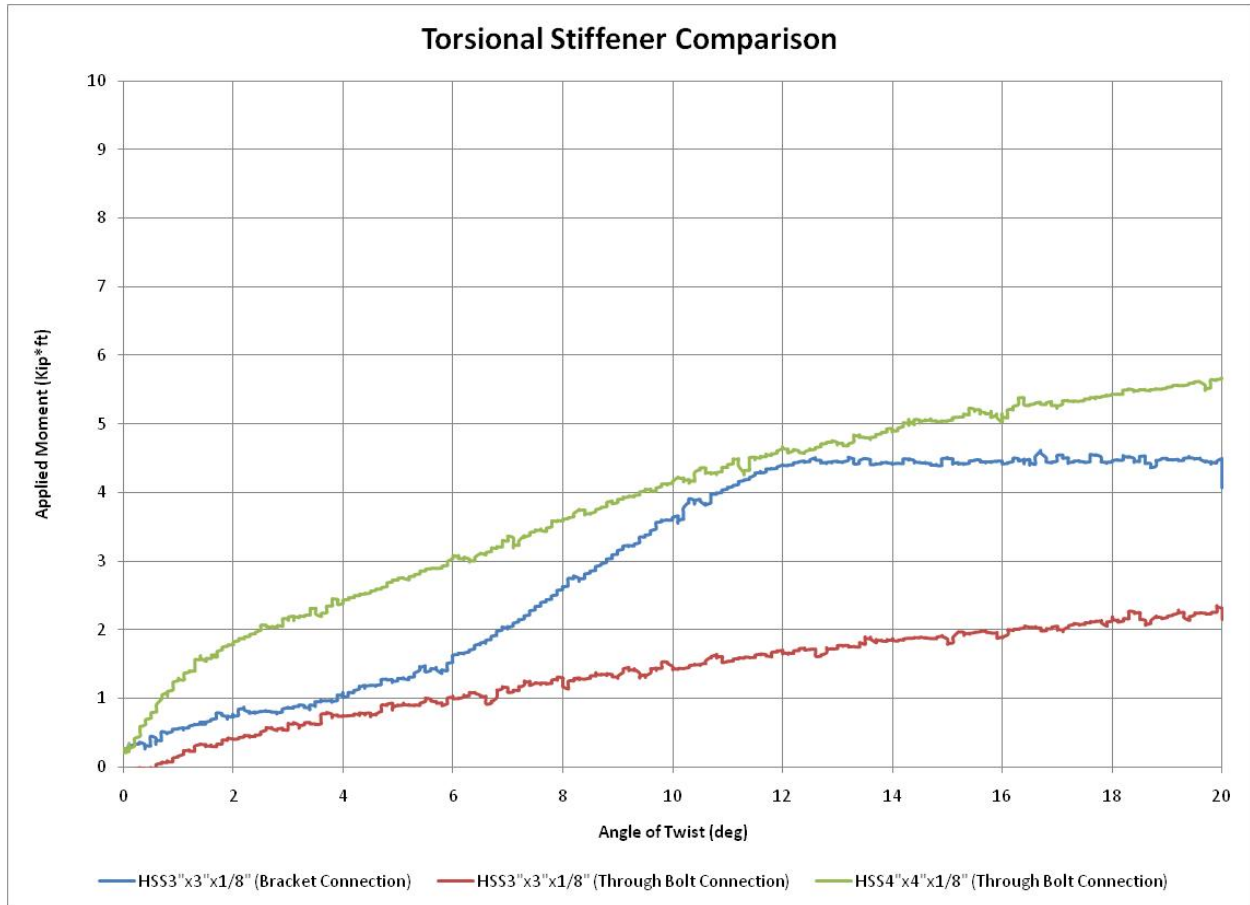


Figure 7.10. Measured Force Times Histories of Torsional Stiffeners.

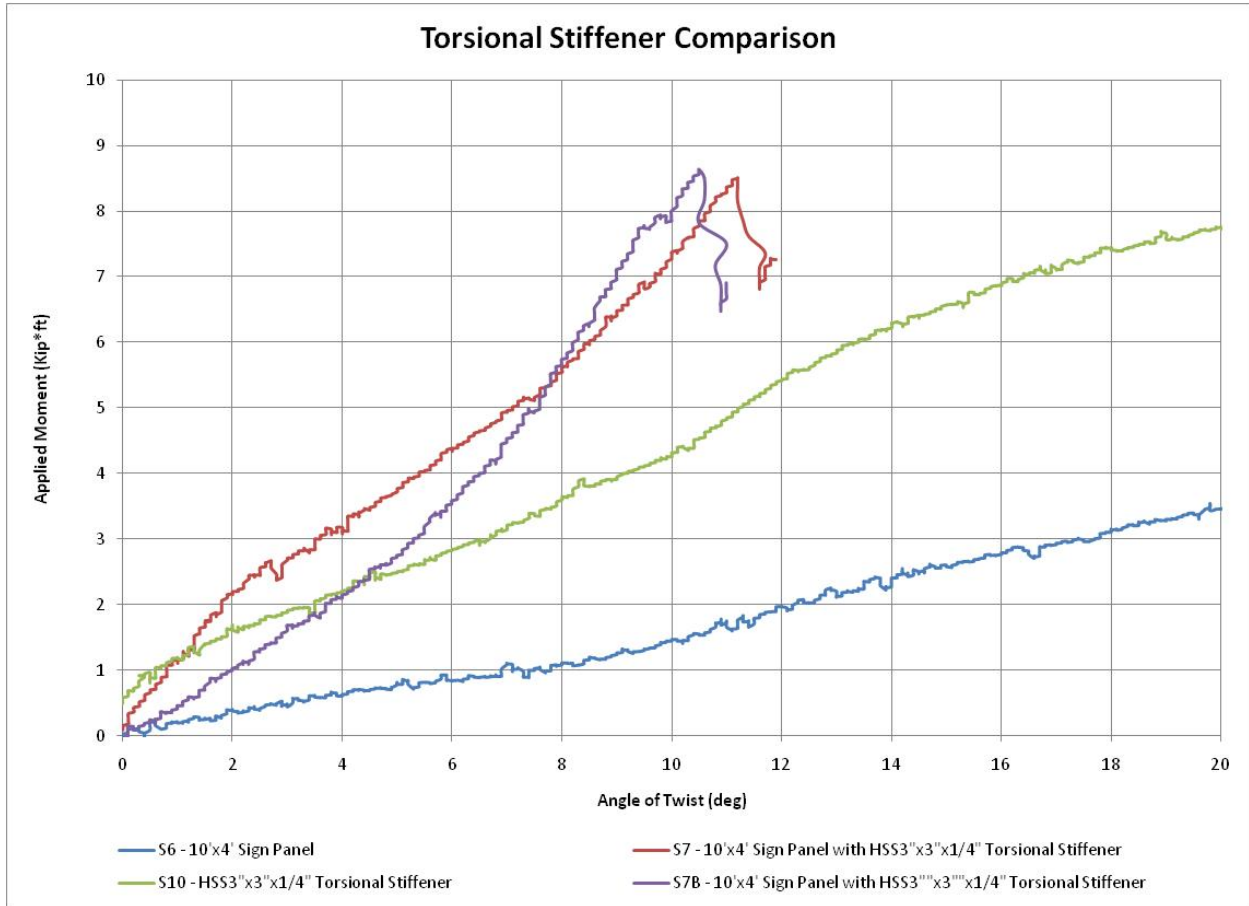


Figure 7.11. Sign Panel and Torsional Stiffener Force Time History Comparison.

Table 7.5. Design Table of Torsional Stiffeners and Capacities.

| Mts = Max Moment Capacity of Torsional Stiffener | | |
|--|---------|----------|
| Post Section | (lb/ft) | (kip*ft) |
| HSS4.5"x4.5"x1/8" | 7.3 | 5.4 |
| HSS4.5"x4.5"x3/16" | 10.7 | 7.8 |
| HSS4.5"x4.5"x1/4" | 13.9 | 10.2 |
| HSS4.5"x4.5"x5/16" | 16.9 | 12.3 |
| HSS4.5"x4.5"x3/8" | 19.7 | 14.3 |
| HSS4.5"x4.5"x1/2" | 24.9 | 17.8 |
| Some Sections are more readily available than others | | |

With this additional torsional stiffness, a final design procedure can be formulated. Let us revisit the problem from before (8 ft × 12 ft mounted on a W8x21 sign support). From Table 7.3, the torsional capacity (M_s) of the 8 ft × 12 ft sign assembly is 4.5 kip*ft. From Table 7.4, the torsional capacity (M_f) of a W8×21 fuse plate connection is 48.30 kip*ft. This then leads to the following two design equations:

$$M_r = M_f - 6 * M_s$$
$$M_{ts} \geq M_r / N_{ts}$$

M_r is the required total torsional stiffener capacity, N_{ts} is the number of torsional stiffeners, and finally, M_{ts} is the torsional stiffener capacity from Table 7.5. In this case, $M_r = 21.3$ kip*ft; therefore, it is assumed that $N_{ts} = 2$, then M_{ts} must be greater than 10.7 kip*ft. When looking at Table 7.5, it appears that the best option for torsional stiffeners is either an HSS4.5×4.5×5/16 or an HSS4.5×4.5×3/8. Availability will need to be factored into the selection of the torsional stiffener. For instance, the 5/16-inch stiffener may actually be more expensive than the 3/8-inch stiffener, depending on availability.

To test this procedure according to *MASH*, a series of test installations needed to be selected for fabrication and testing. The 2270P (pickup) impact vehicle is expected to be a less critical case than the 1100C (small car), if the fuse plate connection fails as designed. The small car is considered a worst case for large sign supports because the larger mass of the pickup results in lower OIV values. As the slipbase connection details have remained unchanged from current *NCHRP Report 350* approved details, the small car low-speed impact was considered less critical than the high-speed small car impact.

Two impact conditions were selected for high-speed testing. The first was selected to provide the highest stiffness for a 10-ft wide sign panel. Figure 7.12 is the updated wind load chart (according to current method) for a 90 mph wind zone and a mounting height of 7 ft. A 10 ft × 16 ft sign panel was selected which has a predicted static torsional capacity of 81.1 kip*ft. This is well in excess of the capacity required to fail the W8×18 fuse plate connection selected from Figure 7.12. Therefore, no torsional stiffeners will be installed. This installation will verify that the sign panel without stiffeners will provide sufficient capacity to fail the optimized W8×18 fuse plate connection without failing the OIV requirements.

The second test was formulated to provide the weakest system to verify that the fuse plate would fail before the weakened post would yield/buckle when struck by an impacting vehicle. Again, a 10-ft wide sign panel was selected for testing. Figure 7.13 is a plot of updated wind load charts using current method of determining wind pressures. A 10 ft × 4 ft sign was selected to be mounted on a W6×9 post assembly. A 10 ft × 4 ft sign assembly has a capacity of 1.6 kip*ft.

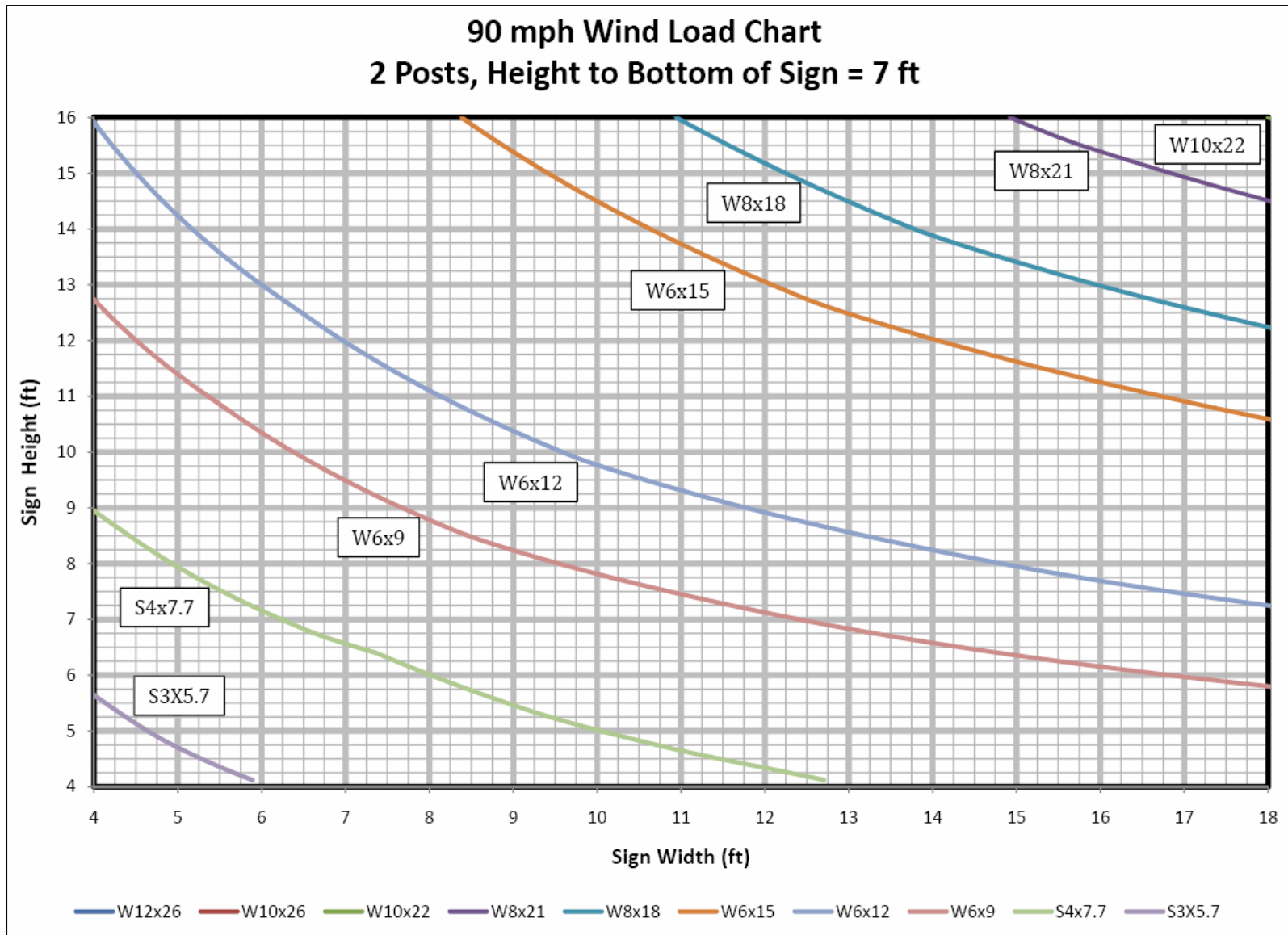


Figure 7.12. 90 mph Selection Chart for Optimized Fuse Plate Hbs = 7 ft (Current Method).

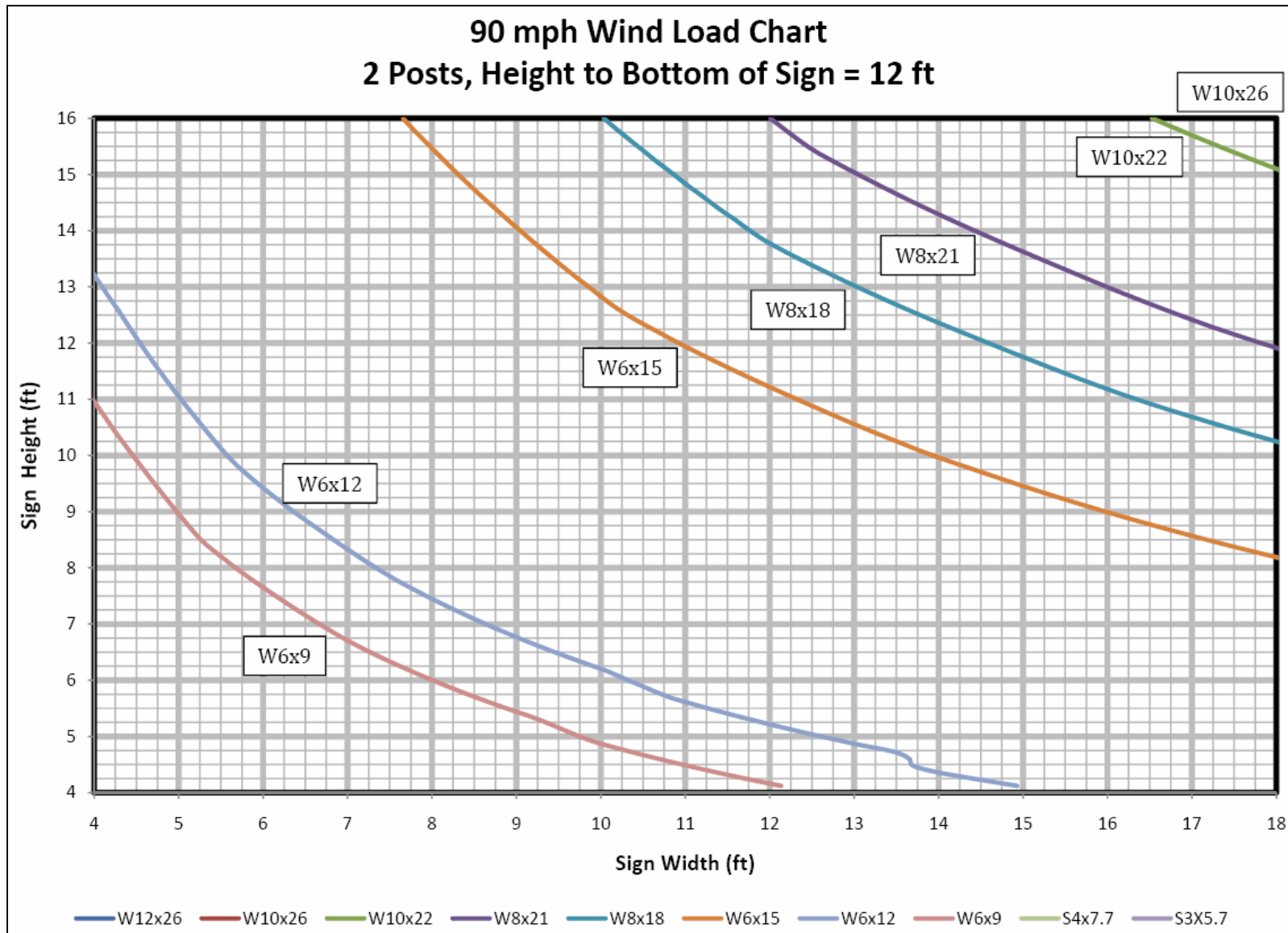


Figure 7.13. 90 mph Selection Chart for Optimized Fuse Plate Hbs = 12 ft (Current Method).

This testing resulted in the activation of slipbase and fuse plate connections as designed. The posts hinged about the rear fuse plates and rotated up and out of the way of the impacting vehicle. Both tests passed all requirements that the *MASH* testing criteria have set. Chapter 7.2 and Appendix D further discuss testing.

To visualize the benefit of the optimized fuse plate connections when compared to the current fuse plate design, one must compare the support selection charts. Figures 7.12 and 7.14 both represent charts generated for 90 mph wind zones according to the current method of calculating wind pressures. Both charts assume dual supports and a sign mounting height of 7 ft. Figure 7.14 was generated for the optimized fuse plate design, and Figure 7.12 was generated for the current fuse plate design. Note the substantial increase in almost all the support assemblies' wind load capacity.

7.2 FULL-SCALE CRASH TESTS

7.2.1 Crash Test Matrix

According to *MASH*, three tests are recommended to evaluate large sign supports to test level 3 (TL-3):

- ***MASH* Test 3-60:** An 1100C (2425 lb/1100 kg) vehicle impacting the device at a nominal impact speed of 30 mi/h and critical impact angle (CIA) judged to have the greatest potential for test failure. This test will investigate a device's ability to successfully activate by breakaway, fracture, or yielding mechanism during low-speed impacts with a small vehicle.
- ***MASH* Test 3-61:** An 1100C (2425 lb/1100 kg) vehicle impacting the device at a nominal impact speed of 62 mi/h and CIA judged to have the greatest potential for test failure. This will evaluate the behavior of the device during high-speed impacts with a small vehicle.
- ***MASH* Test 3-62:** A 2270P (5000 lb/2270 kg) vehicle impacting the device at a nominal impact speed of 62 mi/h and CIA judged to have the greatest potential for test failure. This will evaluate the behavior of the device during high-speed impacts with a pickup truck.

The two tests performed under this project correspond to *MASH* Test 3-61.

The crash test and data analysis procedures were in accordance with guidelines presented in *MASH*. Chapter 4 has brief descriptions of these procedures.

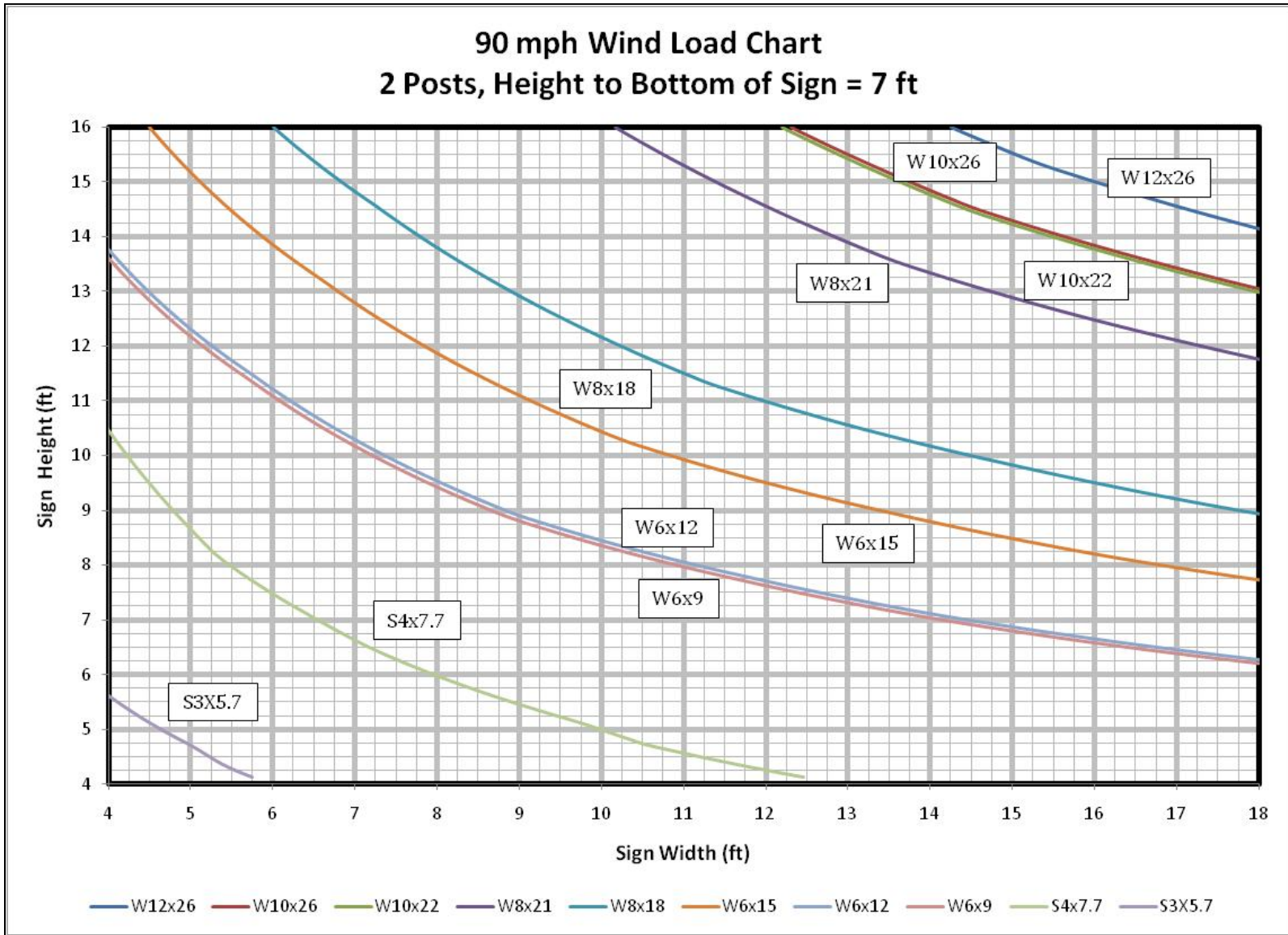


Figure 7.14. 90 mph Selection Chart for Current Fuse Plate Hbs = 7 ft (Current Method).

7.2.2 Evaluation Criteria

The crash test was evaluated according to the criteria presented in *MASH*. The performance of the large sign support is judged on the basis of three factors: structural adequacy, occupant risk, and post impact vehicle trajectory. *Structural adequacy* is judged on the ability of the large sign support to contain and redirect the vehicle, or bring the vehicle to a controlled stop in a predictable manner. *Occupant risk criteria* evaluate the potential risk of hazard to occupants in the impacting vehicle and, to some extent, other traffic, pedestrians, or workers in construction zones, if applicable. *Post impact vehicle trajectory* is assessed to determine potential for secondary impact with other vehicles or fixed objects, creating further risk of injury to occupants of the impacting vehicle and/or risk of injury to occupants in other vehicles. The appropriate safety evaluation criteria from Table 5.1 of *MASH* were used to evaluate the crash tests reported here, and are listed in further detail under the assessment of each of the crash tests.

7.2.3 Crash Test No. 463630-1 (MASH Test 3-61) W6×9 – 4-ft × 10-ft Large Sign Support Test Installation

7.2.3.1 Test Installation Description

The test installation was constructed to support a 10-ft × 4-ft tall sign at a mounting height of 12 ft. The sign assembly was constructed using four 1-ft × 10-ft long extruded aluminum panels. Panels were fastened together using $\frac{3}{8}$ -inch × $\frac{3}{4}$ -inch bolts and washers spaced every 24 inches along the length of the panels. Each panel was fastened to the support post using a cast sign clip and aluminum bolt that locked into slots incorporated into the design of the extruded panels.

The support post was constructed using a W6×9 hot rolled section. The support post was constructed in three sections: top, middle, and ground stub. The top section was a 52-inch long W6×9 beam section and had four $\frac{11}{16}$ -inch holes drilled through the flanges at one end to allow splicing of the support section using milled fuse plates. The holes were drilled 1 inch from the end and at a center-to-center spacing of $2\frac{1}{4}$ inches, centered about the central axis of the beam.

The middle section was fabricated from an 11 ft-5 inch long section of W6×9 beam section. This section again had the same hole pattern that was found in the top section at one end. This again allowed for the splicing of the top and middle sections using a milled fuse plate. The other end of the middle section had two slipbase feet, meeting TxDOT's W6×9 specifications, welded to each flange. These plates were made from $2\times 5\times\frac{3}{4}$ -inch plates. The two slots were cut into each plate at a spacing of $2\frac{3}{4}$ inches. Each slot was fabricated to receive a $\frac{5}{8}$ -inch slipbase connecting bolt. Then, a $2\times 5\times\frac{1}{2}$ -inch gusset plate supported the slipbase feet. The slipbase foot assembly was centered on each of the external flanges of the W6×9 beam support section.

The ground stub was fabricated from a 24-inch long W6×9 beam section. Again, the slipbase foot assemblies, described above, were attached to one end of the ground stub. Four $2\frac{3}{4}$ -inch long $\frac{5}{8}$ -inch diameter A325 bolts were used in the slipbase connection to splice the ground stub to the middle support section. A 30-gauge slipbase bolt keeper plate was placed between the ground stub and the middle support section to hold the bolts in the slots until an errant vehicle impacted the support. A single $\frac{5}{8}$ -inch washer was placed between the keeper

plate and the middle support section to reduce friction in the slipbase connection. Each slipbase connecting bolt was tightened to a torque between 36 and 38 ft-lb.

The ground stub was installed in a 48-inch deep 24-inch diameter concrete foundation. The foundation was reinforced with eight 42-inch #5 vertical rebar. The foundations were shear reinforced using a single #2 spiral rebar with a 6-inch pitch with three flat turns at the top and one flat turn at the bottom. The foundations were spaced 72 inches on center. Each ground stub protruded 3 inches out of the foundation.

An HSS 4.5×4.5× $\frac{1}{4}$ -inch stiffener was attached to the back of the W6×9 support post using a specialty torsional bracket sleeve, which is designed so that it could be used with any of the approved torsional stiffeners. The bracket sleeve was also designed to fill all standard support sections (W6×9 thru W12×26) without modification. The bracket was designed to clamp to the W6×9 post section, removing the need to drill holes in the top post section.

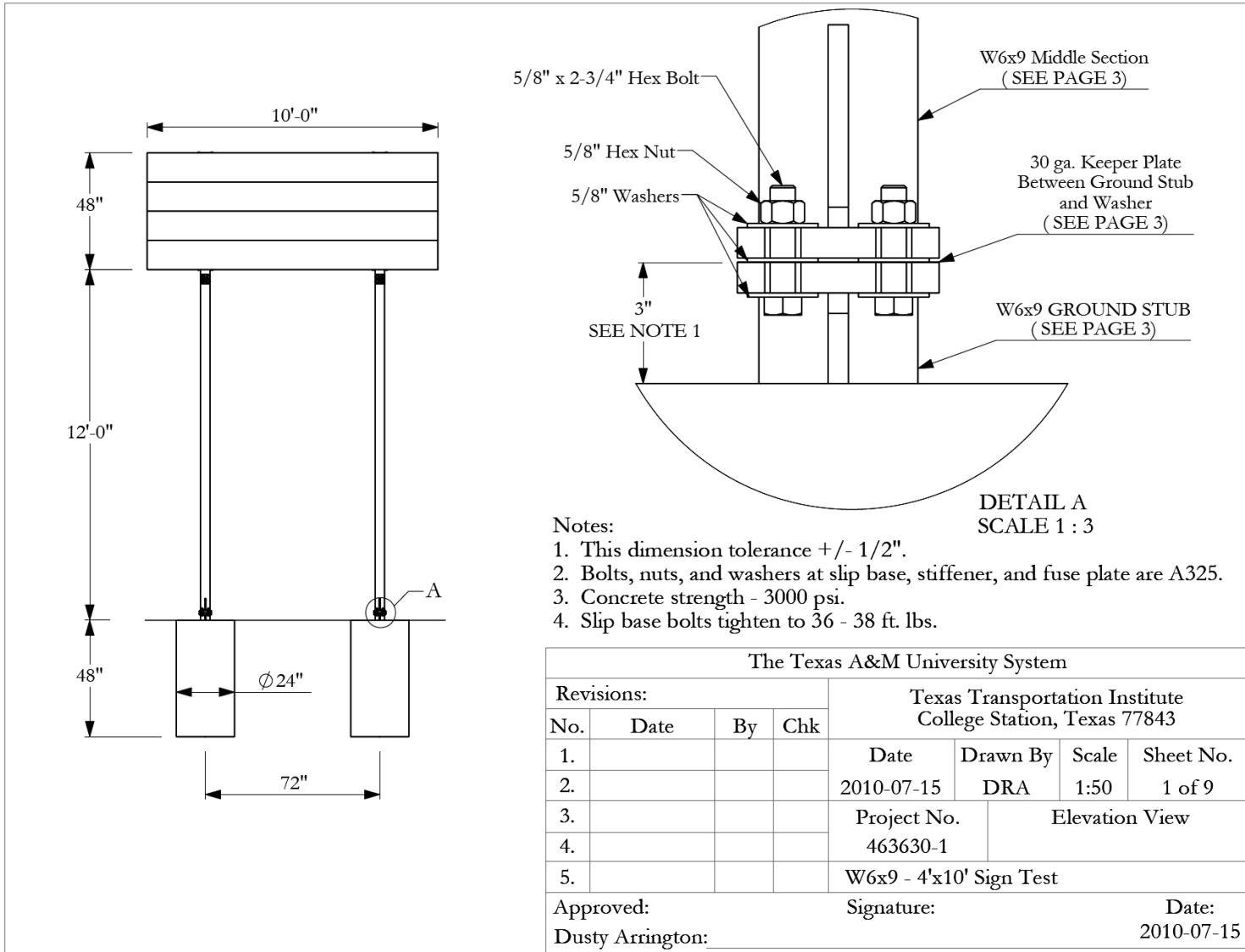
The sleeve bracket was made of four main components.

- First is the HSS 5×5× $\frac{3}{16}$ -inch sleeve, which allows for a telescoping fit to all 4 $\frac{1}{2}$ -inch stiffener sections. Each sleeve had two set-screws to hold the torsional stiffener in place.
- Second is the 9×15× $\frac{1}{2}$ -inch bracket base plate. This plate has a total of eight 11/16 inch bolt holes allowing the bracket to attach to any of the standard size support posts.
- Third is the $\frac{1}{4}$ -inch bracket gusset plate. This plate prevents the bracket sleeve from rotating when resisting torsional stresses.
- Finally, two 2×9× $\frac{1}{2}$ -inch clamp plates. Each of these fabricated plates has a total of four 11/16-inch holes allowing the bracket to attach to all of the standard post section sizes. In this case, four $\frac{5}{8}$ ×8-inch A325 bolts were used to clamp the W6×9 post section between the sleeve base plate and the clamp plate, creating a torsion-resisting connection. The stiffener was centered 12 inches above the bottom of the sign panel.

Two milled fuse plates were used to splice each top and middle support post sections. Each fuse plate was milled from a 4 × 3 $\frac{7}{8}$ × $\frac{1}{4}$ -inch A36 plate. The plate was attached to the support post sections at two locations, each using $\frac{5}{8}$ × 1 $\frac{1}{2}$ -inch A325 bolts and nuts. Four inch drilled holes at the splice location weakened the plate. These holes were spaced at 15/16 inch center-to-center spacing and the pattern was centered on the face of the plate.

Figure 7.15 is a diagram of the test installation as tested, and Figure 7.16 presents photographs of the installation as tested. Appendix E, Figure E1 features further fabrication details and specifications.

All hot rolled W-sections conform to A992 material specifications. Every tube section conforms to A500 grade B specification. All bolts and nuts meet A325 material specifications. The State of Texas Prison System supplied all extruded sign panels and post clamps, which meet AASHTO and TxDOT material specifications. All other steel sections and plate meet A36 specifications. The concrete used in the foundation has a compression strength in excess of 3000 psi.



T:\2009-2010\463630-TxDOT\463630-1 and -2 Tests\SolidWorks\Drawings\Test 1 Drawing

Figure 7.15. Details of the TxDOT W6x9 – 4-ft x 10-ft Large Sign Support Test Installation.



Figure 7.16. TxDOT W6×9 – 4-ft × 10-ft Large Sign Support before Test No. 463630-1.

7.2.3.2 Test Designation and Actual Impact Conditions

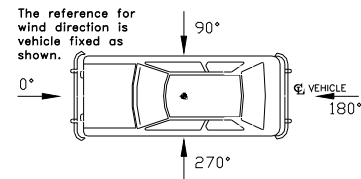
MASH test 3-61 was performed on the TxDOT W6×9 – 4 ft × 10 ft large sign support. This test involves an 1100C vehicle weighing 2420 lb ±55 lb and impacting the test article at an impact speed of 62.2 mi/h ±2.5 mi/h and critical impact angle (CIA) judged to have the greatest potential for test failure. The 2004 Kia Rio used in the test weighed 2414 lb and the actual impact speed and angle were 62.0 mi/h and 0 degrees, respectively. The actual impact point was the quarter-point of vehicle with centerline of the left support.

7.2.3.3 Test Vehicle

Figures 7.17 and 7.18 show the 2004 Kia Rio used for the crash test. Test inertia weight of the vehicle was 2414 lb, and its gross static weight was 2575 lb. The height to the lower edge of the vehicle bumper was 8.50 inches, and it was 22.75 inches to the upper edge of the bumper. Table E1 in Appendix E gives additional dimensions and information on the vehicle. The vehicle was directed into the installation using the cable reverse tow and guidance system, and was released to be free-wheeling and unrestrained just prior to impact.

7.2.3.4 Weather Conditions

The test was performed on the morning of July 30, 2010. Eight days prior to the test 0.35 inch of rain was recorded, and two days prior to the test 0.74 inch of rain was recorded. Moisture content of the soil was 8.1 percent. Weather conditions at the time of testing were as follows: wind speed: 5 mi/h; wind direction: 218 degrees with respect to the vehicle (vehicle was traveling in a northerly direction); temperature: 85°F, relative humidity: 72 percent.



7.2.3.5 Test Description

The 1100C vehicle, traveling at an impact speed of 62.0 km/h, impacted the left support leg of the large sign support at 0 degrees with the quarter point of the vehicle aligned with the centerline of the support leg. Shortly after impact, the left support leg began to move, and at 0.005 s after impact, the left support leg slipped away at the slipbase.

At 0.054 s, the vehicle lost contact with the left support leg and was traveling at 58.0 mi/h. The upper hinge connection on the left support leg began to activate at 0.061 s, and the upper hinge connection on the right support leg began to activate at 0.118 s.

By 0.406 s, the upper hinge connection on the left support leg completely ruptured, and at 0.424 s, the upper hinge connection on the right support leg completely ruptured. At 0.468 s, the right post began to move toward the field side, then rebounded back toward the impact side, and at 0.603 s, ceased moving. One corner of the sign panel touched ground at 0.774 s, and by 1.324 s, the sign panel was resting on the ground surface.

At 1.854 s, the left support leg touched the ground surface, and by 1.900 s, the leg was resting on the ground surface. Brakes on the vehicle were applied at 0.7 s, and the vehicle subsequently came to rest 525 ft downstream of impact. Figure E2 in Appendix E shows sequential photographs of the test period.



Figure 7.17. Vehicle/Installation Geometrics for Test No. 463630-1.



Figure 7.18. Vehicle before Test No. 463630-1.



Figure 7.19. Installation/Vehicle Positions after Test No. 463630-1.

7.2.3.6 *Damage to Test Installation*

Figures 7.20 and 7.21 show damage to the sign support. The slipbase and fuse plates (hinge connections) activated as designed. The right support leg remained standing but was leaning 15 degrees in the direction of where the left support leg originally was installed before the test. The left support leg was resting on the ground surface 9 ft toward the field side. The sign panel was resting on the ground surface face down on the impact side of the installation. The lower left corner of the sign panel was deformed.

7.2.3.7 *Vehicle Damage*

Figure 7.21 shows that the 1100C vehicle sustained minimal damage. The front bumper, hood, radiator, and radiator support were deformed, and the right headlight was broken. Maximum external crush to the vehicle at the right front quarter point at bumper height was 3.5 inches. No occupant compartment deformation occurred. Figure 7.22 shows photographs of the interior of the vehicle. Tables E2 and E3 in Appendix E, provide the exterior crush and occupant compartment measurements.

7.2.3.8 *Occupant Risk Factors*

Data from the accelerometer, located at the vehicle center of gravity, were digitized for evaluation of occupant risk. In the longitudinal direction, the occupant impact velocity was 2.3 ft/s at 0.897 s, the highest 0.010-s occupant ridedown acceleration was -0.3 Gs from 0.899 to 0.909 s, and the maximum 0.050-s average acceleration was -1.3 Gs between 0.002 and 0.052 s. In the lateral direction, the occupant impact velocity was 1.0 ft/s at 0.897 s, the highest 0.010-s occupant ridedown acceleration was -0.3 Gs from 0.929 to 0.939 s, and the maximum 0.050-s average was 0.4 Gs between 0.037 and 0.087 s. Theoretical Head Impact Velocity (THIV) was 2.6 km/h or 0.7 m/s at 0.888 s; Post-Impact Head Decelerations (PHD) was 0.4 Gs between 0.890 and 0.900 s; and Acceleration Severity Index (ASI) was 0.11 between 0.002 and 0.052 s. Figure 7.9 summarizes these data and other pertinent information from the test. Figures E3 through E9 in Appendix E presents the vehicle angular displacements and accelerations versus time traces.

7.2.3.9 *Assessment of Test Results*

An assessment of the test based on the applicable *MASH* safety evaluation criteria is provided below.

Structural Adequacy

B. The test article should readily activate in a predictable manner by breaking away, fracturing, or yielding.

Results: When impacted by the 1100C vehicle, the W6×9 4-ft × 10-ft large sign support activated by breaking away at the slipbase and at the upper hinge connections. (PASS)



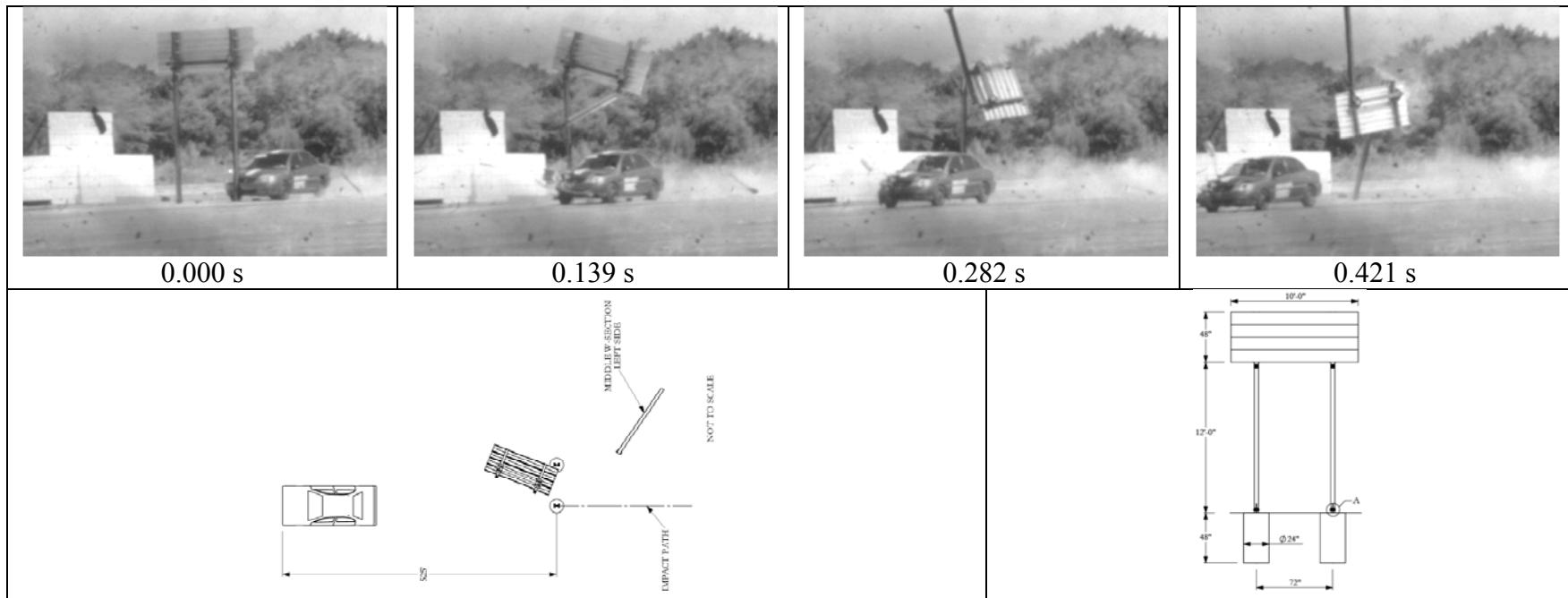
Figure 7.20. Installation after Test No. 463630-1.



Figure 7.21. Vehicle after Test No. 463630-1.



Figure 7.22. Interior of Vehicle for Test No. 463630-1.



General Information

Test Agency..... Texas Transportation Institute (TTI)
 Test Standard Test No. MASH Test 3-61
 TTI Test No. 463630-1
 Date 2010-07-30

Test Article

Type..... Sign Support
 Name..... TxDOT W6x9 – 4-ft x 10-ft Large Sign Support
 Installation Height..... 12 ft mounting height
 Material or Key Elements

Soil Type and Condition..... Concrete footing in crush limestone, dry

Test Vehicle

Type/Designation..... 1100C
 Make and Model 2004 Kia Rio
 Curb 2423 lb
 Test Inertial..... 2414 lb
 Dummy 161 lb
 Gross Static..... 2575 lb

Impact Conditions

Speed62.0 mi/h
 Angle0 degrees
 Location/OrientationRight qtr point

Exit Conditions

Speed58.0 mi/h
 Angle0 degrees

Occupant Risk Values

Impact Velocity
 Longitudinal2.3 ft/s
 Lateral1.0 ft/s
 Ridedown Accelerations
 Longitudinal-0.3 G
 Lateral-0.3 G
 THIV2.6 km/h
 PHD0.4 G
 ASI0.11
 Max. 0.050-s Average
 Longitudinal-1.3 G
 Lateral0.4 G
 Vertical0.5 G

Post-Impact Trajectory

Stopping Distance 525 ft dwnstrm

Vehicle Stability

Maximum Yaw Angle..... 1 degree
 Maximum Pitch Angle..... -1 degree
 Maximum Roll Angle -1 degree
 Vehicle Snagging No
 Vehicle Pocketing No

Test Article Deflections

Dynamic
 Permanent.....
 Working Width.....

Vehicle Damage

VDS 12RF2
 CDC..... 12FREW2
 Max. Exterior Deformation 3.5 inches
 OCDI RF0000000
 Max. Occupant Compartment Deformation 0

Figure 7.23. Summary of Results for MASH Test 3-61 on the TxDOT Large Sign Support (W6x9 – 4-ft x 10-ft).

Occupant Risk

- D. *Detached elements, fragments, or other debris from the test article should not penetrate or show potential for penetrating the occupant compartment, or present an undue hazard to other traffic, pedestrians, or personnel in a work zone.*

Deformation of, or intrusions into, the occupant compartment should not exceed limits set forth in Section 5.3 and Appendix E of MASH. (roof ≤ 4.0 inches); windshield = ≤ 3.0 inches; side windows = no shattering by test article structural member; wheel/foot well/toe pan ≤ 9.0 inches; forward of A-pillar ≤ 12.0 inches); front side door area above seat ≤ 9.0 inches; front side door below seat ≤ 12.0 inches; floor pan/transmission tunnel area ≤ 12.0 inches).

Results: The left support leg and sign panel separated from the installation. However, the 1100C vehicle traveled beneath these elements, which came to rest near impact. The elements did not penetrate or show potential for penetrating the occupant compartment, nor to present hazard to others in the area. (PASS)

No occupant compartment deformation occurred during the test with the 1100C vehicle. (PASS)

- F. *The vehicle should remain upright during and after collision. The maximum roll and pitch angles are not to exceed 75 degrees.*

Results: The 1100C vehicle remained upright during and after the collision event. Maximum roll and pitch angles were -1 degree for both. (PASS)

- H. *Occupant impact velocities should satisfy the following:*

Longitudinal and Lateral Occupant Impact Velocity

| <u>Preferred</u> | <u>Maximum</u> |
|------------------|----------------|
| 10 ft/s | 16.4 ft/s |

Results: Longitudinal occupant impact velocity was 2.3 ft/s, and lateral occupant compartment impact velocity was 1.0 ft/s. (PASS)

- I. *Occupant ridedown accelerations should satisfy the following:*

Longitudinal and Lateral Occupant Ridedown Accelerations

| <u>Preferred</u> | <u>Maximum</u> |
|------------------|----------------|
| 15.0 Gs | 20.49 Gs |

Results: Longitudinal ridedown acceleration was -0.3 G, and lateral ridedown acceleration was -0.3 G. (PASS)

Vehicle Trajectory

N. *Vehicle trajectory behind the test article is acceptable.*

Result: The 1100C vehicle came to rest 525 ft toward the field side of the sign support. (PASS)

7.2.4 Crash Test No. 463630-2 (MASH Test 3-61) on W8×18 – 16-ft × 10-ft Large Sign Support Test Installation

7.2.4.1 Test Installation Description

The test installation was constructed to support a 10-ft × 16-ft tall sign at a mounting height of 7 ft. The sign assembly was constructed using sixteen 1-ft × 10-ft long extruded aluminum panels. Panels were fastened together using $\frac{3}{8}$ -inch × $\frac{3}{4}$ -inch bolts and washers spaced every 24 inches along the length of the panels. Each panel was fastened to the support post using a cast sign clip and aluminum bolt locked into slots incorporated into the design of the extruded panels.

The support post was constructed using a W8×18 hot-rolled section. The support post was constructed in three sections: top, middle, and ground stub. The top section was a 16 ft 6 inch long W8×18 beam section and had four 13/16-inch holes drilled through each flange at one end to allow splicing of the support section using milled fuse plates. The holes were drilled 1-5/16 inches and 3-7/16 inches from the end, and at a center-to-center spacing of 2 $\frac{3}{4}$ inches centered about the central axis of the beam.

The middle section was fabricated from a 75-inch long section of W8×18 beam section. This section again had the same hole pattern that was found in the top section at one end, and that allowed for the splicing of the top and middle sections using a milled fuse plate. The other end of the middle section had two slipbase feet, meeting TxDOT's W8×18 specifications, welded to each flange. These plates were made from 2×5× $\frac{3}{4}$ -inch plates. The two slots were cut into each plate at a spacing of 2 $\frac{3}{4}$ inches. Each slot was fabricated to receive a $\frac{5}{8}$ -inch slipbase connecting bolt. A 2×5× $\frac{1}{2}$ -inch gusset plate supported the slipbase feet, and the entire slipbase foot assembly was centered on each of the external flanges of the W6×9 beam support section.

The ground stub was fabricated from a 30-inch long W8×18 beam section. Again, the slipbase foot assemblies, described above, were attached to one end of the ground stub. Four 2 $\frac{3}{4}$ -inch long $\frac{5}{8}$ -inch diameter A325 bolts were used in the slipbase connection to splice the ground stub to the middle support section. A 30-gauge slipbase bolt keeper plate was placed between the ground stub and the middle support section to hold the bolts in the slots until the support was impacted by an errant vehicle. A single $\frac{5}{8}$ -inch washer was placed between the keeper plate and the middle support section to reduce friction in the slipbase connection. Each slipbase connecting bolt was tightened to a torque between 36 and 38 ft-lb.

The ground stub was installed in a 60-inch deep 24-inch diameter concrete foundation, which was reinforced with eight 54-inch # 5 vertical rebar. The foundations were shear

reinforced with a single #2 spiral rebar with a 6-inch pitch with three flat turns at the top and one flat turn at the bottom. The foundations were spaced 72 inches on center. Each ground stub protruded out of the foundation 3 inches.

Two milled fuse plates were used to splice the top and middle support post sections. Each fuse plate was milled from an $11 \times 5\frac{1}{8} \times \frac{1}{2}$ -inch A36 plate. The plate was attached to the support post sections at four locations, each using $\frac{3}{4} \times 2$ -inch A325 bolts and nuts. The plate was weakened at the splice location by four 15/16-inch drilled holes. The holes were spaced at 1-3/16-inch center to center spacing, and the pattern was centered on the face of the plate.

Torsional stiffeners were not used in this installation. Figure 7.24 is a diagram of the test installation as tested, and Figure 7.25 presents photographs of the installation as tested. Further fabrication details and specifications can be found in Appendix F, Figure F1.

All hot rolled W-sections conform to A992 material specifications. All tube sections conform to A500 grade B specification. All bolts and nuts meet A325 material specifications. The State of Texas Prison System supplied all extruded sign panels and post clamps, and these all meet AASHTO and TxDOT material specifications. All other steel sections and plate meet A36 specifications. The concrete used in the foundation has a compression strength in excess of 3000 psi.

7.2.4.2 Test Designation and Actual Impact Conditions

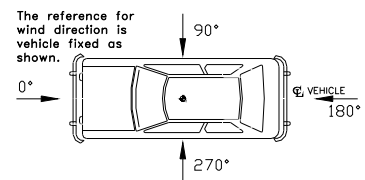
MASH test 3-61 was performed on the TxDOT W8×18 – 16 ft × 10 ft large sign support. This test involves an 1100C vehicle weighing 2420 lb ±55 lb and impacting the test article at an impact speed of 62.2 mi/h ±2.5 mi/h and critical impact angle (CIA) judged to have the greatest potential for test failure. The 2005 Kia Rio used in the test weighed 2431 lb and the actual impact speed and angle were 62.2 mi/h and 0 degrees, respectively. The actual impact point was quarter-point of vehicle with centerline left support.

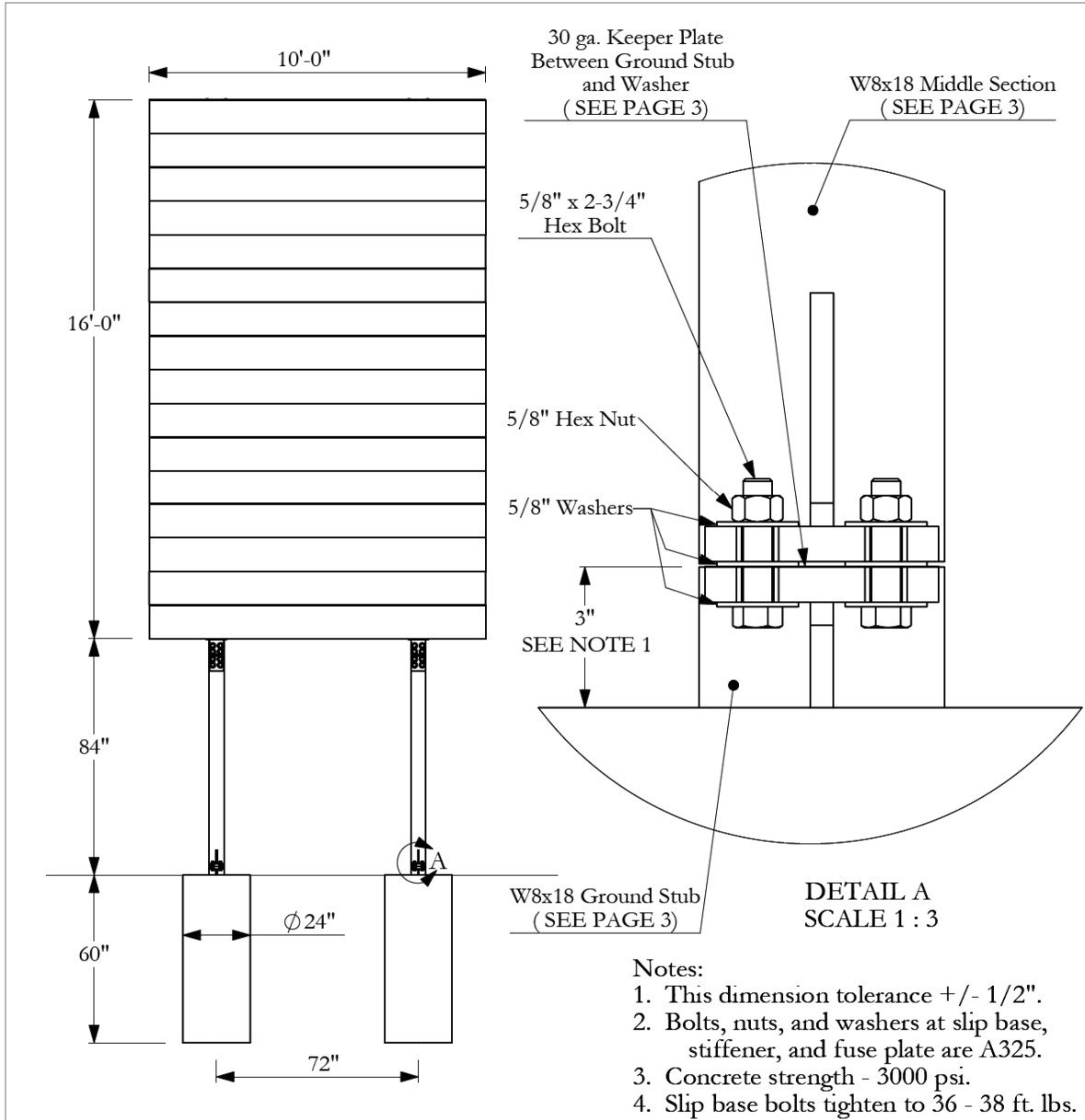
7.2.4.3 Test Vehicle

Figures 7.26 and 7.27 show the 2005 Kia Rio used for the crash test. Test inertia weight of the vehicle was 2431 lb, and its gross static weight was 2606 lb. The height to the lower edge of the vehicle bumper was 8.50 inches, and it was 22.75 inches to the upper edge of the bumper. Tables F1 and F2 in Appendix F give additional dimensions and information on the vehicle. The vehicle was directed into the installation using the cable reverse tow and guidance system, and was released to be free-wheeling and unrestrained just prior to impact.

7.2.4.4 Weather Conditions

The test was performed on the morning of July 30, 2010. Eight days prior to the test 0.35 inch of rain was recorded, and two days prior to the test 0.74 inch of rain was recorded. Moisture content of the soil was 8.1 percent. Weather conditions at the time of testing were as follows: wind speed: 6 mi/h; wind direction: 178 degrees with respect to the vehicle (vehicle was traveling in a northerly direction); temperature: 93°F, relative humidity: 54 percent.





| The Texas A&M University System | | | | | | | |
|---------------------------------|------|----|-----|---|----------------|---------------------|-----------|
| Revisions: | | | | Texas Transportation Institute College Station, Texas, 77843 | | | |
| No. | Date | By | Chk | Date | Drawn By | Scale | Sheet No. |
| 1. | | | | 2010-07-15 | DRA | 1:50 | 1 of 7 |
| 2. | | | | | | | |
| 3. | | | | Project No. | Elevation View | | |
| 4. | | | | 463630-2 | | | |
| 5. | | | | W8x18 - 16'x10' Sign Test | | | |
| Approved: Dusty Arrington: | | | | Signature: | | Date: 2010-07-15 | |

T:\2009-2010\463630-TxDOT\463630-1 and -2 Tests\SolidWorks\Drawings\Test 2 Drawing

Figure 7.24. Details of the TxDOT W8×18 – 16-ft × 10-ft Large Sign Support Test Installation.



Figure 7.25. TxDOT W8×18 – 16-ft × 10-ft Large Sign Support before Test No. 463630-2.

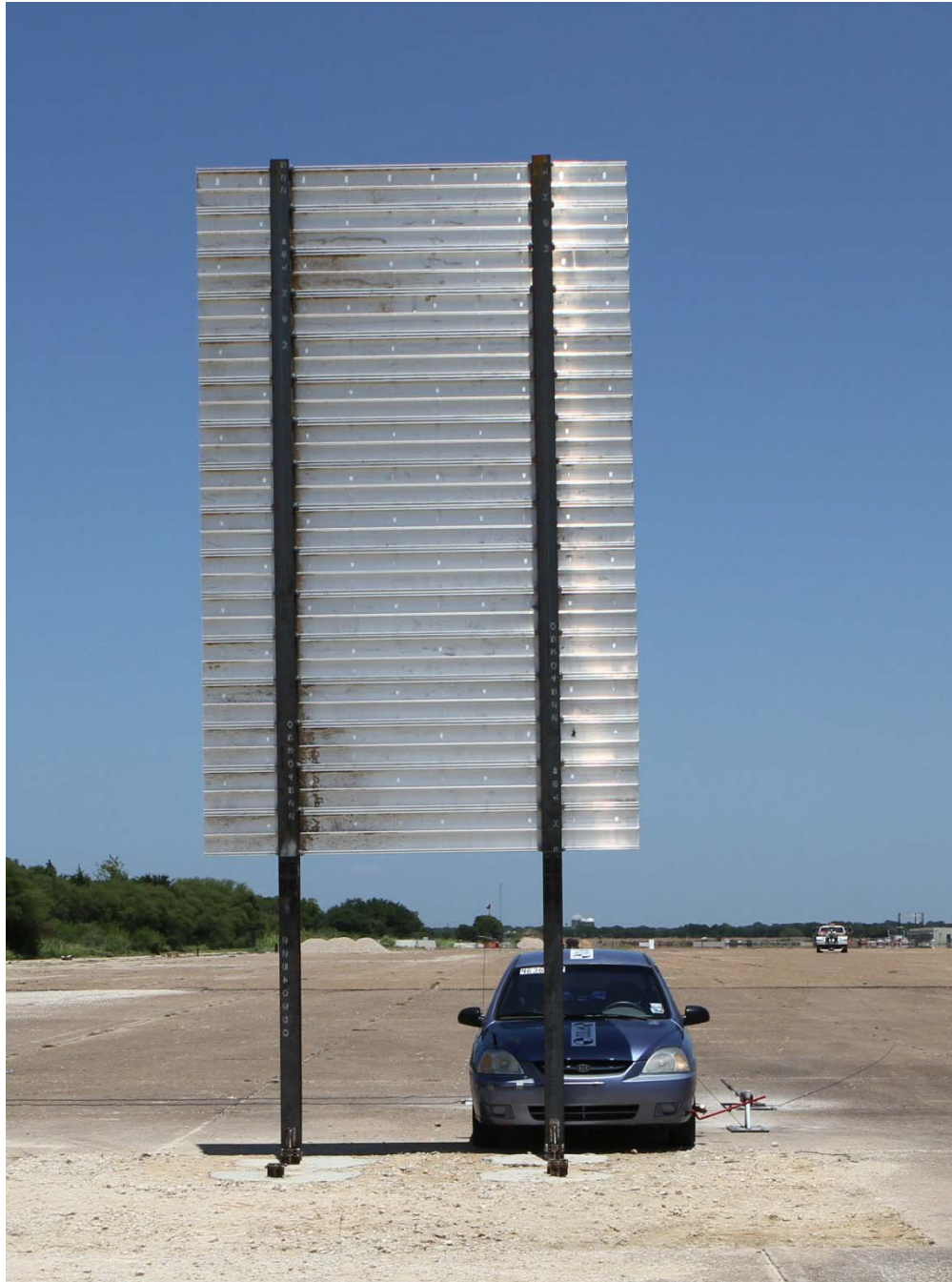


Figure 7.26. Vehicle/Installation Geometries for Test No. 463630-2.



Figure 7.27. Vehicle before Test No. 463630-2.

7.2.4.5 Test Description

The 1100C vehicle, traveling at an impact speed of 62.2 mi/h, impacted the left support leg of the large sign support at 0 degrees with the quarter point of the vehicle aligned with the centerline of the support leg. Shortly after impact, the left support leg began to move toward field side, and at 0.012 s, the left support post slipped away at the slipbase. The upper hinge connection began to activate at 0.026 s. At 0.054 s, the vehicle lost contact with the left support leg and was traveling at an exit speed of 61.5 mi/h. The right support leg began to deflect toward the field side at 0.079 s. At 0.203 s, the upper hinge connection on the left support leg completely activated, allowing the sign panel to rotate around the right support leg. The sign panel stopped rotating at 1.058 s and began to rebound. At 2.577 s, the left support leg came to rest on the ground surface. Brakes on the vehicle were applied at 1.03 s after impact and the vehicle subsequently came to rest 212 ft downstream of impact. Figure F2 in Appendix F shows sequential photographs of the test period.

7.2.4.6 Damage to Test Installation

Figures 7.28 and 7.29 show damage to the sign support. The slipbase and fuse plates (hinge connections) activated as designed. The right support leg remained standing but was leaning 10 degrees in the direction of where the left support leg originally was installed before the test. The left support leg was resting on the ground surface 15 ft toward the field side and 22.5 ft to the right of centerline of the vehicle path. The sign panel remained attached to the

right support, and there was minimal deformation of the slipbase plates. Several of the post clips pulled free of the extruded sign panels during the impact event.

7.2.4.7 Vehicle Damage

Figure 7.30 shows the damaged 1100C vehicle. The front bumper, hood, radiator, and radiator support were deformed, and the right headlight was broken. Maximum external crush to the vehicle in the front plane at the right front quarter point at bumper height was 10.0 inches. No occupant compartment deformation occurred. Figure 7.31 contains photographs of the interior of the vehicle. Tables F3 and F4 in Appendix F provide the exterior crush and occupant compartment measurements.

7.2.4.8 Occupant Risk Factors

Data from the accelerometer, located at the vehicle center of gravity, were digitized for evaluation of occupant risk. In the longitudinal direction, the occupant impact velocity was 4.6 ft/s at 0.443 s, the highest 0.010-s occupant ridedown acceleration was -1.0 Gs from 0.587 to 0.597 s, and the maximum 0.050-s average acceleration was -3.3 Gs between 0.002 and 0.052 s. In the lateral direction, the occupant impact velocity was 4.3 ft/s at 0.443 s, the highest 0.010-s occupant ridedown acceleration was 0.5 Gs from 0.444 to 0.454 s, and the maximum 0.050-s average was 0.7 Gs between 0.038 and 0.088 s. Theoretical Head Impact Velocity (THIV) was 7.2 km/h or 2.0 m/s at 0.452 s; Post-Impact Head Decelerations (PHD) was 1.0 Gs between 0.587 and 0.597 s; and Acceleration Severity Index (ASI) was 0.28 between 0.002 and 0.052 s. These data and other pertinent information from the test are summarized in Figure 7.32. Figures F3 through F9 in Appendix F present the vehicle angular displacements and accelerations versus time traces.



Figure 7.28. Installation/Vehicle Positions after Test No. 463630-2.

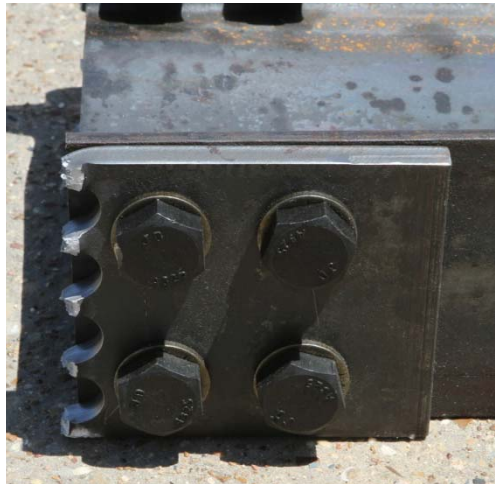


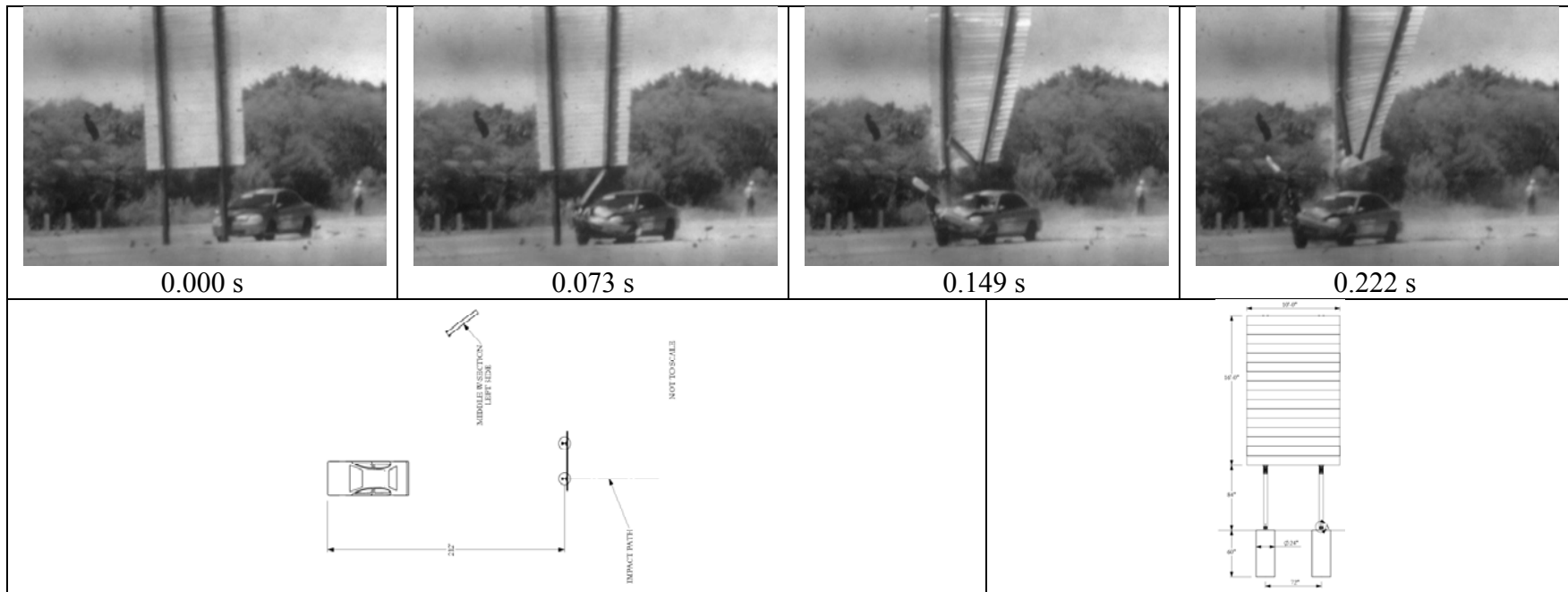
Figure 7.29. Installation after Test No. 463630-2.



Figure 7.30. Vehicle after Test No. 463630-2.



Figure 7.31. Interior of Vehicle for Test No. 463630-2.



General Information

Test Agency..... Texas Transportation Institute (TTI)
 Test Standard Test No. MASH Test 3-61
 TTI Test No. 463630-2
 Date 2010-07-30

Test Article

Type..... Sign Support
 Name TxDOT W8x18 – 16-ft x 10-ft Large Sign Support
 Installation Height 12 ft mounting height
 Material or Key Elements

Soil Type and Condition..... Concrete footing in crush limestone, Dry

Test Vehicle

Type/Designation..... 1100C
 Make and Model 2005 Kia Rio
 Curb 2403 lb
 Test Inertial 2431 lb
 Dummy 175 lb
 Gross Static 2606 lb

Impact Conditions

Speed62.2 mi/h
 Angle.....0 degrees
 Location/Orientation.....

Exit Conditions

Speed61.5 mi/h
 Angle.....0 degrees

Occupant Risk Values

Impact Velocity
 Longitudinal4.6 ft/s
 Lateral4.3 ft/s
 Ridedown Accelerations
 Longitudinal-1.0 G
 Lateral 0.5 G
 THIV7.2 km/h
 PHD1.0 G
 ASI0.28
 Max. 0.050-s Average
 Longitudinal-5.4 G
 Lateral-2.1 G
 Vertical 4.8 G

Post-Impact Trajectory

Stopping Distance 212 ft dwnstrm

Vehicle Stability

Maximum Yaw Angle..... 5 degrees
 Maximum Pitch Angle.....-2 degrees
 Maximum Roll Angle-5 degrees
 Vehicle Snagging No
 Vehicle Pocketing..... No

Test Article Deflections

Dynamic
 Permanent.....
 Working Width.....

Vehicle Damage

VDS 12RF3
 CDC..... 12FREW3
 Max. Exterior Deformation 10.0 inches
 OCDI RF0000000
 Max. Occupant Compartment
 Deformation 0

Figure 7.32. Summary of Results for MASH Test 3-61 on the TxDOT W8×18 – 16-ft × 10-ft Large Sign Support.

7.2.4.9 Assessment of Test Results

An assessment of the test based on the applicable *MASH* safety evaluation criteria is provided below.

Structural Adequacy

- B. *The test article should readily activate in a predictable manner by breaking away, fracturing, or yielding.*

Results: When impacted by the 1100C vehicle, the W8×18 16-ft × 10-ft large sign support activated by breaking away at the slipbase and at the upper hinge connections. (PASS)

Occupant Risk

- D. *Detached elements, fragments, or other debris from the test article should not penetrate or show potential for penetrating the occupant compartment, or present an undue hazard to other traffic, pedestrians, or personnel in a work zone.*

Deformation of, or intrusions into, the occupant compartment should not exceed limits set forth in Section 5.3 and Appendix E of MASH. (roof ≤4.0 inches; windshield = ≤3.0 inches; side windows = no shattering by test article structural member; wheel/foot well/toe pan ≤9.0 inches; forward of A-pillar ≤12.0 inches; front side door area above seat ≤9.0 inches); front side door below seat ≤12.0 inches; floor pan/transmission tunnel area ≤12.0 inches).

Results: The left support leg separated from the installation. However, the 1100C vehicle traveled beneath these elements, which came to rest near impact. The elements did not penetrate or show potential for penetrating the occupant compartment, nor to present hazard to others in the area. (PASS)

No occupant compartment deformation occurred during the test with the 1100C vehicle. (PASS)

- F. *The vehicle should remain upright during and after collision. The maximum roll and pitch angles are not to exceed 75 degrees.*

Results: The 1100C vehicle remained upright during and after the collision event. Maximum roll and pitch angles were –5 degrees and –2 degrees. (PASS)

- I. *Occupant impact velocities should satisfy the following:*

Longitudinal and Lateral Occupant Impact Velocity

Preferred
10 ft/s

Maximum
16.4 ft/s

Results: Longitudinal impact velocity was 4.6 ft/s, and lateral occupant impact velocity was 1.3 ft/s. (PASS)

I. *Occupant ridedown accelerations should satisfy the following:*

Longitudinal and Lateral Occupant Ridedown Accelerations

Preferred

15.0 Gs

Maximum

20.49 Gs

Results: Longitudinal ridedown acceleration was -1.0 G, and lateral ridedown acceleration was 0.5 G. (PASS)

Vehicle Trajectory

N. *Vehicle trajectory behind the test article is acceptable.*

Result: The 1100C vehicle came to rest 212 ft behind the sign support installation. (PASS)

7.3 SUMMARY OF TEST RESULTS

7.3.1 MASH Test 3-61 on the TxDOT Large Sign Support (W6×9 – 4-ft × 10-ft)

When impacted by the 1100C vehicle, the W6×9 4-ft × 10-ft large sign support activated by breaking away at the slipbase and at the upper hinge connections. The left support leg and sign panel separated from the installation. However, the 1100C vehicle traveled beneath these elements, which came to rest near impact. The elements did not penetrate or show potential for penetrating the occupant compartment, nor present hazard to others in the area. No occupant compartment deformation occurred during the test with the 1100C vehicle. The 1100C vehicle remained upright during and after the collision event. Maximum roll and pitch angles were -1 degree for both. Occupant risk factors were within limits specified in *MASH*. The 1100C vehicle came to rest 525 ft toward the field side of the sign support.

7.3.2 MASH Test 3-61 on the TxDOT Large Sign Support (W8×18 – 16-ft × 10-ft)

When impacted by the 1100C vehicle, the W8×18 – 16-ft × 10-ft large sign support activated by breaking away at the slipbase and at the upper hinge connections. The left support leg separated from the installation. However, the 1100C vehicle traveled beneath this element, which came to rest near impact. The elements did not penetrate or show potential for penetrating the occupant compartment, nor to present hazard to others in the area. No occupant compartment deformation occurred during the test with the 1100C vehicle. The 1100C vehicle remained upright during and after the collision event. Maximum roll and pitch angles were -5 degrees and -2 degrees. Occupant risk factors were within the limits specified in *MASH*. The 1100C vehicle came to rest 212 ft behind the sign support installation.

7.4 CONCLUSIONS

Both installations with new optimized fuse plate connections meet all evaluation criteria defined in MASH and are therefore considered crashworthy. However, TxDOT determined that the cost of adding the torsional stiffener would most likely outweigh the cost benefits of using the optimized fuse plate. Problems associated with a transitioning from the current fuse plate standard to the new optimized fuse plate standard further complicated the issue. For this reason, TxDOT decided to update the wind load charts for the current configuration instead of the optimized fuse plate configuration.

Table 7.6. Performance Evaluation Summary for MASH Test 3-61 on the TxDOT W6×9 – 4-ft x 10-ft Large Sign Support.

Test Agency: Texas Transportation Institute

Test No.: 463630-1

Test Date: 2010-07-30

| MASH Test 3-61 Evaluation Criteria | Test Results | Assessment |
|---|--|-------------------|
| <p>Structural Adequacy</p> <p><i>B. The test article should readily activate in a predictable manner by breaking away, fracturing, or yielding.</i></p> | <p>When impacted by the 1100C vehicle, the W6×9 4 ft × 10-ft large sign support activated by breaking away at the slipbase and at the upper hinge connections.</p> | <p>Pass</p> |
| <p>Occupant Risk</p> <p><i>D. Detached elements, fragments, or other debris from the test article should not penetrate or show potential for penetrating the occupant compartment, or present an undue hazard to other traffic, pedestrians, or personnel in a work zone.</i></p> | <p>The left support leg and sign panel separated from the installation. However, the 1100C vehicle traveled beneath these elements, which came to rest near impact. The elements did not penetrate or show potential for penetrating the occupant compartment, nor present hazard to others in the area.</p> | <p>Pass</p> |
| <p><i>Deformations of, or intrusions into, the occupant compartment should not exceed limits set forth in Section 5.3 and Appendix E of MASH.</i></p> | <p>No occupant compartment deformation occurred during the test with the 1100C vehicle.</p> | <p>Pass</p> |
| <p><i>F. The vehicle should remain upright during and after collision. The maximum roll and pitch angles are not to exceed 75 degrees.</i></p> | <p>The 1100C vehicle remained upright during and after the collision event. Maximum roll and pitch angles were –1 degree for both.</p> | <p>Pass</p> |
| <p><i>H. Longitudinal and lateral occupant impact velocities should fall below the preferred value of 10 ft/s, or at least below the maximum allowable value of 16.4 ft/s.</i></p> | <p>Longitudinal occupant impact velocity was 2.3 ft/s, and lateral occupant compartment impact velocity was 1.0 ft/s.</p> | <p>Pass</p> |
| <p><i>I. Longitudinal and lateral occupant ridedown accelerations should fall below the preferred value of 15.0 Gs, or at least below the maximum allowable value of 20.49 Gs.</i></p> | <p>Longitudinal ridedown acceleration was –0.3 G, and lateral ridedown acceleration was –0.3 G.</p> | <p>Pass</p> |
| <p>Vehicle Trajectory</p> <p><i>N. Vehicle trajectory behind the test article is acceptable.</i></p> | <p>The 1100C vehicle came to rest 525 ft toward the field side of the sign support</p> | <p>Pass</p> |

Table 7.7. Performance Evaluation Summary for MASH Test 3-61 on the TxDOT W8×18 – 16-ft × 10-ft Large Sign Support.

Test Agency: Texas Transportation Institute

Test No.: 463630-2

Test Date: 2010-07-30

| MASH Test 3-61 Evaluation Criteria | Test Results | Assessment |
|---|---|-------------------|
| <p>Structural Adequacy</p> <p><i>B. The test article should readily activate in a predictable manner by breaking away, fracturing, or yielding.</i></p> | <p>When impacted by the 1100C vehicle, the W8×18 – 16-ft × 10-ft large sign support activated by breaking away at the slipbase and at the upper hinge connections.</p> | <p>Pass</p> |
| <p>Occupant Risk</p> <p><i>D. Detached elements, fragments, or other debris from the test article should not penetrate or show potential for penetrating the occupant compartment, or present an undue hazard to other traffic, pedestrians, or personnel in a work zone.</i></p> | <p>The left support leg separated from the installation. However, the 1100C vehicle traveled beneath these elements, which came to rest near impact. The elements did not penetrate or show potential for penetrating the occupant compartment, nor present hazard to others in the area.</p> | <p>Pass</p> |
| <p><i>Deformations of, or intrusions into, the occupant compartment should not exceed limits set forth in Section 5.3 and Appendix E of MASH.</i></p> | <p>No occupant compartment deformation occurred during the test with the 1100C vehicle.</p> | <p>Pass</p> |
| <p><i>F. The vehicle should remain upright during and after collision. The maximum roll and pitch angles are not to exceed 75 degrees.</i></p> | <p>The 1100C vehicle remained upright during and after the collision event. Maximum roll and pitch angles were –5 degrees and –2 degrees.</p> | <p>Pass</p> |
| <p><i>H. Longitudinal and lateral occupant impact velocities should fall below the preferred value of 10 ft/s, or at least below the maximum allowable value of 16.4 ft/s.</i></p> | <p>Longitudinal impact velocity was 4.6 ft/s, and lateral occupant impact velocity was 1.3 ft/s.</p> | <p>Pass</p> |
| <p><i>I. Longitudinal and lateral occupant ridedown accelerations should fall below the preferred value of 15.0 Gs, or at least below the maximum allowable value of 20.49 Gs.</i></p> | <p>Longitudinal ridedown acceleration was –1.0 G, and lateral ridedown acceleration was 0.5 G.</p> | <p>Pass</p> |
| <p>Vehicle Trajectory</p> <p><i>N. Vehicle trajectory behind the test article is acceptable.</i></p> | <p>The 1100C vehicle came to rest 212 ft behind the sign support installation.</p> | <p>Pass</p> |

CHAPTER 8. DEVELOPMENT OF UPDATED LARGE GUIDE SIGN WIND LOAD CHARTS

After review the new optimized fuse plate connection designs, TxDOT determined that the cost savings of placing larger signs on smaller supports did not equate to enough savings to compensate for the cost of the torsional stiffeners. Subsequently, TxDOT has decided to proceed with updating support selection charts for current fuse plate designs.

TxDOT has decided to proceed with generating the wind load charts according to the legacy method of calculating wind pressures. This is to remain consistent with other wind load dependent structures in TxDOT's inventory. If the charts were generated according to the current wind pressure method, this task would require the addition of a second Texas wind load chart, which would only be used for large guide signs. Figure 8.1 shows all other designs would require the use of the legacy wind chart. This would lead to confusion in the design process and may lead to either over- or under-designed structures. The chart breaks Texas into three basic wind zones: Zone 1 (90 mph), Zone 2 (80 mph), and Zone 3 (70 mph).

Again, Figure 8.1 describes the loading in a wind load condition. The process of determining the maximum sign area for each sign support was automated to give results for all support configurations and mounting heights. The results of this process provide for efficient use of each section; however, this process requires the use of 30 selection charts; one chart for each post section, and a chart for each post section for each wind load condition. Currently, TxDOT utilizes three charts to cover all of the sections and all three wind zones.

Figure 8.2 includes the raw results of the wind load analysis for W6×9 and W12×26 support assemblies. Each of the lines represents a different mounting height of the sign panel. Generally, as the mounting height of the sign panel increases, the capacity of the support structure decreases. There is one exception to this rule. If the fuse plate is controlling the capacity of the support assembly, the change in mounting height would not affect the capacity. These two sections were chosen because they represent the two extremes of the effects of changing the mounting heights of the signs. With the W6×9, the fuse capacity generally is greater than the capacity of the post; therefore, the capacity decreases with each increase in mounting height. The W12×26 represents the other extreme, where the fuse plate controls the capacity of the support assembly in almost all situations. For this reason, the support capacity of the W12×26 is generally unaffected by an increase in sign mounting height.

The following supports are generally similar to the W6×9: S3×5.7, S4×7.7, W6×9, W6×12, W6×15, W8×18, and W8×21. Therefore, these sections will be grouped together on a single chart. The following supports are generally similar to the W12×26: W10×22, W10×26, and W12×26. These sections will now be grouped together on a single chart. From previous analysis results, it was determined that the W6×12 and W10×26 are inefficient sections when the fuse plate connection controls the capacity of the sections, and therefore are removed from all future selection charts.

DISCLAIMER: The use of this document is governed by the Texas Department of Transportation. The user assumes all liability for the accuracy of any information contained herein. The user shall indemnify and hold the Department of Transportation harmless from any and all claims, damages, and expenses, including reasonable attorneys' fees, arising from the use of this document.

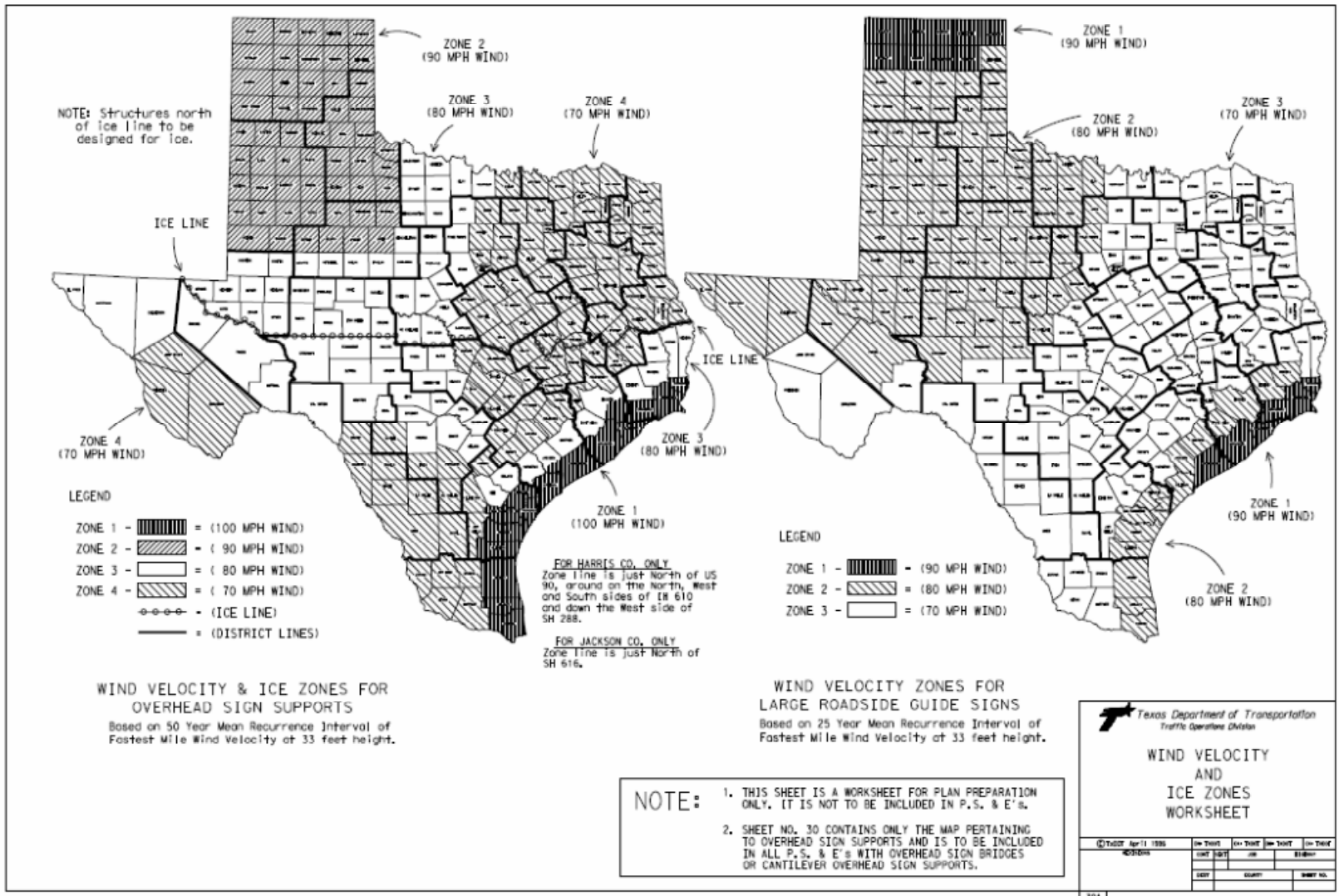


Figure 8.1. TxDOT Wind Zone Chart for Large Guide Signs (Legacy Method).

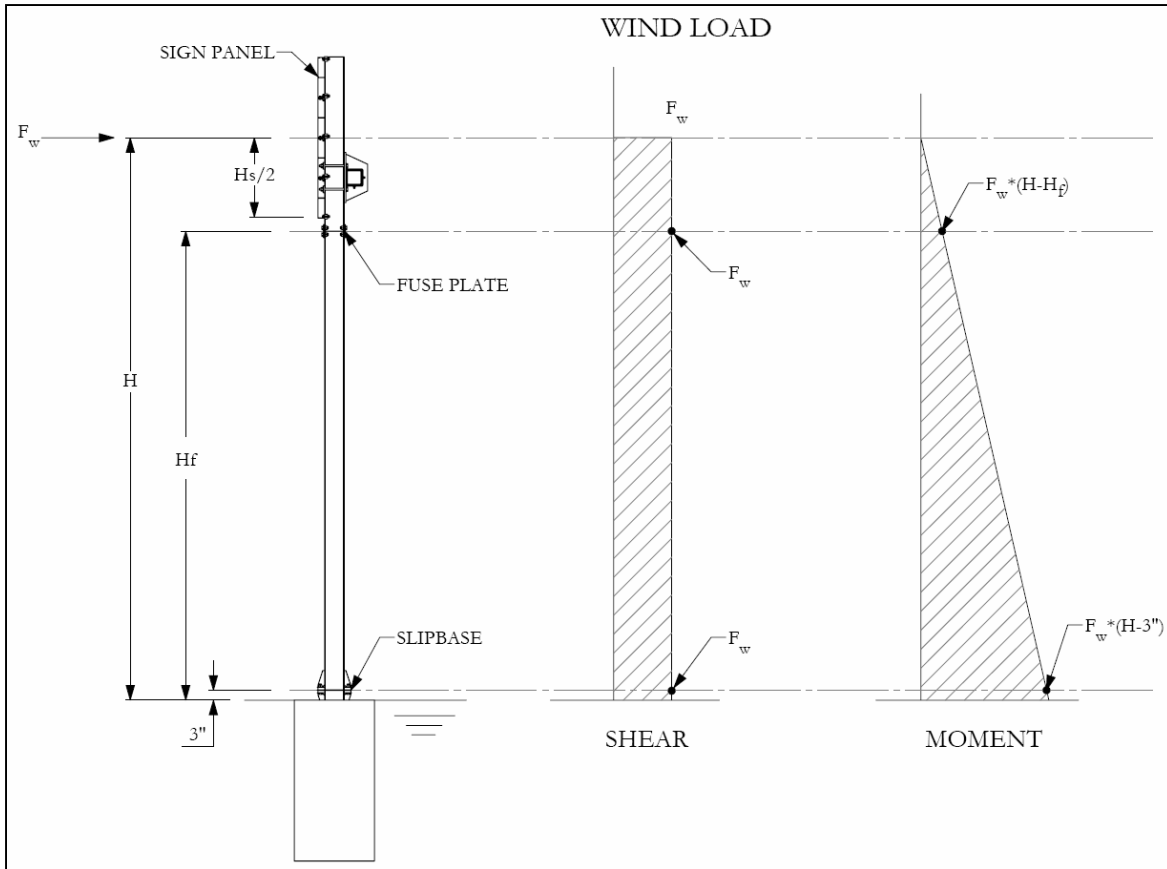


Figure 8.2. Wind Load Condition.

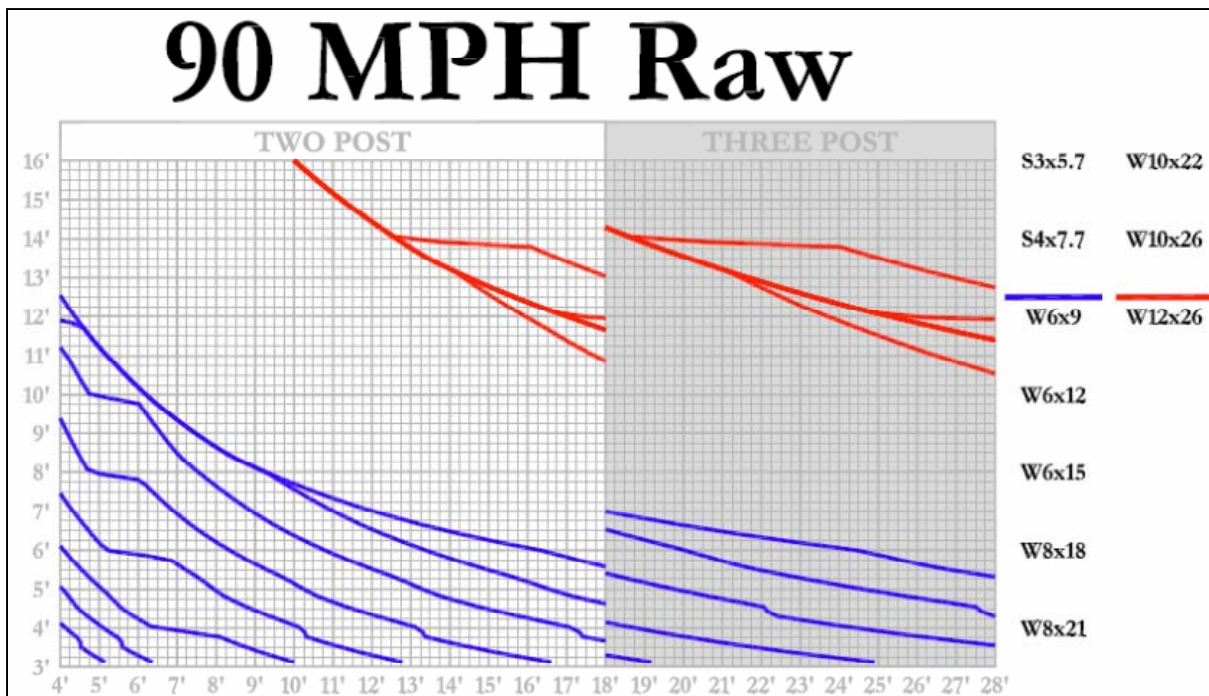


Figure 8.3. 90 mph Raw Support Selection Chart.

To simplify the chart design, the geometry of the capacities of the sections was modified to a simple arc. This arc was best suited to the raw data from the wind load analysis. The vertical height of the axis was then adjusted to account for different mounting heights. This resulted in a simplified selection chart. The final series of charts included two charts for each wind zone. A total of three wind zones were simulated. This brings the total number of charts to six, which is twice the number of current support selection charts that TxDOT currently utilized. Figures 8.4 through 8.9 show the final updated wind charts for the current fuse plate designs, according to the legacy method of determining wind pressures. Appendices G1 and G2 have representative proof calculations.

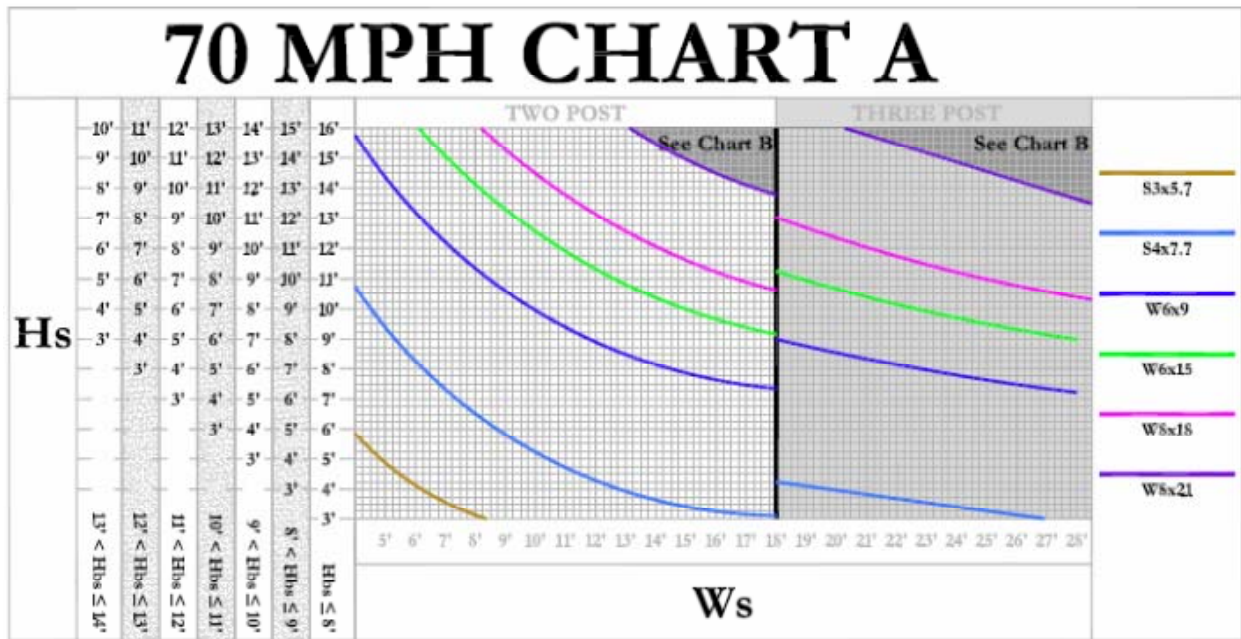


Figure 8.4. Updated Zone 3 Chart A Support Selection Chart (Current Method).

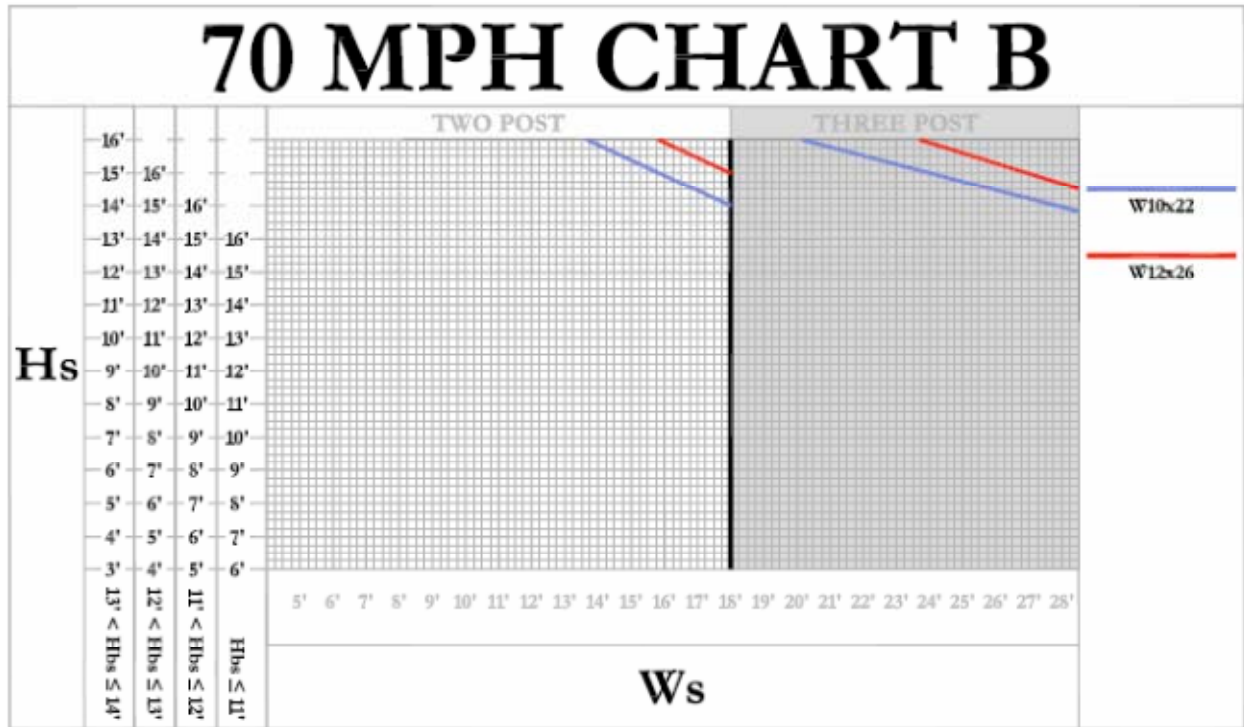


Figure 8.5. Updated Zone 3 Chart B Support Selection Chart (Current Method).

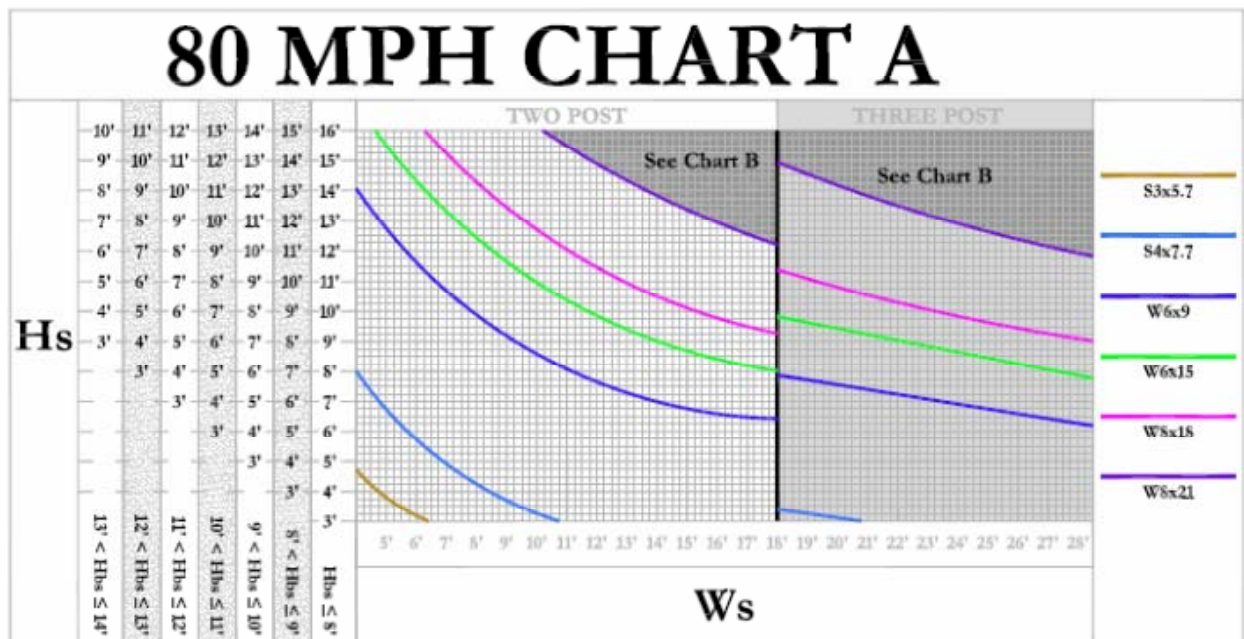


Figure 8.6. Updated Zone 2 Chart A Support Selection Chart (Current Method).

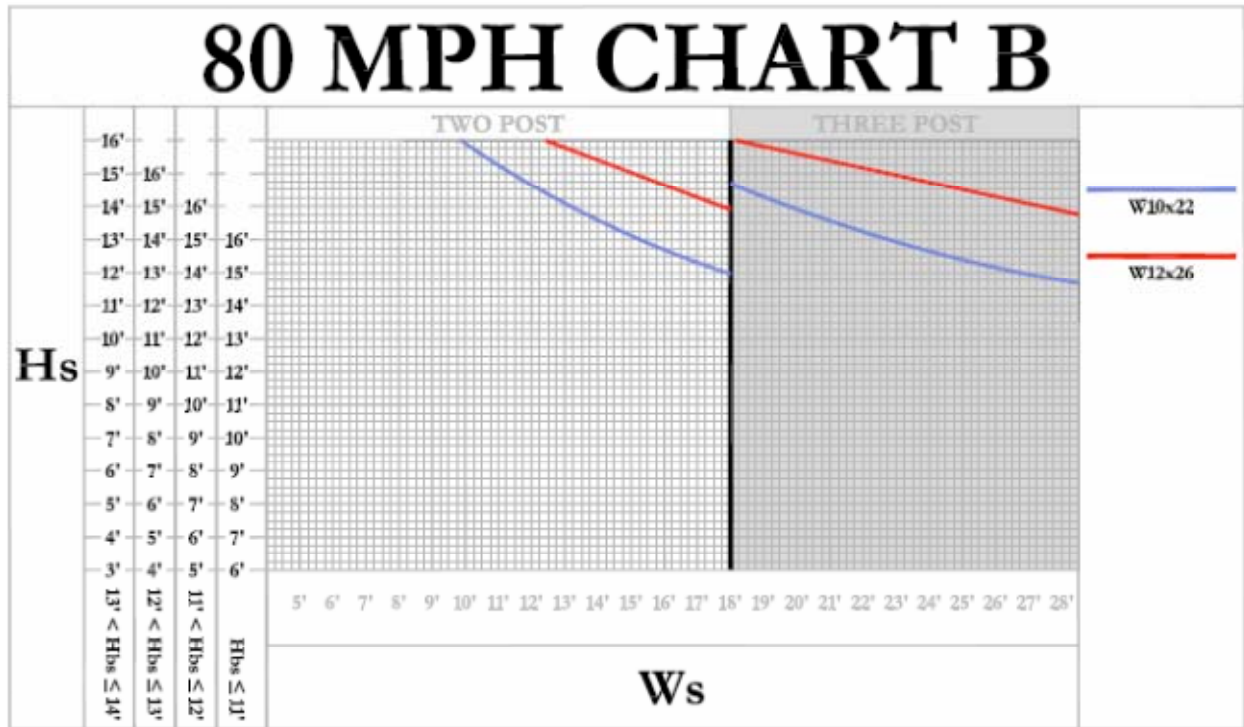


Figure 8.7. Updated Zone 2 Chart B Support Selection Chart (Current Method).

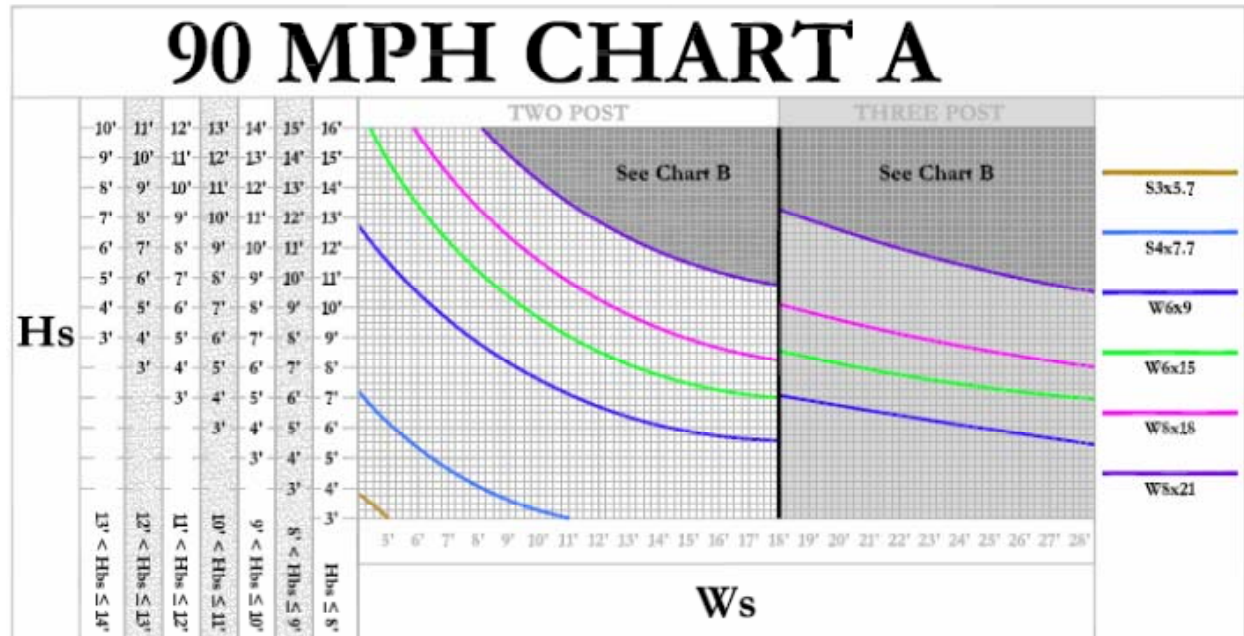


Figure 8.8. Updated Zone 1 Chart A Support Selection Chart (Current Method).

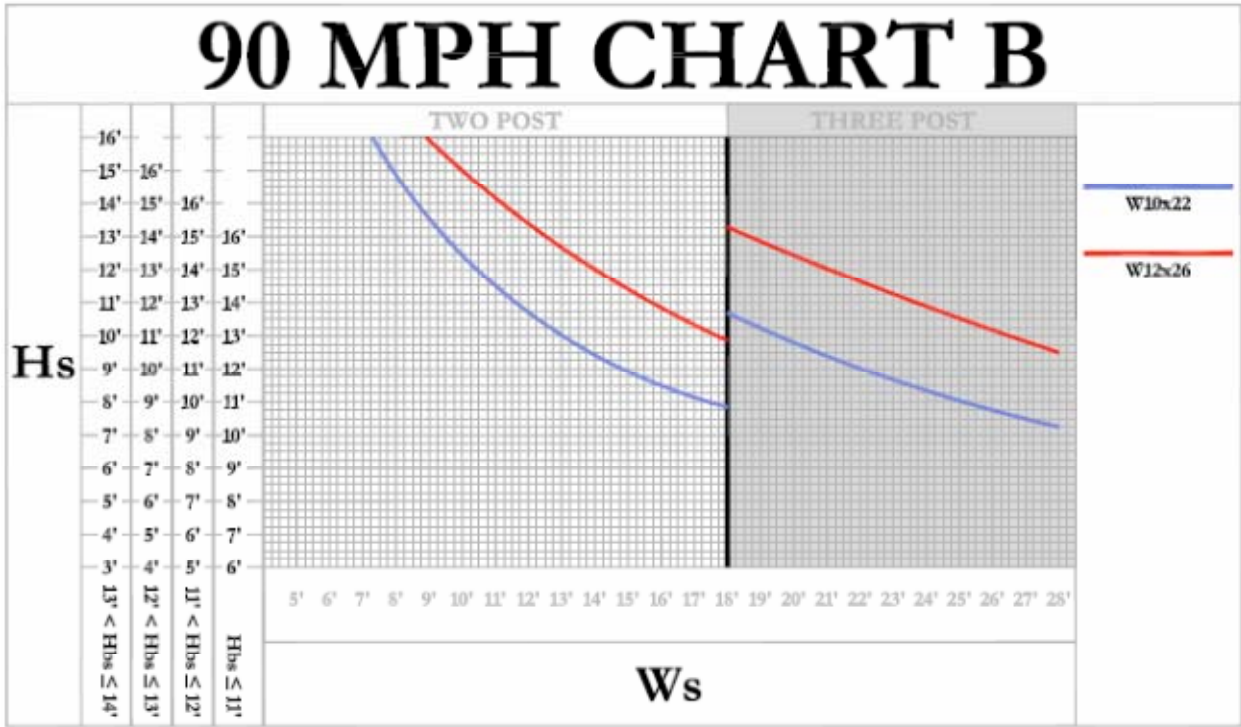


Figure 8.9. Updated Zone 1 Chart B Support Selection Chart (Current Method).

CHAPTER 9. DEVELOP GUIDANCE FOR MINIMUM SIGN AREA FOR SLIPBASE SUPPORTS

9.1 INTRODUCTION

The most commonly used sign support system in Texas is the triangular slipbase, a multidirectional breakaway design that uses three bolts tightened to a prescribed torque to clamp two opposing fixtures together to form a moment-carrying splice connection. One plate is attached to a rigid foundation and the other is attached to the bottom of the sign support. When the impact force applied by a vehicle exceeds the frictional clamping force, the upper plate “slips” relative to the lower plate and the support structure is “released” from its foundation. In an ideal situation, the released sign support system rotates over the impacting vehicle without striking the vehicle. However, in some tests, the support system will rotate too quickly, causing it to impact the roof of the vehicle, resulting in occupant compartment deformation.

The current Texas slipbase system utilizes two different 2.875-inch outside diameter support posts: 1) the 10 BWG steel tube that has a nominal wall thickness of 0.134 inches and a 55,000 psi minimum yield strength; and 2) the schedule 80 pipe that has a nominal wall thickness of 0.276 inches and a 46,000 psi minimum yield strength.

TxDOT standards (SMD (SLIP-2)-08) accept the use of 10 BWG posts for sign areas up to 16 ft², and schedule 80 pipe supports for larger sign areas up to 32 ft² (5). Sign mounting standards current do not specify a minimum sign area for use with the slipbase system. Current Texas district practices include use of signs as small as 4-ft² mounted on schedule 80 supports. The motivation behind this practice was to reduce inventory costs associated with maintaining reserves of multiple supports sizes.

Existing sign support configurations mounted on a slipbase system have been widely tested in accordance with the requirements of *NCHRP Report 350*, which was published in 1993. Later that year, the Federal Highway Administration (FHWA) formally adopted the report as the national standard, for implementation in late 1998. In 1998, the American Association of State Highway and Transportation Officials (AASHTO) and FHWA agreed that most types of safety features installed along the National Highway System (NHS) must meet *NCHRP Report 350* safety-performance evaluation criteria.

An update to *NCHRP Report 350* was developed under NCHRP Project 22-14(02), “Improvement of Procedures for the Safety-Performance Evaluation of Roadside Features.” AASHTO published this document, the *Manual for Assessing Safety Hardware (MASH)*, which contains revised criteria for safety-performance evaluation of virtually all roadside safety features. For example, *MASH* recommends testing with heavier light truck vehicles to better represent the current fleet of vehicles in the pickup/van/sport-utility vehicle class. The large design test vehicle was changed from a ¾ ton pickup with a center of gravity (C.G.) height of approximately 27 inches to a ½ ton, four-door pickup with a minimum C.G. height of 28 inches.

Of primary concern when evaluating the impact performance of small sign supports is the potential for windshield penetration and occupant compartment intrusion resulting from secondary contact between the impact vehicle and the structural components of the sign support system. According to the *NCHRP Report 350*, the maximum allowable roof compartment deformation following an impact event was 5.9 inches. *MASH* selected a much lower limiting extent of deformation for the roof area since the headroom inside the vehicle is limited and impacts to the head are more likely to result in serious or fatal injuries. *MASH* allows for only 4 inches maximum roof compartment deformation based on the recommended guidelines that the Insurance Institute for Highway Safety (IIHS) had developed for evaluating structural performance of vehicles in offset frontal crash tests. With these criteria modifications, test results that were considered satisfactory according to *NCHRP Report 350* requirements might not be acceptable based on the new *MASH* criteria.

A TxDOT-sponsored research study on crash testing and evaluation of TxDOT burn ban signs (6) gives an example. Total sign areas employed for the burn ban project were 8 ft² and 11.5 ft². Crash testing performed under this project met the requirements of *NCHRP Report 350* and considered suitable for implementation of the practice of appending a burn ban sign to an existing slipbase sign support system. However, this testing resulted in significant roof crush when such configurations were impacted, such that the extent of the roof crush would not meet the new *MASH* criteria.

These test results also raised another type of concern that had not been investigated before. Appending a burn ban sign to an existing slipbase sign support at a height less than 7 ft lowered the center of mass (i.e., point of rotation) of the sign support system. Sign mounting height, and also size and weight of the sign and type of support post, significantly affect the impact performance of a slipbase sign support system. The burn ban project was a clear example of how reducing the size, weight, and mounting height of a sign panel would lower the center of mass and mass moment of inertia of the combined sign support system. With the released support system rotating about its center of mass, a lower point of rotation would cause secondary contact with the roof and/or windshield that would not occur with systems incorporating larger sign panels.

Thus, a new objective was raised to investigate and establish a minimum sign area to be mounted on a slipbase system. This would maintain a level of mass moment of inertia high enough to result in a rotational velocity of the support structure after slipbase activation. This rotational velocity would give the impacting vehicle more time to travel under the support before a secondary contact occurs and/or that would reduce the severity of the roof crush and improve safety. Signs below the limit would be mounted on more cost-effective support systems.

This portion of the project seeks to establish a minimum sign area to be mounted on a slipbase system to reduce severity of the roof crush and improve safety according to the new safety-performance evaluation guidelines included in *MASH*.

Computer simulation was used to help predict whether or not secondary contact between a support system and an impacting vehicle would occur, and the probable location of the contact. However, the only reliable way to determine the extent of windshield damage and roof

deformation resulting from such secondary contact is through full-scale crash testing. The proposed crash tests for this project were in accordance with Test Level 3 (TL-3) of *MASH*, which involves a 1100C vehicle (2420-lb passenger car) and the new 2270P vehicle (5000-lb four-door pickup) impacting the sign support at 62 mph with the center of the support aligned with the right quarter point of the impacting vehicle.

9.2 FINITE ELEMENT SIMULATION

9.2.1 Validation of Slipbase Model

In the first part of this task, finite element simulations were used to predict performance of small area signs mounted on a slipbase system after being hit by a small passenger car and a pickup truck.

Finite element simulations were initially run for evaluating and calibrating the behavior of a simplified model of a triangular slipbase system previously developed at TTI (7). Available crash test data was used for these simulations (6).

In a second phase, another set of simulations was run to replicate vehicle impacts against a single sign support mounted on a slipbase system. Sign areas varying from 10–16 ft² were considered for simulations of *MASH* TL-3 type impacts with small passenger car and pickup truck models. The scope of these sets of simulations was to predict the minimum sign area to be mounted on a slipbase system, which would reduce severity of the roof crush and improve safety according to the new safety-performance evaluation guidelines included in *MASH*.

9.2.2 Finite Element Model of the Slipbase

Figure 9.1 shows the upper triangular slipbase casting was explicitly modeled to properly account for the inertial properties of the sign support system. The casting was modeled using solid elements and a rigid material representation. Since the bottom triangular slip-plate remains fixed to the foundation without any significant movement, it was not explicitly modeled. The bolts of the triangular slipbase were also not modeled explicitly. Instead, three nonlinear springs were modeled (see Figure 9.1). One end of each spring was attached to the top slipbase casting, and the other end was attached to the rigid bottom plate. The force-deflection properties of the springs were calibrated using crash test results. The complexity of the slipbase model was greatly reduced using the abovementioned modeling techniques without significant loss of accuracy of results. This technique enabled multiple impact simulations to be conducted within the resources of the project.

Available crash test data was used for FE computer validation of the slipbase system. Three tests involving high-speed impact with a small passenger car and two tests involving high-speed impact with a pickup truck were replicated. The next sections explain the test article, FE model characteristics, and compare the tests/simulation results.

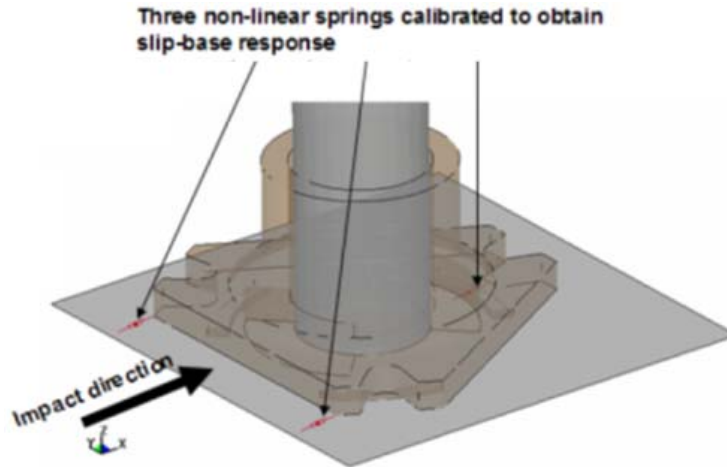


Figure 9.1. Finite Element Model of Slipbase Sign Support System.

9.2.3 Finite Element Models of the Vehicles Used for FE Simulations

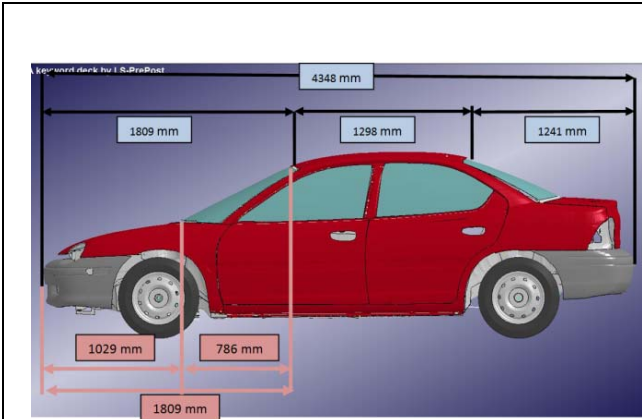
Figure 9.2 illustrates the finite element models of the small passenger car (Dodge Neon) and the pickup truck (Chevrolet Silverado) used in the computer simulations, and compares these with the actual vehicle models employed in the tests (Kia Rio, and Dodge Ram 1500 pickup, respectively).

9.2.4 Analysis with Small Passenger Car

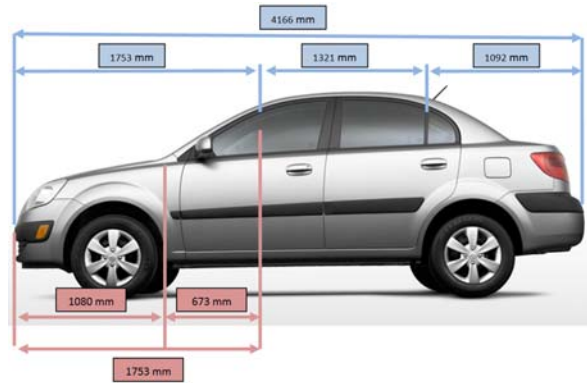
This section reports the results from simulations using the small passenger car, Dodge Neon. These results are compared against full-scale crash tests previously performed under project 452108, which aimed at evaluating the TxDOT practice of appending a burn ban sign to an existing slipbase sign support system according to safety evaluation criteria of *NCHRP Report 350 (6)*. The total sign areas varied between 8 ft² and 11.5 ft², and both schedule 80 and BWG 10 pipe supports were evaluated in different tests.

9.2.4.1 Simulation Burn Ban Test No. 452108-2

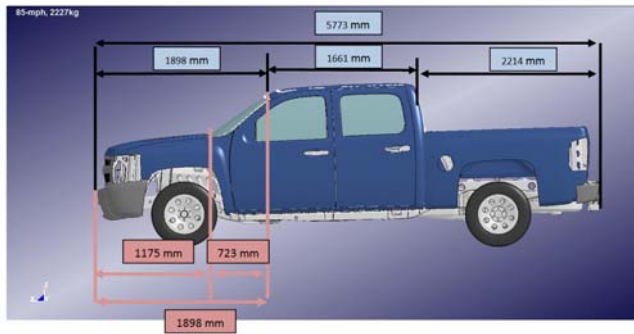
Figure 9.3 shows the finite element model of the sign support for the FE computer simulation aimed at replicating burn ban test no. 452108-2. The support post was a 2.875-inch O.D., 0.276-inch schedule 80 steel pipe, which was modeled using elastic material properties. A 24-inch × 24-inch × 0.080-inch thick aluminum sign panel was constrained to the schedule 80 support using nodal rigid body constraints at the location of connecting bolts. The mounting height to the bottom of the confirmation sign was 7 ft. A second 24-inch × 24-inch × 0.080-inch thick composite sign was constrained to the schedule 80 support in the same manner as the first sign.



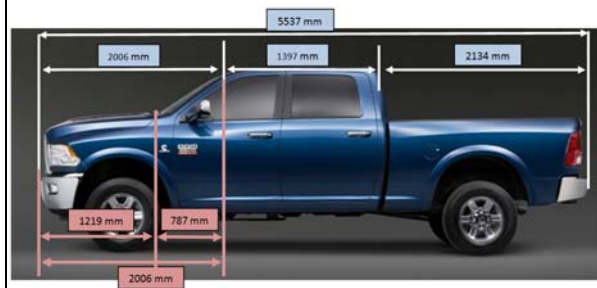
(a) Dodge Neon FE Model



(b) Kia Rio Model



(c) Chevrolet Silverado FE Model



(d) Dodge Ram 1500 Model

Figure 9.2. Vehicles Finite Element Models Employed in the Computer Simulations.

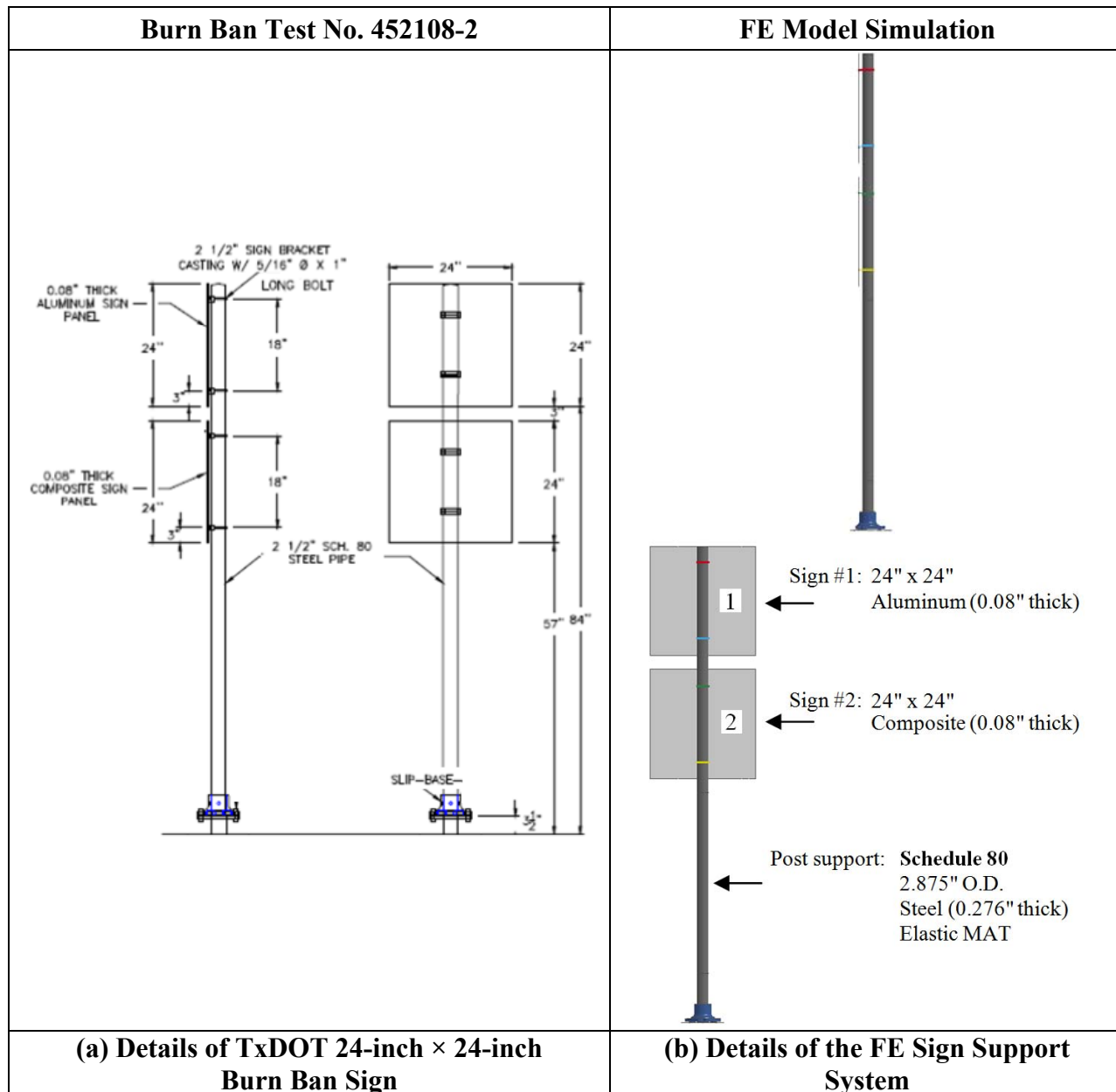


Figure 9.3. Comparison between Burn Ban Test No. 452108-2 and FE Model Sign Support Slipbase System Configurations.

Figure 9.4 shows the Dodge Neon vehicle model impacted the single sign support slipbase model at 62.6 mph and 0 degrees to match the actual crash test conditions. The impact location was 6 inches from the vehicle's centerline, on the driver's side. The properties of the slipbase were calibrated to match the pipe support kinematics after slipbase release and roof sign impact location.


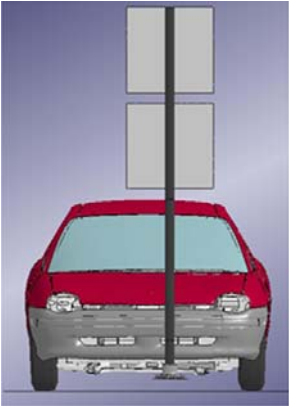
| Pre-Impact Frontal Configuration | | Impact Conditions |
|---|---|---|
|  |  | <ul style="list-style-type: none"> ➤ Impact Speed: 62.6 mph ➤ Impact Angle: 0 degrees ➤ Impact Location: 6 inches from vehicle's centerline, driver's side |
| (a) Burn Ban Test No. 452108-2 | (b) FE Model Simulation | |

Figure 9.4. Comparison between Burn Ban Test No. 452108-2 and FE Model Impact Conditions.

Figure 9.5 compares the results of the roof impact location and roof deformation to those of the crash test. A reasonable correlation was achieved between simulation and test results. The FE simulation predicted a roof crush of 8 inches, while the maximum roof deformation recorded in the test was 5.1 inches.

9.2.4.2 Simulation Burn Ban Test No. 452108-3

Figure 9.6 shows the finite element model of the sign support for the FE computer simulation aimed at replicating burn ban test no. 452108-3. The support post was a 2.875-inch O.D., 0.276-inch thick schedule 80 steel pipe, which was modeled using elastic material properties. A 24-inch × 24-inch × 0.080-inch thick aluminum sign panel was constrained to the schedule 80 support using nodal rigid body constraints at the location of connecting bolts. The mounting height to the bottom of the confirmation sign was 7 ft. A second 30-inch × 36-inch × 0.080-inch thick composite sign was constrained to the schedule 80 support in the same manner as the first sign.


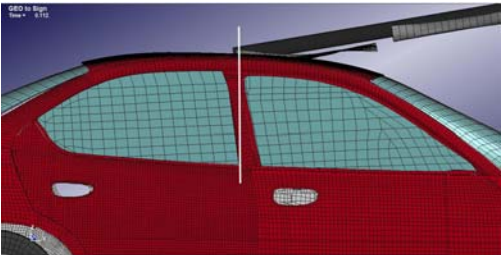


| Burn Ban Test No. 452108-2 | FE Model Simulation |
|---|--|
|  |  |
| (a) Test Roof Impact Location | (b) FE Model Roof Impact Location |
|  <p style="text-align: right;">Roof Crush: 5.1"</p> |  <p style="text-align: right;">Roof Crush: 8"</p> |
| (c) Post-impact Test Vehicle Damage | (d) Post-impact FE Model Damage |

Figure 9.5. Comparison between Burn Ban Test No. 452108-2 and FE Model Impact Results.

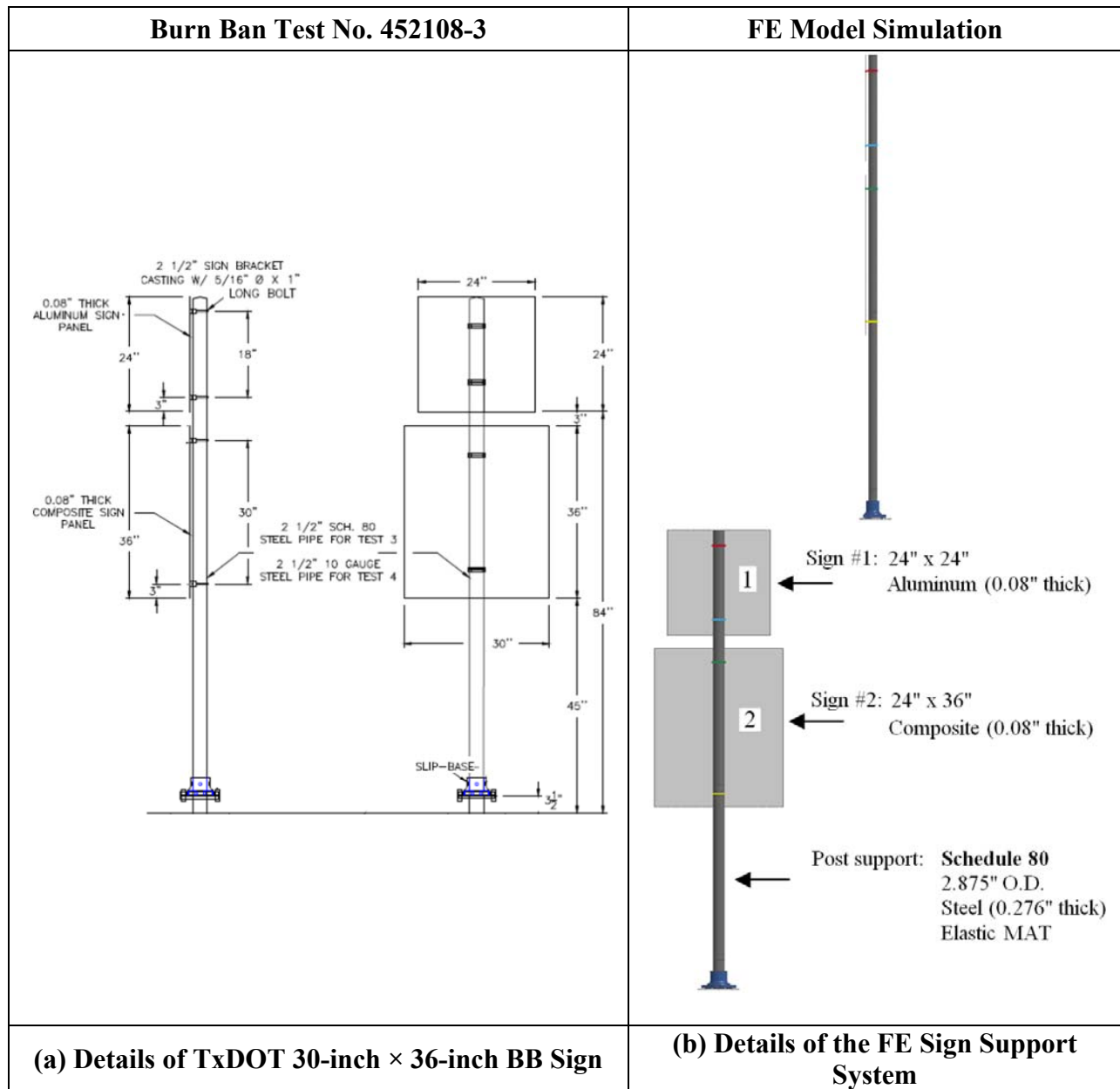


Figure 9.6. Comparison between Burn Ban Test No. 452108-3 and FE Model Sign Support Slipbase System Configurations.

Figure 9.7 shows the Dodge Neon vehicle impacted the single sign support slipbase model at 62.0 mph and 0 degrees to match the actual crash test conditions. The impact location was 6 inches from the vehicle's centerline, on the driver's side. The properties of the slipbase were calibrated to match the pipe support kinematics after slipbase release and roof sign impact location.


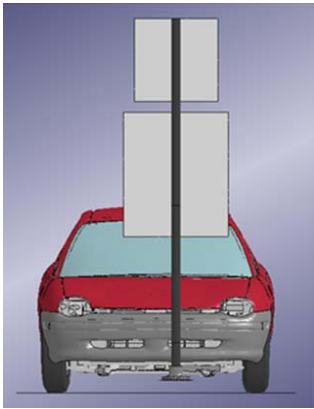
| Pre-Impact Frontal Configuration | | Impact Conditions |
|---|---|---|
|  |  | <ul style="list-style-type: none"> ➤ Impact Speed: 62.0 mph ➤ Impact Angle: 0 degrees ➤ Impact Location: 6 inches from vehicle's centerline, driver's side |
| (a) Burn Ban Test No. 452108-3 | (b) FE Model Simulation | |

Figure 9.7. Comparison between Burn Ban Test No. 452108-3 and FE Model Impact Conditions.

Figure 9.8 compares the results of the roof impact location and roof deformation to those of the crash test. A reasonable correlation was achieved between simulation and test results. FE simulation predicted the roof crush predicted to be 8.1 inches, while the maximum roof deformation recorded in the test was 5.6 inches.

9.2.4.3 Simulation Burn Ban Test No. 452108-4

Figure 9.9 shows the finite element model of the sign support for the FE computer simulation aimed at replicating burn ban test no. 452108-4. The support post was a 2.875-inch O.D., 0.134-inch thick BWG 10 steel pipe, which was modeled using elastic material properties. A 24-inch × 24-inch × 0.080-inch thick aluminum sign panel was constrained to the schedule 80 support using nodal rigid body constraints at the location of connecting bolts. The mounting height to the bottom of the confirmation sign was 7 ft. A second 30-inch × 36-inch × 0.080-inch thick composite sign was constrained to the schedule 80 support in the same manner as the first sign.


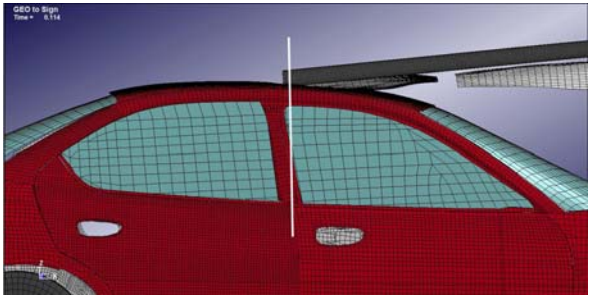

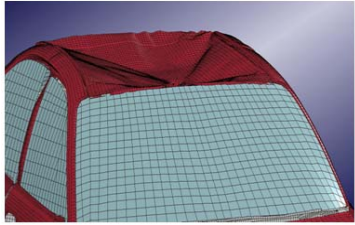
| Burn Ban Test No. 452108-3 | FE Model Simulation |
|---|--|
|  |  |
| (a) Test Roof Impact Location | (b) FE Model Roof Impact Location |
|  <p data-bbox="527 1241 730 1266">Roof Crush: 5.6"</p> |  <p data-bbox="1205 1241 1424 1266">Roof Crush: 8.1"</p> |
| (c) Post-impact Test Vehicle Damage | (d) Post-Impact FE Model Damage |

Figure 9.8. Comparison between Burn Ban Test No. 452108-3 and FE Model Impact Results.

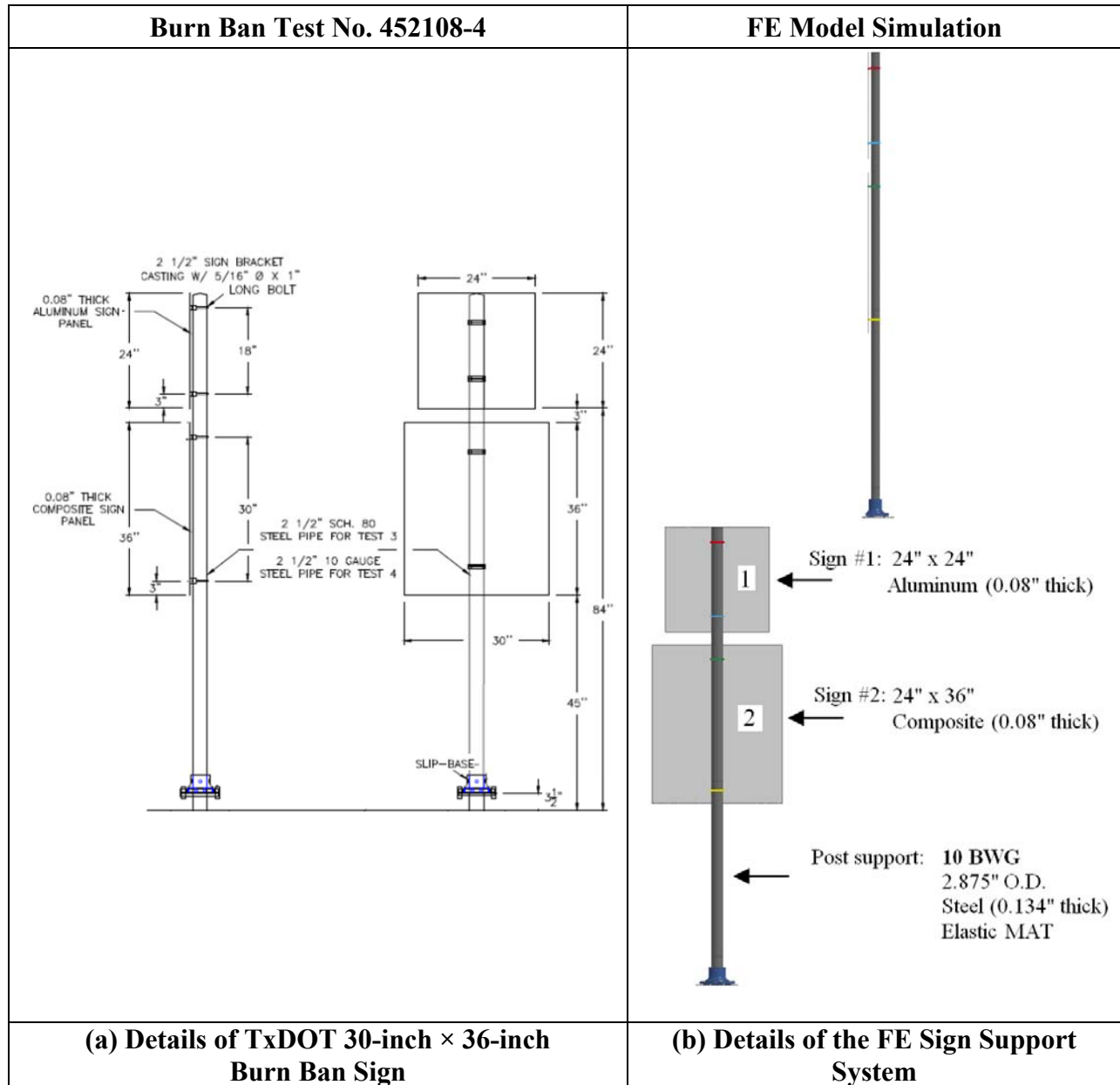


Figure 9.9. Comparison between Burn Ban Test No. 452108-4 and FE Model Sign Support Slipbase System Configurations.

Figure 9.10 shows the Dodge Neon vehicle model impacted the single sign support slipbase model at 62.1 mph and 0 degrees to match the actual crash test conditions. The impact location was 6 inches from the vehicle's centerline, on the driver's side. The properties of the slipbase were calibrated to match the pipe support kinematics after slipbase release and roof sign impact location.


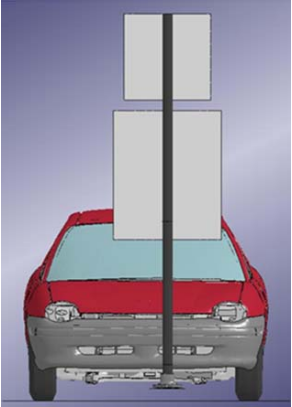
| Pre-Impact Frontal Configuration | | Impact Conditions |
|---|---|---|
|  |  | <ul style="list-style-type: none"> ➤ Impact Speed: 62.1 mph ➤ Impact Angle: 0 degrees ➤ Impact Location: 6 inches from vehicle's centerline, driver's side |
| (a) Burn Ban Test No. 452108-4 | (b) FE Model Simulation | |

Figure 9.10. Comparison between Burn Ban Test No. 452108-4 and FE Model Impact Conditions.

Figure 9.11 compares the results of the roof impact location and roof deformation to those of the crash test. A reasonable correlation was achieved between simulation and test results. FE simulation predicted the roof crush to be 7.6 inches, while the maximum roof deformation recorded in the test was 5.5 inches (windshield damage of the Geo Metro was not due to the impact event in the test, but occurred while the vehicle was transported from the test site).

9.2.5 Analysis with Pickup Truck

This section reports the results from simulations using the Chevrolet Silverado pickup truck that are then compared against full-scale crash tests previously performed under projects 405872 and 455266. Scope of project 405872 was to assess the performance of the North Texas Tollway Authority (NTTA) sign support with multiple sign panels according to the safety performance evaluation guidelines included in *MASH* (8). Scope of project 455266 was to examine the potential effects and impact of the update to *NCHRP Report 350* on current TxDOT triangular slipbase system when impacted by the new quad-cab pickup truck for use in *MASH* (9).




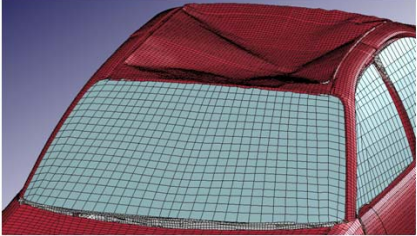
| Burn Ban Test No. 452108-4 | FE Model Simulation |
|---|--|
|  |  |
| (a) Test Roof Impact Location | (b) FE Model Roof Impact Location |
|  <p data-bbox="574 890 756 915">Roof Crush: 5.5"</p> |  <p data-bbox="1237 890 1419 915">Roof Crush: 7.6"</p> |
| (c) Post-impact Test Vehicle Damage | (d) Post-impact FE Model Damage |

Figure 9.11. Comparison between Burn Ban Test No. 452108-4 and FE Model Results.

9.2.5.1 Simulation NTTA Test No. 405872-1

Figure 9.12 shows the finite element model of the sign support for the FE computer simulation aimed at replicating NTTA test no. 405872-1. The support post was a 2.875-inch O.D., 0.134-inch 10 BWG steel pipe, which was modeled using elastic material properties. All sign panels were 0.10-inch aluminum sheet. A 36-inch × 36-inch × 0.1-inch thick aluminum sign panel was mounted at 7 ft to the bottom of the panel from ground level. A second panel measuring 36 inches wide × 24 inches high and was mounted at 8 ft to the bottom of the panel on the opposite side of the support. The third panel was 36 inches wide × 24 inches high and was mounted at 24 inches on the back side of the support. Signs were constrained to the pipe support using nodal rigid body constraints at the location of connecting bolts.

Figure 9.13 shows the Chevrolet Silverado vehicle model impacted the single sign support slipbase model at 64.2 mph and 0 degrees to match the actual crash test conditions. The centerline of the vehicle was aligned with the centerline of the sign support.

Figure 9.14 compares the results of the roof impact location and roof deformation to those of the crash test. A reasonable correlation was achieved between simulation and test results. The FE simulation predicted the roof crush predicted at 6.3 inches, while the maximum roof deformation recorded in the test was 6.5 inches.

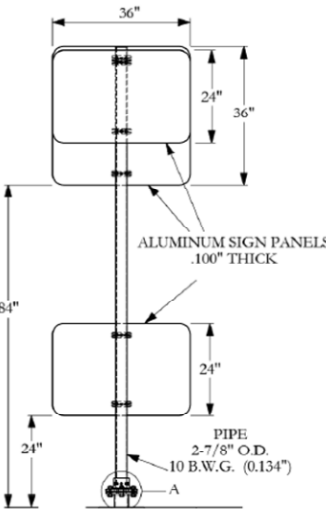
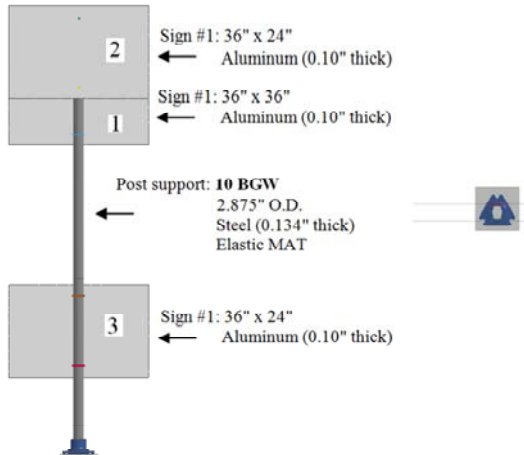
| NTTA Test No. 405872-1 | FE Model Simulation |
|---|--|
|  <p>Technical drawing of the NTTA test article. It shows a vertical post with two aluminum sign panels. The top panel is 36" wide and 24" high. The bottom panel is also 36" wide and 24" high. The total height of the sign assembly is 84". The post is a pipe with a 2-7/8" O.D. and 10 B.W.G. (0.134") thickness. A plan view shows the impact location at the center of the post, with two signs on either side. A detail 'A' shows the base of the post.</p> |  <p>FE Model Simulation diagram of the sign support system. It shows a vertical post with three sign panels. The top panel is 36" x 24" Aluminum (0.10" thick). The middle panel is 36" x 36" Aluminum (0.10" thick). The bottom panel is 36" x 24" Aluminum (0.10" thick). The post support is 10 BWG, 2.875" O.D., Steel (0.134" thick) with an Elastic MAT. A plan view shows the impact location at the center of the post, with two signs on either side.</p> |
| (a) Details of TxDOT NTTA Test Article | (b) Details of the FE Sign Support System |

Figure 9.12. Comparison between NTTA Test No. 405870-1 and FE Model Sign Support Slipbase System Configurations.



| Pre-Impact Frontal Configuration | Impact Conditions |
|--|--|
|  <p>Photograph of a grey pickup truck in a pre-impact configuration, positioned in front of a signpost.</p> |  <p>FE Model Simulation of a blue pickup truck in a pre-impact configuration, positioned in front of a signpost.</p> |
| (a) NTTA Test No. 405872-1 | (b) FE Model Simulation |

Figure 9.13. Comparison between NTTA Test No. 405870-1 and FE Model Impact Conditions.


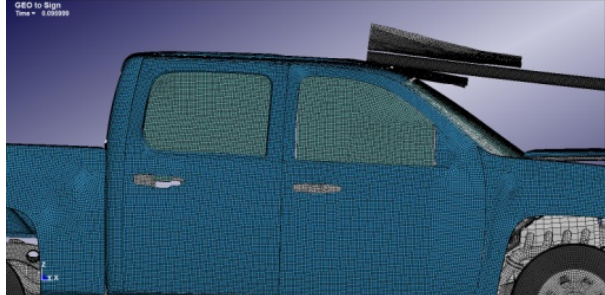


| NTTA Test No. 405872-1 | FE Model Simulation |
|---|--|
|  |  |
| (a) Test Roof Impact Location | (b) FE Model Roof Impact Location |
|  <p data-bbox="529 856 735 888">Roof Crush: 6.5"</p> |  <p data-bbox="1208 856 1414 888">Roof Crush: 6.3"</p> |
| (c) Post-impact Test Vehicle Damage | (d) Post-impact FE Model Damage |

Figure 9.14. Comparison between NTTA Test No. 405870-1 and FE Model Impact Results.

9.2.5.2 Simulation TxDOT Test No. 455266-2

Figure 9.15 shows the finite element model of the sign support for the FE computer simulation aimed at replicating TxDOT test no. 455266-2. The support post was a 2.875-inch O.D., 0.134-inch 10 BWG steel pipe, which was modeled using elastic material properties. A T-shaped bracket was attached to the vertical support to provide bracing for the sign panel. The T-bracket consisted of a 3.25-inch O.D. stub welded to a 2.375-inch O.D. horizontal steel tube. A 48-inch × 48-inch × 0.625-inch thick wooden sign panel was attached to the 2.375-inch O.D. horizontal member and 2.875-inch O.D. vertical support using constrained nodal rigid body. The mounting height to the bottom of the sign blank was 7 ft.

Figure 9.16 shows the Chevrolet Silverado vehicle model impacted the single sign support slipbase model at 63.7 mph and 0 degrees to match the actual crash test conditions. The impact location was 6 inches from the vehicle's centerline, on the passenger side.

Figure 9.17 compares the results of the roof impact location and roof deformation to those of the crash test. A reasonable correlation was achieved between simulation and test results. The FE simulation predicted the roof crush at 4.7 inches, while the maximum roof deformation recorded in the test was 3 inches.

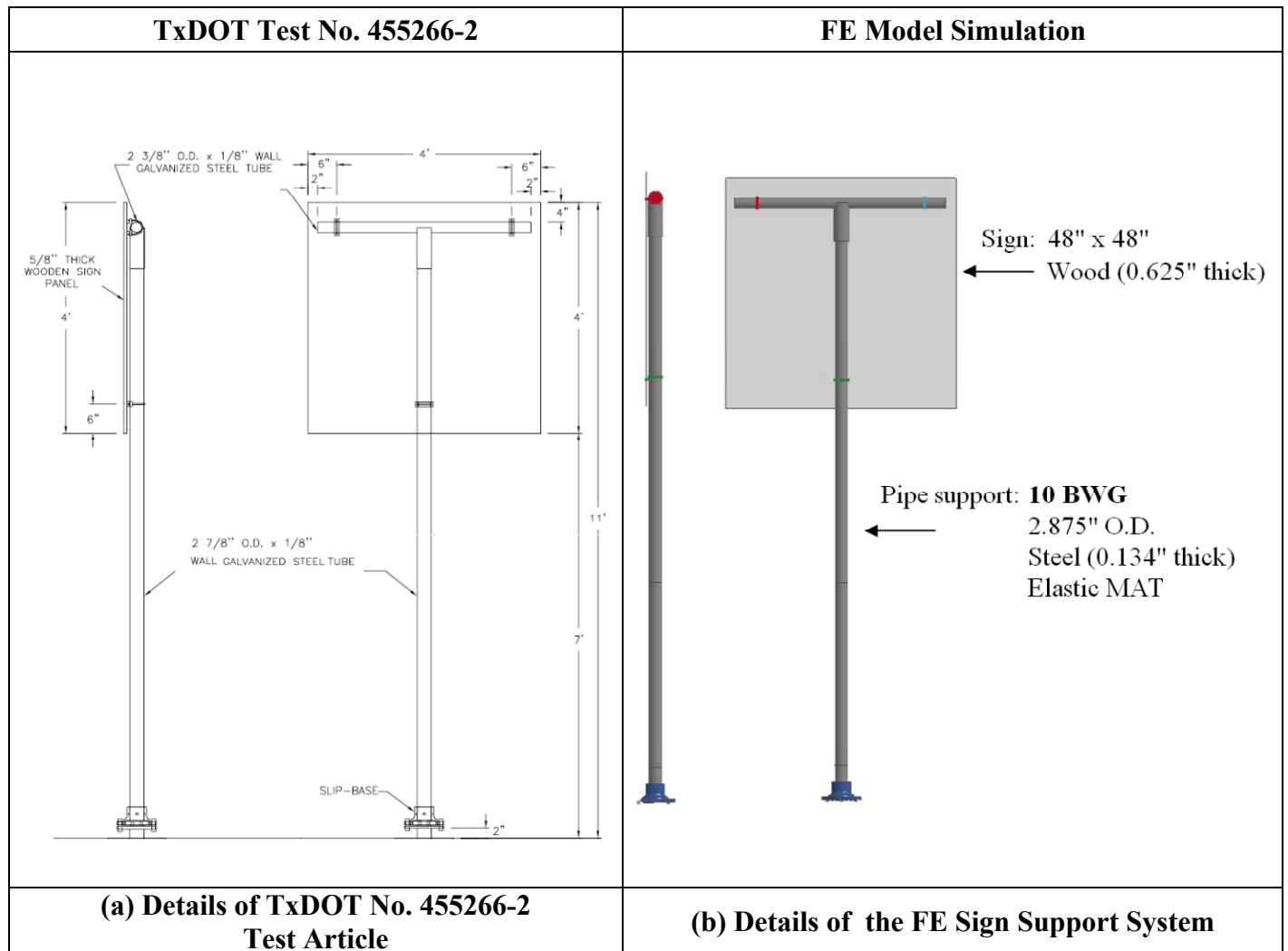


Figure 9.15. Comparison between TxDOT Test No. 455266-2 and FE Model Sign Support Slipbase System Configurations.



| Pre-Impact Frontal Configuration | | Impact Conditions |
|---|--|---|
|  |  | <ul style="list-style-type: none"> ➤ Impact Speed: 63.7 mph ➤ Impact Angle: 0 degrees ➤ Impact Location: 6 inches from vehicle's centerline passenger side |
| (a) TxDOT Test No. 455266-2 | (b) FE Model Simulation | |

Figure 9.16. Comparison between TxDOT Test No. 455266-2 and FE Model Impact Conditions.





| TxDOT Test No. 455266-2 | FE Model Simulation |
|--|---|
|  |  |
| (a) Test Roof Impact Location | (b) FE Model Roof Impact Location |
|  Roof Crush: 3" |  Roof Crush: 4.7" |
| (c) Post-impact Test Vehicle Damage | (d) Post-impact FE Model Damage |

Figure 9.17. Comparison between TxDOT Test No. 455266-2 and FE Model Impact Results.

9.2.6 Conclusions

Scope of this section was to modify slipbase release mechanical properties to closely match the roof sign impact location and crush on the vehicle observed in the tests. Table 9.1 compares the test and FE simulation results in terms of impact roof crush.

Table 9.1. Roof Crush Comparison between Tests and FE Simulations.

| Test No. and FE Simulation | | Pole Type | Roof Crush (inches) |
|--|-------------|-------------|---------------------|
| * Burn Ban No. 452108-2 | <u>Test</u> | Schedule 80 | <u>5.1</u> |
| | FE | | 8 |
| * Burn Ban No. 452108-3 | <u>Test</u> | Schedule 80 | <u>5.6</u> |
| | FE | | 8.1 |
| * Burn Ban No. 452108-4 | <u>Test</u> | 10 BWG | <u>5.5</u> |
| | FE | | 7.6 |
| ** NTTA No. 405870-1 | <u>Test</u> | 10 BWG | <u>6.5</u> |
| | FE | | 6.3 |
| ** TxDOT No. 455266-2 | <u>Test</u> | 10 BWG | <u>3</u> |
| | FE | | 4.7 |
| * Test and simulation performed with small passenger car model | | | |
| ** Test and simulation performed with quad pickup truck model | | | |
| Note: Underlined text is referred to test results | | | |

The FE simulations were able to fairly replicate sign impact location on roof after release of the slipbase. Results from Table 9.1 show that computer simulations, which included use of the small passenger car, overpredicted roof crush by an average difference of 2.5 inches when compared to the roof deformation recorded in the actual tests. In the cases with the quad pickup truck, one simulation had slightly underpredicted roof crush of 0.2 inch, while the second simulation resulted in an over-predicted roof deformation of 1.7 inches.

The difference in roof crush between the test data and the computer simulations can be mainly explained with a few considerations. The types of FE vehicles available for FE analysis are not exactly the ones used in the full-scale crash tests. Although their dimensions are similar and comparable, still some differences can be outlined (and were previously reported in Figure 9.2). Moreover, the FE vehicle models have not been validated previously for roof and windshield impacts. Element types, material models, and contact types for different FE vehicle compartments should be accurately investigated to ultimately validate these models against windshield and roof impacts. Investigation and validation of FE vehicle models is beyond the scope of this project, mainly because of limited funds.

After these considerations, the researchers decided to use the simplified FE slipbase system, understanding that the model generally over predicts occupant compartment deformation resulting from the second impact of a pipe support against vehicle's roof after slipbase release.

9.3 FINITE ELEMENT PREDICTION

9.3.1 FE Simulations

The next step of this research approach was to run predictive FE vehicle impact simulations against slipbase sign support systems. Different pipe support types and square sign sizes were considered. The objective was to evaluate roof impact location and occupant compartment deformation due to the pipe support second impact with vehicle after slipbase release. Results were then compared with *MASH* specification criteria for occupant risk to identify the minimum sign area allowable for slipbase supports. Outcomes obtained by computer simulations were then used to suggest the slipbase single sign support system for evaluation with full-scale crash tests.

Pipe supports were modeled with elastic material properties. Three different types of 2.875-inch outside diameter steel pipe support generally employed for use on slipbase systems were considered for simulations (see Figure 9.18). Having all the same outside diameter, these pipe supports differ only in the inside diameter:

- BWG 10 with a wall thickness of 0.134 inches.
- Schedule 40 with a wall thickness of 0.203 inches.
- Schedule 80 with a wall thickness of 0.276 inches.

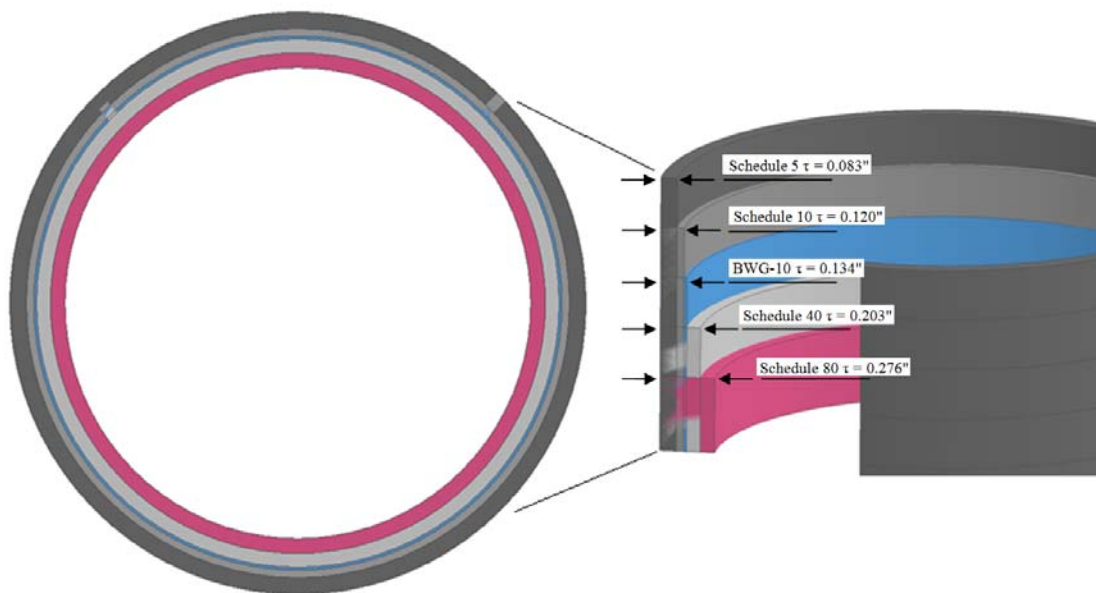


Figure 9.18. Thickness Comparison of Size 2.5-Inch Pipe Supports for Use on Slipbase Systems.

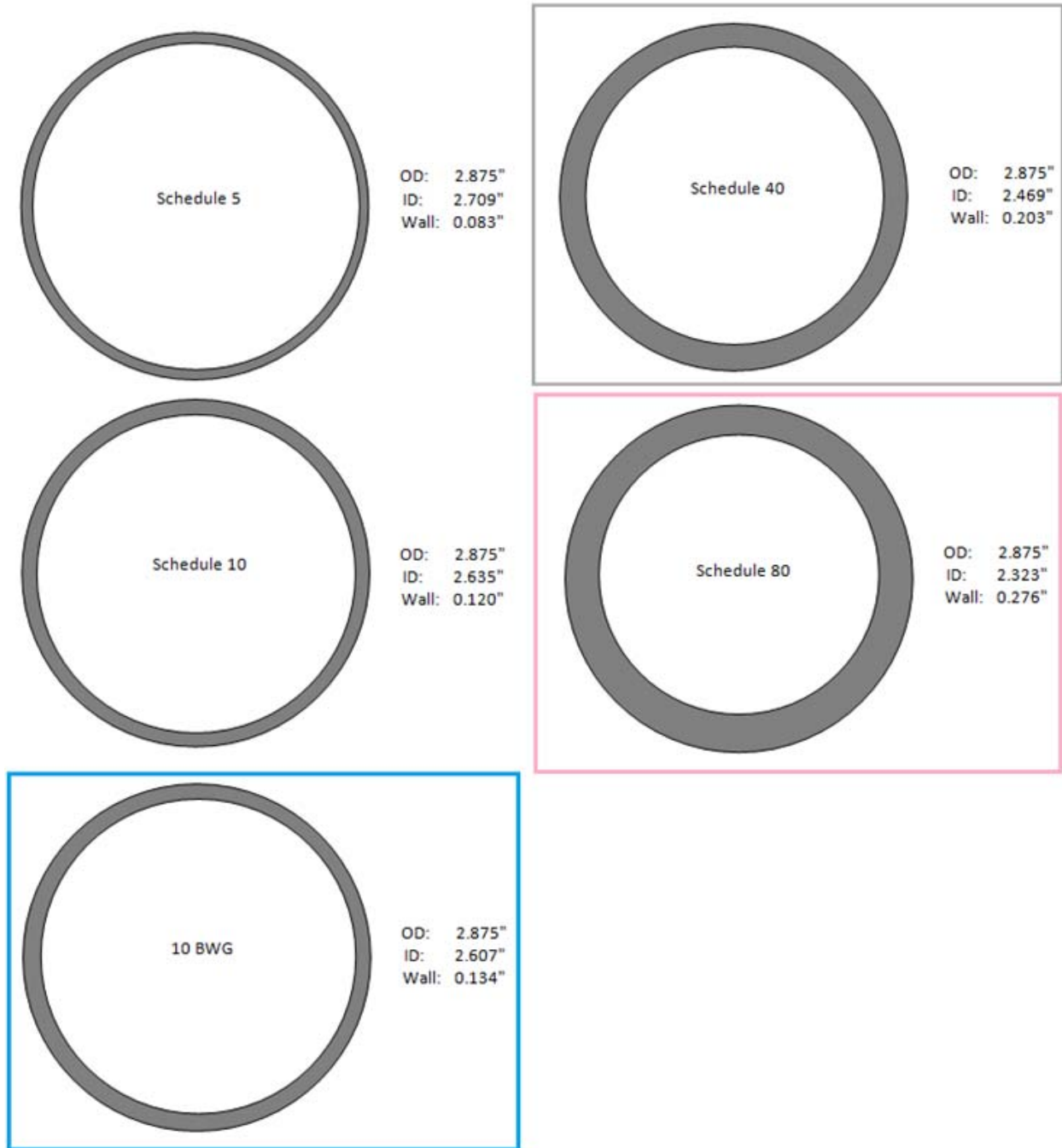
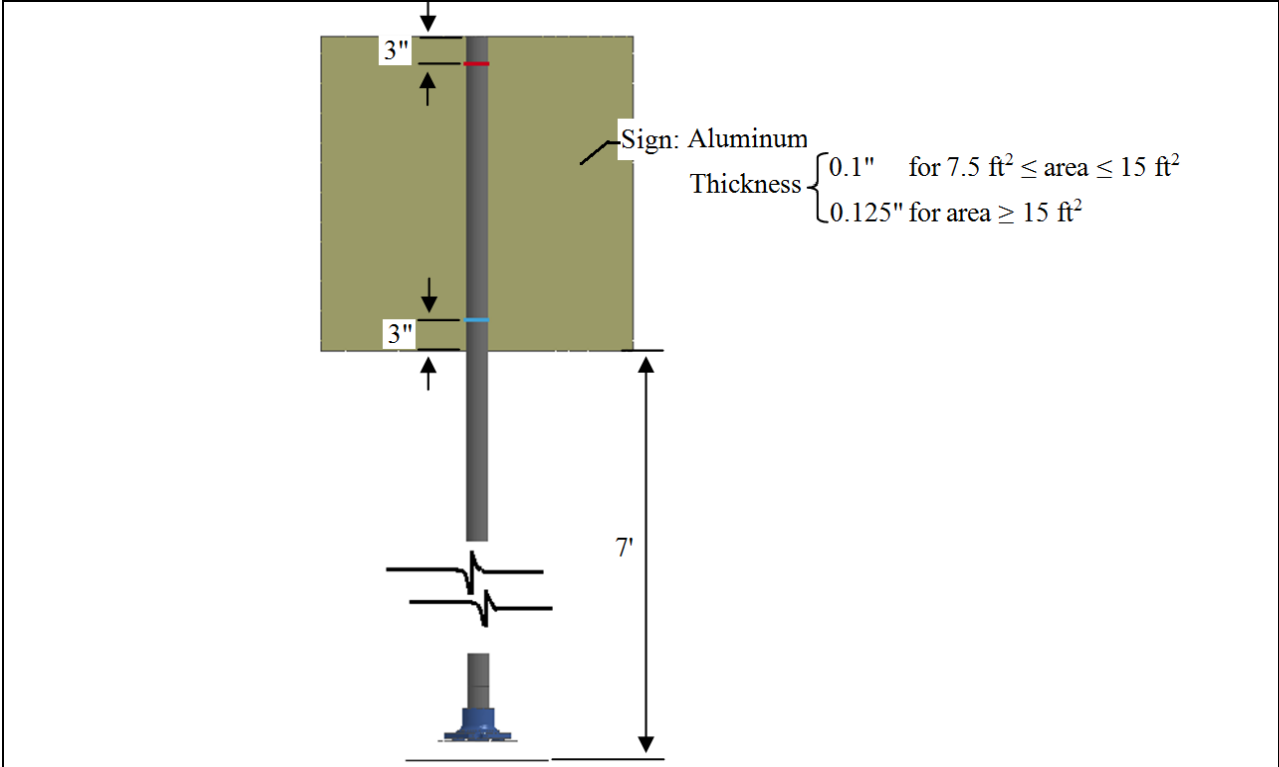


Figure 9.18. Thickness Comparison of Size 2.5-Inch Pipe Supports for Use on Slipbase Systems (Continued).

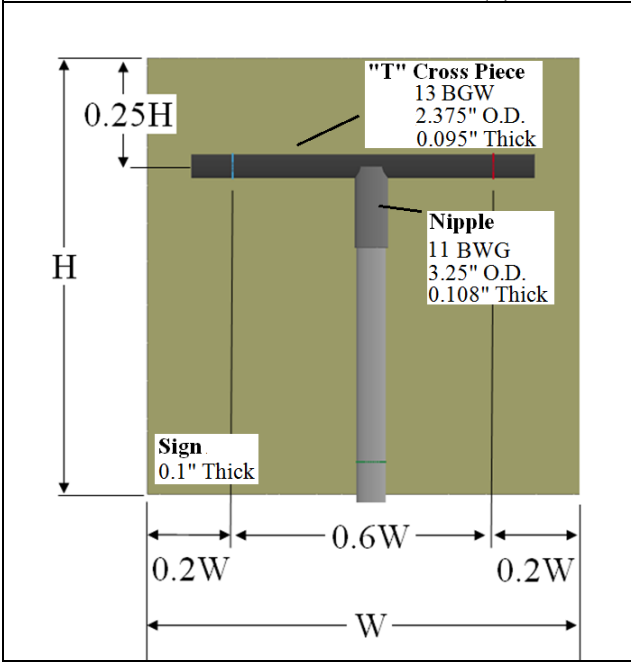
Sign thickness was 0.1 inch for signs 7.5–15 ft² and 0.125 inch for signs greater than 15 ft² to conform to TxDOT Specifications SMD (SLIP-2)-08 (5). The mounting height to the bottom of the sign was 7 ft. The sign was attached to the pipe support using nodal rigid body constraints.

For plain poles, the sign was constrained to the pipe support at two locations: 3 inches from top and 3 inches from bottom of sign edge (see Figure 9.19[a]). Figure 9.19(b) and (c) show two different T-bracket post configurations that were considered. For configuration #1, the sign was constrained at 3 inches above the bottom of sign edge to the pipe support, and at 0.2 (W) inches (where W = sign width) from both lateral sides to the horizontal T-cross support. This configuration was considered to comply with TxDOT sign mounting standards reported in SMD (SLIP-2)-08 for rectangular signs with a maximum width of 8 ft (5). With this configuration, the T-cross piece resulted to be at a distance of 0.25 times the height of the sign from the top of sign edge. Figure 9.19(b) shows that the sign sizes evaluated with this project had heights ranging from 3.5–4 ft and resulted in a considerable distance from the T-cross piece member and the top edge of the sign. Consequently, a second configuration for T-bracket support was defined, where the sign was constrained to the horizontal T-cross support at 3 inches below the top of the sign edge regardless of the actual height of the sign (see Figure 9.19[c]). This new T-bracket configuration with the T-cross piece closer to the top edge of the sign also helped raise the height of the C.G. of the all sign support systems. Since the C.G. also corresponds to the center of rotation of the sign support system, it is expected that this configuration will help avoid impact with the vehicle roof and/or limit the occupant compartment deformation due to a less violent impact.

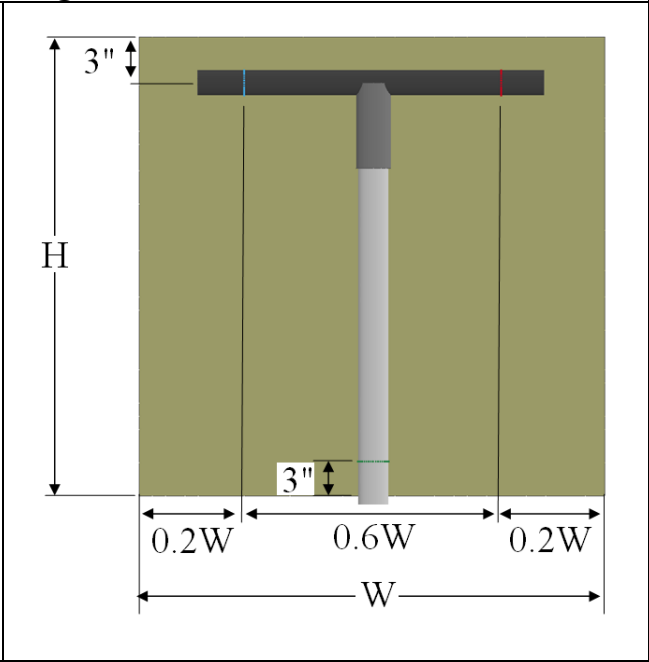
Geometry and material modeling of the T-bracket components was performed to comply with TxDOT standard specifications for the prefabricated T-bracket–Texas universal triangular slipbase system, reported in Figure 9.20 (10). The T-cross piece was modeled as 13 BWG tubing, with a 2.375-inch O.D. and a wall thickness of 0.095 inches. The nipple was modeled as 11 BWG tubing, with a 3.25-inch O.D. and a wall thickness of 0.108 inches. Both T-cross and nipple pieces were modeled with elastic material properties.



(a) Plain Configuration

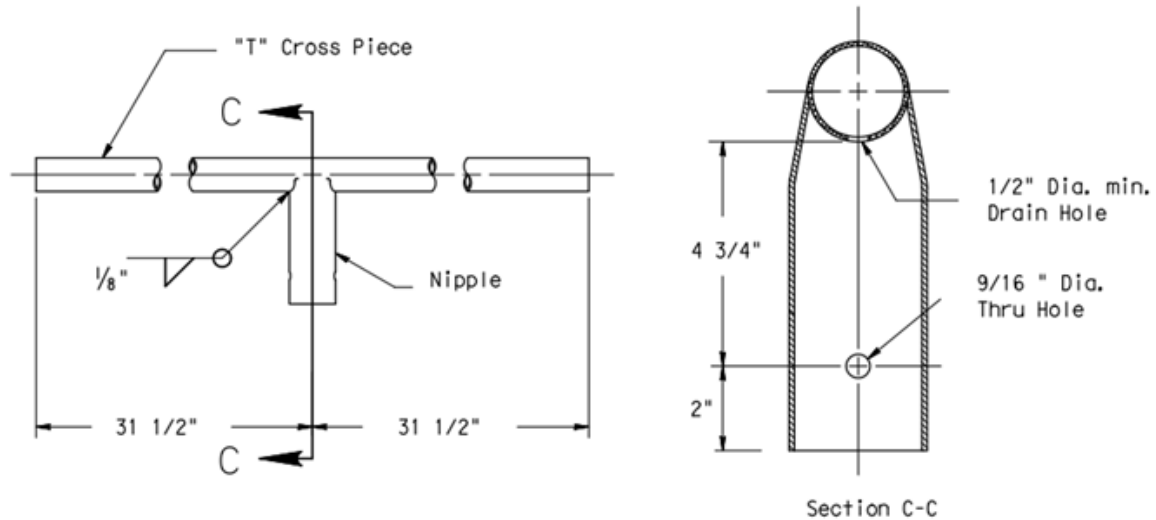


(b) Details T-Bracket Configuration #1



(c) Details T-Bracket Configuration #2

Figure 9.19. Single Sign Support Configurations Used for FE Simulations.



"T" CROSS PIECE

13 BWG Tubing (2.375" outside diameter)
 0.095" nominal wall thickness
 Seamless or electric-resistance welded steel tubing
 Steel shall be HSLAS Gr 55 per ASTM A1011 or ASTM A1008
 Other steels may be used if they meet the following:
 55,000 PSI minimum yield strength
 70,000 PSI minimum tensile strength
 18% minimum elongation in 2"
 Wall thickness (uncoated) shall be within the range of 0.085" to 0.105"
 Outside diameter (uncoated) shall be within the range of 2.355" to 2.395"

NIPPLE

11 BWG or greater Tubing (3.25" outside diameter)
 Seamless or electric-resistance welded steel tubing
 Steel shall be HSLAS Gr 55 per ASTM A1011 or ASTM A1008
 Other steels may be used if they meet the following:
 55,000 PSI minimum yield strength
 70,000 PSI minimum tensile strength
 20% minimum elongation in 2"
 Outside diameter (uncoated) shall be within the range of 3.241" to 3.259"
 Inside diameter (uncoated) shall be a minimum of 2.93"
 Wall thickness shall be a minimum of 0.108"
 Cut length shall be 8.000" ± 0.250". Notched and coped to provide snug fit with cross piece.
 Drilled or punched as shown. Nipple shall provide snug fit with 2.875" post.
 Nipple may be dimpled to provide snug fit.

Figure 9.20. Prefabricated "T" Bracket-Texas Universal Triangular Slipbase System (9).

The following geometries and impact configurations were considered for simulation analysis:

- 10-ft² sign area on BWG-10 plain pole impacted by a 1100C vehicle (passenger car).
- 10-ft² sign area on BWG-10 plain pole impacted by a 2270P vehicle (pickup-quad cab).
- 10-ft² sign area on BWG-10 T-bracket Configuration #1 pole impacted by a 1100C vehicle.

- 10-ft² sign area on BWG-10 T-bracket Configuration #1 pole impacted by a 2270P vehicle.
- 12-ft² sign area on BWG-10 plain pole impacted by a 1100C vehicle.
- 12-ft² sign area on BWG-10 plain pole impacted by a 2270P vehicle.
- 12-ft² sign area on Schedule-80 plain pole impacted by a 1100C vehicle.
- 12-ft² sign area on Schedule-80 plain pole impacted by a 2270P vehicle.
- 12-ft² sign area on Schedule-80 T-bracket Configuration #2 pole by a 2270P vehicle.
- 12-ft² sign area on Schedule-40 T-bracket Configuration #2 pole by a 2270P vehicle.
- 12-ft² sign area on BWG-10 T-bracket Configuration #1 pole impacted by a 1100C vehicle.
- 12-ft² sign area on BWG-10 T-bracket Configuration #1 pole impacted by a 2270P vehicle.
- 12-ft² sign area on BWG-10 T-bracket Configuration #2 pole impacted by a 2270P vehicle.
- 14-ft² sign area on BWG-10 plain pole impacted by an 1100C vehicle.
- 14-ft² sign area on BWG-10 T-bracket Configuration #1 pole impacted by a 1100C vehicle.
- 14-ft² sign area on BWG-10 T-bracket Configuration #1 pole impacted by a 2270P vehicle.
- 16-ft² sign area on BWG-10 T-bracket Configuration #1 pole impacted by a 1100C vehicle.
- 16-ft² sign area on BWG-10 T-bracket Configuration #1 pole impacted by a 2270P vehicle.

The sign support system vertical position of the C.G. depends mainly on the type of pipe support and sign area considered. Increment of sign size and/or choice of T-bracket pipe support with respect to plain support cause the C.G. to have a higher position in the system. A higher C.G. means also a higher position of the center of rotation (CR) of the system, causing all sign supports to rotate slowly after being impacted by the vehicle and the slipbase was released. One of the scopes of this study was to evaluate how sign support systems CR heights affect occupant risk after vehicle impact. Figure 9.21 compares C.G. position for sign support systems with the different configurations evaluated.

Simulations were run with the vehicle impacting head-on into the single sign support at 62 mph. The first impact was located 6 inches from the vehicle's centerline, on the driver's side. Figures 9.22 and 9.23 summarize the configurations and the results of the FE simulations in terms of roof crush. Figures 9.24 through 9.26 report vehicle roof deformation sensitivity with respect to the size of sign area mounted on the pipe support.

| | |
|----------------------------------|--------------------------------------|
| 10-ft² - Plain | 10-ft² - T-Bracket |
| BWG-10 | BWG-10 |
| | |

| | | | | | |
|----------------------------------|--------------------|--------------------------------------|-------------------|--------------------|--------------------|
| 12-ft² - Plain | | 12-ft² - T-Bracket | | | |
| | | Config. #1 | Config. #2 | Config. #2 | Config. #2 |
| BWG-10 | Schedule-80 | BWG-10 | BWG-10 | Schedule-80 | Schedule-40 |
| | | | | | |

| | | |
|----------------------------------|--------------------------------------|--------------------------------------|
| 14-ft² - Plain | 14-ft² - T-Bracket | 16-ft² - T-Bracket |
| BWG-10 | BWG-10 | BWG-10 |
| | | |

Figure 9.21. Center of Gravity for Pole System with Varying Sign Areas.

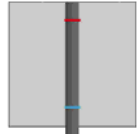
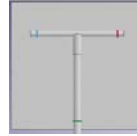
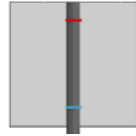
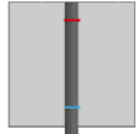
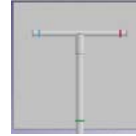
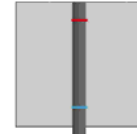
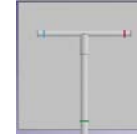
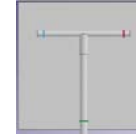








| | Configuration # | | | | | | | |
|----------------------------|---|---|---|--|---|---|---|---|
| | 1 | 2 | 3 | 4 | 5 | 6 | 7 | 8 |
| Sign Area | 10-ft ² | 10-ft ² | 12-ft ² | 12-ft ² | 12-ft ² | 14-ft ² | 14-ft ² | 16-ft ² |
| Pipe Support | BWG 10 | BWG 10 | BWG 10 | Schedule 80 | BWG 10 | BWG 10 | BWG 10 | BWG 10 |
| Pole Type |  |  |  |  |  |  |  |  |
| Impact Location |  |  |  |  |  |  |  |  |
| | Roof | Roof | Back Window | Back Window | End Roof | Back Window | End Roof | Back Window |
| Roof Crush (inches) | 5 | 4.9 | 0.6 | No Roof Crush | 2.9 | No Roof Crush | 1.7 | No Roof Crush |

Figure 9.22. Summary of FE Simulation Impact Predictions with Small Passenger Car, 1100C Vehicle.

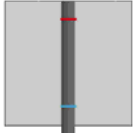
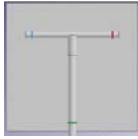
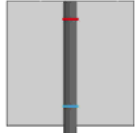
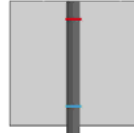
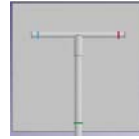

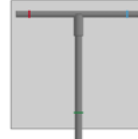
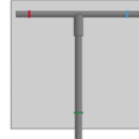
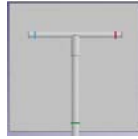
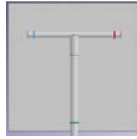











| | Configuration # | | | | | | | | | | |
|----------------------------|---|---|---|---|--|---|---|---|---|---|---|
| | 1 | 2 | 3 | 4 | 5 | 6 | 7 | 8 | 9 | 10 | |
| Sign Area | 10-ft ² | 10-ft ² | 12-ft ² | 12-ft ² | 12-ft ² | 12-ft ² | 12-ft ² | 12-ft ² | 14-ft ² | 16-ft ² | |
| Pipe Support | BWG 10 | BWG 10 | BWG 10 | Schedule 80 | BWG 10 | BWG 10 | Schedule 80 | Schedule 40 | BWG 10 | BWG 10 | |
| Pole Type |  |  |  |  |  |  |  |  |  |  |  |
| Impact Location |  |  |  |  |  |  |  |  |  |  | |
| | Windshield | Roof | Roof | Roof | Roof | Roof | Roof | Roof | Roof | Roof | |
| Roof Crush (inches) | 6.5 | 5.1 | 7 | 10 | 5.8 | 5.1 | 7 | 5.9 | 5.4 | 5.6 | |

Figure 9.23. Summary of FE Simulation Impact Predictions with Pickup Truck, 2270P Vehicle.

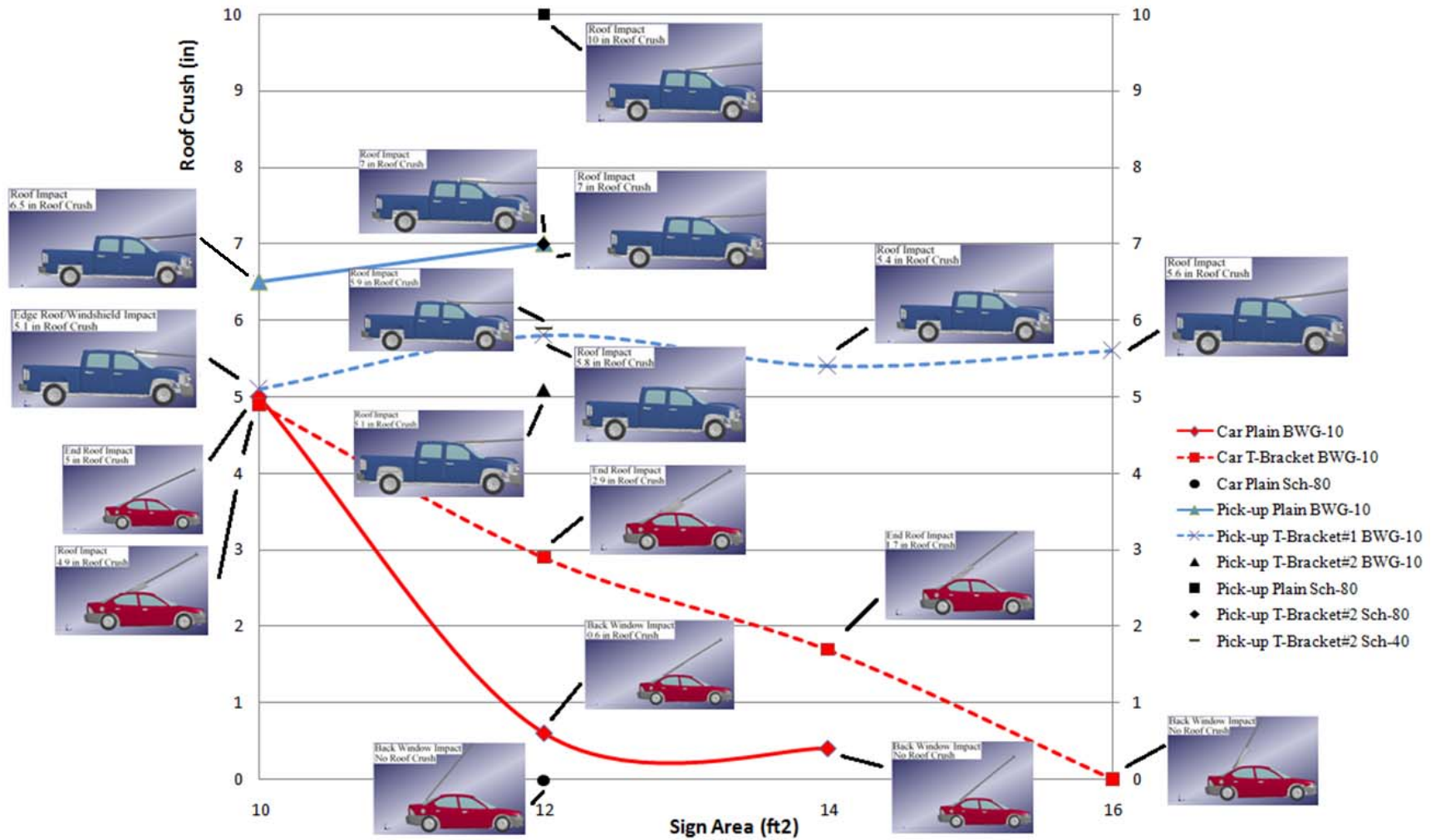


Figure 9.24. Roof Crush Results with Varying Sign Areas and Pole Systems for Both 1100C and 2270P Vehicles.

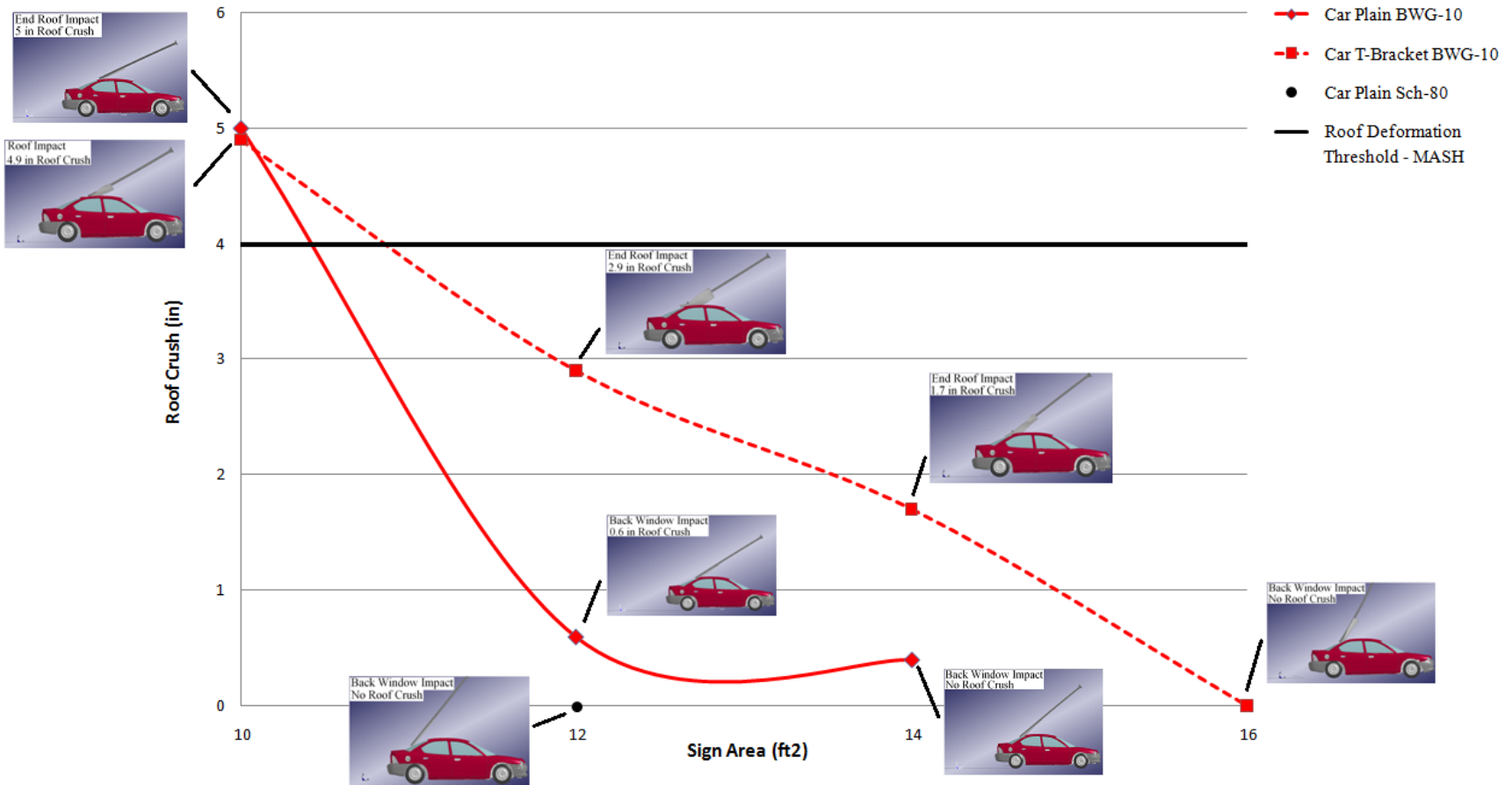


Figure 9.25. Roof Crush Results with Varying Sign Areas and Pole Systems for 1100C Vehicle.

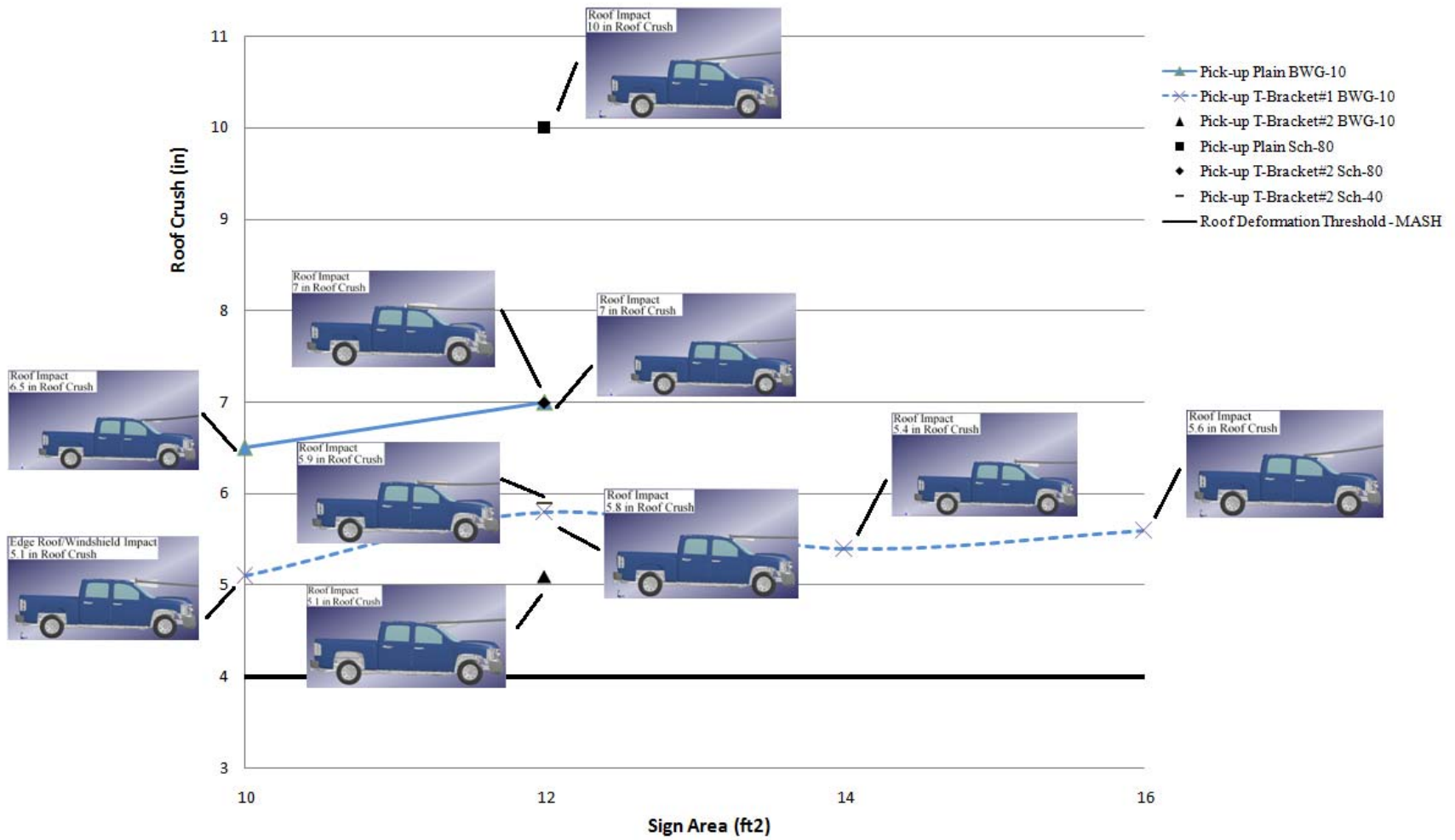


Figure 9.26. Roof Crush Results with Varying Sign Areas and Pole Systems for 2270P Vehicle.

9.3.2 Discussion on Finite Element Prediction and Validation Results

The FE simulation validation results were carefully evaluated with respect to the sign support second impact location on the vehicle after slibase release and to occupant compartment deformation of the vehicle.

Computer simulations showed that in the case of a pickup truck impact against a single sign T-bracket (configuration #1) BWG 10 support with 10 ft² sign area, the pole system would cause 5.1 inches of windshield deformation. When the sign support type was changed to a BWG 10 plain support, the impact location was shifted back along the longitudinal axis of the vehicle, and the new impact location was the roof, which experienced 6.5 inches of crush. In the cases of the passenger car, both impacts simulated with plain and T-bracket (configuration #1) BWG 10 supports for a 10 ft² sign area resulted in roof deformation greater than 4 inches. *MASH* occupant criteria limit the windshield and roof deformation to 3 and 4 inches, respectively. Consequently, simulation results suggested that testing of the pickup truck against a single sign support would more likely result in a failure for a 10 ft² sign area on the slibase support.

With the sign area increased to 12 ft², FE simulations were conducted using different types of pipe supports: BWG 10, schedule 40 and schedule 80. BWG 10 and schedule 80 sign supports were considered for small car impacts, while the pickup truck simulations were run against BWG 10, schedule 80 and schedule 40 types.

Impact of the small car against BWG 10 plain support type resulted in 0.6 inches of roof crush. When a BWG 10 T-bracket configuration #1 support was considered, the pipe impacted the car at the very end of the vehicle's roof, adjacent to the back window line and resulted in 2.9 inches of roof crush. Small car simulation using schedule 80 plain support type predicted back window impact, resulting in no roof deformation.

With pickup truck simulations, the BWG 10 plain and the schedule 80 plain supports caused 7 and 10 inches of roof crush, respectively. When the BWG 10 pipe was connected to a T-bracket sign support, outcomes suggested a resulting lower compartment deformation. When using the first T-bracket model configuration (Figure 9.19[b]), the roof deformation was calculated at 5.8 inches. However, when the second T bracket configuration (Figure 9.19[c]) was used, the roof crush was 5.1 inches. Pickup truck impacts were also simulated against schedule 80 and schedule 40 pipe types with a T-bracket configuration #2 and resulted in roof impact and occupant compartment deformation of 7 inches and 5.9 inches, respectively.

These computational results suggested that preferable results in terms of impact location and roof deformation would be achieved using BWG 10 T-bracket configuration #2 pipe support with respect to schedule 80 and 40 types. Although simulations showed schedule 80 pipes did not impact the roof in the 1100C vehicle case, it predicted very high roof crush with the 2270P vehicle (10 inches).

Simulations with the small car suggested that for sign areas equal or greater than 12 ft², the second impact between the sign support and the vehicle should result in very small or no roof

deformation. For these cases, results indicate that the dynamics of both plain and T-bracket sign supports after slipbase release would allow the system to impact the car close or after the line between roof and back window.

Simulations with pickup truck against single sign T-bracket configuration #1 BWG 10 support predicted the roof deformation to not be very sensitive to sign areas equal to or greater than 12 ft² (5.8 inches for 12 ft² sign area, 5.4 inches for a 14 ft² sign area, and 5.6 inches for a 16 ft² sign area. Results showed that roof impact location was the only remarkable difference for these simulations.

Considering the comparison of roof crushes obtained using the two T-bracket configurations from previous simulations with the same pipe support type, it is believed that using T-bracket configuration #2 would reduce the occupant compartment deformation resulting from sign support impact.

After carefully reviewing and interpreting the computer simulation results, researchers suggested 12 ft² to be the minimum sign size for a slipbase support system. The sign should be mounted on a BWG 10 T-bracket configuration #2 pipe support type. Test 3-61 (1100C passenger car impacting single support head on at a speed of 62 mph) and test 3-62 (2270P pickup truck impacting the sign support at a speed of 62 mph) are to be conducted in accordance with the AASHTO *MASH*. Acceptable impact performance requires roof crush of no more than 4 inches.

9.4 FULL-SCALE CRASH TESTING ON 12 FT² SIGN PANEL

Information on the crash test matrix and evaluation criteria used in the performance of the following crash tests was presented in Section 7.2.1 and 7.2.2. *MASH* tests 3-62 and 3-61 were performed on the 10 BWG steel slipbase sign support with 12 ft² sign panel.

9.4.1 Crash Test 463631-1 (*MASH* Test No. 3-62) on 10 BWG Steel Slipbase Support with 12 ft² Sign Panel

9.4.1.1 Test Installation Description

A 10 BWG galvanized steel tube with an outside diameter of 2.875 inches and a nominal wall thickness of 0.134 inch was used as the vertical support for the slipbase system. A T-shaped bracket was attached to the vertical support to provide bracing for the sign panel. The T-bracket consisted of a 3.25-inch O.D. (11 BWG) stub welded to a 2.375-inch O.D. (13 BWG) horizontal steel tube. The stub of the T-bracket fit over the end of the 2.875-inch O.D. support and was secured using two 3/8-inch diameter ASTM A307 bolts.

A 42-inch × 42-inch × 0.1-inch thick aluminum sign blank was attached to the 2.375-inch O.D. horizontal member and 2.875-inch O.D. vertical support using three mounting clamps. The mounting clamp used to attach the sign panel to the vertical support was located 3 inches from

the lower edge of the sign panel. The two clamps employed to connect the sign panel to the horizontal member were located 4.25 inches from the upper edge of the sign panel and 8.375 inches from the side edge of the sign panel. The mounting height to the bottom of the sign blank was 7 ft. Figures 4.1 through 4.3 give details of the sign support systems.

A triangular slipbase sign support system was installed in the impact position and was offset 6 inches to the right of the vehicle centerline. Consisting of an integral collar and triangular base plate, the upper slipbase casting slides onto the end of the steel pipe support. The lower slipbase assembly consists of a 3-inch diameter \times 3-ft long galvanized schedule 40 pipe stub welded to a $\frac{5}{8}$ -inch thick steel triangular base plate having the same geometry as the upper plate. The pipe stub was embedded in a 12-inch diameter \times 3.5-ft deep unreinforced concrete footing such that the top face of the lower triangular slip plate was approximately 2 inches above the ground. Concrete used in the foundation was non-reinforced Class A.

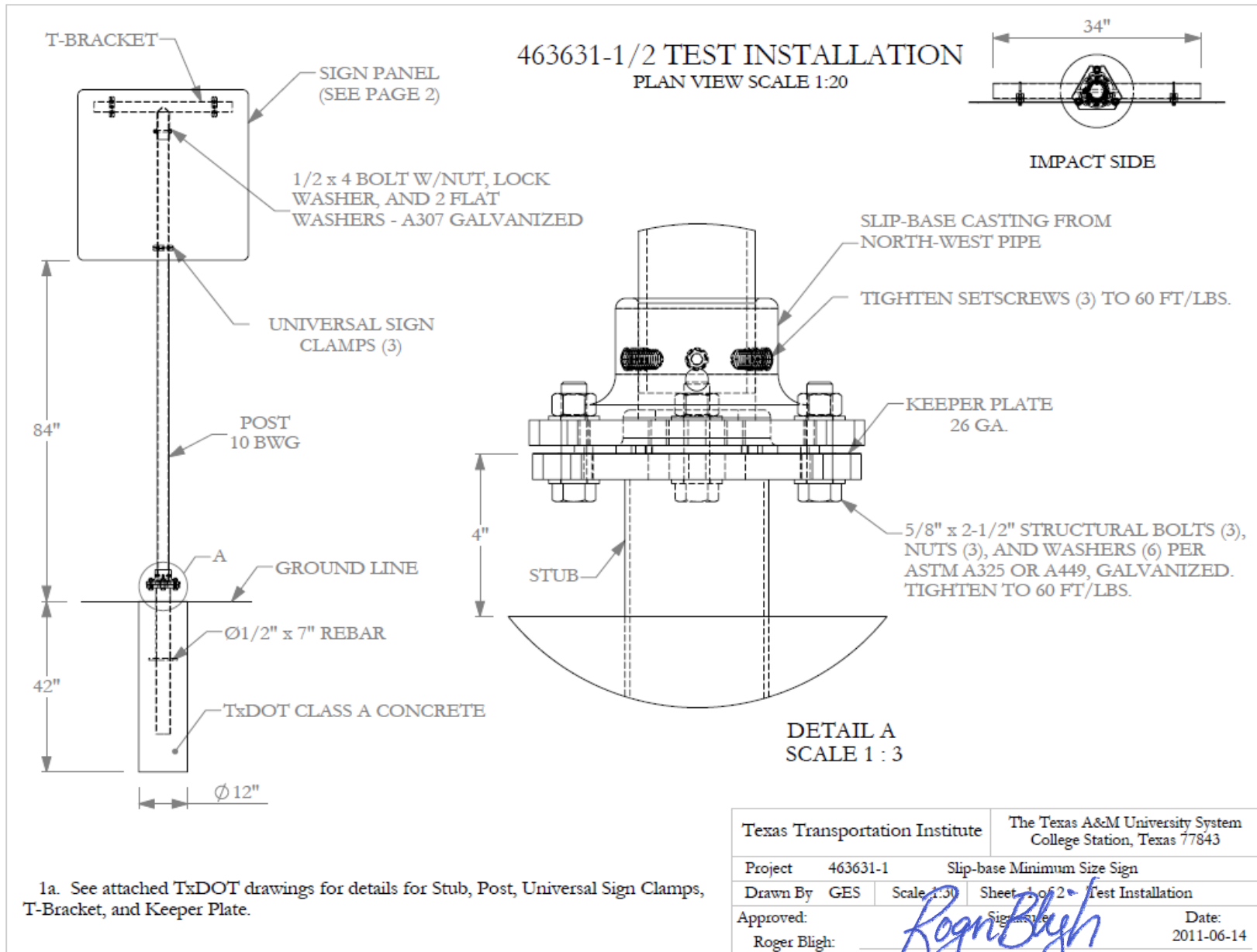
The upper slipbase unit is bolted to the lower slipbase unit using three $\frac{5}{8}$ -inch \times 2.5-inch long A325 or equivalent high strength bolts, which were tightened to a prescribed torque of 60 ft-lb. The slipbase was oriented such that the direction of impact was perpendicular to one of the flat faces of the triangular plate. High-strength washers were used under both the head and nut of each bolt, and an additional washer is used to offset the two slip plates. A keeper plate fabricated from 30 gauge galvanized sheet steel holds the bolts in place. Set screws in the collar of the upper slipbase casting were then tightened to a prescribed torque of 60 ft-lb to secure the vertical support within the casting and keep it from rotating. The slipbase assembly was installed in *MASH* standard soil following details of TxDOT standard drawing SMD(SLIP-1)-08.

The test installation was installed in a concrete footing installed on standard soil meeting AASHTO standard specifications for “Materials for Aggregate and Soil Aggregate Subbase, Base and Surface Courses,” designated M147-65(2004), grading B.

Figures 9.27 through 9.29 show a schematic of the triangular slipbase sign support installation, with further details in Appendix H, Figure H1. Figure 9.30 presents photographs of the completed test installation.

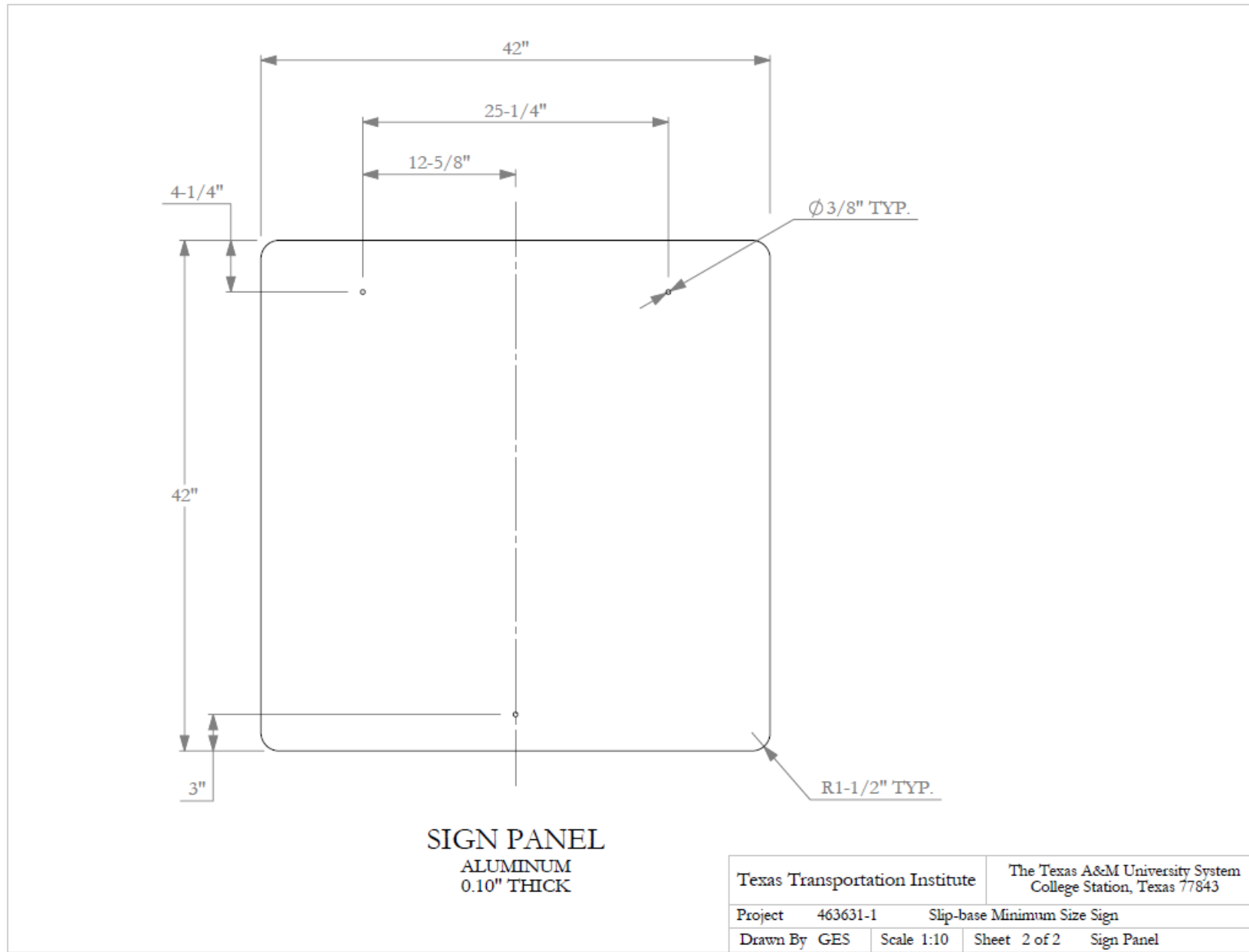
9.4.1.2 Test Designation and Actual Impact Conditions

MASH test 3-62 involves a 2270P vehicle weighing 5000 lb \pm 100 lb and impacting the sign support at an impact speed of 62 mph \pm 2.5 mph and a critical impact angle of 0 degrees \pm 1.5 degrees. The target impact point was the quarter point of the vehicle aligned with the centerline of the support. The 2002 Dodge Ram 1500 pickup used in the test weighed 5070 lb and the actual impact speed and angle were 59.9 mph and 0 degrees, respectively. The actual impact point was the right front quarter point of the vehicle with the centerline of the sign support.



T:\2010-2011\TXDOT\Drafting\463631-1 and 2 Drawing

Figure 9.27. Details of the Sign Support System Used for Test Nos. 463631-1 and 463631-2.



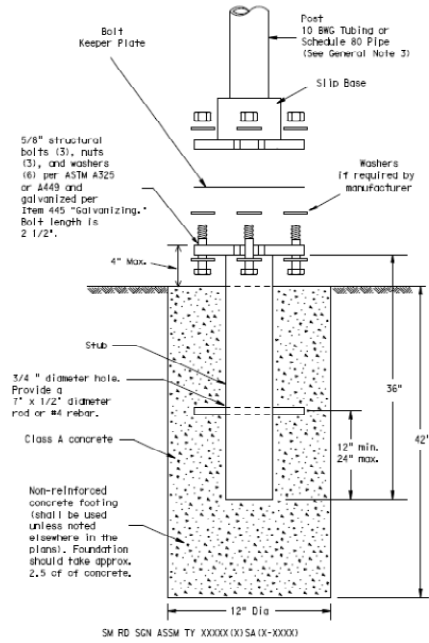
T:\2010-2011\463631-TXDOT\Drafting\463631-1 and 2 Drawing

Figure 9.28. Details of the Sign Panel Used in Test Nos. 463631-1 and 463631-2.

The use of this standard is governed by the Texas Engineering Practice Act. No warranty of any kind is made by the State of Texas for the accuracy or completeness of the information contained herein. This standard is subject to change without notice. The use of this standard is subject to the terms and conditions of the license agreement.

DATE FILE

TRIANGULAR SLIPBASE INSTALLATION GENERAL REQUIREMENTS



NOTE

There are various devices approved for the Triangular Slipbase System. Please reference the Material Producer List for approved slip base systems. http://www.txdot.gov/business/producer_list.htm The devices shall be installed per manufacturers' recommendations. Installation procedures shall be provided to the Engineer by Contractor.

GENERAL NOTES:

- Slip base shall be permanently marked to indicate manufacturer, Method, design, and location of marking are subject to approval of the TxDOT Traffic Standards Engineer.
- Material used as post with this system shall conform to the following specifications:
 10 BWG Tubing (2.875" outside diameter)
 0.134" nominal wall thickness
 Seamless or electric-resistance welded steel tubing or pipe
 Steel shall be HS-LAS Gr 55 per ASTM A1011 or ASTM A1008
 Other steels may be used if they meet the following:
 55,000 PSI minimum yield strength
 70,000 PSI minimum tensile strength
 20% minimum elongation in 2"
 Wall thickness (uncoated) shall be within the range of 0.122" to 0.136"
 Outside diameter (uncoated) shall be within the range of 2.867" to 2.887"
 Galvanization per ASTM A123 or ASTM A653 G210. For pre-coated steel tubing (ASTM A653), recast tube outside diameter weld seam by metallizing with zinc wire per ASTM B855.
 Schedule 80 Pipe (2.875" outside diameter)
 0.276" nominal wall thickness
 Steel tubing per ASTM A400 Gr C
 Other seamless or electric-resistance welded steel tubing or pipe with equivalent outside diameter and wall thickness may be used if they meet the following:
 45,000 PSI minimum yield strength
 62,000 PSI minimum tensile strength
 21% minimum elongation in 2"
 Wall thickness (uncoated) shall be within the range of 0.248" to 0.304"
 Outside diameter (uncoated) shall be within the range of 2.855" to 2.895"
 Galvanization per ASTM A123
- See the Traffic Operations Division website for detailed drawings of sign clamps and Texas Universal Triangular Slipbase System components. The website address is: <https://www.txdot.gov/publications/traffic.htm>
- Sign supports shall not be spliced except where shown. Sign support posts shall not be spliced.

ASSEMBLY PROCEDURE

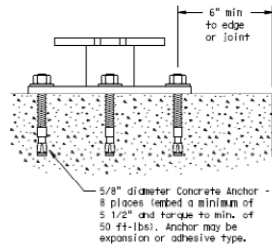
Foundation

- Prepare 12-inch diameter by 42-inch deep hole. If solid rock is encountered, the depth of the foundation may be reduced such that it is embedded a minimum of 18 inches into the solid rock.
- The Engineer may permit batches of concrete less than 2 cubic yards to be mixed with a portable, motor-driven concrete mixer. For small placements less than 0.5 cubic yards, hand mixing in a suitable container may be allowed by Engineer. Concrete shall be Class A.
- Push the pipe end of the slip base stub into the center of the concrete. Rotate the stub back and forth while pushing it down into the concrete to assure good contact between the concrete and stub. Continue to work the stub into the concrete until it is between 2 to 4 inches above the ground.
- Plumb the stub. Allow a minimum of 4 days to set, unless otherwise directed by the Engineer.
- The triangular slipbase system is multidirectional and is designed to release when struck from any direction.

Support

- Out support so that the bottom of the sign will be 7 to 7.5 feet above the edge of the travelway (i.e., edge of the closest lane) when slip plate is below the edge of pavement or 7 to 7.5 feet above slip plate when the slip plate is above the edge of the travelway. The out shall be plumb and straight.
- Attach sign to support using connections shown. When multiple signs are installed on the same support, ensure the minimum clearance between each sign is maintained. See SMD(SLIP-2) for clearances based on sign types.

CONCRETE ANCHOR



Concrete anchor consists of 5/8" diameter stud bolt with UNC series bolt threads on the upper end. Heavy hex nut per ASTM A563, and hardened washer per ASTM F436. The stud bolt shall have a minimum yield and ultimate tensile strength of 50 and 75 KSI, respectively. Nuts, bolts and washers shall be galvanized per Item 445, "Galvanizing." Adhesive type anchors shall have stud bolts installed with Type III epoxy per DMS-6100, "Epoxy and Adhesives." Adhesive anchors may be loaded after adequate epoxy cure time per the manufacturer's recommendations. Top of bolt shall extend at least flush with top of the nut when installed. The anchor, when installed in 4000 psi normal-weight concrete with a 5 1/2" minimum embedment, shall have a minimum allowable tension and shear of 3900 and 3100 psi, respectively.

SIGN MOUNTING DETAILS
SMALL ROADSIDE SIGNS
TRIANGULAR SLIPBASE SYSTEM
SMD(SLIP-1)-08

| © TxDOT July 2002 | | REV | DATE | BY | CHK |
|-------------------|---------|-----|----------|------|-----------|
| 3-08 | REVISED | 01 | 08/01/08 | JWA | SPR/08/01 |
| | | REV | | DATE | SHEET NO. |
| | | | | | 208 |

Figure 9.29. Details of the Triangular Slipbase System.



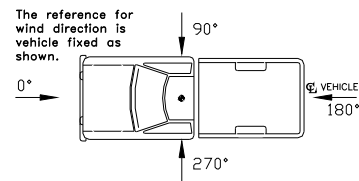
Figure 9.30. Sign Support System prior to Test Nos. 463631-1 and 2.

9.4.1.3 Test Vehicle

A 2002 Dodge Ram 1500 pickup truck (shown in Figures 9.31 and 9.32) was used for the crash test. Test inertia weight of the vehicle was 5070 lb, and gross static weight was 5070 lb. The height to the lower edge of the vehicle front bumper was 13.5 inches, and the height to the upper edge of the front bumper was 26.0 inches. The height to the center of gravity was 28.25 inches. Tables H1 and H2 of Appendix H give additional dimensions and information on the vehicle. The pickup was directed into the installation using the cable reverse tow and guidance system, and was released to be free-wheeling and unrestrained just prior to impact.

9.4.1.3 Weather Conditions

The crash test was performed on the morning of June 21, 2011. Weather conditions at the time of testing were: Wind speed: 9 mph; wind direction: 202 degrees with respect to the vehicle (vehicle was traveling in a southerly direction); temperature: 84°F; relative humidity: 76 percent. No rainfall was recorded during the 10 days prior to the test.



9.4.1.4 Test Description

The 2270P vehicle, traveling at an impact speed of 59.9 mph, contacted the sign support at an impact angle of 0 degrees, with the right front quarter point aligned with the centerline of the support. At approximately 0.002 s, the support began to activate at the slipbase connection. The sign and support rose upward in front of the vehicle and lost contact with the vehicle at 0.041 s. The top of the sign panel contacted the roof at 0.097 s, and between this time and 0.132 s, the bolt on the left side of the sign panel gouged a hole in the roof of the vehicle. At 0.138 s after impact, the top of the sign and support lost contact with the roof of the vehicle and the vehicle was traveling at an approximate exit speed of 59.3 mph. Brakes on the vehicle were applied at 1.19 s after impact. The vehicle subsequently came to rest 300 ft downstream of impact. Figure H2 in Appendix H has sequential photographs of the test period.

9.4.1.5 Test Article and Component Damage

Figure 9.33 shows the sign support activated as designed by slipping away at the base connection. The support was slightly deformed at bumper height of the vehicle. The sign panel clamp connections with the horizontal member failed after impact and interaction with the vehicle's roof. The support with sign panel was resting 180 ft downstream of the impact point.



Figure 9.31. Vehicle/Installation Geometrics for Test No. 463631-1.



Figure 9.32. Vehicle before Test No. 463631-1.



Figure 9.33. Installation after Test No. 463631-1.

9.4.1.6 Test Vehicle Damage

Figure 9.34 shows the 2270P vehicle sustained damage to the center front. The right front bumper quarter point and the roof were deformed. A small dent at the right hood quarter point was recorded. The windshield was cracked at the top near the roof line and on the right side. The maximum exterior crush to the front plane of the vehicle was 1.0 inch at bumper height. The roof was deformed into the occupant compartment 3.625 inches, and a puncture hole slightly right of center over the front passenger compartment resulted from impact and interaction with the bolt of the sign clamp on the left side of the sign panel. Figure 9.35 has photographs of the interior of the vehicle. Tables H3 and H4 in Appendix H show the exterior vehicle crush and occupant compartment measurements.

9.4.1.7 Occupant Risk Values

Data from the accelerometer, located at the vehicle center of gravity, were digitized for evaluation of occupant risk. No occupant contact occurred in the longitudinal or lateral directions prior to activation of the brakes at 1.19 seconds after impact. The maximum longitudinal 0.050-s average acceleration was -0.6 Gs between 0.068 and 0.118 s, and the maximum lateral 0.050-s average was 0.5 Gs between 0.110 and 0.160 s. Theoretical Head Impact Velocity (THIV) and Post-Impact Head Decelerations (PHD) were not calculated due to no occupant impact. Acceleration Severity Index (ASI) was 0.16 between 0.073 and 0.123 s. Figure 9.36 summarizes these data and other pertinent information from the test. Figures H3 through H9 in Appendix H present the vehicle angular displacements and accelerations versus time traces.

9.4.1.8 Assessment of Test Results

An assessment of the test based on the following applicable *MASH* safety evaluation criteria is presented below.

9.4.1.8.1 Structural Adequacy

- B. *The test article should readily activate in a predictable manner by breaking away, fracturing, or yielding.*

Results: The sign support activated readily by slipping away at the base. (PASS)



Figure 9.34. Vehicle after Test No. 463631-1.

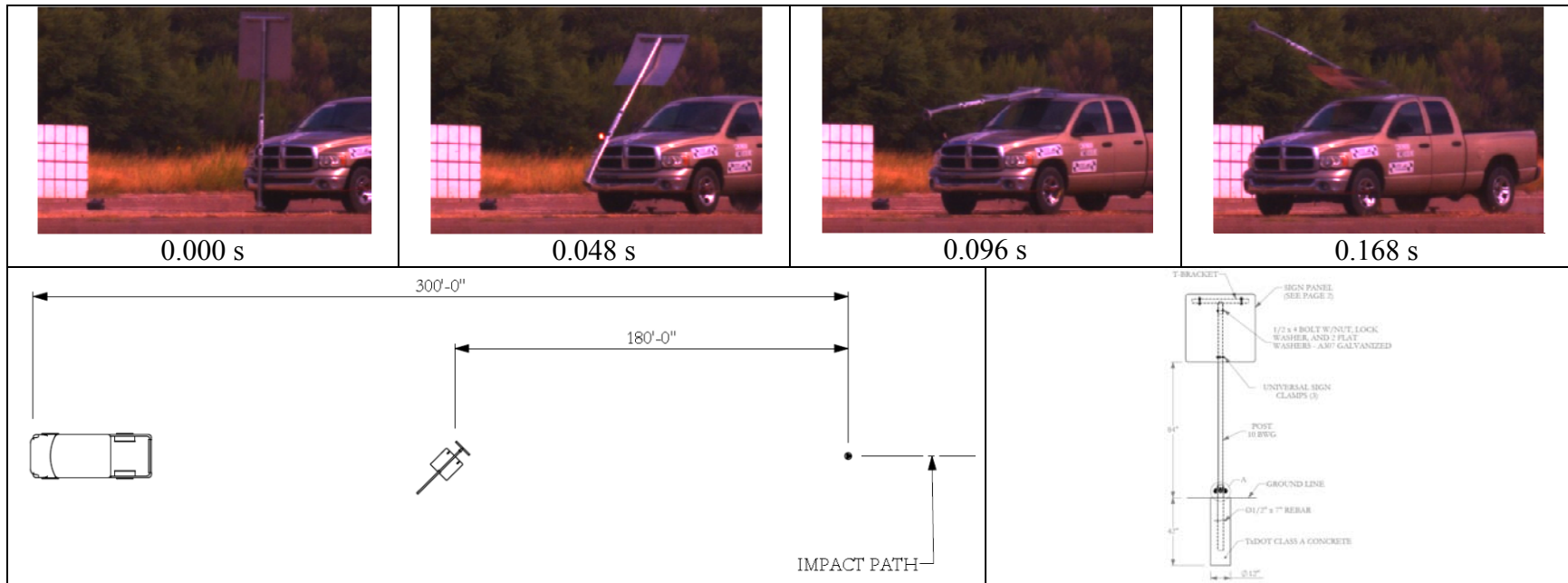


Before Test



After Test

Figure 9.35. Interior of Vehicle for Test No. 463631-1.



General Information

Test Agency..... Texas Transportation Institute
 MASH Test No. MASH Test 3-62
 TTI-PG Test No. 463631-1
 Date 2011-06-21

Test Article

Type..... Single Sign Support
 Name 10 BWG Support/12 ft² Sign Panel
 Installation Height 7 ft to bottom of upper front sign panel
 Material or Key Elements 1 sign panel mounted on a 2-7/8-inch OD pipe support with triangular slipbase

Soil Type and Condition

..... Concrete Footer in Crushed Limestone

Test Vehicle

Type/Designation..... 2270P
 Make and Model 2002 Dodge 1500 Quad Cab Dodge
 Curb 4899 lb
 Test Inertial 5070 lb
 Dummy No dummy
 Gross Static 5070 lb

Impact Conditions

Speed59.9 mph
 Angle0 degrees
 Location/OrientationQuarter point of vehicle with centerline of sign support

Exit Conditions

Speed59.3 mph
 Angle0 degrees

Occupant Risk Values

Impact Velocity
 LongitudinalNo Contact
 LateralNo Contact
 Ridedown Accelerations
 LongitudinalN/A
 LateralN/A
 THIVN/A
 ASI0.16
 Max. 0.050-s Average
 Longitudinal-0.6 G
 Lateral 0.5 G
 Vertical 1.6 G

Post-Impact Trajectory

Stopping Distance 300 ft

Vehicle Stability

Maximum Yaw Angle..... -3 degrees
 Maximum Pitch Angle..... -2 degrees
 Maximum Roll Angle -1 degree
 Vehicle Snagging No
 Vehicle Pocketing..... No

Test Article Deflections

Dynamic 180 ft
 Permanent 180 ft
 Working Width N/A

Vehicle Damage

VDS 12FR1
 CDC..... 12FREN1
 Max. Exterior Deformation..... 1.0 inch
 OCDI..... RR0000000
 Max. Occupant Compartment Deformation..... 3.625 inches

Figure 9.36. Summary of Results for MASH Test 3-62 on the 10 BWG Steel Pipe Slipbase Support with 12 ft² Sign Panel (Test No. 463631-1).

9.4.1.8.2 Occupant Risk

D. Detached elements, fragments, or other debris from the test article should not penetrate or show potential for penetrating the occupant compartment, or present an undue hazard to other traffic, pedestrians, or personnel in a work zone.

Deformation of, or intrusions into, the occupant compartment should not exceed limits set forth in Section 5.3 and Appendix E of MASH. (roof ≤ 4.0 inches; windshield = ≤ 3.0 inches; side windows = no shattering by test article structural member; wheel/foot well/toe pan ≤ 9.0 inches; forward of A-pillar ≤ 12.0 inches; front side door area above seat ≤ 9.0 inches; front side door below seat ≤ 12.0 inches; floor pan/transmission tunnel area ≤ 12.0 inches).

Results: The upper support with sign panel attached slipped away at the base connection and contacted the roof of the vehicle. The windshield was cracked on the top portion next to the roof line. The roof was deformed into the occupant compartment 3.625 inches, and a puncture hole slightly right of center over the front passenger compartment resulted from impact and interaction with the bolt of the sign clamp on the left side of the sign panel. (PASS)

F. The vehicle should remain upright during and after collision. The maximum roll and pitch angles are not to exceed 75 degrees.

Results: The 2270P vehicle remained upright during and after the collision event. Maximum roll and pitch angles were -1 and -2 degrees, respectively. (PASS)

J. Occupant impact velocities should satisfy the following:
Longitudinal and Lateral Occupant Impact Velocity

| <u>Preferred</u> | <u>Maximum</u> |
|------------------|----------------|
| 10 ft/s | 16 ft/s |

Results: No occupant contact occurred in the longitudinal or lateral directions. (PASS)

I. Occupant ridedown accelerations should satisfy the following:
Longitudinal and Lateral Occupant Ridedown Accelerations

| <u>Preferred</u> | <u>Maximum</u> |
|------------------|----------------|
| 15.0 Gs | 20.49 Gs |

Results: No occupant contact occurred in the longitudinal or lateral directions. (PASS).

9.4.1.8.3 Vehicle Trajectory

N. Vehicle trajectory behind the test article is acceptable.

Result: The 2270P vehicle did exit behind the test article. (PASS)

9.4.2 Test 463631-2 (MASH Test No. 3-61) on 10 BWG Steel Slipbase Support with 12 Ft² Sign Panel

9.4.2.1 Test Designation and Actual Impact Conditions

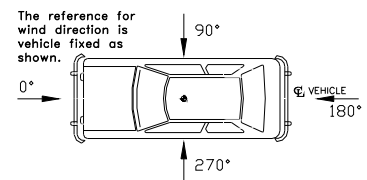
MASH test 3-61 involves an 1100C vehicle weighing 2420 lb \pm 55 lb and impacting the sign support at an impact speed of 62 mph \pm 2.5 mph and a critical impact angle of 0 degrees \pm 1.5 degrees. The target impact point was the quarter point of the vehicle aligned with the centerline of the support. The 2003 Kia Rio used in the test weighed 2429 lb and the actual impact speed and angle were 61.6 mph and 0 degrees, respectively. The actual impact point was the right front quarter point of the vehicle with the centerline of the sign support.

9.4.2.2 Test Vehicle

A 2003 Kia Rio shown in Figures 9.37 and 9.38 was used for the crash test. Test inertia weight of the vehicle was 2429 lb, and its gross static weight was 2595 lb. The height to the lower edge of the vehicle front bumper was 8.5 inches, and the height to the upper edge of the front bumper was 22.75 inches. Table I1 in Appendix I gives additional dimensions and information on the vehicle. The vehicle was directed into the installation using the cable reverse tow and guidance system, and was released to be free-wheeling and unrestrained just prior to impact.

9.4.2.3 Weather Conditions

The crash test was performed on the morning of June 24, 2011. Weather conditions at the time of testing were: Wind speed: 3 mph; wind direction: 138 degrees with respect to the vehicle (vehicle was traveling in a southerly direction); temperature: 92°F; relative humidity: 56 percent. During the 10 days prior to the test, 2.45 inches of rainfall was recorded.



9.4.2.4 Test Description

The 1100C vehicle, traveling at an impact speed of 61.6 mph, contacted the sign support at an impact angle of 0 degrees, with the right front quarter point aligned with the centerline of the support. At approximately 0.003 s, the support began to activate at the slipbase connection. The sign and support rose upward in front of the vehicle and lost contact with the vehicle at 0.031 s. The top of the sign panel and the top of support contacted the roof at 0.115 s and 0.125 s, respectively. At 0.138 s after impact, the rear vehicle glass began to separate from frame, and at 0.147 s it was totally separated from the body of the vehicle. At 0.172 s after impact, the top of the sign lost contact with the roof of the vehicle and the vehicle was traveling at an approximate exit speed of 60.9 mph. Brakes on the vehicle were applied at 1.31 s after

impact, and the vehicle subsequently came to rest 278 ft downstream of impact. Figure I1 in Appendix I shows sequential photographs of the test period.



Figure 9.37. Vehicle/Installation Geometrics for Test No. 463631-2.



Figure 9.38. Vehicle before Test No. 463631-2.

9.4.2.5 *Test Article and Component Damage*

As shown in Figures 9.39 and 9.40, the sign support activated as designed by slipping away at the base connection. The support was slightly deformed at the insertion site with the slipbase support. The sign panel detached from the pipe support. The support and the sign panel were resting 120 ft and 111 ft downstream, 36 ft right of the impact point, respectively.

9.4.2.6 *Test Vehicle Damage*

The 1100C vehicle sustained damage to the center front (see Figures 9.41 and 7.12). The right front bumper quarter point, the hood, and the roof were deformed. Figure 7.12 shows the rear glass was completely shattered and detached from the vehicle body. The maximum exterior crush to the front plane of the vehicle was 1.5 inch at bumper height. A 30-inch × 40-inch dent in the roof with a maximum 4.75-inch depth was documented. Maximum occupant compartment deformation was 4.75 inches in the roof over the back passenger compartment with a 5-inch × 0.25-inch cut. Figures 9.42 and 7.13 show photographs of the roof and interior damage of the vehicle. Tables I2 and I3 in Appendix I show the exterior vehicle crush and occupant compartment measurements.

9.4.2.7 *Occupant Risk Values*

Data from the accelerometer, located at the vehicle center of gravity, were digitized for evaluation of occupant risk. In the longitudinal direction, the occupant impact velocity was 1.6 ft/s at 0.887 s, the highest 0.010-s occupant ridedown acceleration was 0.1 Gs from 0.896 to 0.906 s, and the maximum 0.050-s average acceleration was -0.9 Gs between 0.002 and 0.052 s. In the lateral direction, the occupant impact velocity was 3.3 ft/s at 0.887 s, the highest 0.010-s occupant ridedown acceleration was -0.2 Gs from 0.990 to 1.000 s, and the maximum 0.050-s average was -0.4 Gs between 0.110 and 0.160 s. Theoretical Head Impact Velocity (THIV) and Post-Impact Head Decelerations (PHD) were not calculated. Acceleration Severity Index (ASI) was 0.15 between 0.097 and 0.147 s. Figure 9.44 summarizes these data and other pertinent information from the test. Figures I2 through I8 in Appendix I presents the vehicle angular displacements and accelerations versus time traces.



Figure 9.39. Position of Sign Support/Vehicle after Impact for Test No. 463631-2.



Figure 9.40. Installation after Test No. 463631-2.



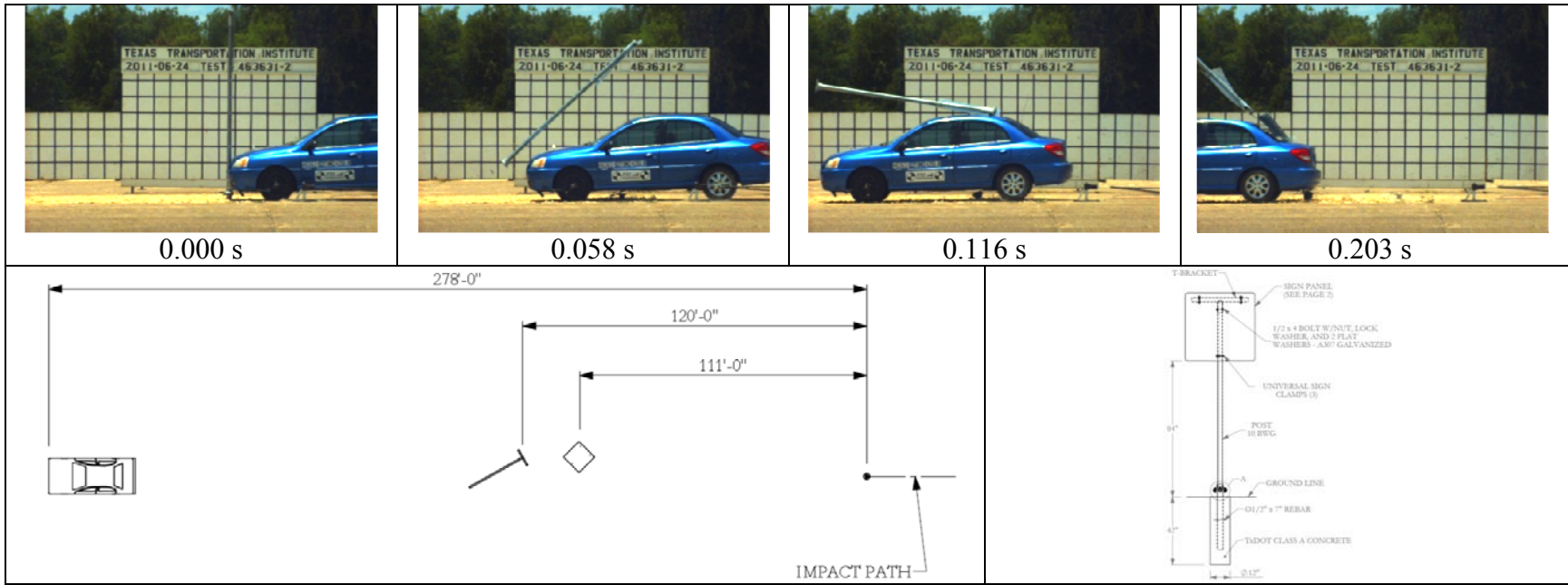
Figure 9.41. Vehicle after Test No. 463631-2.



Figure 9.42. Vehicle Roof Deformation after Test No. 463631-2.



Figure 9.43. Interior of Vehicle after Test No. 463631-2.



General Information

Test Agency..... Texas Transportation Institute
 MASH Test No. MASH Test 3-61
 TTI-PG Test No. 463631-2
 Date 2011-06-24

Test Article

Type..... Single Sign Support
 Name 10 BWG Support/12 ft² Sign Panel
 Installation Height..... 7 ft to bottom of upper front sign panel
 Material or Key Elements 1 sign panel mounted on a 2-7/8-inch OD pipe support with triangular slipbase

Soil Type and Condition

Concrete Footer in Crushed Limestone

Test Vehicle

Type/Designation..... 1100C
 Make and Model 2003 Kia Rio
 Curb 2384 lb
 Test Inertial..... 2429 lb
 Dummy 166 lb
 Gross Static..... 2595 lb

Impact Conditions

Speed61.6 mph
 Angle0 degrees
 Location/OrientationQuarter point of vehicle with centerline of sign support

Exit Conditions

Speed60.9 mph
 Angle0 degrees

Occupant Risk Values

Impact Velocity
 Longitudinal1.6 ft/s
 Lateral3.4 ft/s
 Ridedown Accelerations
 Longitudinal0.1 G
 Lateral-0.2 G
 THIVN/A
 ASI.....0.15
 Max. 0.050-s Average
 Longitudinal-0.9 G
 Lateral-0.4 G
 Vertical1.4 G

Post-Impact Trajectory

Stopping Distance 278 ft

Vehicle Stability

Maximum Yaw Angle..... -15 degrees
 Maximum Pitch Angle..... 2 degrees
 Maximum Roll Angle 8 degree
 Vehicle Snagging No
 Vehicle Pocketing No

Test Article Deflections

Dynamic 120 ft
 Permanent..... 120 ft
 Working Width N/A

Vehicle Damage

VDS 12FR1
 CDC..... 12FREN1
 Max. Exterior Deformation..... 1.5 inches
 OCDI..... RR0300000
 Max. Occupant Compartment Deformation..... 4.75 inches

Figure 9.44. Summary of Results for MASH Test 3-61 on the 10 BWG Steel Pipe Slipbase Support with 12 ft² Sign Panel (Test No. 463631-2).

9.4.2.8 Assessment of Test Results

An assessment of the test based on the following applicable *MASH* safety evaluation criteria is presented below.

9.4.2.8.1 Structural Adequacy

- B. *The test article should readily activate in a predictable manner by breaking away, fracturing, or yielding.*

Results: The sign support activated readily by slipping away at the base. (PASS)

9.4.2.8.2 Occupant Risk

- D. *Detached elements, fragments, or other debris from the test article should not penetrate or show potential for penetrating the occupant compartment, or present an undue hazard to other traffic, pedestrians, or personnel in a work zone.*

Deformation of, or intrusions into, the occupant compartment should not exceed limits set forth in Section 5.3 and Appendix E of MASH. (roof ≤ 4.0 inches; windshield = ≤ 3.0 inches; side windows = no shattering by test article structural member; wheel/foot well/toe pan ≤ 9.0 inches; forward of A-pillar ≤ 12.0 inches; front side door area above seat ≤ 9.0 inches; front side door below seat ≤ 12.0 inches; floor pan/transmission tunnel area ≤ 12.0 inches).

Results: The upper support with sign panel attached slipped away at the base connection and contacted the roof of the vehicle. The rear glass was shattered and completely detached from the body of the vehicle. The roof was deformed into the occupant compartment 4.75 inches, and a 5-inch \times 0.25-inch cut in the roof slightly left of center over the back passenger compartment resulted from impact and interaction with a sign clamp. (FAIL)

- F. *The vehicle should remain upright during and after collision. The maximum roll and pitch angles are not to exceed 75 degrees.*

Results: The 1100C vehicle remained upright during and after the collision event. Maximum roll and pitch angles were 8 and 2 degrees, respectively. (PASS)

- K. *Occupant impact velocities should satisfy the following:*

Longitudinal and Lateral Occupant Impact Velocity

Preferred
10 ft/s

Maximum
16 ft/s

Results: Longitudinal occupant impact velocity was 1.6 ft/s, and lateral occupant impact velocity was 3.3 ft/s. (PASS)

- I. *Occupant ridedown accelerations should satisfy the following:*
Longitudinal and Lateral Occupant Ridedown Accelerations

| <u>Preferred</u> | <u>Maximum</u> |
|------------------|----------------|
| 15.0 Gs | 20.49 Gs |

Results: Longitudinal occupant ridedown acceleration was 0.1 G, and lateral occupant ridedown acceleration was -0.2 G. (PASS).

9.4.2.8.3 Vehicle Trajectory

- N. *Vehicle trajectory behind the test article is acceptable.*

Result: The 1100C vehicle did exit behind the test article. (PASS)

9.5 COMMENTS

With a resulting roof crush of 4.75 inches, the second full scale crash test (Test no. 463631-2) did not meet the *MASH* criteria, which allows for a maximum occupant compartment deformation of 4 inches. Consequently, a single sign support with a sign area of 12 ft² cannot be mounted on a slipbase system. A third full scale crash test was needed to evaluate the minimum sign area to be installed on a slipbase single sign support system that would meet the *MASH* criteria requirements.

In Test no. 463631-2, the sign impacted the roof of the passenger car at around 9 inches from the edge of the vehicle's roof (see Figure 9.45). The FE simulation with the same geometry and impact conditions predicted the sign impact at the roof edge. Consequently, there was a 9 inch gap between the predicted (FE) and the resulting (test) roof impact location.

The next objective was to critically reevaluate the FE results from simulations with other sign areas greater than 12 ft² and compare them with the impact location obtained in the computer simulation with a 12 ft² sign area. The scope was to propose a sign area (greater than 12 ft²) to be evaluated in a full scale crash test as the minimum to be installed on a slipbase system.

According to the previously performed FE simulations for a 62-mph impact, a sign support with a 14 ft² sign area would impact the passenger car around 3 inches behind the impact location predicted with a 12 ft² sign area. On the other hand, a sign support with a 16 ft² sign area would impact the passenger car around 9 inches behind the impact location predicted with a 12 ft² sign area. Consequently, the use of a single sign support with 16 ft² sign area would fill the gap of 9 inches discussed earlier in terms of roof impact location (see Figure 9.46).

With a sign area of 16 ft², thus, the sign support system would be expected to impact the passenger car at the edge of the roof, if not at the back window. *MASH* does not contain any requirements in terms of back window deformation to be met for considering a test article crashworthy. The best result that could be obtained from the third test would be to have the

single sign post impacting the vehicle on the back window. Even an impact on the vehicle at the back edge of the roof is expected to help in terms of lowering the roof deformation.

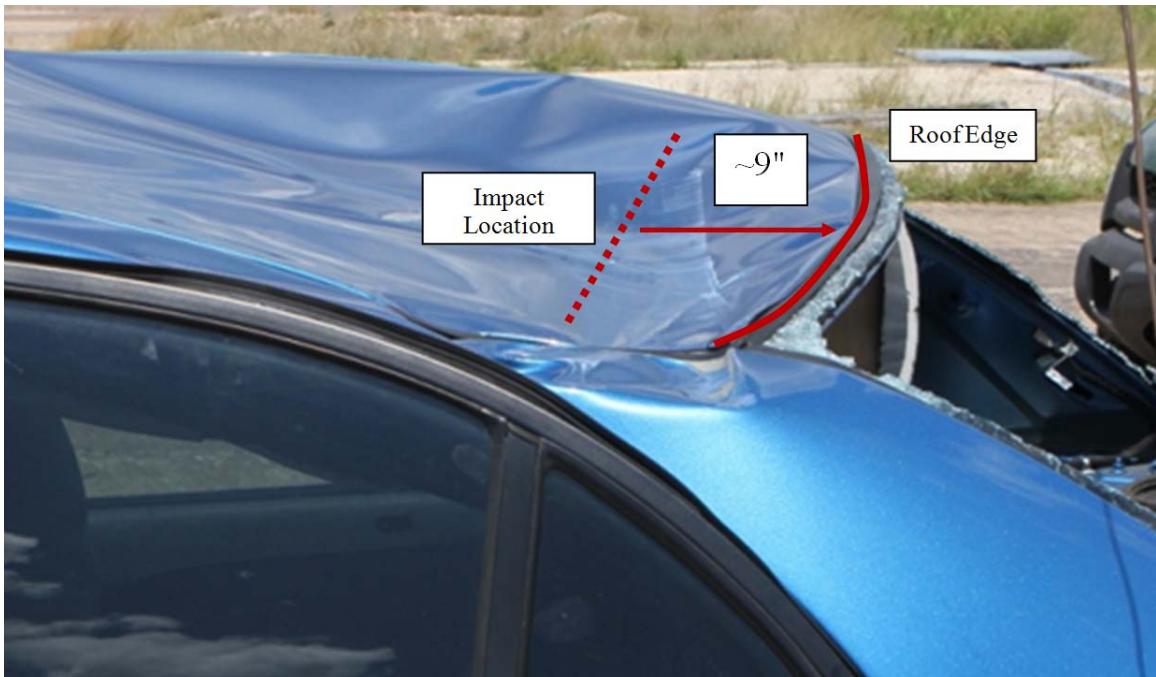


Figure 9.45. Distance of Sign Impact Location to the Roof Edge for Test No. 463631-2.

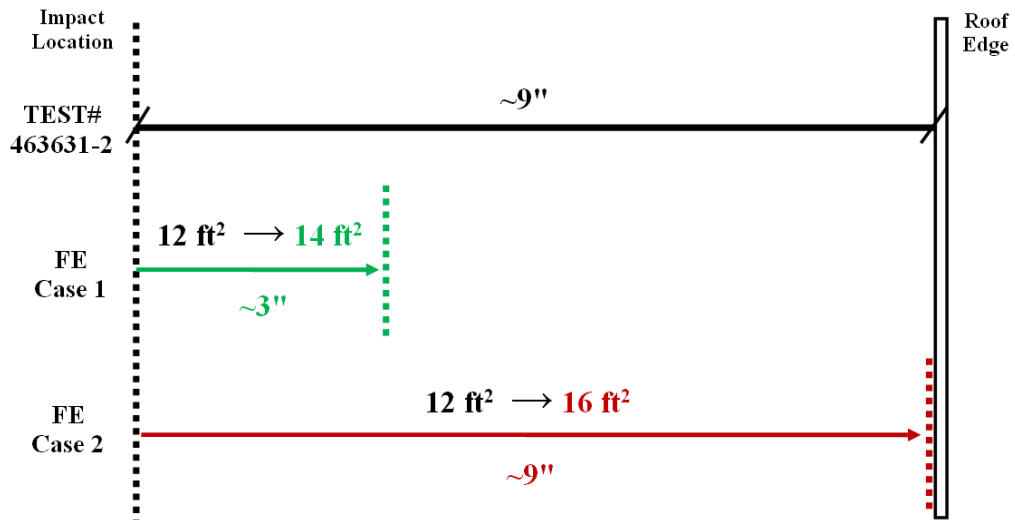


Figure 9.46. Comparison of FE Predicted Sign Impact Locations with Different Sign Areas.

A closer investigation of the vehicle body, however, revealed the presence of a reinforced structure along the edge of the roof, which extends for 5 inches into the occupant compartment (see Figure 9.47).

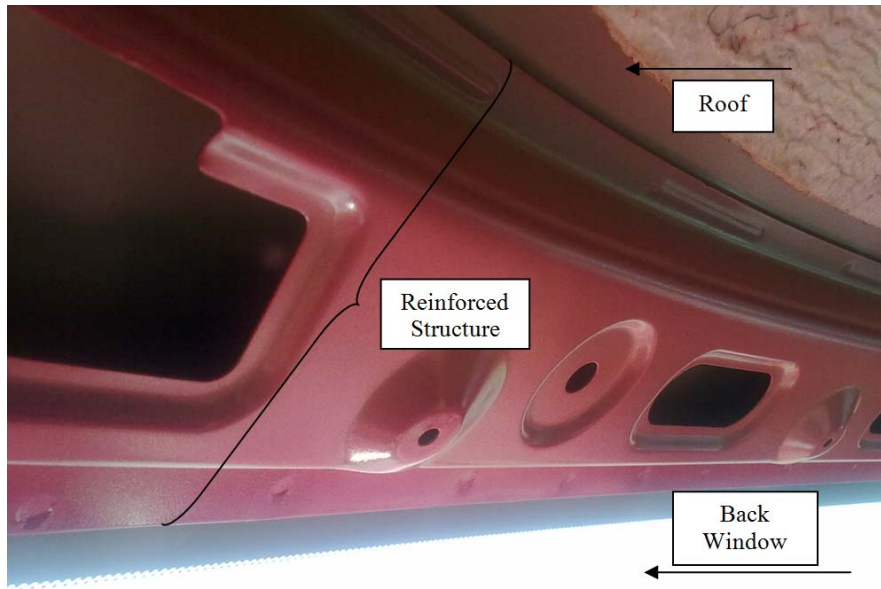


Figure 9.47. Reinforced Structure at the Small Passenger Vehicle's Roof Edge.

It is believed that impacting the reinforced structure would help in containing the roof deformation caused during contact between the sign support system and the vehicle. Thus, the new goal is not necessarily to impact the edge of the roof, but a contact anywhere in the 5-inch region before the end of the roof would be considered desirable according to the consideration made above. The new gap to be filled would be now 4 inches (9 inches initial gap–5 inches of reinforced structure) (see Figure 9.48).

Moreover, the new 90-mph wind load showed that the capacity of a 2.0-inch nominal diameter 13 BWG pipe with a wedge and socket system covers all sign areas up to 14 ft², for a single sign post with a 7-ft mounting height (see Figure 9.49). Signs with an area up to 24 ft² can be mounted on a 2.5-inch nominal diameter 10 BWG pipe with a slipbase support.

Thus, if a crash test is run using a 16 ft² sign area, there would be a need to develop a new support system or modify a current one for use with sign areas included between 14 ft² and 16 ft² (since the current wedge and socket system can only accept sign areas up to 14 ft² on a 13 BWG, while the third test would only define the acceptable use of slipbase systems for sign areas from 16 ft² up).

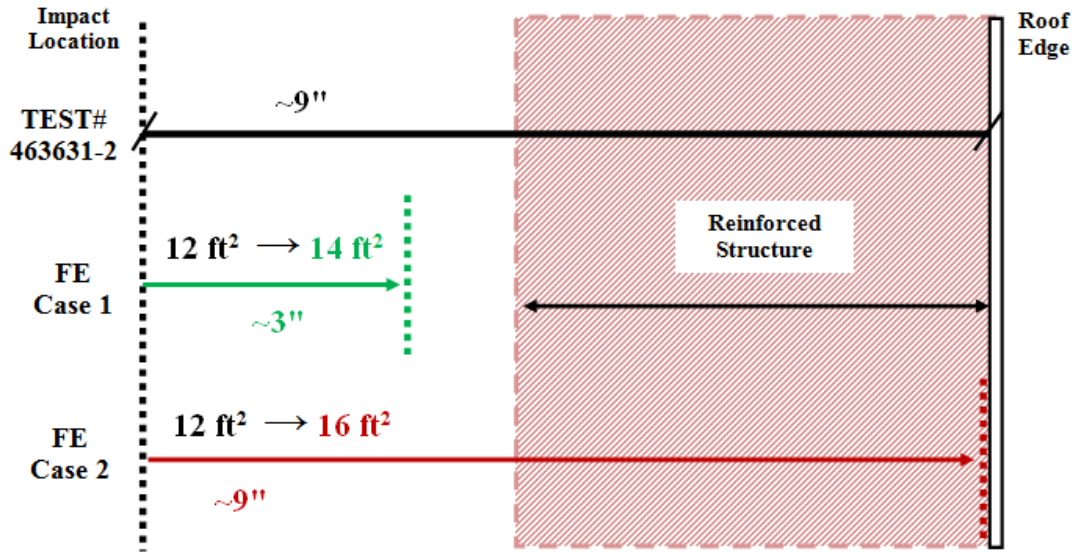


Figure 9.48. Reinforced Structure at the Small Passenger Vehicle's Roof Edge.

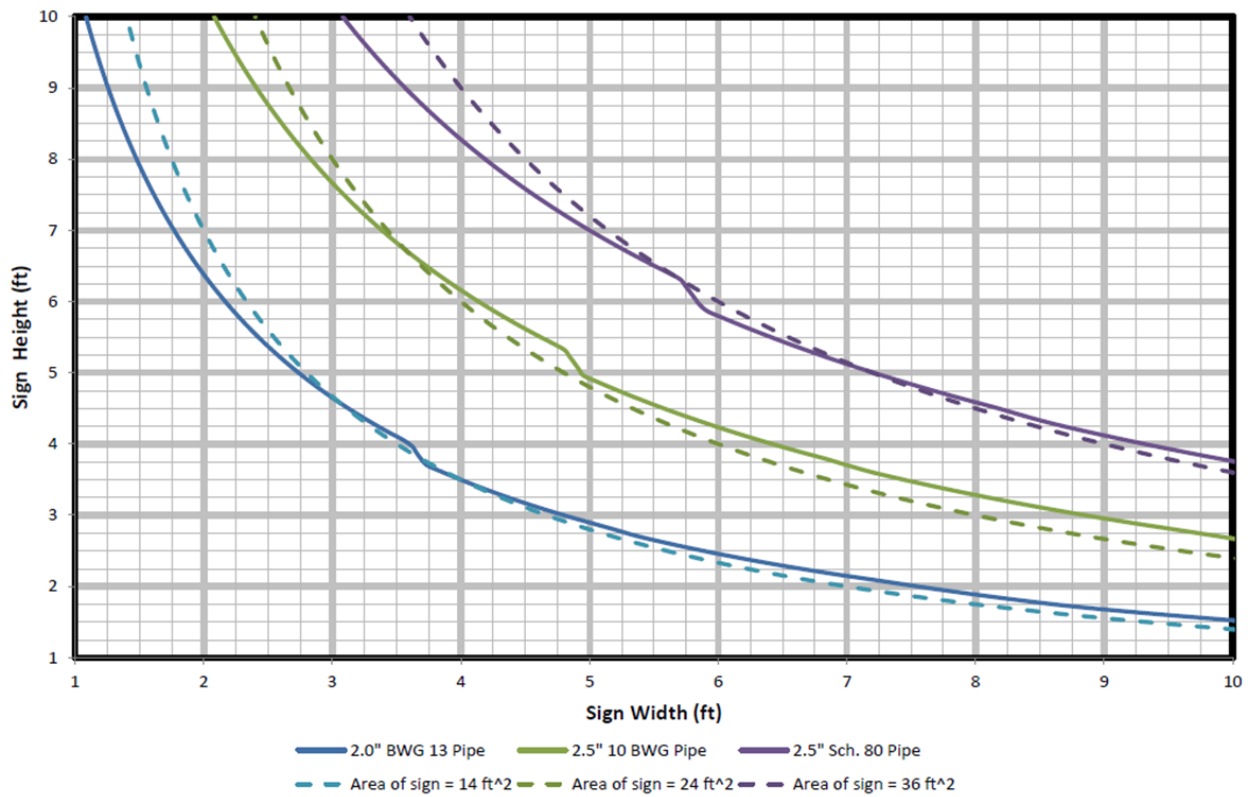


Figure 9.49. 90-mph Wind Load Chart for Single Sign Post with 7-ft Mounting Height.

After all these critical considerations, the researchers decided to propose full-scale crash test *MASH* 3-61 (passenger car) with a 14ft² sign area mounted on a 2.875-inch O.D. 10 BWG pipe support. Since the previous *MASH* test 3-62 (Test no. 463631-1) with a pickup truck and a sign area of 12 ft² was successful, there was no need to run another test with a pickup truck impacting the sign support system with a 14 ft² sign area.

9.6 FULL-SCALE CRASH TESTING ON 14-FT² SIGN PANEL

Sections 7.2.1 and 7.2.2 present information on the crash test matrix and evaluation criteria used in the performance of the following crash tests. *MASH* tests 3-61 was performed on the 10 BWG steel slipbase sign support with a 14 ft² sign panel.

9.6.1 Design Modifications for Test No. 463631-3

A 10 BWG galvanized steel tube with an outside diameter of 2.875-inch and a nominal wall thickness of 0.134-inch was used as the vertical support for the slipbase system. A T-shaped bracket was attached to the vertical support to provide bracing for the sign panel. The T-bracket consisted of a 3.25-inch O.D. (11 BWG) stub welded to a 2.375-inch O.D. (13 BWG) horizontal steel tube. The stub of the T-bracket fit over the end of the 2.875-inch O.D. support and was secured using two 3/8-inch diameter ASTM A307 bolts.

A 45-inch × 45-inch × 0.1-inch thick aluminum sign blank was attached to the 2.375-inch O.D. horizontal member and 2.875-inch O.D. vertical support using a total of three mounting clamps. The mounting clamp used to attach the sign panel to the vertical support was located 3 inches from the lower edge of the sign panel. The two clamps employed to connect the sign panel to the horizontal member were located 4.25 inches from the upper edge of the sign panel and 6 inches from the side edge of the sign panel. The mounting height to the bottom of the sign blank was 7 ft. Figures 9.50 and 9.51 give the details of the sign support systems; Figure J1 in Appendix J provides further details.

The same triangular slipbase sign support system used for Test nos. 463631-1 and 463631-2 was installed in the impact position and was offset 6 inches to the right of the vehicle centerline. The test installation was installed in a concrete footing installed in standard soil meeting AASHTO standard specifications for “Materials for Aggregate and Soil Aggregate Subbase, Base and Surface Courses,” designated M147-65(2004), grading B. Figure 9.52 presents photographs of the completed test.

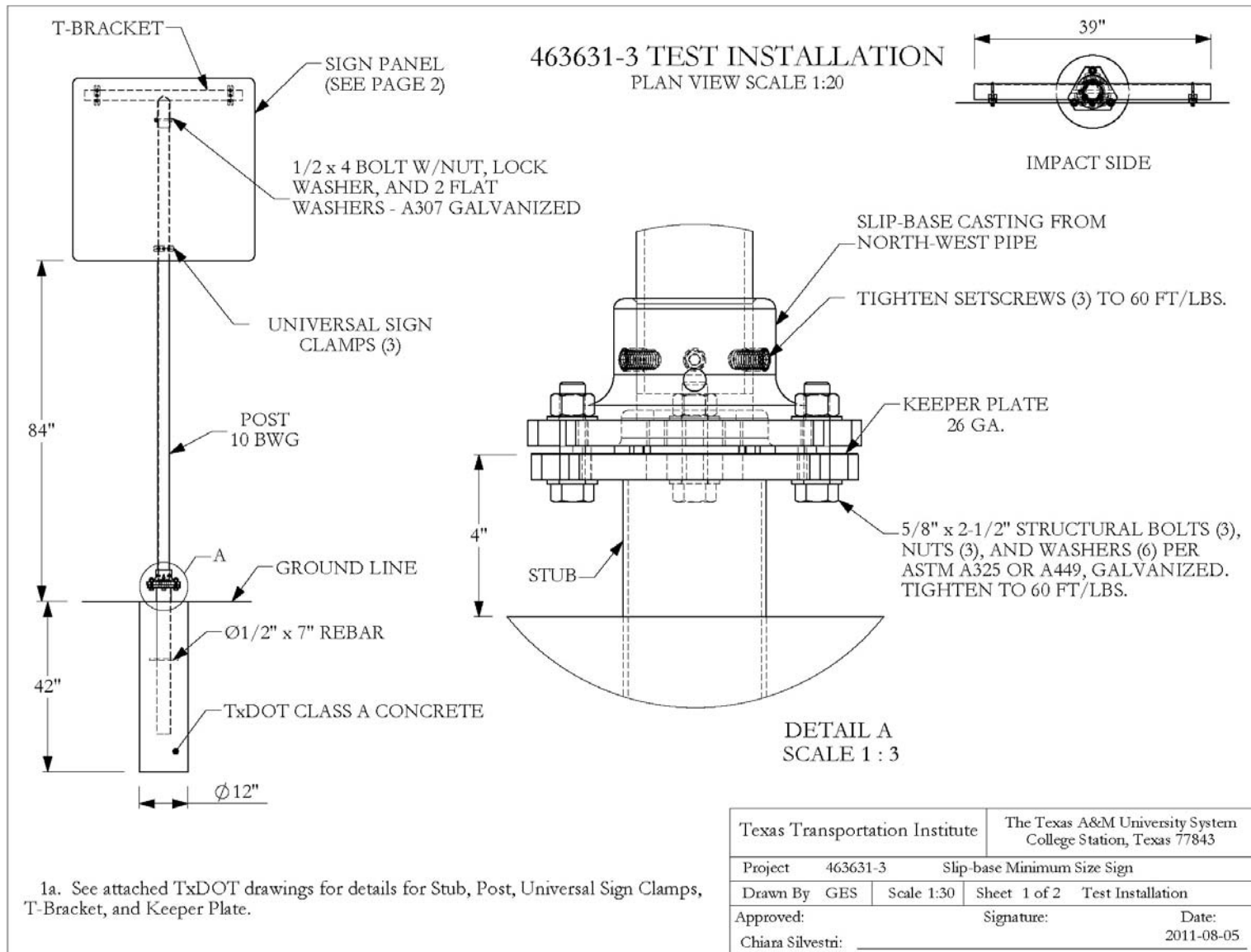


Figure 9.50. Details of the Sign Support System Used for Test No. 463631-3.

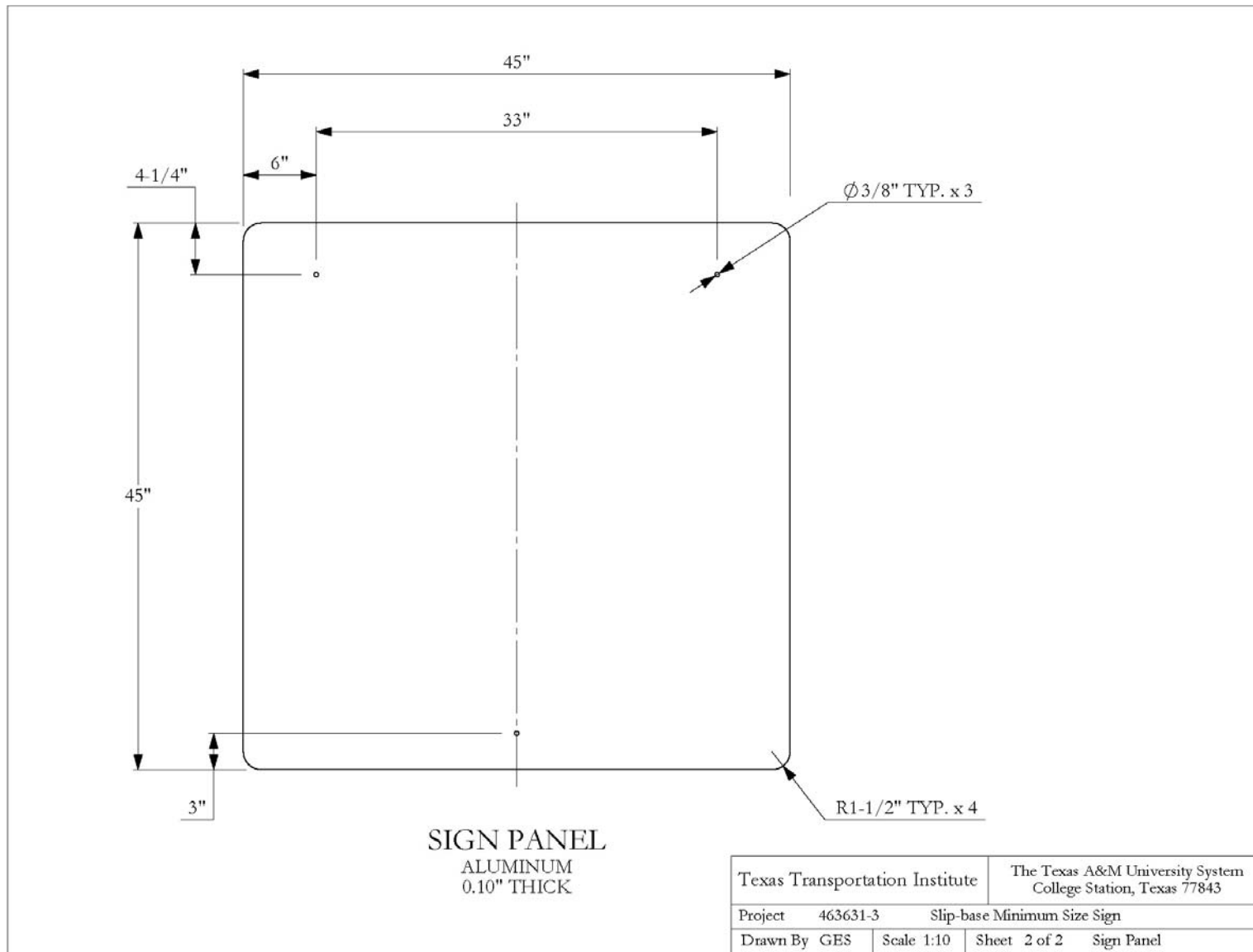


Figure 9.51. Details of the Sign Panel Used for Test No. 463631-3.



Figure 9.52. Sign Support System prior to Test No. 463631-3.

9.6.2 Test 463631-3 (MASH Test No. 3-61) on 10 BWG Steel Slipbase Support with 14 Ft² Sign Panel

9.6.2.1 Test Designation and Actual Impact Conditions

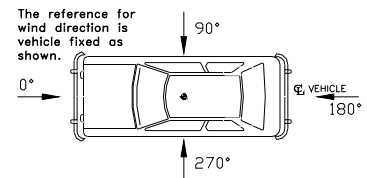
MASH Test 3-61 involves an 1100C vehicle weighing 2420 lb \pm 55 lb and impacting the sign support at an impact speed of 62 mph \pm 2.5 mph and a critical impact angle of 0 degrees \pm 1.5 degrees. The target impact point was the quarter point of the vehicle aligned with the centerline of the support. The 2004 Kia Rio used in the test weighed 2423 lb and the actual impact speed and angle were 61.4 mph and 0 degrees, respectively. The actual impact point was the right front quarter point of the vehicle with the centerline of the sign support.

9.6.2.2 Test Vehicle

A 2004 Kia Rio shown in Figures 9.53 and 9.54 was used for the crash test. Test inertia weight of the vehicle was 2423 lb, and its gross static weight was 2598 lb. The height to the lower edge of the vehicle front bumper was 8.5 inches, and the height to the upper edge of the front bumper was 22.75 inches. Table J1 in Appendix J gives additional dimensions and information on the vehicle. The vehicle was directed into the installation using the cable reverse tow and guidance system, and was released to be free-wheeling and unrestrained just prior to impact.

9.6.2.3 Weather Conditions

The crash test was performed on the morning of August 17, 2011. Weather conditions at the time of testing were: Wind speed: 7 mph; wind direction: 208 degrees with respect to the vehicle (vehicle was traveling in a southerly direction); temperature: 91°F; relative humidity: 55 percent. During the 10 days prior to the test, no rainfall was recorded.



9.6.2.4 Test Description

The 1100C vehicle, traveling at an impact speed of 61.4 mph, contacted the sign support at an impact angle of 0 degrees, with the right front quarter point aligned with the centerline of the support. At approximately 0.002 s, the support began to deform at bumper height, and at 0.003 s, the support began to activate at the slipbase connection. As the sign and support rose upward in front of the vehicle, the bumper split; at 0.050, the vehicle lost contact with the support and the vehicle was traveling at 59.8 mph. The top of the sign panel and the top of support contacted the rear of the roof of the vehicle at 0.1392 s, and the rear window shattered at 0.142 s. At 0.200 s after impact, the top of the sign lost contact with the vehicle and the vehicle was traveling at an approximate exit speed of 58.6 mph. Brakes on the vehicle were applied at 0.820 s after impact, and the vehicle subsequently came to rest 277 ft downstream of impact. Figure J2 in Appendix J shows sequential photographs of the test period.



Figure 9.53. Vehicle/Installation Geometrics for Test No. 463631-3.



Figure 9.54. Vehicle before Test No. 463631-3.

9.6.2.5 *Test Article and Component Damage*

As shown in Figures 9.55 and 9.56, the sign support activated as designed by slipping away at the base connection. The support was very slightly deformed at bumper height. The sign panel remained attached to the pipe support. The support and the sign panel were resting 90 ft downstream and 9 ft left of the impact point.

9.6.2.6 *Test Vehicle Damage*

Figures 9.57 and 9.58 show the 1100C vehicle sustained damage to the center front. The right front bumper quarter point, hood, grill, and the roof were deformed. The rear glass was completely shattered. The maximum exterior crush to the front plane of the vehicle was 2.5 inches at bumper height. A 28.5-inch \times 16-inch dent in the rear roof with maximum 2.5-inch depth was documented. Maximum occupant compartment deformation was 2.5 inches in the roof over the back passenger compartment. Figures 9.58 and 9.59 show photographs of the roof and interior damage of the vehicle. Tables J2 and J3 in Appendix J show the exterior vehicle crush and occupant compartment measurements.

9.6.2.7 *Occupant Risk Values*

Data from the accelerometer, located at the vehicle center of gravity, were digitized for evaluation of occupant risk. In the longitudinal direction, the occupant impact velocity was 1.0 ft/s at 0.713 s, the highest 0.010-s occupant ridedown acceleration was 0.8 Gs from 0.981 to 0.991 s, and the maximum 0.050-s average acceleration was -0.9 Gs between 0.003 and 0.053 s. In the lateral direction, the occupant impact velocity was 2.6 ft/s at 0.7137 s, the highest 0.010-s occupant ridedown acceleration was 0.4 Gs from 1.025 to 1.035 s, and the maximum 0.050-s average was 0.3 Gs between 0.212 and 0.262 s. Theoretical Head Impact Velocity (THIV) was 3.1 km/h or 0.9 m/s at 0.702 s, Post-Impact Head Decelerations (PHD) was 0.8 Gs from 0.981 to 0.991 s, Acceleration Severity Index (ASI) was 0.09 between 0.116 and 0.166 s. Figure 9.60 summarizes these data and other pertinent information from the test. Figures J3 through J9 in Appendix J show vehicle angular displacements and accelerations versus time traces.



Figure 9.55. Position of Sign Support/Vehicle after Impact for Test No. 463631-3.



Figure 9.56. Installation after Test No. 463631-3.



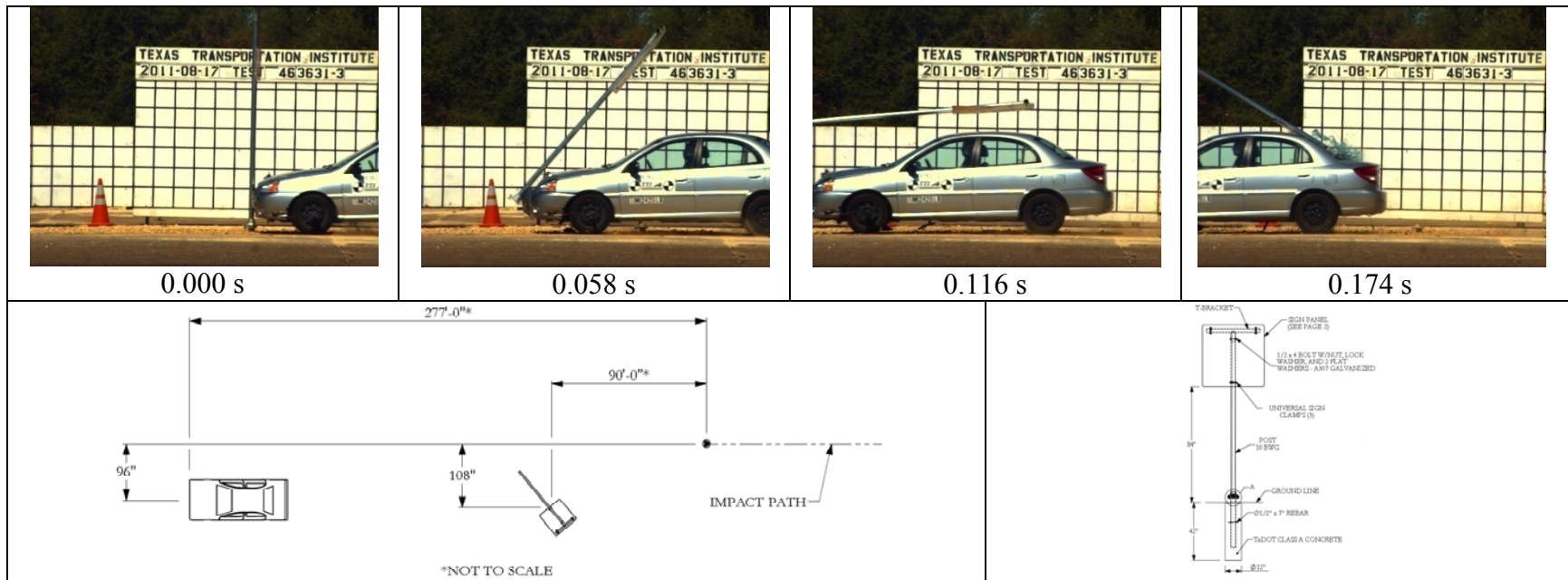
Figure 9.57. Vehicle after Test No. 463631-3.



Figure 9.58. Vehicle Roof Deformation after Test No. 463631-3.



Figure 9.59. Interior of Vehicle after Test No. 463631-3.



General Information

Test Agency..... Texas Transportation Institute
 MASH Test No. MASH Test 3-61
 TTI-PG Test No. 463631-3
 Date 2011-08-17

Test Article

Type..... Single Sign Support
 Name 10 BWG Support/14 ft² Sign Panel
 Installation Height 7 ft to bottom of upper front sign panel
 Material or Key Elements 1 sign panel mounted on a 2-7/8-inch OD pipe support with triangular slipbase

Soil Type and Condition

Concrete Footer in Crushed Limestone

Test Vehicle

Type/Designation..... 1100C
 Make and Model 2004 Kia Rio
 Curb 2410 lb
 Test Inertial 2423 lb
 Dummy 175 lb
 Gross Static 2598 lb

Impact Conditions

Speed 61.4 mph
 Angle 0 degrees
 Location/Orientation Quarter point of vehicle with centerline of sign support

Exit Conditions

Speed 59.8 mph
 Angle 0 degrees

Occupant Risk Values

Impact Velocity
 Longitudinal 1.0 ft/s
 Lateral 2.6 ft/s
 Ridedown Accelerations
 Longitudinal 0.8 G
 Lateral 0.4 G
 THIV 3.1 km/h
 ASI 0.09
 Max. 0.050-s Average
 Longitudinal -0.9 G
 Lateral 0.3 G
 Vertical 0.9 G

Post-Impact Trajectory

Stopping Distance 277 ft

Vehicle Stability

Maximum Yaw Angle 2 degrees
 Maximum Pitch Angle 3 degrees
 Maximum Roll Angle 2 degrees
 Vehicle Snagging No
 Vehicle Pocketing No

Test Article Deflections

Dynamic 90 ft
 Permanent 90 ft
 Working Width N/A

Vehicle Damage

VDS 12RF2
 CDC 12FDEN2
 Max. Exterior Deformation 2.5 inches
 OCDL RR0100000
 Max. Occupant Compartment Deformation 2.5 inches

Figure 9.60. Summary of Results for MASH Test 3-61 on the 10 BWG Steel Pipe Slipbase Support with 14 ft² Sign Panel (Test No. 463631-3).

9.6.2.8 Assessment of Test Results

An assessment of the test based on the following applicable *MASH* safety evaluation criteria is presented below.

9.6.2.8.1 Structural Adequacy

- B. *The test article should readily activate in a predictable manner by breaking away, fracturing, or yielding.*

Results: The sign support activated readily by slipping away at the base. (PASS)

9.6.2.8.2 Occupant Risk

- D. *Detached elements, fragments, or other debris from the test article should not penetrate or show potential for penetrating the occupant compartment, or present an undue hazard to other traffic, pedestrians, or personnel in a work zone.*

Deformation of, or intrusions into, the occupant compartment should not exceed limits set forth in Section 5.3 and Appendix E of MASH. (roof ≤ 4.0 inches; windshield = ≤ 3.0 inches; side windows = no shattering by test article structural member; wheel/foot well/toe pan ≤ 9.0 inches; forward of A-pillar ≤ 12.0 inches; front side door area above seat ≤ 9.0 inches; front side door below seat ≤ 12.0 inches; floor pan/transmission tunnel area ≤ 12.0 inches).

Results: The upper support with sign panel attached slipped away at the base connection and contacted the rear roof of the vehicle. The rear glass shattered and the roof was deformed into the occupant compartment 2.5 inches. (PASS)

- F. *The vehicle should remain upright during and after collision. The maximum roll and pitch angles are not to exceed 75 degrees.*

Results: The 1100C vehicle remained upright during and after the collision event. Maximum roll and pitch angles were 2 and 3 degrees, respectively. (PASS)

- L. *Occupant impact velocities should satisfy the following:*

Longitudinal and Lateral Occupant Impact Velocity

Preferred
10 ft/s

Maximum
16 ft/s

Results: Longitudinal occupant impact velocity was 1.0 ft/s, and lateral occupant impact velocity was 2.6 ft/s. (PASS)

- I. *Occupant ridedown accelerations should satisfy the following:*
Longitudinal and Lateral Occupant Ridedown Accelerations

| <u><i>Preferred</i></u> | <u><i>Maximum</i></u> |
|-------------------------|-----------------------|
| <i>15.0 Gs</i> | <i>20.49 Gs</i> |

Results: Longitudinal occupant ridedown acceleration was 0.8 G, and lateral occupant ridedown acceleration was 0.4 G. (PASS).

9.2.6.8.3 Vehicle Trajectory

- N. *Vehicle trajectory behind the test article is acceptable.*

Result: The 1100C vehicle did exit behind the test article. (PASS)

9.7 SUMMARY OF TEST RESULTS

9.7.1 Test 463631-1 (MASH Test No. 3-62) on 10 BWG Steel Slipbase Support with 12 Ft² Sign Panel

The sign support activated readily by slipping away at the base. The upper support with sign panel attached slipped away at the base connection and contacted the roof of the vehicle. The windshield was shattered and cracked on the top portion next to the roof line. The roof was deformed into the occupant compartment 3.625 inches, and a puncture hole slightly right of center over the front passenger compartment resulted from impact and interaction with a sign clamp. The 2270P vehicle remained upright during and after the collision event. Maximum roll and pitch angles were -1 and -2 degrees, respectively. No occupant contact occurred in the longitudinal or lateral directions. The 2270P vehicle did exit behind the test article.

9.7.2 Test 463631-2 (MASH Test No. 3-61) on 10 BWG Steel Slipbase Support with 12 Ft² Sign Panel

The sign support activated readily by slipping away at the base. The upper support with sign panel attached slipped away at the base connection and contacted the roof of the vehicle. The rear glass was shattered and completely detached from the body of the vehicle. The roof was deformed into the occupant compartment 4.75 inches, and a 5-inch × 0.25-inch cut in the roof slightly left of center over the back passenger compartment resulted from impact and interaction with a sign clamp. The 1100C vehicle remained upright during and after the collision event. Maximum roll and pitch angles were 8 and 2 degrees, respectively. Occupant risk factors were within the specified limits for MASH Test 3-61. The 1100C vehicle did exit behind the test article.

9.7.3 Test 463631-3 (*MASH* Test No. 3-61) on 10 BWG Steel Slipbase Support with 14 Ft² Sign Panel

The sign support activated readily by slipping away at the base. The upper support with sign panel attached slipped away at the base connection and contacted the rear roof of the vehicle. The rear glass shattered and the roof was deformed into the occupant compartment 2.5 inches. The 1100C vehicle remained upright during and after the collision event. Maximum roll and pitch angles were 2 and 3 degrees, respectively. Occupant risk factors were within the specified limits for *MASH* Test 3-61. The 1100C vehicle did exit behind the test article.

9.8 CONCLUSIONS

The objective of this task was to establish a minimum sign area to be mounted on a slipbase system to reduce severity of the roof crush and improve safety according to the new safety-performance evaluation guidelines included in *MASH*. Finite element parametric simulations were used to predict impact location and severity of a sign support system second impact with an errant vehicle, as a function of the sign area. Full-scale, high-speed crash test *MASH* Test 3-61 (passenger car) and Test 3-62 (pickup truck) were performed as verification of the FE parametric study. Tables 9.2 through 9.4 show that tests were evaluated according to the criteria reported in the *MASH*.

Results show that the minimum sign area to be installed on a slipbase single support system is 14 ft². Consequently, all signs with an area smaller than 14 ft² need to be mounted on a 13 BWG pole with a wedge and socket system. It is also recommended that all signs with an area between 14 and 24 ft² would be mounted on a BWG 10 pipe support with slipbase. Sign areas between 24 and 36 ft² should be mounted on a schedule 80 pipe support with a slipbase support system. Table 9.5 summarizes recommendations of types of pole and support system for use with different sign areas.

Table 9.2. Performance Evaluation Summary for MASH Test 3-62 on the 10 BWG Steel Pipe Support with 12 ft² Sign Panel.

Test Agency: Texas Transportation Institute

Test No.: 463631-1

Test Date: 2011-06-21

| MASH Test 3-62 Evaluation Criteria | Test Results | Assessment |
|--|--|-------------------|
| Structural Adequacy | | |
| <i>B. The test article should readily activate in a predictable manner by breaking away, fracturing, or yielding.</i> | The sign support activated readily by slipping away at the base. | Pass |
| Occupant Risk <i>D. Detached elements, fragments, or other debris from the test article should not penetrate or show potential for penetrating the occupant compartment, or present an undue hazard to other traffic, pedestrians, or personnel in a work zone. Deformations of, or intrusions into, the occupant compartment should not exceed limits set forth in Section 5.3 and Appendix E of MASH.</i> | The upper support with sign panel attached slipped away at the base connection and contacted the roof of the vehicle. The windshield was shattered and cracked on the top portion next to the roof line. The roof was deformed into the occupant compartment 3.625 inches, and a puncture hole slightly right of center over the front passenger compartment resulted from impact and interaction with a sign clamp. | Pass |
| <i>F. The vehicle should remain upright during and after collision. The maximum roll and pitch angles are not to exceed 75 degrees.</i> | The 2270P vehicle remained upright during and after the collision event. Maximum roll and pitch angles were -1 and -2 degrees, respectively. | Pass |
| <i>H. Longitudinal and lateral occupant impact velocities should fall below the preferred value of 3.0 m/s (10 ft/s), or at least below the maximum allowable value of 5.0 m/s (16.4 ft/s).</i> | No occupant contact occurred in the longitudinal or lateral directions. | Pass |
| <i>I. Longitudinal and lateral occupant ridedown accelerations should fall below the preferred value of 15.0 Gs, or at least below the maximum allowable value of 20.49 Gs.</i> | No occupant contact occurred in the longitudinal or lateral directions. | Pass |
| Vehicle Trajectory | | |
| <i>N. Vehicle trajectory behind the test article is acceptable.</i> | The 2270P vehicle did exit behind the test article. | Pass |

Table 9.3. Performance Evaluation Summary for MASH Test 3-61 on the 10 BWG Steel Pipe Support with 12 ft² Sign Panel.

Test Agency: Texas Transportation Institute

Test No.: 463631-2

Test Date: 2011-06-24

| MASH Test 3-61 Evaluation Criteria | Test Results | Assessment |
|--|--|-------------------|
| Structural Adequacy | | |
| <i>B. The test article should readily activate in a predictable manner by breaking away, fracturing, or yielding.</i> | The sign support activated readily by slipping away at the base. | Pass |
| Occupant Risk <i>D. Detached elements, fragments, or other debris from the test article should not penetrate or show potential for penetrating the occupant compartment, or present an undue hazard to other traffic, pedestrians, or personnel in a work zone. Deformations of, or intrusions into, the occupant compartment should not exceed limits set forth in Section 5.3 and Appendix E of MASH.</i> | The upper support with sign panel attached slipped away at the base connection and contacted the roof of the vehicle. The rear glass was shattered and completely detached from the body of the vehicle. The roof was deformed into the occupant compartment 4.75 inches, and a 5 inch × 0.25-inch cut in the roof slightly left of center over the back passenger compartment resulted from impact and interaction with a sign clamp. | Fail |
| <i>F. The vehicle should remain upright during and after collision. The maximum roll and pitch angles are not to exceed 75 degrees.</i> | The 1100C vehicle remained upright during and after the collision event. Maximum roll and pitch angles were 2 and 3 degrees, respectively. | Pass |
| <i>H. Longitudinal and lateral occupant impact velocities should fall below the preferred value of 3.0 m/s (10 ft/s), or at least below the maximum allowable value of 5.0 m/s (16.4 ft/s).</i> | Longitudinal occupant impact velocity was 1.0 ft/s, and lateral occupant impact velocity was 2.6 ft/s. | Pass |
| <i>I. Longitudinal and lateral occupant ridedown accelerations should fall below the preferred value of 15.0 Gs, or at least below the maximum allowable value of 20.49 Gs.</i> | Longitudinal occupant ridedown acceleration was 0.1 G, and lateral occupant ridedown acceleration was -0.2 G. | Pass |
| Vehicle Trajectory <i>N. Vehicle trajectory behind the test article is acceptable.</i> | The 1100C vehicle did exit behind the test article. | Pass |

Table 9.4. Performance Evaluation Summary for MASH Test 3-61 on the 10 BWG Steel Pipe Support with 14 ft² Sign Panel.

Test Agency: Texas Transportation Institute

Test No.: 463631-3

Test Date: 2011-08-17

| MASH Test 3-61 Evaluation Criteria | Test Results | Assessment |
|--|--|-------------------|
| Structural Adequacy | | |
| <i>B. The test article should readily activate in a predictable manner by breaking away, fracturing, or yielding.</i> | The sign support activated readily by slipping away at the base. | Pass |
| Occupant Risk <i>D. Detached elements, fragments, or other debris from the test article should not penetrate or show potential for penetrating the occupant compartment, or present an undue hazard to other traffic, pedestrians, or personnel in a work zone. Deformations of, or intrusions into, the occupant compartment should not exceed limits set forth in Section 5.3 and Appendix E of MASH.</i> | The sign support activated readily by slipping away at the base. The upper support with sign panel attached slipped away at the base connection and contacted the rear roof of the vehicle. The rear glass shattered and the roof was deformed into the occupant compartment 2.5 inches. | Pass |
| <i>F. The vehicle should remain upright during and after collision. The maximum roll and pitch angles are not to exceed 75 degrees.</i> | The 1100C vehicle remained upright during and after the collision event. Maximum roll and pitch angles were 2 and 3 degrees, respectively. | Pass |
| <i>H. Longitudinal and lateral occupant impact velocities should fall below the preferred value of 3.0 m/s (10 ft/s), or at least below the maximum allowable value of 5.0 m/s (16.4 ft/s).</i> | Longitudinal occupant impact velocity was 1.0 ft/s, and lateral occupant impact velocity was 2.6 ft/s. | Pass |
| <i>I. Longitudinal and lateral occupant ridedown accelerations should fall below the preferred value of 15.0 Gs, or at least below the maximum allowable value of 20.49 Gs.</i> | Longitudinal occupant ridedown acceleration was 0.8 G, and lateral occupant ridedown acceleration was 0.4 G. | Pass |
| Vehicle Trajectory <i>N. Vehicle trajectory behind the test article is acceptable.</i> | The 1100C vehicle did exit behind the test article. | Pass |

Table 9.5. Recommendation of Support System and Pole Type for Use with Different Sign Areas.

| Sign Area (ft²) | System | Pole Type | Pole Nominal Diameter (inches) |
|-----------------------------------|------------------|------------------|---------------------------------------|
| $0 \leq x \leq 14$ | Wedge and Socket | BWG-13 | 2 |
| $14 \leq x \leq 24$ | Slipbase | BWG-10 | 2.5 |
| $24 \leq x \leq 36$ | Slipbase | Schedule-80 | 2.5 |

CHAPTER 10. DEVELOP MOUNTING STANDARDS FOR CHEVRONS AND MILE MARKERS

10.1 BACKGROUND

The Chevron Alignment (W1-8) sign is used to “provide additional emphasis and guidance for a change in horizontal alignment. This sign may also be used as an alternate or supplement to standard delineators on curves or to the One-Direction Large Arrow (W1-6) sign (11). According to the TxDOT standards reported in the “Barricade and Construction Channelizing Devices Standard” BC(9)-07 sheet, the chevron shall be a vertical rectangle with a minimum size of 12 inches × 18 inches (12). Five chevron sizes are acceptable for use in Texas (see Table 10.1) and their use is related to the type of conventional road and the road speed allowed (13).

Table 10.1. Chevron Alignment Sign Sizes.

| Sign Description | Sign Number or Series | Minimum | Low Speed Conventional Road (<55 mph) | High Speed Conventional Road (≥55 mph) | Expressway | Freeway | Oversized |
|------------------|-----------------------|---------|---------------------------------------|--|------------|---------|-----------|
| Rectangular | W1 – Arrows | 36 x 18 | 48 x 24 | 48 x 24 | --- | --- | 60 x 30 |
| | W1 – Chevron | 12 x 18 | 18 x 24 | 24 x 30 | 30 x 36 | 36 x 48 | --- |
| | W12-3T | 66 x 12 | 84 x 24 | 84 x 24 | 84 x 24 | 84 x 24 | 96 x 18 |
| | W13-2, 3, 5 | 24 x 30 | 24 x 30 | 36 x 48 | 36 x 48 | 48 x 60 | --- |

The current “Typical Delineator and Object Marker Placement Details” (D&OM(2)-04) TxDOT standard specifications require a minimum of 4 ft as mounting height, evaluated from the pavement surface, for installing chevron signs using wedge and anchor systems (14). Current standards also require a minimum of 7-ft mounting height for installation of chevron signs on a slipbase support system.

Current TxDOT practice allows installation of all existing chevron sizes on 7-ft mounting height, but restricts the use of 4-ft mounting height for the three smallest existing chevron signs—that is, 12 inches × 18 inches, 18 inches × 24 inches, and 24 inches × 30 inches.

10.2 OBJECTIVE

This study seeks to investigate the crashworthiness of all the suggested installation configuration of the various chevron sizes shown in Table 10.1. As part of this study, the researchers also evaluated the possibility, from a crashworthiness point of view, of allowing 30-inch × 36-inch and 36-inch × 48-inch chevron sign sizes to be mounted at a 4-ft mounting height. A literature review and engineering analysis were conducted as part of the evaluation

process. While investigating standards for chevron installations, the research team reviewed the current TxDOT D&OM and standard sheets and gave suggestions for a more efficient presentation of material and installation information (15).

10.3 LITERATURE REVIEW

Little research has been performed in the past to evaluate the crashworthiness of chevron signs in relation to different mounting heights. The researchers were able to investigate two research projects previously performed at TTI that could help to better understand post-impact behavior of a chevron sign when impacted by a vehicle at high speed.

TxDOT funded a project entitled “Impact Performance Evaluation of Work Zone Traffic Control Devices” aimed at providing traffic control devices for use in work zones (in accordance with *NCHRP Report 350* guidelines) that would perform acceptably when impacted by errant vehicles. One test performed under this research project was a high-speed passenger car impact against a dual chevron installation with panels at a 4-ft mounting height on flat, level ground. Figure 10.1(a) shows that the installation had a single panel through-bolted to a U channel post, and the other installation had two panels attached to a 13 BWG pole using the standard mounting brackets. Of particular interest for the scope of this research study is the outcome of the vehicle impact with the two-panel chevron. The two-panel sign was 24 inches wide and 30 inches high. A Geo Metro passenger car impacted the sign supports head-on at a speed of 62.0 mi/h (see Figure 10.1[b]).

The U-channel chevron support failed to meet the requirements of *NCHRP Report 350*, since it contacted the windshield and cut the roof just behind the windshield frame, thereby showing potential for penetrating the occupant compartment. The thin wall chevron support performed acceptably according to the guidelines of *NCHRP Report 350*. The pole yielded at the bumper impact location and pulled out the socket system. The impacting vehicle then pushed it away, so it never had a second impact with any part of the passenger car (see Figure 10.1[c]). The sign was able to slide through the pole and leave the support impacting the windshield, but did not cause any deformation or intrusion in the occupant compartment.

Because of the successful result from Test no. 417929-3, all chevron sizes up to 24 inches × 30 inches can be mounted on a 4-ft mounting height using a wedge-and-socket system.

In 1995, the New Hampshire Department of Transportation initiated a crash-test program in cooperation with the Vermont Agency of Transportation with the scope of evaluating the safety performance of small sign supports used in their states (16). The study was performed at the Texas Transportation Institute. During this study, the performance of a 12ft² aluminum sign panel (36 inches × 48 inches), mounted on a 4-inch diameter Schedule 10 support at a 7-ft mounting height on flat, level ground, was evaluated (see Figure 10.2[a]).

In Test no. 405231-7, the test article was installed in strong soil and impacted by a passenger car at 62.3 mi/h. The support was bent, pocketed around the bumper, fractured, and impacted the roof of the vehicle (see Figure 10.2[b]). Maximum roof crush was 2.4 inches. In

Test no. 405231-9, the test article was installed in weak soil and impacted by a passenger car at 63.0 mi/h. The support was bent, collapsed around the bumper, fractured and impacted the roof of the vehicle (Figure 10.2[c]). Maximum roof crush was 4.3 inches. Tests results were evaluated according to the criteria of *NCHRP Report 350*, which allows a maximum occupant compartment deformation of 5.9 inches.

Because of the successful results from Test nos. 405231-7 and 405231-9, all chevron sizes up to 36 inches × 48 inches can be mounted on a 7-ft mounting height.

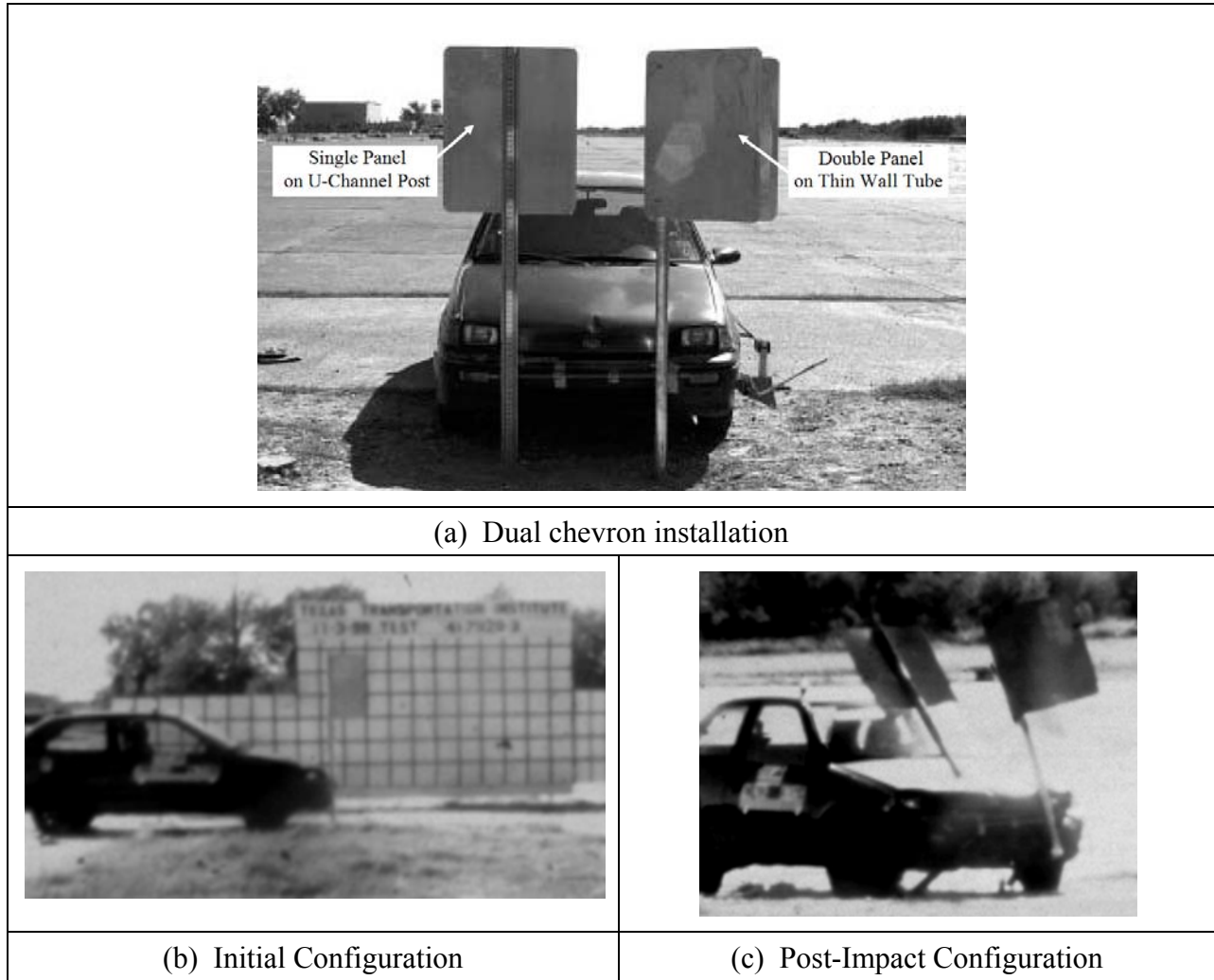


Figure 10.1. Dual Chevron Support Test No. 417929-3.

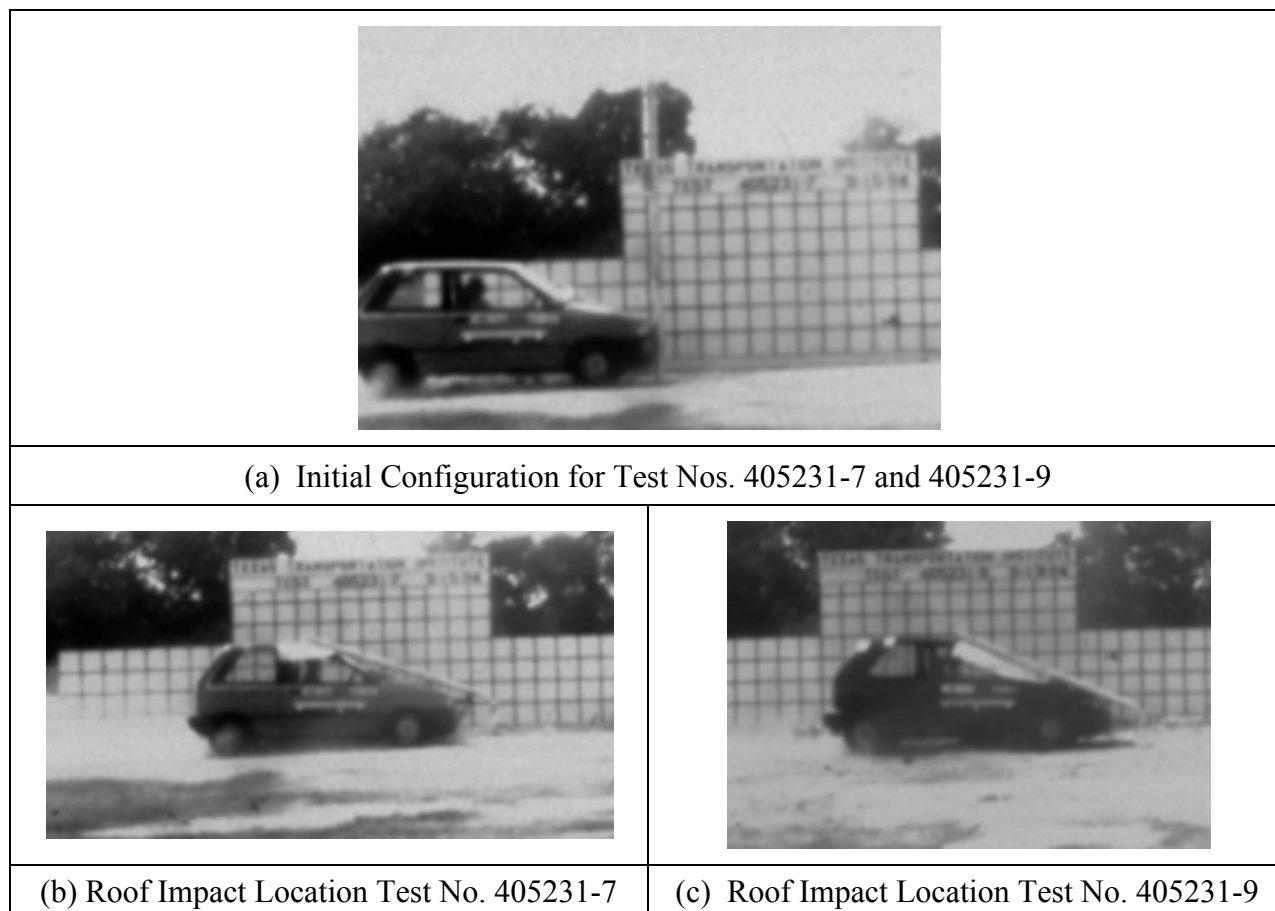


Figure 10.2. Thin-Walled Aluminum Sign Support Tests Nos. 405231-7 and 405231-9.

Table 10.2 summarizes the TxDOT standards for chevron installation on different mounting heights according to sign sizes. The two largest chevron sizes (30 inches × 36 inches, 36 inches × 48 inches) are currently not allowed on 4-ft mounting heights. To evaluate the possibility to mount the two largest chevron sizes on a 4-ft mounting height, the full-scale *MASH* TL-3 crash test is required. A high-speed crash test would need to be performed, with the vehicle impacting a single sign support with a 36-inch × 48-inch sign size attached at a 4-ft mounting height.

Table 10.2. Thin-Walled Aluminum Sign Support Tests Nos. 405231-7 and 405231-9.

| Chevron Sign Sizes | 4 ft Mounting Height | 7 ft Mounting Height |
|--------------------|----------------------|----------------------|
| 12-inch × 18-inch | ✓ | ✓ |
| 18-inch × 24-inch | ✓ | ✓ |
| 24-inch × 30-inch | ✓ | ✓ |
| 30-inch × 36-inch | ✗ | ✓ |
| 36-inch × 48-inch | ✗ | ✓ |

These research projects highlighted two very distinct pole system behaviors once impacted by the vehicle. Test No. 417929-3 showed that the pole yielded at bumper level, pulled out from the socket, and was carried away by the vehicle. No contact between the pole and the vehicle's occupant compartment occurred. However, in both Test nos. 405231-7 and 405231-9, the pole had a secondary impact with the roof of the passenger car, after being yielded at bumper level and pulled out from the socket system. These two different post-impact behaviors are related to the different total mass of the systems, the brittleness of the support post, and the effective height of the pole, which is the height of the pole measured from the vehicle's bumper impact location.

Test no. 417929-3, with a mounting height of 4 ft and a sign height of 30 inches, had a total height of 78 inches. Considering a bumper impact location at approximately 22 inches from ground level, the effective pole height is approximately 56 inches (see Figure 10.3[a]). As for Test nos. 405231-7 and 405231-9, the mounting height was 7 ft, and the sign height was 48 inches. Figure 10.3(b) shows that the effective pole height was approximately 110 inches (The taller pole also resulted in a higher pole system mass and inertia, so that the impacting vehicle cannot be easily pushed away).

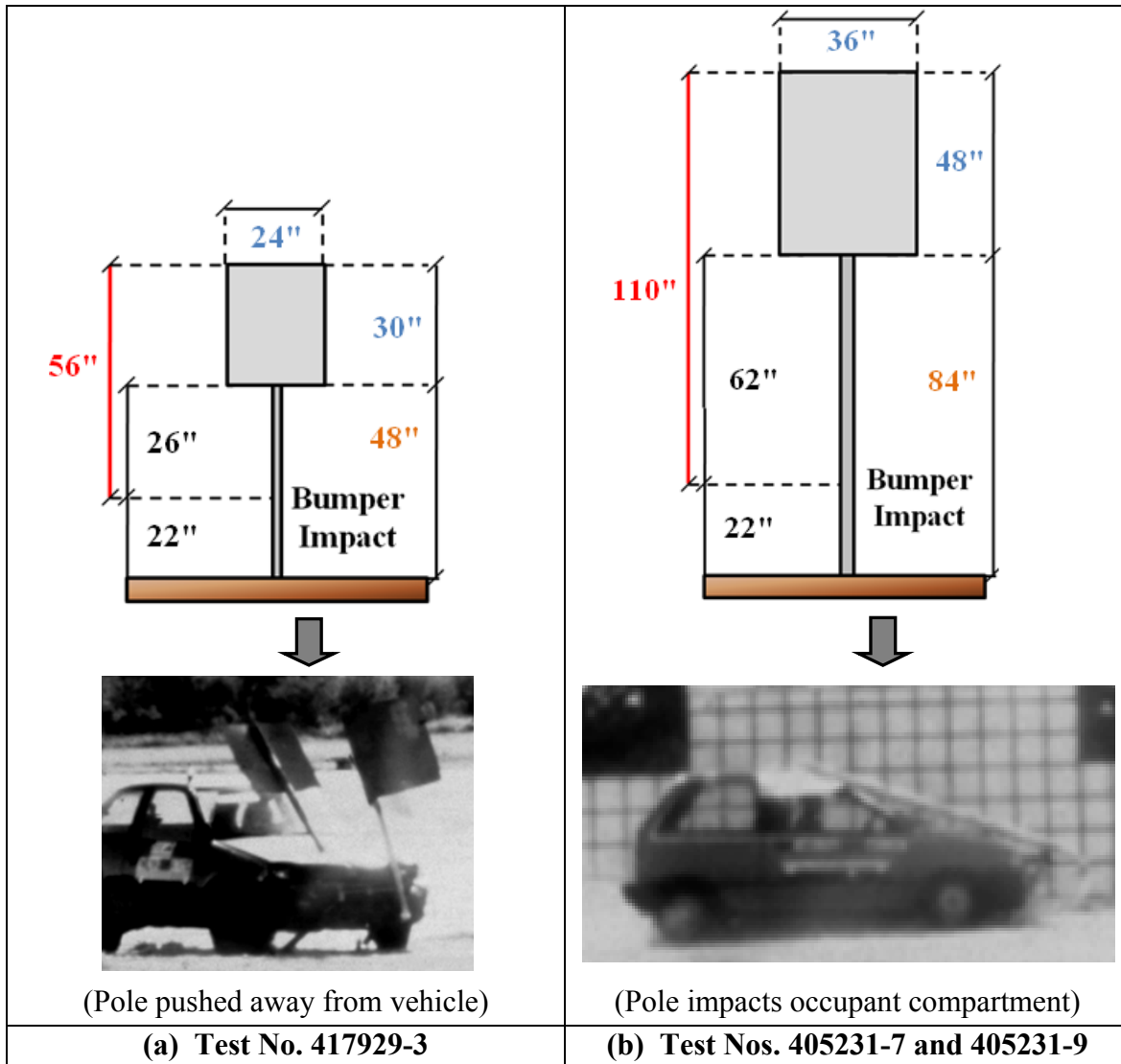


Figure 10.3. Support System's Effective Height and Post-Impact Pole System Behavior.

10.4 EVALUATION OF POLE EFFECTIVE HEIGHT FOR CHEVRON SIGNS INSTALLATION PRACTICE IN DITCHES

A common TxDOT practice is to install chevron sign systems in ditches. For this type of installation, TxDOT standards specify that the sign mounting height has to be considered from the pavement surface. Once a sign support system is installed on a slope, the mounting height of the sign (calculated from ground level at the location of installation) will be greater than the same mounting height evaluated for a sign installed on flat level ground. For an installation of a sign support system on a slope at a general “x” distance offset from the pavement surface, the depth “y” of the ditch itself at the particular installation location contributes to an increase in the total height of the pole and the sign mounting height (see Figure 10.4).

An additional consideration related to chevron sign installations in ditches is related to the actual vehicle bumper impact (BI) location on the sign pole. When an errant vehicle enters the ditch, certain factors influence its trajectory, such as the geometry of the ditch, the speed, and angle at which the vehicle leaves the road. According to the particular trajectory and the chevron installation offset from the road, the vehicle bumper will impact the sign system at a certain height from the ground. Consequently, the effective height of the pole, defined as the length of the pole from the bumper impact location to the top of the pole itself, may vary at each different configuration.

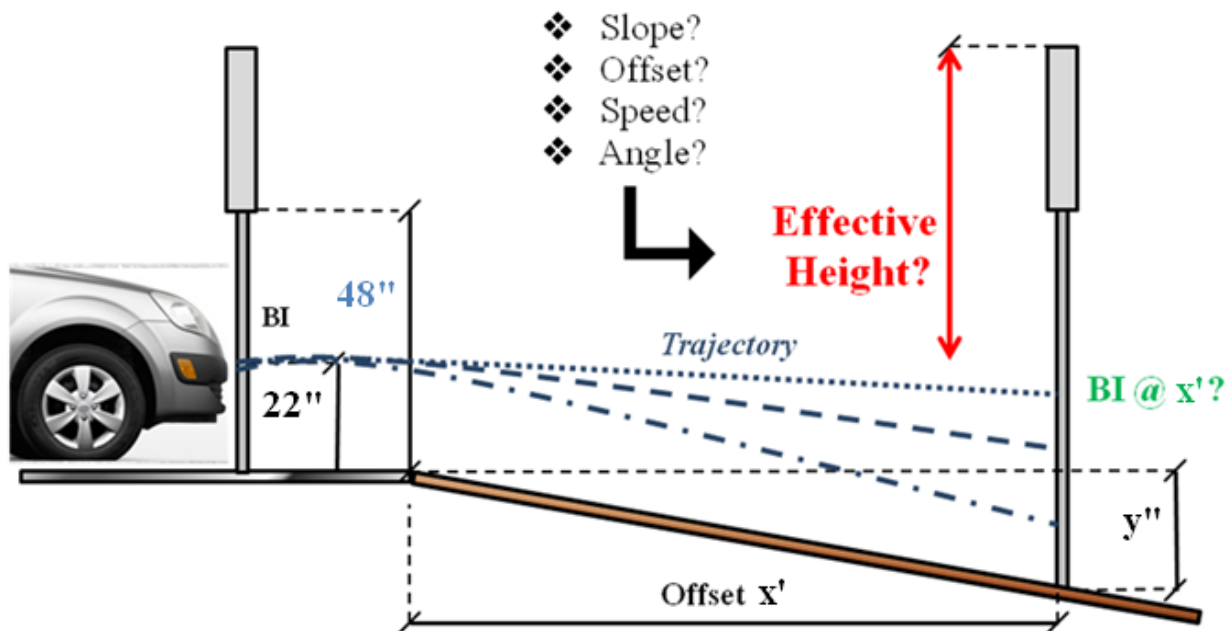


Figure 10.4. Effective Pole Height Variation for Chevron Installation in a Ditch.

In the past, the post-impact behavior of the sign support system was evaluated for a pole effective height of 56 inches and 110 inches in projects FHWA/TX-01/1792-2 and 405231-1F, respectively (17,16). For pole effective heights between these two values, the post-impact sign support behavior has not been investigated. Since it is common practice for TxDOT to install

chevron signs in ditches at a 4-ft mounting height and a lateral offset between 2–8 ft from the pavement surface, it is suggested that this configuration be investigated and evaluated to determine the crashworthiness of these systems in this scenario. This research would be breaking new ground, because little to no crash testing has been performed on signs installed on slopes. This problem has existed for many types of roadside devices and only a few have recently been properly investigated in ditch configurations.

10.5 ENGINEERING ANALYSIS

10.5.1 Trajectory Analysis of an Errant Vehicle Entering a 6:1 Slope Ditch

Trajectory analyses were evaluated for a passenger car entering a 6H:1V slope ditch at different speeds (40 and 60 mph) and angles (5, 10, and 25 degrees). A 6H:1V slope ditch was chosen since it appears to be a reasonable upper limit of maximum common ditch slope in Texas. Also, lateral offset between 2 ft and 8 ft from the pavement surface was considered, since TxDOT standards allow chevron signs installation between 2-ft and 8-ft lateral distance from the road. Trajectory analyses were evaluated using a computer program called CarSim® (18). Figures 10.5 and 10.6 report the results from the trajectory analysis.

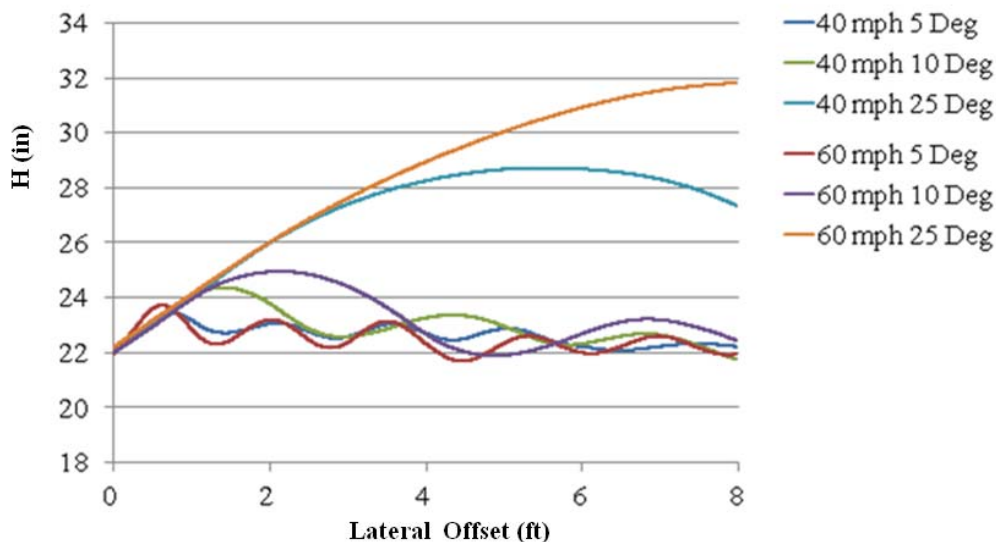


Figure 10.5. Relative Bumper Impact Height for Chevron Installation in a 6H:1V Ditch.

Figure 10.5 shows the relative bumper impact height for the pole support, calculated for different vehicle speed, angles and for a range of lateral offset distances of chevron installation. Analyses show that when the vehicle enters the ditch with an angle smaller than 25 degrees, it is most likely the tires will stay in contact with the ground throughout the whole ditch, no matter what the vehicle’s entering speed. The bumper’s distance from ground, also referred to as the relative bumper impact height, oscillates around a constant value (22 inches) due to the vehicle’s suspension dynamic. On the other hand, if the vehicle enters the ditch at a 25-degree angle, it becomes airborne. The distance of the bumper from ground level can increase from the initial

22 inch value (bumper impact location on pole when on flat level ground) up to 32 inches when the vehicle has a speed of 60 mph.

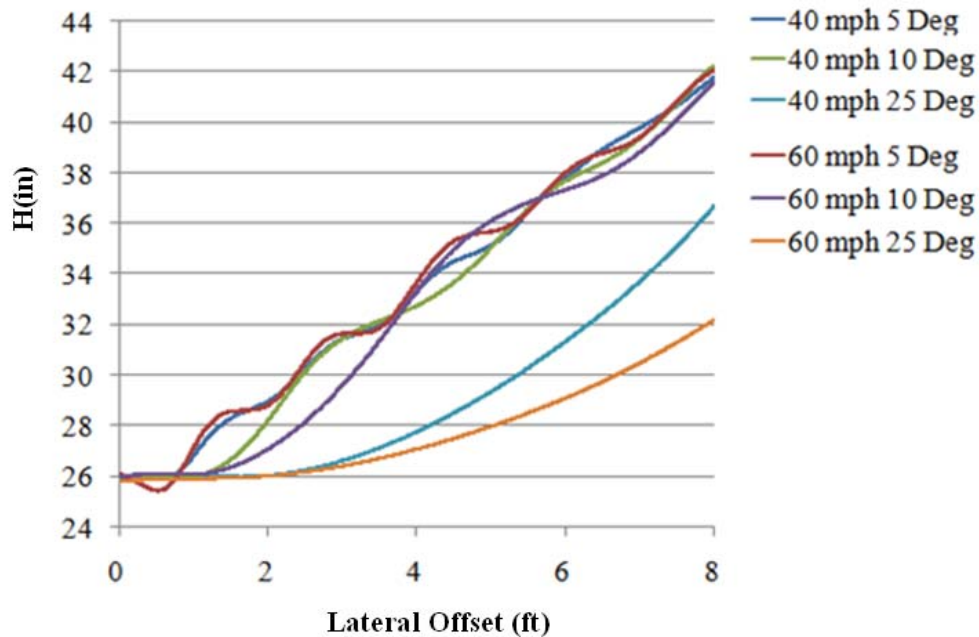


Figure 10.6. Relative Distance between Bumper Impact Location and Bottom Edge of Chevron in a 6H:1V Ditch.

Considering the scope of this study, the worst scenario to be considered for crashworthiness evaluation of chevron signs in ditches is one whereby a vehicle enters the ditch at high speed (60 mph), at an angle of 10 degrees. In this case, the pole length between the bumper impact location and the sign bottom edge is maximized for a given lateral offset of system installation (see Figure 10.5). Also, Figure 10.6 shows that the maximum pole length between bumper impact location and sign bottom edge is reached when the chevron sign system is installed at 8-ft lateral offset from the pavement surface.

In a 6H:1V slope ditch at 8-ft lateral offset, the depth of the ditch is 16 inches. When a 30-inch tall chevron sign is mounted at 8-ft lateral offset on a 4-ft mounting height from the pavement surface, the total height of the pole is 92 inches. Considering an errant vehicle entering the ditch at 60 mph and 10 degrees and impacting the chevron sign system at 8-ft lateral offset, the bumper impacts the pole at approximately 22 inches above the ditch surface (see Figure 10.7).

As a result, the effective height of the chevron pole system is 72 inches. The previous section had stated that the crashworthiness behavior of an impacted pole system with an effective height between 56–110 inches is not currently known. For this reason, the researchers suggest investigating this configuration to determine its crashworthiness. Should the evaluation determine the installation as not crashworthy; the simple solution is to increase the mounting height to 7 ft above the roadway surface. Previous crash testing of 7-ft mounting heights with

larger sign areas demonstrate that a mounting height greater than 7 ft should perform as well as, or better than, one mounted at 7 ft.

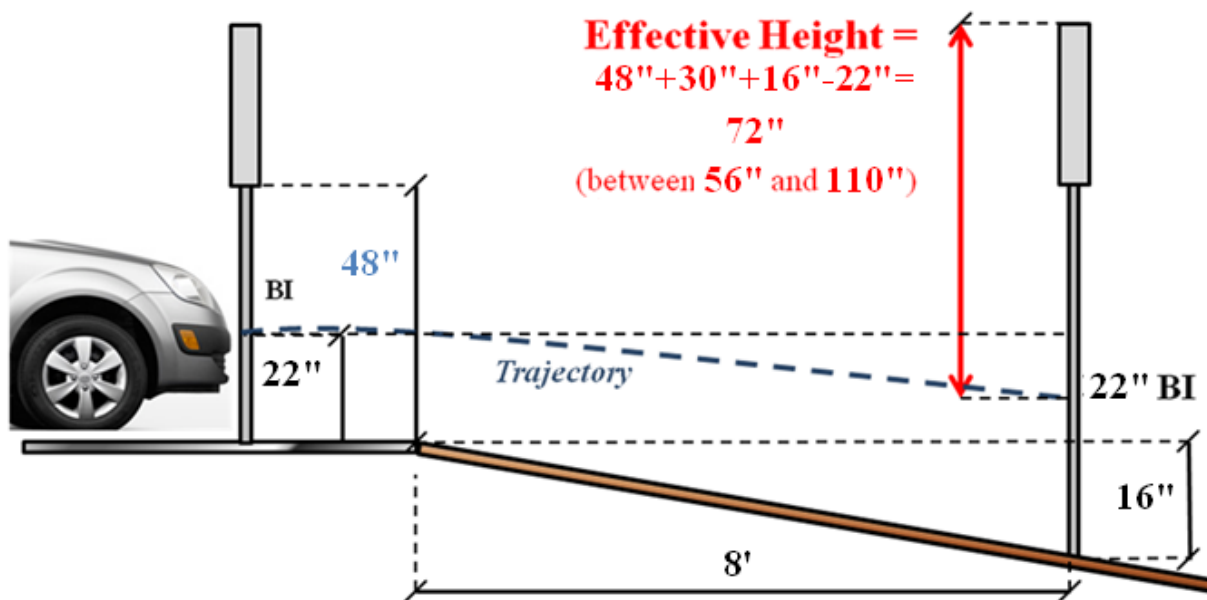


Figure 10.7. Effective Pole Height for a 30-Inch-High Chevron Sign Installation on 4-Ft Mounting Height, at 8-Ft Lateral Offset in a 6H:1V Ditch.

10.5.2 Recommendation

A full-scale crash test is recommended to evaluate the crashworthiness behavior of chevron sign installation in ditches. Researchers recommended considering a 24-inch × 30-inch sign size on a 4-ft mounting height from the pavement surface, installed at 8-ft lateral offset in a 6H:1V slope ditch. The chevron installation should be impacted by a passenger car traveling at 62 mph and entering the ditch at a 10-degree angle. Test results would be evaluated in accordance with the *MASH*.

In case the test results would not pass the *MASH* requirements, it would be recommended that chevrons would have to be mounted on 7-ft mounting height in ditches.

10.6. PROPOSED MODIFICATION FOR CURRENT D&OM TXDOT STANDARD SHEETS

10.6.1 Revision of Current D&OM TxDOT Standard Sheets

To collect the information on sizes and installation details for chevron signs needed for the scope of this project, the researchers accessed various documents, including the Texas

MUTCD and the TxDOT D&OM(1) and (2) standard sheets. The “Typical Delineator and Object Marker Placement Details” standard sheet reports some useful information on the placements details for chevrons. However, no data related to chevron sizes and no correlation between chevron sizes and mounting heights are currently reported in either of the D&OM(1) and (2) standard sheets.

The researchers suggest TxDOT incorporate this type of information in the standards and to update these with the later findings from the parallel research task “Development Guidance for Minimum Sign for Slipbase Supports” funded under this project, since it is directly applicable to the installation requirements for chevron signs.

Table 10.3 explains the changes, modifications, and additions to the current TxDOT D&OM(1) “Delineator and Object Marker Installation and Material Description” and TxDOT D&OM(2) “Typical Delineator and Object Marker Placement Details” and are listed below:

- A descriptive code for chevron signs was included.
- A descriptive and illustrative section for chevron signs was included.
- Both 4-ft and 7-ft mounting height options for chevron signs were shown and correlated with chevron sign sizes.
- Type 1 and 4 object markers sign geometry with inclusion of reflectors was added.
- Wedge and anchor systems (steel and plastic) were included as a mounting option for object markers in the object markers descriptive code.
- Barrier reflector mounts for bridge rail and cable barrier were added in the appropriate section and in the descriptive code.
- Wing channel installation details are reported as a general description, while the wedge and anchor systems are illustrated and related to chevron signs only. Installation and placement details were included without necessarily being related to a particular sign type.
- The same acronym used in the descriptive codes is now recalled when referring to the type of posts and/or mounts for the different articles. General note #3 in the “General Notes” section was modified. It currently refers to all object markers, but was changed to refer only to object markers type 2 and to delineators.
- The mounting height for object markers and chevrons is currently reported as “4' 0" Min” from the pavement surface. It was changed to “4'-0"” from the pavement surface.
- The slipbase system is currently included as a possible option for chevron installation. Since all chevron sizes are smaller or equal to 12 ft², and as a consequence of a performed parallel study that recommended a minimum sign area of 14 ft² for installation on a slipbase support type, the slipbase system cannot be considered an option for chevron installation. Installation options for chevron signs were changed to include only the wedge anchor (steel or plastic) system.

10.6.2 Proposed Layout Alternatives for D&OM(1) and (2)

The researchers decided to propose a couple of options as a layout alternative for the current D&OM(1) standard sheet, aimed at more effectively detail delineator, object marker and chevron details and information to the user. Appendix K reports on these two layout options.

The main idea behind the new layout options was to include a section only for chevron type signs with all appropriate information regarding sizes, directions, post, and mount types for chevrons. Also, the same acronyms reported in the descriptive codes were recalled throughout the standard sheet when describing post and mount types for delineators, objects markers, and chevrons. Moreover, it was decided to organize delineator, object markers, and chevron material and placement details in two separate sheets. According to the researchers, this approach results in a more neat and effective presentation of all information. Figures 10.8 through 10.15 report on sections of this proposed layout.

Two layout options are proposed for the material description sheet, D&OM(1). In the first option, information is presented in a table format and has the same structure throughout the whole sheet. The second option has a very similar structure from the current TxDOT D&OM(1). However, some details regarding installation information were removed and recalled in a placement details sheet, named D&OM(2).

For the current TxDOT D&OM(2) “Delineator and Object Marker Placement Details,” the only modification that the researchers made was the removal of the wedge and anchor system installation for chevrons, since this type of information was already adequately addressed in the proposed D&OM(1) and (2) layouts. Appendix K reports on the new layout of D&OM(2), now named D&OM(3). Since the researchers added one sheet to the current TxDOT D&OM standard specifications, the sheets will have to be renumbered.

10.7 CONCLUSIONS

This research task was aimed at investigating the crashworthiness of the various chevron mounting details. After critically reviewing past crash tests performed at TTI, the research team has recommended that a crash test should be performed to evaluate the crashworthy behavior of the large (36 inches × 48 inches) chevron size at a 4-ft mounting height.

While reviewing standards for chevron installations, the researchers investigated the current TxDOT practice of installing chevron signs in ditches with slopes that can be as steep as a 6H:1V. Literature review and engineering analysis were performed to evaluate the crashworthy behavior of chevron signs once impacted by an errant vehicle in a ditch at a certain offset from the road. As a result, the team recommended evaluating the crashworthiness with a full-scale crash test. The proposed test configuration would include a 24-inch × 30-inch chevron size mounted at a 4-ft mounting height from the pavement surface and installed at 8-ft lateral offset in a 6H:1V slope ditch. The chevron system should be impacted by a passenger car traveling at 62 mph and entering the ditch with a 10-degree angle and test results evaluated in accordance with *MASH*. Testing in a ditch should also be considered during this investigation

due to the limited number of tests that have been performed, making it difficult to predict a reasonable estimation of its performance.

In the case of the full-scale crash test not passing *MASH* requirements, the research team recommended that all chevron sign sizes be mounted at a 7-ft mounting height when installed on slopes.

The researchers also reviewed the current TxDOT D&OM (1) and (2) standard sheets and gave suggestions for a more efficient presentation of material and installation information. Appendix K has the proposed layouts.

Table 10.3. Suggested Modifications to the Current TxDOT D&OM(1) and (2) Standard Sheets.



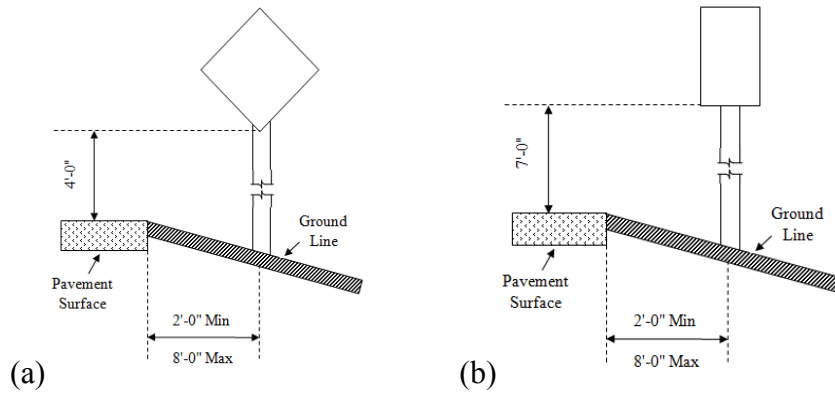
| SUGGESTED MODIFICATIONS | | | | | | COMMENTS |
|--|---|--------------------------|---------------------------|--|----------|--|
| (a) Inclusion of Descriptive Code for Chevron Sign Type | | | | | | |
| <p>INSTL CH ASSM (CH-XX) (XXX)XXX</p> <p>SIZE OF CHEVRON _____ 1, 2, 3, 4, or 5</p> <p>DIRECTION OF CHEVRON _____ L = Left R = Right</p> <p>TYPE OF POST _____ FLX = Flexible Post TWT = Thin Walled Tubing</p> <p>TYPE OF MOUNT _____ GND = Embedded SRF = Surface Mount WAS or WAP = Wedge Anchor (Steel or Plastic)</p> | | | | | | <p>A descriptive code for chevron sign is added. The code references size, direction of the chevron, type of post, and type of mount used for chevron installation are included.</p> |
| (b) Completion of a Descriptive and Illustrative Section for Chevron Sign Type | | | | | | |
| <p>CHEVRONS - Intended to give notice of sharp change of alignment with direction of travel</p> | | | | | | |
| Sign |  | | |  | | <p>A section collecting all information on chevron signs geometry, material properties, and installation is included.</p> |
| | CH-1L/R | CH-2L/R | CH-3L/R | CH-4L/R | CH-5L/R | |
| | Minimum | Low Speed Road (< 55mph) | High Speed Road (≥ 55mph) | Expressway | Freeway | |
| Size (W x L) | 12"x18" | 18"x24" | 24"x30" | 30"x36" | 36"x48" | |
| Post Type | TWT, FLX | TWT, FLX | TWT, FLX | TWT, FLX | TWT, FLX | |
| Mount Type | WAS, WAP | WAS, WAP | WAS, WAP | WAS, WAP | WAS, WAP | |
| NOTE | <p>1. Conform to ASTM B-209 Alloy 6061-T6</p> <p>2. Conform reflective sheeting as per DMS 8300</p> | | | | | |

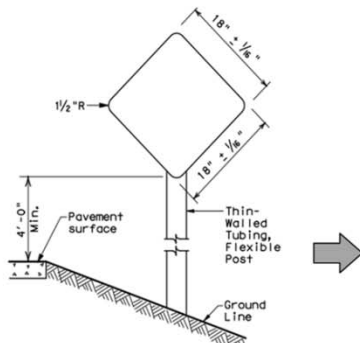
Table 10.3. Suggested Modifications to the Current TxDOT D&OM(1) and (2) Standard Sheets (Continued).

(c) Distinction between 4' and 7' mounting height options for Chevrons



All current sizes of Chevron signs can be mounted at 7'-0" mounting height from the pavement surface. Only certain sizes, however, can be mounted at 4'-0" mounting height. Also, the mounting height is no longer reported as a "Min" height.

(d) Inclusion of Type 1 and 4 Object Markers signs with use of reflectors

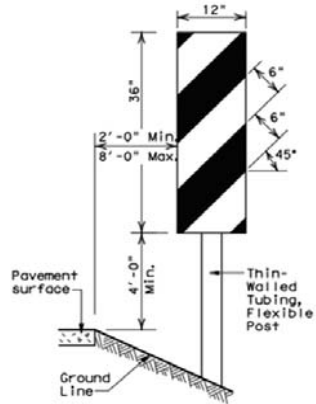


| | Type 1 | | | Type 4 | | |
|-----------------|--|-------|-------|--|-------|-------|
| | OM-11 | OM-12 | OM-13 | OM-41 | OM-42 | OM-43 |
| Sign | | | | | | |
| Characteristics | Diamond Shape; 0.080" τ Aluminum Yellow - Type E Sheeting | | | Diamond Shape; 0.080" τ Aluminum Red - Type D Sheeting | | |
| Post Type | TWT | | | TWT | | |
| Mount Type | WAS, WAP | | | WAS, WAP, GND, SRF | | |
| NOTE | 1. Conform to ASTM B-209 Alloy 6061-T6 2. Conform reflective sheeting as per DMS 8300 | | | 1. Conform to ASTM B-209 Alloy 6061-T6 2. Conform reflective sheeting as per DMS 8300 | | |

In the current TxDOT standard sheet, there is no illustration of the Object Marker (Type 1 and 4) design with use of reflectors and Object Markers type 1, 2 and 4 are not recalled with their descriptive name OM-XX. A new layout for showing all allowable Object Marker Type 1 and 4 signs is proposed. Post types are now recalled with their code.

Table 10.3. Suggested Modifications to the Current TxDOT D&OM(1) and (2) Standard Sheets (Continued).

(e) Inclusion of all Type 3 Object Markers

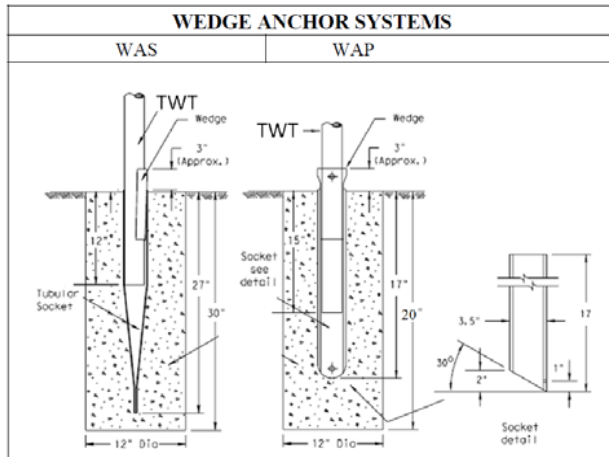


OM-3 Directions
 L - Placed on Left Side
 R - Placed on Right Side
 C - Placed on Center
 Use Sign blank .080" thick sheet aluminum conforming to ASTM B-209 Alloy 6061-T6. Use reflective sheeting in accordance with DMS 8300, Type E. Use at bridges with no approach rails.

| | Type 3 | | |
|-----------------|--|-------|-------|
| | OM-3L | OM-3C | OM-3R |
| Sign | | | |
| Characteristics | Vertical Rectangle, 0.080" x Aluminum Alternating black and reflective yellow - Type E Sheeting | | |
| Post Type | TWT | | |
| Mount Type | WAS, WAP, GND, SRF | | |
| NOTE | <ol style="list-style-type: none"> 1. Conform to ASTM B-209 Alloy 6061-T6 2. Use at bridges with no approach rails 3. Conform reflective sheeting as per DMS 8300 | | |

In the current TxDOT standard sheet, only Object Marker Type 3R is illustrated. In the proposed layout, all Object Markers Type 3 are illustrated.

(f) Inclusion of Wedge and Anchor (steel and plastic) system as a mounting option for Object Markers in their descriptive code

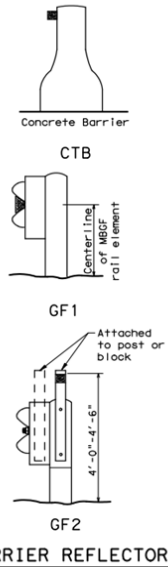


INSTL OM ASSM (OM-XX) (XXX)XXX(XX)
TYPE OF OBJECT MARKER — 1, 2, 3, or 4
NUMBER OF REFLECTORS OR DIRECTION —
 X = 3-Size 2 reflector units (Type 2 only)
 Y = 1-Size 3 reflector unit (Type 2 only)
 Z = 3-Size 1 or 1-Size 4 reflector unit(s) (Type 2 only)
 L = Left Side (Type 3 Object Marker only)
 R = Right Side (Type 3 Object Marker only)
 C = Center (Type 3 Object Marker only)
TYPE OF POST —
 WC = Wing Channel Post
 FLX = Flexible Post
 TWT = Thin Walled Tubing
TYPE OF MOUNT —
 GND = Embedded (drivable or set in concrete)
 SRF = Surface Mount
 WAS or WAP = Wedge Anchor (Steel or Plastic)
DIRECTION —
 If Required
 BI = Bi-Directional

In the current standard sheets, the wedge and anchor system is illustrated only as an installation type for chevron sign type. Also, the type of post (TWT) is not currently reported. With the proposed layout, the wedge and anchor system is illustrated without being related to only to the chevron sign and an acronym has been added in the OM descriptive code.

Table 10.3. Suggested Modifications to the Current TxDOT D&OM(1) and (2) Standard Sheets (Continued).

(g) Illustration of barrier reflector mount for Bridge Rail and Cable Barrier



(a)

| TYPE OF DELINEATOR MOUNTS | | | |
|---------------------------|------------------------|-------------|---------------|
| CABLE BARRIER | GUARD FENCE ATTACHMENT | | SURFACE MOUNT |
| CRR | GF1 | GF2 | SRF |
| | | | |
| CONCRETE BARRIER | | BRIDGE RAIL | |
| CTB | BRD | | |
| | | | |



(b)

D & OM DESCRIPTIVE CODES
 INSTL DEL ASSM (D-XX)SZ X (XXX)XXX(XX)
 NUMBER OF REFLECTORS
 S = Single
 D = Double
 COLOR OF REFLECTORS
 W = White
 Y = Yellow
 R = Red
 REFLECTOR UNIT SIZE
 1 or 2
 TYPE OF POST OF DELINEATOR
 WC = Wing Channel Post
 FLX = Flexible Post
 TYC = Barrier Reflector
 TYPE OF MOUNT
 GND = Embedded (drivable or set in concrete)
 CTB = Concrete Barrier Mount
 BRD = Bridge Rail Mount
 GF1 or GF2 = Guard Fence Attachment
 CRR = Cable Barrier Mount
 SRF = Surface Mount
 DIRECTION
 If Required
 BI = Bi-Directional
 BR = Bi-Directional with red on back

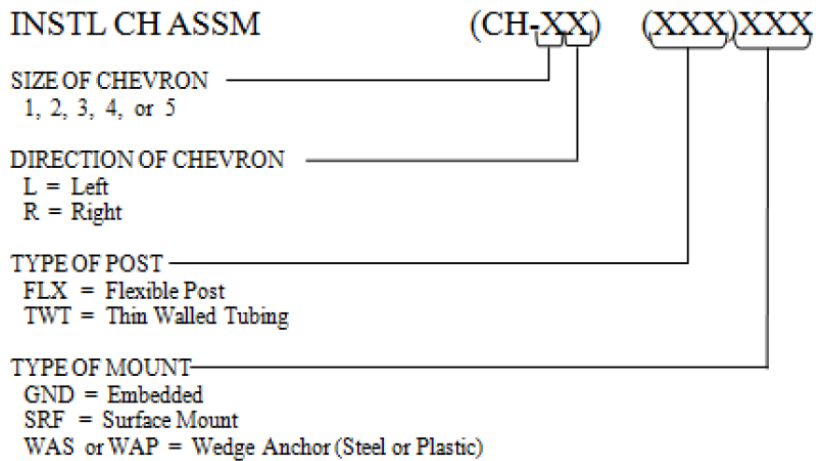
In the current standard sheets, the types of delineator mounts are referenced as “barrier reflectors”. Also, only CTB, GF1, and GF2 are illustrated. With the proposed layout, bridge rail and cable barrier mount pictures are added, and codes are suggested for inclusion in the descriptive code for Delineators.

| OBJECT MARKERS - Mark Obstructions within or adjacent to roadway (Type 1, 2 and 3) and warn of end of roadway (Type 4) | | | | | | | | | | | | | | |
|---|-------|-------|--|-------|-------|--|-------|-------|--|-------|-------|--|--|--|
| Type 1 | | | Type 2 | | | Type 3 | | | Type 4 | | | | | |
| OM-11 | OM-12 | OM-13 | OM-2X | OM-2Y | OM-2Z | OM-3L | OM-3C | OM-3R | OM-41 | OM-42 | OM-43 | | | |
| Sign | | | | | | | | | | | | | | |
| | | | | | | | | | | | | | | |
| Characteristics | | | Diamond Shape; 0.080" r Aluminum | | | 3-size 2 reflector units | | | 1-size 3 reflector unit | | | 3-size 1 reflector units | | |
| Yellow - Type E Sheeting | | | Yellow | | | Alternating black and retroreflective yellow - Type E Sheeting | | | Red - Type D Sheeting | | | | | |
| Post Type | | | TWT | | | WC | | | WC | | | FLX | | |
| Mount Type | | | WAS, WAP | | | GND | | | GND | | | GND, SRF | | |
| NOTE | | | 1. Conform to ASTM B-209 Alloy 6061-T6 2. Conform reflective sheeting as per DMS 8300 | | | 1. Typically used on bridge rail approach ends, some bridge abutments and at bridge rail exits on two-lane, two-way roadways 2. Conform reflective sheeting as per DMS 8300 | | | 1. Conform to ASTM B-209 Alloy 6061-T6 2. Use at bridges with no approach rails 3. Conform reflective sheeting as per DMS 8300 | | | 1. Conform to ASTM B-209 Alloy 6061-T6 2. Conform reflective sheeting as per DMS 8300 | | |

**Figure 10.8. "Object Marker" Section in the Proposed New Layout
TxDOT D&OM(1)-11, Option #1.**

| <u>CHEVRONS</u> - Intended to give notice of sharp change of alignment with direction of travel | | | | | |
|--|--|--------------------------|---------------------------|---|----------|
| Sign |  | | |  | |
| | CH-1L/R | CH-2L/R | CH-3L/R | CH-4L/R | CH-5L/R |
| | Minimum | Low Speed Road (< 55mph) | High Speed Road (≥ 55mph) | Expressway | Freeway |
| Size (W x L) | 12"x18" | 18"x24" | 24"x30" | 30"x36" | 36"x48" |
| Post Type | TWT, FLX | TWT, FLX | TWT, FLX | TWT, FLX | TWT, FLX |
| Mount Type | WAS, WAP | WAS, WAP | WAS, WAP | WAS, WAP | WAS, WAP |
| NOTE | 1. Conform to ASTM B-209 Alloy 6061-T6 2. Conform reflective sheeting as per DMS 8300 | | | | |

(a)



(b)

Figure 10.9. "Chevrons" Section in the Proposed New Layout TxDOT D&OM(1)-11, Option #1.

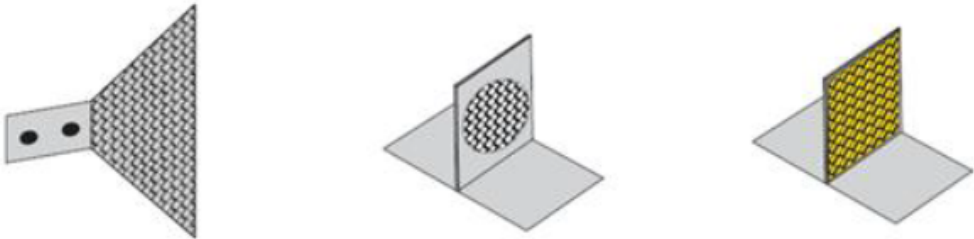
| <u>BARRIER REFLECTORS</u> | |
|--|---|
|  | |
| Characteristics | Yellow, White, Red |
| Mount Type | BRD, CRR, CTB, GF1, GF2, SRF |
| NOTE | <ol style="list-style-type: none"> 1. A list of approved barrier reflectors can be found at : www.txdot.gov 2. Conform reflectors minimum surface area as per DMS 4200 |

Figure 10.10. “Barrier Reflectors” Section in the Proposed New Layout TxDOT D&OM(1)-11, Option #1.

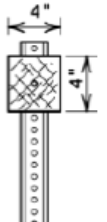
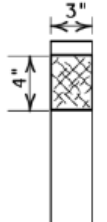
| <u>DELINEATORS</u> - Used when changes in horizontal alignment or pavement width transitions exist | | | | |
|---|--|----------|---|----------|
| | Single | | Double | |
| Sign |  | |  | |
| | 1-size 1 reflector unit | | 1-size 2 reflector unit | |
| Characteristics | D-SY, D-SR or D-SW | | D-SY, D-SR or D-SW | |
| | D-DY or D-DW | | D-DY or D-DW | |
| Post Type | WC | FLX | WC | FLX |
| Mount Type | GND | GND, SRF | GND | GND, SRF |
| NOTE | 1. Length may vary to meet field conditions 2. Minimum dimension required for delineators is 2 3/4 inches (Texas MUTCD Section 2D.02) | | | |

Figure 10.11. “Delineators” Section in the Proposed New Layout TxDOT D&OM(1)-11, Option #1.

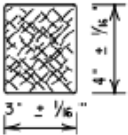
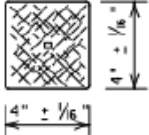
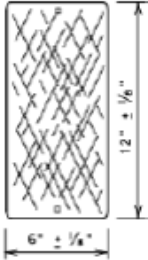
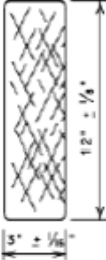
| <u>REFLECTOR UNIT SIZES</u> | | | | |
|------------------------------------|--|---|---|---|
| | Size 1 | Size 2 | Size 3 | Size 4 |
| Sign |  |  |  |  |
| Characteristics | Yellow, White, Red | | | |
| Post Type | WC, FLX | WC Only | WC Only | WC, FLX |
| NOTE | 1. Size 1 and 4 - Direct applied conformable reflective sheeting for use on flexible 2. Size 2 and 3 - Use approved metal, plastic or fiberglass back plate with 17/64" square mounting holes 3. Conform reflective sheeting as per DMS 8300 | | | |

Figure 10.12. "Reflector Unit Sizes" Section in the Proposed New Layout TxDOT D&OM(1)-11, Option #1.

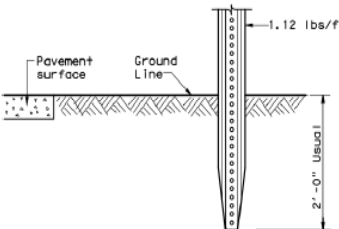
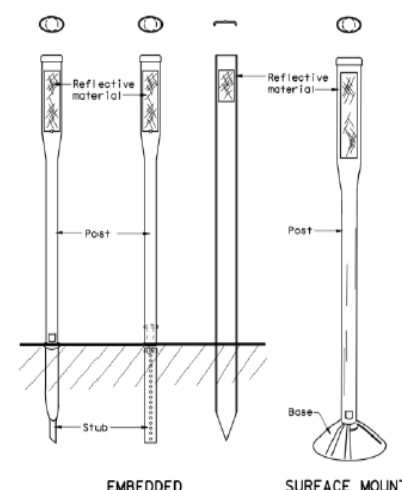
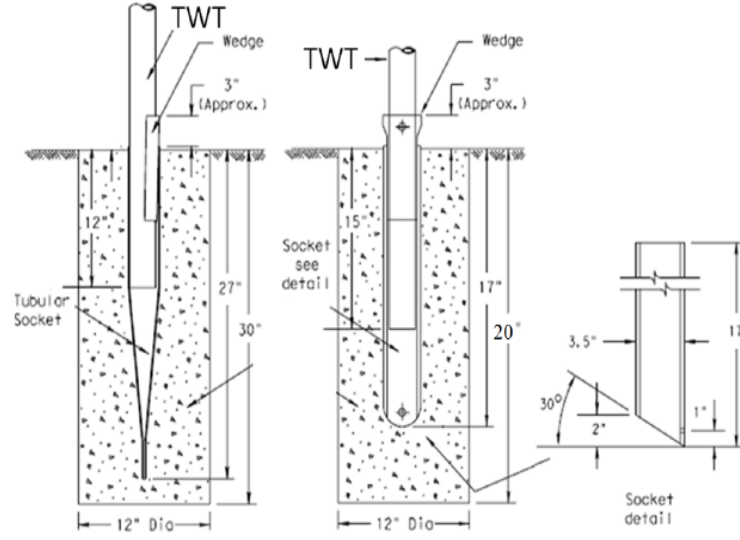
| <u>SUPPORT FOUNDATION DETAILS</u> | | | | |
|---|---|-----|--|-----|
| EMBEDDED | FLEXIBLE POSTS | | WEDGE ANCHOR SYSTEMS | |
| GND | GND | SRF | WAS | WAP |
|  |  | |  | |
| <p>NOTE</p> <ol style="list-style-type: none"> 1. Embedded WC-wing Channel post option may be used for Type 2 Object Markers and Delineators only 2. 1.12 lbs/ft steel per ASTM A 1011 SS Gr. 50, or ASTM A499 | <p>NOTE</p> <ol style="list-style-type: none"> 1. See Material Producer List for approved devices 2. Install to manufacturer's recommendations | | <p>NOTE</p> <ol style="list-style-type: none"> 1. Wedge Anchor (steel or plastic) is used for Type 1, 2, and 3 Object Markers and chevrons 2. 10 BWG thin wall tube (TWT) per ASTM XXXX | |

Figure 10.13. "Support Foundation Details" Section in the Proposed New Layout TxDOT D&OM(1)-11, Options #1 and #2.

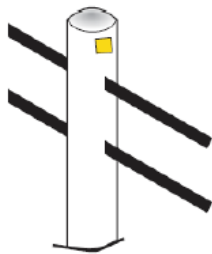
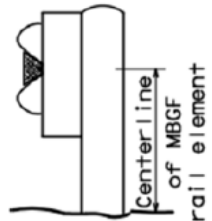
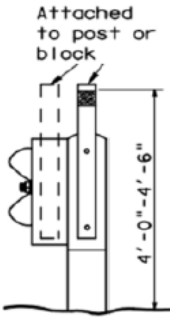
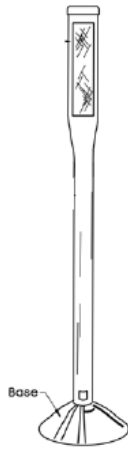
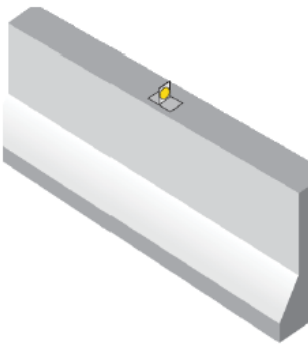
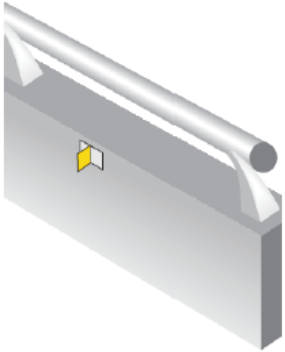
| <u>TYPE OF DELINEATOR MOUNTS</u> | | | | |
|--|--|---|--|--|
| CABLE BARRIER | GUARD FENCE ATTACHMENT | | SURFACE MOUNT | |
| CRR | GF1 | GF2 | SRF | |
|  |  |  |  | |
| CONCRETE BARRIER | | BRIDGE RAIL | | |
| CTB | BRD | | | |
|  |  | | | |

Figure 10.14. “Type of Delineator Mounts” Section in the Proposed New Layout TxDOT D&OM(1)-11, Options #1 and #2.

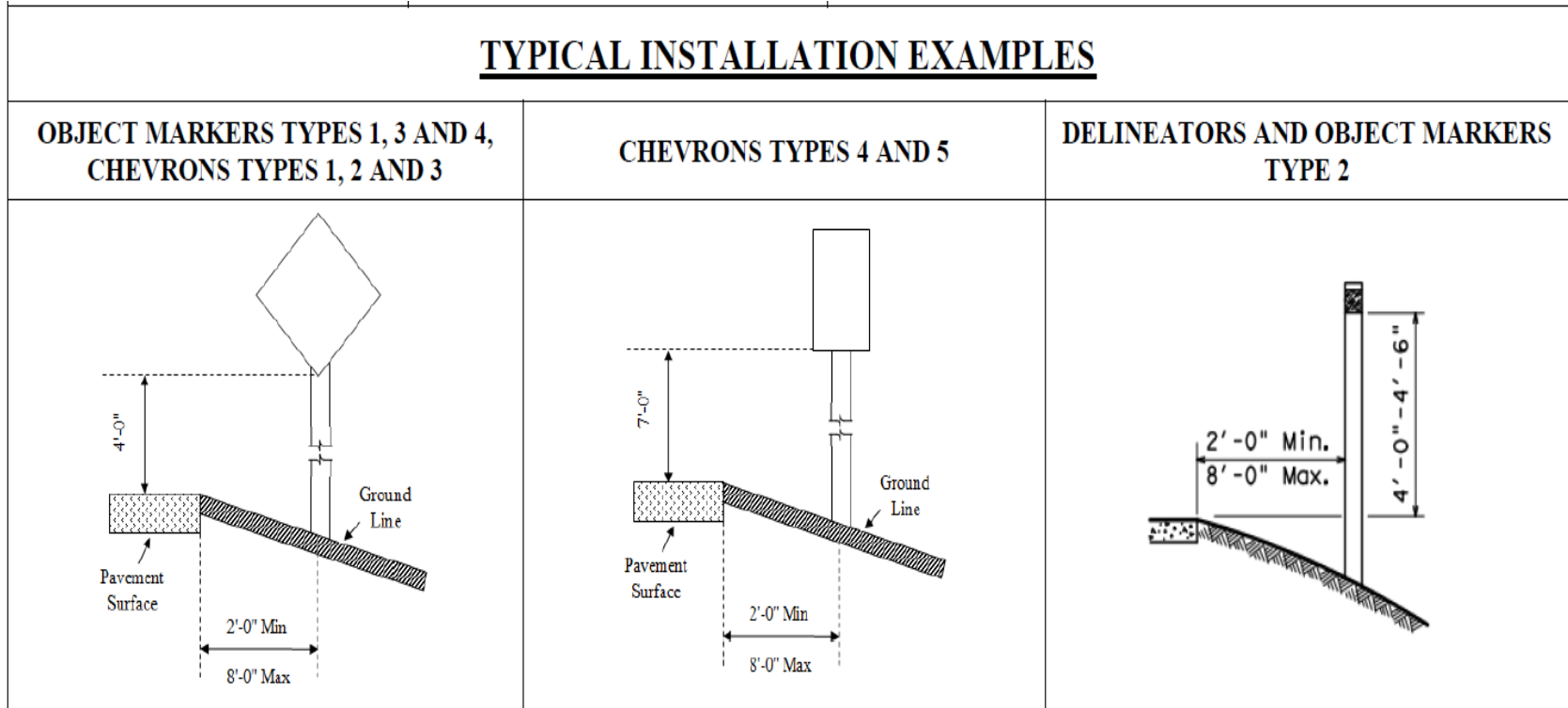


Figure 10.15. “Typical Installation Examples” Section in the Proposed New Layout TxDOT D&OM(1)-11, Options #1 and #2.

CHAPTER 11. ANALYSIS OF “U-BRACKETS” ON SCHEDULE 80 PIPE SUPPORTS

11.1 OBJECTIVES

District maintenance personnel have reported multiple instances of “U-bracket” failures, which can lead to driver confusion and to increased maintenance costs incurred to repair damaged installations. TTI was contracted to analyze the current design to determine the best course of action to prevent this occurrence. The TTI research team first reviewed instances of failures in the field to evaluate witnessed failure modes. Second, they completed a full engineering analysis according to AASHTO “Standard Specifications for Structural Supports for Highway Signs, Luminaires, and Traffic Signals” (3). Next, TTI simulated the support system in LSDYNA to predict likely failure location. Lastly, TTI performed static tests on U-bracket supports to validate results of simulation and engineering analysis. The data were then reviewed and a final suggested course of action was presented.

11.2 PROBLEMS IN THE FIELD

District maintenance personnel have reported multiple instances of “U-bracket” failures. Figures 11.1 through 11.3 show one failure mode reported, which is located in the Bryan district at the northeast corner of the intersection of FM2818 and FM2347. These images show that the sign is still visible to motorists; however, the left upright of the U-bracket is rotated in the direction of travel. After further inspection, researchers have determined that this installation was an older design that has subsequently been discontinued and is no longer being installed.

The current design bends the U-pipe to form the “U” and is fabricated from a 2³/₈-inch 10BWG pipe. This discontinued design utilizes a smaller diameter U-pipe and miters the U-pipe instead of bending it to form the “U.” When inspecting the failed support the cause of the failure was determined to be the weld in the left miter joint. Figure 11.2 shows the large crack that is evident of this mode of failure. A list of possible causes for this weld failure includes: wind overloading event (winds in excess of design speeds), improper fabrication (poor weld quality), cyclic fatigue, or possible corrosion. As the system is still in-service, a further inspection to determine exactly what caused the weld failure was not possible.

Another item to note is that the extension tube at the top of the tube was fabricated to fit the current U-bracket design. As this extension tube is much larger in diameter than the discontinued U-bracket, the extension tube was field modified to make it fit into the smaller U-pipe. However, this damaged much of the protective galvanization, leading to corrosion (see Figure 11.3).

The researchers were not able to locate instances of current U-bracket design failure. This does not mean that they do not exist; however, it does mean that the older designs make up a larger proportion of failures.



Figure 11.1. Example of U-Bracket Failure.



Figure 11.2. U-Bracket Weld Failure.



Figure 11.3. Improper Installation of U-Bracket Extension Tube.

11.3 ENGINEERING ANALYSIS

As there are a multitude of configurations a U-bracket can be installed, a preliminary evaluation of installation configuration was required to determine the controlling design scenario. Generally, the worst case configuration for the U-bracket is described as having maximized height of the U-bracket while minimizing the height of the support post. This configuration will maximize the capacity requirements due to wind loading on the U-bracket, while minimizing the required capacity of tubular support post.

After reviewing TxDOT sign standards, the research team applied two constraints to this problem. First, from TxDOT standard sheets, a U-bracket may not be configured to have a height greater than 11 ft-9 inches. From TxDOT sign support standards, a sign may not be mounted less than 7 ft above the roadway surface. These constraints lead to the configuration shown in Figure 11.4. As this configuration is the worst case, if the calculated wind load capacity (F) for the U-bracket is in excess of the calculated capacity (F) of the tubular support, then it should always be in excess of the support no matter the configuration (as long as the configuration does not violate these constraints). An efficient design will balance the calculated capacities (F) of these components for this configuration.

As a direct comparison of support capacity, an “F” was calculated for each component for this configuration. Table 11.1 shows a full list of the analysis results. The calculated minimum capacity of the U-bracket was due to bending and equated to a 472 lbf. This force exceeded the calculated capacity of the schedule 80 support which equated to 439 lb. The results of the analysis show the U-bracket should never yield before the schedule 80 support due to wind loading. A yield stress of 55 ksi was assumed for BWG sections, and a yield value of 46 ksi was assumed for schedule 80 pipe sections to represent minimum yield values defined in TxDOT standard sheets.

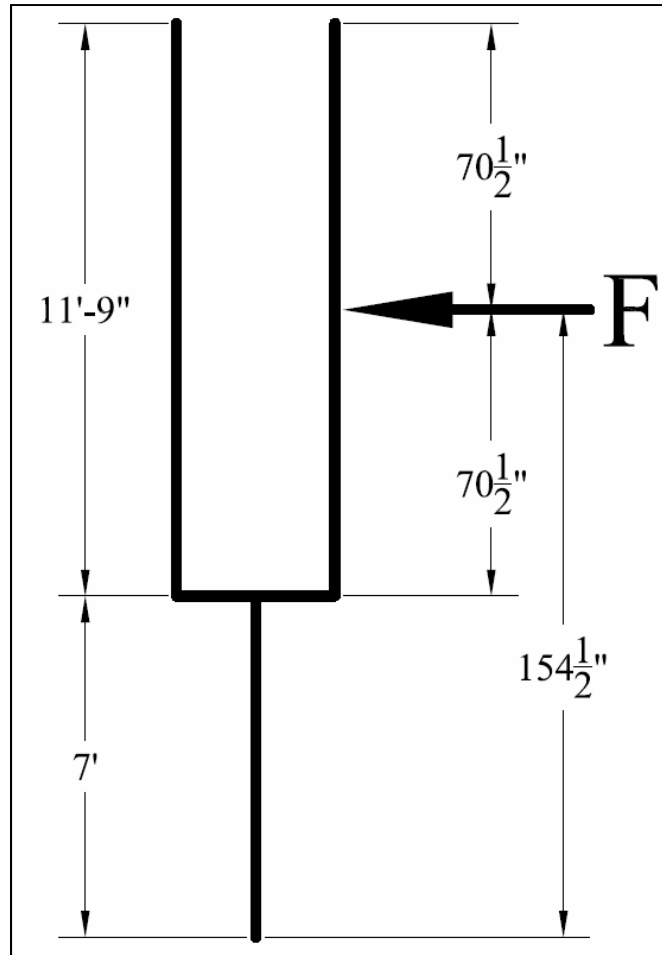


Figure 11.4. U-Bracket Installation Configuration for Engineering Analysis.

Table 11.1. Calculated Capacities of U-Bracket Installation Components.

| Component | Calculated Capacity | |
|-------------|---------------------|---------|
| U-Bracket | Bending | 472 lbs |
| | Torsion | 828 lbs |
| | Shear | 474 lbs |
| 10 BWG | Bending | 237 lbs |
| Schedule 80 | Bending | 439 lbs |

11.4 FINITE ELEMENT SIMULATION RESULTS

The engineering analysis discussed previously in this report only looked at the bending, shear, and torsion in the U-pipe itself. This form of methodology did not allow for the analysis of the U-pipe to sleeve connection due to its complex geometry. Therefore, to analyze this connection, a Finite Element (FE) simulation of a static loading due to wind load needed to be performed. All simulated conditions were based on the configuration presented in Figure 11.4. In these simulations, a displacement, “D,” was applied at the mid height of the U-bracket supports

to represent conditions that would be present in an equivalent static test. The displacement, “D,” was increased until a component of the simulated installation yielded. The component that contains the area of high-yield stress would then be considered the limiting component of the system.

Welds were excluded from this simulation due to the complexity of properly simulating their failure characteristics. It is assumed that the weld dimensions are selected such that they equal or exceed the thickness of the base metal. This assumption makes it conservative to simulate welds as merged steel bodies without failure. The slip base was also not simulated. Instead, the schedule 80 support was simulated with a rigid fixed-end condition. This condition simulated the support being rigidly clamped at the slip base location.

The first simulation was generated to represent the current U-bracket and support configurations. The U-pipe was simulated as a 2.375-inch 10 BWG pipe (55 ksi yield) section that had a 39-inch center to center vertical support spacing. The height of the U-bracket vertical supports was simulated to be 11 ft-9 inches. The U-bracket nipple was simulated as a 3.25-inch 11 BWG pipe (55 ksi yield) support that was necked down to accept the U-pipe at one end. The geometry was a best-fit interpretation of the actual geometry since exact dimension drawings were not available. Finally, a 2.875-inch schedule 80 pipe support was simulated to support the U-bracket. A constant rate displacement was applied perpendicular to the U-bracket at 154.5 inches above the rigid fixed end support. The displacement was increased until a large yield region developed in the U-pipe near at the nipple attachment location (see Figure 11.5). This simulation predicts that the U-pipe will yield at the weld location before the schedule 80 support will yield.

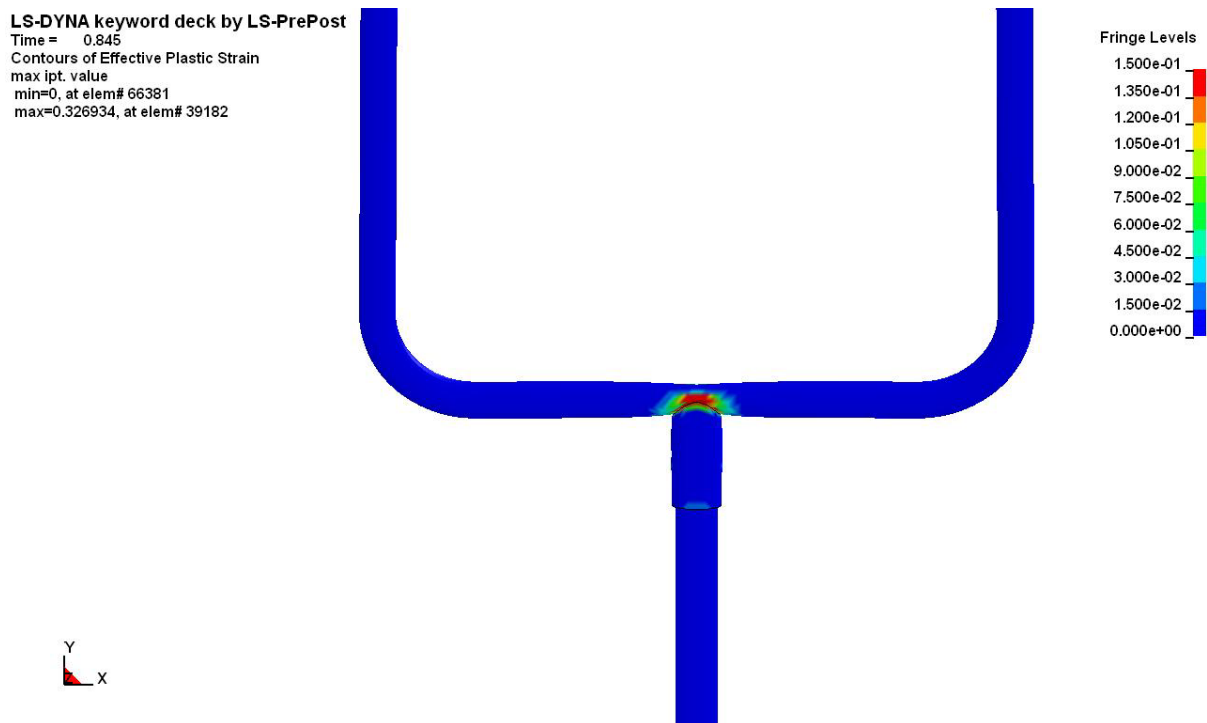


Figure 11.5. Simulation of Current TxDOT Design.

In an attempt to increase the capacity of the system, the thickness of the U-pipe section was increased to schedule 80 from BWG10. The change did prevent the yielding zone in the U-pipe, however, the nipple then became the limiting factor, evident in the large yield region shown in Figure 11.6. This simulation predicts that the nipple will yield before yielding the schedule 80 support.

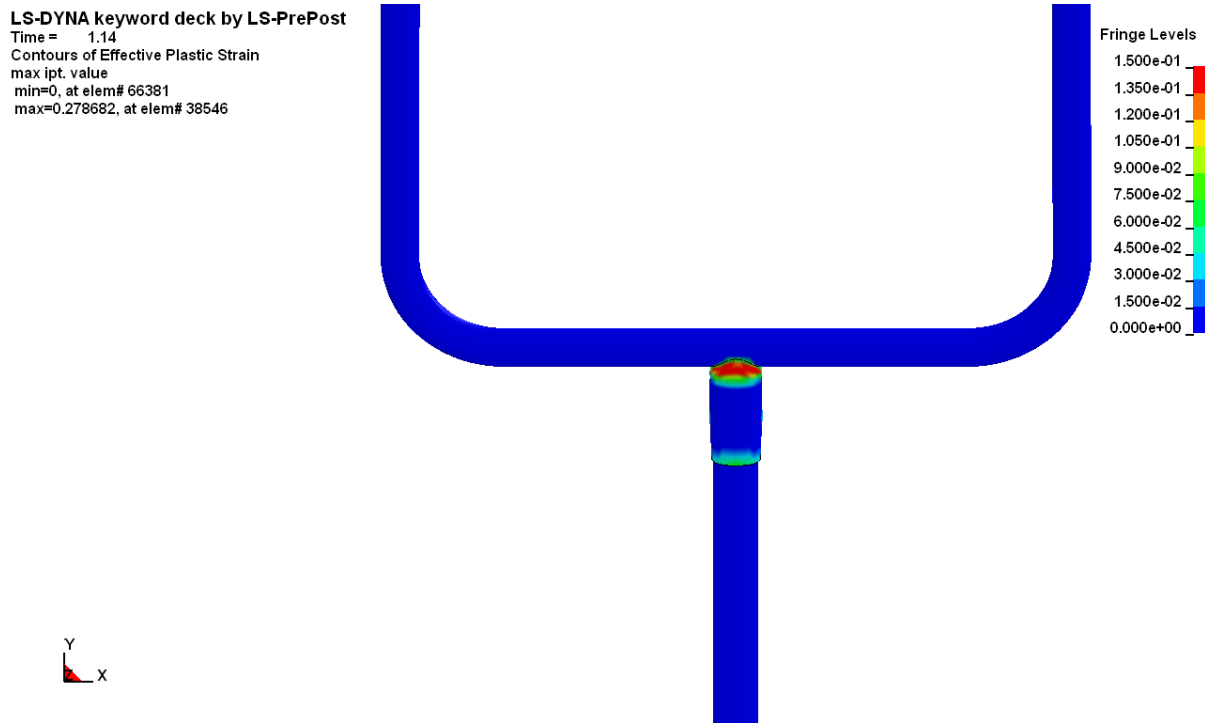


Figure 11.6. Simulation of Schedule 80 U-Pipe.

In an attempt to strengthen the connection between the nipple and the U-pipe, a new design was proposed where the nipple no longer necked down to attach to the U-pipe. Instead, the nipple was extended and a hole was drilled through it. The nipple was then threaded through the hole, and the entire assembly was welded up, giving a much larger connection area between the U-pipe and the modified nipple. This larger area helped to strengthen the connection and resulted in the schedule 80 support post yielding at the rigid fixed end condition (see Figure 11.7). Figure 11.8 shows a full detailed drawing comparing the new proposed U-bracket design to the current TxDOT design. This simulation predicted that the modified design would have a higher capacity than that of the schedule 80 pipe support.

LS-DYNA keyword deck by LS-PrePost
 Time = 1.375
 Contours of Effective Plastic Strain
 max ipt. value
 min=0, at elem# 66381
 max=0.0632953, at elem# 70926

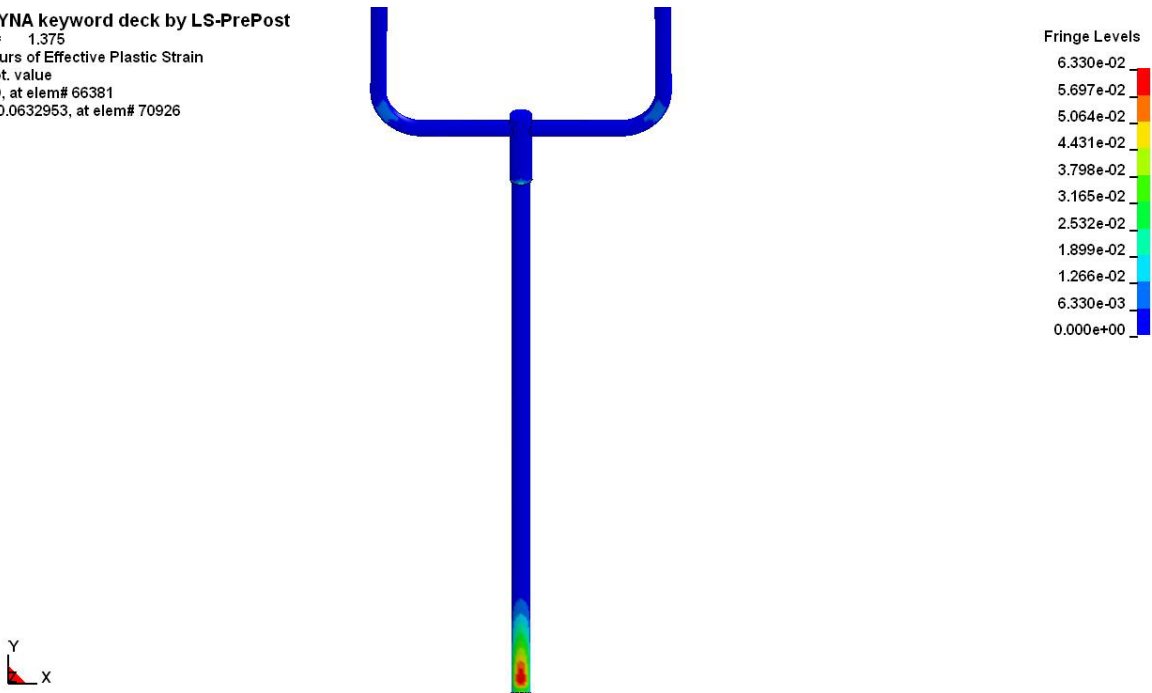


Figure 11.7. Simulation of Modified Nipple Design.

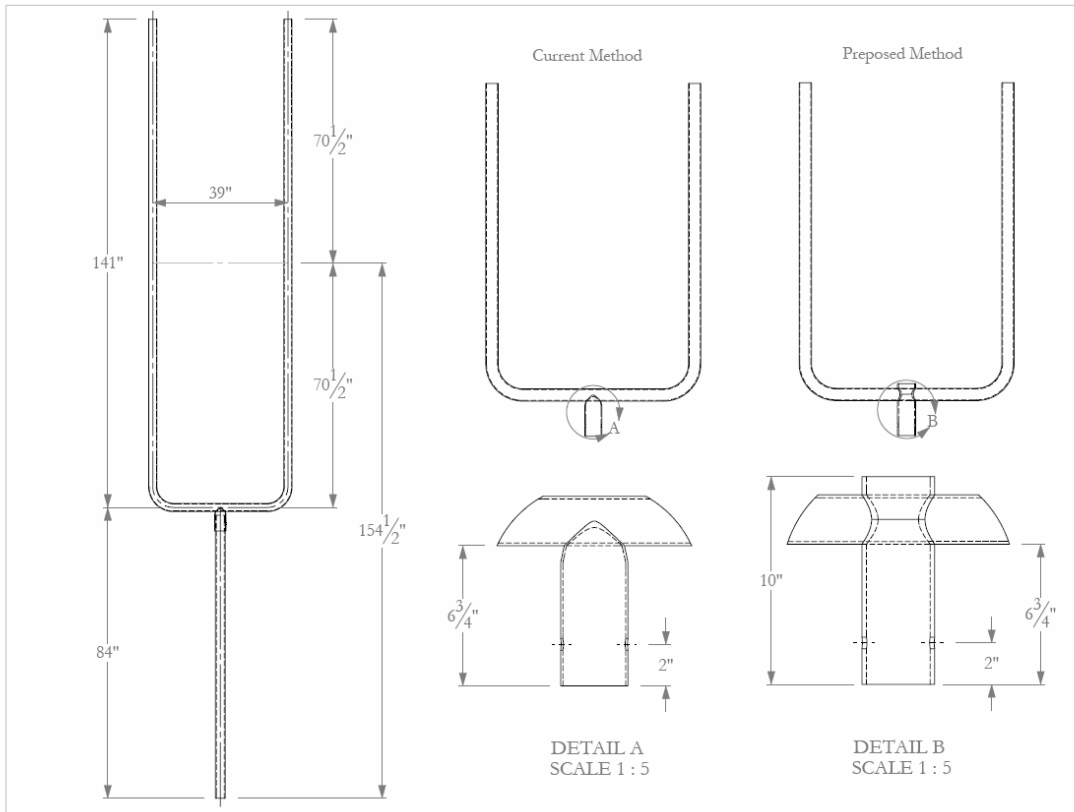


Figure 11.8. U-Bracket Design Comparison.

After further analysis of the simulations, the research team determined that even though the component limiting the capacity of the system did, in fact, shift from the U-pipe to the schedule 80 support, the simulation did not appear to predict a dramatic increase in capacity of the system. Also, on further discussion with manufacturers, the researchers determined that this modification would significantly increase the cost of the U-bracket. The primary reason for the increased cost would have to do with the way the nipple is manufactured. Currently, a die is used to neck down and trim the nipple piece in either one or two actions. This process is much quicker and cheaper than the process required to manufacture the new design. Given this information, TTI suggested that static testing be performed on the current design to determine if a design change would actually be required.

11.5 STATIC TESTING

Eight static tests were performed on donated samples from Trinity Industries/ Northwest Pipe. This series of static tests was developed to compare the capacity of the U-bracket assembly to a single schedule 80 support post.

Tests S1-S3 were developed to measure the maximum wind load force that the U-bracket assembly could withstand at a height of 154.5 inches as previously described in the engineering analysis section of this report. The installation was rigidly cantilevered out horizontally from a load rigid load frame (see Figure 11.9). Figure 11.10 shows the test setup before load application. For this test, the load needed to be spread equally among the two vertical U-bracket supports and will help prevent the U-bracket assembly from twisting in the slip base due to unbalanced applied loads. This was accomplished through the use of a spreader bar shown in Figure 11.11, which ensures both load and deflection are applied to each of the U-brackets vertical supports uniformly while utilizing only a single hydraulic cylinder.

After receiving the U-bracket samples, the research team noticed that the nipple material had a yield stress value in excess of 90 ksi, which is greater than the minimum of 55 ksi required in the TxDOT standards sheet. It is not uncommon to get material that significantly exceeds the minimum specifications; however, this is excessive. After further conversations with the supplier, the research team determined that the company purchased this material because it was the cheapest available that met the minimum TxDOT specifications. In an attempt to locate material more closely representing the minimum specifications, the TTI research team contacted all known Texas suppliers of U-brackets and was not able to locate the type of samples needed. After further review, the researchers determined that this is because most suppliers in Texas are merely resellers of Trinity Industries/Northwest Pipe materials. Therefore, the samples were not any better because all of them were obtained from the same manufacturer. Since time was running out for the project, TxDOT decided to proceed with the high-strength test samples.

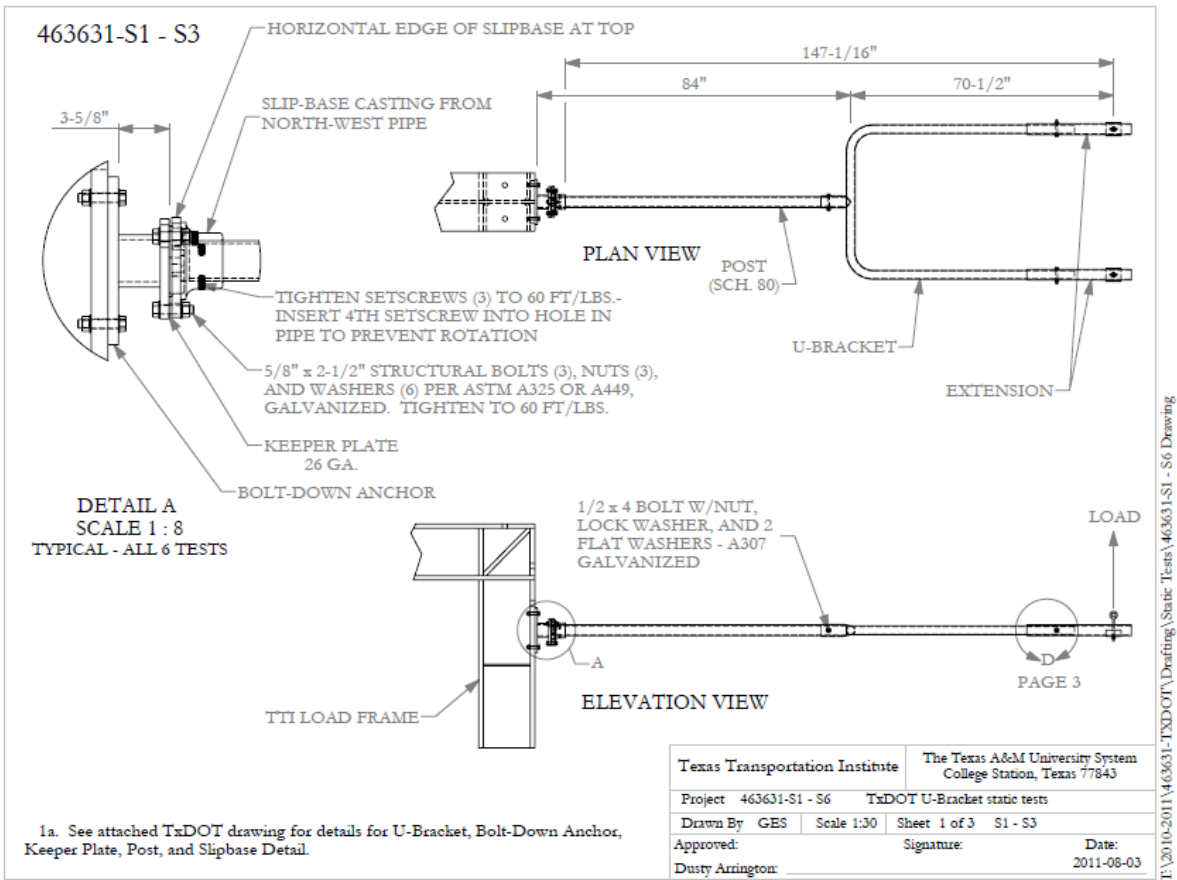


Figure 11.9. U-Bracket Installation Static Test Setup Drawings.



Figure 11.10. Image of U-Bracket Installation Static Test Setup prior to Loading.



Figure 11.11. Image of U-Bracket Load Application.

During the test, a load cell was used to measure the applied load, and a string pot, attached at the load application site, was used to measure deflection. Load application was only halted upon reaching the maximum deflection that the hydraulic cylinder allowed (48 inches). The data was then digitally recorded and plotted for comparison (see Figure 11.12). As seen from the load versus deflection plots, there was very little variance in measured capacity of the supports. Notice that the measured capacity meets/exceeds that of the calculated capacity of the support using the actual material yield strength of 57 ksi. Two dashed lines are plotted on Figure 11.12; one is the calculated capacity of the schedule 80 support, and the other is the adjusted calculated capacity of the support, including the weight of the post. Both were calculated using the actual yield stress defined in the provided mill certificates that came with the samples.



Figure 11.12(a). Image of U-Bracket Installation Static Test Setup at Maximum Load.



Figure 11.12(b). Image of Deformation to Schedule 80 Pipe Support.

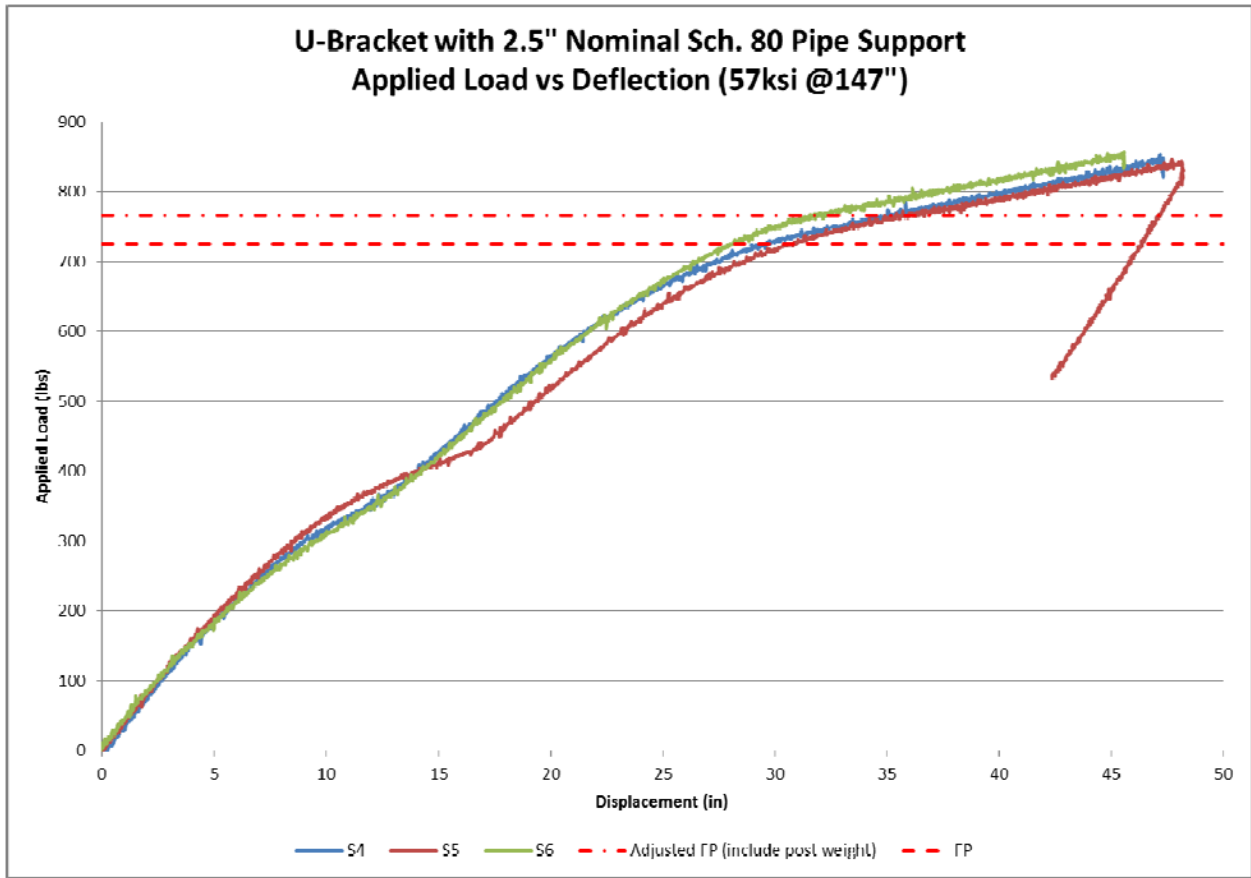
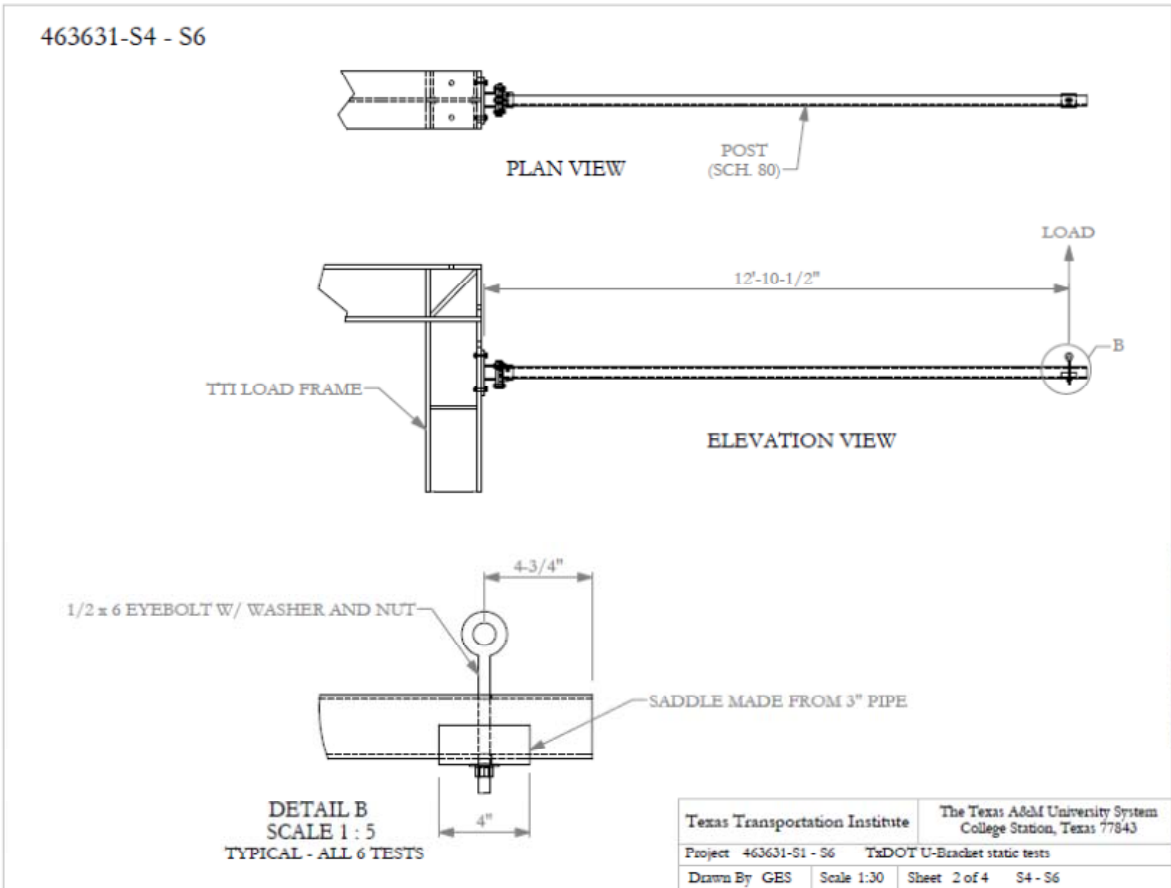


Figure 11.12(c). Load versus Deflection Curves for Tests S1-S3.

Tests S4 through S6 were performed on single schedule 80 pipe supports. The test was set up to reproduce the loading conditions found in tests S1 through S3. Again, in this case, the load was applied at a height of 154.5 inches, as described in the engineering analysis section of this report. Figure 11.13 is a detailed diagram of the test setup. Figures 11.14 and 11.15 are images of the test setup before load application and at maximum load application. Figure 11.16 is an image of the deformed support end of the schedule 80 pipe support.



T:\2010-2011\463631-TxDOT\Drafting, tests 1 and 2\Static Tests\463631-S1 - S6 Drawing

2011-08-29

Figure 11.13. Schedule 80 Pipe Support Static Test Setup Drawings.

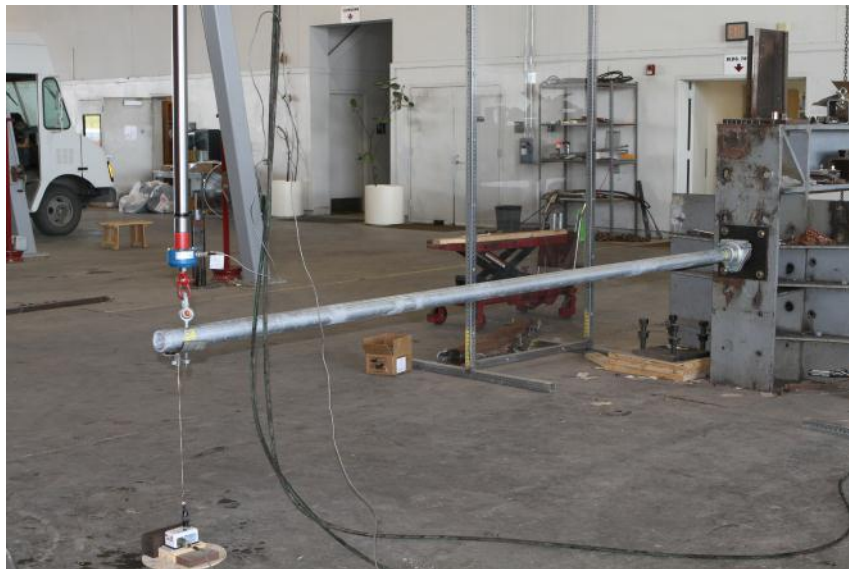


Figure 11.14. Schedule 80 Pipe Support Static Test Setup prior to Loading.



Figure 11.15. Schedule 80 Pipe Support Static Test Setup at Maximum Load.



Figure 11.16. Deformation to Schedule 80 Pipe Support.

The load was continuously increased until a maximum deflection of approximately 48 inches was reached. The measured load and deflection was then digitally recorded and plotted. Figure 11.17 plots all three load versus deflection curves. Notice that the measured values meet/exceeded the calculated force using the actual yield stress of 63 ksi. Once more, the two dashed lines represent the calculated capacity of the support and the adjusted calculated capacity of the support to include the weight of the support.

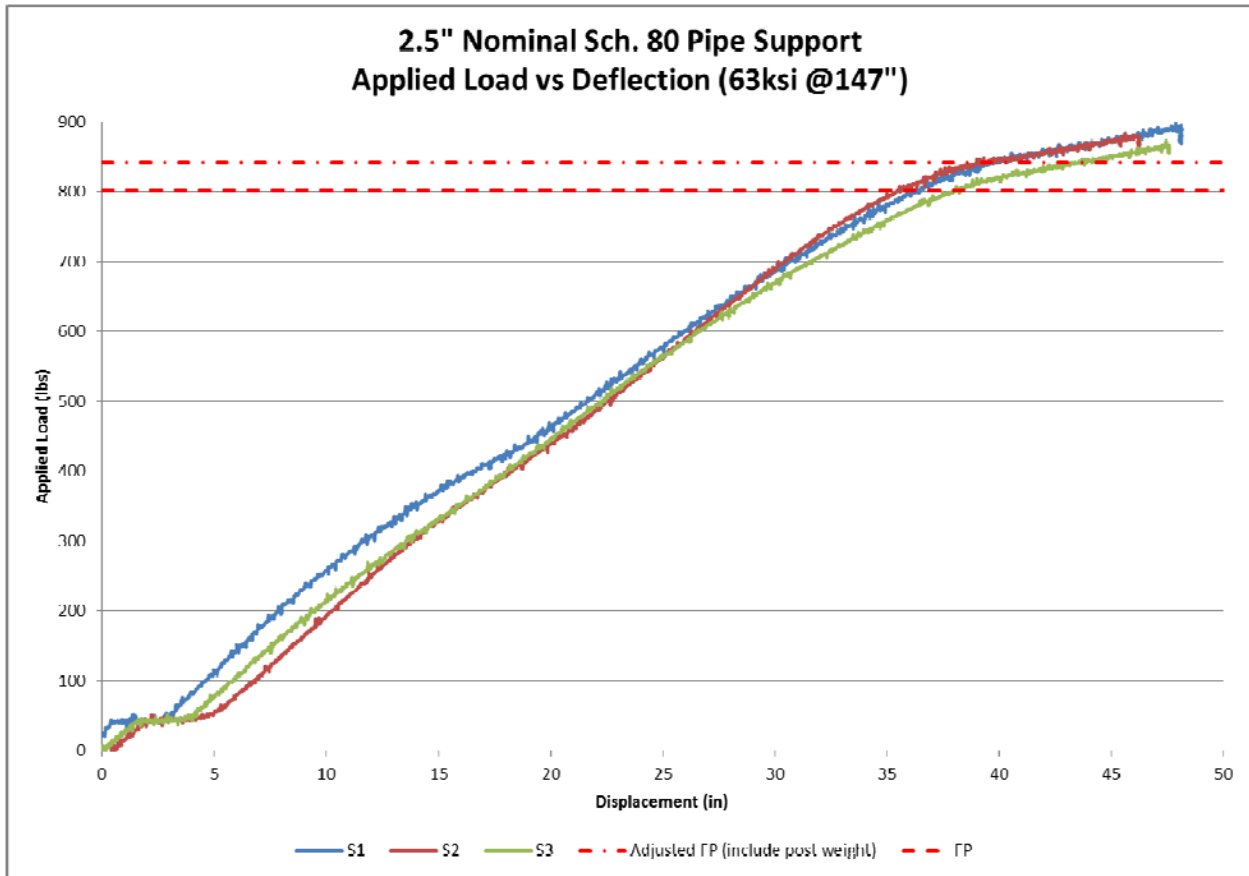
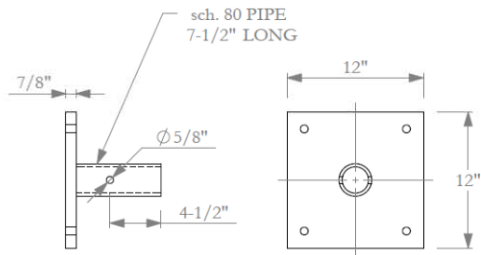


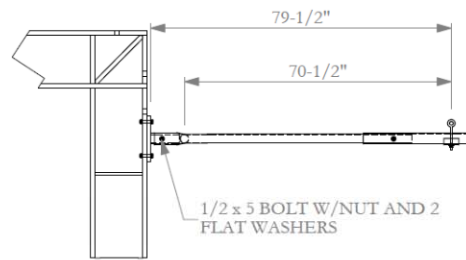
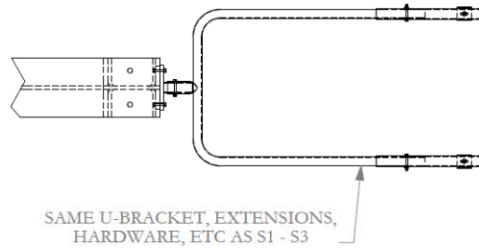
Figure 11.17. Load versus Deflection Curves for Tests S4-S6.

Tests S7 through S8 were performed on single U-bracket supports. The test was set up to directly relate applied load values to those found in Tests S1 through S6. In this case, the load was applied at a height of 70.5 inches, which would directly correspond to the applied loading height (154.5 inches) in Tests S1-S6. Figure 11.13 shows a detailed diagram of the test setup. Figures 11.14 and 11.15 show the test setup before load application and at maximum load application. Figure 11.16 presents the failed support end of the U-bracket support. In this case, the U-pipe failed at the tension side nipple to U-pipe weld location.

463631-S7 - S8



BASE FOR TESTS S7 - S8
SCALE 1:10



| | | | |
|--------------------------------|----------------|---|------|
| Texas Transportation Institute | | The Texas A&M University System College Station, Texas 77843 | |
| Project | 463631-S1 - S6 | TxDOT U-Bracket static tests | |
| Drawn By | GES | Scale | 1:30 |
| Sheet | 3 of 4 | S7 - S8 | |

2011-08-29

T:\2010-2011\463631-TxDOT\Drafting, tests 1 and 2\Static Tests\463631-S1 - S6 Drawing

Figure 11.18. U-Bracket Support Static Test Setup Drawings.



Figure 11.19. U-Bracket Static Test Setup prior to Loading.



Figure 11.20. U-Bracket Static Test Setup at Maximum Load.



Figure 11.21. Deformation and Failure of U-Bracket Support.

Again, the load was continuously increased until a maximum deflection of approximately 48 inches was reached. The measured load and deflection was then digitally recorded and plotted. Figure 11.22 is a plot of all two load versus deflection curves. Notice the measured values meet/exceeded the measured loads recorded in S1-S6.

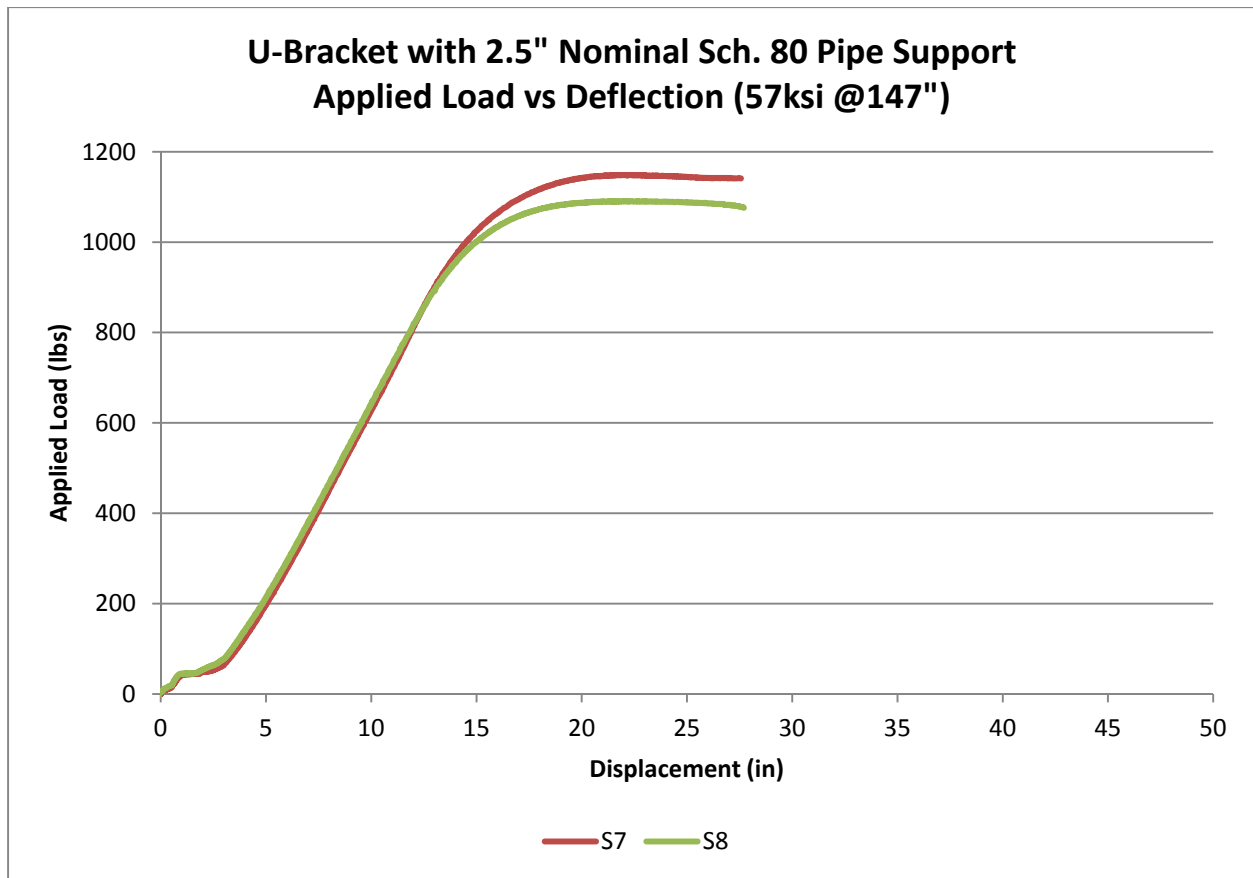


Figure 11.22. Load versus Deflection Curves for Tests S7-S8.

11.6 RECOMMENDATIONS

In Tests S1–S6, the schedule 80 pipe support bending capacity was the limiting factor. In all six static tests, the pipe supports yielded in bending before the U-Bracket failed. In Tests S1-S6, the static tests resulted in a failure load between 700 and 900 lb. These values are significantly lower than the 1000 to 1200 lb recorded in Tests S7 and S8. Finally, all measured values exceeded what was calculated.

This generally means the U-Bracket should not control the capacity of the support system. For this reason, a failure of the U-Bracket due to a wind loading event would not be expected in the field. One instance where this may not be true is if a schedule 80 pipe support with yield strength significantly higher than the minimum specified in the design standard is paired with a U-Bracket support with a yield stress value near the minimum specified. This is a very unlikely scenario.

Evaluations of reported field failures appear to be limited to legacy design installations that have not been replaced due to normal maintenance. Even in these installations, the failures appear to be sporadic and do not warrant system-wide upgrade. Instead, it is suggested that TxDOT upgrade installations only when failures occur or when the installation needs to be replaced for other maintenance reasons.

CHAPTER 12. IMPLEMENTATION

This chapter summarizes what should be done to implement the findings of this project.

- First, the maximum sign area of a schedule 80 support due to wind loading can be increased to 42 ft² if:
 - 1) the minimum yield stress is increased to 66 ksi; or
 - 2) further risk analysis is completed to show that a majority of the posts being supplied have sufficient yield stress to support a 42 ft² sign panel.
- Second, after further review, the research team found that it is not economically efficient to add a schedule 40 sign support to current inventories unless minimum yield stresses are significantly modified.
- Third, researchers found that torsional stiffeners have no bearing on the structural capacities of sign panels, and therefore can be removed from TxDOT standards. However, the stiffeners may serve to protect corners of impacted sign panels if they are moved to within 6 inches of the ends of the sign panels. Stiffeners may also help stabilize the sign panels during installation.
- Next, new optimized fuse plates have been developed and successfully tested according to *MASH* crash testing standards. TxDOT has subsequently decided that the added cost of the torsional stiffeners outweigh the cost savings of the optimized fuse plates and, therefore, will not be utilizing the design. It is suggested that Traffic Operations Division of TxDOT make vertical sign panel stiffeners in Large Guide Sign Standard optional. This would allow the individual districts to make their own evaluation of the need for stiffeners, given the results of this study.
- Next, since TxDOT has decided to maintain the use of current fuse plate designs, TTI has generated new large sign support post guide selection charts meeting current wind load design requirements. These charts conform to the legacy method that AASHTO had defined. TxDOT should replace current selection charts with updated selection charts to prevent further blow down occurrences. The Traffic Operations Division can do this by updating current wind load charts to represent the newly developed wind load design charts.
- Sixth, the minimum sign area allowed to be mounted on a slip base system was found to be 14 ft². Consequently, all newly installed signs with an area smaller than 14 ft² need to be mounted on a 13 BWG pole with a wedge and socket system. Signs with an area greater than 14 ft² and smaller than 24 ft² should be mounted on a 10 BWG pole with a wedge and socket system. It is also recommended that all signs with an area greater than 24 ft² and smaller than 36 ft² would be mounted on a schedule 80 pole with a slipbase support system. The Traffic Operations Division can accomplish this by updating current mounting standards for small signs to comply with the above findings.

- The research team recommends a full-scale crash test to evaluate the crashworthiness of chevron signs when installed at a 4 ft-0 inch mounting height from the pavement surface, on a 6:1 slope, or on steeper ditches. Results will help instill a better understanding on maintaining or modifying the current TxDOT practice of mounting chevron signs at 4 ft-0 inch mounting height in ditches. The researchers reviewed the current TxDOT D&OM standard sheets and gave suggestions for a more efficient presentation of material and installation information. The Traffic Operations Division can implement this by updating and modifying the current D&OM standard sheets to meet the above suggestions.
- Finally, after fully evaluating TxDOT's design standard for U-bracket supports, the research group had determined that the current U-bracket design is adequate. This recommendation is the result of an engineering analysis and has been validated through static testing. It is suggested that most, if not all, the failures in the fields involve an older legacy design that will gradually be replaced through normal maintenance routines. For this reason, no change in U-bracket standards is suggested.

REFERENCES

1. H. E. Ross, D. L. Sicking, R. A. Zimmer, and J. D. Michie, "Recommended Procedures for the Safety Performance Evaluation," *NCHRP Report 350*, National Academy Press, National Cooperative Highway Research Program, Washington, D.C. 1993.
2. AASHTO, *Manual for Assessing Safety Hardware*, American Association of State Highway and Transportation Officials, Washington, D.C., 2009.
3. AASHTO, "Standard Specifications for Structural Supports for Highway Signs, Luminaires and Traffic Signals," American Association of State Highway and Transportation Officials, Washington, D.C., 2006.
4. W. M. Dunn and S. P. Latoski, "Safe and Quick Clearance of Traffic Accidents," NCHRP Synthesis 318, National Cooperative Highway Research Program, Washington, D.C., 2003.
5. TxDOT standard (SMD (SLIP-2)-08):
<ftp://ftp.dot.state.tx.us/pub/txdot-info/cmd/cserve/standard/traffic/smdgen.pdf>.
Third pdf at this web page. Last accessed August 24, 2011.
6. Roger P. Bligh and Wanda L. Menges, Crash Testing And Evaluation of TxDOT Burn Ban Signs, Research Report 0-5210-5, Texas Transportation Institute, Texas A&M University, College Station, TX, August 2009.
7. Nauman M. Sheikh, Rubiat Ferdous, Roger P. Bligh, and Akram Y. Abu-Odeh, Analysis of Roadside Safety Devices for Use on Very High-Speed Roadways, Research Report 0 6017-1, Texas Transportation Institute, Texas A&M University, College Station, TX, September 2009.
8. C. Eugene Buth, Roger P. Bligh, and Wanda L. Menges, Testing and Evaluation of Slipbase Sign Support With Multiple Sign Panels, Test Report No. 405872-1, Texas Transportation Institute, Texas A&M University, College Station, TX, April 2010.
9. Roger P. Bligh and Wanda L. Menges, Initial Assessment of Hardware with Proposed Update to NCHRP Report 350, Research Report No. 0-5526-1, Texas Transportation Institute, Texas A&M University, College Station, TX, September 2007.
10. TxDOT Fabrication Drawings for the Texas Triangular Slip Base and Wedge Anchor System: <ftp://ftp.dot.state.tx.us/pub/txdot-info/cmd/cserve/standard/traffic/slipdetail.pdf>. Fifth pdf at this web page. Last accessed August 31, 2011.
11. *Texas Manual on Uniform Traffic Control Devices (MUTCD)*, Part 3, Ed. 2006, http://www.txdot.gov/txdot_library/publications/tmutcd.htm, retrieved on July 2011.

12. TxDOT Standard: Barricade and Construction Channelizing Devices Standard - BC(9)-07, <ftp://ftp.dot.state.tx.us/pub/txdot-info/cmd/cserve/standard/traffic/bc07.pdf>, retrieved on June 2011.
13. *Texas Manual on Uniform Traffic Control Devices (MUTCD)*, Sign Appendix, Ed. 2006, http://www.txdot.gov/txdot_library/publications/tmutcd.htm, retrieved on July 2011.
14. TxDOT Standard: Typical Delineator and Object Marker Placement Details - D&OM(2) 04, <ftp://ftp.dot.state.tx.us/pub/txdot-info/cmd/cserve/standard/traffic/dom1-10.pdf>, retrieved on June 2011.
15. TxDOT Standard: Delineator & Object Marker Installation and Material Description - D&OM(1)-10, <ftp://ftp.dot.state.tx.us/pub/txdot-info/cmd/cserve/standard/traffic/dom1-10.pdf>, retrieved on June 2011.
16. D. L. Bullard, Jr., and W.L. Menges. Evaluation of the Crashworthiness of Thin-Walled Aluminum and Steel U-Channel Sign Supports, Test Report No. 405231-1F, Texas Transportation Institute, Texas A&M University, College Station, TX, June 1995.
17. R.P. Bligh, L.D. Bullard, W.L. Menges and S.K. Schoeneman. Impact Performance Evaluation of Work Zone Traffic Control Devices, Test Report No. FHWA/TX-01/1792-2, Texas Transportation Institute, Texas A&M University, College Station, TX, 2000.
18. Mechanical Simulation Corporation, *CARSIM. Version: 8.0*. Ann Arbor, MI, 1996.

APPENDIX A. STATIC TESTS ON SCHEDULE 80 CANTILEVER (S6-S8)

TEST ARTICLE DESCRIPTION

Three tests were conducted to quantify the flexural capacity of a schedule 80 pipe sign support. The tests were conducted on a cantilevered schedule 80 pipe attached to a standard TxDOT triangular slip base. This connection utilized three 5/8-inch diameter A325 bolts. The three bolts are installed in the slip base slots and torque to 60 ft-lb. A bolt keeper plate was used between the upper and lower slip plates to help retain the bolts within the slots. The upper slip plate was integral to a ductile iron casting. The schedule 80 pipe support was inserted into a sleeve on top of the casting and secured with a set screw. Figure A1 shows a diagram of the test setup and test article.

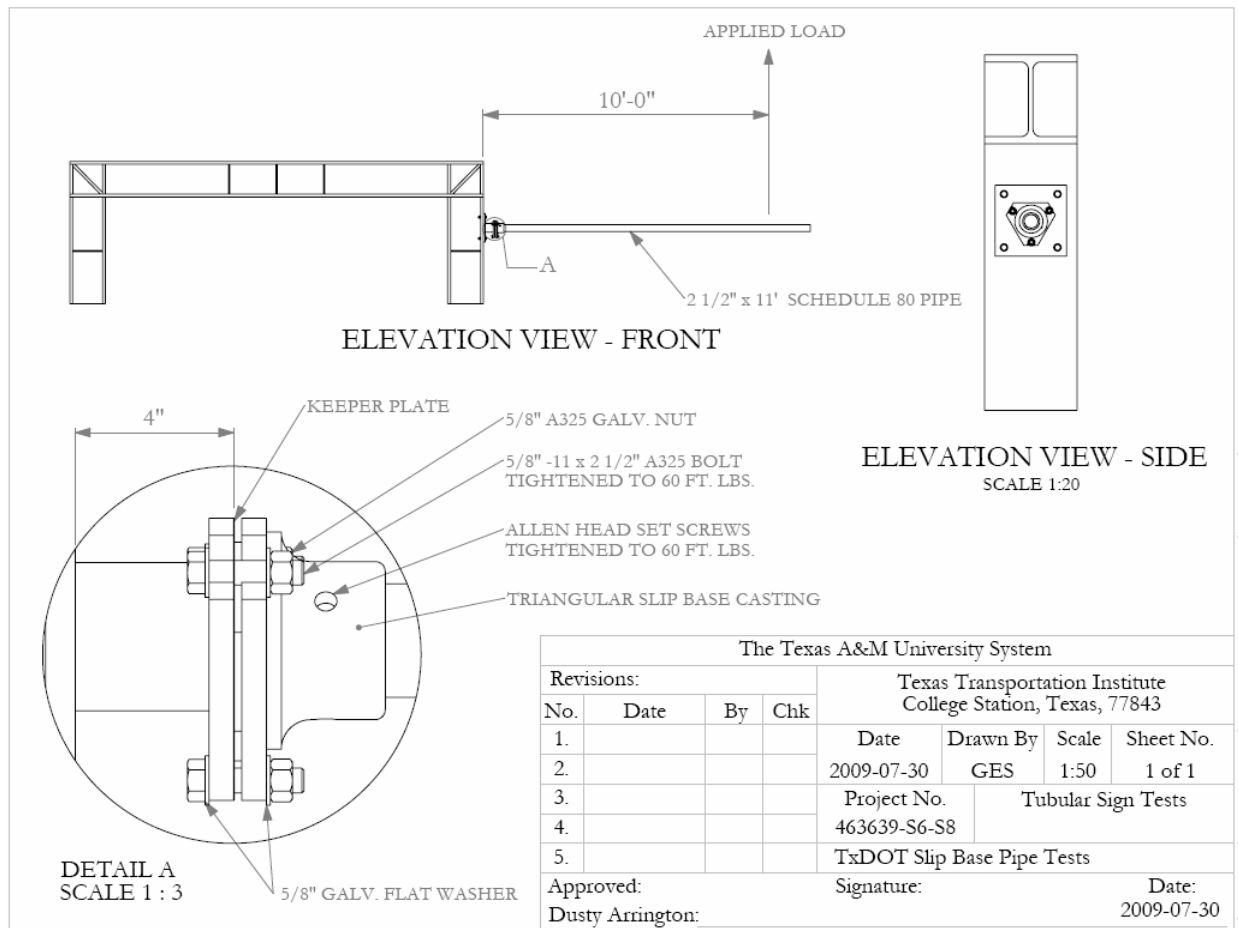


Figure A1. Test Setup for S6-S8.

TEST RESULTS

Tests S6 through S8 were performed on the schedule 80 cantilever support. Table A1 notes the maximum loads and displacements from these tests are noted. Figure A2 shows graphs of the load data. In test S8, the bottom bolt released. Figure A3 shows that the other two tests were halted after the post yielded plastically at the slipbase.

Table A1. Summary of Data for Static Tests on Schedule 80 Cantilever Supports.

| Support Tested | Test No. | Maximum Load | Displacement |
|--------------------------------|----------|--------------|--------------|
| Schedule 80 cantilever support | S6 | 1047 lb | 25.5 inches |
| | S7 | 1047 lb | 25.5 inches |
| | S8 | 971 lb | 20.4 inches |

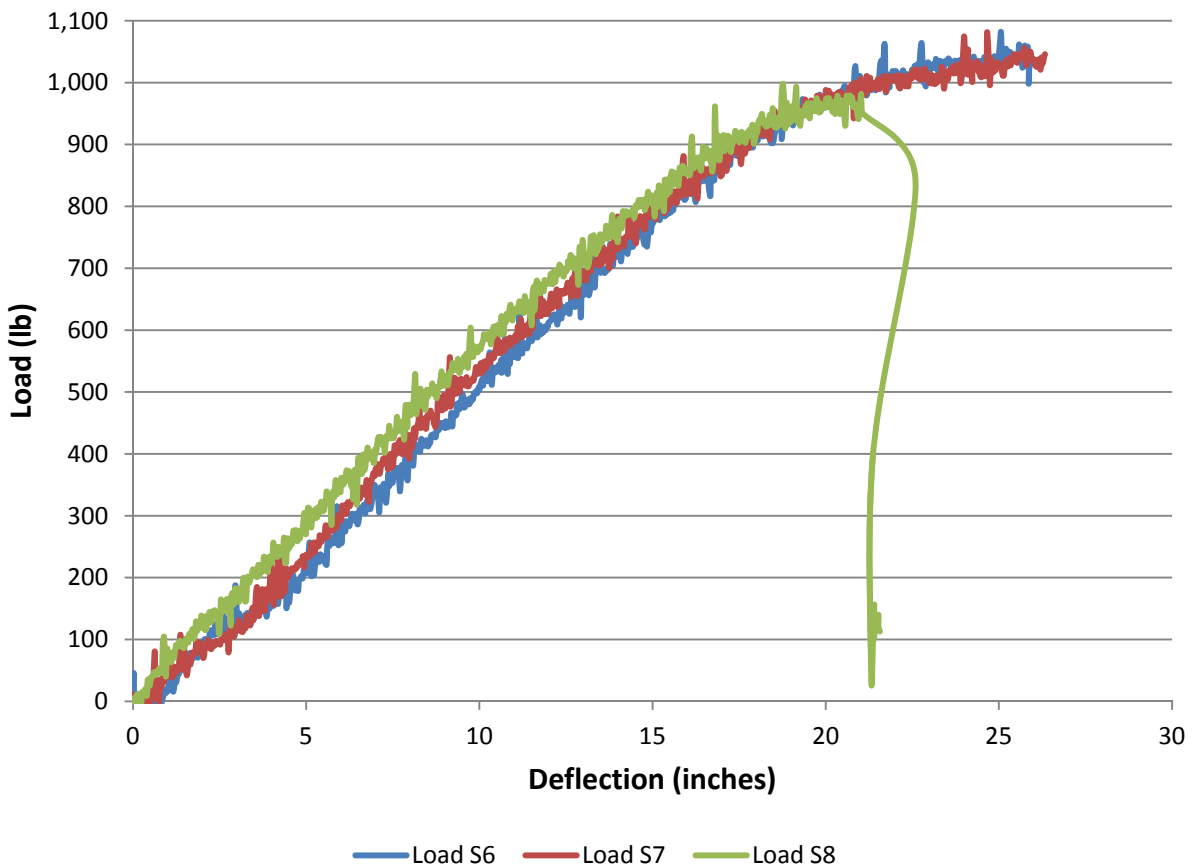


Figure A2. Load for Tests on the Schedule 80 Cantilever Support.

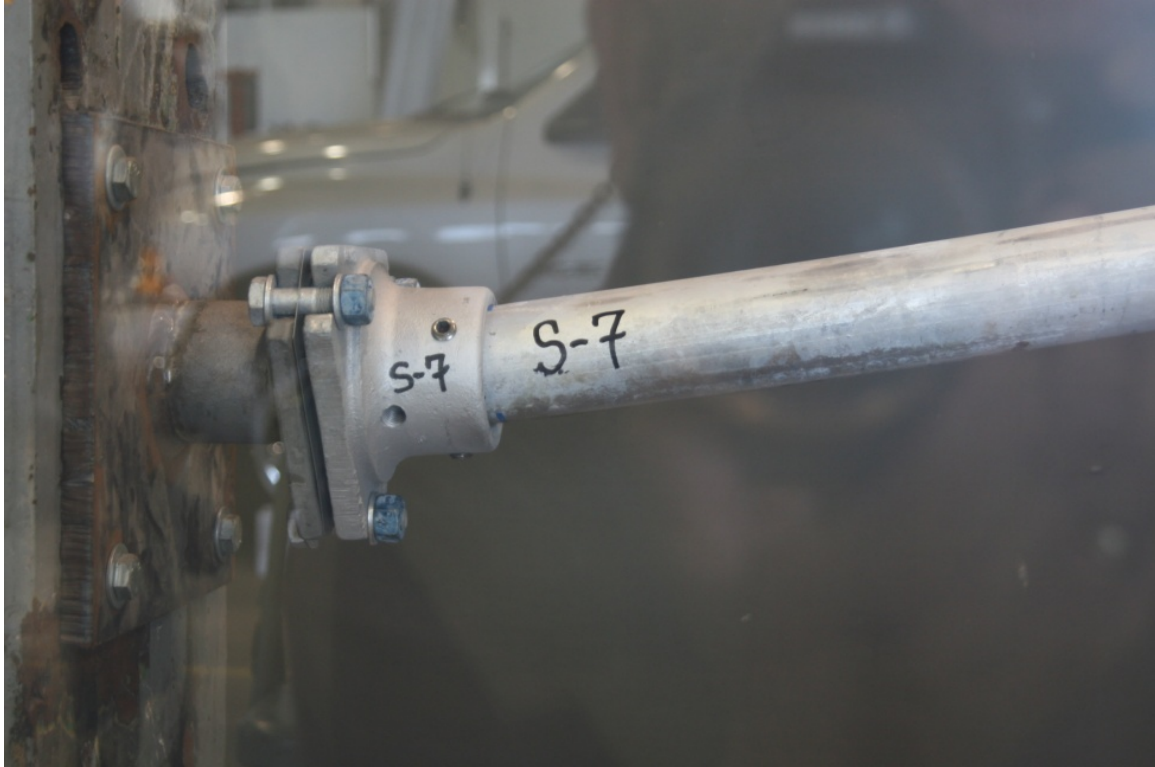


Figure A3. Test Sample S7 at Maximum Load.

APPENDIX B. STATIC TESTS ON FUSE PLATE (S12-S14, S16)

A series of static load tests were conducted to evaluate the tensile capacity of two different fuse plate sizes commonly used on TxDOT sign supports for comparison with nominal design values.

TEST ARTICLE DESCRIPTION

S12-S14: Ungalvanized Standard W8×18 Fuse Plates

The standard fuse plate is made from steel bar or steel plate. The plates used in the testing were fabricated from A36 bar stock having an ultimate tensile capacity less than 80 ksi. The plates are $\frac{3}{8}$ -inch thick and $5\frac{1}{4}$ inches wide. To reduce the rupture strength, four 1-1/16-inch diameter holes are drilled along the centerline of the plate effectively reducing the cross-sectional area (see Figure B1). A plate was bolted to both the compression or tension flanges of the W8×18 post sections using $\frac{5}{8}$ -inch diameter ASTM A325 bolts. The bolts were torqued to 36-38 ft-lb. Figure B2 is the TxDOT standard detail sheet for mounting of large guide signs, and Figure B1 details the generic TxDOT fuse plate design.

S16: Ungalvanized Standard W8×21 Fuse Plates

Figures B1 and B2 also show details of the fuse plate TxDOT used on W8×21 support posts. The plates used in the tensile tests were fabricated from A36 bar stock having an ultimate tensile capacity less than 80 ksi. The plates were $\frac{1}{2}$ -inch thick and $5\frac{1}{4}$ inches wide. To control the rupture mode and strength, four 1-inch diameter holes are drilled along the centerline of the plate effectively reducing the cross-sectional area, (see Figure B2).

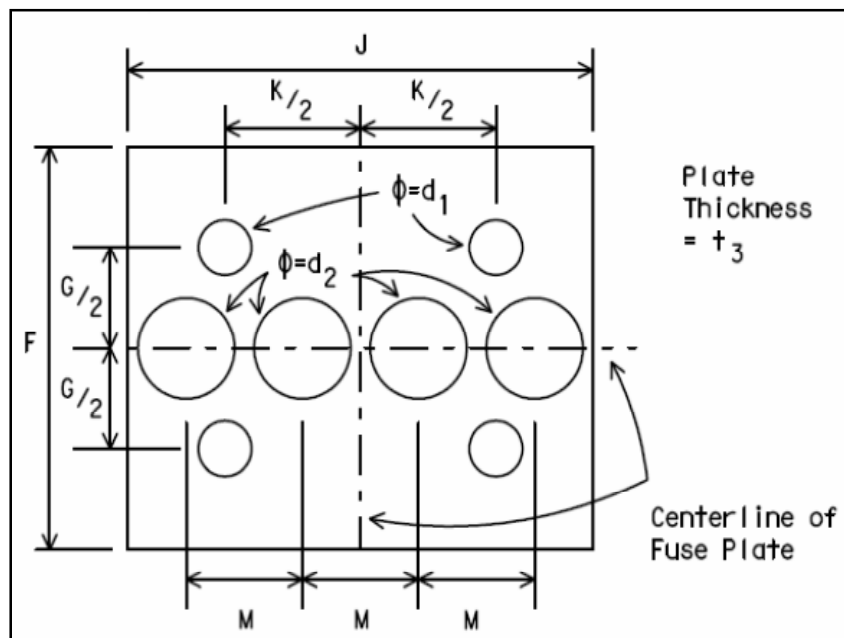


Figure B1. TxDOT Standard Fuse Plate Detail.

TENSION TEST SETUP

Two supports fabricated from 1-inch thick steel plate were mounted to the top of a load frame. A 24-inch stroke hydraulic cylinder was used to apply the load. This cylinder has a maximum tensile capacity of 50 kips. A load cell was installed in line with the hydraulic cylinder to measure tensile load as a function of time. Connecting plates were bolted to the hydraulic cylinder on one end and the support bracket on the other end. These pinned connections enabled the specimens to be loaded in uniaxial tension without bending the vertical plane. Combined stresses arising from bending would effectively reduce the tensile capacity of the fuse plates. Figure B3 shows a diagram of the test setup.

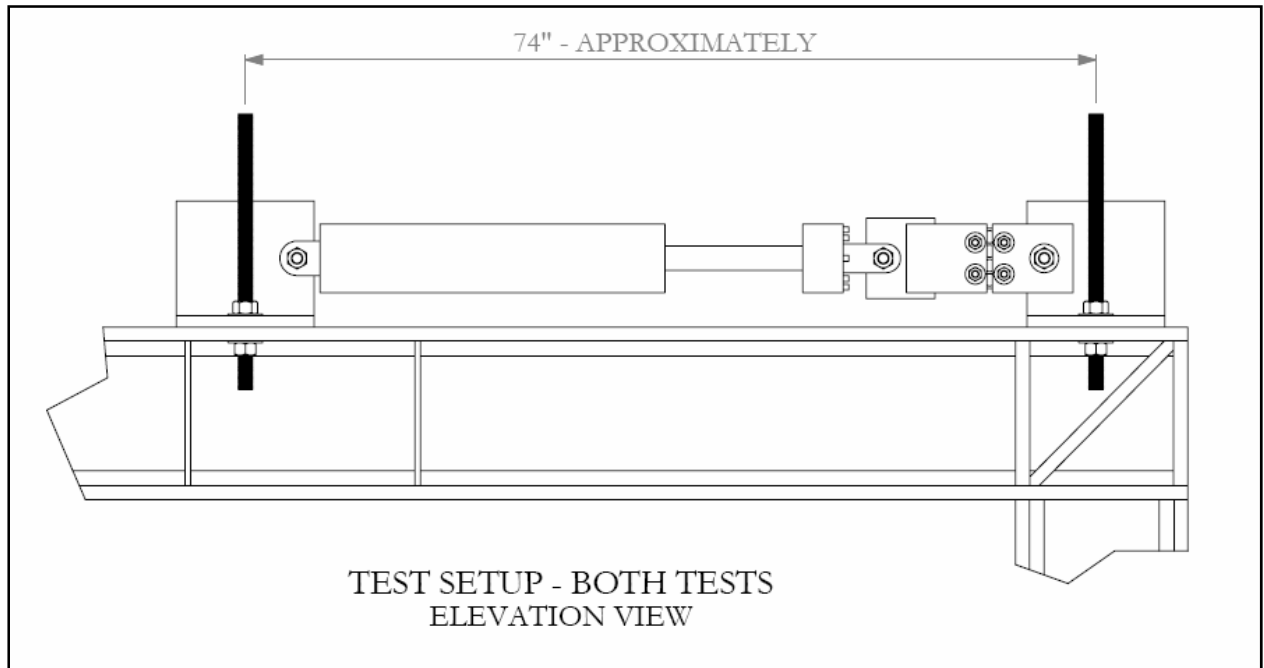


Figure B3. Test Setup for S12–S19.

TEST RESULTS

Table B1 notes the maximum load for Tests S12-S14 and Test S16, and Figure B4 show graphs of the load data for these tests. In Tests S12-S14 the plates failed in tension (see Figure B5). The larger fuse plate used with W8×21 support posts exceeded the force capacity of the hydraulic cylinder. The loading was halted at a force of 50 kips without failing the fuse plate.

Table B1. Summary of Data for Static Tests on Fuse Plates.

| Support Tested | Test No. | Maximum Load | Fuse Plate Failed |
|---|----------|--------------|-------------------|
| Ungalvanized standard 8×18 fuse plates | S12 | 34,250 lb | Yes |
| | S13 | 33,250 lb | Yes |
| | S14 | 32,030 lb | Yes |
| Ungalvanized standard 8×21 fuse plates | S16 | 50,000 lb* | No |

*Test halted when capacity of hydraulic cylinder was reached.

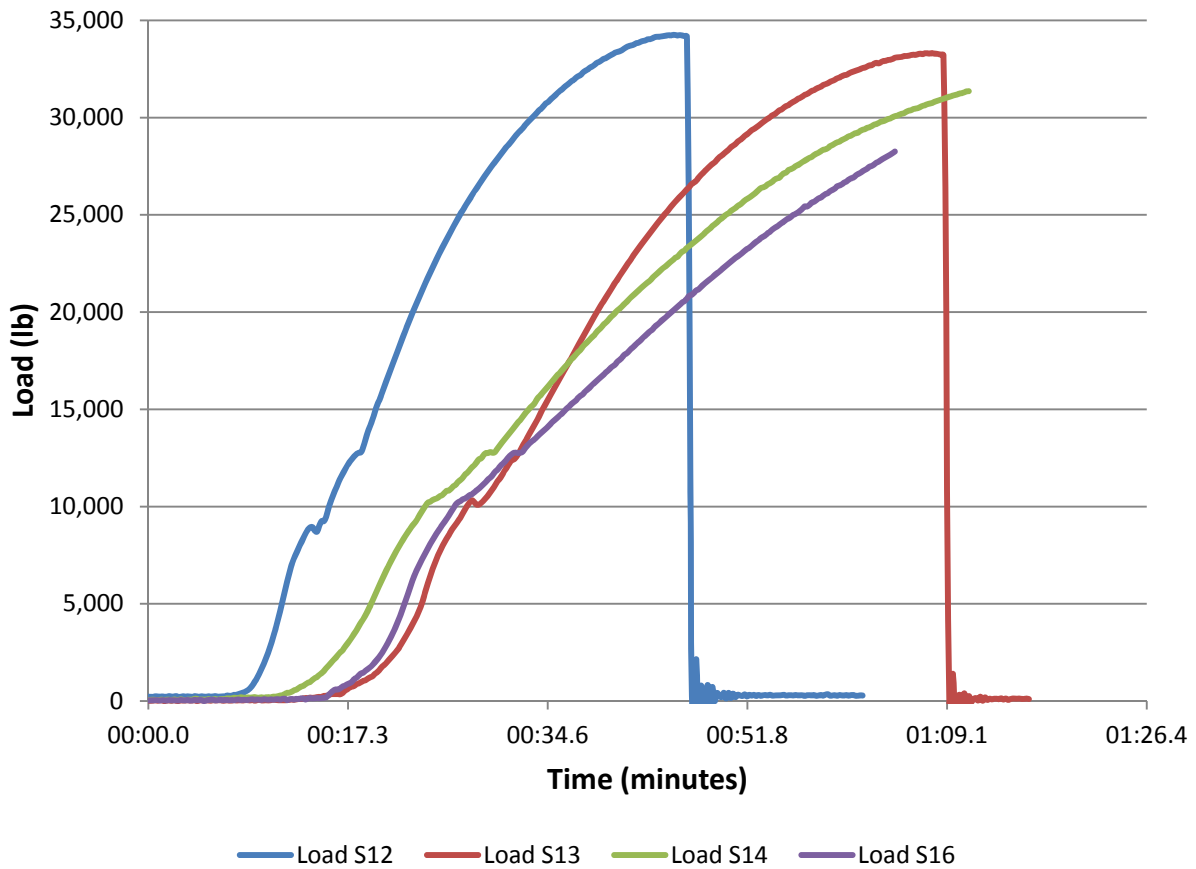


Figure B4. Load for Tests on Fuse Plates.



Figure B5. Test Sample S12 at Rupture.

To simplify inventory and accommodate variations in mounting height, installation of large signs typically involves field cutting and drilling of the steel sign support members. It is generally desired to have the two sections of the support post in bearing when bolted together via the fuse plates. However, the process of field drilling may not be as precise as drilling a support section in a shop setting. Consequently, a separation or gap between the upper and lower post sections has been observed in some field installations. This gap causes the fuse plate on the compression face of the post to take the full compression load associated with the moment couple. Since the fuse plates were initially designed to act in tension, it was not known what effect placing a fuse plate in compression might have on the capacity of the spliced connection. In this test, the splice holes drilled into the W8×18 support post were purposely offset to produce a 3/8-inch gap between the upper and lower sections when spliced using the fuse plates. A 3/8-inch gap was selected in conjunction with TxDOT personnel to be the maximum gap that would be considered acceptable in the field.

TxDOT standard fuse plates and slipbase connections were utilized to erect the W8×18 support post section (see Figure C2). The post assembly was then clamped to a load frame 13.75 inches below the slipbase connection. A vertical force was applied to the W8×18 post section in the strong axis direction 16 ft-3 inches above the clamped location. The force was measured by an in-line load cell, and deflection of the support post was measured at the point of load application using a string pot.

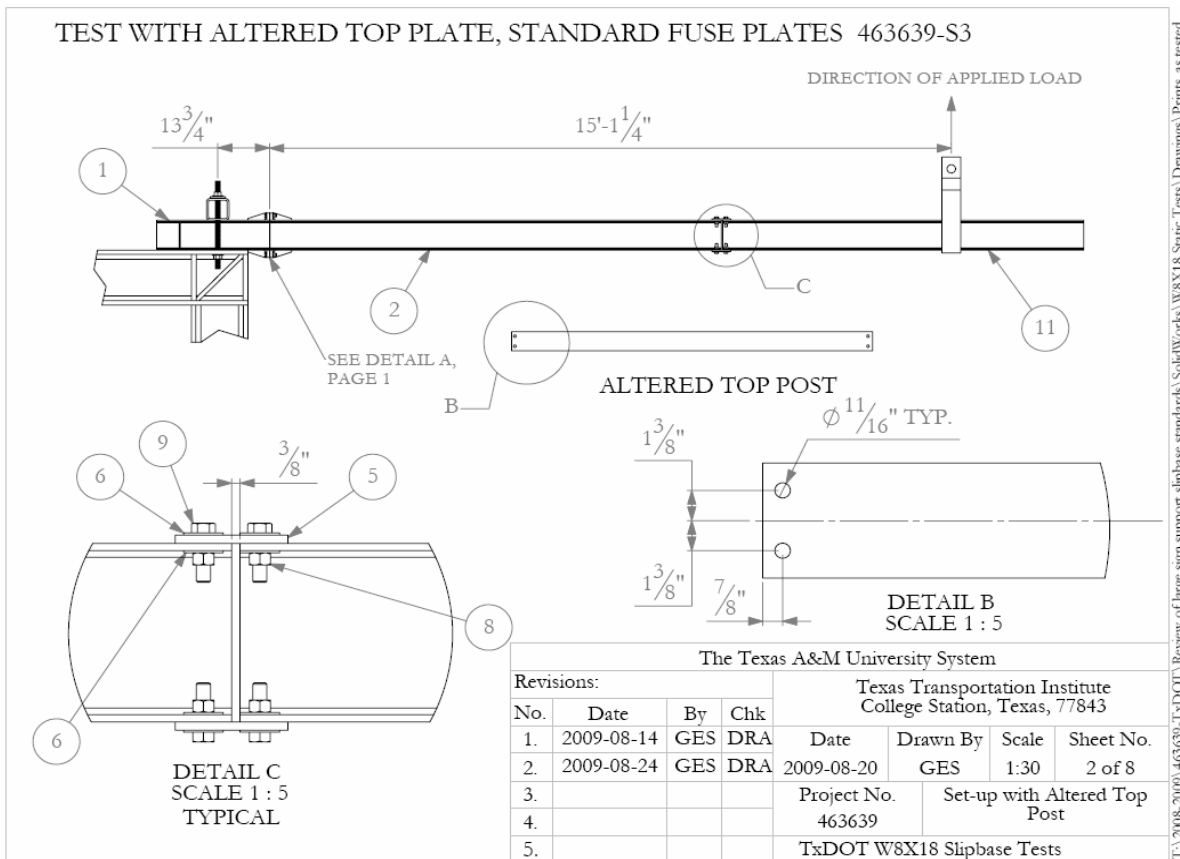


Figure C2. Test Setup for S3.

S20-S23: W8×18 Slip Base Connection

These tests evaluated the capacity of the standard TxDOT slipbase connection for large signs. Two W8×18 post sections were spliced together using a standard TxDOT slipbase connection (see Figure C3). The post assembly was clamped to the load frame 14 inches below the slipbase connection. A vertical load was applied in the strong axis direction of the W8×18 post section 9'-2 inches above the clamped location. An in-line load cell measured the force, and deflection of the support post was measured at the point of load application using a string pot.

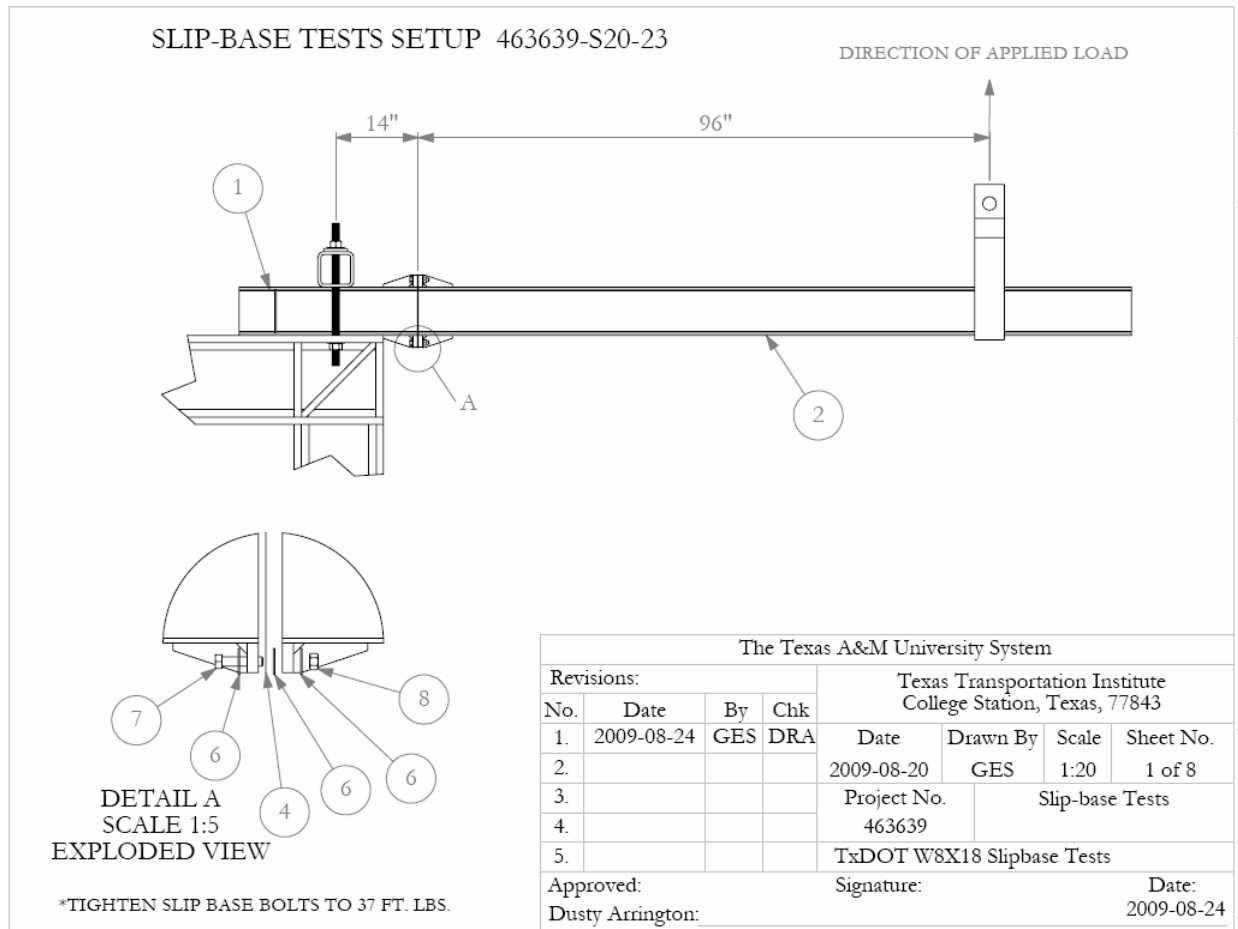


Figure C3. Test Setup for S20-23.

S24-S25: W8×18 with Standard Fuse Plate Splice

These tests evaluated the capacity of a standard splice connection. Two W8×18 post sections were spliced together using a standard TxDOT fuse plate connection (see Figure C4). The test samples were fabricated such that the gap between the spliced post sections was less than 1/8 inch. The post assembly was clamped to the load frame approximately 10.75 inches below the slipbase connection. A vertical load was applied in the strong axis direction of the W8×18 post section approximately 7 ft above the clamped location. Figure C4 has the actual distances for each test. An in-line load cell measured the force, and deflection of the support post was measured at the point of load application using a string pot.

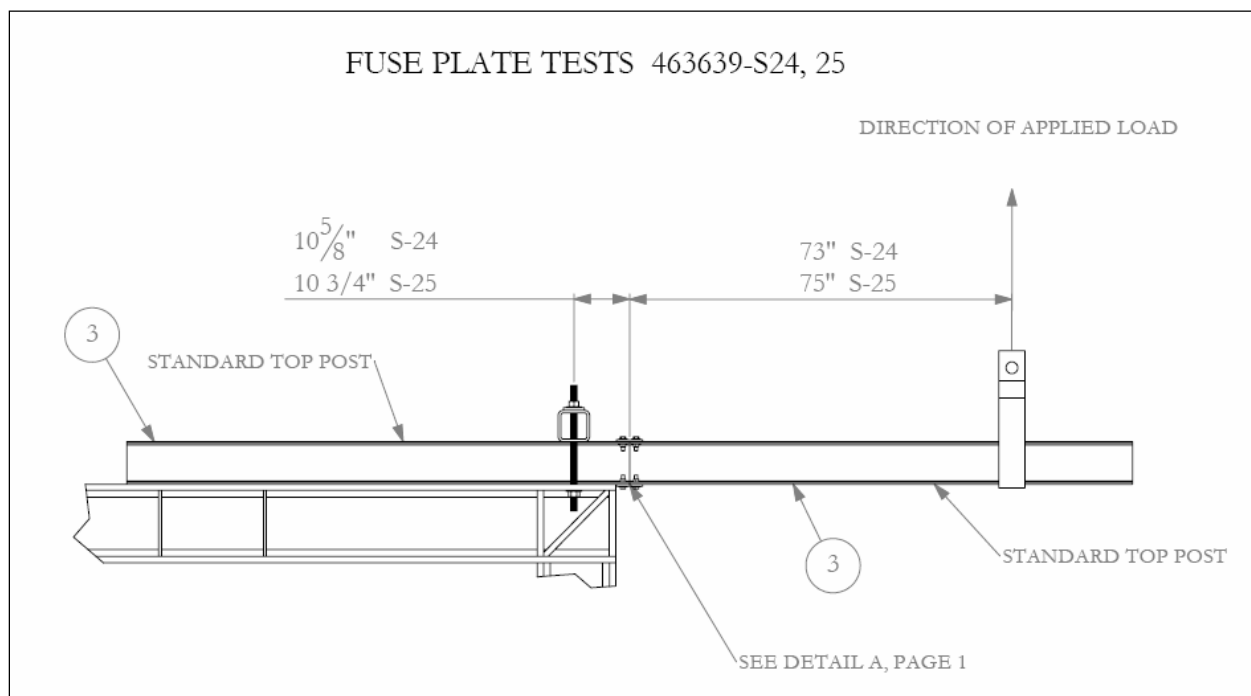


Figure C4. Test Setup for S24 and 25.

S26-S27: W8×18 with Standard Fuse Plate Splice with Gap

These tests evaluated the capacity of a standard splice connection with a separation or gap between the two sections of the support post. Two W8×18 post sections were spliced together using a standard TxDOT fuse plate connection (see Figure C5). The test samples were fabricated such that a ³/₈-inch gap existed between the spliced post sections. The post assembly was clamped to the load frame 11 inches below the slipbase connection. A vertical load was applied in the strong axis direction of the W8×18 post section 7 ft-2.25 inches above the clamped location. An in-line load cell measured the force, and deflection of the support post was measured at the point of load application using a string pot.

TEST RESULTS:

In Test S3, the W8×18 support experienced significant twisting due to lateral torsional buckling (LTB), but there was no failure of the splice connection (see Figure C6). Figures C7 and C8 show that in Tests S20, S21, and S23, the nuts stripped off the threads of the slip bolts on the tension side of the slip base assembly. In Test S22, one of the bolts on the tension side of the slip base assembly ruptures and the threads stripped off the other bolt.

In Tests S24 and 25, the fuse plate on the tension side of the splice connection ruptured. Figure C9 shows that a similar fuse plate failure was observed in tests S26 and S27 on the separated splice connection.

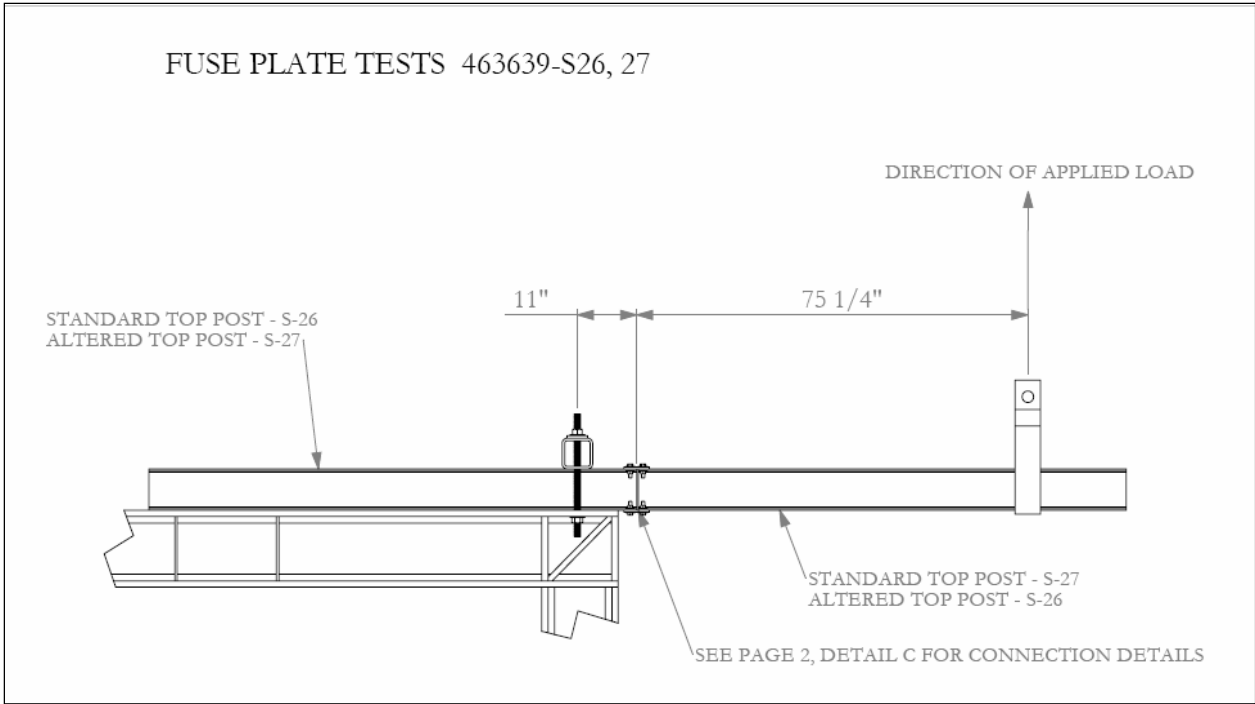


Figure C5. Test Setup for S26 and 27 (with 3/8-inch gap).



Figure C6. Test Sample S3 at Maximum Load.



Figure C7. Test Sample S20 after Slip Bolt Failure.



Figure C8. Slip Bolts after Test S20.



Figure C9. Test Sample S26 after Fuse Plate Rupture.

Table C1 lists the maximum load and displacements from the static load tests. Figure C10 shows the graphs of the load data.

Table C1. Summary of Data for Static Tests on W8×18 Sign Supports.

| Support Tested | Test No. | Maximum Load | Displacement |
|---|----------|--------------|--------------|
| W8×18 with 1/2 inch gap | S3 | 3486 lb | 14.4 inches |
| W8×18 slip base connection | S20 | 6363 lb | 4.6 inches |
| | S21 | 6262 lb | 4.5 inches |
| | S22 | 6376 lb | 4.4 inches |
| | S23 | 6450 lb | 5.8 inches |
| W8×18 with standard fuse plate splice | S24 | 3161 lb | 2.2 inches |
| | S25 | 4255 lb | 3.0 inches |
| W8×18 with standard fuse plate splice with 3/8-inch gap | S26 | 3939 lb | 4.2 inches |
| | S27 | 2980 lb | 3.6 inches |

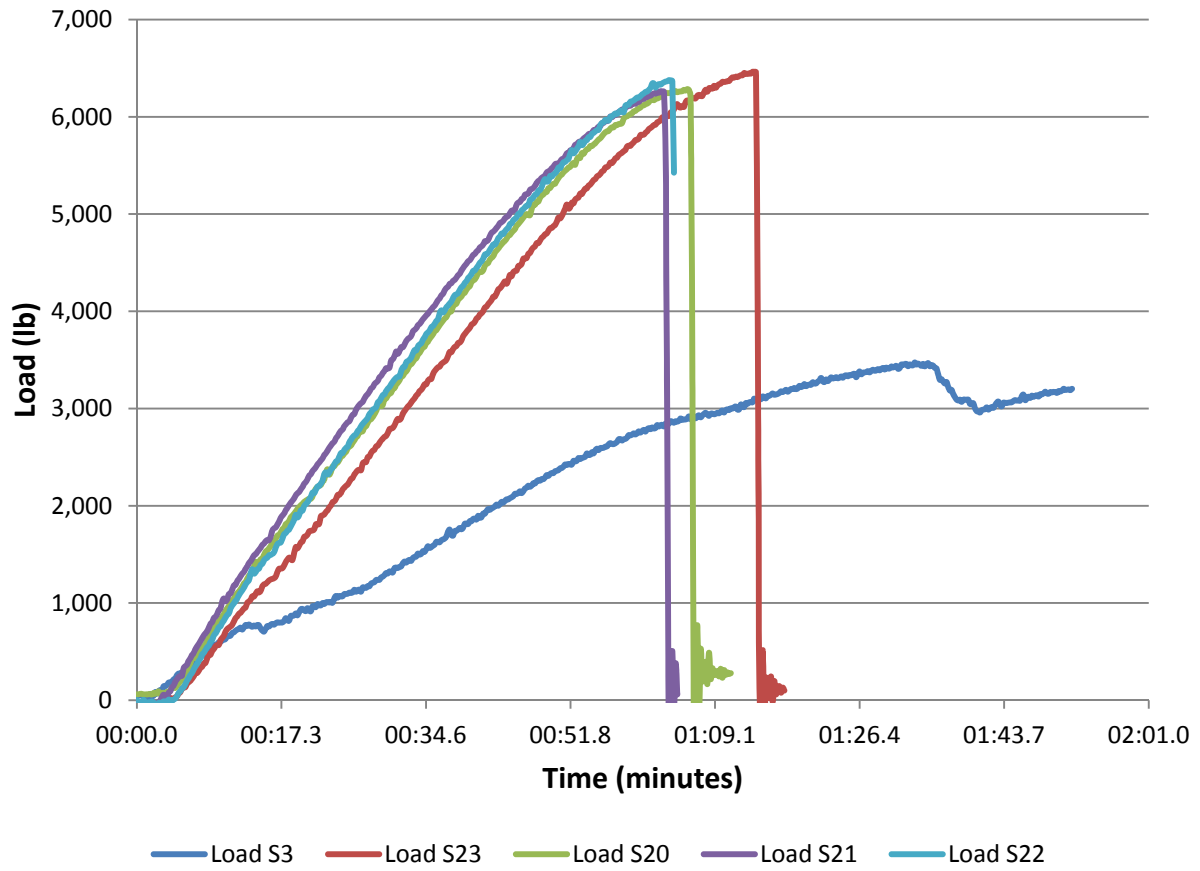


Figure C10. Load for Tests on W8×18 Sign Support.

APPENDIX D. TEST CONDITIONS

TEST FACILITY

The full-scale crash test reported herein was performed at Texas Transportation Institute (TTI) Proving Ground, an International Standards Organization (ISO) 17025 accredited laboratory with American Association for Laboratory Accreditation (A2LA) Mechanical Testing certificate 2821.01. The full-scale crash test was performed according to TTI Proving Ground quality procedures and according to the *MASH* guidelines and standards.

The test facilities at the TTI Proving Ground consist of a 2000 acre complex of research and training facilities situated 10 miles northwest of the main campus of Texas A&M University. The site, formerly an Air Force Base, has large expanses of concrete runways and parking aprons well suited for experimental research and testing in the areas of vehicle performance and handling, vehicle-roadway interaction, durability and efficacy of highway pavements, and safety evaluation of roadside safety hardware. The site selected for the installation of the TxDOT sign support was along a wide out-of-service apron consisting of an unreinforced jointed concrete pavement in 12.5 ft × 15 ft blocks nominally 8–12 inches deep. The aprons and runways are over 50 years old and the joints have some displacement, but are otherwise flat and level.

VEHICLE TOW AND GUIDANCE SYSTEM

The test vehicle was towed into the test installation using a steel cable guidance and reverse tow system. A steel cable for guiding the test vehicle was tensioned along the path, anchored at each end, and threaded through an attachment to the front wheel of the test vehicle. An additional steel cable was connected to the test vehicle, passed around a pulley near the impact point, through a pulley on the tow vehicle, and then anchored to the ground such that the tow vehicle moved away from the test site. A two-to-one speed ratio between the test and tow vehicle existed with this system. Just prior to impact with the installation, the test vehicle was released to be free-wheeling and unrestrained. The vehicle remained free-wheeling, i.e., no steering or braking inputs, until the vehicle cleared the immediate area of the test site, at which time the brakes on the vehicle were activated to bring it to a safe and controlled stop.

DATA ACQUISITION SYSTEMS

Vehicle Instrumentation and Data Processing

The test vehicle was instrumented with a self-contained, on-board data acquisition system. The signal conditioning and acquisition system is a 16-channel, Tiny Data Acquisition System, TDAS Pro©, produced by Diversified Technical Systems, Inc. The accelerometers, that measure the x, y, and z axis of vehicle acceleration, are strain gauge type with linear millivolt output proportional to acceleration. Angular rate sensors, measuring vehicle roll, pitch, and yaw rates, are ultra small size, solid state units designed for crash test service. The TDAS Pro hardware

and software conform to the latest SAE J211, Instrumentation for Impact Test. Each of the 16 channels is capable of providing precision amplification, scaling, and filtering based on transducer specifications and calibrations. During the test, data are recorded from each channel at a rate of 10,000 values per second with a resolution of one part in 65,536. Once the data are recorded, internal batteries back these up should the primary battery cable be severed. Initial contact of the pressure switch on the vehicle bumper provides a time zero mark as well as initiating the recording process. After each test, the data are downloaded from the TDAS Pro unit into a laptop computer at the test site. The Test Risk Assessment Program (TRAP) software then processes the raw data to produce detailed reports of the test results. Each of the TDAS Pro units are returned to the factory annually for complete recalibration. Accelerometers and rate transducers are also calibrated annually with traceability to the National Institute for Standards and Technology.

TRAP uses the data from the TDAS Pro to compute occupant/compartment impact velocities, time of occupant/compartment impact after vehicle impact, and the highest 10-millisecond (ms) average ridedown acceleration. TRAP calculates change in vehicle velocity at the end of a given impulse period. In addition, maximum average accelerations over 50-ms intervals in each of the three directions are computed. For reporting purposes, the data from the vehicle-mounted accelerometers are filtered with a 60-Hz digital filter, and acceleration versus time curves for the longitudinal, lateral, and vertical directions are plotted using TRAP.

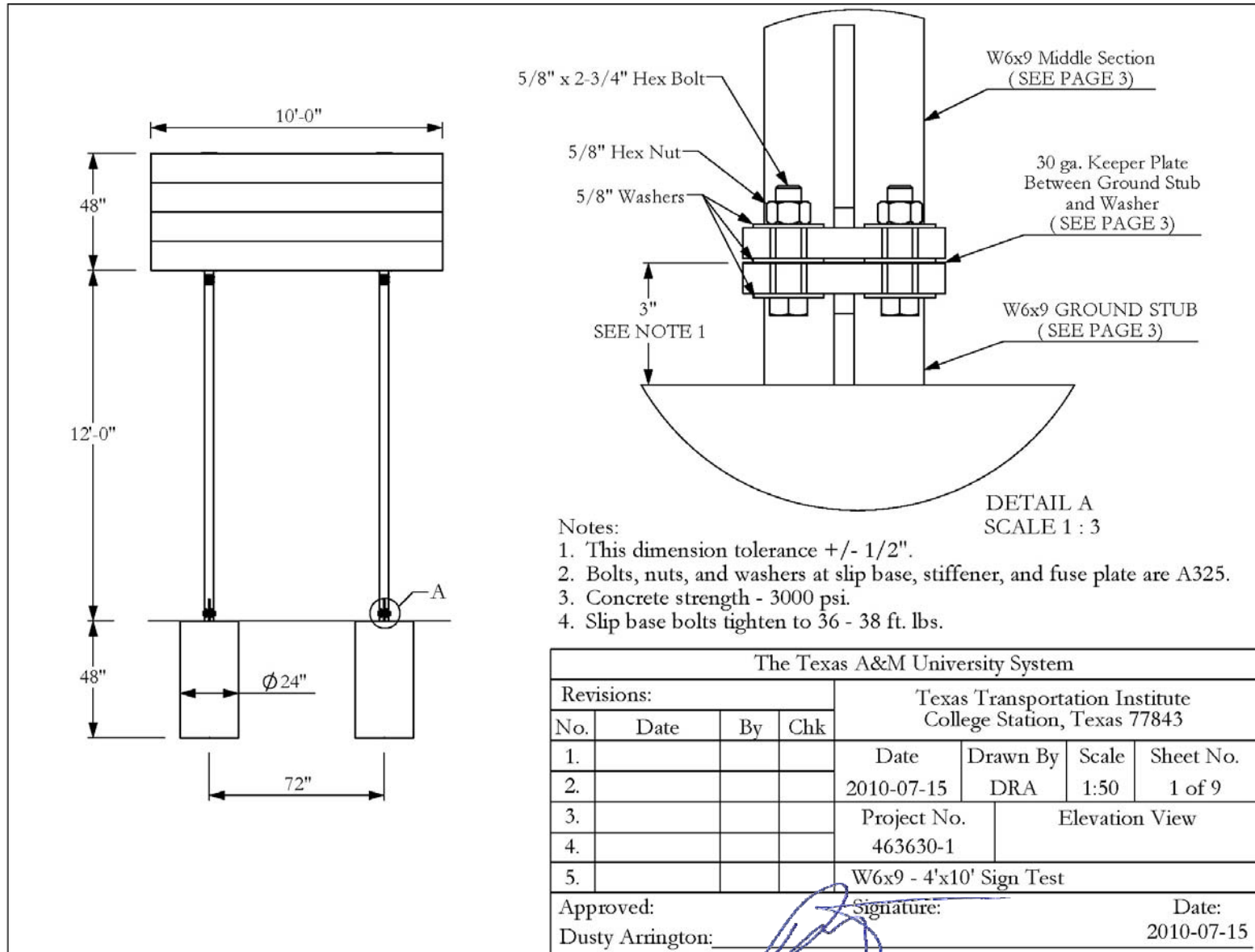
TRAP uses the data from the yaw, pitch, and roll rate transducers to compute angular displacement in degrees at 0.0001-s intervals and then plots yaw, pitch, and roll versus time. These displacements are in reference to the vehicle-fixed coordinate system with the initial position and orientation of the vehicle-fixed coordinate systems being initial impact.

Anthropomorphic Dummy Instrumentation

Use of a dummy in the 2270P vehicle is optional according to *MASH*, and there was no dummy used in the tests with the 2270P vehicle. However, the 1100C vehicle had an Alderson Research Laboratories Hybrid II, 50th percentile male anthropomorphic dummy, restrained with lap and shoulder belts, in the driver's position. The dummy was uninstrumented.

Photographic Instrumentation and Data Processing

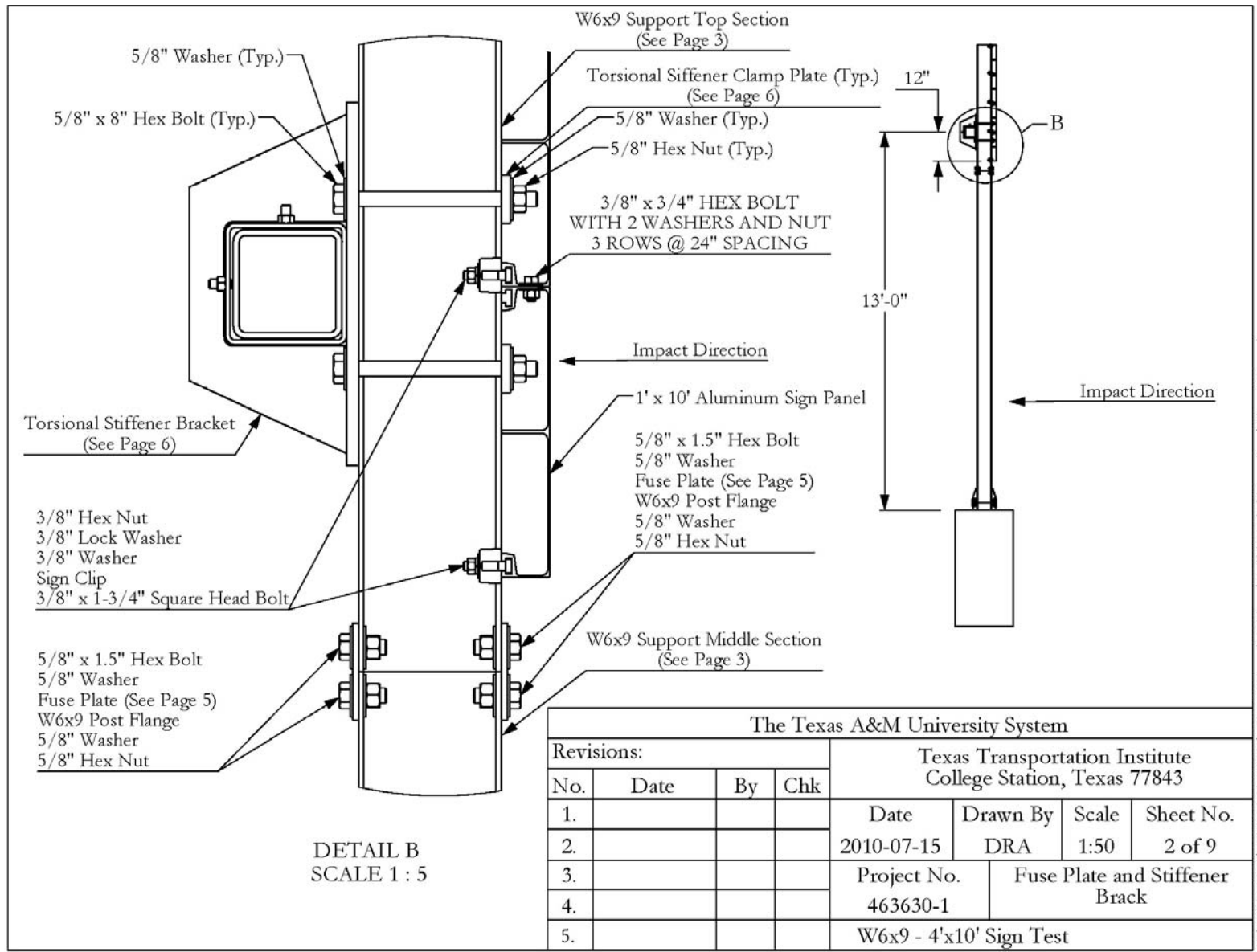
Photographic coverage of the test included two high-speed cameras: one placed perpendicular to the test article/vehicle path, and one placed behind the installation at an angle. A flashbulb activated by pressure-sensitive tape switches was positioned on the impacting vehicle to indicate the instant of contact with the installation and was visible from each camera. The films from these high-speed cameras were analyzed on a computer-linked motion analyzer to observe phenomena occurring during the collision and to obtain time-event, displacement, and angular data. A mini-DV camera and still cameras recorded and documented conditions of the test vehicle and installation before and after the test.



APPENDIX E. CRASH TEST NO. 463630-1

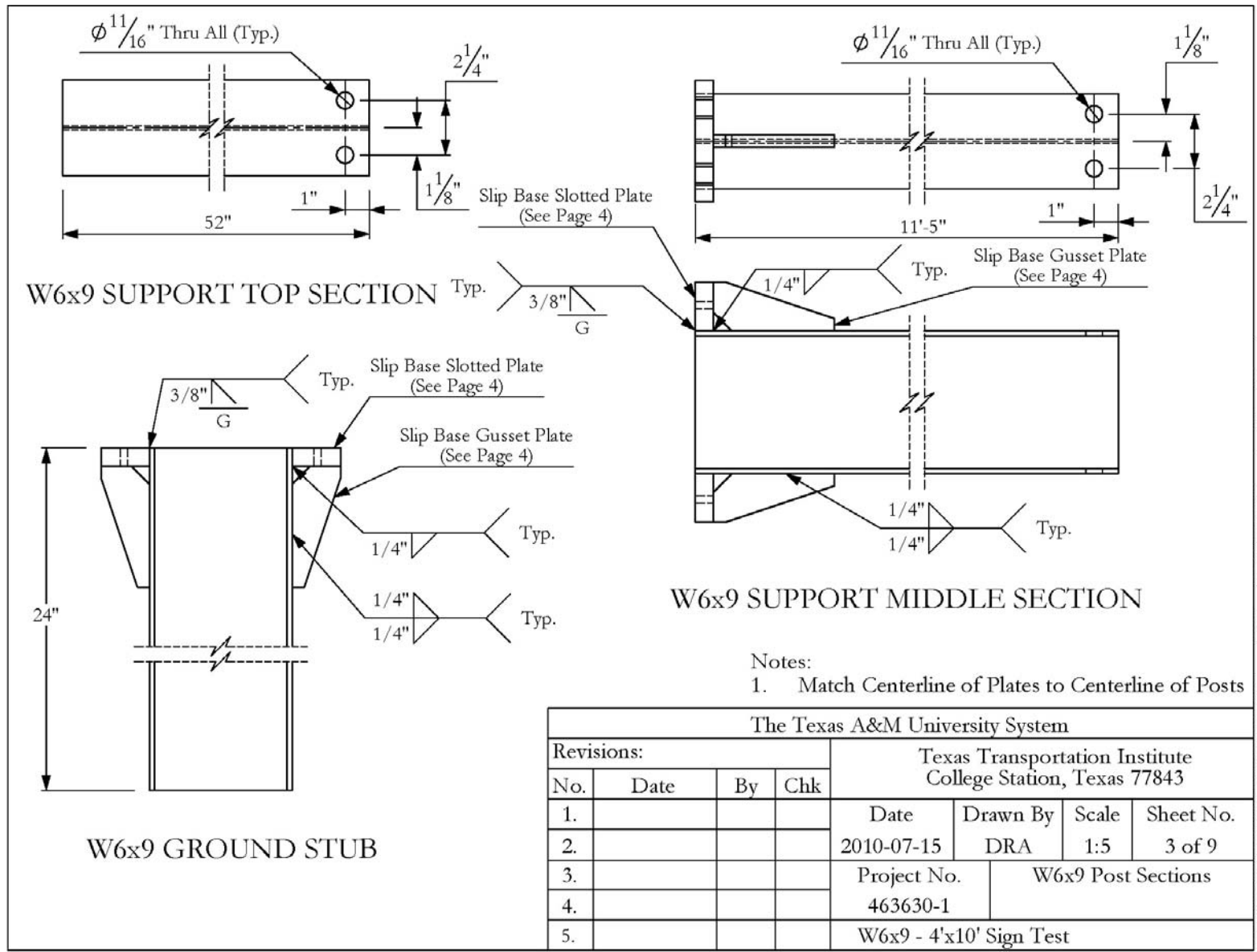
T:\2009-2010\463630-TXDOT\463630-1 and -2 Tests\SolidWorks\Drawings\Test 1 Drawing

Figure E1. Details of the W6x9 with 4-ft x 10-ft Sign.



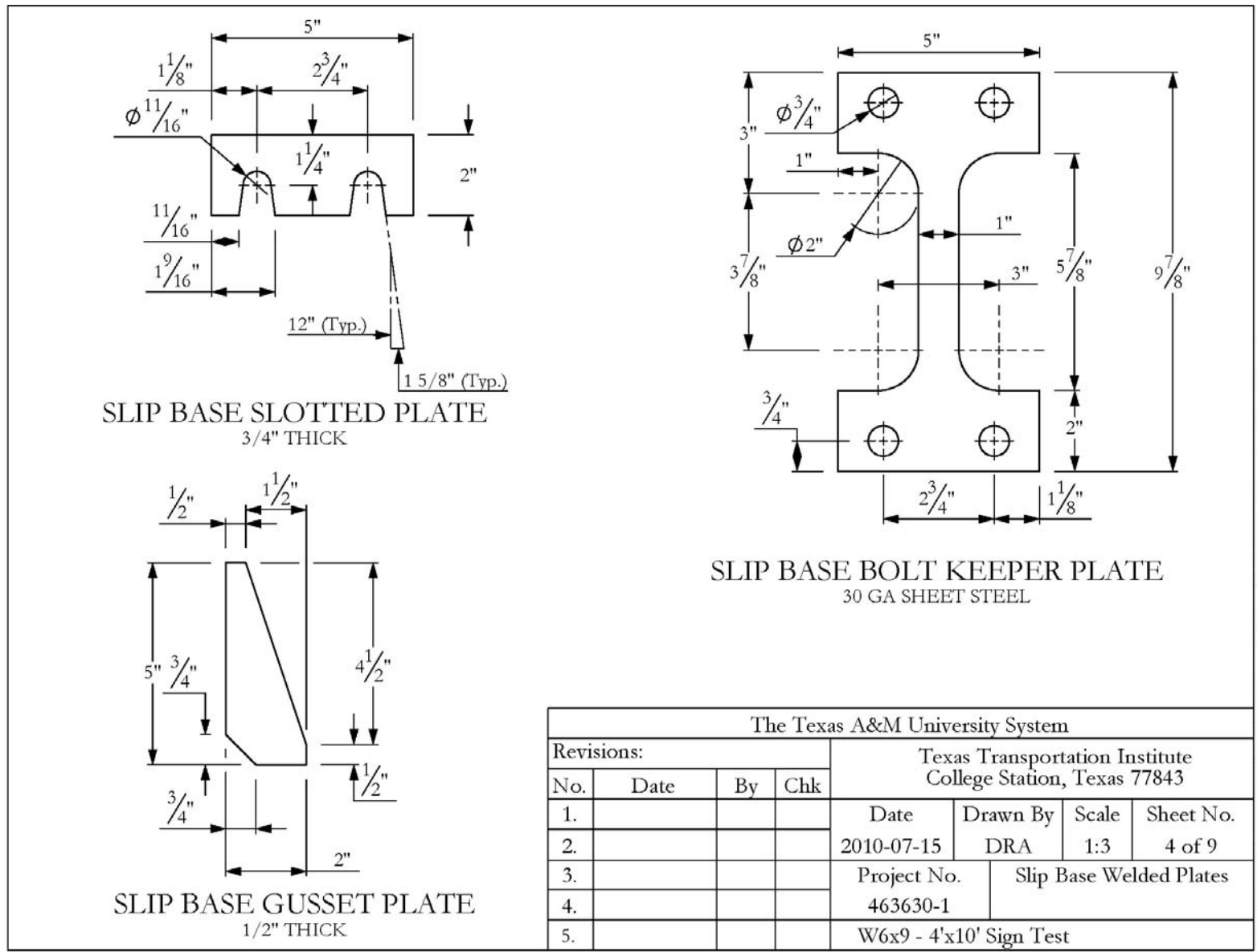
T:\2009-2010\463630-TxDOT\463630-1 and -2 Tests\SolidWorks\Drawings\Test 1 Drawing

Figure E1. Details of the W6x9 with 4-ft x 10-ft Sign (continued).



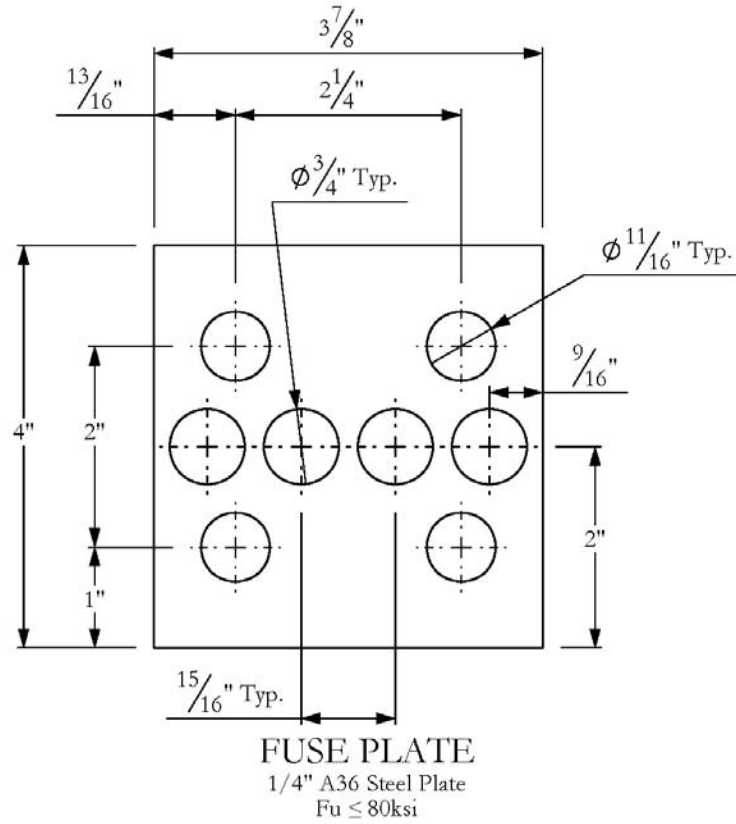
T:\2009-2010\463630-TxDOT\463630-1 and -2 Tests\SolidWorks\Drawings\Test 1 Drawing

Figure E1. Details of the W6x9 with 4-ft x 10-ft Sign (continued).



T:\2009-2010\463630-TxDOT\463630-1 and -2 Tests\SolidWorks\Drawings\Test 1 Drawing

Figure E1. Details of the W6x9 with 4-ft x 10-ft Sign (continued).



| The Texas A&M University System | | | | | | | |
|---------------------------------|------|----|-----|--|----------|-------------|-----------|
| Revisions: | | | | Texas Transportation Institute College Station, Texas 77843 | | | |
| No. | Date | By | Chk | Date | Drawn By | Scale | Sheet No. |
| 1. | | | | 2010-07-15 | DRA | 1:1.5 | 5 of 9 |
| 2. | | | | Project No. | | Fuse Plates | |
| 3. | | | | 463630-1 | | | |
| 4. | | | | W6x9 - 4'x10' Sign Test | | | |
| 5. | | | | | | | |

T:\2009-2010\463630-TxDOT\463630-1 and -2 Tests\SolidWorks\Drawings\Test 1 Drawing

Figure E1. Details of the W6x9 with 4-ft x 10-ft Sign (continued).

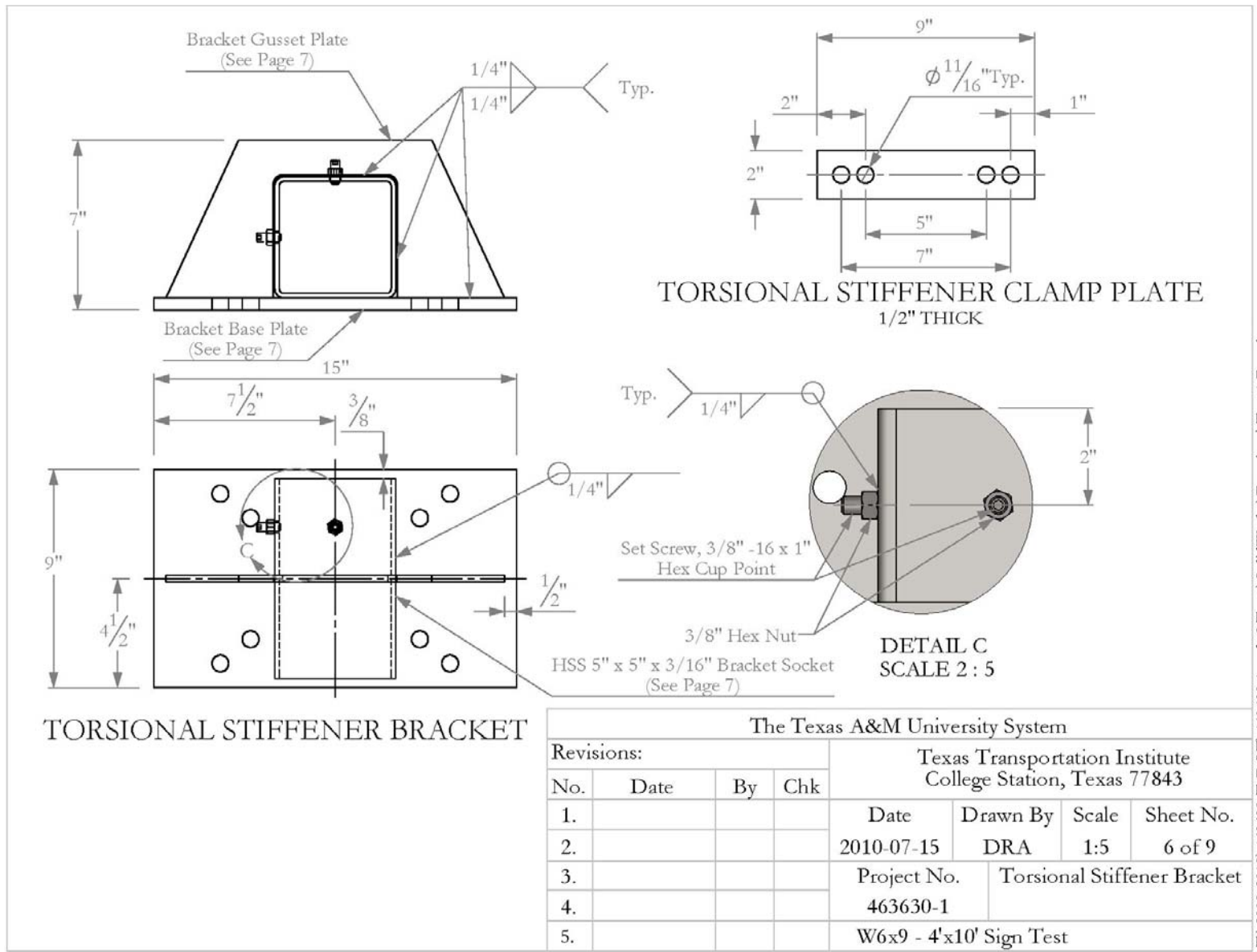
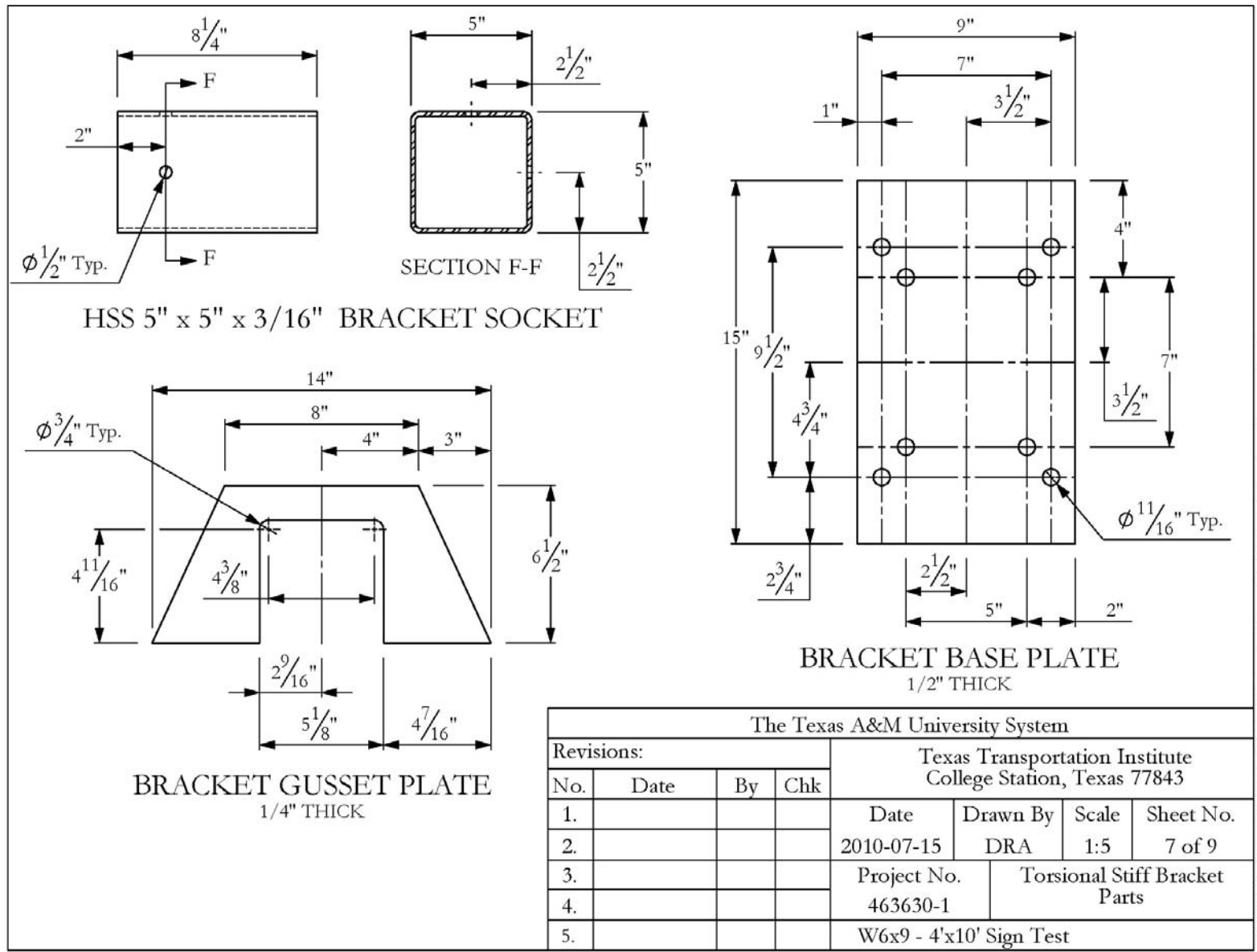
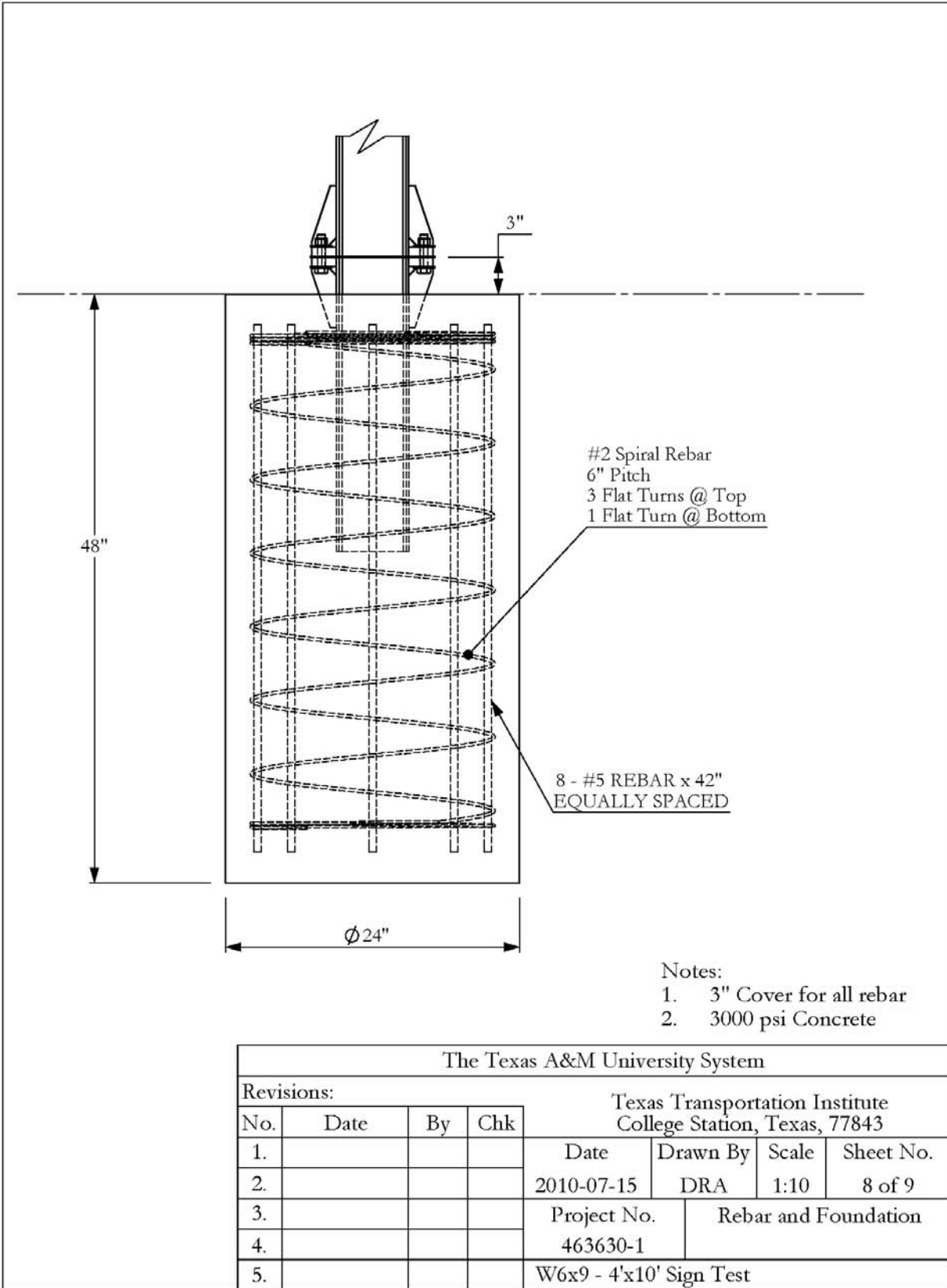


Figure E1. Details of the W6x9 with 4-ft x 10-ft Sign (continued).



T:\2009-2010\463630-TxDOT\463630-1 and -2 Tests\SolidWorks\Drawings\Test 1 Drawing

Figure E1. Details of the W6x9 with 4-ft x 10-ft Sign (continued).



T:\2009-2010\463630-TxDOT\463630-1 and -2 Tests\SolidWorks\Drawings\Test 1 Drawing

Figure E1. Details of the W6x9 with 4-ft x 10-ft Sign (continued).

| # | PART NAME | Material | QTY. |
|----|--|-----------------------------|------|
| 1 | 1' x 10' Aluminum Sign Panel | | 4 |
| 2 | W6x9 Ground Stub | A992 | 2 |
| 3 | W6x9 Support Middle Section | A992 | 2 |
| 4 | W6x9 Support Top Section | A992 | 2 |
| 5 | W6x9, 30 Ga Keeper Plate | | 2 |
| 6 | W6x9 Fuse Plate | A36 $F_u \leq 80\text{ksi}$ | 4 |
| 7 | Torsional Stiffener Bracket | A36 | 2 |
| 8 | Torsional Stiffener Clamp Plate | A36 | 4 |
| 9 | HSS 4.5" x 4.5" x 1/4" Torsional Stiffener x 86" | A500 Gr. B | 1 |
| 10 | Washer, 5/8" hardened steel washer | ASTM F436 | 72 |
| 11 | Washer, 3/8" lock | ASTM F436 | 20 |
| 12 | Washer, 3/8" hardened steel washer | | 50 |
| 13 | Nut, 3/8"-16 hex | A325 | 39 |
| 14 | Nut, 5/8" -11 hex | A325 | 32 |
| 15 | Sign Clip | | 20 |
| 16 | Set Screw, 3/8" -16 x 1" hex cup point | | 4 |
| 17 | Bolt, 3/8" -16 x 3/4" hex | A325 | 15 |
| 18 | Bolt, 3/8" -16 x 1-3/4" square head | A325 | 20 |
| 19 | Bolt, 5/8" -11 x 1-1/2" hex galv. | A325 | 16 |
| 20 | Bolt, 5/8" -11 x 2-3/4" hex | A325 | 8 |
| 21 | Bolt, 5/8" -11 x 8" | A325 | 8 |
| 22 | #2 Rebar Spiral | Gr. 60 | 2 |
| 23 | #5 Rebar x 42" | Gr. 60 | 16 |

| The Texas A&M University System | | | | | | | |
|---------------------------------|------|----|-----|---|----------|-------------------|-----------|
| Revisions: | | | | Texas Transportation Institute College Station, Texas, 77843 | | | |
| No. | Date | By | Chk | Date | Drawn By | Scale | Sheet No. |
| 1. | | | | 2010-07-15 | DRA | 1:20 | 9 of 9 |
| 2. | | | | Project No. | | Bill of Materials | |
| 3. | | | | 463630-1 | | | |
| 4. | | | | W6x9 - 4'x10' Sign Test | | | |
| 5. | | | | | | | |

T:\2009-2010\463630-TxDOT\463630-1 and -2 Tests\SolidWorks\Drawings\Test 1 Drawing

Figure E1. Details of the W6×9 with 4-ft × 10-ft Sign (continued).

Table E1. Vehicle Properties for Test No. 463630-1.

Date: 2010-07-30 Test No.: 463630-1 VIN No.: KNADC125346343022

Year: 2004 Make: Kia Model: Rio

Tire Inflation Pressure: 32 psi Odometer: 72845 Tire Size: P175/65R14

Describe any damage to the vehicle prior to test: _____

Denotes accelerometer location.

NOTE: _____

Engine Type: 4 cylinder

Engine CID: 1.6 liter

Transmission Type:

Auto or Manual

FWD RWD 4WD

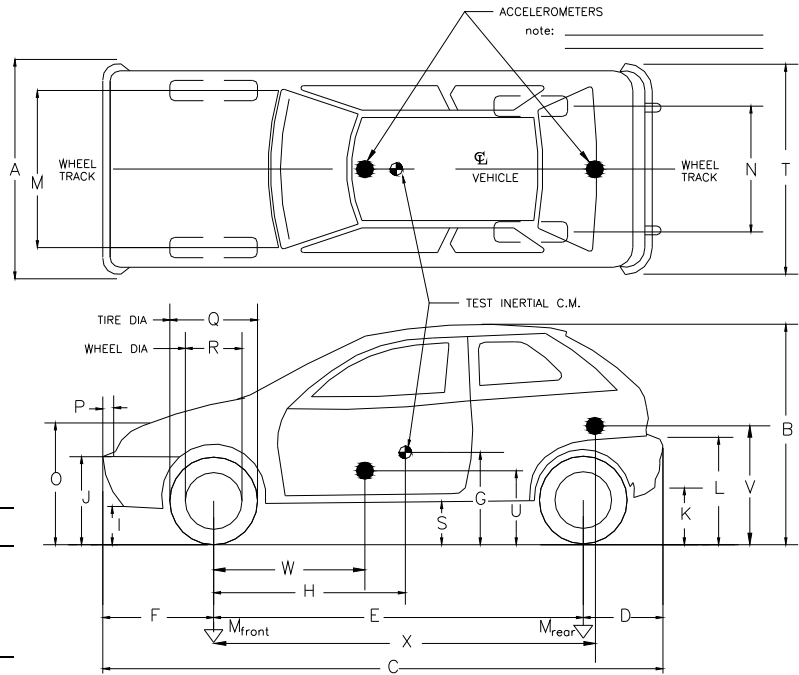
Optional Equipment: _____

Dummy Data:

Type: 50th percentile male

Mass: 161 lb

Seat Position: Driver position



Geometry: Inches

| | | | | | | | | | |
|-----------------------|---------------|----------------------|-----------------|---|--------------|---|--------------|---|---------------|
| A | <u>62.50</u> | F | <u>32.00</u> | K | <u>12.00</u> | P | <u>3.25</u> | U | <u>15.50</u> |
| B | <u>56.12</u> | G | <u> </u> | L | <u>24.25</u> | Q | <u>22.50</u> | V | <u>20.00</u> |
| C | <u>164.25</u> | H | <u>34.52</u> | M | <u>56.50</u> | R | <u>15.50</u> | W | <u>39.50</u> |
| D | <u>37.00</u> | I | <u>8.50</u> | N | <u>57.00</u> | S | <u>8.62</u> | X | <u>103.25</u> |
| E | <u>95.25</u> | J | <u>22.75</u> | O | <u>28.00</u> | T | <u>63.00</u> | | |
| Wheel Center Ht Front | <u>10.75</u> | Wheel Center Ht Rear | <u>11.125</u> | | | | | | |

| GVWR Ratings: | Mass: lb | Curb | Test Inertial | Gross Static |
|---------------|-------------|-------------------------|-------------------------|-------------------------|
| Front | <u>1804</u> | M_{front} <u>1556</u> | <u>1539</u> Allowable | <u>1621</u> Allowable |
| Back | <u>1742</u> | M_{rear} <u>867</u> | <u>875</u> Range | <u>954</u> Range = |
| Total | <u>3379</u> | M_{Total} <u>2423</u> | <u>2414</u> 2420 ±55 lb | <u>2575</u> 2585 ±55 lb |

Mass Distribution:

lb LF: 791 RF: 748 LR: 445 RR: 430

Table E2. Exterior Crush Measurements for Test No. 463630-1.

Date: 2010-07-30 Test No.: 463630-1 VIN No.: KNADC125346343022
 Year: 2004 Make: Kia Model: Rio

VEHICLE CRUSH MEASUREMENT SHEET¹

| | |
|---|---|
| Complete When Applicable | |
| End Damage | Side Damage |
| Undeformed end width _____ Corner shift: A1 _____ A2 _____ End shift at frame (CDC) (check one) < 4 inches _____ ≥ 4 inches _____ | Bowing: B1 _____ X1 _____ B2 _____ X2 _____ Bowing constant $\frac{X1 + X2}{2} = \underline{\hspace{2cm}}$ |

Note: Measure C₁ to C₆ from Driver to Passenger side in Front or Rear impacts – Rear to Front in Side Impacts.

| Specific Impact Number | Plane* of C-Measurements | Direct Damage | | Field L** | C ₁ | C ₂ | C ₃ | C ₄ | C ₅ | C ₆ | ±D |
|------------------------|--------------------------|---------------|--------------|-----------|----------------|----------------|----------------|----------------|----------------|----------------|-----|
| | | Width** (CDC) | Max*** Crush | | | | | | | | |
| 1 | Front plane at bumper ht | 4 | 3.5 | 20 | 0 | 0.5 | 2 | 3.5 | 1.5 | 0 | +13 |
| | | | | | | | | | | | |
| | | | | | | | | | | | |
| | Measurements recorded | | | | | | | | | | |
| | in inches | | | | | | | | | | |
| | | | | | | | | | | | |

¹Table taken from National Accident Sampling System (NASS).

*Identify the plane at which the C-measurements are taken (e.g., at bumper, above bumper, at sill, above sill, at beltline, etc.) or label adjustments (e.g., free space).

Free space value is defined as the distance between the baseline and the original body contour taken at the individual C locations. This may include the following: bumper lead, bumper taper, side protrusion, side taper, etc. Record the value for each C-measurement and maximum crush.

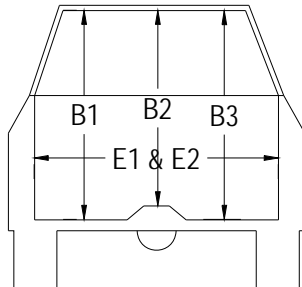
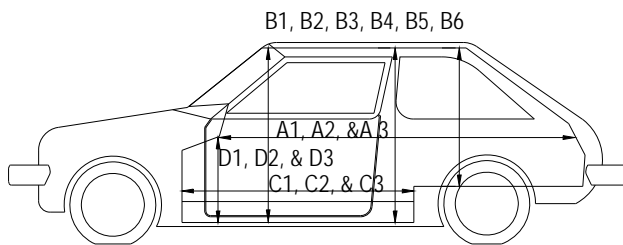
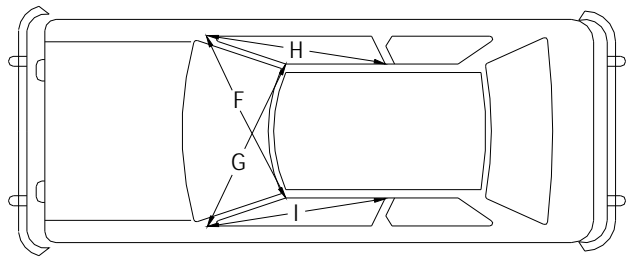
**Measure and document on the vehicle diagram the beginning or end of the direct damage width and field L (e.g., side damage with respect to undamaged axle).

***Measure and document on the vehicle diagram the location of the maximum crush.

Note: Use as many lines/columns as necessary to describe each damage profile.

Table E3. Occupant Compartment Measurements for Test No. 463630-1.

Date: 2010-07-30 Test No.: 463630-1 VIN No.: KNADC125346343022
 Year: 2004 Make: Kia Model: Rio



OCCUPANT COMPARTMENT DEFORMATION MEASUREMENT

| | Before (inches) | After (inches) |
|----|----------------------|---------------------|
| A1 | <u>67.88</u> | <u>67.88</u> |
| A2 | <u>65.25</u> | <u>65.25</u> |
| A3 | <u>37.75</u> | <u>37.75</u> |
| B1 | <u>40.00</u> | <u>40.00</u> |
| B2 | <u>37.25</u> | <u>37.25</u> |
| B3 | <u>39.50</u> | <u>39.50</u> |
| B4 | <u>34.50</u> | <u>34.50</u> |
| B5 | <u>34.62</u> | <u>34.62</u> |
| B6 | <u>34.50</u> | <u>34.50</u> |
| C1 | <u>26.50</u> | <u>26.50</u> |
| C2 | <u>----</u> | <u>----</u> |
| C3 | <u>26.12</u> | <u>26.12</u> |
| D1 | <u>10.25</u> | <u>10.25</u> |
| D2 | <u>----</u> | <u>----</u> |
| D3 | <u>9.00</u> | <u>9.00</u> |
| E1 | <u>47.62</u> | <u>47.62</u> |
| E2 | <u>50.75</u> | <u>50.75</u> |
| F | <u>48.75</u> | <u>48.75</u> |
| G | <u>48.75</u> | <u>48.75</u> |
| H | <u>36.50</u> | <u>36.50</u> |
| I | <u>36.50</u> | <u>36.50</u> |
| J* | <u>50.25</u> | <u>50.25</u> |

*Lateral area across the cab from driver's side kickpanel to passenger's side kickpanel.



0.000 s



0.071 s



0.139 s



0.211 s



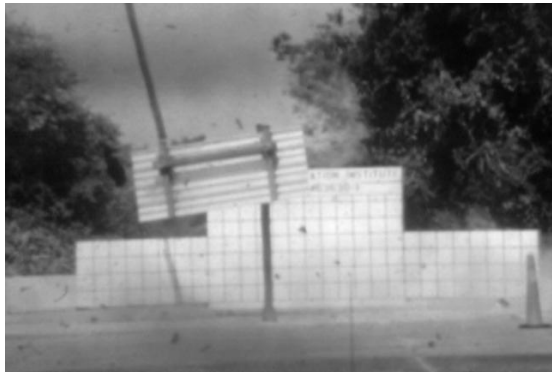
Figure E2. Sequential Photographs for Test No. 463630-1 (Perpendicular and Frontal Oblique Views).



0.282s



0.353 s



0.421 s



0.492 s



Figure E2. Sequential Photographs for Test No. 463630-1 (Perpendicular and Oblique Frontal Views) (continued).

Roll, Pitch, and Yaw Angles

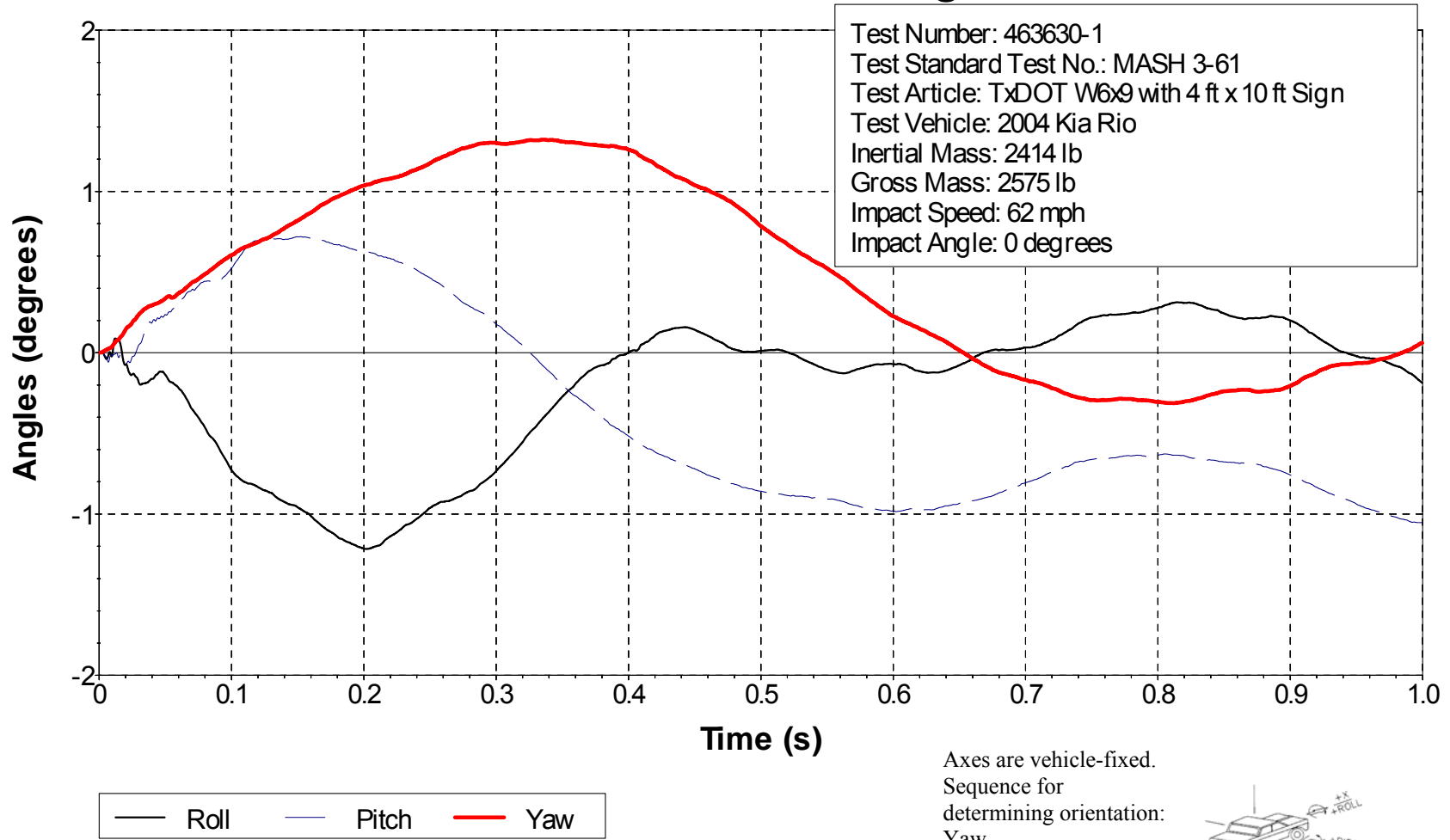
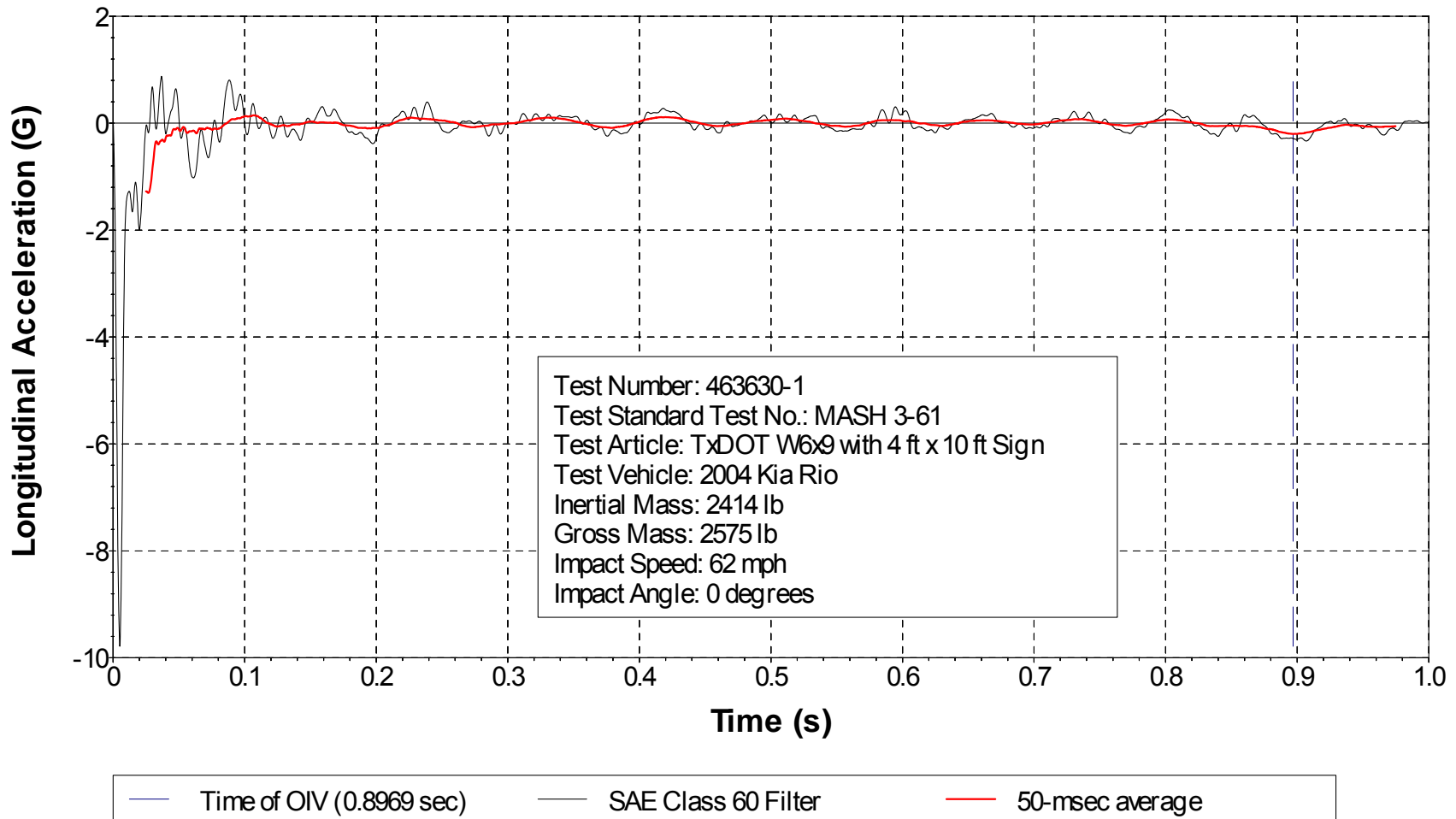


Figure E3. Vehicle Angular Displacements for Test No. 463630-1.

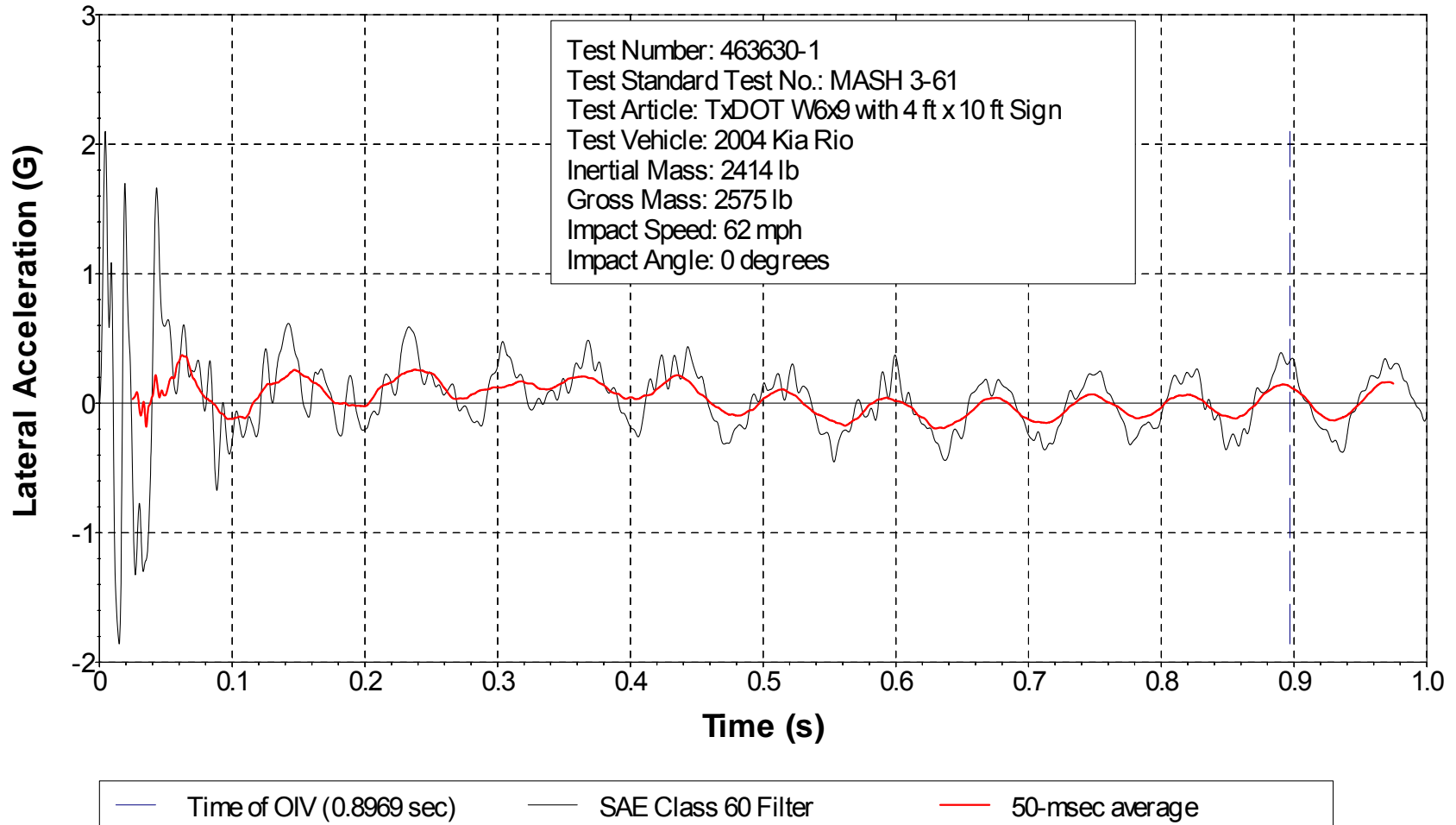
X Acceleration at CG



**Figure E4. Vehicle Longitudinal Accelerometer Trace for Test No. 463630-1
(Accelerometer Located at Center of Gravity).**

Y Acceleration at CG

269



**Figure E5. Vehicle Lateral Accelerometer Trace for Test No. 463630-1
(Accelerometer Located at Center of Gravity).**

Z Acceleration at CG

270

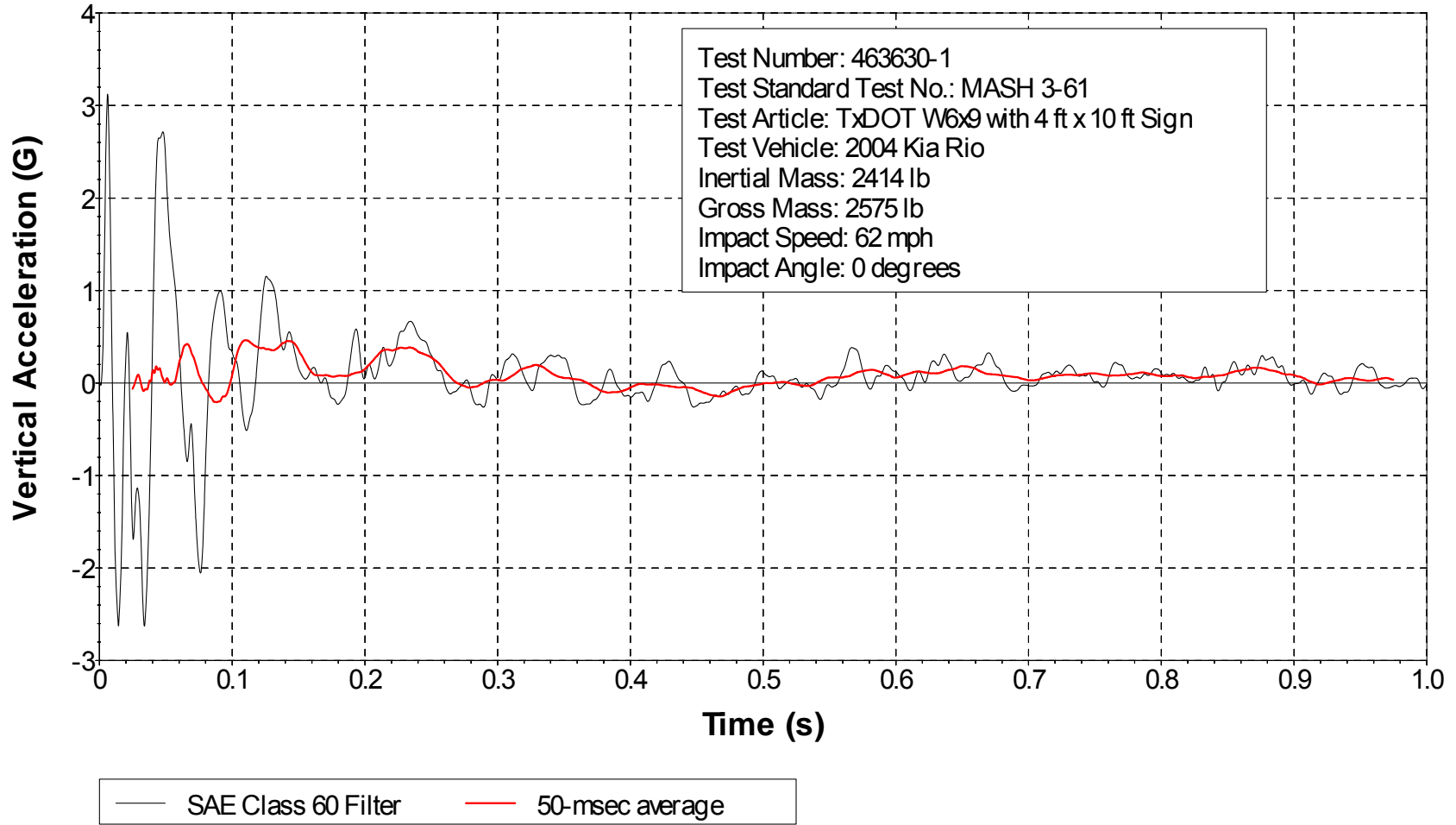
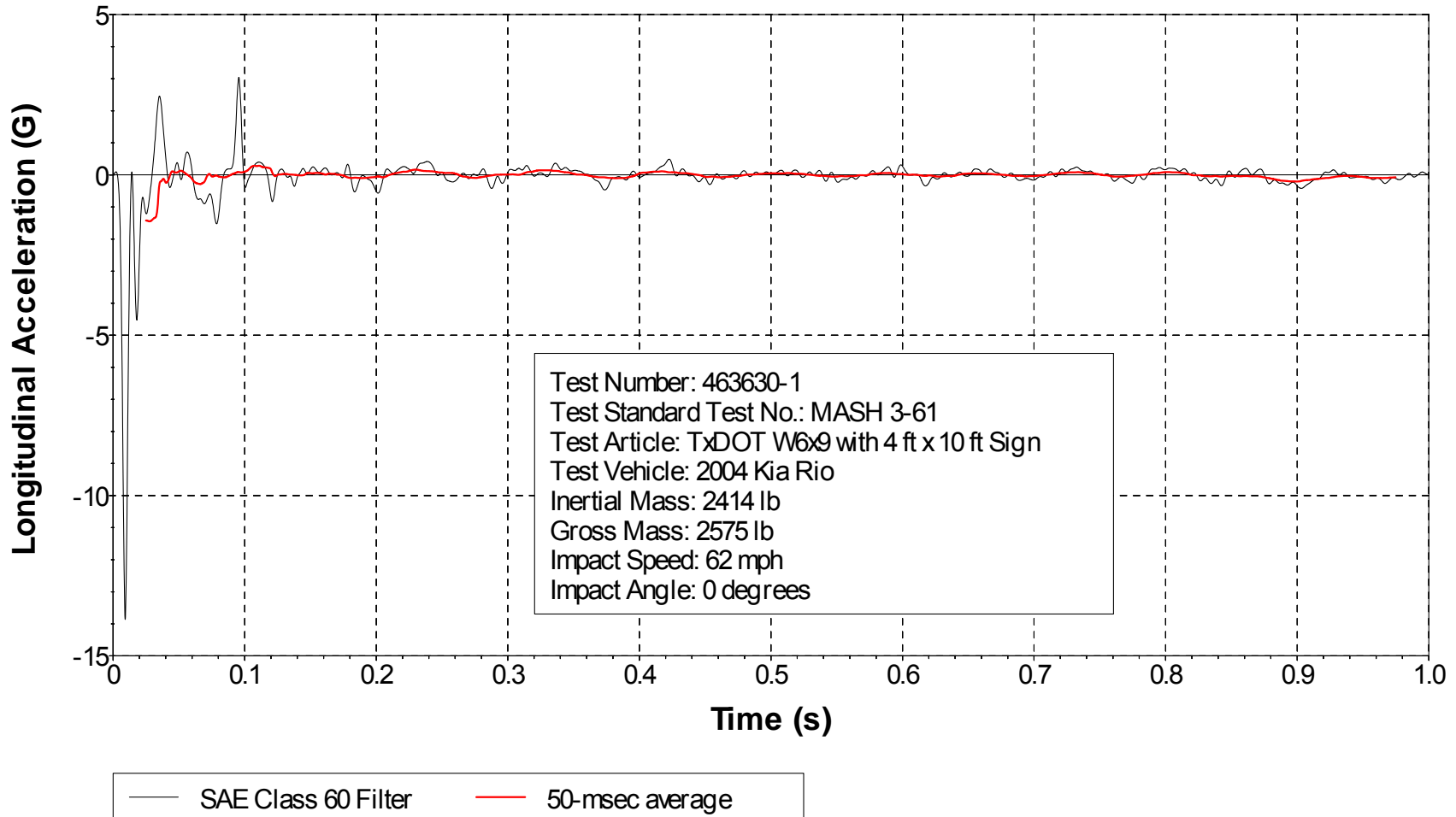


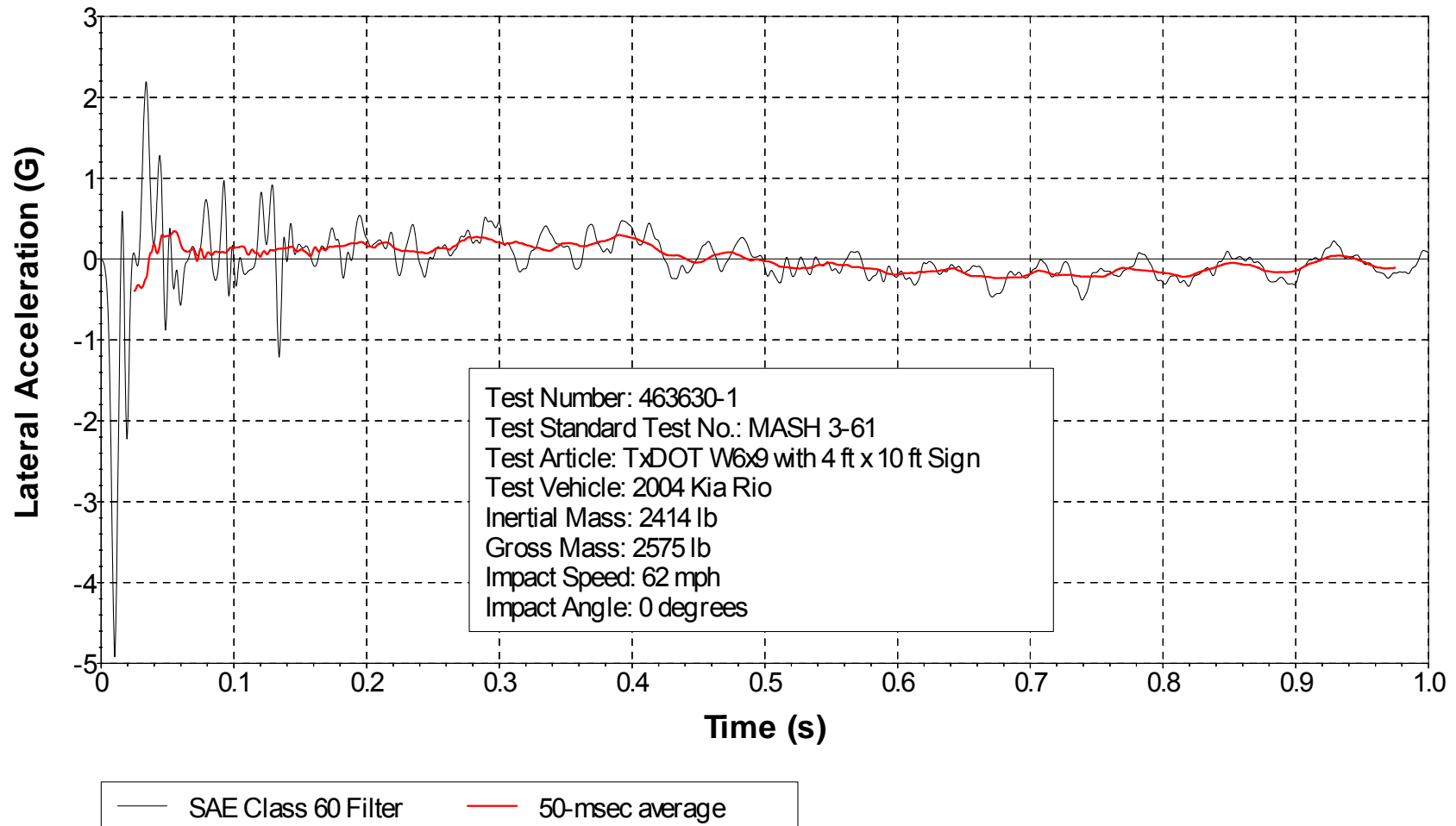
Figure E6. Vehicle Vertical Accelerometer Trace for Test No. 463630-1 (Accelerometer Located at Center of Gravity).

X Acceleration over Rear Axle



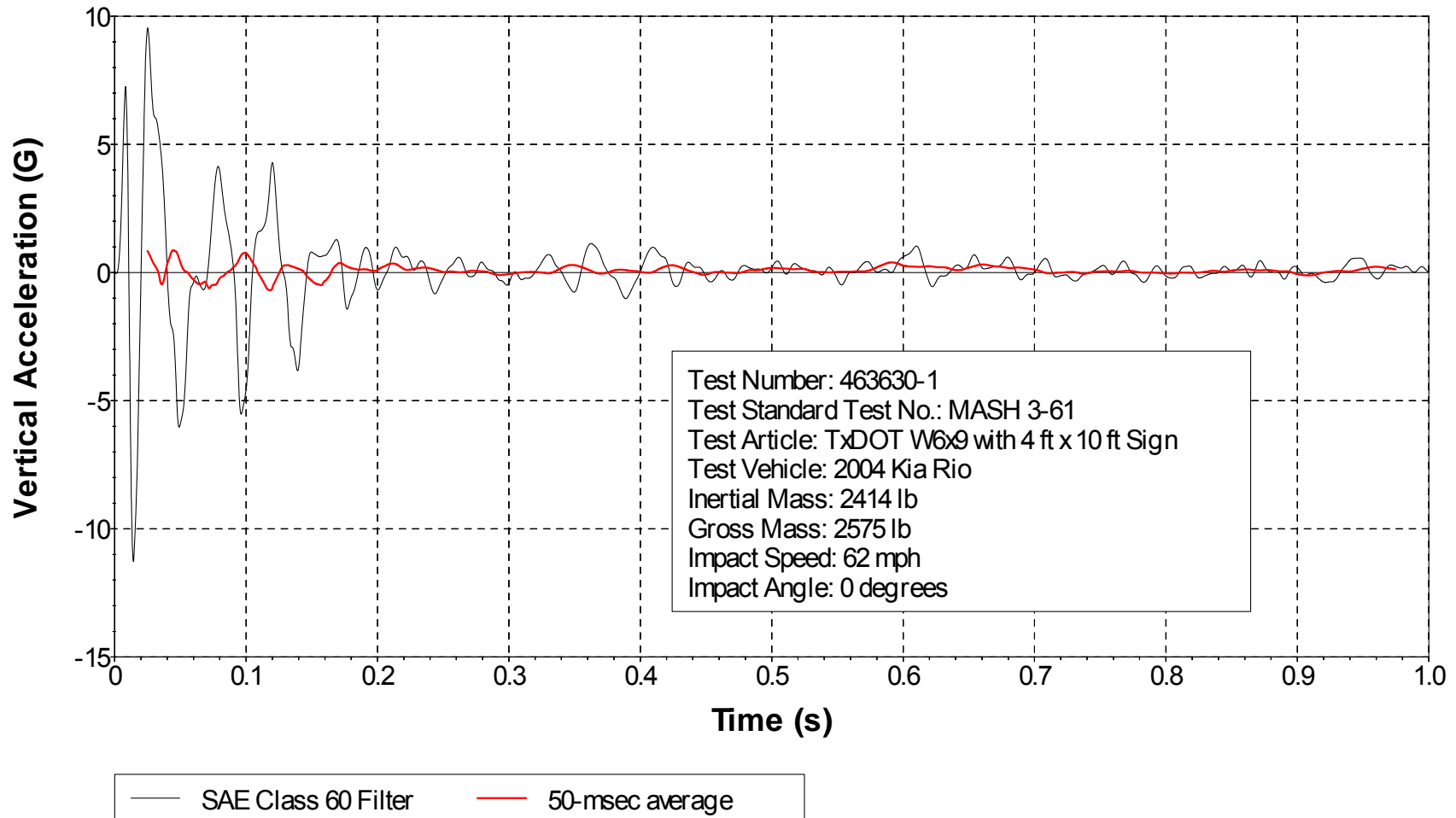
**Figure E7. Vehicle Longitudinal Accelerometer Trace for Test No. 463630-1
(Accelerometer Located over Rear Axle).**

Y Acceleration over Rear Axle



**Figure E8. Vehicle Lateral Accelerometer Trace for Test No. 463630-1
(Accelerometer Located over Rear Axle).**

Z Acceleration over Rear Axle



**Figure E9. Vehicle Vertical Accelerometer Trace for Test No. 463630-1
(Accelerometer Located over Rear Axle).**

APPENDIX F. CRASH TEST NO. 463630-2

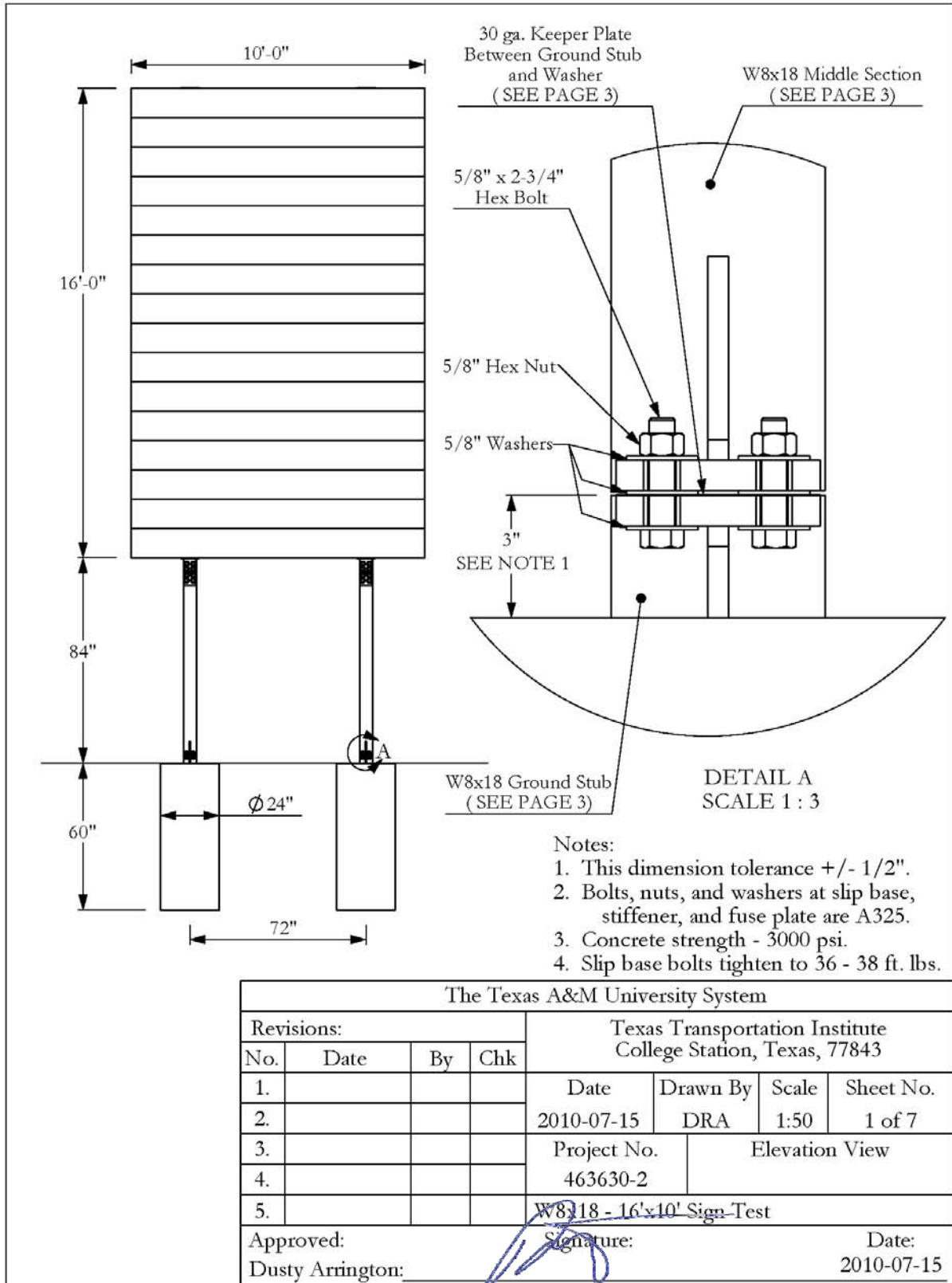
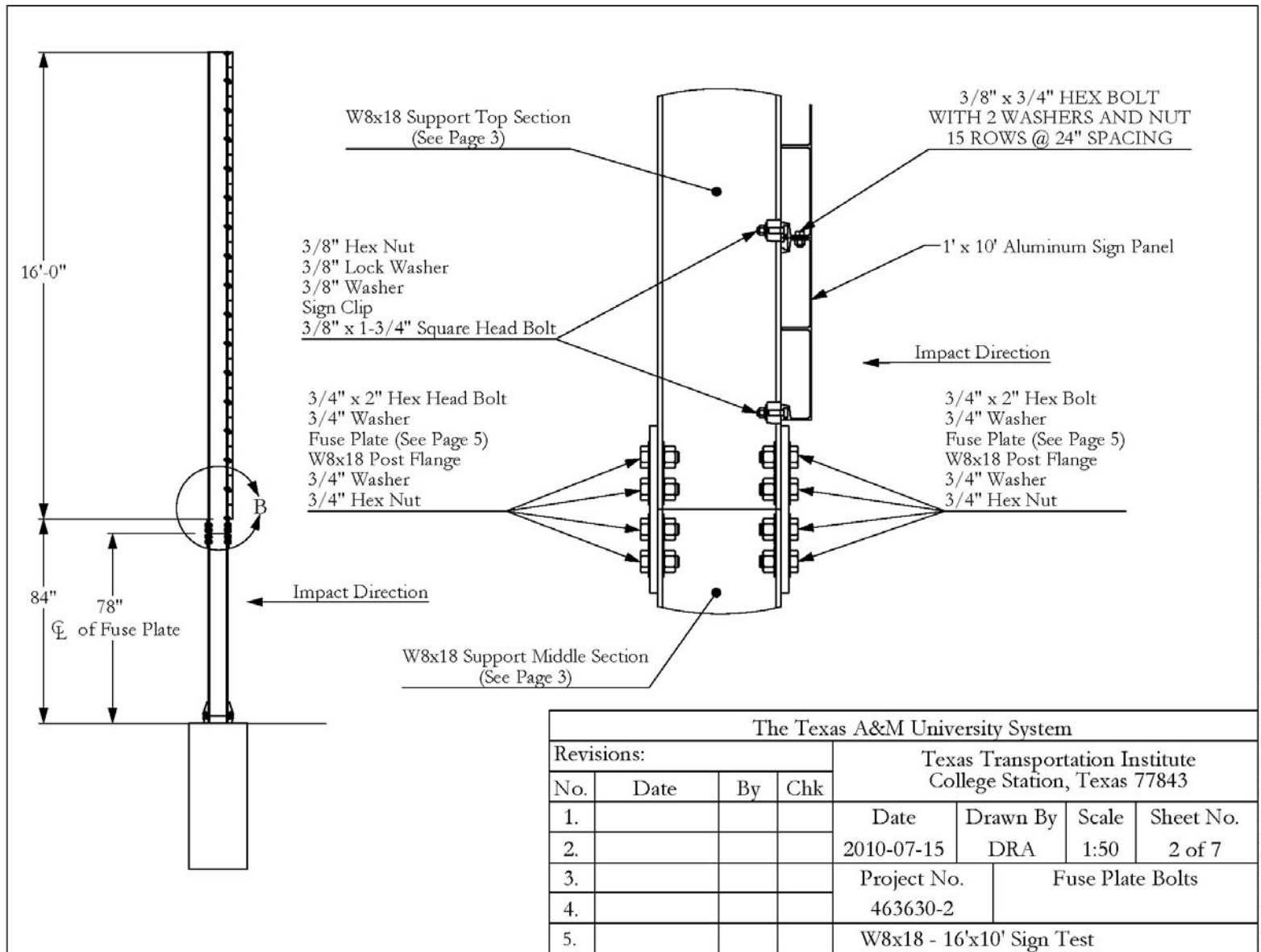


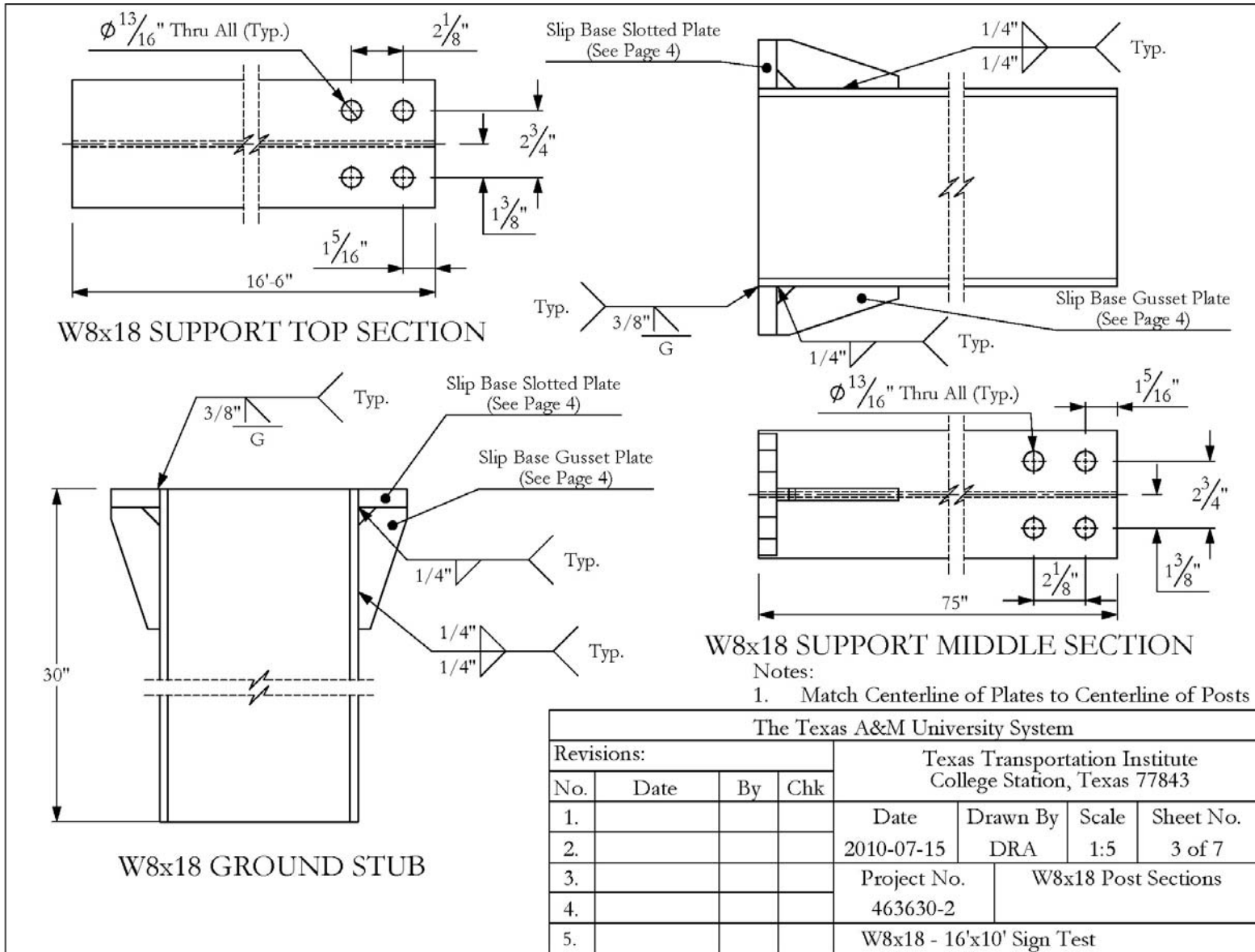
Figure F1. Details of the W8×18 with 16-ft × 10-ft Sign.

T:\2009-2010\463630-TxDOT\463630-1 and -2 Tests\SolidWorks\Drawings\Test 2 Drawing



T:\2009-2010\463630-TxDOT\463630-1 and -2 Tests\SolidWorks\Drawings\Test 2 Drawing

Figure F1. Details of the W8x18 with 16-ft x 10-ft Sign (Continued).



T:\2009-2010\463630-TxDOT\Drawings\Test 2 Drawing

Figure F1. Details of the W8x18 with 16-ft x 10-ft Sign (Continued).

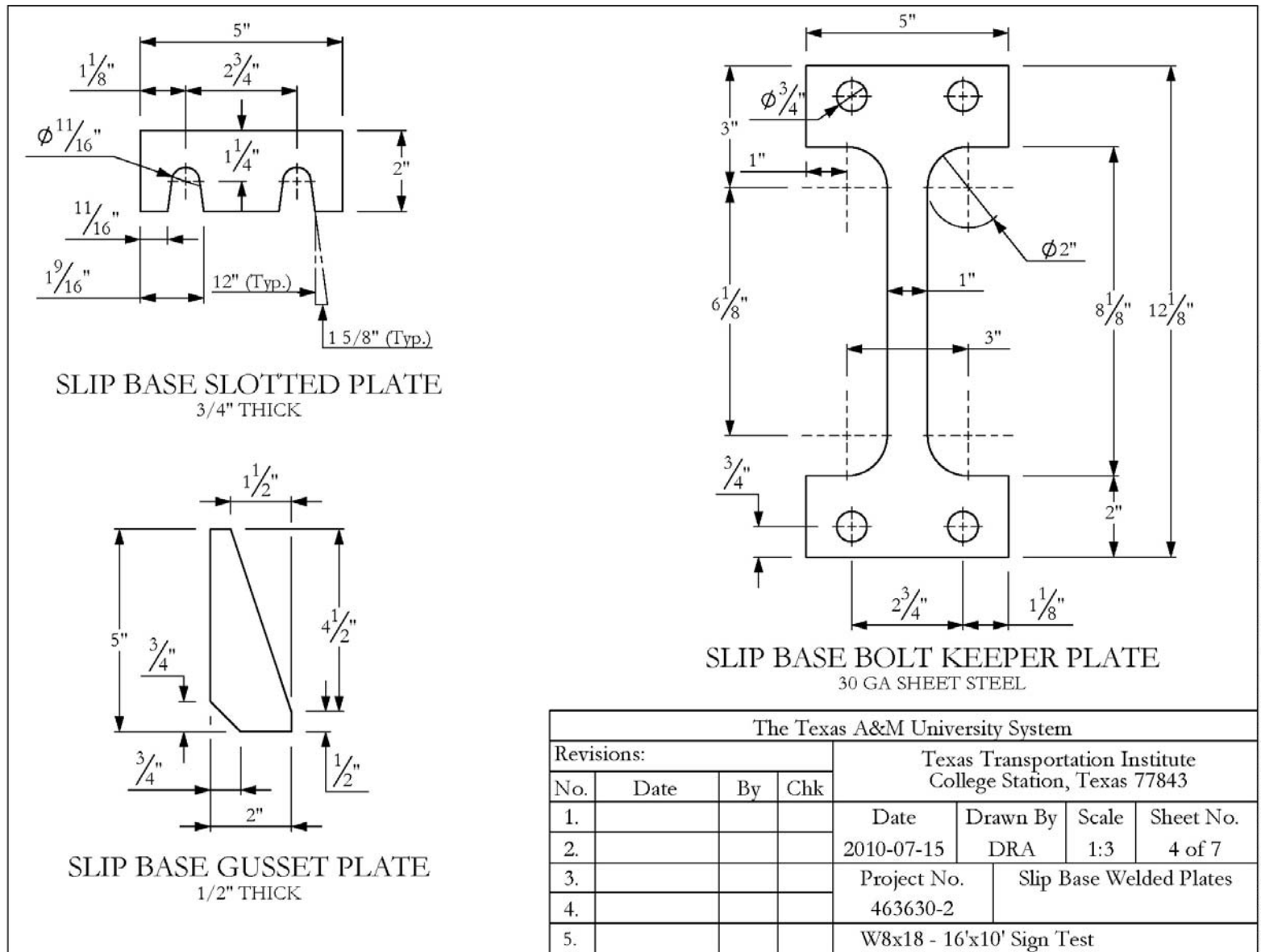
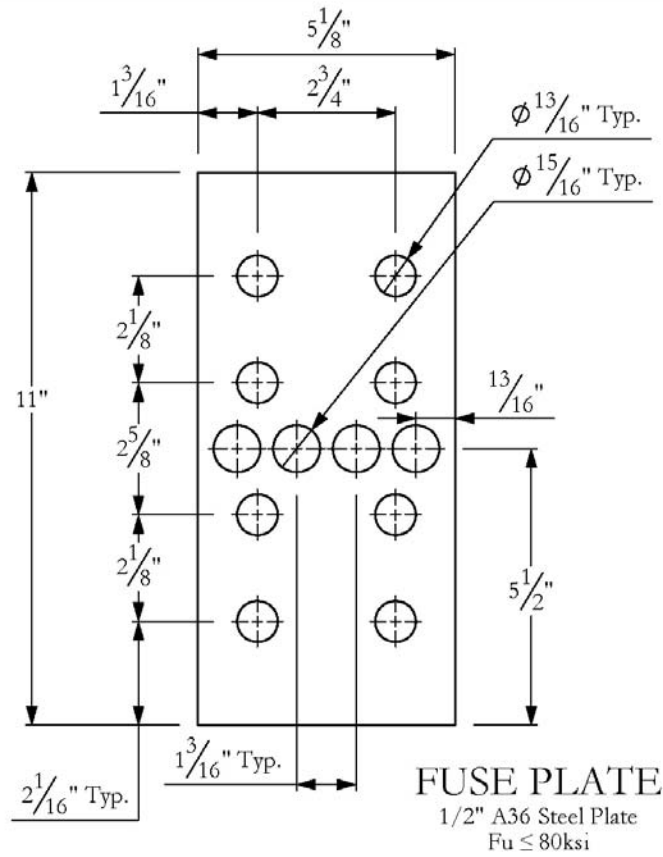


Figure F1. Details of the W8×18 with 16-ft × 10-ft Sign (Continued).

T:\2009-2010\463630-TxDOT\463630-1 and -2 Tests\SolidWorks\Drawings\Test 2 Drawing



| The Texas A&M University System | | | | | | | |
|---------------------------------|------|----|-----|--|----------|-------------|-----------|
| Revisions: | | | | Texas Transportation Institute College Station, Texas 77843 | | | |
| No. | Date | By | Chk | Date | Drawn By | Scale | Sheet No. |
| 1. | | | | 2010-07-15 | DRA | 1:3 | 5 of 7 |
| 2. | | | | Project No. | | Fuse Plates | |
| 3. | | | | 463630-2 | | | |
| 4. | | | | W8x18 - 16'x10' Sign Test | | | |
| 5. | | | | | | | |

T:\2009-2010\463630-TxDOT\463630-1 and -2 Tests\SolidWorks\Drawings\Test 2 Drawing

Figure F1. Details of the W8×18 with 16-ft × 10-ft Sign (Continued).

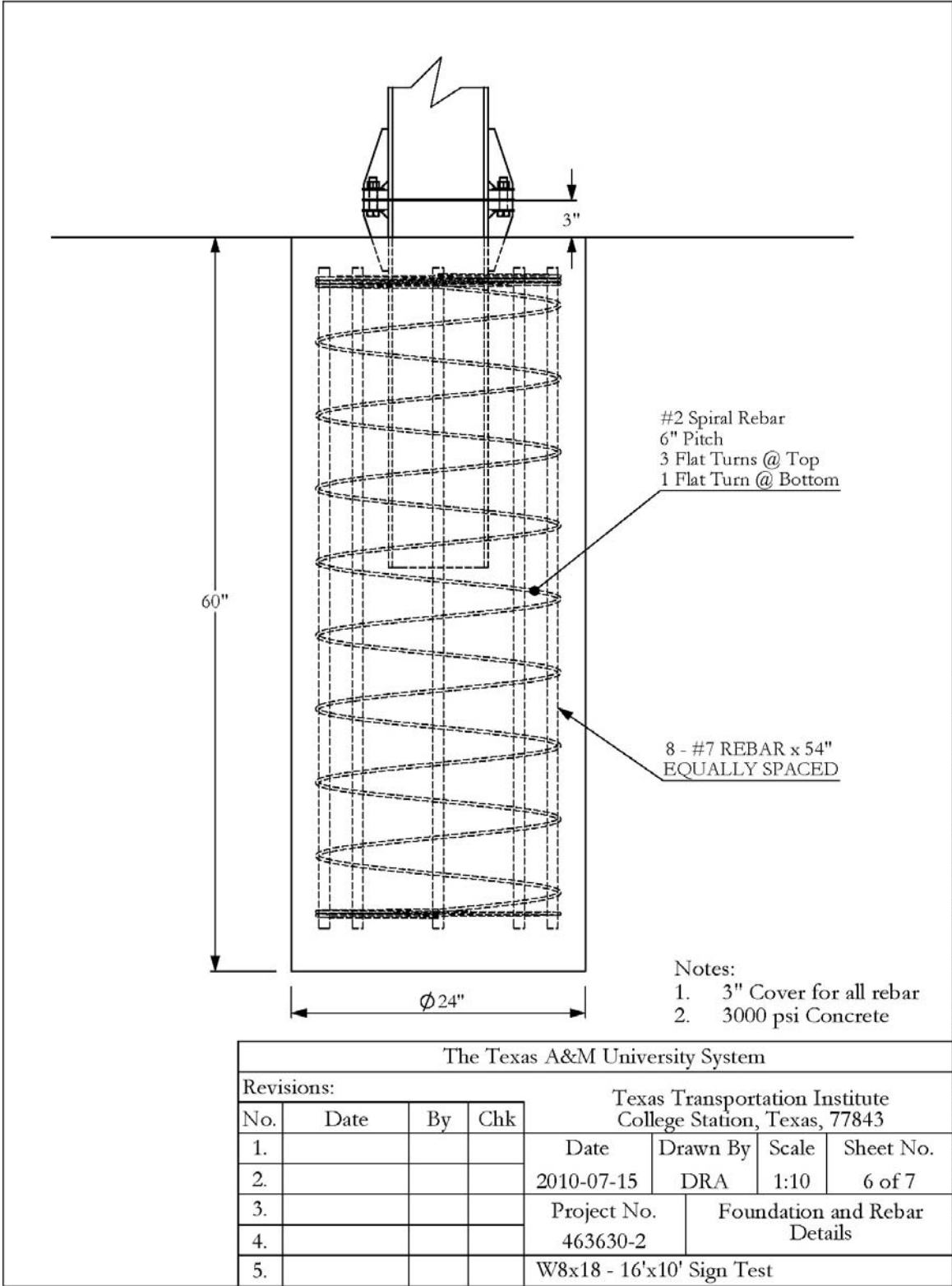


Figure F1. Details of the W8×18 with 16-ft × 10-ft Sign (Continued).

| # | PART NAME | Material | QTY. |
|----|-------------------------------------|----------------|------|
| 1 | 1' x 10' Aluminum Sign Panel | | 16 |
| 2 | W8x18 Ground Stub | A992 | 2 |
| 3 | W8x18 Support Middle Section | A992 | 2 |
| 4 | W8x18 Support Top Section | A992 | 2 |
| 5 | W8x18, 30 Ga Keeper Plate | | 2 |
| 6 | W8x18 Fuse Plate | A36 Fu ≤ 80ksi | 4 |
| 7 | Nut, 5/8" -11 hex | A325 | 8 |
| 8 | Nut, 3/8"-16 hex | A325 | 143 |
| 9 | Nut, 3/4" - 10 Hex | A325 | 32 |
| 10 | Sign Clip | | 68 |
| 11 | Washer, 3/8" hardened steel washer | ASTM F436 | 218 |
| 12 | Washer, 3/8" lock | | 68 |
| 13 | Washer, 3/4" hardened steel washer | ASTM F436 | 64 |
| 14 | Washer, 5/8" hardened steel washer | ASTM F436 | 24 |
| 15 | Bolt, 3/8" -16 x 3/4" hex | A325 | 75 |
| 16 | Bolt, 3/8" -16 x 1-3/4" square head | A325 | 68 |
| 17 | Bolt, 3/4" -10 x 2" hex | A325 | 32 |
| 18 | Bolt, 5/8" -11 x 2-3/4" hex | A325 | 8 |
| 19 | #2 Rebar Spiral | Gr. 60 | 2 |
| 20 | #7 Rebar x 54" | Gr. 60 | 16 |

| The Texas A&M University System | | | | | | | |
|---------------------------------|------|----|-----|---|----------|-------------------|-----------|
| Revisions: | | | | Texas Transportation Institute College Station, Texas, 77843 | | | |
| No. | Date | By | Chk | Date | Drawn By | Scale | Sheet No. |
| 1. | | | | 2010-07-15 | DRA | 1:10 | 7 of 7 |
| 3. | | | | Project No. | | Bill of Materials | |
| 4. | | | | 463630-2 | | | |
| 5. | | | | W8x18 - 16'x10' Sign Test | | | |

T:\2009-2010\463630-TxDOT\463630-1 and -2 Tests\SolidWorks\Drawings\Test 2 Drawing

Figure F1. Details of the W8×18 with 16-ft × 10-ft Sign (Continued).

Table F1. Vehicle Properties for Test No. 463630-2.

Date: 2010-07-30 Test No.: 463630-2 VIN No.: KNADC125656389834

Year: 2005 Make: Kia Model: Rio

Tire Inflation Pressure: 32 psi Odometer: 104016 Tire Size: P175/65R14

Describe any damage to the vehicle prior to test: _____

Denotes accelerometer location.

NOTE: _____

Engine Type: 4 cylinder

Engine CID: 1.6 liter

Transmission Type:

Auto or Manual

FWD RWD 4WD

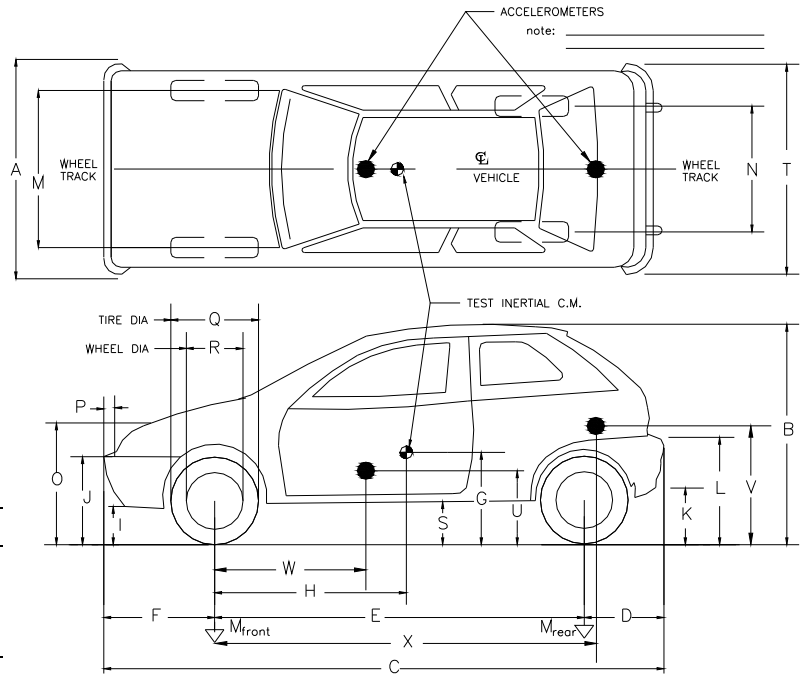
Optional Equipment:

Dummy Data:

Type: 50th percentile male

Mass: 175 lb

Seat Position: Driver position



Geometry: Inches

| | | | | | | | | | |
|-----------------------|---------------|----------------------|-------------------|---|--------------|---|--------------|---|---------------|
| A | <u>62.50</u> | F | <u>32.00</u> | K | <u>12.00</u> | P | <u>3.25</u> | U | <u>15.50</u> |
| B | <u>56.12</u> | G | <u> </u> | L | <u>24.25</u> | Q | <u>22.50</u> | V | <u>20.00</u> |
| C | <u>164.25</u> | H | <u>34.09</u> | M | <u>56.50</u> | R | <u>15.50</u> | W | <u>39.50</u> |
| D | <u>37.00</u> | I | <u>8.50</u> | N | <u>57.00</u> | S | <u>8.62</u> | X | <u>103.25</u> |
| E | <u>95.25</u> | J | <u>22.75</u> | O | <u>28.00</u> | T | <u>63.00</u> | | |
| Wheel Center Ht Front | <u>10.75</u> | Wheel Center Ht Rear | <u>11.125</u> | | | | | | |

| GVWR Ratings: | Mass: lb | Curb | Test Inertial | Gross Static |
|---------------|-------------|--------------------|-------------------------|-------------------------|
| Front | <u>1804</u> | M _{front} | <u>1561</u> Allowable | <u>1647</u> Allowable |
| Back | <u>1742</u> | M _{rear} | <u>870</u> Range | <u>959</u> Range = |
| Total | <u>3379</u> | M _{Total} | <u>2431</u> 2420 ±55 lb | <u>2606</u> 2585 ±55 lb |

Mass Distribution: lb LF: 791 RF: 770 LR: 433 RR: 437

Table F2. Exterior Crush Measurements for Test No. 463630-2.

Date: 2010-07-30 Test No.: 463630-2 VIN No.: KNADC125656389834
 Year: 2005 Make: Kia Model: Rio

VEHICLE CRUSH MEASUREMENT SHEET¹

| | |
|---|---|
| Complete When Applicable | |
| End Damage | Side Damage |
| Undeformed end width _____ Corner shift: A1 _____ A2 _____ End shift at frame (CDC) (check one) < 4 inches _____ ≥ 4 inches _____ | Bowing: B1 _____ X1 _____ B2 _____ X2 _____ Bowing constant $\frac{X1 + X2}{2} = \underline{\hspace{2cm}}$ |

Note: Measure C₁ to C₆ from Driver to Passenger side in Front or Rear impacts – Rear to Front in Side Impacts.

| Specific Impact Number | Plane* of C-Measurements | Direct Damage | | Field L** | C ₁ | C ₂ | C ₃ | C ₄ | C ₅ | C ₆ | ±D |
|------------------------|--------------------------|---------------|--------------|-----------|----------------|----------------|----------------|----------------|----------------|----------------|----|
| | | Width** (CDC) | Max*** Crush | | | | | | | | |
| 1 | Front plane at bumper ht | 5 | 10 | 46 | 0 | 1.5 | 3.5 | 7 | 10 | 1 | 0 |
| | | | | | | | | | | | |
| | | | | | | | | | | | |
| | Measurements recorded | | | | | | | | | | |
| | in inches | | | | | | | | | | |
| | | | | | | | | | | | |

¹Table taken from National Accident Sampling System (NASS).

*Identify the plane at which the C-measurements are taken (e.g., at bumper, above bumper, at sill, above sill, at beltline, etc.) or label adjustments (e.g., free space).

Free space value is defined as the distance between the baseline and the original body contour taken at the individual C locations. This may include the following: bumper lead, bumper taper, side protrusion, side taper, etc. Record the value for each C-measurement and maximum crush.

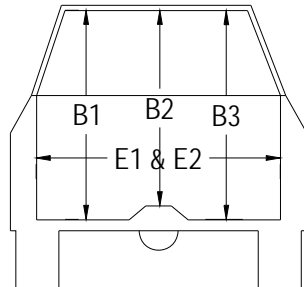
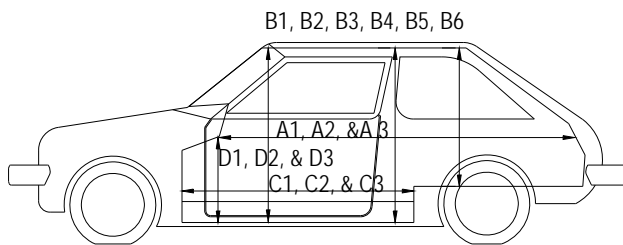
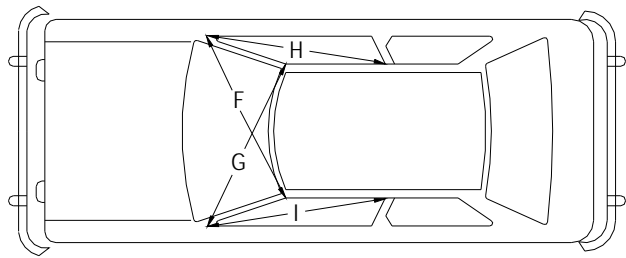
**Measure and document on the vehicle diagram the beginning or end of the direct damage width and field L (e.g., side damage with respect to undamaged axle).

***Measure and document on the vehicle diagram the location of the maximum crush.

Note: Use as many lines/columns as necessary to describe each damage profile.

Table F3. Occupant Compartment Measurements for Test No. 463630-2.

Date: 2010-07-30 Test No.: 463630-2 VIN No.: KNADC125656389834
 Year: 2005 Make: Kia Model: Rio



OCCUPANT COMPARTMENT DEFORMATION MEASUREMENT

| | Before (inches) | After (inches) |
|----|----------------------|---------------------|
| A1 | <u>67.75</u> | <u> </u> |
| A2 | <u>65.00</u> | <u> </u> |
| A3 | <u>67.75</u> | <u> </u> |
| B1 | <u>39.50</u> | <u> </u> |
| B2 | <u>37.38</u> | <u> </u> |
| B3 | <u>39.50</u> | <u> </u> |
| B4 | <u>35.12</u> | <u> </u> |
| B5 | <u>35.25</u> | <u> </u> |
| B6 | <u>35.12</u> | <u> </u> |
| C1 | <u>26.75</u> | <u> </u> |
| C2 | <u>----</u> | <u> </u> |
| C3 | <u>27.00</u> | <u> </u> |
| D1 | <u>10.25</u> | <u> </u> |
| D2 | <u>----</u> | <u> </u> |
| D3 | <u>9.25</u> | <u> </u> |
| E1 | <u>48.25</u> | <u> </u> |
| E2 | <u>50.25</u> | <u> </u> |
| F | <u>48.75</u> | <u> </u> |
| G | <u>48.75</u> | <u> </u> |
| H | <u>36.25</u> | <u> </u> |
| I | <u>36.25</u> | <u> </u> |
| J* | <u>50.50</u> | <u> </u> |

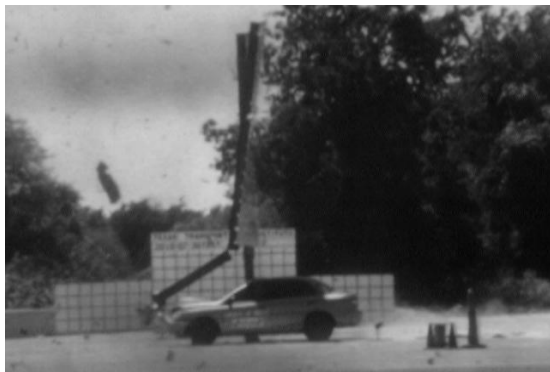
*Lateral area across the cab from driver's side kickpanel to passenger's side kickpanel.



0.000 s



0.038 s



0.073 s



0.111 s



**Figure F2. Sequential Photographs for Test No. 463630-2
(Perpendicular and Frontal Oblique Views).**



0.149s



0.186 s



0.222 s



0.2592 s



Figure F2. Sequential Photographs for Test No. 463630-2 (Perpendicular and Oblique Frontal Views) (continued).

Roll, Pitch, and Yaw Angles

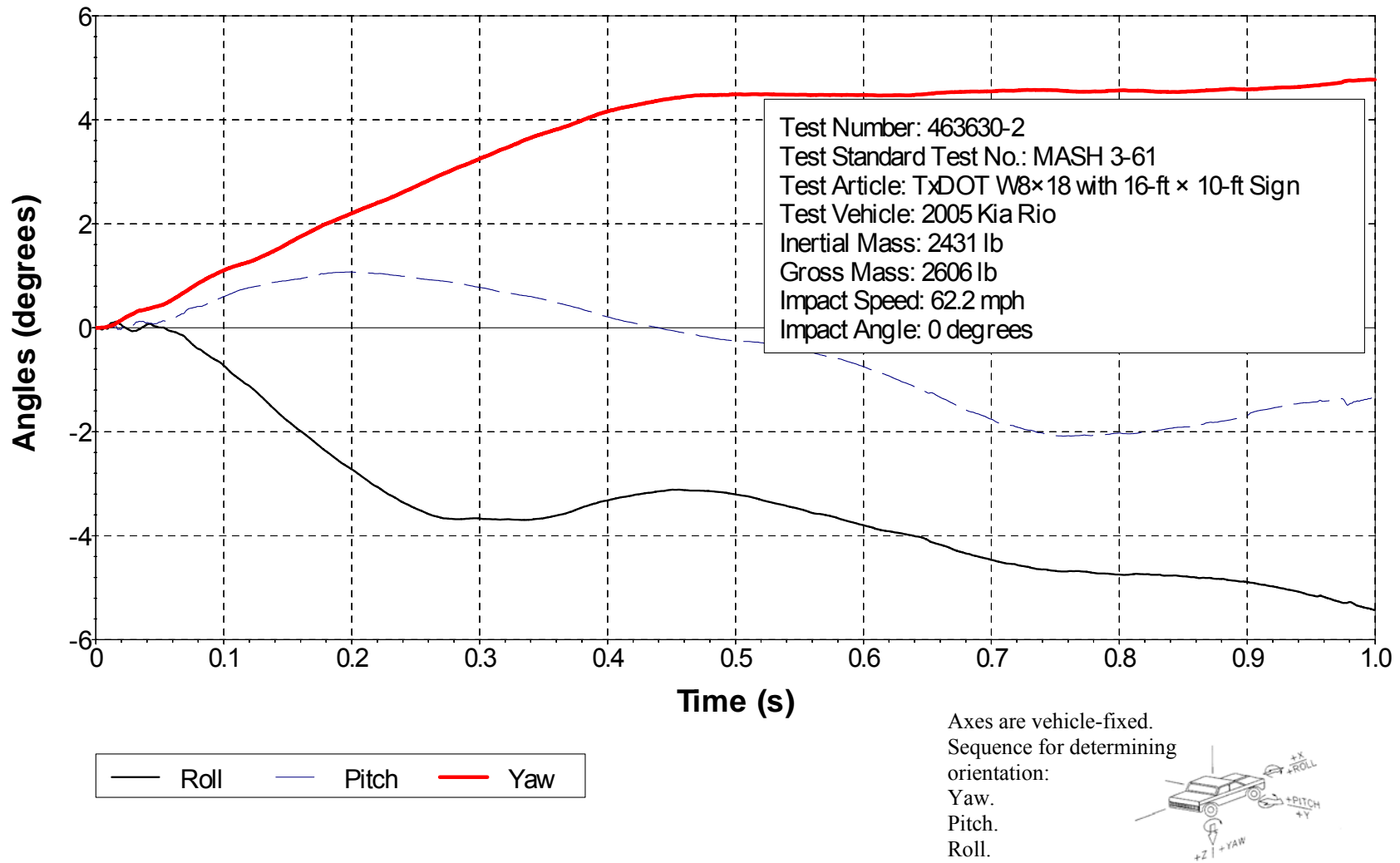
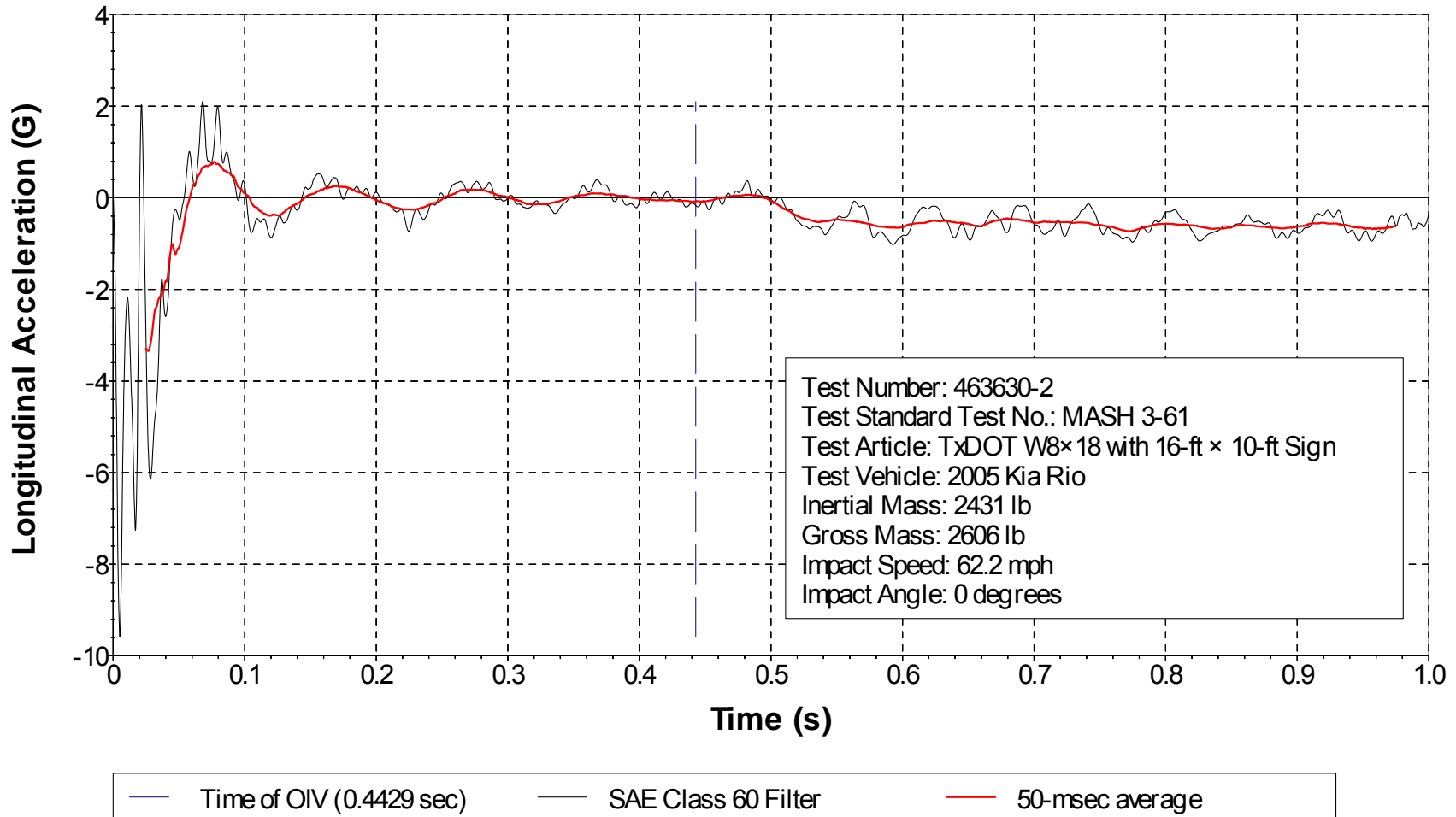


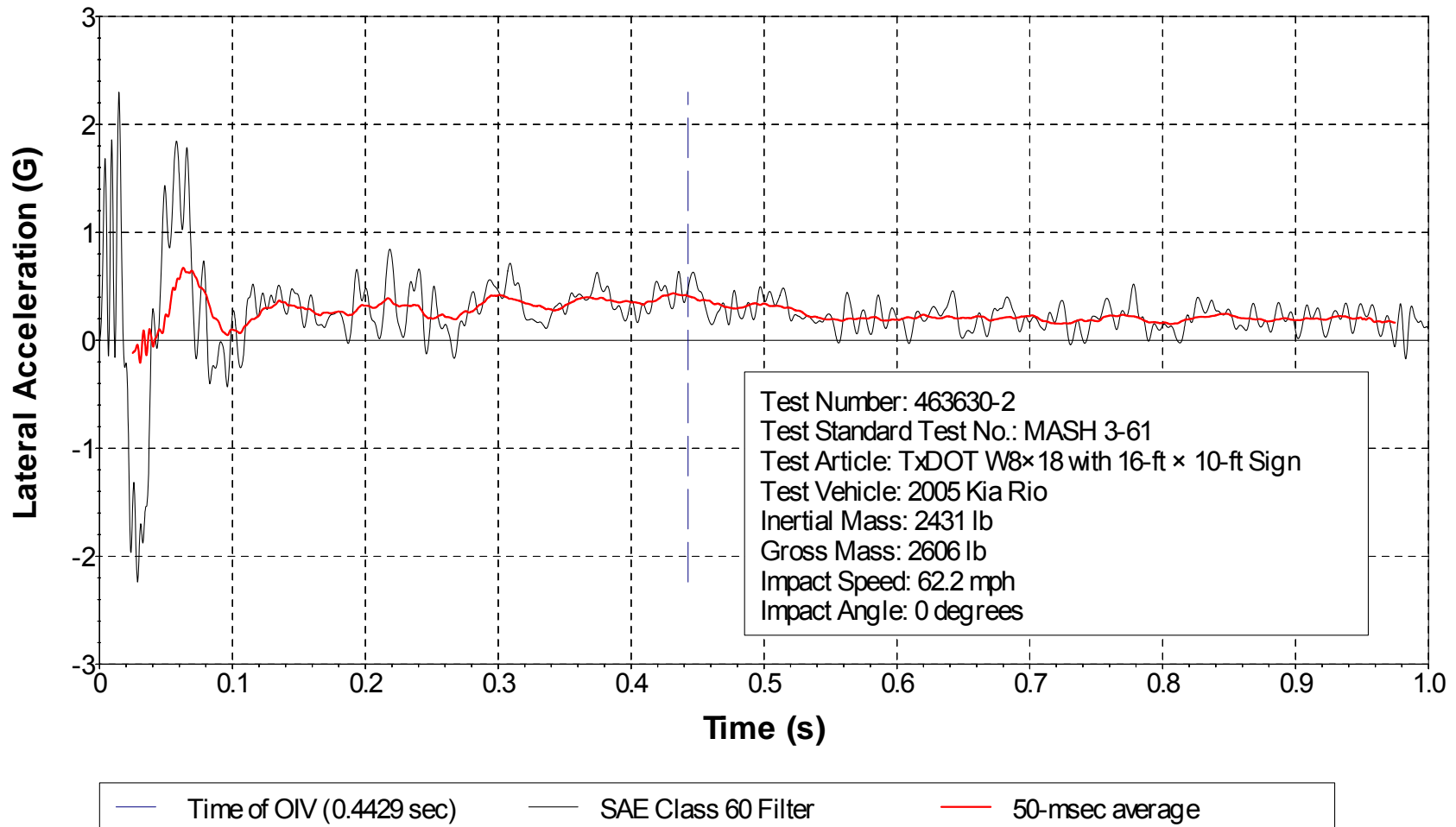
Figure F3. Vehicle Angular Displacements for Test No. 463630-2.

X Acceleration at CG



**Figure F4. Vehicle Longitudinal Accelerometer Trace for Test No. 463630-2
(Accelerometer Located at Center of Gravity).**

Y Acceleration at CG



**Figure F5. Vehicle Lateral Accelerometer Trace for Test No. 463630-2
(Accelerometer Located at Center of Gravity).**

Z Acceleration at CG

290

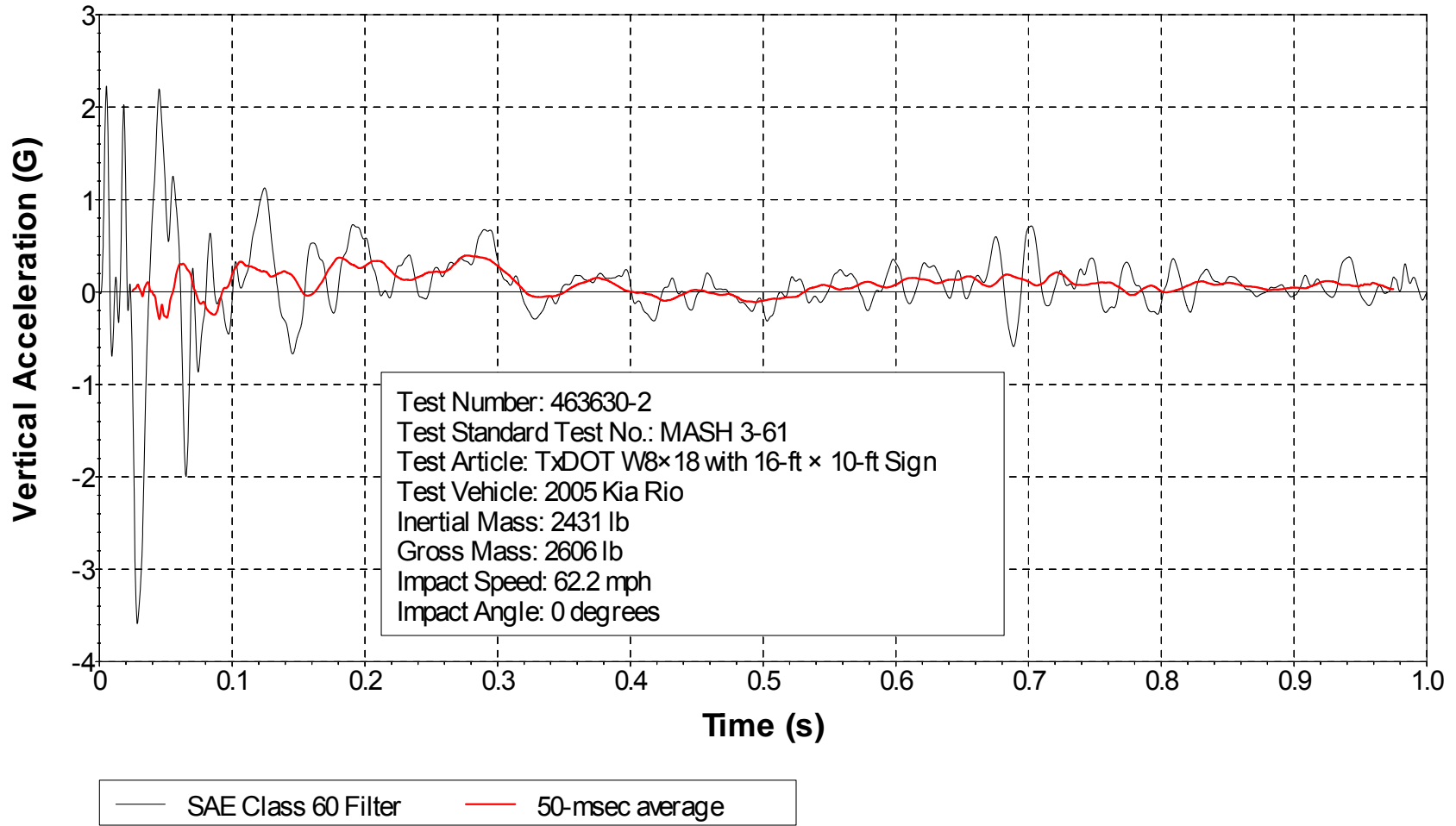
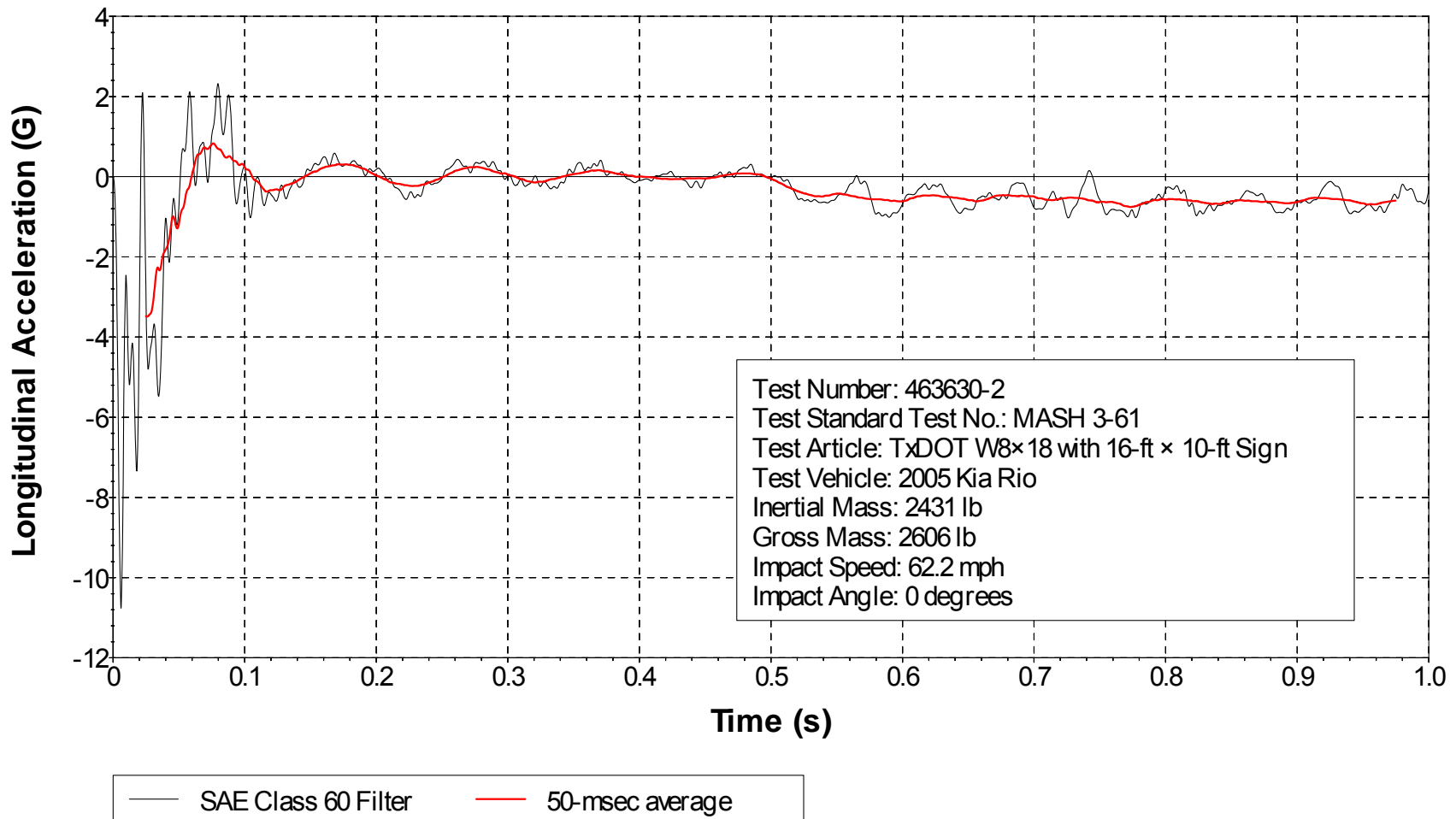


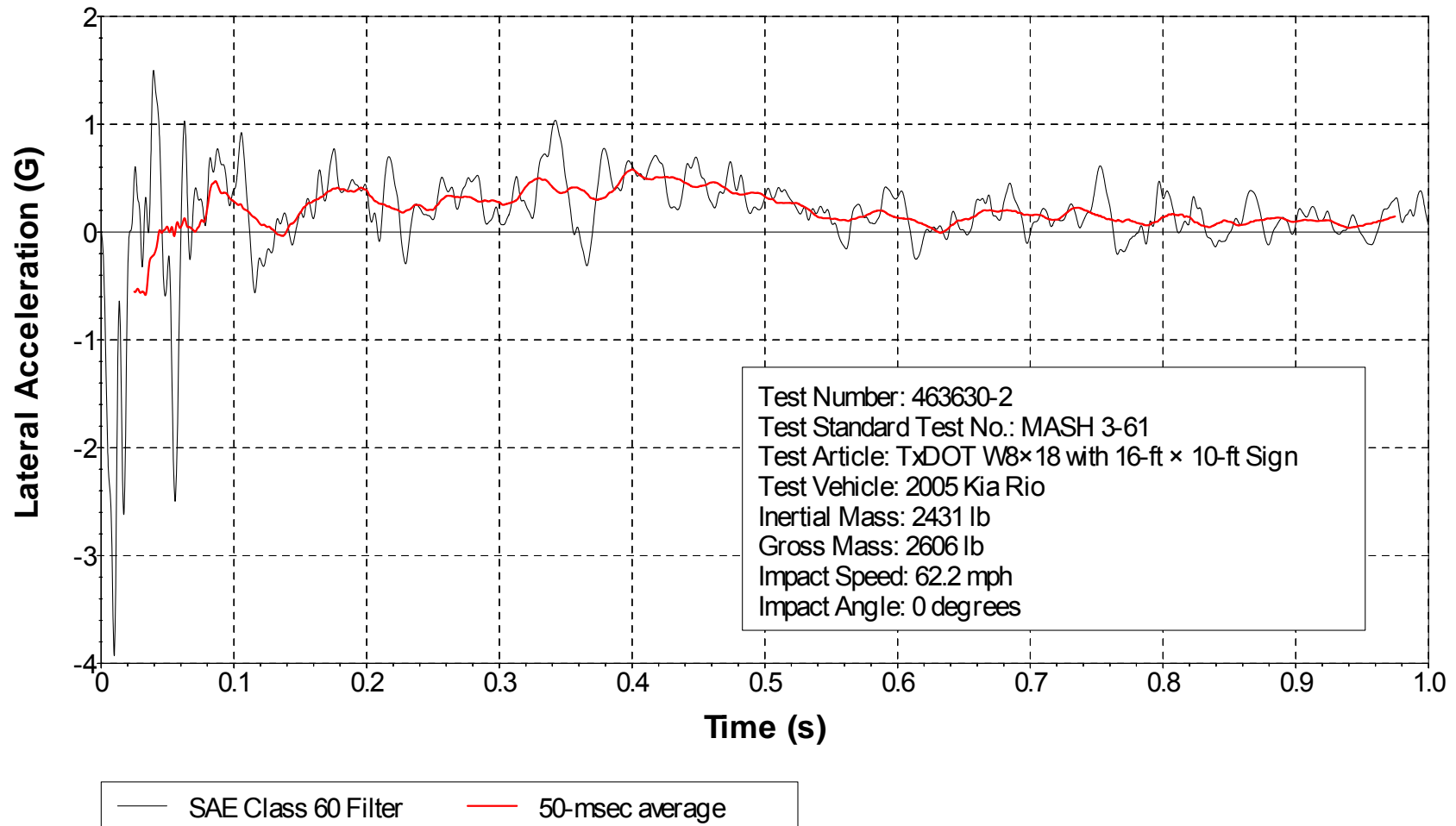
Figure F6. Vehicle Vertical Accelerometer Trace for Test No. 463630-2 (Accelerometer Located at Center of Gravity).

X Acceleration over Rear Axle



**Figure F7. Vehicle Longitudinal Accelerometer Trace for Test No. 463630-2
(Accelerometer Located over Rear Axle).**

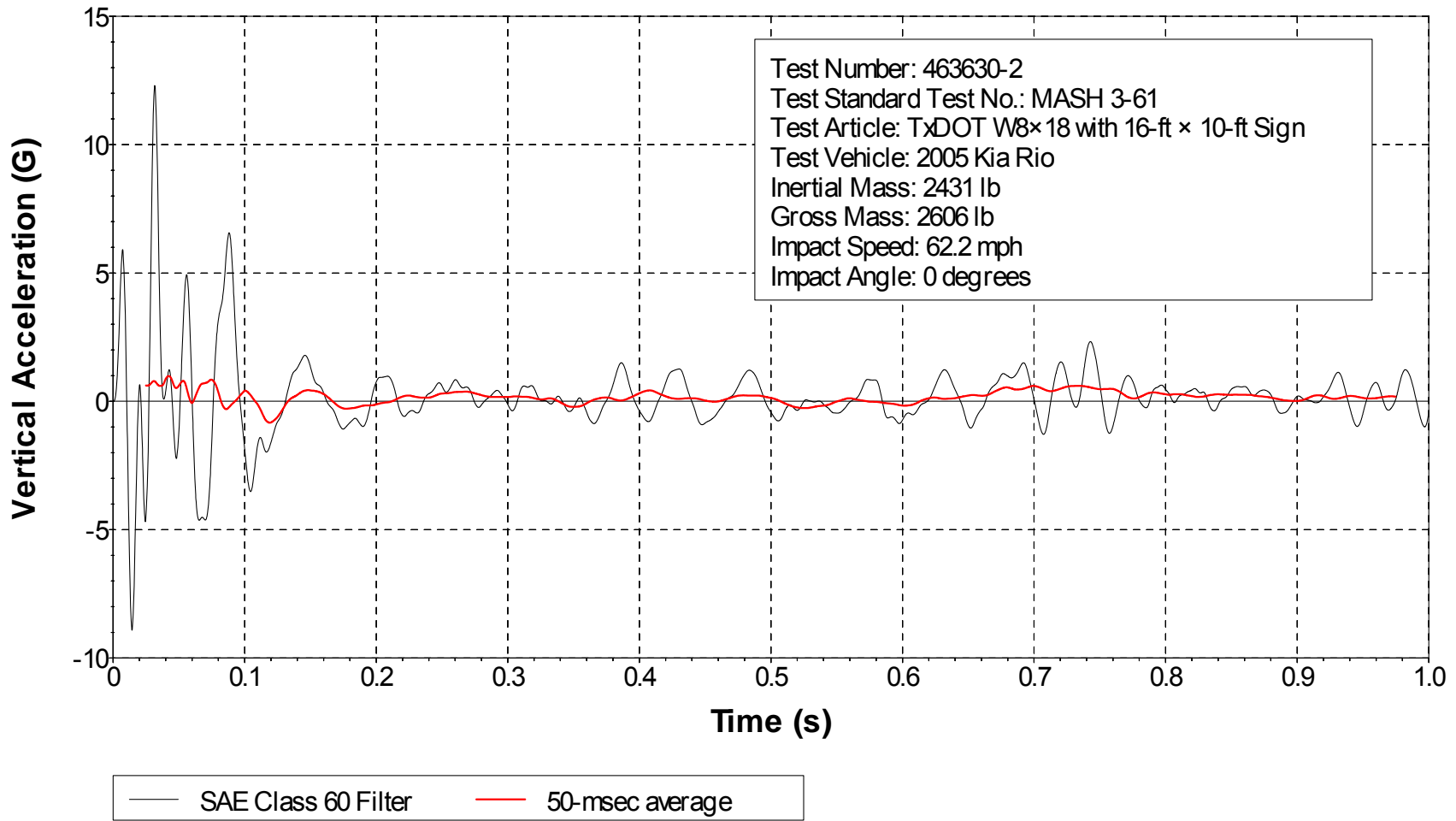
Y Acceleration over Rear Axle



**Figure F8. Vehicle Lateral Accelerometer Trace for Test No. 463630-2
(Accelerometer Located over Rear Axle).**

Z Acceleration over Rear Axle


293



**Figure F9. Vehicle Vertical Accelerometer Trace for Test No. 463630-2
(Accelerometer Located over Rear Axle).**

APPENDIX G. REPRESENTATIVE PROOF CALCULATIONS

G1. S4x7.7, 8 FT TALL SIGN AT 7-FT MOUNTING HEIGHT



**Texas
Transportation
Institute**

PAGE: 1 of 3
 JOB NO: 463631
 DATE: 2010-03-03

BY: Dusty Arrington

SUBJECT: Wind load Proof Cals Per. AASHTO Standard Specifications for Structural Supports for Highway Signs, Luminaires, and Traffic Signals 5th ed 2009 Appendix C Method

TEST ARTICLE: S4x7.7, 8ft Tall Sign @ 7ft Mounting Height

| Properties: | Inputs | Results |
|--|-----------------------------|---------|
| Fb := (15.637·ksi)·1.33 = 20.8·ksi | Allowable Bending Stress | |
| Fv := (11.88·ksi)·1.33 = 15.8·ksi | Allowable Shear Stress | |
| Mfuse := (2.89·kip·ft)·1.33 = 3.84·kip·ft | Fuse Plate Bending Capacity | |
| Hbs := 7ft | Height of Bottom of Sign | |
| Hfp := 7ft | Height of Fuse Plate | |
| Hs := 8ft | Height of Sign | |
| Vwind := 70mph | Wind Velocity | |
| NumPosts := 2 | Number of posts | |
| Sx := 3.03in³ | Elastic Section Modulus | |
| Tw := 0.193in | Thickness of Web | |
| d := 4in | Depth of Member | |

Calculations

| | |
|---|-------------------------------|
| Mpost := Fb·Sx = 5.25·kip·ft | Height of Wind Force |
| Hforce := Hbs + $\frac{Hs}{2}$ = 11·ft | Height of Wind Force |
| Fpost := $\frac{NumPosts Mpost}{Hforce}$ = 0.95·kip | Post Max Resistive Wind Force |
| Fshear := NumPosts Fv·d·Tw = 24.4·kip | Post Max Resistive Wind Force |

BY: Dusty Arrington

SUBJECT: Wind load Proof Cals Per. AASHTO Standard Specifications for Structural Supports for Highway Signs, Luminaires, and Traffic Signals 5th ed 2009 Appendix C Method

$$F_{postSys1} := \frac{\frac{-1}{F_{post}} + \sqrt{\left(\frac{1}{F_{post}}\right)^2 - \frac{4}{F_{shear}^2} \cdot (0.025 - 1)}}{\left(\frac{2}{F_{shear}^2}\right)} = 0.93 \cdot kip$$

$$F_{postSys2} := \frac{\frac{-1}{F_{post}} - \sqrt{\left(\frac{1}{F_{post}}\right)^2 - \frac{4}{F_{shear}^2} \cdot (0.025 - 1)}}{\left(\frac{2}{F_{shear}^2}\right)} = -624.27 \cdot kip$$

$$F_{postSys} := \max(F_{postSys1}, F_{postSys2}) = 0.93 \cdot kip$$

$$F_{fuse} := \frac{NumPosts \cdot M_{fuse}}{H_{force} - H_{fp}} = 1.92 \cdot kip \quad \text{Fuse Plate Max Resistive Wind Force}$$

$$F_{windmax} := \min(F_{postSys}, F_{fuse}) = 0.93 \cdot kip \quad \text{System Max Resistive Wind Force}$$

Wind Load Calculations

Cd Values

Table C-2—Wind Drag Coefficients, C_d ^a

| Sign Panel $L_{sign}/W_{sign} =$ | | |
|-------------------------------------|--|------|
| 1.0 | | 1.12 |
| 2.0 | | 1.19 |
| 5.0 | | 1.20 |
| 10.0 | | 1.23 |
| 15.0 | | 1.30 |

Assume $1.0 < L/W \leq 2$ $C_d := 1.12$

BY: Dusty Arrington

SUBJECT: Wind load Proof Cals Per. AASHTO Standard Specifications for Structural Supports for Highway Signs, Luminaires, and Traffic Signals 5th ed 2009 Appendix C Method

Ch Values

Table C-1—Coefficient of Height, C_h

| Height, m (ft) | C_h |
|-------------------------------|-------|
| 0 (0) < H < 4.3 (14) | 0.80 |
| 4.3 (14) < H < 8.8 (29) | 1.00 |
| 8.8 (29) < H < 14.9 (49) | 1.10 |
| 14.9 (49) < H < 30.2 (99) | 1.25 |
| 30.2 (99) < H < 45.4 (149) | 1.40 |
| 45.4 (149) < H < 60.7 (199) | 1.50 |
| 60.7 (199) < H < 91.1 (299) | 1.60 |

Hforce < 14 **Ch := 0.8**

Wind Pressure Equation

C3—WIND PRESSURE FORMULA

Wind pressure may be computed using the following formula:

$$P_z = 0.0473(1.3V_{fm})^2 C_d C_h \text{ (Pa)} \quad \text{(C-1)}$$

$$P_z = 0.00256(1.3V_{fm})^2 C_d C_h \text{ (psf)}$$

$$P_z := 0.00256 \left(\frac{\text{psf}}{\text{mph}^2} \right) \cdot (1.3 \cdot V_{\text{wind}})^2 \cdot C_d \cdot C_h$$

$$P_z = 18.99 \cdot \text{psf}$$

Sign Size Calculations

$$A_{\text{sign}} := \frac{F_{\text{windmax}}}{P_z} = 48.94 \text{ ft}^2$$

Maximum area of sign

$$W_s := \frac{A_{\text{sign}}}{H_s} = 6.12 \text{ ft}$$

Width of sign

G2. W8×18, 8 FT TALL SIGN AT 14-FT MOUNTING HEIGHT



PAGE: 1 of 3
 JOB NO: 463631
 DATE: 2010-03-03

BY: Dusty Arrington

SUBJECT: Wind load Proof Cals Per. AASHTO Standard Specifications for Structural Supports for Highway Signs, Luminaires, and Traffic Signals 5th ed 2009 Appendix C Method

TEST ARTICLE: W8x18, 8ft Tall Sign @ 14ft Mounting Height

Properties:

| | Inputs | Results |
|---|-----------------------------|---------|
| Fb := (16.34·ksi)·1.33 = 21.73·ksi | Allowable Bending Stress | |
| Fv := (16.5·ksi)·1.33 = 21.95·ksi | Allowable Shear Stress | |
| Mfuse := (7.72·kip·ft)·1.33 = 10.27·kip·ft | Fuse Plate Bending Capacity | |
| Hbs := 14ft | Height of Bottom of Sign | |
| Hfp := 14ft | Height of Fuse Plate | |
| Hs := 8ft | Height of Sign | |
| Vwind := 90mph | Wind Velocity | |
| NumPosts := 2 | Number of posts | |
| Sx := 15.2in³ | Elastic Section Modulus | |
| Tw := 0.23in | Thickness of Web | |
| d := 8.14in | Depth of Member | |

Calculations

| | |
|---|-------------------------------|
| Mpost := Fb·Sx = 27.53·kip·ft | Height of Wind Force |
| Hforce := Hbs + $\frac{Hs}{2}$ = 18·ft | Height of Wind Force |
| Fpost := $\frac{NumPosts·Mpost}{Hforce}$ = 3.06·kip | Post Max Resistive Wind Force |
| Fshear := NumPosts·Fv·d·Tw = 82.17·kip | Post Max Resistive Wind Force |

BY: Dusty Arrington

SUBJECT: Wind load Proof Cals Per. AASHTO Standard Specifications for Structural Supports for Highway Signs, Luminaires, and Traffic Signals 5th ed 2009 Appendix C Method

$$F_{postSys1} := \frac{\frac{-1}{F_{post}} + \sqrt{\left(\frac{1}{F_{post}}\right)^2 - \frac{4}{F_{shear}^2} \cdot (0.025 - 1)}}{\left(\frac{2}{F_{shear}^2}\right)} = 2.98 \cdot kip$$

$$F_{postSys2} := \frac{\frac{-1}{F_{post}} - \sqrt{\left(\frac{1}{F_{post}}\right)^2 - \frac{4}{F_{shear}^2} \cdot (0.025 - 1)}}{\left(\frac{2}{F_{shear}^2}\right)} = -2.21 \times 10^3 \cdot kip$$

$$F_{postSys} := \max(F_{postSys1}, F_{postSys2}) = 2.98 \cdot kip$$

$$f_v := \frac{F_{postSys}}{NumPosts \cdot d \cdot T_w} = 0.8 \cdot ksi \quad \text{Actual Shear Stress}$$

$$f_b := \frac{F_{postSys} \cdot H_{force}}{NumPosts \cdot S_x} = 21.16 \cdot ksi \quad \text{Actual Bending Stress}$$

$$0.025 + \frac{f_b}{F_b} + \left(\frac{f_v}{F_v}\right)^2 = 1 \quad \text{Combined Stress Equation}$$

$$F_{fuse} := \frac{NumPosts \cdot M_{fuse}}{H_{force} - H_{fp}} = 5.13 \cdot kip \quad \text{Fuse Plate Max Resistive Wind Force}$$

$$F_{windmax} := \min(F_{postSys}, F_{fuse}) = 2.98 \cdot kip \quad \text{System Max Resistive Wind Force}$$

Wind Load Calculations

Cd Values

Table C-2—Wind Drag Coefficients, C_d ^a

| Sign Panel $L_{sign}/W_{sign} =$ | C_d |
|-------------------------------------|-------|
| 1.0 | 1.12 |
| 2.0 | 1.19 |
| 5.0 | 1.20 |
| 10.0 | 1.23 |
| 15.0 | 1.30 |

Assume $1.0 < L/W \leq 2$ $C_d := 1.12$

BY: Dusty Arrington

SUBJECT: Wind load Proof Cals Per. AASHTO Standard Specifications for Structural Supports for Highway Signs, Luminaires, and Traffic Signals 5th ed 2009 Appendix C Method

Ch Values

Table C-1—Coefficient of Height, C_h

| Height, m (ft) | C_h |
|-------------------------------|-------|
| 0 (0) < H < 4.3 (14) | 0.80 |
| 4.3 (14) < H < 8.8 (29) | 1.00 |
| 8.8 (29) < H < 14.9 (49) | 1.10 |
| 14.9 (49) < H < 30.2 (99) | 1.25 |
| 30.2 (99) < H < 45.4 (149) | 1.40 |
| 45.4 (149) < H < 60.7 (199) | 1.50 |
| 60.7 (199) < H < 91.1 (299) | 1.60 |

$$29 \geq H_{\text{force}} > 14 \quad C_h := 1.0$$

Wind Pressure Equation

C3—WIND PRESSURE FORMULA

Wind pressure may be computed using the following formula:

$$P_z = 0.0473(1.3V_{fm})^2 C_d C_h \quad (\text{Pa}) \quad (\text{C-1})$$

$$P_z = 0.00256(1.3V_{fm})^2 C_d C_h \quad (\text{psf})$$

$$P_z := 0.00256 \left(\frac{\text{psf}}{\text{mph}^2} \right) \cdot (1.3 \cdot V_{\text{wind}})^2 \cdot C_d \cdot C_h$$

$$P_z = 39.25 \cdot \text{psf}$$

Sign Size Calculations

$$A_{\text{sign}} := \frac{F_{\text{windmax}}}{P_z} = 75.88 \text{ ft}^2$$

Maximum area of sign

$$W_s := \frac{A_{\text{sign}}}{H_s} = 9.48 \text{ ft}$$

Width of sign

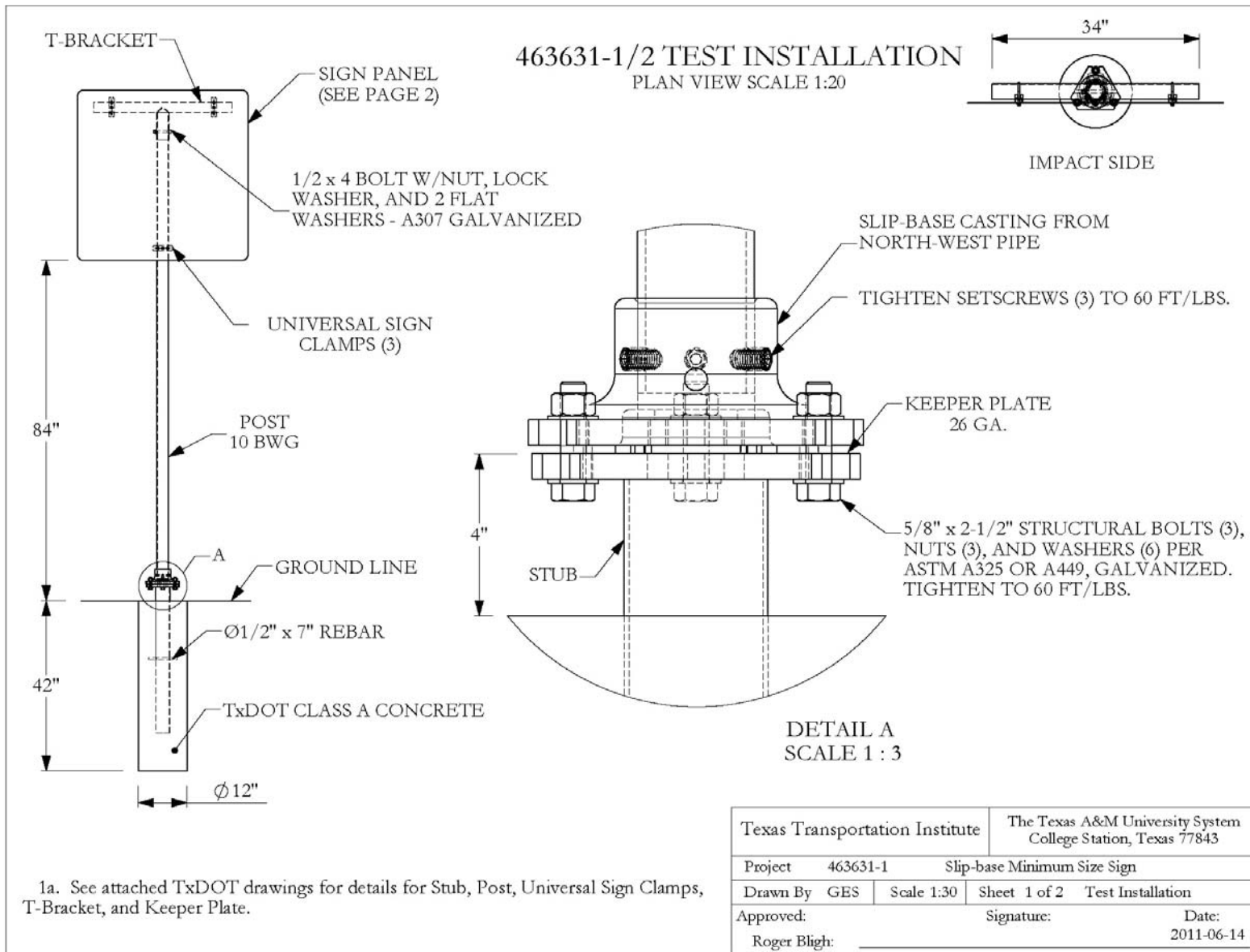
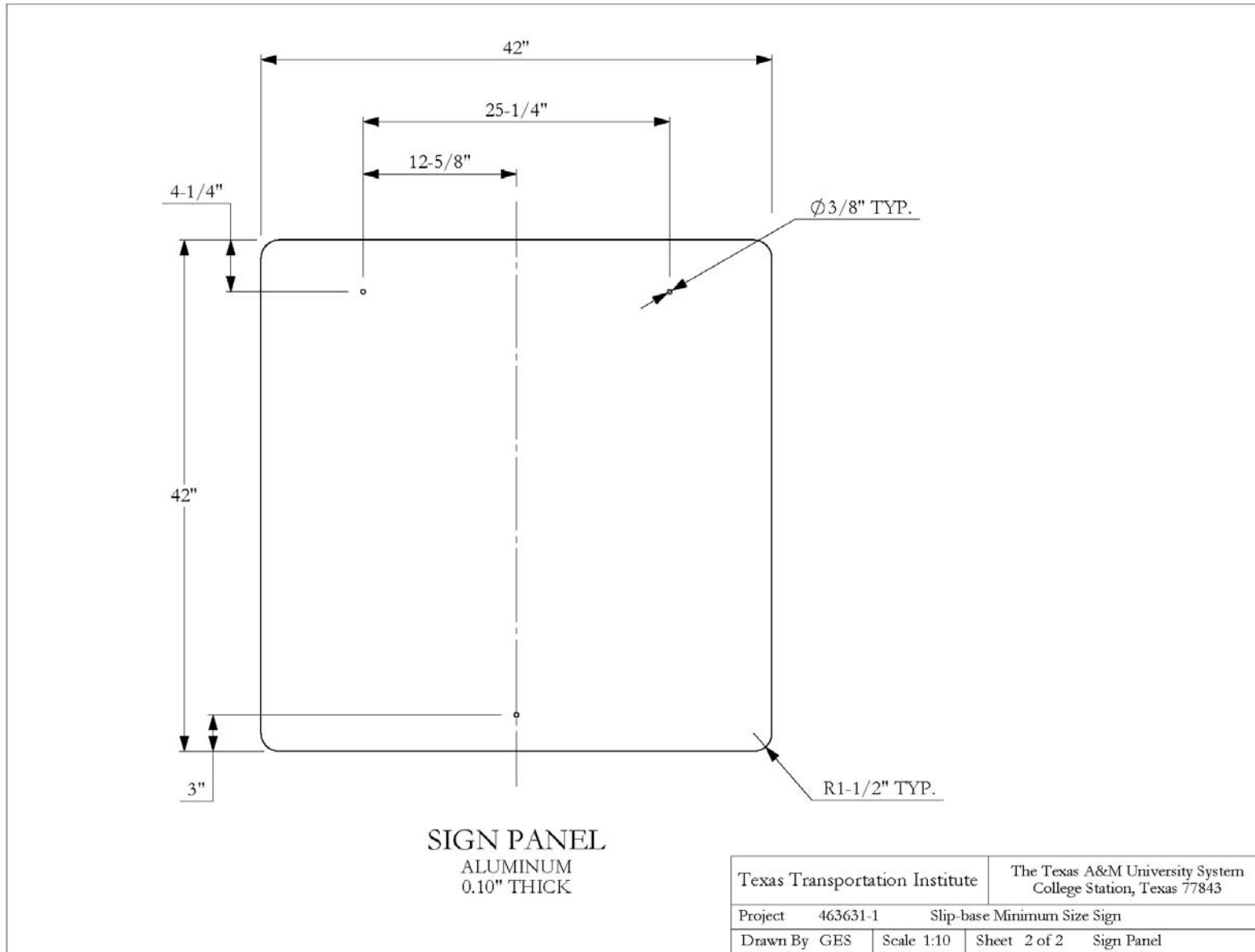


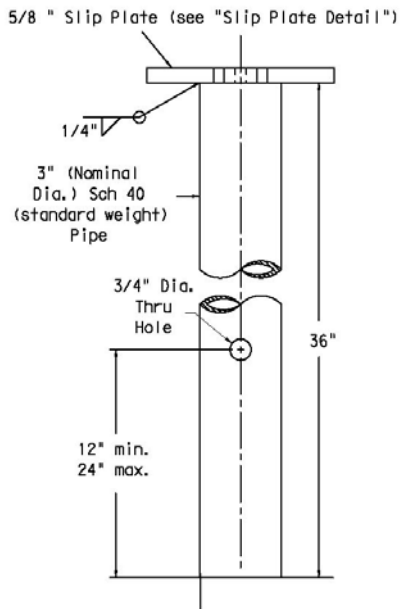
Figure H1. Details of the 10 BWG Steel Pipe Support with 12 ft² Sign.

T:\2010-2011\463631-TxDOT\Drawing\463631-1 and 2 Drawing



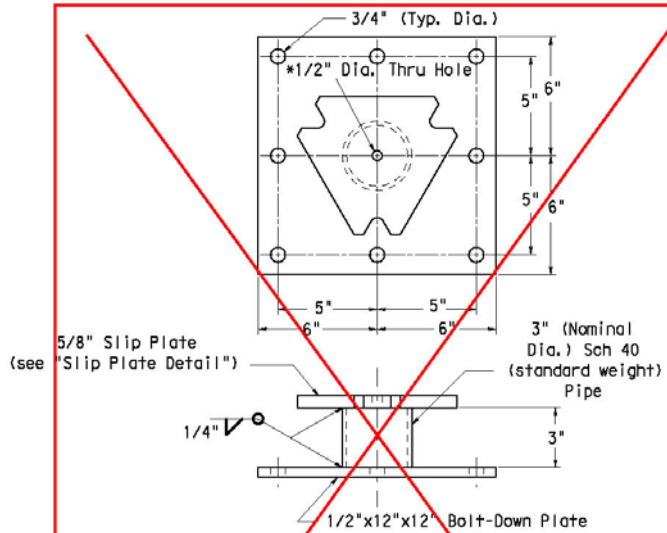
T:\2010-2011\463631-TXDOT\Drafting\463631-1 and 2 Drawing

Figure H1. Details of the 10 BWG Steel Support with 12 ft² Sign (Continued).



Pipe shall conform to ASTM A53 Gr B, A500 Gr B, or A501. Galvanize according to ASTM A123 after all fabrication is completed. Finished components shall be permanently marked to indicate manufacturer. Method, design and location of markings are subject to the approval of the TxDOT Traffic Standards Engineer.

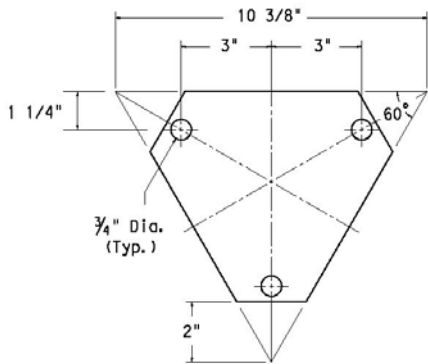
STUB



Pipe shall conform to ASTM A53 Gr B, A500 Gr B, or A501. Bolt-down plate shall conform to the same material requirements specified for the slip plate. Galvanize according to ASTM A123 after all fabrication is completed. Finished components shall be permanently marked to indicate manufacturer. Method, design and location of markings are subject to the approval of the TxDOT Traffic Standards Engineer.

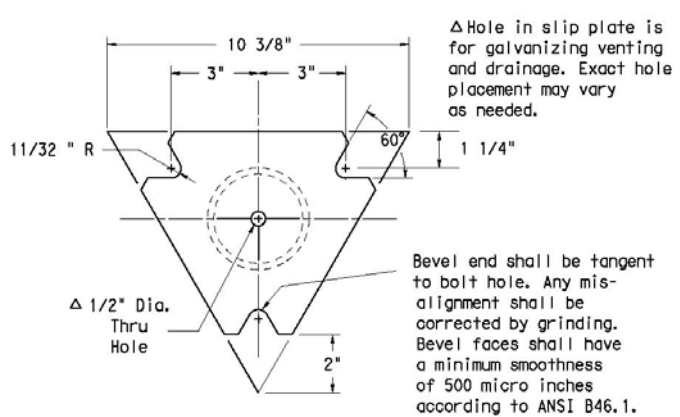
* Hole in slip plate and bolt-down plate is for galvanizing venting and drainage. Exact hole placement may vary as needed.

BOLT-DOWN ANCHOR



Bolt Keeper Plate shall be manufactured from 26 to 30 gauge galvanized sheet steel.

BOLT KEEPER PLATE

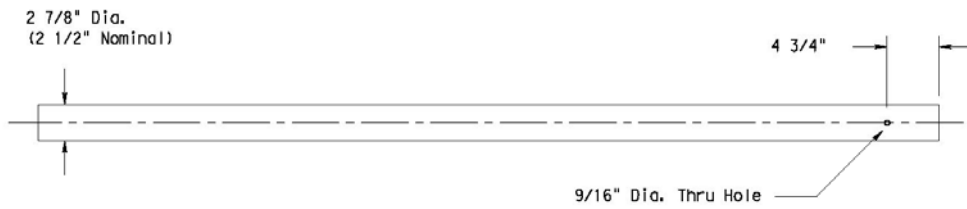
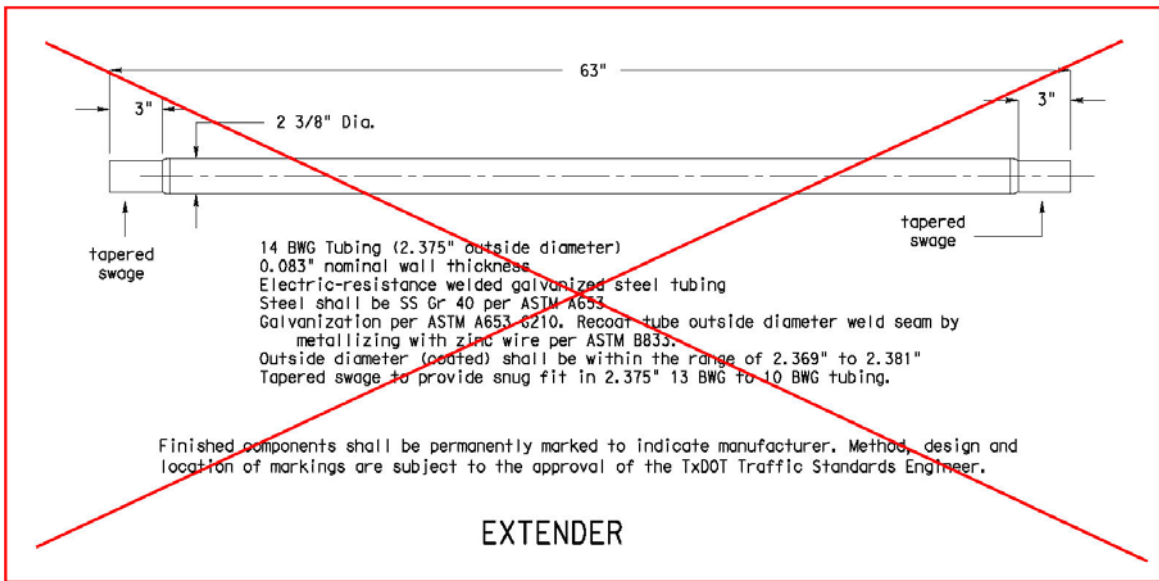


Slip plate shall conform to ASTM A36 or A572.

SLIP PLATE DETAIL

11.25.02

Figure H1. Details of the 10 BWG Steel Support with 12 ft² Sign (Continued).



10 BWG Tubing (2.875" outside diameter)

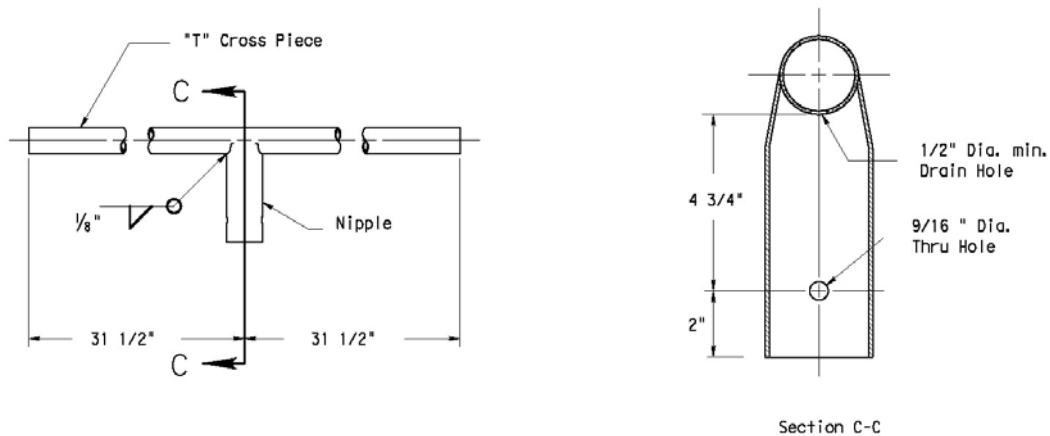
0.134" nominal wall thickness
 Seamless or electric-resistance welded steel tubing or pipe
 Steel shall be HSLAS Gr 55 per ASTM A1011 or ASTM A1008
 Other steels may be used if they meet the following:
 55,000 PSI minimum yield strength
 70,000 PSI minimum tensile strength
 20% minimum elongation in 2"
 Wall thickness (uncoated) shall be within the range of 0.122" to 0.138"
 Outside diameter (uncoated) shall be within the range of 2.867" to 2.883"
 Galvanization per ASTM A123 or ASTM A653 G210. For pre-coated steel tubing (ASTM A653), recoat tube outside diameter weld seam by metallizing with zinc wire per ASTM B833.

Schedule 80 Pipe (2.875" outside diameter)

0.276" nominal wall thickness
 Steel tubing per ASTM A500 Gr C
 Other seamless or electric resistance welded steel tubing or pipe with equivalent outside diameter and wall thickness may be used if they meet the following:
 46,000 PSI minimum yield strength
 62,000 PSI minimum tensile strength
 21% minimum elongation in 2"
 Wall thickness (uncoated) shall be within the range of 0.248" to 0.304"
 Outside diameter (uncoated) shall be within the range of 2.855" to 2.895"
 Galvanization per ASTM A123.

POST

Figure H1. Details of the 10 BWG Steel Support with 12 ft² Sign (Continued).



"T" CROSS PIECE

13 BWG Tubing (2.375" outside diameter)
 0.095" nominal wall thickness
 Seamless or electric-resistance welded steel tubing
 Steel shall be HSLAS Gr 55 per ASTM A1011 or ASTM A1008
 Other steels may be used if they meet the following:
 55,000 PSI minimum yield strength
 70,000 PSI minimum tensile strength
 18% minimum elongation in 2"
 Wall thickness (uncoated) shall be within the range of 0.085" to 0.105"
 Outside diameter (uncoated) shall be within the range of 2.355" to 2.395"

NIPPLE

11 BWG or greater Tubing (3.25" outside diameter)
 Seamless or electric-resistance welded steel tubing
 Steel shall be HSLAS Gr 55 per ASTM A1011 or ASTM A1008
 Other steels may be used if they meet the following:
 55,000 PSI minimum yield strength
 70,000 PSI minimum tensile strength
 20% minimum elongation in 2"
 Outside diameter (uncoated) shall be within the range of 3.241" to 3.259"
 Inside diameter (uncoated) shall be a minimum of 2.93"
 Wall thickness shall be a minimum of 0.108"
 Cut length shall be 8.000" ± 0.250". Notched and coped to provide snug fit with cross piece.
 Drilled or punched as shown. Nipple shall provide snug fit with 2.875" post.
 Nipple may be dimpled to provide snug fit.

FABRICATED "T" BRACKET

Galvanize according to ASTM A123 after all fabrication is completed.

Finished components shall be permanently marked to indicate manufacturer. Method, design and location of markings are subject to the approval of the TxDOT Traffic Standards Engineer.

**PREFABRICATED "T" BRACKET-TEXAS UNIVERSAL
 TRIANGULAR SLIPBASE SYSTEM**

11.25.02

Figure H1. Details of the 10 BWG Steel Support with 12 ft² Sign (Continued).

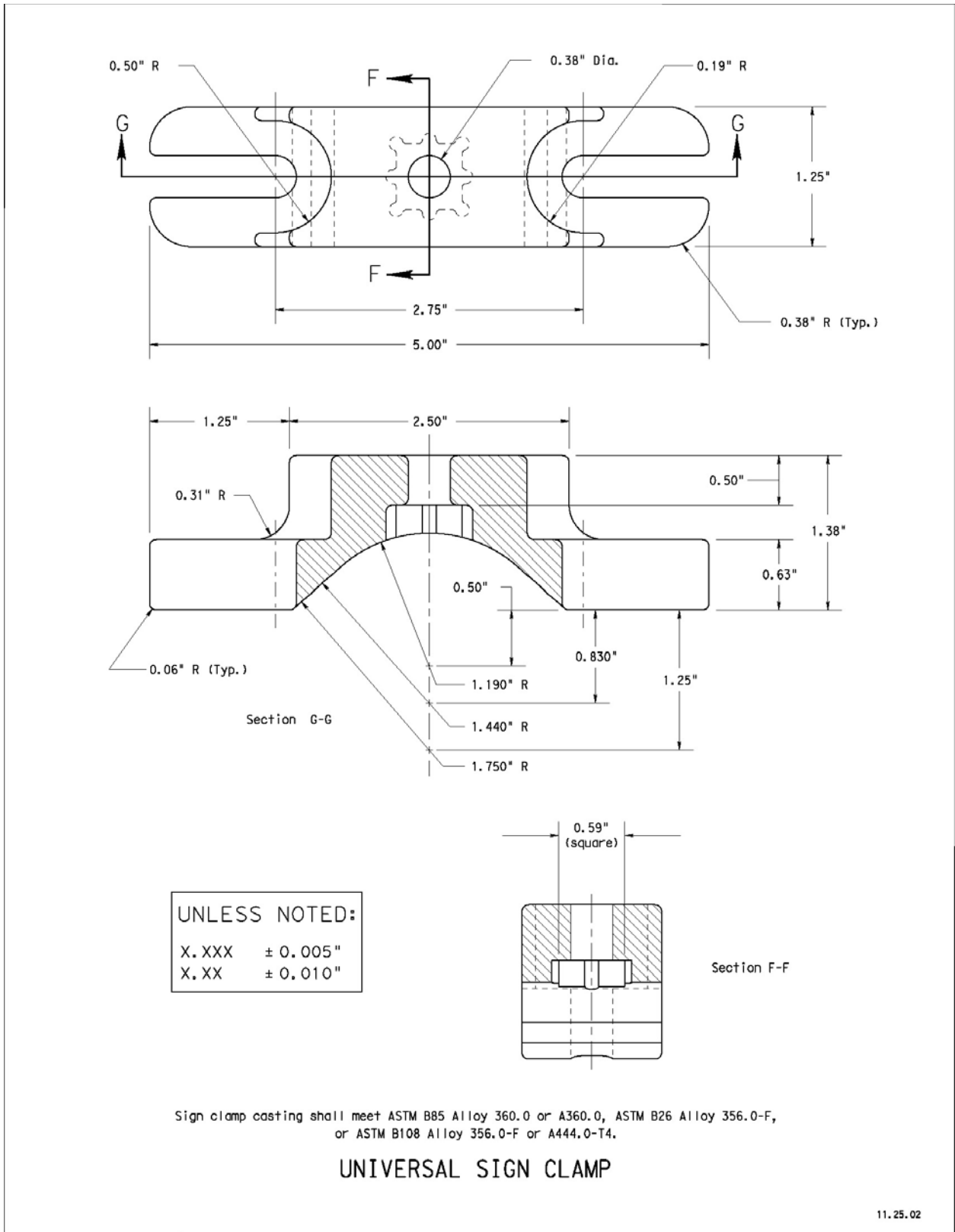
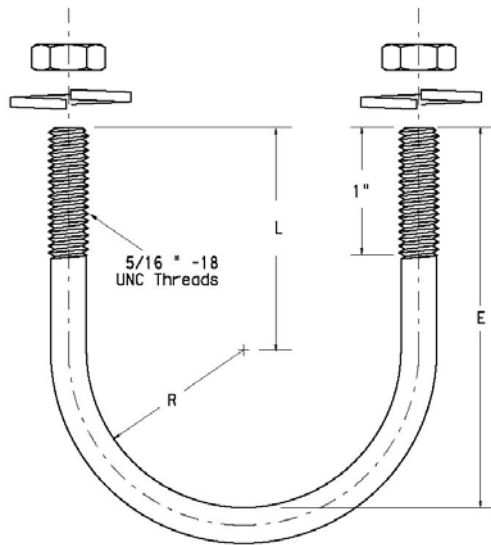


Figure H1. Details of the 10 BWG Steel Support with 12 ft² Sign (Continued).



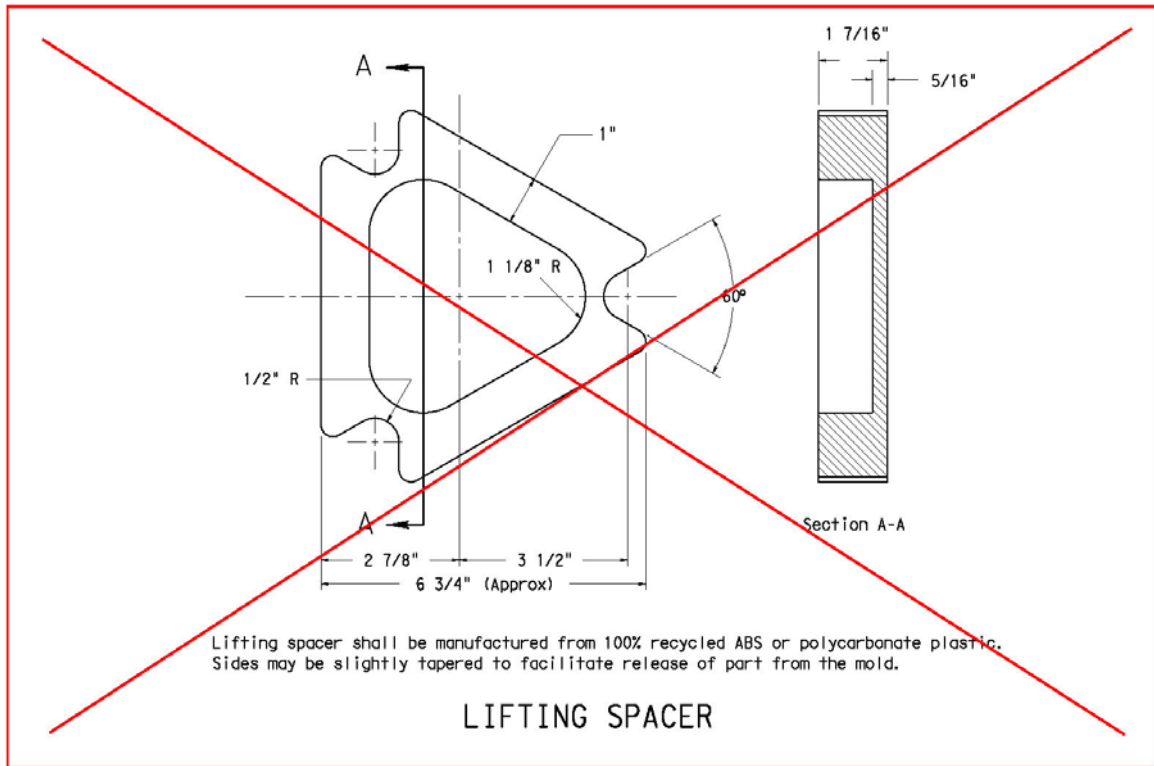
American National Standard Hex Nut and Helical Spring Lock Washer

U-bolt, nut and washers shall be manufactured according to ASTM A307 Grade C and galvanized according to Item 445, "Galvanizing."

9/32" diameter stock is permissible.

| Standard Pipe Size | R | L | E |
|--------------------|----------|----------|----------|
| 2" | 1 7/32" | 1 15/32" | 2 11/16" |
| 2 1/2" | 1 15/32" | 1 23/32" | 3 3/16" |
| 3" | 1 25/32" | 2 1/32" | 3 13/16" |

SIGN CLAMP U-BOLT



Lifting spacer shall be manufactured from 100% recycled ABS or polycarbonate plastic. Sides may be slightly tapered to facilitate release of part from the mold.

LIFTING SPACER

11.25.02

Figure H1. Details of the 10 BWG Steel Support with 12 ft² Sign (Continued).

Table H1. Vehicle Properties for Test No. 463631-1.

Date: 2011-06-20 Test No.: 463631-1 VIN No.: 1D7HA18NO35102404

Year: 2002 Make: Dodge Model: Ram 1500 crew

Tire Size: 245/70R17 Tire Inflation Pressure: 35 psi

Tread Type: Highway Odometer: 137454

Note any damage to the vehicle prior to test: _____

Denotes accelerometer location.

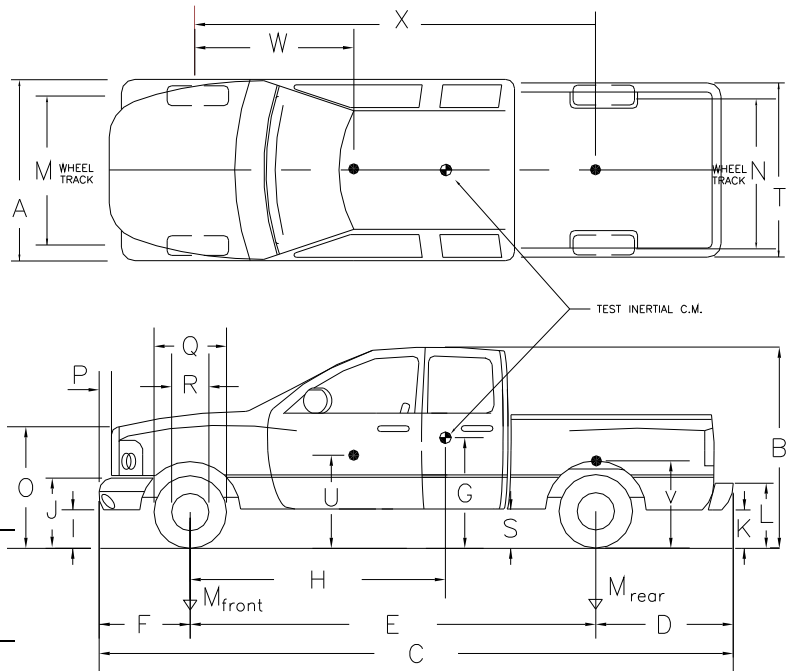
NOTE: _____

Engine Type: V-8
Engine CID: 4.7 liter

Transmission Type:
x Auto or _____ Manual
_____ FWD x RWD _____ 4WD

Optional Equipment:

Dummy Data:
Type: None
Mass: _____
Seat Position: _____



Geometry: inches

| | | | | | | | | | |
|---|---------------|---|--------------|---|--------------|---|--------------|---|---------------|
| A | <u>77.00</u> | F | <u>39.00</u> | K | <u>20.50</u> | P | <u>3.00</u> | U | <u>27.50</u> |
| B | <u>73.25</u> | G | <u>28.25</u> | L | <u>28.75</u> | Q | <u>29.50</u> | V | <u>33.00</u> |
| C | <u>22.70</u> | H | <u>64.29</u> | M | <u>68.25</u> | R | <u>18.50</u> | W | <u>59.50</u> |
| D | <u>47.50</u> | I | <u>13.50</u> | N | <u>67.25</u> | S | <u>14.25</u> | X | <u>140.50</u> |
| E | <u>140.50</u> | J | <u>26.00</u> | O | <u>44.75</u> | T | <u>75.50</u> | | |

| | | | | | |
|-----------------------|---------------|---------------------------|--------------|---------------|---------------|
| Wheel Center Ht Front | <u>14.125</u> | Wheel Well Clearance (FR) | <u>6.125</u> | Frame Ht (FR) | <u>16.625</u> |
| Wheel Center Ht Rear | <u>14.25</u> | Wheel Well Clearance (RR) | <u>11.25</u> | Frame Ht (RR) | <u>24.25</u> |

| GVWR Ratings: | Mass: lb | Curb | Test Inertial | Gross Static |
|---------------|-------------|-------------------------|---------------|---------------------|
| Front | <u>3650</u> | M_{front} <u>2799</u> | <u>2750</u> | Allowable |
| Back | <u>3900</u> | M_{rear} <u>2100</u> | <u>2320</u> | Range |
| Total | <u>7550</u> | M_{Total} <u>4899</u> | <u>5070</u> | <u>5000 ±110 lb</u> |

Mass Distribution: lb LF: 1380 RF: 1370 LR: 1140 RR: 1180

Table H2. Vehicle Parametric Measurements for 2270P Vehicle Used in Test No. 463631-1.

Date: 2011-06-20 Test No.: 463631-1 VIN No.: 1D7HA18NO35102404
 Year: 2002 Make: Dodge Model: Ram 1500 crew
 Body Style: Quad cab Mileage: 137454
 Engine: V-8 Transmission: Automatic
 Fuel Level: Empty Ballast : 330 lb (440 lb max)
 Tire Pressure: Front: 35 psi Rear: 35 psi Size: 245/70R17

Measured Vehicle Weights: (lb)

LF: 1415 RF: 1303 Front Axle: 2718
 LR: 1189 RR: 1103 Rear Axle: 2292
 Left: 2604 Right: 2406 Total: 5010
 5000 ±110 lb allowed

Wheel Base: 140.5 inches Track: F: 68.25 inches R: 67.25 inches
 148 ±12 inches allowed Track = (F+R)/2 = 67 ±1.5 inches allowed

Center of Gravity, SAE J874 Suspension Method

X: 64.28 in Rear of Front Axle (63 ±4 inches allowed)
 Y: -1.35 in Left - Right + of Vehicle Centerline
 Z: 28.25 in Above Ground (minumum 28.0 inches allowed)

Hood Height: 44.50 inches Front Bumper Height: 26.00 inches
 43 ±4 inches allowed
 Front Overhang: 39.00 inches Rear Bumper Height: 27.50 inches
 39 ±3 inches allowed
 Overall Length: 224.50 inches
 237 ±13 inches allowed

Table H3. Exterior Crush Measurements for Test No. 463631-1.

Date: 2011-06-20 Test No.: 463631-1 VIN No.: 1D7HA18NO35102404

Year: 2002 Make: Dodge Model: Ram 1500 crew

VEHICLE CRUSH MEASUREMENT SHEET¹

| | |
|---|---|
| Complete When Applicable | |
| End Damage | Side Damage |
| Undeformed end width _____ Corner shift: A1 _____ A2 _____ End shift at frame (CDC) (check one) < 4 inches _____ ≥ 4 inches _____ | Bowing: B1 _____ X1 _____ B2 _____ X2 _____ Bowing constant $\frac{X1 + X2}{2} = \underline{\hspace{2cm}}$ |

Note: Measure C₁ to C₆ from Driver to Passenger side in Front or Rear impacts – Rear to Front in Side Impacts.

| Specific Impact Number | Plane* of C-Measurements | Direct Damage | | Field L** | C ₁ | C ₂ | C ₃ | C ₄ | C ₅ | C ₆ | ±D |
|------------------------|--------------------------|---------------|--------------|-----------|----------------|----------------|----------------|----------------|----------------|----------------|-------|
| | | Width** (CDC) | Max*** Crush | | | | | | | | |
| 1 | Front plane bumper ht | 2 | 1 | 12 | 0 | 1 | 0 | 0 | 0 | 0 | +14.5 |
| | | | | | | | | | | | |
| | | | | | | | | | | | |
| | Measurements recorded | | | | | | | | | | |
| | in inches | | | | | | | | | | |
| | | | | | | | | | | | |

¹Table taken from National Accident Sampling System (NASS).

*Identify the plane at which the C-measurements are taken (e.g., at bumper, above bumper, at sill, above sill, at beltline, etc.) or label adjustments (e.g., free space).

Free space value is defined as the distance between the baseline and the original body contour taken at the individual C locations. This may include the following: bumper lead, bumper taper, side protrusion, side taper, etc. Record the value for each C-measurement and maximum crush.

**Measure and document on the vehicle diagram the beginning or end of the direct damage width and field L (e.g., side damage with respect to undamaged axle).

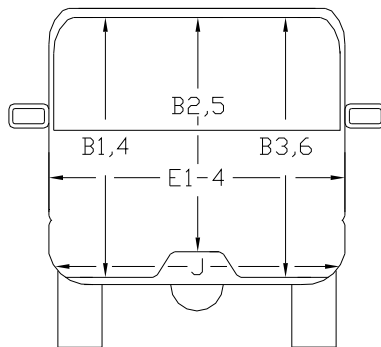
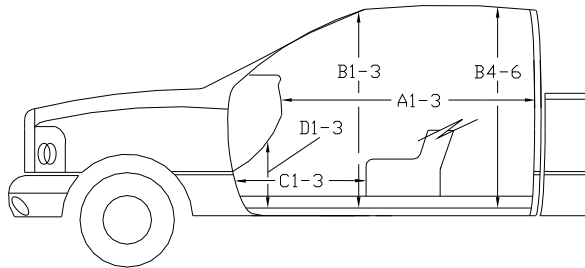
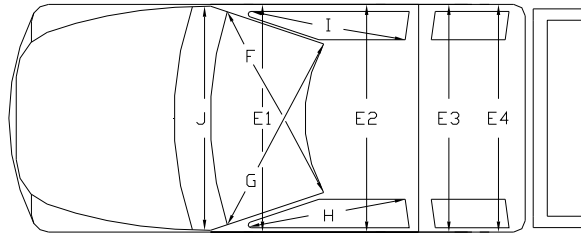
***Measure and document on the vehicle diagram the location of the maximum crush.

Note: Use as many lines/columns as necessary to describe each damage profile.

Table H4. Occupant Compartment Measurements for Test No. 463631-1.

Date: 2011-06-20 Test No.: 463631-1 VIN No.: 1D7HA18NO35102404
 Year: 2002 Make: Dodge Model: Ram 1500 crew

OCCUPANT COMPARTMENT DEFORMATION MEASUREMENT



| | Before (inches) | After (inches) |
|----|----------------------|---------------------|
| A1 | 63.50 | 63.50 |
| A2 | 63.50 | 63.50 |
| A3 | 64.25 | 64.25 |
| B1 | 44.50 | 44.50 |
| B2 | 38.75 | 37.00 |
| B3 | 44.75 | 44.50 |
| B4 | 41.00 | 41.00 |
| B5 | 41.50 | 41.50 |
| B6 | 39.50 | 38.75 |
| C1 | 29.50 | 29.50 |
| C2 | 70.75 | 70.75 |
| C3 | 27.00 | 27.00 |
| D1 | 10.50 | 10.50 |
| D2 | 2.00 | 2.00 |
| D3 | 11.00 | 11.00 |
| E1 | 63.50 | 63.50 |
| E2 | 63.75 | 63.75 |
| E3 | 63.50 | 63.50 |
| E4 | 63.50 | 63.50 |
| F | 59.00 | 59.00 |
| G | 59.00 | 59.00 |
| H | 34.50 | 34.50 |
| I | 34.50 | 34.50 |
| J* | 61.00 | 61.00 |

*Lateral area across the cab from driver's side kickpanel to passenger's side kickpanel.

Maximum roof crush 3.5 inches in center area



0.000 s



0.024 s



0.048 s



0.072 s



Figure H2. Sequential Photographs for Test No. 463631-1 (Oblique Views).



0.096s



0.120 s



0.144 s



0.168 s



Figure H2. Sequential Photographs for Test No. 463631-1 (Oblique Views) (continued).

Roll, Pitch, and Yaw Angles

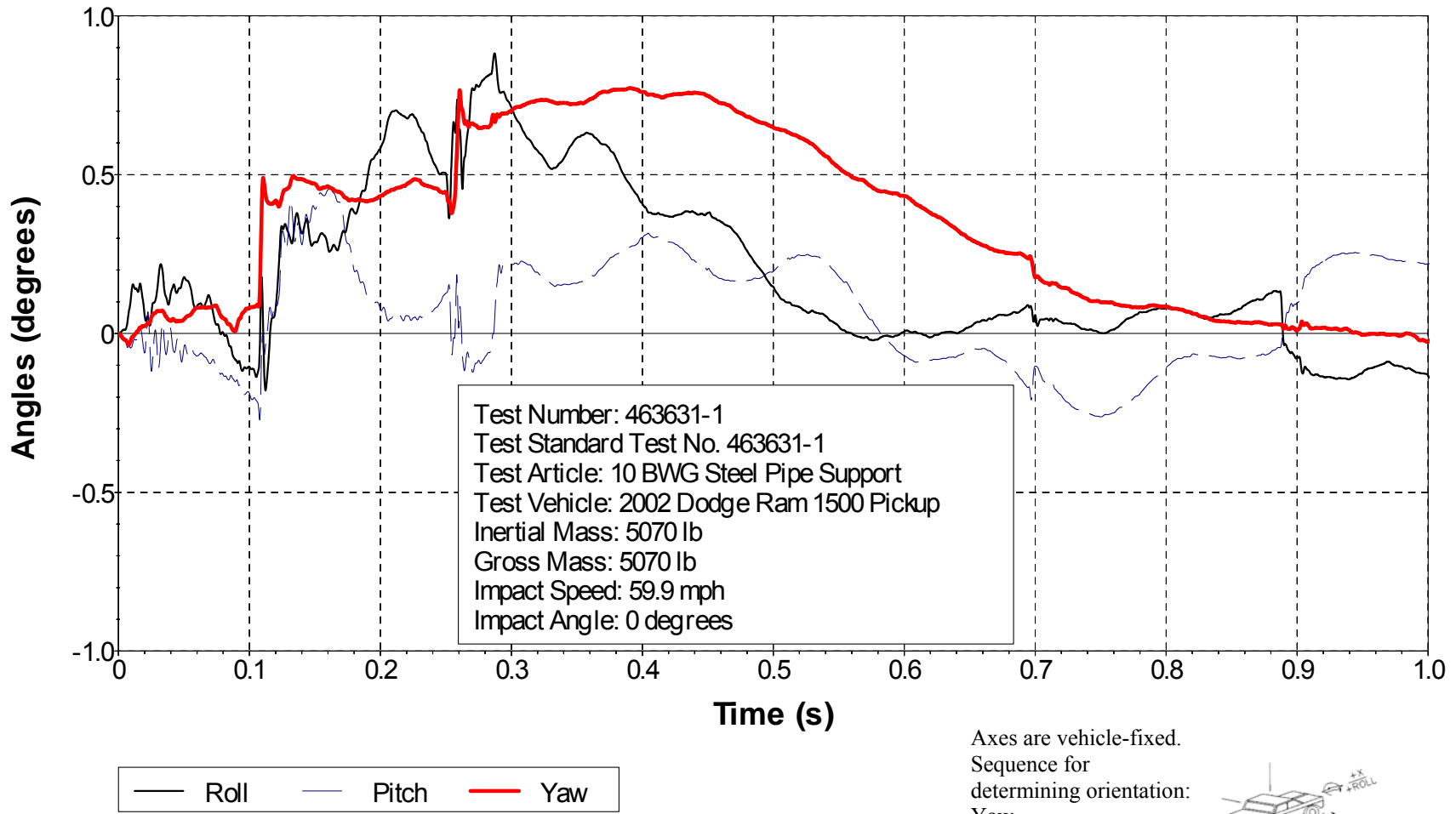
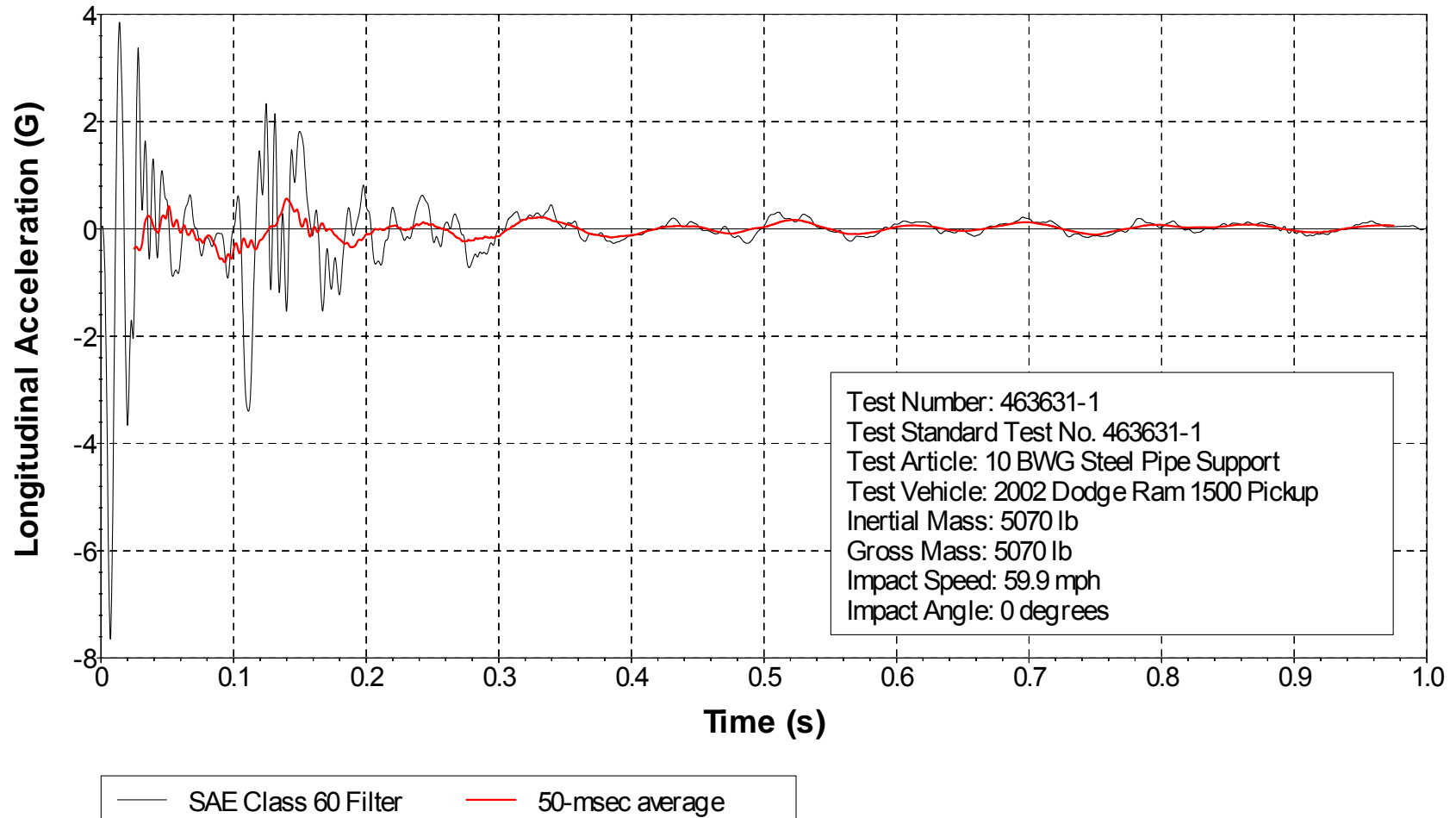


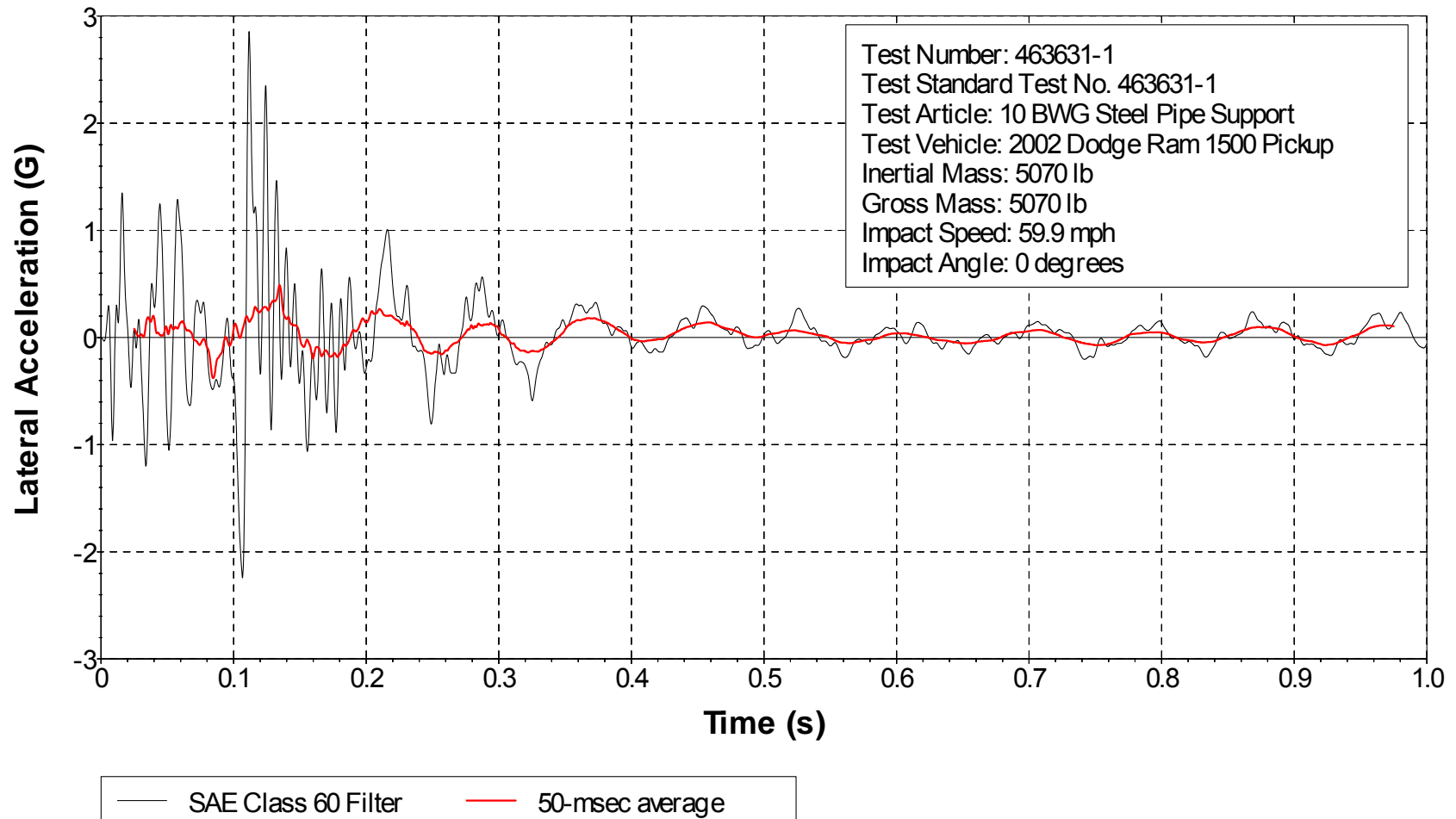
Figure H3. Vehicle Angular Displacements for Test No. 463631-1.

X Acceleration at CG



**Figure H4. Vehicle Longitudinal Accelerometer Trace for Test No. 463631-1
(Accelerometer Located at Center of Gravity).**

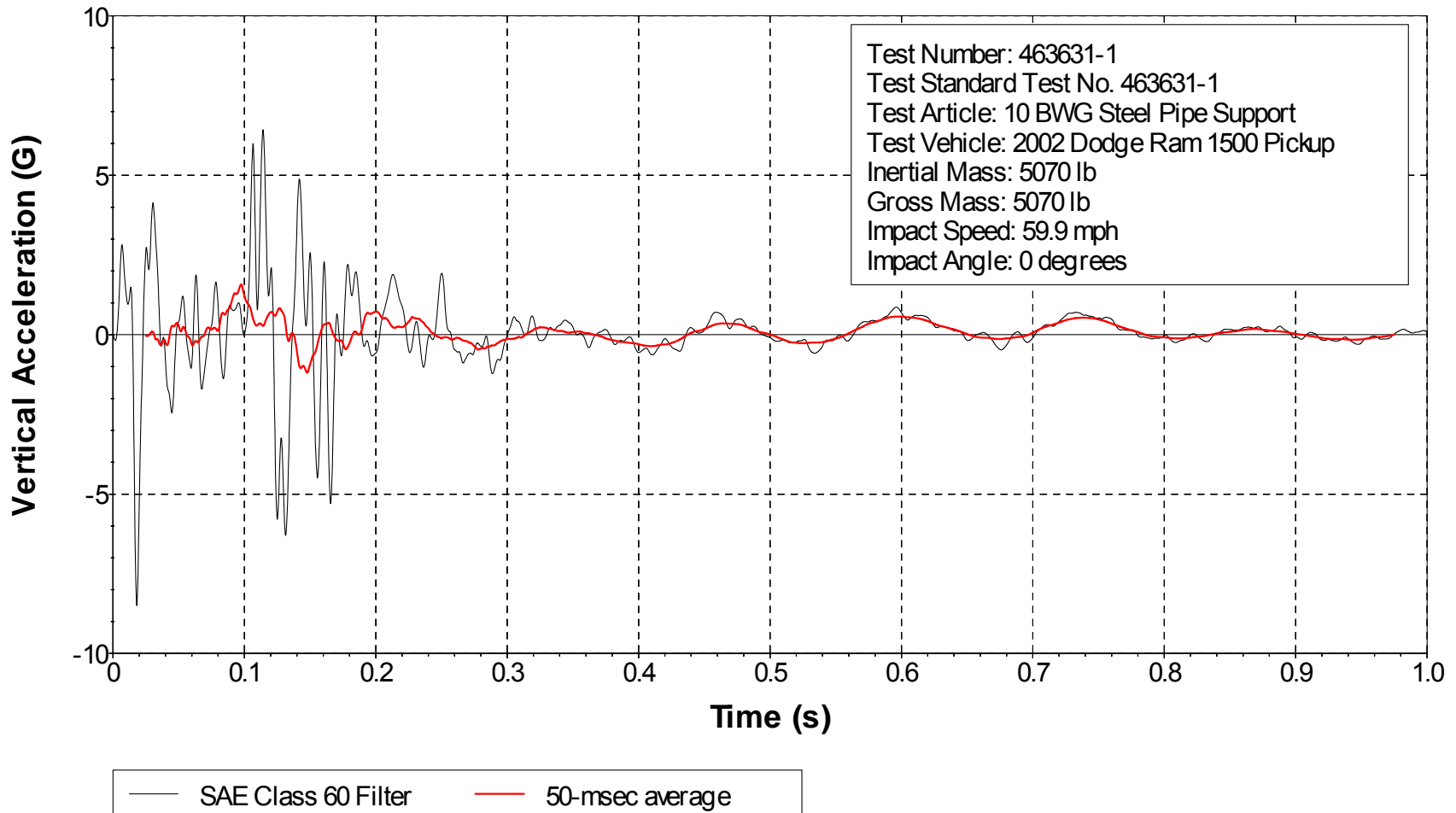
Y Acceleration at CG



**Figure H5. Vehicle Lateral Accelerometer Trace for Test No. 463631-1
(Accelerometer Located at Center of Gravity).**

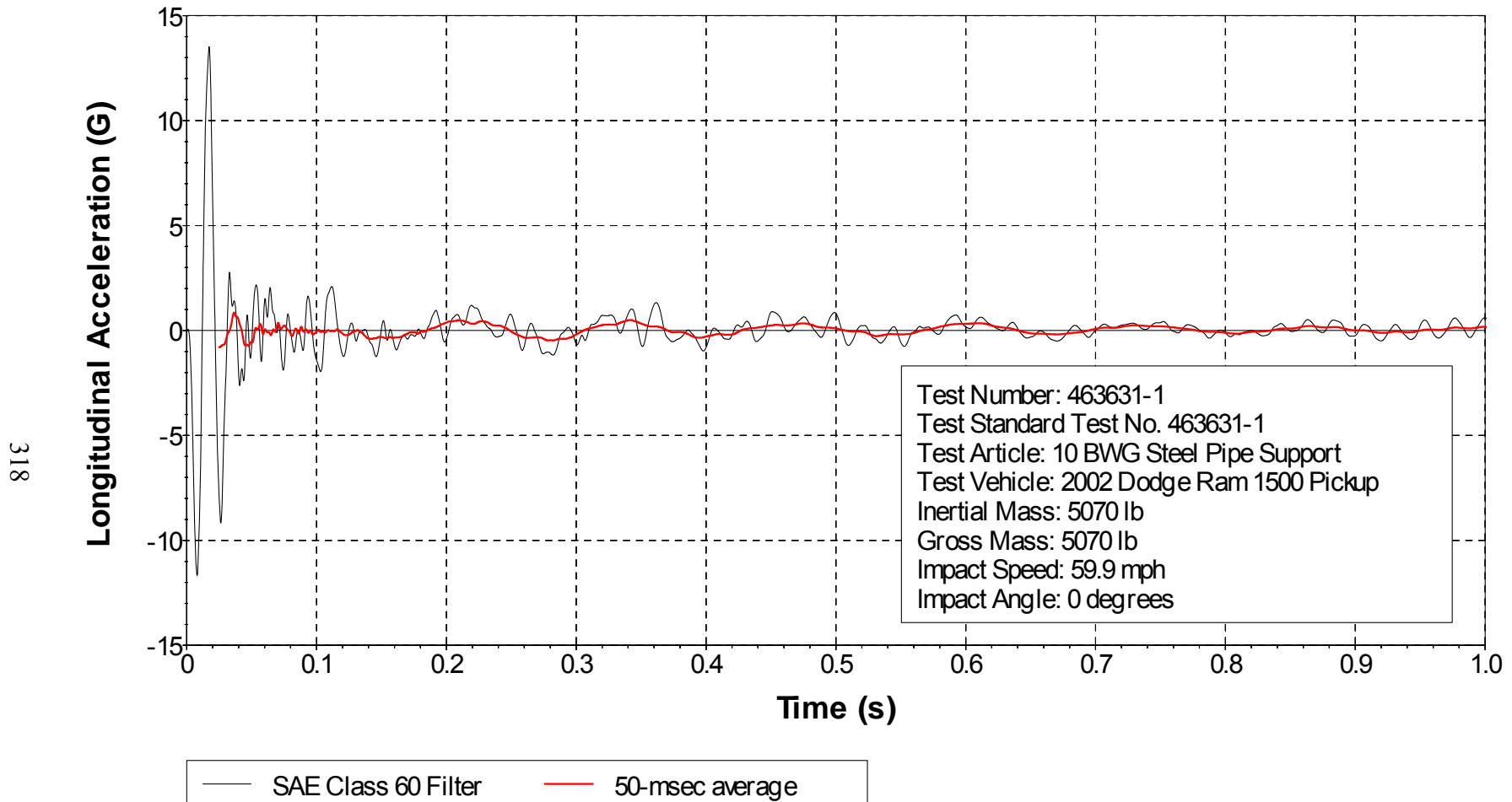
Z Acceleration at CG

317



**Figure H6. Vehicle Vertical Accelerometer Trace for Test No. 463631-1
(Accelerometer Located at Center of Gravity).**

X Acceleration over Rear Axle



**Figure H7. Vehicle Longitudinal Accelerometer Trace for Test No. 463631-1
(Accelerometer Located over Rear Axle).**

Y Acceleration over Rear Axle

319

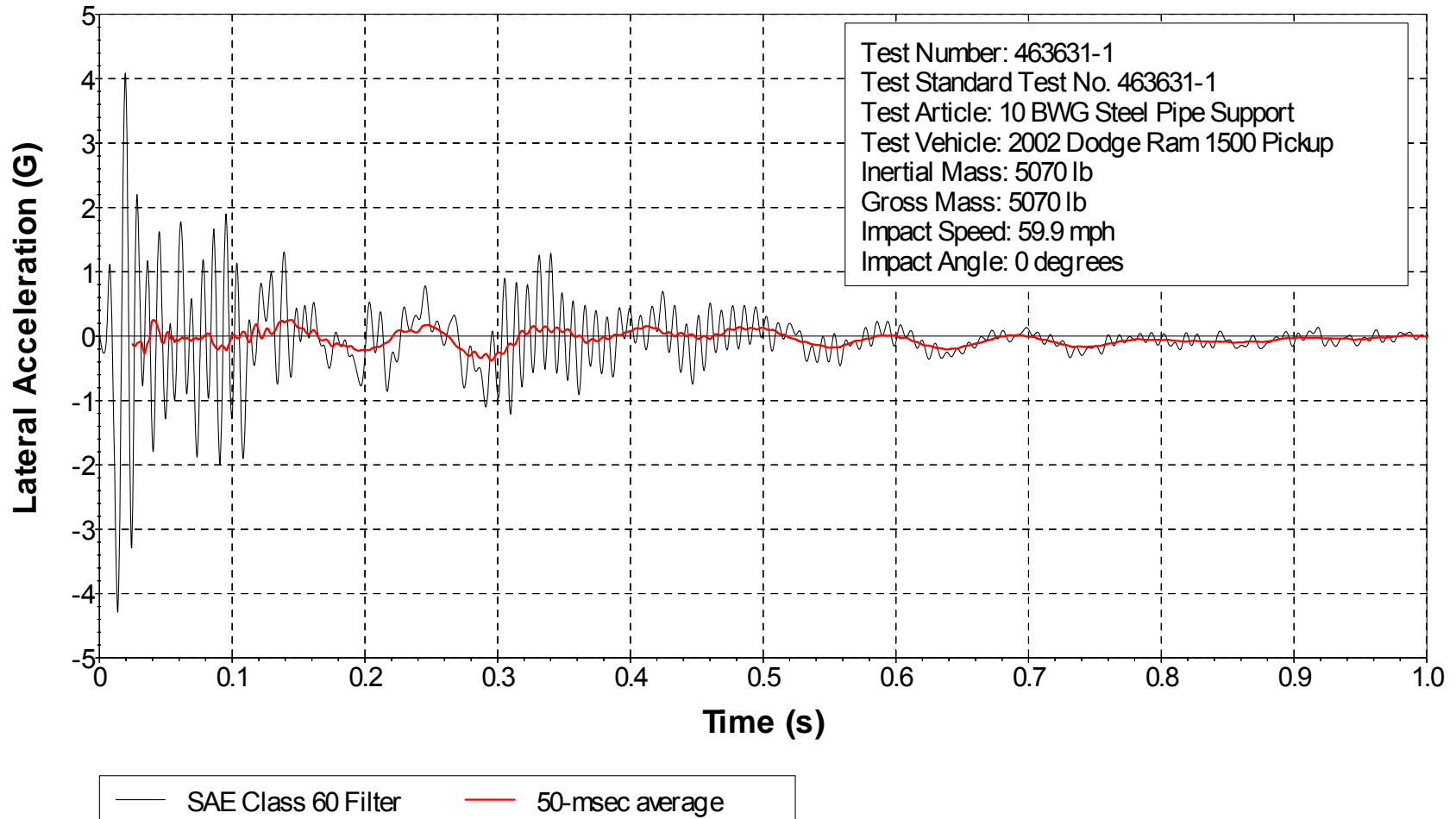


Figure H8. Vehicle Lateral Accelerometer Trace for Test No. 463631-1 (Accelerometer Located over Rear Axle).

Z Acceleration over Rear Axle

320

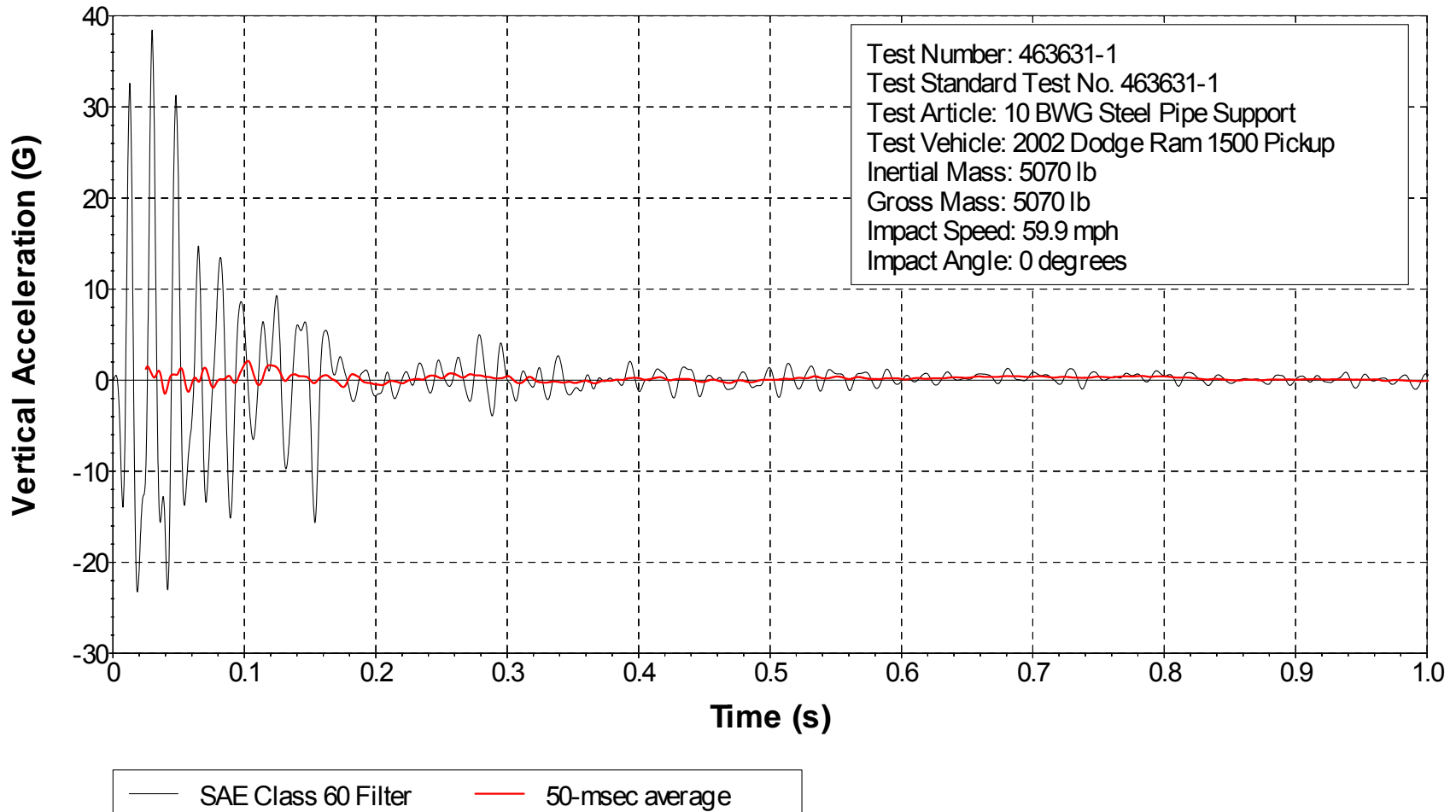


Figure H9. Vehicle Vertical Accelerometer Trace for Test No. 463631-1 (Accelerometer Located over Rear Axle).

APPENDIX I. CRASH TEST NO. 463631-2

Table II. Vehicle Properties for Test No. 463631-2.

Date: 2011-06-24 Test No.: 463631-2 VIN No.: KNADC125636273420

Year: 2003 Make: Kia Model: Rio

Tire Inflation Pressure: 29 psi Odometer: 105084 Tire Size: 175/65R14

Describe any damage to the vehicle prior to test: _____

Denotes accelerometer location.

NOTE: _____

Engine Type: 4 cylinder

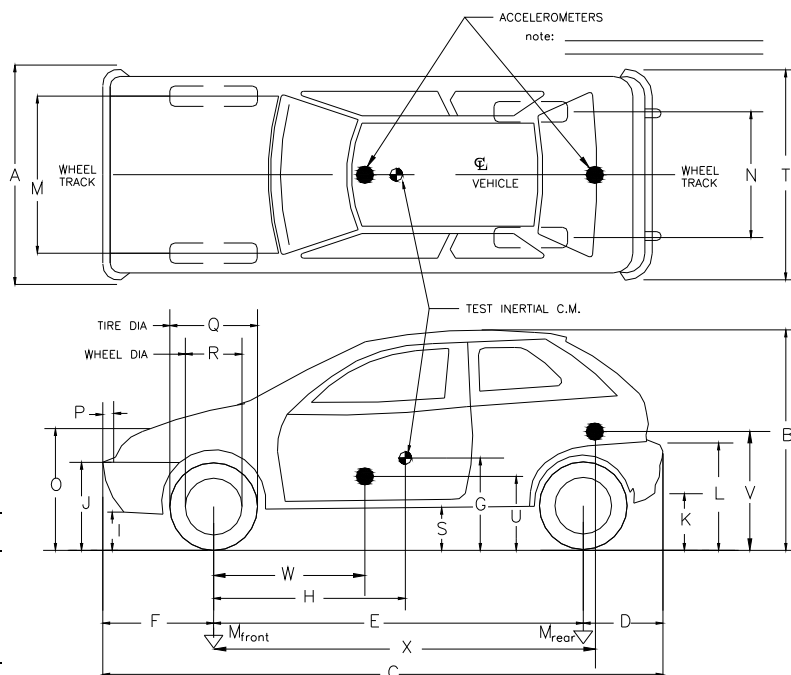
Engine CID: 16. liter

Transmission Type:

 Auto or x Manual

 x FWD RWD 4WD

Optional Equipment: _____



Dummy Data:

Type: 50th percentile male

Mass: 166 lb

Seat Position: Driver

Geometry: Inches

| | | | | | | | | | |
|---|---------------|---|--------------|---|--------------|---|--------------|---|---------------|
| A | <u>62.50</u> | F | <u>32.00</u> | K | <u>12.00</u> | P | <u>3.25</u> | U | <u>15.50</u> |
| B | <u>56.12</u> | G | <u> </u> | L | <u>24.25</u> | Q | <u>22.50</u> | V | <u>21.50</u> |
| C | <u>164.12</u> | H | <u>34.70</u> | M | <u>56.50</u> | R | <u>15.50</u> | W | <u>35.50</u> |
| D | <u>37.00</u> | I | <u>8.50</u> | N | <u>57.00</u> | S | <u>8.62</u> | X | <u>106.00</u> |
| E | <u>95.25</u> | J | <u>22.75</u> | O | <u>28.00</u> | T | <u>63.00</u> | | |

Wheel Center Ht Front 10.75 Wheel Center Ht Rear 11.125

| GVWR Ratings: | Mass: lb | Curb | Test Inertial | Gross Static |
|---------------|-------------|-------------------------|-------------------------|-------------------------|
| Front | <u>1808</u> | M_{front} <u>1490</u> | <u>1544</u> Allowable | <u>1619</u> Allowable |
| Back | <u>1742</u> | M_{rear} <u>894</u> | <u>885</u> Range= | <u>976</u> Range = |
| Total | <u>3315</u> | M_{Total} <u>2384</u> | <u>2429</u> 2420 ±55 lb | <u>2595</u> 2585 ±55 lb |

Mass Distribution: lb LF: 782 RF: 762 LR: 424 RR: 461

Table I2. Exterior Crush Measurements for Test No. 463631-2.

Date: 2011-06-24 Test No.: 463631-2 VIN No.: KNADC125636273420
 Year: 2003 Make: Kia Model: Rio

VEHICLE CRUSH MEASUREMENT SHEET¹

| | |
|---|---|
| Complete When Applicable | |
| End Damage | Side Damage |
| Undeformed end width _____ Corner shift: A1 _____ A2 _____ End shift at frame (CDC) (check one) < 4 inches _____ ≥ 4 inches _____ | Bowing: B1 _____ X1 _____ B2 _____ X2 _____ Bowing constant $\frac{X1 + X2}{2} = \underline{\hspace{2cm}}$ |

Note: Measure C₁ to C₆ from Driver to Passenger side in Front or Rear impacts – Rear to Front in Side Impacts.

| Specific Impact Number | Plane* of C-Measurements | Direct Damage | | Field L** | C ₁ | C ₂ | C ₃ | C ₄ | C ₅ | C ₆ | ±D |
|------------------------|--------------------------|---------------|--------------|-----------|----------------|----------------|----------------|----------------|----------------|----------------|-----|
| | | Width** (CDC) | Max*** Crush | | | | | | | | |
| 1 | Front plane at bumper ht | 3 | 1.5 | 5 | --- | --- | --- | --- | --- | --- | -14 |
| | | | | | | | | | | | |
| | | | | | | | | | | | |
| | Measurements recorded | | | | | | | | | | |
| | in inches | | | | | | | | | | |
| | | | | | | | | | | | |

¹Table taken from National Accident Sampling System (NASS).

*Identify the plane at which the C-measurements are taken (e.g., at bumper, above bumper, at sill, above sill, at beltline) or label adjustments (e.g., free space).

Free space value is defined as the distance between the baseline and the original body contour taken at the individual C locations. This may include the following: bumper lead, bumper taper, side protrusion, side taper, etc. Record the value for each C-measurement and maximum crush.

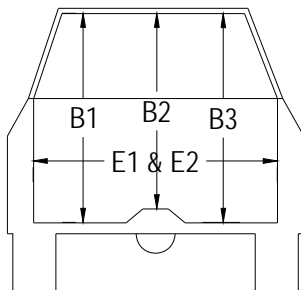
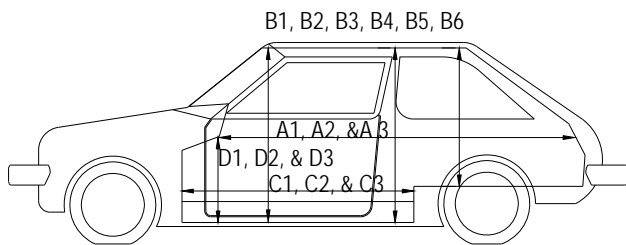
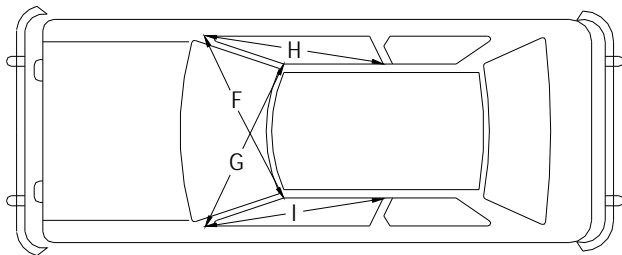
**Measure and document on the vehicle diagram the beginning or end of the direct damage width and field L (e.g., side damage with respect to undamaged axle).

***Measure and document on the vehicle diagram the location of the maximum crush.

Note: Use as many lines/columns as necessary to describe each damage profile.

Table I3. Occupant Compartment Measurements for Test No. 463631-2.

Date: 2011-06-24 Test No.: 463631-2 VIN No.: KNADC125636273420
 Year: 2003 Make: Kia Model: Rio



OCCUPANT COMPARTMENT DEFORMATION MEASUREMENT

| | Before (inches) | After (inches) |
|----|----------------------|---------------------|
| A1 | <u>66.50</u> | <u>66.50</u> |
| A2 | <u>67.00</u> | <u>67.00</u> |
| A3 | <u>66.50</u> | <u>66.50</u> |
| B1 | <u>39.00</u> | <u>39.00</u> |
| B2 | <u>36.00</u> | <u>36.00</u> |
| B3 | <u>39.00</u> | <u>39.00</u> |
| B4 | <u>33.25</u> | <u>32.50</u> |
| B5 | <u>34.75</u> | <u>30.00</u> |
| B6 | <u>33.25</u> | <u>32.00</u> |
| C1 | <u>50.75</u> | <u>50.75</u> |
| C2 | <u>39.12</u> | <u>39.12</u> |
| C3 | <u>51.25</u> | <u>51.25</u> |
| D1 | <u>9.00</u> | <u>9.00</u> |
| D2 | <u>6.50</u> | <u>6.50</u> |
| D3 | <u>8.50</u> | <u>8.50</u> |
| E1 | <u>50.25</u> | <u>50.25</u> |
| E2 | <u>50.00</u> | <u>50.00</u> |
| F | <u>47.50</u> | <u>47.50</u> |
| G | <u>47.50</u> | <u>47.50</u> |
| H | <u>35.50</u> | <u>35.50</u> |
| I | <u>35.50</u> | <u>35.50</u> |
| J* | <u>49.75</u> | <u>49.75</u> |

*Lateral area across the cab from driver's side kickpanel to passenger's side kickpanel.



0.000 s



0.029 s



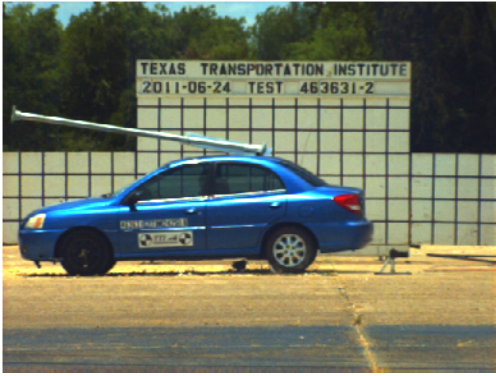
0.058 s



0.087 s



Figure II. Sequential Photographs for Test No. 463631-2 (Perpendicular and Oblique Views).



0.116 s



0.145 s



0.174 s

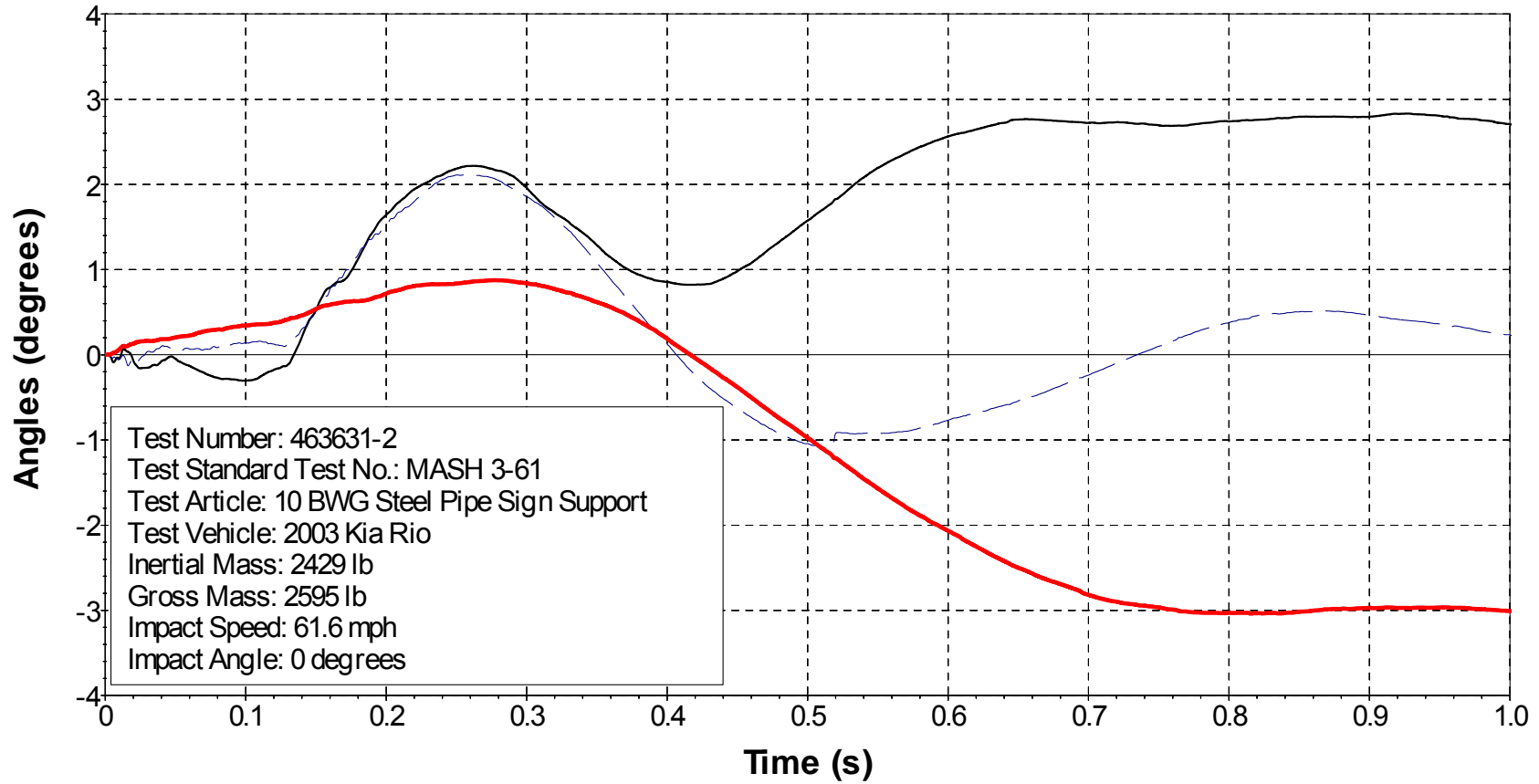


0.203 s



Figure I1. Sequential Photographs for Test No. 463631-2 (Perpendicular and Oblique Views) (continued).

Roll, Pitch, and Yaw Angles



— Roll — Pitch — Yaw

Axes are vehicle-fixed. Sequence for determining orientation:
 Yaw.

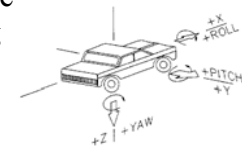


Figure I2. Vehicle Angular Displacements for Test No. 463631-2.

X Acceleration at CG

327

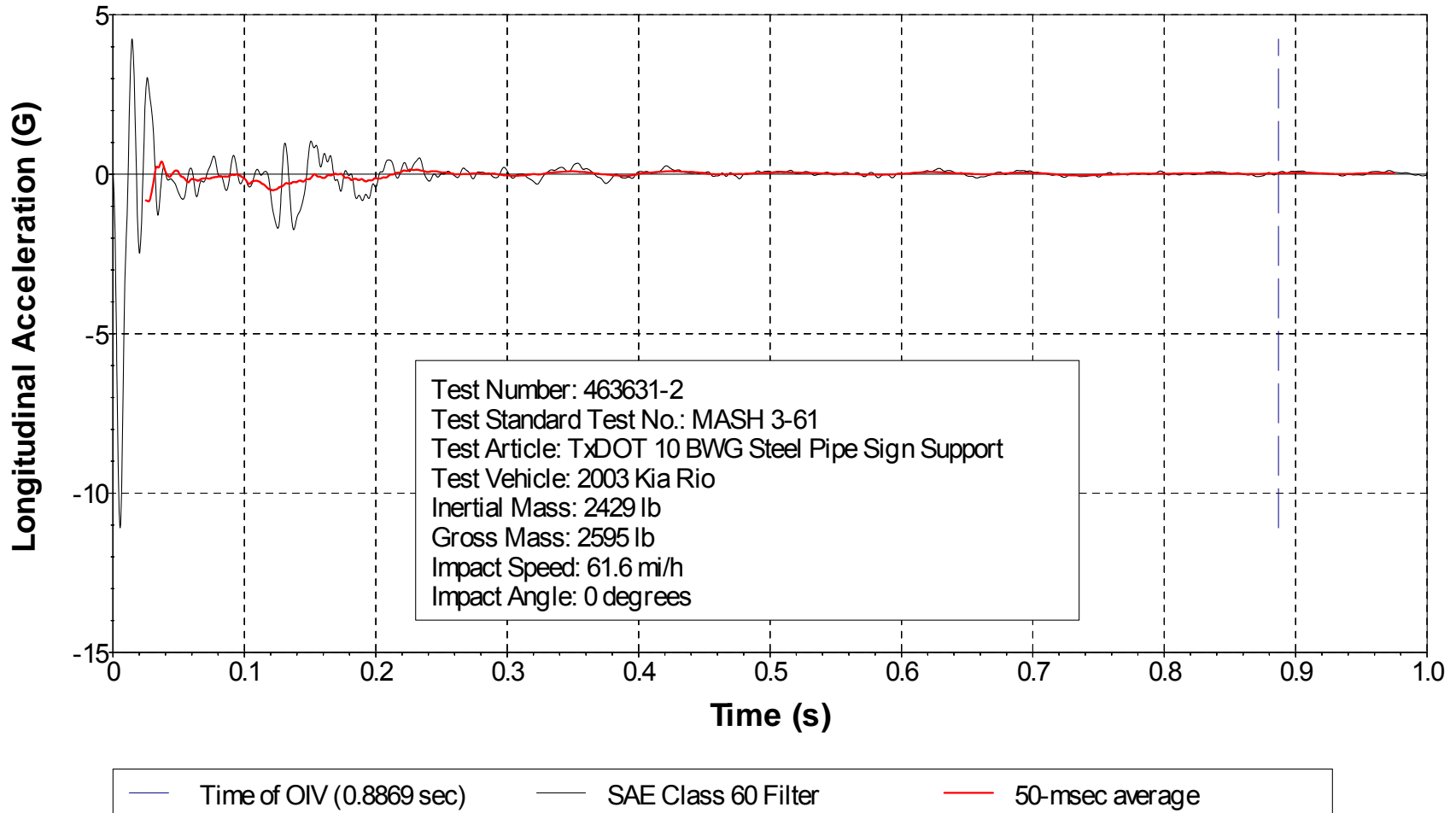


Figure I3. Vehicle Longitudinal Accelerometer Trace for Test No. 463631-2 (Accelerometer Located at Center of Gravity).

Y Acceleration at CG

328

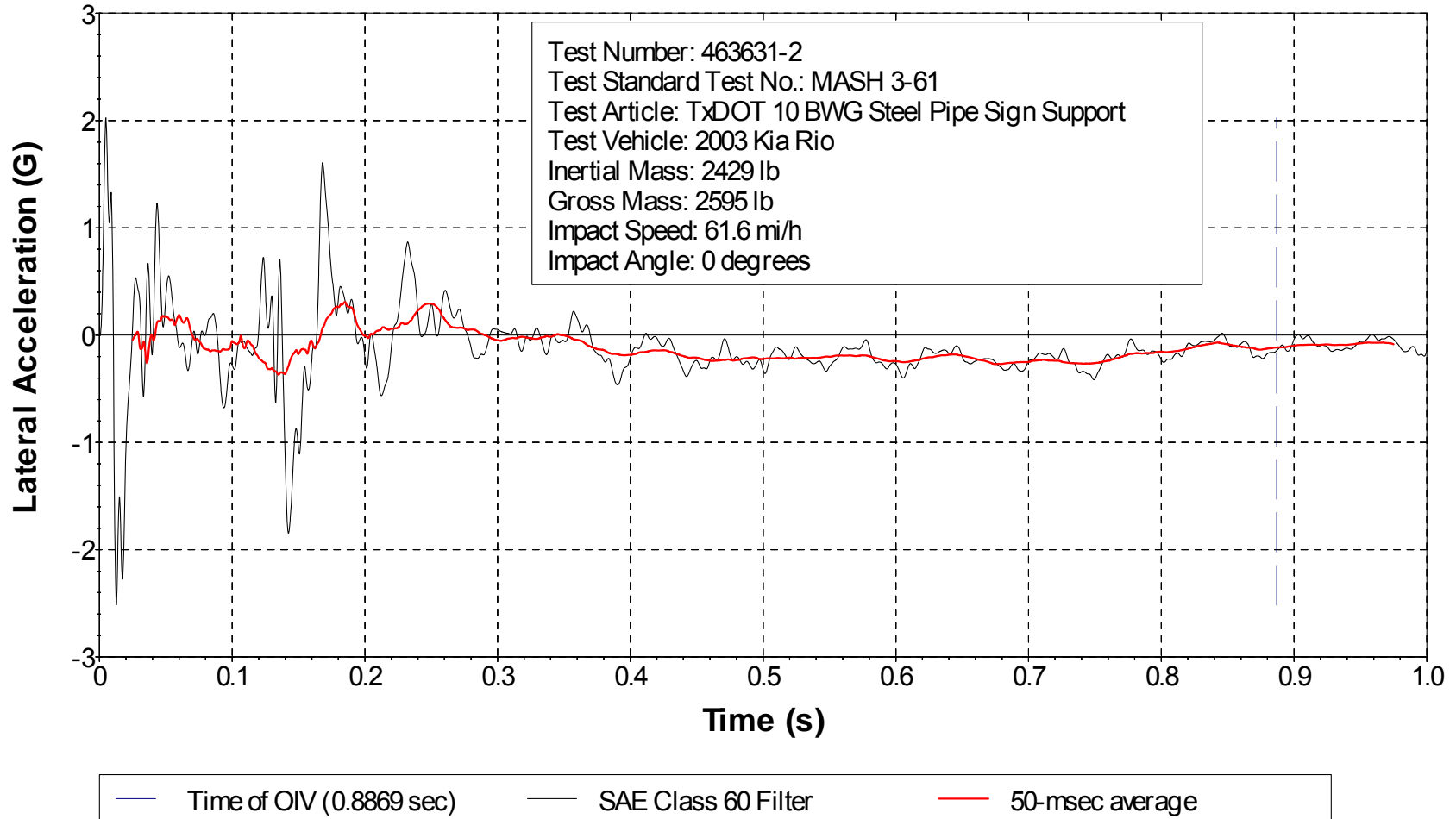
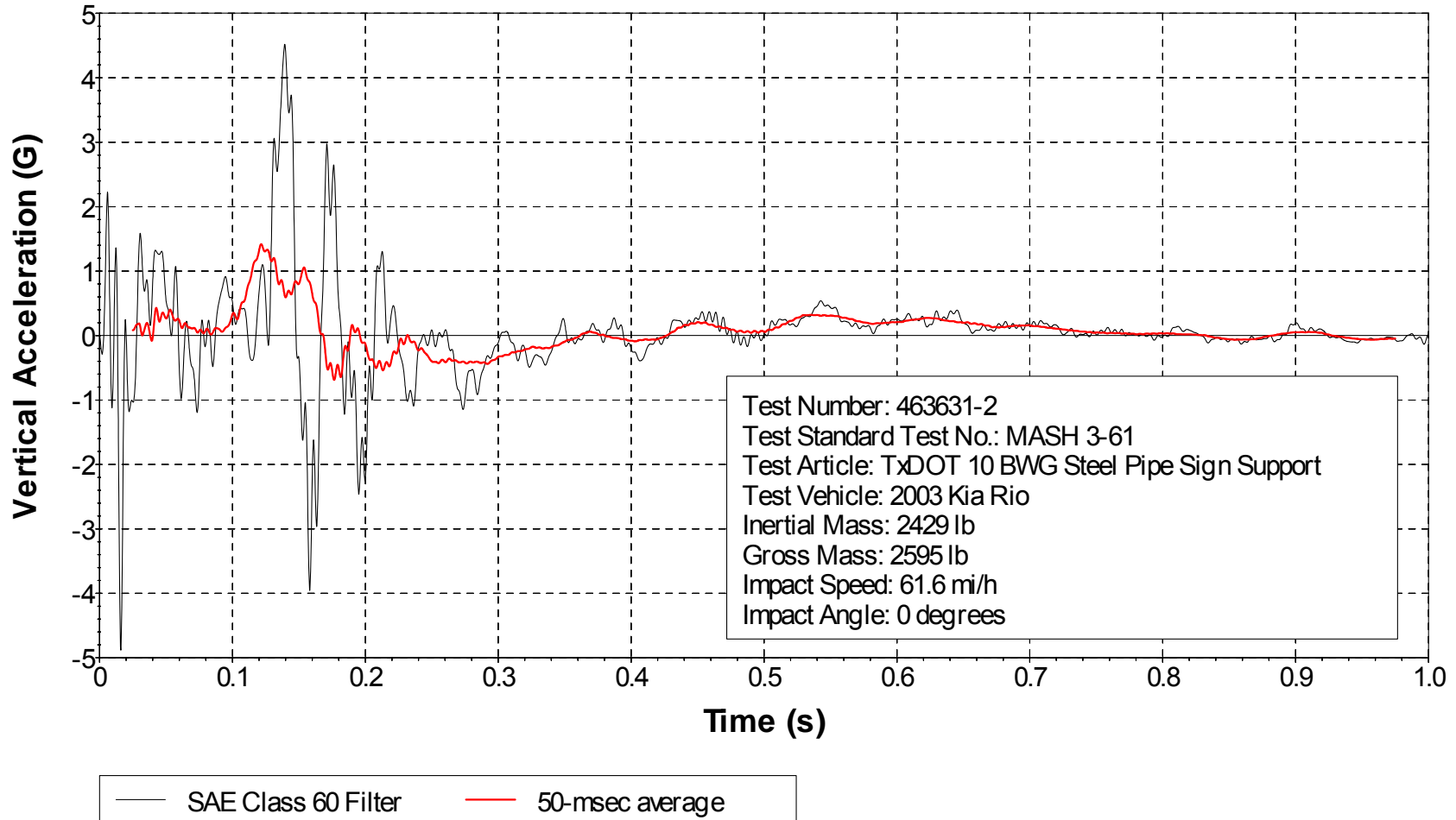


Figure I4. Vehicle Lateral Accelerometer Trace for Test No. 463631-2 (Accelerometer Located at Center of Gravity).

Z Acceleration at CG

329



**Figure I5. Vehicle Vertical Accelerometer Trace for Test No. 463631-2
(Accelerometer Located at Center of Gravity).**

X Acceleration over Rear Axle

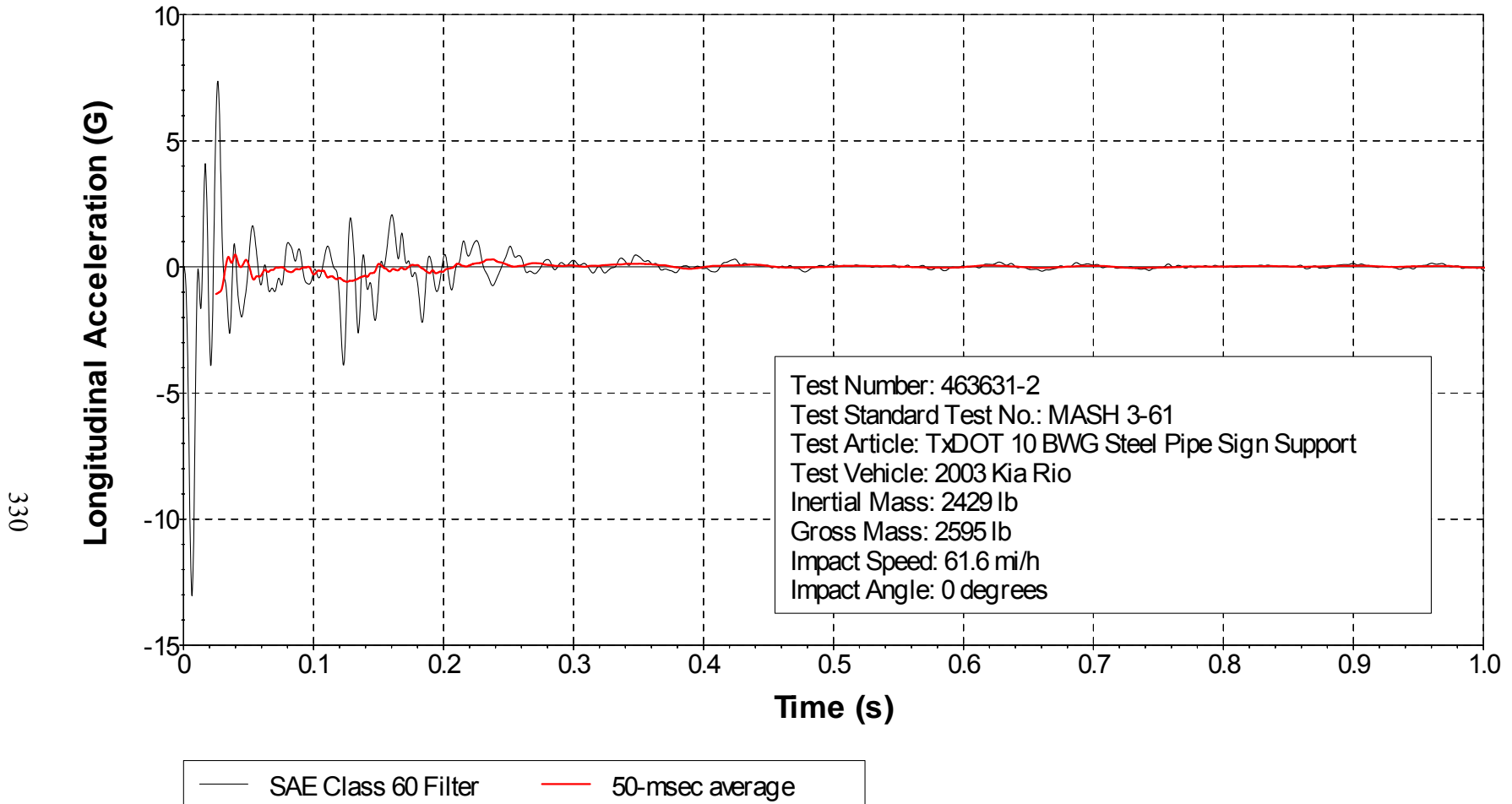
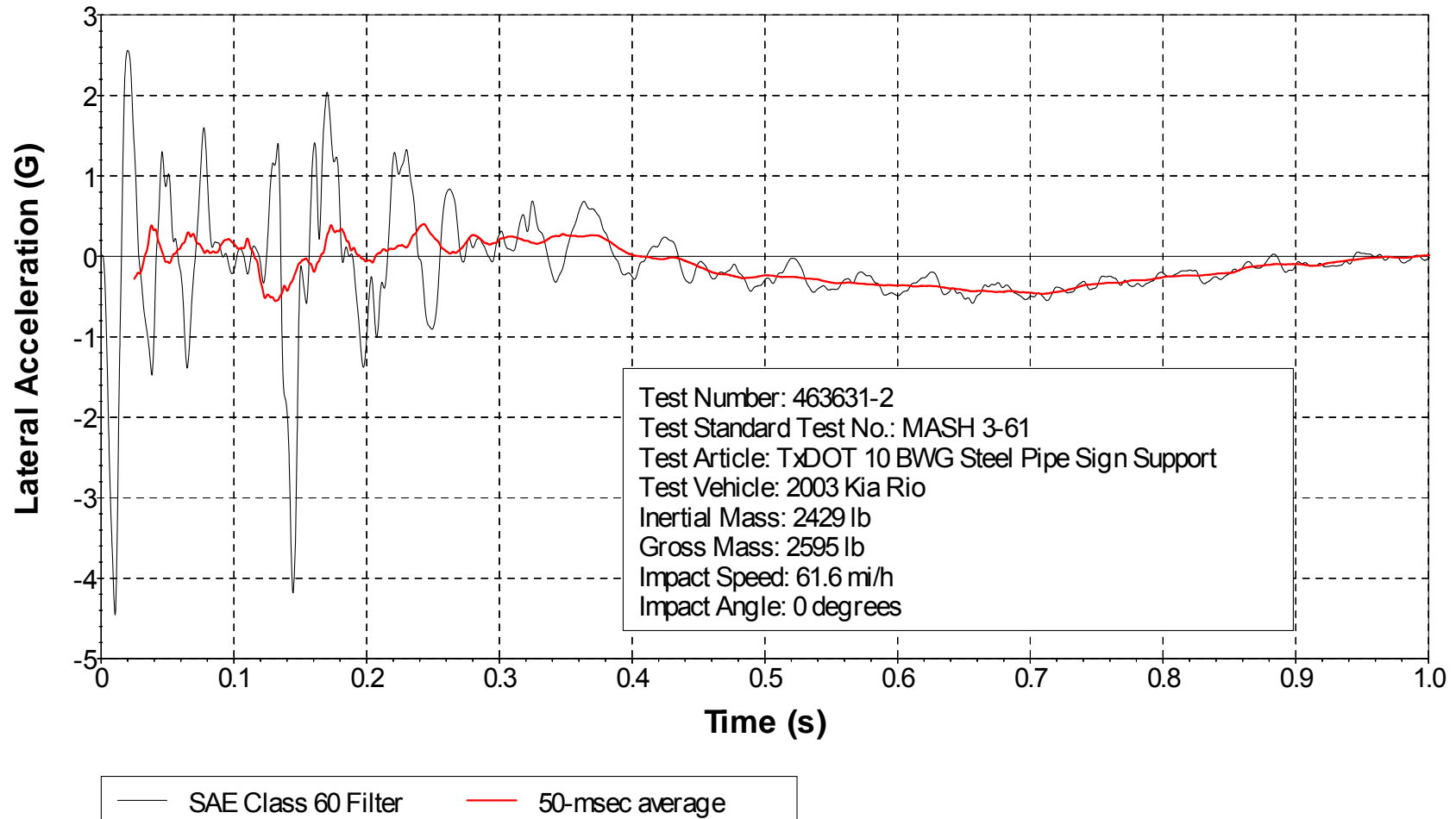


Figure I6. Vehicle Longitudinal Accelerometer Trace for Test No. 463631-2 (Accelerometer Located over Rear Axle).

Y Acceleration over Rear Axle



**Figure I7. Vehicle Lateral Accelerometer Trace for Test No. 463631-2
(Accelerometer Located over Rear Axle).**

Z Acceleration over Rear Axle

332

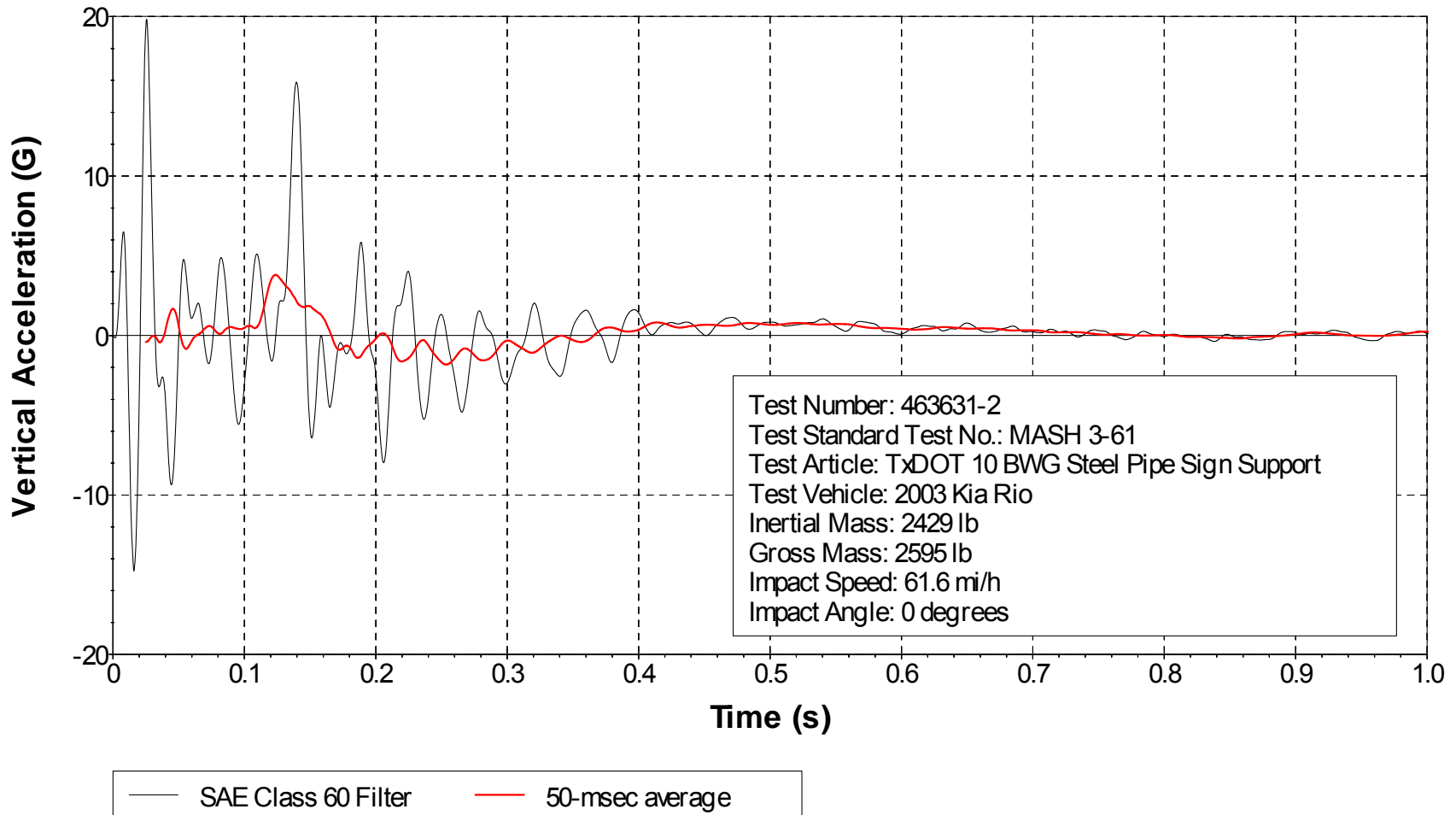


Figure I8. Vehicle Vertical Accelerometer Trace for Test No. 463631-2 (Accelerometer Located over Rear Axle).

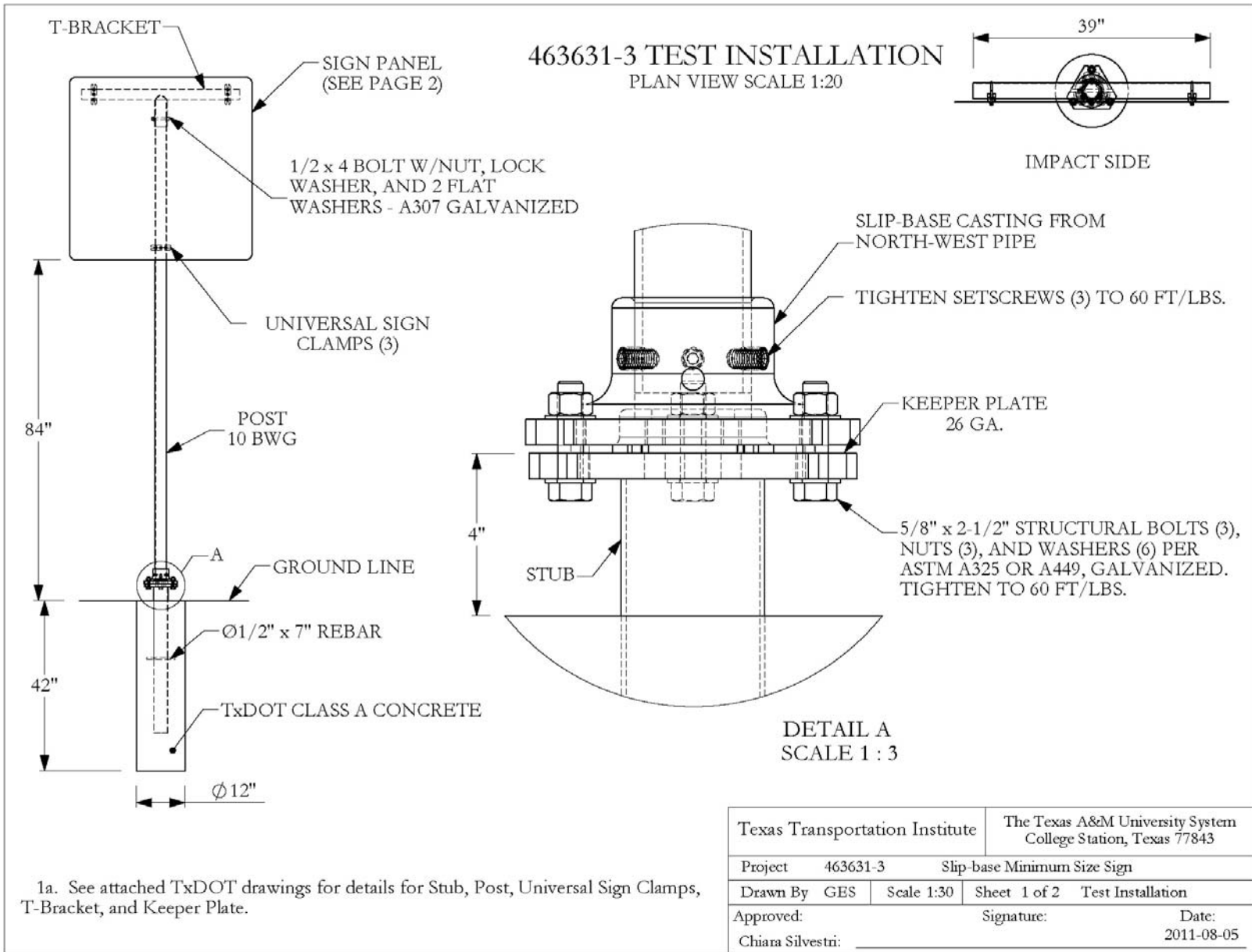
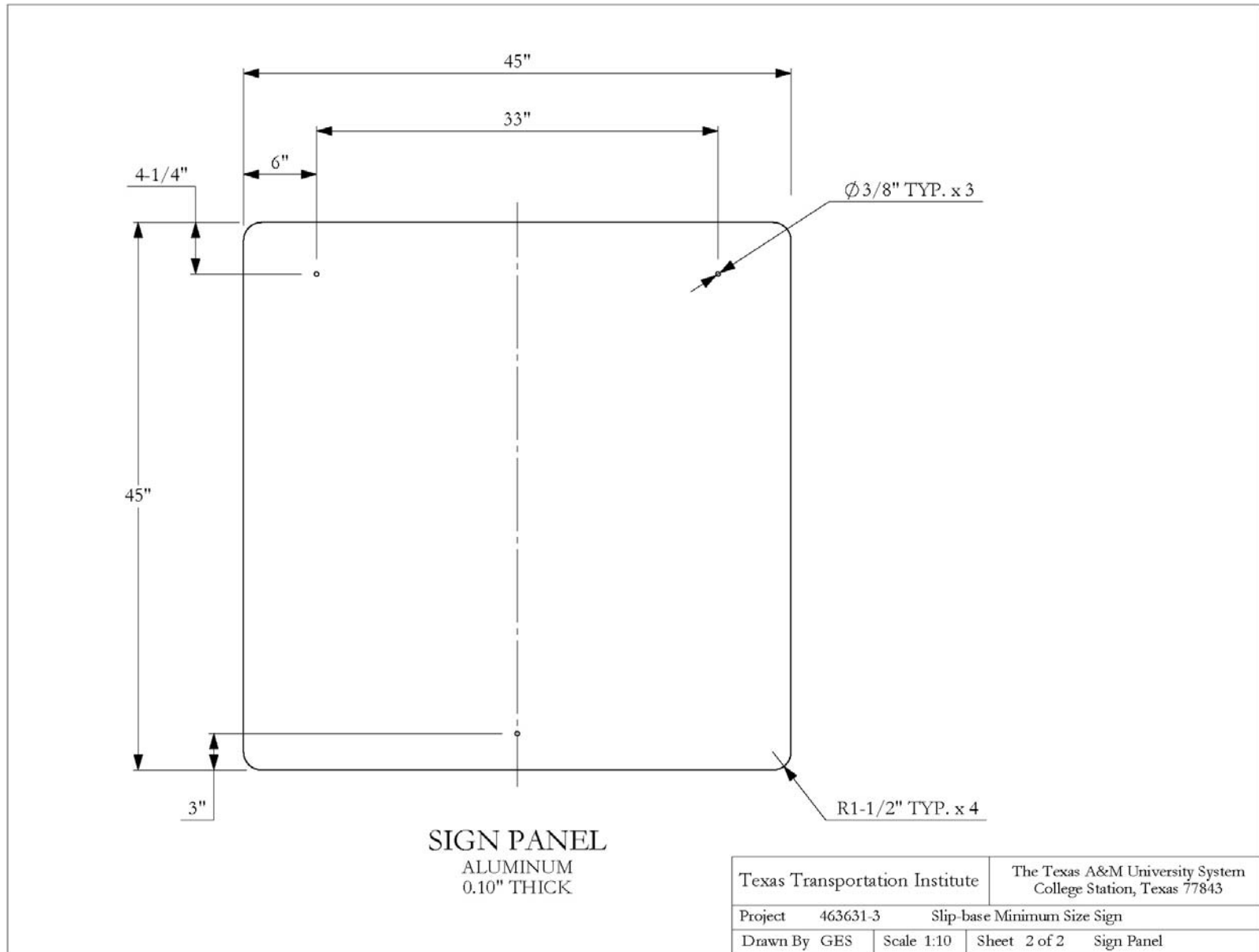
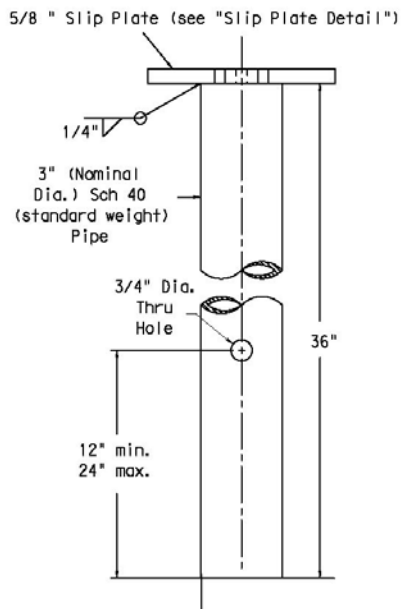


Figure J1. Details of the 10 BWG Steel Support with 14 ft² Sign.



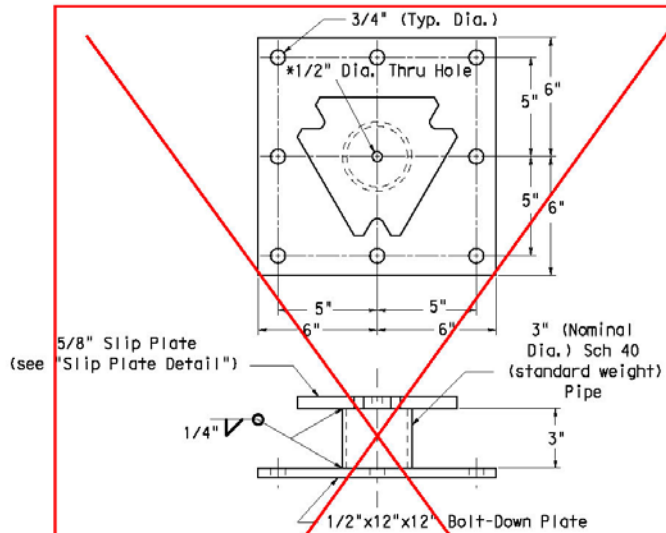
T:\2010-2011\463631-TXDOT\Test 3\Drafting\463631-3 Drawing

Figure J1. Details of the 10 BWG Steel Support with 14 ft² Sign (Continued).



Pipe shall conform to ASTM A53 Gr B, A500 Gr B, or A501. Galvanize according to ASTM A123 after all fabrication is completed. Finished components shall be permanently marked to indicate manufacturer. Method, design and location of markings are subject to the approval of the TxDOT Traffic Standards Engineer.

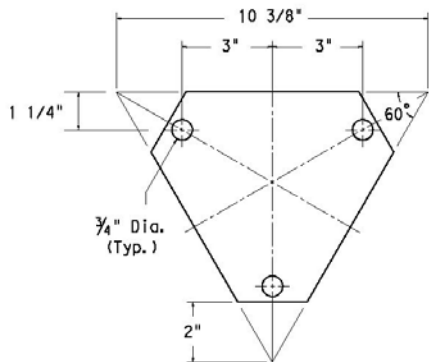
STUB



Pipe shall conform to ASTM A53 Gr B, A500 Gr B, or A501. Bolt-down plate shall conform to the same material requirements specified for the slip plate. Galvanize according to ASTM A123 after all fabrication is completed. Finished components shall be permanently marked to indicate manufacturer. Method, design and location of markings are subject to the approval of the TxDOT Traffic Standards Engineer.

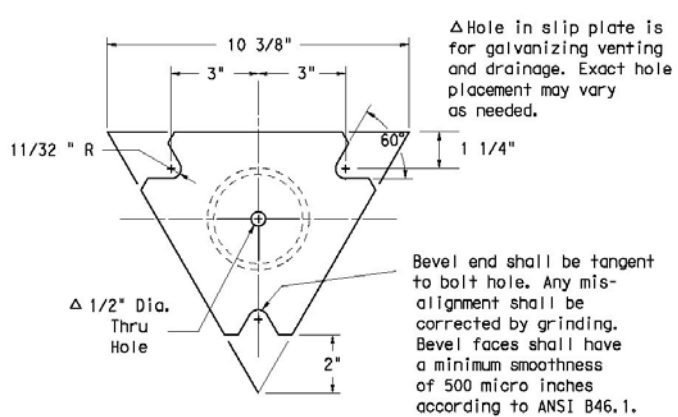
* Hole in slip plate and bolt-down plate is for galvanizing venting and drainage. Exact hole placement may vary as needed.

BOLT-DOWN ANCHOR



Bolt Keeper Plate shall be manufactured from 26 to 30 gauge galvanized sheet steel.

BOLT KEEPER PLATE

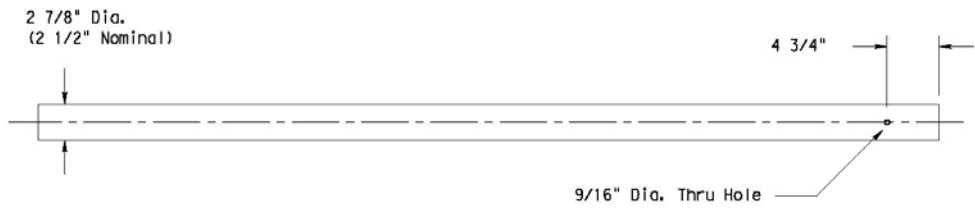
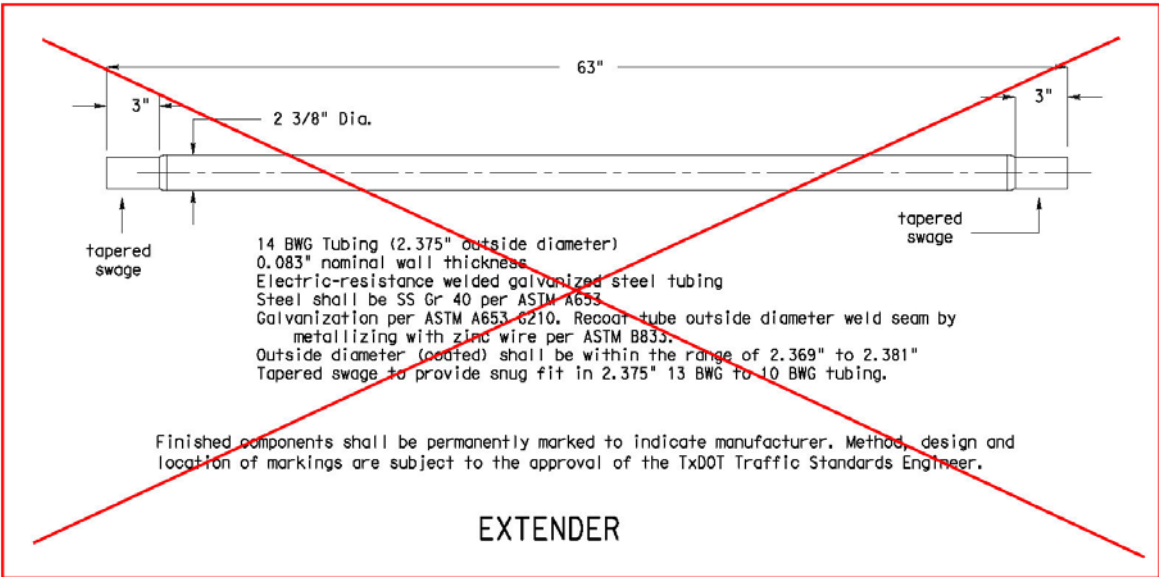


Slip plate shall conform to ASTM A36 or A572.

SLIP PLATE DETAIL

11.25.02

Figure J1. Details of the 10 BWG Steel Support with 14 ft² Sign (Continued).



10 BWG Tubing (2.875" outside diameter)

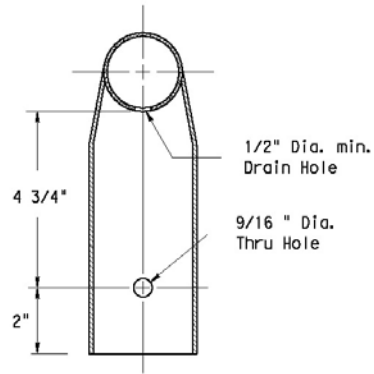
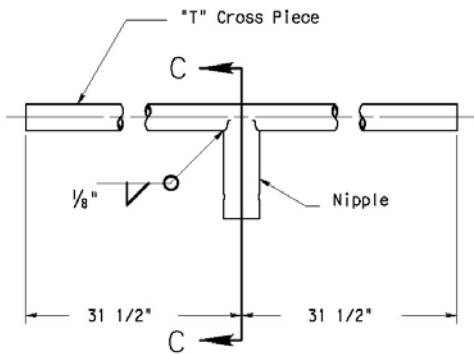
0.134" nominal wall thickness
 Seamless or electric-resistance welded steel tubing or pipe
 Steel shall be HSLAS Gr 55 per ASTM A1011 or ASTM A1008
 Other steels may be used if they meet the following:
 55,000 PSI minimum yield strength
 70,000 PSI minimum tensile strength
 20% minimum elongation in 2"
 Wall thickness (uncoated) shall be within the range of 0.122" to 0.138"
 Outside diameter (uncoated) shall be within the range of 2.867" to 2.883"
 Galvanization per ASTM A123 or ASTM A653 G210. For pre-coated steel tubing (ASTM A653), recoat tube outside diameter weld seam by metallizing with zinc wire per ASTM B833.

Schedule 80 Pipe (2.875" outside diameter)

0.276" nominal wall thickness
 Steel tubing per ASTM A500 Gr C
 Other seamless or electric resistance welded steel tubing or pipe with equivalent outside diameter and wall thickness may be used if they meet the following:
 46,000 PSI minimum yield strength
 62,000 PSI minimum tensile strength
 21% minimum elongation in 2"
 Wall thickness (uncoated) shall be within the range of 0.248" to 0.304"
 Outside diameter (uncoated) shall be within the range of 2.855" to 2.895"
 Galvanization per ASTM A123.

POST

Figure J1. Details of the 10 BWG Steel Support with 14 ft² Sign (Continued).



Section C-C

"T" CROSS PIECE

13 BWG Tubing (2.375" outside diameter)
 0.095" nominal wall thickness
 Seamless or electric-resistance welded steel tubing
 Steel shall be HSLAS Gr 55 per ASTM A1011 or ASTM A1008
 Other steels may be used if they meet the following:
 55,000 PSI minimum yield strength
 70,000 PSI minimum tensile strength
 18% minimum elongation in 2"
 Wall thickness (uncoated) shall be within the range of 0.085" to 0.105"
 Outside diameter (uncoated) shall be within the range of 2.355" to 2.395"

NIPPLE

11 BWG or greater Tubing (3.25" outside diameter)
 Seamless or electric-resistance welded steel tubing
 Steel shall be HSLAS Gr 55 per ASTM A1011 or ASTM A1008
 Other steels may be used if they meet the following:
 55,000 PSI minimum yield strength
 70,000 PSI minimum tensile strength
 20% minimum elongation in 2"
 Outside diameter (uncoated) shall be within the range of 3.241" to 3.259"
 Inside diameter (uncoated) shall be a minimum of 2.93"
 Wall thickness shall be a minimum of 0.108"
 Cut length shall be 8.000" ± 0.250". Notched and coped to provide snug fit with cross piece.
 Drilled or punched as shown. Nipple shall provide snug fit with 2.875" post.
 Nipple may be dimpled to provide snug fit.

FABRICATED "T" BRACKET

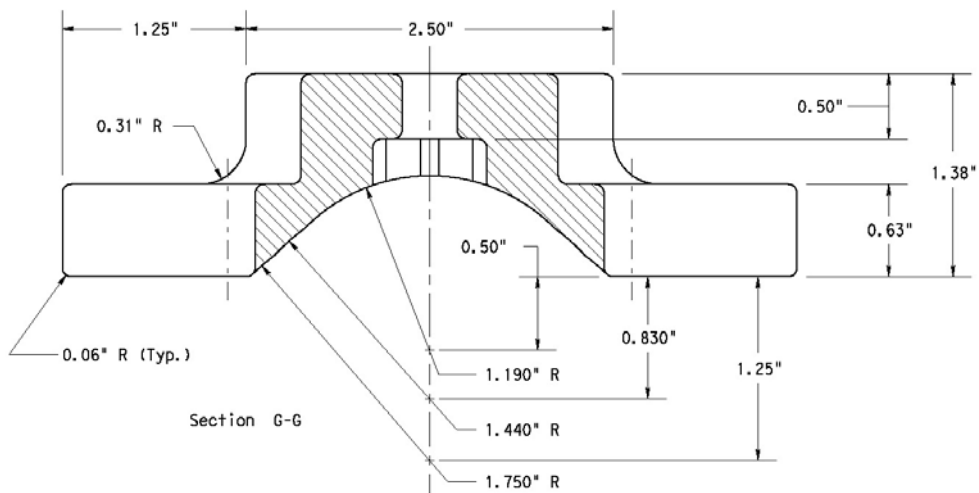
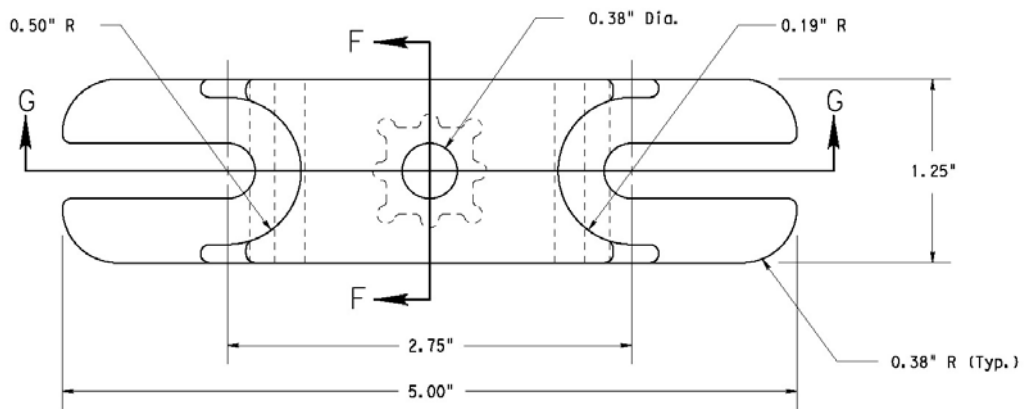
Galvanize according to ASTM A123 after all fabrication is completed.

Finished components shall be permanently marked to indicate manufacturer. Method, design and location of markings are subject to the approval of the TxDOT Traffic Standards Engineer.

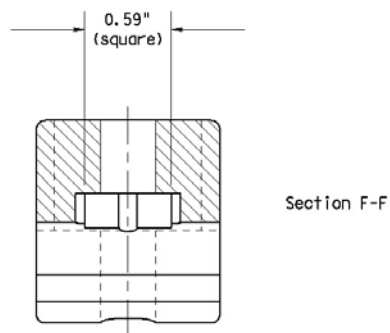
**PREFABRICATED "T" BRACKET-TEXAS UNIVERSAL
 TRIANGULAR SLIPBASE SYSTEM**

11.25.02

Figure J1. Details of the 10 BWG Steel Support with 14 ft² Sign (Continued).



UNLESS NOTED:
 X.XXX ± 0.005"
 X.XX ± 0.010"

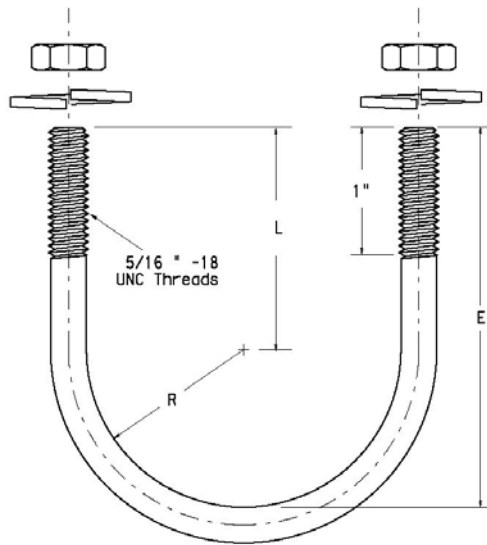


Sign clamp casting shall meet ASTM B85 Alloy 360.0 or A360.0, ASTM B26 Alloy 356.0-F, or ASTM B108 Alloy 356.0-F or A444.0-T4.

UNIVERSAL SIGN CLAMP

11.25.02

Figure J1. Details of the 10 BWG Steel Support with 14 ft² Sign (Continued).



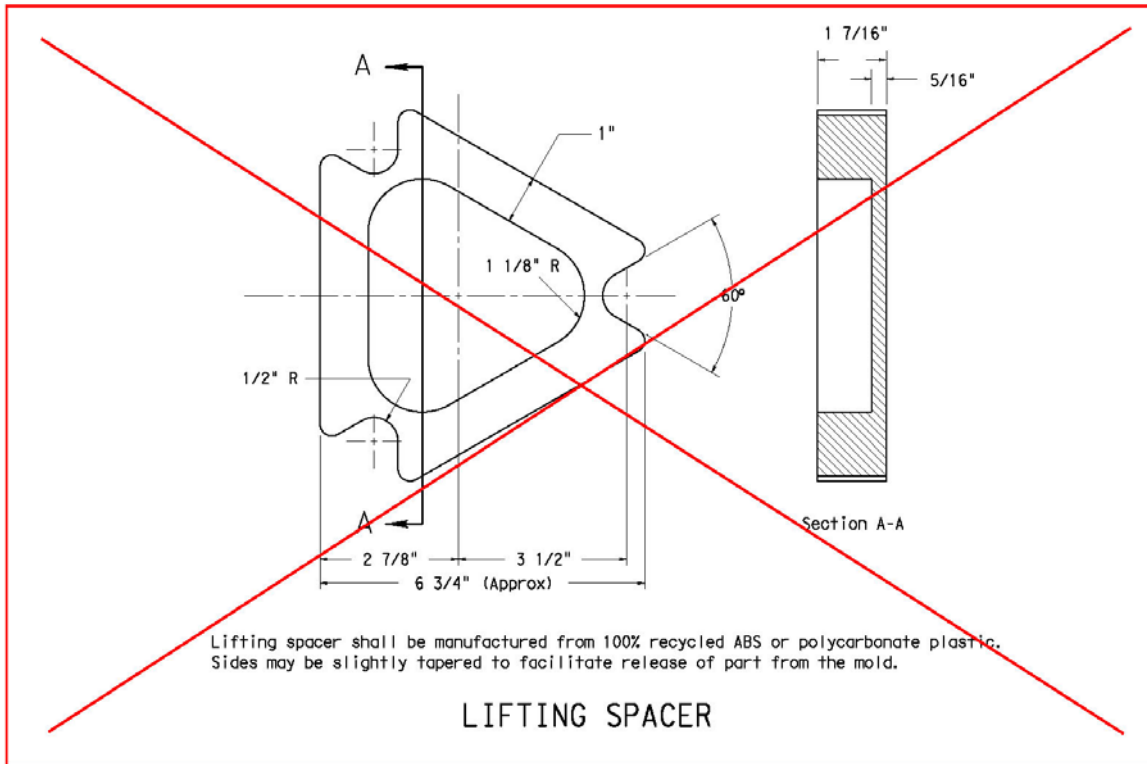
American National Standard Hex Nut and Helical Spring Lock Washer

U-bolt, nut and washers shall be manufactured according to ASTM A307 Grade C and galvanized according to Item 445, "Galvanizing."

9/32" diameter stock is permissible.

| Standard Pipe Size | R | L | E |
|--------------------|----------|----------|----------|
| 2" | 1 7/32" | 1 15/32" | 2 11/16" |
| 2 1/2" | 1 15/32" | 1 23/32" | 3 3/16" |
| 3" | 1 25/32" | 2 1/32" | 3 13/16" |

SIGN CLAMP U-BOLT



Lifting spacer shall be manufactured from 100% recycled ABS or polycarbonate plastic. Sides may be slightly tapered to facilitate release of part from the mold.

LIFTING SPACER

11.25.02

Figure J1. Details of the 10 BWG Steel Support with 14 ft² Sign (Continued).

Table J1. Vehicle Properties for Test No. 463631-3.

Date: 2011-08-17 Test No.: 463631-3 VIN No.: KNADC125446333969

Year: 2004 Make: Kia Model: Rio

Tire Inflation Pressure: 29 psi Odometer: 102650 Tire Size: 175/65R14

Describe any damage to the vehicle prior to test: _____

Denotes accelerometer location.

NOTE: _____

Engine Type: 4 cylinder

Engine CID: 16. liter

Transmission Type:

Auto or Manual

FW

D RWD 4WD

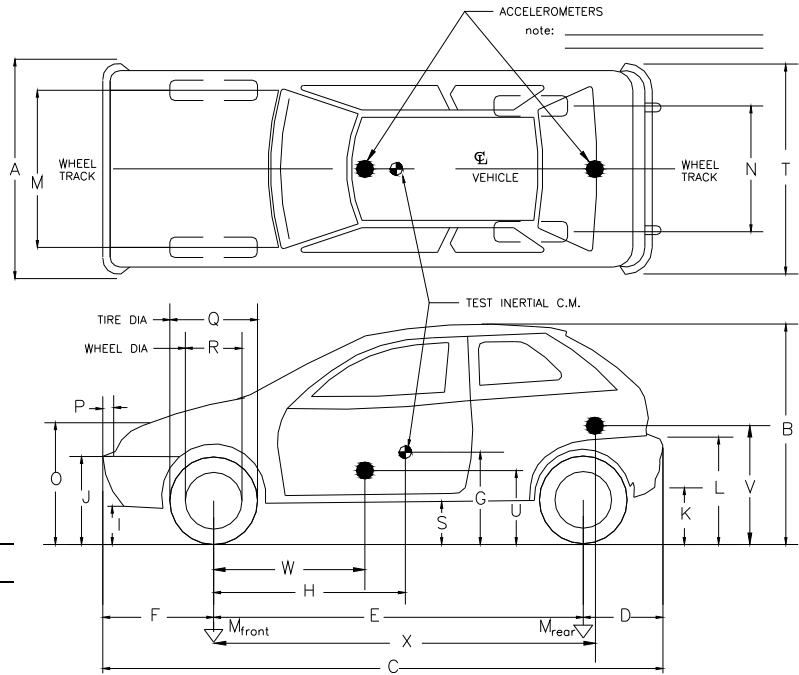
Optional Equipment: _____

Dummy Data:

Type: 50th percentile male

Mass: 175 lb

Seat Position: Driver



Geometry: Inches

| | | | | | | | | | |
|---|---------------|---|-------------------|---|--------------|---|--------------|---|---------------|
| A | <u>62.50</u> | F | <u>32.00</u> | K | <u>12.00</u> | P | <u>3.25</u> | U | <u>15.50</u> |
| B | <u>56.12</u> | G | <u> </u> | L | <u>24.25</u> | Q | <u>22.50</u> | V | <u>21.50</u> |
| C | <u>164.25</u> | H | <u>34.44</u> | M | <u>56.50</u> | R | <u>15.50</u> | W | <u>35.50</u> |
| D | <u>37.00</u> | I | <u>8.50</u> | N | <u>57.00</u> | S | <u>8.62</u> | X | <u>106.00</u> |
| E | <u>95.25</u> | J | <u>22.75</u> | O | <u>28.00</u> | T | <u>63.00</u> | | |

Wheel Center Ht Front 10.75 Wheel Center Ht Rear 11.125

| GVWR Ratings: | Mass: lb | Curb | Test Inertial | Gross Static |
|---------------|-------------|--------------------------|---------------|--------------|
| Front | <u>1691</u> | <u>M_{front}</u> | <u>1547</u> | <u>1636</u> |
| Back | <u>1559</u> | <u>M_{rear}</u> | <u>876</u> | <u>962</u> |
| Total | <u>3250</u> | <u>M_{Total}</u> | <u>2423</u> | <u>2598</u> |
| | | | 2420 ±55 lb | 2585 ±55 lb |

Mass Distribution: lb LF: 788 RF: 759 LR: 431 RR: 445

Table J2. Exterior Crush Measurements for Test No. 463631-3.

Date: 2011-08-17 Test No.: 463631-3 VIN No.: KNADC125446333969
 Year: 2004 Make: Kia Model: Rio

VEHICLE CRUSH MEASUREMENT SHEET¹

| | |
|---|---|
| Complete When Applicable | |
| End Damage | Side Damage |
| Undeformed end width _____ Corner shift: A1 _____ A2 _____ End shift at frame (CDC) (check one) < 4 inches _____ ≥ 4 inches _____ | Bowing: B1 _____ X1 _____ B2 _____ X2 _____ Bowing constant $\frac{X1 + X2}{2} = \underline{\hspace{2cm}}$ |

Note: Measure C₁ to C₆ from Driver to Passenger side in Front or Rear impacts – Rear to Front in Side Impacts.

| Specific Impact Number | Plane* of C-Measurements | Direct Damage | | Field L** | C ₁ | C ₂ | C ₃ | C ₄ | C ₅ | C ₆ | ±D |
|------------------------|--------------------------|---------------|--------------|-----------|----------------|----------------|----------------|----------------|----------------|----------------|-----|
| | | Width** (CDC) | Max*** Crush | | | | | | | | |
| 1 | Front plane at bumper ht | 3 | 2.5 | 8 | 1 | 2.5 | 1.--- | --- | --- | --- | --- |
| | | | | | | | | | | | |
| | Measurements recorded | | | | | | | | | | |
| | in inches | | | | | | | | | | |
| | | | | | | | | | | | |

¹Table taken from National Accident Sampling System (NASS).

*Identify the plane at which the C-measurements are taken (e.g., at bumper, above bumper, at sill, above sill, at beltline, etc.) or label adjustments (e.g., free space).

Free space value is defined as the distance between the baseline and the original body contour taken at the individual C locations. This may include the following: bumper lead, bumper taper, side protrusion, side taper, etc. Record the value for each C-measurement and maximum crush.

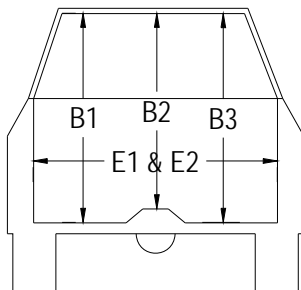
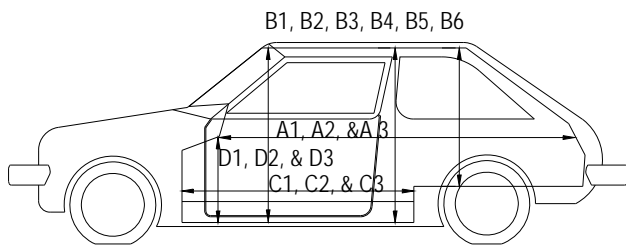
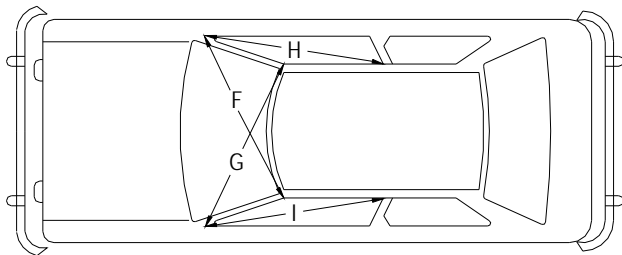
**Measure and document on the vehicle diagram the beginning or end of the direct damage width and field L (e.g., side damage with respect to undamaged axle).

***Measure and document on the vehicle diagram the location of the maximum crush.

Note: Use as many lines/columns as necessary to describe each damage profile.

Table J3. Occupant Compartment Measurements for Test No. 463631-3.

Date: 2011-08-17 Test No.: 463631-3 VIN No.: KNADC125446333969
 Year: 2004 Make: Kia Model: Rio



OCCUPANT COMPARTMENT DEFORMATION MEASUREMENT

| | Before (inches) | After (inches) |
|----|----------------------|---------------------|
| A1 | <u>67.00</u> | <u>67.00</u> |
| A2 | <u>65.25</u> | <u>65.25</u> |
| A3 | <u>67.25</u> | <u>67.25</u> |
| B1 | <u>39.75</u> | <u>39.75</u> |
| B2 | <u>35.50</u> | <u>35.50</u> |
| B3 | <u>39.75</u> | <u>39.75</u> |
| B4 | <u>30.50</u> | <u>30.50</u> |
| B5 | <u>31.00</u> | <u>29.00</u> |
| B6 | <u>30.50</u> | <u>28.00</u> |
| C1 | <u>26.50</u> | <u>26.50</u> |
| C2 | <u>----</u> | <u>----</u> |
| C3 | <u>26.50</u> | <u>26.50</u> |
| D1 | <u>9.75</u> | <u>9.75</u> |
| D2 | <u>----</u> | <u>----</u> |
| D3 | <u>9.25</u> | <u>9.25</u> |
| E1 | <u>48.75</u> | <u>48.75</u> |
| E2 | <u>50.50</u> | <u>50.50</u> |
| F | <u>49.00</u> | <u>49.00</u> |
| G | <u>49.00</u> | <u>49.00</u> |
| H | <u>36.50</u> | <u>36.50</u> |
| I | <u>36.50</u> | <u>36.50</u> |
| J* | <u>50.25</u> | <u>50.25</u> |

*Lateral area across the cab from driver's side kickpanel to passenger's side kickpanel.



0.000 s



0.029 s



0.058 s



0.087 s



Figure J2. Sequential Photographs for Test No. 463631-3 (Perpendicular and Oblique Views).



0.116 s



0.145 s



0.174 s

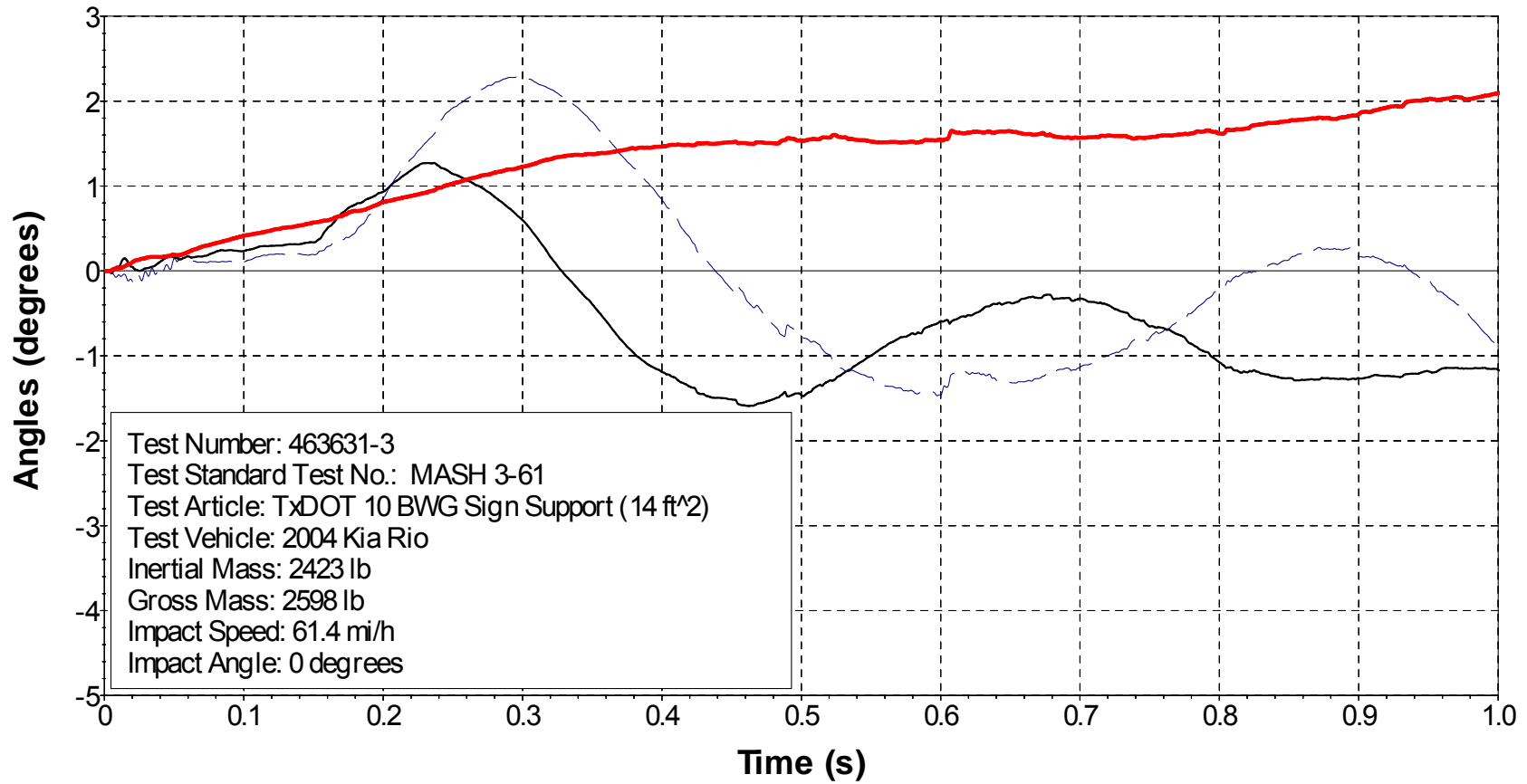


0.203 s



Figure J2. Sequential Photographs for Test No. 463631-3 (Perpendicular and Oblique Views) (continued).

Roll, Pitch, and Yaw Angles



— Roll — Pitch — Yaw

Axes are vehicle-fixed.
 Sequence for determining
 orientation:
 Yaw.
 Pitch.
 Roll.

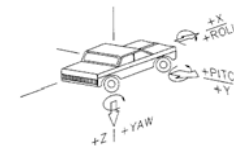


Figure J3. Vehicle Angular Displacements for Test No. 463631-3.

X Acceleration at CG

346

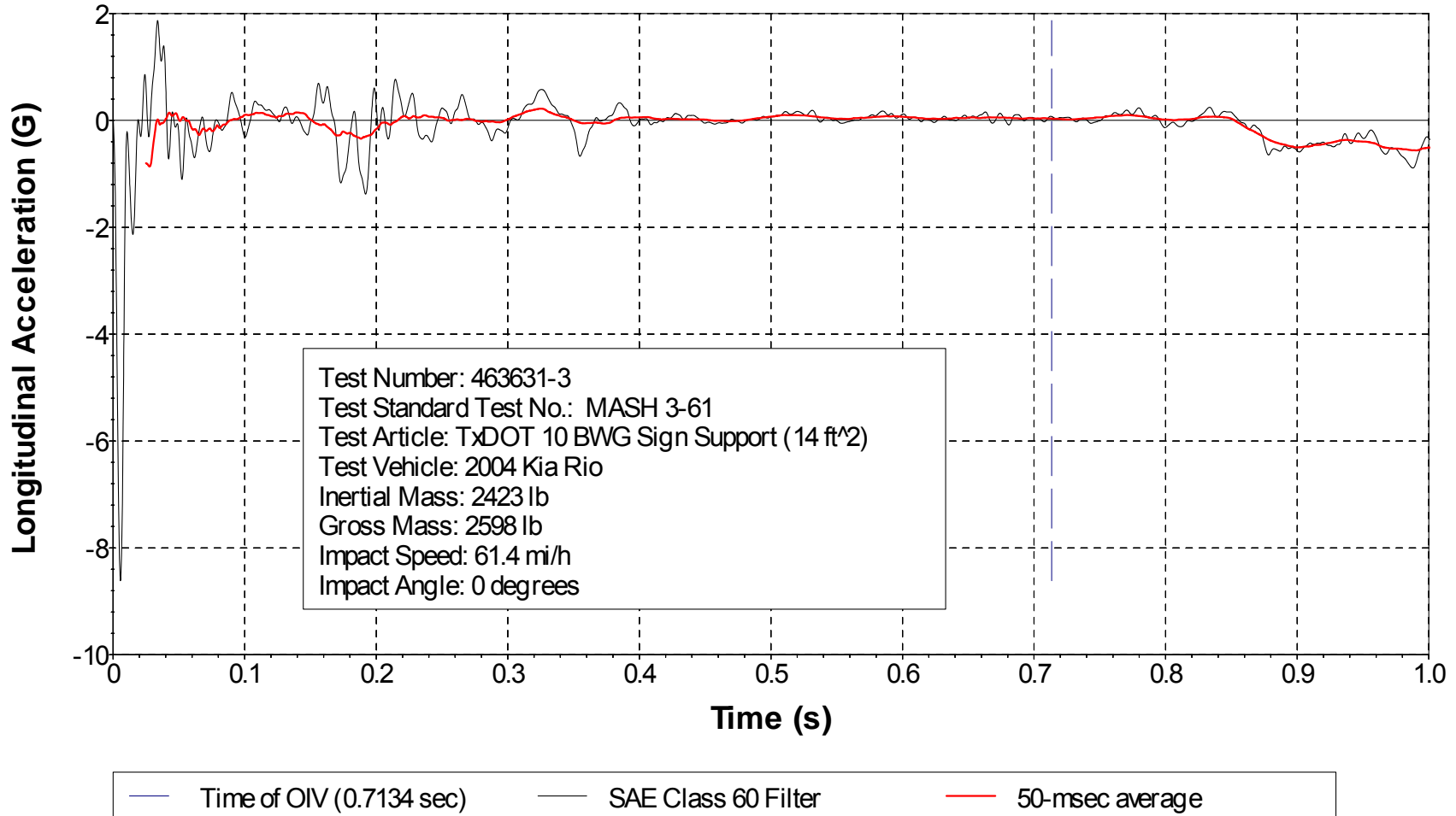


Figure J4. Vehicle Longitudinal Accelerometer Trace for Test No. 463631-3 (Accelerometer Located at Center of Gravity).

Y Acceleration at CG

347

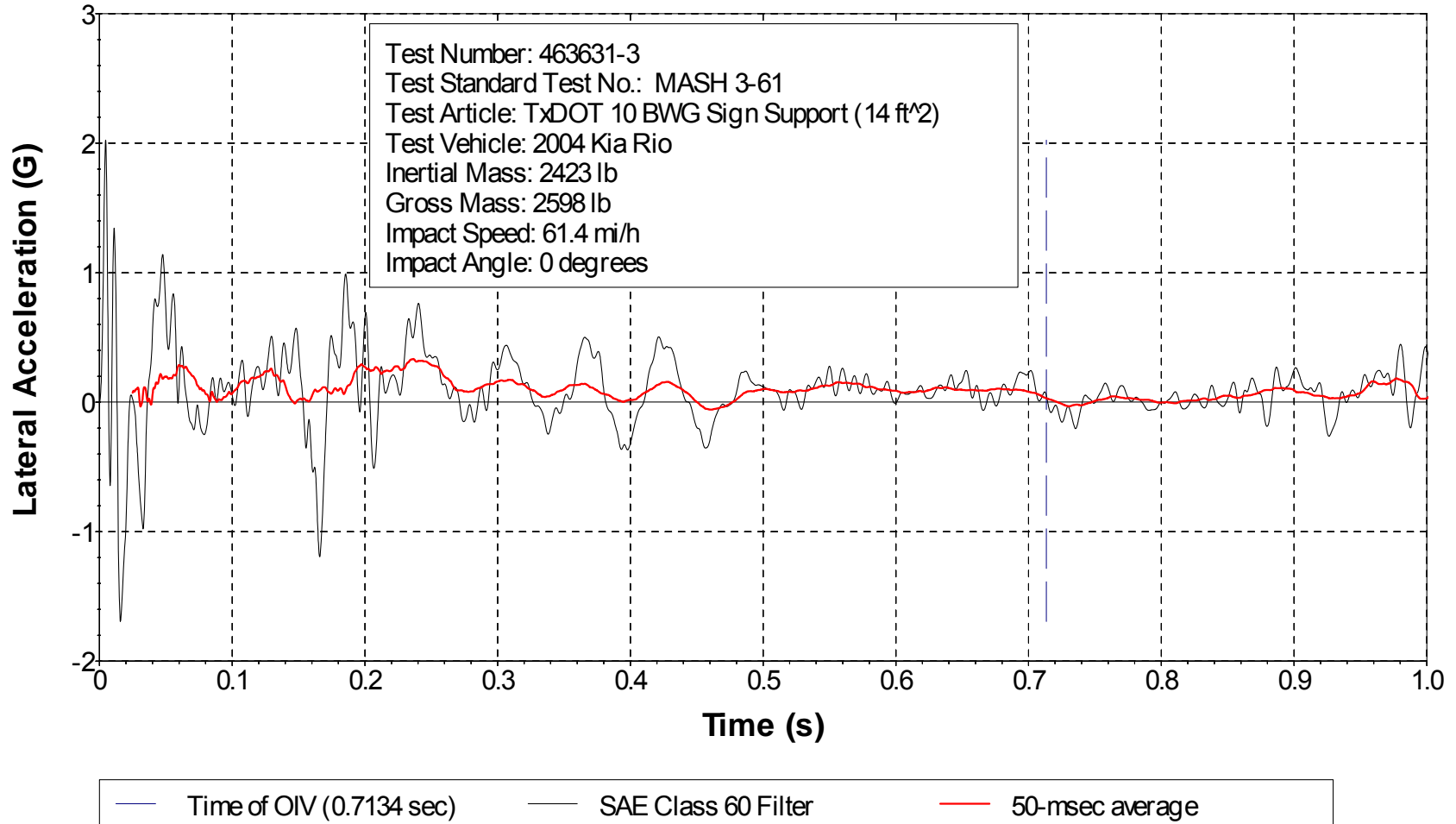


Figure J5. Vehicle Lateral Accelerometer Trace for Test No. 463631-3 (Accelerometer Located at Center of Gravity).

Z Acceleration at CG

348

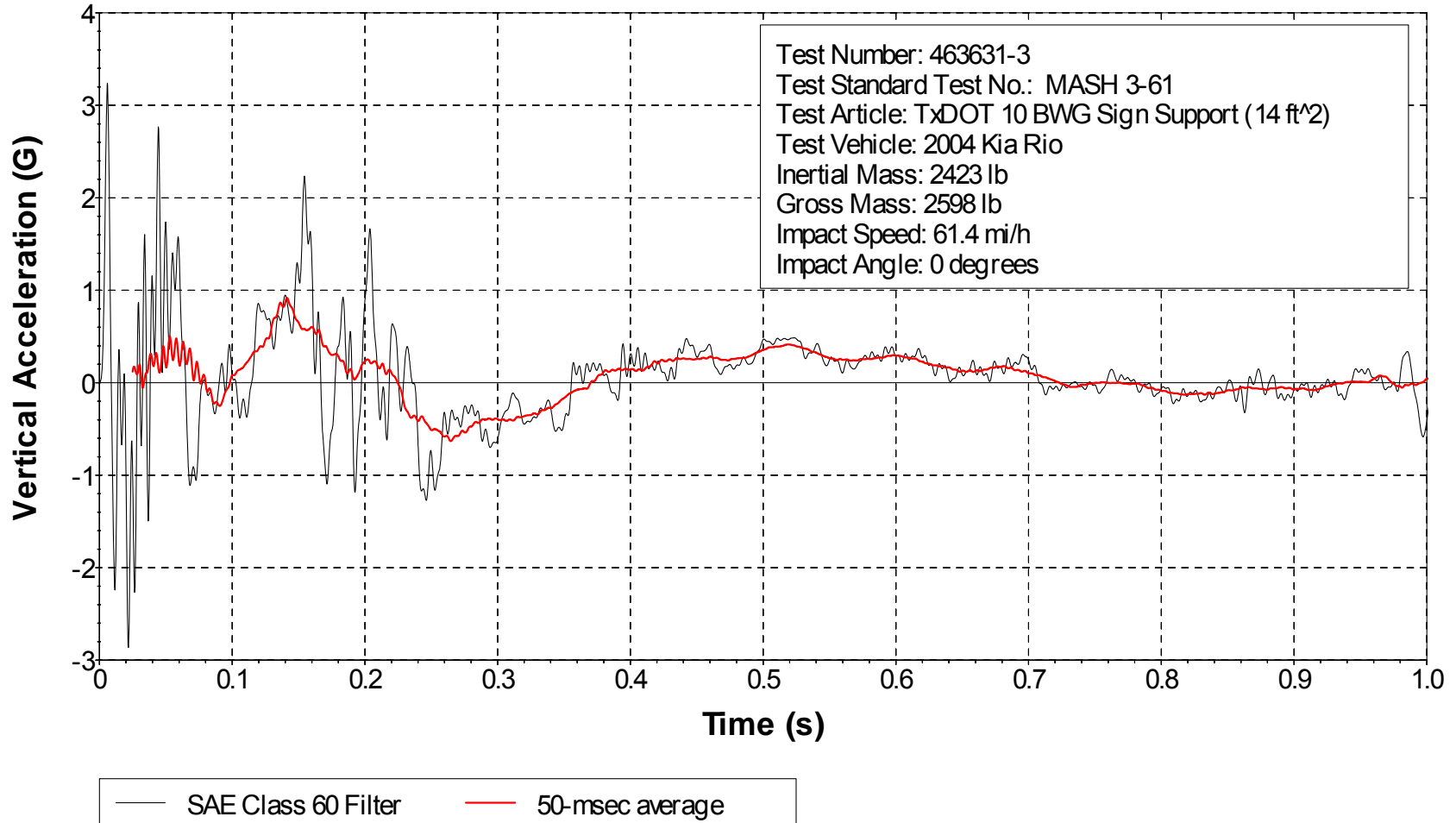


Figure J6. Vehicle Vertical Accelerometer Trace for Test No. 463631-3 (Accelerometer Located at Center of Gravity).

X Acceleration over Rear Axle

349

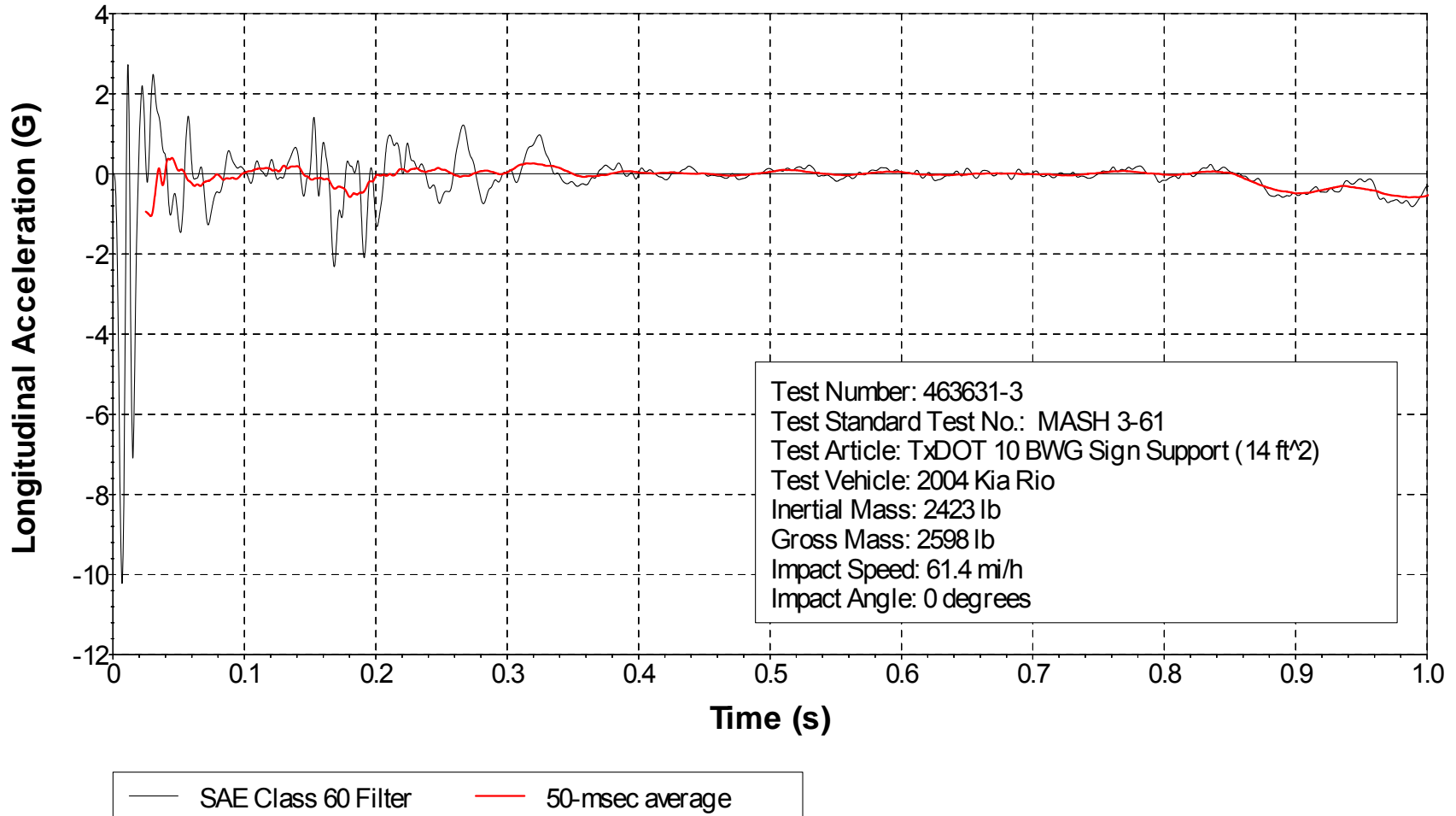
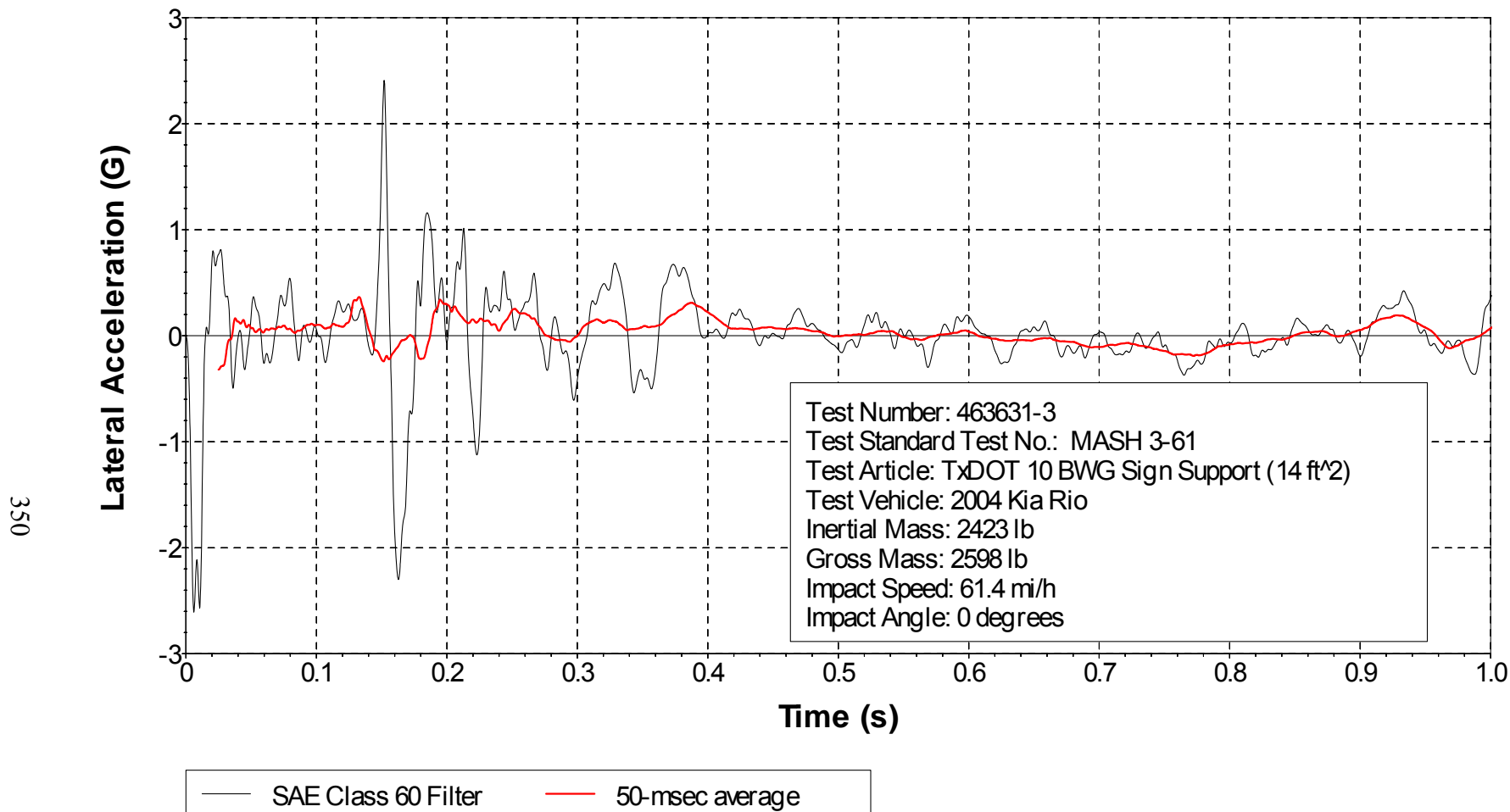


Figure J7. Vehicle Longitudinal Accelerometer Trace for Test No. 463631-3 (Accelerometer Located over Rear Axle).

Y Acceleration over Rear Axle



**Figure J8. Vehicle Lateral Accelerometer Trace for Test No. 463631-3
(Accelerometer Located over Rear Axle).**

Z Acceleration over Rear Axle

351

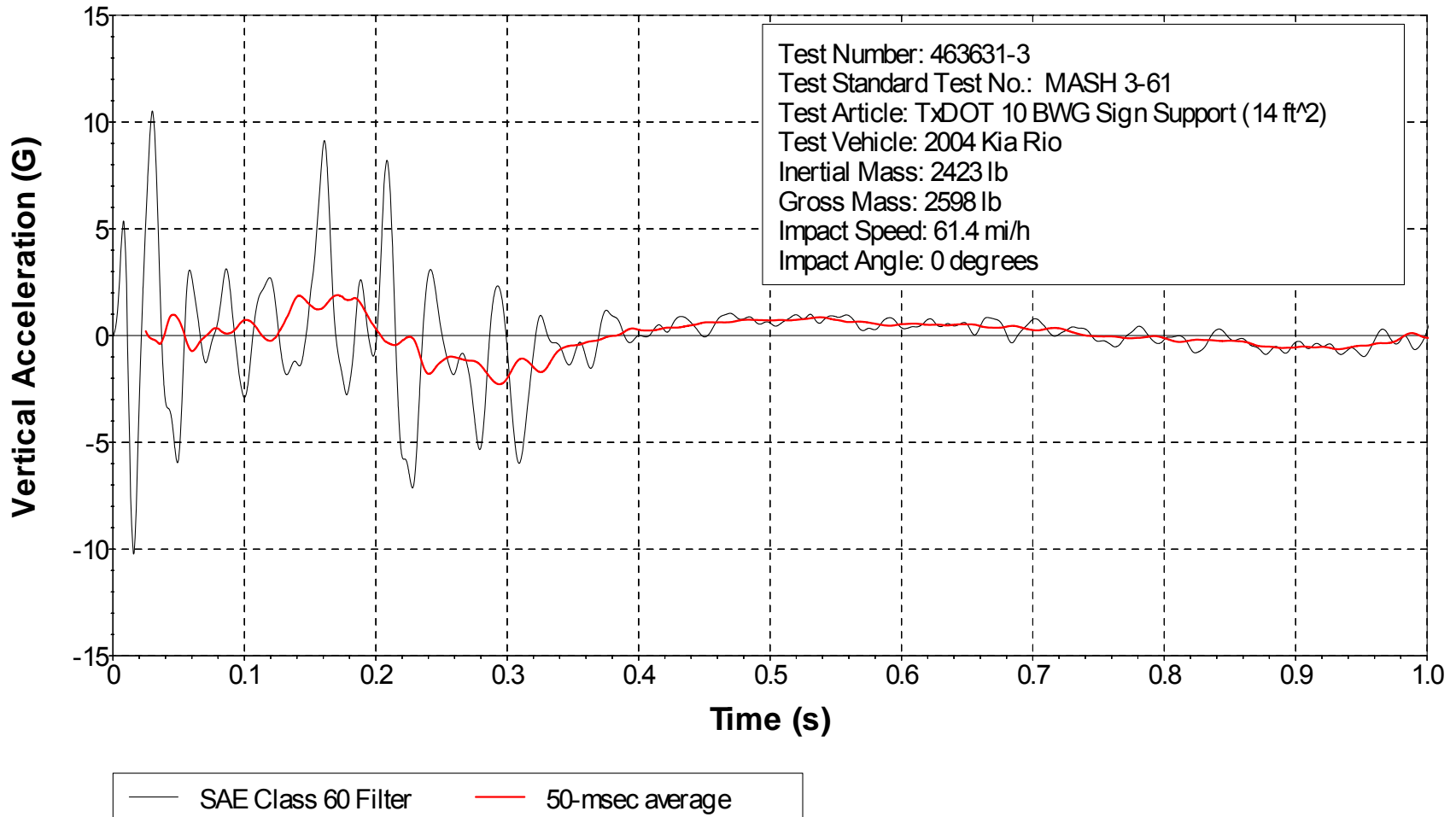


Figure J9. Vehicle Vertical Accelerometer Trace for Test No. 463631-3 (Accelerometer Located over Rear Axle).

APPENDIX K. PROPOSED MOUNTING STANDARDS FOR CHEVRONS AND MILE MARKERS

Appendix K shows the layout options proposed as an alternative to the current TxDOT D&OM(1) and (2) standard sheets. The following layouts are included:

Figure K1. Proposed TxDOT D&OM(1)-11, Option #1
“Delineator, Object Marker & Chevron Material Description D&OM(1) – 11”

Figure K2. Proposed TxDOT D&OM(1)-11, Option #2
“Delineator, Object Marker & Chevron Material Description D&OM(1) – 11”

Figure K3. Proposed TxDOT D&OM(2)-11
“Typical Delineator, Object Marker & Chevron Placement Details D&OM(2) – 11”

Figure K4. Proposed TxDOT D&OM(3)-11
“Typical Delineator, Object Marker & Chevron Placement Details D&OM(3) – 11”

| OBJECT MARKERS - Mark Obstructions within or adjacent to roadway (Type 1, 2 and 3) and warn of end of roadway (Type 4) | | | | | | | | | | | | D & OM DESCRIPTIVE CODES | |
|---|-------|------------------------------------|--|--|-------|--|-------|--------------------------|--|---------------|-------|---|--|
| Type 1 | | | Type 2 | | | Type 3 | | | Type 4 | | | INSTL DEL ASSM (D-XX)SZ X (XXX)XXX(XX) NUMBER OF REFLECTORS: S = Single D = Double COLOR OF REFLECTORS: W = White Y = Yellow R = Red REFLECTOR UNIT SIZE: 1 or 2 TYPE OF POST OF DELINEATOR: WC = Wing Channel Post FLX = Flexible Post TWT = Thin Walled Tubing TYPE OF MOUNT: GND = Embedded (drivable or not in concrete) CTB = Concrete Barrier Mount BRD = Bridge Rail Mount GF1 or GF2 = Guard Fence Attachment CRR = Cable Barrier Mount SRF = Surface Mount DIRECTION: If Required BI = Bi-Directional BR = Bi-Directional with red on back | |
| OM-11 | OM-12 | OM-13 | OM-2X | OM-2Y | OM-2Z | OM-3L | OM-3C | OM-3R | OM-41 | OM-42 | OM-43 | | |
| Sign | | | | | | | | | | | | INSTL OM ASSM (OM-XXX) (XXX)XXX(XX) TYPE OF OBJECT MARKER: 1, 2, 3, or 4 NUMBER OF REFLECTORS OR DIRECTION: X = 3-Size 2 reflector units (Type 2 only) Y = 1-Size 3 reflector unit (Type 2 only) Z = 3-Size 1 or 1-Size 4 reflector unit(s) (Type 2 only) L = Left Side (Type 3 Object Marker only) R = Right Side (Type 3 Object Marker only) C = Center (Type 3 Object Marker only) TYPE OF POST: WC = Wing Channel Post FLX = Flexible Post TWT = Thin Walled Tubing TYPE OF MOUNT: GND = Embedded (drivable or not in concrete) SRF = Surface Mount WAS or WAP = Wedge Anchor (Steel or Plastic) DIRECTION: If Required BI = Bi-Directional | |
| Characteristics | | | Diamond Shape; 0.080" τ Aluminum | | | Vertical Rectangle; 0.080" τ Aluminum | | | Diamond Shape; 0.080" τ Aluminum | | | INSTL CH ASSM (CH-XXX) (XXX)XXX SIZE OF CHEVRON: 1, 2, 3, 4, or 5 DIRECTION OF CHEVRON: L = Left R = Right TYPE OF POST: FLX = Flexible Post TWT = Thin Walled Tubing TYPE OF MOUNT: GND = Embedded SRF = Surface Mount WAS or WAP = Wedge Anchor (Steel or Plastic) | |
| Post Type | | | Yellow - Type E Sheeting | | | Alternating black and retroreflective yellow - Type E Sheeting | | | Red - Type D Sheeting | | | DEPARTMENTAL MATERIAL SPECIFICATIONS FLEXIBLE DELINEATOR & OBJECT MARKER POST (EMBEDDED & SURFACE MOUNT TYPES) DMS-4400 SIGN FACE MATERIALS DMS-8300 DELINEATORS AND OBJECT MARKERS DMS-8600 REFLECTORS MINIMUM SURFACE AREA DMS-4200 | |
| Mount Type | | | WAS, WAP | | | WAS, WAP, GND, SRF | | | WAS, WAP, GND, SRF | | | | |
| NOTE | | | 1. Conform to ASTM B-209 Alloy 6061-T6 2. Conform reflective sheeting as per DMS 8300 | | | 1. Conform to ASTM B-209 Alloy 6061-T6 2. Use at bridges with no approach rails 3. Conform reflective sheeting as per DMS 8300 | | | 1. Conform to ASTM B-209 Alloy 6061-T6 2. Conform reflective sheeting as per DMS 8300 | | | | |
| CHEVRONS - Intended to give notice of sharp change of alignment with direction of travel | | | | | | BARRIER REFLECTORS | | | | | | | |
| Sign | | | | | | Sign | | | | | | | |
| CH-1L/R | | CH-2L/R | | CH-3L/R | | CH-4L/R | | CH-5L/R | | | | | |
| Minimum | | Low Speed Road (< 55mph) | | High Speed Road (\geq 55mph) | | Expressway | | Freeway | | | | | |
| Size (W x L) | | 12"x18" | | 18"x24" | | 24"x30" | | 30"x36" | | 36"x48" | | | |
| Post Type | | TWT, FLX | | TWT, FLX | | TWT, FLX | | TWT, FLX | | TWT, FLX | | | |
| Mount Type | | WAS, WAP | | WAS, WAP | | WAS, WAP | | WAS, WAP | | WAS, WAP | | | |
| NOTE | | | | | | NOTE | | | | | | | |
| 1. Conform to ASTM B-209 Alloy 6061-T6 | | | | | | 1. A list of approved barrier reflectors can be found at : www.txdot.gov | | | | | | | |
| 2. Conform reflective sheeting as per DMS 8300 | | | | | | 2. Conform reflectors minimum surface area as per DMS 4200 | | | | | | | |
| DELINEATORS - Used when changes in horizontal alignment or pavement width transitions exist | | | | | | REFLECTOR UNIT SIZES | | | | | | | |
| Single | | | Double | | | Size 1 | | Size 2 | | Size 3 | | Size 4 | |
| Sign | | | Sign | | | Sign | | Sign | | Sign | | Sign | |
| 1-size 1 reflector unit | | | 1-size 2 reflector unit | | | 2-size 1 reflector units | | 2-size 2 reflector units | | | | | |
| Characteristics | | | D-SY, D-SR or D-SW | | | D-DY or D-DW | | | D-DY or D-DW | | | Yellow, White, Red Post Type WC, FLX Mount Type GND, SRF | |
| NOTE | | | 1. Length may vary to meet field conditions | | | 1. Size 1 and 4 - Direct applied conformable reflective sheeting for use on flexible | | | 2. Size 2 and 3 - Use approved metal, plastic or fiberglass back plate with 17/64" square mounting holes | | | 3. Conform reflective sheeting as per DMS 8300 | |
| 2. Minimum dimension required for delineators is 2 3/4 inches (Texas MUTCD Section 2D.02) | | | | | | | | | | | | | |

Figure K1. Proposed TxDOT D&OM(1)-11, Option #1.

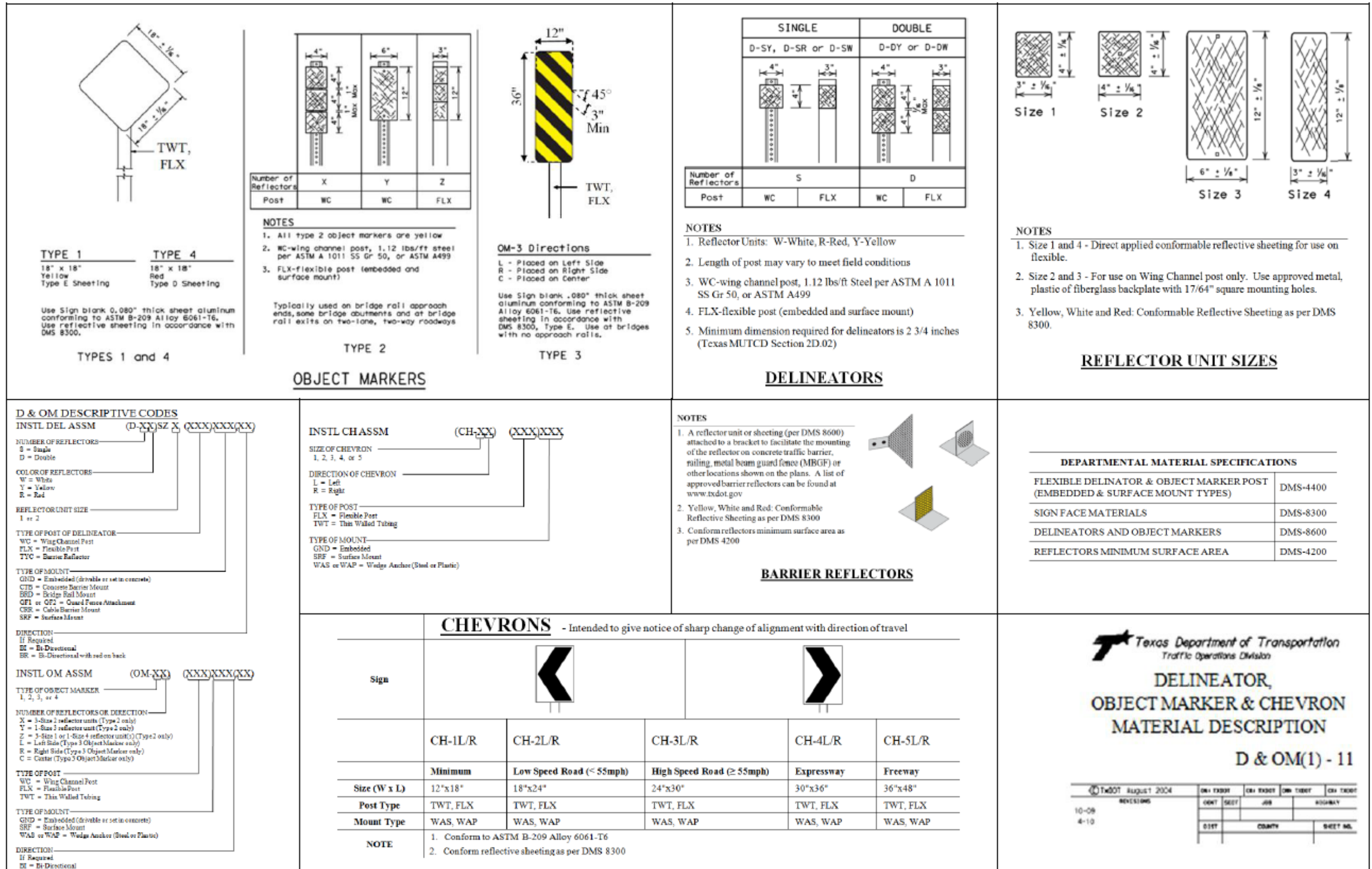


Figure K2. Proposed TxDOT D&OM(1)-11, Option #2.

| SUPPORT FOUNDATION DETAILS | | | | TYPE OF DELINEATOR MOUNTS | | | | | | | | | | | | | | | | | | | | |
|---|---|------------------------|---|---------------------------------------|---|------------------------|-----|---------------|----------|----------|----------|----------|------|------|-----|--------|------|--|--------|--|--|--|-----------|--|
| EMBEDDED | FLEXIBLE POSTS | | WEDGE ANCHOR SYSTEMS | | CABLE BARRIER | GUARD FENCE ATTACHMENT | | SURFACE MOUNT | | | | | | | | | | | | | | | | |
| GND | GND | SRF | WAS | WAP | CRR | GF1 | GF2 | SRF | | | | | | | | | | | | | | | | |
| | | | | | | | | | | | | | | | | | | | | | | | | |
| <p>NOTE</p> <ol style="list-style-type: none"> 1. Embedded WC-wing Channel post option may be used for Type 2 Object Markers and Delineators only 2. 1.12 lbs/ft steel per ASTM A 1011 SS Gr. 50, or ASTM A499 | <p>NOTE</p> <ol style="list-style-type: none"> 1. See Material Producer List for approved devices 2. Install to manufacturer's recommendations | | <p>NOTE</p> <ol style="list-style-type: none"> 1. Wedge Anchor (steel or plastic) is used for Type 1, 2, and 3 Object Markers and chevrons 2. 10 BWG thin wall tube (TWT) per ASTM XXXXX | | <p>GENERAL NOTES</p> <ol style="list-style-type: none"> 1. Place delineators on a section of roadway the same distance from the edge of pavement. 2. Where a restriction prevents consistent placement from the pavement edge, place the affected object markers in line with the innermost edge of the obstruction. 3. When object markers Type 2 and delineators are more than 8'-0" from the edge of the pavement, it may not be possible to maintain a height of 4'-0"-4'-6". If this is the case, place the object marker or delineator as close to the desired height as possible. 4. Install all delineators, object markers and barrier reflectors in accordance with the manufacturer's recommendation. 5. Barrier reflectors should be installed a minimum of 18 inches above the edge of the pavement surface. | | | | | | | | | | | | | | | | | | | |
| TYPICAL INSTALLATION EXAMPLES | | | | | | | | | | | | | | | | | | | | | | | | |
| OBJECT MARKERS TYPES 1, 3 AND 4, CHEVRONS TYPES 1, 2 AND 3 | | CHEVRONS TYPES 4 AND 5 | | DELINEATORS AND OBJECT MARKERS TYPE 2 | | | | | | | | | | | | | | | | | | | | |
| | | | | | | | | | | | | | | | | | | | | | | | | |
| | | | | | <p>TYPICAL DELINEATOR, OBJECT MARKER & CHEVRON PLACEMENT DETAILS</p> <p>D & OM(2) - 11</p> | | | | | | | | | | | | | | | | | | | |
| <p>TxDOT August 2004</p> <p>10-09</p> <p>4-10</p> | | | | | <table border="1"> <tr> <td>DM TxDOT</td> <td>CM TxDOT</td> <td>DM TxDOT</td> <td>CM TxDOT</td> </tr> <tr> <td>CONT</td> <td>SECT</td> <td>JOB</td> <td>REMARK</td> </tr> <tr> <td colspan="2">DIST</td> <td colspan="2">COUNTY</td> </tr> <tr> <td colspan="2"></td> <td colspan="2">SHEET NO.</td> </tr> </table> | | | | DM TxDOT | CM TxDOT | DM TxDOT | CM TxDOT | CONT | SECT | JOB | REMARK | DIST | | COUNTY | | | | SHEET NO. | |
| DM TxDOT | CM TxDOT | DM TxDOT | CM TxDOT | | | | | | | | | | | | | | | | | | | | | |
| CONT | SECT | JOB | REMARK | | | | | | | | | | | | | | | | | | | | | |
| DIST | | COUNTY | | | | | | | | | | | | | | | | | | | | | | |
| | | SHEET NO. | | | | | | | | | | | | | | | | | | | | | | |

Figure K3. Proposed TxDOT D&OM(2)-11.

| Type of Road or Condition | | Condition for use | | | | Delineator Spacing |
|--|---------|--|--|---|--|----------------------|
| | | Required (shall be used) | Recommended (should be used) | Optional (may be used) | Prohibited (cannot be used) | |
| Freeways or Expressways | Tangent | D-SW on right or raised pavement markers | | | | 200-530 ft |
| | Curve | D-SW on right | | | | see Table |
| | Ramp | D-SW on one side See Note 1 * | On outside of interchange ramp curves | | | |
| Other Than Freeways or Expressways | Tangent | | | D-SW on right or left side | | 200-530 ft |
| | Curve | | | | D-SY or D-DY on left side of two-way roads | see Table |
| Acceleration and Deceleration Lanes | | | D-DW or D-DY | | | 100 ft spacing |
| Crossovers | | | D-DY on left side of through road on far side of crossover | | | |
| Wrong-way | | | | D-SR for wrong-way traffic | | |
| Pavement Narrowing (lane merge) | | | | D-SW (right) or D-SY (left) adjacent to affected lane for full length of transition See Note 2 ** | | |
| Truck escape ramps | | | D-SR on both sides of ramp | | | 50 ft spacing |
| With guard fence, bridge rail, or concrete barrier | | | | | | 100 ft use min. of 3 |

General Notes: Unless indicated otherwise, the color of a delineators must conform to the color of the pavement edge line on the side of the road where the delineators are placed. Barrier markers can be used to replace required delineators. DS-R can be mounted on the back side of existing delineator posts.

- * 1. Delineation required on one side either SY or SW.
- ** 2. Minimum of 3.

When degree of curve or radius is not known

| Advisory Speed (MPH) | Spacing in Curve | Spacing in Strtawy | Chevron Spacing in Curve |
|----------------------|------------------|--------------------|--------------------------|
| | A | 2xA | B |
| 65 | 130 | 260 | |
| 60 | 110 | 220 | |
| 55 | 100 | 200 | 160 |
| 50 | 85 | 170 | 160 |
| 45 | 75 | 150 | 160 |
| 40 | 70 | 140 | 120 |
| 35 | 60 | 120 | 120 |
| 30 | 55 | 110 | 80 |
| 25 | 50 | 100 | 80 |
| 20 | 40 | 80 | 80 |
| 15 | 35 | 70 | 40 |

If the degree of curve is not known, delineator spacing may be determined based on the Advisory Speed of the curve. Use the delineator curve spacing for each Advisory Speed (MPH).

When degree of curve or radius is known

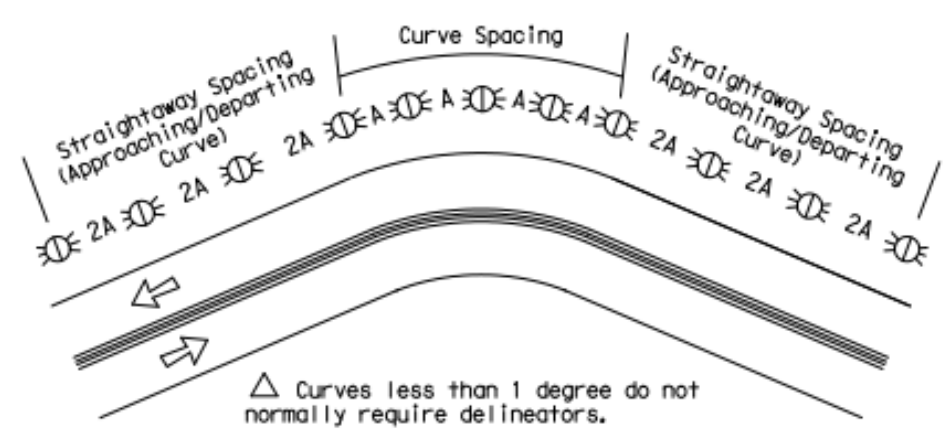
| Degree of Curve | Feet | | | |
|-----------------|-----------------|------------------|--------------------|--------------------------|
| | Radius of Curve | Spacing in Curve | Spacing in Strtawy | Chevron Spacing in Curve |
| | | A | 2A | B |
| 1 | 5730 | 225 | 450 | |
| 2 | 2865 | 160 | 320 | |
| 3 | 1910 | 130 | 260 | |
| 4 | 1433 | 110 | 220 | |
| 5 | 1146 | 100 | 200 | 160 |
| 6 | 955 | 90 | 180 | 160 |
| 7 | 819 | 85 | 170 | 160 |
| 8 | 716 | 75 | 150 | 160 |
| 9 | 637 | 75 | 150 | 120 |
| 10 | 573 | 70 | 140 | 120 |
| 11 | 521 | 65 | 130 | 120 |
| 12 | 478 | 60 | 120 | 120 |
| 13 | 441 | 60 | 120 | 120 |
| 14 | 409 | 55 | 110 | 80 |
| 15 | 382 | 55 | 110 | 80 |
| 16 | 358 | 55 | 110 | 80 |
| 19 | 302 | 50 | 100 | 80 |
| 23 | 249 | 40 | 80 | 80 |
| 29 | 198 | 35 | 70 | 40 |
| 38 | 151 | 30 | 60 | 40 |
| 57 | 101 | 20 | 40 | 40 |

Curve delineator approach and departure spacing should include 3 delineators spaced at 2A. This spacing should be used during design preparation or when the degree of curve is known.

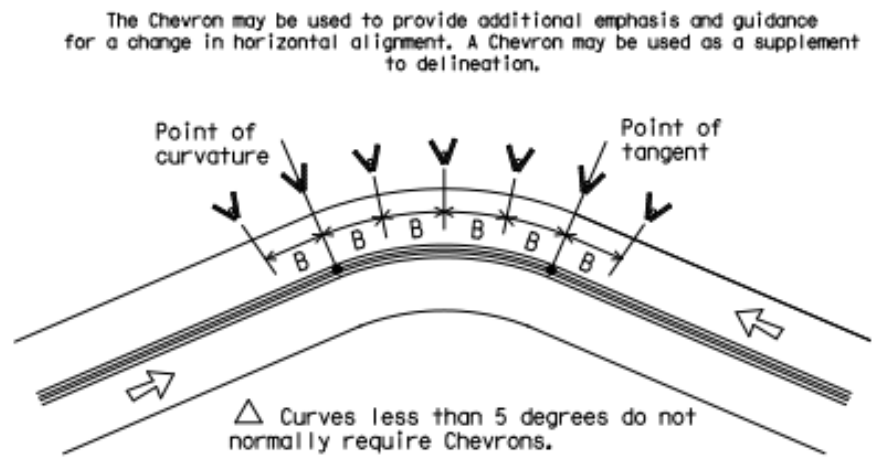
GUIDELINES FOR USE OF WARNING DEVICES AT CURVES WITH ADVISORY SPEED LIMITS

| Amount by which Advisory Speed Is less than Posted Speed | Warning Devices Needed |
|--|------------------------|
| 0 to 14 MPH | RPMS |
| 15 to 24 MPH | RPMS and Delineators |
| 25 MPH or greater | RPMS and Chevrons |

Suggested Spacing for Highway Delineators on Horizontal Curves Δ



Suggested Spacing for Chevrons on Horizontal Curves Δ



Texas Department of Transportation
Traffic Operations Division

TYPICAL DELINEATOR, OBJECT MARKER & CHEVRON PLACEMENT DETAILS

D & OM(3) - 11

| | | | | |
|---------------------|-----------|-----------|-----------|-----------|
| © TxDOT August 2004 | THE TxDOT | ENR TxDOT | TPM TxDOT | ENR TxDOT |
| REVISIONS | DATE | BY | CHKD | APP'D |
| | | | | |
| | | | | |

Figure K4. Proposed TxDOT D&OM(3)-11.

