



MICHIGAN OHIO UNIVERSITY TRANSPORTATION CENTER  
*Alternate energy and system mobility to stimulate economic development.*

---

Report No: MIOH UTC TS1 2008 - Final



# **CONGESTION RELIEF BY TRAVEL TIME MINIMIZATION IN NEAR REAL TIME**

-----

## **DETROIT AREA I-75 CORRIDOR STUDY**

### **FINAL REPORT**

#### **PROJECT TEAM**

**Dr. Charles Standridge  
Dr. Shabbir Choudhuri  
Andrew Even  
Jason Gallivan  
Ashfaq Rahman  
Vishnu Yada  
School of Engineering**

**Dr. David Zeitler  
Andrew Van Garderen  
Allison Wehr  
Department of Statistics  
Grand Valley State University  
301 West Fulton  
Grand Rapids, MI 49504**

**With Contributions By  
Dr. Snehamay Khasnabis  
S. Mishra  
A. Manori  
S. Swain  
College of Engineering  
Wayne State University  
2168 Engineering Building  
Detroit, MI 48202**

Report No: MIOH UTC TS1 2008 – Final  
TS 1, Series, Projects 2 & 3, December, 2008  
FINAL REPORT

**Developed By:**

**Charles R. Standridge**  
**Principal Investigator, GVSU**  
[standric@gvsu.edu](mailto:standric@gvsu.edu)  
616-331-6759

**Shabbir Choudhuri**  
**Investigator, GVSU**  
[choudhus@gvsu.edu](mailto:choudhus@gvsu.edu)  
616-331-6845

**With Contributions By:**

**Snehamay Khasnabis**  
**WSU**  
[skhas@wayne.edu](mailto:skhas@wayne.edu)  
313-577-3915

**SPONSORS**

This is a Michigan Ohio University Transportation Center project supported by the U.S. Department of Transportation, the Michigan Department of Transportation, Grand Valley State University, and Wayne State University.

**ACKNOWLEDGEMENT**

The Project Team would like to acknowledge support from the Michigan Department of Transportation (MDOT), the Michigan Intelligent Transportation System Center (MITSC), and the Southeastern Michigan Council of Governments (SEMCOG) during the course of this research.

**DISCLAIMERS**

The contents of this report reflect the views of the authors, who are responsible for the facts and the accuracy of the information presented herein. This document is disseminated under the sponsorship of the Department of Transportation University Transportation Centers Program, in the interest of information exchange. The U.S. Government assumes no liability for the contents or use thereof.

The opinions, findings and conclusions expressed in this publication are those of the authors and not necessarily those of the Michigan State Transportation Commission, the Michigan Department of Transportation, or the Federal Highway Administration.

## I. Overview

This document summarizes the activities concerning the project: Congestion Relief by Travel Time Minimization in Near Real Time -- Detroit Area I-75 Corridor Study since the inception of the project (Nov. 22, 2006 through September 30, 2008).

This project was motivated by the premise that congestion due to traffic accidents and other incidents can be avoided by using computer re-routing models combined with the analysis of voluminous data collected by intelligent transportation systems (ITS). Congestion avoidance reduces travel time and fuel consumption as well as the need for additional roadways and infrastructure, making the transportation system more efficient.

During the same time period as this project, personal travel assistants (PTAs) have become more and more common. This trend should continue until PTAs are ubiquitous. These devices are able to both access current commercial traffic data provided by companies such as traffic.com as well as to determine routes based on this data. Thus, the problem of routing individual vehicles appears to be solved and commercialized.

Several issues remain to be addressed:

1. How to route voluminous traffic around an incident that closes or reduces the capacity of a segment of a traffic corridor.
2. How to use the traffic data collected by an ITS to describe the flow of traffic.
3. How to forecast the speed of traffic on a traffic segment a short time from the current time.

Thus, the major and primary contribution of our project was established:

*To describe, explain, and predict the flow of traffic in a corridor with respect to time and space as well as to apply these results in the routing of traffic.*

The results of this project are targeted at ITS that seek to reduce congestion by better routing large volumes of traffic at a small time interval as opposed to PTAs that route one vehicle at a time. One potential downside of rerouting large volumes of traffic in a small time interval is to simply move the congestion to a different place in the traffic corridor. This requirement is addressed.

The project was organized around three subprojects:

1. Statistical analysis of traffic data from the Michigan Intelligent Transportation Systems Center (MITSC) in Detroit for the purpose of describing, explaining and predicting the flow of traffic.
2. Computer-based models for re-routing large volumes of traffic around an incident with both software- and hardware-based solvers. These models can include statistical analysis results for predicting traffic flow.
3. Traffic simulation models for validating the results produced by the re-routing models.

Project highlights are summarized. The organization of the project is given. Technical progress is summarized for each of the three subprojects. The vision for the third year of the project, September 2008 through August 2009, is described.

## II. Highlights

The major accomplishments of each subproject are summarized.

1. Collection and management of traffic data.
  - a. Acquired archival data from MITSC center for the years 2000-2006 as well as establishing and implementing procedures for continuing to obtain data starting with January 2007. Currently, data is obtained via FTP transfer from MITSC to GVSU twice a month.
  - b. Implemented a database management system (DBMS) in MySQL to properly organize and control the data.
    - i. The volume of data is such that the initial database was limited to the I-75 corridor data for one year. This conclusion was reached after much trial and error.
    - ii. Designed and implemented a user interface that supports data retrieval through SQL queries.
    - iii. Traffic data: sensor occupancy, volume, and speed as well as sensor location data are stored in the database.
  - c. Conducted, and are continuing to conduct, a descriptive statistics study of the MITSC data showing traffic patterns in time and space.
    - i. The graphs show when and to what degree rush hour traffic volumes reduce speed for each I-75 southbound sensor for 30 days.
    - ii. The graphs identify “non-routine” periods of volume increases and speed reductions perhaps correlated in time with a traffic incident or adverse weather conditions.
    - iii. The graphs show that speed remains constant until volume reaches a particular threshold level.
    - iv. The graph shows how traffic volumes dissipate in time and space, including how far-reaching the effect of a traffic incident is.
    - v. The graphs provide the basis for proposing and testing formal explanatory and predictive statistical models.
2. Designed and implemented a traffic routing algorithm and alternative solvers for re-routing voluminous traffic around an incident in a corridor.
  - a. We believe this algorithm to be unique, since existing routing algorithms are designed for routing a single vehicle and do not consider the consequences of re-routing a large number of vehicles in a relatively short span of time.
  - b. The algorithm includes the idea that the selected route may change because of the volume of previously rerouted traffic. Thus, the route selected for current traffic may be different from the route selected for prior traffic. Thus, this is a dynamic routing algorithm.
  - c. The algorithm can consider multiple types of vehicles separately, such as cars and trucks.

- d. The corridor is modeled in the usual way as a set of nodes and arcs. Each arc represents a segment of a highway, an arterial road, or a street. The metric associated with each arc is computed each time it is needed and may be a function of any variable: time, volume of traffic, arc capacity, type of vehicle and the like.
  - e. The M-131 / I-196 junction in downtown Grand Rapids was modeled and data available from the GVMC was employed. Routing effectiveness was evaluated by simulating traffic incidents on M-131 and I-96.
  - f. The traffic corridor surrounding southbound I-75 in Detroit was modeled and data available from MDOT was employed. The model includes a traffic simulator to predict the volume increase in any arc due to re-routing. Analyses based on the model are ongoing.
  - g. Extension of the algorithm to include multiple simultaneous traffic incidents is ongoing.
  - h. Concepts for an analog, hardware-based solver for the dynamic traffic routing problem were developed and demonstrated using an eight-arc, seven-node traffic network. The solver instantaneously identifies the optimal route.
  - i. The development of a hardware solver for the model of the traffic corridor surrounding southbound I-75 in Detroit has been designed. Its implementation is ongoing.
3. An analytic framework for the calibration and application of a micro-simulation model (AIMSUN) for validating the effectiveness of alternate incident management strategies (IMS) on an urban transportation network was developed.
    - a. A conceptual framework was developed and demonstrated through the modeling of the I-75 corridor in Detroit area.
    - b. This model was calibrated and its application demonstrated.
    - c. Initial results are positive. Full-scale validation and testing with larger networks are ongoing.
  4. Effective relationships with external constituents at MDOT, MITSC, SEMCOG, the Grand Valley Metropolitan Council (GVMC), and Traffic.com have been made.

### III. Project Organization

The project organization is shown in Figure 1, with the three primary subprojects displayed. Current project staffing is indicated along with our external constituents.

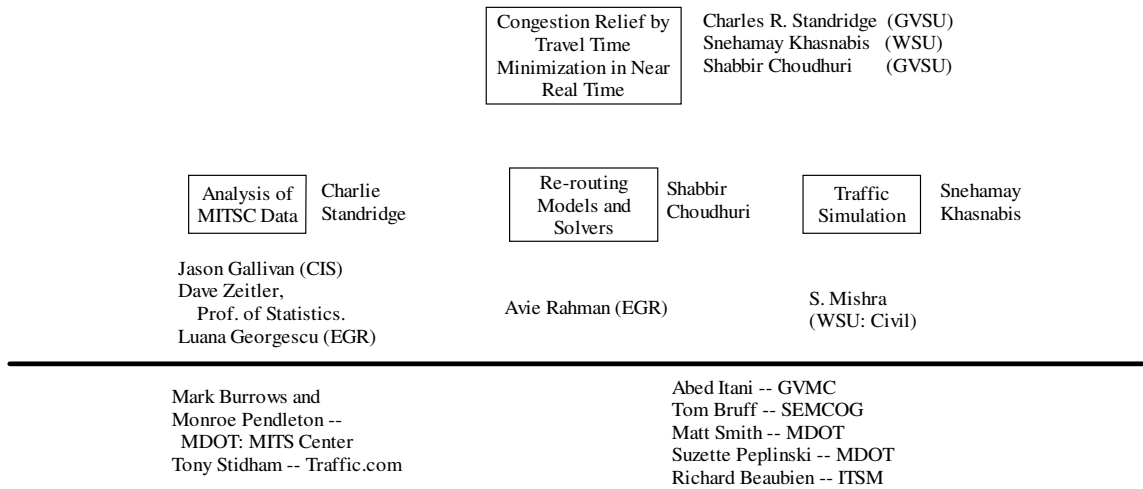

Figure 1: Project Organization

We have made contact and met with our external constituents representing the following organizations as shown in Figure 1:

1. Grand Valley Metropolitan Council – Abed Itani, Transportation Director, and staff
2. SEMCOG – Tom Bruff and staff
3. MDOT
  - a. Michigan Intelligent Transportation Center Detroit – Monroe Pendleton
  - b. Michigan Intelligent Transportation Center Grand Rapids – Suzette Peplinski and staff
  - c. Southfield Office – Matt Smith
4. Traffic.com – Tony Stidham
5. Intelligent Transportation Society of Michigan – Richard Beaubien

Project activities have been supported by graduate assistants and undergraduate students as shown in Table 1. All students who have participated in the project since its inception are shown.

Table 1: Student Participation

Student	Faculty Mentor	Department	Degree Program	Status on Project	When on Project
Vishnu Yada	Shabbir Choudhuri	GVSU, Computer Information Systems	Master of Science	20 hours weekly, Graduate Assistant	January – December 2007
Ashfaq Rahman	Shabbir Choudhuri	GVSU, Engineering	Master of Science	20 hours weekly, Graduate Assistant	August 2007 – present
Andrew Even	Shabbir Choudhuri	GVSU, Engineering	Master of Science	Capstone project, unpaid	January – December 2007
S. Mishra A. Manori S. Swain	Snehamay Khasnabis	WSU, Civil Engineering	Ph.D.	Hourly, Graduate Assistant	January 2007 – present September 2007- December 2007 February 2008-Present
Jason Gallivan	Charlie Standridge	GVSU, Computer Information Systems	Master of Science	20 hours weekly, Graduate Assistant	January 2007 – present
Andrew Van Garderen	Dave Zeitler	GVSU, Statistics Department	Bachelor of Science	Semester stipend	August 2007 – May 2008
Allison Wehr	Dave Zeitler	GVSU, Statistics Department	Bachelor of Science	Semester stipend	January – May 2008

## IV. Technical Progress toward Objectives and Deliverables

### *Analysis of MITSC Data*

Objective: Developing and applying statistical methods for the analysis of ITS data, with application to the Detroit area I-75 corridor.

Deliverables: Methods and procedures for the statistical analysis of the MITSC data with application to the Detroit area I-75 corridor.

Analysis of the MITSC data requires its acquisition and management as well as the application of statistical analysis techniques.

Arrangements for acquiring the MITSC data were made with Monroe Pendleton and Mark Burrows of the MITSC staff. Data from 2000-2006 were obtained on CD-ROM. Starting in January 2007, data have been transferred from MITSC to GVSU twice monthly via FTP.

The MITSC data required significant preparation before use in statistical analysis. The data is organized in tabular form with each row representing one time for one sensor and columns containing occupancy, speed, and volume data. However, the data is recorded as a string that must be parsed to extract the data for subsequent use. Missing values must be taken into account. Invalid rows, identified by a year of 1969, are ignored. Data were grouped into minute intervals based on the hour-minute-second time stamp.

A custom pivot operation on the data was programmed in JAVA to create a table with each row representing a one-minute time interval and a set of occupancy-volume-speed columns for each sensor of interest. This was done to facilitate time-oriented statistical analysis of the data.

The database management system was implemented using MYSQL, freeware that is commonly used both in academics and industry. One table was created for the traffic data and a second table for the list of sensor devices. A web based query system is found at: [utc.egr.gvsu.edu](http://utc.egr.gvsu.edu). The query system supports any SQL query and has an interface for queries by sensor device and data range. Query results are placed in a .csv file.

Descriptive statistical modeling was done by generating graphs of the occupancy, volume and speed for each sensor using the R statistical programming environment. R is freeware. For southbound I-75, graphs showed patterns in the flow of traffic.

1. Speed seems to be function of volume. When the volume is below a threshold, speed is constant and slightly above the posted speed limit. When the volume is above the threshold, speed decreases as volume increases, potentially in a non-linear fashion.
2. Speed does not appear to be a function of sensor occupancy. Sensor occupancy can be seen to increase at times while speed remains constant.



3. Monday through Friday, morning rush hour is shown by large volume increases between 7:30 and 10:00 a.m. that result in a significant drop in speed. Evening rush hour is shown by a small change in volume that exceeds the threshold resulting in a small drop in speed.
4. Saturday and Sunday, volume and speed are approximately constant throughout the day.
5. Significant changes in volume at non-rush hour times indicated planned or unplanned disruptions such as traffic incidents or inclement weather.
6. There is significant sensor noise in the data, as seen by values that appear to be excessive compared to most values.
7. Throughput is not affected until a drop in speed is seen. Then throughput goes down.

Figure 1 is a graph showing data from Wednesday, Nov. 9, 2005 for one sensor.<sup>1</sup> This graph illustrates points 1, 2, 3, and 6 above.

Figure 2 is a graph showing data from Wednesday, Nov. 23, 2005, the day before Thanksgiving, for the same sensor as in Figure 2. This graph illustrates point 5. Note the smaller volume of traffic during the morning rush hour as well as the spike in traffic from about 4-6 p.m. that day. This could be explained by weather data showing about 2 inches of snow or perhaps many people were leaving work at the same time to prepare for the Thanksgiving holiday.

Graphs can be used to see how congestion changes in time and space. This is illustrated in Figures 3 and 4 that show occupancy, volume, and speed data from Wednesday, Nov. 23, 2005 for the sensor north of the one shown in Figure 2 (Figure 3) as well as the sensor south of the one shown in Figure 2 (Figure 4). Note the following:

1. The volume increase and speed decrease shown in Figure 2 occurs slightly later in Figure 3, indicating that time lag for traffic to backup to the north.
2. This volume increase is not seen in Figure 3, showing that traffic flow has returned to normal at this location.
3. The speed decrease shown in Figure 4 at about 12:00 p.m. is also seen in Figures 2 and 3.

For northbound I-75, graphs indicated that the sensors were not generating usable information. Note the occupancy graphs in Figure 5 where data from 12 sensors is displayed. Only two of the 12 sensors generate usable data.

---

<sup>1</sup> Our analysis shows that the date labels are determined as follows: Data is collected from 4:00 a.m. one day to 4:00 a.m. the next day for each file obtained from MITSC. The date label on the file is the date associated with the last item collected. Since the majority of data, including rush hours, are from the preceding day, the date labels appear to be off by one day.

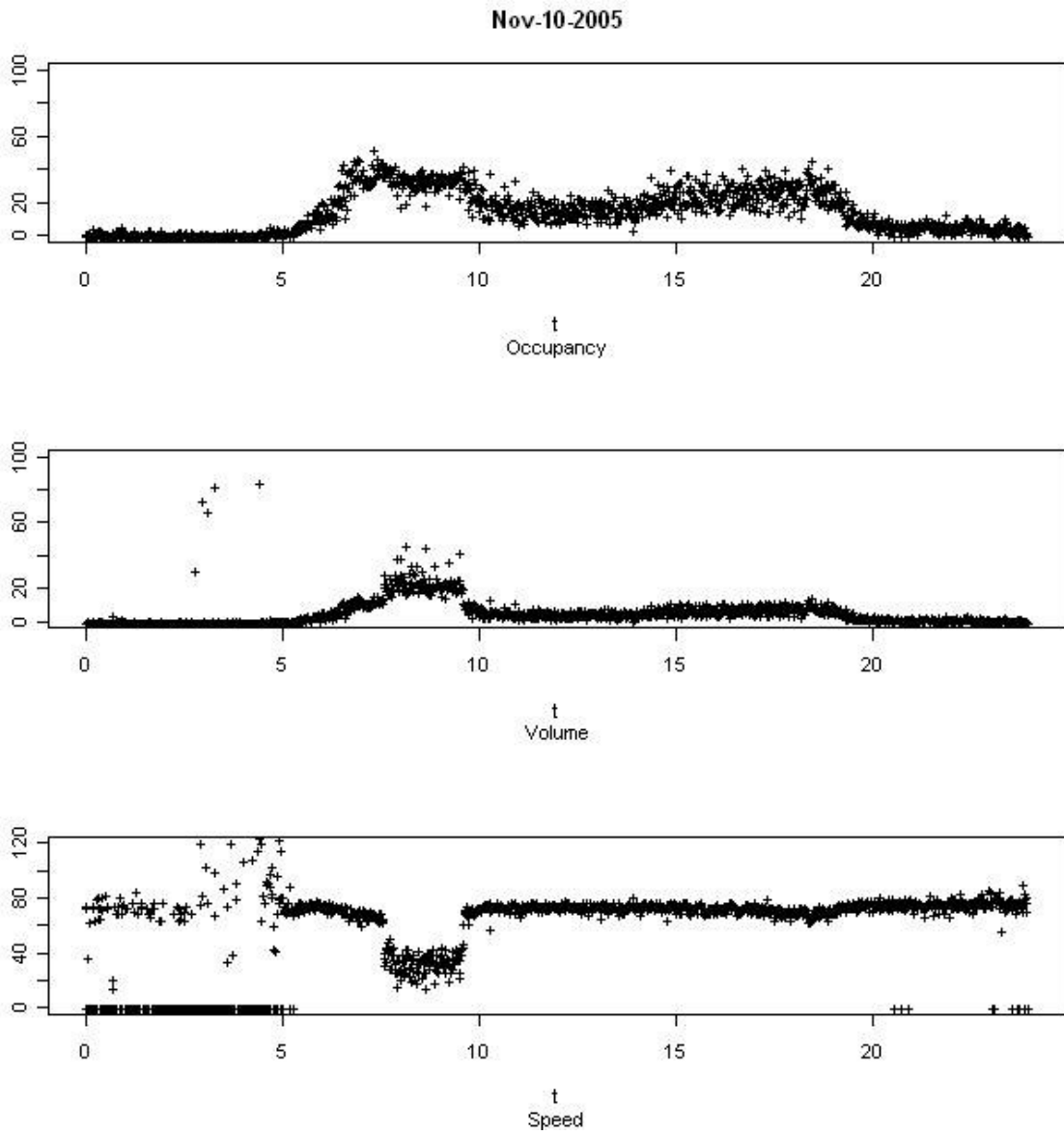

**Figure 1. Occupancy, Volume, and Speed Data for Nov. 9, 2005**

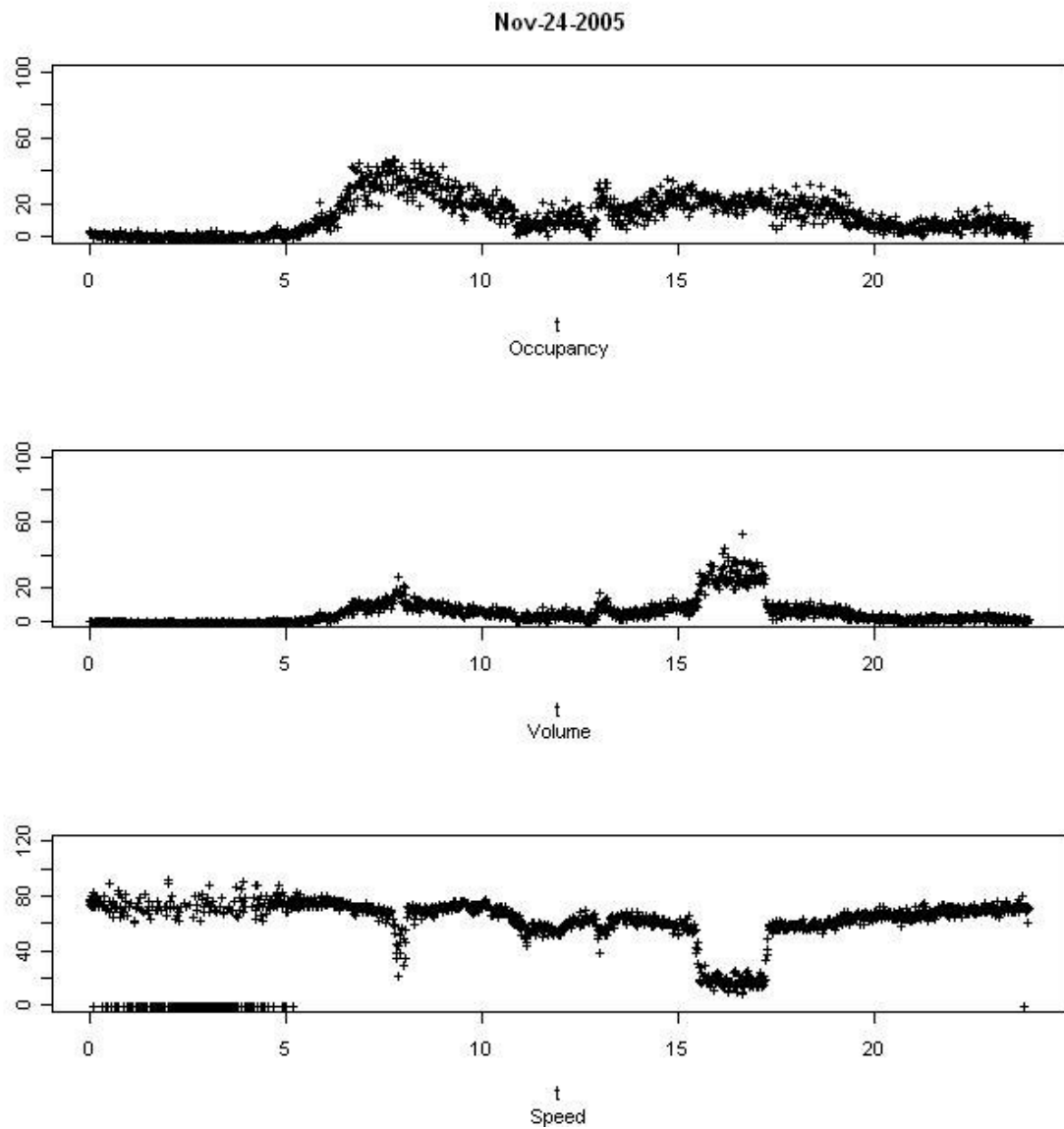

**Figure 2. Occupancy, Volume, and Speed Data for Nov. 23, 2005**

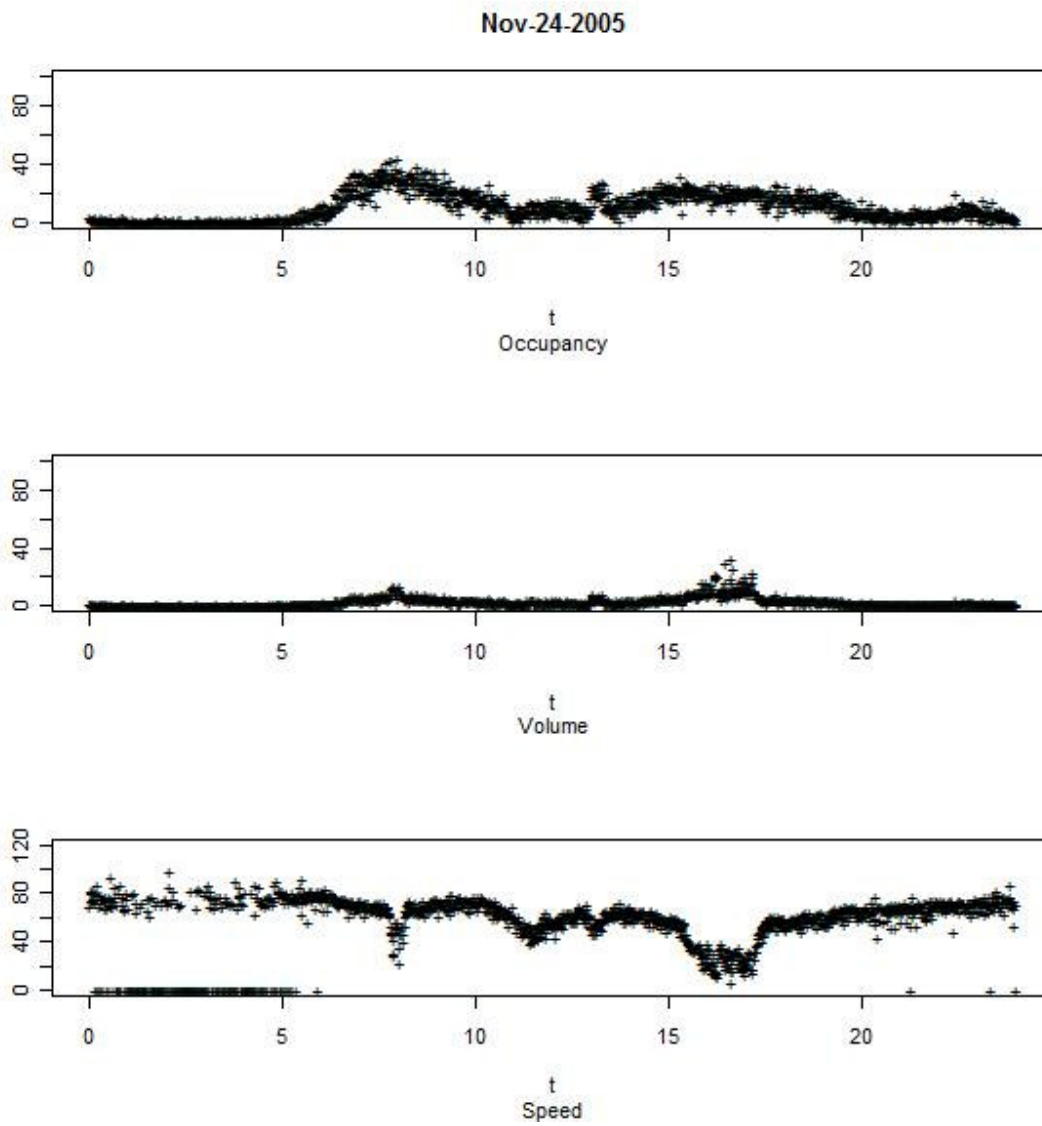

**Figure 3. Occupancy, Volume, and Speed Data for Nov. 23, 2005 for the Sensor Northbound from the One in Figure 2.**

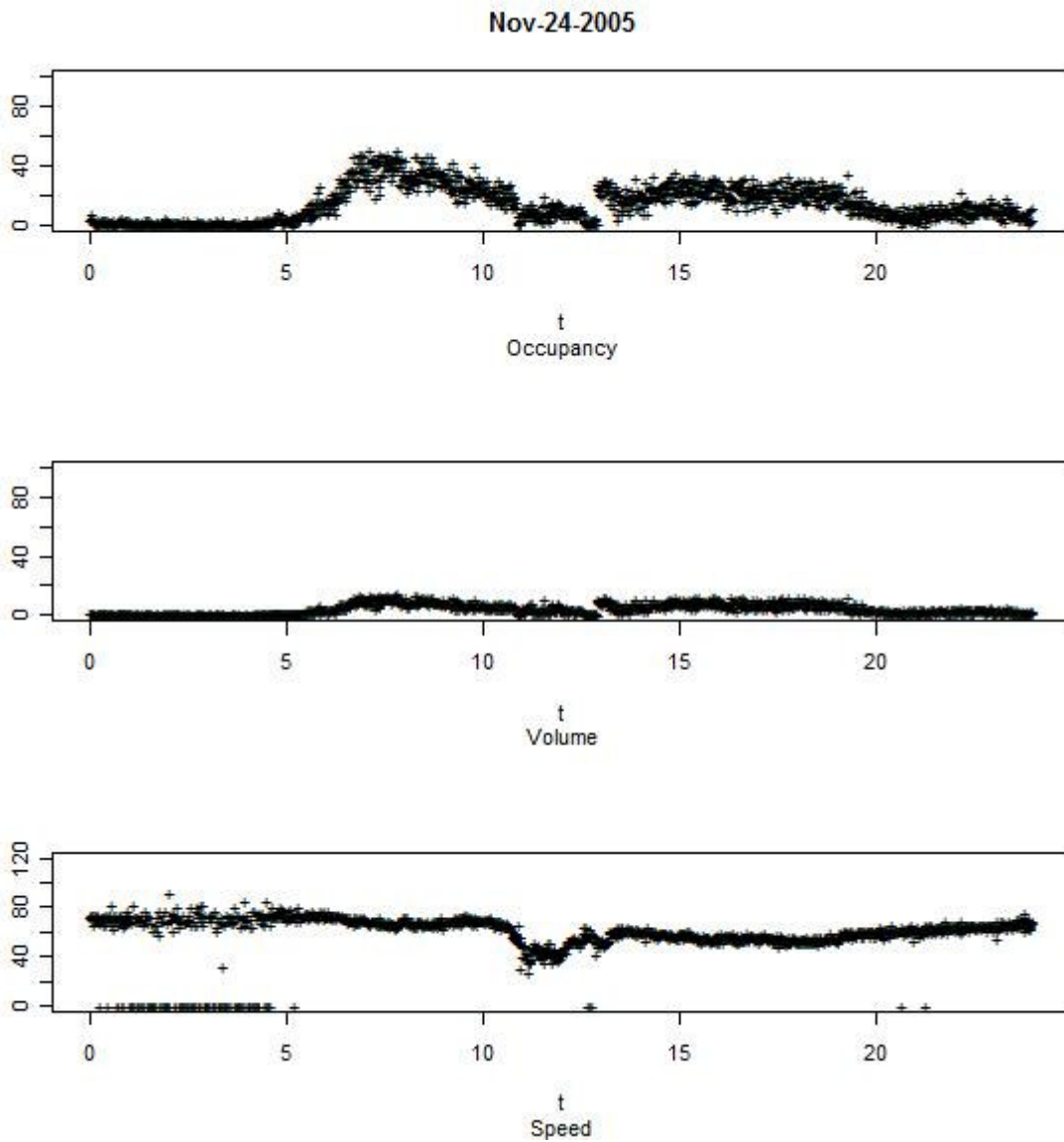

**Figure 4. Occupancy, Volume, and Speed Data for Nov. 23, 2005 for the Sensor Southbound from the One in Figure 2.**

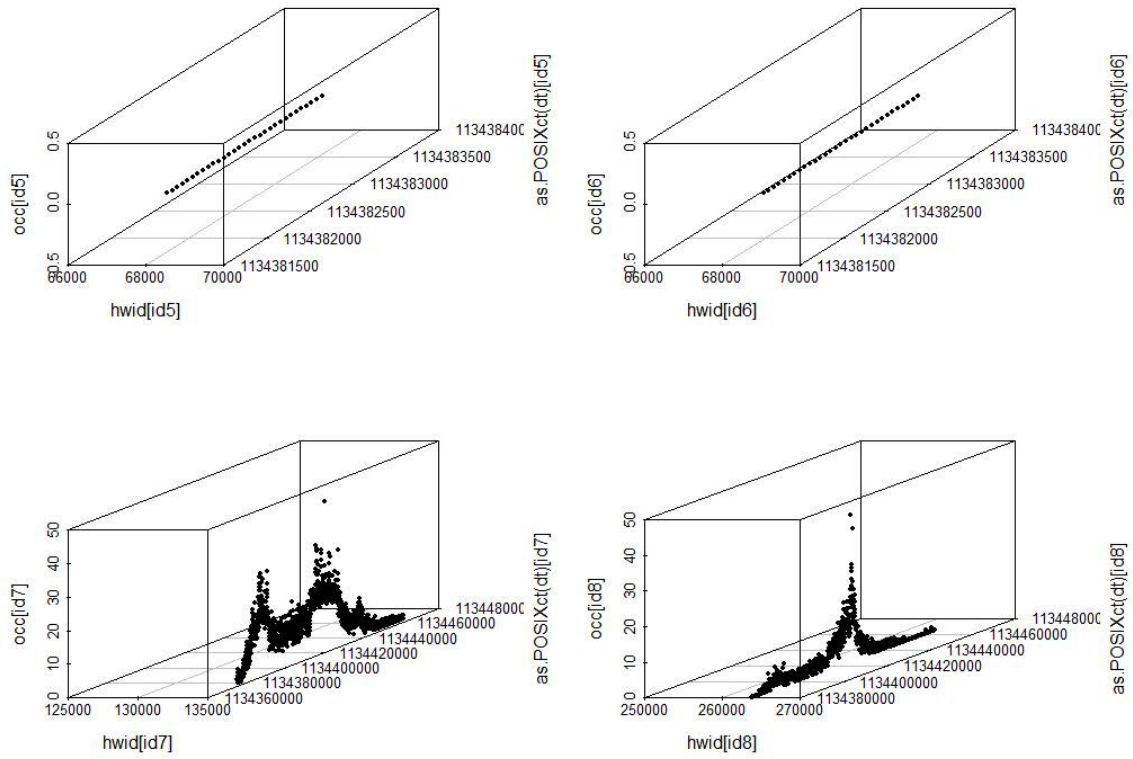

**Figure 5. Occupancy Data for Northbound I-75 Graphs**

### *Rerouting Models and Solvers*

Objective: Extension of the previously developed routing algorithm with application to the Detroit area I-75 corridor.

Deliverables: The improved algorithm with both a software- and a hardware-based solver, including a model of the Detroit area I-75 corridor.

During the first project year, a dynamic traffic rerouting algorithm around a disturbance in a freeway was developed. Based on the algorithm, test software was developed to model the M-131/I-196 junction in downtown Grand Rapids. The system was populated with the data available from GVMC. The dynamic routing capacity was evaluated by simulating interruptions on M-131 and I-96. (Even 2007; Even, Choudhuri, and Standridge 2007). The results revealed that for the similar incidences, the detour route from M-131 changes more rapidly than that of I-196 to keep traffic moving in the surrounding network.

The algorithm takes into account that the same route may not be optimal for all routed vehicles. Vehicles may belong to different classes, such as cars and trucks. Not all classes may be allowed to use all routes. Over time, the previous rerouting of vehicles may cause the performance of a selected route to change. Thus, another route may be better. Thus, the algorithm must be dynamic.

The algorithm models a traffic corridor as a set of nodes and arcs. The metric associated with each arc may depend on a number of variables that can change in time: capacity that could be reduced due to a traffic incident, traffic volume, traffic speed and the like. The metric could depend on projections of such quantities at the time the vehicle is expected to arrive to the arc. Our algorithm allows this metric to be computed arbitrarily and for this computation to change over time.

In the current year, the traffic network shown in Figure 6, surrounding I-75 S in the Detroit metro area, was modeled. This is the same network considered in the traffic simulation discussed in the next section. The implementation also includes a simple traffic simulator to predict the volume increase in any arc of the traffic network due to rerouting.

Additional work on this model is currently ongoing including:

1. Obtaining the required input data from MDOT.
2. Analyzing I-75 south.
3. Investigating the effect of multiple simultaneous traffic incidents.

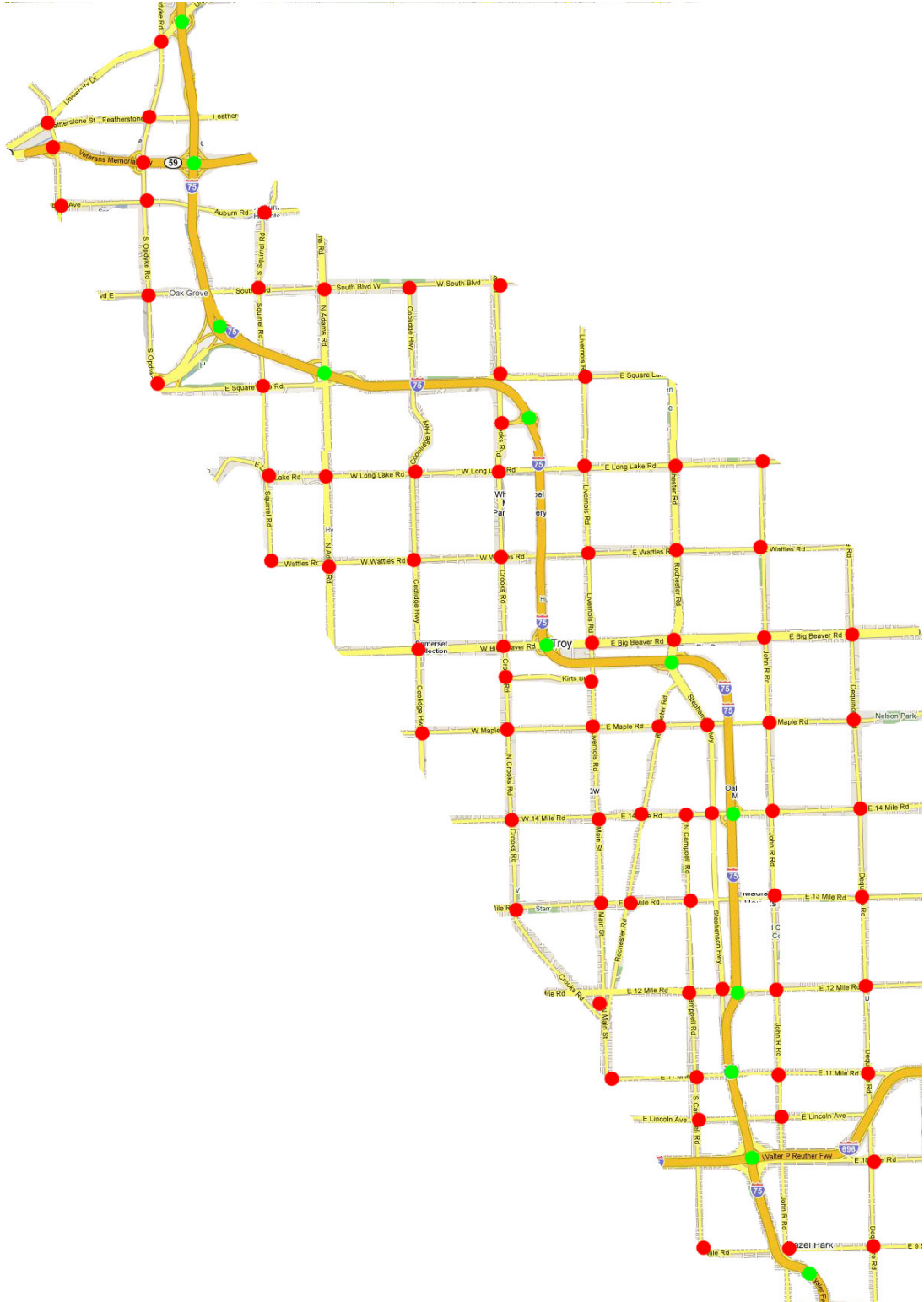

Figure 6. Map of the Detroit Area I-75 Corridor – Software Solver.



Results from the software-based rerouting algorithm showed that the best detour path, with respect to avoiding congestion, changes frequently. The computational cost of finding the optimal path for numerous evaluations may become prohibitive.

An analog solver for the dynamic traffic routing algorithm was developed. The concept was demonstrated through a small prototype traffic network (Figure 7).

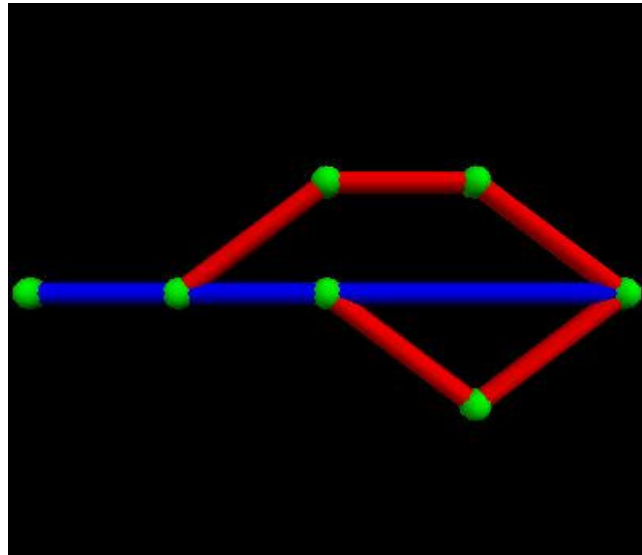

Figure 7. Prototype Traffic Network for the Hardware Solver.

The traffic network is implemented as an electric circuit. The resistance on each arc of the electric circuit corresponds to the “resistance” to traffic flow in the traffic network. The best detour path is the path of “least resistance” in the circuit. This is found by inducing a current into the circuit and monitoring which path the current takes, which occurs almost instantaneously.

A Graphical User Interface was developed to control the system as shown in Figure 8. This interface provides the hardware solver with the parameters of the network describing the current situation. The solver determines the most optimal reroute in the time it takes electricity to flow through the circuit, virtually instantaneously.

Ongoing work includes building an analog solver for a traffic network surrounding Detroit. The map of the planned area is shown in Figure 9. The same section of traffic network will be simulated using the AIMSUM software as discussed in the next section.

An equivalent electric circuit is shown in Figure 10.

Figure 8. Hardware Solver Interface.

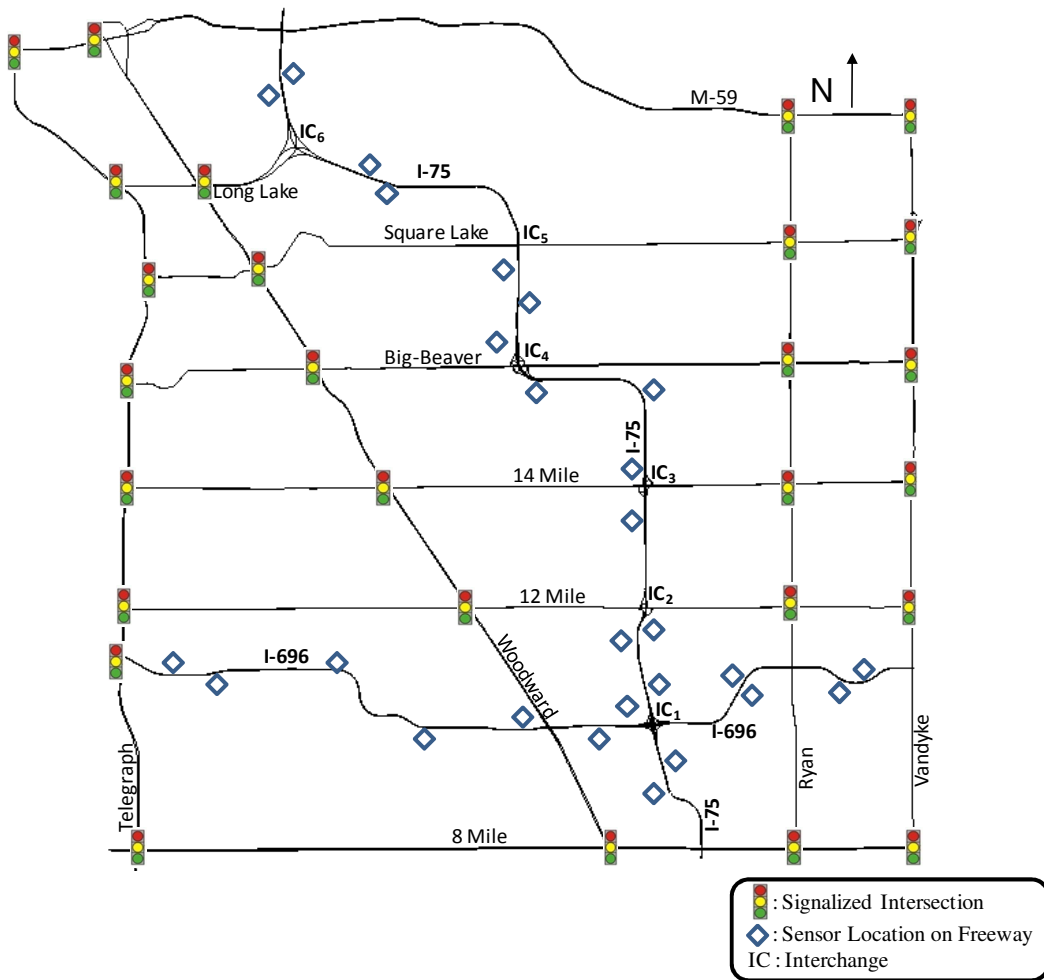

Figure 9. Map of the Detroit Area I-75 Corridor - Analog Solver

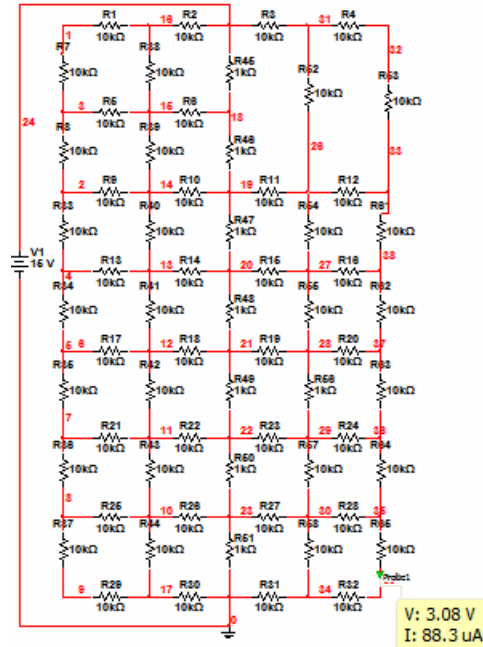

Figure 10. Electrical Schematic Representation of the Figure 9 Map.

The circuit shown in Figure 10 was modeled in SPICE and then MATLAB to iteratively decide the parameters for the hardware components. The 63 traffic arcs require 63 potentiometers and the 38 nodes require 38 amplifiers and corresponding microcontrollers. The following parameters were considered:

- O-D Voltage Range: 0-30V (starting from maximum)
- Gain: 5 to very high depending on the requirement  
(Starting with 5 to avoid the need for a gain resistor)
- Offset serial resistor: Starting with 1K
- Highway Arc Resistors: 100K Max
- Detour Resistors: 100K Max

From the iterative evaluation, the following parameter values were selected:

- O-D Voltage: 30V
- R\_Highway: 4K
- R\_Detour: 20K

The maximum current is ~1mA. The offset voltage and amplifier gain were reevaluated using the selected parameter values. The ADC voltage is within range. Based on this evaluation, the 100 MCP41100-I/P-ND digital potentiometer has been selected for use in the analog solver.

## *Traffic Simulation*

**Objective:** Extension of traffic simulation modeling capabilities, with application to the Detroit area I-75 corridor.

**Deliverables:** An AIMSUN-based traffic simulation model for the Detroit area I-75 corridor.

An analytic framework for the calibration and application of micro-simulation techniques was developed and applied to test the impact of alternate IMS on the Detroit area I-75 corridor. A thorough review of the pertinent literature was conducted in four specific areas: (1) IMS and alternate route diversion on freeways and arterials, (2) various types of path and route choice models applied in IMS, (3) measures of effectiveness (MOE) used to evaluate IMS, and (4) the application of micro-simulation models to analyze IMS. Much of the data used in the calibration and application of the model was extracted from archived records of MITSC.

The analytic framework can be summarized as follows;

1. Network creation and assembling different databases.
2. Identification of policies and development of algorithm that comprise the IMS.
3. Calibration of micro-simulation model.
4. Conducting micro-simulation-based experiments, by creating incidents on the network, and by using the databases, algorithm and policies identified in the earlier steps.
5. Analysis of results.

The micro-simulator available in the Advanced Interactive Microscopic Model for Urban and Non-urban Networks (AIMSUN) software is used to test the methodology. AIMSUN is developed by Transportation Simulation Systems (TSS), Barcelona, Spain, and is capable of incorporating various types of incidents in a network consisting of detectors, traffic signals, variable message signs and other attributes. The input data requirement for AIMSUN is a set of scenarios (network description, traffic control plan and traffic demand data) and parameters (simulation time, statistical intervals, reaction time, etc.) which define the experiment. MOE used in assessing the performance of the model are: travel time, delay and queue length.

The methodology is applied to test a heavily traveled portion of urban network in the Detroit metropolitan area. The network consists of two freeways and 11 arterials (Figure 9 above). The freeways I-75 and I-696 provide major mobility needs in the region in the North-South and East-West directions respectively. The arterials serve a combination of mobility and access function in the region.

The network consists of 47 nodes and 108 links. There are 3,152 sections in the network, where a section is defined as a group of contiguous lanes where vehicles move in the same direction. The partition of the traffic network into sections is usually governed by the physical boundaries of the area and the existence of turning movements. There are 26

centroids representing 26 zones that comprise 676 origin destination (O-D) pairs. Variable message signs (VMS) can be placed before freeway exits to inform drivers of regulations that are applicable only during certain periods of the day or under certain traffic conditions. Freeway ramps, merging points and exit points are coded according to their lengths and curvatures. Traffic volume and signal timing data were collected from SEMCOG, Macomb County Road Commission (MCRC), and Traffic.com.

The model calibration process was accomplished following the steps described earlier. Key features of calibration are as follows:

- First, a set of volume data was collected from sensors on I-75 and I-696 on a given Tuesday, June 2008, for three hours between 7 a.m. and 10 a.m. Turning movements and traffic signal data collected for the same period are also given as input to the network.
- These volume data, when input to AIMSUN, were instrumental in creating a 26 x 26 O-D matrix for the exact time period between 7 a.m. and 10 a.m.
- This trip table, when assigned to the network, produced a set of volume data on the freeway and arterials in five minute intervals for a total of 36 intervals for the three hour period.
- For assessing the goodness-of-fit of the assigned volume data, a second set of traffic volume data on the freeways was collected on another Tuesday, in June 2008, between 7 a.m. and 10 a.m. from archived records.

Results of the statistical tests of calibration are presented in Table 1. For all the tests conducted, the goodness-of-fit measures are acceptable, either by error or by degree of correlation.

**TABLE 1. Summary of Goodness-of-fit Measures**

Location	Root Mean Square Error (RMSE) % Error	Correlation Coefficient ( <i>r</i> )	Theil's Weight of Large Errors ( <i>U<sub>i</sub></i> )	Theil's Variance Proportion ( <i>U<sub>s</sub></i> )	Theil's Covariance Proportion ( <i>U<sub>c</sub></i> )	Theil's Bias Proportion ( <i>U<sub>m</sub></i> )
I-75 at I-696	0.036	0.988	0.015	0.053	0.928	0.045
I-75 at 14 Mile	0.054	0.988	0.018	0.002	0.873	0.014
I-696 at Telegraph	0.053	0.975	0.024	0.046	0.922	0.058
I-696 at Telegraph	0.044	0.970	0.020	0.089	0.915	0.013
I-75 Corridor	0.001	0.995	0.013	0.000	0.987	0.014

A composite Root Mean Square Error (RMSE) test was also conducted for the goodness-of-fit between the two sets of volume data in the network for I-75. The simulated volume and actual volume are plotted in Figure 2 showing 612 data points being the result of multiplying 17 locations with 36 five minute counts at each location. The RMSE value computed as 0.001. Other goodness-of-fit statistics for I-75 corridor are presented in the

last row of Table 2. Further, the two sets of values, when plotted on a graph, formed a linear representation at 45<sup>0</sup> (Figure 11).

The model was used to analyze the effects of IMS on three types of incidents: lane closures, section incidents, and forced turnings. In the absence of archived data, a comparison of MOE can only be made between “guided” and “unguided” conditions, assuming that “unguided” conditions represent actual actions of drivers. For each IMS tested, two types of performance data are obtained: unit travel time and unit delay, both measured in seconds/mile/vehicle over one hour of simulated time.

The model output is sensitive to the operational changes associated with the strategies tested and that the trends observed in the model output appear to be logical and reasonable. A more detailed description of this work is found in Khasnabis, et al. (2008).

Conclusions of this effort are;

- The framework is conceptually sound and robust, and it incorporates five critical steps that lend themselves testing of various policy options, as well as operational changes reflecting different IMS.
- Model calibration demonstrated with two sets of independent data sources collected from sensors in the freeway system appears to reflect a reasonable correspondence between the model output and observed data.

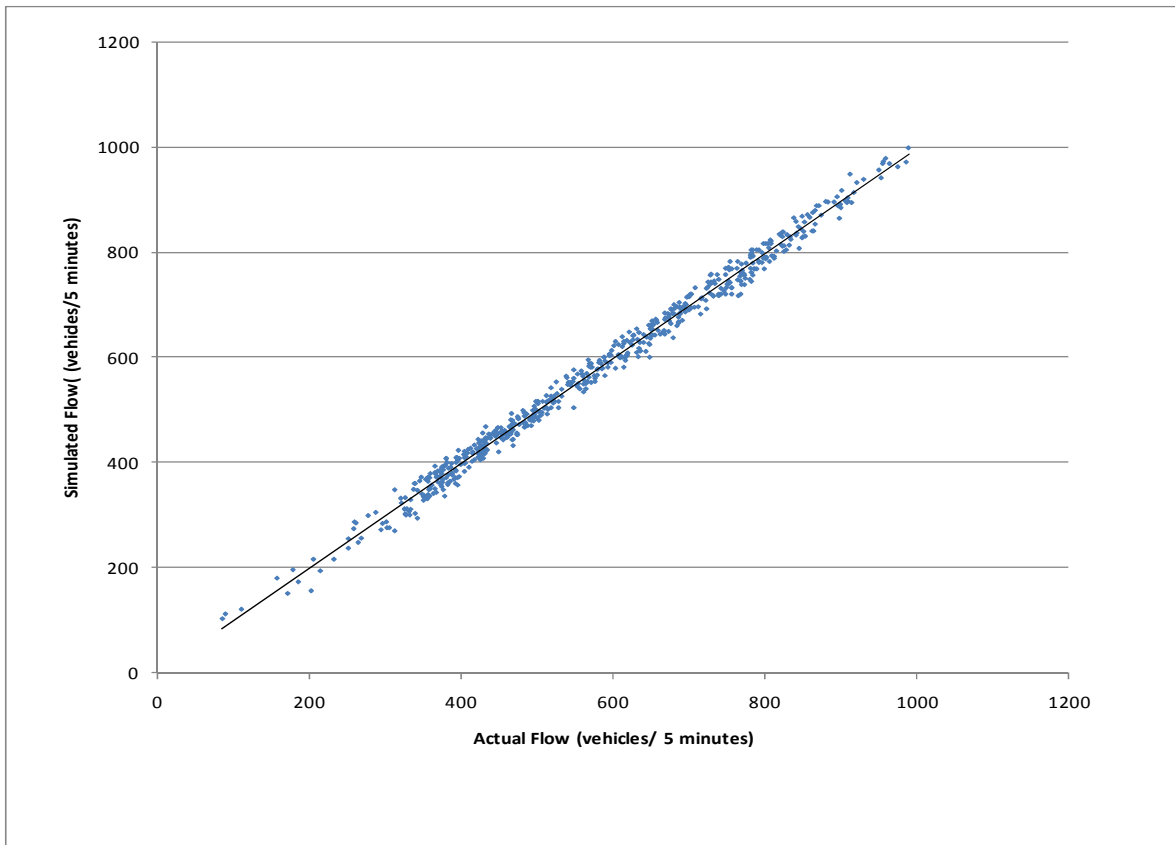

Figure 11. Actual and Simulated flow on I-75 (7 a.m. -10 a.m.)

## **V. Research Vision for September 2008 – August 2010**

To meet its fundamental goals of understanding traffic flow in time and space, as well as to apply this understanding in routing voluminous traffic, the research team intends to transform the speed, volume, and occupancy data collected by MITSC concerning the interstate system in the Detroit metropolitan area into a highly usable public resource. Meeting this objective will involve the following, which can be addressed over a two year period:

1. Systematically acquire the MITSC data. This has been accomplished.
2. Design and implement a database management system for this voluminous data, about 50 gigabytes per year within a MySQL database. Database design and implementation has been demonstrated for a small, less than 10%, subset of the data concerning the Detroit area I-75 corridor.
3. Evaluate the quality of the data and “clean” the data as necessary. This includes determining missing data values and replacing them using proper statistical techniques as well as evaluating the effectiveness of the traffic sensors in consistently collecting data.
4. Develop and implement procedures descriptive, explanatory, and predictive statistical model building to represent the movement of traffic in time and space.
5. Apply these results to voluminous traffic rerouting in the Detroit area I-75 corridor, thus demonstrating their utility.
  - a. Continue refining routing models that take into account time and space.
  - b. Continue refining both software- and hardware based solvers for these models.
  - c. Validate these models using traffic simulation.
  - d. Develop a procedure to assist an ITS in finding alternate routes in an efficient manner in response to traffic incidents.
  - e. Develop a procedure to use the validated model(s) to assess the impact of traffic incidents on the network, in partnership with an ITS.
6. Make the MITSC data, as improved by the activities in 2 above, as well as the statistical modeling procedures, openly available via the World Wide Web.



## **Bibliography**

Even, Andrew. 2007. Multi-Commodity Dynamic Vehicle Routing Subject to Capacity Constraints With Real Time Transportation Information. Unpublished Masters Project. School of Engineering, Padnos College of Engineering and Computing, Grand Valley State University.

Even, Andrew, Shabbir Choudhuri, and Charles Standridge. 2007. Dynamic Traffic Rerouting with Feedback from Infrastructure, INFORMS Annual Meeting, Seattle.

Khasnabis, Snehamay, Sabyasachee Mishra, Subrat Swain, and Anshuman Manori. 2008. Traffic Simulation: Congestion Relief By Travel Time Minimization In Near Real Time. Department of Civil Engineering, College of Engineering, Wayne State University.

Misra, Sabyasachee and Snehamay Khasnabis. 2007. Survey of Literature Review: Congestion Relief By Travel Time Minimization In Near Real Time. Department of Civil Engineering, College of Engineering, Wayne State University.

Misra, Sabyasachee. 2008. A Micro Simulation Model Application for Incident Management Strategies. Institute of Transportation Engineers (ITE) Great Lakes District.

Tusch, Guenter. 2007. ITS Data Analysis Preliminary Results. School of Computing and Information Systems, Padnos College of Engineering and Computing, Grand Valley State University.

Yada, Vishnu, Shabbir Choudhuri, and Charles Standridge. 2007. Web Based Data Repository for Collaboration among ITS Researchers, INFORMS Annual Meeting, Seattle.