

Human Performance Evaluation of Heavy Truck Side Object Detection Systems

Elizabeth N. Mazzae
Transportation Research Center Inc.

W. Riley Garrott
National Highway Traffic Safety Administration
Vehicle Research and Test Center

ABSTRACT

Side object detection systems (SODS) are collision warning systems which alert drivers to the presence of traffic alongside their vehicle within defined detection zones. The intent of SODS is to reduce collisions during lane changes and merging maneuvers. This study examined the effect of right SODS on the performance of commercial vehicle drivers as a means of assessing the impact of these systems on safety.

In this study, eight professional truck drivers drove a tractor-semitrailer equipped with four different sets of SODS hardware or side view mirror configurations. These subjects had no previous experience with SODS. Subjects were tested with two right SODS (a radar-based system and an ultrasonic-based system), a fender-mounted convex mirror, and, for comparison, standard side view mirrors only. For each case, subjects drove the test vehicle through a set route for one day.

The effect of these systems on driver behavior and the extent to which safety may be improved by implementing SODS in combination-unit trucks were assessed based upon the correctness of responses and verbal response times to the question, "Is the right clear?" which prompted subjects to assess the traffic situation to the right side of the test vehicle. Subject glance behavior during right lane changes and normal driving was also examined. Additionally, a debriefing questionnaire was used to acquire subjects' subjective reactions to these systems.

Overall, driver performance with the SODS involved in this study was not significantly improved over that observed with standard side view mirrors. Analysis of the correctness of responses to Right Clear questions showed that subjects' accuracy in assessing the traffic situation along the right side of the vehicle was not improved in the SODS cases, but was improved in the fender-mounted convex mirror case. Verbal response times to Right Clear questions were significantly shorter in the SODS and fender-mounted convex mirror cases than with standard side view mirrors alone. However, this difference may have resulted from a learning effect caused by presenting the standard mirrors first to each subject. Although this data suggests that driver performance was not improved

with SODS, it is important to note that no apparent decline in performance was observed either.

Subjective responses to debriefing questionnaires indicated that subjects were very positive about the fender-mounted convex mirror. Although, subjects reported using the SODS often while driving in the study, glance data showed that subjects only sometimes visually sampled the SODS displays. In general, subjects seemed receptive to the concept of SODS and welcomed any potential improvement to safety.

Although it appears that SODS currently have the potential to provide some benefit, overall results of this study suggest that in order for SODS to make significant improvements to safety in the future, more work is needed to improve their performance and design.

AS INTELLIGENT VEHICLE HIGHWAY SYSTEMS concepts become reality the need arises to ensure that introducing them into vehicles will improve safety. Assuming that the technology behind these systems performs adequately, their success in preventing accidents will depend on how information is presented to the driver. Assessing the degree of benefit provided by current systems is an important step in determining their future potential. The evaluation of system performance and the effect of SODS on driver behavior will help assess their validity as crash avoidance countermeasures.

Statistical examinations of crash data indicate that commercial vehicles are approximately ten times more likely to be involved in angle/sideswipe lane change/merge crashes over their operational lifetimes than are passenger vehicles [1]. In this type of crash, drivers may not be aware of traffic on their right sides due to a blind spot in which traffic cannot be seen in the side view mirrors or by direct viewing out the windows [2].

One proposed solution to this crash problem is side object detection systems (SODS). SODS are intended to supplement standard side view mirror systems by warning

¹ Numbers in parenthesis represent references at the end of this paper.

drivers of adjacent vehicles located in defined detection zones. For commercial vehicles, these systems focus on the right side blind spot area. An alternative proposed solution is the use of a right fender-mounted convex mirror.

In this study, driver performance was observed with two SODS (one radar-based, one ultrasonic-based) and a fender-mounted convex mirror and compared to that observed with standard side view mirrors. Initially a total of four SODS and two alternative mirror cases, in addition to the baseline mirror case, were studied in the on-road experiment. Descriptions of the mirror systems, as used in this experiment, are given in Table 1. Brief descriptions of the sensor technologies and SODS driver interfaces are given in Tables 2 and 3, respectively. However, a preliminary examination of data obtained from the first two subjects showed that some systems received consistently unfavorable responses to debriefing questionnaires and had performance problems including high incidence of inappropriate alarms or missed vehicles. As a result, it was judged that further testing of two SODS, one radar-based system (System N) and one ultrasonic-based system (System K), and one alternative mirror case (System H) would not be worthwhile and so they were dropped from the experiment.

The intention of these systems is to make drivers more aware of surrounding traffic and, therefore, less likely to maneuver their vehicle into an unsafe situation. The overall goal of this research was to determine whether the SODS would indeed increase the safety of driving a combination-unit truck. Since safety cannot be directly measured, this assessment was reduced to the following research questions:

- 1.) Do these SODS help drivers make more accurate assessments of the traffic situation in the lane area to the right of the tractor-semitrailer than do standard side view mirrors?
- 2.) Do these SODS help drivers make quicker assessments of the traffic situation to the right of the tractor-semitrailer than do standard side view mirrors?
- 3.) Based upon glance data, how do drivers use these SODS?
- 4.) Do drivers believe that these SODS are helpful?

METHOD

SUBJECTS - Eight male professional truck drivers participated in this experiment. These subjects had no previous experience with SODS. The subjects' average age was 55.6 years and average experience driving a heavy truck was 30.6 years. Subjects were obtained through Teamsters Unions in Columbus and Zanesville, Ohio. Subjects were paid for their participation in the experiment.

APPARATUS - An extensive array of equipment and instrumentation was utilized in this experiment. The test vehicle used in this study was a 1992 18-speed White Volvo GM conventional tractor with a sleeper cab. This tractor was equipped with a 16.15 m (53 foot) long Fruehauf van trailer. The trailer contained a secured load of concrete which produced a gross vehicle weight of approximately 320,000 Newtons. The tractor came equipped with a side view mirror system consisting

of a 38.4 by 16.8 cm standard West Coast plane mirror and a shallow convex mirror having a 37.3 cm radius of curvature and a diameter of 16.8 cm. This combination of mirrors was present on both the left and right sides of the vehicle.

For the purpose of collecting data, the test vehicle was equipped with 4 video cameras mounted on the outside of the truck. These four cameras were Panasonic WV-CL352 color cameras with Computar 12 mm Autoiris TV lenses. Two were situated on the front fenders of the tractor to record the forward road scene and position of the truck within the lane. The remaining two cameras were mounted on the right side of the trailer to record the traffic in the lane to the right of the truck. This second set of cameras was situated such that both were facing downward at approximately a 45 degree angle, with one camera looking forward and one looking backward. Figure 1 shows the locations of these two cameras on the right side of the trailer and also illustrates the positioning of sensors for the two systems tested. This positioning of the cameras allowed for the monitoring of traffic flow in the lane area along the entire length of the combined tractor and semitrailer. The outside cameras were used to record the traffic environment so that analysts could determine the degree to which the SODS assisted drivers in executing lane changes effectively and safely.

The test vehicle was also equipped with three cameras inside the cab to record driver actions and behavior. Three Ikegami Tsushinki Model #ICD4212 black and white video cameras were installed. One was equipped with a Computar TV Zoom Lens 1.2/8.5-5 1 and was used to record the performance of the SODS displays. Two other cameras of this type were equipped with Computar 12 mm Autoiris TV lenses and focused on driver eye movements and the position of the driver's hands on the steering wheel. Figure 2 illustrates the locations of these cameras and other equipment within the cab of the test vehicle.

Additional video equipment, also shown in Figure 2, was necessary to manage the output of the cameras. Two Robot MV85 Color Multivision Processor quad mixers were present in the rear of the cab to allow the video signals from four cameras to be combined into one frame and recorded on a single VCR, therefore requiring fewer VCRs to record the data. Three Panasonic VHS AG-7400 compact video recorders were used to record data. These VCRs also recorded stereo sound with the assistance of two Realistic 33-1052 lapel microphones and a Realistic 32-1105A 4-Channel Stereo Microphone Mixer. Three time code generator units manufactured by Horita, one model TRG-50 and two models TG-50, were used to imprint timing information on the video frames. A Memorex Portavision 16-244 color video monitor was also present in the rear of the cab to allow the experimenter to monitor the signal being sent to any VCR with the assistance of an Archer Video/Audio Selector Model 15-1956A. A Horita BSG-50 sync generator was used to synchronize the cameras, VCRs and the data acquisition system.

Equipment used also included various types of electronic data gathering devices and associated hardware. A Labeco Performance Monitor was used to monitor the speed of the test vehicle and display the information to the experimenter. Turn signal status and "operator event button" activations were also obtained. These data facilitated the location of events of interest for data extraction and analysis of the video data

TABLE 1. Mirror System Dimensions and Locations

DEVICE	Mirror Dimensions	Location of Mirrors During Testing
B	Plane: 38.4cm x 16.8 cm Shallow Convex: 37.3 cm x 16.8 cm	Both on tractor cab at A-pillar
F	25.4 cm diameter, 19.8 cm radius of curvature	On tractor cab, 0.6 m aft of front of cab, 1.9 m above ground
H	20.3 cm diameter, 10.5 cm radius of curvature	On tractor cab at A-pillar, replaced baseline shallow convex mirror

TABLE 2. Side Object Detection System Sensor Technologies and Locations

DEVICE	Sensor Technology	Commercially Available?	Number of Sensors	Location of Sensors During Testing
Armatron Echovision (K)	Ultrasonic	Yes	1 Transmitter/Receiver Pair	On tractor cab, 3.6 m aft of front of cab, 1.0 m above ground.
N	Relative Velocity Radar	No, Prototype	2 Transmitter/Receiver Pairs	One pair measured ground speed. Second pair on side of tractor cab, 2.1 m aft of the front of the cab, 0.8 m above ground, aimed at the trailer.
R	Position Radar	No, Prototype	3 Transmitter/Receiver Pairs	One pair on tractor cab, 3.2 m aft of front of cab, 0.9 m above ground. Other two pairs on trailer, one 5.8 m from front of trailer and the other 1.8 m from rear of trailer. Both 0.9 m above ground.
Dynatech Scan II (U)	Ultrasonic	Yes	2 Transmitter/Receiver Pairs	One pair on tractor cab, 3.8 m aft of front of cab, 0.8 m above ground. Second pair longitudinally centered on trailer, 0.9 m above ground.

TABLE 3. Side Object Detection System Driver Interface Characteristics

DEVICE	Type of Warning	Warning Levels	Activated by Right Turn Signal	Display Location	Display Description
Armatron Echovision (K)	Visual/Auditory		Visual: No Auditory: Yes	Center of dash; Auxiliary display: A-pillar	38 mm x 101 mm box, red warnings LEDs, green power LED, red 'X' warning light over right side window
N	Visual	See description	No	Center of dash	70 mm x 190 mm box, digital readout of target vehicle relative velocity, LED indication of target vehicle approach or recession
R	Visual/Auditory		Visual: No Auditory: Yes	Center of dash	35 mm x 108 mm box, red LEDs indicate position of object by tractor or trailer
Dynatech Scan II (U)	Visual/Auditory	Distance to object within 10 ft, auditory alarm for objects within 5 ft	No	Center of dash	64 mm X 64 mm box, red digital readout of distance to object, red LEDs surrounding truck figure to indicate position of object

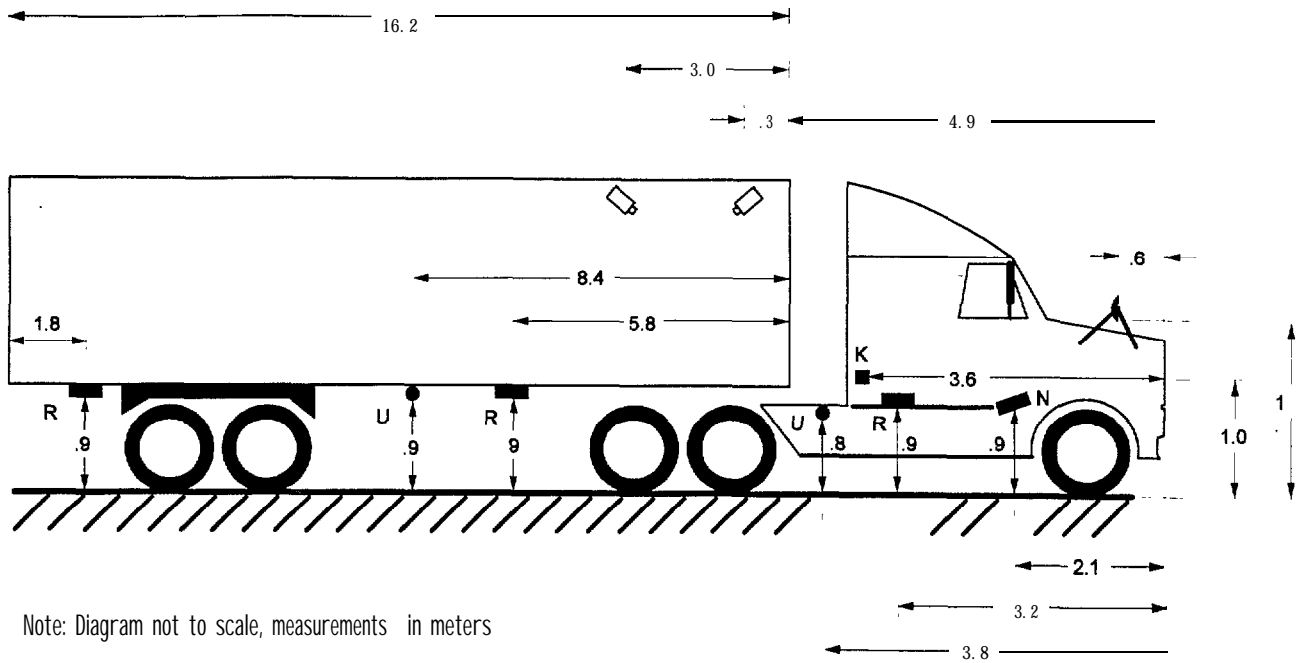

Figure 1. Right side profile of test vehicle illustrating camera and sensor locations for systems R and U

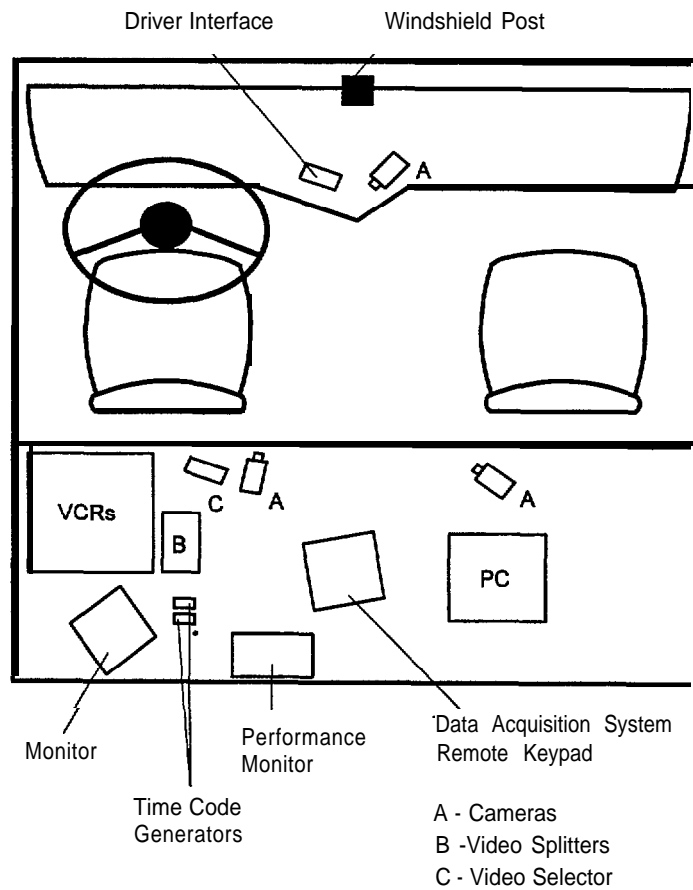

Figure 2. Overhead view of equipment layout in the test vehicle

Additionally, lateral and longitudinal acceleration, yaw and roll rates, steering wheel angle and rate of rotation, lane position, throttle position, and brake activation were recorded. Due to the difficulty of its analysis, this data has not been used to date.

Non-video data was recorded using an Optim Megadac 128 Channel 20 kHz Data Acquisition System which was installed in the left side compartment under the cab of the truck. A Grid 286 Model 1525 laptop personal computer was installed in the rear of the cab to run specialized software to control the operation of the data acquisition system. An Optim Megadac 2000RK Remote Keyboard/Display was present in the cab to allow the experimenter to monitor the status of the Megadac system from within the vehicle.

EXPERIMENTAL DESIGN - The experiment consisted of a 4 X 2 X 3 factorial within-subjects complete randomized block design. A counterbalanced presentation order was used excepting the baseline case, which was presented to subjects first to obtain a sample of the subjects' normal driving style before it was affected by SODS use. On subsequent days, individual SODS were tested. The factors included system case (DEVICE), road type (ROAD) (arterial or freeway), and traffic location (TRAFFIC) (beside the tractor, beside the trailer, or no vehicle present). Subjects drove the same 5.5 hour route for each

DEVICE case, resulting in a total of four testing days per subject. The route employed contained an approximately equal amount of driving on freeway and arterial roads. The number of Right Clear questions per TRAFFIC location and ROAD type was approximately equal.

The DEVICE cases tested were: 1) System B (standard side view mirrors only, served as the Baseline case), 2) System F (right Fender-mounted moderately convex mirror [19.8 cm radius of curvature, 25.4 cm diameter]), 3) System R (Radar-based SODS prototype), and 4) System U (Ultrasonic-based SODS). Standard side view mirrors, consisting of a 38.4 by 16.8 cm plane mirror and a shallow (37.3 cm radius of curvature, 16.8 cm diameter) convex mirror, were present on both sides of the test vehicle in all DEVICE cases. These standard side view mirrors, or System B, represented a baseline to which other DEVICE cases could be compared. The fender-mounted convex mirror was present in the System F case only.

Figure 3 shows each of the mirrors involved in this study. It is important to note that the mirror labeled "A" in Figure 3 was not part of any system case, but rather was used by the experimenter to monitor traffic along the right side of the test vehicle. This mirror was used only by the experimenter and could not be seen by subjects while driving the test vehicle. The measured fields of view for Systems B and F are shown in Figure 4.

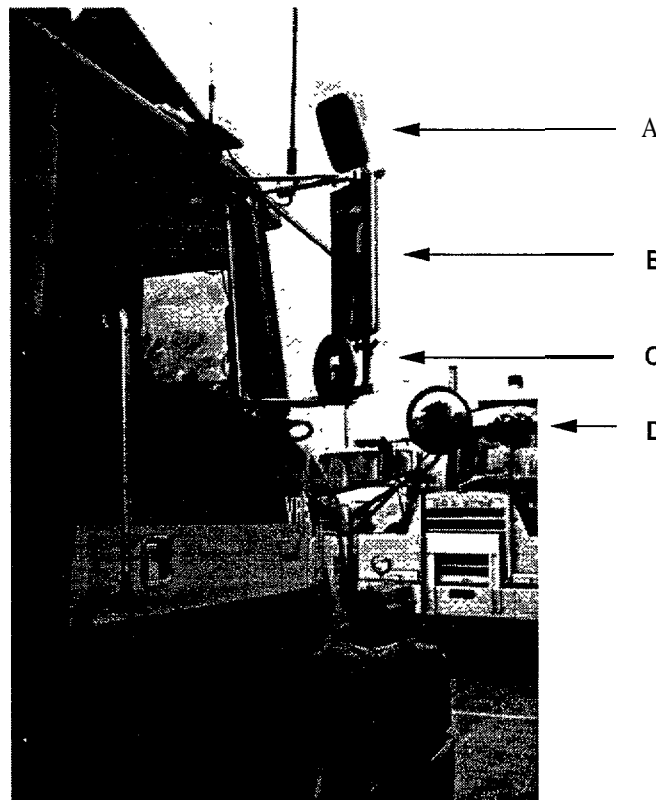

Figure 3. Right Side View Mirrors: A, experimenter mirror; B, plane mirror; C, shallow convex mirror; and D, fender-mounted convex mirror

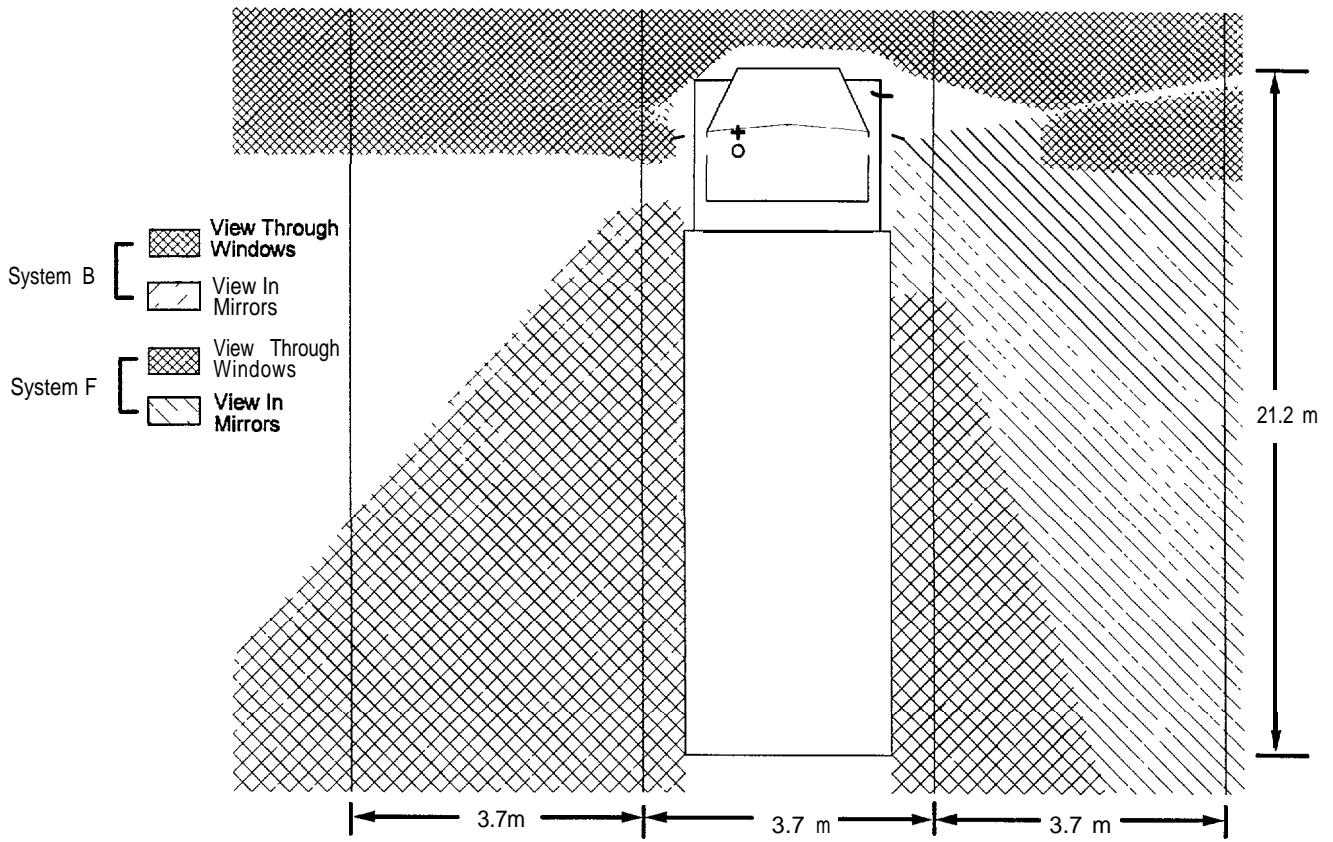

Figure 4. Fields of view for Systems B and F

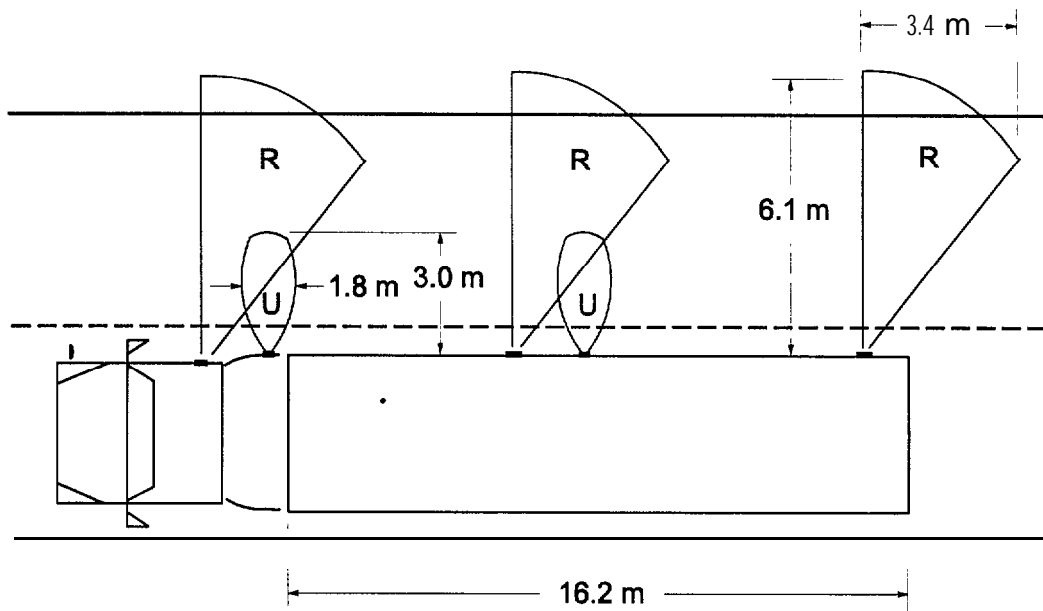

Figure 5. Detection zones for Systems R and U

The zones in which the SODS sensors detected vehicles are depicted in Figure 5. System R (radar-based prototype) had one tractor and two trailer sensors, while System U (ultrasonic-based) had one tractor and one trailer sensor.

Both systems had visual displays which were mounted on the center of the dashboard. The visual display for System R (shown in Figure 6) consisted of red tractor and trailer warning LEDs with different flash rates. System R's auditory warning operated only when the turn signal was activated and featured different beep rates for tractor and trailer warnings. The visual display for System U (shown in Figure 7) contained a truck figure surrounded by warning LEDs positioned to correspond to sensor locations. These visual warning LEDs turned orange when a vehicle was within 3 m of the sensor and red when a vehicle was within 1.5 m. System U also had a red LED display which indicated the distance to a vehicle present in a detection zone. System U had an auditory warning which produced two short beeps when a vehicle was within 1.5 m of a sensor.

Additional information about the sensors and driver displays for these systems is contained in the paper "Hardware Evaluation of Heavy Truck Side and Rear Object Detection Systems [3]."

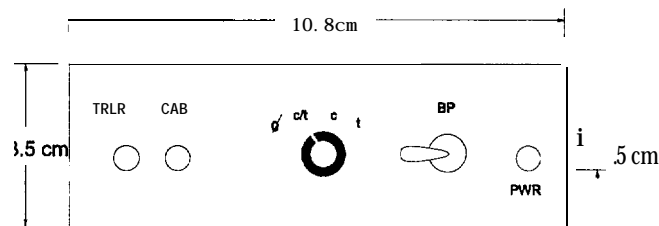

Figure 6. Driver display for System R

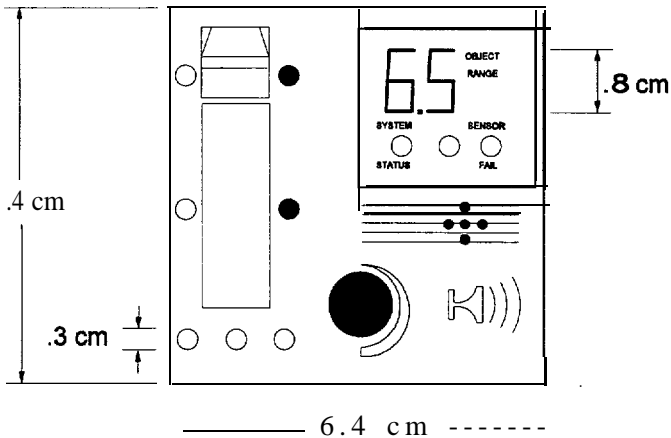

Figure 7. Driver display for System U

PROCEDURE - Each subject drove the same defined test route for each DEVICE case. Before beginning the test route, subjects were provided written and prerecorded audio instructions detailing the test procedures and operation of the SODS. During testing, an experimenter was present in the test

vehicle. Subjects were asked to drive normally while the experimenter provided directional instructions and asked Right Clear questions.

The test day began with a 1.25 hour section of the route used as "familiarity time" in which subjects were given the opportunity to become accustomed to using the SODS being tested that day. The amount of familiarity time given was determined through a pilot study involving four subjects. The subjects were asked to drive with one side object detection system on the first day and a different system on the second day. Each subject was asked to drive the same route segment a total of four times the first day and twice the second day. Drivers were read instructions explaining the nature of the testing, the testing procedures, and the use of the SODS. After each time the route segment was driven, subjects were asked to complete a questionnaire which addressed the issues of system performance, driver interface characteristics, and the influence of the system on their own driving behavior. Questionnaire responses were based on a 5-point scale. The assumption was made that as a driver becomes familiar with a particular system, his or her responses to certain questions should stabilize to a particular value. Analysis of the pilot study results indicated that subjects needed approximately one hour to become accustomed to using a SODS. The amount of time required to become familiar with a second system, after having been familiarized with a first system, was also approximately one hour. As a result, subjects were allowed 1.25 hours of familiarization time per DEVICE case for the on-road experiment.

During each of the 3 remaining sections of the test route, subjects were asked to drive normally while following instructions given by the experimenter. The experimenter instructed the subjects of what exits to take and what turns to make. Subjects were also asked by the experimenter to respond to Right Clear questions. These inquiries were scheduled to be performed during certain segments of each of the last three sections of the route. Subjects were instructed that at all times they were in control of the vehicle and had the option and responsibility to exercise their own judgement as to the appropriateness of making a maneuver or responding to a Right Clear question.

Data, including both the video and audio recordings and the vehicle motion channels, was collected continuously throughout testing using the instrumentation described. Each time the subject was asked to perform a task, the experimenter pressed an "operator event button" which created a visual landmark on the video recording. The purpose of this landmark was to expedite analysis of the video data by allowing the data analyzer to scan through the video recording and stop on only those points where an event of interest occurred.

Right Clear Question - The intent of the Right Clear question was to induce mirror and SODS sampling behavior similar to that observed during lane change maneuvers. The subjects responses to these questions were used to determine whether their accuracy of assessment of the right side traffic situation and response times were affected by DEVICE cases and TRAFFIC locations.

A Right Clear question consisted of the experimenter asking the subject, "Is the right clear?". Subjects were instructed that upon hearing this question they were to use whatever sources of information they had available to determine whether traffic was present in the lane area to the immediate right of the tractor-semitrailer. Available sources of information included the view through the windows of the cab, the right side view mirrors, and the SODS or fender-mounted convex mirror. Subjects were instructed to respond "no." to indicate that a vehicle was present, or "yes", to indicate that no vehicle was present. There was no penalty for an incorrect response. The number of Right Clear questions was approximately equal among TRAFFIC locations and ROAD types for all subjects.

Dependent variables for the Right Clear question included the correctness of responses, verbal response times (VRT), and the number and duration of glances to the SODS and right mirrors. VRT was defined as the elapsed time, in seconds, from the beginning of the Right Clear question to the start of the subject's verbal response.

"Natural Driving" - Periods of "natural driving" were conducted during which the experimenter refrained from asking Right Clear questions. Periods of natural driving were performed on both arterial roads and freeways to record glance behavior during straight-ahead driving. Data collected during natural driving provided a means for comparison with data from the Right Clear questions by which effects on performance could be determined. The dependent variable examined for the natural driving segments was the duration of glances to the SODS displays and right side view mirrors.

Right Lane Changes - Natural right lane changes were also examined during periods of natural driving. Subject glance behavior was recorded during right lane changes on both freeway and arterial ROAD types. The dependent variable examined for right lane changes was the duration of glances to the SODS displays and right side view mirrors.

Debriefing Questionnaire - Upon the completion of driving the test route for a DEVICE case, subjects were asked to complete a debriefing questionnaire. Subjects were asked to rate on a scale of 1 to 5 (1 = lowest, 5 = highest) such issues as the success of the SODS in detecting vehicles, the degree to which the DEVICE increased **driving** safety, and driver interface design. Response scores for individual questions were averaged across subjects to obtain ratings for individual DEVICE cases on a variety of issues.

DATA ANALYSIS

Data analyzed for this experiment was extracted from video recordings made during testing. Unless noted otherwise, analyses of variance were used to determine significance at the 95% level. Newman-Keuls post hoc comparisons were used to further examine significant effects.

VIDEO-POST PROCESSING OF DATA - Post-processing of video data required a person to examine video recordings using a video cassette recorder with frame-by-frame viewing capability, where one frame of video contained 1/30 second of data. The person, or "data reducer," would scan the video looking for an event of interest signified by the operator event LED being illuminated within the video frame. Upon encountering an event of interest, such as a Right Clear question or lane change, the data reducer would record the location and duration of glances associated with that event. The correctness of response and verbal response time to Right Clear questions were also determined by this method.

Glance data was organized by task (i.e., Right Clear questions, natural driving, and right lane changes). A glance was defined as the time interval between glance onset and glance end for a specific location in the visual field. Glance locations examined included the right side view mirrors, the SODS displays, and the forward roadway. These data were further described by ROAD type, DEVICE case, and TRAFFIC location. Glance locations and durations were examined for the period beginning 5 seconds before the Right Clear question and ending 5 seconds after the question. Glance locations and durations for lane changes were examined from 20 seconds before the start of the lane change through the completion of the maneuver.

ANALYSIS OF DATA FOR RIGHT CLEAR QUESTIONS -

Correctness of Response - The significance of the independent variables for the correctness of responses to Right Clear questions were tested using two methods. The ROAD type and TRAFFIC location variables were analyzed using chi-square tests. For the DEVICE variable, a method [4] of calculating confidence intervals about the observed percent correct by DEVICE was used.

Verbal Response Time - The verbal response times (VRT) to Right Clear questions were analyzed by performing an analysis of variance (ANOVA) on the mean VRTs per DEVICE case, TRAFFIC location, and ROAD type. VRT was defined as the elapsed time, in seconds, from the beginning of the Right Clear question to the beginning of the subject's verbal response. A model for a completely randomized block design with fixed block and treatment effects was used for this analysis. In order to determine which levels of the independent variables were significantly different from each other, for those effects found to be significant for VRT, Newman-Keuls post hoc comparisons were used.

Number of Glances - The significance of independent variables for the number of glances to the right side view mirrors and SODS displays during Right Clear questions was determined using ANOVAs. A model for a completely randomized block design with fixed block and treatment effects was used for this analysis. Newman-Keuls post hoc comparisons were used to examine significant effects observed for this dependent variable.

Duration of Glances - To determine the significance of independent variables for the duration of glances to the right side view mirrors and SODS displays during Right Clear questions, an ANOVA was performed on the mean glance durations to each of these locations for each DEVICE case, TRAFFIC location, and ROAD type. A model for a completely randomized block design with fixed block and treatment effects was used for this analysis. Newman-Keuls post hoc comparisons were used to further examine significant effects observed for this dependent variable.

ANALYSIS OF DATA FOR “NATURAL DRIVING” -

Duration of Glances - Analyses of variance were used to determine the significance of independent variables for the duration of glances to the right side view mirrors and SODS displays during natural driving. ANOVAs were performed on the mean glance durations to each of these locations for each DEVICE case, TRAFFIC location, and ROAD type. A model for a completely randomized block design with fixed block and treatment effects was used for this analysis. Newman-Keuls post hoc comparisons were used to further examine significant effects observed for this dependent variable.

ANALYSIS OF DATA FOR RIGHT LANE CHANGES -

Duration of Glances - To determine the significance of independent variables for the duration of glances to the right side view mirrors and SODS displays during Right Clear questions, ANOVAs were performed on the mean glance durations to these locations for each DEVICE case, TRAFFIC location, and ROAD type. A model for a completely randomized block design with fixed block and treatment effects was used for each of these analyses. Newman-Keuls post hoc comparisons were used to further examine significant effects for this dependent variable.

ANALYSIS OF DEBRIEFING QUESTIONNAIRES -

Questions contained in the debriefing questionnaires varied according to the DEVICE case being tested. Subjects were asked to respond to inquiries about such issues as the degree to which they used the SODS, whether or not the presence of the SODS affected the safety of driving the tractor-semitrailer, and whether or not warnings from the SODS were actually helpful to the subjects. These questions were grouped into 10 representative measures in order to simplify their analysis. The 10 measures included system use, safety, awareness of traffic, lane change comfort, and measures relating to system interface characteristics and systems performance. Subjective responses were grouped according to these measures and summarized to examine any apparent trends in the data.

RESULTS

Results of this experiment were based on the examination of data collected during 31 testing days involving 8 subjects. Each subject drove one day with each of the 4 DEVICE cases. (Note: Due to illness, Subject 7 served in only three of the four DEVICE cases.) Data analyzed included 1473

Right Clear questions, 186 minutes of natural driving, 132 right lane changes (sampled from a total of 570 non-commanded lane changes executed throughout the experiment), and from the questionnaire. A total of 8,939 visual glances were examined. Subjective responses collected for all 8 subjects using a debriefing questionnaire were also examined.

RIGHT CLEAR QUESTION - Overall, the average number of Right Clear questions asked per DEVICE case was approximately 368. Table 4 shows the numbers of errors made by subjects per DEVICE and TRAFFIC location. Tables 5, 6 and 7 show selected data from Right Clear questions differentiated by DEVICE, TRAFFIC, and ROAD.

Correctness of Response - Subjects responded correctly to 98.1% of all Right Clear questions. Since this is categorical (noncontinuous) data, due to the small number of errors observed for System F shown in Table 4, standard statistical significance tests for the DEVICE variable could not be used. Instead, a method [4] of calculating confidence intervals about the observed percent correct by DEVICE was used. This method found the DEVICE cases of Systems U and F to be significantly different at $\alpha=0.05$, but no system was found to be different from System B at this level. Use of 80% confidence intervals showed System F to be significantly different from System B.

TABLE 4. Right Clear Errors by DEVICE and TRAFFIC Locations

TRAFFIC Location	B	F	R	U
No Vehicle	2	1	4	4
Vehicle by Tractor	2	0	4	6
Vehicle by Trailer	3	0	0	2

Verbal Response Time - The results of a Newman-Keuls post hoc test on the VRT to Right Clear questions by DEVICE (given in Table 5) showed System B to be significantly different from all other DEVICE cases.

Glances The results of the post hoc analysis of right side view mirror glance durations during Right Clear questions by TRAFFIC location (given in Table 6) showed the “no vehicle” case to be significantly different from the other two cases.

“NATURAL DRIVING” - During natural driving, significant effects were found for right side view mirror glance durations due to ROAD type ($F[1,789]=30.33, p<0.0001$) with 1.39 s for arterial and 1.16 s for freeway roads. The interaction of DEVICE by ROAD type ($F[3,789]=3.87, p=0.0092$) was also statistically significant for right mirror glance durations. This interaction showed that mean right mirror glance durations during natural driving were longer for arterial roads than

TABLE 5. Right Clear Question Results by DEVICE (RM=right side view mirrors)

Dependent Variable	B	F	R	U	Statistically Significant?
% Correct	97.9	99.7	97.9	96.6	No, $\alpha=0.05$ Yes, $\alpha=0.20$
Mean VRT (s)	1.94	1.70	1.75	1.63	Yes, $F[3,1442]=19.89$, $p \leq 0.0001$
# of RM Glances	1.07	1.02	1.03	1.06	No, $F[3,1413]=0.61$, $p=0.6076$
RM Glance Duration (s)	1.38	1.31	1.31	1.34	No, $F[3,1506]=1.19$, $p=0.3121$

TABLE 6. Right Clear Results by TRAFFIC location

Dependent Variable	By Tractor	By Trailer	No Vehicle	Statistically Significant?
%Correct	97.3	98.9	98.0	No, $X^2(df=2)=3.18$, $p=0.2043$
Mean VRT (s)	1.65	1.69	1.88	Yes, $F[2,1442]=39.48$, $p \leq 0.0001$
# of RM Glances	1.01	1.04	1.07	No, $F[2,1413]=1.01$, $p=0.3632$
RM Glance Duration (s)	1.22	1.27	1.48	Yes, $F[1,1506]=58.54$, $p \leq 0.0001$

TABLE 7. Right Clear Results by ROAD type

Dependent Variable	Arterial	Freeway	Statistically Significant?
%Correct	97.3	98.9	Yes, $x^2(df=1)=5.36$, $p=0.0206$
Mean VRT (s)	1.75	1.75	No, $F[1,1442]=0.15$, $p=0.7024$
# of RM Glances	1.05	1.04	No, $F[1,1413]=0.07$, $p=0.7863$
RM Glance Duration (s)	1.32	1.35	No, $F[1,1506]=2.22$, $p=0.1362$

TABLE 8. SODS Visual Sampling Rate from Glance Data

SODS	Right Clear Question	Right Lane Change	Natural Driving
System R	13.5 %	41.2 %	2.0 per min.
System U	7.6 %	75.8 %	1.0 per min.

TABLE 9. SODS Performance Metrics

SODS	% of Vehicles Undetected	Ratio of Inappropriate to Appropriate Alarms	Average Minutes Between Inappropriate Alarms
System R	3.2	0.22:1	15
System U	6.3	0.03:1	126

freeways for all systems except R, for which these glance durations were equal for both road types.

RIGHT LANE CHANGES - The mean number of right side view mirror glances during right lane changes was not significant for DEVICE, with the average number of glances across DEVICE cases being 4.3 (4.30 for System B, 4.22 for F, 4.21 for R, and 4.52 for U).

Glance durations to the right side view mirrors during right lane changes showed a significant effect due to DEVICE ($F[3,554]=2.81, p=0.0387$). These glances were shortest for System U (1.26 s), followed by System R (1.35 s), System F (1.41 s), and System B (1.42 s), respectively. The results of a Newman-Keuls post hoc test showed glances to the right side view mirrors with System U were significantly shorter than those with Systems B and F.

Glance durations to the right side view mirrors during right lane changes also showed a significant effect due to ROAD type ($F[1,554]=7.40, p=0.0065$). Right side view mirror glance durations averaged 1.28 s on arterial roads and 1.45 s on freeways.

OVERALL SODS VISUAL DISPLAY SAMPLING - Overall, the number and duration of glances to SODS displays showed no significance due to any independent variable during Right Clear questions, right lane changes, and natural driving. Table 8 shows the percent of Right Clear questions and right lane changes in which subjects visually sampled the SODS displays, and the number of times per minute drivers looked at the displays during natural driving.

OVERALL SODS PERFORMANCE - The SODS involved in this experiment did not perform flawlessly. Performance problems included missed vehicles and inappropriate alarms due either to objects other than adjacent vehicles or to unknown causes. Table 9 shows the percentage of passing vehicles that were missed by all of each systems' sensors, the ratio of inappropriate alarms to appropriate alarms, and the number of minutes between inappropriate alarms for the two systems.

DEBRIEFING QUESTIONNAIRE - Subjects reported that System F increased the safety of driving most, followed by Systems U and R. Subjects also felt that System F increased their awareness of surrounding traffic, followed by Systems U and R. Subjects stated that information could be acquired most quickly with System F's display, followed by Systems U and R. Subjects estimated that System R produced fewer inappropriate warnings than did System U. Warnings provided by System R were considered more timely and useful than those provided by System U.

DISCUSSION

Overall, the data show that driver performance was not significantly improved by the presence of these SODS. However, it is important to note that no apparent decline in driver performance was observed with the use of these SODS either. The discussion of these dependent variables follows and is conducted based upon the previously defined research questions.

DO THESE SODS HELP DRIVERS MAKE MORE ACCURATE ASSESSMENTS OF THE TRAFFIC SITUATION IN THE LANE AREA TO THE RIGHT OF THE TRACTOR-SEMITRAILER THAN DO STANDARD SIDE VIEW MIRRORS? - The assumption behind this research question was that systems which help drivers make more accurate assessments of the right side traffic situation enhance safety.

Results listed in Table 5 indicate that, across all levels of the TRAFFIC and ROAD variables, these SODS do not help drivers make more accurate assessments of the right side traffic situation as compared to the baseline case (System B). However, with 80% confidence it can be said that drivers made more accurate assessments of the right side traffic situation with System F than with System B.

Table 6 shows that subjects' accuracy of response to Right Clear questions did not significantly vary between TRAFFIC locations. Had an effect on response accuracy been found due to TRAFFIC location, this information could have provided guidance to systems designers on the appropriate number and the most strategic placement of sensors.

Table 8 shows that, over all DEVICE cases, subjects made 2.5 times more errors on arterial roads as on freeways. This may be due to the higher traffic density on arterial roads.

DO THESE SODS HELP DRIVERS MAKE QUICKER ASSESSMENTS OF THE TRAFFIC SITUATION TO THE RIGHT OF THE TRACTOR-SEMITRAILER THAN DO STANDARD SIDE VIEW MIRRORS? - One assumption behind this research question is that the more certain subjects are of the traffic situation to the right of the tractor-semitrailer, the quicker their assessment of it will be. In other words, if subjects are unsure as to what traffic is to their right, they will make more glances at the mirrors and SODS systems, resulting in a longer VRT. A second assumption was that safety was enhanced by being more certain of the traffic situation to the right.

The longer mean VRT for System B in Table 5 may result from a learning effect caused by presenting this case to each subject first. Graphing VRTs as a function of time during the day showed that the VRTs became shorter as the day went on for each subject's first day of testing. Time of day had no effect on VRT for the other three days of testing. The mean VRTs of System U and System F were better than that of System R; however, the relationships of these mean VRTs to those of System B that would have been obtained had there not been an order effect cannot be known.

Table 6 shows that VRT was significantly greater for the 'no vehicle' value of TRAFFIC. This is reasonable since it corresponds to the greater difficulty of determining that no vehicle is present in the side view mirrors.

BASED UPON GLANCE DATA, HOW DO DRIVERS USE THESE SODS?

The impact of SODS use on subjects' glance behavior was of interest in terms of SODS visual display sampling behavior, the effect of SODS on right side view mirror usage, and whether the SODS displays were a distraction.

Table 8 shows the percentage of tasks that subjects looked at each SODS during Right Clear questions and natural right lane changes, and the number of times per minute subjects looked at the SODS during natural driving. Subjects visually sampled the SODS displays some, but not all of the time. Glance rate was higher during right lane changes when there was a penalty for error (a potential crash). Visual sampling of SODS displays during natural driving was one-fourth to one-half that of the right side view mirrors. The low SODS driver interface visual sampling rate suggests that the SODS were not distracting to the subjects.

Although drivers reported using the systems frequently in the debriefing questionnaires, glance data showed that subjects only sometimes visually sampled the SODS interfaces. The contradicting subjective response may reflect subjects' use of the auditory warnings.

The lack of significance for the number and duration of right mirror glances, shown in Table 5, indicates that these SODS did not affect subject's right side view mirror usage. This lack of effect on right mirror sampling rate is viewed as a good result since SODS are generally intended to supplement right mirror usage.

DO DRIVERS BELIEVE THAT THESE SODS ARE HELPFUL? - The assumption behind this research question is that subjects are accurate assessors as to whether SODS improve safety. Subjects' overall attitudes towards the SODS were favorable, but they did not appear to prefer one system over another. Subjects especially liked the fender-mounted convex mirror. Overall, subjects stated that they welcomed any device which might decrease their chances of having a collision and improve safety.

SUMMARY OF RESULTS

Overall, of the 1473 Right Clear questions, 98.1 percent of subjects' responses were correct. Analysis of the correctness of responses to Right Clear questions showed that subjects' accuracy of assessment of the traffic situation along the right side of the test vehicle was not significantly improved ($\alpha=0.05$) with the presence of the SODS or the fender-mounted convex mirror as compared to the baseline case. There was, however, a significant difference between the correctness of responses observed for the fender-mounted convex mirror and that of the ultrasonic-based system. The effect of ROAD type on accuracy of response was significant, with 2.5 times more errors committed on arterial roads than on freeways. The significance of this effect is likely to be attributed to the higher traffic densities present on arterial roads.

Analysis of the verbal response times to Right Clear questions showed that response times were significantly lower in the SODS and fender-mounted convex mirror cases than in the baseline case. However, this difference may have been due to a learning effect caused by presenting the baseline case first to each subject. The location of TRAFFIC in the lane to the immediate right of the test vehicle did significantly affect verbal response times to Right Clear questions. ROAD type, however, did not have a significant effect on the verbal response times to the Right Clear question.

The presence of the SODS did not affect subjects' use of the right side view (baseline) mirrors during Right Clear questions. However, DEVICE type was found to have a significant effect on right mirror glance duration during right lane changes and natural driving. DEVICE did not have a significant effect on SODS display glance duration during right lane changes and natural driving.

Although subjects reported that they thought the systems were beneficial, glance data showed that they only sometimes visually sampled the SODS displays during Right Clear questions (5 to 15 percent of questions). Subjects used the SODS more while performing lane changes (41 percent for System R and 75 percent for System U). This may indicate that subjects found the systems to be helpful. However, it was not clear from other measures whether or not safety was improved.

Subjective data collected using the debriefing questionnaire indicated that subjects were receptive to the concept of SODS and welcomed any potential benefit to safety. Subjects were very positive about the fender-mounted convex mirror. Responses to questions regarding subjects' comfort in making lane changes showed the baseline case (right side view mirrors only) to be significantly better than System U. Examination of trends in the questionnaire responses show an apparent order in which the subjects gave the most favorable responses for the baseline case, followed by the fender-mounted convex mirror, and lastly the two SODS, which fared approximately equally.

CONCLUSIONS: ARE SODS A VIABLE SOLUTION TO THE LANE CHANGE/MERGE CRASH PROBLEM FOR HEAVY TRUCKS?

Overall, driver performance observed with these SODS was not significantly improved over that observed with the standard side view mirrors. Although subjects reported that they thought the SODS were beneficial, glance data showed that they only sometimes visually sampled the SODS displays during Right Clear questions and while performing lane changes. Analysis of the correctness of responses to Right Clear questions showed that subjects' accuracy in assessing the traffic situation along the right side of the truck was not significantly improved over the baseline case. Analysis of response times to Right Clear questions showed that response times were significantly shorter in the SODS and fender-mounted convex mirror cases than in the baseline case. However, this difference may have been due to a learning effect caused by presentation of the baseline case first to each subject.

Subjective data indicated that subjects were receptive to the concept of SODS and welcomed any potential benefit to safety.

Overall, subjects seemed most positive about the fender-mounted convex mirror. Results show with 80% confidence that this mirror did produce an improvement in the correctness of responses to Right Clear questions. This result suggests that fender-mounted convex mirrors may currently be a better solution to the angle/sideswipe lane change/merge crash problem, or at minimum may be considered a viable interim solution while anticipating the production of new SODS which perform more accurately and reliably. However, one beneficial quality of most SODS which the fender-mounted mirror does not have is an auditory alarm which may be especially useful in alerting inattentive drivers to surrounding traffic.

In principle, right SODS have the potential to provide benefit to drivers of heavy vehicles in monitoring surrounding traffic and preventing accidents. However, if these SODS are to offer significant safety benefits in the future, more work is needed to refine their design and performance.

SUGGESTIONS FOR METHODOLOGICAL IMPROVEMENTS AND FUTURE WORK

As in any study, some potential improvements to methodologies can be realized in retrospect. However, solutions to concerns about methodologies for assessing the degree of safety benefit provided by collision warning systems are not, in many cases, readily apparent.

- There appears to be a need to allow more time for drivers to become familiarized with the use of the SODS. Additional time for familiarization should allow drivers to become comfortable with the presence of the device and overcome the initial novelty associated with it. However, the length of time necessary for drivers to become accustomed to using a system has not been determined.
- The use of experimental tasks such as Right Clear questions should be delayed in the test runs to allow more time for naturalistic driving behavior to be observed before drivers' behavior is affected by SODS use. This would allow for a stronger comparison to be made between driver behavior with and without SODS.
- The occasional use of Left Clear questions may help to deemphasize the drivers' perception of the study's focus on right side traffic and, therefore, not bias them to attend to the right side traffic situation more than they normally would.
- Although ROAD type had a significant effect on subjects' correctness of response to Right Clear questions, the overall effect of ROAD type was minimal in this study. Therefore, future testing could be limited to freeways only. Testing on freeway sections with high traffic density would also allow for the examination of the effects of SODS use on drivers' headway maintenance.
- Additional work is also needed to develop more sensitive measures for the evaluation of these systems. Methods used in this study did provide some interesting results, but did not allow for many clear conclusion to be drawn.

ACKNOWLEDGEMENTS

The authors acknowledge the contributions of Neil Lemer of COMSIS and Bari Kotwal, formerly of COMSIS, toward the development of the on-road experiment. Also acknowledged are Dr. Thomas H. Rockwell and Steven M. Kiger of R & R Research for their extensive support of this research.

REFERENCES

1. U.S. Department of Transportation, National Highway Traffic Safety Administration. (1994, January). *A Study of Commercial Motor Vehicle Electronics-Based Rear and Side Object Detection Systems*. (DOT HS 808 075). Washington, D.C.: National Highway Traffic Safety Administration.
2. U.S. Department of Transportation, National Highway Traffic Safety Administration. (1994, January). *Lane change/merge crashes: Problem size assessment and statistical description*. (DOT HS 808 080). Washington, D.C.: National Highway Traffic Safety Administration.
3. Garrott, W. R., Flick, M.A. and Mazzae, E. N. (1995). *Hardware evaluation of heavy truck side and rear object detection systems*. (SAE Technical Paper Series No. 951010). Warrendale, PA: Society of Automotive Engineers.
4. Ostle, B. (1963). *Statistics in research*. Ames, IA: The Iowa State University Press.