

|  |  |   |   |  |                  |
|--|--|---|---|--|------------------|
| <b>1. Report No.</b><br>SWUTC/11/476660-00080-1  |  | <b>2. Government Accession No.</b>                          |   | <b>3. Recipient's Catalog No.</b>  |                  |
| <b>4. Title and Subtitle</b><br><br>Hybrid Distribution Trucks: Costs and Benefits   |  |   |   | <b>5. Report Date</b><br>June 2011                                       |                  |
|  |  |   |   | <b>6. Performing Organization Code</b>                                   |                  |
| <b>7. Author(s)</b><br>Garrett Anderson and Rob Harrison   |  |   |   | <b>8. Performing Organization Report No.</b><br>Report 476660-00080-1    |                  |
| <b>9. Performing Organization Name and Address</b><br>Center for Transportation Research<br>University of Texas at Austin<br>1616 Guadalupe Street<br>Austin, TX 78701   |  |   |   | <b>10. Work Unit No. (TRAIS)</b>   |                  |
|  |  |   |   | <b>11. Contract or Grant No.</b><br>DTRS99-G-0006                        |                  |
| <b>12. Sponsoring Agency Name and Address</b><br>Southwest Region University Transportation Center<br>Texas Transportation Institute<br>Texas A&M University System<br>College Station, Texas 77843-3135   |  |   |   | <b>13. Type of Report and Period Covered</b><br>September 2010-June 2011 |                  |
|  |  |   |   | <b>14. Sponsoring Agency Code</b>  |                  |
| <b>15. Supplementary Notes</b><br>Supported by a grant from the U.S. Department of Transportation, University Transportation Centers Program.  |  |   |   |  |                  |
| <b>16. Abstract</b><br>The respective populations of the United States and Texas are expected to significantly increase over to the next several decades, primarily in urban and metropolitan areas. Economists have also predicted that oil prices will rise in real terms during the same period. Air quality is getting worse in a number of metropolitan areas, triggering non-attainment penalties and spurring an interest in cleaner transportation. Incentives and new policies must be adopted to increase the efficiency of the transportation system and thus move freight with a reduced impact on society and the environment. Hybrids can potentially help solve this issue through their increased fuel economy and reduced emissions. This project evaluated a package delivery truck, beverage delivery truck, and a refuse truck. The research determined that the additional cost (with current prices) of the hybrid refuse truck was justified, but not for the other two trucks. The social cost of emissions was also estimated to help justify hybrids' implementation. With this information, the rate of hybrid truck adoption was estimated for various policy scenarios. The results indicated that a correctly designed incentive program can greatly increase the rate of hybrid adoption and could be justified by the additional social benefits of emissions reduction. |  |   |   |  |                  |
| <b>17. Key Words</b><br>Hybrid, Distribution, Costs, Benefits, Demand, Fuel Consumption, Freight, Air Quality, Emissions, Texas  |  |   | <b>18. Distribution Statement</b><br>No restrictions. This document is available to the public through NTIS:<br>National Technical Information Service<br>5285 Port Royal Road<br>Springfield, Virginia 22161 |  |                  |
| <b>19. Security Classif. (of this report)</b><br>Unclassified  |  | <b>20. Security Classif. (of this page)</b><br>Unclassified |   | <b>21. No. of Pages</b><br>119   | <b>22. Price</b> |



# **Hybrid Distribution Trucks: Costs and Benefits**

By

Garrett Anderson

Robert Harrison

Research Report 476660-00080-1

Southwest Region University Transportation Center

Center for Transportation Research

University of Texas at Austin

Austin, Texas 78701

June 2011



## **Abstract**

The respective populations of the United States and Texas are expected to significantly increase over to the next several decades, primarily in urban and metropolitan areas. Economists have also predicted that oil prices will rise in real terms during the same period. Air quality is getting worse in a number of metropolitan areas, triggering non-attainment penalties and spurring an interest in cleaner transportation. Incentives and new policies must be adopted to increase the efficiency of the transportation system and thus move freight with a reduced impact on society and the environment. Hybrids can potentially help solve this issue through their increased fuel economy and reduced emissions. This project evaluated a package delivery truck, beverage delivery truck, and a refuse truck. The research determined that the additional cost (with current prices) of the hybrid refuse truck was justified, but not for the other two trucks. The social cost of emissions was also estimated to help justify hybrids' implementation. With this information, the rate of hybrid truck adoption was estimated for various policy scenarios. The results indicated that a correctly designed incentive program can greatly increase the rate of hybrid adoption and could be justified by the additional social benefits of emissions reduction.

## Disclaimer

The contents of this report reflect the views of the authors, who are responsible for the facts and the accuracy of the information presented herein. This document is disseminated under the sponsorship of the Department of Transportation, University Transportation Centers Program in the interest of information exchange. The U.S. Government assumes no liability for the contents or use thereof.

An important concept to understand for this report is the difference between fuel economy and fuel consumption. Fuel economy is typically specified in miles/gallon while fuel consumption is specified in gallons/mile. Therefore a 25% increase in fuel economy does not equal a 25% percent reduction in fuel consumption. The relationship between the two quantities can be seen in the equation as well as a reference between the two in the accompanying table.

### Reference between increase and fuel economy and reduction in fuel consumption.

| <b>Percent Increase In Fuel Economy</b> | <b>Percent Reduction in Fuel Economy</b> |
|---|--|
| 10%                                     | 9%                                       |
| 15%                                     | 13%                                      |
| 20%                                     | 17%                                      |
| 25%                                     | 20%                                      |
| 30%                                     | 23%                                      |
| 35%                                     | 26%                                      |
| 40%                                     | 29%                                      |
| 45%                                     | 31%                                      |
| 50%                                     | 33%                                      |

## **Acknowledgment**

This research was supported by a grant from the U.S. Department of Transportation's University Transportation Centers Program to the Southwest Region University Transportation Center. The authors appreciate the careful and constructive editing of Maureen Kelly, CTR Editor.





## Executive Summary

The U.S. population is expected to grow by 85.6 to 106.9 million people by the year 2040 from the current population of 308.7 million (U.S. Census Bureau), and the Texas population is predicted to grow by 14.9 million people from the current population of 25.1 million (Texas State Data Center), as Figure 1 depicts. This additional population will create a larger demand for freight to bring in the goods that people require and also to dispose of their increased refuse. The population growth should also create an increase in jobs, which will most likely cause an increase in raw materials, equipment, produced goods, and services, all of which will require transportation.

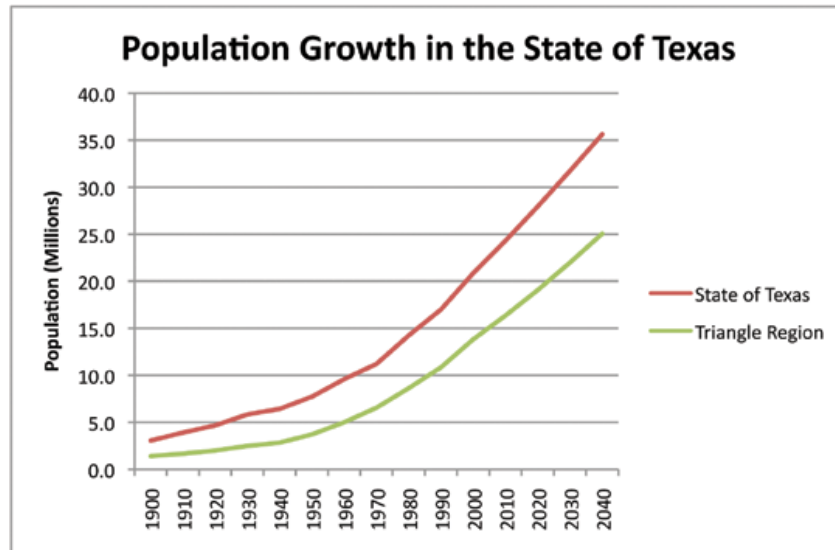

Source: Butler et al.

Figure 1. Comparison of actual and estimated population growth of the state of Texas and the “Texas Triangle” megaregion.

A large percentage of the additional growth in Texas is predicted to occur in what is known as the “Texas Triangle” megaregion. A megaregion is made up of two or more metropolitan areas that are linked through multimodal transportation infrastructures, environmental systems, and complementary economies. Megaregions have the benefit of concentrating people, jobs, and capital, which makes them attractive in a global economy (Butler et al.).

Clearly the growing freight demand in Texas will require a more efficient transportation system at many levels. Creating a more efficient system will require many solutions, and hybrid trucks offer the potential to fill a niche where specific types of freight movement exist. Their adoption could potentially reduce emissions as well as fuel consumption.

The objectives of this study were to identify current users of hybrids. This study utilizes the available information to estimate the operating costs of hybrids in these applications and determine the potential social benefits in order to determine a total cost model. This report seeks to estimate the true cost of truck operations by using the social cost of vehicle emissions estimated by the Environmental Protection Agency (EPA). With this data, the rate of adoption of these hybrid trucks will be estimated for various policy scenarios.

Coca-Cola, UPS, FedEx, and Waste Management are examples of companies that are either using hybrid trucks or evaluating them. The common thread between all of these companies is that they all operate in urban environments, and their trucks make frequent stops during the course of a day to either pick up or deliver materials. Many manufacturers like Peterbilt, Kenworth, Freightliner, and International now build hybrid trucks or chassis that are commercially available.

Three truck applications were selected based on current usage of hybrids and vehicle type. The three applications selected were a package delivery step van, a beverage delivery tractor trailer, and a refuse truck. All three of these applications have seen some usage of hybrids, and they all have drive cycles that lend themselves to hybrid drivetrains.

The package delivery truck considered was a step van assumed to cost \$115,000 (\$75,000 base cost with an additional \$40,000 hybrid system). The operating cost was evaluated under two conditions. The first was meant to simulate an urban environment with the truck traveling 17,000 miles/year with a fuel economy of 8 mpg. The second was meant to approximate a more suburban route with an annual mileage of 21,000 miles/year with a fuel economy of 11.2 mpg. The system did not appear to pay for itself when maintenance, depreciation, fuel, and interest costs were considered. The fuel cost was assumed to vary between \$3.50 and \$6.50 per gallon. With a cost of \$6.50 per gallon, the urban system cost an additional \$65,000 to operate over a period of 10 years. The truck on the suburban route was estimated to cost an additional \$69,000 to operate over the same period.

The beverage delivery truck was assumed to cost \$140,000 (\$100,000 base cost with an additional \$40,000 hybrid electric system). Only one condition was evaluated for this particular application. The annual mileage was assumed to be about 40,000 miles/year with a fuel economy of 4.7 mpg. This analysis greatly resembled the package delivery truck's because they both utilize very similar systems manufactured by Eaton. Unlike the package delivery truck, this application appears to pay for itself with a fuel cost between \$4.50 and \$5.00 per gallon, due to the increased utilization and higher fuel consumption.

A refuse truck was also evaluated for use as a hybrid. The system evaluated for this application was a hydraulic hybrid system. This system uses compressed fluid to store and transmit energy during vehicle operation rather than electricity. This system was estimated to cost \$20,000 and reduce fuel consumption by 25%. Brake wear was also included in this analysis because it represents a large percentage of a refuse truck's operating cost and data is available from actual vehicle operation. The hybrid system data show that brake life (in miles) is at least twice that of conventional diesel engine refuse trucks. A brake replacement would cost \$2,000 and occur every 4 months for a conventional refuse truck and 8 months for the hybrid version. This truck was evaluated in two settings. The truck in the urban setting was assumed to travel 10,234 miles/year with a fuel economy of 1.8 mpg. In the suburban setting, the truck was assumed to travel 23,898 miles/year with a fuel economy of 3 mpg. With these assumptions the system appears to pay for itself in about 7 years with fuel prices of \$3.50 per gallon in the urban setting. The system takes only a little over 2 years to pay for itself in the urban setting with fuel prices of \$6.50 per gallon. In the rural setting the system does not pay for itself within a 10-year period until fuel prices reach \$5.50 per gallon. Even with fuel prices of \$6.50 the system takes over 8 years to pay for itself.

Additional government incentives and benefits that may be associated with hybrids were then considered for the package delivery and beverage delivery trucks, but not for refuse trucks. The combined total of these factors was estimated to be about \$32,000. With these benefits included, the beverage truck could justify the hybrid system. However, the package delivery truck still cost more to operate.

Vehicle emissions are very important and should be considered despite the fact that the operator experiences no financial benefit from their reduction. The EPA regulates several common air pollutants through the Clean Air Act. These pollutants can chest pain, asthma, cancer, congestion, and permanent lung damage. Due to these issues, the emissions place a cost on society now being estimated by a variety of transportation engineers and economists.

The EPA is required to periodically estimate the costs and benefits of the Clean Air Act. Their most recent report was released in March 2011. Table 1 lists the estimated health benefits. Also estimated was the amount each pollutant was reduced because of the Clean Air Act Table 2.

**Table 1. Estimated avoided sickness and deaths attributed to Clean Air Act regulation.**

|                        | <b>Annual Monetized Benefits</b> |
|------------------------|----------------------------------|
| <b>PM Mortality</b>    | \$ 1,200,000,000,000.00          |
| <b>PM Morbidity</b>    | \$ 46,000,000,000.00             |
| <b>Ozone Mortality</b> | \$ 33,000,000,000.00             |
| <b>Ozone Morbidity</b> | \$ 1,300,000,000.00              |

*Source: Industrial Economics, Incorporated*

**Table 2. Estimated reduction in U.S. emissions due to Clean Air Act regulation.**

| <b>Pollutant</b>        | <b>Emissions Reduction (tons/year)</b> |
|-------------------------|--|
| <b>VOC</b>              | 12,626,000                             |
| <b>NO<sub>x</sub></b>   | 14,877,000                             |
| <b>PM<sub>10</sub></b>  | 5,992,000                              |
| <b>PM<sub>2.5</sub></b> | 682,000                                |

*Source: U.S. EPA Office of Air and Radiation, "The Benefits and Costs of the Clean Air Act from 1990 to 2020"*

Using additional tools from the EPA, the reduction in emissions of each of these vehicles could be estimated. This information was then used in conjunction with the benefits of the Clean Air Act to determine the benefit a hybrid truck would provide to society. These benefits were not limited only to health but included increased visibility and agricultural and forestry productivity. Table 3 presents the estimated benefit of each vehicle.

**Table 3. Estimated benefits of hybrid truck adoption for three truck applications.**

|                        | <b>Package Delivery Truck</b> | <b>Beverage Delivery Truck</b> | <b>Refuse Truck</b> |
|------------------------|-------------------------------|--------------------------------|---------------------|
| <b>Health Benefits</b> | \$ 7,561.03                   | \$ 13,237.15                   | \$ 7,706.76         |
| <b>Other Benefits</b>  | \$ 2,738.21                   | \$ 4,823.64                    | \$ 2,797.18         |
| <b>Total Benefits</b>  | \$ 10,299.24                  | \$ 18,060.79                   | \$ 10,503.94        |

The adoption rate of hybrids in each of these applications was then estimated with various levels of incentive. The researchers determined that widespread adoption of hybrids will most likely not occur for some time without any incentives. For the delivery application, research indicates that with no incentive very few hybrids will be purchased. However, the refuse truck industry is estimated to begin adopting hybrid trucks sooner than the beverage and package delivery industries with little incentive.

Further improving upon this analysis requires two additional elements, other than actual data. The first would be a mechanistic-based vehicle model to better estimate the performance of a hybrid through various drive cycles. This model would help illuminate issues such as fuel economy, hybrid system performance, brake wear, and vehicle emissions. The other element that could significantly add to these results is a detailed analysis of the health effects of these emissions in a specific urban area. The estimation performed in this report simply uses a national average. Programs like BenMAP, which is used by the EPA, could help to provide this type of analysis.

## Table of Contents

|   |           |
|---|-----------|
| <b>Chapter 1 - Introduction and Background .....</b>                                    | <b>1</b>  |
| Air Quality, EPA Standards and Internal Combustion Improvements and Hybrid Systems..... | 4         |
| Air Quality Regulation and Enforcement .....  | 5         |
| Logistics and the Growth of Metro Inland Ports .....                                    | 7         |
| Study Objectives .....  | 8         |
| <b>Chapter 2 - Metro Truck Operations .....</b>   | <b>9</b>  |
| Current Usage of Hybrid Trucks .....  | 12        |
| <b>Chapter 3 - Current Hybrid Truck Technologies and Vehicles.....</b>                  | <b>15</b> |
| Hybrid Architectures.....   | 15        |
| Parallel Hybrid Architecture .....  | 15        |
| Series Hybrid Architecture.....   | 16        |
| Split Hybrid Architecture .....   | 16        |
| Energy Storage and Conversion.....  | 17        |
| Electric Hybrid System .....  | 18        |
| Hydraulic Hybrid System.....  | 18        |
| Current Heavy Duty Hybrid Vehicles.....   | 19        |
| BAE Systems.....  | 19        |
| Capacity of Texas.....  | 20        |
| GM Allison.....   | 21        |
| Freightliner .....  | 21        |
| International Truck (Navistar).....   | 22        |
| Oshkosh Defense.....  | 23        |
| Peterbilt/Kenworth (Paccar).....  | 24        |
| Volvo.....  | 27        |
| Conclusion .....  | 27        |
| <b>Chapter 4 - Truck Operating Costs .....</b>  | <b>28</b> |
| Hybrid Type 1 – Parcel Delivery Truck .....   | 29        |
| Hybrid Type 2 – Beverage Delivery Truck .....   | 33        |
| Hybrid Type 3 – Refuse Truck .....  | 36        |
| Consideration of Additional Benefits and Incentives .....                               | 41        |
| <b>Chapter 5 - Emissions, the EPA, and Carbon.....</b>                                  | <b>46</b> |
| Economic Impact of EPA Air Quality Regulations.....                                     | 47        |
| Proposed Reduced Ground Level Ozone Levels .....  | 49        |

|   |           |
|---|-----------|
| Recent and Proposed Truck Regulations .....                                     | 50        |
| <b>Chapter 6 - Internalizing Emission Costs into Total Trucking Costs .....</b> | <b>55</b> |
| Criteria Pollutants .....   | 55        |
| Ozone .....   | 55        |
| Particulate Matter .....  | 56        |
| Nitrogen Dioxide (NO <sub>2</sub> ) .....                                       | 57        |
| Carbon Monoxide (CO) .....  | 57        |
| Sulfur Dioxide (SO <sub>2</sub> ) .....   | 57        |
| Social Benefits .....   | 58        |
| Health Benefits .....   | 58        |
| Visibility Benefits .....   | 60        |
| Agricultural and Forestry Productivity Benefits .....                           | 61        |
| Materials Damage and Ecological Benefits .....                                  | 62        |
| Conclusions .....   | 62        |
| <b>Chapter 7 - Study Findings.....</b>  | <b>63</b> |
| Estimated Rates of Hybrid Adoption .....  | 63        |
| Parcel Delivery Truck Adoption .....  | 64        |
| Beverage Delivery Truck Adoption .....  | 65        |
| Refuse Truck Adoption .....   | 68        |
| Adoption Conclusions .....  | 70        |
| Recommendations .....   | 71        |
| <b>References.....</b>  | <b>74</b> |
| <b>Appendix A: Technical Hybrid Vehicle Information.....</b>                    | <b>80</b> |
| <b>Appendix B: Hydraulic Hybrid Service Breakdown Calculations .....</b>        | <b>89</b> |
| <b>Appendix C: Other Notable Trucks.....</b>                                    | <b>93</b> |
| <b>Appendix D: Hybrid Adoption Estimation Procedure .....</b>                   | <b>97</b> |

## List of Figures

|   |    |
|---|----|
| Figure 1-1. Comparison of actual and estimated population growth of the state of Texas and the Texas Triangle megaregion..... | 1  |
| Figure 1-2. Map depicting counties and metropolitan statistical areas that make up Texas Triangle megaregion.....             | 2  |
| Figure 1-3. Map of Texas counties that are at or near non-attainment levels for air quality. ....                             | 5  |
| Figure 2-1. Percent of distance traveled by four types of commercial vehicles in Madrid and Soria, Spain.....                 | 11 |
| Figure 2-2. Breakdown of current users of hybrids for urban freight applications by type and architecture.....                | 13 |
| Figure 3-1. Layout of Eaton parallel hydraulic hybrid vehicle.....  | 15 |
| Figure 3-2. Layout of Eaton series hydraulic hybrid vehicle.....  | 16 |
| Figure 3-3. Block diagram of Allison split hybrid vehicle architecture.....   | 17 |
| Figure 3-4. Operating mode of the Allison split hybrid system based on vehicle speed.....                                     | 17 |
| Figure 3-5. Breakdown of manufactured hybrids and hybrid systems by type and architecture.....                                | 19 |
| Figure 3-6. Layout of typical BAE hybrid electric bus.....  | 20 |
| Figure 3-7. Image of Capacity PHETT hybrid yard truck.....  | 20 |
| Figure 3-8. Image of New Flyer/Allison hybrid electric bus.....   | 21 |
| Figure 3-9. Layout of Freightliner/Eaton electric hybrid system.....  | 21 |
| Figure 3-10. Image of International Durastar truck.....   | 22 |
| Figure 3-11. Layout of UPS series hydraulic hybrid delivery truck chassis.....  | 23 |
| Figure 3-12. Image of Oshkosh HEMTT-A3 hybrid truck with component locations.....   | 24 |
| Figure 3-13. Image of Peterbilt/Eaton hybrid electric drivetrain.....   | 24 |
| Figure 3-14. Image of Peterbilt packaging of lithium ion batteries.....   | 25 |
| Figure 3-15. Image of Peterbilt model 330 hybrid.....   | 25 |
| Figure 3-16. Image of Peterbilt model 337 hybrid.....   | 25 |
| Figure 3-17. Image of Peterbilt model 386 hybrid.....   | 26 |
| Figure 3-18. Image of Peterbilt model 320 hybrid.....   | 26 |
| Figure 3-19. Image of Volvo parrallel electric hybrid drivetrain.....   | 27 |
| Figure 4-1. Historical U.S. average diesel price at the pump from 4/5/2010 to 4/4/2011.....                                   | 29 |
| Figure 4-2. Time at speed plot for UPS delivery truck.....  | 30 |
| Figure 4-3. Differential cost of operating a hybrid delivery truck in place of a conventional truck.....                      | 32 |
| Figure 4-4. Estimated operating cost per mile of a conventional and hybrid package delivery truck in a rural setting.....     | 32 |
| Figure 4-5. Estimated operating cost per mile of a conventional and hybrid package delivery truck in an urban setting.....    | 33 |
| Figure 4-6. Breakdown of annual beverage delivery vehicle mileage.....  | 34 |
| Figure 4-7. Estimated differential cost of adopting a hybrid beverage delivery truck over a 10-year period of ownership.....  | 35 |
| Figure 4-8. Estimated operating cost per mile of hybrid and conventional beverage delivery trucks.....                        | 35 |
| Figure 4-9. Estimated operating cost per ton-mile of hybrid and conventional beverage delivery trucks.....                    | 36 |

|   |    |
|---|----|
| Figure 4-10. Estimated time for return on investment of hydraulic hybrid refuse truck for various settings and system costs. ....     | 39 |
| Figure 4-11. Estimated operating cost per mile for refuse conventional and hybrid refuse trucks in various settings. ....             | 40 |
| Figure 4-12. Estimated operating costs on a per ton-mile basis for conventional and hybrid refuse trucks. ....                        | 41 |
| Figure 4-13. Survey result for primary reasons of beverage companies to adopt green fleets.....                                       | 42 |
| Figure 4-14. Estimated differential cost of operating a hybrid package delivery truck with assumed benefits and tax incentives. ....  | 44 |
| Figure 4-15. Estimated differential cost of operating a hybrid beverage delivery truck with assumed benefits and tax incentives. .... | 45 |
| Figure 5-1. Percent ozone reduction from 2000 to 2009. ....   | 47 |
| Figure 5-2. Allowable heavy duty diesel exhaust emission levels for particulate matter and NO <sub>x</sub> from 1998 to 2010. ....    | 51 |
| Figure 5-3. Estimated incremental costs of implementation of each emission requirement. ....  | 52 |
| Figure 5-4. Navistar proprietary combustion bowl design used to meet 2010 emission standards. ....                                    | 53 |
| Figure 5-5. Image of Kenworth W900 tractor. ....  | 54 |
| Figure 7-1. Estimated pump price of diesel from 2008 to 2035. ....  | 63 |
| Figure 7-2. Estimated fuel economy of conventional package delivery truck as a function of annual mileage. ....                       | 64 |
| Figure 7-3. Estimated rate of adoption of package delivery truck with various levels of incentive. ....                               | 65 |
| Figure 7-4. Estimated fuel economy of conventional beverage delivery truck as a function of annual mileage. ....                      | 66 |
| Figure 7-5. Estimated improvement in fuel economy of beverage delivery truck as a function of annual mileage. ....                    | 67 |
| Figure 7-6. Estimated rates of beverage delivery trucks with various levels of incentive. ....  | 67 |
| Figure 7-7. Comparison of estimated adoption rates with variable improvements in fuel economy of hybrid system. ....                  | 68 |
| Figure 7-8. Estimated rate of hybrid refuse trucks based on payback in 10-year period of ownership. ....                              | 69 |
| Figure 7-9. Estimated purchase rate of hybrid trucks based on return on investment. ....  | 70 |
| Figure 7-10. Estimated rate of adoption with refuse trucks with variable rates of purchase based on return on investment. ....        | 70 |
| Figure A-1. Schematic of passive parallel architecture. ....  | 84 |
| Figure A-2. Schematic of bi-directional DC-DC converter architecture. ....  | 84 |
| Figure A-3. Schematic of two input bi-directional DC-DC converter architecture. ....  | 85 |
| Figure A-4. Cross-section of bladder-type hydraulic accumulator. ....   | 85 |
| Figure B-1. Line drawing of Eaton Hydraulic Launch Assist system. ....  | 89 |
| Figure B-2. Exploded view of main system oil filter. ....   | 90 |
| Figure B-3. Cross-sectional view of bladder-type accumulator. ....  | 91 |
| Figure B-4. Replacement accumulator bladder cost per gallon as a function of bladder size. ....                                       | 92 |



|   |    |
|---|----|
| Figure D-1. Estimated correlation between annual mileage and fuel economy for package delivery truck..... | 97 |
| Figure D-2. Estimated distribution of refuse trucks for year 2020.....                                    | 98 |



## List of Tables

|  |    |
|--|----|
| Table 1-1. Actual and estimated U.S. freight demand for 2007, 2009, and 2040 by mode in millions of tons. ....   | 3  |
| Table 1-2. Actual and estimated U.S. freight demand for 2007, 2009, and 2040 by mode in billions of 2007 dollars. ....   | 3  |
| Table 1-3. Actual and estimated Texas freight demand for 2007, 2009, and 2040 by mode in thousands of tons. ....   | 4  |
| Table 1-4. Actual and estimated Texas freight demand for 2007, 2009, and 2040 by mode in millions of 2007 dollars. ....  | 4  |
| Table 2-1. General product categories that were delivered within the CBD to shippers participating in study. ....  | 9  |
| Table 2-2. General product categories that were transported into the CBD by motor carriers participating in study. ....  | 10 |
| Table 2-3. Usage statistics for commercial vehicles operating in Madrid and Soria, Spain. ....   | 11 |
| Table 2-4. Operating characteristics of New York City refuse truck during a typical operating cycle. ....  | 12 |
| Table 3-1. Advertised fuel economy improvement of Freightliner electric hybrid system based on application. ....   | 22 |
| Table 4-1. Operating characteristics of refuse trucks in various locations. ....   | 37 |
| Table 4-2. Hydraulic hybrid system cost. ....  | 38 |
| Table 4-3. Possible sources of money and estimated additional benefits for hybrid truck implementation. ....   | 43 |
| Table 5-1. Number of 31 currently monitored counties in non-attainment at proposed primary ground level ozone standard. ....   | 50 |
| Table 5-2. Proposed 2017 vocation truck emissions regulations. ....  | 53 |
| Table 6-1. Current EPA National Ambient Air Quality Standards. ....  | 55 |
| Table 6-2. Estimated avoided sickness and deaths attributed to Clean Air Act regulation. ....  | 58 |
| Table 6-3. Estimated reduction in emissions due to Clean Air Act regulation. ....  | 59 |
| Table 6-4. Estimated cost per ton of PM, NO <sub>x</sub> , and VOC emissions based on the EPA report “The Benefits and Costs of the Clean Air Act from 1990 to 2020.” .... | 59 |
| Table 6-5. Reduction in emissions attributed to adoption of hybrid truck calculated with Clean Cities Emission Benefit Tool. ....  | 59 |
| Table 6-6. Estimated societal benefits for hybrid trucks derived from data estimated in EPA’s report “The Benefits and Costs of the Clean Air Act from 1990 to 2020.” .... | 60 |
| Table 6-7. Estimated visibility benefit attributed to emissions reductions of Clean Air Act. ....  | 61 |
| Table 6-8. Estimated cost per ton of VOC, NO <sub>x</sub> , and PM <sub>2.5</sub> emissions based on visibility benefits. ....   | 61 |
| Table 6-9. Estimated benefit of hybrid truck adoption due to increased visibility. ....  | 61 |
| Table 6-10. Estimated benefit of hybrid adoption of each truck application due to impact of agricultural and forestry productivity. ....                                   | 62 |
| Table 6-11. Estimated benefits of hybrid truck adoption for three truck applications. ....   | 62 |
| Table 7-1. Estimates of potential incentives for hybrid trucks based on averages from TERP and ERIG data. ....   | 71 |
| Table A-1. Typical characteristics of various types of batteries. ....   | 83 |



## Chapter 1 - Introduction and Background

The U.S. population is expected to grow by 85.6 to 106.9 million people by the year 2040 from the current population of 308.7 million (U.S. Census Bureau). The Texas population is predicted to grow by 14.9 million people from the current population of 25.1 million (Texas State Data Center). This additional population will create a larger demand for freight to bring in goods and also to dispose of the increased refuse. The population growth should also create an increase in jobs, which will most likely cause an increase in raw materials, equipment, produced goods, and services, all of which require transportation.

A large percentage of the additional growth in Texas is predicted to occur in what is known as the “Texas Triangle” megaregion, as Figure 1-1 depicts. A megaregion is made up of two or more metropolitan areas that are linked through multimodal transportation infrastructures, environmental systems, and complementary economies. Megaregions have the benefit of concentrating people, jobs, and capital, which makes them attractive in a global economy (Butler et al.). Figure 1-2 illustrates the Texas Triangle composition.

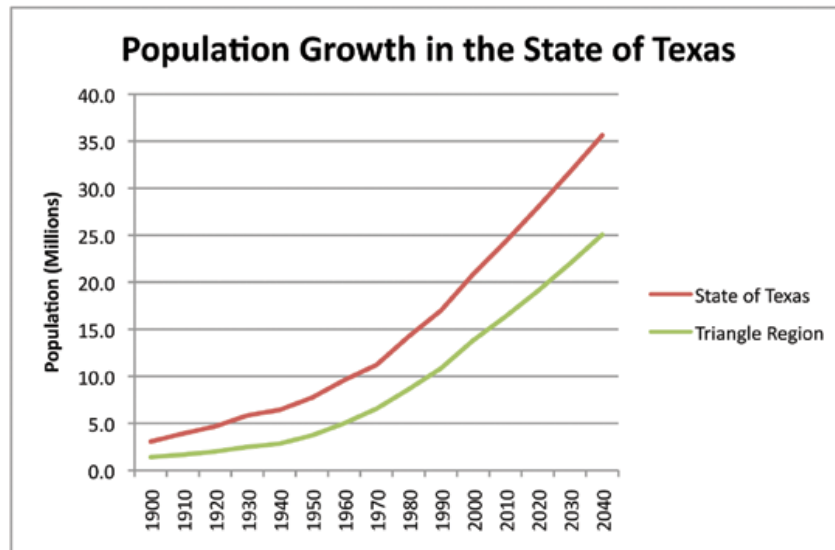

Source: Butler et al.

Figure 1-1. Comparison of actual and estimated population growth of the state of Texas and the Texas Triangle megaregion.

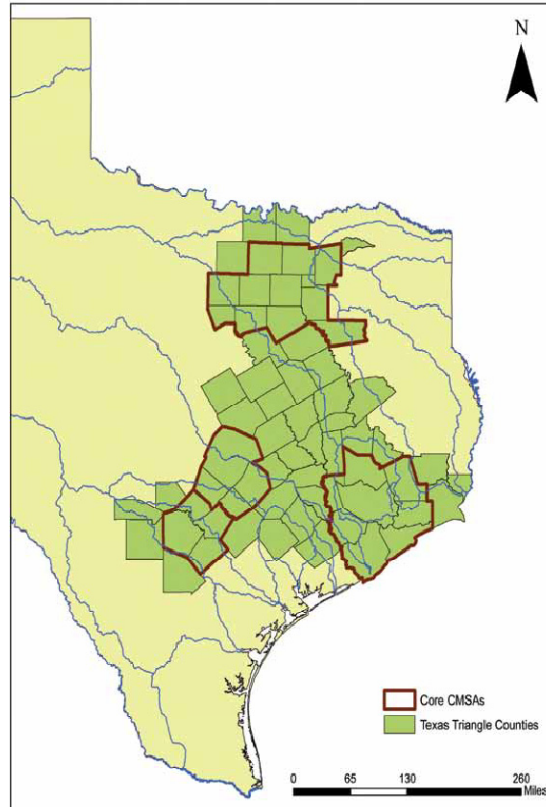

*Source: Butler et al.*

*Figure 1-2. Map depicting counties and metropolitan statistical areas that make up Texas Triangle megaregion.*

Because most of the population and a significant portion of the state’s economic activity occurs in a confined portion of the state, many problems present themselves. Two of these issues revolve around transportation: congestion and air pollution. The movement of goods can occur through many modes of travel, but the three primary modes are truck, rail, and air. The increased truck traffic coupled with the increased commuter traffic can cause significant road congestion. However, rail and air travel can become congested as well. This increase in congestion generates additional air pollution.

In addition to the increase in population and economic activity in the Texas Triangle, the total demand for freight in the U.S. is estimated to increase. This demand by weight is estimated to increase by 1.6% per year from 2010 until 2040. However, the average value per ton shipped is estimated to increase at a higher rate than the weight. The average value per ton of freight was \$890 in 2007 and is estimated to climb to \$2,145 by 2040. The estimated tonnage and value of these shipments by mode are provided in Table 1-1 and Table 1-2 (U.S. Department of Transportation: Federal Highway Administration).

**Table 1-1. Actual and estimated U.S. freight demand for 2007, 2009, and 2040 by mode in millions of tons.**

|                                  | <b>2007 Total</b> | <b>2009 Total</b> | <b>2040 Total</b> |
|----------------------------------|-------------------|-------------------|-------------------|
| <b>Total</b>                     | 18,581            | 16,122            | 27,104            |
| <b>Truck</b>                     | 12,766            | 10,868            | 18,445            |
| <b>Rail</b>                      | 1,894             | 1,689             | 2,408             |
| <b>Water</b>                     | 794               | 734               | 1,143             |
| <b>Air, air &amp; truck</b>      | 13                | 11                | 41                |
| <b>Multiple modes &amp; mail</b> | 1,531             | 1,336             | 3,119             |
| <b>Pipeline</b>                  | 1,270             | 1,220             | 1,509             |
| <b>Other &amp; unknown</b>       | 313               | 265               | 440               |

*Source: U.S. Department of Transportation: Federal Highway Administration*

**Table 1-2. Actual and estimated U.S. freight demand for 2007, 2009, and 2040 by mode in billions of 2007 dollars.**

|                                  | <b>2007 Total</b> | <b>2009 Total</b> | <b>2040 Total</b> |
|----------------------------------|-------------------|-------------------|-------------------|
| <b>Total</b>                     | 16,536            | 14,647            | 39,294            |
| <b>Truck</b>                     | 10,783            | 9,511             | 21,656            |
| <b>Rail</b>                      | 511               | 421               | 733               |
| <b>Water</b>                     | 286               | 263               | 412               |
| <b>Air, air &amp; truck</b>      | 1079              | 884               | 4347              |
| <b>Multiple modes &amp; mail</b> | 2,923             | 2,639             | 10,520            |
| <b>Pipeline</b>                  | 623               | 595               | 728               |
| <b>Other &amp; unknown</b>       | 331               | 334               | 898               |

*Source: U.S. Department of Transportation: Federal Highway Administration*

As would be expected, the freight demand for Texas is projected to increase in a similar manner to the U.S. trends. The tonnage and values for the demand in Texas are projected in Table 1-3 and 1-4. These tables indicate that trucks will play a large part in transporting goods through Texas as well as the entire country. This growth in freight demand will then increase exhaust emissions from trucks, trains, ships, and airplanes, leading to air quality issues unless technologies that lower or remove tail pipe emissions are adopted.

**Table 1-3. Actual and estimated Texas freight demand for 2007, 2009, and 2040 by mode in thousands of tons.**

|                                  | 2007      | 2009      | 2040      |
|----------------------------------|-----------|-----------|-----------|
| <b>Truck</b>                     | 1,132,508 | 1,009,375 | 1,813,287 |
| <b>Rail</b>                      | 285,144   | 249,827   | 455,226   |
| <b>Water</b>                     | 81,260    | 80,833    | 135,222   |
| <b>Air (include truck-air)</b>   | 563       | 3,710     | 1,796     |
| <b>Multiple modes &amp; mail</b> | 106,869   | 99,706    | 174,637   |
| <b>Pipeline</b>                  | 352,927   | 337,067   | 470,300   |
| <b>Other and unknown</b>         | 46,901    | 42,275    | 72,372    |
| <b>No domestic mode</b>          | 134,947   | 117,009   | 185,869   |

*Source: U.S. Department of Transportation: Federal Highway Administration*

**Table 1-4. Actual and estimated Texas freight demand for 2007, 2009, and 2040 by mode in millions of 2007 dollars.**

|                                  | 2007      | 2009    | 2040      |
|----------------------------------|-----------|---------|-----------|
| <b>Truck</b>                     | 1,062,624 | 980,459 | 2,368,641 |
| <b>Rail</b>                      | 96,017    | 100,574 | 183,301   |
| <b>Water</b>                     | 35,648    | 33,618  | 57,249    |
| <b>Air (include truck-air)</b>   | 67,724    | 57,178  | 248,143   |
| <b>Multiple modes &amp; mail</b> | 190,516   | 168,258 | 735,267   |
| <b>Pipeline</b>                  | 184,314   | 162,726 | 246,655   |
| <b>Other and unknown</b>         | 59,163    | 55,851  | 138,803   |
| <b>No domestic mode</b>          | 60,991    | 45,269  | 84,006    |

*Source: U.S. Department of Transportation: Federal Highway Administration*

### **Air Quality, EPA Standards and Internal Combustion Improvements and Hybrid Systems**

The Environmental Protection Agency (EPA) regulates air quality levels through the Clean Air Act with a set of National Ambient Air Quality Standards. These standards regulate levels of carbon monoxide, lead, nitrogen dioxide, particulate matter, ozone, and sulfur dioxide U.S. EPA).

Several areas in Texas are in or near non-attainment for ground level ozone. The Houston-Galveston-Brazoria, Dallas-Fort Worth, and the Beaumont-Port Arthur areas are in violation of the 8-hour ground level ozone level. The El Paso area is in violation of PM<sub>10</sub> level. Figure 1-3 presents areas that are at or near non-attainment.



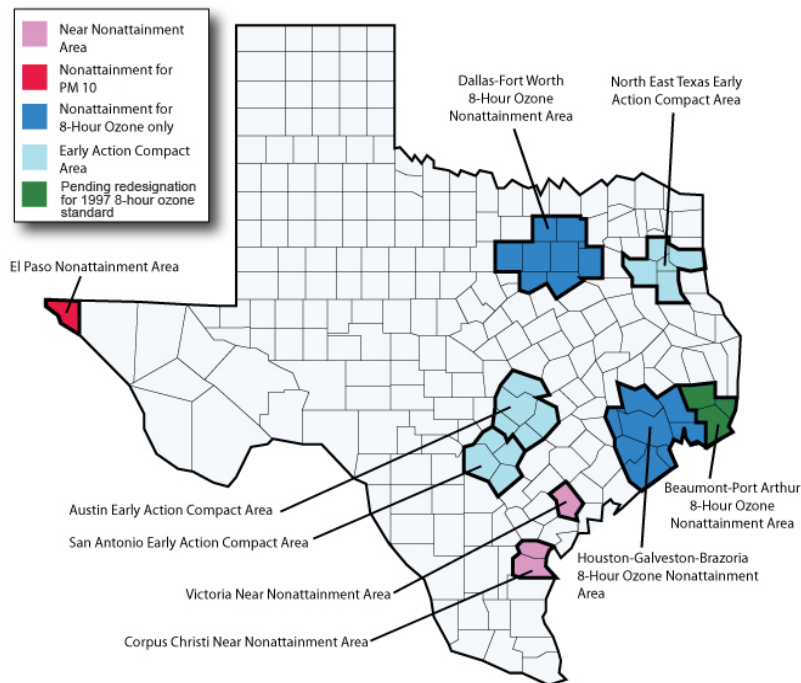

Source: Hildebrand, "Update of Air Quality in Texas"

Figure 1-3. Map of Texas counties that are at or near non-attainment levels for air quality.

The EPA regulates these pollutants because they pose potential health risks for the public. These risks include but are not limited to asthma, coughing, chronic bronchitis, throat irritation, cancer, lung damage, and even death. The acceptable levels set by the EPA are determined through epidemiological studies and extensive modeling. These studies, in conjunction with the models, are used to estimate the benefits to society as well as the costs to comply in order to set an appropriate air quality standard (U.S. EPA, 2010).

### Air Quality Regulation and Enforcement

The EPA was given the power to regulate and enforce air quality standard through the Clean Air Act. To regulate various sources across a range of industries, the EPA divides them up into two categories: stationary and mobile sources (U.S. EPA, "Key Elements of the Clean Air Act").

All stationary sources must operate under standards that are set by the EPA, but large stationary sources must also obtain an additional permit to operate. These permits contain information about what pollutant and how much will be released. Power plants and large factories are typical entities that may require a permit (U.S. EPA, "Key Elements of the Clean Air Act"). Most of these permits are issued through state and local governments (U.S. EPA, "Operating Permits: Basic Information").

Mobile sources are regulated by EPA standards in all states but California. California is allowed to set its own standards because its agency was in operation prior to the passage of the Clean Air Act. Mobile sources can include cars, trucks, buses, and construction equipment. Because the

EPA sets all the regulations, states have very little authority to regulate these sources. The states' only regulatory option is to offer incentives to reduce their emissions (EPA, 2010).

Mobile sources can contribute to large portions of emissions in an area. The EPA estimates that mobile sources account for over half of all nitrogen oxide (NO<sub>x</sub>) emissions and 75% of all carbon monoxide (CO) emissions nationwide. Heavy duty trucks and buses have been estimated to contribute about one-third of NO<sub>x</sub> emissions and about one-fourth of particle pollution from all transportation sources. In large cities these contributions can be even greater.

The EPA's regulation of on-road vehicle emissions varies somewhat. Light duty vehicles are regulated at a vehicle level in terms of grams of a given emission per mile. However, heavy duty vehicles are regulated at an engine level. Therefore, engine manufacturers must ensure that an engine meets certain requirements. The engine is then sold to a vehicle manufacturer who designs and builds the truck. The heavy duty vehicles are regulated this way because the applications for these trucks vary widely. Trying to regulate heavy duty vehicles in the same manner as the light duty vehicles presents certain issues (Matthews, 2010).

Because the heavy duty vehicles are regulated at an engine level, a great deal of research and development has gone into improving them. The current diesel engines are clean because of advances such as turbo charging, direct injection, electronic controls, exhaust gas recirculation (EGR), exhaust after-treatment systems, and advanced computer design tools. Gasoline engines have also benefitted from many of the same improvements. However, their exhaust systems are not as complex as modern diesel engines due to the makeup of their emissions. Another improvement that gasoline engines have seen is the wide adoption of fuel injected systems over a carbureted system.

With each incremental improvement made to the engine, the next step of improvement becomes that much more difficult. Additional improvements in vehicle aerodynamics, transmissions, differentials, and tires have been driven by rising fuel prices and other government incentives, but room for improvement remains. Additional improvements to engines and other components are still possible, but significant changes to the conventional vehicle architecture are necessary to greatly improve efficiency.

A hybrid vehicle has the potential to provide the necessary significant improvements in efficiency. It accomplishes this by capturing energy normally lost as heat while braking, using this energy to assist the engine during periods of high load, and also turning the engine off when it is not needed. Trucks operating in an urban environment must frequently make stops in traffic and while making deliveries. These frequent stops create many opportunities to regain large amounts of energy and significantly improve fuel economy. The focus of this report is on these trucks rather than line haul trucks that travel long distances on highways. While these trucks could possibly benefit from a hybrid system, the benefit would not be nearly as great.

A great deal of current design, experimentation, and testing of various hybrid technologies is ongoing but positive results do not come without cost or risk. The addition of a hybrid system has been estimated to increase a vehicle's cost by up to \$50,000. The added complexity also means more components, increasing either maintenance or potential system failure.

## Logistics and the Growth of Metro Inland Ports

Improved logistics and distribution strategies are another method of reducing congestion, air pollution, and cost. Wal-Mart was able to deliver 161,000 more cases while traveling 87 million fewer miles in 2008, saving an estimated 15 million gallons of diesel (Wal-Mart). While many corporations are adopting better logistics technologies or working with a third party logistics partner to better route their freight, additional work is being done at the regional level to create more efficient movement of goods.

One method of improving freight movement is to create what is called an *inland port* or *distribution hub*. An inland port is an area that offers access to the interstate highway system as well as other modes of transportation such as rail or air to shippers and large companies. They offer space for warehousing and manufacturing to create a competitive economic environment by placing businesses near the supply chain (Harrison 2002). These areas can also offer services like processing and sorting of containers outside of the traditional port to reduce the time and cost of their delivery. Two inland ports within Texas are Alliance in Fort Worth and Kelly USA in San Antonio (Harrison 2003)<sup>1</sup>.

Despite the improvement in logistics that inland ports may offer, freight movement that requires trucks to move through urban areas still pose issues. These ports can receive freight from several locations. Some freight may come from other major hubs but a portion will come from nearby urban locations. Freight delivery through an urban area might be required if, for example, the inland port is located by the airport but shipments need to be taken to a rail facility across town. In this specific case, a hybrid truck is needed because of the requirement to travel through a congested urban area. The adoption of a hybrid could offer benefits to society as well as the truck owner through potential reduced operating costs.

New York City has taken another approach to improve urban freight delivery. They have evaluated the use of night deliveries for downtown areas. A pilot study was conducted with 8 delivery companies and 25 businesses where deliveries occurred between 7:00 p.m. and 6:00 a.m. The primary goal was to reduce congestion in these downtown areas, but several other benefits were found as well for both the businesses and the delivery companies. Following are the benefits experienced by the various parties (“NYC DOT - Manhattan Off Hours Delivery Program”).

- Delivery Companies
  - Average delivery times were reduced to 30 min from 100 min
  - A drastic reduction in parking tickets which can total \$1,000 per month
  - Lower fuel costs because of less time idling in traffic
  - Better utilization of equipment because it can be used both night and day
- Businesses
  - Fewer daytime deliveries allow employees to focus on customers
  - Staff is more productive because less time is spent waiting for deliveries

---

<sup>1</sup> Recently, GE announced it was building a new locomotive assembly plant at the Alliance inland port.

- Drivers
  - Parking is much easier
  - Much lower stress levels
  - An increased feeling of safety

While the night delivery does help to solve many problems associated with urban delivery, adopting a hybrid truck still provides potential benefits. The operation of a truck during off peak hours will reduce the amount of time spent idling, but a route with a significant amount of stops at traffic lights and delivery locations could justify the use of a hybrid.

### **Study Objectives**

Clearly the growing freight demand in Texas will require a more efficient transportation system at many levels. Many solutions will be required to accomplish this, and hybrid trucks can potentially fill a niche for specific types of freight movement. Their adoption could potentially reduce emissions as well as fuel consumption.

The objectives of this study were to identify current users of hybrids, and utilize the available information from these applications to estimate the operating costs of hybrids in these applications and determine the potential social benefits to determine an overall cost model. This report attempts to estimate the true cost of truck operations by using the social cost of vehicle emissions as estimated by the EPA. With this data, the researchers estimated the adoption rate adoption of these hybrid trucks for various policy scenarios.

## Chapter 2 - Metro Truck Operations

The urban vehicle population is very diverse due to the wide variety of vehicular needs in an urban transportation environment. These vehicles include cars, buses, fire trucks, step vans, delivery trucks, garbage trucks, and many more. Each of these applications has its own requirements that dictate the most suitable vehicle.

The delivery of urban freight is just as diverse as the urban vehicles. The different types of freight and originating locations demand different options for delivery. Some goods will originate outside of an urban area or at a more distant warehouse or distribution center, while other goods may be shipped within a city from one customer to another. One longstanding solution is using couriers to quickly deliver smaller goods and documents within a single area (Derballa).

A study conducted in the New York Central Business District (CBD) described a great variety of routes, vehicles, and delivered goods. The study was conducted by working with motor carriers and various businesses within the CBD through a series of interviews, focus groups, time and motion studies of dock activities, and a survey of commercial office building managers (Morris, Kornhauser, and Kay). Table 2-1 lists the goods shipped to CBD businesses. Table 2-2 lists the goods transported by the participating motor carriers.

**Table 2-1. General product categories that were delivered within the CBD to shippers participating in study.**

|                          |    |  |   |
|--------------------------|----|--|---|
| Accessories-Children     | 4  | Hardware & Plumbing                      | 1 |
| Accessories-Home Fashion | 4  | Health & Personal Products               | 7 |
| Accessories-Women        | 7  | Hospital/Surgical-Medical Supplies       | 3 |
| Apparel-Children's       | 4  | Household Goods/Housewares               | 3 |
| Apparel-Men's            | 7  | Office Products, Computers, Copies, Etc. | 2 |
| Apparel-Women's          | 7  | Office Supplies                          | 5 |
| Appliances               | 1  | Over the Counter Drugs                   | 3 |
| Automotive               | 1  | Paper                                    | 2 |
| Beverages                | 3  | Pharmaceuticals                          | 7 |
| Chemicals                | 2  | Publications                             | 4 |
| China-Glass-Gifts        | 4  | Sporting Goods                           | 2 |
| Consumer products        | 7  | Telecommunications                       | 2 |
| Constructions            | 0  | Toys                                     | 2 |
| Cosmetics                | 8  | Batteries                                | 1 |
| Film/Video/Entertainment | 5  | Jewelry                                  | 1 |
| Food-Packaged            | 10 | Photographic Equipment                   | 1 |
| Food-Perishable          | 3  | Restaurant Supplies                      | 1 |
| Footwear                 | 2  | Samples/Fabrics, etc.                    | 1 |

*Source: Morris, Kornhauser, and Kay*

The wide variety of goods shown in Table 2-1 demonstrates how diverse an urban environment can be as well as its shipping requirements. A shipment of jewelry would require much different transportation than a shipment of beverages. The methods of shipment included private fleet, truckload, less-than-truckload, and express/small package carrier. These goods also came from many different types of locations. The most prevalent starting point for goods were warehouses and distribution centers, but terminals, manufacturers, corporate headquarters, consolidation centers, and cross-docks were also utilized as starting points. The starting points ranged from 3 to 50 miles from their final destinations, and the vehicles that transported these goods were vans, step vans, pickup trucks, straight trucks, and tractor trailers (Morris, Kornhauser, and Kay).

**Table 2-2. General product categories that were transported into the CBD by motor carriers participating in study**

|                          |   |  |    |
|--------------------------|---|--|----|
| Accessories-Children     | 0 | Hardware & Plumbing                      | 0  |
| Accessories-Home Fashion | 0 | Health & Personal Products               | 1  |
| Accessories-Women        | 0 | Hospital/Surgical-Medical Supplies       | 0  |
| Apparel-Children's       | 1 | Household Goods/Housewares               | 0  |
| Apparel-Men's            | 1 | Office Products, Computers, Copies, Etc. | 1  |
| Apparel-Women's          | 1 | Office Supplies                          | 2  |
| Appliances               | 0 | Over the Counter Drugs                   | 1  |
| Automotive               | 0 | Paper                                    | 1  |
| Beverages                | 0 | Pharmaceuticals                          | 1  |
| Chemicals                | 0 | Publications                             | 0  |
| China-Glass-Gifts        | 0 | Sporting Goods                           | 0  |
| Consumer products        | 4 | Telecommunications                       | 0  |
| Constructions            | 0 | Toys                                     | 1  |
| Cosmetics                | 2 | All Product Categories                   | 10 |
| Film/Video/Entertainment | 0 | Retail                                   | 1  |
| Food-Packaged            | 2 | Utilities                                | 1  |
| Food-Perishable          | 0 |  |    |
| Footwear                 | 0 |  |    |

The motor carriers involved in the study provided express/small package, truckload, and less-than-truckload services. These companies used vans, straight trucks, and tractor trailers. The vehicles varied in length from 14 ft to 53 ft. The number of dropoffs that less than truckload and express carrier made ranged from 8 to 250. The truckload carriers typically only made 1 to 2 drop offs.

The study identified several transportation issues associated with operating in the CBD. Congestion was a major issue for both pickup and delivery. The time of the day was also very important. The morning (7:00–9:00 a.m.) and afternoon (3:00–6:00 p.m.) are peak hours for both freight pickup and delivery. Unfortunately, these times are associated with heavy congestion. Other physical constraints included a lack of loading docks, an insufficient number of freight elevators, limitations on shipment size due to truck regulations, and a lack of legal parking.

Another study conducted in Spain monitored how various vehicles moved through an urban environment. The study was conducted in Madrid and Soria, Spain, and monitored the movements of mail, food, service, and construction vehicles. The construction vehicles included repair shops and construction companies.

The results in Table 2-3 demonstrate how differently a vehicle may be used based on its application. The mail delivery vehicle made many quick stops that were close together while the food and service vehicles made fewer stops that were longer in duration and farther apart.

**Table 2-3. Usage statistics for commercial vehicles operating in Madrid and Soria, Spain.**

|                     | Stops/Day |       | Average Stop Length (min) |       | Distance Between Stops |       | Van Utilization (driving time/time stopped) |       |
|---------------------|-----------|-------|---------------------------|-------|------------------------|-------|---|-------|
|                     | Madrid    | Soria | Madrid                    | Soria | Madrid                 | Soria | Madrid                                      | Soria |
| <b>Mail</b>         | 43.6      | 31.3  | 8.8                       | 7.3   | 1.8                    | 0.9   | 0.6   | 0.7   |
| <b>Food</b>         | 5.1       | 10.7  | 22.5                      | 10.7  | 15.3                   | 20.3  | 0.8   | 1.9   |
| <b>Service</b>      | 8.1       | 8.2   | 11.6                      | 16.1  | 10.6                   | 3.9   | 2.5   | 1     |
| <b>Construction</b> | 12.6      | 8.8   | 23.4                      | 19.2  | 12                     | 7.2   | 1   | 1.2   |

*Source: Comendador et al.*

Figure 2-1 helps to illustrate even further how these differences in operation can have an impact on the average speed of the vehicle. All four vehicle categories spend a significant amount of time at speeds lower than 50 kph (31 mph). While some differences exist, they may be due to the differences in what routes they travel, how many stops they make, and where they make these stops.

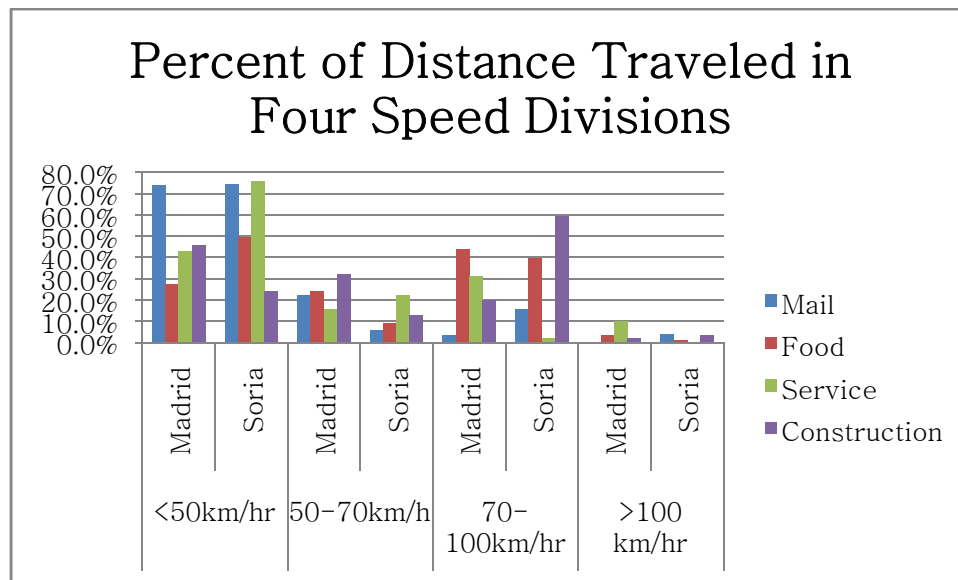

*Source: Comendador et al.*

*Figure 2-1. Percent of distance traveled by four types of commercial vehicles in Madrid and Soria, Spain.*

Just as important as processing freight is the removal of refuse or garbage. The City of New York operates about 2,000 refuse trucks that remove 12,000 tons of refuse and 6,000 tons of recycling each day from its 5 boroughs. These trucks operate 6 days a week (Ivanič).

A study conducted New West Technologies for the City of New York collected over 450 hours of data during a 6-month period. The study found the trucks operated in five distinct modes of operation. The characteristics of each operating mode as well as the entire cycle are presented in Table 2-4 (Ivanič). Collection represents the largest portion of the total cycle, and also has the lowest fuel economy of the entire cycle at 0.4 mpg. Fuel economy may not be the best method of comparison among the various cycle segments because of the operational differences of the vehicle's extra functions. However, it does demonstrate the impact that the starting, stopping, and the secondary functions have on fuel economy.

**Table 2-4. Operating characteristics of New York City refuse truck during a typical operating cycle.**

|                                   | <b>Cycle Average</b> | <b>Approach</b> | <b>Collection</b> | <b>Transfer to Dump</b> | <b>Dump</b> | <b>Return</b> |
|-----------------------------------|----------------------|-----------------|-------------------|-------------------------|-------------|---------------|
| <b>Time (s)</b>                   | 9,688                | 798             | 7,194             | 731                     | 479         | 482           |
| <b>Distance (mi)</b>              | 11.1                 | 3.1             | 2.2               | 3.5                     | 0.2         | 2.2           |
| <b>Stops/mile</b>                 | 12.4                 | 4.3             | 49.3              | 2.9                     | 22.3        | 1.8           |
| <b>Average Speed (mph)</b>        | 13.5                 | 13.8            | 1.1               | 17                      | 1.7         | 17            |
| <b>Max Speed (mph)</b>            | 50                   | 33.8            | 28.4              | 50                      | 17          | 40            |
| <b>Idle Time</b>                  | 51.4%                | 18.5%           | 62.3%             | 14.9%                   | 40.5%       | 10.0%         |
| <b>PTO Time</b>                   | 18.1%                | 0.0%            | 21.8%             | 0.0%                    | 37.6%       | N/A           |
| <b>Fuel Used (gal)</b>            | 8.6                  | 1.1             | 5                 | 1.4                     | 0.3         | 0.8           |
| <b>Idle Fuel</b>                  | 25.4%                | 9.6%            | 37.5%             | 6.2%                    | 23.2%       | 4.5%          |
| <b>PTO Fuel</b>                   | 19.5%                | 0.0%            | 30.5%             | 0.0%                    | 43.6%       | 0.0%          |
| <b>Average Fuel Economy (mpg)</b> | 1.3                  | 2.8             | 0.4               | 2.5                     | 0.7         | 2.8           |

*Source: Ivanič*

Obviously many urban vehicles operate in congested areas and make frequent stops. While this type of operation is not desirable for a conventional vehicle, a hybrid can take advantage of the frequent starting and stopping to improve fuel economy and reduce emissions. A hybrid does offer these benefits, but it does have a certain cost associated with the additional hardware.

#### *Current Usage of Hybrid Trucks*

Hybrids in heavy duty applications are being evaluated and slowly implemented. Coca-Cola, UPS, FedEx, and Waste Management are just a few of the companies that are either using hybrid trucks or evaluating them. The common thread between all of these companies is that they all operate in urban environments, and their trucks make frequent stops during the course of a day to



either pick up or deliver materials. Many manufacturers like Peterbilt, Kenworth, Freightliner, and International now offer hybrid trucks or chassis that are commercially available. Figure 2-2 illustrates current usage of hybrids in urban areas.

While detailed data is somewhat hard to obtain, some very good information is available on the performance of these vehicles in real world settings. A good source of information is the National Renewable Energy Lab. Their Fleet Test and Evaluation team has worked with many companies to evaluate the performance of hybrids and other advanced vehicle technologies. The reports from these projects include fuel economy data, but also important data such as maintenance and drive cycle information. Other sources of data include SAE technical papers, literature from the various vehicle and system manufacturers, and trade magazines.

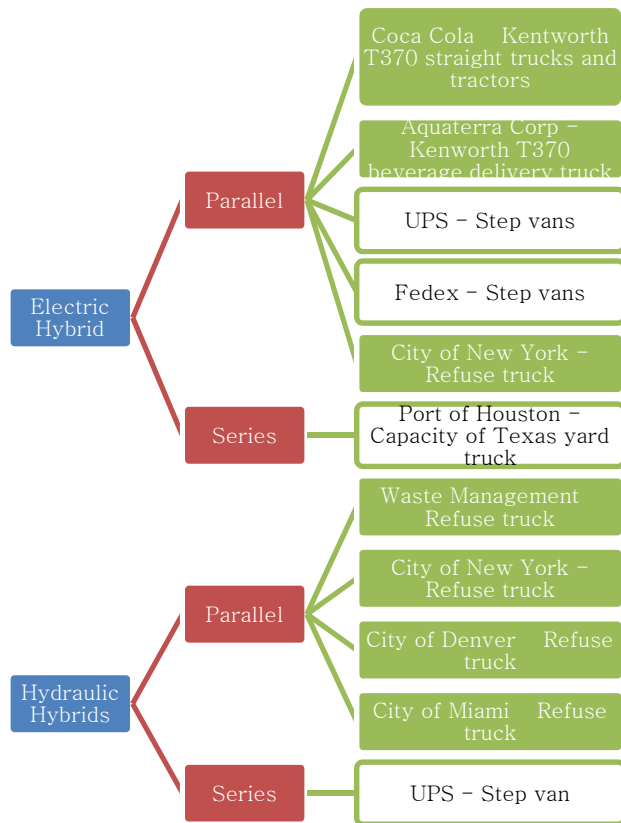

*Figure 2-2. Breakdown of current users of hybrids for urban freight applications by type and architecture.*



## Chapter 3 - Current Hybrid Truck Technologies and Vehicles

A hybrid drivetrain is a system consisting of two or more types of power sources that are used to propel a vehicle. A typical hybrid drivetrain consists of an internal combustion engine, the required powertrain components to transmit the power to the ground, and an alternative energy source that can both provide power and store energy for later use. Many different combinations of vehicle architectures, alternative energy sources, and control strategies can be implemented in a hybrid vehicle. Some of these components, strategies, and systems are better suited for heavy duty applications than others (Ehsani, Gao, and Ali Emadi).

### Hybrid Architectures

The three main hybrid architectures are parallel, series, and split architectures. These three architectures are all applicable to heavy duty vehicles.

#### *Parallel Hybrid Architecture*

The parallel hybrid architecture is the closest to a standard drivetrain. It is constructed by adding an alternative drivetrain in parallel with the standard drive train. The two drivetrains are coupled in a variety of way, but only two methods are now widely used on heavy duty vehicles. The first method used by the Eaton hybrid electric system (Figure 3-1) is to place an electric motor between the engine and transmission to couple the two drivetrains. The second method used by most parallel hydraulic hybrids is through a transfer case that is located between the transmission and differential.

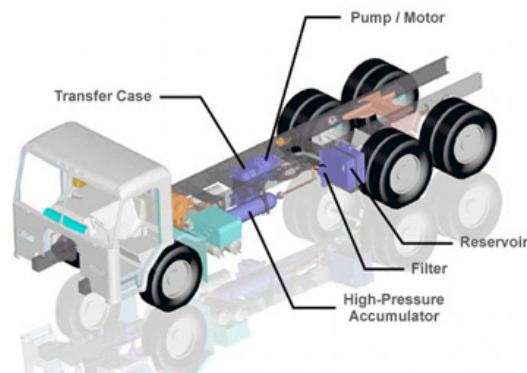

Source: Eaton Corporation, "Hydraulic Hybrid"

Figure 3-1. Layout of Eaton parallel hydraulic hybrid vehicle.

The benefit of a parallel architecture is that it allows power to be transmitted directly through the traditional drivetrain to the ground. This method gives the drivetrain very high efficiencies from the engine to the wheel. This architecture also allows the vehicle to operate in the event that the secondary drivetrain fails. The control system for this architecture is also the simplest (Ehsani, Gao, and Ali Emadi).

The disadvantage of this system is that the engine is directly coupled to the drive wheels. This architecture can force the engine to operate outside its most efficient region during certain periods of operation. For some parallel hybrids the secondary power source cannot be charged, which results if the two drivetrains are connected between the transmission and differential. This

factor is important in applications where the vehicle has secondary functions like a bucket truck or an idling semi (Ehsani, Gao, and Ali Emadi).

Some examples of heavy duty parallel hybrids are Eaton's Hydraulic Launch Assist used on the Peterbilt Model 320, Volvo's FE hybrid concept, and the Freightliner Business Class M2e Hybrid (Daimler Trucks North America LLC; Peterbilt Motors Company; Volvo Trucks Global).

### *Series Hybrid Architecture*

A series hybrid differs from a parallel hybrid because all energy from the engine must be passed through the secondary drivetrain. Thus, a pump or generator mounted directly to the engine converts the mechanical energy from the engine to a form that can be stored. This energy is then either stored in a battery or used by a motor that converts the energy back into mechanical energy to drive the wheels (Wong). Figure 3-2 presents the Eaton series hydraulic hybrid.

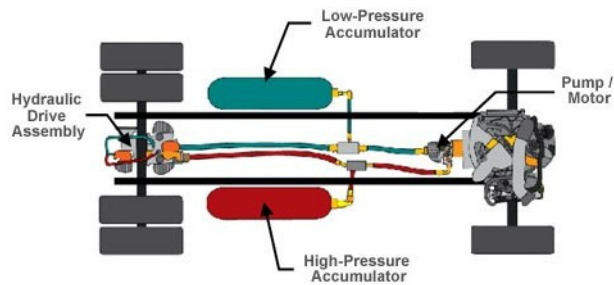

*Source: U.S. EPA, "Clean Automotive Technology: Hydraulic Hybrid Research"*

*Figure 3-2. Layout of Eaton series hydraulic hybrid vehicle.*

The benefit of a series hybrid is that the engine is completely decoupled from the rear wheel. This structure allows the engine to operate in its most efficient region regardless of vehicle speed. It also allows for the battery or hydraulic accumulator to be charged in all configurations while the vehicle is not moving (Ehsani, Gao, and Ali Emadi).

The disadvantage of the system is that the overall efficiency of the drivetrain is reduced because of the need to convert the energy twice before it is transmitted to the ground. However, this drawback can be offset by the more efficient operation of the engine. This architecture also has a more complex control system because of the need to control both a generator and a motor where the parallel system has only a motor to control (Ehsani, Gao, and Ali Emadi).

Examples of heavy duty series hybrid vehicles are the BAE Hybridrive system, Oshkosh Propulse system, and the UPS hydraulic hybrid delivery truck built by a partnership between Eaton, UPS, the EPA, and International Truck ("Hybridrive Propulsion Systems;" Oshkosh Corporation; Barry).

### *Split Hybrid Architecture*

The split hybrid architecture tries to capture all of the benefits of the series and parallel architectures in one system. It allows for power from the engine to be transmitted directly to the drive wheels while still allowing for the engine to be somewhat decoupled from the drive wheels. This type of operation is accomplished by using a planetary gear set to provide two paths for power to reach the ground. Figure 3-3 and Figure 3-4 present GM's Allison hybrid architecture.

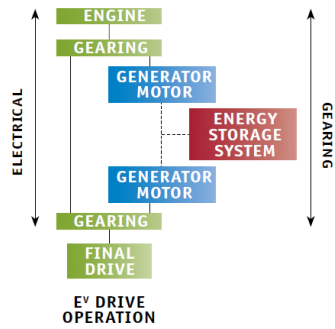

Source: "It's the Right Thing to Do"

Figure 3-3. Block diagram of Allison split hybrid vehicle architecture.

One benefit of this system is that the drivetrain efficiency is high when transmitting power directly from the engine to the drive wheels whenever the vehicle speed permits optimal engine operation. It also allows for the engine to operate in its most efficient region more often by decoupling the rear wheels from the engine when the vehicle speed does not allow the engine to operate optimally (Ehsani, Gao, and Ali Emadi).

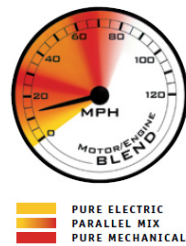

Source: "It's the Right Thing to Do"

Figure 3-4. Operating mode of the Allison split hybrid system based on vehicle speed.

The disadvantage of this architecture is that it is the most complex of the three and contains the most components. The added complexity not only increases cost due to the added components but also increases the complexity of the system controller and adds weight to the vehicle (Ehsani, Gao, and Ali Emadi).

The GM Allison Hybrid EP system is an example of this type of architecture that is used in a heavy duty vehicle (*It's the Right Thing to Do*).

### Energy Storage and Conversion

Just as there are various vehicle architectures, various options are available to create the secondary energy storage system. The two main options available for heavy duty vehicles are electrical systems and hydraulic systems. Both systems have their merits and are well suited for various applications.

### *Electric Hybrid System*

An electric hybrid system will typically consist of an array of batteries, one to two motors, associated wiring, power electronics to connect the batteries to the motors, and a cooling system for the motors. The motors in these systems also serve as generators under certain conditions to capture energy that would normally be lost under braking.

The most widely used batteries in electric hybrids are lithium ion and nickel metal hydride batteries. These batteries offer greater energy density than the lead acid battery used in most cars and trucks (Ehsani, Gao, and Ali Emadi).

The motors used in these systems can be either DC or AC motors. The power electronics that connect the battery to the motors are then used to either modulate voltage or current to control the speed or torque of the motor. The control and design of these power electronics will be dictated by the size and type of motor (Ehsani, Gao, and Ali Emadi).

The benefit of the electric system is its high energy density. This feature allows the vehicle to operate for periods with the engine off. The electric system has fewer maintenance items than the hydraulic system. The two maintenance items specified in the Eaton service manual are for the cooling fluid to be changed periodically and an air filter on the battery pack that must be changed occasionally. Fewer moving parts can also add to the reliability of the system (Ehsani, Gao, and Ali Emadi).

The disadvantage of the system is that it has a lower power density than the hydraulic system, meaning it can assist less when accelerating and capture less energy when braking. The other drawback to this type of system is that some of these components are specially designed for this application and can be rather expensive (*Clean Automotive Technology*).

### *Hydraulic Hybrid System*

The hydraulic hybrid has many of the equivalent components as an electric hybrid. The hydraulic accumulator is used in place of a battery, a hydraulic pump or motor is used in place of an electric motor, and hoses are used instead wires to transmit energy. An extra set of hoses is not necessary for a cooling system because the hydraulic fluid also acts as a coolant for the system. However, components like a radiator are still required to dissipate the heat that is generated. No power electronics are used because the pump torque is modulated through the displacement of the pump.

The type of pump typically used in the hydraulic hybrid system is a piston pump, which consists of a set of pistons that rotate around an axis. Their stroke is determined by the angle of a plane to their rotating axis. There are two types of piston pumps. The first is an axial piston pump with a plate that rotates to either increase or decrease the stroke and displacement of the pump. The second type of piston pump is a bent axis pump. This type has a stationary plate and axis that moves relative to the plate.

The advantage of this system is that it has a very high power density. Thus, it can assist a great deal when starting from rest and capture a large amount of energy when braking. This aspect of the system makes it well suited for heavy vehicles like refuse trucks. The other advantage is that it uses many off-the-shelf components, which reduces cost.

The disadvantage of the system is that it has a low energy density—significant assistance is possible only for a short period. This system would excel running a 100 yard dash where the electric system would be much better at running a marathon. Also, many more components must be serviced in the hydraulic hybrid system than in the electric hybrid system.

### Current Heavy Duty Hybrid Vehicles

Figure 3-5 presents hybrid systems by type and architecture.

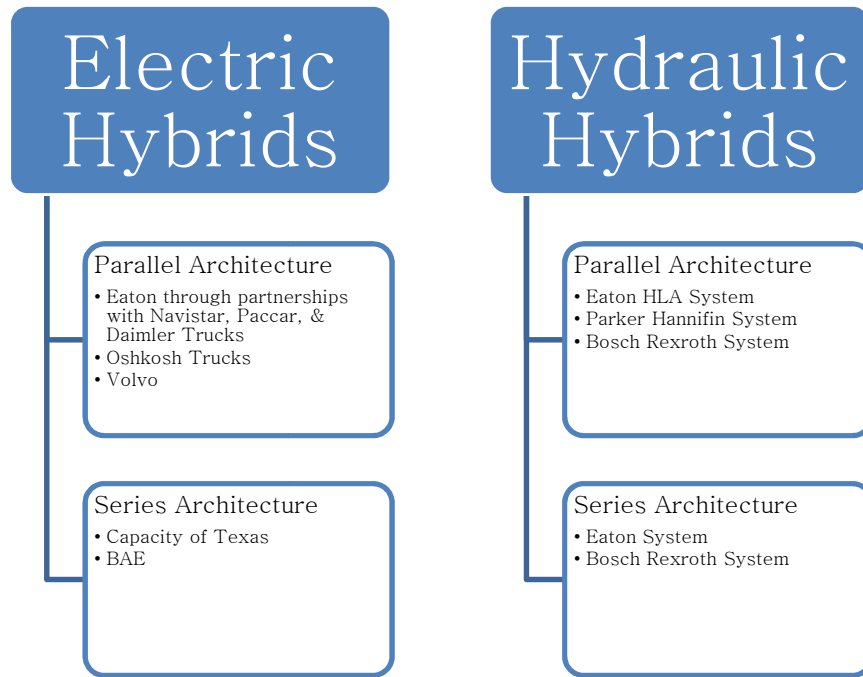
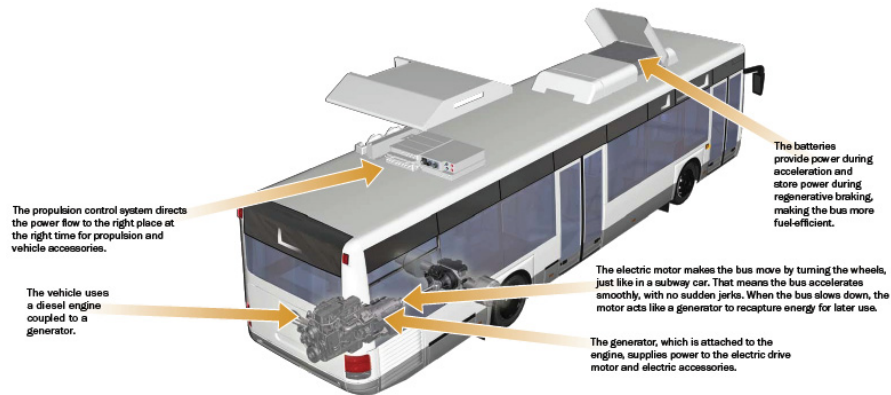

Figure 3-5. Breakdown of manufactured hybrids and hybrid systems by type and architecture.

#### BAE Systems

BAE offers a series electric hybrid called the HybriDrive system (Figure 3-6). First developed for use in buses, the system is in operation in buses produced by Alexander Dennison Limited (UK), Isuzu, Daimler Buses North America, New Flyer, and Iveco. Its lithium ion batteries, which store energy, are typically mounted on the roof of the bus. Alexander Dennison advertises that this system can reduce CO<sub>2</sub> emissions by 30%. They also state that their system has greater than 94% availability. Daimler Buses advertises a 35% improvement in fuel economy (“Hybridrive Propulsion Systems”).



Source: BAE

Figure 3-6. Layout of typical BAE hybrid electric bus

### Capacity of Texas

Capacity of Texas, Inc. manufactures terminal tractors that are used for moving trailers and containers short distances, such as in rail or port terminals. They offer a diesel/electric series hybrid called the PHETT (Figure 3-7). It is powered by a 40 HP tier 4 compliant diesel engine. It uses a 225 HP three-phase motor to drive the vehicle and 52 lead acid batteries to store the electricity. The batteries operate at 330V and can supply a current of up to 500 amps. Lead acid batteries were chosen for this application because the cost of lithium ion (Li-ion) batteries was so high. Capacity advertises a 60% reduction in fuel consumption and a 30% reduction in audible dB over a comparable standard vehicle (Capacity of Texas, Inc.).



Source: Capacity of Texas, Inc.

Figure 3-7. Image of Capacity PHETT hybrid yard truck.

Capacity tested a prototype of this model at the Port of Houston. This truck was operated for 600 hours, but the generator operated for only 300 hours. Because the engine is running only half the time, a considerable amount of fuel is saved, emissions are reduced, and the engine has to be serviced less often. Also, as a series hybrid, the engine has no transmission, reducing required service (Sturgis).

Capacity has also announced a partnership with Vision Motor Corp. to produce a fuel cell powered terminal tractor (“ZETT - Vision Motor Corp”).



### GM Allison

Allison began offering an electric power-split hybrid powertrain for buses and coaches in 2003 (Figure 3-8). About 2,600 of these systems are in operation today and have driven a combined 166,000,000 miles. They are used in Chicago, Philadelphia, Washington DC, Seattle, Houston, Minneapolis-St. Paul, Oahu, Vancouver, and Yosemite National Park (*It's the Right Thing to Do*).



Figure 3-8. Image of New Flyer/Allison hybrid electric bus.

This system advertises a NO<sub>x</sub> emissions reduction of up to 50% and actual fuel economy improvements of 20–54%. It also offers quieter operation and improved, seamless acceleration over traditional drivetrains (*It's the Right Thing to Do*).

The batteries used in this system are a nickel metal hydride battery manufactured by Panasonic. This current production battery is an updated version of the original, but the original series of battery was driven a combined 100,000,000 miles without an end-of-life battery cell failure (*It's the Right Thing to Do*).

### Freightliner

Freightliner offers a parallel electric hybrid in their Business Class M2 series through a partnership with Eaton (Figure 3-9). This medium duty truck is used for refuse, beverage, delivery, and utility applications. They offer improvements in fuel economy, which vary according to application (Table 3-1). They also advertise an 87% reduction in idle time, quieter operation for bucket trucks, and a 100% brake life increase in urban delivery applications (Daimler Trucks North America LLC).

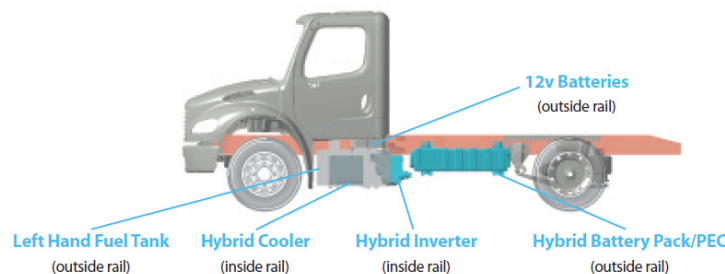

Source: Daimler Trucks North America LLC

Figure 3-9. Layout of Freightliner/Eaton electric hybrid system.

**Table 3-1. Advertised fuel economy improvement of Freightliner electric hybrid system based on application.**

| <b>Application</b> | <b>FE Improvement</b> |
|--------------------|-----------------------|
| City Delivery      | 25–40%                |
| Utility            | 40–60%                |
| Deliver Tractor    | 20–30%                |

*Source: Daimler Trucks North America LLC*

*International Truck (Navistar)*

International claims to be the first truck manufacturer to begin line production of commercial hybrid trucks. The system that is offered commercially is a parallel electric hybrid system produced in conjunction with Eaton. It is based on the Durastar chassis, which is available in classes 4–7 (Figure 3-10). International claims it improves fuel economy by up to 60%. The emissions are reduced by 65% for hydrocarbons, 58% for carbon monoxide, and 41% for NO<sub>x</sub>. The hybrid drivetrain also improves 0–60 mph acceleration by 9 seconds. The regenerative braking also reduces brake wear (Navistar, Inc.).



*Source: Navistar, Inc.*

*Figure 3-10. Image of International Durastar truck.*

International has also worked on two other systems that are not commercially available. The first system is a series hydraulic hybrid (Figure 3-11). UPS, Eaton, and the EPA formed a partnership with International Truck for the development of this system. This system differs from the hydraulic hybrids offered by other manufacturers because it decouples the engine from the rear wheels and has no traditional drivetrain. In 2008 UPS placed an order for seven of these delivery trucks to be put into service in 2009 and 2010 in the Minneapolis area. It is advertised as reducing emissions by 30% and increasing fuel economy by up to 50% (Navistar, Inc.).

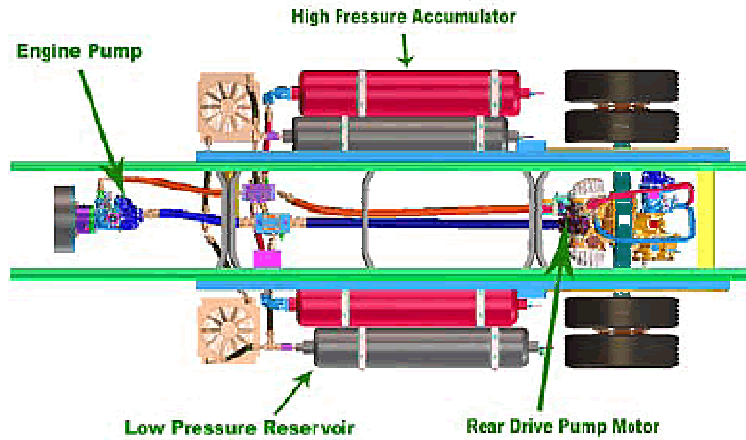

Source: U.S. EPA, "Clean Automotive Technology: Hydraulic Hybrid Research"

Figure 3-11. Layout of UPS series hydraulic hybrid delivery truck chassis.

The second system that International is developing is a class 8 electric hybrid targeted at the long haul market. It is being developed in conjunction with ArvinMeritor. Available literature does not specify the system architecture. This truck can be operated entirely on electric power up to 48 mph. At highway speeds the electric motors provide power as needed while climbing grades. Wal-Mart took the delivery of the first prototype for testing in 2009 (*Walmart Tests New Hybrid Trucks, Alternative Fuels*).

#### *Oshkosh Defense*

Oshkosh offers their Propulse system in their HEMTT-A3 truck for military applications (Figure 3-12). A series electric hybrid system, it uses ultracapacitors as its energy storage method because of their reliability and power density. These capacitors can store 1.9 MJ of energy. The drive motors are 480V induction motors. The generator is rated for 340 kW and is powered by a 470 hp diesel engine. The vehicle has a curb weight of 35,000 lbs and a gross vehicle weight rating (GVWR) of 70,000 lbs. This vehicle claims to increase fuel economy by 20% over current models. Other benefits include the ability to export up to 200 kW of electricity, a reduced heat signature attained by powering equipment from capacitors with the engine off, and the means to discharge capacitors completely for maintenance (Oshkosh Corporation).

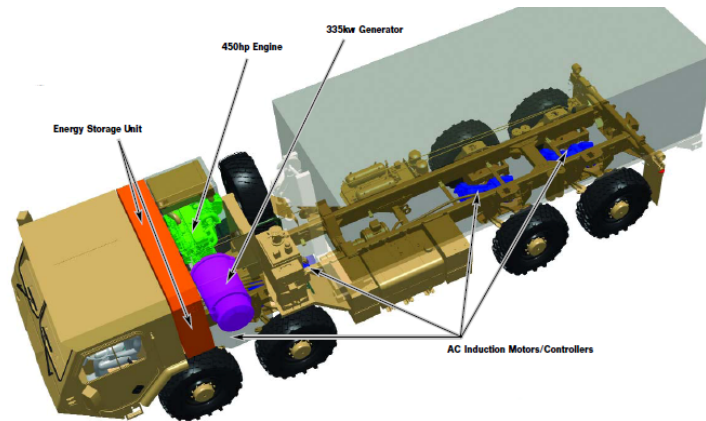

*Source: Oshkosh Corporation*

*Figure 3-12. Image of Oshkosh HEMTT-A3 hybrid truck with component locations.*

*Peterbilt/Kenworth (Paccar)*

In the medium range, Peterbilt offers an electric hybrid system (Figure 3-13). The models that offer this option are the 330, 337, and the 348. In the heavy duty range, they offer two different hybrid systems. The first system is a hydraulic hybrid that is offered on the 320 model. The second system is an electric hybrid offered in the 386 model. All of the hybrid systems offered by Peterbilt were developed through a partnership with Eaton (Peterbilt Motors Company).



*Source: Peterbilt Motors Company*

*Figure 3-13. Image of Peterbilt/Eaton hybrid electric drivetrain.*

The four electric hybrid models that Peterbilt offers utilize Li-ion batteries. Li-ion batteries were chosen because they have the highest energy density of the available battery technologies. The battery pack that is used on Peterbilt trucks (Figure 3-14) weighs about 110 lbs and is equivalent to about 1900 lbs of lead acid batteries (Peterbilt Motors Company).



*Source: Peterbilt Motors Company*

*Figure 3-14. Image of Peterbilt packaging of lithium ion batteries.*

The model 330, shown in Figure 3-15, is a class 6 vehicle that advertises a fuel economy improvement of 30%.



*Source: Peterbilt Motors Company*

*Figure 3-15. Image of Peterbilt model 330 hybrid.*

The model 337 is a class 7 vehicle (Figure 3-16). Its target uses are pickup and delivery, fire and rescue, beverage, municipal, and refuse applications. It advertises a 30–40% improvement in fuel economy and an 80% reduction in idling time. It is available with an electrically powered PTO that can be operated with the engine off (Peterbilt Motors Company).



*Figure 3-16. Image of Peterbilt model 337 hybrid.*

The model 386 hybrid designed for long haul applications (Figure 3-17). Peterbilt engineers claim that it will improve fuel economy by 5–7%. It can also reduce idle time significantly. At 95 °F and 50% humidity, the engine can charge the battery in 4.5 minutes to run the air conditioner for 50 minutes (Peterbilt Motors Company). The first model was delivered to Wal-Mart in 2007. At that time Wal-Mart said it did not make business sense because the payback did

not exist, but it was evaluating the model for certain applications. An interesting feature that it does offer is a "hill holder" operation where the electric motor holds the truck while the clutch is engaged on a slope. The Peterbilt engineers also stated that the largest cost of the system is the Li-ion battery but hoped that as production increased the price would come down (Berg).



*Figure 3-17. Image of Peterbilt model 386 hybrid.*

The model 320 hybrid is designed for refuse applications (Figure 3-18). It utilizes Eaton's Hydraulic Launch Assist system. This system is a parallel hybrid that joins the two powertrains together behind the transmission. Peterbilt advertises that the system can recapture 75% of the energy normally lost through regenerative braking. It claims that in testing the system improved fuel economy by 30%, reduced emissions by 30–40%, reduced brake wear by 50%, and increased productivity by 28%. This system has a performance operating mode that increases acceleration by 18% while still allowing for a double-digit improvement in fuel economy (Peterbilt Motors Company). This truck was tested by Waste Management in Fort Worth, Texas, in 2008 and is currently in use in Denver (*2008 Sustainability Report*; Eaton Corporation).



*Figure 3-18. Image of Peterbilt model 320 hybrid.*

Kenworth offers an electric hybrid in their T270 and T370 models produced in conjunction with Eaton: class 6 and 7 trucks, respectively. This system appears to be same one used on the Peterbilt trucks based on vehicle installation and component packaging. According to the Kenworth literature, the battery pack is a 340V Li-ion system. The motor/generator is rated at 60 hp and can produce 310-ft-lbs of torque. The T370 hybrid is currently being used by Coca-Cola in several cities across the U.S.



## *Volvo*

Volvo is developing a hybrid system that is aimed at refuse and city delivery applications. It uses an integrated starter, alternator, and motor that is mounted between the engine and transmission (Figure 3-19). It is currently in testing as an advanced prototype across Europe. Volvo advertises a 20% fuel saving potential for refuse application, but claims a 30% improvement if the secondary functions of the vehicle are powered by the electrical system. For city delivery applications they advertise a 12–20% fuel savings (Volvo Trucks Global).

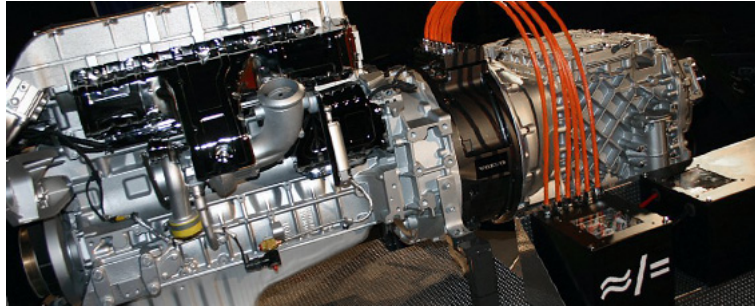

*Figure 3-19. Image of Volvo parallel electric hybrid drivetrain.*

At speeds below 20 kph (12.4 mph), the electric motor provides all the propulsions. The diesel engine is the primary source of power above this speed. The motor used in this vehicle is a six-phase permanent magnet synchronous motor. It has a 120 kW power rating and can provide 800 Nm of torque (Volvo Trucks Global).

Volvo also claims to be developing improved lead acid batteries. The new battery is called the Effpower, which Volvo claims will double the power output and significantly reduce manufacturing costs (Volvo Trucks Global).

## **Conclusion**

Currently, the Eaton parallel electric hybrid appears to dominate the market. This system seems to be the most widely used by medium duty trucks in the delivery and utility sectors with either a great deal of stop-and-go driving or idling. However, a great deal of testing and possible implementation of parallel hydraulic hybrids has apparently occurred in refuse trucks.

The heavy duty market seems to differ from the light duty market in how these systems are developed. For light duty vehicles the systems are developed by the vehicle manufacturer. The heavy duty vehicle manufacturers have partnered with a third party to help with the development and implementation of these systems. This development is not surprising because many truck manufacturers do not make many of the major components like engines, axles, and transmissions. They simply offer several options to their customers, options manufactured by various other companies.





## Chapter 4 - Truck Operating Costs

Hybrid trucks are currently being tested and used in several applications—primarily as parcel delivery trucks, beverage delivery trucks, and refuse trucks. These applications all share some common features that lend themselves well to hybrids.

One common characteristic among all these applications is that they operate in urban environments with a great deal of starting and stopping. The interest of this study is urban environments, but a more rural or suburban environment has been evaluated for two applications due to the availability of the data. This data also helps to prove what has been mentioned many times in literature: that hybrids work well when put on the correct drive cycle.

The other shared aspect is that they all typically use diesel trucks. The current diesel price as of April 4, 2011, is \$3.98/gal. During the past year, as shown in Figure 4-1, diesel has averaged \$3.20/gal and increased in price by about a dollar per gallon (U.S. Department of Energy). The Department of Energy (DOE) is predicting that this price will continue to increase above \$6.00/gal by 2035 (U.S. Department of Energy, “Annual Energy Outlook - 2011”). For this analysis the price of diesel is assumed to vary between \$3.50 and \$6.50 per gallon. This range should cover most variations in price that will be seen in the near future.

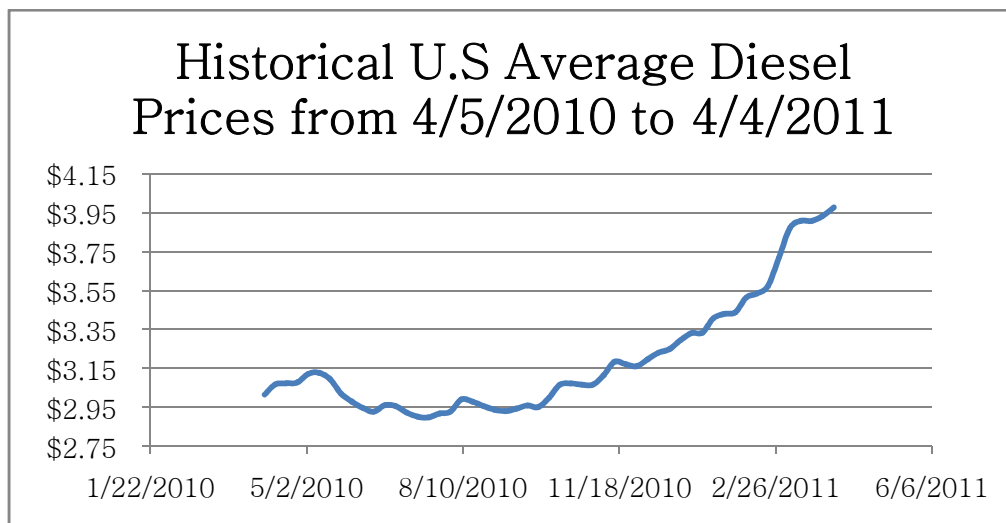

Source: U.S. Department of Energy

Figure 4-1. Historical U.S. average diesel price at the pump from 4/5/2010 to 4/4/2011.

### Hybrid Type 1 – Parcel Delivery Truck

The delivery truck is an application that has seen a lot of activity for heavy duty hybrids. Both FedEx and UPS have tested and are further evaluating hybrids. UPS reported on February 14, 2011, that they use 100,069 package cars, vans, tractors, and motorcycles to deliver 15.1 million packages and documents each day (UPS Public Relations).

Delivery vehicles operate in urban areas with a drive cycle that lends itself well to a hybrid vehicle. The National Renewable Energy Lab (NREL) has performed two studies on hybrid delivery vehicles. The studies were conducted with FedEx and UPS. Both studies involved some analysis of the drive cycles of the study vehicles. The average speed for the vehicles in the two

studies ranged from about 17 to 23 mph with top speeds that ranged from 69 to 74 mph in the UPS study (Figure 4-2). The vehicles experienced from 0.7 to 5.5 stops per mile in both studies (Barnitt and NREL; Lammert and NREL).

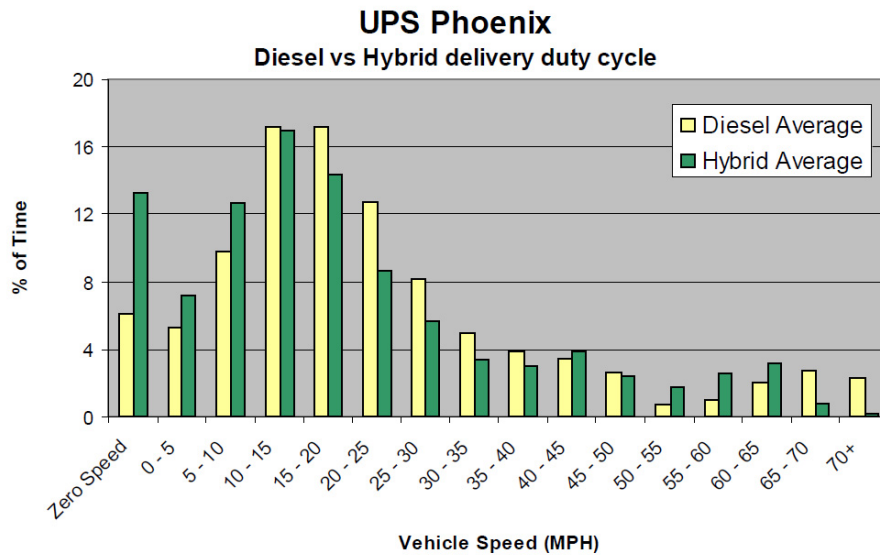

Source: Lammert and NREL

Figure 4-2. Time at speed plot for UPS delivery truck.

The typical, “boxy” UPS or FedEx delivery vehicle is referred to as a *step van* and is most likely to be either a class 4 or 6 vehicle. This type of vehicle is usually constructed by two manufacturers. The first company will build the chassis while the second company will construct the body that creates a finished product designed for a specific purpose. Due to the nature of this vehicle, FedEx and UPS use similar vehicles that have differences due to variances of each vehicle manufacturer. For this study some aspects of the various vehicles will be used to create an average vehicle as data is available.

The researchers assumed that the base vehicle price would be about \$75,000. This price was determined from comparing prices of various box vans available on the internet. The criteria for this search was that it must be a new, class 6 box van that had a GVWR of about 17,000 lbs. These values were derived from the trucks used in the NREL UPS and FedEx studies. These trucks have GVWRs that ranged from 14,000 to 17,000 lbs (Barnitt and NREL; Lammert and NREL).

The average urban truck was assumed to travel 17,000 miles per year; the average rural truck was estimated to travel 21,000 miles per year. These averages were based on the UPS study where truck utilization ranged from 12,000 to 23,000 miles per year but with distinctions between the urban and rural groups (Lammert and NREL).

The hybrid system cost was assumed to range from \$30,000 to \$50,000 and reduce fuel consumption about 25%. A reduction of 22.5% was observed in the NREL study. Note that a slightly higher improvement would have been observed if the two sets of trucks had more similar drive cycles. The maintenance cost was also assumed to be about 8% lower based on the NREL

UPS study. This maintenance does not include the replacement of the battery because it was based on only 1 year of data (Lammert and NREL).

Because battery replacement is a major cost that must be considered, it was included as an additional input into the model. The replacement was estimated to cost \$5,000 and require 8 hours to replace. The labor rate was assumed to be \$50/hr. With these assumptions the replacement costs a total of \$5,400. Because the batteries in the Eaton hybrid system are guaranteed for only 7 years, the researchers assumed that the batteries would be replaced at the end of the 7-year period. Even if the battery were to fail at 8 years, the average cost for the 10-year cost of ownership would not change (Kelley).

Because the truck cycles in the studies varied, the analysis was conducted for two different settings. The difference in the analysis was simply the fuel economy of the base vehicle. The more urban setting assumed the truck had a fuel economy of 8 mpg, and the rural/suburban setting assumed that the truck would have a fuel economy of 11.2 mpg. These values were taken from the NREL UPS study from the conventional diesel trucks (Lammert and NREL). These two values were the extremes observed in the study. By analyzing the two extremes, the average conditions are bounded.

The analysis estimates that the hybrid system will not pay for itself within a 10-year period, as Figure 4-3 indicates. The two settings appear to have only a small impact on the total cost per mile to operate the vehicle, because a hybrid's savings are based on vehicle utilization as well as the improvement in fuel economy. The difference in operation was not assumed to affect fuel economy improvement for the hybrid vehicle in the two settings. However, it will probably have some effect. Because this differential was not known, the fuel economy improvement was assumed to be 25% to create a best case scenario for the adoption of a hybrid, as the payback did not appear to be present in most cases.

Because a payback does not appear to exist, companies are assumed to be either absorbing the cost of the hybrid system or assigning some value to other benefits associated with the hybrid truck. The benefits must be at least \$5,000 per year at a diesel price of \$3.50 for the \$30,000 system to break even in an urban environment. Figure 4-4 and Figure 4-5 illustrate the estimated operating costs of conventional and hybrid trucks in a rural and urban setting, respectively.

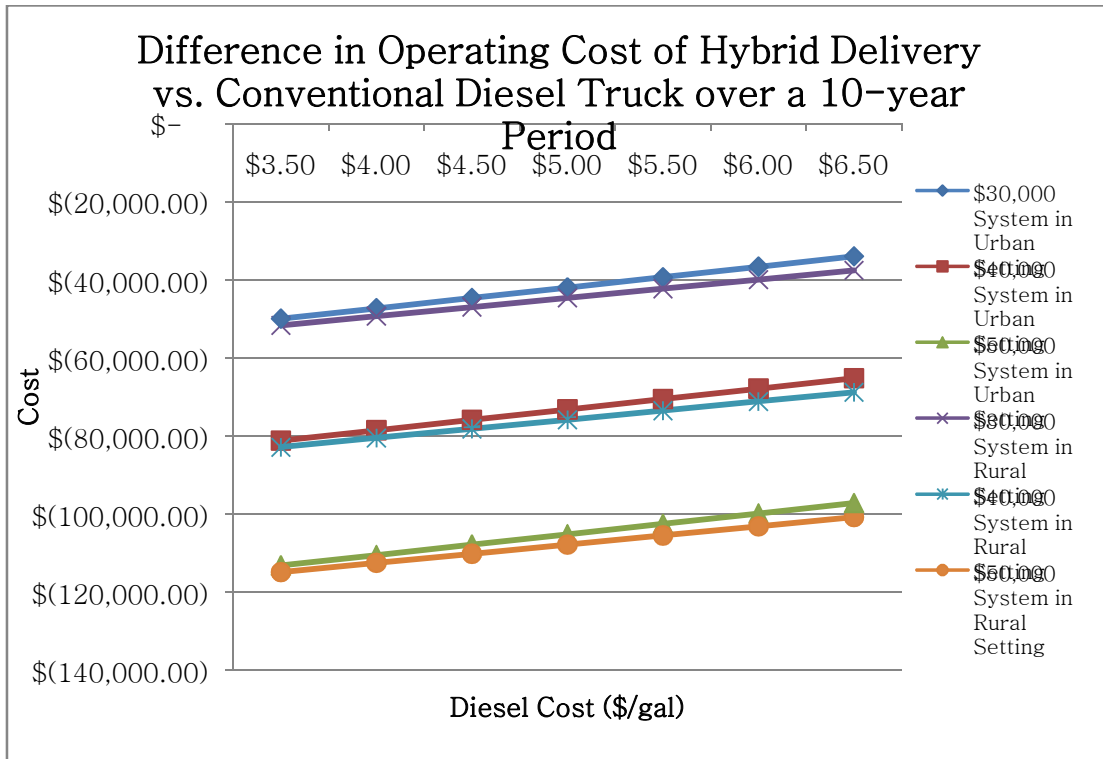

Figure 4-3. Differential cost of operating a hybrid delivery truck in place of a conventional truck.

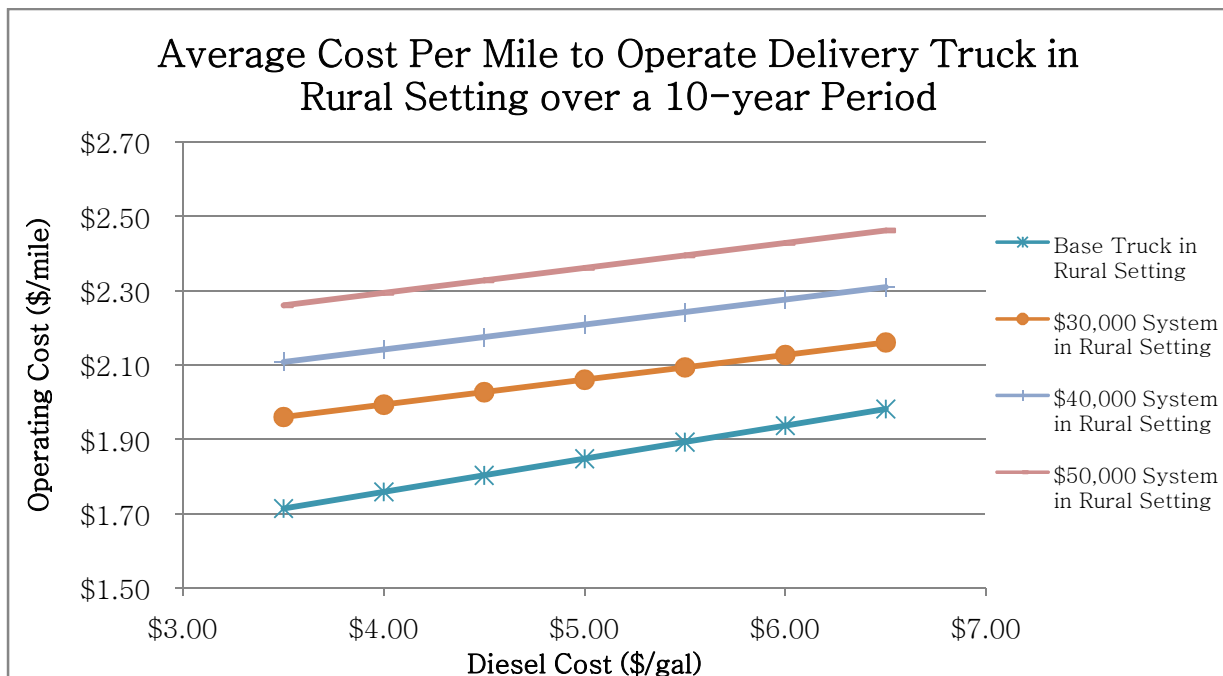

Figure 4-4. Estimated operating cost per mile of a conventional and hybrid package delivery truck in a rural setting.

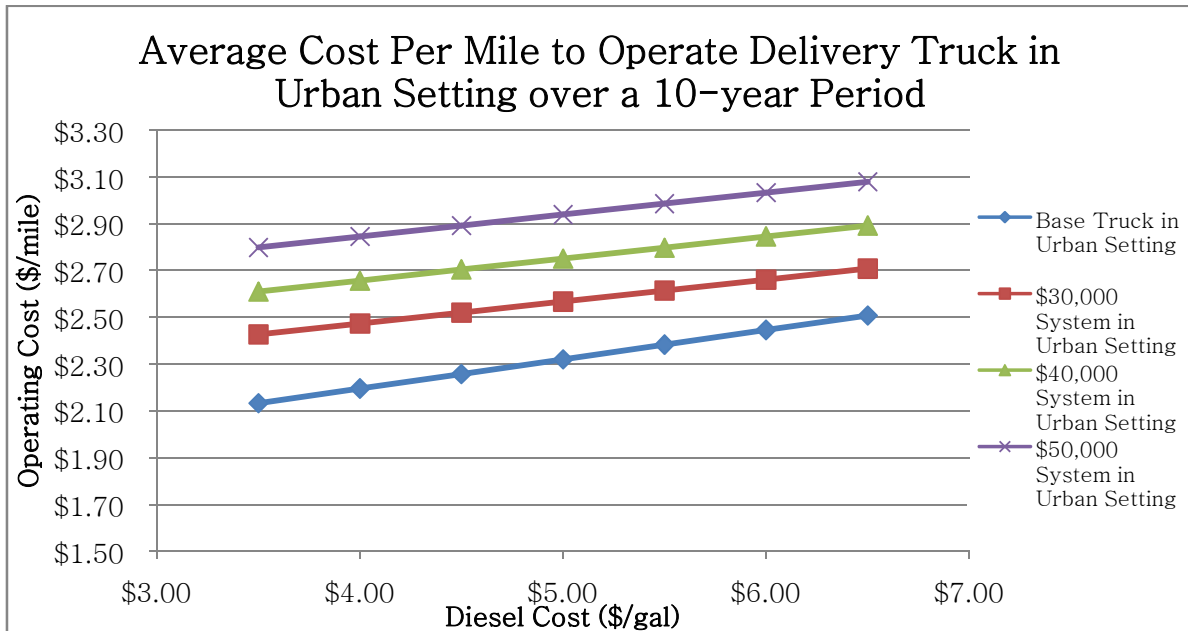

Figure 4-5. Estimated operating cost per mile of a conventional and hybrid package delivery truck in an urban setting.

Assumptions must be made about the cargo that a truck carries in order to calculate the cost per ton mile to operate the truck. The class 6 UPS step vans tested in the lab for the NREL study had a weight capacity of 6,000 lbs. A parcel delivery truck is unlikely to regularly exceed this cargo weight and will most likely run out of cargo volume and “cube out.” In this application, the cubed out weight was estimated to be one-third of the maximum cargo weight or an estimated cargo weight of 2,000 lbs (1 ton).

### Hybrid Type 2 – Beverage Delivery Truck

The beverage delivery fleet constitutes a large portion of the private urban delivery carrier fleet. The 2010 Transport Topics Top 100 Private Carriers surveys placed PepsiCo, Coca-Cola, and the Dr. Pepper Snapple Group all in the top 10. These three distributors operate an estimated combined 24,222 tractors and 61,946 straight trucks, pickups, and cargo vans (Transport Topics). As of February 2011, Coca-Cola claims to have 634 hybrids in operation (Cioletti, McCall, and Saltgiver).

Many of these trucks operate in an urban environment with significant starting and stopping in addition to frequent stops that are required to deliver their product. According to the 2011 *Beverage World* Truck Trends Survey, the average truck travels 39,949 miles annually (Cioletti, McCall, and Saltgiver). Figure 4-6 provides a breakdown of annual beverage vehicle mileage.

## Breakdown of Annual Beverage Delivery Vehicle Mileage

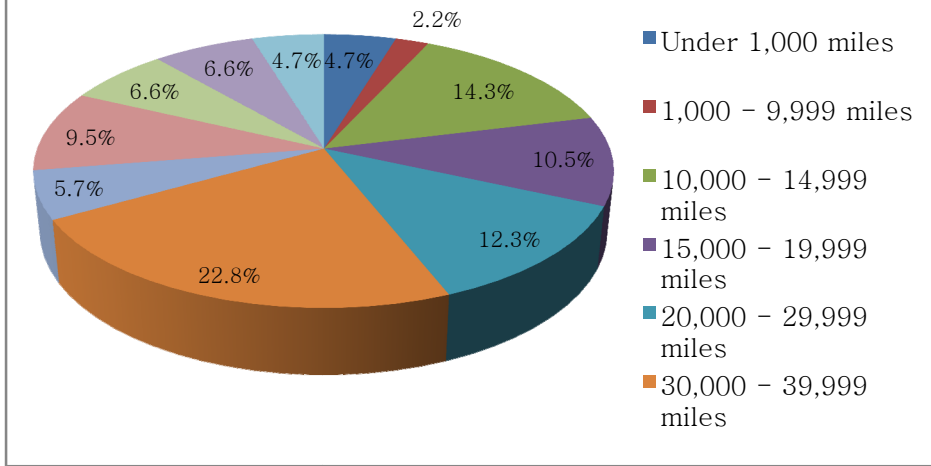

*Source: Cioletti, McCall, and Saltsgiver*

*Figure 4-6. Breakdown of annual beverage delivery vehicle mileage.*

The assumed vehicle for this application was a Class 7 double axle tractor. The base cost of the vehicle was assumed to be about \$100,000. The estimated cost of the hybrid system ranged from \$30,000 to \$50,000. This cost was based on estimates for the Kenworth system of \$40,000 and a cost estimate of \$50,000 made by Mengo McCall of Canadian Spring, who recently began leasing two Kenworth T370 hybrids (Cioletti, McCall, and Saltsgiver; Gonzalez; Carey).

The fuel economy of these vehicles is not readily available. One specific value found was reported by County Beverage Company, Inc. in Lee Summit, MO. They report that their 2006 570 International was achieving 3.26 mpg. The DOE estimated that the average fuel economy of all class 7 trucks in 2002 was about 6.4 mpg. However, the DOE estimate includes trucks that operate in other conditions as well. Argonne National Laboratories analysis predicts the fuel economy of a class 6 or 7 truck to be 5.0 mpg and 4.4 mpg through the “Central Business District Truck” drive cycle and the “New York Truck” drive cycle, respectively. Therefore, the average fuel economy was assumed to be 4.7 mpg. A 25% reduction in fuel consumption was assumed for application as well.

Clearly the \$30,000 system pays for itself during its 10-year service life. However, this cost estimate is most likely to be lower than the actual cost of the system today. Based on available data, the system most likely costs between \$40,000 and \$50,000. With today’s diesel prices, the hybrid system would not pay for itself. The operator must weigh additional costs against overall benefits, subsidies, or incentives that make up this difference. Figure 4-7 and Figure 4-8 compare the 10-year costs of hybrid and conventional beverage delivery trucks.

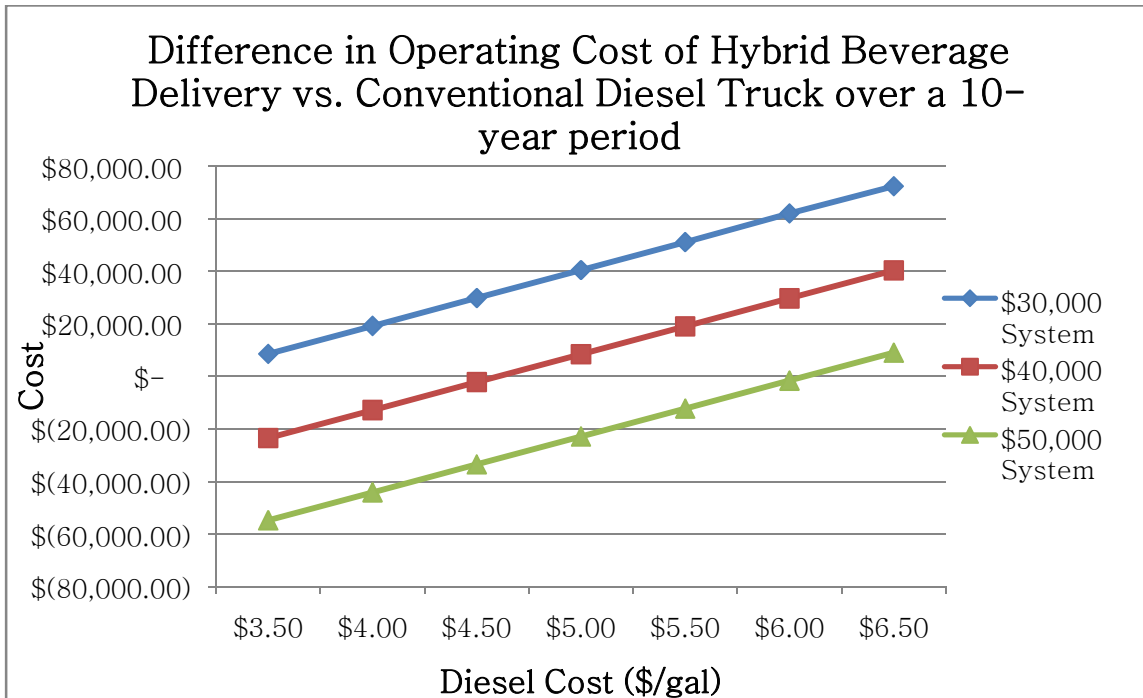

Figure 4-7. Estimated differential cost of adopting a hybrid beverage delivery truck over a 10-year period of ownership.

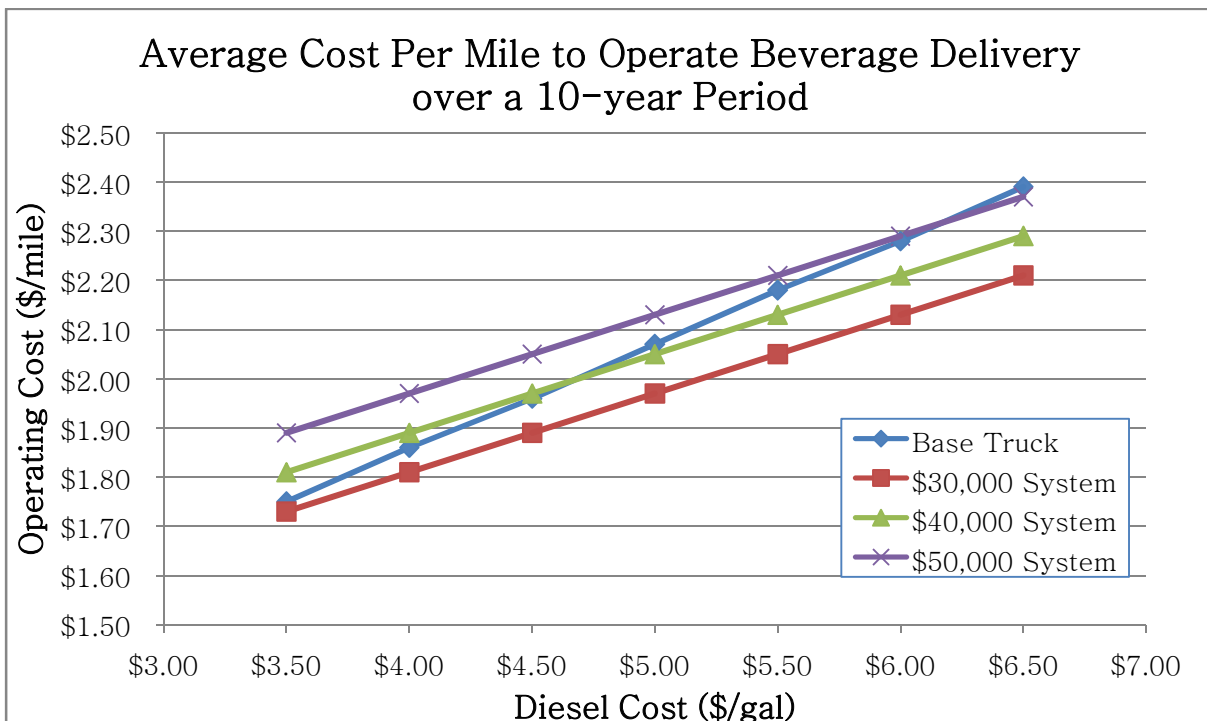

Figure 4-8. Estimated operating cost per mile of hybrid and conventional beverage delivery trucks.

According to the NREL Coca-Cola study, the average loaded truck weight leaving the warehouse was 42,800 lbs. The curb weight of the tractor was 11,600 lbs. If the tare weight of the trailer is assumed to be 12,000 lbs, the price ranges from \$0.18 to \$0.25 per ton mile (Figure 4-9).

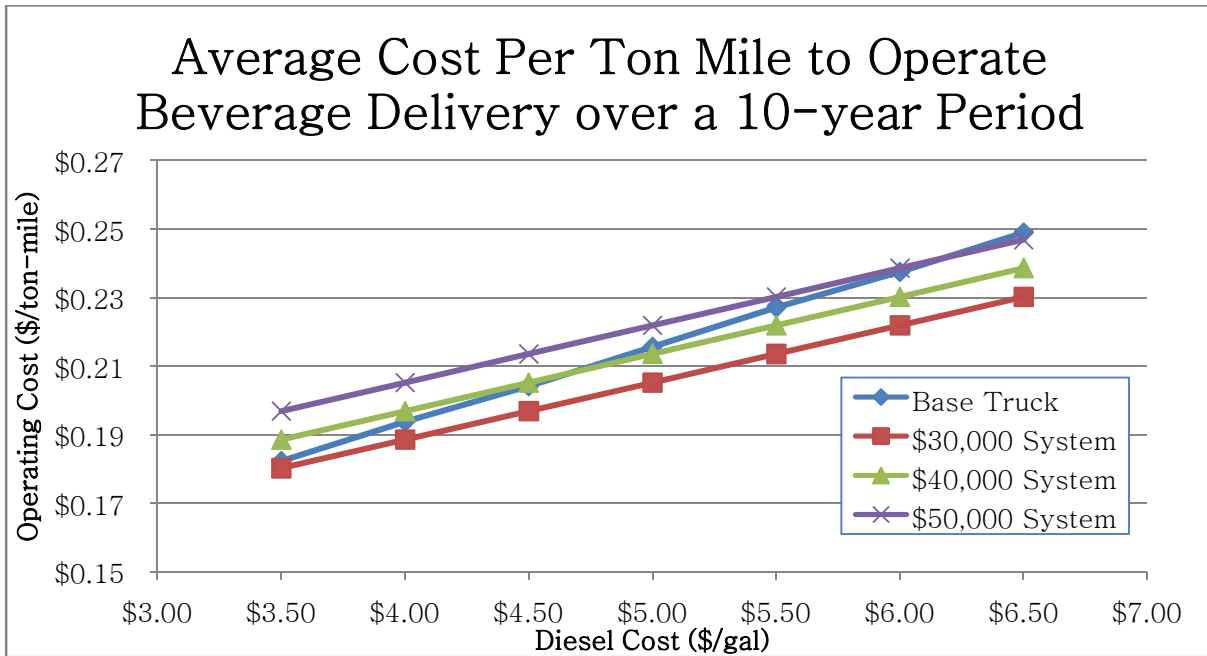

Figure 4-9. Estimated operating cost per ton-mile of hybrid and conventional beverage delivery trucks.

### Hybrid Type 3 – Refuse Truck

Refuse trucks represent an essential segment of the urban truck population. They perform a vital function but also contribute significantly to urban air pollution. The 2002 U.S. census estimated about 96,000 garbage trucks operating in the United States but other estimates have been as high as 136,000 trucks (Inventory; Gordon, Burdelski, and Cannon). These trucks have actual fuel economies that range from 1.3 to about 2.8 mpg (Ivanič; Chandler, Norton, and Clark). The average refuse truck for the city of Denver travels 8,400 miles annually with an average fuel economy of 2.3 mpg (Eaton Corporation). Based on these figures, the average Denver truck consumes about 3,650 gallons of fuel per year.

The Denver operating conditions are just one data point in a much larger picture. In 2007, a study was conducted on New York City garbage trucks to determine the average New York City refuse truck drive cycle. During the study, 450 hours of data were collected on various routes to compile a final cycle. The results showed an average fuel economy of 1.3 mpg with an average speed of 4.1 mph. The paper also states that the trucks were operated 6 days a week. If a 10-hour work day was assumed, the annual mileage of the truck could be estimated at 10,234 miles/year (Ivanič). A study conducted by the NREL in Washington, PA, estimated that the annual mileage of one group of trucks in their study was much higher at 27,540 miles/year with an average speed of 11.5 mph. The other group of trucks in the study were liquefied natural gas (LNG) trucks. The LNG trucks had similar but slightly less extreme statistics because closer routes were specifically chosen, due to uncertainty about their reliability at that time. Under these conditions the Waste



Management trucks averaged about 2.8 mpg (Chandler, Norton, and Clark), as shown in Table 4-1. Refuse truck annual utilization will have a wide range of values, as some metropolitan areas have several processing sites, while others are few in number and processing is remote.

**Table 4-1. Operating characteristics of refuse trucks in various locations.**

| <b>Location</b> | <b>Fuel Economy</b> | <b>Average Speed</b> | <b>Annual Mileage</b> |
|-----------------|---------------------|----------------------|-----------------------|
| New York, NY    | 1.3                 | 4.1                  | 10,234 (estimated)    |
| Washington, PA  | 2.8                 | 11.5                 | 23,898                |
| Denver, CO      | 2.3                 | Unknown              | 8400                  |

*Source: Eaton Corporation; Ivanič; Chandler, Norton, and Clark*

Further investigation into the large discrepancy of these datasets found that Washington, PA has a population of only about 15,000 (City of Washington, PA). Thus, the trucks operating in the NREL study had routes that were likely somewhat rural or suburban in nature. Because of this difference, two sets of analysis were conducted to evaluate a truck in an urban and a somewhat rural or suburban setting.

As mentioned earlier, the City of New York has worked to define the typical refuse truck drive cycle. They found that the average speed of the truck is only 4.1 mph. This average includes the trip to and from the landfill where the vehicle reaches speeds of up to 50 mph. However, the truck spends almost 75% of its time collecting garbage. During this operation the vehicle averages 1.1 mph with about 49 stops per mile (Ivanič). This high frequency of stops fits the performance of hybrid systems.

The hybrid system being used in refuse trucks is somewhat different than the system used in the previous two applications. The system being evaluated in this application is a hydraulic hybrid system and has proven itself in refuse truck applications. This system uses hydraulic pumps, valves, and accumulators to store and release energy during the drive cycle. This system has two main benefits. The first is that it has a very high power density. The Hydraulic Launch Assist (HLA) system that Eaton sells has an estimated maximum power of 380 hp. The second benefit is that it uses a great deal of off-the-shelf components, which greatly reduces the cost. Estimated costs for the system range from \$7,000 to \$38,000 (U.S. EPA, “Clean Automotive Technology: Hydraulic Hybrid Research;” Operations Division). If the cost of the truck has been assumed to cost \$200,000, the percent increase in the cost of the truck is anywhere from 4% to 19% as shown in Table 4-2.

**Table 4-2. Hydraulic hybrid system cost.**

|   | <b>Cost of System</b> | <b>Percent Increase in Cost of Truck (\$200,000 truck cost)</b> |
|---|-----------------------|---|
| <b>EPA Estimate</b>                             | \$ 7,000.00           | 4%  |
| <b>vePower Technologies Production Estimate</b> | \$ 14,000.00          | 7%  |
| <b>vePower Technologies Prototype Estimate</b>  | \$ 22,500.00          | 11%   |
| <b>Denver System Cost</b>                       | \$ 38,000.00          | 19%   |

*Source: U.S. EPA, "Clean Automotive Technology: Hydraulic Hybrid Research;" Operations Division; (Canada), Drozd, and Technologies*

The two areas where the hybrid reduces operating cost are fuel consumption and brake wear. Fuel consumption is a major cost for refuse trucks, but brakes are also a large cost. The city of Denver estimates that they service their brakes every 3 to 4 months with an average cost of \$2,000 per change. The Eaton HLA system has seen improvements in fuel consumption of 25% and a doubling of brake life (Eaton Corporation). Parker Hannifin has done extensive testing on their parallel system and has seen improvements in fuel consumption ranging from 27% to 49%. During the Parker studies, brake wear was verified by a third party. The average service interval for the conventional truck was found to be about 12 weeks while the hybrids trucks had a 102-week service interval (Soderberg). This large variance suggests that the hydraulic hybrid may be very sensitive to its drive cycle. Therefore, a fuel savings of 25% and a doubling of brake life were chosen to ensure that savings would not be overestimated.

The addition of the hybrid system also creates a need for additional maintenance and repairs. The main resource for this estimation was the Eaton HLA Service Manual (Eaton Corporation, "Service Manual: Eaton Hydraulic Launch Assist (HLA)"). The recommendations included from this document were hydraulic oil changes, hydraulic reservoir breather changes, transfer case oil changes, and replacement of the accumulator bladder. While the frequencies of these maintenance requirements were available, the costs for the specific components were not. However, estimates were made by using available pricing for similar components. Estimated labor times were not available either so estimates were made by reading and understanding the procedures in the service manual. Values for these estimates can be found in Appendix 2 of the Eaton Service manual.

The maintenance for the rest of the truck was assumed to be constant between a conventional truck and a hybrid truck. The tires for the truck were assumed to be changed every 2 years, with an average cost per tire of \$300. While tire prices for the tires in the rear had an average price of about \$250, the tires in the front of the truck ranged from \$400 to \$500 due to the increased width for the heavy duty front axle. The data for the rest of the maintenance of the vehicle was taken directly from the NREL Waste Management study. While this study was done in 2001 and had some differences in drive cycle, it was still deemed acceptable because the largest maintenance costs for a refuse truck are brakes and tires (Chandler, Norton, and Clark).

Additional costs for depreciation and interest were also included in the model to evaluate the payback of the hybrid system. The depreciation was figured using the fixed declining balance

method that is built into Microsoft Excel. The final value of the truck was assumed to be \$6,000 after 10 years. The interest rate was assumed to be 4% for 5 years.

The final results were calculated using estimated system costs of \$7,000, \$14,000, and \$20,000. The upper system cost of \$20,000 was used instead of the \$38,000 Denver cost because the Denver truck was somewhat of an advanced prototype. The trucks were also assumed to have a fuel economy of 1.8 mpg and travel 10,234 miles per year in the urban setting. In the rural setting, they were assumed to have a fuel economy of 3 mpg and travel 23,898 miles per year. The estimated payback times are depicted in Figure 4-10. In both cases the improvement in fuel consumption was estimated to be 25% for the urban setting and 10% for the rural setting.

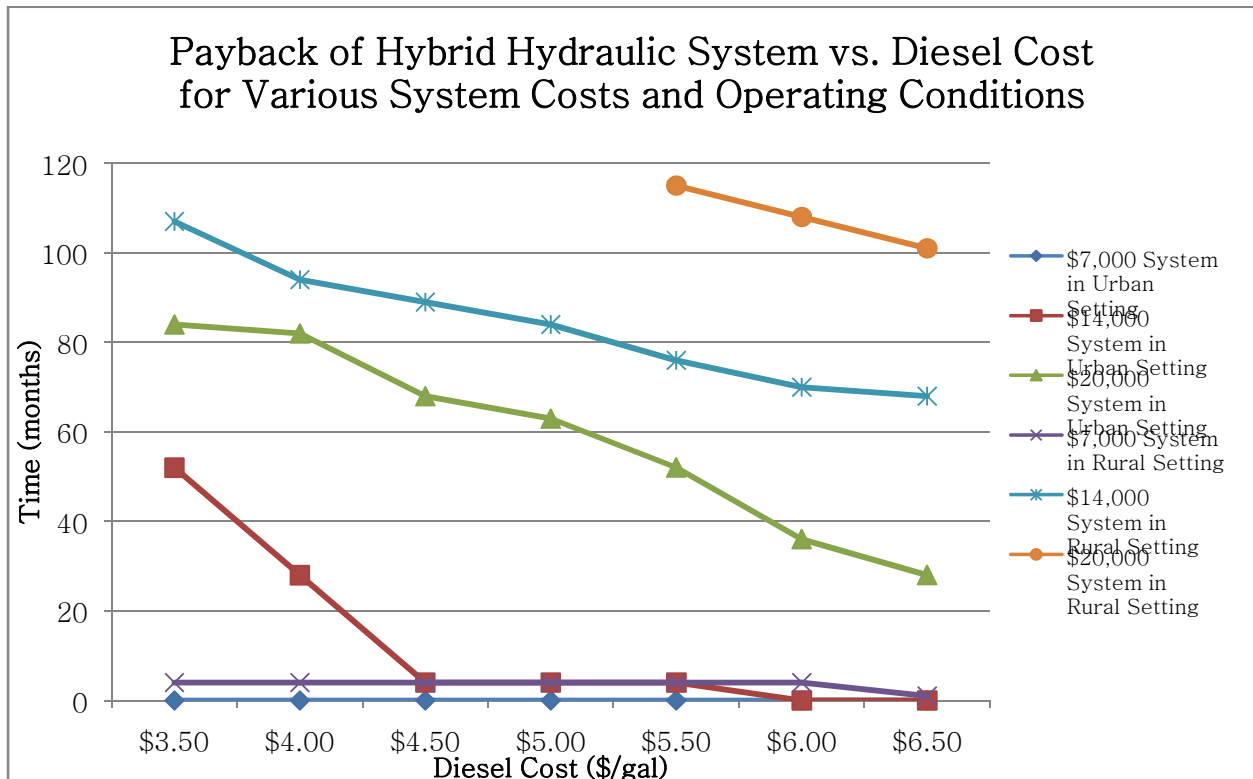

Figure 4-10. Estimated time for return on investment of hydraulic hybrid refuse truck for various settings and system costs.

Clearly the urban setting has a shorter return on investment for the hybrid system. The \$7,000 system immediately pays for itself, and the \$14,000 system pays for itself in less than 5 years. Note that the \$7,000 estimate was made by the EPA in 2006 and may be low as prices of commodities like steel and rubber have significantly risen since then. The dependence on fuel price should be linear as in the previous two case but is not in this case because the maintenance costs for brakes, tires, and the hybrid system were assumed to occur at discrete points in time.

The more rural setting presented conditions where the \$20,000 system did not have a payback within 10 years. With diesel prices of \$5.00 or less, the payback did not exist. However, the two lower cost estimates at least break even within the 10-year period of ownership for all possible conditions.

A further analysis of the estimated cost per mile shows that the two operating conditions can have a significant effect on the overall cost of operating the vehicle. Figure 4-11 shows the estimated cost per mile of operating the vehicle over the 10-year period of ownership as a function of diesel prices. Evidently the urban setting has a much higher operating cost per mile. Therefore, a lower annual mileage is required to pay for the hybrid system in the urban setting if fuel and brake savings are held constant between the two settings.

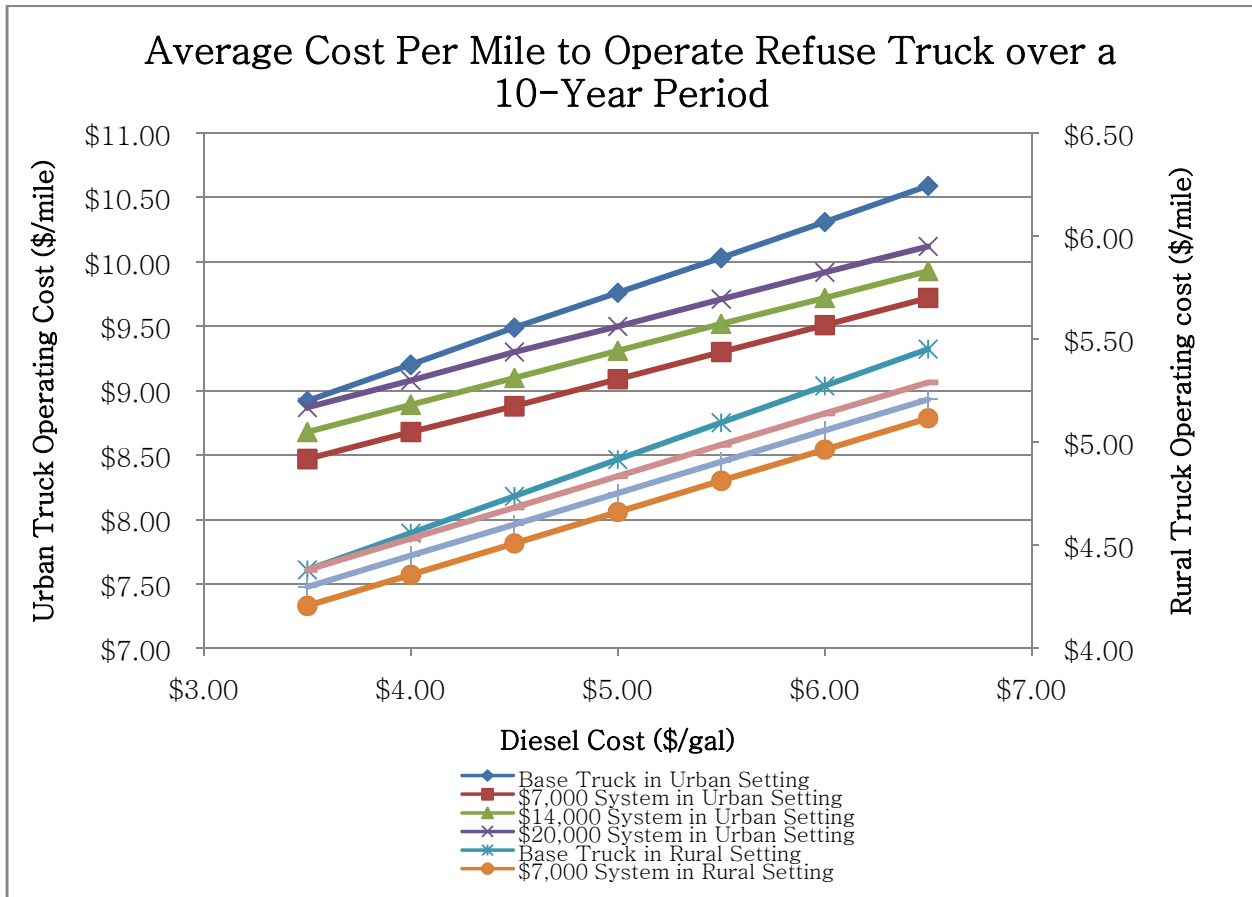

Figure 4-11. Estimated operating cost per mile for refuse conventional and hybrid refuse trucks in various settings.

The assumption made to calculate the cost per ton mile of refuse collection was that the empty truck would weigh 39,000 lbs (Labrie). This assumption was based on data from the New York drive cycle study. The maximum loaded weight was assumed to be 56,000 lbs based on Texas truck weight regulations (TxDOT). Also assumed was that the refuse truck would cube out like the delivery truck except it would be much closer to weighing out than the delivery truck. For this situation, the truck was assumed to cube out at 75% of its possible cargo weight. This assumption would allow for 8.5 tons of refuse to be carried, which yields the following cost per ton mile in an urban setting (Figure 4-12).

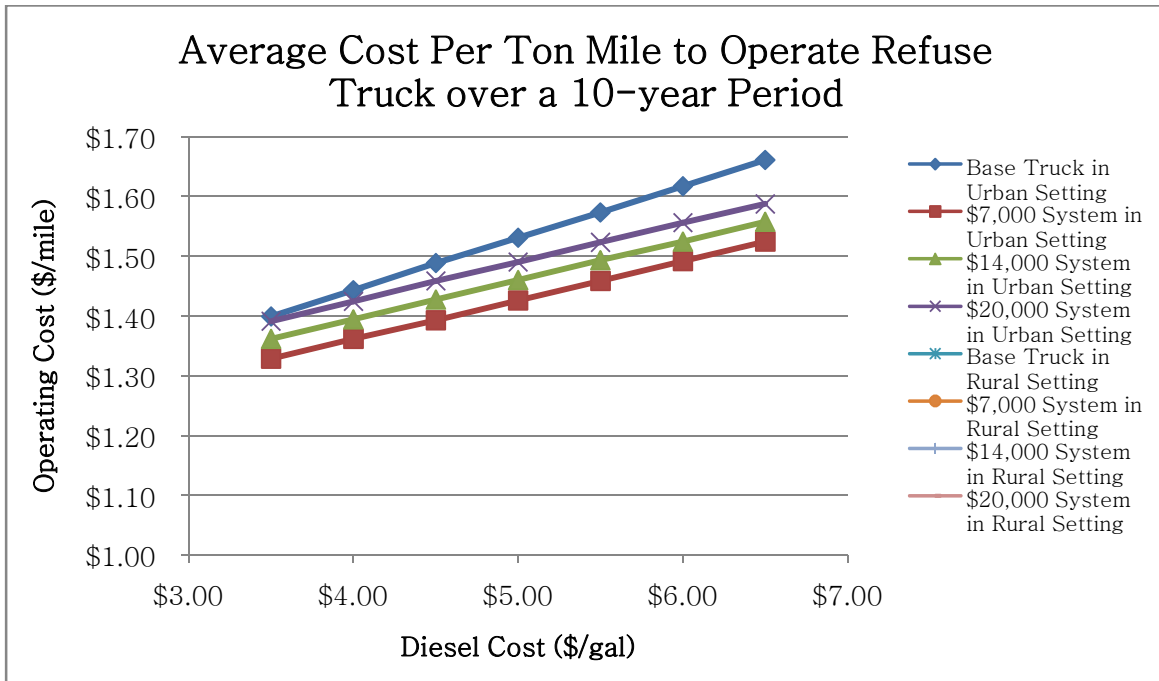
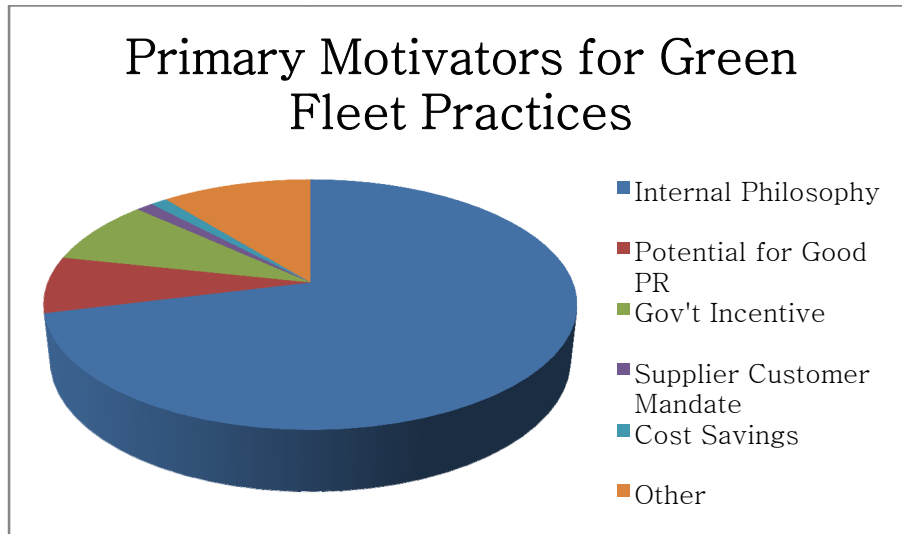

Figure 4-12. Estimated operating costs on a per ton-mile basis for conventional and hybrid refuse trucks.

### Consideration of Additional Benefits and Incentives

Most of the electric hybrids did not pay for themselves as estimated, but they are still being used and adopted currently. Obviously government incentives and other benefits that businesses are considering help to justify the implementation of these hybrid trucks.

*Beverage World* reported during a recent webinar that 63.9% of the participants in its 2011 Vehicle Trends Survey are implementing “green” business strategies (Figure 4-13). An internal company philosophy was the reason for this strategy for 71.1% of these companies, while only 1.2% of the respondents listed cost savings as their reason. A large percentage of companies outside of this specific industry likely have green business strategies as well (Cioletti, McCall, and Saltsgiver).



*Source: Cioletti, McCall, and Saltsgiver*

*Figure 4-13. Survey result for primary reasons of beverage companies to adopt green fleets.*

Good public relations were another reason behind these strategies. Mengo McCall of Aquaterra Corp. discussed how implementing hybrid trucks and other green practices have helped with the product perception of their bottled water. People associate a cleaner environment with hybrid vehicles in general. They believe that this perception is carried through to their bottled water as a clean product (Cioletti, McCall, and Saltsgiver).

Additional media attention through meetings with government officials, parades, and magazine articles is another benefit gained through the adoption of hybrids. In 2009 *Beverage World* conducted a roundtable discussion with 10 fleet managers from major distributors that had adopted hybrids. These hybrids ranged from cars to trucks, and most of these fleet managers had examples of where they were able to showcase their vehicles at events or were featured in magazine articles (Kelley).

Based on this data, certain benefits should be considered in the analysis of these hybrid trucks to offset the cost differential. This benefit could be the improved product perception attained through use of these vehicles or additional media coverage.

According to Lamar Advertising's website, the average cost to rent one panel of a billboard on IH 35 in Austin, TX is about \$1,500 per week. However, an equivalent size billboard on IH 35 in San Marcos, TX, costs about \$800 per week (Lamar Advertising). A standard delivery truck is already a moving billboard. If a hybrid improves upon the advertising that a standard truck gives, it could offset some of this cost. It would be equivalent to moving a billboard on a less traveled road to a more prominent location. Assuming that this improvement exists and that a truck is visible to the public one-fourth of the year, an advertising benefit of \$9,100 per year could be achieved. However, the effect of this improvement will most likely decrease as the novelty of these trucks is lost over time. If the improvement is assumed to be lost linearly by the fifth year of ownership, a benefit of \$22,750 can be achieved.

Another cost that could help to justify the use of hybrids is the reduction in carbon footprint that the hybrid offers. UPS now offers an option to ship a package as carbon neutral for a fee. This fee varies from \$0.05 to \$0.20 per package depending on the shipping method for domestic shipments. For international shipments the fee ranges from \$0.10 to \$0.75 (United Parcel Service of America).

Per the laboratory tests of the NREL UPS study, the base UPS delivery vehicle emits 1,252 g CO<sub>2</sub>/mile. The hybrid truck reduces these emissions by about 27% on average, resulting in a reduction of emitted CO<sub>2</sub> by 338 g/mile. Assuming that the truck travels 20,000 miles/year, the resulting reduction would be about 7.5 tons/year. If a cost of \$30 per ton is assumed over that period, the resulting savings would be \$2,250 over the life of the vehicle (Lammert and NREL; Kollmuss, Zink, and Polycarp).

Government subsidies are another means to help offset the cost of a hybrid, as outlined in Table 4-3. The federal government provides tax incentives of up to \$6,000 for hybrids that improve their fuel economy by 40% to 50%. However, the vehicles studied in the paper will qualify for only \$4,500. State and local governments also provide incentives (Eaton Corporation, “Hybrid Solutions for MD Commercial Vehicles”). Texas provides these subsidies through its emissions reduction program (detailed in Chapter 5). Based on past results of these programs, Texas will pay about \$4,900 per ton of reduced NO<sub>x</sub> emissions. In November 2010, UPS was awarded a grant to replace 55 trucks, potentially eliminating an estimated 29.6 tons of NO<sub>x</sub> emissions. Thus, an average of about one-half ton of NO<sub>x</sub> reductions per truck is achieved, which equates to \$2,450 per truck (Texas Commission on Environmental Quality).

**Table 4-3. Possible sources of money and estimated additional benefits for hybrid truck implementation.**

| Source              | Amount       |
|---------------------|--------------|
| Federal Subsidy     | \$ 4,500.00  |
| State Grant         | \$ 2,450.00  |
| Carbon Offset       | \$ 2,250.00  |
| Advertising Benefit | \$ 22,750.00 |
| Total               | \$ 31,950.00 |

With these additional inputs into the analysis, the beverage delivery truck seems to make business sense. However, the delivery truck does not seem to break even in most cases with these additional benefits. The results of the beverage truck and delivery truck breakeven analyses are presented in Figure 4-14 and Figure 4-

The companies operating these package delivery trucks must either be placing a greater emphasis on advertising than is being assumed, considering other benefits, or are willing to absorb the additional cost to be a green company. They may be placing some value on the experience and knowledge gained by operating these trucks now so that they are prepared when fuel prices do reach the critical level where they must adopt hybrids.

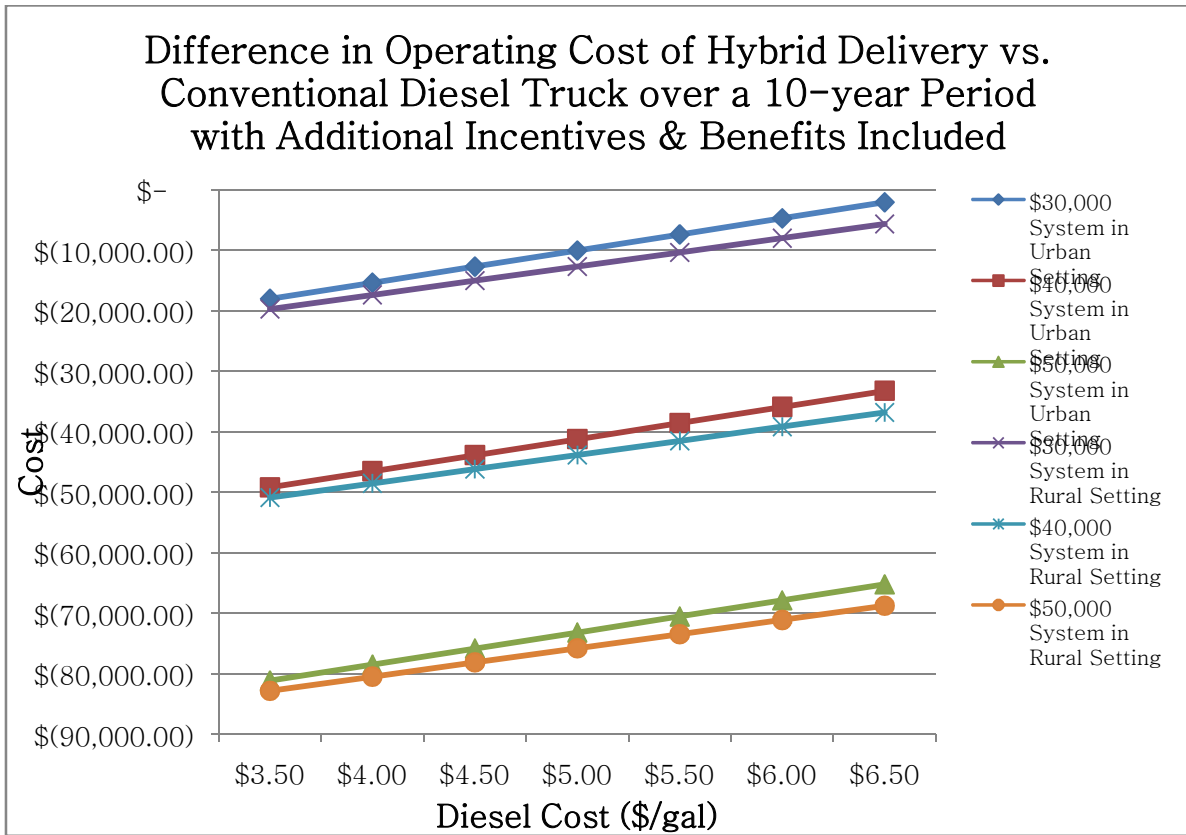

Figure 4-14. Estimated differential cost of operating a hybrid package delivery truck with assumed benefits and tax incentives.



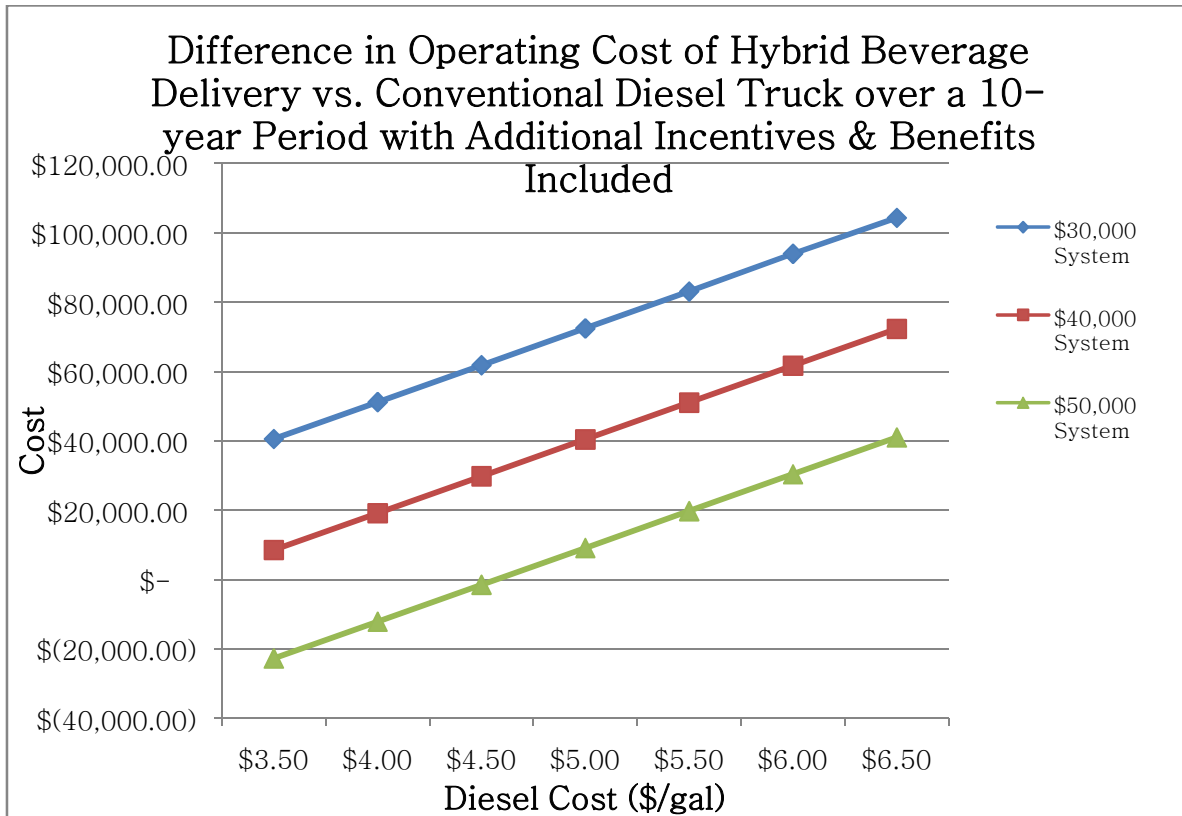

Figure 4-15. Estimated differential cost of operating a hybrid beverage delivery truck with assumed benefits and tax incentives.

Further analysis was not conducted on the refuse truck because it greatly differs from the other two applications. Waste handling companies typically do not advertise significantly, and the hydraulic hybrid system seemed to pay for itself. With government assistance, the system would clearly make financial sense for a company willing to take the risk on a new system.



## Chapter 5 - Emissions, the EPA, and Carbon

The EPA regulates air quality through the Clean Air Act. In 1990, an amendment was passed that requires the EPA to periodically report on the estimated costs and benefits of the current regulations. Through extensive modeling they estimate that these regulations have generated between \$160,000,000,000 and \$3,800,000,000,000 in benefits to society. They also estimate that reducing emissions to comply with regulations has cost about \$53,000,000,000. These figures include all regulated industries and sources across the nation. However, many states have implemented programs to help them meet these regulations, programs that are tailored to work with each specific industry in its jurisdiction (U.S. EPA Office of Air and Radiation).

### Economic Impact of EPA Air Quality Regulations

Because Texas has had three large urban areas in non-attainment for ground level ozone, it has vigorously worked to improve air quality. The three main regions in non-attainment are Houston-Galveston-Brazoria, Dallas-Fort Worth, and Beaumont-Port Arthur. In addition to these three areas, several others are almost at non-attainment levels (Hildebrand, “Update of \_Air Quality \_in Texas”).

The programs and regulations that were implemented to control NO<sub>x</sub> emissions and ground level ozone have proven successful. Texas has led the nation by reducing ground level ozone by 27% from 2000 to 2009. Figure 5-1 compares the reduction of various states (Texas Commission on Environmental Quality).

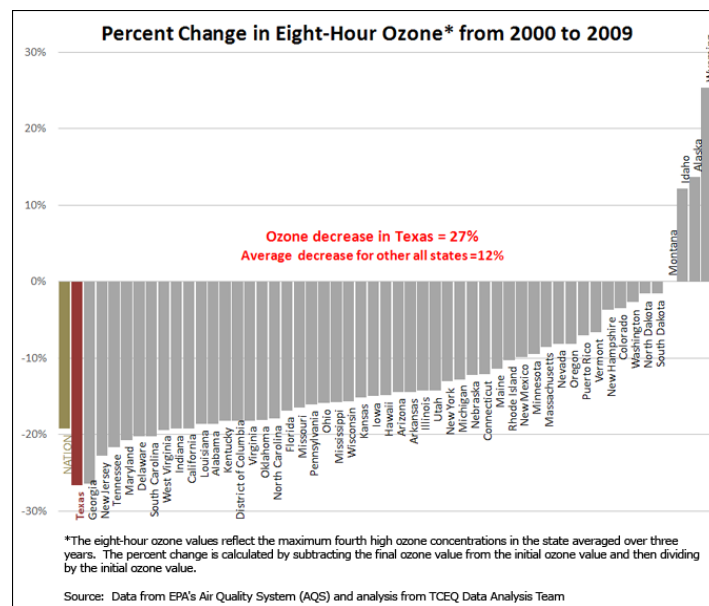

Source: Texas Commission on Environmental Quality

Figure 5-1. Percent ozone reduction from 2000 to 2009.

However, these various programs have cost the states a considerable amount of money to implement. One large program implemented in Texas is the “Texas Emissions Reduction Plan” (TERP). This program provides incentives for businesses, individuals, and local governments to either replace older, polluting equipment with newer, cleaner equipment or retrofit it with

additional emissions controls. To date this program has cost the state \$780 million and has reduced NO<sub>x</sub> emissions by an estimated 158,613 tons. Based on this information, the state projects that each ton of NO<sub>x</sub> has cost about \$4,918 (Texas Commission on Environmental Quality).

Within the TERP program are several different programs that focus on various aspects of emission reduction. The focus of these programs range from grants to assist with the replacement of older equipment to the funding of technology development to improve air quality.

The Emissions Reduction Incentive Grants Program (ERIG) is a portion of the TERP program that seeks to assist with the replacement of older equipment in counties in non-attainment. The equipment can be on-road or off-road equipment, including stationary equipment. The selected 2010 projects included but were not limited to rail locomotives, terminal tractors, long-haul trucks, cements trucks, agricultural tractors, off-road forklifts, and even the repowering of a few irrigation sets. A total of 1,063 projects cost \$90,916,062.97 and are projected to eliminate 12,632 tons of NO<sub>x</sub>. These results put a value of \$7,197 per ton of NO<sub>x</sub> reduction for the 2010 projects (Texas Commission on Environmental Quality).

Another TERP program is the Texas Clean Fleets Program (TCFP). It provides incentive to larger fleets to replace on-road vehicles with hybrid or alternative fuel vehicles in counties that are in non-attainment. Funding can be used to purchase light or heavy duty vehicles. The latest approved projects, announced in November 2010, have an estimated average cost of \$103,746 per ton of NO<sub>x</sub>. These projects all deal with replacing either refuse trucks, school buses, or delivery trucks (Texas Commission on Environmental Quality).

The “Drive a Clean Machine” program helps lower-income individuals replace or repair polluting vehicles in participating counties. To date this program has cost the state about \$105 million to repair 11,460 and replace 33,140 vehicles. Unfortunately, no information is available on how many tons of NO<sub>x</sub> or other emissions have been reduced (Texas Commission on Environmental Quality).

Outside of Texas, the ports of Los Angeles and Long Beach have been working to reduce emissions by implementing a clean truck program (CTP). This program was motivated by the restrictions imposed on port expansion due to the amount of pollution that ports create. Local communities present a large opposition to port expansion as well. The California Air Resource Board (CARB) estimates that the current drayage truck system imposes a health cost between \$100 and \$590 million each year on the public, which is estimated to have a cumulative cost of up to \$10.1 billion by the year 2025. The Boston Consulting Group estimates in its study that the current drayage system costs the public between \$500 million and \$1.7 billion each year. This estimate includes factors such as added traffic congestion, truck underutilization, lack of driver health benefits, vehicle safety, additional road maintenance, environmental damage, and health impacts (Port of Los Angeles).

The first stage of the CTP was to ban all trucks manufactured prior to 1989 from entering the port on October 1, 2008. The port of Los Angeles estimated that the trucks that replaced this oldest segment of the population have 90% lower emissions. Starting on January 1, 2010, all trucks manufactured from 1989 to 1993 were then banned as well as trucks manufactured from 1994 to 2003 that were not retrofitted with additional emissions hardware. Beginning January 1,

2012, all trucks that do not meet 2007 clean truck requirements will be banned. In addition to these regulations, motor carriers are required to register with the port and document the maintenance on their trucks so that they continue to meet the current emissions standards (Port of Los Angeles, “Clean Truck Program Frequently Asked Questions”).

The port estimated that these regulations have driven a private investment of about \$600 million in truck purchases. To offset this cost, the Port of Los Angeles has provided \$56.5 million in incentives to purchase new trucks. To fund this program they have implemented a "Clean Truck" fee to enter the port for trucks not meeting 2007 emissions standards (Port of Los Angeles, “Port of Los Angeles Clean Truck Program Fact Sheet”). The November 2010 container movement analysis of gate moves showed that 97% of all moves were completed by 82% of the fleet, which includes trucks that have year model 2007 or newer engines (Port of Los Angeles, “Port of Los Angeles - Clean Truck Program - Gate Move Data Analysis”). In addition to this program, other programs in the area focus on reducing emissions from ships and other sources (Port of Los Angeles, “The Port of Los Angeles: America’s Port”).

The carbon credit system is a system that was implemented in many countries under the Kyoto protocol. However, this system is not mandatory in the U.S. because the U.S. has not agreed to this treaty. Therefore, all companies in the U.S. can participate in this system voluntarily. Several different standards and methodologies govern the accounting of these credits that have various restrictions. Due to all of these variances, placing a specific monetary value on a credit is rather difficult in general. Despite the controversy over this system and its effectiveness, some companies are still choosing to use the system to be environmentally responsible and present a green image (Kollmuss, Zink, and Polycarp).

In the U.S., the Chicago Climate Exchange (CCX) is an organization that was created to facilitate the trade and regulation of carbon credits under its own set of standards. However, a voluntary system, this is not the only alternative that U.S. companies have. The CCX has two different systems that companies can utilize. The first is a cap and trade system where member companies are given a set number of allowances for emissions. Any emissions greater than the allowed amount are required to be offset by the purchase of others’ unused allowances. They also have a baseline and offset system where companies purchase offsets from a project that sequesters carbon. These projects might involve forest management, energy efficiency, methane capture, and renewable energy, but they have various restrictions based on which standard is used (Kollmuss, Zink, and Polycarp).

The CCX has its own standards that it abides by, but one of the foremost standards used currently is the Clean Development Mechanism (CDM). This standard is modeled after the United Nations Framework Convention on Climate Change. The average cost per carbon offset utilizing this standard ranged from €12 to €30. Assuming an exchange rate of \$1.4/€, the average cost would be \$16.80 to \$42.00 per offset (Kollmuss, Zink, and Polycarp).

### **Proposed Reduced Ground Level Ozone Levels**

In January of 2010 the EPA announced a proposal to further reduce the acceptable levels of ground level ozone from 0.075 ppm to 0.070–0.060 ppm (EPA website). This announcement caused concern for many states. Even states who traditionally have not had issues meeting ground level ozone requirements, like Minnesota, are concerned. Minnesota estimates that at the

0.070 ppm level the state will stay in attainment, but if the level is dropped to 0.065 or below issues may arise (Lien).

Despite the drastic improvements made in Texas, the reduced level could cause problems. Currently 31 counties in Texas are monitored for ozone. Analysis by the TCEQ estimates that large numbers of these counties could be in non-attainment. These results are shown in Table 5-1. In addition to the large number of counties being in non-attainment, 10 additional urban areas could require monitoring: Texarkana, Bryan-College Station, Abilene, Amarillo, Lubbock, Midland, Odessa, San Angelo, Sherman-Denison, and Wichita Falls (Texas Commission on Environmental Quality, “Proposed 2010 Ozone Standards”).

**Table 5-1. Number of 31 currently monitored counties in non-attainment at proposed primary ground level ozone standard.**

| <b>Ground Level Ozone Level (ppm)</b> | <b>Number of Counties in Non-Attainment</b> |
|---------------------------------------|---|
| 0.070                                 | 20  |
| 0.065                                 | 26  |
| 0.06                                  | 29  |

*Source: Texas Commission on Environmental Quality, “Proposed 2010 Ozone Standards”*

Dr. Bryan Shaw, the TCEQ Commissioner, responded to the EPA’s proposal shortly after it was announced. He brought up several points about the methodology for determining these levels, but that is beyond the scope of this paper. He explained that the state is nearing natural levels of ground level ozone in some areas and that additional reductions in ozone could be costly. He also mentioned that the state has spent more than \$1 billion dollars to reach attainment for the original 1997 standards (Texas Commission on Environmental Quality, “TCEQ Commissioners’ Response to EPA’s Ozone Standard Proposal”).

### **Recent and Proposed Truck Regulations**

In recent years major emissions requirements have been put in place for diesel engines in commercial vehicles. These regulations came into effect in 2004, 2007, and 2010 to further extend regulations that were already in place. With these regulations came a need to improve diesel engine technology. Figure 5-2 illustrates the changes in allowable levels since 1998.

## 2010 Emissions Regulations

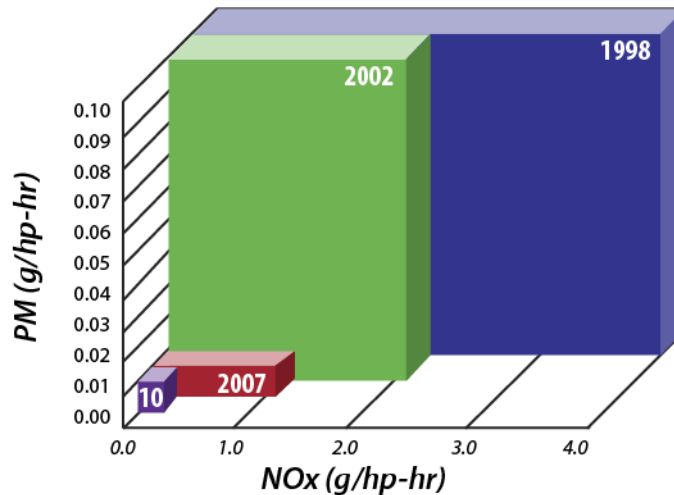

Source: The Pete Store

Figure 5-2. Allowable heavy duty diesel exhaust emission levels for particulate matter and NO<sub>x</sub> from 1998 to 2010.

The 2004 emissions regulation reduced the amount of allowable NO<sub>x</sub> and hydrocarbons (HC) emissions. The previous allowable emission for NO<sub>x</sub> and HC emissions were 4 g/bhp-hr and 1.3 g/bhp-hr respectively for diesel engines. The 2004 regulations reduced this to a combined level of 2.4 g/bhp-hr. For gasoline engines the prior levels were 4.0 g/bhp-hr NO<sub>x</sub> and 1.9 g/bhp-hr HC. The combined reduced level implemented was 1.0 g/bhp-hr for gasoline engines. The EPA estimated a cost increase of \$400 for diesel engines and \$300 for gasoline engines prior to implementation.

The 2007 regulation restricted emissions of diesel engines even further but also placed new requirements on diesel fuel. The 2007 engine requirements reduced the amount of allowable particulate matter to 0.01 g/bhp-hr, allowable NO<sub>x</sub> emissions to 0.20 g/bhp-hr, and non-methane hydrocarbons to 0.14 g/bhp-hr. The diesel fuel requirements reduced the allowable level of sulfur in diesel fuel. The allowable level of sulfur prior to these regulations was 500 ppm. The new regulations reduced this to 15 ppm. The EPA projected that these regulations would increase the cost of heavy duty vehicles by \$1,200 to \$1,900 per vehicle. Diesel was expected to increase by \$0.045 to \$0.05 per gallon.

Because of the stringent levels implemented in 2007, more complex solutions were required. To meet the 2007 regulations, manufacturers implemented electronic control systems, exhaust after-treatments, enhanced EGR, and fuel/air ratio changes. The exhaust after-treatments used were diesel particulate filters and catalytic converters. With this additional equipment comes additional maintenance and costs. *Work Truck* estimated in 2008 that these additions increased cost of a new truck by \$5,000 to \$13,000 excluding possible incentives. Note that this estimate is from a trade magazine while the prior estimates were made by the EPA. They also mention that the particulate filter will need to be cleaned or exchanged every 150,000 to 200,000 miles which is estimated to cost between \$150 and \$400. Other issues with the particulate filters are that they cost \$3,000 to \$4,000 to replace, can weigh 100 to 120 lbs, and have a potential for theft because

they can contain about \$1,800 in precious metals (GE Capital Solutions Fleet Services). Figure 5-3 charts the estimated implementation costs through 2010.

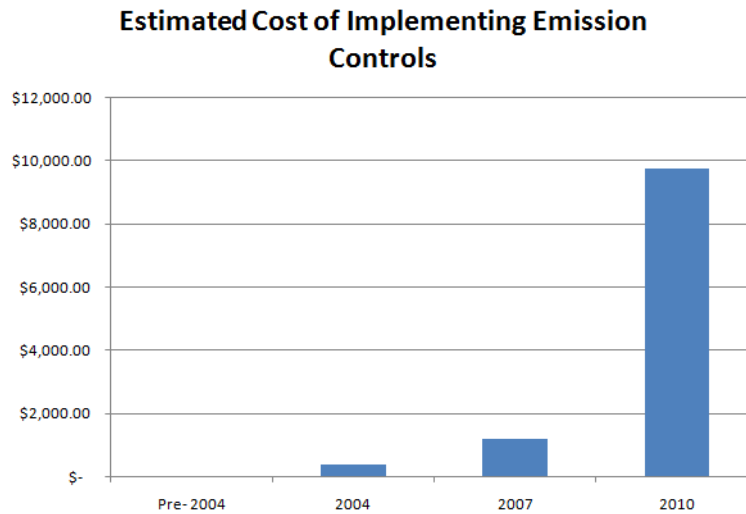

Source: The Pete Store; U.S. EPA Office of Air and Radiation, "Heavy Trucks, Buses, and Engines"

Figure 5-3. Estimated incremental costs of implementation of each emission requirement.

The 2010 requirements are even more restrictive and require more emissions controls. Two strategies are being used to meet these requirements in addition to the 2007 strategies. The strategy implemented by most manufacturers is a "Selective Catalytic reduction" system. This system uses diesel exhaust fluid (DEF) injected into the exhaust to reduce NO<sub>x</sub> into water vapor and N<sub>2</sub>. The use of DEF also requires an additional tank for storage, but its consumption is expected to be less than 5% of fuel consumption. Some concerns arose over availability of the DEF because of the need for additional infrastructure. However, a quick search found several companies and parts stores that could supply DEF in several different packaging options. Love's Travel Stops advertises on their website that they now have 61 locations selling bulk DEF as of May 20, 2011. The nine locations in Texas are Dallas, Edinburg, El Paso, Hearne, Houston, Laredo, Ranger, San Antonio, and Wichita Falls (Love's Travel Stops and Country Stores). Another concern is the cost of the DEF. The cost at O'Reilly Auto Parts ranged from \$3.82 to \$4.99 per gallon (O'Reilly Auto Parts).

The second strategy being used to meet the 2010 regulations is EGR. Navistar is currently the only manufacturer using this strategy. The advantage to this solution is that it does not require any extra fluids. According to Navistar's literature, their strategy is accomplished through advanced fuel injection, a proprietary combustion bowl, advanced air management, and advanced electronic calibration strategies. The injection strategy involves multiple injections per cycle. This method allows combustion to occur over a longer period, which results in lower NO<sub>x</sub> formation, more complete combustion, and better fuel efficiency. The bowl design appears in Figure 5-4. This design helps to break the fuel into a finer mist and spread it more evenly throughout the cylinder. The advanced air management consists of turbo matching and advanced EGR cooling. The electronic calibration also takes advantage of increased computing power available today by continuously calculating the optimum fuel-air mix rather than using pre-calculated lookup tables (Navistar, Inc., "Maxxforce 7").



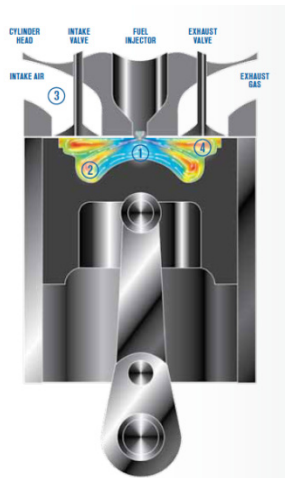

Source: Navistar, Inc., “Maxxforce 7”

Figure 5-4. Navistar proprietary combustion bowl design used to meet 2010 emission standards.

The current regulations address emissions based solely on engine performance rather than vehicle performance. A proposal was recently announced by the EPA and the National Highway Traffic Safety Administration (NHTSA) to regulate emissions off of engine performance and vehicle performance, as light vehicles are regulated. These new regulations would not be implemented until 2014 to 2018. The vehicle performance would be regulated on gal/1000 ton-mile and g CO<sub>2</sub> / ton-mile. The proposed vocational vehicle regulations are listed in Table 5-2 (Reiskin, “CO<sub>2</sub> Rule to Pose Few Hurdles in Initial Round, OEMs Predict”).

**Table 5-2. Proposed 2017 vocation truck emissions regulations.**

|                        | EPA Full Useful Life Emissions Standards (g CO <sub>2</sub> /ton-mile) | NHTSA Fuel Consumption Standards (gal/1,000 ton-mile) |
|------------------------|--|---|
| Light Heavy Class 3-5  | 344  | 33.8  |
| Medium Heavy Class 6-7 | 204  | 20  |
| Heavy Heavy Class 8    | 107  | 10.5  |

Source: U.S. EPA, “EPA and NHTSA Propose First-Ever Program to Reduce Greenhouse Gas Emissions and Improve Fuel Efficiency of Medium- and Heavy-Duty Vehicles: Regulatory Announcement”

The new regulations were a topic of interest at the 2010 American Trucking Association’s Management Conference and Exhibition (MCE). The general consensus was that the method for regulating fuel economy and emissions on a per ton-mile basis was relevant. However, some of the proposed levels do concern the industry. Representatives from Volvo, Daimler Trucks, and Navistar all agreed that the 2014 standards were easily attainable with current technologies. However, a general consensus held that the 2018 levels would be very difficult to reach with the technologies available today at a reasonable cost. To meet the 2018, goals a complete design will need to be considered that incorporates engine improvements, weight reductions, aerodynamic improvements, idle reduction technologies, and low rolling resistance tires. The general manager of Kenworth Trucks also mentioned that the “Long and Tall Cowboy trucks” like the Kenworth W900L (Figure 5-5) will most likely be replaced entirely by trucks with more aerodynamic designs (Reiskin, “CO<sub>2</sub> Rule to Pose Few Hurdles in Initial Round, OEMs Predict,” Reiskin, “Designers Ponder How to Boost Ton-Mileage of Class 8 Fleets”).



*Source: Kenworth Truck Company*

*Figure 5-5. Image of Kenworth W900 tractor.*

## Chapter 6 - Internalizing Emission Costs into Total Trucking Costs

In addition to more efficient operation, hybrid vehicles also have the potential to reduce emissions. Even though the costs of emitting diesel exhaust into the atmosphere are not met by the operators, there is still a negative impact on society and the environment. The EPA regulates the emissions of several components of vehicle exhaust through the Clean Air Act and has done extensive work to estimate the benefits and costs of these regulations.

### Criteria Pollutants

The Clean Air Act requires the EPA to set standards for six common air pollutants known as “criteria pollutants.” Table 6-1 lists the pollutants commonly found throughout the United States and the current regulated levels (U.S. EPA, “National Ambient Air Quality Standards”).

**Table 6-1. Current EPA National Ambient Air Quality Standards.**

| Pollutant                                    | Level                          | Averaging Time          |
|--|--------------------------------|-------------------------|
| <b>Carbon Monoxide</b>                       | 9 ppm (10 mg/m <sup>3</sup> )  | 8-hour                  |
|  | 35 ppm (40 mg/m <sup>3</sup> ) | 1-hour                  |
| <b>Lead</b>                                  | 0.15 µg/m <sup>3</sup>         | Rolling 3-Month Average |
|  | 1.5 µg/m <sup>3</sup>          | Quarterly Average       |
| <b>Nitrogen Dioxide</b>                      | 53 ppb                         | Annual                  |
|  | 100 ppb                        | 1-hour                  |
| <b>Particulate Matter (PM<sub>10</sub>)</b>  | 150 µg/m <sup>3</sup>          | 24-hour                 |
| <b>Particulate Matter (PM<sub>2.5</sub>)</b> | 15.0 µg/m <sup>3</sup>         | Annual                  |
|  | 35 µg/m <sup>3</sup>           | 24-hour                 |
| <b>Ozone</b>                                 | 0.075 ppm (2008 std)           | 8-hour                  |
|  | 0.08 ppm (1997 std)            | 8-hour                  |
|  | 0.12 ppm                       | 1-hour                  |
| <b>Sulfur Dioxide</b>                        | 0.03 ppm                       | Annual                  |
|  | 0.14 ppm                       | 24-hour (1)             |
|  | 75 ppb                         | 1-hour [t]              |

*Source: U.S. EPA, “National Ambient Air Quality Standards”*

### Ozone

Ozone can be both a good and a bad compound for environmental quality. When ozone is located in the stratosphere, it has a beneficial effect by filtering the sun’s UV rays. However,

when ozone is at ground level, it can cause the following symptoms (U.S. EPA, “Air and Radiation: Basic Information”).

- Chest pain
- Coughing
- Throat irritation
- Congestion

Ground level ozone can also affect plants by preventing them from producing and storing food, damaging their leaves, reducing crop yield, and reducing forest growth. Ozone is formed from the reaction of  $\text{NO}_x$  and volatile organic compounds (VOC) in the presence of sunlight. Because ozone is more readily formed in hot, sunny weather, it is more commonly a hazard in the summer (U.S. EPA, “Air and Radiation: Basic Information”).

### *Particulate Matter*

Particulate matter differs from the other principle pollutants in that it is actually small solid particles or liquid droplets in the atmosphere rather than a gas. The EPA regulates two classes of particulate matter. The distinction between the two is the size of the particle. The first class is fine particles that are smaller than  $2.5 \mu\text{m}$  in diameter. This class is known as  $\text{PM}_{2.5}$ . The second class is for larger particles that are less than  $10 \mu\text{m}$  and larger than  $2.5 \mu\text{m}$  in diameter, and it is referred to as  $\text{PM}_{10}$ . Although these two pollutants have similarities, they come from very different sources (U.S. EPA, “Air and Radiation: Basic Information”).

The larger  $\text{PM}_{10}$  particles can consist of dust, soot, or smoke. These emissions are usually direct emissions from unpaved roads, fields, smokestacks, fires, diesel trucks, and power plants (EPA Report, EPA  $\text{PM}_{10}$  page). These complications can include the following (U.S. EPA, “Air and Radiation: Basic Information”).

- Damage to lung tissue
- Cancer
- Premature death

The smaller  $\text{PM}_{2.5}$  particles are not typically direct emissions. These particles are typically formed by reactions of various gases in the atmosphere. The gases include sulfur dioxide ( $\text{SO}_2$ ),  $\text{NO}_x$ , VOCs, and ammonia ( $\text{NH}_3$ ). The VOCs consumed in these reactions are typically emissions from power plants, industries, and automobiles. The main source of the ammonia is various agricultural operations and practices.  $\text{PM}_{2.5}$  can cause serious health problems because these particles can reach far into the lungs. The following health problems have been linked to  $\text{PM}_{2.5}$  pollution (U.S. EPA, “Air and Radiation: Basic Information”).

- Irritation of airways
- Coughing
- Difficult breathing
- Decrease in lung function
- Aggravated asthma
- Chronic bronchitis

- Irregular heartbeat
- Heart attacks
- Premature death

### *Nitrogen Dioxide (NO<sub>2</sub>)*

Nitrogen dioxide is part of a larger family of gases known as NO<sub>x</sub>. This compound is formed through the oxidation of nitric oxide (NO). NO is formed by the combustion of fuel at high temperatures. Major sources of NO<sub>x</sub> are power plants, automobiles, and any other sources that burn fuel. Exposure to this pollutant has been known to cause the following (U.S. EPA, “Air and Radiation: Basic Information”).

- Increases risk of respiratory illness in children
- Exposure to low levels for less than 3 hours may decrease lung function for individuals with respiratory illness.
- Long-term exposure to high concentrations may cause permanent lung damage.

### *Carbon Monoxide (CO)*

Carbon monoxide is the result of incomplete combustion of fuel. Common sources of this pollutant include cars, trucks, aircraft, locomotives, and construction equipment. Other sources include metal processing, chemical manufacturing, residential wood burning, and forest fires. Up to 95% of all CO emissions are estimated to come from vehicle exhaust. Exposure to CO can have many effects that can include the following (U.S. EPA, “Air and Radiation: Basic Information”).

- Chest pain
- Reduction in ability to exercise
- Vision problems
- Reduced ability to work
- Reduced manual dexterity
- Death

### *Sulfur Dioxide (SO<sub>2</sub>)*

This pollutant is formed by the burning of fuels that contain sulfur, extracting gasoline from oil, and extracting metal from ore. SO<sub>2</sub> is harmful in this form, but it can also react with water to form acid rain, ammonia, and particles to form other harmful chemical compounds. The health effects of SO<sub>2</sub> can include the following (U.S. EPA, “Air and Radiation: Basic Information”).

- Respiratory illness
- Aggravate existing heart disease
- Sulfate particle can accumulate in the lungs to cause
  - Lung disease
  - Breathing difficulty
  - Death

## Social Benefits

The social benefits of the reduction of these emissions are not limited to the health benefits. Additional benefits are obtained through increased visibility, reduction in acid rain, improved productivity of agricultural and forestry operations, and other ecological benefits. Because of the vast differences in these benefits, they must be estimated in much different ways with varying degrees of certainty.

### Health Benefits

Health benefits are estimated through a multistep approach that requires several sets of data. Two of these pieces of data are a distribution of the population and actual or estimated concentrations of the various pollutants. The final piece of data is the relationship between the concentration of a pollutant and the incidence rate of a given health issue and an associated cost for its occurrence. A typical health impact function may look like Equation 1.

$$\Delta y = y_0(e^{\beta \Delta x} - 1) \quad (1)$$

$y_0 = \text{baseline incidence rate}$   
 $\beta = \text{effect estimate}$   
 $\Delta x = \text{estimated change in pollutant concentration}$

Each particular health issue, such as chronic bronchitis or mortality, caused by a given pollutant will have one of the relationships. The EPA has evaluated many epidemiological studies to estimate what the values for the equations parameters should be for each health issue. These relationships are then combined with the population and pollutant concentrations in a single model to estimate the benefits of a given reduction in emissions. The EPA uses a program called BenMAP to complete this analysis (Industrial Economics, Incorporated).

The EPA estimated in their recent report, “*The Benefits and Costs of the Clean Air Act from 1990 to 2020*,” that through reductions in ground level ozone and particulate matter a great amount of societal benefits have been achieved. These estimates are presented in Table 6-2. The amount of reductions in emissions of the criteria pollutants were also estimated in the same report. These results are presented in

Table 6-3 (U.S. EPA Office of Air and Radiation, “The Benefits and Costs of the Clean Air Act from 1990 to 2020”).

**Table 6-2. Estimated avoided sickness and deaths attributed to Clean Air Act regulation.**

|                        | <b>Annual Monetized Benefits</b> |
|------------------------|----------------------------------|
| <b>PM Mortality</b>    | \$ 1,200,000,000,000.00          |
| <b>PM Morbidity</b>    | \$ 46,000,000,000.00             |
| <b>Ozone Mortality</b> | \$ 33,000,000,000.00             |
| <b>Ozone Morbidity</b> | \$ 1,300,000,000.00              |

*Source: Industrial Economics, Incorporated*

**Table 6-3. Estimated reduction in emissions due to Clean Air Act regulation.**

| <b>Pollutant</b>        | <b>Emissions Reduction<br/>(tons/year)</b> |
|-------------------------|--|
| <b>VOC</b>              | 12,626,000                                 |
| <b>NO<sub>x</sub></b>   | 14,877,000                                 |
| <b>PM<sub>10</sub></b>  | 5,992,000                                  |
| <b>PM<sub>2.5</sub></b> | 682,000                                    |

*Source: U.S. EPA Office of Air and Radiation, "The Benefits and Costs of the Clean Air Act from 1990 to 2020"*

These values can then be used to place a value on the emissions of NO<sub>x</sub>, PM, and VOCs. Because VOCs and NO<sub>x</sub> both contribute to the formation of ground level ozone, these emissions were added together to find a combined cost for their emissions. The estimated cost per ton of these emissions can be seen in Table 6-4 (U.S. EPA Office of Air and Radiation, "The Benefits and Costs of the Clean Air Act from 1990 to 2020").

**Table 6-4. Estimated cost per ton of PM, NO<sub>x</sub>, and VOC emissions based on the EPA report "The Benefits and Costs of the Clean Air Act from 1990 to 2020."**

|                                     | <b>Cost (\$/ton)</b> |
|-------------------------------------|----------------------|
| <b>PM Emissions</b>                 | \$ 186,694.64        |
| <b>NO<sub>x</sub>/VOC Emissions</b> | \$ 1,247.14          |

*Source: U.S. EPA Office of Air and Radiation, "The Benefits and Costs of the Clean Air Act from 1990 to 2020"*

The reduction in emissions for the three applications through the adoption of hybrids were estimated using a spreadsheet developed by the EPA for their Clean Cities program. This spreadsheet uses the days of operation and average daily mileage to estimate the reduction of VOC, NO<sub>x</sub>, PM<sub>2.5</sub>, CO, and greenhouse gas emissions for the adoption of various vehicles (U.S. Department of Energy, "Argonne Transportation - AirCRED Model"). The resulting estimates for annual emissions are presented in Table 6-5.

**Table 6-5. Reduction in emissions attributed to adoption of hybrid truck calculated with Clean Cities Emission Benefit Tool.**

|                              | <b>Average<br/>Annual<br/>Mileage</b> | <b>Annual NO<sub>x</sub><br/>Credit (lbs)</b> | <b>Annual PM<sub>2.5</sub><br/>Credit (lbs)</b> | <b>Annual VOC<br/>Credit (lbs)</b> |
|------------------------------|---------------------------------------|---|---|------------------------------------|
| <b>Package<br/>Delivery</b>  | 17,025                                | 380.1   | 5.5   | 9.1                                |
| <b>Beverage<br/>Delivery</b> | 30,000                                | 669.7   | 9.6   | 16                                 |
| <b>Refuse Truck</b>          | 17,400                                | 388.3   | 5.6   | 9.3                                |

The benefits to society can then be calculated assuming a 10-year life span for the vehicle. These results are shown in Table 6-6. Based on these estimates, the beverage truck is the only application that would justify the highest level of incentive analyzed earlier. However, these values are generalized for emissions benefits of adopting a heavy duty hybrid, and the assumption made in the spreadsheet may present varying degrees of error for each particular application.

**Table 6-6. Estimated societal benefits for hybrid trucks derived from data estimated in EPA’s report “The Benefits and Costs of the Clean Air Act from 1990 to 2020.”**

|                          | <b>NO<sub>x</sub> Health Benefit</b> | <b>PM<sub>2.5</sub> Health Benefit</b> | <b>VOC Health Benefit</b> |
|--------------------------|--------------------------------------|--|---------------------------|
| <b>Package Delivery</b>  | \$ 2,370.18                          | \$ 5,134.10                            | \$ 56.74                  |
| <b>Beverage Delivery</b> | \$ 4,176.04                          | \$ 8,961.34                            | \$ 99.77                  |
| <b>Refuse Truck</b>      | \$ 2,421.32                          | \$ 5,227.45                            | \$ 57.99                  |

*Visibility Benefits*

The economic benefit of increased visibility is valued in a much different manner than health benefits due to its somewhat subjective nature. Some common pieces of data are required, such as concentrations of a given pollutant, but the value for the increased visibility must be determined by determining a person’s “willingness to pay” through surveys and other methods (Turner, Pearce, and Bateman). The value can be difficult to obtain, and the EPA does state in their report that placing a value on this benefit is difficult because a person’s perception of increased visibility may be associated with a clean environment (Industrial Economics, Incorporated).

The EPA used various studies to determine values for various levels of visibility in both residential and recreational areas. To estimate the visibility levels in the future for various scenarios, they used several models. The first model is an air quality model that predicts concentrations of various pollutants spatially. This data is then put into a model that estimates visibility based on the concentration of the various pollutants, which itself is based on physical interactions between the fine particulate matter and the light (Industrial Economics, Incorporated).

The estimated benefits associated with the Clean Air Act are evident in Table 6-7. Visibility is dependent upon concentrations of ozone and fine particulate matter (Industrial Economics, Incorporated). The sum of the emissions of VOCs, NO<sub>x</sub>, and fine particulate matter was used to determine the cost per ton of emissions. The pollutants were all assumed to equally impact visibility because the research team lacked a full understanding of this complex system. VOCs and NO<sub>x</sub> were used because they are required to create ground level ozone. Table 6-8 lists the results for these emission costs.



**Table 6-7. Estimated visibility benefit attributed to emissions reductions of Clean Air Act.**

|                           | <b>Visibility Benefit</b> |
|---------------------------|---------------------------|
| <b>Residential Areas</b>  | \$ 25,000,000,000.00      |
| <b>Recreational Areas</b> | \$ 8,600,000,000.00       |

*Source: Industrial Economics, Incorporated*

**Table 6-8. Estimated cost per ton of VOC, NO<sub>x</sub>, and PM<sub>2.5</sub> emissions based on visibility benefits.**

|                           | <b>Emission Cost (\$/ton)</b> |
|---------------------------|-------------------------------|
| <b>Residential Areas</b>  | \$ 887.00                     |
| <b>Recreational Areas</b> | \$ 305.13                     |

Using the emissions reductions determined with the Emissions Reduction tool, the visibility benefit of each vehicle application can be estimated, as shown in Table 6-9.

**Table 6-9. Estimated benefit of hybrid truck adoption due to increased visibility.**

|                               | <b>Package Delivery<br/>Visibility Benefit</b> | <b>Beverage Delivery<br/>Visibility Benefit</b> | <b>Refuse Truck<br/>Visibility Benefit</b> |
|-------------------------------|--|---|--|
| <b>Residential Areas</b>      | \$ 1,750.49                                    | \$ 3,083.64                                     | \$ 1,788.19                                |
| <b>Recreational<br/>Areas</b> | \$ 602.17                                      | \$ 1,060.77                                     | \$ 615.14                                  |
| <b>Total</b>                  | \$ 2,352.66                                    | \$ 4,144.42                                     | \$ 2,403.32                                |

#### *Agricultural and Forestry Productivity Benefits*

The main contributor to the reduction in agricultural and forestry yields is ozone. Ozone affects yields by altering photosynthesis and carbon allocation. A great deal of literature is available on this subject to determine the effect that various ozone concentrations have on various yields. Some of these studies have even been conducted in laboratories where plants can be studied under controlled conditions (Industrial Economics, Incorporated).

Many of the same models are used in conjunction with these crop response functions to determine the effects on various yields. To accomplish this analysis, the air quality data is input into the response function to determine the impact on yields in various the areas. This data is then further processed to include information about the crops or tree species growing in each area. The estimated benefit was \$5,500,000,000 (U.S. EPA Office of Air and Radiation, “The Benefits and Costs of the Clean Air Act from 1990 to 2020”). Using the VOC and NO<sub>x</sub> emissions results in a value of \$200/ton. This figure results in the benefits for each application that are shown in Table 6-10.

**Table 6-10. Estimated benefit of hybrid adoption of each truck application due to impact of agricultural and forestry productivity.**

| <b>Package Delivery Ag &amp; Forestry Benefit</b> | <b>Beverage Delivery Ag &amp; Forestry Benefit</b> | <b>Refuse Truck Ag &amp; Forestry Benefit</b> |
|---|--|---|
| \$ 385.56   | \$ 679.23  | \$ 393.86                                     |

*Materials Damage and Ecological Benefits*

The EPA does consider in their analysis the value of damage to manmade structures due to acid rain and other ecological damages such as lake acidification. However, material and ecological damages were not considered for this analysis because they have an estimated value much less than other impacts. The EPA estimated that the benefit of reduced material damage to be \$93,000,000 and ecological benefits to be \$7,500,000 (U.S. EPA Office of Air and Radiation, “The Benefits and Costs of the Clean Air Act from 1990 to 2020”).

**Conclusions**

Based on the current analysis of the benefits associated with the Clean Air Act, a significant value can be placed on the potential benefits of hybrid adoption. Table 6-11 presents the estimated benefits of the adoption of a hybrid truck based on the previous analyses.

**Table 6-11. Estimated benefits of hybrid truck adoption for three truck applications.**

|                        | <b>Package Delivery Truck</b> | <b>Beverage Delivery Truck</b> | <b>Refuse Truck</b> |
|------------------------|-------------------------------|--------------------------------|---------------------|
| <b>Health Benefits</b> | \$ 7,561.03                   | \$ 13,237.15                   | \$ 7,706.76         |
| <b>Other Benefits</b>  | \$ 2,738.21                   | \$ 4,823.64                    | \$ 2,797.18         |
| <b>Total Benefits</b>  | \$ 10,299.24                  | \$ 18,060.79                   | \$ 10,503.94        |

## Chapter 7 - Study Findings

### Estimated Rates of Hybrid Adoption

Based on the previous analysis of operating costs of various hybrid vehicles, an estimate of the rate of adoption is possible with only a little more information. However, note that this process entailed some generalizations and the characteristics of vehicle operation will vary according to the situation.

A major piece of information that is required to estimate the rate of adoption is an estimate for the price of diesel. This information was taken from the Department of Energy's "2010 Annual Energy Outlook." This document estimates diesel prices at the pump from 2008 until 2035, as illustrated in Figure 7-1. One issue with this estimate is that it was made prior to the start of the current unrest in the Middle East. Therefore, the current estimated price is lower than the actual price at the pump (U.S. Department of Energy, "Annual Energy Outlook - 2011").

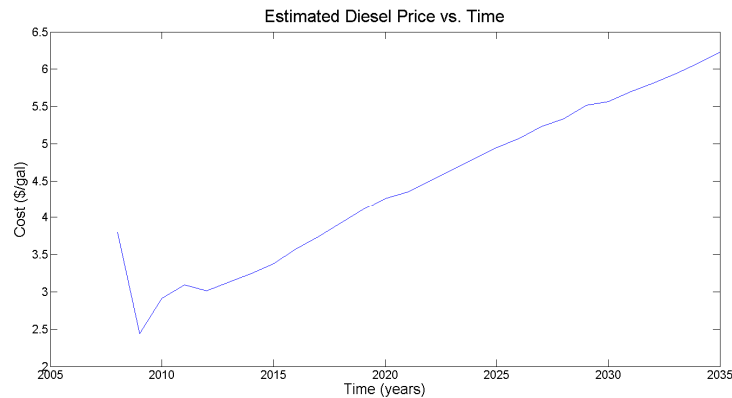

Source: U.S. Department of Energy, "Annual Energy Outlook - 2011"

Figure 7-1. Estimated pump price of diesel from 2008 to 2035.

Other information required to estimate the adoption rate is how the fuel economy of each specific vehicle varies as a function of annual mileage. An attempt to estimate this figure was made by fitting a linear curve to the available data. However, a much better estimate could be obtained by using an actual vehicle model in conjunction with actual or estimated vehicle drive cycles. The performance of the hybrid system under a given condition is another large uncertainty. This variable was also assumed to linearly decrease as annual mileage increases. The upper and lower values were taken from available sales literature. This estimate would also be much better if an actual vehicle model was available.

Despite having these possible sources of error, estimates of the adoption of hybrids for each of the three applications were attempted in the following sections. Note that the basic methodology was followed for each of the three estimates with a small degree of variation. This variation is discussed in the following sections. A detailed explanation of the adoption rate estimation can be found in Appendix D.

### *Parcel Delivery Truck Adoption*

The parcel delivery truck adoption estimate was the most difficult of the three estimates. The difficulty arose because the hybrid in the delivery application did not pay for itself in most cases. However, this estimate still has potential value. Applications where a hybrid would have large societal benefits through its reduced emissions may arise. If these conditions exist, understanding how incentives could impact the adoption of the vehicles will be very important.

The annual mileage of these vehicles was based on the two NREL studies conducted with UPS and FedEx. The average for this mileage was determined to be 17,025 miles/year with a standard deviation of 3,733 miles/year (Lammert and NREL). This estimate was compared to the 2002 vehicle use census and found to be in the same range. The 2002 census estimated an average of 16,500 miles/year for step vans with a standard deviation of 2,800 miles/year (Inventory). The fuel economy of these trucks was derived by placing a linear fit to the data from the NREL studies and is shown in Figure 7-2. This calculation yielded a very poor fit and could be improved greatly with an actual vehicle model. Other fits were attempted but yielded poor results. The increase in fuel economy was assumed to decrease linearly as annual mileage increased. The upper and lower bounds for this were assumed to be 40% and 10%. These values were taken from the Freightliner literature for delivery applications (Daimler Trucks North America LLC).

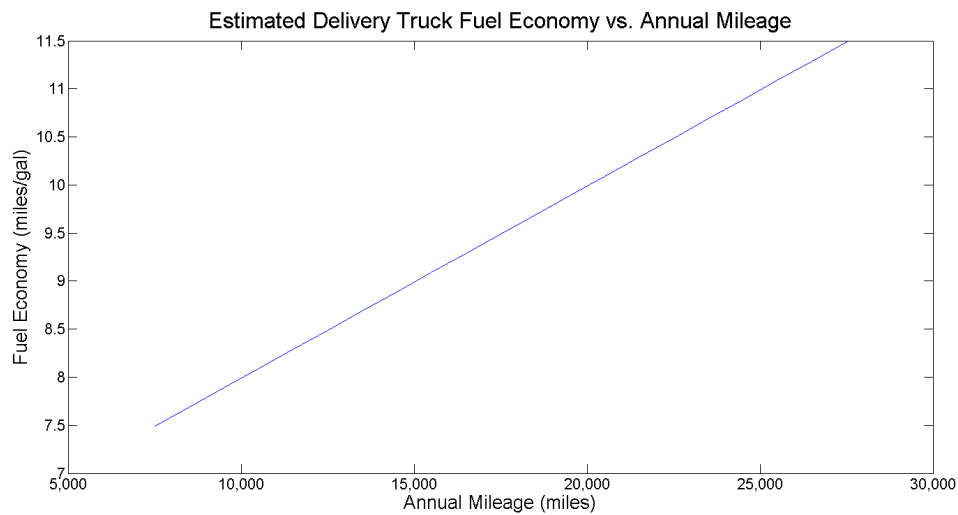

*Figure 7-2. Estimated fuel economy of conventional package delivery truck as a function of annual mileage.*

Accounting for the additional benefits of the hybrid truck is what makes this estimate so difficult. The three benefits taken into account were federal tax incentives, state incentives, and benefits obtained through improved perception of the truck. The federal incentive was assumed to stay constant at \$4,500 as estimated in the previous chapter. The state incentive, however, was assumed to be \$7,500 and \$10,000. This figure was initially assumed to be about \$2,500 but was not great enough to encourage the adoption of any hybrid delivery trucks. This lower value is closer to level of the ERIG money awarded in 2010 rather than the program as a whole, and the higher value is much less than the \$57,000 per truck that the state paid to UPS for the Texas

Clean Fleets program in 2010 (Texas Commission on Environmental Quality, “Texas Emissions Reduction Plan (TERP)”. This is also less than California’s Hybrid Vehicle Incentive Program’s \$15,000 credit for the purchase of a package delivery truck (California Air Resource Board). The advertising benefit was assumed to be \$22,750 as discussed in a previous chapter.

The last adjustment was the additional cost required for cleaner trucks as regulations become more stringent. This figure was assumed to be \$10,000 and begin in 2018. This value was an estimate based on comments made by executives for several major truck manufacturers about the current proposed truck emissions requirements for 2014 and 2017 (Reiskin, “CO2 Rule to Pose Few Hurdles in Initial Round, OEMs Predict,” Reiskin, “Designers Ponder How to Boost Ton-Mileage of Class 8 Fleets”).

The estimated rate of adoption for package delivery trucks is displayed in Figure 7-3. Clearly the hybrid package delivery trucks are not expected to be heavily adopted until around 2030 when diesel prices are expected to reach a price of \$5.57 per gallon. The drop in hybrids leading up to their rapid adoption is due to the fact that programs that encourage the early adoption of hybrids like the Texas Clean Fleets program are not included in the model. These programs were omitted to simplify the model, under the assumption that these programs would only contribute to a small percent of hybrid adoption for the entire truck population. However, programs like these could play an important role by preparing the manufacturing chain to be ramped up for production when the demand does exist and also gives fleets an opportunity to learn about these systems.

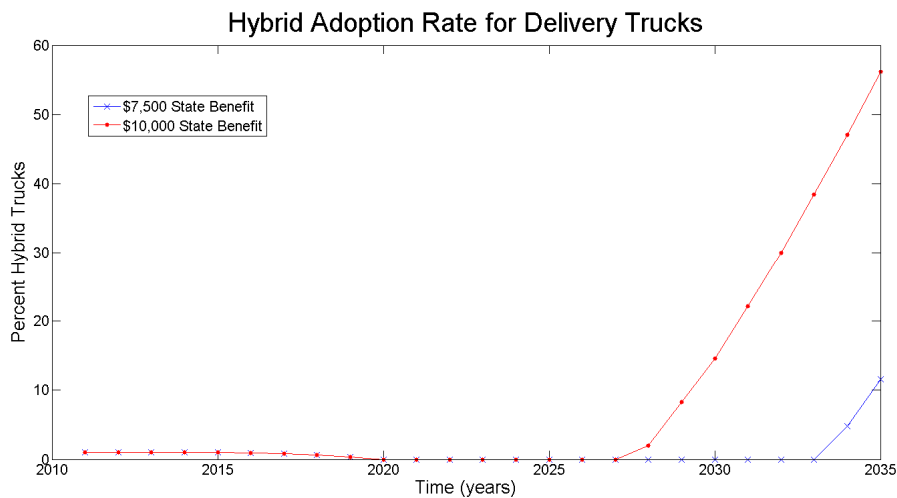

Figure 7-3. Estimated rate of adoption of package delivery truck with various levels of incentive.

### *Beverage Delivery Truck Adoption*

The beverage delivery truck adoption estimate was conducted in much the same way as the package delivery truck. The annual mileage was taken from the 2002 truck census and was found to be 30,000 miles/year with a standard deviation of 5,300 miles per year for trucks in the accommodation and food service (Inventory). This value was chosen rather than the data from the *Beverage World* webinar because it may encompass a greater truck population. Other companies like Sysco or U.S. Foodservice operate large fleets of similar trucks that must make

frequent deliveries like beverage delivery trucks. These two companies ranked third and fifth in Transport Topics 2010 Top 100 Private Carriers (Transport Topics).

The estimated mileage was a bit more difficult to calculate due to a lack of individual data points to correlate fuel economy to mileage. To estimate a fit, 3.3 miles/gallon was established as a minimum that occurs at 1,000 miles/year (“County Beverage Talks Fuel”). A maximum of 7 miles/gallon was estimated to occur at 100,000 miles/year. Figure 7-4 presents the resulting correlation.

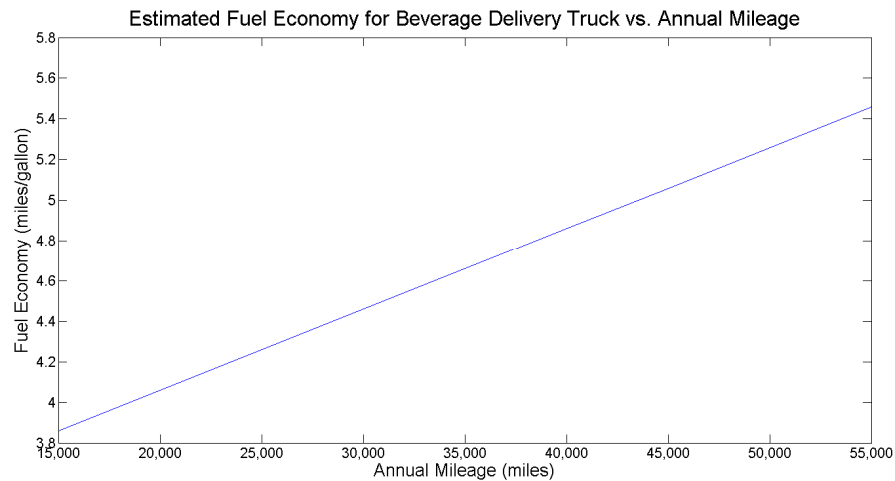

*Figure 7-4. Estimated fuel economy of conventional beverage delivery truck as a function of annual mileage.*

The improvement in fuel economy of the hybrid was estimated in two different ways. The first was identical to the method used with the package delivery truck. The second method was to assume that the fuel economy improvement was non-linear. This approach was used to show the effect that this aspect of the estimate has on the overall result. This step was accomplished by placing a knee in the curve near the average mileage (Figure 7-5).

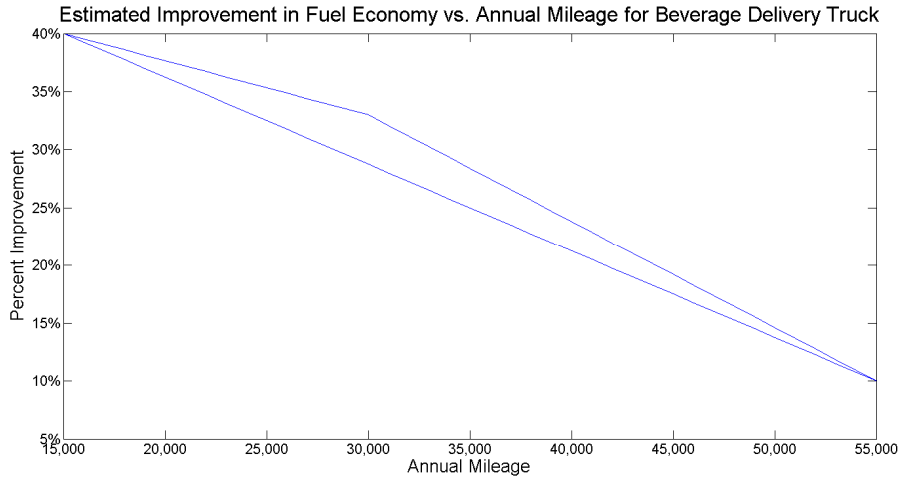

Figure 7-5. Estimated improvement in fuel economy of beverage delivery truck as a function of annual mileage.

The first set of adoption estimates shown in Figure 7-6 compares various levels and types of incentives for the linear assumption of fuel economy improvement. The three lines shown are for a \$40,000 system with no incentive or assumed benefits, a \$40,000 system with the highest level of incentive and assumed benefits used with the delivery truck, and a \$30,000 system with no incentive or assumed benefits. The \$30,000 system was evaluated to simulate what effect a \$10,000 instant rebate would have on adoption rates. This method assumes that, despite having tax credits and other state incentives, operators would still borrow the full purchase price of the vehicle. This approach generates additional interest expenses that must be overcome for the system to pay for itself. The estimate for the \$30,000 system did not include any other liabilities that must be assumed by the purchaser.

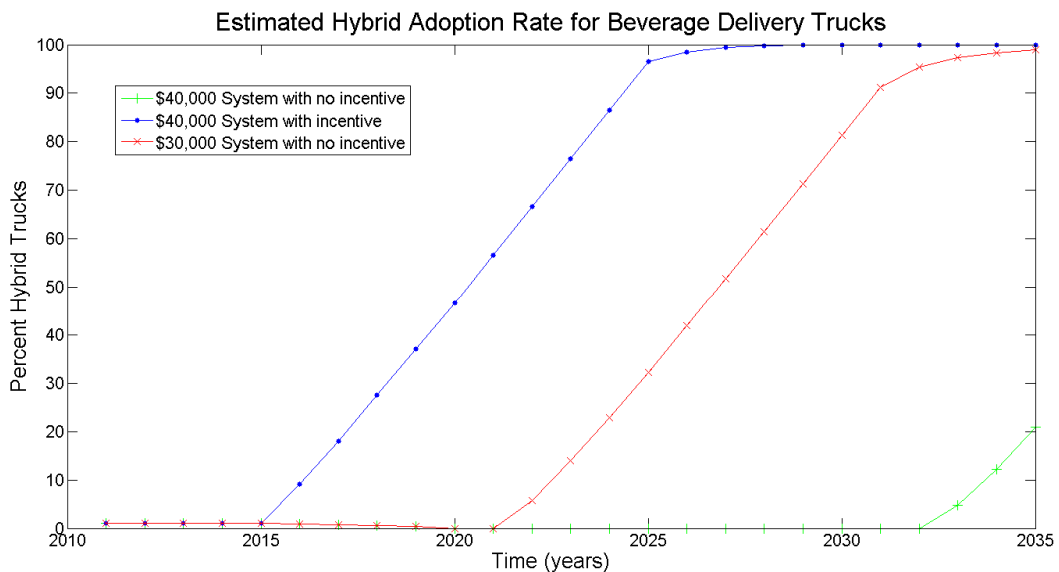

Figure 7-6. Estimated rates of beverage delivery trucks with various levels of incentive.

The second estimate shown in Figure 7-7 compares the effect the assumed improvement of fuel economy has on the results. Both of these estimates include no additional benefits or incentives. Because this relationship will be highly dependent upon drive cycle, making a confident estimate for the general truck population will be difficult. However, a local estimate could most likely be obtained with the acquisition or estimation of the actual drive cycles for the local truck population. This data could then be put into the model to obtain a more accurate estimate.

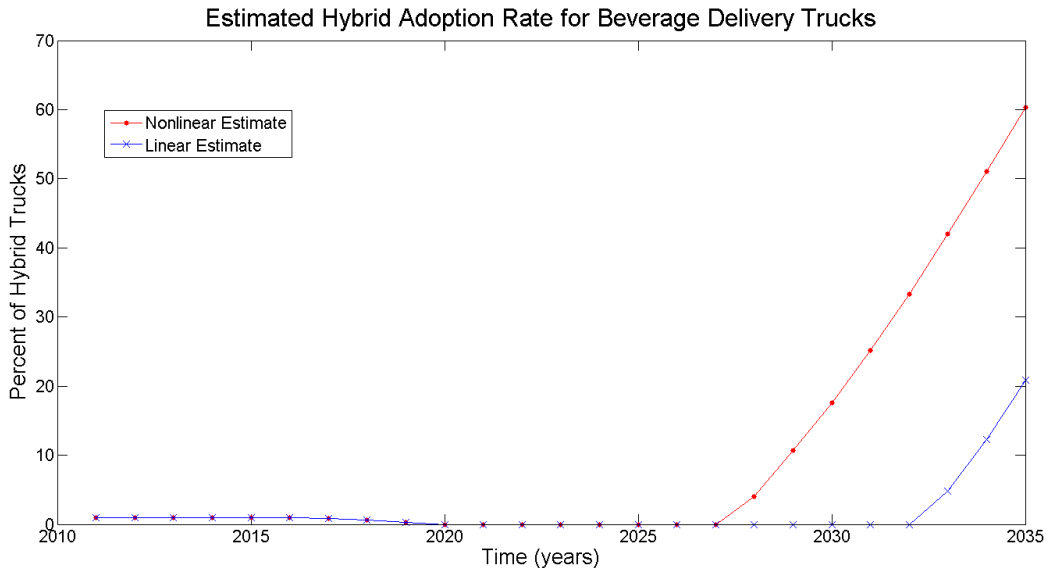

Figure 7-7. Comparison of estimated adoption rates with variable improvements in fuel economy of hybrid system.

### Refuse Truck Adoption

The refuse truck estimate differed from the other two estimates because the refuse truck hybrid has the potential to easily pay for itself with no incentives. The confidence for the cost estimate of the system is also not as good as for the other systems. It is also a newer system. Therefore, the adoption was estimated with a few variations.

The estimates for the vehicle use came from the 2002 U.S. vehicle use census. The average annual mileage was found to be 17,400 miles/year with a standard deviation of 2,700 miles/year (Inventory). This estimate does seem high in comparison to values reported by the cities of New York and Denver (Eaton Corporation, “Success Story: City of Denver Colorado;” Ivanič). This variation is due to the fact that the census does not include any data from vehicles owned by federal, state, or local governments. The estimates for fuel economy and improvement in fuel economy were determined using the linear fit method used in the previous two estimates. Because the system cost is somewhat of an unknown, it was estimated to be \$20,000 and \$15,000.

Because the system shows that it will pay for itself under most conditions, fewer incentives were considered. The only incentive considered was the \$4,500 federal tax credit. However, the estimate was run with and without this addition. The advertising benefit was not considered for a refuse truck because garbage collection is a required service, and people were likely less



concerned with the green image of a waste management company despite their efforts to reduce their emissions and be responsible corporate citizens.

The relationship between the adoption rates seen in Figure 7-8 are what would be expected. The \$20,000 system with no incentive is adopted the slowest while the \$15,000 system with an incentive is adopted the fastest. All of the estimates began with an initial hybrid population of 1%. The difference between the adoption of the \$15,000 system and the \$20,000 system with a \$4,500 tax incentive agrees with the results of the beverage delivery truck.

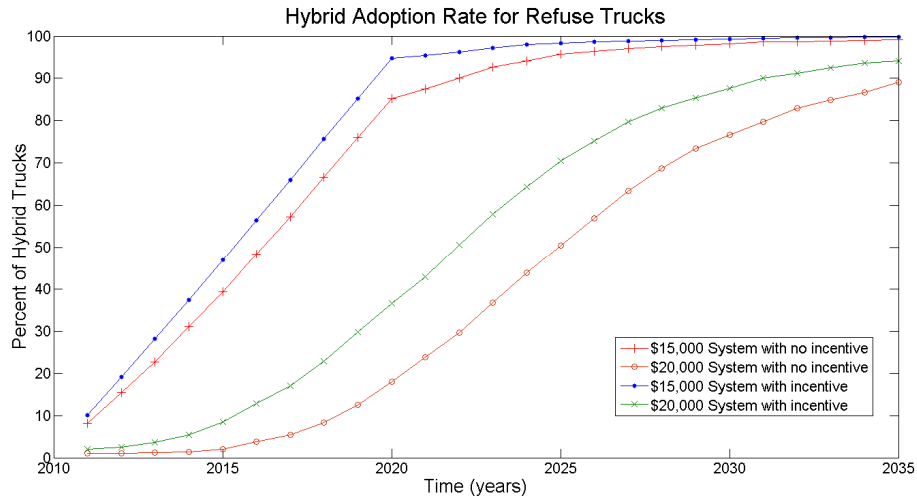

Figure 7-8. Estimated rate of hybrid refuse trucks based on payback in 10-year period of ownership.

This estimate does predict that a large percentage of hybrid refuse trucks will exist by 2035. For the \$15,000 estimate, the trucks will be adopted almost as fast as old trucks are retired. This trend does not seem logical or possible based on current usage. The decision to purchase a truck was made simply if it paid for itself within 10 years. More likely, the percent of hybrids purchased will increase as the payback time decreases. To attempt to model this behavior, a non-linear function was estimated. This function can be seen in Figure 7-9. The basis for this curve is somewhat subjective, but it comes from comments made in an article on the adoption of new technologies in truck fleets (Reiskin, “Fleets Seek New Technology To Aid Safety, Savings, Fuel”).

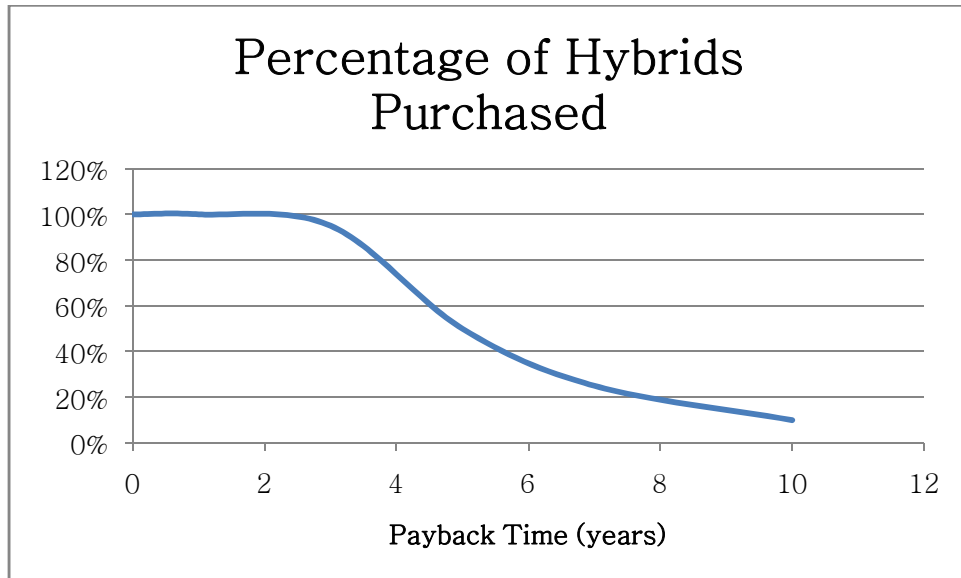

Figure 7-9. Estimated purchase rate of hybrid trucks based on return on investment.

Figure 7-10 presents the results with the variability of the percentage of hybrids purchased. This addition not only changes the shape of the resulting curves, but it also magnifies the difference in adoption rate between the \$15,000 system and the \$20,000 system with an incentive.

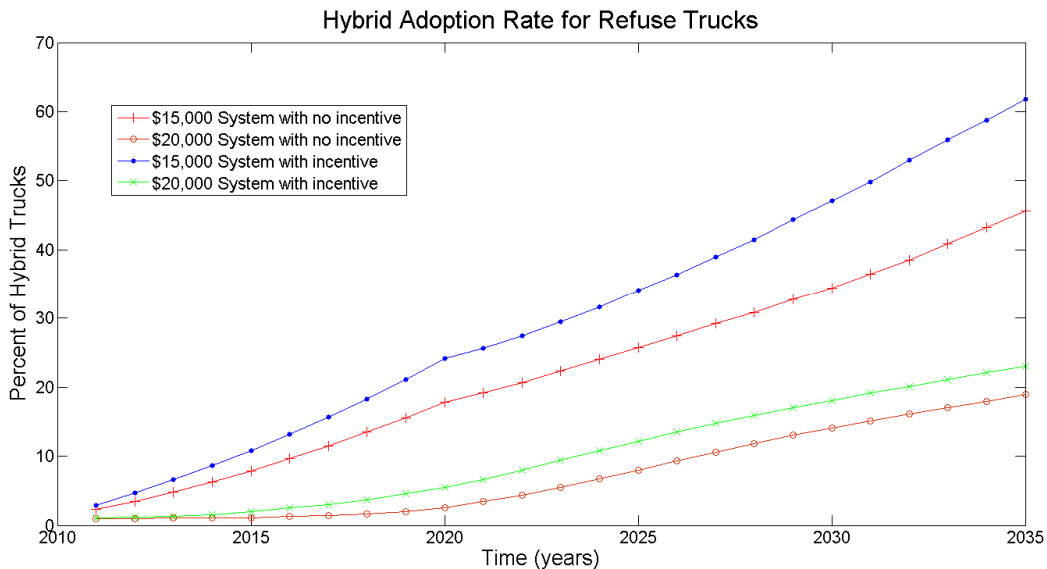

Figure 7-10. Estimated rate of adoption with refuse trucks with variable rates of purchase based on return on investment.

### Adoption Conclusions

The various adoption estimates show that various incentives and assumed benefits will have a large impact on the adoption of hybrid trucks. They also show that the structure of these policies and programs will determine their effectiveness. However, no analysis has been conducted to

determine whether the proposed level of government incentives is justified by any potential social benefits.

Based on the analysis performed in the previous chapter, all three applications could justify at least a \$10,000 incentive when all the benefits are considered. However, applications like the beverage truck could justify a much larger amount.

When other estimates for the cost of NO<sub>x</sub> emissions were also evaluated, the package delivery truck did come close to justifying the high level of incentive. The estimated NO<sub>x</sub> benefits based on the TERP and ERIG data are displayed in Table 7-1. It is unknown what analysis went into the justification of these expenditures by the state, but it does show that the incentives estimated in the previous sections may not be excessive.

**Table 7-1. Estimates of potential incentives for hybrid trucks based on averages from TERP and ERIG data.**

|                          | <b>NO<sub>x</sub> Benefit TERP</b> | <b>NO<sub>x</sub> Benefit ERIG</b> |
|--------------------------|------------------------------------|------------------------------------|
| <b>Package Delivery</b>  | \$ 9,346.66                        | \$ 13,677.90                       |
| <b>Beverage Delivery</b> | \$ 16,467.92                       | \$ 24,099.15                       |
| <b>Refuse Truck</b>      | \$ 9,548.30                        | \$ 13,972.98                       |

One aspect not included in this analysis is the growth of populations in urban areas. A growth in population would require more trucks to operate in a confined area. Therefore, each truck would need to emit fewer pollutants to maintain the same air quality while operating at the same levels. As the population density increases, the cost of the health impacts may increase because more people are exposed to the same level of pollution. These two factors could significantly increase the cost of vehicle emissions over time justifying a higher level of incentive.

## **Recommendations**

Given current demographic trends and the predicted growth of U.S. metropolitan and megaregions, urban goods will inevitably need to be moved in a cleaner, more efficient manner to protect the environment. The current regulations focus on the improvement of the engine and associated systems, but only so much improvement can be achieved by modifying a single component in a complex system. Therefore, hybrids have the potential to fill a niche within the transportation sector by improving the efficiency of the drivetrain in transmitting power to the ground.

However, hybrids face these remaining barriers to their adoption.

1. First, many are in the early stages of their life cycle and they have only become commercially available in recent years. Prior to that, only large companies like Coca-Cola, UPS, and FedEx tested them as advanced prototypes. They remain, for most urban operators, as somewhat of a mystery: their costs remain unknown and purchase risky. In addition, data on reliability are sparse and not generally available in the public domain so operators are concerned about using these vehicles where operations need to be highly reliable and demand a near 100% uptime.

2. The second barrier is the incremental cost of the system. Smaller businesses—which operate in many urban areas—may find it hard to justify purchasing an asset that may not pay for itself within 2 to 3 years. Potential buyers could be concerned that they will even see the advertised savings. Additional maintenance costs and uncertainty about component life may also add to this concern.
3. Clearly, a more detailed cost analysis is needed to demonstrate how specific hybrid systems perform in a given operating cycle. The large variation in performance of the hydraulic hybrid system relative to fuel economy and brake life needs to be evaluated further. The hydraulic system seems to show a lot of potential, but much uncertainty remains about how well it will perform in all conditions and over the life cycle of the vehicle.
4. Programs do exist to undertake a mechanistic type analysis. Packages like PSAT, ADVISOR, or CRUISE are engineering programs that simulate vehicles with component level detail. A higher level program that contained component level detail but only gave the user the option to choose a few representative vehicle configurations to evaluate under various conditions could be very beneficial to non-technical users. This model would allow someone to obtain an accurate analysis, but keep them from evaluating a vehicle that did not exist. A tool like this could have several uses.
  - a. The first would be a more detailed analysis of hybrid performance (rather than an informed estimate) to better determine actual costs. It could also help determine whether a hydraulic system would perform well in other applications with vastly different drive cycles.
  - b. The second use would be to incorporate it into a tool allowing policy makers to make informed decisions about how adoption of hybrids would impact emissions and fuel tax revenue, as well as answer other questions that may arise. Additional potential users of this tool would be individuals and companies. It could allow them to better understand how hybrids may work under certain conditions. This understanding could help provide some level of confidence and help to mitigate risk when making expensive purchasing decisions.
  - c. An additional feature that this model could include would be for brake wear analysis. The software packages that are mentioned above focus more on fuel economy and vehicle performance. Brake wear seems to be very important for the refuse trucks, but its importance varies greatly in literature. If the brake change intervals seen in the Parker hydraulic hybrid studies are representative, that cost saving alone could pay for most, if not all, of the hybrid system within 2 to 3 years.
5. An in-depth study to determine the social cost of the vehicle emissions for a specific location would be necessary to place a value on the social costs. In this report, an attempt was made to place an approximate cost on various emissions, but this figure is valid only as a generalization. Urban areas vary and higher concentrations of a

given pollutant may be linked to industrial activity specific to the region—such as the coastal chemical plants near Houston. Therefore, a higher cost would be placed on a ton of emissions in an urban area rather than in a rural area. The method reported in this study essentially linearizes the equation and loses the ability to account for the increasing cost of emissions as concentrations become higher.

6. The EPA has created a tool called BenMAP. This tool was specifically designed to incorporate spatial relationships of air quality and population into the estimation of health impacts. It also has the capability to incorporate hypothetical policies into its estimates (U.S. EPA, “BenMAP”). The use of this tool could be used to account the variation in populations and pollutant concentrations to determine how effective a given hybrid vehicle policy may be.

Determining the social cost for the entire lifecycle of a hybrid vehicle also needs to be studied. An example of this type of cost would be the environmental damage caused by the manufacturing, recycling, and disposal of a hybrid truck battery. Many other costs of this nature exist for the various hybrid systems. Other alternative vehicle architectures should be considered when choosing which hybrid system to adopt. Alternatives such as compressed natural gas (CNG) or LNG trucks offer lower emissions when compared to a conventional diesel engine but have their own set of operational issues as well—such as availability and range before refilling. In some settings, these trucks may be a better alternative.

This report was undertaken during the early stages of the life cycle for hybrid vehicle adoption and development but a substantial improvement in vehicle emissions is already under way. Conventional fuel—gasoline and diesel—consumption is falling on a per mile basis as more efficient engines are offered in new vehicles. Many urban commuters are choosing smaller conventional models and beginning to purchase hybrid vehicles based on superior fuel consumption or perceived social benefits. Fuel consumption has already led the operators of large trucks to adopt a wide variety of design and operational changes to increase the number of miles per gallon for conventional diesels. The report indicates a high degree of experimentation and prototype testing in the commercial trucking sector and in the near future hybrid truck systems will likely be seen in special operations. However, the trucking sector is conservative and cautious about new technologies. It needs large capital outlays (as do all transportation modes) and generally achieves a modest return on investment. Furthermore, its competitiveness depends on the high level of service and reliability it offers to customers—characteristics that some hybrid systems have yet to offer. Nevertheless, the long-term growth in fossil fuels, air quality issues in metropolitan areas, and the social costs of transportation all indicate that engine designs by 2040 will be very different from and substantially cleaner than 2011 engine designs.



## References

- (Canada), Transportation Development Centre, P. Drozd, and VePower Technologies. *Hybrid Refuse Truck Feasibility Study*. Transportation Development Centre, 2005. Print.
- 2008 Sustainability Report. Houston, Texas.
- Balqon Corporation. *Morningstar® Document Research<sup>SM</sup> FORM 10-KBALQON CORP. - BLQN*. 2011. Web. 15 May 2011.
- . "Mule M150: Zero Emission Electric Delivery Truck." 2009. Web. 15 May 2011.
- . "Nautilus XE20: Zero Emission Electric Tractor." 2009. Web. 10 May 2011.
- . "Nautilus XE30: Zero Emission Electric Tractor." 2009. Web. 15 May 2009.
- Barnitt, R., and National Renewable Energy Laboratory. *FedEx Gasoline Hybrid Electric Delivery Truck Evaluation: 6-Month Interim Report*. National Renewable Energy Laboratory, 2010. Print.
- Barry, Keith. "UPS to Roll Out Hydraulic Hybrids." 28 Oct 2008. Web. 15 Sept 2010.
- Berg, Tom. "Peterbilt's 386 Hybrid." *Heavy Duty Trucking: The Fleet Business Authority* Nov 2007. Web. 27 Sept 2010.
- Buchmann, Isidor. *Batteries in a Portable World: A Handbook on Rechargeable Batteries for Non-Engineers, Second Edition*. 2nd ed. Cadex Electronics Inc, 2001. Print.
- Butler, Kent et al. *Reinventing the Texas Triangle: Solutions for Growing Challenges*. Austin, Texas: The University of Texas at Austin Center for Sustainable Development, 2009. Web. 23 May 2011.
- California Air Resource Board. "HVIP: Hybrid Truck and Bus Voucher Incentive Project." 2011. Web. 29 Apr 2011.
- Capacity of Texas, Inc. "PHETT: Pluggable Hybrid Electrical Terminal Truck." 2010. Web. 21 Dec 2010.
- Carey, Jeff. "Paccar's Medium and Heavy Duty Hybrid Trucks." *HybridTruck.NET* 29 Dec 2008.
- Chandler, K., B. P Norton, and N. Clark. "Waste Management's LNG Truck Fleet: Final Results." *DOE Report, January (2001)* : n. pag. Print.
- Cioletti, Jeff, Mengo McCall, and Steve Saltsgiver. "Green Fleets: The Road Ahead." 24 Feb 2011.
- City of Washington, PA. "City of Washington." *Clean Automotive Technology*. Washington, DC.
- Comendador, J. et al. "On the Characterization of Urban Freight Transport." *Transportation Research Board 90th Annual Meeting*. 2011. Print.
- "County Beverage Talks Fuel." *Beverage World* 11 Mar 2010.
- Daimler Trucks North America LLC. "Freightliner Hybrid Trucks." 17 Sept 2009. Web. 14 Sept 2010.

- Derballa, Bryan. "Bike Messengers Pedal Past Bandwidth in Data Race." *Wired* 25 Apr 2011. Web. 25 May 2011.
- Desai, C., and S. S Williamson. "Comparative Study of Hybrid Electric Vehicle Control Strategies for Improved Drivetrain Efficiency Analysis." *Electrical Power and Energy Conference (EPEC), 2009 IEEE*. 2009. 1–6. Print.
- Eaton Corporation. *Eaton Mobile Hydraulics Manual*. Eden Prairie, Minnesota: Eaton Corporation, 2006. Print.
- . "Hybrid Solutions for MD Commercial Vehicles." 10 June 2009 : n. pag. Print.
- . "Hydraulic Hybrid." 2010. Web. 15 Sept 2010.
- . "Service Manual: Eaton Hydraulic Launch Assist (HLA)." Nov 2011. Web. 27 Feb 2011.
- . "Success Story: City of Denver Colorado." Apr 2009. Web. 1 Oct 2010.
- Ehsani, Mehrdad, Yimin Gao, and Ali Emadi. *Modern Electric, Hybrid Electric, and Fuel Cell Vehicles: Fundamentals, Theory, and Design, Second Edition*. 2nd ed. CRC Press, 2009. Print.
- Esposito, A. *Fluid Power with Applications*. Prentice Hall, 2003. Print.
- GE Capital Solutions Fleet Services. "One Year Later: 2007 Diesel Emission Standards Implications for Fleet Operators." *Work Truck Online* Jan 2008. Web. 20 Dec 2010.
- Gonzalez, Angel. "Paccar's Fuel-saving Hybrid Trucks Aimed at Nation's Distribution Industry." *The Seattle Times* 29 July 2008. Web. 28 Feb 2011.
- Gordon, D., J. Burdelski, and J. S Cannon. "Greening Garbage Trucks." (2003) : n. pag. Print.
- Harrison, R. *Impacts of Inland Ports on Trade Flows and Transportation in Texas: A Summary*. Center for Transportation Research, University of Texas at Austin, 2003. Print.
- Harrison, R., and University of Texas at Austin. Center for Transportation Research. *Inland Port Transportation Evaluation Guide*. Center for Transportation Research, University of Texas at Austin, 2002. Print.
- Hildebrand, Susana. "Update of \_Air Quality \_in Texas." 2010. Web. 28 Oct 2010.
- . "Update of Air Quality in Texas." n. pag. Print.
- "Hybridrive Propulsion Systems." 2006. Web. 15 Sept 2010.
- Industrial Economics, Incorporated. *Health and Welfare Benefits Analyses to Support the Second Section 812 Benefit-Cost Analysis of the Clean Air Act*. Washington, DC: United States Environmental Protection Agency, 2011. Web. 15 May 2011.
- Inventory, V. "Use Survey, US Census Bureau, 2002 Economic Census, US Department of Commerce." *Economics and Statistics Administration* (2004) : n. pag. Print.
- It's the Right Thing to Do*. Indianapolis, Indiana, 2008.
- Ivanič, Ž. "Data Collection and Development of New York City Refuse Truck Duty Cycle." *SAE Technical Paper* (2007) : 01–4118. Print.
- Kelley, Tom. "A Virtual Roundtable." *Beverage World* 16 Nov 2009. Web. 6 Feb 2011.



Kenworth Truck Company. "Kenworth Truck Company: W900." 2011. Web. 20 May 2011.

Kollmuss, A., H. Zink, and C. Polycarp. "Making Sense of the Voluntary Carbon Market: A Comparison of Carbon Offset Standards." *Germany: WWF* (2008) : n. pag. Print.

Labrie. "Leach: 2R-III Spec Sheet." Web. 19 Apr 2011.

Lamar Advertising. "State Rates: Texas." 2011. Web. 2 Apr 2011.

Lammert, M., and National Renewable Energy Laboratory. *Twelve-month Evaluation of Ups Diesel Hybrid Electric Delivery Vans*. National Renewable Energy Laboratory, 2009. Print.

Lien, Dennis. "Ozone Rules Could Cost State." *San Antonio Express News* 13 Dec 2010 : n. pag. Print.

Love's Travel Stops & Country Stores. "Love's Fuel Price Search." 2011. Web. 20 May 2011.

Lukic, S. M et al. "Power Management of an Ultracapacitor/Battery Hybrid Energy Storage System in an HEV." (2006) : 1-6. Web. 23 May 2011.

Matthews, Ronald Douglas. "Internal Combustion Engines and Automotive Engineering." 2010 : n. pag. Print.

"Maxwell Technologies - Ultracapacitors." Web. 23 May 2011.

"McMaster-Carr." Web. 20 May 2011.

Morris, A. G, A. L Kornhauser, and M. J Kay. "Getting the Goods Delivered in Dense Urban Areas: A Snapshot of the Last Link of the Supply Chain." *Transportation Research Record: Journal of the Transportation Research Board* 1653.-1 (1999) : 34-41. Print.

Navistar, Inc. "Going Green While Saving Some Green." 2011. Web. 24 Sept 2010.

---. "Maxxforce 7." 2010. Web. 20 Dec 2010.

"NYC DOT - Manhattan Off Hours Delivery Program." Web. 4 June 2011.

O'Reilly Auto Parts. "O'Reilly Auto Parts." 2010. Web. 20 Dec 2010.

Operations Division. *In the Works*. Denver Colorado: City of Denver, 2008. Web. 14 Apr 2011.

Oshkosh Corporation. "Oshkosh Corporation - Technology and Innovation - ProPulse." 2010. Web. 18 Sept 2010.

Peterbilt Motors Company. "Peterbilt Green Technologies." 2010. Web. 15 Sept 2010.

Port of Los Angeles. "Clean Truck Program Frequently Asked Questions." 23 Sept 2009. Web. 15 Feb 2011.

---. "Port of Los Angeles - Clean Truck Program - Gate Move Data Analysis." 17 May 2011. Web. 20 May 2011.

---. "Port of Los Angeles Clean Truck Program Fact Sheet." 27 Aug 2010. Web. 15 Feb 2010.

---. "The Port of Los Angeles: America's Port." 2011. Web. 20 May 2011.

Reiskin, Jonathan. "CO2 Rule to Pose Few Hurdles in Initial Round, OEMs Predict." *Transport Topics* 25 Oct 2010 : 1, 57. Print.

- . "Designers Ponder How to Boost Ton-Mileage of Class 8 Fleets." *Transport Topics* 25 Oct 2010 : 57. Print.
- . "Fleets Seek New Technology To Aid Safety, Savings, Fuel." *Transport Topics* 29 Nov 2010 : n. pag. Print.
- Soderberg, Peter. "Less Is More." *International Industrial Vehicle Technology* Mar 2011 : 92-93. Print.
- Sturgess, Steve. "Hybrid Yard Jockey Delivers - Truckinginfo.com." *Truckinginfo* 26 Feb 2010. Web. 21 Dec 2010.
- Texas Commission on Environmental Quality. "Proposed 2010 Ozone Standards." 3 Sept 2010. Web. 28 Oct 2010.
- . "TCEQ Commissioners' Response to EPA's Ozone Standard Proposal." 10 Jan 2010. Web. 28 Oct 2010.
- . "Texas Emissions Reduction Plan (TERP)." 2011. Web. 19 Apr 2011.
- Texas Dept. of Transportation. "Texas Legal Size and Weight Limits." 2011. Web. 2 Apr 2011.
- Texas State Data Center. "Texas Population Projections Program." 3 June 2009. Web. 4 June 2011.
- The Pete Store. "EGR Vs. SCR: What You Need to Know." 6 Jan 2010. Web. 28 Oct 2010.
- Training, Eaton Hydraulics. *Mobile Hydraulics Manual*. 2nd ed. Eaton Hydraulics Training, 2006. Print.
- Transport Topics. "The 2010 Transport Topics Top 100 Private Carriers." 23 Aug 2010 : A6 - A18. Print.
- Turner, R. Kerry, David W. Pearce, and Ian Bateman. *Environmental Economics: An Elementary Introduction*. The Johns Hopkins University Press, 1993. Print.
- "Tyrano - Vision Motor Corp." Web. 20 May 2011.
- U.S. Census Bureau. "Population Projections - 2009 National Population Projections." Web. 4 June 2011.
- U.S. Department of Energy. "Annual Energy Outlook - 2011." 2011. Web. 24 Mar 2011.
- . "Argonne Transportation - AirCRED Model." Web. 2 June 2011.
- . "Weekly Retail On-Highway Diesel Prices." 2011. Web. 7 Apr 2011.
- U.S. Department of Transportation: Federal Highway Administration. "Freight Analysis Framework - FHWA Freight Management and Operations." 24 May 2011. Web. 4 June 2011.
- U.S. Environmental Protection Agency Office of Air and Radiation. "Heavy Trucks, Buses, and Engines." 2010. Web. 20 Dec 2010.
- . "The Benefits and Costs of the Clean Air Act from 1990 to 2020." Apr 2011. Web. 20 Apr 2011.

United Parcel Service of America. "Pricing for Daily and Standard List Rates Customers." 2011. Web. 2 Apr 2011.

United States Environmental Protection Agency. "Air and Radiation: Basic Information." Web. 21 Dec 2011.

---. "BenMAP." 2011. Web. 20 May 2011.

---. "Clean Automotive Technology: Hydraulic Hybrid Research." 2010. Web. 25 Sept 2010.

---. "EPA and NHTSA Propose First-Ever Program to Reduce Greenhouse Gas Emissions and Improve Fuel Efficiency of Medium- and Heavy-Duty Vehicles: Regulatory Announcement." 2011. Web. 15 Apr 2011.

---. "Key Elements of the Clean Air Act." Web. 21 Dec 2011.

---. "National Ambient Air Quality Standards (NAAQS)." Web. 21 Dec 2010.

---. "Operating Permits: Basic Information." Web. 21 Dec 2010.

UPS Public Relations. "UPS Fact Sheet." 2011. Web. 14 Feb 2011.

Volvo Trucks Global. "Volvo FE Hybrid - New Trucks□: Volvo Trucks." 2010. Web. 18 Sept 2010.

Wal-Mart. "Wal-Mart: A Leader in Logistics." May 2009. Web. 20 May 2011.

*Walmart Tests New Hybrid Trucks, Alternative Fuels.* Bentonville, Arkansas.

Wong, J. Y. *Theory of Ground Vehicles.* 4th ed. Wiley, 2008. Print.

"ZETT - Vision Motor Corp." Web. 20 May 2011.



## Appendix A: Technical Hybrid Vehicle Information

### Alternative Power Sources/Storage Devices

---

Several different energy storage methods can be used in heavy duty hybrid vehicles. The main groups that these fall into are electric, hydraulic, and mechanical energy storage methods. Each one of these strategies has benefits for certain applications.

#### **Electrical Energy Storage**

##### ***Batteries***

The most widely known energy storage method for electricity is a battery. This option allows for a large amount of energy to be stored, but it does have its issues. The primary issue is its lack of tolerance for cold weather. Also limiting is the rate at which they can be recharged and the length of their life cycle. The two types currently used in electric hybrids are nickel- and lithium-based batteries (Ehsani, Gao, and Ali Emadi).

##### Lead Acid Batteries

Lead acid batteries have been in production for over a century and are still widely used in automotive applications, although not in hybrids. The sealed maintenance-free version that is widely used today was developed in the 1970s. This type of battery is commonly used to start a vehicle. It is very low cost, has a high power capability, and very good charge retention. It does require little maintenance, and does not have a memory. However, this battery does have some issues. The first issue is that its performance is greatly reduced below 10 °C (50 °F). It also contains sulfuric acid and releases hydrogen gas from certain reactions. Both of these chemicals pose safety risks. A few other problems are that the charge rate of these batteries is very slow, they do not tolerate deep cycling, and they must be stored in a charged state. However, improvements are still being made to this type of battery despite its status as old technology (Ehsani, Gao, and Ali Emadi; Buchmann).

##### Nickel-Based Batteries

The next family of batteries is nickel-based. There four different types are nickel-iron, nickel-zinc, nickel-cadmium (NiCd), and nickel-metal hydride (Ni-MH). Because nickel is lighter than lead, these batteries are lighter. Nickel also has many desirable chemical properties for battery applications (Ehsani, Gao, and Ali Emadi).

The nickel-iron battery was developed in the early twentieth century and has been used in forklifts, mine locomotives, and railway locomotives. This type of battery does have a higher power density and better cold weather performance than lead acid batteries. These batteries can also tolerate many deep discharges without affecting battery performance. The disadvantages of this type of battery are the release of hydrogen gas, corrosion, and self-discharge. The water level of these batteries must also be maintained. Some of the problems have been solved or reduced in this type of battery, but no commercial solutions for hybrid vehicles are available yet (Ehsani, Gao, and Ali Emadi).

The NiCd battery is similar to the nickel iron battery, but recent technological advances have drastically improved this type of battery. This battery has a very high specific power, a small voltage drop over a wide range of currents, and a very low self-discharge rate. It can tolerate many cycles, a great deal of mechanical and electrical abuse, and very low temperatures, and can be charged rapidly with a simple charger. The disadvantages of the NiCd battery are high initial cost, low cell voltage, and issues with disposal because of the cadmium they contain. Major manufacturers of this type of battery are SAFT and VARTA (Ehsani, Gao, and Ali Emadi; Buchmann).

The nickel-metal hydride battery has been commercially available since 1990, and its characteristics are similar to the NiCd battery. The two areas where it is superior are energy density and the lack of cadmium. It is also less prone to memory issues than a NiCd battery. However, it still has a high initial cost and is inferior to the NiCd in some ways as well. It does not tolerate high discharge rates and deep cycling as well as NiCd batteries and it is more difficult to charge. Major manufacturers include GM Ovonic, GP, GS, Panasonic, SAFT, VARTA, YUASA. This type of battery is what is used in the Toyota Prius, Honda Insight, and GM Allison hybrid (Ehsani, Gao, and Ali Emadi).

### Lithium Batteries

Lithium ion (Li-ion) batteries have been commercially available since the early 1970s. However, the first rechargeable Li-ion batteries became available only in 1991. Research on rechargeable versions of this battery did not begin until the early 1980s and was hindered by lithium's stability issues. The current versions of these batteries offer a high energy density, relatively low self-discharge, and no memory. However, because of lithium's instability, additional circuit protection is required, the battery is subject to aging even if it is not in use, and large shipments of Li-ion batteries may be subject to regulatory control. It also only offers a moderate power density and is expensive to manufacture (Buchmann).

The lithium polymer battery is much newer than the Li-ion battery. The original design dates back to the 1970s. While its energy density and cost are not as favorable as the Li-ion's, it does offer some advantages. It has a very flexible form factor and is not bound by the standard cell formats used by other batteries. It is also very lightweight and offers better safety than a Li-ion battery (Buchmann).

Table A-1 summarizes the characteristics of the batteries described.

**Table A-1. Typical characteristics of various types of batteries.**

|  | Nickel-based         |                      | Lead Acid       | Lithium                |                        |
|--|----------------------|----------------------|-----------------|------------------------|------------------------|
|  | NiCd                 | NiMH                 |                 | Li-ion                 | Li-ion Polymer         |
| <b>Gravimetric Energy Density (Wh/kg)</b>          | 45-80                | 60-120               | 30-50           | 110-160                | 100-130                |
| <b>Internal Resistance (mΩ)</b>                    | 100 to 200 (6V Pack) | 200 to 300 (6V pack) | <100 (12V Pack) | 150 to 250 (7.2V pack) | 200 to 300 (7.2V pack) |
| <b>Cycle Life (to 80% of initial capacity)</b>     | 1500                 | 300 to 500           | 200 to 300      | 500 to 1000            | 300 to 500             |
| <b>Fast Charge Time</b>                            | 1h typical           | 2-4h                 | 8-16h           | 2-4h                   | 2-4h                   |
| <b>Self-discharge / Month (@ room temp)</b>        | 20%                  | 30%                  | 5%              | 10%                    | 10%                    |
| <b>Peak Load Current</b>                           | 20C                  | 5C                   | 5C              | >2C                    | >2C                    |
| <b>Best Load Current</b>                           | 1C                   | 0.5C or lower        | 0.2C            | 1C or lower            | 1C or lower            |
| <b>Operating Temperature (discharge only)</b>      | -40 to 60°C          | -20 to 60°C          | -20 to 60°C     | -20 to 60°C            | 0 to 60°C              |
| <b>Maintenance Requirement</b>                     | 30 to 60 days        | 60 to 90 days        | 3 to 60 months  | not req.               | not req.               |
| <b>Typical Battery Cost (US\$, reference only)</b> | \$50 (7.2V)          | \$60 (7.2V)          | \$25 (6V)       | \$100 (7.2V)           | \$100 (7.2V)           |
| <b>Commercial use since</b>                        | 1950                 | 1990                 | 1970            | 1991                   | 1999                   |

Source: Buchmann

### ***Ultracapacitors***

An ultracapacitor is a large capacitor that can store a great deal of energy. It differs from a battery in that it uses a different electrochemical reaction to store energy. This difference gives an ultracapacitor a much greater power density than batteries. This density is especially important in heavy duty vehicles where a large amount of power can be demanded during acceleration or generated through regenerative braking. Other benefits of an ultracapacitor are that they can be cycled up to 1,000,000 cycles (“Maxwell Technologies - Ultracapacitors”). The drawback is that an ultracapacitor has an energy density of 1 to 10 Wh/kg, which is much lower than a battery. It also has a varying voltage that is proportional to its stored energy, which creates a requirement for a power controller to either increase or decrease the voltage output sent to the drive motor (Ehsani, Gao, and Ali Emadi).

While the ultracapacitor is not widely used as a primary energy storage method, a significant amount of research has been conducted on how to use them in conjunction with batteries. The goal of this combination is to create a hybrid power supply that can provide large amount of energy while also being able to provide intermittent large bursts of power. While a battery can

supply a large amount of power in intermittent conditions, it usually has a negative effect on battery life. Three main topologies have been studied. All three have the battery and capacitor in parallel. The three architectures are passive parallel, bidirectional DC-DC converter, and the two input bidirectional DC-DC converter (Lukic et al.).

The passive parallel architecture connects the battery and capacitor directly in parallel and is the simplest of the three architectures (Figure A-1). However, it allows the capacitor to operate only in a small range of its operating voltage, which limits the usable storage capacity, but it does not require any additional control (Lukic et al.).

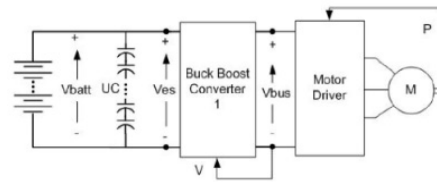

Source: Lukic et al.

Figure A-1. Schematic of passive parallel architecture.

The second architecture is the bidirectional DC-DC converter (Figure A-2). This method utilizes a DC-DC converter between the battery and capacitor to allow a wider range of the capacitor's storage to be used. This architecture does require an additional controller and converter to control the current output of the battery. The major disadvantage to this architecture is that the energy from the battery must pass through two conversions prior to reaching the motor driver, leading to a less efficient system (Lukic et al.).

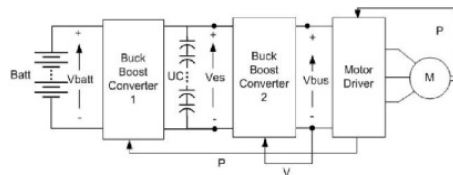

Source: Lukic et al.

Figure A-2. Schematic of bi-directional DC-DC converter architecture.

The third architecture is the two input bidirectional DC-DC converter (Figure A-3). This architecture tries to accomplish the same thing as the prior architectures but in a more efficient manner. It does this by placing the two DC-DC converters in parallel to feed a common power bus. This structure allows the energy from the battery to pass through only one converter to reach the motor driver. Like the second architecture, this architecture requires an additional converter and controller (Lukic et al.)



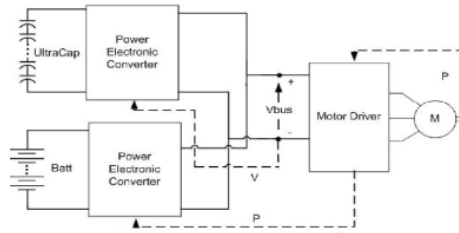

Source: Lukic et al.

Figure A-3. Schematic of two input bi-directional DC-DC converter architecture.

## Hydraulic Energy Storage

Hydraulics is an area of recent interest for hybrid vehicles because it is a very mature technology. Many off-the-shelf components are available, potentially reducing the payback time of a hybrid. The hydraulic component used to store energy is an accumulator (Figure A-4). Accumulators offer a very high power density over batteries and typically do not use materials that are expensive or pose a severe environmental risk. Most accumulators use compressed nitrogen to store energy. Because of this, most accumulators must be serviced as the nitrogen charge is lost slowly over time (U.S. EPA, “Clean Automotive Technology: Hydraulic Hybrid Research”). The disadvantages are that they are large and can be heavy, the compressed fluid can be dangerous, the energy density is much lower than batteries, and certain types of hydraulic fluid can pose an environmental risk if spilled (Eaton Corporation, *Eaton Mobile Hydraulics Manual*)

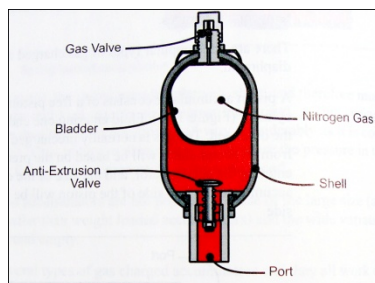

Source: Eaton Corporation, Eaton Mobile Hydraulics Manual

Figure A-4. Cross-section of bladder-type hydraulic accumulator.

## Mechanical Energy Storage

High-speed flywheels can be used to store mechanical energy by rotating at high speeds. Speeds of 60,000 rpm have been achieved in some prototypes. This alternative offers a high power and energy density. They also offer high energy efficiency, can be recharged quickly, have maintenance-free characteristics, and are cost effective and environmentally friendly. Because of its high speeds, the flywheel can be difficult to couple to the drive train. Currently an electric motor is connected to it to either store or harvest energy, but the potential exists for use of a continuously variable transmission. Because of the extremely high rotating speeds, the flywheel is housed in a vacuum to reduce aerodynamic losses. The high speeds also cause a large gyroscopic force, which can cause issues when the vehicle changes direction. This problem can

be solved by having two flywheels rotating in opposite directions. Damage to the flywheel also poses a great risk. If it is damaged, a great deal of energy will be released very rapidly. This sudden energy release could cause major damage to the vehicle and potentially passengers. Containing the flywheel in the event of a catastrophic failure is critical for passenger safety (Ehsani, Gao, and Ali Emadi).

## **Prime Movers**

---

A prime mover is the device that is used to convert the alternative energy source to rotational mechanical energy. This component is required to join the two drivetrains together.

### **Electrical Prime Movers**

Electric motors come in many different types that can be broken down into two groups. The two groups are commutator and commutatorless motors (Ehsani, Gao, and Ali Emadi).

Commutator type motors are generally DC motors. A commutator is a mechanical switch in the motor that is part of the rotor. The need for this mechanical switch reduces the reliability of this type of motor. They also have a low power density, but they are still widely used because of their mature technology and ease of control. The four main types of commutator motors are series, shunt, field excited, and permanent magnet excited motors (Ehsani, Gao, and Ali Emadi).

Commutatorless motors typically accept AC power. The lack of a commutator greatly increases the reliability of these motors and can allow for maintenance-free operation. These motors also offer higher efficiency, higher power density, and lower operating cost, due to recent developments in this area. The main disadvantage of commutatorless motors is the difficulty in controlling them. Some control schemes require additional sensors that decrease their robustness, but advances are being made in this area. The main types of commutatorless motors are induction, synchronous, permanent magnet brushless, switched reluctance, and permanent magnet hybrid motors (Ehsani, Gao, and Ali Emadi).

### **Hydraulic Prime Movers**

Hydraulic pumps and motors are available in several different types that include gear, vane, piston, and gerotor pumps. However, piston pumps predominate in hybrid vehicles because they offer high efficiencies, can operate at high pressures, and are available with variable displacement. Other benefits of hydraulics are that they offer a very high power density, a very flat torque curve vs. speed, and are a very mature technology. As mentioned earlier, many off-the-shelf components can be used with little or no modifications. The hydraulic fluid also acts as a lubricant and coolant throughout the system. The disadvantages of hydraulics are that they offer a much lower energy density than electricity, leaks at high pressure can be very dangerous and pose an environmental risk, and certain components can be difficult to package in the vehicle because of size or flexibility. The environmental risks can be mitigated by using biodegradable fluid or a water glycol mixture, but these fluids usually require derating of components (U.S. EPA, "Clean Automotive Technology: Hydraulic Hybrid Research;" Training; Esposito).

## **Control Strategies**

---

The control strategy is a very important aspect of a hybrid vehicle. Regardless of the architecture, the two main types of control strategies are rule-based and optimization-based strategies. Within each of these two categories are additional classifications that contain strategies with their own strengths and weaknesses.

Rule-based strategies are based on rules specified by the engineer designing the system. These rules typically seek to optimize a single parameter like fuel consumption. These strategies are usually very simple and easy to implement, but they usually only look to optimize a single parameter (Desai and Williamson).

Optimization-based strategies seek to find the most efficient operating strategy for a vehicle through a given drive cycle or set of drive cycles. These strategies can take into account the efficiencies of several components in the system much more easily. They are also able to easily optimize vehicle operation based on several parameters. These parameters could include but are not limited to fuel consumption and various emissions (Desai and Williamson).



## Appendix B: Hydraulic Hybrid Service Breakdown Calculations

Just like the oil in a car, the oil in a hydraulic system must be periodically changed. In addition to this maintenance, other components must be serviced and periodically checked. Other items that wear and need replacement on hydraulic hybrids are the hydraulic fluid, breather, the system and secondary oil filters, accumulator bladder, accumulator gas charge, and transfer case oil. Figure B-1 illustrates a hydraulic system.

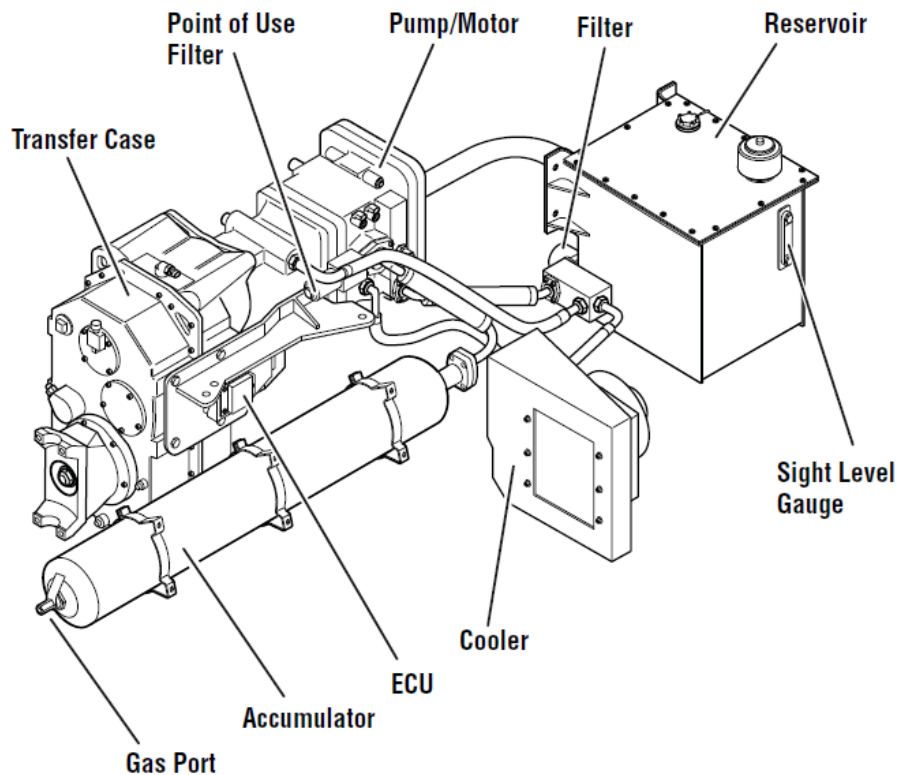

Source: Eaton Corporation, "Service Manual: Eaton Hydraulic Launch Assist (HLA)"

Figure B-1. Line drawing of Eaton Hydraulic Launch Assist system.

### Hydraulic Fluid

The hydraulic fluid in a system serves several purposes. The first purpose is to transmit power. The other two functions are to help cool and lubricate the system (Esposito). As the fluid ages, some of its properties change, making it less suitable for the system, and it must be changed (Eaton Corporation, *Eaton Mobile Hydraulics Manual*). The fluid capacity of the hydraulic system was not specified by the Eaton service manual, but was estimated based on information presented in the manual. The volume of the accumulator is 21 gallons, which was used as the system capacity. An accumulator is never filled all the way with oil because some space must always be available for the gas-charged bladder to occupy. The manual specifies that the technician use a 25-gallon pan to drain the system (Eaton Corporation, "Service Manual: Eaton Hydraulic Launch Assist [HLA]"). A gallon of hydraulic fluid was estimated to be \$8.00/gallon. This figure was based on prices obtained from O'Reilly Auto Parts for a 5-gallon bucket of AW46 hydraulic

fluid (O'Reilly Auto Parts). The service manual names a specific Eaton fluid for the system for which no pricing information could be found. The researchers assumed that the price of a general fluid would have a comparable cost to the Eaton fluid. Changing the oil was estimated to take 3 hours at a labor cost of \$50/hour. Under these assumptions, the cost of a fluid change would be \$318.

## Breather

The breather on the hydraulic reservoir typically has two functions. The first is to allow air to enter and exit the reservoir as the fluid level changes. Its other function is to filter the air as it enters the reservoir to minimize oil contamination. Components in hydraulic systems have very tight clearances. Therefore, small pieces of dirt and other material can significantly degrade the performance of the system if allowed into the oil. Over time the filter in the breather will become clogged and need replacement. The breather was estimated to cost \$15 based on the author's personal experience as a hydraulic systems engineer. The labor was estimated to be 30 minutes. Thus, a breather change should run approximately \$40.

## System and Secondary Oil Filters

The filter for a hydraulic system is very similar to an engine oil filter. However, they can be much larger when higher flows are required by the system. Both filters for this system use a design where the element (rather than the assembly that includes the metal "can") is changed, much like on an engine. Figure shows an exploded view of this design. The advantage to this design is that less trash is generated and the reduced material requirements reduce cost. The two filters for the system were estimated to have a combined cost of \$50. This maintenance would presumably be conducted in conjunction with a system oil change, so no labor was included for this item.

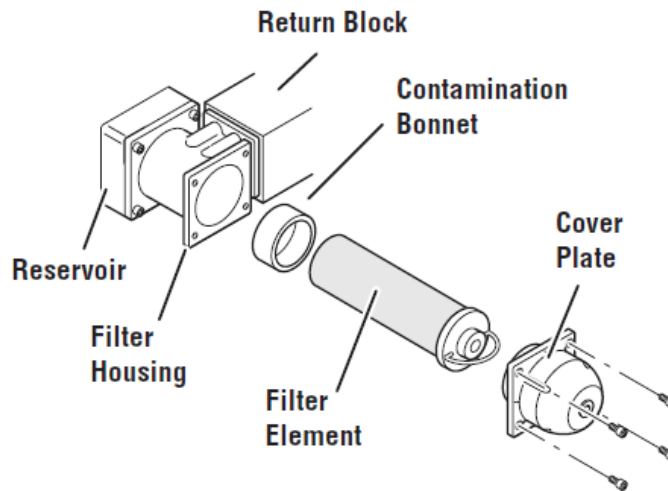

Source: Eaton Corporation, "Service Manual: Eaton Hydraulic Launch Assist (HLA)"

Figure B-2. Exploded view of main system oil filter.

## Accumulator Bladder and Gas Charge

The accumulator is the energy storage device for the hydraulic hybrid system (Figure B-3). It stores energy through the compression of nitrogen gas stored in the bladder (Esposito). Over time this bladder can become worn from the compression and expansion it experiences as oil enters and exits the accumulator. Constant exposure to oil can also degrade the rubber over time. The gas charge contained in bladder can also gradually leak through the rubber, much like helium from a latex balloon.

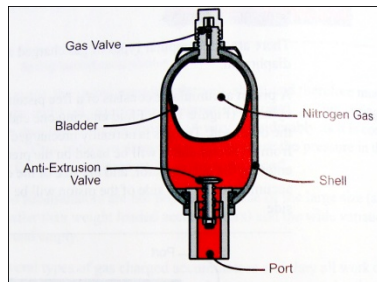

Source: Eaton Corporation, Eaton Mobile Hydraulics Manual

Figure B-3. Cross-sectional view of bladder-type accumulator.

Periodically the charge in the accumulator must be checked and refilled. This aspect of the maintenance was not considered because its potential frequency was unknown and is mostly likely a small cost. The service manual specifies that the accumulator bladder must be changed every 2 years, and the charge would be refilled then. The exact cost of the replacement parts was unknown, and costs of similar parts were not available because a 21-gallon accumulator is not an “off the shelf” type part. To estimate this cost, replacement bladders for smaller accumulators were priced at McMaster Karr. A curve was then fit to the costs to extrapolate a 21-gallon accumulator bladder’s cost (Figure B-4). The estimated cost of the bladder was \$925. The labor was assumed to be 8 hours because the accumulator must be removed from the vehicle and completely disassembled. With these assumptions, the total estimated cost is \$1,325.

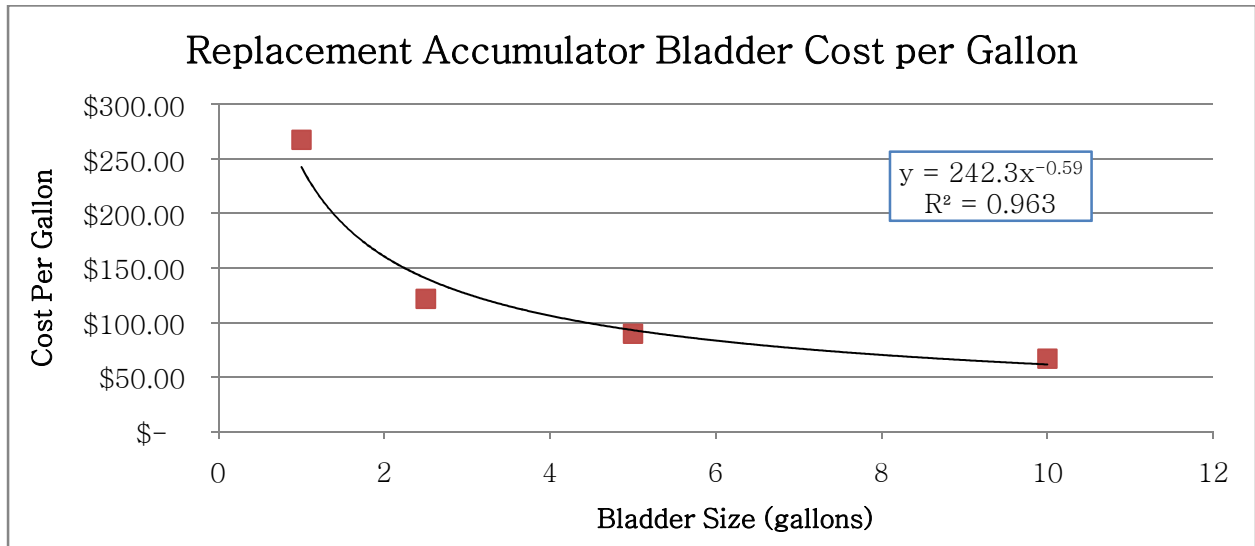

Source: "McMaster-Carr"

Figure B-4. Replacement accumulator bladder cost per gallon as a function of bladder size.

### Transfer Case Oil

The transfer case is not a component in the hydraulic system, but is required to couple the hydraulic system to the drivetrain. The service manual specifies that its fluid must be changed every 5 years. The capacity of the transfer case is 1.9 gallons, and the fluid is a 75W-90 gear synthetic oil (Eaton Corporation, "Service Manual: Eaton Hydraulic Launch Assist [HLA]"). The estimated price of this oil was \$25. This price was derived from oils that were available at O'Reilly Auto Parts, which ranged from \$15 to \$32 per gallon (O'Reilly Auto Parts).



## Appendix C: Other Notable Trucks

In addition to the diesel hybrids discussed in the body of the text, several other hybrids and alternative fuel vehicles show some merit. While these vehicles may not see wide use due to infrastructure requirements or other limitations, they can potentially fill niche applications very well.

### Balqon Electric Yard Truck



The Natilus XE20 is a yard truck manufactured by Balqon Motors. It has a gross combination weight rating (GCWR) of 90,000 lbs and can reach a maximum speed of 25 mph. The unloaded range of the truck is 94 miles, and the loaded range is 50 miles. It is powered by a 200 hp AC motor. The lithium ion batteries have a capacity of 140 kW-hr and a nominal voltage of 324 V. They can be recharged in 6–8 hours with the standard 20 kW charger (Balqon Corporation).

These trucks are primarily used at the Port of Los Angeles. The port purchased 20 at a cost of \$189,950 per truck. Fourteen of the trucks had been delivered as of April 12, 2011. Ford Motor Company is leasing 10 of them for use at their assembly plant in Wayne, Michigan. Only three of these trucks were delivered there as of April 12, 2011 (Balqon Corporation, *Morningstar*® Document Research <sup>SM</sup>FORM 10-KBALQON CORP. - BLQN).

## Balqon Electric Drayage Truck



The Nautilus XE30 is a drayage truck manufactured by Balqon Motors. It has a GVWR of 52,500 lbs and can reach a maximum speed of 55 mph. The unloaded range of the truck is 150 miles, and the loaded range is 90 miles. It is powered by a 300 hp AC motor. The lithium ion batteries have a capacity of 280 kW-hr and a nominal voltage of 324 V. They can be recharged in 6–8 hours with the standard 20 kW charger (Balqon Corporation, “Nautilus XE30: Zero Emission Electric Tractor”).

The Port of Los Angeles purchased five of these trucks at a price of \$208,500. However, only one has been delivered as of April 12, 2011. The Port has also purchased five battery chargers for a total cost of \$542,250 (Balqon Corporation, *Morningstar® Document Research* <sup>FORM 10-K</sup> *BALQON CORP. - BLQN*).

## Balqon Electric City Delivery Truck



The Natilus M150 is a delivery truck manufactured by Balqon Motors. It has a GVWR of 52,500 lbs and can reach a maximum speed of 55 mph. The unloaded range of the truck is 150 miles, and the loaded range is 90 miles. It is powered by a 300 hp AC motor. The lithium ion batteries have a capacity of 280 kW-hr and a nominal voltage of 324 V. It is available with a 100 kW, multi-vehicle fast charger that can charge the batteries in 6 hours with an 80% depth of discharge (Balqon Corporation, “Mule M150: Zero Emission Electric Delivery Truck”). It is unclear if any of these trucks are in use at this time.

## Capacity of Texas-Vision Motors FETT Yard Truck



The Zero Emission Terminal Tractor (ZETT) is hydrogen fuel cell hybrid terminal tractor. It is produced through a partnership between Capacity of Texas and Vision Motors. The tractor is powered by a 225 hp 3 phase motor and has a GCWR of 130,000 lbs. The 58 kW-hr lithium ion batteries are continuously charged by the hydrogen fuel cells during operation. It has the potential to run two 8-hour shifts before refueling with hydrogen (“ZETT - Vision Motor Corp”).

## Vision Motors Hydrogen Fuel Cell Hybrid Truck



The Tyrano is a drayage truck produced by Vision Motors with a GVWR of 80,000 lbs. The range of the truck varies between 200 and 400 miles based on configuration. The electric motor is rated between 400 and 536 hp. The limit on the power is based on the maximum input torque of the transmission. The truck is capable of traveling at speeds of 55 to 70 mph depending on the limit that is set in the controller (“Tyrano - Vision Motor Corp”).

## Appendix D: Hybrid Adoption Estimation Procedure

The method used to estimate the rate of hybrid adoption is somewhat of a discrete method that utilizes the spreadsheet/cost data that was developed to estimate operating costs. With the current data sets, estimating adoption is possible up to the year 2035. This limitation is imposed because of the limit on the diesel price prediction estimated by the DOE. The entire estimation process is described in the following paragraphs.

1. The first step is to establish a relationship between annual miles traveled and fuel economy. For the package delivery truck the data from the UPS and FedEx reports was used, as shown in Figure (Lammert and NREL; Barnitt and NREL). A linear fit was then applied to these data points to establish an equation. Other fits were evaluated with similar results.

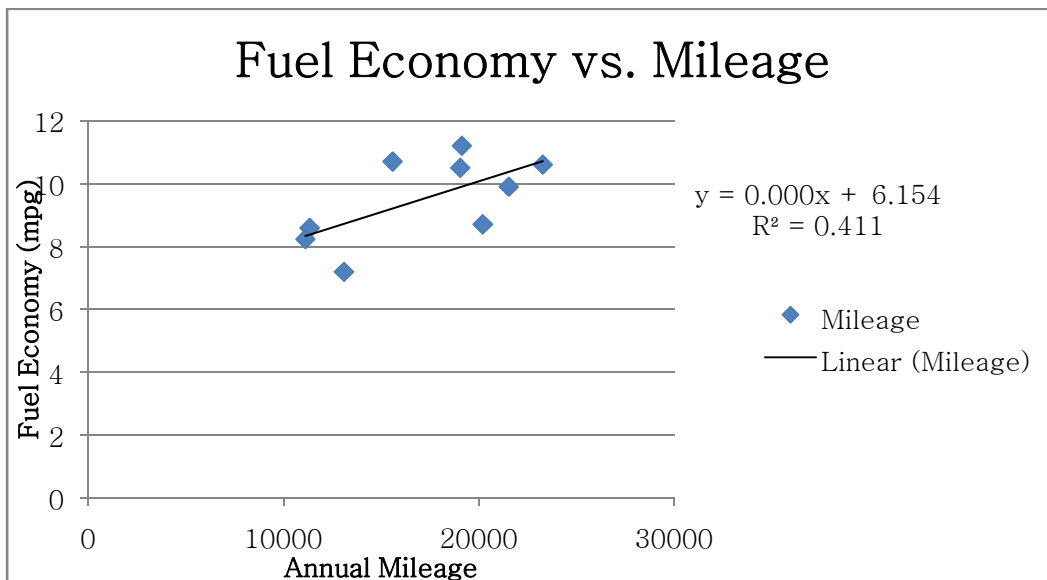
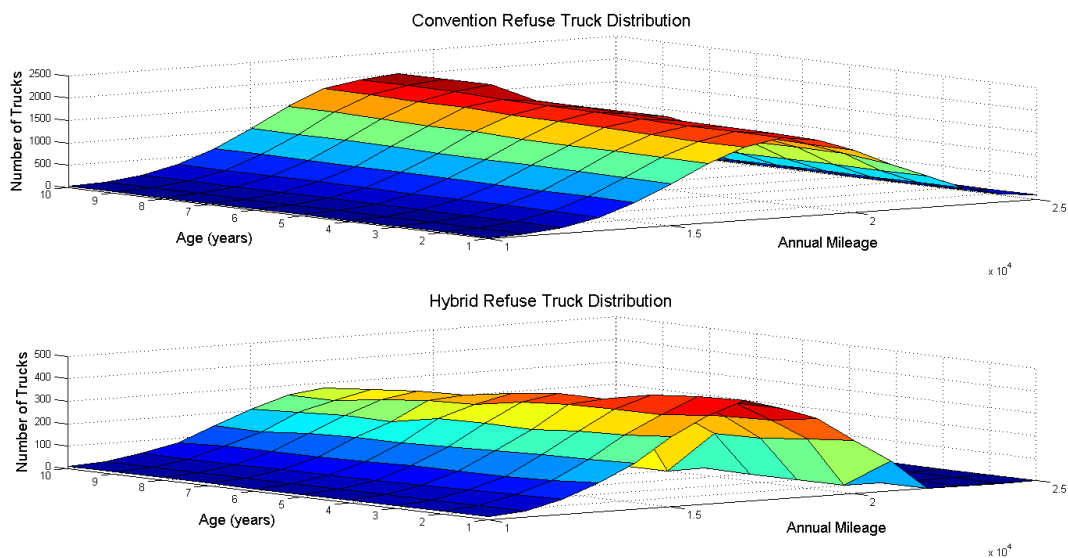

Figure D-1. Estimated correlation between annual mileage and fuel economy for package delivery truck.

2. The mean and standard deviation of the mileage was then calculated or taken from various sources. The population was then assumed to be normally distributed, allowing for the calculation of the number of trucks that would fall into each range for the simulation.
3. In MATLAB, various parameters such as system cost, various incentives, and the range of annual mileage were established. The mileage was then broken in 1,000-mile increments. The upper and lower values for this array were established through trial and error by ensuring that the upper and lower mileage classifications contained zero trucks.
4. The diesel prices were then input into MATLAB to allow data to be used from 2008 to 2035.

5. An equation in fuel economy improvement was then established based on values seen in literature, assuming that it would linearly decrease as mileage increased.
6. Another input to the simulation is the size of the truck population and the amount of hybrid trucks in current operation. The age of the oldest hybrid truck is also an input. This data is used to create a matrix for the truck population. This truck population matrix has three dimensions. The first dimension is the annual mileage of the truck. The second dimension has two elements: the number of hybrid trucks and the number of conventional trucks. The third dimension is the age of the truck. The truck population is assumed to be evenly distributed for each year of age. Then, for each truck age group, the three dimensions are normally distributed based on the distribution established in step 5. An example of this matrix depicted as two surfaces is shown in Figure D-2.



*Figure D-2. Estimated distribution of refuse trucks for year 2020.*

7. The initial set of hybrid trucks are then assumed to linearly decrease as you go back in time to the age of the oldest hybrid truck. They are also placed in the range with the lowest mileage as that will have the lowest fuel economy. This placement is arbitrary, and should not affect any of the future calculations because the decisions will be made on whether hybrid adoption makes business sense.
8. Another matrix is then set up to track the number of hybrids that are in operation each year of the simulation.
9. The program then loops through all possible cases for each year to determine if hybrids or conventional trucks should be purchased. At each time step, the Excel spreadsheet is called to calculate the cost of buying a hybrid for each mileage at each time. If the hybrid saves money, hybrids are bought. If they don't, standard trucks are bought. The exception to this is with the second evaluation of the refuse truck system. A variable buying rate was established based on payback of the system.

10. At the next time step, the next oldest set of trucks is evaluated and the same decisions are made.