

AN EXPERIMENTAL BLOWING DUST ALARM
SYSTEM FOR HIGHWAYS
HP&R STUDY #5162

Victor Shinsel
Communications Technician II

Oregon Department of Transportation
Highway Division
Communications Unit
LaGrande, Oregon 97850

June, 1985

1. Report No. FHWA-OR-84-5		2. Government Accession No.		3. Recipient's Catalog No.	
4. Title and Subtitle AN EXPERIMENTAL BLOWING DUST ALARM SYSTEM FOR HIGHWAYS				5. Report Date JULY 1984	
				6. Performing Organization Code	
7. Author(s) Victor Shinsel				8. Performing Organization Report No. 84-5	
9. Performing Organization Name and Address Communications Unit Highway Division Oregon Department of Transportation Salem, Oregon 97310				10. Work Unit No. (TRAIS)	
				11. Contract or Grant No. HPR 084-5162	
12. Sponsoring Agency Name and Address U.S. Department of Transportation Federal Highway Administration Office of Research & Development Washington, D.C. 20590				13. Type of Report and Period Covered Final	
				14. Sponsoring Agency Code	
15. Supplementary Notes					
16. Abstract Blowing dust storms pose a visibility hazard to highway motorists. An experimental alarm which senses electrification of a metal antenna by blowing dust particles is described. The metal antenna can be an ordinary radio whip antenna or an insulated top strand of barbed-wire right of way fence to monitor a greater area. The sensor responded favorably under conditions of half mile visibility and 20 mph winds. Field tests were conducted by telemetry to an office microcomputer. Dust related radio noise which blanks out broadcast reception is attributed to electrification of metallic objects and subsequent corona or spark discharge. An experimental acoustic sensor for blowing sand is also described, along with comment on application of an ionization chamber to detect motionless dust.					
17. Key Words DUST, BLOWING DUST, VISIBILITY, ALARM, SENSOR, DETECTOR, SAND, ANTENNA, RADIO NOISE, STATIC, ELECTRIFICATION, ACOUSTIC			18. Distribution Statement No Restrictions		
19. Security Classif. (of this report) Unclassified		20. Security Classif. (of this page) Unclassified		21. No. of Pages	22. Price

ABSTRACT

Blowing dust storms pose a visibility hazard to highway motorists. An experimental alarm which senses electrification of a metal antenna by blowing dust particles is described. The metal antenna can be an ordinary radio whip antenna or an insulated top strand of barbed-wire right of way fence to monitor a greater area. The sensor responded favorably under conditions of half mile visibility and 20 mph winds. Field tests were conducted by telemetry to an office microcomputer.

Dust related radio noise which blanks out broadcast reception is attributed to electrification of metallic objects and subsequent corona or spark discharge.

An experimental acoustic sensor for flowing sand is also described, along with comment on application of an ionization chamber to detect motionless dust.

TABLE OF CONTENTS

ABSTRACT	i
ACKNOWLEDGMENTS	ii
DISCLAIMER	ii
INTRODUCTION	1
OBJECTIVE	1
BACKGROUND	1
PROCEDURE	2
RESULTS	5
DISCUSSION	9
CONCLUSION	12
RECOMMENDATIONS	13
REFERENCES	15
APPENDIX I: ELECTRICAL DIAGRAMS	16
APPENDIX II: REMOTE PROCESSOR PROGRAM	20
APPENDIX III: OFFICE COMPUTER PROGRAM EXAMPLES	26

ACKNOWLEDGMENTS:

This project was conducted at the direction of Pat Schwartz, Assistant State Highway Engineer, Oregon Department of Transportation.

Field support was provided by Harry Oswald, District Engineer at Pendleton. Mr. Oswald's courteous assistance in site location and constructive comment are gratefully acknowledged. Maintenance personnel under his supervision cheerfully fabricated and installed pipe mounts, reported dust conditions, and monitored computer performance.

Patient administrative support was provided by Gordon Beecroft, Research Engineer, Charlie Johnson, Chief Radio Engineer, and Bob Aldrich, Operations Services Engineer.

This project was HPR funded, and conducted in cooperation with the U.S. Department of Transportation, Federal Highway Administration.

DISCLAIMER

The contents of this report reflect the views of the author who is responsible for the facts and accuracy of the data presented herein. The contents do not necessarily reflect the official views or policies of the Oregon Department of Transportation or the Federal Highway Administration. This report does not constitute a standard, specification, or regulation.

AN EXPERIMENTAL BLOWING DUST ALARM SYSTEM

INTRODUCTION:

Blowing dust occasionally endangers highway motorists. Dust clouds can obscure lane boundaries, landmarks, and motor vehicles so that no one knows what is ahead or behind. Some drivers continue at full speed, fearing collision from the rear, or because of under-estimating the extent of the cloud. Others may stop in their paths, or become disoriented and suffer collision.

The need for a qualitative "dust sensor" becomes apparent as accident prevention measures are considered. Dust monitoring equipment is difficult to specify, particularly where the application involves a large geographical area. A survey of available reduced visibility equipment is provided in Reference 1.

Fog or pollutant monitors which measure light extinction or radio transmissivity over long paths cannot discriminate dangerous dense local clouds from harmless diffuse haze. The energy attenuation may be similar in both cases. Back-scattering and contrast measurement devices can recognize dense pollutants, but each illuminator or video camera consumes electricity, and several expensive detector sites would be required to monitor a lengthy highway area. Microwave and optical radar are expensive and have the disadvantage that distant clouds may be obscured by local obstructions. Reference 2 describes effective use of National Weather Service radar for dust storm alerting in Arizona.

OBJECTIVE:

It was the purpose of this study to investigate low cost alternative methods of detecting blowing dust, and to develop a device or a system that could be used to provide a warning of the existence of blowing dust in concentrations that would seriously impair driver visibility. A secondary goal was to determine feasibility of a remote automatic warning system.

BACKGROUND:

During a 1979 dust storm on Interstate Freeway I-84 near Hermiston, poor visibility caused multiple fatality accidents. (A series of 30 accidents had occurred during the preceding decade, some involving multiple injuries, and one fatal.) Nearby staff employees of the

Oregon Department of Transportation asked truckers to call police on CB radios to summon aid for the injured and to secure flaggers. When the radios proved ineffective, similar fruitless attempts were made on VHF industrial radios.

After previous dust storms, highway division VHF radios had been occasionally reported defective. These were submitted for evaluation to a highway communications technician, and were found to be fully operational. A subsequent interview of the radio users revealed the impression of radio failure had derived from a strong "static interference" which accompanied the dust clouds. The crackling noise was simply masking all incoming calls. The transmitters were operational, yet no response would be heard by the callers until they left the vicinity of the dust clouds. It was also reported that AM and FM music radios were disrupted by the dust clouds.

It has long been known that severe storms such as tornados are accompanied by strong electrical noise. The highly publicized consumer tornado warning system advocated by Weller utilizes increase of television receiver "snow" (radio noise) as a detection method. See Reference 3. Mr. William L. Taylor of the U.S. Commerce Department's NOAA has been working on specialized receivers to process tornado noise, and has deployed several since 1971.

The accidents mentioned above involved wind velocities of 25-35 miles per hour, certainly less severe than tornado class winds. When soil conditions are unfavorable to dust cloud formation and the winds are clear, we do not encounter similar disruptive radio noise in Eastern Oregon. It was suggested that the noise might be "precipitation static", similar to the interference caused by electric charge build up on aircraft antennae shrouds as they pass through clouds. See References 4-7 regarding precipitation static.

PROCEDURE:

An elementary sensor was sought through cursory study of electrostatic, acoustic, ionization, and radio noise phenomena related to blowing dust. Seven experimental dust sensors were fabricated and three of those which showed promise were interfaced to a microprocessor board for remote field evaluation. A telemetry link was established between the field evaluation site and the Highway Division's District 12 maintenance office in Pendleton, where a microcomputer was employed to monitor and log field response. Three sensors were tried over a 2 year period.

A UHF portable hand held radio transmitter was obtained and outfitted with a 20 watt 12 volt solar panel power system. The transmitter and processor served as a semi-portable field data acquisition system. A point-closure anemometer was interfaced to the microcomputer, along with a thermistor-controlled oscillator. This allowed wind speed and

air temperature measurements to be telemetered from the field. A crude resistive comb was added to detect moisture at the remote site. The microprocessor was programmed to accumulate counts of digitized data from the experimental dust sensors, and to transmit a periodical report by emulating a type 103 telephone modem. The modem signals were radioed to a receiving station 60 miles away, then relayed by microwave and telephone line to the office microcomputer. A beeper was provided to call attention to prominent events, and a printer and real time clock were installed for routine logging. Calibration formulae for the weather instruments were obtained by regression analysis of empirically obtained points, and the derived equations were included in the BASIC interpretive program at the office.

A multi-band communications receiver was obtained and tape recordings were made in various naturally occurring dust clouds over a two year period. The receiver was tuned to various frequencies of interest ranging from 10 kilohertz to 30 megahertz. A spectrum monitor was also employed for frequencies of 1 megahertz to 1000 megahertz. The receiver demonstrated that radio noise interference was indeed severe in all cases of dust cloud observation. A 5000 watt AM radio station less than 15 miles distant was totally masked by noise when the receiver and antenna were carried into visible dust clouds. Absolute field strength readings were not taken, but attenuator substitution revealed that the dust noise at the receiver was in excess of 40 db stronger than the local radio station.

Spectrum monitor presentations were difficult to interpret because of the asynchronous impulse nature of the electrical signal. Rather than the expected semi-uniform "white" noise, a repetitive crackling noise predominated in all cases, and the character of the noise changed as the antenna was disturbed or even approached by the observer. Amplitude was generally independent of frequency. These observations implied that the noise encountered in these dust clouds was a manifestation of nearby electrostatic effects not to be confused with broadcast effects emanating and radiating from a distant dust storm cloud.

In order to investigate both the nearby electrostatic effects and the low frequency AC effects of the dust cloud, an electricians "Tic Tracer" (TM, trade mark of TIF Instruments, Inc., Miami, FL) was used to probe the antenna. This device is an audio oscillator which is coupled to an amplified capacitive probe. It is mainly used by electricians in tracing electrical wiring. The electric field variations cause "ticks" in the speaker when held near a current carrying wire. It will also respond when waved near an electrostatically charged surface, such as a TV screen. The electrostatic tracer coupled to the antenna produced a lively response to the blowing dust. If there was visible dust, there was a ticking response roughly inversely proportional to visibility. For control purposes, the same tracer was exposed to wind just outside the visible cloud, and later observed during heavy lightning and thunderstorm activity, with no response in either case.



Figure 1
Installing Telemetry Station

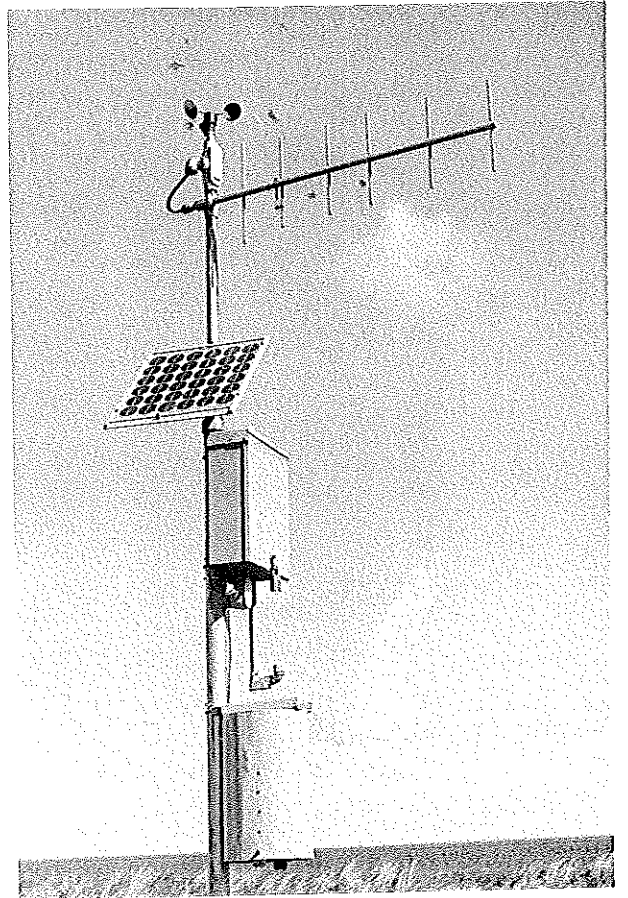

Figure 2
Telemetry Station



Figure 3
Wide Load Emerging From Dust Cloud

While using the tracer, another interesting effect was observed. The test antenna had been insulated so that it could be supported and maneuvered by hand. As dust clouds passed by, the antenna was shocking the observer, and sparks of one-quarter to one-half inch were seen jumping between the antenna and the truck. Sparking had not been noted while the antenna was connected to the communications receiver because the antenna was terminated by the receiver antenna port which constantly drained away the electric charge otherwise accumulating on the antenna. All evidence suggested that the principal repetitive component of the radio noise was a relaxation oscillation of high-voltage charge rapidly built up on the antenna and then abruptly discharged as breakdown potential of the capacitor formed between truck and antenna was exceeded. The effect was not observed between two horizontally spaced antennas, or between a vertical antenna and a grounded object.

The communications receiver was connected to a separate vehicular antenna and monitored again. A loud component of the noise was correlated with the discharge from the second antenna, which was supported by hand. It was possible to walk around the truck while holding any metallic object, and touch near the vehicle and get the same effect: first an electric "corona" noise, then a repetitive chirp characteristic of a relaxation oscillator. It appeared the dust particles were electrified by friction and carried a substantial electric charge relative to the earth. These observations were repeated upon several different occasions at different locations.

A.K. Kamra, of the Atmospheric Sciences Research Center of State University of New York, has done extensive research on the electrification of the atmosphere by dust storms. See reference 8. He reports that potential gradients of many kilovolts per meter are not uncommon, and that all available data show that all dust storms are electrically active, citing references since 1914. Kamra was utilizing radioactive polonium probes in conjunction with an ionization chamber to measure the space charge and potential gradient.

RESULTS:

An inexpensive and simply constructed electrostatic detector can be useful in sensing dangerous blowing dust. A neon relaxation oscillator can be used to monitor the rate of accumulation of charge on an antenna caused by blowing dust particles. Detector power is derived from the moving dust itself. See Figure 4. The flash rate has been observed to be roughly inversely proportional to visual range. See Figure 5. These data were obtained with an eight foot whip antenna at mile post 172 on I-84, where flash rate was correlated to visual observation of sight posts spaced every 200 feet. This example should not be regarded as an absolute calibration curve. Variations in humidity, soil composition, and wind velocity are expected to influence the curve.

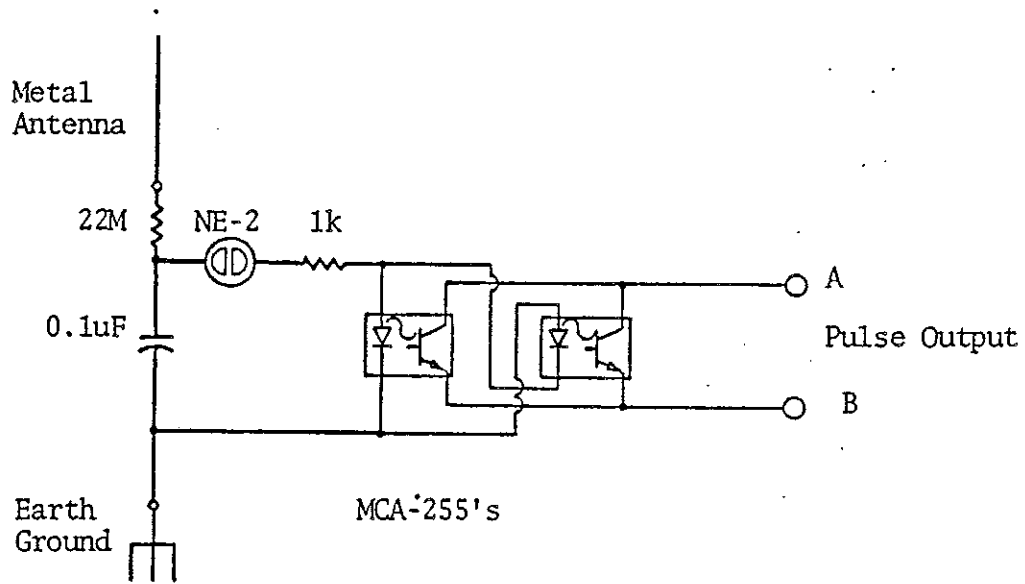

Figure 4.
Experimental Electrostatic Blowing Dust Sensor

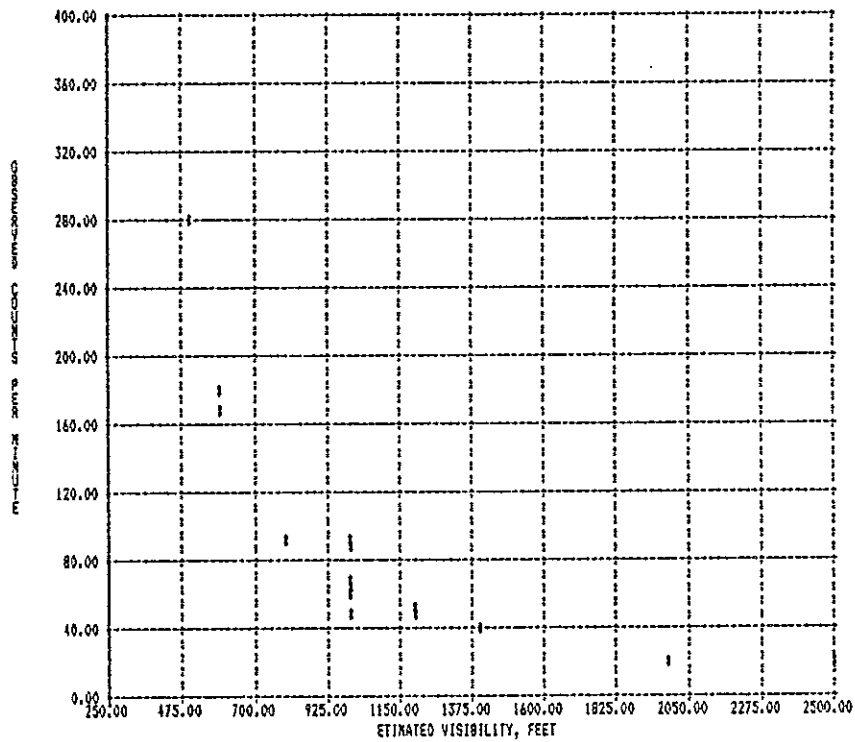

Figure 5.
Electrostatic Sensor Response

According to Schmidt, visual range for snow and sand particles is inversely proportional to particle frequency and the square of particle diameter. See Reference 9. Intuitively, the size and frequency of dust particles passing near the antenna depends on soil characteristics, humidity, and wind velocity. This sensor has consistently maintained a "Flashing Threshold" of approximately 18-22 miles per hour wind velocity for local soil conditions which give rise to visible dust cloud formation. Clouds ranged from "face powder" to "very fine sand" consistency. Soil in the experimental area is described as very fine sandy loam, developed principally from alluvial sediments. See Reference 10.

The electrostatic dust sensor is easily interfaced to telemetry or remote alarm equipment by means of back-to-back opto-isolators. This simple interface has the advantage of indifference to voltage polarity. The antenna may be a standard insulated-base eight foot steel whip to monitor a very small area, or it may be an insulated tip strand of a section of right-of-way fence to monitor a broad (1 mile or more) area. A section of barbed wire right-of-way fence was insulated with standard livestock fence insulators for a distance of one-half mile near a cultivated field which had been producing dust clouds. The solar powered telemetry station was placed in an uncultivated area outside the dust path for control purposes. The far end of the fence "antenna" extended about 100 feet west, into the dust path. The whip antenna was removed so that the fence strand was the sole antenna for the sensor.

A few days later, the office computer reported high winds, and indicated a blowing dust condition, with counts being detected on the relaxation oscillator at a rate of 40 counts per minute. Site inspection revealed that a portion of the barbed wire was within the dust path and was collecting the expected electrical charge. Visibility was estimated as one-half mile. When a local antenna was substituted at the telemetry site outside the dust cloud, no response was observed. Barbed wire extending eastward, away from the visible cloud, also showed no response.

A light truck was equipped with a similar neon lamp detector attached to a 4 foot mobile whip communications antenna, and repeatedly driven through dust clouds of various mild storms during the year. In all cases, as the wind velocity approached 20 mph and the visibility deteriorated to one-half mile, the neon lamp began to flash increasingly with the increasing concentrations of dust. Tape recordings were made of impulses from the lamp, along with observers comment on comparative visibility.

Early in the study, an acoustic sensor was fabricated with the intent of monitoring fine sand particles which were expected to impinge upon a microphone during a dust blow. Initial experiments utilizing a capacitor microphone and high pass filter met with marginal success in suppressing undesired sounds. Later a piezoelectric transducer (solid state beeper) was substituted. The PZT element proved to be a far

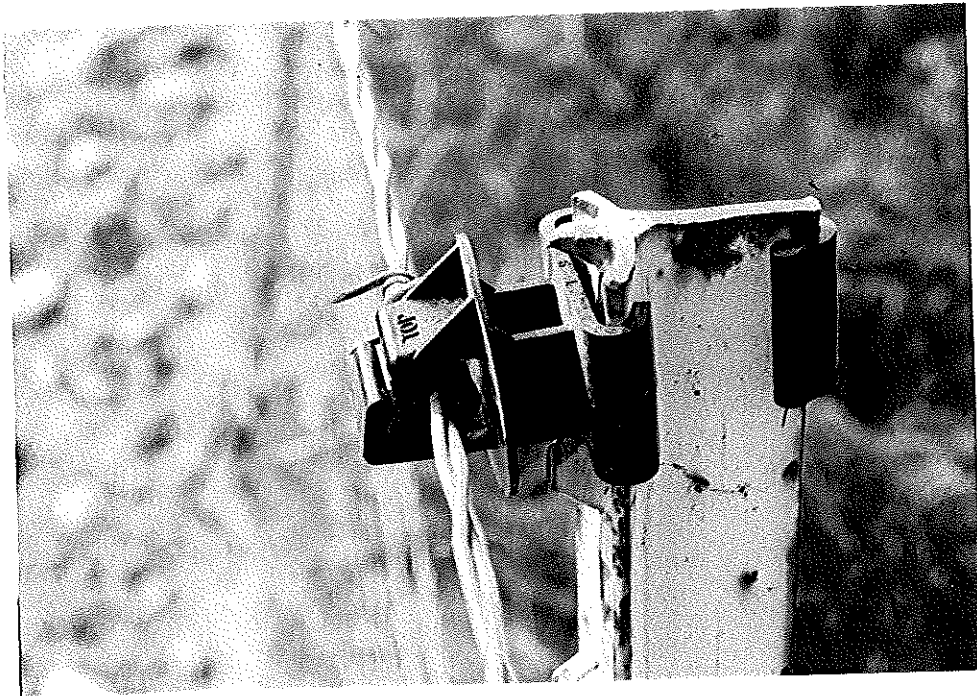

Figure 6.
Livestock Fence Insulator

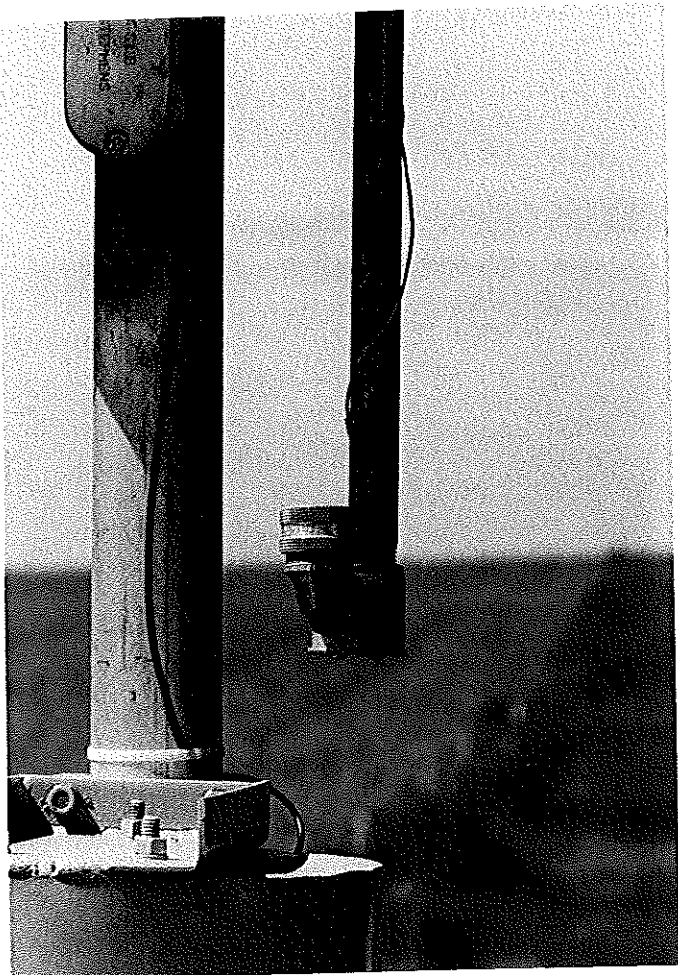

Figure 7.
Acoustic Sensor Mount

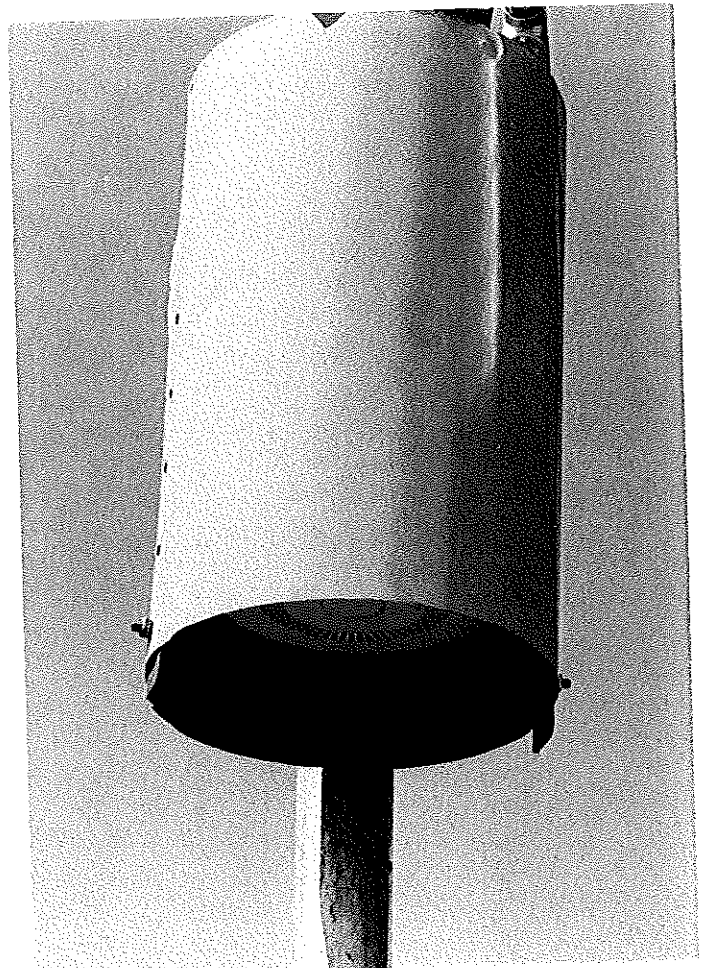

Figure 8.
Recessed Smoke Alarm Chamber

superior microphone for this application. The PZT element, which was self resonant at 6.8 kilohertz, was coupled to a bandpass amplifier tuned to 13.6 kilohertz (2nd harmonic) followed by a limiting amplifier. See Figure 4.

The PZT-amplifier combination easily rejected loud unwanted sounds such as nearby (25 feet) train and truck horns and movements, tire noise, and yelling, thumping and tampering by humans. Response to sprinkled fine sand was good, providing high counts of zero crossings which were easily discriminated from unwanted noise. Similar results were obtained with fan-blown and wind-blown sand near ground level. The fine sand grains were collected from dust storm deposits and had average diameters about five percent the size of table salt crystals. In early tests, the fine sand was blown at the acoustic sensor with a one-third horsepower squirrel-cage blower. The acoustic sensor was coupled to the remote telemetry unit and monitored for a year. Only one satisfactory response to a known dust storm was recorded. There were instances where the acoustic sensor responded to rain and dry snow, but the office computer promptly rejected those events because of the relatively low sustained count of particles. There were two instances of unexplained low counts in zero wind conditions, which may have been caused by insects walking on the sensor.

An ultrasonic 40 kHz PZT, Massa #TR-89, showed good oscilloscope sensitivity to sprinkled fine sand, and moderate rejection of undesired sounds without a bandpass amplifier. This transducer is totally enclosed in metal, and is expected to make a superior sand sensor. The ultrasonic transducer has not been field tested. Three brands of household smoke alarms were hand carried into three dust blows, and each gave alarm when exposed to visibility less than 500-700 feet. The ionization chamber from one smoke alarm was recess mounted into a cylindrical drum enclosure. Extra mounting holes were drilled to facilitate crude sensitivity adjustment by controlled exposure. The ionization chamber was interfaced to the remote unit and observed for two years. The ionization chambers were abandoned when false alarms resulted from wind disturbance of previously settled dust and from spraying of agricultural chemicals. The smoke alarms were also responsive to fog.

DISCUSSION:

Possible accident prevention measures might include:

1. Prevent or control dust cloud formation. (Irrigation).
2. Prevent or limit travel through dangerous dust clouds.
3. Increase visibility within cloud. (Lighting, Markings).
4. Warn drivers that poor visibility is ahead.
5. Instruct drivers on course of conduct.

Prevention or control of dust clouds relates to agricultural practice, especially where cultivated land abuts highways. Oregon highway



Figure 9. Passive Signing

Figure 10. 1000 Foot Visibility



Figure 11. Telemetry Site



Figure 12. Passive Signing



Figure 13. Fence Insulator

officials have occasionally requested voluntary activation of existing corporate-farm irrigation sprinklers with immediate effective results. (Accident victims have sought redress from farmers adjacent to the highway, alleging unnecessary hazard was created by poor conservation practice.) We have seen a benefit from having monitoring equipment in the field so that timely irrigation requests could be made.

Flaggers can warn drivers and control access through the dust cloud if there is awareness of the storm in time to dispatch them. The effectiveness of fixed passive signing has not been established. For examples of active and passive dust signing practices, see References 2 and 11.

Active warning signs require apparatus to detect the presence of the dust, and detectors must be placed in locations which correctly anticipate the storms. Appropriate active warning messages and their effects on motorists have not been investigated here.

CONCLUSION:

It was our goal to develop and test an inexpensive means of detecting dangerous dust clouds. The desired detector would be suitable for deployment at various locations within a broad area, such as along a ten mile stretch of highway. A secondary goal was to demonstrate that the sensor could interface with a computer by telemetry to form an automatic warning device to alert highway crews or activate variable message signs. The surprisingly simple neon relaxation oscillator used as an electrostatic voltmeter was the simplest and most reliable of sensors examined here. This device gave alarm in each of thirteen separate exposures to known dust clouds in separate locations.

The electrostatic detector authenticated by an anemometer is an effective qualitative instrument for detecting hazardous blowing dust. It will not detect motionless dust. In order to acquire the electric charge, the dust particles apparently need to be carried by the wind for a short distance. The electrostatic detector has the advantage that it does not respond to local minor puffs of dust kicked up by autos or trucks on nearby gravel or dirt roads. The detector has a slight sensitivity to blowing fine snow, but the telemetry computer can distinguish snow. The effectiveness as a quantitative measuring instrument has not been established.

The acoustic sensor was unsatisfactory on the test range, but may be of benefit where sand content is higher. The acoustic resonant piezoelectric detector is sensitive to blowing sand, and easily rejects loud vehicle noise and people sounds. However, it may be responsive to insects walking and birds calling, and to precipitation. The office computer can reject most of these undesired effects. For example, it can distinguish snow from steady blowing sand, which yields higher

sustained counts. The acoustic sensor does not respond to fine face powder dust.

The ionization sensor is generally unsatisfactory as a stand alone sensor, but could prove useful when used in conjunction with an anemometer. The ionization detector (smoke alarm) is responsive to face-powder dust, but may be fooled by agricultural spraying, smoke from field burning, pollen, fog, or secondary disturbance of previously settled dust. Brief false alarms occur when settled dust accumulated on the detector is disturbed by new wind. Local puffs kicked up by passing autos can trigger the ionization detector. Strong radio noise always accompanied nearby dust clouds. Pursuit of radio or audio detectors was curtailed because of the relative simplicity of the electrostatic detector. The demonstration of automatic incident detection capability is satisfied by the office microcomputer. The office computer can communicate with remote sign equipment by telephone modem.

RECOMMENDATIONS:

For experimental purposes, the office computer program was simply stored on cassette tape, so that it could be easily modified. This would be unsatisfactory in a permanent installation. The computer program must reside in permanent memory or be self initializing from mass-storage media so that the interpretive program need not be reloaded manually after commercial power failure. Power Failure is more likely to occur during wind storms giving rise to dust. A permanent computer should not produce radio noise in communications equipment, as was experienced during the experimental period.

An on site dust alarm for automatic incident detection and activation of a warning sign does not need the office computer to function. The program of the remote processor board could be modified to evaluate its own data and provide a contact closure or logic level when wind velocity and sensor counts exceed established thresholds.

Roadside advisory broadcasting from low power transmitters should not be used to alert drivers, unless the transmitters are well away from the affected area. The radio noise interference may mask the broadcasts.

Agricultural practices in the study area have changed greatly during the period since this study was proposed and the time of preparation of this paper. Many acres of previously untilled arid land have been placed under cultivation and irrigation by corporate farm development of Columbia River water resources. Although the capacity to automatically operate a proposed variable message sign has been demonstrated, that application is not necessarily advocated by the author. The problem remains of determining the feasibility and effectiveness of active signing over a 40 mile stretch of highway, and

in anticipating proper placement of the sensors and signs under changing agricultural usage. A current effective use of the dust alarm has been to notify highway maintenance crews of hazards and call for irrigation. The remote anemometer and thermometer announce high probability of dust hazard, and the dust alarm described above confirms the hazard in the area covered by the sensors.

The response of the electrostatic detector to lightning needs further study. Recordings were made during three vigorous Eastern Oregon lightning storms with no occurrence of sensor response. It is probable that individual lightning strokes would not produce sustained sensor counts. However, the electrification of the atmosphere associated with thunderstorms may yield sustained counts in other locales.

The ultimate appropriate length of the livestock-insulated fence line has not been determined. A five or ten mile section may be useful.

REFERENCES:

1. Study of the Effectiveness of Reduced Visibility Guidance Techniques, equipment survey, Volume 2, 1978, U. S. Federal Highway Administration publication FHWA-RD-78-116, obtainable from National Technical Information Service, Springfield, Virginia 22161.
2. User Guidelines for Reduced Visibility System Design, U.S. Federal Highway Administration Implementation Package 79-2, Apr., '79, obtainable from U.S. Government Printing Office, Washington, D.C. 20402.
3. Fox, Tom, Unique Electronic Weather Projects, paperback, Howard W. Sams & Co. publication number 21484, 1978, ISBN no. 0-672-21484-9, Library of Congress card no. 77-87332, obtainable from Howard Sams & Co., Indianapolis, Indiana 46268.
4. Herman, J. R., Precipitation Static and Blowing Snow in Antarctica, Antarctic Research and Data Analysis Scientific Report no. 5, Report no. RAD-TR-63-21, Journal Announcement USRDR3922, 31 May, '63, obtainable from National Technical Information Service.
5. Ikrath, Kurt, Interference with Aircraft Radio and Communications by Precipitation Static from Ice and Snow Clouds, final report ECOM-4319, Dec., '74, U.S. Army Electronics Command, Fort Monmoth, New Jersey. Abstract obtainable from DIALOG Information Services.
6. Barbelt, Carl, Autogeneous Electrification of a B-45 Aircraft, Wright Air Development Center technical report WADC-TR-52-34, Dec., '51, Wright Air Development Center, Wright-Patterson Air Force Base, Ohio.
7. Ikrath, Kurt, The Susceptibilities of Electrical and Magnetic Antennas to Precipitation Static Noise, final report ECOM-4319 phase 2, Dec., '74, U.S. Army Electronics Command, Fort Monmoth, New Jersey
8. Kamra, A. K., "Measurements of the Electrical Properties of Dust Storms", Journal of Geophysical Research, Vol 77, Oct. 20, '72.
9. Schmidt, R. A., A System That Measures Blowing Snow, research paper RM-194, Oct., '77, Rocky Mt. Forest and Range Experiment Station, U.S. Department of Agriculture, Fort Collins, Colorado 80521.
10. Harper, W. G., Soil Survey of the Umatilla Area, Oregon, Soil Survey series 1937, number 21, 1948, obtainable from U.S. Government Printing Office, Washington D.C. 20402.
11. Ireland, Eugene F., "Haboobs and Arizona Traffic", Western-IEE, Volume 28, Nov.-Dec., '73, published by Institute of Traffic Engineers, Western District, P.O. Box 2126, Cheyenne, Wyoming 82001.

APPENDIX I
ELECTRICAL DIAGRAMS

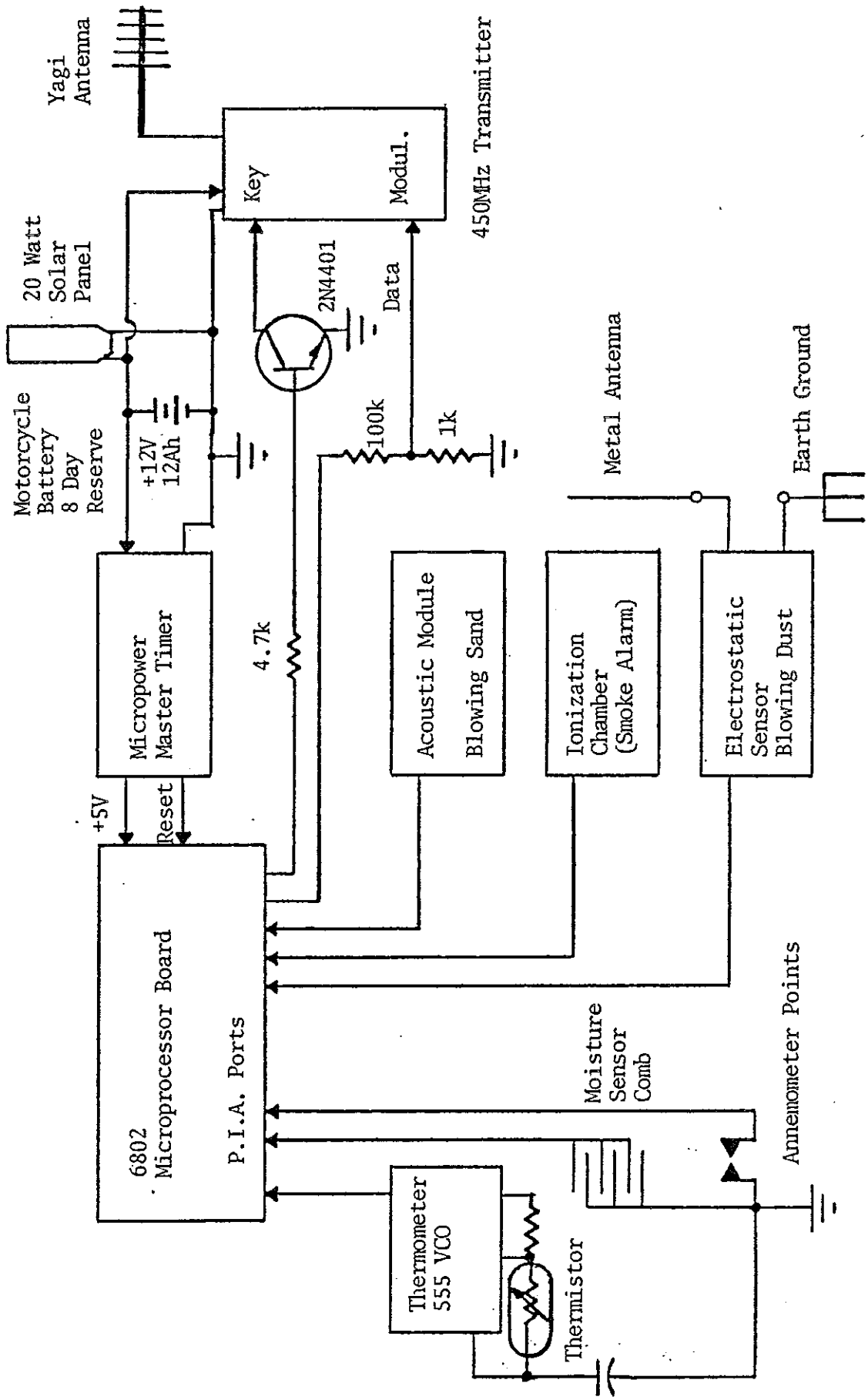

Remote Telemetry Station
Block Diagram

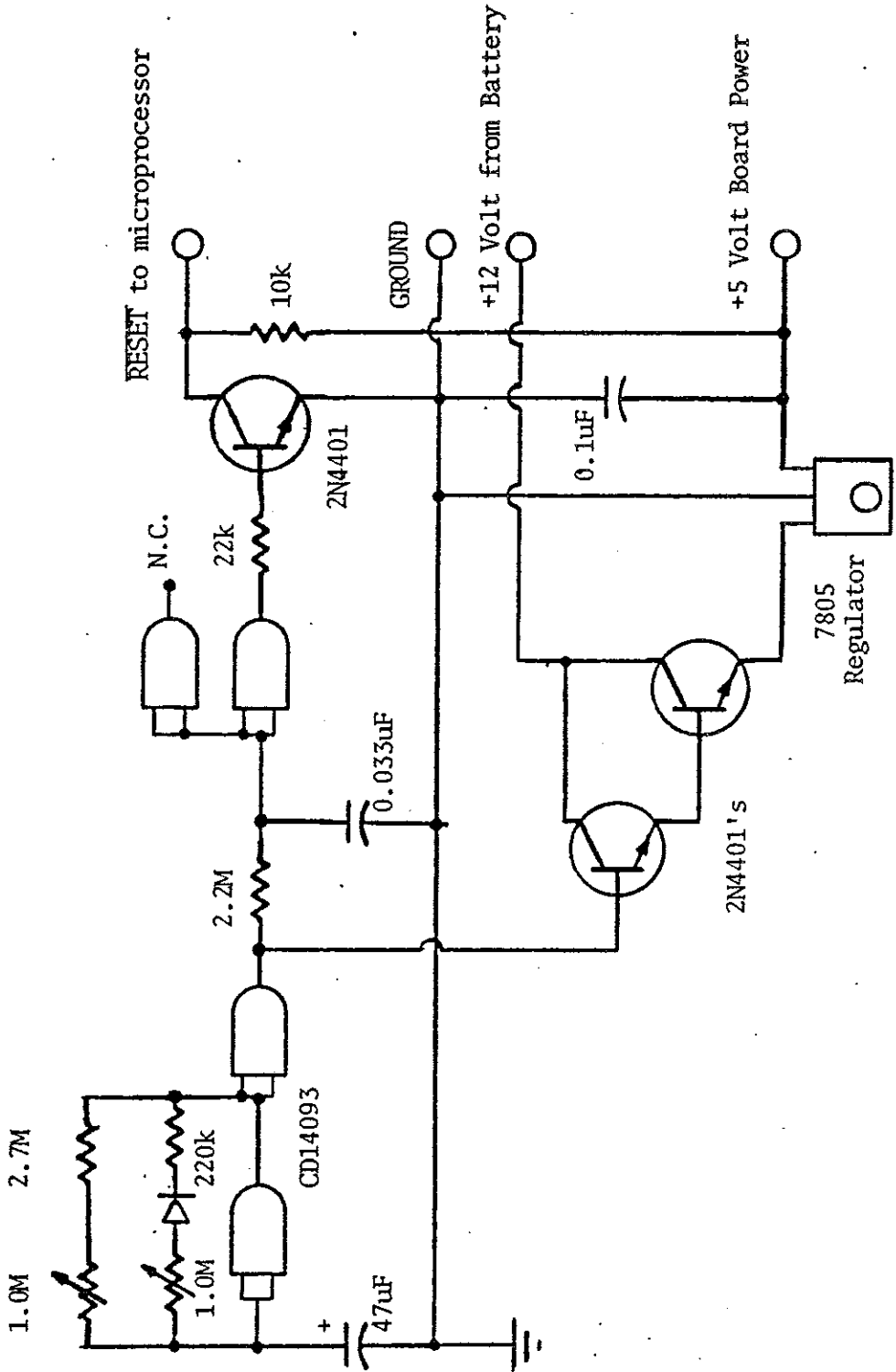

Micropower Master Timer

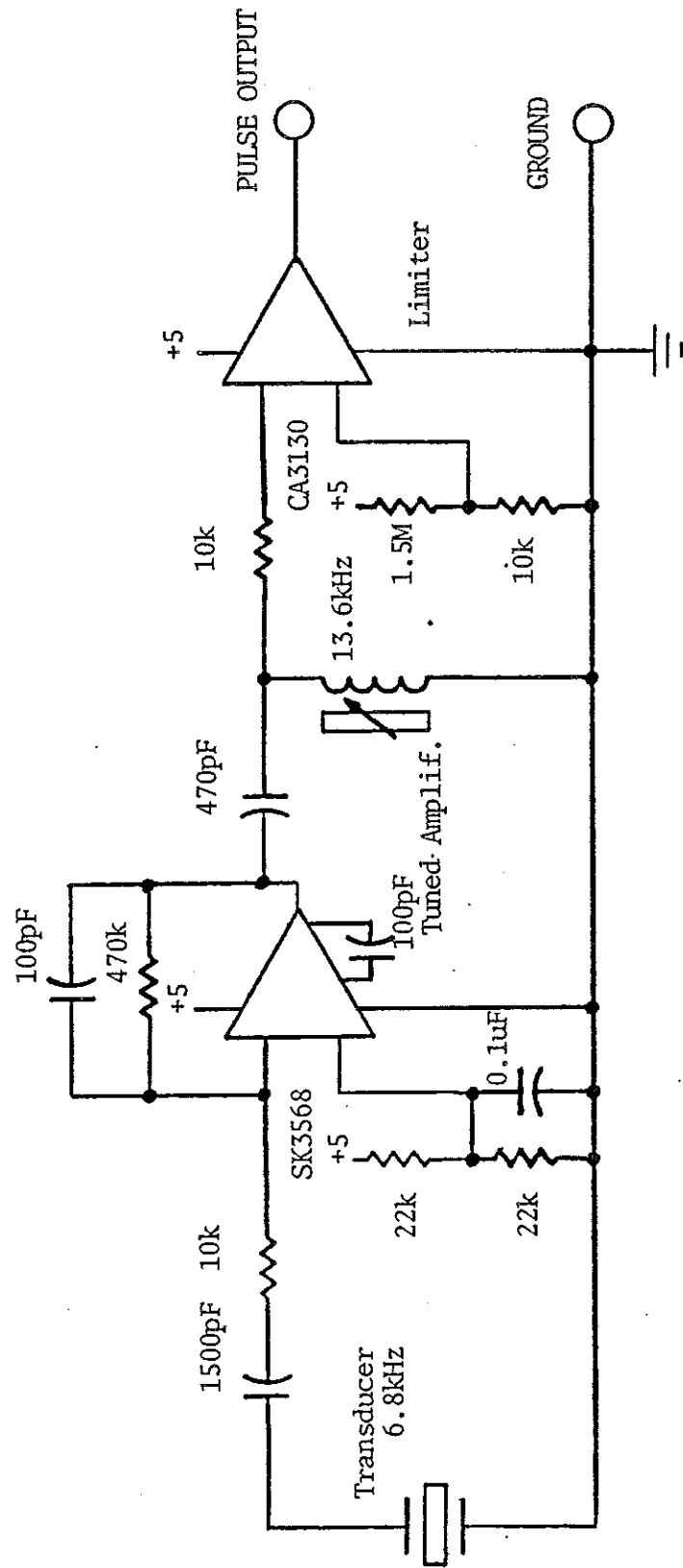

Experimental Acoustic Sensor for Blowing Sand

APPENDIX II

REMOTE PROCESSOR PROGRAM

```

*****
*           HIGHWAY HAZARD MONITOR           *
*                                           *
*   SOFTWARE FOR HERMISTON REMOTE UNIT       *
*   6802 CPU, 3.58 Mhz crystal               *
*   written by Vic Shinsel, Radio Tech II   *
*   REVISED 4/83                           *
*****

```

```

;---PROGRAM DESCRIPTION---

```

```

; The remote unit is solar powered. Every 60 seconds, a CMOS
; timer energizes and resets the microprocessor.

```

```

; The microprocessor scans a peripheral port for a three
; second sample period, acquiring data from anemometer contacts,
; a thermistor oscillator, an ionization detector, an acoustic
; or electrostatic sensor, and a moisture detector.

```

```

; At the end of the sample period, the processor transmits a
; serial report with checksum. Software emulates a 300 baud
; 103 originate modem. "M-lead" keying is provided to activate
; the radio transmission link.

```

```

; Report format is as follows;

```

```

; A leader of 75 marks, followed by an Ascii carriage return.
; 3 ascii characters for station identifier.
; 4 ascii characters for thermistor count.
; 4 ascii characters for hexadecimal anemometer count.
; 4 ascii characters for hexadecimal detector counts.
; 2 ascii characters for hexadecimal port data byte.
; 2 ascii characters for hexadecimal checksum byte.

```

```

;---PERIPHERAL INTERFACE ADAPTOR ASSIGNMENTS---

```

```

INPORT EQU    $C000           ;PIA INPUT PORT
OUTPORT EQU   $C002           ;PIA OUTPUT PORT
CRA EQU       $C001           ;CONTROL REGISTER A
CRB EQU       $C003           ;CONTROL REGISTER B

```

```

;---HARDWARE ASSIGNMENTS---

```

```

TONEBIT EQU   %00000001      ;BIT0 OUTPORT (PB0) MASK=1
TXMBIT EQU    %00000100      ;BIT2 OUTPORT (PB2) MASK=4
TEMPBIT EQU   %00000001      ;BIT0 INPORT (PA0) MASK=1
WINDBIT EQU   %00000010      ;BIT1 INPORT (PA1) MASK=2
WATRBIT EQU   %00000100      ;BIT2 INPORT (PA2) MASK=4
TINKBIT EQU   %10000000      ;BIT7 CRA (CA1) MASK=128

```

```

;---RAM ASSIGNMENTS---
BUFR  ORG    $0000      ; RAM BEGINS HERE
TEMPH DS     2          ; TEMPERATURE COUNT
TEMPL DS     2
WINDH DS     2          ; WIND COUNT
WINDL DS     2
TINKH DS     2          ; ACOUSTIC TINK COUNT
TINKL DS     2
HBYTE DS     2          ; HARDWARE STATUS
ENDBUF DS    1          ; END OF BUFFER
CKSUM  DS    1          ; CHECKSUM WORK AREA
CHAR   DS    1          ; SOFTWARE UART BUFFER
BITCOUN DS   1          ; BIT COUNTER FOR UART
ANSTAT DS    1          ; ANNEMOMETER POINTS FLAG
STACK  EQU   $7F       ; TOP OF RAM

;---PROM---
PROM   ORG    $F800      ; START OF PROM PROGRAM

;---START OF PROGRAM---
INIT   LDS    #STACK    ; PUT STACK AT RAM TOP
        CLRA                    ; INITIALIZE PIA
        STAA  CRA          ; SELECT CONTROL REGISTERS
        STAA  CRB
        STAA  INPORT       ; DEFINE PORT A=INPUT
        COMA                    ; DEFINE PORT B=OUTPUT
        STAA  OUTPORT
        LDAA  #6            ; DESELECT CRA - SETUP CA1
        STAA  CRA          ; SET BITS 1 & 2
        LDAA  #4            ; DESELECT CRB
        STAA  CRB
        LDAA  #TONEBIT     ; OUTPORT QUIESCENT:
        STAA  OUTPORT      ; TONEBIT HI, TXMBIT LO

;---MAIN PROGRAM---
MAIN   BSR    GETDATA     ; GET WIND & TINK COUNTS
        BSR    TEMP        ; GET TEMPERATURE COUNT
        BSR    ASSEMBL     ; READ PORT & ASSEMBLE REPORT
        JSR    SENDRPT     ; TRANSMIT 300 BAUD REPORT
        JSR    GETDATA     ; 3 SEC DELAY
        JSR    GETDATA     ; 3 SEC DELAY AGAIN
LOOP   BRA    MAIN        ; START OVER

;---SUBROUTINE TO MEASURE WIND & ACOUSTIC 'TINKS'---
GETDATA CLRA              ; CLEAR WIND COUNTER
        STAA  WINDH
        STAA  WINDL
        STAA  TINKH       ; CLEAR TINK COUNTER
        STAA  TINKL
        LDX  #3000        ; 3 SEC SAMPLE PERIOD
CHEKW  LDAA  INPORT       ; CHECK ANNEMOMETER POINTS
        ANDA  #WINDBIT
        CMPA  ANSTAT      ; GO IF NO CHANGE
        BEQ  NOCHANG
        STAA  ANSTAT      ; UPDATE STATUS

```

```

        BEQ     DEBOUNC      ; GO IF POINTS OPENING
        INC     WINDL      ; POINTS CLOSING-COUNT UP
        BNE     DEBOUNC      ; GO IF NO OVERFLOW
        INC     WINDH      ; COUNT OVERFLOW
DEBOUNC BSR     MSEC1      ; 1 MILLISEC DEBOUNCE
        BEQ     RET        ; GO IF 3 SEC TIMED OUT
        BSR     MSEC1      ; 1 MS MORE DEBOUNCE
        BEQ     RET
NOCHANG BSR     MSEC1
        BNE     CHEKW      ; LOOP IF MORE TIME
RET     RTS

```

;---SUBROUTINE TO WATCH FOR TINKS DURING 1MS INTERVAL---

```

MSEC1  LDAA    INPORT      ; RESET TINK LATCH BY READING IT
        LDAA    #146      ; 1MILLISEC DELAY CALIBR
WAIT1  DECA
        BNE     WAIT1
        LDAA    CRA        ; GET TINK LATCH
        ANDA   #TINKBIT   ; WAS IT TRIPPED?
        BEQ    TIMER3     ; GO IF NO TINK DETECTED
        INC    TINKL      ; COUNT TINKS
        BNE    TIMER3     ; GO IF NO OVERFLOW
        INC    TINKH      ; COUNT OVERFLOW
TIMER3 DEX        ; ADVANCE 3 SEC TIMER
        RTS             ; RETURN WITH TIMER FLAG

```

;---SUBROUTINE TO MEASURE TEMP OSC PERIOD

```

TEMP   LDX     #0          ; CLEAR COUNTER
WAITHI LDAA    INPORT      ; LOOK AT THERMISTOR SIGNAL
        BITA   #TEMPBIT
        BEQ    WAITHI     ; WAIT FOR +EDGE OF WAVEFORM
WAITLO LDAA    INPORT      ; LOOK AGAIN
        BITA   #TEMPBIT
        BNE    WAITLO     ; WAIT FOR -EDGE OF WAVEFORM
CNTUP  INX
        LDAA    INPORT
        BITA   #TEMPBIT   ; WHILE SIGNAL REMAINS LOW
        BEQ    CNTUP
        STX    TEMPH      ; SAVE TEMPERATURE COUNT
        RTS

```

;---SUBROUTINE TO ASSEMBLE REPORT---

```

ASSEMBL LDAA    INPORT      ; LOOK AT HARDWARE SIGNALS
        STAA   HBYTE      ; SAVE A COPY
        LDX   #BUFR      ; POINT AT BUFFER START
        BSR   ASCON      ; CONV TEMP (HEX TO ASCII)
        BSR   ASCON      ; CONV WIND
        BSR   ASCON      ; CONV TINK
        BSR   ASCON      ; CONV HBYTE
        LDAA  #3          ; INSTALL END OF TEXT MARK
        STAA  ENDBUF

```

```

;---CALCULATE CHECKSUM---
CHEKSUM CLRA          ;CLEAR CHECKSUM REGISTER
                    LDX      #BUFR      ;POINT AT START OF BUFFER
SUMMATE ADDA         0,X          ;ADD CHARACTER VALUE
                    INX          ;POINT AT NEXT CHAR
                    CPX      #ENDBUF   ;SEE IF LAST CHAR
                    BNE      SUMMATE   ;LOOP IF MORE CHAR
                    STAA     CKSUM     ;STORE CHECKSUM BEHIND BUFFER

```

```

;---CONVERT HEX BYTES TO ASCII---
ASCON  LDAA         1,X          ;GET LSB HEX BYTE
        PSHA        ;SAVE A COPY
        LDAA         0,X          ;GET MSB HEX BYTE
        BSR         CNVRT2       ;GO CONVERT HEX TO ASCII
        PULA        ;GET LSB BYTE AGAIN
CNVRT2  PSHA        ;SAVE A COPY
        LSRA        ;SHIFT MSB NYBL INTO LSB NYBL
        LSRA
        LSRA
        LSRA
        BSR         CNVRT1       ;CONVERT MSB NYBBLE
        PULA        ;GET LSB NYBBLE
CNVRT1  ANDA        #0F          ;MASK IT
        ADDA        #'0'        ;CONVERT 0-9 TO ASCII
        CMPA        #'9'        ;CHECK FOR A-F
        BLS         STOW
        ADDA        #7          ;CONVERT A-F TO ASCII
STOW    STAA        0,X          ;STOW ASCII CHAR IN BUFFER
        INX          ;POINT TO NEXT BUFFER SPOT
        RTS

```

```

;---SUBROUTINE TO SEND SERIAL DATA REPORT---
SENDRPT LDAA        OUTPUT      ;KEY TX 'M' LEAD
        ORAA        #TXMBIT     ;MAKE IT HI STATE
        STAA        OUTPUT
        LDAA        #75         ;75 MARKS LEADER
LEADR   PSHA
        BSR         MARK        ;SEND LEADER
        PULA        ;LOOP IF MORE LEADER
        DECA
        BNE        LEADR

IDENT  LDX          #IDMSG       ;POINT AT IDENT MESSAGE
        BSR         MSGOUT      ;SEND MESSAGE
        LDX          #BUFR      ;POINT AT REPORT BUFFER
        BSR         MSGOUT      ;SEND REPORT
        LDX          #CKSUM     ;POINT AT CHECKSUM BYTE
        BSR         CHAROUT     ;SEND CHEKSUM
        LDAA        #TONEBIT    ;KILL TX 'M' LEAD & TONE
        STAA        OUTPUT
        RTS

```

```

MSGOUT  LDAA    0,X          ;GET CURRENT CHAR INTO BUFFER
        STAA    CHAR
        CMPA    #3         ;END OF TEXT MARK?
        BEQ     RET1       ;DONE IF ETX
        BSR     CHAROUT    ;SEND CHARACTER TO MODEM
        INX
        BRA     MSGOUT     ;NEXT CHAR
                          ;LOOP FOR MORE

;---300 BAUD SOFTWARE MODEM---
CHAROUT BSR     SPACE      ;SEND A SPACE ('STOP' PULSE)
        LDAA    #8        ;8 ASCII BITS
        STAA    BITCOUN    ;SAVE BIT COUNT
SHIFT   ROR     CHAR       ;SHIFT BIT OUT
        BCC     ZERO       ;GO IF SPACE
        BSR     MARK       ;SEND A MARK
        BRA     COUNT      ;ONE LESS BIT
ZERO    BSR     SPACE      ;SEND A SPACE
COUNT  DEC     BITCOUN    ;LOOP IF MORE BITS
        BNE     SHIFT
MARKS   BSR     MARK       ;SEND 2 MARKS ('STOP' PULSE)

MARK    LDAB    #15        ;FOR 15 HALF CYCLES--
MRKTONE LDAA    OUTPORT    ;MAKE MARK TONE (2225 HZ)
        EORA    #TONEBIT   ;FLIP TONE BIT OVER
        STAA    OUTPORT
        LDAA    #30        ;225 MICROSEC CALIBR
HALFCY1 DECA
        BNE     HALFCY1
        DECB
        BNE     MRKTONE
RET1    RTS

SPACE   LDAB    #13        ;FOR 13 HALF CYCLES--
SPCTONE LDAA    OUTPORT    ;MAKE SPACE TONE (2025 HZ)
        EORA    #TONEBIT   ;FLIP TONE BIT
        STAA    OUTPORT
        LDAA    #33        ;247 MICROSEC CALIB
HALFCY2 DECA
        BNE     HALFCY2
        DECB
        BNE     SPCTONE
        RTS

;---ID MESSAGE STRING---
IDMSG   DB      13        ;CARRIAGE RETURN
        DB      'HRM'     ;HERMISTON IDENTIFIER
        DB      3         ;END OF TEXT MARKER

;---DEFINE RESET VECTOR---
        ORG     $FFFE     ;POWER-ON RESET LOOKS HERE
RESET   DB      FROM     ;FOR FROM ADDRESS
END     END              ;END OF PROGRAM

```

APPENDIX III

OFFICE COMPUTER PROGRAM EXAMPLES

('I' SYMBOL REPRESENTS EXPONENT IN THIS LISTING)

```
1000 *****
1010 * OREGON STATE HIGHWAY DIVISION *
1020 * DISPLAY SOFTWARE FOR *
1030 * DUST HAZARD MONITOR *
1040 * REVISED 4/12/83, VIC SHINSEL *
1050 * THIS VERSION FOR TRS-80 MOD 1 *
1060 *****
1070 :
1080 REM LOG ON SYSTEM
1090 CLEAR 300
1100 ON ERROR GOTO 2820
1110 CLS:PRINT:PRINT "USE MEMSIZE 32500."
1120 FOR JJ=1 TO 1000:NEXT
1130 CLS:GOSUB 2480 :PRINT TI$:PRINT:PRINT:PRINT
1140 PRINT"DATE & TIME CORRECT? (Y/N)"
1150 YN#=INKEY$:IF YN#="N" GOSUB 2540 :GOTO 1130
1160 IF YN#<>"Y" GOTO 1150
1170 :
1180 REM SERIAL PORT INITIALIZATION
1190 ' FOR PROPRIETARY MICRO CONNECTION MODEM
1200 OUT 209,7:FOR J=1 TO 10:NEXT:OUT 209,64:OUT 209,78:OUT 209,7
1210 :
1220 REM INSTALL USER CODE FOR MODEM
1230 FOR J=32512 TO 32589:REM FROM 7FOOH TO 7F4DH
1240 READ K:POKE J,K:NEXT
1250 DATA 217,33,78,127,54,77,17,64,156,14,70,219
1260 DATA 209,203,79,32,13,27,123,178,32,245,17,64
1270 DATA 156,13,32,239,217,201,219,208,230,127,254
1280 DATA 13,32,15,33,78,127,119,6,20,245,58,78
1290 DATA 127,254,13,241,32,214,119,35,16,210,62,0
1300 DATA 6,20,33,78,127,134,35,16,252,190,62,71
1310 DATA 40,2,62,66,119,217,201
1320 POKE 16526,0:POKE 16527,127:REM USER VECTOR TO 7FOOH
1330 BU=32590 :REM REC. BUFFER ADDRESS, 7F4EH
1340 :
1350 REM OPTIONS
1360 AB=1: REM ENABLE ALARM BEEPER
1370 :
1380 REM MAIN PROGRAM ENTRY
1390 CLS:PRINT
1400 PRINT"I AM WAITING FOR DATA FROM REMOTE SITES."
1410 :
1420 REM MAIN PROGRAM LOOP--LISTEN FOR TELEMETRY STATION
1430 JJ=INP(208):REM FLUSH UART'S RECEIVE BUFFER
1440 Z=USR(Z) :REM GET TELEMETRY DATA, CALL 7FOOH
1450 POKE 15400,PEEK(BU) :REM COPY ERROR FLAG TO SCREEN
1460 GOSUB 2710 :REM VALIDATE CHECKSUM
1470 POKE 15400,ASC(LEFT$(E$,1)) :REM DISPLAY POLL FLAG
1480 GOSUB 2480 :REM GET TIME & DATE
1490 IF E#="G" AND DT=11 LG#="RESTORED -":LPRINT LG$:TI#
1500 IF E#="G" THEN DT=0:LP#=MI# :REM RESET DROPOUT TIMER
1510 IF E#="G" THEN 1570 :REM GO PROCESS GOOD DATA
1520 IF LP#<>MI# THEN LP#=MI#:DT=DT+1 :REM ADV DROPOUT TIMER
1530 IF DT>10 THEN DT=11
1540 IF DT<>10 THEN 1420 :REM BAD DATA, GO LISTEN AGAIN
1550 CLS:DT=11:LG#="SIGNAL DROPOUT-":PRINT LG$:TI#
```



```

1560 :
1570 REM COPY GOOD DATA FROM RECEIVE BUFFER TO M#
1580 M#="":FOR J=1 TO 19:M#=M#+CHR$(PEEK(BU+J)):NEXT
1590 :
1600 REM IDENTIFY REMOTE UNIT
1610 ID#=LEFT$(M#,3)
1620 IF ID#="HRM" THEN ID#="STANFIELD" :GOTO 1660
1630 IF ID#="CAB " THEN ID#="CABBAGE HILL":E#="T":GOTO 1660
1640 E#="N":GOTO 1470 : REM ID ERROR
1650 :
1660 REM PARSE FIELDS & CNVRT TO DECIMAL
1670 FI=BU+4 :GOSUB 2210 :T=FX:REM TEMPERATURE
1680 FI=BU+8 :GOSUB 2210 :W=FX:REM WIND
1690 FI=BU+12:GOSUB 2210 :A=FX:REM ACOUSTIC
1700 IF A<0 OR A>1000 THEN E#="0" :GOTO 1420 :REM OVER RANGE
1710 :
1720 REM SEPARATE AND CONVERT PARALLEL DATA PORT INFO
1730 P1=PEEK(BU+17)--48:IF P1 >9 P1=P1-7
1740 P2=PEEK(BU+18)--48:IF P2 >9 P2=P2-7
1750 DW#="DRY":IF P1 AND 4 THEN DW#="WET"
1760 QN#=STR$(A)
1770 :
1780 REM TEMPERATURE CALIBRATION & INTERPOLATION
1790 IF ID#<>"STANFIELD" THEN E#="N":GOTO 1470 :REM NOT CALIB
1800 IF T<50 OR T>800 THEN E#="0":GOTO 1470 :REM OVER RANGE
1810 IF T< 85 THEN T=626.032*TI-.412765 :GOTO 1860
1820 IF T< 139 THEN T=722.121*TI-.445458 :GOTO 1860
1830 IF T< 249 THEN T=1399 *TI-.579455 :GOTO 1860
1840 IF T< 395 THEN T=3514.27*TI-.748473 :GOTO 1860
1850 T=35532.1*TI-1.13665
1860 T=INT(T*10+.5)/10 :REM ROUND OFF TEMPERATURE
1870 :
1880 REM WIND CALIBRATION
1890 IF W<0 OR W>300 THEN E#="0":GOTO 1470 :REM OVER RANGE
1900 IF W=1 THEN W=0 :REM THRESHOLD
1910 W=3.3333*W/3.1
1920 W=INT(W+.5) :REM ROUND OFF WIND
1930 :
1940 REM INTERPRETATION OF DATA
1950 CX#="GREEN":GOSUB 2480 :REM GET TIME
1960 IF W >18 CX#="YELLOW"
1970 IF W>18 AND DW#="DRY" AND A>1 THEN CX#="RED"
1980 GOSUB 2640 :REM CONSTRUCT LOG MESSAGE
1990 :
2000 REM DISPOSITION
2010 IF LEFT$(CX#,1)="R" GOSUB 2330 ELSE IF CR>0 CR=CR-1
2020 IF LEFT$(CX#,1)="Y" GOSUB 2440
2030 IF A>0 LPRINT LB#
2040 GOSUB 2260 : REM BEEP AT NOON

```

```

2050 :
2060 REM WRITE REPORT ON TV SCREEN
2070 CLS:PRINT CHR$(28);"CONDITION: ";CX$;TAB(43);M$
2080 PRINT@ 192;"STATION";TAB(15);"COND";TAB(25);"TEMP";
2081 PRINT TAB(35);"WIND";TAB(55);"SENSOR"
2090 FOR JJ=1 TO 12:PRINT"-----";:NEXT:PRINT
2100 PRINT ID$;TAB(16);DW$;TAB(25);T;TAB(35);W;TAB(55);QN$
2110 PRINT@580,
2120 IF AB<>1 THEN PRINT"* ALARM BEEPER DISABLED"
2130 IF A>0 THEN PRINT"* ELECTROSTATIC CHARGE DETECTED"
2140 IF A>4 THEN PRINT"* RAPID CHARGE ACCUMULATION"
2150 IF W>18 THEN PRINT"* HIGH WINDS"
2160 IF DW$="WET"AND T>31 AND T<34 THEN PRINT"* ICE POSSIBLE"
2170 IF DW$="DRY" AND T<32 THEN PRINT"* FREEZING"
2180 PRINT@ 984;"LAST DATA REC'D: ";TI$;
2190 GOTO 1420
2200 :
2210 REM SUBROUTINE TO CONVERT ASCII HEX TO DECIMAL
2220 FX=0:FOR N=0 TO 3
2230 Z=PEEK(FI+N)-48:IF Z>9 THEN Z=Z-7
2240 FX=FX+Z*16[(3-N):NEXT:RETURN
2250 :
2260 REM BEEP AND LOG NOONTIME DATA
2270 IF HR$<"11" OR VAL(MI$)<56 OR PM$<>"AM" THEN RETURN
2280 GOSUB 2480 :IF MI$>"00" THEN 2280
2290 CLS:PRINT CHR$(23);"NOON CHECK...";LPRINT CHR$(7);
2300 FOR JJ=1 TO 3000:NEXT
2310 GOSUB 2640 :LPRINT LG$:RETURN
2320 :
2330 REM PROCEDURE FOR CONDITION RED
2340 CR=CR+1
2350 IF CR= 1 THEN LPRINT LG$:RETURN
2360 IF CR=10 THEN LPRINT LG$:CR=5
2370 FOR RR=1 TO 3
2380 :CLS:PRINT CHR$(23);"CONDITION RED! BLOWING DUST!"
2390 :IF AB=1 AND CR<4 THEN LPRINT CHR$(7); 'SOUND ALARM!
2400 :FOR JJ=1 TO 500:NEXT:CLS:FOR JJ=1 TO 300:NEXT
2410 NEXT RR
2420 RETURN
2430 :
2440 REM PROCEDURE FOR CONDITION YELLOW
2450 CY=CY+1:IF CY>14 THEN CY=0:LPRINT LG$
2460 RETURN

```

```

2470 :
2480 REM READ TIME DATE
2490 'PROPRIETARY CODE TO READ REAL TIME CLOCK
2500 'INTO VARIABLES SHOULD BE PLACED HERE.
2510 GOSUB 2540 'DUMMY TIME VARIABLES
2520 RETURN
2530 :
2540 REM SET TIME DATE
2550 'PROPRIETARY CODE TO INITIALIZE REAL TIME CLOCK
2560 'AND DAILY CALENDAR SHOULD BE PLACED HERE.
2570 'WE USED ALPHA TIMEDATE 80 CLOCK
2580 'AND ACCOMPANYING SOFTWARE.
2590 'DUMMY VARIABLES FOLLOW....
2600 TI$="CLOCK DISABLED"
2610 YR$="0";MO$="0";DA$="0";HR$="0";MI$="0"
2620 PM$="PM"
2630 RETURN
2640 :
2650 REM CONSTRUCT LOG MESSAGE
2660 LG$=LEFT$(CX$,1)
2670 LG$=LG$+" "+TI$+" "+M$+" "+DW$+" "+QN$+" T"+STR$(T)+" W"+STR$(W)
2680 RETURN
2690 :
2700 REM CHECKSUM VERIFICATION
2710 CSUM=0:FOR JJ=0 TO 17
2720 CSUM=CSUM+PEEK(BU+JJ):NEXT JJ
2730 IF CSUM>255 THEN CSUM=CSUM-256:GOTO 2730
2740 N=PEEK(BU+19)-48:IF N>9 THEN N=N-7
2750 RSUM=N
2760 N=PEEK(BU+18)-48:IF N>9 THEN N=N-7
2770 RSUM = RSUM+16*N
2780 IF CSUM=RSUM THEN E$="G" ELSE E$="C"
2790 RETURN
2800 :
2810 :REM RUN TIME ERROR PROCESSING
2820 CLS:PRINT "ERROR";ERR;"IN LINE";ERL"
2830 FOR JJ=1 TO 3000:NEXT
2840 RESUME 1420

```

```

; *****
; * USER CODE FOR OFFICE COMPUTER *
; * TRS-80 BASIC INTERPRETER *
; *****

```

```

; This user code is called by the BASIC program which resides in the
; office computer. The purpose of this program is to check status of
; the serial modem port, and fill a buffer with the data collected by
; the remote telemetry unit. The checksum is validated, and then control
; is returned to the BASIC program for interpretation & logging of data.
;

```

```

; The buffer is at memory location 32590d (7F4Eh), and consists of 19
; ascii characters.

```

```

SECAL    EQU    40000    ; 1 SECONND CALIBRATION
TIME     EQU    10      ; 10 SEC LISTENING TIME
DPORT    EQU    208     ; UART RECEIVE DATA PORT
SPORT    EQU    209     ; UART RECEIVE STATUS PORT

START    ORG    7F00H    ; USER PROGRAM BEGINS HERE
        EXX
        LD     HL,BUFFER ; POINT AT BUFFER
        LD     (HL),'M'   ; BUFFER EMPTY FLAG
        LD     DE,SECAL   ; LOAD 1 SEC TIMER
        LD     C,TIME     ; LOAD 10 SEC LISTEN TIMER
CHECK    IN     A,(SPORT) ; CHECK UART STATUS PORT
        BIT    1,A        ; ANY CHARACTER RECEIVED?
        JR     NZ,GOTCHAR# ; yes: GO PROCESS CHAR.
        DEC   DE          ; no : COUNTDOWN 1 SEC TIMER
        LD     A,E        ; 1 SEC EXPIRED?
        OR    D
        JR     NZ,CHECK-# ; no : CONTINUE CHECKING STATUS
        LD     DE,SECAL   ; yes: RESET 1 SEC TIMER
        DEC   C           ; 10 SEC EXPIRED?
        JR     NZ,CHECK-# ; no : CONTINUE CHECKING STATUS
EXPIRE   JP     DONE      ; yes: RETURN TO BASIC PROGRAM

GOTCHAR  IN     A,DPORT    ; GET UART CHARACTER
        AND   7Fh        ; STRIP PARITY
        CP    13         ; IS IT CARRIAGE RETURN?
        JR     NZ,CONFIRM-# ; no : GO SEE IF CR IS IN PLACE
        LD     HL,BUFFR   ; yes: POINT AT START OF BUFFER
        LD     (HL),A     ; PUT CR IN BUFFER
        LD     B,20       ; SET BUFFER SIZE
CONFIRM  PUSH   AF
        LD     A,(BUFFR) ; CONFIRM 1ST CR IS IN BUFFER
        CP    13
        POP   AF
        JR     NZ,CHECK-# ; RESTART IF 1ST CR ABSENT
PUTBUF   LD     (HL),A     ; PUT CHARACTER IN BUFFER
        INC   HL          ; POINT AT NEXT BUFFER LOCATION
        DJNZ  CHECK-#     ; CONTINUE UNTIL BUFFER FULL
CKSUM    LD     A,0        ; CLEAR CHECKSUM COUNT
        LD     B,20       ; NUMBER OF BYTES TO SUM
        LD     HL,BUFFR   ; POINT AT BUFFER START

```

```

CALC    ADD    A, (HL)    ; CALCULATE CHECKSUM
        INC    HL
        DJNZ   CALC-#
        CP     (HL)      ; COMPARE AGAINST RCVD CHECKSUM
        LD     A, 'G'    ; FLAG GOOD CHECKSUM
        JR     Z, DONE-# ; DONE IF GOOD CHECKSUM
        LD     A, 'B'    ; FLAG BAD CHECKSUM
DONE     LD     (HL), A   ; PUT FLAG IN BUFFER
        EXX
        RET
        ; RESTORE REGISTERS
        ; RETURN TO BASIC PROGRAM

        ORG    32590     ; DEFINE BUFFER LOCATION
BUFFR   DS    20
END

```

B>