

1. Report No. DOT/FAA-AM-86-	2. Government Accession No.	3. Recipient's Catalog No.	
4. Title and Subtitle INHALATION TOXICOLOGY: V. EVALUATION OF RELATIVE TOXICITY TO RATS OF THERMAL DECOMPOSITION PRODUCTS FROM TWO AIRCRAFT SEAT FIRE-BLOCKING MATERIALS		5. Report Date NOVEMBER 1985	
		6. Performing Organization Code AAM-114	
7. Author(s) Donald C. Sanders, Charles R. Crane, and Boyd R. Endecott		8. Performing Organization Report No. FAA-AM-85-	
9. Performing Organization Name and Address FAA Civil Aeromedical Institute P.O. Box 25082 Oklahoma City, OK 73125		10. Work Unit No. (TRAIS)	
		11. Contract or Grant No.	
12. Sponsoring Agency Name and Address Office of Aviation Medicine Federal Aviation Administration 800 Independence Ave., SW Washington, D.C. 20591		13. Type of Report and Period Covered OAM Report, October 1983 to September 1984	
		14. Sponsoring Agency Code Task AM-B-84-TOX-43	
15. Supplementary Notes This work was performed under task AM-B-84-TOX-43.		<i>Hint of cabin - fire + the pr. Aircraft - Seats - "</i>	
<p>16. Abstract Two fire-blocking layer (FBL) materials, designed to delay the thermal decomposition of polyurethane foam seat cushions during an aircraft cabin fire, were evaluated for the relative toxicity of their gaseous combustion products. Each material was thermally decomposed under five distinct thermal environments: two contact temperatures (600 and 750 °C) in a horizontal hot tube furnace and three flux levels (2.5, 5.0, and 7.5 W/cm²) in a radiant heat furnace. The measured toxicological endpoint was time-to-incapacitation (ti) in the albino rat; this endpoint is believed to be the most relevant one for assessing smoke hazard in a fire environment.</p> <p>In three of the five test environments, Norfab, an aluminized synthetic fabric, produced shorter t_i's--and was thus more toxic--than Vonar, a neoprene foam. However, at 2.5 W/cm² in the radiant furnace system, the Norfab test specimen lost only 13 percent of the sample weight and did not incapacitate any of the test animals during the exposure period and, at 750 °C (flaming) in the combustion tube assembly, Norfab produced longer and more variable t_i's than did Vonar.</p> <p>Hydrogen cyanide (HCN) was detected in the combustion products from Norfab under all test conditions except the 2.5 W/cm² radiant flux level; no HCN was detected in the combustion products from any of the Vonar tests. Since Norfab routinely produced lower concentrations of carbon monoxide than did Vonar under all test conditions, the greater apparent toxicity (shorter ti's) of Norfab would appear to be caused by the cyanide production.</p>			
7. Key Words Inhalation toxicology; fire-blocking Layers; cabin fires; seat cushions; time-to-incapacitation; animal exposure systems		18. Distribution Statement Document is available to the public through the National Technical Information Service, Springfield, VA 22161.	
9. Security Classif. (of this report) Unclassified	20. Security Classif. (of this page) Unclassified	21. No. of Pages 13	22. Price

INHALATION TOXICOLOGY: V. EVALUATION OF RELATIVE
TOXICITY TO RATS OF THERMAL DECOMPOSITION PRODUCTS
FROM TWO AIRCRAFT SEAT FIRE-BLOCKING MATERIALS

INTRODUCTION

The ubiquitous flexible polyurethane foam has perhaps achieved wider acceptance by the transportation industry for upholstering seats in various mass transit vehicles than any other commercial cushioning polymer. Aircraft manufacturers, in particular, have been appreciative of polyurethane's light weight, excellent mechanical characteristics, and low cost. Indeed, the seat cushions, backs, and headrests of an average 200-seat commercial transport aircraft cabin contain about 640 ft³ (1,200 lb) of fire-retarded polyurethane foam (6). Unfortunately, polyurethane is thermally quite sensitive and begins to decompose at temperatures as low as 250 °C, producing relatively high yields of combustible and toxic gases and posing a potential threat to safety in fire situations aboard aircraft, in subway vehicles, or in any other closed environment. Fire retardants that can be incorporated into the foam itself are only marginally effective in suppressing combustible vapor formation when polyurethane foam is exposed to a sustained high heat flux, and the possible substitutes for polyurethane that can be made sufficiently fire resistant to inhibit flame propagation and flashover (phenolics, polyimides, and polybenzimidazoles) all suffer from prohibitive limitations of comfort, durability, and cost (6).

With the options of fire retardants and substitute cushioning materials considered ineffective or impractical, safety considerations have led to the fire-blocking-layer (FBL) concept. This involves covering the thermally sensitive polyurethane foam cushions with a layer of a fire-resistant, high-char-yield polymer that would be slowly consumed but would delay the fire involvement of the polyurethane. Tests conducted by the Federal Aviation Administration (FAA) have shown that certain FBL materials are effective in containing (or delaying the release of) combustible molten and gaseous polyurethane products inside the cushion, thereby increasing passenger escape time and thus survival in a potential fire situation (1,5,6). The new flammability performance requirements for aircraft seat cushions are based on the performance attained by FBL construction (4).

The purpose of this study was twofold: (i) to examine, under defined laboratory test conditions, the relative toxicity of the combustion products of two of these FBL materials and (ii) to make an initial evaluation of a new combustion/exposure assembly that decomposes test samples by radiant heat from one side only, a directional heat flux likely to be encountered by panels, seat cushions, and other flat surfaces during a cabin fire.

Both the FBL materials examined had been found to provide similar thermal protection in both small-scale laboratory tests and large-scale (Cabin Fire Simulator) studies (1,6). One material, Vonar, is a high-char-yield neoprene foam that cools the heated zone by emission of water vapor as it decomposes.

This foam is relatively heavy, requiring about 4 lb to cover the polyurethane foam cushion and seat back in an aircraft seat. The second material, Norfab, is a composite fabric bonded to an aluminum foil layer that slows flame propagation by containing the molten polyurethane inside the seat cushions. It carries a lesser weight penalty than Vonar (6). The acceptable performance of these materials as fire-blocking layers made it desirable to determine whether any unusual toxic hazard was likely to arise from their use in transport aircraft.

We have noted previously that marked variations in the composition and toxicity of combustion gases can occur when polymeric materials are decomposed under different thermal conditions. The combustion/exposure system used at the Civil Aeromedical Institute for several years pyrolyzes sample material inside a quartz combustion tube encircled by a small furnace and has enabled us to test materials at different temperatures, as well as under flaming or nonflaming conditions (2,3). Radiant heat from this furnace impinges on the sample from the perimeter of the combustion tube, and conductive heat is transferred to the sample through the quartz combustion boat, thereby causing rapid and complete pyrolysis. These laboratory pyrolysis conditions may or may not be duplicated in a "real" cabin fire. In a large-scale fire, flat surfaces such as seat cushions and panels are more likely to be exposed initially to unidirectional radiant heat from some single source than to the omnidirectional radiant and conductive heating conditions found in the combustion tube.

To duplicate, as closely as possible, these hypothetical "real" fire conditions and thus to assess more accurately the potential toxic hazard of the FBL materials, we designed and constructed a combustion/exposure assembly that pyrolyzes flat materials by radiant heat directed onto the upper surface of the sample only. The relative toxicity of the combustion gases was measured by determining time-to-incapacitation (ti) in the laboratory rat, the same endpoint that was used in the older (and smaller) combustion tube assembly.

In this study, we tested equivalent samples of the same FBL materials in both systems to determine the effect of the two pyrolysis methods on relative toxicity. Sample equivalency for the two combustion/exposure systems, which differ over twentyfold in volume, was based on the ratio of sample surface area to chamber volume, instead of the more familiar weight-to-volume concept, a modification based on the end-use requirement for equal surface areas of each of the FBL materials.

MATERIALS AND TEST SYSTEMS

Animals. Albino rats of Sprague-Dawley origin were obtained from the Charles River Breeding Laboratories, Wilmington, MA. They were ordered in a weight range of 100 to 120 g and were held in isolation for 8 days prior to use. All were maintained for 4 days on drinking water containing 1.5 g/L of sulfathiazole, then normal tap water for the remaining 4 days of isolation.

Rats were fasted overnight before testing to establish an equivalent metabolic state, and each animal was weighed and marked with an identifying color code just before use.

Test Materials. The two materials investigated were previously determined to be acceptable when tested as fire-blocking layers over polyurethane foam cushions (1,6). Material descriptions are as follows.

Norfab 11HT-26-A1: This material is a woven composite of 70 percent Kevlar (poly(p-phenyleneterephthalamide)), 25 percent Nomex (poly(imino-1,3-phenyleneiminocarbonyl-1,3-phenylenecarbonyl)), and 5 percent Kynol (novolak, a phenol-formaldehyde polymer). One side of the fabric is bonded to an aluminum foil layer; the finished material weight is 0.40 kg/m². This composite is representative of the aluminized, char-forming, **high-temperature-resistant**, reradiation-cooling type of materials. The supplier was Amatex Corp., 1032 Stonebridge St., Norristown, PA.

Vonar-3: This material is a 3/16-inch-thick neoprene (polychloroprene) foam attached to a cotton fabric backing, with Al(OH)₃ added as a fire retardant. Vonar is representative of the transpirational and dissipative cooling class of materials. Finished weight is 0.91 kg/m². The product was supplied by Chris-Craft Industries, 1980 E. State Street, Trenton, NJ.

Combustion/Exposure Assemblies. Two animal exposure systems were used in this study, a 265-L and a 12,6-L system. The larger, recently constructed system was equipped with a radiant heat furnace designed to deliver heat to only the upper surface of the sample. The older, smaller system utilized a combustion tube assembly enclosed by a cylindrical heating unit that provided omnidirectional radiant heat around the perimeter of the tube and conductive heat through the tube wall.

265-L System: A diagram of this unidirectional radiant heat system is shown in Figure 1. The larger chamber, in which the animals were exposed, was constructed of polymethylmethacrylate (PMMA) and had an internal volume of 203 L. The smaller 42-L plenum was positioned above the combustion assembly to allow cooling and dilution of the hot combustion gases before entry into the animal chamber. The plenum was constructed of polycarbonate (for heat resistance), and the chambers were connected by two 7-cm-diameter PMMA tubes. A flexible tube allowed the continuous circulation of air from the floor of the animal chamber to the combustion assembly, underneath and around the decomposing test sample, into the plenum, and back into the animal chamber. The experimental animals were contained inside the animal chamber in four individual 20-cm rotating cages mounted on a motor-driven shaft. Perimeter velocity for the rotating cages was 6.4 cm/s.

The combustion assembly was constructed of stainless steel with triangular end sections; full-length quartz windows allowed radiant heat from four 2,000-watt quartz lamps (two on each side) to impinge on the sample surface at approximately 45° angles. In use, the radiant heat flux reached its specified level within 30 seconds of initiation. This rapid equilibrium was attained by using a graduated heating schedule, with an initially high and gradually decreasing power setting that allowed the rapid development and maintenance (within ± 0.2 W/cm²) of the selected heat flux level. All radiant heat measurements were made at the center of the sample position with the sample tray removed. The maximum sample size accepted by the combustion assembly was 7.6 by 22.9 cm (3 by 9 in); the assembled system had a total volume of 265 L.

12.6-L System: The smaller animal exposure system has been described in detail in previous publications (2,3); a diagram of the specific configuration used in this study is shown in Figure 2. Briefly, it consisted of a PMMA box containing a motor-driven rotating cage with compartments for three rats; perimeter velocity for this cage was also 6.4 cm/s. A recirculating blower forced chamber air through the combustion tube and over the sample, then moved the combustion gases into the animal chamber. Two 425-watt, semicylindrical heating units encircled the combustion tube, providing radiant (and conductive) heat for decomposition of the test sample. The total system volume was 12.6 L.

Atmosphere Analysis and Control. Similar analytical protocols were used for both systems. Periodic samples of the chamber atmosphere were analyzed for hydrogen cyanide (HCN), carbon monoxide (CO), and oxygen (O₂) by gas chromatography (GC) during each test. Oxygen was resupplied manually to the animal chamber as required to maintain a concentration within 90 percent of the ambient level. Air temperatures were monitored with thermocouples mounted in the animal chambers, and power to the combustion units routinely was shut off after 10 minutes to prevent overheating the chamber air.

Test sample size for both systems was based on the maximum size (7.6 by 22.9 cm) accommodated by the sample tray in the radiant heat combustion assembly; this 174-cm² sample, in the 265-L system, equated to a sample-area-to-volume loading of 0.66 cm²/L. To obtain an equivalent area-to-volume ratio for the 12.6-L system, the surface area (174 cm²) of the larger sample was multiplied by the ratio of the relative system volumes:

$$\text{Equivalent area} = \frac{12.6 \text{ L}}{265 \text{ L}} \times 174 \text{ cm}^2 = 8.3 \text{ cm}^2 \text{ (or a square 2.9 cm on a side).}$$

Samples of each material with 2.9-cm-long sides were then cut to provide equivalent area-to-volume loadings for the 12.6-L system.

EXPERIMENTAL PROCEDURE

For tests in the 265-L chamber, fasted albino rats were weighed and placed in the individual rotating cages; the chamber cover was replaced and connected to the adjoining polycarbonate plenum. The test specimen of FBL material (previously conditioned overnight at 50 percent relative humidity) was weighed and placed in the sample tray. The system was sealed; the external oxygen resupply, the gas sampling, and the temperature monitoring equipment were connected; and the power control for the radiant heat assembly was set to supply the desired heat flux level. At zero time, the cage rotation motor, heater power supply, recirculating fans, and timer were activated simultaneously. The test specimen was observed for the first indication of thermal breakdown (melting/smoke) and for ignition. Samples of chamber atmosphere were removed manually by syringe and analyzed (by GC) for O₂, CO, and HCN; oxygen was resupplied manually as needed. Time-to-incapacitation (t_i) was noted when each rat could no longer perform the coordinated act of walking in the rotating cage; i.e., when sliding or tumbling began. When all rats were incapacitated, cage rotation was stopped; time-to-death (t_d) was recorded for each rat when visible signs of respiration ceased.

Tests in the small (12.6-L) chamber were carried out in the same manner except for the methods of sample insertion and chamber atmosphere sampling. Since the cylindrical heating unit required several minutes to reach a stable temperature, the unit was preheated to the desired temperature before inserting the sample. The weighed sample was placed in a quartz combustion boat and, at time zero, the boat was moved into the center of the heated area in the combustion tube. A fraction of the test atmosphere was constantly pumped through a closed loop from the animal chamber, through the sampling loops on the two GC's, and back into the chamber. Relays that controlled the pneumatic sampling valves on the GC were activated every 1.8 minutes for CO and 3.6 minutes for HCN; these sampling intervals were the minimum times required to elute the respective gas peaks from the GC columns.

RESULTS AND DISCUSSION

It should be noted again that the toxicity comparisons between Norfab and Vonar that follow are based on equal sample surface areas instead of the more common equal weights of materials. The rationale for this choice is that an equal area of each FBL material would be required to cover and protect any specific surface area of polyurethane foam seat cushions; we feel that this end use of the materials dictates equal surface area as the more logical unit for relative toxicity comparisons. The equivalent chamber loadings, expressed as the ratios of weights of test material loaded (milligrams) to system volume (liters), were 26 mg/L for Norfab and 60 mg/L for Vonar.

The mean observed response times are presented in Table 1 for each material and test condition. Statistical precision for the data is indicated by the standard deviation (S.D.) and relative standard deviation (rsd) for each set of animal responses. Times-to-incapacitation observed for Norfab and Vonar ranged from 8.6 to 19.1 min in the 265-L (radiant heat) assembly and from 7.1 to over 45 min in the 12.6-L (combustion tube) system. Deaths were noted during the test period for both materials under all conditions except Norfab at 2.5 W/cm² (265 L), a condition that produced incomplete (and minimal) pyrolysis of the test specimen. Norfab and Vonar both showed increasing toxicity (shorter t_i's) with each increase in radiant heat flux when exposed to unidirectional heat in the 265-L system, but only Vonar produced a similar response to omnidirectional heat in the combustion tube (12.6-L) system. When Norfab was pyrolyzed at 750 °C (flaming), t_i's varied from 17.1 to 36.4 min with two of the six rats not incapacitated after 45 min. Norfab's variable behavior at 750 °C contrasted with the 600 °C tests, where it produced a mean t_i of 7.1 min with only a 4-percent rsd.

The loss in weight of FBL materials pyrolyzed in the 12.6-L system was 60 to 64 percent of the sample weight at both 600 and 750 °C, indicating that the observed differences in response times between the two conditions were more likely due to differences in the composition, not quantity, of the combustion products, or to differences in the rates of gas evolution. The original design of the radiant heat assembly (265 L) did not permit quantitative recovery of the sample residues, so comparisons of weight losses between the two systems could not be made. At the lowest flux level (2.5 W/cm²), however, Norfab samples were only partly decomposed, and were recovered essentially intact; the weight loss was only 13 percent of Norfab's preburn weight.

Peak values for CO concentrations are listed in Table 2. Except for the 2.5-W/cm² tests (265 L), the peak CO concentrations differed only slightly in magnitude. The rate at which these peak values were attained, however, varied with increasing radiant heat flux or temperature. At the higher temperatures, sample decomposition was more rapid and peak CO concentrations were reached earlier, thereby exposing the rats to high CO levels for a greater fraction of the observation period.

Hydrogen cyanide was detected in the Norfab tests at both temperatures in the 12.6-L system. Peak values were 250 ppm at 600 °C, but only 70 ppm at 750 °C (flaming). Norfab also produced detectable levels of HCN in the 265-L system at 5.0 and 7.5 W/cm², but not at 2.5 W/cm². Detection of HCN in the 265-L system was qualitative only. For this initial evaluation of the system, chamber air samples were removed manually, by syringe, and injected into the GC sample loop. Quantitation of the detected HCN was not possible because of the tendency for HCN to dissolve in any condensed moisture on the syringe walls and therefore to not be introduced quantitatively into the GC. Vonar did not produce detectable quantities of HCN, in either system, under any of the test conditions. Analytical values for HCN are shown in Table 3.

SUMMARY AND CONCLUSIONS

We have described the testing of two fire-blocking-layer materials, Norfab and Vonar, for the relative toxicities of their combustion products, in two different laboratory-scale systems. We have studied the characteristics of a new 265-L system, in which flat material samples are thermally decomposed by radiant heat incident on the top surface only, and compared the results with those from an older 12.6-L system, in which materials are pyrolyzed inside a preheated combustion tube assembly. Time-to-incapacitation in the laboratory rat was the measured response used to compare the relative toxicity of the combustion gases produced from the two materials.

Because of the intended end use of the fire-blocking materials, we have based the relative toxicity for each test system on the animal response times obtained when equal surface areas of each material were pyrolyzed. For comparisons between the two combustion systems, we selected sample surface areas proportional to the respective system volumes.

In summary, Vonar proved less toxic (longer t_i 's) than Norfab in three of the five test conditions. The mean t_i 's for Norfab and Vonar were significantly different at the P_{.05} level by Student's t-test (7) in the 265-L system (at 5.0 and 7.5 W/cm²), and in the 12.6-L system at 600 °C. In one exception (265-L system, 2.5 W/cm²), Norfab lost only 13 percent by weight (21 percent of its combustible components) and did not produce an animal response within the test period. In the other exception, Norfab produced an unusually wide range of response times in the 12.6-L system at 750 °C (flaming). One explanation could be the low concentration of CO produced by this combustion condition. We have noted that CO concentrations of 3,000 ppm and below tend to produce not only longer t_i 's, but also increased variation in individual rat response times. Also, the low HCN concentration (70 ppm) was present for only the first 4 to 5 min and probably produced a minimal additional toxic insult.

The lowest heat flux (2.5 W/cm^2) selected for radiant heat pyrolysis proved inadequate to decompose Norfab to the extent necessary to produce an animal response, at least at the 26-mg/L weight loading. Vonar produced incapacitation at the same flux level, but at a weight loading of 60 mg/L, a loading that we have considered optimum for testing aircraft cabin materials in the older 12.6-L combustion tube system (3). Both FBL materials produced reasonable and reproducible $t_{1/2}$'s, however, at the higher 5.0- and 7.5-W/cm^2 flux levels.

At present, we believe the maximum sample size accepted by the radiant heat chamber to be adequate, although some extremely lightweight materials may prove inadequate with a 7.6- by 22.9-cm sample. To increase the size of the combustion chamber to accommodate a larger sample surface area would also increase the problems of uniform sample heating, increase the cumulative temperature in the animal chamber, and increase the probability of producing a flammable gas concentration with subsequent ignition. For most panels, floorings, and other flat-surfaced materials, the present sample-size-to-volume ratio appears to be an acceptable compromise between versatility and practicality.

The preliminary evaluation of the two combustion systems has indicated certain modifications in equipment and procedures for future studies. We have modified the radiant heat combustion assembly to allow the quantitative recovery of sample residues; this will enable us to determine the extent of sample pyrolysis at different flux levels. We have installed a constant-flow, closed-loop air sampling assembly on the 265-L system, which will permit automatic, direct sampling at preset intervals and will allow the quantitative GC determination of HCN.

Table 1. Animal Response Times to Combustion Products of Norfab and Vonar at 0.66-cm²/L System Loading Level

265-L System - Top Radiant Heating Only									
<u>Material</u>	Heat Flux (W/cm ²)	<u>t_i</u> (min)				<u>t_d</u> (min)			
		<u>N</u>	<u>Mean</u>	<u>S.D.</u>	<u>rsd(%)</u>	<u>N</u>	<u>Mean</u>	<u>S.D.</u>	<u>rsd(%)</u>
Norfab 11HT-26-Al	2.5	8	NR*	---	---	8	NR*	---	---
	5.0	16	9.0	1.16	12.9	16	15.4	2.42	15.7
	7.5	20	8.6	1.49	17.4	20	16.8	3.99	23.8
Vonar-3	2.5	12	19.1	2.93	15.3	12	27.2	5.37	19.8
	5.0	12	12.1	1.39	11.4	12	17.6	3.18	18.0
	7.5	20	10.4	1.02	9.8	20	16.0	3.10	19.3

12.6-L System - Combustion Tube Pyrolysis									
<u>Material</u>	Furnace T (°C)	<u>t_i</u> (min)				<u>t_d</u> (min)			
		<u>N</u>	<u>Mean</u>	<u>S.D.</u>	<u>rsd(%)</u>	<u>N</u>	<u>Mean</u>	<u>S.D.</u>	<u>rsd(%)</u>
Norfab 11HT-26-Al	600	6	7.1	0.29	4.0	6	17.0	2.36	14.0
	750 (F1)	6**	(range 17.1 to 45+)			6	(range 40 to survival)		
Vonar-3	600	6	11.5	2.04	17.8	6	27.9	10.13	36.2
	750 (F1)	6	8.9	1.16	13.2	6	18.5	4.59	24.8

N = Number of rats tested; Mean = mean response time in minutes;
 S.D. = standard deviation; rsd(%) = relative standard deviation in percent,
 i.e., rsd = (S.D./Mean) x 100; F1 = flaming combustion.

* NR = No response within test period.

**At 750 °C, in the 12.6-L system, Norfab produced t_i's at 17.1, 25.4, 32.3 and 36.4 min with 2 rats not incapacitated after 45 min; 2 deaths at 40 and 120 min were noted and the remaining 4 rats were alive after 24 h.

Table 2. Peak Carbon Monoxide Concentrations
Attained in Chamber Atmospheres

265-L System (Top Radiant Heating Only)

Test Material	Test Condition		
	2.5 W/cm ²	5.0 W/cm ²	7.5 W/cm ²
Norfab 11HT-26-A1	500 ppm at 15 min	4,000 ppm at 8 min	3,500 ppm at 4 min
Vonar-3	4,600 ppm at 10 min	5,200 ppm at 8 min	6,000 ppm at 6 min

12.6-L System (Combustion Tube Pyrolysis)

Test Material	Test Condition	
	600 °C	750 °C (Flaming)
Norfab 11HT-26-A1	4,400 ppm at 5 min	3,000 ppm at 3 min
Vonar-3	5,300 ppm at 5 min	5,300 ppm at 5 min

Table 3. Hydrogen Cyanide Concentrations
Attained in Chamber Atmospheres

265-L System (Top Radiant Heating Only)*			
Test Material	Test Condition		
	2.5 W/cm ²	5.0 W/cm ²	7.5 W/cm ²
Norfab 11HT-26-A1	Not Detected at 4 min	Detected at 4 min	Detected at 3 min
Vonar-3	Not Detected at 7 min	Not Detected at 5 min	Not Detected at 5 min

12.6-L System (Combustion Tube Pyrolysis) ^{**}			
Test Material	Test Condition		
	600 °C	750 °C (Flaming)	
Norfab 11HT-26-A1	250 ppm at 4.6 min	70 ppm at 4.6 min	
Vonar-3	None Detected	None Detected	

*One sample only was removed by syringe for qualitative analysis; sampling times correspond to the times of maximum (visual) smoke concentration in the chamber. See text, page 6.

**HCN analyses for the 12.6-L system were quantitative and the values shown are the peak concentrations determined during the tests. Initial samples were taken at 1 min and succeeding samples were at 3.6-min intervals.

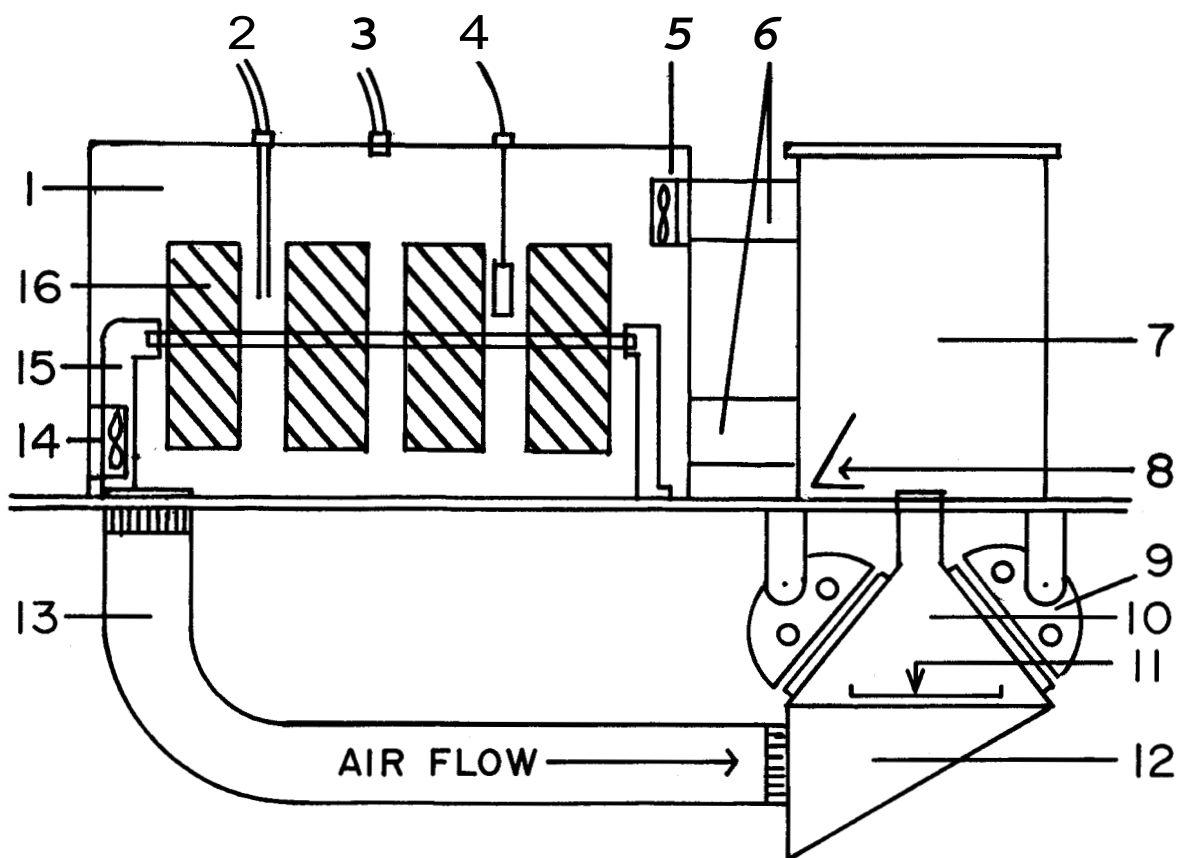

Figure 1. Combustion/Exposure Assembly (265 L)

1. Animal exposure chamber
2. Gas sampling inlet
3. Oxygen inlet
4. Thermocouple (air temperature)
5. Muffin fan (recirculation assembly), Rotron Mfg. Co., Woodstock, NY
6. Chamber connecting tubes
7. Mixing/cooling plenum
8. Gas deflector
9. Heat lamp reflector with two 2000-watt General Electric quartz lamps (GE QH2M/T3/CL/HT 240 V)
10. Sample combustion chamber
11. Sample combustion tray (stainless steel, for 7.6- by 22.9-cm sample)
12. Combustion chamber air plenum
13. Flexible tube, 10-cm diameter (to recirculate chamber air through the sample combustion chamber)
14. Muffin fan (for mixing chamber air)
15. Cage motor drive shaft and axle support
16. Individual rotating cage

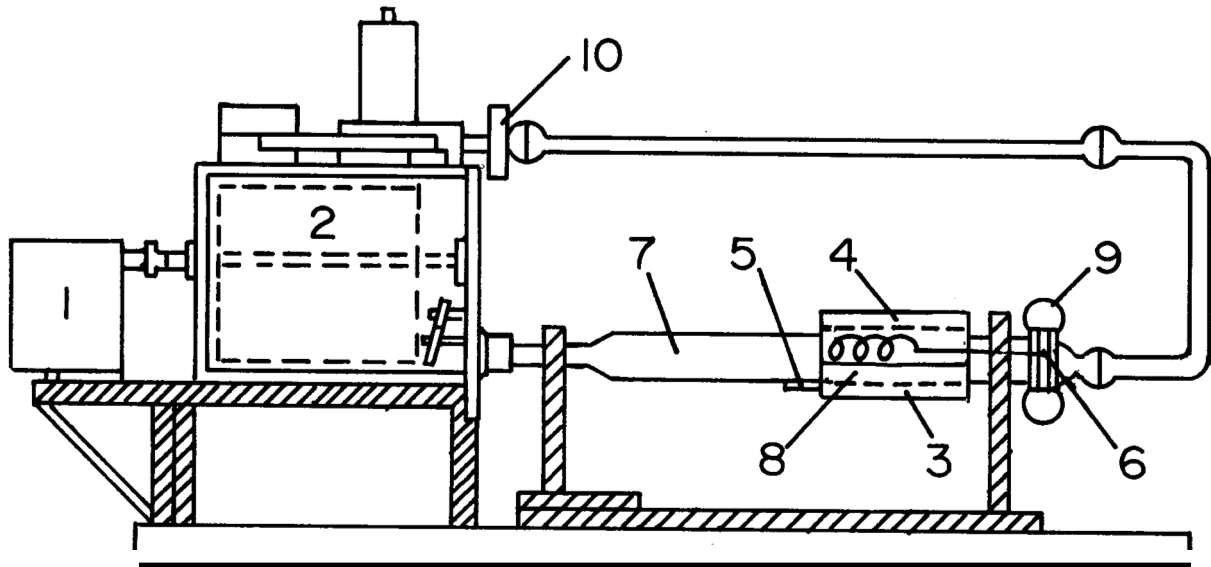

Figure 2. Combustion/Exposure Assembly (12.6 L)

1. Gearmotor, Model 3M126, 6 rpm, 1/20 hp; Dayton Manufacturing Company, Chicago, IL
2. Animal Exposure Chamber
3. Heating unit, Model NV2X6, 425 watts at 57.5 volts, semicylindrical; Watlow Electric Manufacturing Company, 12001 Lackland Road, St. Louis, MO
4. Same as No. 3
5. Thermocouple, chromel-alumel; Omega Engineering Inc., Stamford, CT
6. Hot wire igniter
7. Combustion tube
8. Combustion boat
9. Spring clamp
10. Smoke detector

REFERENCES

1. Brown LJ, Johnson RM. Correlation of Laboratory-Scale Fire Test Methods for Seat Blocking Layer Materials with Large-Scale Test Results. Report No. DOT/FAA/CT-83/29. Washington, D.C.: U.S. Department of Transportation, Federal Aviation Administration, 1983.
2. Crane CR, Sanders DC, Endecott BR, Abott JK. Inhalation Toxicology: 111. Evaluation of Thermal Degradation Products from Aircraft and Automobile Engine Oils, Aircraft Hydraulic Fluid, and Mineral Oil. Report No. FAA-AM-83-12. Washington, D.C.: Federal Aviation Administration, Office of Aviation Medicine, 1983.
3. Crane CR, Sanders DC, Endecott BR, Abbott JK, Smith PW. Inhalation Toxicology: I. Design of a Small-Animal Test System; 11. Determination of the Relative Toxic Hazards of 75 Aircraft Cabin Materials. Report No. FAA-AM-77-9. Washington, D.C.: Federal Aviation Administration, Office of Aviation Medicine, 1977.
4. Federal Aviation Regulations 14 CFR, Part 25.853(c), November 26, 1984.
5. Hall JR, Stiefel SW. Decision Analysis Model for Passenger-Aircraft Fire Safety With Application to Fire-Blocking Seats. Report No. DOT/FAA/CT-84/8. Washington, D.C.: U.S. Department of Transportation, Federal Aviation Administration, 1984.
6. Kourtides DA, Parker JA, Ling AC, Hovatter WR. Optimization of Aircraft Seat Cushion Fire-Blocking Layers. Report No. DOT/FAA/CT-82/132. Washington, D.C.: U.S. Department of Transportation, Federal Aviation Administration, 1983.
7. Steel RGC, Torrie JH. Principles and Procedures of Statistics. New York: McGraw-Hill Book Co., 1960.



