

63-17

HD 428 849
NE4-14411

CARI-63-17



APPLICATION OF A
 "RELATIVE" PROCEDURE
 TO A PROBLEM IN
 BINAURAL BEAT PERCEPTION



63-17

JAN 5 1965 Code 61

ORDER NUMBER	
FOR TECHNICAL DOCUMENTS AND	
PERIODICALS INFORMATION	
Library	
1.00	10 - 100
PRIME COPY	

PROCESSED COPY

FEDERAL AVIATION AGENCY
 AVIATION MEDICAL SERVICE
 AEROMEDICAL RESEARCH DIVISION
 CIVIL AEROMEDICAL RESEARCH INSTITUTE
 OKLAHOMA CITY, OKLAHOMA

AUGUST 1963

**APPLICATION OF A "RELATIVE" PROCEDURE
TO A PROBLEM IN BINAURAL BEAT PERCEPTION**

JERRY V. TOBIAS, Ph.D.

*Research Psychologist (Physiological and Experimental)
Psychology Branch*

63-17

**FEDERAL AVIATION AGENCY
AVIATION MEDICAL SERVICE
AEROMEDICAL RESEARCH DIVISION
CIVIL AEROMEDICAL RESEARCH INSTITUTE
OKLAHOMA CITY, OKLAHOMA
AUGUST 1963**

APPLICATION OF A "RELATIVE" PROCEDURE TO A PROBLEM IN BINAURAL BEAT PERCEPTION

Jerry V. Tobias

The existence of binaural beats has long been considered an indication of binaural interaction for timing and for periodicity information. In the past, bilaterally matched sound pressure or sensation levels have been used in the investigation of these beats and the measuring technique was one which may be termed "absolute." However, the present study, in investigating with a "relative" technique the limits of dichotic intensity which permit binaural beats, shows that listeners respond to the presence of beats whenever the tones to both ears are above threshold. It is suggested that this new result fits more neatly into current theoretical formulations. The frequencies investigated ranged from 100 to 2000 cps. As other authors have previously reported, the best performance occurred in the 400-600 cps range. The present findings strengthen the case for an auditory nervous system with timing channels independent of other transmission lines and, thereby, also have implications for pitch theory.

Binaural beats are heard when two sinusoids of slightly differing frequency are led independently to the two ears. The subjective effect is most often described as a fluctuation in loudness. Auditory theory has profited from investigations of the phenomenon because, in order to be heard as a beating complex, the tones must be brought together neurally by a mechanism which preserves time or phase relations. That is, for the frequencies at which binaural beats can be heard, auditory tract responses change in synchrony with the stimulus. Here, then, is a perceptual process whose existence constitutes good evidence for "periodicity following" of low frequency tones by the auditory nervous system.

Antecedents of the work reported here date back as far as 1839, and continue very nearly to

'the present.' Apparently, each previous investigator has used a physical approach rather than a physiological one, even though physiological implications have frequently been

¹Detailed historical references (starting with H. W. Dove, "Nachtrag zu den Combinationstonen," *Reportorium d. Physik* 3, 404-405 (1839) can be found in G. W. Stewart's series of three papers, "Binaural beats," *Phys. Rev.* 9, 502-508, 509-513, 514-528 (1917); additional discussion of the early work can be found in H. Fletcher, *Speech and Hearing* (D. Van Nostrand Company, Inc., New York, 1929), Part III, Chap. 3. E. G. Wever, *Theory of Hearing* (John Wiley and Sons, Inc., New York, 1949), pp. 427-434, and J. C. R. Licklider, J. C. Webster, and J. M. Hedden, "On the frequency limits of binaural beats," *J. Acoust. Soc. Am.* 22, 468-473 (1950) include further comments and several references to later articles not mentioned in the present paper. Little writing on theoretical aspects of binaural beats has appeared since, except perhaps J. Fulford, "The binaural beat phenomenon," *J. Laryngol. and Otol.* 69, 685-686 (1953).

drawn. In general, people working with binaural beats have designed their experiments as if they were dealing with physical beats. For the physicist, beats are the result of alternate reinforcement and cancellation of two added waveforms that have a constantly changing phase relation.² For the psychologist, beats are what a listener hears when presented with physical beats within a certain range of beat frequencies. For both the physicist and the psychologist, the detectability of beats is related to the relative amplitudes of the two beating tones. Occasionally, one uses two tones with *unmatched* levels for detecting auditory distortion,³ for measuring the size of a difference threshold,⁴ or for noting similar physical or psychophysical entities. The psychologist who uses beats for such purposes rapidly discovers that two tones, although unmatched in magnitude, must still be fairly close together for subjects to report the preception of beats. If one approaches the study of binaural beats with knowledge of the psychological response to physical beats, he finds considerable logic—and almost overwhelming evidence—favoring the concept that binaural beats also will occur only when the two tones used are matched in level. However, if one holds the theoretical bias that phenomena such as pitch and auditory localization are based at least partly on temporal processes, then the older work must be re-evaluated. A physiological logic must be applied where reasoning based in physics was previously used.

Consider the possible existence of separate neural pathways for the conduction of place-pitch information and for the conduction of timing information. From this viewpoint, bin-

²"Beats are periodic variations that result from the superposition of two simple harmonic quantities of different frequencies f_1 and f_2 . They involve the periodic increase and decrease of amplitude at the *beat frequency* ($f_2 - f_1$)." American Standard Acoustical Terminology (American Standards Association, New York, 1960), S1.1, sect. 1.32. (By permission from the American Standards Association.)

³For example, M. Lawrence and C. L. Blanchard, "Prediction of susceptibility to acoustic trauma by determination of threshold of distortion," *Ind. Med. and Surgery* 23, 193-200 (1934).

⁴R. R. Biesz, "Differential intensity sensitivity of the ear for pure tones," *Phys. Rev.* 31, 867-873 (1928).

aural beats (which are generally accepted as being associated with a timing or counting process) must be perceptible so long as the tones to the two ears are both above threshold in the timing pathways. Working from this concept, it became necessary to investigate the limits of dichotic (i.e., different at the two ears) intensity which would still allow for the perception of binaural beats.

PROCEDURE

Although a large number of methods for measuring the limits of dichotic intensity for binaural beats are possible, all of them may be classified in one of two categories. These two classes represent basically different (although not novel) techniques. In one, termed "relative," the subject is asked to make judgments about a variable stimulus which alternates with a reference stimulus; in the other, termed "absolute," no reference is given. This particular categorization is useful not only for differentiating between species of psychophysical methods, but also for showing why no previous work has reported binaural beat perception with unmatched interaural levels (see Results and Discussion below).

Absolute binaural beats. For the production of *absolute* binaural beats, instrumentation as illustrated in Figure 1 was used. The two

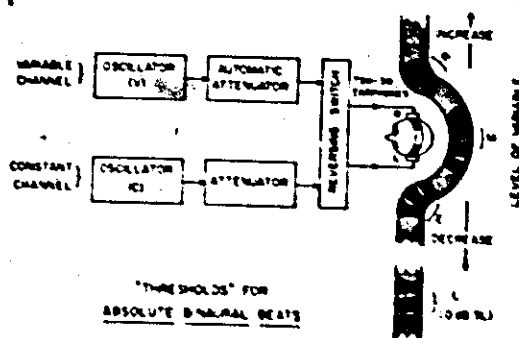

FIGURE 1. Instrumentation for the production of absolute binaural beats is shown. The subject controls the increase or decrease of attenuation in the variable channel and the automatic attenuator accordingly plots his "threshold" as a function of time. A sketch representing the listener's intracranial beating images is included on the right, showing a perceived beat when the image is shifted to the right ear (R), when the image is shifted to the left ear (L), when it is centered (M), and when the tone in the variable channel is near threshold.

tones were generated by Hewlett-Packard Model 201CR oscillators fed separately to two attenuators. The attenuator in the "constant channel" was a Hewlett-Packard Model 350B; the attenuator in the "variable channel" was a Grason-Stadler Model E3262A recording attenuator. From the attenuators, the tones were led independently to matched TDH 39-300Z earphones mounted in NAF48490-1 doughnut cushions. The sound booth contained only the subject, the earphones, and a control key for the recording attenuator. The experimenter, outside the booth, in addition to determining settings for the oscillators and for the 350B attenuator, had control of an override switch for the recording attenuator and a reversing switch which allowed him to select the ear receiving signals from the constant channel.

Relative binaural beats. For the production of *relative* binaural beats, instrumentation as shown in Figure 2 was used. Most of the items

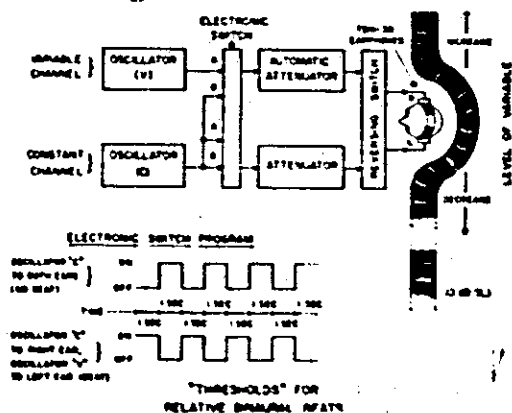

FIGURE 2. Instrumentation for the production of relative binaural beats is shown. The "threshold" is plotted as in Fig. 1. On the right is a sketch representing the subject's intracranial beating images, showing that he hears a beat whenever the tones are both above threshold.

of apparatus were identical to those used for the measurement of absolute binaural beats with the addition of a Grason-Stadler Model 829S electronic switch. This switch, set for an approximate 100 μ s rise and decay time, served to program the stimulus in the variable channel (the rise-decay time was selected so that the stimulus in the constant channel appeared continuous). In the variable channel, during the "A-on" part of the switching cycle, the tone from oscillator V was gated on; during the "B-on" part of the cycle, the tone from oscillator C (which also fed the constant channel) was on.

The variable tone was then led through the recording attenuator and reversing switch to one earphone. The constant tone went to its 350B attenuator, through the reversing switch, and to the other earphone as before. Levels in the two channels were adjusted so that, with both attenuators at zero, the two channels were matched. The electronic switch program was adjusted so that the earphone receiving the output of the variable channel received one second of signal from oscillator V alternating with one second of signal from oscillator C.

In both arrangements, line impedances for the entire system were matched as necessary.

Using the apparatus described for the production of absolute binaural beats, one would expect an ideal listener to hear beats continuously. Using the apparatus described for the production of relative binaural beats, one would expect him to hear one second of beating alternating with one second of non-beating.

Subjects. Subjects in the major experiment were four men, ranging in age from 22 to 44 years, who were experienced in listening to binaural beats. Twenty-five additional subjects served in pilot experiments.

Method. The technique of plotting a "binaural beat threshold" is simplified considerably by the use of the recording attenuator which allows the subject essentially continuous control over the level of the tone in the variable channel. As he alters the stimulus magnitude with this instrument, a graph of his changes in level with time is produced. For the work reported here, the recording attenuator was adjusted to change the level at a rate of 4 dB per second.

Because work preliminary to the present study showed fairly large individual variation in the ability to hear binaural beats, subject-training procedures were improvised to meet individual problems. As much as possible, listening during training was divided equally between absolute and relative stimuli. Few other restrictions were practical. The first training session began in a standard fashion, but variations were introduced whenever they became necessary. Typically, the experimenter first described the sound of a beating stimulus, including in this orientation the demonstration through a loudspeaker system of physical beats

at several beat frequencies. For most subjects, binaural beats were first introduced with a 500 cps tone to one ear and a 503 cps tone to the other; levels at the two ears were matched. The selection of 500 cps and matched interaural levels was based both upon previous reports of binaural beat perceptions³ and upon experience gained in preliminary investigations. That subjects were hearing the beats was most easily tested by producing changes in the beat frequency and requiring the listeners to reproduce the rate by tapping a finger. When a subject seemed to be responding to the beat, he was instructed to press the key (controlling the recording attenuator) until the beat disappeared, then to release the key until the beat returned, and so on. A few pilot study subjects, several days after training, were found to respond not to the beat but to the difference in pitch between the ears. An interview in which the subject was asked to describe just what he was listening to helped protect against such responses; more important though, subjects making judgments on the basis of a pitch difference produced response curves on the recording attenuator which differed characteristically in slope and variability from the curves produced by subjects listening for the beat.

Every tested subject can now hear binaural beats. The population includes the selected subjects from the present experiment, the 25 unselected subjects used in preliminary work, and 40 more unselected subjects used in another study.

Following a training period of several hours, subjects were asked to find "binaural beat thresholds" — that is, attenuator traces around the variable-channel level at which beats disappeared — both for absolute and for relative stimuli. Frequencies ranging from 100 to 2000 cps were investigated with beat frequencies varying from 1 to 10 cps. The similarity of thresholds from 100 to 800 cps and the lack of reliable beat perception above about 900 cps led to the collection of most of the data with one set of stimulus parameters; the tone to one ear was 500 cps, to the other, 503 cps.

Since a primary source of error in such studies is sound leaking across the head,⁴ care was taken that the tone in the constant ear never exceeded a level of 40 dB the threshold in the variable ear. Thus, the term "sensation level" (SL) as used here always refers to the threshold on the variable side. A representative trial would start with a threshold for the tone in the variable channel. Following that, in random order, would be binaural beat thresholds with the constant ear at 40 dB, 30 dB, 20 dB, 10 dB, and 0 dB SL. Last in a trial was an additional tone threshold. Trials for absolute and for relative beats were similar.

RESULTS AND DISCUSSION

Absolute binaural beats. From the hypothesis of a separate time-sensitive system, one would expect subjects to hear binaural beats whenever the tone to the ear receiving the lower-level stimulus was above threshold. Unhappily, no such clear result occurred for absolute beats. What did happen is shown in Figure 3, a composite curve illustrating many

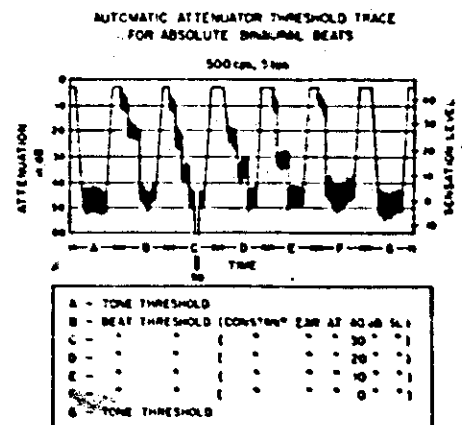

FIGURE 3. Curve illustrates several types of response to absolute binaural beats. Each part of the figure (i.e., A, B, ..., G) is selected from a different trial; three subjects are represented. For ease of reading, the traces are equated for sensation level and ordered according to the level at the constant ear.

of the kinds of responses given. Remember in reading this curve that the subjects were asked to find the place or places where the perception of a "wobble" fades into the per-

³J. C. R. Licklider, J. C. Webster, and J. M. Hedlund, "On the frequency limits of binaural beats," *J. Acoust. Soc. Am.* 22, 468-473 (1950).

⁴Differences between "true" or "subjective" binaural beats and "leakage" or "objective" binaural beats are detailed in C. E. Lane, "Binaural beats," *Phys. Rev.* 26, 401-411. (1925).

ception of a continuous tone. Remember too that the decision about this "threshold" is absolute — dependent upon no external reference.

Subjects report a strong beat when the sound image is near the center of the head; only with the image centered do they feel very sure that they are hearing what they are supposed to. If a subject raises the level in the variable channel until it is approximately 10 dB higher than in the constant channel, he hears a beat — sometimes — and he hears it on the louder side. This lateralized beat is readily confused with head noises, but when the beat is reported at all, the record shows an invariant and reliable 10 dB difference in level between ears. There is a symmetrical beat on the other side when the 10 dB favors the constant ear, but it too is very easily lost. One further nebulous set of beats is heard when the sound on the softer side is near threshold. A sketch of the intracranial positions of these various images is included in Figure 1.

The record in Figure 3 can be easily interpreted in the light of these reported percepts. (Although this record shows the listener approaching each new beating image from above, the traces for ascending trials were similar.) A tone threshold for the subject's "variable ear" is shown first ("A"). Following it are beat thresholds for several values of sensation level in the "constant ear." When he felt that he had stabilized a particular threshold, the subject reduced the level in the variable ear until he found another beat or until he had reduced the level so far that the experimenter recognized that no other beat was forthcoming. In part "B," then, the top beat threshold represents the median plane image; the next one, the 10-dB-difference image; and the third one, the "threshold threshold." In "C," with a 30 dB SL in the constant ear, the subject found all four images noted in Figure 1. Also, as frequently happened, after the "threshold threshold" he continued to increase the attenuation. Not finding anything subliminal, he raised the level in the variable channel until he found a beat again; note that it matches the beat he heard before. In part "D," the first beating area occurred when the interaural difference was 10 dB, although some subjects tended

to search for a beating image in the 10 dB attenuation vicinity. This process appears in "E" and in "F." From later reports about this phenomenon, it seems safe to conclude that the searching occurred because the subject knew that a beat often appeared a few seconds after he started increasing the attenuation. Parts "E" and "F" show the subject's work at 10 and 0 dB SL in the constant ear, and part "G" shows another tone threshold. In any presentation of absolute stimuli, subjects felt confident only when the levels in the two ears were matched. No subject perceived every possible image in any single trial.

To avoid misinterpretation of Figure 3, recall that the curves were selected to illustrate a range of responses. Thus, for instance, although it does not appear in the figure, the 0 dB curves frequently showed a beat threshold region near 10 dB SL. The other curves similarly vary according to which images a subject did or did not perceive.

Relative binaural beats. The inclusion of a non-beating reference tone made the subjects' task strikingly easier and produced completely different response patterns. Using relative rather than absolute stimuli leads to a situation in which the beat can *always* be heard when both tones are at or above threshold. As in the case for absolute beats, the image is invariably on the louder side. (Although it is possible to interpret this fact as the result of an illusion, it may be considered useful evidence that the beat did not result from physical mixing of the two tones because of leakage across the head.)

The sketch of intracranial images for relative binaural beats shown in Figure 2 illustrates that listeners find only one beat threshold — when the tone in the variable channel reaches its threshold. The existence of a single limiting value of stimulus magnitude for the perception of binaural beats is obvious in Figure 4. This

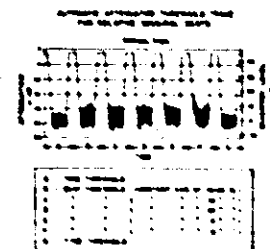

FIGURE 4. Curve illustrates consistency of response at any interaural intensity difference when relative stimuli are used.

figure is plotted from the responses of one subject during one trial; the only change made has been to order the curves from highest to lowest level in the constant ear. The curves are literally typical; the responses of any subject during any trial would look the same.

Individual differences. Problems of population variability were minimized with the selection of subjects used here. However, the unsophisticated subjects used in pilot experiments performed similarly. Individual differences, then, appear to be effectively nonexistent except as was noted in the discussion of absolute beats and except for the performance of one subject. The subject in question was the only one tested who could not hear binaural beats at all. She was also the only female in the population. No amount of indoctrination and no reasonable amount of listening experience either to physical beats or to absolute or relative binaural beats helped. After 10 hours of training, an extension of the frequency range from the previously determined optimum 400-600 cps was made. As soon as the frequency was dropped to 350 cps, she heard the beats, and the magnitudes of her beat thresholds were similar to the others. Apparently, her best range is in the 200 to 300 cps band — a striking variation from the best range of any of the male subjects. It is not to be inferred that binaural beat perception can serve as an adequate screening test for sex. However, additional work is in progress and preliminary data indicate a remarkably reliable sex difference in maximum frequency at which binaural beats are heard.

Relations with previous work. The results of this study raise several questions. Perhaps foremost is the problem of why previous authors have insisted on the need for matched levels in binaural beat perception. Part of the answer may be that most of the early writers were physicists who recognized that physical beats are perceptible only when the mixed tones are fairly closely matched in amplitude. By extension, they had to conclude that binaural beats should also require matched levels. With one exception, recent writers have not departed from the physically based concepts. That ex-

ception, Wever and his students,⁷ is interesting because there too the comment is made that "the adjustment of the intensity at the two ears is highly critical." It now seems obvious that their critical adjustment resulted from the use of absolute beats (which, of course, were quite adequate for measuring the processes they investigated), and they naturally found only a highly restricted range of magnitude differences in which binaural beats could be perceived. In work preceding the present study, using fixed rather than constantly changing attenuations, confidence ratings from subjects indicated that only matched levels (within plus or minus 3 dB) give any certainty about the existence of absolute beats. The long history of notes about the need for matched levels in binaural beat perception, then, probably can be laid both to the interpretation of this binaural neural phenomenon in terms of physical beating phenomena and to the use of absolute judgments.

Another question that must be asked pertains to studies in which a measurement depends upon the hearing of beats. If binaural beats can be heard with the softer tone at or near threshold, can one thrust the results of experiments in which a probe tone is used to find "best beats," for instance, with a distortion product? Although the answer offered here is the result of informal listening and not of systematic investigation, there is some pertinence to the presentation of these data. Two minor pieces of work are involved. The first was a study with two subjects on the hearing of binaural beats with tones of frequency f and $(2f + 5)$. Either tone was set at 40 dB SL; the other was adjusted by the listener. In this experiment, one subject had no difficulty at all either in hearing beats or in producing a beat threshold. The second subject found a nebulous beating image, but reported that

⁷ Particularly J. C. Loesch and B. L. Kapell, "The frequency limit for the perception of binaural beats and for cyclic binaural localization," senior thesis, Princeton University (1948).

⁸ E. G. Wever, *Theory of Hearing* (John Wiley and Sons, Inc., New York, 1949), p. 434. Lane reports rather that true binaural beats at 80 dB SL can be heard with an interaural intensity difference that approaches 20 dB (reference 8, pp. 402 and 408-409).

the percept was extremely difficult to maintain. The other pertinent study, with one listener, used a high-level (set by the experimenter at values from 30 to 90 dB SL) 500 cps tone and a low-level (independently set at from 0 to 50 dB SL) 505 cps tone added in one ear, and a 500 cps tone alone in the other ear. Levels in the second ear were controlled by the listener. The subject was unable to hear any beat. Although it might be true that in such a complex stimulus a beat is somehow masked, this finding may well be the result of a sampling error — the subject was the same one who had difficulty with the f and $(2f + 5)$ stimulus.

The relation of these experiments to the "best beat" studies is straightforward. When a high level tone is presented to one ear, the same tone can be present at a 40 or 50 dB lower level in the other ear as a result of leakage. A probe tone in the louder ear might possibly produce a binaural beat with the leakage product in the contralateral ear. Thus, even with tones whose difference in level mitigates against the production of monaural physical beats, one might hear binaural beats. Depending upon the experimental procedure and purpose, these binaural beats would be between f and either $(f \pm \Delta f)$ or $(2f \pm \Delta f)$. Subjects often have trouble hearing a beat in measurements of distortion, and perhaps that trouble could be accounted for if one considered that they were really listening for an absolute binaural beat. Similarly, one must examine any work which measures cross-hearing with a contralateral probe tone on the basis that responses can result from binaural beats at or near the "threshold threshold."

Finally, it is necessary to point out that the thresholds of those nerve fibers forming timing circuits apparently match the thresholds in audibility circuits.

CONCLUSIONS

From the present data, one can interpret that there is in the binaural system a timing network which is separate in function from other channels which carry only loudness or place-pitch information. The concept of such functional

separation is certainly not new — it fits the proposed binaural interaction networks of Jeffress⁹ and Licklider¹⁰; it is related to work on timing processes in the basal turn of the cochlea¹¹; and it certainly fits Huggins's principle of diversity.¹² Moreover, people studying problems of periodicity pitch and the residue (e.g., G. v. Békésy, E. de Boer, J. Nordmark, J. F. Schouten, and A. M. Small, Jr.) have necessarily held that time-sensitive devices must exist in the auditory nervous system. For these mechanisms to be functional, they must somewhere be essentially separate entities. These new data, then, were collected to test whether binaural beat perception conforms to the theory of an independent timing system. The results add to the evidence confirming the existence of that independence.

Anyone attempting similar work should not think that binaural beat thresholds are strongly influenced by the method of stimulus presentation. One would properly question the concept of departing from matched levels in listening for binaural beats if he had data from experiments which used absolute stimulus consideration of the data gathered using relative stimuli, though, leaves no room for doubt

⁹ L. A. Jeffress, "A place theory of sound localization," *J. Comp. Physiol. Psychol.* 41, 35-39 (1948).

¹⁰ (a) J. C. R. Licklider, "A duplex theory of pitch perception," *Experientia* 7, 128-134 (1951).

(b) J. C. R. Licklider, "Auditory frequency analysis in C. Cherry (ed.), *Information Theory: Third London Symposium* (Butterworths Scientific Publications, London 1955), Chap. 27.

¹¹ (a) B. H. Deatherage, D. H. Eldredge, and H. Davy, "Latency of action potentials in the cochlea of the guinea pig," *J. Acoust. Soc. Am.* 31, 479-486 (1959).

(b) B. H. Deatherage and I. J. Hirsh, "Auditory localization of clicks," *J. Acoust. Soc. Am.* 31, 486-491 (1959).

¹² "The principle of diversity states that the nervous system often hedges. Instead of presenting a single train of the peripheral stimulation to the higher center the auditory tract may present a number of trains. Given a number of views of the stimulus, the cortex will look them over and take the most useful one. Or it will accept them all and operate upon them all, trying to put together a consistent picture of the outside world." W. Huggins and J. C. R. Licklider, "Place mechanisms in auditory frequency analysis," *J. Acoust. Soc. Am.* 23, 229 (1951), p. 299. (By permission from *The Journal of the Acoustical Society of America*.)

ACKNOWLEDGMENTS

Particular thanks are due to Herndon Snyder who conducted the first pilot experiment as part of a classroom project; to Joel Wernick who served usefully as experimenter, subject, and critic; to G. von Békésy who took time to discuss his own measurements of binaural beat phenomena; and to E. G. Wever whose help solved a major bibliographic problem.