



---

# ***MASH TEST 3-11 OF THE TxDOT SINGLE SLOPE BRIDGE RAIL (TYPE SSTR) ON PAN-FORMED BRIDGE DECK***



Crash testing performed at:  
TTI Proving Ground  
3100 SH 47, Building 7091  
Bryan, TX 77807

## **Research/Test Report 9-1002-3**

**Cooperative Research Program**

**TEXAS TRANSPORTATION INSTITUTE  
THE TEXAS A&M UNIVERSITY SYSTEM  
COLLEGE STATION, TEXAS**

**TEXAS DEPARTMENT OF TRANSPORTATION**

in cooperation with the  
Federal Highway Administration and the  
Texas Department of Transportation  
<http://tti.tamu.edu/documents/9-1002-3.pdf>



1. Report No. FHWA/TX-11/9-1002-3		2. Government Accession No.		3. Recipient's Catalog No.	
4. Title and Subtitle MASH TEST 3-11 OF THE TXDOT SINGLE SLOPE BRIDGE RAIL (TYPE SSTR) ON PAN-FORMED BRIDGE DECK				5. Report Date November 2010 Published: March 2011	
				6. Performing Organization Code	
7. Author(s) William F. Williams, Roger P. Bligh, and Wanda L. Menges				8. Performing Organization Report No. Report 9-1002-3	
9. Performing Organization Name and Address Texas Transportation Institute Proving Ground The Texas A&M University System College Station, Texas 77843-3135				10. Work Unit No. (TRAIS)	
				11. Contract or Grant No. Project 9-1002	
12. Sponsoring Agency Name and Address Texas Department of Transportation Research and Technology Implementation Office P.O. Box 5080 Austin, Texas 78763-5080				13. Type of Report and Period Covered Technical Report: September 2009–August 2010	
				14. Sponsoring Agency Code	
15. Supplementary Notes Project performed in cooperation with the Texas Department of Transportation and the Federal Highway Administration. Project Title: Roadside Safety Device Crash Testing Program URL: <a href="http://tti.tamu.edu/documents/9-1002-3.pdf">http://tti.tamu.edu/documents/9-1002-3.pdf</a>					
16. Abstract  <p>The objective of this crash test was to determine whether the TxDOT Single Slope Traffic Rail (Type SSTR) would perform acceptably on a pan-formed deck when tested according to the guidelines set forth in <i>Manual for Assessing Safety Hardware (MASH)</i>. The crash test performed was <i>MASH</i> test 3-11 involving a 2270P vehicle (5000-lb pickup truck) impacting the critical impact point (CIP) of the bridge rail at an impact speed and angle of 62 mi/h and 25 degrees, respectively.</p> <p>This report presents the details of the TxDOT Type SSTR on pan-formed bridge deck, description of the crash test performed, an assessment of the test results, and the implementation plan.</p> <p>The TxDOT Type SSTR bridge rail on pan-formed deck performed acceptably for <i>MASH</i> test 3-11.</p>					
17. Key Words Bridge Rail, Roadside Safety, Crash Test, <i>MASH</i>			18. Distribution Statement No restrictions. This document is available to the public through NTIS: National Technical Information Service Springfield, Virginia 22161 <a href="http://www.ntis.gov">http://www.ntis.gov</a>		
19. Security Classif.(of this report) Unclassified		20. Security Classif.(of this page) Unclassified		21. No. of Pages 62	22. Price



**MASH TEST 3-11 OF THE TXDOT SINGLE SLOPE BRIDGE RAIL  
(TYPE SSTR)  
ON PAN-FORMED BRIDGE DECK**

by

William F. Williams, P.E.  
Assistant Research Engineer  
Texas Transportation Institute

Roger P. Bligh, P.E.  
Research Engineer  
Texas Transportation Institute

and

Wanda L. Menges  
Associate Research Specialist  
Texas Transportation Institute

Report 9-1002-3  
Project 9-1002  
Project Title: Roadside Safety Device Crash Testing Program

Performed in cooperation with the  
Texas Department of Transportation  
and the  
Federal Highway Administration

November 2010  
Published: March 2011

TEXAS TRANSPORTATION INSTITUTE  
The Texas A&M University System  
College Station, Texas 77843-3135



## DISCLAIMER

This research was performed in cooperation with the Texas Department of Transportation (TxDOT) and the Federal Highway Administration (FHWA). The contents of this report reflect the views of the authors, who are responsible for the facts and the accuracy of the data presented herein. The contents do not necessarily reflect the official view or policies of the FHWA or TxDOT. This report does not constitute a standard, specification, or regulation, and its contents are not intended for construction, bidding, or permit purposes. In addition, the above listed agencies assume no liability for its contents or use thereof. The United States Government and the State of Texas do not endorse products or manufacturers. Trade or manufacturers' names appear herein solely because they are considered essential to the object of this report. The engineer in charge of the project was Roger P. Bligh, P.E. (Texas, #78550).

## TTI PROVING GROUND DISCLAIMER

The results of the crash testing reported herein apply only to the article being tested.

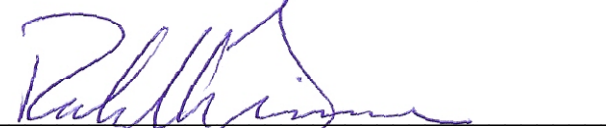

  
Wanda L. Menges, Research Specialist  
Deputy Quality Manager

  
Richard A. Zimmer, Senior Research Specialist  
Test Facility Manager  
Quality Manager  
Technical Manager

## **ACKNOWLEDGMENTS**

This research project was conducted under a cooperative program between the Texas Transportation Institute, the Texas Department of Transportation, and the Federal Highway Administration. The TxDOT project director for this research was Rory Meza, P.E. with the Design Division. John Holt, P.E., and Jon Reis with the Bridge Division served as project advisors and helped guide this research. The TxDOT research engineer was Wade Odell, P.E. with the Research and Technology Implementation Office. The authors acknowledge and appreciate their guidance and assistance.



# TABLE OF CONTENTS

	Page
LIST OF FIGURES .....	ix
LIST OF TABLES .....	x
CHAPTER 1. INTRODUCTION .....	1
1.1 INTRODUCTION .....	1
1.2 BACKGROUND .....	1
1.3 OBJECTIVES/SCOPE OF RESEARCH .....	1
CHAPTER 2. SYSTEM DETAILS .....	3
2.1 TEST ARTICLE DESIGN AND CONSTRUCTION .....	3
2.2 MATERIAL SPECIFICATIONS .....	4
CHAPTER 3. TEST REQUIREMENTS AND EVALUATION CRITERIA .....	7
3.1 CRASH TEST MATRIX .....	7
3.2 EVALUATION CRITERIA .....	7
CHAPTER 4. CRASH TEST PROCEDURES .....	9
4.1 TEST FACILITY .....	9
4.2 VEHICLE TOW AND GUIDANCE PROCEDURES .....	9
4.3 DATA ACQUISITION SYSTEMS .....	9
4.3.1 Vehicle Instrumentation and Data Processing .....	9
4.3.2 Anthropomorphic Dummy Instrumentation .....	10
4.3.3 Photographic Instrumentation and Data Processing .....	10
CHAPTER 5. CRASH TEST RESULTS .....	11
5.1 TEST DESIGNATION AND ACTUAL IMPACT CONDITIONS .....	11
5.2 TEST VEHICLE .....	11
5.3 WEATHER CONDITIONS .....	11
5.4 TEST DESCRIPTION .....	11
5.5 DAMAGE TO TEST INSTALLATION .....	14
5.6 VEHICLE DAMAGE .....	14
5.7 OCCUPANT RISK FACTORS .....	14
CHAPTER 6. SUMMARY AND CONCLUSIONS .....	21
6.1 ASSESSMENT OF TEST RESULTS .....	21
6.1.1 Structural Adequacy .....	21
6.1.2 Occupant Risk .....	21
6.1.3 Vehicle Trajectory .....	22
6.2 CONCLUSIONS .....	22
CHAPTER 7. IMPLEMENTATION STATEMENT .....	25

## TABLE OF CONTENTS (CONTINUED)

	<b>Page</b>
REFERENCES .....	27
APPENDIX A. DETAILS OF THE TEST ARTICLE .....	29
APPENDIX B. CERTIFICATION DOCUMENTATION .....	35
APPENDIX C. TEST VEHICLE PROPERTIES AND INFORMATION .....	41
APPENDIX D. SEQUENTIAL PHOTOGRAPHS .....	45
APPENDIX E. VEHICLE ANGULAR DISPLACEMENTS AND ACCELERATIONS .....	49

## LIST OF FIGURES

Figure	Page
Figure 2.1. Details of the TxDOT Pan-Formed Bridge Rail Installation.....	5
Figure 2.2. TxDOT Pan-Formed Bridge Rail Installation Before Test No. 420020-3.....	6
Figure 5.1. Vehicle/Installation Geometrics for Test No. 420020-3.....	12
Figure 5.2. Vehicle Before Test No. 420020-3.....	13
Figure 5.3. After Impact Vehicle Position for Test No. 420020-3.....	15
Figure 5.4. Installation After Test No. 420020-3.....	16
Figure 5.5. Vehicle After Test No. 420020-3.....	17
Figure 5.6. Interior of Vehicle for Test No. 420020-3.....	18
Figure 5.7. Summary of Results for <i>MASH</i> Test 3-11 on the TxDOT Pan-Form Bridge Rail.....	19
Figure C1. Vehicle Properties for Test No. 420020-3.....	41
Figure D1. Sequential Photographs for Test No. 420020-3 (Overhead and Frontal Views). ....	45
Figure D2. Sequential Photographs for Test No. 420020-3 (Rear View).....	47
Figure E1. Vehicle Angular Displacements for Test No. 420020-3.....	49
Figure E2. Vehicle Longitudinal Accelerometer Trace for Test No. 420020-3 (Accelerometer Located at Center of Gravity). ....	50
Figure E3. Vehicle Lateral Accelerometer Trace for Test No. 420020-3 (Accelerometer Located at Center of Gravity). ....	51
Figure E4. Vehicle Vertical Accelerometer Trace for Test No. 420020-3 (Accelerometer Located at Center of Gravity). ....	52

## LIST OF TABLES

<b>Table</b>		<b>Page</b>
Table 6.1.	Performance Evaluation Summary for <i>MASH</i> Test 3-11 on the TxDOT Pan-Form Bridge Rail.....	23
Table C1.	Exterior Crush Measurements for Test No. 420020-3.....	42
Table C2.	Occupant Compartment Measurements for Test No. 420020-3.....	43

# CHAPTER 1. INTRODUCTION

## 1.1 INTRODUCTION

This project was set up to provide Texas Department of Transportation (TxDOT) with a mechanism to quickly and effectively evaluate high priority issues related to roadside safety devices. Roadside safety devices shield motorists from roadside hazards such as non-traversable terrain and fixed objects. To maintain the desired level of safety for the motoring public, these safety devices must be designed to accommodate a variety of site conditions, placement locations, and a changing vehicle fleet. As changes are made or in-service problems encountered, there is a need to assess the compliance of existing safety devices with current vehicle testing criteria and, if problems are identified, to modify the device or develop a new device with enhanced performance and maintenance characteristics.

## 1.2 BACKGROUND

Pan form girders with bridge decks were developed in the late 1940s in anticipation of a need for low cost bridges in rural areas in Texas that were soon to be funded by the federal government. The terminology depicts the modular steel forms required for cast-in-place reinforced concrete spans. When assembled, bolted together and supported from bent caps, a metal pan is used to form the concrete and support the weight in flexure without intermediate support. Forms and falsework are combined in a sturdy reuseable package. The original span length was 30 ft for 20-inch wide caps and no skew. It was soon discovered that trestle piling would seldom fit inside a 20-inch wide cap. The cap width was changed to 24 inches and, since the distance face to face of caps had to remain the same to allow form removal, the basic span length became 30 ft-4 inches.

In 1956, a design was introduced for 40-ft spans to be constructed on a skew. In the 1960s, standard drawings were distributed for superstructure and substructure for different combinations or span ranges, roadway widths, and skew angles. Prior to the use of prestressed concrete beams, pan form girders were the most economical method for constructing a highway bridge over small to moderate streams. By 1988, approximately 3750 pan form girder bridges had been constructed on the Texas highway system. Many of these bridges are presently still in use.

## 1.3 OBJECTIVES/SCOPE OF RESEARCH

The objective of this crash test was to determine if the TxDOT Type SSTR bridge rail retrofitted on a pan-formed bridge deck would perform acceptably according to the guidelines set forth in American Association of State Highway and Transportation Officials (AASHTO) *Manual for Assessing Safety Hardware (MASH) (I)*. The crash test performed was *MASH* test 3-11 involving a 2270P vehicle (5000-lb pickup truck) impacting the critical impact point (CIP) of the bridge rail at an impact speed and angle of 62 mi/h and 25 degrees, respectively.

This report presents the details of the TxDOT SSTR bridge rail retrofitted on a typical pan-formed bridge deck installation, description of the crash test performed, an assessment of the test results, and the implementation plan.

## CHAPTER 2. SYSTEM DETAILS

### 2.1 TEST ARTICLE DESIGN AND CONSTRUCTION

The TxDOT Single-Slope Traffic Rail (Type SSTR) bridge rail was anchored to the top of a 6-inch thick reinforced concrete deck cantilever. The TxDOT Type SSTR bridge rail is 36 inches in height and has a single sloped traffic face. The bridge rail is 13 inches wide at the base and 7½ inches wide at the top. The traffic face of the bridge rail is sloped 7 inches over the 36-inch height of the bridge rail. Reinforcement in the bridge rail consisted of pre-fabricated deformed welded wire (WWR) provided by Insteel Industries, Inc., Mount Airy, North Carolina. The welded wire mesh consisted of 31 ft preformed units with all unions of longitudinal and vertical wires welded. TTI received a drawing from Insteel Industries, Inc. entitled “SSTR Bridge Rail Texas DOT,” (Insteel Drawing No. 09-DS-99) and dated May 22, 2009. This drawing provided fabrication details for the welded wire reinforcement used in the TxDOT Type SSTR bridge rail tested for this project. Longitudinal reinforcement between the preformed units was lapped approximately 12 inches. The specified yield strength of the deformed wire used to fabricate the panels was specified to be 70 ksi steel material.

The TxDOT Type SSTR bridge rail was anchored to the 6-inch thick deck using 1-inch diameter ASTM F1554 Grade 55 galvanized anchor bolts 24 inches in length near the traffic side face of the bridge rail. The bolts were anchored through the deck in 1¼-inch diameter core drilled holes. The anchor bolts were located approximately 11 inches from the edge of the deck and were fabricated with a 15-degree bend. This bend helped accommodate approximately 15 inches of anchorage embedment within the deformed welded wire reinforcement of the TxDOT Type SSTR bridge rail. The bridge rail was additionally anchored to the deck using #4 dowels spaced on 48-inch centers 4½ inches from the edge of the deck and approximately 4 inches into the deck using the Hilti RE 500 Epoxy anchoring system. The length of these #4 dowels was approximately 16 inches.

A 6-inch thick by 21¼ inches wide deck cantilever was constructed for this project. Reinforcement in the deck cantilever consisted of one layer of steel reinforcement. Transverse reinforcement consisted of #4 bars located on 6-inch centers. One longitudinal #4 bar was placed within the deck approximately 1¾ inch from the field side edge of the deck.

The test installation for this project measured approximately 75 ft-¾ inch in length. The installation was constructed with a ¾-inch wide expansion joint in both the TxDOT Type SSTR bridge rail and 6-inch thick deck. This joint in the bridge rail and deck was located approximately 32 ft from the upstream end of the installation. Two #8 deformed bars, approximately 60 inches in length, were used to provide additional lateral strength to the two opposing ends of the bridge rail at the joint. The #8 bars were anchored approximately 31¾ inches within one end of the TxDOT Type SSTR bridge rail at the joint. On the adjacent bridge rail end, these dowels extended through the joint and were placed in sleeved PVC pipe sections. These pipe sections were approximately 32½ inches in length and accommodated movement in the opposing end of the bridge rail. For additional information, please refer to Figures 1 and 2 and the drawings in Appendix A.

## **2.2 MATERIAL SPECIFICATIONS**

Reinforcement in the bridge rail consisted of pre-fabricated deformed welded wire provided by Insteel Industries, Inc., Mount Airy, North Carolina. The specified compressive strength of the concrete for the TxDOT Type SSTR bridge rail and the deck were 3600 psi and 3000 psi, respectively. The compressive strengths of the bridge rail and deck on the day the test was performed measured 4360 psi on the upstream end of the parapet (upstream from the expansion joint), 3525 psi on the downstream end of the parapet (downstream from expansion joint), and 3450 psi on the deck. Appendix B contains mill certifications sheets and other certification documents for the materials used in the TxDOT Type SSTR bridge rail information.



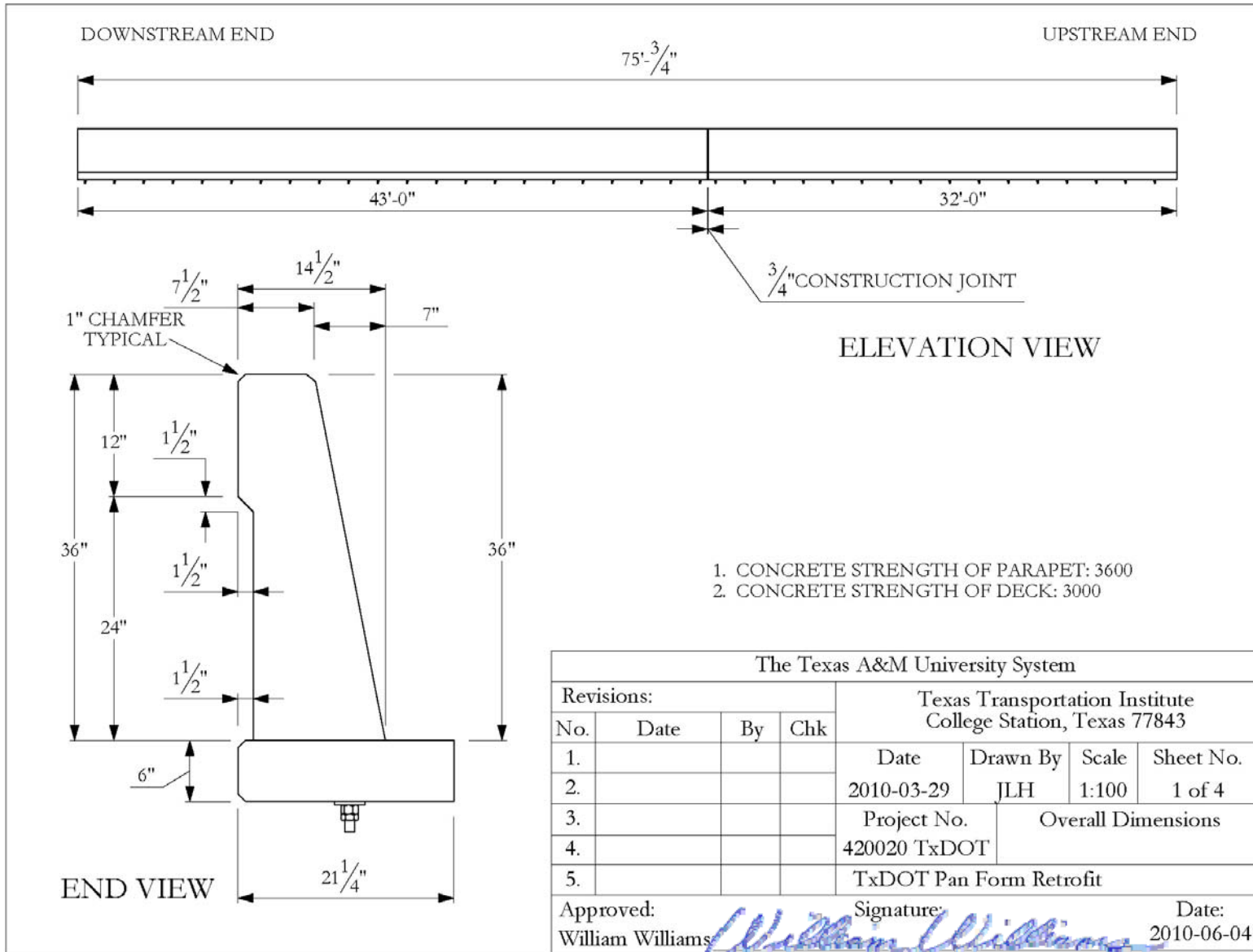

T:\2009-2010\420020 TxDOT\3 Pan-Form Retrofit\SolidWorks\Drawings\Pan-form Drawing

**Figure 2.1. Details of the TxDOT Pan-Formed Bridge Rail Installation.**



**Figure 2.2. TxDOT Pan-Formed Bridge Rail Installation before Test No. 420020-3.**

## CHAPTER 3. TEST REQUIREMENTS AND EVALUATION CRITERIA

### 3.1 CRASH TEST MATRIX

According to *MASH*, two tests are recommended to evaluate longitudinal barriers to test level three (TL-3). Details of the tests are as described below.

***MASH* test 3-10:** An 1100C (2425 lb/1100 kg) vehicle impacting the critical impact point (CIP) of the length of need (LON) of the barrier at a nominal impact speed and angle of 62 mi/h and 25 degrees, respectively. This test is to investigate a barrier's ability to successfully contain and redirect a small passenger vehicle.

***MASH* test 3-11:** A 2270P (5000 lb/2270 kg) vehicle impacting the CIP of the LON of the barrier at a nominal impact speed and angle of 62 mi/h and 25 degrees, respectively. This is a strength test to verify a barrier's performance for impacts involving light trucks and SUVs for all test levels.

The test performed on the TxDOT pan-formed bridge rail was *MASH* test 3-11. The target CIP was determined to be 4.3 ft upstream of joint centerline in the TxDOT Type SSTR bridge rail. The crash test and data analysis procedures were in accordance with guidelines presented in *MASH*. Chapter 4 presents brief descriptions of these procedures.

### 3.2 EVALUATION CRITERIA

The crash test was evaluated in accordance with the criteria presented in *MASH*. The performance of the TxDOT Type SSTR bridge rail on pan-formed bridge rail is judged on the basis of three factors: structural adequacy, occupant risk, and post impact vehicle trajectory. Structural adequacy is judged upon the ability of the TxDOT Type SSTR bridge rail on pan-formed bridge rail to contain and redirect the vehicle, or bring the vehicle to a controlled stop in a predictable manner. Occupant risk criteria evaluates the potential risk of hazard to occupants in the impacting vehicle, and to some extent other traffic, pedestrians, or workers in construction zones, if applicable. Post impact vehicle trajectory is assessed to determine potential for secondary impact with other vehicles or fixed objects, creating further risk of injury to occupants of the impacting vehicle and/or risk of injury to occupants in other vehicles. The appropriate safety evaluation criteria from table 5-1 of *MASH* were used to evaluate the crash test reported herein, and are listed in further detail under the assessment of the crash test.



## **CHAPTER 4. CRASH TEST PROCEDURES**

### **4.1 TEST FACILITY**

The full-scale crash test reported herein was performed at Texas Transportation Institute (TTI) Proving Ground. TTI Proving Ground is an International Standards Organization (ISO) 17025 accredited laboratory with American Association for Laboratory Accreditation (A2LA) Mechanical Testing certificate 2821.01. The full-scale crash test was performed according to TTI Proving Ground quality procedures and according to the *MASH* guidelines and standards.

The Texas Transportation Institute Proving Ground is a 2000-acre complex of research and training facilities located 10 miles northwest of the main campus of Texas A&M University. The site, formerly an Air Force base, has large expanses of concrete runways and parking aprons well suited for experimental research and testing in the areas of vehicle performance and handling, vehicle-roadway interaction, durability and efficacy of highway pavements, and safety evaluation of roadside safety hardware. The site selected for construction and testing of the TxDOT SSTR bridge rail on pan-formed bridge deck evaluated under this project is along the edge of an out-of-service apron. The apron consists of an unreinforced jointed-concrete pavement in 12.5 ft by 15 ft blocks nominally 8 to 12 inches deep. The apron is over 50 years old, and the joints have some displacement, but are otherwise flat and level.

### **4.2 VEHICLE TOW AND GUIDANCE PROCEDURES**

The test vehicle was towed into the test installation using a steel cable guidance and reverse tow system. A steel cable for guiding the test vehicle was tensioned along the path, anchored at each end, and threaded through an attachment to the front wheel of the test vehicle. An additional steel cable was connected to the test vehicle, passed around a pulley near the impact point, through a pulley on the tow vehicle, and then anchored to the ground such that the tow vehicle moved away from the test site. A two-to-one speed ratio between the test and tow vehicle existed with this system. Just prior to impact with the installation, the test vehicle was released to be free-wheeling and unrestrained. The vehicle remained free-wheeling, i.e., no steering or braking inputs, until the vehicle cleared the immediate area of the test site, at which time brakes on the vehicle were activated to bring it to a safe and controlled stop.

### **4.3 DATA ACQUISITION SYSTEMS**

#### **4.3.1 Vehicle Instrumentation and Data Processing**

The test vehicle was instrumented with a self-contained, on-board data acquisition system. The signal conditioning and acquisition system is a 16-channel, Tiny Data Acquisition System (TDAS) Pro produced by Diversified Technical Systems, Inc. The accelerometers, that measure the x, y, and z axis of vehicle acceleration, are strain gauge type with linear millivolt output proportional to acceleration. Angular rate sensors, measuring vehicle roll, pitch, and yaw

rates, are ultra small size, solid state units designs for crash test service. The TDAS Pro hardware and software conform to the latest SAE J211, Instrumentation for Impact Test. Each of the 16 channels is capable of providing precision amplification, scaling, and filtering based on transducer specifications and calibrations. During the test, data are recorded from each channel at a rate of 10,000 values per second with a resolution of one part in 65,536. Once recorded, the data are backed up inside the unit by internal batteries should the primary battery cable be severed. Initial contact of the pressure switch on the vehicle bumper provides a time zero mark as well as initiating the recording process. After each test, the data are downloaded from the TDAS Pro unit into a laptop computer at the test site. The raw data are then processed by the Test Risk Assessment Program (TRAP) software to produce detailed reports of the test results. Each of the TDAS Pro units are returned to the factory annually for complete recalibration. Accelerometers and rate transducers are also calibrated annually with traceability to the National Institute for Standards and Technology.

TRAP uses the data from the TDAS Pro to compute occupant/compartiment impact velocities, time of occupant/compartiment impact after vehicle impact, and the highest 10-millisecond (ms) average ridedown acceleration. TRAP calculates change in vehicle velocity at the end of a given impulse period. In addition, maximum average accelerations over 50-ms intervals in each of the three directions are computed. For reporting purposes, the data from the vehicle-mounted accelerometers are filtered with a 60-Hz digital filter, and acceleration versus time curves for the longitudinal, lateral, and vertical directions are plotted using TRAP.

TRAP uses the data from the yaw, pitch, and roll rate transducers to compute angular displacement in degrees at 0.0001-s intervals and then plots yaw, pitch, and roll versus time. These displacements are in reference to the vehicle-fixed coordinate system with the initial position and orientation of the vehicle-fixed coordinate systems being initial impact.

#### **4.3.2 Anthropomorphic Dummy Instrumentation**

Use of a dummy in the 2270P vehicle is optional according to *MASH*, and there was no dummy used in this test.

#### **4.3.3 Photographic Instrumentation and Data Processing**

Photographic coverage of the test included three high-speed cameras: one overhead with a field of view perpendicular to the ground and directly over the impact point; one placed behind the installation at an angle; and a third placed to have a field of view parallel to and aligned with the installation at the downstream end. A flashbulb activated by pressure-sensitive tape switches was positioned on the impacting vehicle to indicate the instant of contact with the installation and was visible from each camera. The films from these high-speed cameras were analyzed on a computer-linked motion analyzer to observe phenomena occurring during the collision and to obtain time-event, displacement, and angular data. A mini-DV camera and still cameras recorded and documented conditions of the test vehicle and installation before and after the test.

## CHAPTER 5. CRASH TEST RESULTS

### 5.1 TEST DESIGNATION AND ACTUAL IMPACT CONDITIONS

*MASH* test 3-11 involves a 2270P vehicle weighing 5000 lb  $\pm$ 100 lb and impacting the TxDOT pan-formed bridge rail at an impact speed of 62.2 mi/h  $\pm$ 2.5 mi/h and an angle of 25 degrees  $\pm$ 1.5 degrees. The target impact point was 4.3 ft upstream of the joint centerline in the TxDOT Type SSTR bridge rail. The 2005 Dodge Ram 1500 Quad-Cab pickup truck used in the test weighed 5036 lb and the actual impact speed and angle were 63.8 mi/h and 24.8 degrees, respectively. The actual impact point was 5.2 ft upstream of the joint centerline in the TxDOT Type SSTR bridge rail. Impact severity was calculated at 3881 kip-ft or 5.2 percent above the target value.

### 5.2 TEST VEHICLE

A 2005 Dodge Ram 1500 Quad-Cab pickup, shown in Figures 5.1 and 5.2, was used for the crash test. Test inertia weight of the vehicle was 5036 lb, and its gross static weight was 5036 lb. The height to the lower edge of the vehicle bumper was 13.5 inches, and it was 26.00 inches to the upper edge of the bumper. The height of the vertical center of gravity was measured at 28.38 inches. Figure C1 in Appendix C gives additional dimensions and information on the vehicle. The vehicle was directed into the installation using the cable reverse tow and guidance system, and was released to be free-wheeling and unrestrained just prior to impact.

### 5.3 WEATHER CONDITIONS

The test was performed on the morning of August 3, 2010. Weather conditions at the time of testing were as follows: wind speed: 2 mi/h; wind direction: 192 degrees with respect to the vehicle (vehicle was traveling in a southwesterly direction); Temperature: 97°F, Relative humidity: 56 percent.

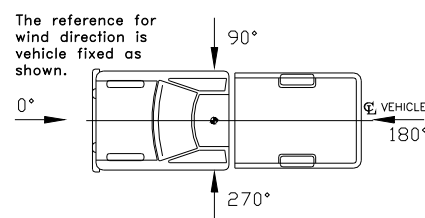

### 5.4 TEST DESCRIPTION

The 2270P vehicle, traveling at an impact speed of 63.8 mi/h, impacted the TxDOT pan-formed bridge rail with the right front corner of the bumper 5.2 ft upstream of the joint centerline in the TxDOT Type SSTR bridge rail at an impact angle of 24.8 degrees. Shortly after impact, the right front tire contacted the bridge rail, and the vehicle began redirection at 0.074 s after impact. The vehicle was traveling parallel with the bridge rail at 0.189 s, and was traveling at a speed of 50.6 mi/h. At 0.430 s, the 2270P vehicle lost contact with the bridge rail, traveling at an exit speed and angle of 49.5 mi/h and 7.2 degrees, respectively. Brakes on the vehicle were applied at 1.2 s after impact. The vehicle subsequently came to rest 170 ft downstream and 6 ft toward traffic lanes. Figures D1 and D2 in Appendix D show sequential photographs of the test period.





**Figure 5.1. Vehicle/Installation Geometrics for Test No. 420020-3.**





**Figure 5.2. Vehicle before Test No. 420020-3.**

## **5.5 DAMAGE TO TEST INSTALLATION**

Figures 5.3 and 5.4 show damage sustained by the TxDOT pan-formed bridge rail. Gouges and tire marks were evident in the length of contact for 12 ft beyond impact. The top traffic side corner of the downstream joint spalled off. Working width was 10 inches. No measurable dynamic deflection or permanent deformation occurred.

## **5.6 VEHICLE DAMAGE**

The vehicle sustained damage to the right front quarter and right side, as shown in Figure 5.5. The right upper and lower ball joints, right front frame rail, right front upper and lower A-arms and right rear axle were damaged. Also deformed were the front bumper, hood, grill, right front fender, right front door, right rear door, right rear cab, right rear exterior bed, rear bumper, and tail gate. The right front wheel assembly, tire, and wheel rim separated from the vehicle, and the right rear tire and rim and part of the wheel assembly separated from the vehicle. The windshield sustained stress cracks. Maximum exterior crush to the vehicle in the side plane at the right front corner at bumper height was 18.0 inches. Maximum occupant compartment deformation was 2.75 inches in the firewall area near the toe pan on the right front passenger area. Figure 5.6 shows photographs of the interior of the vehicle. Exterior crush and occupant compartment deformation is provided in Appendix C, Tables C1 and C2.

## **5.7 OCCUPANT RISK FACTORS**

Data from the accelerometer, located at the vehicle center of gravity, were digitized for evaluation of occupant risk. In the longitudinal direction, the occupant impact velocity was 22.0 ft/s at 0.087 s, the highest 0.010-s occupant ridedown acceleration was  $-5.3$  Gs from 0.095 to 0.105 s, and the maximum 0.050-s average acceleration was  $-10.9$  Gs between 0.026 and 0.076 s. In the lateral direction, the occupant impact velocity was 29.9 ft/s at 0.087 s, the highest 0.010-s occupant ridedown acceleration was  $-11.7$  Gs from 0.206 to 0.216 s, and the maximum 0.050-s average was  $-15.5$  Gs between 0.026 and 0.076 s. Theoretical Head Impact Velocity (THIV) was 40.6 km/h or 11.3 m/s at 0.085 s; Post-Impact Head Decelerations (PHD) was 11.7 Gs between 0.206 and 0.216 s; and Acceleration Severity Index (ASI) was 2.02 between 0.026 and 0.076 s. Figure 5.7 summarizes these data and other pertinent information from the test. Vehicle angular displacements and accelerations versus time traces are presented in Appendix E, Figures E1 through E4.





**Figure 5.3. After Impact Vehicle Position for Test No. 420020-3.**





**Figure 5.4. Installation after Test No. 420020-3.**





**Figure 5.5. Vehicle after Test No. 420020-3.**





Before Test



After Test

**Figure 5.6. Interior of Vehicle for Test No. 420020-3.**

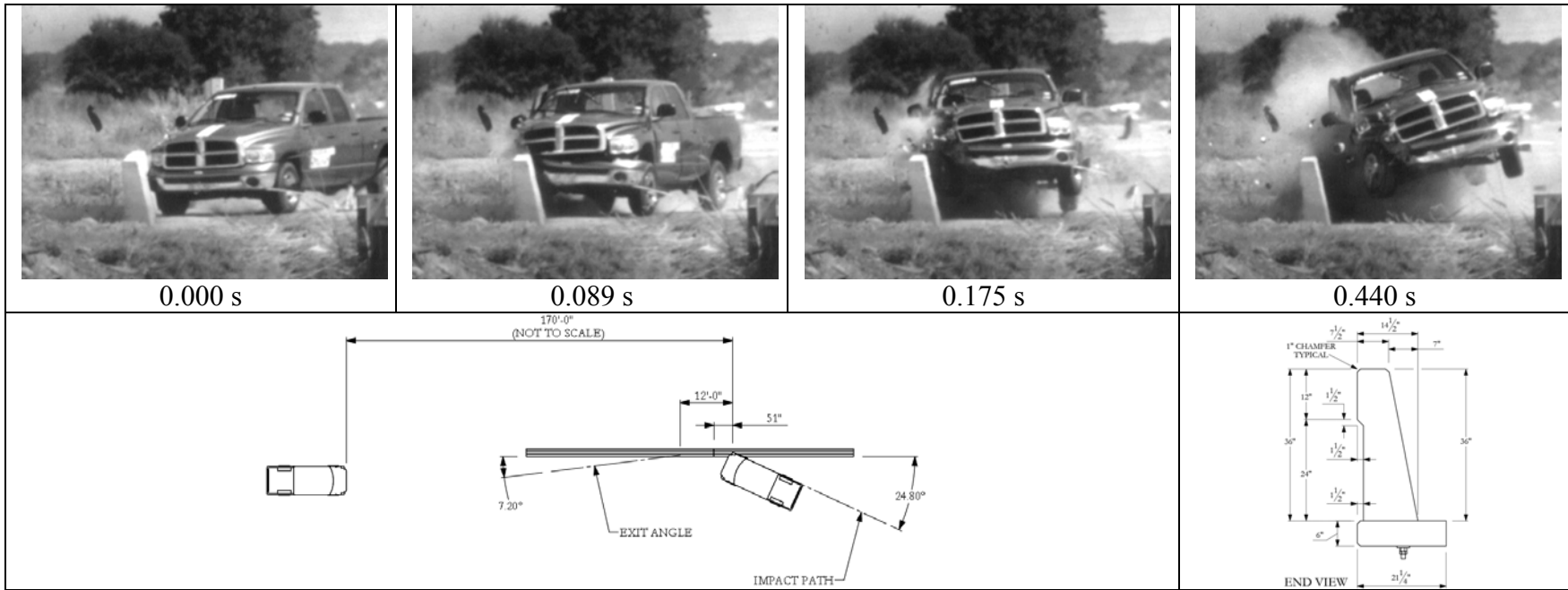

**General Information**

Test Agency..... Texas Transportation Institute (TTI)  
 Test Standard Test No. .... MASH Test 3-11  
 TTI Test No. .... 420020-3  
 Date ..... 2010-08-03

**Test Article**

Type..... Bridge Rail  
 Name ..... TxDOT Pan-Formed Bridge Rail  
 Installation Length ..... 75 ft  
 Material or Key Elements ..... TxDOT Single Slope Traffic Rail (Type SSTR) anchored to top of 6-inch thick reinforced concrete deck cantilever

**Soil Type and Condition**

Concrete Bridge Deck, Dry

**Test Vehicle**

Type/Designation..... 2270P  
 Make and Model ..... 2005 Dodge Ram 1500  
 Curb ..... 4723 lb  
 Test Inertial ..... 5036 lb  
 Dummy ..... No dummy  
 Gross Static ..... 5036 lb

**Impact Conditions**

Speed .....63.8 mi/h  
 Angle .....24.8 degrees  
 Location/Orientation .....5.2 ft upstream of joint

**Exit Conditions**

Speed .....49.5 mi/h  
 Angle .....7.2 degrees

**Occupant Risk Values**

Impact Velocity  
 Longitudinal .....22.0 ft/s  
 Lateral .....29.9 ft/s  
 Ridedown Accelerations  
 Longitudinal ..... -5.3 G  
 Lateral .....-11.7 G  
 THIV .....40.6 km/h  
 PHD .....11.7 G  
 ASI .....2.02  
 Max. 0.050-s Average  
 Longitudinal .....-10.9 G  
 Lateral .....-15.5 G  
 Vertical ..... -6.1 G

**Post-Impact Trajectory**

Stopping Distance ..... 170 ft dwnstrm  
 6.0 ft twd traffic

**Vehicle Stability**

Maximum Yaw Angle.....-34 degrees  
 Maximum Pitch Angle..... 8 degrees  
 Maximum Roll Angle ..... 26 degrees  
 Vehicle Snagging ..... No  
 Vehicle Pocketing..... No

**Test Article Deflections**

Dynamic ..... Nil  
 Permanent..... Nil  
 Working Width ..... 10 inches

**Vehicle Damage**

VDS ..... 01RFQ5  
 CDC..... 01RDEW4  
 Max. Exterior Deformation ..... 18.0 inches  
 OCDI ..... RF0020000  
 Max. Occupant Compartment Deformation ..... 2.75 inches

**Impact Severity**..... 3881 kip-ft (+5%)

**Figure 5.7. Summary of Results for MASH Test 3-11 on the TxDOT Pan-Formed Bridge Rail.**





## CHAPTER 6. SUMMARY AND CONCLUSIONS

### 6.1 ASSESSMENT OF TEST RESULTS

An assessment of the test based on the applicable *MASH* safety evaluation criteria is provided below.

#### 6.1.1 Structural Adequacy

- A. *Test article should contain and redirect the vehicle or bring the vehicle to a controlled stop; the vehicle should not penetrate, underride, or override the installation although controlled lateral deflection of the test article is acceptable.*

Results: The TxDOT pan-formed bridge rail contained and redirected the 2270P vehicle. The vehicle did not penetrate, underride, or override the installation. No measurable dynamic deflection was noted. (PASS)

#### 6.1.2 Occupant Risk

- D. *Detached elements, fragments, or other debris from the test article should not penetrate or show potential for penetrating the occupant compartment, or present an undue hazard to other traffic, pedestrians, or personnel in a work zone.*  
*Deformation of, or intrusions into, the occupant compartment should not exceed limits set forth in Section 5.3 and Appendix E of MASH. (roof  $\leq 4.0$  inches; windshield  $\leq 3.0$  inches; side windows = no shattering by test article structural member; wheel/foot well/toe pan  $\leq 9.0$  inches; forward of A-pillar  $\leq 12.0$  inches; front side door area above seat  $\leq 9.0$  inches; front side door below seat  $\leq 12.0$  inches; floor pan/transmission tunnel area  $\leq 12.0$  inches).*

Results: A small piece of concrete broke off the top traffic side corner of the downstream joint of the bridge rail. This debris did not penetrate nor show potential for penetrating the occupant compartment, or present undue hazard to others in the area. (PASS)  
Maximum occupant compartment deformation was 2.75 inches in the firewall area near the toe pan on the front right passenger side. (PASS)

- F. *The vehicle should remain upright during and after collision. The maximum roll and pitch angles are not to exceed 75 degrees.*

Results: The 2270P vehicle remained upright during and after the collision event. Maximum roll and pitch angles during the test were 26 degrees and 8 degrees, respectively. (PASS)

H. *Occupant impact velocities should satisfy the following:*

Longitudinal and Lateral Occupant Impact Velocity

Preferred

30 ft/s

Maximum

40 ft/s

Results: Longitudinal occupant impact velocity was 22.0 ft/s, and lateral occupant impact velocity was 29.9 ft/s. (PASS)

I. *Occupant ridedown accelerations should satisfy the following:*

Longitudinal and Lateral Occupant Ridedown Accelerations

Preferred

15.0 Gs

Maximum

20.49 Gs

Results: Longitudinal ridedown acceleration was -5.3 G, and lateral ridedown acceleration was -11.7 G. (PASS)

### 6.1.3 Vehicle Trajectory

*For redirective devices, the vehicle shall exit the barrier within the exit box.*

Result: The vehicle exited within the exit box. (PASS)

## 6.2 CONCLUSIONS

The TxDOT pan-formed bridge rail performed acceptably for *MASH* test 3-11, as shown in Table 6.1.

**Table 6.1. Performance Evaluation Summary for MASH Test 3-11 on the TxDOT Pan-Formed Bridge Rail.**

Test Agency: Texas Transportation Institute

Test No.: 420020-3

Test Date: 2010-08-03

<b>MASH Test 3-11 Evaluation Criteria</b>	<b>Test Results</b>	<b>Assessment</b>
<p>Structural Adequacy</p> <p>A. <i>Test article should contain and redirect the vehicle or bring the vehicle to a controlled stop; the vehicle should not penetrate, underride, or override the installation although controlled lateral deflection of the test article is acceptable.</i></p>	<p>The TxDOT pan-formed bridge rail contained and redirected the 2270P vehicle. The vehicle did not penetrate, underride, or override the installation. No measurable dynamic deflection was noted.</p>	<p>Pass</p>
<p>Occupant Risk</p> <p>D. <i>Detached elements, fragments, or other debris from the test article should not penetrate or show potential for penetrating the occupant compartment, or present an undue hazard to other traffic, pedestrians, or personnel in a work zone.</i></p>	<p>A small piece of concrete broke off the top traffic side corner of the downstream joint. This debris did not penetrate nor show potential for penetrating the occupant compartment, or present undue hazard to others in the area.</p>	<p>Pass</p>
<p><i>Deformations of, or intrusions into, the occupant compartment should not exceed limits set forth in Section 5.3 and Appendix E of MASH.</i></p>	<p>Maximum occupant compartment deformation was 2.75 inches in the firewall area near the toe pan on the front right passenger side.</p>	<p>Pass</p>
<p>F. <i>The vehicle should remain upright during and after collision. The maximum roll and pitch angles are not to exceed 75 degrees.</i></p>	<p>The 2270P vehicle remained upright during and after the collision event. Maximum roll and pitch angles during the test were 26 degrees and 8 degrees, respectively.</p>	<p>Pass</p>
<p>H. <i>Longitudinal and lateral occupant impact velocities should fall below the preferred value of 30 ft/s, or at least below the maximum allowable value of 40 ft/s.</i></p>	<p>Longitudinal occupant impact velocity was 22.0 ft/s, and lateral occupant impact velocity was 29.9 ft/s.</p>	<p>Pass</p>
<p>I. <i>Longitudinal and lateral occupant ridedown accelerations should fall below the preferred value of 15.0 Gs, or at least below the maximum allowable value of 20.49 Gs.</i></p>	<p>Longitudinal ridedown acceleration was -5.3 G, and lateral ridedown acceleration was -11.7 G.</p>	<p>Pass</p>
<p>Vehicle Trajectory</p> <p><i>For redirective devices, the vehicle shall exit the barrier within the exit box.</i></p>	<p>The 2270P vehicle exited within the exit box.</p>	<p>Pass</p>



## CHAPTER 7. IMPLEMENTATION STATEMENT

The objective of this crash test was to determine if the TxDOT Type SSTR bridge rail on pan-formed retrofit bridge deck would perform acceptably according to the guidelines set forth in *MASH*. The crash test performed was *MASH* test 3-11 involving a 2270P vehicle (5000-lb pickup truck) impacting the critical impact point (CIP) of the bridge rail at an impact speed and angle of 62 mi/h and 25 degrees, respectively.

The TxDOT Type SSTR bridge rail retrofitted to the 6-inch thick pan-formed bridge deck as tested and described herein performed acceptably for *MASH* test 3-11. In addition, the two #8 deformed bars, used in the expansion joint between the barrier ends to provide additional lateral strength to the two opposing ends of the barrier at the joint performed as designed. The retrofit SSTR bridge rail as tested for this project with the #8 expansion dowels in the barrier expansion joints are recommended\* for implementation on any pan-form bridge upgrade projects with 6-inch minimum deck thickness.

---

\* *The opinions/interpretations expressed in this section are outside the scope of TTI Proving Ground's A2LA accreditation.*



## REFERENCES

1. AASHTO, "Manual for Assessing Safety Hardware," Fourth Edition: American Association of State Highway and Transportation Officials, Washington, D.C., 2009.





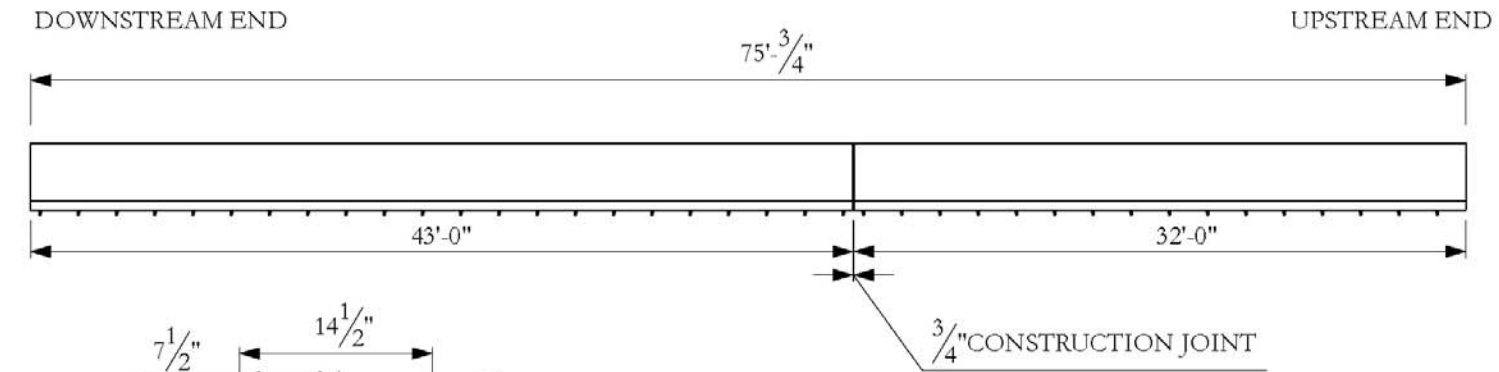

ELEVATION VIEW

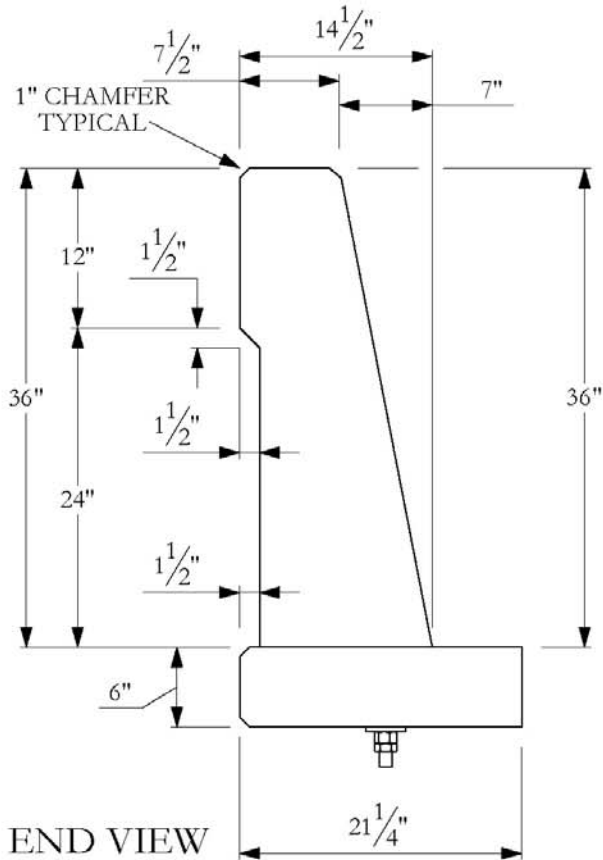

END VIEW

1. CONCRETE STRENGTH OF PARAPET: 3600
2. CONCRETE STRENGTH OF DECK: 3000

The Texas A&M University System							
Revisions:				Texas Transportation Institute College Station, Texas 77843			
No.	Date	By	Chk	Date	Drawn By	Scale	Sheet No.
1.				2010-03-29	JLH	1:100	1 of 4
2.							
3.				Project No.	Overall Dimensions		
4.				420020 TxDOT			
5.				TxDOT Pan Form Retrofit			
Approved: William Williams				Signature: <i>William Williams</i>		Date: 2010-06-04	

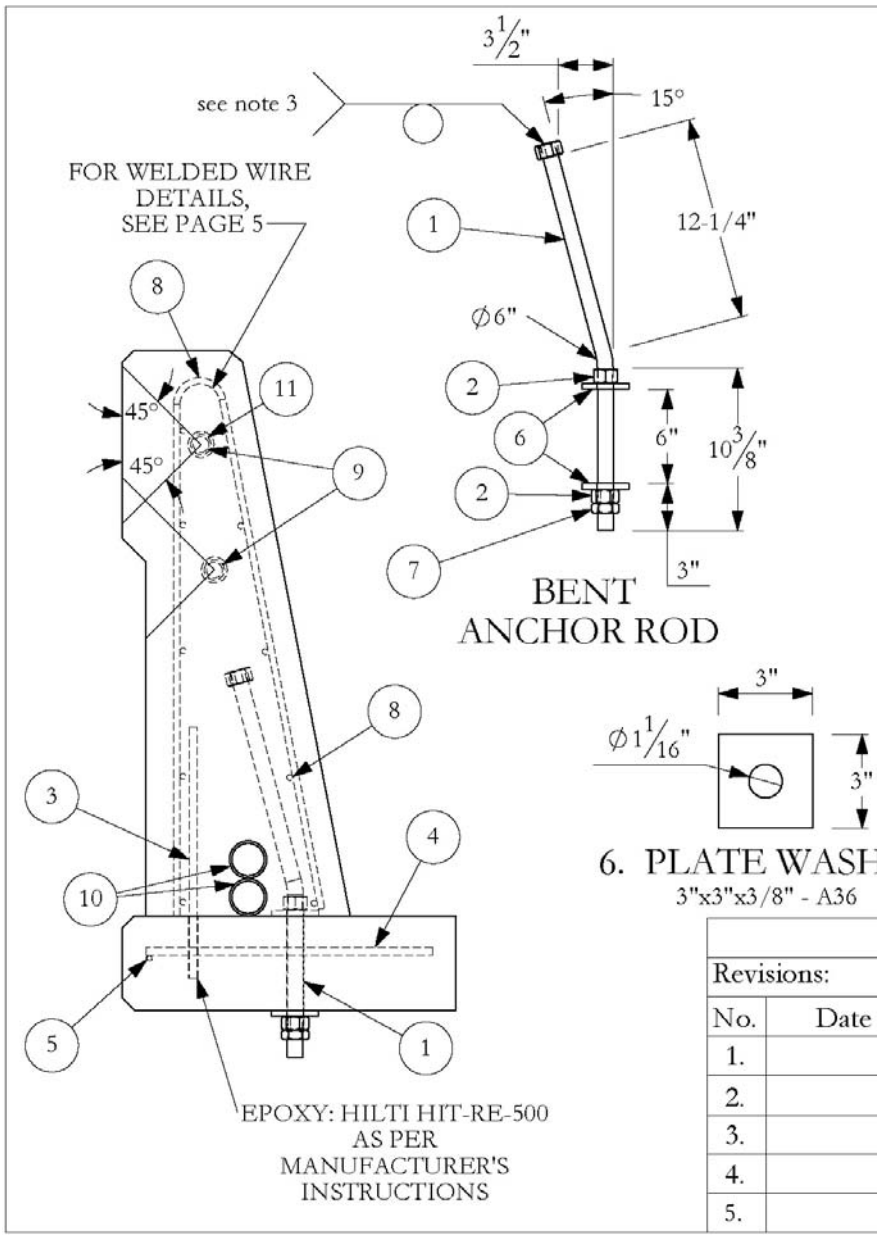

ITEM NO.	PART NAME	QTY.
1	ASTM F1554 Grade 55 anchor bolt or threaded rod, 1" dia. x 24"	38
2	Nut, 1" -8 hex	114
3	Rebar, parapet anchor, #4 x 16"	19
4	Transverse bar, #4 x 18-1/4"	150
5	#4 rebar, grade 60, longitudinal	/
6	plate washer, 3 x 3 x 3/8" A36	76
7	Jam Nut, 1" -8 hex	38
8	InSteel welded wire, Vx6-D10.7/D13.4, Fy=70KSI	/
9	#8 rebar, grade 60	2
10	2" pvc conduit	/
11	1 1/4" pvc sleeve, sch 80	2

6. PLATE WASHER  
3"x3"x3/8" - A36

- 3. IF NUT AND ALL-THREAD ROD IS USED
- 4. ALL REBAR GRADE 60
- 5. #4 REBAR LAP: 34"

The Texas A&M University System							
Revisions:				Texas Transportation Institute College Station, Texas 77843			
No.	Date	By	Chk	Date	Drawn By	Scale	Sheet No.
1.				2010-03-29	JLH	1:10	2 of 4
2.				Project No.		Materials	
3.				420020 TxDOT			
4.				TxDOT Pan Form Retrofit			
5.							

EPOXY: HILTI HIT-RE-500  
AS PER  
MANUFACTURER'S  
INSTRUCTIONS

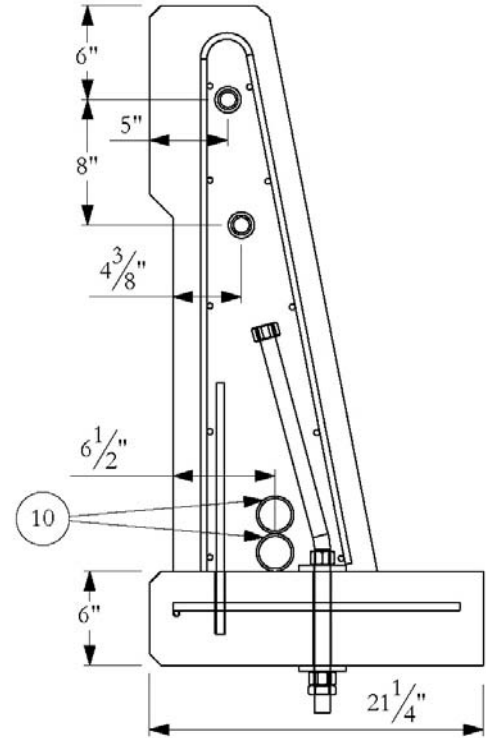
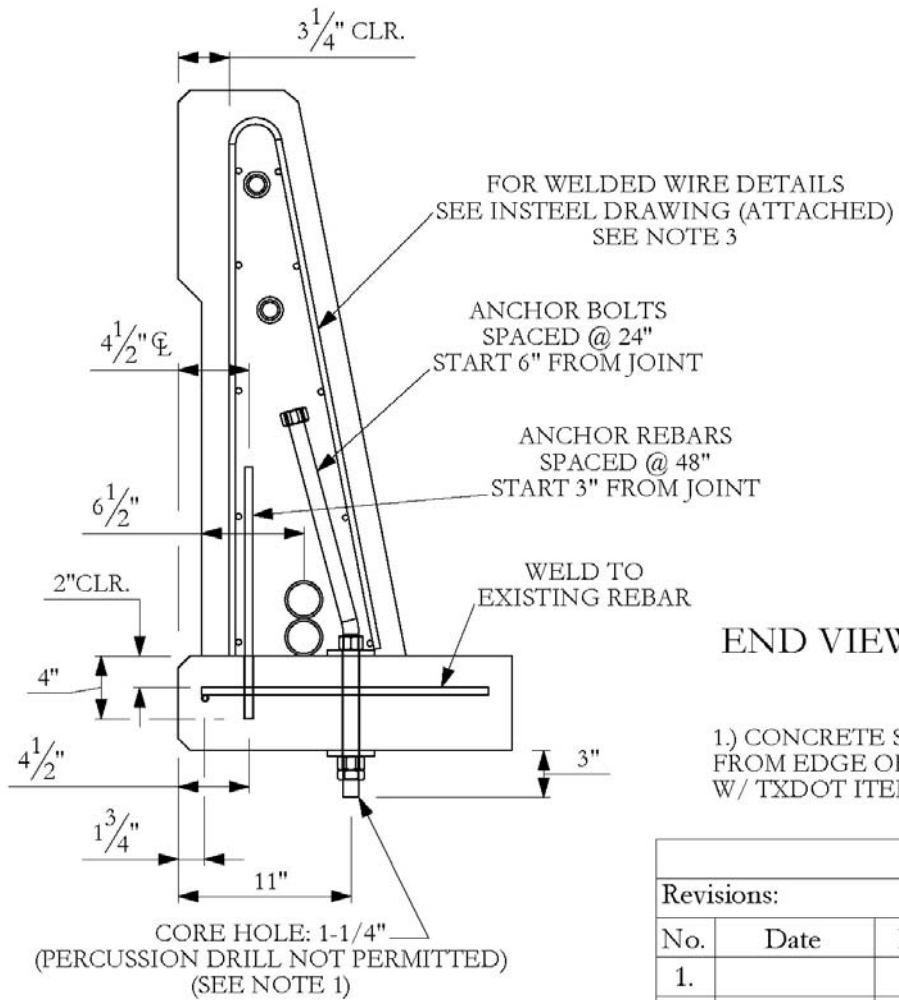

END VIEWS

1.) CONCRETE SPALLS IN BOTTOM OF DECK EXCEEDING 1/2" FROM EDGE OF HOLES SHALL BE PATCHED ACCORDING W/ TXDOT ITEM 429 CONCRETE STRUCTURE REPAIR

- 2.) ALL REBAR 1- 1/2" CLR. UNLESS OTHERWISE NOTED.
- 3.) WELDED WIRE SHALL MEET THE REQUIREMENTS OF ASTM A496 MATERIAL WITH A MINIMUM YIELD OF 70 KSI AND WELDED IN ACCORDANCE WITH ASTM A497 SPECIFICATIONS.

The Texas A&M University System							
Revisions:				Texas Transportation Institute College Station, Texas 77843			
No.	Date	By	Chk	Date	Drawn By	Scale	Sheet No.
1.				2010-03-29	JLH	1:10	3 of 4
2.				Project No.		Rebar Details	
3.				420020 TxDOT			
4.				TxDOT Pan Form Retrofit			
5.							

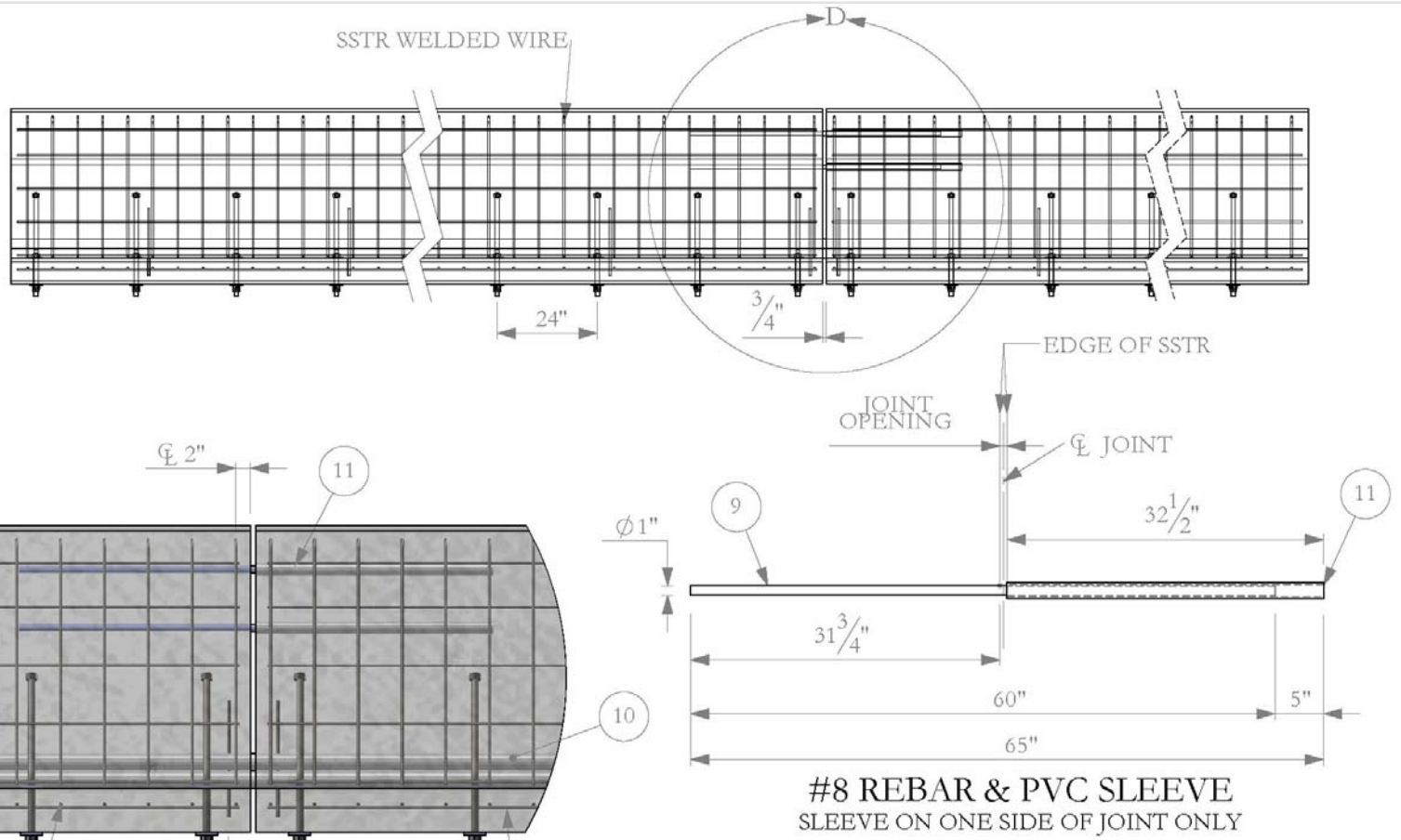

**#8 REBAR & PVC SLEEVE**  
SLEEVE ON ONE SIDE OF JOINT ONLY

**DETAIL D**  
SCALE 1 : 20

The Texas A&M University System

Revisions:				Texas Transportation Institute College Station, Texas 77843			
No.	Date	By	Chk	Date	Drawn By	Scale	Sheet No.
1.				2010-03-29	JLH	1:35	4 of 4
2.				Project No.		Detailed Dimensions	
3.				420020 TxDOT			
4.				TxDOT Pan Form Retrofit			
5.							

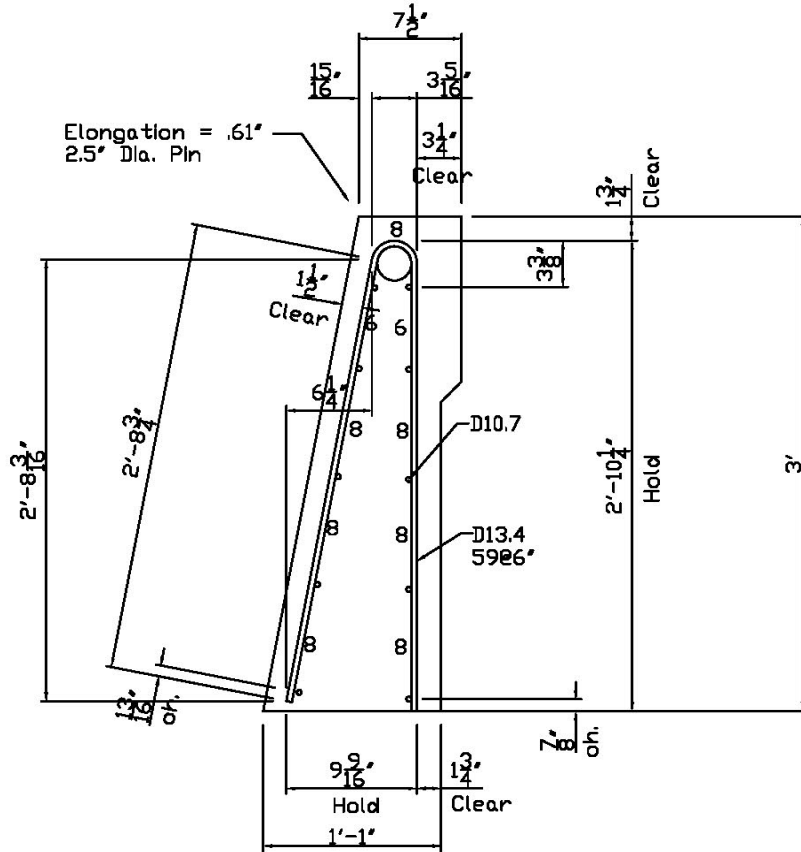

SSTR BRIDGE RAIL  
TEXAS DOT

VX6-D10.7/D13.4 68" Wide(0.8125,0.875) X 31'-0"(12,6)  
0.8125"oh,3@8,6,8,6,3@8,0.875"oh

Customer Approval:	Date:	Cust. P.O. #:
Signature:		IWP Order #:

 <b>INSTEEL WIRE PRODUCTS .</b> 1373 Boggs Drive Mount Airy, N.C. 27030 Tel. 800-334-9504	Title: Texas SSTR	
	Customer:	Mark No:
	Project:	Quantity:
	Date: 5-22-09	Insteel Dwg. #: 09-DS-99



## APPENDIX B. CERTIFICATION DOCUMENTATION

		MATERIAL USED		
TEST NUMBER	420020-3	Pan-form Bridge Rail		
DATE	2010-08-03			
DATE RECEIVED	ITEM NUMBER	DESCRIPTION	SUPPLIER	HEAT #
2010-07-01	Bolt, 1.000-1	1"-8 x 24"	Mack Bolt & Steel	3012005
2010-07-01	Nut, 1.000-4	1" -8 hex	Mack Bolt & Steel	
2010-07-01	Nut, 1.000-5	1" -8 hex jam	Mack Bolt & Steel	
2010-07-01	Strap 3-1	3/8" x 3" x 20'	Mack Bolt & Steel	.1W0R17B4F001
2010-07-14	Weldec Wire-1	Welded Wire for Parapet	Insteel	TOE1834
2010-04-22	Rebar 04-16	1/2" x 20' gr 60 - SLV	CMC-Sheplers	3015574

July 13, 2010

**Original Mill Test Report**

**Company:** Mack Bolt & Steel  
**Part Description:** 40 pcs 1 – 8 X 24” Hex Bolts  
**Material Specification:** ASTM F1554-Grade 55  
**Coating Specification:** ASTM A153-'93a Type C  
**Purchase Order Number:** 18879  
**Lot Number:** 10839-1  
**Comments:** None  
**Material Heat Number:** 3012005  
**Testing Laboratory:** CMC

**Chemical Analysis- Weight Percent**

C	Mn	P	S	Si	Cu	Cr	Ni	Mo	V	Sn	Cb	Ti	B	Al	Ta	N
.21	1.03	.012	.026	.21	.28	.12	.10	.022	.020	.013	.002	.001	.0003	-	-	-

100% Melted & Manufactured in the USA. Values reflect originating Steel Mill

**Tensile and Hardness Test Results**

**Date:** June 24, 2010

**Property**      **#1 psi**  
Tensile:      **88.400**  
Proof/Yield:    **63.800**  
Elongation:    **26**  
ROA:            **55**  
Hardness:      **179 HBN**

**Comments**

Test results meet mechanical requirements of specification.

All reports are the exclusive property of K-T Bolt Manufacturing Company, Inc. ®. Any reproduction must be in their entirety and at the permission of the same.



SOLD TO: NAMASCO CORP  
500 COLONIAL CENTER PKWY  
STE 500  
ROSWELL, GA 30076-

**NUCOR**  
NUCOR CORPORATION  
NUCOR STEEL TEXAS

**CERTIFIED MILL TEST REPORT**

Page: 1

SHIP TO: NAMASCO  
SOUTH LOOP 4  
BUDA, TX 78610-

Ship from:  
Nucor Steel - Texas  
8812 Hwy 79 W  
JEWETT, TX 75846  
800-527-6445

Date: 29-Jan-2010  
B.L. Number: 534673  
Load Number: 151816

Material Safety Data Sheets are available at [www.nucorbar.com](http://www.nucorbar.com) or by contacting your inside sales representative.

NSMG-06 March 24, 2009

HEAT NUM. -	DESCRIPTION	PHYSICAL TESTS					CHEMICAL TESTS									
		YIELD P.S.I.	TENSILE P.S.I.	ELONG % IN 8"	BEND	WT% DEF	C	Mn	P	S	Si	Cu	Sn	C.E.		
							Ni	Cr	Mo	V	Cb	Sn	C.E.			
PO# => 6248113 JW0910071301	Nucor Steel - Texas 3/4x10" Flat 20' A529 Gr55 ASTM A529/A529M-05 GR 55 Mn/C = 9.36 COMPLIES WITH DIN 50049 PARA 3.1B & EN 10204-3.1	60,400 416MPa	81,600 563MPa	17.0%			.11 .21	1.03 .16	.016 .061	.033 .002	.22 .026	.26	.40			
PO# => 6248113 JW0910648001	Nucor Steel - Texas 3/8x3" Flat 20' A36 ASTM A36/A36M-08, A709/A709M-07 GR36, ASME SA36-07	45,300 312MPa	64,100 442MPa	25.0%			.11 .16	.64 .14	.019 .042	.030 .004	.20 .002	.32	.29			
PO# => 6248113 JW1010009401	Nucor Steel - Texas 3/8x6" Flat 20' A529 Gr 55 ASTM A529/A529M-05 GR 55 Mn/C = 4. COMPLIES WITH DIN 50049 PARA 3.1B & EN 10204-3.1	65,300 450MPa	89,200 615MPa	21.0%			.23 .15	.92 .15	.015 .039	.034 .003	.22 .022	.40	.50			
PO# => 6248113 JW1010012301	Nucor Steel - Texas 1/4x4" Flat 20' A36 ASTM A36/A36M-08, A709/A709M-07 GR36, ASME SA36-07	49,300 340MPa	67,500 465MPa	25.0%			.12 .14	.75 .17	.018 .042	.040 .002	.21 .001	.38	.32			

I HEREBY CERTIFY THAT THE ABOVE FIGURES ARE CORRECT AS CONTAINED IN THE RECORDS OF THE CORPORATION.

ALL MANUFACTURING PROCESSES OF THE STEEL MATERIALS IN THIS PRODUCT, INCLUDING HEATING, HAVE OCCURRED WITHIN THE UNITED STATES. ALL PRODUCTS FINISHED AND WELD MADE REBURY, IN ANY FORM, HAS NOT BEEN USED IN THE PRODUCTION OR FINISHING OF THIS MATERIAL.

QUALITY ASSURANCE: Ben C&V

*Ben C&V*

**Insteel Wire Products**  
**500 Klemp Road**  
**Dayton, TX 77535**  
Metals Tensile

Job Number: 330005-01 Heat Number (XW): TO91834  
Item Number: 533-153483-(2)  
Product Style: VARX6D10.7/D13.4  
Prod. Style Cont.: 68"(.8125+.875)X31'  
Rod Size & Origin (LW): W11716  
Heat Number (LW): TO92121  
Rod Size & Origin (XW): W1112

Oper. #	Sample #	Diameter in	CS Area in <sup>2</sup>	Ultimate lbf	Ultimate ksi	Red Area %	Bend Test OK
4667/7230	1	0.369	0.1069	10420	97.5	0	YES
4667/7230	2	0.369	0.1069	10730	100.4	0	YES
4667/7230	1	0.413	0.134	13200	98.6	0	YES
4667/7230	2	0.413	0.134	13220	98.7	0	YES
Avg.		0.391	0.1205		98.8		
SD		0.0254	0.0156		1.196		
Min.				10420			
Max.				13220			

The use of this product conforms with Buy America Requirements set forth in 23 CFR Subpart D, Section 635.410, Buy America Requirements and Title 49 - Transportation, Chapter VI - Federal Transit Administration, Department of Transportation Part 661 - Buy America Requirements - Surface Transportation Assistance Act of 1982, As Amended

This is to certify that the material listed above conforms to the following specifications.:

ASTM: A 496-07/ A 497-0 Test Requirements.

Signature:  Date: 7/12/2009



CMC STEEL TEXAS  
 1 STEEL MILL DRIVE  
 SEGUIN TX 78155-7510

**CERTIFIED MILL TEST REPORT**

For additional copies call  
 830-372-8771

We hereby certify that the test results presented here  
 are accurate and conform to the reported grade specification

*Daniel J. Schacht*  
 Daniel J. Schacht

Quality Assurance Manager

HEAT NO.:3015574 SECTION: REBAR 13MM (#4) 20'0" 420/60 GRADE: ASTM A615-09 Gr 420/60 ROLL DATE: 03/22/2010 MELT DATE: 03/21/2010	S O L D T O	CMC Construction Svcs College Stati  10650 State Hwy 30 College Station TX US 77845-7950 979 774 5900	S H I P T O	CMC Construction Svcs College Stati  10650 State Hwy 30 College Station TX US 77845-7950 979 774 5900	Delivery#: 80282609 BOL#: 70095403 CUST PO#: 45057e CUST P/N: DLVRY LBS / HEAT: 4382.000 LB DLVRY PCS / HEAT: 328 EA
---	----------------------------	--	----------------------------	--	---

Characteristic	Value	Characteristic	Value	Characteristic	Value
C	0.42%				
Mn	0.80%				
P	0.009%				
S	0.033%				
Si	0.20%				
Cu	0.48%				
Cr	0.16%				
Ni	0.25%				
Mo	0.064%				
V	0.001%				
Cb	0.001%				
Sn	0.014%				
Al	0.002%				
Yield Strength test 1	68.2ksi				
Tensile Strength test 1	106.3ksi				
Elongation test 1	12%				
Elongation Gage Lgth test 1	8IN				
Bend Test Diameter	1.750IN				
Bend Test	Passed				

THIS MATERIAL IS FULLY KILLED, 100% MELTED AND MANUFACTURED IN THE USA, WITH NO WELD REPAIR OR MERCURY CONTAMINATION IN THE PROCESS.  
 REMARKS :



## APPENDIX C. TEST VEHICLE PROPERTIES AND INFORMATION

Date: 2010-08-03 Test No.: 420020-3 VIN No.: 1D7HA18N455243883  
 Year: 2005 Make: Dodge Model: Ram 1500 Quad-Cab  
 Tire Size: 245/70R17 Tire Inflation Pressure: 35 psi  
 Tread Type: Highway Odometer: 138200

Note any damage to the vehicle prior to test: \_\_\_\_\_

- Denotes accelerometer location.

NOTES: \_\_\_\_\_

Engine Type: V-8  
 Engine CID: 4.7 liter

Transmission Type:  
 Auto or \_\_\_\_\_ Manual  
 FWD  RWD  4WD

Optional Equipment:  
 \_\_\_\_\_

Dummy Data:  
 Type: No dummy  
 Mass: \_\_\_\_\_  
 Seat Position: \_\_\_\_\_

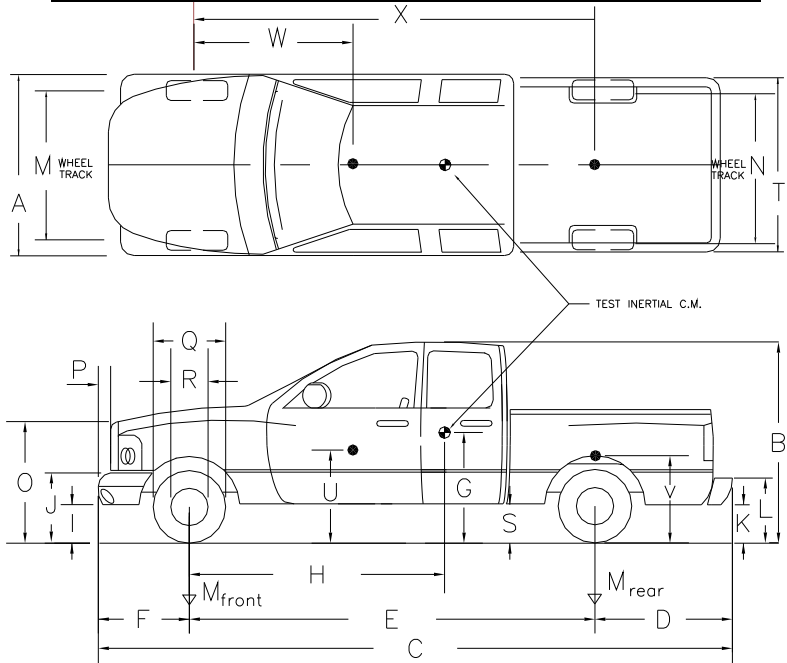

**Geometry:** inches

A	<u>77.00</u>	F	<u>37.00</u>	K	<u>20.50</u>	P	<u>3.00</u>	U	<u>27.50</u>
B	<u>73.25</u>	G	<u>28.38</u>	L	<u>28.75</u>	Q	<u>29.50</u>	V	<u>34.00</u>
C	<u>227.00</u>	H	<u>63.86</u>	M	<u>68.25</u>	R	<u>18.50</u>	W	<u>53.50</u>
D	<u>47.50</u>	I	<u>13.50</u>	N	<u>67.25</u>	S	<u>14.25</u>	X	<u>140.50</u>
E	<u>140.50</u>	J	<u>26.00</u>	O	<u>44.75</u>	T	<u>75.50</u>		

Wheel Center Ht Front 14.125 Wheel Well Clearance (FR) 6.125 Frame Ht (FR) 16.685  
 Wheel Center Ht Rear 14.25 Wheel Well Clearance (RR) 11.25 Frame Ht (RR) 24.25

RANGE LIMIT: A=78 ±2 inches; C=237 ±13 inches; E=148 ±12 inches; F=39 ±3 inches; G = > 28 inches; H = 63 ±4 inches; O=43 ±4 inches; M+N/2=67 ±1.5 inches

GVWR Ratings:	Mass: lb	Curb	Test Inertial	Gross Static
Front <u>3650</u>	$M_{front}$ <u>2736</u>	<u>2736</u>	<u>2747</u> Allowable	_____ Allowable
Back <u>3900</u>	$M_{rear}$ <u>1987</u>	<u>1987</u>	<u>2289</u> Range	_____ Range
Total <u>6650</u>	$M_{Total}$ <u>4723</u>	<u>4723</u>	<u>5036</u> 5000 ±110 lb	_____ 5000 ±110 lb

**Mass Distribution:**

lb LF: 1408 RF: 1339 LR: 1141 RR: 1148

**Figure C1. Vehicle Properties for Test No. 420020-3.**



**Table C2. Occupant Compartment Measurements for Test No. 420020-3.**

Date: 2010-08-03      Test No.: 420020-3      VIN No.: 1D7HA18N455243883  
 Year: 2005      Make: Dodge      Model: Ram 1500 Quad-Cab

**OCCUPANT COMPARTMENT DEFORMATION MEASUREMENT**

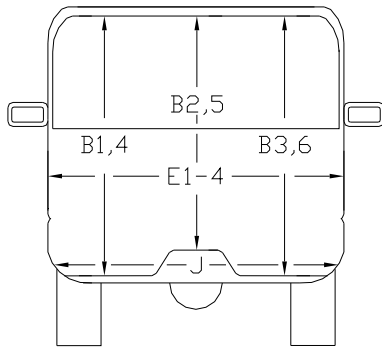
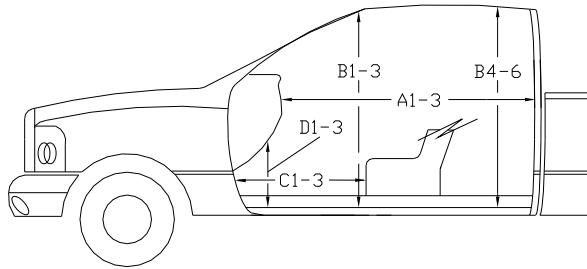
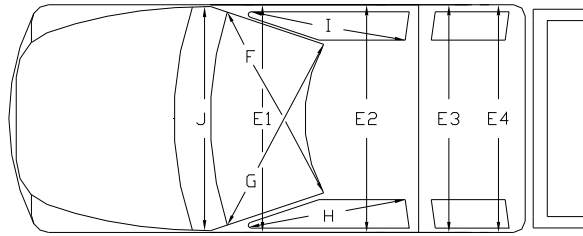

	<b>Before</b> ( inches )	<b>After</b> ( inches )
A1	64.25	64.25
A2	64.50	64.50
A3	65.25	65.50
B1	45.50	45.50
B2	39.25	38.25
B3	45.50	45.75
B4	42.25	42.50
B5	42.50	43.00
B6	42.25	42.62
C1	29.50	29.50
C2	----	----
C3	26.75	24.00
D1	12.50	12.50
D2	2.50	2.12
D3	11.50	12.50
E1	62.50	62.75
E2	64.25	66.00
E3	63.88	64.12
E4	64.00	64.25
F	60.00	60.00
G	60.00	60.00
H	39.50	39.50
I	39.50	39.50
J*	62.25	61.00

\*Lateral area across the cab from driver's side kickpanel to passenger's side kickpanel.





## APPENDIX D. SEQUENTIAL PHOTOGRAPHS



0.000 s



0.089 s



0.175 s



0.263 s



**Figure D1. Sequential Photographs for Test No. 420020-3  
(Overhead and Frontal Views).**

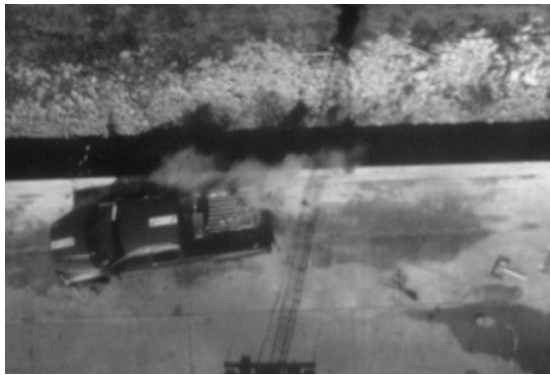

0.352 s

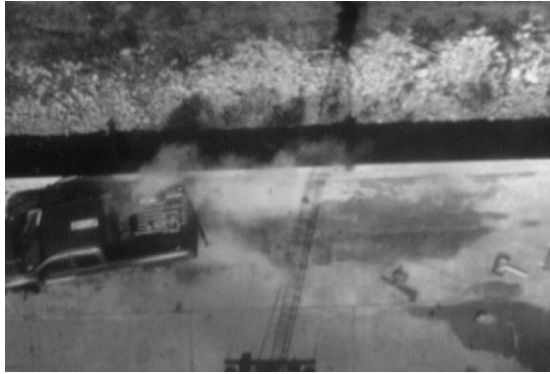

0.440 s

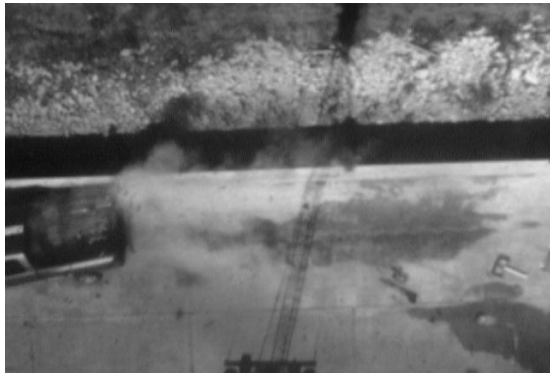

0.526 s

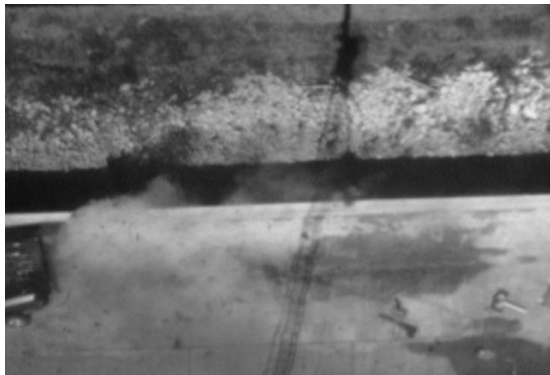

0.615 s



**Figure D1. Sequential Photographs for Test No. 420020-3 (Overhead and Frontal Views) (Continued).**



0.000 s

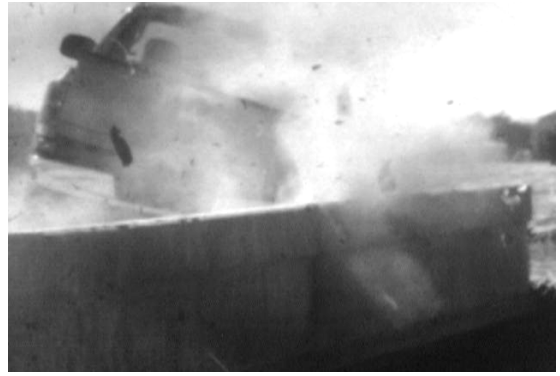

0.352 s



0.089 s

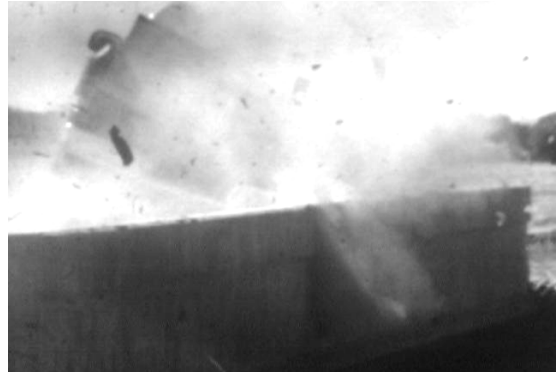

0.440 s



0.175 s



0.526 s



0.263 s

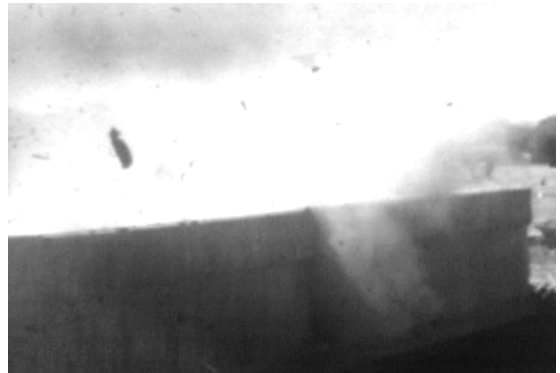

0.615 s

**Figure D2. Sequential Photographs for Test No. 420020-3 (Rear View).**



### Roll, Pitch, and Yaw Angles

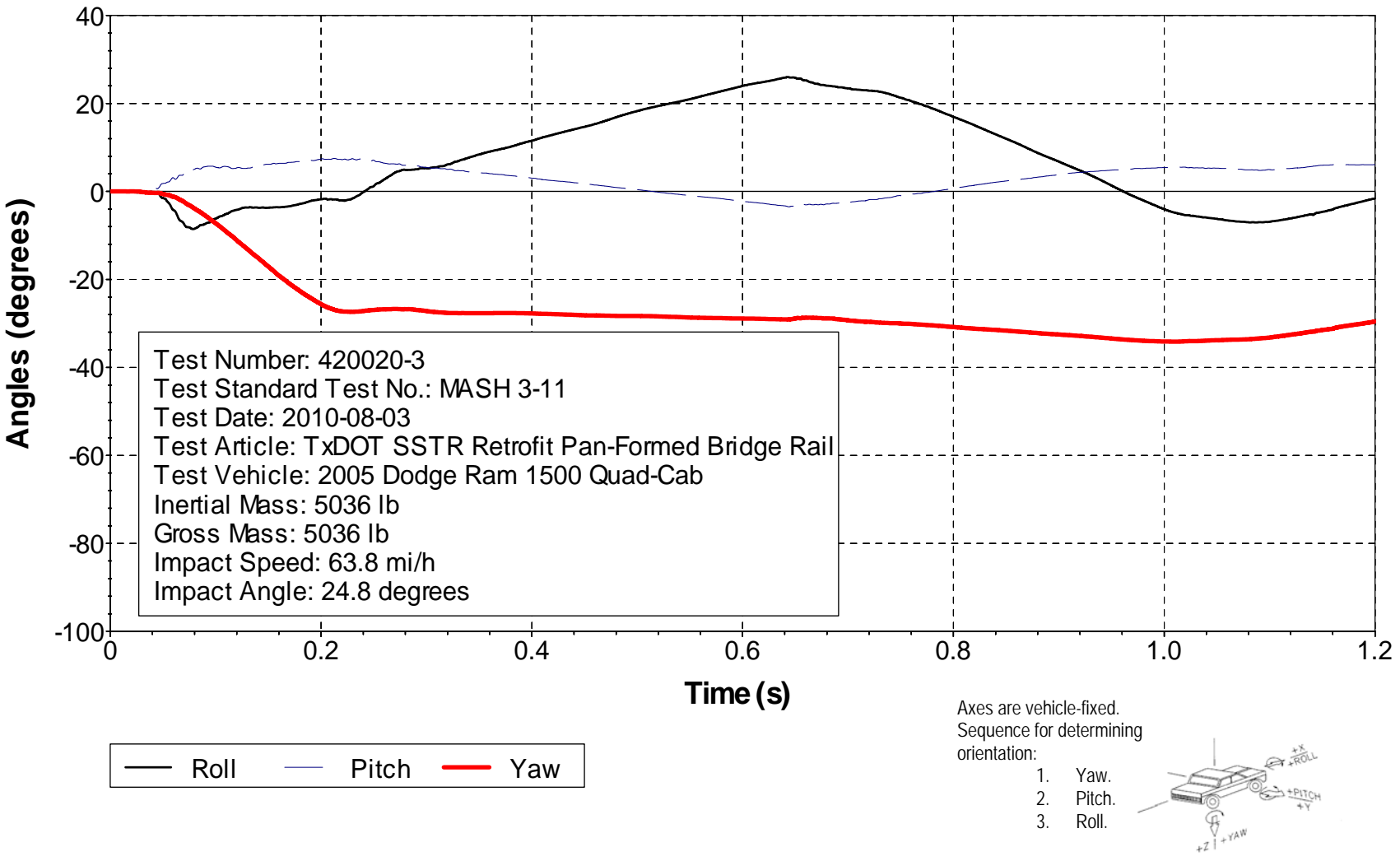

49

Figure E1. Vehicle Angular Displacements for Test No. 420020-3.

# X Acceleration at CG

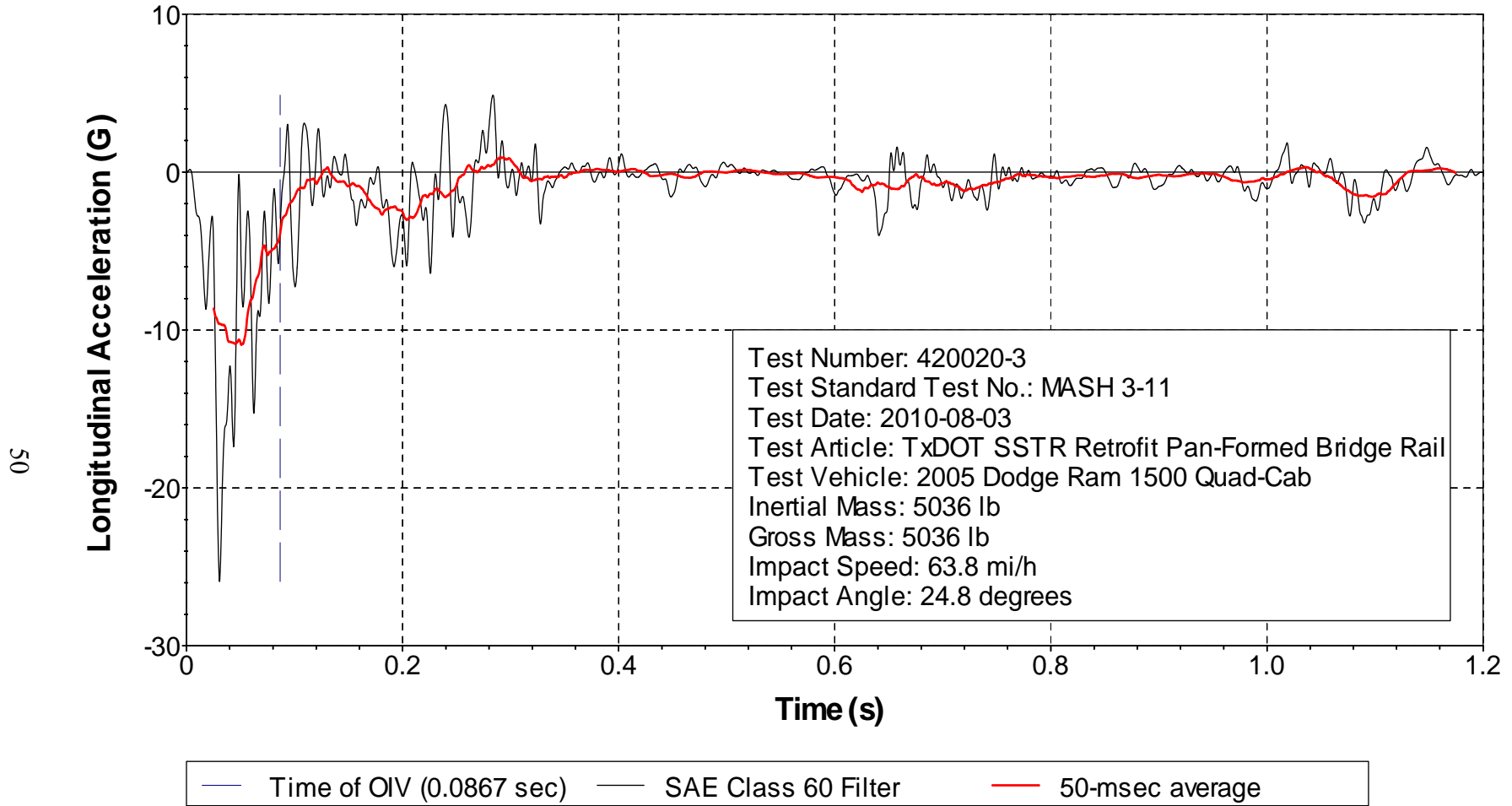

**Figure E2. Vehicle Longitudinal Accelerometer Trace for Test No. 420020-3  
(Accelerometer Located at Center of Gravity).**

# Y Acceleration at CG

51

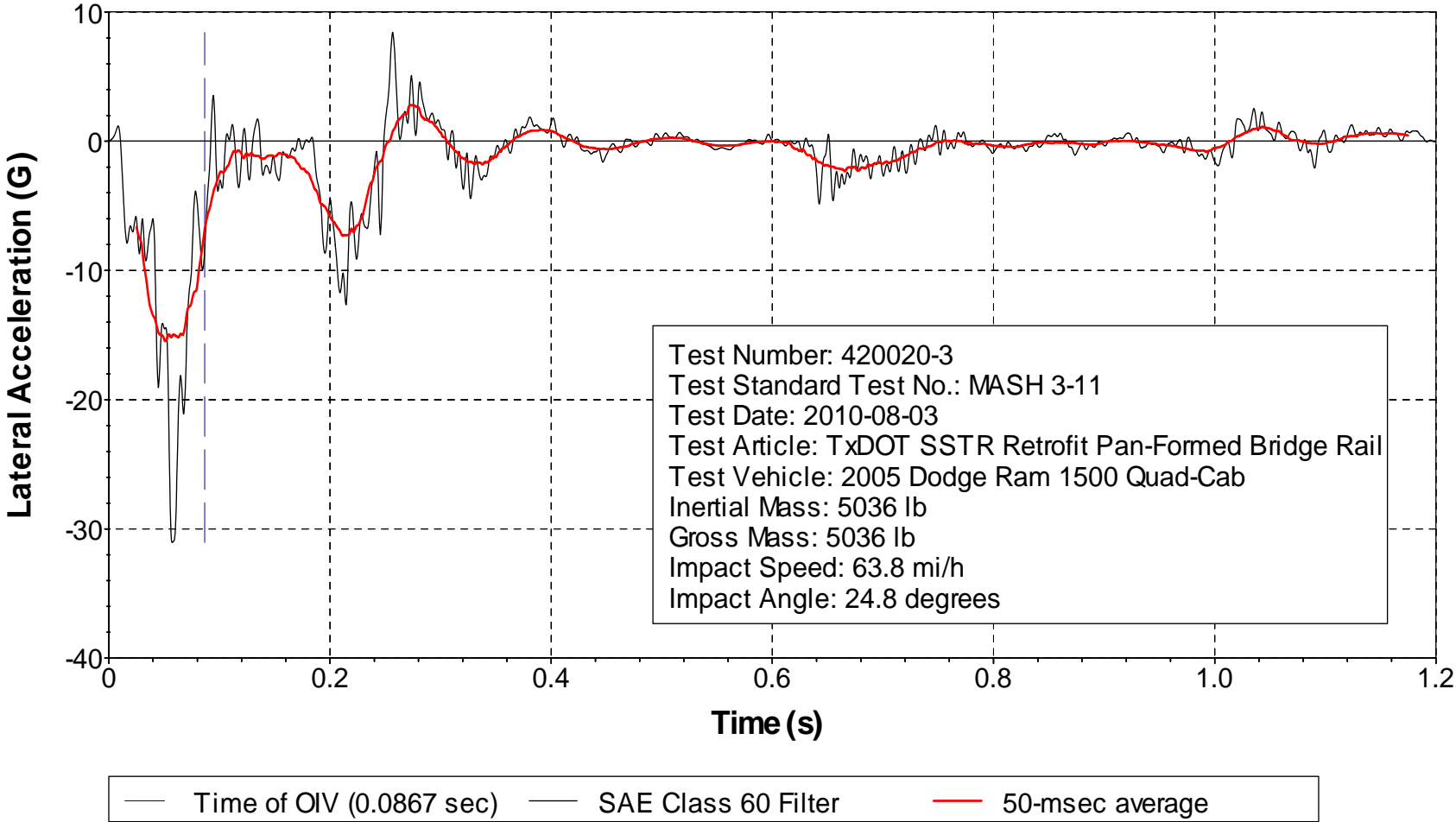

**Figure E3. Vehicle Lateral Accelerometer Trace for Test No. 420020-3 (Accelerometer Located at Center of Gravity).**

## Z Acceleration at CG

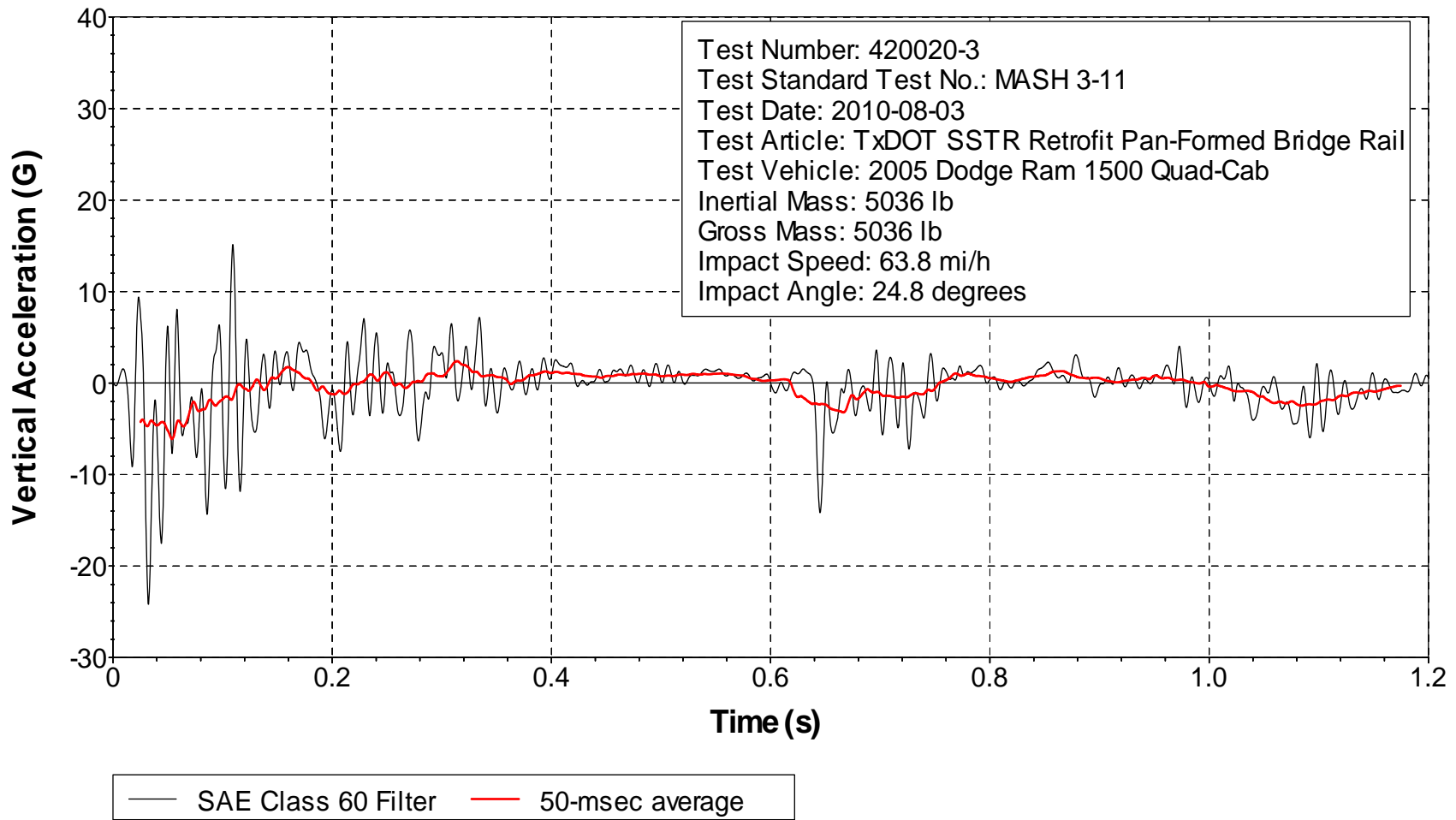

**Figure E4. Vehicle Vertical Accelerometer Trace for Test No. 420020-3  
(Accelerometer Located at Center of Gravity).**