

FINAL REPORT

**FIELD STUDY
OF AN
INTEGRAL BACKWALL BRIDGE**

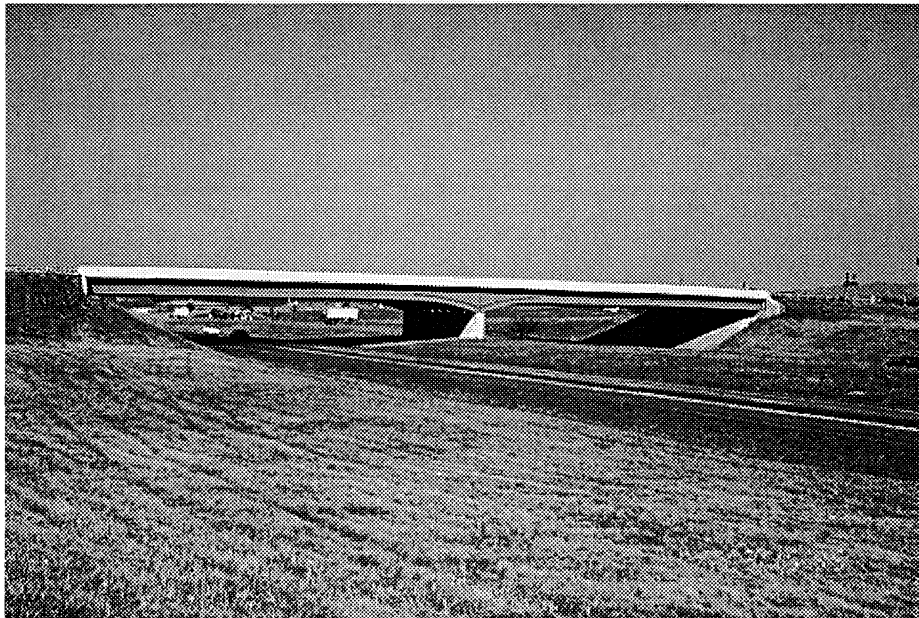

EDWARD J. HOPPE, Ph.D., P.E.
Research Scientist

JOSÉ P. GOMEZ, Ph.D., P.E.
Research Scientist



FINAL REPORT

**FIELD STUDY OF AN
INTEGRAL BACKWALL BRIDGE**

**Edward J. Hoppe, Ph.D., P.E.
Research Scientist**

**José P. Gomez, Ph.D., P.E.
Research Scientist**

**Virginia Transportation Research Council
(A Cooperative Organization Sponsored Jointly by the
Virginia Department of Transportation and
the University of Virginia)**

**In Cooperation with the U.S. Department of Transportation
Federal Highway Administration**

**October 1996
VTRC 97-R7**

Copyright 1996, Commonwealth of Virginia

ABSTRACT

Integral bridges offer reduced maintenance expenditures, primarily due to the elimination of deck expansion joints. The design of an integral bridge, however, is complicated by the soil-structure interaction associated with thermal movements. It has been widely recognized that more data on the actual stresses and their distribution within the structure are needed for an optimal design. Current integral designs are often conservative and based on empirical values. This study is an analysis of an integral backwall bridge which was instrumented during construction and monitored for 2.5 years. Field instrumentation included strain gages, temperature probes and earth pressure cells. Data were collected continuously using electronic dataloggers. The results demonstrate a satisfactory performance of the structure; however, some maintenance problems associated with excessive approach settlement were observed. Soil pressures exerted on the back of the integral backwall showed significant daily variation as a result of ambient air temperature fluctuation.

Final Report

FIELD STUDY OF AN INTEGRAL BACKWALL BRIDGE

Edward J. Hoppe, Ph.D., P.E.
Research Scientist

José P. Gomez, Ph.D., P.E.
Research Scientist

INTRODUCTION

The most attractive aspect of integral bridge design is the elimination of deck expansion joints and their associated maintenance problems. Defective expansion joints often allow water and deicing chemicals to corrode key bridge components. In fully integral construction the superstructure is rigidly connected to abutments which expand against the soil backfill. In the semi-integral or integral backwall type of construction the superstructure is cast together with the backwall but separate from the underlying abutment and a horizontal joint is provided at the interface. Figure 1 shows typical design examples of each case (Soltani and Kukreti, 1992).

Several states, notably Tennessee, Iowa, North Dakota, Ohio, and California, have been constructing integral bridges for over 20 years, primarily to reduce maintenance costs. Burke (1996) reports 26 state DOTs using semi-integral bridges, and two states that have been building such structures for at least 40 years. In most cases jointless bridges have performed well. The key impediment to their greater use has been insufficient information about the effects of secondary forces. These forces are primarily thermally induced, complemented by creep and shrinkage of concrete. Currently there is no universal agreement on the maximum practical integral bridge length. It is recognized, however, that present design practices are generally conservative and longer integral bridges could potentially be constructed.

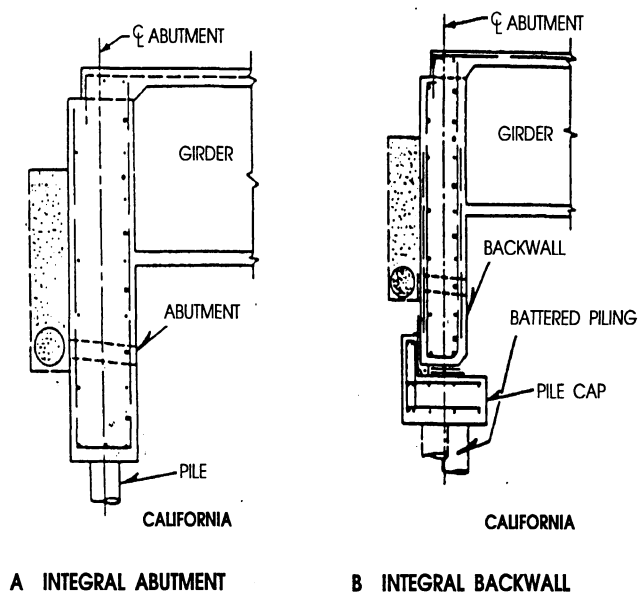

Figure 1. Examples of integral abutment and integral backwall design.

Jointless bridges reportedly reduce construction and maintenance expenses, improve riding quality, and provide excellent seismic resistance (Russell and Gerken, 1994). Different states use varying length limitations. Typically, bridge lengths range from 60 to 150 m for composite steel girder structures, 60 to 240 m for bridges with prestressed concrete superstructures, and 45 to 240 m for cast-in-place reinforced concrete construction. The maximum design length criteria reflect each state's experience with integral bridges.

In fully integral bridges, research with abutments supported by steel piles has shown that flexural piling stresses can sometimes exceed the yield strength (Burke, 1993). This condition does not occur in semi-integral bridges since there is no moment transfer to the abutment. Provisions that can mitigate pile overstress include orienting abutment supporting piles with weak axes parallel to the abutment centerline, reducing bridge skews to less than 30 degrees, and installing piles in prebored holes filled with granular material. Neither integral nor semi-integral bridges should be constructed where abutment piles cannot be driven through at least 3 to 5 m of overburden, at sites where the stability of subsurface soils is uncertain, and when the abutment settlement is likely. Approach slabs anchored to the bridge are typically recommended, in order to prevent vehicular traffic from consolidating backfill adjacent to abutments.

In spite of their attributes, integral and semi-integral bridges are not totally devoid of maintenance problems. It appears that the elimination of bridge joints shifted some of these problems from the structure to the adjacent fill embankments. California, Minnesota, and Oregon DOTs report frequent repairs necessitated by excessive settlement of a backfill material that is continually compressed and released (Burke and Gloyd, 1996).

In addition to accelerated backfill settlement, thermally induced superstructure movements often result in adjoining pavement distress. Currently available cycle control joints are limited in their ability to function effectively for an extended period of time (Burke, 1987). Longitudinal pressures at debris-infiltrated pavement joints are usually magnified by the cyclic movement of the bridge. In a number of cases, excessive longitudinal pressures caused approach slab failure and distress cracks in the superstructure and abutments (Steiger, 1993).

Among the relatively unknown factors requiring further research is the effect of passive pressure behind the abutments as a result of superstructure thermal expansion (Soltani and Kukreti, 1992). The type of backfill material has a great effect on the magnitude of the soil pressure and its spatial distribution. Problems associated with soil-structure interaction also include potential stress relief that accompanies the superstructure expansion and contraction process (Russell and Gerken, 1994).

PURPOSE AND SCOPE

This study evaluated the long term performance of an integral backwall bridge to determine the effects of secondary forces acting on the superstructure. A 98 m long, two span composite steel

girder structure, the longest of its type yet built in Virginia, was investigated. The following work was performed:

1. Evaluation of soil pressures acting behind the integral backwall and the abutment due to thermal expansion of the superstructure.
2. Evaluation of accompanying stresses at the bottom flanges of steel girders.
3. Evaluation of approach settlement in proximity to the abutment.
4. Evaluation of the structure for signs of distress.

The field monitoring program began during bridge construction in the summer of 1993 and continued until January 1996.

METHODS

Project Description

An integral backwall bridge was constructed on Route 257 over Interstate 81 in Rockingham County, Virginia (Figure 2). This integral backwall bridge is a two span, steel girder composite structure, 98 m long, 25 m wide, and aligned on a 5 degree skew. Figure 3 shows the elevation view of the structure. Girders were fabricated from a high strength steel of 345 MPa yield stress. A set of bridge plans is included in Appendix A. The structure exceeds current VDOT maximum design length guidelines of 90 m. A significant design exception of this bridge is the lack of concrete approach slabs. The flexible pavement directly abuts the superstructure. Bridge designers were concerned that any remedial action necessary to rectify potential approach slab settlement would be significantly more expensive and inconvenient to the traveling public than re-grading a settling approach pavement.

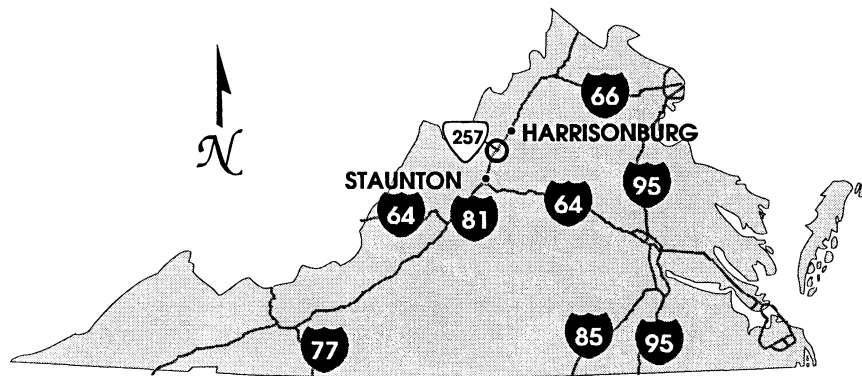

Figure 2. Site location.

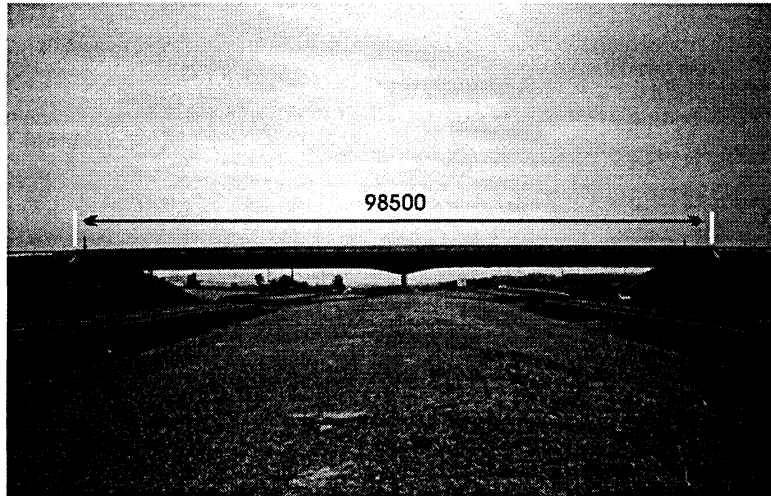

Figure 3. Bridge on Rte 257 over I-81.

The bridge was designed for a fully passive earth pressure. Backfill material with an angle of internal friction of 40 degrees and a unit weight of 18.8 kN/m^3 was assumed. An estimated passive thrust of 242 kN per linear meter of backwall was used in the design. It was determined that the passive thrust would generate approximately a 14 MPa compressive stress in the lower flange of a girder.

Before backfill placement the trench behind each abutment was approximately 2.5 m wide at the bottom and sloping back at a 1.5:1 grade. Free draining crushed stone backfill material (VDOT Type No. 78) was used. Figure 4 shows grain size distribution. Uniformly graded material is not typically used for abutment backfill in Virginia. It was selected for this particular project on an experimental basis, primarily due to its excellent drainage properties and low compressibility.

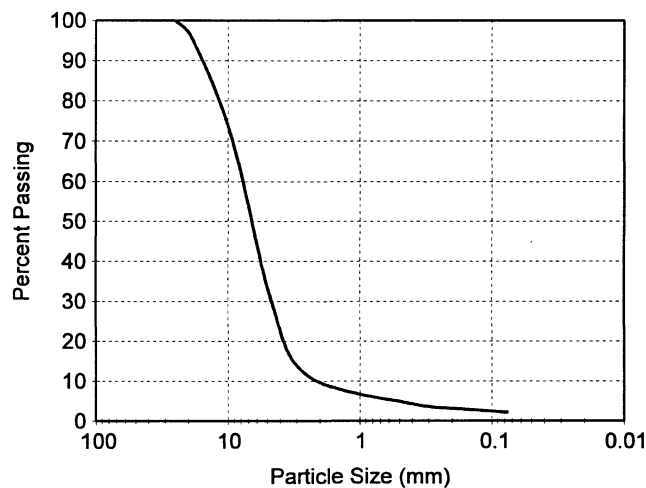

Figure 4. Backfill grain size distribution.

Instrumentation and Monitoring

Pressure, strain, and temperature measurements were collected using three Campbell Scientific CR-10 dataloggers, synchronized in time, installed at both abutments and at the pier. All sensors were sampled at 20 minute time intervals. When the dataloggers reached their storage capacity, in approximately one month, the data were transferred to a portable PC for subsequent analysis. Monthly inspections at the site typically consisted of data download, elevation survey, and a visual assessment of the structure.

All sensors were installed on or in line with steel girders G7 and G10. Figure 5 shows a partial framing plan including the instrumented girders. All strain gages were installed after the girders were erected, but before the deck was cast. Bottom girder flanges were instrumented due to their unsupported condition, which could possibly result in lateral buckling under extreme compressive loads. Dataloggers were installed at each abutment and at the pier. Abutment dataloggers were grounded in the surrounding backfill material using 1 m long copper grounding rods. The pier datalogger was left ungrounded.

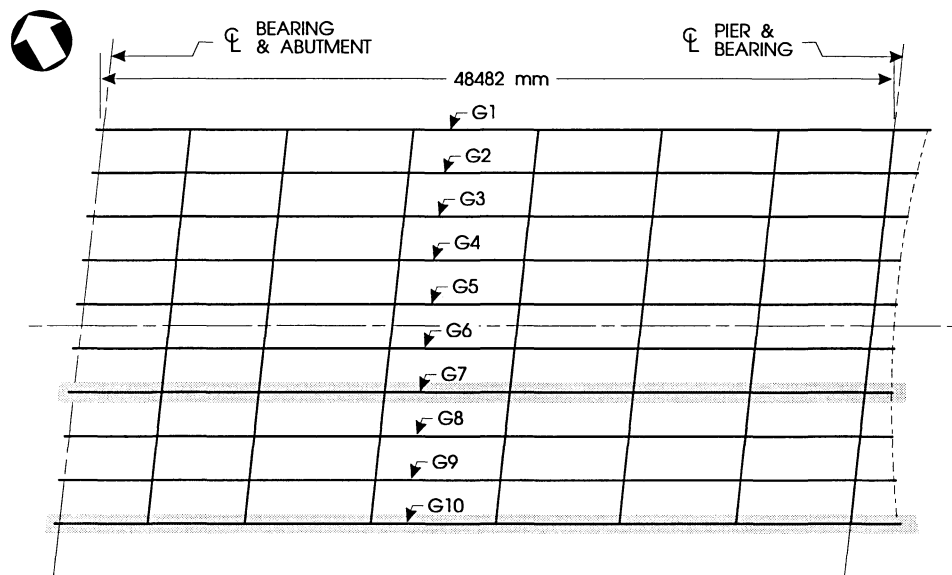

Figure 5. Instrumented girders G7 and G10.

Instrumentation installed at Abutment A consisted of two soil pressure sensors and two strain gages interfaced with a datalogger. One soil pressure gage was installed at the back of the integral backwall and the other at the back of the abutment, on the centerline of girder G7. Geokon vibrating wire earth pressure cells, model 4800E with a range of 345 kPa, were attached to the concrete surface using a high strength epoxy compound. The location of soil pressure

sensors is shown in Figure 6. Each sensor was approximately 228 mm in diameter. Resistance strain gages produced by Measurements Incorporated were attached on top of the lower flange of girders G7 and G10, between the bearing centerline and the face of the integral backwall, as shown in Figure 7. All strain gages were of 350 ohms resistance and interconnected with Measurement Incorporated bridge completion modules. The excitation signal was provided by the datalogger.

Pier instrumentation included four strain gages (two at each span) installed on girders G7 and G10, adjacent to the fixed bearing assembly, and two temperature probes. One probe measured ambient air temperature in the vicinity of girder G7 over the pier. The other was coupled with a silicone grease to girder G7 to record the superstructure steel temperature.

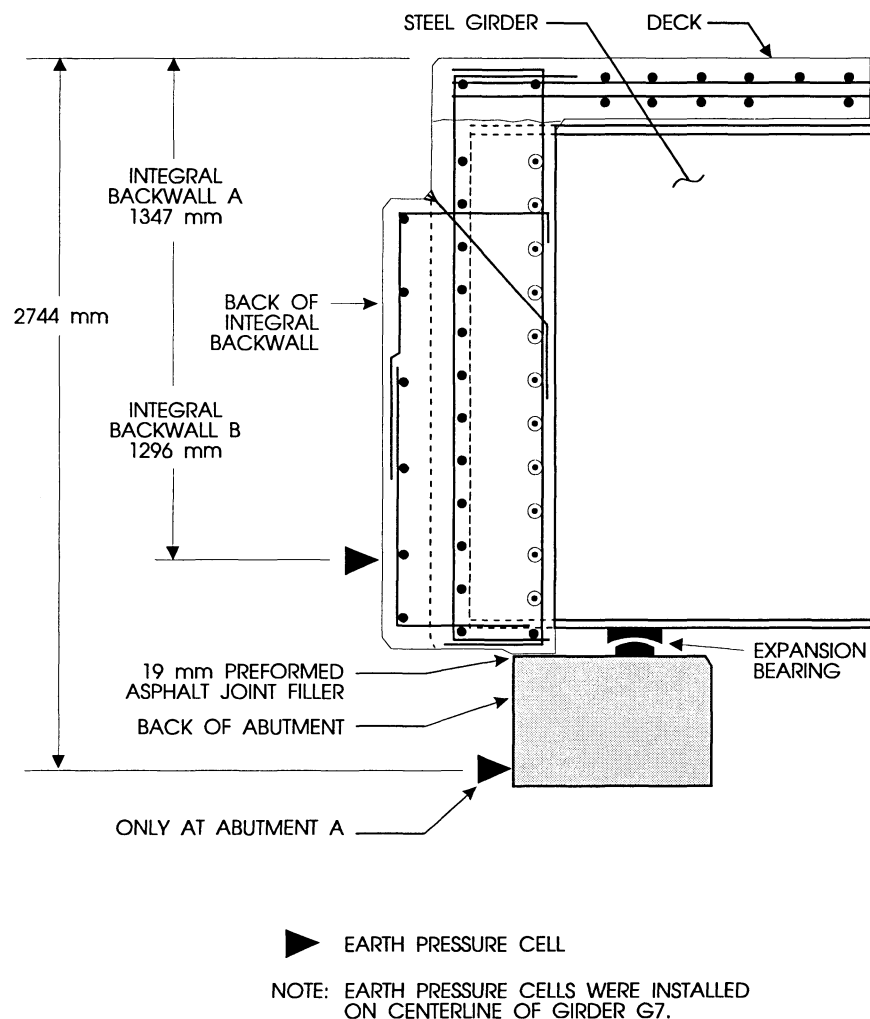

Figure 6. Location of earth pressure cells.

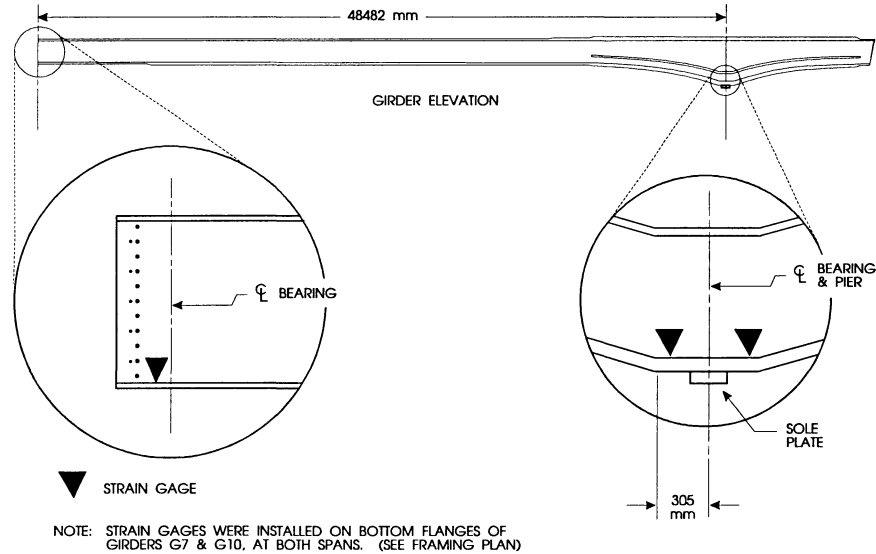

Figure 7. Location of strain gages.

Abutment B instrumentation was identical to that of abutment A, except that the soil pressure gage at the back of the abutment was eliminated. The earth pressure cell at the back of integral backwall, in line with girder G7, was installed at approximately the same depth as the one at abutment A, as shown in Figure 6. All earth pressure sensors also provided soil temperature data.

It was recognized that some measurements may be affected by live loads. However, in view of a relatively light volume of traffic, estimated at 4000 vehicles per day, and frequent data sampling, the live load influence was considered negligible.

Besides monitoring thermally induced stresses, two live load tests using a heavily loaded dump truck were conducted on the bridge. Two Applied Geomechanics tiltmeters, one installed at the top of the pier and the other at the bottom flange of girder G7 over the pier, were used with the existing instrumentation. Live load test results will be published in a separate report.

RESULTS AND DISCUSSION

Appendix B includes examples of processed field data. A full set of results covering the entire 2.5 year monitoring period from June 8, 1993 (bridge under construction) to January 27, 1996 is available as a separate publication (Hoppe and Gomez, 1996). In each plot, time 0:00 indicates midnight corresponding to a given date. Occasional breaks in data continuity resulted from a datalogger battery failure or late collection, causing some data stored in memory

to be overwritten. Steel stress magnitude was computed from strain measurements using the relationship:

$$\sigma = \epsilon E$$

where $E = 200 \text{ GPa}$.

Soil Pressure

Soil pressures measured by the sensor located behind abutment A and below the integral backwall ranged between 14 and 28 kPa, with an average magnitude of approximately 21 kPa at a depth of 2.74 m. This value correlates with an estimate of earth pressure at rest. Soil pressure variations at the back of the abutment are most likely caused by the cyclic lateral movement of the overlying integral backwall. It appears that as the superstructure begins to expand or contract the integral backwall exerts static friction on the underlying abutment. It can be seen that the abutment pressure builds up and dissipates ahead of the integral backwall pressure. The resulting displacement of the abutment in turn causes the soil pressure to fluctuate about the at-rest value. No significant change in mean soil pressure acting behind abutment A was observed during the entire monitoring period.

Soil pressure behind integral backwall A varied considerably on a daily basis, in response to changes in the ambient air temperature. Maximum pressure was typically observed in the late afternoon and minimum in the early morning hours. Figure 8 shows a trend of maximum weekly soil pressures at integral backwall A from January 1994 to January 1996. The average magnitude increased for the first year of monitoring and leveled off in the second year. Maximum soil pressure behind the integral backwall reached approximately 175 kPa, correlating with a passive stress condition at a depth of 1.35 m.

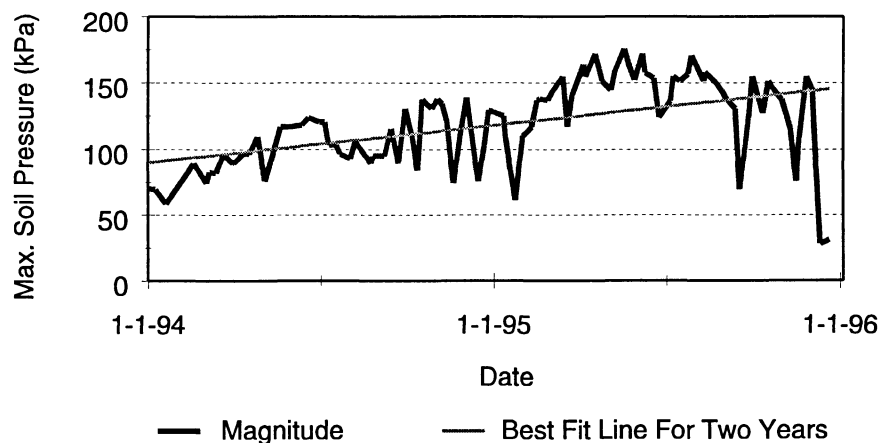

Figure 8. Maximum weekly soil pressures at integral backwall A.

Soil pressures behind integral backwall B were found to be perfectly in phase with the corresponding pressures at integral backwall A; however, the magnitudes were slightly greater. Possibly the difference was caused by a varied degree of backfill compaction at each abutment. Figure 9 shows a combined plot of maximum weekly soil pressures acting behind integral backwall B. The pattern is virtually identical to that observed at integral backwall A, with the maximum value reaching approximately 200 kPa at a depth of 1.30 m.

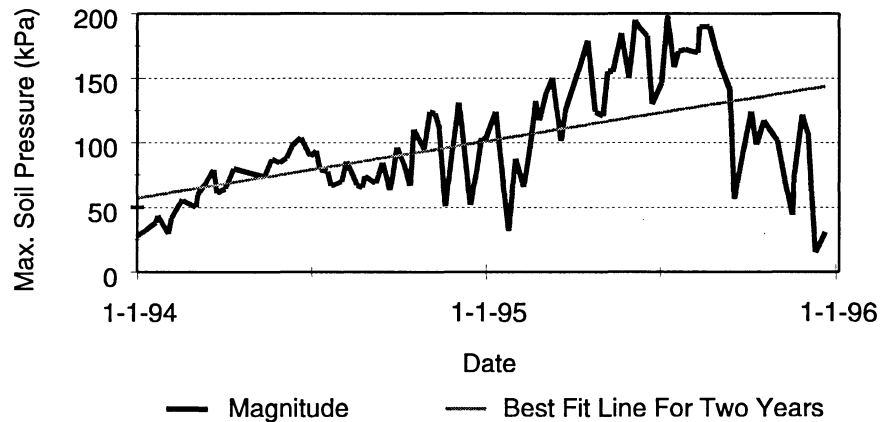

Figure 9. Maximum weekly soil pressures at integral backwall B.

Field data imply that the backfill material properties which satisfy both the at-rest pressure acting behind the abutment and the passive pressure exerted by the integral backwall are approximately as follows:

Angle of Internal Friction: 35 degrees
 Unit Weight: 18 kN/m³

These parameters were computed using Coulomb's analysis, assuming an angle of wall friction equal to 20 degrees. These derived values produce higher soil pressure than the assumed ones used in the design.

Steel Stress

Stresses measured at the bottom flanges of steel girders generally corresponded to the pattern of soil pressures acting behind the integral backwalls. Typically, stress magnitudes at the ends of girders near abutment B were seen to change in response to the soil pressure exerted on the integral backwall. The shape of the steel stress plot at girder G7 was virtually the same as the shape of the soil pressure graph at integral backwall B.

Frequently, stresses at the exterior girder G10 varied in magnitude significantly more than at the interior girder G7, at both backwalls. Also, while stress patterns at G7 and G10 were similar,

they were shifted in phase. Changes in stress were often seen to occur at G10 ahead of G7 (Appendix B, Aug. 8-14, 1994 @ Abutment B). These conditions might have occurred because the outside girder G10 is exposed to direct sunlight (facing south), thus more susceptible to thermal influence.

There was some concern during data collection about the validity of relatively high stresses detected in the girders at abutment A. A sudden increase in compressive strain was recorded on July 25, 1994. It was decided to conduct independent strain measurements using a nondestructive technique. Measurements were performed in collaboration with the National Institute of Standards (NIST) and the University of West Virginia Constructed Facilities Center, using electromagnetic-acoustic transducers (EMAT). The method relies on the acousto-elastic effect in steel, i.e. the variation of ultrasonic velocity in the presence of stress. The velocity change is proportional to the average stress in the region of wave propagation.

Nondestructive tests using EMAT's were conducted in the proximity of the resistance strain gages. The results indicated an average stress difference between abutments A and B of about 24 and 69 MPa at G10 and G7, respectively, with steel stresses being generally higher at abutment A (Lozev et al., 1996). It was recognized that the measurements may reflect some locked-in stresses generated in the process of girder fabrication, but should nevertheless provide a reasonable estimate of relative magnitudes. Based on the nondestructive test results it was concluded that abnormally high steel stresses recorded at abutment A after July 25, 1994 are most likely invalid and should be discounted. A new datalogger was installed at abutment A on November 10, 1995. Steel stress readings consistent with those at abutment B were observed following the replacement, but on a few occasions unexplained "spikes" in the data were recorded. In comparison, strain gage data collected from abutment B and from the pier appeared consistent over the entire monitoring period.

One would expect to find the steel stress at the end of the girder to vary only in the compressive range, but data collected from the bridge indicate occasional tensile stresses approaching 20 MPa. This may reflect bending stresses generated within the structure. It is conceivable that some moment was present at the girder ends due to a rigid connection with the integral backwall (Appendix A). Also, frictional forces between the backwall and the abutment may have contributed to the development of tensile stresses.

As expected, when ambient air temperature increased the soil pressure behind the backwall and the compressive stress at girder ends increased simultaneously. The typical daily increase in steel compressive stress was in the 28 MPa range, occasionally reaching 40 MPa, significantly above the estimated value of 14 MPa.

The relationship between temperature and stress was not always consistent at the steel girder flanges over the pier bearing assembly. Frequently, a decrease in a compressive stress was associated with a rise in air temperature, most likely due to the fact that steel stresses measured in the arch over the pier reflected combined axial and bending effects. Substantial stress variations,

most likely thermally induced, were observed on a daily basis. Typical fluctuations were in the 40 MPa range.

Elevated compressive stresses in the girder flanges at points in both spans were also observed during low ambient temperatures. Figures 10 through 12 (see following pages) present data from January 16-22, 1994, during a period of exceptionally cold weather. It can be seen that between January 18 and 19 compressive stresses increased by about 40 MPa, reaching peak values as air temperature plunged to -22°C (Fig. 11). At the same time soil pressures acting on both integral backwalls were practically negligible (Figs. 10 and 12). Maximum steel compressive stresses of approximately 90 MPa were recorded, significantly in excess of stresses associated with passive soil pressures. A possible explanation for this phenomenon may be the development of a thermal gradient between top of the deck and bottom of the girder. Russell and Gerken (1994) reported that stresses due to a thermal gradient through the vertical section of a structure can attain very high levels.

Bridge girders were designed for a maximum allowable compressive stress of 186 MPa. The live load and impact contributions due to the MS18 design load were estimated at approximately 8.5 MPa, based on a scaled field loading test. Thus, stresses due to thermal effects and a dead load of the deck, as presented in the graphs, appear to be well below the maximum allowable.

Approach Settlement

Damage to the approach pavement due to excessive settlement of the fill was the biggest maintenance problem observed with this bridge. The approach pavement was completed in October 1993, approximately 2 months after bridge construction. Although traffic was allowed to run on the base material before paving, a significant amount of approach settlement followed. The first major resurfacing was performed in May 1994. In the two years following construction the cost of repeated approach pavement patching due to continuous settlement amounted to approximately \$10,000.

Figures 13 and 14 show approach elevations between June and November 1994 at abutments A and B, respectively. Elevations were measured at 1.5 m intervals with reference to the bridge centerline at the back of the backwall. The settlement was concentrated within 5 m of the bridge near abutment A. At abutment B the approach settlement extended uniformly beyond 10 m from the bridge.

Figures 15 and 16 show approach elevations between August and November 1995 at abutments A and B, respectively. The rate of settlement slowed down substantially in the second year of operation. The pavement approaching abutment B continued to settle more extensively than the abutment A approach. Poor channeling of surface water away from the bridge, causing erosion behind abutment B, may have been a contributing factor.

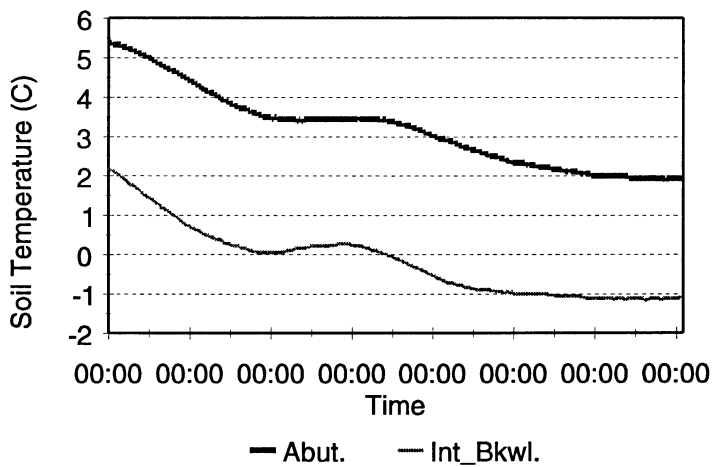
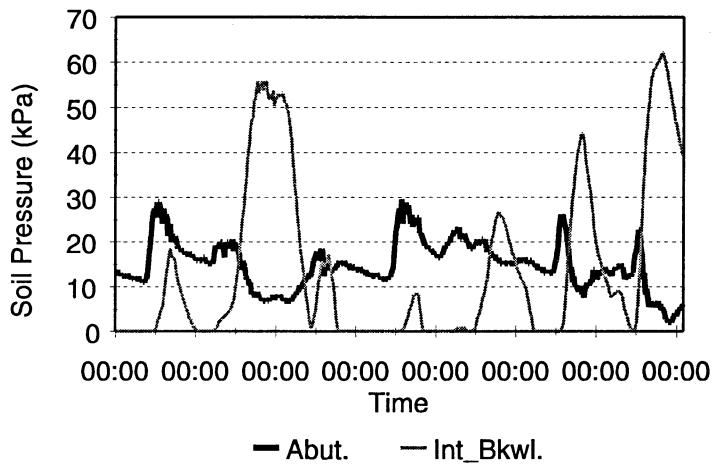
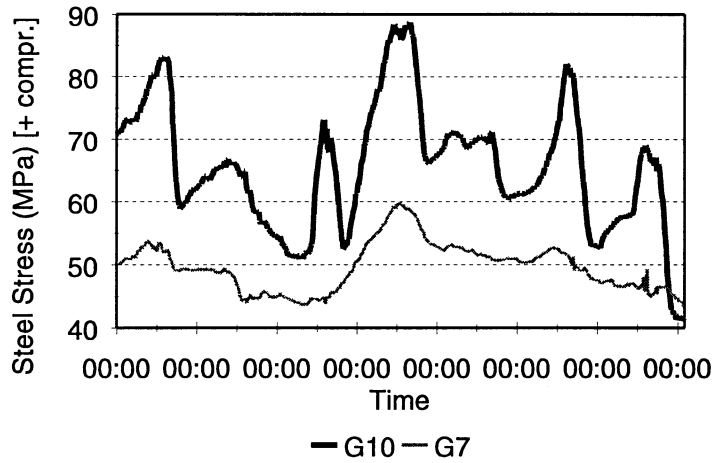

Figure 10. Abutment A data from January 16-22, 1994.

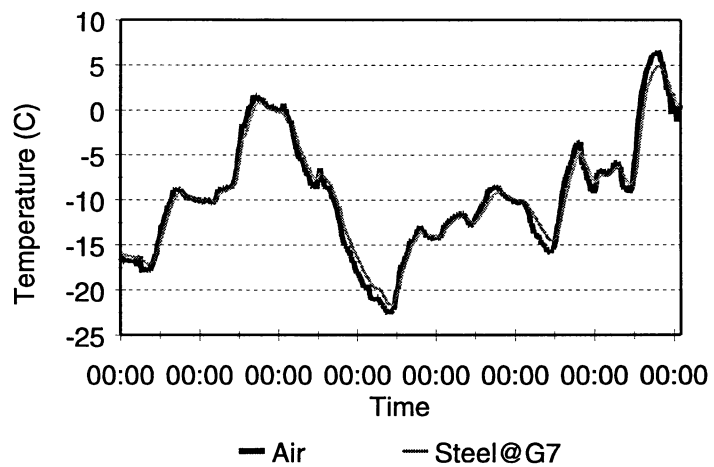
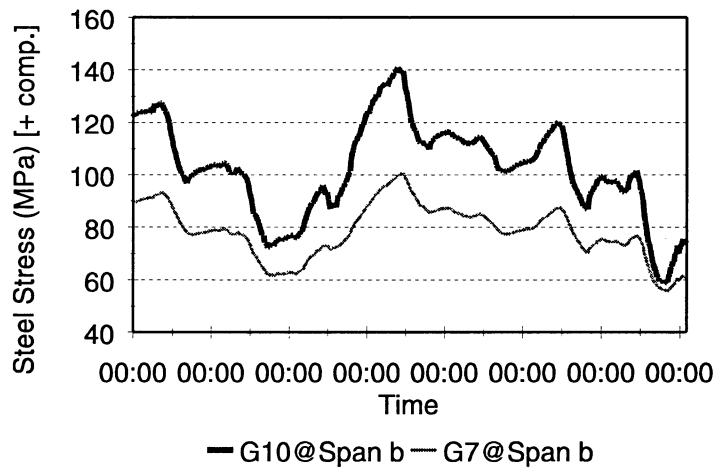
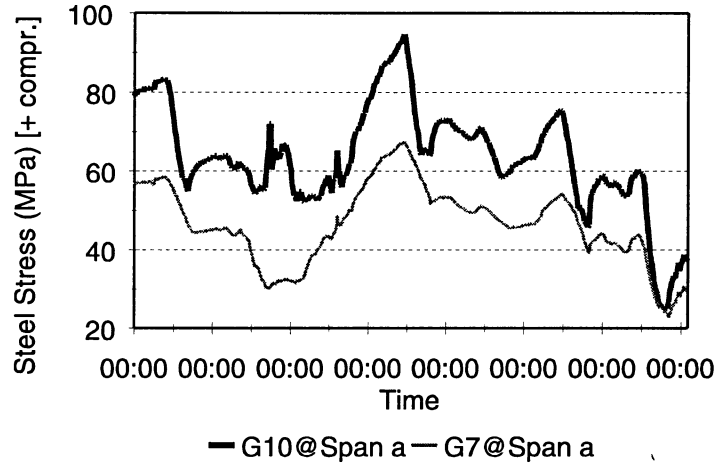

Figure 11. Pier data from January 16-22, 1994.

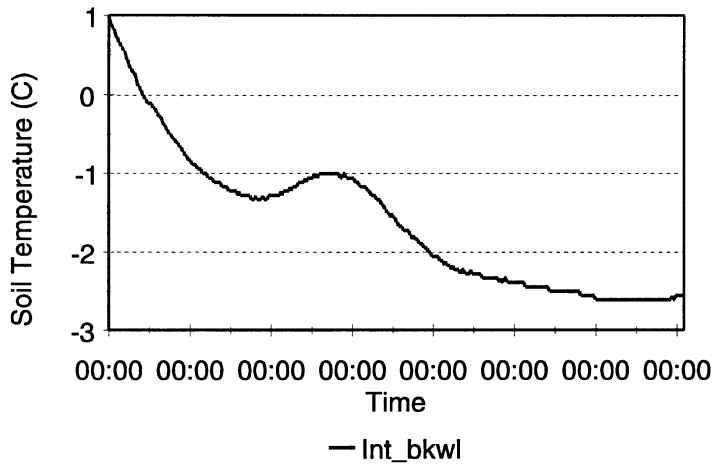
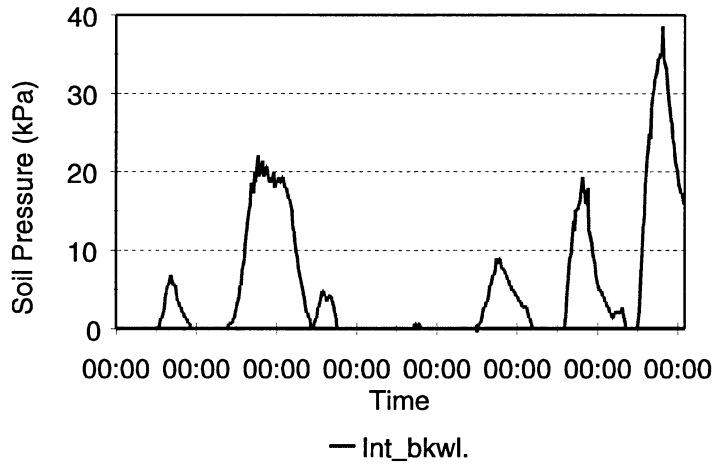
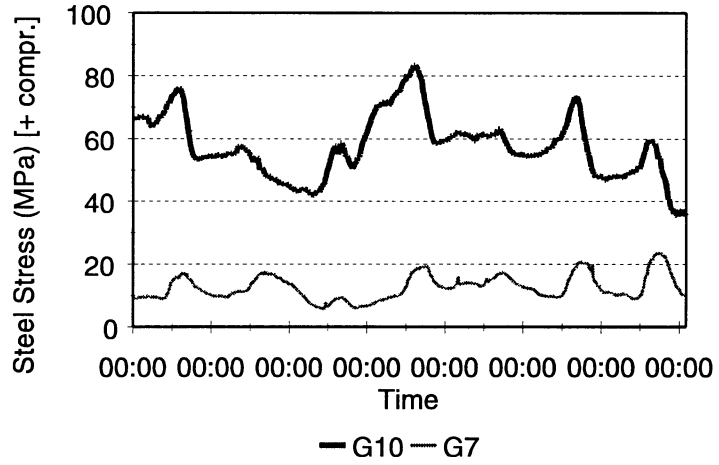

Figure 12. Abutment B data from January 16-22, 1994.

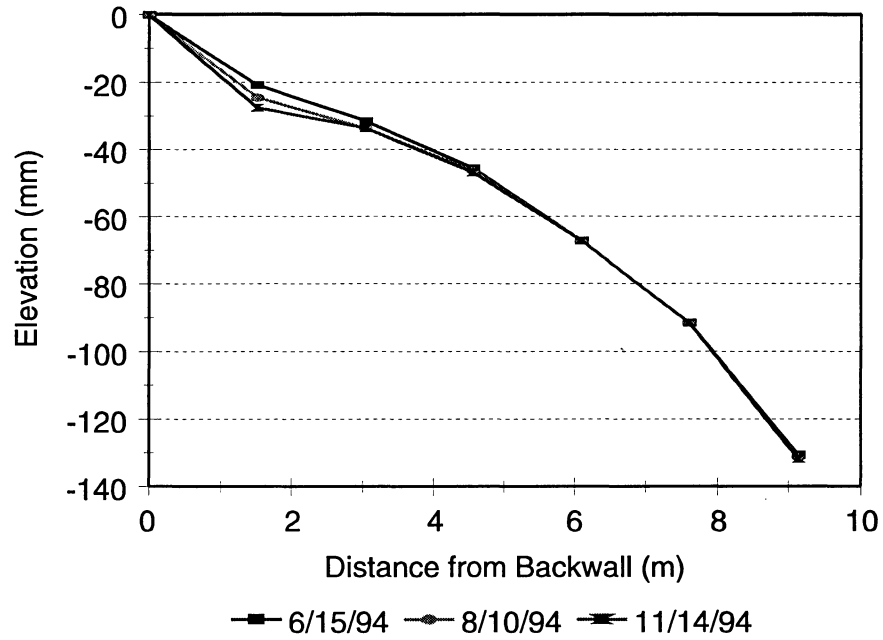

Figure 13. Abutment A approach elevations (1994).

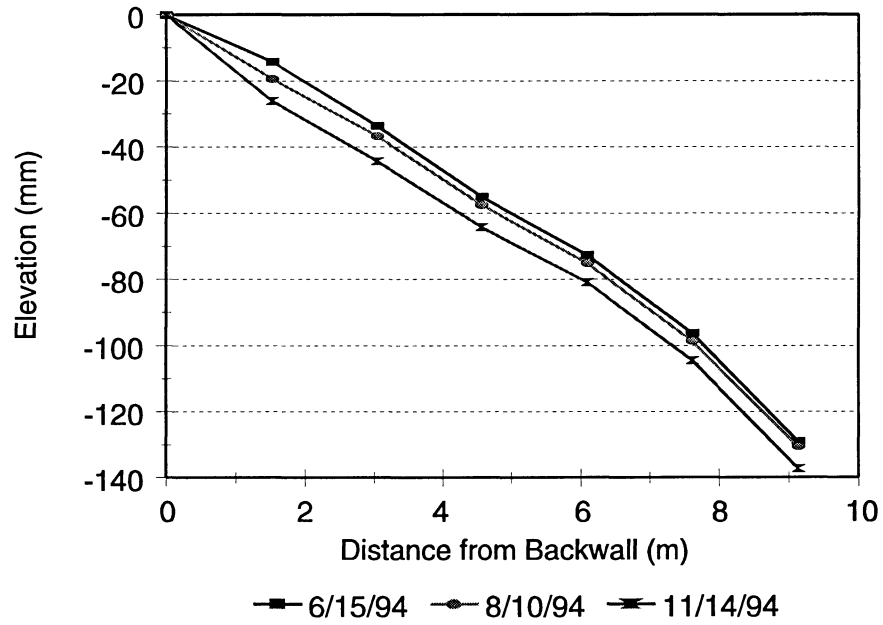

Figure 14. Abutment B approach elevations (1994).

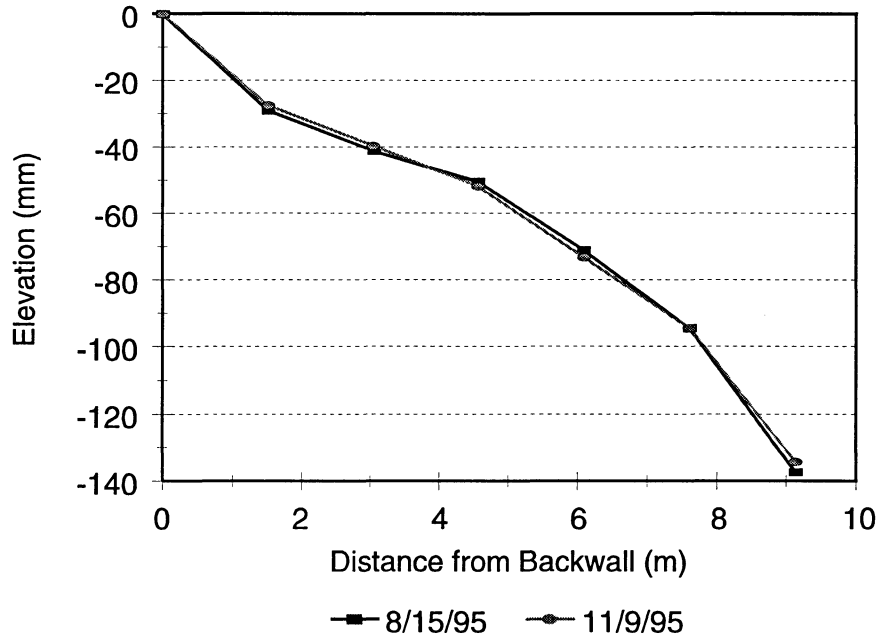

Figure 15. Abutment A approach elevations (1995).

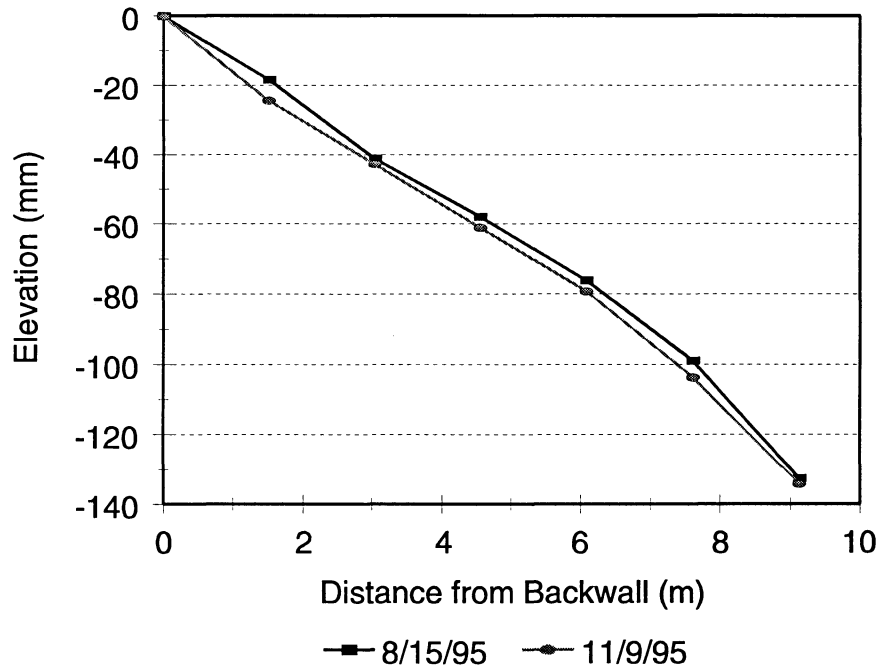

Figure 16. Abutment B approach elevations (1995).

Structure Condition

No significant signs of structural distress were observed during the monitoring period. Some transverse cracking was noted in the negative moment area of the deck and in the parapets, but it was regarded as typical for a continuous structure.

As expected, some horizontal rotation of the superstructure was detected. It resulted in a sealer disturbance at vertical joints between the backwall and the abutment, creating a minor spillage of backfill material at both abutments. Horizontal rotation of skewed integral bridges is caused by non-collinear resultant soil forces acting at each backwall.

CONCLUSIONS AND RECOMMENDATIONS

The integral backwall bridge performed satisfactorily in a 2.5 year monitoring period. No evidence of structural distress was observed. The field monitoring data did not indicate steel stresses in excess of the allowable values. Based on the accumulated results, the 90 m length limitation for VDOT integral bridges appears to be conservative. Although it is not feasible to establish a new limit based on a single study, incremental changes to the existing design criteria should be considered.

Fully passive earth pressure was recorded at the back of the integral backwall. Its magnitude increased following the end of construction as a result of continuous backwall movement. Maximum values were reached in the summer months of the second year of operation.

Soil pressure approaching at-rest condition was encountered at the back of the underlying abutment. Its mean value remained essentially constant throughout the monitoring period. Some daily variations in soil pressure were caused by the abutment interaction with the integral backwall. The at-rest pressure condition is normally expected in rigid retaining structures.

Significant daily variations occurred in steel stress (bottom girder flange) and soil pressure in response to the superstructure expansion and contraction caused by ambient air temperature fluctuations. Surprisingly, data collected during a period of very cold weather indicated elevated compressive stresses in steel girders in the absence of corresponding soil pressures. This might indicate that in some cases thermal stresses caused by temperature gradients in steel girder structures could be more critical than stresses resulting from passive soil pressures.

Settlement of bridge approaches has been the most evident maintenance problem. Fill settlement was most likely magnified by a cyclic movement of the integral backwall. It is not obvious, however, that the presence of concrete approach slabs would have minimized or prevented asphalt pavement repairs, especially at abutment B, where the fill settlement extended beyond the length of a typical approach slab. The soil-structure interaction is significantly more acute in an integral design. Thermally induced movements of the superstructure need to be effectively

accommodated in the adjacent fill without creating undue settlement and distress in the approach pavement.

It is recommended that:

- 1) Current design criteria for integral bridges should be examined, with a view to increasing VDOT's length limitation beyond 90 m.
- 2) Additional research should be directed at backfill materials and embankment construction techniques associated with integral bridges, with the goal of solving the problem of excessive fill settlement due to the temperature-driven expansion and contraction of the bridge superstructure.

ACKNOWLEDGMENTS

This study was supported by HPR funds from the Federal Highway Administration (FHWA). The authors are grateful for the technical support of Mr. Park Thompson of VDOT Staunton District Bridge Office, Mr. Mark Huffman of Mt. Crawford Area Headquarters and Messrs. Jim French and Arthur Wagner of the Research Council. Data reduction and plotting were made possible by Ms. Shea De Lutis and Mr. Brian Casto of the Research Council.

REFERENCES

- Burke, M. P. (1987) *Bridge approach pavements, integral bridges and cycle control joints*. Transportation Research Board, 66th Annual Meeting.
- Burke, M. P. (1993) *Integral bridges: attributes and limitations*. Transportation Research Board, 72nd Annual Meeting.
- Burke, M. P., and Gloyd, S. (1996) *Semi-integral bridges: a revelation*. Transportation Research Board, 75th Annual Meeting.
- Hoppe, E. J., and Gomez, J. P. (1996) *Route 257 over I-81, field monitoring results, June 8, 1993 to January 27, 1996*. Virginia Transportation Research Council, Charlottesville, Va.
- Lozev, M. G., Clark, A. V., and Fuchs, P. A. (1996) *Application of electromagnetic-acoustic transducers for nondestructive evaluation of stresses in steel bridge structures*. Virginia Transportation Research Council, Charlottesville, Va.
- Russell, H. G., and Gerken, L. J. (1994) Jointless bridges - the knowns and the unknowns. *Concrete International*, April, pp. 44-48.
- Soltani, A. A., and Kukreti, A. R. (1992) *Performance evaluation of integral abutment bridges*. Transportation Research Board, 71st Annual Meeting.
- Steiger, D. J. (1993) 'Jointless' bridges provide fuel for controversy. *Roads & Bridges*, November, pp. 48-54.

APPENDIX A

Bridge Plans

NOTE: The plans reproduced in this appendix were prepared using English units. The following conversion factors are provided for convenience:

$$1 \text{ inch} = 25.4 \text{ mm}$$

$$1 \text{ S.Y.} = 0.83 \text{ m}^2$$

$$1 \text{ C.Y.} = 0.76 \text{ m}^3$$

$$1 \text{ Lb} = 0.454 \text{ kg}$$

FEDERAL ROAD DISTRICT NO.	STATE	FEDERAL AID PROJECT NO.	ROUTE	PROJECT	SHEET NO.
3	VA	81-1-009-082-105(10)0528			5/2

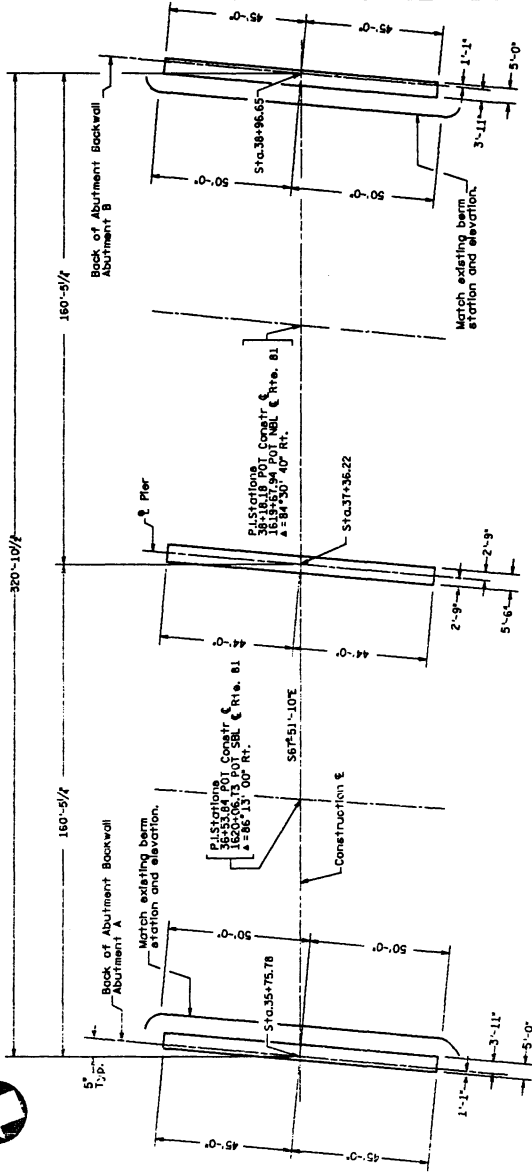

SUBSTRUCTURE LAYOUT

Note: this layout is to be used only for the purpose of locating fill slopes and footings of abutments and piers. For details of masonry, see abutment and pier details. This layout is to be used to confirm stationing prior to beginning construction of the bridge.

Point	Span a																Span b																					
	0	1	2	3	4	5	6	7	8	9	10	11	12	13	14	15	16	0	1	2	3	4	5	6	7	8	9	10	11	12	13	14	15	16				
L.C.C.P.	1224.41	1224.58	1224.73	1224.84	1224.92	1224.97	1224.99	1224.99	1224.98	1224.96	1224.93	1224.88	1224.78	1224.66	1224.50	1224.31	1224.09	1223.65	1223.57	1224.41	1224.58	1224.73	1224.84	1224.92	1224.97	1224.99	1224.99	1224.98	1224.96	1224.93	1224.88	1224.78	1224.66	1224.50	1224.31	1224.09	1223.65	1223.57
±	1225.23	1225.41	1225.56	1225.67	1225.76	1225.82	1225.84	1225.84	1225.84	1225.81	1225.81	1225.81	1225.79	1225.65	1225.53	1225.20	1224.99	1224.75	1224.48	1225.23	1225.41	1225.56	1225.67	1225.76	1225.82	1225.84	1225.84	1225.81	1225.81	1225.79	1225.65	1225.53	1225.20	1224.99	1224.75	1224.48		
Rt. Curb	1224.35	1224.53	1224.68	1224.80	1224.89	1224.96	1224.98	1224.99	1224.99	1224.98	1224.96	1224.93	1224.82	1224.70	1224.56	1224.36	1224.17	1223.94	1223.67	1224.35	1224.53	1224.68	1224.80	1224.89	1224.96	1224.98	1224.99	1224.98	1224.96	1224.93	1224.82	1224.70	1224.56	1224.36	1224.17	1223.94	1223.67	

Note: Slab elevations as shown in table above are on top of finished roadway or faces of curbs; those shown on L.C.C.P. are on top of finished grade denoted on Transverse Section. Points along faces of curbs are aligned at eighth points with intermediate elevations shown. Interpolation for intermediate elevations on top of finished roadway may be made in any direction between any two adjacent points located opposite carrying stations.

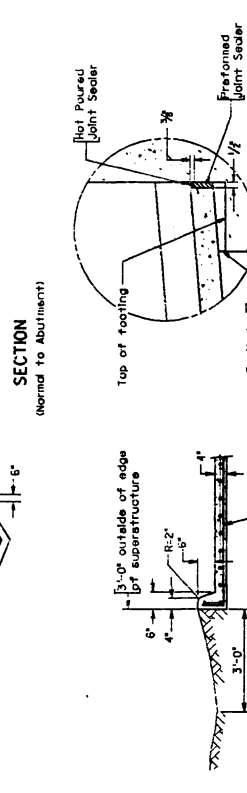
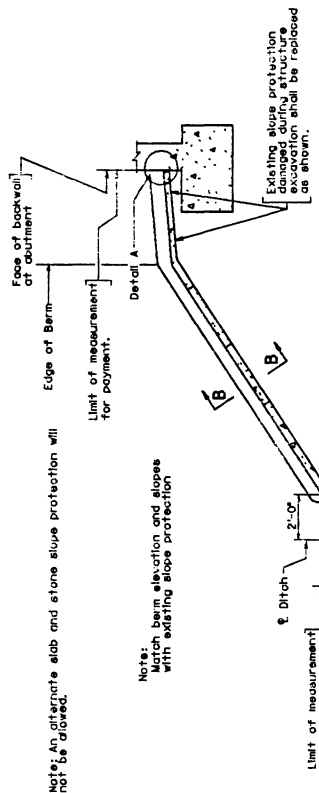

DETAIL A

New concrete slope protection

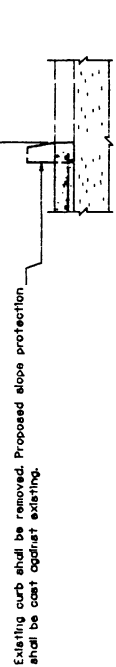

CONCRETE SLAB SLOPE PROTECTION

Note: Slope protection is shown at opposite hand of Abutment A are opposite hand.

COMMUNITY OF VIRGINIA		NOV 1991		269-70		2 of 13	
DEPARTMENT OF TRANSPORTATION		Nov. 1991		269-70		2 of 13	
STRUCTURE AND BRIDGE DIVISION		Nov. 1991		269-70		2 of 13	
SUBSTRUCTURE LAYOUT & SLOPE PROTECTION		Nov. 1991		269-70		2 of 13	

No Scale

FEDERAL AID	STATE PROJECT	ROUTE	PROJECT	DATE	SHEET
3	VA	91	0281-02E-182PE(0)A828	8/01	8/01

REINFORCING STEEL SCHEDULE

Mark	Number	Length	Pin #	Location
SA0401	120	4'-11"	2"	App. Slab Start
SA0402	12	33'-0"	—	App. Slab Start
SA0403	120	3'-11"	2"	App. Slab Start
SA0404	12	3'-11"	—	App. Slab Start
SR0501	272	41'-0"	3/8"	Slab
SR0502	272	48'-2"	3/8"	Slab
SC0501	550	40'-2"	—	Slab
SC0502	550	46'-11"	—	Slab
SH0501	132	3'-3"	3/8"	Integral Bkwl.
SH0502	52	42'-11"	—	Integral Bkwl.
SH0503	52	43'-11"	—	Integral Bkwl.
SL0401	1632	41'-6"	—	Slab
SL0502	468	35'-4"	—	Slab
SV0401	160	8'-2"	2"	Integral Bkwl.
SV0502	160	8'-8"	2 1/2"	Integral Bkwl.

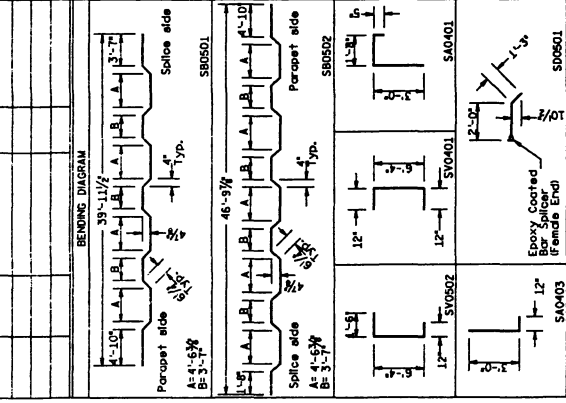

Note: Bar Splicer is included in bid item for Epoxy Coated Reinforcing Steel.

Note: Dimensions in Bending Diagram are for Epoxy Coated Reinforcing Steel.

Note: All reinforcing steel to be epoxy coated.

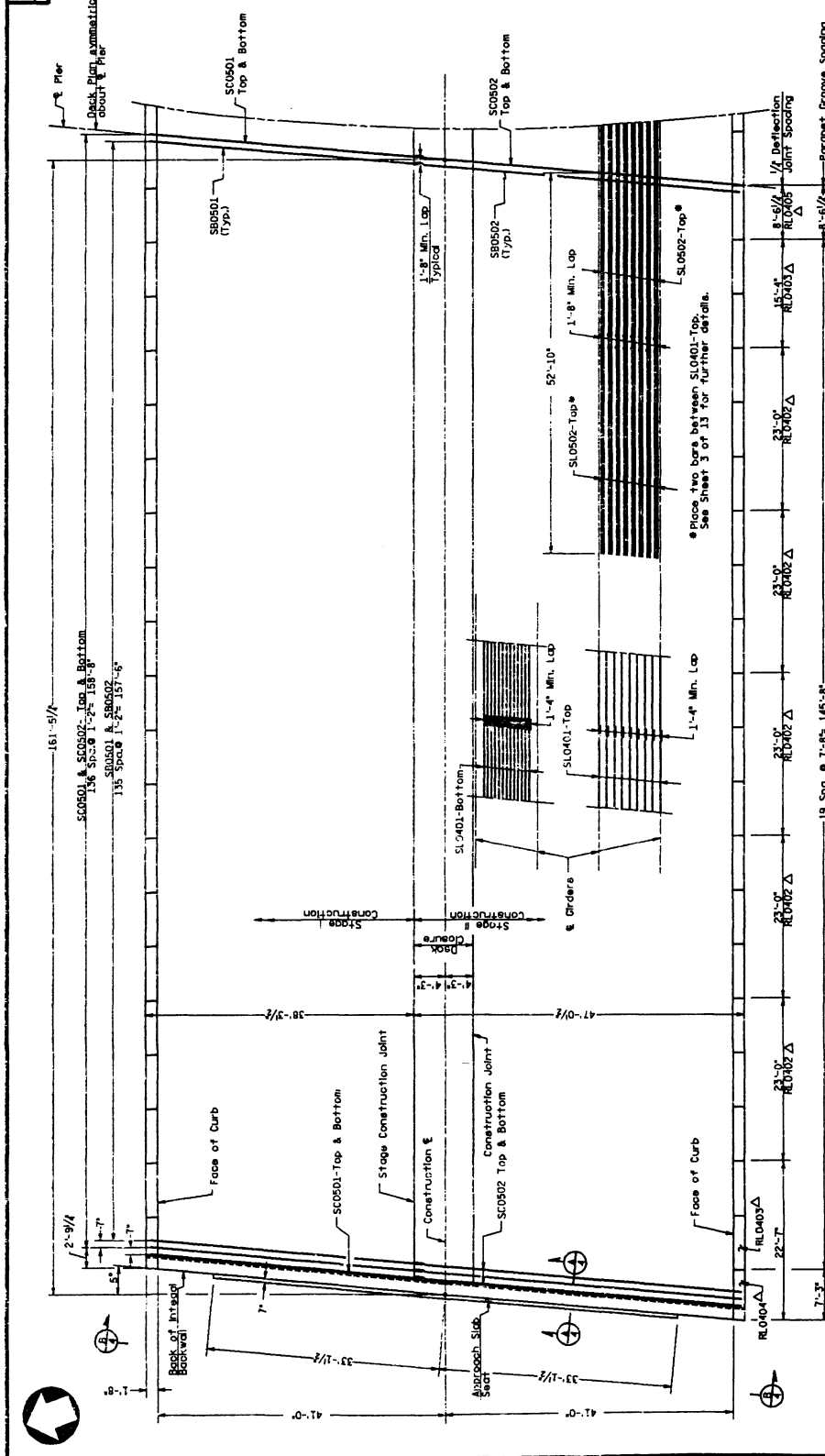

DECK PLAN
Scale: 1/8" = 1'-0"

Note: See Sheet 5 of 13 for Section A-A and Section B-B.

△ Backwall location of RL041 Surface bars in top portion of parapet. See Sheet 9 of 13 for details.

- SEQUENCE OF INTEGRAL BACKWALL & DECK SLAB CONSTRUCTION:
- Place concrete in integral backwalls in ① and ② up to the limits shown on Sheet 5 of 13.
 - After concrete in integral backwalls has reached design strength, place remainder of deck slab concrete in ③ & ④.
 - Place concrete in ⑤.
 - Place concrete in integral backwalls in ⑥ and ⑦ up to the limits shown on Sheet 5 of 13.
 - After concrete in integral backwalls has reached design strength, place remainder of concrete in ⑧ & ⑨.
 - Place concrete in ⑩.
 - Place concrete in Deck Closure and Integral Backwall Closure in ⑪ & ⑫.
 - Place concrete in ⑬.

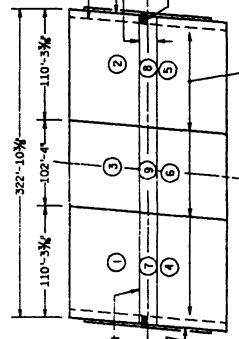

CONCRETE PLACEMENT SCHEDULE
No Scale

Note: The numbers shown indicate the suggested order of deck slab placement.

Note: Concrete Class A4 to be used in the construction of the integral backwall and is included in the quantity for Concrete Class A4.

Note: Concrete shall be placed and finished at the minimum rate of 25 C.Y./hr.

Note: Parapet grooves and deflection joint spacing are typical for both sides of bridge.

COMMITTEE ON TRANSPORTATION	
STRUCTURE AND BRIDGE DIVISION	
DECK PLAN	
Date	10/27/70
Drawn by	W. J. ...
Checked by	...
Scale	1/8" = 1'-0"
Sheet No.	269-70
4 of 13	

FEDERAL AID	STATE	PROJECT	SHEET
ROUTE	ROUTE	NO.	NO.
3	14	B1 0091-082-1BPE101(552) 3(6)	161

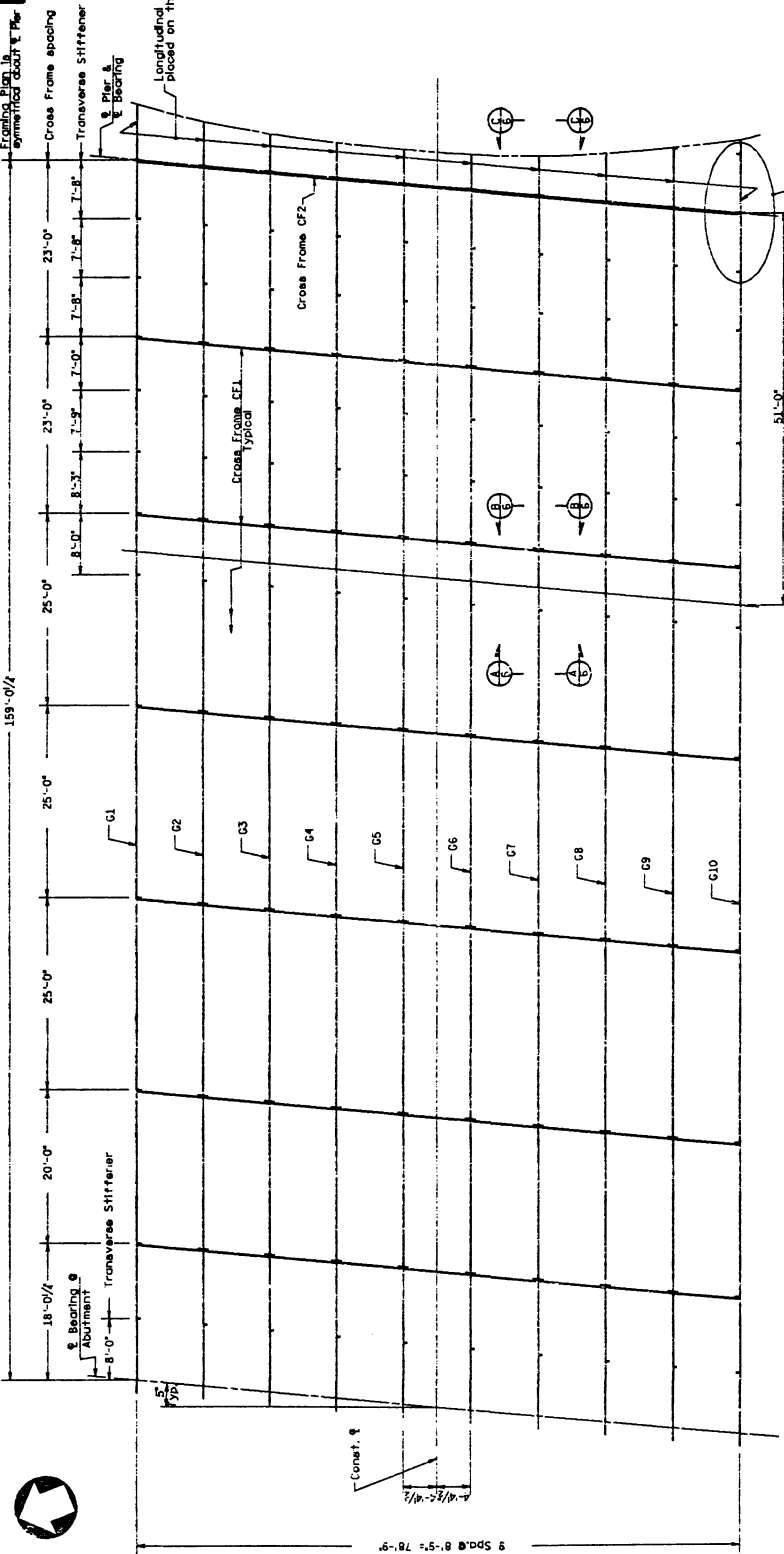

FRAMING PLAN
Scale: 1/4" = 1'-0"

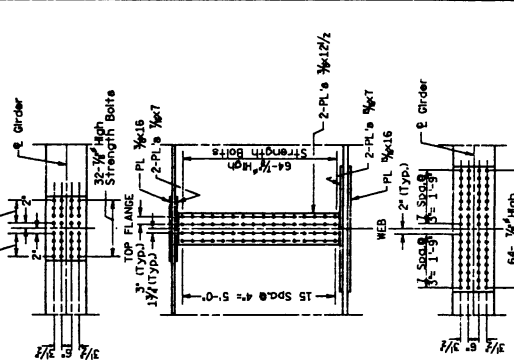

BOLTED SPLICE DETAIL

DETAIL B

Note: If butt joint is required in longitudinal stiffener, it shall be joined with a complete penetration (CJP) weld. The weld shall be made prior to attachment to girder.

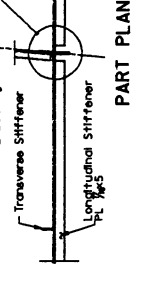

PART PLAN

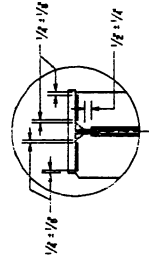

DETAIL A

No Scale

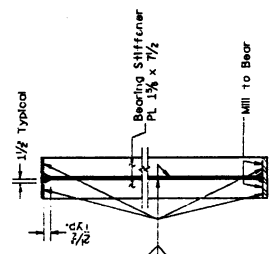

SECTION A-A

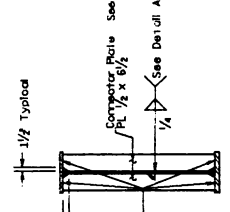

SECTION B-B

SECTION C-C

Stifflet weld (both sides) to compression flange. Tight fit to tension flange. For limits see Girder Elevation on Sheet 1 of 13.

No Scale or As Shown

CONTRACT TITLE OF WORK		DATE	DESIGNED BY	CHECKED BY	SCALE	SHEET NO.
DEPARTMENT OF TRANSPORTATION		Nov. 1931			269-70	6 of 13
STRUCTURE AND BRIDGE DIVISION						
FRAMING PLAN						
No.	Description	Date	Revisions			

FEMA REGION	STATE	FEDERAL AID	ROUTE	PROJECT	STATE	PROJECT	SHEET NO.
3	VA		81	0281-095-110-PE(01)R628			910

NOTES:

Fill slots and holes in masonry plate around anchor bolts with a non-hardening caulking compound or elastic joint sealer.

For expansion bearing, bevel sole plate to match grade if grade exceeds 1%. For fixed bearing, bevel sole plate if grade exceeds 3%.

Bearing stiffeners shown are omitted if rolled beam is used.

Radius may be machined to compensate for grade.

Bearing shall be set so that at 60° F it is at the midpoint of 1/8" movement.

For expansion bearings, 15" Radius tolerances:
Sole PL $+0.1, -0.1$
Bronze PL $+0.1, -0.1$

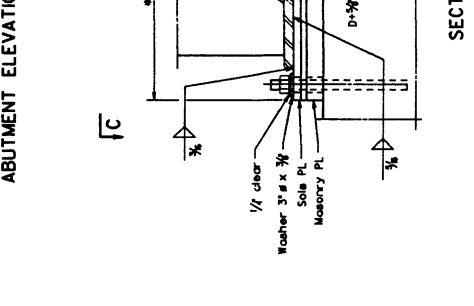
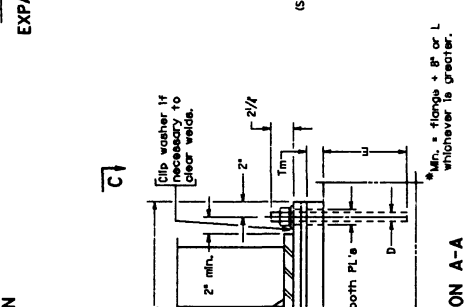
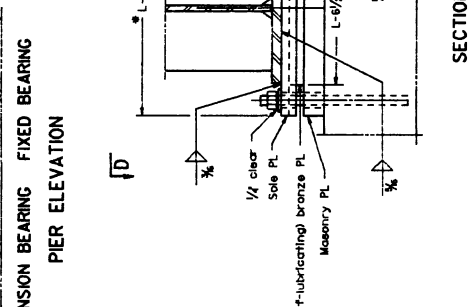
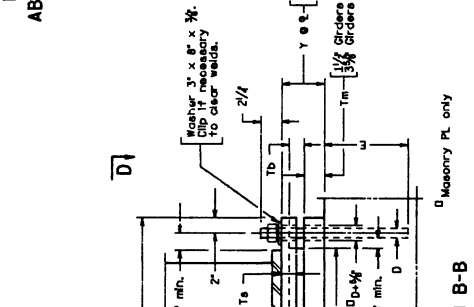
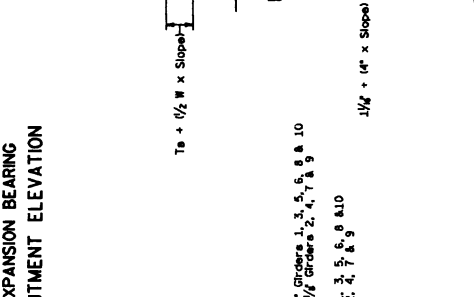
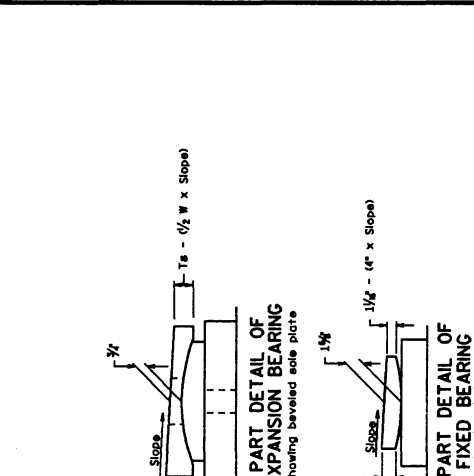
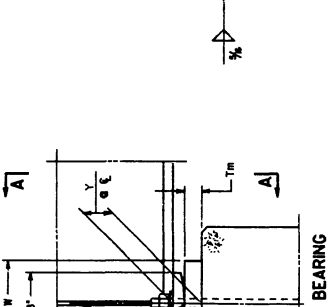
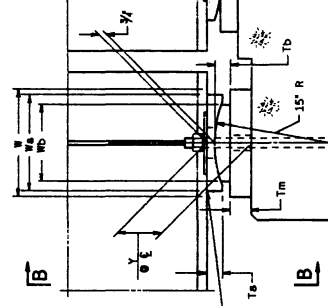
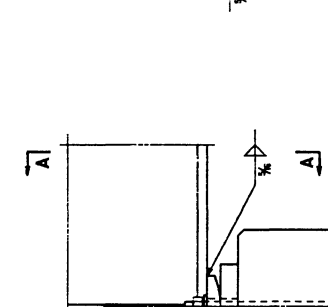
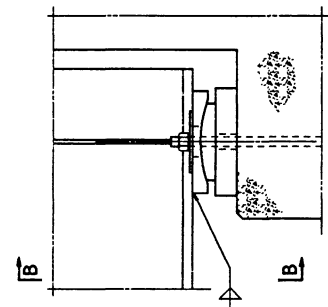

DESIGNATION TABLE		Type		Y		Tm	
Span	Abut. Pier	EB-3	Δ	Δ	Δ	Δ	Δ
a & b	1	EB-14	4 3/4"	2 3/4"			
b	B	EB-3	Δ	Δ	Δ	Δ	Δ

Δ Varies. See Section B-B

Reaction	Type	L	W	WB	To	Tb	D	E	Sole Plate Slots	Ws
120k	EB-1	20	10 1/2"	8	1 1/2"	1 1/2"	1 1/4"	12	1 1/2" x 2 1/2"	
140k	FB-8	20	8		1 1/2"	1 1/2"	1 1/4"	12		
180k	EB-2	22	12	9 1/2"	1 1/2"	1 1/2"	1 1/4"	12	1 1/2" x 2 1/2"	
	FB-9	22	9		1 1/2"	1 1/2"	1 1/4"	12		
220k	EB-3	24	12 1/2"	10	1 1/2"	1 1/2"	1 1/4"	15	2 1/4" x 3 1/4"	11
	FB-10	24	10		1 1/2"	1 1/2"	1 1/4"	15		
260k	EB-4	26	13 1/2"	11	2	1 1/2"	1 1/4"	15	2 1/4" x 3 1/4"	
	FB-11	26	10		2	1 1/2"	1 1/4"	15		
300k	EB-5	28	14	11	2	1 1/2"	1 1/4"	15	2 1/4" x 4 1/4"	
	FB-12	28	11		2	1 1/2"	1 1/4"	15		
340k	EB-6	30	14 1/2"	11 1/2"	2 1/4"	2 1/4"	1 1/2"	15	2 1/4" x 4 1/4"	
	FB-13	30	12		2 1/4"	2 1/4"	1 1/2"	15		
400k	EB-7	32	15 1/2"	12 1/2"	2 1/2"	2 1/2"	1 1/2"	15	2 1/4" x 4 1/4"	
	FB-14	32	16		2 1/2"	2 1/2"	1 1/2"	15		

Slootted holes in sole plate may be drilled or machine burned. Dimensions T_a, T_b and Y are measured at 1/8" of bearing. All dimensions in table are in inches.

No.	Description	Date	Revisions

COMMONWEALTH OF VIRGINIA
DEPARTMENT OF TRANSPORTATION
STRUCTURE AND BRIDGE DIVISION

BEARING DETAILS

Designed by: [Signature]
Checked by: [Signature]
Date: Nov. 1991
Project No.: 269-70
Sheet No.: 8 of 13

FEDERAL AID	STATE	SHEET
ROUTE	PROJECT	NO.
3	0081-082-116-F(01)8528	1 OF 13

NOTES:
 Rounded edges with 1" radius may be used in lieu of bevels along top of parapet.
 All reinforcing steel shall be epoxy coated.
 Barrier, Delinctor, size, color, and spacing to be in accordance with the Specifications. Cost of Delinctor to be included in the Bid. Delinctor shall be 1/2" dia. epoxy coated.
 Delinctor, in all instances, to be facing oncoming traffic.
 All concrete shall be Class A4.
 Terminal Walls are detailed to take guardrail attachment BR-F04-2. Holes, where shown, shall be formed with sleeves of 1/2" dia. nominal pipe.
 Bolts, where shown, shall be 3/4" dia. expansion anchor bolts, 6" long to be drilled and installed when sub rail is attached.

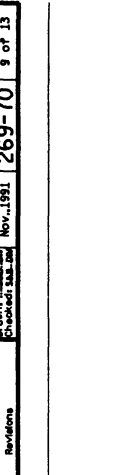
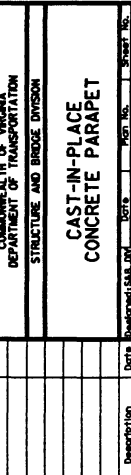
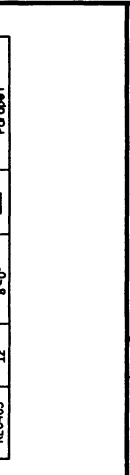
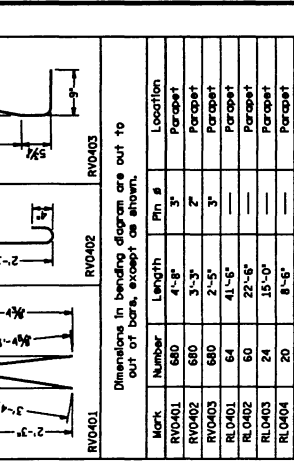
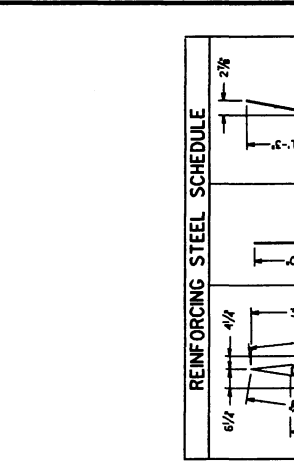

REINFORCING STEEL SCHEDULE

Mark	Number	Length	Fin. #	Location
RV0401	680	4'-8"	3"	Parapet
RV0402	680	3'-3"	2"	Parapet
RV0403	680	2'-5"	3"	Parapet
RL0401	64	41'-6"	---	Parapet
RL0402	60	22'-6"	---	Parapet
RL0403	24	15'-0"	---	Parapet
RL0404	20	8'-6"	---	Parapet
RL0405	12	8'-0"	---	Parapet

Dimensions in bending diagrams are out to out of bars, except as shown.

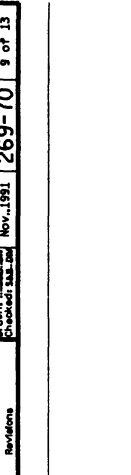
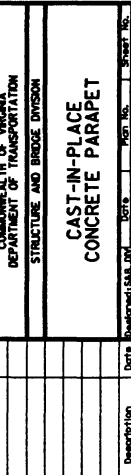
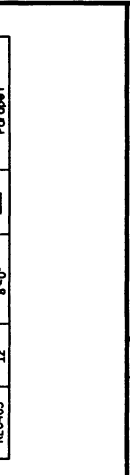
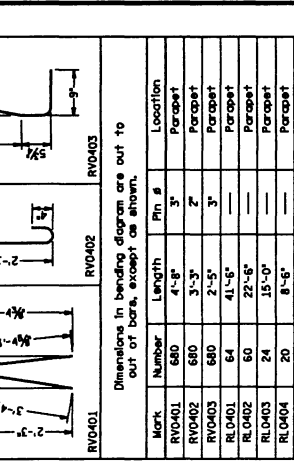
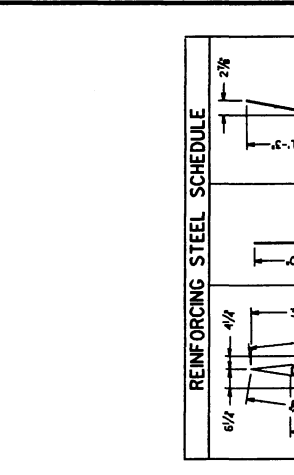
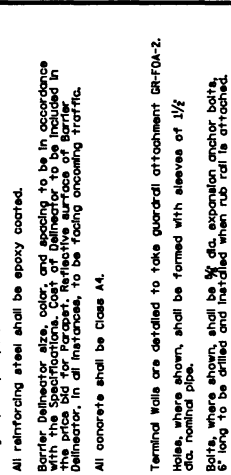

REINFORCING STEEL SCHEDULE

Mark	Number	Length	Fin. #	Location
RV0401	680	4'-8"	3"	Parapet
RV0402	680	3'-3"	2"	Parapet
RV0403	680	2'-5"	3"	Parapet
RL0401	64	41'-6"	---	Parapet
RL0402	60	22'-6"	---	Parapet
RL0403	24	15'-0"	---	Parapet
RL0404	20	8'-6"	---	Parapet
RL0405	12	8'-0"	---	Parapet

Dimensions in bending diagrams are out to out of bars, except as shown.

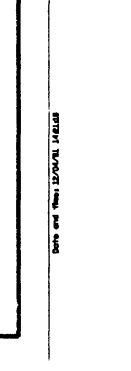
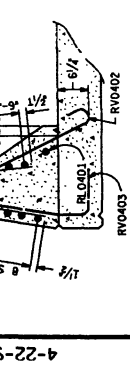
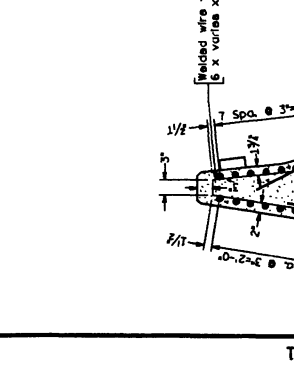
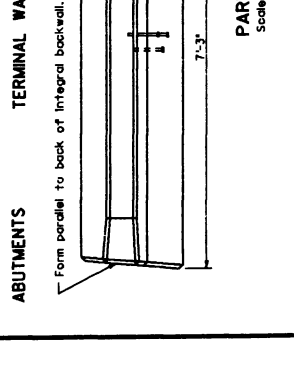
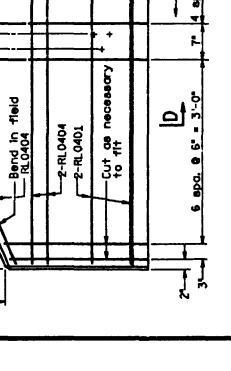

FEDERAL AID PROJECT NO.	STATE ROUTE	STATE PROJECT NO.	STATE SHEET NO.
DAKOTA 1081-082-103E-101852 (S1)	101	101852 (S1)	11 of 13

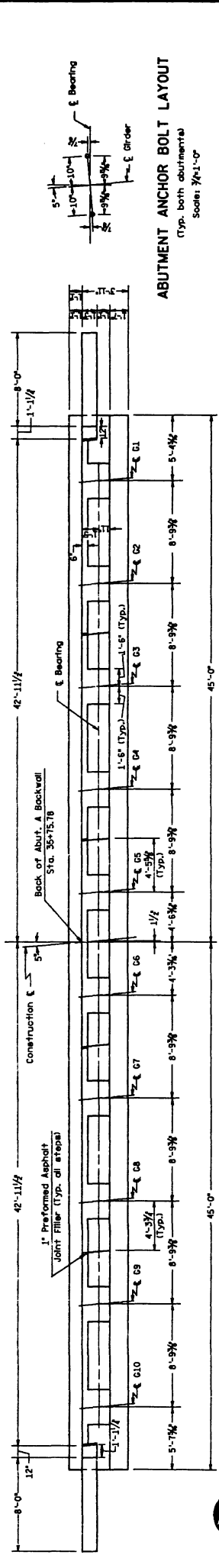

PLAN

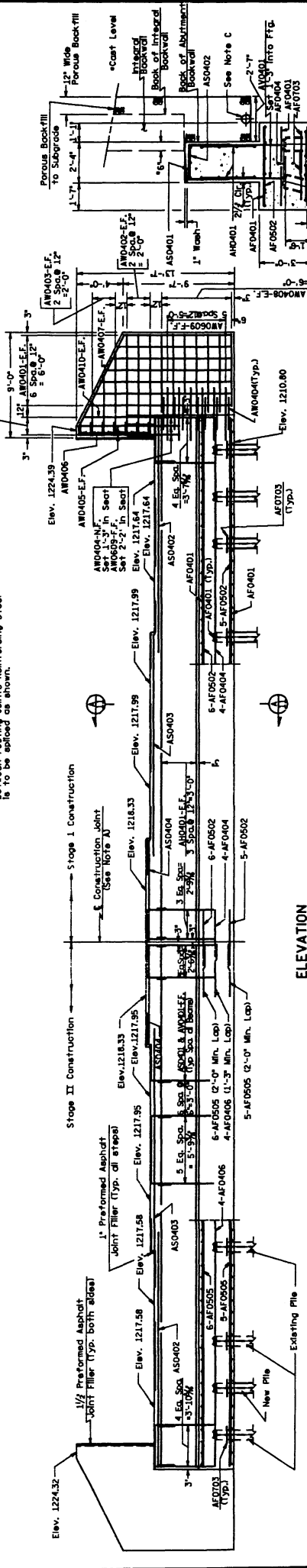

ELEVATION

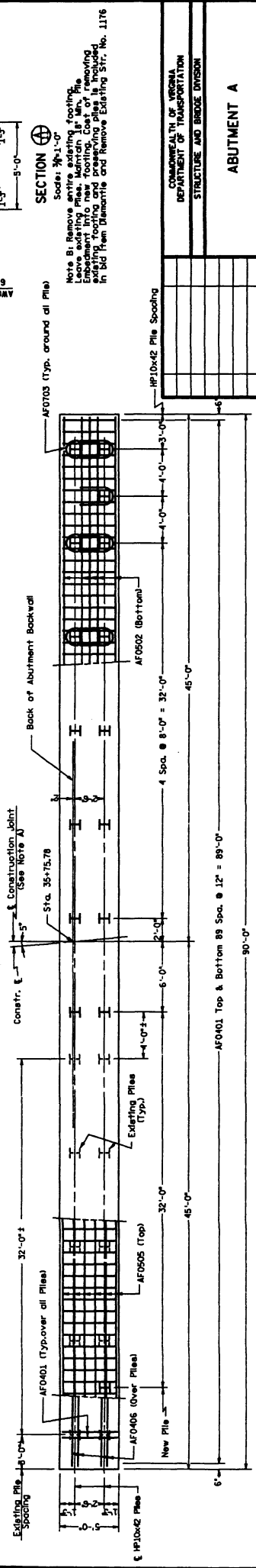

SECTION

Legend:
 denotes each face.
 FF denotes for face.
 NF denotes near face.

Note A:
 Provide Construction Joint as shown.
 Between Footing Joints Reinforcing Steel
 is to be spliced as shown.

Note B:
 Remove entire existing footing.
 Leave existing pile within 1/2" Min. of
 Embedment into new footing. Cost of removing
 in Bid Item Demolition and Remove Existing Str. No. 1176

Note C:
 6" Dia. Pile. Min. Underdrain.
 Grade to drain to surface
 of approach fill.

Note D:
 12" Wide
 Forous Backfill
 e Coat Level
 Back of Integral
 Backfill
 Back of Abutment

Note E:
 See Note C

Note F:
 1" Wash

Note G:
 2'-T
 Set into FFG

Note H:
 6 Spd. @ 12"

No.	Description	Date	Drawn by	Checked by	Scale
					269-70

CONTRACT NO. 101-1991
 NOV. 1991

COMMISSIONER OF HIGHWAYS
 DEPARTMENT OF TRANSPORTATION
 STRUCTURE AND BRIDGE DIVISION

ABUTMENT A

Scale: 1/2"=1'-0" (except as shown)

FOOTING AND PILE PLAN

Scale: 1/2"=1'-0" (except as shown)

Scale: 1/2"=1'-0" (except as shown)

Scale: 1/2"=1'-0" (except as shown)

Scale: 1/2"=1'-0" (except as shown)

FEDERAL AD	STATE	PROJECT	SHEET NO.
VA	81	DOB-1082-118-PC-10-1858	3(12)

MARK	ABUTMENT	LENGTH	FIN #	LOCATION
AF0401	208	4'-6"	—	Footing
AF0502	11	46'-6"	—	Footing
AF0703	26	9'-3"	177/8"	Footing
AF0404	4	46'-3"	—	Footing
AF0905	11	44'-9"	—	Footing
AF0406	4	44'-9"	—	Footing
AS0401	16	44'-6"	—	Backwall
AS0401	116	5'-3"	2"	Seal
AS0402	6	18'-6"	—	Seal
AS0403	6	18'-6"	—	Seal
AS0404	6	8'-2"	—	Seal
AS0401	232	4'-9"	—	Seal
AW0401	8	9'-2" to 12'-2"	—	Wing
AW0402	12	8'-7"	—	Wing
AW0403	12	3'-3" to 7'-3"	—	Wing
AW0404	34	2'-9"	—	Wing
AW0405	8	6'-6"	—	Wing
AW0406	14	2'-8"	—	Wing
AW0407	4	9'-6"	—	Wing
AW0408	28	6'-10"	—	Wing
AW0409	18	4'-6"	—	Wing
AW0410	4	6'-0"	—	Wing

REINFORCING STEEL SCHEDULE

Δ Epoxy Coated Reinforcing Steel

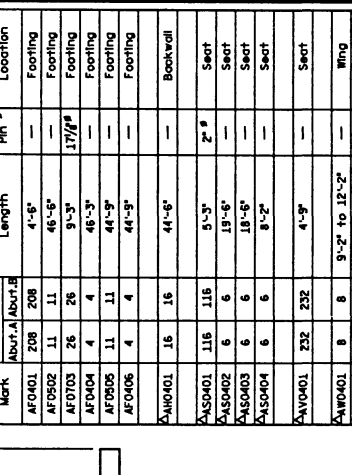

Notes:
 Note A: Provide Construction Joint as shown. Between Footing Joints Reinforcing Steel is to be spliced as shown.
 Note B: Remove entire existing footing pile embankment into new footing. Cost of removing existing footing and preserving piles is included in Bid from Bimacrite and Remove Existing Str. No. 1176

No.	Description	Date	Revisions

ABUTMENT B

COMMONWEALTH OF VIRGINIA
 DEPARTMENT OF TRANSPORTATION
 STRUCTURE AND BRIDGE DIVISION

Nov. 1991

269-70

12 of 13

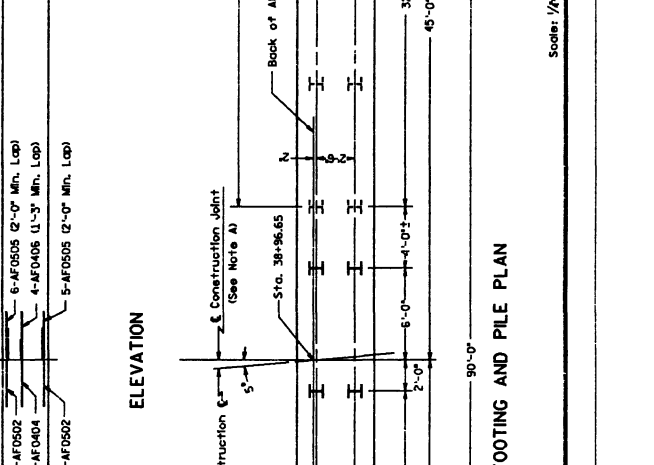
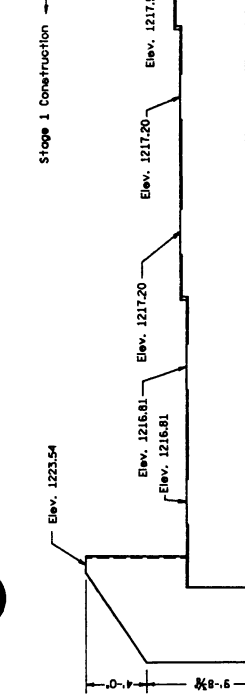
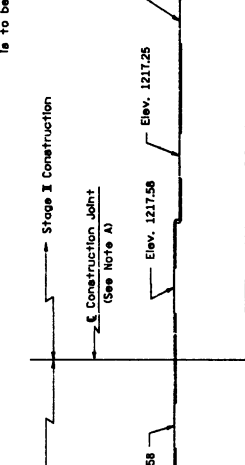

Soiler: 1/11-0'

APPENDIX B

Examples of Field Monitoring Results

Abutment A

Aug. 1 - 7, 1993

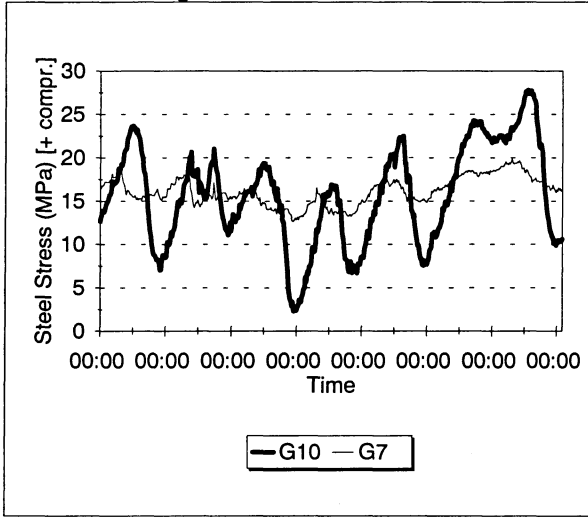

Aug. 8 - 14, 1993

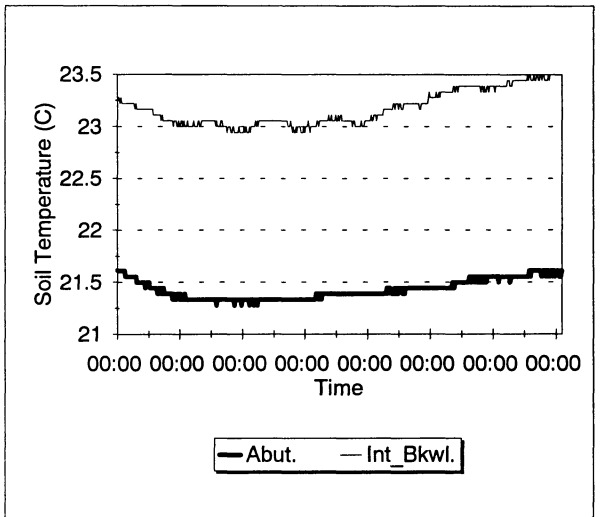
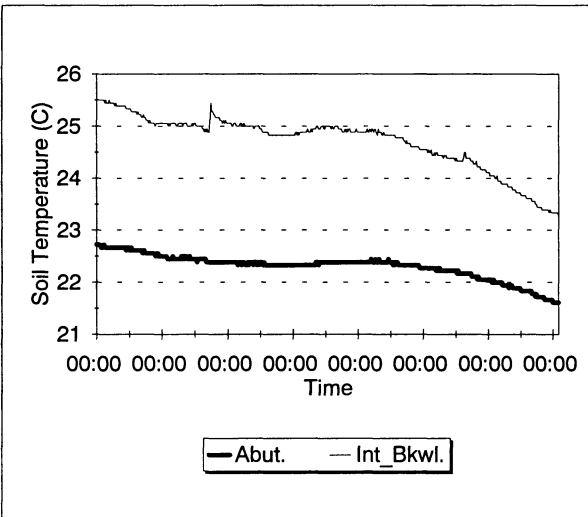
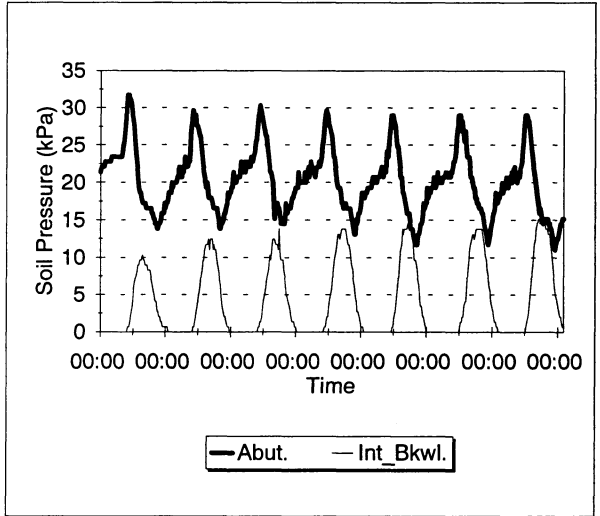
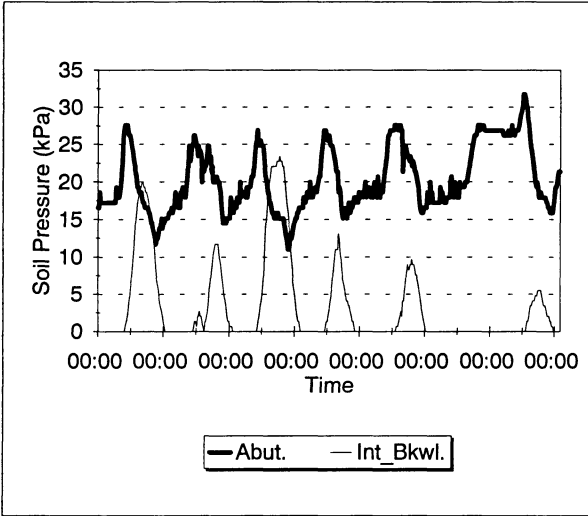
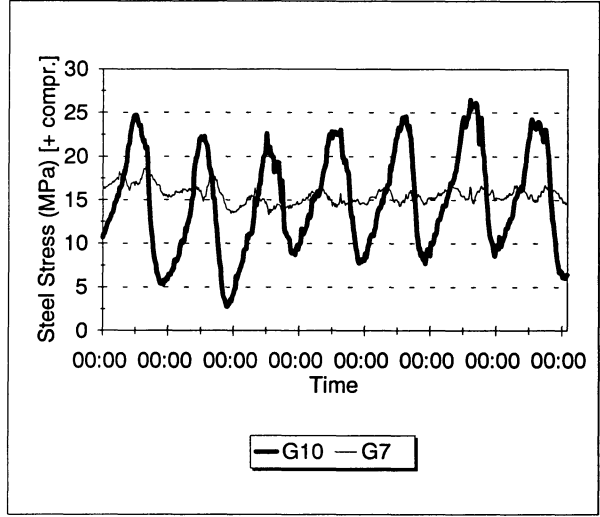

Pier

Aug. 1 - 7, 1993

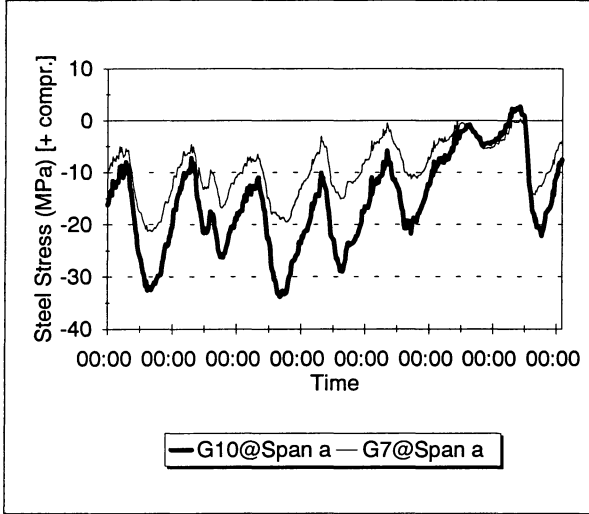

Aug. 8 - 14, 1993

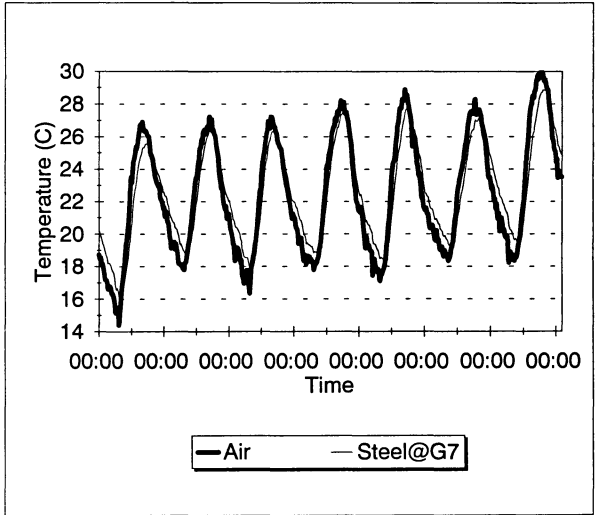
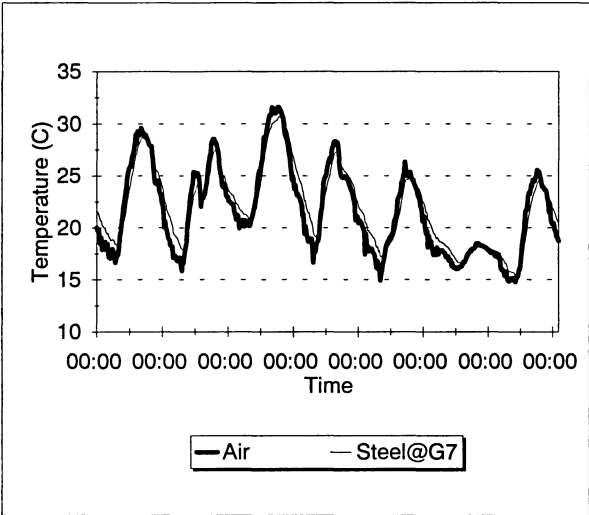
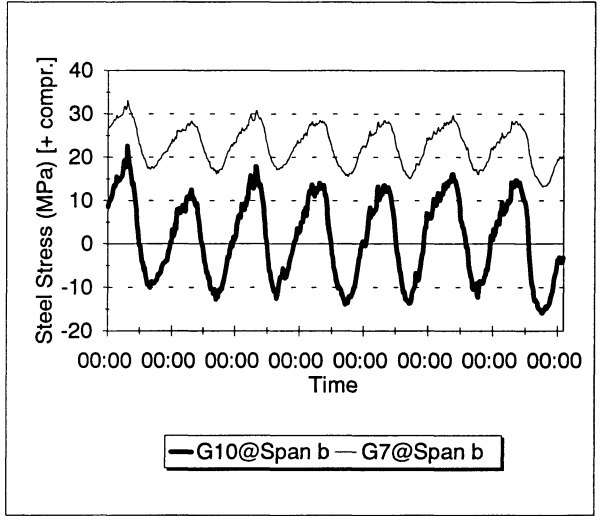
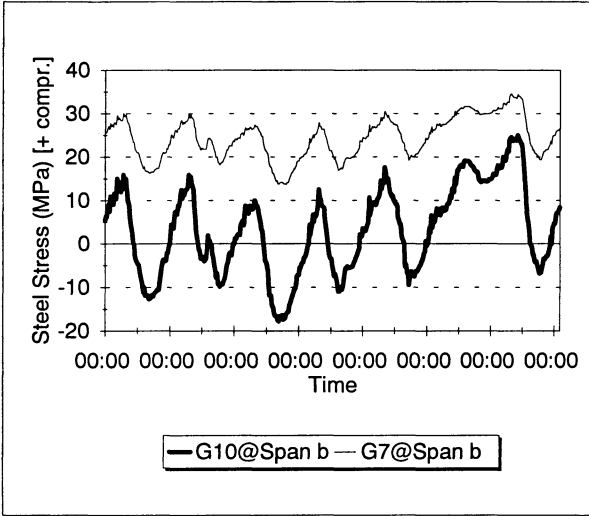
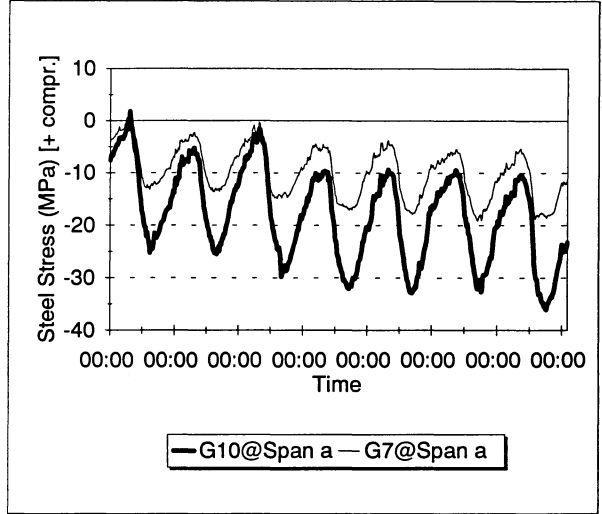

Abutment B

Aug. 1 - 7, 1993

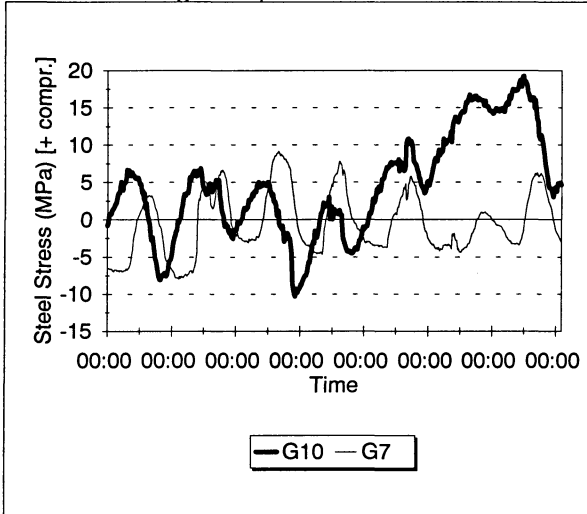

Aug. 8 - 14, 1993

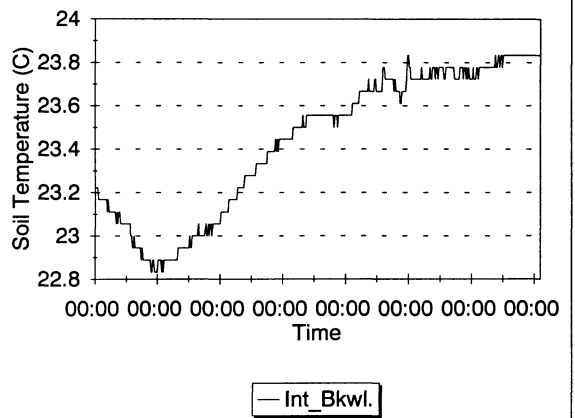
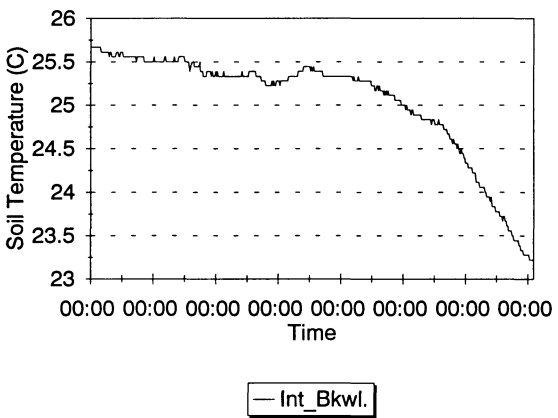
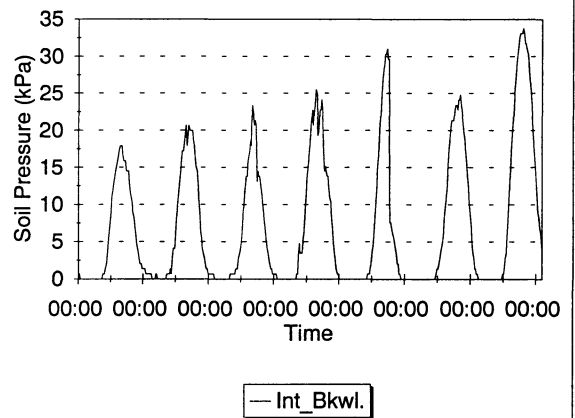
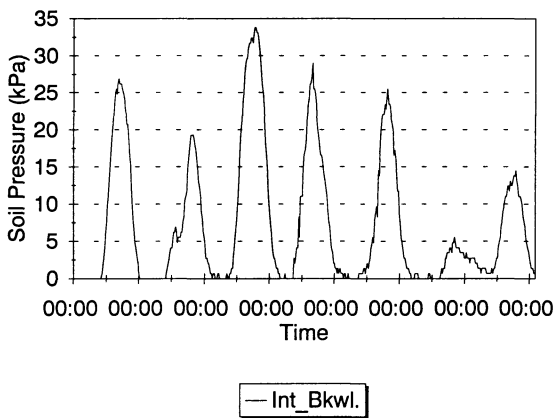
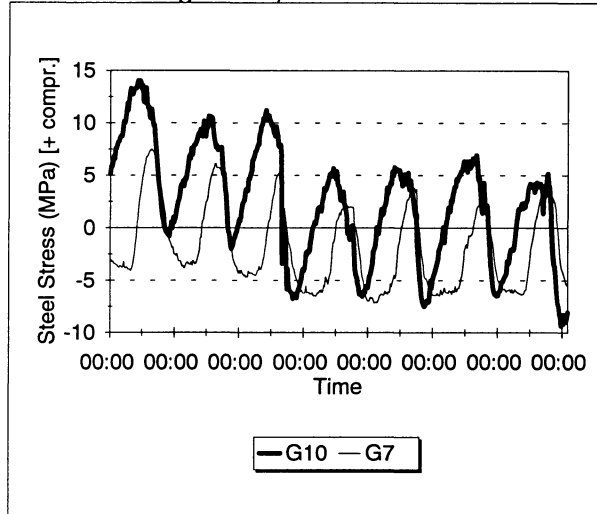

Abutment A

Aug. 1 - 7, 1994

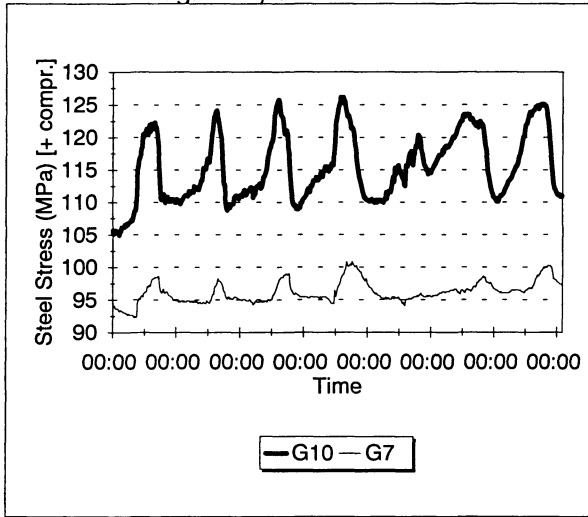

Aug. 8 - 14, 1994

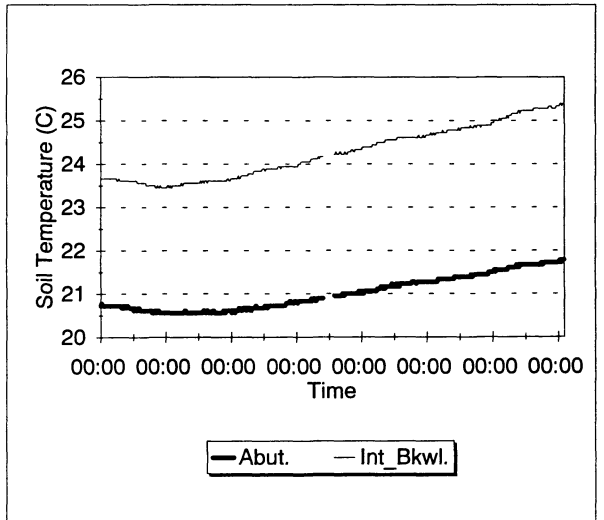
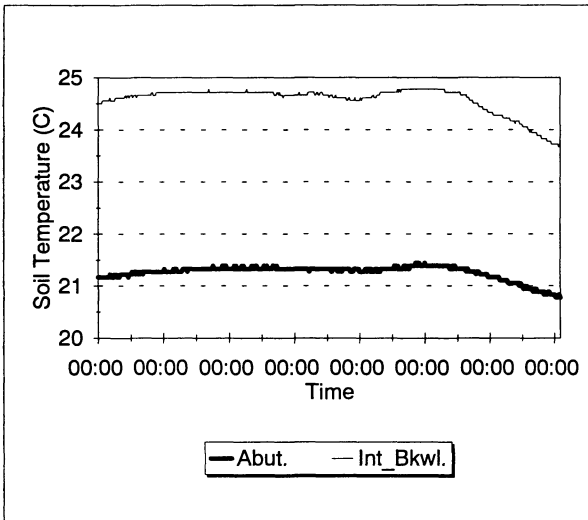
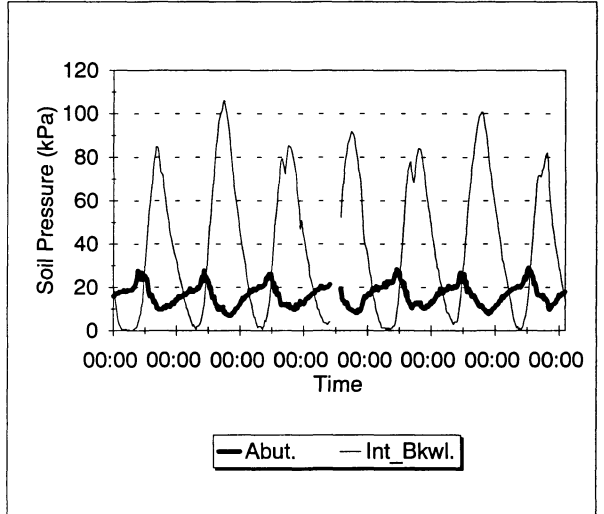
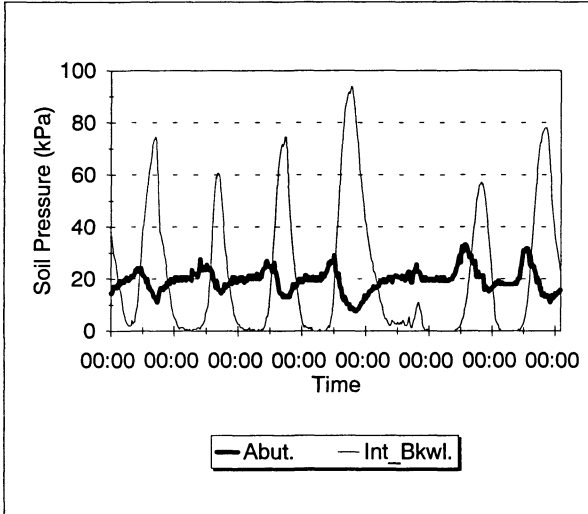
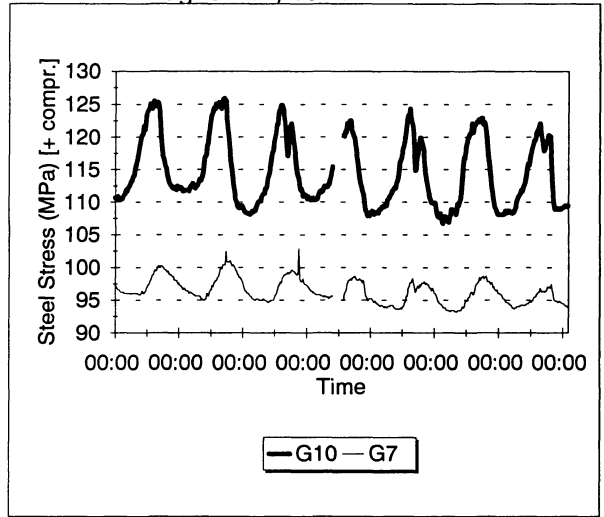

Pier

Aug. 1 - 7, 1994

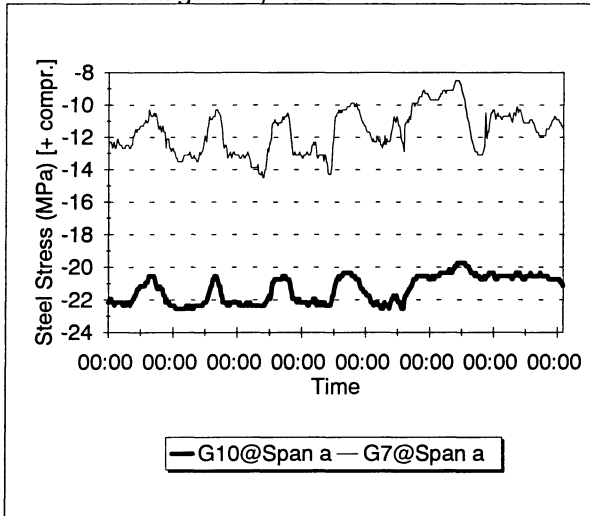

Aug. 8 - 14, 1994

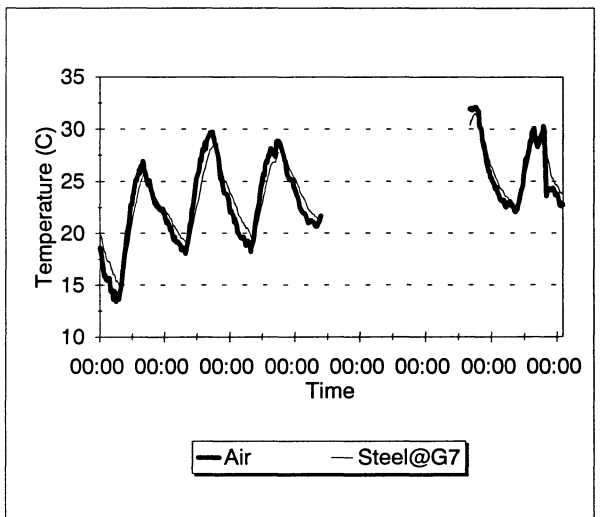
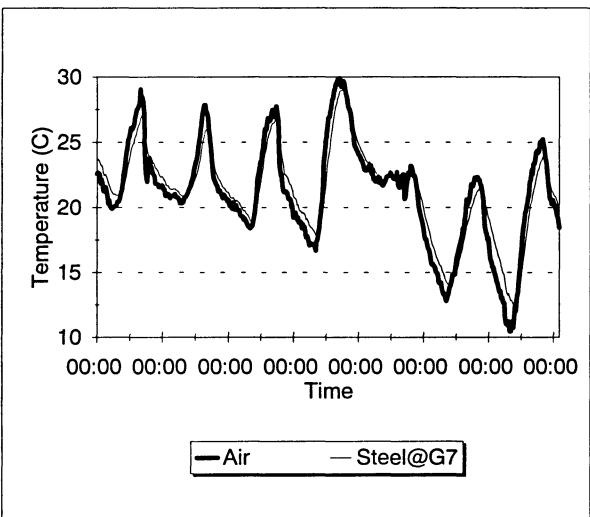
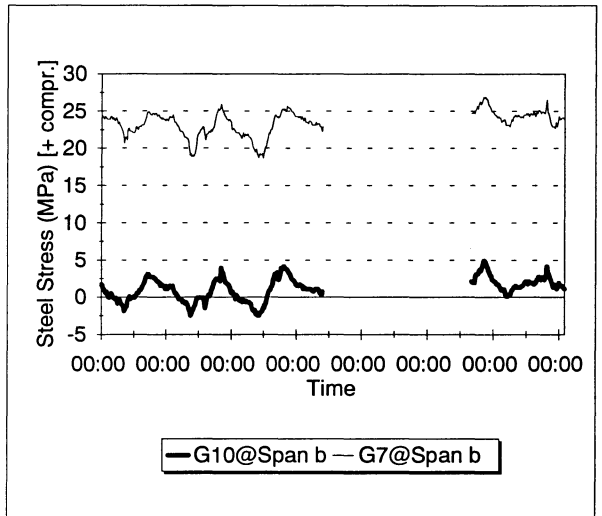
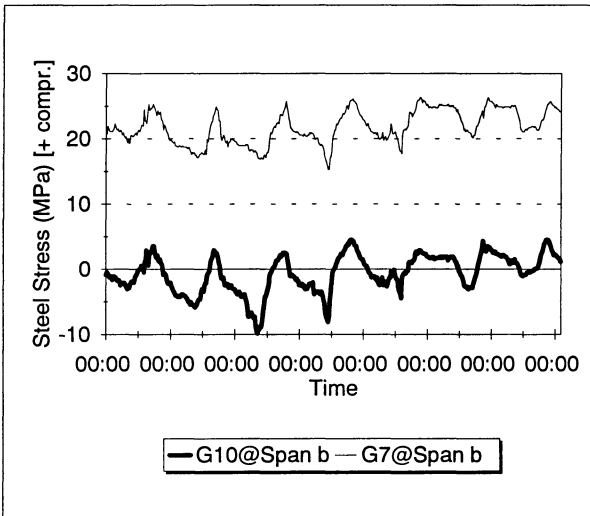
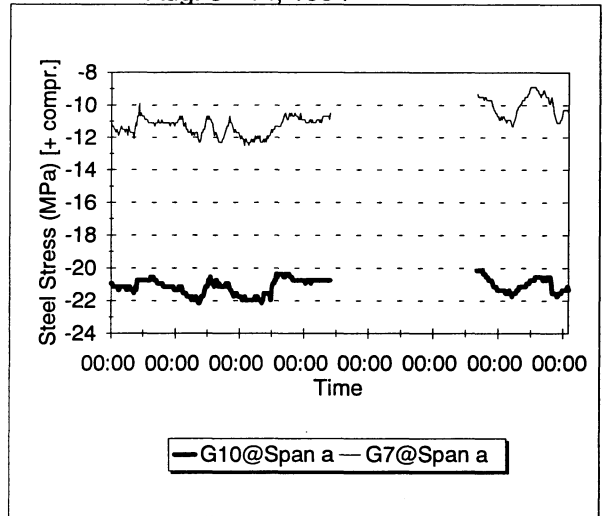

Abutment B

Aug. 1 - 7, 1994

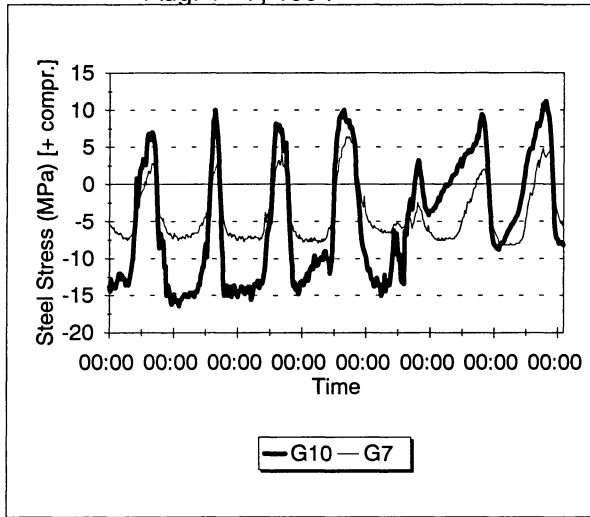

Aug. 8 - 14, 1994

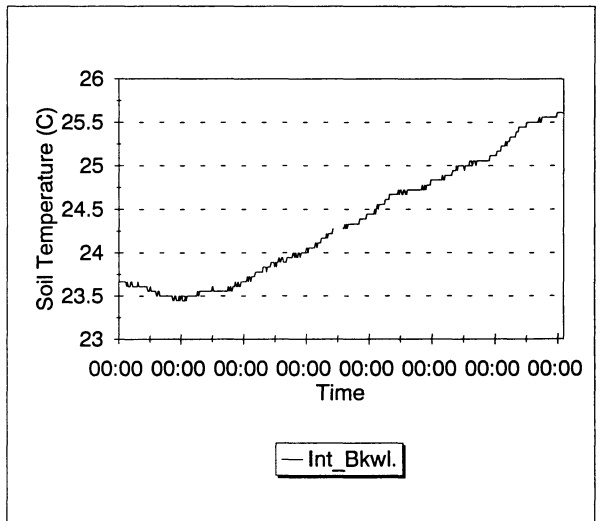
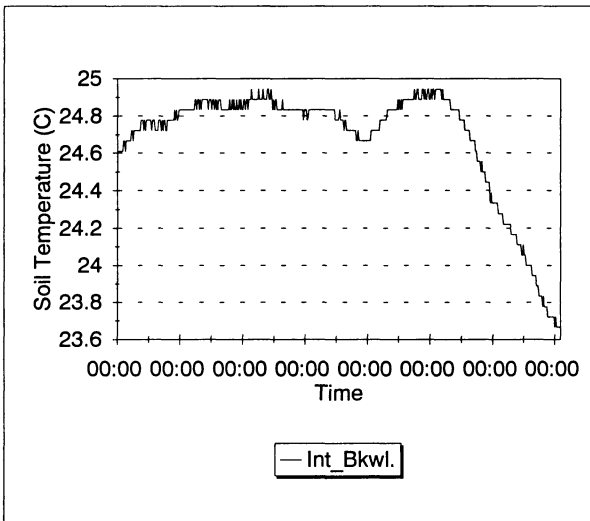
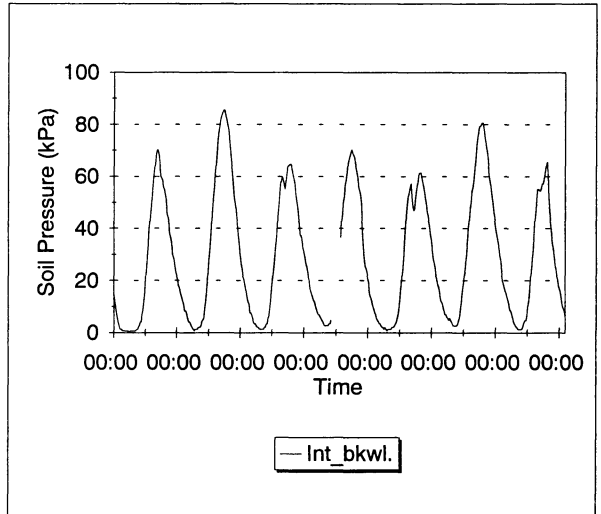
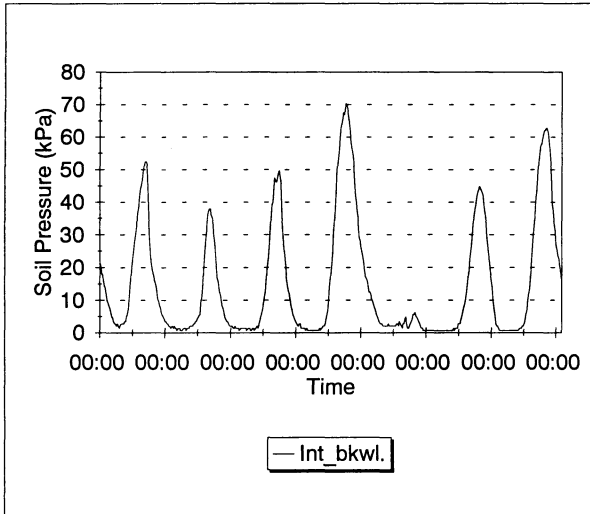
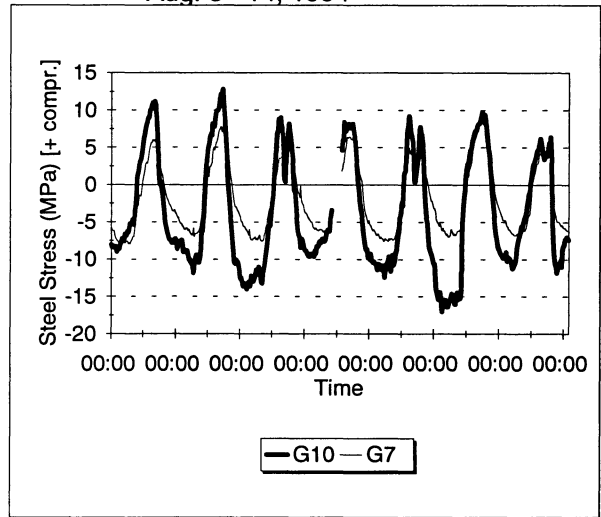

Abutment A

Aug. 1- 7, 1995

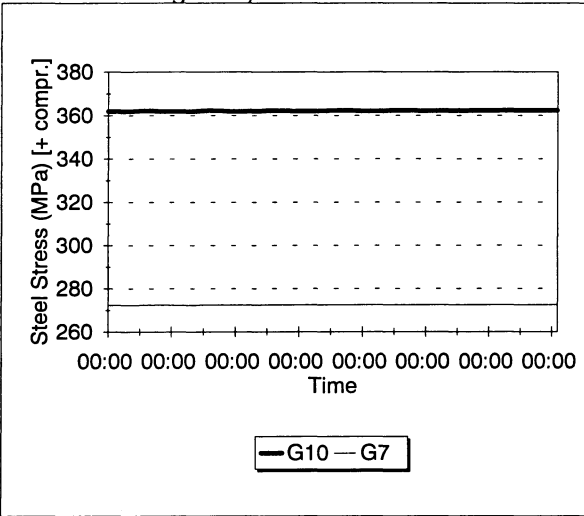

Aug. 8 - 14, 1995

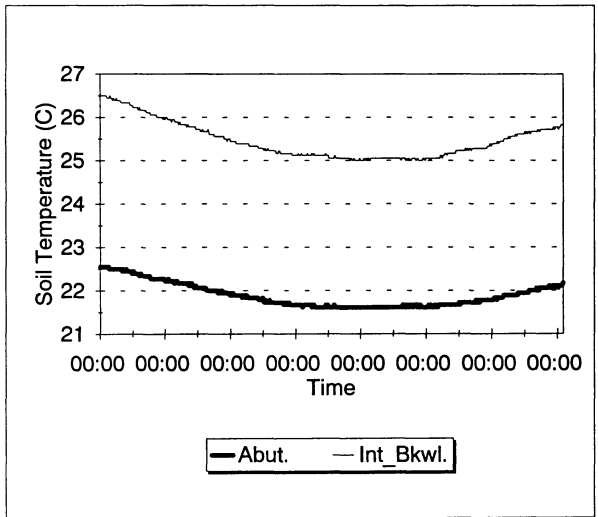
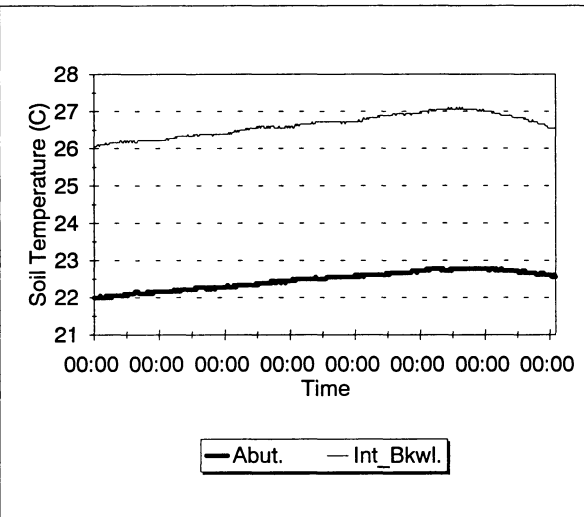
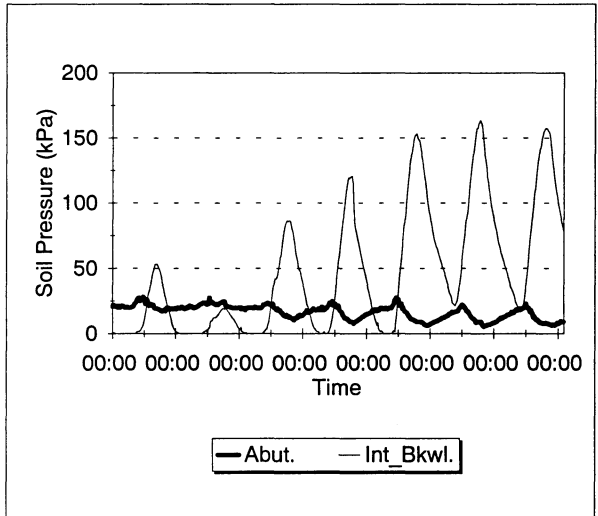
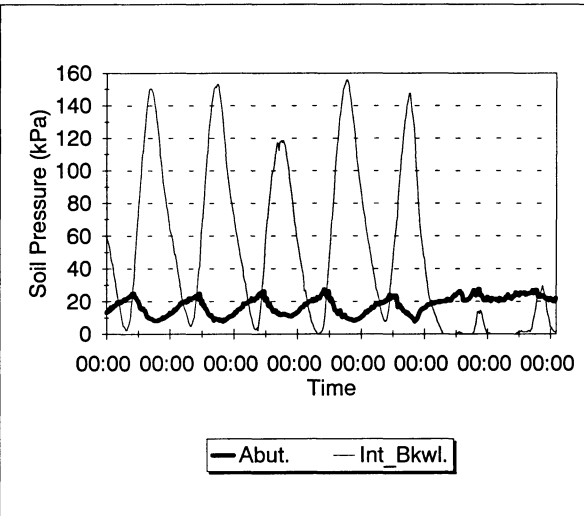
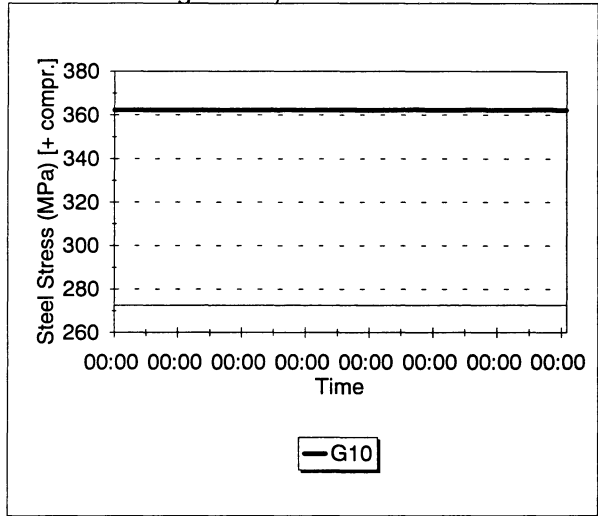

Pier

Aug. 1 - 7, 1995

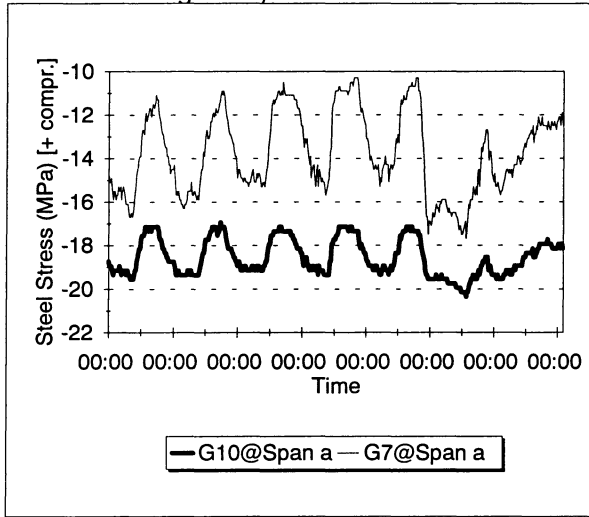

Aug. 8 - 14, 1995

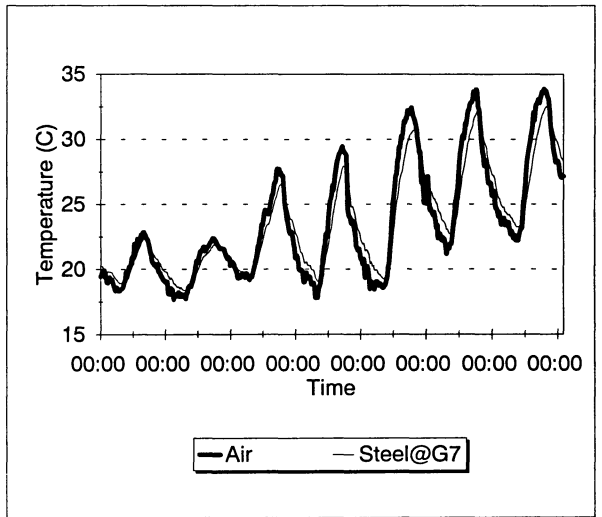
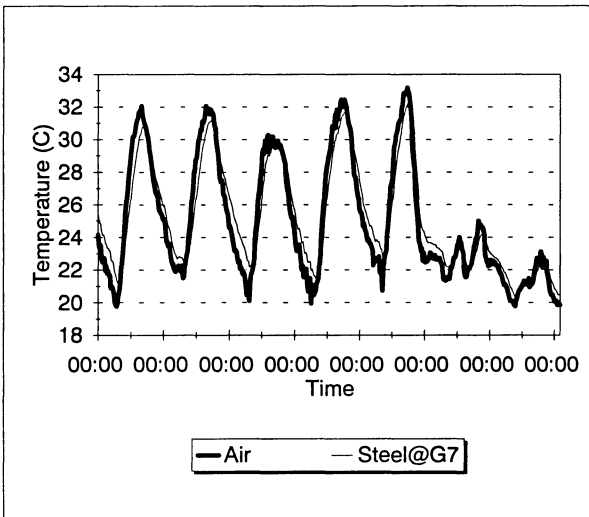
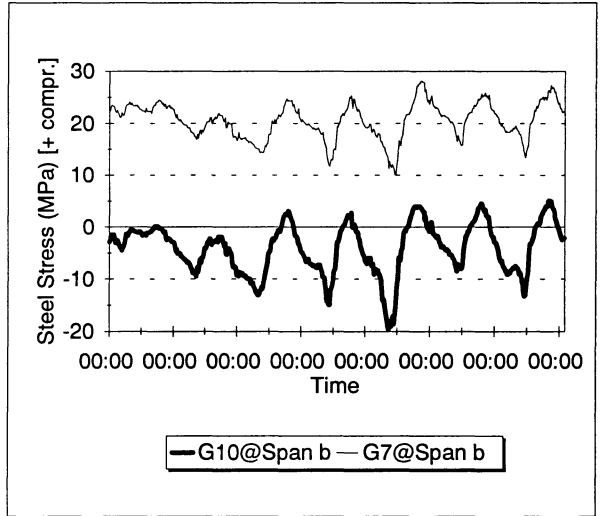
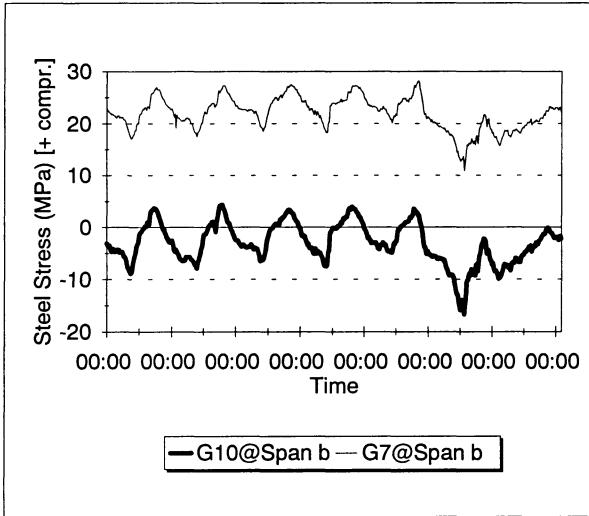
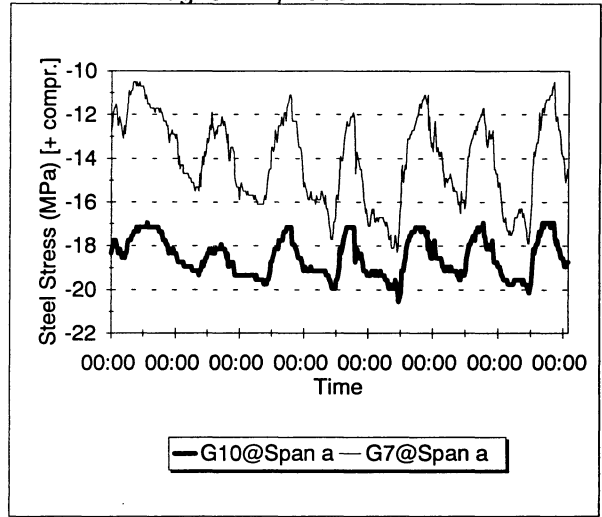

Abutment B

Aug. 1 - 7, 1995

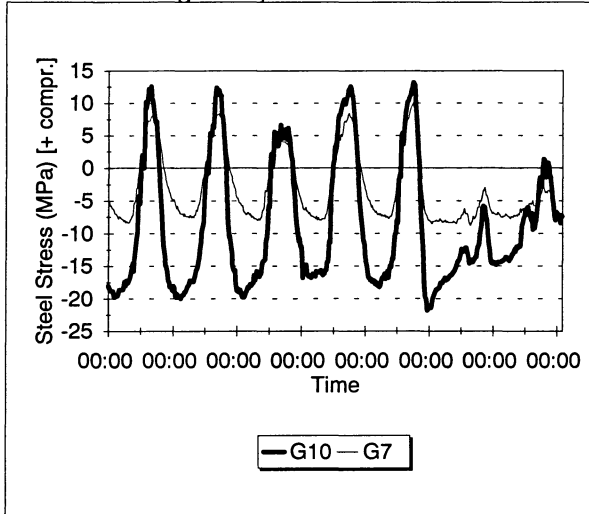

Aug. 8 - 14, 1995

