

NOTABLE CONTEMPORARY HIGHWAY
BRIDGES AND TUNNELS
OF VIRGINIA

by Dr. Vasil Zuk

Professor of Architecture
University of Virginia and
Faculty Research Engineer
Virginia Highway & Transportation
Research Council

Virginia Highway & Transportation Research Council
(A Cooperative Organization Sponsored Jointly by the Virginia
Department of Highways & Transportation and
the University of Virginia)

Charlottesville, Virginia

June 1977
VHTRC 77-R55

(The opinions, findings, and conclusions expressed in this
report are those of the author and not necessarily those of
the sponsoring agencies.)

NOTABLE CONTEMPORARY HIGHWAY BRIDGES AND TUNNELS OF VIRGINIA

by

Dr. Vasil Zuk
Professor of Architecture,
and Faculty Research Engineer

INTRODUCTION

Bridges and tunnels perhaps are of as much interest to the general public as to engineers, particularly if they are in some way notable. Because of the wide interest in such structures, a documentation of notable contemporary highway bridges and tunnels in the state of Virginia is herewith presented.

Beginning as early as the Colonial Period in Virginia's history, the need for transportation facilities gave rise to many inventive types of bridges, ranging from early eighteenth century log bridges to late nineteenth century iron and steel bridges, to early twentieth century steel and reinforced concrete bridges. No highway tunnels were built prior to the twentieth century in Virginia.* However, this publication does not specifically include structures in the early period of Virginia as the subject of historical bridges is actively being researched by a team headed by Howard H. Newlon, Jr. of the Virginia Highway & Transportation Research Council. Rather, this publication includes only contemporary bridges and tunnels.

*A number of railroad tunnels were built in the nineteenth century, the most notable of which penetrates Afton Mountain.

The date of 1932 was chosen as the time dividing historical from contemporary highway structures. There were three reasons for choosing this date. First, 1932 is well within the lifetime of many people living today, making the post-1932 period contemporary. Second, Newlon's historical studies deal primarily with pre-1932 structures. Third, a major reorganization of the Virginia Department of Highways and Transportation took place in 1932*, at which time much of the control of highway matters was transferred from the local counties to a central state authority and there was an accompanying policy change in highway design and construction.

Of great importance in regard to how bridges and tunnels are designed in Virginia is the "Bridge Engineer", who is in charge of all bridge and tunnel work. W. R. Glidden, who had been with the Highway Department since 1917, became the first Bridge Engineer in 1938. In 1952 Glidden was promoted to Assistant Chief Engineer, making J. N. Clary (with the Department since 1926) the second Bridge Engineer. The present Bridge Engineer

*At that time called the Virginia Department of Highways.

is F. G. Sutherland, who took over after Clary's retirement in 1972. During the period from 1932 to the present, the central bridge division staff grew from about eight people to over one hundred. In addition to these bridge engineers at the central office in Richmond, there are other bridge engineers assigned to eight construction districts around the state to direct local work in their respective regions.

Highway bridges and tunnels are designed either by engineers with the Virginia Department of Highways and Transportation or by private engineering firms acting as consultants for the Department. With few exceptions, the construction of bridges is done under contract by private firms. Routine maintenance of highway structures, however, is done by personnel with the Department, except for work on some special structures operated by separate tunnel or turnpike authorities. Where the structure is on federally owned land, as the Colonial National Parkway, the U. S. government has control of both design and maintenance.

To assist the many departmental bridge engineers, a Bridge Research Section was established by the Virginia Highway and Transportation Research Council in 1958,* and was headed originally by Dr. W. Zuk. The Virginia Highway and Transportation Research Council, located in Charlottesville, is a research arm of the Virginia Department of Highways and Transportation, and is supported in part by the University of Virginia. The

*At that time called the Virginia Council of Highway Investigation and Research.

Bridge Research Section can be credited with a number of innovations in bridge design since its inception.

A brief review of how bridge structures generally evolved in Virginia during the period from 1932 to the present might be instructive to those not familiar with the subject. Although the time span of about forty-five years by some measures is not very long, it is quite long in regard to technological development. In the early 1930's bridges were built either of steel or reinforced concrete. The use of timber was restricted to planks for bridge decks and to piles for bridge foundations.

Steel bridges were generally of two types. Bridges with short spans between supports were designed using rolled steel beams as the primary structural members. Bridges with long spans used trusses built up of small steel members. Connections of these members were made by riveting.

Reinforced concrete bridges also generally were of two types. Most used cast-in-place concrete girders between supports. Some of the long span bridges used the arch form, particularly where the site conditions were suitable.

Although Virginia had had its own standard bridge specifications since 1926, in 1931 the first national standard bridge specifications were drawn up by the American Association of State Highway Officials. As a result, the basic allowable steel design stress was raised from 16,000 to 18,000 pounds per square inch. At the same time, American steel companies, through technological

development, began producing larger rolled members up to 36 inches deep. The combination of these two factors then permitted use of the economical rolled steel beams for spans up to about 100 feet. This simple design replaced the need for the more expensive trusses, except for the case of very long spans.

Several other devices were employed in the early 1930's to stretch span lengths without recourse to trusses. One was to rivet cover plates onto the flanges of rolled beams to strengthen them. Another was to fabricate beams (called plate girders) from steel plates and angles by riveting to produce beams deeper than 36 inches. Still another was to make multiple spans continuous over the supports, thereby reducing the bending stresses. Splices between beams to achieve continuity were made by splice plates and rivets.

The 1930's saw changes taking place in reinforced concrete design as well. Technological improvements in the quality of both concrete and reinforcing steel allowed reinforced concrete girders to be stronger and thus to span further. Although some concrete arch bridges still continued to be built through the early 1940's, bridges of this type proved to be more expensive than girder bridges and so were phased out.

Further developments in steel technology in the 1940's permitted raising the basic allowable design stresses to 20,000 pounds per square inch. Welding of steel also became a reliable technique in the 1940's, so riveting gave way to welding.

The results were cleaner looking, more esthetically pleasing details.

In the mid-1950's a major change took place in concrete bridges. Precast, prestressed piles and beams were introduced for Virginia bridges. The concept of prestressing further reduced costs. Prestressing induces an initial compressive stress in the concrete member which offsets tensile stresses that are produced by service loads on the bridge. The net effect is to improve the strength and efficiency over those of conventionally reinforced concrete members. Various forms of prestressed concrete flexural members for spanning between supports are now in use. They include such diverse shapes as I beams, T beams, and hollow box beams.

The 1960's saw two totally new forms of metal bridges introduced in Virginia. One is the rigid frame bridge in which the steel support legs are welded rigidly to the spanning beams. The rigid frame configuration not only presents a graceful appearance but also permits increased span distances between supports. The second new form is the box girder in which metal plates are joined to form a hollow box (as a triangle or a trapezoid). This box then becomes the main spanning member as well as the riding deck. Normal beams or girders are thereby eliminated. When viewed from the underside, these box structures have an uncluttered graceful appearance.

In addition to the aforementioned major developments, several important developments in regard to details and specifications should be noted. Concerning steel bridges,

the following list is presented.

1. Composite construction in which the concrete deck is made to act jointly with the supporting beams by means of studs welded to the top flange of the beams has become standard practice. As a result, steel beam strength is greatly increased.
2. High strength steel bolts have largely replaced field welding or rivets. Erection costs have been thereby reduced.
3. Substitution of inexpensive flexible elastomeric bearing supports (except for long spans) in place of expensive metal bearings has taken place.
4. Introduced on some bridges has been the use of "weathering steel", a high strength steel that requires no painting. This steel forms a tight skin of iron oxide (rust) which inhibits further deterioration.
5. On curved bridges, beams are being fabricated curved instead of being left straight. The esthetics of these bridges are thus improved.

Likewise, a few developments in concrete can be cited.

1. Through quality control and the use of special admixtures (as air entraining agents), durable concrete

strengths exceeding 4,000 pounds per square inch ultimate in compression are being routinely obtained.

2. In standard use is a specially developed concrete parapet that prevents out-of-control vehicles from going over the edge of a bridge.
3. Improvements in concrete construction machinery now permit faster and better placement of concrete on the bridge as by pumping concrete through hoses, slip-forming for continuous placement and forming of concrete, and automatic screeding for leveling.

Relevant to all structures is the growing use of digital computers in design. Computers not only save countless hours of routine calculations, but also permit the design of more sophisticated and complex types of bridges and tunnels which require involved mathematical computations. Such computers have been in use by the bridge division of the Virginia Department of Highways and Transportation since 1959.

The overview presented on the evolution of bridge engineering in Virginia will be evident in the next section, where specific bridges will be described in greater detail. A clear pattern of the evolution of tunnel construction in Virginia is not so evident, as only a relatively few tunnels have been built. Consequently, the description of each tunnel will be described separately.

Similarly, movable bridges are each unique, so they, too, will be described separately.

In the next section forty-eight bridges out of the fourteen thousand in Virginia are selected by the author as being notable. The many people invaluabley aiding the writer in this selection are noted in the Acknowledgements Section. However, it remained for the author, by weighing the following factors, to make the final selection.

1. Magnitude of the work (as length, height, or cost*
2. Technical innovations (as unusual form, material, foundation, construction procedure, or other design feature)
3. Esthetic quality
4. Historical importance
5. Recipient of regional or national award.

*Cost is a relative factor because of changes in economic conditions. For example, a structure costing \$1 million in 1932 would cost approximately \$2 million in 1950, \$3 million in 1961, \$4 million in 1970 and \$5 million in 1977.

The same factors were used to select notable tunnels; however, as there are but a handful of highway tunnels in Virginia, the task of selection was relatively simple.

In all cases, the writer personally inspected the bridges and tunnels listed to ensure that the same criteria were used in the selection of all structures. It may be said in general that the structures finally chosen as being notable are those which a person with some interest in bridges or tunnels would find worthwhile to go out of his or her way to see. Many other nice or interesting contemporary bridges do exist in the state; however, because they do not meet the relatively high standards set forth, they are not presented here.

The bridges and tunnels described clearly show a wide range of material, form and use. In large part, this variation is because of the great variation in land and water features in the state of Virginia. The eastern part of the state is relatively flat with many bodies of water. The western part is quite mountainous, with many deep gorges. The rest of the state consists essentially of rolling hills with numerous streams and rivers.

Traditionally, economy and safety have been the guiding factors in bridge construction in Virginia. Although the record on both economy and safety is very good, most of the thousands of bridges constructed are rather undistinguished. However, here and there a notable structure was built. Represented

among these are bridges of all modern construction material as laminated wood, steel (both normal and weathering), concrete (both reinforced and prestressed), aluminum, and reinforced plastic. Configurations of most forms are represented, including beams or girders, trusses, arches, rigid frames, and movable spans of several kinds. Only two major forms do not exist; namely, the suspension bridge and the cable-stayed bridge.

Several bridges have received national awards of recognition for both technical and esthetic reasons, and there is reason to believe that the esthetic quality of new structures is on the rise. The future should produce many more notable structures. To keep those persons interested in bridges and tunnels updated, periodically, subsequent to the date of this report, supplemental reports will be issued on notable highway bridges and tunnels constructed in Virginia.

As a guide, the descriptions of the structures in the following section are presented in chronological order based on the year of completion. The scales shown on the drawings are in feet, unless otherwise noted.

D E S C R I P T I O N S

NEW RIVER BRIDGE

Type of Structure: Multiple arch bridge

Location: Old Rte 460 over New River in
Giles County at Ripplemead

Date of Completion: 1934

Overall Length: 1,328 feet

Roadway: 24 feet

Designer: Virginia Department of Highways &
Transportation

Prime Builder: Sannous-Robertson Co.

Approximate Cost: \$230,000



Figure 1. A misty view of the old New River Bridge looking toward Ripplemead.

Now a "ghost" bridge in that it has been closed to traffic since 1974, it was at the time of construction the longest arch bridge in Virginia. However, it is still clearly visible as viewed from the new bridge crossing on Rte 460 just to the south.

The bridge consists of ten open spandrel reinforced concrete arches ranging in length from 100 to 145 feet, plus two short reinforced concrete beam approach spans each 22

feet long. The arch ribs rest on large reinforced concrete piers, which in turn rest on solid rock located relatively close to the ground surface. Because of the alignment of the roadway over the river, the entire bridge has a 39 degree skew.

Although this bridge is still standing (as of 1977), its future is uncertain. Eventually it may be razed, just as was its predecessor located downstream on old Rte 8.

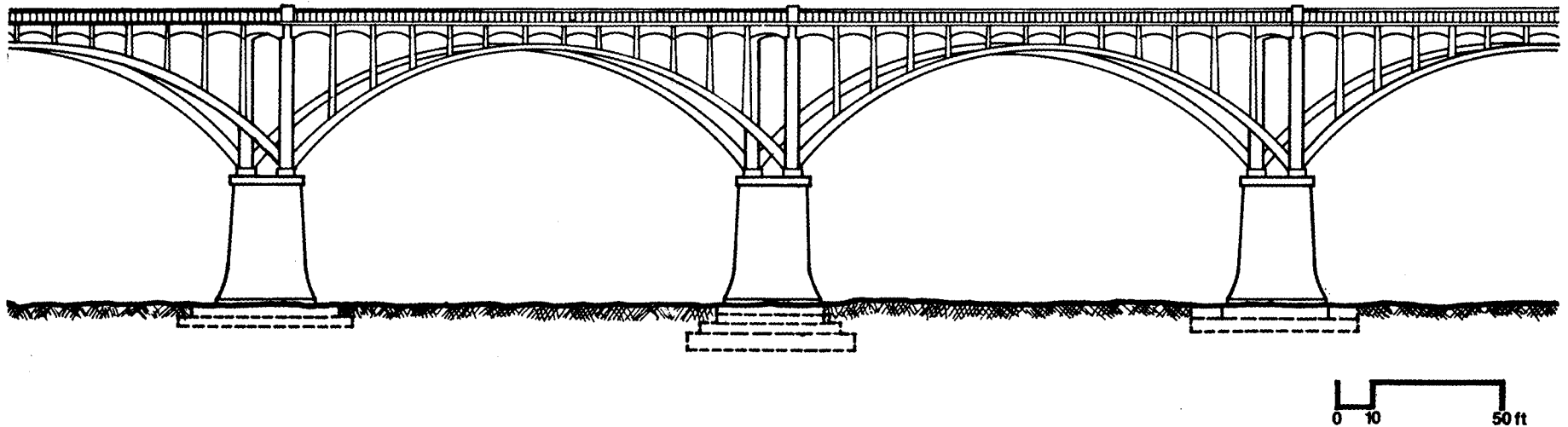

Figure 2. Elevation of a portion of the New River Bridge.

COCKE MEMORIAL BRIDGE

Type of Structure: Combination beam and
truss bridge

Roadway: 24 feet

Location: Rte 15 over James River between
Fluvanna and Buckingham Counties

Designer: Virginia Department of Highways &
Transportation

Date of Completion: 1934

Prime Builder: Boxley Brothers Co., Inc.

Overall Length: 1,786 feet

Approximate Cost: \$180,000



Figure 3. The John H. Cocke Memorial Bridge over James River,
showing the large steel trusses.

Known as the John H. Cocke Memorial Bridge in commemoration of General Cocke, who once owned the property on which it was built, the bridge was one of the major river crossings of its time in Virginia. The structure consists of fifteen steel beam approach spans from the north and two steel beam approach spans from the south. The beam spans range in length from 50 to 100 feet. The river crossing consists of seven steel truss spans ranging from 100 to 120 feet between supports. As was the practice at the time, the large

steel truss components were designed as lattice members made of relatively small pieces and joined together by riveting. To accommodate thermal expansion and contraction of such a long bridge, a number of hinge and expansion joints are built into the structure. The pier supports are of reinforced concrete and rest on rock located at the level of the river bottom. These stout piers supporting the bridge high off the water have successfully resisted numerous heavy floods.

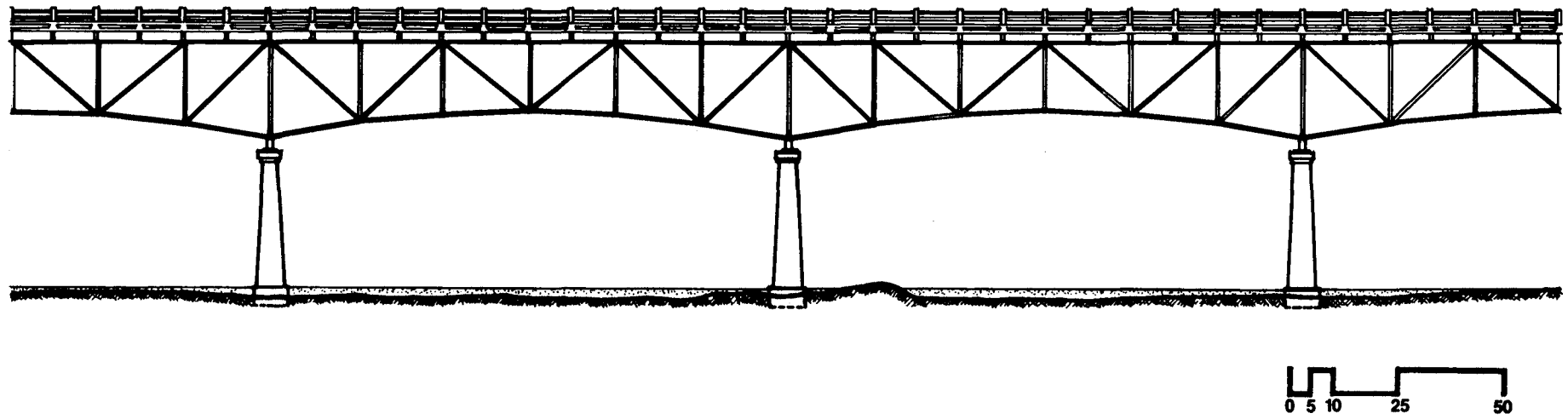

Figure 4. Elevation of a portion of the truss bridge.

2ND STREET BRIDGE

Type of Structure: Through arch bridge

Roadway: 38 feet

Location: Rte 60 over the Chesapeake and Ohio
Railroad (north of James River) in
the city of Richmond

Designers: Allen J. Saville, Inc.; Smith and
Van Dervoort, Inc.; and Alfredo C.
Janni

Date of Completion: 1934

Prime Builder: Richmond Bridge Corporation

Overall Length: 425 feet

Approximate Cost: \$100,000

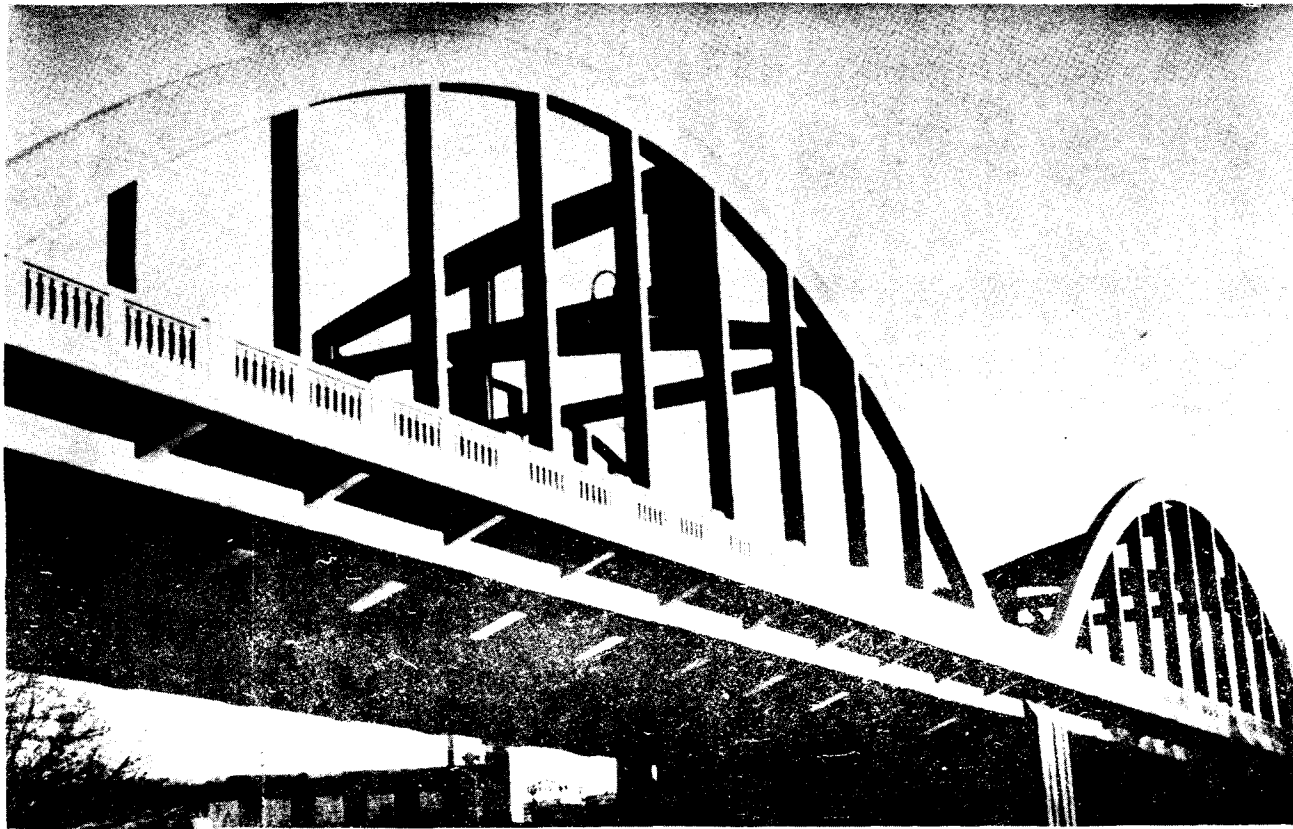

Figure 5. 2nd Street (Rte 60) Bridge. Note the unusual asymmetrical arch bracing caused by the skew.

This bridge is one of four of this type constructed in Virginia about the same time. A nearby similar single-span bridge is located just south of the James River on Rte 1 over the Seaboard Coastline Railroad in the city of Richmond. The Rte 60 (or 2nd Street Bridge) basically is a double-span reinforced concrete tied arch structure with two short reinforced concrete beam approach spans. The arches are each 152 feet-6 inches long on a 43 degree skew. The approach spans are each 60 feet long.

Although the bridge is on a large skew, the overhead portal bracings (also arched of reinforced concrete) are positioned at right angles to the arch ribs, creating an odd asymmetrical appearance. The hangers from the arch to the deck, as well as the deck, handrails and piers are all of reinforced concrete.

The original concept for this type of esthetically unusual and interesting design is believed due to the state's first Bridge Engineer, W. R. Glidden.

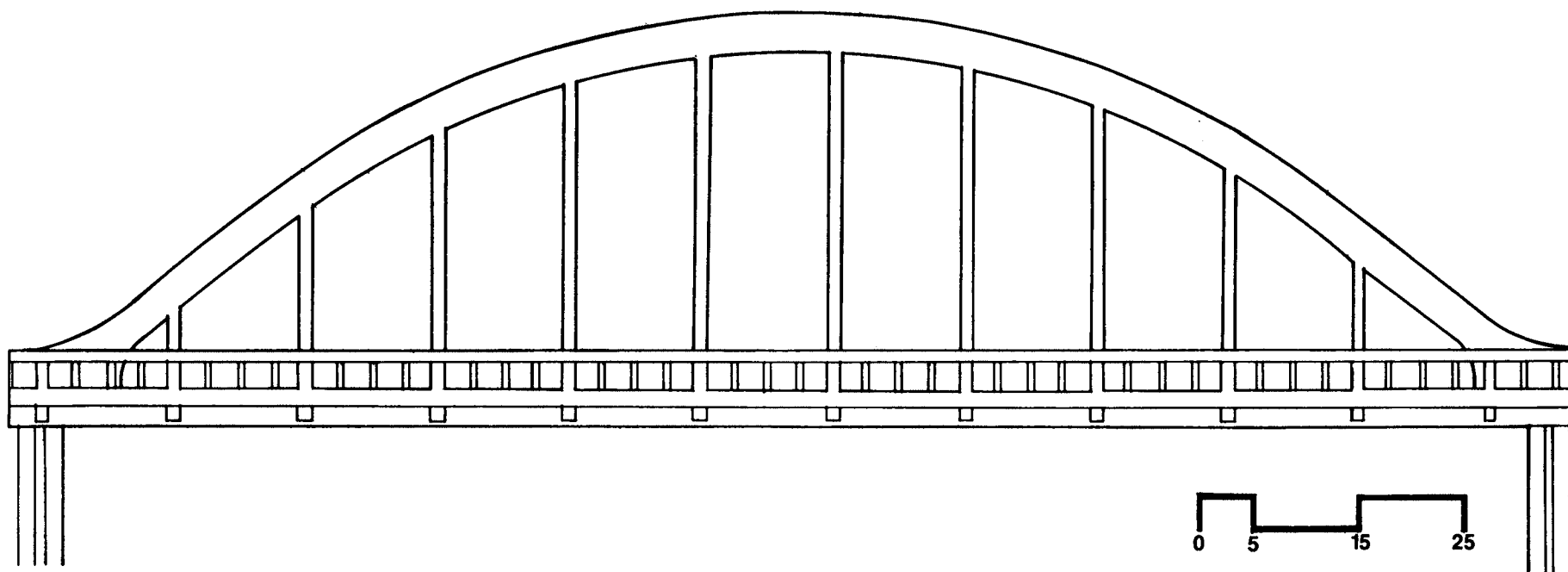

Figure 6. Elevation of one tied arch segment.

CAT POINT CREEK BRIDGE

Type of Structure: Retractable draw bridge

Roadway: 11 feet

Location: Rte 634 over Cat Point Creek in
Richmond County

Designer: Virginia Department of Highways &
Transportation

Date of Completion: 1934

Prime Builder: Virginia Department of High-
ways & Transportation

Overall Length: 663 feet

Approximate Cost: \$25,000

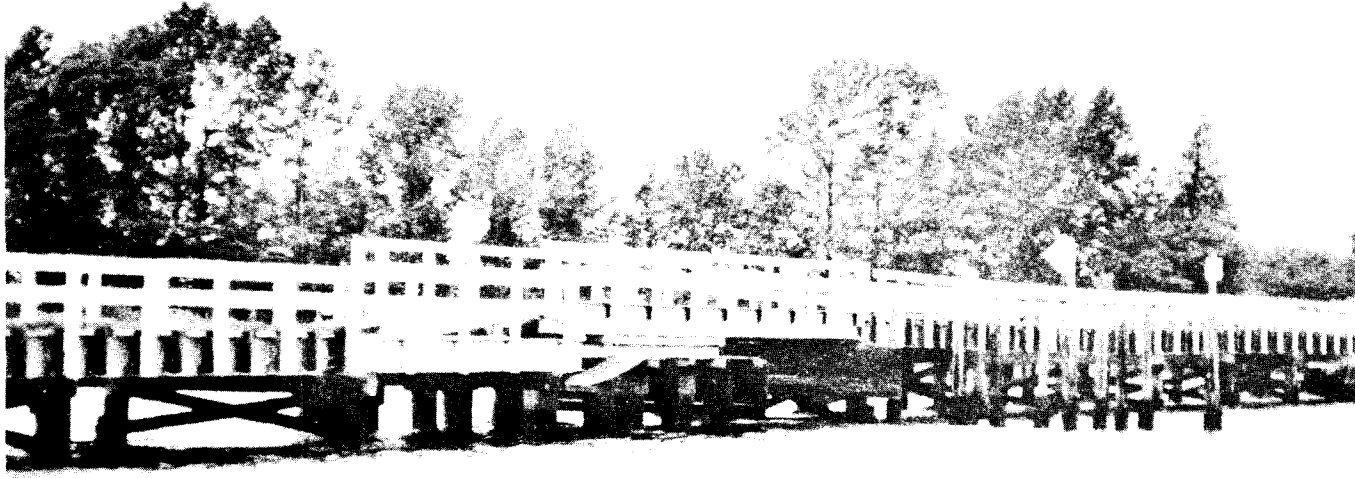

Figure 7. Cat Point Creek Bridge. The center section shows the retractile portion of the structure.

The bridge is a modest one-lane structure of simple steel beams resting on timber piles. The deck is made of timber planks. Its unusual feature, however, is that it is the only retractile drawbridge in Virginia. One 66-foot long center section span pulls back and rolls over a fixed portion of the bridge, leaving a 32-foot clear channel opening for boats to pass through. (The underside of the bridge beams are only about 5

feet above mean high water.) On rare occasions when the draw span must be opened, it is pulled open by a truck. Because of the simple retractile construction, vehicles must ramp up or down a bump across this movable section.

Extensive repairs were made on this bridge in 1958 in which much of the original steel and timber were replaced.

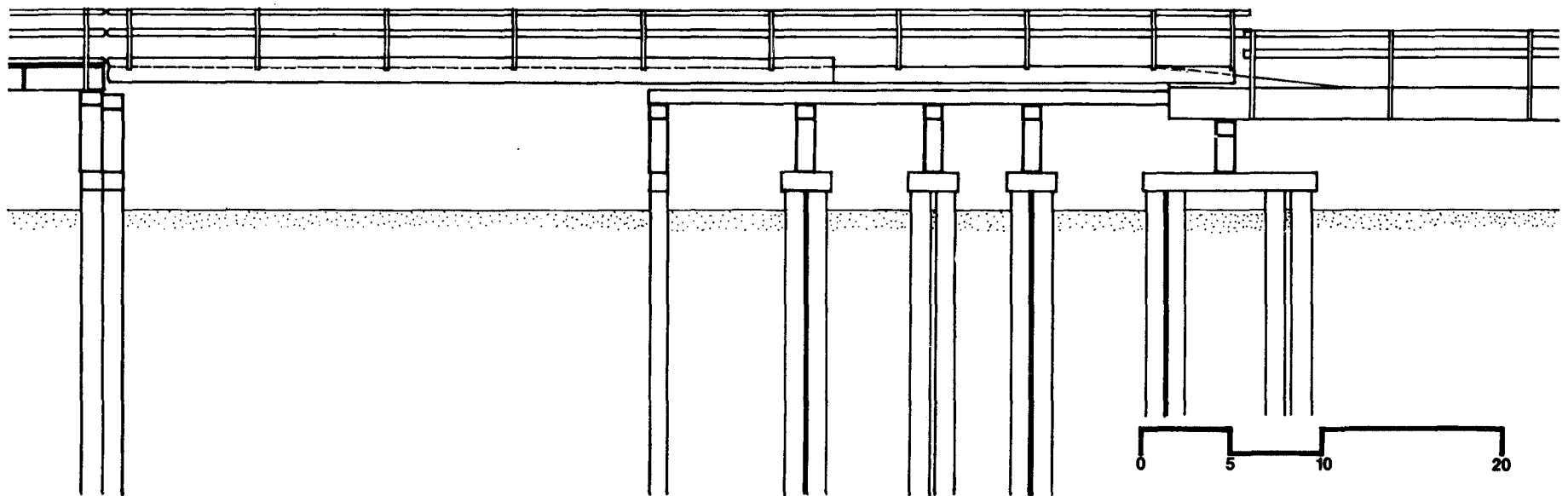

Figure 8. Elevation of the retractile section.

LEE BRIDGE

Type of Structure: Multiple arch Bridge

Location: Rte 1 over James River in city of
Richmond

Date of Completion: 1936

Overall Length: 3,710 feet

Roadway: 40 feet

Designer: Alfredo C. Janni

Prime Builders: Allen J. Saville, Inc., and
Lee, Smith and Van Dervoort,
Inc.

Approximate Cost: \$1,000,000

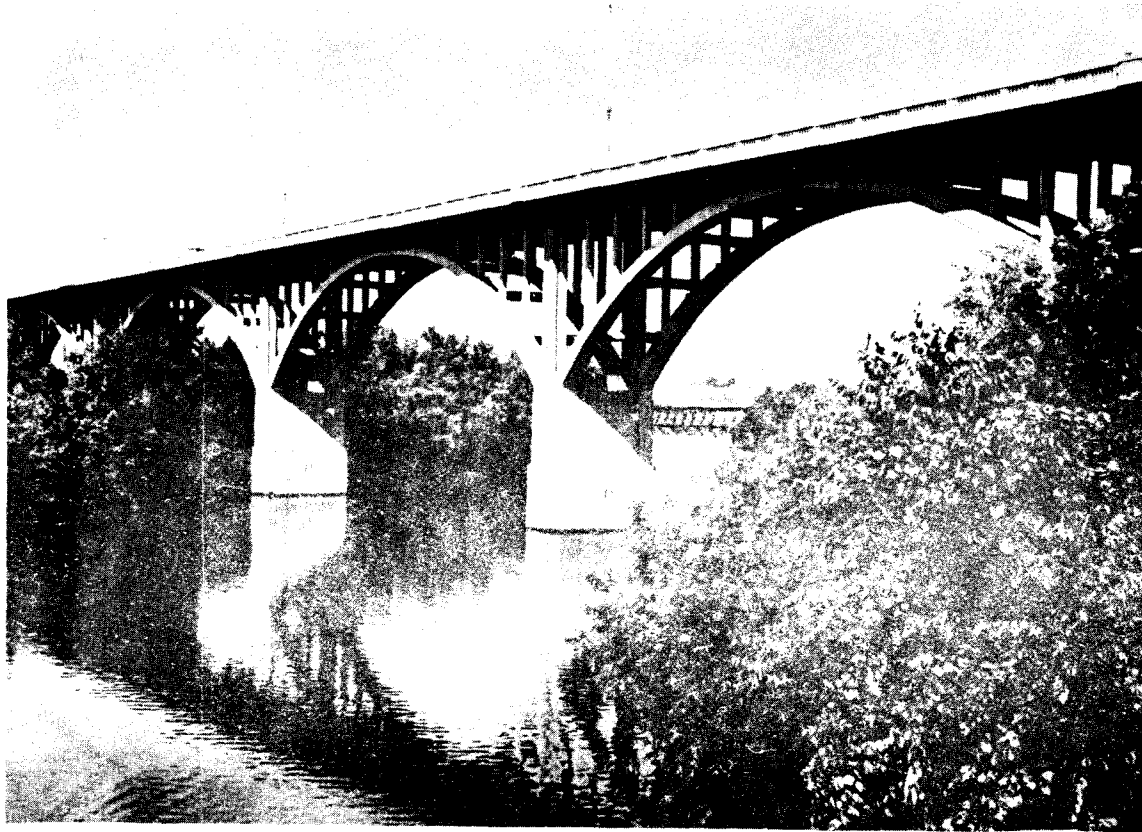

Figure 9. Four of the sixteen spans of the Robert E. Lee Bridge over James River at Richmond.

This bridge is locally known as the Lee Bridge, being named after General Robert E. Lee. It consists of sixteen contiguous open spandrel arches of reinforced concrete each spanning 192 feet. Several short reinforced concrete beam type approach spans are at each end. The piers are also of reinforced concrete resting on bed rock near the bottom

of the river. The piers and arches lift the roadway approximately 75 feet above the flood level of the river. Its great length and rhythmic arches have made it an esthetic landmark in Richmond. However, there are plans to possibly replace this imposing structure with a new bridge.

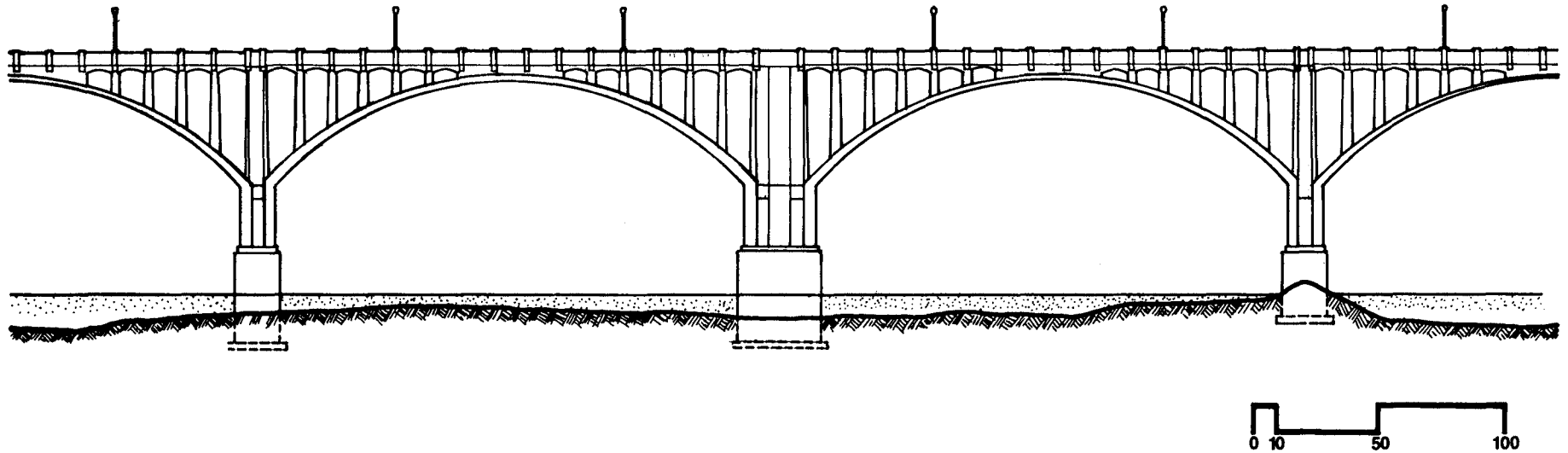

Figure 10. Elevation of a portion of the bridge. The pier shown in the center of the drawing is one of four along the structure enlarged for extra stability.

SHENANDOAH RIVER BRIDGES

Type of Structure: Multiple span truss
bridge

Location: Rte 340 over north and south forks
of Shenandoah River in Warren
County

Date of Completion: 1941

Overall Lengths: 1,090 feet over north fork
and 1,925 feet over south
fork

Roadway: 34 feet over north fork and 40
feet over south fork

Designer: Virginia Department of Highways
& Transportation

Prime Builder: George F. Hazelwood Co.

Approximate Cost: \$238,000 for north fork
and \$480,000 for south
fork

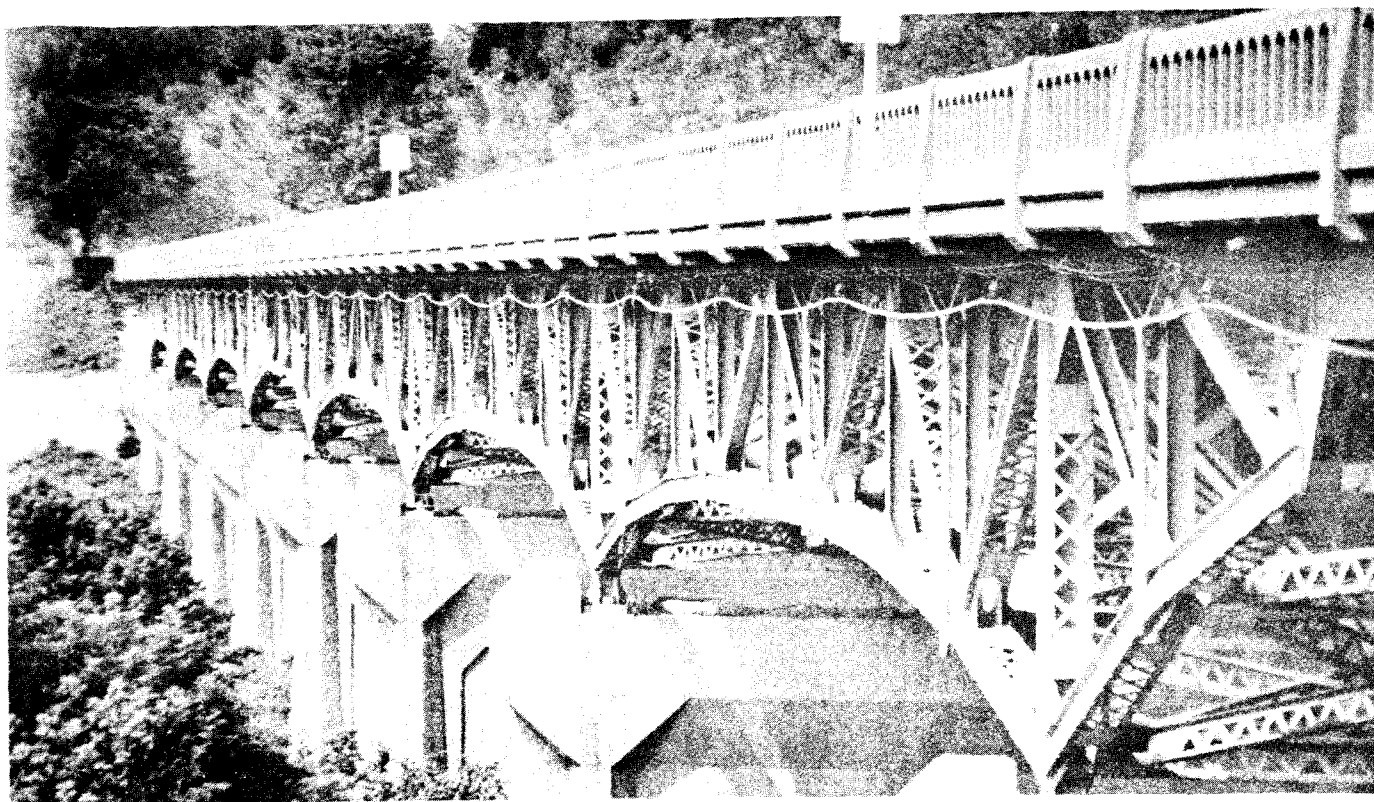

Figure 11. View of the bridge on Rte 340 crossing the north fork of the Shenandoah River. The construction of the bridge over the south fork is similar.

These companion bridges that replaced old ones on the site are separated by less than one-third of a mile on the same route and are constructed of steel in similar fashion. The structure of the north fork bridge consists of seven truss spans of 120 feet-8 inches each plus 60-foot approach beam spans on each end. The south bridge con-

sists of eight truss spans of 195 feet-5 inches each plus 60-foot approach beam spans on each end. The piers are ornamentally cast reinforced concrete. Both bridges have small skews, but in opposite directions because of the convergences of the two forks of the river. Together, they make a handsome pair.

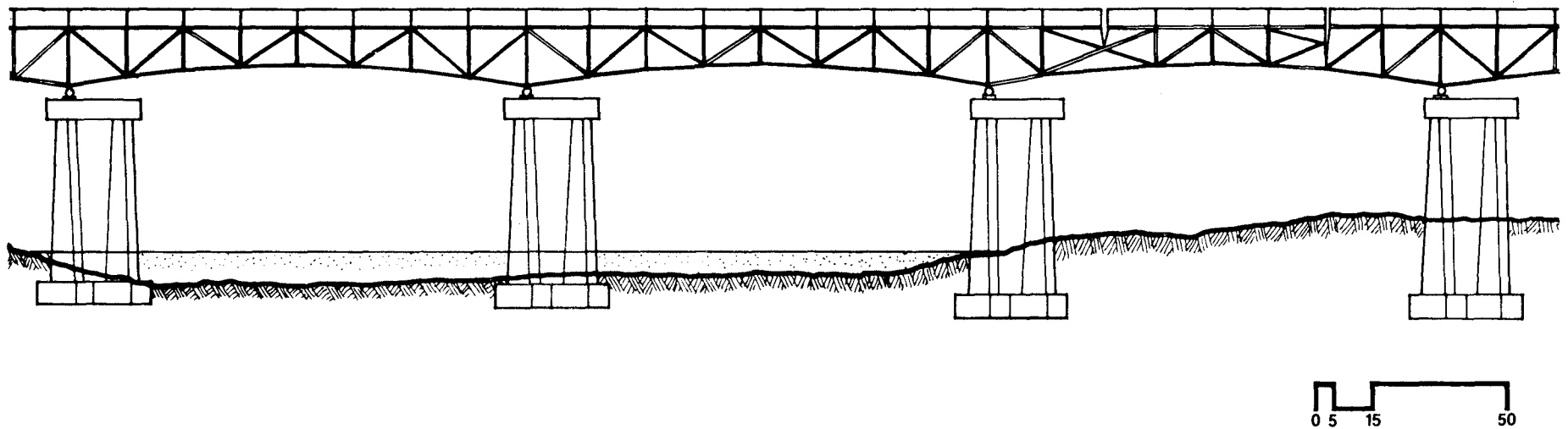

Figure 12. Elevation of part of the north fork bridge. Note the breaks in the span shown on the right to reduce secondary stresses.

COLONIAL PARKWAY TUNNEL & BRIDGES

Type of Structure: Tunnel and related bridges

Roadway: 25 feet

Location: Colonial National Memorial Parkway at Williamsburg

Designer: Federal Highway Administration

Date of Completion: 1942

Prime Builder: J. G. Attaway Construction Co.

Overall Length: 1,183 feet

Approximate Cost: \$276,000

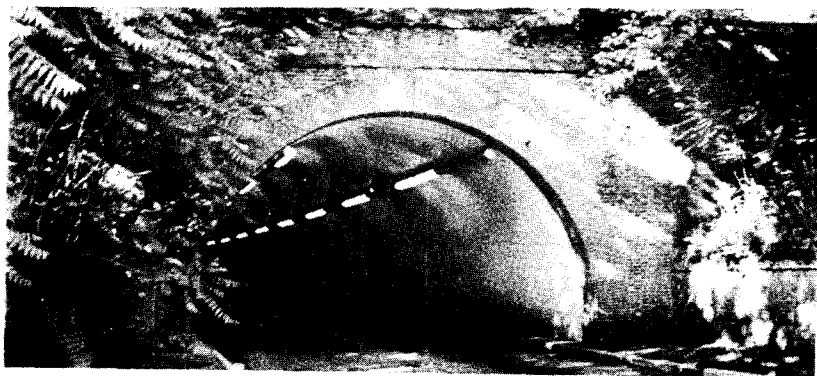

Figure 13A. Tunnel portal under historic Williamsburg.

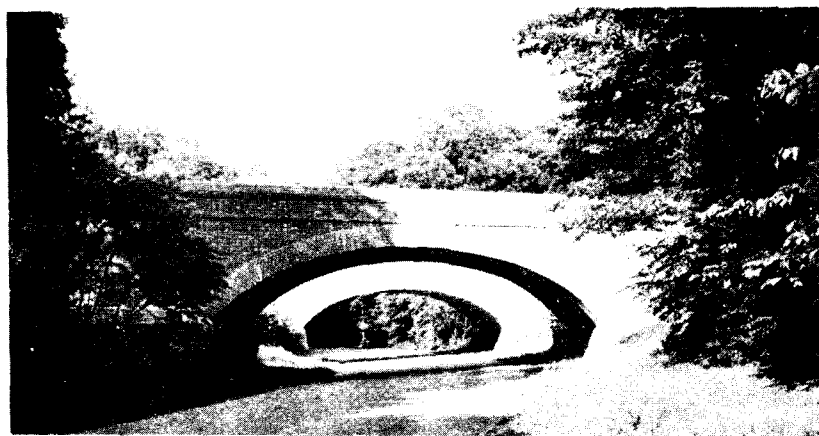

Figure 13B. Typical bridge overpasses along the Parkway near Williamsburg.

The tunnel is unique in that it passes directly under historic Williamsburg. The tunnel structure is essentially a semicircular barrel of reinforced concrete 1 foot thick at the crown and 3 feet thick at the springing. The inside radius of the barrel is 15 feet. The base of the barrel is tied together under the roadway by reinforced concrete struts 25 feet apart. The tunnel was constructed by the "cut and cover" method wherein a cut or a trench approximately 40 feet wide and 25 feet deep was excavated. The tunnel was then built in the open trench and was covered with soil. To harmonize with the historic character of

the area, the portals of the tunnel are architecturally faced with colonial brick.

Along the route of the Parkway between Yorktown and Jamestown are numerous arch bridges of reinforced concrete, also faced with colonial brick. The tunnel and the related bridges, along with the many scenic natural views, make the Parkway a highly pleasant esthetic experience.

The Parkway is owned and maintained by the National Park Service.

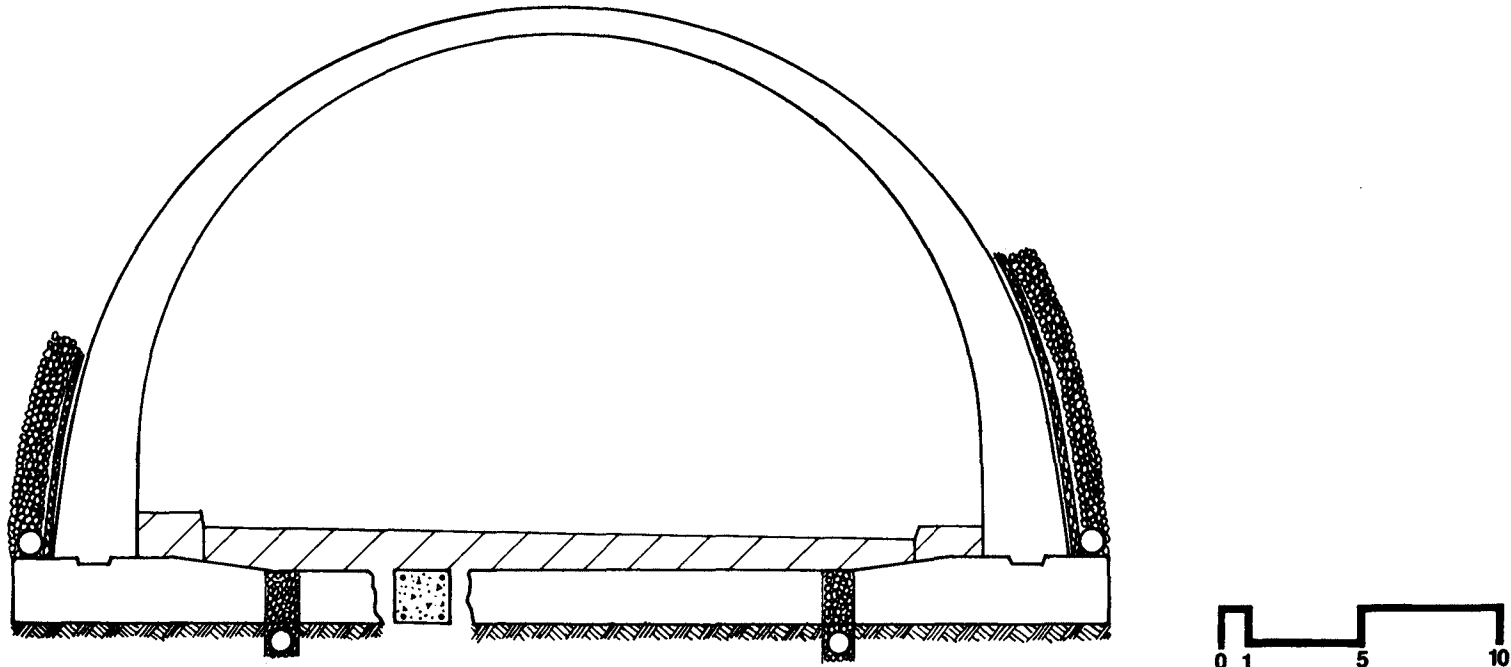

Figure 14. Cross section of tunnel under Williamsburg.

NORFOLK & WESTERN BRIDGE

Type of Structure: Tri-level bridge
Location: Rte 13 (Business) over Norfolk and
Western Railroad over Rte 460 in
the city of Chesapeake
Date of Completion: 1949
Overall Length: 271 feet (upper bridge)

Roadway: 54 feet (upper bridge)
Designer: Norfolk and Western Railway Co.
Prime Builder: E. W. Grannis, Lewis and
Bowman Co.
Approximate Cost: \$742,500

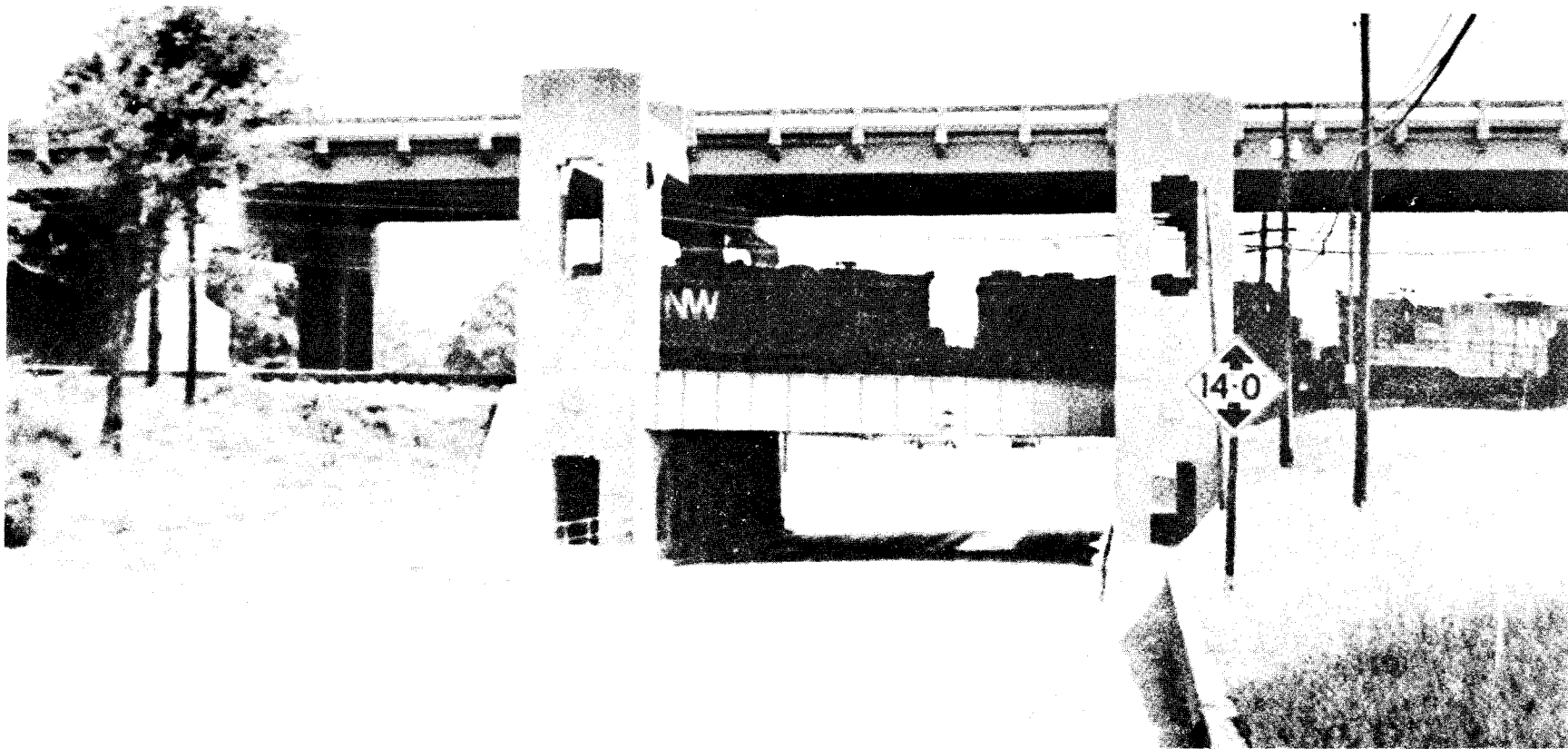

Figure 15. Tri-level bridge in the city of Chesapeake. A train is seen traversing the middle level.

This bridge is very unusual in both appearance and construction. The upper highway bridge, approximately 28 feet above grade, is of reinforced concrete beam construction continuing over five spans ranging from 45 feet to 55 feet in length. The middle railway bridge, located on grade, is of steel beam construction spanning a single 50-foot distance. The lower highway with a 45-foot roadway is excavated to approximately 20 feet below grade at the underpass. Because of poor soil conditions, the lower roadway is of reinforced concrete supported on timber piles

placed along the roadway for several hundred feet on each side of the underpass. All the bridge piers and abutments are also supported by timber piles. The two central piers of reinforced concrete flanking the lower roadway are unusually massive, having been made so for architectural effect. Sidewalks, in fact, penetrate them at the lower level. The structure also incorporates a pump well to remove water in the underpass in the event of flooding.

Although not a graceful bridge, it is nonetheless esthetically interesting.

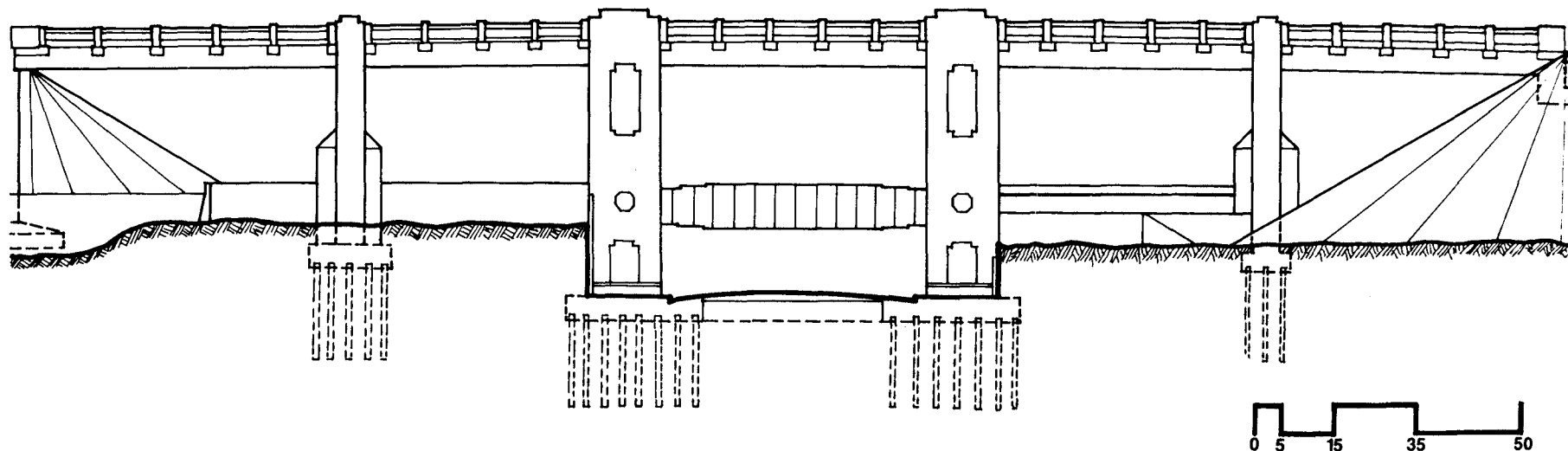

Figure 16. Elevation of the combined highway and railway bridge.

JOHN RANDOLPH BRIDGE

Type of Structure: Multiple span bridge
Location: Rte 304 over Dan River in Halifax
County
Date of Completion: 1950
Overall Length: 2,120 feet

Roadway: 28 feet
Designer: Virginia Department of Highways &
Transportation
Prime Builder: Guy H. Lewis and Son
Approximate Cost: \$716,400

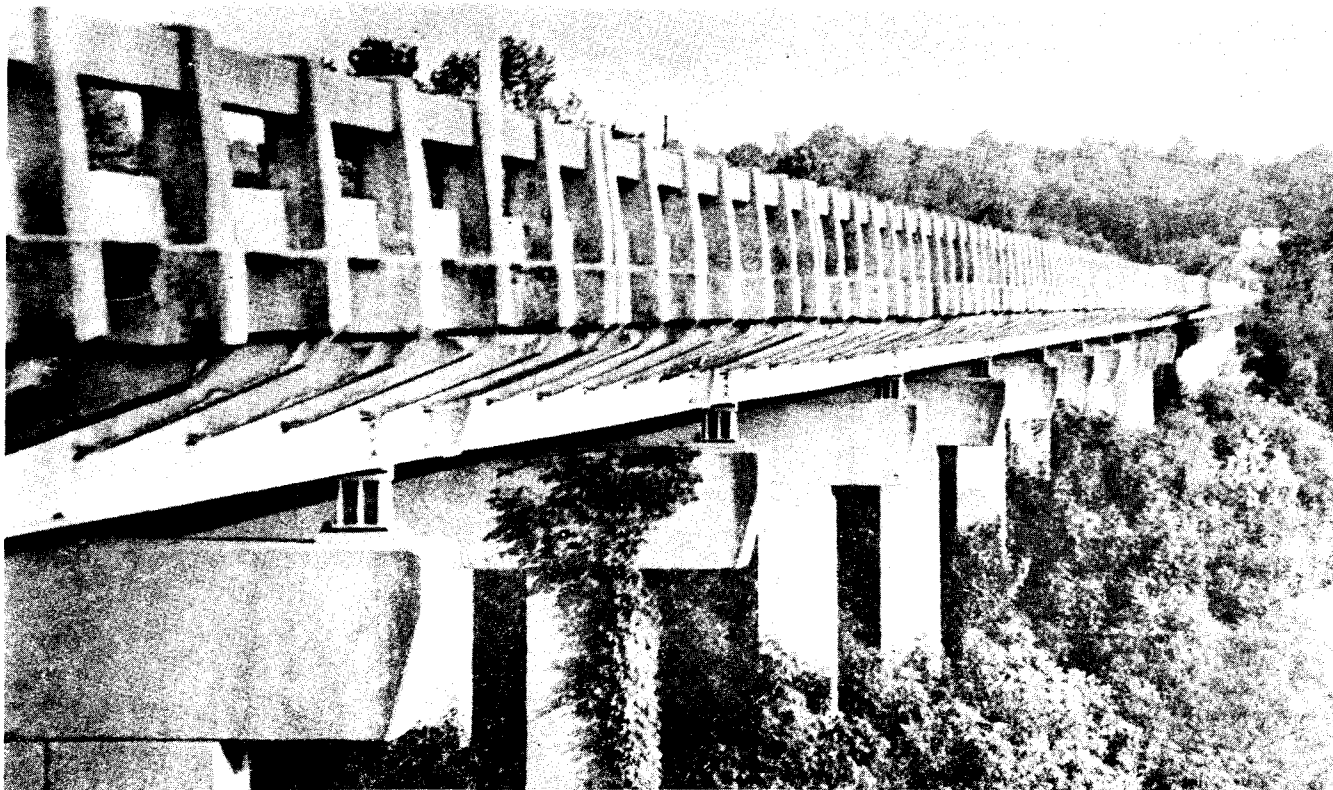

Figure 17. View of the John Randolph Bridge, looking toward the city of South Boston.

This bridge is officially named the John Randolph Bridge, after the Halifax County statesman. It is constructed of thirty-one semicontinuous steel beam spans ranging in length from 41 to 99 feet. Every third span is suspended with a hinge to allow for thermal expansion and contraction. The piers are reinforced concrete. All but two rest on bedrock

located within 12 feet of the ground surface. The others, along with the abutments, are supported by timber piles.

The absolute straightness of this long bridge on only a slight 1.12% grade gives it an appearance of almost endless length when viewed from the ends.

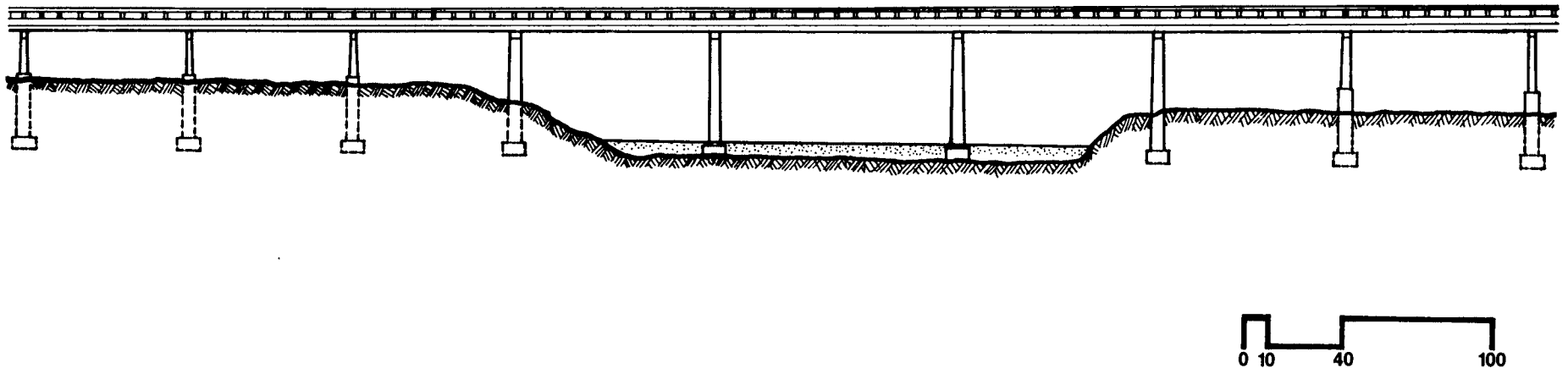

Figure 18. Portion of the bridge over Dan River. The remainder of the structure is over a wide floodplain.

COLEMAN MEMORIAL BRIDGE

Type of Structure: Swing span bridge
Location: Rte 17 over York River between
York and Gloucester Counties
Date of Completion: 1952
Overall Length: 3,750 feet

Roadway: 26 feet
Designer: Parsons, Brinckerhoff, Hall and
MacDonald
Prime Builder: Virginia Bridge Co.
Approximate Cost: \$9,000,000

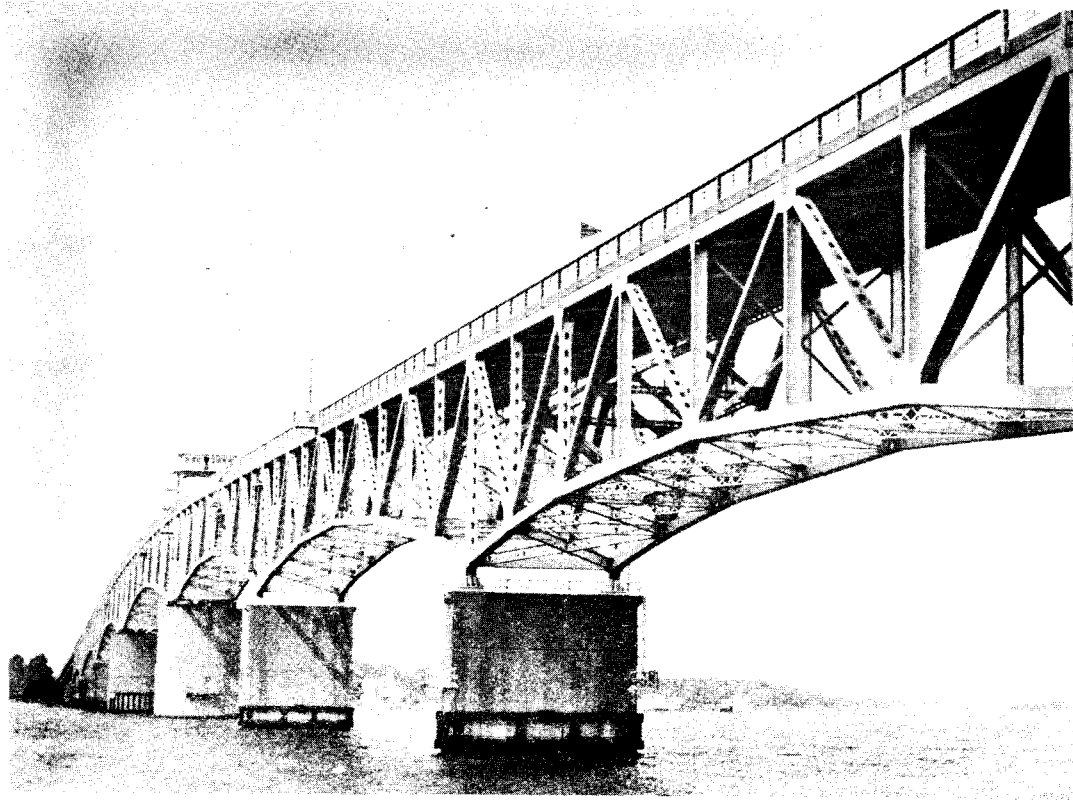

Figure 19. View of the George P. Coleman Memorial Bridge as seen from historic Yorktown.

This structure is called the George P. Coleman Memorial Bridge, being named after the former Commissioner of the State Highway Department. The most notable aspects of this bridge are its long steel truss tandem swing spans, each 500 feet in length (cantilevering 250 feet each side of each pier), which make it the world's longest for a highway bridge. Even when the movable spans are closed, the vertical clearance from mean high water is 80 feet. The horizontal clearance is 450 feet. In addition to the 500-foot center swing span, the bridge has six other steel deck truss spans over water that range in length from 280 to 390 feet. There are eight 90-foot long steel girder approach spans on the north side and six steel girder approach spans of 65- or 90-foot lengths on the south side.

The six reinforced concrete piers located in the York River were constructed by the caisson method and penetrate approximately 60 feet into the river bottom. Water depth is as much as 70 feet in the channel. The reinforced concrete piers on land for the approach structures are supported by timber piles.

A preliminary design for this bridge called for a suspension structure, but the high towers for such a design were felt to be overpowering in relation to certain historic features in nearby Yorktown. The existing bridge, even so, is rather monumental and imposing, although not unattractive.

Figure 20A. Elevation of the truss portion of the bridge.

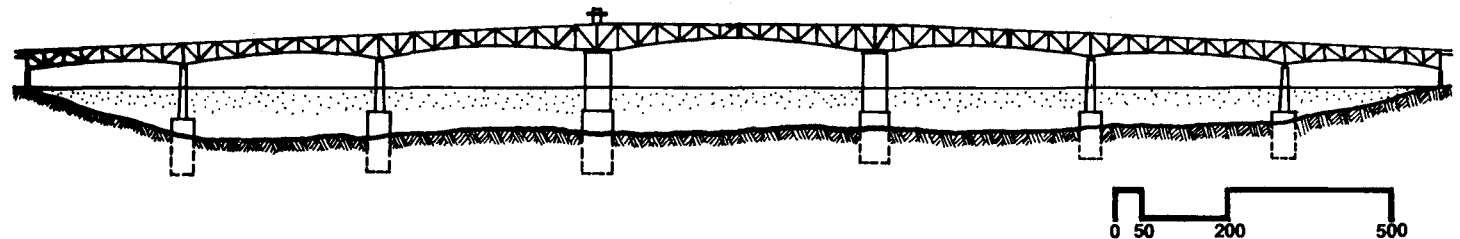
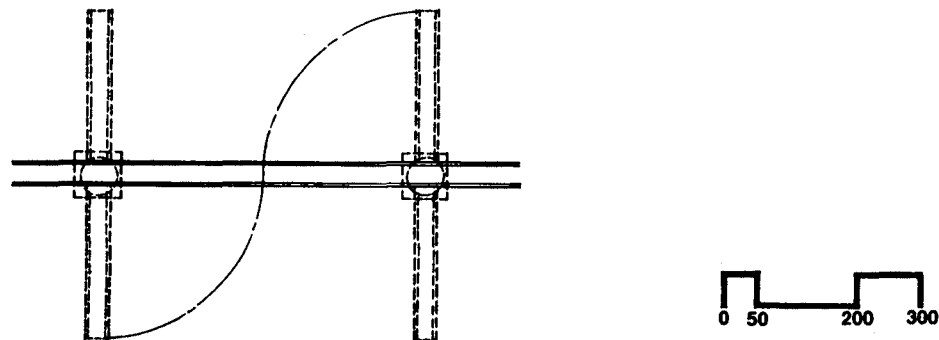

Figure 20B. Plan view of the center span showing how the movable cantilever span swings open.



DOWNTOWN TUNNEL & BERKLEY BRIDGE

Type of Structure: Tunnel and bascule bridge

Location: Rte 337 under south branch of Elizabeth River (tunnel) and over east branch of Elizabeth River (bridge) between the cities of Norfolk and Portsmouth

Date of Completion: 1952

Overall Length: 3,350 feet (tunnel); 2,124 feet (bridge)

Roadway: 22 feet (tunnel); 46 feet (bridge)

Designers: Parsons, Brinckerhoff, Hall and MacDonald (tunnel); J. E. Brinder Co. (bridge)

Prime Builders: Merritt-Chapman and Scott (tunnel); Tidewater Construction Co. (bridge)

Approximate Cost: \$11,700,000 (tunnel); \$ 5,269,000 (bridge)

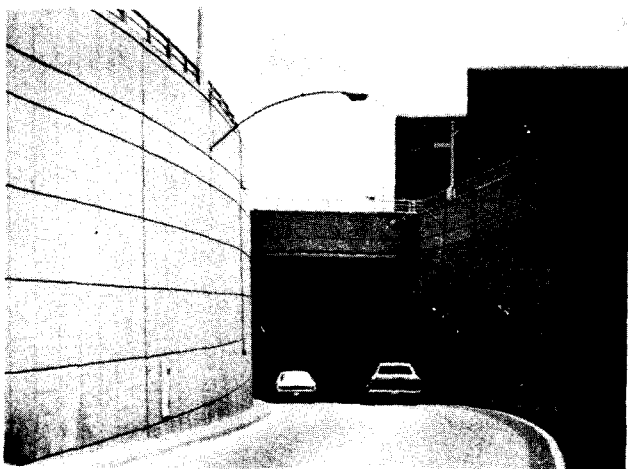

Figure 21A. West portal of the Downtown Tunnel.

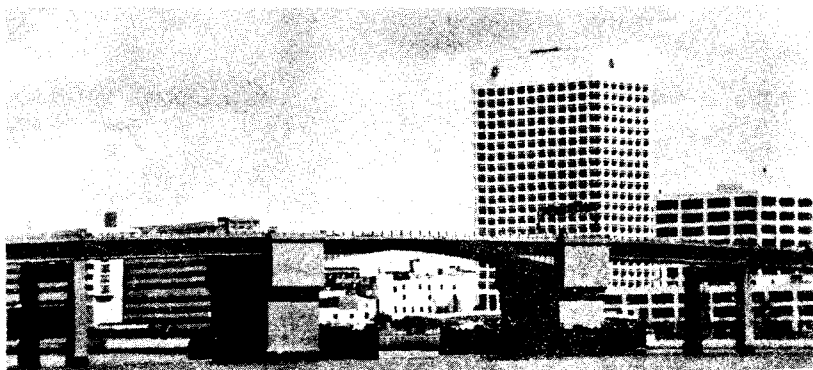

Figure 21B. Bascule portion of the Berkley Bridge, with the city of Norfolk in the background.

The tunnel, known as the Downtown Tunnel, and the bridge, known as the Berkley Bridge, are along the same route, which is separated by a narrow spit of land in Norfolk (called Berkley). As the structures are close together and were constructed at the same time, they are treated here as a combination bridge-tunnel project.

The tunnel was constructed by two methods. The shallow portions on land near the portals were built by the "cut and cover" method where an open trench was dug and a cast-in-place reinforced concrete tube was constructed. The trench was then backfilled with soil. The portion under water was built by the "trench tube" method, which was done by dredging a

trench in the river bottom approximately 40 feet deep and then placing prefabricated steel and concrete tubes in the trench. The bottom of the tube is about 90 feet below mean water level.

The bascule, or draw, bridge is of steel with concrete piers resting on steel piles. The center span, which opens for passage of tall vessels, provides a horizontal clearance of 150 feet. Flanking the bascule span are a total of nineteen steel girder spans ranging in length from 94 to 112 feet.

The volume of traffic on this bridge-tunnel is so great that a second bridge-tunnel is being planned for construction next to it.

Figure 22A. Profile of tunnel under Elizabeth River.

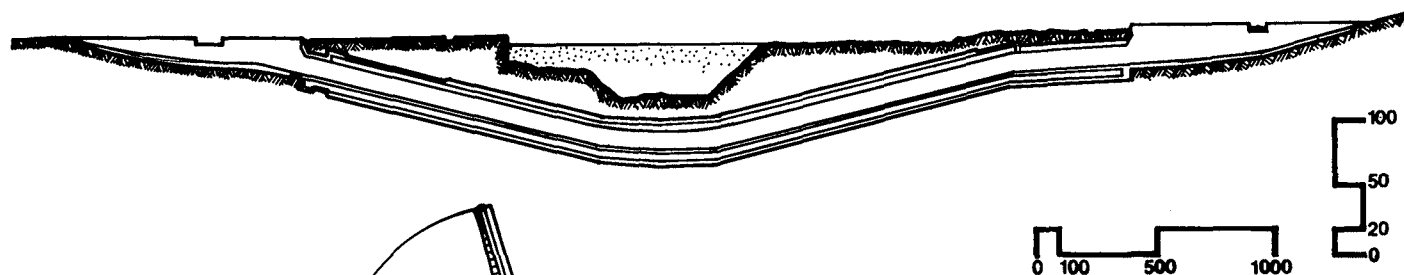
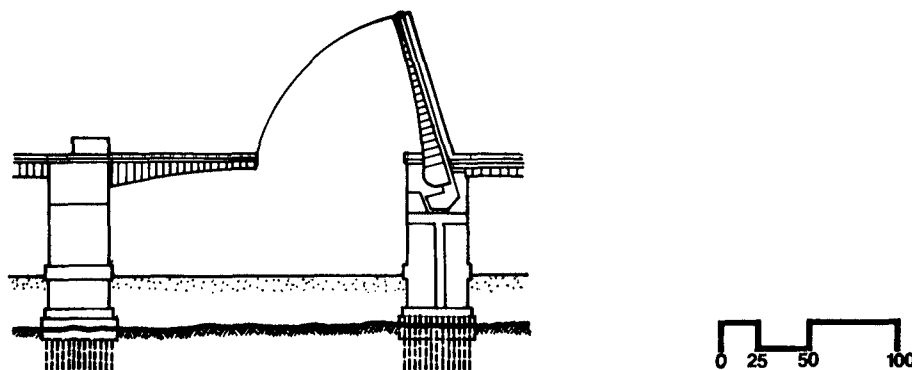

Figure 22B. Movable section of the bridge showing left leaf closed and right leaf open. In operation, they would open and close together.



HAMPTON ROADS BRIDGE-TUNNEL

Type of Structure: Bridge-tunnel
Location: Rte 64 across Hampton Roads between
the cities of Hampton and Norfolk
Date of Completion: 1957
Overall Length: 3.48 miles: 3,250 feet
(north bridge); 6,150 feet
(south bridge); 7,479 feet
(tunnel)

Roadway: 30 feet (bridge); 23 feet (tunnel)
Designers: Parsons, Brinckerhoff, Hall and
MacDonald
Prime Builders: Merritt-Chapman and Scott Corp.

Approximate Cost: \$45,000,000

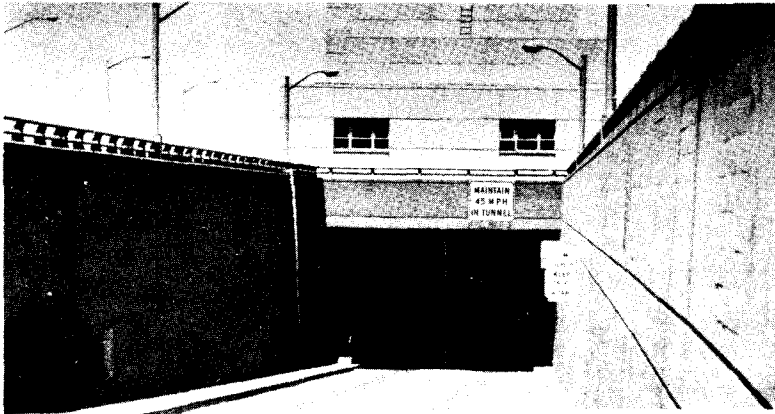

Figure 23A. South portal of Hampton Roads Tunnel with ventilator plant visible above.



Figure 23B. Trestle bridge approach to Tunnel as viewed from Hampton side.

Replacing a ferry, the bridge-tunnel took three years to build and was at the time the Virginia Highway Department's largest single project. The bridges were the first in Virginia to be made of prestressed concrete. The precast, prestressed girders span between a series of reinforced concrete trestle bents spaced about 50 feet apart. The legs of the bents are piles driven into the bottom of the bay. The terminals of the tunnel begin and end on separate man-made islands of soil and rock flanking the channel. This was the first tunnel built with such portals. The tunnel itself was constructed by the trench tube

method in which a trench was dredged approximately 40 feet into the Bay bottom, and prefabricated, steel lined, reinforced concrete tubes were placed in the trench. When constructed, it was the longest trench tube type tunnel in the world. At its lowest point, the tunnel is about 113 feet below mean water level.

Traffic volume in the bridge-tunnel has grown so greatly that a second adjacent bridge-tunnel had to be built less than twenty years later, which converted this first crossing from a two-way roadway to a one-way roadway northbound.

Figure 24A. General plan of Hampton Roads Bridge-Tunnel.

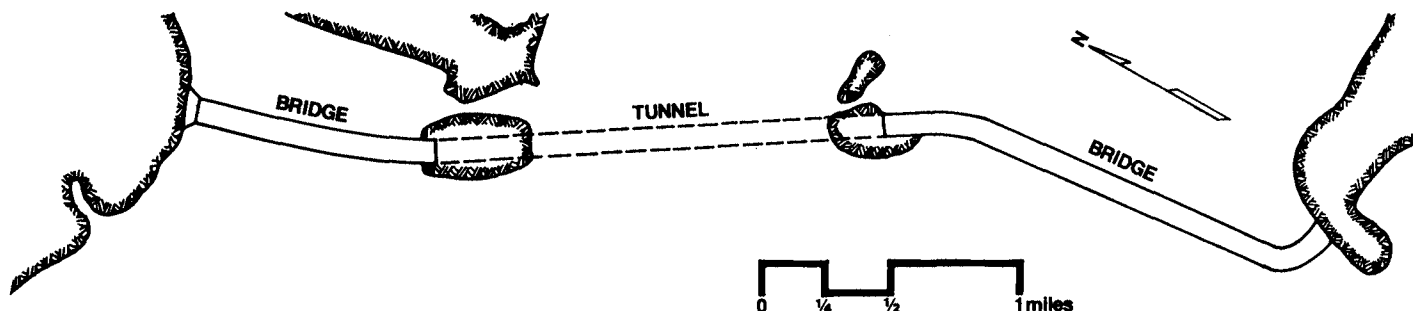

Figure 24B. Profil of tunnel portion under water.



NORRIS BRIDGE

Type of Structure: Steel truss bridge
Location: Rte 3 over Rappahannock River between Lancaster and Middlesex Counties
Date of Completion: 1957
Overall Length: 9,985 feet

Roadway: 22 feet
Designers: Modjeski and Masters
Prime Builders: Bethlehem Steel Corp. and Diamond Construction Co.
Approximate Cost: \$15,500,000

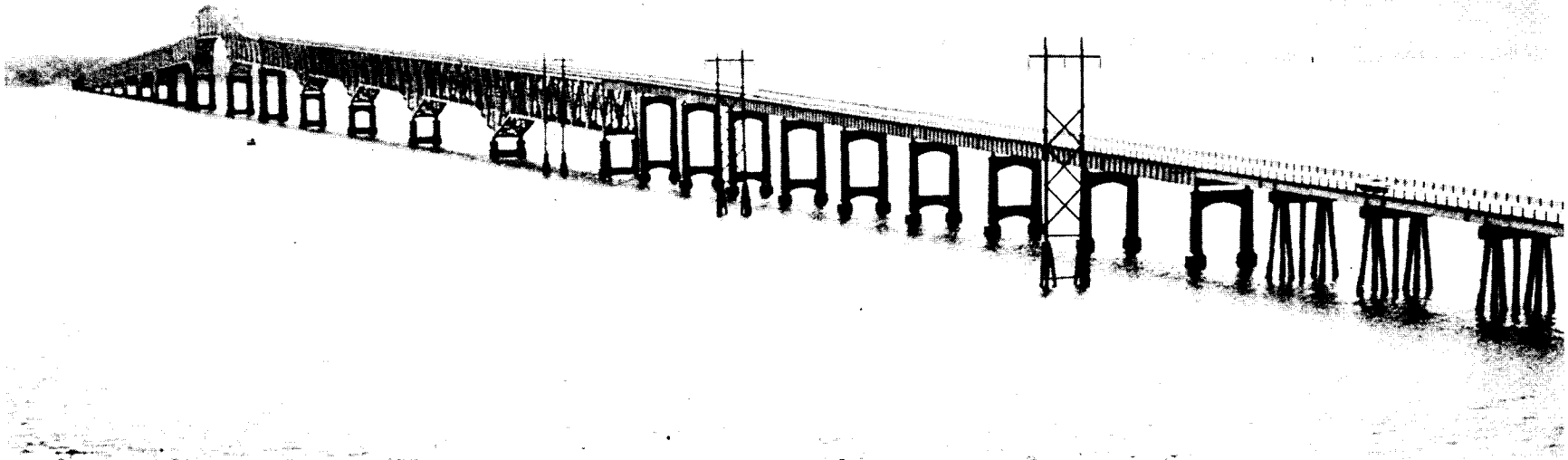

Figure 25. The Robert Opie Norris, Jr. Bridge looking toward Greys Point.

Named in commemoration of former State Senator Robert Opie Norris, Jr., this structure, when built, was the largest high-level bridge constructed in Virginia. The center through truss spans 648 feet and provides 110 feet of vertical clearance at mean high tide. Although looking somewhat like an arch, the high-level span consists of a suspended central portion supported by cantilever trusses, eight more deck trusses extend to the south and six more to the north, with spans of from 351 to 469 feet.

Approach spans on both sides are of steel beam or girder construction of lengths varying

from 78 to 125 feet. The truss portion of the bridge is supported by reinforced concrete piers resting on large caissons of reinforced concrete (42 by 61 feet in plan) sunk to depths up to 153 feet below the water surface. The approach structures are supported by concrete or timber piles.

The main truss spans are impressive and handsome, but the approach spans of two kinds of construction (done for economic reasons), unfortunately do not relate esthetically to the truss work.

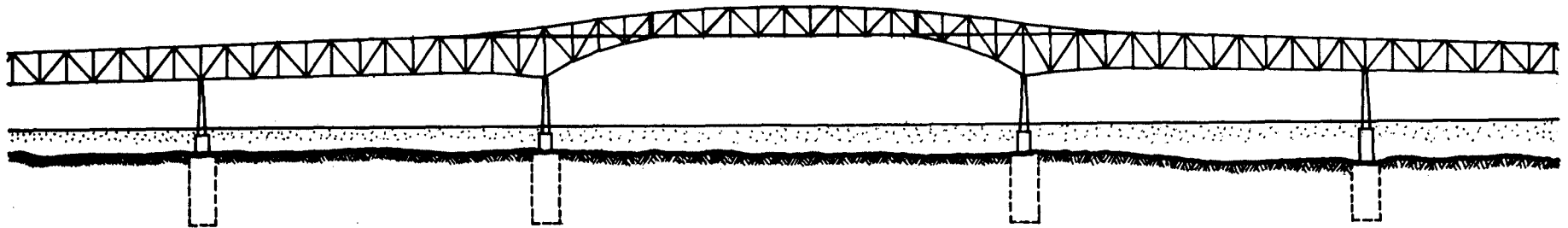

Figure 26. High level portion of the bridge.

ELTHAM BRIDGE

Type of Structure: Swing span bridge

Roadway: 26 feet

Location: Rte 33 over Pamunky River between
King William and New Kent Counties

Designers: Virginia Department of Highways
and Transportation

Date of Completion: 1957

Prime Builder: Diamond Construction Co.

Overall Length: 2,337 feet

Approximate Cost: \$1,118,600

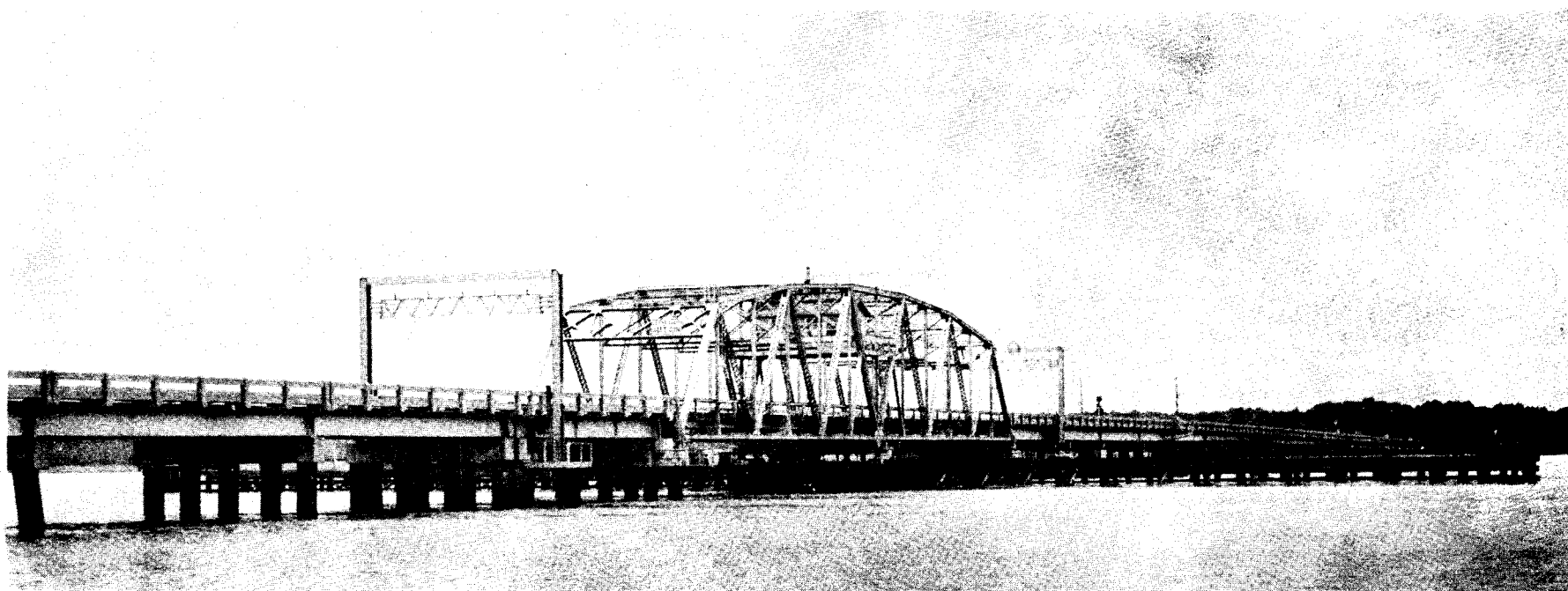

Figure 27. The Eltham Bridge, named after Eltham, the colonial home of the Burwell Bassett family of Virginia.

Known as the Eltham Bridge, the notable feature of this structure is the 237-foot steel swing truss. The truss rotates horizontally about a reinforced concrete pivot pier located at the center of the truss to allow large barges to pass through the bridge.

Approaching the movable portion from the south are seventeen steel or reinforced concrete beam spans ranging from 40 to 60 feet.

From the north, there are thirty similar beam spans. The beams are supported by concrete pile bents. The pivot pier also rests on piles.

The bridge is not particularly beautiful, but it does serve a most vital function in carrying heavy industrial traffic across the river.

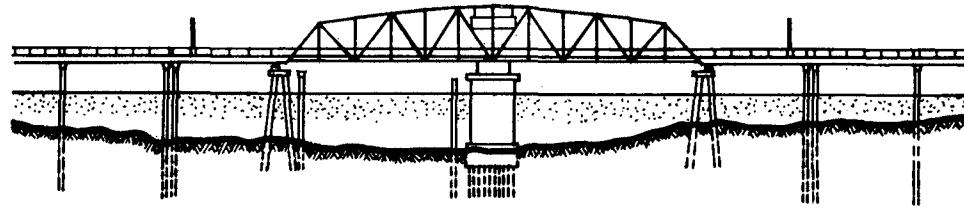
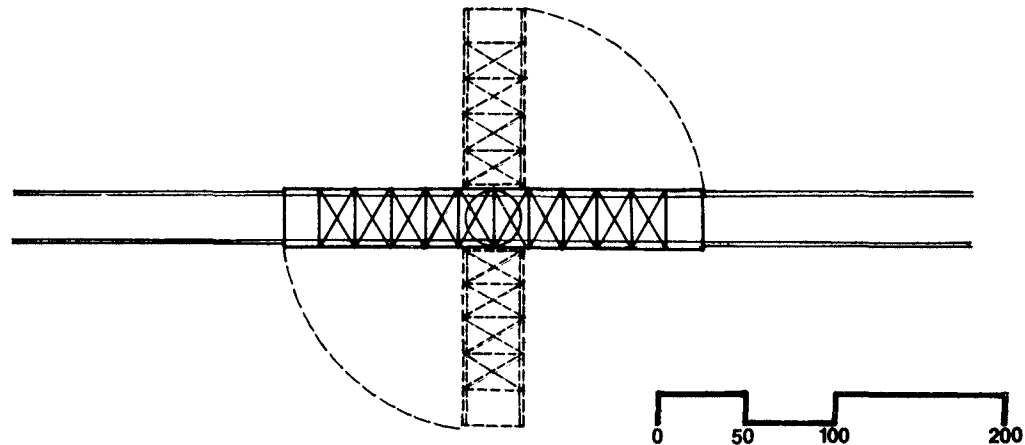

Figure 28A. Swing truss span, with several adjacent beam spans.

Figure 28B. Plan of swing span, showing manner of movement.



JAMES RIVER BRIDGE

Type of Structure: Steel beam, girder and
truss bridge

Roadway: 84 feet

Location: Rte 95 over James River in city of
Richmond

Designer: D. B. Steinman

Date of Completion: 1958 (ramp additions in
1976)

Prime Builder: U. S. Steel Corporation

Overall Length: 4,185 feet

Approximate Cost: \$8,670,000

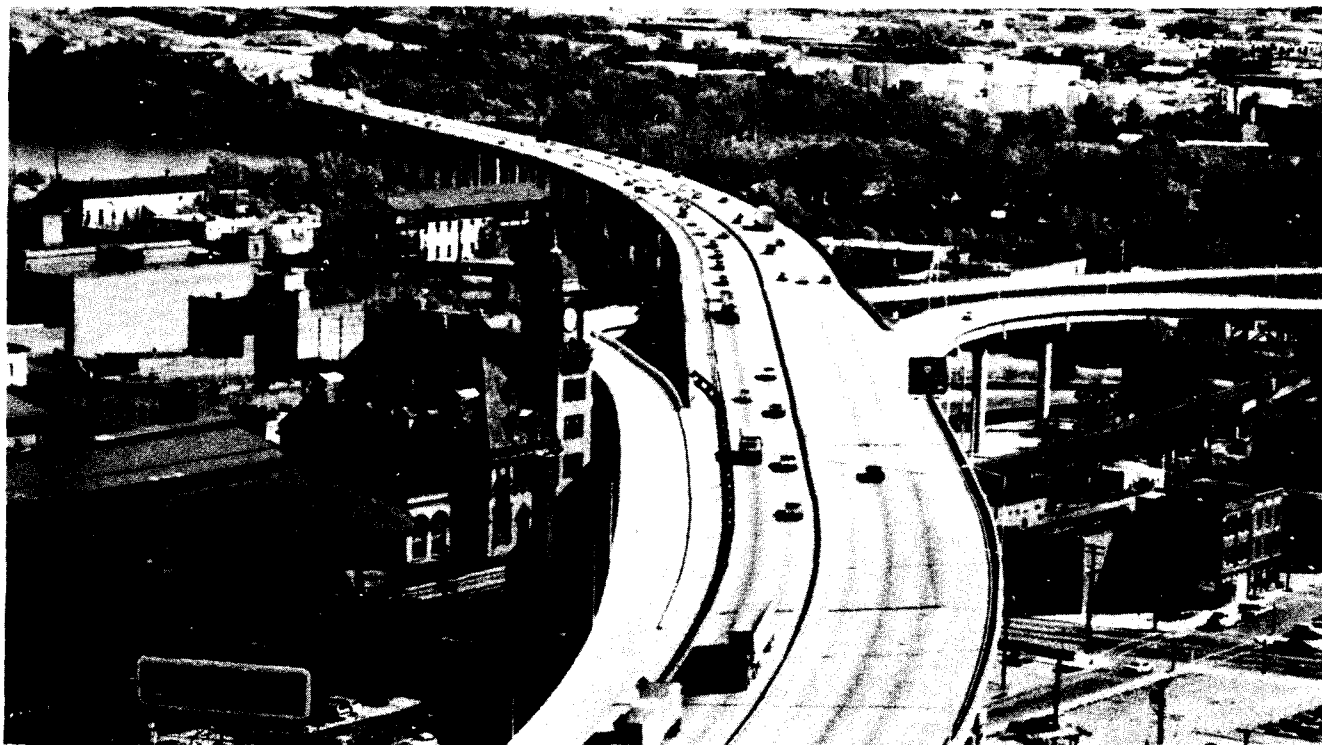

Figure 29. Crossing of James River, looking south. The curved on-off ramps in the foreground were added in 1976.

Constructed for the Richmond-Petersburg Turnpike Authority, this heavily travelled bridge rises to a height of 75 feet above mean high water. It consists of fifty-one spans ranging in length from 55 to 269 feet. The longest span, over railroad tracks on the north side, is a truss, and the other, shorter ones are beams or girders. The piers are reinforced concrete shafts. Piers on the land portion of the bridge rest on short piles, while the piers in the water rest directly on

rock at the level of the river bed. Increased traffic demand necessitated the addition of several connecting on-off ramps.

From an engineering point of view, the most difficult part of designing the structure was the involved positioning of the one-hundred piers so as not to interfere with the many streets, tracks, and buildings in the path of the bridge.

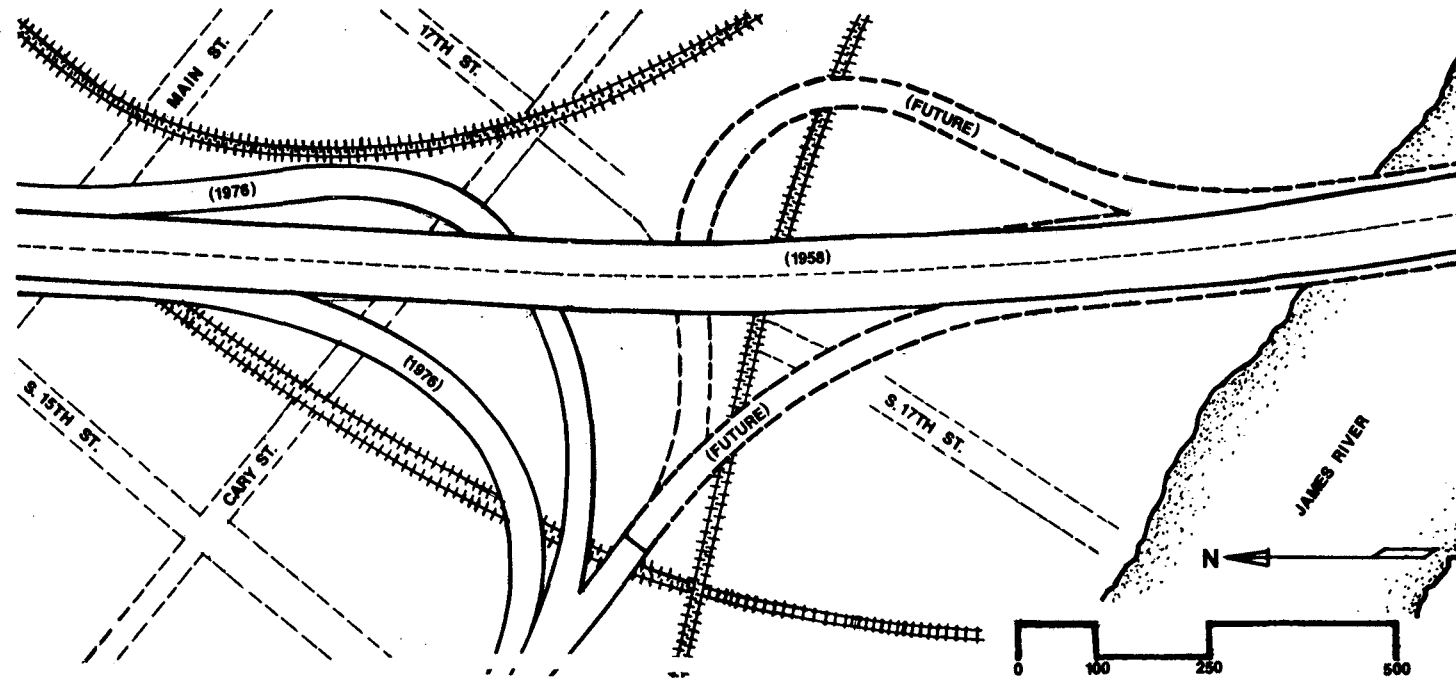

Figure 30. Plan of the north portion of the bridge, showing the original bridge and ramps added (or to be added) at a later date. The ramps generate a complex multilevel structure.

APPOMATTOX RIVER BRIDGE

Type of Structure: Aluminum box girder bridge

Roadway: 84 feet

Location: Rte 36 over Appomattox River in
Petersburg

Designer: Hayes, Seay, Mattern and Mattern
(with Reynolds Metal Co.)

Date of Completion: 1961

Prime Builder: Sanford Construction Company

Overall Length: 100 feet

Approximate Cost: \$89,000

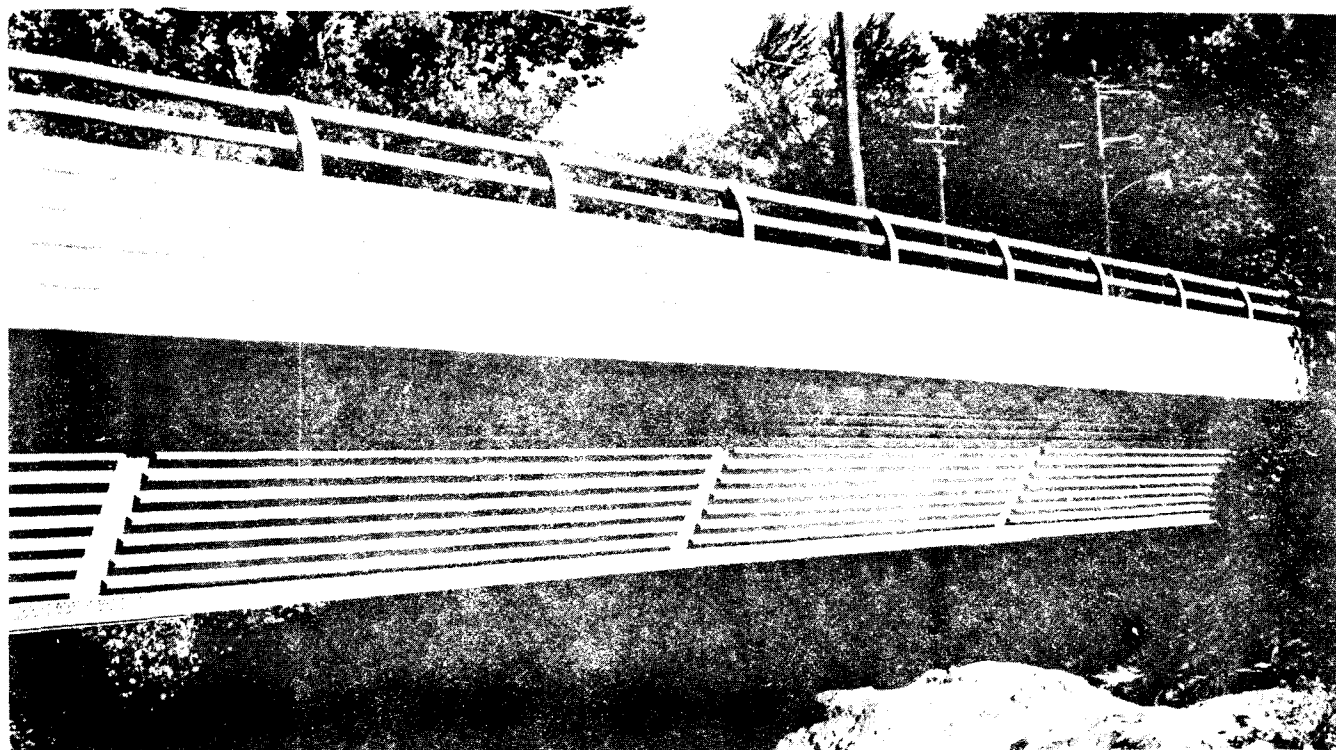

Figure 31. The unique aluminum bridge in Petersburg. The horizontal angles on the sides keep the web from buckling.

This single-span bridge lays claim to one first in the United States and to two firsts in Virginia. In the United States, it was the first sheet aluminum bridge ever built. In Virginia, it was not only the first aluminum bridge, but also the first to have lightweight concrete as a deck. Its unusual construction of thin stiffened triangular box girders was patterned after the construction of aluminum aircraft. Its weight is about one-quarter that of a conventional steel bridge. The superstructure was largely prefabricated and erected full-length in single

box modules. The concrete deck was field placed and acts compositely with the girders.

By contrast, these high technology box girders rest on old masonry abutments left from the remains of an earlier steel truss bridge on the site. The masonry itself bears on rock outcropping. This bridge, although not very large, is notable for its innovative technology and pleasing appearance. Unfortunately, the girders are difficult to see from the roadway and many motorists crossing the span are unaware of the uniqueness of the bridge they are riding on.

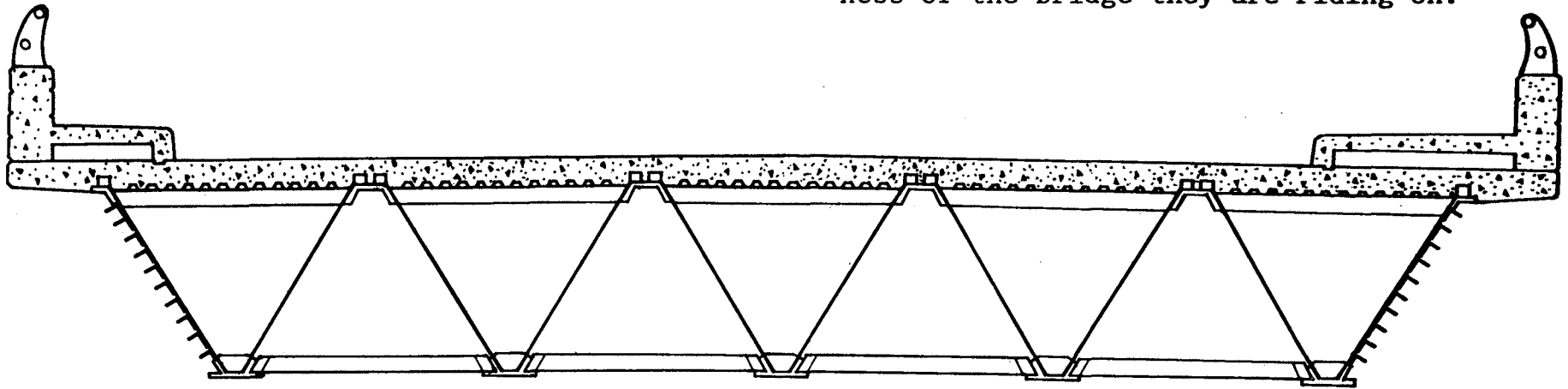

Figure 32. Cross section through the bridge, showing the novel triangular box girders of aluminum. The deck is lightweight concrete.

ELIZABETH RIVER BRIDGE

Type of Structure: Double-leaf bascule bridge

Roadway: 28 feet

Location: Rte 104 over South Branch of Elizabeth River in the city of Chesapeake

Designer: Hardesty and Hanover

Date of Completion: 1962

Prime Builder: Tidewater Construction Co.

Overall Length: 552 feet

Approximate Cost: \$1,296,000

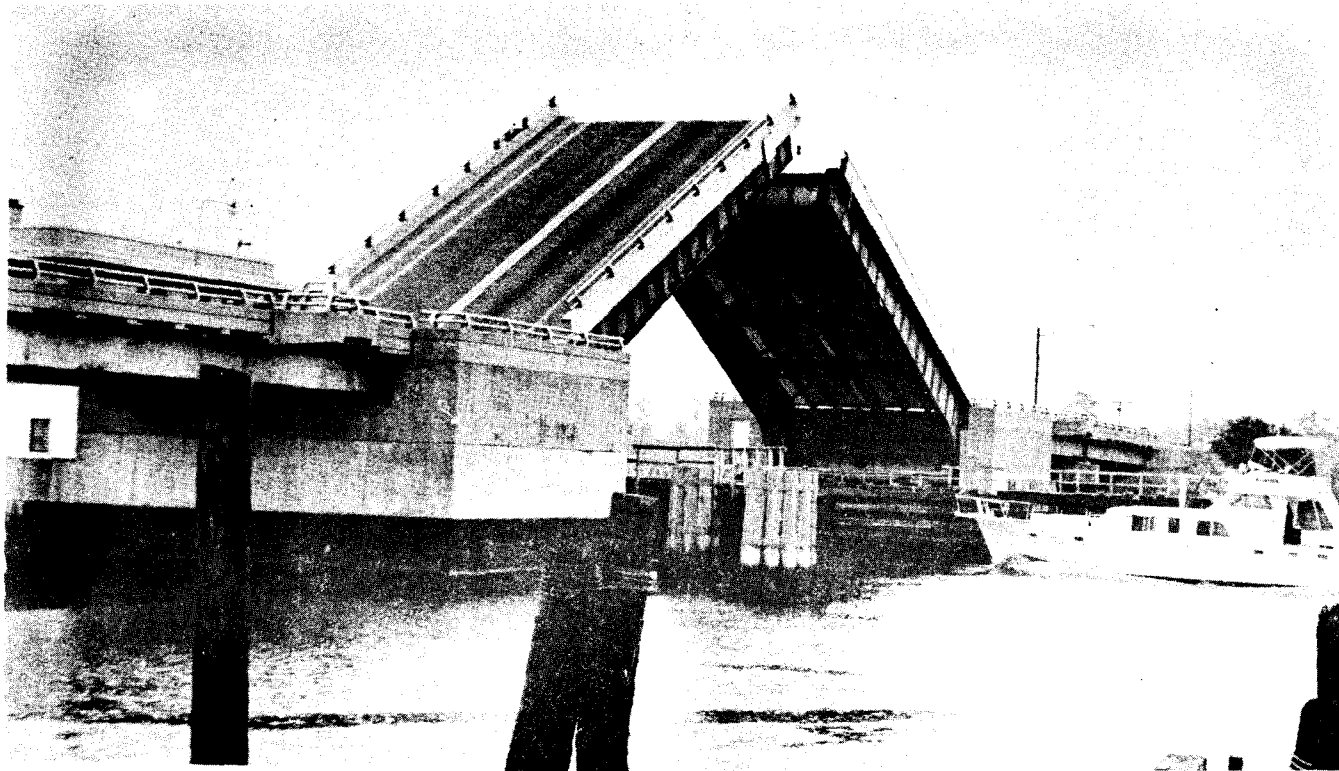

Figure 33. Bascule bridge (also known as a drawbridge) shown in open position.

This bridge won the national Award of Merit by the American Institute of Steel Construction in 1962. Its 171-foot movable opening provides an open channel clearance of 125 feet. Three composite steel spans of 66 feet each lead to the movable span from the north, and two similar spans of 62 feet each lead to the movable spans from the south.

The large piers flanking the bascule span are reinforced concrete, supported by clusters

of piles. Supports for the other spans are simple pile bents of reinforced concrete. Because of poor soil conditions, many of the piles had to be driven about 70 feet into the river bottom.

In appearance, the bridge itself is nicely designed, although the general site is less than scenic.

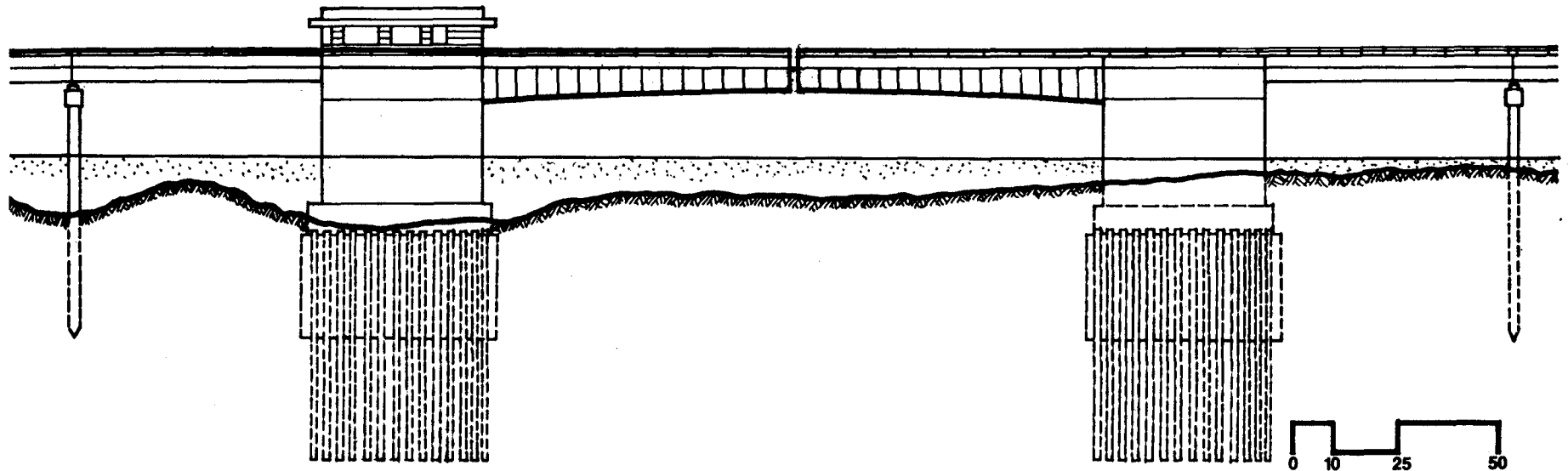

Figure 34. Elevation of the bascule bridge, shown in closed position.

MIDTOWN TUNNEL

Type of Structure: Underwater tunnel
Location: Rte 58 under Elizabeth River between the cities of Norfolk and Portsmouth

Roadway: 23 feet
Designers: Parsons, Brinckerhoff, Quade and Douglas

Date of Completion: 1962
Overall Length: 4,194 feet

Prime Builder: Diamond Construction Company
Approximate Cost: \$19,831,000

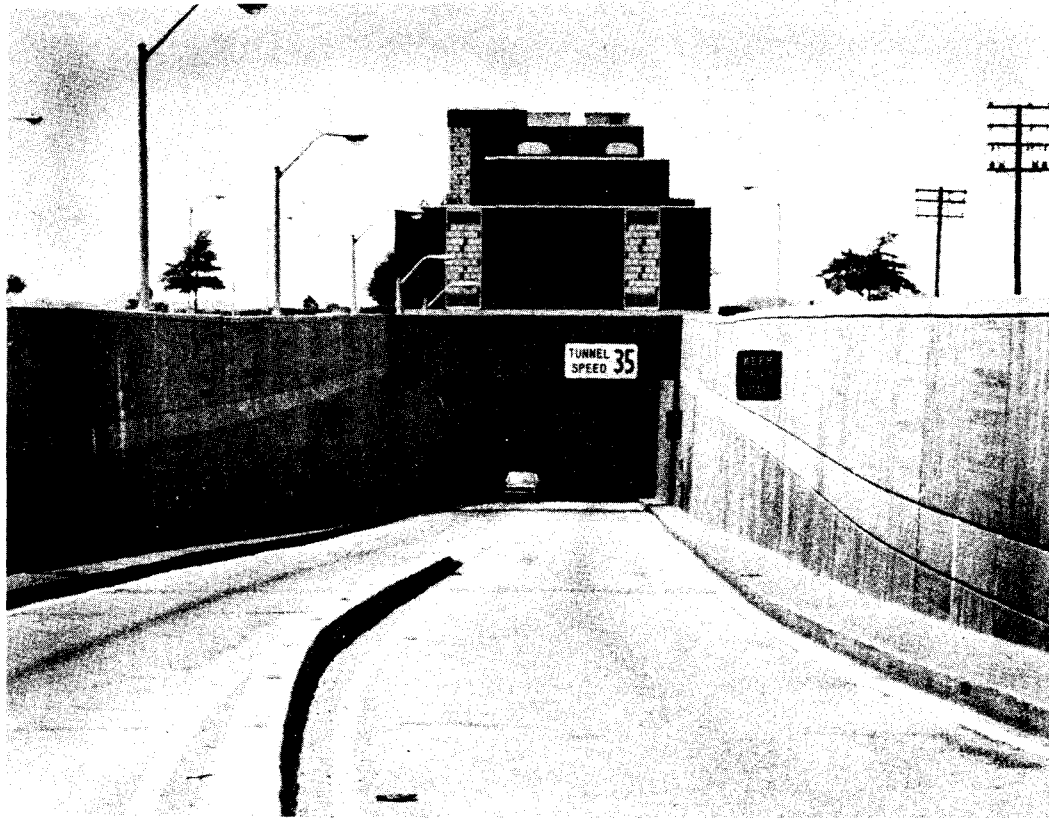

Figure 35. East portal of Midtown Tunnel

Locally known as the Midtown Tunnel, this tunnel is the second to connect Norfolk with Portsmouth. (The Downtown Tunnel, completed ten years earlier, was the first.) Except for short portions near the portals, built by the "cut and cover" method, the tunnel was constructed of eleven prefabricated steel and concrete tubes. These sections, each approximately 300 feet long and 40 feet in diameter,

were sunk in prepared trenches under water. The tubes are protected by a 5-foot deep backfilling of stone. At its deepest point, the tunnel is about 100 feet under mean water level.

Construction took a period of twenty-eight months.

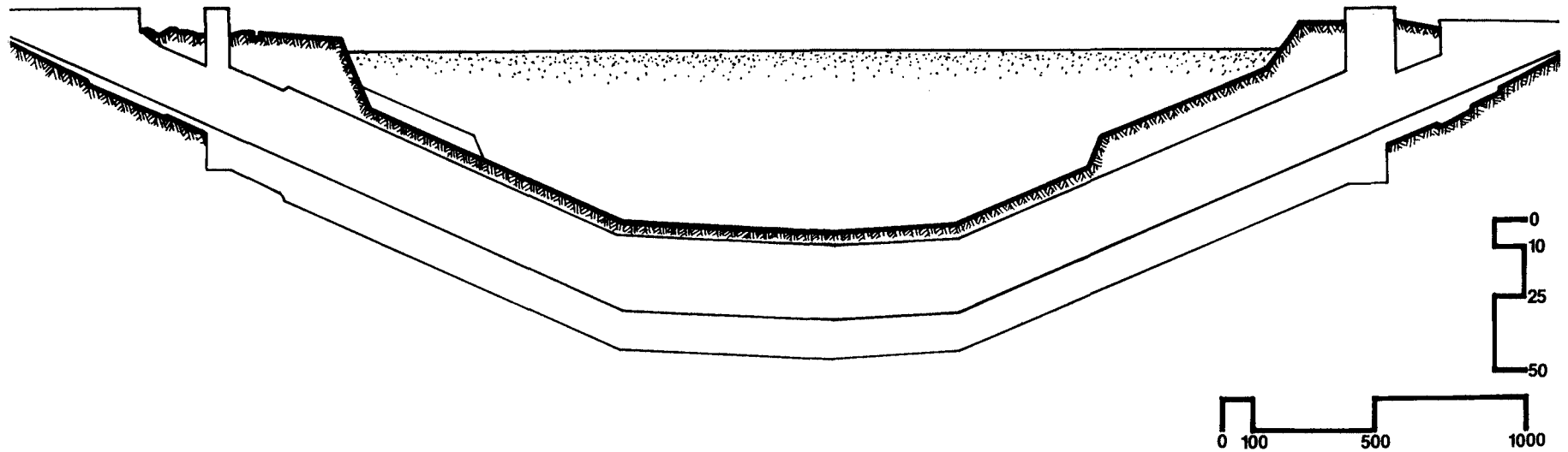

Figure 36. Profile of the tunnel under the river. (Note that the vertical scale as drawn is ten times larger than the horizontal scale.)

HALE'S FORD BRIDGE

Type of Structure: Plate girder bridge
Location: Rte 122 over Smith Mountain Lake
between Bedford and Franklin
Counties

Roadway: 24 feet
Designers: Hayes, Seay, Mattern and Mattern

Date of Completion: 1963
Overall Length: 1,035 feet

Prime Builder: McDowell and Wood, Inc.
Approximate Cost: \$1,041,000

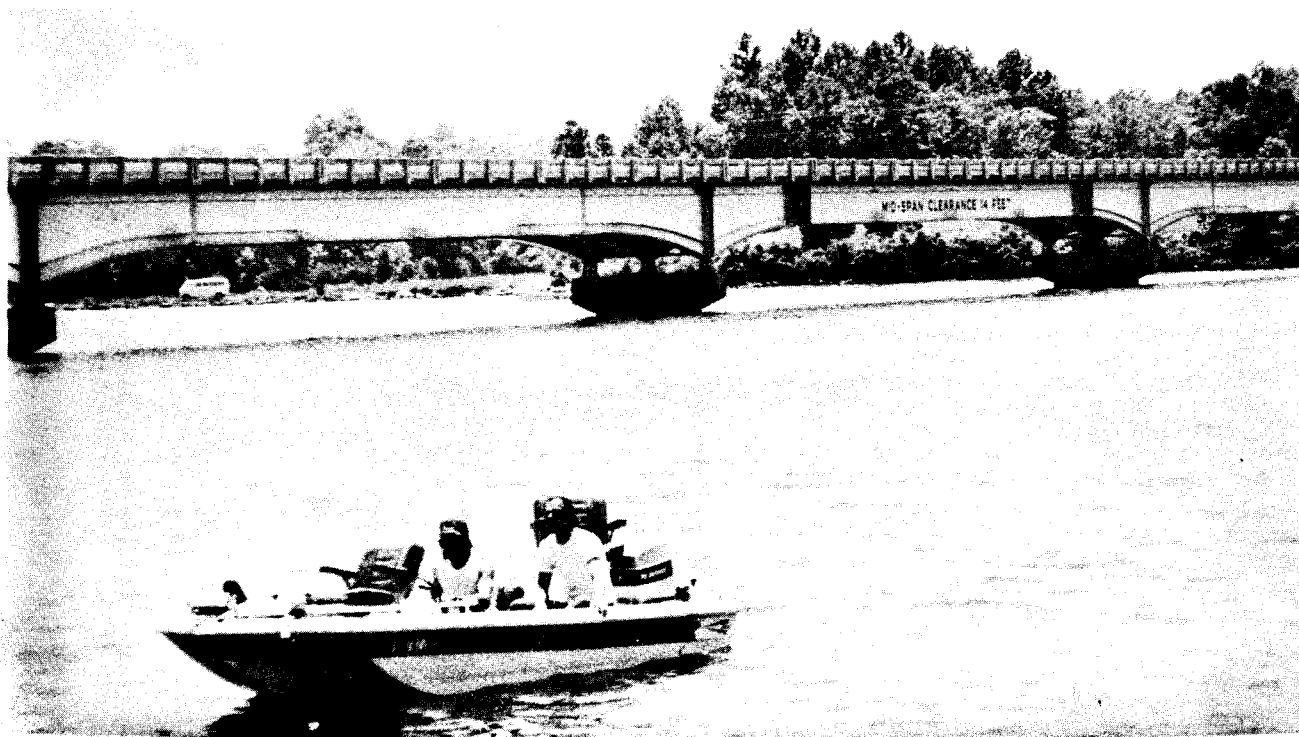

Figure 37. Bridge with the tall piers almost completely submerged in about one hundred feet of water.

Locally known as the Hale's Ford Bridge, (after an old-time resident named Hale), this structure is part of the Smith Mountain hydro-electric project financed by the Appalachian Power Company. The bridge consists of five spans ranging from 182 to 234 feet in length. The main members are continuous steel plate girders, deepened or haunched over the supports to resist greater bending forces at these positions. The piers of reinforced concrete

are unusually tall, because of the depth of the man-made lake at this location. The piers rest on rock within 30 feet of the lake bottom.

In 1963, the American Institute of Steel Construction selected this bridge for a national Award of Merit for its generally attractive design.

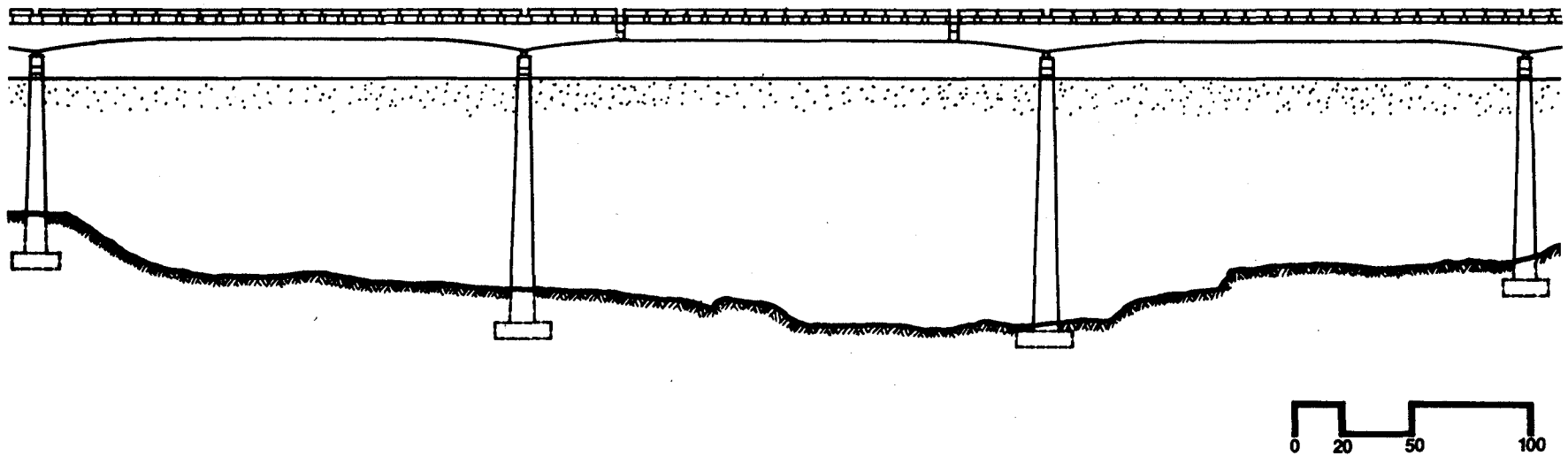

Figure 38. Elevation of portion of the structure. Note the expansion joint in the girder of the center span.

DOWNING BRIDGE

Type of Structure: Multiple span bridge
Location: Rte 360 over Rappahannock River
between Essex and Richmond Counties
Date of Completion: 1964
Overall Length: 5,605 feet

Roadway: 28 feet
Designer: Virginia Department of Highways
and Transportation
Prime Builder: Diamond Construction Co.
Approximate Cost: \$2,185,800



Figure 39. View of bridge from the south bank.

Located in an area of early colonial history, this bridge is the second at the site to be called the Thomas J. Downing Bridge. The first, now removed, was built in 1927. Thomas Downing was a State Senator from Lancaster County.

This long bridge consists of 101 spans varying from 50 to 122 feet. All but three of the longest spans used prestressed concrete beams. The longest ones at the channel use steel girders. The piers are bents of reinforced concrete, supported by piles driven into the river bottom.

Whereas the first bridge had a swing span to open the channel for navigation, the second bridge is fixed, with a high-level portion over the channel. A vertical clearance of 50 feet from mean high water is provided.

The gentle curving of the roadway, both horizontally and vertically, contributes to the attractiveness of this bridge. Unfortunately, the use of two different designs for the pier bents is somewhat distracting visually.

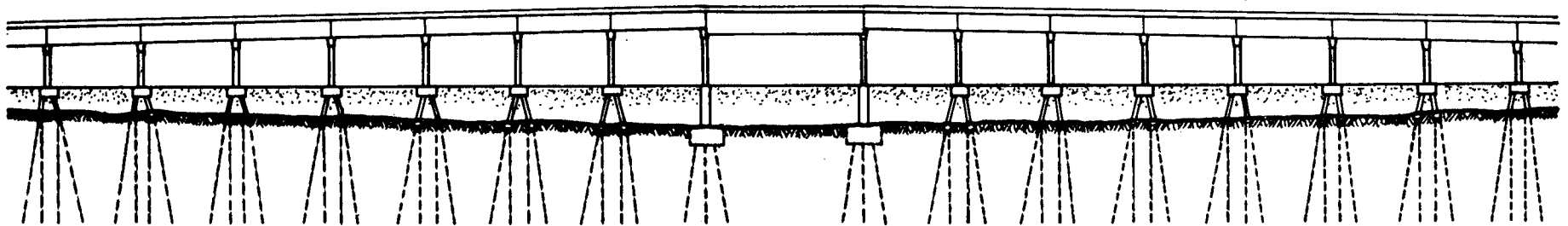

Figure 40. Elevation of the high-level portion of the structure.

CHESAPEAKE BAY BRIDGE-TUNNELS

Type of Structure: Bridge-tunnels

Location: Rte 13 across Chesapeake Bay between Virginia Beach and Northampton County

Date of Completion: 1964

Overall Length: 17.64 miles, consisting of four bridges separated by two tunnels (5,738 and 5,450 ft.) and one causeway on Fisherman Island (8,329 ft.)

Roadway: 28 feet (bridges); 24 feet (tunnels)

Designers: Sverdrup and Parcel

Prime Builders: Tidewater-Merritt-Raymond-Kiewitt and American Bridge Co.

Approximate Cost: \$200,000,000

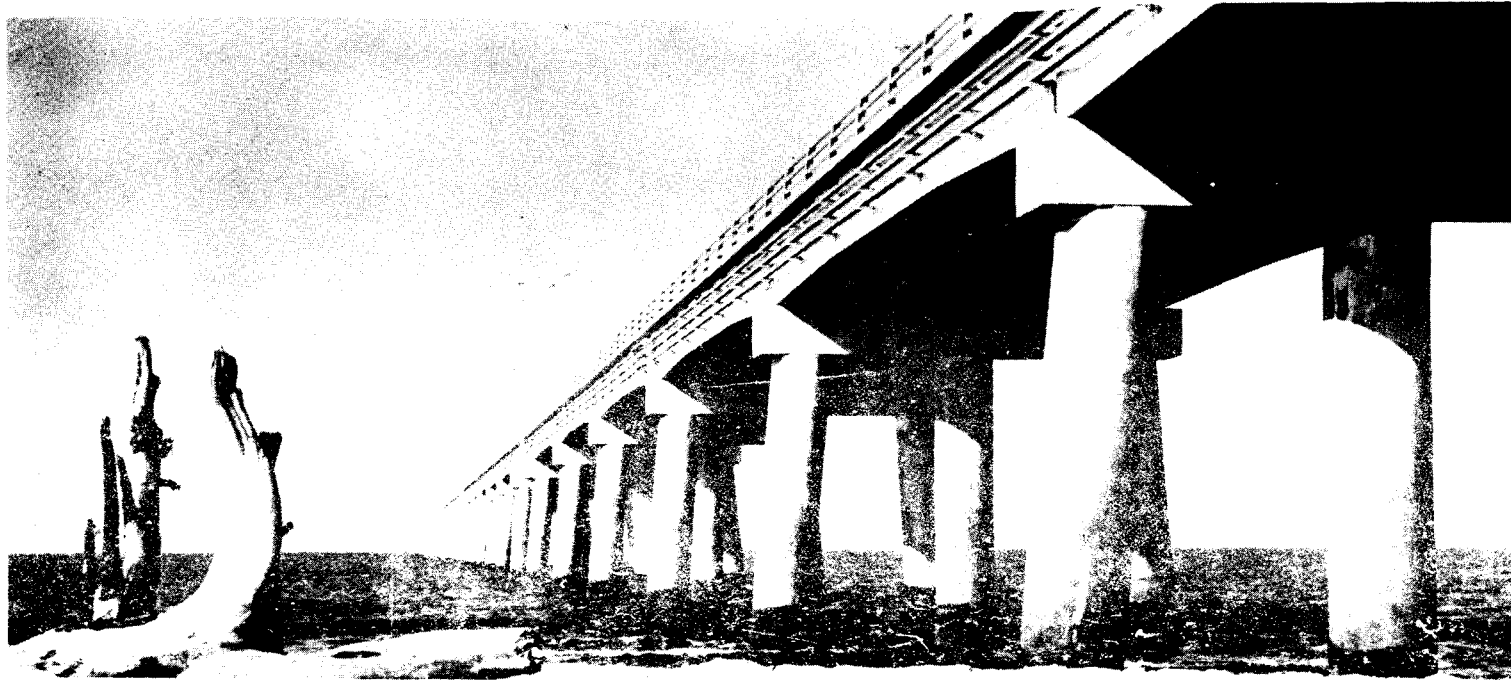

Figure 41. Trestle portion of the Bay Bridge as seen from the south bank.

This crossing is the longest bridge-tunnel structure in the world. Of the total length, 64,505 ft. are trestles consisting of pre-stressed concrete sections spanning 75 ft. between precast pile bent supports. Also 2,523 precast prestressed concrete piles (as long as 172 ft.) were driven into the Bay bottom. The roadway lies about 30 ft. above the water. The Thimble Shoal Tunnel (5,738 ft.) and the Chesapeake Channel Tunnel (5,450 ft.) were made of prefabricated steel and concrete tube sections (approximately 300 ft. long) sunk in prepared trenches to depths as much as 100 feet below mean low water. A 40 ft. minimum navigational water depth is provided over the tunnels. The tunnel portals are located on four man-made islands of sand and rock in about 40 ft. of water. The North Channel Bridge is 3,795 ft.

long and is fabricated of sixteen steel girder spans and one steel truss span. The truss span provides a navigational opening 300 ft. wide and 75 ft. high. The piers are reinforced concrete, supported on steel piles. The Fisherman Inlet Bridge is 465 ft. long, and consists of three steel girder spans. The center span of 175 ft. provides 40 ft. of vertical navigational clearance. The supports here are prestressed concrete piles. An added feature is the Sea Gull fishing pier, projecting 625 ft. off the south Thimble Shoal island. The entire project is incomparable in magnitude, and was given the "Outstanding Achievement Award for 1964" by the Consulting Engineers Council and the "Outstanding Engineering Achievement" by the ASCE in 1965. Three and a half years in the building, it is considered to be one of the seven wonders of the modern world.

Figure 42A. Overall plan of Bridge-Tunnel between Virginia Beach and Northampton County.

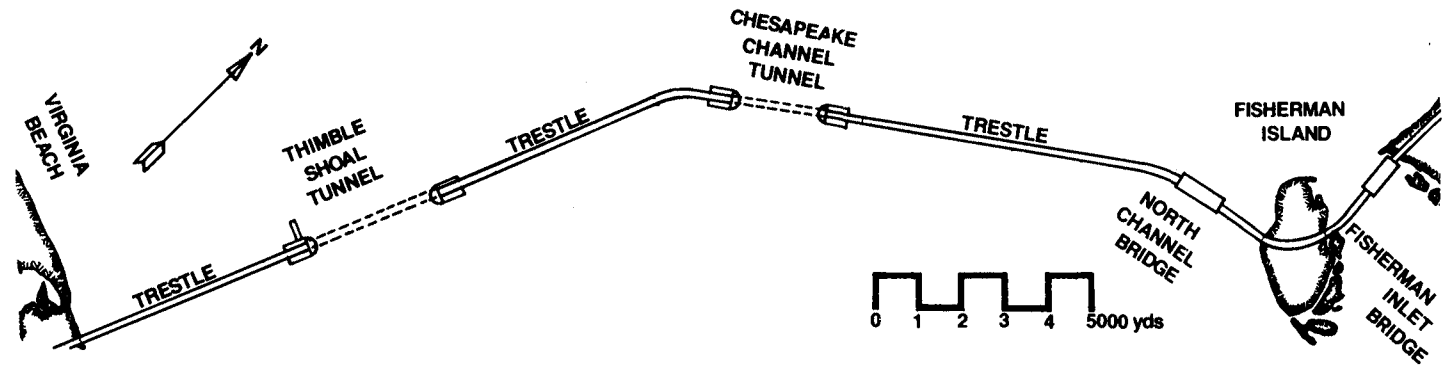
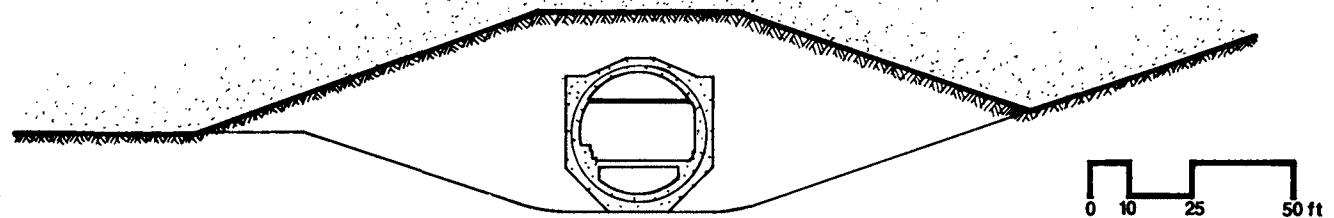

Figure 42B. Cross section through the Thimble Shoal Tunnel. (The Chesapeake Channel Tunnel is similar.) Note the protective covering of sand and rock over the tunnel.



INGLES FERRY BRIDGES

Type of Structure: Twin multiple span bridges

Roadway: 29 feet (each)

Location: Rte 81 over New River in Montgomery
County

Designers: Harrington and Cortelyou

Date of Completion: 1965

Prime Builder: Bowers Construction Co.

Overall Length: 1,658 feet (southbound)
1,600 feet (northbound)

Approximate Cost: \$1,735,000

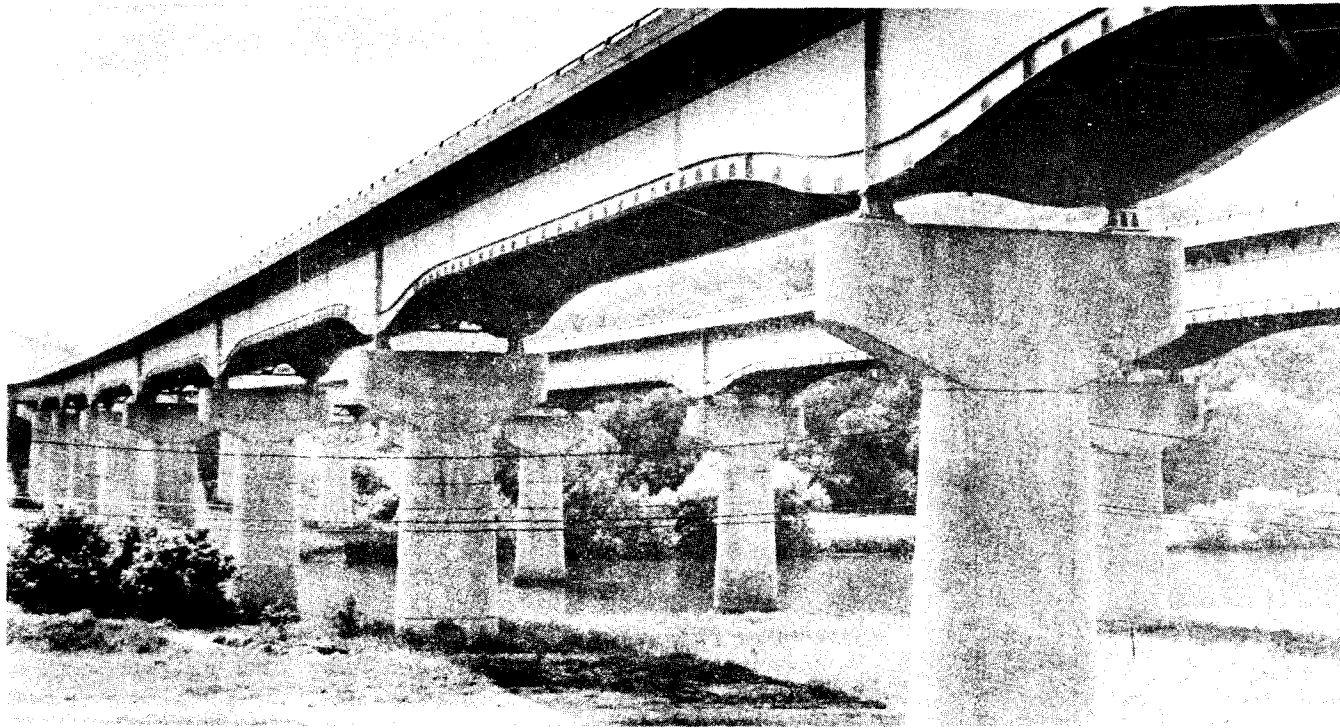

Figure 43. Interstate crossing of New River. The girders are deeper at the supports as the bending forces are greater there.

Called the Ingles Ferry Bridge after an old ferry crossing at nearby Fort Ingles, the structures consist of separate north- and southbound bridges, each with 10 spans of welded plate girders. The spans are continuous, except at the center and end piers. The spans range in length from 133 to 176 feet, and 65 feet of vertical clearance is provided above mean high water.

The piers are of reinforced concrete and rest on spread footings.

The bridges are attractively designed and sited. The wide separation of the twin structures reduces the impact a bridge of this size normally would have on the landscape.

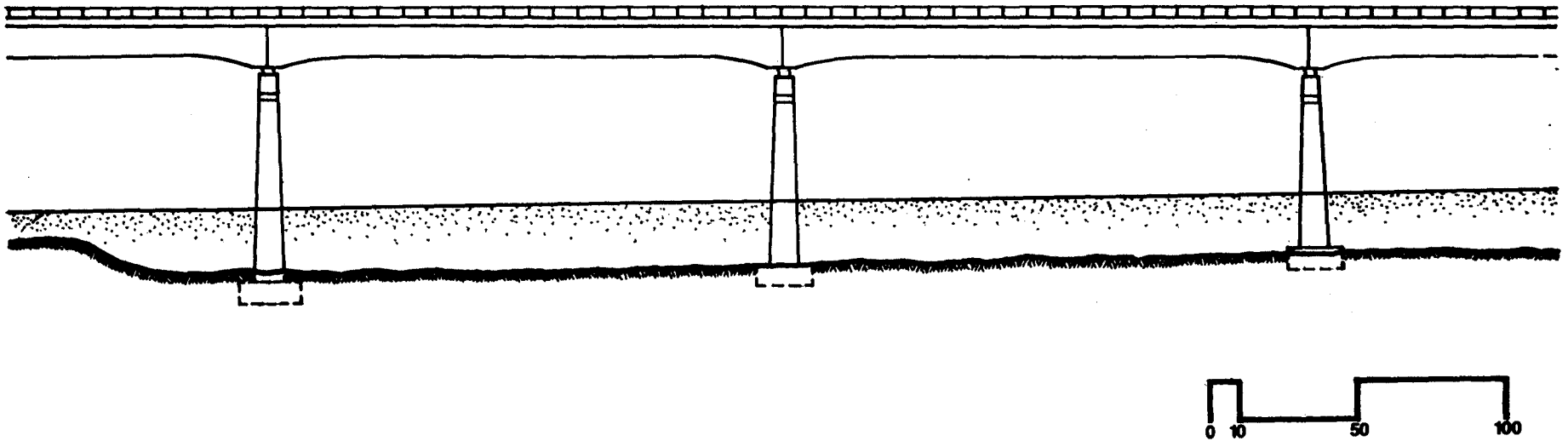

Figure 44. Elevation of a typical portion of the bridge.

FLANNAGAN DAM BRIDGE

Type of Structure: Dam bridge

Roadway: 24 feet

Location: Rte 739 over John W. Flannagan Dam
in Dickenson County

Designers: Tippetts-Abbett-McCarthy-Stratton

Date of Completion: 1966

Prime Builder: Wiley N. Jackson Co.

Overall Length: 292 feet

Approximate Cost: \$100,000

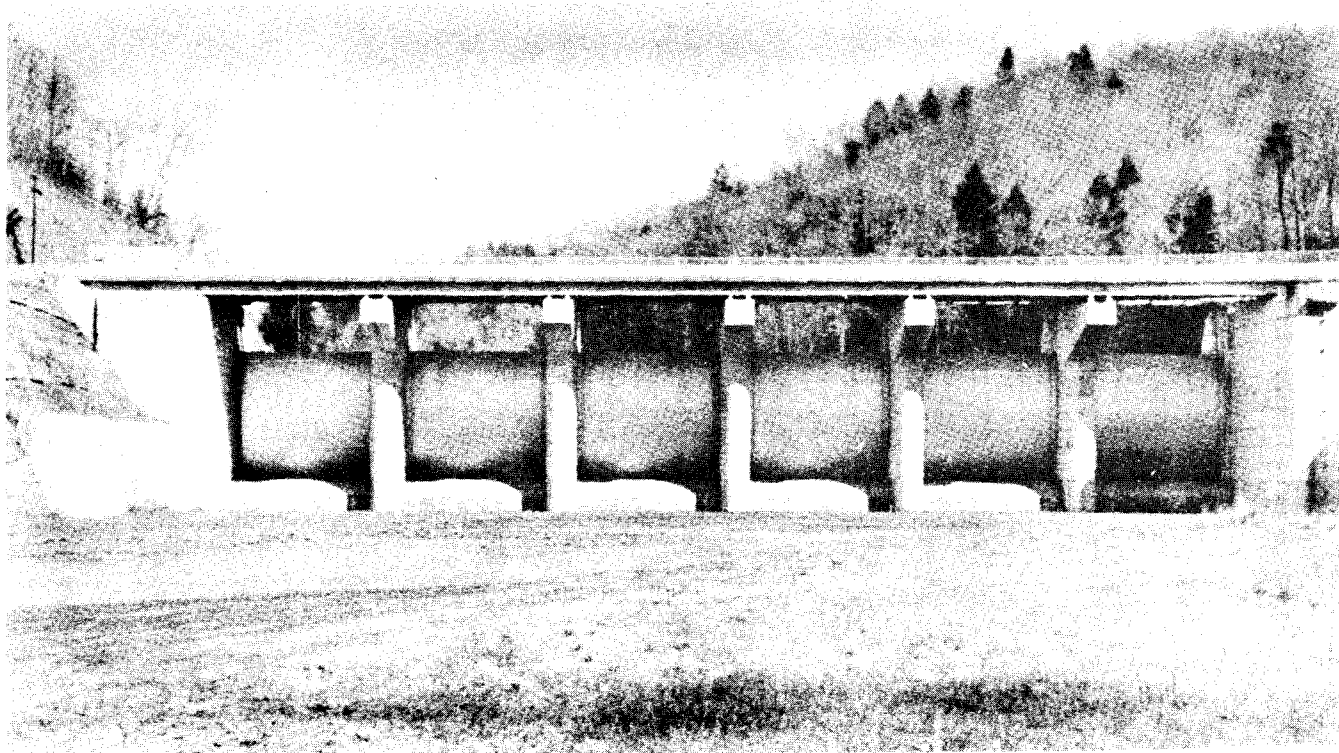

Figure 45. Bridge crossing over the John W. Flannagan Dam
seen from the upstream side.

This unusual bridge is the only one of its kind in Virginia in that the highway bridge is built as part of a dam. The superstructure is cast-in-place reinforced concrete with two 46-foot and four 50-foot spans atop the dam. The reinforced concrete piers supporting the bridge also support the movable

(Tainter) gates of the spillway. The solid piers rest on rock, approximately 25 feet below ground.

The complex of bridge, dam, and reservoir was constructed for the U. S. Army Corps of Engineers as a flood control project in that mountainous region.

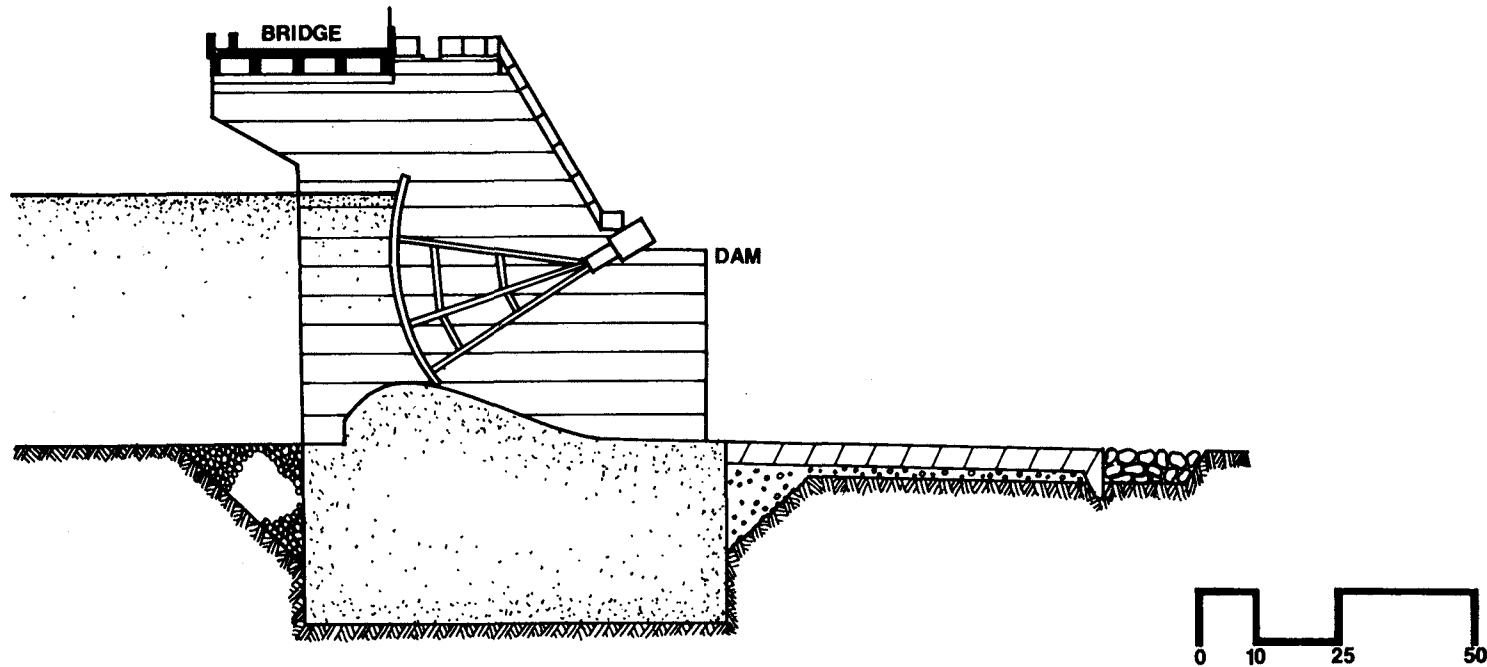

Figure 46. Cross section through the bridge and dam, with the bridge portion shown in the upper left corner.

BENJAMIN HARRISON MEMORIAL BRIDGE

Type of Structure: Lift span bridge

Roadway: 26 feet

Location: Rte 156 over James River between
Prince George and Charles City
Counties

Designers: Hardesty and Hanover

Prime Builders: T. A. Loving Co. and
Bethlehem Steel Corp.

Date of Completion: 1967

Overall Length: 4,463 feet

Approximate Cost: \$5,500,000

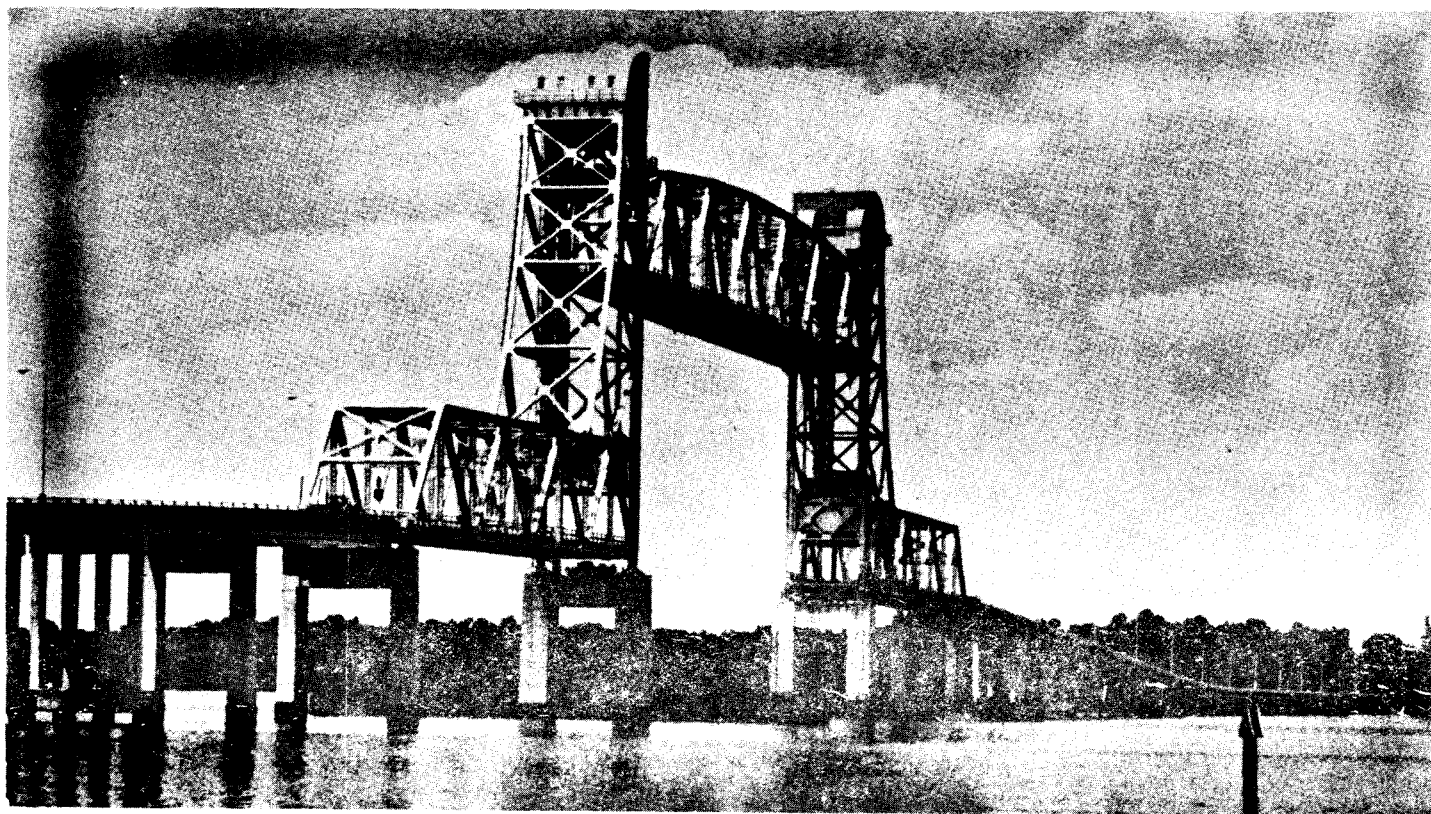

Figure 47. The Benjamin Harrison Memorial Bridge seen in raised position.

"The rise and fall of the Benjamin Harrison Memorial Bridge" might be an apt heading for describing this structure. The major portion of the bridge is a 356 foot long steel lift span truss that rides up and down on flanking steel truss towers to provide a vertical navigational clearance of 50 feet closed and 145 feet open. On each side of the lift spans are truss spans each 241 feet long, joined to the towers. Adjacent to the fixed truss spans are single-span 114 foot long steel girders.

The remaining forty-three approach spans from the north and eighteen approach spans from

the south are prestressed concrete beams ranging in length from 54 to 70 feet. All piers are concrete and rest on piles driven into the river bed.

On February 24, 1977, a tanker rammed into the pier supporting the north fixed truss and girder, eventually causing the collapse of the pier, girder, truss, north tower and lift span. Repairs to this important bridge named after a former governor of Virginia and president of the United States are expected to be completed in 1979 at a cost of about \$4 million.

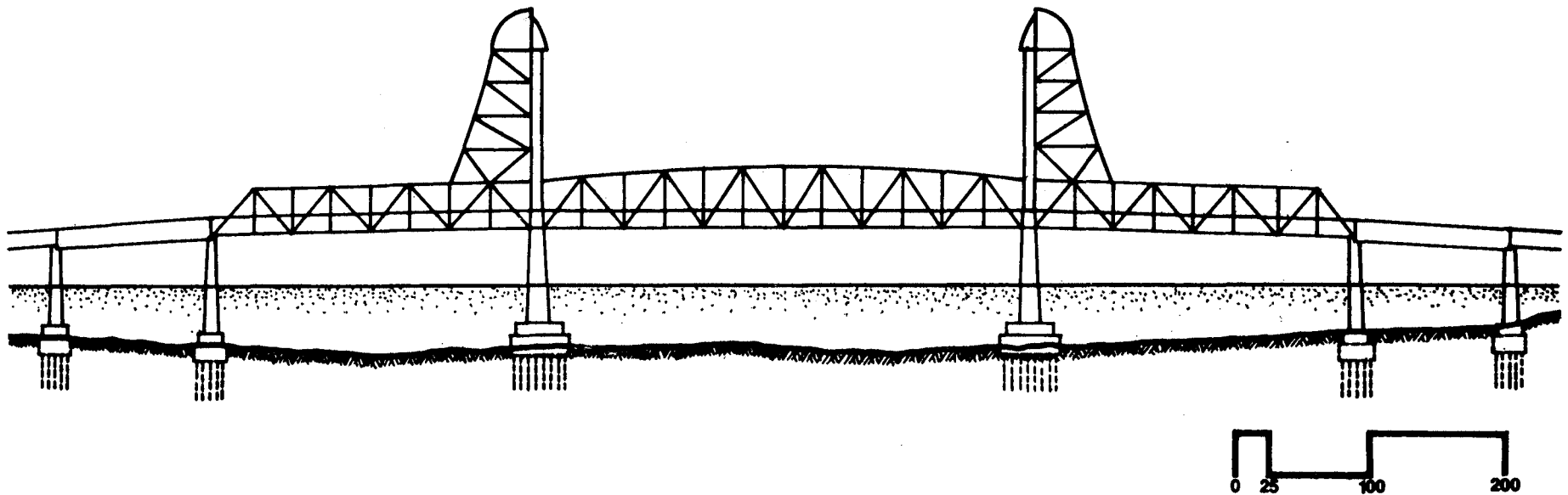

Figure 48. Elevation of the lift bridge in closed position.

JAMES RIVER BRIDGE

Type of Structure: Multiple span bridge
Location: Rte 501 over James River between
Amherst and Bedford Counties
Date of Completion: 1968
Overall Length: 656 feet

Roadway: 24 feet
Designer: R. W. Schwartz
Prime Builder: Thomas M. Nunnally Co.
Approximate Cost: \$419,000

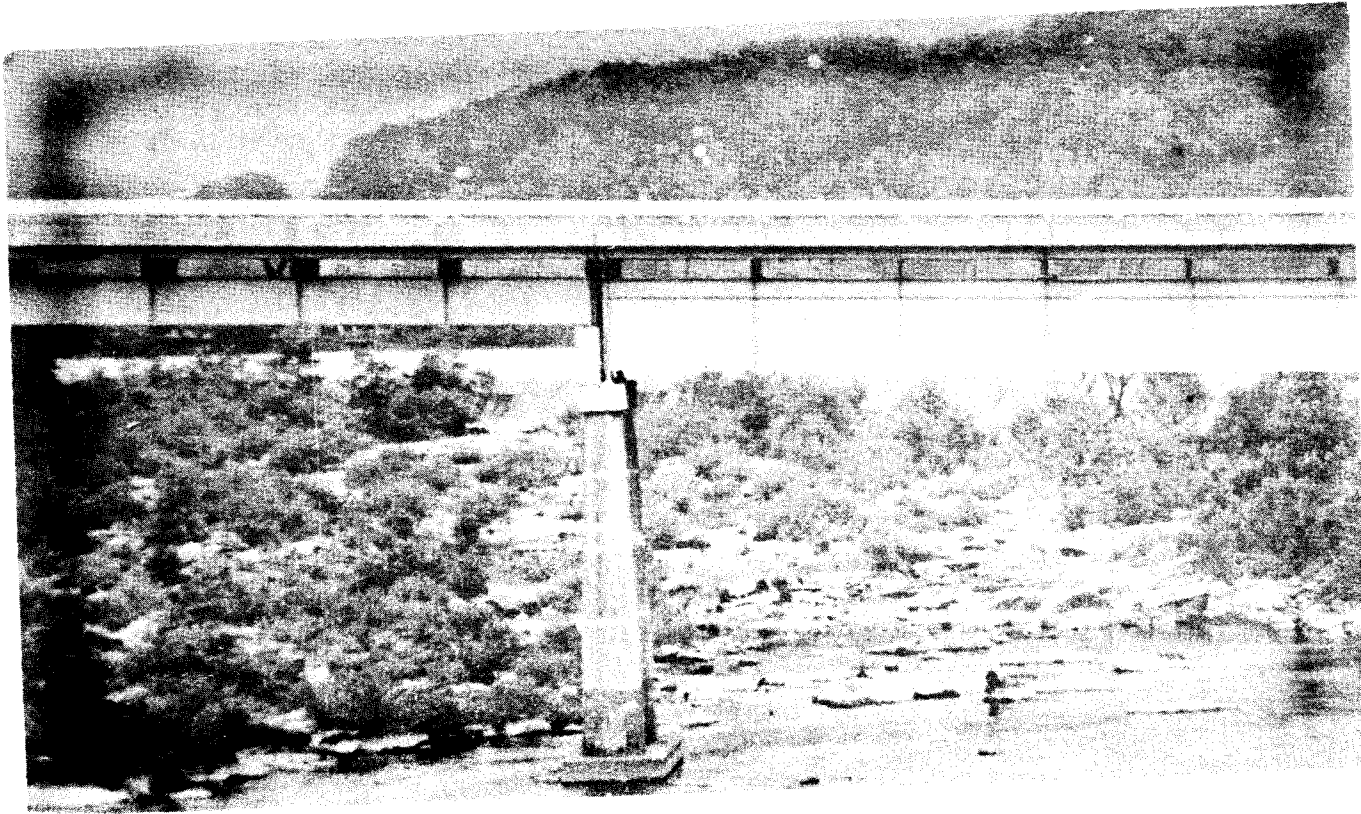

Figure 49. Portion of the unusual "see-through" bridge, with the deck lifted off the support girders.

Located in a very scenic valley, this bridge sits awkwardly across the river, but in an unusual way. The northern half of the structure consists of two deep steel girder spans of 159 feet each, while the southern half consists of three shallow steel girders ranging in length from 80 to 92 feet. Even more unusual are the transverse steel beams supporting the roadway, which rest on top of

the girders, giving the bridge a "see-through" appearance.

The piers are reinforced concrete resting directly on rock at the river bottom.

In part, the odd design of the bridge is because of the several extensive modifications to the original bridge built in 1921.

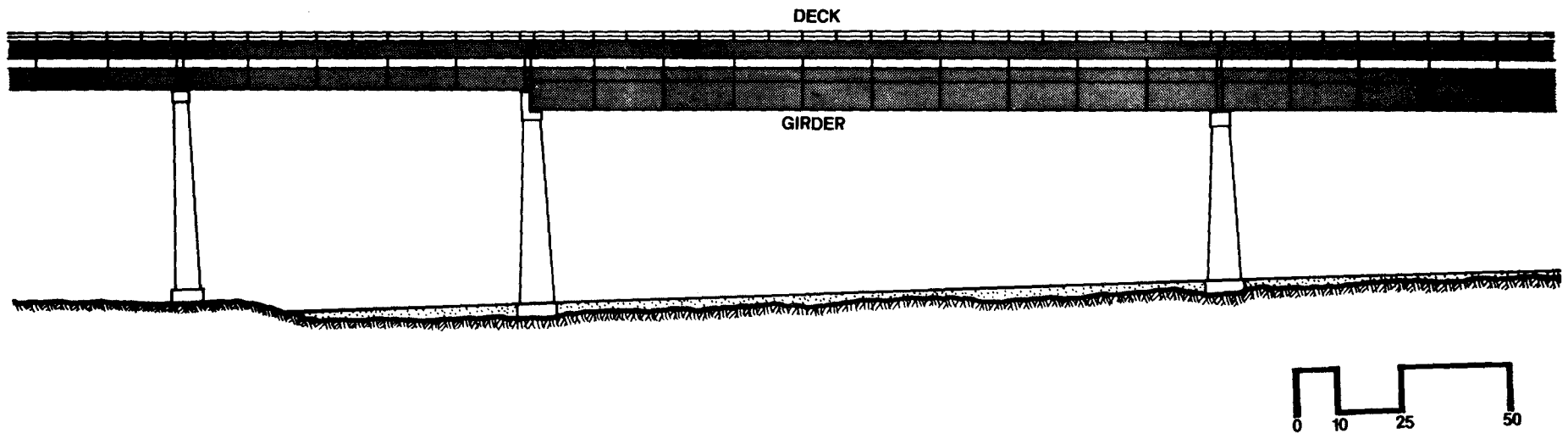

Figure 50. Elevation of part of the structure. Steel beams, placed transversely, separate the roadway from the longitudinal girders.

SLANT-LEG BRIDGES

Type of Structure: Twin rigid frame bridges

Location: Rte 64 over Rte 250 in Albemarle
County

Date of Completion: 1969

Overall Length: 219 feet

Roadway: 39 feet (each)

Designers: Hayes, Seay, Mattern & Mattern

Prime Builder: Moore Bros. Co.

Approximate Cost: \$272,000

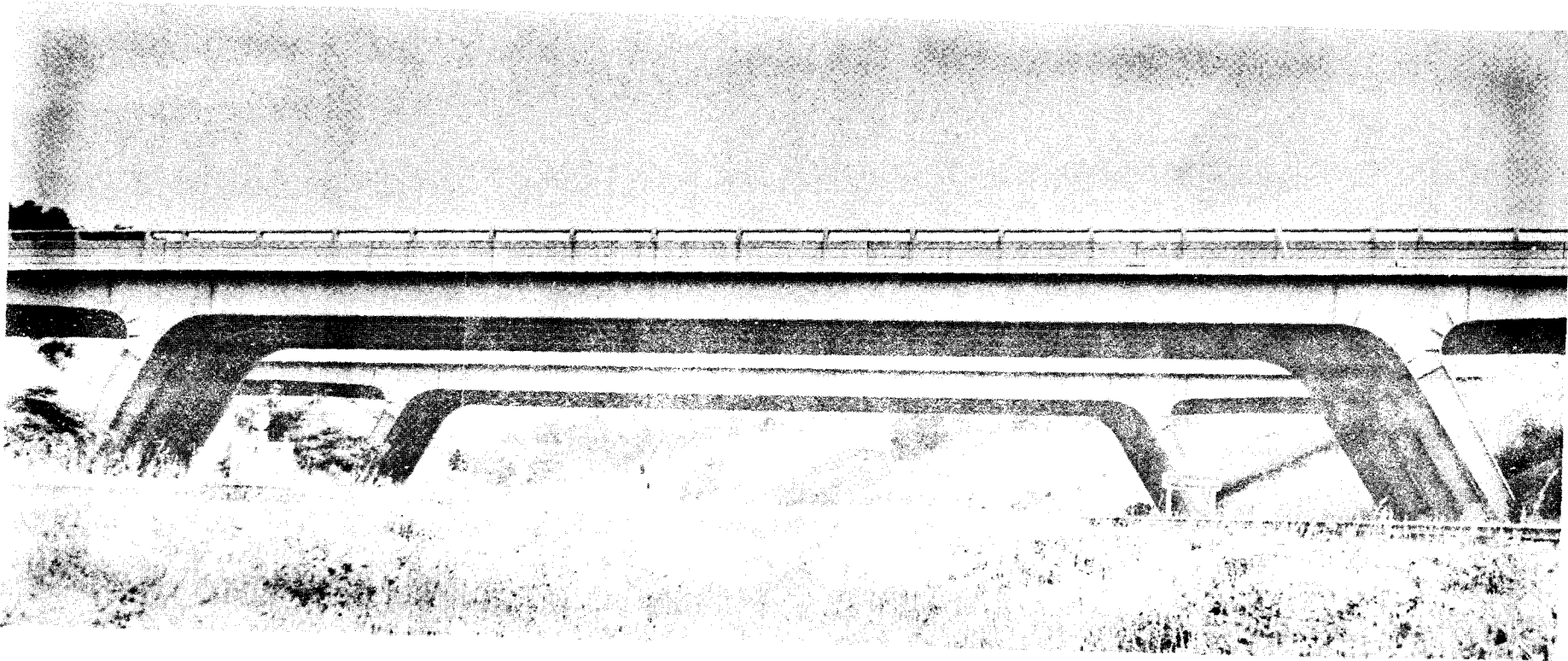

Figure 51. Twin slant-leg bridges on Rte 64.

These adjacent bridges are the first slant-leg, steel rigid frame highway structures constructed in Virginia. Through welded connections between the legs and the horizontal spanning beams, the depth of the beams is reduced. The horizontal distance between the bases of the legs is 137 feet, which provides ample pier-free clearance across a four-lane undivided highway. The bridges are on a 15-degree skew and a slight grade.

Because of the uniqueness of the design, special attention was paid to both the engineering analysis and esthetics of these bridges. As a result, these handsome structures were given the top award for innovative engineering projects in Virginia by the Consulting Engineers Council of Virginia in 1970.

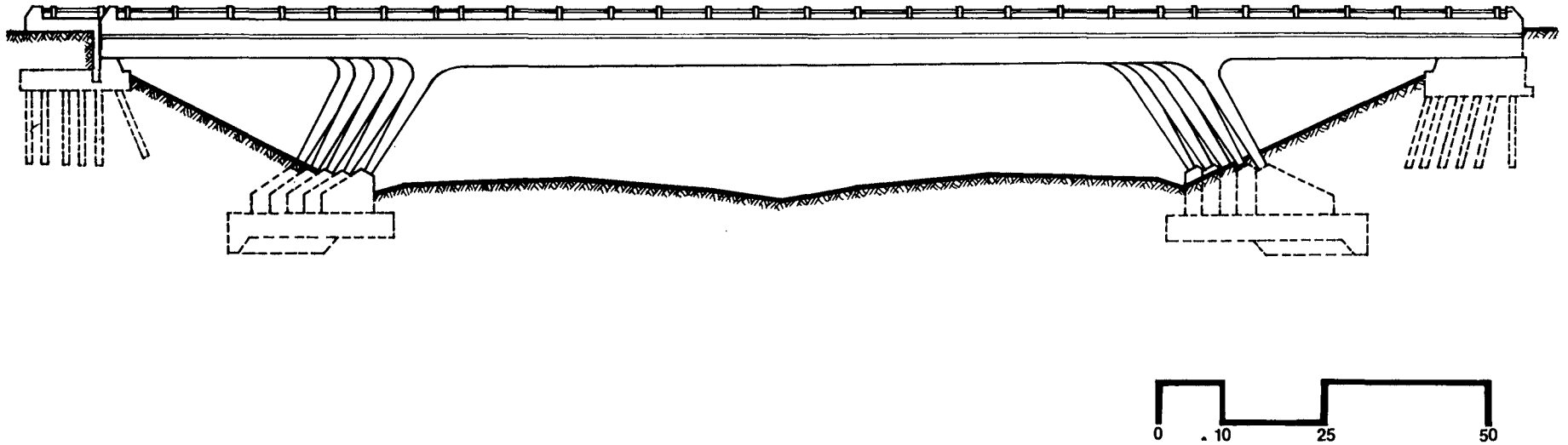

Figure 52. Elevation of bridge. Note specially shaped foundations at legs to resist horizontal forces.

ELIZABETH RIVER BRIDGE

Type of Structure: Double-leaf bascule bridge

Roadway: 62 feet

Location: Rte 64 over Southern Branch of
Elizabeth River in the city of
Chesapeake

Designers: Hayes, Seay, Mattern & Mattern
(with J. E. Greiner, Co.)

Date of Completion: 1969

Prime Builders: Diamond Construction Co.

Overall Length: 4,825 feet

Approximate Cost: \$9,617,000

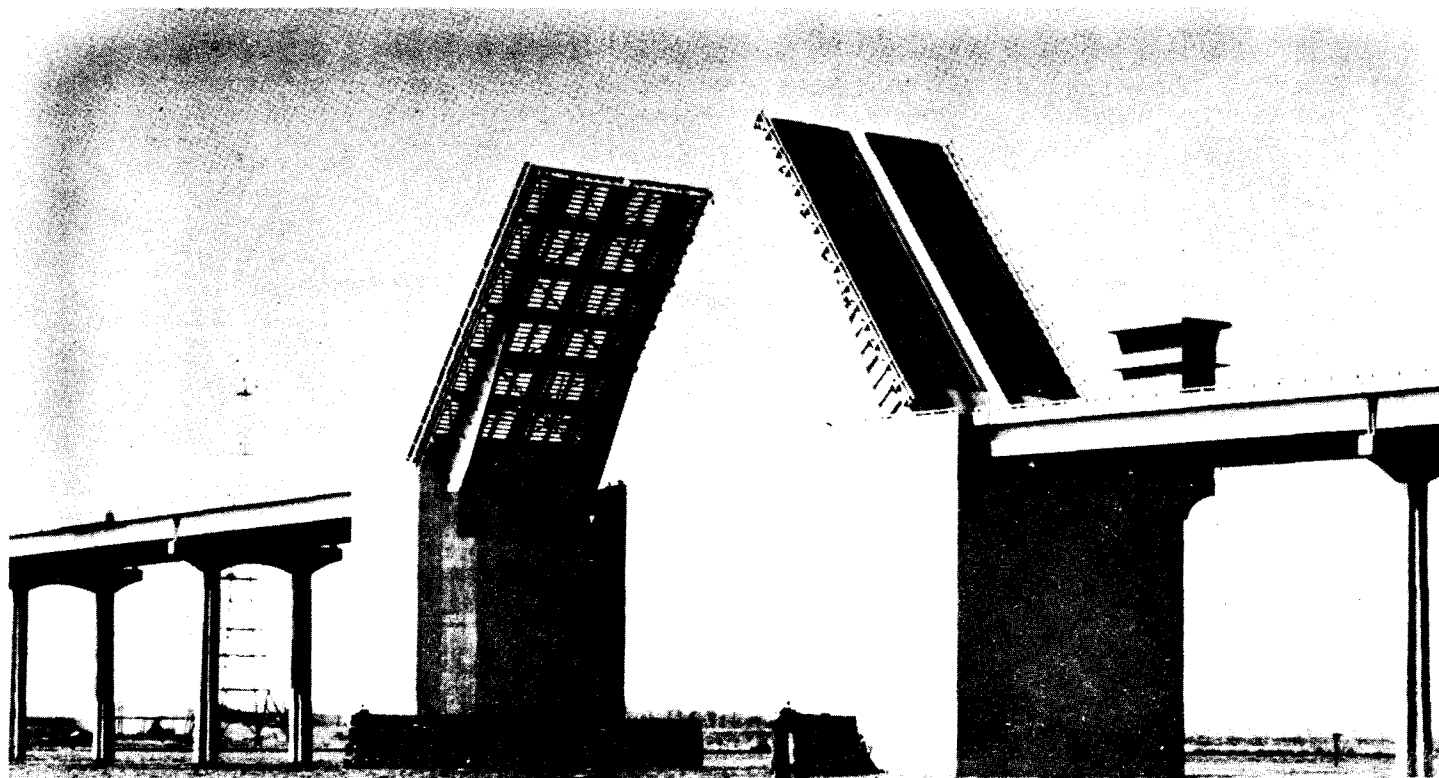

Figure 53. Double-leaf bascule bridge in open position.

SMITH CREEK BRIDGES

Type of Structure: Twin girder bridges

Roadway: 38 feet (each)

Location: Rte 64 over Smith Creek in the city
of Clifton Forge

Designers: Brockenbrough & Watkins

Date of Completion: 1971

Prime Builder: Paramount Pacific, Inc.

Overall Length: 606 feet (westbound);
609 feet (eastbound)

Approximate Cost: \$1,545,800

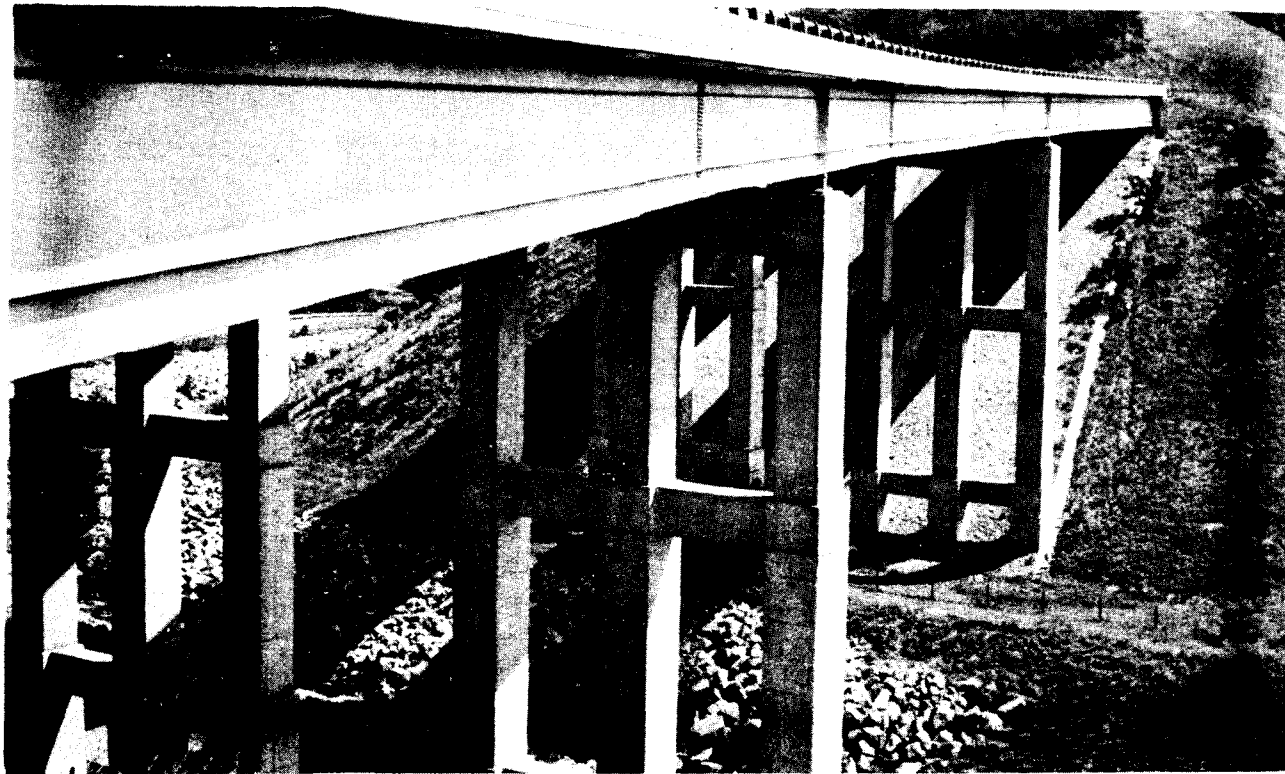

Figure 55. Rte 64 bridge over Smith Creek.

The bridge consists of thirty-nine fixed spans ranging in length from 49 to 146 feet and one movable span 280 feet long. The fixed spans are steel beams on girders supported by relatively slender reinforced concrete piers, which in turn are supported by piles driven into the river bed. The steel double-leaf bascule, or draw, span, when open, provides an unobstructed horizontal clearance of 125 feet. When closed,

the vertical clearance above mean high water is 65 feet. The two large piers supporting the movable span are of reinforced concrete and are supported by clusters of piles.

This structure is the only bridge in the U. S. on the national interstate highway system to have a draw span. In 1970, the bridge won the Award of Merit for Movable Span Bridges of the American Institute of Steel Construction.

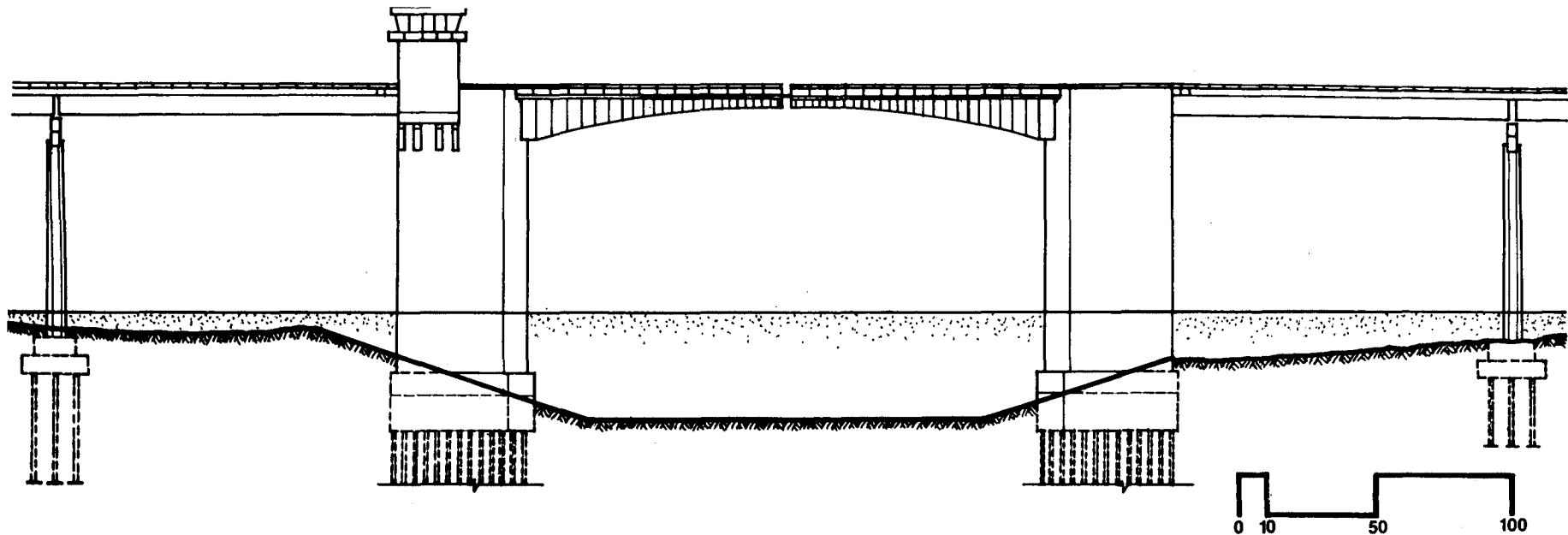

Figure 54. Elevation of movable portion of the bridge shown in closed position.

These bridges span a deep ravine, which necessitates reinforced concrete piers about 100 feet tall, resting on rock. The superstructure of each bridge consists of three continuous steel girder spans, two of approximately 183 feet, and one of approximately 241 feet. The girder depth is kept to a minimum by use of continuity as well as composite

action between the girders and the deck slab of reinforced concrete.

Although subtly expressed, the roadways are on a vertical grade, a horizontal curve, and at a skew. Overall the visual effect of these twin bridges, located in scenic and mountainous terrain, is rather dramatic. Nearby on Rte 64 over the Jackson River is another pair of scenic bridges similar to these two.

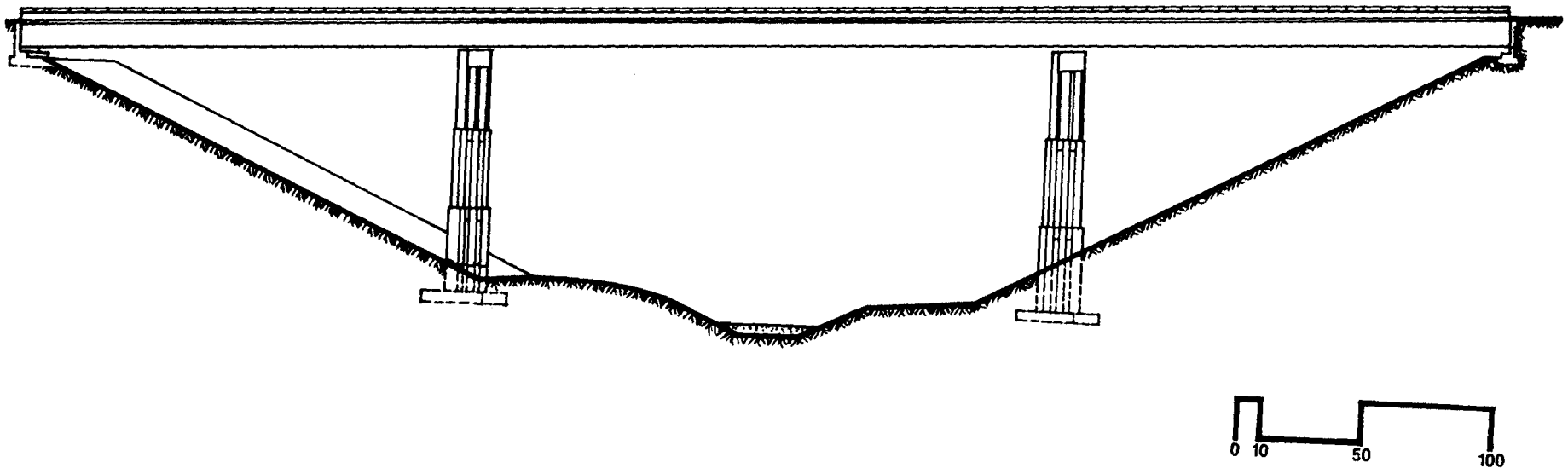

Figure 56. Elevation of structure. Note the unusually tall piers.

CLAYTOR LAKE BRIDGE

Type of Structure: Multiple span bridge

Location: Rte 672 over Claytor Lake in
Pulaski County

Date of Completion: 1972

Overall Length: 1,416 feet

Roadway: 28 feet

Designers: Virginia Department of Highways
and Transportation

Prime Builders: McDowall and Wood, Inc.

Approximate Cost: \$1,249,000

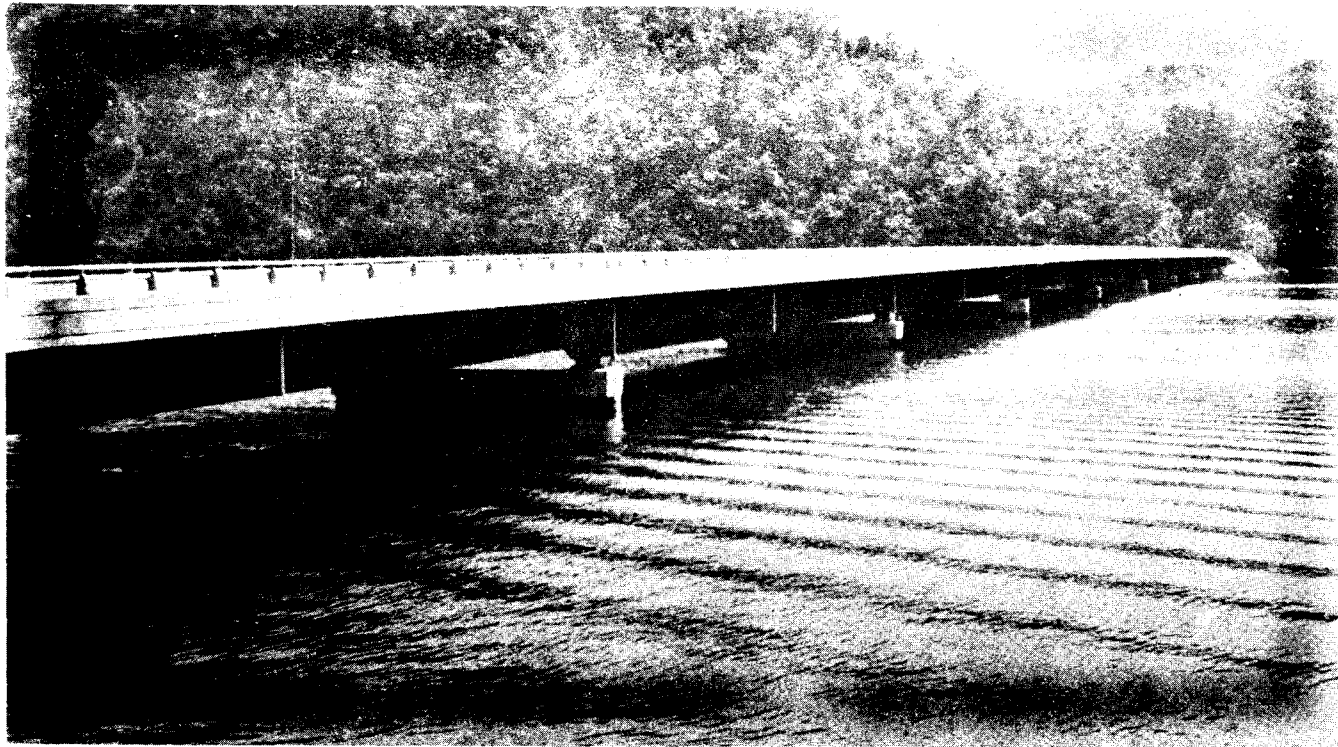

Figure 57. Bridge across Claytor Lake. The tall piers are shown submerged.

The construction of this bridge was somewhat novel. Prior to damming of the man-made lake, the piers of reinforced concrete were built "in the dry". The piers rest directly on rock very close to the surface of the ground. After the lake was flooded, the steel girder superstructure spans were floated out to the piers on barges and placed in position. There are eleven spans ranging in length from 64 to 157 feet. The girders are made of rust

inhibiting "weathering" steel which does not need painting. The natural dark iron oxide coloring contrasts attractively with the light color of the concrete parapet.

The bridge appears almost to float on the surface of the lake, although the submerged piers are about 70 feet high. The vertical clearance of 7 feet is only enough for small boats.

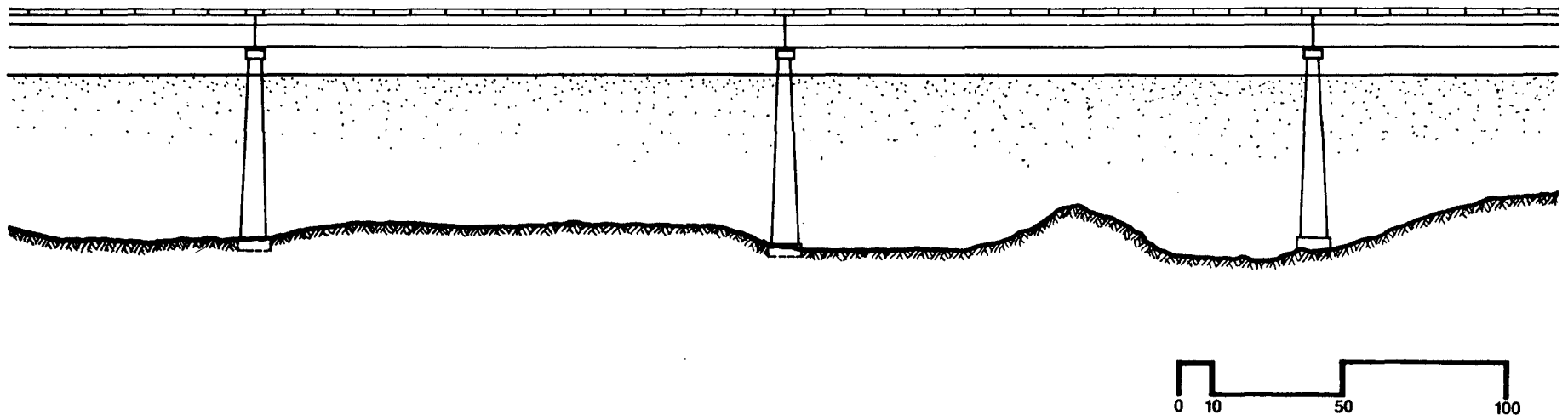

Figure 58. Typical portion of the elevation of the bridge.

SHIRLINGTON CIRCLE PEDESTRIAN BRIDGE

Type of Structure: Pedestrian bridge
Location: Over Rte 95 at Shirlington Circle
between cities of Arlington and
Alexandria
Date of Completion: 1973
Overall Length: 1,082 feet

Pathway: 10 feet
Designers: Howard, Needles, Tammen &
Bergendoff
Prime Builder: Majac Co.
Approximate Cost: \$554,300

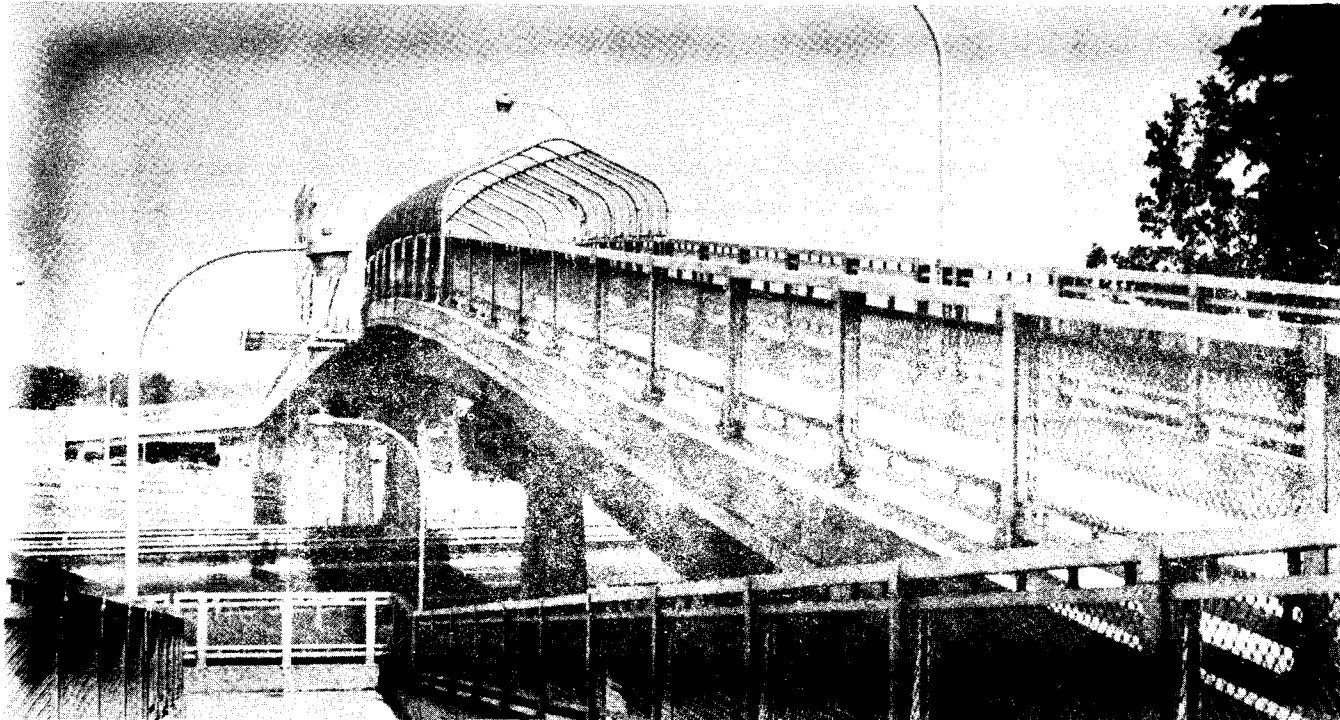

Figure 59. Pedestrian bridge across the heavily trafficked Rte 95. Overhead wire screening is for the protection of motorists below against objects thrown from the bridge.

This pedestrian and bicycle bridge is the largest and most expensive in the state. Built for the Department of Highways and Transportation, it spans six separate heavily used roadways and connects a large apartment complex on the east and a shopping center on the west. There is a U-shaped ramp on the east side and

an L-shaped ramp on the west. Crossing the highway are eight steel beam spans ranging in length from 70 to 129 feet. The piers are of reinforced concrete and are supported by piles. A 30-foot vertical clearance is provided over Rte 95. For safety, high chain link fence railings guard the pathway.

Figure 60A. Plan of ramp at east end.

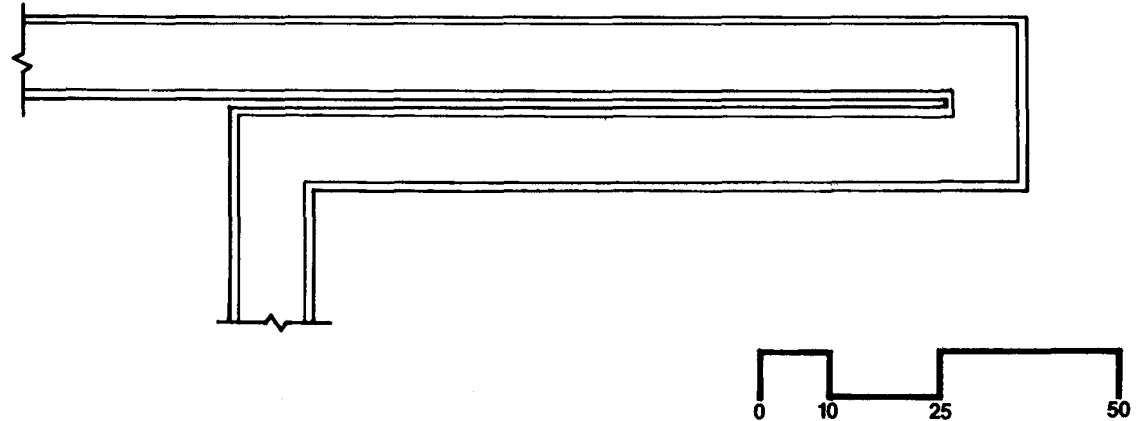
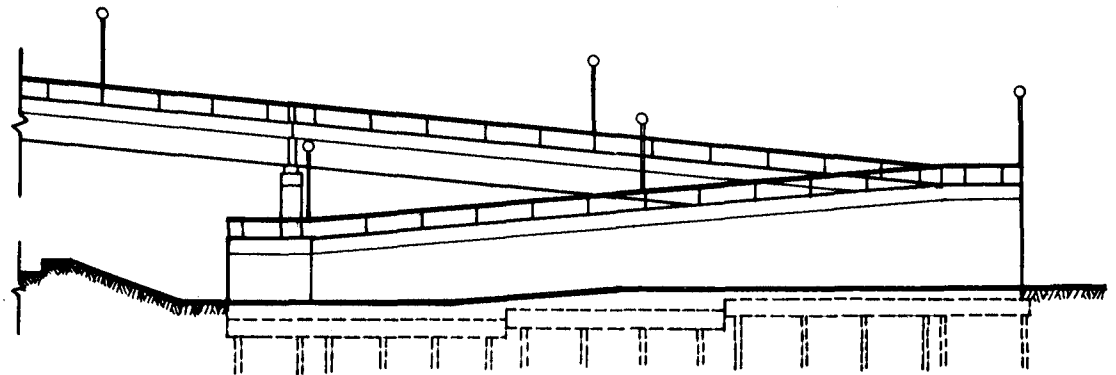

Figure 60B. Elevation of ramp at east end.



BIG WALKER MOUNTAIN TUNNELS

Type of Structure: Twin underground tunnels

Roadway: 26 feet (each)

Location: Rte 77 through Big Walker Mountain
in Bland County

Designers: Singstad, Kehart, November and
Hurka

Date of Completion: 1973

Prime Builders: C. J. Langenfelder & Son,
Inc. and Raymond International,
Inc.

Overall Length: 4,229 feet

Approximate Cost: \$22,624,000

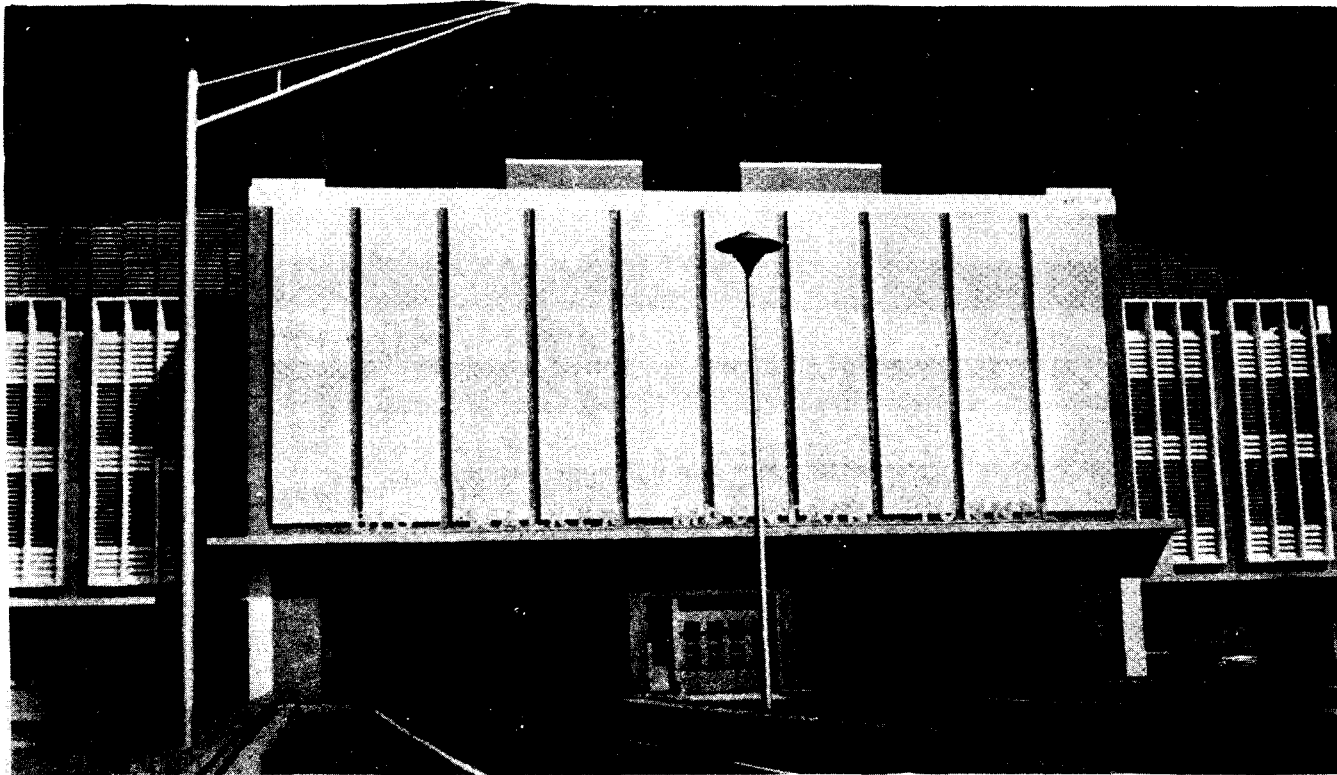

Figure 61. South portal of Big Walker Mountain Tunnel.

The tunnels, over 2,800 feet above sea level, pass 800 feet under the crest of the mountain. The separate east- and westbound tunnels were constructed by removing the rock with a battery of pneumatic drills that took fifteen months to penetrate the mountain. The drilled bores were then lined with over two feet of reinforced concrete. The tunnels

are well ventilated by large air ducts above the roadway. Special ventilation buildings are located at each portal.

Unlike large bridges, these tunnels have little visual impact. Nonetheless, they are dramatic works of engineering.

Figure 62A. Profile of tunnel through Big Walker Mountain.

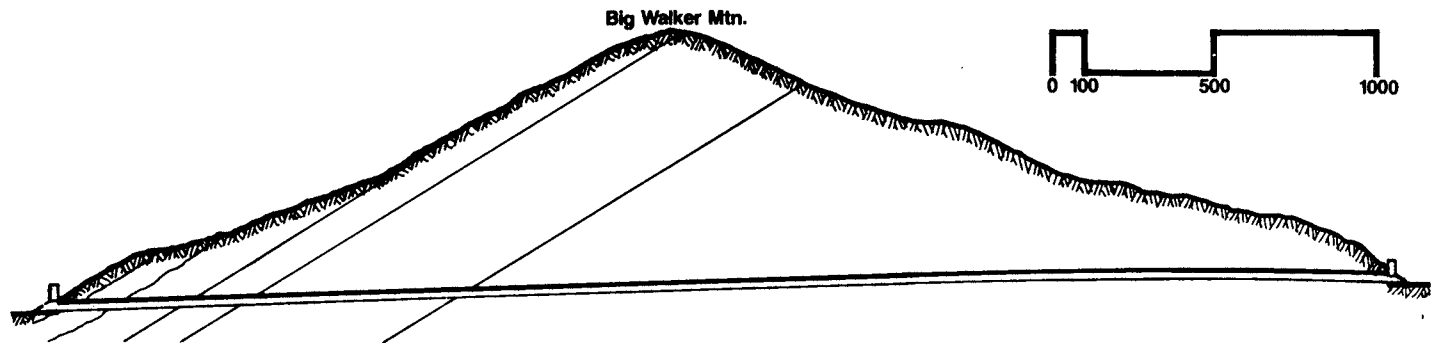
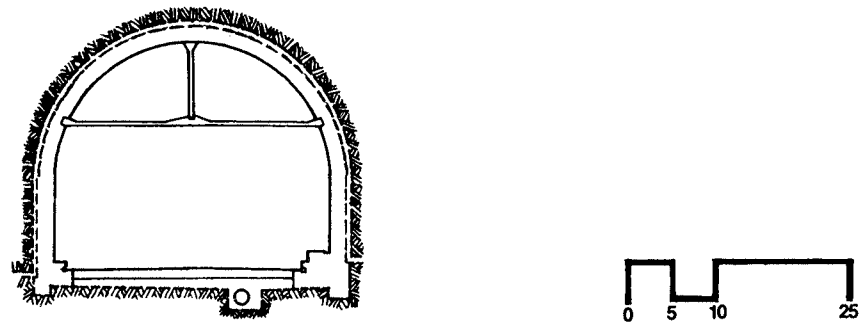

Figure 62B. Cross section through one of the tunnels.



STAUNTON RIVER BRIDGES

Type of Structure: Twin girder bridges

Roadway: 38 feet (each)

Location: Rte 29 (Bypass) over Staunton
(Roanoke) River between Campbell
and Pittsylvania Counties

Designers: American Engineers

Date of Completion: 1973

Prime Builder: English Construction Co.

Overall Length: 545 feet

Approximate Cost: \$1,136,200

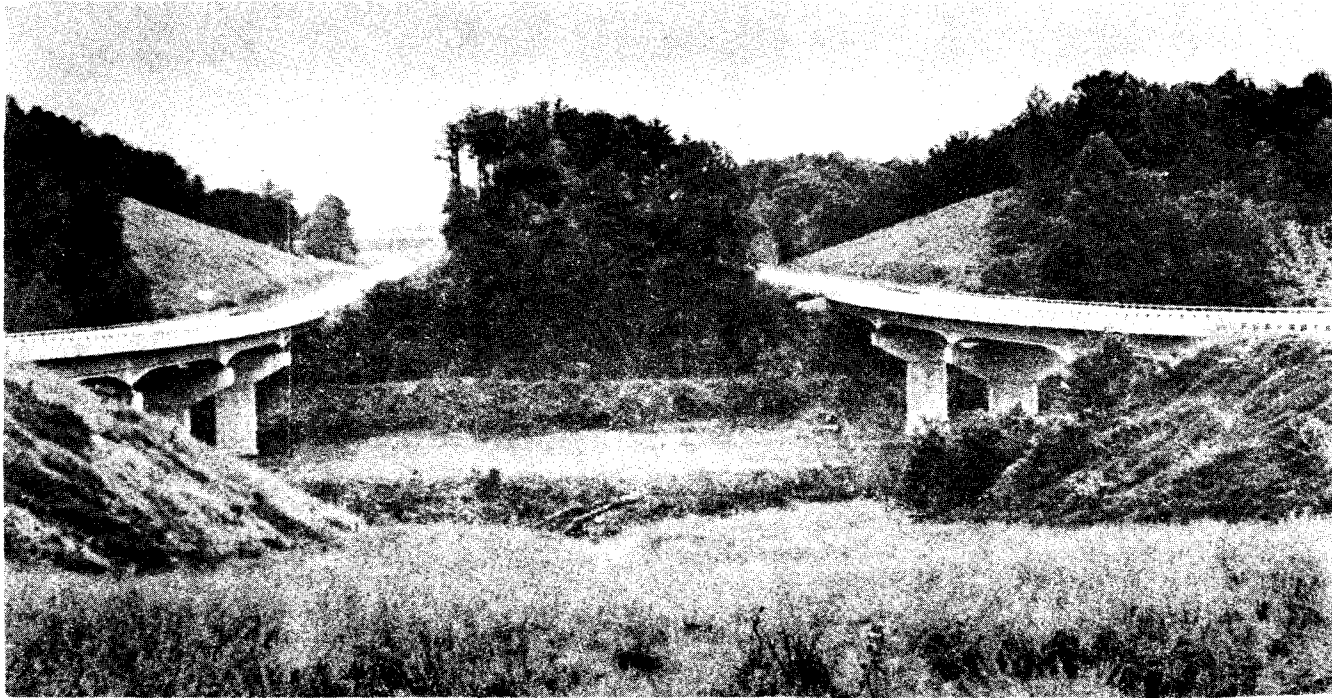

Figure 63. Scenic view of twin bridges on Rte 29. Note the unusual symmetry of the landscape as well as the structures.

These bridges are cleanly and attractively designed as four-span, continuous steel plate girder structures. On both structures, the two center spans are each 148 feet and the two end spans are each 123 feet. Haunches over the piers give the superstructure the suggestion of arches. The piers are well shaped T piers of reinforced concrete resting on spread footings.

The north- and southbound bridges are separated by a distance of several hundred feet, which minimizes the intrusion of the bridge into the rural landscape. Overall these bridges are esthetically well designed and nicely sited.

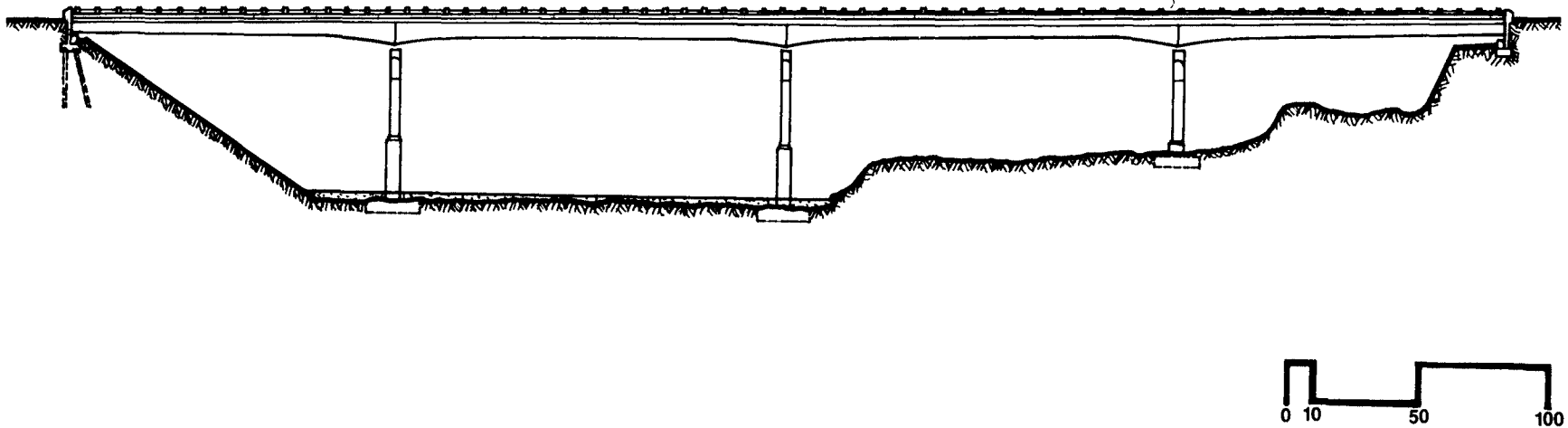

Figure 64. Elevation of the southbound lane bridge. The northbound lane bridge is similar.

MANCHESTER BRIDGE

Type of Structure: Multiple span bridge

Location: 9th Street over James River in
city of Richmond

Date of Completion: 1973

Overall Length: 2,906 feet

Roadway: 110 feet (with 14-foot median)

Designers: Howard, Needles, Tammen &
Bergendoff

Prime Builders: Saltsman Construction Co.,
Central Contracting Co., and
Robert A. Smith, Inc.

Approximate Cost: \$17,700,000

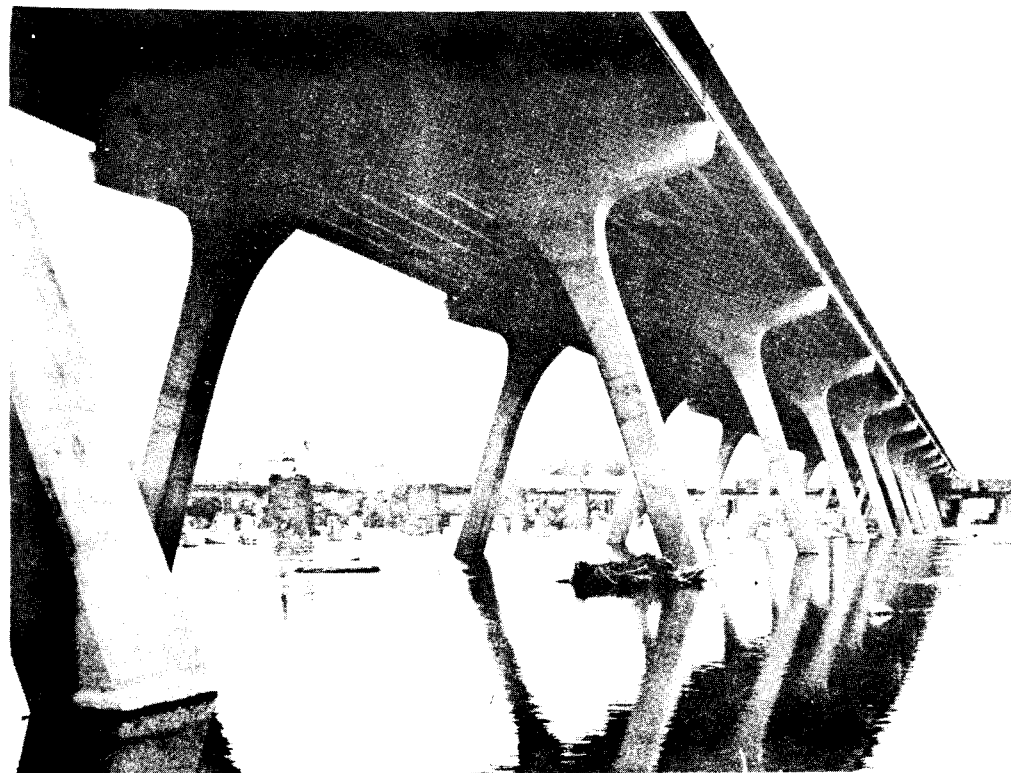

Figure 65. Manchester Bridge in Richmond,
looking north.

Locally known as the Manchester Bridge, (after the section of Richmond called Manchester and served by the bridge), this structure replaced an old bridge built in 1873. As early as 1913, planning was under way for a replacement bridge. However, due to a succession of problems, the replacement bridge was not to be built until 60 years later.

This unusually wide structure consists of twenty-two spans ranging in length from 94 to 153 feet and made of steel plate girders. The piers are relatively thin, gracefully shaped

arch frames of reinforced concrete, supported on rock at the bed of the river. At its highest point, the bridge stands 110 feet above the water. The raised median is unusual in that it serves the purposes of dividing traffic, and providing a pedestrian walkway and a bay for utilities.

The bridge is both a functional and esthetic asset to the city.

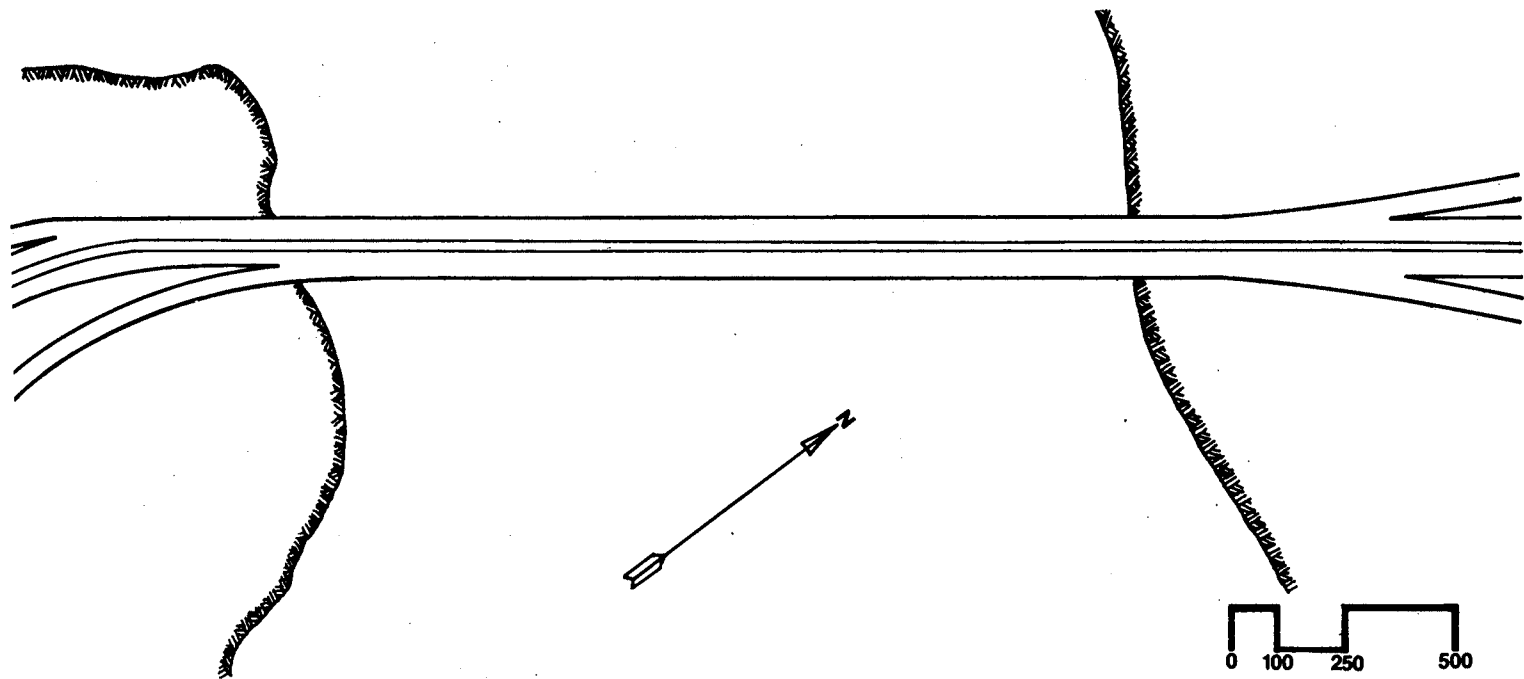

Figure 66. Overall plan of bridge crossing James River.

MIXING BOWL

Type of Structure: Multiplex of twenty-three bridges

Roadways: 34 to 100 feet

Location: Along Rte 95 in Arlington County

Designers: Howard, Needles, Tammen & Bergendoff

Date of Completion: 1974

Prime Builders: Shirley Constructors

Overall Length of Project: 1.08 miles

Approximate Cost: \$51,500,000 (including connecting roadwork)

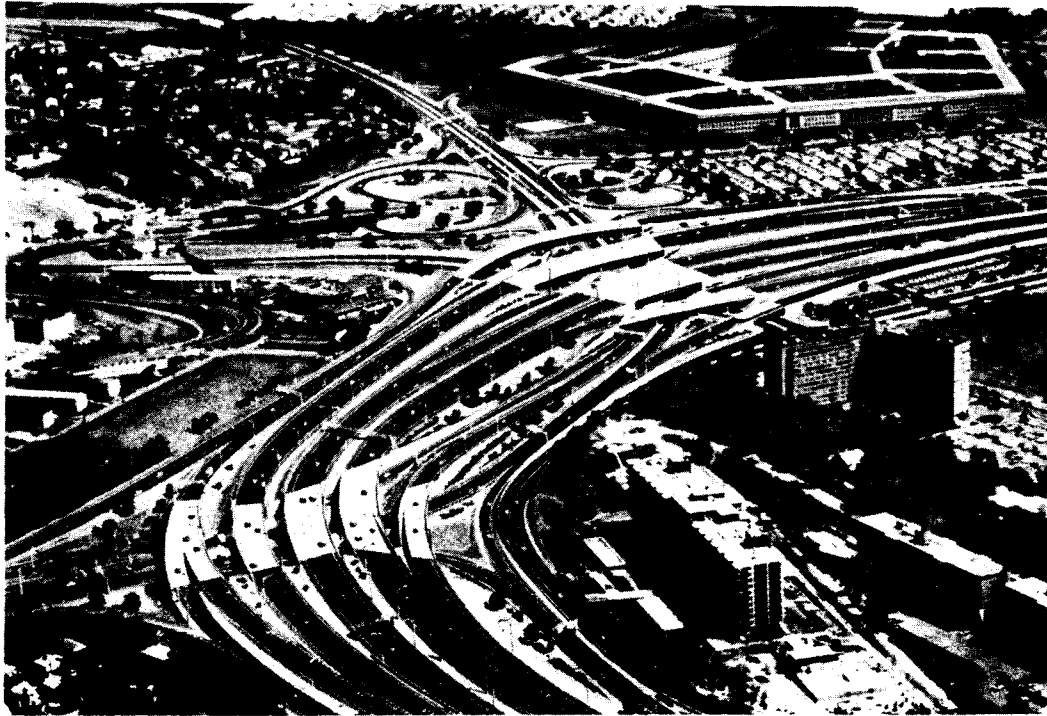

Figure 67. Aerial view of the "Mixing Bowl" interchange near the Pentagon.

Known as the "Mixing Bowl" because of the interlacing of numerous highways, roads, and ramps, this complex of bridges represents a remarkable engineering accomplishment. As the construction time extended over four years, much of the building had to be done while maintaining a heavy volume of vehicular traffic in a congested area. The bridges have a variety of skews, horizontal and vertical curves, grades, and superelevations. Seven

involve three-level crossings. The bridges are all of steel beams or girders with reinforced concrete piers and abutments supported by piles.

This section of construction on the Henry G. Shirley Memorial Highway stands as the most expensive mile of bridges in the state.

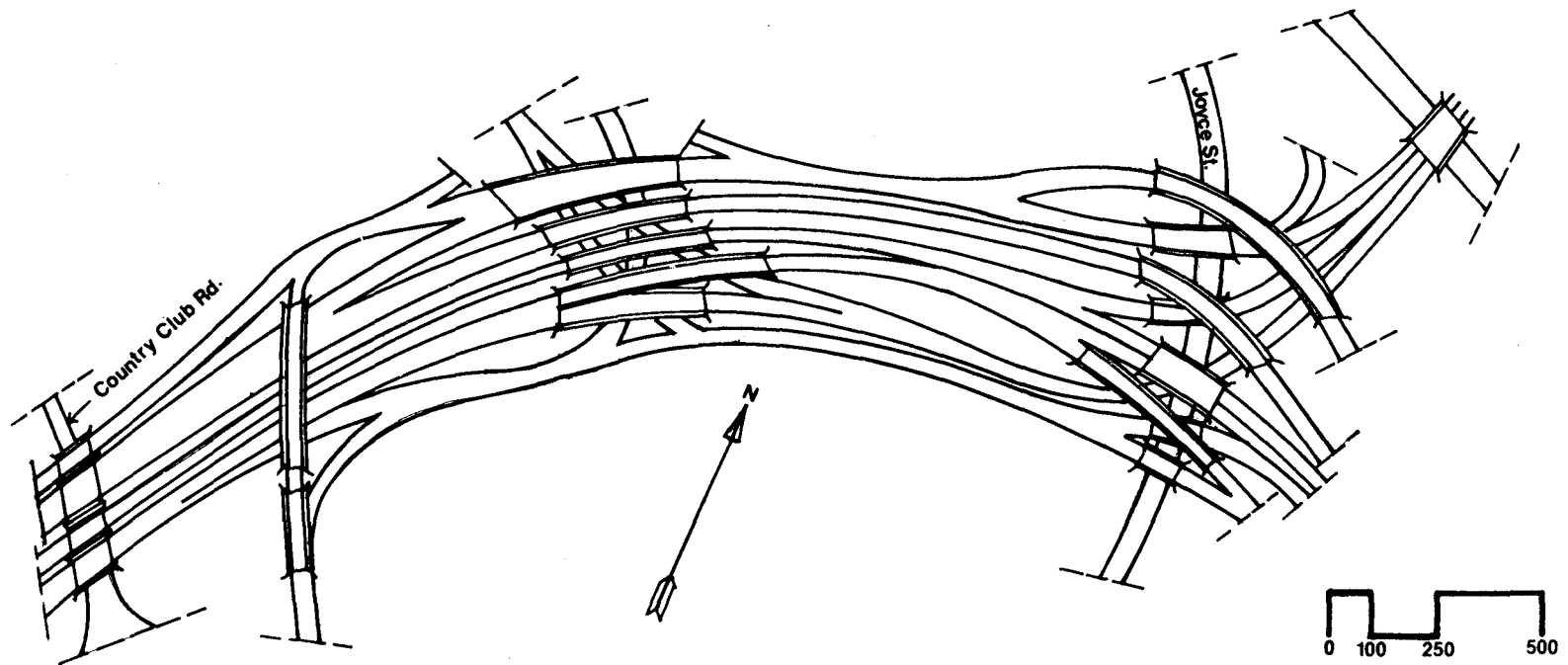

Figure 68. General plan of the complex of bridges and ramps.

CARTERSVILLE BRIDGE

Type of Structure: Steel bridge, with remains
of old timber bridge

Roadway: 34 feet

Location: Rte 45 over James River between
Goochland and Cumberland Counties

Designers: Virginia Department of Highways
and Transportation

Date of Completion: 1974

Prime Builder: W. W. Warsing Construction Co.

Overall Length: 944 feet

Approximate Cost: \$929,000



Figure 69. The new Cartersville Bridge in the background, with the remains of the old bridge in the foreground.

The steel bridge is a plate girder structure of eight equal 118-foot spans supported by reinforced concrete piers. The piers rest directly on rock at the bed of the James River. Although a generally attractive bridge, it is notable for being adjacent to the remnants of an early timber truss bridge constructed around 1886, and called the Cartersville

Bridge because of its proximity to the city of Cartersville. The piers of the timber bridge are of heavy stone construction. The timber bridge remained in service until 1972, when several spans were destroyed in a flood. The two end spans of the old bridge are preserved at their original locations for historical interest.

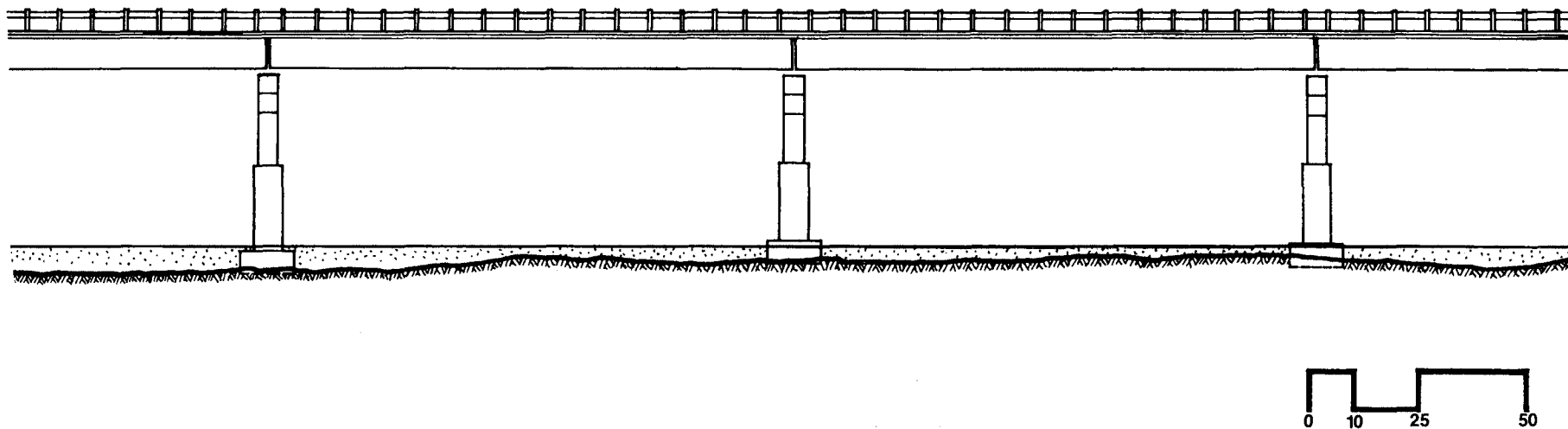

Figure 70. Portion of the elevation of the steel bridge.

COLISEUM MALL FLYOVER

Type of Structure: Flyover bridge
Location: Ramp over Rte 258 and Coliseum
Drive (near Rte 64) in the city of
Hampton
Date of Completion: 1974
Overall Length: 576 feet

Roadway: 18 feet
Designers: Wilbur Smith and Associates
Prime Builders: Luke Construction Co.
Approximate Cost: \$527,600

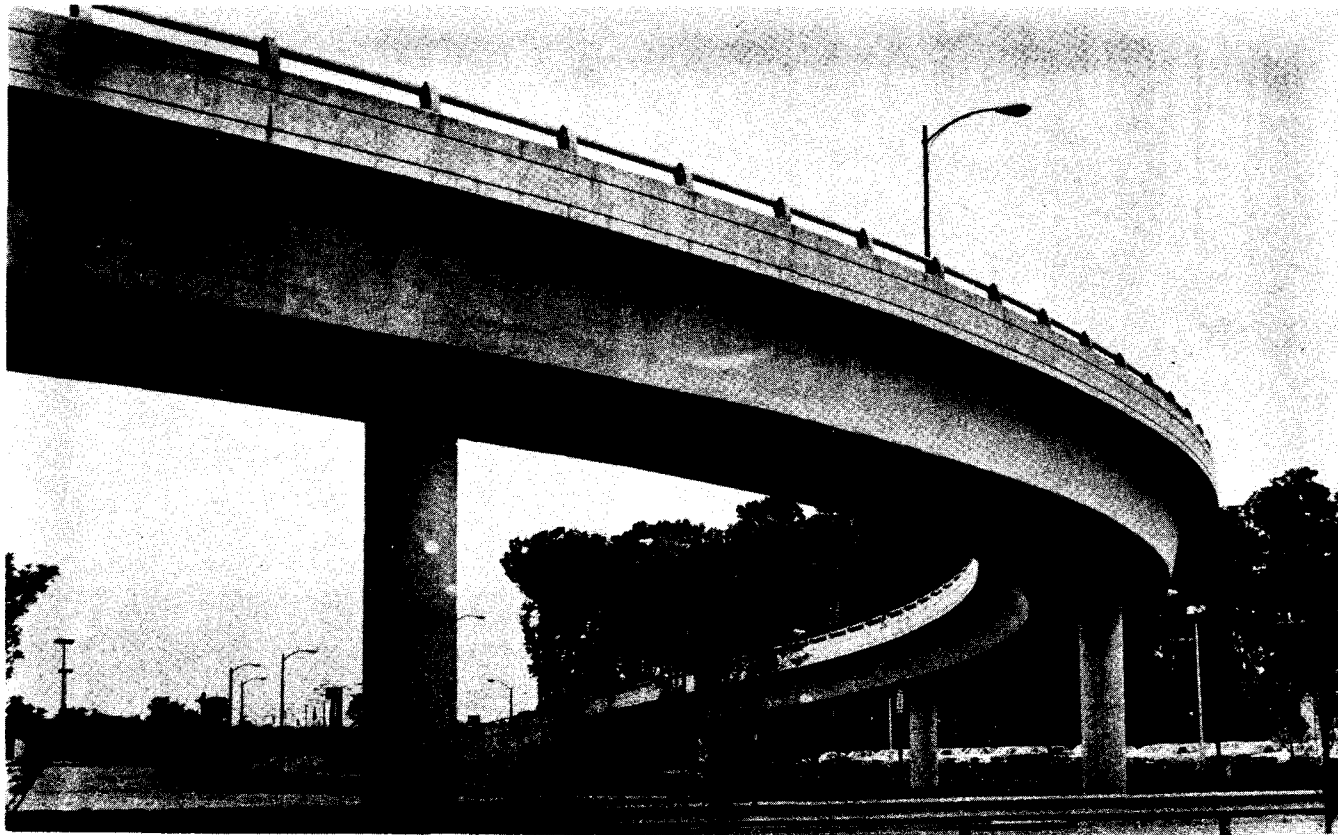

Figure 71. Curved ramp over Rte 258 (Mercury Boulevard), showing the visual simplicity and grace of the structure.

This single-lane flyover is on a vertical curve, superelevation, and sharp horizontal curve. The ramp consists of six spans ranging from 64 to 114 feet in length. The piers are single circular piers of reinforced concrete resting on prestressed concrete piles. A

notable feature of the superstructure is its construction as a double-cell box girder of reinforced concrete.

The combined curves and clean lines of this structure make it an unusually attractive bridge.

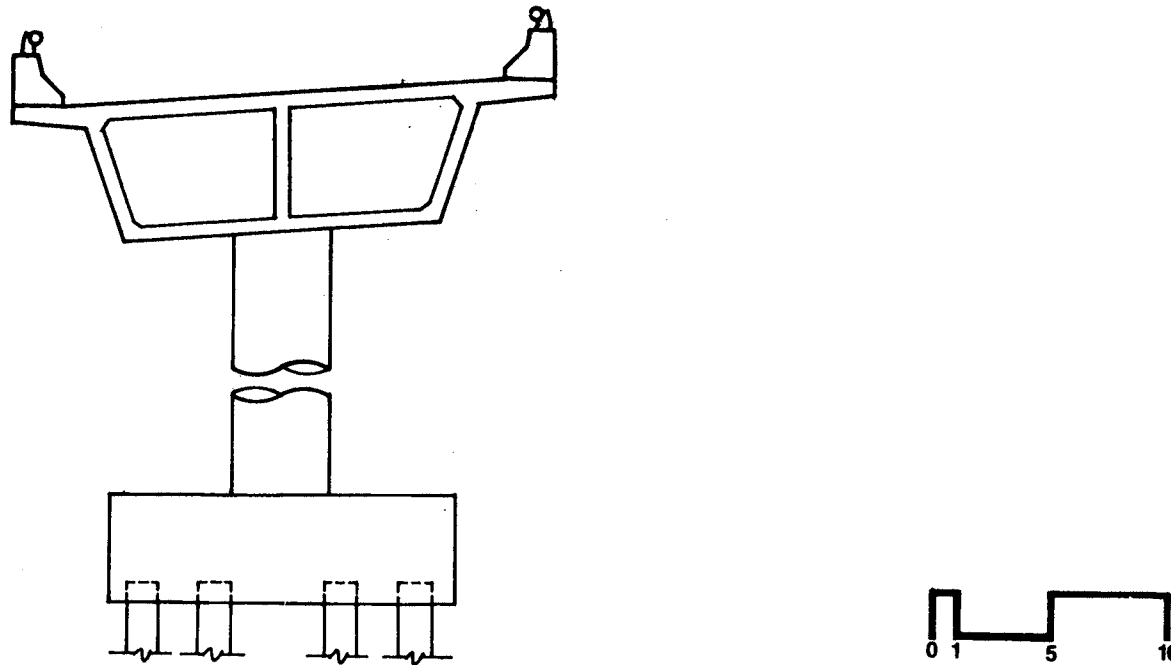

Figure 72. Typical cross section of the box girder through the ramp.

LAUREL CREEK BRIDGES

Type of Structure: Twin girder bridges

Roadway: 40 feet (each)

Location: Rte 77 over Laurel Creek in Bland
County

Designers: Harrington and Cortelyou

Date of Completion: 1974

Prime Builders: R. G. Pope Construction Co.
and Saltsman Construction Co.

Overall Length: 562 feet

Approximate Cost: \$1,571,000



Figure 73. Rte 77 bridge over Laurel Creek in mountainous Bland County.

Located in mountainous terrain, the north- and southbound lane bridges are practically alike. They each have three spans of welded steel plate girders ranging in length from 191 to 231 feet. The two central piers of reinforced concrete are impressively high, about 125 feet. The piers rest on rock, approximately at the level of the creek bed. The end abutments, however, rest on soil and rock fill almost 135 feet deep.

Unusual is the manner in which the center girders (200 feet long) were placed in position. These girders were placed on the valley floor beside the central piers and then simultaneously jacked up by rods hung from the pier caps to the desired position.

It is unfortunate, esthetically, that the long girder spans on the north ends do not match the other girders, which results in a jog in the bottom flanges.

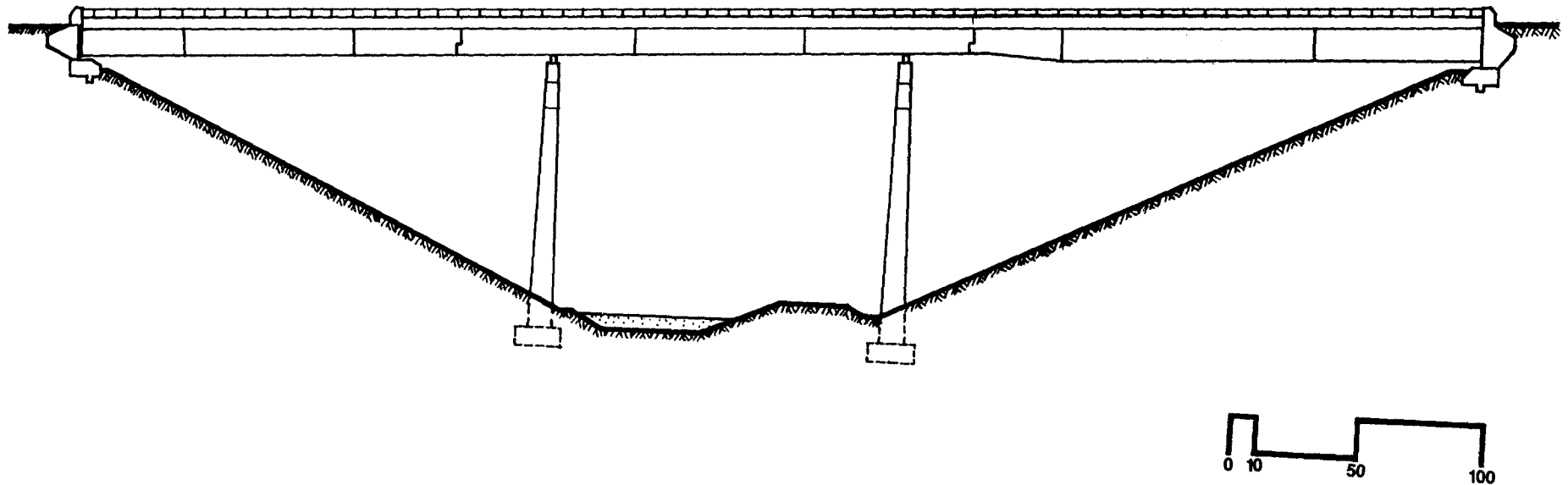

Figure 74. Elevation of the bridge with its unusually tall piers.

NEW RIVER BRIDGES

Type of Structure: Twin multiple span bridges

Roadway: 36 feet (each)

Location: Rte 460 over New River (near Ripplemead) in Giles County

Designers: Virginia Department of Highways and Transportation

Date of Completion: 1974

Prime Builders: McDowall and Wood, Inc.

Overall Length: 1,270 feet

Approximate Cost: \$2,937,460

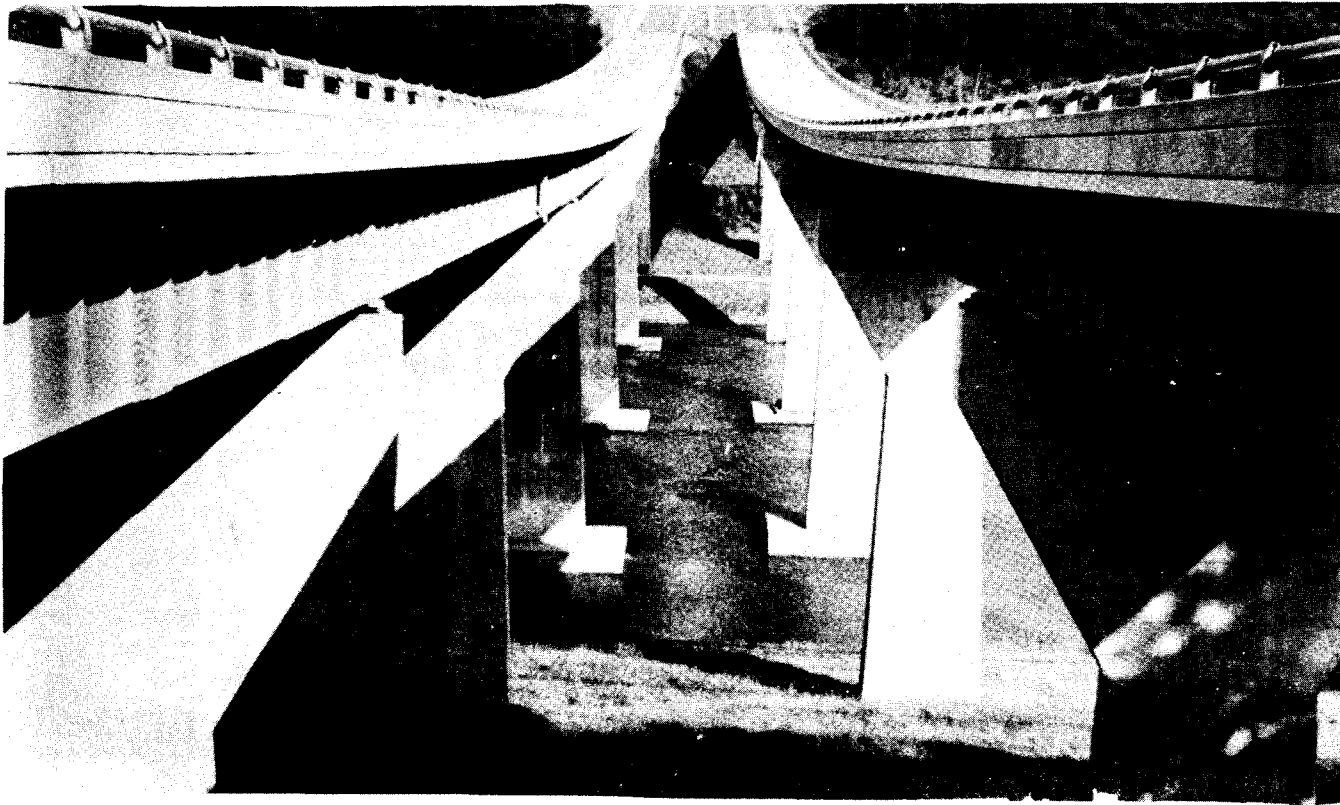

Figure 75. Twin bridges over New River. Note the pleasing visual effect of the vertical curve of the roadway.

These bridges constitute the longest single group of continuous steel girder spans on any highway bridge in Virginia. For both the east- and westbound lanes, the end spans are 125 feet each and the other six spans are 170 feet. The piers are of reinforced concrete and resting on spread footings on rock.

Within sight of this bridge to the north still stands (as of 1977) an abandoned multiple arch bridge of reinforced concrete built in 1934.

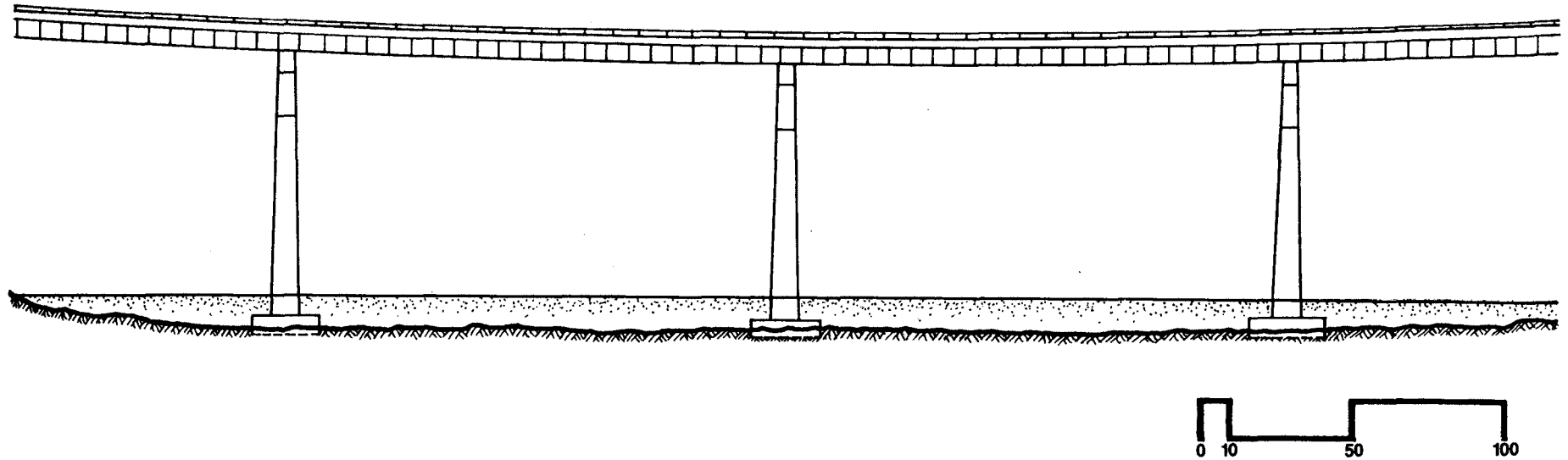

Figure 76. Elevation of the central portion of the bridge over water.

BEAVER DAM CREEK BRIDGE

Type of Structure: Glue laminated timber
bridge

Roadway: 16 feet

Location: Tour Road over Beaver Dam Creek in
Colonial National Historic Park at
Yorktown

Designers: Federal Highway Administration

Date of Completion: 1975

Prime Builders: Bishop & Settle Construction
Co. and Koppers Company, Inc.

Overall Length: 72 feet

Approximate Cost: \$60,000

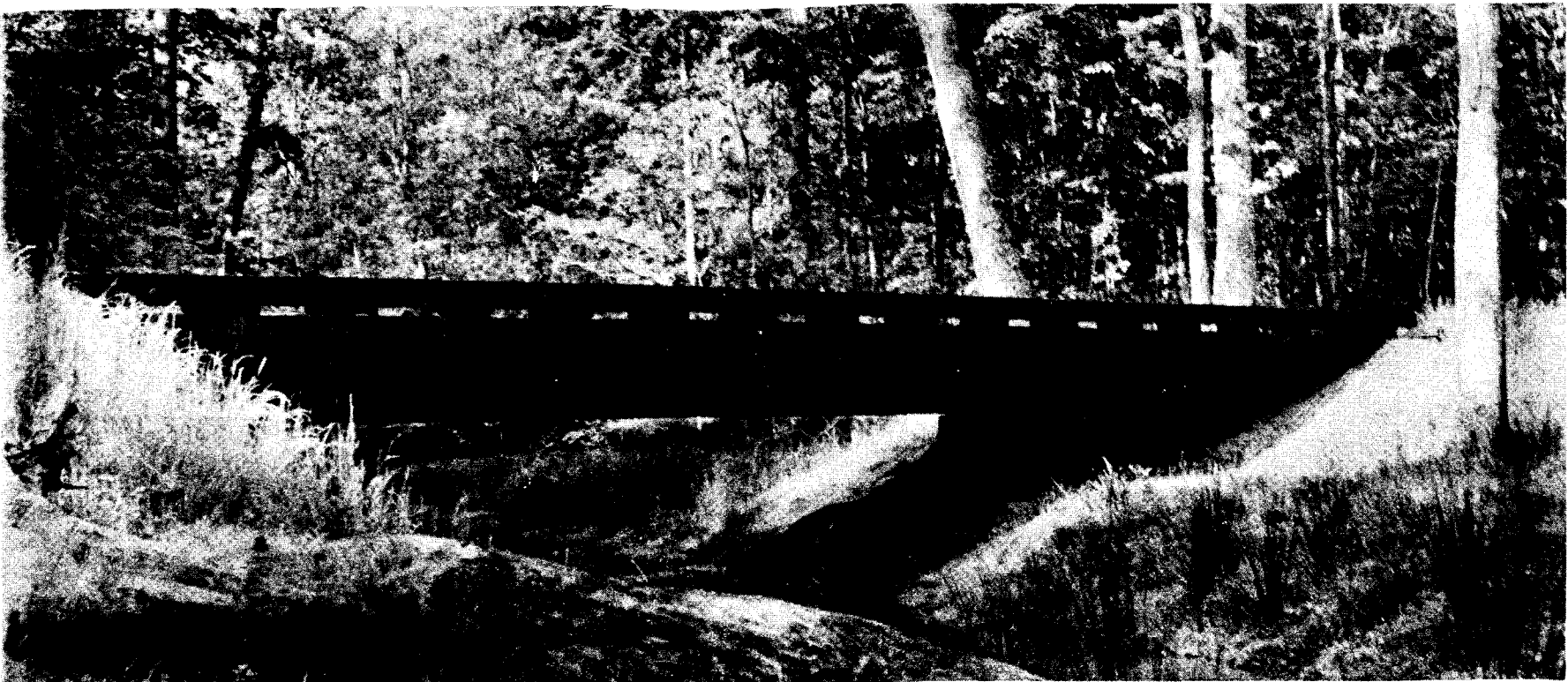

Figure 77. Glued laminated timber bridge scenically placed in Yorktown Battlefield.

This highway bridge, built for and maintained by the National Park Service, is the first in Virginia to be made of glue laminated wood. All the timber superstructure members, as girders and deck panels, were prefabricated and erected as a package. It is actually a three-span girder bridge, with 11 foot long end spans and a 50-foot center span. The piers are timber pile bents. All the wood is treated

with creosote to deter environmental deterioration and the deck is surfaced with asphalt to resist wear.

The low wheel guard, also of glue laminated wood, presents an attractive low profile to the bridge. This wood structure, set in a secluded wooded area, blends harmoniously with its surroundings.

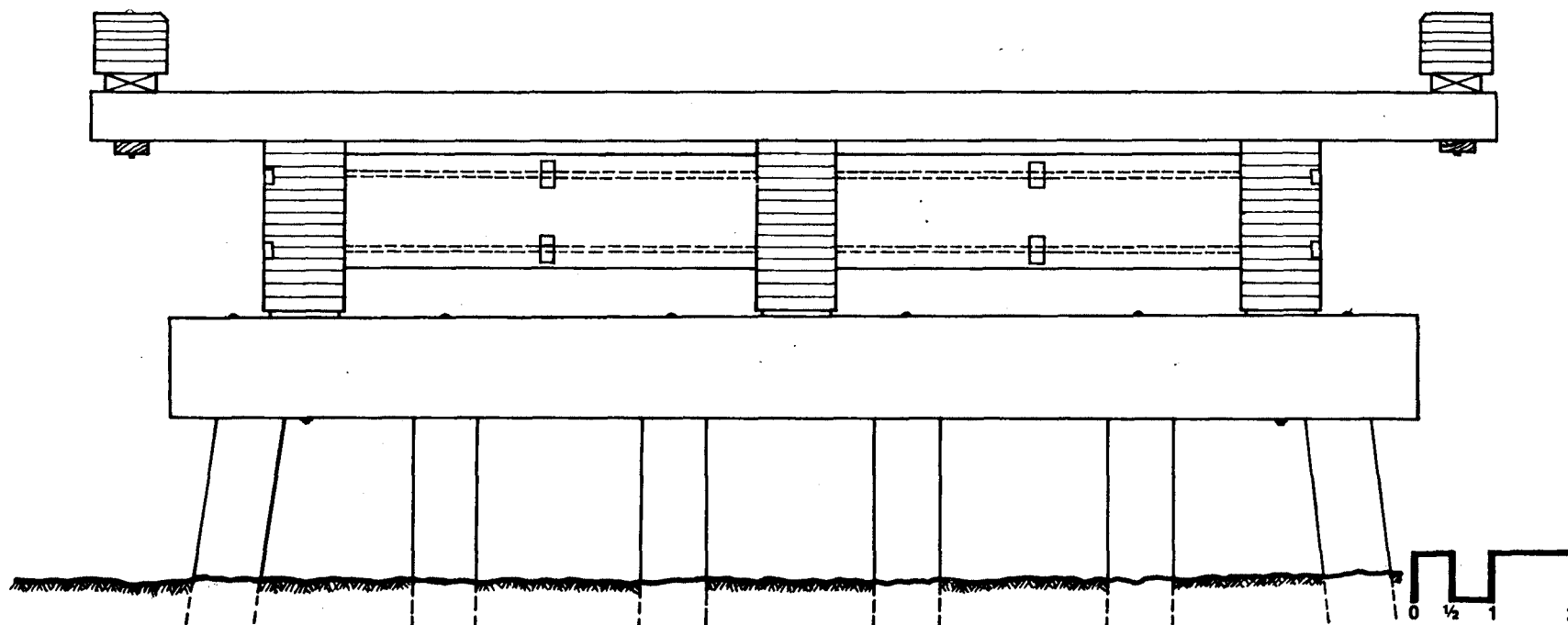

Figure 78. Cross section through the bridge. The pile bents are located inconspicuously near the end abutments.

EAST RIVER MOUNTAIN TUNNELS

Type of Structure: Twin underground tunnels

Roadway: 26 feet (each)

Location: Rte 77 through East River Mountain
in Bland County

Designers: Michael Baker, Jr., Inc.

Date of Completion: 1975

Prime Builders: Ball and Healy Construction
Co.

Overall Length: 5,412 feet

Approximate Cost: \$26,090,500



Figure 79. South portal of the East River Mountain Tunnel.

Located about 2,500 feet above sea level, these tunnels pass approximately 1,200 feet under the crest of the mountain. Their construction is similar to the tunnels on the same route 18 miles south at Big Walker Mountain, in which the bores are reinforced with reinforced concrete walls over 2 feet thick.

Because the northern parts of the East

River Mountain tunnels are located in the state of West Virginia, over \$11 million of the construction money was paid for by West Virginia. Maintenance, however, is by Virginia.

This tremendous engineering undertaking has made these twin highway tunnels the seventh longest in the United States.

Figure 80A. Profile of tunnel through East River Mountain.

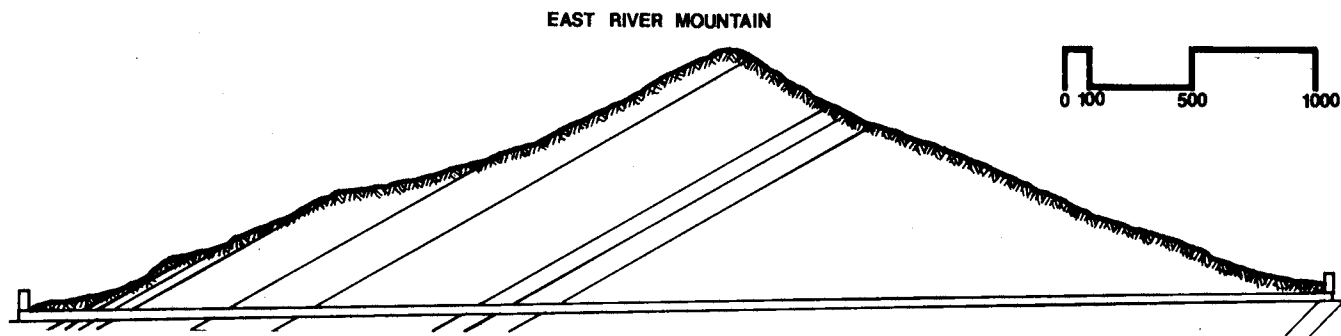
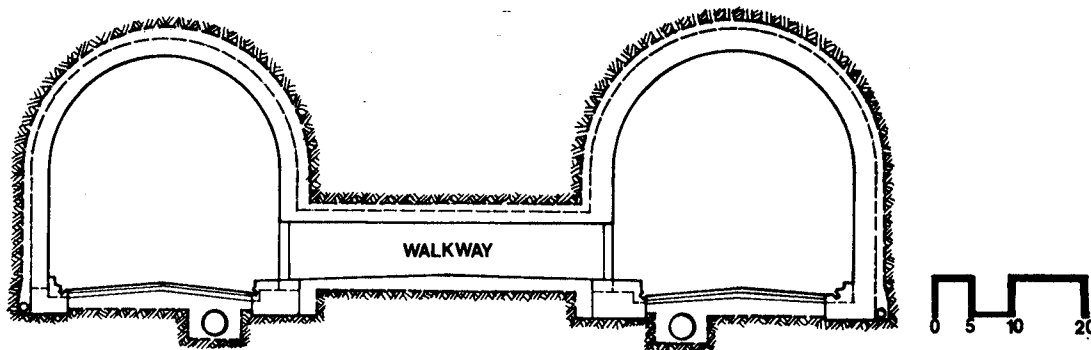

Figure 80B. Cross section through the twin tunnels.



JAMES RIVER BRIDGE

Type of Structure: Trestle bridge with lift span

Roadway: 32 feet

Location: Rte 17 over James River between the city of Newport News and Isle of Wight County

Designers: Parsons, Brinckerhoff, Quade and Douglas

Date of Completion: 1975 (except for new lift span)

Prime Builders: Tidewater-Raymond-Kiewit

Overall Length: 4.31 miles

Approximate Cost: \$16,135,000 (excluding the new lift span)

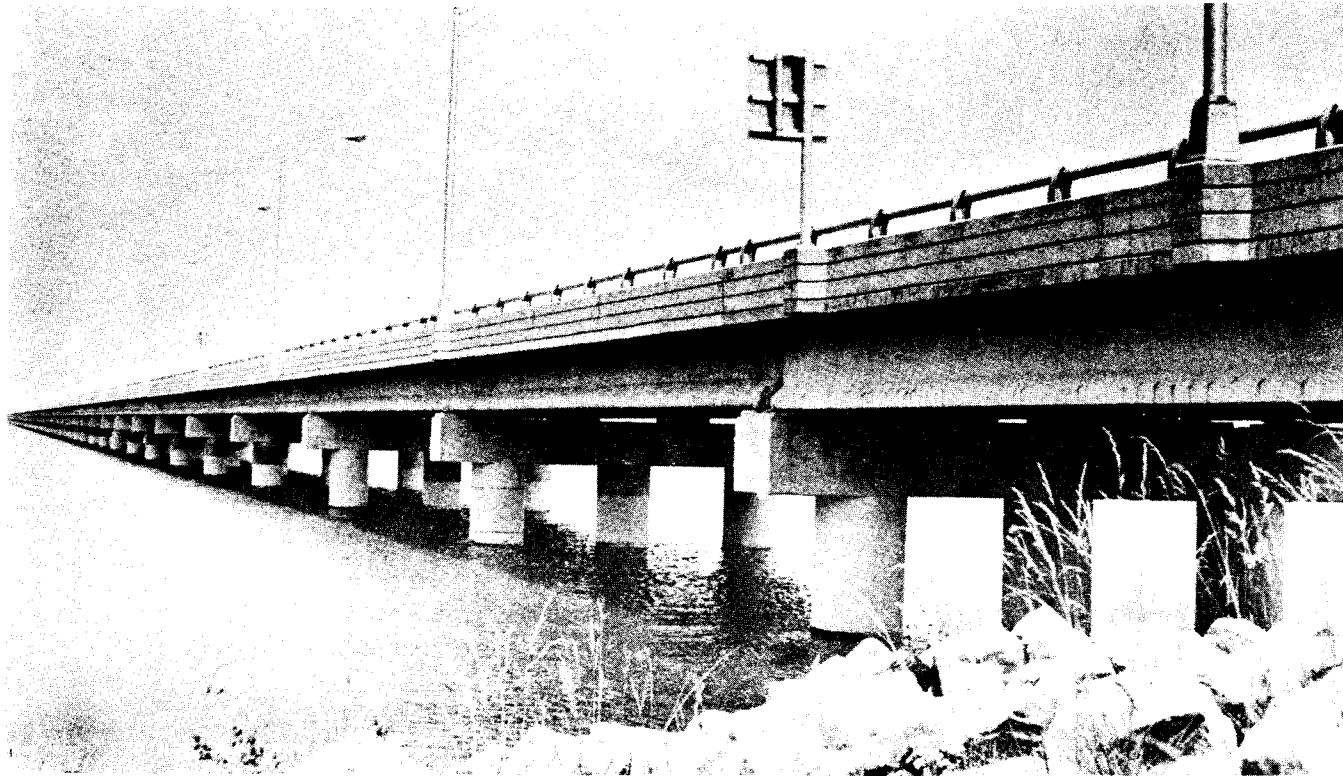

Figure 81. South portion of the new bridge on Rte 17 across the James River.

Except for the lift span section, this unusually long bridge is on concrete pile bents or trestles, with the majority at low level spaced 75 feet apart. On the two high-level portions of the bridge, the trestles are spaced up to 120 feet apart. The superstructure spans on the trestles are prestressed concrete girders precast integrally with the concrete deck. This is the first use of such construction on any bridge in Virginia. These precast sections were floated to the site for

erection directly onto the bents. The new lift span portion (yet to be completed as of 1977) is a steel truss 415 feet long supported by flanking steel truss towers.

Until such time as the new lift span is completed, traffic crosses over to the old adjacent lift span bridge. A 1,500-foot section of the north end of the old adjacent trestle bridge also has been left standing to serve as a fishing pier.

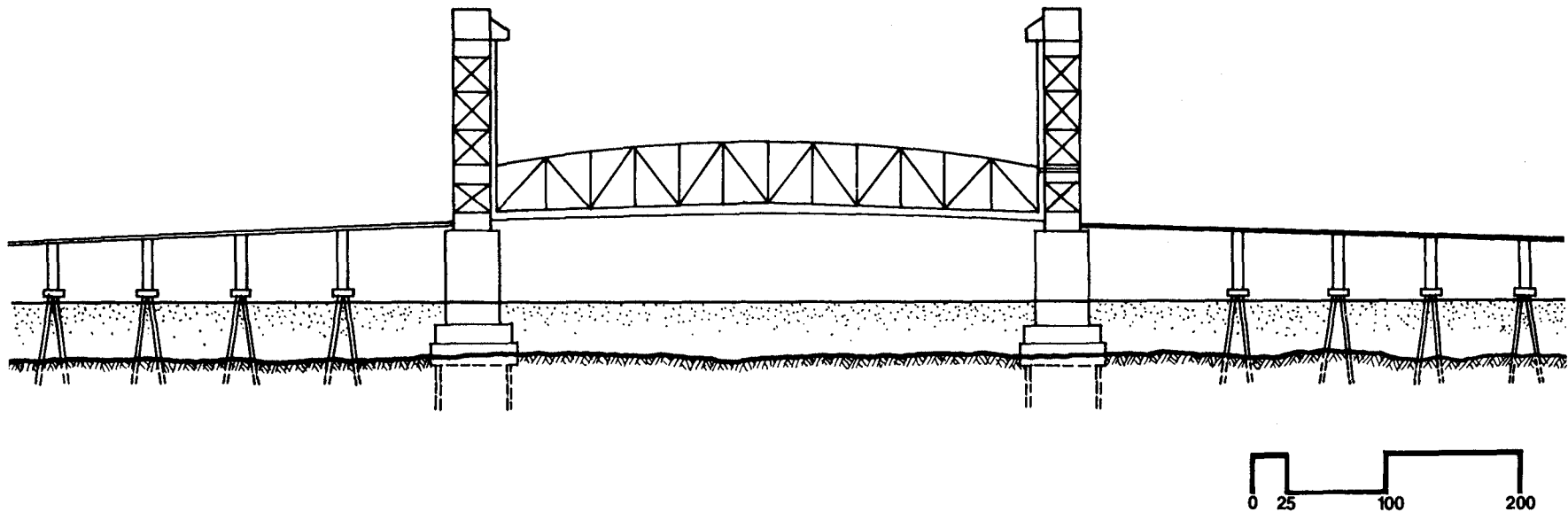

Figure 82. Proposed elevation of the central lift span portion of the new bridge.

KINGSMILL CREEK BRIDGE

Type of Structure: Delta-leg Bridge

Roadway: 24 feet

Location: Mount's Bay Road over Kingsmill
Creek in "Kingsmill on the James"
(off Rte 60 near Rte 199) in James
City County

Designers: Fraioli-Blum-Yesselman Assoc., Inc.

Date of Completion: 1975

Prime Builder: Sandford Construction Co.

Overall Length: 430 feet

Approximate Cost: \$902,000

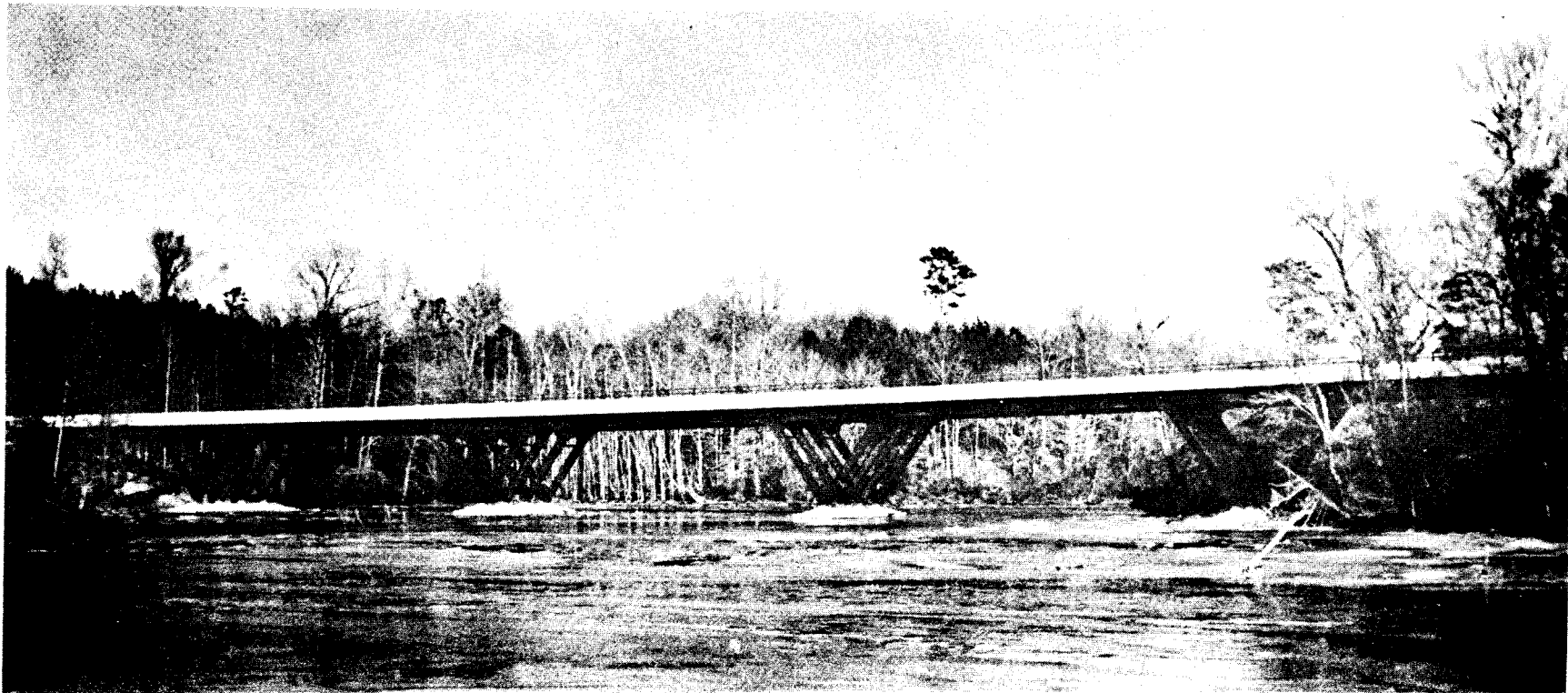

Figure 83. Overall view of the award winning bridge over Kingsmill Creek.

Built for private owners, Busch Properties, Inc., this multiple delta-leg bridge is made of weathering steel which requires no painting. The natural rust coloring of the steel, along with the tan colored concrete deck, combine to blend harmoniously with the natural wooded and watery setting.

The steel is continuous across the five

spans that range from 67 to 99 feet in length and is continuous with the support legs. The low profile piers are of reinforced concrete and are supported by piles.

This handsome bridge won the Prize Bridge Award of the American Institute of Steel Construction in 1976.

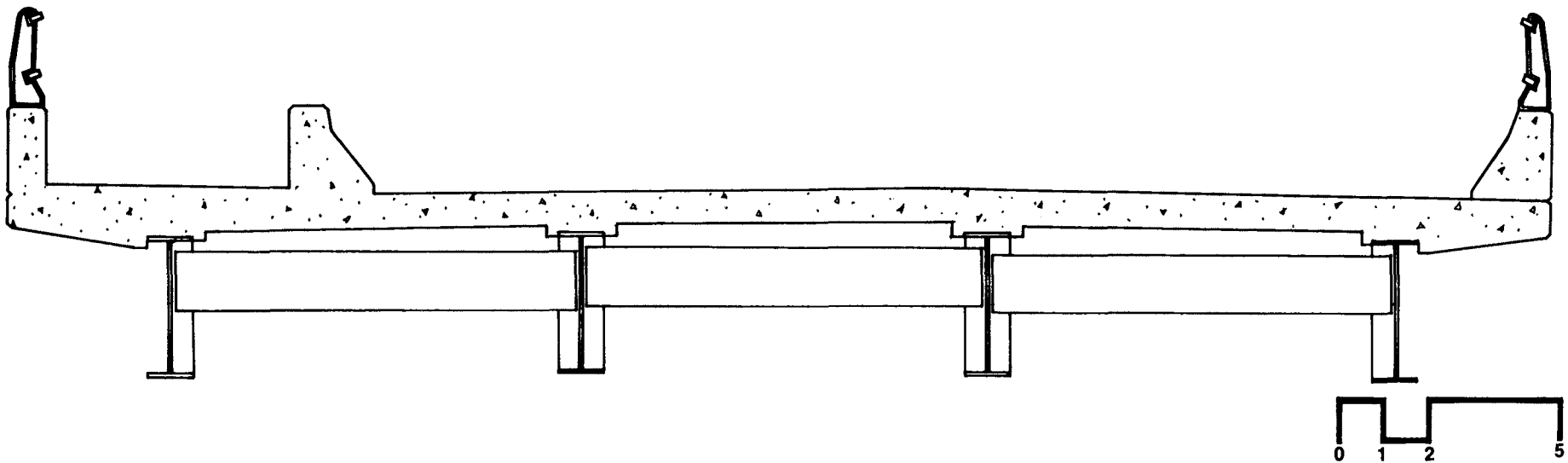

Figure 84. Cross section of the superstructure of the bridge. Note the concrete protection barrier between the sidewalk and the roadway.

HAMPTON ROADS BRIDGE-TUNNEL

Type of Structure: Bridge-tunnel (southbound)

Location: Rte 64 across Hampton Roads between
the cities of Hampton and Norfolk

Date of Completion: 1976

Overall Length: 3.48 miles:3,226 feet (north
bridge); 5,925 feet (south
bridge); 7,315 feet (tunnel)

Roadway: 40 feet (bridge); 26 feet (tunnel)

Designers: Parsons, Brinckerhoff, Quade, and
Douglas

Prime Builders: Tidewater-Raymond-Kiewit and
Diamond Construction Co.

Approximate Cost: \$95,900,000

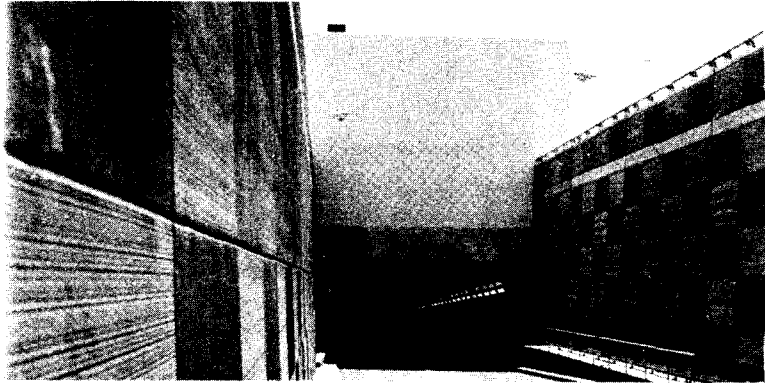

Figure 85A. North portal of the second Hampton Roads Tunnel.

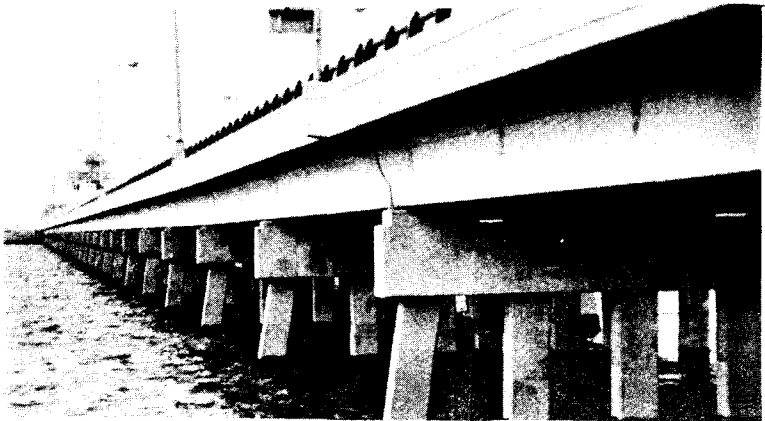

Figure 85B. Bridge approach to the second tunnel, looking south.

Because of increased traffic demand, a second crossing at Hampton Roads had to be constructed. The first two-way crossing, completed in 1957, became one-way northbound and the new crossing was made southbound. Basically, the second bridge construction was similar to the first, with prestressed concrete girders resting on concrete pile bents spaced 75 feet apart (with several at 50 feet). The tunnel construction also was similar to the first, with both portals being located on man-made islands. Prefabricated steel and

concrete tunnel sections, roughly 300 feet long, were laid into prepared trenches in the Bay bottom. At its lowest point, the tunnel is approximately 108 feet below mean water level, which provides a water channel depth of 60 feet for navigation.

Just south of the crossing on Rte 64 is the Willoughby Bay Bridge (constructed with this new bridge-tunnel) that further extends this extensive project.

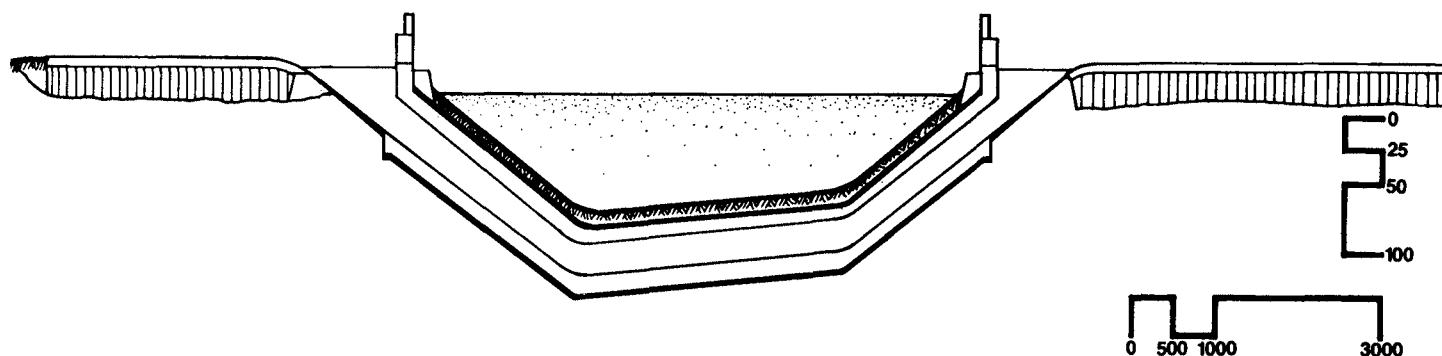

Figure 86A. Profile of the second Hampton Roads Tunnel.

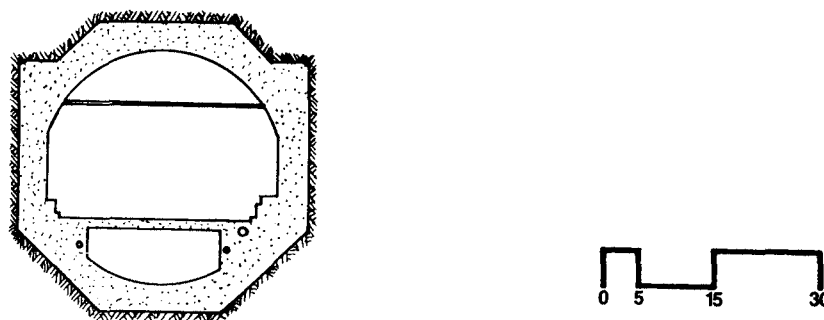

Figure 86B. Typical cross section through the tunnel.

MAURY RIVER BRIDGES

Type of Structure: Twin delta-leg bridges
Location: Rte 64 over Maury River in Rock-
bridge County

Date of Completion: 1976

Overall Length: 845 ft. (each)

Roadway: 39 feet (each)

Designer: Joseph K. Knoerle

Prime Builder: Crowder Construction Co.

Approximate Cost: \$2,980,000

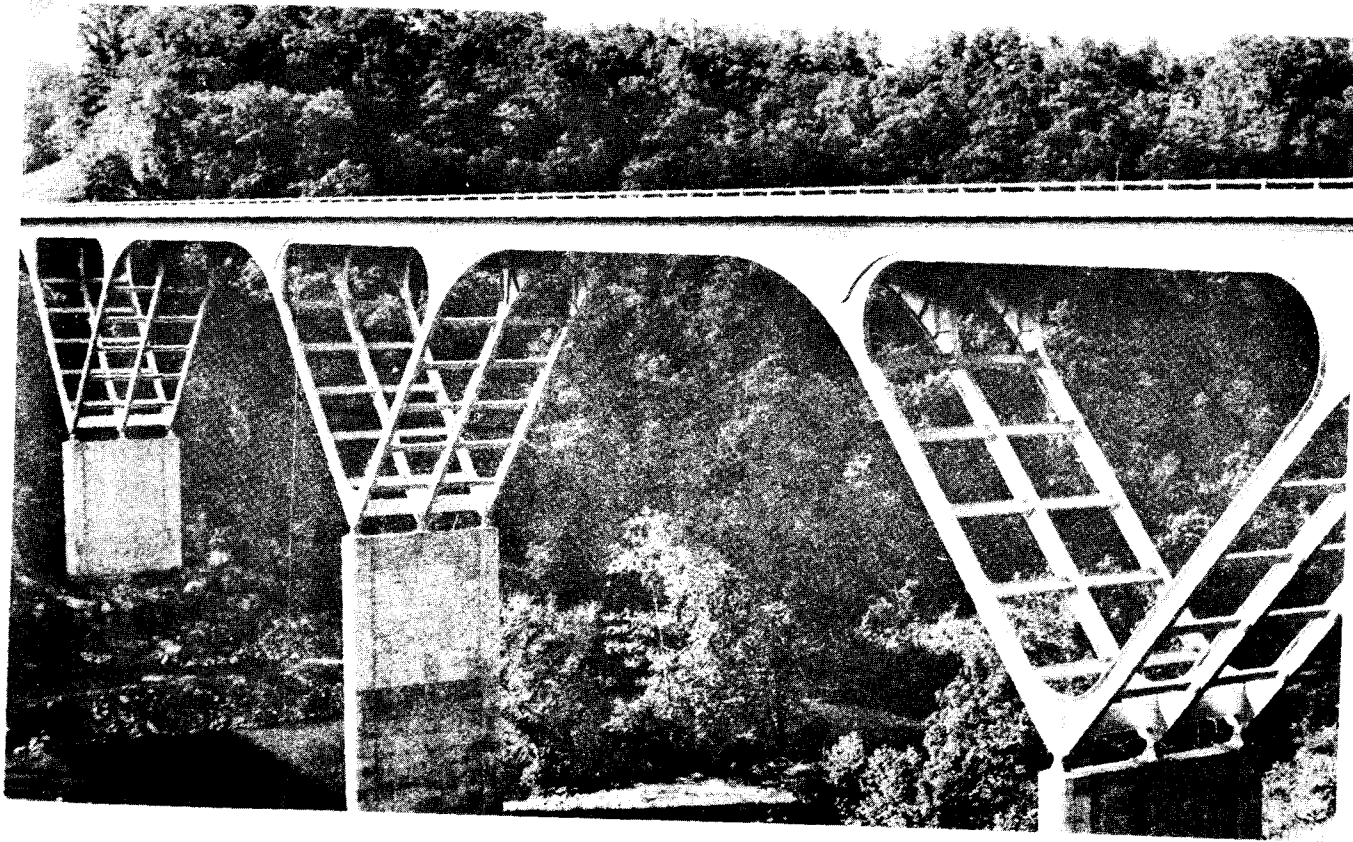

Figure 87. Eastbound span over Maury River. The adjacent westbound span is similar.

These twin steel structures spanning a deep valley are dramatically impressive. Each end span (from abutment to piers) is about 183 feet, and the center spans (between piers) are each 240 feet. The actual girder spans are considerably reduced by virtue of the delta-leg supports springing from the piers, which makes for a graceful superstructure. The entire superstructure is one rigid frame welded together (except for field connections of high

strength steel bolts). The only expansion joints are at the end abutments.

The legs are supported by solid reinforced piers resting on rock, just below the ground surface.

The roadways, on a relatively steep 5% grade, soar approximately 150 feet above the river.

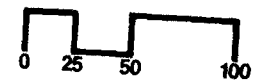
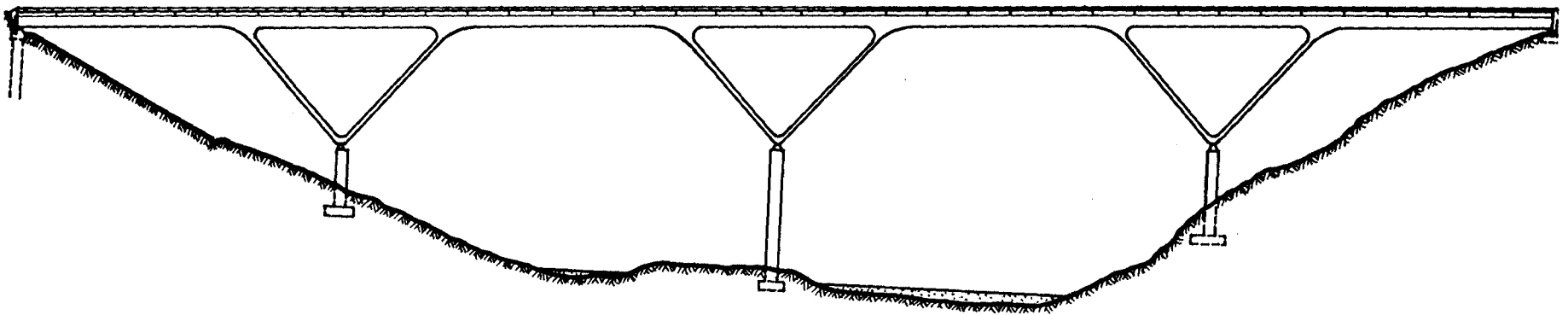

Figure 88. Elevation of the high-level, delta-leg bridge on Rte 64.

KING MEMORIAL BRIDGE

Type of Structure: Box girder bridge

Roadway: 87 feet

Location: Rte 33 over Shockoe Valley (Leigh Street Viaduct) in the city of Richmond

Designers: Parsons, Brinckerhoff, Quade and Douglas

Date of Completion: 1976

Prime Builders: Moore Brothers, Inc., Robert A. Smith Co., and Central Contracting Co.

Overall Length: 2,151 ft.

Approximate Cost: \$20,000,000

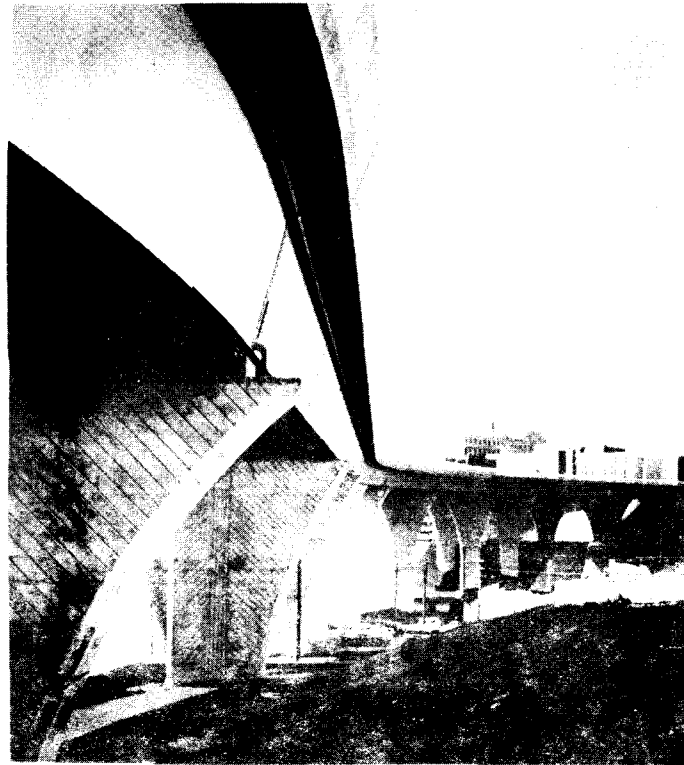

Figure 89. The Martin Luther King, Jr. Memorial Bridge as seen looking toward downtown Richmond.

This bridge is named after Martin Luther King, Jr., the well-known civil rights leader.

In plan, the bridge is basically S shaped, passing over three streets, an interstate highway, and ten sets of railroad tracks. It is the first continuous steel box girder bridge built in Virginia. The superstructure is constructed of eleven spans ranging in length from 125 to 282 feet. Many of the box girders were fabricated on a horizontal curve to conform with the curved path of the roadway.

Supporting the superstructure are ten sets of hollow reinforced concrete piers, trumpet-shaped and textured for esthetic reasons. Steel piles support the piers.

Flanking the roadway on each side are well-protected sidewalks for pedestrians.

Overall, the bridge combines difficult and advanced technology with a serious concern for esthetics.

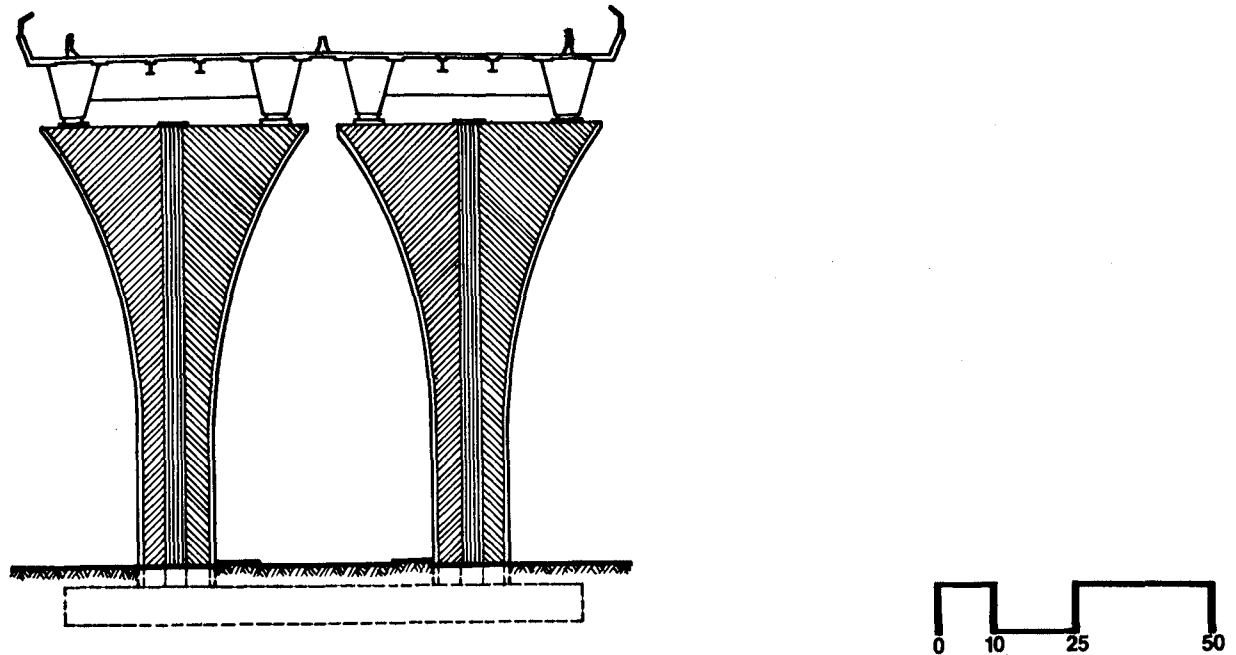

Figure 90. Typical cross section through the bridge.

SLANT-LEG BRIDGES

Type of Structure: Twin rigid frame bridges

Location: Rte 705 over Rte 77 in Carroll
County

Date of Completion: 1977

Overall Length: 198 feet (each)

Roadway: 26 feet (each)

Designers: Hayes, Seay, Mattern & Mattern

Prime Builders: Pendleton Construction Corp.

Approximate Cost: \$177,630

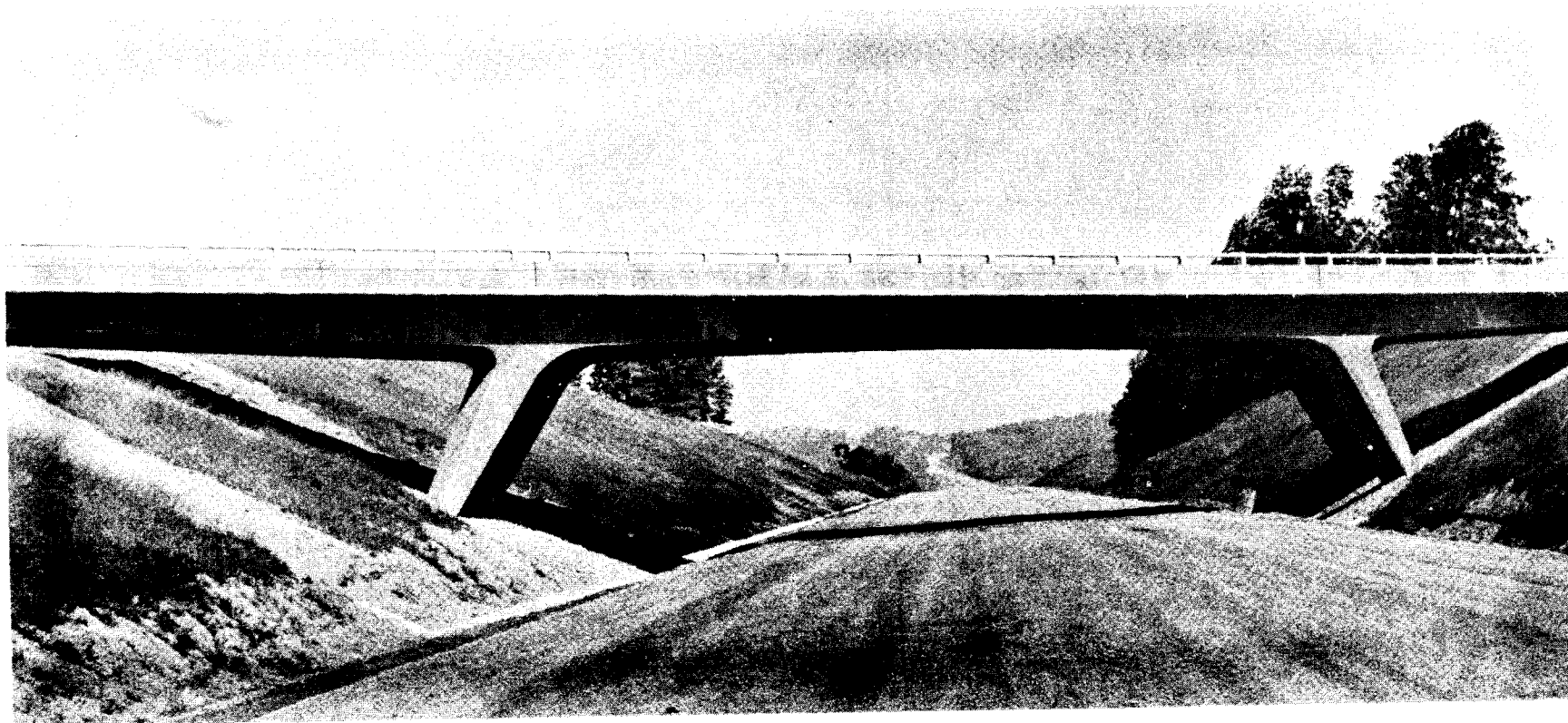

Figure 91. Bridge on southbound lane of Rte 77. Bridge over northbound lane is similar.

These bridges are the first slant-leg bridges constructed of reinforced concrete in the state. The horizontal distance between the base of the legs is approximately 110 feet; however, by virtue of the slant of the legs, the center span of the concrete girders is reduced to 87 feet. The end spans are each 54 feet. The legs and the girders are constructed monolithically.

The foundations under the legs rest on firm soil and are specially shaped to resist both the downward and horizontal forces of the legs.

The bridges are on a relatively large skew of 30 degrees and on a slight vertical curve.

The overall design of the structures is both functional and visually pleasing.

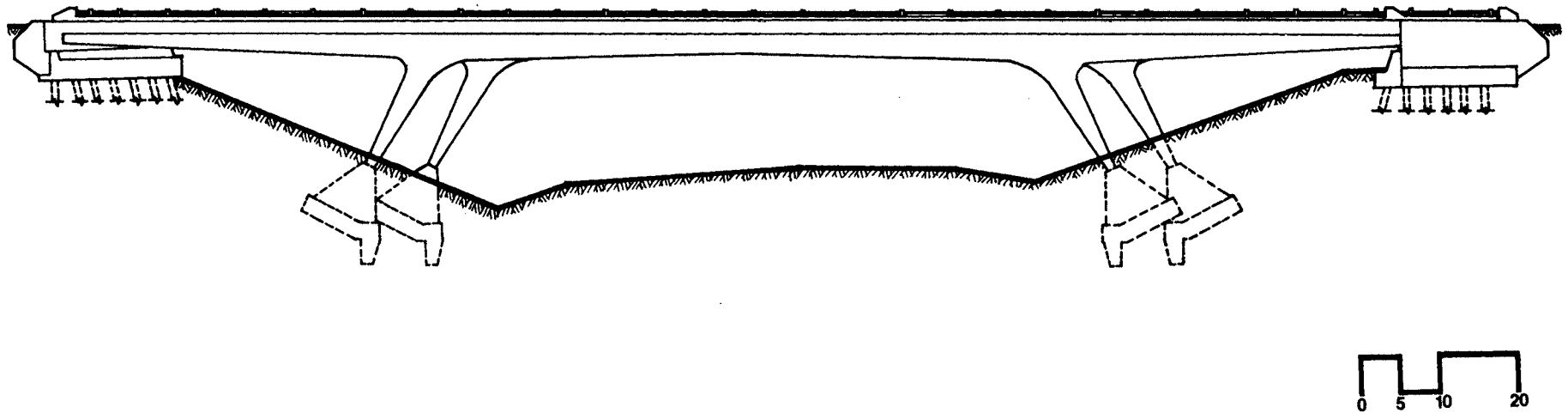

Figure 92. Elevation of the reinforced concrete slant-leg bridge over SBL of Rte 77.

WAYSIDE PEDESTRIAN BRIDGE

Type of Structure: Plastic pedestrian bridge

Pathway: 6 feet

Location: Over stream at Rest Area on east-bound lane on Rte 66 in Warren County

Designer: F. C. McCormick

Date of Completion: 1977

Prime Builder: Virginia Department of Highways and Transportation

Overall Length: 16 feet

Approximate Cost: \$8,200

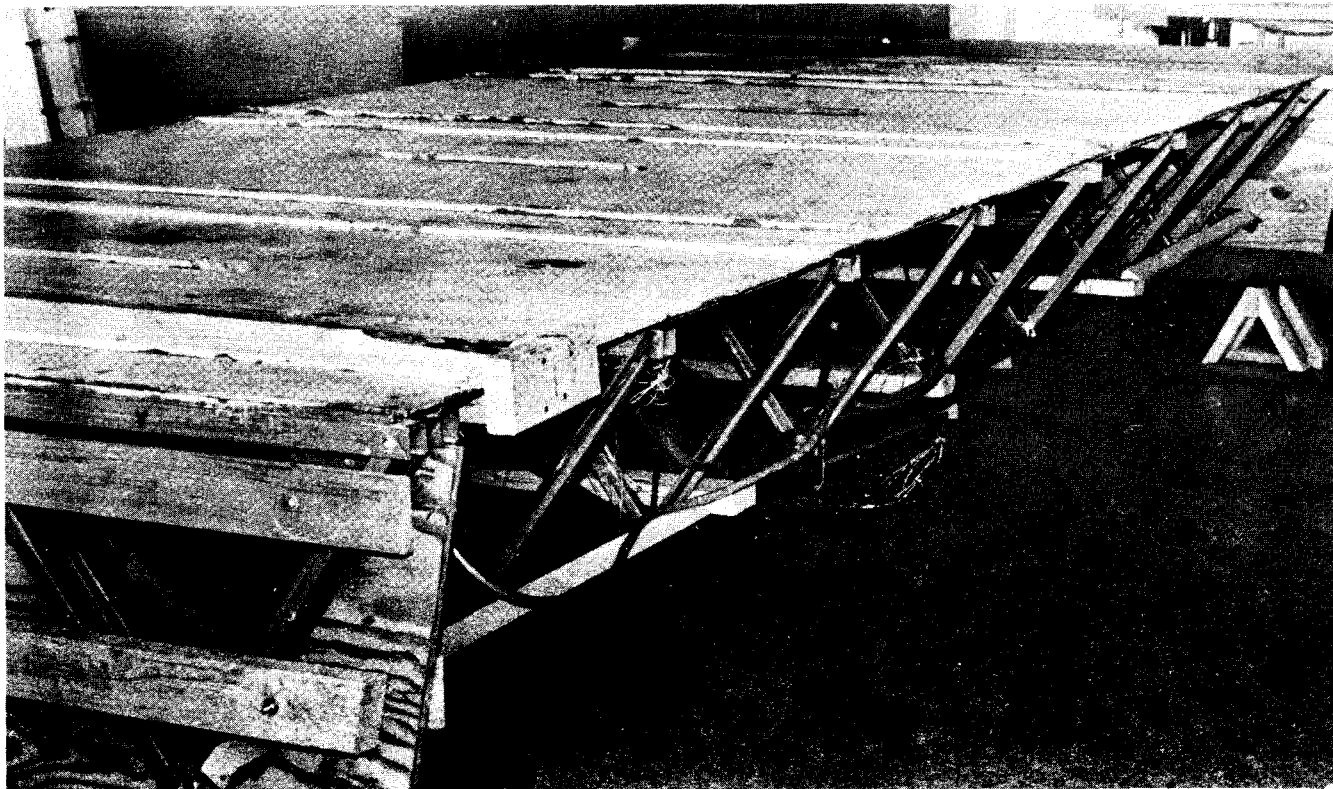

Figure 93. Plastic bridge as seen after fabrication, but prior to field erection.

This small but unique bridge is the first on any highway system in Virginia or the United States to be made almost entirely of reinforced plastic. The superstructure consists basically of three single-span, triangular box truss girders positioned side by side. On the upper deck is 3 inches of concrete for structural reinforcement and for wear resistance. All other superstructure members are made of glass reinforced plastic. Thin solid panels of reinforced plastic (nonstructural) on the sides and bottom of the girders are added as pro-

tection for the box trusses.

The abutments are of conventional reinforced concrete on spread footings. It is unfortunate, however, that the old-fashioned wooden railings are incompatible with the superstructure.

The structure is experimental and its behavior is being monitored by the Virginia Highway and Transportation Research Council.

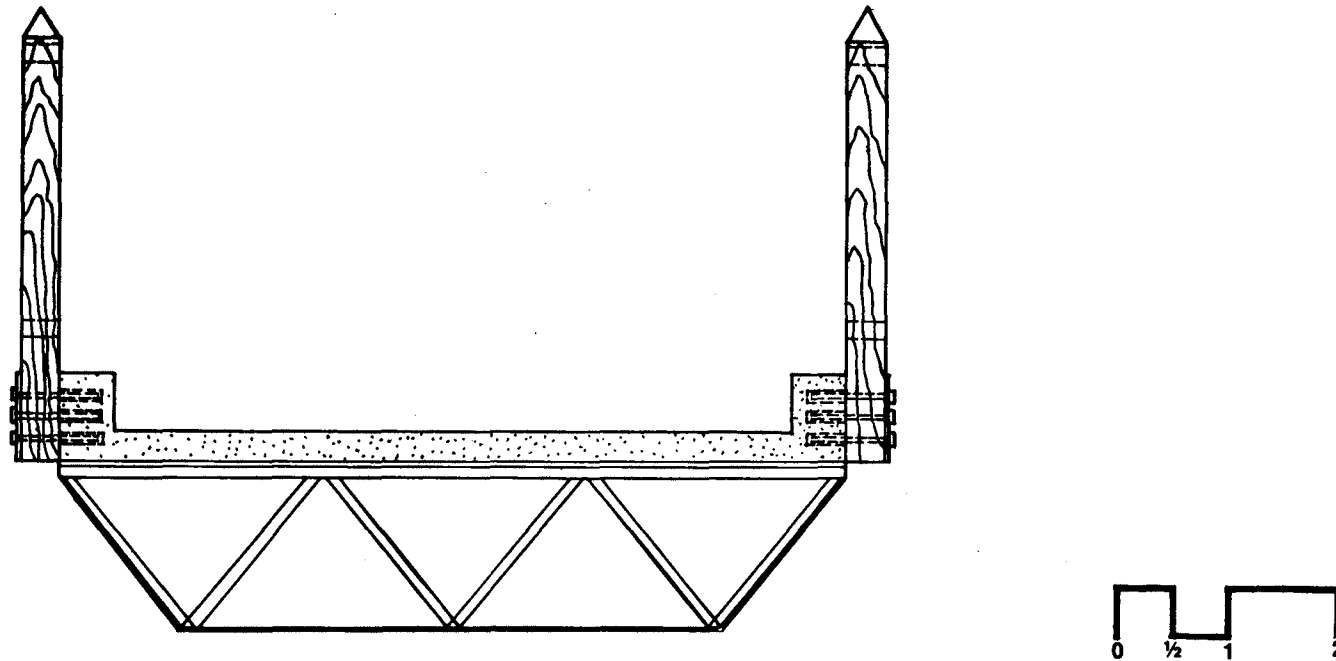

Figure 94. Cross section through the reinforced plastic superstructure.

ELIZABETH RIVER BRIDGE

Type of Structure: Multiple span beam and girder bridge

Roadway: 87 feet (42 feet eastbound)

Location: Rte 164 over Western Branch of Elizabeth River in the city of Portsmouth

Designers: Hayes, Seay, Mattern & Mattern

Date of Completion: 1978

Prime Builder: T. A. Loving Co.

Overall Length: 3,403 feet

Approximate Cost: \$12,000,000

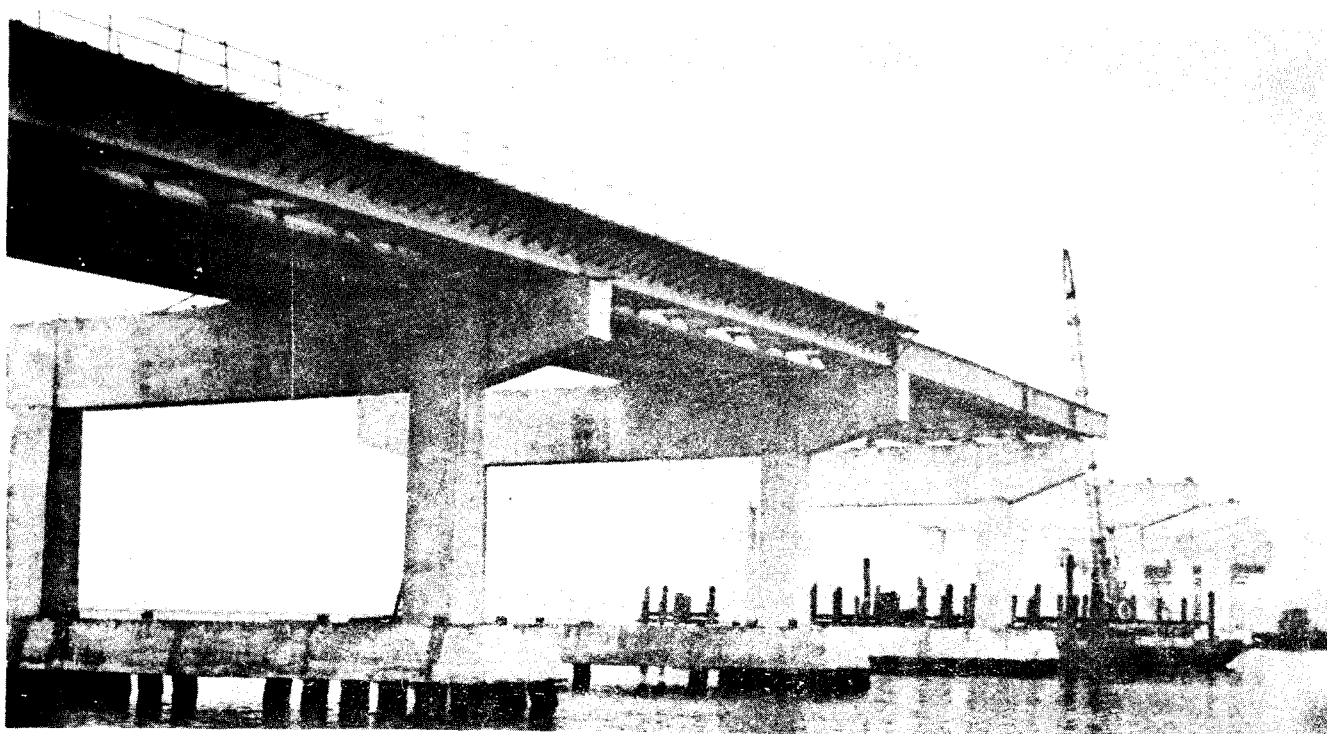

Figure 95. North end of bridge seen under construction.

Only the two eastbound lanes have been constructed as of 1977, with construction proceeding on the westbound lanes. However, two-way traffic can be able to traverse the bridge with east- and westbound traffic moving in single lanes. The bridge, built on a horizontal curve, consists of thirty-four spans ranging in length from 74 to 160 feet. The three largest spans, located at the channel, are made of steel girders. Two are 120 feet in length and one is 160 feet. All other

spans are made of prestressed concrete beams. The longest beams are 115 feet, which makes them the longest prestressed concrete beams on any bridge in Virginia.

The thirty-three piers are of reinforced concrete and are supported by piles. At the channel, the high-level bridge provides a navigational clearance of 100 feet horizontally and 46 feet vertically above mean high water.

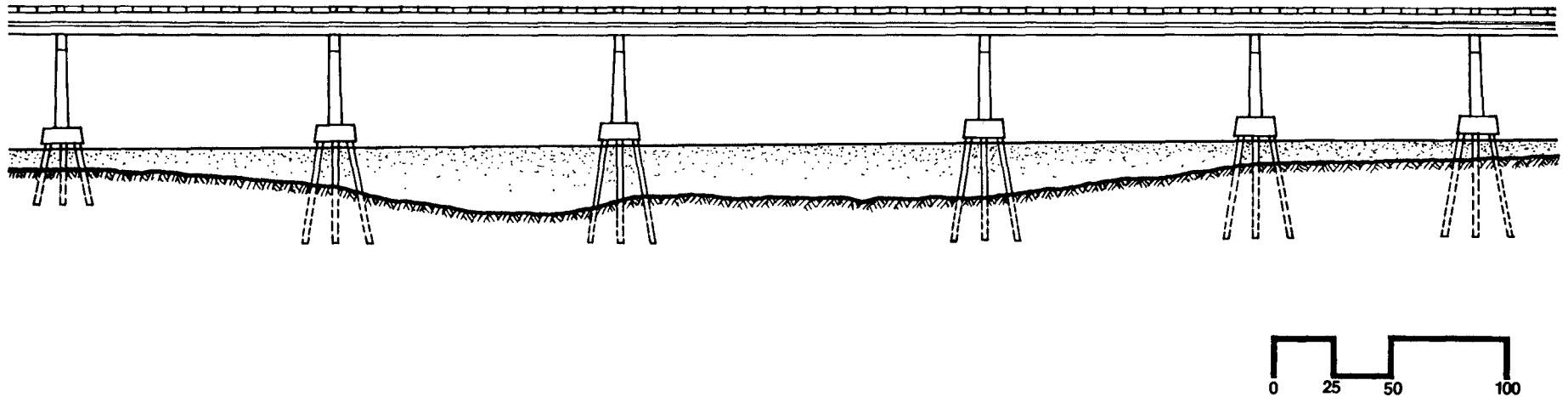

Figure 96. Elevation of the central high-level portion of the bridge.

ACKNOWLEDGEMENTS

A study as comprehensive as this one in nature certainly could not be possible without the willing help and cooperation of many people familiar with the bridges and tunnels in Virginia. Particular note is made of the following individuals.

J. N. Clary, Bridge Engineer (Retired), for his historical overview of the subject.

F. G. Sutherland, Bridge Engineer, and J. M. McCabe, Jr., Assistant Bridge Engineer, for their cooperation in providing drawings and other information.

The district engineers and district bridge engineers for their help in selecting structures in their particular construction districts. These respective officials were:

J. F. Turner and W. T. Ramey in Bristol;
D. B. Hope and F. L. Prewoznik in Culpeper;
H. L. Chryssikos and R. H. Morecock in Fredericksburg .
D. H. Gaulden, Jr. and R. W. Schwartz, in Lynchburg;
L. E. Brett, Jr. and J. A. Tavenner in Richmond;
M. E. Wood, Jr. and D. V. Cranford in Salem;
P. F. Cecchini and L. L. Misenheimer in Staunton;
J. T. Warren, former District Engineer, and D. G. Hagwood, former District Bridge Engineer in Suffolk.

T. O. Edick, Regional Engineer for the Federal Highway Administration, for providing information on projects of the National Park Service.

S. B. Smith, District Engineer, U. S. Corps of Engineers, for providing plans for the John W. Flannigan Reservoir bridge.

A. Shishman of Fraioli-Blum-Yesselman Assoc., Inc., for providing plans and other information on the bridge they designed for Kingsmill.

G. C. Wingfield, City of Richmond Bridge Engineer, for providing several old drawings.

C. P. Albus, H. P. Farber, and J. Clough of the Department for their assistance in securing drawings, photographs and other documents.

W. T. Heath, Jr., Photography Supervisor of the Department, for providing many of the photographs.

P. D. Hughes, Staff Photographer of the Research Council, for processing all of the photographs.

C. W. Burton, former Graduate Assistant of the Research Council, for his help in locating many old drawings and records.

R. Reames, Student Assistant of the Council, for his skillful delineation of the line drawings in this report.

Others as J. Kennedy, J. Vanderberry, and
H. Craft of the Council for their
assistance in the preparation of this
report are also not forgotten.

APPENDIX I

LISTS OF NOTABLE BRIDGES AND TUNNELS BY REGION

Northern Virginia

1. Double bridges on Rte 340 over North and South Forks of Shenandoah River in Warren County (1941).
2. Pedestrian bridge over Rte 95 at Shirlington Circle (between cities of Arlington and Alexandria) (1973).
3. Multiplex of bridges at Rte 95 in city of Arlington (1974).
4. Plastic pedestrian bridge at wayside rest stop on Rte 66 in Warren County (1977).
5. Bridge-Tunnel on Rte 337 under Elizabeth River between Norfolk and Chesapeake (1952).
6. Bridge-Tunnel on Rte 64 at Hampton Roads between Hampton and Norfolk (1957).
7. Truss bridge on Rte 3 over Rappahannock River between Lancaster and Middlesex Counties (1957).
8. Movable bridge on Rte 33 over Pamunky River in New Kent County (1957).
9. Movable bridge on Rte 104 over South Branch of Elizabeth River in Chesapeake (1962).

Eastern Virginia

1. Movable bridge on Rte 634 over Cat Point Creek in Richmond County (1934).
2. Bridges and tunnel on Colonial National Memorial Parkway between Yorktown and Jamestown (1942).
3. Triple deck bridge on Rte 13 (Business) over Norfolk & Western Railroad and Rte 460 in Chesapeake (1949).
4. Truss bridge on Rte 17 over York River between York and Gloucester Counties (1952).
10. Tunnel on Rte 58 under Elizabeth River between Norfolk and Portsmouth (1962).
11. Multiple span beam bridge on Rte 360 over Rappahannock River between Essex and Richmond Counties (1964).
12. Bridge-Tunnels on Rte 13 over Chesapeake Bay between Virginia Beach and Northampton County (1964).
13. Movable bridge on Rte 64 over South Branch of Elizabeth River in Chesapeake (1969).
14. Flyover over Rte 258 near Rte 64 in Hampton (1974).

15. Timber bridge on Tour Road over Beaver Dam Creek in Colonial National Historic Park at Yorktown (1975).
16. Delta-leg bridge on Mount's Bay Road over Kingsmill Creek in "Kingsmill" development off Rte 60 near Rte 199 (1975).
17. Multiple span beam bridge on Rte 17 across the mouth of James River between Newport News and Isle of Wight County (1975).
18. Bridge-Tunnel on Rte 64 at Hampton Roads between Hampton and Norfolk (1976).
19. Multiple span beam and girder bridge on Rte 164 over West Branch of Elizabeth River in Portsmouth (1978).

Central Virginia

1. Truss bridge on Rte 15 across James River between Fluvanna and Buckingham Counties (1934).
2. Concrete arch bridge on Rte 60 over the Chesapeake & Ohio Railroad, north of James River in Richmond (1934).
3. Multiple span arch bridge on Rte 1 across James River in Richmond (1936).
4. Multiple steel girder span on Rte 95 over James River in Richmond (1958).
5. Aluminum bridge on Rte 36 over Appomattox River in Petersburg (1961).

6. Lift bridge on Rte 156 over James River between Prince George and Charles City Counties (1967).
7. Steel girder bridge on Rte 501 over James River between Amherst and Bedford Counties (1968).
8. Slant-leg steel bridge on Rte 64 over Rte 250 in Albemarle County (1969).
9. Girder bridge on Rte 64 over Smith Creek in Clifton Forge (1971).
10. Multiple span girder bridge on 9th Street over James River in Richmond (1973).
11. Girder bridge on Rte 45 over James River between Goochland and Cumberland Counties (1974).
12. Delta-leg bridges on Rte 64 over Maury River in Rockbridge County (1976).
13. Box girder bridge on Rte 33 over Shockoe Valley in Richmond (1976).

South-Central Virginia

1. Multiple span bridge on Rte 304 over Dan River in Halifax County (1950).
2. Steel girder bridge on Rte 122 over Smith Mountain Lake between Bedford and Franklin Counties (1963).
3. Steel girder bridges on Rte 29 (Bypass) over Staunton (Roanoke) River between Campbell and Pittsylvania Counties (1973).

Western Virginia

1. Multiple concrete arch bridge on old Rte 460 over New River in Giles County at Ripplemead (1934).
2. Girder bridges on Rte 81 over New River in Montgomery County (1965).
3. Bridge over dam on Rte 739 at John W. Flanagan Reservoir in Dickenson County (1966).
4. Multiple span girder bridge on Rte 672 over Claytor Lake in Pulaski County (1972).
5. Tunnels on Rte 77 through Big Walker Mountain in Bland County (1973).
6. Multiple span steel girder bridges over New River in Giles County near Ripplemead (1974).
7. Girder bridges on Rte 77 over Laurel Creek in Bland County (1974).
8. Tunnels on Rte 77 through East River Mountain in Bland County (1975).
9. Slant-leg concrete bridges on Rte 705 over Rte 77 in Carroll County (1977).

APPENDIX II

LIST OF BRIDGES AND TUNNELS NAMED BY THE GENERAL ASSEMBLY OR THE
STATE HIGHWAY AND TRANSPORTATION COMMISSION

ALTIZER BRIDGE: Route 8 over Little River at the Floyd-Montgomery County Line.

W. N. ANGLE MEMORIAL BRIDGE: Business Route 220 over the Norfolk & Western Railroad in Rocky Mount, Franklin County.

APPOMATTOX BRIDGE: Route 1-301 over Appomattox River at the Colonial Heights-Petersburg City Limits.

JAMES V. BICKFORD MEMORIAL BRIDGE: Route 351 over Hampton River in Hampton.

CHARLES BICKLEY MEMORIAL BRIDGE: Alternate Route 58 over Clinch River at the South Corporate Limits of Saint Paul.

THE J. SINCLAIR BROWN BRIDGE: Route 11 over the Norfolk & Western Railroad in Salem.

HARRY FLOOD BYRD BRIDGE: Route 17-50 over Shenandoah River near Millwood in Clarke County.

LEANDER SANDERS CALFEE MEMORIAL BRIDGE: Route 100 over New River, north of Barren Springs in Wythe County.

J. P. CARICO MEMORIAL BRIDGE: Route 58-221 over New River west of Galax in Grayson County.

CASTLEMAN'S FERRY BRIDGE: Route 7 over Shenandoah River east of Berryville in Clarke County.

CHATHAM BRIDGE: Route 3 over Rappahannock River at the East Corporate Limits of Fredericksburg.

CHICKAHOMINY BRIDGE: Route 5 over Chickahominy River at the James City-Charles City County Line.

JOHN H. COCKE MEMORIAL BRIDGE: Route 15 over James River at Brems Bluff in Fluvanna County.

GEORGE P. COLEMAN MEMORIAL BRIDGE: Route 17 over York River at Yorktown.

COLONEL IRA B. COLTRANE MEMORIAL BRIDGE: Route 52 over Little Reed Island Creek northwest of Hillsville in Carroll County.

JOHN COUNTS MEMORIAL BRIDGE: Route 82 over Clinch River at Cleveland in Russell County.

ROBERT F. CRAFT MEMORIAL BRIDGE: Route 60-220 over Smith Creek and the Chesapeake & Ohio Railroad in Clifton Forge.

LORD DELAWARE BRIDGE: Route 33 over Mattaponi River at the East Corporate Limits of West Point.

R. A. DOUGHTON MEMORIAL BRIDGE: Route 21-221 over New River in Grayson County.

THOMAS J. DOWNING BRIDGE: Route 360 over Rappahannock River at Tappahannock.

NATHANIEL B. EARLY BRIDGE: Route 29 over Rapidan River at the Greene-Madison County Line.

ELTHAM BRIDGE: Route 30-33 over Pamunkey River at the West Corporate Limits of West Point.

THOS. L. FELTS MEMORIAL BRIDGE: Route 58-221 over Crooked Creek northeast of Galax in Carroll County.

JAMES H. FLETCHER BRIDGE: Route 231 over Hughes River at the Madison-Rappahannock County Line.

GARTHRIGHT MEMORIAL BRIDGE: Washington Avenue over the Norfolk & Western Railroad in Vinton.

T. J. GEORGE MEMORIAL BRIDGE: Route 8 over Mayo River at the South Corporate Limits of Stuart in Patrick County.

CHARLES HAYES GILMER BRIDGE: Route 19 over Big Cedar Creek east of Lebanon in Russell County.

HENRY G. GILMER BRIDGE: Route 460 and Business Route 13 over the Southern Branch of the Elizabeth River in Chesapeake.

CARTER GLASS MEMORIAL BRIDGE: Route 29 over James River at the North Corporate Limits of Lynchburg.

GEORGE PORTER GRIFFIN MEMORIAL BRIDGE: Route 15 over Carys Creek south of Palmyra, Fluvanna County.

BENJAMIN HARRISON MEMORIAL BRIDGE: Route 156 over James River at the Charles City-Prince George County Line.

HUGUENOT MEMORIAL BRIDGE: Route 147 over James River at the Corporate Limits of Richmond.

WILLIAM PEARCE HUNTER BRIDGE: Route 11-221-116 over the Norfolk & Western Railroad in Roanoke.

STANHOPE HURT BRIDGE: Route 40 over Pigg River, west of Gretna in Pittsylvania County.

INGLES FERRY BRIDGE: Route 81 over New River at the Pulaski-Montgomery County Line.

JOHN M. JOHNSON MEMORIAL BRIDGE: Route 23 over North Fork of Holston River at the South Corporate Limits of Weber City in Scott County.

MAJOR JOHN R. KERRICK BRIDGE: Route 229 over Hazel River, north of Rixeyville in Culpeper County.

CHARLES T. LASSITER MEMORIAL BRIDGE: Route 1-460 over the Seaboard Coast Line Railroad in Petersburg.

CHARLES CARTER LEE MEMORIAL BRIDGE: Bypass Route 220 over Route 40 at the East Corporate Limits of Rocky Mount in Franklin County.

JOHN A. LESNER BRIDGE: Route 60 over Lynnhaven Inlet, west of Fort Story in Virginia Beach.

JAMES MADISON MEMORIAL BRIDGE: Route 301 over Rappahannock River at Port Royal, King George-Caroline County Line.

RAWLEY WHITE MARTIN MEMORIAL BRIDGE: Route 29 over Banister River South of Chatham in Pittsylvania County.

THE COLONEL THOMAS McCULLOCH MEMORIAL BRIDGE: Route 19 and Alternate Route 58 over North Fork of Holston River, south of Holston in Washington County.

WILLIAM WALTHALL MICHAUX BRIDGE: Route 522 over James River south of Maidens at the Goochland-Powhatan County Line.

GENERAL JOHN H. MORGAN MEMORIAL BRIDGE: Route 11 over the Norfolk & Western Railroad at the East Corporate Limits of Abingdon.

THE ROBERT OPIE NORRIS, JR. BRIDGE: Route 3 over Rappahannock River at the Middlesex-Lancaster County Line.

PEMBROKE PETTIT BRIDGE: Route 15 over Rivanna River at Palmyra in Fluvanna County.

PIONEER MEMORIAL BRIDGE: Route 11 over Middle Fork of Holston River at Seven Mile Ford in Smyth County.

MARY PORTER BRIDGE: Route 460 over East River in Glen Lyn, Giles County.

THE COLONEL ROBERT PRESTON MEMORIAL BRIDGE: Route 11-19 over Beaver Creek northeast of Bristol in Washington County.

REVEREND J. W. RADER MEMORIAL BRIDGE: Route 21 over Elk Creek, north of Longs Gap in Grayson County.

JOHN RANDOLPH BRIDGE: Route 304 over Dan River at the South Corporate Limits of South Boston.

GEORGE W. ROBERTSON BRIDGE: Park Avenue over Dan River in Danville.

SAMUEL P. ROBINETTE MEMORIAL BRIDGE: Route 70 over Blackwater Creek south of Jonesville in Lee County.

ANDREW S. ROWAN BRIDGE: Route 460 over New River at the North Corporate Limits of Glen Lyn in Giles County.

PETER SAUNDERS MEMORIAL BRIDGE: Business Route 220 over Pigg River at the South Corporate Limits of Rocky Mount in Franklin County.

D. C. SEWELL, SR. MEMORIAL BRIDGE: Route 70 over Powell River south of Jonesville in Lee County.

SHERIFF W. SHIVELY MEMORIAL BRIDGE: Route 40 over the Norfolk & Western Railroad at Ferrum in Franklin County.

SHUGART MEMORIAL BRIDGE: Route 11 over Holston River in Marion.

ANDERSON E. SHUMATE MEMORIAL BRIDGE: Route 460 over New River west of Pearisburg in Giles County.

SOUTHWEST VIRGINIA MEMORIAL BRIDGE: Route 11 over New River at the North Corporate Limits of Radford.

SPANISH-AMERICAN WAR VETERANS MEMORIAL BRIDGE: Route 1-460 over Rohoic Creek at the West Corporate Limits of Petersburg.

WILLIAM D. THOMPCKINS MEMORIAL BRIDGE: Route 221 over Big Reed Island Creek east of Hillsville in Carroll County.

G. A. TREAKLE MEMORIAL BRIDGE: Route 168, Great Bridge Bypass over the Albemarle Canal in Chesapeake.

JOHN ANDREW TWIGG BRIDGE: Route 3 over Piankatank River at the Mathews-Middlesex County Line.

GENERAL C. C. VAUGHAN, JR. BRIDGE: Route 258
over Nottoway River south of Franklin in South-
ampton County.

TAYLOR G. VAUGHAN MEMORIAL BRIDGE: Route 58-
221 over Chestnut Creek in Galax.

TUCKER C. WATKINS, JR. MEMORIAL BRIDGE: Route
501 over Dan River at the South Corporate Limits
of South Boston.

HUGH WILLIAMS MEMORIAL BRIDGE: Route 23 over
Powell River in Big Stone Gap.

PHILIP ST. JULIEN WILSON MEMORIAL BRIDGE:
Route 15-49-58 over Buggs Island Lake at Clarks-
ville in Mecklenburg County.

ROBERT W. WITHERS MEMORIAL BRIDGE: Route 10-32-
460 Business over Nansemond River at the Old
North Corporate Limits of Suffolk.