

## METHODS OF MODIFYING HISTORIC BRIDGES FOR CONTEMPORARY USE

by

William Zuk, Faculty Research Scientist  
Howard H. Newlon, Jr., Associate Head  
Wallace T. McKeel, Jr., Research Scientist

(The opinions, findings, and conclusions expressed in this report are those of the authors and not necessarily those of the sponsoring agencies.)

Virginia Highway & Transportation Research Council  
(A Cooperative Organization Sponsored Jointly by the Virginia  
Department of Highways & Transportation and  
the University of Virginia)

In Cooperation with the U. S. Department of Transportation  
Federal Highway Administration

Charlottesville, Virginia

June 1980  
VHTRC 80-R48

## HISTORY RESEARCH ADVISORY COMMITTEE

MR. H. M. SHAVER, JR.  
Chairman, Location & Design Engr., VDH&T

MR. J. E. ANDREWS  
Bridge Design Engineer Supervisor, VDH&T

MR. A. W. COATES, JR.  
Special Assistant for Public Relations, VDH&T

PROFESSOR O. A. GIANNINY, JR.  
Associate Professor of Humanities, U. Va.

MR. W. D. GILBERT  
Environmental Planner, VDH&T

MR. D. L. GRIFFIN  
Chief, Historic American Engineering Record

MR. G. W. HESTERBERG  
Environmental Specialist, FHWA

PROFESSOR E. L. KEMP  
Chairman, History of Science & Technology,  
West Virginia University

MR. K. E. LAY, JR.  
Assistant Dean, School of Architecture, U. Va.

MR. E. B. MILLIRONS  
Associate Transportation Planning Engineer, VDH&T

MR. H. NEWLON, JR.  
Associate Head, VH&TRC

MR. J. K. SKEENS  
Asst. Urban Engineer, VDH&T

## BRIDGE RESEARCH ADVISORY COMMITTEE

J. M. MCCABE, JR., Chairman, Asst. Bridge Engineer, VDH&T  
F. L. BURROUGHS, Construction Engineer, VDH&T  
C. L. CHAMBERS, Division Bridge Engineer, FHWA  
H. L. Kinnier, Consultant, VH&TRC  
J. G. G. MCGEE, Construction Control Engineer, VDH&T  
W. T. MCKEEL, JR., Highway Research Scientist, VH&TRC  
M. F. MENEPEE, JR., Structural Steel Engineer, VDH&T  
L. L. MISENHEIMER, District Bridge Engineer, VDH&T  
R. H. MORECOCK, District Bridge Engineer, VDH&T  
W. W. PAYNE, Professor of Civil Engineering, VPI & SU  
F. L. PREWOZNIK, District Bridge Engineer, VDH&T  
M. M. SPRINKEL, Highway Research Scientist, VH&TRC  
F. G. SUTHERLAND, Bridge Engineer, VDH&T  
D. A. TRAXNHAM, Prestressed Concrete Engineer, VDH&T

## FOREWORD

As described in the working plan dated August 1977, this study was undertaken in an effort to preserve a fast disappearing part of America — its early metal truss bridges. Even during the period of the study, four of the twenty-four historic bridges selected to be studied were replaced and destroyed. To illustrate the many potential contemporary uses for these old bridges, uses both conventional and unconventional were explored. Although the selected bridges are those in Virginia, the findings should have application for bridges in other states as well.

2792

## ABSTRACT

Studied by a team of experts in the fields of history, bridge engineering, architecture, and computer analysis were 21 old trussbridges of historical importance located in Virginia. These old bridges are narrow and have low load-carrying capacities, making them targets for replacement and destruction. On a case-by-case basis, the bridges were investigated as to their potentials for strengthening and widening for normal vehicular use. Also explored were non-vehicular uses as for conversion into craft centers, museums, restaurants, housing, bicycle structures, and the like, at either the present site or a new one.

The wide array of possibilities for continued use of the old bridges described in this report show that old bridges do indeed have much useful life left in them and it is not always necessary that they be demolished.

2794

## METHODS OF MODIFYING HISTORIC BRIDGES FOR CONTEMPORARY USE

by

William Zuk, Faculty Research Scientist  
Howard H. Newlon, Jr., Associate Head  
Wallace T. McKeel, Jr., Research Scientist

## INTRODUCTION

Because of the unique role that Virginia has played in the development of America, the preservation of its historic sites and buildings associated with people or events important in the history of America is a well-established tradition within the Commonwealth. In recent years agencies responsible for major construction activities such as transportation facilities have directed increased attention to the impact of their construction on these historic sites and structures, particularly as a result of the National Historic Preservation Act of 1966, Executive Order 11593 signed in 1971, and the requirements of the various Department of Transportation Acts.

These mandates greatly restrict the use of federal funds for projects that would detrimentally impact sites or structures either on or eligible for the National Register of Historic Places. Traditionally, properties placed upon the Register have been buildings and prehistory sites as opposed to engineering structures such as bridges, roads, and dams. Currently, however, such structures are rapidly being added to the Register.

Within Virginia, millions of tourists annually visit national monuments such as Mt. Vernon, Monticello, Jamestown, and Colonial Williamsburg. Special care and consideration is required to provide access to such sites with minimal impact upon the visual experiences of the visitor. Thus, Virginia has a long heritage of transportation planning to accommodate historic values.

The importance of these national monuments is universally recognized. It is rather the numerous other sites and items meeting the eligibility requirements of the National Register of Historic Places that require new approaches, consideration, and informed judgment. Eligibility for the National Register is defined as:

The quality of significance in American history, architecture, archeology and culture is present in districts, sites, buildings, structures and objects of state and local importance that possess integrity of location, design, setting, materials, workmanship, feeling and association....

Requirements of the National Historic Preservation Act (Section 106) and the Department of Transportation Act (paragraph 4f) dictate that consideration be given to avoiding or mitigating adverse impact upon properties or objects on or eligible for the National Register when projects are federally funded.

Until recently, a conflict inherent in meeting the requirements of preservation legislation in the case of highway bridges resulted from the bridge replacement program, also largely financed by federal funds. Although it was the policy of the Federal Highway Administration to encourage either the removal of an inadequate bridge to a suitable location or bypassing it by routing traffic to a new bridge over another alignment where possible, this legislation tended to foster the total replacement of structures that do not meet stipulated safety requirements. These bridges are characterized as "structurally deficient and/or functionally obsolete" according to calculations that result in a "sufficiency rating". Obviously, bridges old enough to be historically significant are often deficient with regard to current traffic demands as indicated by the sufficiency rating. The conflict was recognized and a possibility for its resolution was provided in the Surface Transportation Assistance Act of 1978, which deals with the rehabilitation of bridges as well as replacement. Under this Act, structures can now be inventoried for historic significance.

Since metal truss bridges as a class are particularly affected by these conflicting legislative requirements, and in recognition of the responsibility of the Virginia Department of Highways & Transportation to preserve, if possible, those structures of historic significance, in 1974 the Research Council initiated a statewide survey of surviving metal truss bridges constructed prior to 1932. Results of the survey have been published in a series of reports, each covering one of the state's construction districts.<sup>(1,2)</sup> This work was the essential first step since any coordinated plan requires a knowledge of the entire population of bridges that might need special consideration.

Subsequently, the project was broadened to include other types of bridges and the development of criteria to aid in estimating potential historic significance. Factors to be considered and a resulting numerical rating system were suggested for establishing those metal trusses that would be expected to possess sufficient historic significance to require consideration in the planning of future projects.<sup>(3)</sup>

As a result of these studies, 7 metal truss bridges were nominated by the Department to the State and National Registers in 1978. These were entered on the National Register, joining 2 of Virginia's metal trusses that were already so designated. Additionally, approximately 40 trusses, while judged not to be of sufficient importance to justify Register nomination, were identified as worthy of some consideration, and approximately 500 were judged to possess no potential historic significance.



The goal of preservation legislation is to minimize unintentional or uninformed detrimental impact upon a structure that possesses historic significance. It is recognized that continued use for vehicular traffic is not always a viable option, even if it is a desirable goal. The identification of a bridge as historically significant carries with it the responsibility to develop strategies for continuing the structure in service or finding sympathetic adaptive uses. Since Virginia has been at the forefront of activity relating to the identification of potentially historic bridges, the exploration of such strategies was the logical next step.

### OBJECTIVE AND SCOPE

The purpose of the project was to explore, for a representative sample of Virginia's metal truss bridges, the technical aspects of upgrading old bridges for vehicular use or sympathetic, adaptive non-vehicular uses. Twenty-one bridges were studied, including 10 listed on the Virginia and National Registers of Historic Places and 11 judged to be of lesser historic significance but endangered by proposed replacement projects because of lower than desired sufficiency ratings or other factors.

In an effort to preserve as many of these bridges as possible, a wide variety of possible ways to modify these bridges for continued use were studied. An extensive computer analysis was used in the investigation of the strength of the bridge trusses, both as they are now and how they might be modified for higher or different load capacities.

Although practical engineering and architectural considerations were taken into account in all phases of the study, specific costs for making the many suggested modifications were not determined. It is possible that some bridges would be attractive for private development rather than any treatment at public expense, and this alternative would result in a cost savings to the Department. Certain aspects of site considerations also remain incomplete as the exact location of possible replacement bridges with their associated rights-of-way have not yet been established by the Department. Suggestions made for specific structures might be possible only with appropriate consideration for realignment of the approaches and site of the replacement structure.

Nonetheless, as the purpose of the study was to set forth an array of ideas for dealing with the preservation of historic or potentially historic bridge structures, it is believed that the scope of the work done was fully adequate.

Although the scope of the study was limited to the selection of a number of bridges of a given type located in Virginia, many of the ideas and concepts presented are valid for bridges of other types and in other states. In that sense, the scope of the study extended well beyond the borders of Virginia.

## PROCEDURE

### Staff

Because of its interdisciplinary nature, the study was done by a team of three senior members of the Research Council's staff. Howard Newlon's expertise is in the history of technology, Wallace McKeel's is in bridge engineering, and William Zuk's is in architecture. George Kirby, a graduate engineering student, was subsequently added to perform computer analyses. Reid Reames, an architectural student, also assisted in the study. Except for Reames, all members of the team have a background in civil engineering.

### Study Bridges

A sample of 24 historic or potentially historic truss bridges located in Virginia were selected for special study with guidance from the Council's History Research Advisory Committee. A list of the bridges is given below. Throughout the report, these bridges are referred to by the numbers 1 through 24.

1. Rte. 630 over the James River in Botetourt County (Figure 1)
2. Rte. 746 over the Calfpasture River in Rockbridge County (Figure 2)
3. Rte. 653 over the Southern Railroad in Nelson County (Figure 3)
4. Rte. 715 over the Meherrin River in Brunswick County (Figure 4)
5. Rte. 646 over the Southern Railroad in Prince William County (Figure 5)
6. Rte. 1421 over Linville Creek in Rockingham County (Figure 6)

7. Rte. 640 over the Staunton (Roanoke) River in Campbell County (Figure 7)
8. Rte. 685 over Craig Creek in Rockingham County (Figure 8)
9. Rte. 673 over Catoctin Creek in Loudoun County (Figure 9)
10. Rte. 615 over the Clinch River in Russell County
11. Rte. 620 over the Rappahannock River in Fauquier/Culpeper Counties (Figure 10)
12. Rte. 619 over Cripple Creek in Wythe County (Figure 11)
13. Rte. 613 over the Little River in Montgomery County
14. Rte. 812 over Catoctin Creek in Loudoun County
15. Rte. 640 over Reed Creek in Wythe County (Figure 12)
16. Rte. 657 over the Southern Railroad in Amherst County (Figure 13)
17. Rte. 720 over Buffalo Branch in Augusta County
18. Rte. 632 over the South River in Augusta County (Figure 14)
19. Rte. 615 over the Pamunkey River in King William/Hanover Counties (Figure 15)
20. Rte. 675 over the North Fork of the Shenandoah River in Shenandoah County (Figure 16)
21. Rte. 645 over the Rappahannock River in Fauquier/Rappahannock Counties (Figure 17)
22. Rte. 613 over the Rockfish River in Nelson County (Figure 18)
23. Rte. 747 over Goose Creek in Bedford County (Figure 19)
24. Rte. 677 over Allen's Creek in Mecklenburg County (Figure 20)

Soon after the initiation of the study, bridges 10, 13, 14, and 17 were replaced and disposed of. Substituted was another bridge on Rte. 291 over the N & W Railroad in the city of Lynchburg. The substituted bridge will be referred to as "The Fink Truss Bridge" as shown in Figure 21. Bridge no. 1 is a wooden truss bridge. All others are of either the steel or iron truss type. Bridges 1 through 9 have been placed on the National Register of Historic Places. The Fink Truss Bridge, a unique old structure, has been officially designated as a National Civil Engineering Landmark and singled out for special attention. The others, although currently not listed nationally as "historic", rank very high as determined by the criteria presented in reference 3.

### Acquisition of Information

Information and data on all the bridges were first acquired. Few original drawings could be found, but drawings based on inspection reports by the Department's district personnel were available. In on-site inspections of the bridges, particular attention was paid to special features of the structures and the surrounding regions as might suggest adaptive uses of the bridges. The bridges are illustrated in figures that appear at the end of the report, preceded by a notation sheet.

In seeking further information on possible uses of the bridges, people outside the Research Council were contacted. These included representatives of the operating divisions of the Department, the Virginia Division of State Parks, the Virginia Game Commission, the Virginia Commission on Outdoor Recreation, and the Federal Highway Administration, building inspection officials, and bridge contractors, and their views proved very helpful. In addition, the legal code of Virginia was examined to determine the conditions for the sale, lease, or transfer of public property such as highway bridges.

### Strategies Employed

The research team formulated the following eleven strategies for the useful preservation of the bridges.

1. Upgrade the bridge for continuing use at its present site by discreetly strengthening it.
2. Geometrically modify the bridge for use at its present site as by discreetly widening the deck.

3. Modify the approach roadway so that the old bridge carries only one-way traffic. A parallel bridge would carry traffic in the opposite direction. The parallel bridge could be another old bridge specially moved to the site or a harmoniously designed new bridge.
4. Change the use of the bridge from vehicular to non-vehicular at the present site and construct a new bridge so as not to destroy the old one. Depending on the situation, the old bridge could be used as a pedestrian crossing, fishing pier, or historical landmark, or possibly could even be converted into an architectural use as a picnic shelter, restaurant, or souvenir shop.
5. Move the bridge to another less demanding traffic location. This alternative is particularly feasible for timber or metal bridges. Possible non-vehicular uses are for pedestrian bridges in parks, play structures in parks, camping shelters (when covered), roadside information buildings, museums or restaurants (when enclosed), or technological museum pieces.
7. Discreetly incorporate portions of the old bridge into a new bridge, either structurally or decoratively.
8. If it is a timber or metal bridge, match-mark, disassemble, and store the structure until a use can be found for it.
9. In special situations, declare the bridge a historical ruin and place it off limits for anything but viewing.
10. If the structure must be razed, "save" it by completely documenting it on paper (by making measured drawings) and film (by making general and detailed photographs). Not to be overlooked is the use of stereophotography or holography to capture the three-dimensional quality of the structure.
11. Use the bridge as part of a bikeway, at either the existing or a new site.

The strategies relating to the continued use of the structures by highway vehicles were studied by McKeel and Kirby, and those relating to non-vehicular uses by Zuk and Reames. Coordination with outside agencies was undertaken by Newlon. Frequent conferences between all members of the study team were held for the sharing of ideas.

## CASE STUDIES OF BRIDGES

Vehicular UsePhilosophy

As noted, one portion of the study sought to develop means to retain historic or potentially historic bridges in service without compromising their significance. Virginia's older trusses would be judged functionally obsolete by existing federal standards as they do not have the structural capacity to carry modern highway loadings and their roadway clearances or geometrics limit traffic flow. As a result, it is common practice to replace these structures with new ones. There are ways to strengthen trusses and, in some cases, to widen them, but these methods generally do not consider preservation of the historic aspects of the bridges. Instead, weak members are replaced or modified as dictated by practicality.

A more desirable approach appears to be to reinforce either the entire truss or individual members by the addition of supplementary elements that are readily discernible from the original structure. In this report, emphasis is placed on preserving the truss itself rather than the floor system. Procedures for strengthening the floor system members are available in the literature on bridge rehabilitation, and these members, which often control the capacity of a bridge, have been replaced in the past on some of Virginia's historic bridges.

Widening of the trusses was also eliminated from consideration. It is generally acknowledged that while it is sometimes possible to widen pony trusses, widening the longer through trusses is seldom practical. The widening of a through truss bridge would require replacement of the portal bracing, often cited as an attractive aspect of the bridge, and the altering of its proportions might adversely affect the appearance of the structure.

Ideally, the bridges would remain in service on the highway system, and it was decided to concentrate on raising the capacities to the AASHTO HS20 standard loading used for all modern bridges in Virginia.<sup>(4)</sup> Admittedly, a lighter design loading might be acceptable for many structures on the secondary highway system, but it was felt that procedures that appeared effective in attaining the HS20 capacity would be equally applicable to any lighter loadings.

The development of firm plans for all 21 historically significant structures was beyond the means of this study and the needs of the Department. Instead, several strengthening techniques were applied to one of the historic bridges chosen as typical of the group. Only a few limited analyses of other structures were performed.

## Related Work

Three major publications related to the subject study have been prepared recently in response to the nation's much publicized bridge crisis. These are an ASCE publication, Repair and Strengthening of Old Steel Truss Bridges;<sup>(5)</sup> an FHWA research report, Extending the Service Life of Existing Bridges by Increasing Their Load Carrying Capacity, prepared by the firm of Byrd, Tallamy, McDonald, and Lewis;<sup>(6)</sup> and a soon to be released Manual of Recommended Practice for the rehabilitation and replacement of secondary highways and local road bridges, prepared at the Research Council for the National Cooperative Highway Research Program.<sup>(7)</sup> These publications provide general guidelines for the inspection, rating, strengthening, widening, and repair of truss bridges. While their emphasis is on general rehabilitation rather than preservation, they have some applicability to the goals of the subject study. In particular, those procedures for strengthening floor system members, including the deck, stringers, and floor beams, proved useful. Information from these and related publications is discussed more fully in the following sections.

### Trusses and Truss Members

There are procedures for the replacement of virtually any truss member, including a technique developed by the Massachusetts Department of Transportation for replacing an entire lower chord system without the use of falsework.<sup>(7)</sup> A detail developed by the Virginia Department of Highways and Transportation as a replacement for a diagonal tension member,<sup>(5,7)</sup> Figure 22, may be used as a supplementary member, if it can be accommodated within the existing joint. In one case, a new eyebar was installed between two existing ones by slightly heating it and bolting it in place while elongated. When the new bar cooled, it assumed a share of the load.<sup>(8)</sup>

Railroad engineers have apparently had some success in doubling trusses on a span.<sup>(5)</sup> In such cases a weak truss is supplemented by another truss of the same length between bearings placed next to it and connected to it. Doubling was not used in the present study because suitable supplementary trusses were not available, but a related procedure, the use of a specially fabricated supplemental truss to share the load with a historic truss, was investigated. Pony trusses have been strengthened in this manner by Bailey bridge spans.<sup>(5)</sup>

Posttensioning of the tension members of a truss, particularly the lower chords, has been used with some success.<sup>(5,6,7)</sup> Cables or

rods placed along the members and attached at the connecting pin or to reinforced fittings are tensioned, usually by means of turn-buckles. Entire trusses have been strengthened in this manner, with rods along the lower chords being supplemented by additional reinforcement elsewhere in the structure.<sup>(9)</sup> If only live load is to be carried, the rods or cables are tightened only until snug. To overcome dead load stresses in the truss, the rods or cables are tightened until camber is induced in the truss, which must be monitored during the application of the force.

Occasionally, the capacity of a truss can be increased by connecting adjacent spans to form a continuous structure.<sup>(5,6)</sup> Individual truss members must, of course, be able to withstand the stresses induced in the continuous structure, and this often limits the applicability of the technique. A similar problem can occur when the clear span of a truss is shortened by building intermediate supports under the first interior panel points.<sup>(6)</sup>

It may also be possible to increase the live load capacity of a truss by reducing its dead load through the use of a lighter deck. Among the deck systems documented in the literature are open or concrete-filled steel grids, aluminum panels with a sand-filled epoxy wearing surface, corrugated steel "bridge planks" filled with asphalt concrete, glued-laminated (glulam) timber panels, and orthotropic steel plate deck sections.<sup>(6,10,11,12,13)</sup> Concrete decks can be replaced with significant savings in weight, but it is doubtful if similar advantages would be realized in the case of the timber plank decks commonly found on older truss bridges in Virginia.

In one instance, a steel orthotropic deck bridge inside of a covered bridge in Connecticut carried the full live load of the old wooden structure, allowing it to remain in place despite severe deterioration.<sup>(14)</sup> Several local factors influenced the decision to use this rather expensive structural element. Similar use of a separate bridge completely relieving a historic truss of live load, while it is a possible course of action, was not considered in the present study.

### Floor Systems

As mentioned earlier, the floor systems were considered less crucial than the trusses to the historical significance of the bridges. Some modification of the floor elements may prove necessary. The live loading applied in the original design of many older trusses had the form of a uniform load in pounds per square foot of floor surface. This resulted in stringers and floor beams of much less capacity than the trusses, and the floor members are often cited as the weak points in the bridges.



Common practices in strengthening floor systems include adding stringers and floor beams or welding cover plates to the flanges of these members to improve their sectional properties.<sup>(5,6)</sup> New stringers are connected to their existing counterparts to ensure uniform deflections, and the addition of members is possible only if the trusses can sustain the added dead load.

A unique approach to strengthening a floor beam is the use of a king post truss beneath the beam as shown in Figure 23.<sup>(6,7)</sup> This procedure is similar in concept to the posttensioning arrangement used to strengthen trusses, and similar schemes have been used to increase the capacities of steel beam spans.<sup>(15)</sup>

It is possible for the floor system to provide some reserve to the strength of the bridge, as the stringers and floor share the applied load with the chords of the trusses.<sup>(16)</sup> This can occur if the floor members connect to the truss near the level of the chords, but rigorous methods of analysis, possibly supplemented by field testing, is usually required to evaluate the extent of the strength reserves. The role of secondary members in sharing the truss live loads was not considered in the present study, but any such redundancy would increase the safety of a bridge.

#### Geometrics

While horizontal clearances on old through truss bridges are usually severely limited, the widening of such structures is extremely difficult and generally impractical.<sup>(6)</sup> Procedures are available for widening pony truss bridges, generally by shifting one of the trusses laterally and framing the existing floor beams into a heavy longitudinal member, such as a double-plate girder, at the truss position. New floor beams span from the girder to the shifted truss.<sup>(5)</sup> Widening of a through truss would require the fabrication of new top bracing, and, because of the generally greater lengths of through trusses, a more substantial longitudinal member would usually be required.

Although widening does not appear feasible, some potentially useful details are available. The portal bracing may be altered in its configuration to increase the vertical clearance if required, but the portal bracing itself may be historically significant. While horizontal clearance is more or less fixed, rail systems, such as that shown in Figure 24, may be installed.<sup>(7)</sup> The rail, based on a detail developed by the North Carolina Department of Transportation, is supported independently of the trusses. It does not meet current AASHTO requirements for bridge rails, but it does provide some degree of protection to the trusses and to occupants of impacting vehicles and other traffic. Depending upon the circumstances, it may be possible that a different railing system meeting AASHTO requirements can be designed and installed on historic bridges.

In lieu of widening a bridge to accommodate two lanes of traffic, the authors suggest moving some of the historic trusses adjacent to others of similar length and configuration to accommodate the second traffic lane. Bridges located at their original sites or at attractive sites would remain in place. The feasibility of such an approach was indicated by a review of the 21 structures in this study that showed 6 matching pairs of truss bridges.

### Analytical Studies of a Typical Truss Bridge

The effectiveness of several selected strengthening procedures in increasing the capacity of a truss bridge was evaluated analytically at the University of Virginia.<sup>(17)</sup> It was desired to test the procedures using the properties of an actual truss span. Realizing that application of the detailed analyses to each of the historic trusses was not feasible, it was decided to select one typical bridge and to try to extrapolate the results to the other structures. Fortunately, the few practical strengthening techniques for old metal trusses were found to be generally applicable.

Some limitations were necessarily placed on the analytical work. One- and two-span bridges were included in the study, but only a single-truss configuration, a Pratt truss described later, was analyzed. Analyses of other types of trusses were made only as required to verify the generality of the findings. Only an HS20 loading was incorporated in most of the analyses, although limited comparative studies of an HS15 loading were performed. Emphasis was given to the truss members, with relatively little time being devoted to studies of the connection details. Strengthening of the floor system was believed adequately covered in the section on related work, and widening of the bridges was not considered.

### Typical Truss

The structure used in most of the analyses was one span of the bridge carrying Rte. 632 over the South River in Augusta County, Virginia (bridge no. 18). The bridge is composed of two Pratt truss spans with lengths of 80 and 82.5 feet (24.4 and 25.2 m) as shown in Figure 25. The superstructure is believed to be made of steel with wrought iron tension eyebars. It is believed that the bridge was designed and built in 1887 by the Pittsburgh Bridge Company. A single lane of traffic is carried on a 10 ft., 9 in. (3.3 m) clear roadway and vertical clearance is limited by the portal bracing to 13 ft., 1 in. (4 m) over the center 7 ft., 6 in. (2.3 m) of the roadway and to 11 ft., 11 in. (3.6 m) at the intersection of the knee

braces and the truss end posts. The truss is pin-connected with riveted splices. The deck is composed of 3 in. by 10 in. (76 x 254 mm) timbers with a 3/4 in. (19 mm) thick surface treatment. Currently the bridge, which is not on the federal-aid system, is scheduled for inspection each year and posted for a load limit of 8 tons (7260 kg). No plans are available beyond the detailed inspection report prepared by the Department of Highways and Transportation in May 1976.(18) The following controlling capacities, with critical members, were calculated for the inspection report:

Type 3 Loading — 7 tons (6350 kg) (deck and floor beam critical)

Type 3S2 Loading — 10 tons (9070 kg) ( $U_2L_3$  critical)

Type 3-4 Loading — 12 tons (10,880 kg) ( $U_2L_3$  and floor beam critical)

(See reference 19 for a description of the loading types.)

Some signs of structural distress were noted during the inspection. Several of the floor beams were found to be canted, and several bent members were noted throughout the structure. There was evidence that one  $U_2L_2$  member had been replaced, and the two channels comprising one of the  $U_3L_3$  members had cracked and been welded, with a reinforcing plate being added to the member. The effects of these irregularities were not considered in the subject analyses, but they would demand consideration in the development of plans to restore the bridge.

In spite of the apparent replacement of members in the past, only those strengthening techniques that required neither modification nor replacement of truss members were considered in the ensuing analyses.

#### Methods of Analysis

Two finite element computer programs, SPAR<sup>(20)</sup> and STAPLER,<sup>(21)</sup> were utilized in the analyses of the typical truss. STAPLER is a two-dimensional program that uses bar and rectangular plane stress elements to model the structure. SPAR, a large general purpose program, handles a wider assortment of finite elements, including both beam and bar elements. Since the computer costs associated with the simpler STAPLER were less than those associated with SPAR, the former was generally used.

The HS20 live load was applied as a uniform loading with a movable concentrated load applied at panel points, both loads being equally divided between the two trusses. Both the live load and the dead load taken from the inspection report were assumed to act at the lower panel points.

Assumptions of the material properties of the steel used in the truss were required due to the age of the structure and a lack of knowledge of the origin of the metal. As prescribed by the AASHTO,<sup>(19)</sup> a yield stress of 26 ksi (179 MPa) was assumed, and the allowable axial tensile stress was computed as  $0.55 F_y$  (the yield stress) or 14 ksi (96 MPa). The allowable compressive stress was given by the expression  $12.26 - 0.28 \left(\frac{KL}{r}\right)^2$ , using  $K = 1.0$  based on the assumption of pin-connected columns. The contribution to section properties by the lattice bracing on compression members was neglected. Table 1 contains the computed areas and allowable stresses for the truss members.

#### Stresses in the Unreinforced Trusses

As a first step it was necessary to determine the stresses in the members of the unreinforced truss under the applied HS20 loading. Table 2 shows the results of this analysis (members with symmetrical counterparts are not listed).

As indicated in Table 2, the very light hanger  $L_1U_1$  and counter  $L_2U_3$ , with their counterparts  $U_4L_4$  and  $U_2L_3$ , are most seriously overstressed by the heavy live loading. These are the lightest tension members in the truss with areas of only 1.202 sq. in. (775 mm<sup>2</sup>) for the hangers and 0.601 sq. in. (388 mm<sup>2</sup>) for the counters. The remaining tension members were less critically stressed, and, in fact, the overstress of only 235 psi (1.6 MPa) in the heavier midspan lower chord,  $L_2L_3$ , could probably be ignored.

Of interest was the finding that the compression members are adequate except for a slight overstress, 572 psi (3.9 MPa), in the end posts. Some reinforcement of the end posts, critical to the stability of the span, might be considered, particularly if inspection disclosed any evidence of corrosion or other distress.

Having established the performance of the unmodified structure, the investigation proceeded to consider procedures for strengthening the two-span bridge as a unit and the individual 80-ft. (24.4 m) span.

Table 1  
Area and Allowable Stresses For Each Truss Member

Member	Area Sq. in.	Tensile Stress, ksi	Compressive Stress, ksi
L <sub>0</sub> L <sub>1</sub>	2.0	14.0	0.305
L <sub>1</sub> L <sub>2</sub>	2.0	14.0	0.305
L <sub>2</sub> L <sub>3</sub>	2.75	14.0	0.577
L <sub>3</sub> L <sub>4</sub>	2.0	14.0	0.305
L <sub>4</sub> L <sub>5</sub>	2.0	14.0	0.305
L <sub>1</sub> U <sub>1</sub>	1.202	14.0	0.350
L <sub>2</sub> U <sub>2</sub>	4.8	14.0	10.368
L <sub>3</sub> U <sub>3</sub>	4.8	14.0	10.368
L <sub>4</sub> U <sub>4</sub>	1.202	14.0	0.350
L <sub>0</sub> U <sub>1</sub>	6.44	14.0	7.052
L <sub>2</sub> U <sub>1</sub>	2.0	14.0	0.153
L <sub>2</sub> U <sub>3</sub>	0.601	14.0	0.175
L <sub>3</sub> U <sub>2</sub>	0.601	14.0	0.175
L <sub>3</sub> U <sub>4</sub>	2.0	14.0	0.153
L <sub>5</sub> U <sub>4</sub>	6.44	14.0	7.052
U <sub>1</sub> U <sub>2</sub>	6.44	14.0	9.656
U <sub>2</sub> U <sub>3</sub>	6.44	14.0	9.656
U <sub>3</sub> U <sub>4</sub>	6.44	14.0	9.656

Conversion to S.I.

$$1 \text{ sq. in.} = 645.16 \text{ mm}^2$$

$$1 \text{ ksi} = 6.895 \text{ MPa}$$

Table 2  
 Analysis of Original Structure: HS20 Loading

Member	Dead Load Stress, ksi	Live Load Stress, ksi	Impact Stress 0.175xL.L., ksi	Total Stress, ksi	Allowable Stress, ksi	Overstress, ksi
L <sub>0</sub> L <sub>1</sub>	5.211	10.320	1.806	17.337	14.000	3.337
L <sub>2</sub> L <sub>3</sub>	4.544	8.248	1.443	14.235	14.000	0.235
L <sub>0</sub> U <sub>1</sub>	-2.288	-4.541	-0.795	-7.642	-7.052	-0.572
U <sub>1</sub> U <sub>2</sub>	-2.427	-4.799	-0.840	-8.066	-9.656	0.000
U <sub>2</sub> U <sub>3</sub>	-2.913	-5.275	-0.923	-9.111	-9.656	0.000
L <sub>1</sub> U <sub>1</sub>	4.336	15.076	2.638	22.050	14.000	8.050
L <sub>2</sub> U <sub>1</sub>	3.685	9.856	1.725	15.226	14.000	1.266
L <sub>2</sub> U <sub>2</sub>	-0.651	-1.722	-0.301	-2.674	-10.368	0.000
L <sub>2</sub> U <sub>3</sub>	7.337	19.462	3.406	30.205	14.000	16.205

Conversion to S.I.

1 ksi = 6.895 MPa

## Reinforcement of a Two-Span Bridge

A logical first approach seemed to be to investigate any advantages that might be gained by modifying the two-span bridge, which was analyzed as two identical 80-ft. (24.4 m) spans. Two basic procedures were considered: the development of continuity by connecting the top chords of the two spans, and the more innovative use of a pylon at the center pier with cable stays to the truss panel points.

Continuous Spans. As illustrated in Figure 26, continuity was developed by connecting the upper chords by a bar,  $U_4U_1$ , assumed for analytical purposes to have a cross-sectional area of 2 sq. in. (1300 mm<sup>2</sup>).

Continuity between the spans did not prove advantageous because heavier loads were transmitted to those members nearest the pier. While stresses in the counters were reduced, those in the end posts and diagonals nearest the pier were actually increased. More seriously, compressive stresses were induced in the lower chords,  $L_2L_3$  and  $L_4L_5$ , and the diagonal,  $L_2U_1$ . These light tension members were unable to carry compressive forces of any large magnitude. None of the overstresses in the tension members of the unreinforced truss were reduced below the allowable level by developing continuity between the spans.

Pylon and Cable Stays. The pylon with cable stays shown in Figure 27 was conceived by the research team. For the purposes of analysis, the pylon was assigned a height of 32 ft. (9.8 m), but no design of the pylon or detailing of its connection to the bridge was performed. A limited number of stay configurations were investigated, culminating with the configuration shown in Figure 6, in which the stays connect to panel points  $U_1$ ,  $L_1$ ,  $U_3$ , and  $L_4$  on the left truss and to symmetrical points on the right truss.

Stress levels in most of the members other than the hangers, counters, and diagonal  $L_3U_4$  were reduced to acceptable levels, but, as in the continuous bridge scheme, sizeable compressive stresses were induced in some lower chords. It was apparent that unavoidable stress reversals in flexible tension members would render a cable-stayed structure impractical, and the idea was discarded.

### Summary of Two-Span Reinforcement

It was concluded that no advantages could be gained by considering the two-span configuration. Stress reversals in the flexible tension members typically found on old trusses were unacceptable,

and certain members — the hangers, counters, and diagonals — generally required additional individual reinforcement. It was evident that strengthening procedures for individual spans would be more practical and more widely applicable than schemes based on a multi-span configuration.

### Strengthening of a Single-Truss Span

The remaining analyses focused on the reinforcement of the individual 80-ft. (24.4 m) span described earlier. Several of the techniques disclosed in the literature search, some with modifications, were evaluated.

Posttensioning — Lower Flange Reinforcement. Reinforcement of trusses through the use of posttensioning rods placed along the lower chords and tightened by turnbuckles has apparently enjoyed some success. As described earlier, the rods can be tightened until they share in the dead load stresses or simply snugged to act only under live load. Plans were available showing details proposed in the restoration of a pony truss bridge, but no application of the technique to a through truss span was discovered.<sup>(9)</sup>

Because of the experience with stress reversal in the lower chords, it was decided to tighten the rod only to a snug fit. Two rod sizes, 0.5 sq. in. (322 mm<sup>2</sup>) and 1.0 sq. in. (645 mm<sup>2</sup>), were analyzed with the latter providing the better results. The scheme relieved the overstress conditions in the lower chords of the unreinforced truss and reduced stresses in the diagonals to less than 1 ksi (6.9 MPa) over the allowable stress. The end posts remained slightly overstressed and the hangers seriously overstressed, as none of these members were affected by the reinforcement. The stresses in the counters remained high, despite some reduction. Certainly, the hangers and counters would require additional reinforcement, perhaps using a detail similar to that shown in Figure 22.

Queen Post Truss. It appeared promising to extend the lower chord reinforcement concept to the use of a queen post truss such as that shown in Figure 28. Extension of the posttensioning rod or cable below struts positioned under the hangers would provide an upward component to relieve those members as well as the lower chords.

Overstresses in the lower chords were eliminated and those in the hangers were only 610 psi (4.2 MPa) above the allowable value.



Unfortunately, stresses in the diagonals were not affected and the the counters remained seriously overstressed. However, the principal disadvantage lay in the length of the queen post struts required. Using an assumed posttensioning force of 20 kips (89 kN), the length of the struts (Figure 28) was determined to be 8 ft. (2.4 m). Use of an acceptably shorter (3 ft. [0.9 m]) strut required a much higher force to relieve the hangers and resulted in stress reversals in the lower chords.

Extension of the queen post truss a distance of 8 ft. (2.4 m) below the bridge eliminated it from practical consideration due to vulnerability to damage at times of high water.

Intermediate Supports. Sources in the literature indicate that the construction of intermediate supports can occasionally be advantageous in relieving a weak truss bridge. A trial analysis was performed of the truss span with intermediate piers at panel points L<sub>1</sub> and L<sub>4</sub>, as shown in Figure 29.

Stresses in the lower chord members were reduced to acceptable levels, but those in the diagonals increased slightly. While stresses in the counters were reduced below those in the unmodified truss, both the counters and diagonals will require additional reinforcement. Hangers L<sub>1</sub>U<sub>1</sub> and L<sub>4</sub>U<sub>4</sub> over the piers would be placed in compression, unless spring supports such as elastomeric bearings were used. Parameters such as the effective spring constants or deflection characteristics of the required elastomeric bearings were not fully investigated, but, given additional reinforcement in some truss members, a refined design may yield a practical solution. The bridge site must, of course, accommodate the piers.

Longitudinal Beams and Trusses. In the widening of pony truss bridges, longitudinal members are used to share the live load with the trusses. Various configurations of members acting in conjunction with the typical through truss were investigated. Initially, a single rolled steel beam was tried under each of the trusses, but it was found that the optimum beam section did not provide compatibility of deflections with the trusses. The analysis indicated that the truss actually carried the beam in the central portion of the span.

A second approach utilized a grid composed of six reinforcing beams, one under each line of stringers, supporting the floor beams. Use of the optimum rolled section, W36 x 230, relieved all overstressed members, except for a 150 psi (1.0 MPa) overstress in lower chord L<sub>2</sub>L<sub>3</sub>. However, a great quantity of structural steel, nearly 28 tons (25,400 kg), was required.

In an effort to reduce the material requirements, it was decided to evaluate the performance of a supplemental truss on each side of the span, as in Figure 30. This is similar to the doubling of railroad trusses, except that the supplemental truss would be specially fabricated.

The use of a Warren truss with a span of 80 feet (24.4 m) and a height of 8 feet (2.4 m), fabricated of steel tubular members, was chosen for evaluation. Its diagonals had the same slope as the existing Pratt truss, and the lower panel points coincided. For the purpose of analysis, it was assumed that the trusses were joined at the upper and lower panel points of the Warren truss, but in practice the auxiliary truss might be separated by a sidewalk or bike path. Compatibility of deflections will be required, however.

Several iterations indicated that the most efficient design was a truss composed of 4 by 4 by 3/16 in. (101 by 101 by 5 mm) chord members and 3 by 3 by 1/4 in. (76 by 76 by 6 mm) web members weighing slightly more than 2 tons (1800 kg). All stresses in the Pratt truss were reduced below allowable levels. While the Warren truss was effective and relatively economical, it is visually intrusive. If material economy is not a crucial factor, the use of hybrid longitudinal members, such as box beams, might be investigated.

#### Studies of Connection Details

The strength of the joints in an old truss can also limit its capacity. Reinforcement of the joints is a difficult problem from both the engineering and philosophical viewpoints. Joints are difficult to reinforce in any event, and strengthening may be impossible without replacing some portion of the connection.

Analyses of the joint details, Figure 31, from the typical Pratt truss were made to determine any limitations on structural capacity. The results are shown in Table 3 for both HS20 and HS15 live loadings.

Table 3 indicates difficulties at six of the ten joints under an HS20 loading. Joint L<sub>1</sub> is particularly troublesome, because many components of the joint are deficient, but any of the deficiencies might be difficult to correct. It is likely that the joints would limit the capacity of the truss to an HS15 loading. Note that the pin at joint L<sub>2</sub> is slightly overstressed under an HS15 loading, but this may not be consequential.

Table 3

Performance of Joints  
Rte. 632 Truss Over South River

<u>Joint</u>	<u>Loading</u>	
	<u>HS20 Loading</u>	<u>HS15 Loading</u>
L <sub>0</sub>	OK	OK
L <sub>1</sub>	Upper pin fails in shear (11.0 ksi > 10.4 ksi) Rivets in R <sub>L</sub> fail (14.4 ksi > 13.5 ksi) Rivets in angle fail (14.4 ksi > 13.5 ksi) R <sub>L</sub> @ upper pin fails due to bearing (30.3 ksi > 29.3 ksi)	OK
L <sub>2</sub>	Pin fails in shear (13.0 ksi > 10.4 ksi)	Pin fails in shear (10.7 ksi > 10.4 ksi)
U <sub>1</sub>	R <sub>L</sub> fails in bearing (36.0 ksi > 29.3 ksi)	OK
U <sub>2</sub>	OK	OK

Conversion to S.I.

$$1 \text{ ksi} = 6.895 \text{ MPa}$$

A spot check of a few of the joints of the Pratt bedstead truss carrying Rte. 747 over Goose Creek in Bedford County, bridge no. 23 on the list, yielded similar results. Failures of pins in shear induced by an HS20 loading were noted at two of the joints checked, and a plate bearing failure was noted at one of them. Interestingly, a similar pin failure under an HS15 loading was also noted. In considering the use of an old truss for carrying traffic, the first step must be a complete analysis of the structure including connection details to determine all points of weakness.

### Analyses of Other Truss Bridges

Three other bridges from the list of historic bridges were analyzed under HS20 loadings for comparison with the results obtained for the Pratt truss. These were the Parker truss (span 9) of bridge no. 7 carrying Rte. 640 over the Staunton River (Figure 32); the Thacher through truss (bridge no. 6) carrying Rte. 1421 over Linville Creek (Figure 33); and the Pratt bedstead truss (bridge no. 23) carrying Rte. 747 over Goose Creek (Figure 34). In addition, the Parker truss was analyzed under HS15 loading and some of the connection details of the bedstead truss were evaluated.

The Parker truss on Rte. 640, a much longer bridge than the Pratt truss analyzed earlier, proved to be relatively more substantial. Only four counters were overstressed by the HS20 loading; two by the HS15 loading. Stresses induced in the truss members by the lighter loading were about 15% to 25% lower. Supplemental rods placed with the counters would easily strengthen the bridge to accommodate either loading.

Individual member reinforcement would also provide sufficient reinforcement for the Thacher truss in which six members were relatively slightly overstressed (1.14 - 2.29 ksi [7.8 - 15.8 MPa]) by the HS20 loading.

On the contrary, the heavy loading significantly overstressed several members in the bedstead truss, and, as discussed in an earlier section, some of the connection details were found deficient. It is likely that the capacity of the bridge would be limited to no more than an HS15 loading.

Reports prepared for these three bridges by Department of Highways and Transportation bridge inspectors indicate various floor system members controlling the capacities. This is in accordance with the findings of other agencies, and it is likely that upgrading of the stringers and floor beams on historic bridges may be required in order to realize the capacities of the trusses.<sup>(5)</sup>

### Applicability of Analytical Studies

The strengthening of old truss bridges to carry modern traffic loadings is difficult. The capacity of a given structure can be limited by the strengths of the truss elements, the connections, and the floor system members, all of which must be evaluated. Care should also be given to the magnitude of the design loading required. The strength of other structures on the system or other local conditions may render an HS20 capacity unnecessary. The results of the analytical study indicate that lesser loadings would be more easily attained.

Most of the methods evaluated in the study are reasonably independent of the truss configuration, but the length of the existing truss may limit the number of useful reinforcing techniques. A few of the procedures appear promising.

1. An auxiliary truss, such as the Warren truss evaluated in the study, might be effective if its visual intrusion were not objectionable. As the length of the existing span becomes greater, the auxiliary truss will, of course, become more prominent.
2. Longitudinal beams or hybrid members under the truss may be effective if the span length is not too great and economy of materials is not a critical factor.
3. The use of posttensioning rods at or just below the lower chords is apparently feasible on shorter spans. Additional reinforcement of critical truss members may be required.
4. The addition of individual reinforcement to supplement critical members may be sufficient if the proposed capacity is not extreme.

#### Vehicular Use of the Fink Truss Bridge

The Fink truss span on Rte. 291 in Lynchburg is a unique bridge of special historic interest. It is at a location, not its original site, at which it cannot easily be seen, so its relocation is likely and probably desirable.

There apparently are no plans for the truss that would form the basis of a structural analysis, but experience in this study would indicate that the truss could be strengthened. However, some modification of the relatively light structure, such as the addition of reinforcing rods to act with the tension members, might be required. In the case of a very important historic bridge, even the most discreet reinforcement might be undesirable.

It must be remembered that the bridge is carrying significant loads at present. Should consideration be given to keeping it in service, the following steps are recommended.

1. A thorough inspection should document the dimensions and condition of the truss and a structural analysis based on these data should be performed.

2. The span should be used at a site where the loads and resulting stresses will allow the truss to serve without deterioration for an indefinite period at its unreinforced capacity. Strengthening should be regarded as a last resort.
3. The selected site should allow a side view of the bridge to interested persons. As is the case with all deck trusses and arches, nothing of the real structure can be seen from a crossing vehicle. A small pull-off adjacent to the bridge could be provided, or the bridge could be placed in a wayside. Viewing points have been provided adjacent to the record steel arch span crossing the New River Gorge in West Virginia.

#### Non-Vehicular Use

Using a bridge for a function other than carrying vehicular traffic is somewhat unorthodox, so a literature study was undertaken to determine what has been done in this regard. Whereas many bridges were found to have multiple uses (as the old London Bridge and the Ponte Vecchio in Florence, Italy) where vehicular traffic coexisted with small shops and houses, several examples were found of bridges that were converted completely from vehicular to non-vehicular use.

The most common conversion was to pedestrian use, either at the existing site or a new one. In each of the states of New Jersey, Ohio, Maryland, and Virginia, an old historic metal truss bridge has been relocated from a highway to a park and used only by pedestrians and bicyclists. The one in Virginia is a bowstring metal arch truss formerly on Rte. 637 over Roaring Run in Bedford County and now relocated to a rest area on Rte. I-81 in Montgomery County. Virginia also has other old highway bridges that have been taken out of service for vehicles but left in place, totally or partially, for pedestrian use. One is a concrete girder structure formerly on Rte. 17 over the James River between the city of Newport News and Isle of Wight County. A 1,500 ft. (457 m) section of the north end at Newport News has been left standing to serve as a fishing pier. The rest of the old bridge has been removed.

A second structure is a partially destroyed wooden truss bridge formerly on Rte. 45 over the James River between Goochland and Cumberland Counties. The end spans remain standing and are used only by pedestrians; primarily as scenic overlooks.

A number of abandoned masonry and concrete arch bridges formerly used for highway and railway vehicles may also be found in Virginia, and several of these are used by pedestrians. The Research Council is currently documenting the ones of importance, so an exact listing is not available at this time.

In the case of the old covered wooden bridges in Virginia, four have been taken out of service and left as historical landmarks or for pedestrian use only. These are located as follows: (1) Old Rte. 615 over the Smith River in Patrick County, (2) Old Rte. 705 over Seneca Creek in Campbell County, (3) Wayside off Rte. 60, three miles west of Covington in Alleghany County, and (4) Off Rte. 42 over Sinking Creek in Giles County.

There are many similar covered wooden bridges in other states and one, in private hands, has been converted to use as a gift shop and museum. This particular one is located in Strasburg, Pennsylvania.

Another bridge, this one in Hancock, New York, and also in private hands, has been converted into a restaurant. A portion of the abandoned 500 ft. (152 m) long steel deck truss railroad bridge (Orange and Western) has been enclosed below the deck for this facility.

There are two major projects still on the drawing boards. The first will convert the historic Eades Bridge across the Mississippi River at St. Louis, Missouri. The plan is to divert all the vehicular traffic on the little used Eades Bridge to the new nearby Poplar Street Bridge and to convert the old bridge into an extensive commercial development. The lower railway deck would be subdivided into offices, restaurants and the like, while the upper automobile deck would become a promenade with an enclosing moving conveyer belt sidewalk.

In a second project the abandoned Big Four railroad bridge in Louisville, Kentucky, a six-span steel through truss bridge across the Ohio River, is being studied for conversion into a large commercial complex. The deep trusses would be used to support two levels of floors, and cantilever platforms outside the trusses would be used to support two levels of floors to provide a total of 500,000 sq. ft. (0.046 km<sup>2</sup>) of floor space. Additional space would be provided at the land approaches of the bridge. In these various spaces would be restaurants, hotels, condominiums, apartments, offices, retail shops, exhibition halls, and parking garages, with a marina beneath the bridge.

With these bridges as precedents, detailed studies were undertaken of each of the 21 bridges chosen for consideration in the present study. Each bridge was inspected by one or more members of the team. Photographs of the structure were taken along with documentation concerning site conditions, regional influences, attitudes of local residents, and location with respect to towns, parks, recreation areas, waysides, major routes, bicycle trails, and the like. Engineering drawings and brief histories of each bridge were also obtained.

It was anticipated that an appropriate adaptive use of some of these Virginia bridges would be for architectural structures as restaurants, museums, craft centers, and housing. To judge the structural feasibility of such use, typical test bridges (nos. 16 and 18) were analyzed with computers using typical floor, roof, wall, and wind loads as required by the building code of Virginia (BOCA). With live loads on the floor and roof assumed at 100 psf (4.79 kPa) and 30 psf (1.44 kPa) respectively, the existing bridges, with only minor reinforcement or repair at particular joints or members, were found to be structurally satisfactory. In the event that any of the bridges studied are actually converted to an architectural use, additional detailed structural analysis should, of course, be carried out.

Aspects of utilities as electricity, water, and sewerage, as would be needed for some conversions, were also investigated, as most of the bridges are located in rural areas. The availability of electricity generally proved to be no problem as power lines could be found nearby all bridges. It was assumed that water would be available either from wells or by hauling for situations requiring small water consumption. Waste could be handled either by conventional septic tanks and drainage fields or commercially available units (as Detroilet) that handle solid wastes with little or no water consumption. In special cases, cleanable privies could be used. Heat for the buildings could be supplied by fuel oil, propane gas, electricity or wood stoves.

In this study, it was assumed that wherever an old bridge was left standing intact, any new replacement bridge would be so located that access to the old bridge would still be possible.

It was anticipated that some of the bridges (up to about 125 ft. [38 m] span) might require moving to a new location; so estimates of moving costs were determined by interviewing several contractors engaged in bridge work in Virginia. The cost figures are for moving a typical metal truss bridge of 80 ft. (24 m) span weighing about 10 tons (9 Mg). Depending on the degree of dismantling required, an estimate for removing the bridge and placing it on a truck for transport is from \$4,000 to \$6,000. Hauling itself costs only about \$2 per mile (\$1.25/km). Reerection is more expensive



than removal as repairs, cleaning, and repainting are necessary; \$10,000 is a rough estimate for this work. Additional costs are involved in the construction of new piers or abutments and other related site work. As these conditions are specific with each situation, no good estimate of these costs are possible, except to suggest a range of from \$2,000 to \$10,000.

Finally, there is the general question of how a highway bridge and related property can be assigned to someone outside the Virginia Department of Highways and Transportation. It is assumed that the Department may not wish to destroy a historic bridge, yet not wish to maintain it as a landmark or operate it as a museum or other enterprise. The Code of Virginia (Sections 2.1-503 through 2.1-513) allows for the sale, lease, or transfer of state property when the property is declared surplus, with the final authority for transfer resting with the Governor. Agencies as the Department and the Division of Engineering and Buildings are also involved.

With the preceding aspects having been investigated and found feasible, case studies of the individual bridges were begun. These are now described, starting with the Fink Truss Bridge and then with the other bridges in numerical order, which represents the order of historical importance.

### Fink Truss Bridge

This bridge is an extremely rare example of an early Fink truss and should be preserved as a museum piece. One location worthy of its display is the Science Museum of Virginia in Richmond. This large museum on Broad Street is undergoing a remodeling from a railroad station. One wing has already been remodeled and plans are under way for remodeling the rest of the building. The concourse area is to have a mezzanine level, and from a discussion with the architects involved (Chappelle and Crothers of Philadelphia) a good location for the old bridge appears to be as part of the mezzanine as shown in Figure 35. At this location, the bridge may actually be used by pedestrians and seen from below as well as the top and sides, as the most interesting views of the Fink truss are from the side and below.

Roanoke also has an outdoor transportation museum where the bridge might be displayed.

### Bridge No. 1

This bridge is the only one of those studied that is a timber truss structure. It is in generally good condition and is located

in a pleasant area over the James River, near the village of Springwood. Several old stores near the end of the bridge add to the historic character of the bridge. From the bridge, views of the mountains to the northeast as well as the river can be had. Because a new highway bridge has been built across the river close by, the timber bridge is rarely used by vehicles. Its principal use at this time is for pedestrians.

Because the bridge is unique (the only other one similar, although partially destroyed, is the old Cartersville Bridge near Rte. 45 over the James River) it is recommended that this bridge be preserved as a historic landmark and pedestrian bridge.

The interesting old buildings near the bridge have the potential of restoration to make them part of a historic complex of early Virginia architecture and technology.

### Bridge No. 2

For a nineteenth century bridge, this structure is unusual in having a relatively large skew of 30°. Its width of 25 ft. (7.6 m) is also unusual in that most other truss bridges of the period are narrower. In terms of possible non-vehicular uses, one of its assets is its proximity to the village of Goshen, which is on the edge of the George Washington National Forest. Goshen itself is located only 10 miles (16 km) from the well-traveled I-64.

The above conditions suggest that one possible adaptive use of this bridge is for a "rustic" general store for the benefit of tourists, campers, antique hunters, and the like. Figure 36 illustrates how the bridge might be modified to function as a general store. A through passageway overlooking the river is cantilevered beyond the trusses to provide extra room for shops or stalls along the length of this two-span structure. A second story for additional shops or storage can be accommodated, as the truss is sufficiently high.

An alternate adaptive use is for a small commercial greenhouse. Natural sunlight is ample as there are no shade trees across the river. The general character of the old metal trusswork is reminiscent of the exposed metal structures of nature conservatories of the same historical period as this bridge. Figure 37 is a drawing of a retail greenhouse that attempts to capture the architectural character of an old conservatory within the framework of the old bridge structure. Figure 38 shows a possible layout of the greenhouse. The height of the bridge (24 ft. [7.3 m]) allows adequate head room for tall plants as well as a small upper mezzanine at the main entrance.

### Bridge No. 3

This bridge in large measure received a high rating as being historical because it is still in its original location.<sup>(3)</sup> However, because of its relatively remote site over railroad tracks, no reasonable conversion to a non-vehicular use at the existing location could be envisioned. Preference is placed on a solution as presented in the section of this report entitled "Vehicular Use".

Should there be a desire to move the bridge (not unreasonable, as it is only 100 ft. [30 m] long), several non-vehicular uses can be proposed. One of these uses is for an information center at a highway wayside. Highways and bridges are naturally compatible, so a building made from a bridge located along a highway seems quite appropriate, as well as eye-catching. Figures 39 and 40 illustrate how an information center might look and function. Note that the bridge is supported so that it still functions as a simply supported bridge, a necessary feature to keep it "alive" as a bridge structure. A reflecting pool is located beneath the bridge for architectural interest. In lieu of a water pool, a landscaped dry gravel bed could also be used. In either case, the bridge should be raised off the ground.

An alternate use of this bridge, if it is to be moved, is for a bicycle bridge along one of the many national or local bike trails being planned. Should it be necessary to remove the bridge from its present location, with no specific need for it at that time, the bridge should first be documented with good color photographs, then be match-marked and carefully dismantled. The components of the structure should be stored in a safe place for some future use. All these extra efforts of salvaging this bridge are deemed appropriate because of its highly rated historical significance.

### Bridge No. 4

The best non-vehicular use of this bridge, located on a river in a pleasant rural area about 3.5 miles (5.6 km) from the small college town of Lawrenceville, is believed to be for housing. It could be made into either a vacation home (at a budget price) or a year-around home (at a somewhat higher cost).

Figure 41 illustrates a possible architectural design solution for converting each span into a separate housing unit. Decks have been added outside the trusses to provide additional width to an otherwise narrow form. The architectural treatment may appear a bit unusual, but it is the intention to preserve the structure with

a clear image of remaining a bridge. The esthetic design of the walls and roof of this house reflect a compatibility with the truss design with its sharp edged angularities.

Figure 42 shows a cross section through an outside wall and cantilevered deck illustrating how the new housing form is related to the old bridge structure. As the walls and roof are inside the through truss bridge, they may be constructed in essentially conventional ways with conventional materials, with the old bridge structure being used basically for vertical and lateral support. Because of the conventional construction, the cost should be similar to that for a conventional house on the ground.

Other non-vehicular uses considered were for a fishing pier, craft center (see bridge no. 15) or, if moved, an information center in the fashion of that described for bridge no. 3.

#### Bridge No. 5

This bridge is located in a semi-rural area over railroad tracks. Because environmental factors of bridges over railroad tracks are generally not as desirable as those for structures over water, the uses of bridges over tracks are limited. This structure, being only 74 ft. (22.6 m) long, can of course be moved relatively easily; however, as the structure is on its original site (an important historical criterion) it is desirable to find a use for it there.

One promising use is as an office for a land developer or realtor, as development in the area seems to be growing rapidly. It is only 5 miles (8 km) from Manassas and 35 miles (56 km) from Washington.

Figure 43 is a photograph of a small-scale architectural model of how an office might look as adapted from the bridge. The distinctive design could be an asset for any commercial establishment. Figure 44 is a plan of this office space. One portion is shown as two stories and another portion extends onto land for the creation of extra floorspace of this relatively short bridge.

Should this bridge not be put to a non-vehicular use at its present location, all that is said of bridge no. 3 (also over railroad tracks) can be said of it.

Bridge No. 6

Located at the edge of the small town of Broadway, this bridge is in the general area of an industrial development, a railroad, and some housing. As much of the historical importance of the bridge derives from its original location, a non-vehicular use compatible with this site was studied.

A craft center or regional museum was considered, as Broadway is relatively close to the well-traveled I-81; but a more appropriate use is believed to be for an office for an engineer or land surveyor. A schematic design for a surveyor's office is shown in Figure 45. The structure has enough height for two levels over part of the bridge. Remodeled old buildings are very popular for professional offices, and it seems particularly appropriate for a surveyor or engineer to have offices in a remodeled bridge.

Bridge No. 7

The size and remote location of this bridge make it a difficult candidate for a non-vehicular use other than a "historic ruin". As a "ruin", the steel beam approach spans to the two main trusses should be removed for safety. Removal of the wooden deck is also recommended to minimize maintenance as well as to discourage trespassers. The use of the word "ruin" is not meant to imply total abandonment of the structure, but to suggest the most minimum of maintenance to keep it from collapsing. Preserved in this way, its primary use would be scenic and historical. Ruins hold a fascination of their own, even if not used functionally.

An alternative vehicular use of the structure is possible if modified as reported in the section entitled "Vehicular Use".

Bridge No. 8

Of all the bridges in this study, this structure is the most ornate, with its prominent cast iron finials, portal bracings, and nameplate. There is little doubt that the structure should be left as it is with little or no modification, for to do otherwise would noticeably detract from its present (and original) historical character.

Because of the limitations of possible modifications, only two non-vehicular uses are proposed. The first is as a bicycle bridge,

assuming that a bicycle trail is developed in the area (perhaps in connection with the development of the Craig Valley Railroad as a recreation area\*). The second possible use is as a historical monument or ruin. As a ruin it would be desirable to remove the approaches to the main through Pratt truss to isolate it from all forms of traffic, pedestrian as well as vehicular. Removal of the wooden deck to reduce maintenance is also desirable. Only a minimum amount of maintenance on the structure would then be required for preservation. To set apart the bridge as a historic monument, moat type barriers at the ends, as shown in Figure 46, are recommended in lieu of any type of unattractive fencing.

#### Bridge No. 9

Two non-vehicular uses are suggested for this bridge located in a quiet rural area near the historic town of Waterford. As with bridge no. 4 previously described, it could be converted into a housing unit. However, because the general region has a distinctive and well kept historic character, a unique use of the bridge as a chapel or small meditation center is believed more appropriate. It is assumed that any new bridge built to replace the old one would be located sufficiently far away that its location would not interfere with the serenity of the old bridge. Figure 47 illustrates how the bridge could be redesigned into a simple meditation center by utilizing the oriental philosophical principle of Yin-Yang (meaning opposites).

Waterford is within 40 miles (64 km) of Washington, so that such a center could be seen as a short-term pastoral retreat for those seeking escape from the activities of that busy metropolitan area.

#### Bridge No. 11

This is a multiple-span, pony truss bridge located in a very pleasant wooded area and spanning a moderate size river. Currently, the spot is used by local people for fishing, swimming and boating. Because the area is a natural draw for recreation, the bridge could become a developed part of the site as a picnic shelter. To reduce maintenance costs, only two spans of the total bridge need be saved. Figure 48 shows how the structure, covered with lightweight shading, could make a handsome picnic shelter. Tables, seats, and even a fireplace could be added.

---

\*A special report on the Craig Valley R. R. site is being prepared by the Research Council.

Bridge No. 12

A number of non-vehicular uses for this bridge are possible. At its present site, it could be remodeled into a vacation home similar to that described for bridge no. 4. Preservation of the structure as a ruin at its present location, in the manner proposed for bridge no. 8, is also a possibility. Moved closer to an urban area, the bridge could be made into a restaurant featuring some of its ornate detailing. Restaurants converted from old railroad stations, warehouses, and factories are very much in fashion. It is reasonable to conceive of old bridges also being converted into restaurants, as is proposed for bridge no. 18.

However, to suggest a novel use, certain ornamental portions of the structure could be incorporated into the new replacement bridge. The old bridge would be in major part destroyed, but a suggestive presence of the old structure would still exist as part of the new replacement bridge. Figure 49 illustrates how some of the ornamental parts could be refashioned into a sign at the approach of the new bridge. Other parts could be made into a railing for the new bridge. The insert in the drawing illustrates how the eyebars of the old bridge could be attached to or set into the concrete parapet of the new bridge. Any number of designs utilizing interesting parts of the old structure are possible.

Bridge No. 15

Residents close by this bridge near Wytheville have expressed interest in the preservation of this old structure. Some continued use for vehicles and pedestrians is possible, although a replacement bridge is planned at this location.

A number of non-vehicular uses are also possible. As Wytheville is on heavily traveled I-81, the structure could be converted into a small but interesting regional craft center as shown in Figure 50. Conversion of the bridge into housing, similar to that suggested for bridge no. 4, is another possibility. As the two spans of this bridge are relatively short, the entire structure could easily be moved to an entirely new site. Several uses close to Wytheville are envisioned. Use as a bicycle bridge in one of the many nearby state parks or as an information center (as suggested for bridge no. 3) at the nearby rest stop on I-81 west of Wytheville are possibilities. A more novel use is to convert the bridge into a play structure at one of the parks. Figure 51 illustrates how, with some added steps, slides, ropes and the like, the bridge could become a unique feature. A historic bridge could become not only useful for recreation but also educational in that young people will be able to become intimate with nineteenth century engineering by being able to see and touch it up close and in safety.

Bridge No. 16

Located over a complex of railroad tracks, this unusual bridge has the potential of being converted into a transportation museum. Already naturally endowed with an active railroad system passing beneath it, the bridge could be enclosed to house an assortment of other forms of transportation as bicycles, motorcycles, and antique cars. Land around the bridge could be acquired and used to display large outdoor modes of transportation as old army tanks, airplanes, and steam engines. Figure 52 illustrates how such a transportation museum might look. The bridge is but a few miles from the city of Lynchburg, which is expected to provide the constituency for this museum.

Bridge No. 18

Because of the particular size and location of this bridge near Waynesboro, a number of possible non-vehicular uses can be proposed. They are as follows:

- a. Regional craft center (see bridge no. 15)
- b. Housing (see bridge no. 4)
- c. Greenhouse (see bridge no. 2)
- d. Cafe/restaurant (see Figure 53)
- e. Picnic shelter (see bridge no. 11)
- f. Open-air bridge museum

Use of this bridge as a picnic shelter could be expanded into that of a recreation-outdoor bridge museum complex featuring an assortment of old highway bridges as shown in Figure 54. On weekends, the bridge could even be used as a flea market, with the old bridge itself seen as an antique. Note that one of the relocated bridges has been remodeled into a snack bar and another is used as a fishing pier. (There are several open-air architectural museums for which historic old buildings have been moved from their original sites and relocated to a common public museum site. One such cluster is the Weald and Downland Museum in southeast England and another is the Museum of Wooden Architecture in Suzdal, U.S.S.R. An open-air bridge museum would be a first anywhere.)

- g. Park Bridge

These trusses are short enough to move and could be utilized in any of the many state and federal parks in the area for bikers and hikers.



Bridge No. 19

A desirable non-vehicular use for this structure is for housing, as it is within easy commuting distance of Richmond. Figure 55 shows how this bridge might be remodeled into a simple two-story dwelling. Views of the Pamunkey River and the foliage of the many trees as seen from the bridge are most pleasant. Living in such a scenic spot would be a unique experience.

Bridge No. 20

This is a rather long bridge that does not lend itself to many non-vehicular uses. It is possible that some institution may be able to utilize it as a waterway or wildlife research facility. Otherwise, the bridge could be removed except for the two unusual Pennsylvania trusses that could be isolated as a historic ruin. (Refer to bridges 7 and 8 for other details on ruins.)

Bridge No. 21

This bridge located in a rural area over the Rappahannock River has several potential non-vehicular uses. If left in place, it is well suited as a vacation home. See Figure 56. Only 98 ft. (29.9 m) long, the bridge could be relocated to a new site where it could become an information center (as bridge no. 3), a craft center (as bridge no. 15), or a bicycle bridge along a new bicycle trail.

Bridge No. 22

In terms of general size and rural location, this structure is similar to bridge no. 21. The non-vehicular uses, therefore, are similar to those described for the preceding bridge. Figure 57 illustrates its use as a vacation home.

Bridge No. 23

This bridge is located in a particularly scenic area in Bedford County. Nearby are a dam and waterfall. Fishing in Goose Creek also seems to be good. Under these conditions the best non-vehicular use of the structure appears to be for conversion into housing. The vertical end posts on the truss give it a rectilinear appearance, an unusual feature for a bridge that makes it particularly compatible with use as a vacation home. Figure 58 shows a simple plan where additional width is attained by means of a cantilevered deck on one side of the bridge. Figure 59 shows how the elevations might look. (See bridge no. 4 for details on construction of the cantilevered deck, walls, and roof.)

2930

Bridge No. 24

This small pony truss (46 ft. [14 m] long), is too small for conversion into any reasonable architectural use. Its best use seems to be as a bicycle or pedestrian bridge at a relocated site in a park or rest area. An example of such a relocated use of a small truss bridge is the bowstring truss bridge in the rest area on I-81 in Montgomery County, which was moved from Rte. 637 over Roaring Run in Bedford County. Some similar relocation is suggested for bridge no. 24.

## CONCLUSIONS

The main conclusion of the study is that there are many possible alternatives for modifying historic bridges so that they can continue to be of use in today's world. The possible use of a given bridge depends on many factors. A list of some such factors includes the condition of the bridge, site considerations, traffic conditions, cost, governmental regulations, legal liability considerations, commercial conditions, and general interest in preservation.

As this report is specifically directed toward historic bridges and not just old bridges which may or may not be historic, special attention is paid to methods of modification that keep the historic qualities of the bridge preserved to the extent possible. Also, as only historic bridges, as defined in reference 3, are considered, it is made clear that the number of bridges that should be modified for preservation is rather small, as compared to the number of all the old bridges extant.

Although many factors must be considered when deciding on a possible modification for a historic bridge, there is a generally agreed upon hierarchy of choices relating to the historic preservation aspects of possible uses.

1. The best use is to continue to use the bridge as a bridge in its present location. If repair or strengthening is needed, it should be done discreetly. Widening of the deck to any major degree is undesirable as it significantly alters the appearance of the structure.
2. Should the traffic situation demand widening, such as providing two-way traffic on a one-lane bridge, the historic structure should be left in place and upgraded discreetly as in (1) above. A second bridge, as similar in design to the existing one as possible, should be moved to the site of the historic one and erected adjacent to it. Depending on site conditions relating to splitting the approach roadway, the distance between the two bridges should be as great as practical so as not to cause undue visual impact on the historic bridge. This "pairing" arrangement would provide two-way traffic, even though each bridge may be only one lane wide.

Of the bridges in this study, the following structures are sufficiently similar in configuration and span to be considered for pairing in the manner described.

- a. Bridge no. 3 stays in place and is paired with bridge no. 22.
  - b. The two-span truss bridge no. 4 stays in place and is paired with bridge no. 21 and the 82 ft. (24.9 m) span from bridge no. 18.
  - c. Bridge no. 5 stays in place and is paired with the 72 ft. (21.9 m) span from bridge no. 15.
  - d. Bridge no. 6 stays in place and is paired with the 127 ft. (38.7 m) span from bridge no. 20.
  - e. The two-span truss bridge no. 7 stays in place and is paired with two 160-ft. (48.8 m) spans from bridge no. 20.
  - f. The two-span truss bridge no. 19 stays in place and is paired with bridge no. 12 and the 70 ft. (21.3 m) span from bridge no. 15.
3. In the event that a historic bridge cannot be left at its original site, it should be moved to another site of a less demanding nature where it can continue to function as a bridge for light vehicles, bicycles, or pedestrians.
  4. If no vehicular use of the historic bridge can be foreseen, it could be converted into some architectural use as described in this report.
  5. In situations where none of the preceding four solutions are possible, the structure should be set off as a historic ruin. Several examples are described in the report. This arrangement allows the structure to remain standing at a minimal cost.
  6. If of necessity the structure can no longer be left standing, it should be match-marked, carefully disassembled, and stored in a protected environment with the hope that at some time and place in the future it could be rebuilt.

7. Further down on the scale of desirability from a preservation point of view is to save only selected components of the bridge that would be otherwise totally destroyed. These components could be made into exhibits, as in museums, or even be incorporated as ornamental elements into a new bridge built on the site of the old one.
8. As a minimum, whenever a historic bridge is to be razed, it should be documented with drawings and photographs and such documents should be preserved in some archive.

An exception to this list of procedures is when a truly rare bridge is to be preserved, as is the case of the Fink truss bridge in this study. Because this bridge is not currently located at its original site and because it is relatively small, its best preservation would be to move it directly to a museum site as a complete structure, and there to use it as a pedestrian bridge.

Preserving or modifying a historic bridge does mean expending some extra thought or effort, but it does not always mean added expense. Upgrading an old bridge may in fact be less costly than building a new one, or converting an old bridge into commercially used architectural space could even be profitable. Regardless of cost and other factors, ways can always be found to preserve selected historic bridges, if there is sufficient commitment to that end.

A final conclusion to be noted is that many of the results of this study on truss bridges in Virginia can be applied to other bridge types and historic bridges in other states. It is hoped that others do, indeed, take the results of this study and apply them to their own special conditions.

#### CONSIDERATIONS FOR IMPLEMENTATION

Implementation of the strategies discussed in this report clearly depends upon their economic viability on a project-by-project basis. Most of the non-vehicular uses would require private development, while upgrading for continued vehicular use should be considered as an economical alternative in project planning. Regardless of the ultimate use of trusses taken out of service, the role of the Department of Highways and Transportation with regard to the conservation of such resources is critical in that a framework for consideration of the various alternatives must be provided at the earliest possible point in the planning process.

Economic consideration should include the usual factors as well as any benefit, tangible or intangible, associated with extending the service life of potentially historic structures.

Under ideal conditions, adaptive use by others would result in actual dollar savings to the Department by eliminating the cost of demolition from the replacement contract. Under some conditions, part of such a saving would be offset by additional cost involved in siting the replacement structure. Those costs could be minimized by advanced planning.

It is likely that adaptive use of an abandoned bridge would always be more economical than creating a new structure for the same use, although some flexibility might be lost. Obviously, there must be a use for any proposed adaptation.

In considering upgrading for continued vehicular use and taking due cognizance of the degree of historic significance of the particular structure, the standards to which the upgrading must be made should be carefully examined to ensure they are not excessive. In recent years a single relatively high standard has been required for all bridges. Changing economic conditions and public opinions warrant a careful evaluation of these standards, particularly with respect to a historic bridge. Many older truss bridges are on lightly traveled secondary roads with rather tortuous approaches. Their relatively good safety record in many cases depends upon the effect of the approaches in controlling the speed and volume of traffic. Obviously, improvements to approaches change the capacity requirements for the bridge itself and both must be considered together as well as the public's concern for the character of the area versus the potential changes resulting from the upgrading.

In the case of historic bridges, precedents exist for modifying geometric and load requirements from those generally applied to federally-aided structures.<sup>(22)</sup> Structures with a high degree of historic significance obviously require considerable flexibility.

Although not within the scope of this project, factors other than economic viability and technology are considerations in the continued use of older bridges. These include questions of right-of-way, legal liability, etc. Because the conversion of older bridges is a new field, these questions have not been generally addressed and will vary with circumstances. The factors must be evaluated but can probably be accommodated in most cases.

Funding sources need to be developed to permit consideration of strategies for continued vehicular or non-vehicular uses of historic bridges. While the funds required will in most cases be comparatively small, their availability from those allocated for

upgrading the secondary roads on which many of these structures serve is severely limited. Combinations of private funds, public funds designated for preservation, and funds from other sources should be available.

The primary role of the Virginia Department of Highways and Transportation is to provide a framework wherein alternatives for the best continued use of a potentially historic structure can be considered at the earliest point in the planning process. Each project will probably bring new questions and require innovative solutions and resolutions. The Department has gained recognition for its pioneering efforts to identify its historic bridges. It now needs to continue its efforts to be a good steward of these resources.

2236



## ACKNOWLEDGMENTS

An interdisciplinary study of this kind is not possible without the cooperation and assistance of many people. Three persons whose names do not appear on the cover of the report and yet who contributed their valued time and talent are Reid Reames, George Kirby, and Michael Leinbach. Others as Professors Furman Barton and Henry Kinnier provided helpful advice. Many people in the Department of Highways and Transportation showed special interest in the preservation of these old bridges, and their efforts are also acknowledged. All those involved in the reproduction of this report at the Highway and Transportation Research Council are also commended for their efforts and cooperation.



## REFERENCES

1. Deibler, Dan G., "Metal Truss Bridges in Virginia: 1865-1932", Reports I, II, III, IV, V, Virginia Highway & Transportation Research Council, 1975-76.
2. Spero, Paula, A. C., "Metal Truss Bridges in Virginia: 1865-1932, Report VI, Virginia Highway & Transportation Research Council, 1979.
3. Newlon, Howard, Jr., "Criteria for Preservation and Adaptive Use of Historic Highway Structures", VHTRC 78-R29, Virginia Highway & Transportation Research Council, January 1978.
4. Standard Specifications for Highway Bridges, American Association of State Highway & Transportation Officials, 1977.
5. Repair and Strengthening of Old Steel Truss Bridges, American Society of Civil Engineers, 1979.
6. Byrd, Tallamy, MacDonald & Lewis, "Extending the Service Life of Existing Bridges by Increasing Their Live Load Carrying Capacity", FHWA-RD-78-133, Federal Highway Administration, 1978.
7. "Bridges on Secondary Highways and Local Roads — Rehabilitation and Replacement", NCHRP, Washington, D. C., February 1980.
8. "New Eyebars Strengthen Truss Bridges", Engineering News Record, February 1976, p. 14.
9. "Plans for Repair of Bridge on S. Maple St. over Scantic River, Enfield, Connecticut", Macchi Engineers, 44 Gillett Street, Hartford, Connecticut.
10. King, J. D., and H. R. Powell, "Redesign Modernizes Old Bridge", Civil Engineering — ASCE, Nov. 1970, pp. 37-39.
11. "Open-grid Decking Material 'Recycles' Old Bridges", Rural and Urban Roads, March 1976, pp. 54-55.
12. "Aluminum Deck Panels Raise Bridges Load Limit", Engineering News Record, August 18, 1968.
13. "Nighttime is the Right Time to Repair a Bridge", Engineering News Record, July 4, 1968, p.26.
14. Victor, R. F., "Orthotropic Bridge Saves Old Covered Bridge", Transportation Research Record 664, Transportation Research Board, Washington, D. C., pp. 80-85.
15. Kendall, C., "Tension Tendon Beefs-up Bridge", Engineering News Record, January 9, 1969, p.3.

16. Bakht, B., and P. F. Csagoly, "Strength Reserves in Highway Bridges", paper presented at the First International Symposium on Transportation Safety, San Diego, California, July 1979.
17. Kirby, George C., An Evaluation of Procedures for Strengthening Historic Truss Bridges, thesis presented for the degree of Master of Science in Civil Engineering, University of Virginia, May 1979.
18. Original Bridge Report — Bridge No. 6049, Virginia Department of Highways and Transportation, Staunton, Virginia, May 1976.
19. Manual for Maintenance Inspection of Bridges, American Association of State Highway and Transportation Officials, 1974.
20. "SPAR", LMSC D403168, Lockheed Missile and Space Company, Palo Alto, California, June 1974.
21. "STAPLER", Naval Research and Development Shipyard, Washington, D. C.
22. Zemhata, Dennis M., "Elm Street Bridge", Woodstock National Historic District Commission Report, Woodstock, Vermont, 1977.

## NOTATION SHEET

For conversion from English to SI units

1 in.	=	25.4	mm	(millimeter)
1 ft.	=	0.305	m	( meter)
1 mi.	=	1.609	km	(kilometer)
1 psi	=	6.895	KPa	(Kilopascal)
1 psf	=	47.880	Pa	(Pascal)
1 ksi	=	6.895	MPa	(Megapascal)
1 ton	=	0.907	Mg	(Megagram)



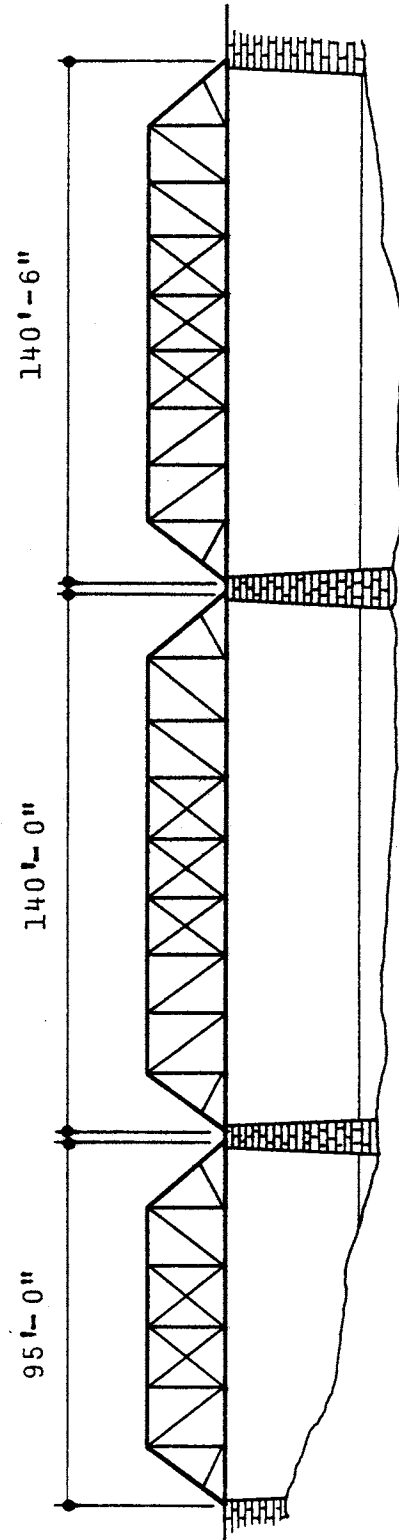
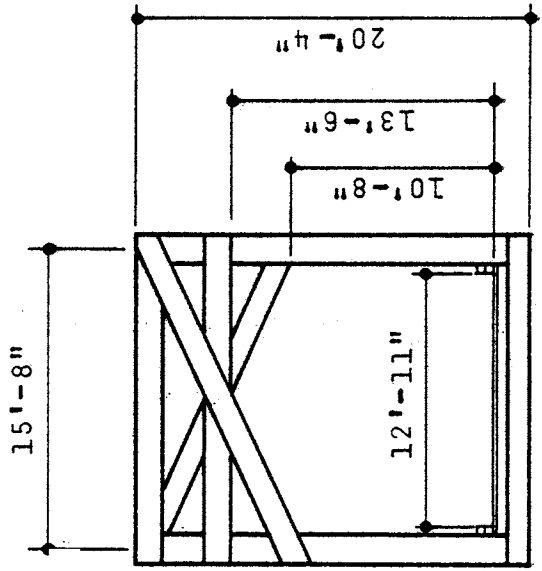
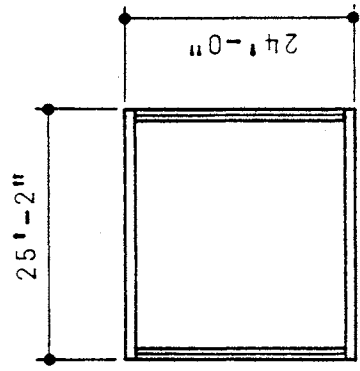

Figure 1: Bridge No. 1.

2941



33° SKEW

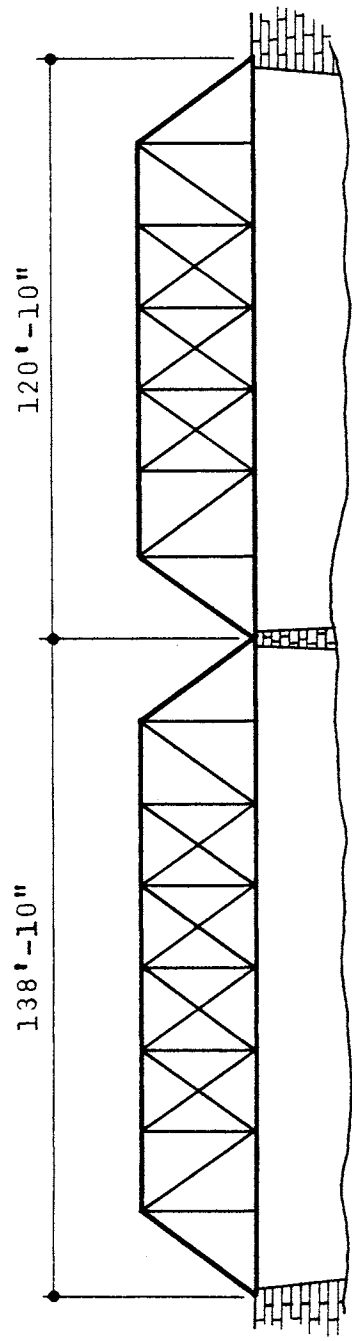

Figure 2: Bridge No. 2.



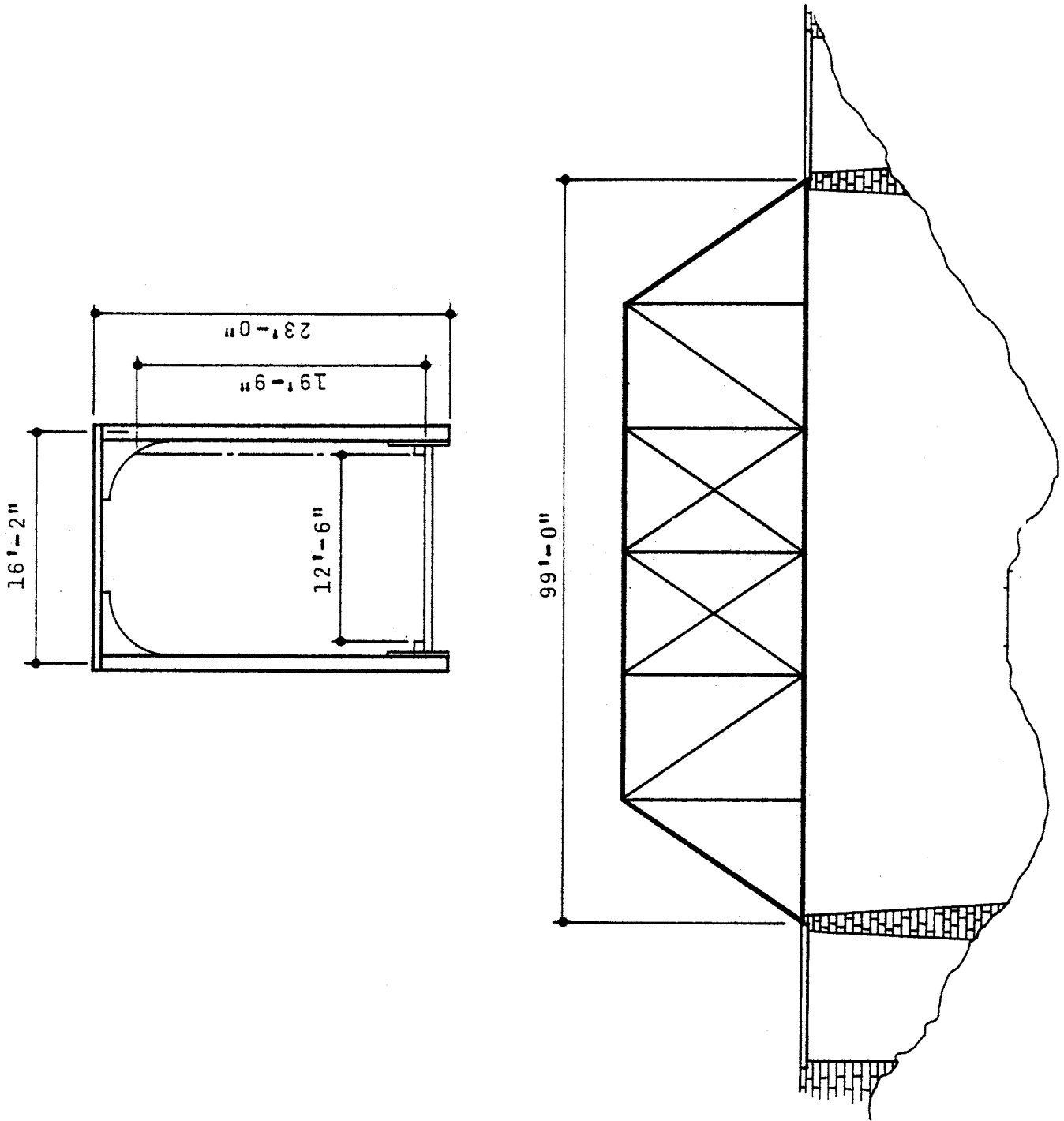

Figure 3: Bridge No. 3.

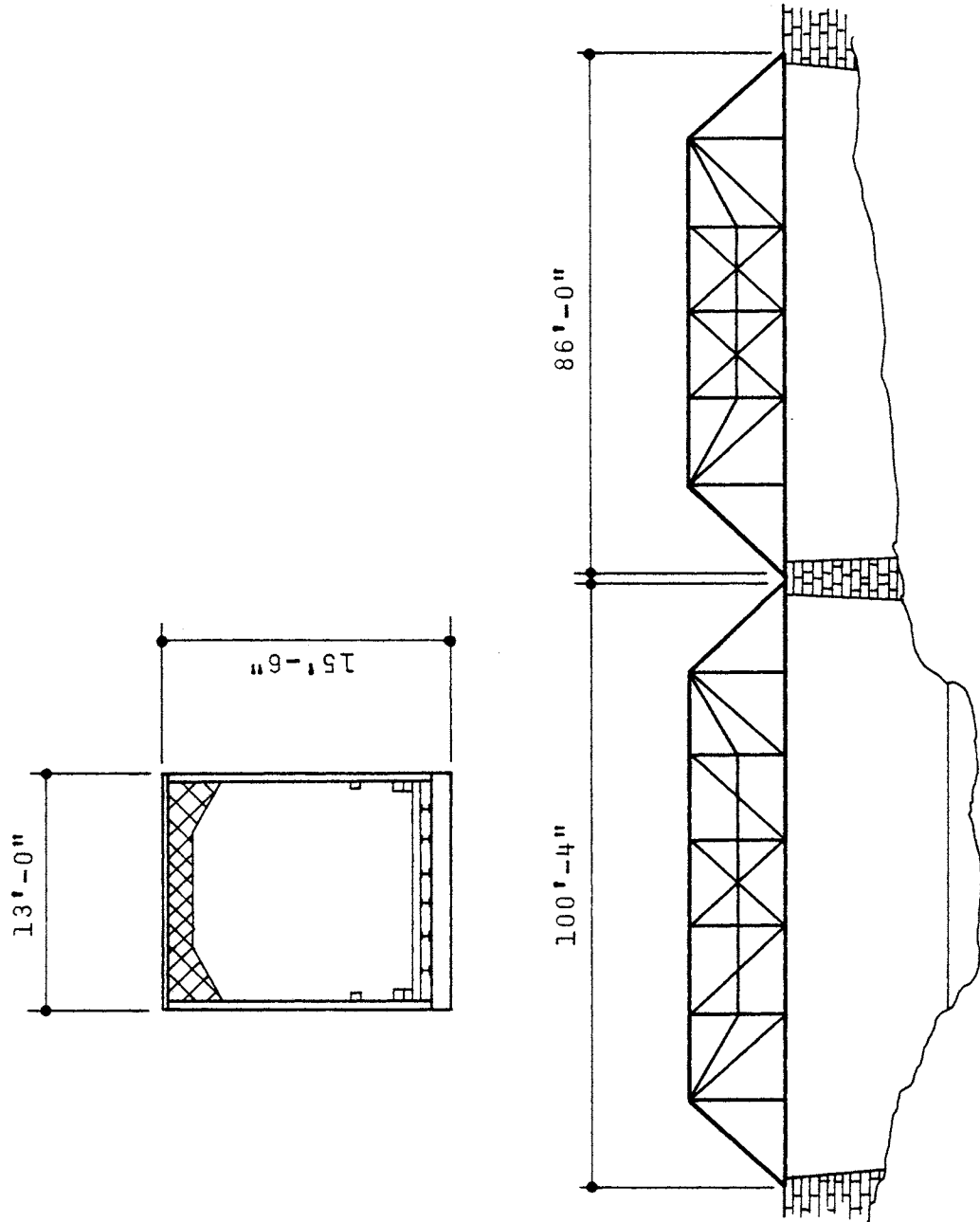

Figure 4: Bridge No. 4.

2847

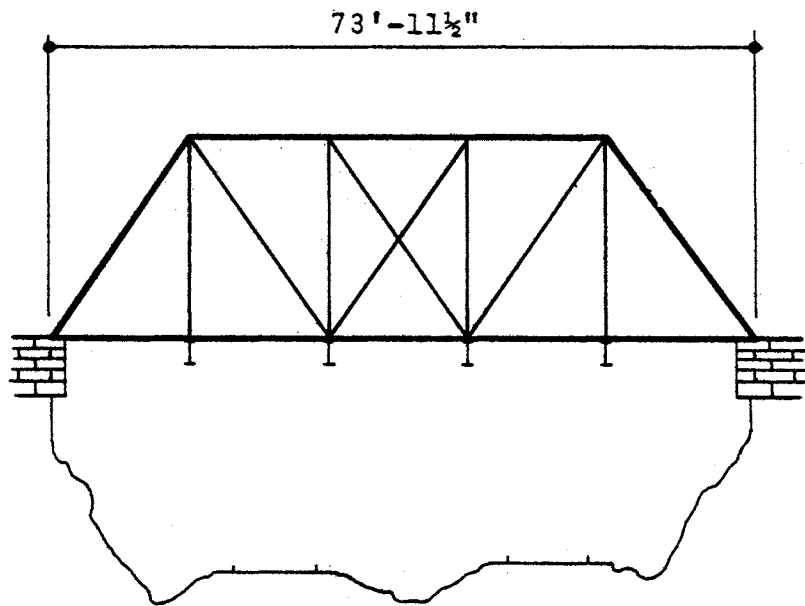
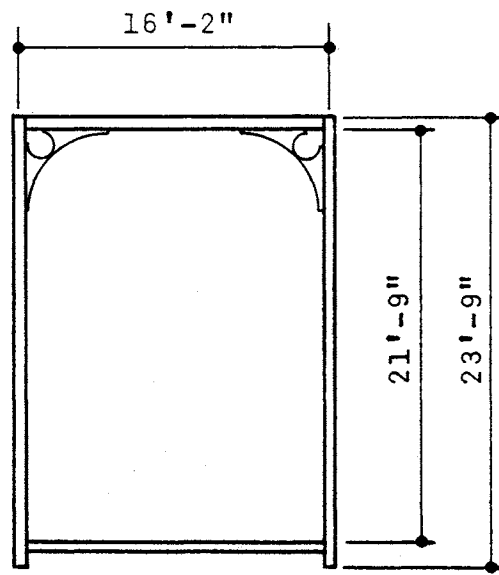

Figure 5: Bridge No. 5.

2848

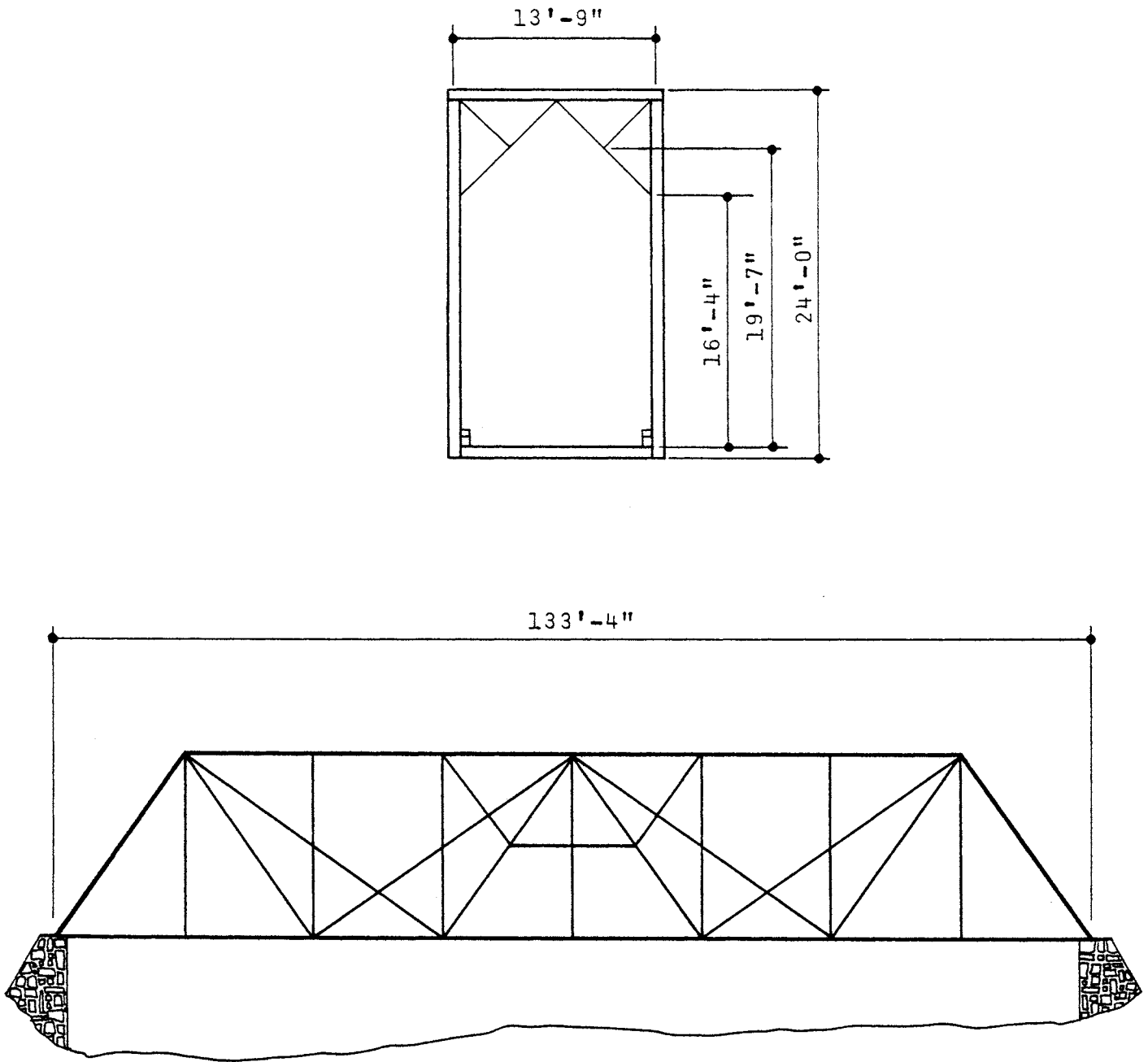

Figure 6: Bridge No. 6.

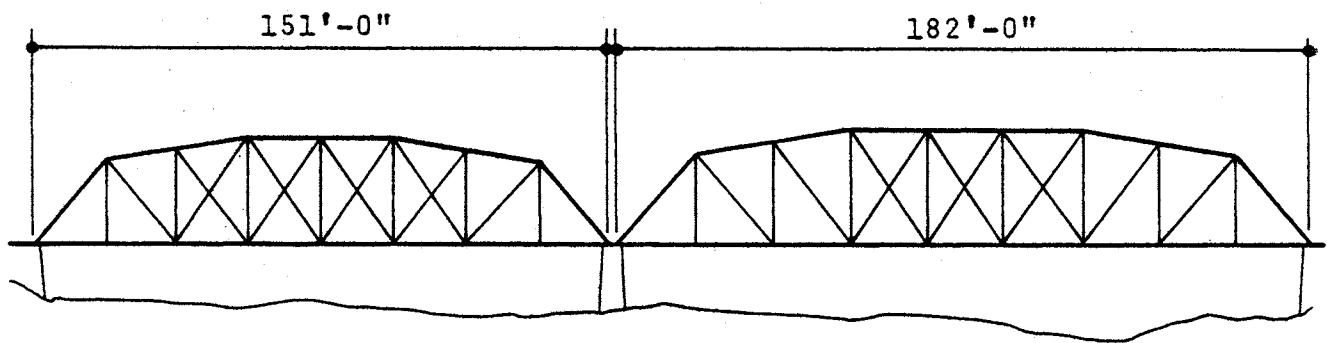
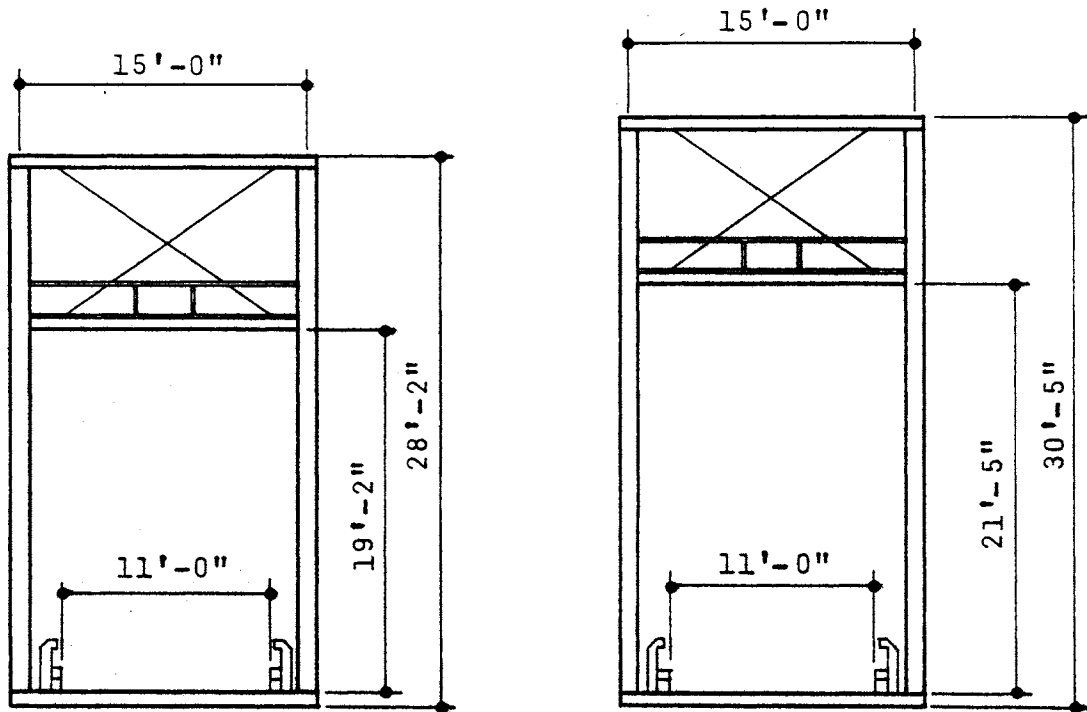

Figure 7: Bridge No. 7.

2359

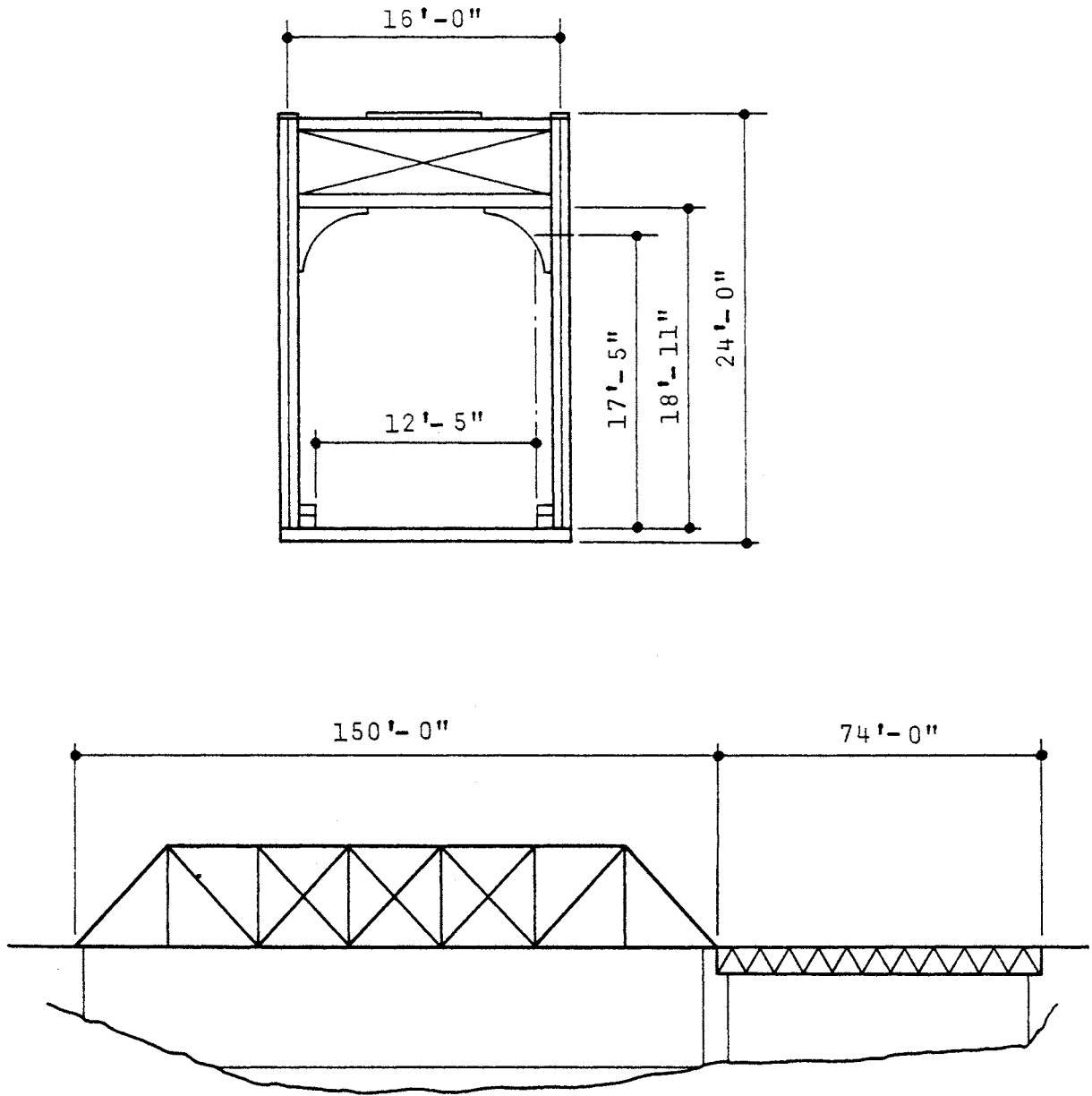

Figure 8: Bridge No. 8.

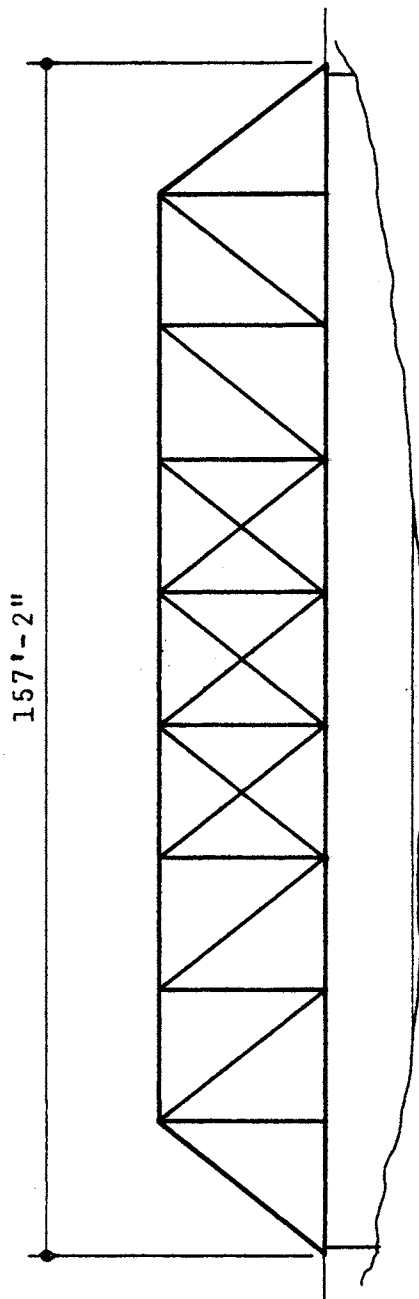
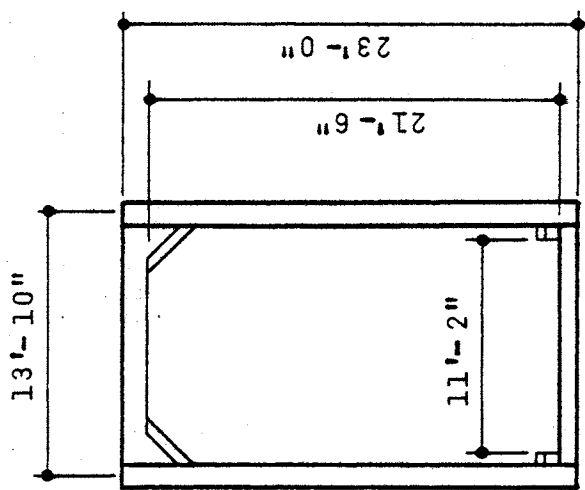

Figure 9: Bridge No. 9.

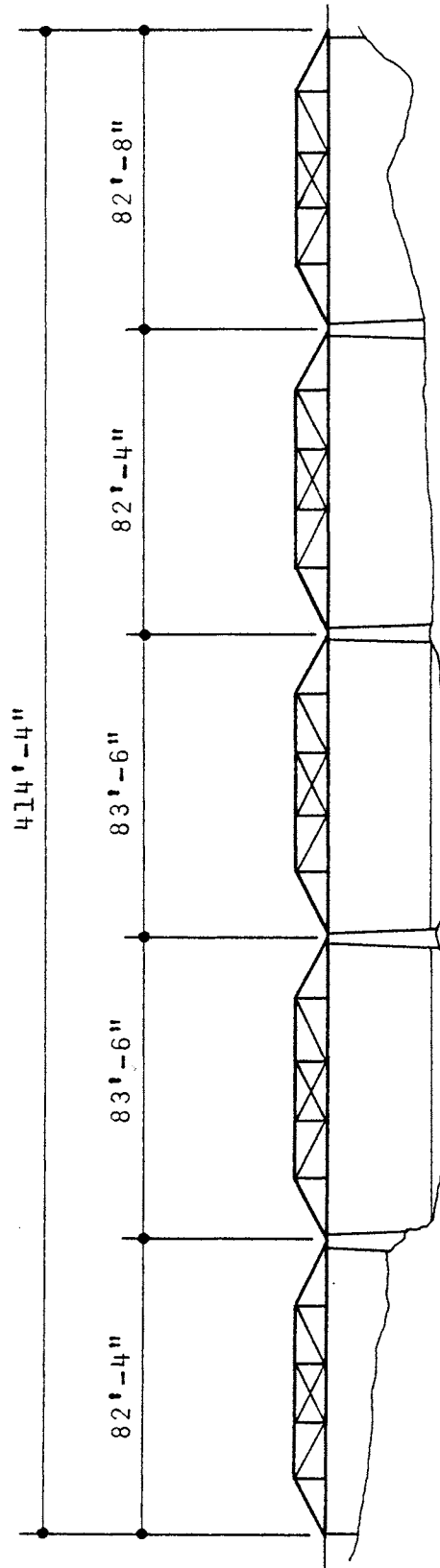
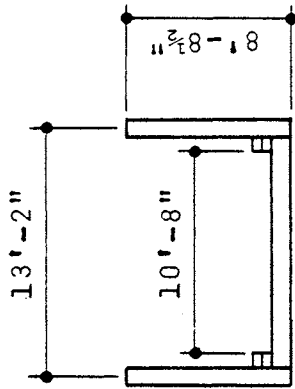

Figure 10: Bridge No. 11.



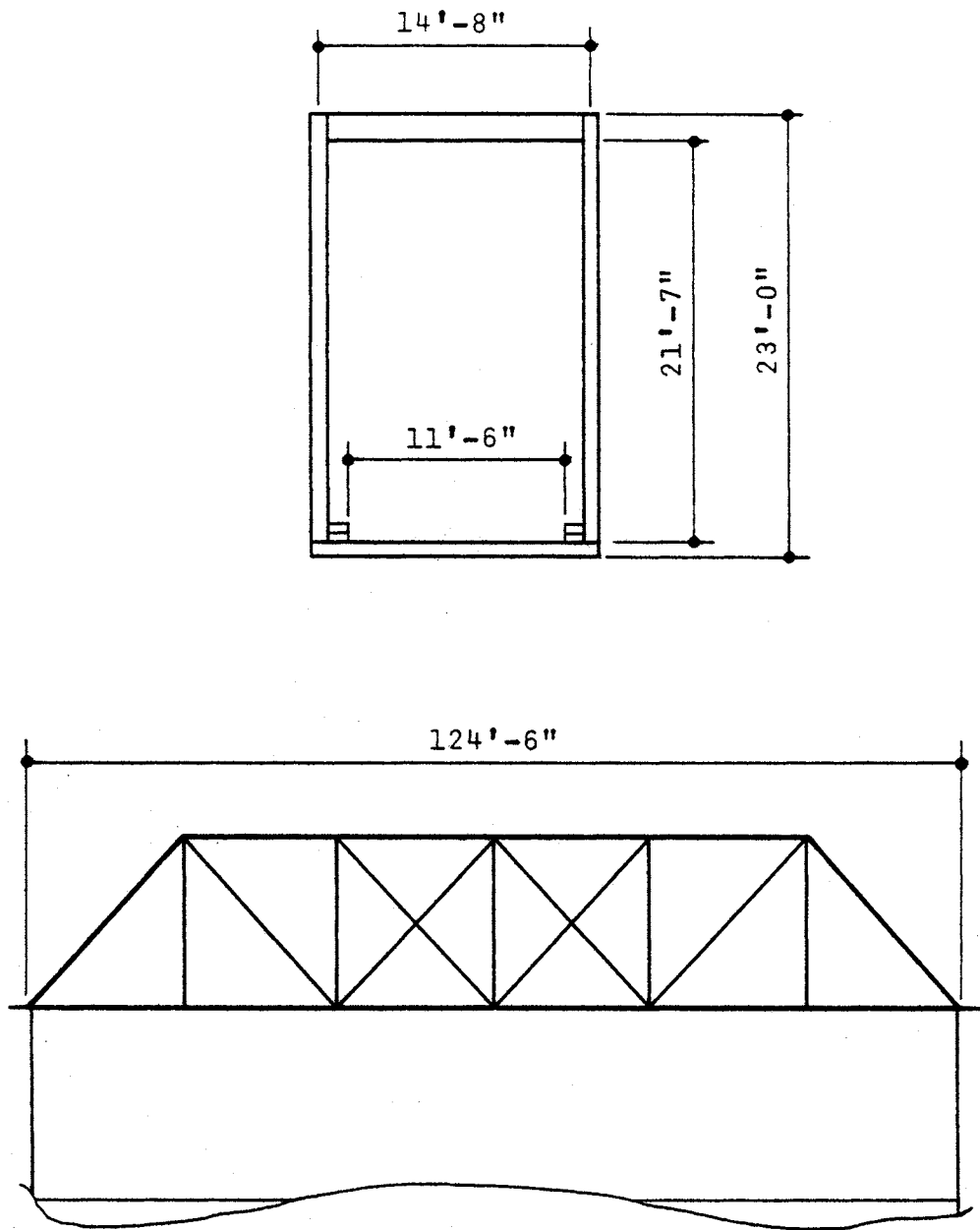

Figure 11: Bridge No. 12.

2854

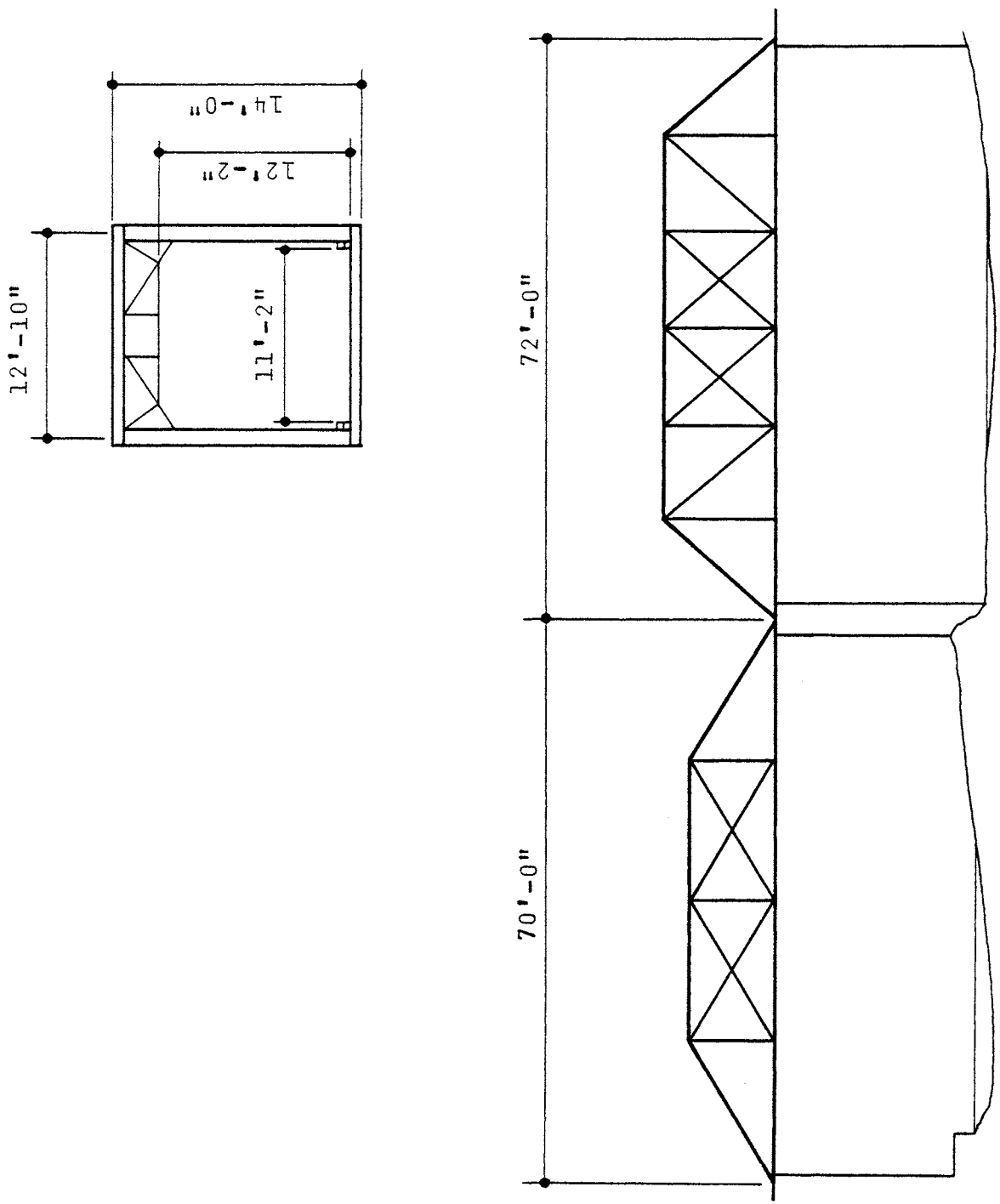
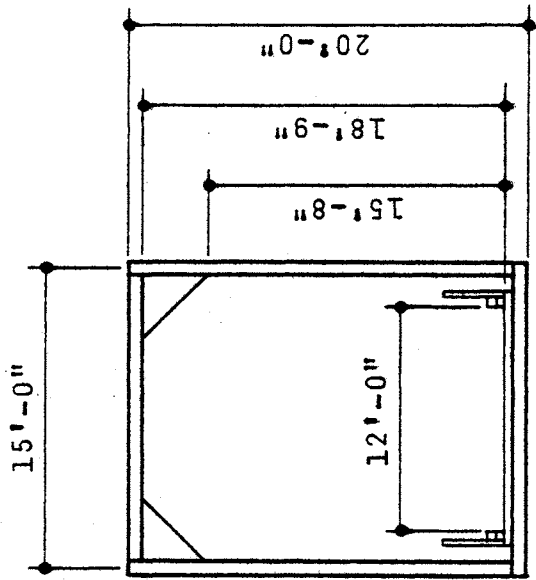

Figure 12: Bridge No. 15.



20° SKEW

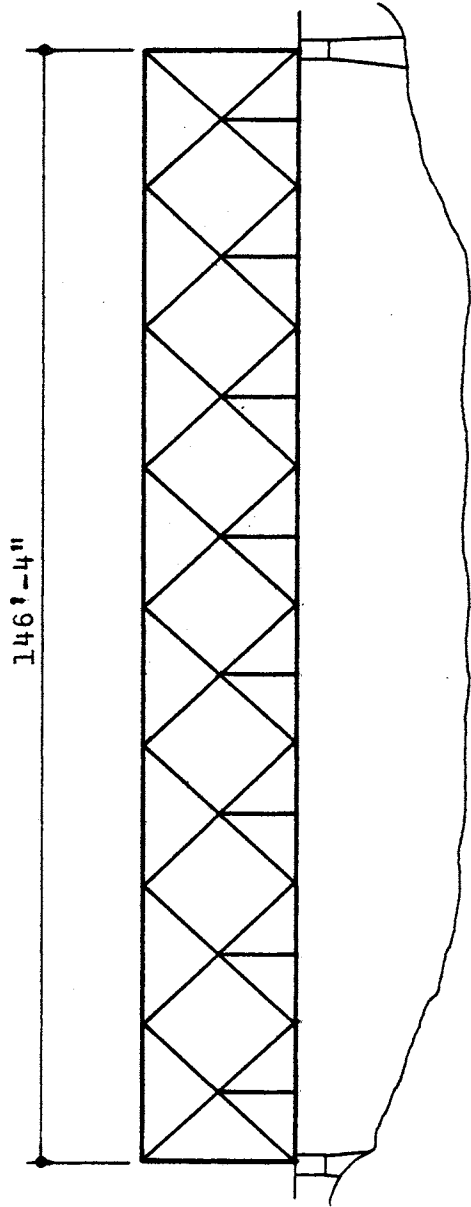

Figure 13: Bridge No. 16.

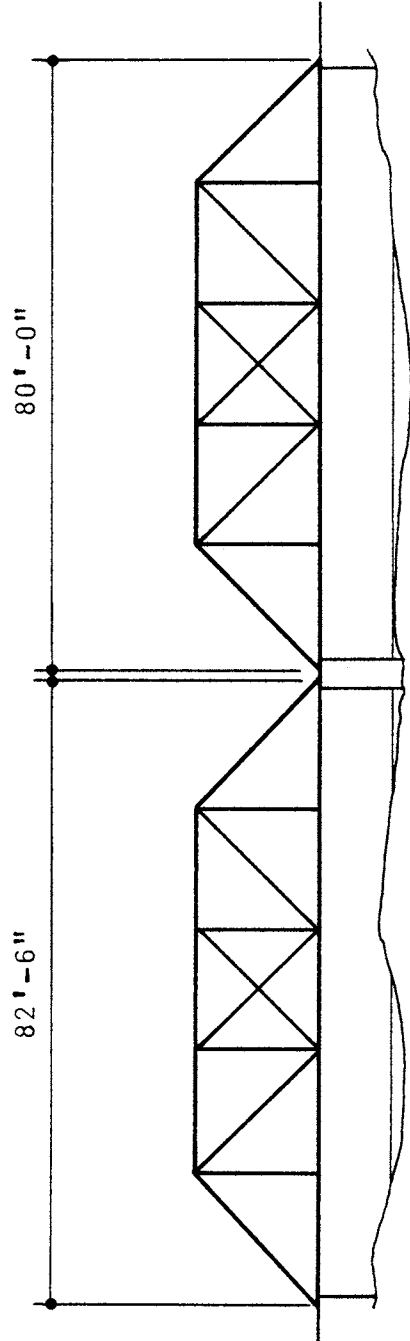
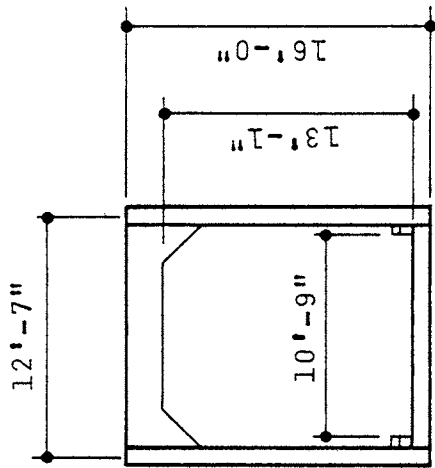

Figure 14: Bridge No. 18.

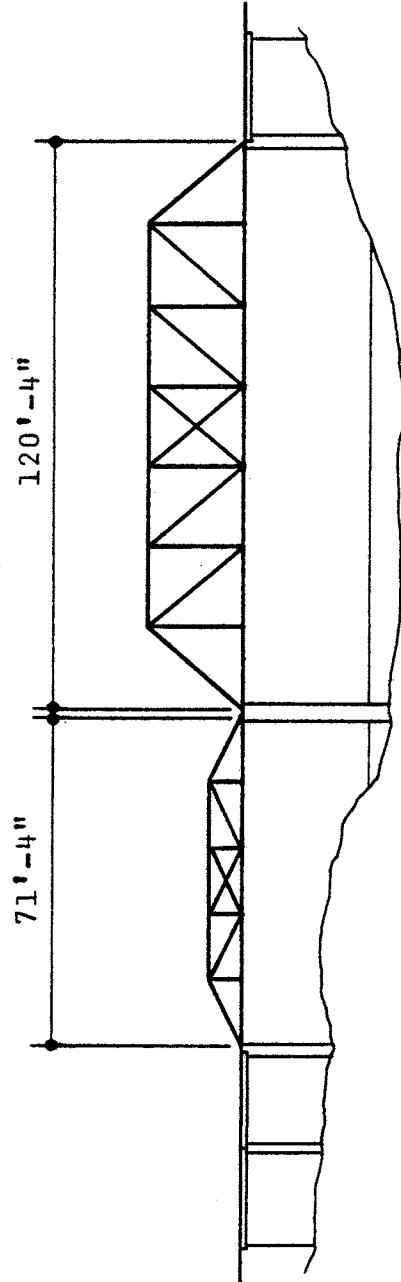
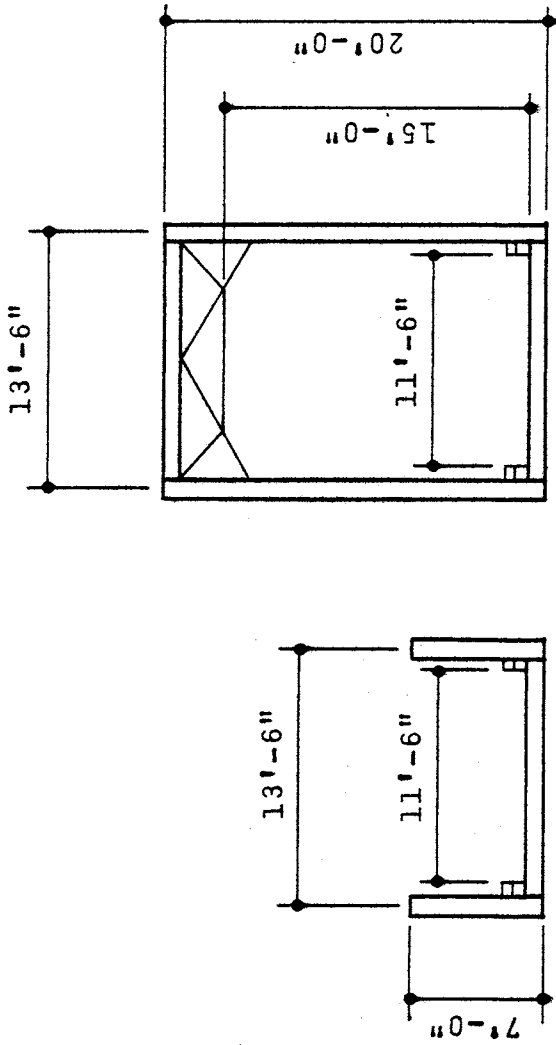

Figure 15: Bridge No. 19.

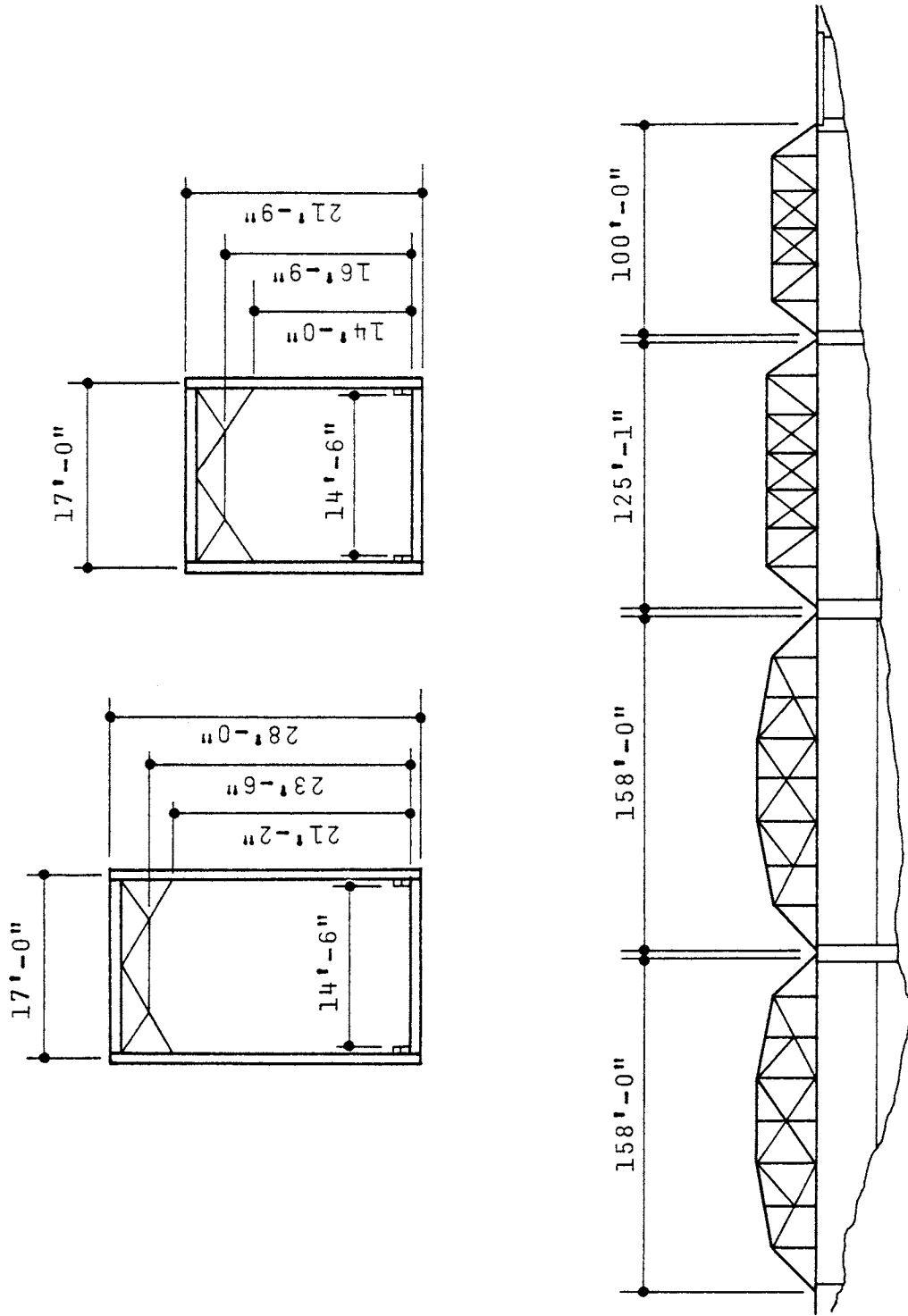

Figure 16: Bridge No. 20.

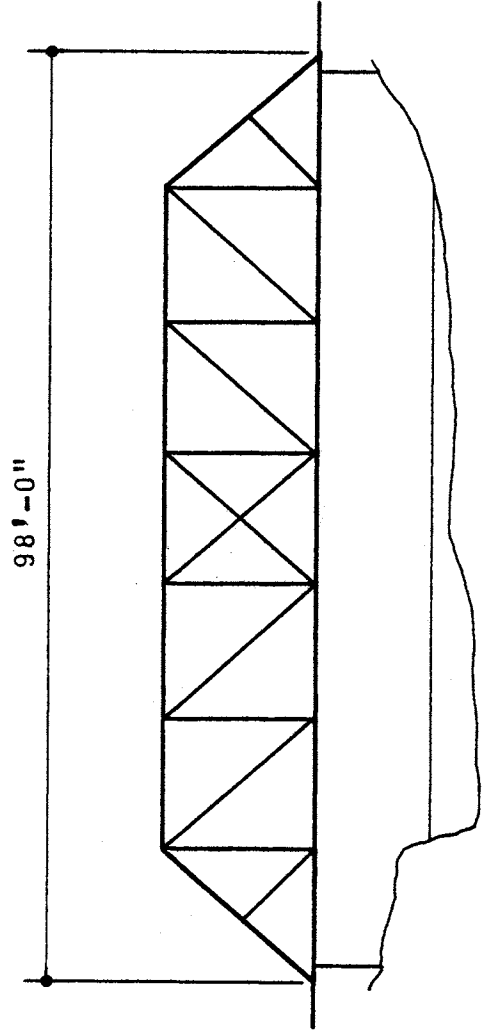
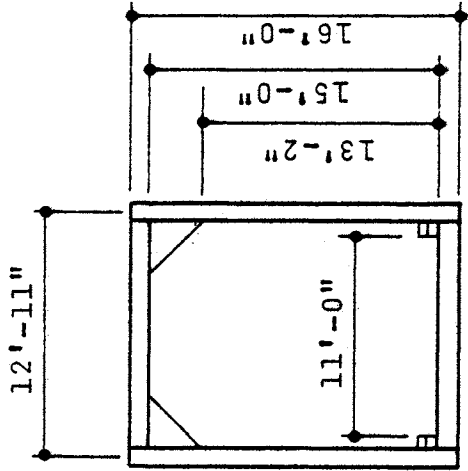

Figure 17: Bridge No. 21.

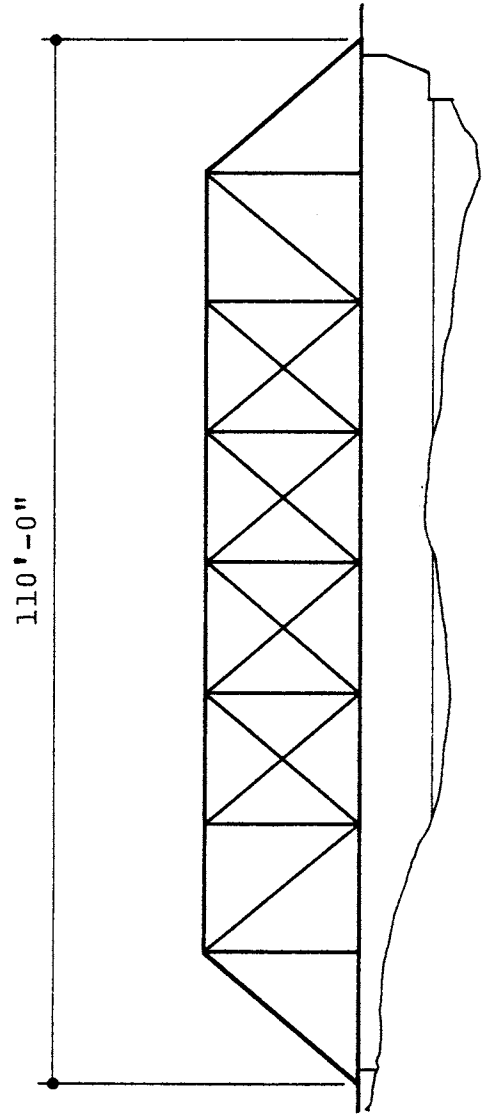
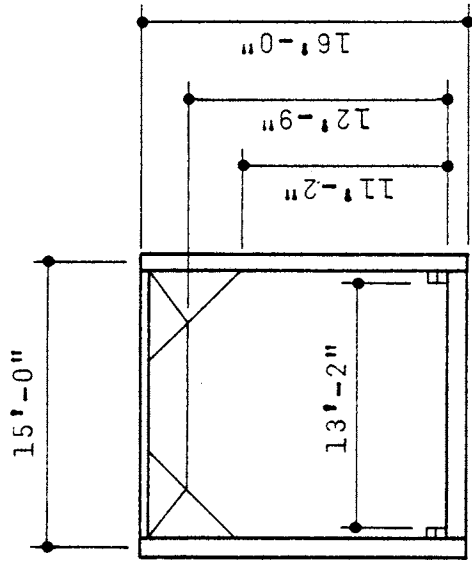

Figure 18: Bridge No. 22.



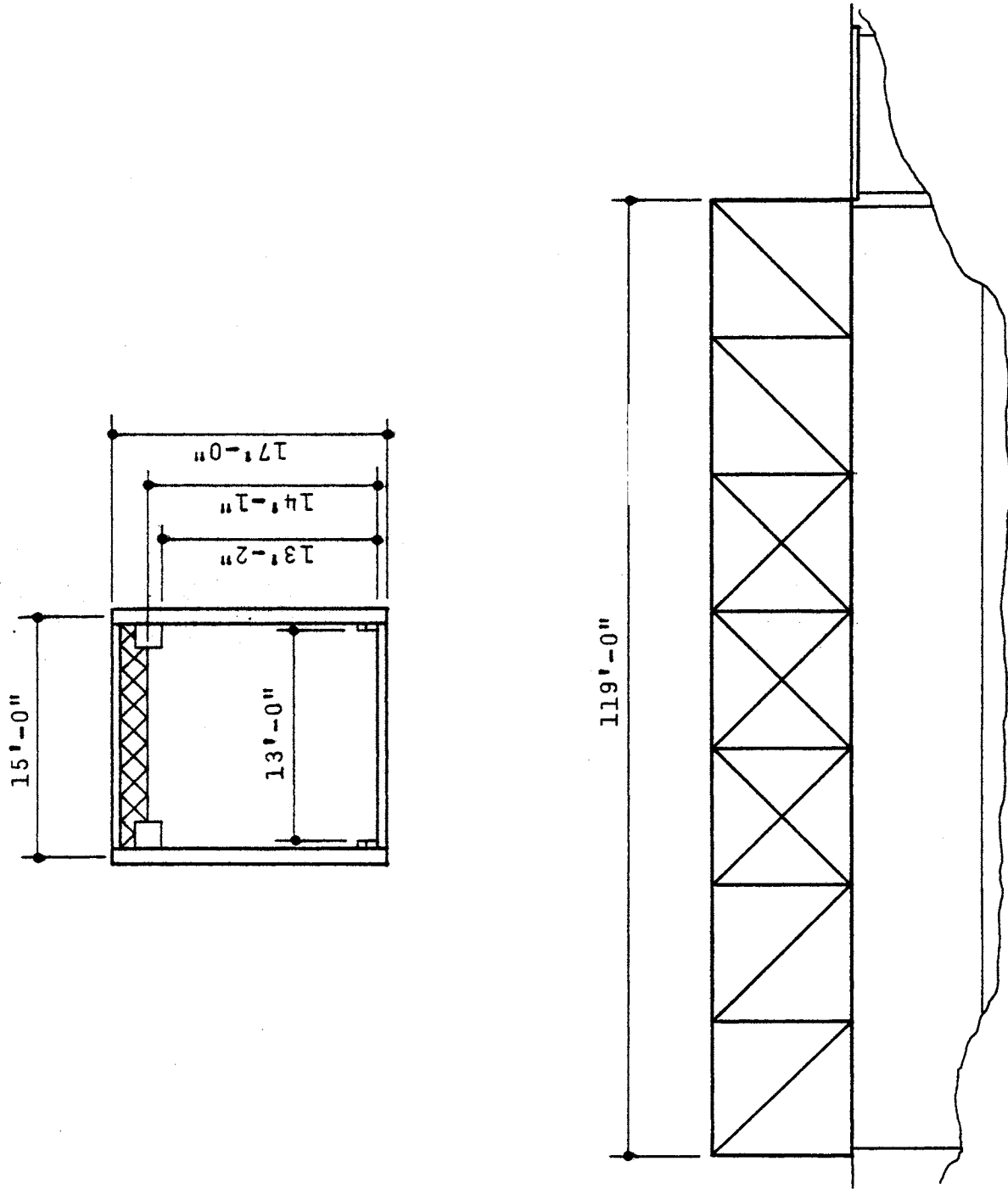

Figure 19: Bridge No. 23.

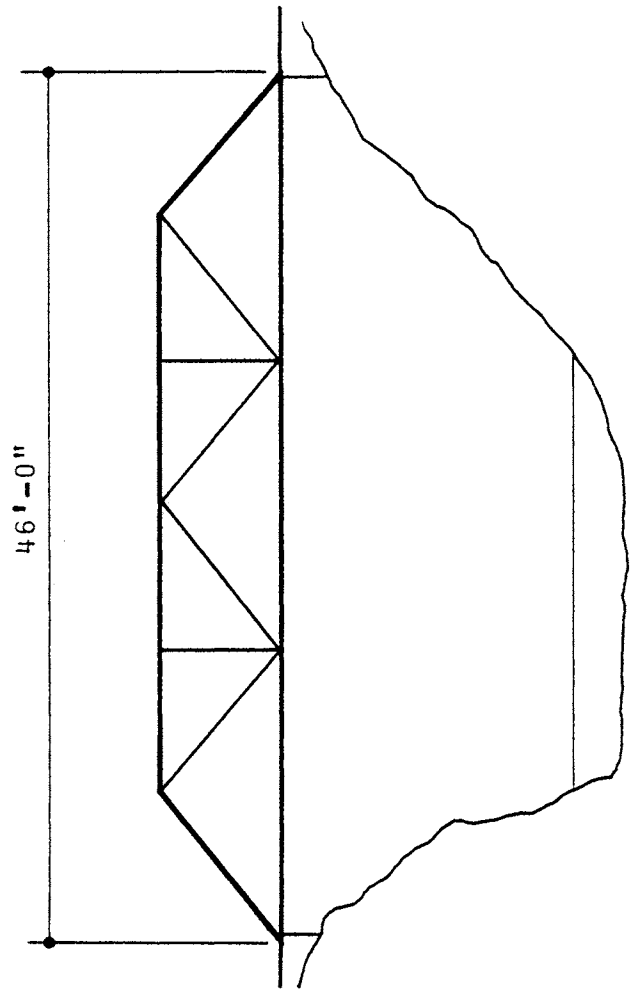
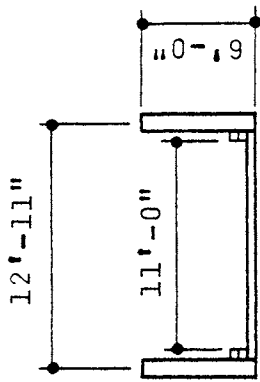

Figure 20: Bridge No. 24.

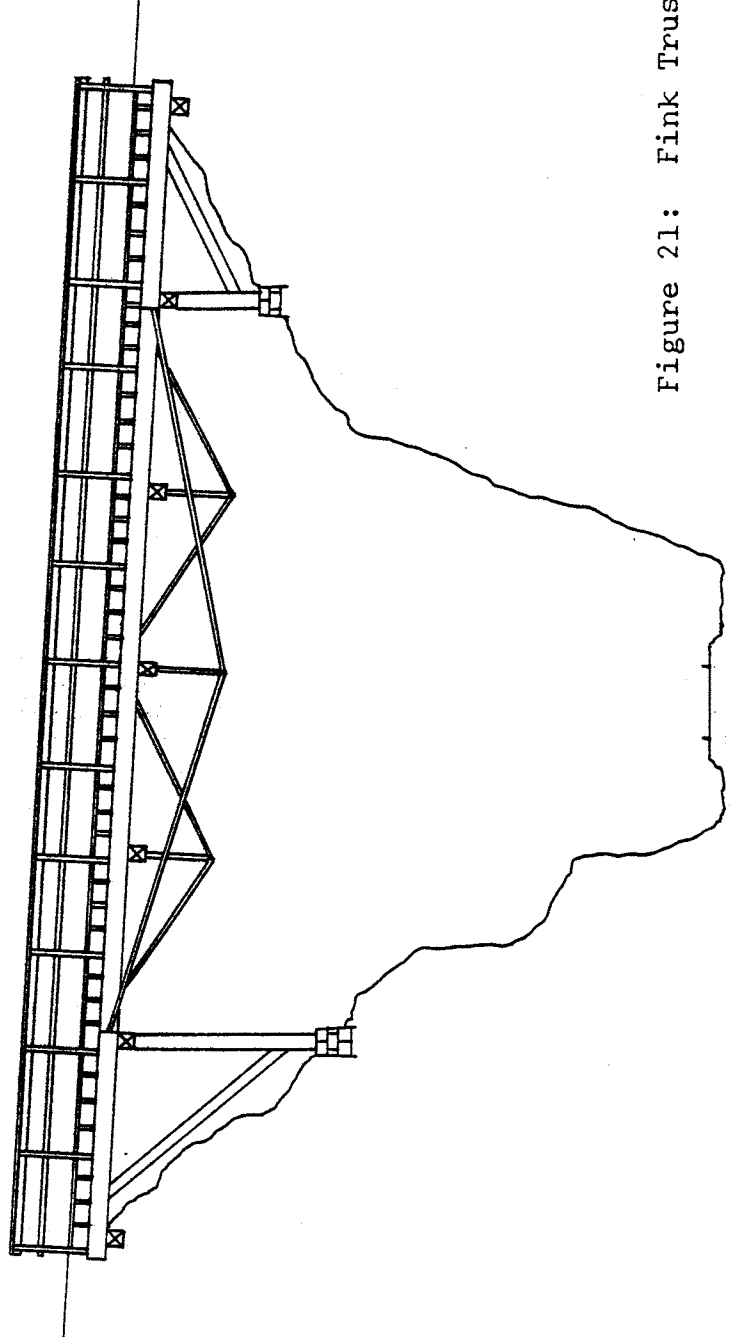
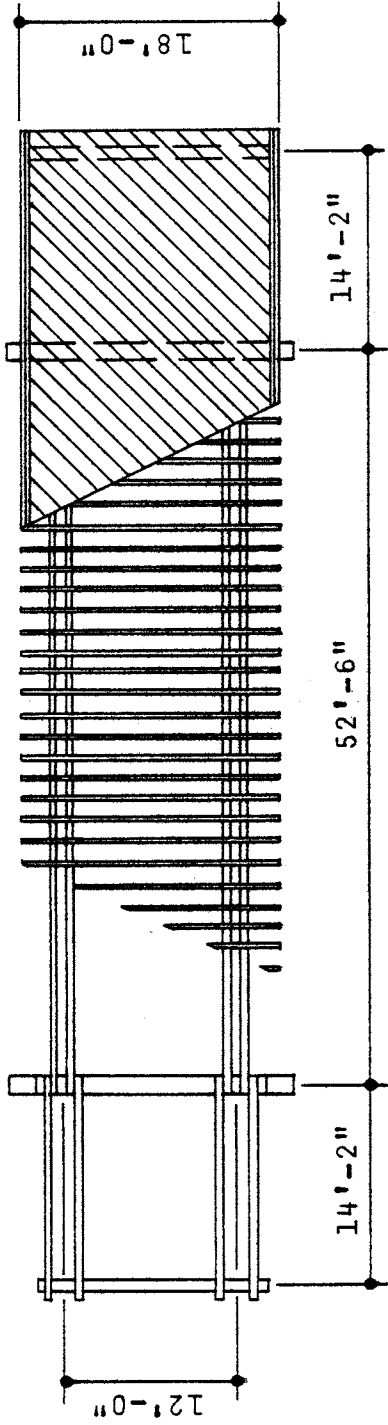

Figure 21: Fink Truss Bridge.

2864

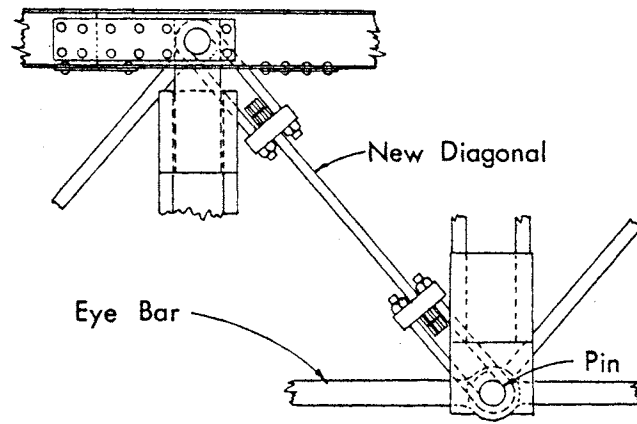
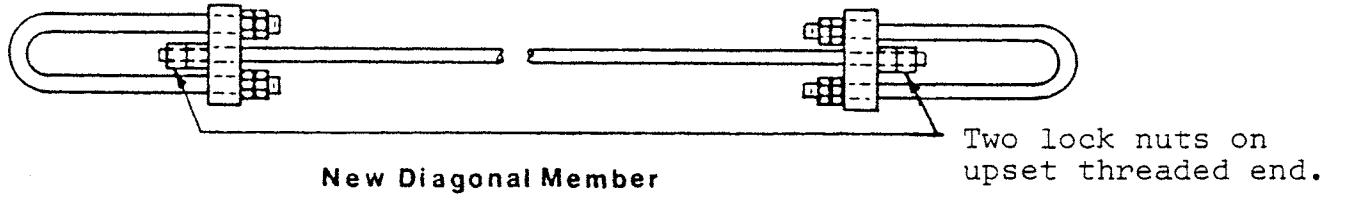

Figure 22. Replacement diagonal used by Virginia.

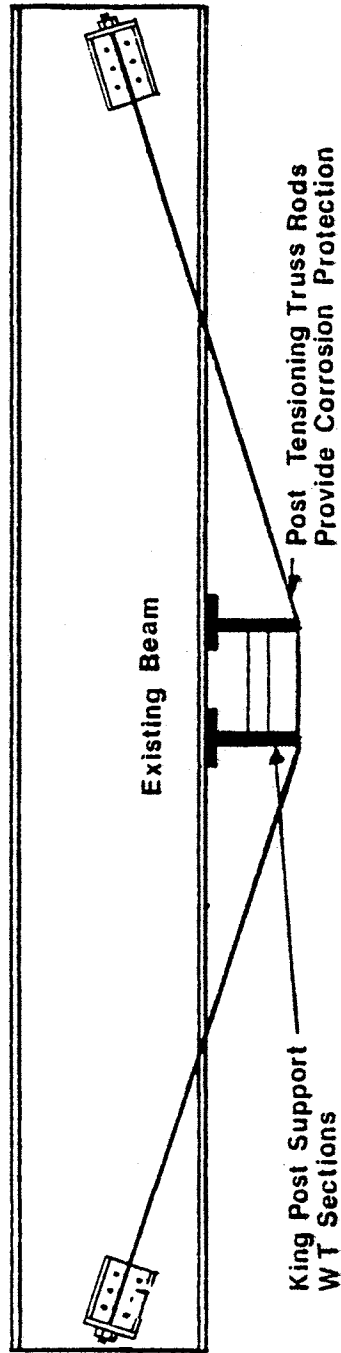

Figure 23. Kingpost truss beam reinforcement.

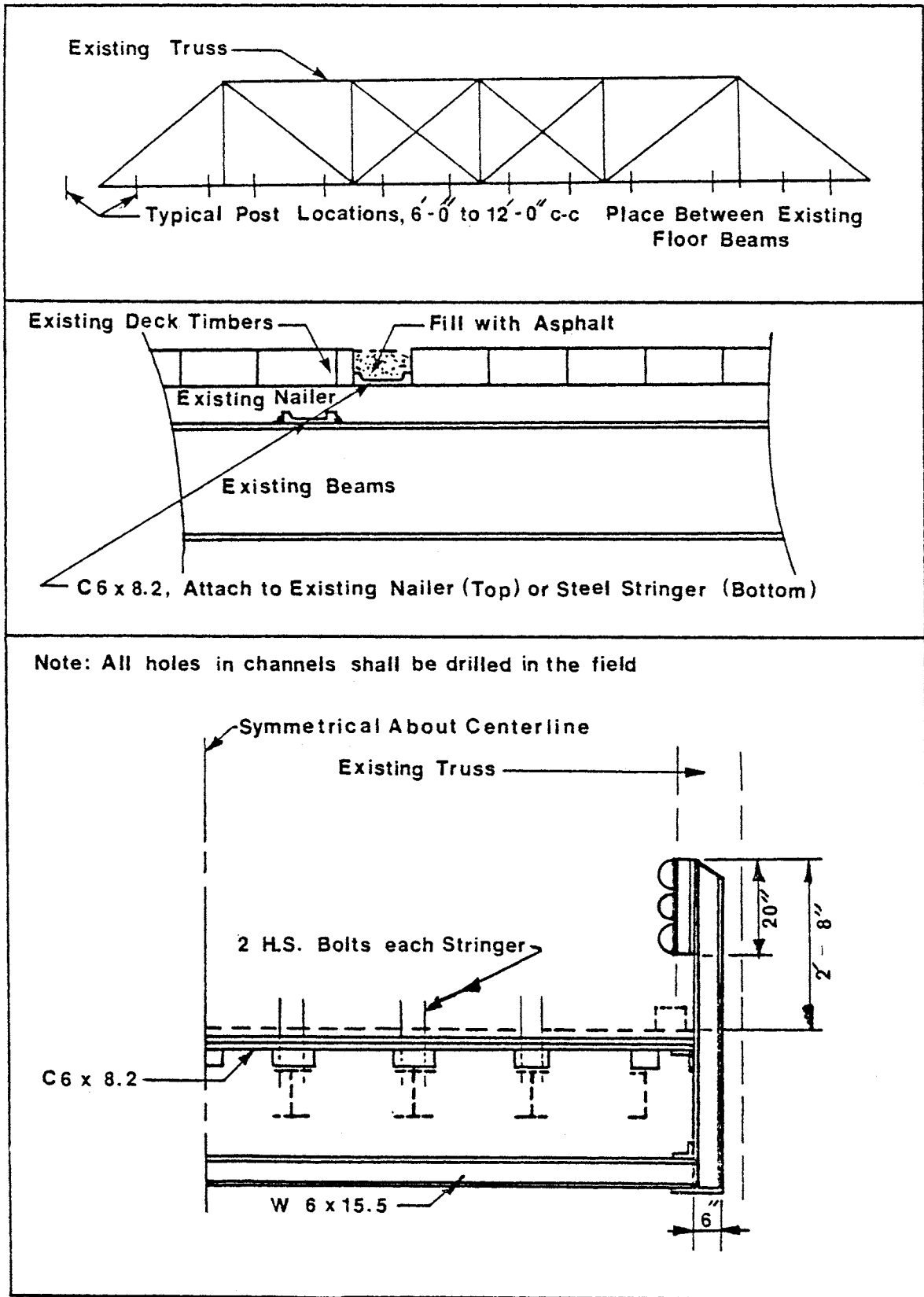

Figure 24. Rail installation on existing truss bridge.

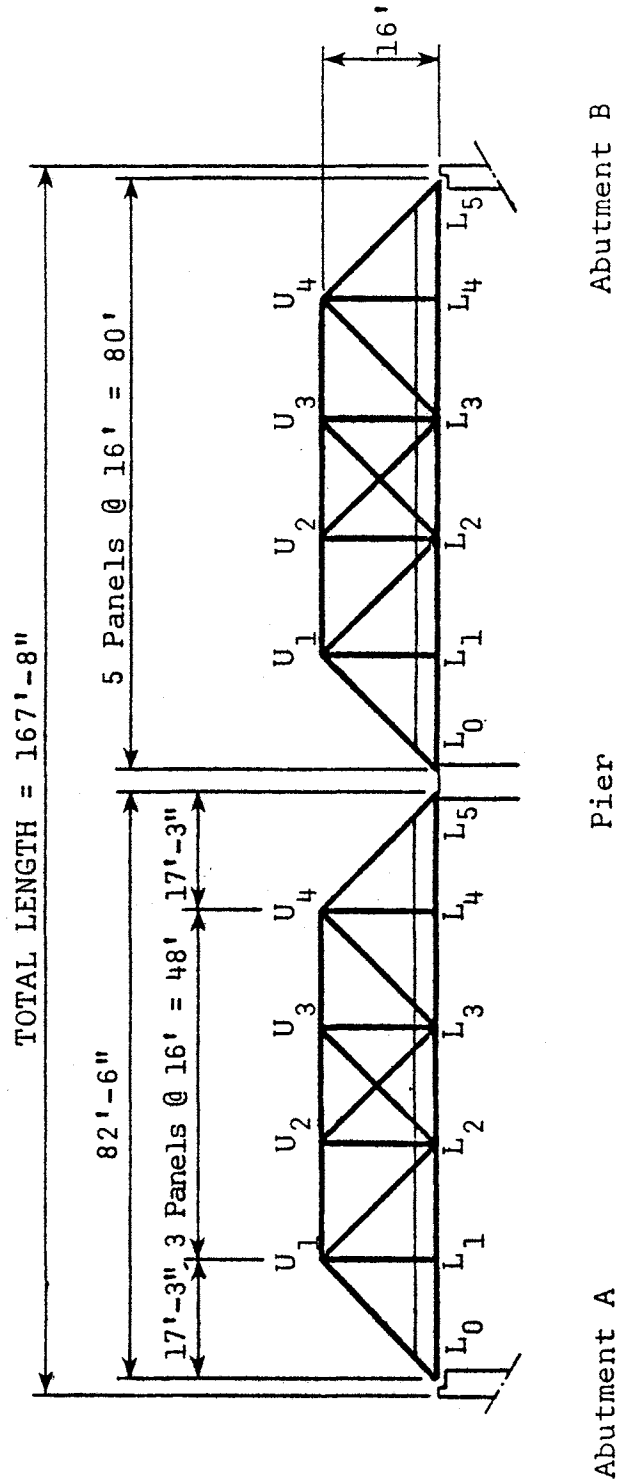

Figure 25. Elevation and profile of the Rte. 632 structure.

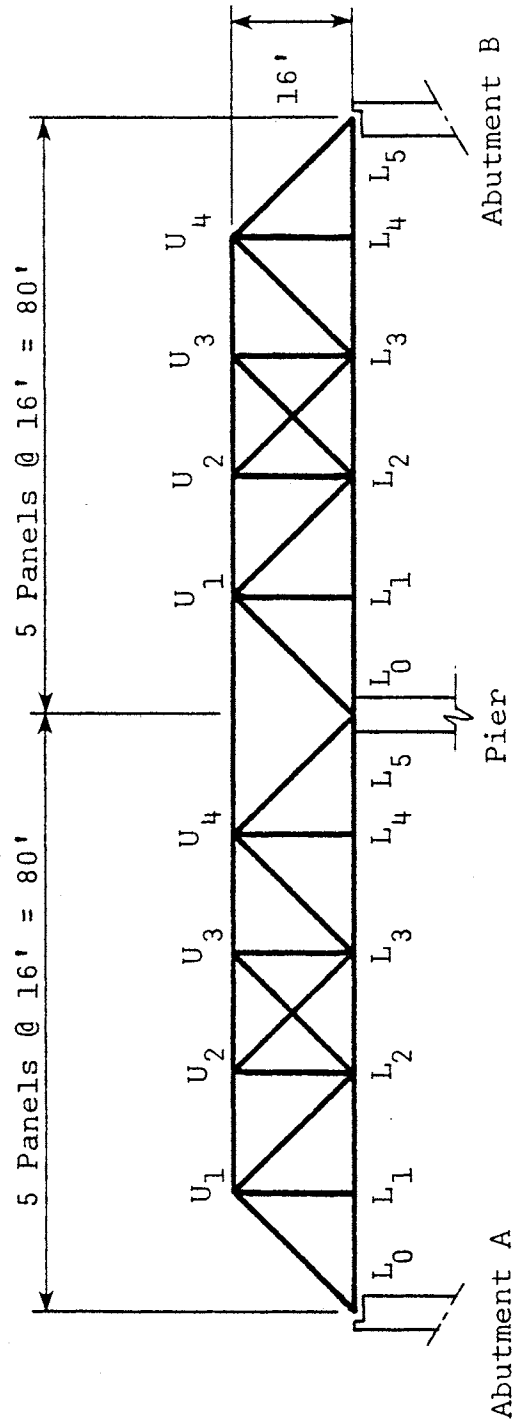

Figure 26. Elevation and profile of the continuous spans.



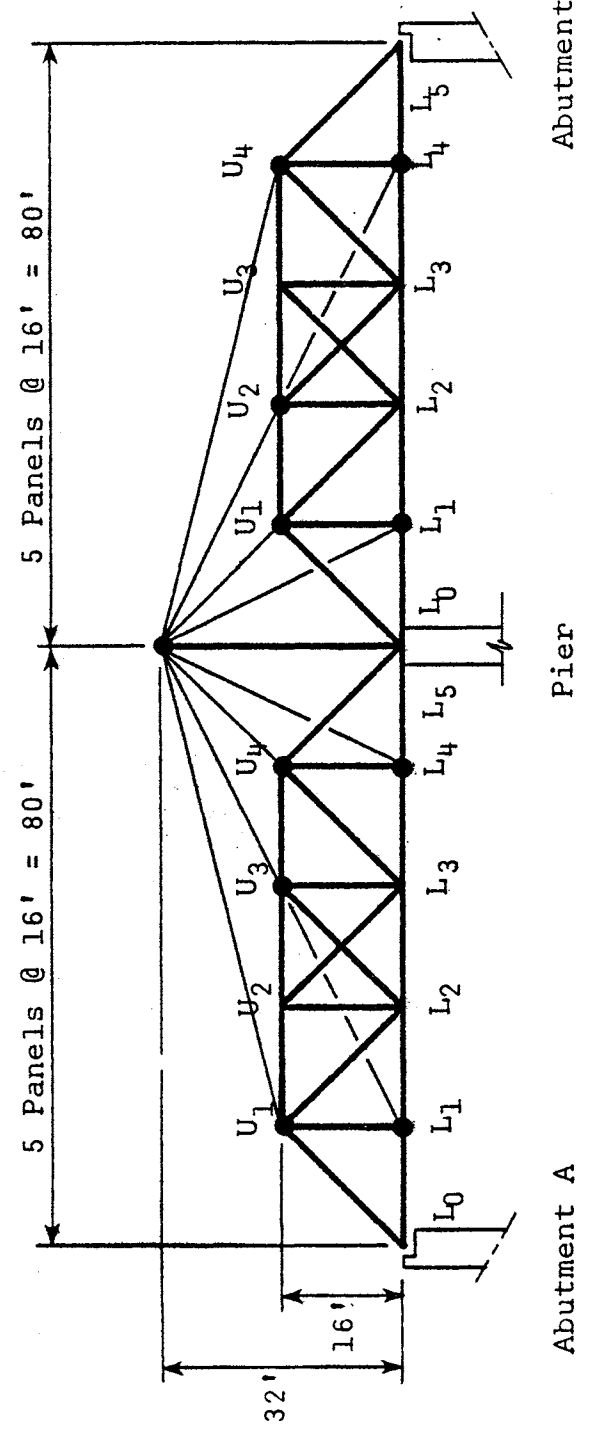

Figure 27. Elevation and profile of pylon tower with cable stays to truss.

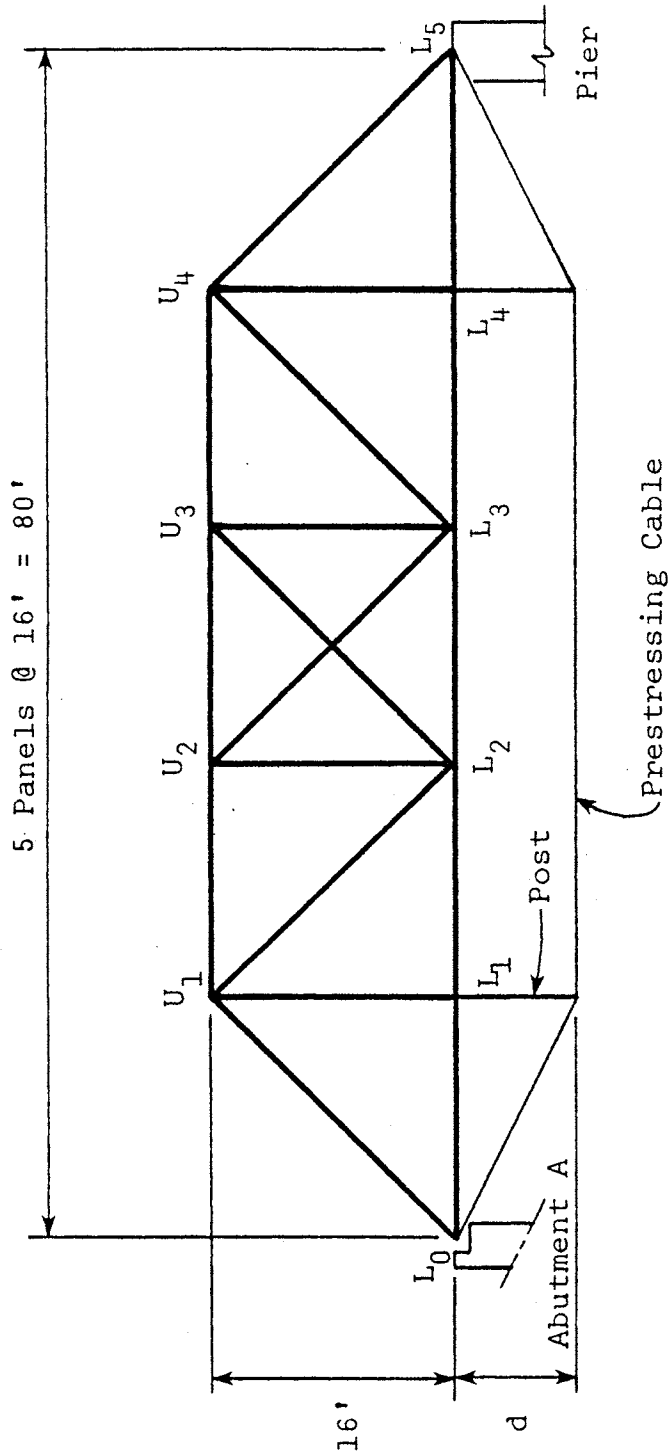

Figure 28. Elevation of Queen post reinforcement.

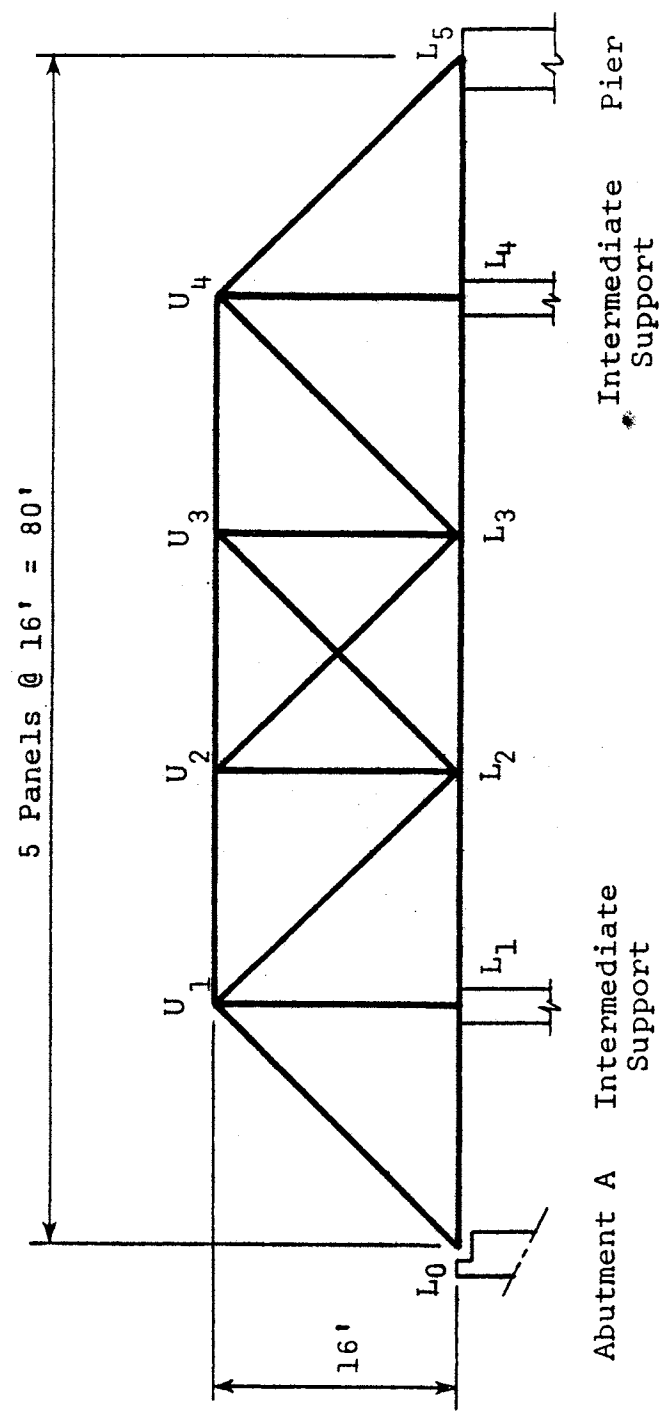

Figure 29. Elevation and profile of truss with intermediate supports.

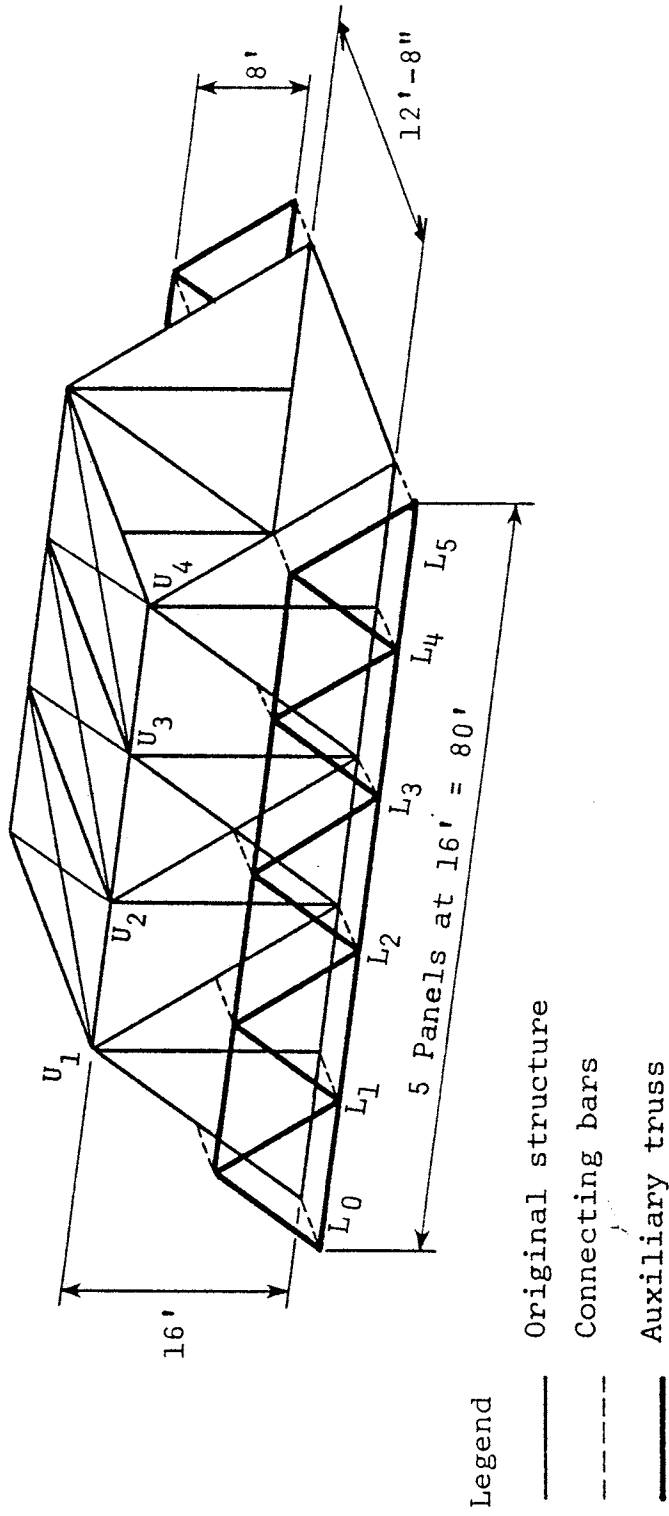

Figure 30. Reinforcement by auxiliary trusses.

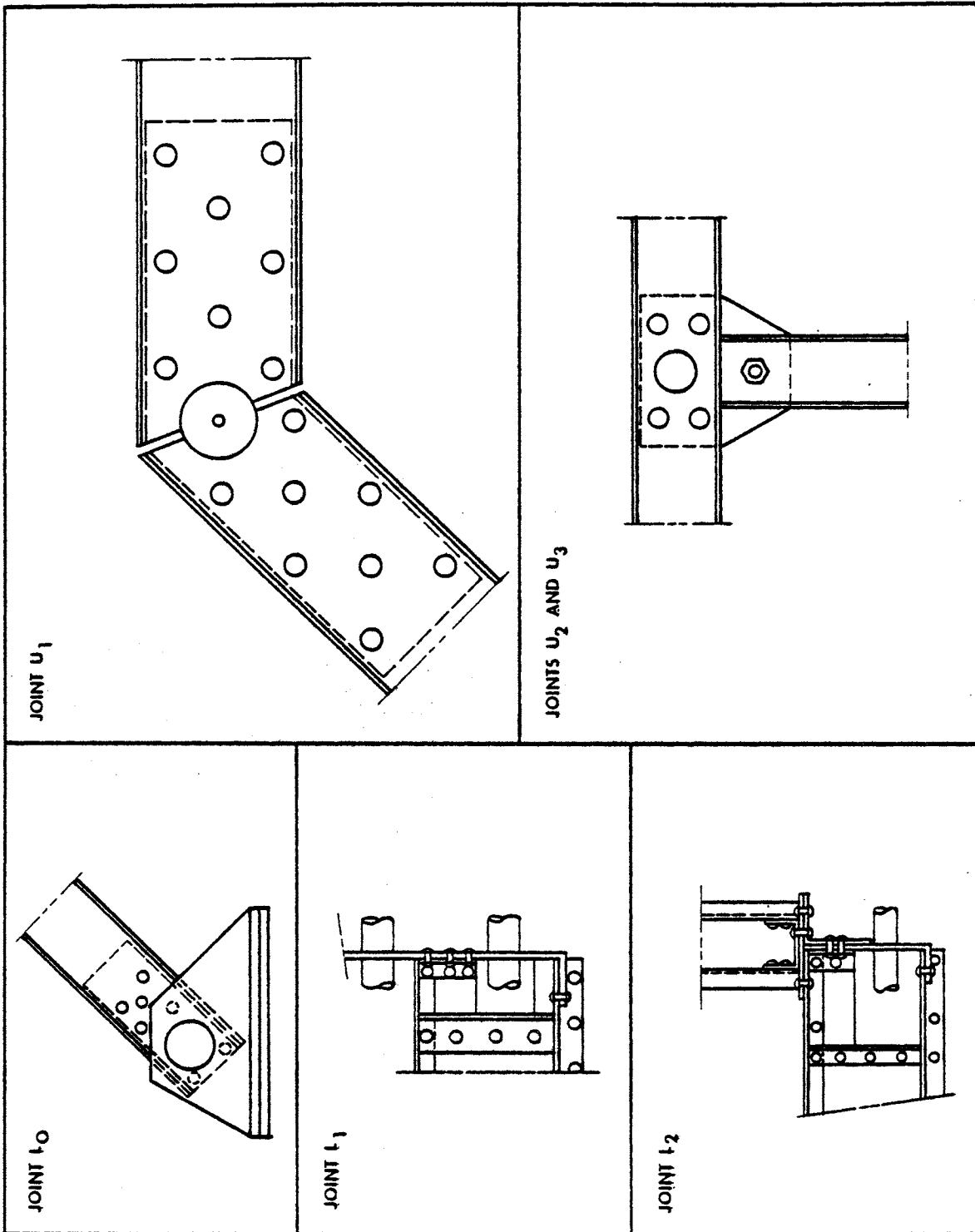

Figure 31. Connection details, Route 632 truss over South River.

287A

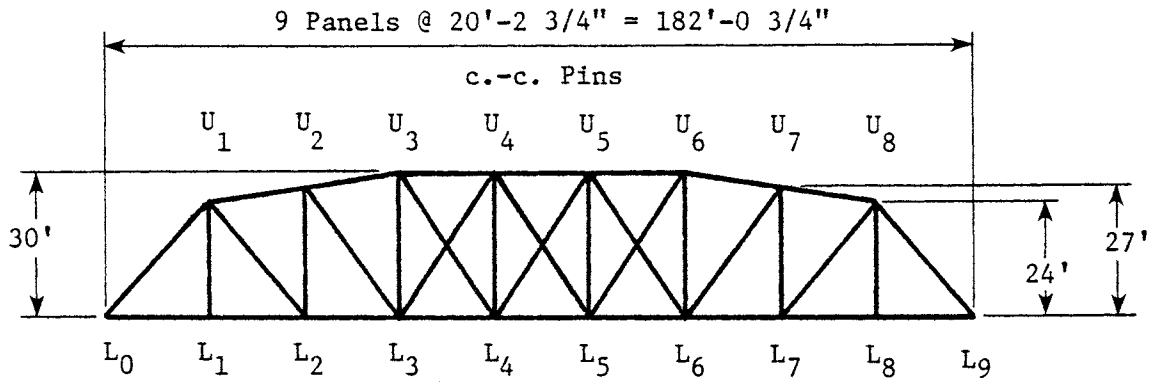

Figure 32. Parker truss.

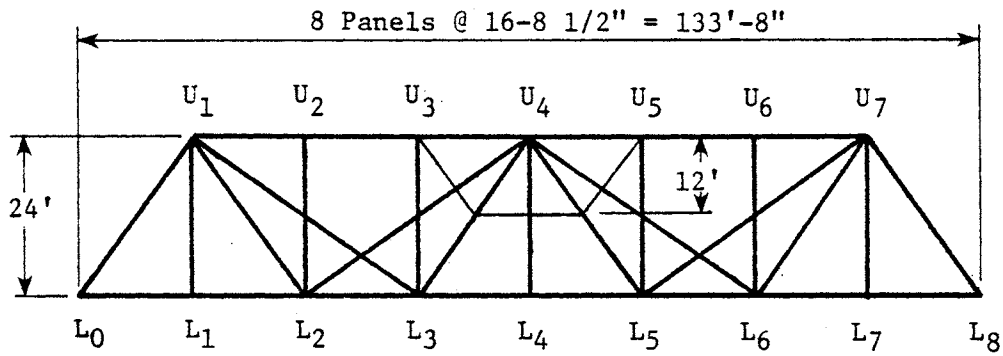

Figure 33. Thacher through truss.

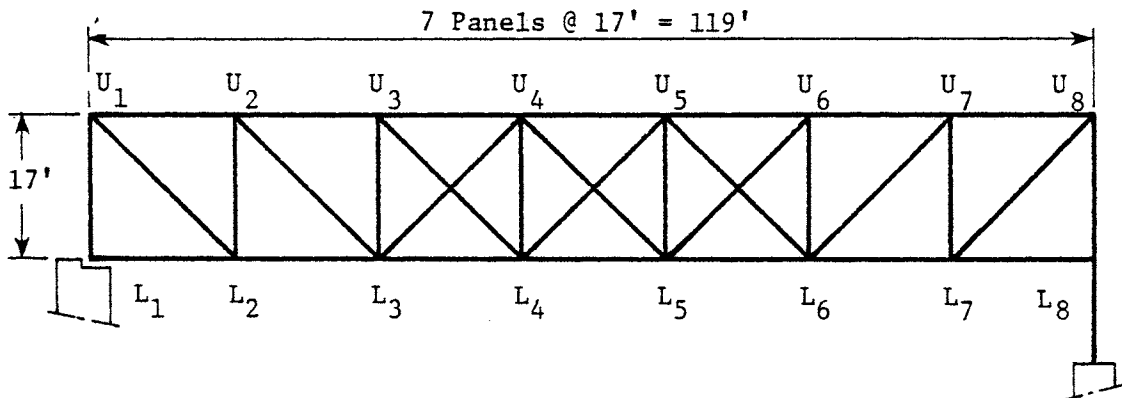

Figure 34. Pratt bedstead truss.

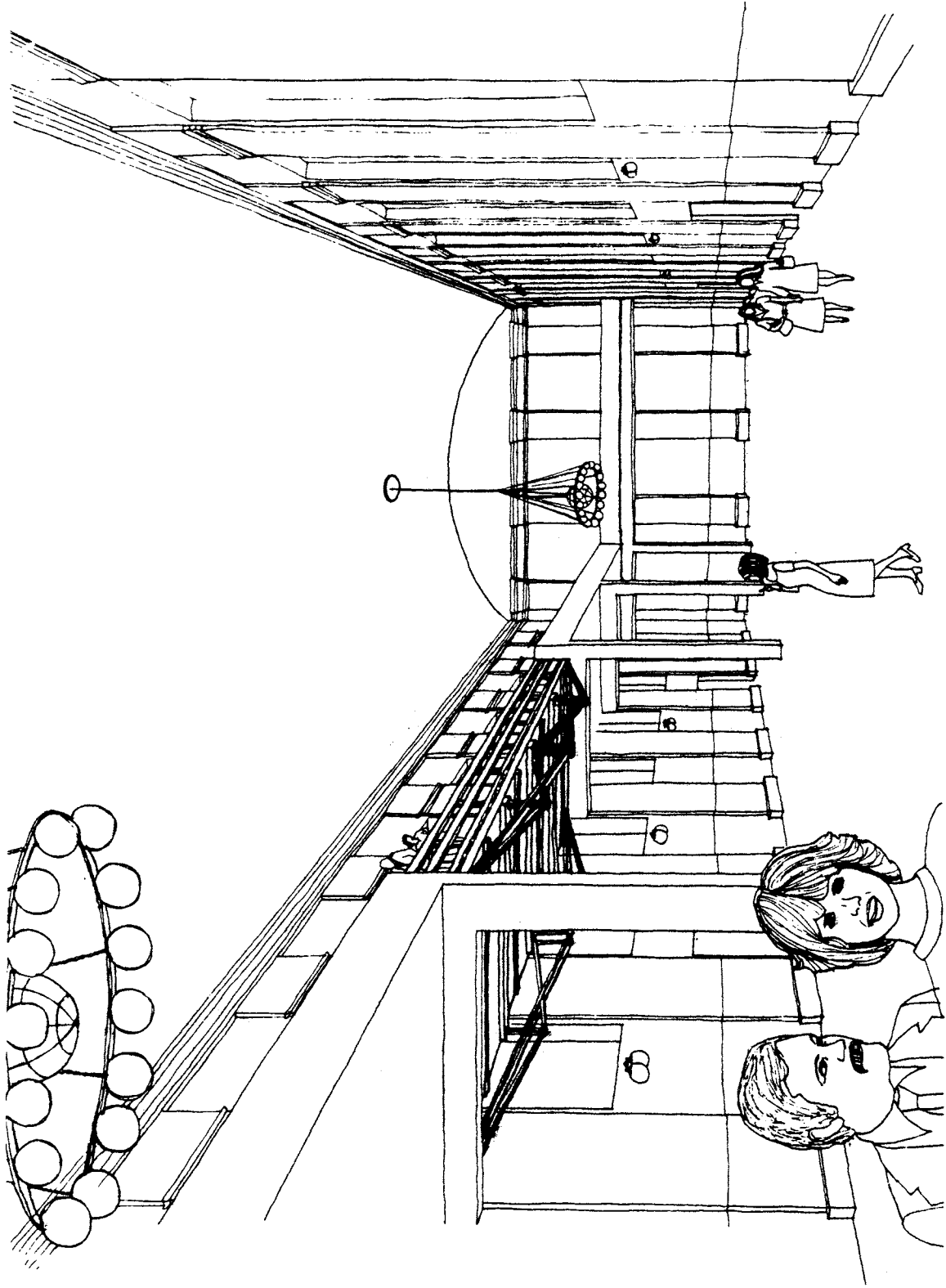

Figure 35: Fink truss bridge as part of a museum.

2876

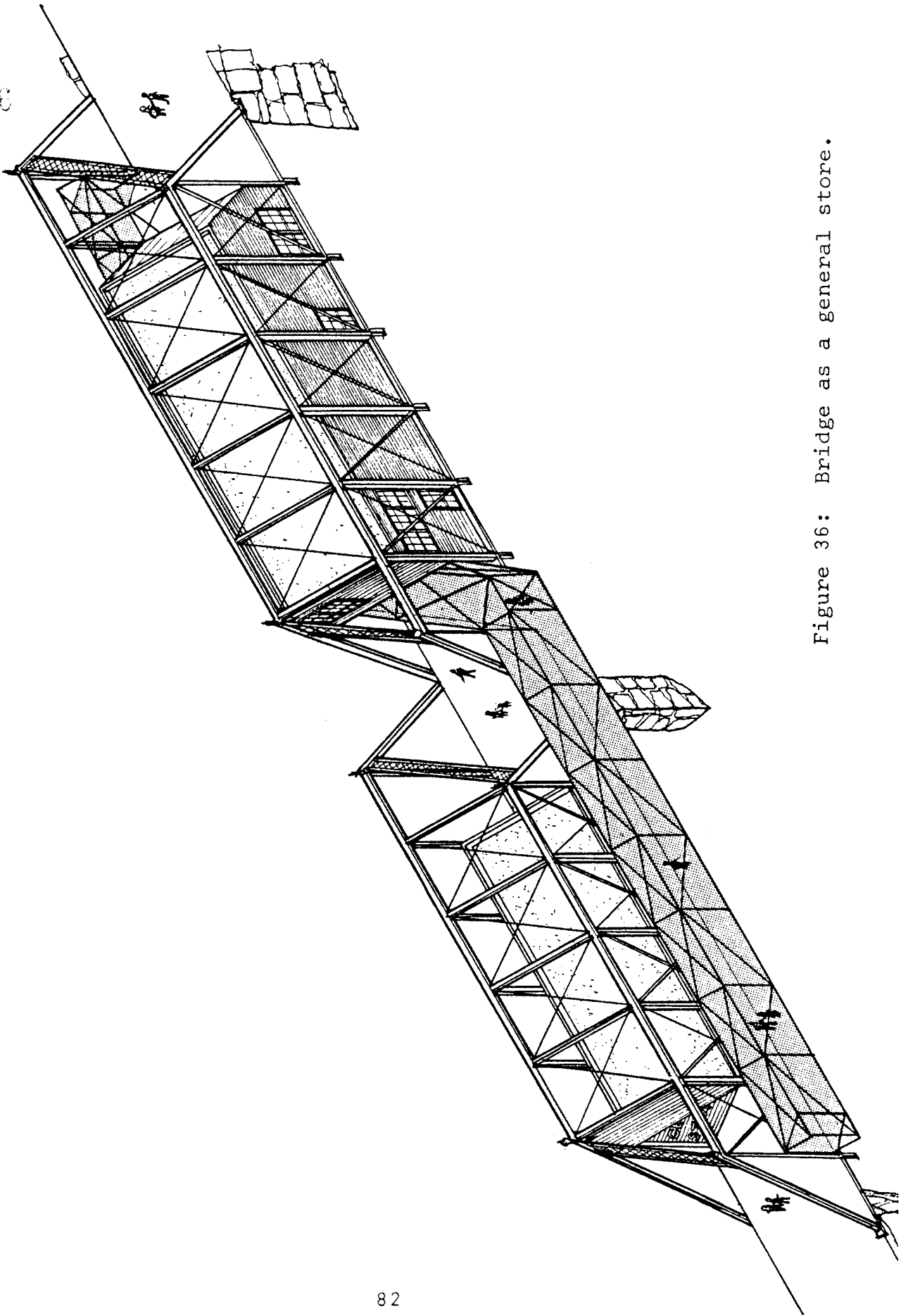

Figure 36: Bridge as a general store.



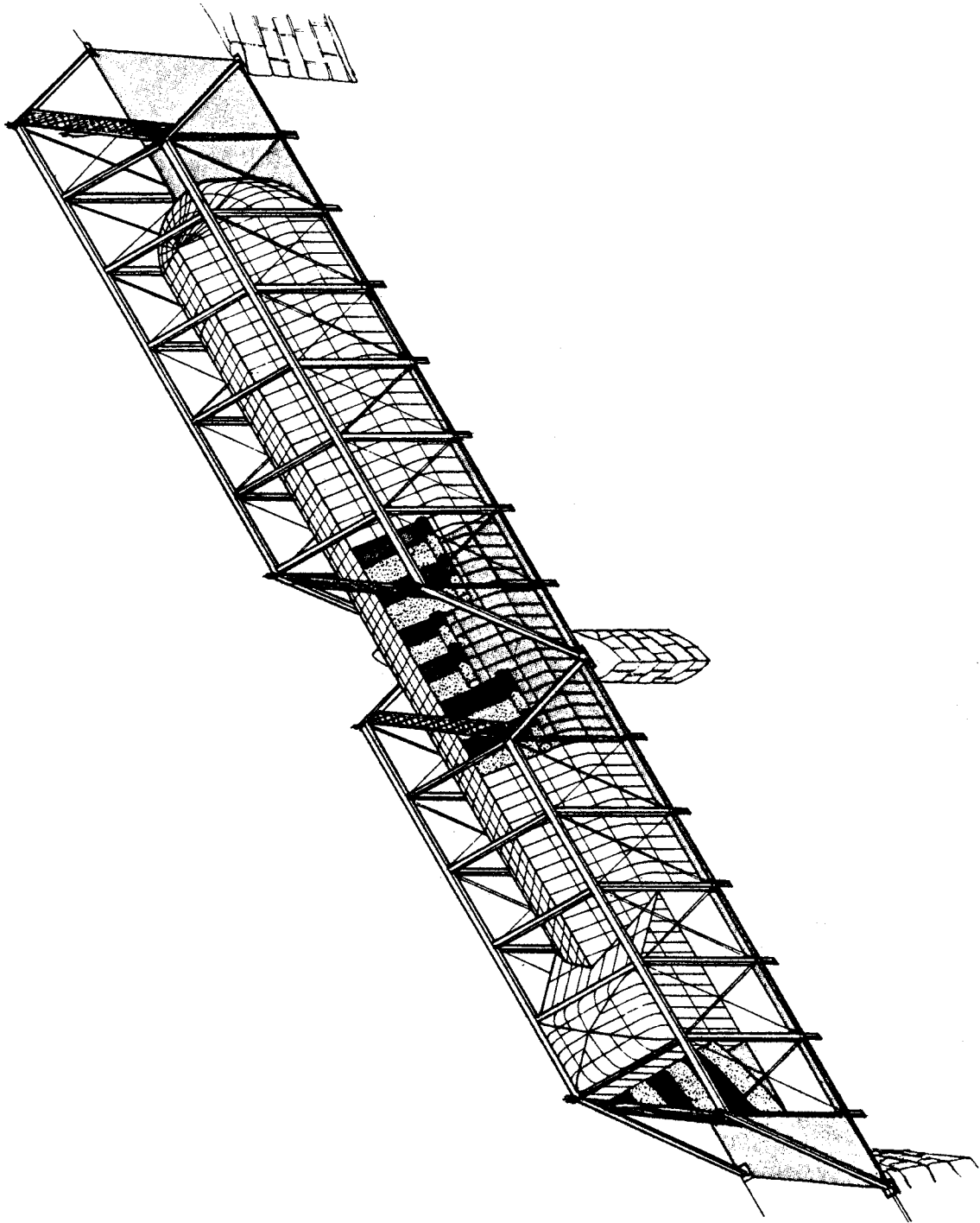
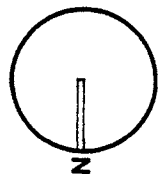
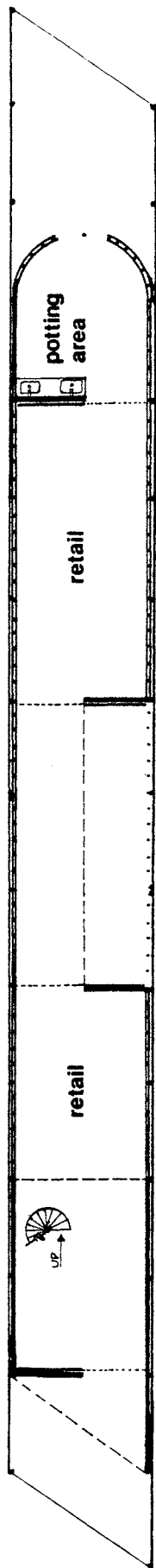

Figure 37: Bridge as a greenhouse.



# Plans



# 1st

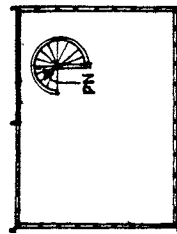

# 2nd

Figure 38: Possible plan of bridge as a greenhouse.

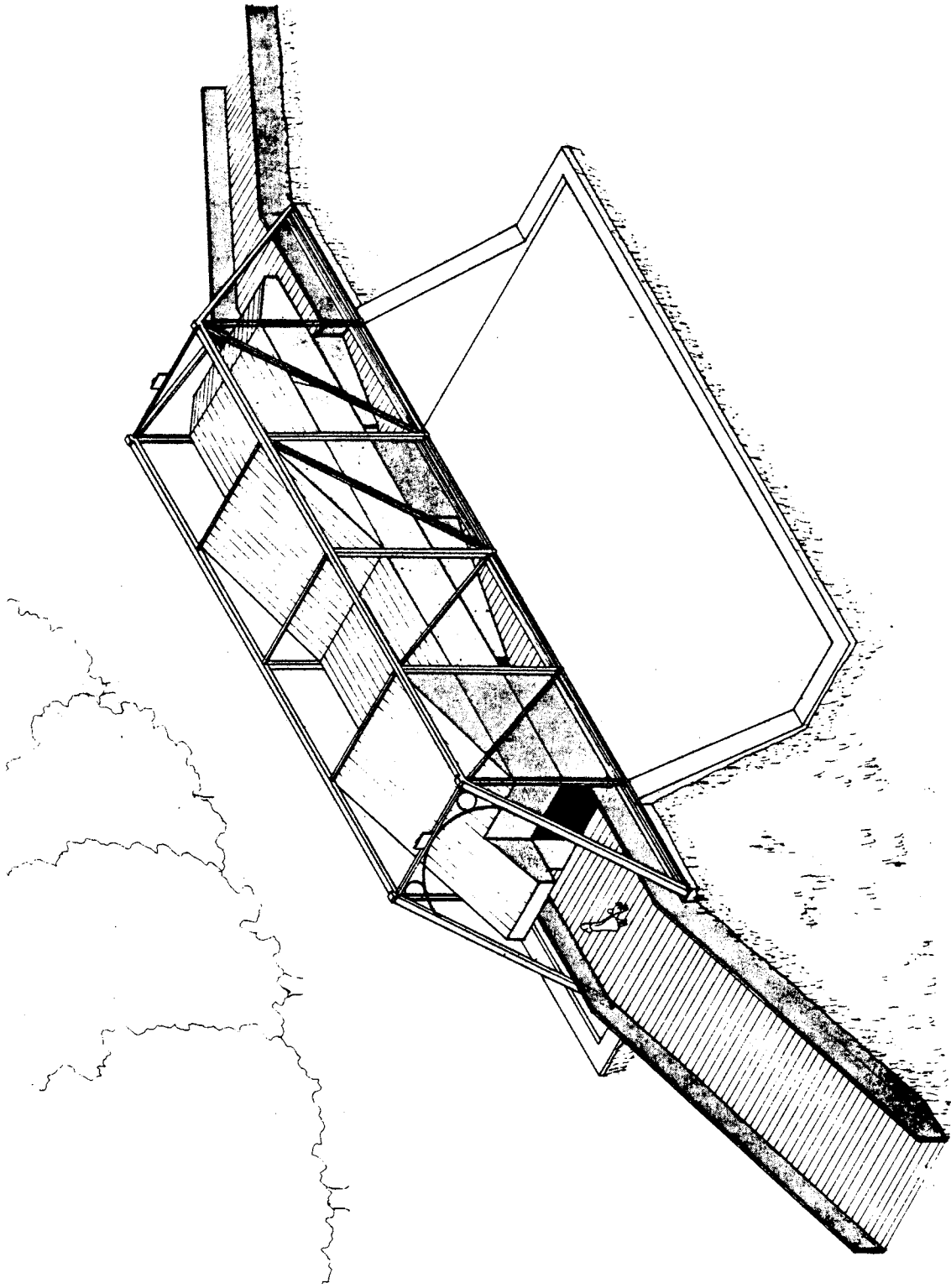
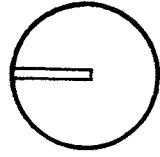

Figure 39: Bridge as an information center.



# Plan

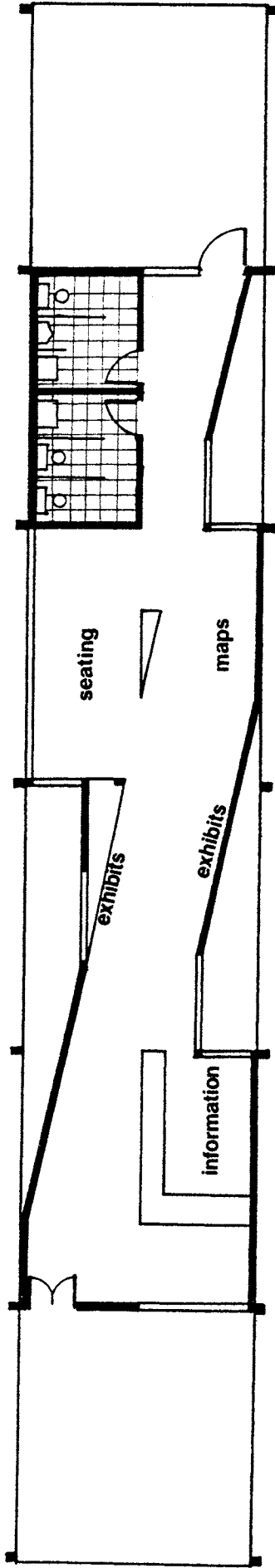
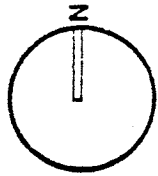
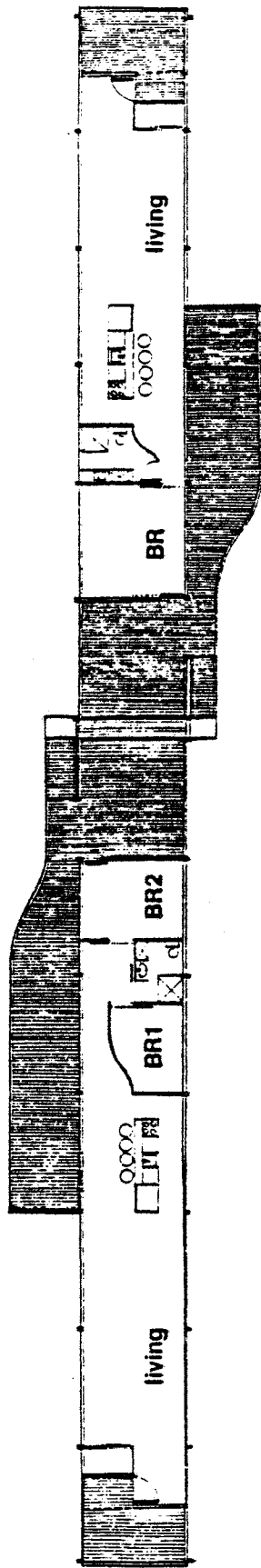

Figure 40: Plan of bridge as an information center.



# Plan



# Elevation

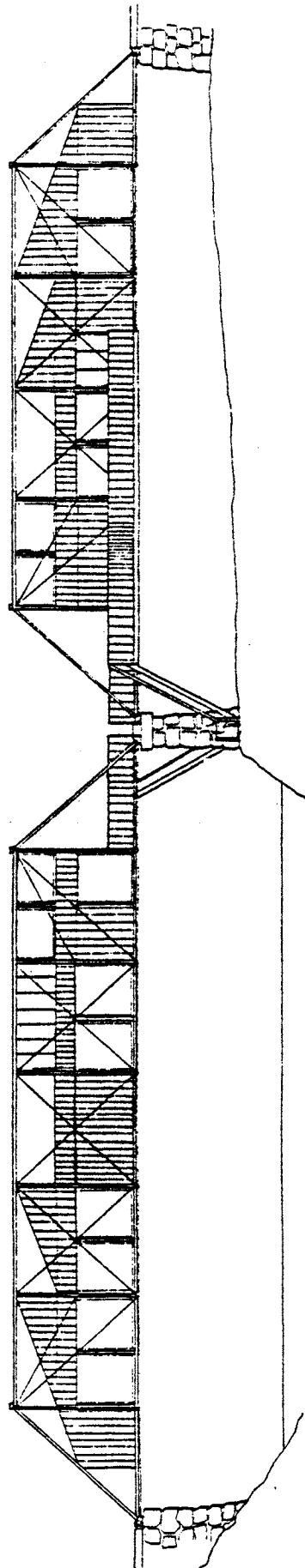

2881

Figure 41: Bridge as housing.

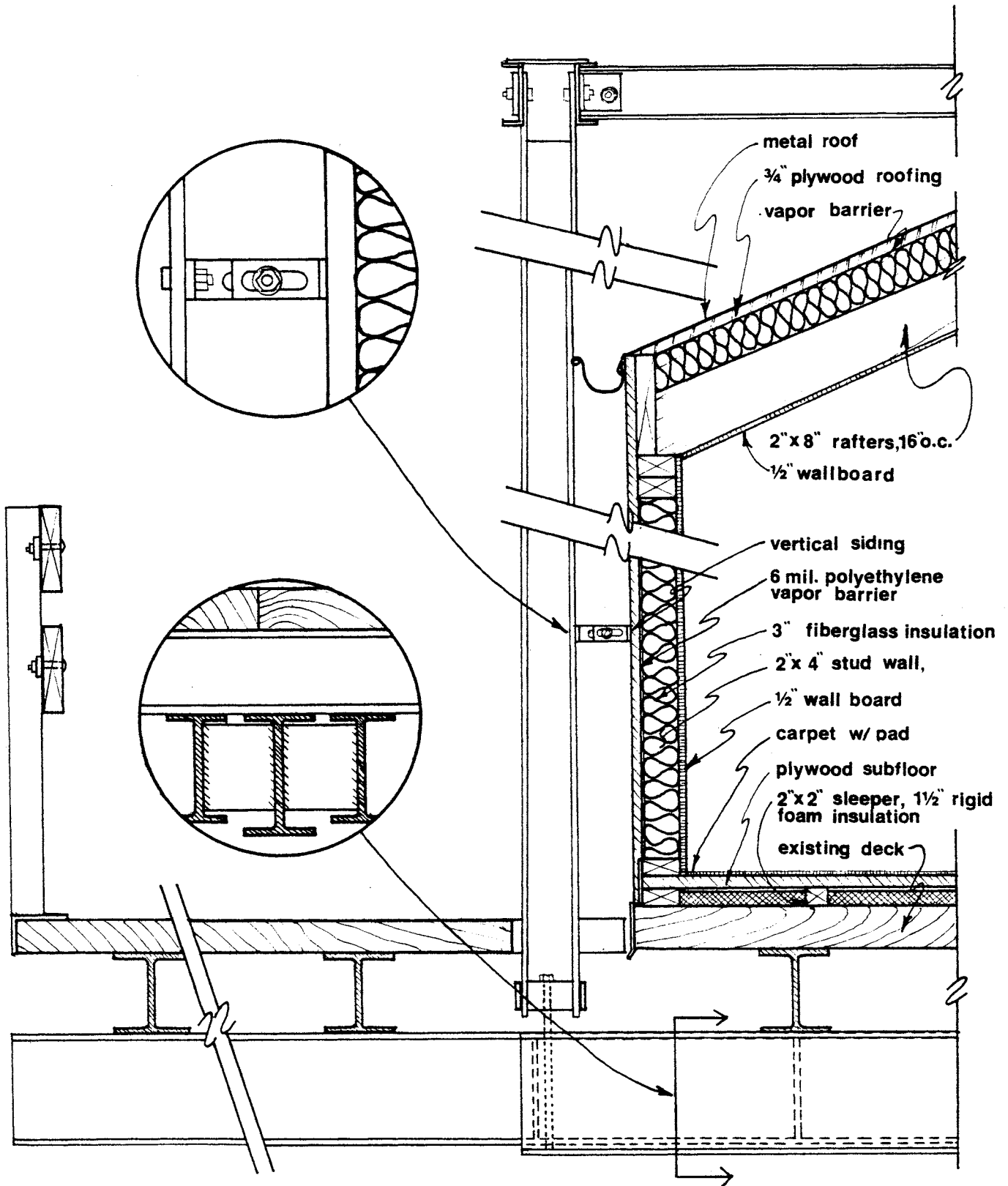

Figure 42. Details of new construction relating to old bridge.

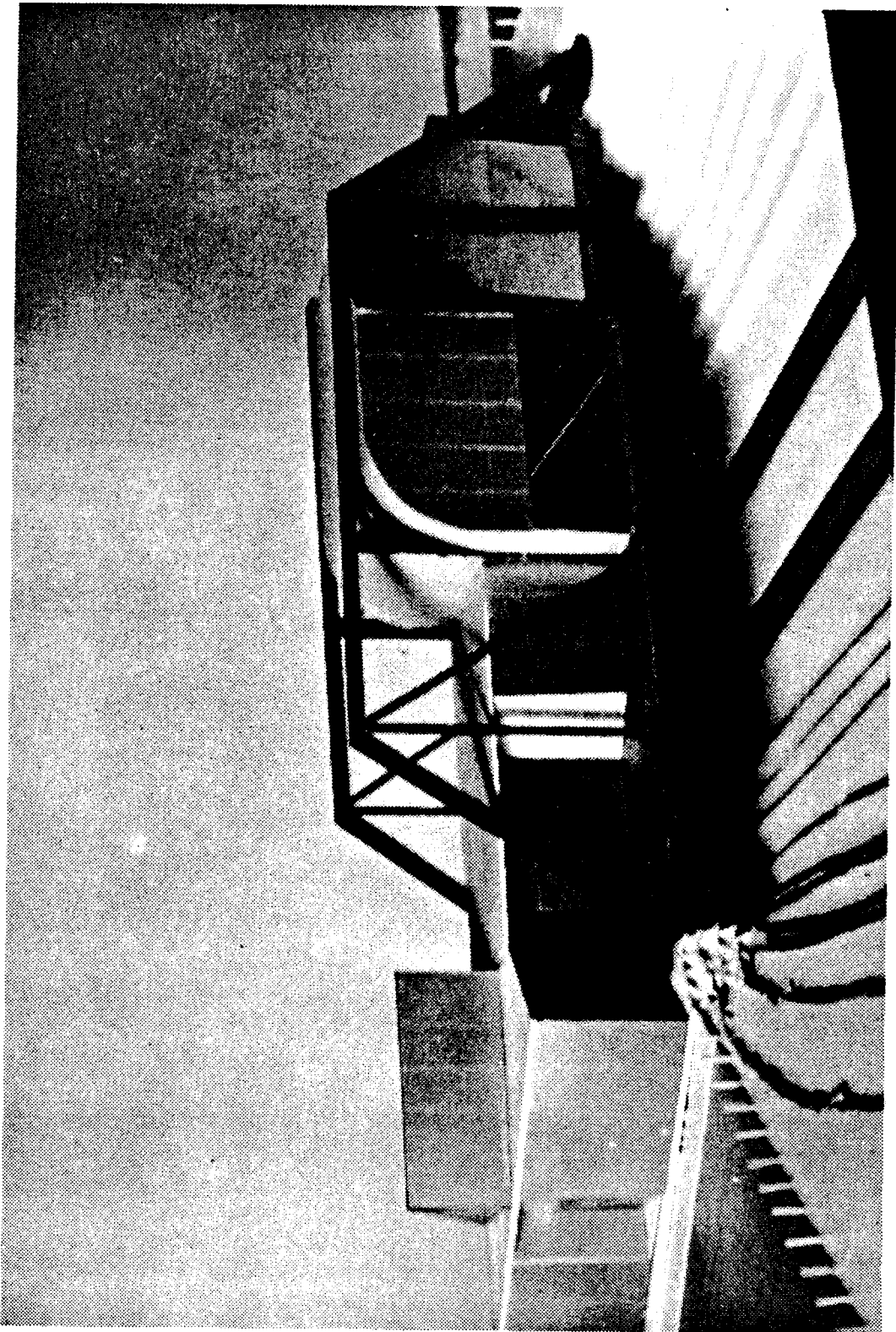
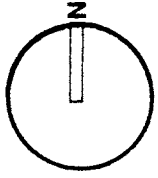

Figure 43: Bridge as a small office.



# Plan

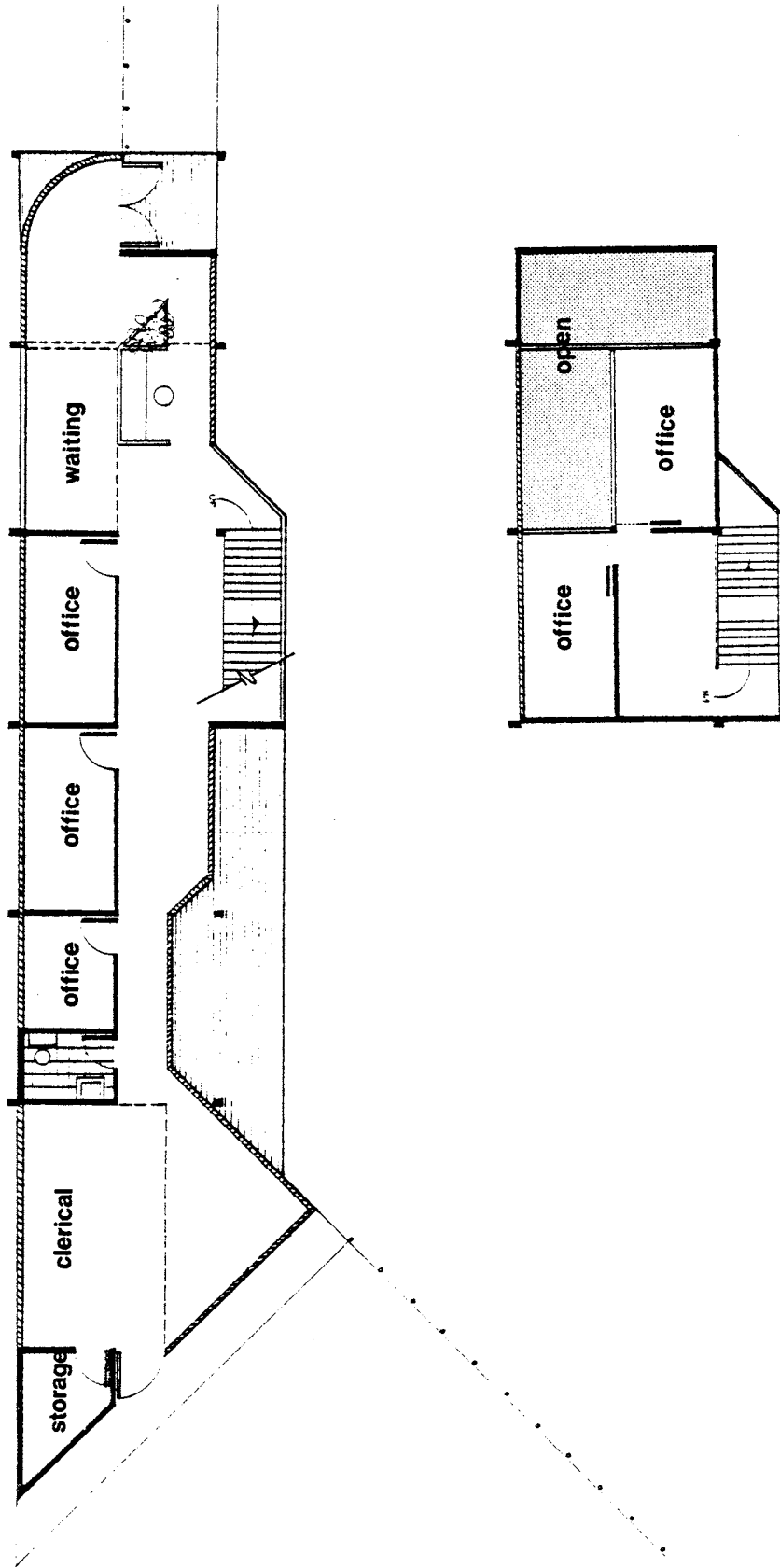

Figure 44: Plan of office.



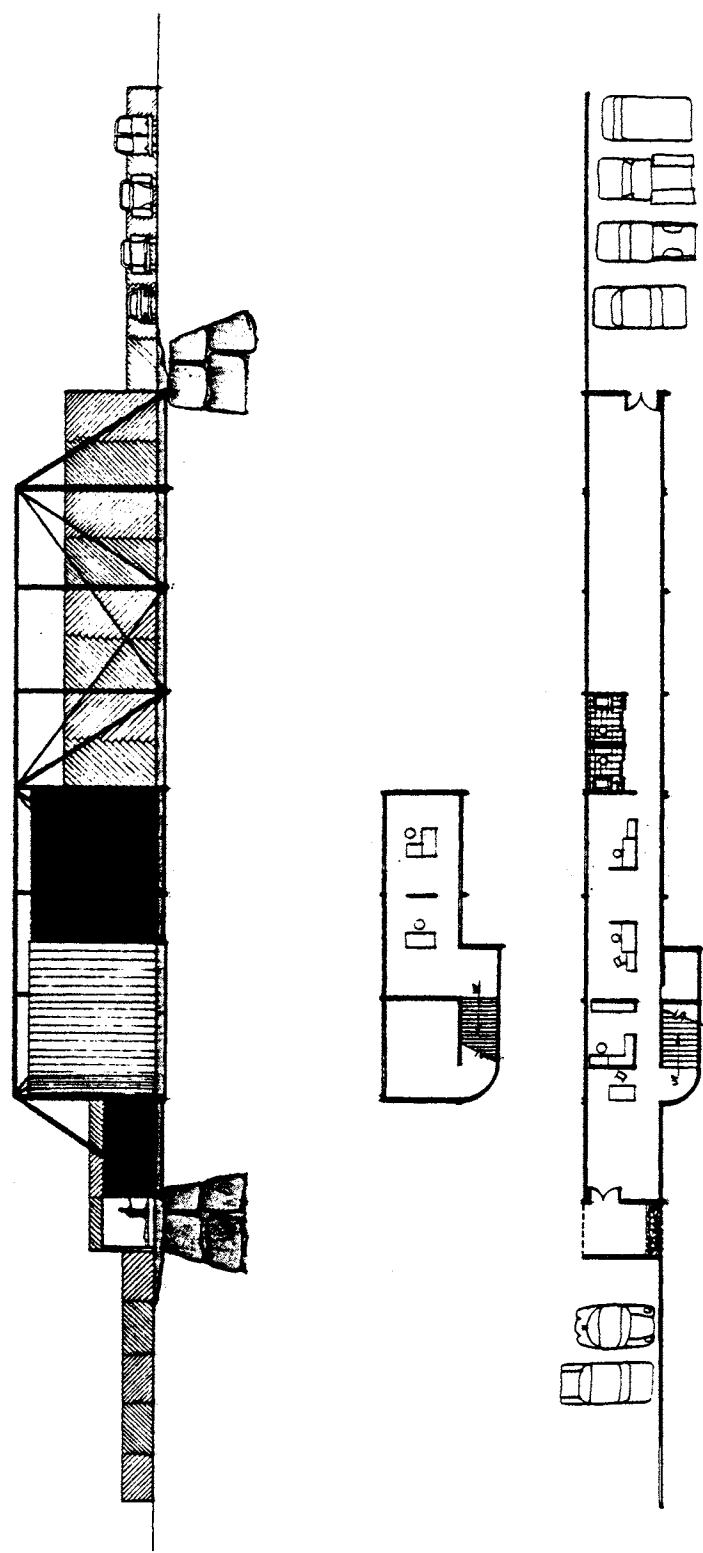

Figure 45: Bridge as an office.

2886

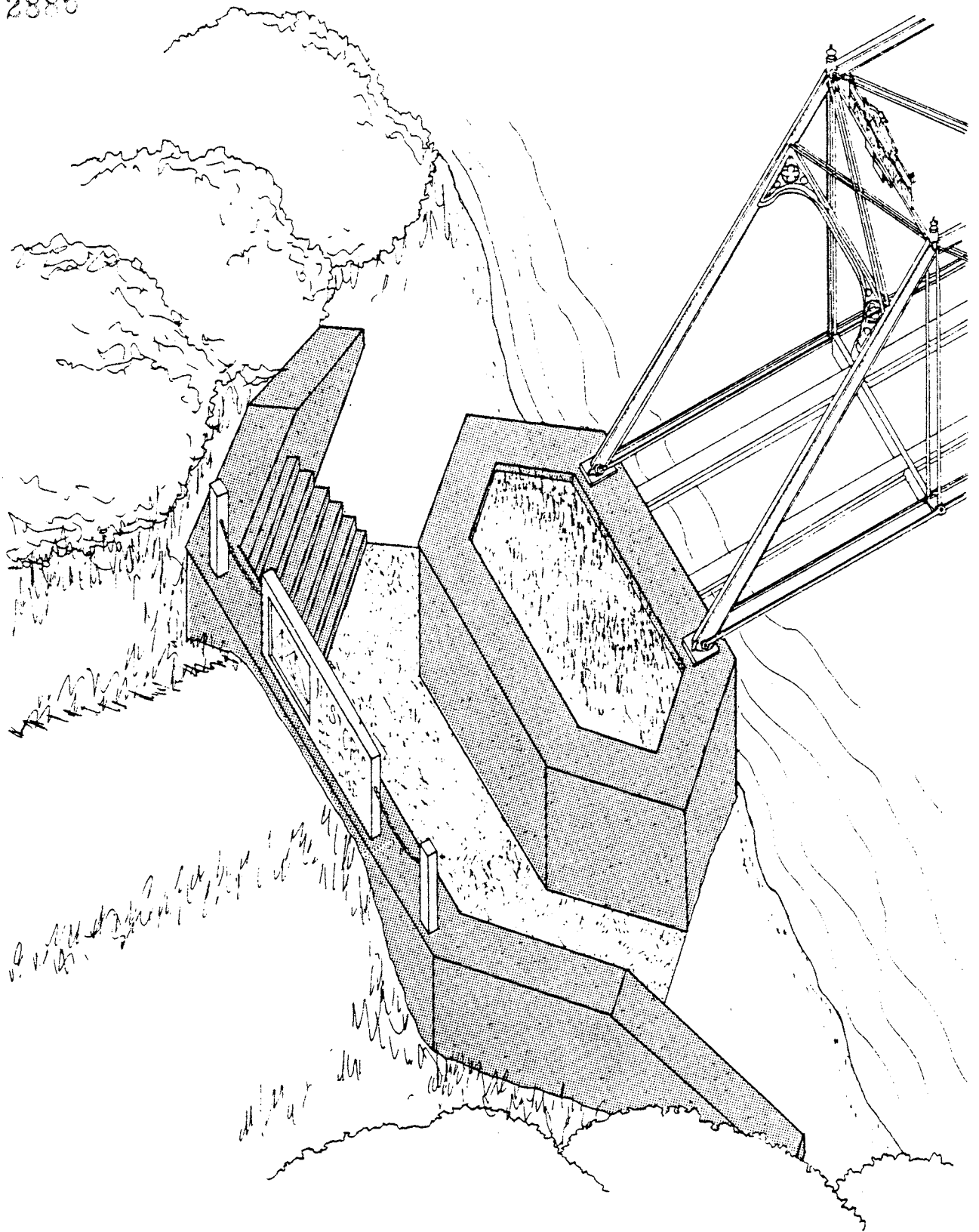
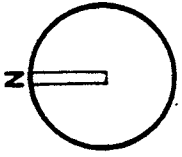
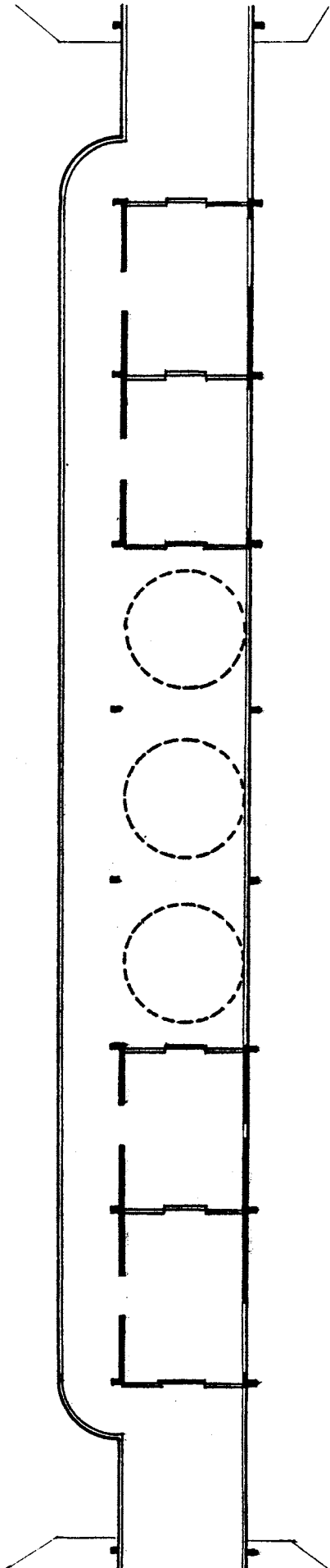

Figure 46: Moat separation of bridge and roadway.



# Plan



# Elevation

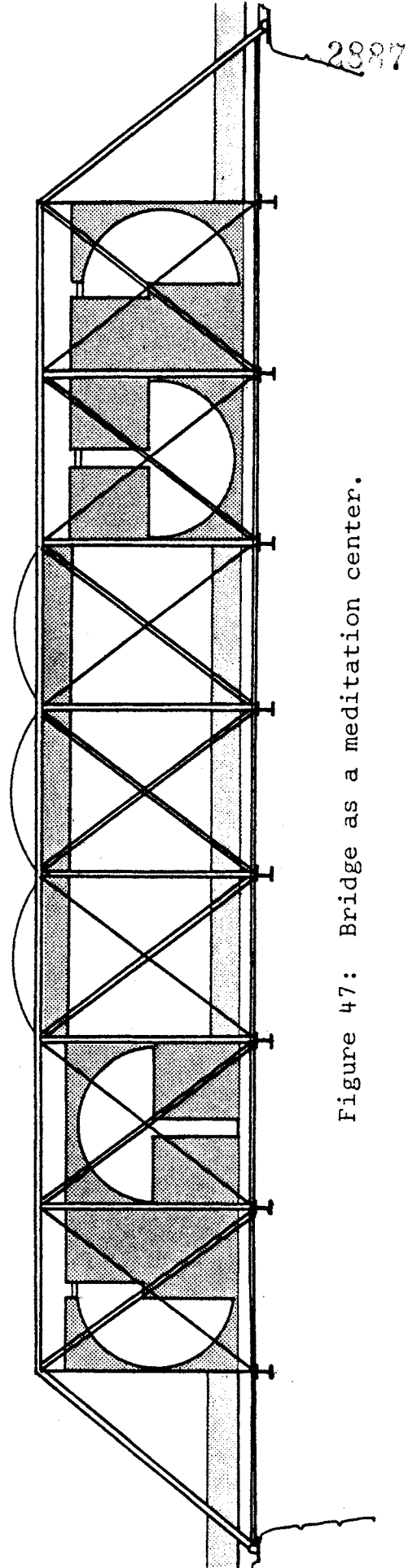

Figure 47: Bridge as a meditation center.

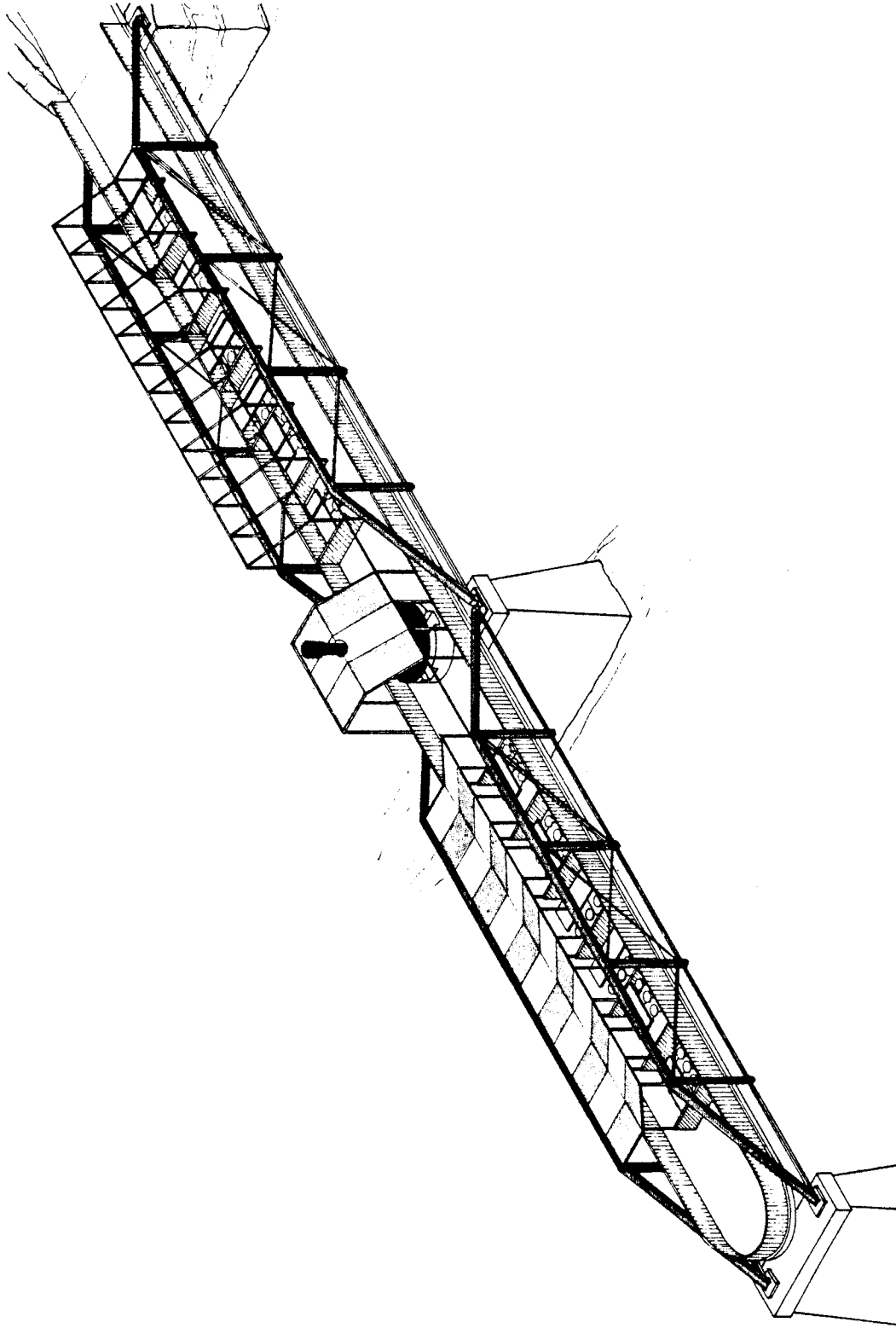

Figure 48: Bridge as a picnic shelter.

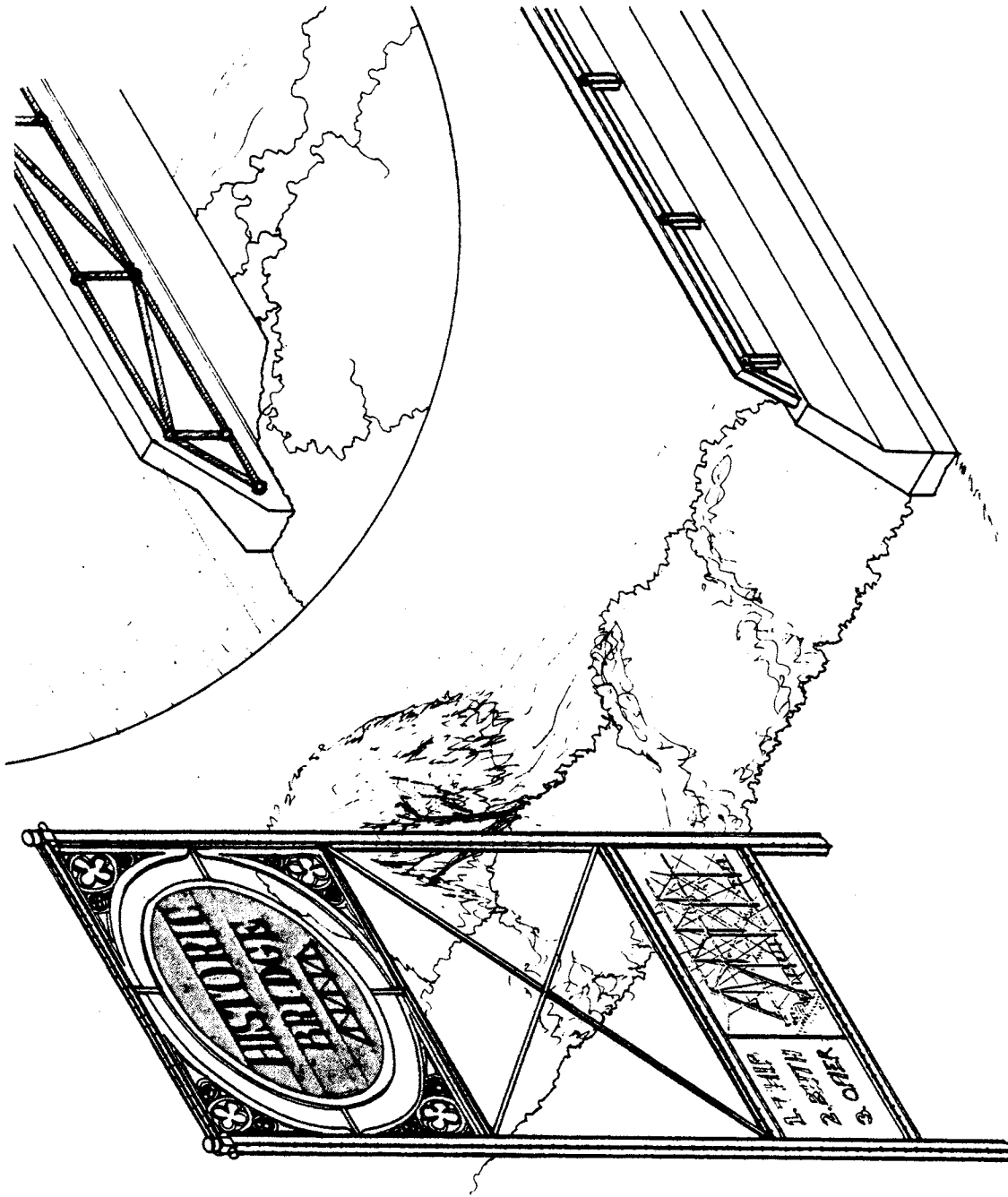

Figure 49: Incorporation of old bridge elements as a sign or features of a new bridge.

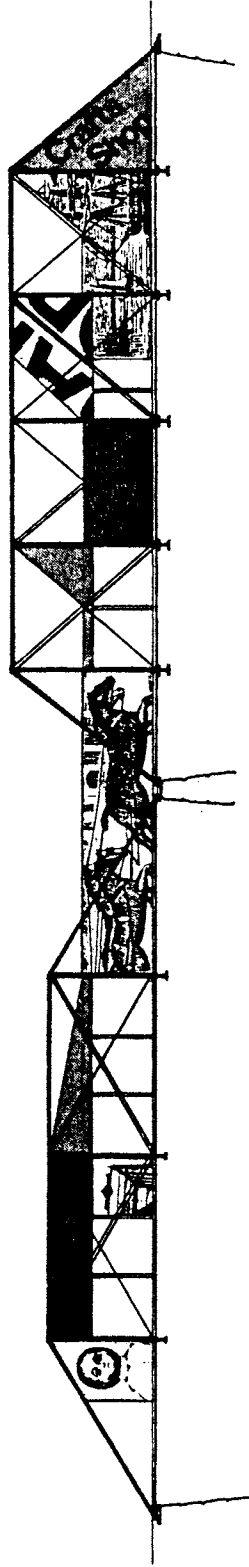

Figure 50: Bridge as a craft center.

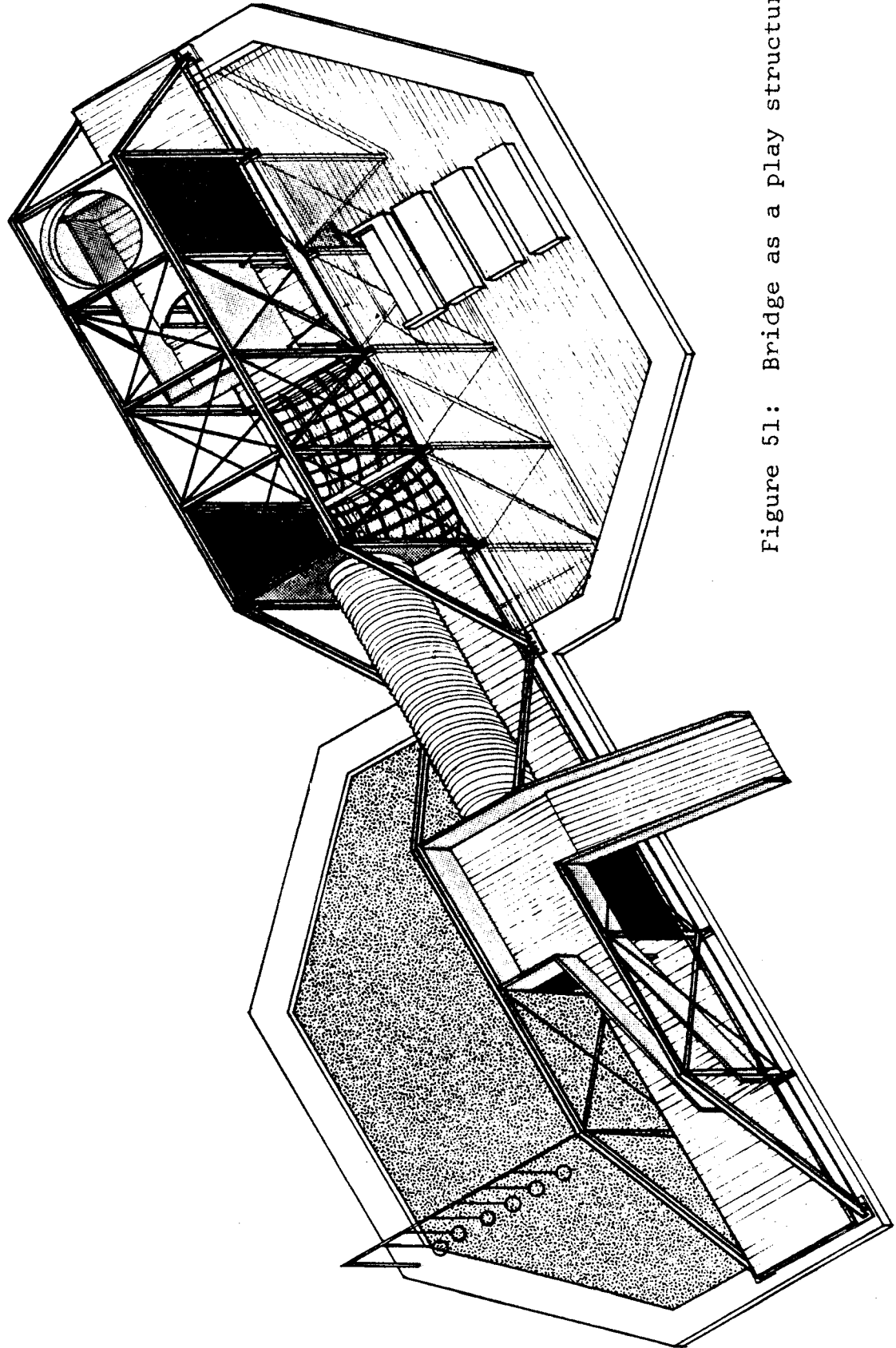

Figure 51: Bridge as a play structure.

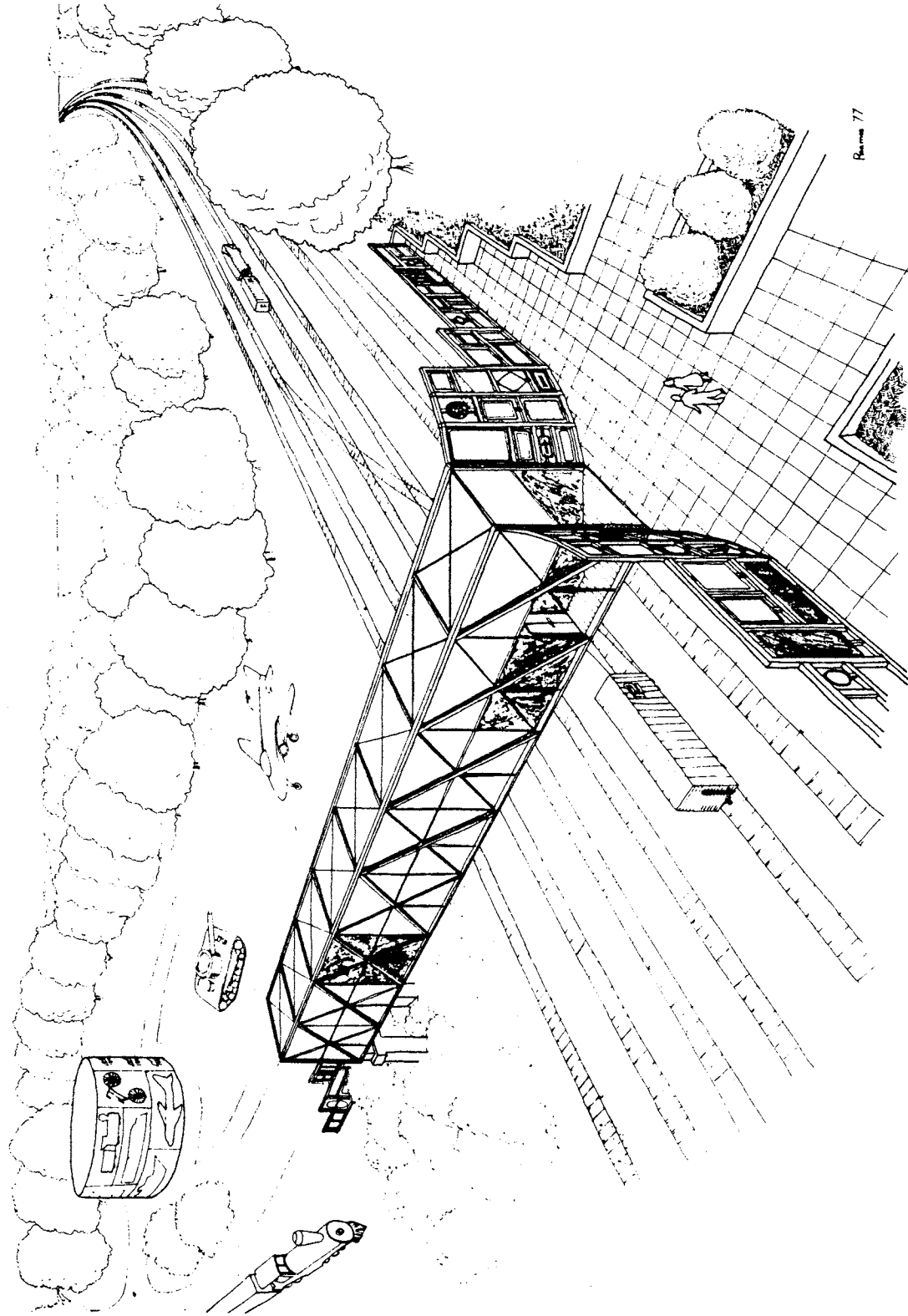

PLATE 77

Figure 52: Bridge as a transportation museum.



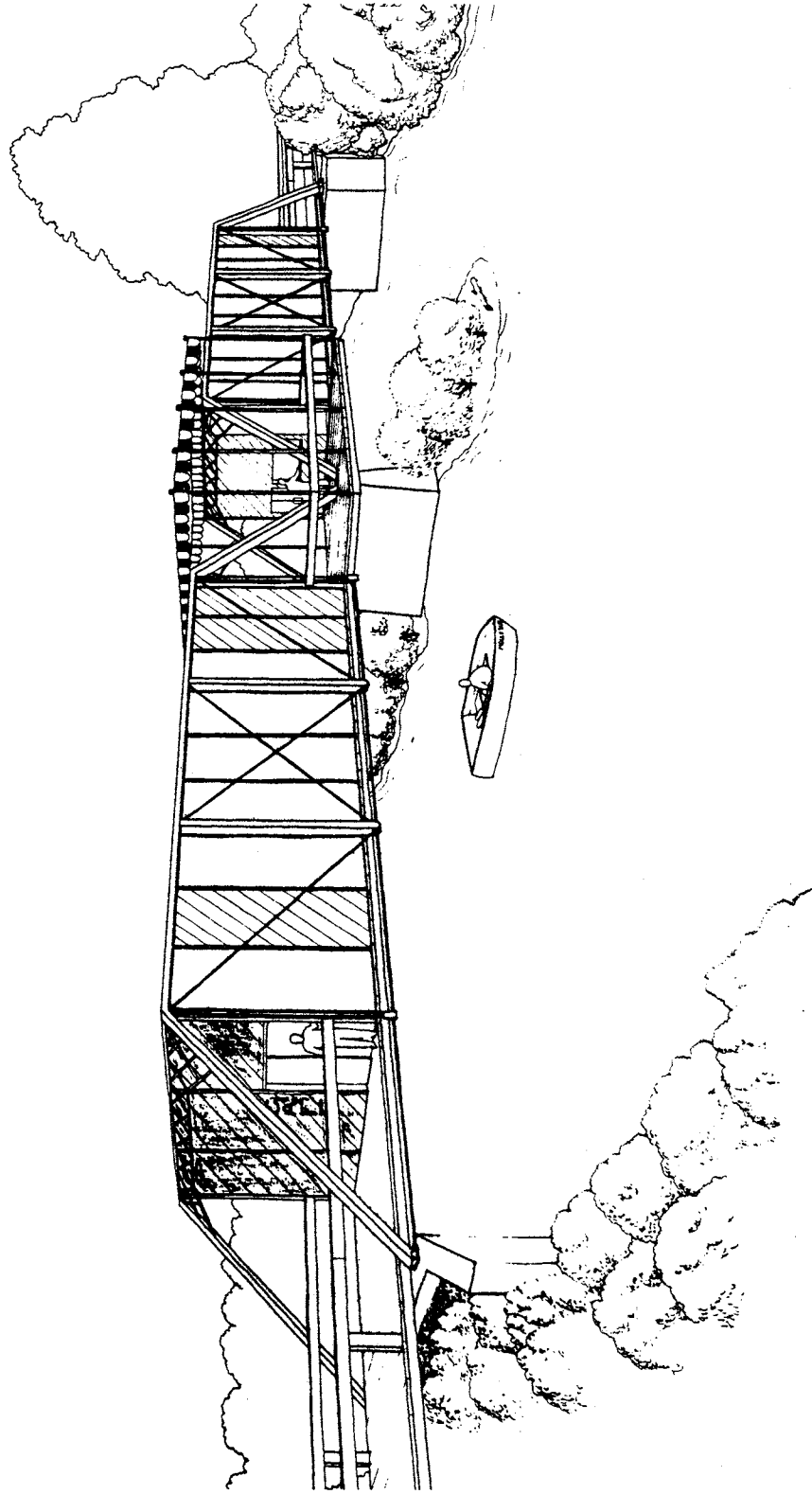

Figure 53: Bridge as a cafe-restaurant.

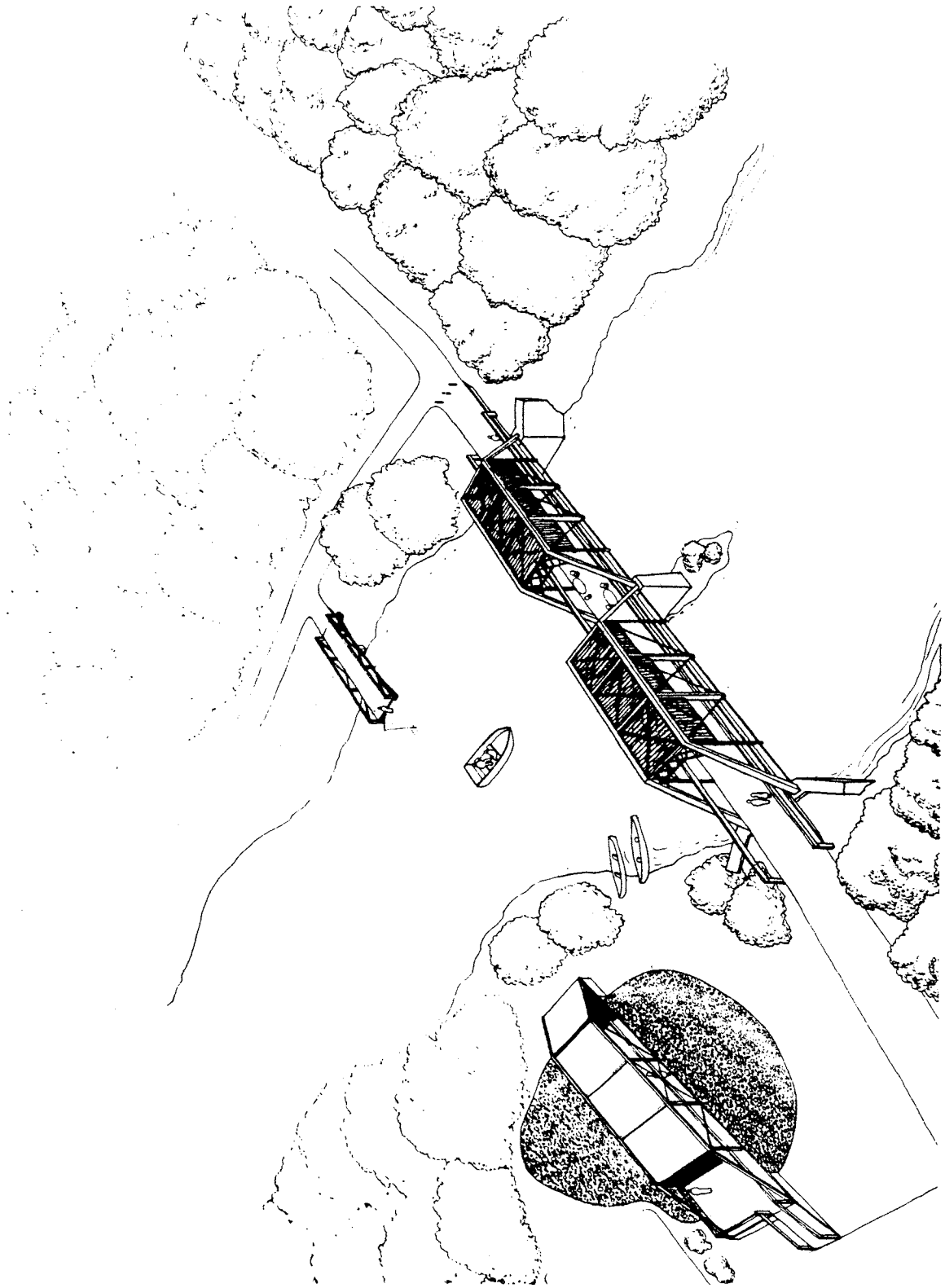
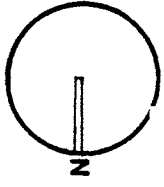
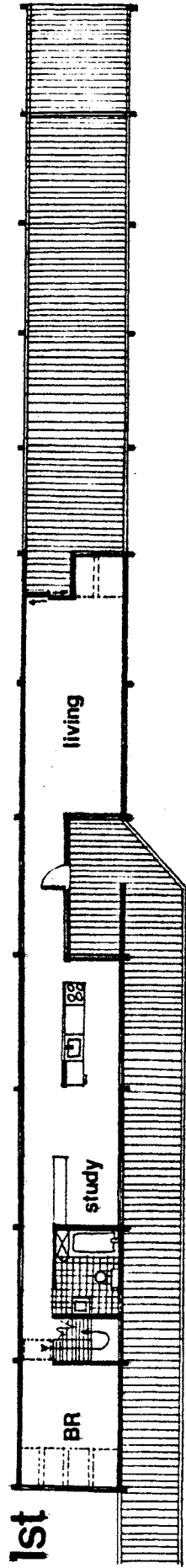

Figure 54: Complex of bridges as an outdoor museum and recreation site.



# Plans



# 2nd

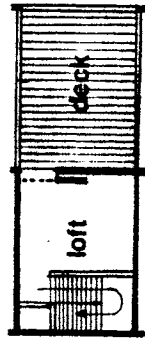

# Elevation

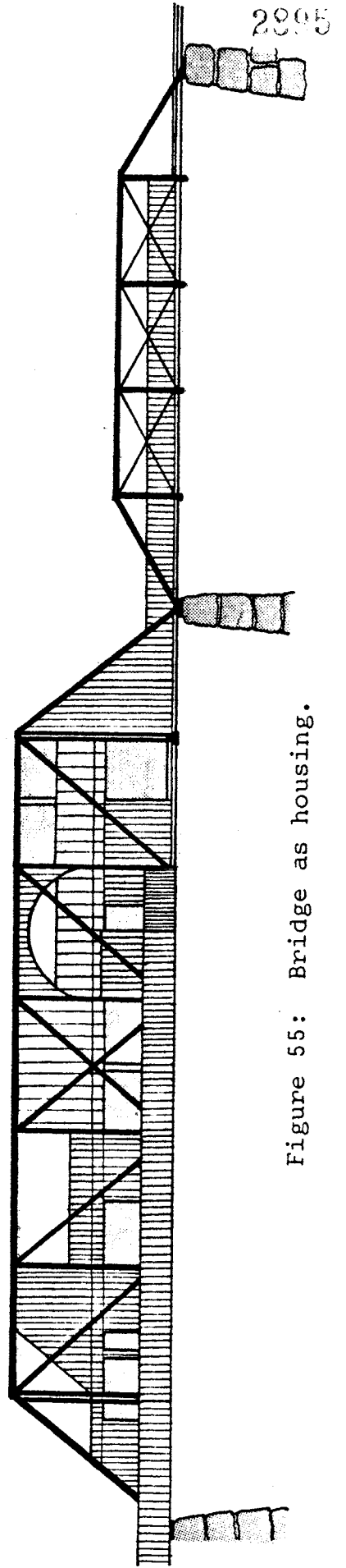
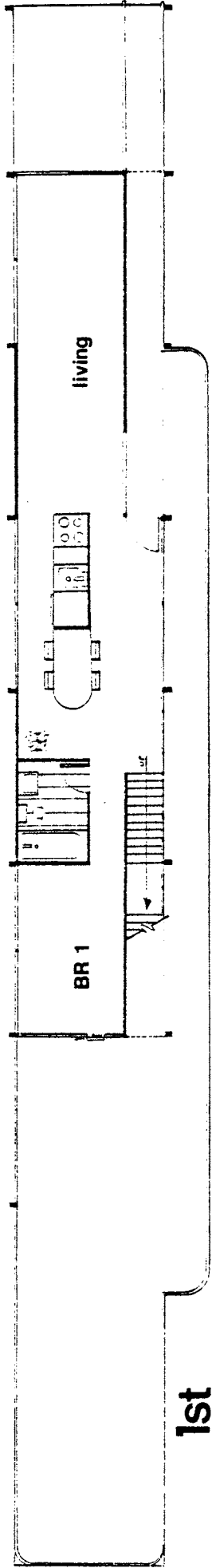
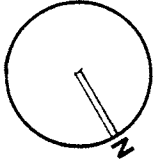

Figure 55: Bridge as housing.

# Plans

2896



1st

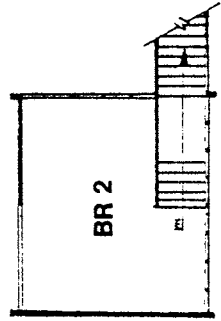

2nd

102

# Elevation

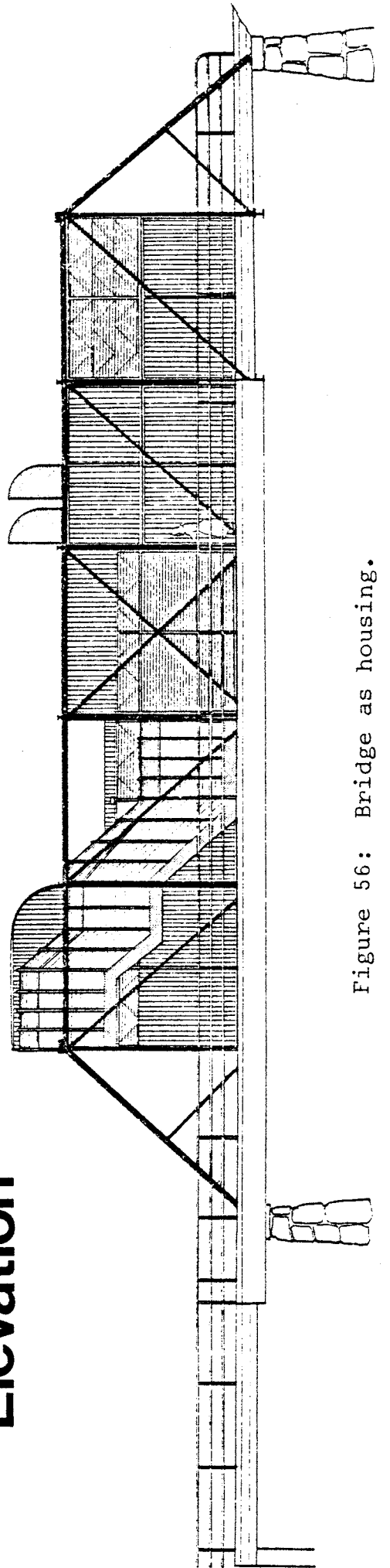
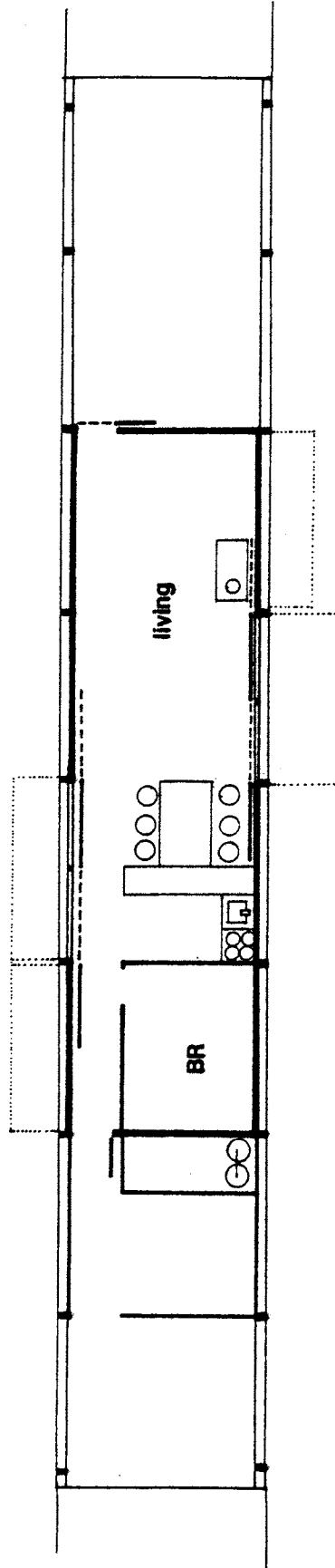
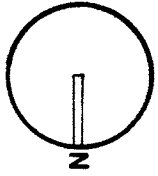

Figure 56: Bridge as housing.

# Plan



# Elevations

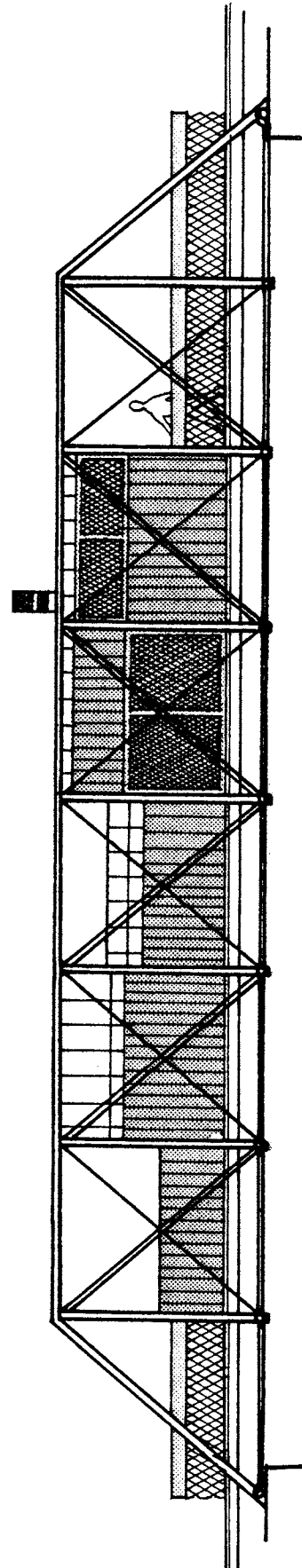
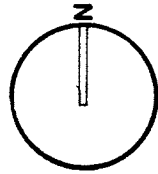

Figure 57: Bridge as a vacation home.



# Plan

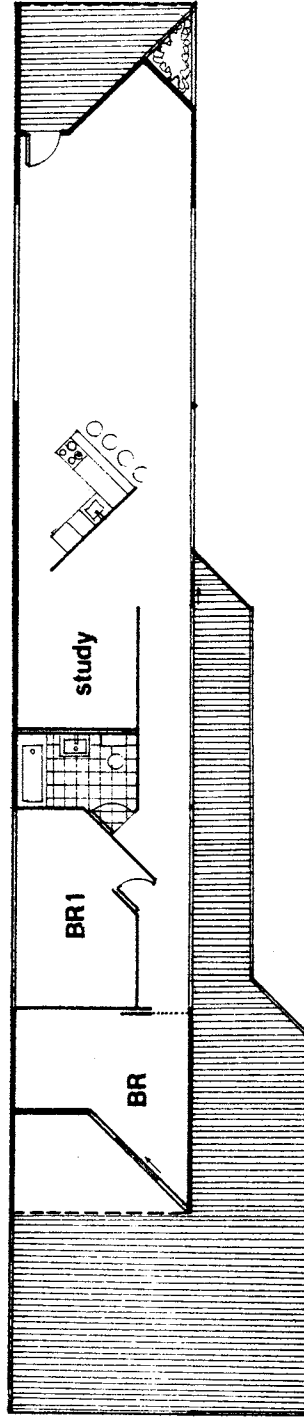
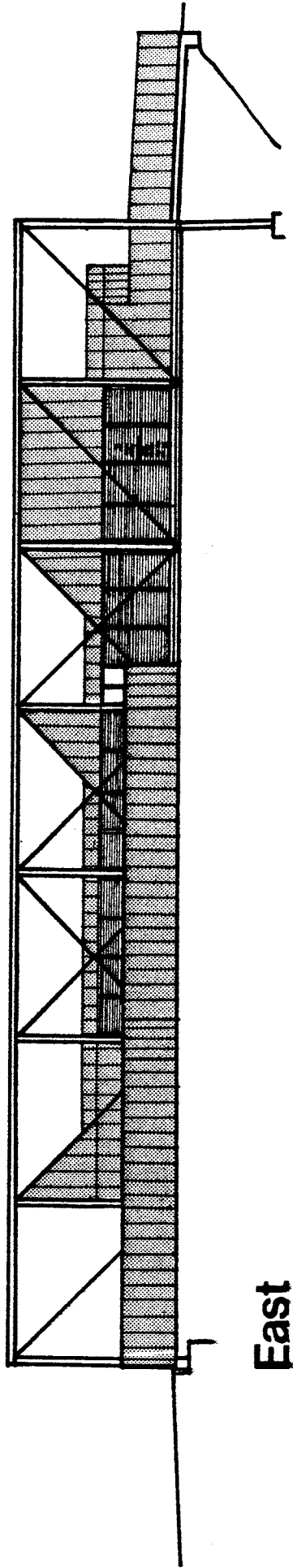
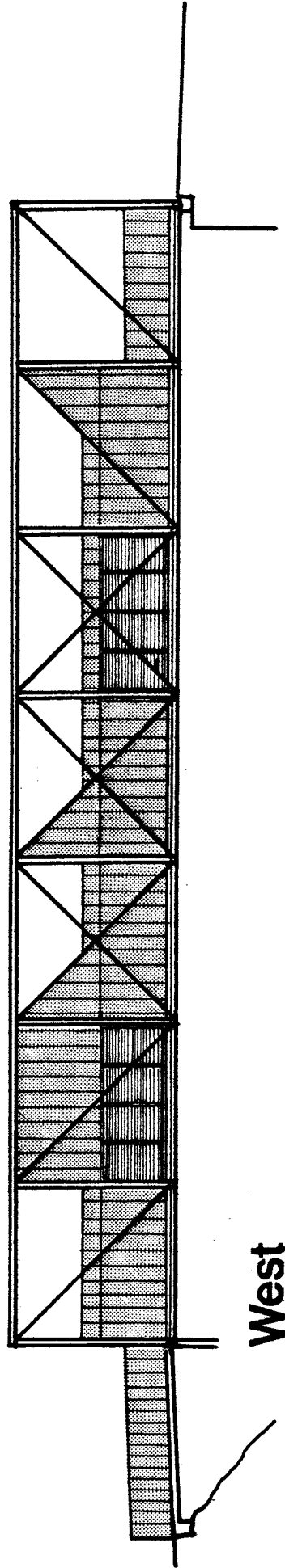

Figure 58: Plan of bridge as a vacation home.

# Elevations



East



West

Figure 59: Elevation of bridge as a vacation home.

2999

2010