

1. Report No. FHWA/TX-11/0-6103-1		2. Government Accession No.		3. Recipient's Catalog No.	
4. Title and Subtitle STUDIES TO DETERMINE THE EFFECTIVENESS OF LONGITUDINAL CHANNELIZING DEVICES IN WORK ZONES				5. Report Date October 2010 Published: January 2011	
				6. Performing Organization Code	
7. Author(s) Melisa D. Finley, LuAnn Theiss, Nada D. Trout, Jeffrey D. Miles, and Alicia A. Nelson				8. Performing Organization Report No. Report 0-6103-1	
9. Performing Organization Name and Address Texas Transportation Institute The Texas A&M University System College Station, Texas 77843-3135				10. Work Unit No. (TRAIS)	
				11. Contract or Grant No. Project 0-6103	
12. Sponsoring Agency Name and Address Texas Department of Transportation Research and Technology Implementation Office P.O. Box 5080 Austin, Texas 78763-5080				13. Type of Report and Period Covered Technical Report: September 2008–August 2010	
				14. Sponsoring Agency Code	
15. Supplementary Notes Project performed in cooperation with the Texas Department of Transportation and the Federal Highway Administration. Project Title: Evaluation of Longitudinal Channelizing Barricade Effectiveness URL: http://tti.tamu.edu/documents/0-6103-1.pdf					
16. Abstract This report describes the methodology and results of analyses performed to determine whether the following longitudinal channelizing device (LCD) applications improve the traffic safety and operations of work zones relative to the use of standard drums: <ul style="list-style-type: none"> • Continuous LCDs in the vicinity of exit ramps on high-speed, limited-access facilities. • Continuous LCDs in the merging taper of a lane closure on low-speed roadways. • Single LCDs (similar to Type 3 barricades) in the merging taper of a lane closure on high-speed roadways. • Continuous LCDs in the vicinity of driveways on low-speed urban roadways. Based on the research findings, researchers recommended the use of continuous LCDs in the immediate vicinity of an exit ramp within a lane closure under the following conditions: <ul style="list-style-type: none"> • When a high number of deliberate intrusions into the work zone are expected or occur while using standard channelizing devices. • In situations where the exit ramp opening (in feet) is less than or equal to two times the posted speed limit (in mph), workers and equipment are in the work area near the exit ramp opening, and there are concerns that drivers may unintentionally enter the work area trying to access the exit ramp. Recommendations regarding the minimum exit ramp opening length within a work zone lane closure and the use of a closer drum spacing in the immediate vicinity of exit ramps are also discussed. Researchers do not recommend the use of continuous LCDs or single barricade style LCDs to form a lane closure merging taper. While continuous LCDs may also be used to delineate the edge of a travel lane in a work zone on an urban roadway, the height and location of the LCDs should be considered since they impact the ability of drivers to view approaching traffic. Researchers also discuss LCD delineation and other implementation considerations.					
17. Key Words Longitudinal Channelizing Devices, Longitudinal Channelizing Barricades, Work Zones, Channelizing Devices, Traffic Control Devices			18. Distribution Statement No restrictions. This document is available to the public through NTIS: National Technical Information Service Springfield, Virginia 22161 http://www.ntis.gov		
19. Security Classif.(of this report) Unclassified		20. Security Classif.(of this page) Unclassified		21. No. of Pages 122	22. Price

STUDIES TO DETERMINE THE EFFECTIVENESS OF LONGITUDINAL CHANNELIZING DEVICES IN WORK ZONES

by

Melisa D. Finley, P.E.
Associate Research Engineer
Texas Transportation Institute

LuAnn Theiss, P.E.
Associate Research Engineer
Texas Transportation Institute

Nada D. Trout
Assistant Research Scientist
Texas Transportation Institute

Jeffrey D. Miles, P.E.
Assistant Research Engineer
Texas Transportation Institute

and

Alicia A. Nelson
Associate Research Specialist
Texas Transportation Institute

Report 0-6103-1

Project 0-6103

Project Title: Evaluation of Longitudinal Channelizing Barricade Effectiveness

Performed in cooperation with the
Texas Department of Transportation
and the
Federal Highway Administration

October 2010

Published: January 2011

TEXAS TRANSPORTATION INSTITUTE
The Texas A&M University System
College Station, Texas 77843-3135

DISCLAIMER

This research was performed in cooperation with the Texas Department of Transportation (TxDOT) and the Federal Highway Administration (FHWA). The contents of this report reflect the views of the authors, who are responsible for the facts and the accuracy of the data presented herein. The contents do not necessarily reflect the official view or policies of the FHWA or TxDOT.

The United States Government and the State of Texas do not endorse products or manufacturers. Trade or manufacturers' names appear herein solely because they are considered essential to the object of this report.

This report does not constitute a standard, specification, or regulation. This report is not intended for construction, bidding, or permit purposes. The engineer in charge of the project was Melisa D. Finley, P.E. (TX-90937).

ACKNOWLEDGMENTS

This project was conducted in cooperation with TxDOT and FHWA. The project was overseen by a Project Monitoring Committee. Doug Skowronek of TxDOT served as the project director, and Wade Odell of TxDOT served as the Research Management Committee 4 Engineer. Tom Beeman of TxDOT, Paul Clutts of FHWA, Michael Jedlicka of TxDOT, Cynthia Landez of TxDOT, Terry McCoy of TxDOT, and Gary Tarter of TxDOT served as project advisors. The assistance and direction provided by these individuals over the course of the project is gratefully acknowledged.

The authors wish to acknowledge the contributions of Sandra Stone, Dan Walker, and the many other Texas Transportation Institute (TTI) staff that assisted in the design and conduct of the various studies completed during this project. In addition, the authors would like to thank The Yodock Wall Company, Inc. for donating all the LCDs used during this project.

TABLE OF CONTENTS

	Page
List of Figures	ix
List of Tables	x
Chapter 1: Introduction	1
Statement of the Problem.....	1
Background.....	1
Traditional Channelizing Devices.....	1
Longitudinal Channelizing Devices.....	6
Current and Potential Use of LCDs in Work Zones	9
Contents of This Report.....	10
Chapter 2: TxDOT Interviews	11
Introduction.....	11
Results.....	11
Summary and Recommendations	15
Chapter 3: Exit Ramp Evaluations	17
Introduction.....	17
Human Factors Studies	17
Experimental Design.....	18
Data Analysis	25
Phase I Results	25
Phase II Results.....	28
Phase III Results	30
Summary	31
Demonstration.....	32
Simulated Work Zone and Treatments	32
Results.....	33
Photometric Analysis.....	35
Treatments.....	35
Data Collection	36
Data Analysis	37
Results.....	37
Summary and Recommendations	40
Chapter 4: Lane Closure Evaluations	43
Introduction.....	43
Driving Simulator Study	44
Experimental Design.....	44
Data Analysis	49
Results.....	51
Detection Distance and Turning Movement Evaluations	52
Experimental Design.....	53
Evaluation Procedure and Data Analysis.....	55
Results.....	57
Summary.....	60

Photometric Analysis	61
Treatments.....	61
Data Collection	62
Data Analysis	63
Results.....	64
Summary and Recommendations	67
Chapter 5: Driveway Evaluations	71
Introduction.....	71
Human Factors Study.....	72
Experimental Design.....	72
Data Analysis	76
Results.....	76
Intersection Sight Distance Investigation	79
Driver Eye Height.....	80
Critical Object Height.....	81
Intersection Sight Distance	82
Summary and Recommendations	84
Chapter 6: Summary and Recommendations	89
Summary	89
Recommendations.....	89
Exit Ramps within Freeway Lane Closures.....	90
Lane Closure Merging Tapers	91
Driveways	91
Additional Research.....	91
Other Considerations	92
Chapter 7: References	95
Appendix A: Exit Ramp Closed-Course Study Treatments	97
Appendix B: Exit Ramp Closed-Course Study Results.....	103
Appendix C: Driving Simulator Study Results.....	105
Appendix D: Detection Distance Evaluation Results.....	107
Appendix E: Turning Movement Evaluation Results	109
Appendix F: Driveway Closed-Course Study Results	111

LIST OF FIGURES

	Page
Figure 1. Channelizing Devices (1).....	2
Figure 2. LCD Depiction in Texas MUTCD (9).....	7
Figure 3. Barrier Reflectors (10).....	7
Figure 4. Simulated Work Zone Layout.....	19
Figure 5. Example of Devices Studied.....	20
Figure 6. Type 3 Object Marker (9).....	35
Figure 7. Photometric Analysis Equipment.....	36
Figure 8. View from the Beginning of the Treatment.....	38
Figure 9. Luminance Data at the Beginning of the Treatment.....	38
Figure 10. View from 120-ft Upstream of the Exit Ramp.....	39
Figure 11. Luminance Data at 120-ft Upstream of the Exit Ramp.....	40
Figure 12. TTI Desktop Driving Simulator.....	45
Figure 13. Lane Closure Treatments for Simulator Study.....	46
Figure 14. Examples of the Lane Closure Treatments for the Detection Distance and Turning Movement Evaluations.....	54
Figure 15. Detection Distance Evaluation Results.....	58
Figure 16. Turning Movement Evaluation Results.....	60
Figure 17. LDS on a LCD.....	63
Figure 18. Phase I Tangent Treatments.....	64
Figure 19. Phase I Taper Treatments.....	65
Figure 20. Luminance Data for Phase I Tangent Treatments.....	65
Figure 21. Luminance Data for Phase I Taper Treatments.....	66
Figure 22. Phase II Taper Treatments.....	67
Figure 23. Luminance Data for Phase II Taper Treatments.....	68
Figure 24. Example of an Urban Roadway under Construction.....	71
Figure 25. Driveway Treatments for Closed-Course Study.....	74
Figure 26. Driver’s View from a Passenger Car on a Minor-Road Approach in a Work Zone..	79
Figure 27. Comparison of Passenger Car Driver Eye Height Distribution to LCD Heights.....	80
Figure 28. Comparison of Critical Object Height Distributions to LCD Heights.....	81
Figure 29. Example of LCD Application around a Driveway.....	82
Figure 30. Calculated Sight Distance to the Center of the Major Road – Left.....	85
Figure 31. Calculated Sight Distance to the Center of the Major Road – Right.....	85
Figure 32. Examples of the End of Continuous LCDs.....	94

LIST OF TABLES

	Page
Table 1. Channelizing Device Spacing in Tapers and Tangents (4).....	4
Table 2. Maryland SHA Channelizing Device Spacing (6).....	5
Table 3. Florida DOT Channelizing Device Spacing (7).	5
Table 4. Characteristics of LCDs.....	9
Table 5. TxDOT Personnel Responses to “In What Types of Situations Do You Think LCDs Should Be Used?”	13
Table 6. Dimensions of Devices Studied.....	21
Table 7. Description of Treatments.	22
Table 8. Treatments by Study Phase.....	23
Table 9. Participant Demographics for Exit Ramp Closed-Course Study.....	24
Table 10. Phase I Results (n=24).	26
Table 11. Phase II Results (n=16).....	28
Table 12. Phase III Results (n=20).	30
Table 13. Exit Ramp Demonstration Treatments.	33
Table 14. Exit Ramp Demonstration Results.....	34
Table 15. Desktop Driving Simulator Study Treatment Order by Participant Group.	47
Table 16. Participant Demographics for the Driving Simulator Study.....	49
Table 17. Driving Simulator Results (n=313).	52
Table 18. Lane Closure Treatments for the Detection Distance and Turning Movement Evaluations.....	54
Table 19. Vehicle Information for Detection Distance and Turning Movement Evaluations.....	55
Table 20. Trial Run Order.....	56
Table 21. Description of Driveway Treatments for Closed-Course Study.....	73
Table 22. Participant Demographics for the Closed-Course Driveway Study.	76
Table 23. Treatment and Driveway Location Interaction.....	77
Table 24. Advantages and Disadvantages by Treatment.	78
Table 25. Descriptive Statistics for Passenger Cars (18).....	80
Table 26. Design Intersection Sight Distance for Passenger Cars Turning Left from a Stop (19).....	83
Table 27. Minimum Distance away from the Center of an Access Point Exit Lane where Continuous LCDs Can Be Located.....	86
Table 28. Cost Comparison for an Exit Ramp Application.	93

CHAPTER 1: INTRODUCTION

STATEMENT OF THE PROBLEM

Work zones create unexpected conditions for all road users. In some cases, the complexity of the work zone can make it difficult for drivers to identify the correct travel path, which can result in driver confusion and possibly intrusion into the work zone.

Longitudinal channelizing devices (LCDs) may be used instead of a line of cones, drums, or barricades. However, research has not been conducted to assess whether LCDs improve the traffic safety and operations of work zones relative to the use of other types of channelizing devices. Thus, in Texas there is currently no guidance regarding the work zone configurations and conditions where LCDs should be considered in lieu of other channelizing devices.

BACKGROUND

Traditional Channelizing Devices

The function of channelizing devices is to warn road users of conditions created by work activities in or near the roadway and to guide them safely through the work zone area.

Traditional channelizing devices include drums, cones, tubular markers, vertical panels, and barricades (shown in Figure 1). The *Manual on Uniform Traffic Control Devices (MUTCD) (1)* defines the minimum (and in some cases maximum) requirements for channelizing devices, including size, retroreflective material, and color. In addition, the MUTCD recommends the following criteria for channelizing device spacing in taper and tangent sections, independent of the specific device used:

- Should not exceed a distance in feet equal to one times the speed limit in mph when used for taper channelization.
- Should not exceed a distance in feet equal to two times the speed limit in mph when used for tangent channelization.

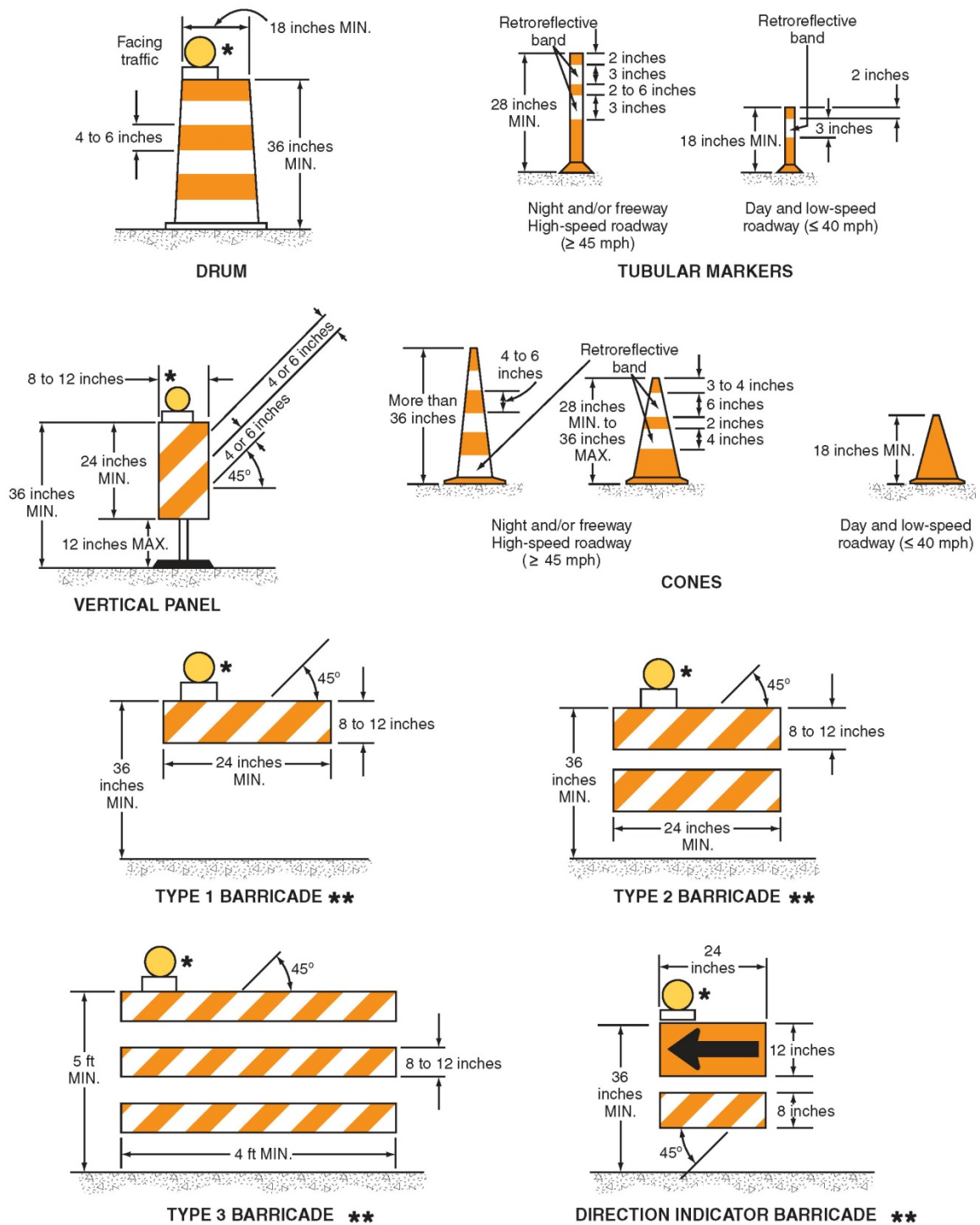

* Warning lights (optional)

** Rail stripe widths shall be 6 inches, except that 4-inch wide stripes may be used if rail lengths are less than 36 inches. The sides of barricades facing traffic shall have retroreflective rail faces.

Figure 1. Channelizing Devices (I).

Previous research has investigated the spacing of channelizing devices. Pain, McGee, and Knapp (2) conducted laboratory, controlled-field, and actual field studies to evaluate the effectiveness of channelizing devices and to determine how these devices should be designed and used, including spacing of devices. Pertinent findings from this study were:

- The optimum spacing is somewhat dependent on the device type, so what is suitable for a drum may not be appropriate for a cone. Unfortunately, this study was not able to assess the optimum spacing for each device type.
- When devices were spaced a distance (in ft) equal to 0.5 times the speed limit in mph, they produced a speed reduction at night.

Overall, the results tended to support the MUTCD standards discussed previously. In addition, researchers recommended that a closer spacing may prove to be useful where speed reduction is desired.

Opiela and Knoblauch (3) conducted laboratory and field studies to determine the most appropriate spacing configurations for eight different channelizing devices. Three different spacing configurations based on a 55 mph posted speed limit were evaluated:

- One times the speed limit (55 ft).
- One and a half times the speed limit (82.5 ft).
- Two times the speed limit (110 ft).

While researchers hypothesized that fewer larger devices (e.g., drums) could be used in lieu of smaller devices (e.g., cones), the results did not indicate a significant difference in motorist understanding and behavior among the devices and spacings evaluated. Researchers also concluded that the findings did not suggest the need for major changes to the basic spacing criteria. However, researchers did recommend the use of larger devices and more devices on the taper at locations where sight distance may be limited.

More recently, Bryden and Mace (4) developed guidelines for identifying the special problems associated with nighttime work that require safety enhancements above and beyond the minimum requirements specified in the MUTCD. They specifically addressed the design requirements for channelizing and guidance devices in lane closures, lane shifts, and temporary median crossovers, and in the vicinity of ramps at night.

With respect to lane closures, Bryden and Mace recommended the use of channelizing devices that are larger and more visible than those required for daytime applications. In addition,

channelizing devices should be more closely spaced to clearly define closed lanes at night. Bryden and Mace recommended the New York State Department of Transportation (NYSDOT) channelizing device spacing in taper and tangents shown in Table 1 to discourage work zone intrusions into lane and shoulder closures. With larger channelizing devices, such as drums, the close device spacing in Table 1 appears to create a more continuous array of retroreflective devices and thus, reduces the risk of drivers entering the closed lane. The guidelines for channelizing lane closures are also applicable to lane shifts and temporary median crossovers, but a further reduction in the spacing of channelizing devices is recommended when used to separate opposing traffic in crossovers.

Table 1. Channelizing Device Spacing in Tapers and Tangents (4).

Estimated Operating Speed (mph)	Maximum Spacing (ft)
20	20
30	30
40+	40

When a freeway lane closure occurs adjacent to an open ramp, the ramp traffic must pass through or around the work space. Thus, Bryden and Mace felt that larger channelizing devices may be suitable at the temporary gore of an exit ramp to make it easier for drivers to identify the correct point to depart the main lane. In addition, Bryden and Mace recommended a further reduction in channelizing device spacing (i.e., maximum spacing of 20 ft) at ramps, intersections, and other potential problem areas.

In addition to New York, several other states require a closer spacing of channelizing devices for certain work zone conditions. The California Department of Transportation (Caltrans) (5) requires a device spacing approximately equal to 0.5 times the speed limit in mph on intermediate and short-term projects for taper and tangent sections where there are no pavement markings or where there is a conflict between existing pavement markings and channelizing devices.

In the Maryland State Highway Administration (SHA) *Work Zone Safety Toolbox* (6), reduced channelizing device spacing is recommended where any of the work zone conditions

listed in Table 2 are present. The spacing between channelizing devices shall be equal to 20 ft for low-speed facilities and 40 ft for high-speed facilities.

Table 2. Maryland SHA Channelizing Device Spacing (6).

Work Zone Location/Condition	Spacing in Feet	
	Low-Speed (45 mph or Less)	High-Speed (Greater than 45 mph)
Transitions and Curves ¹	20	40
Work Zone Activity Area ²		
Intersections		
Conflict Areas ³		
Hazardous Conditions ⁴		
Nighttime Operations		

¹ Use on curves with a degree of curvature greater than 6 degrees.

² Where work is taking place.

³ Areas with no pavement markings or where there is a conflict between existing pavement markings and channelizing devices.

⁴ For example, equipment very near the traffic stream, unusual conditions hidden from motorists, and trucks entering and leaving the traffic stream.

The device spacing in Table 3 is from the Florida Department of Transportation (DOT) (7). Independent of the speed, cones and tubular markers are spaced 25 ft apart on tapers and 50 ft apart on tangents. While the spacing for barricades, vertical panels, and drums does change based on the speed, at some speeds the spacing on a taper is less than the speed, and the spacing on a tangent is less than two times the speed.

Table 3. Florida DOT Channelizing Device Spacing (7).

Speed (mph)	Maximum Distance between Devices (ft)			
	Cones or Tubular Markers		Type I or Type II Barricades or Vertical Panels or Drums	
	Taper	Tangent	Taper	Tangent
25	25	50	25	50
30 to 45	25	50	30	50
50 to 70	25	50	50	100

While all of the findings and recommendations intuitively make sense, the potential advantages discussed (i.e., larger devices and closer device spacing) have not been confirmed with actual data. In addition, traditional channelizing devices, even with the closer device spacings discussed, still have some open space between devices that can be mistaken for the correct travel path. This can be especially true when these devices become misaligned due to passing vehicles or minor impacts.

Longitudinal Channelizing Devices

Longitudinal channelizing devices, previously referred to as longitudinal channelizing barricades (LCBs), were first introduced in the 2003 MUTCD (8) and added to the Texas MUTCD in the 2006 version (9). Per the current version of the MUTCD (1) and the Texas MUTCD, LCDs are lightweight, deformable devices that are highly visible and have good target value. LCDs can be used singly as Type 1, 2, or 3 barricades, or connected together to delineate or channelize vehicles or pedestrians. LCDs may be used instead of a line of cones, drums, or barricades.

If used singly as a Type 1, 2, or 3 barricade, LCDs must comply with the general size, color, stripe pattern, retroreflectivity, and placement characteristics of barricades. Otherwise, the MUTCD does not specify minimum or maximum size requirements for LCDs (unlike other channelizing devices). In addition, while the MUTCD states that LCDs used to channelize vehicular traffic at night should be supplemented with retroreflective material or delineation, the MUTCD does not address the specific design of the retroreflective material or delineation when connected together.

In contrast, the Texas MUTCD does include a 36-inch minimum height for LCDs (Figure 2). The Texas Department of Transportation (TxDOT) also requires that LCDs be retroreflective or supplemented with retroreflective delineation as required for temporary barriers (10). The following are the TxDOT standards for barrier reflectors applicable to this project (10):

- Where traffic is on one side of the concrete traffic barrier (CTB), two barrier reflectors shall be mounted in approximately the midsection of each section of CTB. An alternate mounting location is uniformly spaced at one end of each CTB. The

barrier reflector mounted on the side of the CTB shall be located directly below the reflector mounted on top of the barrier, as shown in Figure 3.

- Barrier reflector units shall be yellow or white in color to match the edgeline being supplemented. White reflectors shall be made with Type D white prismatic sheeting.
- Maximum spacing of barrier reflectors is 40 ft.

While this may be sufficient for longitudinal applications of LCDs, additional delineation (e.g., retroreflective striping, chevrons, vertical panels, etc.) may be needed for LCDs used in non-longitudinal applications where more continuous delineation is desired (e.g., lane closure tapers).

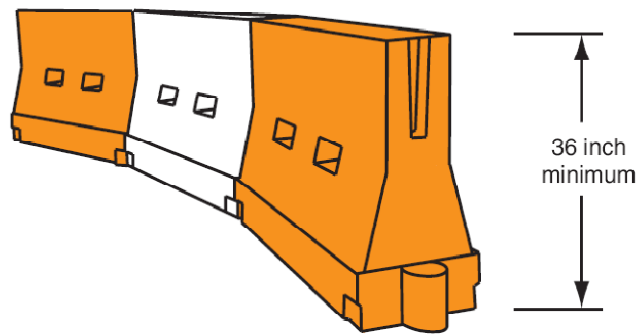

Figure 2. LCD Depiction in Texas MUTCD (9).

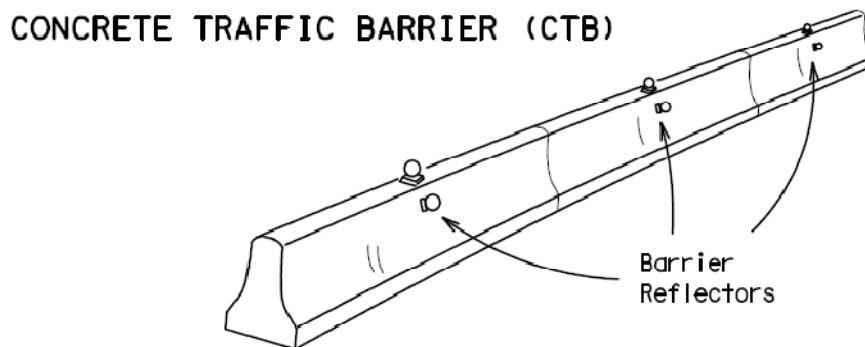

Figure 3. Barrier Reflectors (10).

Texas Transportation Institute (TTI) researchers are also concerned that LCDs are currently delineated the same as barriers. Although continuous line applications of LCDs may appear to form a solid wall, they do not meet the vehicle redirection requirements for temporary traffic barriers. Thus while LCDs must be “crashworthy,” they do not provide positive protection for obstacles, pedestrians, or workers. However, since LCDs look very similar to water-filled barriers, the two devices are often confused with each other. Delineating LCDs the same as barriers may exacerbate the confusion and lead to a false sense of security for both motorists and workers and misapplication of LCDs in work zones.

To help reduce this confusion, the FHWA changed the name of this device from longitudinal channelizing barricades to longitudinal channelizing devices in the 2009 MUTCD (1). In addition, Task Force 13 (11), which serves the American Association of State Highway and Transportation Officials (AASHTO), Associated General Contractors of America (AGC), and American Road and Transportation Builders Association (ARTBA) Joint Subcommittee on New Highway Materials and Technologies, has recognized the potential problems surrounding this confusion and addressed this matter through the development of warning label guidelines that will provide end users with sufficient information to discern between LCDs and water-filled barriers. Task Force 13 members anticipate that these guidelines will educate users about the performance of the different devices in order to avoid the unintentional use of LCDs at sites where actual barriers are intended.

Based on a review of the available products conducted in the fall of 2008, researchers identified seven manufacturers of LCDs. As shown in Table 4, the LCDs produced by these manufacturers vary in design. While all of the LCDs identified are “crashworthy,” the test level for which each device is approved varies. Also, some LCDs can be used with and without ballast (i.e., water or sand), and some LCDs have been approved with or without the use of other traffic control devices (e.g., warning lights, delineators, signs, etc.) (12). To date, TxDOT has approved the use of four types of LCDs (13).

Table 4. Characteristics of LCDs.

Characteristic	Range of Values
Height	18 to 46 inches
Length	45 to 84 inches
Width at base	12 to 30 inches
Width at top	5 to 22 inches
Weight empty	35 to 132 pounds
Color	Orange or white
Crashworthiness	TL-1, TL-2, or TL-3

TL = Test Level

Current and Potential Use of LCDs in Work Zones

To date, LCDs have primarily been used to delineate pedestrian travel paths and keep pedestrians from inadvertently entering the work area. When properly accessorized, LCDs can help ensure that the temporary pedestrian travel path meets the MUTCD accessibility requirements for all road users (including those persons with disabilities) (1).

Within the traveled way, LCDs have mainly been used to close roadways and driveways to vehicular traffic. On occasion, LCDs have also been used on the edge of the travel lane in a longitudinal application to denote the edge of the pavement or separate the active travel lanes from the work area. The limited application of LCDs in the traveled way is not surprising since guidance regarding the work zone configurations and conditions where LCDs should be considered in lieu of other channelizing devices has not been developed. However, LCDs do have some promising qualities that need further investigation in terms of their influence on the driving task.

In contrast to traditional channelizing devices (e.g., cones, drums, etc.) that have some open space between devices (based upon the posted speed), LCDs can be connected together to form a solid line (i.e., no space between devices). Thus, LCDs can prevent drivers and pedestrians from going between devices and entering the work area (whether inadvertent or deliberate). A solid line of LCDs also provides continuous delineation of the travel path that may be beneficial at major decision points in work zones, such as lane closures, exit ramps, business access points (i.e., driveways), and temporary diversions (i.e., crossovers). LCDs are also considered to be highly visible and have good target value; thus, LCDs might increase the sight distance to major decision

points. However, for these attributes to also be advantageous at night, minimum retroreflectivity requirements for LCDs are needed.

Of course, LCDs could also be used in a more traditional fashion. For example, in lane closures, single LCDs acting as Type 3 barricades (i.e., oriented 90 degrees toward oncoming traffic) could be used in lieu of drums to form the merging taper. While the LCDs would not be used in a continuous line (i.e., there would be some open space between devices), due to their larger size the LCDs may still appear to form a solid wall to drivers approaching the lane closure in the closed lane. In addition, the larger size of the LCDs may allow for increased spacing of the devices (i.e., more than one times the speed limit in mph); thus, fewer devices would be needed.

Overall, a number of generally accepted but unconfirmed potential advantages of LCDs have been identified. Research is needed to assess whether LCDs improve the traffic safety and operations of work zones relative to the use of other types of channelizing devices. In addition, guidance regarding the work zone configurations and conditions where LCDs should be considered in lieu of other channelizing devices needs to be developed.

CONTENTS OF THIS REPORT

This report describes the methodology and results of analyses conducted to assess whether LCDs improve the traffic safety and operations of work zones relative to the use of other types of channelizing devices. Chapter 2 contains the results of interviews with TxDOT personnel. Chapter 3, Chapter 4, and Chapter 5 describe the studies conducted regarding exit ramps, lane closures, and driveways, respectively. Chapter 6 contains the recommendations regarding the work zone configurations and conditions where LCDs should be considered in lieu of other channelizing devices.

CHAPTER 2: TXDOT INTERVIEWS

INTRODUCTION

In order to determine the state-of-the-practice regarding LCDs in Texas work zones and the desired work zone configurations and conditions where LCDs could be utilized, TTI researchers conducted telephone interviews with 30 TxDOT personnel (includes at least one person from 23 of the 25 TxDOT districts) in the fall of 2008. Researchers mainly interviewed construction personnel; however, in some cases researchers also interviewed maintenance and traffic operations personnel. In addition, researchers contacted personnel in two Texas cities that had previously used LCDs in work zones. Topics discussed during the telephone interviews included the following:

- Whether or not the district or city has utilized or plans to utilize LCDs in work zones.
- Specific work zone locations where LCDs are installed or planned to be installed.
- Why LCDs were used in lieu of other channelizing devices.
- Characteristics of the work zone where LCDs were utilized (e.g., type of work, type of traffic control [lane closure, crossover, etc.], duration, etc.).
- Characteristics of the LCD application (e.g., where used, color, delineation, supplemental devices [chevrons, vertical panels, etc.] etc.).
- Input with regard to the use of LCDs in work zones (i.e., where and when LCDs should or should not be used).
- Concerns regarding the use of LCDs in work zones.

RESULTS

None of the districts contacted had previously used LCDs in work zones. In fact, in most cases it was necessary for researchers to email TxDOT personnel specifications and other product information on LCDs to familiarize them with the devices before the interview could be conducted. Not surprisingly, most often LCDs were initially confused with water-filled barriers. In addition, LCDs were confused with raised curb systems (which are also referred to as longitudinal channelizers) that are used to separate opposing directions of traffic, restrict turning movements at intersections, etc.

Researchers also informed participants that LCDs are to be used in place of other types of channelizing devices, such as a line of cones or drums, and that LCDs do not provide positive protection like temporary traffic barriers. However, during the interview process it was evident that respondents from both TxDOT and the two cities were confusing LCDs with water-filled barriers. In addition, many of the respondents mistakenly thought LCDs were not crashworthy since they did not provide positive protection. Unfortunately, the lack of knowledge regarding LCDs and the apparent misunderstanding of the intended use of LCDs (i.e., to be used in place of other channelizing devices, not in lieu of temporary traffic barrier) did limit the usefulness of the survey findings.

Most TxDOT personnel were apprehensive about the use of LCDs in work zones since they were unfamiliar with the device. However, two districts (Amarillo and Bryan) did indicate an interest in using LCDs in the future. Also, the Odessa District stated that they currently have LCDs but they were obtained for use with homeland security activities and thus do not currently have plans to use them in work zones.

Personnel from both the City of Austin and the City of San Antonio indicated that they have used LCDs in a continuous line to channelize pedestrian traffic, separate pedestrians from vehicular traffic, and prevent pedestrians from entering the work area. Both cities use an orange and white alternating pattern for better contrast. To date, all applications have been on low speed urban streets mainly for infrastructure projects (e.g., water lines). Even though these are common applications of LCDs, several comments during the city interviews suggested that the devices actually used in these applications may have been water-filled barriers instead of LCDs. For example, respondents used the word “barrier” on multiple occasions, indicated that they thought LCDs were easier to use than concrete barrier, or indicated they would use LCDs where they needed positive protection for pedestrians.

Table 5 shows the situations where TxDOT district personnel thought LCDs should be used. The responses included both work zone and non-work zone applications. While non-work zone situations are not the focus of this research project, researchers thought it was important to report other potential applications for LCDs. Some of the responses addressed specific applications while others were more general in nature.

**Table 5. TxDOT Personnel Responses to
“In What Types of Situations Do You Think LCDs Should Be Used?”**

Category	Situation	Percentage of Respondents
Work zone	Roadway/driveway closures	35%
	Exit/entrance ramps	35%
	Low speed	30%
	Lane closures	26%
	Urban areas	26%
	Short term	17%
	Channelize pedestrians	13%
	Temporary diversions	9%
	Shifting traffic	9%
Non-work zone	Emergencies	9%
	Special events	9%
	Parking lots	9%
	Border patrol check points	4%
	Homeland security	4%
	Where drivers illegally cross median	4%

The most frequent work zone applications mentioned by TxDOT personnel were the use of LCDs to close roadways and driveways and to delineate exit and entrance ramps (35 percent for each situation). District personnel also felt that LCDs could be used in lane closures (26 percent), to channelize pedestrians (13 percent), in temporary diversions (9 percent), and for shifting traffic (9 percent). In general, respondents mentioned that LCDs should be used on low-speed roadways (30 percent), in urban areas (26 percent), and for short-term operations (17 percent).

Some of the TxDOT personnel also indicated situations where LCDs should not be used. Specifically, 17 percent thought LCDs should not be used on high-speed roadways, and another 9 percent thought they should not be used in rural areas. The main reasons cited were that LCDs are not crashworthy at higher speeds and that the temporary traffic barrier is needed on high-speed roadways. Unfortunately, a lack of understanding of LCDs seems to have influenced these perceptions. Some LCDs are approved for use on higher speed roadways (i.e., meets appropriate NCHRP 350 test level 3 evaluation criteria (14)). In addition, LCDs would not replace temporary traffic barriers. LCDs can only be used in place of other channelizing devices (e.g., drums and cones).

TTI researchers also asked TxDOT district personnel to identify advantages and disadvantages to using LCDs in lieu of more traditional channelizing devices. LCD advantages included:

- They provide more path guidance information, especially in continuous line applications (70 percent).
- In continuous line applications, they can keep drivers and pedestrians from going between devices and entering the work zone (57 percent).
- They are more resistant to getting knocked over and thus, may require less maintenance (35 percent).
- Their larger size may yield more respect from drivers; thus, drivers may be less likely to hit them (9 percent).

LCD disadvantages included:

- Their higher cost per device compared to traditional channelizing devices (61 percent).
- They are more difficult to transport, setup, and remove compared to traditional channelizing devices (included concerns about the need for different equipment and additional personnel) (43 percent).
- They may give drivers a false sense of security since they look like barriers (35 percent).
- They may restrict access to work areas when used in a continuous line (22 percent).
- Their width may limit applications (included concerns about LCDs encroaching into the travel lane) (13 percent).
- Their overall size may restrict visibility (i.e., drivers exiting driveways or workers in an existing work area may not be able to see oncoming traffic as well) (13 percent).
- They may be more difficult to replace when they become damaged since they are not as readily accessible as traditional channelizing devices (9 percent).
- Water-filled devices may leak or freeze (4 percent).

Approximately one-third of the districts contacted also expressed the need to determine the appropriate retroreflective markings for LCDs before they could be used at night. Some respondents (17 percent) also commented that contractors would be resistant to using these

devices since they already have large inventories of traditional channelizing devices (i.e., drums and cones).

SUMMARY AND RECOMMENDATIONS

Even though none of the districts contacted had previously used LCDs in work zones, researchers were able to gain insights into desired work zone configurations and conditions where LCDs could be utilized and identify potential advantages and disadvantages to using LCDs. Based on the generally accepted but unconfirmed potential advantages of LCDs discussed previously, interviews with TxDOT personnel, and input from the project panel, researchers decided to evaluate the following:

- Continuous LCDs in the vicinity of exit ramps on high-speed, limited-access facilities.
- Continuous LCDs in the merging taper of a lane closure on low-speed roadways.
- Single transverse LCDs (similar to Type 3 barricades) in the merging taper of a lane closure on high-speed roadways.
- Continuous LCDs in the vicinity of driveways on low-speed urban roadways.

Researchers also examined size standards and retroreflectivity requirements. In addition, the practicality of implementing LCDs in lieu of more traditional channelizing devices was considered.

CHAPTER 3: EXIT RAMP EVALUATIONS

INTRODUCTION

When a freeway lane closure occurs adjacent to an open exit ramp, the ramp traffic must pass through or around the work space. However, it can be difficult for drivers to identify the correct travel path, especially if the length of the exit ramp gap is similar to the spacing of the channelizing devices used to delineate the closed lane. Missing and/or misaligned channelizing devices can make the identification of the correct travel path even more difficult. When a channelizing device is missing due to some event (e.g., knocked over), the resulting space between devices is larger than the other spaces. A driver may misinterpret the larger gap as the exit ramp. Channelizing devices may also become misaligned by passing vehicles, making it more difficult to distinguish the correct travel path. All of these situations may lead to driver confusion, erratic maneuvers, and work zone intrusions.

Larger channelizing devices, such as drums, and closer channelizing device spacing appear to create a more continuous array of devices. Thus, the use of larger, more closely spaced channelizing devices may be suitable at the temporary gore of an exit ramp to assist drivers with identifying the correct point to depart the main lane. LCDs connected together to form a solid line seem to provide an even larger target area and continuous delineation of the travel path, which may also be beneficial in the vicinity of open exit ramps in work zones. In addition, continuous LCDs would reduce the likelihood of deliberate intrusions into the work zone. While these recommendations intuitively make sense, the potential advantages discussed above have not been confirmed with actual data. This chapter documents the experimental design and findings of closed-course human factors studies conducted to determine the effectiveness of continuous LCDs to delineate freeway exit ramps that remain open within a work zone lane closure. In addition, researchers discuss the findings from a demonstration conducted with the project panel and a photometric analysis of the most promising exit ramp treatments.

HUMAN FACTORS STUDIES

The following sections describe the series of closed-course human factors studies designed to determine whether LCDs improve the ability of drivers to detect exit ramp openings within a work zone lane closure relative to the use of drums. While detection distance data in

response to a simulated exit ramp within a lane closure cannot be directly compared to detection distance data collected in an actual lane closure in a work zone, closed-course study data can be used to compare the relative differences in performance between the various treatments evaluated.

Experimental Design

Researchers conducted the closed-course exit ramp study at the Texas A&M University Riverside Campus, which is a 2000-acre complex of research and training facilities located 10 miles northwest of the university's main campus. Trying to assess each application of interest in one study would require an extremely long amount of time per subject and could have resulted in unnecessary data collection. Thus, researchers conducted the study in three phases. The research team believed that this approach provided an opportunity to identify treatments that could be eliminated from further testing; therefore, removing unnecessary data collection and reducing the amount of time to conduct the study. All phases of this study were conducted during daylight hours under dry pavement conditions. The simulated work zone, treatments, phases, study procedure, and participants are described in the following sections.

Simulated Work Zone

The simulated work zone in this study was designed for a 60 mph posted speed limit and was comprised of a tangent section of a right lane closure and a right exit ramp. There was no merging taper. As shown in Figure 4, the simulated work zone was divided into three main parts: the entry tangent, the treatment area, and the exit tangent. The treatments were only applied in the immediate vicinity of the exit ramp, and not along the full length of the tangents. Researchers hoped that the application of the treatments only in the vicinity of the exit ramp opening would help participants recognize the exit.

In all three phases, the entry tangent was 480 ft long, and the exit tangent was 240 ft long. In the first two phases, the treatment area was 360 ft long. In the third phase, the treatment area was 480 ft long. The treatment area length was changed to investigate the effect of a larger exit ramp opening (i.e., 120 ft versus 240 ft). Typical Application 42 in the Texas MUTCD (9) shows a 100 ft exit ramp opening when work is performed in the vicinity of an exit ramp. However, the suggested maximum spacing of channelizing devices on a tangent for a 60 mph posted speed limit is 120 ft. Since it did not seem logical to utilize an exit ramp opening smaller

than the channelizing device spacing, researchers initially used an exit ramp opening equal to the channelizing device spacing (i.e., 120 ft). Researchers also felt that this smaller exit ramp opening was indicative of the spacing used during shorter-term maintenance activities.

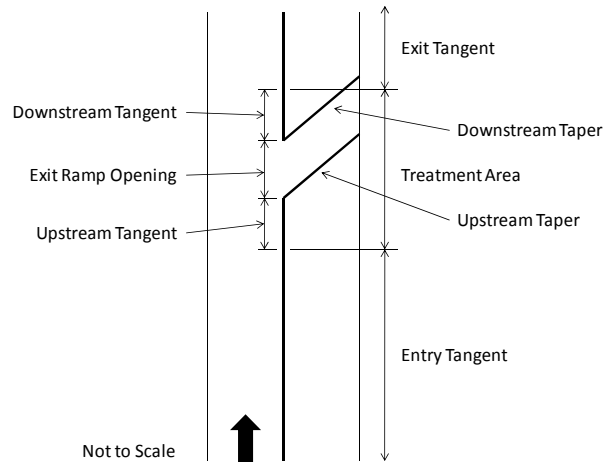

Figure 4. Simulated Work Zone Layout.

One alternative to improve exit ramp delineation might be as simple as expanding the exit ramp opening. Based on discussions with TxDOT personnel and a review of some urban freeway work zone plans, it was clear that gaps much larger than 120 ft were typically used on longer-term construction projects, even when no deceleration lane was provided. Thus, researchers decided to enlarge the exit ramp opening in the third phase of the study. Although researchers anticipated using a 500 ft gap for the exit ramp opening, it was quickly determined that a gap this large could be clearly seen beyond the limits of the closed-course study. Therefore, researchers chose to simply double the length of the previous exit ramp opening (i.e., 240 ft).

The treatment area was further subdivided into the following four geometric components (Figure 4): an upstream tangent (UpTn), an upstream taper (UpTp), a downstream taper (DnTp), and a downstream tangent (DnTn). Both tangents were 120 ft long, and both tapers were approximately 100 ft long. The two tapers formed the exit ramp. A temporary exit sign was not used during this study since researchers wanted to ensure that the participants were identifying the exit ramp opening based solely on their interpretation of the channelizing device configuration.

Treatments

Two types of devices were used during this study. The first was conventional channelizing drums, while the other was LCDs placed in a continuous alignment. Both devices are shown in Figure 5.



(a) Standard Drum



(b) LCD

Figure 5. Example of Devices Studied.

Researchers conducted the closed-course exit ramp study prior to investigating retroreflectivity needs since all phases of the study were performed during the day. However, researchers desired to include a retroreflective component that would mimic a drum or cone (instead of a barrier) and potentially provide continuous delineation at night in a non-longitudinal application (e.g., tapers). Thus, the LCDs were striped similar to a drum. This also reduced the potential for striping differences to influence the detection distance (i.e., impact one treatment, but not another).

Table 6 contains the dimensions of the devices studied. During a demonstration, TxDOT personnel and TTI researchers determined that taller LCDs (46 inches) blocked the view of the exit ramp opening when used in the upstream tangent and taper, which may cause confusion due to a lack of positive guidance. In addition, TxDOT personnel and researchers were concerned that the taller LCDs might block the view of a stalled passenger car on the exit ramp. Thus, researchers decided to use the 32-inch tall LCDs in this study.

The impact of each geometric component of the treatment area on a driver's ability to correctly perceive the exit ramp opening was not known. Thus, in order to determine the most

effective use of the two devices shown in Figure 5, researchers developed a list of treatments that utilized the LCDs and drums in various combinations surrounding the exit gore opening. Table 7 contains a list of the treatments evaluated in all three phases of the study. There were 16 combinations: one treatment consisting of all drums (Treatment 9), one consisting of all LCDs (Treatment 2), and the remaining 14 treatments had a mixture of drums and LCDs. Depictions of each treatment are located in Appendix A.

Table 6. Dimensions of Devices Studied.

Characteristic	LCDs		Drums	
	Range of Values	Used	Range of Values ^a	Used
Height	18 to 46 inches	32 inches	36 inches min. 42 inches max.	38 inches
Length	45 to 84 inches	72 inches	NA	NA
Width at Base	12 to 30 inches	16 inches	36 inches max.	26 inches
Width at Top	5 to 22 inches	8 inches	18 inches min.	18 inches
Width of Stripes	NA	4 inches	4 inches min. 8 inches max.	4 inches

^a Based on TxDOT standards (10).
NA = Not Applicable

Next, researchers established the device spacing. Based on the criteria for shoulder and downstream tapers (9), researchers used a 20-ft drum spacing in the upstream and downstream tapers. The Texas MUTCD (9) suggests a maximum spacing of two times the speed limit (i.e., 60 mph) for channelizing devices placed in a tangent. Therefore, researchers used a 120-ft drum spacing in the entry tangent, both treatment area tangents (upstream and downstream), and the exit tangent during the first phase of the study. In the remaining two phases of the study, researchers also used 60-ft drum spacing (Treatments 9b and 11b) to assess the impact of simply reducing the spacing to one times the speed limit (i.e., half of the maximum distance currently required). The 60-ft drum spacing was also applied in the entry tangent, both treatment area tangents (upstream and downstream), and the exit tangent.

Researchers placed the LCDs in a continuous alignment over the entire length of each geometric component of the treatment area, except the downstream tangent. To facilitate treatment testing, researchers limited the length of the LCDs used on the downstream tangent to 60 ft (i.e., the LCDs were not continuous over the entire 120-ft downstream tangent area).

Researchers believed that this reduced length in the downstream section did not have any influence on the detection of the exit ramp. Researchers placed the LCDs parallel to the roadway in both treatment area tangent sections and angled the LCDs across the closed lane to form the tapers. LCDs were not used in the entry or exit tangents.

Table 7. Description of Treatments.

Trt #	Entry Tangent ^a	Upstream Treatment Area ^{a,b}		Downstream Treatment Area ^{a,b}		Exit Tangent ^a
		Tangent	Taper	Taper	Tangent	
1	Drums (120 ft)	LCDs	LCDs	LCDs	Drums (120 ft)	Drums (120 ft)
2	Drums (120 ft)	LCDs	LCDs	LCDs	LCDs	Drums (120 ft)
3	Drums (120 ft)	LCDs	LCDs	Drums (20 ft)	Drums (120 ft)	Drums (120 ft)
4	Drums (120 ft)	LCDs	Drums (20 ft)	LCDs	Drums (120 ft)	Drums (120 ft)
5	Drums (120 ft)	LCDs	LCDs	Drums (20 ft)	LCDs	Drums (120 ft)
6	Drums (120 ft)	LCDs	Drums (20 ft)	LCDs	LCDs	Drums (120 ft)
7	Drums (120 ft)	LCDs	Drums (20 ft)	Drums (20 ft)	LCDs	Drums (120 ft)
8	Drums (120 ft)	LCDs	Drums (20 ft)	Drums (20 ft)	Drums (120 ft)	Drums (120 ft)
9a	Drums (120 ft)	Drums (120 ft)	Drums (20 ft)	Drums (20 ft)	Drums (120 ft)	Drums (120 ft)
9b	Drums (60 ft)	Drums (60 ft)	Drums (20 ft)	Drums (20 ft)	Drums (60 ft)	Drums (60 ft)
10	Drums (120 ft)	Drums (120 ft)	LCDs	Drums (20 ft)	Drums (120 ft)	Drums (120 ft)
11a	Drums (120 ft)	Drums (120 ft)	LCDs	LCDs	Drums (120 ft)	Drums (120 ft)
11b	Drums (60 ft)	Drums (60 ft)	LCDs	LCDs	Drums (60 ft)	Drums (60 ft)
12	Drums (120 ft)	Drums (120 ft)	LCDs	LCDs	LCDs	Drums (120 ft)
13	Drums (120 ft)	Drums (120 ft)	LCDs	Drums (20 ft)	LCDs	Drums (120 ft)
14	Drums (120 ft)	Drums (120 ft)	Drums (20 ft)	LCDs	LCDs	Drums (120 ft)
15	Drums (120 ft)	Drums (120 ft)	Drums (20 ft)	LCDs	Drums (120 ft)	Drums (120 ft)
16	Drums (120 ft)	Drums (120 ft)	Drums (20 ft)	Drums (20 ft)	LCDs	Drums (120 ft)

Trt # = Treatment Number

^a Drum spacing is shown in parentheses.

^b LCDs were continuous.

Phases

Table 8 shows the treatments evaluated during each phase of the study. Phase I had 14 treatments, all of which consisted of a mixture of devices (drums and LCDs). Researchers divided the 14 treatments into three specific treatment groups due to time limitations per participant (maximum of two hours) and to make efficient use of the field crew during the extreme heat of the summer months. The groupings also allowed researchers to compare specific variables (e.g., holding the devices used on the upstream tangent and taper constant while altering the devices used on the downstream taper and tangent).

Table 8. Treatments by Study Phase.

Treatment Number	Phase I	Phase II	Phase III
1	X		
2		X	X
3	X		
4	X		
5	X		
6	X	X	
7	X	X	
8	X		
9a		X	X
9b		X	X
10	X		
11a	X	X	X
11b		X	X
12	X		
13	X		
14	X		
15	X		
16	X		

X indicates the treatment was observed.

Researchers used Phase II of the study to compare the three most promising Phase I treatments (one from each group [Treatments 6, 7, and 11]) to Treatment 2 (all LCDs) and Treatment 9 (all drums), as well as to determine the impacts of using a 60-ft drum spacing in the tangents (Treatments 9b and 11b). Phase III included Treatments 2, 9a, 9b, 11a, and 11b with a larger exit ramp opening (240 ft). To avoid the occurrence of primacy bias, the order of the treatments was altered within each phase of the study.

Study Procedure

Upon arrival, each participant checked in and a briefing took place at a TTI office building. The researchers then provided the participants with an explanation of the study, including their driving task, and asked them to read and sign the informed consent document. Participants then completed screenings for standard visual acuity, contrast sensitivity, and color blindness. These screenings provided comparison information for data reduction and ensured that all participants had at least minimal levels of acceptable vision prior to beginning the study. No participants were disqualified from the study based on these screenings.

Participants were then told that they would be driving an instrumented state-owned passenger vehicle (i.e., Ford Taurus) on a closed course. They would be accelerating to 60 mph (maximum speed) and continue at that speed throughout the simulated work zone. The researchers instructed participants to verbally acknowledge when they could clearly identify the exit ramp opening. The researchers recorded the exit ramp opening detection distances, as well as any comments made by the participants. The participants continued traveling straight through the work zone (i.e., participants did not take the exit). At the end of the course, researchers asked participants a series of follow-up questions. Each participant repeated this process for each treatment. At the end of the study, researchers asked participants to rank the work zone setups from best to worst in terms of how well they could identify the exit ramp opening.

Participants

Sixty people from the Bryan/College Station area participated in the closed-course exit ramp study. Participants were required to be over the age of 35 and have a current driver’s license. Table 9 summarizes the demographics for each phase of the exit ramp closed-course study, as well as the overall demographics. In Phase I, researchers chose to recruit participants between the ages of 35 and 54, thus obtaining data for middle-aged drivers. However, due to time limitations and the lack of availability of middle-aged participants during the day, researchers felt that participants over age 55 would be easier to schedule during the daytime hours for the study. While some participants in the 40 to 54 age groups were recruited, the majority of the participants were in the over 55 age category.

Table 9. Participant Demographics for Exit Ramp Closed-Course Study.

Sample	Gender		Age			Education	
	M	F	35–40	40–54	55+	HS Diploma or Less	SC (≥2 yrs) and More
Phase I (n=24)	46%	54%	29%	71%		33%	67%
Phase II (n=16)	44%	56%	6%	31%	63%	31%	69%
Phase III (n=20)	45%	55%			100%	45%	55%
Overall (n=60)	45%	55%	13%	37%	50%	36%	64%

M = Male; F = Female; HS = High School; SC = Some College
 Shaded cells indicate there were no participants in the category.

Data Analysis

In each phase of the study, the primary measure of effectiveness was the mean detection distance of the exit ramp opening. Some participants initially identified the wrong location of the exit ramp, but all participants eventually identified the correct location. Researchers only utilized the detection distance data associated with the identification of the correct location. Researchers computed the mean detection distance, standard deviation, minimum detection distance, and maximum detection distance for each treatment (see Appendix B). Researchers then used analysis of variance for one dependent variable and Tukey's Honestly Significant Difference (HSD) procedures to determine if there were significant differences among the mean distances for each treatment. A 95 percent level of confidence was used for all statistical analyses.

Researchers also computed the percentage of participants that correctly identified the location of the exit ramp opening on their first attempt and the percentage of participants who thought some aspect of the treatment was confusing. Researchers analyzed the participants' subjective opinions by calculating the average "helpfulness" rating for each treatment (one was very helpful, two was helpful, and three was not helpful), as well as the overall ranking of the treatments from the best to worst treatment. Researchers determined the overall ranking using a ranking score, which was computed by assigning one point each time a treatment was ranked first (best), two points for second place rankings, etc. with the maximum number of points being assigned each time a treatment was ranked worst. Thus, the treatment perceived to be best would have the lowest score.

Phase I Results

Phase I had 14 treatments, all of which consisted of a mixture of devices (drums and LCDs). Table 10 contains the findings from Phase I. The group 1 results indicate that Treatment 11a had the longest mean detection distance (369 ft) and the best helpfulness rating (1.0). In addition, all of the participants correctly identified the exit ramp opening on their first attempt, and none of the participants were confused by Treatment 11. Thus, it is not surprising that the participants ranked Treatment 11 the best overall in group 1. Participants commented that they preferred this treatment due to the appearance of a solid wall immediately upstream of

the exit, with the break in the wall creating an opening that made it easier to see the exit. Based on these data, researchers decided to include Treatment 11 in Phase II.

Table 10. Phase I Results (n=24).

Trt	LCD Location	Mean Detection Distance (ft)	Percent Correctly Identified Location	Percent Confused	Average Helpfulness Rating	Overall Ranking
Group 1 (n=8)						
4	UpTn & DnTp	211	88%	50%	1.8	2
10	UpTp	358 ^a	88%	25%	1.6	4
11a	UpTp & DnTp	369	100%	0%	1.0	1
13	UpTp & DnTn	302	100%	13%	1.5	3
15	DnTp	242	88%	38%	2.0	4
Group 2 (n=8)						
6	UpTn, DnTp, & DnTn	363	100%	0%	1.1	1
8	UpTn	176	100%	25%	1.4	2
12	UpTp, DnTp, & DnTn	240	88%	38%	1.5	4
14	DnTp & DnTn	173	100%	0%	1.5	3
16	DnTn	154	100%	0%	1.5	5
Group 3 (n=8)						
1	UpTn, UpTp, & DnTp	360	63%	38%	1.4	3
3	UpTn & UpTp	304	100%	13%	1.4	2
5	UpTn, UpTp, & DnTn	378	100%	13%	1.3	1
7	UpTn & DnTn	309	100%	13%	1.3	1

Trt=Treatment; UpTn = Upstream Tangent; UpTp = Upstream Taper; DnTp = Downstream Taper; DnTn = Downstream Tangent

^a Treatment 10 was only seen by seven participants.

Bolded text indicates treatments chosen to be evaluated in Phase II.

The other treatments in group 1 were not viewed to be as effective due to a variety of reasons. When LCDs were only used on one taper (Treatments 10 and 15), participants did not know whether the exit ramp opening was located before or after the LCDs. This confusion regarding the correct location of the exit ramp opening was also noted when LCDs were used on one tangent and the opposite taper (Treatments 4 and 13). For Treatment 4, participants indicated that the change in device on the upstream tangent (from drums to LCDs) helped them identify the exit ramp opening. However, this line of reasoning also led participants to think that the exit ramp opening in Treatment 13 was after the downstream taper, which was composed of

LCDs. Overall, participants did not like the use of two different devices on the tangents (e.g., drums on the upstream tangent and LCDs on the downstream tangent) or the use of two different devices on the tapers (e.g., drums on the upstream taper and LCDs on the downstream taper). In other words, the participants preferred that the same type of device be used on both tangents and the same type of device to be used on both tapers. However the devices on the tangents and tapers did not have to be the same.

The group 2 results indicate that Treatment 6 had the longest mean detection distance (363 ft) and the best helpfulness rating (1.1). In addition, all of the participants correctly identified the exit ramp opening on their first attempt, and none of the participants were confused by Treatment 6. Thus, it is not surprising that the participants ranked Treatment 6 the best overall in group 2. Participants commented that they preferred this treatment due to the change in device on the upstream tangent (from drums to LCDs) and the downstream “V” formed by the LCDs on the downstream taper and tangent. Based on these data, researchers decided to include Treatment 6 in Phase II. For the other four treatments in group 2, the mix of devices on the tangents (drums on one and LCDs on the other) and the use of LCDs on the downstream tangent and not on the upstream tangent resulted in shorter detection distances and in some cases caused confusion.

In group 3, Treatments 5 and 7 were both ranked the best and had the same helpfulness rating (1.3). Although Treatment 5 had the longest mean detection distance (378 ft), researchers decided not to include it in Phase 2 because of its similarity to Treatment 6 and the participants’ preference for a downstream “V” over an upstream “V” formed by LCDs. Treatment 1 also had a longer mean detection distance (360 ft) than Treatment 7 (309 ft), but 37 percent of participants did not correctly identify the location of the exit ramp opening on their first attempt, and 38 percent of participants were confused by the treatment. Again, participants attributed this confusion to the mixture of different devices on the tangents. This was also true for Treatment 3. Overall, researchers decided to include Treatment 7 in Phase II due to its overall ranking, helpfulness rating, and desire to evaluate a treatment that was the opposite of Treatment 11 (i.e., LCDs only on tangents versus LCDs only on tapers).

Phase II Results

Researchers used Phase II of the study to compare the three most promising Phase I treatments (6, 7, and 11) to Treatment 2 (all LCDs) and Treatment 9 (all drums), as well as to determine the impacts of using a 60-ft drum spacing in the tangents (Treatments 9b and 11b). Table 11 contains the findings from Phase II.

Table 11. Phase II Results (n=16).

Trt	LCD Location	Mean Detection Distance (ft)	Percent Correctly Identified Location	Percent Confused ^a	Average Helpfulness Rating	Overall Ranking
2	All LCDs	319	100%	13% (7%)	1.3	1
6	UpTn, DnTp, & DnTn	351 ^b	100%	32% (19%)	1.5	3
7	UpTn & DnTn	258	100%	38% (25%)	1.6	5
9a ^{c,d}	None (all drums)	222	100%	44%	1.8	7
9b ^e	None (all drums)	198	100%	73%	1.9	6
11a ^c	UpTp & DnTp	364 ^b	100%	38% (0%)	1.6	4
11b ^e	UpTp & DnTp	364 ^b	100%	13% (0%)	1.6	2

^a The first percent includes all data. The second percent does not include those participants confused by a drum not being present at the upstream end of the LCDs.

^b Significantly different from Treatments 9a and 9b (alpha=0.05).

^c Drums spacing equaled 120 ft.

^d Only seen by 15 participants.

^e Drums spacing equaled 60 ft.

Treatments 6, 11a, and 11b had significantly longer mean detection distances (351 ft, 364 ft, and 364 ft, respectively) than Treatments 9a and 9b (222 ft and 198 ft, respectively). However, there were not any significant differences in mean detection distance among the LCD treatments (2, 6, 7, 11a, and 11b) and among the all drum treatments (9a and 9b). In addition, all of the participants correctly identified the location of the exit ramp opening on their first attempt for all the treatments.

The main reason why participants were confused by the LCDs treatments was due to a drum not being present at the upstream end of the LCDs. In other words, the last drum in the tangent was located either 120 ft or 60 ft away from the beginning of the LCDs. This missing drum resulted in participants not knowing whether the exit ramp opening was located before or after the LCDs. The reduction in drum spacing from 120 ft (Treatment 11a) to 60 ft

(Treatment 11b) did reduce this confusion (38 percent down to 13 percent), but did not affect the mean detection distance. Based on these findings, researchers decided to place a drum at the upstream end of the LCDs in Phase III.

Considering only those participants confused by some other aspect of the treatment (percentages in parentheses in Table 11), Treatments 11a and 11b did not result in any further confusion. Participants commented that it was easy to see the chute formed by the LCDs on both tapers and that the device change indicated the exit ramp location. Treatment 2 had the second lowest amount of participants confused by the treatment (7 percent), received the best helpfulness rating (1.3), and was ranked best overall. Some participants commented that the LCDs on the upstream tangent blocked their view of the tapers and that the use of LCDs on both tangents looked like a continuous line, especially since the exit ramp opening was so small (120 ft). Treatments 6 and 7 resulted in 19 percent and 25 percent of the participants being confused by some other aspect of the treatments, respectively. For Treatment 6, participants thought that the single drum taper was confusing. In addition, researchers felt that Treatment 6 would not be practical to implement in the field, since it could be confusing to workers who implement the traffic control plan. For Treatment 7, participants felt that the exit ramp was hard to locate even though the LCDs on the tangents indicated an upcoming exit ramp because they could not distinguish between the drums on both tapers (i.e., couldn't tell there was space between the two tapers).

Treatments 9a and 9b resulted in the shortest detection distances (222 ft and 198 ft, respectively) and the largest percent of participants confused by the treatments (44 percent and 73 percent, respectively). Participants attributed the confusion to their inability to distinguish the tapers from the tangents until they were very close to the exit ramp opening and kept referring to the treatments as a “sea of drums.” Surprisingly, participants noted that the closer drum spacing (Treatment 9b) made it more difficult to distinguish the tapers from the tangents and thus the exit ramp opening. However, there were not any significant differences in mean detection distance among the two drum treatments.

Based on the Phase II findings, researchers decided to include Treatments 2, 11a, and 11b in Phase III. Researchers were also interested in the impacts of drum spacing with the all drum treatments when a larger exit ramp opening is used, so Treatments 9a and 9b were also included in Phase III.

Phase III Results

To determine the impact of a larger exit ramp opening on the treatments of interest (2, 9a, 9b, 11a, and 11b), in Phase III the exit ramp opening was increased from 120 ft to 240 ft. Based on the Phase II participants' comments, a drum was placed at the beginning of the upstream tangent of LCDs for Treatment 2 and drums were placed at the beginning of each LCD taper for Treatments 11a and 11b. Researchers believed the addition of these drums would decrease potential confusion when the LCDs were used. Table 12 contains the findings from Phase III.

Table 12. Phase III Results (n=20).

Trt	LCD Location	Mean Detection Distance (ft)	Percent Correctly Identified Location	Percent Confused	Average Helpfulness Rating	Overall Ranking
2	All LCDs	494	100%	5%	1.5	1
9a	None (all drums)	383	100%	25%	1.8	5
9b	None (all drums)	392	100%	15%	1.6	4
11a	UpTp & DnTp	411	100%	0%	1.3	3
11b	UpTp & DnTp	453	100%	0%	1.3	2

There were not any significant differences in mean detection distance among all of the treatments. In addition, all of the participants correctly identified the location of the exit ramp opening on their first attempt for all the treatments. However, there were some differences in percent of participants confused by the treatments, and the participants did rank the LCD treatments (2, 11a, and 11b) better than the all drum treatments (9a and 9b). There was no confusion with Treatments 11a and 11b, and only 5 percent of the participants indicated confusion for Treatment 2. As in Phase II, some participants commented that the LCDs on the upstream tangent blocked their view of the tapers. However, none of the participants commented about not knowing whether the exit ramp opening was located before or after the LCDs. Thus, the addition of the drums at the upstream end of the LCDs did seem to improve the overall understanding of the treatments. For Treatments 9a and 9b, the confusion was again attributed to the inability of participants to distinguish the tapers from the tangents and thus the exit ramp opening. Overall, the participants did rank the three LCD treatments better than the two all drum treatments.

The larger exit ramp opening (240 ft) did result in significantly longer mean detection distances for all of the treatments except 11a and 11b. However as in Phase II, the reduction in drum spacing from 120 ft to 60 ft did not significantly affect the mean detection distances.

Summary

Researchers conducted a three-phase closed-course human factors study during the day to determine the effectiveness of continuous LCDs to delineate freeway exit ramps that remain open within a work zone lane closure compared to the use of drums. The most promising LCD treatments were Treatment 11 (LCDs only on both tapers) and Treatment 2 (LCDs on both tangents and both tapers). The following are the primary findings from this study.

- The significantly shorter mean detection distance and higher percentage of participants confused by Treatment 9a with a 120-ft exit ramp opening confirms the difficulty motorists have with identifying the correct travel path near exit ramps when standard channelizing devices are used.
- While the drum spacing on the tangents did not impact the mean detection distances of Treatment 9, it did affect the level of confusion. With the 120-ft exit ramp opening, the 60-ft drum spacing actually made it more difficult for participants to distinguish the tapers from the tangents and thus locate the exit ramp opening. Conversely, with the 240-ft exit ramp opening, the 60-ft drum spacing improved the ability of the participants to locate the exit ramp opening.
- With the 120-ft exit ramp opening, Treatment 11 had a significantly longer mean detection distances than Treatment 9 (all drums) and resulted in less confusion. Although researchers did not find any significant differences in the mean detection distances with the 240-ft exit ramp opening, Treatment 11 again resulted in less confusion than Treatment 9.
- The drum spacing on the tangents did not impact the effectiveness of Treatment 11.
- For both exit ramp opening sizes, the Treatment 2 mean detection distance was not significantly different than the Treatment 9 (all drums) mean detection distances. However, in both situations, Treatment 2 resulted in less confusion than Treatment 9.
- The larger exit ramp opening resulted in significantly longer mean detection distances for all of the treatments in Phase III, except Treatment 11.

- The addition of a drum at the upstream end of the LCDs reduced the percentage of participants that indicated they did not know whether to turn before or after the LCDs and thus improved the overall understanding of the LCD treatments.
- Participants preferred the LCD treatments to the all drum treatments.

DEMONSTRATION

Due to budget and time limitations, researchers could not conduct a closed-course human factors study at night to determine the effectiveness of continuous LCDs to delineate freeway exit ramps that remain open within a work zone lane closure. Instead, researchers held a demonstration during the day and at night during which seven project panel members and five work zone and retroreflectivity experts viewed and provided input regarding the most promising LCD treatments compared to standard drums.

Simulated Work Zone and Treatments

Researchers utilized the simulated work zone layout from the closed-course human factors studies. The exit ramp opening was 120 ft long. Table 13 contains the demonstration treatments. The main difference between these treatments and those viewed by participants in the closed-course human factors study was the distance upstream and downstream of the exit ramp opening that the drum spacing was reduced. Based on the findings from the closed-course human factors studies (i.e., change in device signifies an upcoming exit ramp), positive guidance principles, and discussions with the project panel and human factors experts, researchers decided to implement the reduced drum spacing only in the area 240 ft immediately upstream of the exit ramp opening or upstream LCDs (approximately 3 seconds of preview time) and 120 ft immediately downstream of the exit ramp opening, instead of over the entire 480 ft entry and 240 ft exit tangents, respectively.

At night, TxDOT requires that LCDs be retroreflective or supplemented with retroreflective delineation as required for temporary barriers (10). When traffic is on one side of the LCDs, two white barrier reflectors must be mounted in approximately the midsection of each section of device. This results in a 6-ft delineator spacing. The white barrier reflector mounted on the side of the LCD was located directly below the white reflector mounted on top of the LCD.

Table 13. Exit Ramp Demonstration Treatments.

Trt	LCD Location	Drum Spacing (ft)	Daytime Demonstration	Nighttime Demonstration
2a	All LCDs	120 ft	X	X
2b	All LCDs	60 ft ^a	X	
9a	None (all drums)	120 ft	X	X
9b	None (all drums)	60 ft ^a	X	X
11a	UpTp & DnTp	120 ft	X	
11b	UpTp & DnTp	60 ft ^a	X	X

X indicates the treatment was observed.

^a 60-ft spacing in the area 240-ft upstream of the exit ramp opening and 120-ft downstream of the exit ramp opening.

During the day, the panel first compared Treatments 9a and 2a, sometimes traveling straight through the work zone and sometimes taking the exit ramp. The panel then compared 2a and 9b, 2b and 9b, 11a and 9b, and 11b and 9b. At night, the panel followed a similar treatment order, except they did not view Treatments 2b and 11a based on daytime opinions.

Results

Table 14 contains the results from the daytime and nighttime observations. With respect to Treatment 9, the project panel felt that the 60-ft drum spacing on the tangent (only in the immediate vicinity of the exit ramp) made it easier to identify the exit ramp opening. Specifically at night, the panel thought the closer drum spacing made the exit ramp opening appear larger.

The panel expressed similar comments regarding the 60-ft drum spacing with Treatment 11. In addition, without the closer drum spacing, the panel was not sure whether to turn before or after the LCDs (analogous to the Phase II data discussed previously even though a drum was located at the beginning of the LCD section). However, the panel members noted that it was hard to see the LCD tapers in Treatment 11b during the day and impossible to see them at night due to the directionality of the barrier reflectors (i.e., barrier reflectors were perpendicular to a line of sight approximately 7 degrees from the motorist's line of sight). In addition, at night the panel did like the placement of a drum at the beginning of each LCD taper.

Table 14. Exit Ramp Demonstration Results.

Trt	LCD Location	Drum Spacing (ft)	Daytime Opinions	Nighttime Opinions
9a	None (all drums)	120 ft	<ul style="list-style-type: none"> • Hard to identify exit 	<ul style="list-style-type: none"> • Hard to identify exit
9b	None (all drums)	60 ft ^a	<ul style="list-style-type: none"> • Liked better than 9a 	<ul style="list-style-type: none"> • Liked better than 9a • Closer spacing made exit ramp opening look larger
2a	All LCDs	120 ft	<ul style="list-style-type: none"> • Liked better than 9a & 9b • Exit ramp opening felt tighter; had to take exit at slower speed • Length of LCDs sections sufficient 	<ul style="list-style-type: none"> • Liked • Need delineation at the apex of the downstream tangent and taper • 6-ft barrier reflector spacing: Provided clear line & makes exit ramp opening clearer • 18-ft barrier reflector spacing: Looked less like a line, but adequate
2b	All LCDs	60 ft ^a	<ul style="list-style-type: none"> • No difference since LCD wall stands out more 	
11a	UpTp & DnTp	120 ft	<ul style="list-style-type: none"> • Not sure whether to turn before or after LCDs 	
11b	UpTp & DnTp	60 ft ^a	<ul style="list-style-type: none"> • Closer spacing made exit ramp opening look larger • Hard to see chute of LCDs on the approach 	<ul style="list-style-type: none"> • Drums at the beginning of the LCD tapers not good • Cannot see chute at all

^a 60-ft spacing in the area 240-ft upstream of the exit ramp opening or upstream LCDs and 120-ft downstream of the exit ramp opening.

Shaded cells indicate there were no observations for that treatment.

The panel did not see a benefit to the 60-ft drum spacing with Treatment 2 during the day due to the very apparent wall of LCDs on the upstream tangent (signifying a change in device and thus an upcoming exit ramp), so Treatment 2 was not evaluated at night. The panel did feel that the length of LCD section upstream of the exit ramp (120 ft) was sufficient. The panel also thought that the continuous line of LCDs made the exit ramp opening feel tighter and noted that they had to take the exit at slower speeds. At night, the panel noted that delineation was needed at the apex of the downstream tangent and taper, but did not like the use of a drum. The panel suggested the Type 3 object marker (OM-3C) shown in Figure 6. The panel also discussed the delineator spacing used on the LCDs. Initially, the panel reviewed the 6-ft barrier reflector spacing and felt that while it provided an obvious line of delineation that made the exit ramp

opening appear clearer, it was too much delineation. An alternate spacing of 18 ft (barrier reflectors in the middle of every third device) was reviewed next. This spacing is similar to the spacing currently used on CTB (20 ft). While the 18-ft spacing looked less like a continuous line, the panel felt that it was adequate. Lastly, even though Treatment 2 also had barrier reflectors that were perpendicular to a line of sight approximately 7 degrees from motorist's line of sight in the tapers, the barrier reflectors on the LCDs in the tangent (perpendicular to oncoming traffic) helped identify the exit ramp opening. Then for those motorists taking the exit, the barrier reflectors on the tapers would become apparent once the vehicle started down the exit ramp and the barrier reflectors became perpendicular to the vehicle.

Overall, the panel preferred Treatments 9b and 2. However, there were still concerns regarding the delineation of the LCDs at night, especially since TxDOT standards (10) require LCDs to be delineated the same as barriers.



Figure 6. Type 3 Object Marker (9).

PHOTOMETRIC ANALYSIS

Next, researchers completed a photometric analysis to visually compare different continuous LCD treatments versus standard drum treatments in work zone scenarios where freeway exit ramps remain open within a lane closure.

Treatments

Researchers utilized the simulated work zone layouts from the project panel demonstration (Table 13). The exit ramp opening was 120 ft. The 60-ft drum spacing was only applied in the area 240 ft immediately upstream of the exit ramp opening or upstream LCDs and

120 ft immediately downstream of the exit ramp opening. The drum spacing on the tapers was always 20 ft.

Per TxDOT standards (10) each drum had two orange and two white retroreflective stripes comprised of high intensity sheeting. Based on the panel demonstration results, researchers utilized a barrier reflector spacing of 18 ft (two white barrier reflectors in the middle of every third device; one on top of the LCD and one mounted on the side of the LCD directly below the one on top). The barrier reflectors had a 3-inch by 4.25-inch reflective area with high intensity prismatic sheeting.

Data Collection

All of the photometric measurements were taken at night on the runway network of the Texas A&M University Riverside Campus. Researchers obtained all of the photometric measurements from a 2009 Ford Explorer using a Radiant Imaging ProMetric 16-bit Charge-Couple Device (CCD) Photometer (see Figure 7). The CCD measurements were captured from the driver's perspective. Researchers set the headlights in the low-beam configuration and placed the vehicle in the center of the travel lane adjacent to the closed lane. The elevation of the center of the headlights was 36 inches from the pavement surface, and the CCD elevation was 60 inches from the pavement surface.



Figure 7. Photometric Analysis Equipment.

For each treatment, researchers took photometric measurements at two distances: the beginning of the treatment and 120 ft upstream of the exit ramp opening. The first distance varied depending upon the treatment. For Treatments 9a, 9b, 11a, and 11b, the distance was 240 ft upstream of the exit ramp opening (i.e., location where 60-ft spacing began). For Treatments 2a and 2b, the distance was 360 ft upstream of the exit ramp opening (i.e., location where 60-ft spacing began, but also included the 120 ft upstream LCD tangent). Researchers also measured the illuminance to ensure that the ambient lighting conditions were similar for each treatment.

Data Analysis

Researchers analyzed the photometric measurements using several large whole regions to capture the entire treatment area within the driver's view. The purpose of the large region measurements was to assess different treatments as a whole array. Researchers believed that this method would allow for a better comparison between treatments as a whole, especially since the treatments had different quantities of retroreflective material or delineation (e.g., standard drums versus LCDs with barrier reflectors). Researchers also analyzed the photometric measurements using several smaller regions at the exit ramp (i.e., tapers only) to assess the visibility of the exit ramp. All regions were analyzed with the Radiant Imaging ProMetric software version 9.1.20.

All of the data presented in the following section are graphed with respect to luminance on a logarithmic scale as it is believed that the humans respond to increasing stimulus intensity in a logarithmic fashion (15). Luminance is the measure of light reflected from a surface or emitted by a light source and is roughly equated to "brightness."

Results

Figure 8 shows the view from the beginning of the six treatments. From this location, the visual field is mainly comprised of the drums on the upstream tangent, and in all but one case (Figure 8a), the exit ramp tapers are not readily apparent. While the closer drum spacing on the upstream tangent (i.e., 60 ft) tended to block the view of the drum taper (Figure 8b), in person the closer drum spacing made the exit ramp opening appear larger. In addition, as shown in Figure 9, the closer drum spacing increased the luminance of the whole array from 1.8 to 5.9 cd/m². Thus, the amount of light reflected back to driver was three times more with the closer drum spacing. Also, the luminance of the exit ramp itself only decreased 0.7 cd/m².

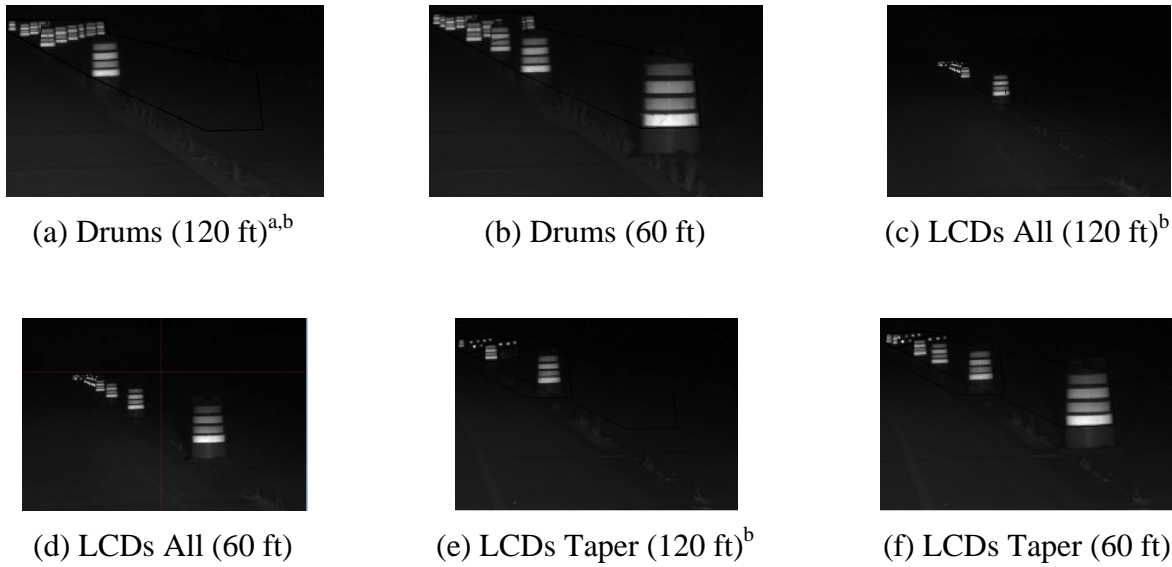

^a Distance in parentheses is the drum spacing on the tangents.
^b Maximum drum spacing on the tangents for a 60 mph posted speed limit (9).

Figure 8. View from the Beginning of the Treatment.

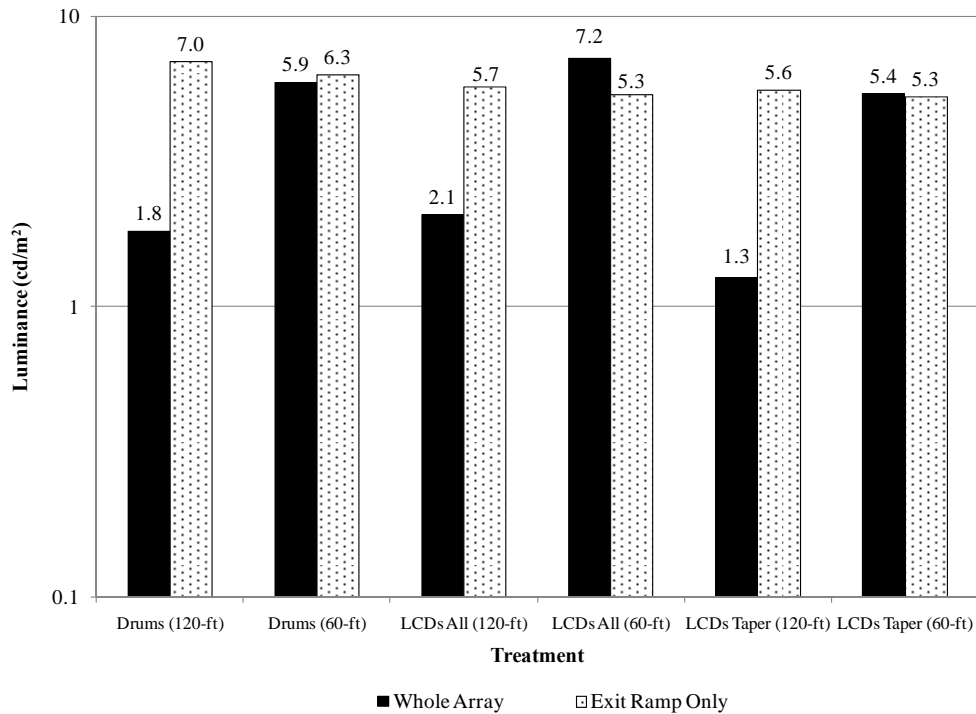
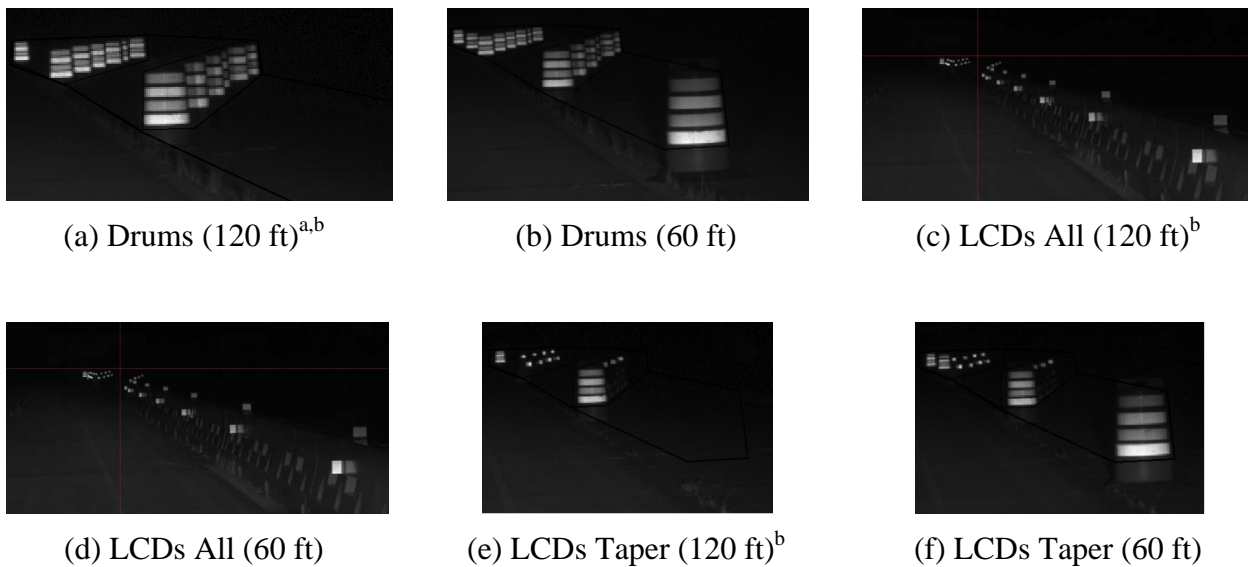

Figure 9. Luminance Data at the Beginning of the Treatment.

As shown in Figure 9, the LCD treatments with the closer drum spacing also increased the luminance of the whole array. In addition, all of the LCD treatments had comparable luminance values of the exit ramp itself (5.3 to 5.7 cd/m^2), and these values were only 1.0 to 1.3 cd/m^2 less than the luminance of the exit ramp itself with all drums.

As shown in Figure 10, at 120 ft upstream of the exit ramp, the exit ramp itself comprises a larger portion of the visual field. Figure 11 shows the whole array and exit only luminance values for the treatments 120 ft upstream of the exit ramp. Again, the closer drum spacing increased the whole array luminance for those treatments with drums on the tangent within 120 ft of the exit ramp. Also, the all LCD treatment produced whole array luminance values (1.2 and 1.1 cd/m^2) similar to the other two treatments with drums spaced every 120 ft (1.9 and 0.9 cd/m^2).



^a Distance in parentheses is the drum spacing on the tangents.

^b Maximum drum spacing on the tangents for a 60 mph posted speed limit (9).

Figure 10. View from 120-ft Upstream of the Exit Ramp.

With respect to the exit ramp itself, the all drum treatments yielded the highest luminance values (5.9 and 5.5 cd/m^2), followed by the LCDs on the tapers only (4.3 and 4.5 cd/m^2), and then the all LCD treatments (1.6 cd/m^2). Researchers hypothesized that the treatment with LCDs on the tapers only exhibited higher exit only luminance values due to the drums on the upstream tangent and not the delineation of the LCDs on the taper. The all LCD treatment had the lowest

exit ramp luminance because no drums were located in the immediate vicinity of the exit ramp, and the retroreflective surface area was significantly less. However, during the demonstration, the panel observed that the barrier reflectors on the LCDs in the tangent did form a line of delineation that when stopped indicated a gap in the devices through which a driver could exit.

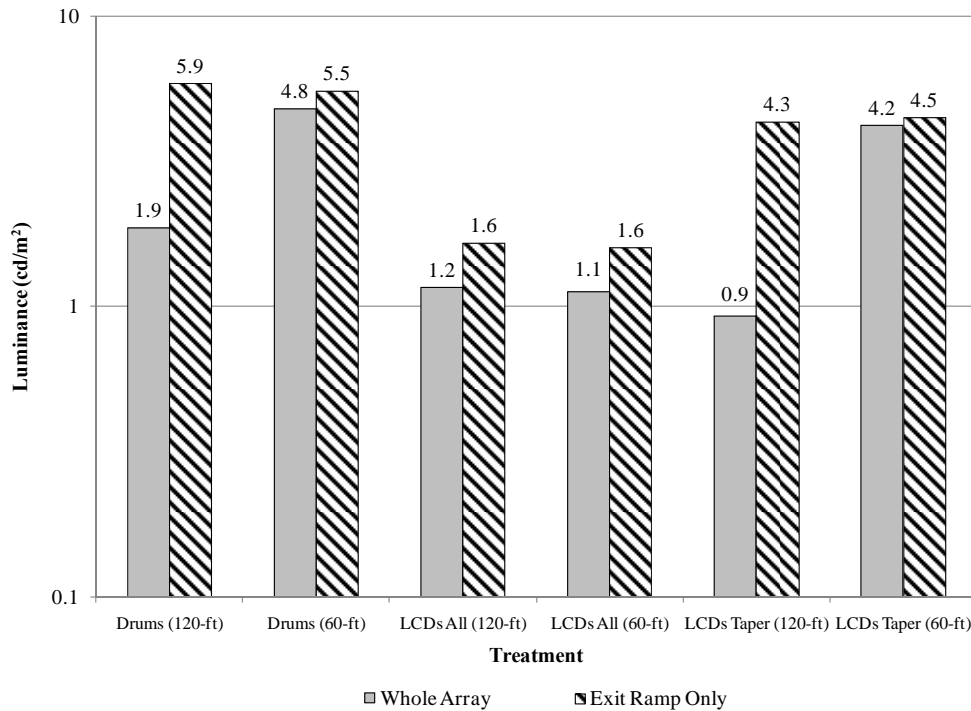

Figure 11. Luminance Data at 120-ft Upstream of the Exit Ramp.

SUMMARY AND RECOMMENDATIONS

Researchers conducted three types of studies to determine the effectiveness of continuous LCDs compared to standard drums to delineate freeway exit ramps that remain open within a work zone lane closure: daytime closed-course human factors studies, a project panel demonstration (day and night), and a nighttime photometric analysis. The daytime closed-course human factors studies confirmed the difficulty motorists have with identifying the correct travel path near exit ramps when standard drums are used and their spacing is equal to the exit ramp opening (i.e., 120 ft). In addition, the 120-ft exit ramp opening resulted in significantly shorter mean detection distances compared to the 240-ft exit ramp opening (i.e., two times the standard

channelizing device spacing). Specifically, the mean detection distance for the 240-ft exit ramp opening was 161 ft longer, which equates to almost 2 additional seconds of reaction time when traveling 60 mph. Thus, researchers recommend that the minimum exit ramp opening within a work zone lane closure be at least equal to the channelizing device spacing on the tangent (i.e., two times the speed limit), with two times the channelizing device spacing on the tangent being preferred (i.e., four times the speed limit).

The closed-course human factors studies showed mixed results when a closer drum spacing (i.e., one times the speed limit) was used on the entire tangent. However, when the closer drum spacing was only used in the immediate vicinity of the exit ramp (240 ft upstream of the exit ramp opening and 120 ft downstream of the exit ramp opening), the project panel felt that the closer drum spacing made it easier to identify the exit ramp opening, especially at night. In addition, the closer drum spacing increased the luminance of the whole array (i.e., the amount of light reflected back to the driver was more with the closer drum spacing). Therefore, researchers recommend that TxDOT consider the use of a drum spacing equal to one times the speed limit on the tangents of a lane closure in the immediate vicinity of the exit ramp. For this research, “immediate vicinity” was defined as 240 ft immediately upstream of the exit ramp opening and 120 ft immediately downstream of the exit ramp opening.

Based on the closed-course human factors studies, the most promising continuous LCD treatments were: (1) LCDs only on both tapers and (2) LCDs on both tapers and both tangents in the immediate vicinity of the exit ramp. While the first of these treatments produced higher luminance values with respect to the exit ramp itself, the panel determined that it was nearly impossible to decipher the exit ramp opening when LCDs were only used on both tapers since the tapers were not visible and the openings between the drums all appeared to be the same, even with the closer drum spacing on the tangent. In addition, researchers believe that this treatment exhibited higher exit only luminance values due to the drums on the upstream tangent. Thus, researchers do not recommend the use of LCDs only on both tapers to delineate freeway exit ramps that remain open within a work zone lane closure.

In contrast, at night the panel did like the use of LCDs on both tapers and both tangents in the immediate vicinity of the exit ramp. In addition, both the closed-course participants and the panel thought that the “change in device” from drums to LCDs on the upstream tangent signified the upcoming exit ramp. While the closed-course participants preferred this LCD treatment and

this treatment decreased confusion as to the location of the exit ramp, researchers did not find any significant differences in the mean detection distance of the exit ramp opening between the standard drum treatment, closer spacing drum treatment, and the use of LCDs on both tapers and both tangents in the immediate vicinity of the exit ramp. Therefore, researchers recommend the use of LCDs on both tapers and both tangents in the immediate vicinity of the exit ramp for either of the following conditions:

- When a high number of deliberate intrusions into the work zone to access the exit ramp are expected to occur or have occurred while using the standard drum treatment.
- In situations where the exit ramp opening is less than or equal to two times the posted speed limit (i.e., the channelizing device spacing on the tangent), workers and equipment are in the work area near the exit ramp opening, and there are concerns that drivers may unintentionally enter the work area when trying to access the exit ramp.

With respect to delineation, the panel noted that delineation was needed at the apex of the downstream tangent and taper and recommended the use of a Type 3 object marker. In addition, the project panel felt that barrier reflectors were not needed on each device (i.e., every 6 ft). Instead, the panel preferred an 18-ft barrier reflector spacing, which is similar to the spacing currently used on CTB (i.e., 20 ft). However, while the 18-ft barrier reflector spacing on the LCDs in the tangent did form a line of delineation, this spacing resulted in the lowest exit ramp luminance (4.3 and 3.9 cd/m^2 lower than the drum treatments, respectively) because the ratio of the retroreflective to non-retroreflective surface area was a lot less than for drums. Unfortunately, researchers did not measure the luminance produced with the barrier reflectors spaced every 6 ft, but researchers anticipate that the luminance values would have also been lower than with the standard drum treatment and the closer drum spacing treatment. Based on these observations, researchers recommend a maximum barrier reflector spacing of 18 ft for LCDs. In addition, adequate delineation is needed at the apex of the downstream LCD tangent and LCD taper. Additional human factors-based research will be needed to investigate the impacts of delineating LCDs similar to concrete barrier and to determine if there is a need for establishing a minimum barrier reflector spacing requirement for these types of devices.

CHAPTER 4: LANE CLOSURE EVALUATIONS

INTRODUCTION

When work is required in the traveled way, lane closures are used to separate road users from the work activity. Lane closures typically consist of an advance warning area that contains a series of signs to inform drivers about the upcoming work zone; a transition area where drivers are redirected out of their normal path; and the work activity area itself. In the transition area, merging tapers, created by using a series of channelizing devices, are used to move traffic out of the closed lane.

The Texas MUTCD (9) recommends that the channelizing device spacing in a taper not exceed a distance in feet equal to one times the speed limit in mph, independent of the specific device used. Larger channelizing devices, such as drums, and closer channelizing device spacing appear to create a more continuous array of devices. Thus, the use of larger, more closely spaced channelizing devices in a merging taper may make it more apparent to motorists and encourage lane changing further upstream of the actual lane closure. LCDs connected together to form a solid line seem to provide an even larger target area and continuous delineation of the travel path (i.e., no space between devices), which may also be beneficial in a merging taper. Of course, LCDs could also be used in a more traditional fashion. For example, in lane closures, single LCDs acting as Type 3 barricades (i.e., oriented 90 degrees toward oncoming traffic) could be used in lieu of drums to form the merging taper. While the LCDs would not be used in a continuous line (i.e., there would be some open space between devices), due to their larger size the LCDs may still appear to form a solid wall to drivers approaching the lane closure in the closed lane. In addition, the larger size of the LCDs may allow for increased spacing of the devices (i.e., more than one times the speed limit in mph); thus, fewer devices would be needed.

While these recommendations intuitively make sense, the potential advantages discussed above have not been confirmed with actual data. This chapter documents the experimental design and findings of a human factors-based driving simulator study, a detection distance evaluation, and a turning movement evaluation conducted to determine the effectiveness of LCDs in a merging taper compared to standard drums. In addition, researchers discuss the findings from a photometric analysis of various delineation treatments for LCDs in a merging taper.

DRIVING SIMULATOR STUDY

The following sections describe the human factors-based simulator study designed to determine whether continuous LCDs in the merging taper of a lane closure on low-speed roadways impact the distance at which drivers exit the closed lane relative to the use of drums. While lane change distance data in response to a simulated lane closure cannot be directly compared to lane change distance data collected in an actual lane closure in a work zone, simulation can be used to compare the relative differences in performance between the various treatments simulated.

Experimental Design

Researchers decided to utilize the TTI desktop driving simulator instead of conducting a closed-course study because an urban, low-speed, four-lane arterial would have been difficult to simulate on the runway system at the Texas A&M University Riverside Campus. Additionally, a simulator can condense the amount of time needed to see all the treatment combinations under study. The desktop driving simulator, treatments, study procedure, and participants are described in the following sections.

Desktop Driving Simulator

The TTI desktop driving simulator provides measurements of participants' responses to roadway situations in a portable system. The desktop simulator is comprised of a steering wheel, pedals, three monitors, three computers, and an audio system. For the purpose of this study, only the center monitor and computer were utilized (Figure 12). Also, because the study only utilized one monitor and thus had limited viewing space, mirrors were not used. A speedometer was displayed in the bottom right corner of the screen to help the participant maintain the desired speed.

The driving simulator offers a library of different roadway cross-sections and interchanges. Using this library, simulator scenarios, or "worlds," were created to represent long drives on an urban four-lane arterial road.



Figure 12. TTI Desktop Driving Simulator.

Treatments

Researchers evaluated three lane closure treatments in the simulator study: drums spaced on a taper at 30 ft (standard spacing of one times the speed limit), drums spaced on a taper at 15 ft (0.5 times the speed limit), and continuous LCDs. Figure 13 shows the three lane closure treatments. Assuming a posted speed limit of 30 mph and a 12-ft offset, researchers computed the taper length for each treatment to be 180 ft. Advance warning signs and an arrow panel were not used during this study, since researchers wanted to ensure that the participants were identifying the lane closure based solely on their interpretation of the channelizing device configuration.

Drivers encountered all three treatments in both the right and the left lane. In addition, for each treatment and lane position, the driver's view was either occluded by a large vehicle travelling in the lane ahead of them (i.e., lead vehicle) or not occluded (i.e., no other vehicles between them and the treatment). All participants viewed the treatments in both lanes under occluded and not occluded conditions. Thus, each participant drove through 12 lane closure treatments.



(a) Drums Spaced at 30 ft



(b) Drums Spaced at 15 ft



(c) Continuous LCDs

Figure 13. Lane Closure Treatments for Simulator Study.

To avoid learning effects and anticipation, researchers added some additional aspects to the participants' driving environments in the simulator.

- Multiple in-lane distractions such as a police vehicle, rock, and tree were placed in the road to add variation to the objects encountered and to force the participant to change lanes.
- Construction items mimicking the orange color of the lane closure treatments were placed in locations alongside the roadway or in the oncoming lanes (not in the drivers' lanes), so that not all the orange objects viewed would cause a lane change.
- A sampling of the merging taper treatments and distracters were placed in the lane adjacent to the drivers' lane, again not causing a lane change.

- Occasionally the lead vehicle would change lanes regardless if there was an obstruction (i.e., lane closure or distracter) in the lane ahead.

To prevent the participants from reacting to the lead vehicle’s brake lights as opposed to an obstacle or lane closure ahead, researchers programmed the lead vehicle’s brake to be off for the duration of its drive. Also, to avoid the possibility of other vehicles blocking the view of the lane closures when a clear view was desired, ambient traffic was not present. Other than the participant’s vehicle, the only vehicles used were the lead vehicle that would pull out onto the roadway in front of the participant to simulate occluded treatment conditions and distracter vehicles either parked alongside the roadway or stopped at an intersection.

Finally, to reduce learning effects, the participants were divided into six groups for which six different environments, or worlds, with the different treatment orders were created (see Table 15). Researchers distributed and balanced the distracters previously mentioned within each world for variety and to maneuver the participant into the correct lane for each merging taper treatment. Researchers also developed a practice world that each participant drove before the actual experiment began.

Table 15. Desktop Driving Simulator Study Treatment Order by Participant Group.

World 1	World 2	World 3	World 4	World 5	World 6
D30RN	D15RN	LCDRN	D30LO	D15LO	LCDLO
D15LO	LCDLO	D30LO	D15RN	LCDRN	D30RN
LCDRO	D15RO	D30RO	LCDLN	D15LN	D30LN
D30LN	LCDLN	D15LN	D30RO	LCDRO	D15RO
D15RO	D30RO	LCDRO	D15LN	D30LN	LCDLN
LCDLO	D30LO	D15LO	LCDRN	D30RN	D15RN
D30RO	LCDRO	D15RO	D30LN	LCDLN	D15LN
LCDLN	D15LN	D30LN	LCDRO	D15RO	D30RO
D15RN	LCDRN	D30RN	D15LO	LCDLO	D30LO
D30LO	D15LO	LCDLO	D30RN	D15RN	LCDRN
D15LN	D30LN	LCDLN	D15RO	D30RO	LCDRO
LCDRN	D30RN	D15RN	LCDLO	D30LO	D15LO

D = Drum; LCD = Longitudinal Channelizing Device; 30 = 30-ft; 15 = 15-ft;
R = Right Lane Closure; L = Left Lane Closure; O = Occluded; N = Not Occluded

Study Procedure

Upon arrival, each participant checked in and a briefing took place at a TTI office building. The researchers then provided the participants with an explanation of the study, including their driving task. Each participant then completed introductory, practice, and experimental sessions. During the introductory session, participants read and signed the informed consent document, filled out a simulator sickness questionnaire, and provided some basic demographic and driving habit information to a researcher.

Before beginning the experimental session, each participant completed a practice session to get accustomed to the simulator and experimental procedure. The practice session included obstructions in the drivers' lane that required lane changes; however, the obstructions were different from those used in the experimental procedure. Participants also gained experience following the lead vehicle during the practice session.

Researchers began each experimental session with a brief review of the overall process that was going to be followed. The driving scene began with the simulator vehicle stopped on the side of the road. Participants pulled onto the roadway and were instructed to accelerate to 40 mph and maintain that speed during the study. While researchers designed the merging tapers for 30 mph conditions, pilot efforts revealed that driving 30 mph in the simulator resulted in the whole study exceeding the two hour time limit. Further pilot efforts showed that the whole study could be completed within the two hour time limit if participants drove 40 mph and that the difference between the two speed limits in the simulated environment was not readily apparent to participants.

As the participants drove through the simulated urban environment, they encountered obstructions (either lane closures or distracters) in the roadway. Participants verbally identified which lane the obstruction was in and what the obstruction was. If participants did not correctly identify the lane the obstruction was in or what the obstruction was, they were allowed to change their answer as they progressed down the roadway. If the obstruction was in the participants' lane, they changed lanes as soon as they could tell the obstruction was in their lane and remained in the new lane until they encountered another obstruction in their lane.

On occasion, a large blue truck (i.e., the lead vehicle) entered the roadway. Researchers instructed participants to let the truck merge safely in front of them and then to stay within a 2 second following range (or tailway time) of the truck. Researchers also told participants that at

times the truck may change lanes, but they were not to change lanes with the truck unless there is an obstruction in their lane. However, when the truck was in the lane next to the participant, they were still required to stay within the 2 second following range.

At the end of the experimental session, researchers showed the participants still images of the lane closure treatments and asked them to rank the treatments from one to three, with one doing the best job of showing the participant the lane closure and guiding them into the open lane. Researchers also asked the participants to explain their rankings.

Participants

Thirty people from the Bryan/College Station area participated in the driving simulator study. Participants were required to be at least 40 years old and have a current driver license. In addition, researchers did not allow any participants from the previously conducted closed-course exit ramp study to participate in this study. Researchers recruited middle-aged (40 to 54) and older (55 and over) participants due to the lack of availability of younger participants during the day and the desire to utilize drivers with reduced motor skills and vision capabilities. Table 16 summarizes the demographics for the driving simulator study.

Table 16. Participant Demographics for the Driving Simulator Study.

Age Category	Education Level				Overall
	High School Diploma or Less		Some College		
	Male	Female	Male	Female	
40–54 (n=13)	23%	3%	10%	7%	43%
55+ (n=17)	3%	20%	17%	17%	57%
Overall (n=30)	26%	23%	27%	24%	100%

Data Analysis

For each participant’s experimental session, the output file from the simulator provided a data line number, time stamp, vehicle speed, distance traveled, headway distance to lead vehicle, tailway time elapsed from lead vehicle, lane the participant was driving in, and lane position (offset). The location of each treatment within each data file was also recorded relative to the

time stamp output. To facilitate data reduction, researchers imported the data into a spreadsheet format.

In each participant file, researchers identified the following for each lane closure treatment: (1) the location of the beginning of the treatment, (2) the location at which the participant's vehicle crossed into the open lane, and (3) the location at which the participant initiated the lane change. The first two locations were output directly into the data file. However, in some cases the time stamp output corresponding to a treatment location was missing. Researchers were able to locate the treatment manually in the file by using the calculated distance from an adjacent treatment in the simulator template. The third location had to be manually identified using the location at which the participant's vehicle crossed into the open lane and lane position data. Since each participant may have executed a lane change differently, researchers used a benchmark value of 0.33 ft/sec for the rate of change of offset to determine the point at which the participant began their lane change maneuver. Small offsets from the lane centerline occur in the natural course of driving; however, researchers considered offset deviation rates that exceeded 0.33 ft/sec to be indicative of an impending lane change. Researchers used graphical interpretation of the lane offset data to establish this empirical threshold value. Ultimately, the distance upstream of each treatment at which the participant initiated the lane change was computed. These data were then used to determine the mean distance upstream of each treatment at which the lane change was initiated. Researchers also computed the standard deviation, minimum lane change distance, and maximum lane change distance for each treatment (see Appendix C).

Researchers used the vehicle speed and tailway time to verify that simulator instructions were followed and that vehicle following behavior was relatively consistent across subjects. In addition, researchers computed the distance upstream of each occluded treatment at which the lead vehicle vacated the closed lane to determine whether the lead vehicle performed in a similar manner across all occluded treatments. Researchers also reviewed information regarding whether a participant correctly identified each obstacle and the lane closure treatment, as well as whether the participant made any incorrect maneuvers (e.g., changed lanes when they were not supposed to) to help interpret data; however, these measures were not scored.

Since each of the participants viewed each lane closure treatment, initially there should have been 360 lane change distance data points. However, during the first experimental session

the simulator did not display the treatments appropriately, which led to the elimination of all data for one subject. In addition, another participant failed to follow instructions regarding vehicle speed and lead vehicle following; this led to their data being eliminated. Of the remaining 28 subjects, 12 data points were missing from the dataset. In some cases, the simulator did not display a treatment at all (five cases), or did not display the lead vehicle for an occluded treatment (seven cases). Based on a review of the tailway time data and the distances upstream of each occluded treatment at which the lead vehicle vacated the closed lane, researchers decided to remove nine data points associated with tailway times that were not within 1.5 seconds of the instructed 2 second following range (i.e., greater than 3.5 seconds or less than 0.5 seconds) and two data points associated with distances less than 200 ft, since values outside these ranges would impact the available time for the participant to view the lane closure treatment after the lead vehicle exited the closed lane. Overall, the simulator produced usable data for 313 treatment observations.

Researchers used analysis of variance for one dependent variable and Tukey's HSD procedures to determine if there were significant differences among the mean distances for each lane closed and each treatment, including whether or not the participant's view was occluded. A 95 percent level of confidence was used for all statistical analyses.

Researchers determined the overall ranking using a ranking score, which was computed by assigning one point each time a treatment was ranked first (best), two points for second place rankings, etc. with the maximum number of points being assigned each time a treatment was ranked worst. Thus, the treatment perceived to be the best would have the lowest score.

Results

Based on the statistical analysis, the lane closed (right or left) did not impact the mean distance upstream of the treatment at which the participant initiated the lane change (p value = 0.595). This was not surprising considering that participants expected obstructions to be in either lane, unlike in actual work zones where left lane closures are typically less expected. Based on this finding, data for both lanes were combined for subsequent analysis.

Table 17 contains the mean lane change distance upstream of each treatment. Based on the statistical analysis, there were no significant differences among the not occluded treatments. This was also true for the occluded treatments. Thus, in a simulated environment without any

advance warning signs or arrow panel, the continuous line of LCDs and the closer drum spacing (i.e., 15 ft) did not impact the mean lane change distance upstream of the lane closure compared to the standard treatment (30-ft spacing). As expected, there were significant differences between the not occluded mean lane change distances and the occluded lane change distances.

Table 17. Driving Simulator Results (n=313).

Treatment	Mean Lane Change Distance (ft)		Overall Ranking
	Not Occluded	Occluded ^a	
Drums (30 ft)	1167	548	3
Drums (15 ft)	1157	562	2
LCDs	1301	561	1

^a All occluded mean distances were significantly different from the not occluded mean distances (p value = 0.000).

The participants did prefer the continuous LCD treatment because the solid line of devices pointed out the correct direction and attracted their attention better. In contrast, participants ranked the standard drum treatment the worst. Reasons included: the drums were spaced too far apart, did not show you where to go, and looks like you can drive through the drums. Participants did rank the closer drum spacing treatment second mainly due to the closer spacing of the drums.

DETECTION DISTANCE AND TURNING MOVEMENT EVALUATIONS

Instead of using a line of continuous LCDs to form the merging taper in a lane closure, LCDs could be used in a more traditional fashion. In the merging taper, single LCDs acting as Type 3 barricades (i.e., oriented 90 degrees toward oncoming traffic) could be used in lieu of drums. While there would be some open space between devices, due to their larger size, the LCDs may still appear to form a solid wall to drivers approaching the lane closure in the closed lane. In addition, the larger size of the LCDs may allow for increased spacing of the devices (i.e., more than one times the speed limit in mph); thus, fewer devices would be needed. However, the project panel was concerned that LCDs in this type of configuration would not deter drivers who intentionally wanted to enter the closed lane (one of the benefits of continuous LCD alignment).

The following sections describe detection distance and turning movement evaluations conducted to determine whether drivers can detect the non-continuous nature of the LCDs when

acting as Type 3 barricades and the driving behavior exhibited while attempting to enter the closed lane through the LCDs. The detection distance evaluation focused on the perception phase of a driver's interaction with the channelizing devices, while the turning movement study focused on the reaction phase.

Experimental Design

Researchers conducted the detection distance and turning movement evaluations during daylight hours under dry pavement conditions at the Texas A&M University Riverside Campus. Due to concerns that participants from the community would be hesitant to drive a state-owned vehicle at high speeds and try to maneuver between devices forming a merging taper, researchers decided to conduct the detection distance and turning movement using only TTI personnel. Also, due to time limitations only one TTI researcher repeatedly drove the vehicle, while a second TTI researcher collected the desired data. While all data were only for one person, the main focus of the study was to compare the relative differences in detection distances between treatments and to determine if a driver could intentionally pull between the channelizing devices studied.

Treatments

The simulated lane closure tapers for both evaluations were designed for a 60 mph posted speed limit and a 12-ft offset; thus, each taper was 720 ft in length. As shown in Figure 14, the tapers were comprised of either channelizing drums or 32-inch tall LCDs placed in barricade style (i.e., oriented 90 degrees toward the approaching driver). Due to the 6-ft length of the LCDs (half the assumed lane width), researchers placed the left edge of the first LCD on the right edge of the closed lane, so that the entire first device was outside of the travel lane. For subsequent devices, the left edge of the LCD was then moved further into the closed lane to form the taper accordingly.

Table 18 contains the treatments used during the detection distance and turning movement evaluations. The drum treatments used a 60-ft (standard spacing) and 40-ft device spacing. Researchers chose the 40-ft drum spacing based on the literature review and that lane stripes are generally placed at 40-ft intervals on the pavement; thus, field personnel could simply place drums according to the lane stripes, making the merging taper simpler to install. The LCD treatments used a 60-ft, 80-ft, and 120-ft device spacing. The 80-ft LCD spacing was two times

the closer drum spacing (or every other lane stripe), and the 120-ft LCD spacing was two times the standard device spacing.



(a) Example of Drum Treatment



(b) Example of LCD Treatment

Figure 14. Examples of the Lane Closure Treatments for the Detection Distance and Turning Movement Evaluations.

Table 18. Lane Closure Treatments for the Detection Distance and Turning Movement Evaluations.

Device Type	Spacing (ft)
Drum	60
Drum	40
LCD	60
LCD	80
LCD	120

Vehicles

Researchers conducted both evaluations using three different state-owned passenger vehicles. The vehicles included a 2001 Ford Taurus, a 2009 Ford Explorer, and a 2006 Ford F-250 Super Duty crew cab long wheelbase truck. Table 19 contains pertinent characteristics of each vehicle. Researchers choose these vehicles because of the differences in driver eye height, vehicle length, and tip-over stability rating. The three vehicles used represented a range of driver eye heights (from approximately 44 to 63 inches), which researchers believed would impact the detection distances. In terms of vehicle length and wheelbase length, the F-250 was significantly longer than the other vehicles, and thus researchers thought it may be more difficult to maneuver between the channelizing devices, especially the LCDs.

Table 19. Vehicle Information for Detection Distance and Turning Movement Evaluations.

Vehicle		Driver Eye Height ^a (inches)	Vehicle Length ^b (inches)	Wheelbase Length ^b (inches)	Tip Over Stability Rating ^b
Year	Make & Model				
2001	Ford Taurus	43.8	198	109	1.41 (stable)
2009	Ford Explorer	55.5	192	114	1.06 (reasonably stable)
2006	Ford F-250	62.5	262	172	1.15 (reasonably stable)

^a Measured from the pavement surface to the TTI researcher's eyes.

^b Obtained from Expert Autostats Version 5.0.

A single vehicle maneuvering between channelizing devices at a high rate of speed can provide opportunities for rollover events. The tip-over stability rating, also known as the static stability factor, represents vehicle stability and is computed by dividing half of the vehicle track width by the center of gravity height. A lower rating indicates a higher risk of a vehicle rolling over in the event of a single vehicle crash, which is the type of crash in which most rollovers occur (16). The Ford Taurus was rated the most stable of all the vehicles, and this stability level may provide more maneuverability than the other vehicles. Overall, researchers felt that each vehicle had unique advantages over the others and that use of these vehicles with varying characteristics would provide a well-rounded data set for the evaluations.

Evaluation Procedure and Data Analysis

Detection Distance

During the detection distance evaluation, researchers sought to quantify driver perception using three measures of effectiveness:

- The distance at which the researcher could recognize that the simulated lane closure was comprised of individual channelizing devices.
- The distance at which the researcher could recognize that longitudinal gaps existed between the channelizing devices (i.e., detect the spacing between devices).

- The distance at which the researcher could recognize that lateral gaps existed between the channelizing devices (i.e., detect the breadth of the gap between devices).

For each treatment shown in Table 18, one researcher completed three separate trial runs in each vehicle, during which the researcher identified the three distances of interest. Thus, a total of 45 trial runs were completed. Table 20 shows the order of the trial runs. The approach speed for all trials was 30 mph, and the driver was traveling in the closed lane.

Table 20. Trial Run Order.

Vehicle	Treatment				
	Drum (60 ft)	Drum (40 ft)	LCD (60 ft)	LCD (80 ft)	LCD (120 ft)
Taurus	1–3	4–6	7–9	10–12	13–15
Explorer	28–30	25–27	22–24	19–21	16–18
F-250	31–33	34–36	37–39	40–42	43–45

Another researcher operated a global positioning system (GPS) device and computer located in the vehicles. The computer downloads the GPS coordinates of the vehicle location every 0.1 second, along with the corresponding time. In addition, the software used allowed the second researcher to mark the file when the driver verbally indicated the three items of interest.

With known GPS coordinates at the beginning of each treatment, researchers computed the distance of each point of interest from the beginning of each treatment. For each treatment-vehicle combination, researchers computed three mean detection distances corresponding to the measures of effectiveness. Researchers also computed the standard deviations, minimum detection distances, and maximum detection distances for each treatment (see Appendix D). Researchers then used analysis of variance for multiple dependent variables and Tukey’s HSD procedures to determine if there were significant differences among the mean distances for each vehicle type and for each treatment. A 95 percent level of confidence was used for all statistical analyses.

Turning Movement

Researchers then used the turning movement evaluation to quantify driver reaction using two measures of effectiveness:

- The speed at which the researcher could execute a turn between channelizing devices.
- The angle at which the researcher could execute a turn between channelizing devices.

Again, for each treatment shown in Table 18, one researcher completed three separate trial runs in each vehicle, resulting in 45 trial runs. Table 20 shows the order of the trial runs. For each trial run, the researcher tried to execute an intrusion maneuver at the highest comfortable speed between the first two devices in the taper and then align the vehicle parallel to the original travel path (as if continuing straight in the closed lane) without striking the channelizing devices. The approach speed for all turning movement trials was 60 mph at a point 1000 ft upstream of the treatment, after which the researcher adjusted the speed of the vehicle as needed to complete the desired maneuver. The driver always approached the lane closure in the closed lane.

During the turning movement study, researchers used the same equipment to collect vehicle speed, vehicle location, and steering angle. For each treatment-vehicle combination, researchers computed two mean values: the mean vehicle speed at the beginning of the intrusion maneuver and the net steering angle undertaken to pull between the channelizing devices (i.e., maximum steering angle minus the steering angle at the first channelizing device). Researchers also computed the standard deviations, minimum values, and maximum values for each treatment (see Appendix E). Researchers again used analysis of variance for multiple dependent variables and Tukey's HSD procedures to determine if there were significant differences among the mean values for each vehicle and for each treatment. A 95 percent level of confidence was used for all statistical analyses.

Results

The researchers first analyzed the detection distance and turning movement data by looking at the differences between the three vehicles used. With regard to the detection distance data, researchers found some differences in vehicles when comparing the mean distances at which the researcher could recognize that the simulated lane closure was comprised of individual channelizing devices and the mean distances at which the researcher could recognize that lateral gaps existed between the channelizing devices. However, due to the small sample sizes, no

meaningful trends could be identified. Similarly, with regard to the turning movement evaluation data, researchers found slight differences between vehicles, but this was expected due to their unique vehicle characteristics. Overall, researchers used the three vehicles to ensure that a variety of passenger vehicles were represented. Thus, all vehicle data were grouped by treatment for further analysis.

Detection Distance

Figure 15 shows the results of the detection distance study. The treatment with drums spaced every 60 ft had the longest mean detection distances for all three measures of effectiveness (898 ft, 628 ft, and 601 ft for individual devices, longitudinal gap, and lateral gap, respectively). In contrast, the treatment with LCDs spaced every 60 ft had the shortest mean detection distances for all three measures of effectiveness (666 ft, 417 ft, and 276 ft, respectively). The significantly shorter detection distances mean that the taper appeared to look like a solid wall of devices until the researcher was closer to the treatment.

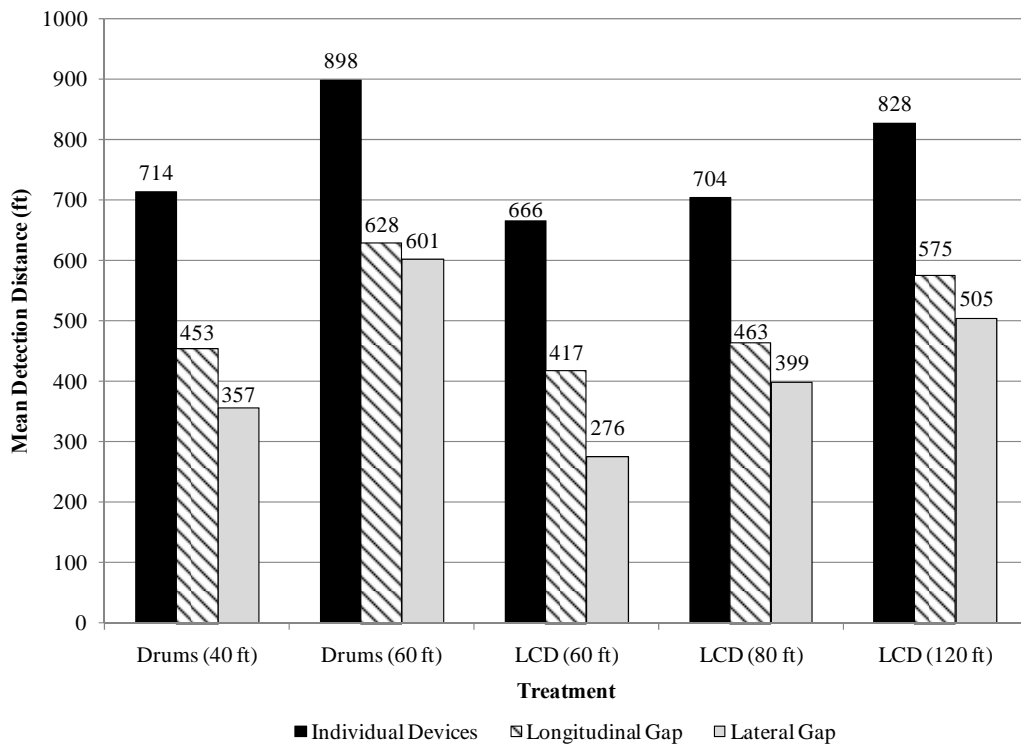

Figure 15. Detection Distance Evaluation Results.

The treatment with the closer drum spacing (40 ft) also appeared to look like a solid wall until closer to the treatment (statistically different from the standard drum spacing) and all but one of the mean detection distances for the treatment with the closer drum spacing were determined not to be significantly different from the treatment with LCDs spaced 60 ft (p value = 0.678, 0.626, and 0.023, respectively). Thus, simply reducing the drum spacing also appears to be an effective way to form the illusion of a wall of channelizing devices.

The treatment with LCDs spaced every 80 ft showed similar improvements as the treatments with LCDs spaced every 60 ft and drums spaced every 40 ft (not statistically different). So, a slightly larger LCD spacing also appears to be comparable to the wall illusion created by a closer drum spacing.

The treatment with the LCDs spaced every 120 ft performed much like the treatment with drums spaced every 60 ft (not significantly different). Thus, at least from the visual perspective of creating “a wall of devices” the largest LCD spacing was comparable to the standard 60-ft drum spacing.

Turning Movement

Figure 16 shows the results of the turning movement study. Not surprisingly, for both types of channelizing device, entry speed appears to increase slightly and steering angle appears to decrease as the device spacing increases. These trends suggest that the researcher felt more comfortable turning between devices when the device spacing is larger.

The treatment with LCDs spaced every 120 ft resulted in the highest mean entry speed (52.5 mph) and lowest mean steering angle (7.8 degrees). However, researchers determined that these data were not significantly different from the standard treatment with drums spaced every 60 ft (47.8 mph and 9.1 degrees, respectively). Thus, the turning maneuver needed to intrude into the lane closure taper at the largest LCD spacing was comparable to the 60-ft drum spacing.

The mean entry speed for the treatment with the standard drum spacing of 60 ft was also not significantly different from the mean entry speed for the treatment with LCDs spaced every 60 ft (46.2 mph), but the mean steering angles for these two treatments were significantly different (9.1 degrees and 13.9 degrees, respectively). Thus while the mean entry speed for these treatments was similar, the LCDs spaced every 60 ft required the researcher to make a sharper turn to enter the closed lane. This is not surprising since the barricade-style LCDs are wider than

conventional channelizing drums. So, at the same spacing, a much larger steering angle is required to execute the turning movement without striking the channelizing devices.

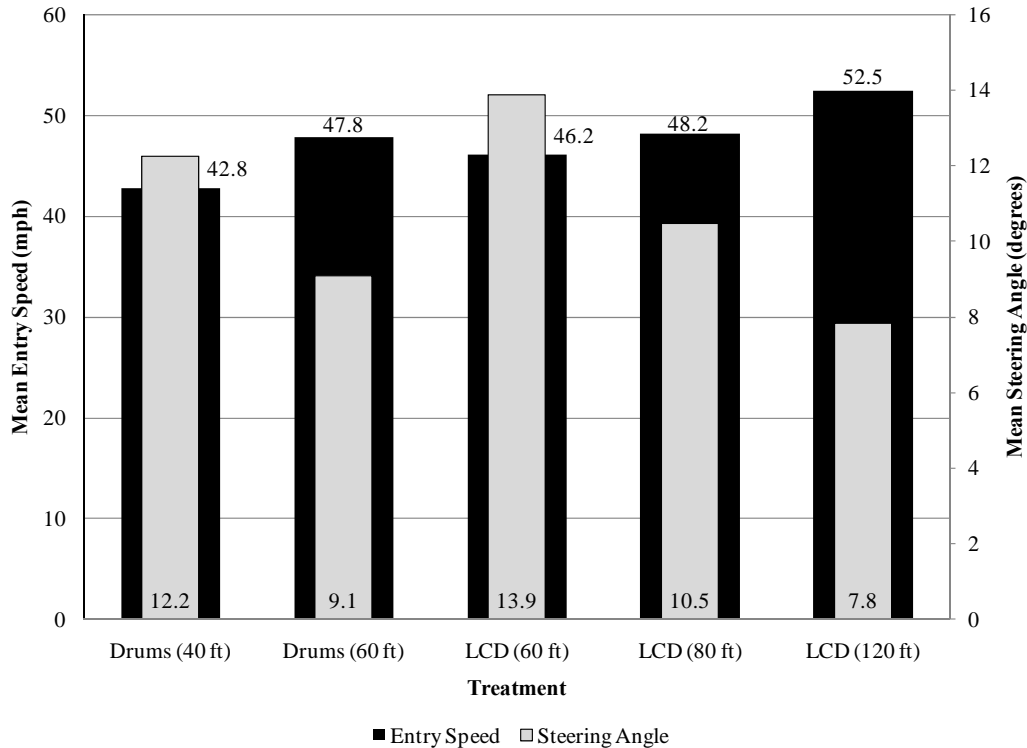

Figure 16. Turning Movement Evaluation Results.

However, the mean entry speed and mean steering angle for the treatment with drums spaced every 40 ft (42.8 mph and 12.2 degrees) were both significantly different from the treatment with drums spaced every 60 ft. In addition, researchers determined that both measures of effectiveness for the treatment with drums spaced every 40 ft were not significantly different from those for the treatment with LCDs spaced every 60 ft. Thus, simply reducing the drum spacing appears to result in similar turning movement characteristics as using LCDs spaced every 60 ft.

Summary

Researchers conducted the detection distance and turning movement evaluations to determine whether drivers can detect the non-continuous nature of the LCDs when acting as Type 3 barricades and to determine if a driver could intentionally pull between LCDs acting as

Type 3 barricades. Based on the detection distance data, researchers concluded that even though the LCDs spaced every 60 ft appeared as a solid wall of devices longer than the drums spaced every 60 ft, the same magnitude of improvement can be accomplished by simply changing the drum spacing from 60 ft to 40 ft. Also, while the LCDs spaced every 60 ft did require a much larger steering angle to execute the turning movement without striking the channelizing devices compared to drums spaced every 60 ft, the entry speed was not different and in one trial was as high as 53.7 mph for the treatment with LCDs spaced every 60 ft. In addition, reducing the drum spacing to 40 ft appeared to result in similar turning movement characteristics as using LCDs spaced every 60 ft. Overall, while LCDs acting as Type 3 barricades do appear as a solid wall upstream of the lane closure, drivers deliberately trying to intrude into the closed lane can still do so at speeds in excess of 40 mph.

PHOTOMETRIC ANALYSIS

Next, researchers completed a photometric analysis to visually compare different LCD treatments versus standard drum treatments in a work zone lane closure. Researchers conducted the photometric analysis in two phases.

Treatments

In Phase I, researchers evaluated eight different treatments: three lane closure tangent treatments and five lane closure merging taper treatments. Researchers designed all of these treatments for a 30 mph posted speed limit and a 12-ft offset. Thus, each treatment was 180 ft long (9).

Within each set of treatments there were two drum treatments. For the lane closure tangent, the drum spacing was 60 ft (standard of two times the posted speed limit) and 30 ft (one times the posted speed limit). For the merging taper, the drum spacing was 30 ft (standard of one times the posted speed limit) and 15 ft (0.5 times the posted speed limit). Per TxDOT standards (10) each drum had two orange and two white retroreflective stripes comprised of high intensity sheeting.

There were four LCD treatments: one on a tangent and three on a taper. The LCD treatment on the tangent was a continuous line of LCDs parallel to the simulated travel lane. One of the LCD taper treatments also consisted of a continuous line of LCDs, while the other

two treatments consisted of single LCDs acting as Type 3 barricades (i.e., oriented 90 degrees toward oncoming traffic). The drum spacing for the latter two treatments was 30 ft (standard of one times the posted speed limit) and 60 ft (two times the posted speed limit). During Phase I, researchers striped the LCDs as shown in Figure 5.

In Phase II, researchers shortened the study treatment length, but increased the number of treatments tested. Researchers decided that the treatment length did not require the entire 180 ft as used in Phase I, as the measurements were solely meant for photometric comparison. Thus, researchers shortened the treatment length to 60 ft, since all of the channelizing device spacings from Phase I were divisible into 60 ft.

Researchers evaluated seven different taper treatments in Phase II. All of the treatments were comprised of continuous LCDs, but each treatment had a completely different retroreflective material configuration. Researchers tested the following retroreflective materials: standard barrier reflectors, 3M™ longitudinal delineation system (LDS) panels, and standard temporary pavement marking tape. Researchers utilized a barrier reflector spacing of 6 ft (two white barrier reflectors in the middle of every device: one on top of the LCD and one mounted on the side of the LCD directly below the one on top). The barrier reflectors had a 3-inch by 4.25-inch reflective area with high intensity prismatic sheeting.

The LDS panels were fabricated from 3M™ Diamond Grade™ white reflective sheeting that was laminated onto a thin gauge of aluminum and formed into a unique crimped shape (Figure 17). This design provides retroreflection across a wider range of entrance and observation angles than typical sheeting. The LDS panels were 34.25 inches long and 4 inches wide. Researchers applied a single row of LDS panels to the side of the LCDs in a continuous fashion (two panels per LCD), with a 3-ft space between panels (one panel in middle of each LCD), with a 6-ft space between panels (two panels in middle of every other LCD), and with a 12-ft space between panels (one panel in the middle of every other LCD). The standard temporary pavement marking tape was applied in a similar fashion as the LDS panels. However, only two spacings were used: continuous and every 6 ft (on every other LCD).

Data Collection

All of the photometric measurements were taken at night on the runway network of the Texas A&M University Riverside Campus. Researchers obtained all of the photometric

measurements from a 2009 Ford Explorer using a Radiant Imaging ProMetric 16-bit CCD Photometer (see Figure 7). As discussed previously in Chapter 3, the CCD measurements were captured from the driver's perspective. Researchers set the headlights in the low-beam configuration and placed the vehicle in the center of the travel lane adjacent to the closed lane. The elevation of the center of the headlights was 36 inches from the pavement surface, and the CCD elevation was 60 inches from the pavement surface. For each treatment, researchers took photometric measurements 100 ft upstream of the beginning of the lane closure. Researchers also measured the illuminance to ensure that the ambient lighting conditions were similar for each treatment during each phase and between phases.



Figure 17. LDS on a LCD.

Data Analysis

As discussed in Chapter 3, researchers analyzed the photometric measurements using one large region to capture the entire treatment area within the driver's view. The purpose of the large region measurements was to assess different treatments as a whole array. Researchers believed that this method would allow for a better comparison between treatments as a whole, especially since the treatments had different quantities of retroreflective material or delineation (e.g., standard drums versus LCDs with barrier reflectors). All regions were analyzed with the Radiant Imaging ProMetric software version 9.1.20, and all data were graphed with respect to luminance on a logarithmic scale.

Results

Figure 18 and Figure 19 show the view of the Phase I tangent and taper treatments, respectively. The whole array luminance data for these treatments are shown in Figure 20 and Figure 21, respectively. As expected, the whole array luminance measurements for the drum treatments with half the standard device spacing (28.2 and 18.1 cd/m^2 , respectively) were slightly higher than the drum treatments with the standard device spacing (21.0 and 11.6 cd/m^2 , respectively) since more retroreflective surface was available. It is also apparent from Figure 18 and Figure 19 that the drum treatments with half the standard device spacing look more like a wall of a devices at night (i.e., the gap between drums is less noticeable).

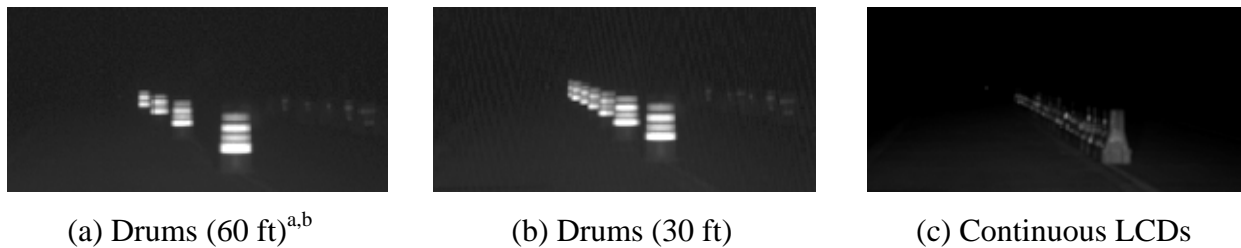

^a Distance in parentheses is the drum spacing.

^b Maximum drum spacing on a tangent for a 30 mph posted speed limit (9).

Figure 18. Phase I Tangent Treatments.

The continuous LCD treatment with retroreflective sheeting applied in a similar fashion to drums had considerably lower luminance values for both tangents and tapers (0.7 and 0.4 cd/m^2 , respectively) and thus is not readily apparent to drivers at night. These findings are not surprising given that retroreflective sheeting is not designed for the steep entrance angles produced when LCDs are used continuously in a lane closure (e.g., 82 degrees at 100 ft upstream of the merging taper). The retroreflective sheeting on the LCDs was only effective when placed as a barricade, perpendicular to the traffic flow (30.3 and 25.0 cd/m^2 , respectively). However, as shown in Figure 19, the longer LCD spacing (60 ft) resulted in less overlap of the devices, and the gap between the first two devices was readily apparent. Thus, the array of LCDs looked less like a wall of devices compared to the 30 ft LCD spacing.

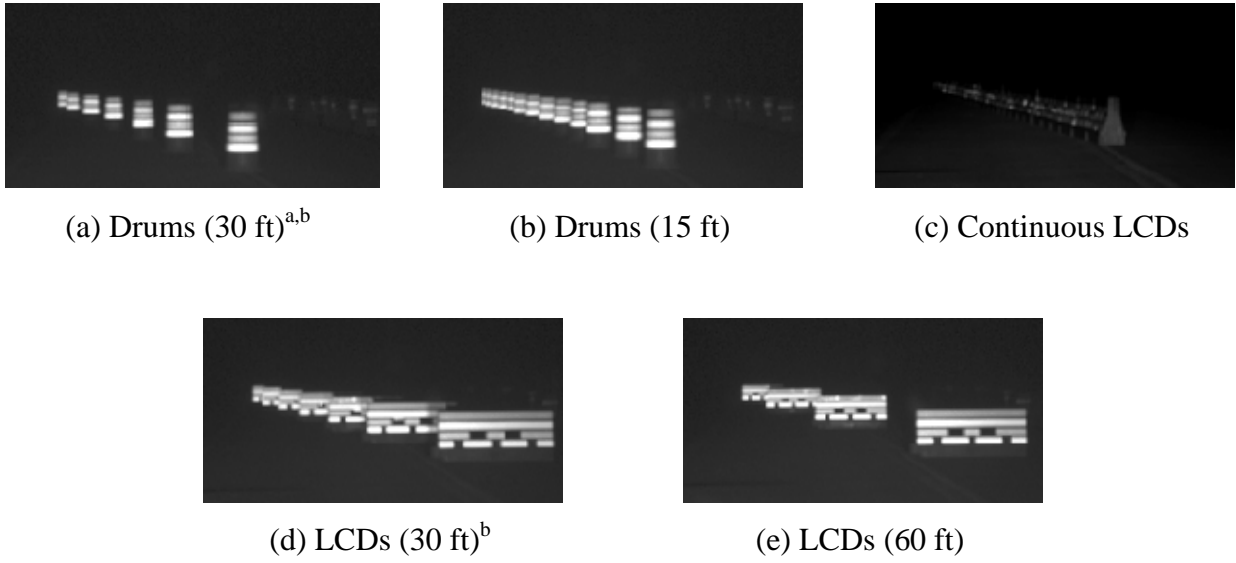

^a Distance in () is the channelizing device spacing.

^b Maximum channelizing device spacing on a taper for a 30 mph posted speed limit (9).

Figure 19. Phase I Taper Treatments.

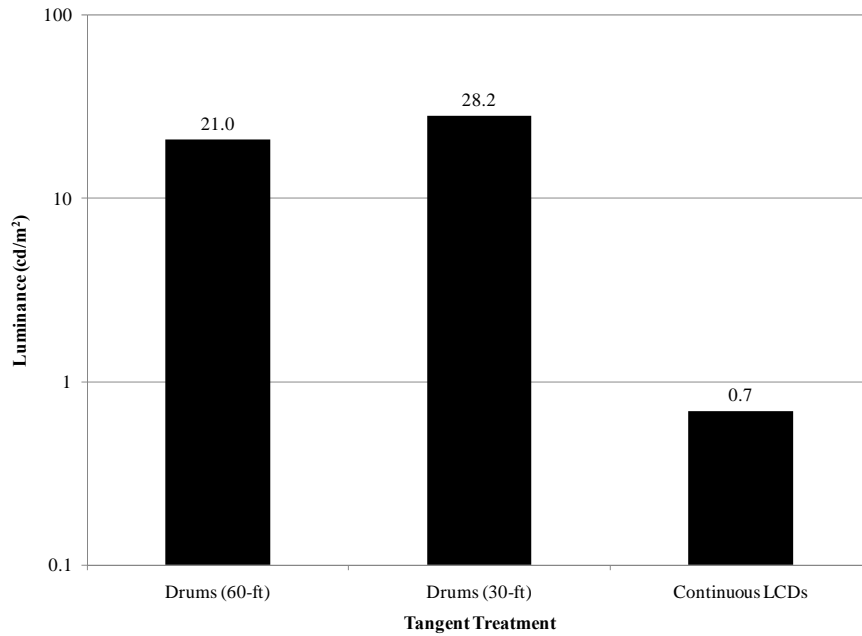

Figure 20. Luminance Data for Phase I Tangent Treatments.

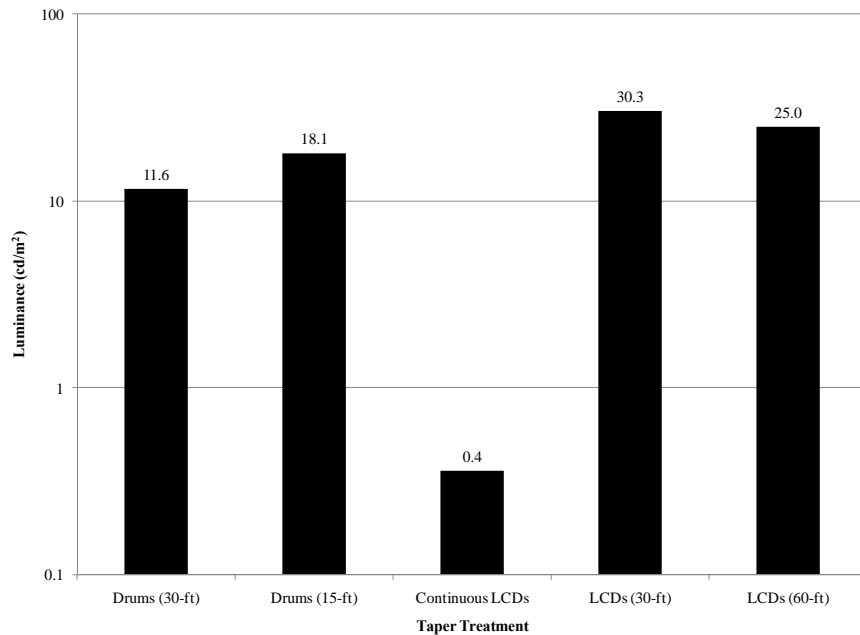
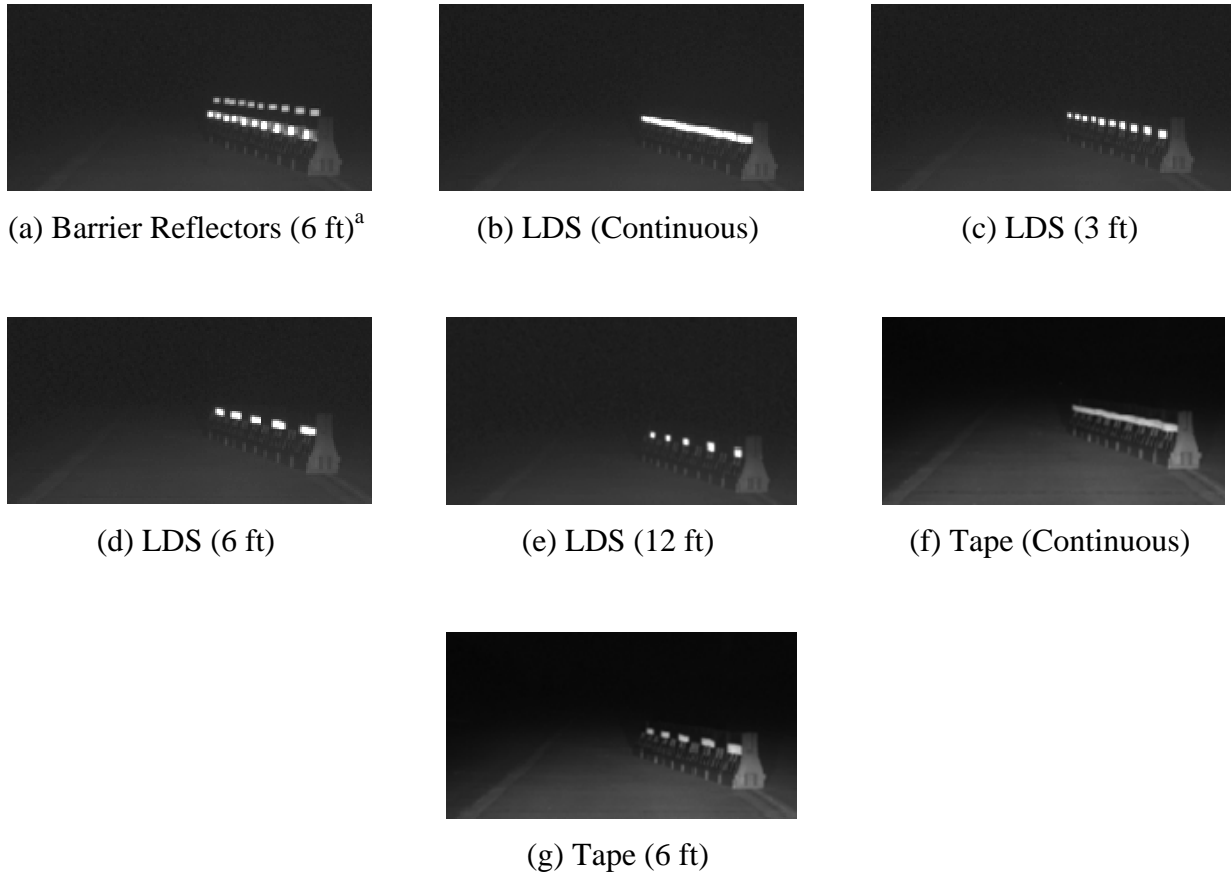

Figure 21. Luminance Data for Phase I Taper Treatments.

Figure 22 shows the view of the Phase II taper treatments, and Figure 23 shows the whole array luminance data for these treatments. The LDS panels in a continuous application produced the highest whole array luminance value (5.5 cd/m^2), followed by the barrier reflectors spaced every 6 ft (4.4 cd/m^2). The LDS panels spaced every 6 ft produced a slightly higher whole array luminance value (2.9 cd/m^2) than the LDS panels spaced every 3 ft (2.5 cd/m^2). This may be due to the use of two panels in the middle of every other LCD to form the 6-ft spacing versus one panel in the middle of each LCD to form the 3-ft spacing. The standard temporary pavement marking tape produced the least amount of whole array luminance (0.7 and 0.5 cd/m^2 , respectively).

Compared to the continuous Phase 1 LCD treatment with retroreflective sheeting (0.4 cd/m^2), all of the Phase II taper treatments produced a higher whole array luminance value; however, the values for the LDS panels spaced every 12 ft and the temporary pavement marking tape were within 1 cd/m^2 . Unfortunately, even the best Phase II treatments (continuous LDS and barrier reflectors spaced every 6 ft) produced less than half of the whole array luminance of the Phase I drum taper treatments (11.6 and 18.1 cd/m^2). In addition, unlike drums, none of the continuous LCD delineation treatments clearly convey to drivers the actual size of the device.

Due to the LCD design variations, it is difficult to attain as much retroreflective surface area as a drum with current off-the-shelf delineation products.



^a Distance in parentheses is the barrier reflector spacing.

Figure 22. Phase II Taper Treatments.

SUMMARY AND RECOMMENDATIONS

Researchers conducted four types of studies to determine the effectiveness of LCDs in a merging taper compared to standard drums: a human factors-based driving simulator study, detection distance evaluation, a turning movement evaluation, and a photometric analysis. These studies evaluated LCDs connected together in a continuous fashion and single LCDs acting as Type 3 barricades (i.e., oriented 90 degrees toward oncoming traffic).

The human factors-based driving simulator study showed that a merging taper comprised of a continuous line of LCDs or drums at a closer device spacing (i.e., 15 ft) did not impact the

mean lane change distance upstream of the lane closure compared to the standard drum treatment (30-ft spacing). While participants did prefer the continuous LCD treatment because the solid line of devices pointed out the correct direction and attracted their attention better, the photometric analysis of various continuous LCD delineation treatments showed that none of the delineation treatments produced luminance values equal to a standard drum treatment. In addition, unlike drums, none of the continuous LCD delineation treatments clearly convey to drivers the actual size of the device. Therefore, researchers do not recommend the use of continuous LCDs to form a lane closure merging taper.

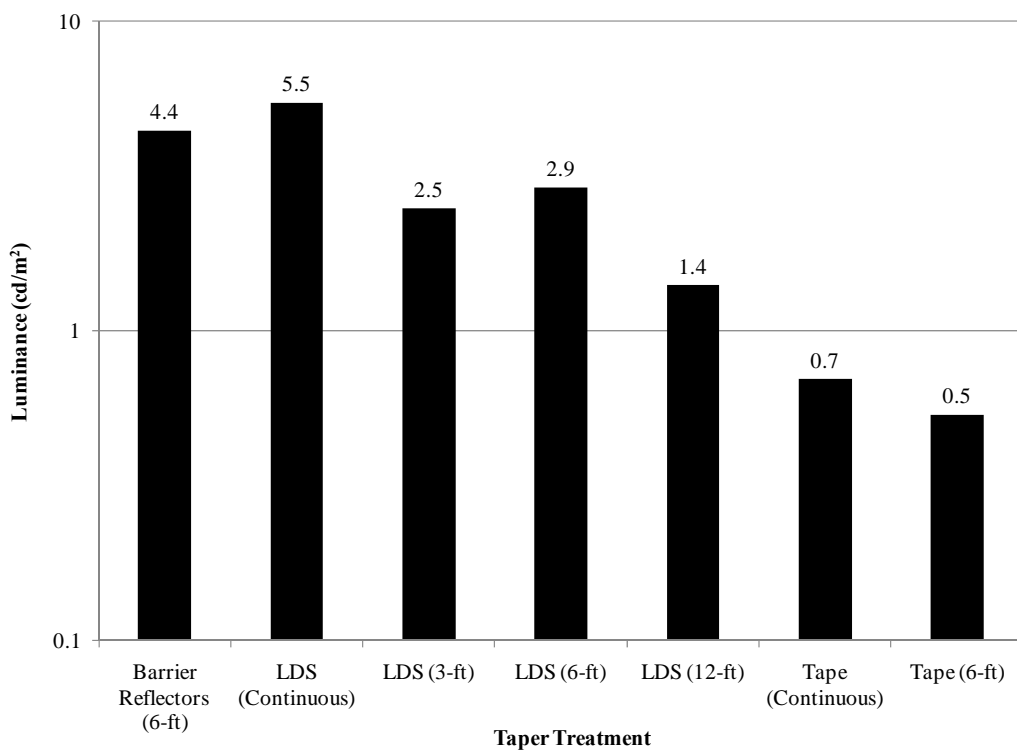

Figure 23. Luminance Data for Phase II Taper Treatments.

Even though single barricade style LCDs at the standard channelizing device spacing appeared as a solid wall of devices longer than a standard drum treatment, the same magnitude of improvement was accomplished by simply reducing the drum spacing. In addition, reducing the drum spacing appeared to result in similar turning movement characteristics as LCDs at the standard channelizing device spacing, and drivers deliberately trying to intrude into the closed lane could still do so at speeds in excess of 40 mph with the barricade style LCDs. While not

investigated, researchers are also concerned that the larger, more imposing size of the barricade style LCDs and the potential for drivers to misidentify them as barrier (which is more formidable) may result in erratic driving behavior in the immediate vicinity of the merging taper. Overall, researchers do not recommend that single barricade style LCDs be used to form a lane closure merging taper.

The barricade style LCDs at the standard channelizing device spacing did produce luminance values greater than both the drum treatments. However, applying retroreflective sheeting to LCDs is not really practical considering their various designs (non-flat surfaces, holes, and indentions in multiple locations along the length of the devices). Besides, if used singly as a Type 1, 2, or 3 barricade, LCDs must comply with the general size, color, strip pattern, retroreflectivity, and placement characteristics of barricades (1,9). Researchers interpret this to mean that the LCDs would need the appropriate number of alternating orange and white retroreflective strips sloping downward at an angle of 45 degrees in the direction road users are to pass. Due to the variety of LCD designs (i.e., angles, forklift holes, ridges, etc.), the most convenient way to delineate an LCD like a barricade is to actually attach a barricade to the top of the LCD; however, this can only be done if the LCD has been approved with the use of a barricade (12).

CHAPTER 5: DRIVEWAY EVALUATIONS

INTRODUCTION

As shown in Figure 24, when an urban roadway is under construction the alteration of the driving environment (e.g., closed lanes, work activity, expanded right-of-way, etc.) may make it more difficult for drivers to determine the location of business and residence driveways. This could lead to driver confusion, erratic maneuvers like hard braking to make a sudden turn, and intrusions when drivers turn into the work zone in the wrong location.



NOTE: A business driveway is located between the second and third drum.

Figure 24. Example of an Urban Roadway under Construction.

As discussed previously, larger channelizing devices, such as drums, and closer channelizing device spacing appear to create a more continuous array of devices. Thus, the use of larger, more closely spaced channelizing devices may be suitable near driveways to make it easier for drivers to identify the correct location of the driveway. LCDs connected together to form a solid line provide continuous delineation of the travel path, which may also help drivers more easily identify the location of driveways within a work zone. In addition, continuous LCDs would reduce the likelihood of intrusions (both non-deliberate and deliberate) into the work zone. This chapter documents the experimental design and findings of a closed-course human factors study conducted to determine the effectiveness of continuous LCDs compared to standard drums

to delineate driveways (and minor roads) within a work zone. In addition, researchers investigated the impacts of LCD height on intersection sight distance.

HUMAN FACTORS STUDY

This section describes the closed-course human factors study conducted to determine whether continuous LCDs improve the ability of drivers to detect driveway openings within a work zone relative to the use of drums. While detection distance data in response to a simulated driveway within a work zone cannot be directly compared to detection distance data collected in an actual work zone, closed-course study data can be used to compare the relative differences in performance between the various treatments evaluated.

Experimental Design

Researchers conducted the closed-course driveway study on the roadway network at the Texas A&M University Riverside Campus during daylight hours under dry pavement conditions. Researchers selected to conduct the study on the roadway network since it more closely replicated an urban environment with driveways and cross-streets but still provided less traffic than an actual urban street. The treatments, study procedure, and participants are described in the following sections.

Treatments

Table 21 and Figure 25 show the three treatments evaluated during the closed-course driveway study. Researchers created two work zones on different roads by placing drums along both sides of the road. Both of the simulated work zones were designed for a 30 mph posted speed limit. The Texas MUTCD (9) suggests a maximum spacing of two times the speed limit for channelizing devices placed in a tangent. Therefore, researchers used a 60-ft drum spacing in the entry and exit tangents for all treatments. No work zone signing was used in the study.

One work zone was approximately 420 ft long. A simulated 24-ft wide driveway was located on the west side of the road in approximately the middle of the work zone. The driveway was marked on each side with three drums placed in a line perpendicular to the roadway. This work zone contained Treatment 1, which consisted of drums spaced every 30 ft (one times the speed limit) in the area 120 ft upstream and 120 ft downstream of the driveway. As in the other studies discussed herein, researchers evaluated the closer drum spacing to assess the impact of

simply reducing the spacing on a driver’s ability to detect a driveway in a work zone environment.

Table 21. Description of Driveway Treatments for Closed-Course Study.

Treatment (Side of the Road)	Work Zone	Work Zone Length (ft)	Entry Tangent^a	Upstream Tangent^b	Downstream Tangent^b	Exit Tangent^a
1 (West)	1	420	Drums (60 ft)	Drums (30 ft)	Drums (30 ft)	Drums (60 ft)
2 (West)	2	900	Drums (60 ft)	Drums (60 ft)	Drums (60 ft)	Drums (60 ft)
3 (East)	2	900	Drums (60 ft)	LCDs	LCDs	Drums (60 ft)

^a Drum spacing is shown in parentheses.

^b The drum spacing varied over the 120-ft section. Drum spacing is shown in parentheses. LCDs were continuous.

The other work zone was approximately 900 ft long and contained two simulated 24-ft driveways. Again, the driveways were marked on each side with three drums placed in a line perpendicular to the roadway. One driveway was located on the west side of the road approximately 300 ft from the north end of the work zone. Surrounding this driveway was Treatment 2, which consisted of drums spaced every 60-ft (standard spacing) in the area 120-ft upstream and 120-ft downstream of the driveway. The second driveway was located on the east side of the road approximately 600 ft from the north end of the work zone. Surrounding this driveway was Treatment 3, which consisted of 32-inch tall LCDs placed in a continuous alignment in the area 120-ft upstream and 120-ft downstream of the driveway. Based on the results from the exit ramp evaluations, researchers utilized barrier reflectors (two white barrier reflectors in the middle of every third device: one on top of the LCD and one mounted on the side of the LCD directly below the one on top) to delineate the LCDs. However, since researchers conducted the driveway study during the day, researchers did not expect this change in delineation from the previous human-factors closed-course studies to impact the results.



(a) Treatment 1



(b) Treatment 2



(c) Treatment 3

Figure 25. Driveway Treatments for Closed-Course Study.

The existing driveways at the Texas A&M University Riverside Campus were fairly obvious due to the sparseness of buildings (more than on the runway system, but less than an actual urban street) and the drainage culverts. Thus, researchers used simulated driveways instead of actual driveways to ensure that participants were not using other cues (building, culverts, etc.) to identify the driveway opening locations. In addition, as shown in Figure 24 these cues are typically removed when construction is located between the travel lanes and the potential destinations.

To reduce learning effects, researchers conducted this study in combination with another study evaluating traffic control devices for use with school crossing guards. Researchers also utilized four different treatment orders. Each participant saw each treatment once on either the

left or right side of the road. Thus, approximately half of the participants saw the treatments on the left side of the road, and the other half saw the treatments on the right side of the road.

Study Procedure

Upon arrival, each participant checked in and a briefing took place at a TTI office building. The researchers then provided the participants with an explanation of the study, including their driving task, and asked them to read and sign the informed consent document. Participants then completed screenings for standard visual acuity, contrast sensitivity, and color blindness. These screenings provided comparison information for data reduction and ensured that all participants had at least minimal levels of acceptable vision prior to beginning the study. No participants were disqualified from the study based on these screenings.

Participants were then told that they would be driving an instrumented state-owned passenger vehicle (i.e., Ford Taurus) on the road network where researchers had set up two simulated work zones. The participants were told to obey all traffic control devices and to drive at the posted speed limit (i.e., 30 mph). However, due to the poor pavement conditions, most participants drove between 20 and 25 mph.

Researchers instructed participants to verbally acknowledge when they could clearly identify the driveway opening, which could be located on either side of the road. Researchers also informed the participants that there could be multiple driveways in each work zone. Researchers recorded the driveway opening detection distances, as well as any comments made by the participants. The participants continued traveling straight through the work zone (i.e., they did not turn into the simulated driveway). After each work zone, researchers asked participants a series of follow-up questions. Each participant repeated this process for each work zone. At the end of the study, researchers asked participants to rank the three treatments from best to worst on how well they could identify the driveway opening.

Participants

Thirty-four people from the Bryan/College Station area participated in the closed-course driveway study. Participants were required to be at least 18 years old and have a current driver's license. In addition, researchers did not allow any participants from the previously conducted closed-course exit ramp and driving simulator studies to participate in this study. Table 22 shows the demographic sample obtained and needed based on the gender and age of the Texas

driving population (17). Overall, researchers believe that the results obtained in this study represent Texas drivers reasonably well.

Table 22. Participant Demographics for the Closed-Course Driveway Study.

Sample	Gender			
	Male		Female	
	18-39	55+	18-39	55+
Study Sample	29%	21%	29%	21%
Texas Data (17)	30%	20%	30%	20%

Data Analysis

The primary measure of effectiveness was the mean detection distance of the driveway opening. In addition, researchers computed the standard deviation, minimum detection distance, and maximum detection distance for each treatment (see Appendix F). Researchers used analysis of variance for one dependent variable and Tukey’s HSD procedures to determine if there were significant differences among the mean distances for each driveway location (left or right) and each treatment. A 95 percent level of confidence was used for all statistical analyses.

Researchers analyzed the participants’ subjective opinions regarding the advantages and disadvantages of each treatment. In addition, researchers calculated the average effectiveness rating for each treatment (one was very effective, two was effective, and three was not effective), as well as the overall ranking of the treatments from the best to worst treatment. Researchers determined the overall ranking using a ranking score, which was computed by assigning one point each time a treatment was ranked first (best), two points for second place rankings, etc. with the maximum number of points being assigned each time a treatment was ranked worst. Thus, the treatment perceived to be best would have the lowest score.

Results

While neither the treatment or driveway location variables were found to be significant ($p=0.866$ and $p=0.824$, respectively), the interaction between these two variables was found to be statistically significant ($p=0.009$). Table 23 shows the mean detection distances for the treatment by driveway location. In the work zone with one treatment (drum spacing of 30 ft), the mean

driveway detection distance on the left side of the road (282 ft) was approximately two times the mean driveway detection distance on the right side of the road (145 ft). Due to the location of cross streets and buildings, and the available locations to create the simulated work zones, the starting points upstream of this treatment were 1074 ft and 512 ft, respectively. Researchers believe that the longer preview distance encouraged longer driveway detection distances.

Table 23. Treatment and Driveway Location Interaction.

Treatment Number	Treatment Description	Mean Detection Distance (ft)		Average Effectiveness Rating	Overall Ranking
		Driveway on Right Side of Road	Driveway on Left Side of Road		
1	Drums (30 ft)	145 (n=16)	282 (n=17)	2.47	3
2	Drums (60 ft)	260 (n=18) ^b	150 ^a (n=15)	2.09	2
3	LCDs	183 (n=16) ^a	210 ^b (n=18)	1.41	1

^a Treatment 2 (left) was located after Treatment 3 (right).

^b Treatment 3 (left) was located after Treatment 2 (right).

In the work zone with two treatments (standard drum spacing and continuous LCDs), the second treatment (on the left) always had a shorter mean detection distance than the first treatment (on the right). A further review of the data showed that in all cases, the participants detected the driveway on the right before the driveway on the left, independent of the treatment. Thus, the mean detection distances for the standard drum spacing and continuous LCD treatments on the left were shorter than would have been expected if the two driveways would have each been in their own work zone. Overall, several study design factors limited the usefulness of the driveway detection distance data.

Table 24 shows the positive and negative opinions obtained during the study. The three main advantages for the drum treatments were: that it was easy to see the driveway opening (39 and 27 percent, respectively), participants could see through the drums (22 and 27 percent, respectively), and participants were familiar with drums (26 percent and 9 percent, respectively). The main disadvantages for the drum treatments were that it was hard to see the driveway opening since all of the devices looked alike (53 and 67 percent, respectively) and that drums can become misaligned or go missing (5 and 11 percent, respectively). In addition, since some participants had already viewed the LCD treatment, a portion of them (11 and 6 percent,

respectively) also commented that the drum treatments were not as effective as the LCD treatment. Comparing the two drum treatments, the closer drum spacing (i.e., 30 ft) resulted in the worst average effectiveness rating (2.47) and 5 percent of the participants thought the devices were spaced too close, limiting their field of vision.

Table 24. Advantages and Disadvantages by Treatment.

	Treatment 1: Drums (30 ft)	Treatment 2: Drums (60 ft)	Treatment 3: LCDs
Advantages	n=23	n=22	n=29
Easy to see driveway	39%	27%	66%
Can see thru devices	22%	27%	--
Solid line of devices	--	--	10%
Familiar with devices	26%	9%	--
Less expensive	--	5%	--
Easy to setup	4%	--	--
Contrast of different device	--	--	21%
Other	9%	32%	3%
Disadvantages	n=19	n=18	n=14
Hard to see driveway opening	53%	67%	--
Could get misaligned	5%	11%	--
Devices spaced too close	5%	--	--
Not as effective	11%	6%	--
No contrast of different device	21%	--	--
Hard to see on the other side of the devices	--	--	86%
Intimidating like concrete barrier	--	--	7%
Other	5%	16%	7%

-- Indicates no responses for the category.

The main advantages for the LCD treatment were: that it was easy to see the driveway opening (66 percent), the contrast in devices (drums to LCDs) helps with driveway detection (21 percent), and the solid line of LCDs alerted participants that something is going to change or happen (10 percent). Disadvantages included: that it was hard to see on the other side of the LCDs (which could also be a benefit from a transportation operations viewpoint) (86 percent) and the LCDs look intimidating like concrete barrier (7 percent). Overall, the LCDs received the best effectiveness rating (1.41) and were ranked best among the treatments.

INTERSECTION SIGHT DISTANCE INVESTIGATION

When considering the use of continuous LCDs on urban arterials, providing adequate intersection sight distance (ISD) is just as important during work zone operations as during normal operations. Drivers stopped at unsignalized intersecting minor roads or driveways must be able to see around or over channelizing devices that may be located near the intersection. Figure 26 shows the driver's view from a passenger car on a minor-road approach in a work zone using drums to delineate the edge of the roadway. In this example, it is possible to see approaching traffic by looking between the drums. If continuous LCDs were used to define the edge of the shoulder, drivers would need to be able to see approaching traffic by looking over the devices. In this case, vertical sight distance depends upon driver eye height, the height of the critical object that the driver is trying to see (i.e., the approaching vehicle), the height of any obstructing objects located between the driver and the critical object (such as LCDs), as well as the relative distances between these three heights. Researchers used the descriptive statistics for passenger cars shown in Table 25 (18).



Figure 26. Driver's View from a Passenger Car on a Minor-Road Approach in a Work Zone.

Table 25. Descriptive Statistics for Passenger Cars (18).

Descriptive Statistic^a	Driver Eye Height	Headlamp Height	Vehicle Height
Sample Size	875	1318	1378
Mean	3.77 (45.24)	2.13 (25.56)	4.54 (54.48)
Standard Deviation	0.18 (2.16)	0.13 (1.56)	0.19 (2.28)
High Value	4.67 (56.04)	3.11 (37.32)	5.54 (66.48)
Low Value	3.13 (37.56)	1.77 (21.24)	3.79 (45.48)
5 th Percentile	3.48 (41.76)	1.94 (23.28)	4.21 (50.52)

^a Descriptive statistics presented in ft (and inches) where applicable.

Driver Eye Height

A passenger car driver’s ability to see over obstructing objects, such as LCDs, is a function of driver eye height and the height of the LCDs. As previously discussed, LCDs range in height from 18 to 46 inches; however, all but one type of LCD is 32 inches tall or higher. Using the descriptive statistics for driver eye height in Table 25, researchers computed the cumulative distribution function for driver eye height shown in Figure 27. It is apparent from the graph that almost all drivers would be able to see over LCDs that are less than 37 inches tall (five products). However, a significant percentage (64 percent) of the passenger car drivers would not be able to see over the tallest LCDs (46 inches).

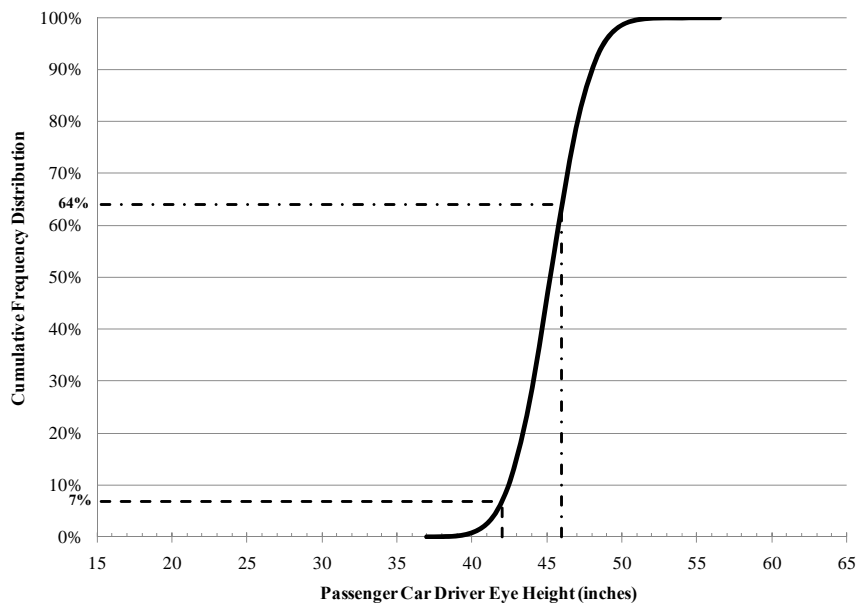

Figure 27. Comparison of Passenger Car Driver Eye Height Distribution to LCD Heights.

Critical Object Height

A passenger car driver's ability to see a critical object located beyond obstructing objects, such as LCDs, is also a function of the critical object height and the height of the LCDs. Figure 28 shows the cumulative distribution functions of two critical object heights (18). During daylight hours, the critical object height is assumed to be the height of vehicles approaching on the major road. It is apparent from the graph that almost all passenger car vehicle heights are higher than the tallest LCDs (46 inches) and thus could likely be seen during daylight conditions. However during a panel demonstration, researchers and TxDOT personnel noted that it was more difficult to distinguish a passenger car from the 46-inch tall LCDs than the 32-inch tall LCDs, especially when the two objects were similar in color (e.g., a red car and orange LCD).

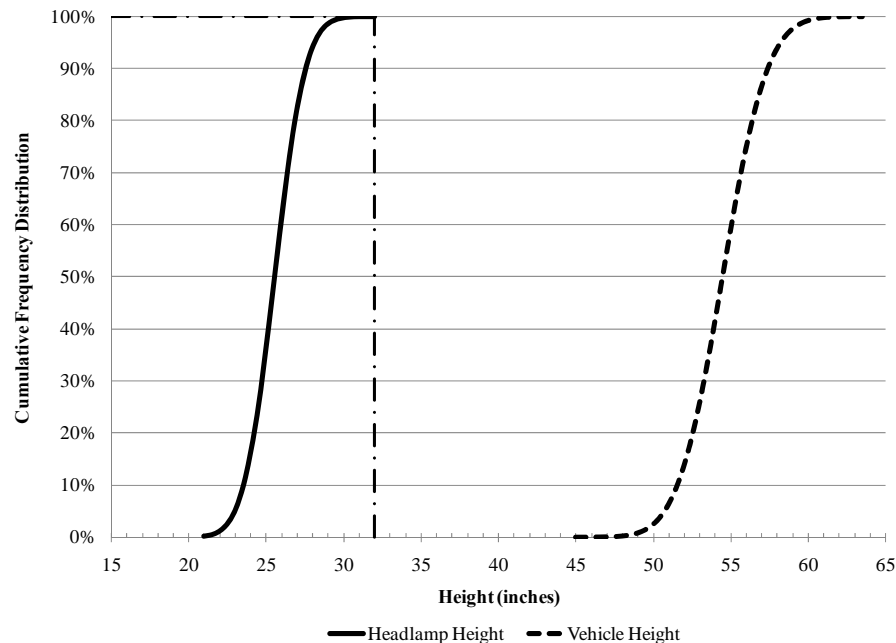

Figure 28. Comparison of Critical Object Height Distributions to LCD Heights.

At night, the critical object height is assumed to be the headlamp height of passenger vehicles approaching on the major road. In this case, none of the passenger car headlamps considered would be visible if located behind LCDs 32 inches tall or higher (height of all products except one).

Intersection Sight Distance

Figure 29 shows an example application of LCDs around a driveway. The line of sight from the driver's eye to the critical object creates the hypotenuse of the intersection sight triangle. The other two sides of the intersection sight triangle were defined as follows: a is the distance between the driver of the vehicle positioned in the center of the driveway and the center of the approaching vehicle on the major road (assumed to be positioned in the center of the major road), and b the distance between the front bumper of the approaching vehicle positioned in the center of the major road and the center of the vehicle in the driveway (assumed to be positioned in the center of the driveway). To simplify the calculations, researchers used measurements from the center of the vehicles even though the driver and headlamps are slightly offset from the center of the vehicle.

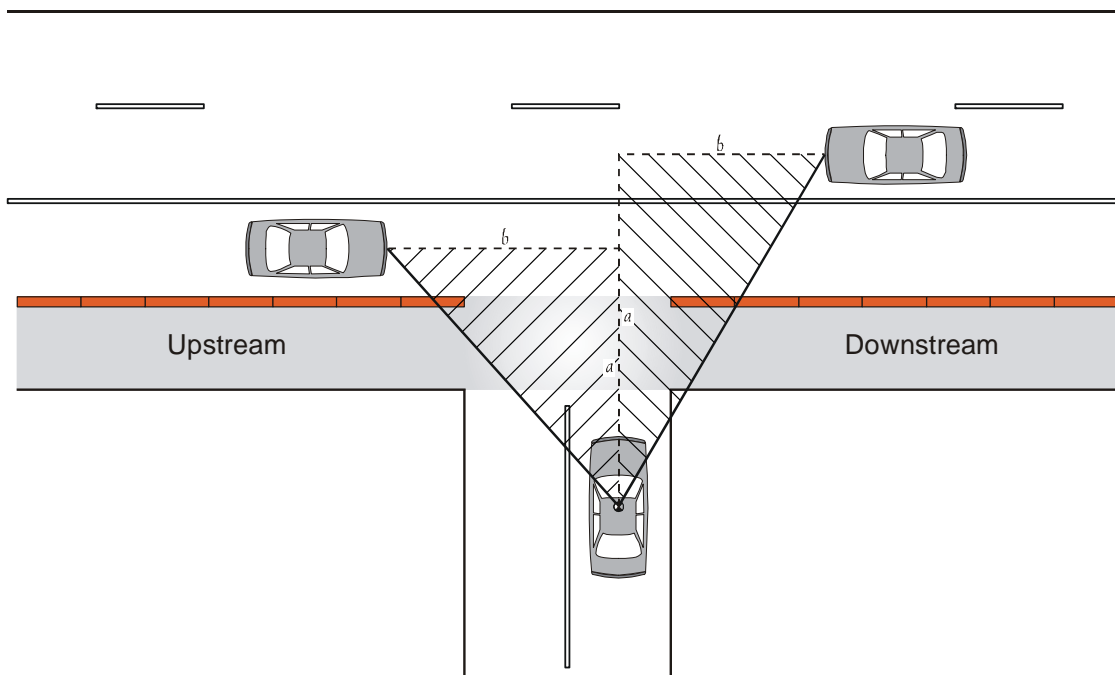

Figure 29. Example of LCD Application around a Driveway.

Sight triangles define areas around intersections (including driveways) that should remain clear of any sight obstructions. The *AASHTO Policy on Geometric Design of Highways and Streets (19)* tabulates design values for intersection sight distance based on clear sight triangles for a stopped passenger car to make a left turn onto a two-lane highway with no median and

grades 3 percent or less. Table 26 shows the recommended intersection sight distance design values for passenger cars based on empirical driver gap-acceptance behavior. Researchers assumed that when a right lane closure is present on a four-lane undivided urban arterial, the resulting roadway design is similar to a two-lane highway. For other conditions, longer sight distances may be required.

A line of LCDs penetrating the intersection sight triangle would not be considered an obstruction if the driver of the vehicle in the driveway can see the critical object by looking over the LCDs. However, the previously discussed comparisons show that a significant percentage (64 percent) of the driving population would not be able to see over the tallest LCDs (46 inches), and that none of the passenger car headlamps considered would be visible if located behind LCDs 32 inches tall or higher (height of all products except one). So if LCDs are used along the side of the road in work zones to delineate driveways, one must determine the proper placement of LCDs so that they help notify drivers of the upcoming driveway but do not block the view of a driver exiting the driveway. To accomplish this, researchers calculated the distance upstream and downstream of the driveway where the LCDs would need to terminate and begin, respectively, to ensure that vehicles in the driveway would have adequate sight distance to the critical object by being able to see around the LCDs.

Table 26. Design Intersection Sight Distance for Passenger Cars Turning Left from a Stop (19).

Design Speed (mph)	Intersection Sight Distance (ft)
15	170
20	225
25	280
30	335
35	390
40	445
45	500
50	555
55	610
60	665

Previous research (19) found that the vertex of the departure sight triangle on the minor road (i.e., decision point) should be 14.5 ft from the edge of the major road. This represents a

driver stopping the front of their vehicle 6.5 ft from the edge of the major road and the driver's eyes being 8 ft back from the front of the vehicle. Researchers recognize that these observations were made during normal operating conditions, and drivers may be more likely to stop closer to the edge of the major road in a work zone, particularly if channelizing devices are blocking part of their view. So, researchers also examined the impacts of the decision point being located 11.25 ft and 8 ft from the edge of the major road, which represent a driver stopping their vehicle 3.25 ft and 0 ft from the edge of the major road, respectively.

The TxDOT *Roadway Design Manual* (20) specifies a 28-ft throat width for a two-lane commercial driveway consisting of one 14-ft exit lane and one 14-ft entry lane. Assuming that the vehicle is centered in the driveway exit lane, researchers computed the distance from the center of the vehicle in the driveway to the first LCD on both sides of the driveway to be 21 and 7 ft, to the left (upstream) and right (downstream), respectively. Assuming 12-ft lanes, researchers varied b in Figure 29 from these initial values to 800 ft for the three decision point values previously discussed (14.5, 11.25, and 8 ft) to calculate the sight distance to the center of the major road lanes of interest in both directions around the end of the continuous LCDs.

Figure 30 and Figure 31 compare the calculated sight distances to the left and right, respectively, to the design intersection sight distance for passenger cars turning left from a stop onto a 45 mph roadway (i.e., 500 ft). These figures show that continuous LCDs would need to be located at least 286 ft to the left and 154 ft to the right from the center of the vehicle in the exit lane of the driveway for drivers to have adequate sight distance to the approaching major road vehicle. Table 27 contains the minimum distance upstream and downstream of the center of the driveway exit lane (or minor road) where continuous LCDs should terminate and begin, respectively, for various speed limits and decision point distances. Placing LCDs at least this far from the center of the driveway ensures that vehicles making left turns from the driveway would have adequate sight distance to approaching major road vehicles' headlamps in both directions.

SUMMARY AND RECOMMENDATIONS

Researchers conducted a closed-course human factors study to determine the effectiveness of continuous LCDs compared to standard drums to delineate driveways (and minor roads) within a work zone. Researchers also investigated the impacts of LCD height on intersection sight distance.

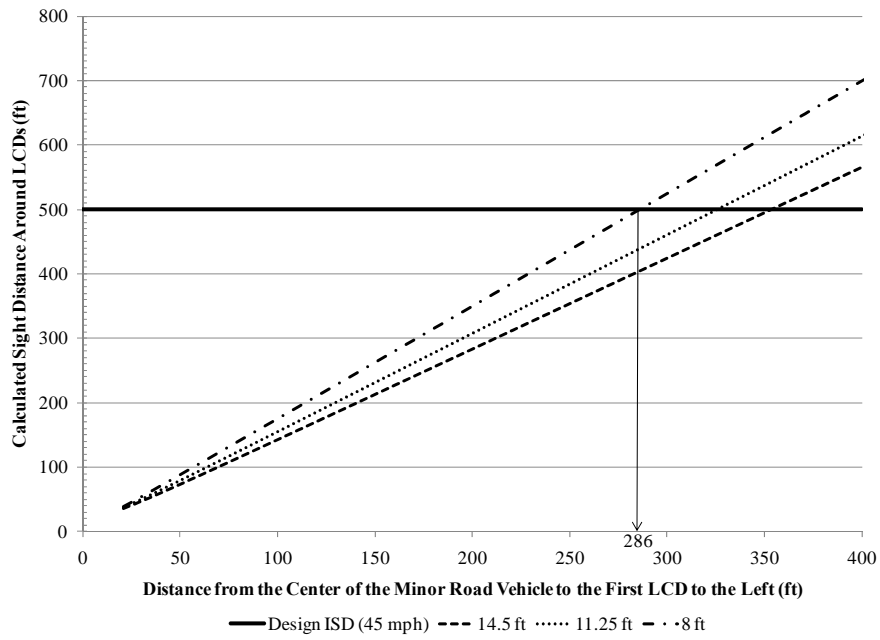

Figure 30. Calculated Sight Distance to the Center of the Major Road – Left.

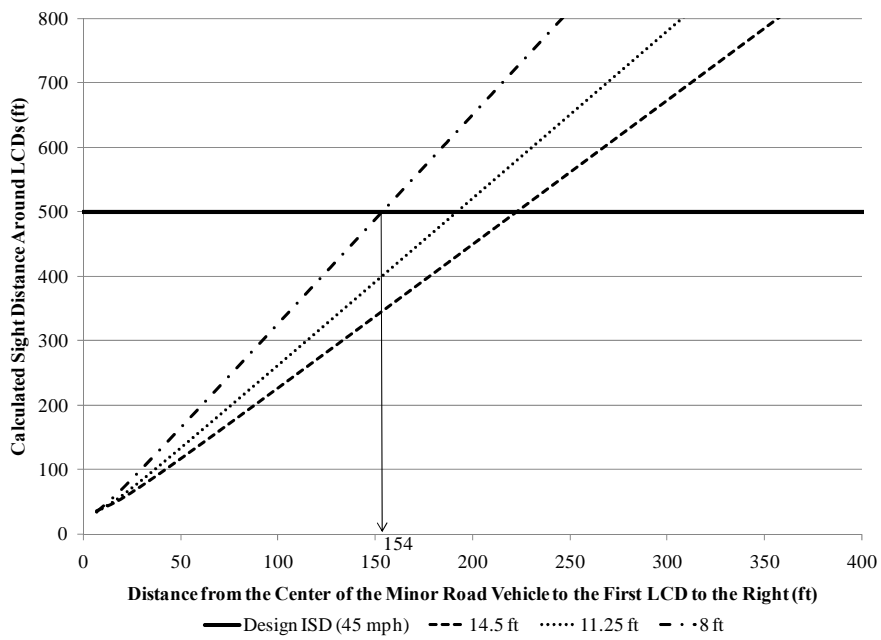

Figure 31. Calculated Sight Distance to the Center of the Major Road – Right.

Table 27. Minimum Distance away from the Center of an Access Point Exit Lane where Continuous LCDs Can Be Located.

Speed Limit (mph)	Minimum Distance Upstream where LCDs Terminate ^a (ft)			Minimum Distance Downstream where LCDs Begin ^a (ft)		
	14.5 ft	11.25 ft	8 ft	14.5 ft	11.25 ft	8 ft
30	240 (236.5)	220 (218.2)	195 (191.3)	150 (148.8)	130 (128.4)	105 (102.8)
35	280 (275.5)	255 (254.1)	225 (222.7)	175 (173.4)	150 (149.6)	120 (119.7)
40	315 (314.4)	295 (290.0)	255 (254.2)	200 (198.0)	175 (170.8)	140 (136.7)
45	355 (353.4)	330 (325.8)	290 (285.6)	225 (222.6)	195 (192.0)	155 (153.6)
50	395 (392.3)	365 (361.8)	320 (317.0)	250 (247.2)	215 (213.2)	175 (170.6)

^a Design value (Calculated value)

Unfortunately, several study design factors limited the usefulness of the closed-course human factors study detection distance data. However, participants did prefer the continuous LCD treatment because the LCDs made the driveway opening more apparent, the contrast in channelizing devices (drums to LCDs) improved their ability to detect the driveway opening, and the solid line of LCDs alerted them that something was going to change or happen.

LCDs range in height from 18 to 46 inches; however, all but one type of LCD is 32 inches tall or higher. Compared to available passenger car driver eye height data, almost all drivers would be able to see over LCDs that are less than 37 inches tall. However, almost two-thirds of the passenger car driver population would not be able to see over the tallest LCDs (46 inches). In addition, while almost all passenger car vehicles are higher than the tallest LCDs, researchers did experience difficulty distinguishing a passenger car from the 46-inch tall LCDs, especially when the passenger car and LCDs were similar in color (e.g., red car and orange LCD). Thus, researchers recommend that the height of the LCDs be considered in continuous applications where motorists will be entering or exiting through the LCDs (e.g., exit ramps and driveways/minor roads). In other applications, such as pedestrian channelization or along the edge of a limited-access roadway (not in the vicinity of an access point), taller LCDs may be desired to block the view of pedestrians and motorists.

At night, a driver exiting a driveway would need to be able to see an approaching major road vehicle's headlamps. However, none of the passenger car headlamps considered would be visible behind LCDs 32 inches tall or higher. Thus, practitioners should either utilize shorter

LCDs (21 inches tall or less) or place continuous LCDs such that they do not block the view of an approaching major road vehicle's headlamps. Researchers recommend that Table 27 be used to determine the minimum distance upstream and downstream of the center of the driveway exit lane (or minor road) where continuous LCDs greater than 21 inches tall should terminate and begin, respectively. Placing LCDs at least this far from the center of the driveway ensures that vehicles making left turns from the driveway would have adequate sight distance to approaching major road vehicle's headlamps in both directions. However, implementing the minimum distances in Table 27 may be difficult in an urban environment where driveways are spaced closer than the recommended distances. Also, since the shortest distance in this table is over 100 ft away from the driveway, other channelizing devices (such as drums or LCDs equal to or less than 21 inches tall) would need to be used to delineate the edge of the travel lane closer to the driveway. While researchers did not evaluate this setup, they believe that the contrast in devices (LCDs to drums) would also signify an upcoming change and improve a driver's ability to detect a driveway within a work zone. Field studies are needed to evaluate the effectiveness of this new driveway delineation treatment.

Overall, continuous LCDs may be used to delineate the edge of a travel lane within a work zone on an urban roadway. However, their height and location relative to the driveway must be considered. In addition, LCDs may be beneficial on urban roadways when a high number of deliberate intrusions into the work zone to access driveways or minor roads are expected to occur or have occurred while using the standard drum treatment.

CHAPTER 6: SUMMARY AND RECOMMENDATIONS

SUMMARY

Work zones create unexpected conditions for all road users. The function of channelizing devices is to warn road users of conditions created by work activities in or near the roadway and to guide them safely through the work zone area. LCDs are lightweight, deformable devices that may be used instead of a line of cones, drums, or barricades. In contrast to traditional channelizing devices (e.g., cones, drums, etc.) that have some open space between devices (based upon the posted speed), LCDs can be connected together to form a solid line (i.e., no space between devices). Thus, LCDs can prevent drivers and pedestrians from going between devices and entering the work area (whether inadvertent or deliberate).

To date, LCDs have primarily been used to delineate pedestrian travel paths and keep pedestrians from inadvertently entering the work area. Within the traveled way, LCDs have mainly been used to close roadways and driveways to vehicular traffic. On occasion, LCDs have also been used on the edge of the travel lane in a longitudinal application to denote the edge of the pavement or separate the active travel lanes from the work area. Researchers conducted the studies documented herein to assess whether the following LCD applications improve the traffic safety and operations of work zones relative to the use of standard drums:

- Continuous LCDs in the vicinity of exit ramps on high-speed, limited-access facilities.
- Continuous LCDs in the merging taper of a lane closure on low-speed roadways.
- Single transverse LCDs (similar to Type 3 barricades) in the merging taper of a lane closure on high-speed roadways.
- Continuous LCDs in the vicinity of driveways on low-speed urban roadways.

RECOMMENDATIONS

The following sections contain the researchers' recommendations regarding LCD and drum applications near exit ramps, in a lane closure merging taper, and near driveways (or minor roads). The need for additional research and other considerations are also discussed.

Exit Ramps within Freeway Lane Closures

The following are the researchers' recommendations regarding the design and delineation of exit ramps that remain open within a work zone lane closure.

- Researchers recommend that the minimum exit ramp opening within a work zone lane closure be at least equal to the suggested maximum spacing of channelizing devices on a tangent shown in Table 6C-4 of the Texas MUTCD (9), with two times the channelizing device spacing on the tangent being preferred.
- Researchers recommend the use of drums spaced (in feet) equal to one times the speed limit (in mph) on the lane closure tangent 240 ft immediately upstream of the exit ramp opening and 120 ft immediately downstream of the exit ramp opening on a high-speed, limited-access facility.
- Researchers recommend the use of continuous LCDs on both the tangents and tapers in the immediate vicinity of an exit ramp for either of the following conditions:
 - When a high number of deliberate intrusions into the work zone to access the exit ramp are expected to occur or have occurred while using the standard drum treatment.
 - In situations where the exit ramp opening (in feet) is less than or equal to two times the posted speed limit (in mph) (i.e., the channelizing device spacing on the tangent), workers and equipment are in the work area near the exit ramp opening, and there are concerns that drivers may unintentionally enter the work area trying to access the exit ramp.

For this research, “immediate vicinity” was defined as 120 ft immediately upstream of the exit ramp opening and 60 ft immediately downstream of the exit ramp opening.

- Continuous LCDs in the immediate vicinity of an exit ramp should follow TxDOT standards with respect to delineation (10); however, the maximum barrier reflector spacing should be 18 ft. In addition, adequate delineation is needed at the apex of the downstream LCD tangent and LCD taper to demarcate the ends of the LCDs.
- Taller LCDs may block the view of the exit ramp opening when used in the upstream tangent and taper, which may cause confusion due to a lack of positive guidance. In addition, taller LCDs might block the view of a stalled passenger car on the exit

ramp. Thus, the height of the LCDs should be considered to ensure positive guidance of the intended travel path and adequate visibility of any hazards that may be located on the exit ramp.

Lane Closure Merging Tapers

The following are the researchers' recommendations regarding the use of LCDs in a merging taper.

- Researchers do not recommend the use of continuous LCDs to form a lane closure merging taper.
- Researchers also do not recommend that single barricade style LCDs be used to form a lane closure merging taper.

Driveways

The following are the researchers' recommendations regarding the use of LCDs to delineate driveways (and minor roads) within a work zone.

- Continuous LCDs may be used to delineate the edge of a travel lane in a work zone on an urban roadway. However, the height of the LCDs should be considered in applications where motorists need to be able to detect approaching vehicles (i.e., intersecting driveways and minor roads). LCDs 21 inches tall or less should be used where it is desired for drivers to be able to view an approaching vehicle's headlamps over the LCDs. If LCDs greater than 21 inches tall are used, practitioners should use Table 27 to determine the minimum distance upstream and downstream of a driveway where continuous LCDs should terminate and begin, respectively, so that drivers can see an approaching vehicle's headlamps around the end of the LCDs.
- Continuous LCDs may also be beneficial on urban roadways when a high number of deliberate intrusions into the work zone to access driveways or minor roads are expected to occur or have occurred while using the standard drum treatment.

Additional Research

While the research documented herein investigated a number of issues related to the application of LCDs in work zones, several items of interest remain unanswered.

- Researchers conducted photometric analyses of various LCD delineation treatments; however, none of the LCD treatments produced luminance values comparable to the standard drum treatments. Human factors-based research is needed to assess the minimum retroreflectivity requirements of LCDs and to investigate the impacts of delineating LCDs similar to concrete barrier.
- Field studies are needed to evaluate the effectiveness of continuous LCDs in the immediate vicinity of exit ramps and along the edge of a travel lane in a work zone on an urban roadway.
- Research is needed to determine whether the color pattern of LCDs impacts their effectiveness and whether certain color patterns of LCDs can be used to help emphasize decision points in work zones. While initially planned as part of this research, the project panel decided to only utilize orange LCDs based on a demonstration held near the beginning of the project.

Other Considerations

In addition to the items already discussed, researchers assessed the practicality of implementing LCDs in work zones. Specifically, the following issues were considered: (1) the cost of using LCDs compared to drums; (2) the transport, setup, maintenance, replacement, and removal of LCDs compared to drums; (3) the potential for misapplication; and (4) the need for additional crash testing.

Based on discussions with two LCD manufacturers, LCDs cost between \$100 and \$500 each dependent upon their length and height. Comparatively, drums cost \$60 each (based on purchases made during this project). Table 28 shows a cost comparison for the standard drum spacing on the tangent (i.e., two times the 60 mph speed limit), half the standard drum spacing on the tangent (i.e., one times the 60 mph speed limit), and continuous LCDs in the immediate vicinity of an exit ramp within a lane closure. For the drum treatments, researchers used an upstream tangent length of 240 ft, a downstream tangent length of 120 ft, and a taper length of 100 ft. The drum spacing in Table 28 was for the tangent sections only. The drum spacing on the tapers was 20 ft. For the continuous LCDs, researchers used an upstream tangent length of 120 ft, a downstream tangent length of 60 ft, a taper length of 100 ft, and an LCD length of 6 ft.

The cost to implement LCDs in this scenario is 7 to 41 times the cost of drums, since LCDs are used continuously (i.e., no space between devices) and they cost more per device.

Table 28. Cost Comparison for an Exit Ramp Application.

Treatment	# of Devices	Estimated Cost^a
Standard Drum Spacing (120 ft)	15	\$900
½ Standard Drum Spacing (60 ft)	18	\$1080
Continuous LCDs	62	\$6200 to \$31,000

^a Assumed drums cost \$60 each and LCDs cost \$100 to \$500 each.

As discussed in Chapter 2, TxDOT personnel expressed concerns regarding the transport, setup, maintenance, replacement, and removal of LCDs compared to drums. Typically, drums are installed by a two-person crew: one person driving the vehicle and one person placing the drums on the pavement from the back of the vehicle. During this research, a three-person crew was needed to install the LCDs: one person driving the vehicle, one person pushing the LCDs off a trailer, and one person on foot to align the LCDs. In addition, the LCDs took longer to deploy than the drums. So, additional personnel and time may be needed to install and remove LCDs compared to drums.

The weight of LCDs may also impact installation and removal methods. LCDs weigh between 35 and 132 lb empty. Comparatively, drums weigh between 33 and 48 lb, including the base. In addition, the vehicle typically used to install and remove drums may not be able to accommodate the larger size of the LCDs. Thus, different equipment may be required to more efficiently install and remove LCDs.

While continuous LCDs may be more resistant to getting knocked over and misaligned, they may be harder to replace when damaged if they are not readily available like drums. In addition, there are concerns about the stability of LCDs when placed on uneven surfaces, especially if ballast is not required. LCDs may also be harder to move than drums when access into and out of the work zone is needed.

Although continuous line applications of LCDs may appear to form a solid wall, they do not meet the vehicle redirection requirements for temporary traffic barriers. Thus, while LCDs must be crashworthy, they do not provide positive protection for obstacles, pedestrians, or workers since they are not designed to prevent penetration by vehicles. However, since LCDs

look very similar to water-filled barriers, the two devices are often confused with each other. Delineating LCDs the same as barriers may exacerbate the confusion and lead to a false sense of security for both motorists and workers and misapplication of LCDs in work zones.

Again, all LCDs must be crashworthy; however, the test level for which each device is approved varies. Also, some LCDs can be used with and without ballast (i.e., water or sand), and some LCDs have been approved with or without the use of other traffic control devices (e.g., warning lights, delineators, and signs). As shown in Figure 32, in the exit ramp and driveway scenarios studied, the blunt end of the continuous LCD sections was either exposed or shielded with a drum. Additional crash testing may be needed to determine the necessity for end treatments if there is a potential for instability when an end-on collision occurs.



(a) Exposed Ends of the Downstream Taper and Tangent – Exit Ramp Scenario.



(b) Drum in Front of Upstream End of Continuous LCDs – Driveway Scenario.

Figure 32. Examples of the End of Continuous LCDs.

CHAPTER 7: REFERENCES

1. *Manual on Uniform Traffic Control Devices*, 2009 Edition, FHWA, U.S. Department of Transportation, December 2009. Available at <http://mutcd.fhwa.dot.gov/>. Accessed August 17, 2010.
2. Pain, R.F., H.W. McGee, and B.G. Knapp. *Evaluation of Traffic Controls for Highway Work Zones*. NCHRP Report 236. Transportation Research Board of the National Academies, Washington, D.C., 1981.
3. Opiela, K.S., and R.L. Knoblauch. *Work Zone Traffic Control Delineation for Channelization*. FHWA-RD-90-089. Federal Highway Administration, Washington, D.C., June 1990.
4. Bryden, J.E. and D. Mace. *Guidelines for Design and Operation of Nighttime Traffic Control for Highway Maintenance and Construction*. NCHRP Report 476. Transportation Research Board of the National Academies, Washington, D.C., 2002.
5. *California Manual on Uniform Traffic Control Devices*. California Department of Transportation, January 21, 2010. Available at http://www.dot.ca.gov/hq/traffops/signtech/mutcdsupp/ca_mutcd2010.htm. Accessed August 20, 2010.
6. *Reduced Channelizing Device Spacing*. Maryland State Highway Administration, Baltimore, Maryland, August 2005. Available at <http://www.sha.maryland.gov/OOTS/09ReducedChannelizingDeviceSpacing.pdf>. Accessed January 4, 2011.
7. *2008 Design Standards – 600 Series, Traffic Control through Work Zones*. Florida Department of Transportation, Tallahassee, Florida. Available at <http://www.dot.state.fl.us/rddesign/rd/rtds/08/2008Standards.shtm>. Accessed on August 20, 2010.
8. *Manual on Uniform Traffic Control Devices*, 2003 Edition, FHWA, U.S. Department of Transportation, November 20, 2003. Available at <http://mutcd.fhwa.dot.gov/>. Accessed August 17, 2010.
9. *Texas Manual on Uniform Traffic Control Devices*. Texas Department of Transportation, Austin, Texas, 2006. Available at http://www.txdot.gov/txdot_library/publications/tmutcd.htm. Accessed September 30, 2010.
10. *Texas Barricade and Construction Standard Sheets*. Texas Department of Transportation, Traffic Operations Division, Austin, Texas. Available at <http://www.dot.state.tx.us/insdtdot/orgchart/cmd/cserve/standard/toc.htm>. Accessed August 18, 2010.
11. AASHTO Task 13 Website. Available at <http://www.aashtotf13.org/>. Accessed March 11, 2008.
12. FHWA Crashworthy Work Zone Traffic Control Devices Website. Available at http://safety.fhwa.dot.gov/roadway_dept/policy_guide/road_hardware/wzd/. Accessed September 30, 2010.
13. *Compliant Work Zone Traffic Control Device List*. Texas Department of Transportation, Traffic Operations Division, Austin, Texas, August 2008. Available at <http://ftp.txdot.gov/pub/txdot-info/trf/pdf/cwzctcd.pdf>. Accessed January 4, 2011.

14. Ross, Jr., H.E., D.L. Sicking, R.A. Zimmer, and J.D. Michie. *Recommended Procedures for the Safety Performance Evaluation of Highway Features*. NCHRP 350, Transportation Research Board of the National Academies, Washington, D.C., 1993.
15. Sekular, R., and R. Blake. *Perception*, 4th Edition. McGraw-Hill: New York, 2002.
16. Boyd, P. *NHTSA's NCAP Rollover Resistance Rating System*. Available at <http://www-nrd.nhtsa.dot.gov/pdf/esv/esv19/05-0450-O.pdf>. Accessed September 8, 2010.
17. U.S. Department of Transportation, Federal Highway Administration Statistics 2005, Table DL-22. Available at <http://www.fhwa.dot.gov/policy/ohim/hs05/htm/dl22.htm>. Accessed July 27, 2010.
18. Fambro, D.B., K. Fitzpatrick, and R.J. Koppa. *Determination of Stopping Sight Distances*. NCHRP 400, Transportation Research Board of the National Academies, Washington, D.C., 1997. Available at http://onlinepubs.trb.org/onlinepubs/nchrp/nchrp_rpt_400.pdf. Accessed January 4, 2011.
19. *A Policy on Geometric Design of Highways and Streets*. Fifth Edition. American Association of State Highway and Transportation Officials, Washington, D.C., 2004.
20. *Roadway Design Manual*. Texas Department of Transportation, Austin, Texas, May 2010. Available at <http://onlinemanuals.txdot.gov/txdotmanuals/rdw/rdw.pdf>. Accessed September 21, 2010.

APPENDIX A: EXIT RAMP CLOSED-COURSE STUDY TREATMENTS

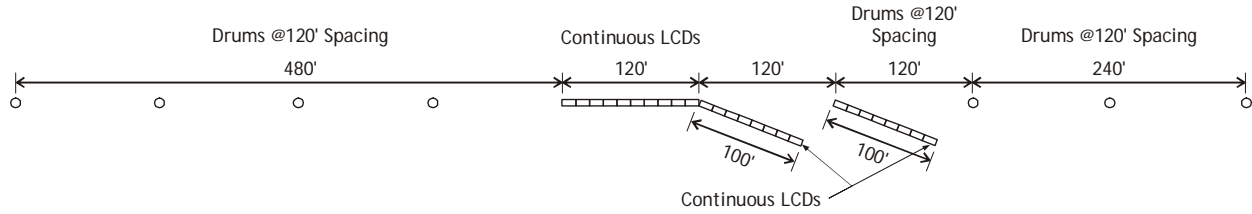

Figure A1. Treatment 1.

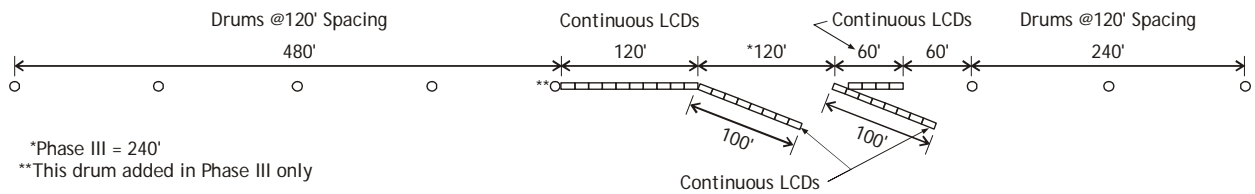

Figure A2. Treatment 2.

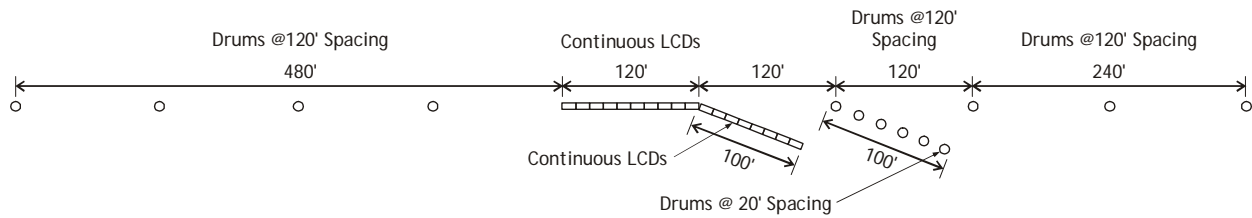

Figure A3. Treatment 3.

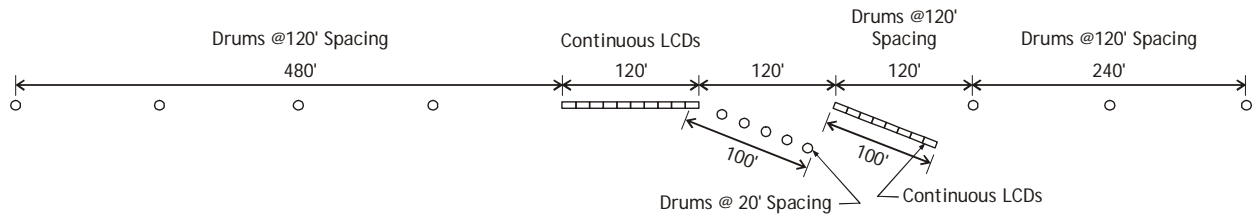

Figure A4. Treatment 4.

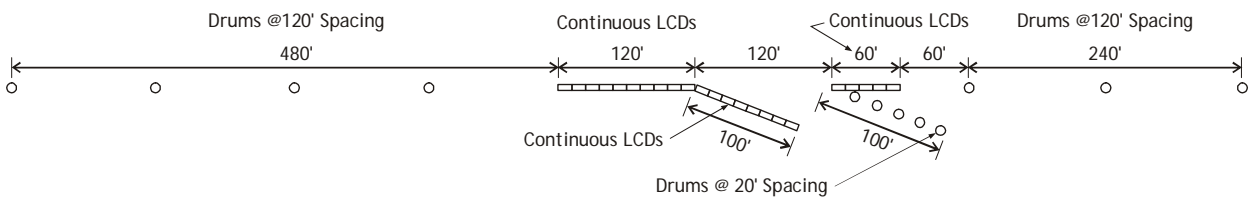

Figure A5. Treatment 5.

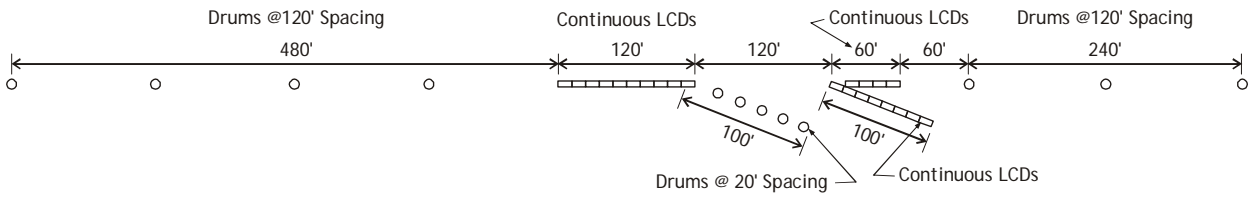

Figure A6. Treatment 6.

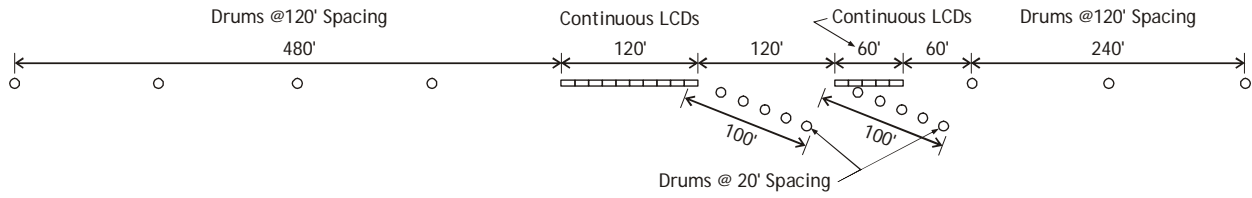

Figure A7. Treatment 7.

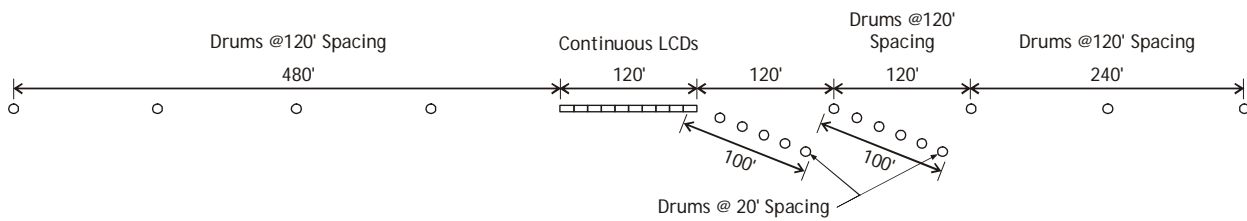

Figure A8. Treatment 8.

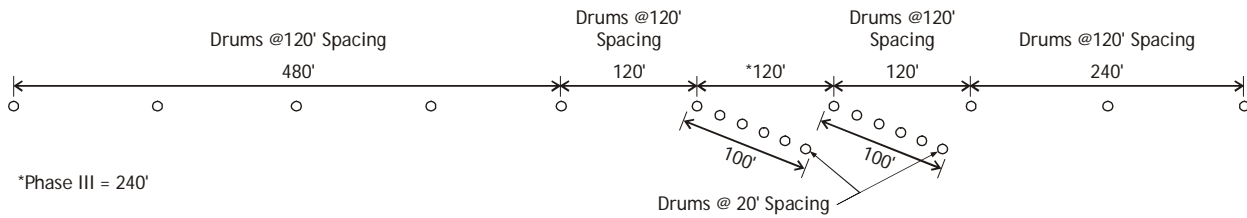

Figure A9. Treatment 9a.

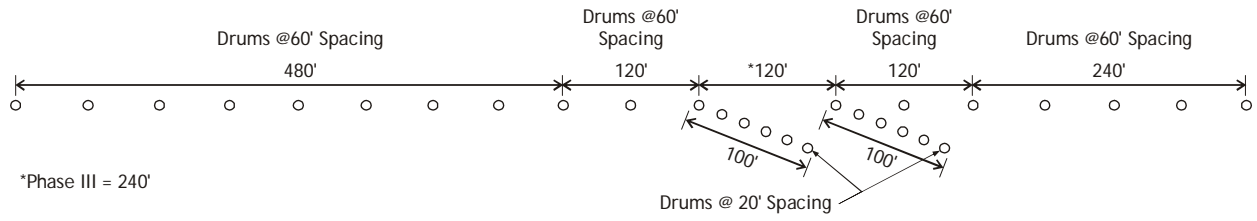

Figure A10. Treatment 9b.

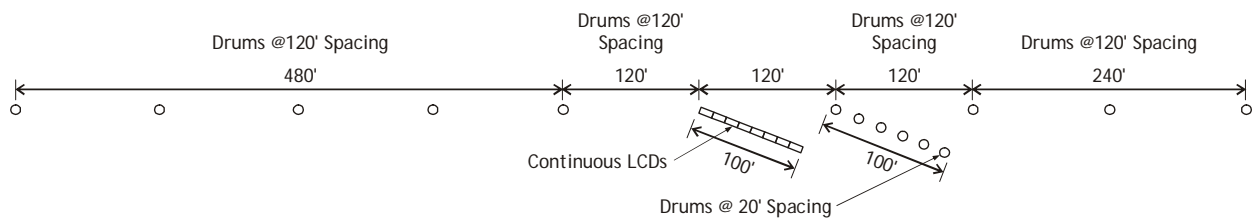

Figure A11. Treatment 10.

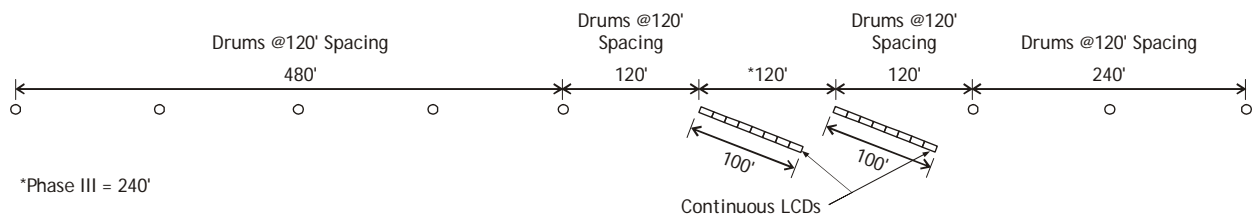

Figure A12. Treatment 11a.

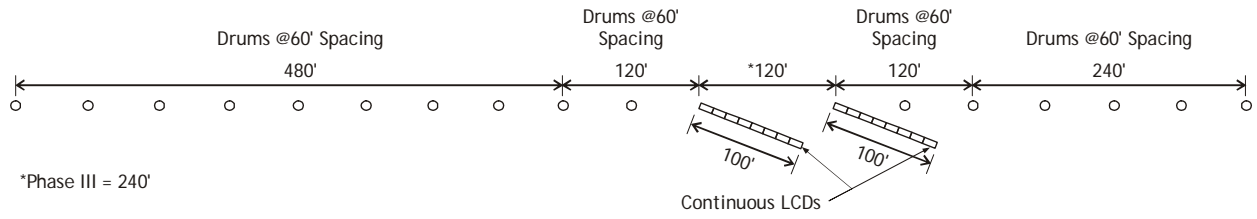

Figure A13. Treatment 11b.

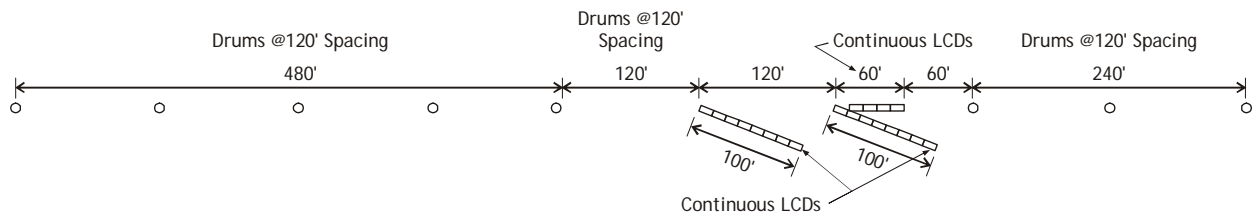

Figure A14. Treatment 12.

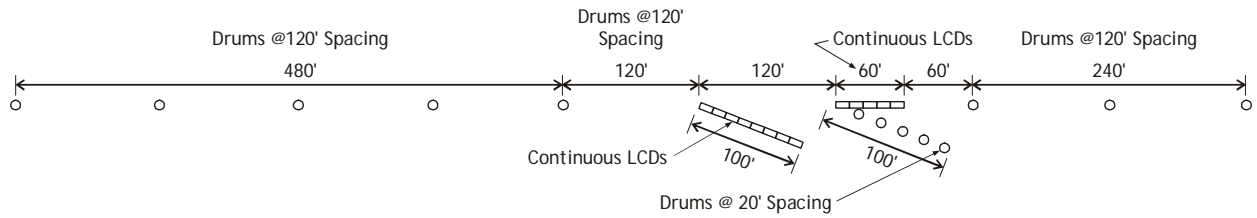

Figure A15. Treatment 13.

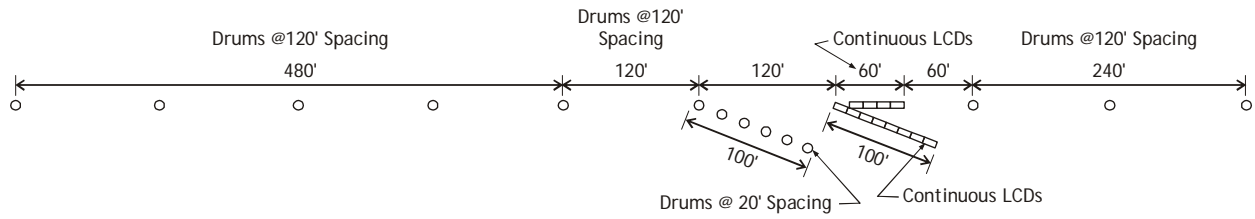

Figure A16. Treatment 14.

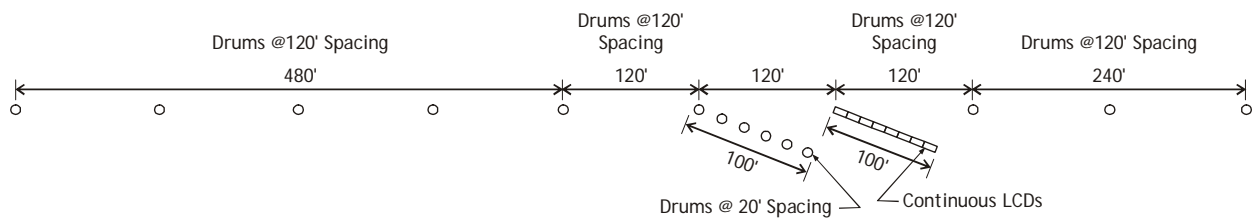

Figure A17. Treatment 15.

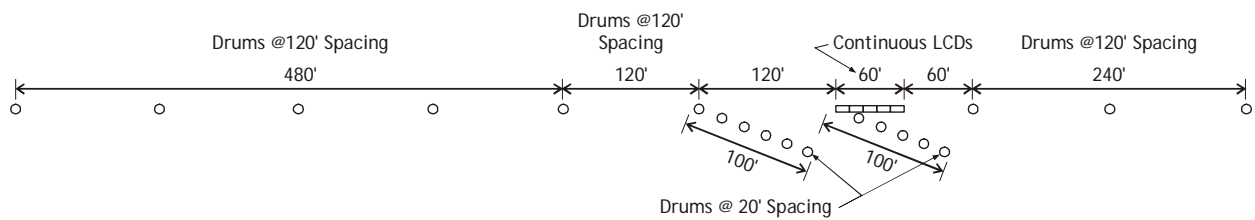

Figure A18. Treatment 16.

**APPENDIX B:
EXIT RAMP CLOSED-COURSE STUDY RESULTS**

Table B1. Phase I Results.

Treatment Number	Sample Size	Mean Detection Distance (ft)	Standard Deviation (ft)	Minimum Detection Distance (ft)	Maximum Detection Distance (ft)
1	8	360	250	122	772
2					
3	8	304	249	104	842
4	8	211	164	7	387
5	8	378	291	60	852
6	8	363	268	99	829
7	8	309	186	51	638
8	8	176	166	36	572
9a					
9b					
10	7	358	175	138	653
11a	8	369	144	178	636
11b					
12	8	240	169	31	555
13	8	302	143	118	584
14	8	173	142	65	501
15	8	242	118	44	440
16	8	154	161	25	517

Shaded cells indicate the treatment was not included in Phase I.

Table B2. Phase II Results.

Treatment Number	Sample Size	Mean Detection Distance (ft)	Standard Deviation (ft)	Minimum Detection Distance (ft)	Maximum Detection Distance (ft)
2	16	319	113	148	520
6	16	351 ^a	163	71	660
7	16	258	104	118	557
9a	15	222	87	115	456
9b	16	198	92	19	395
11a	16	364 ^a	126	160	642
11b	16	364 ^a	111	196	544

^a Significantly different from treatments 9a and 9b (alpha=0.05).

Table B3. Phase III Results.

Treatment Number	Sample Size	Mean Detection Distance (ft)	Standard Deviation (ft)	Minimum Detection Distance (ft)	Maximum Detection Distance (ft)
2	20	494	196	185	853
9a	20	383	117	174	609
9b	20	392	141	39	619
11a	20	411	119	162	571
11b	20	453	180	170	906

**APPENDIX C:
DRIVING SIMULATOR STUDY RESULTS**

Table C1. Not Occluded Results.

Treatment	Sample Size	Mean Lane Change Distance (ft)	Standard Deviation (ft)	Minimum Lane Change Distance (ft)	Maximum Lane Change Distance (ft)
Drums (30 ft)	54	1167	383	327	2000
Drums (15 ft)	56	1157	414	306	2178
LCDs	56	1301	610	437	2650

Table C2. Occluded Results.

Treatment	Sample Size	Mean Lane Change Distance (ft)	Standard Deviation (ft)	Minimum Lane Change Distance (ft)	Maximum Lane Change Distance (ft)
Drums (30 ft)	51	548	125	268	912
Drums (15 ft)	45	562	92	282	829
LCDs	51	561	98	334	875

**APPENDIX D:
DETECTION DISTANCE EVALUATION RESULTS**

Table D1. Detection Distances for Identification of Individual Devices.

Treatment	Sample Size	Mean Detection Distance (ft)	Standard Deviation (ft)	Minimum Detection Distance (ft)	Maximum Detection Distance (ft)
Drums (60 ft)	9	898	150	594	1070
Drums (40 ft)	9	714	162	539	979
LCDs (60 ft)	9	666	62	597	769
LCDs (80 ft)	9	704	65	606	808
LCDs (120 ft)	9	828	69	748	961

Table D2. Detection Distances for Identification of Longitudinal Gap.

Treatment	Sample Size	Mean Detection Distance (ft)	Standard Deviation (ft)	Minimum Detection Distance (ft)	Maximum Detection Distance (ft)
Drums (60 ft)	9	628	78	495	735
Drums (40 ft)	9	453	83	343	591
LCDs (60 ft)	9	417	54	357	518
LCDs (80 ft)	9	463	66	374	605
LCDs (120 ft)	9	575	88	413	684

Table D3. Detection Distances for Identification of Lateral Gap.

Treatment	Sample Size	Mean Detection Distance (ft)	Standard Deviation (ft)	Minimum Detection Distance (ft)	Maximum Detection Distance (ft)
Drums (60 ft)	9	601	68	495	687
Drums (40 ft)	9	357	26	321	401
LCDs (60 ft)	9	276	78	172	422
LCDs (80 ft)	9	399	75	315	553
LCDs (120 ft)	9	505	93	317	590

**APPENDIX E:
TURNING MOVEMENT EVALUATION RESULTS**

Table E1. Vehicle Speeds at the Beginning of the Intrusion Maneuver.

Treatment	Sample Size	Mean Speed (mph)	Standard Deviation (mph)	Minimum Speed (mph)	Maximum Speed (mph)
Drums (60 ft)	9	47.8	5.6	37.1	55.1
Drums (40 ft)	9	42.8	4.7	36.9	50.0
LCDs (60 ft)	9	46.2	4.0	41.5	53.7
LCDs (80 ft)	9	48.2	3.9	44.0	54.8
LCDs (120 ft)	9	52.5	4.7	44.7	57.5

Table E2. Net Steering Angles Undertaken to Pull between Channelizing Devices.

Treatment	Sample Size	Mean Steering Angle (degrees)	Standard Deviation (degrees)	Minimum Steering Angle (degrees)	Maximum Steering Angle (degrees)
Drums (60 ft)	9	9.1	2.0	6.5	11.8
Drums (40 ft)	9	12.2	2.1	9.6	16.3
LCDs (60 ft)	9	13.9	1.1	12.8	15.6
LCDs (80 ft)	9	10.5	1.7	8.2	12.9
LCDs (120 ft)	9	7.8	1.0	6.6	9.6

**APPENDIX F:
DRIVEWAY CLOSED-COURSE STUDY RESULTS**

Table F1. Detection Distances – Right Driveways.

Treatment	Trt No.	Sample Size	Mean Detection Distance (ft)	Standard Deviation (ft)	Minimum Detection Distance (ft)	Maximum Detection Distance (ft)
Drums (60 ft)	2	18	260	137	67	579
Drums (30 ft)	1	16	145	119	32	467
LCDs	3	16	183	67	91	308

Trt = Treatment

Table F2. Detection Distances – Left Driveways.

Treatment	Trt No.	Sample Size	Mean Detection Distance (ft)	Standard Deviation (ft)	Minimum Detection Distance (ft)	Maximum Detection Distance (ft)
Drums (60 ft)	2	15	150	123	31	433
Drums (30 ft)	1	17	282	266	33	731
LCDs	3	18	210	115	38	567

Trt = Treatment

