

INSIGHTS INTO THE ORIGIN AND CHARACTERISTICS OF THE SEDIMENTATION PROCESS AT MULTI-BARREL CULVERTS IN IOWA

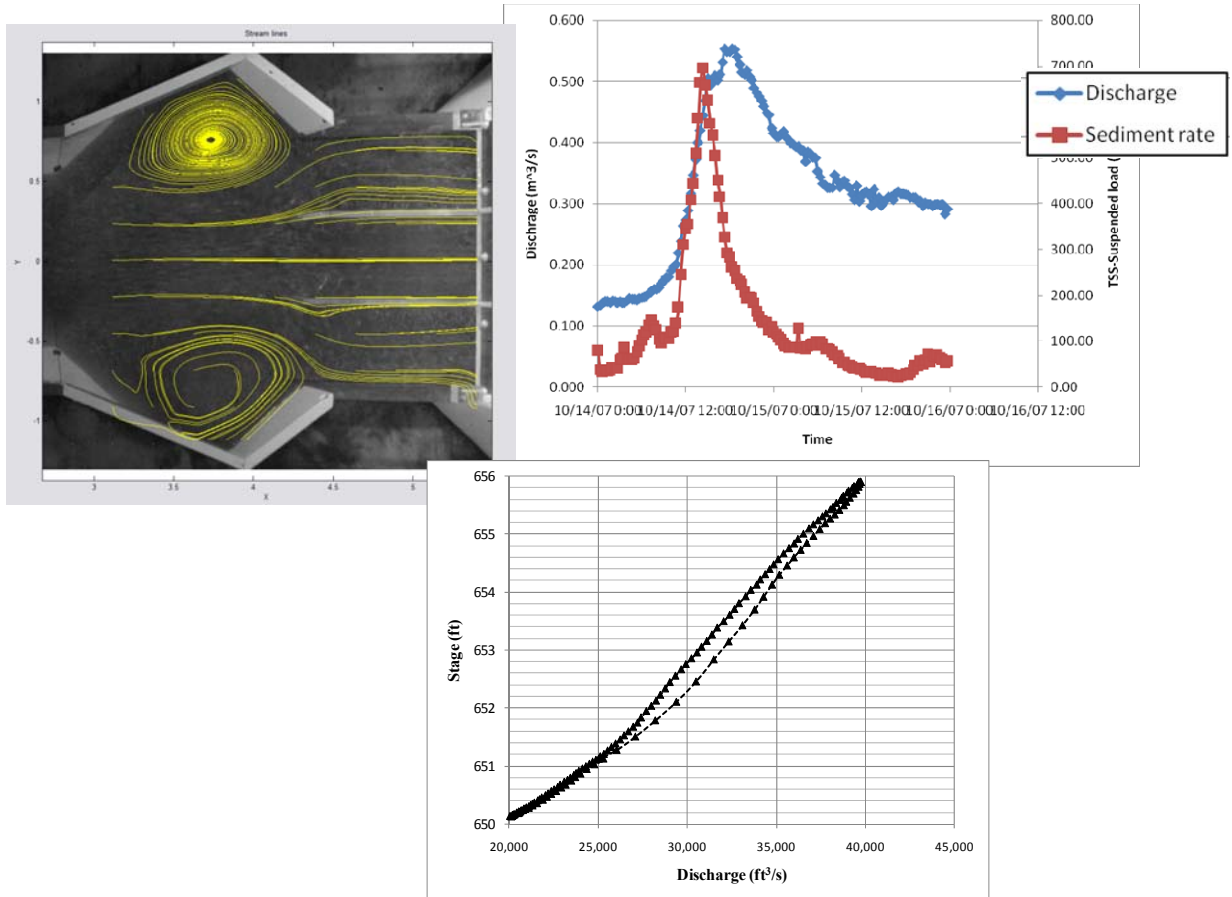

Sponsored by:
The Iowa Highway Research Board
The Iowa Department of Transportation
Research and Technology Bureau
800 Lincoln Way, Ames, Iowa 50010

Investigators: **M. Muste** (PI), **H-C. Ho** (RA), **Daniel Mehl** (RA)
The University of Iowa
IIHR-Hydroscience & Engineering
Hydraulics Laboratory
Iowa City, IA 52242-1585
Phone: 319-335-5237
Fax: 319-335-5238



About the IIHR- Hydrosience & Engineering

IIHR, a unit of The University of Iowa's College of Engineering, is one of the nation's premier and oldest fluids research and engineering laboratories. Situated on the Iowa River in Iowa City, Iowa, IIHR seeks to educate students and to conduct research in the broad fields of hydraulics and fluid mechanics.

Disclaimer Notice

The contents of this report reflect the views of the authors, who are responsible for the facts and the accuracy of the information presented herein. The opinions, findings and conclusions expressed in this publication are those of the authors and not necessarily those of the sponsors.

The sponsors assume no liability for the contents or use of the information contained in this document. This report does not constitute a standard, specification, or regulation.

The sponsors do not endorse products or manufacturers. Trademarks or manufacturers' names appear in this report only because they are considered essential to the objective of the document. The opinions, findings, and conclusions expressed in this publication are those of the author and not necessarily those of the Iowa Department of Transportation

Statement of Non-Discrimination

Federal and state laws prohibit employment and/or public accommodation discrimination on the basis of age, color, creed, disability, gender identity, national origin, pregnancy, race, religion, sex, sexual orientation or veteran's status. If you believe you have been discriminated against, please contact the Iowa Civil Rights Commission at 800-457-4416 or Iowa Department of Transportation's affirmative action officer. If you need accommodations because of a disability to access the Iowa Department of Transportation's services, contact the agency's affirmative action officer at 800-262-0003.

Non-Discrimination Statement

The University of Iowa does not discriminate on the basis of race, color, age, religion, national origin, sexual orientation, gender identity, sex, marital status, disability, or status as a U.S. veteran. Inquiries can be directed to the Director of Equal Opportunity and Diversity at the University of Iowa, (319) 335-0705.

Technical Report Documentation Page

1. Report No. IHRB Project TR-596	2. Government Accession No.	3. Recipient's Catalog No.	
4. Title and Subtitle TR-596 Insights into the Design and Characteristics of the Sedimentation Process at Multi-Barrel Culverts in Iowa		5. Report Date June 2010	
		6. Performing Organization Code	
7. Author(s) Dr. Marian Muste, Hao-Che Ho, Daniel Mehl		8. Performing Organization Report No.	
9. Performing Organization Name and Address The University of Iowa IIHR-Hydrosience & Engineering Hydraulics Laboratory Iowa City, IA 52242-1585 Phone: 319-335-5237 Fax: 319-335-5238		10. Work Unit No. (TRAIS)	
		11. Contract or Grant No.	
12. Sponsoring Organization Name and Address Iowa Highway Research Board Iowa Department of Transportation 800 Lincoln Way Ames, IA 50010		13. Type of Report and Period Covered Final Report	
		14. Sponsoring Agency Code	
15. Supplementary Notes Visit www.iowadot.gov/operationsresearch/reports.aspx or http://www.iihr.uiowa.edu for more information on this project.			
16. Abstract <p>The present study is an integral part of a broader study focused on the design and implementation of self-cleaning culverts, i.e., configurations that prevent the formation of sediment deposits after culvert construction or cleaning. Sediment deposition at culverts is influenced by many factors, including the size and characteristics of material of which the channel is composed, the hydraulic characteristics generated under different hydrology events, the culvert geometry design, channel transition design, and the vegetation around the channel. The multitude of combinations produced by this set of variables makes the investigation of practical situations a complex undertaking.</p> <p>In addition to the considerations above, the field and analytical observations have revealed flow complexities affecting the flow and sediment transport through culverts that further increase the dimensions of the investigation. The flow complexities investigated in this study entail: flow non-uniformity in the areas of transition to and from the culvert, flow unsteadiness due to the flood wave propagation through the channel, and the asynchronous correlation between the flow and sediment hydrographs resulting from storm events. To date, the literature contains no systematic studies on sediment transport through multi-box culverts or investigations on the adverse effects of sediment deposition at culverts. Moreover, there is limited knowledge about the non-uniform, unsteady sediment transport in channels of variable geometry. Furthermore, there are few readily useable (inexpensive and practical) numerical models that can reliably simulate flow and sediment transport in such complex situations.</p> <p>Given the current state of knowledge, the main goal of the present study is to investigate the above flow complexities in order to provide the needed insights for a series of ongoing culvert studies. The research was phased so that field observations were conducted first to understand the culvert behavior in Iowa landscape. Modeling through complementary hydraulic model and numerical experiments was subsequently carried out to gain the practical knowledge for the development of the self-cleaning culvert designs.</p>			
17. Key Words Multi-box culverts, Self-cleaning culvert designs, culvert sedimentation		18. Distribution Statement No restrictions.	
19. Security Classification (of this report) Unclassified.	20. Security Classification (of this page) Unclassified.	21. No. of Pages 82	22. Price NA



Executive Summary

The present study is an integral part of a broader study focused on the design and implementation of self-cleaning culverts, i.e., configurations that prevent the formation of sediment deposits after culvert construction or cleaning. Sediment deposition at culverts is influenced by many factors, including the size and characteristics of material of which the channel is composed, the hydraulic characteristics generated under different hydrology events, the culvert geometry design, channel transition design, and the vegetation around the channel. The multitude of combinations produced by this set of variables makes the investigation of practical situations a complex undertaking.

In addition to the considerations above, the field and analytical observations have revealed flow complexities affecting the flow and sediment transport through culverts that further increase the dimensions of the investigation. The flow complexities investigated in this study entail: flow non-uniformity in the areas of transition to and from the culvert, flow unsteadiness due to the flood wave propagation through the channel, and the asynchronous correlation between the flow and sediment hydrographs resulting from storm events. To date, the literature contains no systematic studies on sediment transport through multi-box culverts or investigations on the adverse effects of sediment deposition at culverts. Moreover, there is limited knowledge about the non-uniform, unsteady sediment transport in channels of variable geometry. Furthermore, there are few readily useable (inexpensive and practical) numerical models that can reliably simulate flow and sediment transport in such complex situations.

Given the current state of knowledge, the main goal of the present study is to investigate the above flow complexities in order to provide the needed insights for a series of ongoing culvert studies. The research was phased so that field observations were conducted first to understand the culvert behavior in Iowa landscape. Modeling through complementary hydraulic model and numerical experiments was subsequently carried out to gain the practical knowledge for the development of the self-cleaning culvert designs.



ACKNOWLEDGEMENTS

The field, laboratory, and numerical simulation work associated with the present project were funded by the Iowa Highway Research Board, as Research Project TR-596. This support is gratefully acknowledged.

A Technical Advisory Committee, provided advice and recommendations during the project development. The members of the Committee and their affiliations are listed below:

David Claman	Iowa Department of Transportation
Roger Schletzbaum	Marion County, Iowa
Bob Younie	Iowa Department of Transportation

Conduct of the project was coordinated with Mark Dunn, Iowa Department of Transportation.



TABLE OF CONTENTS

1. Synopsis of the sedimentation problems at Iowa culverts 1

 1.1 Problem statement..... 1

 1.2 Survey of Iowa engineers..... 4

 1.3 Sedimentation at Iowa culverts..... 6

 1.4 Sediment mitigation 9

2. Insights into the processes involved in the culvert sedimentation 11

 2.1 Flow unsteadiness 11

 2.1.1 Rating curve 11

 2.1.2 Sediment transport during flood events 14

 2.1.3 Unsteady flow at culverts..... 15

 2.2 Field observations 17

 2.3 Flow non-uniformity..... 211

 2.4 Sedimentation at culverts..... 23

 2.5 Rationale for the present research..... 26

3. Research in support of the understanding of culvert sedimentation mechanics 27

 3.1 Investigative tools 27

 3.1.1 Experimental facilities 27

 3.1.2 Numerical simulations 29

 3.1.3 Field observations 30

 3.1.3.1 Large-Scale Particle Image Velocimetry 31

 3.1.3.2 Quantitative mapping at culvert sites..... 32

 3.1.3.3 Waterway vicinity mapping..... 34

 3.1.3.4 Flow measurement..... 35

 3.1.3.5 Assembling flow and terrain data 37

 3.2. Insights from field observations..... 39

 3.2.1 South Ralston Creek in Iowa City 39

 3.2.2 Jordan Creek in Solon..... 43

 3.2.3 Old Mill Creek in Solon..... 46

 3.2.4 Comments 50

 3.3 Considerations on flow unsteadiness 52

 3.3.1 Field survey of 2008 Iowa flood..... 52



3.3.2 Numerical simulation of 2008 Iowa flood..... 55

3.4 Considerations on sediment transport..... 57

3.4.1 Preliminary considerations..... 57

3.4.1.1 Test 1: suspended versus bed load transport..... 58

3.4.1.2 Test 2: Baseline flow 60

3.4.1.3 Test 3: Simulation of discrete sampled hydrograph 62

3.4.1.4 Test 4: Simulation of “uncoupled” flow and sediment hydrographs..... 68

4. Conclusions and further work..... 71

References.....75

Appendix A..... 78

LIST OF FIGURES

Figure 1-1 Typical sedimentation pattern at a culvert in Iowa 1

Figure 1-2 Selected responses regarding culvert sedimentation from Iowa county engineers’ survey 5

Figure 1-3 Selected responses on sedimentation at culverts resulting from the Iowa survey 5

Figure 1-4. Maryland culvert design: a) pre-construction condition in 1992; b) post-construction in 2000 10

Figure 2-1 Rating curve, $Q = f(h)$, in unsteady flow based on laboratory data (Qu, 2003)..... 12

Figure 2-2 Rating curve for flood at Connecticut River (Jansen et al., 1979)..... 13

Figure 2-3 Comparison between rating curve made by USGS and measured discharge using MLSPIV during high flows (Kim, 2006)..... 13

Figure 2-4 Evolution of suspended transport rate during a hydrograph with duration $T_r=40s$ and $T_r = 320s$ (Shutter and Verhoeven, 2001)..... 13

Figure 2-5 A counter-clockwise hysteresis collected at a small basin (Klein, 1984)..... 15

Figure 2-6 Profile of the flume and the culvert model (Meselhe and Hebert, 2007)..... 16

Figure 2-7 Flow experiment for the culvert model (Meselhe and Hebert, 2007)..... 16

Figure 2-8 Flow and sediment hydrograph at Clear Creek (10/02/07~10/04/07)..... 18

Figure 2-9 Flow and sediment hydrograph at Clear Creek (10/14/07 ~10/16/07)..... 18

Figure 2-10 Flow and sediment hydrograph in China (05/22/09 ~06/21/09)..... 19

Figure 2-11 Flow and sediment hydrograph in China (07/16/09 ~08/20/09)..... 19

Figure 2-12 Sediment-discharge rating curve at Clear Creek (10/02/07~10/04/07) 20

Figure 2-13 Sediment-discharge rating curve at Clear Creek (10/02/07~10/04/07) 20



Figure 2-14 Surface flow field (a) Streamlines, (b) Velocity vectors and velocity magnitude contour 22

Figure 2-15 Actual yield versus the prediction of model: particle diameter(1.33mm), bed elevation (154 mm) (Goodridge, 2009) 25

Figure 2-16 Examples of scour at entrance of culvert for 7-mm gravel (A), 16-mm angular gravel (B), 35-mm cobbles (C), and 37-mm angular rock (D) 25

Figure 3-1 The laboratory hydraulic model for the 3-box culvert: a) overview of the 1/20 flume, b) the culvert model (1/20B) with wind wall..... 28

Figure 3-2 Sediment feeder..... 29

Figure 3-3. Illustration of the computational domains: a) 3-box I culvert design, and b) self-cleaning culvert design for a)..... 30

Figure 3-4 MLSPIV unit: a) general view; b) mast deployed and ancillary equipment..... 32

Figure 3-5 River reach plan’s decomposition..... 33

Figure 3-6 Waterway vicinity ortho-rectification protocol: (1) identification of the planar surfaces on the images; (2) ortho-rectification of the surfaces; (3) assembling of the ortho-images of the planar surfaces to obtain the ortho-image of the landscape..... 36

Figure 3-7 LSPIV time-averaged velocity fields for the Jordan Creek site, downstream the culvert. 37

Figure 3-8 Example of mapping: Ortho-image of the studied area (left) and the corresponding digital map containing selected features of the waterway and its vicinity (right) 38

Figure 3-9 Location of the South Ralston Creek study site 39

Figure 3-10 Upstream view from the culvert..... 39

Figure 3-11 Setup of the water level sensor: a) during the installation of the sensor; b) the sensor in its working position 40

Figure 3-12 The Rating Curve and the ancillary equation used to calculate the discharge using the measured water stage 41

Figure 3-13 Comparison of the water stage measurements acquired by the deployed sensor with the USGS stage data at South Ralston Creek (12/4/09 ~ 12/28/09) 42

Figure 3-14 Discharge obtained from the stage measurement at the monitored culvert site..... 42

Figure 3-15 Satellite view of the study site. Gray arrow indicates flow direction 43

Figure 3-16 Hydrograph from 04/07/2007~07/15/2007 43

Figure 3-17 Overlap of the maps of Surveys A (solid lines) and B (dash lines) for the upstream area. The eroded mud area is represented by strips. 45

Figure 3-18 Overlap of the maps of Surveys A and B for the downstream area..... 46

Figure 3-19 Study area in Solon, Iowa: the shaded area is Lake Macbride watershed. The enlarged area shows the location of the culvert and weather stations 47



Figure 3-20 Three-box culvert and sedimentation process in Old Mill Creek in Solon, Iowa (View of the culvert entrance). It can be observed that the sediment and debris trapped in the upstream basin reduce considerably the entrance area of the culvert.. 48

Figure 3-21 Three-box culvert and sedimentation process on Old Mill Creek in Solon, Iowa. Downstream view from the culvert..... 49

Figure 3-22 Precipitation hyetograph used for Old Mill Creek study 50

Figure 3-23 LSPIV measurements during the Iowa River flood of 2008: location of the measurement site (left and right) 53

Figure 3-24 Chronology of the LSPIV measurements during the flood wave propagation 53

Figure 3-25 USGS Rating curve and the LSPIV measurements at the USGS gaging station 05454500 during the Iowa River flood of 2008. The peak of the flood is considered as reference for time to identify the raising (“-“) and falling (“+“) limbs of the rating curves. 54

Figure 3-26 The overview of Iowa River and cross-sections used in HEC-RAS model..... 54

Figure 3-27 Loop rating curve calculated from HEC-RAS for upstream Iowa River.....56

Figure 3-28 Sediment deposited at the culvert: a) using suspended load (crushed nut shells); b) with bed load (silica sand) 59

Figure 3-29 Flow condition in Baseline flow test..... 60

Figure 3-30 Sediment deposited after 2 hours for case B in model B 61

Figure 3-31 Rate of sediment accumulation in the culvert area for flow Case B..... 62

Figure 3-32 Hydrological events investigated in the culvert model..... 63

Figure 3-33 Consecutive simulation of hydrological events: a) Case B, b) Case B → Case C, c) Case B → Case C → Case D, and d) Case B → Case C → Case D → Case B 66

Figure 3-34 Consecutive sedimentation: Case B → Case C → Case B 65

Figure 3-35 Sedimentation a) simulate flow conditions: Case C → Case D; b) simulate flow condition Case B for two hours 67

Figure 3-36 Discrete sediment discharge and “uncoupled” discharge hydrographs 68

Figure 3-37 Sediment deposition pattern upstream the culvert after Test 4 69

Figure 3-38 Synthesis of various experimental approaches adopted in the laboratory study in the 1/20 scale model 70

LIST OF TABLES

Table 3-1 Three flow conditions tested in Baseline flow test..... 60

Table 3-2 Three flow conditions tested in Test 3 63



1. Synopsis of the sedimentation problems at Iowa culverts

1.1 Problem statement

Flow through box culverts in Iowa landscapes is minimal throughout most of the year. For multi-barrel culverts, some of the barrels can silt-in, becoming partially filled with sediment. Silting can reduce considerably the designed capacity of the culvert to pass storm events. During 2007, the research (Muste et al. 2009) assessed the extent and severity of the sedimentation at culverts in Iowa. The assessment entailed a series of field visits to more than 30 culverts in Buena Vista, Marion, and Johnson counties. Though the culverts were of diverse dimensions and shapes, they commonly had experienced extensive blockage by sediment, and had required difficult and costly cleanup operations. Silting situations, such as those illustrated in Figure 1-1 for the Old Mill Creek, were encountered at several of the culverts. The chronic nature of the sedimentation is emphasized by the fact that some of the culverts clogged re-clogged two years after cleanup.



Figure 1-1
Typical sedimentation
pattern at a culvert in
Iowa



The findings show that there is a need to design culverts so that they mitigate or inhibit sediment deposition and blockage. Moreover, the methods should be applicable to new culverts and existing culverts. In regions where high rates of soil erosion occur, there is pressing need for such methods. Iowa is one such area. Its numerous multi-box culverts face chronic sediment problems.

Despite of the ubiquity and severity of the sedimentation problem, little is known about the sedimentation processes at culverts. The relevant literature is scarce. To date, there has been no systematic study in the state, in other U.S. states, or abroad on the mechanics of sediment transport through multi-box culverts, or on the impact of sediment deposition on the capabilities of the culvert to convey the flows during high flows. While it is accepted that sediment transport through culverts is strongly influenced by local soil and land-use conditions in the drainage area adjacent to the culvert, scant information exists on flow to and through multi-barrel culverts. The limitations in our knowledge are due to several considerations, including:

1. The complexity of the flow carrying sediment through multi-barrel culverts;
2. Lack of field, experimental, and numerical simulation observations; and,
3. Overlooking the culvert sedimentation as an engineering concern; culverts are considered ubiquitous structures whose performance often is taken for granted.

The culvert is defined as a short conduit placed transversely under a roadway embankment, so as to convey stream flow from one side of the embankment to the other (Chow, 1959). The combined effects of site layout, highly variable, non-uniform, and varying flow rates, along with sedimentation, vegetation, and debris accumulation factors can make culvert flows rather site-specific, three-dimensional, and unsteady. This uniqueness hampers studies aimed at generalizations of flow field and sediment transport to and through culverts.



The present study is one of the few attempts in this area of research that attempts to study with several investigative approaches. The investigation carried out through this research tackles the interplay between the complex interaction of the flow and sediment transport through culverts during normal and extreme events using field observations, experiments, analytical considerations and numerical simulations coupled synergistically to lead to practical insights. The first complexity relates to the change in flow geometry from the undisturbed cross section of the stream (usually trapezoidal) to the geometry of the multi-box culvert (at least double the stream cross section area in the undisturbed region). This change in geometry occurs twice at the culvert sites: an expansion exists upstream the culvert, and a contraction to the original cross section shape occurs downstream the culvert. The transitions at culvert produce a three-dimensional non-uniform flow behavior gradually varying in space, as the flow moves downstream. The second complexity is the unsteadiness of runoff flows from the catchments drained by a culvert. Flow unsteadiness must be studied with theoretical tools, because laboratory investigations cannot easily replicate transitions the flow and sediment transport during a large time scale as required by the propagation of a flood wave. Even simulations for the simpler cases, such as the unsteady flow through a constant section open-channel, are not yet sufficiently accurate to be applied to the practical situations. The reason for this status is the lack of field observations in unsteady flows due to the high temporal resolution requirements for the instrument and data acquisition system.

Furthermore, there is limited knowledge about the non-uniform, unsteady sediment transport in channels of non-uniform three-dimensional geometry. Presently, there are few readily useable (inexpensive and practical) numerical models that can simulate flow and sediment transport in such situations. Considerable reliance must be placed on field and laboratory work. One additional complexity related to the transport processes in rivers is that several studies suggest that the sediment transport and stream flow hydrographs are not in phase: the peak of sediment hydrograph arrives before or after the peak of discharge.



1.2 Survey of Iowa engineers

A survey of Iowa county engineers and Iowa Department of Transportation (IDOT) staff provided further insights into the scope of sedimentation at multi-barrel culverts in Iowa. The insights revealed several key aspects of the sedimentation at Iowa culverts. The full results of the survey are provided in Appendix A. The main features of the sedimentation at culverts summarized here.

1. Multi-box culverts are commonly used in Iowa, as illustrated in Figure 1-2a.
2. Their major maintenance problems are attributable to accumulation of sediment and debris (see Figure 1-2b).
3. The main causes of culvert sedimentation are little known yet (see Figure 1-3a).
4. The design assumption that the sediment accumulated upstream the culverts will be washed away by storm events is not substantiated by field observations (see Figure 1-3b) in principal due to the fact that the sediment deposits are “fossilized” by the vegetation rapidly growing on the fertile soils and abundant water supply in this area. In actuality, the field observations suggest that some storm events aggravate the sediment deposition.
5. Most notably, about 70% of the survey respondents reported that they have not found a successful design approach to mitigate culvert sedimentation. A portion of the surveyed population reported that the application of terrace or drop inlet seem to mitigate the sediment deposition.
6. In almost all the culverts with sedimentation problem, expensive cleaning operations are usually carried out to remove the sediment upstream, through and downstream the culverts as indicated by Figure 1-3c.

a) How many culverts are in your county?
How many of them are Multi-box?

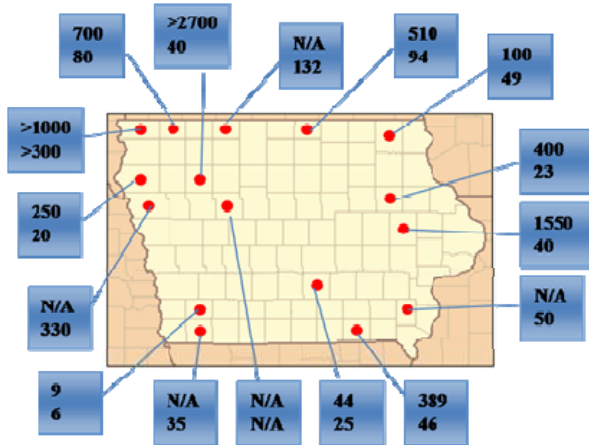

b) Most often encountered problems/concerns

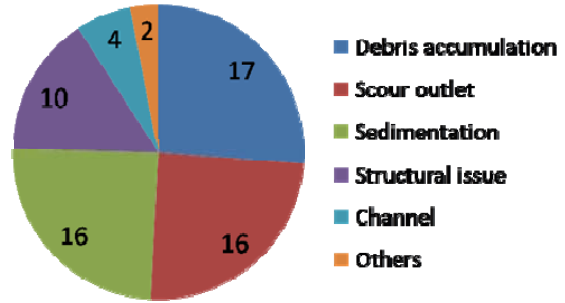
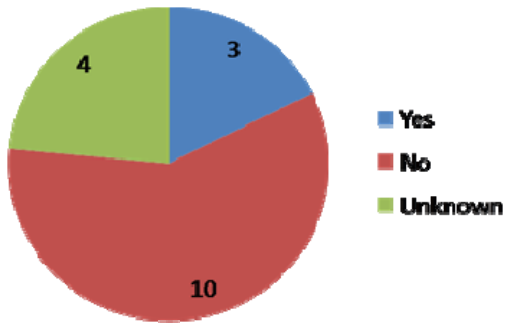
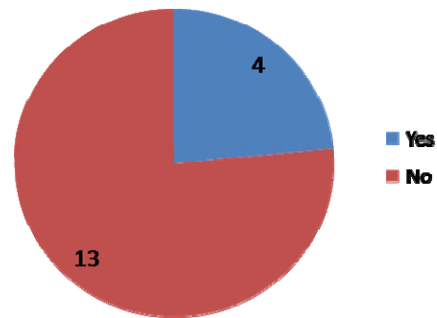

Figure 1-2 Selected responses regarding culvert sedimentation from Iowa county engineers' survey

a) Can you relate the sedimentation at M-B culvert with the season cycling?



c) Do you have successful experiences regarding mitigation of sedimentation?



b) Are the large storm events cleaning or aggravating culvert sedimentation?

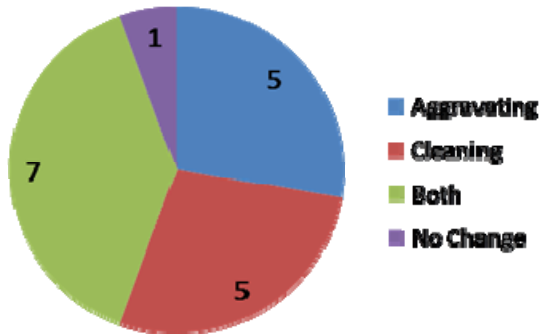

Figure 1-3 Selected responses on sedimentation at culverts resulting from the Iowa survey



1.3 Sedimentation at Iowa culverts

In the first stage of the present research, a series of field visits were carried out to facilitate the investigators in gathering insights on the sedimentation problems at culvert across Iowa. Muste et al. (2009) report on the findings observed at about 30 culverts inspected in Buena Vista, Marion, and Johnson counties. The sites visits revealed different patterns and driving forces for the culvert obstruction. In Buena Vista county (area of headwaters), the blockage of the culverts was driven by sediment washed out from the extensive crop fields in the region. In Marion County, the culvert blockage seemed to be associated with vegetal debris (tree trunks and branches) accumulation at the culvert entrance that eventually are lowering the flow velocity leading to enhanced sediment deposition. The Johnson county culverts seemed to be the most prone to obstructions. The driving factors for the culvert blockage seem to be associated with both vegetal debris accumulation as well as the abundant sediment runoff from the agricultural areas located in the culvert drainage basins. It was obvious from these site visits that there is a need for long-term monitoring in order to understand the origin and development of the obstructions at culverts. Moreover, the sediment deposits “fossilization” further impedes the insights into the processes involved. The visits led to the conclusion that more insightful monitoring can be only obtained if they are initiated right after the culverts are cleaned.

Following the visit, sites displaying fast changes obstruction development were kept under observation. Among them was the Deer Creek Culvert in Johnson County (see the summary observation sheet below). This culvert is approached by a stream that is well aligned with the central barrel. Despite the favorable culvert positioning with respect to the stream, the culvert cross-section displays considerable sedimentation in the central and right barrels. The deposits are developing throughout the two barrels. In the absence of a long-term monitoring program, there are few apparent reasons that can explain the formation of these large deposits.



Characteristics of the Deer Creek Culvert (on Hwy #218) Obstruction

- Location: on Dear Creek 500m downstream from a 2-box culvert (see aerial photo)
- Design: RCB triple-box culvert
- Surroundings: Hilly area in the vicinity of the culvert
- State of sedimentation: advanced stage
- Other considerations: Vegetation debris was not observed upstream the culvert

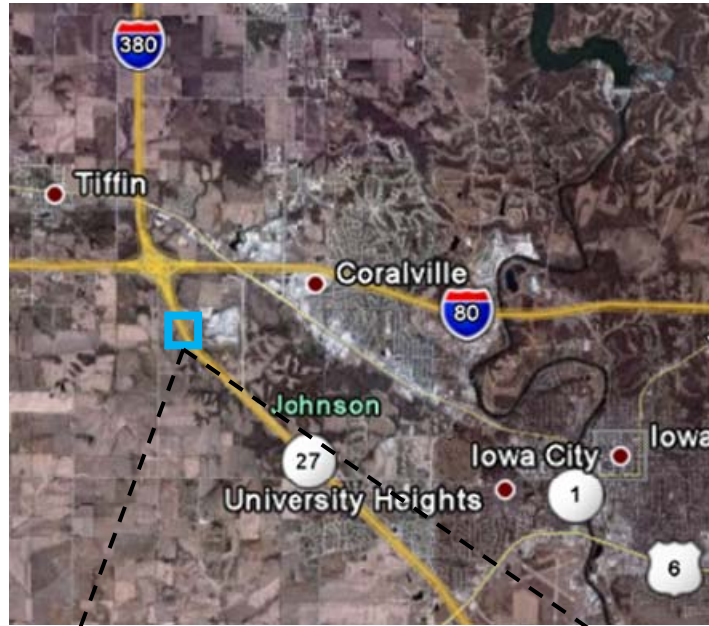

Aerial image

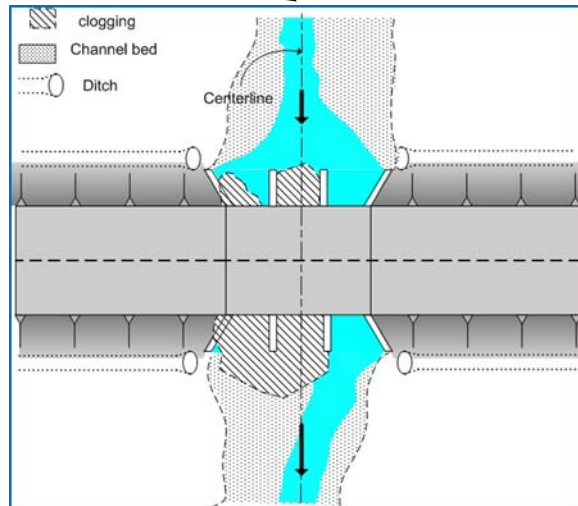

Site sketch



The stream is well aligned with the culvert axis. Steep slopes from all the culvert sides cut strong ditches merging upstream the culvert.



Considerable clogging appears on the right and central boxes of the culvert. The left box is clean; the others are heavily sedimented (about 1 m elevation difference).



A very well defined stream passes through the left barrel indicating a long term sedimentation process.



Constant sedimentation level thought the more than 50m culvert length is blocking the two culvert boxes.



The effect of the long term sedimentation is obvious (with trees already growing on the new deposits)



Mud trapped in the grass – observations made soon after a storm event passed through the culvert

Deer Creek Culvert, near Iowa City, Iowa (April 16, 2007)



1.4 Sediment mitigation

Culvert design fundamentally involves the optimal selection of the barrel cross-section that passes the design discharge. The conventional culvert design procedure, however, does not include considerations given to sediment transport. To date, attempts to include such consideration have been made, but they are mostly limited to recommendations for construction with little or no analytical considerations.

The Maryland State Highway Administration (SHA) initiated new design guidelines to construct a stable culvert system (Kosicki and Davis 2001). The design approach is intuitively based on the goals to maintain the stability of the stream at the passage through the culvert by avoiding scouring or aggradation. Elements of this approach include maintaining the consistency of dimension, pattern, and profile of the stream with particular attention given to maintaining bankfull width. Flood plain culverts are appropriately located on the sides to relieve the extra flow for the main channel. Figure 1-4b shows a reconstructed culvert based on this guideline. In 1992, SHA engineers replaced an existing culvert (Figure 1-4a) with a pipe arch in the main channel because of sediment deposition in the culvert and scour at the outlet. The central barrel of this culvert will accommodate flows up to the bankfull flow and with its invert buried 0.6 m below the streambed to provide for fish passage. As for the side barrels, the inverts of the flanking pipe arch and 3-m round structural plate pipes were placed at the bankfull elevation, approximately 0.6 m above the streambed to convey the out-of-bank flows. The construction was finished in 1994 and Figure 1-4b shows the condition in 2000. During 6 years of post-construction monitoring, the new design has no scour holes downstream and sediment deposit upstream and forms a well-defined thalweg with in the center of the stream.

A similar design guideline was proposed by Minnesota Department of Transportation (Hansen et al. 2009). The approach, named MESBOAC technique, aims to match the culvert width with natural stream dimensions while maintaining sediment balance. Both alternative



culvert designs essentially have the same construction method: burying the central culvert, matching bankfull width and offsetting multiple culvert barrels. Although the study case presented by SHA is happened as expected, the additional consideration for the risk of flooding is required. The aforementioned hydrology analysis shows that the estimation of the hydrograph in the watershed is difficult. Therefore, the bankfull width and offsetting elevation will inherit the potential uncertainties which may jeopardize the safety of traffic.

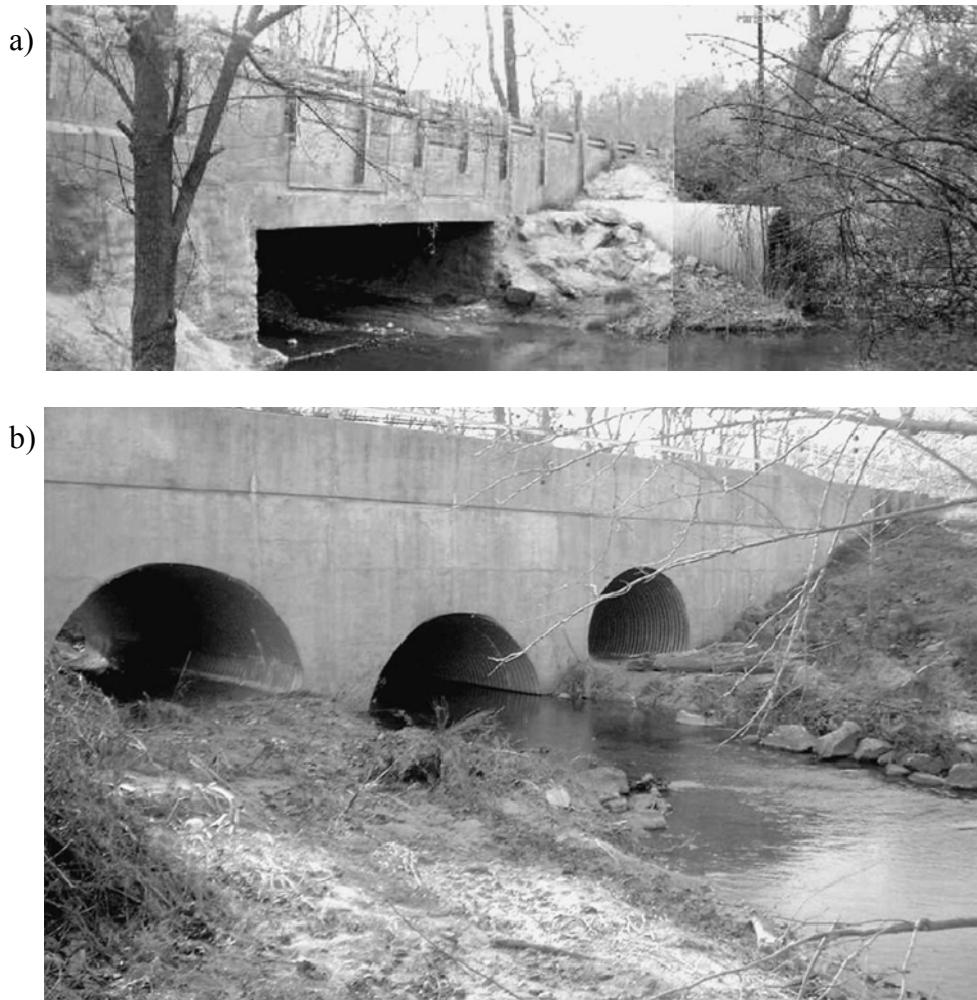

Figure 1-4. Maryland culvert design: a) pre-construction condition in 1992;
b) post-construction in 2000



2. Insights into the processes involved in the culvert sedimentation

2.1 Flow unsteadiness

Culverts are designed to pass a large range of flow rates. Although culverts usually convey relatively small flows, they may encounter some large flows during storm events. A consideration of unsteady flow is therefore required. Unsteadiness occurs during the transition of the flood wave (generated by intense rains) propagation through the river reach from the location of the rain to the river outlet. While there are various theoretical approaches to the analytical treatment of flood wave propagation, the field observations on unsteady flow at culvert is nearly nonexistent. Only one laboratory research of simulation of the flow hydrograph passing through a culvert was notified by these authors so far (Meselhe and Hebert 2007). Given the complexity of the phenomenon, herein only the flow unsteadiness in open channel will be considered. The description of the propagation of flow and sediment in channels during storms is an even more complicated process due to the coupling between the flow phases. Typically, the description of the transport processes for steady flows is provided by two relationships: stage-to-discharge (a.k.a. called rating curve) and sediment rate-to-discharge. For unsteady flows, these relationships are not valid. The former one is not anymore a one-to-one relationship as in steady flow, but develops a loop curve instead. The loop rating curve can theoretically be demonstrated by Saint-Venant equations (Chow 1959). The sediment rate-to-discharge curve also departs from the unique relationship in steady flow, as will be discussed later in Chapter 2.2. Thus chapter reviews the available literature on the effect of the unsteadiness in open channel flows.

2.1.1 Rating curve

When a flood wave propagates in a river, the wave front approaching a cross-section will experience an increase in the velocity (Henderson, 1966). After the flood peak passes the cross-section, the rear of the wave reduces the velocity at a given discharge at the cross-section. Under some conditions, these effects will be manifested as distinctive loops in the

stage–discharge relationship. Suszka (1987) introduced a non-dimensional parameter Γ to characterize the unsteadiness for open channels flows.

$$\Gamma = \frac{1}{u_{*b}} \frac{\Delta h}{\Delta T} \quad (2.1)$$

where u_{*b} is friction velocity of the base flow, Δh is the difference of water level between base flow and the maximum, and ΔT is the duration of the hydrograph

Tu (1992) followed by Song (1994) experimentally showed that the larger value of the above parameter, the more pronounced is the loop. The corresponding loop rating curve result is shown in Figure 2-1.

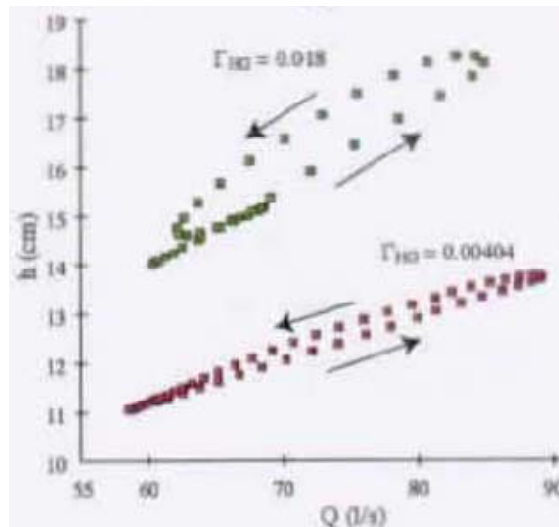

Figure 2-1 Rating curve, $Q = f(h)$, in unsteady flow based on laboratory data (Qu, 2003)

A field data (Jansen et al., 1979) has been measured in Connecticut River at Hartford, Connecticut shows the loop rating in Figure 2-2. During the field measurement, it was experience two flood events. A small flood (curve A) preceding the main flood (curve B) can be observed to form the loop rating curve.

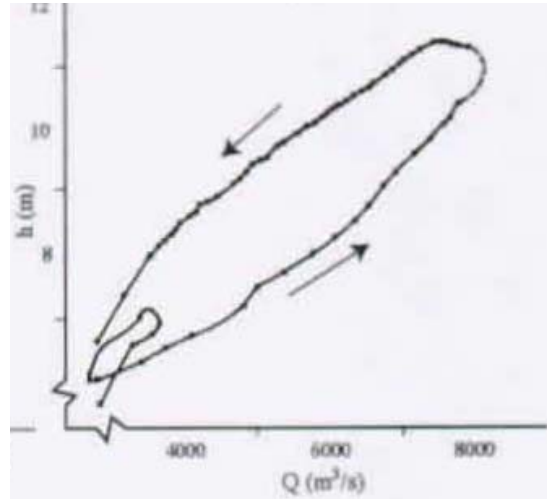

Figure 2-2 Rating curve for flood at Connecticut River (Jansen et al., 1979)

Kim (2006) collected discharge data during flood wave propagation at Clear Creek, Coralville, Iowa. The measured discharge at the peak stage was 3.4 % larger than the estimated discharge from the single-value rating curve made by USGS.

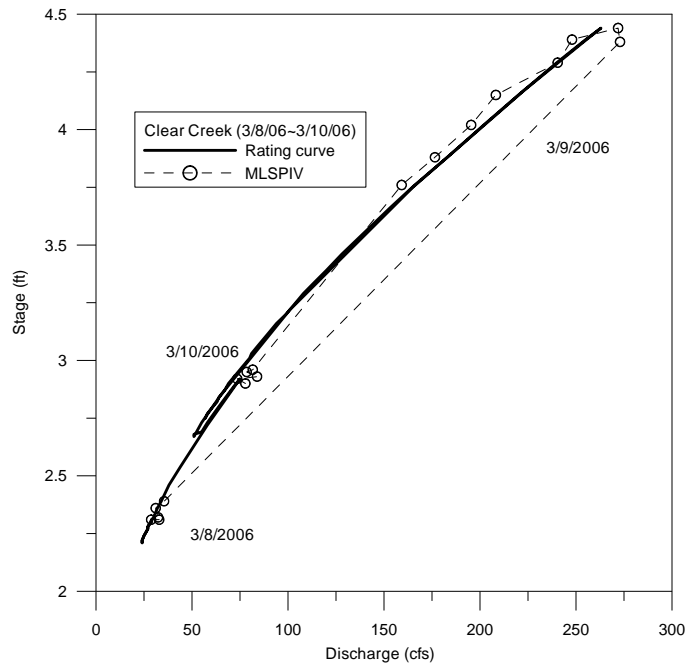

Figure 2-3 Comparison between rating curve made by USGS and measured discharge using MLSPIV during high flows (Kim, 2006)



2.1.2 Sediment transport during flood events

According to the aforementioned loop rating curve, the average velocity in the channel will reach its peak before the maximum discharge. Moreover, Graf (2003) demonstrated that the friction velocity also reached its maximum value before the maximum discharge with the average velocity expressed by a logarithmic law. The sediment discharge rate, however, is unclear when its peak will arrive.

Physically, one would not expect that the change of the sediment discharge rate, q_s , immediately responds to the corresponding variation of velocity. Shutter and Verhoeven (2001) simulated sediment transport during flood events with laboratory and field experiments. Both laboratory and field result presented that suspended sediment transport rate is higher in the rising limb than in the falling limb for the same flow rate (see Figure 2-4). The difference behavior of the sediment rate in the rising limb and the falling limb compromises the use of a traditional sediment transport formula, where discharge and sediment concentration are related in an unique relation.

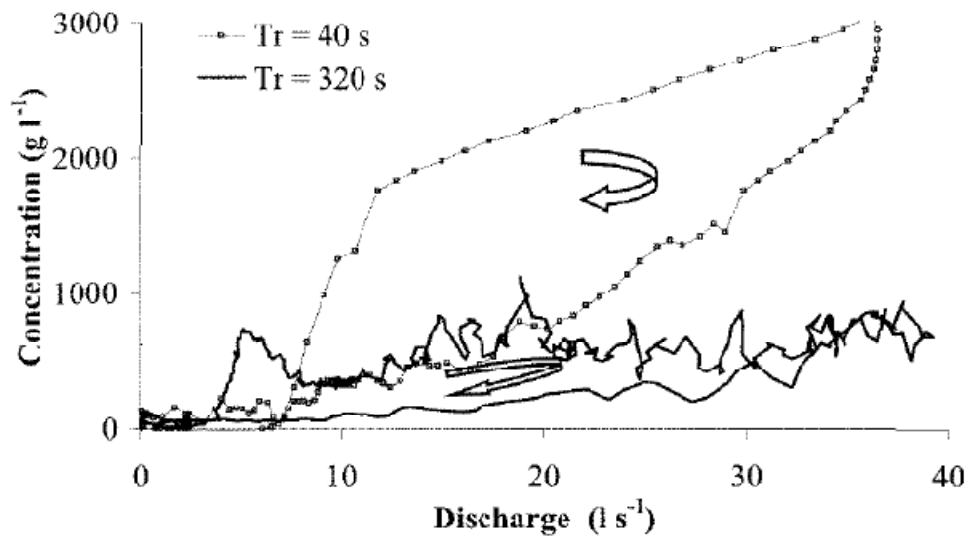

Figure 2-4 Evolution of suspended transport rate during a hydrograph with duration $T_r=40s$ and $T_r = 320s$ (Shutter and Verhoeven, 2001)



Klein (1984) pointed out the importance of the location of sediment sources which may cause a counter-clockwise hysteresis between suspended transport rate and discharge. Figure 2-5 presents his field measurement during storm events in a small basin. Lenzi and Marchi (2000) analyzed suspended load during floods in a small stream in northeastern Italy. Clockwise and counter-clockwise hysteresis loops were both observed in different floods. The above results show an important conclusion. The common clockwise hysteresis occurs when sediment source contributing area is channel itself. On the other hand when sediment source are form the basin's slopes, a counter-clockwise hysteresis occurs.

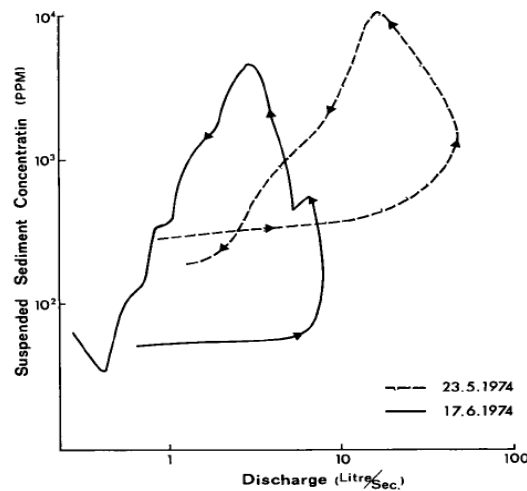

Figure 2-5 A counter-clockwise hysteresis collected at a small basin (Klein, 1984)

2.1.3 Unsteady flow at culverts

Meselhe and Hebert (2007) measured head water depth evolution with flow hydrograph. Their culvert model is a low weir with a two circle barrels culvert (Figure 2-6). In their experiment, as the flow increases the culvert barrels slowly transitions from partially full to full. During the falling limb, the culvert barrel continues to flow full with a lower discharge than during rising limb. Therefore, a counter-clockwise loop was observed in Figure 2-7.

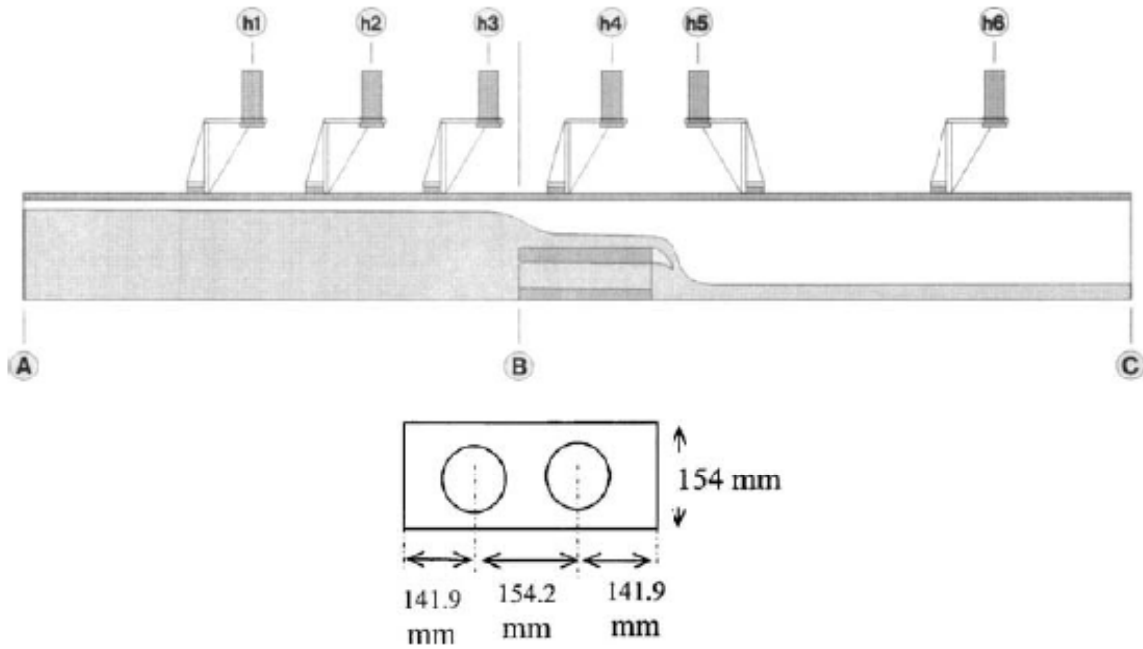

Figure 2-6 Profile of the flume and the culvert model (Meselhe and Hebert, 2007)

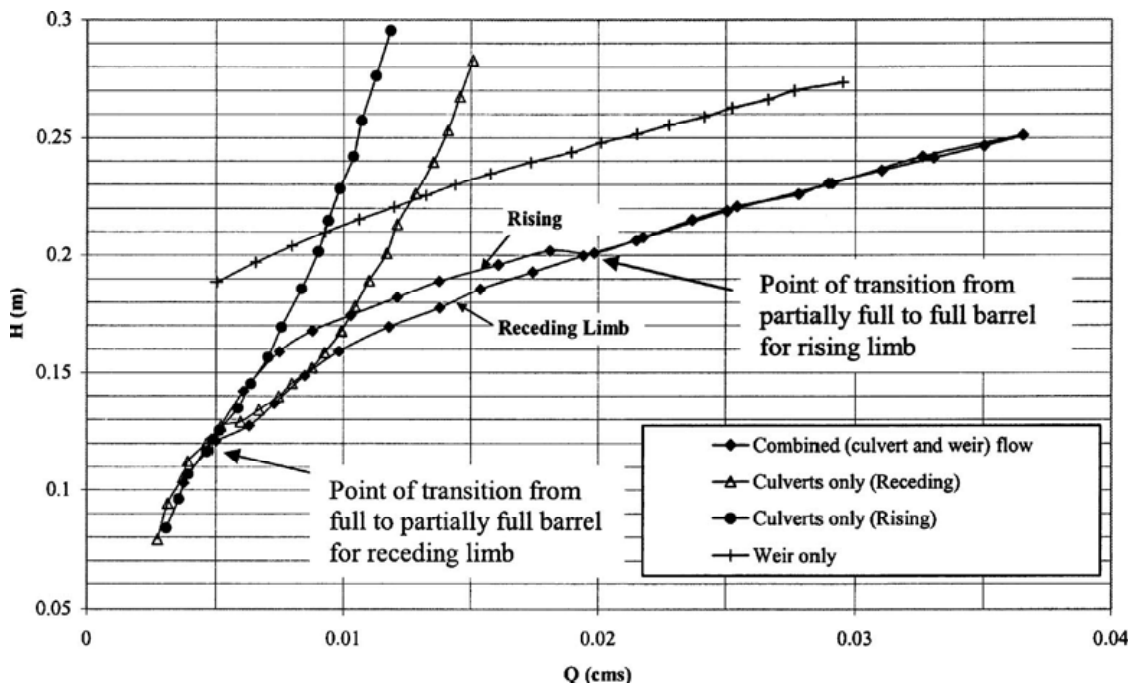

Figure 2-7 Flow experiment for the culvert model (Meselhe and Hebert, 2007)



2.2 Field observations

The phase difference between the peak for the discharge and stage as discussed in the previous section is only one of the complexities associated with the propagation of the flood wave in channels. Similar de-correlations might occur between the flow discharge and sediment transport rates. It is common knowledge that sediment is carried by streams and sediment transport rates increase when stream flow velocity increases. What is less underlined in the literature is that for the same flow velocity in a closed-loop unsteady flow, the sediment rates could be different depending on which of the flood wave limbs the analysis is made: falling or rising limb. The difference manifests as a hysteresis in the relationship between sediment transport and flow rates as is illustrated below in two field observations. One was made by Loperfido (2007) at Clear Creek, Iowa (Figure 2-8 and 2-9). The suspended sediment concentrations are obtained from turbidity measurements through calibrated correlations. The suspended sediment measurements were continuously and simultaneously obtained through a long-term experimental program conducted in the Clear creek watershed in Iowa. The other was observed by Zhang (2009) in China and also showed the phase difference between the peak for discharge and sediment transport rate (Figure 2-10 and 2-11).

The results from Figure 2-8 to 2-11 demonstrate that the largest sediment transport rate does not coincide with the occurrence of the maximum stream discharge. The peak of sediment hydrograph arrives before the peak of discharge. If we point the observed data into sediment-discharge curve, it is not surprised that all of them show a hysteresis loop for the aforementioned observation data. Figure 2-12 and 2-13 reveal that the quantity of sediment transport rate is larger in the rising limb than in the falling limb.

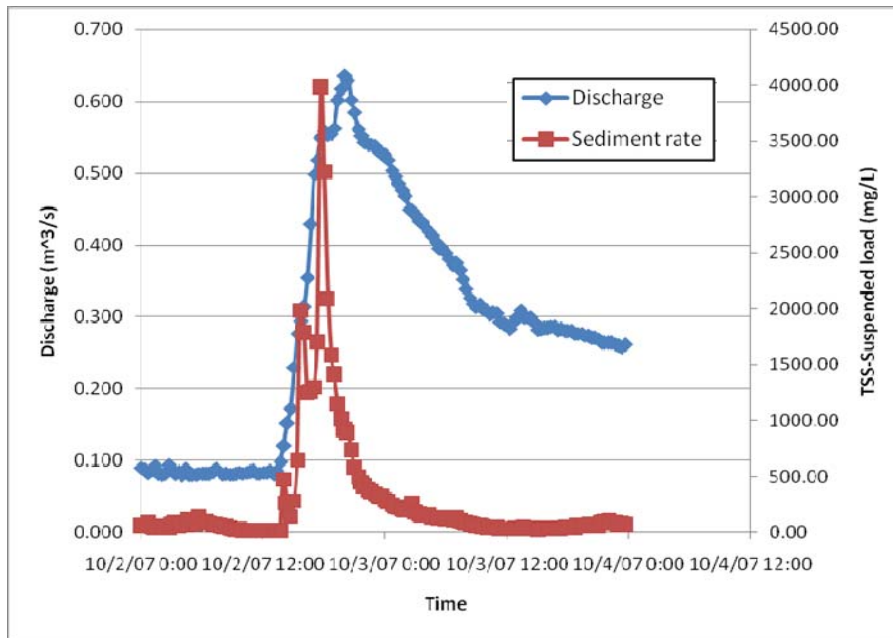

Figure 2-8 Flow and sediment hydrograph at Clear Creek (10/02/07~10/04/07)

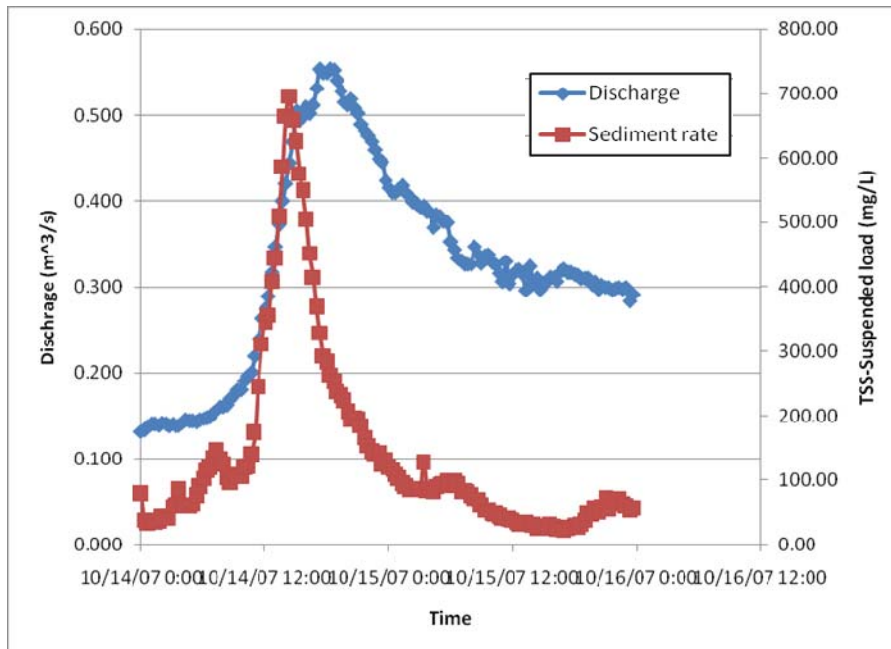

Figure 2-9 Flow and sediment hydrograph at Clear Creek (10/14/07 ~10/16/07)

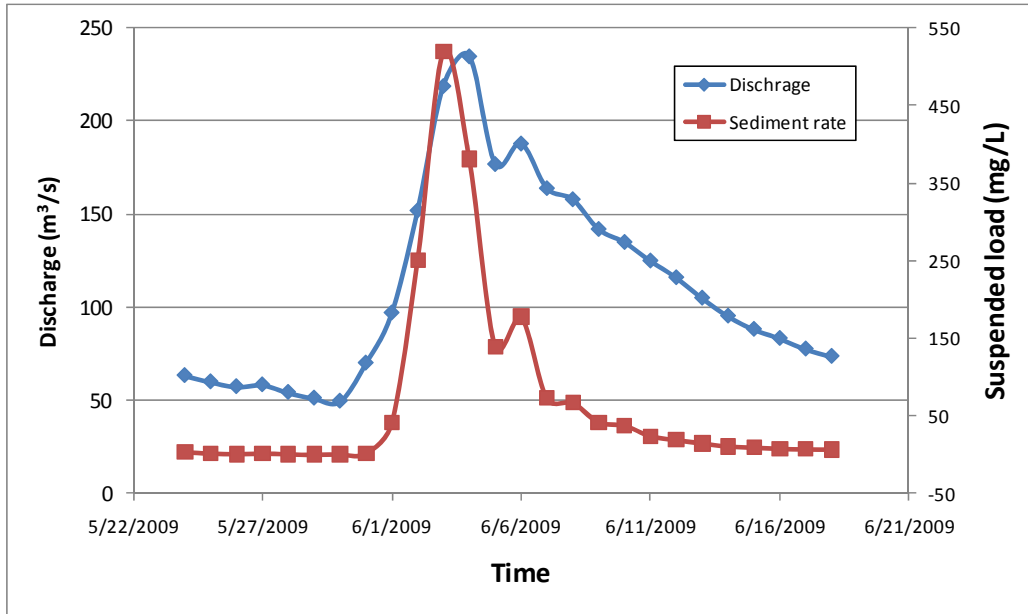

Figure 2-10 Flow and sediment hydrograph in China (05/22/09 ~06/21/09)

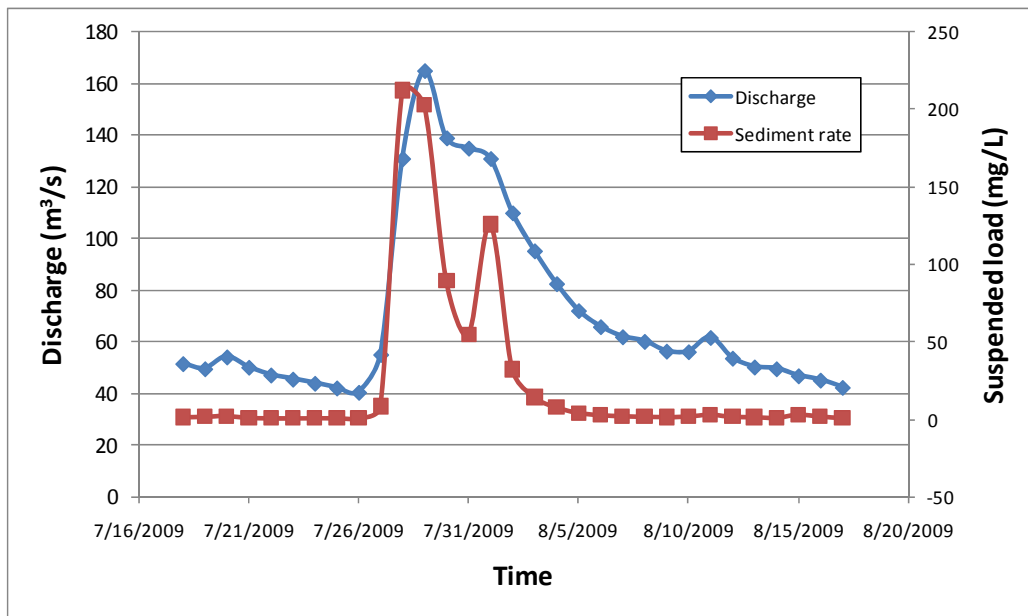

Figure 2-11 Flow and sediment hydrograph in China (07/16/09 ~08/20/09)

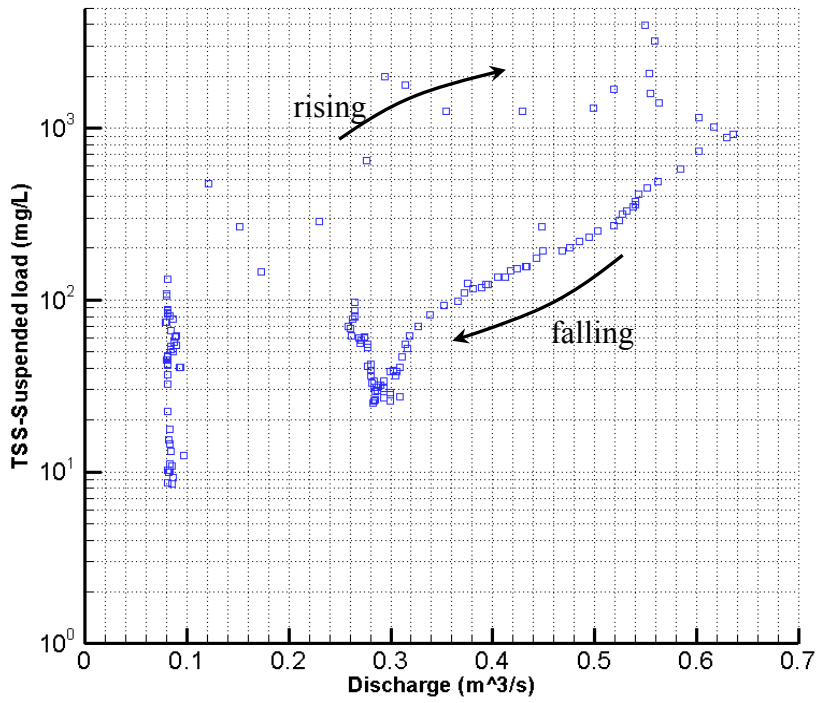

Figure 2-12 Sediment-discharge rating curve at Clear Creek (10/02/07~10/04/07)

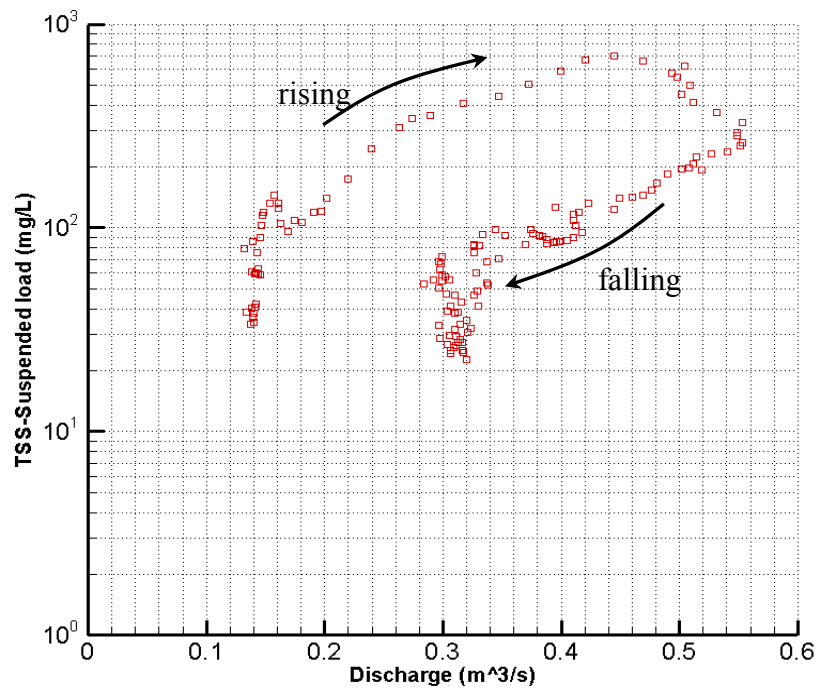

Figure 2-13 Sediment-discharge rating curve at Clear Creek (10/02/07~10/04/07)



According to the considerations presented in the previous section, the hysteresis of stage–discharge curve for unsteady flow can be explained by setting $\partial Q/\partial t = 0$. For example, using the continuity equation one can obtain the following equation:

$$\frac{\partial Q}{\partial t} = A \frac{\partial V}{\partial t} + V \frac{\partial A}{\partial t} = 0 \quad (2.2)$$

It can be observed that from Equation (2.2) that if water stage increases, the term $\partial A/\partial t$ is positive, and $\partial V/\partial t$ becomes negative. This indicates that the velocity reaches the maximum value before the occurrence of the peak discharge. The maximum water stage arrives after the peak discharge. However, the hysteresis of sediment-discharge is much more complicated. The clockwise loop (Figure 2-12 and 2-13) can be explained by either early suspended sediment depletion or the cessation of the rainfall (Peart and Walling, 1988). The clockwise loop is not the only form of hysteresis in the flow-sediment rates relationship. Depending on the local conditions the counter-clockwise hysteresis is also possible. Depending of the interplay between the characteristics of the precipitation and the soil it is possible to use the hysteresis direction as an indicator of sediment source, i.e., from either within-channel or from the soil surface of the drainage area.

2.3 Flow non-uniformity

Flow non-uniformity is defined by the change in the appearance of the flow kinematic lines (i.e., streamlines, streaklines, pathlines) when the geometry of the flow boundaries are also subjected to change. For these situations the basic flow equations (mass, momentum and energy) need to be adjusted to account for the departure from the uniform flow conditions. As expected, the flow non-uniformity is commensurate with the degree of changes in the channel boundary, therefore each change is associated with different flow patterns. Moreover the flow patterns are also dependent on the magnitude of the bulk flow velocity.

Muste et al. (2009) investigated the flow uniformity developed in a laboratory culvert model using Large-Scale Particle Image Velocimetry (LSPIV) technique. Figure 2-14 shows LSPIV results for a specific flow condition. The LSPIV measurements clearly illustrates the deviations of the streamlines in the area of expansion toward the culvert, hence the departure from the uniform flow situation where the streamlines are straight (as they are in an constant cross section open-channel flow). The streamlines in Figure 2-14 indicate that the flow entering the expansion is similar to the one in a jet. Secondary circulation was observed in the sides of the expansion which indicates that these areas are prone to deposit sediment due to the lower and reverse flows developed here. Moreover, the result shows that velocity was much larger in the culvert central barrel than in the side ones. This observation indicates that the assumption typically assumed for the culvert design, i.e., that the flow through the culvert is uniform and the discharge through the side barrels are equal to the central one is not valid. Consequently, the performance curves used for the design of the multi-barrel culverts require further investigation with respect to what corrections are necessary to account for flow non-uniformity. These findings were also highlighted by Charbeneau (2006).

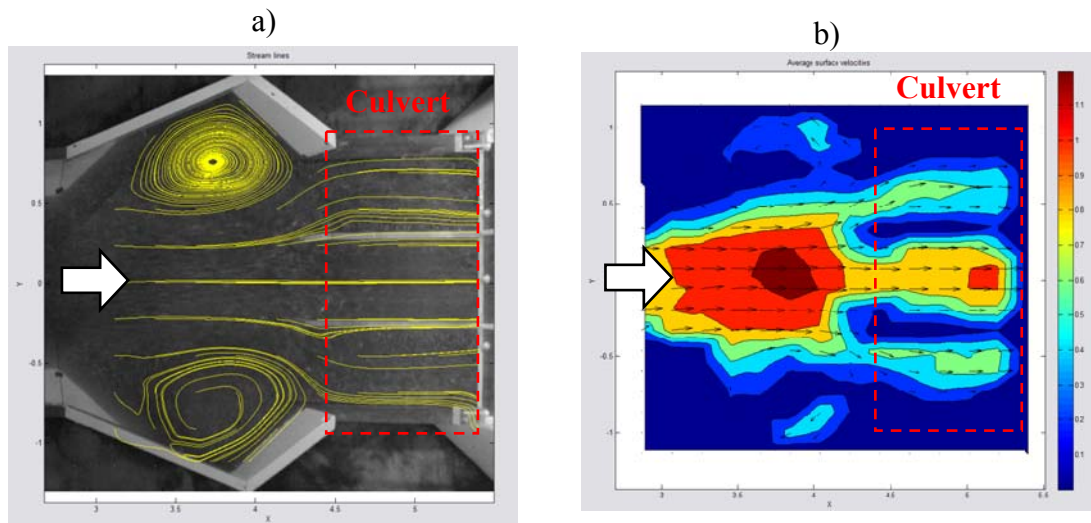

Figure 2-14 Surface flow field (a) Streamlines, (b) Velocity vectors and velocity magnitude contour



2.4 Sedimentation at culverts

Culverts are usually constructed on relative mild channel reaches to avoid supercritical flow upstream the entrance. The relative mild slope will potentially increase the probability of sediment deposition even during storm events. Sediment building up through the culvert can decrease the discharge capacity of the culvert. This decrease in the capacity of the culvert ultimately can lead to flooding under some specific hydrology events. Sediment deposition at culverts is not typically a concern for single barrel culverts, but often times become an issue for multi-barrel culverts. The latter may be necessary due to certain site conditions, stream characteristics, or economic considerations. Multi-barrel box culverts are more economical than a single wide span because the structural requirements for the roof of the long span of a one-barrel design are costly.

Sediment deposition at culverts is influenced by many factors, including the size and characteristics of material of which the channel is composed, the hydraulic characteristics generated under different hydrology events, the culvert geometry design, channel transition design, and the vegetation around the channel. The multitude of combinations produced by this set of variables makes the investigation of practical situation a complex undertaking. Therefore, most the hydraulic manuals provide design specifications only for the clear water conditions. The assumption that sediment might deposit at normal flow condition and then be flushed out during storm events prevails, despite that there is no practical evidence. Actually, for some (and not few) situations the quick growth of vegetation on the fertile sediment deposits in the culvert area “stabilizes” the deposits that continue growing from a storm to another.

Many researches (Vassillios 1995, Charbeneau et al. 2002, and Rigby et al. 2002), however, have shown significant problems at multi-barrel culvert sites, including erosion at the inlet and outlet, sediment buildup in the barrels, and clogging of the barrels with debris. Despite of the reported detrimental situations, the current culvert design considerations pay



limited attention to the effects of the interactions between the stream and the culvert, and to the sedimentation problems.

As the research of sediment deposition at culverts is difficult due to the unsteady and non-uniform flow features developing at culverts, there is limited research available on this subject and most of the accounts are obtained from observations in the field. In one of these studies, Vassilios (1995) observed a significant rainfall occurred in the winter and spring of 1992 at reinforced concrete box culvert constructed in 1991. The city maintenance placed sandbags around the area of inlet of the culvert as a temporary freeboard to provide additional headwater and prevent the coming storm. The expectation was that the coming storm can flush out sediment through the barrel, but this did not occur. The coming large rainfall occurred in May 1992. As the flow and sediment moving through, the culvert was entirely silted and blocked, causing local flooding and creating maintenance difficulties for the city.

Goodridge (2009) investigated the behavior of bed load transport in the culvert with a hydraulic model which was a single pipeline culvert. Incipient motion and critical shear stresses were investigated with the culvert model. The Engelund and Hansen, Meyer-Peter Möller, Shields, Toffaleti, Schoklitsch, DuBoys, Yang, and Rottner methods are investigated to the application into culvert sediment transport. The flow condition in the barrel is under full and partial full. Figure 2-15 shows the result for the culvert under partial full flow regime. Given each model's deviation, the empirical coefficients were then recalibrated.

Excepting sediment deposition at culvert site, the research of scour at culvert inlet and outlet is sometimes taken into consideration of the culvert design for ecological purposes. Bottomless and buried invert culvert designs are concerned for better facilitating fish migration through culverts (Kerenyi et al. 2003, Crookston and Tullis 2008). The resulting scour at the entrance along the foundation and outlet was measured (Figure 2-16). Predictive equations for estimating scour depth were developed and compared to MDSA



methodology. The prevention of scour at culvert inlet and outlet is the main concern of these studies that are different from this research.

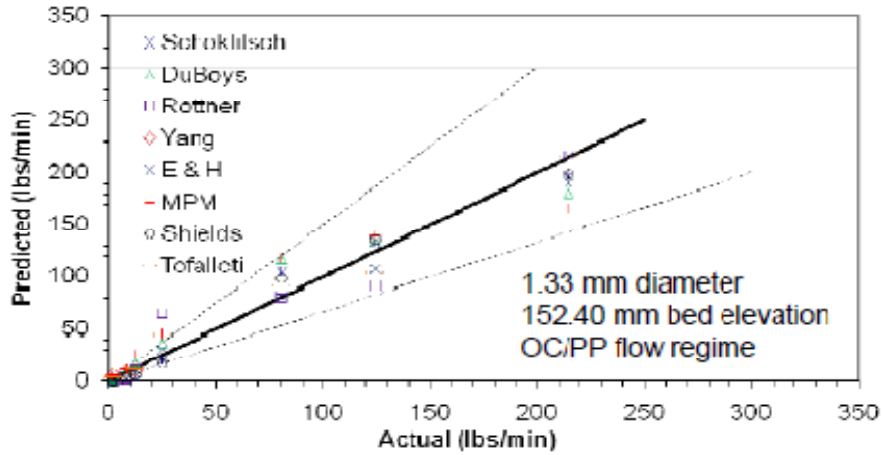

Figure 2-15 Actual yield versus the prediction of model: particle diameter(1.33mm), bed elevation (154 mm) (Goodridge, 2009)



Figure 2-16 Examples of scour at entrance of culvert for 7-mm gravel (A), 16-mm angular gravel (B), 35-mm cobbles (C), and 37-mm angular rock (D)

The significant research of culvert sedimentation is limited at this time, although sediment transport in both open channel and close conduit applications are abundant. Knowledge of sediment transport through the culvert with the unsteady and non-uniform flow condition is deficient in research. Therefore, this literature review has found no research concerning sediment transport in the unsteady non-uniform culvert system. In follow sections, several alternative culvert designs to mitigate sediment deposition and numerical simulation regarding culverts will be presented.



2.5 Rationale for the present research

From the consideration above it is obvious that the current design guidelines, such as those provided in the HDS-5 manual (Normann 1985), are based on a simplifying assumptions with respect to all three flow complexities reviewed in the previous sections: flow unsteadiness, flow non-uniformity and the flow and sediment decoupling during storm events. Typically, the main hydraulic variable taken into consideration is the peak flow without much attention given to the effect of the unsteady flow propagating through the channel, non-uniformity flow distribution upstream culverts, and the fate of sediment transport. While this approach is useful (possibly) in the majority of the situations – obviously commensurate with the magnitude of the deviations from the assumed flow conditions – the essential aspect for the discussion in this context is how to solve practical problems in a flow with complex characteristics difficult to master when they act alone, not to mention that in practical situations the combination of the three effects is always present.

The remainder of the report will review the research conducted to provide insights in these flow complexities. These complexities were analyzed in isolation by observing, measuring, or numerically simulating one effect at a time, in order to be able to discern the impact of individual processes acting individually. Moreover, due to the fact that the resources available for the project have not allowed a full fledge research of each processes involved, several investigative approaches and observation sites/systems were employed to gain the practical knowledge targeted by the overall research effort (Muste et al., 2009). The final objective of this study is to support the design and implementation of the self-cleaning culverts. With the knowledge gained from this research it is hoped to be able to retrofit existing culverts and to improve the design specifications in order to provide sediment deposition mitigation means that does not require post-construction intervention.



3. Research in support of the understanding of culvert sedimentation mechanics

3.1 Investigative tools

This section presents the laboratory flumes, numerical modeling software and field observations to investigate flow and sediment transport through multi-barrel culverts with an approach-channel expansion. The research centered on the multi-barrel culverts as this design was found prone to sedimentation problems.

3.1.1 Experimental facilities

The hydraulic model used for this phase of the culvert research replicates a three-box culvert connected to a channel expansion upstream and channel contraction downstream. The hydraulic model was fitted with fixed boundaries, i.e., the channel and the culvert area had non-erodible materials walls and bed. The model was housed a top of the large-scale sediment recirculating flume located in Model Annex of IIHR, The University of Iowa. The model scale ratio is 1:20 (named 1/20B). Figure 3-1a provides the layout of the flume. The plate form of the flume included four major parts: inlet, channel, culvert model, and outlet. The design provided us the flexibility in dealing different geometries of the stream-culvert system. The model 1/20B was built based on the design blueprints provided by Iowa Department of Transportation. The geometry of this configuration is provided in Figure 3-1b.

Water used for models was pumped from the underground reservoir through a 3hp pump. A valve positioned before the diffuser was used to control the discharge. The diffuser and flow straighteners were installed in the headbox to stabilize the flow before entering the flume channel. A series of eight holes were placed in the diffuser were placed and calibrated to uniformly release the water in the setup. The uniformity was achieved through trial-and-error tests until the flow was appropriate. The checkup of the flow quality was made by taking velocity measurement in the channel.



a)

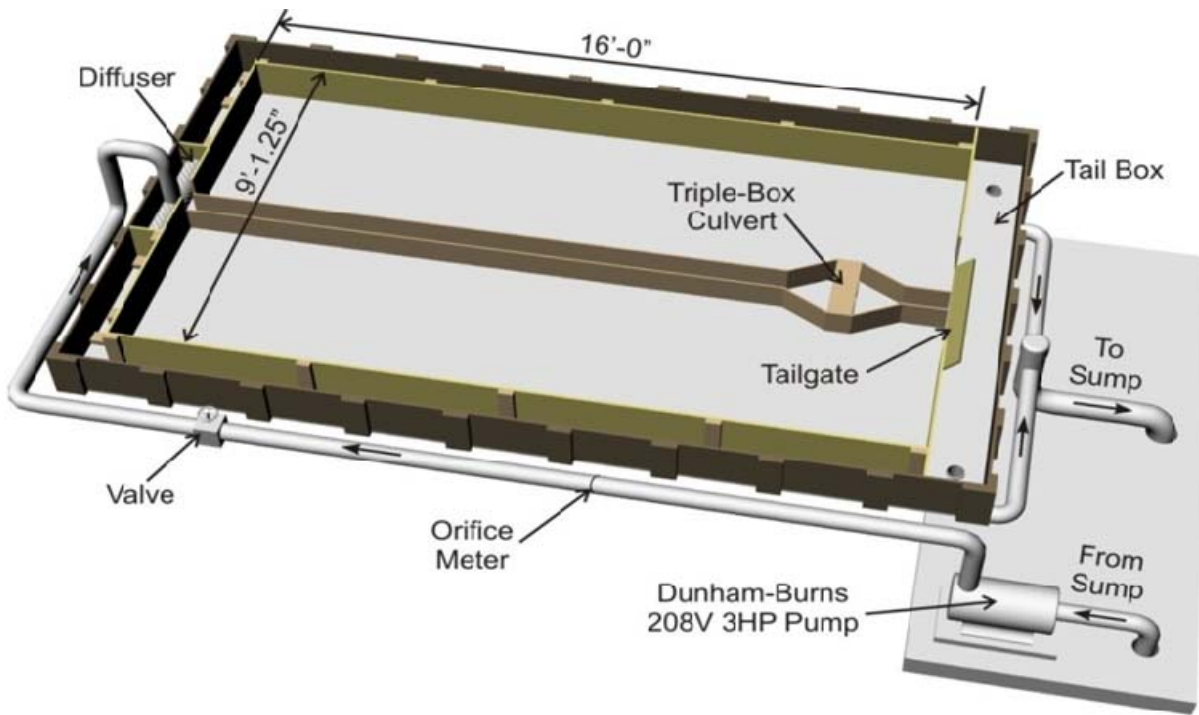

b)

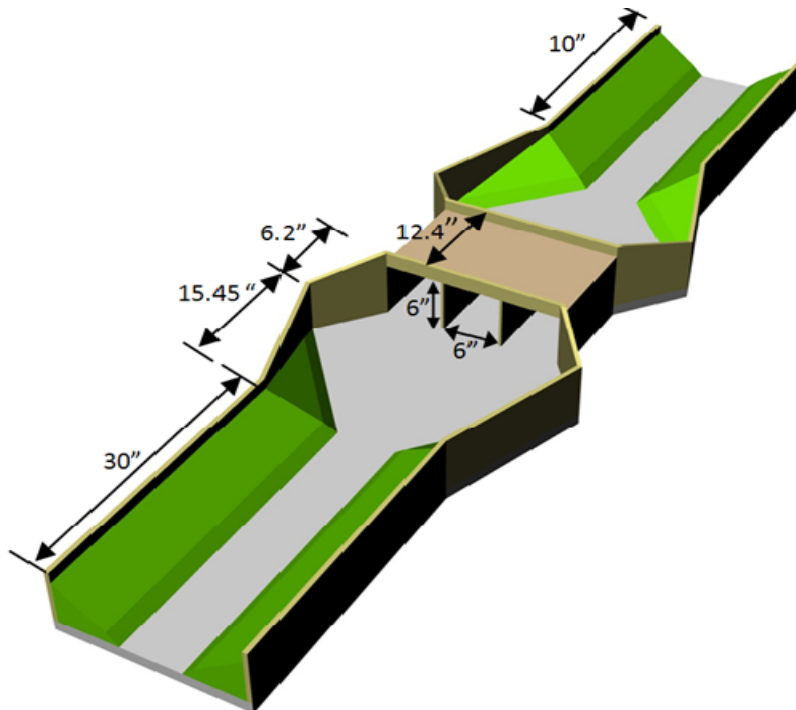

Figure 3-1 The laboratory hydraulic model for the 3-box culvert: a) overview of the 1/20 flume, b) the culvert model (1/20B) with wind wall

An important aspect of the experiments was the modeling of the sediment movement to and through the culverts. Sediment was added into the channel by the feeding machine illustrated in Figure 3-2. Small orifices were drilled on the cylinder wall to release the sand. A variable speed motor was used to control the amount of sediment added into the channel. Special attention was given to ensure a good circulation of sediment in the channel. The flow conditions needed to ensure sediment movement were tested iteratively until the sediment mobility was uniform throughout the channel. Provision was made to trap all the released sediment in order to accurately quantify the sediment transport during the tests.

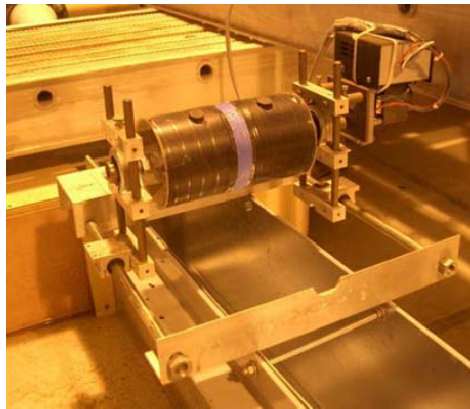

Figure 3-2 Sediment feeder

3.1.2 Numerical simulations

The numerical simulations were aimed at aiding the understanding of the complex processes related to sedimentation at culverts, and to compare simulation results with experiments. HEC-RAS, a widely used one-dimensional open channel flow model, has the capability of analyzing culvert performance within the framework of one-dimensional flow calculations using the energy and momentum equations. The unsteady HEC-RAS was used to investigate the time-dependant hydrograph in the channel leading to the culvert.

FLUENT, a commercial software, was used to simulate and analyze the non-uniform flow through the culvert model. The calculation domains for numerical simulations were



developed for two different culvert designs as illustrated in Figure 3-3. The domain was developed for hydraulic model 1/20B described above. The simulation examined the hydrodynamics of water flow for the conventional culvert design. The other model configuration was developed to investigate the effect of the different self-cleaning systems placed in the culvert area. The calibration of the numerical model used the data collected from the hydraulic models. The results of simulations with FLUENT were provided in Muste et al (2009).

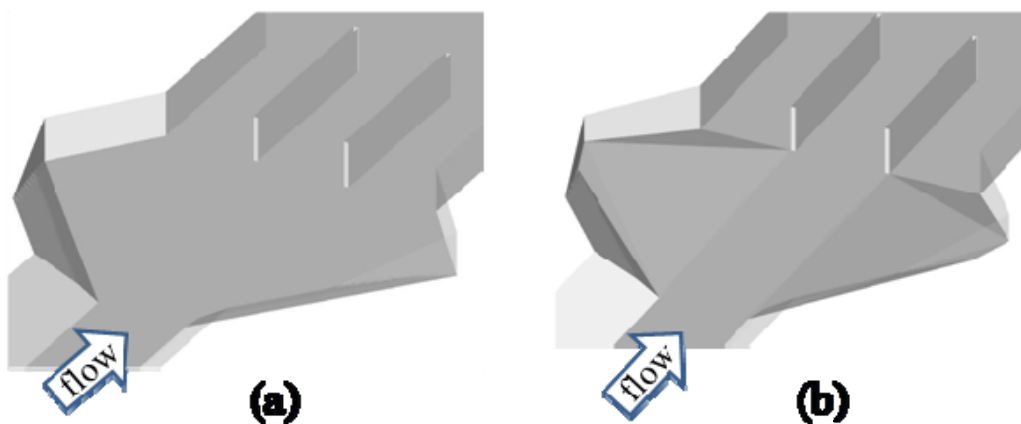

Figure 3-3. Illustration of the computational domains: a) 3-box I culvert design, and b) self-cleaning culvert design for a)

3.1.3 Field observations

The complexity of sedimentation at culvert sites is presented in the aforementioned sections. The understanding of the evolution at culvert sites depends on geomorphic and hydraulic characteristics. The conventional approach to obtain the above information is expensive and time consuming. For this research work the authors used an innovative and fast approach for mapping the culvert vicinity and the dynamics of the changes in this area. The mapping technique is based on the Large-Scale Particle Image Velocimetry (LSPIV) and close-range Photogrammetry (Hauet et al., 2009).



3.1.3.1 Large-Scale Particle Image Velocimetry

The quantitative mapping method proposed herein is based on an imaging technique pioneered at IIHR in 1995 (Muste et al., 2004). The original technique and methodologies were developed for characterizing features derived from free-surface flow velocities in streams over large scale areas (Fujita et al., 1998). The method, dubbed Large-Scale Particle Image Velocimetry (LSPIV), was successfully used in laboratory and field conditions for mapping of the free-surface flow characteristics such as streamlines, large-scale vortices, and velocity gradients. It has been expanded to measure free-surface velocities in cross sections and channel discharges under field conditions (Muste et al., 2004). Currently, IIHR has assembled a mobile (truck-based) LSPIV unit, labeled the Mobile Large-Scale Particle Image Velocimetry (MLSPIV) to enable convenient measurements at field location of interest.

MLSPIV was developed for measuring stream's free-surfaces velocities. The unit, illustrated in Figure 3-4, essentially comprises an imaging device set on a telescopic mast. The light weight aluminum, hydraulically operated mast allows for setting the camera from 15 ft to 50 ft above the ground level to accommodate imaging of various stream widths. Camera positioning and panning control are remotely conducted using a notebook computer located in the truck cabin. The MLSPIV truck is equipped with a power generator, additional batteries, and an uninterrupted power supply (UPS) that provides power for all equipments, a notebook computer, a pan-tilt unit, and a digital camera (Figure 3-4). Three guy wires are used after positioning to secure the mast against wind-induced or accidental vibrations. The mobile imaging platform can be conveniently deployed at sites of interest and can be quickly set up to acquire images in real time, followed by fast processing of the images to obtain the measurement results while at the site. This approach facilitates to decide at the location if there are measurements of poor quality and if some of them need to be taken again.

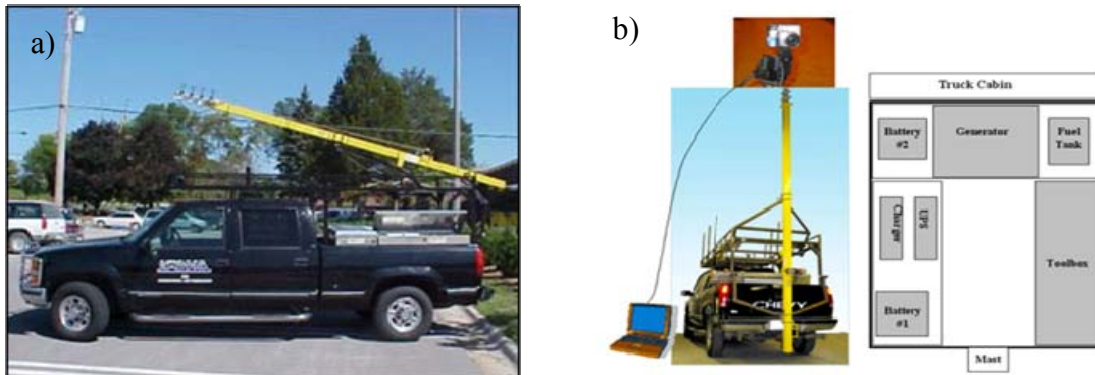

Figure 3-4 MLSPIV unit: a) general view; b) mast deployed and ancillary equipment

3.1.3.2 Quantitative mapping at culvert sites

The technique presented in this research was developed to facilitate the monitoring of waterways characteristics at culvert/bridge sites. The existing analytical, experimental, and numerical simulation prediction of typical sediment deposition patterns at culvert sites are not clear and well documented to date. The continuous monitoring at culverts is of great importance to understand the sedimentation process and map the deposition pattern. The methodology of digital mapping described herein is applicable to waterway bridge monitoring in general, but is especially well suited for monitoring of culverts and small bridges (defined as those that cross waterways with watersheds encompassing less than 300 km²) that are typical for Iowa and surrounding states. The key ingredients of this monitoring methodology are:

1. To provide accurate quantitative mapping of the waterway characteristics (i.e., information about flow distribution and velocity magnitude, channel and bank characteristics, including vegetation presence) in the culvert vicinity;
2. To record waterway changes upstream and downstream of the culvert with an emphasis on quantifying changes in sediment deposition pattern, channel pattern, shape, and elevation. The data must be recorded in a digital format, readily available for tracking aforementioned changes over short or long time periods;

3. To reduce the effort, time, and cost associated with current monitoring methods; and
4. To improve the safety of culvert/bridge inspections conducted during normal and extreme hydrological events.

The newly developed technique assembles innovative means to accomplish the above tasks. In essence, the technique is carried out in 3 steps:

1. Water vicinity mapping: Images of a river reach taken from several angles are ortho-rectified and assembled to obtain a panoramic distortion free image of the area;
2. Flow measurement: Image pairs of the river free-surface flow are analyzed using LSPIV to obtain the surface velocity field;
3. Assembling of flow and terrain data: The information obtained in steps 1 and 2 is assembled, stored and analyzed. Characteristics elements of the waterway are identified and localized in the ortho-rectified image, which leads to the creation of a digital map stored in electronic format.

Given the practicality of the discussed technique, its algorithms are described in conjunction with images acquired in-situ at a culvert site on Jordan Creek near Solon, Iowa.



Figure 3-5 River reach plan's decomposition



3.1.3.3 Waterway vicinity mapping

River reach can be broadly described using quasi-planar surfaces (Figure 3-5), i.e. at least two floodplains, two sloping banks and water flow surface. More quasi-planar surface can be used to describe complex 3D river reach geometry.

The images containing these planar surfaces need to be ortho-rectified, i.e. mapped into a new and free of distortion image where the image coordinate system (in pixel) is linearly related to the actual coordinate system (in meter for example). The ortho-rectification is carried out using an 8-parameter, plan-to-plan transformation (Mikhail et al. [2001]):

$$X = \frac{a_1 i + a_2 j + a_3}{a_7 i + a_8 j + 1} \quad (3.1)$$

$$Y = \frac{a_4 i + a_5 j + a_6}{a_7 i + a_8 j + 1} \quad (3.2)$$

where $[i, j]$ are the coordinates of a point in the image coordinates system (in pixels), $[X, Y]$ are the coordinates of the same point in the actual coordinates system (in meters) and a_i are the projective transformation parameters.

Determination of the transformation parameter is accomplished using an implicit method (Wei, 1994) based on a set of GRPs, i.e. points of known coordinates in the actual coordinate system and in the image coordinate system. At least 4 GRPs are needed to solve for the a_i parameters, and a least square fit is applied if more than 4 GRPs are available. The ortho-rectification of the waterway vicinity is accomplished with a graphical user interface and encompasses three steps, as illustrated in Figure 3-6:

1. Identification of the different planar surfaces on the images;
2. Ortho-rectification of the planar surface using Equation 1;
3. Assembling of the ortho-images of the planar surfaces to obtain the ortho-image of the waterway vicinity.



The result of the above processing steps is a color ortho-image of the area of interest that is a scaled replica of the actual vicinity of the waterway.

3.1.3.4 Flow measurement

LSPIV has been successfully implemented to measure free-surface velocities and discharges in various streams [Bradley et al., 2002, Creutin et al., 2003, Fujita, 1994, Fujita et al., 1998, Hauet et al., 2008, in press]). The technique is the extension of the conventional PIV applied in fluid mechanics [Adrian, 1991]. Estimation of free-surface velocities with LSPIV is based on the same concept as human vision. Specifically, the technique “guesses” using special pattern-recognition algorithms where small particles floating on the free-surface are moving in consecutive images, separated at a known time interval. A classical cross-correlation algorithm is used to determine the movement of flow tracers. In this study, a PIV algorithm for large scale applications with low resolution images, developed by Fincham and Spedding [1997], is used. The advantage of this algorithm is that it decreases the mean bias and root mean square errors [Piiro et al., 2005]. It calculates the correlation between the interrogation area (IA) centered on a point a_{ij} in the first image (image A) and the IA centered at point b_{ij} in the second image (image B) recorded with a time interval of δ_t seconds. The correlation coefficient $R(a_{ij}, b_{ij})$ is a similarity index for the gray-scale intensity of a group of pixels contained in the two compared IAs, expressed as:

$$R(a_{ij}, b_{ij}) = \frac{\sum_{i=1}^{M_i} \sum_{j=1}^{M_j} [(A_{ij} - \overline{A_{ij}})(B_{ij} - \overline{B_{ij}})]}{[\sum_{i=1}^{M_i} \sum_{j=1}^{M_j} (A_{ij} - \overline{A_{ij}})^2 \sum_{i=1}^{M_i} \sum_{j=1}^{M_j} (B_{ij} - \overline{B_{ij}})^2]^{1/2}} \quad (3.3)$$

where M_i , M_j are the sizes of the interrogation areas (in pixels), and A_{ij} and B_{ij} are the distributions of the grey-level intensities in the two interrogation areas.

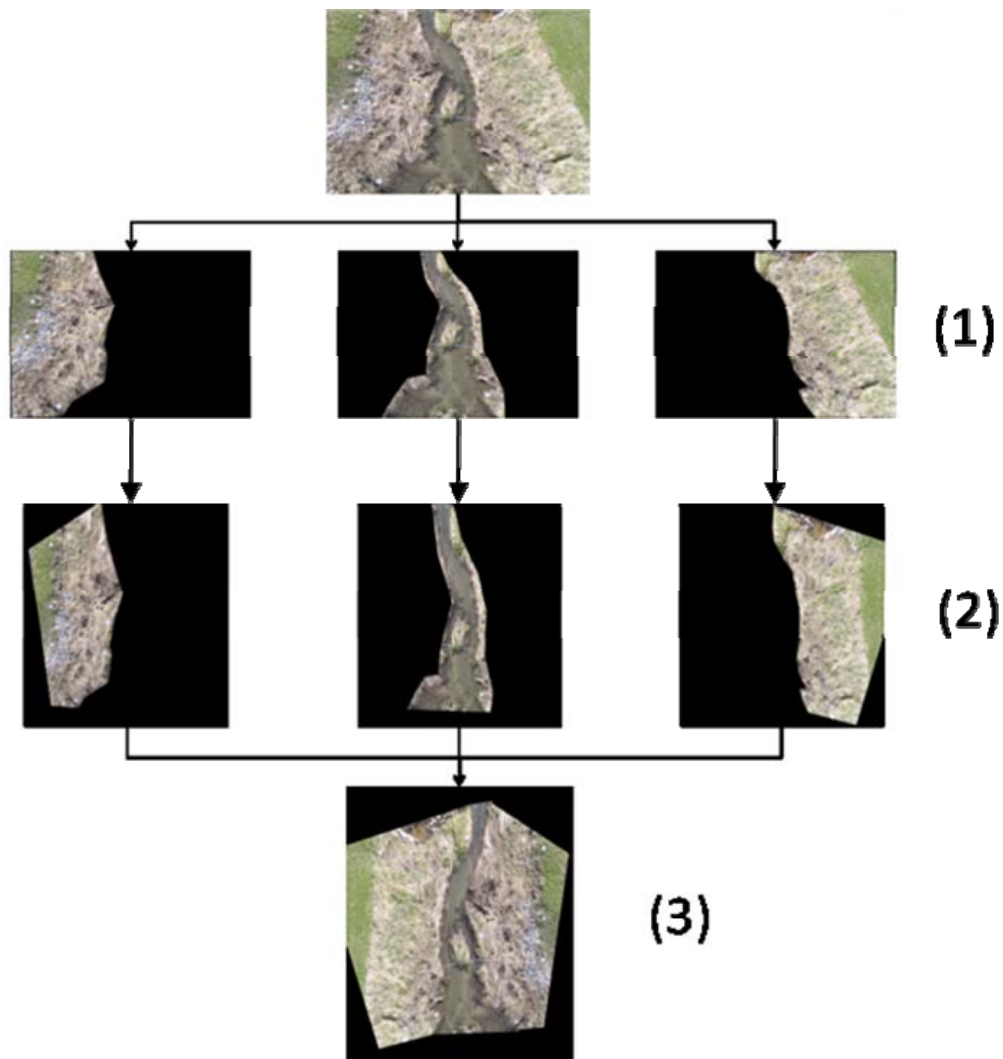

Figure 3-6 Waterway vicinity ortho-rectification protocol: (1) identification of the planar surfaces on the images; (2) ortho-rectification of the surfaces; (3) assembling of the ortho-images of the planar surfaces to obtain the ortho-image of the landscape.

Correlation coefficients are only computed for points within a pre-defined searching area (SA). The SA size is selected so that the displacement of tracer patterns from the first image is contained within the SA of the second image, commensurate with the expected range of velocities of the river. For rivers with small cross-stream velocities, the SA should be asymmetric, elongated in the direction of the flow. The algorithm assumes that the most



probable displacement of the fluid from point a_{ij} during the period δ_t is the one corresponding to the maximum correlation coefficient. Sub-pixel displacement accuracy is reached using a parabolic fit [Fujita and Komura, 1992]. Velocity vectors are derived from these displacements by dividing them by δ_t . The process is iteratively conducted over the entire image using a computational grid. An example of LSPIV surface velocity field for the Jordan Creek site, downstream the culvert, is shown in Figure 3-7.

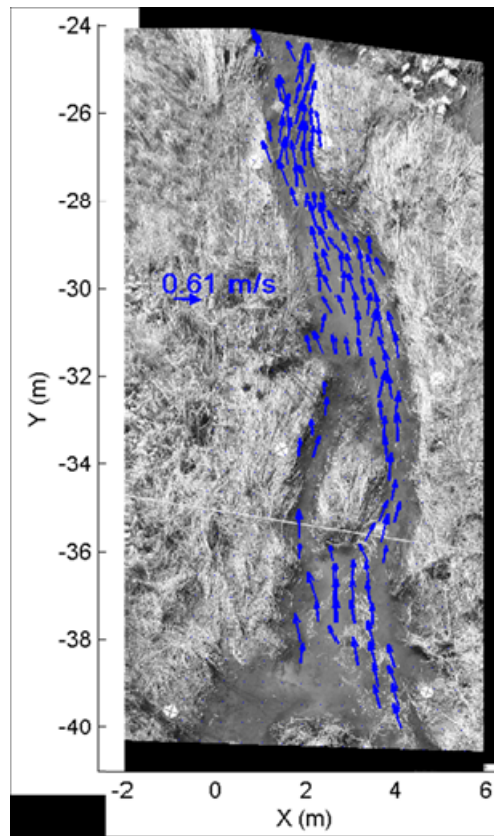

Figure 3-7 LSPIV time-averaged velocity fields for the Jordan Creek site, downstream the culvert.

3.1.3.5 Assembling flow and terrain data

In this step, the ortho-rectified dry land in the vicinity of the water way and the velocity of free-surface are assembled in one map for further analysis. In general, the waterway encompasses the bridged stream or river bed along with its banks, abutments, and



any other local obstructions that significantly impact flow velocity, flow alignment, and scour depth. Software allows identifying, selecting and extracting features of importance for customized analysis. These operations are conveniently carried out by scrawling the mouse over assembled ortho-rectified image of the site. Each feature is labeled with a code name and its coordinates are saved so that a map of the waterway characteristics can be created. For example, the colored ortho-image in Figure 3-8 allows easy identification of:

- The intersection between the banks and the river surface waterline defining the shape and the angle of attack of the stream;
- Islands, debris, deposits or other obstacle in the channel;
- Floodplain characteristics, including land cover (rocks, mud, vegetation), the presence of side ditches, vegetation, debris or other obstacles.

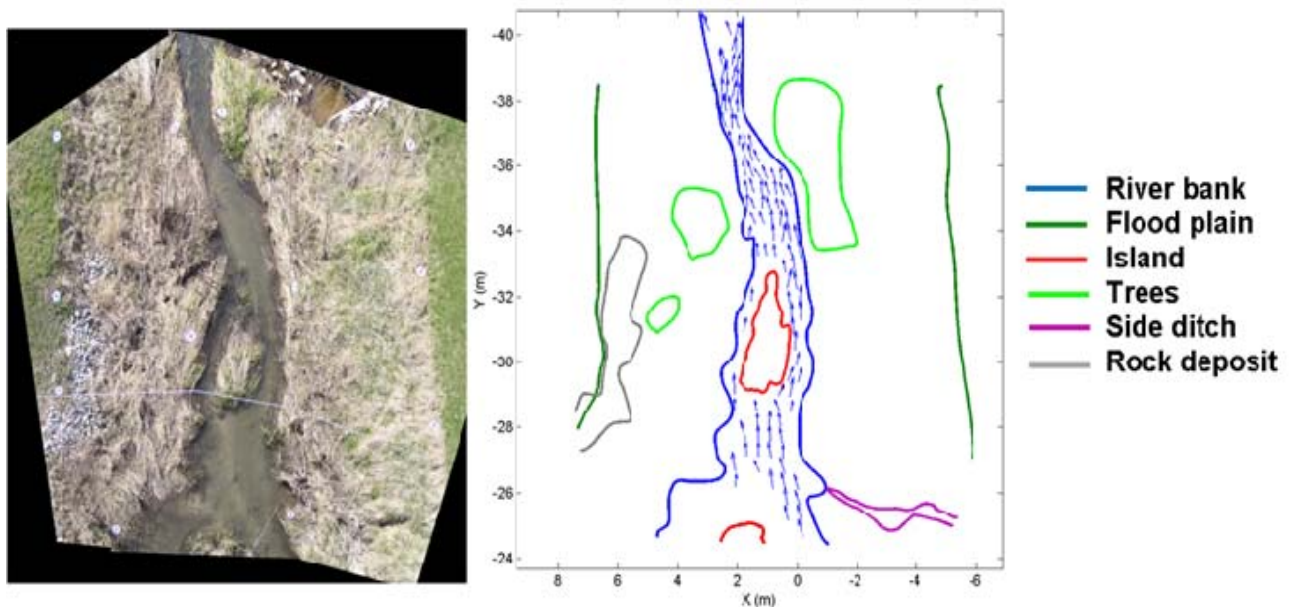

Figure 3-8 Example of mapping: Ortho-image of the studied area (left) and the corresponding digital map containing selected features of the waterway and its vicinity (right)



3.2. Insights from field observations

3.2.1 South Ralston Creek in Iowa City

One of the sites for the present research was a 3-box culvert located on the First Ave in Iowa City, Iowa (Figure 3-9). The culvert seats upon the South Ralston Creek with the central barrel aligned with the stream axis as illustrated in Figure 3-10. As can be noticed from the photo, considerable sedimentation pockets are visible both sides of the culvert. The USGS gaging station 05455010, located 1300ft downstream the culvert, was used to provide a reference for the stage and discharge measurements acquired to the culvert site.



Figure 3-9 Location of the South Ralston Creek study site



Figure 3-10 Upstream view from the culvert

A water level sensor and associated logger (Global Water Instrumentation Inc) was deployed at the culvert central barrel for measuring the water stage at the site. The logger was secured in the steel tube, and attached to the wall of the culvert. The deployment was carried out by the IIHR-Hydrosience & Engineering mechanical shop personnel (Figure 3-11). Periodic readings of the data logger recording were subsequently downloaded by the project personnel.

Before deployment, the level sensor was tested in the laboratory to make sure that it can be referenced to standards and make sure that it provides accurate and reliable water level (water pressure) long-term measurements. The data from the logger was downloaded through a hand-held portable device. Following the deployment, the collected data were compared to USGS gaging station recording at the downstream site. The rating curve built from the data collected from USGS station was used to calculate the discharge at the culvert site (Figure 3-12).



Figure 3-11 Setup of the water level sensor: a) during the installation of the sensor; b) the sensor in its working position

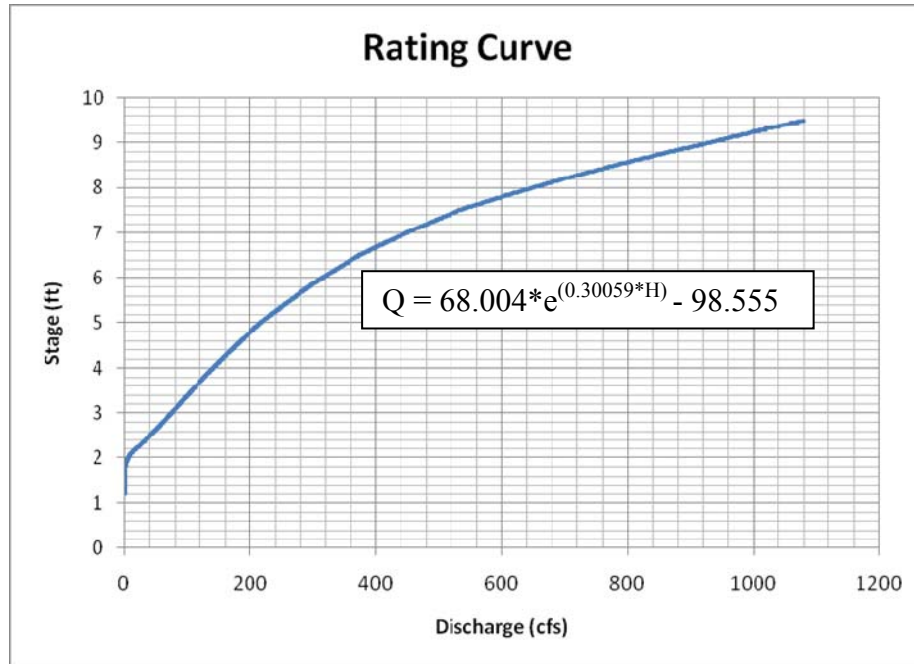

Figure 3-12 The Rating Curve and the ancillary equation used to calculate the discharge using the measured water stage

The recordings were taken continuously over one year with the intention to provide quantitative information for the monitoring of the evolution of the sediment deposits upstream the culvert. Following the deployment comparison between the water level data acquired with our probe and the USGS one used for reference were made to test the reliability of our system. Such a comparison is shown in Figure 3-13 when a storm event passed through the area on December 2009. The figure displays the USGS daily stage along with the level recorded by our probe. Figure 3-14 plots the discharge calculated from the rating curve for the USGS location. The close proximity of the two sites allows to assume that the discharge at the culvert site was the same as the one indicated by the USGS gaging station. As can be observed from the water level plot, the measurements acquired with our sensor were in good agreement with the USGS stage data.

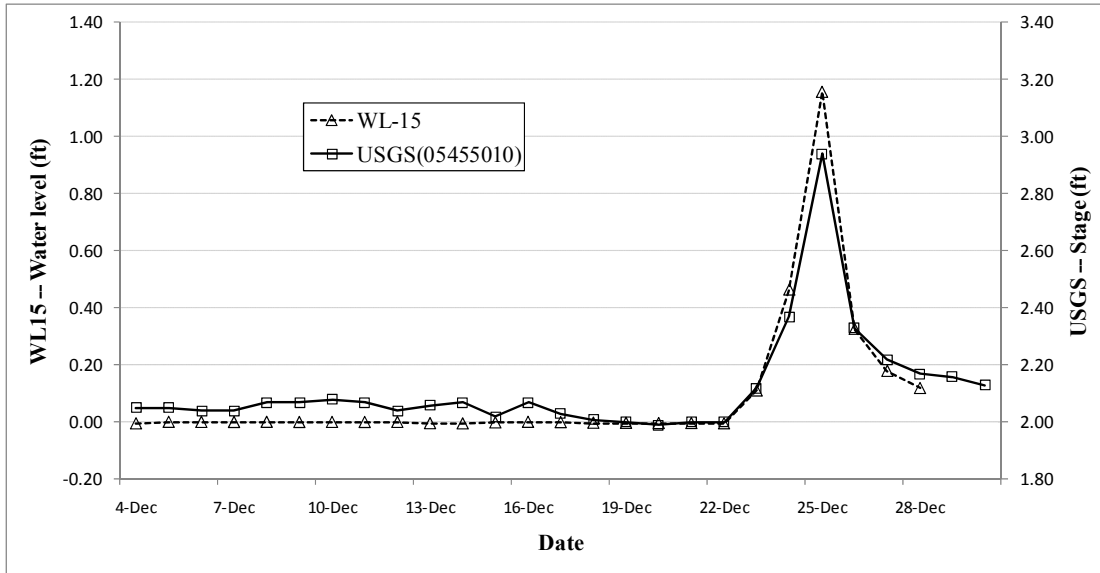

Figure 3-13 Comparison of the water stage measurements acquired by the deployed sensor with the USGS stage data at South Ralston Creek (12/4/09 ~ 12/28/09)

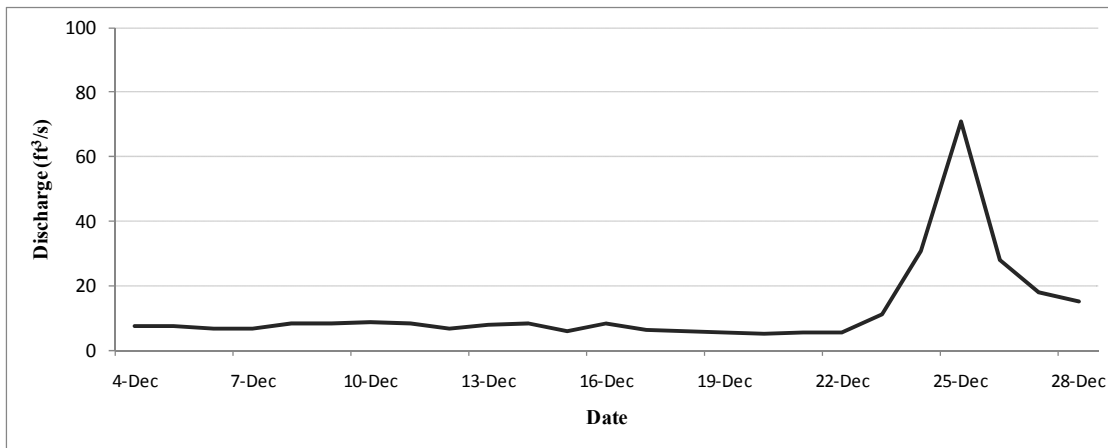

Figure 3-14 Discharge obtained from the stage measurement at the monitored culvert site

Following the 12-months sensor deployment, the monitoring at this site was abandoned because during the observation time there were no changes of the sediment deposits upstream of the culverts. The situation is due to the fact that the deposits became rapidly and vegetated hence “fossilized” in their current shape. The monitoring conducted at this site underpins the importance of judiciously selecting the sites for observations of the sediment deposits formation and evolution.



3.2.2 Jordan Creek in Solon

As described in chapter 2 of this report, the digital mapping is a convenient approach to quantify changes of the morphological features (sediment deposition, island, vegetation growth, debris, etc...) that can occur over time and eventually lead to the culvert sedimentation. The DIGIMAP implementation for a culvert site is demonstrated herein for illustrating the capabilities of the technique. The study area for the mapping is the waterway in the vicinity of a culvert on Jordan Creek, Solon, Iowa, USA. At this location, Jordan Creek is about 3 m wide and flows westward (Figure 3-15). The three-box culvert is 20.6 m long. Two surveys (A and B) out of four are presented in this section. Between these surveys, a storm produced a peak of $44 \text{ m}^3/\text{s}$ on June 22 (Figure 3-16).



Figure 3-15 Satellite view of the study site. Gray arrow indicates flow direction

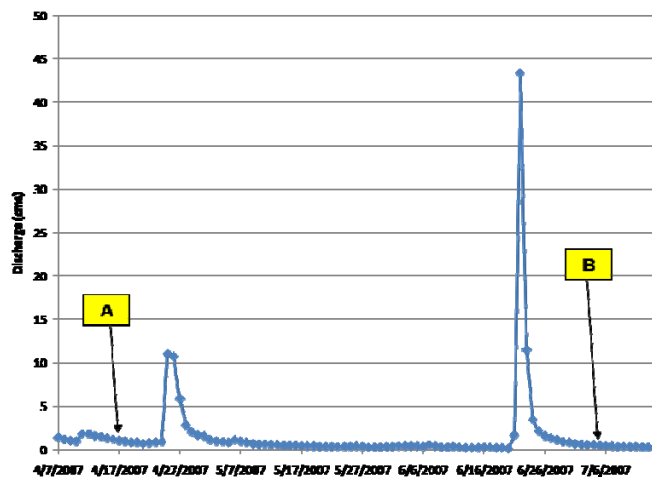

Figure 3-16 Hydrograph from 04/07/2007~07/15/2007



Survey A was carried out at a discharge of $0.7 \text{ m}^3/\text{s}$ that is indicative of a normal flow condition. Survey B was conducted at a discharge of $0.6 \text{ m}^3/\text{s}$, 10 days after the flood event of June 22th. In the absence of drastic changes in the stream bathymetry, it is expected that mapping the area of interest at same discharge will maintain the waterline position in the maps. Consequently, perfect features overlapping indicate changes between surveys. The comparison of the two Surveys A and B allows inferring the effect of the flood occurred between surveys. The comparison was conducted at the same discharge as confirmed by the LSPIV velocities.

Figure 3-17 shows the overlaid maps of Surveys A and B for the culvert upstream area. One of the noticeable differences in this area is the presence of the wood weir created during the flood. The weir is located near an island existing prior to the flood event. It is obvious that this island obstructed the flow and has blocked more and more wood debris during the flood, facilitating the creation of the woody weir. Another drastic change is the shift in the waterway approaching the culvert. The weir produced an upstream pool, with a wideness of the wet area but the channel was also shifted. The ortho-rectified images allow to actually quantifying this shift. Specifically, the upstream waterway has shifted in the positive X direction with about 1 m throughout the mapped area. The new stream path encroached in the vegetated area and an important amount of fresh mud deposition was crowded, as can be seen from Figure 3-17.

Figure 3-18 compares the maps of Surveys A and B for the area downstream the culvert. The changes in this area are numerous. After the flood, the recirculation area existing prior to the flood downstream the left box has disappeared. The middle and left boxes are filled with fresh mud, constraining the flow only in the left box. We can think that this mud material, deposited during the fall of the flood, comes from the muddy area eroded in the upstream part and also from lateral contribution of the erosion ditches. A small sediment bar can be observed close to the confluence of the side ditch and the stream. This deposit can be

explained by the presence of a slow recirculation flow formed in this confluence and favoring deposition. The large in-stream island, of about 4.5 m², has quite not changed between surveys. Its right side has been eroded and deposition of material occurred in the left side. This can be explained regarding the flow characteristics given by the LSPIV as the flow is faster in the right side of the island. This result is consistent with the meander shape of the creek at that location resulting in the erosion of the right bank (concave part of the meander) and the deposition of sediment on the left bank (convex part of the meander). The river banks have not changed considerably. Globally, the channel was shifted of about 0.4 m in the X positive direction. The trees and vegetated areas present downstream the culvert played an important role in maintaining the stream morpho-dynamics before and after the flood, reinforcing their positive role in controlling stream erosion processes (Figure 3-18).

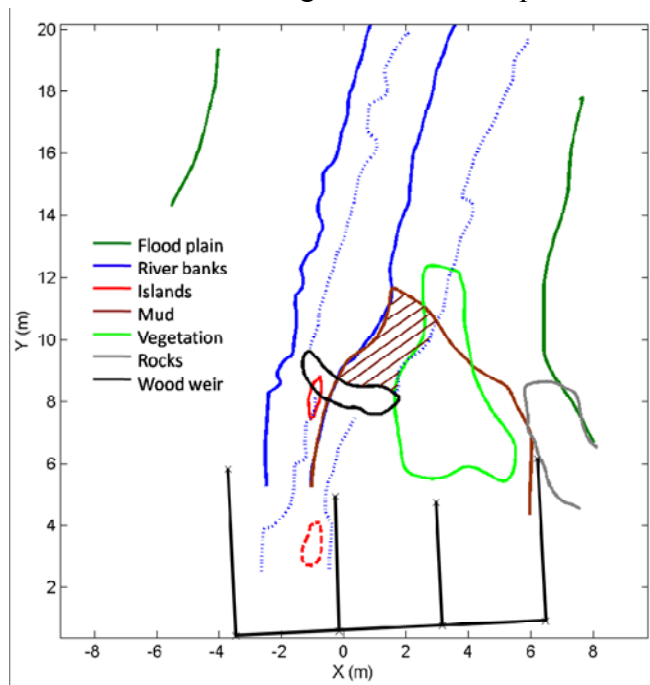

Figure 3-17 Overlap of the maps of Surveys A (solid lines) and B (dash lines) for the upstream area. The eroded mud area is represented by strips.

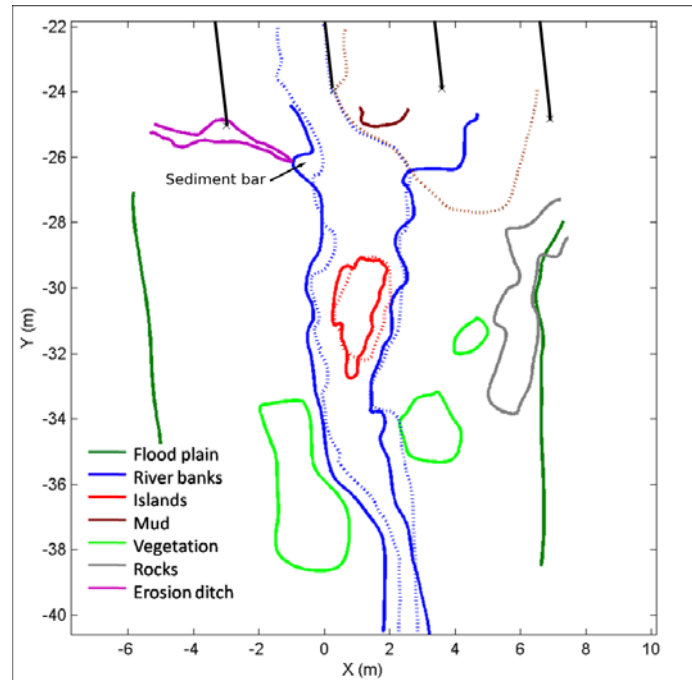

Figure 3-18 Overlap of the maps of Surveys A and B for the downstream area

3.2.3 Old Mill Creek in Solon

Given the lack of knowledge and well-documented field observations about the sedimentation at culverts, the tracking of sedimentation at culvert site represents the most valuable information for obtaining new insights on the process. Sedimentation is a relatively slow process that requires long-term monitoring. One of the culvert sites that showed a remarkable dynamic of the sedimentation process was the one found in Solon on the Old Mill Creek (Figure 3-19). At this location, the use of DIGIMAP was not possible because the site characteristics (steep slopes and narrow road) obstructed to positioning of the MLSPIV truck. The site was also lacking instrumentation to record the hydrological evolution (no USGS gaging station in the vicinity). Consequently, the dynamics of the sediment deposit was tracked by photo documentation in conjunction with the data provided by a weather station in the culvert neighborhood to indirectly provide information about the inflow hydrograph passing through the culvert.

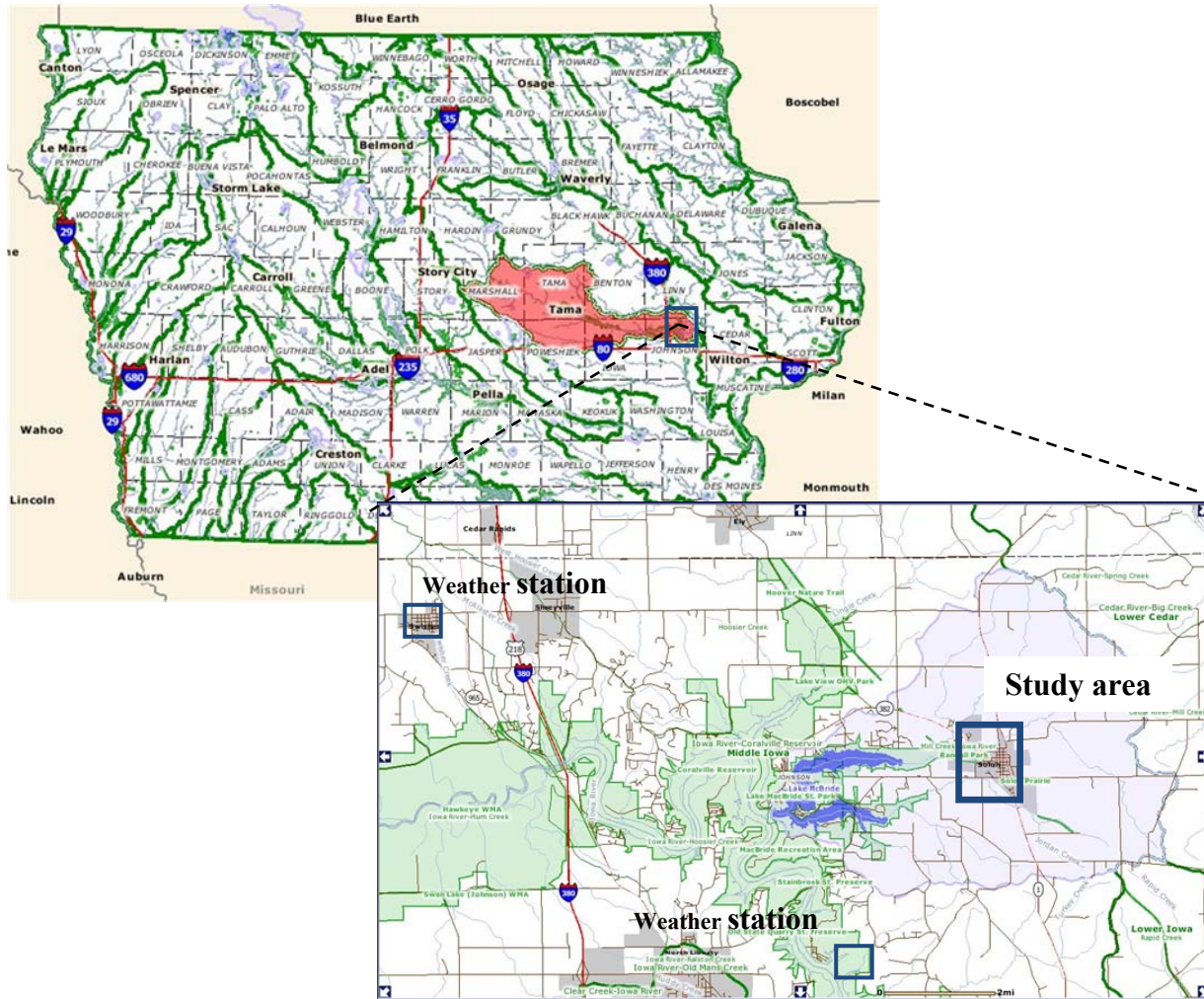

Figure 3-19 Study area in Solon, Iowa: the shaded area is Lake Macbride watershed. The enlarged area shows the location of the culvert and weather stations

Figure 3-20 and 3-21 present the evolution of the sediment deposits at culvert over almost three years. The associated precipitation hyetograph, as recorded by a weather station 5 miles south of the culvert site is provided in Figure 3-22. The culvert was cleaned before our first photo-documentation on March 17th 2007. It can be noticed that the sediment deposited through the culvert by July 10th 2008. The sediment accumulation between the first two visits indicates that the culvert experienced at least one significant storm. Indeed on April 16, 2008 a rainfall (304 mm/hr rate – the largest in 2 years of record) fell in the catchment. Such storms trigger sediment erosion upstream the culvert and convey sediment

ending in the culvert expansion area and the culvert itself. The evolution of the sediment deposits captured in Figures 3-20 and 3-21 also demonstrates the detrimental role of the vegetation “cementing” the sediment deposits and hence decreasing the culvert entrance area.



Figure 3-20 Three-box culvert and sedimentation process in Old Mill Creek in Solon, Iowa (View of the culvert entrance). It can be observed that the sediment and debris trapped in the upstream basin reduce considerably the entrance area of the culvert.

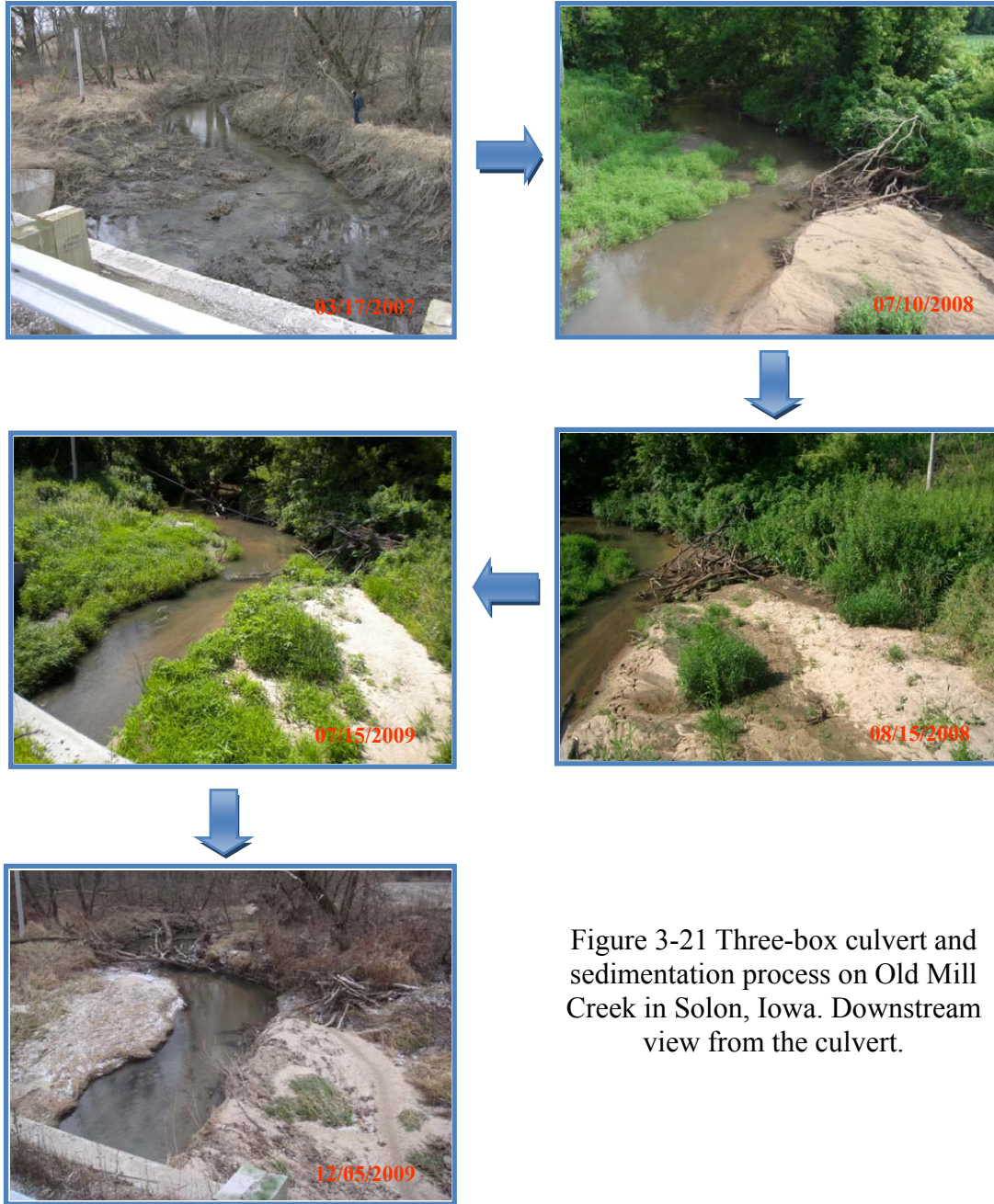

Figure 3-21 Three-box culvert and sedimentation process on Old Mill Creek in Solon, Iowa. Downstream view from the culvert.

The precipitation hyetograph in Figure 3-22 displays several storm events at this culvert site with two of them were more than 200mm/hr. Despite the heavy rains, the more recent two visits on July 15th 2009 and December 5th 2009 do not show any change in the configuration of the sediment deposits. These observations suggest that it is the most important factor leading to culvert sedimentation is the first large storm experienced by the

culvert after construction or cleanup. After this first storm the deposits become quickly fixed by vegetation. It is hypothesized that, during high flows, those deposits act as important obstructions for the flow passing through the culvert area and consequently the river reach develops backwater areas upstream the culvert.

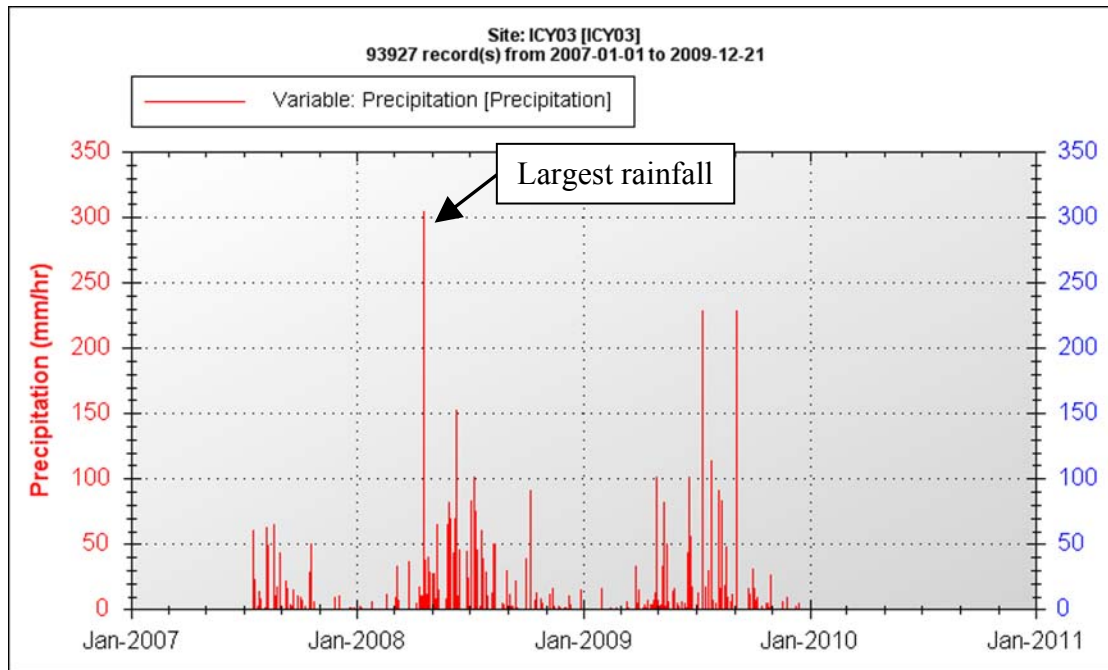

Figure 3-22 Precipitation hyetograph used for Old Mill Creek study

3.2.4 Comments

The sites observations reported in the Sections 3.2.1, 3.2.2, and 3.2.3 provide several relevant elements regarding the suite of culvert studies. The three field campaigns reported above illustrates that sedimentation at culvert sites is usually the result of the “combined” effect of flow non-uniformity developed in the culvert area with commensurate reduction of the culvert performance. The evolution of the sediment accumulation at the Old Mill Creek site demonstrates that a new or just cleaned culvert is displaying an increased dynamics up to the first major storm event. If the time is sufficient for the sediment deposits to settle (usually with the aid of vegetation growth) the deposits become practically permanent.



The observations following the April 16 storm event at Old Mill Creek and those at South Ralston Creek show a common feature: the fossilized sediments become integral parts of the culvert hydraulics. After this stabilization the as-designed culvert loses its role and the local hydraulic is different than the one assumed. Both sites show that large storm events were passed through the culverts without changes in the deposits and (perhaps) no negative consequences on the upstream area. If such, an important question follows: are the Iowa culverts with existing sediment deposits conveying large flood waves without producing inundation? A positive answer will lead to the conclusion that those culverts are oversized. Those locations will not need cleaning. Only the culverts that produce detrimental backwater effects upstream, possibly leading to inundation, should be cleaned in order to bring the culvert capacity within the design parameters. It is obvious that additional attention should be paid to the blocked/silted culverts to provide documented answers to the above questions. The culvert design is for sure prone to oversizing due to, in principal, two reasons. The first reason is associated with the culvert design equations (Normann, 1985) that assume that the multi-box culvert operates with uniform flows equal through all openings. The other obvious reason is related to the hydrologic analysis for establishing the design flow discharge. The analysis uses many variables that are not thoroughly assessed or considered leading to inaccurate flow estimates.

The field campaign for Jordan Creek reveals that small changes in the stream configuration are always involved in the lifetime of the structure. They can be conveniently quantified with the IIHR developed DIGIMAP technique. By introducing a periodic culvert inspection associated with DIGIMAP mapping, the status of culvert performance can rigorously monitored and in association with a matrix of risk of performance deterioration they can be prioritized for cleanup operations.



3.3 Considerations on flow unsteadiness

Generally speaking, sediment will deposit in the culvert area if the sediment discharge in the approaching channel is larger than the one passing through the culvert. There are several factors that are customarily used to estimate the sediment transport through the culvert. They include: the geometry of the culvert, stream hydraulics, channel boundaries, and sediment characteristics. A factor that is usually overlooked is the flow unsteadiness produced during the flood wave propagation. The practical approaches for monitoring flood wave propagation in streams are practically inexistent. Lacking this information, the river monitoring is based on simplified approaches that in some situations, such as the establishment of the hydraulic-related parameters for designing structures, lead to additional problems. The present research provides insights into flow unsteadiness using results from field measurements and numerical simulations conducted in Iowa River. The aim of these illustrations is both to provide the needed insights for the study but also to demonstrate that with proper resources, the research in this area can be further enhanced to include more of the flow complexities.

3.3.1 Field survey of 2008 Iowa flood

The monitoring of the wave propagation in a large scale river were conducted on the Iowa River in Iowa City several days before and after the flood wave reached its peak on June 15, 2008. The measurement site was about 500m upstream from the location of the USGS gaging station #05454500 located on the Iowa River in Iowa City. Measurements were acquired with Large-Scale Particle Image Velocimetry (LSPIV). An aerial photo of the measurement site and the imaged area used for acquiring the LSPIV measurements are shown in Figure 3-23. Also shown in Figure 3-24 is the chronology of the LSPIV measurements.

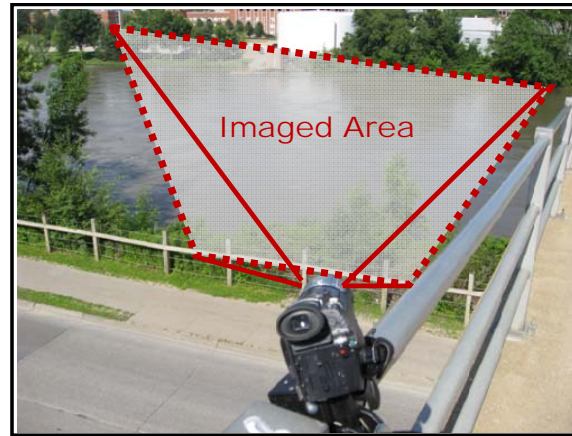

Figure 3-23 LSPIV measurements during the Iowa River flood of 2008: location of the measurement site (left and right)

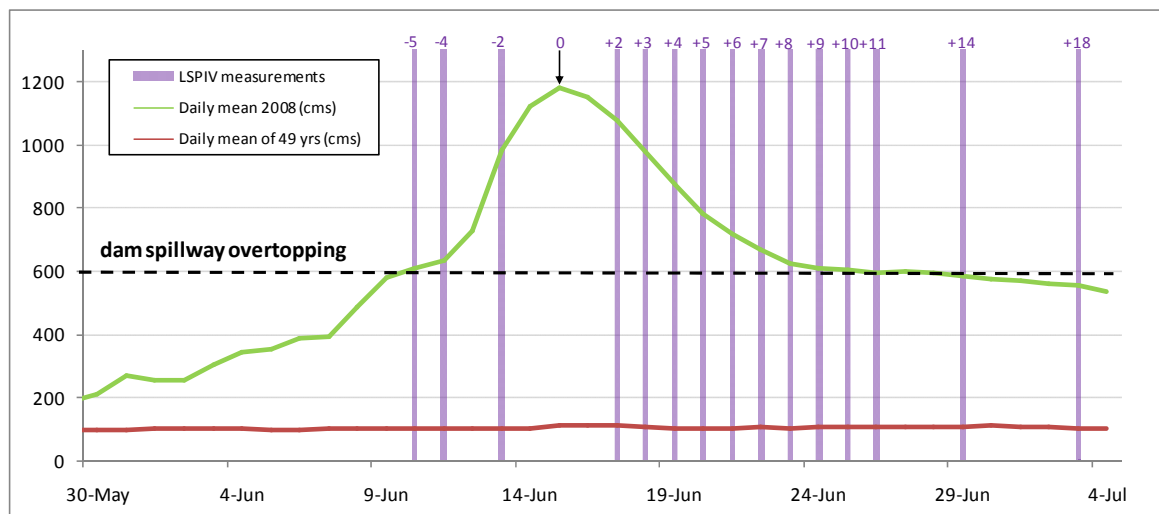

Figure 3-24 Chronology of the LSPIV measurements during the flood wave propagation

LSPIV is a technique pioneered at IIHR-Hydroscience & Engineering since 1996 to measure free-surface velocities and discharges in streams. The technique has been tested against conventional instrument and proved to be within acceptable uncertainty range (less than 5%). The most distinctive feature of LSPIV compared with the conventional velocimeters is its non-intrusive nature, i.e., it does not require deployment of equipment or personnel during the measurements. This feature allows carrying out velocity measurements

under flood conditions which presents difficulties for conventional instruments. LSPIV can be quickly and safely deployed with minimum site preparation, take measurements in a fraction of the time required by alternative instruments to provide quantitative flow information over large areas of flows.

The results obtained with the LSPIV around the 2008 flood peak are shown in Figure 3-25. In this discussion, only measurements taken while water overtopped the spillway of the Coralville Reservoir Dam located 8.2 miles from the measurement site are considered. During normal operation, the river is fed from a sluice gate located at the bottom of the dam. With the dam overtopped, it can be assumed that the flood wave propagation is less obstructed by the presence of the controlling structure.

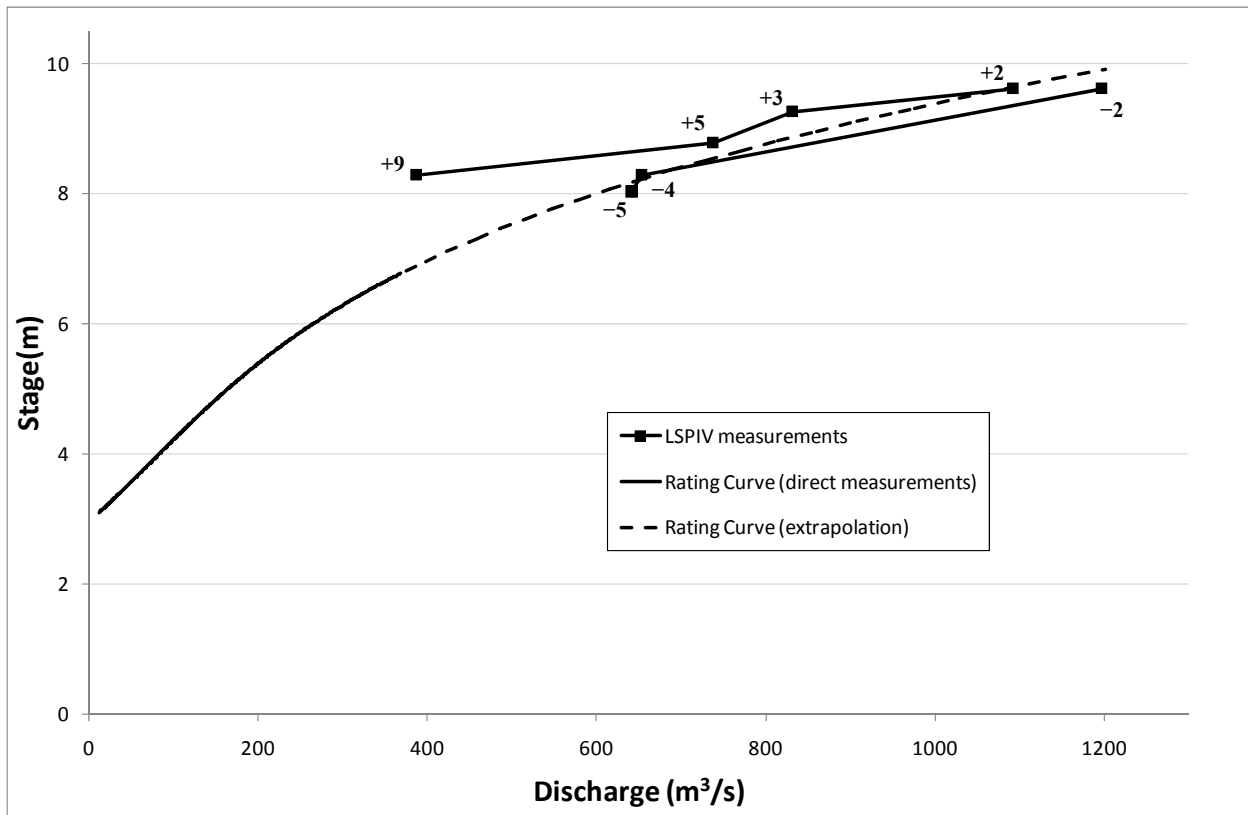

Figure 3-25 USGS Rating curve and the LSPIV measurements at the USGS gaging station 05454500 during the Iowa River flood of 2008. The peak of the flood is considered as reference for time to identify the raising (“-”) and falling (“+”) limbs of the rating curves.



The plots displayed in Figure 3-25 indicate that the seven LSPVI measurements are grouped on separate curves, suggesting graphically the rising and falling limbs of flood wave propagation. The loop curve formed by these two distinct limbs displays stage differences of up to 0.5m for the same discharge value, depending if the measurements are taken on the rising or falling stage of the flood wave propagation. Moreover, neither limb coincides with the conventional rating curve. The latter is itself prone to extrapolation errors due to the limited number of points and range for the direct measurements used to estimate this high flow range of the rating curve. The present study highlights the importance of acquiring high-temporal resolution discharge measurements during floods to capture the unsteadiness in natural channel.

3.3.2 Numerical simulation of 2008 Iowa flood

The model that was used to simulate the one-dimensional unsteady flow in the river is based on the continuity equation and the momentum equation written as:

$$\frac{\partial A_r}{\partial t} + \frac{\partial Q}{\partial x} = 0 \quad (3.4)$$

$$\frac{\partial Q}{\partial t} + \frac{\partial QV}{\partial x} + gA \left(\frac{\partial z}{\partial x} + S_f \right) = 0 \quad (3.5)$$

The input data for the model is the hydrograph developed during the 2008 Iowa flood. The simulation time was from June 1st to June 30th 2008. The geometric input data was Iowa River reach from Coralville Dam to McCollister Bridge (Figure 3-26). The results of the simulations for one of the cross section are provided in Figure 3-27. The plot clearly displays the loop rating curves that developed during the flood propagation. Currently, the standard rating curve is used instead for both monitoring rivers and in the design of the hydraulic structures. The conventional rating curves developed as one-to-one relationships that do not account for the flood wave propagation. The magnitude of the deviations from the traditional curves is dependent on the precipitation and drainage area characteristics.

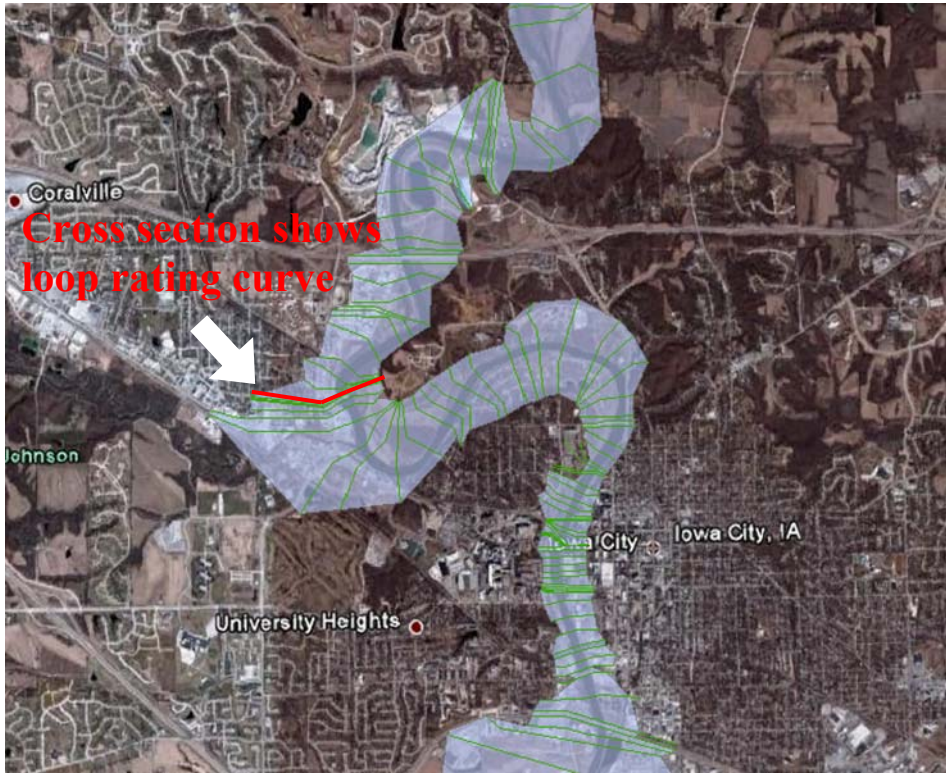

Figure 3-26 The overview of Iowa River and cross-sections used in HEC-RAS model

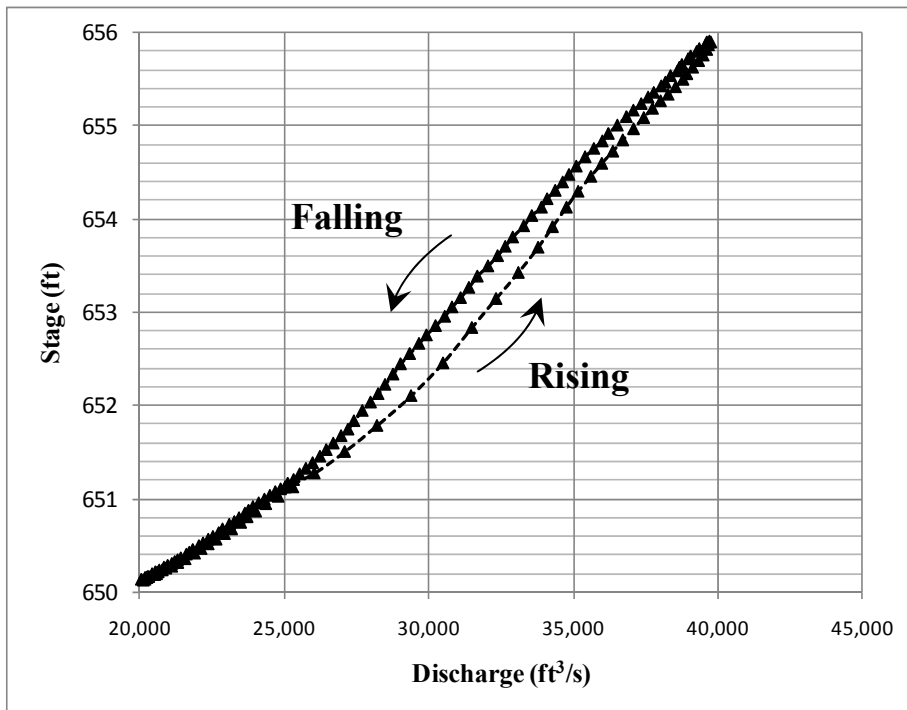

Figure 3-27 Loop rating curve calculated from HEC-RAS for upstream Iowa River



3.4 Considerations on sediment transport

To date, the literature contains neither a systematic study on sediment transport through multi-box culverts, nor on how sediment deposition adversely affects the flow through culverts. While it is known that the sediment transport through culverts is strongly influenced by the nature of the local geological conditions and the soils in the drainage area adjacent to the culvert, there are many gaps in our knowledge about the flow at multi-barrel culverts. Attempts were made in the present research to incorporate the insights gained from the observations in the field and numerical simulations to realistically design the laboratory experiments for investigation of the sedimentation at culverts. This was a critical need in view of the design of the self-cleaning designs that are part of this suite of studies.

The research was phased so that field observations were conducted first to understand the culvert design features in Iowa, and the flow unsteadiness in the open channel. Subsequently, the modeling through complementary hydraulic model and numerical experiments was carried out in this section. Inferences from each research stage were translated to the next stage. Finally observations inferred from all research phases were compiled in a unique framework to provide the needed insights for further practical research.

3.4.1 Preliminary considerations

The main objective of the laboratory investigation is to identify the propensity and location of sediment deposition and accumulation at a representative culvert entrance. Gradually, the flow features were added into the experiments to be able to distinguish among the flow features contributing to the observed sediment deposition at culverts.

A three-box culvert design was used, because it is typical of box culverts in Iowa, and the U.S. generally, and because the field observations were for such culverts. The field observations benefitted the conduct of the laboratory experiments. It the sedimentation problems that are discussed herein are valid for two-box culverts too.



A simple geometry was used as the basis for the study: channel approaching the culvert at normal angle, typical culvert geometry with wing walls and expansion area. Channel transition involving expansion and contraction were included in the model, because they are enhancing the non-uniform nature of the flow in the culvert area. These expansions were also included in the prior studies (Charbeneau 2006). The experiments were conducted using a 1:20 scale model described in Chapter 3.1.

A simplifying assumption made for the experiments is that sedimentation at culverts is mainly associated with bed load transport. While it is expected that the suspended-sediment transport augments silting at culverts, it is assumed that both the bed load and suspended sediment transport are becoming a problem for culverts in areas of relatively low velocity (where we could use bed load and suspended load parameters to characterize those conditions). The field observations supported this assumption. Therefore, by employing the bed load experiments was deemed to be sufficient in order to track the overall sedimentation process and to develop design approaches for sedimentation mitigation.

3.4.1.1 Test 1: suspended versus bed load transport

The assumption that bed-load transport is representative for the sediment deposits in the culvert entrance required assessment. For this purpose, an experiment where only suspended sediment was fed in the facility was designed for a flow that was tested before with bed load. Sediment was supplied above at the free surface using the rolling sediment feeder in the same section where the sediment was released as bed load in previous experiments. Crushed nut shell was served as the model suspended sediment particle for this test, instead of silica sand. The transport rate was kept below the transport capacity in order to avoid bed forms developing in the channel. Figure 3-28 shows the result of sediment deposition around the culvert.

The sediment particles moved as suspended load without deposition in the channel. The dunes were formed in the expansion, and sediment deposited in the barrels. The



secondary current reduced the transport capacity in the sides of the expansion, but not in the central region of the expansion. The deposition patterns developed upstream the culvert were similar to those formed in the experiments with bed load as illustrated in Figure 3-28b. The experiment enforced the assumption that the low flow areas are the culvert regions where it is expected to encounter sediment deposits. The combination of the sediment transport fraction would accelerate the rates of sediment buildup. A further inference to be drawn is that bed load experiments are adequate to track the overall sedimentation process and then to develop approaches for sedimentation mitigation. Although the mechanisms between bed load and suspended load are different, we can assume that the approach worked for bed load can also succeed to suspended load for the similar deposition pattern.

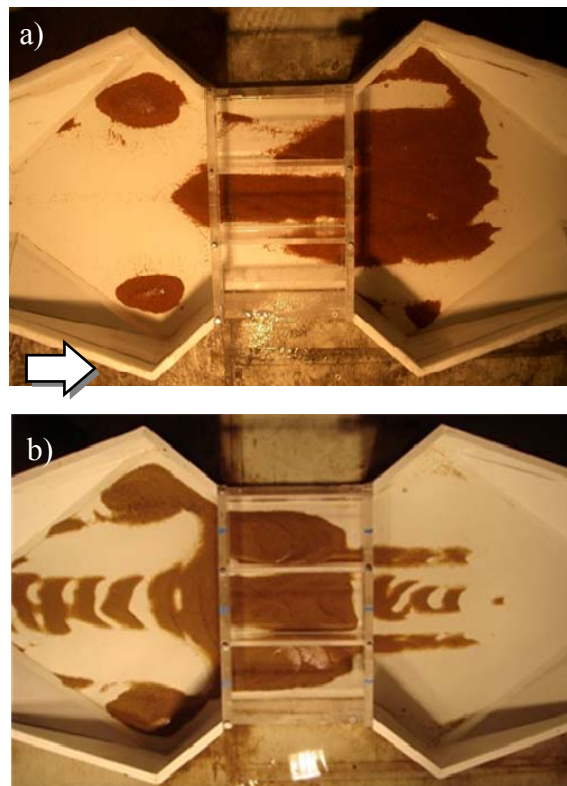

Figure 3-28 Sediment deposited at the culvert: a) using suspended load (crushed nut shells); b) with bed load (silica sand)



3.4.1.2 Test 2: Baseline flow

Baseline flow test was conducted to better understand sediment deposition in expansion and culvert barrels. The first part of the test would be operated under three hydrological conditions (Table 3-1). Those flow conditions were used to simulate storm events. All the modeled flows were with the culvert in an un-submerged control situation flowing through the culvert, and all are in an un-submerged control situation (Figure 3-29).

Table 3-1 Three flow conditions tested in Baseline flow test

Case	Discharge (ft ³ /s)	Headwater (ft)
A	0.065	0.125
B	0.240	0.250
C	0.368	0.382

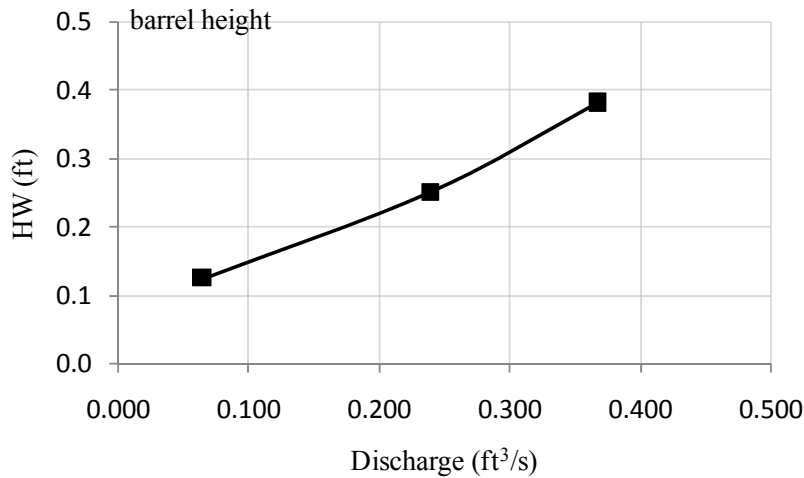

Figure 3-29 Flow condition in Baseline flow test

The depth of the culvert was 0.5ft in the model, corresponding to 10ft in the prototype. Three water depths were investigated. The design discharges based on the water depth were calculated with the performance equation:

$$\frac{HW}{D} = Kg^{M/2} \left[\frac{Q}{A\sqrt{gD}} \right]^M \quad (3.6)$$

where A =full culvert cross section area ($A=BD$ for a box culvert), Q = barrel discharge, and S is slope of the culvert, K and M are the coefficients based on the culvert configuration. Three cases were used to present three hydrological events from small to large. Case A was $\frac{1}{4}$ depth of the culvert ($HW/D=0.25$), case B was half depth of it ($HW/D=0.5$), and case C was $\frac{3}{4}$ depth of it ($HW/D=0.75$).

A subsequent part of this test examined bed-sediment movement through the culvert over an extended time interval of six hours. This experiment was only done for case B, which produced the greatest sediment deposition around the culvert. Photography of sediment deposition pattern was also taken for each hour. Overall, sediment gradually accumulated in the right and left region, but moved smoothly in the central region. Figure 3-30, for example, shows the result of sediment deposition after two hours. The sediment load accumulated in different zones was also quantitatively collected. Figure 3-31 shows that sediment deposition in the central barrel was constant. Sediment, however, gradually accumulated in the expansion and side barrels over time.

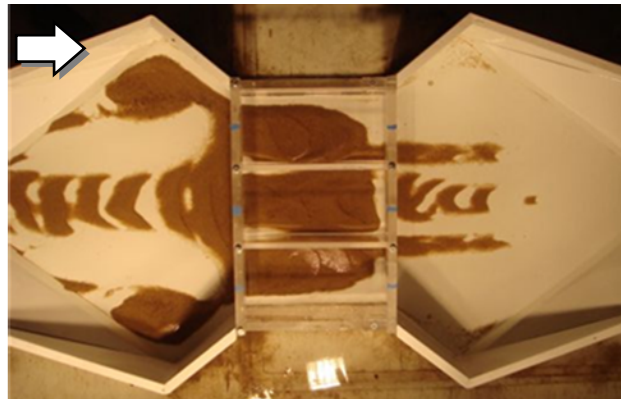

Figure 3-30 Sediment deposited after 2 hours for case B in model B

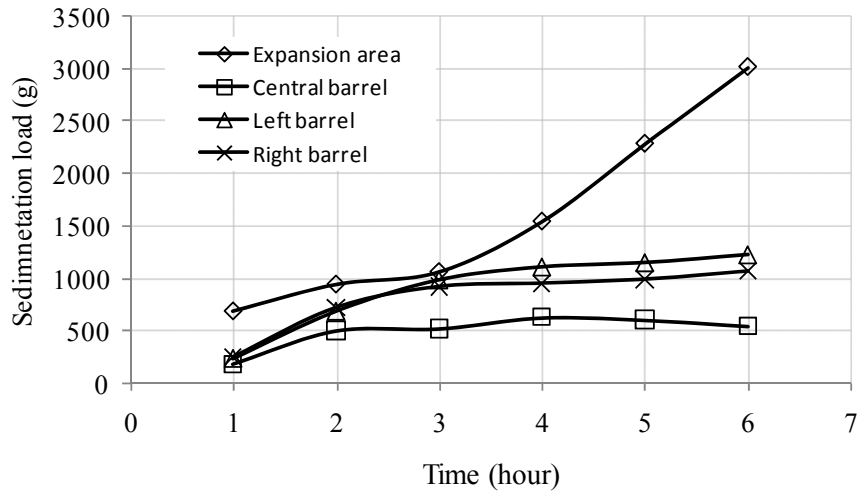

Figure 3-31 Rate of sediment accumulation in the culvert area for flow Case B

3.4.1.3 Test 3: Simulation of discrete sampled hydrograph

As the experiments used a representative culvert design, no specific flow and sediment inflow hydrographs could be simulated in the experiments. In the absence of such information the sediment and flow were kept constant for each flow condition at pre-established water and sediment rates. The simulation of the events was approached using a “stepped” approach, whereby one flow was run for a given period to reach an established time under equilibrium. Subsequently, the resulting sediment deposition pattern was photographed after the operation was stopped. The flow was then set at the next set of operating points and run for an established time under equilibrium and subsequently stopped to allow a new photo documentation of the sedimentation patterns.

The first experiment in this series used three flow conditions that follow the conventional culvert design curve described by the performance equation (3.6). The adjustable rotating cylinder (Figure 3-2) was used to supply sediment into at constant rate into the channel for all three flow conditions. All the modeled flows were modeled for the

culvert operating in an un-submerged situation (Figure 3-32). Three cases were used to present three hydrological events (Table 3-2): case B was half depth of the culvert (HW/D=0.5), case C was 3/4 depth of the culvert (HW/D=0.75), and case D was close to the depth of culvert (HW/D=0.95).

Table 3-2 Three flow conditions tested in Test 3

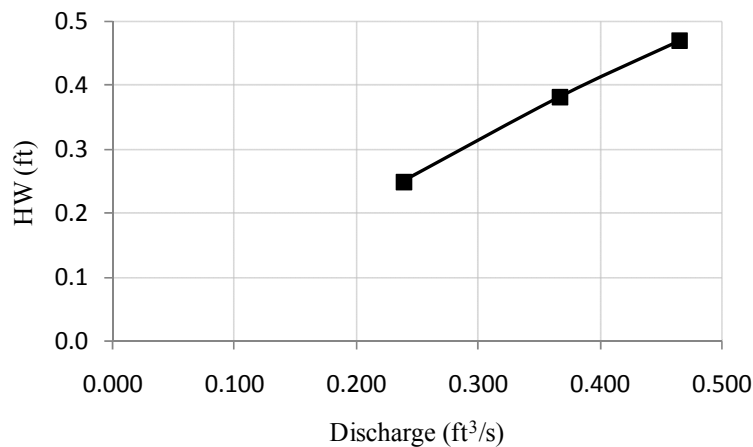
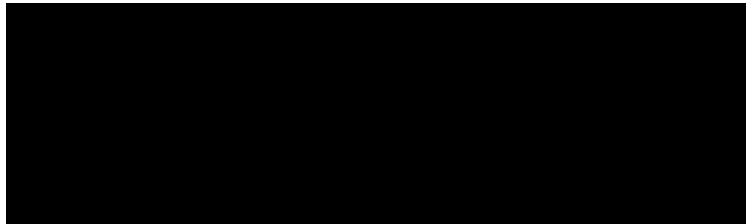

Figure 3-32 Hydrological events investigated in the culvert model

The stream power in the approaching channel based was calculated assuming that the power is the product of force and velocity in the channel:

$$\text{Power} = \text{Force} \times \text{velocity} = (\tau A) \times U = \tau \times Q \quad (3.7)$$

$$\tau = \gamma R S_E \quad (3.8)$$

The results respectively are 0.0026 (ft-lb/s), 0.0025(ft-lb/s), and 0.0022(ft-lb/s) for three cases. Accordingly, the stream power for all flow conditions in the channel is approximately constant. Therefore, it can be inferred that if the sediment was added



constantly from the beginning of the approaching channel and no pile of sediment deposits in the channel was formed, the sediment load in the channel can be assumed the same in all flow conditions.

The modeling was conducted in steps from the lower flow condition to higher flow condition, and back to the lower flow, i.e., Case B→Case C→Case D→Case B. Figure 3-33 shows the result of sedimentation around the culvert model. The photographs reveal that the sediment does not deposit around culvert model under higher flow conditions. Another modeling scenario was conducted in steps connecting the following flow conditions: Case B→Case C→Case B (see Figure 3-34). The resemblance of sedimentation pattern between Figure 3-33d and Figure 3-34 led to the conclusion that sediment does not excessively deposit under higher flow conditions. Therefore it is concluded that a self-cleaning process is already partially in place for high flows passing through the culvert during storm events.

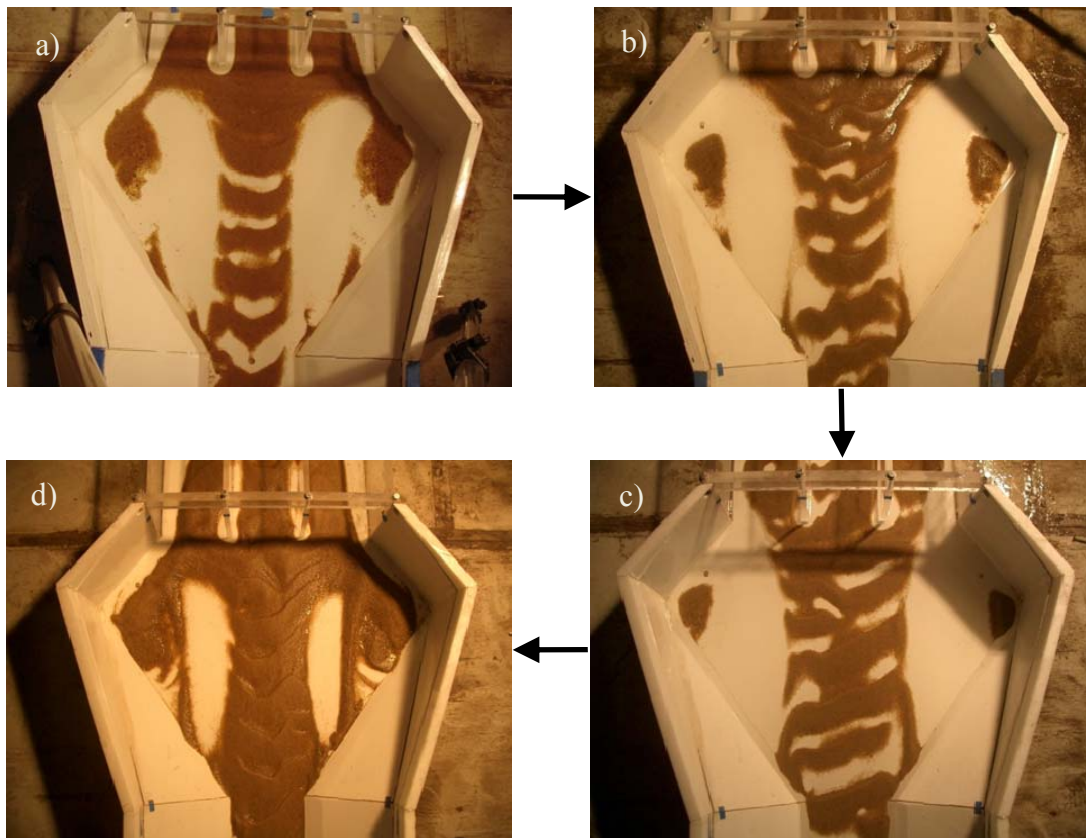

Figure 3-33 Consecutive simulation of hydrological events: a) Case B, b) Case B→ Case C, c) Case B→ Case C→ Case D, and d) Case B→ Case C→Case D→ Case B

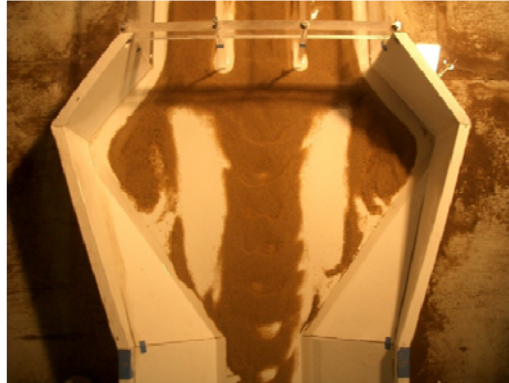

Figure 3-34 Consecutive sedimentation: Case B→Case C→Case B

The following two experiment cases present the sedimentation patterns resulting by modeling high and low flow conditions. The first case aimed at investigating the sedimentation patterns developed by stepping from Case C to Case D. The result (see Figure 3-35a) confirmed the aforementioned situation. Sediment deposition pattern after operating Case B for two hours was also investigated and shown in Figure 3-35b. The resemblance to the above photogrammetric results leads to the conclusion that sediment deposits are formed under specific flow conditions (in the tested scenario corresponding to Case B), but do not accumulate in the vicinity of the culvert if a storm event passes through. This conclusion is reinforced by a comparison of results from Case B, Case C, and Case D whereby the relatively low flow (Case B) led to more sediment accumulations than the “stepped” simulation of a typical storm event.

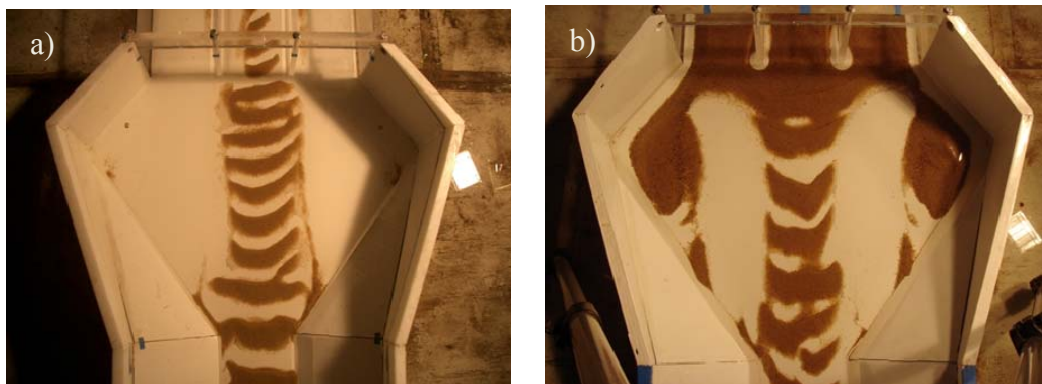

Figure 3-35 Sedimentation a) simulate flow conditions: Case C → Case D; b) simulate flow condition Case B for two hours

This last series of tests pose new issues for the culvert design specifications. Specifically, while the culvert opening area is dictated by the maximum flow, usually a 50-year return flood event, it is this large cross-section area that leads to the situation where during the low flows (present mostly throughout the year) sediment deposits are formed, therefore reducing the available cross section.

3.4.1.4 Test 4: Simulation of “uncoupled” flow and sediment hydrographs

The uncoupled nature of the relationship between sediment transport and flow rates was documented with field observations in Chapter 2.2. The experiments described herein was conducted to investigate the sediment deposition patterns when the peak sediment discharge is delivered before the flow discharge. Flow conditions B and C (as described above) were selected to represent low and, respectively, high flow conditions. Three sediment discharge rates were used. The “stepped” approach used for Test 3 was applied for both flow and sediment discharges. Each test case was run 10 min to reach equilibrium for water and sediment supply. The flow and sediment discharges were uncoupled, i.e., flow and sediment were changed following the uncoupled hydrographs shown in Figure 3-36. The resulting sediment deposition pattern is shown in Figure 3-37. The obtained results show that the lab tests conducted so far are quasi-equivalent.

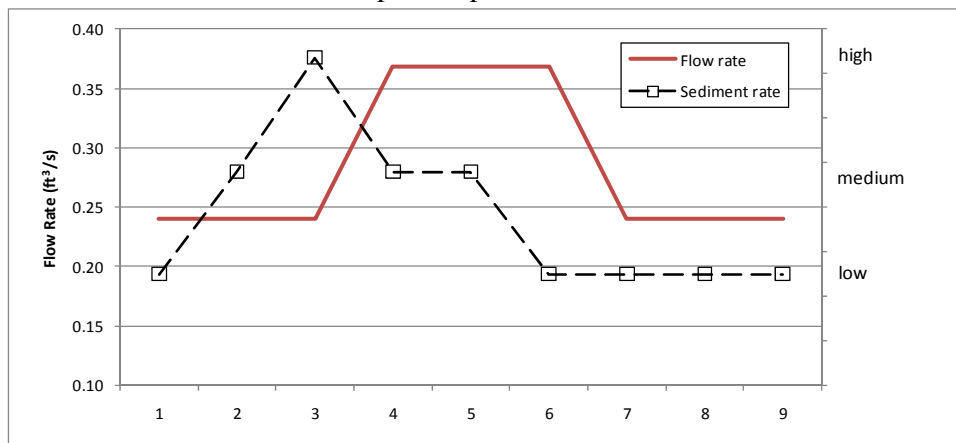

Figure 3-36 Discrete sediment discharge and “uncoupled” discharge hydrographs

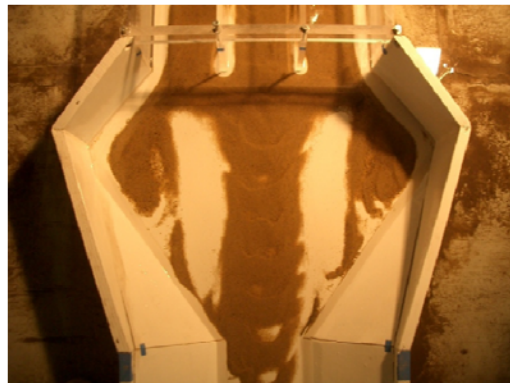
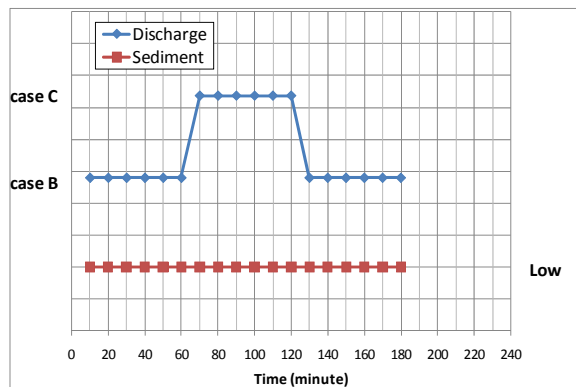
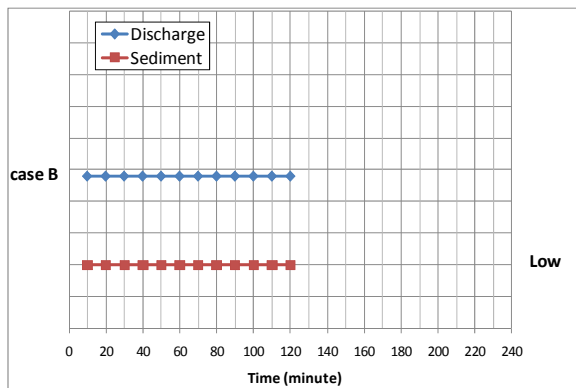

Figure 3-37 Sediment deposition pattern upstream the culvert after Test 4

The synthesis of the laboratory results regarding the performance of various experimental approaches is synthesized in Figure 3-38.

Hydrograph (Discharge & Sediment)

Sediment deposition pattern



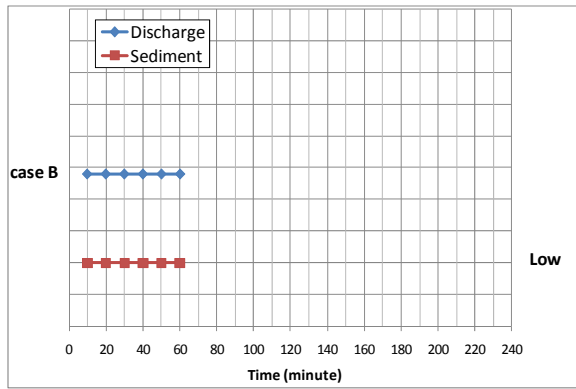
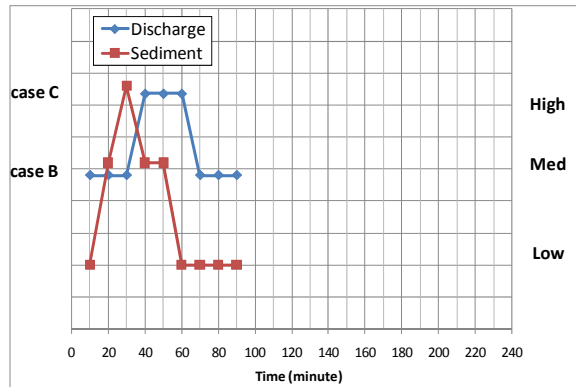
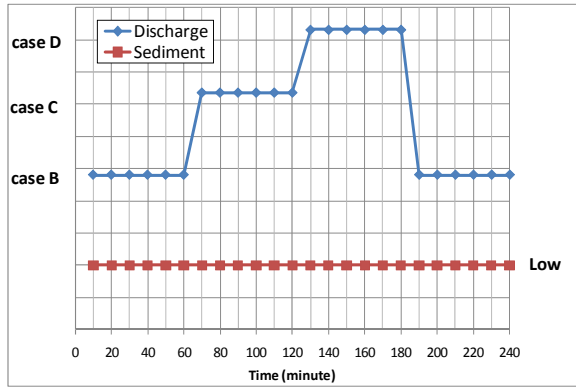

Figure 3-38 Synthesis of various experimental approaches adopted in the laboratory study in the 1/20 scale model



4. Conclusions and further work

Generally speaking, sediment will deposit in the culvert area if the sediment discharge in the approaching channel is larger than the one passing through the culvert. Sediment deposition at culverts is influenced by many factors, including the size and characteristics of material of which the channel is composed, the hydraulic characteristics generated under different hydrology events, the culvert geometry design, channel transition design, and the vegetation around the channel. The multitude of combinations produced by this set of variables makes the investigation of practical situation a complex undertaking. Therefore, most the hydraulic manuals provide design specifications only for the clear water conditions.

In addition to the considerations above, the field and analytical observations have revealed additional complexities of the flow processes involved at flow and sediment transport through culverts that further increase the dimensions of the investigation. The first complexity relates to the **change in flow geometry from the undisturbed cross section of the stream** (usually trapezoidal) **to the geometry of the multi-box culvert** (at least double the stream cross section area in the undisturbed region). This change in geometry occurs twice at the culvert sites: an expansion exists upstream the culvert, and a contraction to the original cross section shape occurs downstream the culvert. The transitions at culvert produce a three-dimensional non-uniform flow behavior gradually varying in space, as the flow moves downstream. The second complexity is the **flows unsteadiness** during the runoff propagation from the catchments to the river and through the river itself. Flow unsteadiness must be studied with theoretical tools, because laboratory investigations cannot easily replicate transitions the flow and sediment transport during a large time scale as required by the propagation of a flood wave. Even simulations for the simpler cases, such as the unsteady flow through a constant section open-channel, are not yet sufficiently accurate to be applied to the practical situations. The reason for this status is the lack of field observations



in unsteady flows due to the high temporal resolution requirements for the instrument and data acquisition system. Finally, an additional complexity is related to the fact that the **sediment and flow hydrographs in rivers are not in phase**: the peak of sediment hydrograph arrives before or after the peak of discharge.

To date, the literature contains neither a systematic study on sediment transport through multi-box culverts, nor on how sediment deposition adversely affects the flow through culverts. Furthermore, there is limited knowledge about the non-uniform, unsteady sediment transport in channels of non-uniform three-dimensional geometry. Presently, there are few readily useable (inexpensive and practical) numerical models that can simulate flow and sediment transport in such situations. Considerable reliance must be placed on field and laboratory work. Given the current state of knowledge, the main goal of the present study is to investigate the above flow complexities to provide the needed insights for a series of culvert-related studies and to demonstrate that with proper resources the research in this area can be further enhanced.

The **field observations** revealed different patterns and driving forces for the initiation of the culvert obstructions. In Buena Vista county (area of headwaters), the blockage of the culverts was driven by sediment washed out from the extensive crop fields in the region. In Marion County, the culvert blockage seemed to be associated with vegetal debris (tree trunks and branches) accumulation at the culvert entrance that eventually are lowering the flow velocity leading to enhanced sediment deposition. The Johnson county culverts seemed to be the most prone to obstructions. The driving factors for the culvert blockage seem to be associated with both vegetal debris accumulation as well as the abundant sediment runoff from the agricultural areas located in the culvert drainage basins. It was obvious from these site visits that there is a need for long-term monitoring in order to understand the origin and development of the obstructions at culverts. Important contributions related to the practical



aspects of the culvert issues were synthesized from the survey completed by the Iowa County Engineers.

The site observations reported in the Sections 3.2.1, 3.2.2, and 3.2.3 provide several relevant elements regarding the suite of culvert studies. The field campaigns conducted in Old Mill Creek, Jordan Creek and South Ralston Creek illustrate that a new or just cleaned culvert is displaying an increased dynamics up to the first major storm event. If the time is sufficient for the sediment deposits to settle (usually with the aid of vegetation growth) the deposits become practically permanent. After this stabilization the as-designed culvert loses its role and the local hydraulic is different than the one assumed. The immediate question is if there are culverts in Iowa where the silted culverts are not producing negative consequences in the upstream area, i.e., backwater areas leading to inundation. It is obvious that additional attention should be paid to the blocked/silted culverts to provide documented answers to the above question and further formulate recommendations for cleaning and prioritization of the cleaning operations.

Field measurements were invaluable to characterize the flow unsteadiness in open channel and the coupling between flow and sediment transport. Typically, the description of the transport processes for steady flows is provided by two relationships: stage-to-discharge (a.k.a. called rating curve) and sediment rate-to-discharge. For unsteady flows, these relationships are not valid. The former one is not anymore a one-to-one relationship as in steady flow, but develops a loop curve instead. The sediment rate-to-discharge curve also departs from the unique relationship in steady flow.

The **numerical simulations** were aimed at aiding the understanding of the complex processes related to sedimentation at culverts, and to compare simulation results with experiments. Of particular relevance are the simulation conducted with HEC-RAS to obtain the time-dependant hydrograph in the channel leading to the culvert. The results of the numerical simulations were in good agreement with the image-based velocimetry



measurements conducted during the 2008 Iowa River flood in Iowa City. Furthermore, simulations with Fluent confirmed the flow field created in the vicinity of the culvert. The numerical as well as laboratory measurements indicate that the flow is non-uniform in the expansion toward the culvert. The velocities in the expansion area are lower (and even reversed) on the sides, hence leading to sediment deposition.

The main role of the **laboratory tests** was to prepare a set of reliable tools to continue the study of various culvert geometry and flow conditions with the confidence that the underlying processes are well understood. The better insights allow to formulate reasonable assumptions that can simplify the study and to further quantitatively document some important features of the flow and sediment through culverts. The laboratory experiments clearly indicate that typical assumptions currently made in the culvert design are not valid. Such assumption is that the flow through the culvert is uniform and the discharge through the side barrels is equal to the central one. These results imply that the performance curves used for the design of the multi-barrel culverts require further investigation with respect to what corrections are necessary to account for flow non-uniformity.

The special tests conducted with discrete, stepped, and uncoupled flow and sediment hydrographs showed that the research team has available a set of experimental tools and procedures to tackle new research geometries and flow conditions for the Iowa culverts. The insights and the understanding of the flow complexities garnered by the present study represent essential knowledge that will be further used to formulate guidelines to retrofit existing culverts and to improve the design specifications in order to provide sediment deposition mitigation means that does not require intervention after construction or cleaning.



References

- Bradley, A.A., Kruger, A., Meselhe, E, and Muste, M. (2002). "Flow Measurement in Streams Using Video Imagery," *Water Resources Research*, 38(12), p. 1315
- Charbeneau, R. J., Henderson A. D., and Sherman L. C., (2006) "Hydraulic Performance Curve for Highway Culverts." *J. Hydraulic Engineering*, Vol. 132, No. 5.
- Charbeneau, R. J., Henderson A. D., Murdock R. C., Sherman L. C., (2002) "Hydraulics of Channel Expansions Leading to Low-Head Culverts" Research Rep. 2109-1, Center for Transportation Research, Univ. of Texas at Austin, Austin, Tex
- Chow, V. T., (1959) "Open-Channel Hydraulics" McGraw-Hill Book Company, INC., New York
- Creutin, J.D., Muste, M., Bradley, A.A., Kim, S.C. and Kruger, A. (2003). "River Gauging Using PIV Technique: Proof of Concept Experiment on the Iowa River, *J. Hydrol.* , 277(3-4), pp. 182 – 194.
- Crookston B. M., and Tullis B. P.(2008). "Scour and Riprap Protection in a Bottomless Arch Culvert.", ASCE Conf. Proc. 316, 230 ,DOI:10.1061/40976(316)230
- Fincham, A. M., and G. R. Spedding. (1997), "Low cost, high resolution DPIV for measurement of turbulent fluid flow." *Experiments in Fluids* 23, pp. 449–462.
- Fujita, I., and Komura, S. (1992) "On the accuracy of the correlation method." *6th International Symposium on Flow Visualization*, pp. 858–862.
- Fujita, I., Muste, M., Kruger, A. (1998), "Large-Scale Particle Image Velocimetry for Flow Analysis in Hydraulic Applications." *J. Hydr. Res.*, 36(3), pp. 397-414.
- Goodridge, W. H. (2009). "Sediment Transport Impacts Upon Culvert Hydraulics." *Graduate Theses and Dissertations, Utah State Univ., Salt Lake, Utah*
- Graf W. H., and Qu Z. (2004) "Flood Hydrographs in Open Channel" *Water Management Issue* 157 p45-52
- Hansen, B., Nieber, J., and Lenhart C. (2009) "Cost Analysis of Alternative Culvert Installation Practices in Minnesota" Minnesota Department of Transportation, Final Report, MN/RC 2009-20
- Hauet, A., A. Kruger, W. Krajewski, A. Bradley, M. Muste, J.-D. Creutin, and M. Wilson (2008), Experimental system for real-time discharge estimation using an image-based method, *J. Hydrol. Eng.*, 13(2), 105–110, doi:10.1061/(ASCE)1084-0699[2008]13:2(105).
- Hauet, A., Muste M., and H-C. Ho (2009) "Digital mapping of Riverine waterway hydrodynamic and geomorphic features" *Earth Surf. Process. Landforms*, 34, pp. 242-252
- Henderson F. M. (1966) "Open Channel Flow" Macmillan Company, INC, New-York



- Jansen P. Ph, Bendegom L. van, Berg J. van den, Vries M de, and Zanen A. (1979) "Principles of River Engineering" Pitman, INC, London
- Kerenyi, K.J. Jones, S., and Stein, S. (2003). "Bottomless Culvert Scour Study: Phase I Laboratory Report." Federal Highway Administration, Report Number FHWA-RD-02-078, McLean, VA, November 2003.
- Kim, Y. (2006), Uncertainty analysis for non-intrusive measurement of river discharge using image velocimetry, Ph.D. thesis, Univ. of Iowa, Iowa City.
- Klein M (1984) "Anti Clockwise Hysteresis in Suspended Sediment Concentration during Individual Storms" *Catena* 11:251 – 257
- Kosicki, A. J., and Davis, S. R. (2001) "Consideration of stream morphology in culvert and bridge design" Transportation research record, Issue Number: 1743
- Lenzi M., and Marchi L. (2000) "Suspended sediment load during floods in a small stream of the Dolomites (northeastern Italy)" *Catena* 39: 267-282
- Meselhe E. A., and Hebert K., (2007) "Laboratory Measurements of Flow through Culverts" *J. Hydr. Engrg.* Vol 133, pp.973 -976
- Mikhail, E. M., Bethel, J.S., and McGlone, J.C. (2001), "Introduction to Modern Photogrammetry", John Wiley & Sons, Inc., New York, NY
- Muste, M., Ettema, R., Ho, H-C. and Miyawaki, S. (2009). "Development of Self-Cleaning Box Culvert Designs," Report for Iowa Highway Research Board TR-545, The Iowa Department of Transportation, Ames, IA
- Muste, M., Hauet, A., Ho, H-C., and Nakato, T. (2008). "Quantitative Mapping of Waterways Characteristics at Bridge Sites," Report for Iowa Highway Research Board TR – 569, The Iowa Department of Transportation, Ames, IA (also IIHR Technical Report No. 470).
- Muste, M., Z. Xiong, J., Schöne, Z. Li (2004). "Flow Diagnostic in Hydraulic Modeling Using Image Velocimetry," *J. Hydr. Engrg.* 130(3), pp. 175-185.
- Normann, J. M., Houghtalen, R. J., and Johnson, W. J., (1985) "*Hydraulic Design of Highway Culverts.*" Hydraulic Design Series No. 5, 2nd Ed., Federal Highway Administration, Washington, D.C.
- Piirto, M., Eloranta, H., Saarenrinne, P., and Karvinen, R. (2005). "A comparative study of five different piv interrogation algorithms." *Experiments in Fluids*, 39:571–588, 2005. doi: DOI 10.1007/s00348-005-0992-6.
- Rigby E. H., Boyd M. J., Roso S., Silveri P., and Davis A. (2002) "Causes and Effects of Culvert Blockage during Large Storms" ASCE Conf. Proc. Vol 112, 298



- Shutter R. D. and Verhoeven R. (2001) “ Simulation of Sediment Transport during Flood Events: Laboratory Work and Field Experiments” Hydrological Sciences Journal, Volume 46, Issue 4 August 2001 , p599 – 610
- Song, T. (1994) “*Velocity and turbulence distribution in non-uniform and unsteady open-channel flow.*” PhD Thesis, EPF Lausanne, Switzerland
- Suszka L. (1987) “Sediment Transport at Steady and Unsteady Flow: a Laboratory Study” PhD Thesis, No 704, EPF Lausanne, Switzerland
- Tu, H. and Graf, W. H. (1992) Velocity distribution in unsteady open-channel flow over gravel beds.. *J. Hydrosci. Hydraul. Engng* 10 , pp. 11-25.
- Vassilios (1995) “*Effects of sediment on Drainage Culvert Serviceability*” J. Performance of Constructed Facility, Vol 9, No3
- Wei, S. D., G. Q. qnd Ma. (1994). “*Implicit and explicit camera calibration: Theory and experiments.*” *IEEE Transactions on Pattern Analysis and Machine Intelligence*, 16(5), pp. 469-480.



Appendix A

Survey of Iowa county engineers

List of Survey County Engineering

No	County	Name	e-mail address
1	Buchanan	Brian Keierleber	bcengineer@trxinc.com
2	Buena Vista	Jon Ites	jites@co.buena-vista.ia.us
3	Davis	David Grove	daviseng@netins.net
4	Emmet	Roger R. Patocka	emmeteng@ncn.net
5	Linn	Steve Gannon	Steve.Gannon@linncounty.org
6	Marion	Roger Schletzbaum	rschletzbaum@co.marion.ia.us
7	Monona	David Carney	mocoeng@longlines.com
8	Montgomery	Brad Skinner	bsmontengr@iowatelecom.net
9	Osceola	Thomas Snyder	tsnyder@osceolacoia.org
10	Page	Brad Skinner	bspagecoeng@iowatelecom.net
11	Winneshiek	Lee Bjerke	lbjerke@co.winneshiek.ia.us
12	Woodbury	Mark Nahra	mnahra@sioux-city.org
13	Lyon	Jeff Williams	
14	Cerro Gordo	Mary Kelly	
15	Calhoun	Ron Haden	
16	District 3 Maintenance Manager	Dwight Rorholm	

QUESTIONNAIRE

1. How many culverts are in your county? How many of them are Multi-box?

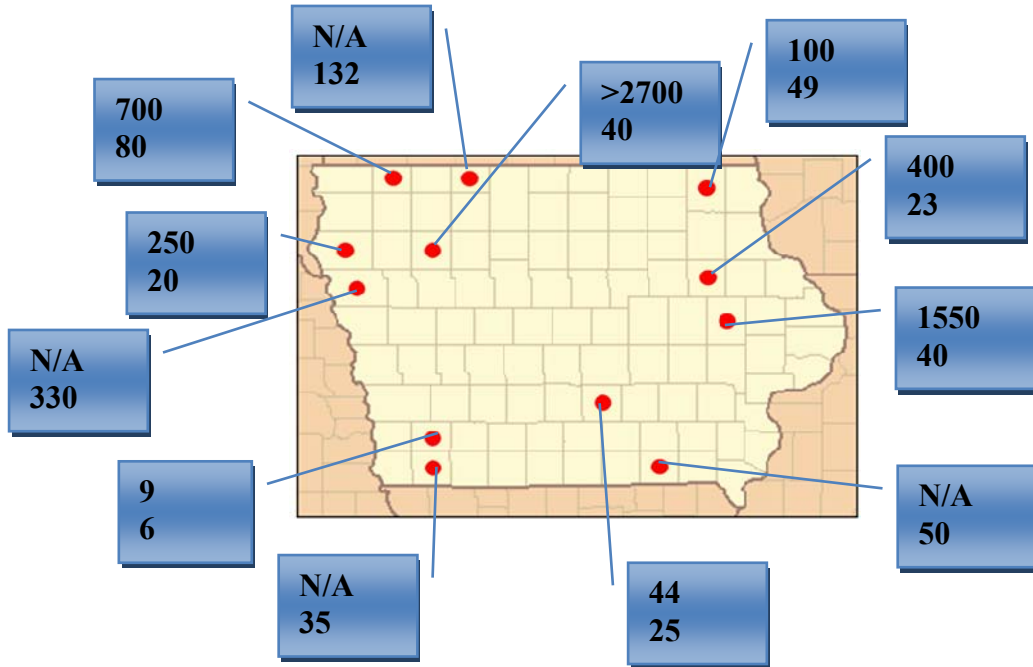

2. How often do you inspect culverts sites and perform maintenance?

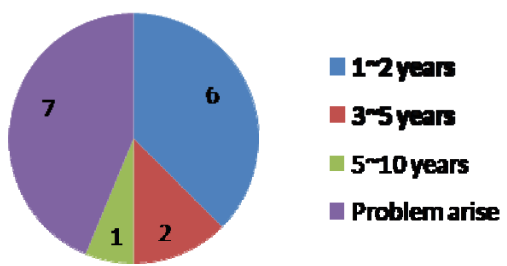

3. Are the large storm events cleaning or aggravating culvert sedimentation?

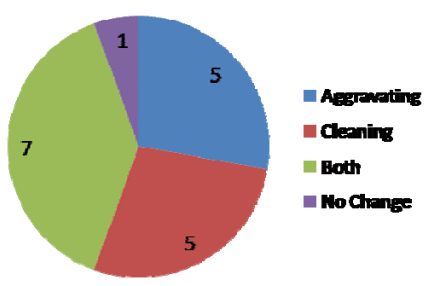



Comment:

- *Steve (Linn County)* provided that only 2008 flood appears to clean out culvert sedimentation, but typical high water does not (category into aggravating).
- It should be noticed that there are 330 Multi-Box culverts in Woodbury County, and *Mark* said cleaning is true for the most.
- *Ron (Calhoun)*: Most of smaller culverts are cleaned by large storms. Larger Multi-Box silt in on barrel
- *Rorholm (District 3 Maintenance Manager)*: There is much soil runoff from field in large events
- HURK underground company said if culverts are only partially silted, a large storm seems to clean out sediment unless the ditch has silted as well (category into cleaning)

4. Please list in order (up to five) the most often encountered problems/concerns related to M-B culverts (e.g. scour, sedimentation, debris accumulation, structural, environmental)

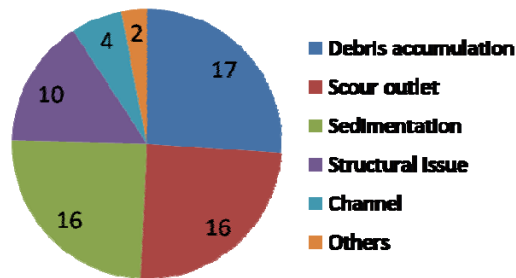

5. Can you relate the sedimentation at M-B culvert with the season cycling?

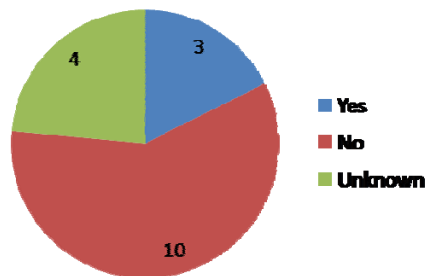



Comment:

- Three engineers pointed out that the sediment is prone to deposit in spring.
- Two engineers said that the process of sedimentation is too slow to relate with a single season.
- One engineer supposed that land use is the factor of sedimentation.

6. Are you providing input in the design of the M-B culverts? If, yes, what input is related to sedimentation?

Yes	6
No	6

Comment:

None of input is related to sedimentation. The inputs for design are considering the range of flows and velocities existing the barrels.

7. Give examples of worst sedimentation situations and provide potential causes

- 11 engineers out of 16 gave examples of sedimentation.
- Linn, Emmet, and Page Counties pointed out only one barrel can handle the flow the rest were filled.
- Woodbury and Winneshiek counties showed that they have sedimentation because of the change of upstream land use.

Steve (Linn County):

Triple barrel RCB's typically have one barrel handle the routine flow and two barrels filled. Having sediment fill inside a culvert barrel is much more difficult to correct mechanically. They also tend to collect large tree debris.

Mark (Woodbury County):

Upstream land use, lack of soil filtration from stormwater has filled barrels almost to top of barrel on up to a 6' high multi barrel. Lower barrel height culverts are more of a problem for sedimentation.



Jeff (Lyon County):

One or two of the holes are partially close. I always thought it had to do with the main channel velocity picking one of the holes as it's favorite

Rorholm (District 3 Maintenance Manager):

Parallel barrels have a tendency to fill (partially) over time to where there is concern the design flow will not blow the partially barrels open.

8. Do you have successful experiences regarding mitigation of sedimentation?

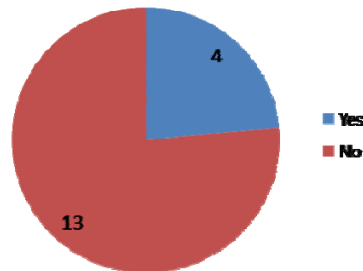

Thomas (Plymouth County): Terraces above the culvert

Jon (Buena Vista County): drop inlets

9. What are the most difficult issues/concerns in cleaning the culvert?

10 out of 12 answered.

Access and moving sediment are most difficult

10. Could you provide an average cost of multi-barrel culvert cleaning (\$/barrel)

Only 4 county engineers answered. Average: \$2750/barrel

HURK underground company charge: $(\$1 \times \text{width} \times \text{length} \times \% \text{full}) / \text{barrel}$



11. Is the culvert clean-up made by your own crews or you contract out the work?

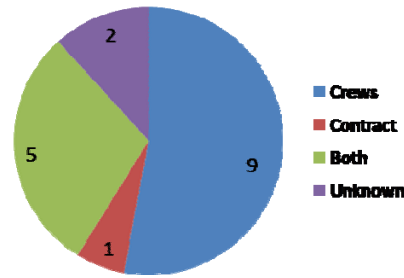

12. Can you exemplify efficient means for culvert cleaning?

13. What is in your opinion the most important design objective for a culvert (please rank in order, from 1 to 7)?

1. Stable, durable structure
2. Public/traffic safety
3. Create a stable stream and condition
4. Cost-effective maintenance
5. Control of sediment/scour/erosion
6. Flood plain management
7. Environmentally friendly

14. List issues/problems associated with culverts that you consider that need further attention/research

10 out of 16 answered.

Here we list issues/problems which they consider need attention/research : 1) sedimentation in barrel, 2) scour protection, 3) culvert structure design (width, numbers), 4) debris, 5) flood design.



Comment:

Steve (Linn County):

RCB culverts have much of the cost associated with inlet and outlet structures on most secondary roads. Providing more cost effective inlet and outlet would make the RCB more practical. Making these structures more cheaply and easily extended would make them more practical as well. Reducing the number of barrels to one and providing design software to customize the design would provide better outcomes for most counties. Precast/prestressed barrel sections bolted together may be able to make a versatile, rapidly placed culvert.