

# Evaluation of Long-Term Pavement Performance and Noise Characteristics of Open-Graded Friction Courses – Project 3

WA-RD 749.1

Mark Russell  
Jeff S. Uhlmeyer  
Tim Sexton  
Jim Weston  
Tom Baker

June 2010





**Post-Construction and Performance Report**  
**Experimental Feature 08-02**

# **Evaluation of Long-Term Pavement Performance and Noise Characteristics of Open-Graded Friction Courses – Project 3**

**Contract 7283**  
**I-405**  
**112<sup>TH</sup> AVE SE to SE 8<sup>TH</sup> ST**  
**MP 9.33 to MP 12.76**



1. REPORT NO. <b>WA-RD 749.1</b>		2. GOVERNMENT ACCESSION NO.		3. RECIPIENT'S CATALOG NO.	
4. TITLE AND SUBTITLE <b>Evaluation of Long-Term Pavement Performance and Noise Characteristics of Open-Graded Friction Courses – Project 3</b>				5. REPORT DATE <b>June 2010</b>	
				6. PERFORMING ORGANIZATION CODE <b>WA 08-02</b>	
7. AUTHOR(S) <b>Mark Russell, Jeff S. Uhlmeyer, Tim Sexton, Jim Weston and Tom Baker</b>				8. PERFORMING ORGANIZATION REPORT NO.	
. PERFORMING ORGANIZATION NAME AND ADDRESS <b>Washington State Department of Transportation Materials Laboratory, MS-47365 Olympia, WA 98504-7365</b>				10. WORK UNIT NO.	
				11. CONTRACT OR GRANT NO.	
12. SPONSORING AGENCY NAME AND ADDRESS <b>Washington State Department of Transportation Transportation Building, MS 47372 Olympia, Washington 98504-7372 Project Manager: Kim Willoughby, 360-705-7978</b>				13. TYPE OF REPORT AND PERIOD COVERED <b>Post-Construction and Performance Report</b>	
				14. SPONSORING AGENCY CODE	
15. SUPPLEMENTARY NOTES <b>This study was conducted in cooperation with the U.S. Department of Transportation, Federal Highway Administration.</b>					
16. ABSTRACT <p>This experimental project is being conducted as a part of WSDOT's effort to produce pavements that reduce the noise generated at the tire/pavement interface. Experimental sections of open-graded friction courses were built using asphalt rubber and SBS modified binders. A section of conventional Class ½ inch hot mix asphalt (HMA) serves as the control section for the two experimental sections.</p> <p>Sound intensity measurements were conducted using the On Board Sound Intensity (OBSI) method after construction. The most recent OBSI readings taken in December of 2009 indicated that the open-graded asphalt rubber and SBS modified sections were 3.5 to 2.0 decibels, respectively, quieter than the Class ½ inch HMA control section.</p> <p>This experimental evaluation will continue for the useful life of the pavement or a minimum of five years.</p>					
17. KEY WORDS <b>quieter pavements, rubber asphalt, open-graded friction courses, on board sound intensity measurements, SBS asphalt</b>			18. DISTRIBUTION STATEMENT <b>No restrictions. This document is available to the public through the National Technical Information Service, Springfield, VA 22616</b>		
19. SECURITY CLASSIF. (of this report) <b>None</b>		20. SECURITY CLASSIF. (of this page) <b>None</b>		21. NO. OF PAGES <b>54</b>	
				22. PRICE	

## **DISCLAIMER**

The contents of this report reflect the views of the authors, who are responsible for the facts and the accuracy of the data presented herein. The contents do not necessarily reflect the official views or policies of the Washington State Department of Transportation or the Federal Highway Administration. This report does not constitute a standard, specification, or regulation.

## TABLE OF CONTENTS

Introduction.....	1
Background.....	2
Project Description.....	2
Mix Design Process .....	4
OGFC-AR.....	4
OGFC-SBS .....	5
Construction.....	6
OGFC-AR Special Provisions .....	6
OGFC-SBS Special Provisions.....	7
Weather Limitations.....	7
Tack Coat .....	7
Asphalt Plant.....	7
Paving .....	8
Tack Coat Application .....	10
Post-Construction Testing.....	11
Friction.....	12
Ride.....	12
Wear/Rutting.....	13
Sound Intensity .....	14
Discussion of Results.....	18
Conclusions.....	18
Future Research .....	19
References.....	20
Appendix A - Mix Design.....	A-1
Appendix B - Specifications .....	B-1
Appendix C - Comments on Construction of Open-Graded Pavements .....	C-1
Appendix D - Experimental Feature Work Plan.....	D-1

## LIST OF FIGURES

Figure 1. Vicinity map for Contract 7283.....	3
Figure 2. Schematic of paving limits for test sections south of I-90 (south section).....	3
Figure 3. Schematic of paving limits for test sections north of I-90 (north section). .....	4
Figure 4. High-shear high speed blender used to add crumb rubber to the PG64-22 asphalt. ....	8
Figure 5. Adding crumb rubber. ....	8
Figure 6. Pallets of fibers to be used in OGFC-SBS. ....	8
Figure 7. Equipment for introducing fibers into asphalt plant.....	8
Figure 8. Distributor applying tack coat. ....	9
Figure 9. Tack coat application.....	9
Figure 10. CAT AP-1055D paver.....	9
Figure 11. RoadTec Shuttle Buggy.....	9

Figure 12. At times, three paving machines and two Shuttle Buggies were used. ....	9
Figure 13. Rollers stayed close behind the paving machines. ....	9
Figure 14. Finished OGFC-AR pavement. ....	10
Figure 15. Close-up of OGFC-AR.....	10
Figure 16. PG asphalt tack coat sticking to Shuttle Buggy tire in HOV lane.....	10
Figure 17. Bare streak left after PG asphalt tack picked up by Shuttle Buggy tire. ....	10
Figure 18. PG asphalt tack coat sticking to tires was not a problem on the old PCCP. ....	11
Figure 19. Members of paving crew removing tack buildup.....	11
Figure 20. Piece of tack buildup from tires left in front of paver. ....	11
Figure 21. Fat spot resulting from a piece of tack buildup from tires. ....	11
Figure 22. Sound intensity level (dBA) measurements for the OGFC-AR sections. ....	15
Figure 23. Sound intensity level (dBA) measurements for the OGFC-SBS sections.....	16
Figure 24. Sound intensity level (dBA) measurements for ½ inch HMA control section.....	17

## LIST OF TABLES

Table 1. Mix design for the OGFC-AR. ....	5
Table 2. Mix design for the OGFC-SBS.....	5
Table 3. Gradation requirement for crumb rubber.....	6
Table 4. FN results from November 19, 2009 .....	12
Table 5. IRI measurements. ....	13
Table 6. Wear/rutting measurements. ....	14
Table 7. Sound intensity measurements (dBA) for the OGFC-AR. ....	14
Table 8. Sound intensity measurements (dBA) for the OGFC-SBS.....	15
Table 9. Sound intensity measurements (dBA) for the ½ inch HMA.....	16
Table 10. December 2009 OBSI readings for each section. ....	17
Table 11. Comparison of average sound intensity levels immediately after construction. ....	18

## Introduction

This is the third in a series of three experimental feature projects involving the construction of open-graded friction course (OGFC) pavements to mitigate tire/pavement noise. The first, on I-5 near the city of Lynnwood, was constructed in August of 2006, and the second, on SR 520 between Lake Washington and I-405 was constructed in July of 2007. All three projects used asphalt rubber (AR) and styrene butadiene styrene (SBS) modified asphalt binders combined with open-graded aggregate structures to produce a quieter pavement surface. The open-graded aggregate structure results in a higher volume of surface voids (around 20 percent air voids) which absorbs some of the noise generated at the tire/pavement interface. The OGFC pavements are thus “quieter” than densely-graded pavements which have between four and eight air percent voids.

Open-graded pavements are not new to the State of Washington or the Washington State Department of Transportation (WSDOT). OGFC’s were used extensively in the state in the early to middle 1980’s. Their use was discontinued in 1995 due to problems with excessive rutting caused by studded tire wear. The renewed interest in open-graded pavements is prompted by successful use of this type of pavement in other states, principally Arizona. The Arizona Department of Transportation (ADOT) has been a leading advocate of rubberized open-graded pavements as one solution to making pavements quieter. Intense interest regarding rubberized open-graded pavement as the answer to making pavements quieter has reached the public sector who are now asking for this type of pavement to be used on the highways that bisect their neighborhoods.

A major difference between the OGFC test section on I-405 and the test sections on I-5 and SR 520 is the underlying pavement type. The underlying pavement on I-5 and SR 520 is dense graded hot mix asphalt (HMA) while portland cement concrete pavement (PCCP) underlies the OGFC placed on I-405. A large proportion of the interstate pavement in the Seattle metropolitan area is older PCCP which can be one of the noisier pavement types. This experimental feature will provide valuable information regarding the performance of OGFC quieter pavement on PCCP.



## **Background**

There are downsides with the use of open-graded pavements. Open-graded pavements are very susceptible to excessive wear from studded tires. This excessive wear produces ruts in the pavements that fill with water during rainy periods and pose the additional hazard of hydroplaning. The other downside is a shortened pavement life. The life of open-graded pavements is cut short by the studded tire wear mentioned previously. Pavement lives of less than 10 years, and as short as three to four years were experienced with these types of pavement in the 1980's in Washington State. States where the use of OGFC has been successful (Florida, Texas, Arizona and California) do not experience extensive studded tire usage. Similarly, these states are southern, warm weather states; a clear advantage when placing a product like OGFC with asphalt-rubber. ADOT, for example, requires the existing pavement to have a minimum surface temperature of 85°F at the time of placement (ADOT 2008). Washington State urban pavements, placed at night to avoid traffic impacts, rarely reach this temperature during the available nighttime hours for paving (10:00 p.m. to 5:00 a.m.), even in summer. Other pavements and bridge decks reach such temperatures at night only on rare occasions, making successful placement of this type of pavement a challenge. A more complete discussion of the performance history of open-graded pavements in Washington State is found in the report on the first two quieter pavement experimental projects (Anderson et al., 2008a and Anderson et al., 2008b).

## **Project Description**

The site selected for the third experiment is located on northbound I-405 where it crosses I-90. The project, Contract 7283, 112th Ave SE to SE 8th St, added an additional lane in each direction of I-405 between MP 9.33 to MP 12.76. The existing pavement was rehabilitated as part of the project which included placing OGFC in two test sections, one south of I-90 between MP 10.26 and MP 10.93 and one north of I-90 between MP 11.76 and MP 12.40. The average daily traffic (ADT) on this section of I-405 is 165,457 with 6.75 percent trucks. A vicinity map for the project is shown in Figure 1.



Figure 1. Vicinity map for Contract 7283.

Each test section included a segment of both OGFC-AR and OGFC-SBS. Prior to paving, the existing PCCP was ground to remove faulting. The existing PCCP in the northern test section also received a dowel bar retrofit prior to paving while the southern test section did not. Most of the widening for the new lane was toward the median so much of the OGFC in the HOV lane is over new dowelled PCCP. The only section of OGFC that was not placed on PCCP is the southernmost section just north of the bridge over Coal Creek Parkway. The paving depth for all of the OGFC was 0.08 feet. The paving limits for the two test sections are shown in Figures 2 and 3.

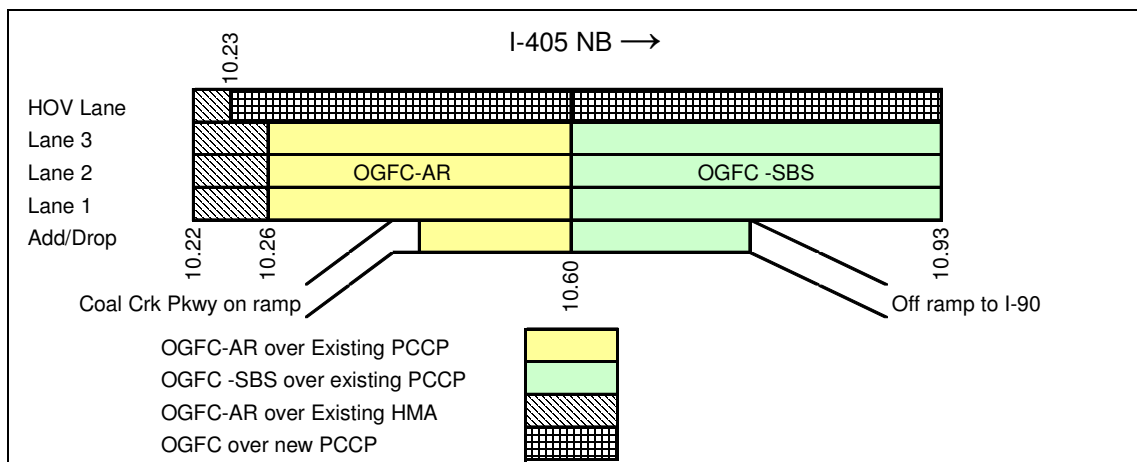

Figure 2. Schematic of paving limits for test sections south of I-90 (south section).

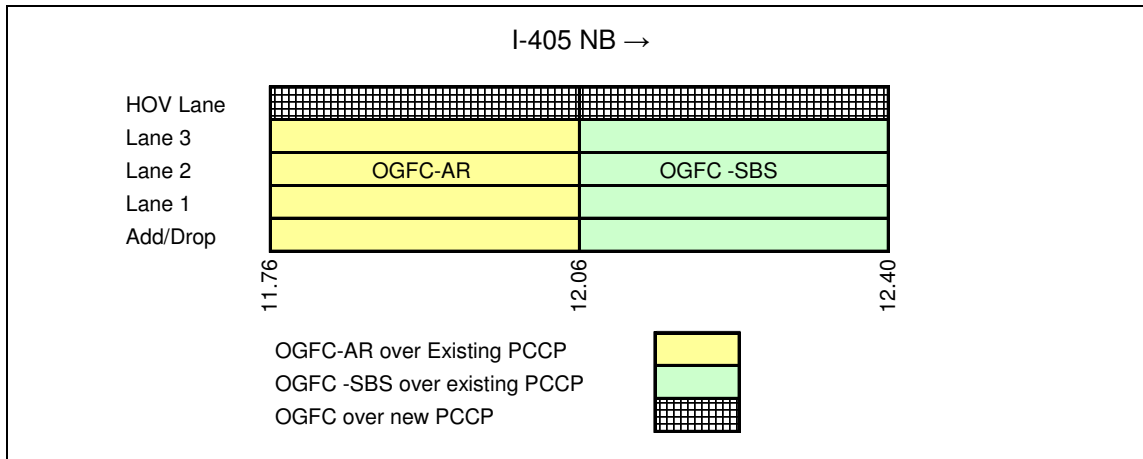

Figure 3. Schematic of paving limits for test sections north of I-90 (north section).

## Mix Design Process

Special mix design processes were required for both the asphalt rubber and SBS open-graded pavements. Both mix designs were done in-house in contrast to the first quieter pavement project near Lynnwood that borrowed the services of ADOT to develop the design for the asphalt rubber mix (Anderson et al., 2008a). The asphalt rubber mix design, however, was still patterned after the ADOT process. The SBS mix design was based on the use of a drain down test as was used on the previous projects. Complete discussions of the two processes can be found in report WA-RD 683.1 (Anderson et al., 2008a). The mix design reports from the HQ Materials Laboratory can be found in Appendix A.

### **OGFC-AR**

The mix design for the OGFC-AR was similar to the design for the I-5 and SR 520 projects (Table 1). The asphalt percentage was slightly higher than the first two projects (9.4 percent vs. 9.2 percent for I-5 and 9.0 percent for SR 520). Crumb rubber was added at 20 percent of the weight of the binder which was lower than the 22 percent used on I-5 and the 23.5 percent used on SR-520. The aggregate gradation for both the OGFC-AR and the OGFC-SBS was similar to the first two projects but the aggregate came from Lakeside Industries' Issaquah pit (A-189) instead of pit site B-335. An important change in the OGFC-AR mix design on I-405 was the use of lime as the anti-stripping additive. The first two projects followed WSDOT's procedure of using liquid anti-stripping additive to prevent stripping. One of the goals of the I-405 paving was to follow ADOT's procedures as close as possible. ADOT uses hydrated lime as

anti-stripping additive in its OGFC mixes so the anti-stripping additive specification was changed to require hydrated lime. Hydrated lime was added at a rate of 1.0 percent of the aggregate weight.

<b>Table 1. Mix design for the OGFC-AR.</b>			
<b>Sieve Size</b>	<b>Gradation</b>	<b>Specifications</b>	<b>Source/Supplier</b>
3/8"	100	100	A-189
#4	35	30-45	A-189
#8	8	4-8	A-189
#200	1.9	0–2.5	A-189
<b>Binder Grade</b>	<b>Percent Asphalt</b>		<b>Source/Supplier</b>
PG64-22	9.4		U.S. Oil, Tacoma WA
<b>Anti-Strip</b>	<b>Percent</b>		<b>Source/Supplier</b>
Hydrated Lime	1% by wt of aggregate		Graymont Inc.
<b>Crumb Rubber</b>	<b>Percent by Wt. of AC</b>		<b>Rubber Granulators Inc.</b>
CRM	20.0		Rubber Granulators Inc.

### **OGFC-SBS**

The mix design for the OGFC-SBS was also similar to the design used for the I-5 and SR 520 projects (Table 2). The asphalt content was 0.3 percent higher than I-5 and 0.2 percent lower than SR 520. As was the case for the OGFC-AR, hydrated lime was used as anti-stripping additive. Fibers were added at a rate of 0.3 percent, to help prevent drain-down, as it was on the other two projects.

<b>Table 2. Mix design for the OGFC-SBS.</b>			
<b>Sieve Size</b>	<b>Gradation</b>	<b>Specifications</b>	<b>Source/Supplier</b>
3/8"	100	100	A-189
#4	38	35-55	A-189
#8	12	9-14	A-189
#200	2.0	0–2.5	A-189
<b>Binder Grade</b>	<b>Percent Asphalt</b>		<b>Source/Supplier</b>
PG70-22	8.6		US Oil, Tacoma, WA
<b>Anti-Strip</b>	<b>Percent</b>		<b>Source/Supplier</b>
Hydrated Lime	1% by wt of aggregate		Graymont Inc.
<b>Fibers</b>	<b>Percent</b>		<b>Source/Supplier</b>
Cellulose Based Paper	0.3		Central Fiber Corporation

# Construction

The Special Provisions for the contract contains several items pertaining to the construction of the two special OGFC pavements. A brief description of these items is included in this section of the report as a guide to understanding the circumstances under which the sections were constructed. The complete OGFC specification for Contract 7283 can be found in Appendix B.

## OGFC-AR Special Provisions

The Special Provisions required that the asphalt binder for the OGFC-AR be either PG58-22 or PG64-22. The crumb rubber was required to conform to the gradation requirements shown in Table 3. The crumb rubber was required to have a specific gravity of  $1.15 \pm 0.05$  and be free of wire or other contaminating materials. The rubber could also not contain more than 0.5 percent fabric. Calcium carbonate could be added to prevent the particles from sticking together. The minimum amount of crumb rubber required in the mix was 20 percent by weight of the asphalt binder.

<b>Sieve Size</b>	<b>Percent Passing</b>
No. 8	<b>100</b>
No. 10	<b>100</b>
No. 16	<b>65 – 100</b>
No. 30	<b>20 – 100</b>
No. 50	<b>0 – 45</b>
No. 200	<b>0 – 5</b>

The temperature of the asphalt binder at the time of the addition of the crumb rubber was required to be between 350 and 400°F. A one-hour reaction period was required after the mixing of the rubber with the binder. At the end of the reaction period the rubber particles were required to be thoroughly “wetted” without any rubber floating on the surface or agglomerations of rubber particles observable. The temperature of the asphalt-rubber immediately after mixing was required to be between 325 and 375°F.

The mixed asphalt-rubber was to be kept thoroughly agitated during the period of use to prevent the settling of the rubber particles. In no case could the asphalt-rubber be held at a temperature of 325°F or above for more than 10 hours. Asphalt-rubber held for more than 10

hours was required to be cooled and could then be gradually reheated to the prescribed temperature. A batch of asphalt-rubber could only be cooled and reheated in this manner once.

## OGFC-SBS Special Provisions

The asphalt binder for the OGFC-SBS was required to be a PG70-22 produced by adding SBS modifier to a neat binder. If needed, fiber stabilizing additive could be included in the mix. If the mix was produced in a dryer-drum plant, fibers were required to be added to the aggregate and uniformly dispersed prior to the injection of the asphalt binder. Storage time for the OGFC-SBS was not to exceed four hours.

## Weather Limitations

ADOT requires a high (by western Washington standards) minimum surface temperature specification of 85°F for paving their OGFC-AR. Traffic volumes on the I-5 and SR 520 projects required paving to occur at night leading to the minimum air temperature specifications of 55°F for the I-5 project and 60°F for the SR 520 project. In order to place the OGFC on I-405 under conditions as close to those of paving in Arizona as possible, WSDOT specified a minimum air temperature of 70°F and allowed placement of the OGFC to occur during the day despite heavy traffic volumes on I-405.

## Tack Coat

The tack coat specification on this project was different from the first two OGFC quieter pavement projects. The first two projects required tack coat consisting of emulsified asphalt but a performance grade (PG) asphalt tack coat was required on I-405. ADOT originally only allowed PG asphalt as tack coat for OGFC paving. Even though ADOT now allows the use of emulsions as tack coat, it was decided to follow ADOT's original procedure and use PG asphalt for the tack coat. The specification allowed tack coat to meet the requirements of either PG58-22 or PG64-22. Lakeside Industries chose to use PG64-22 from U.S. Oil in Tacoma, WA.

## **Asphalt Plant**

This project used the dryer-drum type plant located at Lakeside Industries' Issaquah facility. Lakeside brought in a high-shear high-speed blender manufactured by Phoenix Industries to mix the crumb rubber with the PG64-22 asphalt (Figure 4 and 5). Figures 6 and 7

show pallets of fibers for the OGFC delivered to the project and the equipment used to introduce them into the asphalt plant.



Figure 4. High-shear high speed blender used to add crumb rubber to the PG64-22 asphalt.



Figure 5. Adding crumb rubber.



Figure 6. Pallets of fibers to be used in OGFC-SBS.



Figure 7. Equipment for introducing fibers into asphalt plant.

## ***Paving***

The test sections were paved during the day over the weekend of August 15<sup>th</sup> and 16<sup>th</sup>, 2009. The paving required Northbound I-405 to be restricted to one lane of traffic. A weekend was chosen because the traffic disruption would be less on a weekend than a week day; however the weekend lane closures still resulted in considerable traffic delays. Paving operations began on the 15<sup>th</sup> with the two leftmost lanes of the test section south of I-90. Paving started at the Coal Creek Parkway Bridge and progressed northward toward I-90. Once the left two lanes of the test section south of I-90 were complete the equipment was moved to the test section north of I-90 to pave the left two lanes there. The process was repeated on the 16<sup>th</sup> for the right lanes.

The paving operation is captured in Figures 8 through 15. Temperature differentials were not a problem on this project due to the use of the Shuttle Buggy material transfer vehicle (MTV) that was specified in the Special Provisions (Appendix B). A detailed report of the construction that includes infrared images is included as Appendix C.



Figure 8. Distributor applying tack coat.



Figure 9. Tack coat application.



Figure 10. CAT AP-1055D paver.



Figure 11. RoadTec Shuttle Buggy.



Figure 12. At times, three paving machines and two Shuttle Buggies were used.



Figure 13. Rollers stayed close behind the paving machines.





Figure 14. Finished OGFC-AR pavement. Figure 15. Close-up of OGFC-AR.

### ***Tack Coat Application***

The only significant problem encountered while paving the OGFC was the PG asphalt tack coat sticking to tires on the end dumps and the Shuttle Buggies in the new PCCP HOV lane. The tack coat stuck to equipment tires to the point that bare spots were left where there was no tack coverage (Figure 16). The problem with the tack coat was attributed to dust on the surface of the new PCCP in the HOV lane which had not yet been opened to traffic. The dust prevented the tack from adhering to the pavement so it was picked up by equipment tires (Figure 17). The PG asphalt tack coat did perform adequately on the old PCCP and the existing HMA near the Coal Creek Parkway Bridge (Figure 18). It is not clear if an emulsion based tack coat would have performed better. The lower viscosity of emulsified asphalt may have allowed it to better penetrate the dust and stick to the pavement.



Figure 16. PG asphalt tack coat sticking to Shuttle Buggy tire in HOV lane.



Figure 17. Bare streak left after PG asphalt tack picked up by Shuttle Buggy tire.

The PG asphalt tack coat sticking to tires led to isolated fat spots showing up in the mat due to pieces breaking away from tires. The buildup of tack occasionally required the paving

crew to remove it from the tires (Figure 19). Most of the tack was removed from the roadway but pieces that were left on the mat in front of the paver (Figures 20) would later show up as fat spots in the finished mat (Figure 21).



Figure 18. PG asphalt tack coat sticking to tires was not a problem on the old PCCP.



Figure 19. Members of paving crew removing tack buildup.



Figure 20. Piece of tack buildup from tires left in front of paver.



Figure 21. Fat spot resulting from a piece of tack buildup from tires.

## Post-Construction Testing

Post-construction evaluation of the two sections of open-graded pavement and the control section of Class ½ inch HMA included measurements of friction, smoothness, rutting/wear and noise. This data will be collected throughout the life of the experiment as noted in the experimental feature work plan found in Appendix D.

## **Friction**

Friction tests were performed with a ribbed tire using a locked-wheel friction tester meeting ASTM E-274 requirements. The friction number (FN) results are listed in Table 4. The friction numbers are all in the acceptable category with the Class ½ inch HMA having the highest average for all lanes of 57.4. The average for all lanes of the OGFC-AR was 48.9 while the average for all lanes of the OGFC-SBS was slightly lower at 47.9.

<b>Table 4. FN results from November 19, 2009</b>			
<b>Section</b>	<b>Lane</b>	<b>Average FN</b>	<b>FN Range</b>
Class ½ inch HMA	1	55.6	54.4 – 57.2
Class ½ inch HMA	2	58.6	56.4 – 60.7
Class ½ inch HMA	3	57.5	55.6 – 60.1
Class ½ inch HMA	HOV	57.9	56.7 – 59.5
<b>Class ½ inch HMA Average and Range</b>		<b>57.4</b>	<b>54.4 – 60.7</b>
OGFC-AR	1	48.0	44.2 – 50.8
OGFC-AR	2	51.3	47.1 – 55.2
OGFC-AR	3	50.3	49.2 – 52.1
OGFC-AR	HOV	45.8	41.5 – 48.3
<b>OGFC-AR Average and Range</b>		<b>48.9</b>	<b>41.5 – 55.2</b>
OGFC-SBS	1	47.7	38.1 – 53.9
OGFC-SBS	2	49.3	40.4 – 52.9
OGFC-SBS	3	48.8	47.7 – 51.0
OGFC-SBS	HOV	46.0	44.2 – 47.8
<b>OGFC-SBS Average and Range</b>		<b>47.9</b>	<b>38.1 – 53.9</b>

## **Ride**

Ride measurements were made on November 14, 2009. Table 5 lists the International Roughness Index (IRI) for each lane. All measurements were made with WSDOT's Pathway pavement condition collection van.

Preparation of the existing surface prior to paving the OGFC test sections included diamond grinding the existing PCCP. No IRI measurements were taken after the diamond grinding so there is no way to evaluate the amount of ride improvement after placing the OGFC. WSDOT ride specification for HMA pavements on interstate routes provides a bonus if the IRI is lower than 60 inches/mile and a penalty if the IRI is above 65 inches/mile. Two out of the four lanes for the OGFC-AR and three out of four lanes for the OGFC-SBS had IRI values that were below 60 inches/mile indicating the OGFC provided a high quality ride at these locations. Only

the HOV lane in both OGFC sections had IRI values above 65 inches/mile. The higher IRI values in the HOV lane were mostly due to isolated rough areas. The IRI for all OGFC sections combined was 57 inches/mile indicating the OGFC was able to provide a smooth ride except for the isolated rough areas. The ½ inch HMA control section has excellent IRI values. This was likely due to the control section being paved over a smooth existing HMA pavement with an average pre-paving IRI of 54 inches/mile.

<b>Table 5. IRI measurements.</b>		
<b>Pavement Type</b>	<b>Lane</b>	<b>IRI (inches/mile)</b>
Class ½ inch HMA	1	65
Class ½ inch HMA	2	40
Class ½ inch HMA	3	39
Class ½ inch HMA	HOV	37
OGFC-AR	1	64
OGFC-AR	2	53
OGFC-AR	3	58
OGFC-AR	HOV	68
OGFC-SBS	1	48
OGFC-SBS	2	46
OGFC-SBS	3	57
OGFC-SBS	HOV	67

### ***Wear/Rutting***

The transverse profile measurements, which indicate wear or rutting in the wheel paths, are listed in Table 6. Initial wheel rut depths for the OGFC range from 1.4 to 1.9 mm. Initial rut depths of about 1.0 to 2.0 mm on new HMA pavements are not unusual on Washington State highways. The initial rut depths are attributed to additional consolidation of the HMA pavement in the wheel paths by traffic after construction. The rate of rutting usually decreases after the initial readings. The data was collected using WSDOT’s Pathway pavement condition collection van at the same time that the ride data was collected.

**Table 6. Wear/rutting measurements.**

Pavement Type	Lane	Rut Depth (mm)
Class ½ inch HMA	1	2.1
Class ½ inch HMA	2	2.2
Class ½ inch HMA	3	2.1
Class ½ inch HMA	HOV	1.8
OGFC-AR	1	1.9
OGFC-AR	2	1.7
OGFC-AR	3	1.5
OGFC-AR	HOV	1.6
OGFC-SBS	1	1.9
OGFC-SBS	2	1.6
OGFC-SBS	3	1.4
OGFC-SBS	HOV	1.4

### **Sound Intensity**

Sound intensity measurements were made using the on-board sound intensity (OBSI) method. Table 7 lists the measurements made on the OGFC-AR section and Figure 22 plots them on a bar chart. The noise level on the OGFC-AR appears inconsistent which may be due in part to the incomplete striping at the time of the September and October measurements. The measurements are more consistent in December showing only a maximum 1.7 dBA difference between lanes.

**Table 7. Sound intensity measurements (dBA) for the OGFC-AR.**

Pavement Type	Lane	September 2009	October 2009	December 2009
OGFC-AR	1	94.1	No measurement*	99.2
OGFC-AR	2	96.0	102.6	99.0
OGFC-AR	3	100.3	97.4	100.7
OGFC-AR	HOV	No measurement*	98.8	99.1

\*Data could not be collected due to problems with the equipment.

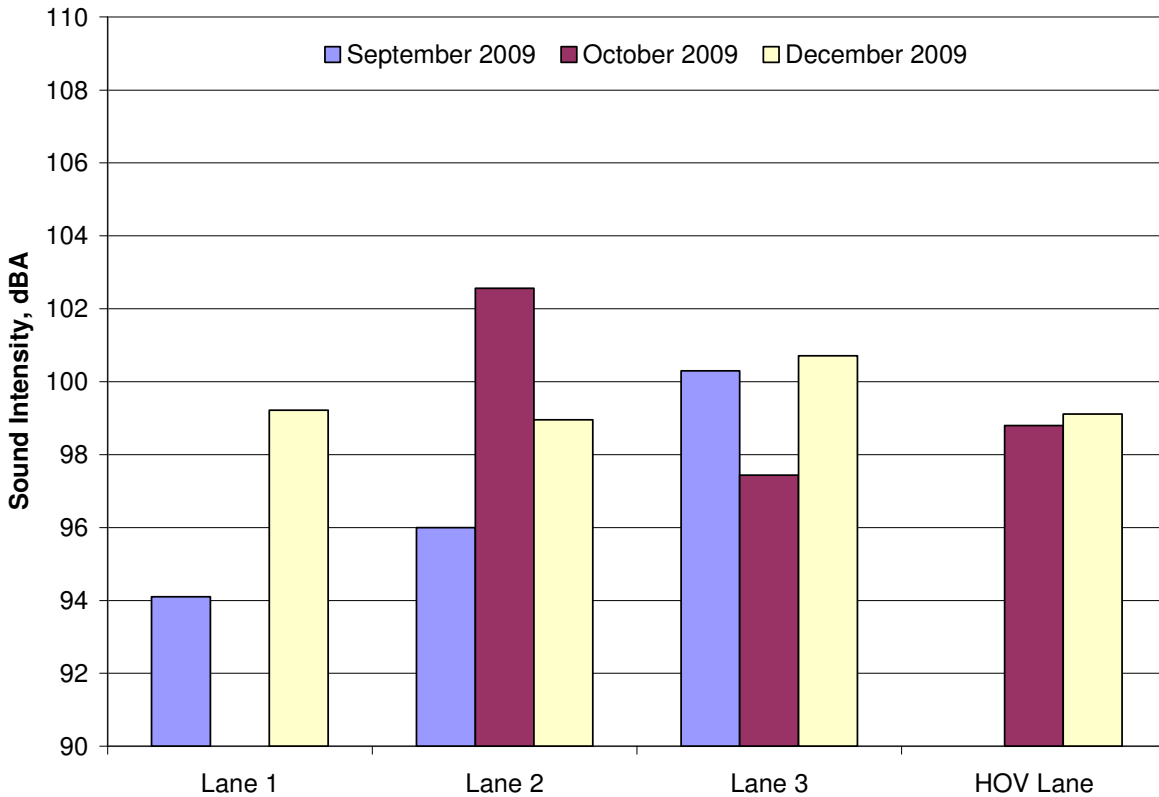

Figure 22. Sound intensity level (dBA) measurements for the OGFC-AR sections.

Table 8 lists the sound intensity measurements for the OGFC-SBS section. Figure 23 shows that the measurements for the OGFC-SBS were also inconsistent. December 2009 measurements appear to be more consistent except for Lane 1. Future readings should help clarify the data.

<b>Table 8. Sound intensity measurements (dBA) for the OGFC-SBS.</b>				
<b>Pavement Type</b>	<b>Lane</b>	<b>September 2009</b>	<b>October 2009</b>	<b>December 2009</b>
OGFC-SBS	1	99.6	No measurement*	103.6
OGFC-SBS	2	95.5	95.1	99.9
OGFC-SBS	3	95.2	98.6	99.8
OGFC-SBS	HOV	96.7	103.3	100.6

\*Data could not be collected due to problems with the equipment.

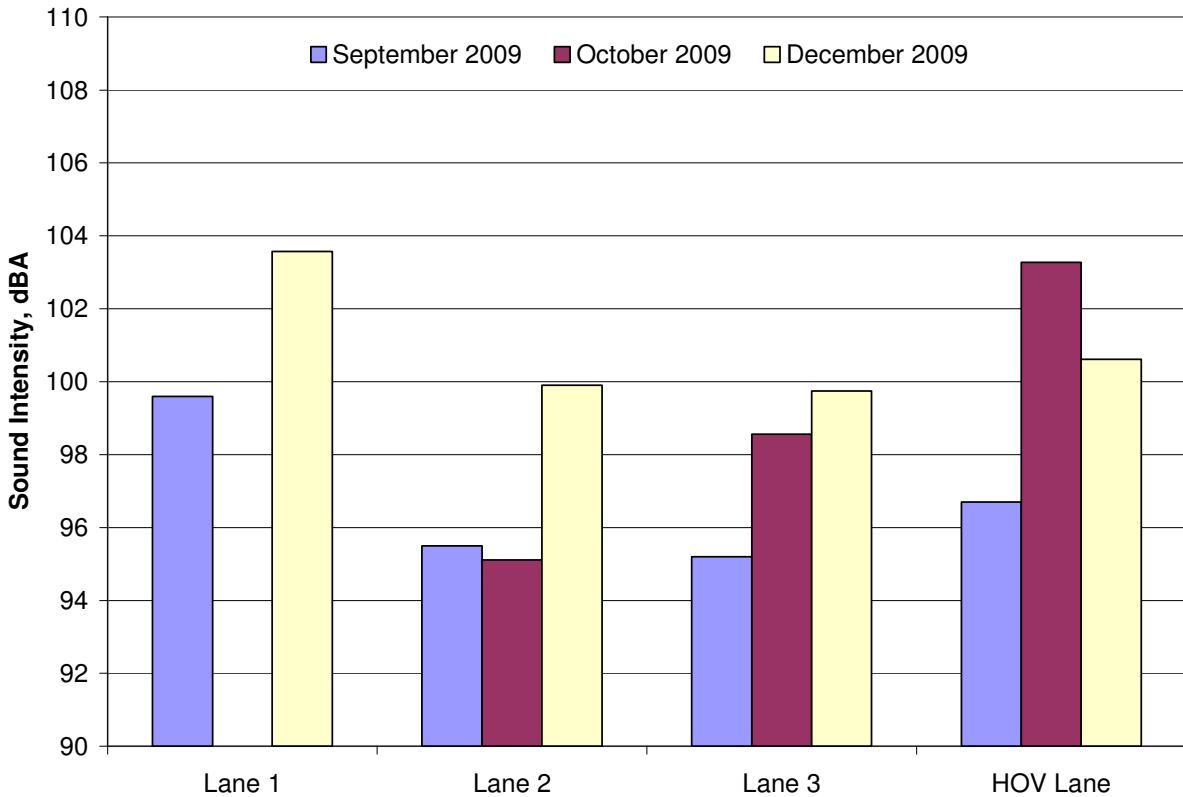

Figure 23. Sound intensity level (dBA) measurements for the OGFC-SBS sections.

Table 9 lists the sound intensity level measurement for the control section of Class ½ inch HMA. Figure 24 shows that the sound intensity measurements of control section were more consistent than either of the OGFC mixes. Sound intensity measurements increased between October and December.

<b>Table 9. Sound intensity measurements (dBA) for the ½ inch HMA.</b>				
<b>Pavement Type</b>	<b>Lane</b>	<b>September 2009</b>	<b>October 2009</b>	<b>December 2009</b>
Class ½ inch HMA	1	101.4	100.3	102.5
Class ½ inch HMA	2	No measurement*	98.2	102.6
Class ½ inch HMA	3	100.3	100.5	102.3
Class ½ inch HMA	HOV	No measurement*	101.5	104.6

\*Data could not be collected due to problems with the equipment.

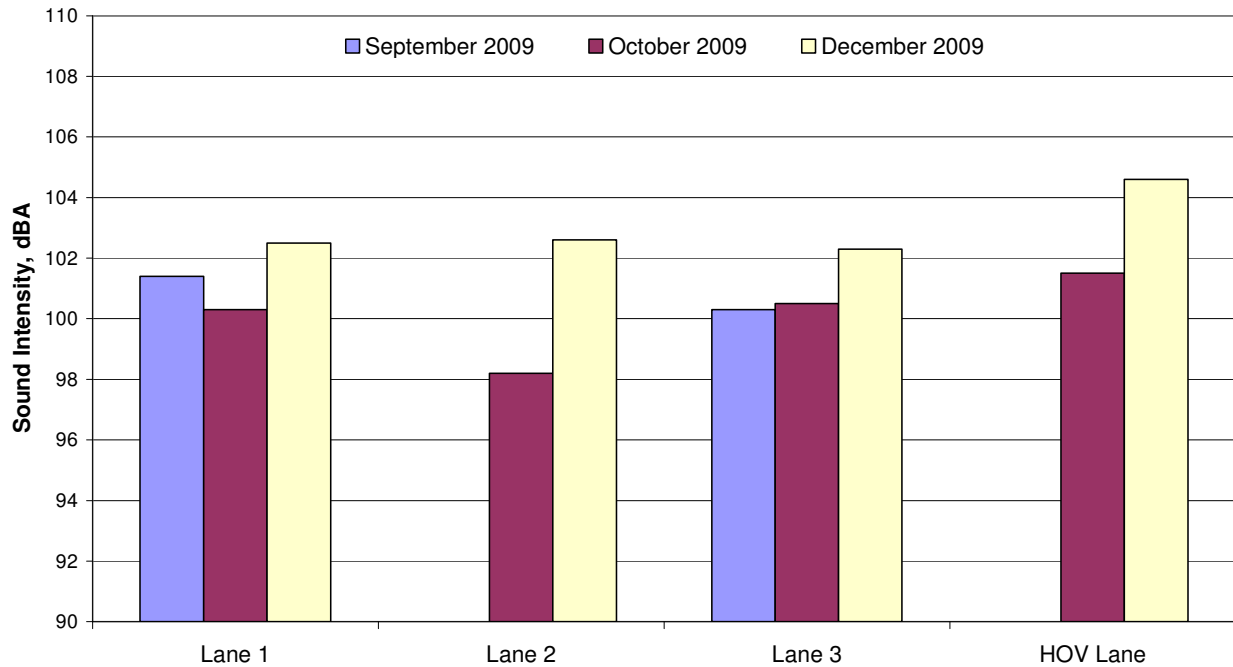

Figure 24. Sound intensity level (dBA) measurements for 1/2 inch HMA control section.

A comparison of the December OBSI readings is shown in Table 10. It reveals that the asphalt rubber section is currently the “quietest” pavement measured. The average sound intensity reading on the OGFC-AR section for the most current set of measurements (99.5 dBA) is 3.5 dBA lower than the average for the control section (103.0 dBA) and 1.5 dBA lower than the average for the SBS section (101.0 dBA).

<b>Table 10. December 2009 OBSI readings for each section.</b>			
<b>Lane</b>	<b>OGFC-AR</b>	<b>OGFC-SBS</b>	<b>1/2 inch HMA</b>
1	99.2	103.6	102.5
2	99.0	99.9	102.6
3	100.7	99.8	102.3
HOV	99.1	100.6	104.6
Average	99.5	101.0	103.0

The sound intensity levels measured immediately after construction are higher for all three types of pavement on this project than on the I-5 and SR-520 projects as shown in Table 11.



**Table 11. Comparison of average sound intensity levels immediately after construction.**

<b>Pavement Type</b>	<b>I-5, Lynnwood</b>	<b>SR-520, Eastside</b>	<b>I-405, Factoria</b>	<b>Difference from I-405</b>
OGFC-AR	95.0	96.1	99.5	+4.5 / +3.4
OGFC-SBS	96.0	97.8	101.0	+5.0 / +3.2
Class ½ inch HMA	98.8	99.8	103.0	+4.2 / +3.2

## Discussion of Results

Several observations can be made when comparing the results from this project to the previous open-graded project done in 2006 on I-5 near Lynnwood, Washington and to the 2007 project on SR-520 near Medina Washington (Anderson et al., 2008a and 2008b). The initial sound intensity measurements for this project follow the same pattern as the Lynnwood and Medina projects with the AR section having the lowest OBSI readings, then SBS and the HMA the highest. The I-405 readings are between four and five dBA higher than the Lynnwood project and over three dBA higher than the Medina project. No specific cause of the higher readings could be identified. The fact that readings on all three pavement types are higher by similar amounts indicates that the cause is likely project specific. If the higher readings were due to problems with the OGFC pavements themselves then the ½ inch HMA would not be higher than the ½ inch HMA on I-5 or SR 520. The important result is the OGFC pavements are quieter than the ½ inch HMA control section by amounts similar to those on the I-5 and SR 520 projects.

## Conclusions

The special test sections of OGFC-AR and OGFC-SBS were constructed, from all indications, according to the specifications. The use of an MTV ensured that the mix going into the paving machine was uniform in temperature and as a result no significant temperature differentials were observed in the mat behind the paver. Post-construction testing confirmed that the pavement placed was up to standards and suitable for the long-term evaluation of the noise mitigating properties of the two types of open-graded pavements placed.

The primary observations that can be made from the data currently available are:

- The initial sound intensity levels for the OGFC-AR have been consistently lower than the readings for the OGFC-SBS and Class ½ inch HMA.
- The sound intensity level readings immediately after construction for all of the sections on I-405 were higher than the initial readings on the I-5 Lynnwood and SR-520 Medina projects.

## **Future Research**

This project will be monitored for a period of at least five years with data collected on friction, ride, wear, noise and qualitative evaluations of splash and spray. Annual reports will be issued that summarize the changes in each of the variables mentioned previously. A final report will be written at the conclusion of the evaluation period. Details of the evaluation plan can be found in Appendix D.

## References

Anderson, K., Pierce, L., Uhlmeier, J., Weston, J. (2008a). *Evaluation of Long-Term Pavement Performance and Noise Characteristics of Open-Graded Friction Courses*. Washington State Department of Transportation. Available at:  
<http://www.wsdot.wa.gov/research/reports/fullreports/683.1.pdf>

Anderson, K., Pierce, L., Uhlmeier, J., Weston, J. (2008b). *Evaluation of Long-Term Pavement Performance and Noise Characteristics of Open-Graded Friction Courses – Project 2*. Washington State Department of Transportation. Available at:  
<http://www.wsdot.wa.gov/research/reports/fullreports/691.1.pdf>

ADOT (2008). Standard Specifications for Road and Bridge Construction. Arizona Department of Transportation. Accessed at:  
<http://www.azdot.gov/Highways/ConstGrp/contractors/PDF/2008StandardSpecifications.pdf>

# **Appendix A**

## **Mix Designs**

**Washington State Department of Transportation - Materials Laboratory**  
**PO Box 47365 Olympia / 1655 S 2nd Ave. Tumwater / WA 98504**  
**BITUMINOUS MATERIALS SECTION - TEST REPORT**

TEST OF: OPEN GRADED FRICTION COARSE (OGFC)  
 DATE SAMPLED: 7/24/2009  
 DATE RECVD HQS: 7/24/2009  
 SR NO: 405  
 SECTION: I-405 112th AVE SE TO SE 8TH STREET WIDENING

WORK ORDER NO: 007283  
 LAB ID NO 00000104bc7  
 TRANSMITTAL NO: 104bc7  
 MIX ID NO: MD090084  
 CONTRACTOR: LAKESIDE

-----CONTRACTOR'S PROPOSAL-----

Mat'l:	3/8" -1/8"	SAND	COMBINED	SPECIFICATIONS
Source:	A-189	A-189		
Ratio:	90%	10%		
3/8"	100.0	100.0	100	100
No. 4	31.2	100.0	38	35 - 55
No. 8	3.5	85.0	12	9 - 14
No. 200	1.9	2.5	2.0	0 - 2.5

-----LABORATORY ANALYSIS-----

	8.1	8.6	9.1	SPECIFICATIONS
ASPH% BY TOTAL WT OF MIX:	8.1	8.6	9.1	
% VOIDS @ Ndes: 50	20.0	18.0	16.8	15.0 Min.
% VMA @ Ndes: 50	33.5	32.8	32.8	24.0 Min.
% Gmm @ Ndes: 50	80.0	82.0	83.2	82.0 Max.
Draindown @ 337°F		0.1		0.3 Max.
Stabilizing Additive (Cellulose Fiber)	0.3	0.3	0.3	0.2 - 0.5
Gmm - MAX S. G. FROM RICE w/ admix	2.557	2.538	2.514	
Gmb - BULK S. G. OF MIX	2.046	2.080	2.091	
Gsb - OF AGGREGATE BLEND	2.828	2.828	2.828	
Gsb - OF FINE AGGREGATE	2.581	2.581	2.581	
Gb - SPECIFIC GRAVITY OF BINDER	1.022	1.022	1.022	

-----LOTTMAN STRIPPING EVALUATION-----

% ANTI-STRIP	0.0%	1.0 % HYDRATED LIME	
Visual Appearance:	NONE	NONE	
% Retained Strength:	95	119	80% Min.

-----RECOMMENDATIONS-----AGGREGATE TEST DATA-----

SUPPLIER	U.S. OIL	TEST	VALUE	SPECIFICATIONS
GRADE	PG70-22	FRACTURE	99	85 Min. (2 Faces)
% ASPHALT (By Total Wt. Mix)	8.6	SAND EQUIVALENT	86	45 Min.
% ANTI-STRIP (By Wt. Aggregate)	1.0			
TYPE OF ANTI-STRIP	HYDRATED LIME			
MIX ID NUMBER	MD090084			
MIXING TEMPERATURE	337°F			

Headquarters:	T152 -	REMARKS:
Construction Engineer-----X	T153 -	
Materials File-----X	T166 - 3	
General File-----X	T172 -	
Bituminous Section-----X	T175 -	
Region: Northwest	T178 - 1	
Construction Office- 41 -----X		THOMAS E. BAKER, P.E.
Materials Eng----- 41 -----X		Materials Engineer
P.E.: S. JAVERI --X(2)		By: Joseph R. DeVol
		(360)709-5421
		Date: 8 / 7 / 2009

SRD

**Washington State Department of Transportation - Materials Laboratory**  
**PO Box 47365 Olympia / 1655 S 2nd Ave. Tumwater / WA 98504**  
**BITUMINOUS MATERIALS SECTION - TEST REPORT**

TEST OF: OPEN GRADED FRICTION COARSE ASPHALT RUBBER (OGFC-AR)	WORK ORDER NO: 007283
DATE SAMPLED: 7/24/2009	LAB ID NO: 00000104bcc
DATE RECVD HQS: 7/24/2009	TRANSMITTAL NO: 104bcc
SR NO: 405	MIX ID NO: MD090085
SECTION: I-405 112th AVE SE TO SE 8TH STREET WIDENING	CONTRACTOR: LAKESIDE

-----CONTRACTOR'S PROPOSAL-----				
Mat'l:	3/8"-1/8"	SAND	COMBINED	SPECIFICATIONS
Source:	A-189	A-189		
Ratio:	95%	5%		
3/8"	100.0	100.0	100	100
No. 4	31.2	100.0	35	30 - 45
No. 8	3.5	85.0	8	4 - 8
No. 200	1.9	2.5	1.9	0 - 2.5

-----LABORATORY ANALYSIS-----		
L.A. ABRASION % @ 500 REVOLUTIONS*	12	SPECIFICATIONS
SAND EQUIVALENT (WSDOT T-176)	86	40 MAX
FRACTURE, % (WSDOT TP-61 2 FACES)	99	45 MIN.
FLAKINESS INDEX, % (AZ 233)	11	85 MIN.
CARBONATES, % (AZ 238)	1.9	25 MAX
COMBINED SPECIFIC GRAVITY (AZ 814)	2.843	30 MAX
COMBINED SPECIFIC GRAVITY (AZ 814 w/ admix)	2.835	2.350 - 2.850
COMBINED WATER ABSORPTION, % (AZ 814)	1.06	
Pba-ASPHALT ABSORPTION	0.8	2.50 MAX
Gsb - OF COARSE AGGREGATE (AZ 210)	2.858	1.00 MAX
Gsb - OF FINE AGGREGATE (AZ 211)	2.581	
Gb - SPECIFIC GRAVITY OF BINDER	1.047	
Gmm - MAX S. G. FROM RICE @ 4.0% Pb (AZ 806)	2.704	
Gmb - BULK S. G. OF MIX (AZ 814)	130.9	

-----RECOMMENDATIONS-----	
SUPPLIER	U.S. OIL
GRADE	PG64-22
% ASPHALT RUBBER (By Total Wt. Mix)	9.4
CRUMB RUBBER MODIFIER TYPE	B
RUBBER SOURCE	RUBBER GRANULATORS
CRM SPECIFIC GRAVITY	1.150
% BY WT. OF ASPHALT CEMENT	20.0
% ANTI-STRIP (By Wt. Aggregate)	1.0
TYPE OF ANTI-STRIP	HYDRATED LIME
MIX ID NUMBER	MD090085
MIXING TEMPERATURE	325°F

Headquarters:	T152 -	REMARKS: *L.A. ABRASION ONLY RUN @ 500
Construction Engineer-----X	T153 -	REVOLUTIONS
Materials File-----X	T166 - 3	
General File-----X	T172 -	
Bituminous Section-----X	T175 -	
Region: Northwest	T178 - 1	
Construction Office- 41 -----X		THOMAS E. BAKER, P.E.
Materials Eng----- 41 -----X		Materials Engineer
P.E.: S. JAVERI --X(2)		By: Joseph R. DeVol
		(360)709-5421
		Date: 8 / 7 / 2009



# **Appendix B**

## **Specifications**

## 2.7.6 QUIETER PAVEMENT SURFACE TREATMENTS AND PAVEMENTS

### 2.7.6.1 HOT MIX ASPHALT

**2.7.6.1.1 Description** The first paragraph of WSDOT Standard Specification Section 5-04.1 is supplemented with the following:

- This work shall consist of providing and placing Quieter Pavement overlays consisting of Open Graded Friction Course (OGFC) and Open Graded Friction Course Asphalt-Rubber (OGFC-AR) on the existing roadway in accordance with these Specifications and lines, grades, thicknesses, and typical cross-sections shown in the Plans and shall meet the requirements for hot-mix asphalt as modified herein.
- OGFC shall consist of a mixture of asphalt, mineral aggregate and other additives properly proportioned, mixed and applied on a paved surface.
- OGFC-AR shall consist of a mixture of rubberized asphalt, mineral aggregate and other additives properly proportioned, mixed and applied on a paved surface.

### 2.7.6.1.2 Materials

WSDOT Standard Specification Section 5-04.2 is supplemented with the following:

- The use of RAP shall not be permitted in the production of OGFC or OGFC-AR.
- Asphalt binder material for the OGFC shall be PG 70-22. SBS modifier shall be added to the neat asphalt to produce a binder that complies with the requirements for PG 70-22.
- Asphalt binder material for the OGFC-AR shall be asphalt-rubber conforming to the requirements of Asphalt Rubber (A). The crumb rubber gradation shall conform to the requirements of Asphalt-Rubber (B).
- In no case shall the asphalt-rubber be diluted with extender oil, kerosene, or other solvents. Any asphalt-rubber so contaminated shall be rejected.

#### 2.7.6.1.2.1 Asphalt-Rubber

- Asphalt Binder  
Asphalt binder shall be PG 58-22 or PG 64-22 conforming to the requirements of 9-02, Bituminous Materials.
- Crumb Rubber

Rubber shall meet the following gradation requirements when tested in accordance with AASHTO T 11/27.

#### **Sieve Size Percent Passing**

No. 8	100
No. 10	100
No. 16	65 – 100
No. 30	20 – 100
No. 50	0 – 45
No. 200	0 – 5



The rubber shall have a specific gravity of  $1.15 \pm 0.05$  and shall be free of wire or other contaminating materials, except that the rubber shall contain not more than 0.5 percent fabric. Calcium carbonate, up to four percent by weight of the granulated rubber, may be added to prevent the particles from sticking together.

Manufacturers Certificate of Compliance conforming to Section 2.25.6.1 shall be submitted to WSDOT. In addition, the certificates shall confirm that the rubber is a crumb rubber, derived from processing whole scrap tires or shredded tire materials; and the tires from which the crumb rubber is produced are taken from automobiles, trucks, or other equipment owned and operated in the United States. The certificates shall also verify that the processing does not produce, as a waste product, casings or other round tire material that can hold water when stored or disposed of above ground.

#### **2.7.6.1.2.2 Asphalt-Rubber Proportions**

The asphalt-rubber shall contain a minimum of 20 percent crumb rubber by the weight of the asphalt binder.

#### **2.7.6.1.2.3 Asphalt-Rubber Properties**

Manufacturers Certificate of Compliance conforming to Section 2.25.6.1 shall be submitted to WSDOT showing that the asphalt-rubber conforms to the following:

<b>Property</b>	<b>Requirement</b>
Rotational Viscosity*: 350 F; pascal seconds	1.5 - 4.0
Penetration: 39.2 F, 200 g, 60 sec. (ASTM D 5); minimum	15
Softening Point: (ASTM D 36); F, minimum	130
Resilience: 77 F (ASTM D 5329); %, minimum	25

\* The viscotester used must be correlated to a Rion (formerly Haake) Model VT-04 viscotester using the No. 1 Rotor. The Rion viscotester rotor, while in the off position, shall be completely immersed in the binder at a temperature from 350°F to 355°F for a minimum heat equilibrium period of 60 seconds, and the average viscosity determined from three separate constant readings ( $\pm 0.5$  pascal seconds) taken within a 30 second time frame with the viscotester level during testing and turned off between readings. Continuous rotation of the rotor may cause thinning of the material immediately in contact with the rotor, resulting in erroneous results.

#### **2.7.6.1.2.4 Asphalt-Rubber Binder Design**

At least 15 business days prior to the use of asphalt-rubber, the Contractor shall submit an asphalt-rubber binder design prepared by one of the following laboratories who have experience in asphalt-rubber binder design:

MACTEC Engineering and Consulting, Inc.  
Contact: Anne Stonex  
Address: 3630 East Wier Avenue  
Phoenix, Arizona 85040  
Phone: (602) 437-0250

Western Technologies, Inc.  
Contact: John Hahle  
Address: 2400 East Huntington Drive  
Flagstaff, Arizona 86004  
Phone: (928) 774-8700

Such design shall meet the requirements specified herein. The design shall show the values obtained from the required tests, along with the following information: percent, grade and source of the asphalt binder used; and percent, gradation and source(s) of rubber used.

### **2.7.6.1.3 Construction Requirements**

WSDOT Standard Specification Section 5-04.3 shall be supplemented with the following:

During production of asphalt-rubber, the Contractor shall combine materials in conformance with the asphalt-rubber design unless otherwise approved by WSDOT.

#### **2.7.6.1.3.1 Mixing of Asphalt-Rubber**

The temperature of the asphalt binder shall be between 350°F and 400°F at the time of addition of the crumb rubber. No agglomerations of rubber particles in excess of two inches in the least dimension shall be allowed in the mixing chamber. The crumb rubber and asphalt binder shall be accurately proportioned in accordance with the design and thoroughly mixed prior to the beginning of the one-hour reaction period. The Contractor shall document that the proportions are accurate and that the rubber has been uniformly incorporated into the mixture. Additionally, the Contractor shall demonstrate that the rubber particles have been thoroughly mixed such that they have been “wetted.” The occurrence of rubber floating on the surface or agglomerations of rubber particles shall be evidence of insufficient mixing. The temperature of the asphalt-rubber immediately after mixing shall be between 325°F and 375°F. The asphalt-rubber shall be maintained at such temperature for one hour before being used.

Prior to use, the viscosity of the asphalt-rubber shall be tested and must conform to the asphalt-rubber properties described in Section 2.7.6.1.2.3, which is to be furnished by the Contractor or supplier.

#### **2.7.6.1.3.2 Handling of Asphalt-Rubber**

Once the asphalt-rubber has been mixed, it shall be kept thoroughly agitated during periods of use to prevent settling of the rubber particles. During the production of asphaltic concrete the temperature of the asphalt-rubber shall be maintained between 325°F and 375°F. However, in no case shall the asphalt-rubber be held at a temperature of 325°F or above for more than 10 hours. Asphalt-rubber held for more than 10 hours shall be allowed to cool and gradually reheated to a temperature between 325°F and 375°F before use. The cooling and reheating shall not be allowed more than one time. Asphalt-rubber shall not be held at temperatures above 250°F for more than four calendar days.

For each load or batch of asphalt-rubber, the Contractor shall provide the Design-Builder with the following documentation:

- The source, grade, amount and temperature of the asphalt binder prior to the addition of rubber.

- The source and amount of rubber and the rubber content expressed as percent by the weight of the asphalt binder.
- Times and dates of the rubber additions and resultant viscosity test.
- A record of the temperature, with time and date reference for each load or batch. The record shall begin at the time of the addition of rubber and continue until the load or batch is completely used. Readings and recordings shall be made at every temperature change in excess of 20°F, and as needed to document other events which are significant to batch use and quality.

### **2.7.6.1.3.3 HMA Mixing Plant**

WSDOT Standard Specification Section 5-04.3(1) is supplemented with the following:

#### **2.7.6.1.3.3.1 Fiber Supply System**

When fiber stabilizing additives are required for OGFC, a separate feed system that meets the following will be required:

- Accurately proportions by weight the required quantity into the mixture in such a manner that uniform distribution will be obtained.
- Provides interlock with the aggregate feed or weigh systems so as to maintain the correct proportions for all rates of production and batch sizes.
  - a. Controls dosage rate accurately to within plus or minus 10 percent of the amount of fibers required.
  - b. Automatically adjusts the feed rate to maintain the material within the 10 percent tolerance at all times.
  - c. Provides flow indicators or sensing devices for the fiber system that are interlocked with plant controls so that mixture production will be interrupted if introduction of the fiber fails or if the output rate is not within the tolerances given above.
- 1. Provides in-process monitoring, consisting of either a digital display of output or a printout of feed rate, in pounds per minute to verify the feed rate.

When a batch type plant is used, the fiber shall be added to the aggregate in the weigh hopper or as approved by the Design-Builder. The batch dry mixing time shall be increased by 8 to 12 seconds, or as directed by the Design-Builder, from the time the aggregate is completely emptied into the mixer. The fibers are to be uniformly distributed prior to the injection of the asphalt binder into the mixer.

When a continuous or drier-drum type plant is used, the fiber shall be added to the aggregate and uniformly dispersed prior to the injection of asphalt binder. The fiber shall be added in such a manner that it will not become entrained in the exhaust system of the dryer or plant.

#### **2.7.6.1.3.3.2 Surge and Storage Systems**

The storage time for OGFC mixtures not hauled immediately to the project shall be no more than 4 hours.

#### **2.7.6.1.3.3.4 Hot Mix Asphalt Pavers**

WSDOT Standard Specification Section 5-04.3(3) is supplemented with the following:

- For OGFC and OGFC-AR the direct transfer of these materials from the hauling equipment to the paving machine will not be allowed. A Shuttle Buggy shall be used to deliver the OGFC and OGFC-AR from the hauling equipment to the paving machine.
- The Shuttle Buggy shall mix the OGFC and OGFC-AR after delivery by the hauling equipment but prior to laydown by the paving machine. Mixing of the OGFC and OGFC-AR shall be sufficient to obtain a uniform temperature throughout the mixture.

#### **2.7.6.1.3.5 Rollers**

WSDOT Standard Specification Section 5-04.3(4) is supplemented with the following:

- The wheels of the rollers used for OGFC and OGFC-AR shall be wetted with water, or if necessary soapy water, or a product approved by the Design-Builder to prevent the OGFC or OGFC-AR from sticking to the steel wheels during rolling.
- A minimum of three static steel wheel rollers, weighing no less than eight tons, shall be provided. The drums shall be of sufficient width that when staggered, two rollers can cover the entire lane width.
- Vibratory rollers must be used in the static mode only.
- A pass shall be defined as one movement of a roller in either direction. Coverage shall be the number of passes as are necessary to cover the entire width being paved.
- Two rollers shall be used for initial breakdown and be maintained no more than 300 feet behind the paving machine. The roller(s) for final compaction shall follow as closely behind the initial breakdown as possible. As many passes as is possible shall be made with the rollers before the temperature of the OGFC or OGFC-AR falls below 220 °F.

#### **2.7.6.1.3.6 Preparation Of Existing Surfaces**

WSDOT Standard Specification Section 5-04.3(5)A is supplemented with the following:

- For OGFC and OGFC-AR, a tack coat of CRS-2 or CRS-2P shall be applied to the existing surface at a rate of 0.12 to 0.20 (0.08 to 0.12 residual) gallons per square yard or as otherwise directed by the Design-Builder.

#### **2.7.6.1.3.7 Mix Design**

WSDOT Standard Specification Section 5-04.3(7)A is supplemented with the following:

**Mix Design (OGFC-AR).** Approximately 500 pounds of produced mineral aggregate, in proportion to the anticipated percent usage, shall be obtained. The mineral aggregate must be representative of the mineral aggregate to be utilized in the OGFC-AR production. The material submitted shall be in individual bags weighing no more than outlined in WSDOT *Materials Manual*, WSDOT FOP for AASHTO T2.

The Design-Builder shall also furnish two sets of representative samples of each of the following materials: a five-pound sample of the crumb rubber proposed for use, four quarts of asphalt binder from the intended supplier, twenty quarts of the proposed mixture of binder and rubber, and one-pint of the liquid anti-strip to be used in the OGFC-AR.

Along with the samples furnished for mix design testing, the Design-Builder shall submit a letter explaining in detail its methods of producing mineral aggregate including wasting, washing, blending, proportioning, etc., and any special or limiting conditions it may propose. The Contractor's letter shall also state the source(s) of mineral aggregate, the source of asphalt binder and crumb rubber and the asphalt-rubber supplier.

Within 15 business days of receipt of all samples and the Contractor's letter in the WSDOT HQ Materials Laboratory, WSDOT will provide the Contractor with the percentage of asphalt-rubber to be used in the mix, the percentage to be used from each of the stockpiles of mineral aggregate, the composite mineral aggregate gradation, the composite mineral aggregate gradation and any special or limiting conditions for the use of the mix.

**Mix Design (OGFC)** Approximately 500 pounds of produced mineral aggregate, in proportion to the anticipated percent usage, shall be obtained and submitted to the WSDOT State Materials Laboratory in Tumwater. The mineral aggregate must be representative of the mineral aggregate to be utilized in the OGFC production. The material submitted shall be in individual bags weighing no more than outlined in WSDOT *Materials Manual*, WSDOT FOP for AASHTO T2.

The Design-Builder shall also furnish two sets of representative samples of each of the following materials: four quarts of asphalt binder from the intended supplier, and one-pint of the liquid anti-strip to be used in the OGFC. Along with the samples furnished for mix design testing, the Design-Builder shall submit a letter explaining in detail its methods of producing mineral aggregate including wasting, washing, blending, proportioning, etc., and any special or limiting conditions it may propose. The Contractor's letter shall also state the source(s) of mineral aggregate, the source of asphalt binder.

Within 15 business days of receipt of all samples and the Design-Builder's letter, the WSDOT will provide the Design-Builder with the percentage of asphalt to be used in the mix, the percentage to be used from each of the stockpiles of mineral aggregate, the composite mineral aggregate gradation and any special or limiting conditions for the use of the mix.

Mixtures shall be compacted with 50 gyrations of a Superpave Gyratory Compactor and the draindown at the mix production temperature (AASHTO T 305) shall be 0.3 maximum.

**Mix Design Revisions.** The Contractor shall not change its methods of crushing, screening, washing, or stockpiling from those used during production of material used for mix design purposes without approval of the WSDOT, or without requesting a new mix design.

During production of OGFC and OGFC-AR, the Design-Builder, on the basis of field test results, may request a change to the approved mix design. WSDOT will evaluate the proposed changes and notify the Design-Builder of WSDOT's decision within two business days of the receipt of the request.

If, at any time, unapproved changes are made in the source of bituminous material, source(s) of mineral aggregate, production methods, or proportional changes in violation of approved mix design stipulations, production shall cease until a new mix design is developed, or the Contractor complies with the approved mix design.

At any time after the mix design has been approved, the Contractor may request a new mix design.

The costs associated with the testing of materials in the developing of additional mix designs after a mix design acceptable to the Department has been developed shall be borne by the Contractor.

WSDOT Standard Specification Section 9-02.1(4) shall be supplemented with the following:

The phase angle on the unaged PG70-22 binder used in the production of OGFC shall be no more than 75 degrees.

WSDOT Standard Specification Section 9-03.8(1) is supplemented with the following:

Tests on aggregates outlined in the following table, other than abrasion, shall be performed on materials furnished for OGFC-AR mix design purposes and composited to the mix design gradation. Abrasion shall be performed separately on samples from each source of mineral aggregate. All sources shall meet the requirements for abrasion.

<b>MINERAL AGGREGATE CHARACTERISTICS</b>		
<b>Characteristic</b>	<b>Test Method</b>	<b>Requirement</b>
Combined Bulk Specific Gravity	Arizona Test Method 814	2.35 – 2.85
Combined Water Absorption	Arizona Test Method 814	0 – 2.5%
Fractured Coarse Aggregate Particles	Arizona Test Method 212	Minimum 85% (two fractured faces)
Flakiness Index	Arizona Test Method 233	Maximum 25
Carbonates in Aggregate	Arizona Test Method 238	Maximum 30%
Abrasion	AASHTO T 96	100 Rev., Max. 9% 500 Rev., Max. 40%

WSDOT Standard Specification Section 9-03.8(2) is supplemented with the following:

The OGFC mixture shall meet the following criteria:

<b>Design Parameter</b>	<b>Design Criteria</b>
Percent of $G_{mm}$ at $N_d$ of 50 gyrations (AASHTO T 209)	$\leq 82\%$
Effective air voids	$\geq 15\%$
VMA at $N_d$ of 50 gyrations	$\geq 24\%$
WSDOT FOP for AASHTO TP 61 (two fractured faces)	Minimum 85%
WSDOT T 718 Method of Test for Determining Stripping of Asphalt Concrete	TSR 80% min
Draindown, maximum, percent of total mass (AASHTO T 305)	0.3

WSDOT Standard Specification Section 9-03.8(4) is supplemented with the following:

For use with OGFC and OGFC-AR, blending sand shall meet the following quality requirement in accordance with WSDOT FOP for AASHTO T 176:

Sand Equivalent: Minimum 45

**Fiber Stabilizing Additive.** If needed, cellulose fiber stabilizing additive shall meet the properties described below. Dosage rates given are typical ranges but the actual dosage rate used shall be approved by the Design-Builder.

Cellulose Fibers: Cellulose fibers shall be added at a dosage rate between 0.2% and 0.5% by weight of the total mix as approved by the Design-Builder. Fiber properties shall be as follows:

1. Fiber length: 0.25 inch (6 mm) max.
2. Sieve Analysis:
  - a. Alpine Sieve Method  
Passing No. 100 sieve: 60-80%
  - b. Ro-Tap Sieve Method  
Passing No. 20 sieve: 80-95%  
Passing No. 40 sieve: 45-85%  
Passing No. 100 sieve: 5-40%
3. Ash Content: 18% non-volatiles ( $\pm 5\%$ )
4. pH: 7.5 ( $\pm 1.0$ )
5. Oil Absorption (times fiber weight) 5.0 ( $\pm 1.0$ )
6. Moisture Content: 5.0% max.

WSDOT Standard Specification Section 9-03.8(6) is supplemented with the following:

**OGFC Mineral Aggregate**

Mineral aggregate shall conform to the following grading limits:

Sieve Size	Percent Passing
3/8 Inch	100
No. 4	35 – 55
No. 8	9 – 14
No. 200	0 – 2.5

The percent of fractured coarse aggregate particles is at least 85 (two fractured faces) when tested in accordance with WSDOT FOP for AASHTO TP 61.

**OGFC-AR Mineral Aggregate**

Sieve Size	Percent Passing
3/8 Inch	100
No. 4	30 - 45
No. 8	4 - 8
No. 200	0 - 2.5

The percent of fractured coarse aggregate particles shall be at least 85 (two fractured faces) when tested in accordance with WSDOT FOP for AASHTO TP 61.

**2.7.6.1.3.8 Acceptance Sampling and Testing - HMA Mixture**

All acceptance testing will be performed by WSDOT or their representatives.

WSDOT Standard Specification Section 5-04.3(8)A is revised as follows:

- Item 1 is supplemented with the following:
- Nonstatistical evaluation will be used for the acceptance of OGFC & OGFC-AR.
- Item 3 is supplemented with the following:

**Sampling - OGFC and OGFC-AR**

OGFC and OGFC-AR will be evaluated for quality of gradation, sand equivalency and fracture based on samples taken from the cold feed bin.

- Item 5 is supplemented with the following:

**Test Results - OGFC and OGFC-AR**

**Mineral Aggregate Gradation - OGFC**

For each approximate 300 tons of OGFC, at least one sample of mineral aggregate shall be taken. Samples shall be taken in accordance with WSDOT FOP for AASHTO T-2 on a random basis just prior to the addition of bituminous materials. Samples will be tested for conformance with the mix design gradation. The gradation of the mineral aggregate shall be considered to be acceptable, unless average of any three consecutive tests or the result of any single test varies from the mix design gradation percentages as follows:

**Passing Sieve Mixture Control Tolerance**

- No. 4  $\pm$  5.5
- No. 8  $\pm$  4.5
- No. 200  $\pm$  2.0

**Mineral Aggregate Gradation - OGFC-AR**

For each approximate 300 tons of OGFC-AR, at least one sample of mineral aggregate shall be taken. Samples shall be taken in accordance with WSDOT FOP for AASHTO T-2 on a random basis just prior to the addition of bituminous materials. Samples will be tested for conformance with the mix design gradation. The gradation of the mineral aggregate shall be considered acceptable, unless the average of any three consecutive tests or the result of any single test varies from the mix design gradation percentages as follows:

Passing Sieve	Number of Tests	
	3 Consecutive	One
No. 4	$\pm$ 4	$\pm$ 4
No. 8	$\pm$ 3	$\pm$ 4
No. 200	$\pm$ 1.0	$\pm$ 1.5



- Item 7 is supplemented with the following:

Prior to starting any OGFC or OGFC-AR paving operation, including calibration sections, the Contractor shall provide at least 14 business days written notice to the Design-Builder so that the Design-Builder can provide notification to WSDOT.

#### **Calibration Section – OGFC**

A mixture calibration section shall be constructed on or off-site prior to production paving of the OGFC. The calibration section shall be used to determine if the mix meets the requirements of mineral aggregate gradation and recommended asphalt binder content.

The minimum calibration section shall be 12 ft wide by 200 ft long. For an onsite calibration section, the minimum placement temperature shall satisfy 2.7.6.1.3.9, “Weather Limitations.” For an off-site calibration section, the minimum air temperature for placement shall be 60°F. If the calibration section is to be left in place as a permanent pavement feature, it shall meet requirements defined in 2.7 of the Technical Requirements.

For the calibration section to be acceptable the mineral aggregate gradation shall be within the limits as shown in WSDOT Standard Specification Section 5-04.3(8)A as supplemented and the asphalt content varies by no more than  $\pm 0.5$  percent.

#### **Calibration Section - OGFC-AR**

A mixture calibration section shall be constructed on or off-site prior to production paving of the OGFC-AR. The calibration section shall be used to determine if the mix meets the requirements of mineral aggregate gradation and recommended asphalt-rubber binder content.

The minimum calibration section shall be 12 ft wide by 200 ft long. For an onsite calibration section, the minimum placement temperature shall satisfy 2.7.3.1.3.9, “Weather Limitations.” For an off-site calibration section, the minimum air temperature for placement shall be 60°F. If the calibration section is to be left in place as a permanent pavement feature, it shall meet requirements defined in 2.7 of the Technical Requirements.

For the calibration section to be acceptable the mineral aggregate gradation shall be within the limits as shown in WSDOT Standard Specification Section 5-04.3(8)A as supplemented and the asphalt-rubber content varies by no more than  $\pm 0.5$  percent.

### **2.7.6.1.3.9 Weather Limitations**

WSDOT Standard Specification Section 5-04.3(16) is supplemented with the following:

The mixing and placing of OGFC and OGFC-AR shall not be performed when the existing pavement is wet or frozen. In the northbound direction, OGFC and OGFC-AR shall not be placed when the air temperature is less than 70°F. In the southbound direction, OGFC and OGFC-AR shall not be placed when the air temperature is less than 60°F.

### **2.7.6.1.3.10 Traffic Limitations**

The OGFC and OGFC-AR pavement must cool to minimum surface temperature of 100°F prior to being opened to general traffic.

#### **2.7.6.1.3.11 Temporary Pavement Marking Limitations**

WSDOT Standard Specification Section 8-23.3(1) is supplemented with the following:

In order not to damage permanent OGFC and OGFC-AR work caused by removing temporary pavement markings the Design-Builder should consider the use of either removable tape or temporary raised pavement markers. If paint is used as a temporary pavement marker, it must be located along the permanent edge line or lane line.

### **2.7.7 SUBMITTALS**

#### **2.7.7.1 PAVEMENT DESIGN**

The Design-Builder shall prepare and submit a draft and final pavement report to WSDOT. The final pavement report must be approved by WSDOT prior to the start of any permanent paving on the Project. Supplemental submittals may also be required as described in Section 2.7.4.1 for temporarily running traffic on the shoulders of I-405 to accommodate construction activities.

#### **2.7.7.2 ASPHALT-RUBBER BINDER DESIGN SUBMITTAL**

Fifteen business days prior to the use of asphalt-rubber, the Design-Builder shall submit to the WSDOT an asphalt binder design. See section 2.7.6.1.2.4 for submittal details.

#### **2.7.7.3 MIX DESIGN OGFC-AR**

See section 2.7.6.1.3.7 for submittal requirements for OGFC-AR mineral aggregate, crumb rubber proposed for use, asphalt binder from the intended supplier, mixture of binder and rubber, liquid anti-strip to be used in the OGFC-AR and accompanying letter.

The above materials and letter shall be shipped to the WSDOT HQ Materials Laboratory at 1655 South 2<sup>nd</sup> Avenue, Tumwater, WA 98512. Along with the appropriate transmittal for each component, WSDOT Form 350-056 EF

#### **2.7.7.4 MIX DESIGN OGFC**

See section 2.7.6.1.3.7 for submittal requirements for OGFC mineral aggregate, asphalt binder from the intended supplier, liquid anti-strip to be used in the OGFC and accompanying letter.

The above materials and letter shall be shipped to the WSDOT HQ Materials Laboratory at 1655 South 2<sup>nd</sup> Avenue, Tumwater, WA 98512. Along with the appropriate transmittal for each component, WSDOT Form 350-056 EF

# **Appendix C**

## **Comments on Construction of Open-Graded Pavements**

## **Eastside Quite Pavements I-405, 112<sup>th</sup> Ave SE to SE 8<sup>th</sup> St Construction Comments**

The comments within this document are only those of Jim Weston and are not necessarily the views of the WSDOT.

### **TACK APPLICATION**

During the paving of Interstate 405 a Bear Cat (CRC, Computerized Rate Control) tack truck applied paving grade asphalt (PG64-22) to the pavement surface. The rate of application for coverage was 0.08 gallons per square yard which remained unchanged for the duration of paving. Application was very consistent with uniform distribution on the pavement surface.



Image of tack application on new PCCP surface

Tack placed on portions of the new PCCP located along the HOV lane was generally picked up by the Roadtec Shuttle Buggy material transfer device (MTD). Although sweeping equipment was used to clean all paved surfaces prior to paving, fine dust and curing compound was not completely removed from the roadway. Tracking was seen within the wheel paths caused by the MTD and delivery truck tires for portions of the new concrete roadway. This was likely a result of the lane not being opened to traffic prior to the placement of the OGFC materials. As ambient air temperature increased ( $\geq 75^{\circ}\text{F}$ ), along with pavement surface temperature, pickup of the tack coat material was minimized from the pavement surface. For the remaining portions of the project, pickup was not an issue.



Image of tack pickup on new PCCP



Pickup of tack when temperature was warmer

### DELIVERY VEHICLES

During this particular project trucks and trailers were used to deliver OGFC-AR and OGFC-SBS to the project limits. Project limits were about seven miles from plant operations. Typical temperatures of the cooler outer crust which formed on the loads during transport were around 185°F with internal temperatures around 345°F. Delivery vehicles were not having to wait for paving operations to catch up but rather paving, at times, needed to wait for delivery vehicles. This was predominant during production of OGFC-AR.

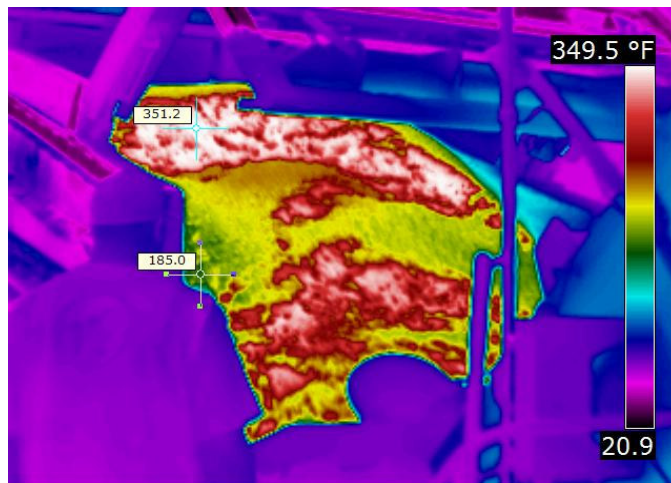

Delivery vehicle dumping into Shuttle Buggy (Note internal and crust temperatures).

## MATERIAL TRANSFER VEHICLE

This project employed the use of two (on two occasions three were utilized) Roadtec Shuttle Buggy's as the material transfer device (MTD). Because of the remixing characteristics and storage ability of this vehicle, it was an ideal transfer device for this project. Temperatures from the MTD into the paver hopper were typically around 325°F. The insulating and remixing capability of this device allowed for the pavement to have consistent temperatures across the mat and behind the screed even as three pavers were utilized at the same time.

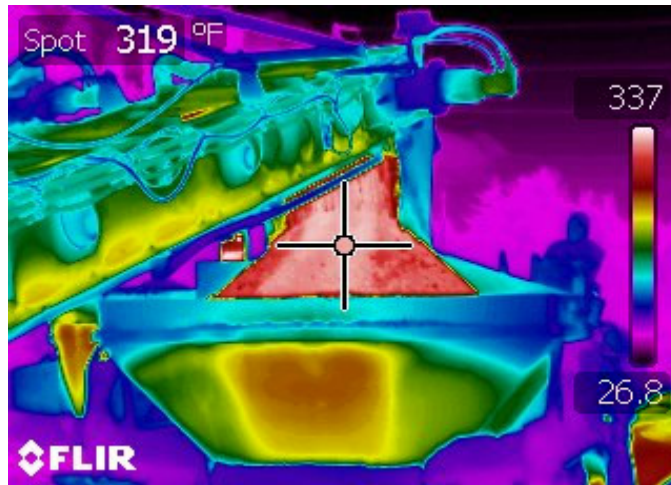

Image of temperature from MTD to paver hopper

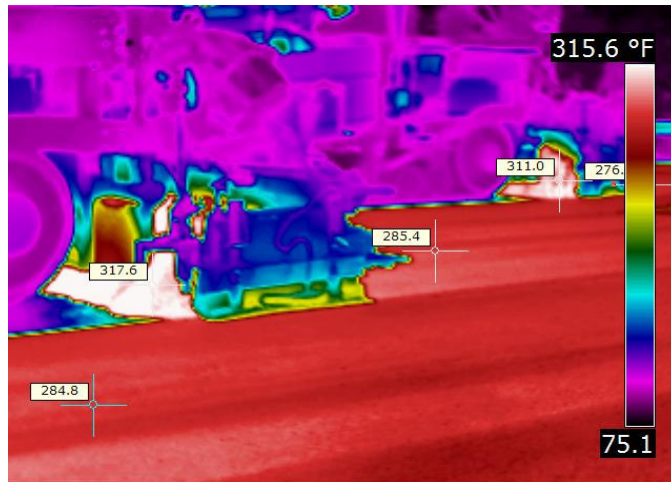

Image from back of screed looking towards the rollers

## PAVER

For this project two pavers were predominantly used with a third used on two occasions. All three pavers were CAT AP-1055D. All three were equipped with a hopper box and Carlson EZ

screed. The two predominant pavers utilized the Carlson EZ IV screed and the third paver was equipped with the Carlson EZ III screed. The CAT pavers are equipped with reverse augers near the gearbox.



Looking towards the three pavers

## **ROLLERS**

There were a total of six rollers (three for each paver) typically used for the paving of OGFC-AR and OGFC-Polymer. When the third paver was added so were three additional rollers. Of the breakdown rollers, one was an Ingersoll-Rand DD-118 and the other was a Dynapac CC-522. The remaining rollers were all Dynapac CC-522 rollers. All rollers were used in static mode as specified in the contract Special Provisions. In addition, all rollers worked in unison with the breakdown rollers taking three passes for complete coverage of the lane. All remaining compaction equipment stayed approximately 100 feet behind the roller in front of it and also worked in tandem shadowing the rollers in front.



Looking at breakdown and intermediate rollers

One issue that was a problem with the first Quieter Pavement project was that of matching the longitudinal joint. Because most of the paving was done using two or three pavers (hot-lapping), there was only one cold joint caused from the previous days paving. Matching the joint on this project was not an issue and the longitudinal joint does not show any defects.



Image of the longitudinal joint

### **OGFC-AR**

OGFC-AR liked to adhere to the paving equipment (i.e.: rakes, truck beds, MTD tires, etc.). Because of this, working with material that was placed near utilities often created results that were not as aesthetically pleasing as most hot mix asphalt (HMA) applications. This material also seemed to promote the use of release agent on all the equipment used.

Temperatures behind the screed were 290 to 300°F. These temperatures were consistent with those found in Arizona when paving with the same materials. The pavement surface gave the impression that the material was setting up directly behind the paver.

On this particular project paving with OGFC-AR was consistent although hauling was impacted by traffic in the area and on a few occasions the paver had to stop. The greatest impact to the production of OGFC-AR was that the existing PCCP had been milled, but the milling was not able to remove all the rutting caused by studded tires. Because the binder used in OGFC-AR has to be blended in advance, it takes time to manufacture this material. The quantity of binder produced is based on the amount of OGFC-AR to be placed (depth x width x length). Because the milling was not perfectly smooth the calculated yield quantities were underestimated. This resulted in a few hundred feet of shoulder that was paved with OGFC-SBS that was originally designed to be OGFC-AR. Below are photos showing the amount of rutting or mismatched milling present.





Amount of rutting present after milling

### **OGFC-SBS**

This material was more easily produced and paving operations were not halted as often as that of the OGFC-AR. The paving grade (PG64-22) tack coat used on this project worked well. Globules were not present as they were with the CRS-2P.

### **INSPECTION**

The one common thread that must be emphasized in the inspecting of HMA placement is temperature. Large temperature differences can result in substantial surface defects if not addressed. Because of this, it is recommended that an infrared (IR) camera be present for all production paving or at a minimum, a temperature gun. The use of a stick thermometer is not practical since the surface thickness and aggressive roller operations would likely destroy it. In addition, it would likely damage the pavement when removed because of the adhesion characteristics of the asphalt.

In the case of this project, the Project Engineering Office did an outstanding job of collecting temperature information. Although the predominant means of collecting temperature information was a temperature gun, temperature was collected at the truck, paver hopper, at the paver augers and behind the screed. In addition, the IR camera was used to collect temperature images behind the screed during the placement of OGFC-AR and OGFC-Polymer materials. The systematic method of collecting temperature on this project was quite impressive.

### **RECOMMENDATIONS**

- The use of performance grade asphalt as tack coat material should be considered as an alternative to standard tack coat materials in areas where time is a consideration. Since this material does not need to break, once it is placed, paving can begin.
- Specify that tarps be used on delivery vehicles as “mandatory” to ensure heat retention is maximized.
- Because of the thin surface of the OGFC material and the need for even temperature distribution, the Roadtec Shuttle Buggy or equivalent equipment should be specified for use.
- Keep paving production, delivery vehicles, and paving operations consistent. Impacts of traffic have to be considered in the equation.
- Systematic documentation of the temperature of OGFC materials at the truck, paver hopper, paver augers and behind the screed is fundamental to the correct assessment of the proper construction of the pavement.
- Provide an IR camera to inspection staff.

### **INSTRUCTION FOR INSPECTORS AND CONTRACTORS**

- Pay careful attention to the construction of longitudinal joints to avoid high points.
- Make sure the screed temperature is as close to paving temperature as possible prior to paving.
- The timing of construction is primary to keeping rollers within 300 feet of paver (specification).
  - Don’t load too many trucks prior to working at a construction joint.
  - Allow the rollers time to work effectively at the construction joint.
  - Keep the pavers moving consistently at a slow speed.
    - Ensure paver doesn’t speed up until rollers have completed the work at a construction joint.
- Minimize handwork as much as possible.
- Keep delivery trucks and MTD tires as clean as possible to avoid bringing debris into work area.
- Keep work area as clean as possible at all times. If material gets dumped onto roadway, or build-up on tires becomes excessive, clean thoroughly.
- Remember that this is a thin surface and large defects will reflect through.
- Record Temperature Information (preferably by use of the IR camera)

# **Appendix D**

## **Experimental Feature Work Plan**



**WORK PLAN**

**EVALUATION OF LONG-TERM PAVEMENT  
PERFORMANCE AND NOISE CHARACTERISTICS  
OF OPEN-GRADED FRICTION COURSES**

**I-405**  
**112<sup>TH</sup> AVE SE to SE 8<sup>TH</sup> ST**  
**Quieter Pavement Test**  
**MP 9.33 to MP 12.76**

Washington State Department of Transportation  
State Materials Laboratory – Pavement Section

## Introduction

Hot-mix asphalt (HMA) open-graded friction courses (OGFC) can reduce traffic noise and splash and spray from rainfall. These performance benefits come at a cost in durability, greatly reducing pavement life compared to traditional asphalt and concrete pavements. The benefit of noise reduction, and splash and spray reduction degrades over relatively short periods of time, reducing the effectiveness of the OGFC pavement. Pavement lives of less than 10 years, and as short as three to four years, have occurred with the use of OGFC pavements in Washington's high traffic corridors. The life of asphalt based quieter pavement in the USA and around the world tends to average between eight and 12 years. Compare this to an average pavement life of 16 years in western Washington and the loss of durability is clear. Under RCW47.05, WSDOT is instructed to follow lowest life cycle cost methods in pavement management. Less durable pavements do not meet this legislative direction.

Studded tire usage in Washington State is another complicating factor. Studded tires rapidly damage OGFC pavements, resulting in raveling and wear. When OGFC was used on I-5 in Fife, the pavement had significant wear in as little as four years. States where the use of OGFC has been successful (Florida, Texas, Arizona and California) do not experience extensive studded tire usage. Similarly, these states are southern, warm weather states; a clear advantage when placing a product like OGFC with asphalt-rubber. Arizona DOT, for example, requires the existing pavement to have an 85°F surface temperature at the time of placement. Washington State urban pavements, placed at night to avoid traffic impacts, rarely reach this temperature during the available nighttime hours for paving (10:00 p.m. to 5:00 a.m.), even in summer. Other pavements and bridge decks reach such temperatures at night only on rare occasions, making successful placement of rubberized OGFC difficult or impossible at night.

## Plan of Study

The objective of this research study will be to determine the long-term pavement performance characteristics of OGFC pavements. It will focus primarily on the OGFC surface's resistance to studded tire wear, its durability, its friction resistance, and its splash/spray characteristics. In addition, noise reduction characteristics will also be a major part of the evaluation effort. WSDOT, at a minimum, will be evaluating noise levels using sound intensity measurement equipment to capture tire/pavement noise, in-vehicle noise and wayside noise.

## Scope

This project will construct three types of asphalt pavement and diamond grinding existing PCC pavement as noted in the following description of the project:

- 10.19 to 10.85, NB lanes – install one section of open-graded rubberized asphalt and one section of open-graded polymer modified asphalt over existing and proposed Portland cement concrete (no pre-conditioning of concrete prior to installation)
- 11.76 to 12.37, NB lanes – install one section of open-graded rubberized asphalt and one section of open-graded polymer modified asphalt over existing and proposed Portland cement concrete (pre-conditioning of concrete prior to installation)
- The Next Generation Concrete Surface originally planned for this project will be constructed on I-5 under a separate experimental feature.

The OGFC will be placed to a depth of 0.06 ft (3/4 inch) on the existing asphalt pavement sections and 0.08 ft (1 inch) on the existing PCC pavement sections. Class 1/2-inch HMA will be placed to a depth of 0.15 ft following the milling of the existing pavement to the same depth.

The OGFC mixes will be designed in accordance with the Arizona DOT specifications rubberized and polymer modified open-graded pavements.

## Layout

The specific location and number of test sections will be determined after the project has been constructed. At a minimum there will be test sections on the OGFC-asphalt rubber, on the OGFC-polymer.

## Staffing

This research project will be conducted through the combined efforts of the WSDOT Materials Laboratory and the WSDOT Acoustics Program Office. The Northwest Region Project office will coordinate and manage all aspects of the construction. Representatives from the WSDOT Materials Laboratory (one – three persons) will also be involved in monitoring the construction activities.

### **Contacts**

Jeff Uhlmeier, PE  
State Pavement Engineer  
Washington State DOT  
(360) 709-5485  
FAX (360) 709-5588  
uhlmej@wsdot.wa.gov

Mark Russell, PE  
Pavement Design Engineer  
Washington State DOT  
(369) 709-5479  
FAX (360) 709-5588  
[russelm@wsdot.wa.gov](mailto:russelm@wsdot.wa.gov)

## Testing

The following testing procedures will be conducted on the test sections and control section.

- Pavement condition (bi-annually)
  - Surface condition (cracking, patching, flushing, etc)
  - Rutting/wear (using the INO laser which provides true transverse profile)
  - Roughness
  - Friction
- Sound intensity noise measurements (monthly)
- Wayside noise measurements
- In-vehicle noise measurements

## Reporting

An “End of Construction” report will be written following completion of the test sections. This report will include details of the construction of the test sections and control section, construction test results, and initial sound, friction, roughness and rutting/wear results from all of the test sections. Annual summary reports will also be issued over the next five years that document any changes in the performance of the test sections. A final report will be written at the end of the five year evaluation period which summarizes performance characteristics and future recommendations for use of the OGFC pavements.

## Cost Estimate

### Construction Costs

Construction costs are unknown at the time of the development of this work plan, however, the following table summarizing the costs from the first two quieter pavement projects should provide some idea of the possible costs of the three types of asphalt pavements included in the study.

Bid Item	I-5, Lynnwood			SR-520 Bellevue		
	Tons	Cost	Cost (ln-mi)	Tons	Cost	Cost (ln-mi)
Class ½ “ HMA	28,853	\$ 62.50	\$ 45,188	2,840	\$ 85.00	\$ 61,455
OGFC-AR	1,686	\$ 130.00	\$ 39,091	910	\$ 285.00	\$ 85,700
OGFC-SBS	2,441	\$ 90.00	\$ 27,063	1,190	\$ 155.00	\$ 46,609

### Testing Costs

Funds for all testing will come from the Quieter Pavements testing budget.

### Report Writing Costs

Initial Report – 60 hours = \$4,800  
Annual Report – 20 hours (4 hours each) = \$1,600  
Final Report – 100 hours = \$8,000

**Total Evaluation Cost = \$14,400**

## Schedule

Estimated Project Ad Date – April 2008  
Estimated Construction – August 2009

Date	Pavement Condition Survey	Roughness Wear/Rutting	Friction	Sound Intensity	End of Construction Report	Annual Report	Final Report
Summer 2009		X	X	X			
October 2010		X		X	X		
April 2010	X	X	X	X			
October 2010		X		X		X	
April 2010	X	X	X	X			
October 2010		X		X		X	
April 2011	X	X	X	X			
October 2011		X		X		X	
April 2012	X	X	X	X			
October 2012		X		X		X	
April 2013	X	X	X	X			
October 2013		X		X			
December 2013							X