



# Hydrodynamic Separator Sediment Retention Testing

Minnesota  
Department of  
Transportation

**RESEARCH  
SERVICES**

Office of  
Policy Analysis,  
Research &  
Innovation

Omid Mohseni, Principal Investigator  
St. Anthony Falls Laboratory  
University of Minnesota

**March 2010**

Research Project  
Final Report #2010-10



*Your Destination... Our Priority*



## Technical Report Documentation Page

1. Report No. <b>MN/RC 2010-10</b>	2.	3. Recipients Accession No.	
4. Title and Subtitle <b>Hydrodynamic Separator Sediment Retention Testing</b>		5. Report Date <b>March 2010</b>	
		6.	
7. Author(s) <b>David A. Sadoris, Kurtis D. McIntire, Omid Mohseni and John S. Gulliver</b>		8. Performing Organization Report No.	
9. Performing Organization Name and Address <b>St. Anthony Falls Laboratory University of Minnesota 2 Third Ave SE Minneapolis, MN, 55414</b>		10. Project/Task/Work Unit No.	
		11. Contract (C) or Grant (G) No. <b>(c) 89261 (wo) 53</b>	
12. Sponsoring Organization Name and Address <b>Minnesota Department of Transportation 395 John Ireland Boulevard, MS 330 St. Paul, MN 55155-1899</b>		13. Type of Report and Period Covered <b>Final Report</b>	
		14. Sponsoring Agency Code	
15. Supplementary Notes <a href="http://www.lrrb.org/pdf/201010.pdf">http://www.lrrb.org/pdf/201010.pdf</a>			
16. Abstract (Limit: 250 words) <p>Hydrodynamic separators are widely used in urban areas for removal of suspended sediments and floatables from stormwater due to limited land availability for the installation of above ground stormwater best management practices (BMPs). Hydrodynamic separators are often sized based on 2-yr stormwater runoff from the drainage basins that they serve. However, during less frequent storm events, e.g. 10-yr storm events, device design treatment rates are exceeded and previously captured sediments can be scoured and washed out.</p> <p>At the St. Anthony Falls Laboratory, three devices have been studied and tested and, subsequently, a testing method has been developed to assess sediment retention in hydrodynamic separators under flow rates exceeding their maximum design treatment rates (MDTR). This new testing protocol has been used in controlled field and laboratory tests on full-scale commercial devices under high water flow conditions to determine sediment retention performance of hydrodynamic separators. In addition, velocity profiles have been taken to observe the complex flow patterns in these devices. Application of this work is primarily to establish the frequency of required cleaning for installed devices.</p>			
17. Document Analysis/Descriptors <b>Bedforms; Effluents; Concentration (chemistry); Environment 21, LLC; Downstream Defender®; Hydrodynamics; Scaling; Scour; Stromceptor®; Swirl flow; Test procedures; Underground devices; Commercial devices; Washout; Performance based specifications</b>		18. Availability Statement <b>No restrictions. Document available from: National Technical Information Services, Springfield, Virginia 22161</b>	
19. Security Class (this report) <b>Unclassified</b>	20. Security Class (this page) <b>Unclassified</b>	21. No. of Pages <b>130</b>	22. Price

# **Hydrodynamic Separator Sediment Retention Testing**

## **Final Report**

*Prepared by:*

David A. Saddoris  
Kurtis D. McIntire  
Omid Mohseni  
John S. Gulliver

St. Anthony Falls Laboratory  
University of Minnesota

**March 2010**

*Published by:*

Minnesota Department of Transportation  
Research Services Section  
395 John Ireland Boulevard, MS 330  
St. Paul, Minnesota 55155-1899

This report represents the results of research conducted by the authors and does not necessarily represent the views or policies of the Minnesota Department of Transportation or the University of Minnesota. This report does not contain a standard or specified technique.

The authors, the Minnesota Department of Transportation, and the University of Minnesota do not endorse products or manufacturers. Any trade or manufacturers' names that may appear herein do so solely because they are considered essential to this report.

## **Acknowledgements**

The work reported herein was funded by the Minnesota Department of Transportation and the Minnesota Local Roads Research Board. Mike Eastling from the City of Richfield and Shirlee Sherkow from the Minnesota Department of Transportation were the technical and administrative liaisons, respectively.

We would like to thank David Olson, Public Works Superintendent from the City of New Brighton, for help with the field testing on Environment 21. Also we would like to acknowledge and thank Rinker Materials and Hydro International for providing the internal components of STC1200 Stormceptor and 6-ft Downstream Defender, respectively, and Environment 21 for allowing us to test their device for this project.

We would also like to thank Brian Bell, Pat Brockamp, Teigan Gulliver, Matthew Lueker, Ben Plante, Adam Howard, Andrew Fyten, Mike Plante, Ben Erickson, Craig Hill, Sara Johnson, Andrew Sander, Greg DeGroot, Luke Schmidt, Ann Dienhart, Brian Sweezy and Seth Weeks from St. Anthony Falls Laboratory for help with the experimental setup, field tests and data collection.

Last but not least, we would like to thank the members of the Technical Advisory Panel, Scott Carlstrom, Mike Eastling, Jack Frost, Marilyn Jordahl-Larson, Susan McDermott, Shirlee Sherkow and Bruce Wilson for their valuable input and feedback throughout the project.

# Table of Contents

1. Introduction.....	1
1.1. Hydrodynamic Separator Overview .....	1
1.2. Scope of Research.....	1
1.3. Significance of Sediments in Stormwater.....	2
1.4. Previous Studies.....	2
1.5. Existing Testing Protocols.....	2
2. Methods and Materials.....	4
2.1. Identification of Devices for Field Testing.....	4
2.1.1. Hydrant Flow Testing.....	5
2.2. Full Scale Device Testing.....	5
2.2.1. Environment 21 V2B1- Field Testing.....	5
2.2.2. Environment 21 V2B1 - Laboratory Testing.....	6
2.2.3. Stormceptor - Laboratory Testing.....	7
2.2.4. Downstream Defender - Laboratory Testing.....	7
3. Test Results.....	9
3.1. Identification of Devices for Field Testing.....	9
3.2. Full Scale Device Testing.....	9
3.2.1. Environment 21 V2B1 - Field Testing.....	9
3.2.2. Environment 21 V2B1 - Laboratory Testing.....	11
3.2.3. Stormceptor - Laboratory Testing.....	12
3.2.4. Downstream Defender - Laboratory Testing.....	14
4. Scale Model Study.....	18
4.1. Swirl Flow Scale Model.....	18
4.2. Idealized Swirl Flow Device.....	20
4.3. Scale Model Velocity Profiles.....	22
4.3.1. Swirl Flow Device Scale Model Velocity Profiles.....	22
4.3.2. Idealized Swirl Flow Scale Model.....	25
5. Sediment Retention Functions.....	29
5.1. Velocity Measurement in Environment 21 V2B1.....	29
5.2. Velocity Measurement in 6-ft Diameter Downstream Defender.....	32
5.3. Proposed Functions.....	36
6. Application of Results.....	39
6.1. Maintenance.....	39
6.2. Implications of Work.....	39
6.3. Predict Maintenance Schedules.....	39
7. Summary and Conclusions.....	41
References.....	43
Appendix A: Device Configuration and Test Procedures – Full Scale Devices	
Appendix B: Device Configuration and Test Procedures – Scale Models	
Appendix C: Sediment Measurement Techniques	
Appendix D: Size Distributions for Commercial Silica Sand Gradations	
Appendix E: Calculation of Sediment in Devices	
Appendix F: Retention Testing Results - Tables	
Appendix G: Velocity Profiles	

## List of Figures

Figure 3-1: Environment 21 V2B1 Model 4 - field testing .....	10
Figure 3-2: Environment 21 V2B1 Model 4 - laboratory testing .....	11
Figure 3-3: Environment 21 V2B1 Model 4 – sediment retention testing results .....	12
Figure 3-4: Cloudy and clear water on top of insert in Stormceptor .....	14
Figure 3-5: The results of sediment retention testing conducted on a 6-ft Downstream Defender, with sediment deposit prior to the tests at 75% sump storage capacity or less. ....	15
Figure 3-6: The results of all sediment retention tests conducted on a 6-ft Downstream Defender. .....	16
Figure 3-7: Sediment cone near Downstream Defender benching skirt .....	17
Figure 4-1: Sediment retention testing results of the swirl flow device scale model .....	19
Figure 4-2: Bedforms in swirl flow device scale model .....	19
Figure 4-3: Dune movement in the swirl flow device scale model .....	20
Figure 4-4: Large vortex formation in the idealized swirl flow scale model.....	21
Figure 4-5: A wooden cross baffle inserted inside the inner cylinder .....	21
Figure 4-6: Sediment retention testing results for the idealized swirl flow device scale model ..	22
Figure 4-7: Swirl flow device scale model with ADV setup .....	23
Figure 4-8: ADV positions in the swirl flow device scale model for velocity measurement .....	23
Figure 4-9: Normalized velocity profiles measured at position 1 (1/4 position) and position 2 (3/4 position) at 4.3 gpm discharge.....	24
Figure 4-10: Normalized velocity profiles measured at position 1 (1/4 position) and position 2 (3/4 position) at 14.6 gpm discharge .....	25
Figure 4-11: ADV positions in the idealized swirl flow scale model.....	26
Figure 4-12: Normalized velocity profiles measured at four positions at 7 gpm discharge .....	27
Figure 4-13: Normalized velocity profiles measured at four positions at 15 gpm discharge .....	27
Figure 4-14: Normalized velocity profiles measured at four positions at 20 gpm discharge .....	28
Figure 5-1: Plan view of the Environment 21 V2B1 Model 4 at SAFL and the positions of the 3- D ADV used to measure velocity profiles.....	29
Figure 5-2: Velocity profiles measured in the Environment 21 V2B1 Model 4 at 1.5 cfs discharge .....	30
Figure 5-3: Velocity profiles measured in the Environment 21 V2B1 Model 4 at 2.5 cfs discharge .....	31
Figure 5-4: Velocity profiles measures in the Environment 21 V2B1 Model 4 at 3.5 cfs discharge .....	31
Figure 5-5: The ADV bracket installed on top of the Downstream Defender holding the ADV in the sump.....	32
Figure 5-6: ADV positioned above the river rock bed .....	33
Figure 5-7: Plan view of ADV positions inside the sump of the Downstream Defender (all dimensions shown are in inches).....	33
Figure 5-8: Vertical positions of the ADV inside the 6-ft Downstream Defender (all dimensions shown are in inches) .....	34
Figure 5-9: Profiles of $\theta$ -component of velocity at a discharge of 4 cfs .....	35
Figure 5-10: Profiles of $\theta$ -component of velocity at a discharge of 5.5 cfs .....	35
Figure 5-11: Profiles of $\theta$ -component of velocity at a discharge of 7 cfs .....	36
Figure 5-12: Proposed Environment 21 washout functions for two particle sizes .....	37

Figure 5-13: Proposed Downstream Defender washout function for silica sand with a $d_{50}$ of 110 microns .....	38
Figure A-1: Fire hydrant and piping system for water supply.....	A-1
Figure A-2: Plan and section of V2B1 Model 4, New Brighton, MN. (Source: Environment 21, 2005. Project design worksheets. Project: Rice Creek Road Area 4.) .....	A-2
Figure A-3: Rendering of Environment 21 V2B1 (image from <a href="http://www.env21.com/V2B1.html">http://www.env21.com/V2B1.html</a> on 10/20/08).....	A-3
Figure A-4: Flow rate measurement using a weir, pressure transducer and data acquisition computer .....	A-4
Figure A-5: Sediment capture screen at Rice Creek.....	A-4
Figure A-6: Field site with confined space entry tripod .....	A-5
Figure A-7: Environment 21 V2B1 laboratory testing – device drawing.....	A-7
Figure A-8: Environment 21 V2B1 laboratory testing – flow measurement .....	A-8
Figure A-9: Environment 21 V2B1 laboratory testing – device setup .....	A-8
Figure A-10: Environment 21 V2B1 laboratory testing – load cell screenshot.....	A-9
Figure A-11: Stormceptor water feed piping.....	A-11
Figure A-12: Stormceptor drawing including dimensions (image from <a href="http://www.stormceptor.com/downloads/Drawings/US/Rinker/Stc1200.PDF">http://www.stormceptor.com/downloads/Drawings/US/Rinker/Stc1200.PDF</a> on 12/6/09).....	A-12
Figure A-13: Stormceptor drop tee.....	A-12
Figure A-14: Stormceptor rendering (image from <a href="http://www.stormceptor.ca/en/products/stormceptor-classic-systems/enlarge.html">http://www.stormceptor.ca/en/products/stormceptor-classic-systems/enlarge.html</a> on 10/20/08).....	A-13
Figure A-15: Channel discharge flow measurement .....	A-14
Figure A-16: Downstream Defender rendering images from <a href="http://www.hydro-international.biz/us/stormwater_us/downstream.php">http://www.hydro-international.biz/us/stormwater_us/downstream.php</a> on 10/20/08 and 09/14/09.....	A-16
Figure A-17: Dimensions of different components of Downstream Defender (all dimensions are in inches). .....	A-17
Figure A-18: Photo of the Downstream Defender insert used at SAFL.....	A-17
Figure A-19: Water flowing through Downstream Defender during the laboratory tests.....	A-18
Figure A-20: Bedforms in the sump of Downstream Defender at high flow conditions.....	A-18
Figure B-1: Dimensions of the swirl flow device scale model (all dimensions are in inches)... ..	B-1
Figure B-2: Photos of the swirl flow device scale model .....	B-2
Figure B-3: Dimensions of the idealized swirl flow device. All dimensions are in inches.....	B-4
Figure C-1: Sediment depth measurement using the metal ruler stick .....	C-1
Figure C-2: Laser range finder with bracket.....	C-2
Figure C-3: Load cell installed under device.....	C-7
Figure C-4: Screen shot of the LabView program.....	C-8
Figure C-5: Load cell data during two sediment retention tests .....	C-9
Figure C-6: Load cell data collected during sediment retention test# 14 .....	C-10
Figure C-7: Load cell data collected during sediment retention test# 15 .....	C-10
Figure C-8: Stilling basin and point gauge used for water level measurement .....	C-11
Figure D-1: Sieve analysis for US Silica F Series including F110 silica sand (source: US Silica. Found online on 7/7/08 at: <a href="http://www.u-s-silica.com/PDS/Ottawa/OTTAWA%20FDY%20SANDS%202004.pdf">http://www.u-s-silica.com/PDS/Ottawa/OTTAWA%20FDY%20SANDS%202004.pdf</a> ) .....	D-1

Figure D-2: Sieve analysis for AGSCO 70-100 (source: AGSCO. Found online on 7/7/08 at:  
<http://agsco.thomasnet.com/Asset/Silica-Sand-technical-data-sheet.pdf>)..... D-2

Figure D-3: Sieve analysis for SCS-250..... D-3



## List of Tables

Table 2-1: Hydrant flow testing results .....	5
Table 3-1: Stormceptor Model STC 1200 retention testing.....	13
Table C-1: Laser range finder repeatability at St. Anthony Falls Laboratory .....	C-3
Table C-2: New Brighton Environment 21 V2B1 level measurement repeatability .....	C-5
Table C-3: Level measurement technique comparison – Environment 21 V2B1 field sediment retention tests.....	C-6
Table C-4: Tovey Engineering load cell model FR specifications (From <a href="http://www.toveyengineering.com/fr.pdf">http://www.toveyengineering.com/fr.pdf</a> on 10/23/08).....	C-8
Table F-1: Test conditions and results for Environment 21 V2B1 Model 4–field testing .....	F-1
Table F-2: Test conditions and results for Environment 21 V2B1 Model 4–laboratory testing .....	F-1
Table F-3: Test conditions and results for Stormceptor STC 1200 – laboratory testing .....	F-2
Table F-4: Test conditions and results for Downstream Defender – bag fed .....	F-3
Table F-5: Test conditions and results for Downstream Defender – ~85% bag fed.....	F-4
Table F-6: Test conditions and results for Downstream Defender – stick leveled.....	F-4
Table F-7: Test conditions and results for Downstream Defender – AccuRate fed .....	F-4
Table F-8: Test conditions and results for swirl flow device scale model.....	F-5

## Executive Summary

Hydrodynamic separators are widely used in urban areas for removal of suspended sediments and floatables from stormwater due to limited land availability for the installation of above ground stormwater best management practices (BMPs). Hydrodynamic separators are often sized based on some relatively frequent storm events. However, during less frequent storm events, device design treatment rates are exceeded and previously captured sediments can be washed out of the device.

Three hydrodynamic separators were studied at the St. Anthony Falls Laboratory to (1) develop a testing procedure for the measurement of the washout rate, i.e. the sediment retention potential, (2) determine their potential washout rates under a variety of flow conditions, and (3) develop a method for the maintenance schedule of hydrodynamic separators.

An Environment 21 V2B1 Model 4 was tested both in the laboratory and in the field; the results of both test series were in general agreement with each other. An STC1200 Stormceptor and a 6-ft Downstream Defender were only tested in the laboratory.

Several full scale testing procedures were developed in this study. In all procedures studied, the sump of the tested device was preloaded with commercially available sediments with a relatively narrow particle size distribution. The device was then subject to a high flow rate for an extended period of time. Either the volume or the weight of sediments in the sump before and after each test was measured, where the difference between the two during the test period was determined to be the washout rate. Since in these tests a significant amount of sediments had to be measured before and after each test, the error was significantly higher than is commonly perceived.

The results of the tests showed that the washout rate of the STC1200 Stormceptor is approximately zero for the F110 Silica sand gradation (with a median size of 110 microns) and SCS250 (with a median size of 45 microns). The near zero washout rate is primarily due to the bypass built inside the device and the flow patterns entering the sump.

For the 6-ft Downstream Defender, laboratory tests indicated that when the deposit was less than 75% of the maximum storage capacity, the washout rates were not significant, with a maximum effluent concentration of 110 mg/l at a discharge of 8 cfs with the sump preloaded with the F110 Silica sand gradation. The low washout rate is due to the presence of a benching skirt which protects the deposit in the sump. As the deposit exceeded 75% of the maximum storage capacity, the washout rates from the 6-ft Downstream Defender increased considerably, with a maximum effluent concentration of about 2,000 mg/l at a discharge of about 8 cfs. Therefore, decreasing the maximum sump capacity of Downstream Defenders by 25% is recommended.

For the Environment 21 V2B1 Model 4, the maximum effluent concentration was measured to be 1,300 mg/l at a discharge of 4.2 cfs with the sump preloaded with the F110 silica sand gradation. The maximum effluent concentration decreased as the size of the sediments in the device increased.

For further understanding of swirl flow hydrodynamic separators, two hypothetical scale models of swirl flow type hydrodynamic separators were built and tested. The result of these tests showed that in general swirl flow hydrodynamic separators are more prone to higher washout rates due to high flow velocities inside of these devices. In order to suppress the washout rate, either the deposit should be protected or the energy of the flow should be dissipated.

Finally, a washout function was developed for a 6-ft Downstream Defender for a particle size distribution with a median size of 110 microns and two washout functions were developed for Environment 21 V2B1 Model 4 for particle size distributions with median sizes of 110 and 200 microns. The washout functions in combination with removal efficiency functions and a continuous runoff model for urban drainage basins can be employed to determine the required maintenance frequency of these devices for a given installation.

# 1. Introduction

## 1.1. Hydrodynamic Separator Overview

Hydrodynamic separators are used as stormwater best management practices (BMPs) in urban areas for removing contaminants from stormwater. These underground devices are attractive in areas where land is at a premium because of their small footprint. Hydrodynamic separators are flow-through devices used as pre-treatment in a multi-BMP treatment train or as stand-alone BMPs. Water either enters these devices tangentially, thus creating a swirl, or plunges into the main sump. Hydrodynamic separators may be single or multiple sump devices. They have no moving parts and rely on flowing water as their source of energy, so they require no power.

Hydrodynamic separators principally function as enhanced settling devices over a small space and commonly include a mechanism for capturing hydrocarbon products (e.g. oil) and gross solids. Consequently, they are most effective at removing heavy particulates and floatables from stormwater ([US EPA, 1999](#)), and to the extent that they are bound to larger sediments, nutrients and heavy metals. Hydrodynamic separators are less effective at removing fine particulates ([US EPA, 1999](#)) and cannot remove dissolved compounds.

There are two important criteria to consider when determining the overall performance of hydrodynamic separators: 1) their efficiency at removing contaminants under treatment flow conditions and 2) their ability to retain accumulated sediments under high flow conditions. Hydrodynamic separators are sized based on the runoff from the drainage basins they serve. As most rainfall events result in flow rates less than the maximum design treatment rates (MDTR) for the installed devices, removal efficiency under treatment rates is an important characteristic for assessing the performance of these devices. However, during less frequent storm events, MDTRs are exceeded, and previously captured sediment can be subject to scouring, resuspension and washout from these devices.

Historically, monitoring programs have been used to assess the performance of hydrodynamic separators. Monitoring offers the advantage of assessing the performance of BMPs under a wide range of actual hydraulic and pollutant loading conditions for a given drainage basin ([WILSON ET AL., 2007 AND 2009](#)). However, monitoring is limited by the accuracy of sample collection strategies ([GETTEL ET AL., 2009](#)) as well as the magnitude and frequency of storm events. In addition, due to numerous uncontrolled variables in actual runoff events, it is difficult to use the results of a monitoring study to estimate a device's performance under different flow and sediment particle size conditions. As a result, new protocols for testing the performance and sediment retention of hydrodynamic separators utilizing controlled field and laboratory testing need to be developed. Carlson et al. ([2006](#)) and Wilson et al. ([2007 AND 2009](#)) have developed laboratory and field testing methods to assess removal efficiency of these devices. In this study, we have developed field and laboratory testing methods to assess sediment retention of these devices.

## 1.2. Scope of Research

This report addresses the potential for scour and washout of non-floatable solids in hydrodynamic separators during discharges at or above MDTR.

Gross solids (e.g., plastic bottles) and floatable liquids (e.g., hydrocarbons) can be pollutants in stormwater. The effectiveness of hydrodynamic separators at capturing and retaining floatables is outside the scope of this research project and the project report.

### **1.3. Significance of Sediments in Stormwater**

Sediments in stormwater can facilitate the transport of pollutants, and are typically considered as pollutants themselves.

A number of pollutants, including some nutrients and heavy metals, can bind to sediments. As sediments are transported by stormwater, any attached pollutants are also transported. The pollutants may later be released from the sediments into the water body, triggered by changing temperature, oxygen, pH, etc. The released pollutants may then be available to impact organisms and subsequently the ecosystem of receiving water bodies.

In addition to the pollutants that are bound to sediments, the sediments themselves can act as pollutants. Sediments of certain sizes, compositions, concentrations and quantities can negatively impact receiving water bodies. Sediments in rivers and lakes can reduce light penetration, cover sensitive fish spawning areas and interfere with fish gill function. In sufficient quantities, sediments can also fill water bodies, impeding navigation and reducing waters available for aquatic species.

### **1.4. Previous Studies**

A number of studies have been conducted to determine the effectiveness of hydrodynamic separators at removing sediments from stormwater under design water flow conditions. However, research on the retention of sediments under high water flow conditions is limited.

Avila and Pitt ([AVILA ET AL., 2008 AND 2009](#)) pre-loaded a full scale physical model with solid particles and collected effluent samples to determine sediment washout. The studies also included velocity measurements in the physical model, and development and calibration of a 3-dimensional (3-D) computational fluid dynamics (CFD) model. This work was the continuation of a project by Avila, Pitt and Durrans ([AVILA ET AL., 2007](#)).

A number of studies have investigated CFD models of hydrodynamic separators, including recent work by Pathapati and Sansalone ([PATHAPATI ET AL., 2009](#), [SANSALONE ET AL., 2009](#)). However, sediment scouring, resuspension and washout were not a focus of these studies.

### **1.5. Existing Testing Protocols**

Currently, two testing protocols of hydrodynamic separators provide methods to assess the potential for washout of previously deposited sediments in hydrodynamic separators ([WDC AND WDNR 2007](#); [NJDEP 2009](#)). In both methods, the sump shall be preloaded with sediments with specific particle size distributions. The proposed distributions vary from large sand particles to silt and clay size particles. In both methods, scour potential is assessed by sampling the effluent. Unfortunately, sampling of sand and coarse silt particles can result in errors that may be unacceptable ([DEGROOT AND GULLIVER 2009](#)). In addition, assessing the scour potential of a

sediment gradation with a wide range of particle sizes will not illustrate how these devices function under conditions with different particle sizes and particle densities in stormwater runoff.

## 2. Methods and Materials

The net removal of contaminants by hydrodynamic separators is a function of their performance at capturing pollutants at frequent design storm events, e.g. 2-yr events, and smaller and their ability to retain previously captured sediments during high flow events, e.g. 5-yr or 10-yr events. In hydrodynamic separators two processes cause the washout of deposited sediments: 1) scouring and resuspension of deposited sediments and 2) turbulence in the sump which overcomes the resettling of resuspended sediments, dispersing them upward to the outlet of the device.

A new methodology has been developed at the St. Anthony Falls Laboratory (SAFL) to assess sediment resuspension and washout in hydrodynamic separators under flow rates exceeding their design MDTRs. The test methodology follows as Procedure 2-1.

Procedure 2-1: Procedure for Controlled Sediment Retention Testing of Hydrodynamic Separators using Mass Balance

- 1) Drain and clean the device
- 2) Pre-load the device sump with sediments of known particle sizes
- 3) Measure the amount of sediments in the device
- 4) Flow water through the device for a set time duration at rates at or above the device MDTR
- 5) Measure the amount of sediments remaining in the device
- 6) Determine the amount of sediments washed out via mass balance

Procedure 2-1 has been applied in the testing of four full scale commercial devices: 1) an Environment 21 V2B1 Model 4 in the field and in the laboratory by the authors, 2) a Stormceptor STC 1200 in the laboratory by the authors and 3) a 6-ft diameter Downstream Defender in the laboratory by the authors and 4) an ecoStorm Model 3 by Mohseni and Fyten ([MOHSENI ET AL., 2008](#)).

### 2.1. Identification of Devices for Field Testing

Prior to the start of device testing, a survey was conducted to find hydrodynamic separators that are installed in the Twin Cities (Minnesota) area that are appropriate for field testing. To be suitable for field testing, the devices should have the following conditions:

- 1) Within a 45 minute drive of St. Anthony Falls Laboratory to limit travel time
- 2) Have safe access and the ability to maintain a safe work zone with limited impacts to traffic
- 3) Have adequate water supply for sediment retention testing

A list of installed devices in the Twin Cities, previously developed by SAFL, was reviewed and possible devices for field testing were identified, with the goal of field testing devices from three different manufacturers. A field trip was conducted and the top candidate sites for field testing were selected and were as follows:

- A Contech Solution CDS model PMSU20\_25 device in Heritage Park, a redevelopment site in Minneapolis, MN
- A Stormceptor Model STC 4800 in Fridley, MN
- An Environment 21 V2B1 Model 4 device in New Brighton, MN

**2.1.1. Hydrant Flow Testing**

Controlled field sediment retention testing requires controlled water supply at flow rates at and above the MDTRs for the devices tested. Controlled field testing of device sediment removal performance, as described by Wilson et al (2007), utilized water supplied by fire hydrants. For retention testing, fire hydrants are also a potential source for water supply. Another source considered for retention testing was water trucks, which do not have adequate capacity to supply water for the entire test duration.

In the early summer of 2007 a field crew from St. Anthony Falls Laboratory (SAFL) conducted a field study to determine the maximum water flow rate available for supply to the hydrodynamic separator devices at the three field sites. A weir and transducer were installed in sewer piping downstream from the outlet of the devices to monitor water flows through the devices. Previous studies at SAFL proved the accuracy and robustness of this flow measurement technique and provided calibration for the specific sewer pipe and weir size utilized. Water was routed from a nearby fire hydrant to a catch basin upstream from the device tested. The fire hydrant was opened to full open, allowing water to flow into the catch basin, through the device, and across the weir and transducer. A laptop was used to monitor and record water level readings at the weir as reported from the transducer, which were then correlated to flow rates utilizing the previously developed calibrations. The results of the hydrant flow testing are given in Table 2-1.

**Table 2-1: Hydrant flow testing results**

<b>Device</b>	<b>Location</b>	<b>Mode</b>	<b>Maximum Design Treatment Rate (cfs)</b>	<b>Hydrant Max. Flow Rate (cfs)</b>
CDS	Minneapolis (Heritage Park), MN	PMSU20_25	1.6	1.3
Stormceptor	Fridley, MN	STC 4800	1.8	3.9
Environment 21	New Brighton, MN	V2B1-Model 4	1.4	4.2

**2.2. Full Scale Device Testing**

**2.2.1. Environment 21 V2B1- Field Testing**

Controlled field testing of an Environment 21 V2B1 Model 4 was completed utilizing Procedure 2-1 in the summer and fall of 2007 on an in-service device in New Brighton, MN. The equipment and methods for the testing are described in detail in Appendix A, Section A.1.



A total of fourteen sediment retention tests were completed under a variety of flow rates, and with two particle sizes. Six tests were conducted in the summer (“Initial Tests”), followed by six duplicate tests in the fall (“Repeat Tests”). For the first twelve tests, US Silica F110 gradation was utilized. Two additional tests were conducted in the fall using AGSCO 70-100 gradation. US Silica F110 and AGSCO 70-100 are commercial silica sand gradations with specific gravities of approximately 2.6. US Silica F110 has a  $d_{50}$  of 120  $\mu\text{m}$ , a  $d_{15}$  of 80 $\mu\text{m}$  and a  $d_{85}$  of 170 $\mu\text{m}$ . AGSCO 70:100 has a  $d_{50}$  of 200  $\mu\text{m}$ , a  $d_{15}$  of 120 $\mu\text{m}$  and a  $d_{85}$  of 280 $\mu\text{m}$ . The size distributions for silica sand gradations used during sediment retention testing are shown in Appendix D.

Sediment was added to the device sump prior to each test so that the starting sediment level was approximately six inches. The manufacturer’s recommended sediment depth requiring cleaning is 6-12” ([ENVIRONMENT 21, 2009](#)). Before and after water flow, a trowel was used to flatten and level the surface of the deposit and a 2 foot level was used to check if the deposit was truly level. After leveling, two methods were used to determine the amount of the sediment in the V2B1 device: 1) A graduated ruler stick measuring the depth of the sediment to the floor of the device and 2) A laser range finder measuring the distance between the top of the sediment and the ceiling of the device. These methods are described in detail in Appendix C.

The sediment retention tests were conducted with water supplied from a fire hydrant. The discharge was set at the beginning of the test and was constant during each test. The tests utilized discharges ranging from 1.7 to 4.1 cfs. The maximum design treatment rate for this device is 1.4 cfs. The test durations ranged from 30 to 120 minutes. The results of the tests are discussed in Section 3.2.1.

### ***2.2.2. Environment 21 V2B1 - Laboratory Testing***

An Environment 21 V2B1 Model 4 was tested at SAFL in December 2008 and January 2009 following Procedure 2-1. For the laboratory testing, fiberglass manholes were utilized. Environment 21 supplied the internal components and the fiberglass manholes. The equipment and methods for the testing are described in detail in Appendix A, Section A.2.

The device tested in the laboratory in 2008/2009 had a smaller outlet pipe from the first chamber to the second chamber than the device tested in the field in 2007 as described in this report. In addition, a different sediment measurement technique was used for laboratory testing than was used for field testing.

For laboratory testing the entire full-scale device was placed on a frame, which was placed on Tovey Engineering Model FR10 load cells. These load cells have a published non-repeatability of 0.01% of their rated capacity. Numerous tests were conducted on the setup to confirm that load cell measurement drift and non-repeatability were minimized. Appendix C, Section C.2 contains discussion on load cells and sediment measurement.

The amount of sediment washed out during a test was determined by measuring the weight change of the entire device from the start of the test to the end of the test. Prior to each test, the system was disconnected from the piping and weighed using the load cells, and the water levels in the sumps were recorded. The piping was then connected and a test was conducted at the specified flow rate for the specified duration. At the conclusion of each test the suspended sediment was allowed to settle, and then water was drained from the device to approximately the

pre-test water level in the sumps. The piping was disconnected, and the final weight and water level were recorded. At the end of every test an adjustment was made to the recorded weight to compensate for the difference in water height, and the amount of sediment washed out was calculated based on the weight change of the device and the densities of the sediment and water. Twelve tests were conducted utilizing US Silica F110 gradation, and five tests were conducted using AGSCO 70-100 gradation.

The tests were conducted with water supplied from the Mississippi River, which had temperatures ranging from 0 to 2 degrees Celsius during these tests. The discharge was set at the beginning of the test and was constant during each test. The tested discharges ranged from 1.7 to 3.5 cfs. The test durations ranged from 45 to 180 minutes. The results of the testing are described in Section 3.2.2.

### ***2.2.3. Stormceptor - Laboratory Testing***

A Stormceptor Model STC 1200 was tested at SAFL in December 2008 following Procedure 2-1. The experimental setup utilized a fiberglass manhole and an insert of standard design provided by Rinker Materials, which manufactures and markets Stormceptor. The equipment and methods for the testing are described in detail in Appendix A, Section A.3.

Four Tovey Engineering Model FR10 load cells were used for sediment measurement following the same protocol as used for the Environment 21 V2B1 laboratory testing (see Section 2.2.2).

Prior to the first test, approximately five inches of US Silica F110 gradation was charged to the sump of the Stormceptor device. Three tests were conducted with US Silica F110, and then approximately three inches of US Silica Sil-Co-Sil 250 (SCS 250) was added on top of the F110 and allowed to settle overnight, bringing the entire sediment height to approximately eight inches. The manufacturer's recommended sediment depth requiring cleaning is 10" ([RINKER MATERIALS, 2009](#)). US Silica Sil-Co-Sil 250 is a commercial silica sand gradation with specific gravity of approximately 2.6. US Silica SCS 250 has a  $d_{50}$  of 45  $\mu\text{m}$ , and a  $d_{85}$  of about 120  $\mu\text{m}$ . The size distribution of SCS250 used during sediment retention testing is given in Appendix D.

The tests were conducted with water supplied from the Mississippi River, which had temperatures ranging from 0 to 1 degree Celsius during the tests. The discharge was set at the beginning of the test and was constant during each test. The tested discharges ranged from 0.5 to 8.3 cfs. The test durations ranged from 60 to 120 minutes. The results of the testing are given in Section 3.2.3.

### ***2.2.4. Downstream Defender - Laboratory Testing***

A six foot diameter Downstream Defender was tested at SAFL from March to May 2009 following Procedure 2-1. The experimental setup utilized a fiberglass manhole and internal components of standard design provided by Hydro International, which manufactures and markets Downstream Defender. Equipment and methods for testing are described in detail in Appendix A, Section A.4.

Downstream Defender sediment retention testing was conducted with Tovey Engineering Model FR10 load cells, consistent with the Stormceptor STC1200 and Environment 21 V2B1 testing at SAFL and the protocol detailed in Appendix C, Section C.2.

Prior to the first test, approximately 4-3/4 inches of US Silica F110 gradation (see Appendix D) was charged to the sump of the Downstream Defender device. The manufacturer's recommended sediment depth requiring cleaning is 24" ([HYDRO INTERNATIONAL, 2009](#)). The device was charged with sediment by directly pouring sediment onto the benching skirt and allowing the particles to settle into the sump.

A total of 65 tests were completed using US Silica F110. During the first 47 tests, sediment was recharged by directly pouring US Silica F110 onto the Downstream Defender's benching skirt. For the next nine tests, prior to each test the sediment was recharged by directly pouring US Silica F110 onto the benching skirt, followed by rough leveling of sediment in the sump with a PVC pole. For the last six tests, US Silica F110 was fed into the system using an AccuRate sediment feeder. For these last six tests, the sediment was not leveled prior to the tests. The sediment feeder was used to charge sediment for the last six tests to somewhat mimic accumulation of sediments in the sump of Downstream Defender under actual operating conditions. When using the sediment feeder, sediments were fed through the influent pipe over a 6-hr period with a flow rate set at 2 cfs.

The tests were conducted with water supplied from the Mississippi River, which had temperatures ranging from 1 to 23 degrees Celsius over the three month testing period. The discharge was set at the beginning of the test and was constant during each test. The tested discharges ranged from 2.0 to 8.1 cfs. The device is rated at a treatment flow rate of 3 cfs for the range of particle sizes introduced in these tests. The test durations ranged from 9 to 240 minutes. The results of the testing are given in Section 3.2.4.

### **3. Test Results**

#### **3.1. Identification of Devices for Field Testing**

To enable a range of test conditions to adequately test sediment retention, the underground device is required to be tested at flow rates which are often approximately two to three times the design maximum treatment rate (e.g. 10-year storm events ). Because only water supply of less than the design maximum treatment rate was available at the CDS site in Heritage Park (Table 2-1), this site was not suitable for sediment retention testing. The CDS PMSU20\_25 device also has limited access into the sump and limited room for movement in the sump to measure the amount of sediments retained in the device after each test. This site was determined to be not feasible for controlled field sediment retention testing.

The Stormceptor site in Fridley, MN had water available at a flow rate of approximately two times the design maximum treatment flow rate. This discharge is marginal to test the device for sediment retention. In addition, the Stormceptor STC 4800 device has a 10 ft diameter sump, so large quantities of sediments would be needed to test the device for sediment retention. Charging large quantities of silica sand into the device, protecting the sand between testing, and removing the sand after testing would be labor intensive and expensive. Therefore this site was determined to be not feasible for controlled field sediment retention testing.

The Environment 21 site in New Brighton, MN had water available at three times the maximum treatment flow rate. This site had good, safe access and limited impacts to traffic to perform testing. This site was previously utilized by St. Anthony Falls Laboratory researchers for sediment removal efficiency testing (2007 AND 2009). This site was appropriate for sediment retention controlled field testing, and testing was conducted on this device in the summer and fall of 2007, as described in this report.

#### **3.2. Full Scale Device Testing**

##### ***3.2.1. Environment 21 V2B1 - Field Testing***

The results of the fourteen sediment retention tests conducted in 2007 in New Brighton, MN on the Environment 21 V2B1 Model 4 are shown in Figure 3-1. The conditions and results for each test are shown in Appendix F, Table F-1.

### Environment 21 V2B1 - Field Retention Testing

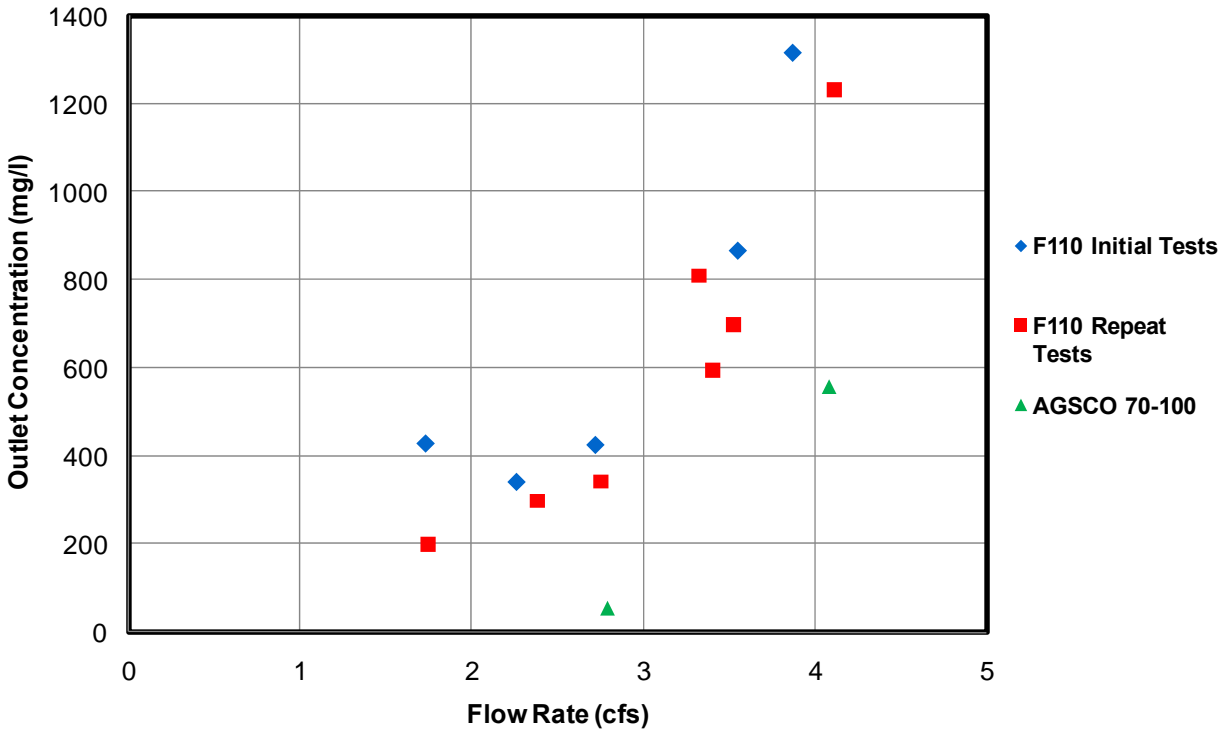

**Figure 3-1: Environment 21 V2B1 Model 4 - field testing**

All reported test results for the Environment 21 V2B1 are for sediment retention in the primary chamber only. At the conclusion of each test, any sediment that accumulated in the secondary chamber during the test was removed and disposed. Any sediment that accumulated in the secondary chamber was considered to be washed out from the device. Visual observations indicated that sediment accumulation in the second chamber was minimal, and never appeared to be more than a light dusting on the bottom of the sump. The low accumulation of sediment in the secondary chamber is likely due to the baffle wall design. Water in the secondary chamber is directed under the baffle wall, providing high velocities at the device floor which prevent suspended sediments from settling, and also cause scour and resuspension of any sediment that settle at low flow conditions.

It was identified during Test 5 that the thermometer used to measure the water temperature was faulty and the water temperature data for Tests 1-5 was not reliable. A new thermometer that was checked for accuracy was then used to record temperature for Tests 6-14. Efforts to estimate water temperature for the tests with missing temperature data were unsuccessful.

By reviewing the data in Figure 3-1 and Table F-1, it was evident that the AGSCO 70:100 sand was better retained than the US Silica F110 gradation. Larger particles are less likely to scour, due to the higher shear stresses required to scour larger particles. Larger particles that have been scoured and resuspended are more likely to resettle due to their higher settling velocities. Both

of these principles act to improve sediment retention for larger particles, which was demonstrated for the two tests conducted on the ASGCO 70-100 sand gradation.

The repeat tests on the F110 silica sand gradation, which were conducted later in the year, demonstrated slightly better sediment retention. It is believed that the water temperature was lower for the repeat tests in the fall than for the initial tests in the summer. Viscosity increases as water temperature decreases. The settling rate of suspended sediments decreases as the viscosity of the fluid increases; thus, with colder water, i.e. more viscous fluid, any sediment that was resuspended by scour will stay in the water column longer. Sediments that stay suspended longer have a higher likelihood of being washed out of the device, leading to higher effluent concentrations. However, fluids with higher viscosity dissipate more energy in the water column, so less energy should be available at the sediment bed to scour particles when water temperatures are lower. Lower bed forces should correlate with lower resuspension of particles, which should lead to lower effluent concentrations. These two effects of viscosity (particles settling velocity and energy dissipation) are believed to partially counteract each other when considering the effect of varying water temperature on sediment retention in hydrodynamic separators.

### 3.2.2. Environment 21 V2B1 - Laboratory Testing

The results of the seventeen sediment retention tests conducted in 2008-2009 at St. Anthony Falls Laboratory (SAFL) on the Environment 21 V2B1 Model 4 are shown in Figure 3-2. The conditions and results for each test are shown in Appendix F, Table F-2.

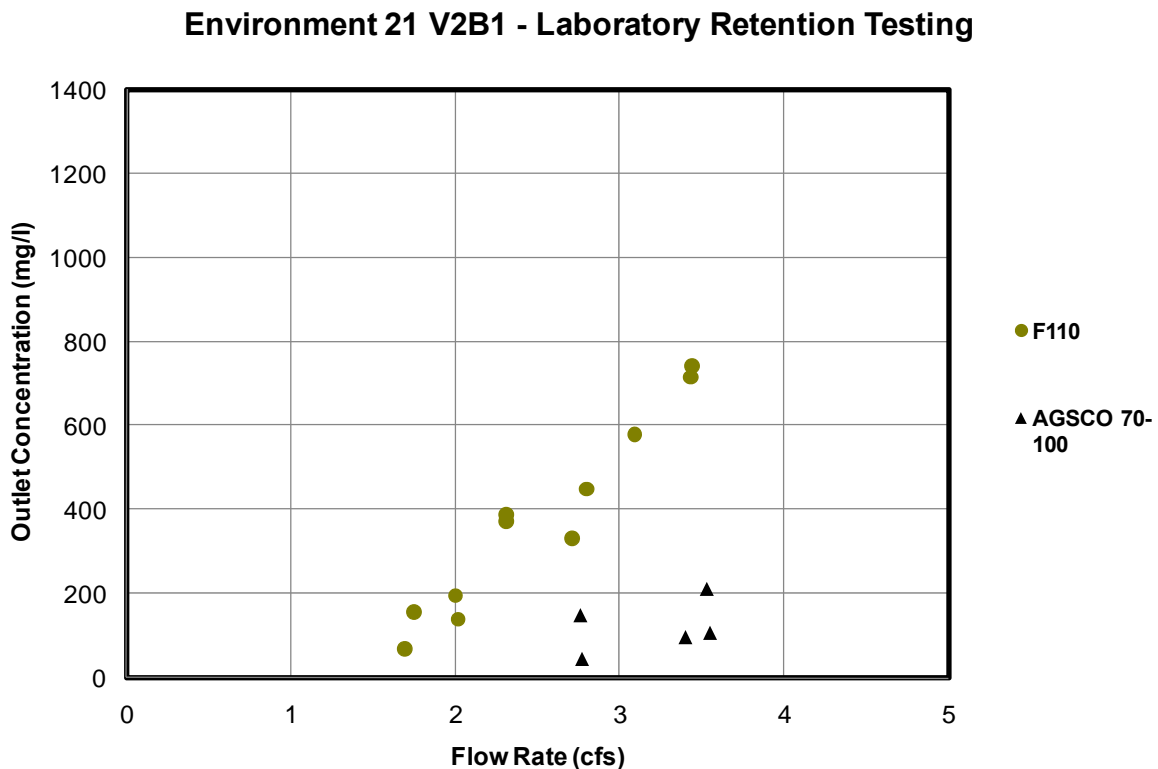

**Figure 3-2: Environment 21 V2B1 Model 4 - laboratory testing**

The tests were conducted with the sump preloaded with either US Silica F110 or AGSCO 70-100 sand gradation. Water temperature throughout the test period varied from 0 to 2 degrees Celsius. The results of the lab testing are very similar to those obtained in the field (The connection pipe between the primary and secondary chamber was larger in the device tested in the field than in the device tested at SAFL).

There was a difference between the two Environment 21 V2B1 devices tested: As witnessed during field testing of the Environment 21 V2B1 in 2007, the larger AGSCO 70-100 sediment was better retained in the device.

The results of the field and laboratory testing of the Environment 21 V2B1 Model 4 devices are shown in Figure 3-3. In spite of a significant water temperature difference between the laboratory and field testing, the similarities between the results indicate that the variability in sediment retention due to changes in water temperature may be smaller than errors associated with the sediment retention testing. Considering these results, the effect of water temperature may be insignificant over the range of water temperatures encountered by an in-service device.

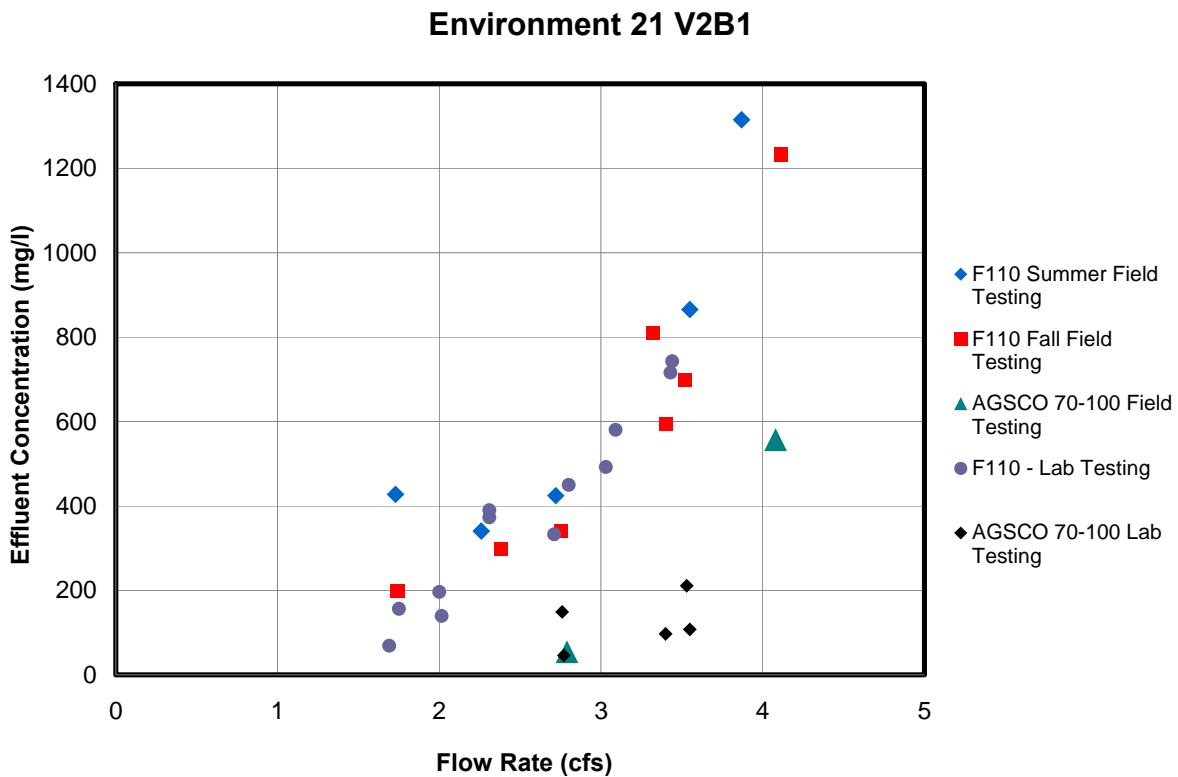

Figure 3-3: Environment 21 V2B1 Model 4 – sediment retention testing results

### 3.2.3. Stormceptor - Laboratory Testing

The results of the seven retention tests conducted in 2008 at St. Anthony Falls Laboratory (SAFL) on the Stormceptor Model STC 1200 are shown in Table 3-1 and Appendix F, Table F-

3. In Tests 4-7 the sediment level was approximately eight inches, which is 80% of the manufacturer's recommended sediment cleaning level.

**Table 3-1: Stormceptor Model STC 1200 retention testing**

Test	Test Date	Location	Sediment	Water Temperature, °C	Run Duration, minutes	Flowrate, cfs	Primary Manhole Weight Change, lb	Outlet Concentration, g sediment/m <sup>3</sup> water
1	12/11/2008	SAFL	F110	1.3	120	0.47	-8	60
2	12/12/2008	SAFL	F110	1.4	120	2.91	-9	11
3	12/15/2008	SAFL	F110	1.4	90	4.95	-7	6
4	12/18/2008	SAFL	F110 + SCS250	1.2	96	0.47	-25	245
5	12/19/2008	SAFL	F110 + SCS250	1.2	90	4.83	4	-4
6	12/19/2008	SAFL	F110 + SCS250	1.6	90	0.49	2	-23
7	12/23/2008	SAFL	F110 + SCS250	1.7	60	8.34	2	-2

Reviewing the data in Table 3-1, measurable sediment removal did not occur during any of these tests, i.e. the measured weight change in the system from pre to post test was near the estimated error of the measurement system ( $\pm 8$  lbs), with the exception of Test 4, which is described below. Sediment was not visually observed in the discharge water during the test, and sediment did not settle in the outlet channel or on top of the Stormceptor insert after the flow was stopped. Measurements of sediment levels from the outside of the fiberglass manhole (the edge of the deposit was visible from outside of the fiberglass manhole) before and after retention testing showed no change in sediment level at the perimeter of the device, indicating that sediment was not moving at the perimeter of the sump. All these measurements and observations supported that sediment was not washed out of the device in measurable amounts during testing, except during Test 4.

Test 4 indicated an effluent concentration of 245 mg/l. This effluent concentration was much higher than the effluent concentration calculated for the other six tests due to the initial addition of SCS 250 sediment on top of F110 sediment before Test 4. With the addition of three inches of SCS 250, very fine particles in the sediment gradation did not settle even after 12 hours. By the next morning after charging, the water column was still cloudy in appearance as the fine sediments remained in suspension. When the water flow was started, the suspended sediments were washed out, leading to the relatively high measured effluent concentration for this test. The picture on the left in Figure 3-4 shows the cloudy water on the outlet side of the device as the water in the sump is being replaced with clear water at the start of the test. The picture on the right in Figure 3-4 shows the condition of the effluent water later in the test, indicating that previously settled sediment was not being washed out. Following the small, initial washout of suspended sediment during Test 4, negligible washout was observed during the remainder of the test and during subsequent tests.





**Figure 3-4: Cloudy and clear water on top of insert in Stormceptor**

The SCS250 Silica Silt gradation has a median particle size of about 45 microns and most hydrodynamic separators are not capable of removing this particle size from stormwater runoff unless the flow rate through the device in comparison to MDTR becomes very small.

The results of sediment retention testing of a Stormceptor STC 1200 at St. Anthony Falls Laboratory showed that under high water flow conditions there was no measurable scour and washout of sediments that Stormceptor STC 1200 could remove from stormwater runoff.

#### ***3.2.4. Downstream Defender - Laboratory Testing***

In 2009, a total of 65 sediment retention tests were conducted on a 6-ft Downstream Defender. The results of the retention tests are shown in Figures 3-5 and 3-6. The conditions and results for each test are shown in Appendix F, Tables F-4, F-5, F-6 and F-7.

The sump of the Downstream Defender was initially filled with approximately 5 inches of sediment, or 20% of its maximum storage capacity (i.e. 2 ft above the bed), by pouring bags of F110 silica sand gradation in the top of the manhole and onto the benching skirt. Three retention tests were conducted at this capacity, and minimal washout of sediment was observed. Following Test 3, sediment was poured into the unit from the top, replacing the small amount of washed out sediment as well as increasing the height of the deposit prior to testing. This process of performing sediment retention tests and then increasing the amount of deposit in the sump was repeated at approximately 38%, 51%, 65% and 75% of the maximum storage capacity of the device. As Figure 3-5 shows, at a sump sediment height at 75% of capacity or less and for all discharges tested, the measured effluent concentration was less than 120 mg/l.

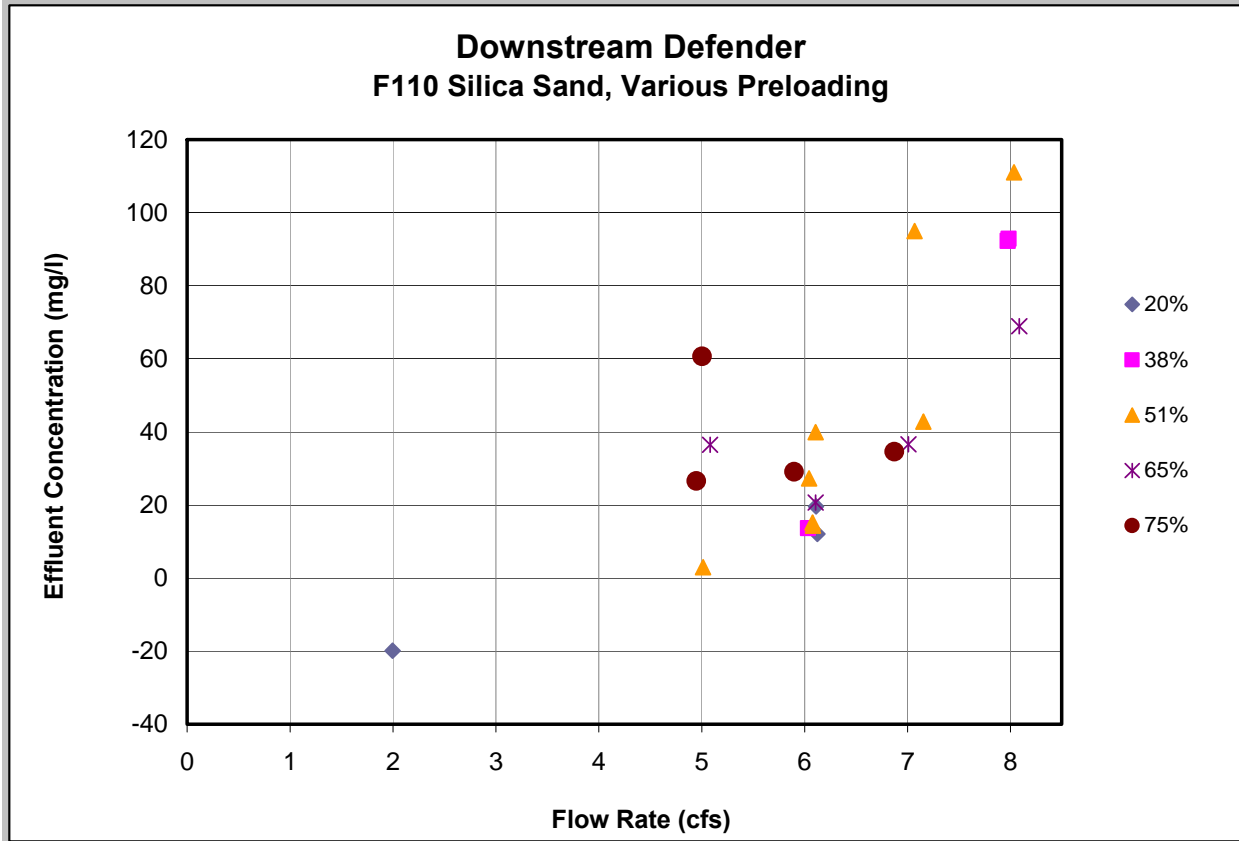

**Figure 3-5: The results of sediment retention testing conducted on a 6-ft Downstream Defender, with sediment deposit prior to the tests at 75% sump storage capacity or less.**

When the deposit prior to testing was charged to about 85% of the maximum storage capacity of the Downstream Defender, the washout rate increased considerably. Twelve tests were performed with the deposit at 81% to 86% of the maximum storage capacity prior to the tests (labeled as 85% in Figure 3-6), with flow rates ranging from 2.5 to 8 cfs. The estimated effluent concentration varied from approximately 200 mg/l to 2,000 mg/l. The significant difference between these tests and the previous tests led us to conduct a couple of repeat tests with the deposit at less than 75% of the maximum storage capacity. The repeat tests showed a washout rate similar to the previous tests with a deposit at 75% or less. Therefore, it was concluded that scour and washout increase considerably as the deposit exceeds 75% of the maximum capacity.

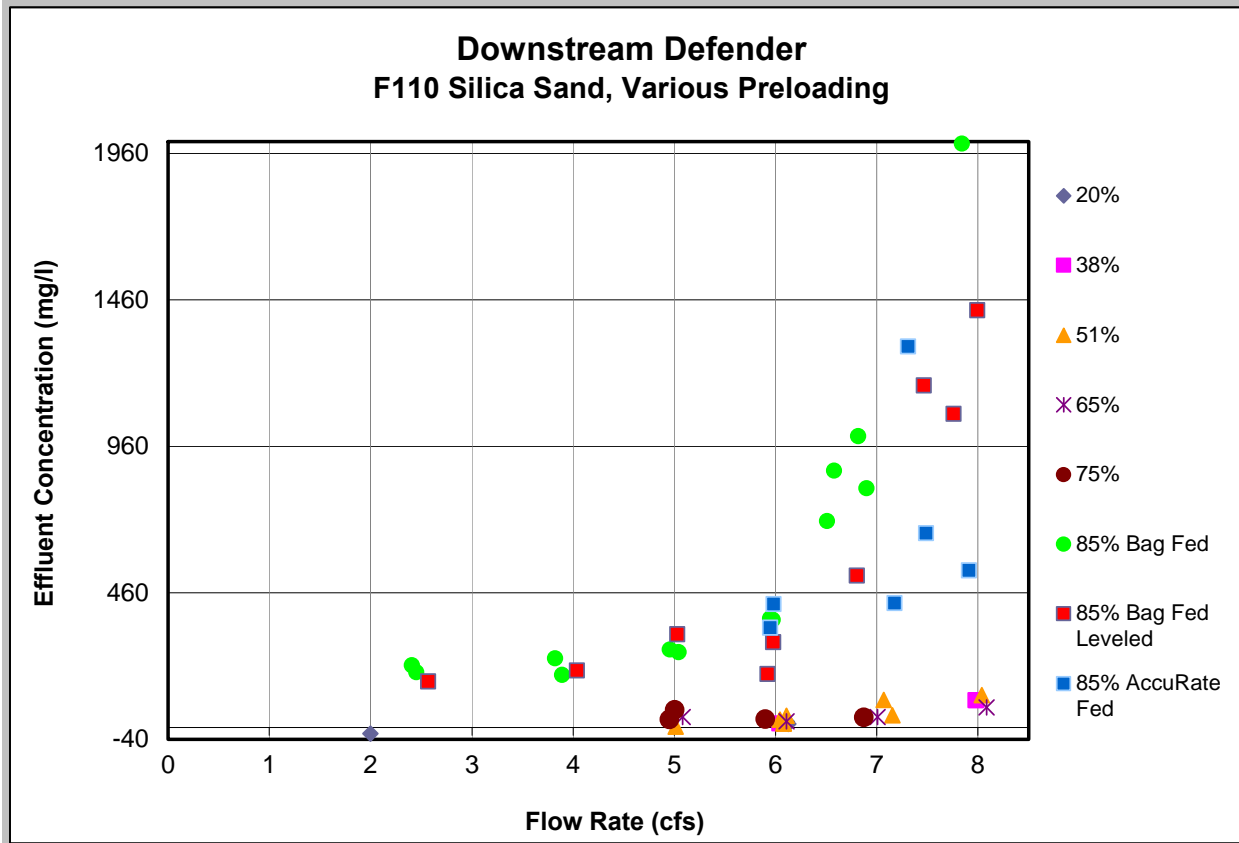

**Figure 3-6: The results of all sediment retention tests conducted on a 6-ft Downstream Defender.**

Near 85% of the maximum storage capacity, a sediment cone was observed above the benching skirt of the unit, i.e. at the center of the sump sediments were piling into a cone (Figure 3-7). Therefore, it was decided to perform sediment retention testing with the deposit at 85% of the maximum storage capacity with a flat sediment surface. Using a PVC pipe attached to a hose, the sediment cone was somewhat flattened (since there was no access to the sump below the benching skirt when the device was charged with sediment, flattening of the cone was performed from the top of the device). A tape measure was then used to verify the relative uniformity of the deposit depth in the sump. The shape of the deposit surface could be observed from the side window also. Subsequently, nine tests were performed with the flattened (levelled) surface (Figure 3-6). The results were similar to the results for tests conducted when the deposit was in a conic shape in the middle of the sump.



**Figure 3-7: Sediment cone near Downstream Defender benching skirt**

To ensure that the washout rates determined with a deposit at 85% of the maximum storage capacity were not due to the method of charging sediment, it was decided to create a condition of the sediment bed that approximated sediment conditions which would form in a real world installation. In order to mimic the real world accumulation of sediments in the sump, sediments were fed using an AccuRate feeder through the influent pipe over a 6-hr period. The flow rate was set at 2 cfs, a rate at which the device was expected to remove the majority of the particles. Also, 2 cfs was chosen as no particles would settle in the influent pipe at this discharge. Sediment retention tests were then performed at about 85% of the maximum storage capacity. After each test, the feeder was utilized to replenish the washed out sediments. The results of this series of tests showed that the washout rate (outlet concentration) at discharges equal to or less than 6 cfs was similar, within measurement uncertainty, to the washout rate with a flat surface or conic shape deposit. At discharges above 6 cfs, however, the washout rate was somewhat lower with the fed sediments (600 mg/l versus 1200 mg/l at 7.5 cfs). Nevertheless, the results of the tests showed that in order to maintain the washout rate below 100 mg/l in the Downstream Defender, the device should be cleaned before the sediment deposit exceeds 75% (42.4 cubic feet or 18”) of the device maximum storage capacity (56.5 cubic feet or 24”).

## 4. Scale Model Study

### 4.1. Swirl Flow Scale Model

A 1:10 scale model of a hypothetical ten foot diameter separator with a swirling flow and two concentric cylinders was built at St. Anthony Falls Laboratory to advance the understanding of the principal processes which govern sediment scouring, resuspension and washout in swirl flow hydrodynamic separators. Equipment and methods for testing are described in detail in Appendix B, Section B.1.

Prior to testing, US Silica F110 silica sand gradation was sieved to obtain two particle size distributions: 125-180 microns and 180-250 microns. The first 11 retention tests were run with particle sizes ranging from 180 to 250 microns. Initially, approximately 26 pounds of 180-250 micron sediment was charged into the device. Charging was performed by pouring the sediment into the device. Recharging for the subsequent tests was conducted by calculating the amount of sediment washed out in the previous test and charging that amount back into the device. This method maintained a sediment load within the device to be approximately 26 pounds at the beginning of each test. After 11 tests with sand particle sizes from 180-250 microns, 10 new tests were completed with sand particle sizes from 125 to 180 microns. Tests were conducted in the same initial charging procedures as were used for the 180-250 micron particle distribution.

Tests utilized discharges ranging from 4.2 to 16.2 gpm. Discharge into the device was set at the beginning of each test and monitored throughout the test to ensure it remained constant throughout the test. Test durations ranged from 20 to 120 minutes. The results of the 21 retention tests conducted in 2009 on the Swirl Flow Device Scale Model are shown in Figure 4-1. The conditions and results for each test are shown in Appendix F, Table F-8.

The washout rate never exceeded 400 mg/l when the scale model was preloaded with the 180-250 micron sand distribution. When the 125-180 micron sediment was used, effluent concentrations varied from 1000-2700 mg/l as discharged varied from 15.5 to 16.5 gpm. The large variability in the latter washout rate was suspected to be due to flow instabilities observed in the influent pipe.

Both particle size distributions exhibited significant bed movement and dune development (see Figure 4-2), however, bed erosion and movement varied between particle size distributions and discharges.

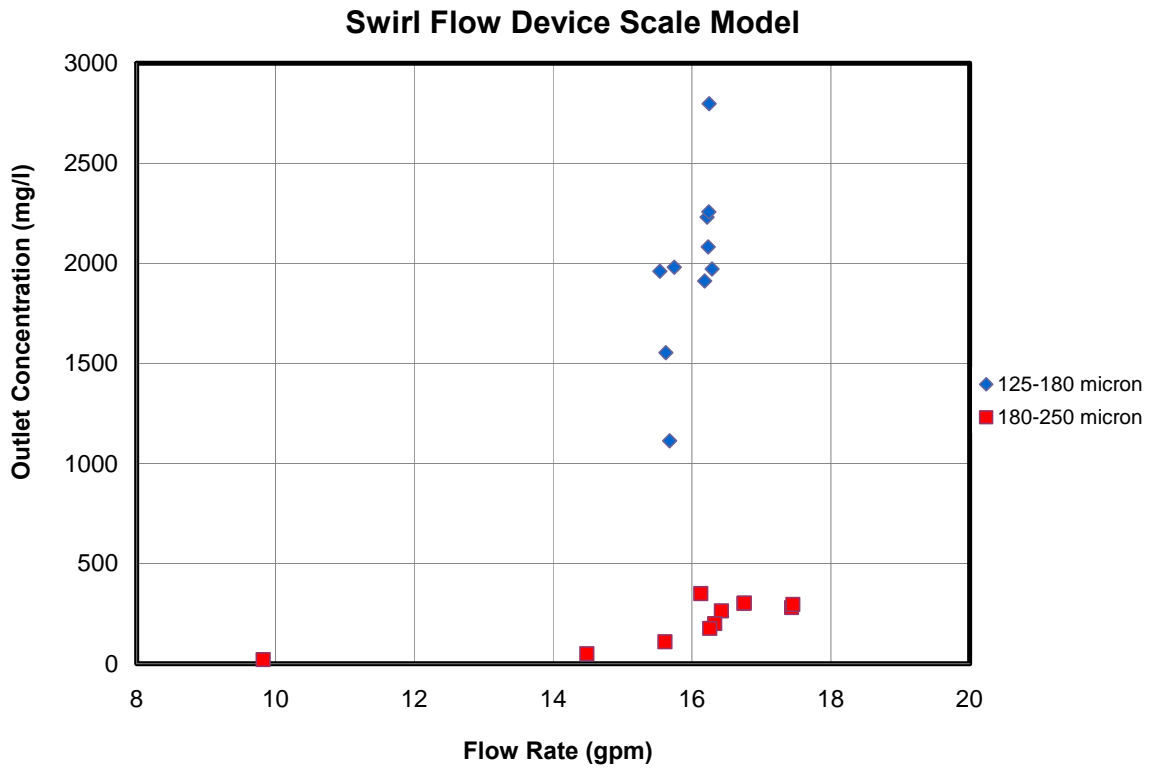

**Figure 4-1: Sediment retention testing results of the swirl flow device scale model**



**Figure 4-2: Bedforms in swirl flow device scale model**

Figure 4-3 shows sediment height versus time at a single position on the perimeter of the outer cylinder of the model for four retention tests (Runs 1, 3, 7, and 8). Dunes traveled in wavelike

patterns. Figure 4-3 shows that as sediment scours from the system, the height of the dunes decreases. This decrease in the sediment bed height can be seen in the form of linear trend lines, which are fitted to the dune height data for each test. The linear trend lines are roughly parallel for the four tests, indicating that the rate of sediment loss was approximately constant for these tests. Bedform peaks, relative to their trough base, did not appear to become smaller over the 20 minute test durations.

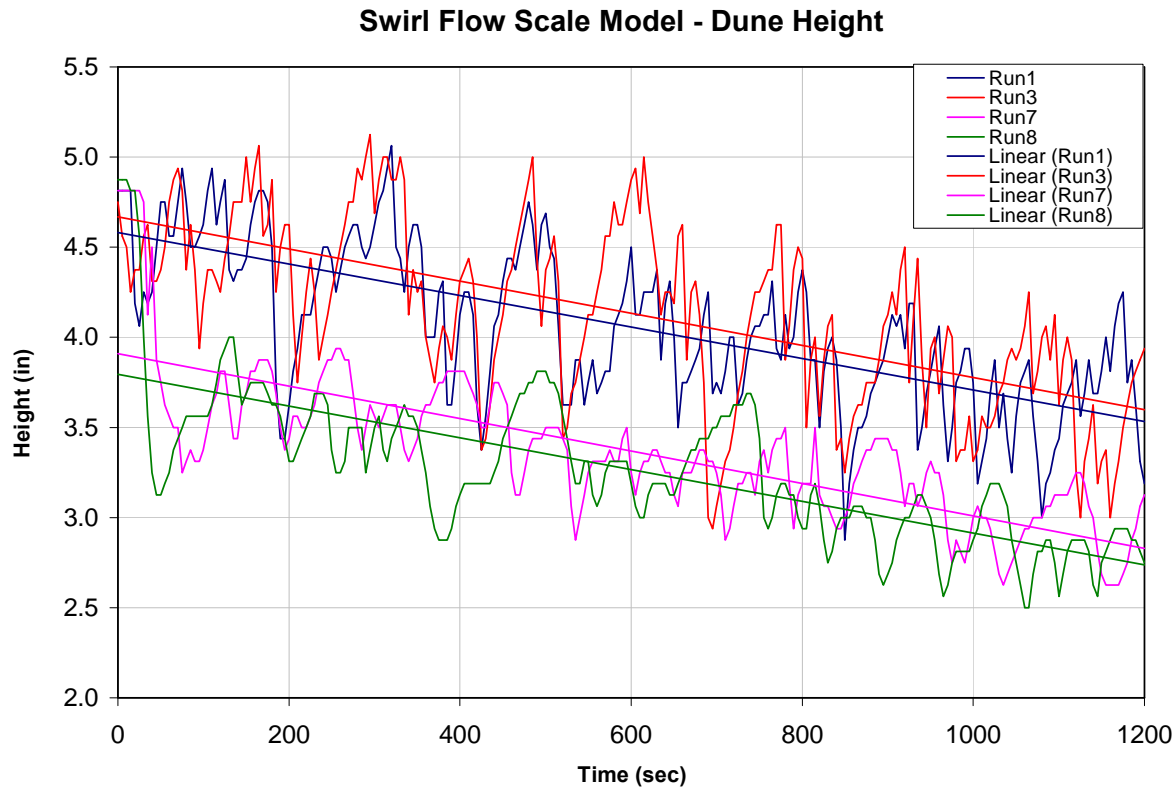

**Figure 4-3: Dune movement in the swirl flow device scale model**

## 4.2. Idealized Swirl Flow Device

A simplified scale model of a swirl flow separator was built at St. Anthony Falls Laboratory to advance understanding of the principal processes which govern sediment scouring, resuspension and washout. Equipment and methods for testing are described in detail in Appendix B, Section B.1. This model differed from the Swirl Flow Device Scale Model in two ways: 1) water entered the inner cylinder tangentially with no obstruction of flow and 2) water exited the bottom of the inner cylinder, again with no obstruction of flow. The inner and outer cylinder diameters, as well the inlet pipe sizes and device heights were the same as for the Swirl Flow Device Scale Model.

Initial water flow tests in this device showed large vortices (see Figure 4-4). To maintain a relatively obstruction free device while reducing large vortices, a number of vortex reduction

devices were tested by inserting them into the inner cylinder. A wooden cross baffle that stretched the entire height of the inner cylinder was finally chosen for its effectiveness and practicality (Figure 4-5).

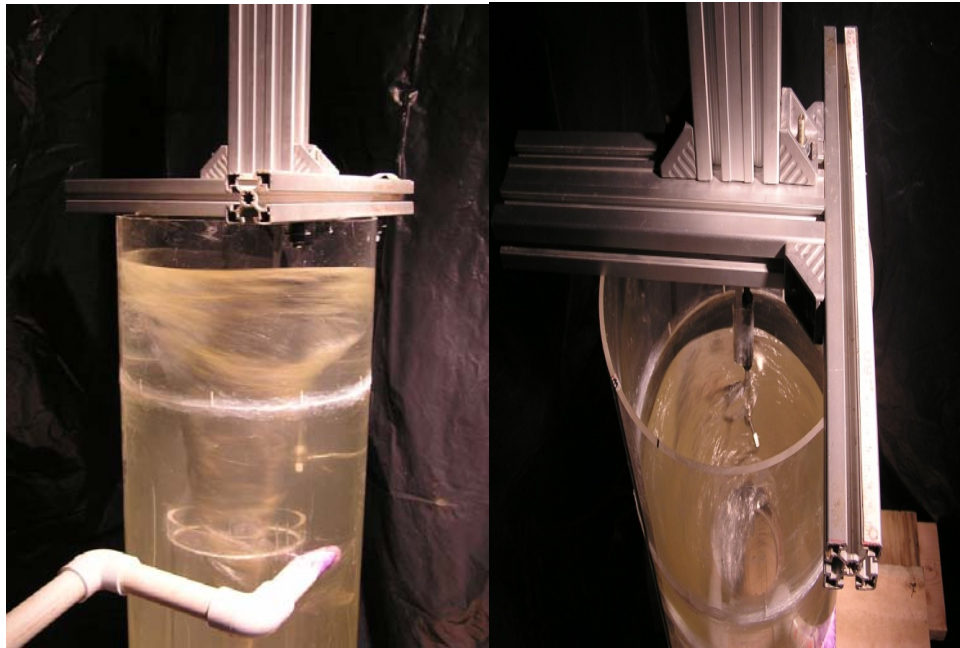

**Figure 4-4: Large vortex formation in the idealized swirl flow scale model**

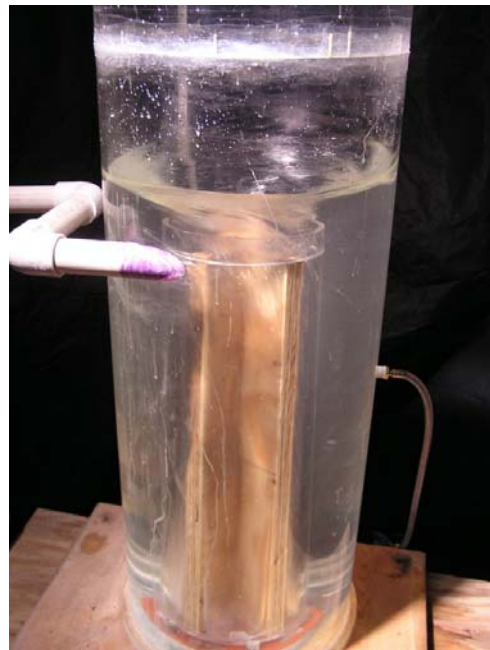
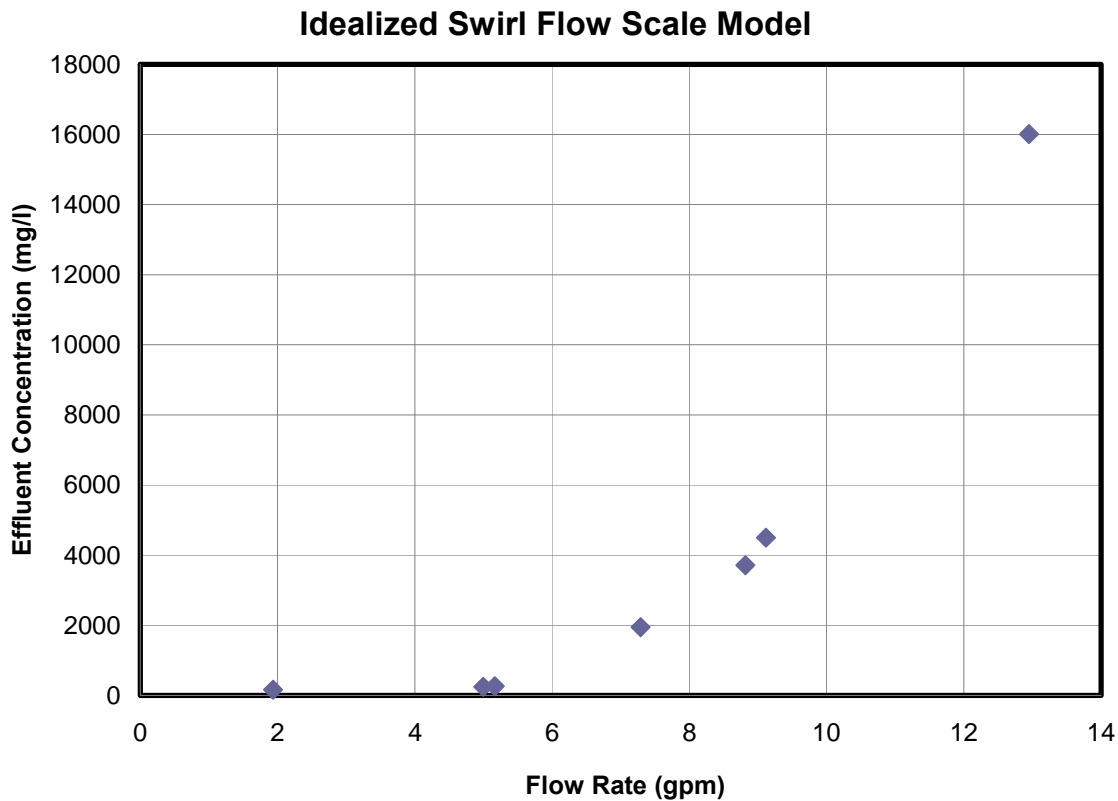

**Figure 4-5: A wooden cross baffle inserted inside the inner cylinder**

A total of seven sediment retention tests were conducted using sediment particle sizes ranging from 125 to 250 microns. Flow rates varied from 2 gpm to 13 gpm. The maximum discharge tested (13 gpm) was 25% less than the maximum discharge used for testing the Swirl Flow



Device Scale Model (16.2 gpm). The results of the sediment retention tests are shown in Figure 4-6. At a discharge of 9 gpm, the effluent concentration exceeded 4,000 mg/l. A maximum effluent concentration of 16,000 mg/l was measured at 13 gpm, which was more than five times the maximum effluent concentration of the swirl flow device scale model with sediment particle sizes ranging from 125-180 microns, i.e. smaller, and at a higher flow rate of 16.3 gpm. Based on these results, it appears that obstructions in the water column dissipate energy and reduce bed shear stress and sediment washout.

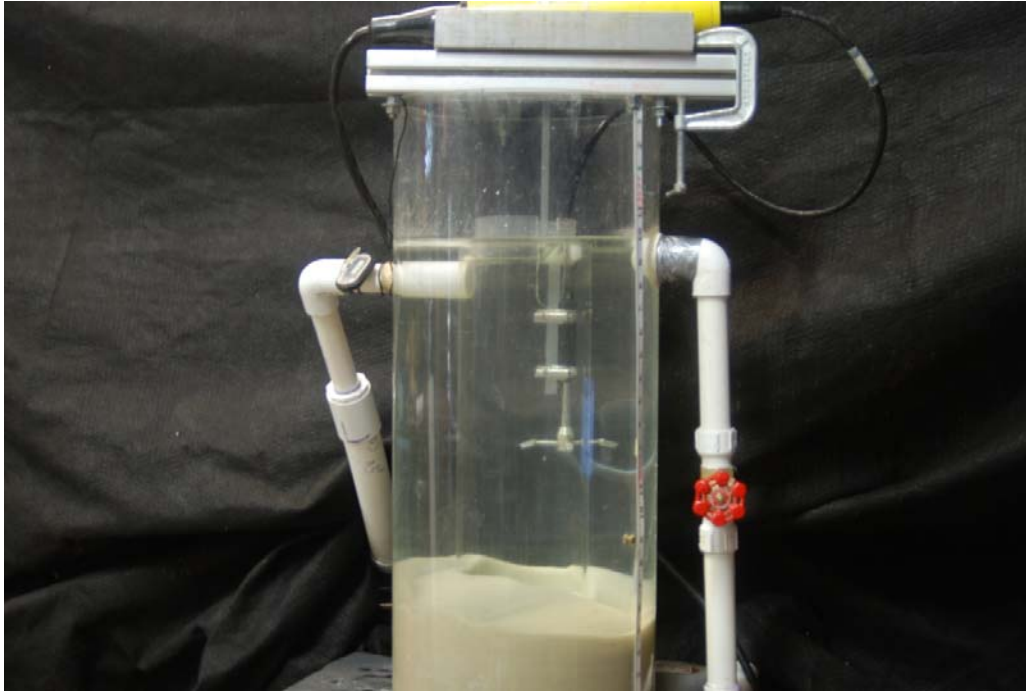

**Figure 4-6: Sediment retention testing results for the idealized swirl flow device scale model**

### 4.3. Scale Model Velocity Profiles

#### 4.3.1. Swirl Flow Device Scale Model Velocity Profiles

Velocity measurements were taken in the Swirl Flow Device Scale Model under a variety of discharges using a 3-dimensional Acoustic Doppler Velocimeter (ADV). Figure 4-7 shows the model with the ADV setup.



**Figure 4-7: Swirl flow device scale model with ADV setup**

Vertical velocity profiles were measured at one quarter of the cylinder downstream of the inlet pipe (Position 1 in Figure 4-8) and at three quarters of the cylinder downstream of the inlet pipe (Position 2 in Figure 4-8). The velocity readings were taken at a position equidistant between the outer cylinder and the inner cylinder of the device. Measurements were taken starting at the bottom of the model with  $\frac{1}{2}$  inch vertical increments for the first three inches and 1 inch vertical increments for the remaining 18 inches of the water column.

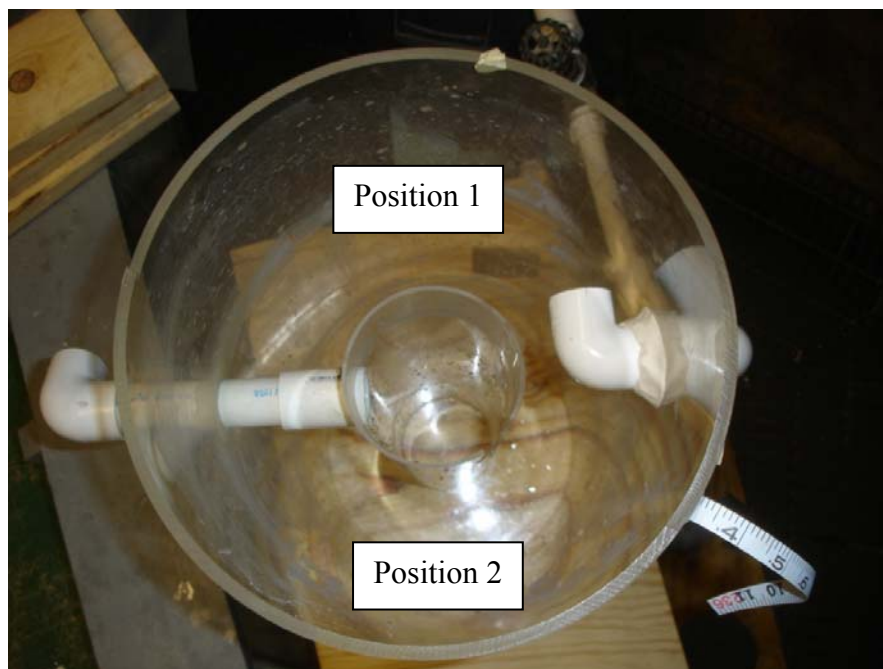
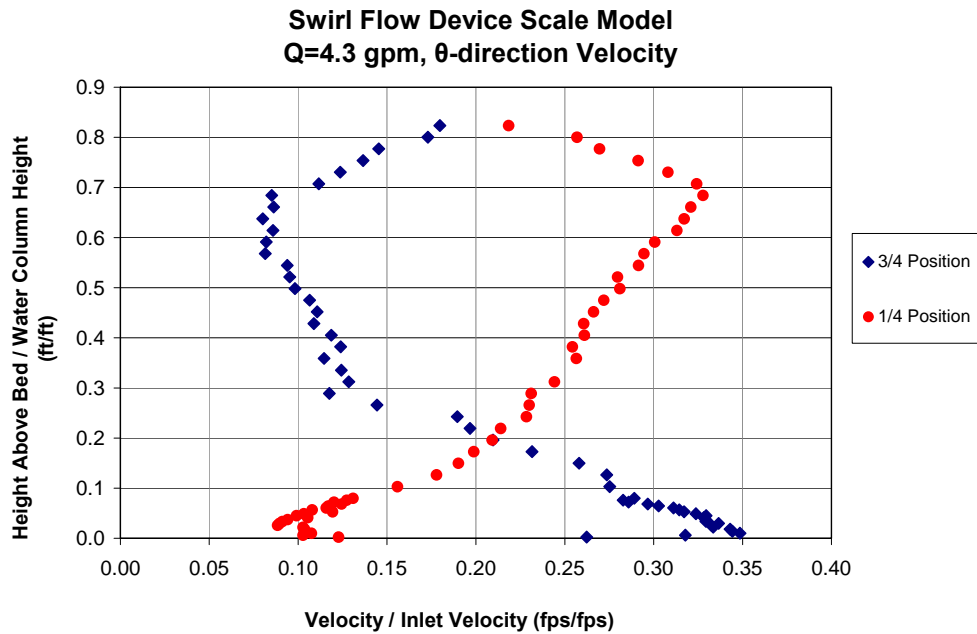

**Figure 4-8: ADV positions in the swirl flow device scale model for velocity measurement**

A variety of discharges were tested, and the results at 4.3 and 14.6 gpm discharges are shown in Figures 4-9 and 4-10. The  $\theta$ -direction was tangential to the radius in the horizontal plane. In the figures, the velocities are normalized by dividing the measured velocity by the inlet jet velocity, i.e. the calculated influent pipe velocity. The vertical axis is the normalized height, which is the reading height above the sediment bed divided by the height of the water column for the given discharge. Additional velocity profiles for the Swirl Flow Device Scale Model for several discharges and all three components of velocity ( $\theta$ , R and Z) can be found in Appendix G, Section G.3.

The velocity measurements taken in the model indicate:

- 1) There are high flow velocities near the bed (see results for Position 2 (3/4 position) in Figures 4-9 and 4-10), and therefore substantial energy for scouring
- 2) The velocity profiles can be dramatically different at different positions in the device
- 3) At Position 2, velocities drop off at some height in the water column, potentially reducing the washout rate. The velocity reduction in the water column could be due to the obstruction to flow caused by the outlet pipe.
- 4) Flow patterns in swirl flow devices are complex



**Figure 4-9: Normalized velocity profiles measured at position 1 (1/4 position) and position 2 (3/4 position) at 4.3 gpm discharge**

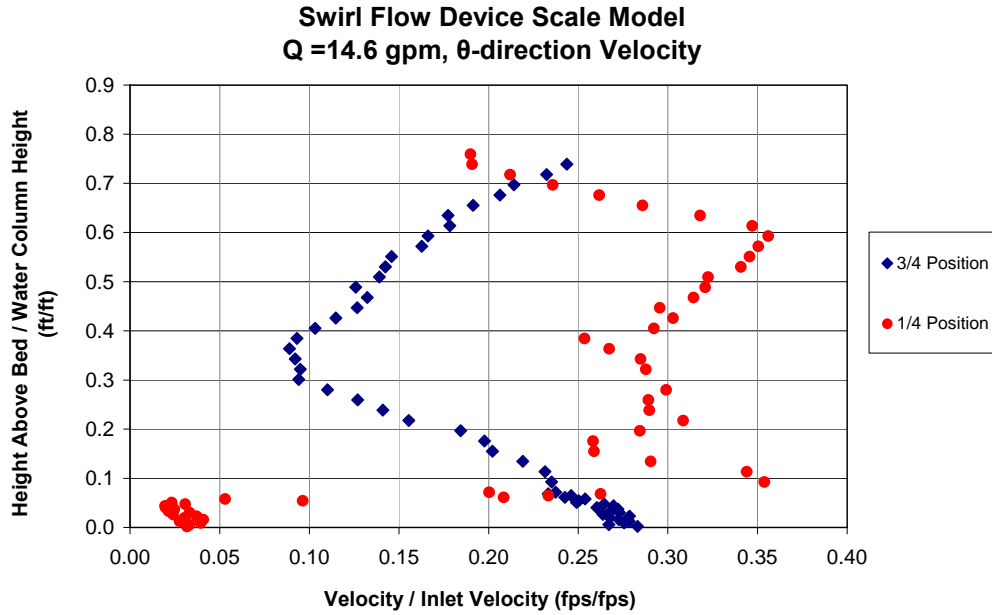

**Figure 4-10: Normalized velocity profiles measured at position 1 (1/4 position) and position 2 (3/4 position) at 14.6 gpm discharge**

#### ***4.3.2. Idealized Swirl Flow Scale Model***

To better understand the difference in hydraulic conditions between an idealized swirl flow condition and a swirl flow hydrodynamic separator with obstructions, velocities were also measured in the Idealized Swirl Flow Scale Model using the 3-D ADV. In the idealized scale model, there were no obstructions in the flow through the outer cylinder, allowing velocities to be measured at four locations. Figure 4-11 shows the four ADV positions in plan view, and the 25 vertical positions as the pink notched lines in the side view. The four reading positions were 90 degrees from one another around the device, and were at a distance halfway between the inner cylinder and the outer cylinder of the device. Measurements were taken starting at the bottom of the model with 1/2 inch vertical increments for the first three inches and 1 inch vertical increments for the remaining 18 inches of the water column. The water depth varied with discharge. Therefore, based on the discharge tested and corresponding water height, roughly 25 vertical readings could be taken for some tests.

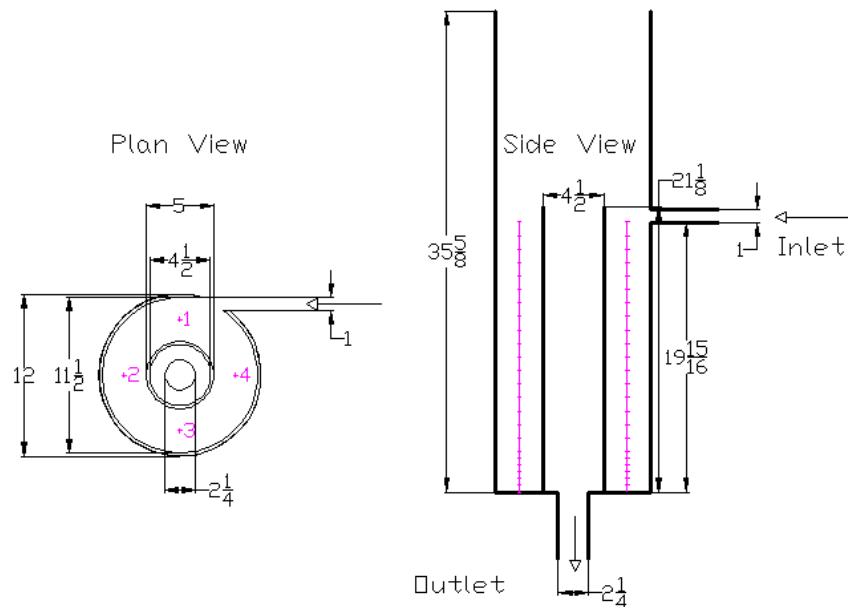

**Figure 4-11: ADV positions in the idealized swirl flow scale model**

The results at 7 gpm, 15 gpm and 20 gpm are shown in Figures 4-12, 4-13 and 4-14 for the  $\theta$ -direction. In the figures, the velocities are normalized by dividing the measured velocity by the inlet jet velocity, i.e. the calculated influent pipe velocity. The vertical axis is the normalized height, which is the reading height above the sediment bed divided by the height of the water column for the given discharge. The velocity profiles for all three components of velocity ( $\theta$ , R and Z) are included in Appendix G, Section G.4.

The measured near bed velocities show that at lower flow rates only the particles in the 3rd quadrant of the device were subject to high shear stresses, so that sediments were more significantly mobilized in that region of the sump. As the discharge increased to 15 gpm, more areas of the bed were subject to higher shear stresses, while the overall magnitude of the velocities and the corresponding shear stresses also increased. At the highest tested discharge (20 gpm), all areas of the bed were subject to high shear stresses and the entire sediment bed was mobilized.

Comparing the maximum near bed velocities (0.24 fps/fps) measured at 15 gpm in the Idealized Swirl Flow Scale Model (see Figure 4-13) with the maximum near bed velocities (0.27 fps/fps) measured at 14.6 gpm in the Swirl Flow Device Scale Model (Figure 4-10) indicates that the bed shear stresses exerted on the bed materials could be similar in both devices (the inlet velocities were similar between the two models). Thus the scour rates in both scale models could be comparable. However, in the Idealized Swirl Flow Scale Model, velocity increased moving up the water column, where in the Swirl Flow Device Scale Model there was a drop in velocity in the water column. It is believed that the drop in velocity caused the lower washout rate in the Swirl Flow Device Scale Model, as resuspended sediments were able to resettle more frequently

with the dip in velocity. Therefore, obstructions in swirl flow devices may lead to increased settling of resuspended sediments and better sediment retention.

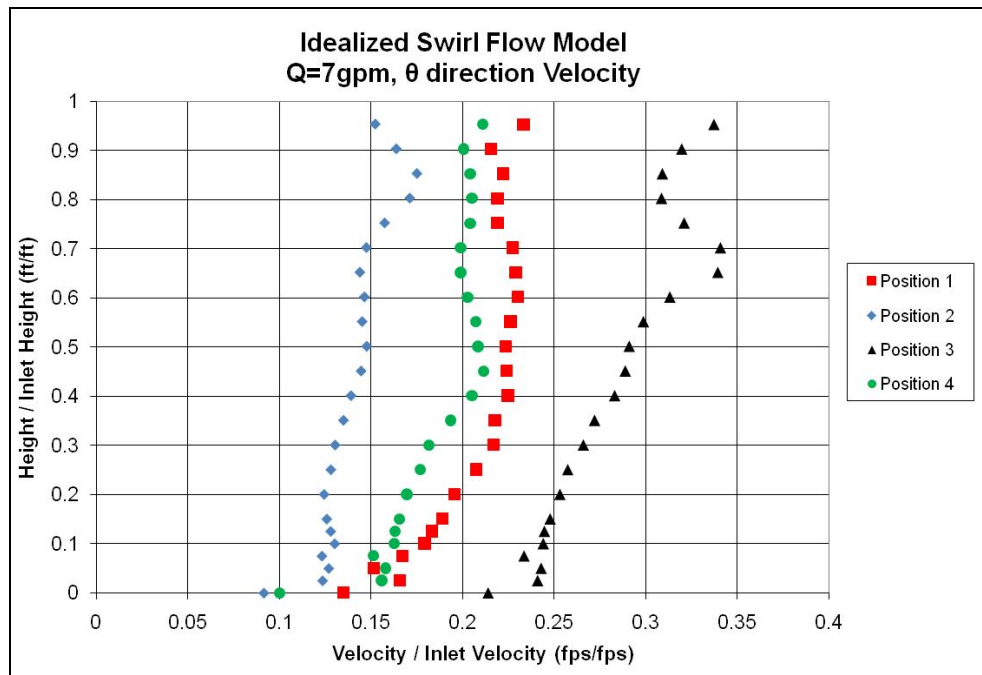

Figure 4-12: Normalized velocity profiles measured at four positions at 7 gpm discharge

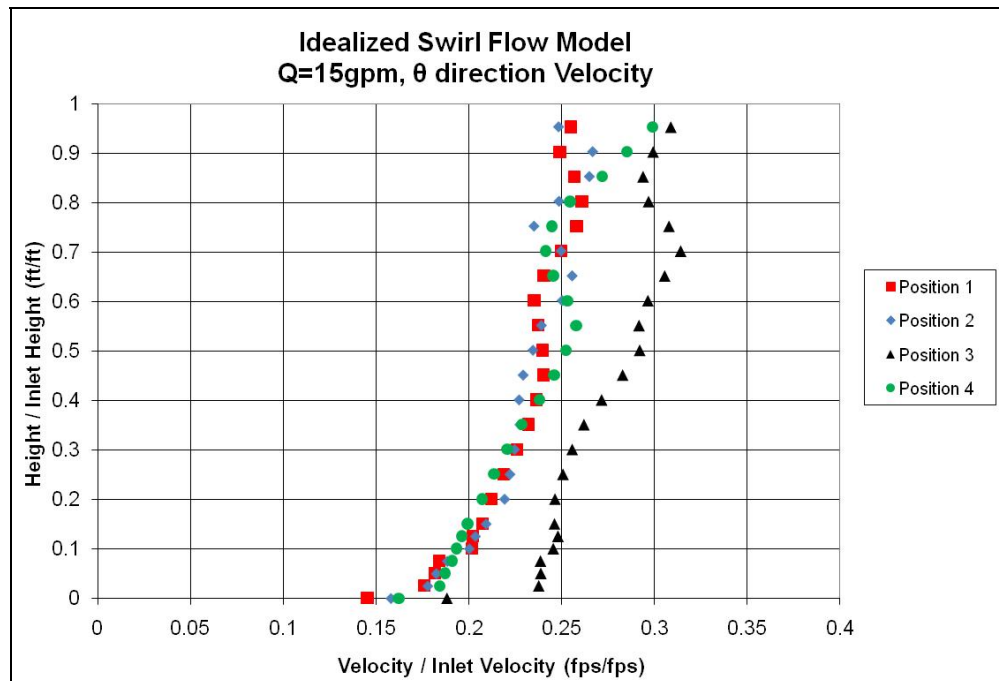
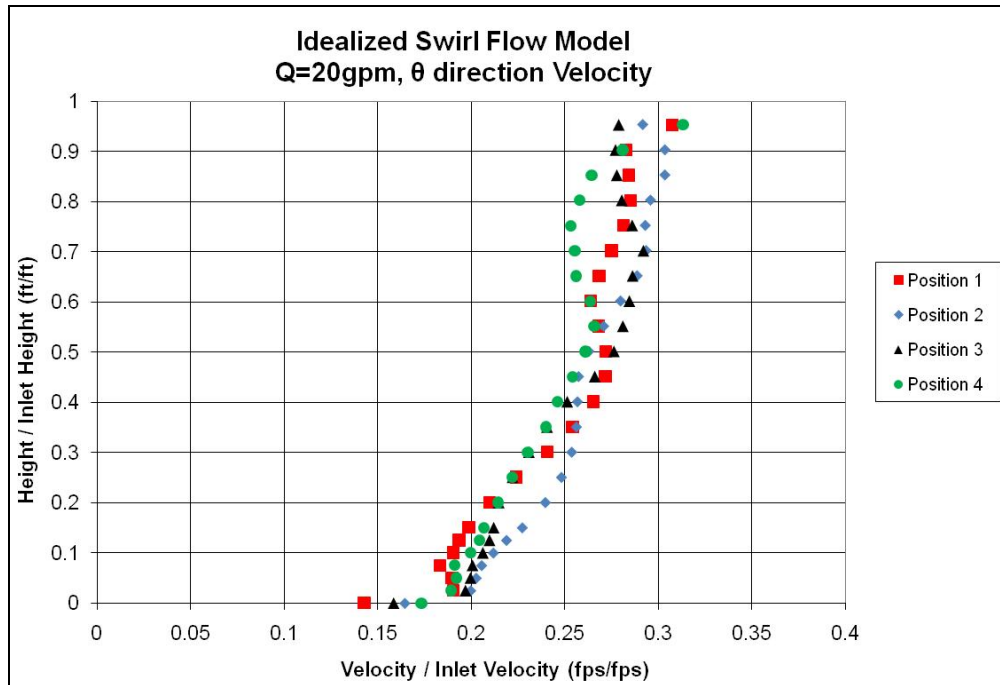

Figure 4-13: Normalized velocity profiles measured at four positions at 15 gpm discharge



**Figure 4-14: Normalized velocity profiles measured at four positions at 20 gpm discharge**

## 5. Sediment Retention Functions

Three full scale hydrodynamic separators were tested in the field and laboratory, of which two were swirl flow type devices and one was a plunge flow type with a bypass under high flow conditions. The latter did not show any measurable scour under high flow conditions, while the swirl flow devices showed some level of scour under high flow conditions. Two hypothetical swirl flow scale models were also tested to develop an understanding of the mechanics of scour, resuspension and washout in swirl flow devices. It was concluded that crucial processes which occur in swirl flow devices can be complex due to the geometry of the device and, therefore, it would be difficult to develop a general sediment retention function that would predict sediment retention for all swirl flow devices. However, the velocity profiles can shed some light on scour, resuspension and washout in swirl flow devices. Therefore, it was decided to measure velocities in both the Environment 21 and Downstream Defender devices.

### 5.1. Velocity Measurement in Environment 21 V2B1

A 3-D Acoustic Doppler Velocimeter (ADV) was utilized to measure velocity profiles in the Environment 21 V2B1 Model 4 at SAFL. The ADV was inserted into the first chamber of the V2B1, and velocity measurements were taken at two separate positions in the manhole. Figure 5-1 shows the two positions at which 24 vertical velocity readings were taken for several discharges.

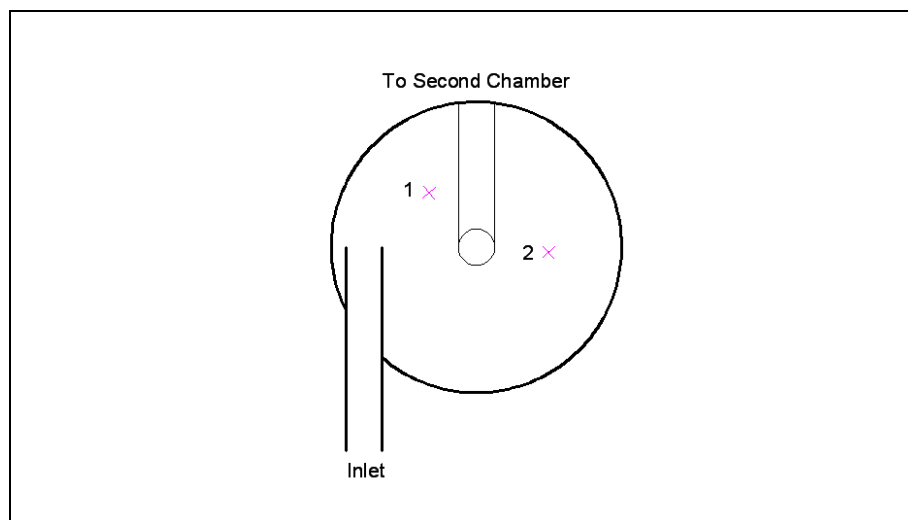

**Figure 5-1: Plan view of the Environment 21 V2B1 Model 4 at SAFL and the positions of the 3-D ADV used to measure velocity profiles**

Readings were taken vertically starting at the sediment bed (F110 Silica Sand). Readings were taken in  $\frac{1}{2}$  inch increments for the first half foot and 1 inch increments for the next foot above the sediment bed, and 6 inch increments to a height of six feet above the bottom of the V2B1. ADV readings were completed at flow rates of 1.5, 2.0, 2.5, 3.0, and 3.5 cfs. Several normalized velocity profiles are included as Figures 5-2, 5-3 and 5-4. In the figures, the velocities are normalized by dividing the measured velocity by the inlet jet velocity, i.e. the calculated influent pipe velocity. The vertical axis is the normalized height, which is the reading height above the



sediment bed divided by the height of the water column for the given discharge. Additional velocity profiles for all discharges tested and all three components of velocity ( $\theta$ , R and Z) can be found in Appendix G, Section G.1.

Normalized velocities were high near the bed, indicating substantial energy available for scour and resuspension of accumulated sediments. As witnessed in the Swirl Flow Device Scale Model, a dip in the velocity profiles measured is evident in the water column, thereby reducing scoured particles that were washed out of the device.

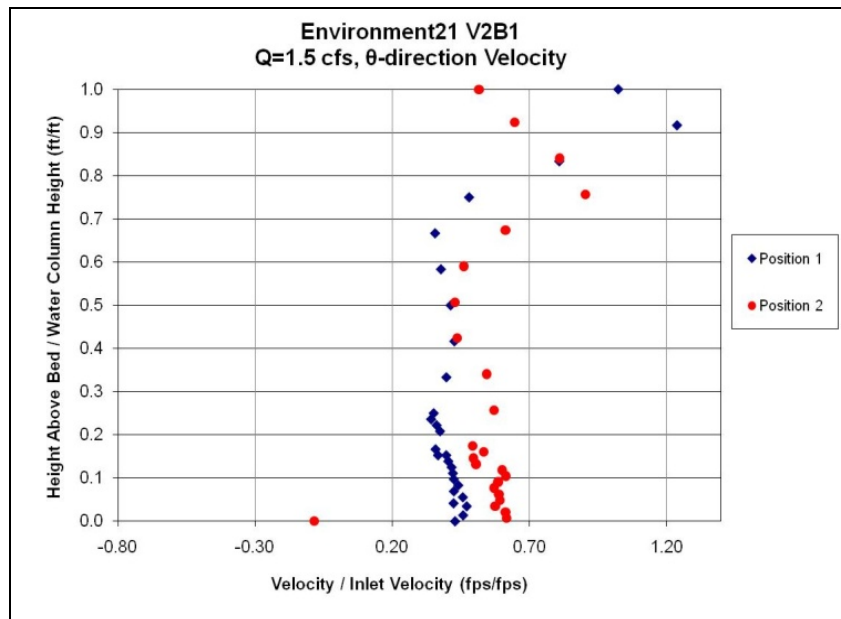

**Figure 5-2: Velocity profiles measured in the Environment 21 V2B1 Model 4 at 1.5 cfs discharge**

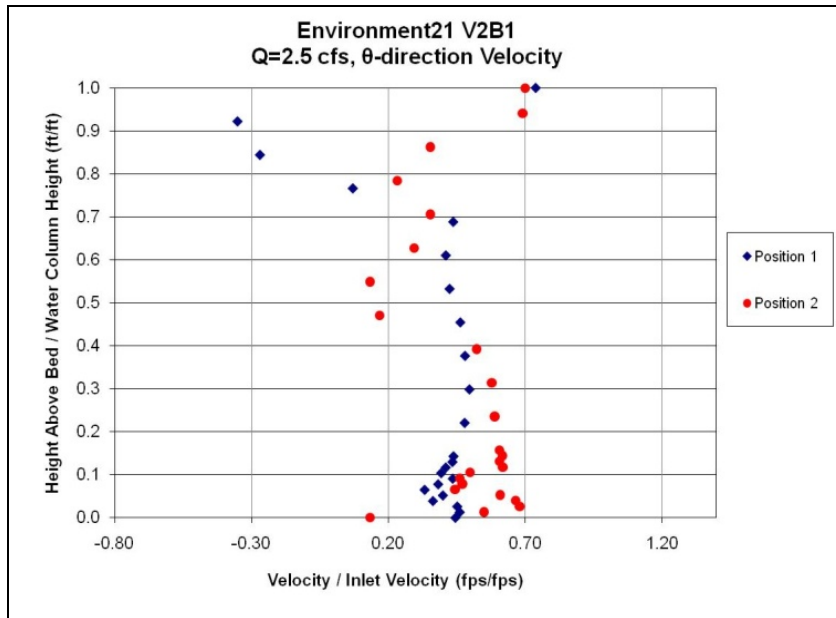

**Figure 5-3: Velocity profiles measured in the Environment 21 V2B1 Model 4 at 2.5 cfs discharge**

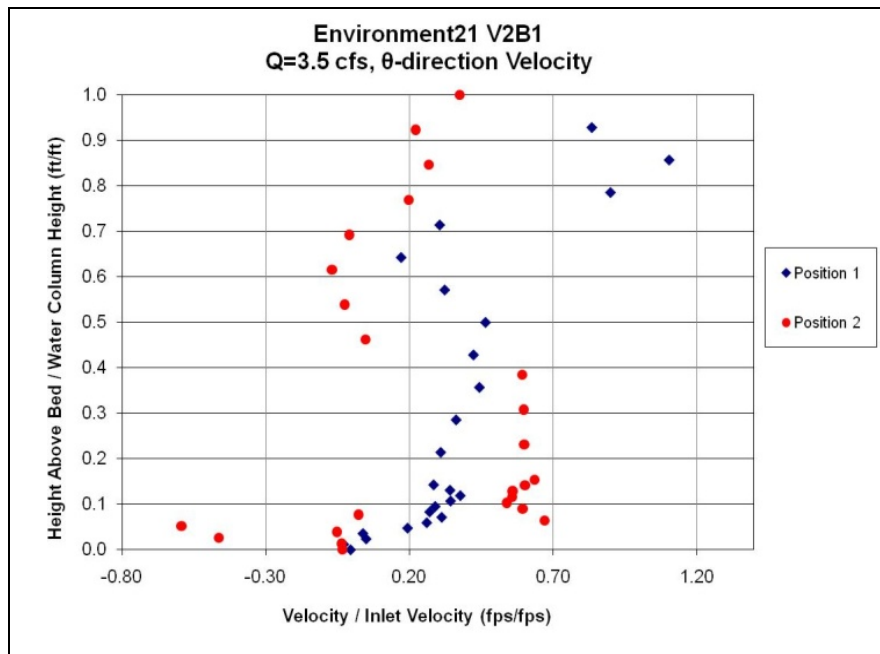

**Figure 5-4: Velocity profiles measures in the Environment 21 V2B1 Model 4 at 3.5 cfs discharge**

## 5.2. Velocity Measurement in 6-ft Diameter Downstream Defender

A 3-D Acoustic Doppler Velocimeter (ADV) was also utilized to measure velocity profiles in the 6 foot diameter Downstream Defender. The ADV was inserted through the center shaft from the top of the device (see Figure 5-5). The center shaft is used for maintenance of the device (hoses from vacuum trucks are put into the center shaft to suck out accumulated sediments in the sump).

For velocity testing, six inches of the F110 silica sand gradation was placed in the Downstream Defender sump. In order to prevent scouring during the tests, a tarp and 2.5 inches of river rock were placed on top of the sediment layer (see Figure 5-6).

Velocity measurements were taken at 112 locations (seven positions with 16 vertical readings at each position). Figure 5-7 shows the locations of the seven positions of the ADV in plan view, and Figure 5-8 shows the 16 measurement heights for each position. Readings were taken vertically from the rock bed to the bottom of the inner cylinder. Velocities were measured at flow rates of 4.0, 5.5, and 7.0 cfs, with sampling times of 1 minute, 2 minutes, and 10 minutes, respectively.



**Figure 5-5: The ADV bracket installed on top of the Downstream Defender holding the ADV in the sump**



**Figure 5-6: ADV positioned above the river rock bed**

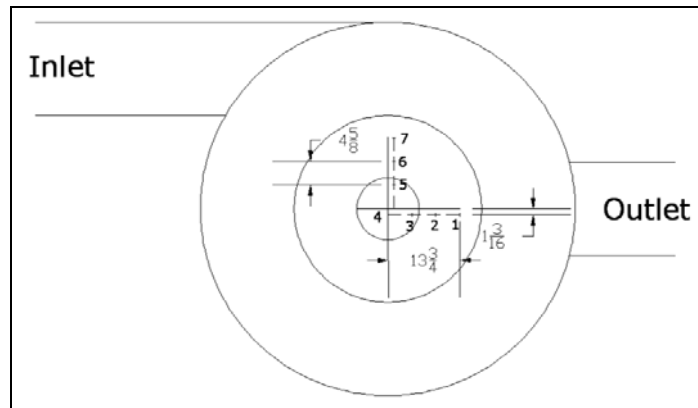

**Figure 5-7: Plan view of ADV positions inside the sump of the Downstream Defender (all dimensions shown are in inches)**

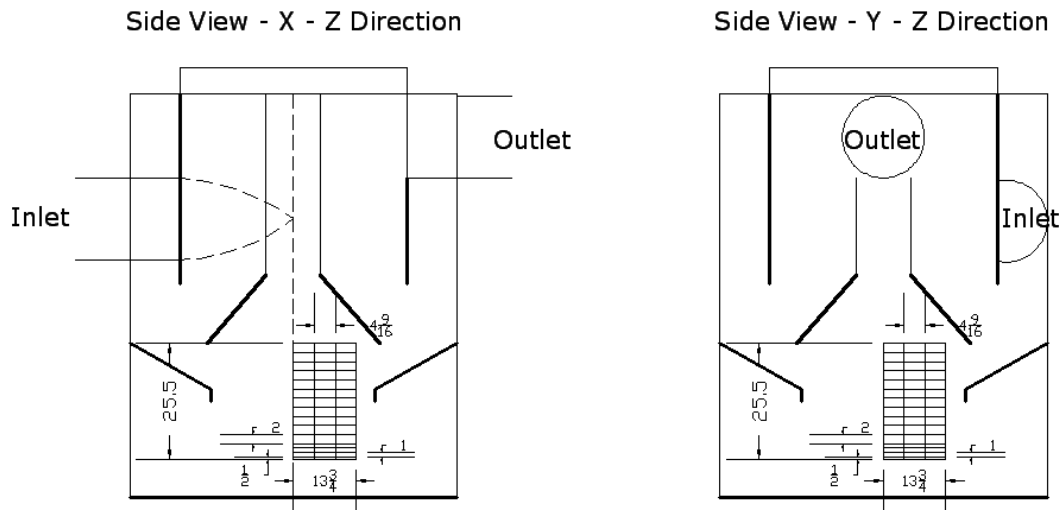

**Figure 5-8: Vertical positions of the ADV inside the 6-ft Downstream Defender (all dimensions shown are in inches)**

Figures 5-9, 5-10 and 5-11 show  $\theta$ -direction velocity profiles for Positions 1-7 for flow rates of 4.0, 5.5, and 7.0 cfs. In the figures, the velocities are normalized by dividing the measured velocity by the inlet jet velocity, i.e. the calculated influent pipe velocity. The vertical axis is the normalized height, which is the reading height above the sediment bed divided by the height of the water column for the given discharge. Velocity profiles for the three discharges tested and all three components of velocity ( $\theta$ , R and Z) can be found in Appendix G, Section G.2.

Velocity profiles varied from position to position, with  $\theta$ -component velocities being generally higher near the benching skirt and lower near the center of the device. In general, velocities in the R-direction (radial components which were towards the wall of the device) were negative, indicating water traveling towards the center of the device. This supported observations during sediment retention testing, in which the sediments moved towards the center of the device and formed a cone of sediment. The Z-components of velocities were relatively negligible. However, it appears that there were eddies in the Z-direction. For example, at 7 cfs an eddy is apparent in the velocity data as in water travels upwards at Position 7 and downwards at Positions 3 and 4. In comparison to the velocities observed in the Environment 21 V2B1 device and the swirl flow scale models, the Downstream Defender exhibited smaller velocities near the bed, resulting in smaller scour potential. The lower velocities near the bed were due to the presence of the benching skirt and the center shaft and cone which protected the bed. As the velocities were low at the bed, the scour rates and the suspended sediment concentrations above the bed during sediment retention testing would have been small. With low suspended sediment concentrations, the higher velocities observed above the rim of the benching skirt (about 0.5 to 0.6 normalized height) at 5.5 and 7 cfs flow rates could not significantly impact the washout rate. However, when the sediment cone was near the rim of the benching skirt (85% capacity tests), the high velocities immediately above the rim of the benching skirt scoured the sediments and increased the washout rates appreciably.

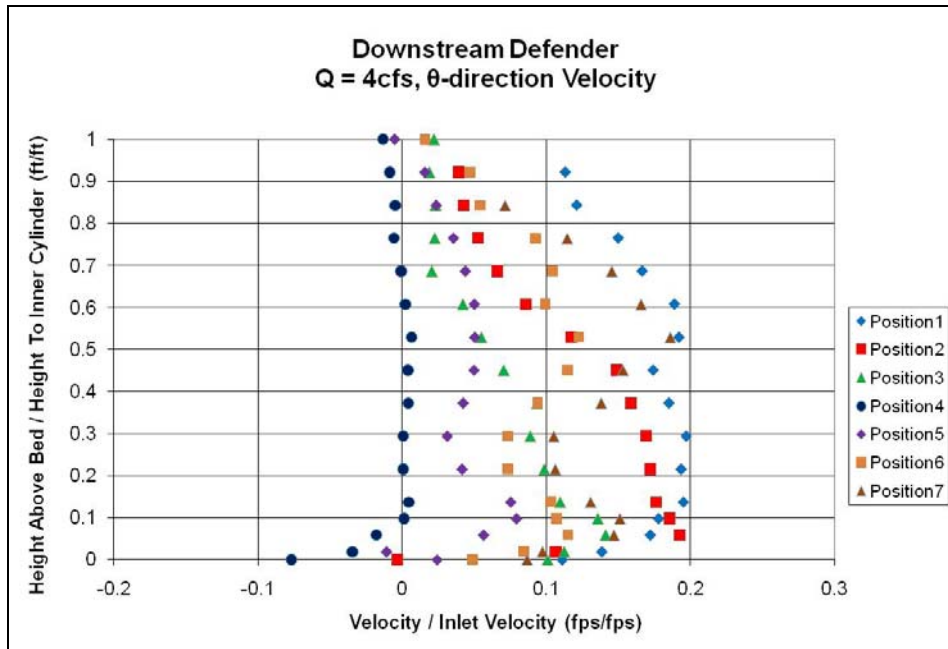

**Figure 5-9: Profiles of  $\theta$ -component of velocity at a discharge of 4 cfs**

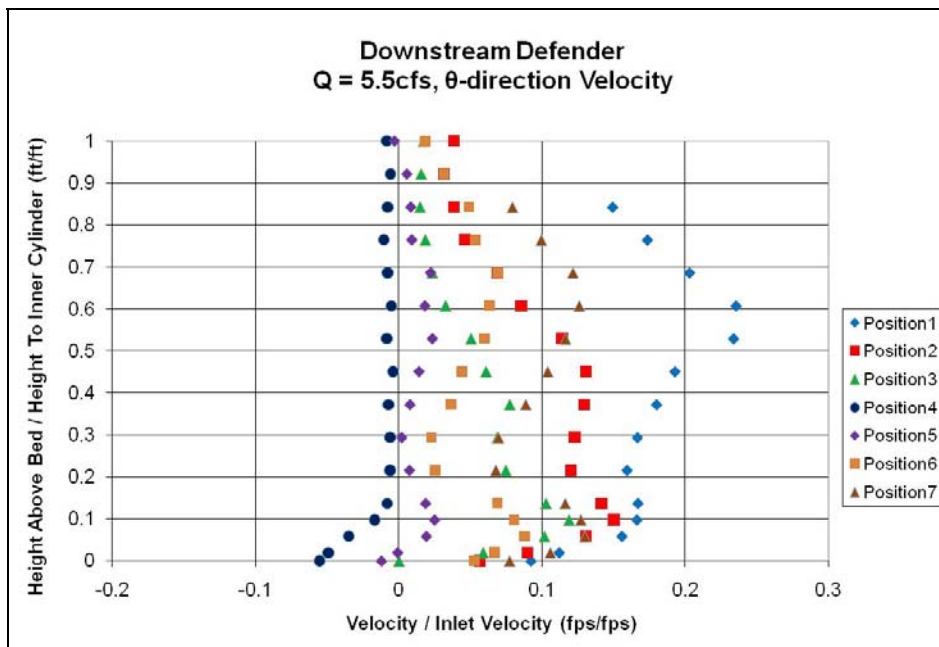

**Figure 5-10: Profiles of  $\theta$ -component of velocity at a discharge of 5.5 cfs**

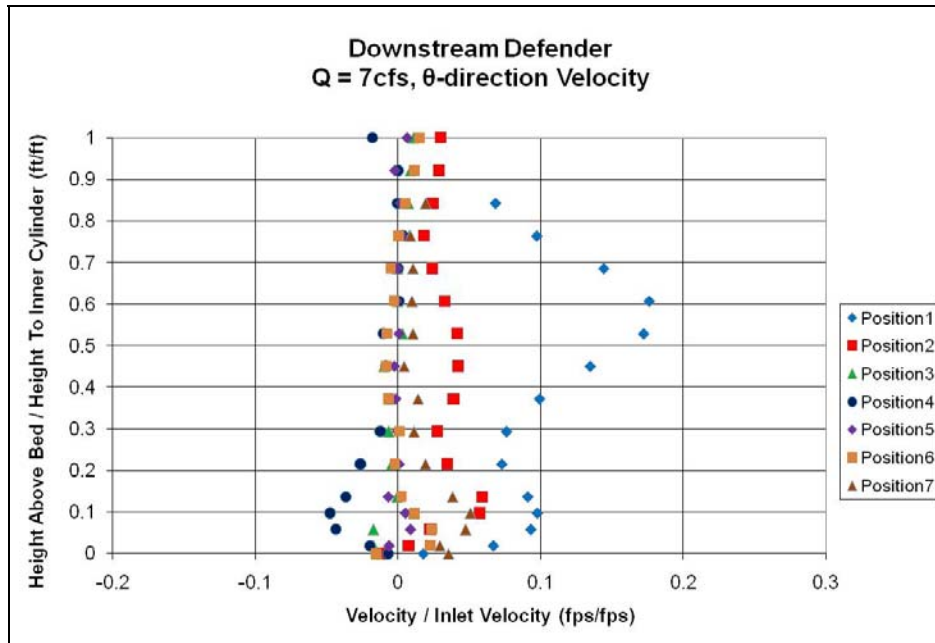

Figure 5-11: Profiles of  $\theta$ -component of velocity at a discharge of 7 cfs

### 5.3. Proposed Functions

The results obtained from measuring velocity profiles showed that relatively high washout rates in the Environment 21 V2B1 are due to swirl in the sump which causes high shear stresses on the deposit in the sump. However, the presence of an outlet pipe and the presence of the extension of the inlet pipe into the water column impact the velocities at lower depths from the surface and thus washout is not as significant as it could be with no obstructions to flow. Similarly, the relatively very low washout rates in the Downstream Defender when the deposit in the sump is less than 85% of the maximum storage capacity are due to low velocities near the bed, i.e. not many particles can be scoured and thus suspended to washout from the device. Since discharge and particle size seem to be the two major factors impacting the washout rate, one could develop a washout function based on the results of the tests. It is important to note that armoring of particles may influence sediment retention under actual operating conditions, so the results obtained from these tests are not necessarily what in-service devices may exhibit under infrequent storm events. However, the proposed functions can be applied to help understand the impact of varying conditions on sediment retention, providing information for device design and maintenance.

Two functions have been fitted to the data measured for the Environment 21 V2B1 Model 4 to explain effluent concentration as a function of discharge. Each function is applicable to the median particle size of the sediment size distribution tested. The functions are power law functions and have been fitted to the data after removing the potential outliers and are as follows:

$$C = 32.673 Q^{2.55} \quad \text{For a } d_{50} = 110 \text{ microns} \quad (5.1)$$

$$C = 0.095 Q^{6.04} \quad \text{For a } d_{50} = 200 \text{ microns} \quad (5.2)$$

In the above equations,  $C$  is the effluent concentration in mg/l and  $Q$  is discharge in cfs. The two functions are presented in Figure 5-12.

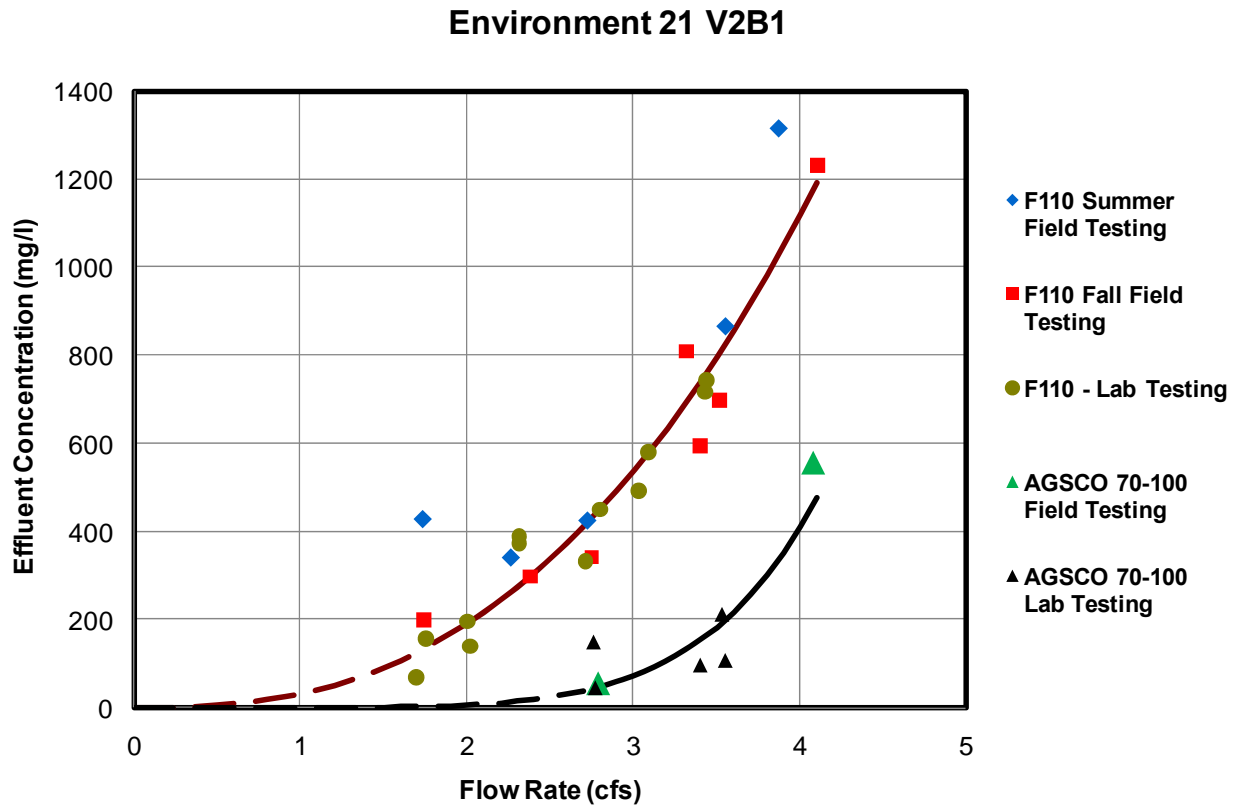

**Figure 5-12: Proposed Environment 21 washout functions for two particle sizes**

As a result of this study it was assumed that the maximum storage capacity of Downstream Defender would be set at 75% of the current maximum capacity, i.e. 6 inches below the rim of the bench skirt. Therefore, for the Downstream Defender, a single washout function is proposed for a median particle size of 110 microns when the deposit is less than 80% of the maximum storage capacity. Since the effluent concentrations increased in those tests conducted immediately after sediment was poured in the sump and it is perceived that the conic shape of the poured sediments could have caused some bias in the data, it was decided to exclude those data points and fit a function to the rest of the data. The function is as follows

$$C = 0.008 Q^{4.41} \quad \text{For a } d_{50} = 110 \text{ microns} \quad (5.3)$$

In Equation 5.3,  $C$  and  $Q$  are the same as in Equations 5.1 and 5.2. Equation 5.3 is shown in Figure 5-13.



### Downstream Defender

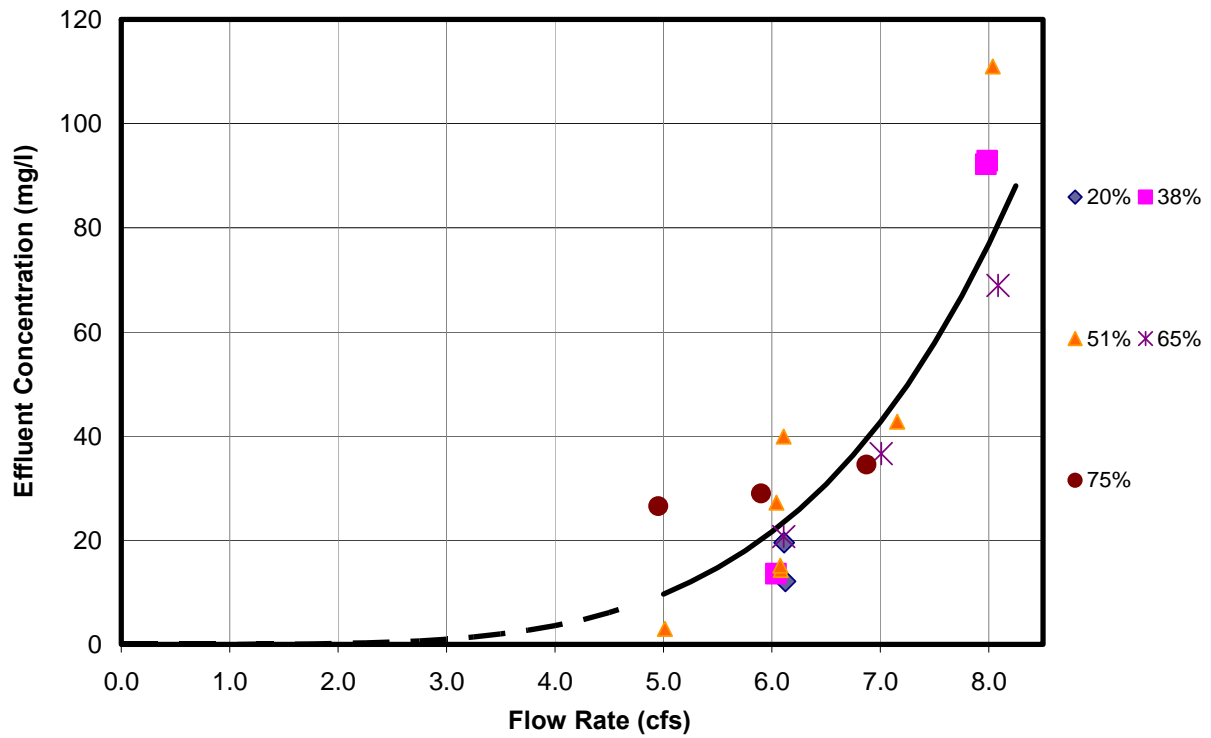

Figure 5-13: Proposed Downstream Defender washout function for silica sand with a  $d_{50}$  of 110 microns

## **6. Application of Results**

### **6.1. Maintenance**

Future maintenance demands are an important consideration when evaluating hydrodynamic separators as a stormwater treatment option, since full life-cycle costs can be dramatically impacted by maintenance needs. The primary maintenance activity required with hydrodynamic separators is cleaning of accumulated sediments. These devices have design sediment capacities, and sediments must be occasionally removed to prevent resuspension and washout of accumulated sediments under high flow conditions. Cleanout is typically accomplished utilizing a vacuum truck, which is a reasonably costly procedure, so accurate prediction of required cleanout frequency would provide vital information on total life-cycle costs for hydrodynamic separators. However, many variables affect the accumulation of sediments, including watershed hydrology, runoff suspended sediment particle size distributions and densities, device performance efficiencies and device sediment retention capabilities.

Typically, manufacturers recommend frequent inspections of sediment accumulations for the first one to two years of service so that sediment accumulation rates and cleanout schedules can be predicted. This procedure is time consuming and subject to inaccuracies, as rainfall conditions can vary significantly from year to year. In addition, the results of the inspections cannot be applied to different devices in different watersheds. If crucial variables affecting net sediment accumulation were well understood, models could be developed to predict cleanout frequencies and better estimate total suspended sediment removals for regulatory compliance.

Full cleanout of sediments from hydrodynamic separators may not be fully accomplished due to limited access. Hydrodynamic separators are often classified as confined spaces, so cleaning from above ground is preferred. However, in some devices internal components prevent reaching the full extent of the sump from above ground with a vacuum hose, complicating maintenance procedures or causing incomplete cleaning.

### **6.2. Implications of Work**

Prior to this study, sediment retention testing of hydrodynamic separators had not been conducted in a methodical way. The testing method developed in this study, in spite of relatively large errors in measuring the washout rate from these devices (approximately 25 to 50 mg/l), has triggered further research across the country by manufacturers and other laboratories. In addition, the foundation of the method developed in this study is currently being reviewed by different organizations, e.g. the ASCE/EWRI Committee for Certification Guidelines of Manufactured BMPs and also by the ASTM, to be possibly incorporated or adopted in their guidelines and standards.

### **6.3. Predict Maintenance Schedules**

The results of this study showed that the sediments which can be removed from stormwater runoff by Stormceptor are not scoured or washed out of the device; therefore, the maintenance schedule of Stormceptor hydrodynamic separators is only dependent on when the maximum

storage capacity of the sump is filled with sediments. In the study done by Wilson et al. (2007 and 2009), a removal efficiency function was developed for Stormceptor which can be used to predict the time the sump is full of sediment at the maximum storage capacity.

For Environment 21 V2B1 Model 4, two functions for two particle sizes are proposed by the authors (Equations 5.1 and 5.2). Using these equations, one could determine the washout rate under different flow conditions for the two particle sizes. By utilizing linear interpolation, one could estimate a first approximation of washout rate for all other particle sizes between 110 and 200 microns.

For Downstream Defender, only one function has been proposed by the authors and it is only applicable to particle sizes of 110 microns with a specific gravity of 2.6. Since the effluent concentration is relatively small at even 5 or 6 cfs, Downstream Defender maintenance schedules can probably be set based on the amount of sediments removed throughout a year. It was assumed that as a result of this study, the maximum storage capacity of Downstream Defender should be set at 75% of the current maximum capacity, i.e. 6 inches below the rim of the bench skirt to minimize the washout rate.

Similar washout functions can be developed by conducting sediment retention testing on other hydrodynamic separators. By utilizing the output of a continuous urban runoff model, one could predict the depth of the deposit in these devices using removal efficiency functions (as has been done in SHSAM by Mohseni et al. 2009); and by incorporating the washout function, one could predict the cleaning frequency required for these devices.

## 7. Summary and Conclusions

To study the potential for scour and washout of previously deposited sediments in the sumps of hydrodynamic separators under infrequent storm events, e.g. 5 or 10-year storm events, three hydrodynamic separators were tested in the field and laboratory. The hydrodynamic separators were Environment 21 V2B1 Model 4, STC1200 Stormceptor and 6-ft Downstream Defender. The Environment 21 V2B1 Model 4 was tested in the field, under fully controlled conditions, and also in a laboratory setting. In the field, a volume based method was utilized to measure the washout rates from the device. Sediment was placed in the sump prior to each test. Two relatively narrow particle size distributions (F110 Silica sand gradation and AGSCO 70-100) were used for a total of 14 sediment retention tests. Water was supplied from a nearby hydrant into the device at discharges higher than the device maximum design treatment rate. No sediment was fed into the influent pipe during the tests and discharge was measured using a pre-calibrated circular weir installed in the effluent pipe. After each test, the volume of sediments retained in the sump was measured and the washout rate was estimated. In the laboratory setting, the washout rate was measured using a weight based method, and was verified with the volume based method. In the weight based method load cells were used to measure the weight of the device containing water and sediment before and after each test. Despite the errors in weight based and volume based methods, the results of both methods were in general agreement. The washout rates measured in the laboratory for the same particle size distributions were in agreement with the washout rates measured in the field. The maximum effluent concentration was measured to be 1,300 mg/l at a discharge of 4.2 cfs with the sump preloaded with the F110 silica sand gradation. Finally, two washout functions were developed for the Environment 21 V2B1 Model 4 for two particle size distributions; one for a  $d_{50}$  of 110 microns and one for a  $d_{50}$  of 200 microns.

A similar weight based method was used to conduct seven sediment retention tests on the STC1200 Stormceptor in a laboratory setting. The sump was preloaded with the F110 Silica sand gradation and the SCS250 gradation. The results of the tests showed no significant washout from the device for the two particle size distributions. Given our previous knowledge on the performance of Stormceptor hydrodynamic separators at removing suspended sediments from stormwater runoff, it was concluded that the suspended sediments which can be removed by Stormceptor are not washed out under high flow conditions as long as the deposit in the sump does not exceed its maximum storage capacity.

A total of 65 sediment retention tests were conducted on the 6-ft Downstream Defender and only the weight based method was used to determine its washout rates under a variety of flow conditions. Due to lack of access for the cleaning crew to enter the sump area, the volume based method could not be used to assess the performance of Downstream Defender under high flow conditions. Laboratory tests indicated that when the deposit was less than 75% of the maximum storage capacity, the washout rates were not significant. The maximum washout rate measured was 110 mg/l at a discharge of 8 cfs with the sump preloaded with the F110 Silica sand gradation. Subsequently, a washout function was developed for a particle size distribution with a  $d_{50}$  of 110 microns. As the deposit exceeded 75% of the maximum storage capacity, the washout rates from the 6-ft Downstream Defender increased considerably, with a maximum effluent concentration of about 2,000 mg/l at a discharge of about 8 cfs. This is believed to be the result

of some of the sediment extending above the rim of the benching skirt and as such being subject to washout at high flow rates.

Two hypothetical scale models of swirl flow hydrodynamic separators were also tested to understand scour potential, resuspension of sediments, and washout processes in swirl flow models. In addition, velocity profiles were measured in scale models as well as the Environment 21 V2B1 Model 4 and the 6-ft Downstream Defender.

The results of the study showed that:

- Using load cells for sediment retention testing under high flow condition is a reliable method to measure the washout rates from hydrodynamic separators.
- The results of sediment retention testing using load cells are in general agreement with the results of tests obtained from the volume based method. Therefore, anywhere load cells cannot be utilized for sediment retention testing, e.g. in fully controlled field testing or in the laboratory when the device is extremely heavy, the volume based method is a reliable method to be adopted for sediment retention testing.
- Uncertainty in measuring the effluent concentration due to washout can vary from 25 mg/l to 50 mg/l depending on discharge and the device type. The maximum acceptable washout rate should be set above these uncertainty levels.
- The sediments deposited in the sump of hydrodynamic separators at low flow conditions can be mobilized (scoured) at high flow conditions, but the mobilized particles may or may not be washed out of the device. Washout is a different process which is dependent on the flow patterns in the device and the geometry of the device.
- In swirl flow devices, the velocity profiles can be significantly different at different locations inside the device.
- Swirl flow hydrodynamic separators are inherently subject to high scour rates. However, the washout rates can be suppressed due to presence of flow obstructions in the device, e.g. the presence of inlet and outlet pipes inside the sump. In the case of the Downstream Defender, under high flow conditions the deposit in the sump is protected by a benching skirt, a center shaft and cone. Significant washout is only observed when the deposit approaches the rim of the benching skirt. For Environment 21, the washout rates are relatively high. If the connecting pipe between the two manholes had not been extended into the first manhole, the washout rates could have been significantly higher than the current washout rates measured for this device.

Scour, resuspension and washout processes are quite unique to each device and at this moment it would be difficult if not impossible to develop a general washout function for all hydrodynamic separators. In order to develop a maintenance schedule for a hydrodynamic separator, it is essential for that device to be tested for sediment removal efficiency and sediment retention. By incorporating the performance functions developed from these tests into a continuous urban runoff model, the end users can develop a maintenance schedule for these devices for any given particle size distribution in stormwater runoff and the climate condition of the region wherein the device is installed.

## References

- Avila, H. and Pitt, R. (2009). "Physical Experimentation and CFD Modeling to Evaluate Sediment Scour in Catchbasin Sumps." *Proceedings of the World Environmental and Water Resources Congress 2009: Great Rivers*, Kansas City, MO: pp. 3539-3548.
- Avila, H. and Pitt, R. (2008). "Evaluating Scour Potential in Stormwater Catchbasin Sumps Using a Full-Scale Physical Model and CFD Modeling." *Proceedings of the Water Environment Federation*, WEFTEC 2008, Chicago, IL: Session 91 through Session 100, pp. 6958-6977(20).
- Avila, H., Pitt, R. and Durrans, S.R. (2007). "Analysis of Shear Stress and Potential Scour of Sediments from Stormwater Catchbasin Sumps Using a 2-Dimensional Computational Fluid Dynamic Model." *Proceedings of the Water Environment Federation*, WEFTEC 2007, San Diego, CA: Session 81 through Session 90, pp. 6993-7013(21).
- Carlson, L., Mohseni, O., Stefan, H. and Lueker, M. (2006). *Performance Evaluation of the BaySaver Stormwater Separation System*. St. Anthony Falls Laboratory Project No. 472, Minneapolis, MN.
- Environment 21. (2009). "V2B1 Maintenance." p. 1. Found online on 10/4/09 at: <http://www.env21.com/media/docs/v2b1/drawings/V2B1%20maintenance.pdf>.
- Fyten, A. and Mohseni, O. (2009). *Environment21 V2B1 Model 4 Performance Function*. St. Anthony Falls Laboratory Project Report No. 528, Minneapolis, MN.
- DeGroot, G. and Gulliver, J.S. (2009). "Accurate Sampling: Implications for Meeting TMDLs." *Proceedings of the 8th Annual StormCon*, August 16-19, Anaheim, CA.
- Hydro International. (2009). "Downstream Defender: Operation and Maintenance Manual." Table 1, p. 5. Found online on 10/4/09 at: <http://www.hydro-international.biz/us/restricted/download.php>.
- Mohseni, O. and Fyten, A. (2008). *Performance Assessment of Modified ecoStorm Hydrodynamic Separator*. St. Anthony Falls Laboratory Project Report No. 495B, Minneapolis, MN.
- Mohseni, O., Kieffer, J.A. and Koehler, J.A. (2009). "A Tool for the Performance Assessment of Hydrodynamic Separators." *Proceedings of the World Environmental and Water Resources Congress 2009: Great Rivers*, Kansas City, MO.
- New Jersey Department of Environmental Protection. (2009). *Protocol for Manufactured Hydrodynamic Sedimentation Devices for Total Suspended Solids on Laboratory Analysis*. Found online 9/15/09 at: [http://www.njstormwater.org/pdf/hydrodynamic\\_protocol\\_12\\_15.pdf](http://www.njstormwater.org/pdf/hydrodynamic_protocol_12_15.pdf).

- Pathapati, S. and Sansalone, J. (2009). "CFD Modeling of a Stormwater Hydrodynamic Separator." *ASCE Journal of Environmental Engineering*, 135(4), 191-202.
- Rinker Materials. (2009). "Stormceptor STC: Technical Manual." p. 21. Found online on 10/4/09 at:  
[http://www.stormceptor.com/downloads/pdf/Stormceptor\\_STC\\_tech\\_manualUSA.pdf](http://www.stormceptor.com/downloads/pdf/Stormceptor_STC_tech_manualUSA.pdf).
- Saddoris, D., Mohseni, O. and Gulliver, J. (2009a). "Assessing Hydrodynamic Separators under High Water Flow Conditions." *Proceedings of the World Environmental and Water Resources Congress 2009; Great Rivers*, Kansas City, MO: pp. 864-874.
- Saddoris, D., Gulliver, T., Bell, B., Mohseni, O. and Gulliver, J. (2009b). "Evaluation of Hydrodynamic Separators as an Urban Stormwater BMP." *Proceedings of an International Prospective on Environmental and Water Resources Conference*, January 5-7, Bangkok, Thailand.
- Sansalone, J. and Pathapati, S. (2009). "Particle Dynamics of a Hydrodynamic Separator Subject to Transient Rainfall-Runoff." Submitted to *Water Resources Research*, in press.
- United States Environmental Protection Agency (US EPA). (1999). *Storm Water Technology Fact Sheet: Hydrodynamic Separators*. Office of Water, Washington, D.C., EPA 832-F-99-017.
- Wisconsin Department of Commerce and Wisconsin Department of Natural Resources. (2007). *Method for Predicting the Efficiency of Proprietary Storm Water Sedimentation Devices*. Found online 9/15/09 at:  
<http://www.socwisconsin.org/pdf/Broad%20Review/Proprietary%20Stormwater%20Devices%20Std.-Draft6.pdf>.
- Wilson, M.A., Gulliver, J.S., Mohseni, O. and Hozalski, R.M. (2007). *Performance Assessment of Underground Stormwater Treatment Devices*. St. Anthony Falls Laboratory Project Report No. 494, Minneapolis, MN.
- Wilson, M., Mohseni, O., Gulliver, J., Hozalski, R. and Stefan, H. (2009). "Assessment of Hydrodynamic Separators for Stormwater Treatment." *ASCE Journal of Hydraulic Engineering*, 135(5), 383-392.

**Appendix A: Device Configuration and Test Procedures – Full Scale Devices**



## **A.1. Environment 21 V2B1 Field Testing**

Field testing was conducted on an in-service Environment 21 V2B1 Model 4 located at the southwest corner of Long Lake Road and Rice Creek Road in New Brighton, MN.

### **A.1.1. Field Conditions and Equipment**

The source of water for the experiments was a fire hydrant located on the north side of Rice Creek Road. From the hydrant the water was piped approximately 15 feet and discharged directly into a storm sewer catch basin. A valve was included in the piping system to adjust the flow rate. Figure A-1 shows the fire hydrant and piping setup on the northwest corner of Long Lake Road and Rice Creek Road. From the catch basin the water flowed through a storm sewer pipe under Rice Creek Road to another catch basin, and then into the first chamber of the V2B1 device.



**Figure A-1: Fire hydrant and piping system for water supply**

The Environment 21 V2B1 device consists of two 5' diameter underground chambers in series. The first chamber is designed to remove suspended sediment, and the second chamber is designed to remove floatables from stormwater. Figure A-2 includes a drawing of the device, and Figure A-3 contains a rendering of an Environment 21 V2B1 device. For the Environment 21 V2B1 device tested in New Brighton, the inlet pipe enters the first chamber creating a counterclockwise flow (in plan view), not a clockwise flow as indicated in Figure A-3. In



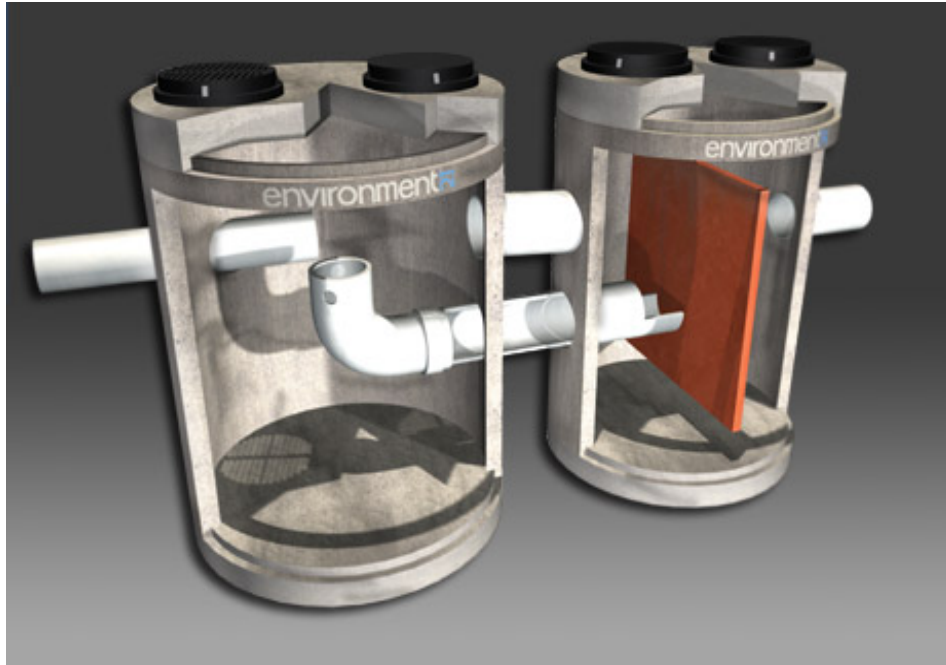

**Figure A-3: Rendering of Environment 21 V2B1 (image from <http://www.env21.com/V2B1.html> on 10/20/08).**

Water flow rate was measured utilizing a circular weir and pressure transducer installed downstream of the outlet from the secondary chamber, immediately before the pipe discharges to the Long Lake Road storm sewer header. A laptop was used to record the level measurements upstream of the weir over the course of the tests. Figure A-4 shows the weir and pressure transducer installed in the outlet pipe from the secondary chamber and the above ground data acquisition. Previous work at Saint Anthony Falls Laboratory provided the calibration for flow rate as a function of water height above the weir.

A sediment capture screen with an opening size of 44 microns was utilized at the downstream storm sewer outfall to Rice Creek to contain washed-out sediments, as shown in Figure A-5. The capture pool was cleaned during the testing period to recover captured sediments.



**Figure A-4: Flow rate measurement using a weir, pressure transducer and data acquisition computer**



**Figure A-5: Sediment capture screen at Rice Creek**

### **A.1.2. Test Procedures**

The testing required entry into the device chambers for cleaning and sediment measurements. All chamber entries were performed following a confined space entry procedure. An emergency egress tripod, a harness and ropes, gas analyzer and communications equipment were all required to safely make entries into the device. Figure A-6 shows the tripod setup over the primary chamber of the Environment 21 V2B1 device. Other safety equipment included safety vests for visibility of workers and traffic cones to maintain separation from vehicles.



**Figure A-6: Field site with confined space entry tripod**

The detailed procedure for field testing of the Environment 21 V2B1 in New Brighton, MN is included as Procedure A-1. Procedure A-1 follows the general procedure for controlled sediment retention testing of hydrodynamic separators, Procedure 2-1.

Procedure A-1: Detailed Procedure for Sediment Retention Testing – Environment 21 V2B1 Field Testing

- 1) Arrive at site, secure site and setup for confined space entry
- 2) Connect water piping from hydrant to catch basin
- 3) Install pressure transducer upstream of the weir in the device outlet pipe
- 4) Pump any water from the two chambers using a sump pump, and dispose of water in the storm sewer downstream of the device

- 5) Remove the sediment cover and any material (sediment and debris) accumulated during previous rainfall events
- 6) Charge sediment by dumping sediment from bags into the top of the first chamber through the access manhole
- 7) Level the sediment using a shovel, rake and level
- 8) Use a laser range finder to measure the distance from the top of the sediment to the device ceiling and to the bottom of the inlet pipe at 28 marked locations in the first chamber of the device
- 9) Use a ruler to measure the depth of the sediment (top of the sediment to the device floor) at 18 locations in the device
- 10) Slowly fill the device with water until both chambers are full of water to their outlet pipes, and then shut off the water
- 11) Start the water flow at the test flow rate and run water for the designed time for the test
- 12) Record the temperature of the water at the discharge from the piping into the catch basin upstream of the device
- 13) Record the water height above the weir as measured by the transducer every minute during the run
- 14) After desired test duration has been reached, turn off water supply
- 15) Wait 10 minutes for suspended sediment to settle
- 16) Pump water from the two chambers using a sump pump, being careful not to resuspend and remove sediment
- 17) Level the sediment using a shovel and level
- 18) Use a laser range finder to measure the distance from the top of the sediment to the device ceiling and to the bottom of the inlet pipe at the 28 marked locations in the device
- 19) Use a ruler to measure the depth of the sediment (top of the sediment to the device floor) at 18 locations in the device
- 20) Cover the sediment using an assembly of interconnecting boards covered with sand bags
- 21) Clean accumulated sediment from the Long Lake Road storm sewer header and the capture pool at the outfall at Rice Creek
- 22) Disconnect piping from the hydrant and replace manhole covers

Sediment measurement using the laser range finder and ruler stick are described in detail in Appendix C, Section C.1. Appendix E, Section E.1 includes discussion on the calculation of sediment in a device based on level of the sediment. Based on measured level, the before test and the after test sediment in the device was calculated, and a mass balance was used to determine the sediment removed from the device. The sediment outlet concentrations were calculated by dividing the total amount of sediment removed during a test by the total water volume that flowed through the device during the test.

There were several constraints which limited productivity of field testing the Environment 21 V2B1 device. Due to the time required for transportation, setup, testing, measurement and securing the site, no more than one test could be completed in a day. Testing could not occur on

days with a reasonable likelihood of rain. As three people were required for confined space entries, labor constraints also limited field days.

## A.2. Environment 21 V2B1 Laboratory Testing

### A.2.1. Equipment

An Environment 21 V2B1 Model 4 full scale prototype model was constructed at SAFL using two fiberglass manholes and the Environment 21 piping and baffle wall design. Water from the Mississippi River was used for testing the Environment 21 V2B1 model. Water was fed from the SAFL supply channel to a 12 inch supply pipe, through an expander, and then to a 15 inch supply pipe. This 20 foot long corrugated HDPE supply pipe was set at a slope of 2% and connected to the inlet of the V2B1 device. Once to the device, water enters the first of two in-line manholes. Refer to Figure A-7 for a drawing of the device. Under low flow conditions, water fills the first chamber (M1), and travels through the elbow pipe to the next chamber (M2). The majority of sediment removal from stormwater occurs in the first manhole (M1), and the second manhole (M2) primarily serves as a floatables treatment chamber. The high flow bypass pipe was plugged for the sediment retention tests described in this report. Water traveling through the elbow pipe travels under a baffle wall before reaching the outflow pipe. Once to the outflow pipe, effluent water travels through another 15" HDPE pipe, over a circular weir, and back into the Mississippi River.

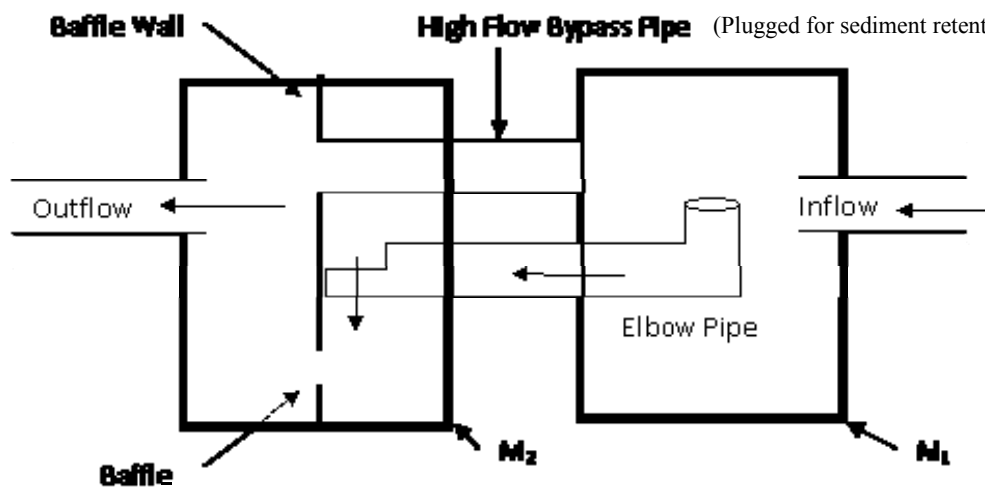

Figure A-7: Environment 21 V2B1 laboratory testing – device drawing

In order to measure discharge from the device, a circular weir and submerged pressure transducer were placed at the downstream end of the model's outlet pipe. Real time flow measurements were sent back to a computer for monitoring before, during, and after tests. Refer to Figure A-8 for images of the downstream circular weir, pressure transducer and data acquisition hardware.



**Figure A-8: Environment 21 V2B1 laboratory testing – flow measurement**

Each manhole was placed on a steel frame, and each steel frame rested on three load cells. Figure A-9 shows the device's setup at SAFL. The use of load cells is described in Appendix C, Section C.2.

Load cell and flow rate readings were sent directly to a computer for monitoring within a LabView program. Figure A-10 shows a screen shot of real time load cell and flow rate readings.



**Figure A-9: Environment 21 V2B1 laboratory testing – device setup**



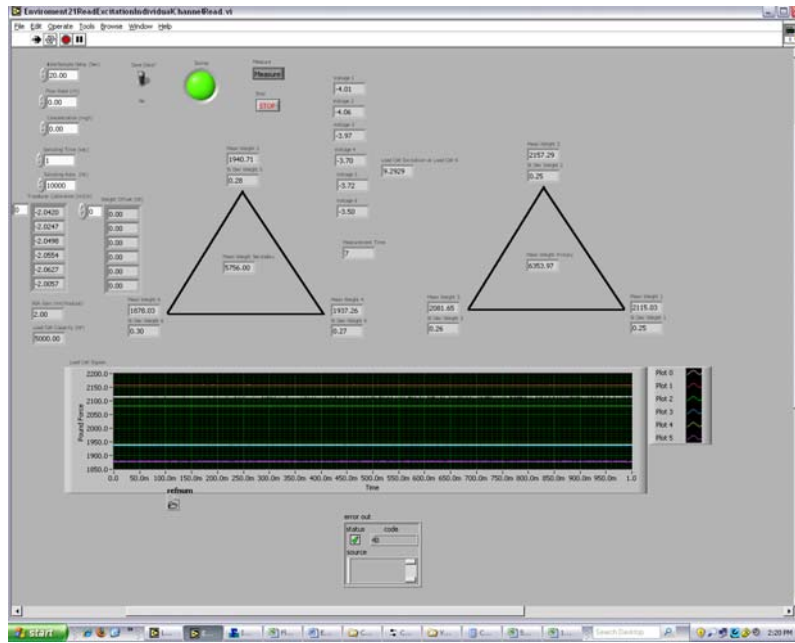

**Figure A-10: Environment 21 V2B1 laboratory testing – load cell screenshot**

### **A.2.2. Test Procedures**

The detailed procedure for laboratory testing of the Environment 21 V2B1 at St. Anthony Falls Laboratory is included as Procedure A-2. Procedure A-2 follows the general procedure for controlled sediment retention testing of hydrodynamic separators, described in Procedure 2-1.

Procedure A-2: Detailed Procedure for Sediment Retention Testing – Environment 21 V2B1 Laboratory Testing

- 1) Charge sediment by dumping sediment from bags into the top of the first manhole (M1)
- 2) Disconnect the upstream pipe from the inlet pipe and the downstream pipe from the outlet pipe
- 3) Tap load cell brackets with a rubber mallet to ensure the system components are not binding
- 4) Check load cell bearing plate clearances using a piece of paper
- 5) Add or remove water until the water is at a known elevation
- 6) Close the drain valve and remove drain piping
- 7) Ensure the device is not touching the inlet piping
- 8) Record the weight of the two manholes using load cells and data acquisition computer
- 9) Measure water elevation in the two manholes using stilling basins and point gauges
- 10) Measure air temperature and device water temperature
- 11) Attach upstream pipe to inlet pipe and downstream pipe to the outlet pipe using flexible couplers
- 12) Start water flow at a low flow rate and fill device slowly until water begins to discharge from the outlet pipe

- 13) After desired test duration has been reached, turn off water supply
- 14) Measure air temperature and device water temperature
- 15) Wait 10 minutes for sediment to settle
- 16) Start water flow and set to desired discharge
- 17) Once discharge is set, record the weight of both manholes and the static water pressure of the inlet pipe, primary manhole (M1), secondary manhole (M2) and outlet pipe
- 18) In the middle of the test record the weight of both manholes and the static water pressure of the inlet pipe, primary manhole (M1), secondary manhole (M2) and outlet pipe
- 19) Prior to turning off water record the weight of both manholes and the static water pressure of the inlet pipe, primary manhole (M1), secondary manhole (M2) and outlet pipe
- 20) After desired test duration has been reached, turn off water supply
- 21) Wait 10 minutes for sediment to settle
- 22) Attach drain piping
- 23) Drain water slowly to initial measurement elevation
- 24) Close drain valve and remove drain piping
- 25) Remove flexible couplers from inlet and outlet pipes
- 26) Tap load cell brackets with a rubber mallet to ensure the system components are not binding
- 27) Ensure the device is not touching the inlet piping
- 28) Record the weight of the two manholes using load cells and data acquisition computer
- 29) Measure water elevation in the two manholes using stilling basins and point gauges

The use of load cells for sediment measurement is described in Appendix C, Section C.2. All of the laboratory sediment retention tests conducted on the Environment 21 utilized load cells and weight measurements as described in Procedure A-2. Level measurements were also used for several tests to confirm the weight measurement test results. For the tests using level measurement in addition to weight measurement, the sediment was leveled and sediment height was measured with a stick ruler at 25 known locations before and after each test. Sediment level measurements required the water to be pumped from the system using a sump pump. The procedure for sediment level measurements is similar to Procedure A-1. Utilizing the pre and post test weights and water levels, the amount of sediment washed out from the device during the test was calculated using the methodology described in Appendix E, Section E.2. For several tests where sediment levels were measured, the amount of sediment washed out from the system was also calculated using the methodology described in Appendix E, Section E.1. Any sediment in the secondary manhole was assumed to be washed out from the system. Sediment effluent concentrations were calculated by dividing the total amount of sediment removed during a test by the total water volume that flowed through the device during the test.

The primary manhole to secondary manhole connection pipe and the bypass pipe had flexible connectors, but the connectors were not removed when weights were measured. The flexible connections between the two manholes likely influenced the weight readings for each individual manhole, although it is believed by the authors that the affects were minor. Water was drained

below the primary to secondary manhole connection pipe when taking weight readings. The bypass pipe was drained prior to taking weight readings to ensure that no water was retained in the bypass pipe that would influence weight readings.

### **A.3. Stormceptor Laboratory Testing**

#### **A.3.1. Equipment**

A Stormceptor STC1200 full scale prototype model was constructed at SAFL using a fiberglass manhole and proprietary components provided by Rinker Materials, manufacturer of Stormceptor. Water from the Mississippi River was used for testing the Stormceptor model. Water was fed from the SAFL supply channel through a piping system to the device. Discharge was controlled by a gate valve and small drain valve upstream from the device. The gate valve coarsely controlled water input and the small drain valve finely tuned the flow rate. Prior to reaching the device, water travelled through a 20 foot long 18" inner diameter pipe at a slope of 1%. Figure A-11 shows the gate valve as well as upstream piping leading to the Stormceptor.

Figure A-12 includes a drawing of the Stormceptor with dimensions of the device. A picture of the drop tee inlet pipe is shown in Figure A-13, and a rendering of the device is included as Figure A-14.



**Figure A-11: Stormceptor water feed piping**

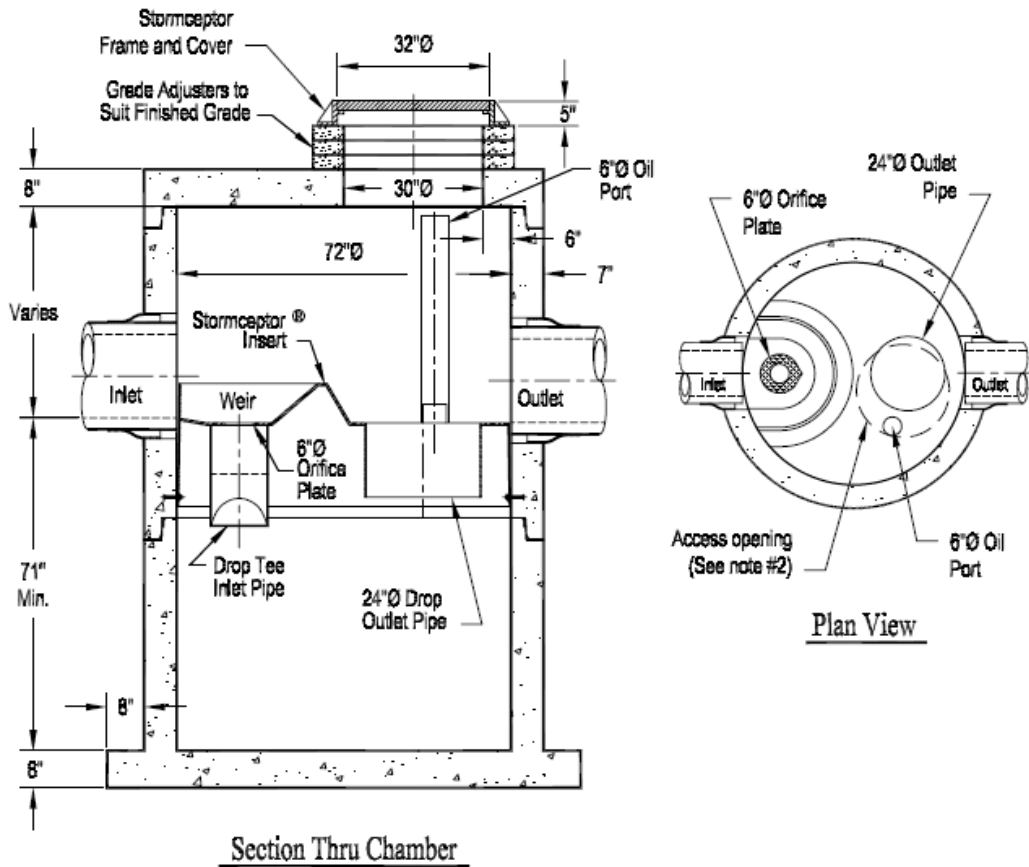

**Figure A-12: Stormceptor drawing including dimensions (image from <http://www.stormceptor.com/downloads/Drawings/US/Rinker/Stc1200.PDF> on 12/6/09).**



**Figure A-13: Stormceptor drop tee**



**Stormceptor®**  
Stormwater pollutant removal (STC)

**Figure A-14: Stormceptor rendering (image from <http://www.stormceptor.ca/en/products/stormceptor-classic-systems/enlarge.html> on 10/20/08).**

Water enters the Stormceptor's upper chamber through an 18" inlet pipe. At low discharges, a weir directs water downward through a drop tee inlet pipe and into the lower chamber of the device. Once the lower chamber fills with water, water exits the lower chamber through a vertical outlet pipe. From the vertical pipe, water exits the device through an 18" outlet pipe. At high flow rates, water is able to overtop the weir, bypassing treatment in the lower chamber. Prior to sediment retention testing, hydraulic testing determined that water begins to overflow the weir and bypass the treatment chamber at 0.48 cfs.

The Stormceptor is designed to have sediment treatment only in the lower chamber (sump). Upon exiting the device, water free-flowed from the outlet pipe into a rectangular channel. Water travelled through a river rock crib wall to reduce turbulence. A weir at the downstream end of the channel and a level transducer allowed calculation of the discharge through the device (see Figure A-15Figure ). A computer continuously recorded water level and calculated discharge during testing. After traveling over the weir, water exited the rectangular channel and returned to the Mississippi River through a floor trench and channel.



**Figure A-15: Channel discharge flow measurement**

Air temperature and sump water temperature were continuously recorded throughout the test period, including overnight.

### **A.3.2. Test Procedures**

The detailed procedure for laboratory testing of the Stormceptor at St. Anthony Falls Laboratory is included as Procedure A-3. Procedure A-3 follows the general procedure for controlled sediment retention testing of hydrodynamic separators, as described in Procedure 2-1.

Procedure A-3: Detailed Procedure for Sediment Retention Testing – Stormceptor Laboratory Testing

- 1) Charge sediment by dumping sediment from bags into the top of the manhole and through the 24" vertical sump outlet pipe, being careful not to spill sediment on the Stormceptor insert
- 2) Disconnect the upstream pipe from the inlet pipe
- 3) Tap load cell brackets with a rubber mallet to ensure the system components are not binding
- 4) Check load cell bearing plate clearances using a piece of paper
- 5) Add or remove water until the water is at a known elevation
- 6) Close the drain valve and remove drain piping
- 7) Ensure the device is not touching the inlet piping
- 8) Record the weight of the manhole using load cells and the data acquisition computer
- 9) Measure water elevation in the manhole using a stilling basin and point gauge
- 10) Attach upstream pipe to inlet pipe

- 11) Start water flow at a low flow rate and fill device slowly until water begins to discharge from the outlet pipe
- 12) Turn off water supply
- 13) Wait 10 minutes for sediment to settle
- 14) Start water flow and set to desired discharge
- 15) Once discharge is set, record the weight of the manhole and the static water pressure of the inlet pipe, the manhole and outlet pipe
- 16) In the middle of the test record the weight of the manhole and the static water pressure of the inlet pipe, the manhole and outlet pipe
- 17) Prior to turning off water record the weight of the manhole and the static water pressure of the inlet pipe, the manhole and outlet pipe
- 18) After desired test duration has been reached, turn off water supply
- 19) Wait 10 minutes for sediment to settle
- 20) Attach drain piping
- 21) Drain water slowly to initial measurement elevation
- 22) Close drain valve and remove drain piping
- 23) Vacuum any remaining sediment and water from the Stormceptor insert
- 24) Remove flexible coupler from inlet pipe
- 25) Tap load cell brackets with a rubber mallet to ensure the system components are not binding
- 26) Ensure the device is not touching the inlet piping
- 27) Record the weight of the manhole using load cells and data acquisition computer
- 28) Measure water elevation in the two manholes using stilling basins and point gauges

The use of load cells for sediment measurement is described in Appendix C, Section C.2.

Utilizing the pre and post test weights and water levels, the amount of sediment washed out from the device during the test was calculated using the methodology described in Appendix E, Section E.2. Any sediment on the Stormceptor insert at the end of the test was assumed to be washed out from the system. Sediment effluent concentrations were calculated by dividing the total amount of sediment removed during a test by the total water volume that flowed through the device during the test.

## **A.4. Downstream Defender Laboratory Testing**

### **A.4.1. Equipment**

A 6-ft Downstream Defender full scale prototype model was constructed at SAFL using a fiberglass manhole and proprietary components provided by Hydro International, manufacturer of Downstream Defender. Water from the Mississippi River was used for testing the Stormceptor model. Water was fed from the SAFL supply channel through a piping system to

the device. Discharge was controlled by a gate valve and small drain valve upstream from the device. The gate valve coarsely controlled water input and the small drain valve finely tuned the flow rate. Prior to reaching the device, water travelled through a 20 foot long 18" inner diameter pipe at a slope of 1%. Figure A-11 shows the gate valve as well as upstream piping leading to the Stormceptor.

Water enters the 18" inlet pipe of the Downstream Defender tangentially and travels clockwise (looking down on the device) around an outer cylinder. Along its circular path, water travels downward underneath the outer cylinder, following the path of the red arrow in Figure A-16. To exit, water travels upward on the inside of the outer cylinder (following the path of the blue arrow in Figure A-16) to the outlet pipe.

The Downstream Defender is designed to have sediment removal at the benching skirt at the bottom of the upper chamber, and subsequent sediment migration along the benching skirt the bottom chamber (sump).

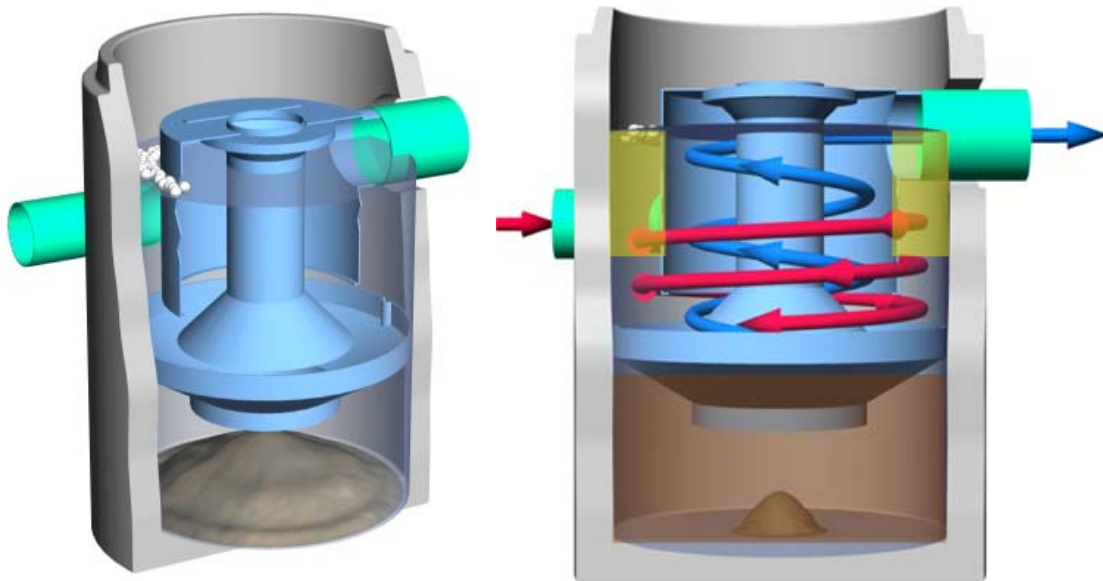

**Figure A-16: Downstream Defender rendering images from [http://www.hydro-international.biz/us/stormwater\\_us/downstream.php](http://www.hydro-international.biz/us/stormwater_us/downstream.php) on 10/20/08 and 09/14/09**

Figure A-17 is a drawing of the Downstream Defender with relevant dimensions for the device. All units in this drawing are in inches. Figure A-18 includes a picture of the insert before it was installed in the device



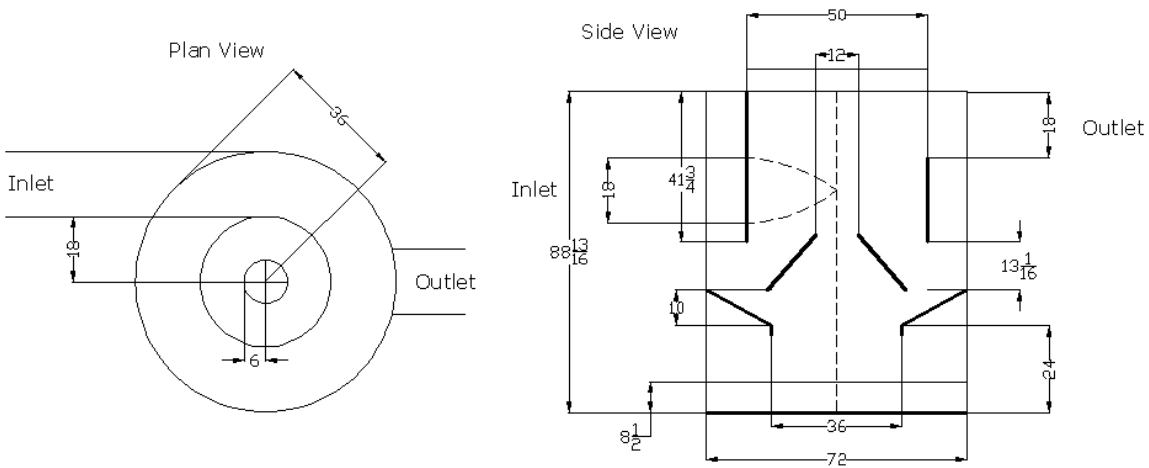

**Figure A-17: Dimensions of different components of Downstream Defender (all dimensions are in inches).**



**Figure A-18: Photo of the Downstream Defender insert used at SAFL**

A light was installed in the center shaft of the Downstream Defender. The light illuminated the lower chamber (sump) of the Downstream Defender, increasing the ability to see sediments in

the sump and to measure sediment deposit heights around the perimeter of the fiberglass manhole. In Figure A-19, the light and its power cable can be seen from the top of the manhole.



**Figure A-19: Water flowing through Downstream Defender during the laboratory tests**

A window was installed in the lower chamber of the Downstream Defender to allow visual inspection of sediment movement during retention tests. Figure A-20 shows the window and F110 sediment collected within the device. Bedforms formed during the testing were visible through the window, as seen in Figure A-20.

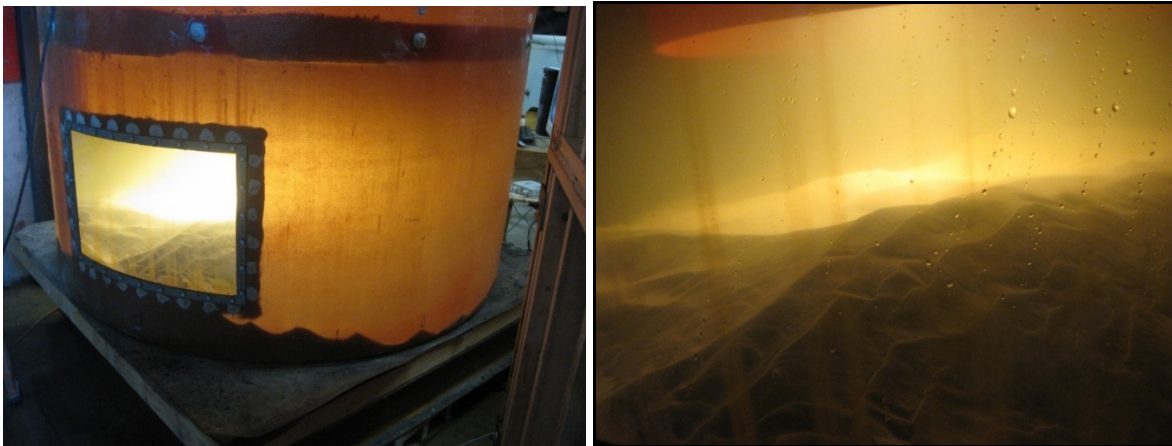

**Figure A-20: Bedforms in the sump of Downstream Defender at high flow conditions**

Upon exiting the device, water free-flowed from the outlet pipe into a rectangular channel. Water travelled through a river rock crib wall to reduce turbulence. A weir at the downstream end of the channel and a level transducer allowed calculation of the discharge through the device (see Figure A-15). A computer continuously recorded water level and calculated discharge during testing. After traveling over the weir, water exited the rectangular channel and returned

to the Mississippi River through a floor trench and channel. Air temperature and sump water temperature were continuously recorded throughout the test period, including overnight.

#### **A.4.2. Test Procedures**

The detailed procedure for laboratory testing of the Downstream Defender at St. Anthony Falls Laboratory is included as Procedure A-4. Procedure A-4 follows the general procedure for controlled sediment retention testing of hydrodynamic separators, as described in Procedure 2-1.

##### Procedure A-4: Detailed Procedure for Sediment Retention Testing – Downstream Defender Laboratory Testing

- 1) Charge sediment either by dumping sediment from bags into the top of the manhole and onto the benching skirt or by feeding with an AccuRate sediment feeder (see Section 2.2.4)
- 2) Disconnect the upstream pipe from the inlet pipe
- 3) Tap load cell brackets with a rubber mallet to ensure the system components are not binding
- 4) Check load cell bearing plate clearances using a piece of paper
- 5) Add or remove water until the water is at a known elevation
- 6) Close the drain valve and remove drain piping
- 7) Ensure the device is not touching the inlet piping
- 8) Record the weight of the manhole using load cells and the data acquisition computer
- 9) Measure water elevation in the manhole using a stilling basin and point gauge
- 10) Attach upstream pipe to inlet pipe
- 11) Start water flow at a low flow rate and fill device slowly until water begins to discharge from the outlet pipe
- 12) Turn off water supply
- 13) Wait 10 minutes for sediment to settle
- 14) Start water flow and set to desired discharge
- 15) Once discharge is set, record the weight of the manhole and the static water pressure of the inlet pipe, the manhole and the outlet pipe
- 16) In the middle of the test record the weight of the manhole and the static water pressure of the inlet pipe, the manhole and outlet pipe
- 17) Prior to turning off water record the weight of the manhole and the static water pressure of the inlet pipe, the manhole and outlet pipe
- 18) After desired test duration has been reached, turn off water supply
- 19) Wait 10 minutes for sediment to settle
- 20) Attach drain piping
- 21) Drain water slowly to initial measurement elevation
- 22) Close drain valve and remove drain piping
- 23) Remove flexible coupler from inlet pipe

- 24) Tap load cell brackets with a rubber mallet to ensure the system components are not binding
- 25) Ensure the device is not touching the inlet piping
- 26) Record the weight of the manhole using load cells and data acquisition computer
- 27) Measure water elevation in the two manholes using stilling basins and point gauges

The use of load cells for sediment measurement is described in Appendix C, Section C.2.

Utilizing the pre and post test weights and water levels, the amount of sediment washed out from the device during the test was calculated using the methodology described in Appendix E, Section E.2. Sediment effluent concentrations were calculated by dividing the total amount of sediment removed during a test by the total water volume that flowed through the device during the test.

**Appendix B: Device Configuration and Test Procedures – Scale Models**

## B.1. Swirl Flow Device Scale Model

### B.1.1. Equipment

The Swirl Flow Device Scale Model was a 1:10 scale model of a hypothetical swirl flow hydrodynamic separator. A schematic of the Swirl Flow Device Scale Model is included below as Figure B-1 (all units within this drawing are in inches). A clear plastic pipe with an inner diameter of 11.5 inches and a height of 28 inches was used as the exterior wall of the model. Inside of the scale model was an inner cylinder with a height of  $22 \frac{13}{16}$  inches and an outer diameter of 4.5 inches. A 1 inch wide rectangular cut was made at the top of the inner cylinder to a depth of 3.75 inches below the top of the inner cylinder to allow water to exit the pipe even when water elevations were not higher than the inner cylinder.

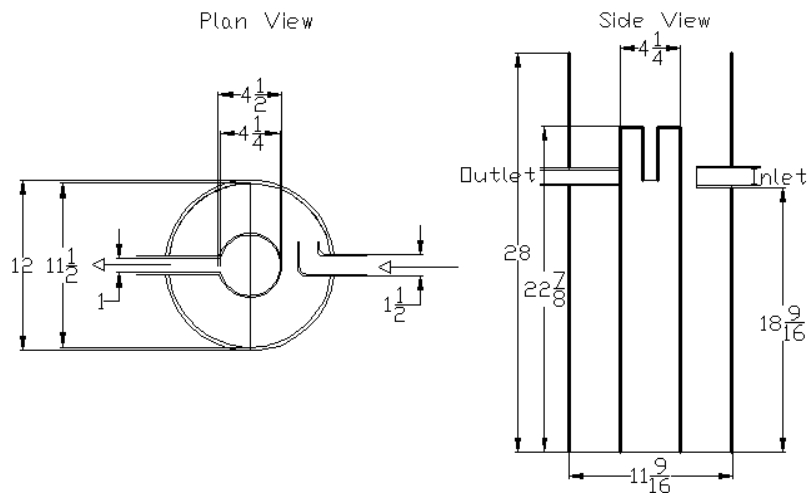

**Figure B-1: Dimensions of the swirl flow device scale model (all dimensions are in inches).**

Figure B-2 includes two pictures of the Swirl Flow Device Scale Model. Water was supplied to the inlet of the Swirl Flow Device Scale Model by a pump, and flow rate was controlled by a valve after the pump. The inlet pipe directed water at a 90 degree angle into the device. This can be seen in Figure B-2. At very low discharges, water entered a narrow notch inside the vertical inner cylinder and filled the inner cylinder. Water exited the inner cylinder through a pipe out the side of the cylinder. At moderate and high discharges, in addition to flowing through the notch, water overtopped the inner cylinder to exit through the outlet pipe.

The outlet from the device was piped to a reservoir tank. On top of the reservoir tank water travelled through a filter designed to collect sediment and prevent sediment recirculation through the pump back into the device. A head tank was connected to the storage reservoir to maintain constant head and ensure constant flow rates while the pump was running. Tap water was supplied to the head tank, and water overflowed out the reservoir tank via piping to the sewer.

During testing, the tap water flow rate was varied to provide cold water to the system. The cold water was necessary to remove heat generated by the pump to maintain constant water temperature in the system.

Prior to testing, a function of discharge versus device water height was developed. Water discharge during testing was determined by measuring the height of water in the device at a known point.

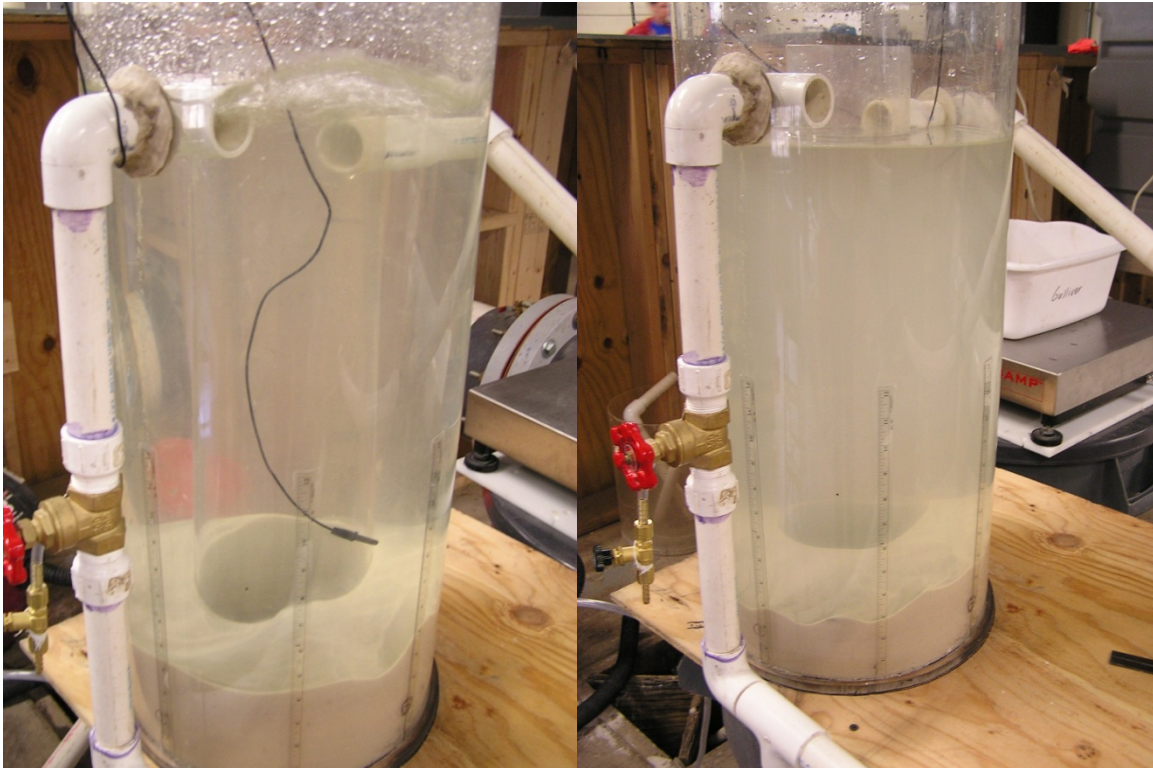

**Figure B-2: Photos of the swirl flow device scale model**

### **B.1.2. Test Procedures**

The detailed procedure for laboratory testing of the Swirl Flow Device Scale Model at St. Anthony Falls Laboratory is included as Procedure B-1. Procedure B-1 follows the general procedure for controlled sediment retention testing of hydrodynamic separators, as described in Procedure 2-1.

Procedure B-1: Detailed Procedure for Sediment Retention Testing – Swirl Flow Device Scale Model Laboratory Testing

- 1) Charge sieved sediment to the device to the approximate level desired for the test, maintaining saturation by adding water as needed, and being careful not to spill sediment into the inner cylinder
- 2) Level sediment

- 3) Record the level of the sediment bed at 8 known locations around the perimeter of the device
- 4) Add or remove water until water depth is approximately 12"
- 5) Attach point gauge bracket to top of device
- 6) Record initial water level using the point gauge
- 7) Record initial water temperature
- 8) Remove point gauge
- 9) Ensure inner cylinder is empty of water and sediment
- 10) Weigh entire system on a bench top scale
- 11) Replace model and align to markings on base board
- 12) Connect inlet and outlet piping
- 13) Slowly fill with water until water discharges from device
- 14) Shut off water
- 15) Record water height and temperature
- 16) Start water supply and stopwatch
- 17) Set water level based on desired discharge for test
- 18) Record water level and temperature every one minute during testing
- 19) Adjust tap water supply to upstream head tank as necessary to maintain water temperature in device
- 20) After desired test duration has been reached, turn off pump
- 21) Allow sediment to settle and system to drain to the invert of the outlet pipe
- 22) Record the level of the sediment bed at 8 known locations around the perimeter of the device (pre-leveling readings)
- 23) Level sediment bed
- 24) Record the level of the sediment bed at 8 known locations around the perimeter of the device (post-leveling readings)
- 25) Drain system down to a water depth of 12"
- 26) Disconnect all piping
- 27) Record final water temperature
- 28) Attach point gauge bracket to top of device
- 29) Record final water level using the point gauge
- 30) Remove point gauge
- 31) Vacuum out inner cylinder
- 32) Weigh entire system on a bench top scale

Utilizing the pre and post test weights and water levels, the amount of sediment washed out from the device during the test was calculated using the methodology described in Appendix E, Section E.2. Any sediment in the inner cylinder at the end of the test was assumed to be washed out from the system. Sediment effluent concentrations were calculated by dividing the total amount of sediment removed during a test by the total water volume that flowed through the device during the test.



## B.2. Idealized Swirl Flow Device Model

### B.2.1. Equipment

The Idealized Swirl Flow Device Model was constructed in order to better understand hydrodynamics in swirl flow devices without the influence of obstructions which are typically encountered in actual devices due to internal piping and components. This idealized model was similar in design to the Swirl Flow Device Scale Model (described in Section B.1). However, there are two primary differences between the two models. The Idealized Swirl Flow Device has water entering tangentially through an inlet pipe that is flush with the inside wall of the outer cylinder. Therefore, the inlet pipe does not protrude into the device and the water flow, as it does in the Swirl Flow Device Scale Model, and water does not encounter obstructions during its rotational path. Secondly, the water leaves the device through a relatively large pipe at the bottom of the inner cylinder, limiting the affects of the flooded inner cylinder that influenced the flow regimes in the Swirl Flow Device Scale Model. The Idealized Swirl Flow Device Model also did not have a notch in the inner cylinder. Figure B-3 includes a drawing of the Idealized Swirl Flow Device Model in plan and elevation views.

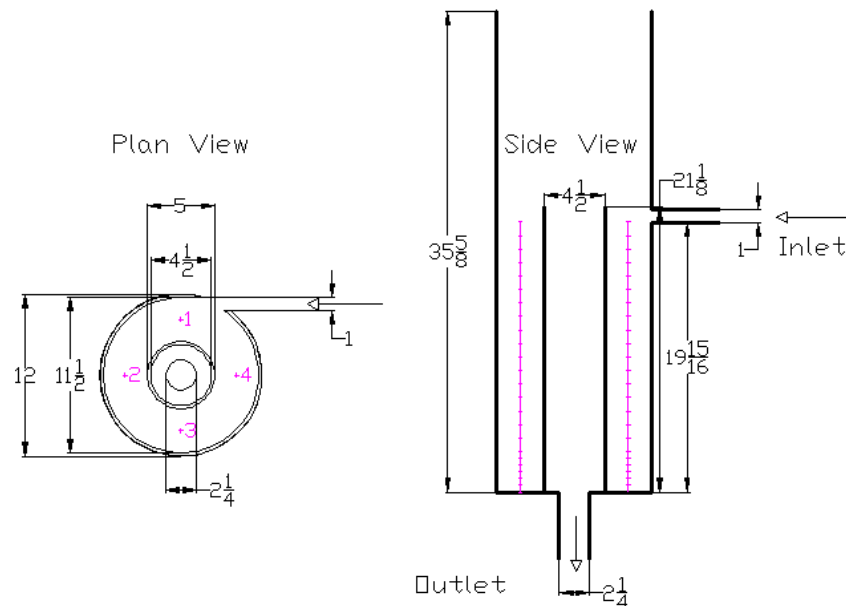

**Figure B-3: Dimensions of the idealized swirl flow device. All dimensions are in inches**

Water was supplied to the inlet of the Idealized Swirl Flow Device Model by a pump, and flow rate was controlled by a valve after the pump. The all water flowed over the top of the inner cylinder to exit the device, as there was no notch in the inner cylinder. The outlet from the device was piped to a reservoir tank. On top of the reservoir tank water travelled through a filter designed to collect sediment and prevent sediment recirculation through the pump back into the device. A head tank was connected to the storage reservoir to maintain constant head and ensure constant flow rates while the pump was running. Tap water was supplied to the head tank, and water overflowed out the reservoir tank via piping to the sewer. During testing, the tap water

flow rate was varied to provide cold water to the system. The cold water was necessary to remove heat generated by the pump to maintain constant water temperature in the system.

Prior to testing, a function of discharge versus device water height was developed. Water discharge during testing was determined by measuring the height of water in the device at a known point.

### **B.2.2. Test Procedures**

The detailed procedure for laboratory testing of the Swirl Flow Device Scale Model at St. Anthony Falls Laboratory is included as Procedure B-2. Procedure B-2 follows the general procedure for controlled sediment retention testing of hydrodynamic separators, as described in Procedure 2-1.

#### Procedure B-2: Detailed Procedure for Sediment Retention Testing – Idealized Swirl Flow Device Model Laboratory Testing

- 1) Charge sieved sediment to the device to the approximate level desired for the test, maintaining saturation by adding water as needed, and being careful not to spill sediment into the inner cylinder
- 2) Level sediment
- 3) Record the level of the sediment bed at 8 known locations around the perimeter of the device
- 4) Add or remove water until water depth is approximately 12"
- 5) Attach point gauge bracket to top of device
- 6) Record initial water level using the point gauge
- 7) Record initial water temperature
- 8) Remove point gauge
- 9) Ensure inner cylinder is empty of water and sediment
- 10) Weigh entire system on a bench top scale
- 11) Replace model and align to markings on base board
- 12) Connect inlet and outlet piping
- 13) Slowly fill with water until water discharges from device
- 14) Shut off water
- 15) Record water height and temperature
- 16) Start water supply and stopwatch
- 17) Set water level based on desired discharge for test
- 18) Record water level and temperature every one minute during testing
- 19) Adjust tap water supply to upstream head tank as necessary to maintain water temperature in device
- 20) After desired test duration has been reached, turn off pump
- 21) Allow sediment to settle and system to drain to the invert of the outlet pipe

- 22) Record the level of the sediment bed at 8 known locations around the perimeter of the device (pre-leveling readings)
- 23) Level sediment bed
- 24) Record the level of the sediment bed at 8 known locations around the perimeter of the device (post-leveling readings)
- 25) Drain system down to a water depth of 12"
- 26) Disconnect all piping
- 27) Record final water temperature
- 28) Attach point gauge bracket to top of device
- 29) Record final water level using the point gauge
- 30) Remove point gauge
- 31) Vacuum out inner cylinder
- 32) Weigh entire system on a bench top scale

Utilizing the pre and post test weights and water levels, the amount of sediment washed out from the device during the test was calculated using the methodology described in Appendix E, Section E.2. Any sediment in the inner cylinder at the end of the test was assumed to be washed out from the system. Sediment effluent concentrations were calculated by dividing the total amount of sediment removed during a test by the total water volume that flowed through the device during the test.

## **Appendix C: Sediment Measurement Techniques**

## C.1. Level Measurements: Laser Range Finder and Ruler Stick

### C.1.1. Test Methods

Two methods were used to determine the amount of the sediment in the Environment 21 V2B1 device during field testing at New Brighton, MN: 1) A ruler measuring the depth of the sediment to the floor of the device and 2) A laser range finder measuring the distance between the top of the sediment and the ceiling of the device.

#### Ruler Stick

A standard metal ruler stick was used to measure the depth of the sediment at 18 locations in the device. The same 18 locations were used for each sediment level measurement, and the 18 readings were averaged to obtain average sediment depths. Figure C-1 shows sediment measurement in the Environment 21 V2B1 device using the metal ruler stick.

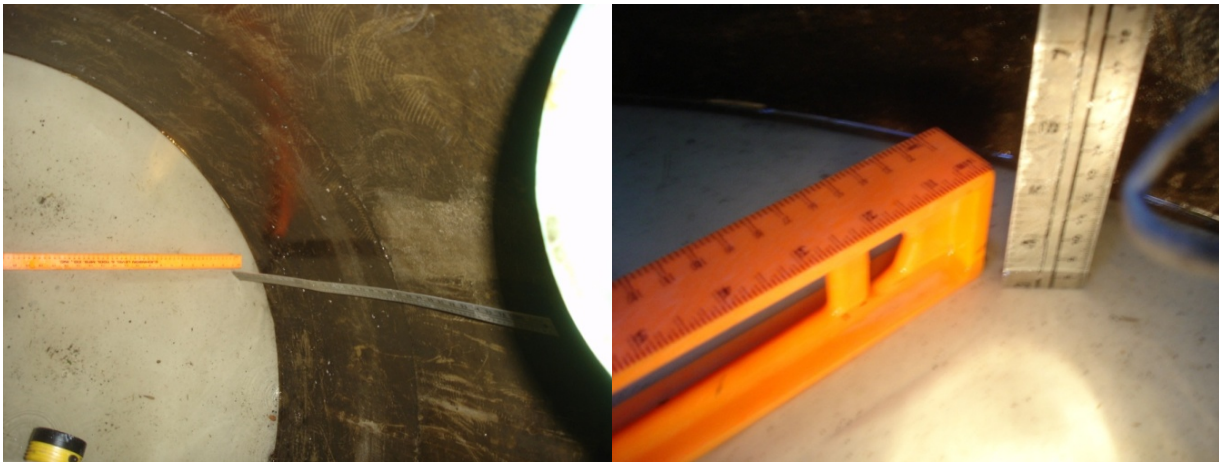

**Figure C-1: Sediment depth measurement using the metal ruler stick**

#### Laser Range Finder

A Hilti Model PD 30 laser range finder was used to measure the distance from the top of the sediment to the ceiling of the device. This device has a published accuracy of  $\pm 1/16^{\text{th}}$  inch over its entire measurement range of 660 feet. A custom bracket was fabricated, and the laser range finder was securely fastened in the bracket. The bracket incorporates a bubble level. Figure C-2 contains pictures of the laser range finder installed in the custom bracket with the bubble level.



**Figure C-2: Laser range finder with bracket**

The laser range finder was used to measure the distances between the top of the sediment and the ceiling of the device and the top of the sediment and the bottom of the inlet pipe at a total of 28 marked locations. To take a reading the laser range finder bracket was placed on the top of the sediment and moved until the bracket was level and laser beam was on target on the mark on the ceiling or the bottom of the inlet pipe for the respective reading. Before the first retention test, readings were taken when the device was empty to determine the distances between the floor of the device and the ceiling of the device and between the floor of the device and the bottom of the inlet pipe at each of the 28 points. The depth of sediment at each point was determined by subtracting the distance between the top of the sediment and the ceiling or the bottom of the inlet pipe from the distance from the floor of the device and the ceiling of the device or the bottom of the inlet pipe. Readings were taken at each of the 28 points before and after each retention test. The 28 sediment depths were averaged to obtain average sediment depths.

### **C.1.2. Verification of Test Methods**

Prior to the beginning of the Environment 21 V2B1 field sediment retention testing in New Brighton, the repeatability of the laser range finder was verified by testing in a full scale Royal Environmental Systems ecoStorm Model 3 device at Saint Anthony Falls Laboratory. Procedure C-1 describes the test method.

Procedure C-1: Laser Range Finder Repeatability in ecoStorm Device at St. Anthony Falls Laboratory

- 1) A plywood ceiling was constructed on top of the ecoStorm Device
- 2) The laser range finder was used to measure the distance from the floor to the ceiling of the device at 35 locations
- 3) Dry F110 gradation silica sand was weighed and added to the ecoStorm device. A total of 6424 pounds of F110 was added
- 4) Water was added and the sand was mixed until the sand was fully wetted
- 5) The sand was leveled
- 6) The laser range finder was used to find the distance from the top of the sand to the ceiling of the device at the same 35 locations for which the empty distances were taken
- 7) The distance from the top of the sand to the ceiling was subtracted from the distance from the bottom of the device to the ceiling to determine the depth of the sediment at each of the 35 locations
- 8) The depths of sediment at the 35 locations were averaged to determine an average sediment depth
- 9) The sediment was moved around using a shovel so that the sediment bed was not level
- 10) Steps 5 through 9 were repeated until a total of three average sediment depths were measured with the laser range finder

The results of the laser range finder repeatability test in the ecoStorm using Procedure C-1 are included in Table C-1.

**Table C-1: Laser range finder repeatability at St. Anthony Falls Laboratory**

	<b>Amount</b>	<b>Units</b>
Measured average depth of sediment, Test 1 =	10.31	in
Measured average depth of sediment, Test 2 =	10.23	in
Measured average depth of sediment, Test 3 =	10.26	in
Average depth of sediment, Test 1-3 =	10.26	in
% variation = (high - low)/(average)	0.7%	

Table C-1 shows that the laser range finder produced repeatable measurements for sediment in the ecoStorm device at Saint Anthony Falls Laboratory. The difference between the high reading and the low reading was only 0.08 inches (less than 3/32”), or 0.7% of the average total sediment height.

To verify the repeatability of the laser range finder and the stick measurement techniques in the Environment 21 V2B1 in the field, a test was conducted in the device in New Brighton, MN. Procedure C-2 was utilized to conduct this evaluation.

Procedure C-2: Level Measurement Repeatability in Environment 21 V2B1 at New Brighton, MN

- 1) The ceiling of the V2B1 and the bottom of the inlet pipe were marked with a total of 28 points
- 2) With the device empty, the laser range finder was used to measure the distance from the floor to the ceiling and the bottom of the inlet pipe at the 28 marked points
- 3) Dry F110 gradation silica sand was added to the V2B1 device until a sediment level of approximately 6" was reached
- 4) Water was added and the sand was mixed until the sand was fully wetted
- 5) The sand was leveled
- 6) The laser range finder was used to find the distance from the top of the sand to the ceiling of the device and to the bottom of the inlet pipe at the same 28 locations for which the empty distances were taken
- 7) The distances from the top of the sand to the ceiling and to the bottom of the inlet pipe were subtracted from the distances measured when the device was empty at each of the 28 locations
- 8) The depths of sediment at the 28 locations were averaged to determine an average sediment depth
- 9) The metal ruler stick was used to measure the sediment depth at 18 locations in the device
- 10) The sediment depths at the 18 locations were averaged to determine an average sediment depth
- 11) The sediment was moved around using a shovel so that the sediment bed was not level
- 12) Steps 5 through 11 were repeated until a total of three average sediment depths were measured with the laser range finder and with the ruler stick

The results of the New Brighton V2B1 level measurement repeatability test completed using Procedure C-2 are included in Table C-2.



**Table C-2: New Brighton Environment 21 V2B1 level measurement repeatability**

<b><i>Laser readings (28 points)</i></b>	<b>Amount</b>	<b>Units</b>
Measured average height of sediment, Laser, Test 1 =	6.38	in
Measured average height of sediment, Laser, Test 2 =	6.51	in
Measured average height of sediment, Laser, Test 3 =	6.50	in
Average depth of sediment, Test 1-3 =	6.47	in
% variation = (high - low)/(average)	1.92%	
<b><i>Stick readings (18 points)</i></b>		
Measured average depth of sediment, Stick, Test 1 =	6.33	in
Measured average depth of sediment, Stick, Test 2 =	6.38	in
Measured average depth of sediment, Stick, Test 3 =	6.35	in
Average depth of sediment, Test 1-3 =	6.36	in
% variation = (high - low)/(average)	0.76%	
<b><i>Laser vs. stick readings</i></b>		
Difference (averages)	0.11	in
% difference (averages)	1.68%	

Table C-2 shows that the laser range finder produced repeatable measurements for sediment depth in the Environment V2B1 device in New Brighton. The difference between the high reading and the low reading was 0.13 inches (1/8”), or 1.9% of the average total sediment height. The ruler stick was even more repeatable in this field test, with a difference between the high and low reading of only 0.05 inches (less than 1/16”), or 0.8% of the average total sediment height. The two level measurement methods also compared favorably to each other, with the average sediment depth for the three tests for the laser range finder being only 0.11 inches (less than 1/8”), or 1.7% of the total average sediment height, different than the average of the sediment depths for the three tests with the ruler stick method.

Both measurement techniques (the laser range finder and the ruler stick) were used to measure pre-run and post-run sediment depths for the 14 sediment retention tests conducted in New Brighton, MN.

Table C-3 shows the results of the two sediment measurement techniques for the field sediment retention tests. Note that stick readings were not taken for the first two tests in New Brighton.

**Table C-3: Level measurement technique comparison – Environment 21 V2B1 field sediment retention tests**

Test	Pre-run Sediment Level				Post-run Sediment Level			
	Laser Range Finder Reading, inches	Stick Reading, inches	Difference, inches	Difference, %	Laser Range Finder Reading, inches	Stick Reading, inches	Difference, inches	Difference, %
1	5.3				1.8			
2	5.9				5.2			
3	6.2	6.1	0.1	1.4%	5.1	4.9	0.2	4.4%
4	6.2	5.9	0.3	4.2%	4.6	4.4	0.2	3.7%
5	6.3	5.9	0.4	6.3%	3.2	3.0	0.2	7.1%
6	6.4	6.6	-0.2	-3.6%	2.7	2.7	0.0	0.8%
7	6.3	6.3	0.0	-0.4%	5.5	5.4	0.1	1.0%
8	7.6	7.2	0.4	4.9%	6.1	5.9	0.2	3.7%
9	7.1	7.0	0.1	1.9%	4.5	4.5	-0.1	-1.4%
10	6.5	6.5	0.0	0.2%	3.1	3.0	0.0	1.2%
11	6.6	6.5	0.1	1.9%	4.7	4.7	-0.1	-1.4%
12	6.3	6.2	0.0	0.4%	3.7	3.8	0.0	-0.3%
13	5.8	5.9	0.0	-0.5%	3.6	3.8	-0.2	-5.1%
14	6.0	5.8	0.1	2.3%	5.6	5.3	0.3	4.7%

The results show that both level measurement techniques have good agreement, as the average of the absolute values of the differences for the pre-run measurements is 0.15 inches, or 2.3% of the average total sediment height, and the post-run measurements is 0.13 inches, or 3.0% of the average total sediment height. The standard deviation for the absolute values of the differences for the pre-run measurements is 0.13 inches, and the standard deviation for the post-run measurements is 0.09 inches.

The verification testing demonstrates that the metal stick and laser range finder sediment level measurement techniques are repeatable and compare favorably to each other within tolerances anticipated to be acceptable for full scale sediment retention testing.

## **C.2. Weight Measurements: Load Cells**

### **C.2.1. Equipment**

Load cells are devices that are used to measure weight in a wide variety of applications. There are three types of load cells: hydraulic, pneumatic and strain gauge. Load cells are selected based on the application's environment and required precision.

For hydrodynamic separator testing at St. Anthony Falls Laboratory, precision strain gauge load cells were used to measure the weight of hydrodynamic separator devices and their contents. Strain gauge load cells utilize a transducer to convert force applied (i.e. weight of the device) to a measureable electric signal. As the weight in the device changes the force applied to the load cell changes, and the electrical resistance across the gauges changes in proportion to the load.

During setup, the hydrodynamic separators were set on a steel frame. The steel frame was then jacked up and load cells were installed under the steel frame. Depending on the device tested, either three or four load cells were used. The load cells had load buttons installed, so the weight of the system was directly applied to a specific point. One load cell sat on a fixed plate. The remaining load cells (two or three depending on the device tested) sat on plates with bearings to allow movement laterally. Free lateral movement prevented the system from being constrained

and prevented side loading on the load cells, which would introduce error in measurements and could damage the load cells. Figure C-3 shows a load cell installed under the device under the steel frame and on a bearing plate.



**Figure C-3: Load cell installed under device**

To measure weight with high repeatability, clean power must be provided to the load cells. Building power at 120V was supplied to an Uninterrupted Power Supply (UPS), which served to provide continuous power with level voltage and current to the load cell system. From the UPS, power was supplied to Interface Model SGA signal conditioners, which transformed and filtered the power supplied to the load cells. Each load cell was supplied conditioned low voltage power by its own dedicated Interface SGA box. In the load cell, weight applied changes the resistance across strain gauges, causing a proportional change in the output voltage. The low voltage output signal was amplified to a measureable signal using a card in the data acquisition computer. The computer continuously recorded the output voltage from the load cells. For calibration and troubleshooting, the computer also continuously recorded the building voltage and phase, and the voltage and current supplied to each load cell.

Tovey Engineering Model FR10-5K load cells were used. These load cells have a capacity of 5,000 lbs each, and a published non-repeatability of  $\pm 0.01\%$  of total capacity, or  $\pm 0.5$  lbs/load cell (see Table C-4). Considering all errors (non-repeatability, amplification errors, an over constrained system (when four load cells are used)), the estimated accuracy of the complete measurement system is  $\pm 0.04\%$  of total capacity, or  $\pm 8$  lbs when four Model FR10-5K load cells are used and  $\pm 6$  lbs when three Model FR10-5K load cells are used.

**Table C-4: Tovey Engineering load cell model FR specifications (From <http://www.toveyengineering.com/fr.pdf> on 10/23/08)**

<b>SPECIFICATIONS</b>				
<b>PARAMETERS</b>	<b>MODEL</b>			
	FR10	FR10	FR20	FR30
	150, 250 500, 1K	<b>CAPACITY (lbf)</b> 2.5K, 5K      12.5K, 25K		50K
<b>Accuracy</b>				
Static Error Band, % R.O.	+/- .03	+/- .04	+/- .05	+/- .05
Nonlinearity, % R.O.	+/- .04	+/- .04	+/- .05	+/- .05
Hysteresis, % R.O.	+/- .03	+/- .04	+/- .05	+/- .05
Nonrepeatability, % R.O.	+/- .01	+/- .01	+/- .01	+/- .01
Creep, % in 20 minutes	+/- .025	+/- .025	+/- .025	+/- .025
Off-Center Load Sensitivity, %/inch	+/- .10	+/- .10	+/- .10	+/- .10
Side Load Sensitivity, %	+/- .10	+/- .10	+/- .10	+/- .10
Zero Balance, % R.O.	+/- 1.0	+/- 1.0	+/- 1.0	+/- 1.0
<b>Temperature</b>				
Range, Compensated, °F	+15 to +115	+15 to +115	+15 to +115	+15 to +115
Range, Operating, °F	-65 to +200	-65 to +200	-65 to +200	-65 to +200
Effect on Sensitivity, % Rdg/100°F	+/- .08	+/- .08	+/- .08	+/- .08
Effect on Zero, % R.O./100°F	+/- .15	+/- .15	+/- .15	+/- .15
<b>Electrical</b>				
Rated Output, mV/V, Nominal	1.0	2.0	2.0	2.0
Excitation Voltage, VDC	10	10	10	10
Input Resistance, Ohms	350	350	350	350
Output Resistance, Ohms	350	350	350	350
Insulation Resistance, Megohm	5000	5000	5000	5000
<b>Mechanical</b>				
Safe Overload Range, % R.O.	+/- 300	+/- 300	+/- 300	+/- 300
Weight (lbs.)	1.0	2.9	9.1	23.5
Weight w/base (lbs.)	2.5	6.5	21.5	52.5
Flexure Material	Aluminum	Steel	Steel	Steel

Once the load cells were installed, LabView computer software was utilized to display real time information about load cell voltage input/output, weight readings, and the standard deviations of weight measurements. Figure C-4 shows a screen shot of the computer program utilized during testing.

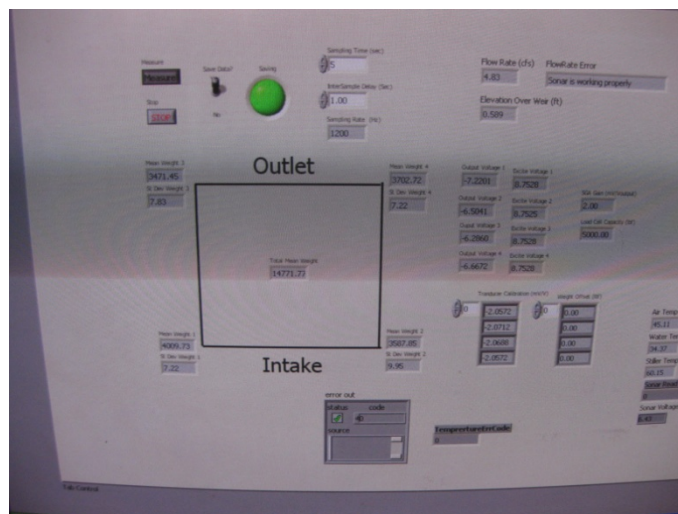
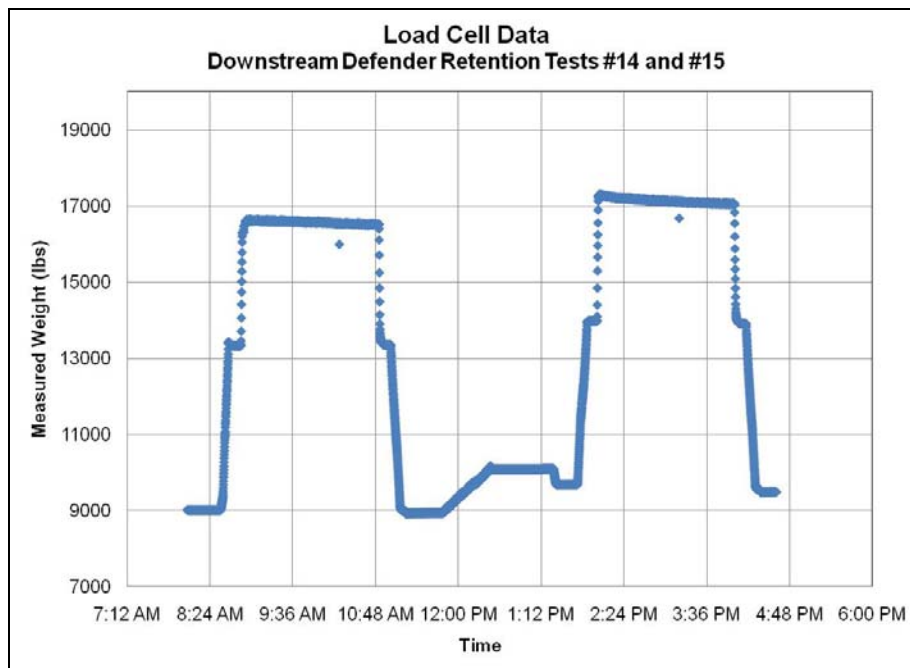

**Figure C-4: Screen shot of the LabView program**

Weight monitoring of the system can be used for a few different purposes:

- 1) To observe changes during testing, which can indicate problems
- 2) To obtain accurate static weights before and after the tests, which can be used to calculate sediment washout
- 3) To record dynamic weights during the tests (requires post-run analysis)

Figures C-5, C-6 and C-7 show an example of the weight changes that can be observed using load cells. Figure C-5 shows the weight changes observed during sediment retention Test# 14, the period the sump was charged with sediments between tests, and during sediment retention Test# 15. Figure C-6 shows a close-up of the weight change during Test# 14, and Figure C-7 shows a close-up of the weight change during Test# 15. These close-up images show that the rate of sediment washout during these two tests is not consistent, as Test# 14 shows a linear loss of sediment, while Test# 15 shows a non-linear loss. This can possibly be explained by the difference in starting conditions of the two tests; no sediment was added before Test# 14, and the starting sediment levels in the sump were different before the two tests.



**Figure C-5: Load cell data during two sediment retention tests**

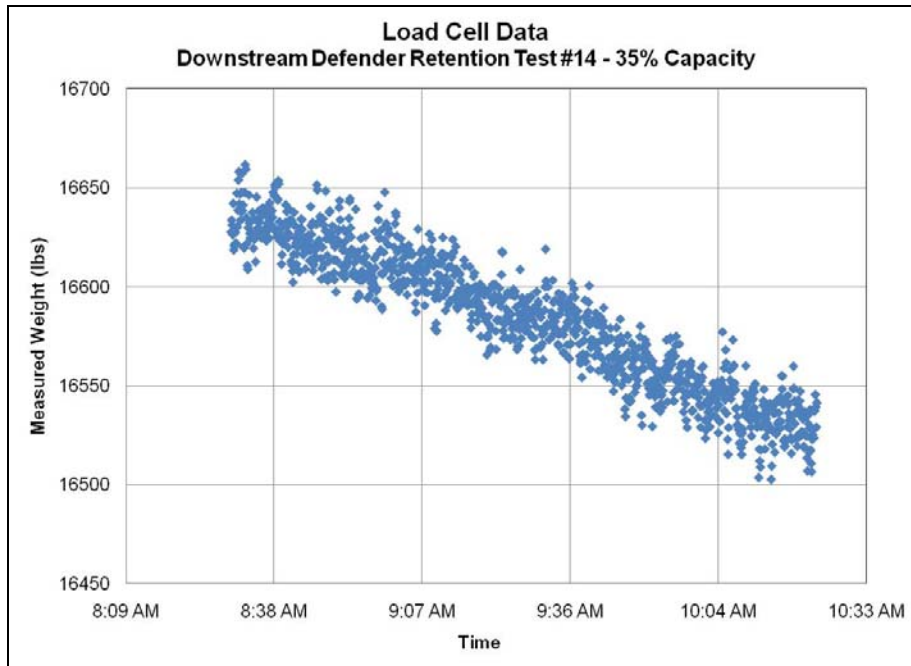

**Figure C-6: Load cell data collected during sediment retention test# 14**

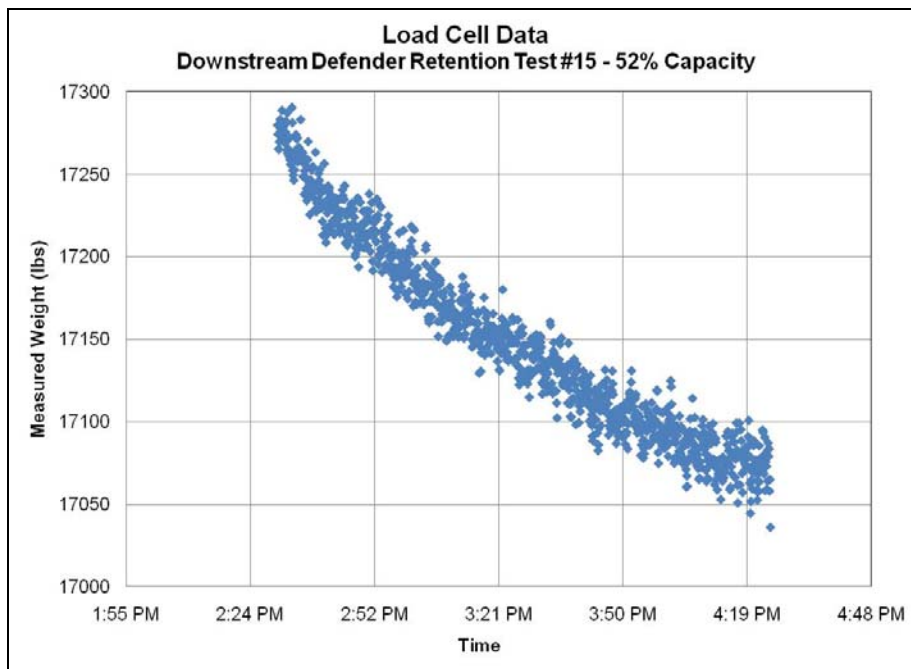

**Figure C-7: Load cell data collected during sediment retention test# 15**

The water level in the sump before and after testing was accurately measured using a stilling basin and point gauge (see Figure C-8).



**Figure C-8: Stilling basin and point gauge used for water level measurement**

### **C.2.2. Test Methods**

The procedure for system weight measurement using load cells is included as Procedure C-3.

#### **Procedure C-3: System Weight Measurement using Load Cells**

- 1) Pre-retention test weight reading
  - a. Add or remove water from the manhole until the water level in the manhole is approximately at a pre-marked elevation
  - b. Disconnect all piping from the system
  - c. Measure and record the elevation of water in the manhole using the stilling basin and point gauge (see Figure C-8)
  - d. Tap load cells with rubber mallet to ensure the system components are not binding
  - e. Verify load cells plate clearances with a piece of paper (to confirm that load cells are not touching their safety brackets)
  - f. Ensure the device is not touching any piping
  - g. Average 10 load cell weight readings to obtain the pre-test weight
  - h. Record pre-test weight
  
- 2) Post-retention test weight reading

- a. Following the conclusion of the retention test, wait 10 minutes for sediment to settle in the device
- b. Slowly drain water in the device to the pre-marked elevation
- c. Disconnect all piping from the system
- d. Measure and record elevation of water in tank using the stilling basin and point gauge (see Figure C-8)
- e. Tap load cells with rubber mallet to ensure that the system components are not binding
- f. Verify load cells plate clearances with a piece of paper (to confirm that load cells are not touching their safety brackets)
- g. Average 10 load cell weight readings to obtain the pre-test weight
- h. Record the post-test weight

The pre and post test weights and water levels are used to calculate the sediment loss and average effluent concentration for the test, using the methodology described in Appendix E, Section E.2.



**Appendix D: Size Distributions for Commercial Silica Sand Gradations**

## D.1. US Silica F110

% RETAINED ON	GRADE						
	F-65	F-70	F-75	F-80	F-85	F-95	F-110
30	<1						
40	3	1	<1	<1	<1	<1	
50	15	9	6	5	2	1	<1
70	29	30	24	19	12	9	4
100	31	35	38	36	38	30	18
140	18	20	25	31	38	42	44
200	3	4	6	8	9	15	25
270	<1	<1	<1	1	1	3	8
Pan						<1	<1
AFS GFN	67	70	76	80	85	95	110

Figure D-1: Sieve analysis for US Silica F Series including F110 silica sand (source: US Silica. Found online on 7/7/08 at: <http://www.u-s-silica.com/PDS/Ottawa/OTTAWA%20FDY%20SANDS%202004.pdf>)

## D.2. AGSCO 70-100

<b>SILICA SAND</b>									
TYPICAL SCREEN ANALYSIS									
<b>ROUND GRAIN SAND</b>									
US SIEVE	(Percent Retained)								
	<u>12-20</u>	<u>16-30</u>	<u>20-40</u>	<u>(#1)</u> <u>35-50</u>	<u>(#2)</u> <u>40-70</u>	<u>50-80</u>	<u>(#7)</u> <u>70-100</u>	<u>(#10)</u> <u>100-140</u>	<u>(#16)</u> <u>140-270</u>
12	0.1								
14	1.3								
16	10.3								
18	44.2	1.4							
20	40.4	35.7	2.3						
25	3.5	58.0	19.7	0.3					
30	0.2	4.7	28.0	2.0	0.3				
35		0.2	30.3	20.5	5.2				
40			15.8	35.3	16.5	2.7			
50			3.6	32.7	37.0	39.3	8.2		
60			0.3	4.7	14.2	23.8	16.3	3.2	
70				2.2	9.3	16.2	22.3	4.6	
80				2.3	5.5	9.1	24.0	11.6	
100					4.8	5.4	13.5	19.8	
120					7.2	3.5	9.3	20.3	5.1
140							3.6	23.9	22.7
170							2.5	7.0	26.5
200							0.3	5.3	24.4
230								3.5	13.4
270								0.8	5.9
325									2.0
	100.0	100.0	100.0	100.0	100.0	100.0	100.0	100.0	100.0
AFS Grain Number	10	16	25	35	47	50	66	94	144
Effective Size (mm)	.85	.71	.43	.30					

**Figure D-2: Sieve analysis for AGSCO 70-100 (source: AGSCO. Found online on 7/7/08 at: <http://agsco.thomasnet.com/Asset/Silica-Sand-technical-data-sheet.pdf>)**

### D.3. US Silica Sil Co Sil 250 (SCS 250)

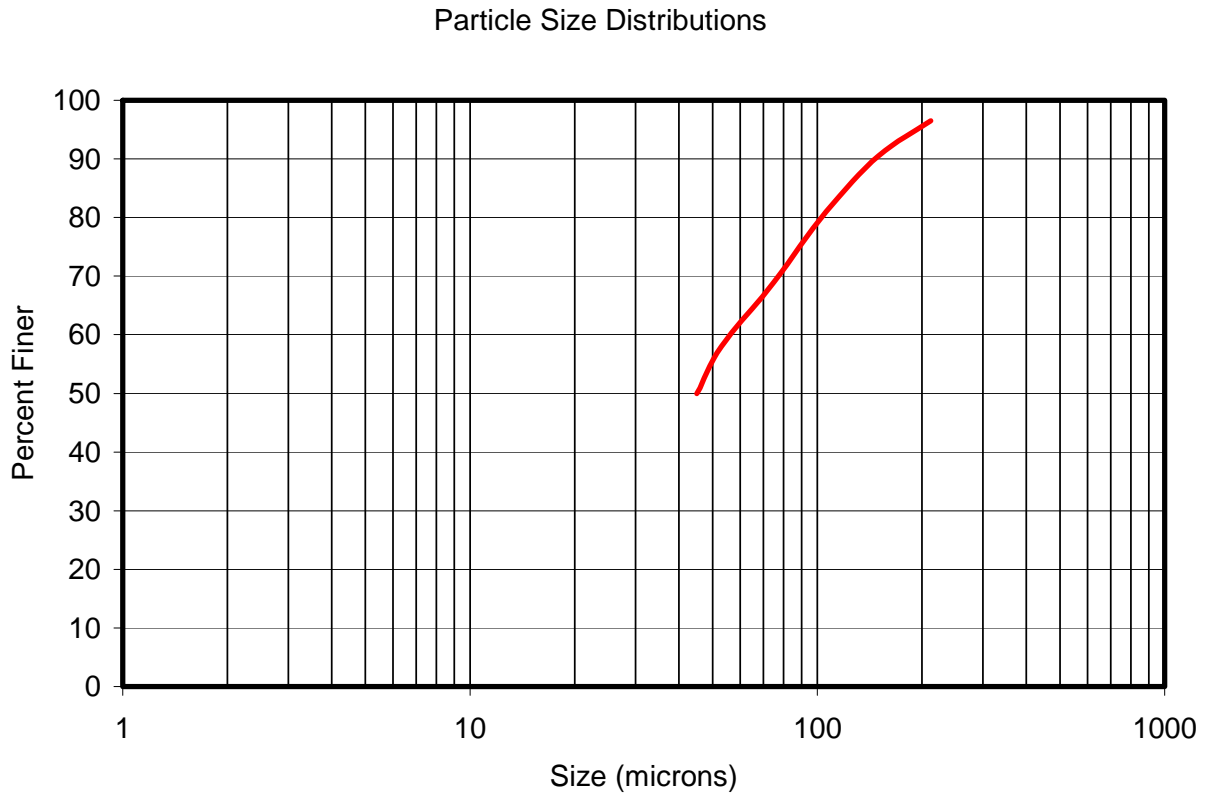

**Figure D-3: Sieve analysis for SCS-250**

## **Appendix E: Calculation of Sediment in Devices**

## E.1. Calculating Sediment Washout using Level Measurements

### Key assumption:

The bulk density of wet US Silica F110 is 107 lb dry sediment/ft<sup>3</sup> wetted sediment. This bulk density was based on numerous measurements at SAFL. Bulk density of wet sediments were tested at SAFL at varying levels of compaction, and in a variety of apparatuses, including graduated cylinders, trays and full scale hydrodynamic separator prototype models.

The bulk density in weight of dry sediment per volume of wetted sediment can be determined by following Procedure E-1.

#### Procedure E-1: Determination of Bulk Sediment Density

- 1) Use a vessel with known geometry and dimensions (such as a round manhole)
- 2) Add water to the vessel
- 3) Weigh and charge sediment to the vessel
- 4) Add water and mix as needed to ensure that sediment is fully wetted
- 5) Level the sediment
- 6) Measure the depth of the sediment at numerous locations in the device and average the measured depths to obtain the sediment depth

Bulk density tests should be repeated several times following Procedure E-1 to ensure that the measured bulk density is repeatable.

Calculation E-1 shows an example calculation of bulk density for the Environment 21 V2B1 device in New Brighton.

#### Calculation E-1: Sediment Bulk Density

Device geometry: Round manhole

D = Device diameter = 60 inches

H = Wetted sediment height = 5.31 inches

W = Weight of dry sediment added = 900 lbs

$V_s = \text{Volume of wetted sediment} = \pi r^2 * H = \Delta H = \pi (60 \text{ in}/2)^2 * 5.31 \text{ inches} = 15,014 \text{ in}^3 = 8.69 \text{ ft}^3$

$\rho_d = \text{Bulk density (weight of dry sediment/volume of wetted sediment)} = W/V_s$

$\rho_d = W/V_s = 900 \text{ lbs} / 8.69 \text{ ft}^3 = \underline{104 \text{ lb dry sediment/ft}^3 \text{ wetted sediment}}$

Using bulk density and test results, Procedure E-2 can be used to calculate average effluent concentration for sediment retention tests using sediment level measurements.

#### Procedure E-2: Calculation of Sediment Washout using Sediment Level:

1. Record difference in sediment level between pre and post test
2. Calculate change in sediment level

3. Calculate sediment washout by weight of sediment
4. Calculate average effluent concentration

Calculation E-2 shows an example calculation of average effluent concentration following Procedure E-2 using sediment level measurements.

Calculation E-2: Calculation of Average Effluent Concentration Using Sediment Level Measurements

D = Device diameter = 60 inches

$\rho_d$  = Bulk density (weight of dry sediment/volume of wetted sediment) = 107 lb/ft<sup>3</sup> H<sub>1</sub> = Pre-test sediment level = 7.58 inches

H<sub>2</sub> = Post-test sediment level = 6.11 inches

Q = Average discharge = 2.38 cfs

T = Duration of test = 90 minutes

$\Delta H$  = Difference in level = H<sub>2</sub> – H<sub>1</sub> = 7.58 in – 6.11 in = 1.47 inches

V = Volume of wet sediment washed out =  $\pi r^2 * \Delta H = \pi (60 \text{ in}/2)^2 * 1.47 \text{ inches} = 4,160 \text{ in}^3 = 2.41 \text{ ft}^3$

W<sub>d</sub> = Weight of dry sediment washed out = V \*  $\rho_d$  = 2.41 ft<sup>3</sup> \* 107 lb/ft<sup>3</sup> = 258 lb dry sediment

C = Average effluent concentration = W<sub>d</sub> / (Q \* T) = 258 lb / (2.38 cfs \* 90 min \* 60 s/min) = 0.020 lb/ft<sup>3</sup>

C = 0.020 lb/ft<sup>3</sup> \* (454 g/lb) \* (35.3 ft<sup>3</sup>/m<sup>3</sup>) = 331 g sediment/m<sup>3</sup> water

## E.2. Calculating Sediment Washout using Weight Measurements

Using test results, Procedure E-3 can be used to calculate average effluent concentration for sediment retention tests using system weight change.

Procedure E-3: Calculation of Sediment Washout using System Weight Change

1. Record system weight difference between pre and post test
2. Record manhole water level difference between pre and post test
3. Adjust weight change to compensate for water weight difference
4. Calculate total weight change due to sediment removal
5. Calculate sediment washout by weight of sediment
6. Calculate average effluent concentration

Calculation E-3 shows an example calculation of average effluent concentration following Procedure E-3 using sediment level measurements.

Calculation E-3: Calculation of Average Effluent Concentration using System Weight Change

D = Device diameter = 72 in = 6.0 ft

$\rho_w$  = Density of water = 62.4 lb/ft<sup>3</sup>

SG<sub>s</sub> = Sediment specific gravity = 2.6

$W_1$  = Pre test system weight = 10,807 lbs

$W_2$  = Post test system weight = 10,713 lbs

$\Delta W$  = Change in system weight from pre to post test =  $W_2 - W_1 = 10,713 \text{ lbs} - 10,807 \text{ lbs} = -94 \text{ lbs}$

$L_1$  = Pre test water level in manhole = 1.2925 ft

$L_2$  = Post test water level in manhole = 1.3055 ft

$\Delta L$  = Change in water level from pre to post test =  $L_2 - L_1 = 1.3055 \text{ ft} - 1.2925 \text{ ft} = 0.013 \text{ ft}$

$W_a$  = Weight adjustment due to water level change =  $-\Delta L * \pi D^2 * \rho_w$

$W_a = -0.013 \text{ ft} * \pi * (6\text{ft}/2)^2 * 62.4 \text{ lb/ft}^3 = -22.9 \text{ lb}$

$\Delta W_s$  = Weight change due to sediment loss =  $\Delta W + W_a = -94 \text{ lb} - 22.9 \text{ lb} = -117 \text{ lb}$

$W_d$  = Weight of dry sediment washed out =  $-\Delta W_s * (SG_s / (SG_s - 1))$

$W_d = 117 \text{ lb} * (2.6 / (2.6 - 1)) = 190 \text{ lbs}$

$Q$  = Average discharge = 8.0 cfs

$T$  = Duration of test = 60 minutes

$C$  = Average effluent concentration =  $W_d / (Q * T) = 190 \text{ lb} / (8.0 \text{ cfs} * 60 \text{ min} * 60 \text{ s/min}) = 0.0066 \text{ lb/ft}^3$

$C = 0.0066 \text{ lb/ft}^3 * (454 \text{ g/lb}) * (35.3 \text{ ft}^3/\text{m}^3) = \underline{106 \text{ g/m}^3}$



## **Appendix F: Retention Testing Results - Tables**

## F.1. Environment 21 V2B1 Model 4 - Field Testing

**Table F-1: Test conditions and results for Environment 21 V2B1 Model 4—field testing**

Test	Test Date	Location	Sediment	Water Temperature, °C	Run Duration, minutes	Flowrate, cfs	Sediment Start Height, inches	Sediment Finish Height, inches	Sediment Washout, inches	Outlet Concentration, g sediment/m <sup>3</sup> water
1	8/24/2007	New Brighton	F110	Unknown	30	3.9	5.5	2.0	3.5	1315
2	8/26/2007	New Brighton	F110	Unknown	45	1.7	6.1	5.3	0.8	428
3	8/29/2007	New Brighton	F110	Unknown	60	2.3	6.4	5.3	1.1	340
4	8/30/2007	New Brighton	F110	Unknown	60	2.7	6.4	4.8	1.6	424
5	8/31/2007	New Brighton	F110	Unknown	45	3.6	6.5	3.4	3.2	866
6	9/6/2007	New Brighton	F110	17.2	60	3.3	6.6	2.9	3.7	809
7	9/11/07-9/13/07	New Brighton	F110	18.0	90	1.7	6.4	5.7	0.7	198
8	9/27/2007	New Brighton	F110	16.2	90	2.4	7.8	6.3	1.5	298
9	10/4/2007	New Brighton	F110	16.0	60	3.4	7.4	4.6	2.8	594
10	10/9/077	New Brighton	F110	13.9	30	4.1	6.7	3.2	3.5	1233
11	10/11/2007	New Brighton	F110	15.1	90	2.8	6.8	4.8	1.9	342
12	10/12/2007	New Brighton	F110	15.1	45	3.5	6.4	3.8	2.5	698
13	10/23/2007	New Brighton	AGSCO 70:100	14.8	45	4.1	5.9	3.6	2.3	557
14	10/25/2007	New Brighton	AGSCO 70:100	14.4	120	2.8	6.1	5.7	0.4	55

## F.2. Environment 21 V2B1 Model 4 - Laboratory Testing

**Table F-2: Test conditions and results for Environment 21 V2B1 Model 4—laboratory testing**

Test	Test Date	Location	Sediment	Water Temperature, °C	Run Duration, minutes	Flowrate, cfs	Primary Manhole Weight Change, lb	Outlet Concentration, g sediment/m <sup>3</sup> water
1	12/1/2008	SAFL	F110	1.7	60	2.7	-126	333
2	12/2/2008	SAFL	F110	0.2	60	2.8	-176	450
3	12/3/2008	SAFL	F110	0.5	90	2.3	-189	390
4	12/4/2008	SAFL	F110	0.2	90	2.3	-181	373
5	12/5/2008	SAFL	F110	0.6	45	3.4	-268	743
6	12/5/2008	SAFL	F110	-0.1	45	3.4	-258	716
7	12/6/2008	SAFL	F110	0.4	120	1.8	-77	157
8	12/6/2008	SAFL	F110	0.3	120	1.7	-33	69
9	12/8/2008	SAFL	F110	0.3	120	2.0	-79	140
10	12/8/2008	SAFL	F110	0.1	60	3.1	-251	581
11	12/11/2008	SAFL	F110	0.5	120	2.0	-110	197
12	12/12/2008	SAFL	F110	0.4	60	3.0	-209	493
13	12/18/2008	SAFL	AGSCO 70:100	0.1	180	2.8	-172	149
14	12/19/2008	SAFL	AGSCO 70:100	0.1	90	3.5	-156	211
15	12/24/2008	SAFL	AGSCO 70:100	0.2	95	3.4	-73	97
16	12/29/2008	SAFL	AGSCO 70:100	0.3	94	3.6	-84	108
17	1/5/2009	SAFL	AGSCO 70:100	0.2	180	2.8	-54	46

### F.3. Stormceptor Model STC 1200 Laboratory Testing

**Table F-3: Test conditions and results for Stormceptor STC 1200 – laboratory testing**

Test	Test Date	Location	Sediment	Water Temperature, °C	Run Duration, minutes	Flowrate, cfs	Primary Manhole Weight Change, lb	Outlet Concentration, g sediment/m <sup>3</sup> water
1	12/11/2008	SAFL	F110	1.3	120	0.47	-8	60
2	12/12/2008	SAFL	F110	1.4	120	2.91	-9	11
3	12/15/2008	SAFL	F110	1.4	90	4.95	-7	6
4	12/18/2008	SAFL	F110 + SCS250	1.2	96	0.47	-25	245
5	12/19/2008	SAFL	F110 + SCS250	1.2	90	4.83	4	-4
6	12/19/2008	SAFL	F110 + SCS250	1.6	90	0.49	2	-23
7	12/23/2008	SAFL	F110 + SCS250	1.7	60	8.34	2	-2

## F.4. Downstream Defender 6 ft. Diameter Laboratory Testing

**Table F-4: Test conditions and results for Downstream Defender – bag fed**

Test	Test Date	Location	Sediment	Water Temperature, °C	Run Duration, minutes	Flowrate, cfs	Manhole Weight Change, lb	Outlet Concentration, g sediment / m3 water	Sediment Capacity at Start of Run by Weight
1	3/5/2009	SAFL	F110	2.5	121	2.00	11	-20	19%
2	3/6/2009	SAFL	F110	3.6	122	6.11	-33	20	20%
3	3/6/2009	SAFL	F110	3.6	120	6.13	-20	12	19%
4	3/11/2009	SAFL	F110	1.4	120	6.04	-22	14	38%
5	3/12/2009	SAFL	F110	1.1	60	7.99	-100	93	37%
6	3/12/2009	SAFL	F110	1.1	60	7.98	-99	92	35%
7	3/13/2009	SAFL	F110	0.9	120	6.04	-44	27	51%
8	3/13/2009	SAFL	F110	1.0	120	6.11	-66	40	50%
9	3/16/2009	SAFL	F110	4.3	120	6.08	-23	14	48%
10	3/16/2009	SAFL	F110	4.2	120	6.08	-25	15	48%
11	3/17/2009	SAFL	F110	4.6	120	8.04	-240	111	47%
12	3/17/2009	SAFL	F110	4.2	120	8.02	-194	90	40%
13	3/18/2009	SAFL	F110	3.1	240	4.01	5	-2	35%
14	3/19/2009	SAFL	F110	2.2	120	7.00	-70	37	35%
15	3/19/2009	SAFL	F110	2.4	120	7.07	-181	95	52%
16	3/20/2009	SAFL	F110	2.0	240	5.01	-8	3	47%
17	3/24/2009	SAFL	F110	3.2	120	7.16	-82	43	47%
18	4/23/2009	SAFL	F110	11.7	120	5.08	-50	36	65%
19	4/24/2009	SAFL	F110	13.8	120	6.11	-34	21	63%
20	4/29/2009	SAFL	F110	11.8	120	7.01	-69	37	62%
21	5/1/2009	SAFL	F110	12.0	120	8.09	-150	69	60%
22	5/14/2009	SAFL	F110	15.5	120	5.02	-9	7	56%
23	5/18/2009	SAFL	F110	16.4	120	5.01	-82	61	75%
24	5/19/2009	SAFL	F110	17.3	120	4.95	-35	27	73%
25	5/19/2009	SAFL	F110	17.7	120	5.90	-46	29	72%
26	5/20/2009	SAFL	F110	18.6	120	6.87	-64	35	70%
27	5/20/2009	SAFL	F110	19.1	180	4.00	-9	6	69%
28	5/21/2009	SAFL	F110	17.1	60	7.77	-58	56	68%
29	6/3/2009	SAFL	F110	17.6	35	8.08	-354	559	81%
30	6/3/2009	SAFL	F110	18.0	30	5.99	-22	54	71%
31	6/10/2009	SAFL	F110	16.7	28	2.78	-1	7	82%
32	6/16/2009	SAFL	F110	18.7	19.5	7.44	-67	206	81%
33	6/16/2009	SAFL	F110	19.0	24	8.08	-83	191	79%
34	6/18/2009	SAFL	F110	19.3	44	7.18	-56	79	77%

**Table F-5: Test conditions and results for Downstream Defender – ~85% bag fed**

Test	Test Date	Location	Sediment	Water Temperature, °C	Run Duration, minutes	Flowrate, cfs	Manhole Weight Change, lb	Outlet Concentration, g sediment / m3 water	Sediment Capacity at Start of Run by Weight
1	5/21/2009	SAFL	F110	17.1	120	4.96	-354	265	86%
2	5/26/2009	SAFL	F110	17.8	45	2.41	-52	213	86%
3	5/26/2009	SAFL	F110	17.7	30	3.82	-61	237	85%
4	5/26/2009	SAFL	F110	17.9	19.5	5.97	-96	368	83%
5	5/27/2009	SAFL	F110	16.9	20	6.90	-253	817	86%
6	5/27/2009	SAFL	F110	17.0	30	2.45	-31	189	85%
7	5/28/2009	SAFL	F110	16.2	19	3.89	-30	180	84%
8	5/28/2009	SAFL	F110	16.7	20	5.04	-58	258	83%
9	5/28/2009	SAFL	F110	16.7	20	5.95	-99	371	81%
10	5/28/2009	SAFL	F110	17.1	14.5	6.82	-220	993	86%
11	5/29/2009	SAFL	F110	16.9	15	6.51	-154	705	86%
12	5/29/2009	SAFL	F110	17.2	10	7.84	-350	1993	86%
13	6/2/2009	SAFL	F110	18.1	14.5	6.58	-188	877	86%

**Table F-6: Test conditions and results for Downstream Defender – stick leveled**

Test	Test Date	Location	Sediment	Water Temperature, °C	Run Duration, minutes	Flowrate, cfs	Manhole Weight Change, lb	Outlet Concentration, g sediment / m3 water	Sediment Capacity at Start of Run by Weight
1	6/4/2009	SAFL	F110	18.1	20	6.80	-158	519	85%
2	6/4/2009	SAFL	F110	18.2	20	5.92	-48	183	81%
3	6/8/2009	SAFL	F110	16.8	26.5	2.57	-24	156	86%
4	6/9/2009	SAFL	F110	16.4	19	4.04	-34	195	85%
5	6/9/2009	SAFL	F110	16.7	18	5.03	-64	318	85%
6	6/9/2009	SAFL	F110	16.7	19	5.98	-74	292	83%
7	6/10/2009	SAFL	F110	16.8	9	7.47	-176	1167	87%
8	6/11/2009	SAFL	F110	17.2	9	7.99	-230	1424	87%
9	6/11/2009	SAFL	F110	17.4	9.5	7.76	-177	1071	86%

**Table F-7: Test conditions and results for Downstream Defender – AccuRate fed**

Test	Test Date	Location	Sediment	Water Temperature, °C	Run Duration, minutes	Flowrate, cfs	Manhole Weight Change, lb	Outlet Concentration, g sediment / m3 water	Sediment Capacity at Start of Run by Weight
1	6/22/2009	SAFL	F110	23.0	19	5.95	-86	340	85%
2	6/24/2009	SAFL	F110	23.2	18	5.98	-102	421	87%
3	6/24/2009	SAFL	F110	23.3	9	7.18	-61	424	84%
4	6/25/2009	SAFL	F110	23.2	9	7.31	-192	1300	88%
5	6/26/2009	SAFL	F110	23.1	9.5	7.91	-90	536	82%
6	6/29/2009	SAFL	F110	21.9	9	7.49	-100	663	85%

## F.5. Swirl Flow Device Scale Model Laboratory Testing

**Table F-8: Test conditions and results for swirl flow device scale model**

Test	Test Date	Location	Sediment	Water Temperature, °C	Run Duration, minutes	Flow rate, gpm	Weight Change, lb	Outlet Concentration, g sediment / m <sup>3</sup> water
1	4/2/2009	SAFL	180-250 micron	3.4	120	4.19	-3.23	325
2	4/3/2009	SAFL	180-250 micron	6.3	120	4.50	-2.62	258
3	4/3/2009	SAFL	180-250 micron	6.1	120	4.25	-3.00	291
4	4/6/2009	SAFL	180-250 micron	6.1	120	4.38	-3.10	300
5	4/6/2009	SAFL	180-250 micron	6.5	120	4.38	-3.31	308
6	4/7/2009	SAFL	180-250 micron	6.3	120	4.56	-3.31	308
7	4/7/2009	SAFL	180-250 micron	6.6	120	4.88	-2.19	218
8	4/8/2009	SAFL	180-250 micron	6.9	120	4.88	-1.78	177
9	4/8/2009	SAFL	180-250 micron	7.6	120	5.31	-1.06	110
10	4/9/2009	SAFL	180-250 micron	6.9	120	5.19	-0.52	58
11	4/10/2009	SAFL	180-250 micron	6.7	120	5.38	0.02	-3
12	4/13/2009	SAFL	125-180 micron	7.9	20	15.54	-3.4	1961
13	4/13/2009	SAFL	125-180 micron	7.7	30	15.63	-3.9	1554
14	4/16/2009	SAFL	125-180 micron	8.6	20	15.75	-3.2	1981
15	4/17/2009	SAFL	125-180 micron	9.6	30	15.68	-3.2	1113
16	4/20/2009	SAFL	125-180 micron	8.6	20	16.22	-3.9	2231
17	4/20/2009	SAFL	125-180 micron	8.7	20	16.18	-3.4	1912
18	4/21/2009	SAFL	125-180 micron	7.9	20	16.24	-3.7	2257
19	4/27/2009	SAFL	125-180 micron	3.2	20	16.25	-4.6	2798
20	4/27/2009	SAFL	125-180 micron	8.4	20	16.29	-3.3	1973
21	4/28/2009	SAFL	125-180 micron	8.3	20	16.23	-3.4	2082

## **Appendix G: Velocity Profiles**

## G.1. Introduction

Velocity profiles are presented in a dimensionless format. The vertical axis is the relative height above the bed, i.e. it is the ratio of ADV reading height above the bed to the height of the water column in the device. The horizontal axis is the ratio of the measured velocity to the computed influent pipe velocity. All flow rates tested and all three cylindrical components of velocity are shown in the figures. The  $\theta$ -component is tangential flow velocity (main direction), the R-component is the radial component towards or away from the wall, and the Z-component is the vertical component of velocity. The positive directions of the three components are clockwise, towards the wall and upward, respectively.

## G.2. Environment 21 V2B1 Velocity Profiles

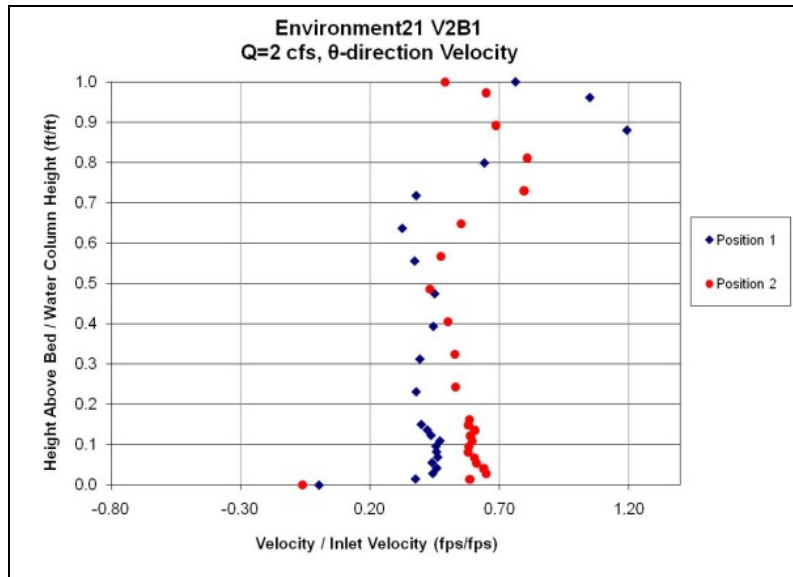
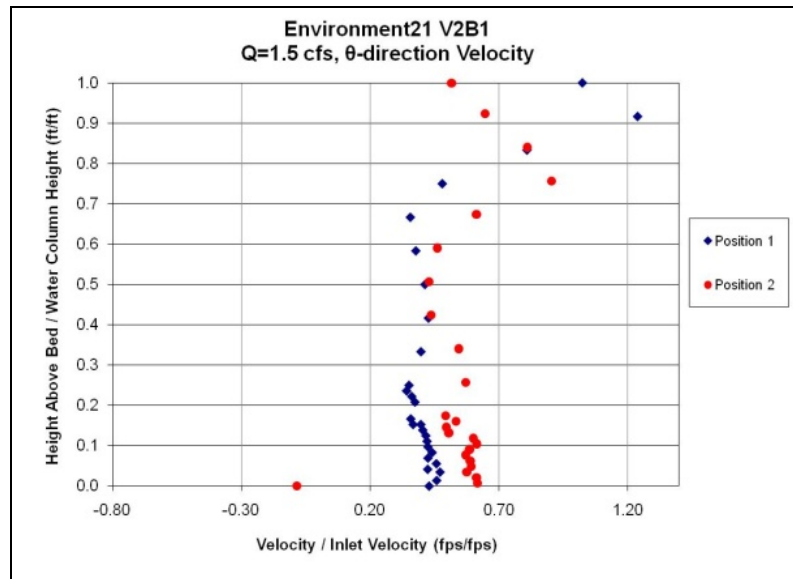



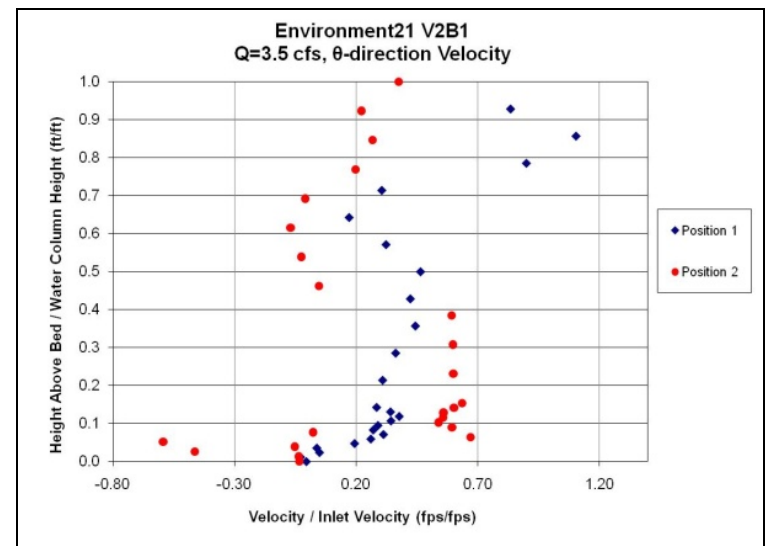
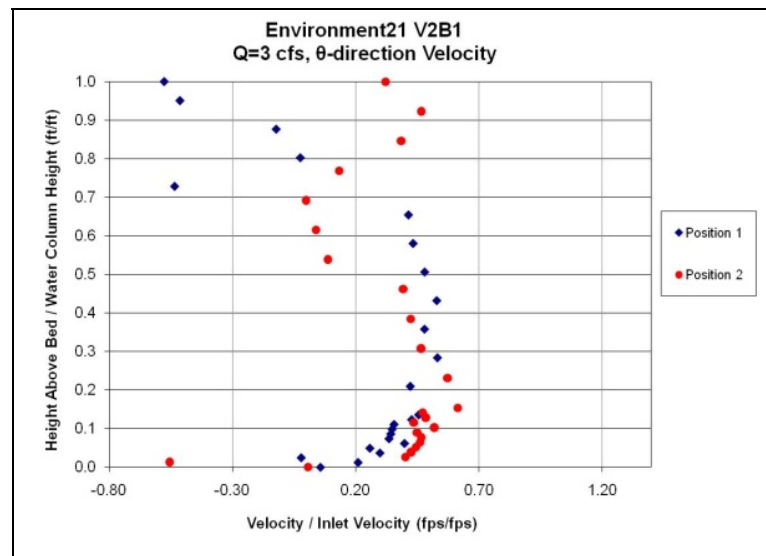
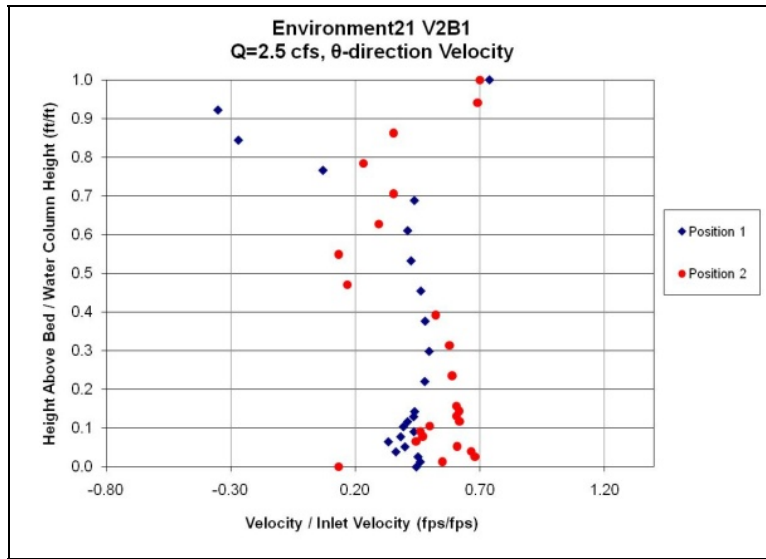

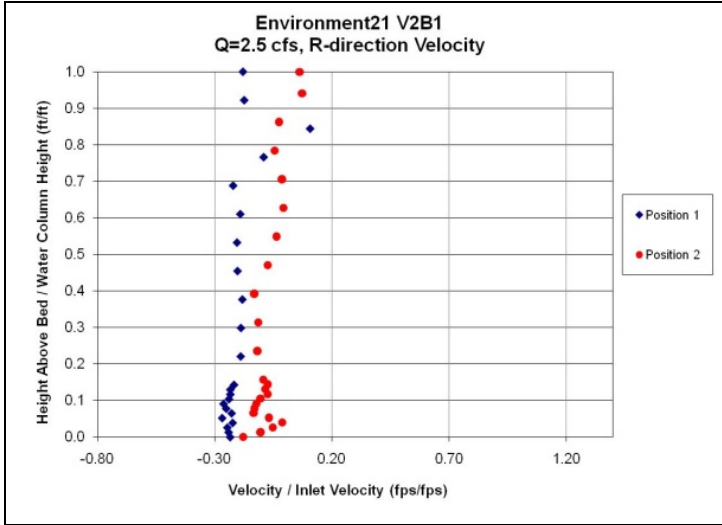
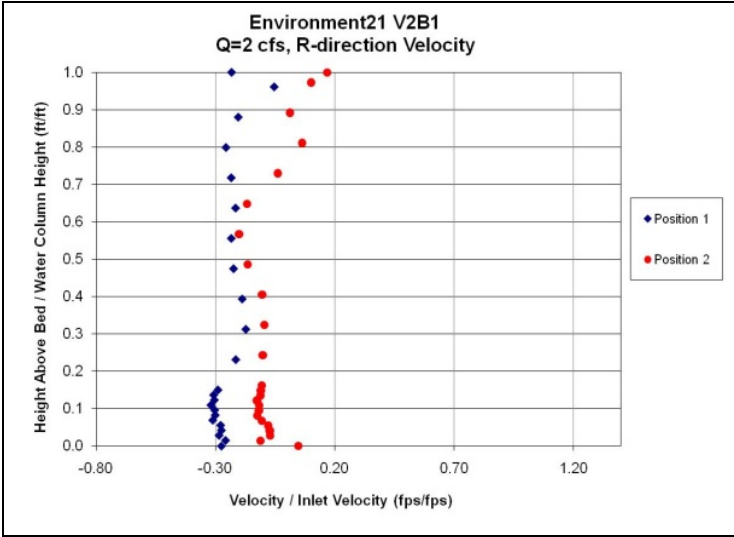
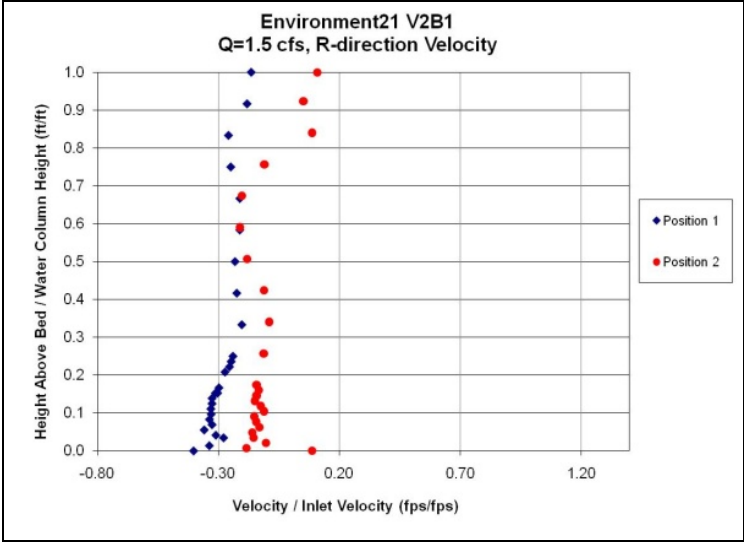

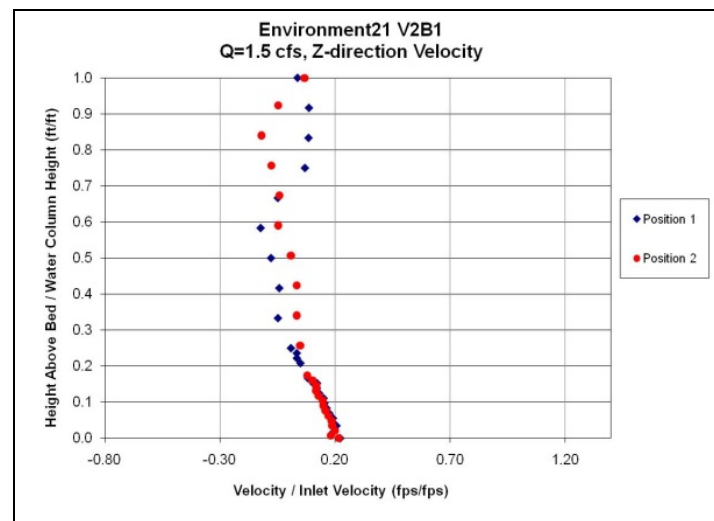
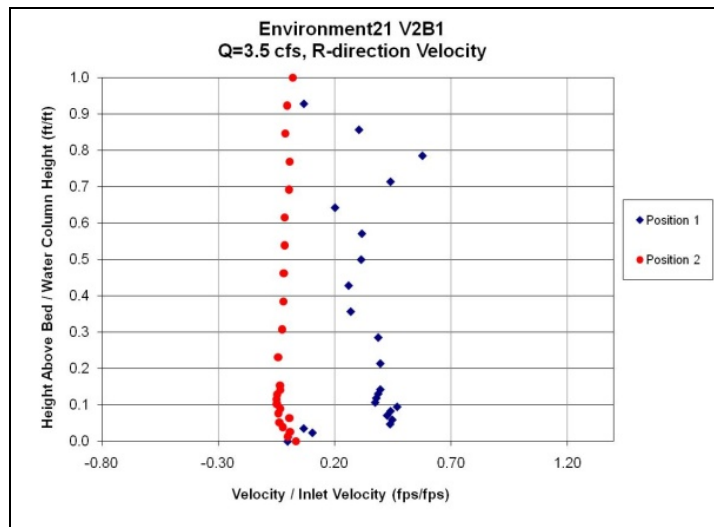
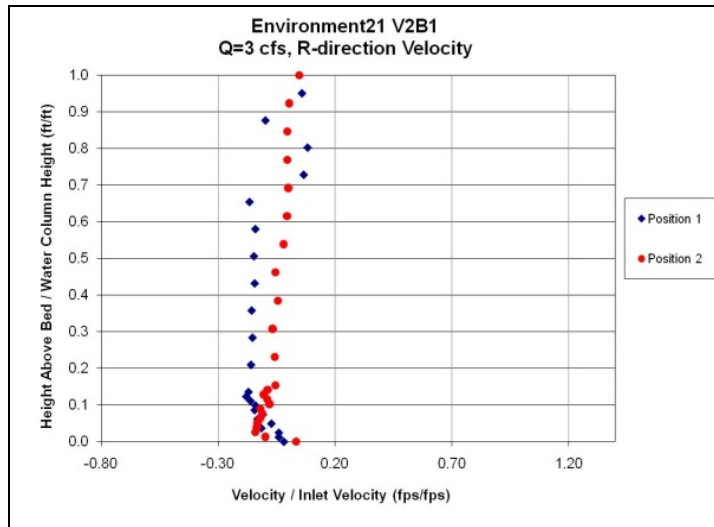

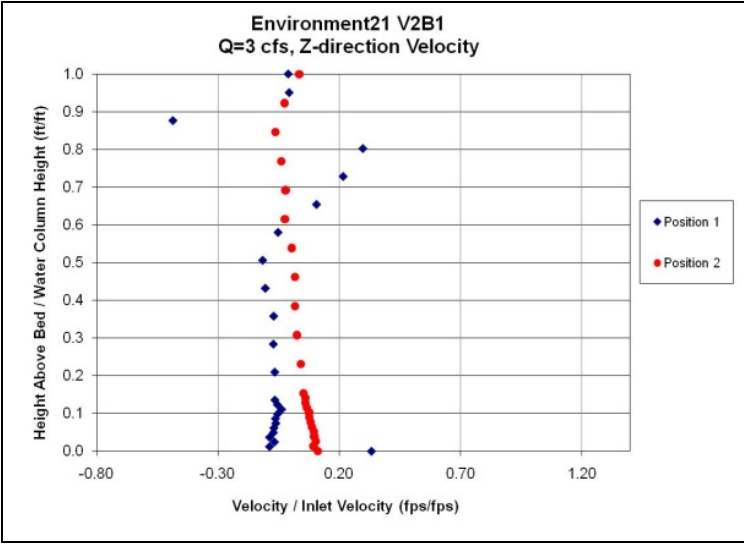
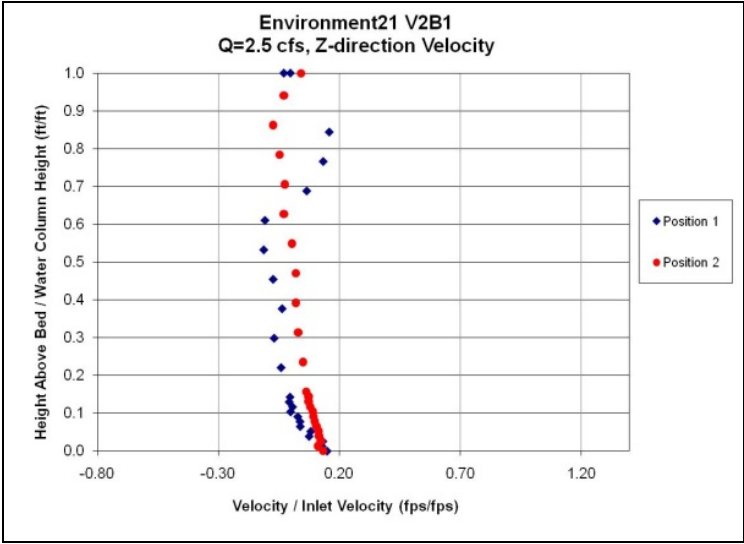
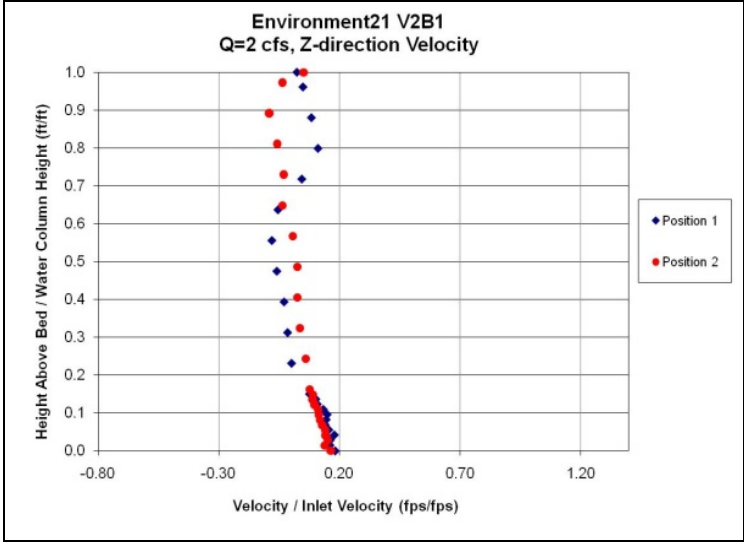

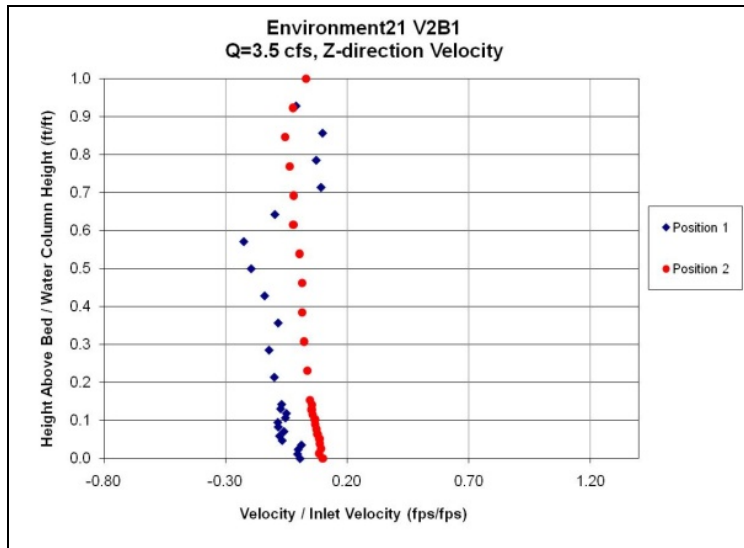

## G.2. Downstream Defender Velocity Profiles

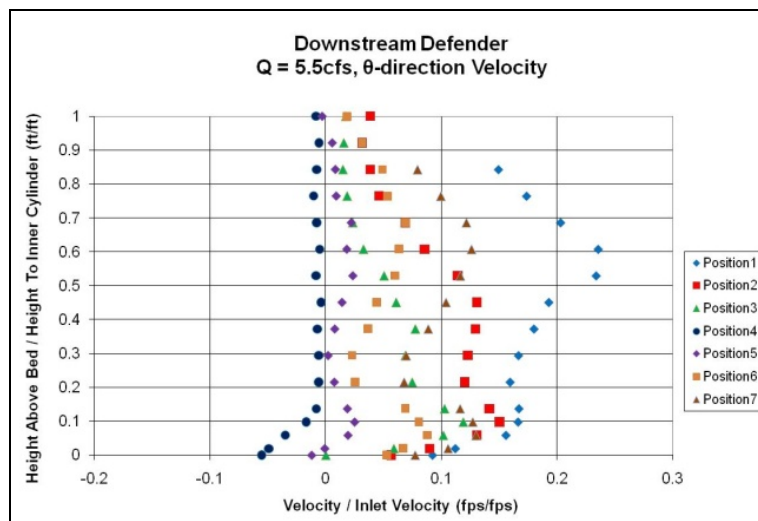
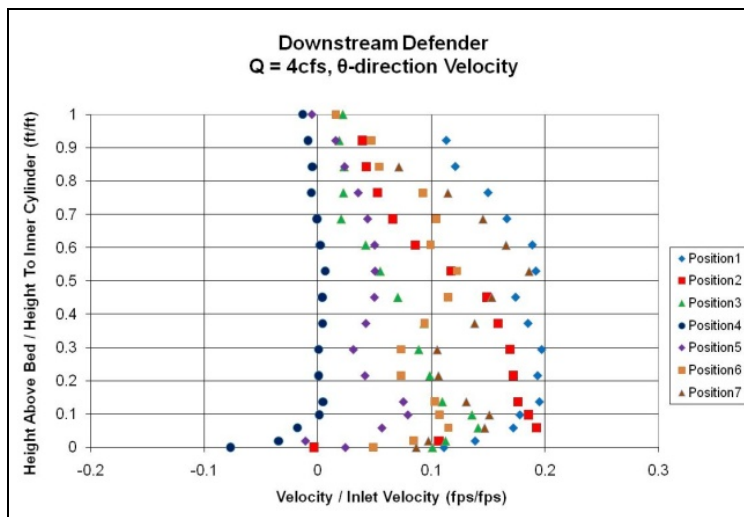

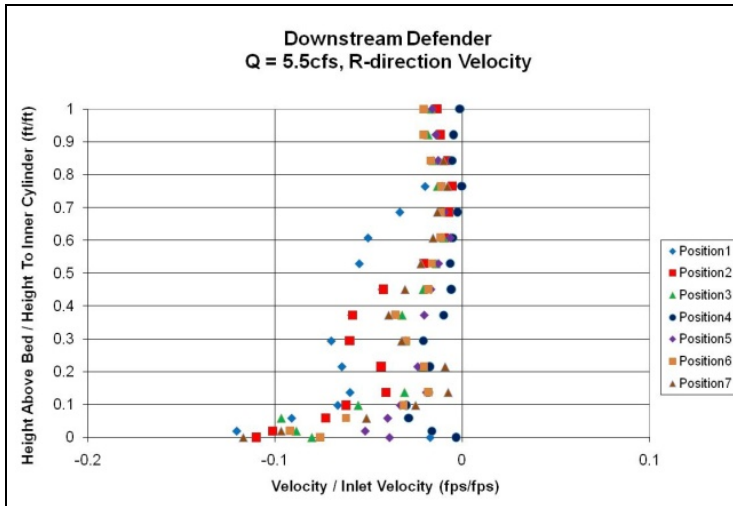
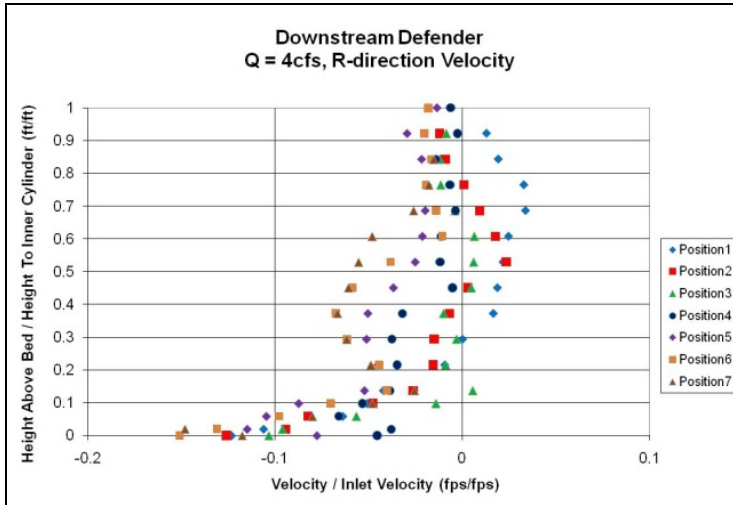
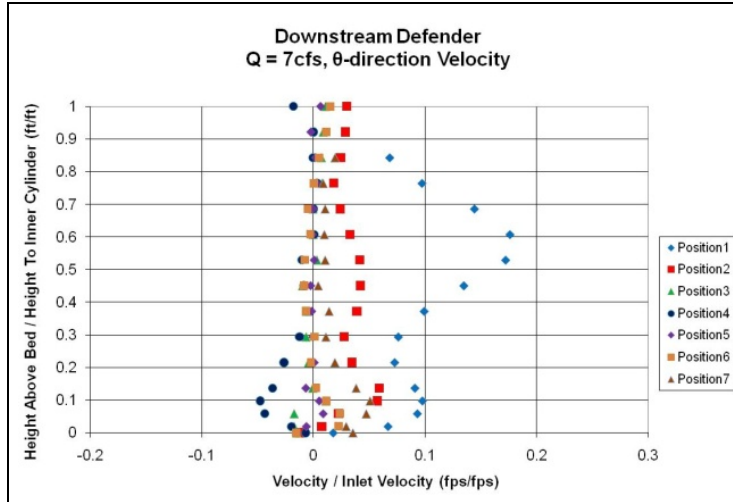

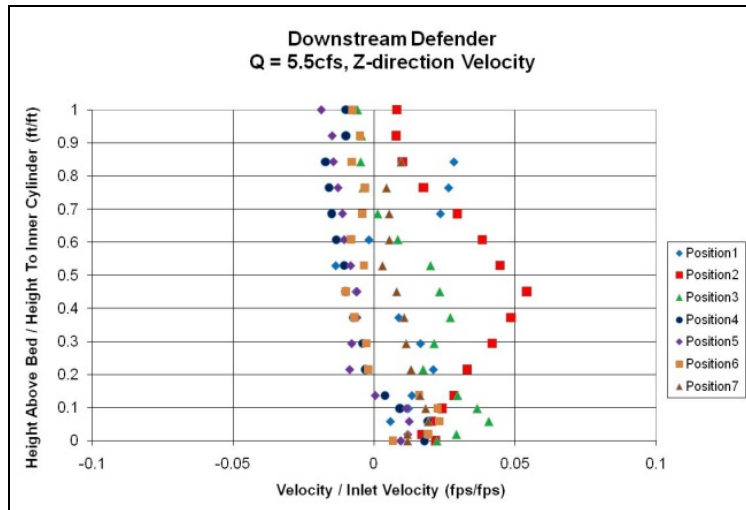
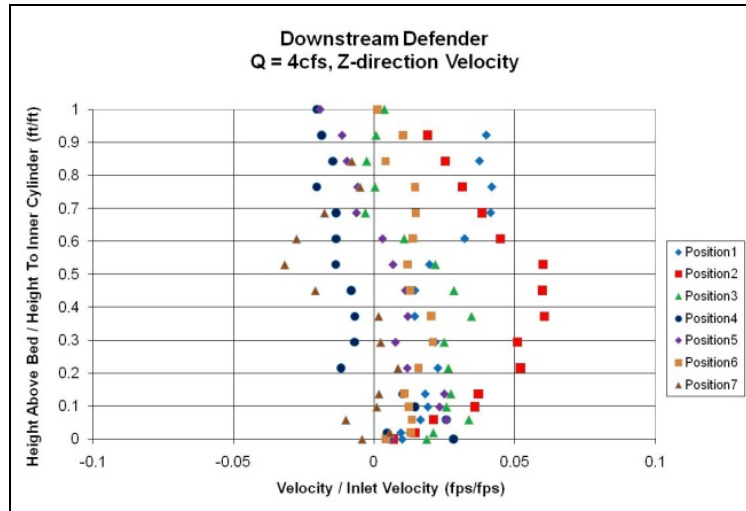
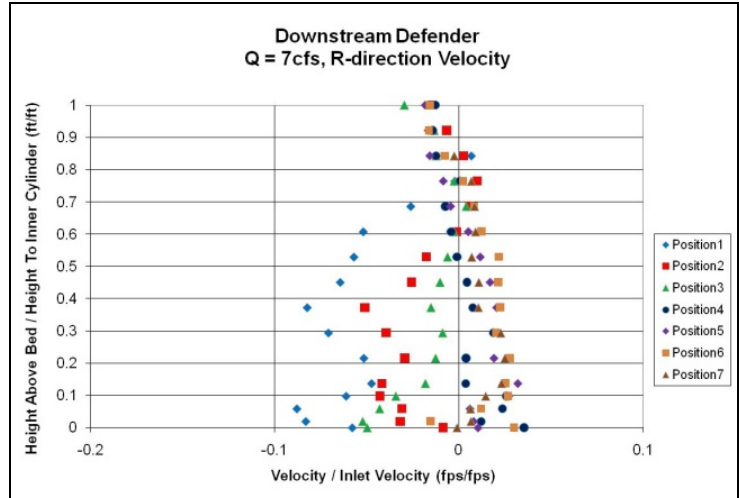

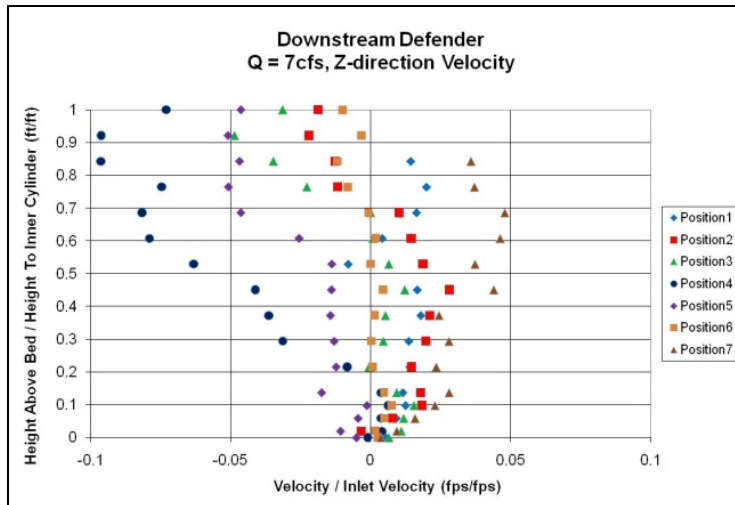

### G.3. Swirl Flow Device Scale Model Velocity Profiles

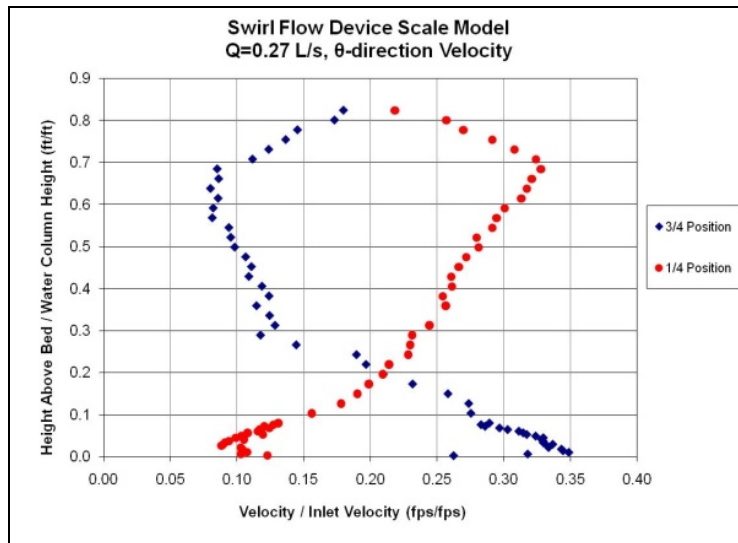



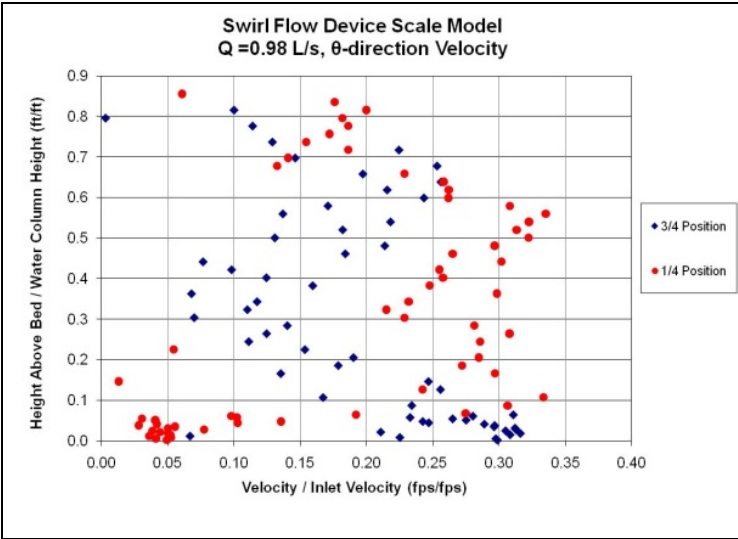
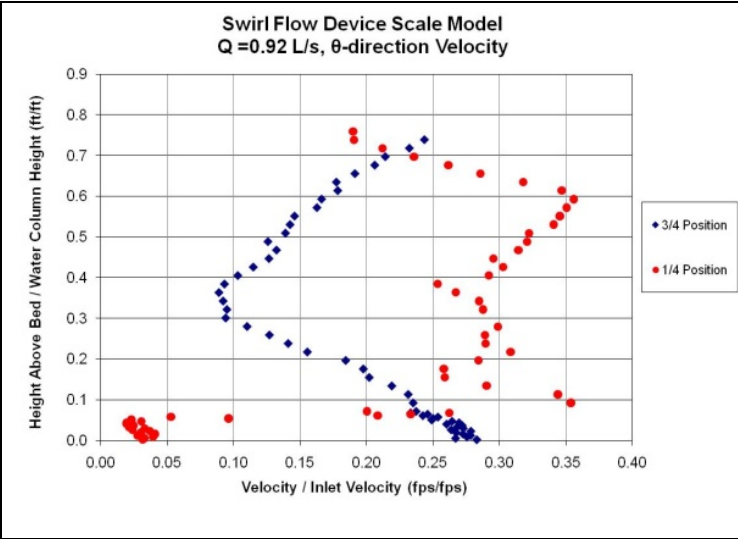
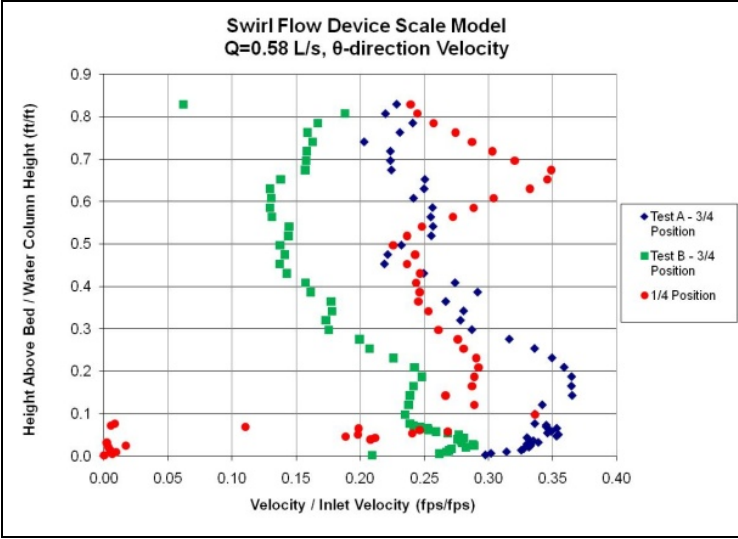

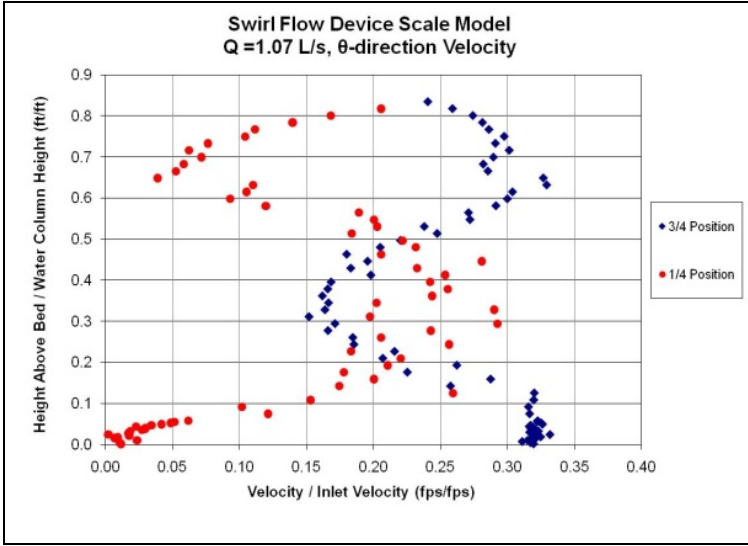
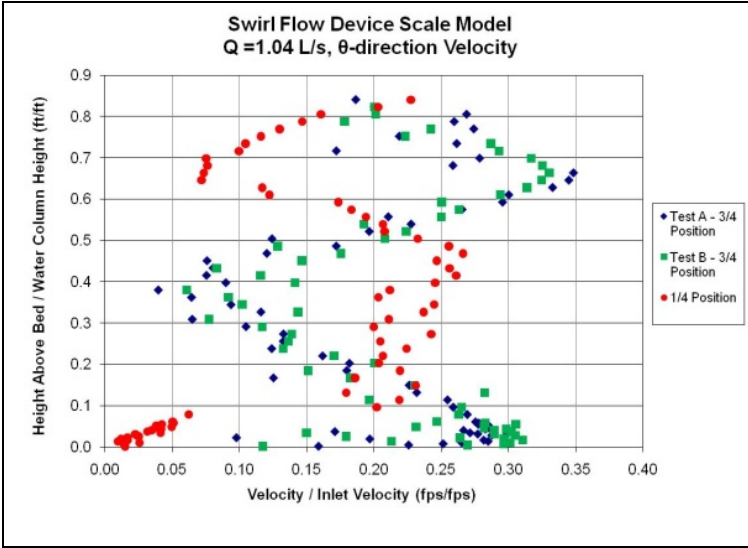
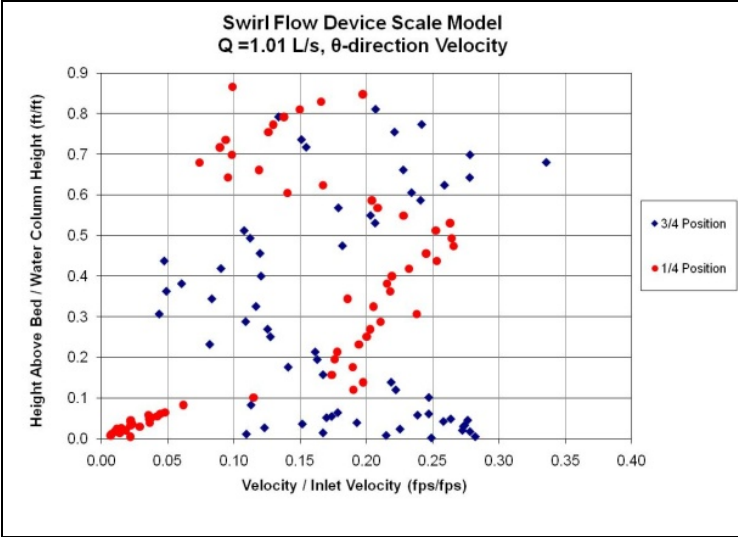

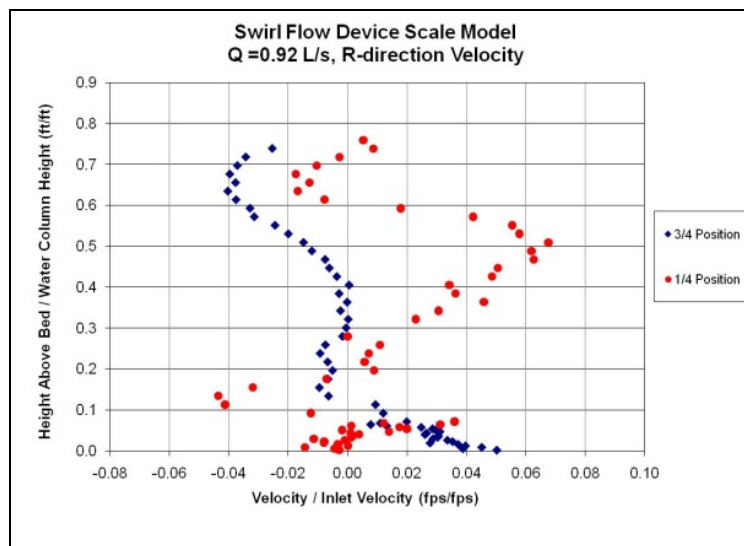
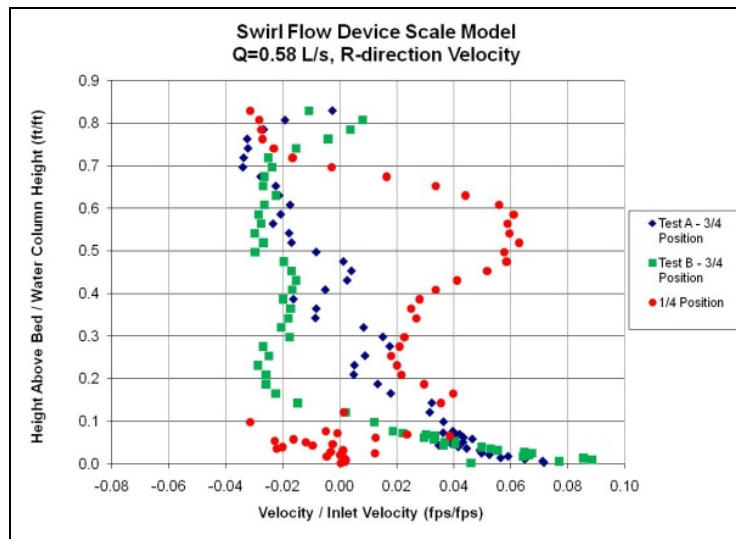
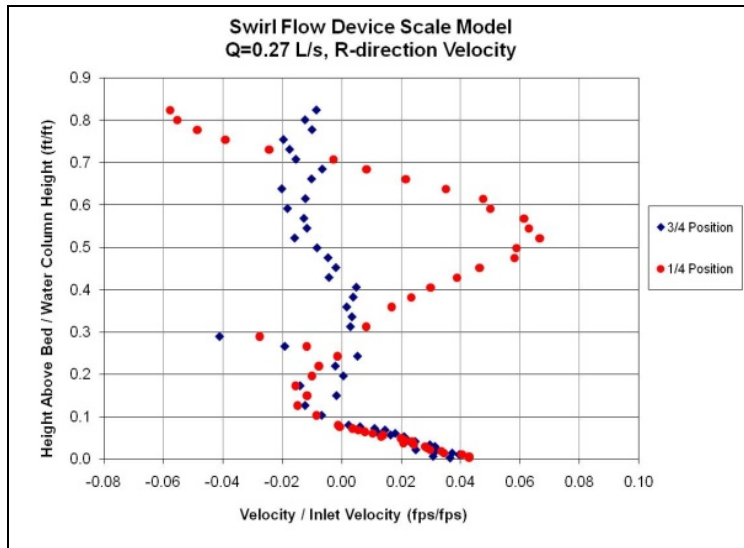

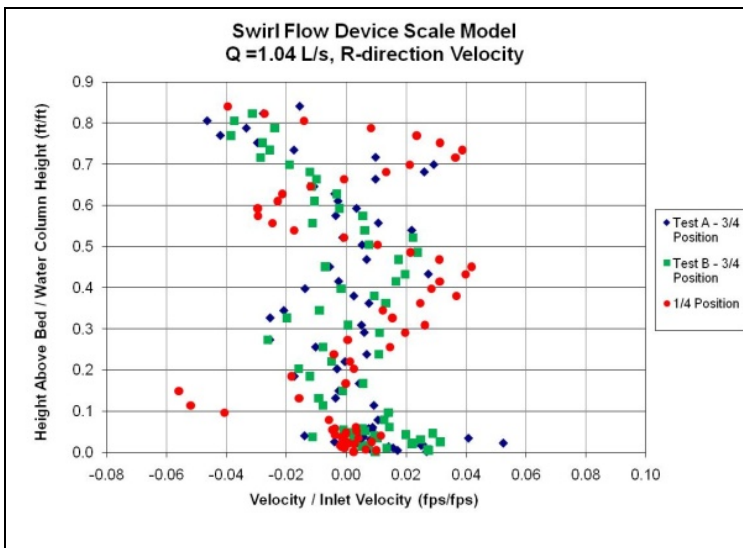
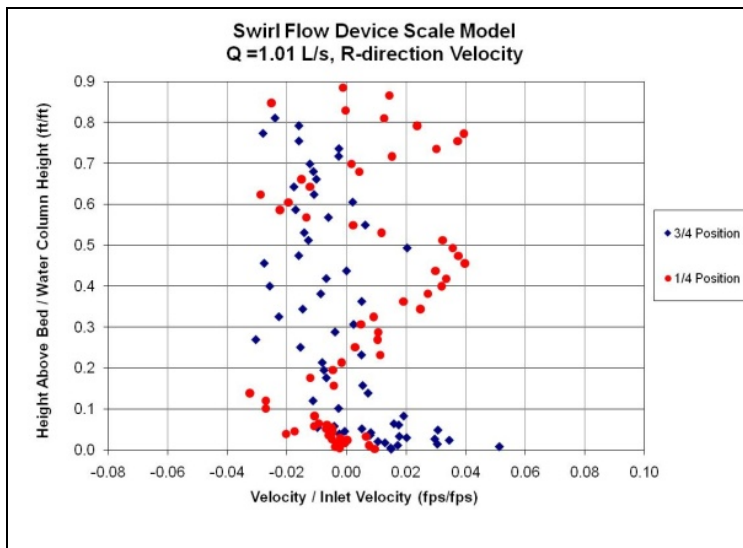
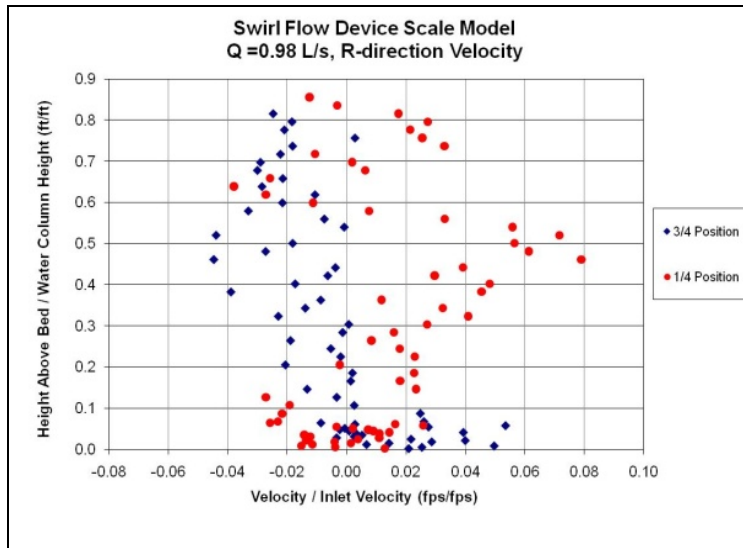

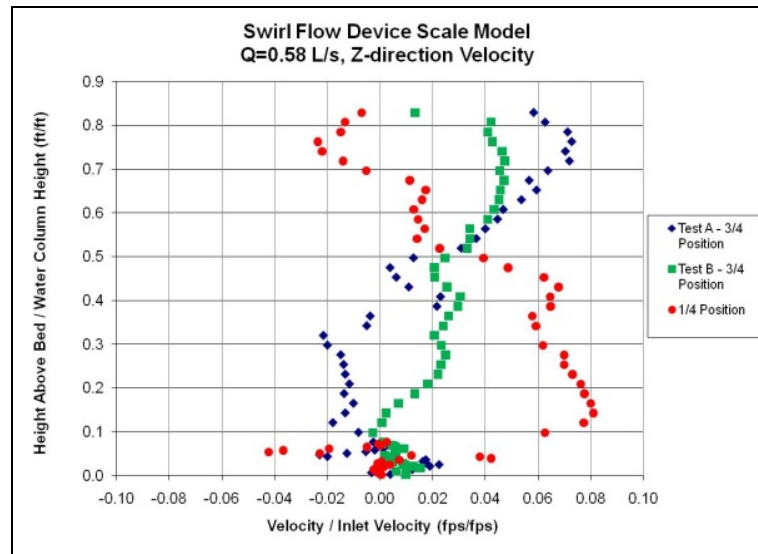
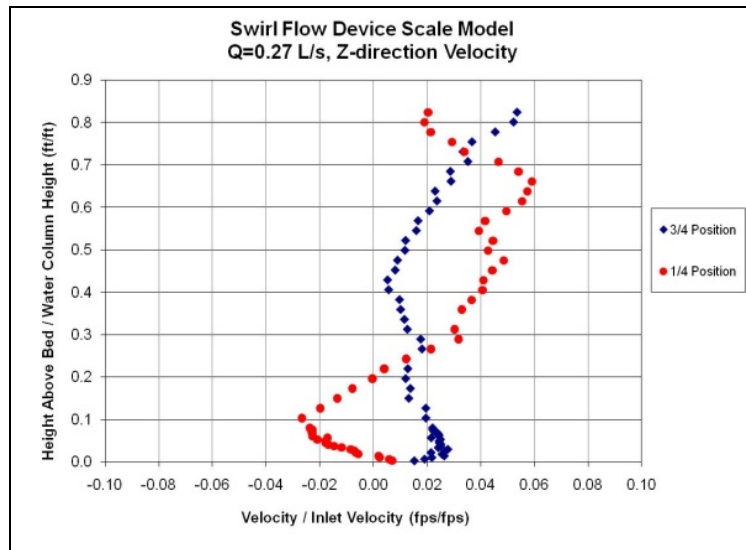
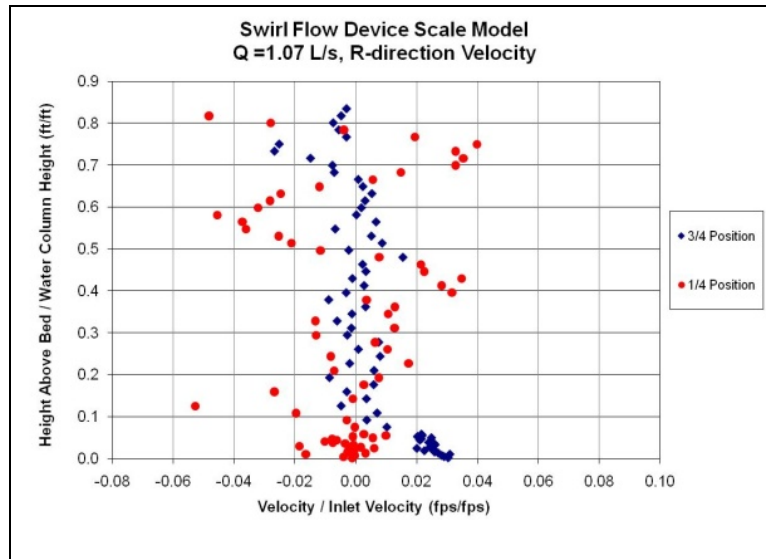

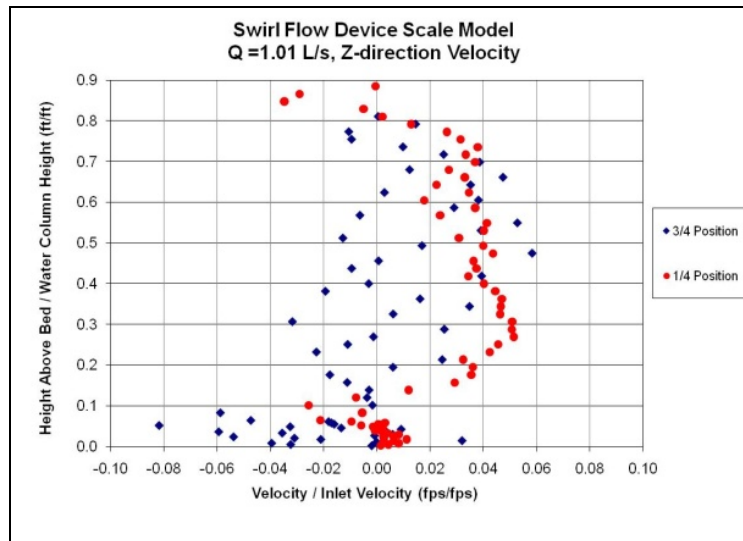
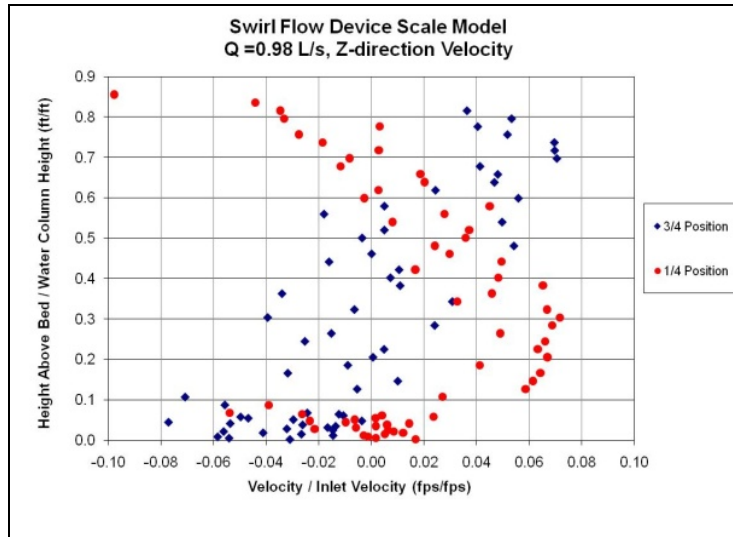
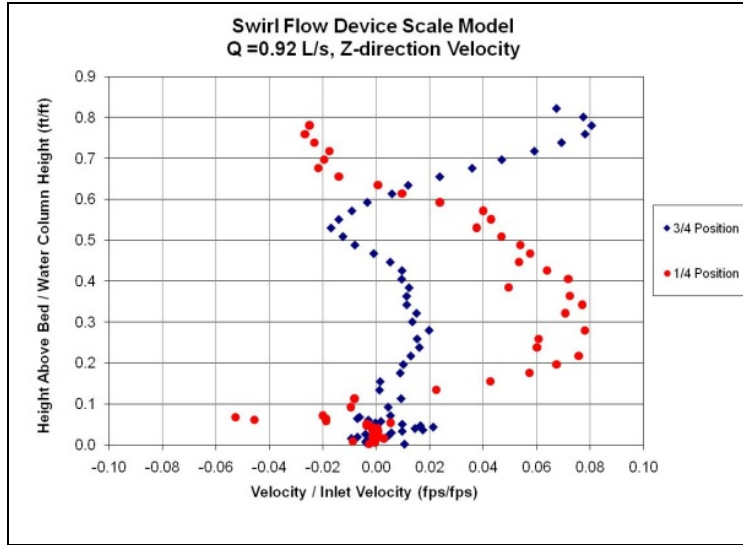

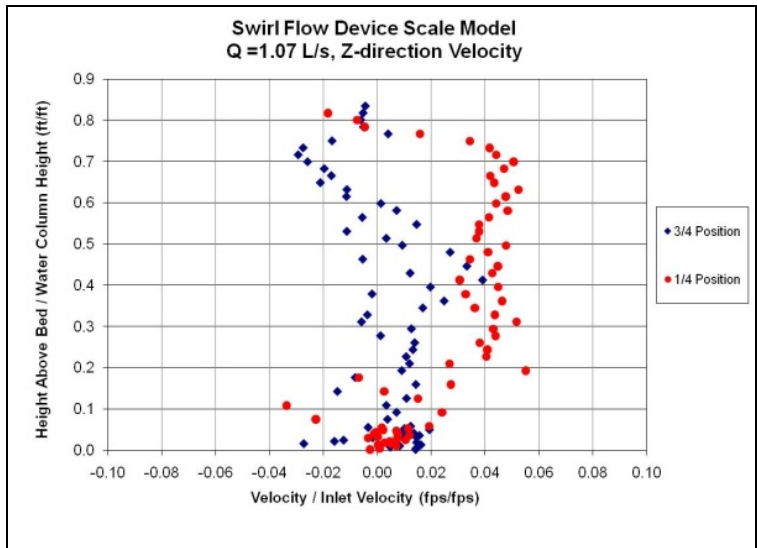
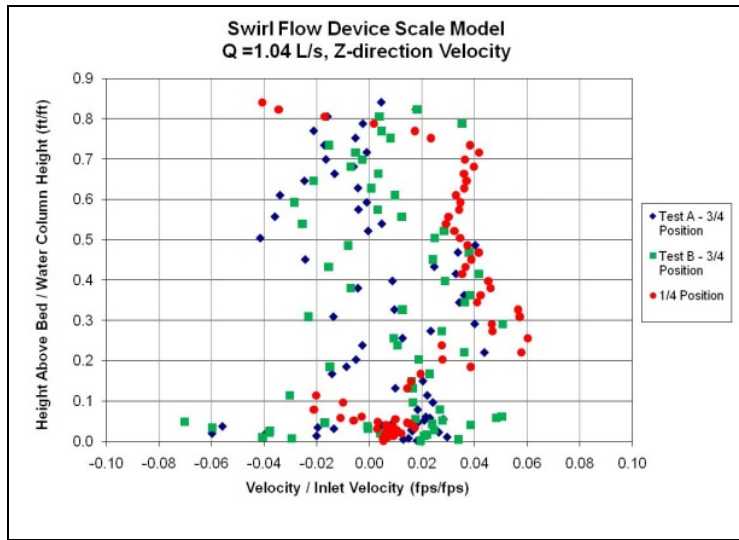

#### G.4. Idealized Swirl Flow Model Velocity Profiles

