

# Viability of Personal Rapid Transit In New Jersey

## FINAL REPORT

February 2007

### Presented to

Governor Jon S. Corzine

and

The New Jersey State Legislature

### Prepared for:

New Jersey  
Department of Transportation  
Bureau of Research

and

NJ TRANSIT

### Prepared by:

Jon A. Carnegie, AICP/PP  
Alan M. Voorhees Transportation Center  
Rutgers, The State University of New Jersey

And

Paul S. Hoffman  
Booz Allen Hamilton, Inc.



## TABLE OF CONTENTS

	Page
I. Executive Summary.....	1
II. Background and Study Overview.....	16
III. Fundamental Elements of PRT.....	18
On-Demand, Origin-To-Destination Service .....	19
Small, Automated Vehicles.....	19
Small, Exclusive-Use Guideways .....	20
Off-Line Stations.....	20
Network of Connected Guideways .....	20
IV. Literature Review.....	22
Early History of PRT .....	22
Aerospace Research Program .....	23
Morgantown Group Rapid Transit.....	23
International Developments.....	25
Other Activities .....	25
PRT Development Since the 1970's.....	26
UMTA AGRT Program.....	26
Chicago RTA/Raytheon Program .....	28
PRT Application Studies.....	30
Recent Developments .....	34
Summary and Lessons Learned from History.....	35
V. State of the PRT Industry .....	38
Survey of PRT System Developers .....	38
Industry Expert Questionnaire and Interviews .....	47
Summary Assessment.....	49
VI. Comparing PRT to Other Modes .....	52
Average Speed of Travel.....	53
Total Trip Time .....	54

System Capacity.....	55
Capital Cost Comparison.....	56
Operating and Maintenance (O&M) Costs.....	58
Ridership and Potential to Reduce Congestion .....	59
Environmental Impact.....	60
Energy Use.....	60
Summary .....	60
VII. Potential PRT Applications in New Jersey	65
Areas Potentially Appropriate for PRT in New Jersey .....	65
Summary Viability Assessment .....	67
VIII. PRT Implementation Assessment and Conclusions .....	69
Challenges to Implementation .....	69
Conclusion: Options for New Jersey.....	72

**VOLUME 2: TECHNICAL APPENDICES (AVAILABLE UPON REQUEST)**

- Appendix 1 – PRT Technology Assessment
- Appendix 2 – Industry Expert Survey
- Appendix 3 – Comparison of PRT with Other Modes

## LIST OF TABLES AND FIGURES

	Page
Table 1: PRT Design Features .....	18
Table 2: Travel Time Comparisons .....	55
Table 3: Capital Costs – Conventional Transit vs. PRT.....	57
Table 4: Areas Potentially Appropriate for PRT Applications .....	66
Figure 1: Morgantown Off-line Station.....	24
Figure 2: Morgantown Vehicle.....	24
Figure 3: Raytheon PRT Test Track.....	28
Figure 4: Rosemont PRT Demonstration Layout.....	29
Figure 5: Final Raytheon PRT Design.....	30
Figure 6: Heathrow PRT Layout.....	34
Figure 7: SkyWeb Express System.....	39
Figure 8: SkyWeb Express Prototype.....	40
Figure 9: ULTra System .....	41
Figure 10: ULTra Vehicles.....	41
Figure 11: ULTra Test Track .....	42
Figure 12: Vectus PRT Vehicle .....	43
Figure 13: POSTECH Prototype .....	43
Figure 14: Vectus Component Testing.....	44
Figure 15: Vectus Test Track Layout.....	44
Figure 16: Cabintaxi System .....	45
Figure 17: Cabintaxi Test Track Station .....	46
Figure 18: Cabintaxi Emergency Evacuation .....	46
Figure 19: Observed Average Speed on Fixed Route Transit vs. PRT Estimates .....	54
Figure 20: Total Trip Time Examples .....	54
Figure 21: Theoretical Versus Observed Transit Line Capacities .....	56
Figure 22: Operations and Maintenance Costs per Passenger Mile .....	58
Figure 23: Transportation Energy Use Comparison .....	61

## **I. EXECUTIVE SUMMARY**

The following report was prepared for the New Jersey Legislature to document the current state of Personal Rapid Transit (PRT) development and implementation and to explore the potential viability of implementing PRT in New Jersey. The report summarizes the history of PRT development efforts worldwide, documents lessons learned from past research and development activities, explores the opinions of several PRT industry experts regarding the current state of PRT development, presents the theoretical benefits of PRT when compared to other modes of public transportation, identifies the challenges and risks associated with PRT implementation and presents a series of options for advancing PRT development in New Jersey should decision makers decide to do so.

PRT has been the subject of research and development efforts for approximately 40 years. However, there has yet to be a full scale deployment of this technology. A fully operational PRT system is needed to demonstrate the theoretical benefits of PRT and establish commercial readiness and significant research and development activities must still be undertaken. Such a research and demonstration program has been conceptually estimated to require \$50-100 million over a three year period. It is important to note that PRT is an emerging public transportation technology and has not yet advanced to the stage of commercial deployment or achieved wide-spread public operation. As such, much of the information presented in the report, especially information related to the potential benefits of PRT, is based on conceptual engineering and theoretical research from PRT developers, government researchers, or independent consultants. Wherever appropriate the potential or theoretical nature of particular data and information is made clear and the source of information is noted.

### **Background and Research Overview**

In October 2004, the New Jersey Legislature passed P.L. 2004, Chapter 160 directing the Commissioner of Transportation, in consultation with the Executive Director of NJ TRANSIT, to prepare a report evaluating the viability of Personal Rapid Transit (PRT) in New Jersey. The bill recognized that New Jersey's transportation needs are broad and diverse and noted that it is in the State's interest to actively improve and diversify a transportation system that has proven fundamental to its long-term economic success.

In July 2005, the New Jersey Department of Transportation (NJDOT) contracted with the Alan M. Voorhees Transportation Center at Rutgers University (VTC) and Booz Allen Hamilton (BAH) to conduct a study of PRT designed to:

1. Provide a complete and thorough description of the key elements of PRT technology and identify PRT components that have been demonstrated successfully and those that are conceptual in nature;
2. Identify potential PRT system developers and assess the current status of PRT relative to implementation readiness;
3. Compare and evaluate the potential benefits and costs of PRT to other modes of transportation in terms of: capital costs, operations and maintenance (O&M) costs, energy use, ability to reduce congestion, and potential environmental/community impacts; and
4. Evaluate the viability of integrating PRT as a supplement to NJ TRANSIT's current and future transportation networks and services.

### **Fundamental Elements of PRT Technology**

As previously stated, PRT is an emerging public transportation technology designed to address the needs of urban transportation in a variety of settings. Since it was first conceived in the 1960's as a new, yet complementary mode of transport, it has undergone a variety of design and technology innovations. The literature provides a variety of descriptions and definitions of PRT that have evolved over its history. Today, there is general consensus among transit experts and PRT developers that the key characteristics of PRT include:

- On-demand, origin-to-destination service – At the originating station, a traveler using a PRT system would input his or her desired destination station. A waiting PRT vehicle or one dispatched to the station would then transport the traveler to the desired destination with no intermediate stops. There are no pre-determined schedules;
- Small, fully-automated vehicles – PRT vehicles are intended to operate under computer control and require no operator or driver. Prototype vehicles are designed for two to four passengers and can be ADA accessible;
- Exclusive-use guideways – Tracks or “guideways” for PRT vehicles must be designed to prohibit at-grade crossings with pedestrians or other types of vehicles. The guideways are usually designed as elevated systems with beams and support structures sized appropriately for lightweight two-four passenger vehicles ;
- Off-line stations – Off-line stations are designed with a “siding” track or guideway so that vehicles not stopping at a particular station can bypass that station and are not delayed by other vehicles boarding and alighting passengers; and

- A network or system of fully-connected guideways – Unlike conventional public transportation systems that are generally constructed as a single line or a line with branches, PRT systems are usually conceived as an interconnected system or “grid” of guideways, with junctions at the intersecting points of the grid. These junctions allow PRT vehicles to select from a variety of paths through the network, similar to autos operating on a street grid. The density and extent of the PRT grid system will determine the maximum walk distances to stations and the number of origin and destination points to be served by the system.

These characteristics are fundamentally distinctive from conventional guideway transit systems that typically involve larger vehicles operating on a schedule using larger guideways in a line-haul configuration with on-line stations. As a new technology, PRT combines the elements of current automotive, computer networking and transit technologies using state-of-the-art technologies including: advanced propulsion systems, on-board switching and guidance, and high speed controls and communication. As such, PRT systems represent a new paradigm for urban public transportation.

### **Current State of PRT Development**

According to the Advanced Transit Association (ATRA), there are more than 90 new transportation technology systems under development including many PRT systems. In 2003, ATRA studied various PRT systems under development evaluating and comparing their technology, features and development status. The study reaffirmed that PRT is technically feasible and concluded that the most persisting barriers to implementation are financial and political (ATRA, 2003).

Based on a review of the literature and research team experience, four prototype PRT systems were selected for more detailed review and analysis. These four systems provide the fundamental PRT characteristics, have a current or past development program, and have potential to support a near-term PRT implementation. They include:

<u>System</u>	<u>Developer</u>
SkyWeb Express	Taxi 2000 Corporation
ULTra	Advanced Transport Systems
Vectus	Vectus PRT
Cabintaxi	Cabintaxi Corporation USA

Other systems considered for analysis included those from Austrans, Coaster, Ecotaxi, Skytran, Megarail, RUF, York PRT and 2getThere. These systems are less well

advanced but are recognized as having development programs that may result in commercial system capabilities.

To understand better the current state of the PRT industry and to learn from the history of PRT development, the research team conducted a survey of leading PRT system developers and industry “experts” to gather insight into the future of the technology and the challenges inherent to PRT implementation. The following is a summary assessment of the current state of the industry based on the survey of PRT developers and expert interviews:

- **PRT systems are approaching but not yet ready for public deployment.** Significant PRT research, engineering, development and application study programs have been conducted over the past 40 years. These programs have been supported by a variety of academic, governmental and private industry organizations around the world. Several system development programs are nearing completion of an initial pilot or demonstration system. Although these past efforts provide a foundation of engineering and test information that can be used for initial application and alternatives analysis, additional development work is needed to validate the capital and operating costs associated with deployment of this technology for a specific application and minimize any risk for a public deployment.
- **Many of the technical components needed to support PRT systems are commercially available and are used in other industries.** These components include:
  - Advanced control and communication systems to deliver the required levels of safety, reliability and performance;
  - Network management systems and on-board switching or guidance needed to achieve short headways in order to optimize system capacity; and
  - Advanced propulsion and braking systems to provide the required vehicle performance in all weather conditions.

While each of these components has been tested in small-scale PRT development programs and/or may be commonly used in related automated transit or industrial automation applications, the task remains to assemble, integrate and test such components under rigid safety requirements and the demanding day-to-day reliability requirements of a transit environment.



- **Global PRT interest and development programs are expanding.** Cities and regions continue to display interest in PRT around the world. The most advanced PRT development efforts include:
  - An active test track in Cardiff Wales and a joint development program between **ULTra** and the British Airport Authority for an installation at Heathrow Airport;
  - A comprehensive development program including test tracks in Sweden and Korea for the **Vectus** system;
  - A prototype vehicle and section of guideway in Minnesota as well as a small-scale network model for the **SkyWeb Express** system in the United States; and
  - An extensive test track (not currently operating) that verified system technology and operation of the **Cabintaxi** system.
  
- **A fully operational PRT system is needed to demonstrate the theoretical benefits of PRT and establish commercial readiness.** The Morgantown system serving the University of West Virginia is the only active operating automated guideway system with off-line stations and on-demand service similar to the PRT concept of operations. This system is no longer commercially available and uses large vehicles. A fully operational PRT system of reasonable scale with multiple small vehicles operating on-demand with off-line stations is needed to verify commercial viability and gain public support. Even further, to fully understand the benefits of competing technology configurations, several demonstration systems may require completion to help select a preferred configuration.
  
- **A comprehensive technology research and demonstration program is needed to develop a PRT system.** As noted above, PRT technology has not yet advanced to a state of commercial readiness and several competing designs are under development. The development of PRT technology requires a comprehensive system engineering program that includes alternatives analysis, initial design, prototyping, component testing, system design, testing and certification. The programs reviewed for this report are meeting these goals with various degrees of rigor, funding, public support and eventual success. New Jersey has the option to monitor these development programs or pursue a new program that builds upon these efforts. According to the industry experts interviewed for this study, a comprehensive program to develop and test a commercially-viable PRT system including a small test track is estimated to require \$50-100 million over a three-year program that will require consistent support to maintain program objectives.

## Potential Applications of PRT in New Jersey

Many factors affect the viability of a public transportation system for a specific location. Key factors include population, employment and household density, as well as other factors such as household income, automobile ownership rates, land use mix, site design, and even the quality of the pedestrian environment in a particular area. Not all places in the State are appropriate for public transportation service.

The viability of PRT to effectively serve transportation demands in New Jersey is conditioned upon matching the technology with the local need. Using the lessons learned from previous PRT research and development activities, the following examples are local needs that could potentially be served by a PRT system:

- **Areas with high demand for local circulation:** PRT systems have the potential to be viable in areas that exhibit significant demand for local circulation such as regional activity centers and campuses. PRT networks could effectively support areas that have many origins and many destinations derived from a mix of land uses such as residential, retail, employment and entertainment. PRT has the potential to be quite effective where the origins and destinations have travel demand throughout the day in addition to a peak commuter travel demand.
- **Areas with the potential to extend the reach of nearby conventional public transportation:** PRT systems have the potential to be viable where the system provides an intermodal connection to conventional fixed-guideway or fixed-route transit services such as an existing express commuter bus terminal and high ridership rail stops or stations. PRT systems could be used to extend the reach of the conventional public transportation system by connecting nearby areas and neighborhoods to the station or terminal. Within that context, PRT could also be used to manage parking demand at the station or terminal by providing an alternative to auto access and the ability to connect to remote/satellite parking facilities.
- **Areas with constrained access and/or congested local circulation:** Individual mode choice decisions are often made based on travel time considerations comparing public transportation alternatives to the private automobile. Consequently, areas with congested travel conditions on roadways that provide access to and circulation within a location may be an attractive location for a PRT system as an alternative to private auto travel. The viability of a PRT system in such locations would be even further enhanced where access is constrained and limited land availability limits the ability to expand capacity on congested circulation routes and local street networks. In these constrained and congested locations, PRT could provide an opportunity to connect the core area

with remote and satellite parking facilities reducing the need to travel within the core area.

- **Areas with constrained and/or expensive parking:** Although regional and local congestion helps to shape individual mode choice decisions, an even more significant factor is the availability and cost of parking. As in the case with conventional public transportation modes, areas with limited and/or expensive parking would be expected to generate higher demand for PRT service. PRT could provide an opportunity to connect to/from remote parking facilities helping to manage parking demand at these places.
- **Areas requiring connectivity between high activity centers:** Initial PRT system implementations could potentially be viable in the areas previously described such as regional centers, campuses, congested locations and as extensions to conventional public transportation system station. PRT could also be expected to be viable as a connector of these initial systems, providing an integrated public transportation network across a region, eliminating the need to transfer between modes or within the mode. As a scaleable network system, PRT could initially be deployed to support the locations with the highest need and then expand to connect these initial deployments as demand and economic conditions allow.

It could be anticipated that initial PRT systems will be deployed in non-residential areas along commercial roadways with limited potential community impact and disruption. Initial PRT systems will require thorough testing and must achieve public acceptance before they would be considered for larger scale expansion. The scalability and reliability of the system would need considerable validation. If this is achieved, PRT systems could also be envisioned to expand along secondary roadways and potentially serve residential areas as community interests would require.

### **Challenges to Implementation**

Currently the PRT development industry receives only limited support from the public and private sector. There are only a few small firms advancing the development of PRT technology. There are limited industry standards guiding PRT development and there is limited expertise and understanding of PRT concepts in conventional transportation consulting, engineering, planning and policy-making sectors. As an emerging technology, the market processes of product evaluation, acceptance, and standardization are to be anticipated before full technology maturation is achieved. Since there are only a few PRT systems in development and only one hybrid system in operation, any State or agency choosing to implement an initial PRT system will

assume higher risks of system implementation and operation and may incur greater expense and other difficulties in addressing problems that may arise from public operation.

The following challenges will need to be addressed as PRT development continues:

- **Engineering and planning expertise:** There is limited depth of experience or understanding in the transit industry regarding the advanced technology concepts central to PRT design and operations. This experience does exist, however, in other industries that support advanced technology development such as aerospace, automotive, defense, computing and networking. It will be important to draw upon the technology expertise from these industries and combine it with the operating expertise from the transit industry to develop an advanced, robust and “public ready” PRT system.
- **Open technology development:** PRT technology is currently under development by independent suppliers that are seeking to develop products that have a competitive advantage to other suppliers. This is a normal and advisable business practice in the early stages of product development. As the industry matures, it will be in the interest of potential customers of PRT suppliers to encourage the use of open technology that avoids proprietary designs and vendor exclusivity. It will also be in the interest of potential customers to encourage the use of commercially available components to avoid specialized product development, unique support and maintenance requirements, higher costs, and less flexible and responsive operating environments.
- **Development and application of standards:** As a new technology, PRT could benefit from the development and application of appropriate performance and operating standards as the technology advances. Standards will be needed in various areas including safety, security and interoperability. It will be important to ensure that technology standards do not unnecessarily limit innovation and competition which could improve the performance of PRT systems overall. Conversely, it will also be important to guide the development of the technology with standards that protect the public’s health, safety and welfare.

In terms of standardization, lessons can be learned from the past experience of the American Society of Civil Engineers which developed standards for Automated People Mover industry and the National Fire Protection Association (NFPA), which developed NFPA Standard 130 covering fire protection and fire life safety issues applicable to fixed guideway transit and passenger rail system including Automated Guideway Transit. Additional analysis will be needed to

determine the efficacy of applying current industry standards versus the development of new standards.

- **Intellectual capital management:** To provide for competition in the PRT marketplace, it will be important to seek multiple vendors with the capability to provide interoperable components and sub-systems. If patents are owned solely by the initial system provider, that provider may monopolize the market and set high prices for system extensions, upgrades and replacement parts. In addition to open architectures and interface standards, it will be important to foster sharing of key patented technology through licensing or other arrangements between vendors, suppliers and customers.
  
- **Institutional framework support:** Currently, there is minimal institutional infrastructure and expertise (i.e., experienced and knowledgeable design, operations and maintenance professionals within the conventional transit industry) to support the specialized analysis, design, construction and operations needed to implement PRT and ensure safety and security. This expertise can be acquired by retraining personnel, hiring additional staff or contracting with private firms, as appropriate, depending on the implementation agency's needs.
  
- **Consistent political, economic and technology support:** The development and implementation of an initial PRT system and the subsequent implementation of PRT in other locations will require a long-term commitment of financial resources. It will also require vision, innovation and consistent political support. The history of PRT has many examples of development programs that started with good intentions but were halted due to changing political agendas, incomplete funding, inadequate engineering and economic analysis, inappropriate design standards and many other factors. Specific attention should be given to the lessons learned from the Chicago Regional Transportation Authority (RTA) effort to develop a PRT system in partnership with the Raytheon Corporation. Changes in requirements, technology, political leadership caused this program to fail. The lessons learned from these previous development programs can be used to simplify and streamline any future PRT development efforts but may not eliminate all potential pitfalls.

### **Comparing PRT to other modes**

Although largely untested under “real-world” operating conditions and despite the many challenges to implementation, PRT developers, researchers and advocates believe that PRT has the potential to provide a unique level of cost and service for certain specific urban applications some time in the future. This section compares PRT to other modes of transportation. In reviewing this section, the reader should note that some of the

comparative information has been extrapolated from limited PRT experience. As such, the comparisons made as part of this study should be reviewed and validated over time as additional “real-world” application data becomes available.

- **Average travel speed and overall trip times for comparable trips:** When comparing observed national data for conventional public transportation modes to model data from conceptual PRT simulations, it appears that, PRT could conceptually achieve between 14 and 65 percent faster average travel speeds and between 14 and 125 percent faster overall trip times than bus, light rail and heavy rail transit. This is primarily due to the non-stop, on-demand nature of PRT operations. Estimates are for station to station travel and do not include walking or other mode travel times to access transit stations/stops which will vary by mode and the unique characteristics of each transit system.
- **System capacity:** Conceptual PRT simulation data also indicate that PRT systems could have theoretical capacities up to 10,000 people per hour per direction (pphpd) with operating capacities of 3,000 to 7,000 pphpd. This capacity is similar to the observed operating capacity of most current light rail and bus rapid transit applications.
- **Capital costs:** Engineering cost estimates provided by various PRT developers and empirical data from comparable conventional elevated guideway systems built in the United States were used as part of this study to derive engineering capital cost estimates for potential PRT applications. These estimates indicate that capital costs for constructing a two-way PRT system could be expected to average \$30-50 million per mile. The estimates assume that initial pilot PRT systems have been developed, successfully operated in a test environment and that manufacturing efficiencies have been achieved. It can be anticipated that early PRT systems may have higher costs due to development issues and initial manufacturing startup inefficiencies.

Although these estimates compare favorably to other larger guideway, larger-vehicle modes, actual costs will depend on the specifics of guideway design, local land use and geological conditions and the extent of the guideway network. Furthermore, it should be noted that the actual capital cost of transportation infrastructure investments constructed in New Jersey have frequently exceeded original cost estimates. Costs in certain categories have risen sharply over the years. Increases in many of these categories, including those associated with land acquisition, environmental mitigation, utility relocation, financing, engineering, insurance, administration and construction management, are likely to apply to PRT as well as conventional transit systems. Finally, it is also worth noting that the Morgantown, WV system, the only PRT-like system constructed in

the United States, exceeded estimated construction cost by four times. Until more commercially-viable PRT systems are built in the United States or elsewhere, capital cost estimates will remain somewhat speculative.

- **Operating and maintenance (O&M) costs:** As conceived, PRT systems would be highly automated with low staffing levels, energy use and maintenance requirements. A comparison of observed national average O&M cost data for conventional public transportation modes and O&M cost estimates developed for this study using data provided by PRT developers and observed O&M cost estimates for APM systems, indicate that PRT O&M costs per passenger mile might range from \$0.30 to \$0.80. This compares favorably to other modes. However, since PRT vendors have very limited O&M experience, until more commercially-viable PRT systems are built, O&M cost estimates will remain somewhat speculative. Also, when comparing vendor O&M estimates with observed transit operating costs, it should be noted that transit agencies incur a number of cost categories that may not be reflected in vendor estimates, such as policing and security, fare vending and collection, station cleaning and maintenance, claims and insurance.
  
- **Ridership and congestion relief:** Depending on the system scale, design, and fare policy, PRT systems could theoretically attract a high level of ridership in certain transit markets due to potentially improved service characteristics such as shorter travel times, lower cost, and greater comfort, access and availability when compared to other conventional public transportation modes. These service characteristics could theoretically be competitive with automobile travel under some circumstances. To the extent they are, PRT possesses the potential to attract auto users and thereby reduce congestion.
  
- **Energy use and environmental impact:** As conceived, PRT systems will operate non-stop, on-demand service using lightweight vehicles on exclusive-use guideways. As such PRT developers estimate that PRT systems will consume 50 to over 300 percent less energy than conventional public transportation systems and could achieve an automotive equivalent energy use of 70-90 miles per gallon. In addition, because of their conceptual design using rubber tires and electric propulsion, PRT systems could be expected to have lower noise and local pollution impacts than other conventional public transportation modes. Given the fact that PRT system will most likely be built utilizing elevated guideways, they could have potentially more visual impact than comparable at-grade systems. It should also be noted that elevated guideway systems by their very nature are likely to engender citizen concern as part of any public project development process.

The comparative conceptual benefits of PRT described above are predicated on the assumption that PRT technology development achieves the goals described in Section V of this report. As discussed in Section V, PRT technology development is progressing with limited funding and without the coordinated support or endorsement of a major public entity. The conceptual benefits of PRT are fully realizable using current technology. However, in order to fulfill the promise of PRT, system developers will need to apply rigorous, methodical and careful engineering to final system design in order to achieve the proper balance of performance, cost, service, safety and security. Many past PRT technology development programs have attempted to demonstrate these benefits but have not been successful in one or more areas.

### **Options for New Jersey**

The following options are presented for consideration by decision-makers to advance the state of PRT and become viable options to address transportation needs within the State of New Jersey:

#### ***Option 1 – Monitoring and support***

Under Option 1, State officials would play no active role in advancing the development of PRT. The State would monitor PRT development activities conducted by private developers and other governmental organizations around the world and reconsider the State's role in the future, as appropriate. This option requires no commitment of State funds and eliminates the risk of State agencies selecting sub-optimum technology configurations for early implementation. At the same time, this option limits the State's ability to influence the pace and direction of PRT development. In addition, PRT development activities may favor technology solutions not appropriate for implementation in New Jersey. For example, technology solutions that operate in fair weather climates may advance while those appropriate for cold weather operation do not. Finally, this option may prevent the State from capitalizing on an opportunity to develop a new PRT industry centered in New Jersey.

#### ***Option 2 – Research and analysis***

Under Option 2, the State would sponsor New Jersey-based research in areas that will advance PRT development, including the use of tools, analysis techniques and data that support the understanding, development, implementation and operation of PRT systems. This option could provide a foundation for effective demonstration and implementation of PRT systems in the



State and elsewhere. It could also raise New Jersey's profile as a leader in helping to guide and shape the new technology and industry. This option could help to ensure that advancements in PRT technology are appropriate for New Jersey applications (i.e., systems capable of operating in cold climates). Finally, this option could help to cultivate a base of knowledgeable and experienced engineers, designers and planners to support the growth of a PRT industry in the State.

Option 2 requires a level of risk and investment of State resources in research that may not have tangible results in the short or long term. Further, research alone, with no commitment to a comprehensive research and development program and/or implementation, could be of limited effectiveness. Finally, even with additional research, PRT developers may fail to secure the investment funds needed to advance PRT to operational deployment.

### ***Option 3 – Detailed application studies***

Under Option 3, State officials would identify and select a limited number of potential PRT application sites and conduct feasibility assessments of one or more applications including cost, performance, ridership, layout and impact analysis. This option could also include public outreach activities to explore public perceptions of PRT as a viable mode of transport.

This option lays the foundation for potential PRT implementation if PRT technology development and demonstration systems prove successful. It enhances PRT developers' ability to secure private investment by identifying potential applications and creates an opportunity to educate the public regarding the technology and its potential benefits. At the same time, this option requires the commitment of limited State resources without any guarantee of tangible benefits. It may also raise expectation among the public and policy makers before the technology is ready for implementation.

### ***Option 4 – “Proof-of-concept” public/private program to develop and operate a pilot test track***

Under Option 4, State officials would help build, partially fund and support a public/private partnership to conduct a comprehensive program to develop and operate one or more test tracks to demonstrate PRT performance. The comprehensive program would include product design and engineering, prototype and component testing, construction of at least one full-scale test track,

system testing for reliability and safety, and efforts to achieve commercial readiness. From previous PRT and similar development programs, it is expected that the program may require between \$50 and \$100 million depending on the selection of technology from previous and current programs and the degree of test track construction and testing.

This approach would establish a shared risk funding and ownership program with other state and federal transportation agencies and various private partners. Under this option, the State could limit its share of the program to some acceptable level of investment. To help to ensure success, the State could take a leadership role in developing system performance requirements, testing the technology, and working with the partnership to construct initial system demonstrations.

This option could provide New Jersey with the opportunity to demonstrate international leadership in shaping the future of the technology; structure a program around New Jersey applications; and create a network of engineers, planners, technology developers, manufacturers, and support organizations in New Jersey to foster the creation of a new PRT industry in the State. It may also shorten the implementation time frame and provide a higher probability of success with an opportunity for the State to receive return on its investment from revenue sharing and economic development benefits.

At the same time, this option requires the State to commit public funding to support the development partnership. Given the nature of public/private partnerships, this option comes with risk. There is some potential to develop sub-optimal technology solutions as experienced in the Chicago RTA program and public/private partnerships are vulnerable to leadership change over time. This could negatively impact success, especially if political support weakens, or technology development is delayed.

It should be noted that this development program would result in a full technology readiness and the ability for the State to begin implementations of the technology for public operation. It is expected that the test track from the development effort would remain an ongoing test and development facility for the partnership or a research university that may be part of the partnership.

## **Conclusion**

PRT is an emerging and innovative transportation concept designed to offer the comfort and convenience of the private automobile with the efficiency of public transportation. PRT offers the theoretical potential to increase travel speed, quality of public transportation service and mobility while potentially reducing the costs and

environmental impacts associated with travel. PRT has the potential to be a mode of urban transportation that offers a flexible and scalable capacity with higher levels of service and less expense than many current public transportation alternatives. Conceptually, PRT could serve as a stand-alone public transportation system or be part of the larger multi-modal network of urban transportation services.

If system development continues as expected, PRT could theoretically become an effective tool to improve urban congestion, sustainability and livability. PRT offers a mode of service that could be more competitive with the private automobile than conventional public transportation systems and potentially attract more drivers from their cars. Further, PRT offers the potential to reduce the energy use, land use, and environmental impact of transportation allowing the implementation of more sustainable transportation solutions in today's congested infrastructure.

While PRT may offer future potential, it requires additional development and demonstration. PRT has undergone significant research and development but has not fully advanced to a state of commercial readiness. Current PRT development activities are proceeding with limited resources and limited public support or guidance. Although initial PRT systems may potentially be available for commercial implementation in several years, the full development and implementation of PRT must be a long-term strategic initiative. Additional support and resources will be needed to help PRT to reach maturation and to realize its theoretical benefits.

As an emerging technology, PRT requires a market that is receptive to the new paradigms of smaller scale infrastructure, automated small vehicles, off-line stations and on-demand service. The development and support must continue throughout the emergence PRT must complete before it can become a full member of the transportation community. Each of the options presented above would be legitimate responses to the current state of PRT development. Ultimately, State decision-makers will need to determine how proactive they wish to be. Option 1 requires no investment of public funds or political capital. Options 2 and 3 carry some risk but also limit potential gains. Option 4 represents the greatest risk to the State in terms of financial investment and exposure in a time of significant fiscal constraint and commitment to a specific policy direction; however, it also may result in firmly establishing the real costs and benefits of employing PRT and therefore the greatest return.

PRT has the potential to help the State address certain transportation needs in a cost-effective, environmentally-responsible, traveler-responsive manner. The ability of the State to take advantage of this technology will depend upon the State's ability to sustain an adequate level of investment and commitment to support the full maturation of the technology.

## II. BACKGROUND AND STUDY OVERVIEW

The transportation challenges we face in the twenty-first century are increasingly complex. Congestion is worsening, the costs associated with making transportation improvements are increasing and the public is often weary of the potential negative community and environmental effects of transportation projects. Improved roads and highways provide some level of congestion relief, but these benefits are often short-lived. In dense urban and suburban areas, land for new road capacity is limited and improvement costs are high. New commuter and light rail transit is expensive and serves generally origins and destinations proximate to stations. Conventional bus services have a lower cost, but are inefficient in lower density environments, in areas where road congestion is common and in places where ample free parking is ubiquitous. To make these challenges even more acute, limited government funding for transportation projects must be stretched further and further to meet the demands of operating and maintaining our existing infrastructure.

In October 2004, the New Jersey Legislature passed P.L. 2004, Chapter 160 directing the Commissioner of Transportation, in consultation with the Executive Director of NJ TRANSIT, to prepare a report evaluating the viability of Personal Rapid Transit (PRT) in New Jersey. The bill recognized that New Jersey's transportation needs are broad and diverse and noted that it is in the State's interest to actively improve and diversify a transportation system that has proven fundamental to its long-term economic success.

In July 2005, the New Jersey Department of Transportation (NJDOT) contracted with the Alan M. Voorhees Transportation Center at Rutgers University (VTC) and Booz Allen Hamilton (BAH) to conduct a study of PRT designed to:

1. Provide a complete and thorough description of the key elements of PRT technology and identify PRT components that have been demonstrated successfully and those that are conceptual in nature;
2. Identify potential PRT system developers and assess the current status of PRT relative to implementation readiness;
3. Compare and evaluate the potential benefits and costs of PRT to other modes of transportation, in terms of: capital costs, operations and maintenance costs, energy use, ability to reduce congestion, right-of-way needs, and potential environmental, land use, utility and visual impacts; and
4. Evaluate the viability of integrating PRT as a supplement to NJ TRANSIT's current and future transportation networks and services.

Major components of the research plan for the study included a comprehensive review of available literature on PRT; an analysis comparing PRT to other conventional modes of transit; an examination of the potential viability of PRT in New Jersey; and a critical assessment of the steps necessary to advance PRT implementation in New Jersey. This report documents the research findings from the study.

- Section I provides an executive summary of the research findings and conclusions.
- Section II (this section) provides background and a brief study overview.
- Section III describes the fundamental elements of PRT technology and service.
- Section IV summarizes the literature on PRT, including the history of PRT development and the results of past implementation studies.
- Section V presents a current assessment of the PRT industry based on the results of a vendor survey and interviews with industry experts interviewed for the study.
- Section VI compares PRT to other transit modes relative to speed of travel, system capacity, capital costs, operating and maintenance costs and a number of other characteristics.
- Section VII examines the potential viability of PRT applications in New Jersey.
- Section VIII provides a critical assessment of the steps necessary to advance PRT implementation, summarizes the challenges to implementation, proposes a possible business model for PRT development and presents a series of options for advancing PRT in New Jersey should decision makers decide to move to the next stage of PRT development in the State.

PRT has been the subject of research and development efforts for approximately 40 years. However, there has yet to be a full scale deployment of this technology. A fully operational PRT system is needed to demonstrate the theoretical benefits of PRT and establish commercial readiness and significant research and development activities must still be undertaken. Such a research and demonstration program has been conceptually estimated to require \$50-100 million over a three year period. It is important to note that PRT is an emerging technology and has not yet advanced to the stage of commercial deployment or achieved wide-spread public operation. As such, much of the information presented in the report, especially information related to the potential benefits of PRT, is based on conceptual engineering and theoretical research from PRT developers, government researchers, or independent consultants. Wherever appropriate, the potential or theoretical nature of particular data and information is made clear and the source of information is noted.

### III. FUNDAMENTAL ELEMENTS OF PRT

Since its introduction as a concept in the late 1950's and early 1960's, PRT has evolved to its current state through a variety of academic, governmental and private industry development programs. PRT is designed to provide a completely new mode of transport to address the needs of urban transportation in a variety of settings. Although PRT is still in the final stages of engineering and development, Table 1 provides an overview of the basic design features of current PRT systems and the transportation needs each is designed to address.

**Table 1 - PRT Design Features**

Need	Design Feature and Goal
Provide faster service	<ul style="list-style-type: none"> <li>▪ Non-stop, on-demand service</li> </ul>
Lower operating costs	<ul style="list-style-type: none"> <li>▪ Increased levels of automation</li> <li>▪ Reduced energy use</li> </ul>
Lower capital costs	<ul style="list-style-type: none"> <li>▪ Reduced size of infrastructure for stations, track and right-of-way</li> </ul>
Improve integration	<ul style="list-style-type: none"> <li>▪ Smaller footprint and tighter turning radius to integrate better into dense urban environments</li> </ul>
Reduce congestion	<ul style="list-style-type: none"> <li>▪ Faster and personalized service to attract private automobile users</li> </ul>
Reduce pollution	<ul style="list-style-type: none"> <li>▪ Electric vehicles</li> </ul>
Reduce energy use	<ul style="list-style-type: none"> <li>▪ Small, lightweight vehicles</li> <li>▪ Non-stop, on-demand service to eliminate unnecessary vehicle movements</li> </ul>
Increase safety and security	<ul style="list-style-type: none"> <li>▪ Distributed demand and continuous flow to eliminate crowds</li> <li>▪ Advanced monitoring and control systems</li> </ul>

The literature provides a variety of descriptions and definitions of PRT that have evolved over its history. Today, there is general consensus among transit experts and PRT developers that the key characteristics of PRT include:

- On-demand, origin-to-destination service;
- Small, fully automated vehicles;
- Small, exclusive-use guideways;
- Off-line stations; and
- A network or system of fully connected guideways.

As a new technology, PRT combines the elements of current automotive, computer networking and transit technologies using state-of-the-art technologies including: advanced propulsion systems; on-board switching and guidance; and high-speed controls and communication. As such, PRT systems represent a new paradigm for urban transportation.

### **On-Demand, Origin-To-Destination Service**

PRT is differentiated from other fixed guideway transit modes by its on-demand, origin-to-destination service. PRT provides non-stop, on-demand, personalized service in a public vehicle using a public conveyance. In order to provide this type of service, PRT must utilize small, automated vehicles with short headways, off-line stations, network management and vehicle flow systems, and highly redundant and fault tolerant control and communications. The theoretical benefits of this type of service include: shorter wait times and no interim stops resulting in shorter trip times, and a comfortable seated trip. On-demand, origin-to-destination service has been demonstrated successfully on a small scale at the University of West Virginia at Morgantown and several prototype test tracks around the world (Raney and Young, 2004; Anderson 1998).

### **Small, Automated Vehicles**

PRT systems are designed to use automated vehicles with all-seated passengers that are sized to meet the travel demand unique to each application. For example, according to the National Household Transportation Survey (2001), 93 percent of all urban trips in the United States are made by traveling groups of 3 persons or less. The PRT vehicles reviewed for this study have 3-4 seats. Small vehicles, designed for seated passengers, provide private, individualized service in a protected environment. Vehicles can be designed for full accessibility and compliance with ADA requirements.

Depending on system needs and guideway capacity, PRT vehicles could also be designed to accommodate group travelers or baggage handling at locations such as entertainment venues or airports. PRT systems could also be designed to accommodate special vehicles to haul freight and thereby increase the revenue potential of the system.

### **Small, Exclusive-Use Guideways**

PRT systems are expected to use exclusive guideways either at-grade, elevated or underground that support small vehicles with all-seated passengers. Conceptually, small vehicles with all-seated passengers will permit the use of smaller elevated guideways, higher acceleration/deceleration rates and smaller curve radii than conventional elevated guideway systems using large vehicles and standing passengers. Smaller-sized guideways with reduced foundation requirements have the potential to reduce disruption of existing infrastructure, and provide greater opportunity to integrate PRT within existing rights-of-way. Small guideways may also allow stations to be more easily integrated into existing buildings than conventional transit systems and permit rapid, prefabricated modular construction.

### **Off-Line Stations**

A central component of PRT systems is the use of off-line stations which function like ramps on a freeway to maximize the flow of vehicles on the mainline guideway system while passengers board and disembark at stations. Conceptually, this also allows vehicles to move individually through a station or wait at a station if there is no demand or to anticipate future demand. Stations need not be “one size fits all.” Each station could be designed and sized to meet local demand. For example, in areas of high demand, stations would have many loading/unloading vehicle berths and vehicles may move through the station in virtual platoons similar to traditional rail transit. Conversely in areas of lower demand, stations would have fewer berths and vehicles could move on an individual basis.

### **Network of Connected Guideways**

Conventional guideway transit is typically designed to provide line-haul service which aggregates trip demand in corridors. This type of service helps to minimize the capital cost of the system but limits the number of origins and destinations that can be efficiently served and the total area “covered” by transit service. Conceptually, PRT systems have been designed as interconnected, scalable networks of guideways capable of serving more origins and destinations covering a larger area. If PRT systems achieve the goal of lower capital costs, this network approach may allow more



stations which could provide greater individual mobility for a comparable level of capital investment than a conventional fixed guideway system. The network approach also minimizes the need for transfers within the system. Conventional bus and paratransit systems can achieve access to numerous origin and destinations at much lower cost than fixed guideway systems but are limited by congestion on the surface street infrastructure. Conceptually, PRT networks could combine the greater levels of access provided by bus and paratransit systems with the unobstructed flow and speed of fixed guideways in one transit system.

#### **IV. LITERATURE REVIEW**

Personal Rapid Transit (PRT) as a conceptual mode of transportation has a history of technical development that spans over 40 years. It has been studied by state, local and federal governments, universities and research organizations, and transportation agencies around the world. It has also been investigated by a wide range of real estate developers, entrepreneurial manufacturers, technical component providers and large manufacturing entities.

Literature summaries and the history of PRT have been widely documented by several authors. A recent review of the PRT publications conducted by Dr. Wayne Cottrell of the University of Utah's Department of Civil and Environmental Engineering found that "about two hundred PRT writings have been published since 1964" (Cottrell 2005). Dr. J. Edward Anderson has written several documents that chronicle the development of PRT since 1953 (Anderson 2005). These documents provide context for various development programs and historical reference for current development activities.

The literature on PRT is wide-ranging and includes books, scholarly articles and technical reports that address: technology development programs, demonstration projects, alternatives analyses, preliminary system design and layout, technical and operational analyses, economic and business case modeling, environmental impact analysis, patronage analysis, technology and network management, and cost and performance comparisons. More than one hundred PRT publications were reviewed for this study and are listed as references at the end of this report. This section summarizes the history of PRT development with details regarding key development programs, recent application studies, a status report on PRT interest around the world and "lessons learned" from history.

##### **Early History of PRT**

The idea of PRT can be traced back to many inventors and researchers that worked independently to address the need for better urban transportation. An historical review of PRT development prepared by J. Edward Anderson in 1998 credits the earliest work on PRT to Donn Fichter who started developing concepts in 1953 that resulted in a 1964 publication entitled, "Individualized Automated Transit and the City" (Anderson 1998). This early book addressed the need for a total transportation system that could integrate into the cityscape with the smallest and lowest-cost guideways possible and a service designed to support the individual needs of travelers with the smallest and lightest possible vehicles. Anderson's review also chronicles numerous other early PRT development programs (1998).

A review of the literature reveals that, until the Urban Mass Transportation Act was passed in 1964, PRT development activities mostly occurred independent of one another. Following the act, many federal activities were undertaken to support the development of PRT and other advanced transportation systems. The Urban Mass Transportation Administration (UMTA) and the Housing and Urban Development (HUD) Administration undertook several joint studies that resulted in a 1968 Scientific American article entitled "Systems Analysis of Urban Transportation," as well as a summary document entitled *Tomorrow's Transportation: New Systems for the Urban Future* (Cole & Merritt 1968). These studies led to many PRT development initiatives including the Aerospace Corporation research program, the Morgantown system in the United States, and other programs funded by central governments around the world.

### **Aerospace Research Program**

A major PRT research study was conducted by the Aerospace Corporation between 1968 and 1976. The Aerospace Corporation is a not-for-profit corporation established by the United States Air Force to support missile system development. In 1968, the firm decided to use aerospace technology to solve urban problems and concluded that high-capacity PRT would have this potential based on the HUD reports.

The program included comprehensive analysis of the requirements for a PRT system and a tradeoff analysis of components. They developed a prototype system that included a narrow, U-shaped guideway and a vehicle suspended above the guideway propelled by on-board linear electric motors. The system employed electromagnetic switching in the guideway. The Aerospace Corporation also developed computer simulations to provide the feasibility of operating large PRT networks with many thousands of vehicles. They performed economic and patronage analyses of PRT for Los Angeles, CA and Tucson, AZ, and lectured widely on the advantages of PRT. The study findings were documented in the book Fundamentals of Personal Rapid Transit published in 1978 (Irving 1978). Because the Aerospace Corporation is a not-for-profit corporation, it did not advance its research program beyond recommending further development of the concept by the U.S. Department of Transportation.

### **Morgantown Group Rapid Transit**

With the advent of the Apollo program in the late 1960's and the interest in advanced automated transportation technology, the University of West Virginia in Morgantown became interested in PRT systems through the efforts of Professor Sammy Elias, the then Head of the Industrial Engineering Department. The University was land-constrained and distributed among three campuses in a city with congested streets. A PRT system was identified as the best method to move students between campuses and the Alden staRRcar system was selected for implementation under an UMTA

funded comparative study. Following the selection of the staRRcar system, the U.S. Department of Transportation and UMTA initiated a rapid follow-on program to engineer the system and complete construction in time for the 1972 presidential elections, so that then President Richard Nixon could ride it and use it as an important example of progress being made by his administration. In December 1970, UMTA contracted the NASA Jet Propulsion Laboratory to be the system manager. At the same time UMTA selected Boeing as the vehicle manufacturer, Bendix Company as the control system supplier, and F. R. Harris to design and construct the guideway, stations, and other fixed facilities.

According to researchers, at the time the Morgantown system was being designed, the scheduled opening date was a central concern. Cost-effective construction was not a principal objective. Further, none of the firms that were working on the project had ever worked with PRT before and had limited time to fully learn about the technology. The focus on completing the system by a certain date rushed the development and forced design compromises. For example, the system uses large heavy vehicles which necessitated the use of larger guideways and stations. As a result, cost of construction was four times the initial projections (Anderson 1998, Raney and Young 2004).

The Morgantown system began limited operation in 1972 and was expanded to its current capacity in 1975. The system is a fully automated, on-demand, off-line station transit system as shown in Figure 1. The Morgantown system has been in continuous operation since 1972. The system includes 8.7 lane miles of guideway and a fleet of more than 70 operating vehicles that log more than 1.5 million miles annually. The system carries two million passengers per year and since 1972, more than 63 million passengers have used the system. At peak travel times, the system can serve 30,000 passengers per day (Raney and Young 2004). Although it is commonly referred to as a PRT system, it is technically a Group Rapid Transit (GRT) because it uses vehicles that can transport up to 21 passengers as shown in Figure 2.

PRT researchers appear to agree that Morgantown cost overruns seriously compromised PRT advancement and fueled skepticism regarding the viability of PRT to deliver on theoretical cost savings and system efficiency. Unfortunately, a fact that is



**Figure 1 - Morgantown Off-line Station**



**Figure 2 - Morgantown Vehicle**

often overlooked is that the Morgantown system successfully demonstrated the viability of key PRT technology components, including off-line stations, on-demand service, nonstop origin-to-destination transport and fully automated control systems (Raney and Young, 2005). Since it began operating, the system has demonstrated very high reliability of 98% or greater.

### **International Developments**

Beyond interest in PRT in the United States, many other national government programs were developing PRT technology around the world in the late 1960's and early 1970's. These programs included:

- Aramis –France
- Cabtrack – England
- Cabintaxi – Germany
- CVS – Japan
- Krauss Maffei – Germany

Each of these programs was funded with central government support and included full-size demonstration tracks and testing programs.

For various technical, economic and political reasons, none of these demonstration programs evolved into ongoing commercial systems. Only the Cabintaxi program resulted in a commercial application at the Schwalmstadt-Ziegenhain hospital in Germany. The majority of systems had technical issues that limited their capacity or created high capital costs. In the 1970's, advanced communication and control systems were not available that could have supported higher capacities. Similarly, the optimization of the design for the lowest capital cost was not inherently part of these programs. These system designs did, however, contribute significantly to the knowledge base of PRT design and operations. For example, the Cabintaxi system developed in Germany was extensively studied by the US and German governments resulting in a comprehensive study on PRT development and deployment (UMTA 1977). The Cabintaxi system is the only system from this era that is currently being marketed.

### **Other Activities**

The world-wide PRT development activity during the 1970's generated considerable interest within the research and engineering community. Three major international conferences were held in 1972, 1973 and 1975, resulting in over a hundred published papers. In addition, in May 1972, UMTA sponsored an international transportation exhibition called "Transpo72" at Dulles Airport. The exhibition included temporary

demonstration tracks for four systems – TTI; Monocab; Dashaveyor; and Ford. Transpo72 was primarily a demonstration project and not a development program and therefore did not result in any advances in technology.

In addition to the development programs described above, a number of feasibility or application studies were also conducted in the 1970's. These included major studies for Denver, CO; Los Angeles, CA; and Minneapolis, MN in the United States, as well as studies completed in Germany, Sweden, Japan, and England (Anderson 1998).

The culmination of early PRT development efforts in the United States came with the Office of Technology Assessment report to Congress in June of 1975 entitled "Automated Guideway Transit: An Assessment of PRT and Other New Systems" (OTA 1975). This report stated there were many technical issues to be solved with PRT systems including the development of computer control systems and advanced control and braking systems. The report also recommended that improvements were needed in system reliability and crash survivability. A study of alternative engineering concepts was also recommended in order to develop cost-effective systems and components. The report concluded that PRT had significant potential but there were many issues to be addressed that would require sustained capital investment over time. The findings and recommendations of the report led to an expansion of UMTA's Advanced Group Rapid Transit (AGRT) program rather than PRT development efforts. According to the report's authors, AGRT had more near-term potential than PRT and did not require as much capital investment in further research and development.

### **PRT Development Since the 1970's**

Since the 1970's, PRT development has continued with varying levels of support and interest. Developers and local governments around the world have continued to express interest in the features and benefits of PRT. Cottrell documented an additional 107 PRT-related publications between 1976 and 2004, with the most activity occurring between 1996 and 2000 (Cottrell 2005). Between the 1970's and 2000, the major efforts to develop or analyze PRT or related technologies were the UMTA AGRT program and the Raytheon/RTA program described in the following sections. For the sake of brevity, many smaller PRT programs such as the University of Minnesota PRT effort or related automated people mover development programs are not described in this literature review.

### **UMTA AGRT Program**

As mentioned above, after the 1970's, the majority of U.S. government support for advanced automated transit system development was focused in UMTA's AGRT

program. The objective of the AGRT program was to develop larger vehicles that needed less frequent headways than PRT systems and therefore less advanced technology sub-systems. As a result of the AGRT program, several automated large-vehicle transit systems were planned and implemented in the 1980's. These included the Dallas Airport Airtrans system and the Tampa Airport People Mover System.

In 1980, the Office of Technology Assessment submitted another report to Congress. This report was entitled "Impact of Advanced Group Rapid Transit" (OTA 1980) and focused on a class of systems called Automated Guideway Transit that included shuttle loop transit, GRT and PRT. The study addressed these systems with the following observations:

- **Need for more advanced automated systems:** "AGRT technologies appear capable of providing service levels that the public wants but cannot get with currently available transit technologies. Capital and operating cost estimates for AGRT compare favorably with the costs of installing and operating heavy-rail systems on exclusive guideways; however, there are large variations in capital and operating costs among the 10 operational automated guideway systems. Precise comparisons with other transit technologies will require further testing of AGRT systems and real-world experience. Additional system optimization studies are needed to determine the preferred vehicle size, seating capacity, guideway configuration, headway, and line speed of future AGT systems. The views of transit operators and the public should play a central role in this analysis."
- **Prototype development:** "Money invested in alternative AGRT technologies during the early phases of the R&D program can provide relatively inexpensive insurance against the risk of picking an inferior design. At this early stage in the development cycle, there is no sound technical basis for discontinuing work or providing any promising technology with significantly less funding."
- **Government/industry relationships:** "Introduction of innovative transit systems is constrained not only by the need to more adequately develop the technology, but by major institutional and economic barriers as well. Recent experience suggests that the promise of 80-percent Federal funding is no longer sufficient inducement for cities to accept transit technologies if there is a question relative to whether they will meet local needs at a reasonable cost. Both West Germany and Japan have fostered a cooperative relationship between government and industry that has helped ensure an orderly program of long-range transit innovation. Further consideration is needed of alternative institutional arrangements for managing transit R&D in the United States. The potential of broad international leadership in the transit technology field is no longer a

credible prospect for U.S. industry; however, component or system leadership in AGT is possible if pursued more effectively than in the past.”

The AGRT program was cancelled in the 1980’s with little funding provided to support these recommendations or technology development. Several downtown people mover programs such as the Detroit People Mover were funded; however, these systems were implemented on a small scale and never achieved the scale or ability to address larger urban transportation needs.

### **Chicago RTA/Raytheon Program**

The most significant PRT program undertaken since the 1970’s in the United States occurred in the mid 1990’s, when the Chicago Regional Transportation Authority (RTA) embarked upon a large-scale program to develop PRT technology in partnership with the Raytheon Corporation. Under the leadership of then Chairman Gayle Franzen, the RTA initiated a multi-phase program to study, develop and implement PRT systems for the Chicago region. In announcing the program, Chairman Franzen stated that “PRT is an experiment of necessity. Suburban growth has had staggering impact on traffic congestion. Present mass transit technologies have not fully met suburban transportation demand.” Phase one of the program began in 1990 with the funding of two evaluation studies of competing PRT technologies. Stone & Webster Engineering and Intamin AG were selected as the two technologies for evaluations from 12 competing proposals. The Taxi 2000 design was the technology component of the Stone and Webster proposal. The studies were completed in 1992 and resulted in the selection of the Taxi 2000 design as the preferred alternative in 1993.



**Figure 3 - Raytheon PRT Test Track**

In June 1993, as part of phase two of the program, the RTA selected the Raytheon Corporation to join in a public/private partnership for the development of a PRT system. Under terms of the agreement, the RTA and Raytheon jointly funded a \$40M technology development program. In return, Raytheon was given the rights to the technology and provided the RTA with a 1.3 percent commission on future sales. A three-year program was structured to complete the Taxi 2000 system design, engineer various system components, develop a prototype test track, and conduct system testing.



The program resulted in the construction of a 2,200 foot test track in Marlborough, Massachusetts with three vehicles and one off-line station shown in Figure 3. The test track successfully demonstrated off-line station maneuvers, 2.5 second headway operations and network management of vehicles (Anderson 2005).

In parallel with the initial technology evaluations and demonstrations, the RTA requested local communities to submit expressions of interest for an initial PRT demonstration in Phase Three of the program. After reviewing four local applications, the RTA selected Rosemont, IL as the initial demonstration site. The Rosemont system was designed to connect hotels, retail, a convention center and office buildings with the Chicago Transit Authority rail transit line that runs to O'Hare airport (see Figure 4).

Despite successful testing at the Marlborough test track and favorable study findings, a demonstration system was never constructed in Rosemont. In 2000, the Raytheon/RTA program was cancelled for various political, economic and technical reasons including the high cost of system construction resulting from large guideway infrastructure, low fare-box recovery estimates, change in leadership at the RTA and fear of financial risks to be born by local leaders in the Village of Rosemont (Samuel 1999, Anderson 2005).

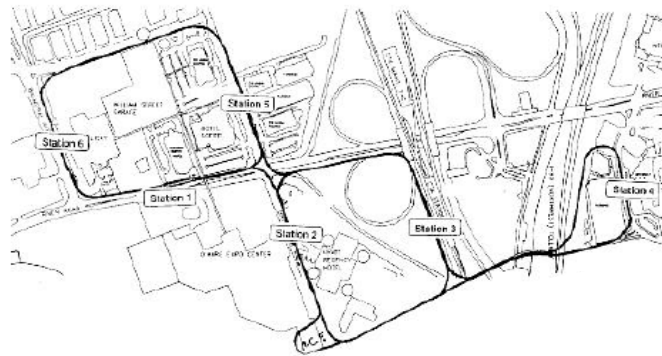

**Figure 4 - Rosemont PRT Demonstration Layout**

It is important to examine the history of this program and lessons learned to guide any future PRT development programs. These lessons learned include:

- **Technical Design:** The original RTA program was initiated based on the Taxi 2000 design. This initial design specified small, light-weight, three-passenger vehicles powered with linear induction motors and used a narrow gauge chassis and side lateral support wheels. The design also called for a small space-frame

guideway. Through iterations of design involving conventional automotive and transit designs, the system evolved into a much larger and heavier, four-passenger vehicle that used rotary motors and automotive-style suspension. The guideway was then designed to accommodate this wider and heavier vehicle. Instead of the originally planned 39 inch by 39 inch guideway, the demonstration system required a much larger 72 inch by 72 inch guideway that was significantly more expensive to build (see Figure 5).

By failing to learn from previous designs and PRT developments, and using conventional vehicle design paradigms, the Raytheon program significantly increased the cost, complexity and visual intrusion of the guideway. They also limited the ability of the system to support short headway operations by selecting rotary propulsion systems.

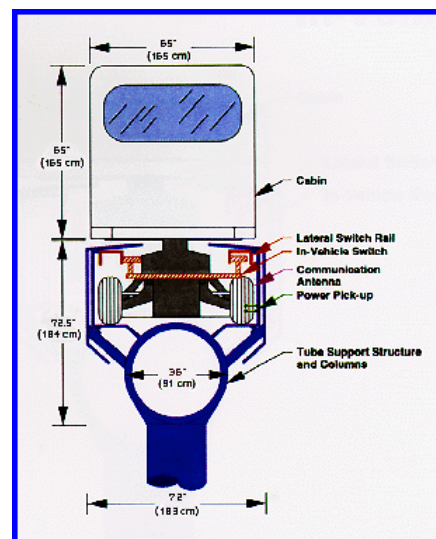

Figure 5 - Final Raytheon PRT Design

- **Cost Focus:** The Raytheon program was originally conceived with a target system cost of \$15 million per mile. After the design modifications described above that increased the guideway and vehicle costs, the target system cost was estimated at over \$40 million per mile. This increased cost was not competitive with other currently available transit systems. It also altered the economic justification for the demonstration system and the expected future market for the system.
- **Political Support:** During the development program, RTA Chairman Franzen, the Authority's Executive Director, and several board members left the RTA. This change in leadership, challenging economic conditions and complications from the increased cost and decreased performance of the system led to the cancellation of the program in 1999.

### PRT Application Studies

Since the 1970's, a number of significant PRT studies have been conducted in the United States as well as Europe and Korea. These studies have resulted in a considerable body of knowledge regarding the theoretical benefits of PRT, application and development considerations, costing and modeling techniques, as well as guidance for development programs. The following subsections describe the European EDICT

program which included perhaps the most extensive PRT studies conducted to date, as well as other large studies from Europe and the United States.

### **EDICT Program**

The Evaluation and Demonstration of Innovative City Transport (EDICT) program was a European Union 5<sup>th</sup> Framework program supporting the “City of Tomorrow.” The EDICT program sought to analyze and develop PRT as a potential urban transport solution to meet the need for sustainable new transport systems. EDICT was a 30-month project that began in December 2001 and ran through May 2004. The program’s budget was approximately \$3.5M. It involved a consortium of sixteen organizations including local authorities, consultants, industry representations and academics from seven European countries. The objectives of the EDICT program included the following:

- Demonstrate and evaluate PRT in Cardiff Wales;
- Study the opportunities for PRT implementation in Cardiff, Wales; Huddinge, Sweden; Eindhoven, Netherlands; and Ciampino, Italy;
- Assess environmental, social, economic, and cultural issues related to PRT implementation; and
- Assess the potential benefits of PRT for Europe.

The EDICT program was led by the Cardiff Wales County Council and included independent program management and assessment teams. It was financially supported by the European Commission Directorate-General Research through its Key Action “City of Tomorrow and Cultural Heritage”. The EDICT project used the ULTra PRT system developed by Advanced Transport Systems as a model PRT technology. The ULTra system is described in Section V of this report.

The first PRT application examined as part of the EDICT studies was for **Cardiff, Wales, UK**. The study focused on the docklands redevelopment area next to city center. The PRT network designed for the Cardiff application included a five mile network of guideways designed to serve 5.7 million trips per year. The study included considerable economic modeling and traveler acceptance testing.

The results of the first passenger trials for an operational PRT model were conducted at the ULTra Cardiff test track. According to the Summary Report on ULTra Passenger Trials (ATS 2003), all of the passengers who participated agreed that the system was either “easy” or “very easy” to use, that they felt the system was “secure” or “very secure”, and that the overall experience was either “pleasant” or “very pleasant.” The

results of the economic modeling estimated that the system would achieve 100% operating and significant capital cost recovery; a 348,000 person-hours per year reduction in area-wide congestion; an 8 percent increase in mode share over other modes (EDICT 2003).

The second PRT application examined as part of the EDICT studies was in **Ciampino, Italy**. This application consisted of designing a PRT system to connect Ciampino Airport to the center of town. The selected route would serve the airport, remote parking areas, the Ciampino central railway station, and downtown Ciampino.

The third application looked at PRT in **Eindhoven, Netherlands**. Here, a proposed system was designed to serve the Technical University of Eindhoven and improve accessibility to/from the nearby rail/bus station. The study examined the feasibility of constructing a PRT system between the university and rail/bus station.

The last city investigated as part of the EDICT study was **Huddinge, Sweden**. In Huddinge, the area considered for potential PRT service was Kungens Kurva or King's Curve, a large shopping center that attracts over 5 million annual visitors. The proposed PRT system was designed to service the shopping center and nearby rail lines, with the intention of alleviating congestion and parking demand by drawing visitors away from their cars. The simulated PRT network included 7.5 miles of guideway and twelve stations. Simulation results projected a 26 percent reduction in average travel time; ridership 300 percent greater than bus service; a 17 percent increase in overall travel demand due to improved service; and an eight percent reduction in road traffic. Capital costs were estimated to be 35 percent less and operating costs 60 percent less than comparable fixed guideway transit alternatives (EDICT 2003).

### **Seattle Seatac Airport Circulator**

In 1996, a Major Investment Study was conducted for the City of SeaTac, WA. A major focal point for this study was the SeaTac Airport. This study followed up an earlier people mover study conducted for SeaTac in 1992. PRT was found to be the preferred technology of the 1992 study. In the 1996 study, two different PRT system configurations were compared with a consolidated shuttle system and a baseline option of assuming existing and planned services.

The study found that while the service provided by PRT would be superior to the other options, there would be significant financial and technical risk in the implementation of PRT until a proven system was developed. The study recommended establishing a public/private partnership for the implementation of the PRT system. This franchise business model was recommended to capture the value of replacing the current shuttle

systems and the added real estate improvement opportunities created by the implementation of the PRT system. PRT was selected as the Locally Preferred Transportation Investment Strategy using the public/private partnership franchise model. Since the study, no fixed guideway systems have been implemented for the application (BRW 1997).

### **Cincinnati Downtown Circulator**

In August 2000, the Ohio-Kentucky-Indiana (OKI) Regional Council of Governments managed a transit modes study called the Central Area Loop Study (CALS). This study investigated alternatives for creating a downtown circulator service between Covington, Newport, and Cincinnati. The three alternatives considered were conventional bus, light rail transit and PRT. The PRT network considered in the study was designed by a local business consortium called Sky Loop PRT using the Taxi 2000 system as the baseline technology. In 2001, the CALS committee voted against PRT on the recommendations of OKI and their consultant. According to one researcher that reviewed the study, the analysis of the PRT system used costs derived by the OKI consultant that were four times higher than the estimates submitted by Taxi 2000. As a result, OKI opted for improvements to the existing bus shuttle system and further study of LRT. PRT was rejected because of higher costs, lower performance and lack of proven technology. The study also recommended that Taxi 2000 create a full-scale demonstration project to resolve questions of feasibility and cost (Tappan, 2001).

It should be noted that there was considerable disagreement between Sky Loop and OKI over the PRT costs and characteristics used in the study and the analysis of PRT operations. The disagreement centered on the characteristics and engineering estimates proposed for the Taxi 2000 design and the consultant estimates. Claims were made that the consultant used conventional automated guideway characteristics in the evaluation of the PRT system and did not fully account for the advanced technology of the PRT system. This disagreement highlights the need for more comprehensive and rigorous understanding of PRT by the transportation industry. It also is characteristic of the challenge faced by the Chicago RTA program where conventional transit ideas were imposed on a new technology development program and limited the ability of the program to develop innovative results. As shown later in this report, PRT systems are expected to have improved cost and service levels than those of conventional automated guideway transit systems.

### **Sweden Studies**

There have been a number of studies that examined PRT applications for various Swedish cities. For example, a feasibility assessment for constructing a PRT system in Gothenburg, Sweden was completed in 1973. This system featured a unique grid and

“spider web” configuration. Researchers found PRT to be a feasible option for the city (Blide 1993). In 1994, Andréasson conducted a study in which he designed and simulated PRT networks for the cities of Gävle and Gothenburg. The PRT systems were intended to service the needs of the entire cities. Through the use of point synchronous control, the platooning of empty vehicles, and vehicle depots, the simulated network for Gothenburg was shown to accommodate 600,000 trips per day with an average wait time of only 1.3 minutes (Andréasson 1994).

These and many other studies have suggested that PRT has the potential to capture ridership, improve personal mobility and provide economic and energy benefits; however, many also concluded that PRT was not a viable option because the technology was not fully developed and there are no operational systems in existence to demonstrate performance and reliability (Anderson 2005, BRW 1997, 1998, Poor and Stewart 1993, Samuel 1999, Szeto et al 1996; Tappan 2001, Wilson 2001; Yoder 2000). The challenge for these applications is the development of a capable and commercially available PRT system that can meet their needs.

### Recent Developments

Since 2000, there continues to be considerable development and interest in PRT around the world. Beyond this New Jersey study, there are several active procurements for PRT systems in the United States, England and Dubai, a research program in Korea, and application studies in Europe discussed in this section. There are also many PRT development programs discussed in Section V.

### Heathrow Airport Procurement

In October 2005, the British Airport Authority (BAA) and Automated Transport Systems (ATS) announced an agreement to procure a pilot implementation of the ULTra PRT system for Heathrow Airport. The agreement between BAA and ATS also includes an investment of approximately \$13 million in ATS in return for 25 percent of the firm’s equity. The agreement calls for ATS to complete the development of the ULTra system with investment funds distributed upon meeting various developmental milestones.

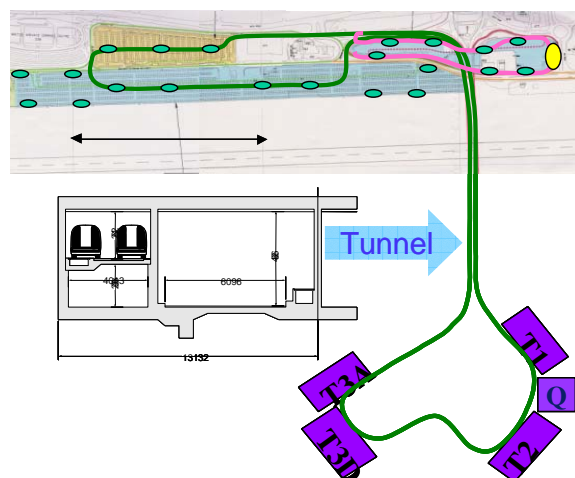

Figure 6 - Heathrow PRT Layout  
Image Courtesy of ATS

The initial Heathrow application was designed to link remote parking lots with the Central Terminal Area using the ULTra system operating through a small access tunnel. The design called for 4.7 miles of guideway, 78 vehicles and 27 stations serving multiple parking stops and Terminals 1, 2 and 3 as shown in Figure 6. The Ultra system is intended to replace shuttle buses serving 8,000 passengers per day. It is anticipated that the PRT system will save an estimated 8.4 minutes per trip. Recent developments call for the pilot system to now support the new Terminal 5. Plans call for the pilot to be complete in 2008.

### **Dubai, UAE**

Several planned PRT procurements have been publicly announced for applications in Dubai, UAE. A tender notice for a PRT application for the Dubai Financial District was published in October 2005 (MEED 2005). Several news articles have also described other PRT interest and commercial applications in Dubai but not verified for this report.

### **Other PRT Studies**

The recent success of the ULTra system in Europe has generated new interest in PRT planning studies in Europe and around the world. According to Trans21, there are studies underway for PRT systems in cities such as Arosa, Switzerland; Cardiff, Wales; Houston, Texas; Nottingham, England; Almelo, Holland; Huddinge, Sweden; Ciampino, Italy; Pleasanton, California; and Seattle, Washington (ITT 2006).

### **Summary and Lessons Learned from History**

Since 1953, the evolution and history of PRT is an extended story of many individuals, organizations and governments pursuing an enduring idea. Many systems have been developed. Many studies have been conducted. Many programs have been cancelled. And yet through this long history, the need to find better urban transportation solutions and interest in PRT remains.

PRT is a new form of public transportation. It is a new type of service, a new combination of technical components, a new infrastructure, and a new way of thinking. Developing a new transit system is a complex undertaking. As with most efforts, it can be done well or poorly. Some estimate that to develop a PRT system, designers and engineers must select parameters and alternatives from 46 categories (Anderson, 1998). There are roughly ten quadrillion ( $10^{16}$ ) possible combinations of these choices, only a few of which are viable and will prove to be economical with the desired levels of performance, safety, security and impact. PRT systems require advanced computer,

control and communication systems. They also require the careful design of vehicle, guideway, power, propulsion, guidance and braking systems.

The theory of PRT systems and their prospective benefits have been analyzed by many government agencies, academic institutions and independent researchers. Application studies conducted for implementations all over the world continue to show that PRT has the theoretical ability to serve a range of urban environments and transportation needs. From downtown and campus circulators to extensions of conventional rail systems, PRT has the potential to be an effective tool in the urban planner's toolkit. The challenge is to complete the PRT development process and demonstrate that PRT can meet expected performance and cost goals.

The development programs of the past contributed to a significant body of existing knowledge regarding PRT systems and development processes. These programs provide a sound foundation to continue PRT development and will be used to guide future efforts. The following summarizes some of the lessons learned from past efforts:

- **Systems engineering and risk management are important:** PRT development is a complex task that is best undertaken with a multi-disciplinary, systems engineering approach using a full understanding and balancing of technical, political, economic, environmental and social requirements and risks.
- **Strong leadership is needed:** PRT development and implementation requires understanding of the transportation need, a vision for the solution, an awareness of the past, and the ability to lead the political and institutional environment.
- **Performance-based design criteria should drive the development process:** Further engineering or product development activities should be guided by a performance-based approach to system specification. This will require analysis focused on developing realistic performance criteria for things such as cost, capacity, speed, size, weight, safety and security. A preliminary engineering program should include a trade-off and alternatives analysis to identify and refine system designs that can best meet these criteria.
- **The design process should seek to optimize system performance criteria:** PRT is a complex system of systems that requires balancing of many design and engineering parameters. The engineering process needs to incorporate a continuous process to optimize cost, capacity, weight and performance. Safety, reliability, and security should be inherent in all activities and designs.



- **Future development activities should seek use of proven technology components in innovative ways:** Wherever possible, future designs should include the use of proven technology components to minimize the cost and complexity of the system. Future design efforts should develop custom components only when necessary and using proven development methods.
- **Provide adequate time and enough funding to support completion of the development process:** Do not constrain the development program with artificial deadlines that limit the development team's ability to conduct a thorough engineering analysis, design and test program. A complete program is needed that can work through and test alternatives away from the public view before public service is committed.

## V. STATE OF THE PRT INDUSTRY

Personal Rapid Transit (PRT) is part of the larger industry that includes Automated Guideway Transit (AGT) and Automated People Mover (APM) systems. AGT and APM systems use automated control systems but typically with larger vehicles and on-line station configurations. AGT systems are used for urban applications while APM systems are typically used in shuttle applications like an airport. According to Trans21, there are more than 120 AGT and APM systems operating world-wide providing over 4.6 million rides per day (ITT 2006). These systems are supported by a base of established vendors and suppliers. PRT, as a subset of the AGT and APM industry, has had a slower development and implementation path that includes several operational test tracks and the Morgantown system that provides group rapid transit (GRT) service using automated controls and off-line stations.

According to the Advanced Transit Association (ATRA), there are more than 90 new transportation technology systems under development including many PRT systems. In 2003, ATRA studied various PRT systems under development, evaluating and comparing their technology, features and development status. The study reaffirmed that PRT is technically feasible and concluded that the most persisting barriers to implementation are financial and political (ATRA, 2003). To understand better the current state of the PRT industry and to learn from the history of PRT development, the research team conducted a survey of leading PRT system developers and industry “experts” to gather insight into the future of the technology and the challenges inherent to PRT implementation.

### Survey of PRT System Developers

To focus the results of this study, the research team selected four systems that met the study criteria for a PRT system, had current or past development programs, and have potential to support near-term implementations. These systems and developers are:

<u>System</u>	<u>Developer</u>
SkyWeb Express	Taxi 2000 Corporation
ULTra	Advanced Transport Systems
Vectus	Vectus PRT
Cabintaxi	Cabintaxi Corporation USA

Other systems considered for analysis included those from Austrans, Coaster, Ecotaxi, Skytran, Megarail, RUF, York PRT and 2getThere. These systems did not receive detailed analysis but are recognized as having development programs that may result in commercial system capabilities or implementations.

Using previous studies and knowledge of current PRT and other transit systems as a foundation, the research team distributed a survey questionnaire and conducted a series of key informant interviews with representatives from these four PRT developers. The purpose of the questionnaire and interviews was to document the most accurate and up-to-date information available on each system. The following subsections summarize the current status of each system. Appendix 1 provides a summary of PRT technical characteristics and the systems reviewed in this study.

### **SkyWeb Express**

The Skyweb Express system offers the following key features:

- Body on bogie form factor
- Vehicle linear induction motor propulsion
- Guideway supplied electrical power
- High speed and capacity
- Narrow, enclosed tracked guideway
- On-board switch
- Sliding canopy door
- Distributed asynchronous control
- Suitable for cold climate operation



**Figure 7 - SkyWeb Express System**

Image Courtesy of Taxi 2000

The Skyweb Express System is being developed by the Taxi 2000 Corporation. Taxi 2000 is small, privately funded corporation operating in Fridley, Minnesota. Starting with a patent development grant from the University of Minnesota in 1982, Taxi 2000 has conducted extensive research on their SkyWeb Express system and provided considerable outreach on the use and benefits of PRT technology. The Skyweb Express system was selected as the preferred PRT technology in many PRT studies including initial selection for the Chicago RTA/Rosemount program and the Cincinnati Downtown Circulator program previously cited.

The SkyWeb Express system has undergone many years of engineering and development. The Skyweb Express system has: an innovative, fail-safe switch; a light-

weight and small guideway; redundant and fault-tolerant design control, power and propulsion systems; and advanced network management, control and communications. Taxi 2000 has developed a control and communication system that is designed to manage the operation of a large number of vehicles in large networks including the distributed real-time control of many stations, merges and diverges. They have also developed a system simulator that can be used to model potential applications including the detail modeling of patronage analysis and station operations.

The current development program has a single prototype vehicle that operates on a 60 foot section of straight track shown in Figure 8. This test section is currently located in the Taxi 2000 offices in Fridley, Minnesota. The vehicle and track section was first demonstrated in public providing rides to thousands of Minnesota State Fair attendees in 2003. Taxi 2000 has developed a reduced-scale test track that demonstrates the control and communication of multiple vehicles operating on a network with multiple stations using the Taxi 2000 proprietary control system. The reduced scale test track was operational and running 20 vehicles at the time of this writing.



**Figure 8 - SkyWeb Express Prototype**  
Image Courtesy of Taxi 2000

Taxi 2000 is operating with a staff of approximately five employees supplemented by consultants and partner staff. They are funded by private investors with in-kind contribution from partners. They have developed partnerships with many suppliers to support the engineering, manufacturing and construction of future system implementations. These partners include Honeywell for communications, Knutson for construction, Bendtec for guideways, Krech Ojard for engineering and Force Engineering for LIM propulsion. Taxi 2000 intends to leverage their technology through these partnerships and does not have manufacturing or construction capabilities.

Taxi 2000 has also developed relationships with several agents that represent the firm in a marketing and sales capacity. Some of these agents have formed partnerships with Taxi 2000 creating corporations using the SkyWeb Express name. Taxi 2000 has developed their system designs with current or past staff and patented many of their original system features. Overall control and management of the system is supported by control systems developed by Taxi 2000. These original patents have expired and no active patents were reported by Taxi 2000.

Taxi 2000 is currently seeking to raise capital funds to complete their development program that includes the construction of a full scale test track with an off-line station and multiple vehicles. This test track would allow Taxi 2000 to demonstrate full system functionality including line speed operations, merges, station operations and network control. Additional information on the Taxi 2000 Corporation and the SkyWeb Express system can be found at [www.skywebexpress.com](http://www.skywebexpress.com).

## **ULTra**

The ULTra system offers the following key features:

- Automotive form factor
- Battery power with opportunity recharging
- Rotary motors driving rubber tires
- Moderate speed and capacity
- Open roadbed style guideway
- Guided steering
- Bi-parting double doors
- Synchronous control system
- Moderate application for cold climate operation



**Figure 9 - ULTra System**  
Image Courtesy of ATS

The ULTra System is being developed by Advanced Transport Systems (ATS). ATS is a small, privately funded corporation operating in Bristol, England with an operating test facility located in Cardiff, Wales. ATS and the ULTra system have been actively involved with the Evaluation and Demonstration of Innovative City Transport (EDICT) trials in Europe and have been widely supported across many European studies and analysis. The ULTra system has been selected by the British Airport Authority (BAA) for pilot implementation at Heathrow Airport. BAA has also partnered with ATS and is making capital investments in the firm.



**Figure 10 - ULTra Vehicles**  
Image Courtesy of ATS

ATS began developing the ULTra system in 1995 in association with the University of Bristol as part of research and analysis into urban transport problems. ATS has exclusive access to the commercial exploitation of the core intellectual property rights (IPR) developed during that work and has since added significantly to its own IPR portfolio. The ULTra system uses an automotive-based design that involves battery-powered rotary motors driving rubber tires on an open roadbed. The ULTra vehicle uses on-board sensors and control systems to guide the steering of the vehicle within the constrained guideway path. Overall control and management of the system is supported by control and communication systems developed by ATS.

ATS has completed the initial prototype development and has undertaken passenger trials at the Cardiff test track. The prototype system and test track shown in Figure 11 was established in 2001. This facility contains elevated sections, sections at-grade, various banked and unbanked curves, inclines and declines, merges and diverges and a station with total guideway length just less than 1km. The facility has one vehicle approved for passenger operations and three that support engineering and demonstration functions. ATS also has a research track on a six-acre site at Avonmouth Bristol, England. The Cardiff test track is in continuous use for development and demonstrations and has consent from the UK Regulatory Authority (HM Rail Inspectorate) to carry the public. ATS has also developed their own system simulation capability which is used in the system development program and for detailed sizing of applications.



**Figure 11 - ULTra Test Track**  
Image Courtesy of ATS

ATS financed the initial phases of development from internal sources, in-kind support from partners, and contract funding from the UK Government and potential customers. They recently received additional investment from BAA that will potentially reach £7.5M or \$13M. This supplements the previous £15M or \$26M in capital or in-kind support received. ATS is operating with a staff of approximately ten employees supplemented by consultants and partner staff. Their partners include ARUP for engineering and construction, CORUS for manufacturing and construction, AMEC for design, project management and support, and Altran for systems and software. Partners are providing development support and may support engineering, manufacturing and construction of future system implementations. ATS has been responsible for design, manufacture and construction of the prototype system, but expects to move to a prime contractor role for production systems, subcontracting manufacture to specialist subcontractors, while retaining key responsibilities for system integration and safety. ATS has not stated any relationships with agents that represent the firm in a marketing and sales capacity.



ATS is nearing completion of the ULTra development. The BAA investment will cover the final product development and commercialization phase of the system. This includes enhancing the vehicle and system components for commercial use, adding enhancements and refinements to the control and communication system, and testing and verification of all system functions for safety and reliability. Initial production vehicles are expected in the first quarter of 2007. Initial installation at Heathrow is planned for late 2007 with full passenger carrying operation expected in June 2008. Additional information on ATS and the ULTra system can be found at [www.atsltd.co.uk](http://www.atsltd.co.uk).

### **Vectus**

The Vectus system offers the following key features:

- Body on bogie form factor
- Guideway mounted linear induction motor propulsion
- On-board electrical generator
- High speed and capacity
- Sliding double door
- Open, tracked guideway
- On-board switch
- Distributed asynchronous control
- Suitable for cold climate operation



**Figure 12 - Vectus PRT Vehicle**  
Image Courtesy of Vectus

The Vectus PRT system is being developed by Vectus Limited (Vectus), a subsidiary of POSCO. POSCO is one of the world's largest steel producers with sales over \$21B, approximately 20,000 employees and operations primarily in Korea. POSCO is interested in creating new growth areas for their firm. They initially became involved with PRT in 2001 as an indirect sponsor of the program at POSTECH University and the prototype shown in Figure 13. They supported various PRT studies in



**Figure 13 - POSTECH Prototype**  
Image Courtesy of Postech

2003 including an application study of Fornebu in Norway. The Vectus subsidiary was created by POSCO in 2005. They are currently supporting internal PRT development as well as research in cooperation with the Korean government. Vectus has offices in Seoul and is a registered firm in the United Kingdom.



**Figure 14 - Vectus Component Testing**  
Image Courtesy of Vectus

Vectus has an active development program underway that includes: technology development at the Korean Technical Development Center; a test track development at Uppsala Sweden; and a small scale development system. The Technical Development Center is directly or indirectly through partners engaged in development and testing and reliability analysis for components such as motors, wheels, sensors, communication, and control systems as shown in Figure 14. The Technical Development Center is also developing a system simulator and the overall system engineering and design.

Vectus has started construction of a 400m test track in Uppsala, Sweden. The test track will include an off-line station and three operating vehicles. The test track is intended to validate system design, support certification for passenger use and serve as a marketing and demonstration facility. The test track will include a variety of track curvatures as well as merge and diverge switches as shown in Figure 15. The environment in Uppsala will also allow testing in winter weather conditions. Final testing and certification is expected to be complete in 2008. Vectus is also developing a reduced scale test track at the Technical Development Center in Korea. The reduced scale track will be used to develop and test larger networks with a large number of vehicles, stations and depots.

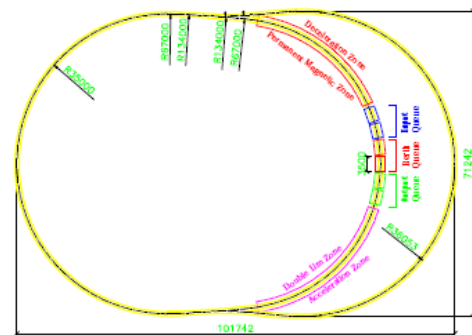

**Figure 15 - Vectus Test Track**  
Image Courtesy of Vectus

Vectus is currently operating with approximately fifteen employees and supported by many consultants and staff from partners. Vectus has developed a large group of partners to support the development, manufacturing and implementation of their PRT system. Many of the partners are also subsidiaries of POSCO that provide engineering and manufacturing services. In Europe, Vectus has partnered with firms such as WGH



for vehicles, Noventus for control system, Force Engineering for LIM propulsion, and Skanska for construction. POSCO is providing the primary funds for the development and testing of the Vectus PRT system with additional contribution from partners.

Vectus is planning to complete their development, testing and certification program in 2008 and complete their first commercial installation by 2010. Vectus has chosen to focus their development and commercial interests in the European and Asian markets. They are developing their system before marketing to customers. Vectus has not stated any relationships with agents that represent the firm in a marketing and sales capacity. Additional Vectus information can be found at [www.vectuspvt.com](http://www.vectuspvt.com).

### **CabinTaxi**

The Cabintaxi system offers the following key features:

- Body on bogie form factor
- Vehicle mounted linear induction motor propulsion
- Guideway supplied electrical power
- Moderate speed and capacity
- Sliding single door
- Enclosed, tracked guideway
- Unique two-way, over/under design
- On-board switch
- Distributed asynchronous control
- Suitable for cold climate operation

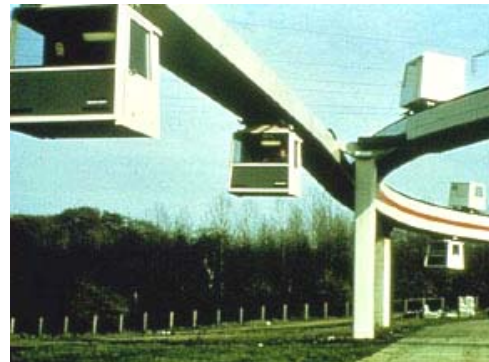

**Figure 16 - Cabintaxi System**  
Image Courtesy of Cabintaxi

The Cabintaxi system is the result of a large-scale, eleven-year German development program. In 1969, the Messerschmitt-Bolkow-Blohm (MBB) and Demag firms, separately, started design studies that led to the Cabintaxi development program. The German government combined the development activities of both firms into the jointly funded program in 1972. The program continued until 1980 resulting in a 1.1 mile test track in Hagen, Germany with 24 operating vehicles as well as one commercial system in operation since 1976 at a hospital in Ziegenhain, Germany. The Ziegenhain system operates similar to a horizontal elevator with no attendants.

Cabintaxi system definition and component development began in 1969. Control system development began in 1972 using the modern analog capabilities of the time. The initial test facility was completed near Hagen in 1973 and consisted of 500 feet of double track guideway, two stations and three vehicles. By 1974 the track had been extended to a 0.7 mile closed loop with two by-passes and five vehicles. In 1975, the test facility had three stations and nine fully automated vehicles. In 1976, the test facility had 1.1 miles of guideway, six stations, including those for maintenance and rescue vehicles, and 24 operating vehicles with 3, 6, 12 and 18 passenger capacities as well as freight handling features.



**Figure 17 - Cabintaxi Test Track Station**

Image Courtesy of Cabintaxi

The Cabintaxi program included extensive research, system engineering, alternatives analysis and testing for safety and reliability. Cabintaxi designers and government safety experts worked together to explore the elements of the evacuation and safety issue. Cabintaxi underwent extensive fire testing, reliability analysis and endurance testing. The goal was to design a system with sufficient safety and reliability so that emergency walkways would generally not be needed. An emergency evacuation system was developed as shown in Figure 18. The Cabintaxi technology logged over 400,000 miles of vehicle testing and operations from 1975 to 1978. The testing included 7,500 continuous vehicle hours in 1977 and 10,000 continuous vehicle hours in 1978.



**Figure 18 - Cabintaxi Emergency Evacuation**

Image Courtesy of Cabintaxi

The Cabintaxi tests are the only fleet endurance test of this magnitude completed with vehicle separations under 3 seconds. At the completion of testing and development in 1979, the system met the safety and compliance requirements of the Hamburg Hochbahn, the Technischer Überwachungsverein (TÜV), the German Railway, and the Federal Ministry of Research and Technology resulting in the certification that public safety would not be placed in jeopardy through the installation of this new technology.

The Cabintaxi system was extensively studied by the US DOT (UMTA 1977). It was also selected for many application studies including an extensive application study conducted for Hagen, Germany in 1971-72 and the Indianapolis study in 1981. A large

scale Cabintaxi implementation was planned in 1978 for Hamburg, Germany including 20 miles of double-track guideway and 180 vehicles. Due to federal budgetary constraints, the Hamburg and Cabintaxi programs were halted in 1979. Through the end of the program, the Cabintaxi effort had received over \$200M in 2006 dollars and was funded 85% by the German Ministry of Research and Technology.

With the termination of the Hamburg project, MBB and Demag withdrew from the field, but allowed the two companies' portions of the technology to be combined through Cabintaxi Corporation, a United States firm based today in Detroit, Michigan. Cabintaxi Corporation is a small, privately funded firm that is actively seeking projects where it can apply systems based on the Cabintaxi technology. Cabintaxi Corporation seeks to be the owner/operator of systems, selling service to end users, and sees its market being mainly in the private sector. Cabintaxi Corporation is seeking investment funds and industrial partners to support updating the system to current technology capabilities as well as supporting manufacturing and construction. Additional information on the Cabintaxi system can be found at <http://faculty.washington.edu/jbs/itrans/cabin.htm>.

### **Industry Expert Questionnaire and Interviews**

In addition to the vendor survey, the research team circulated a questionnaire to leading PRT experts. The questionnaire was accompanied by follow up telephone interviews for clarification and exploration of topics of interest. The expert interview process was intended to gather high level insights from specific experts and was not a general review of opinions from the transportation industry.

The following is a list of the experts interviewed for this study. The experts were selected in consultation with the Research Project Selection and Implementation Committee, and include transportation consultants, as well as PRT advocates, operators, researchers and planners.

- **J. Edward Anderson:** Dr. Anderson has worked on PRT systems for 25 years at the University of Minnesota and Boston University, and for the next 11 years as CEO of Taxi 2000 Corporation. He chaired four international conferences on PRT, authored the textbook *Transit Systems Theory*, gave many professional courses on transit systems analysis and design in the U.S. and abroad, and authored over 100 papers on PRT topics. In 1981 he initiated the design of a new PRT system that won competitions in SeaTac, Chicago and Cincinnati. He designed and supervised the construction of a PRT vehicle and 60-ft guideway that ran automatically for over 4000 rides with no failures, and also developed the software and hardware for a PRT control system capable of handling a network of any size. He is currently working through PRT International, LLC.

- **Lawrence Fabian:** Mr. Fabian is a regional land use and transportation planner. He is also the founder and principal of Trans21, a technical clearinghouse on Automated People Mover developments around the world. He has over thirty years of experience and is an office holder in the Advanced Transit Association, the American Planning Association and the American Society of Civil Engineers. He maintains a current understanding and regularly speaks on PRT developments around the world.
  
- **Bob Hendershot:** Mr. Hendershot is the operations and maintenance manager of the Morgantown PRT system at West Virginia University. He has over thirty years of experience with the University and the M-PRT system. His present duties include responsibility for all engineering and safety functions and being the director of financial operations and principle investigator for all grants and contracts. Mr. Hendershot is the technical liaison for the M-PRT system providing information to planners, suppliers and potential installers of AGT systems, particularly PRT concepts and technology.
  
- **Hal Lindsey:** Mr. Lindsey is a Senior Associate with Lea+Elliott, providing transportation consulting services to clients in North America and overseas. He has been involved in transportation operations (Walt Disney World Company), the supply of turnkey transit systems (Bombardier Transportation) and consulting services (Lea+Elliott) for 30 years. Since joining Lea+Elliott, he has participated in the evaluation of emerging technology, feasibility studies and technology and market assessments. He is Vice Chair of APTA's Automated Guideway Transit Technical Forum and frequently makes presentations at various airport and transit industry conferences.
  
- **Sam Lott:** Mr. Lott is a Senior Vice President with Kimley-Horn and has more than 30 years of experience in the planning and engineering of ground transportation systems and terminals. His experience with guideway transit systems includes conceptual design and analysis through computer simulations, performance and operations analyses, cost estimating, system specifications, verification review and testing. He has significant experience with automated people mover systems for airports and other major activity centers, as well as escalators, elevators, light rail, rapid transit, and commuter rail systems. He has also been a leader in the application of simulation software to the planning and operations analysis of multimodal transportation systems, passenger terminals, and major activity centers.
  
- **Jerry Schneider:** Dr. Schneider is Professor Emeritus from the Departments of Urban Planning and Civil Engineering at the University of Washington in Seattle.

He was actively engaged in transportation and land use teaching and research for 30 years. Dr. Schneider has developed and maintained the Innovative Transportation Technologies website: <http://faculty.washington.edu/jbs/itrans>. This website includes descriptions of more than 80 innovative transit technologies from around the world as well as information on the history and current status of PRT technology problems and potentials. He has been an active member of the Advanced Transit Association and has served many years as the Vice-President of the Association.

Appendix 2 includes a copy of the industry expert survey questionnaire and a summary of the major observations drawn from the surveys and interviews. Appendix 2 also includes a summary of major criticisms often cited by PRT critics and how the industry has responded.

### **Summary Assessment**

The following is a summary assessment of the current state of the industry based on the survey of PRT developers and expert interviews:

- **PRT systems are approaching but not yet ready for public deployment.** Significant PRT research, engineering, development and application study programs have been conducted over the past 40 years. These programs have been supported by a variety of academic, governmental and private industry organizations around the world. Several system development programs are nearing completion of an initial pilot or demonstration system. Although these past efforts provide a foundation of engineering and test information that can be used for initial application and alternatives analysis, additional development work is needed to validate the capital and operating costs associated with deployment of this technology for a specific application and minimize any risk for a public deployment.
- **Many of the technical components needed to support PRT systems are commercially available and are used in other industries.** These components include:
  - Advanced control and communication systems to deliver the required levels of safety, reliability and performance;
  - Network management systems and on-board switching or guidance needed to achieve short headways in order to optimize system capacity; and

- Advanced propulsion and braking systems to provide the required vehicle performance in all weather conditions.

While each of these components have been tested in small-scale PRT development programs and/or may be commonly used in related automated transit or industrial automation applications, the task remains to assemble, integrate and test such components under rigid safety requirements and the demanding day-to-day reliability requirements of a transit environment .

- **Global PRT interest and development programs are expanding.** Cities and regions continue to display interest in PRT around the world. The most advanced PRT development efforts include: an active test track in Cardiff, Wales and a joint development program between *ULTra* and the British Airport Authority for an installation at Heathrow Airport; a comprehensive development program including test tracks in Sweden and Korea for the *Vectus* system; a prototype vehicle and section of guideway in Minnesota as well as a small-scale network model for the *SkyWeb Express* system in the United States; and an extensive test track (not currently operating) that verified system technology and operation of the *Cabintaxi* system.
- **A fully operational PRT system is needed to demonstrate the theoretical benefits of PRT and establish commercial readiness.** The Morgantown system serving the West Virginia University is the only active operating automated guideway system with off-line stations and on-demand service similar to the PRT concept of operations. This system is no longer commercially available and uses large vehicles. A fully operational PRT system of reasonable scale with multiple small vehicles operating on-demand with off-line stations is needed to verify commercial viability and gain public support. Even further, to fully understand the benefits of competing technology configurations, several demonstration systems may require completion to help select a preferred configuration.
- **A comprehensive technology program is needed to develop a PRT system.** As noted above, PRT technology has not yet advanced to a state of commercial readiness and several competing designs are under development. The development of PRT technology requires a comprehensive system engineering program that includes alternatives analysis, initial design, prototyping, component testing, system design, testing and certification. The programs reviewed for this report are meeting these goals with various degrees of rigor, funding, public support and eventual success. New Jersey has the option to monitor these development programs or pursue a new program that builds upon these efforts. According to the industry experts interviewed for this study, a comprehensive program to develop a new PRT system including a small test track is estimated

to require \$50-100 million over a three year program that will require consistent support to maintain program objectives.

## VI. COMPARING PRT TO OTHER MODES

The comparison and selection of one transit system over another requires balancing the needs and requirements for a specific application against the cost of implementation and operation for that application. There are many types of transit systems with a range of features and costs that fit a range of application needs. Specific transit application needs and requirements are generally stated in terms such as the ability to support ridership levels, station locations, route alignment, travel times, and potential to encourage development. Costs are generally stated in terms such as capital cost, operating cost, land use, energy use, environmental impact and visual impact.

Balancing need and cost will drive decision makers to select specific transit technologies. The need to accommodate high ridership is usually supported by a system that may have high capital costs and impact such as a heavy rail system. Low ridership demand is usually accommodated by systems with low costs and impact such as bus systems. The middle ground of applications with moderate ridership distributed over a wide area has been the most difficult transit problem and the domain of the private automobile.

In order to consider the potential viability of PRT in New Jersey, the research team examined how PRT might compare to other transit modes in terms of:

- System speed and capacity;
- Capital and operating costs;
- Ridership and congestion relief potential; and
- Energy and environmental considerations.

For the purposes of comparison, the research team utilized a generalized representation of PRT that reflects the “average” features of the systems reviewed in this study. As previously acknowledged, the Morgantown system is the only semi-PRT system operating in the world. Therefore, PRT factors such as ridership, capital and operating costs must be estimated based on previous engineering or application studies, or analysis techniques used for similar Alternatives Analysis conducted under FTA guidelines. For the purposes of this study, potential PRT ridership characteristics were based on literature values derived from previous studies that have analyzed ridership potential using relative factors of service features such as travel time, wait time, and system accessibility. Estimates of PRT capital or operating costs were derived from demonstration systems, similarly scaled APM or GRT systems, and engineering estimates from researchers or system developers.



As with any complex capital project, a fixed guideway transit system, either elevated, at-grade or in a tunnel, will have many factors that affect cost and performance. The choice of the technology is just one of those factors. There are many transit technologies that have similar characteristics such as average speed and capacity but may have a large range in capital and operating costs. Spending more for a particular technology does not necessarily guarantee more performance.

This section compares PRT to other modes of transportation. In reviewing this section, the reader should note that some of the comparative information has been extrapolated from limited PRT experience. As such, the comparisons made as part of this study should be reviewed and validated over time as additional “real-world” application data becomes available. The comparison that appear in this section use a range of factors and data from national sources. Whenever possible, data specific to NJ TRANSIT services were used. Each factor should be viewed in context of the other factors to gain a full perspective of the placement of PRT within the spectrum of transit options. Detailed comparison information is provided in Appendix 3.

### **Average Speed of Travel**

The average speed of a transit system directly impacts the relative attractiveness of the system to other modes and, therefore, the potential ridership. As a general rule of thumb, the faster the average speed of travel, the more attractive the service. The average speed of an average trip on a transit system is determined by the line speed, the number of stops for a given trip, the distance between stops, the dwell time at stops, and the length of the trip. The average speed of various transit modes in the United States is shown in Figure 19.

The PRT systems considered in this review are estimated to have an average travel speed of 23 miles per hour (mph). This is higher than national transit average speed of approximately 14 mph or the heavy rail average of 20 mph. A higher average speed is achieved despite a low line speed, demonstrating the advantage of the non-stop trip characteristic and exclusive guideway configuration of PRT systems.

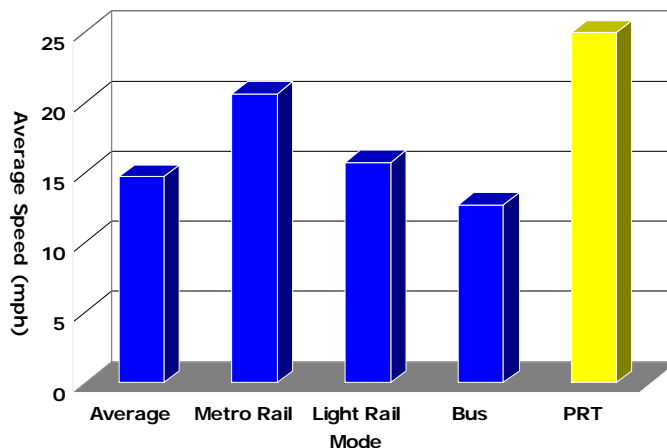

**Figure 19 – Observed Average Speed on Fixed Route Transit vs. PRT Estimates**  
 Source – APTA, Vendor Estimates

### Total Trip Time

Similar to average speed, the total trip time of a transit trip directly impacts the relative attractiveness of the trip to other modes and therefore the potential ridership of the transit system. Total trip time includes access, wait and travel times. Conceptually, PRT systems could reduce the wait time for the initial boarding as well as eliminate the need for transfers and associated waiting for trips served by the PRT network. To compare total trip times for PRT, heavy rail, light rail and bus modes, two hypothetical trips shown in Figure 20 were examined. Trip 1 is a simple trip from Station A to Station B along a single corridor. Trip 2 is a trip along two corridors following a path including Stations A, B and C. Trip 1 is four miles long and Trip 2 is eight miles long. Trip 2 involves a transfer for the conventional modes and no transfer for the PRT system. The total travel times are shown in Table 2 using the average speeds listed previously for each mode. Estimates are for station to station travel and do not include walking or other mode travel times to access transit stations/stops which will vary by mode and the unique characteristics of each transit system.

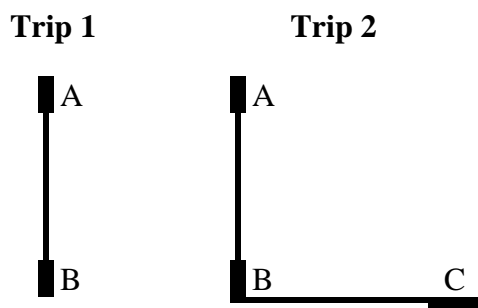

**Figure 20 - Total Trip Time Examples**

**Table 2 - Travel Time Comparisons**

Mode	Trip 1 Times (minutes)	Increase Over PRT	Trip 2 Times (minutes)	Increase Over PRT
Heavy Rail	13.0 - 17.0	14-49%	31.0 - 39.0	42 – 78%
Light Rail	17.0 - 21.0	49-84%	39.0 - 47.0	78 – 115%
Bus	18.1 - 22.1	59-94%	41.3 - 49.3	89 – 125%
PRT	11.4	-	21.9	-

PRT systems have typically been considered not well suited for urban travel due to their lower line speeds; however, from this analysis, it is clear that even with lower line speeds, PRT systems could have shorter travel times than conventional transit modes for moderate length trips in applications such as a central business district as well as longer trips in urban applications. The need to stop at intermediate stations for conventional rail systems negates the value of higher line speeds and puts conventional transit systems at a disadvantage to PRT systems with moderate line speeds.

### **System Capacity**

The capacity of a transit system can be described in many ways that can cause confusion or misunderstanding if not carefully understood. The capacity of a transit system can be described by the ability of a given line to handle the peak flow of people or by the capacity of the overall network to handle peak flow. Capacity can also be described by the ability of the system to handle a total amount of people for a given hour or day. It is important to use measures that clearly describe capacity in a normalized or standard manner so that systems can be compared independent of the unique characteristics of a given implementation. For this discussion, the theoretical and expected capacity of an individual transit line will be used.

Line capacity can be described as the ability to move a certain number of passengers past a given point per hour in a specific direction or passengers per hour per direction (pphpd). The theoretical capacity of an individual transit line per direction of travel is determined by the minimum headway between vehicles and the maximum capacity of each vehicle or train. In practice, a transit system does not operate with every seat filled and every vehicle maintaining minimum headway. The load factor, or percentage of passengers relative to available capacity, is typically below 100 percent for most systems except during the highest demand portions of the peak period. The theoretical

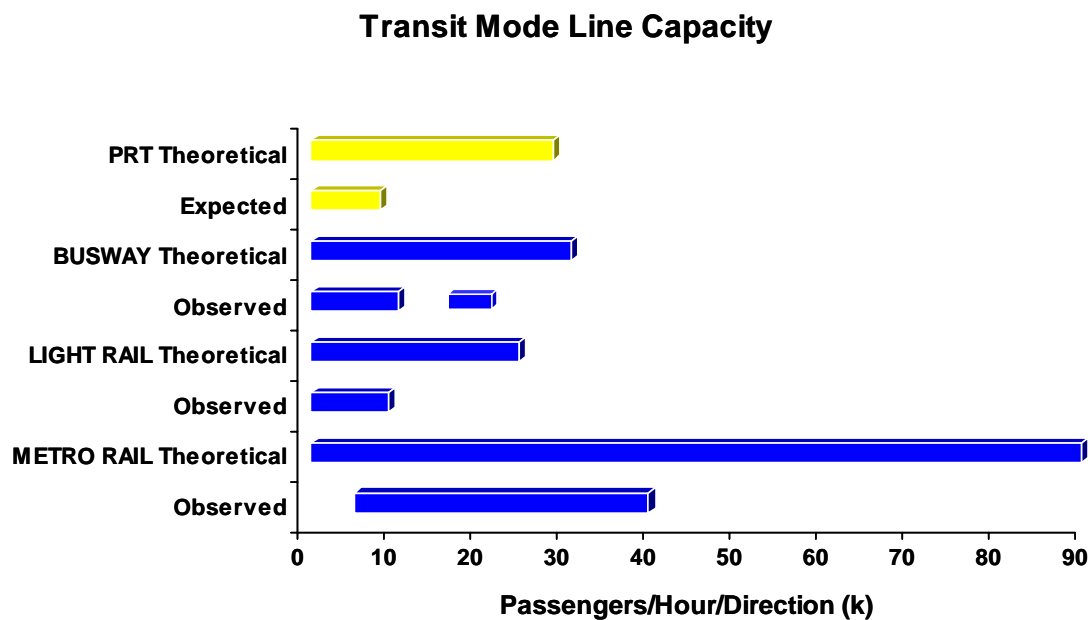

**Figure 21 – Theoretical Versus Observed Transit Line Capacities**

Source: TCRP Transit Capacity Manual, NYNJ Port Authority, Engineering Estimates

and observed line capacities of various fixed guideway transit systems and the expected capacity of PRT systems are shown in Figure 21.

As shown in Figure 21, there is considerable variation in the theoretical and actual capacities of transit systems. As expected, heavy rail systems have large trains that provide considerable theoretical peak capacity and in fact can have very high use in peak periods for cities such as New York and Washington DC. Light rail and busway systems also have considerable theoretical peak capacity. The actual peak loading of most light rail and busway systems, however, can be considerably below capacity. Peak usage for light rail systems in the United States averages between 3,000 to 7,000 pphpd for most systems. The highest patronage systems serve between 9,000 and 10,000 pphpd. Using short headways, PRT systems have theoretical and expected line capacities that could be equal to or higher than comparable bus and light rail lines. The challenge for PRT is to achieve these headways in a safe and reliable manner.

### Capital Cost Comparison

Similar to overall capacity, the capital costs for fixed guideway transit systems are highly specific to each application. Capital costs for a transit system are determined by many factors including the layout and length of the line, the selected technology, the use of elevated, at-grade or subway structures, the number and complexity of stations, as well as the local conditions and cost factors.

Using information from a range of PRT research and development programs, similar automated guideway implementations and conventional transit system implementations, the research team developed a range of conservative capital cost estimates for PRT and other transit systems. (see Table 3). Detailed costs from actual demonstration systems or implementations such as the Cabintaxi and Indianapolis programs were combined with detail cost estimates from the PRT vendors surveyed for this report. Summary costs were also gathered for other PRT systems as well as actual implementations of similar small guideway implementations. The costs were then adjusted based on the experience and judgment of the research team to reflect expected near-term ranges.

The range of costs provides guidance relative to the implementation complexity and the selected technology. For example, the low range for capital costs are for very simple implementations with limited right-of-way requirements and favorable climate locations. For PRT, the low costs reflect systems that have simple guideway and station designs and no provision to support severe weather or higher speeds. The high cost figures represent applications constructed in the most complex, dense urban environments with high cost factors such as New York City.

**Table 3 - Capital Costs – Conventional Transit vs. PRT**

Mode	Capital Cost/Mile (\$M)		
	Low	Average	High
Observed Construction Costs			
Heavy Rail	\$110	\$175- \$250	\$2,000*
Light Rail	\$25	\$50-\$70	\$195
APM – Urban	\$30	\$100-\$120	\$145
APM – Airport	\$50	\$100-\$150	\$237
BRT Busway	\$7	\$14-\$25	\$50
BRT Tunnel	\$150	\$200 - \$250	\$300
Theoretical Engineering Cost Estimates			
PRT One Way	\$15	\$20-\$35	\$50
PRT Two Way	\$25	\$30- \$50	\$75

Notes: \* Includes tunnel construction

Sources: Kerr 2005, TCRP R90, GAO 2000, Vendor estimates & case studies

The average figures can be used as planning guides for most moderately sized and complex applications. The PRT capital costs are estimates for system implementations completed after the first pilot systems are developed and manufacturing efficiencies are

achieved. It is expected that the first PRT systems may have higher costs than listed in Table 3 due to development issues and initial manufacturing start-up inefficiencies.

Although these estimates compare favorably to other larger guideway, larger-vehicle modes, actual costs will depend on the specifics of guideway design, local land use and geological conditions and the extent of the guideway network. Furthermore, it should be noted that the actual capital cost of transportation infrastructure investments constructed in New Jersey have frequently exceeded original cost estimates. Costs in certain categories have risen sharply over the years. Increases in many of these categories, including those associated with land acquisition, environmental mitigation, utility relocation, financing, engineering, insurance, administration and construction management, are likely to apply to PRT as well as conventional transit systems. Finally, it is also worth noting that the Morgantown, WV system, the only PRT-like system constructed in the United States, exceeded estimated construction cost by four times. Until more commercially-viable PRT systems are built in the United States or elsewhere, capital cost estimates will remain somewhat speculative.

### Operating and Maintenance (O&M) Costs

The operating and maintenance (O&M) costs for a transit system are highly dependent on a number of factors including the ridership, level of service, efficiency, scale, selected technology, and management practices of the system. To normalize the O&M

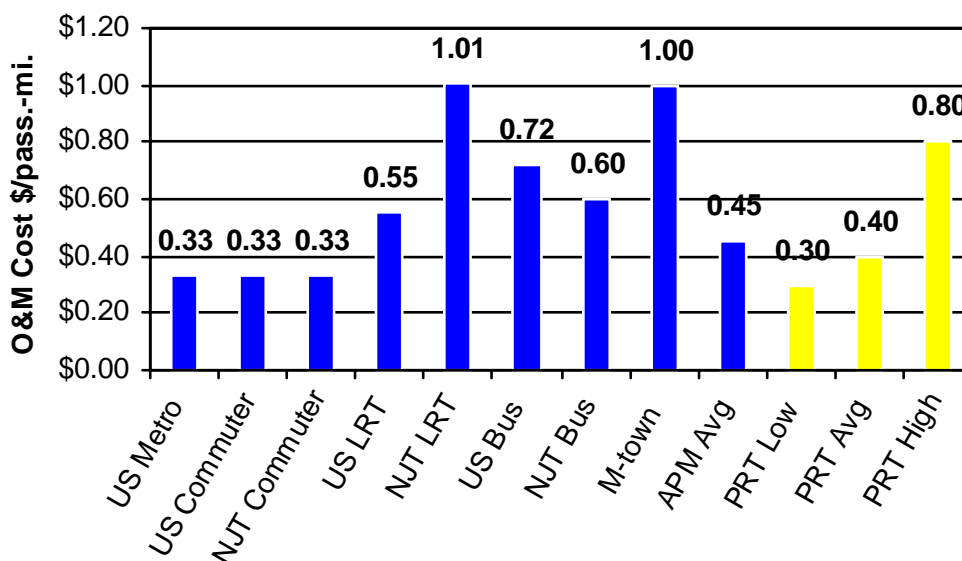

**Figure 22 - Operations and Maintenance Costs per Passenger Mile**

Notes: NJT = NJ TRANSIT, M-town = Morgantown Group Rapid Transit System  
 Source: 2005 APTA Transit Fact Book, NJT, FTA, Case Studies, PRT Vendors  
 PRT O&M numbers are estimates only

costs across many systems and technologies, the total O&M costs of a system per passenger mile provides an effective measure of total system cost effectiveness. Figure 22 presents national and NJ TRANSIT O&M costs for conventional transit modes. Figure 22 also presents the O&M costs for the Morgantown system (referenced as M-town), the average for APM systems, as well as the expected cost range for PRT systems. The PRT cost estimates are based on previous engineering studies, vendor estimates and comparable APM systems.

PRT systems could be expected to offer comparable O&M cost levels to heavy and commuter rail systems if they are deployed effectively and have achieved a level of maturity and scale of deployment similar to moderately sized heavy systems. PRT systems are expected to offer equal or lower O&M cost levels than bus, light rail or APM systems. This is due to higher expected levels of automation reducing staffing needs, the use of on-demand service reducing energy use and vehicle wear, and the use of advanced components such as linear motors that require less maintenance and repair. As with any transit system, PRT systems could experience comparatively high O&M cost levels if they are deployed in a limited scale with small patronage demand.

Although these O&M cost estimates compare favorably to other modes. It should be noted that PRT vendors have very limited O&M experience. As such, until more commercially-viable PRT systems are built, O&M cost estimates will remain somewhat speculative. Also, when comparing vendor O&M estimates with observed transit operating costs, it should be noted that transit agencies incur a number of cost categories that may not be reflected in vendor estimates, such as policing and security, fare vending and collection, station cleaning and maintenance, claims and insurance.

### **Ridership and Potential to Reduce Congestion**

The ability of a transit system to attract ridership and address congestion is directly related to the relative attractiveness and accessibility of the system compared with other modes of transportation. Travelers are economic consumers. They generally choose a certain mode of travel that maximizes their preferences across many factors. The theoretical capacity of PRT to attract ridership and thereby reduce congestion has been modeled in a variety of past studies. These studies have typically compared PRT with other modes. Examples include:

- Seattle SeaTac MIS Study: The study projected that a PRT system could reduce overall surface traffic by nine percent in the study area (BRW 1997).
- Cincinnati Central Area Loop: The study projected that a PRT system would have ridership 3-5 times higher than alternative modes (OKI 2001).

- EDICT – Sweden Kungens Kurva: The study projected that a PRT system would result in a 26 percent reduction in average travel time, a 300 percent increase in ridership over bus, a 17 percent increase in overall area demand for travel due to improved transit service, and an eight percent reduction in road traffic (Tegner, Andreasson 2005).
- EDICT - Cardiff Wales: The study projected that a PRT system would increase transit mode share by eight percent (EDICT 2003).
- Downtown Minneapolis: The study projected a PRT system would serve eight percent of the total daily trips (BRW 1979).

### **Environmental Impact**

As conceptually designed, PRT vehicles are expected to have very quiet operation primarily due to the use of rubber tire on steel rails or concrete roadways. The use of electric motors also reduces noise when compared with automobiles, buses and trains. Average noise levels from the Cabintaxi system were measured at 60 to 65dBA with the lowest level measured at 43 dBA (UMTA 1977). By way of comparison, average noise from a motorcycle or subway is 90 dBA and near a highway is 70 dBA (Rodrigue 2006). PRT systems are also expected to generate less air pollution than bus systems due to the use of all electric operation. PRT systems may potentially have lower construction impact when compared to conventional fixed guideway modes due to the use of smaller guideway structures and prefabricated components. Given the fact that PRT system will most likely be built utilizing elevated guideways, they could have potentially more visual impact than comparable at-grade systems. Although the cross-section of a PRT elevated guideway may be smaller than that typically used for conventional elevated transit modes such as people movers and monorail systems, the potential for visual intrusion may be greater for PRT systems because they rely on a more extensive network of interconnected guideways rather than a single line. It should also be noted that elevated guideway systems by their very nature are likely to engender citizen concern as part of any public project development process.

### **Energy Use**

The energy consumed by various transportation modes is influenced by many factors, including: speed, number of starts and stops, vehicle size and weight, passenger loading factors, propulsion system efficiency, and use of auxiliary power. To compare the energy consumed by a range of transportation systems, Anderson (1998) analyzed the energy use for each element of the system and combined them into a normalized factor of energy use per passenger-mile. Figure 23 provides the results of this analysis for Heavy Rail Transit (HR); Light Rail Transit (LR); Trolley Bus (TB); Motor Bus (MB); Van Pool (VP); Dial-a-Bus (DB); Automobile (A); Personal Rapid Transit (PR).



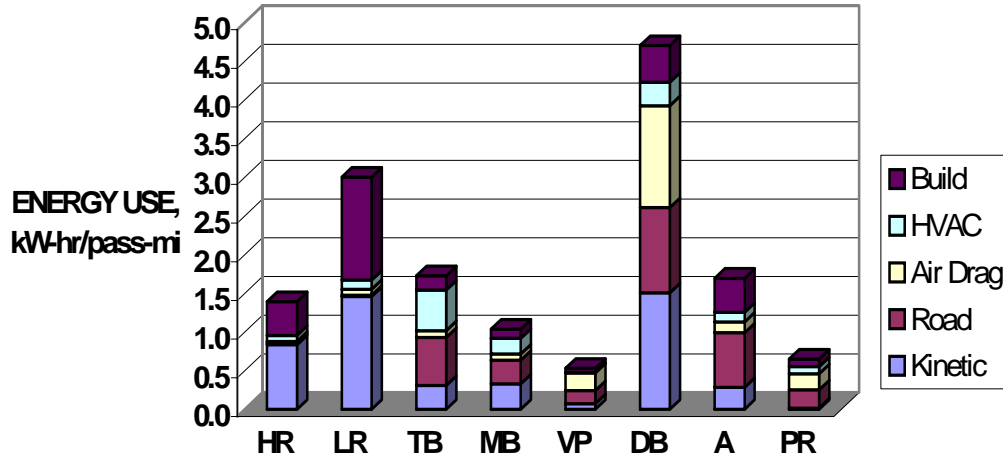

**Figure 23 - Transportation Energy Use Comparison**  
 Source: Anderson 1998 - Note: PRT figures are engineering estimates only

As shown in Figure 23, PRT systems theoretically would use less energy per passenger-mile than all other modes except van pools. This low energy use profile is primarily due to the non-stop nature of PRT service which results in low kinetic energy use from stopping and starting the vehicle. According to Anderson (2005), a PRT system could theoretically achieve an auto equivalent fuel efficiency of 70-90 mpg. Under electric propulsion, generation could be from conventional coal, nuclear or petroleum plants or alternative sources such as solar, wind or fuel-cell technologies. With the current level of energy prices and the concern over dependence on imported foreign oil, the increased energy efficiency of PRT over the automobile and other modes makes PRT a potentially attractive environmental, economic and political alternative.

## Summary

Based on the above comparisons, it appears that, in concept, PRT systems could have a number of theoretical benefits when compared to conventional transit modes. It is important to note however, that no fully operational PRT system exists today. Further research and development activities are still needed to demonstrate the promise of PRT and to realize its potential benefits, which may include:

- **Average travel speed and overall trip times for comparable trips:** When comparing observed national data for conventional public transportation modes to model data from conceptual PRT simulations, it appears that, PRT could conceptually achieve between 14 and 65 percent faster average travel speeds and between 14 and 125 percent faster overall trip times than bus, light rail and heavy rail transit. This is primarily due to the non-stop, on-demand nature of PRT operations. Estimates are for station to station travel and do not include walking or other mode travel times to access transit stations/stops which will vary by mode and the unique characteristics of each transit system.
- **System capacity:** Conceptual PRT simulation data also indicate that PRT systems could have theoretical capacities up to 10,000 people per hour per direction (pphpd) with operating capacities of 3,000 to 7,000 pphpd. This capacity is similar to the observed operating capacity of most current light rail and bus rapid transit applications.
- **Capital costs:** Engineering cost estimates provided by various PRT developers and empirical data from comparable conventional elevated guideway systems built in the United States were used as part of this study to derive engineering capital cost estimates for potential PRT applications. These estimates indicate that capital costs for constructing a two-way PRT system could be expected to average \$30-50 million per mile. The estimates assume that initial pilot PRT systems have been developed, successfully operated in a test environment and that manufacturing efficiencies have been achieved. It can be anticipated that early PRT systems may have higher costs due to development issues and initial manufacturing startup inefficiencies.

Although these estimates compare favorably to other larger guideway, larger-vehicle modes, actual costs will depend on the specifics of guideway design, local land use and geological conditions and the extent of the guideway network. Furthermore, it should be noted that the actual capital cost of transportation infrastructure investments constructed in New Jersey have frequently exceeded original cost estimates. Costs in certain categories have risen sharply over the

years. Increases in many of these categories, including those associated with land acquisition, environmental mitigation, utility relocation, financing, engineering, insurance, administration and construction management, are likely to apply to PRT as well as conventional transit systems. Finally, it is also worth noting that the Morgantown, WV system, the only PRT-like system constructed in the United States, exceeded estimated construction cost by four times. Until more commercially-viable PRT systems are built in the United States or elsewhere, capital cost estimates will remain somewhat speculative.

- **Operating and maintenance (O&M) costs:** As conceived, PRT systems would be highly automated with low staffing levels, energy use and maintenance requirements. A comparison of observed national average O&M cost data for conventional public transportation modes and O&M cost estimates developed for this study using data provided by PRT developers and observed O&M cost estimates for APM systems, indicate that PRT O&M costs per passenger mile might range from \$0.30 to \$0.80. This compares favorably to other modes. However, since PRT vendors have very limited O&M experience, until more commercially-viable PRT systems are built, O&M cost estimates will remain somewhat speculative. Also, when comparing vendor O&M estimates with observed transit operating costs, it should be noted that transit agencies incur a number of cost categories that may not be reflected in vendor estimates, such as policing and security, fare vending and collection, station cleaning and maintenance, claims and insurance.
- **Ridership and congestion relief:** Depending on the system scale, design, and fare policy, PRT systems could theoretically attract a high level of ridership in certain transit markets due to potentially improved service characteristics such as shorter travel times, lower cost, and greater comfort, access and availability when compared to other conventional public transportation modes. These service characteristics could theoretically be competitive with automobile travel under some circumstances. To the extent they are, PRT possesses the potential to attract auto users and thereby reduce congestion.
- **Energy use and environmental impact:** As conceived, PRT systems will operate non-stop, on-demand service using lightweight vehicles on exclusive-use guideways. As such PRT developers estimate that PRT systems will consume 50 to over 300 percent less energy than conventional public transportation systems and could achieve an automotive equivalent energy use of 70-90 miles per gallon. In addition, because of their conceptual design using rubber tires and electric propulsion, PRT systems could be expected to have lower noise and local pollution impacts than other conventional public transportation modes. Given the fact that PRT system will most likely be built utilizing elevated guideways, they could have potentially more visual impact than comparable at-

grade systems. It should also be noted that elevated guideway systems by their very nature are likely to engender citizen concern as part of any public project development process.

The comparative conceptual benefits of PRT described above are predicated on the assumption that PRT technology development achieves the goals described in Section V of this report. As discussed in Section V, PRT technology development is progressing with limited funding and without the coordinated support or endorsement of a major public entity. The conceptual benefits of PRT are fully realizable using current technology. However, in order to fulfill the promise of PRT, system developers will need to apply rigorous, methodical and careful engineering to final system design in order to achieve the proper balance of performance, cost, service, safety and security. Many past PRT technology development programs have attempted to demonstrate these benefits but have not been successful in one or more areas.

## **VII. POTENTIAL PRT APPLICATIONS IN NEW JERSEY**

Many factors affect the viability of a transit system for a specific location. Key factors include population, employment and household density, as well as other factors such as household income, automobile ownership rates, land use mix, site design, and even the quality of the pedestrian environment in a particular area. New Jersey is the most densely populated state in the Nation. According to the 2000 U.S. Census, the State had an average population density of more than 1,100 persons per square mile. Many parts of the State, including much of Bergen, Essex, Union Middlesex, Mercer and Camden Counties as well as parts of Passaic, Somerset, Atlantic, Gloucester, Ocean and Monmouth have population, employment and household densities that support some level of transit service. As a rule of thumb, those places with higher density, lower average incomes and lower levels of automobile ownership are generally the most transit supportive.

For this study, the research team conducted a qualitative analysis to examine the potential for PRT implementation in New Jersey. The analysis, which is described in the following subsections, was not a detailed investigation or feasibility assessment of specific PRT applications in specific locations. Rather, it considers the types of New Jersey locations that might be appropriate for future PRT applications given the theoretical service characteristics of PRT found in the literature. The mode comparisons described in Section VI help to provide a framework for the analysis.

### **Areas Potentially Appropriate for PRT in New Jersey**

Historically, PRT applications have most often been considered as a means of circulating passengers within areas with reasonably high levels of transit demand. Applications considered in PRT feasibility assessments have included: circulator services in central business districts and within activity centers, campuses and airports; neighborhood connector services; feeder services to existing transit stations/hubs; and connector/distributors from satellite or remote parking facilities. These places generally have sufficient travel demand to support higher capital cost transit service and/or levels of localized congestion or other conditions (e.g., limitations on available parking) that make private automobile use less attractive.

As shown in Section VI, PRT has the theoretical system capacity to accommodate ridership similar to most light rail and bus rapid transit applications with potentially lower capital costs and more personalized service. Using off-line stations and non-stop trips, a PRT system could provide faster overall service than comparable modes and therefore increase the attractiveness of transit service versus the private automobile.

PRT could also be considered as a service complement and/or an alternative to light rail and bus rapid transit service. While not a primary focus of the technology, depending on system demand factors, PRT could potentially be considered as an alternative to longer distance line-haul transit services such as commuter rail or intercity bus services if the line speed of the PRT system was adjusted for longer distance applications.

As described in Section VI, PRT capital costs are estimated to average \$20-35 million per mile of guideway. This is analogous to low capital cost LRT. Although many factors determine the viability of transit in any particular location, those places in New Jersey where low to medium cost LRT is most feasible include areas where demand for transit utilization may be high enough to support a fixed guideway capital investment.

Not all places in the State are appropriate for transit service. Those places potentially most appropriate for lower to moderate cost fixed guideway transit, such as PRT, include areas with demographic profiles that include lower rates of vehicle ownership, concentrations of jobs greater than 100 employees per acre and residential densities greater than 15 units per acre. Depending on specific local conditions, PRT may also be appropriate in areas that do not meet this profile but that provide an intermodal connection to NJ TRANSIT's regional rail lines connecting to areas meeting these criteria. In addition, PRT is likely to work best where existing or planned land uses can be easily connected over relatively short distances. The most suitable areas will include a mix of land uses with multiple origins and destinations, buildings that are located reasonably close in proximity to one another with minimum setbacks from roads and adequate pedestrian facilities and amenities.

**Table 4 - Areas Potentially Appropriate for PRT Applications**

Area Type	2020 Employment Forecast	Municipalities
Urbanized Areas	30,000 +	Newark*, Jersey City*, Atlantic City*, Trenton*, Paterson, Camden, Elizabeth, Secaucus, Hackensack, Morristown *Municipalities with greater than 60,000 jobs
Suburban Employment Centers	30,000+	Paramus, Wayne, Clifton, Edison, Woodbridge, Piscataway, Bridgewater-Raritan-Somerville; Cherry Hill; Parsippany Troy Hills; Piscataway; and West Windsor/Plainsboro.
Activity Centers & Campuses	Varies	The Meadowlands Sports Complex and Entertainment District; Rutgers University's five New Brunswick area campuses

Note: The information presented in this table was adapted from NJ TRANSIT's 2020 Transit Score Report: Possibilities for the Future (NJT 2000)

Table 4 provides a partial list of municipalities projected to have employment concentrations and other characteristics that could potentially support low to medium cost fixed guideway transit service. It is important to remember that demographic criteria and conditions are only a planning tool. Implementation of any transit service, especially PRT, should be considered only after a comprehensive feasibility assessment and alternatives analysis has been conducted in the context of local conditions.

### **Summary Viability Assessment**

The viability of PRT to effectively serve transportation demands in New Jersey is conditioned upon matching the technology with the local need. Using the lessons learned from previous PRT research and development activities, the following examples are local needs that could potentially be served by a PRT system:

- **Areas with high demand for local circulation:** PRT systems have the potential to be viable in areas that exhibit significant demand for local circulation such as regional activity centers and campuses. PRT networks could effectively support areas that have many origins and many destinations derived from a mix of land uses such as residential, retail, employment and entertainment. PRT has the potential to be quite effective where the origins and destinations have travel demand throughout the day in addition to a peak commuter travel demand.
- **Areas with the potential to extend the reach of nearby conventional transit:** PRT systems have the potential to be viable where the system provides an intermodal connection to conventional fixed-guideway or fixed-route transit services such as an existing express commuter bus terminal and high ridership rail stops or stations. PRT systems could be used to extend the reach of the conventional transit system by connecting nearby areas and neighborhoods to the station or terminal. Within that context, PRT could also be used to manage parking demand at the station or terminal by providing an alternative to auto access and the ability to connect to remote/satellite parking facilities.
- **Areas with constrained access and/or congested local circulation:** Individual mode choice decisions are often made based on travel time considerations comparing transit alternatives to the private automobile. Consequently, areas with congested travel conditions on roadways that provide access to and circulation within a location may be an attractive location for a PRT system as an alternative to private auto travel. The viability of a PRT system in such locations would be even further enhanced where constrained access and

limited land availability limits the ability to expand capacity on congested circulation routes and local street networks. In these constrained and congested locations, PRT could provide an opportunity to connect the core area with remote and satellite parking facilities reducing the need to travel within the core area.

- **Areas with constrained and/or expensive parking:** Although regional and local congestion helps to shape individual mode choice decisions, an even more significant factor is the availability and cost of parking. As in the case with conventional transit modes, areas with limited and/or expensive parking would be expected to generate higher demand for PRT service. PRT could provide an opportunity to connect to/from remote parking facilities helping to manage parking demand at these places.
- **Areas requiring connectivity between high activity centers:** Initial PRT system implementations could potentially be viable in the areas previously described such as regional centers, campuses, congested locations and as extensions to conventional transit system station. PRT could also be expected to be viable as a connector of these initial systems, providing an integrated transit network across a region, eliminating the need to transfer between modes or within the mode. As a scaleable network system, PRT could initially be deployed to support the locations with the highest need and then expand to connect these initial deployments as demand and economic conditions allow.

It could be anticipated that initial PRT systems will be deployed in non-residential areas along commercial roadways with limited potential community impact and disruption. Initial PRT systems will require thorough testing and must achieve public acceptance before they would be considered for larger scale expansion. The scalability and reliability of the system would need considerable validation. If this is achieved, PRT systems could also be envisioned to expand along secondary roadways and potentially serve residential areas as community interests would require.



## VIII. PRT IMPLEMENTATION ASSESSMENT AND CONCLUSIONS

PRT is an innovative transportation concept designed to combine the comfort and convenience of private automobile travel with the efficiency of public transit. It has the theoretical potential to provide a higher level of personal mobility than comparable transit modes at a potentially reduced capital and operating cost. It also holds the promise of being potentially more energy efficient, less land consumptive and more environmentally responsible while improving the overall service, speed and attractiveness of public transportation. Conceptually, PRT could provide a stand-alone network or be part of the larger multi-modal network of urban transit services. Unfortunately, as documented in previous sections of this report, PRT has not yet advanced to a state of commercial readiness. Additional development work is needed.

When considering what potential role PRT could play in New Jersey's transportation future, decision-makers must first understand the challenges that remain to system development and implementation. The development and implementation of PRT must be a long-term strategic initiative. Advancement of PRT will require not only additional technology development but also the development of a new and different business model to support the new transit technology.

### Challenges to Implementation

PRT is an emerging technology and industry with limited support from the public and private sector. There are only a few small firms advancing the development of PRT technology. There are limited industry standards guiding PRT development and there is limited expertise and understanding of PRT concepts in conventional transportation consulting, engineering, planning and policy-making sectors. As an emerging technology, the market processes of product evaluation, acceptance, and standardization are to be anticipated before full technology maturation is achieved. Since there are only a few PRT systems in development and only one hybrid system in operation, any State or agency choosing to implement an initial PRT system will assume higher risks of system implementation and operation and may incur greater expense and other difficulties in addressing problems that may arise from public operation.

The following challenges will need to be addressed as PRT development continues:

- **Engineering and planning expertise:** There is limited depth of experience or understanding in the transit industry regarding the advanced technology concepts central to PRT design and operations. This experience does exist,

however, in other industries that support advanced technology development such as aerospace, automotive, defense, computing and networking. It will be important to draw upon the technology expertise from these industries and combine it with the operating expertise from the transit industry to develop an advanced, robust and “public ready” PRT system.

- **Open technology development:** PRT technology is currently under development by independent suppliers that are seeking to develop products that have a competitive advantage to other suppliers. This is a normal and advisable business practice in the early stages of product development. As the industry matures, it will be in the interest of potential customers (i.e., transit agencies) of PRT suppliers to encourage the use of open technology that avoids proprietary designs and vendor exclusivity. It will also be in the interest of potential customers to encourage the use of commercially available components to avoid specialized product development, unique support and maintenance requirements, higher costs, and less flexible and responsive operating environments.
  
- **Development and application of standards:** As a new technology, PRT could benefit from the development and application of appropriate performance and operating standards as the technology advances. Standards will be needed in various areas including safety, security and interoperability. It will be important to ensure that technology standards do not unnecessarily limit innovation and competition which could improve the performance of PRT systems overall. Conversely, it will also be important to guide the development of the technology with standards that protect the public’s health, safety and welfare.

In terms of standardization, lessons can be learned from the past experience of the American Society of Civil Engineers which developed standards for Automated People Mover industry and the National Fire Protection Association (NFPA), which developed NFPA Standard 130 covering fire protection and fire life safety issues applicable to fixed guideway transit and passenger rail system including Automated Guideway Transit. Additional analysis will be needed to determine the efficacy of applying current industry standards versus the development of new standards.

- **Intellectual capital management:** To provide for competition in the PRT marketplace, it will be important to seek multiple vendors with the capability to provide interoperable components and sub-systems. If patents are owned solely by the initial system provider, that provider may monopolize the market and set high prices for system extensions, upgrades and replacement parts. In addition

to open architectures and interface standards, it will be important to foster sharing of key patented technology through licensing or other arrangements between vendors, suppliers and customers.

- **Institutional framework support:** Currently, there is minimal institutional infrastructure and expertise (i.e., experienced and knowledgeable design, operations and maintenance professionals within the conventional transit industry) to support the specialized analysis, design, construction and operations needed to implement PRT and ensure safety and security. This expertise can be acquired by retraining personnel, hiring additional staff or contracting with private firms, as appropriate, depending on the implementation agency's needs.
- **Consistent political, economic and technology support:** The development and implementation of an initial PRT system and the subsequent implementation of PRT in other locations will require a long-term commitment of financial resources. It will also require vision, innovation, and consistent political support. The history of PRT has many examples of development programs that started with good intentions but were halted due to changing political agendas, incomplete funding, inadequate engineering and economic analysis, inappropriate design standards, and many other factors. Specific attention should be given to the lessons learned from the Chicago Regional Transportation Authority (RTA) effort to develop a PRT system in partnership with the Raytheon Corporation. Changes in requirements, technology, political leadership and a clear commercial focus caused this program to fail. The lessons learned from these previous development programs can be used to simplify and streamline any future PRT development efforts but may not eliminate all potential pitfalls.

## **Conclusion: Options for New Jersey**

The promise of PRT has been in the public discussion for over 40 years. It has not reached maturation for a variety of reasons but remains an enduring idea that offers the unique and rare combination of potentially improving the quantity and quality of transit service while reducing costs, congestion, and environmental impact. This opportunity is available through the innovative application of advanced yet commercially available technology in a new form designed for public transportation. PRT may provide an opportunity for New Jersey to develop a new mode of transportation that could meet urban transportation needs not currently met by conventional modes. It may also provide an opportunity to develop a new industry centered in New Jersey.

The following options are presented for consideration by decision makers to advance the state of PRT and become a viable option to address transportation needs within the State of New Jersey:

### **Option 1 – Monitoring and support**

- Action:**
- Play no active role in the development of PRT
  - Monitor PRT development activities conducted by private developers and other governmental organizations around the world and reconsider the State's role in the future, as appropriate
- Pro's:**
- Requires no commitment of State funds
  - Eliminates the risk of selecting sub-optimum technology configurations for early implementations
- Con's:**
- Limits the State's ability to influence the pace and direction of PRT development. PRT development activities may favor technology solutions not appropriate for New Jersey (e.g., technologies that operate best in fair weather climates)
  - May prevent the State from capitalizing on an opportunity to develop a new PRT business/industry centered in the New Jersey

### **Option 2 – Research and analysis**

- Action:**
- Conduct New Jersey-based research in areas that will advance PRT development, including the use of tools, analysis techniques and data that support the development, implementation and operation of PRT systems
- Pro's:**
- Provides a foundation for effective demonstration and implementation of PRT systems in the State and elsewhere
  - Could raise New Jersey's profile as a leader in helping to guide and shape new technologies and industries
  - Helps to ensure that advancements in PRT technology are appropriate for New Jersey applications
  - Provides a base of knowledgeable/experienced engineers, designers and planners to support the growth of a PRT industry in the State
- Con's:**
- With no commitment to implementation, research activities conducted in New Jersey may have limited effectiveness
  - Exposes the State to some financial risk by investing in research that may not have tangible results in the short term
  - Research occurring outside of a comprehensive systems engineering and development program may be of limited use
  - Even with additional research, PRT developers may fail to secure investment funds resulting in little or no additional PRT development

### **Option 3 – Detailed application studies**

- Action:**
- Identify potential PRT applications and conduct preliminary analysis of one or more applications including cost, performance, ridership, layout and potential community impacts
  - Conduct public outreach, develop potential plans and secure public endorsement of PRT as a viable mode of transport
- Pro's:**
- Lays the foundation for realizing the theoretical benefits of PRT technology if development and demonstration systems prove successful

- Enhances PRT developers ability to secure private investment by creating a passive endorsement of the technology
  - Creates an opportunity to educate elected officials and the public regarding the technology and its potential benefits
- Con's:**
- Requires commitment of State resources without any guarantee of tangible benefits
  - May raise public and policy maker expectations before technology is ready for implementation

**Option 4 – “Proof-of-concept” public/private program to develop and operate a pilot test track**

- Action:**
- Help build, partially fund and support a public/private partnership to conduct a comprehensive program to develop and operate one or more test tracks to demonstrate PRT performance. The comprehensive program would include product design and engineering, prototype and component testing, construction of at least one full-scale test track, system testing for reliability and safety, and efforts to achieve commercial readiness. From previous PRT and similar development programs, it is expected that the program may require between \$50 and \$100 million depending on the selection of technology from previous and current programs and the degree of test track construction and testing.
  - Establish shared risk, funding and ownership program with private and public partners to limit New Jersey's share of program costs
  - Create mechanism to create institutional infrastructure for research, development, manufacturing, engineering and operational support within the State
- Pro's:**
- Provides New Jersey with the opportunity to demonstrate international leadership in shaping the future of the technology
  - Provides an opportunity to structure program around New Jersey applications
  - Provides an opportunity to create a network of engineers, planners, technology developers, manufacturers, and support organizations in New Jersey to foster the creation of a new PRT industry in the State

- Provides an opportunity to distribute and share potential risks, funding and future rewards
- Shortens implementation time frame and provides a higher probability of success with an opportunity for the State to receive return on investment from revenue sharing and economic development

**Con's:**

- Requires the commitment of public funding to support the development partnership
- Given the nature of a public/private partnership, there is potential to develop sub-optimal technology solutions – as experienced in the Chicago RTA program
- Public/private partnerships are vulnerable to leadership change over time which could negatively impact success especially if political support weakens or technology development is delayed

It should be noted that this development program would result in a full technology readiness and the ability for the State to begin implementations of the technology for public operation. It is expected that the test track from the development effort would remain an ongoing test and development facility for the partnership or a research university that may be part of the partnership. Additional funds would be required for operational systems for public operations.

PRT is an emerging and innovative transportation concept designed to offer the comfort and convenience of the private automobile with the efficiency of public transit. PRT offers the unique and rare potential to increase travel speed, quality of transit service and mobility while reducing the costs and environmental impacts associated with travel. PRT has the potential to be a mode of urban transportation that offers a flexible and scalable capacity with higher levels of service and less expense than many current transit alternatives. Conceptually, PRT could serve as a stand-alone transit system or be part of the larger multi-modal network of urban transit services.

If system development continues as expected, PRT could theoretically become an effective tool to improve urban congestion, sustainability and livability. PRT offers a mode of service that could be more competitive with the private automobile than conventional transit systems and potentially attract more drivers from their cars. Further, PRT offers the potential to reduce the energy use, land use, and environmental impact of transportation allowing the more sustainable implementation of transportation solutions in today's congested infrastructure.

While PRT offers much potential, it requires additional development and demonstration. PRT has undergone significant research and development but has not fully advanced to a state of commercial readiness. Current PRT development activities are proceeding with limited resources and limited public support or guidance. Although initial PRT systems may potentially be available for commercial implementation in several years, the full development and implementation of PRT must be a long-term strategic initiative. Additional support and resources will be needed to help PRT reach maturation and to realize its theoretical benefits.

As an emerging technology, PRT requires a market that is receptive to the new paradigms of smaller scale infrastructure, automated small vehicles, off-line stations and on-demand service. The development and support must continue throughout the emergence PRT must complete before it can become a full member of the transportation community. Each of the options presented above would be legitimate responses to the current state of PRT development. Ultimately, State decision makers will need to determine how proactive they wish to be. Option 1 requires no investment of public funds or political capital. Options 2 and 3 carry some risk but also limit potential gains. Option 4 represents the greatest risk to the State in terms of financial investment and exposure in a time of significant fiscal constraint and commitment to a specific policy direction; however, it also may result in the greatest return.

PRT has the potential to help the State address certain transportation needs in a cost-effective, environmentally-responsible, traveler-responsive manner. The ability of the State to take advantage of this technology will depend upon the State's ability to sustain an adequate level of investment and commitment to support the full maturation of the technology.



## REFERENCES

- Advanced Transit Association (2003). "Personal Automated Transportation: Status and Potential of Personal Rapid Transit." Retrieved November 15, 2005 from the website: <http://advancedtransit.org/pub/2002/prt/main6.pdf>
- Advanced Transport Systems Ltd. (2003). "Summary Report on ULTra Passenger Trials." Provided on CD ROM by ULTra in August 2005.
- Anderson, J. E. (1998). "Some Lessons from the History of PRT." Elevator World, 46(9). Retrieved October 2005 from the website: [http://www.skywebexpress.com/pdf\\_files/150k\\_additional/History.pdf](http://www.skywebexpress.com/pdf_files/150k_additional/History.pdf)
- Anderson, J.E. (1998). "Simulation of the Operation of Personal Rapid Transit Systems." Retrieved January 2006 from the website <http://faculty.washington.edu/~jbs/itrans/jeasim.htm>
- Anderson, J.E. (2005). "The Future of High-Capacity Personal Rapid Transit." PRT International, LLC. Minneapolis, MN. Retrieved January 2006 from the website: <http://kinetic.seattle.wa.us/prt.html>
- Andréasson, I. (1994). Vehicle Distribution in Large Personal Rapid Transit Systems. Transportation Research Record. Retrieved January 2006 from the website: <http://faculty.washington.edu/jbs/itrans/ingsim.htm>
- Blide, B. (1993). "APM Activities in Gothenburg." Proc., 4th Int'l. Conf. on Automated People Movers: Enhancing Values in Major Activity Centers, Mar. 18-20, Irving, TX, 566-574.
- BRW, Inc. (1997). "City of SeaTac Personal Rapid Transit (PRT) Feasibility Project: Major Investment Study." Retrieved June 24, 2005 from the website: <http://faculty.washington.edu/jbs/itrans/exec.htm>
- BRW / Kaiser Engineers, a Joint Venture (1979). "Saint Paul Downtown People Mover. Final Report." City of St. Paul, Metropolitan Transit Commission,
- Center for Urban Transportation Research (CUTR) (2005). "Public Transit in America: Results from the 2001 National Household Travel Survey." University of South Florida, Tampa, FL.
- Cole, L., Merritt, H. (1968). "Tomorrow's Transportation: New Systems for the Urban Future." U.S. Department of Housing and Urban Development, Office of Metropolitan Development

- Cottrell, W. (2005). "Critical Review of the Personal Rapid Transit Literature." Proceedings of the 10th International Conference on Automated People Movers May 1–4, 2005, Orlando, FL
- Danchenko, D. (2006). Public Transportation Fact Book 57<sup>th</sup> Edition. American Public Transportation Association. Washington, DC
- EDICT Consortium (2003). Midterm Assessment Report. Transport & Travel Research Ltd. Retrieved November 9, 2005 from the website:  
[http://www.cdv.cz/text/vz/vz1/pvz1\\_6.pdf](http://www.cdv.cz/text/vz/vz1/pvz1_6.pdf)
- Golob, T. F., and Dobson, R. 1974. "Perceived Attribute Importance in Public and Private Transportation." General Motors Publication GMR-1465.
- Irving, J. H., Bernstein, H., Olson, C. L., and Buyan, J. (1978). Fundamentals of Personal Rapid Transit. Lexington Books, D. C. Heath and Company.
- Innovative Transportation Technologies (2006). Information accessed via the ITT website <http://faculty.washington.edu/~jbs/itrans/index.html>.
- Marchwinski, T. (2000). "The 2020 Transit Score Report: Possibilities for the Future." NJ TRANSIT, Newark, NJ.
- MacDonald, R.A. (1996). "PRT Planning in Korea." International Conference on Personal Rapid Transit (PRT) and Emerging Transportation Systems. Retrieved January 12, 2006 from the website:  
<http://faculty.washington.edu/%7Ejbs/itrans/prtabs.htm>
- National Household Travel Survey (NHTS) (2001). <http://nhts.ornl.gov/2001/index.shtml>
- Ohio-Kentucky-Indiana Regional Council of Governments (OKI) (2001). "Central Area Loop Study: Final Report." Retrieved January 2006 from [www.skyloop.org](http://www.skyloop.org)
- Poor, G. and Stewart, R. (1993). "Beyond the Airport Terminal: People Mover Technologies at Seattle-Tacoma International Airport." Proc. 4<sup>th</sup> Int'l Conf. on Automated People Movers: Enhancing Values in Major Activity Centers. March 18-20, Irving, TX
- Pushkarev, B. S., and Zupan, J. M. 1977. Public Transportation and Land Use Policy. Indiana University Press.
- Pushkarev, B. S. 1982. Urban Rail in America. Indiana University Press

- Raney, S. and Young, S. E. (2005). "Morgantown People Mover – Updated Description." Transportation Research Board Reviewing Committee: Circulation and Driverless Transit. Retrieved October 16, 2005 from the website: [http://www.cities21.org/morgantown\\_TRB\\_111504.pdf](http://www.cities21.org/morgantown_TRB_111504.pdf)
- Rodrigue, J. (2006). "Transportation Pollutants and Environmental Externalities." Retrieved June 2006 from the website: <http://people.hofstra.edu/geotrans/eng/ch8en/conc8en/ch8c3en.html>
- Ryan, T. A. and Davis, C. F. 1983. "Auto Occupancy Variations." Transportation Research Board, 63rd Annual Meeting, Washington, D.C.
- Samuel, P. (1999). "Raytheon PRT Prospects Dim but not Doomed." ITS International Retrieved November 13 2005 from the website: <http://faculty.washington.edu/~jbs/itrans/samuel2.htm>
- Schupp, B.W., Gluck, S.J., and Tauber, R. (1994). "Design and commercialization of the PRT 2000 personal rapid transit system." Proc., 27th Int'l., Symp. On automotive technology and automation, Oct. 31- Nov. 4, Aachen, Germany, 523+.
- Szeto, C., Shimizo, R. and Schroeder, J. (1996). "A Ridership Study for a PRT System in Rosemont, Illinois." Proceedings from the International Conference on Personal Rapid Transit and Emerging Transportation Systems, Nov. 18-20. Minneapolis, MN.
- Tappan, C.S. (2001). Why the Central Area Loop Study Committee Failed to Adopt PRT. Sky Loop Committee. Retrieved January 11, 2006 from the website: <http://www.skyloop.org/cals/SLC-FinalReportonCALs.pdf>
- Tegner, G., Andreasson, I. (2005). "PRT- a High-quality, Cost-efficient and Sustainable Public Transport system for Kungens Kurva." Evaluation and Demonstration of Innovative City Transport (EDICT).
- Thompson, W. I. III. 1982. "Supplement IV Cost Experience of Automated Guideway Transit Systems." Urban Mass Transportation Administration Report No. UMTA-MA-06-0126-82-3.
- Transportation Cooperative Research Program Report 90: Bus Rapid Transit, Volumes 1 and 2. (2003). Transportation Research Board. Washington, DC
- Transportation Cooperative Research Program Report 100: Transit Capacity and Quality of Service Manual, 2<sup>nd</sup> Edition. (2003). Transportation Research Board. Washington, DC

United States Congress Office of Technology Assessment (OTA) (1975). "Automated Guideway Transit: An Assessment of PRT and Other New Systems." Report to Senate Committee on Appropriations, Transportation Subcommittee. U.S. Government Printing Office, Washington, DC. Retrieved in June 2005 from the website: <http://ntl.bts.gov/lib>

United States Congress Office of Technology Assessment (OTA) (1980). "Impact of Advanced Group Rapid Transit." U.S. Government Printing Office, Washington, DC. Retrieved in June 2005 from the website: <http://ntl.bts.gov/lib>

Urban Mass Transportation Administration (1977). "Development/Deployment Investigation of Cabintaxi/Cabinlift System." US Department of Transportation Systems Center. UMTA-MA-06-0067-77-02.

Urban Mass Transportation Administration (1982). "National Urban Mass Transportation Statistics. Urban Mass Transportation Administration Section 15 Report No. UMTA-MA-06-0107-83-1.

Wilson, S., Ehrlich, J. (2001). "PRT Forecasts for Downtown Minneapolis." SRF Consulting Group. Retrieved January 2006 from [http://www.skywebexpress.com/pdf\\_files/150k\\_additional/Prtforecast.pdf](http://www.skywebexpress.com/pdf_files/150k_additional/Prtforecast.pdf)

Yoder, S., Wesemen, S. and DeLaurentiis, J. (2000). "Capital Costs and Ridership Estimates of Personal Rapid Transit." Journal of the Transportation Research Board: Transportation Research Record 1872. National Research Council, Washington, DC

**TABLE OF CONTENTS**

## Appendix 1

Survey of PRT System Developers.....	A1-1
PRT System Characteristics.....	A1-1
Guideway and Vehicle Interface.....	A1-4
Switching and Guidance.....	A1-9
Wheels and Suspension.....	A1-11
Vehicle and Passenger Accommodations.....	A1-12
Power, Propulsion, Braking.....	A1-15
Control and Communications.....	A1-18
Network Navigation and Management.....	A1-20
Stations, Fare Collections, Passenger Information.....	A1-21
Maintenance and Storage Facilities.....	A1-22
Certifications, Standards, Codes and Patents.....	A1-23
Construction of PRT Systems.....	A1-25
Operation of PRT Systems.....	A1-29
Standards and Interoperability.....	A1-29
Safety, Security and Reliability.....	A1-30

## Appendix 2

Industry Expert Questionnaire and Interviews.....	A2-1
PRT Development Process.....	A2-3
Potential Applications.....	A2-4
Costs and Service.....	A2-5
Performance and Standards.....	A2-5
Technology.....	A2-6

## Appendix 3

Comparison of PRT With Other Modes .....	A3-1
Average Speed of Travel Comparison.....	A3-1
Total Trip Time Comparison .....	A3-2
System Capacity Comparison .....	A3-5
Capital Cost Comparison.....	A3-8
Operating and Maintenance (O&M) Costs Comparison .....	A3-12
Ridership and Congestion Comparison .....	A3-13
Congestion and Ridership Case Studies .....	A3-14
Environmental Comparison .....	A3-15
Energy Comparison.....	A3-16

**LIST OF TABLES AND FIGURES**

Table A-1: PRT System Characteristics .....	A1-1
Table A-2: Trip 1 Total Time Comparison .....	A3-4
Table A-3: Trip 2 Total Time Comparison .....	A3-4
Table A-4: Transit Line Capacities .....	A3-6
Table A-5: Example Transit Fixed Guideway Capital Costs .....	A3-9
Table A-6: Capital Costs – Conventional Transit vs. PRT .....	A3-10
Figure A-1: SkyWeb Express Vehicle Guideway Interface .....	A1-5
Figure A-2: Skyweb Express Bogie Inside The Guideway .....	A1-5
Figure A-3: ULTra Vehicle Guideway Interface .....	A1-6
Figure A-4: ULTra Vehicle On Surface Guideway .....	A1-7
Figure A-5: Vectus Vehicle Guideway Interface .....	A1-7
Figure A-6: Vectus Rail and Bogie Interface .....	A1-8
Figure A-7: Cabintaxi Vehicle Guideway Interface .....	A1-8
Figure A-8: Cabintaxi Rail Configuration .....	A1-9
Figure A-9: Switch Interchange .....	A1-9
Figure A-10: Vectus Switching Wheel Operation .....	A1-10
Figure A-11: Skyweb Express Bogie .....	A1-11
Figure A-12: ULTra Vehicle Interior .....	A1-12
Figure A-13: Skyweb Express Vehicle .....	A1-14
Figure A-14: ULTra Wheelchair Access .....	A1-14
Figure A-15: ULTra Door Opening .....	A1-14
Figure A-16: Linear Induction Motor .....	A1-16
Figure A-17: Vectus Control and Communication System .....	A1-20
Figure A-18: Off-line Station .....	A1-21
Figure A-19: Station Berth Configurations .....	A1-21
Figure A-20: PRT Guideway and Column .....	A1-27
Figure A-21: Conventional Transit Guideway .....	A1-27
Figure A-22: Observed Average Speed on Fixed Route Transit vs. PRT Estimates ..	A3-1
Figure A-23: Total Trip Time Examples .....	A3-3
Figure A-24: Theoretical Versus Observed Transit Line Capacities .....	A3-6
Figure A-25: Operations and Maintenance Costs per Passenger Mile .....	A3-12
Figure A-26: Transportation Energy Use Comparison .....	A3-16

## APPENDIX 1

### SURVEY OF PRT SYSTEM DEVELOPERS

To focus the results of this study, the research team selected four systems that met the study criteria for a PRT system, had current or past development programs, and have potential to support near-term implementations. These systems and developers are:

<u>System</u>	<u>Developer</u>
SkyWeb Express	Taxi 2000 Corporation
ULTra	Advanced Transport Systems
Vectus	Vectus PRT
Cabintaxi	Cabintaxi Corporation USA

Other systems considered for analysis included those from Austrans, Coaster, Ecotaxi, Skytran, Megarail, RUF, York PRT and 2getThere. These systems did not receive detail analysis but are recognized as having development programs that may result in commercial system capabilities or implementations. The main body of the report provides a summary of the current status of each system. This appendix provides a summary of PRT technical characteristics and the systems reviewed in this study.

### PRT System Characteristics

The following section describes the technical characteristics and design considerations of a PRT system. Table A-1 presents the design characteristics as reported by the four system developers reviewed for this study. This is followed by a summary description of key technical elements of a PRT system and evaluations of the systems reviewed.

**Table A-1 - PRT System Characteristics**

Characteristic	Skyweb Express	ULTra	Vectus	Cabintaxi KK3
Vehicle Position	Supported above	Supported above	Supported above	Supported above and below
Guideway Structure	Enclosed u-shaped steel space-frame with internal rails	Concrete roadbed with side steel box beam supports	Open steel beam with overhead rails	Enclosed steel box beam with side mounted rails
Guideway Height	36 in	18 in.	26 in.	52 in. (2-way)
Guideway Width	35 in.	82 in.	42 in.	69 in.
Guideway Design Span	90 ft.	60 ft.	60 ft.	130 ft
Guideway Weight	135 lb./ft.	403 lb./ft.	N/A	N/A
Typical Post Height	16 ft.	16 ft.	16 ft.	16 ft.



Characteristic	Skyweb Express	ULTra	Vectus	Cabintaxi KK3
Typical Post Base Diameter	24 in.	20 in.	16 in.	N/A
Minimum Turning Radius	36 ft.	16 ft.	50 ft.	50 ft.
Max. Operating Gradient	10%	10%	10%	10%
Cabin Height	65 in.	71 in.	78 in.	63 in.
Cabin Width	62 in.	55 in.	55 in.	67 in.
Vehicle Length	105 in.	146 in.	144 in.	79 in.
Wheelbase	80 in.	84 in.	71 in.	N/A
Track	21 in.	37 in.	29 in.	54 in.
Vehicle Empty Weight	1,200 lb.	1,543 lb.	1,785 lb.	1,984 lb.
Maximum Payload	650 lb.	1,102 lb.	880 lb.	661 lb.
Vehicle Gross Weight	1,850 lb	2,645 lb.	2665 lb.	2,645 lb.
Capacity/Seating Configuration	3 forward facing	2 forward and 2 rearward facing	2 forward and 2 rearward facing	3 forward facing
Initial Headway	2.5 sec.	3 sec.	2.5 sec	2.5 sec
Minimum Headway	0.5 sec	2 sec	2.5 sec	0.5 sec
Initial Expected Line Capacity	1,440 veh./hour	1,200 veh./hour	1,440 veh./hour	1,440 veh./hour
Maximum Line Capacity	7,200 veh./hour	1,800 veh./hour	1,440 veh./hour	7,200 veh./hour
Max. Passenger Capacity/Line	21,600 pass./hour	7,200 pass./hour	5,760 pass./hour	21,600 pass./hour
Guideway Configuration	One-way nominal; two-way with parallel guideways	One-way nominal; two-way with parallel guideways	One-way nominal; two-way with parallel guideways	One way or two-way with over-under design
Operating Speed	30 mph	25 mph	28 mph	22 mph
Maximum Speed	40 mph	25 mph	37 mph	34 mph
Standard Acceleration Rate	8 ft/sec <sup>2</sup>	8 ft/sec <sup>2</sup>	8 ft/sec <sup>2</sup>	8 ft/sec <sup>2</sup>
Standard Braking Rate	8 ft/sec <sup>2</sup>	8 ft/sec <sup>2</sup>	8 ft/sec <sup>2</sup>	8 ft/sec <sup>2</sup>
Emergency Braking Rate	16 ft/sec <sup>2</sup>	16 ft/sec <sup>2</sup>	16 ft/sec <sup>2</sup>	16 ft/sec <sup>2</sup>
Propulsion Power at Line Speed	11 kW	3.75 kW	9.5 kW	10 kW
Propulsion Energy Use at 25 mph	0.44kWh/veh-mi.	0.15kWh/veh-mi	0.38kWh/veh-mi	0.40 kWh/veh-mi
Guidance and switching	Lateral guidance rails and on-board switch	Guided steering via vehicle sensors	Lateral guidance rails and on-board switch	Lateral guidance rails and on-board switch
Suspension	Rubber pneumatic tire riding on horizontal steel rails	Rubber pneumatic tire riding on horizontal road bed	Polyurethane faced wheel riding on horizontal rails	Rubber faced wheel riding or suspended from horizontal rails

Characteristic	Skyweb Express	ULTra	Vectus	Cabintaxi KK3
Support wheels	4	4	4	4
Guidance wheels	8	0	8	4
Switch wheels	4	0	8	4
Driven support wheels	0	2	0	0
Propulsion	Redundant, on-board, single-sided linear induction motors	Rotary electric motor driving vehicle tires	Single-sided linear induction motor mounted in guideway	Redundant, on-board, double-sided linear induction motors
Primary Vehicle Power	600V DC internal guideway electric rails	Battery power with opportunity recharging	On-board generator	500 V AC internal guideway electric rails
Auxiliary Power	Battery	Battery	Battery	Battery
Propulsion Control	Redundant on-board variable frequency drives	On-board controller	In-track controller per LIM	On-board inverter controllers
Weather Protection	Guideway cover panels	Open guideway with snow removal or optional heating	Open guideway with snow removal	Guideway cover panels
Braking	LIM braking and electro-mechanical emergency brake	Electro-hydraulic brake through tire/roadway interface	LIM braking, permanent magnet station braking and electro-hydraulic emergency brake	LIM braking and electro-mechanical emergency brake
Heating, Ventilation Air Conditioning	Standard	Limited with option for full service	Standard with limited service at station	Limited with option for full service
Wayside control	Proprietary asynchronous distributed control system	Proprietary synchronous central control system	Proprietary asynchronous distributed control system	Proprietary asynchronous distributed control system
Vehicle control	Interactive vehicle/wayside control	Autonomous with vehicle sensors	Interactive vehicle/wayside control	Interactive vehicle/wayside control
Vehicle Protection System	Vehicle safety controller, sensors and wayside interaction	Guideway inductive loop and vehicle sensors	Vehicle safety controller, sensors and wayside interaction	Vehicle safety controller, sensors and wayside interaction
Vehicle Communication	Guideway lossy cable transceivers	Wireless network	Multiple wireless networks	Guideway lossy cable transceivers
Door Type	Single sliding canopy	Dual bi-parting doors on one side	Dual bi-parting doors on both sides	Single sliding door on both sides.
Door Opening	34 in.	34 in.	36 in.	27 in.
ADA compliance	Yes	Yes	Yes	No but potentially
Station Operations	In line sequential or platooning	In line sequential, platooning or bypass	In line sequential or platooning	In line sequential or platooning

## **Guideway and Vehicle Interface**

The overall design of the guideway and the vehicle/guideway interface (VGI) are critical features of a PRT system. The guideway is one of the largest cost factors of any system and determines the physical impact on the environment. Larger guideways increase cost and physical impact. Smaller guideways limit cost and physical impact. The size of the guideway is determined primarily by the size, weight and speed of the vehicles as well as the span of the guideway between columns. The small size and weight of PRT vehicles allows a PRT guideway to be significantly smaller than the guideway needed for conventional rail or BRT operations. It is therefore less expensive and intrusive than a guideway that supports large conventional transit vehicles.

The VGI determines critical cost, complexity, flexibility, reliability, interoperability, maintenance and operational elements of the system. It is therefore a critical feature that requires careful design. Vehicles can ride above, below, or on the side of the guideway. Vehicles can be suspended and supported by rails on the inside or outside of the guideway, magnetic devices above or below the guideway, or simply by an open roadbed in the guideway. Over the years, each of these combinations have been designed, engineered and tested by PRT developers. As evidenced by the variety of configurations represented in the systems reviewed for this study, the optimum configuration has yet to be determined. Each configuration has merit but also has characteristics that require further analysis and market testing. The Cabintaxi system is the only actively promoted system that has undergone extensive configuration analysis, development and testing of the vehicle/guideway interface.

As with any new technology development initiative, it is important to experiment with various alternatives until the preferred configuration is determined based on market, economic and regulatory considerations. The VGI will be a critical element that may set the standard for future PRT developments. With competing VGI's, clients will potentially be limited to proprietary system designs and non-competitive market pricing. With a standardized VGI, clients and deployments may be able to use multiple vehicle and guideway suppliers. With a standardized VGI, systems could be expanded more easily and vehicles could operate on any section of a network regardless of its original developer, owner or manufacturer.

The following sections provide an analysis of the guideway and VGI for the systems reviewed in this study.

### ***SkyWeb Express Guideway and Vehicle Interface***

As shown in Figure A-1 and Figure A-2, the SkyWeb Express design utilizes a vehicle body supported by a chassis or bogie that rides inside of a U-shaped steel space-frame guideway. The SkyWeb Express guideway design uses redundant, single-sided linear induction motors (LIM) mounted on the bogie. Similar to a monorail, the walls of the guideway are used to provide lateral support. Unlike a monorail, the Skyweb design uses rails to provide vehicle stability and guidance on the inside versus outside of the beam. The guideway design includes upper rails for guidance and switching and lower rails for suspension and stability. The lower rails include a horizontal copper plate for a running and LIM reaction surface. The design also includes power and communication rails between the upper and lower guidance and support rails.

The guideway space-frame structure is covered by panels that protect the interior rails from precipitation and debris and eliminate power rail frosting from exposure to the night sky. This configuration allows the bogie to ride in a benign environment and to switch without having complex rail interchange structures. The guideway is completely covered with panels except for a narrow slot at the top to allow passage of the chassis and a slot at the bottom to allow passage of precipitation.

As with all guideways, the depth of the beam is sized to provide adequate strength and stiffness across the design span. The Skyweb Express guideway requires a 39 inch depth to support a 90 foot design span. For reference purposes, the typical width of a four-lane divided highway with safety shoulders is 84 feet. A shorter design span would allow a shorter guideway depth and visa versa.

The Skyweb Express design has innovative features that will require validation in a larger scale testing and development program. The space-frame design has proven to be effective in many structural uses and generally offers the lowest material requirements. The lower material costs will

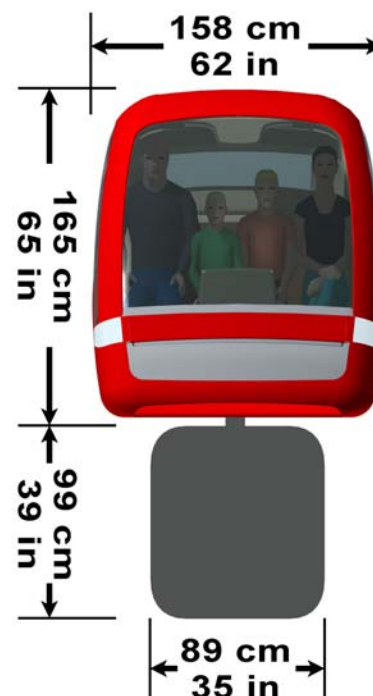

**Figure A-1 - SkyWeb Express Vehicle Guideway Interface**  
Image Courtesy of Taxi 2000



**Figure A-2 - Skyweb Express Bogie Inside The Guideway**  
Image Courtesy of Taxi 2000

need to be balanced with manufacturing and construction methods to keep overall costs low. The multiple guidance, support, power and communication rails will require further development and testing to ensure adequate ride comfort, tolerance adjustment and durability in the field. Experience from other automated systems has shown that ride comfort may deteriorate over time without adequate ability to adjust rails. Experience has also shown that without proper design, power rails may be high maintenance items. The copper plating of the running surfaces will also require investigation for manufacturability and durability.

The guideway panels provide a decorative feature of the design. They allow the system to adjust to different architectural needs and integration with the urban landscape. The panels could be made from different materials with a variety of colors, textures and surface patterns. The panels could be easily removed allowing access to the guideway elements as well as allowing a vehicle to be lifted from the guideway if necessary.

### ***ULTra Guideway and Vehicle Interface***

As shown in Figure A-3 and Figure A-4, the ULTRA configuration utilizes a narrow, open roadbed guideway that may either be elevated or placed at grade. In the elevated configuration, the guideway is supported by steel box beams on either side of the roadbed. Vehicles are guided through automated steering that receives guideway location from vehicle sensors and embedded guideway magnets. The guideway also has imbedded inductive loops to support automatic vehicle control. The design does not utilize any structural elements such as rails for guidance or lateral support.

The open roadbed design offers many benefits including a universal interface that could support a variety of vehicle configurations that conform to the gauge of the roadbed and weight requirements. The design is simple, easily constructed and therefore should prove to be quite economical. It does not require tight tolerances or accurate alignment of rails. The open design is quite applicable to temperate climates where there is little snow or ice. However, as in the case of the Morgantown system, in more severe climates such as New Jersey, guideway heating will most likely be needed to maintain adequate roadway traction. Guideway heating systems are proven technology but add to the expense and complexity of system construction and maintenance, and therefore system viability. The open roadbed design could be adapted to include changes in texture and color for design and aesthetic purposes.

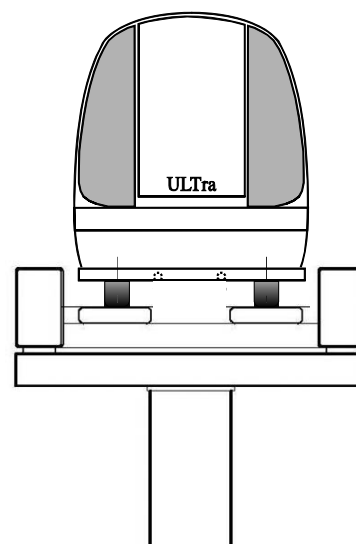

**Figure A-3 - ULTra Vehicle  
Guideway Interface**  
Image Courtesy of ATS

At 18 inches tall and 82 inches wide, the ULTra guideway is shorter and wider than the other guideways reviewed for this study. The guideway is shorter due to the 60 foot design span for the guideway. A taller guideway may be necessary for larger spans. The guideway is necessarily wider to provide lateral support to the vehicle as well as tolerance for guided steering. The ULTra guideway has been constructed at grade and in a short elevated section on the ULTra test track in Wales. Further development and testing will be needed to verify the design for continuous lengths of elevated sections including loading with multiple vehicles and heavy wind conditions.



**Figure A-4 - ULTra Vehicle On Surface Guideway**  
Image Courtesy of ATS

### ***Vectus Guideway and Vehicle Interface***

The Vectus design utilizes a body supported by a bogie that rides on a parallel set of rails above an open beam guideway as shown in Figure A-5 and Figure A-6. The parallel rail structure is similar to conventional rail systems with the addition of a guidance and stability rail above and to the outside of each main support rail creating a rail assembly. The rail assemblies have a box rail for vertical support and an angle rail for guidance and switching. The angle rail replaces the use of the side of the main rail in conventional systems to provide guidance and stability. It also allows on-board switching as required in the PRT criteria and is used as a gripping surface for the emergency brake. This design allows simple switching interchanges without complex structures.

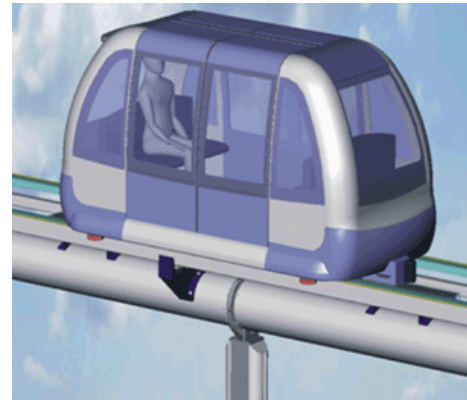

**Figure A-5 - Vectus Vehicle Guideway Interface**  
Image Courtesy of Vectus

Vectus has selected a circular tube as the main guideway beam structure. The design utilizes the interior of the tube as a conduit for electrical, communication and other cables that are needed to support the system. Flanges are periodically spaced along the length of the beam to support the rail assemblies. Vectus has not described any covers for the guideway and none are expected to be required for rail protection since power rails are not included in the design. Snow and ice management techniques may be needed for winter climates such as New Jersey but guideway heating is not expected to be a requirement. The guideway does not present a streamlined design that may be a concern for certain locations. Decorative guideway treatments or covers may be used if desired to meet local requirements.

The Vectus design uses linear induction motors (LIM's) mounted in the guideway. This design requires motors to be spaced for every length of the vehicle reaction plate to provide continuous propulsion and braking at any point along the guideway. For the Vectus design, LIM's are mounted approximately every 3 m or approximately 10 feet in the guideway. Vectus utilizes a primary LIM design to provide propulsion and braking along the main guideway and an alternate LIM to provide higher propulsion and braking levels in acceleration and deceleration guideway sections. Permanent magnets are mounted in the guideway to supplement LIM braking in deceleration sections.

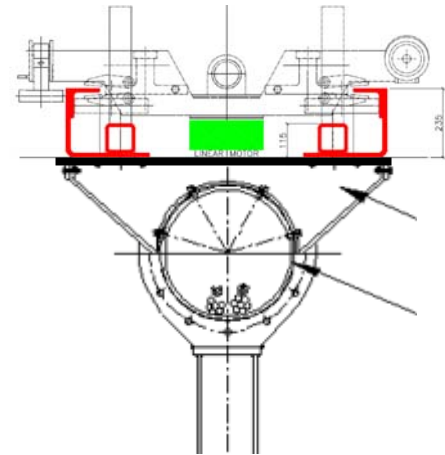

**Figure A-6 - Vectus Rail and Bogie Interface**

Image Courtesy of Vectus

The Vectus guideway and vehicle interface design is currently within the state of the art of commercial transit, material handling and entertainment systems. It uses an innovative approach of closely spaced LIM's that will require further development and testing to validate performance and economics.

### ***Cabintaxi Guideway and Vehicle Interface***

The Cabintaxi design utilizes a unique design with vehicle bodies either supported above or suspended below the guideway. As shown in Figure A-7, the bodies are attached to bogies that straddle a box girder beam and ride on rails attached to the beam. The Cabintaxi design is also unique with the guideway capable of supporting vehicles with 3, 6, 12 or 18 passenger capacities. The same bogie design is used to support the different body configurations with multiple bogies used for larger bodies. The KK3 three passenger vehicle was considered for this review.

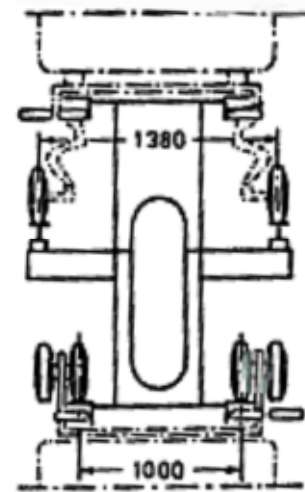

**Figure A-7 - Cabintaxi Vehicle Guideway Interface**

The supported body design uses parallel upper and lower rails for bogie support and guidance. The suspended body design only requires two parallel rails. Since the Cabintaxi design straddles the beam, switching sections are more complicated than the other systems reviewed. In a switch, the main beam is removed and replaced by side structures with additional rails to support the vehicle during a switching maneuver with the on-board switch. This maneuver requires weight transfer of the main load bearing wheels and tight tolerances for adequate ride comfort.



The Cabintaxi guideway design uses redundant, double-sided LIM's mounted on the bogie. This design requires horizontal aluminum reaction rails on either side of the beam as shown in Figure A-8. The design also requires power rails that are mounted under the reaction rail in the Cabintaxi design. Similar to the SkyWeb Express design, the Cabintaxi guideway is covered with panels that protect the rails from precipitation, debris and night exposure. The Cabintaxi guideway requires precise manufacturing and construction to support the required alignment of LIM reaction rails, and switching interchanges. This precision was achieved with the Hagen test track and is within the state of the art of many manufacturing and construction firms but not within the general construction industry. Due to the over/under and straddle design, the Cabintaxi guideway is taller and wider than the other tracked designs reviewed in this study. The guideway could utilize a shorter profile if a single, one-way design was selected.

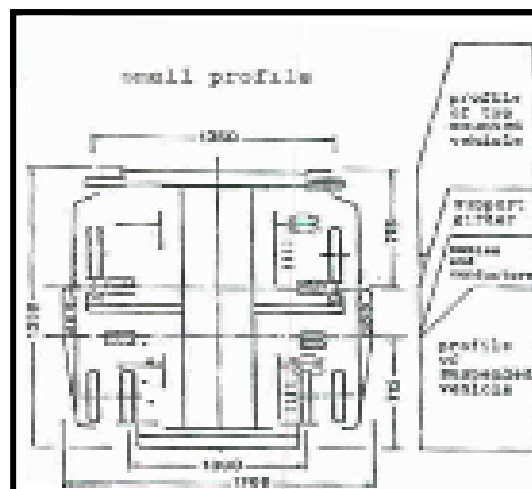

Figure A-8 - Cabintaxi Rail Configuration

### Switching and Guidance

A fundamental requirement of a PRT system is fast and reliable switching or guidance. Unlike conventional transit vehicles that typically serve a dedicated route, PRT vehicles navigate the guideway network moving between origin and destination station pairs unique to each trip. Moving through the network requires vehicles to navigate through many potential interchanges that merge or diverge different guideway sections. A Vectus interchange diagram is shown in Figure A-9. The navigation of the interchange could be supported by a vehicle/guideway switching mechanism or through guided steering of the vehicle. In either case, the navigation should occur without degrading vehicle headway and/or speed. Interchange navigation should also not be a single point of failure that would disrupt the network operation should the interchange mechanism fail.

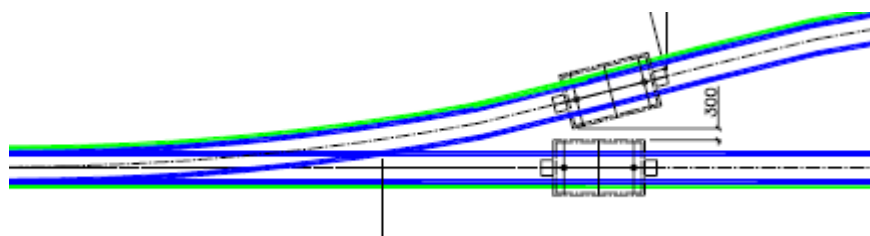
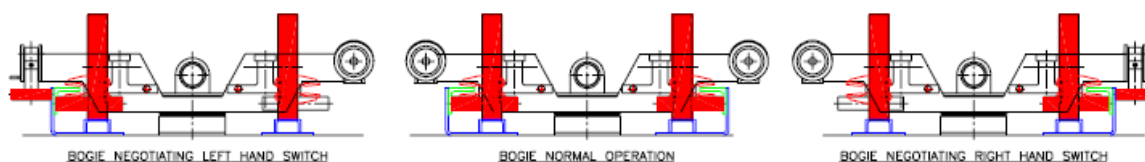

Figure A-9 - Switch Interchange Image Courtesy of Vectus



Small PRT vehicles must necessarily be able to operate closely spaced to provide adequate capacity and full utilization of the PRT guideway infrastructure. This close spacing results in very short headways on the order of three or less seconds. Vehicles must navigate an interchange at full speed and line headway to maintain the overall capacity of the system. The need for high frequency and reliability of interchange navigation has directed most PRT system developers to use on-board switching or guidance mechanisms. The track-based switches used in conventional railroad, monorail and transit systems do not switch fast enough to support PRT headways and also create single points of failure in network operation.

The systems reviewed in this study utilize two fundamental methods of switching or guidance. The Skyweb Express, Vectus and Cabintaxi systems utilize on-board switching mechanisms that involve switching wheels engaging a guidance rail embedded in the guideway. As a vehicle approaches an interchange, the switching mechanism is commanded to engage the guidance rail on the right or left side of the vehicle. The lateral switching wheels positively engage with the rail before the interchange and provide secure guidance through the interchange. Guidance rails are generally only installed at the interchange, allowing the switching mechanism to alter positions prior to the interchange. The Vectus design is shown as an example of this type of switching layout in Figure A-10.



**Figure A-10 - Vectus Switching Wheel Operation** Image Courtesy of Vectus

The ULTra system uses a guided steering mechanism to navigate an interchange. Similar to an automobile, the front wheels of the vehicle are steered to follow the desired path through an interchange. Sensors on-board the ULTra vehicle provide position input to the control system that directs the automation devices to adjust the steering angle of the wheels. This guidance method is considerably less complex than the other systems reviewed since it requires no positive physical interaction with the guideway. However, the lack of positive guidance at an interchange could result in collisions in the event of power or control system failure. Failure monitoring and redundant systems are needed to address this concern.

The Skyweb Express system has a unique switching feature that allows the switch mechanism of a failed vehicle to be engaged by a trailing rescue vehicle. The rescue vehicle, which could be any vehicle on the network, is designed to engage the failed vehicle's switch allowing the rescue vehicle to navigate both vehicles and push the

failed vehicle to an off-line location. This feature has been the subject of various development programs and requires full analysis and testing of the operational, safety, and liability issues.

On-board switching or guidance mechanisms are critical elements of a PRT vehicle and require very high reliability and durability. PRT vehicles will navigate interchanges with much higher frequency than conventional transit systems and therefore must have very reliable switching or guidance. The experience of the Morgantown system has proven that switching wheels are one of the highest maintenance items since they are constantly being engaged, spun up to speed and placed under high loading. To address this concern, PRT developers need to adequately develop and test their mechanism using a comprehensive life-cycle approach. Past PRT designs and several current conceptual designs have considered electromagnetic switching whereby the vehicle is attracted to one side of an interchange using electromagnets embedded in the guideway. While these are novel designs that have the potential to reduce switching maintenance, they have not evolved to point of commercial readiness.

### **Wheels and Suspension**

The horizontal and lateral support and suspension of a passenger cabin is a primary function of any transit vehicle. All systems reviewed for this study use some combination of tires and wheels to provide primary horizontal and lateral support. The Skyweb Express and Ultra systems each use four pneumatic tires and wheels for primary horizontal support. The Skyweb Express tires are only used for support while the rear ULTra tires are also driven by an electric motor. The Skyweb Express system does not have a primary suspension system and uses the compliance of the tire and the alignment of the guideway rails to provide adequate ride comfort. The bogie is shown in Figure A-11. The ULTra vehicle has a primary suspension system to accommodate roadbed irregularities.



**Figure A-11 - Skyweb Express Bogie**  
Image Courtesy of Taxi 2000

The Cabintaxi and Vectus systems each employ four rubber or polyurethane faced wheels to provide primary horizontal support supplemented by primary suspension systems. This type of tire/wheel design is common on amusement park rides but requires attention to detail and durability. The Cabintaxi design with a rubber faced wheel calls for a 37,000 mile design life. The newer Vectus design with a polyurethane faced wheel calls for a 75,000 mile design life.

The Skyweb Express, Vectus and Cabintaxi systems also use rubber or polyurethane faced wheels to provide lateral support and stability. This is conventional technology and does not present a concern other than the need to inspect, maintain and replace these wheels. Since all of these wheels are free-spinning without a motor or drive mechanism, they should not be a complex maintenance issue. Given the very low maintenance requirements of linear induction motors, wheels and tires may prove to be the only significant maintenance item on these systems.

The ULTra system does not require lateral support wheels due to the automotive design and wide wheel track. However, the vehicle will require steering and drive train maintenance similar to an automobile. This will include wheel and suspension adjustments and alignments as well as repair and replacement of the tires. Given the benign operating environments characteristic of all PRT systems, maintenance should be quite predictable and environmental impact should be limited to weather changes.

### Vehicle and Passenger Accommodations

In addition to the vehicle and passenger amenities required of in all modern public transit vehicles, a PRT vehicle has the unique requirement that all passengers be seated. Seated passengers allow the vehicle to comfortably accelerate and decelerate twice as fast as a vehicle with standing passengers.

Two general vehicle configurations are used in the systems reviewed for this study. The Vectus and ULTra vehicles carry four passengers using two forward and two rear facing seats. The interior of the ULTra vehicle is shown in Figure A-12. The Taxi 2000 and Cabintaxi vehicles carry three passengers using a single forward-facing seat. Given their smaller capacity and seating area, the Taxi 2000 and Cabintaxi vehicles are shorter than Vectus and ULTra vehicles. With the exception of the Taxi 2000 vehicle, all vehicles have approximately the same gross weight. The weight of the Taxi 2000 vehicle is estimated because a production design vehicle has not yet been constructed.



**Figure A-12 - ULTra Vehicle Interior**

Image Courtesy of ATS

PRT vehicles are generally designed to accommodate a typical traveling group of approximately three passengers. For urban environments, studies have shown that the typical private automobile has 1.63 occupants for all trips, 1.14 occupants for work trips, and that over 93% of urban trips have three or fewer co-travelers (NHTS 2001). PRT designers have chosen vehicles with three or four seats, rather than design for the 7% of trips that require more than four seats.

The interior accommodations of each vehicle vary by developer. A PRT vehicle must be designed for extreme durability since they will be used by many unsupervised travelers. At a minimum, it is expected that each vehicle will be fitted with vandal resistant materials, communication systems, emergency stop buttons and primary ventilation systems.

The ability to provide heating, ventilation and air conditioning (HVAC) functions is dependent upon the system's power capacity. The Skyweb Express and Cabintaxi vehicles receive power from a guideway pickup and are designed to support full HVAC service depending on the needs of the local climate. The ULTra system uses battery power and would require additional battery capacity and weight to provide full HVAC service. The Vectus vehicle receives power from an on-board generator that only operates when the vehicle is propelled by the guideway LIM's. Full HVAC service would be available during a trip but is currently limited to battery-powered ventilation when vehicles are stopped. Other services that could be provided in the vehicle include audio and video entertainment, travel information and interactive data panels. Depending on the application, both the Vectus and ULTra vehicle systems may require additional power to provide full HVAC service during stopped conditions. This could be accomplished by adding battery power or through the use of other power alternatives such as power rails. The later alternative would add significantly to system cost and is not preferred by the system developers. It should be noted that full HVAC service may be needed in certain climates, including New Jersey.

The size and function of a PRT vehicle may be adjusted to the needs of the application. Many PRT developers have described a vehicle body that could be modified to handle local freight distribution. The Cabintaxi design was unique in the use of the same chassis supporting small and large vehicles. A 12 passenger vehicle was designed that used two bogies in an articulated configuration.

PRT vehicles may be designed to be accessible for people with disabilities, including those traveling with wheelchairs or other assistive devices. The Skyweb Express, Vectus and ULTra systems report door openings wider than 30 inches. The Cabintaxi KK3 design would require modification for a wider door opening. The Skyweb vehicle accommodates a wheelchair as shown in Figure A-13. Most designs call for a seat to flip up to accommodate a wheelchair rather than a special vehicle or location for the wheelchair. This design allows each vehicle to support wheelchairs without special cost, complexity, or services. The ULTra flip-seat and wheelchair access example is shown in Figure A-14.



**Figure A-13 - Skyweb Express Vehicle**  
Image Courtesy of Taxi 2000



**Figure A-14 - ULTra  
Wheelchair Access**  
Image Courtesy of ATS

### ***Vehicle Door***

Since PRT vehicles only have seated passengers, it is not necessary to have tall vehicles to accommodate standing passengers. Shorter vehicles have many advantages including reduced weight, wind resistance and visual impact. However, with shorter vehicles, a wide range of passengers with a range of abilities must be able to enter the vehicle comfortably and quickly to keep the flow of traffic at a station moving. The vehicle door, therefore, becomes a critical element in the design of the vehicle and the capacity of the system.

A transit vehicle door is a high maintenance item and requires attention to design detail similar to the switching mechanism and wheels. The door must have automatic operation, allow free and rapid access to the vehicle as well as protect the passengers from harm during operation. The Skyweb Express vehicle uses a unique canopy design that opens the entire cavity of the passenger area. As shown in Figure A-13, the open canopy allows passengers to walk in standing up and sit down without encumbrance. The full opening canopy design requires stations to have walls or floors that are accurately placed on the far side of the vehicle opposite the platform to prevent passengers and items from falling from the open side of the vehicle. This design will require full passenger trials to verify the operation and safety features.

The ULTra and Vectus vehicles use a bi-parting door design that provides access to the open area between the front and rear facing seats. The ULTra design has a single pair of doors on one side of the vehicle as shown in Figure A-15. The ULTra door also



**Figure A-15 - ULTra Door Opening**



has a partial roof opening to provide access with minimal need to stoop. The Vectus design previously shown in Figure A-5 has doors on both sides of the vehicle allowing flexibility in station design. The Vectus door also has a partial roof opening that minimizes the need to stoop on entry. The Cabintaxi KK3 and KK6 vehicles were designed before ADA requirements were in place and would require modifications including an automatic door as well as a wider and taller opening. This is not seen as a major issue and would require conventional design and technology to make the vehicles fully accessible.

### **Power, Propulsion, Braking**

The type of power, propulsion and braking used in PRT systems is a critical design feature that affects performance, cost, capacity, reliability, and general operating characteristics. The need for short headways between PRT vehicles requires a propulsion system that is very stable, predictable, reliable and accurate. The propulsion and braking system must maintain very tight position and speed control during main guideway operations, interchange maneuvers and station operations. Furthermore, to achieve high system capacity, the propulsion and braking systems must provide higher levels of acceleration and braking than used on conventional transit system. For optimal performance, this level of control must be achieved for all weather conditions, all gradients in the network, and all levels of system loading.

The systems reviewed for this study employ diverse combinations of power, propulsion and braking systems. The ULTra system uses battery power feeding an on-board rotary electric motor that propels the vehicle through the tire interaction with the roadbed. Service braking is provided through the use of conventional brakes applied through the vehicle drive train. The propulsion and braking system are within the state-of-the-art for guided vehicles and present no development concerns. However, the use of rubber tires on concrete roadbeds for propulsion and braking could be problematic during inclement weather. The ULTra system may need to degrade service during inclement weather or develop techniques such as guideway heating or traction surfaces to maintain system performance. This may be a particular challenge to operating the ULTra system in New Jersey and places with similar climates.

The use of battery power presents various issues such as the possible length of trip, the need to recharge batteries, and the maintenance of batteries. According to ATS, they are in the process of developing recharging capabilities during station loading as well as quick change battery designs. The use of batteries in a large fleet will require careful design and development of operational procedures.

The Skyweb Express, Vectus and Cabintaxi systems all use LIM's as the primary method of propulsion and braking. A LIM is essentially a rotary induction motor commonly used in industrial applications in a flat versus round configuration as shown in Figure A-16. LIM's are commonly used in advanced amusement rides as well as industrial material handling applications. They provide many advantages over conventional rotary propulsion and braking systems including the elimination of moving parts, reduction of overall components, reduced maintenance, quiet operation and high power capability. A LIM provides both propulsion and braking independent of the coefficient of friction of the guideway or rails.

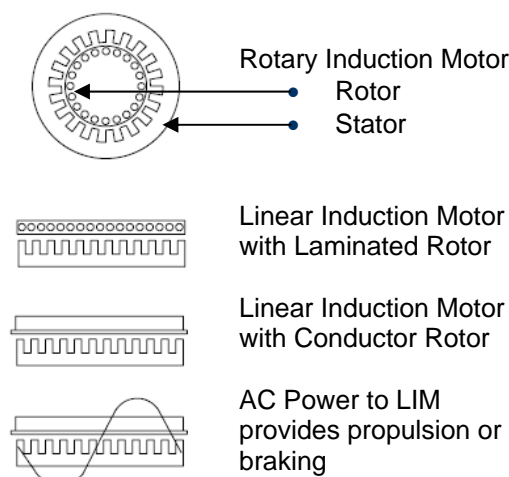

**Figure A-16 - Linear Induction Motor**

The systems reviewed for this study each had unique LIM and power configurations. The Skyweb Express design uses redundant, single-sided LIM's that are mounted in the vehicle chassis. The LIM's are controlled by variable frequency drives using DC power supplied by power pickup shoes engaging guideway power rails. This arrangement provides considerable reliability and full control of the vehicle over all operating conditions. PRT vehicles are constantly switching and therefore the power pickup shoes are engaging and disengaging from power rails, creating wear and maintenance concerns. As evidenced by the high wear-out rate of the Morgantown system, the power pickup is an area that will need attention to materials and reliability. The Skyweb Express design minimizes this concern by supplying DC power and therefore only needing two guideway power rails. The Skyweb design utilizes the horizontal running surface of the main support rails as the reaction plate for the LIM. These steel rails must be covered with a conductive material such as copper or aluminum to support motor operation. This conductive material may become a durability and maintenance issue that requires investigation.

The Cabintaxi design also uses redundant on-board LIM's but in a two-sided versus one-sided configuration of the Skyweb Express design. The two-sided design is more energy efficient but requires a more complex motor arrangement to maintain the alignment with the guideway reaction rail. The two-sided motor only requires an aluminum reaction rail that is not a running surface, thereby minimizing wear considerations. The Cabintaxi design uses AC guideway power that requires four power rails and therefore has a higher amount of material and wear than the Skyweb Express design.

The Vectus system uses in-track LIM coils and a reaction plate mounted on the vehicle. This design eliminates the need to carry motors and controllers on each vehicle and to provide guideway power rails. This design simplifies each vehicle but makes the guideway infrastructure more complex and expensive. The LIM coils need to be spaced for every length of the reaction rail on the vehicle or approximately 10ft in the case of the Vectus design. Each LIM must also be supported by a separate motor controller and control system to manage the vehicle propulsion and braking. This is necessary to provide continuous propulsion and braking along the length of the guideway. The high number of LIM's and controllers may potentially make the Vectus infrastructure more expensive than the Skyweb Express and Cabintaxi systems for applications that have a small number of vehicles. For larger systems with a large number of vehicles, the economics of this design may prove to be beneficial. The Vectus LIM design is similar to the design of the US Senate subway and therefore within the state of the art.

Beyond the need for propulsion, a PRT vehicle needs power for on-board systems and passenger comfort. As stated earlier, the current design and battery power of the ULTra system supports limited HVAC services as well as vehicle control and communications. Additional battery capacity and therefore weight would be needed to support heating and air conditioning services. The Skyweb Express and Cabintaxi systems could both support full HVAC services with the supplied guideway power but neither system currently includes a full HVAC system in the prototype vehicles. The Vectus system utilizes an on-board generator to provide vehicle power for control, communications and passenger systems. A wheel connected to the generator engages the guideway and uses the motion of the vehicle to drive the generator. Battery power is used to provide vehicle services should the vehicle stop during a trip or at a station.

The safe headway and therefore capacity for a PRT system is determined in part by the ability of the propulsion and braking system to effectively, rapidly and dependably brake a vehicle in the event of an emergency. The rate of braking is dependent upon the type of braking system used. For automotive type systems such as the Ultra design, braking is limited by the coefficient of friction between the tire and roadway. For LIM systems, braking is limited by the power of the motor. Under normal circumstances, acceleration and braking of a PRT vehicle would be set at comfort levels for seated passengers of  $\frac{1}{4}$  g or 8 feet/second/second. For emergency situations, braking levels would be set at  $\frac{1}{2}$  g or 16 feet/second/second. Both LIM and rotary motor design have the ability to provide these braking levels under normal conditions. Rotary motor design braking levels are reduced for inclement weather and the resulting loss of traction on the running surface. The LIM design provides predictable braking levels independent of the weather and roadway coefficient of friction. LIM's also provide the added benefit of reduced mechanical complexity and therefore potential for failure.



Conventional design standards call for an emergency braking system that is able to operate without power, control or release once the emergency brake action has been executed. The Vectus system applies these design standards using multiple emergency brakes that grip the guideway rails. The other systems reviewed had similar emergency braking systems or systems under development.

### **Control and Communications**

A PRT system will require the design and engineering of many elements to create a control and communication system. PRT systems are very similar to current automated guideway systems and industrial material handling systems and therefore could adapt many of the technologies and techniques used in these systems for use with PRT. However, it is important to note that PRT networks have a number of unique operating and control system requirements. For example, PRT systems need to provide a high degree of safety, speed and accuracy to effectively manage potentially large fleets of vehicles over complex networks. The networks and systems must be also able to operate under a diverse range of conditions. A PRT control and communication system needs to be flexible, scalable, resilient, efficient and above all safe.

A PRT control and communication system involves on-board vehicle systems as well as off-vehicle or wayside systems. These systems work together to provide the overall control of the PRT network. Control and communication systems could be developed using standard commercial components such as computers, radios, sensors and logic controllers, which could be designed, programmed and assembled using various techniques, degrees of redundancy and reliability, and operating scenarios. Control and communication systems use centralized or distributed control models with variations of synchronous or asynchronous control techniques.

A centralized control model assumes that all command, control and communication with vehicles is supported by a centralized system. This has the benefit of simplified design but the disadvantage of a single point of failure. Distributed control uses a combination of centralized controllers, zone controllers and station controllers that work with vehicle controllers to manage the operation of the network. This model has the benefit of being very adaptive, flexible and scalable but requires a more complex design.

Synchronous control generally describes an operational strategy where vehicles are placed into defined positions relative to other vehicles and do not vary from their defined position during a trip. Asynchronous control describes an operational strategy where vehicles navigate the network and adjust their speed and position relative to the surrounding conditions with guidance from wayside controllers. Each of the systems reviewed for this study have developed their own proprietary control and communication system using commercial components.

The ULTra system uses a synchronous control strategy whereby vehicles are commanded to enter the guideway network after a centralized control system determines a clear path is available for the vehicle from origin to destination station. The vehicle then traverses the network autonomously using on-board sensors to control speed and position, and maintain safe distance from other vehicles. With the exception of a safety monitoring control signal from inductive loops in the guideway, the vehicle is not commanded by the wayside control system. This design follows generally accepted practices for automated guided vehicles used in industrial material handling applications. It will require additional investigation to determine its scalability to large networks and ability to handle exceptions that require system restarts.

The Skyweb Express, Vectus and Cabintaxi systems have each developed a proprietary, asynchronous and distributed control system. Each system has various levels of sophistication and state of development. The Vectus system layout is shown in Figure A-17. The Vectus system uses a combination of central, station, node, wayside motor and vehicle controllers. These controllers communicate with each other using various wired and wireless networks and protocols. The controllers receive input from a variety of wayside and vehicle sensors that measure characteristics such as position, speed, temperature, current, presence, and contact. The Vectus design is unique because it uses a passive vehicle. All propulsion and braking commands and control functions are executed by wayside controllers. The Skyweb Express and Cabintaxi systems use a similar overall control design; however, the vehicle propulsion and braking commands are executed on-board the vehicle.

Each of the control systems under development by the PRT vendors will require additional development, testing and verification before they are ready for commercial deployment. The control system is one of the most complex elements of a PRT system and needs to be fully developed and tested. It is expected that the control systems will evolve and be enhanced over the life of the system. Unlike the vehicle guideway interface, control systems do not necessarily need a definitive design for initial deployment. A control system could be replaced or upgraded during the life span of the infrastructure. With a distributed system, this process is generally more flexible since local controllers could be installed and upgraded as the system expands or changes and only affect sections of the network. With a centralized system, the central computer will generally need to be replaced or upgraded. This will affect the entire system.

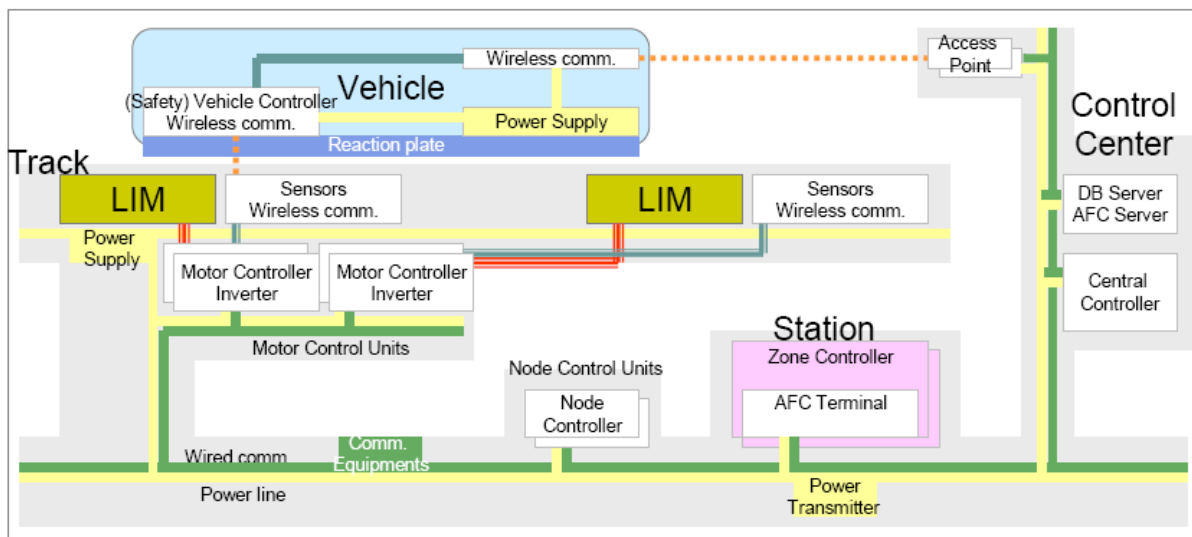

**Figure A-17 - Vectus Control and Communication System**

Image Courtesy of Vectus

## Network Navigation and Management

The means by which occupied and empty vehicles are managed is a fundamental difference between conventional transit systems and PRT systems. As a PRT vehicle traverses a network, it must be given commands to navigate right or left for each interchange. These commands are unique to each vehicle and each trip. For occupied vehicles, the commands relate to the desired trip destination received from the passenger at the time of ticketing or boarding. Generally vehicles will navigate via the most direct route through the network to minimize trip time. For empty vehicles, navigation commands move vehicles around the network to achieve the desired distribution of empty vehicles as determined by the central and/or regional controllers.

Empty vehicle management is a unique function of PRT operations required to serve both real-time and anticipated travel demand at each station. Similar to an elevator system, a passenger will request a vehicle via station ticketing or user control panel. If a passenger requests a vehicle and none is waiting at the platform, the empty vehicle control system will send the nearest empty vehicle to that station, thereby minimizing wait time and keeping vehicles fully utilized. Similarly, by tracking and anticipating demand during the day for each station, empty vehicles could be routed to the station and be waiting for passengers before a request is made. Each PRT developer must develop, program and test custom software and hardware to manage vehicle navigation and management. The developers could take advantage of many commercial tools to support this development as well as best practices developed in analogous industries like supply chain logistics, computer networking, factory automation and material handling. The unique capabilities of each system will distinguish its developer and the market acceptance of the system.

## Stations, Fare Collections, Passenger Information

PRT stations would be designed to handle a continuous flow of passengers and vehicles. Similar to a large taxi stand, a PRT station handles individuals or traveling groups as they approach the station. For an urban system with a fare collection requirement, a passenger or traveling group would approach the station, select their destination and purchase a ticket. They may also encode a smart card with the desired destination. The ticket or smart card would be entered into a reader in front of the first available vehicle or perhaps be inserted into a reader on the vehicle. The passenger would enter the vehicle, sit down, perhaps push a button to activate the ride and the vehicle would leave the station and merge onto the main guideway. All PRT stations would have off-line guideways as shown in Figure A-18



**Figure A-18 - Off-line Station**  
Image Courtesy of Vectus

A PRT station would be sized with the number of loading berths needed to handle the demand at each station. A high demand station would have many berths and a low demand station would have a few berths as shown in Figure A-19. This design flexibility allows station layout to reflect the unique needs of each station location and could help to minimize cost. For example, rather than requiring every station to accommodate the largest train as in conventional transit systems, a PRT station could be sized to serve demand. As demand increases at a station location, the loading platform and off-line guideway could be expanded without impacting the main guideway.

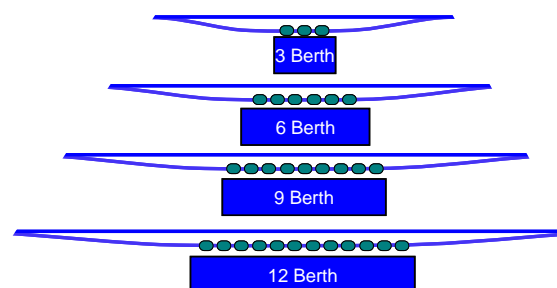

**Figure A-19 - Station Berth Configurations**

Each of the PRT systems reviewed for this study utilizes off-line stations and guideways, and sequential movement of vehicles through the station. According to PRT developers, off-line stations could accommodate up to 1,500 vehicles per hour using a 15 berth station (Anderson 2005). This capacity could be achieved by platooning groups of vehicles into the station as a virtual train, boarding and alighting passengers, and then platooning vehicles out of the station as a virtual train. The virtual train would then decouple on the main guideway and allow each vehicle to navigate the network to their unique destination. The ULTra system is unique in the ability to by-pass a vehicle in the event loading is delayed by a preceding vehicle or a vehicle becomes disabled in a station.

As is the case with conventional transit operations, the ticketing and fare collection systems to be used in a PRT system would need to be specially configured for each application. There are many commercial transit ticketing and fare collection vendors that provide systems that employ advanced technology such as smart cards. A PRT system could integrate one of these commercial ticketing systems with the PRT control system or use a custom system developed by the PRT vendor.

Similarly, conventional transit services utilize a variety of passenger information systems available from many commercial providers. A PRT system could use one of these commercial systems or purchase a custom system from the PRT vendor. It is expected that with the high degree of automation involved with a PRT system, there will be considerable information available to passengers and the primary task will be providing this information in useful formats. Unlike conventional transit systems where passengers would want to know when the next vehicle is arriving, a PRT passenger would want information such as clear instructions on how to use the system, when their vehicle would arrive at the destination, and any system information that may affect their trip. Custom in-vehicle displays are also possible that could provide travel information, advertising, and services such as internet access or restaurant reservations.

### **Maintenance and Storage Facilities**

PRT systems will require dedicated facilities to maintain and store vehicles during off-peak times. Maintenance facilities could be centralized or distributed through the system depending on the size of the network and number of vehicles. These facilities would require specialized equipment to inspect, test, maintain, repair, replace and rebuild vehicle and guideway components and systems. Although there would be more equipment required than a facility supporting a comparable large vehicle transit fleet, the equipment would be relatively small compared to the equipment used in a large transit vehicle maintenance facility and therefore potentially no more expensive than a comparable transit facility.

A PRT maintenance facility would require guideway access to maneuver vehicles around and into maintenance bays. The maintenance guideway would need to be sized to service the vehicles utilized for each operation. The ULTra system may need less maintenance guideway than the Skyweb Express, Vectus and Cabintaxi due to the use of non-contact guidance systems. A cleaning facility would be needed for each PRT system. The cleaning facility could be automated like an automotive car wash and could also include an automated inspection and interior cleaning system. Depending on the materials used on the interior of the vehicles, interior washing could be automated as well.

The storage of PRT vehicles during off-peak periods could be accomplished at dedicated storage facilities, dedicated off-line holding stations, and/or at off-line stations. The unique nature of a PRT system allows vehicles to wait at stations without affecting the flow of traffic or capacity of the main guideway. During off-peak periods, empty vehicles could first be routed to wait at all available stations. To effectively serve demand throughout a network, distributed off-line holding stations could also be used similar to a taxi queuing area. A dedicated storage facility would be needed to hold the remaining vehicles that would not fit within the off-line or holding stations. This storage facility is likely to be smaller than a storage facility needed to accommodate a comparable conventional transit fleet because PRT vehicles could be stored at stations throughout the network.

### **Certifications, Standards, Codes and Patents**

The operation of a PRT system in the United States must first receive safety and security certification from the State. The process is typically a self-certification by the transit owner and operator that is verified and validated by the State. The system may also be certified for fire safety by the local Fire Marshall. The State uses a variety of standards and codes to issue a certificate of operation.

For systems that receive federal funding, the Federal Transit Administration (FTA) looks to states to develop their own safety and security standards in response to 49 CFR Part 659, and issue them through their oversight agencies. In New Jersey, the NJDOT Office of State Safety Oversight has jurisdiction over all fixed guideway systems, including PRT. The current standard NJAC 16:53E is currently being updated for submission to the FTA. The standard calls for the owner or contract operator to implement compliant programs which must be included in the contract, including the responsibility for certifying all the elements on the system. This certification is submitted for review and approval by the oversight agency as a condition of revenue service.

The major standards and codes that would be applied to a PRT system are:

- **American Society of Civil Engineers (ASCE) Automated People Mover (APM) Standard**

The ASCE standard is developed by the APM Standards Committee. It establishes a set of requirements to achieve an acceptable level of safety and performance for APM systems. An APM is defined as a fully automated, guided transit system featuring vehicles that operate on exclusive right-of-way guideways. The ASCE APM standard is designed to assist the industry and support the safety certification process. It is published in 4 parts as follows:

- Part 1: Operating environment, Safety requirements, System dependability, Automatic Train Control (ATC), Audio and visual Communications (ASCE 21-96);
- Part 2: Vehicles, Propulsion and Braking (ASCE 21-98);
- Part 3: Electrical, Stations, Guideways (ASCE 21-00); and
- Part 4: Security, Emergency Preparedness, System Verification and Demonstration, Operations-Maintenance-Training, Operational Monitoring, Recommended Practices for Acceptance and Demonstration

The PRT systems reviewed in this study generally comply with the majority of the ASCE APM standards. There are several exceptions that would require review and potentially modification of either the standard or the PRT system to achieve compliance. The ACSE standard carries no specific legal authority but may be referenced in legal regulations.

- **NFPA-130: Standard for Fixed Guideway Transit and Passenger Rail Systems**

National Fire Protection Association (NFPA) Standard 130 covers fire protection and fire life safety issues applicable to fixed guideway transit and passenger rail system including Automated Guideway Transit. The NFPA standard is approved as an American National Standard and is referenced by the ACSE APM standards. NFPA-130 provides specific requirements for stations, power equipment, guideways, protection systems, emergency procedures, and various aspects of a transit to provide a safe environment. If implemented, the PRT systems reviewed in this study would need to comply with the NFPA-130 standards. There are several areas that are subject to interpretation within the standards and thus, will need review to determine compliance. As with the ASCE standards, the NFPA-130 standards do not carry the weight of law but may be referenced in legal regulations.

The Handbook for Transit Safety and Security Certification issued by the FTA in document FTA-MA-90-5006-02-01 provides guidance on the certification process. The FTA has also issued hazard analysis guidelines in document FTA-MA- 26-5005-00-01. These documents provide guidelines to assess safety and security issues and award certification but do not carry the weight of law. At this time, there are no federal regulations or legal certification standards that specifically address PRT systems. Each PRT application would require self-certification that meets local codes and provides sufficient safety and security to meet owner liability requirements.

Over 50 US patents have been filed since 1976 that claim specific elements of PRT technology and operations. Based on the knowledge of the research team, none of these patents are active or apply to the systems reviewed for this study. As with any developing technology, it is within the rights of the developing entity to file for and receive a patent for a unique design protecting the intellectual capital of the developing entity. It is expected that current PRT patents or those that may be filed in the future could potentially create a competitive advantage for a specific firm if the patented design proves to be commercially superior. At this point in PRT development, an optimal or defacto design has not been selected from commercial operation. The concern for patented technology would need review during any implementation process.

### **Construction of PRT Systems**

The construction of a fixed guideway transit system involves many considerations and steps. These include:

- Property acquisition;
- Utility relocation and obstruction removal;
- Site preparation;
- Foundation construction;
- Guideway construction and installation;
- Station design and construction;
- Station area parking and intermodal access;
- Maintenance and storage facility construction; and
- Testing and commissioning.

In concept, the construction of a PRT system could potentially be less complicated and disruptive to existing physical infrastructure than a comparable large-vehicle transit system. For example, if small vehicles are used as PRT developers intend, then PRT guideways and stations would have a smaller physical footprint and therefore may integrate more easily into the existing built environment than conventional transit. However, it is important to remember that the specific circumstances of each transit deployment vary greatly depending on unique local conditions. Consequently, as with any transportation project, potential impacts and issues from PRT deployments must be determined on a location specific basis.



The following list outlines the major steps required to develop a fixed guideway transit project and how PRT might compare to other large-vehicle transit system deployments.

- **Property acquisition:** Fixed guideway transit systems often require significant right-of-way. Conventional surface transit may require as little as a 12 foot wide travel lane for an exclusive bus lane; while larger multi-track regional rail systems may require as much as 70 feet or more of right-of-way. Concept designs for PRT networks anticipate less significant right-of-way needs. This is primarily due to the smaller scale of PRT components. For example, PRT systems are likely to have smaller stations and there may be greater opportunity to integrate stations within existing buildings. In addition, PRT guideways are likely to have smaller columns and foundation footing requirements as well as tighter turning radii which may reduce building interference in congested areas.

In areas with congested roads and expensive real estate, the use of public road right-of-way and/or the acquisition of private property for transit use is often a very significant design and cost consideration. Conceptually, for a PRT system, the proposition of small foundation pads every 50 to 90 feet and small station footprints could potentially reduce land acquisition costs compared with surface transit options because the system footprint may be smaller and there may be greater potential to share existing public rights of way. As with all fixed guideway systems, PRT systems will require easements for emergency access and service for portions of installations on non-public right-of-way. If existing public rights of way cannot be shared by PRT operations and to the extent right of way and or easements must be purchased, then property acquisition costs for PRT can be expected to be similar to that required for conventional fixed guideway modes.

- **Utility relocation and obstruction removal:** Installation of transit guideways of all kinds (elevated, at-grade, and underground) often requires the relocation of public utilities and or the removal of various obstructions. The comparatively smaller scale of PRT guideway systems may require less utility relocation and obstruction removal. Although a PRT system would have approximately the same above-grade utility relocation and obstruction removal needs (e.g., power lines, telephone and cable lines, and trees) as a large-vehicle transit system, the smaller size of elevated PRT guideway column foundations may result in less interference with subterranean utilities. Visual impact studies have suggested that the smaller scale of PRT guideways may allow the system to be built farther away from utility lines and trees than other transit systems and therefore have a lower need for relocation and removal. Even further, design studies have suggested the PRT guideway could replace street elements such as street lighting and poles and therefore enhance the overall visual appeal of the streetscape (Kautzky, 1994).

- **Foundation construction:** Preliminary design specifications for the PRT systems investigated as part of this study call for guideway foundations that are less deep and less massive than those required for large vehicle elevated systems. This is due to lighter guideway structures and vehicle loading. While this is true in general, the size of the foundations for specific PRT application will depend on soil conditions, underlying utilities, the span of the overhead guideway and local regulations. The above grade structure and columns for a PRT system are also expected to be smaller than those required for large-vehicle transit guideways. The PRT systems reviewed for this study had column base diameters of 16 to 24 inches compared with 30 to 60 inch columns for larger monorails or elevated transit systems. The size of the column depends on many elements including the height and offset of the guideway as well as the loading from the guideway spans and vehicles. An example of a PRT column and guideway is shown in Figure A-20. This can be compared to the conventional column and guideway shown in Figure A-21.



Figure A-20 - PRT Guideway and Column



Figure A-21 - Conventional Transit Guideway

- **Guideway construction and installation:** Conventional transit systems, whether constructed at-grade or elevated, are typically custom installations which use very labor-intensive processes. This custom-built approach is time consuming, disruptive to the local environment, and expensive. Many manufacturers of monorail systems are now developing off-site manufacturing capabilities to reduce the costs and disruption of on-site work. Off-site manufacturing involves the construction of the beam to exact specifications and then rapid on-site installation on pre-built columns. The comparatively smaller size of PRT guideway components could be readily adapted to off-site manufacturing techniques. Using automated equipment and offsite manufacturing, PRT guideway systems could potentially be easier to build than conventional elevated guideway transit systems. Once brought to a site, the pre-built guideways could be fitted with necessary equipment such as power, communication and rails depending on the system selected. This installation method could reduce the cost and complexity of guideway construction for PRT systems.

- **Station construction:** PRT stations require the same custom design and construction of any building or transit station. A PRT station will generally require elevators and/or escalators to reach an elevated platform, ticketing areas and platforms sized to handle the travel demand unique to the station. In addition to a passenger waiting and loading facility, PRT stations will also require off-line guideway structures for deceleration, vehicle queuing, and acceleration. These off-line guideways will require foundation support and overhead clearance in addition to the main guideway that by-passes the station.

A typical PRT vehicle is about 10 feet long. As such, a three berth station would require a loading platform approximately 30 feet long. A larger 15 berth platform would require a 150 foot platform. Conventional fixed guideway rail systems typically require platforms ranging from 90 to more than 600 feet depending on mode and length of train. For safety reasons, stations may also need automatic station doors in front of each loading berth. This is a typical configuration for many automated systems in the U.S. but is not a required element. Since PRT stations do not require large passenger waiting areas and could be sized to the demand for each station, it is reasonable to assume that the cost of constructing PRT stations will be incrementally lower than a comparable conventional transit system. Moreover, since PRT systems, in concept, will be relatively light weight, low impact and quiet there may be opportunities to integrate stations into the second or third floor of existing buildings. This could reduce station construction costs even further.

- **Station area parking and intermodal access:** Most conventional transit stations require some level of on-site or nearby parking and areas for intermodal access. The same would be true for a PRT system. However, if a PRT station is being built as an extension to an existing transit system, additional parking may not be required. The PRT station could even reduce the need for parking at a conventional transit station because the PRT system would act as a local circulator which effectively extends the reach of the conventional system. This may obviate the need to park at the station to access the transit system.
- **Maintenance and storage facility construction:** As previously discussed, PRT systems are likely to require smaller vehicle storage facilities than comparable conventional transit systems. This is due to the ability to store PRT vehicles at stations when not in use. A PRT system will generally have comparable or lower maintenance facility requirements as conventional transit systems; however, due to the smaller size and simplified mechanical design of the vehicles requirements may be lower.

- **Testing and commissioning:** All conventional transit systems must be thoroughly tested and verified safe for public use prior to beginning passenger operations. This will be true for PRT systems as well. Given the generally unproven nature of full scale PRT operations, the process of testing and commissioning the initial PRT deployments may be more extensive and therefore more expensive than conventional transit systems.

### **Operation of PRT Systems**

The operation of PRT systems will be similar to most automated people mover systems. Like most automated people movers, PRT systems will not require drivers or operators to support individual vehicle movement. Operations will involve staff to support central control, maintenance, security, and station services as dictated by local needs. Many automated systems do not have regular station attendants after the public has learned to use the system. Using surveillance cameras and automated sensors, system operations and response could generally be supported by centralized or regionally distributed staff. Given the specialized nature of automated systems, they are generally operated and maintained under contract to the system manufacturer or specialized contractor familiar with and trained on system operations and maintenance. A similar arrangement would likely be used to support PRT operations.

### **Standards and Interoperability**

As previously described, the design and technical characteristics of vehicles, guideways, control and communication systems and other PRT elements vary widely depending on the system developer. This is not dissimilar from the majority of conventional transit systems in the industry. Most rail transit systems are generally unique and not designed to be interoperable with other systems. The transit industry has not generally sought to develop technical standards that could be applied across systems. The transit industry has a history of developing systems with varying vehicle length, height, width, capacity, propulsion, control, wheel size and many other factors. Although there are standardized safety and security guidelines that apply to different systems, there are very few technical standards. Despite various attempts to instill more standardization, efforts have been impeded by a pervasive history of unique technical design.

As a new system being developed without the legacy of previous implementation, there is an opportunity to establish technical standards for PRT that would allow owners, manufacturers and developers to purchase, build and operate systems with common and interoperable technologies. Standards are a common technique used in many industries such as computing, networking, telephony, machinery and many others. For example, the standardization of time tables by the railroads led to use of time zones.

The standardization of screw threads led to the common and mass manufacturing of fasteners. The adoption of the TCP/IP standard allowed the creation of the Internet. Throughout the history of industrial development, the standardization of core technologies has provided many benefits including competitive sourcing from multiple suppliers, mass production and economies of scale.

The creation of standards is typically a rigorous process that may involve many stakeholders including manufacturers, developers, owners, regulators and industry associations. Technical standards are generally set after a certain level of development has been achieved or an industry de facto standard has emerged. In the case of PRT, a clearly superior technical configuration has not emerged nor has one been proven in commercial operation. Even further, the current developers are in competition with one another for product superiority and are not engaged in standards development.

After one or more technically superior products emerge, it will be in the interest of the owner and operator community to engage the vendors and developers in the development of standards. As described later in this report, PRT systems have the potential to operate as regulated utilities similar to the telephone, cable television, or cellular phone industries. These utilities operate on the basis of standards that allow developers, regulators, owners, users, and operators to benefit from common technology, interoperability, economies of scale, and competitive market forces. PRT systems could potentially be developed, owned and operated using private funds using a franchise model for specific territories. This model would be most effective if PRT systems and vehicles in one territory would interoperate with systems and vehicles in adjacent territories, thereby increasing the overall connectivity, value and utility of each system for the owners, users and developers of the system.

### **Safety, Security and Reliability**

First and foremost, a transit system should be safe. Users on any part of a transit trip should not be exposed to unsafe conditions that may cause them harm. This includes entering the station, riding in the vehicle, and leaving the station. The transit system must also be equipped to handle emergencies in a safe and secure manner.

As discussed earlier, the ASCE and NFPA have issued standards for automated guideway systems that could be applied to a PRT system for the safe operation of the system. These are conservative standards that will provide the owner and operator of a system a low degree of risk and a relatively safe operating environment. PRT developers would be well-advised to develop their systems to the spirit of these standards as well as the letter of the standard as appropriate. This development process should include comprehensive testing and independent evaluation of system safety to provide validation and acceptance for public use.

One commonly cited PRT safety concern relates to the use of very short headways. The transit industry has generally adopted the “brick-wall” criteria for vehicle spacing. The brick-wall criteria requires that a vehicle be spaced far enough behind a leading vehicle such that the following vehicle is able to come to complete stop without hitting the leading vehicle should the leading vehicle instantaneously stop. This criteria is somewhat controversial since under this scenario, only the passengers in the trailing vehicles are offered protection. If this is the required condition, it has been suggested that all vehicles be able to withstand such a collision without injury.

Proponents of short PRT headways advocate that the occurrence of such a brick-wall stop is highly unlikely and that a PRT system could be designed to make this occurrence almost impossible. Instead of the brick-wall criteria, PRT proponents recommend setting headway restrictions such that a trailing vehicle is able to stop without hitting a leading vehicle if the leading vehicle suddenly fails in the most severe condition possible due to system failure. This failure mode is generally a lock-up of the emergency brakes on the leading vehicle, which would not produce an instantaneous stop. Therefore, the time it takes for a trailing vehicle to detect the failure or lose information of a leading vehicle and apply its emergency brakes would be considered the safe headway in this scenario. For automated PRT systems, this headway has been stated as under one second. This short headway is the subject of significant controversy within the transit industry and will require testing and validation before operation is approved for public use.

A second commonly cited safety concern is the lack of emergency walkways in conceptual PRT guideway designs. Walkways are not required but are recommended in the absence of another method to safely evacuate passengers in the event of a system failure. The use of walkways adjacent to elevated guideway transit systems has become a common practice in the United States. These walkways provide a high degree of safety and minimize the risk of the system owner. However, walkways also add considerable cost and visual intrusion to the guideway infrastructure.

The PRT developers reviewed for this study generally expect to develop their systems to a high degree of reliability such that system failure and the need to evacuate passengers is a rare event. To address the eventuality of system failure, developers have devised various alternative means for passenger evacuation. For example, the ULTra system uses an open guideway and has an emergency access system whereby passengers would be able to walk along the guideway to safety. The Skyweb Express system expects to have a failed vehicle pushed by an operating trailing vehicle to the nearest station. All systems are being designed to include emergency wayside power generation and on-board batteries in the event of an electric utility failure. Most developers advocate the use of emergency rescue vehicles as a primary backup and the use walkways for guideway sections where rescue vehicles could not access the

guideway. As is the case with conventional transit systems, the need for emergency walkways should be evaluated on a case-by-case basis for each PRT application based on local needs and desires.

In the post September 11<sup>th</sup> planning environment, public transportation security issues are a matter of significant concern and interest. Public transportation, by its very nature is an “open” system. Passengers are generally allowed to use the system with minimal restrictions in order to maintain maximum passenger flow and system utility. Security concerns include safety issues related to individual passengers and the targeting and/or use of vehicles by terrorists. Patterns of passenger gathering and wait time are likely to be different when comparing PRT systems to conventional transit systems. Given the automated nature of PRT systems and the use of personal vehicles to make customized trips, PRT developers anticipate little passenger gathering and shorter wait times at stations. This could reduce risk exposure for passengers. If an assailant is waiting in a station to do harm to a passenger, this would be detected by security cameras and appropriate actions could be taken to deter and prevent criminal activity.

In terms of larger system security issues, PRT systems would be vulnerable to the same types of threats as conventional transit systems. As with any transit system, appropriate security precautions would be necessary to protect the system against terrorist use or attack. However, some aspects of PRT operations may make them less a target for terrorist activity. For example, unlike conventional transit systems which are designed to carry large groups of passengers at a time, as conceived, PRT systems would provide individuals and small traveling groups with customized trips to and from numerous origins and destinations throughout the network. Instances of large groups of passengers gathering or traveling together would be rare.

At the same time, these same characteristics of PRT operations may require special precautions to ensure that individual vehicles are not used by suicide bombers or to deliver explosives remotely. Careful design using existing technologies may allow PRT developers to equip stations and/or vehicles with detection devices to prevent the vehicles from being used in this way. This is an element of PRT system design that will need to evolve as industry standards and world experience and circumstances dictate.

## APPENDIX 2

### INDUSTRY EXPERT QUESTIONNAIRE AND INTERVIEWS

In addition to the vendor survey, the research team circulated a questionnaire to leading PRT experts. The questionnaire was accompanied by follow up telephone interviews for clarification and exploration of topics of interest. The expert interview process was intended to gather high level insights from specific experts and was not a general review of opinions from the transportation industry.

The following is a list of the experts interviewed for this study. The experts were selected in consultation with the Research Project Selection and Implementation Committee, and include transportation consultants, as well as PRT advocates, operators, researchers and planners.

- **J. Edward Anderson:** Dr. Anderson has worked on PRT systems for 25 years at the University of Minnesota and Boston University, and for the next 11 years as CEO of Taxi 2000 Corporation. He chaired four international conferences on PRT, authored the textbook *Transit Systems Theory*, gave many professional courses on transit systems analysis and design in the U.S. and abroad, and authored over 100 papers on PRT topics. In 1981 he initiated the design of a new PRT system that won competitions in SeaTac, Chicago and Cincinnati. He designed and supervised the construction of a PRT vehicle and 60-ft guideway that ran automatically for over 4000 rides with no failures, and also developed the software and hardware for a PRT control system capable of handling a network of any size. He is currently working through his new firm, PRT International, LLC.
- **Lawrence Fabian:** Mr. Fabian is a regional land use and transportation planner. He is also the founder and principal of Trans.21, a technical clearinghouse on Automated People Mover developments around the world. He has over thirty years of experience and is an office holder in the Advanced Transit Association, the American Planning Association and the American Society of Civil Engineers. He maintains a current understanding and regularly speaks on PRT developments around the world.
- **Bob Hendershot:** Mr. Hendershot is the operations and maintenance manager of the Morgantown PRT system at West Virginia University. He has over thirty years of experience with the University and the M-PRT system. His present duties include responsibility for all engineering and safety functions, director of financial operations and principle investigator for all grants and contracts. Mr. Hendershot is the technical liaison for the M-PRT system providing information to



a planners, suppliers and potential installers of AGT systems, particularly PRT concepts and technology.

- **Hal Lindsey:** Mr. Lindsey is a Senior Associate with Lea+Elliott providing transportation consulting services to clients in North America and overseas. He has been involved in transportation operations (Walt Disney World Company), the supply of turnkey transit systems (Bombardier Transportation) and consulting services (Lea+Elliott) for 30 years. Since joining Lea+Elliott, he has participated in the evaluation of emerging technology, feasibility studies and technology and market assessments. He is Vice Chair of APTA's Automated Guideway Transit Technical Forum and frequently makes presentations at various airport and transit industry conferences.
- **Sam Lott:** Mr. Lott is a Senior Vice President with Kimley-Horn and has more than 30 years of experience in the planning and engineering of ground transportation systems and terminals. His experience with guideway transit systems includes conceptual design and analysis through computer simulations, performance and operations analyses, cost estimating, system specifications, verification review and testing. He has significant experience with automated people mover systems for airports and other major activity centers, as well as escalators, elevators, light rail, rapid transit, and commuter rail systems. He has also been a leader in the application of simulation software to the planning and operations analysis of multimodal transportation systems, passenger terminals, and major activity centers.
- **Jerry Schneider:** Dr. Schneider is Professor Emeritus from the Departments of Urban Planning and Civil Engineering at the University of Washington in Seattle. He was actively engaged in transportation and land use teaching and research for 30 years. Dr. Schneider has developed and maintained the Innovative Transportation Technologies website: <http://faculty.washington.edu/jbs/itrans>. This website includes descriptions of more than 80 innovative transit technologies from around the world as well as information on the history and current status of PRT technology problems and potentials. He has been an active member of the Advanced Transit Association and has served many years as the Vice-President of the Association.

As stated above, the industry expert interview process included the distribution of a questionnaire which included 44 statements requiring an agreement rating ranging from one to four and six open-ended questions. The 44 agreement statements covered topics related to the PRT development process; potential applications; costs and service; performance and standards; and technology components. The open-ended questions requested input on the limitations and future of the PRT technology.

After reviewing the responses received to the questionnaire, the research team conducted telephone interviews to clarify their answers as needed and discuss additional topics of interest. The following section provides a summary of the major observations drawn from interviews. The following major observations were drawn from the results of the industry expert questionnaire and interviews:

### **PRT Development Process**

- PRT technology has been proven in smaller systems using older technology.
- Technology and design experience from previous systems should enable the development of effective PRT systems in the future.
- PRT requires additional development to achieve commercial readiness. This should include a pilot and testing program before operational deployment for public use.
- PRT technology components such as linear induction motors or advanced communication systems do not require additional fundamental research. Current state-of-the-art technologies are sufficient for demonstration and deployment.
- Initial PRT applications are expected to focus on smaller networks with a migration path such as airport and downtown circulators. These applications will most likely be scalable to larger networks in the future.
- Additional research and development is still needed on the operations and management of larger networks.
- Private organizations have been unable to raise sufficient development funds without public endorsement of the technology. As such, some level of government funding, support, and/or endorsement will likely be necessary to advance PRT development and implementation.
- Public/private partnerships are recommended as an effective tool to develop and/or operate PRT systems.
  - Public/private partnerships could allow the public to realize the potential benefits of PRT system implementation, while reducing risk, achieving a recurring return of investment and possibly establishing the base for cultivating a new industry focused on the design, manufacture, operation and management of PRT systems.
  - Public/private partnerships could allow private entities to secure capital development funds, participate in a defined development program, and achieve a defined market.

- State and local needs should drive development efforts.
- To the maximum extent feasible, State and local governments should collaborate and secure appropriate Federal funding that is not too restrictive or burdensome.
- Government involvement should be limited to providing system requirements and performance standards rather than directing technology development.
- Private organizations should lead the technology development.

### **Potential Applications**

- PRT systems have the theoretical potential to be a “strong” alternative mode of transit for a wide range of applications.
- PRT systems are expected to evolve from small initial networks with a small number of vehicles and stations to larger networks with large number of vehicles and stations.
- With careful design, PRT systems could be effectively integrated within urbanized, high density areas. Potential impacts from system implementation will derive primarily from the size and design of guideway systems. It will be critical to ensure that vehicles remain small, allowing small guideway/station footprints and tight turning radii.
- PRT systems could effectively serve activity centers and campuses in a variety of settings, provided the systems support distributed movement among many destinations. Large central business districts could also be served after operation has been progressively proven in smaller activity centers and moderately sized central business districts.
- PRT may be particularly well suited to airport applications where the PRT network could connect destinations such as terminals, hotels, parking, rental car facilities and rail stations.
- PRT systems could be used to improve access to rail stations, from adjacent neighborhoods and remote parking facilities.
- When considering various applications, system designers should consider issues related to potential visual impact and baggage handling as well the potential to expand service to address freight handling and goods movement.

## Costs and Service

- According to industry estimates, PRT could potentially provide:
  - Lower operating costs than other transit modes. Most potential cost savings is attributed to reduced operations staff, energy use and maintenance needs.
  - Lower capital costs than other fixed guideway transit modes. Most potential capital costs savings derives from the use of smaller guideways and reduced civil construction needs.
  - Faster travel times than other transit modes due to non-stop, on-demand service; and shorter travel times than the automobile in congested areas with limited available parking.
  - Lower energy use than other transportation modes due to the use of lightweight vehicles and the movement of vehicles only on demand.
- Industry experts agree that PRT systems could potentially:
  - Attract higher levels of patronage than other transit modes and command premium fares due to higher levels of service.
  - Provide higher levels of security than other transit modes due to constant flow of travelers and higher levels of automation and monitoring inherent to PRT systems.
  - Reduce the risk of terrorist threat due the lack of large crowds from the distributed nature of travelers and stations
  - Lower environmental impact and reduce foreign oil dependence due to the use of all electric vehicles.

## Performance and Standards

- Standards for PRT system design and operation should be allowed to emerge from development and testing processes and initial implementations of PRT technology before “official” standards are set. Government agencies should only set standards that protect the public interests of safety, access and environmental protection.

- Government agencies should specify performance and operational requirements that could be met by a variety of technologies in a competitive manner.
- Government agencies should cooperate and develop consistent requirements that promote the development of a common set of technologies and encourage economies of scale, reduced cost structures, flexible and scaleable systems, and interoperability of equipment.
- Government agencies should not set standards that specify technical designs or limit the use of technology to serve a specific functional or operational requirement.
- Private developers should work together to establish technical standards that enhance the development and effectiveness of PRT technologies. Standards such as communication protocols and vehicle-guideway interfaces could encourage competition and open markets
- PRT methods for short headways and alternative evacuation techniques should be reviewed and included in the ASCE APM standards if they can be demonstrated for safe and reliable operation.

### **Technology**

- PRT technology is not generally understood by the larger transportation planning and engineering community or by the general public.
- The core technical elements of PRT control, communication, power and propulsion are commercially available today. The development of a fully operational PRT system is currently possible given the current state-of-the-art and generally requires only the engineering and application of proven technologies.
- The system engineering, design, testing and validation of a fully configured PRT system is needed to advance implementation. Engineering design should include performance targets for system cost, reliability, safety, performance, scalability, and flexibility of implementation and operations
- A development, testing and validation program is needed with adequate capital funding and systems engineering approach that is not constrained to implementation before development is completed
- PRT technology is expected to evolve from smaller scale systems to larger scale systems. Larger scale systems will require more advanced engineering efforts but will not require fundamental research or technology development

## APPENDIX 3

### COMPARISON OF PRT WITH OTHER MODES

#### Average Speed of Travel Comparison

The average speed of a transit system directly impacts the relative attractiveness of the system to other modes and therefore the potential ridership. As a general rule of thumb, the faster the average speed of travel, the more attractive the service. The average speed of an average trip on a transit system is determined by the line speed, the number of stops for a given trip, the distance between stops, the dwell time at stops, and the length of the trip. The average speed of various transit modes in the United States is shown in Figure A-22. From Figure A-22, the average speed for all conventional fixed route transit modes is approximately 15 miles per hour (mph).

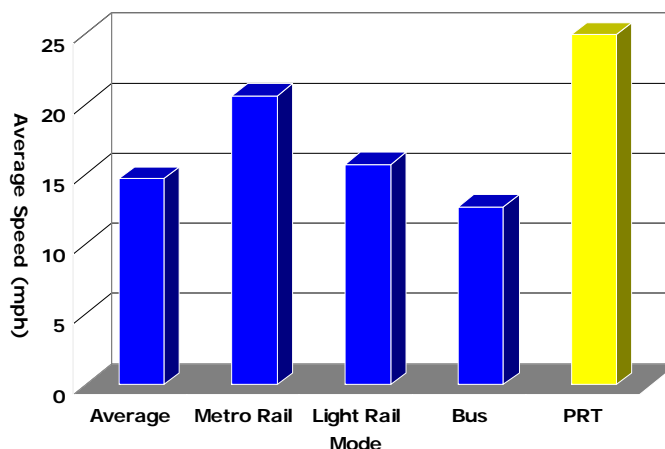

**Figure A-22 - Observed Average Speed on Fixed Route Transit vs. PRT Estimates**

Source – APTA, Vendor Estimates

While most conventional transit systems have relatively high line speeds, the need to stop along the route or operate in mixed surface traffic significantly limits the average speed. A metro rail system may have a line speed of 60 or 70 mph but must stop every mile or half mile for example to serve on-line stations resulting in a national average speed of approximately 20 mph. Some systems have implemented local and express service to bypass stations and increase the average speed of the line. Light rail, BRT and bus systems also have high line speeds but are limited by the need to stop at frequent stations, resulting in lower average speeds. Even further, if they operate in mixed-use traffic, they are limited by the same congested conditions as the private automobile. These factors lead to a national average speed of 14 mph for bus systems and 15 mph for light rail systems.

To address the need for high average speed, PRT designers have selected to use exclusive guideways separated from surface traffic, the innovative use of off-line stations and all seated passengers. These features allow all PRT vehicles to by-pass intermediate stations, maintain line speed for the majority of the trip and utilize higher yet comfortable acceleration and deceleration levels. Every trip is an express trip. A typical PRT trip would include acceleration to line speed from a station, full or almost full line speed during the trip, and deceleration at the final station off-line track. This use of almost full line speed throughout the trip allows a PRT system to use lower line speeds than conventional transit yet achieve higher average speeds. The lower line speed and the single stop and start for each trip has many other benefits such as reduced energy use, tighter turning radii and reduced weight to handle smaller propulsion systems.

Reduced speeds would be needed for special operations or negotiating curves that cannot support full line speed. For example, a PRT system with seated passengers could conceptually negotiate a 242 foot radius curve at a line speed of 30 mph or a 107 foot radius curve at a reduced speed of 20 mph. Tighter curves could be used if the guideway is super-elevated. For reference, a roadway with 5 12-foot traffic lanes, 2 12-foot parking lanes and 15 foot sidewalks on both sides would be 114 feet wide.

The average speed of a PRT system will vary depending on the line speed of the system, the length of the average trip and the need to reduce speed for operations or negotiating tight curves in congested areas. As an example, consider a PRT trip of four miles with a line speed of 30 mph with 20% of the trip operating at a reduced speed of 20 mph. The average speed of this trip would be 27 mph or 90% of the line speed. The reported line speed of the PRT systems reviewed in this report range from 22 to 30 mph. The average trip speeds for these systems are therefore estimated between 20 and 27 mph. For this analysis, a 23 mph average trip speed is used to represent PRT.

### **Total Trip Time Comparison**

Similar to average speed, the total trip time of a transit trip directly impacts the relative attractiveness of the trip to other modes and therefore the potential ridership of the transit system. The total trip time for a transit trip includes the following elements:

- **Non-transit travel time:** The travel times to the origin station and away from the destination station are related to the distribution of the transit system within the community. The larger the system, the more stations and coverage provided by the system and therefore the shorter the non-transit travel times. The size and coverage of the system relates to the cost of the system and the demand for travel within a specific area. The lower the cost of the system, the more coverage can be provided by the system. For this analysis, the coverage of all systems is assumed equal and not used as a comparison factor.

- **Wait time:** The wait time for the original vehicle and the wait time for the transfer vehicle relate directly to the headway of the system for conventional transit systems. These headways could be as short as one minute and over 15 minutes depending on the level of service provided during the day. A range of frequent headways are used for this analysis. For a PRT system, wait time relates to the level of vehicles used in the system to match travel demand, and the algorithms used to manage empty vehicles. Since vehicles do not operate on a schedule, they either wait at the station or are summoned to a station if a trip is requested or anticipated by the central control system. The literature search revealed expected PRT wait times of 15 seconds up to one minute. For a conservative analysis, a one minute wait time was used. For trips that require a transfer, an additional wait time is needed. The wait time for a transfer depends on headway of the system providing the secondary leg of the trip. If a PRT system covers all legs of the trip, transfer are not needed due to the network feature of the system.
  
- **Travel Time:** The travel time is determined by the length of the trip multiplied by the average speed of the trip. If transfers are involved, the travel time is the time it takes to complete each leg of the trip using the average speed of each leg.

To compare total trip times for PRT, heavy rail, light rail and bus modes, two hypothetical trips shown in Figure A-23 are used for this analysis. Trip 1 is a simple trip from Station A to Station B along a single corridor using only one mode of transit. Trip 2 is a trip along two corridors following a path including Stations A, B and C. Trip 1 is four miles long and Trip 2 is eight miles long. The average speeds listed previously for each mode are used in this analysis.

Trip 1		Trip 2		
A		A		
B		B		C

**Figure A-23 - Total Trip Time Examples**

The total trip times for all modes in example Trip 1 are shown in Table A-2. A range of headways were used for the conventional transit modes. In the example of Trip 1 using a total length of four miles and no transfers, all conventional transit trips would be longer than the PRT trip. Heavy metro rail trips would only be slightly longer using two minute headways whereas bus trips would be almost twice as long using ten minute headways.



For this length of trip, the headway used for conventional transit modes and therefore average wait time has considerable relative weight on the total trip time and competitiveness with the PRT trip.

**Table A-2 - Trip 1 Total Time Comparison**

Leg A-B				Total Trip Time (min)	Increase over PRT
Mode	Average Headway (min)	Average Wait Time (min)	Average Line Speed (mph)		
Heavy Rail	10	5	20	17.0	49%
Heavy Rail	2	1	20	13.0	14%
Light Rail	10	5	15	21.0	84%
Light Rail	2	1	15	17.0	49%
Bus	10	5	14	22.1	94%
Bus	2	1	14	18.1	59%
PRT	0.05	1	23	11.4	

Trip 2 provides an example of a trip along two corridors that includes a transfer between transit lines at a common station. For this analysis, conventional transit trips are constructed using the same mode and headway for both corridors. A five minute walk time is used to move from one line to the other at the transfer station. A range of PRT trips are used for the analysis including each of the modes for the first leg of the trip and PRT for the second leg of the trip. A baseline PRT trip is also included that uses the PRT system for both legs of the trip without a transfer. The range of total trip times for Trip 2 are shown in Table A-3.

**Table A-3 - Trip 2 Total Time Comparison**

Leg A-B				Leg B-C				Total Trip Time (min)	Increase over full PRT	
Mode	Average Headway (min)	Average Wait Time (min)	Average Line Speed (mph)	Mode	Average Headway (min)	Average Wait Time (min)	Transfer Walk Time (min)			Average Line Speed (mph)
Heavy Rail	10	5	20	Heavy Rail	10	5	5	20	39.0	78%
Heavy Rail	2	1	20	Heavy Rail	2	1	5	20	31.0	42%
Light Rail	10	5	15	Light Rail	10	5	5	15	47.0	115%
Light Rail	2	1	15	Light Rail	2	1	5	15	39.0	78%
Bus	10	5	14	Bus	10	5	5	14	49.3	125%
Bus	2	1	14	Bus	2	1	5	14	41.3	89%
PRT	0.05	1	23	Heavy Rail	10	5	5	20	31.9	46%
PRT	0.05	1	23	Heavy Rail	2	1	5	20	27.9	27%
PRT	0.05	1	23	Light Rail	10	5	5	15	31.9	46%
PRT	0.05	1	23	Light Rail	2	1	5	15	27.9	27%
PRT	0.05	1	23	Bus	10	5	5	14	31.9	46%
PRT	0.05	1	23	Bus	2	1	5	14	27.9	27%
PRT	0.05	1	23	PRT	0.05	0	0	23	21.9	

The baseline PRT trip demonstrates that significant travel time savings are possible using a fully integrated network without any intermediate station stops or transfers. Compared with this baseline PRT trip, a heavy rail system with a frequent headway of two minutes would have a 42 percent longer total trip time. A bus system with a ten minute headway would have a 125 percent longer total trip time.

PRT systems have typically been considered not well suited for urban travel due to their lower line speeds. However, from this analysis, it is clear that even with lower line speeds, PRT systems would have shorter travel times than conventional transit modes for moderate length trips in applications such as a central business district as well as longer trips in urban applications. The need to stop at intermediate stations for conventional rail systems negates the value of higher line speeds and puts conventional transit systems at a disadvantage to PRT systems with moderate line speeds.

It should be noted that travelers perceive the time waiting and walking differently than the time spent traveling in a vehicle. In a modal split and patronage analysis, these portions of the total trip time are given a higher weighting to reflect this perception. The feature of potentially shorter waiting time would give further advantage to a PRT system. This analysis only included the actual travel and waiting times with no factor added for perceived time.

### **System Capacity Comparison**

The capacity of a transit system can be described in many ways that can cause confusion or misunderstanding if not carefully understood. The capacity of a transit system can be described by the ability of a given line to handle the peak flow of people or by the capacity of the overall network to handle peak flow. Capacity can also be described by the ability to handle a total amount of people for a given hour or day. It is important to use measures that clearly describe capacity in a normalized or standard manner so that systems can be compared independent of the unique characteristics of a given implementation.

For this discussion, the theoretical and expected capacity of an individual transit line will be used. Line capacity can be described as the ability to move a certain number of passengers past a given point per hour in a specific direction or passengers per hour per direction (pphpd). The theoretical capacity of an individual transit line per direction of travel is determined by the minimum headway between vehicles and the maximum capacity of each vehicle or train. For example, a bus system with 60 passenger buses operating every ten minutes would have a theoretical line capacity of 360 pphpd. A light rail system using 300 passenger capacity vehicles operating every five minutes would have a theoretical line capacity of 3,600 pphpd.

In practice, a transit system does not operate with every seat filled and every vehicle maintaining minimum headway. The load factor, or percentage of passengers relative to available capacity, is typically below 100 percent for most systems except during the highest demand portions of the peak period. The theoretical and observed line capacities of various fixed guideway transit systems and the expected capacity of PRT systems are shown in Table A-4 and Figure A-24.

**Table A-4 - Transit Line Capacities**

Mode	Heavy Rail	Light Rail	Busway	PRT
Headway (sec)	120 to 200	60 to 360	15 to 300	0.5 to 3
Vehicle/Train Capacity	360 to 3000	240 to 360	40 to 70	3 to 6
Theoretical Line Capacity (1,000 Persons/hour)	6 to 90	2 to 20	0.5 to 16	3.6 to 43
Peak Load Factor	0.4 to 0.8	0.5 to 0.7	0.3 to 0.6	0.2 to 0.5
Observed/Expected Line Capacity (1,000 Persons/hour)	6 to 50	1 to 10	1 to 11	1 to 9

**Transit Mode Line Capacity**

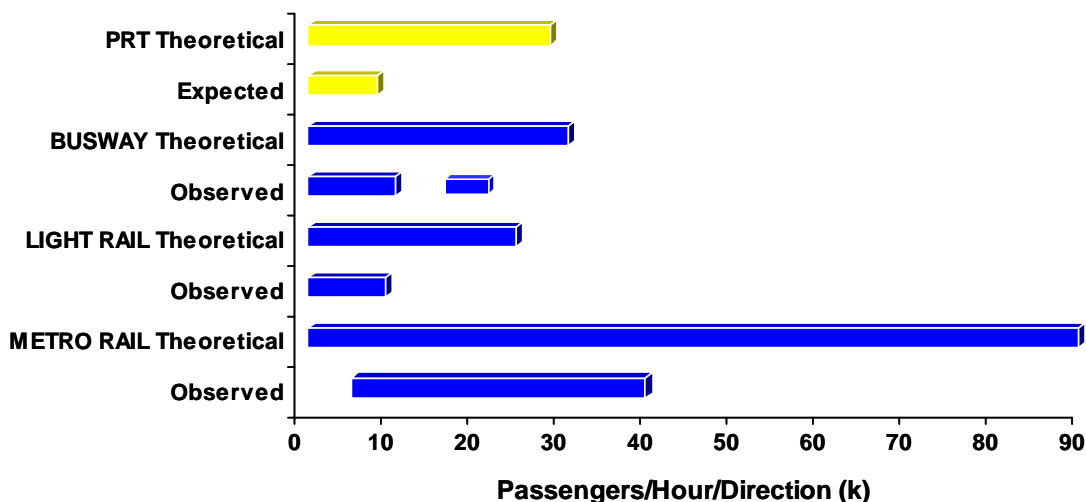

**Figure A-24– Theoretical Versus Observed Transit Line Capacities**

Source: TCRP Transit Capacity Manual, NJ Port Authority, Engineering Estimates

As shown in Figure A-24 , there is considerable variation in the theoretical and actual capacities of transit systems. As expected, heavy rail systems have large trains that provide high theoretical peak capacity and can have very high use in peak periods for cities such as New York and Washington DC. Light rail and busway systems also have high theoretical peak capacity. The actual peak loading of most light rail and busway systems, however, can be considerably below capacity. Peak usage for light rail systems in the United States averages between 3,000 to 7,000 pphpd for most systems. The highest patronage systems serve between 9,000 and 10,000 pphpd.

PRT systems have theoretical line capacities that could be equal to or higher than comparable bus and light rail lines. For example, the six person Cabintaxi vehicle had a demonstrated headway of 0.5 seconds equaling a theoretical line capacity of 43,200 pphpd assuming all seats are occupied. In reality, PRT systems are expected to have vehicle loading equal to current automobile travel of 1.1 to 1.3 average persons per vehicle. For a three or four passenger PRT vehicle, this is a load factor of 0.3 to 0.4.

PRT systems are also expected to have higher headways than the theoretical minimum until the safety and reliability of sub-second headways are proven and validated in testing. The Cabintaxi and Raytheon PRT systems demonstrated reliable headway operations of three seconds. With 1.2 passengers per vehicle, this equals a peak line capacity of 1,440 pphpd. Higher capacities could be realized with shorter headways and higher load factors. For example, two passengers per vehicle and two second headways equals 3,600 pphpd. A one second headway with a national average of 1.63 persons per vehicle equals 5,868 pphpd. These are competitive capacities with the observed capacities of all transit modes with the exception of heavy rail systems. The challenge for PRT is to achieve these headways in a safe and reliable manner. Short headways have been demonstrated in test track facilities but need verification under various operating conditions prior to public use.

The actual usage and required capacity of a transit system is influenced by the overall demand and the level of service provided by the system. The overall demand on the system varies by the time of day and at each station in the system. The variation in demand during the day will follow a peaking during the early morning and late afternoon for systems that primarily support commuter service.

Systems supporting activity centers, airports, and other campuses will have a range of demand profiles depending on the activities of the application. For all applications, it is important to size the transit system to support the maximum peak load expected for the system, usually over a specified time period. Since it is not practical to immediately serve all passengers when they enter the station with unlimited capacity, transit systems are designed to meet a prescribed level of service that includes some level of waiting.

Conventional fixed-route, on-line station transit systems are designed to serve peak demand at a uniform level of service throughout the peak period. For rail systems, vehicles seek to maintain a constant headway for all segments of the line during the peak period. The headway and number of cars in a train or number of buses used are designed to balance waiting time with the cost of frequent service and potential unused capacity for various sections of the line and lower demand portions of the peak period. Conventional systems must provide a high level of service independent of the actual variations in demand during the peak period.

PRT systems could be designed to serve the peak demand in a more flexible manner than conventional transit systems. Rather than all vehicles operating on a fixed schedule and fixed headway, vehicles operate on demand. The fleet of vehicles would be sized to handle the peak load for the entire system. During peak periods, vehicles would operate at the minimum headway necessary to serve demand. The system would also allocate vehicles within the network to serve variations in demand.

With on-demand service, vehicles would wait at stations or at distributed storage facilities until needed. Vehicles would operate only if serving a passenger or moving to a station to support a trip. With off-line stations, the capacity and size of each station is designed for the demand at that station. Rather than sizing a station to handle the longest train as in conventional transit systems, the number of station berths and the length of the off-line guideway would be designed to handle the specific peak demand for that station.

The capacity of a transit system is also often described by the daily or yearly loadings on the system. The daily and yearly figures are influenced by the capacities of each line in the system, the number of lines, the length of each line, the number of stations, the demand at each station, and the frequency of service during the weekday and weekend. This complex matrix of variables makes it difficult to compare the effectiveness or capacity of specific systems and therefore should be done with care.

### **Capital Cost Comparison**

Similar to overall capacity, the capital costs for fixed guideway transit systems are highly specific to each application. Capital costs for a transit system are determined by many factors including the layout and length of the line, the selected technology, the use of elevated, at-grade or subway structures, the number and complexity of stations as well as the local conditions and cost factors. Table A-5 demonstrates the range of capital costs for recently constructed or planned transit systems around the country expressed in total cost per mile.

**Table A-5 - Example Transit Fixed Guideway Capital Costs**

<b>Mode</b>	<b>Capital Cost/mile (\$M)</b>
<b>Heavy Rail</b>	
NY City 2nd Avenue Subway	\$2,000
Los Angeles Red Line	\$258
Dulles Metro Extension (Wash. DC)	\$170
<b>Light Rail</b>	
Los Angeles Gold Line	\$65
Minneapolis Hiawatha Line	\$60
Houston Metro	\$43
NJ TRANSIT River Line LRT	\$29
<b>Automated Guideway</b>	
JFK Airport Airtrain	\$148
Seattle Monorail	\$150
Indianapolis Clarian	\$28
<b>Busway</b>	
Exclusive average (GAO)	\$13.5
HOV average (GAO)	\$9.0

Sources: Respective Transit Agencies and GAO

As shown in the table, underground metro rail systems in congested urban areas can be very expensive and are only applicable to the highest use areas. For example, the New York 2<sup>nd</sup> Avenue Subway is expected to cost approximately \$2 billion per mile. Light rail systems are typically less expensive than metro rail systems but can have quite a range depending on the degree of land acquisition, bridge and tunnel construction as well as complexity and frequency of stations. Light rail systems are typically built at grade consuming street surface area or use existing railroad right-of-way. They also typically have at-grade, open-platform stations spaced between a quarter and one mile apart. Light rail systems such as the Los Angeles and Minneapolis systems have elevated or underground sections of the network driving up costs to over \$60 million per mile. Systems built mostly at grade along existing right-of-way can have much lower costs. New Jersey TRANSIT's River Line cost \$29 million per mile to construct.

Automated guideway systems such as airport people movers or urban monorails can cost \$100 million or more per mile due to the use of large structures constructed in constrained locations. They also can be much less expensive under certain conditions. The Clarian Peplemover in Indianapolis for example was constructed at \$28 million per mile using a private development process, rapid implementation techniques and limited right-of way acquisition.

Busway or Bus Rapid Transit (BRT) is a relatively new transit alternative that uses advanced buses operating on various degrees of exclusive roadways including

dedicated lanes or high occupancy vehicle (HOV) lanes. BRT systems can have low capital costs and provide the flexibility of allowing the vehicle to leave the fixed guideway to serve local areas. BRT can also be very expensive if new roadway lanes are required or tunneling is used.

As described in Sections III and IV of this report, PRT systems use small vehicles and therefore smaller guideways than other large vehicle transit systems. It is reasonable to expect that the capital costs of constructing PRT systems may be lower than other grade-separated, fixed guideway rail systems. Lower capital costs would be primarily attributable to smaller guideways and stations and reduced civil work and material costs associated with system design and construction.

As also noted previously, PRT only has a history of prototype and test track operations. This lack of implementation history complicates the ability to accurately predict the capital costs of a future PRT system. To estimate the capital costs of a PRT system, the research team collected engineering estimates from the selected PRT developers, reviewed past costs of historical PRT developments and reviewed past cost studies of comparable AGT systems. To the knowledge of the research team, the Cabintaxi program developed the most rigorous cost information of any program and calibrated this information against the actual cost for the program's test track. The Cabintaxi program also developed estimates for large scale implementations using conventional estimating techniques. Other cost information included the analysis performed on AGT systems by the US DOT and the cost estimates developed for the EDICT program. Using this information, the research team developed a range of conservative capital cost estimates for PRT and other transit systems shown in Table A-6.

**Table A-6 - Capital Costs – Conventional Transit vs. PRT**

Mode	Capital Cost/Mile (\$M)		
	Low	Average	High
Observed Construction Costs			
Heavy Rail	\$110	\$175- \$250	\$2,000
Light Rail	\$25	\$50-\$70	\$195
APM – Urban	\$30	\$100-\$120	\$145
APM – Airport	\$50	\$100-\$150	\$237
BRT Busway	\$7	\$14-\$25	\$50
BRT Tunnel	\$150	\$200 - \$250	\$300
Theoretical Engineering Cost Estimates			
PRT One Way	\$15	\$20-\$35	\$50
PRT Two Way	\$25	\$30- \$50	\$75

Sources: Kerr 2005, TCRP R90, GAO 2000, Vendor estimates & case studies

The range of costs provides guidance relative to the implementation complexity and the selected technology. For example, the low range for capital costs are for very simple implementations with limited right-of-way requirements and favorable climate locations. For PRT, the low costs reflect systems such as ULTra that have simple guideway and station designs and no provision to support severe weather or higher speeds. The high cost figures represent applications constructed in the most complex, dense urban environments with high cost factors such as New York City. The average figures can be used as planning guides for most moderately sized and complex applications. The PRT capital costs are estimates for system implementations completed after the first pilot systems are developed and manufacturing efficiencies are achieved. It is expected that the first PRT systems may have higher costs than listed in Table A-6 due to development issues and initial manufacturing start-up inefficiencies.

PRT systems could be constructed with one-way or two-way guideways or a combination of both. PRT capital costs are listed for one-way or two-way configurations. Using one-way guideways formed into networks, similar to one-way streets of a downtown, a PRT system is able to minimize overall impact for a given location while maximizing access. This configuration also provides broader transit coverage with an increased number of stations than a simple corridor layout.

Placing PRT lines along major parallel and intersecting arterial roadways rather than along a single arterial is practical, however, only if the capital costs of each line are low enough to warrant the distributed access. The system must also be able to support sophisticated network management and reliable, rapid switching needed for network operation. PRT systems appear ready to support these lower costs and ability to handle network operations. PRT systems could also support two-way guideways with parallel beams in a conventional configuration if needed by application requirements. Most PRT application studies have used one-way guideways to provide the benefits of additional coverage and minimal impact. The Cabintaxi system provides the unique over/under configuration for two-way service with a single guideway beam.

The range of system costs and configurations will vary considerably depending on local conditions and unique system requirements. For example, a PRT system that must be elevated over many surface structures and support very complex stations could be much more expensive than a light rail system that uses an existing railroad right-of-way with infrequent stations. However, as shown in Table A-6, assuming PRT cost estimates are realized, average PRT capital costs may be equal to or lower than most comparable fixed guideway transit systems. For example, on average, a PRT system could be expected to be half as expensive as a comparable light rail system. This is due to the lower expected right-of-way costs, lower need for civil work, lower expected manufacturing costs, and lower construction costs.



PRT systems could also be expected to cost between 30-75 percent less than comparable people mover or monorail systems. This is due to the smaller guideway structures, lower civil and integration efforts, and smaller stations required for the PRT system. PRT systems are expected to be more expensive than a comparable BRT system if the BRT system uses the existing roadway infrastructure. If additional travel lanes are needed or if substantial infrastructure improvements are needed to support the BRT system, the costs could be comparable or higher than a PRT system.

### Operating and Maintenance (O&M) Costs Comparison

The operating and maintenance (O&M) costs for a transit system are highly dependent on a number of factors including the ridership, level of service, efficiency, scale, selected technology, and management practices of the system. To normalize the O&M costs across many systems and technologies, the total O&M costs of a system per passenger mile provides an effective measure of total system cost effectiveness.

Figure A-25 presents national and NJ TRANSIT O&M costs for conventional transit modes. Figure A-25 also presents the O&M costs for the Morgantown system (referenced as M-town), the average for APM systems, as well as the expected cost range for PRT systems. The PRT cost estimates are based on previous engineering studies, vendor estimates and comparable APM systems.

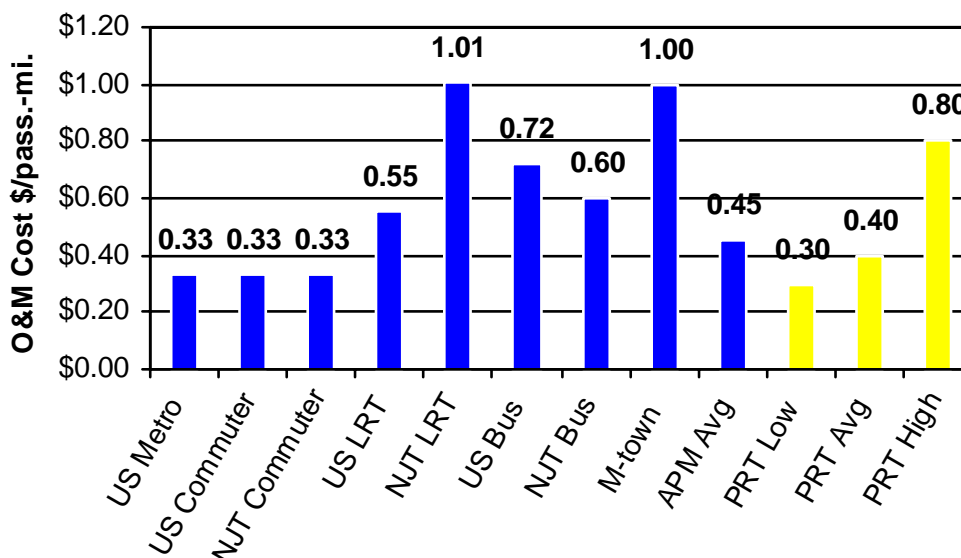

**Figure A-25 - Operations and Maintenance Costs per Passenger Mile**

Notes: NJT = NJ TRANSIT, M-town = Morgantown Group Rapid Transit System  
 Source: 2005 APTA Transit Fact Book, NJT, FTA, Case Studies, PRT Vendors  
 PRT O&M numbers are estimates only

As shown in Figure A-25, O&M costs per passenger mile (OMCPPM) can range from as low as \$0.33 per passenger mile for commuter and metro rail services to more than \$1.00 for NJ TRANSIT operated light rail services and the Morgantown system. The commuter and metro rail system costs are low due to many factors including the long history of these systems and the efficiencies gained over many years of system improvements. These systems are also typically quite large with significant ridership allowing fixed costs to be spread over the ridership base. The light rail and Morgantown systems are much smaller scale systems and therefore must spread fixed costs over a smaller ridership base resulting in a higher OMCPPM. Bus systems have higher OMCPPM than rail systems due to higher staffing costs from higher operator to vehicle capacity ratios. Automated people mover (APM) systems typically have lower OMCPPM than bus systems due to reduced operator costs. They have higher OMCPPM than rail systems due to the typically smaller scale of the systems and therefore lack of economies of scale.

PRT systems could be expected to offer comparable OMCPPM levels to heavy and commuter rail systems if they are deployed effectively, have achieved a level of maturity and scale of deployment similar to moderately sized metro systems. PRT systems are expected to offer equal or lower OMCPPM levels than APM systems. This is due to higher expected levels of automation reducing staffing needs, the use of on-demand service reducing energy use and vehicle wear, and the use of advanced components such as linear motors that require less maintenance and repair. As with any transit system, PRT systems could experience comparatively high OMCPPM levels if they are deployed in a limited scale with small patronage demand. The Morgantown system is an excellent example of a very efficient operations and maintenance organization with a total O&M budget of only \$3.4M that is supporting a small annual ridership of two million passengers and 3.5 million passenger miles (Hendershot 2005).

### **Ridership and Congestion Comparison**

According to the US Bureau of Transportation Statistics, transit systems nationally provided 4.4 percent of all commuter work trips in 2003 (BTS 2003). The automobile provided 88.1 percent of all work trips in 2003 with single occupant automobiles provided 79.4 percent of all work trips. According to the 2000 US Census, New Jersey commuters selected transit for 11.6 percent of all work trips. This higher percentage of transit trips is due in part to the largest state-wide transit system in the country operated by NJ Transit and the influence of transit commuting into New York City.

NJ Transit provides over 800,000 daily trips and almost 2.6 billion annual passenger miles. According to the Texas Transportation Institute, the New Jersey and New York metropolitan area ranks as 18<sup>th</sup> most congested area in the country. Despite the large

transit network, the average New Jersey and New York driver spends 49 hours per year delayed in traffic. This compares favorably with Los Angeles where the average driver spends 93 hours per year delayed in traffic.

The ability of a transit system to attract ridership and address congestion is directly related to the relative attractiveness and accessibility of the system compared with other modes of transportation. Travelers are economic consumers. They generally choose a certain mode of travel that maximizes their preferences across many factors. The relative ability of PRT to address these factors, reduce congestion and increase ridership compared with other modes are discussed in the following sections.

### **Congestion and Ridership Case Studies**

To truly understand the ability of a mode to impact congestion requires a comprehensive analysis of the specific conditions of an application. Modeling and patronage studies provide insight into each application if done with care using the appropriate parameters and accurate information regarding current and future travel conditions. Many past modeling studies that have attempted to project demand for PRT systems have not accurately portrayed PRT operational and cost parameters or have made assumptions that do not favor the PRT system. Other studies have been performed that too optimistically portray PRT characteristics and costs and therefore portray PRT in a more favorable than realistic condition. Unfortunately, modeling and forecasting is an inexact process sometimes influenced by political or other considerations. The following are examples of past ridership forecasting studies, intended to model potential demand for PRT services:

- **Seattle SeaTac MIS Study:** This Major Investment Study (MIS) looked at transit alternatives to circulate airport travelers around Seattle-SeaTac airport and connect the airport to the regional rail system in SeaTac, WA. PRT was selected as the preferred local alternative. The study determined that a PRT system could reduce overall surface traffic by 9% in the study area. The study recommended the use of a franchise arrangement for the system and a public/private development process (BRW 1997)
- **Cincinnati Central Area Loop:** This study examined implementation of PRT as a downtown circulator and cross-river connector in Cincinnati, Ohio. The study projected PRT to have ridership 3-5 times higher than alternative modes providing 17-32,000 trips per day (CALIS 2001)
- **EDICT - Cardiff Wales:** This study explored the viability of implementing PRT in support of redeveloping the docklands next to the city center. It included

considerable economic modeling and traveler acceptance testing of the PRT technology. The five mile PRT network was projected to serve 5.7 million trips per year, increase transit mode share by eight percent and provide for a 348,000 person-hours/year reduction in area-wide congestion (EDICT 2004)

- **EDICT – Sweden Kungens Kurva:** This study examined PRT and other transit options to serve a large shopping area seeking to reduce congestion, improve travel time and connect with a regional rail system. It studied a PRT network with 7.5 miles of guideway and 12 stations. The system was projected to result in a 26 percent reduction in average travel time, a 300 percent increase in ridership over bus, a 17 percent increase in overall area demand due to improved transit service, and an 8 percent reduction in road traffic. Capital costs for the PRT system were projected to be 35 percent less than comparable fixed guideway modes and operating costs were projected to be 60 percent less (EDICT 2004)
- **Downtown Minneapolis:** This 2001 study examined the use of PRT to serve downtown commuting trips, intra-downtown trips and special events. The study including a sensitivity analysis of fare structures, wait times and parking access. For the study year of 2010, the downtown PRT network of 29 stations and eight guideway miles was forecasted to serve 73,400 daily trips or 8% of the total market of 895,000 daily trips. (SRF 2001)

### Environmental Comparison

PRT vehicles are expected to have very quiet operation primarily due to rubber tire on steel rails or concrete roadways. The use of electric motors also reduces the noise generated compared with automobiles, buses and trains. Average noise levels from the Cabintaxi system were measured at 60 to 65dBA with the lowest level measured at 43 dBA(UMTA 1977). As conceptually designed, PRT systems could also be expected to generate less air pollution than bus systems due to the use of all electric operation. PRT systems may potentially have lower construction impact when compared to conventional fixed guideway modes due to the use of smaller guideway structures and prefabricated components. Given its conceptually smaller guideway profile, PRT systems could result in less visual impact than comparable monorail, automated guideway or conventional elevated rail systems; however, PRT systems could be expected to have greater visual impact than surface transit systems. As such, similar to most fixed guideway transit projects, some level of citizen opposition should be anticipated.

### Energy Comparison

The energy consumed by various transportation modes is influenced by many factors, including: speed of travel, number of starts and stops, vehicle size and weight, passenger loading factors, propulsion system efficiency, and use of auxiliary power. To compare the energy consumed by a range of transportation systems, Anderson (1988) analyzed the energy use for each element of the system and combined them into a normalized factor of energy use per passenger-mile.

Figure A-26 provides the results of this analysis for Heavy Rail Transit (HR); Light Rail Transit (LR); Trolley Bus (TB); Motor Bus (MB); Van Pool (VP); Dial-a-Bus (DB); Automobile (A); Personal Rapid Transit (PR). As shown in the table, PRT systems theoretically would use less energy per passenger-mile than all other modes except van pools. This low energy use profile is primarily due to the non-stop nature of PRT service which results in low kinetic energy use from stopping and starting the vehicle.

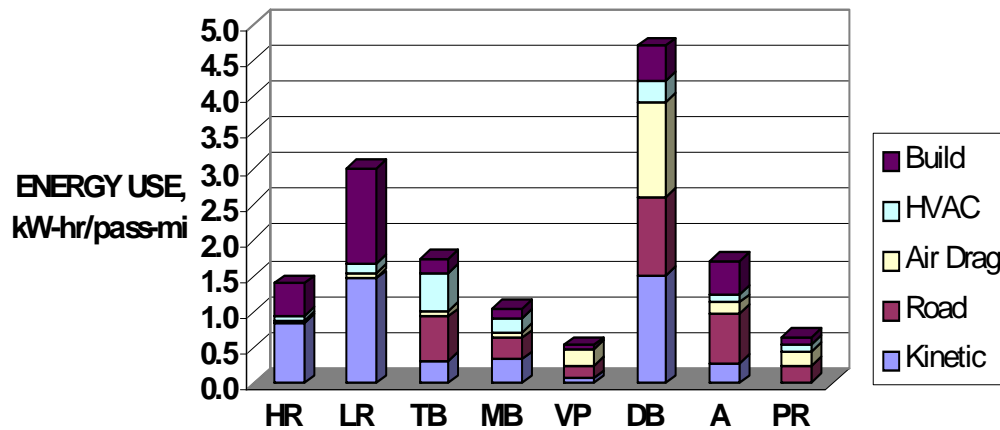

**Figure A-26 - Transportation Energy Use Comparison**  
 Source: Anderson 1998 - Note: PRT figures are engineering estimates only

With the current level of energy prices and the concern over dependence on imported foreign oil, the increased energy efficiency of PRT over the automobile and other modes makes PRT an attractive environmental, economic, political alternative.

According to Anderson (2005) an average fuel efficiency of an automobile is 20 to 30 mpg. A PRT system could theoretically achieve a fuel efficiency equivalent to 70-90 mpg. Under electric propulsion, generation could be from conventional coal, nuclear or petroleum plants or alternative sources such as solar, wind or fuel-cell technologies. .