

Guidelines for Traffic Signal Energy Back-Up Systems

SPR RESEARCH PROJECT No. C-06-08

Final Report



Prepared for:

New York State Department of Transportation

Prepared by:

Rensselaer Polytechnic Institute
Advanced Energy Conversion, LLC

Center for Infrastructure and Transportation Studies

Technical Report No: 09-05

August 2009

DISCLAIMER

This report was funded in part through grant(s) from the Federal Highway Administration, United States Department of Transportation, under the State Planning and Research Program, Section 505 of Title 23, U.S. Code. The contents of this report do not necessarily reflect the official views or policy of the United States Department of Transportation, the Federal Highway Administration or the New York State Department of Transportation. This report does not constitute a standard, specification, regulation, product endorsement, or an endorsement of manufacturers.

1. Report No. SPR#: C-06-08	2. Government Accession No.	3. Recipient's Catalog No.	
4. Title and Subtitle Guidelines for Traffic Signal Energy Back-up Systems Final Report		5. Report Date July 2009	
		6. Performing Organization Code	
7. Author(s) William A. Wallace, Jeffrey Wojtowicz, David Torrey, Nicholas Renna and Jiewei Tan		8. Performing Organization Report No.	
9. Performing Organization Name and Address Rensselaer Polytechnic Institute 110 Eighth St. Troy, NY 12180		10. Work Unit No.	
		11. Contract or Grant No. C-06-08	
12. Sponsoring Agency Name and Address NYS Department of Transportation 50 Wolf Road Albany, New York 12232		13. Type of Report and Period Covered Final Report	
		14. Sponsoring Agency Code	
15. Supplementary Notes Project funded in part with funds from the Federal Highway Administration.			
16. <i>Abstract</i> Power outages affect traffic signalized intersections, leading to potentially serious problems. Current practices of responding to power failures are very basic, ranging from 'do nothing' to installing portable generators. The purpose of this research project was to provide the NYSDOT with a better understand the practices of other agencies in dealing with dark traffic signals and to develop guidelines for instrumenting uninterrupted backup power at intersections across the state. The main goals of the project are to: (1) recommend cost effective methods for alternative power at traffic signals in NYS; (2) identify the pros and cons of each of alternative power source; and (3) develop a methodology for identifying those NYS traffic signals for installation of alternative energy power sources. The research activities consisted of the following eight tasks: <ul style="list-style-type: none"> - Task 1: Kickoff meeting - Task 2: Conduct Assessment of Alternative Energy Solutions - Task 3: Identify and Evaluate Possible Technologies - Task 4: Develop Prioritization Guidelines - Task 5: Perform a Historical Power Outage Analysis for NYS - Task 6: Develop a Specification for the Alternative Energy Sources - Task 7: Plan to Integrate the Selected Alternatives with the Existing Signal Structure - Task 8: Deployment Plan 			
17. Key Words inoperable, dark traffic signals, battery backup, uninterrupted, safety		18. Distribution Statement No Restrictions	
19. Security Classif. (of this report) Unclassified	20. Security Classif. (of this page)Unclassified	21. No. of Pages	22. Price

Form DOT F 1700.7 (8-72)

Executive Summary

The Guidelines for Traffic Signal Energy Back-Up Systems Project began in March 2007 with submission of the original response to request for proposal C-06-08 from the New York State Department of Transportation (NYSDOT). Rensselaer Polytechnic Institute (RPI) partnered with Advanced Energy Conversion, LLC (AEC) on this project that was administered by the University Transportation Research Center (UTRC).

Power outages affect traffic signalized intersections, leading to potentially serious traffic conditions. Current practices of responding to power failures are very basic, ranging from 'do nothing' to installing portable generators. The primary goal of this project was to study the effects of dark signals on traffic and provide guidelines for using alternative technologies for powering intersections when the traditional power source fails. Additional goals were to provide an evaluation of the state of the practice of employing alternative sources of power for intersections and to provide a plan to integrate alternative power sources with the existing signal structure. Due to the different geographic areas of New York, it was necessary to understand the existing needs for alternative power sources for traffic signals across the entire state.

Contract award and administration were completed in July 2007 with an expected start date of November 2007. Research and planning functions for the project were conducted from May 2007 to February 2009. The team began by doing a state of the practice review of transportation agencies use of uninterrupted power supplies (UPS). The team then created intersection prioritization guidelines and a plan for integrating UPS's with the existing signal system found across New York. This final report is the culmination of the project-related work.

A brief summary of the research that was completed is listed below. Each specific task report is included as a separate chapter in this final report.

Approach and Methodology

Tasks 1 through 3 and 5 involved the collection of information necessary to understand the types of technology available and the needs for the state of New York both in terms of safety and efficiency. A summary of each task is provided below in chronological order.

Task 1: Kickoff Meeting

This task occurred in April 2007. To fully understand the direction of this project a kickoff meeting was required. The team met with the appropriate members of NYSDOT and the FHWA to learn the pertinent background information on the project. This meeting outlined the direction for the project and gave the team members an opportunity to exchange information relating to the issue of dark traffic signals.

Task 2: Conduct Assessment of Alternative Energy Solutions and Task 3: Identify and Evaluate Possible Technologies

A state-of-the-practice assessment was completed to determine what technologies are available and how they are being used to resolve the issue of dark traffic signals. A combination of literature and web searches, and phone calls were conducted to find this information. One conclusion was that few agencies deal with this issue. However, there have been very proactive agencies; e.g. California DOT (CalTrans), the British Columbia Ministry of Transportation, the City of Scottsdale, Arizona, Howard County, Maryland, the City of Suffolk, Virginia and the City of Overland Park, Kansas. These are the agencies that are being more proactive in terms of deploying alternative energy sources to minimize dark signals within their jurisdiction. The most prevalent technology that is deployed is battery backup systems (BBS); however other technologies such as auto-start natural gas generators, solar power and fuel cells have begun to emerge.

Site visits to NYSDOT's three backup power sources were also conducted as part of Task 3. These visits allowed the team to understand the criteria that warranted an installation of a backup system. These visits also allowed the team to understand the different characteristics of the intersections found across New York State and the ability to use different technologies at each of these sites. The results of both Task 2 and 3 aided the completion of Tasks 4, 6, 7 and 8. Task reports were completed for each of these tasks and were led by RPI and supported by AEC.

Task 5: Historical Power Outage Analysis

This task provided a historical perspective on power outages across New York State. The team was able to obtain aggregate historical outage data from the NYS Public Service Commission (PSC). This data provided an understanding how the various regions of the state compare with respect to power outages. It was discovered the NYS PSC also reports on the performance of the major utility companies each year. Each of the utility companies should continue to improve their system equipment and continue with their tree trimming programs to ensure that power outages across the state are minimized. During the summer months is typically when the largest number of outages occur across NYS; the utility companies should investigate ways to reduce these outages.

The team compiled this data into a geographical information system (GIS) database to create maps showing the various results. The report made use of the GIS plots to identify areas in NYS that have historically had poor performance in terms of power outages.

This task commenced in November 2007 when the team began soliciting the data. The task was completed by RPI in June of 2009.

Findings and Conclusions

Task 4: Prioritization Guidelines for Installation at Intersections

This task was started in December 2007 and completed in June 2009 with the submission a technical report. The task was conducted by RPI with assistance from AEC and NYSDOT. The task's purpose was to develop prioritization guidelines for intersections to be instrumented with backup power sources.

The team analyzed accident records across NYS for a five year period between 2003 and 2007 to determine if there were any trends in accidents at dark traffic signals. This analysis was included as part of the task report. The accident records were integrated with the historical power outage report data that was compiled as part of Task 5. With this data combined a correlation between power outage data and the accident locations was evident. The analysis provided graphs that showed a correlation between areas with higher power outage rates and the number of dark signal related accidents. The data also indicated that most of the dark signal related accidents in NYS occurred during the summer months; this also agrees with the findings from the Task 5 report that most of the power outages occur during the summer months. Some of the other findings from the dark signal related accidents include the following:

- 41% of the dark signal related accidents occurred at intersections with 4 to 6 total lanes;
- In 2004, 2005 and 2006 Region 11 had the most dark signal related accident across the state but in 2006 Region 5 had almost the same number. In 2003 Region 10 had the most and in 2007 Region's 1 and 8 had the most. Region's 2, 6, 7 and 9 had reported the least during the five year period;
- Historically July and August have the most dark signal related accidents, approximately double of most other months;
- Injuries at dark signal accidents are nearly twice as likely as non-injury accidents;
- There does not appear to be any relationship between time of day and when dark signal accidents occur;
- 77.7% of all reported dark signal related accidents were right angle collisions and 11.2% were rear-end collisions;
- 47% of the dark signal accidents occurred at intersections with turn bays. For all types of accidents across NYS the average is only 29%, this indicates that intersections with turn bays are more dangerous when the power is out; and

- It is more likely that injury accidents at dark signals will occur between the hours of 2:00 PM and 5:00 PM based on the data from 2003 to 2007. There is also a 31.3% chance that no injuries will be reported while 40.7% will have one injury.

Based on the historical data the team analyzed, plus with meetings with NYSDOT officials, a scoring system was created that is applicable across NYS. The scoring criterion was designed to be simple yet take into account the most important factors found at intersections across NYS. Figure 15 presents the proposed prioritization scoring sheet. It has been designed to apply various weighting values depending on the different factors. As intersections become outfitted with BBS it is anticipated that the scoring criteria will be modified. The scoring could be performed on a case by case basis or it could be automated for larger subsets of intersections. To score all of the nearly 6000 NYSDOT operated intersections in New York, it would be desirable to ensure all of the data is readily available in a common format and automate the scoring process. The Task 4 report defines in more detail the various input parameters used in the spreadsheet.

Prioritization Factor	Input Value	Weighting Factor	Total
Priority Intersection Location: How many times in the last three years does the intersection get rated on the NYSDOT 'priority intersection' list (# occurrences in last 3 years)		15	0
MUTCD Warrant: Does intersection meet MUTCD warrant #7 (crash experience) (Y/N)		15	0
Power Outage History: Using historical power outage data how does the site score above the statewide normalized mean (for at least the last 3 years) (<= mean=" 0 "; up to 75% higher than the mean=" 1 ", 75% or above the mean=" 2 ")		10	0
Proximity to Grade Crossing: Is intersection within less than 75' from a grade crossing (enter " 1 "), is intersection between 75' and 200' from grade crossing (enter " 2 ")		10	0
Speed: Is the posted speed of any approaching lane greater than 40 MPH OR part of a freeway exit ramp (Y/N)		10	0
Volume at Intersection: AADT of all approach lanes combined (nearest 5000)		5	0
Evacuation Route: Is this intersection part of an evacuation route (Y/N)		5	0
Truck Route: Is this intersection part of a designated truck route (Y/N)		5	0
Left turn bays present: (Y/N)		5	0
If turn bays are present are any multilane? (Y/N)		5	0
Proximity to other signalized intersections: Is this intersection within 2 miles of another traffic signal? (Y/N)		5	0
Total Score:			0

Figure 1 Proposed prioritization scoring sheet

Ultimately the score of an intersection is a rating that identifies intersections that would likely be more unsafe than others during power outages. Without installing backup systems at each and every intersection there is no way to eliminate all dark signal related accidents. However, the goal is to substantially reduce the number of dark signal related crashes and reduce the number of injuries. When the methodology is followed engineering judgment by regional DOT officials should also be used when choosing intersections to be outfitted with backup power systems. The reason is that the engineers within each of the NYSDOT Regions are more likely to

be aware of the performance of many of the intersections within the region, especially the ones that are rated with a higher score.

Task 6: Develop a Specification for the Alternative Energy Sources

This report summarized an investigation on the methods available to keep signals operating at traffic intersections during utility power interruptions. Present and future technologies for energy storage and power generation were reviewed. The report provided the data for the Task 7 report that presents short- and long-term implementation plans for outfitting traffic signals with backup power.

The Task 6 report includes an analysis of the power requirements that are necessary to operate the traffic signal lights, associated sensors and electronics of a typical traffic intersection. Alternative methods of power to keep the intersection operating when the utility power is interrupted were examined. This established the minimum requirements for a complete battery backup system for use with Light Emitting Diode (LED) traffic signal systems in NYS.

A technical report was completed for this task and was prepared by AEC and reviewed by RPI. This task began in the spring of 2008 and the technical report was submitted in November 2008.

Task 7: Plan to Integrate the Selected Alternatives with the Existing Signal Structure

This task began in the spring of 2008 and concluded in November 2008 with the submission of the technical report. The work was led by AEC and supported by RPI. This report builds on the report for Task 6. This report addresses practical implementation of energy storage to keep traffic signals operating during power failures of up to four hours in duration.

The report provides two approaches to integrate alternative power sources with the existing signal structure. The first approach is appropriate for existing traffic signal systems, representing an approach based on adding energy storage while changing as little equipment in the system as possible. The second is appropriate for new traffic signal systems. It represents an opportunity to save energy, space, weight while improving reliability. It accomplishes this by eliminating a number of conversions between AC and DC that are really unnecessary.

A technical report was completed for this task and was prepared by AEC and reviewed by RPI. This task began in the spring of 2008 and the technical report was submitted in November 2008.

Task 8: Develop a Deployment Plan

Task 8 was started in May 2009. This task was conducted by both RPI and AEC. The task documented a plan for deployment of backup power systems throughout NYS. The report assumed that it is not feasible in the short term to install backup systems at every NYSDOT operated signal. However it is desirable to deploy them at critical intersections in a timely manner. The deployment should make use of the guidelines specified in the Task 4 report. The report also noted that when new signalized intersections are constructed or rehabilitated they should be outfitted with backup power systems.

Table of Contents

TASK 1: Kick-off meeting

1.1	PURPOSE.....	1
------------	---------------------	----------

TASK 2: Assessment of Alternative Energy Solutions

2.1	INTRODUCTION.....	2
2.2	STATE OF THE PRACTICE.....	2
2.2.1	Do-Nothing Approach	3
2.2.2	Police Controlled or Folding Stop Signs	3
2.2.3	Portable Power Supplies.....	5
2.2.4	Uninterruptible Power Supplies	6
2.2.4.1	Battery Backup Systems.....	6
2.2.4.2	Solar Power.....	10
2.2.4.3	Automatic Generator.....	11
2.2.4.4	Fuel Cells.....	13
2.3	CONCLUSIONS.....	14
2.4	REFERENCES.....	14

TASK 3: Identify and Evaluate Possible Technologies

3.1	INTRODUCTION.....	18
3.2	BACKUP SYSTEMS DEPLOYED BY THE NEW YORK STATE DEPARTMENT OF TRANSPORTATION.....	18
3.2.1	NYS DOT Region 1 Deployment.....	19
3.2.2	NYS DOT Region 3 Deployment.....	20

3.3	EVALUATION OF EXISTING UNINTERRUPTIBLE POWER SUPPLY TECHNOLOGIES.....	22
3.3.1	Battery Backup Systems.....	22
3.3.1.1	Types of Batteries	23
3.3.2	Solar Power	26
3.3.3	Automatic Generators	26
3.3.3.1	Natural gas internal combustion engine with generator.....	26
3.3.3.2	Gasoline internal combustion engine with generator	27
3.3.3.3	Compressed air motor with generator	27
3.3.4	Fuel Cells	27
3.4	FUTURE TECHNOLOGIES.....	28
3.4.1	Ultracapacitors	28
3.4.2	Pseudocapacitor	29
3.4.3	Dedicated Standby Power Line.....	29
3.5	CONCLUSIONS.....	29
3.6	REFERENCES	31

TASK 4: Prioritization Guidelines for Installation at Intersections

4.1	INTRODUCTION.....	33
4.2	REVIEW OF CURRENT PRACTICES FOR INSTALLING BACKUP SYSTEMS AT INTERSECTIONS	33
4.3	ANALYSIS OF ACCIDENTS AT DARK SIGNALS IN NEW YORK	37
4.3.1	Data Entry Process.....	37
4.3.2	Results of Dark Signal Accident Analysis.....	38
4.3.2.1	Summary statistics	42
4.3.2.2	Regional Events.....	43
4.3.2.3	Locations with multiple dark signal related accidents.....	44

4.4	PRIORITIZATION GUIDELINES	46
4.4.1	Scoring Criteria	47
4.4.1.1	Priority intersection locations.....	48
4.4.1.2	MUTCD intersection 'warrant #7'	50
4.4.1.3	Power outage history.....	51
4.4.1.4	Intersection proximity to grade crossings	52
4.4.1.5	Speed approaching the intersection.....	53
4.4.1.6	Vehicular volume through the intersection.....	53
4.4.1.7	Designated evacuation route.....	54
4.4.1.8	Designated truck route	54
4.4.1.9	Presence of left turn bays	54
4.4.1.10	Proximity of intersection to other intersections.....	55
4.4.2	Prioritization Summary	55
4.5	CONCLUSIONS	55
4.6	REFERENCES	56

TASK 5: Historical Power Outage Analysis

5.1	INTRODUCTION	58
5.2	HISTORICAL POWER OUTAGE DATA	58
5.3	DATA ANALYSIS.....	60
5.3.1	Frequency & Duration Analysis	63
5.3.2	Power Interruption Analysis	65
5.3.3	2007 Recommendations from PCS	67
5.4	CONCLUSIONS.....	68
5.5	REFERENCES	68

TASK 6: Alternative Energy Sources

6.1	INTRODUCTION.....	70
6.2	ANALYSIS OF A TYPICAL TRAFFIC INTERSECTION	70
6.2.1	Requirements.....	73
6.2.2	Plan for Integrating Selected Alternatives with Existing Signal Structure.....	74
6.2.3	Alternative Power Sources for Backup/Standby Power	74
6.2.3.1	Batteries.....	74
6.2.3.2	Fuel Cells.....	78
6.2.3.3	Ultracapacitors.....	78
6.2.3.4	Pseudocapacitor	79
6.2.3.5	Gasoline internal combustion engine with generator	79
6.2.3.6	Natural gas internal combustion engine with generator.....	79
6.2.3.7	Compressed air motor with generator	79
6.2.3.8	Dedicated Standby Power Line	79
6.3	SUMMARY	81

TASK 7: Integration of Energy Storage into Traffic Signals

7.1	INTRODUCTION.....	82
7.2	INTEGRATION OF ENERGY STORAGE INTO TRAFFIC SIGNALS.....	82
7.2.1	Approach for Retrofit Into Existing Signal Systems	82
7.2.2	Approach for New Installations.....	84
7.3	SUMMARY	85

TASK 8: Deployment Plan

8.1	INTRODUCTION.....	86
8.2	DEPLOYMENT PLAN	86

8.2.1	Existing Signalized Intersections.....	86
8.2.2	New or Retrofit Signalized Intersections.....	87
8.3	DEPLOYMENT OPTIONS.....	87
8.4	FUTURE STEPS	88
8.5	CONCLUSIONS AND SUMMARY.....	89

Appendices

TASK 1: KICK-OFF MEETING

Appendix 1-A: Kick-off Meeting Minutes

TASK 2: ASSESSMENT OF ALTERNATIVE ENERGY SOLUTIONS

Appendix 2-A: Florida Generator Guidelines

Appendix 2-B: California Specification for BBS

Appendix 2-C: Illinois UPS Standards

Appendix 2-D: California Energy Commission Battery Backup Report

Appendix 2-E: British Columbia Specification for BBS

Appendix 2-F: British Columbia Memo for Deploying BBS

TASK 4: PRIORITIZATION GUIDELINES FOR INSTALLATION AT INTERSECTIONS

Appendix 4-A: Key for interpreting form MV-104a

Appendix 4-B: MS Excel table with all dark signal related accident records

Appendix 4-C: Dark signal accident location plots along with historical power outage data (2003 – 2006) (for NYSDOT regions)

Appendix 4-D: Dark signal accident location plots along with historical power outage data (2003 – 2006) (shown by power company boundaries)

Appendix 4-E: Dark signal related accidents summary tables and figures.

Appendix 4-F: Microsoft Excel file with prioritization guidelines

TASK 5: HISTORICAL POWER OUTAGE ANALYSIS

Appendix 5-A: Historical power outage data in MS Excel

Appendix 5-B: 2001 NYS PSC interruption report

Appendix 5-C: 2002 NYS PSC interruption report

Appendix 5-D: 2003 NYS PSC interruption report

Appendix 5-E: 2004 NYS PSC interruption report

Appendix 5-F: 2005 NYS PSC interruption report

Appendix 5-G: 2006 NYS PSC interruption report

Appendix 5-H: 2007 NYS PSC interruption report

Appendix 5-I: GIS plots containing CAIDI and SAIFI data 2003 and 2006

Appendix 5-J: GIS plots containing length of time of power outage over total customers served between 2003 and 2006

Appendix 5-K: GIS plots containing length of time of power outage over total customers served between 2003 and 2006 shown for NYSDOT Regions

Appendix 5-L: Data for utility company subareas in NYS that have performed worse than the statewide average in terms of event power outage hours

Appendix 5-M: GIS plots containing power interruption data between 2003 and 2006 for the utility company subareas

Appendix 5-N: GIS plots containing power interruption data between 2003 and 2006 for the NYSDOT Regional boundaries

TASK 6: ALTERNATIVE ENERGY SOURCES

Appendix 6-A: Proposed specifications for battery back-up systems for traffic signals utilizing light emitting diodes (LED) traffic signal systems

TASK 1: Kick-off meeting

1.1 Purpose

To fully understand the direction of this project a kickoff meeting was required, this occurred in April 2007. The team met with the appropriate members of NYSDOT and the FHWA to learn the pertinent background information on the project. This meeting outlined the direction for the project and gave the team members a chance to exchange information relating to the issue of dark traffic signals. The minutes of this meeting can be found in Appendix 1-A.

TASK 2: Assessment of Alternative Energy Solutions

2.1 Introduction

During power outages signalized intersections typically lose all functionality. Whether the outage is a few seconds or an extended period of time, safety at the intersection is compromised. Many motorists do not know who has the right of way when approaching a dark signal. Typically, two actions take place: motorists on the ‘main’ road assume they have the right of way and do not stop, or motorists will treat the dark signal as an all way stop. In both cases safety is compromised because motorists have different views on how the intersection should operate. In addition to safety, the efficiency of the intersection can quickly degrade.

Current practices of operating these intersections are somewhat primitive, ranging from ‘do nothing’ to installing portable generators. As stated in the RFP during the years 2003 and 2004, 80 – 90% of dark signal accidents resulted in injuries compared to 33% for the average New York State accident.

These safety and efficiency issues can be combated by using alternative energy technologies at intersections. This chapter briefly describes some of the alternative energy solutions available and a state of the practice assessment from various agencies deploying these technologies. Section 2.2 describes the state of the practice for dealing with inoperable traffic signals; and Section 2.3 has some concluding remarks. There are also supporting appendices.

2.2 State of the Practice

Currently there are few standards and policies for controlling signalized intersections that have lost power. In many cases there is a ‘do-nothing’ approach. In other cases the agency in charge may decide to use some form of intervention and in a more select set of cases some agencies are installing in certain intersections automatic power backup systems or uninterruptible power supplies (UPS). The following sections describe existing practices for operating dark traffic signals; this data was gathered from internet searches, publications and phone calls.

Recognizing the difficulty in documenting the practices of each state and local transportation agencies the following represent an illustrative sample of the current state of the practice throughout the world.

In 1998 a report, “Dark Signals, A Report on Laws Concerning Dark, Malfunctioning or Inoperative Traffic Signals” was conducted by the Minnesota DOT (1). The purpose of the report was to present the results of a survey that was sent to all 50 State DOT’s to determine

their practices for dark traffic signals. At the time of the survey (1994) only two of the nine responding states had installed uninterruptible power supplies (UPS). The remaining states who answered the survey said that it was too costly to build a system that would power their intersections. In several cases a backup system was installed at critical intersections, such as a grade crossing with preemption in MN (1).

2.2.1 Do-Nothing Approach

In many cases when the power is lost at a traffic signal there is no alternative control mechanism in place to ensure safety and efficiency. This is the norm because in many cases authorities that can take action may not know the power at an intersection is out or by the time the proper resources are notified to respond, the power may have been restored. During longer outages the agencies may decide to send resources to certain intersections to help maintain traffic flow but since resources are limited there will be intersections operating with no control.

The major safety problem is that motorists may approach a dark intersection and not be aware of the conflicting traffic. This could result in serious injury or death. Also, in many cases when a vehicle is stopped at a dark intersection they are often confused because they often do not know who has the right of way.

2.2.2 Police Controlled or Folding Stop Signs

Another solution is to install temporary stop signs or deploy police officers to direct traffic. Since most power outages are unknown in advance the intersections that are controlled via these means are often uncontrolled until the proper resources respond to the intersection.

Temporary or fold-up stop signs may be used at intersections without power. This may be slightly safer than doing nothing but it is labor intensive. Figure 2 shows an example of a fold-up stop sign being used during a power outage. The USDOT Manual on Uniform Traffic Control Devices (MUTCD) specifies rules for using a foldable stop sign as follows (2):

The following three requirements govern the use of folding STOP signs for traffic signal power outages:

- 1. If State traffic laws require a motorist to always stop at a traffic signal that has a power outage, then a folding STOP sign is appropriate for use (see MUTCD Section*



Figure 2 Fold-up stop sign

2B.04).

2. *If the signal indication for an approach is a flashing red at all times, then a folding STOP sign is appropriate for use (see MUTCD Section 4D.01).*
3. *A folding STOP sign is appropriate for use at a minor street or driveway that is located within or adjacent to the area controlled by a traffic signal during a power outage.*

The State highway department should develop and adopt a policy for the use of folding STOP signs for traffic signal power outages. The policy should ensure that a STOP sign is not displayed at the same time as any signal indication is displayed other than a flashing red. If the State highway department cannot ensure that the traffic signal will be in red flashing mode upon restoration of power, then folding STOP signs shall not be used.

The State highway department policy should also include as a minimum the following:

1. *Explicit procedures for emergency responders to set the signal in the signal cabinet police door to flashing mode before unfolding the STOP signs. The signal shall be visible to traffic on all approaches and all of these approaches will flash red upon restoration of power.*
2. *Upon restoration of power, the emergency responder shall refold the STOP signs so that the legend is not visible to approaching traffic and then to restore signal operation in accordance with the procedures set forth in Section 4D.12 for transition from flashing mode to steady mode.*

Once the power is restored it is necessary to remove all of the signs before motorists become confused. A memo from the Michigan Department of Transportation urges caution when using temporary stop signs, as they must be closely monitored to ensure they do not face the wrong side of an approach and they are immediately removed upon restoration of power (3).

In some cases police officers are used at dark intersections to improve the efficiency. This is still unsafe as there is a person standing in the middle of the intersection trying to direct multiple lanes of traffic.



Figure 3 Police controlled intersection

For instance in Figure 3 the police officer in the photo directing traffic is in charge of more than eight lanes of traffic including several turn bays. Often times the police officer is difficult to see as there might be vehicles blocking the view.

2.2.3 Portable Power Supplies

Fuel-powered generators are another way to supply power to a signalized intersection in the event of a power outage. The advantages to this option are that the power supplies can be stronger (for non-LED intersections) and can last a longer amount of time, and that the fuel can be easily replenished. Generators may either operate automatically upon a loss of utility power or be turned on manually, depending on the model and system being used. Automatic systems may thus be classified as an uninterruptible power supply and are discussed in Section 2.2.4.3. Portable gasoline or diesel generators are typically used by many agencies to power larger intersections when the power outage duration is going to be relatively long. These generators require a trained person to bring them to the site and install before operations can commence. Also, these generators are usually in short supply and, therefore, for wide-spread power outages only a few intersections can be powered.

Generators also require maintenance, with regular checks of fuel, oil, and coolant. It is also necessary to coordinate where the generators will be deployed and stored. Portable

generators also have environmental impacts associated with them such as noise and exhaust emissions that must be considered. When deployed these devices must also be properly secured to the site due to prevent theft.

In March of 2007, the Washington D.C. Department of Transportation received \$3 million in Homeland Security grant funds to purchase generators for key intersections along an evacuation route. It is reported that with these generators the evacuation routes may be functional within 90 minutes after losing power, which may or may not be sufficient with the accumulated traffic at that point in a crisis (4). Though state specifications for automatic generators are limited, Florida has available guidelines on the use of traditional switch-on generators – see Appendix 2-A (5).

2.2.4 Uninterruptible Power Supplies

An uninterruptible power supply (UPS) is a device that will provide continuous power even when the utility power fails. This section discusses the various technologies that are available as UPS systems and highlights some of the agencies who are making use of the technologies. In a 2000 press release it was noted that backup systems in California significantly improve the safety of an intersection, “according to Caltrans' research that began in 1993, traffic accidents have been reduced by 90% in certain high-risk intersections due to battery back-ups” (6).

2.2.4.1 Battery Backup Systems

A battery backup system, or BBS, is an addition to the circuitry of a signalized intersection that will allow it to run on battery power in the event of a power outage. Most of the current reported BBS systems include batteries that are charged by utility power and expel their electricity when a power outage occurs. The switch from utility power to battery power typically occurs within milliseconds without a noticeable stutter in signal operations. Hence the term UPS, is often used interchangeably with BBS, although the former may also apply to other forms of non-grid power. Charging of the battery commences upon restoration of utility power. Battery backup systems may provide full-operation, flash-operation, or a combination of both depending on the power requirements. In full-operation, the power is supplied such that the traffic lights can continue operating in their normal phasing modes. In flash-operation, the approaches may either flash red or yellow, depending on the conditions. Flash-operation uses less electricity than full-operation and hence can run for longer periods of time under the same power supply. Some systems provide both operations, when the grid power initially fails the signal is operated under full operation for a period up to several hours, once that threshold is met and the grid power is still out, the BBS switches to flash mode to conserve battery power.

To use a BBS efficiently, the lights in the traffic signal should be converted to light emitting diodes (LEDs). LEDs can typically run at up to 85% less power than the standard incandescent

lamps used in the majority of intersections across the country (7). Many states have already stated that the use of LEDs is imperative for a feasible implementation of UPS systems. In California, power standards have made LEDs the only available option for UPS systems (8). In addition to the power savings, LEDs are capable of greater brightness, which is an advantage in foggy or darkened conditions (7). LEDs are also advantageous due to their longer life span of about 10 years, compared to one year for incandescent lights (9).

A study conducted by the University of Illinois in 2001 surveyed 36 states and found that among the seven states using UPS systems, the most common vendors for BBS's were Clary; Online Power; APC; Lite Saver; UTCS; Airpax Dimensions Unlimited; and Electro-Tech (10). However, of all these states California was the only one at that time to have written guidelines on the use of UPS; Appendix 2-B contains these guidelines (11). In California, the only vendors with pre-approved models for use were US Traffic Corporation; Alpha Technologies, Inc.; Airpax Dimensions Unlimited, Inc.; and Myers Power Products, now called Quixote Traffic Corporation (12). In New York State, there are at least two suppliers for the few locations with battery backup systems: SignalSense / Sense Products and Myers Power Products (now Quixote); more information on these systems will be presented in the Task 3 report (13).

Another study conducted by the University of Illinois in 2005 reported the performance of some of the more popular "name-brand" models of UPS systems. The models came from Myers/Quixote, TechPower, and Dimensions. The tests administered focused on electric grid compatibility and checks to see if the power supply were up to Illinois Department of Transportation state standards. However, the study also tested for Illinois' requirement that the functioning of a BBS under battery power alone must last at least two hours at 700 W, and the requirement that the time required for the battery to fully recharge on utility power be less than twenty hours. It also mentioned that systems such as these in Illinois should have features such as a temperature sensor for the battery, an automatic charge switch based on temperature, and alert functions for when battery power reaches a critical level, which were problematic for some of the models (14). The majority of the state requirements were met in the tests., The Illinois specifications are listed in Appendix 2-C.

Currently, the major shortcomings and reported complaints about battery backup systems include the limitations on battery capacity/life, sensitivity to temperature, and the high initial capital cost. Nearly all municipalities using these systems stated that although a UPS system would be desirable in every signalized intersection, the cost was a limiting factor (10). In a memo from the City of Lodi, California in 2001, it was reported that the average price of a full-operation UPS unit was \$3250 with replacement batteries costing \$635. For flash-only operating UPS units, the price is \$1300 and \$240 for replacement batteries (15).

As mentioned above, the greatest hurdle municipalities are facing in the development of battery backup systems is the deployment cost. A report issued by the California Energy Commission noted that between April 2002 and April 2004, BBS costs dropped by 22%. The report attributed some of this decrease in the fact that gel cell batteries were becoming a more readily available alternative to the traditional lead-acid batteries in battery backup systems. Using lead-acid batteries typically meant the need to purchase a separate controller cabinet for the BBS due to ventilation concerns for the fumes and corrosive acids that could damage parts of the main circuitry in the original controller cabinet. Gel cells do not have these problems, and thus many purchasers were able to avoid buying a second cabinet, which are typically around \$700. It was also noted that price decreases were the result of more and more government agencies purchasing the equipment, which allowed the manufacturers to sell wholesale for lower rates (8). To offset the retrofitting costs locations such as British Columbia, Canada and the State of Virginia are requiring that all new intersections come with battery backup systems to avoid a costly addition (16, 17). Overall, the trend is that battery backup systems are steadily becoming more affordable. The following subsections outline more specifically how other agencies and states are dealing with the issue of dark traffic signals.

2.2.4.1.1 California

Even with prices dropping, many municipalities will need financial aid to upgrade their current intersections with UPS. In California, \$8.5 million in matching grants was set aside in 2002 to subsidize the purchase of BBSs in LED-lighted intersections in towns and cities across the state. The intersections that were chosen could receive up to 70% of the cost for an upgrade. The California Energy Commission accepted applications from cities and counties desiring upgrades and formed a committee of representatives from city and county governments, local utilities and the California Department of Transportation (CalTrans). This committee reviewed the applicant intersections on a point system based on a set of criteria including traffic volume, frequency of injury accidents, proximity to a school zone, speed of approach traffic, and availability of pedestrian pre-emption controls. The greater the number of points, the higher priority an intersection has with regards to being chosen as a candidate for the upgrade subsidy. From the 2002 solicitation grant funds were provided for over 4,500 BBS sites throughout California. Appendix 2-D contains details containing California's rating system in their BBS subsidy program and a listing of which agencies received funding as part of this project (4). It is highly recommended that intersections be prioritized based on their need for a UPS and implement the technology first in the areas of greatest need (10). As such, many states have adopted California's unique point system to rank intersections (13).

Joseph Van Hecke from the California Department of General Services informed us that the various agencies in California are currently working on a new solicitation for more battery

backup systems within California. Since the solicitation is not finalized there is currently no further information available (18).

2.2.4.1.2 Maryland

In Maryland the Howard County Department of Public Works deployed BBS at all 84 county signalized intersections. These sites were completed in early 2008 and were all installed by the Howard County signal shop which consisted of two employees. Howard County also participated with the MD State Highway Administration (SHA) in a cost sharing project to install the BBS at 20 state locations which were considered to be priority intersections (19, 20).

Prior to installing all of the BBS the County tested and compared five different systems. Of the five systems, the Alpha Novus system was chosen. The systems have been designed to power the intersections for approximately 8-10 hours. Overall their experience with the systems has been very good. There were a few minor firmware issues but they were quickly resolved. Between January 1, 2008 and mid September 2008 there were over 120 times when one of the BBS's was active for more than 15 minutes. The systems also have notification alarms that are sent periodically when the system is running on backup power to let the appropriate staff know if a backup generator should be deployed in the event an outage is going to last longer than the life of the batteries (19).

2.2.4.1.3 Scottsdale, Arizona

The City of Scottsdale, AZ wanted to improve the efficiency of signalized intersections and prevent dark signals during blackouts and brownouts. BBS systems were selected and deployed starting approximately in 2000. The City tested several systems before full deployment and decided to use two systems, the Tesco and the Myers Powerback systems. The systems were designed to power an intersection fully for two hours then switch to flash mode when the batteries started to drain (21).

Currently Scottsdale has 30 of their largest intersections outfitted with BBS. When they deployed their BBS the criteria was to use the systems where two major arterials intersected and intersections near vital facilities such as hospitals, airports, city buildings, police and fire stations (22). The 30 intersections represent approximately 10% of all of the city's traffic signals.

When the City was asked about their experience with the systems to date they stated that regular maintenance needs to be adhered to, or the batteries will fail and the batteries do not last long in the summer heat. They also stated that it is important to research each brand carefully as some are more reliable than others (21).

2.2.4.1.4 British Columbia, Canada

The Ministry of Transportation and Infrastructure in the Canadian province of British Columbia has produced specifications and deployment criteria for BBS systems (23, 17 & 24). Their specifications can be found in Appendix 2-E and a memo outlining the deployment criteria can be found in Appendix 2-F.

There are approximately 200 uninterruptible power supplies throughout British Columbia. Most of the sites use the Alpha Novus FXM 1100 BBS. The system is supposed to provide between 4-8 hours of operation at a particular site depending on the load. To date the systems have been performing as expected. The systems are setup to run in full operation until a certain battery threshold is met, at that time it will switch to flash operation.

The deployment evaluation criteria as stated in the memo in Appendix 2-F states,

Effective immediately;

1.) Existing traffic signals will be prioritized by Regional Traffic Engineers and traffic signal UPS installed on a Provincial priority basis subject to the availability of funding.

2.) UPS shall be added to all new traffic signal and railway interconnected traffic control and warning device specifications (25).

The scaling criteria gives a higher priority to sites in close proximity to rail, bridges, emergency facilities, abnormal geometry at the intersection, power reliability and the accident rates at a particular intersection (26).

2.2.4.2 Solar Power

There are a limited number of municipalities around the world that are trying to implement solar power at signalized intersection to prevent dark signal occurrences, reduce strain on the electric power grid and save money in utility costs. There are extremely few vendors that have traffic light systems designed to be supply by solar systems, rather most solar systems are geared towards warning lights for signs. The solar system includes a battery for sustained operation in the absence of adequate solar power.

In the Gujarat province of India, for instance, the Energy Development Agency has technical specifications for solar powered LED traffic signals that may be used. They may run at least 14 hours at full operating capacity and 10 hours on flashing mode, either on automatic or manual operation. The solar system can interact with the utility grid to power the traffic signals. The solar battery alone can operate the system fully for 10 hours in the event of a simultaneous grid and solar panel failure (27).

In South Africa, the major electricity supplier Eskom sponsored a project to install the first solar-powered traffic light in the country in 2007. According to the news brief, the system can be used for three consecutive days in cloudy weather and the battery can store power for continuous night use. The project was designed partly as an experiment to see how well similar systems can run without utility power (28). After a month of operation, the project was recognized as a great success and there were many requests for solar intersections throughout the country. The National Energy Efficiency Agency thus put in a proposal to the government for the money required to install a total of 2000 more solar powered intersections throughout 20 major metropolitan areas (29). These cases illustrate that the future of solar powered systems in roadways is promising, but at present it is still in its early stages of implementation, due to limitations of cost and physical size.

There was no cost information available on these systems.

2.2.4.3 Automatic Generator

As described in Section 2.2.3 portable generators are currently used during long duration events at key intersections. This section outlines the auto-start generator technology that could be deployed to provide uninterrupted power at intersections.

Unlike the portable generator this system would require a freestanding generator to be positioned in close proximity to the intersection. The fuel for these systems is normally compressed natural gas (CNG) (when available) but some systems can run on diesel. The CNG systems are truly freestanding as the fuel source provides for indefinite run times. This is as long as there is CNG at the site and the supply is not shut off for some reason, but if there is a power outage the gas flow should still be available.

GotPower Inc. offers the GP2000, which is a semi-automatic system that is rated at 6 kW and can resume normal signal operations within seven seconds after a power loss. It can function anywhere between 25 and 40 hours on a tank of fuel, depending on the load at the intersection. Although this system powers the system within a short period of time the diesel fuel supply needs to be monitored and replenished when needed. This system is also much louder than the properly functioning intersection, roughly 65 dB at 23 feet away (30). The capacity of the generator is also substantially larger than necessary to support a single intersection that uses LEDs. This will potentially create fuel efficiency issues and, particularly in the case of diesel, maintenance issues.

2.2.4.3.1 Suffolk, Virginia

In light of Hurricane Isabel in 2003 the City of Suffolk, VA decided to investigate backup power alternatives for their signalized intersections. Suffolk serves as a main evacuation route for the Hampton Roads area. The city engineers decided that if a hurricane were to strike it would

likely knock power out for more than 10 hours, which is longer than most BBS systems can function.

The City worked with The Alpha Group to modify an existing BBS. The purpose was to create a system that could power an intersection without ever dropping service and function as long as needed. A system in which a BBS would operate for approximately five minutes and then automatically transfer to a CNG was built. The reason a BBS was used was to ensure a seamless transfer of power as there was no 'auto-start' generators on the market. If the BBS were operational for more than five minutes the system would then turn on the natural gas generator. The reason five minutes was chosen was that roughly 90% of the cities outages were less than five minutes. When the generator assumes power it charges the BBS which in turns powers the intersection. The reason for this is to ensure that clean power is constantly transferred to the system. To date the city has deployed nine sites with this technology and plans on installing more each time there is a new signal or an existing signal is modified. The total cost for such a system is estimated to be \$22,500 which includes the equipment and installation (31).

2.2.4.3.2 Overland Park, Kansas

The City of Overland Park, Kansas has been outfitting their signalized intersections with a combination of BBS and BBS with CNG. This was prompted by a 2002 ice storm in which approximately 70 traffic signals lost power and the city estimates 15 accidents occurred as a result (32) The City currently has 39 BBS systems and 17 with both BBS and CNG with plans to install more in the future. The City has decided to deploy backup systems at most major intersections and use the CNG alternative at any location with a CCTV camera. The backup system in this case keeps power at both the signal and camera. The CNG system used in Overland Park is an Alpha system.

When asked if there were any problems with the system, Bruce Wacker the City Engineer responded, "We have had some problems associated with the cabinet design that has been resolved. We are still trying to communicate with each one of them so it polls the intersection and reports back when we are in backup mode. Otherwise, we have to poll each intersection routinely to see how many incidences there were. Like any system of its kind, you don't know how effective it is unless you go back to check to see how many times you were without power. The battery seems to be the weakest link" (32).

The estimated cost to install a similar system is roughly \$30,000, and according to Mr. Wacker, the cost of one injury accident in 2005 dollars is \$44,900. So the backup system pays for itself when one accident is saved (32).

In doing the literature search it appears that this technology has to yet become a readily available solution. If the deployments in Suffolk and Overland Park prove are shown to be beneficial, it is likely that more vendors will pursue this option. The preliminary results from these two agencies are promising.

2.2.4.4 Fuel Cells

A literature review for fuel cells to provide power for traffic signals yielded very limited results. There are scattered reports of certain municipalities experimenting with fuel cell power sources for their signal cabinets, but details are limited as to the exact systems in place.

Recently, Smart Fuel Cell (SFC) AG a company based in Germany announced a new line targeted for powering traffic applications. The company has been using their EFOY fuel cells along the autobahn in North Munich and Augsburg since 2006 to power illuminated traffic signs along the highway. The reason they were deployed there was because the authorities did not want to run power to each and every site; in the past the authority used battery systems and are now experimenting with fuel cells. These traffic signs are to advise motorists of conditions and provide guidance, and use less power than a typical traffic signal. However, they are off the grid and function solely on these EFOY fuel cells. The Munich North Autobahn Authorities stated,

Previously, we drove out to the Autobahn every eight hours, including weekends, to exchange the signal trailers because of empty batteries. The EFOY Pro Series fuel cells enable continuous operation of the trailer for seven days without user intervention. This saves our company 108 man-hours per month, a cost advantage of almost 9,000 Euros (\$13,000 US), or 89 percent compared to battery-powered signal trailers (33).

Of course this is a unique case where the site had to be off the grid and is not typical of a signalized intersection. Although there are likely to be various vendors selling fuel cells once the technology becomes more main stream the EFOY product is capable of operating between -4°F and 110°F and connected to either 12 or 24 volt batteries. This particular system also can be monitored remotely and controlled using a mobile phone or computer via an integrated user interface (33). The EFOY Pro fuel cell can provide maximum 1560 Wh/day. However, up to five fuel cells can operate in parallel. The EFOY Pro automatically charges 12 V or 24 V batteries (lead-acid or lead-gel). The only time manual operation is necessary with the system is when the fuel cartridge needs to be changed, when this is done it only takes a few seconds to change (34).

If power from any other energy source is available (solar, wind, electricity grid) the battery is fully charged. The fuel cell always monitors the battery voltage and, in this condition, there is

no need to switch on. It should be noted that the fuel cell only operates in combination with a battery though (34).

2.3 Conclusions

Currently the most common technological solution provides uninterrupted power at a signalized intersection has been the use of battery backup systems in conjunction with LED lights. In recent years more and more agencies are deploying backup systems at their intersections as opposed to doing nothing and letting the signal stay dark, or bring generators to the field once the power has been lost, both inefficient and unsafe.

Although most agencies have been using the widely available battery backup systems some agencies have experimented with auto-start generators, solar panels and even fuel cells to address this issue. These options have not yet achieved widespread use in the industry but as technological advancements continue they are likely to grow in popularity.

At present there are no standards for deploying backup power systems for signalized intersections. As described in this report many state and local agencies are taking it upon themselves to safeguard their intersections.

2.4 References

- (1) Minnesota Department of Transportation - Office of Traffic Engineering, "Dark Signals - A Report on Laws Concerning Dark, Malfunctioning or Inoperative Traffic Signals." 1998. <http://www.dot.state.mn.us/trafficeng/standards/signals/news/DRKSigREPORT.pdf>
- (2) Manual on Uniform Traffic Controls Devices with Revisions Number 1 and 2 Incorporated. 2003 ed. 2007. http://mutcd.fhwa.dot.gov/kno_2003r1r2.htm
- (3) Michigan Department of Transportation. "Bureau of Highway Instructional Memorandum 2004-24 Dark Signals Due to Power Outage." October 7, 2004.
- (4) Linden, Erik. "DDOT Announces New Traffic Signal Generators." The Washington Post. March 13 2007.
- (5) Florida Department of Transportation. "Generator Power for Signalized Intersection Package." May 27, 2006.
- (6) Mitzi, Amon. California Traffic Light Programs Sets National Standards. Emerson Process Management. September 28, 2000.
- (7) California Energy Commission. "Battery Backups at Critical Traffic Signals Prevent Accidents During Power Outages." News Release. May 20, 2002.

- (8) Rogers, M. and Rubens, D. Commission Report – Senate Bill 84 XX – Battery Backup Program for Light Emitting Diode (LED) Traffic Signals. California Energy Commission. May 2004.
- (9) "Traffic Signals LED Technology." SCOTTSDALEAZ.GOV. 2008. City of Scottsdale, Arizona. 14 May 2008 <<http://www.scottsdaleaz.gov/Traffic/SignsSignals/led.asp>>.
- (10) Chapman, Jeremy R., and Rahim F. Benekohal. "Light-Emitting Diode (LED) Traffic Signal and Uninterruptible Power Supply (UPS) Usage: A Nationwide Survey." Civil Engineering Studies - University of Illinois at Urbana-Champaign: Transportation Engineering Series 115 (December 2001).
- (11) "Specification for Battery Back-up System For Traffic Signals utilizing Light Emitting Diodes (LED) Traffic Signal Modules." OnlinePower.com. 18 Nov 2002. Online Power, CalTrans. July 2004 <http://www.onlinepower.com/PDF/specification/IPC_caltran.pdf>.
- (12) "CALIFORNIA DEPARTMENT OF TRANSPORTATION PRE-QUALIFIED PRODUCT LIST FOR BATTERY BACKUP SYSTEM INVERTER." California Department of Transportation. 16 Jan 2008 Rev. for July 2004 Spec. CalTrans Laboratory. 23 Oct 2008 <http://www.dot.ca.gov/hq/esc/ttsb/electrical/pdf/BBS_Inverter_Only.pdf>.
- (13) Naumiec, Michael. Personal e-mail correspondence (17 Dec 2007). Subject: "Re: Traffic Signal Back-up system." Recipients: Abdus Salam, Guillermo Ramos, John Litteer. Albany, New York. Contact: mnaumiec@dot.state.ny.us
- (14) Chitturi, Madhav V., and Rahim F. Benekohal. "Evaluation of Three Recent Models of UPS for Intersection Traffic Signals with LEDs." Civil Engineering Studies - University of Illinois at Urbana-Champaign: Transportation Engineering Series 139 (July 2005).
- (15) Prima, Richard C.. "Adopt a Resolution Authorizing the Purchase of Uninterrupted Power Systems (UPS) for Traffic Signals (\$77,500); and Appropriate Funds for the Project." City of Lodi - Council Communication – City Council, Public Works and Electric Utility (21 Feb 2001).
- (16) "Hundreds of traffic signals equipped with backup power systems." WRIC Richmond - 8 News. 07 May 2008. Associated Press; Virginia Department of Transportation. <<http://www.wric.com/Global/story.asp?S=8282988>>.
- (17) Casey, R. "Subject: Uninterruptible Power Supplies (UPS) at Signalized Intersections and at Traffic Control or Warning Devices Interconnected with Railways." Technical Bulletin – Ministry of Transportation – British Columbia, Canada. Engineering Branch: Traffic, Electrical, Highway Safety and Geometric Standards. Section Bulletin Number: TE-2006-01. 31 May 2006.

- (18) Van Hecke, Joseph. Personal correspondence (26 Sep 2008). Subject: "Battery Back-up Systems (BBS) Contract 1-05-63-01." Recipient: Jeffrey Wojtowicz. West Sacramento, California and Troy, New York. Contact: Joseph Van Hecke, California Department of General Services.
- (19) "County Maintained Traffic Signals Receive Battery Power Back-up." News release. Howard County Department of Public Works. Howard County, Maryland. 8 Feb 2008.
- (20) Schwarzman, Diane. Personal correspondence (19 Sep 2008). Subject: "Battery backup systems (BBS)." Recipient: Jeffrey Wojtowicz. Howard County, Maryland and Troy, New York. Contact: www.howardcountymd.gov/PublicWorks; Diane Schwarzman, Chief – Traffic Engineering Division.
- (21) Dye, Jeremy. Personal correspondence (19 May 2008). Subject: "Traffic Signal Energy Backup." Recipient: Jeffrey Wojtowicz. Scottsdale, Arizona and Troy, New York.
- (22) Ramsey, Steve. Personal correspondence (18 Sep 2008). Subject: "Signal Power?" Recipient: Jeffrey Wojtowicz. Scottsdale, Arizona and Troy, New York.
- (23) Casey, R. "Subject: Traffic Signal Uninterruptible Power Supply Maintenance Standards." Technical Bulletin – Ministry of Transportation – British Columbia, Canada. Engineering Branch: Traffic, Electrical, Highway Safety and Geometric Standards. Section Bulletin Number: TE-2006-04. 31 July 2006.
- (24) Casey, R. "Subject: Traffic Signal Uninterruptible Power Supply Material Standards." Technical Bulletin – Ministry of Transportation – British Columbia, Canada. Engineering Branch: Traffic, Electrical, Highway Safety and Geometric Standards. Section Bulletin Number: TE-2006-03. 31 July 2006.
- (25) Nyland, D. "Subject: Uninterruptible Power Supplies (UPS) at Signalized Intersections and at Traffic Control or Warning Devices Interconnected with Railways." Technical Circular – Ministry of Transportation – British Columbia, Canada. Engineering Branch. Circular Number: T-07/06. 1 May 2006.
- (26) Steve Drew. Personal correspondence (22 Sep 2008). Subject: "Dark Traffic Signals." Recipient: Jeffrey Wojtowicz. British Columbia, Canada and Troy, New York. Contact: Steve Drew, Ministry of Transportation.
- (27) "SOLAR POWERED LED TRAFFIC SIGNALS." Gujarat Energy Development Agency. 13 Sep 2007. Gujarat Organisation. 14 May 2008
<http://www.geda.org.in/solar/so_slr_traffic_signal.htm>.

- (28) Van der Merwe, Christy. "Cape Town intersection hosts SA's first solar-powered traffic light." Creamer Media's Engineering News Online. 12 Oct 2007. Engineering News Online; South Africa National Energy Efficiency Agency; Eskom.
<http://www.engineeringnews.co.za/article.php?a_id=118129>.
- (29) Van der Merwe, Christy. "Energy efficiency agency pushes for more solar traffic lights." Creamer Media's Engineering News Online. 06 Nov 2007. Engineering News Online; South Africa National Energy Efficiency Agency.
<http://www.engineeringnews.co.za/article.php?a_id=120632>.
- (30) Haight, Brent. "Keeping Traffic Moving When The Power Goes Out - GotPower Inc.'s diesel-driven generator system - Brief Article." Diesel Progress North American Edition May 2001
- (31) "Alpha's Generator Backup Solution." Power Connection - The Alpha Group Newsletter Volume 2. Issue 2. Nov 2007 22 Sep 2008
<<http://www.alpha.com/Newsletter/Alphaamr/Volume-2-Issue-2/15/>>.
- (32) Wacker, Bruce. Personal correspondence (22 Sep 2008). Subject: "BBS for traffic signals." Recipient: Jeffrey Wojtowicz. City of Overland Park, Kansas and Troy, New York.
- (33) "The new EFOY Pro Series - power for traffic applications." Smart Fuel Cell. 19 Sep 2008. EFOY (Germany). 23 Sep 2008
<http://www.efoy.de/index.php?option=com_content&task=view&id=941&Itemid=177>=en>.
- (34) Himmelreich, Tobias. Personal correspondence (26 Sep 2008). Subject: "Fuel cell for traffic signals." Recipient: Jeffrey Wojtowicz. Brunenthal, Germany and Troy, New York. Contact: Tobias Himmelreich, SFC Smart Fuel Cell AG, Brunenthal, Germany.

TASK 3: Identify and Evaluate Possible Technologies

3.1 Introduction

The *Assessment of Alternative Energy Solutions* (Task 2) report presented the main technologies that are currently being implemented across the county to address the issue of dark traffic signals (1). The Task 2 report identified battery backup systems to be the most commonly used solution but also showed that there are agencies experimenting with technologies such as natural gas generators, solar power and even fuel cells.

This chapter builds on the results of the Task 2 report and presents an evaluation of the existing technologies. The primary focus of this chapter is on low cost auto-starting technologies. It should be noted that this chapter is not intended to evaluate technologies from specific vendors but rather to provide an evaluation of the different technologies based on the data gathered to date from the various systems. Section 3.2 describes what the New York State DOT has done to date dealing with the issue of powering dark traffic signals; Section 3.3 provides an evaluation of the existing technologies; Section 3.4 identifies some future technologies that could be used to combat this issue, and Section 3.5 provides some conclusions.

3.2 Backup Systems Deployed by the New York State Department of Transportation

The New York State Department of Transportation (NYSDOT) has been interested in backup systems for approximately five years. During this time the DOT has acquired several battery backup systems (BBS) and tested them at their signal shop and then deployed them in various regions across the state. NYSDOT wanted to ensure that they chose a suitable solution to meet the needs of the state before widespread installations. Since the time NYSDOT started looking at backup systems there have been significant advancements and price reductions, especially with BBS.

It should also be noted that the signal controller that is currently being adopted by NYSDOT is the model 2070L ATC built by Siemens Intelligent Transportation Systems and Eagle Advanced Transportation Controller. NYSDOT has made an investment to switch from incandescent to LED bulbs for the traffic lights. In most areas this switch has already been made for red and

green signals; the transition for yellow signals is much slower because the economics are much different due to the very short intervals during which the yellow signals are used.

Currently NYSDOT has three BBS systems installed across the state. One in the outskirts of Albany (Region 1), another in a more rural region near Oswego (Region 3) and another in a more densely populated area on Long Island (Region 10). NYSDOT identified these locations because both their physical characteristics were different and the weather conditions can be much different. Each of these systems is further described in the following subsections of the chapter.

3.2.1 NYSDOT Region 1 Deployment

NYSDOT has deployed a BBS in Galway, NY at the intersection of NY Routes 67 and 149. This intersection could be described as a high speed rural intersection. The reason a test system was deployed at this location was due to a high number of crashes and a high rate of power outages at this location. The product installed at this location is a 24V battery backup system built by Signal Sense Products LLC as shown in Figure 4.



Figure 4 Signal Sense BBS

The large majority of the power outages at this location were found to be less than thirty seconds; however when the power was restored it was often in flash mode. This required personnel from NYSDOT to drive to the site and reset the controller. This BBS is capable of supplying full power to the intersection for approximately four hours, then switching to flash mode to save on power consumption. The batteries are checked approximately once per year by the NYSDOT.

The backup system at this location requires a separate cabinet due to its size. Under normal operation the power first goes through the backup system cabinet and then to the controller, so in essence the signal is always powered via the backup system.

The representatives from NYSDOT did not identify any major issues with this system and were happy with its performance.

3.2.2 NYSDOT Region 3 Deployment

NYSDOT Region 3 is located in Central New York, at the crossroads of I-81 and the New York State Thruway (I-90). It includes six counties - Cayuga, Cortland, Onondaga, Oswego, Seneca and Tompkins. A portion of Wayne County signals are also maintained by Region 3. The traffic volume varies, from small town roads, with only a few hundred vehicles per day; to sections of Interstate 81 in Syracuse, with over 100,000 vehicles per day. While there are multiple residencies performing maintenance work throughout the Region; there is only one signal shop, with a crew of 9 people, for all Region 3 signals. Within the Region there are 684 NYSDOT signals (451 three color signals, 70 flasher signals and 163 sign beacons) (2).

Typically most power outages occur during the summer months and are usually sporadic. When a signal is dark NYSDOT normally hears about it either by the NYSDOT signals answering service, the regional TMC, the 911 center and/or the travelling public. The current practice for dealing with dark signals is to verify there is a power outage in a reported area; if there is a power outage there is typically no response until the power is restored. In some cases, depending on the intersection, a portable generator may be brought to the site (2).

The NYSDOT deployment in Region 3 is at the intersection of NYS Route 3 @ NYS Route 104 in Hannibal, NY, which is near Oswego. This is a high speed rural intersection with 4 approaches, each with one lane in and one lane out. The vehicles traveling on Route 104 WB have limited sight distance as they crest a hill and approach the intersection as shown in Figure 5. The other approaches seem to have ample sight distance. This location has a high historical accident record. The reason that a system was installed at this location was not so much do to the fact that the power was frequently out but rather that DOT wanted to be proactive in case of power failures due to the already high accident rate at this location. The truck volumes at this intersection are particularly high; this is likely due to the Port of Oswego which is several miles to the east on Route 104.



Figure 5 NYS Route 104 WB approach

The backup power system is a Meyers PowerBack System and was installed 4-5 years ago. According to the NYSDOT representatives the system has been problem free. The line power first goes through the backup system and charges the batteries in the backup system. When

the line power is lost the backup system will automatically switch over and continue operation at the signal. The system is designed to power the entire intersection (all phases) for approximately 6-7 hours. When the system starts to lose battery strength it automatically switches to flash mode and continues to operate for approximately 3 more hours. When the main power is lost an alarm is logged in the controller and this information is sent back to DOT via a radio communication.

Power outage data was analyzed from this site from June 27, 2008 to October 24, 2008. These dates were the only time period that was logged on the device because a new controller was installed in June and the historic data was lost. During this 4 month period there were less than eight outages (exact number unknown since some were manual checks of the system) typically for less than 30 seconds each.

The backup system is in a second cabinet and is rather large as shown in Figure 6. The system is a 48V system and each of the batteries rest on heaters to ensure that the proper temperature is maintained. To charge the batteries completely from a discharged state it takes about 3 days to achieve a full charge. Since NYSDOT took delivery of this system Myers was sold to Peek Traffic Corp.



Figure 6 Myers PowerBack BBS interior

3.2.3 NYSDOT Region 10 Deployment

NYSDOT Region 10 is located on Long Island, New York. It includes Nassau and Suffolk Counties which are suburban. There are 65 closed loop signal systems (CLSS) consisting of 597 signals. There are approximately 1,100 NYSDOT traffic signals throughout the Region.

Typically most power outages occur during the summer months from thunder storms and are usually wide-spread, there are also some in the winter months. When a signal is dark NYSDOT normally hears about it either by the NYSDOT signals answering service, the regional TMC, the 911 center and/or the travelling public. The current practice for dealing with dark signals is to verify there is a power outage in a reported area; if there is a power outage and there are enough resources a police officer will direct traffic. (3).

The system deployed in NYSDOT's Region 10 is at NYS Route 454 and Connetquot Ave in Central Islip, NY. The system is very similar to the Signal Sense Product described in Section 3.2.1. This intersection is a "T" intersection and the reason a backup system was deployed was because there seemed to be fairly frequent outages at this location for unknown reasons (4).

3.3 Evaluation of Existing Uninterruptible Power Supply Technologies

The Task 2 report highlighted various types of deployments with different uninterruptible power supplies (UPS) (1). Besides the battery backup systems the other systems were essentially demonstrations of emerging technologies.

3.3.1 Battery Backup Systems

The most common UPS available today as a backup power source for traffic signals is the battery backup system (BBS). There are multiple vendors that have field tested products on the market. There are more and more agencies using this type of system to provide continuous power at traffic signals, therefore, the vendors keep improving their products and making them more cost effective.

The length of time a signal will be powered during an outage depends on the BBS and varies from two to ten hours. Many of the companies offer a system that switches from full power operation to flash mode when the battery voltage drops below a certain threshold. This feature allows the system to still provide some warning to the motorist while conserving the batteries. Since most power outages are less than one hour these systems provide continuous operation.

Although there are advances in battery technology the BBS systems are rather bulky and often require a separate pole mounted cabinet. The way in which the power to the traffic signal cabinet is provided is also cumbersome. The power from the grid first passes through the BBS system and charges the DC batteries before being converted again to AC to power the traffic signal controller. Another problem with the BBS is the wide temperature swings that the batteries experience. It is desirable to minimize the temperature fluctuations to maximize the life of the batteries.

Also, during the interviews for Task 2 it was found that the maintenance of the BBS is often expensive and time consuming. When it is possible alarm notifications should be sent to the proper authorities so that informed decisions can be made. Diane Schwartzman from Howard County, MD stated:

We believe that it is critical to have an alarm notification system, in place, at all locations. We receive alarms by text message 24/7. The alarm intervals we use are on BBS for 15 minutes, on BBS for 2 hours, and 33% remaining battery. We also receive an “alarm clear” message when power is restored. This enables us to wait a reasonable time before calling the local power company to see if they are aware of a power outage that might be affecting our signal. If they are unaware of any problem, then we will go to the intersection to verify loss of power before asking them to respond. If they are aware and in route or are already working on the problem, then we will wait for the 33% alarm and then plan to arrive with a portable generator before battery failure. The generator will power the signal for approx. 10 hours and recharge the BBS also. If at this time the generator runs out of gas, then the batteries should be fully charged and revert back to BBS. In total, this gives about 30 hours of backup with just 1 visit to install the generator (5).

3.3.1.1 Types of Batteries

If batteries are to be used with existing equipment a 120VAC, 60Hz inverter would be required to convert the DC output to AC. Converting the DC to AC would not be a problem since there are many available products on the market. One of the problems with batteries is that they degrade over time and battery capacity and life changes greatly with the operating and storage temperature. The Task 6 report discusses in more detail the issues associated with batteries. The major battery chemistries are described as follows:

Nickel Cadmium (NiCd) — chemistry is mature and well understood but relatively low in energy density. The NiCd is used where long life, high discharge rate, and economical price are important. Main applications are two-way radios, biomedical equipment,

professional video cameras, and power tools. The NiCd contains toxic metals and is not environmentally friendly.

Nickel-Metal Hydride (NiMH) — chemistry has a higher energy density compared to the NiCd at the expense of reduced cycle life. NiMH contains no toxic metals. Applications include mobile phones, laptop computers, and hybrid electric automobiles.

Lead Acid — chemistry is the most economical for larger power applications where weight is of little concern. The lead acid battery is the preferred choice for hospital equipment, wheelchairs, emergency lighting, automotive, and UPS systems.

Lithium Ion (Li-ion) — chemistry is the fastest growing battery system. Li-ion is used where high-energy density and light weight is of prime importance. The Li-ion chemistry is more expensive than other systems and must follow strict guidelines to assure safety. Applications include notebook computers and cellular phones. Future applications are expected to include hybrid electric automobiles.

Lithium Ion Polymer (Li-ion polymer) — chemistry is a potentially lower cost version of the Li-ion chemistry. This chemistry is similar to the Li-ion in terms of energy density. It enables very slim geometry and allows simplified packaging. Its main application is mobile phones.

The following table compares the characteristics of the six most commonly used rechargeable battery systems in terms of energy density, cycle life, exercise requirements and cost. Exotic batteries with above average ratings are not included.

Table 1 A comparison of battery technologies.

	NiCd	NiMH	Lead Acid	Li-ion	Li-ion polymer	Reusable Alkaline
Gravimetric Energy Density (Wh/kg)	45-80	60-120	30-50	110-160	100-130	80 (initial)
Internal Resistance (includes peripheral circuits) in mW	100 to 200 ¹ 6V pack	200 to 300 ¹ 6V pack	<100 ¹ 12V pack	150 to 250 ¹ 7.2V pack	200 to 300 ¹ 7.2V pack	200 to 2000 ¹ 6V pack
Cycle Life (to 80% of initial capacity)	1500 ²	300 to 500 ^{2,3}	200 to 300 ²	500 to 1000 ³	300 to 500	50 ³ (to 50%)
Fast Charge Time	1h typical	2-4h	8-16h	2-4h	2-4h	2-3h
Overcharge Tolerance	moderate	low	high	very low	low	moderate
Self-discharge / Month (room temperature)	20% ⁴	30% ⁴	5%	10% ⁵	~10% ⁵	0.3%
Cell Voltage (nominal)	1.25V ⁶	1.25V ⁶	2V	3.6V	3.6V	1.5V
Load Current						
- peak	20C	5C	5C ⁷	>2C	>2C	0.5C
- best result	1C	0.5C or lower	0.2C	1C or lower	1C or lower	0.2C or lower
Operating Temperature (discharge only)	-40 to 60°C	-20 to 60°C	-20 to 60°C	-20 to 60°C	0 to 60°C	0 to 65°C
Maintenance Requirement	30 - 60 days	60 - 90 days	3 - 6 month ⁸	not req.	not req.	not req.
Typical Battery Cost (US\$, reference only)	\$50 (7.2V)	\$60 (7.2V)	\$25 (6V)	\$100 (7.2V)	\$100 (7.2V)	\$5 (9V)
Cost per Cycle (US\$) ⁹	\$0.04	\$0.12	\$0.10	\$0.14	\$0.29	\$0.10-0.50
Commercial use since	1950	1990	1970	1991	1999	1992

Source 6

1. Internal resistance of a battery pack varies with cell rating, type of protection circuit and number of cells. Protection circuit of Li-ion and Li-polymer adds about 100mW.
2. Cycle life is based on battery receiving regular maintenance. Failing to apply periodic full discharge cycles may reduce the cycle life by a factor of three.
3. Cycle life is based on the depth of discharge. Shallow discharges provide more cycles than deep discharges.
4. The discharge is highest immediately after charge, then tapers off. The NiCd capacity decreases 10% in the first 24h, then declines to about 10% every 30 days thereafter. Self-discharge increases with higher temperature.
5. Internal protection circuits typically consume 3% of the stored energy per month.
6. 1.25V is the open cell voltage. 1.2V is the commonly used value. There is no difference between the cells; it is simply a method of rating.
7. Capable of high current pulses.
8. Maintenance may be in the form of 'equalizing' or 'topping' charge.
9. Derived from the battery price divided by cycle life. Does not include the cost of electricity and chargers.

Overall the BBS are improving and the costs are coming down. The telecom industry has been using batteries for standby power for many years and is always looking for alternatives. In a stationary application like this the most cost effective battery has been the lead-acid type. It appears that this will remain the case for some time to come. There are many products available on the market offering different capacity lead-acid type batteries specializing in standby power. One of the problems with batteries is that they degrade over time and battery capacity and life changes greatly with the operating and storage temperature.

3.3.2 Solar Power

The literature search conducted as part of Task 2 indicated that some agencies in South Africa were using solar panels to power traffic signals. At this time the team does not advise using solar technologies to power traffic signals in NYS. The reason for this is that the solar technology is still rather large to be installing at intersections and the weather conditions in New York do not guarantee the proper amount of sunlight for proper charging.

It should also be noted that NYSDOT does have a specification for a portable solar powered traffic signal (7). The main use for these systems is for work zone applications. The specification requires that the system operate for at least 14 consecutive days on batteries alone. If similar standards are applied to traffic signals, this would result in a prohibitively expensive system.

3.3.3 Automatic Generators

BBS provide power under most normal power outages but under some extreme events power outages can be measured in days without power, not hours. This was the case in Buffalo, NY during a mid-October snow storm in 2006. The power in some areas was out for over a week. It is in cases like this that a BBS would not be useful as there would be no power to charge the batteries. The following sections outline some of the various types of auto starting generators that could be used to power a traffic signal.

3.3.3.1 Natural gas internal combustion engine with generator

One of the recognized names in BBS, the Alpha Group has built and deployed compressed natural gas (CNG) generators that are designed to power an intersection indefinitely as long as there is a fuel source available. Unlike a portable generator the CNG generator gets its fuel from the natural gas line provided by the utility company, therefore, an uninterrupted source as long as there is not damage to the natural gas supply.

This system currently has a small BBS built in to detect the loss of power and after several minutes on the BBS the power is transferred to the generator. Because of this the system is

rather large and bulky as there is a standalone BBS and generator permanently installed near the intersection. The installed price of such a system has been estimated to be \$30,000. If other manufactures decide to pursue this technology the price may come down.

Although it is impossible to predict which intersections will experience power outages longer than what a standard BBS can function it makes sense to look at this technology for certain locations. Locations where an automatic generator backup system may be appropriate are along an evacuation route or at high volume intersections in areas with historically long power outages. Another factor to consider when choosing sites for this technology is to ensure that there is CNG available, many rural locations may be without it.

Another option is storing propane on site in a tank or cylinder. Disadvantages of this technology include requiring a battery for starting and maintaining the engine in a state where it can be started reliably.

3.3.3.2 Gasoline internal combustion engine with generator

A very compact generator set could be built using a small internal combustion engine such as a model airplane engine with a DC generator attached. An inverter would convert the DC generated voltage to 120VAC 60Hz power. Disadvantages of this setup are that there would need to be a method to store the stabilized fuel/oil mixture and a battery would be required for starting. The anticipated low frequency of utility outages raises concerns of maintaining the engine in a state where it can be started reliably. There are also the issues of periodic maintenance and fuel supply.

3.3.3.3 Compressed air motor with generator

A very compact generator set could be built using a small air-driven motor with a DC generator attached. An inverter would convert the DC generated voltage to 120VAC 60Hz power. Advantages of this configuration would be no requirement for batteries, no pollutants, no toxic or flammable chemicals would need to be stored, it would require very little maintenance, and it operates over the full operating temperature. Disadvantages of this setup are that there would need to be a compressor to recharge the air tank. In addition, the energy density is relatively low, suggesting a large storage tank would be required.

3.3.4 Fuel Cells

Recent research suggests that fuel cells might be used in the future to provide backup power for traffic signals. To date however, the technology is not at a point where it should be used to provide backup power for traffic signals. The fuel cell functions similar to a battery, which uses

electrochemical conversion. The fuel cells take in hydrogen-rich fuel and oxygen and turn them into electricity and heat. The waste product is water. The hydrogen can be derived from gasoline, natural gas, propane or methanol through a process known as reformation. The advantages are high energy density and lack of pollution. The disadvantages are very high cost, and batteries are required for starting the system.

It is anticipated that the technology will need another 3-5 years before it is a viable solution for this problem. The systems that are currently available are mainly to support lower powered beacon or warning lights, not an entire intersection.

3.4 Future Technologies

In addition to the technologies described in the Task 2 report there are several other alternatives that may be viable solutions in the future. These technologies are described in more detail in the following sections.

3.4.1 Ultracapacitors

The ultracapacitor is a growing technology and new products are appearing often. The ultracapacitor (UC), sometimes also known as a supercapacitor or electrochemical double layer capacitor, is a cross between a capacitor and a battery. Construction of the UC is similar to a battery but there is no chemical reaction taking place. This allows millions of charge/discharge cycles resulting in a much longer life. The UC voltage decreases to zero like a capacitor as it discharges where a battery will hold its voltage until it is nearly depleted. Another advantage is that the internal resistance of the UC is very low and very high charge and discharge current will not harm it. The UC will work at much larger temperature extremes compared to batteries and at -20C with no degradation of performance. The UC has been commonly used for backup power for memory power in computers. Recently larger devices have been created for energy recovery for vehicles because of the advantages of its high current capabilities. As UC technology improves energy densities in ultracapacitors are expected to reach several kW/kg in comparison to between 0.1 kW/kg and 0.5 kW/kg in lead acid batteries. Ultracapacitors are not being used for long term power requirements because of the cost. For example, a Maxwell Technologies 350F D size cell is \$15, so it will be quite some time before the UC will be challenging the battery for long term standby power. Ultracapacitors may, however, be a useful component within a battery backup system by virtue of their ability to source large amounts of power quickly, in comparison with batteries that are much better at providing continuous power.

3.4.2 Pseudocapacitor

The pseudocapacitor is the newest technology showing promise for higher energy density and lower cost than the ultracapacitor. The pseudocapacitor has a structure and characteristics similar to the ultracapacitor. The pseudocapacitor differs from the UC in that it uses a metal oxide rather than an activated carbon for the electrode material. Nesscap has developed a credit card size product with 30W of power (8). If the pseudocapacitor can compete with the cost of batteries, it has a promising future. Pseudocapacitors with small ratings have been demonstrated and are becoming available commercially. It is expected to be some time before pseudocapacitors can be reliably integrated into sufficiently large arrays to support an application such as backup of traffic signals.

3.4.3 Dedicated Standby Power Line

In locations where there might be many intersections close by, a dedicated backup power line could be installed. A generator could be located at a central location to provide 120VAC power for multiple intersections. An advantage is that maintenance is reduced to much fewer generator locations. The major disadvantage is the initial installation cost of wiring dedicated circuits.

3.5 Conclusions

Of all of the technologies that are currently on the market the BBS are the most developed systems, therefore the most cost effective alternative. Those systems however are still advancing. This does not mean however that the BBS should be the only technology that is suitable for traffic signals in New York State. The automatic generators are certainly advancing and once the devices are field hardened and the prices become more competitive, they are a great alternative for locations where maintaining backup power for long periods of time are critical. Also, advances in technologies such as ultra and pseudocapacitors are likely to provide backup power at intersections for the majority of outages which only last a few seconds.

Table 2 summarizes the advantages and disadvantages of the backup energy sources discussed above.

Table 2 A summary of backup energy options

Power Source	Pros	Cons
Batteries		
Lead-Acid	Lowest Cost. Mature Technology.	Loss of power at low temp. Shortened life at high temp. -20 to 60°C operating range. Medium maintenance.
Nickel-Metal-Hydride	Higher Cost than Lead-Acid. Mature Technology. Widely available.	High maintenance Medium maintenance required.
Nickel-Cadmium	Excellent temperature performance -40 to 60°C. Mature Technology. Widely available.	High maintenance. Poor self discharge. Environmentally unfriendly.
Lithium Polymer	No maintenance required. Highest power density.	Highest cost. 0 to 60°C operating range. Special charging required.
Fuel Cells	High energy density. Non polluting.	Very high cost. Moderate maintenance. Batteries required.
Ultracapacitors	Works well at temperature extremes.	Very high cost. Low energy density; large number of cells required.
Pseudocapacitor	Works well at temperature extremes. Cheaper than ultra capacitors.	New technology. Not widely available. Low power density; large number of cells required.
Gasoline internal combustion engine with generator	Generator backup systems are readily available. Works well at temperature extremes. High pollutant levels.	Batteries still needed for starting. Moderate maintenance required. On site fuel storage required.

Natural gas internal combustion engine with generator	Unlimited run time. Works well at temperature extremes. Low pollutant levels.	Batteries still needed for starting. Costly gas line installation, or on site fuel storage required. Medium maintenance required.
Compressed air (or CO ₂) motor with generator	No batteries required. No pollutants. No toxic chemicals. Not affected by temperature. Extremely low maintenance.	Development required, not commercially available. Charging air or (or CO ₂) tank might be a problem.
Dedicated Power Line	Low maintenance.	High cost to run cable. Not applicable for single intersections. Does not eliminate the need for a backup power solution.

3.6 References

- (1) Renna, N. and Wojtowicz, J. *Task 2: Assessment of Alternative Energy Solutions*. Technical Report 08-01. Center for Infrastructure and Transportation Studies, Department of Civil and Environmental Engineering, Rensselaer Polytechnic Institute, 2008.
- (2) Bates, Scott. Personal correspondence (21 July 2008). Subject: "C-06-08: Develop Guidelines for Traffic Signal EnergyBack-Up Systems" Recipient: Jeffrey Wojtowicz. Syracuse, New York and Troy, New York.
- (3) Huckstadt, Eric. Personal correspondence (21 Oct 2008). Subject: "C-06-08: Develop Guidelines for Traffic Signal EnergyBack-Up Systems" Recipient: Jeffrey Wojtowicz. Hauppauge, New York and Troy, New York.
- (4) Huckstadt, Eric. Phone conversation (6 Oct 2008). Hauppauge, New York and Troy, New York.
- (5) Schwarzman, Diane. Personal correspondence (19 Sep 2008). Subject: "Battery backup systems (BBS)." Recipient: Jeffrey Wojtowicz. Howard County, Maryland and Troy, New York. Contact: www.howardcountymd.gov/PublicWorks; Diane Schwarzman, Chief – Traffic Engineering Division.
- (6) Buchmann, I. *The Battery Comparison Table*. Cadex Electronics Inc. Richmond, British Columbia, Canada, 2008.

- (7) "Portable Solar Powered Traffic Signal (APL Specification)." TSU Spec Portable Solar-Powered Signal. New York State Department of Transportation, Albany, New York. Rev. Sept 2007.
- (8) New Energy Systems New Electroluminescent Systems. 27 Oct 2008.
<<http://www.nesscap.com/>>.

TASK 4: Prioritization Guidelines for Installation at Intersections

4.1 Introduction

The installation of alternative energy sources at every signalized intersection in New York State (NYS) is cost prohibitive. Therefore, as part of this chapter guidelines are provided for prioritization for installing alternative energy sources at intersections throughout New York State.

This chapter provides a methodology for prioritizing traffic signals throughout NYS with backup power sources. Section 4.2 outlines some current practices in the United States and Canada for installing backup systems at intersections; Section 4.3 provides an analysis of dark signal related accidents across NYS; Section 4.4 presents the prioritization guidelines for installing backup systems at intersections across NYS and Section 4.5 presents conclusions of the study.

4.2 Review of Current Practices for Installing Backup Systems at Intersections

The New York State Department of Transportation (NYSDOT) has not begun to install backup power systems at intersections in large numbers. As mentioned in the *Identification and Evaluation of Possible Technologies* report (Task 3) NYSDOT has installed ‘test’ systems in Regions 1, 3 and 10. These systems are all battery backups and are deployed at various types of intersections. The intersections that were chosen for these backup systems were based on historical knowledge of the intersection having either safety problems or a high frequency of power outages.

When the *State of the Practice* report (Task 2) was being prepared each of the agencies contacted were asked to elaborate on their current practices for outfitting intersections with backup power systems. Most of the agencies responded that they do not have any formal guidelines for choosing a site. They are primarily selected on an as needed basis and use engineering judgment to aid in the final selection.

The California Department of Transportation (CalTrans) had a program that would allow municipalities to receive up to 70% of the cost of a battery backup system or BBS (1). To be eligible for this program a committee reviewed applications from the municipalities and used a point system to score each site. The criteria included traffic volume, frequency of injury accidents, proximity to a school zone, speed of approach traffic, and availability of pedestrian pre-emption controls. A sample copy of the criteria is given in

Figure 7. The greater the number of points, the higher priority an intersection has in being chosen as a candidate for the upgrade subsidy.

The CalTrans approach is a quick and simple scoring criterion. This has advantages and disadvantages.

The scoring can be applied to any intersection very quickly and it can be scored in comparison with all the others. However, this scoring does not consider many factors in the decision such as historical power outage problems and proximity to other systems (i.e. other signals or grade crossings). For example a rural high speed intersection that historically has a high rate of injury accidents may not even be considered a “priority three” intersection.

Evaluation Criteria and Points

Intersection Criterion	Key Element	How evaluated?	Maximum Points
Traffic volume	<ul style="list-style-type: none"> Maximum traffic volume over a 24 hour period Only intersections will be used for traffic volume calculations 	The number of vehicles traveling through each intersection over a 24 hour period would be evaluated as follows: <ul style="list-style-type: none"> Less than 2,500 = 0 2,501 to 10,000 = 2 points 10,001 to 20,000 = 3 points 20,001 to 30,000 = 4 points Greater than 30,001 vehicles = 5 points 	5 points
Injury Accidents	<ul style="list-style-type: none"> Intersections with more than one injury accident per million vehicles per intersection per year 	<ul style="list-style-type: none"> Intersections meeting this criterion = 1 point Intersection not meeting this criterion = 0 points 	1 point
Children	<ul style="list-style-type: none"> Intersections within a one mile radius of a K-12 school 	<ul style="list-style-type: none"> Intersections meeting this criterion = 1 point Intersection not meeting this criterion = 0 points 	1 point
Speed of Approach Traffic	<ul style="list-style-type: none"> Approach traffic speed of 45 miles per hour or greater for <u>each</u> cross street 	<ul style="list-style-type: none"> Intersections meeting this criterion = 1 point Intersection not meeting this criterion = 0 points 	1 point
Pre-emption	<ul style="list-style-type: none"> Intersections equipped with audible sound, accessible signals or pre-emption controls 	<ul style="list-style-type: none"> Intersections meeting this requirement = 1 point Intersection not meeting this criterion = 0 points 	1 point
MAXIMUM POINTS AVAILABLE			9 POINTS

- Priority one intersections are those with 7 or more points
- Priority two intersections are those scoring between 6 and 7 points
- Priority three intersections are those scoring between 5 and 6 points

Funding priority: Priority one intersections would be funded first, followed by priority two and three.

Figure 7 CALTRANS evaluation criteria (1)

Similar to CalTrans, the British Columbia Ministry of Transportation in Canada has established evaluation criteria for backup power systems. They state the following:

Effective immediately;

1.) Existing traffic signals will be prioritized by Regional Traffic Engineers and traffic signal UPS installed on a Provincial priority basis subject to the availability of funding.

2.) UPS shall be added to all new traffic signal and railway interconnected traffic control and warning device specifications (2)

The scaling criteria shown in Figure 8 gives a higher priority to sites in close proximity to rail, bridges, emergency facilities, abnormal geometry at the intersection, power reliability and the accident rates at a particular intersection.

This particular prioritization scheme considers many more factors than the CalTrans evaluation criteria. The team feels that this criterion is more in line with what NYSDOT should consider using as prioritization guidelines. It would however, be necessary to adjust the weighting factors and the specific attributes based on conditions found across New York State.

The team has evaluated the three sites where NYSDOT has installed BBS systems. These three sites were identified in the Task 3 report (3). The results from the evaluations can be seen in Table 3. According to the CalTrans scoring the Galway and Central Islip deployments were rated a priority 2 and the Hannibal site was only scored a priority 3. Although the factors used to compute the score for both methodologies are different, the resulting scores are similar.

Table 3 Evaluation scores

Location	Region	Score	
		CalTrans	British Columbia
Galway	1	6	45
Hannibal	3	5	30
Central Islip	10	6	45

	Location Description	Municipality	Geometry	Rail Pre-empt	Emergency Services	Advance Warning Flashers	Crash Prone Sites	Power Problems	Disaster or Truck Rte	High Volumes	Proximity to other UPS	Total Score	Type	Note
	<p>PRIORITIZATION FACTORS for Traffic Signals at intersections including interchange ramps and pedestrian signals.</p> <p>Geometry: - Locations where right of way assignment for a 4 way stop operations is difficult Single Point Interchanges, Permanent One-way Bridge Signals, Conflicting Left Turns using Lead/Lag - (20), Protected Only Left Turn intersections including intersections with Split Phasing (15) Otherwise (0)</p>													
	<p>Rail Pre-empt: - Intersections with Rail pre-emption (20), Otherwise 0.</p>													
	<p>Power Problems: - History of signal malfunction due to chronic power quality or reliability problems (20), otherwise (0)</p>													
	<p>Crash Prone Sites: - Locations on the Ministry Crash Prone Location List or the ICBC Crash Prone Location List (10), otherwise (0)</p>													
	<p>Advance Warning Flashers Installed: - Presence of AWF (5 per AWF sign)</p>													
	<p>High Volume intersections: - intersection with volumes entering the intersection of >15,000 AADT (10), otherwise (0)</p>													
	<p>Emergency Services: Intersection is within 400m of a fire hall, ambulance station or Hospital or with Emergency Proc exempt (5), otherwise (0)</p>													
	<p>Disaster/Truck Routes: Disaster or Truck Routes(5), otherwise (0)</p>													
	<p>System: - The signal is part of a co-ordinated system or are part of a corridor (conventional highway or non-freeway) that function as a major arterial in urbanized areas including interchange off ramps (5), otherwise (0)</p>													
	<p>Proximity to other UPS signal: - Intersection is within 200 meters of a municipal intersection with UPS (5), otherwise (0)</p>													
	<p>Type: 1) Single Point Interchange (SPI), 2) Diamond Interchange, 3) Tunnel, 4) One Way Bridge, 5) Pod Signal, 6) Lead/Lag Turns, 7) Protected Only Turns, 8) Split Phase Signal 9) Fire Signal, 10) Ramp Metering, 11) Ferry/Weigh scale signals, 12) Rail-way Advance Warning Signal</p>													
	<p><i>Note: Fire Hall Driveway Special Ped Xings and non Ministry signals are not evaluated. Rail crossings are operated by Rail and all have existing backup power.</i></p>													

Figure 8 British Columbia Ministry of Transportation scaling criteria

4.3 Analysis of Accidents at Dark Signals in New York

To aid in the development of prioritization guidelines for backup systems across NYS, the team studied historical accident reports to see if any trends could be identified. In 1998, the Minnesota DOT (MNDOT) conducted a report entitled *Dark Signals, A Report on Laws Concerning Dark, Malfunctioning or Inoperative Traffic Signals* (3). In this report they state:

A search of the statewide accident accounting system was conducted for crashes that occurred at intersections where the signal was “non-working”. No conclusions could be drawn from the data obtained.

4.3.1 Data Entry Process

Although the MNDOT report found accident data to be inconclusive when finding trends for dark signal related accidents, we found it necessary to continue the analysis for dark signal related accidents. NYSDOT provided the project team with historical accident records across NYS for the years 2003 through 2007. These records were all form MV-104A from the New York State Department of Motor Vehicles (NYSDMV). NYSDOT staff compiled the list of records to be included in the analysis. Appendix 4-A includes a key for identifying the various fields found on form MV-104A. Unfortunately, there is no way to directly determine from the fields on form MV-104A that an accident was a result of a dark signal. The best indicator on the form is fields 19 and 20 where the police officer enters the “apparent contributing factors” of the accident. The NYSDOT staff pulled the accidents that had a ‘68’ entered in either fields 19 or 20, this referred to ‘traffic control device non-working / inoperative.’ This, however, does not only provide accidents at dark signals but provides accidents due to other factors such as signals with burnt out bulbs, snow on the signal head or missing stop or yield signs. Upon receiving the accident reports the team then read the accident description to try and determine if the accident was truly the cause of a dark signal. If it was not or if it was unclear it was not included in the analysis. It should also be noted that the reports that were given to the team were only MV-104A forms. The team believes that there were other accidents dealing with dark signals in NYS that were recorded by other jurisdictions and not on the MV-104A form.

The team received over 1000 accident records between the years of 2003 and 2007 from NYSDOT. Each report was manually inserted into a database that contained all pertinent information. From all the records received, only 310 were found to be related specifically to dark signals. In addition to the 310 reports there were 58 accidents at intersections with the light on flash as a result of an earlier power outage. Although the number of accidents reported is relatively low, the number of near misses is expected to be much higher. Unfortunately, there is no way to quantify this number.

Once all off the dark signal specific accident records were identified the team geocoded each report. The purpose of this effort was to aid the team in identifying problematic areas across the state. Although the MV-104A forms have a placeholder for latitude and longitude coordinates, they were rarely entered by the police officer. Instead the team had to use the accident location fields and find the location using Google Earth. Once the location was found in Google Earth the coordinates were recorded. Also, at this time the team recorded characteristics of the intersections for the aerial photographs. This information included the geometry of the intersection, the number of lanes present including turn bays, the type of area where it was located (i.e. rural, urban, suburban) and any other unique features to the site. Each of these characteristics has been recorded in the master accident database which can be found in Appendix 4-B.

4.3.2 Results of Dark Signal Accident Analysis

The distribution of dark signal related accidents by year is presented in Table 4. The average number reported per year is 62 but in 2006 a large number were a result of an early snow storm in the Buffalo, NY region. These results will be presented later in this section. Upon reviewing the 310 dark signal specific accidents the team did not find any clear identifying characteristics as to where dark signal related accidents occur. This review included a multitude of characteristics including but not limited to the following:

- Geographic area (i.e. rural, suburban, urban);
- Number of lanes at the intersection, including turn bays;
- Number of legs at the intersection;
- Time of day or time of year; and
- Road surface condition (i.e. wet, dry).

Table 4 NYS Dark signal accidents by year

Year	Count
2003	62
2004	40
2005	55
2006	109
2007	44
TOTAL	310

Regions across NYS vary significantly in many different ways, including the number of traffic signals found within each of the regions of NYS DOT. For example, the number of NYS DOT traffic signals in Region 7, which is in Northern NY, has only 169 and Region 8 has 1187. Due to this fact it was necessary to normalize the data. To normalize the total number of accidents by region were divided by the total number of signalized intersections within that region. Figure 9 contains plots of the normalized accident rates by region and by year. For example, Region 1 has a five year rate of 0.05, and each year is approximately 0.01. Regions 2, 3, 4, 6, 7 and 9 have the best accident rates and regions 1, 5, 8 and 10 all have rates above 0.04 for the five year period. In Region 5 there were a large number of accidents in 2006. This was due to an

early snow storm which knocked power out to much of the region for an extended period of time (see Section 4.3.2.2 for more information). Region 11 was not reported because NYSDOT does not operate any signals with its boundaries. Figure 10 shows on a map how the NYSDOT Regions compare with one another during the five year period.

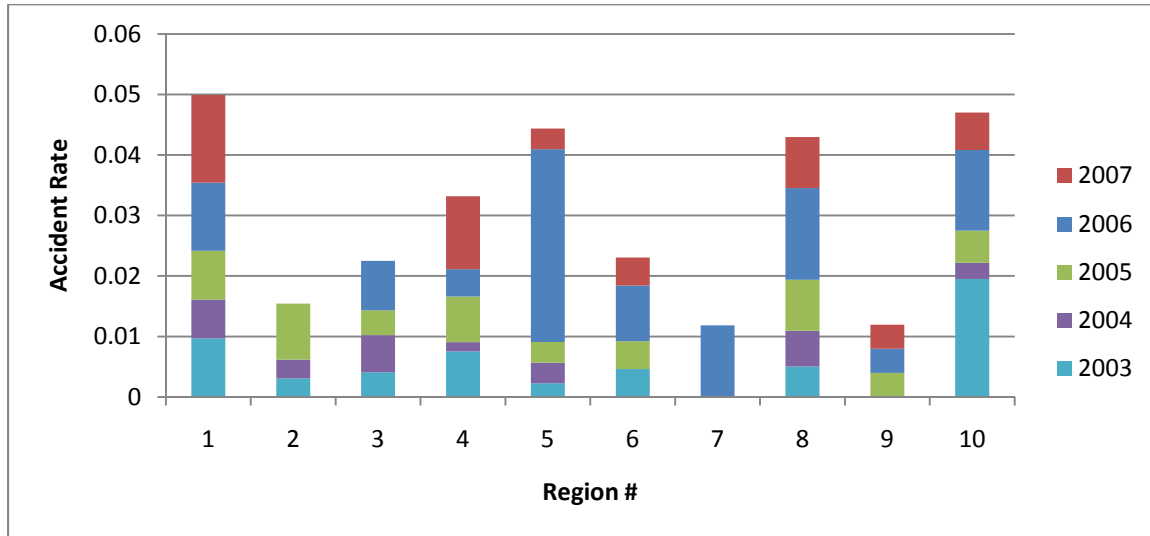

Figure 9 Normalized accident rates per DOT region by year (2003 - 2007)

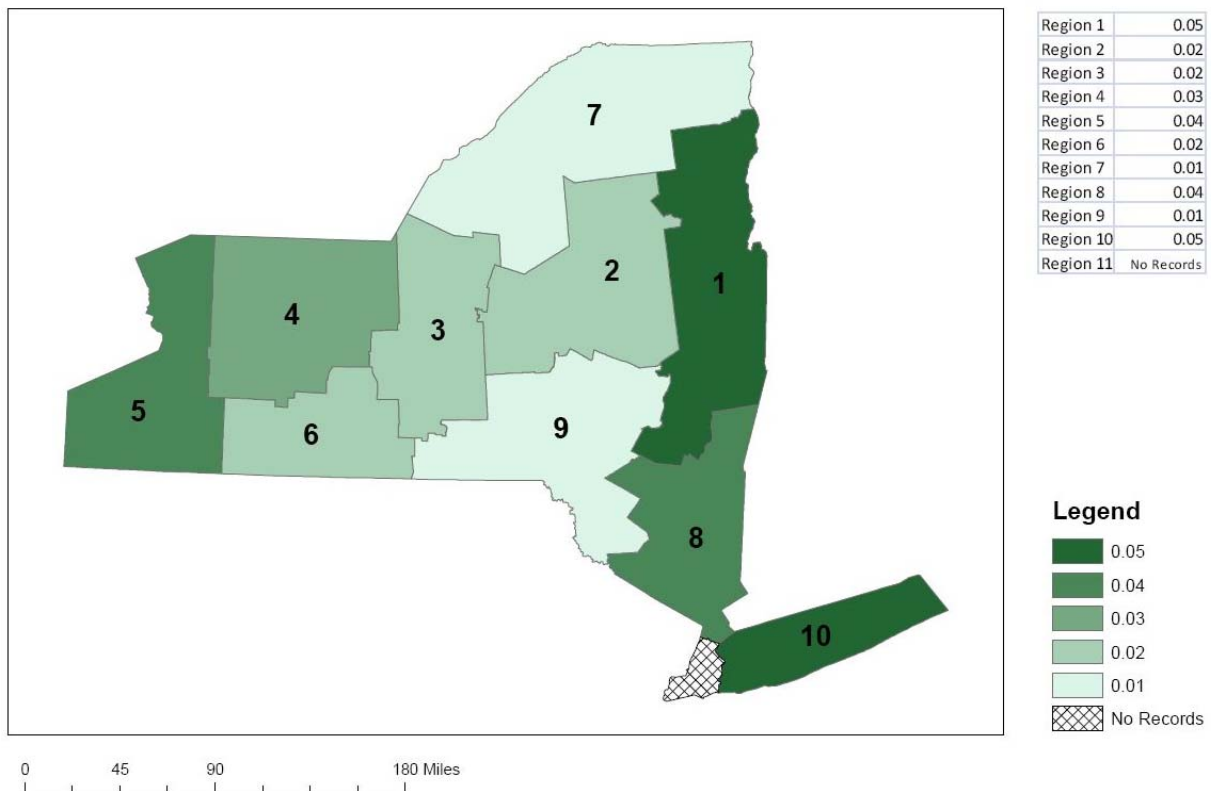

Figure 10 Dark signal related accidents within NYSDOT Regions between 2003 and 2007 (normalized)

Although Figure 10 identifies the NYSDOT regions that are more prone to dark signal related accidents, it is difficult to draw conclusions based on the data. The Task 5 report presents a historical perspective on power outages across NYS. As part of this report the team was able to compile maps showing where power outages are more prevalent across the state based on both the power company boundaries and the NYSDOT regions. A more comprehensive discussion about this data and how it was plotted can be found in the Task 5 report. As part of this task report it is worthwhile to use the power outage data and present a correlation between areas with higher historical outage rates and dark signal accidents. Figure 11 and Figure 12 make use of the historical power outage data provided by the New York State Public Service Commission (NYS PSC). The outage data has been normalized to make comparisons can be done across NYS. Figure 11 shows an average normalized power outage data between the years 2003 and 2006 across NYS, along with the dark signal related accidents during the same time period. Figure 12 is similar but shows the outage data divided more precisely which is shown for each of the utility company boundaries within NYS. It should be noted that the utility company boundaries cross regional boundaries. In both figures the darker shades of green represent higher rates of power outages per customer served.

Based on the data, Figure 11 and Figure 12 show a correlation between areas with higher outage rates and the number of dark signal related accidents. For instance, in Figure 11 Regions 2 and 7 have low historic power outage rates and a relatively few number of dark signal related accidents. On the other hand Regions 4 and 8 have much higher power outage rates and have a greater number of dark signal related accidents during the same time period. Furthermore, if the power company boundaries are used instead of the NYS DOT regions, the areas with large numbers of dark signal related accidents can typically be linked to power company boundaries with the worst results. For example, Figure 11 shows that many of the accidents with Region 4 are centrally located. When looking at Figure 12 it is clear that many of the accidents fall within the jurisdiction of the power company with the darker shade of green. The same is also true for Regions 5 and 8. Plots for each separate year between 2003 and 2006 with the historical power outage data shown by NYSDOT Region can be found in Appendix 4-C and the plots shown by power company boundary can be found in Appendix 4-D. Additionally, Figure 12 shows the times of year when the accidents occurred. In most cases the accidents occurred in the summer months. One exception is in Region 5, where many of the accidents occurred during the October snow storm that caused power outages for several days.

Average Normal Data Summary of DOT Regions between 2003 and 2006
(Radial Event Outage Hours per Customer Served per Square Mile)

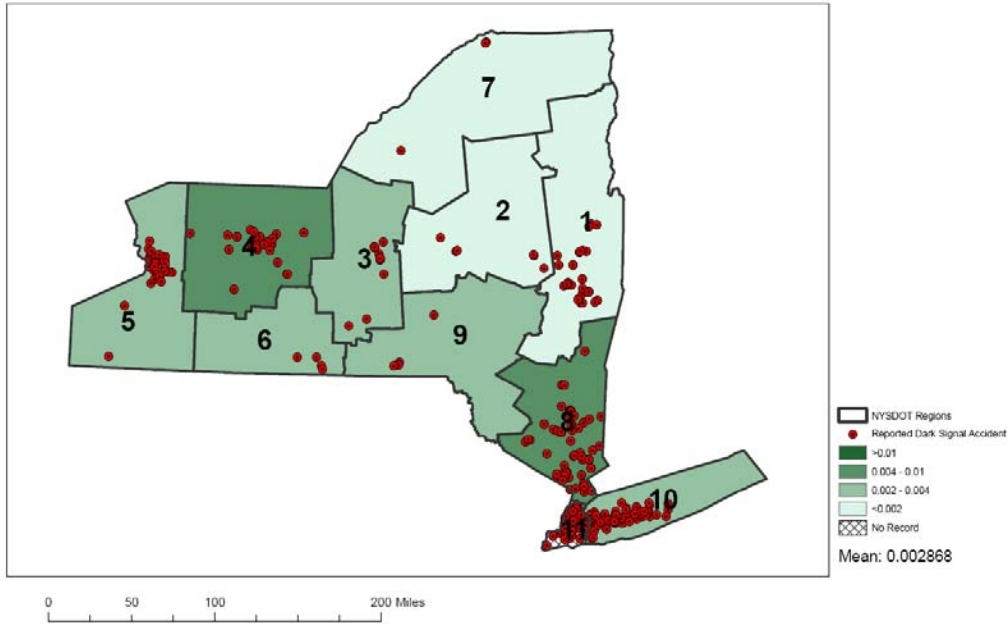

Figure 11 Normalized power outage data by NYSDOT Region and dark signal related accidents (2003 to 2006)

Average Normal Data between 2003 and 2006
(Radial Event Outage Hours Per Customer Served)

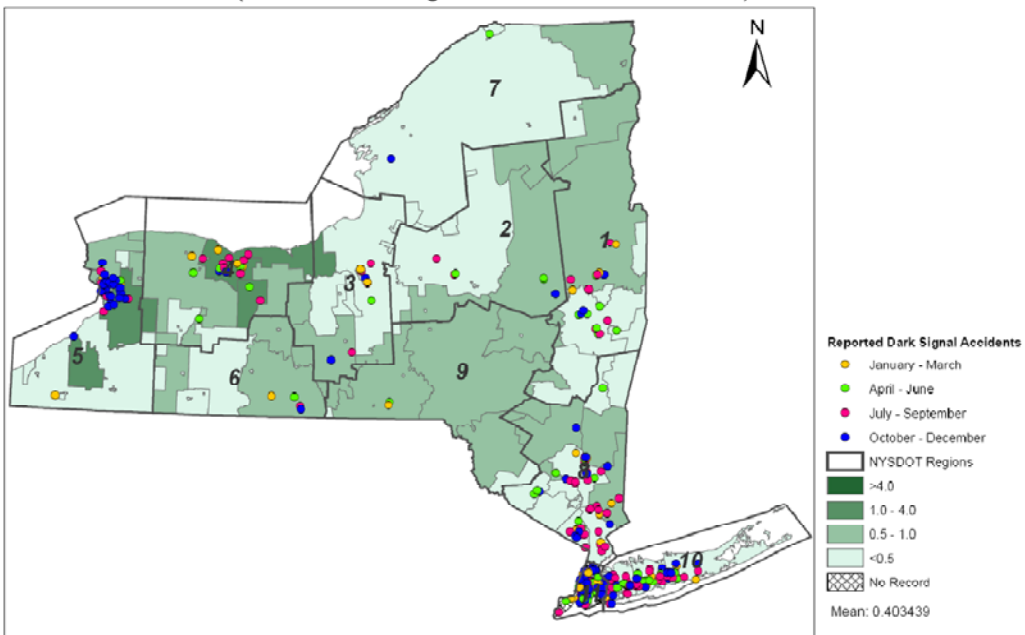

Figure 12 Normalized power outage data by power company boundary and dark signal related accidents (2003 to 2006)

4.3.2.1 Summary statistics

Below are some of the key findings from the analysis for the accidents between 2003 and 2007, supporting tables can be found in Appendix 4-E.

- 41% of the dark signal related accidents occurred at intersections with 4 to 6 total lanes;
- In 2004, 2005 and 2006 Region 11 had the most dark signal related accidents across the state but in 2006 Region 5 had almost the same number. In 2003 Region 10 had the most and in 2007 Region's 1 and 8 had the most. Region's 2, 6, 7 and 9 had reported the fewest accidents during the five year period;
- Historically July and August are the most dark signal related accident months of the year, approximately double compared to most other months (see Figure 13);
- Injuries at dark signal accidents are nearly twice as likely as non-injury accidents;
- There does not appear to be any relationship of time of day and when dark signal accidents occur;
- 77.7% of all reported dark signal related accidents were right angle collisions and 11.2% were rear-end collisions;
- 47% of the dark signal accidents occurred at intersections with turn bays. For all types of accidents across NYS the average is only 29%, this indicates that intersections with turn bays are more dangerous when the power is out; and
- It is more likely that injury accidents at dark signals will occur between the hours of 2:00 PM and 5:00 PM based on the data from 2003 to 2007. There is also a 31.3% chance that no injuries will be reported while 40.7% will have one injury.

The most prevalent accident type that was recorded at dark traffic signals was right angle collisions. 77.7% of reported dark signal accidents were right angle collisions and 11.2% were rear-end collisions. For all intersection accidents reported to NYSDOT between the same time period only 17.8% were right angle collisions. This difference of 60% is substantial, especially since right angle collisions are more likely to involve injury to the people involved.

Year	Type of Accident								Total
	Fixed Obj	Head on	Left Turn	Rear-End	Right Angle	Right Turn	Sideswipe	Unknown	
2003	2		1	2	56	1			62
2004			1	3	34	2			40
2005		1	4	8	40		1	1	55
2006		1	6	19	76	1		6	109
2007			4	3	35	1		1	44
Total	2	2	16	35	241	5	1	8	310

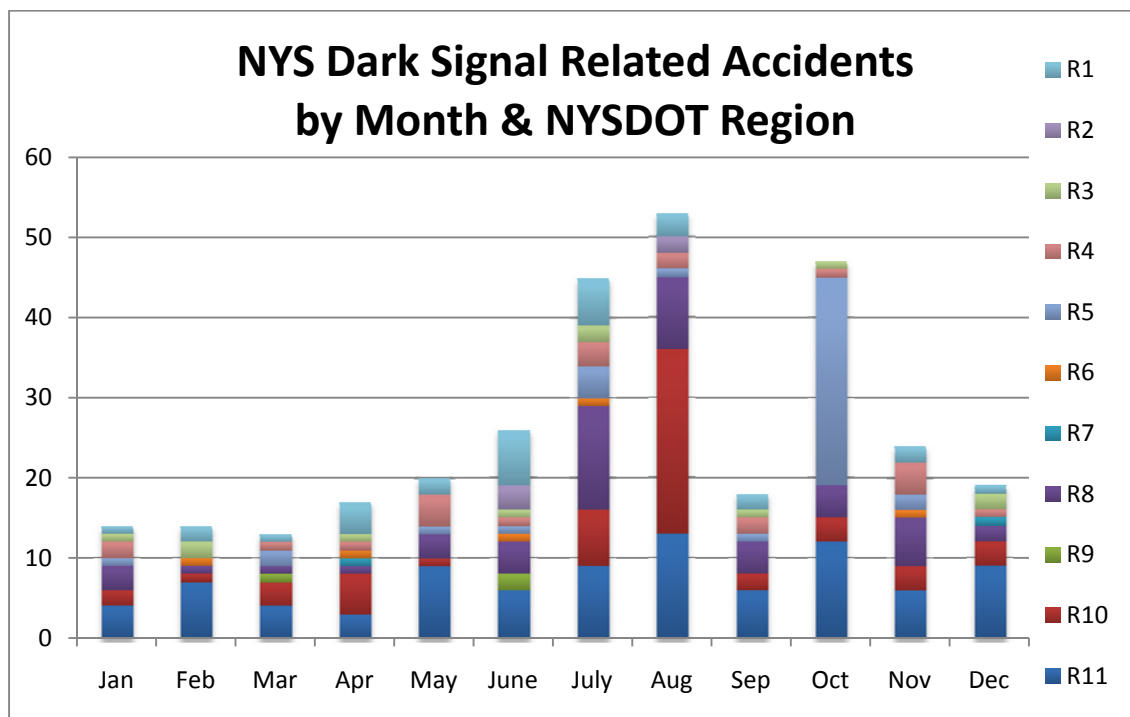

Figure 13 Dark signal related accidents by month and NYSDOT region (all between 2003 and 2007)

Upon analyzing the dark signal related traffic accidents, it was found that July and August were the months when the majority of the dark signal related accidents occur as shown in Figure 13. The spike that is shown in October is a result of an early snow storm in October of 2006 in Region 5. As part of Task 3 the team interviewed several DOT representatives from various regions across the state. They all indicated that they experience more dark signals during the summer months. These results validate this. This indicates that the traffic signals are more susceptible to electrical storms than to snow and ice during the winter months.

4.3.2.2 Regional Events

Occasionally a power outage will be more wide-spread and will last longer than normal. During the time period between 2003 and 2007 there were two notable outages across New York. The first was the Northeast Blackout on August 13th, 2003 which affected over 40 million people in

eight U.S. states and 10 million people in Ontario Canada (6). The second was an early lake effect snow storm in Buffalo, NY beginning on October 12th, 2006. This snow storm knocked power out to much of Erie County, NY (Region 5) for up to eight days. There are numerous dark signal related accidents for both events. The team has 27 accident reports associated with the 2003 blackout. Although this number is substantial for one day, the team does not think they have all the reports of dark signal related accidents. This is because most of the 27 accidents were in Regions 10 and 11 and almost none in other parts of the state. For the snow storm the team has recorded 26 accidents in an eight day period in Region 5. Some of the data analysis from the Region 5 storm is included in Appendix 4-E.

These two incidents alone identify a great need for installing uninterrupted power supplies across New York State. In addition to the traffic accidents that were caused based on those two events, the safety and the efficiency of the transportation network were greatly jeopardized.

4.3.2.3 Locations with multiple dark signal related accidents

The team was able to identify locations that had multiple dark signal related accidents between 2002 and 2007. The results can be seen in Table 5. Of the 17 locations with multiple reports there was only one location having four and one location having three dark signal related accidents; all others had two. The team used Google Streetview to visually inspect each of the intersections. Five of the locations did not have Streetview maps online, but the others did not appear to have any major design flaws. No definitive conclusions could be drawn from studying the images.

Table 5 Locations with multiple dark signal related accidents between 2002 and 2007

City	Road Name	Intersecting Road	# of Occurances
Somers	Route 100	Route 35	4
Tonawanda	Sheridan Dr	Parkhurst Blvd	3
Ballston	Route 50	Brookline Rd	2
Bronx	Allerton Ave	Bronxwood Ave	2
Brooklyn	New York Ave	Winthrop St	2
Clarence	Transit Rd	Coricner Rd	2
Cortlandt	State Route 6	Westbrook Ave	2
Hempstead	Front St	Penninsula Blvd	2
Hempstead	Carmen Ave	Salisbury Park	2
Hunington	Route 110	S Service Rd	2
Huntington	Route 110	N Service Rd	2
Montgomery	Route 52 E	Albany Post Rd	2
Poestenkill	State Route 66	State Route 351	2
Queens	Woodhaven Blvd	103 rd Ave	2
Queens	94 th St	31 st Ave	2
Smithtown	Route 347	Terry Rd	2
West Seneca	Transit Rd	Clinton St	2

It should be noted that NYSDOT realizes that it is important to document where accidents are occurring throughout the state and for what reason. NYSDOT has been working on an Accident Location Information System (ALIS) to aid in the reporting of accidents. Once this is fully operational it should be much simpler to view and study accident locations across the state. As part of this project they have stated one of the goals to be:

Develop a “state of the art” GIS system to identify areas of “High Accident Locations (HALS)” and “unusual concentrations of accident types” to support mitigation strategies for accidents and road hazards reduction and ensure safer roadways for NYS’ traveling public (5).

NYSDOT also provided the team with a listing of priority investigation intersections (PII). This list has been compiled for NYS intersections where the accident rate in accidents per million entering vehicles (MEV) significantly exceeds the average state intersection rate for similar intersections and meets a minimum threshold of crashes. The analysis is based on a 99.9 percent level of confidence with similar intersections being identified based on functional class, traffic control, and configuration. There were 27 PII’s identified between 2005 and 2007 that also had a dark signal related accident. There were no locations on the PIL that had more than one dark signal related accident. Figure 14 shows where the 27 locations are across the state.

Note that in many cases the areas seem to be clustered within DOT Regions. The cause for this is unknown.

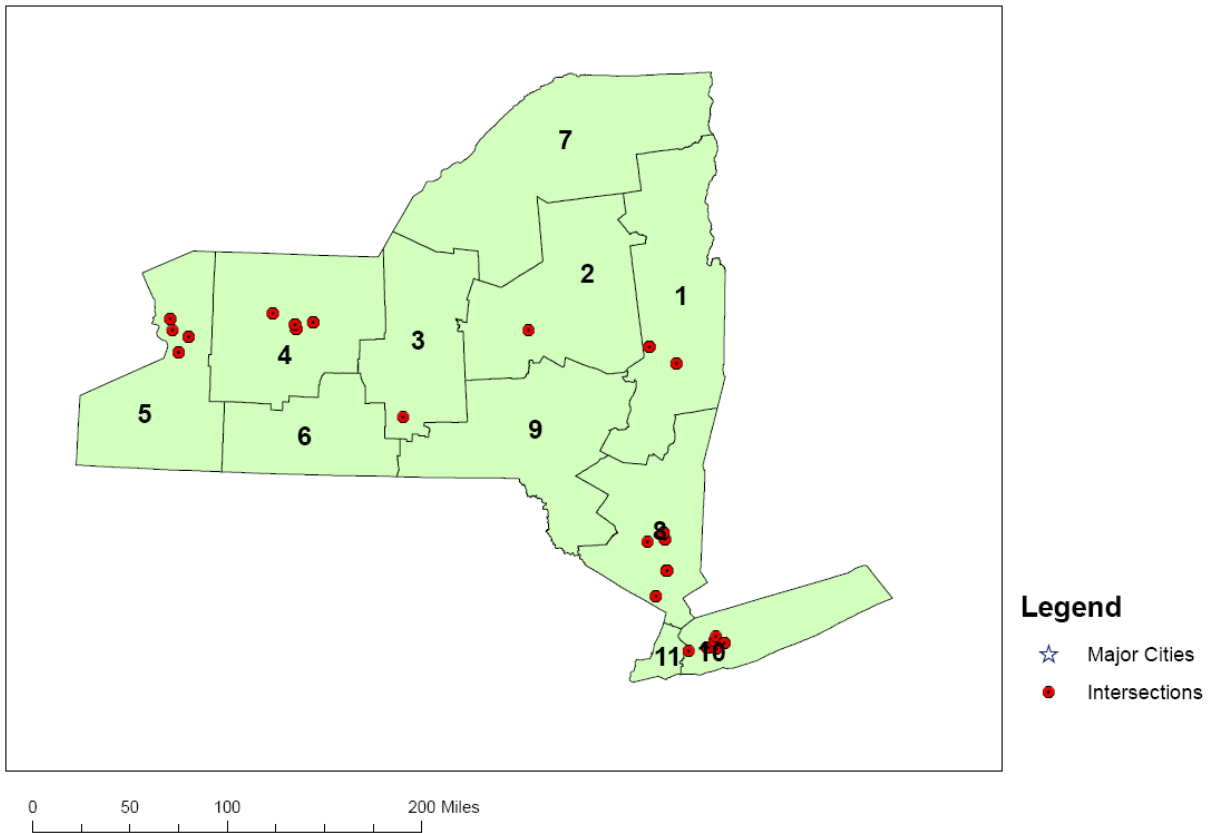

Figure 14 PII locations that also had dark signal accidents

Although no clear trends could be identified from the data analysis, the team found interesting results worthy of documenting. It was seldom noted in the accident reports that the driver was unaware they were entering an intersection without control. Rather, in many of the reports the drivers remarked that they were often confused as to who had the right of way at the intersection. Unfortunately there is no way to know for sure what the driver was seeing or how they reacted; this is only what they reported to the police after the event.

4.4 Prioritization Guidelines

Section 4.2 discussed what other agencies have done to prioritize deployment of UPS at intersections. This section presents the factors and a scoring methodology for prioritizing intersections across NYS. Each intersection has its own unique attributes and, depending on the conditions, some may be more susceptible to accidents than another. For example, an intersection in an urban area such as Long Island may have a need for a backup power system while a rural intersection with a much lower volume in the Adirondacks may also have a need.

The proposed scoring methodology is intended to reduce this variability. The dark signal accident results presented in Section 4.3.2 indicate that there are no clear patterns as to where and why dark signal related accidents occur. It is more a function of how frequently the power is out at a certain intersection. Therefore, it is crucial for a scoring methodology to be adaptable to the many different areas of the state.

The team considered using a variety of different scoring methodologies. Some of the factors that were considered include the following:

- Accident history at intersection (both under normal conditions and 'dark');
- Historical power outage problems;
- Proximity to other systems (i.e. railroad crossing, emergency services, etc);
- Average Annual Daily Traffic (AADT) through the intersection;
- Design speed of approaching lanes;
- Number of approach lanes per direction;
- Geometry (normal versus abnormal);
- Stopping sight distance;
- Evacuation or truck routes; and
- Proximity to special events (consider number of 'event' vehicles and recurrence of event and familiarity of the 'spectators' with the area).

Ideally NYSDOT should be able to score each and every intersection they operate across the state before choosing the intersections to be outfitted with BBS. Since they operate nearly 6000 intersections this would be a daunting task. Therefore, NYSDOT should use these guidelines on a case by case basis for evaluating intersections.

4.4.1 Scoring Criteria

Based on the historical data the team analyzed in conjunction with meetings with NYSDOT officials the team was able to create a scoring system that is applicable across NYS. The scoring criterion was designed to be simple yet take into account the most important factors found at intersections across NYS. Figure 15 presents the proposed prioritization scoring sheet. The interactive version of the sheet can be found as a Microsoft Excel file in Appendix 4-F. It has been designed to apply various weighting values depending on the different factors. As intersections become outfitted with BBS it is anticipated that the scoring criteria will be modified. It is anticipated that the scoring could be done on a case by case basis, or it could be automated for larger subsets of intersections. To score all of the nearly 6000 NYSDOT operated intersections in New York it would be desirable to ensure all of the data is readily available in a common format and to automate the process. The following subsections describe in more detail the various factors, the anticipated input, and the reason behind the existing weighting factors.

Prioritization Factor	Input Value	Weighting Factor	Total
Priority Intersection Location: How many times in the last three years does the intersection get rated on the NYSDOT 'priority intersection' list (<i># occurrences in last 3 years</i>)		15	0
MUTCD Warrant: Does intersection meet MUTCD warrant #7 (crash experience) (Y/N)		15	0
Power Outage History: Using historical power outage data how does the site score above the statewide normalized mean (for at least the last 3 years) (<= mean="0"; up to 75% higher than the mean="1", 75% or above the mean="2")		10	0
Proximity to Grade Crossing: Is intersection within less than 75' from a grade crossing (enter "1"), is intersection between 75' and 200' from grade crossing (enter "2")		10	0
Speed: Is the posted speed of any approaching lane greater than 40 MPH OR part of a freeway exit ramp (Y/N)		10	0
Volume at Intersection: AADT of all approach lanes combined (nearest 5000)		5	0
Evacuation Route: Is this intersection part of an evacuation route (Y/N)		5	0
Truck Route: Is this intersection part of a designated truck route (Y/N)		5	0
Left turn bays present: (Y/N)		5	0
If turn bays are present are any multilane? (Y/N)		5	0
Proximity to other signalized intersections: Is this intersection within 2 miles of another traffic signal? (Y/N)		5	0
Total Score:			0

Figure 15 Proposed prioritization scoring sheet

4.4.1.1 Priority intersection locations

NYSDOT has compiled a list of intersections where the accident rate in accidents per million entering vehicles (MEV) significantly exceeds the average state intersection rate for similar intersections and meets a minimum threshold of crashes. The analysis is based on a 99.9 percent level of confidence with similar intersections being identified based on functional class, traffic control, and configuration. This list is compiled annually.

This list effectively identifies the unsafe intersections across the state. It is expected that if there is a power failure that these intersections will become even more unsafe. For the input value it is anticipated that the user will insert the number of times a particular intersection was on the list within the last three years. For example, if an intersection was on the list in 2005 and in 2007 the user would enter a '2'. The weighting factor is set to be 15, therefore the maximum score an intersection could receive for this entry is 45 points.

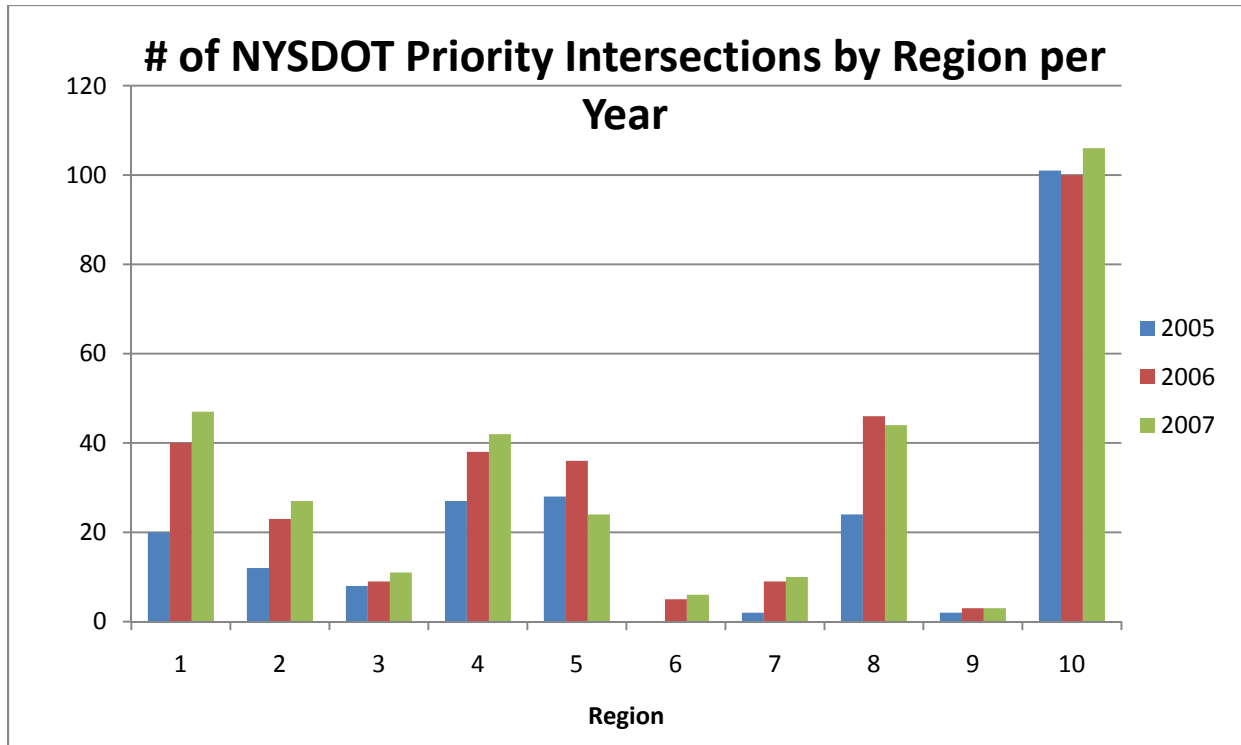

Figure 16 Number of NYSDOT priority intersection locations by region per year

Figure 16 contains the total number of priority intersections within each region. If an intersection appeared on the list in multiple years the intersection will be counted each year. Figure 17 shows the frequency of the priority intersection locations between 2005 and 2007 as they appear across NYS. As the figure shows there are 115 intersections that appeared on the priority intersection list for all three year. Therefore these 115 would be the only intersections that would receive the maximum score of 45; similarly there are 179 locations that were on the list for two years, therefore receiving 30 points each; there are 186 intersections only appearing once therefore, receiving 15 total points.

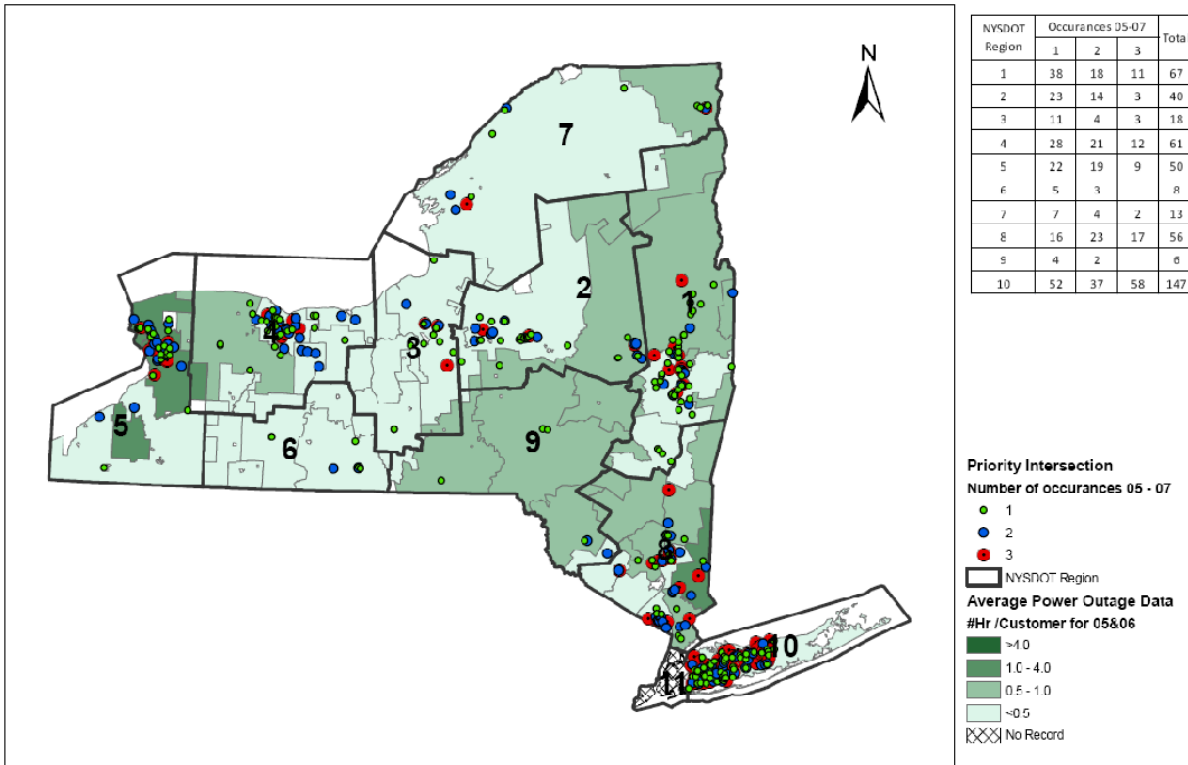

Figure 17 Frequency of NYSDOT priority intersection locations

4.4.1.2 MUTCD intersection ‘warrant #7’

The Manual on Uniform Traffic Control Devices (MUTCD) serves as a guide for a great deal of traffic control devices (7). There is no guidance within the MUTCD on installing backup power systems at traffic signals. There is however a great deal of discussion on the basis of installation of traffic control signals (Section 4B.02). Within this section there are eight warrants that are presented to justify installing a traffic control signal. Warrant 7 (Section 4C.08) deals with crash experience at an intersection and it states the following:

The Crash Experience signal warrant conditions are intended for application where the severity and frequency of crashes are the principal reasons to consider installing a traffic control signal.

Standard:

The need for a traffic control signal shall be considered if an engineering study finds that all of the following criteria are met:

- A. Adequate trial of alternatives with satisfactory observance and enforcement has failed to reduce the crash frequency; and***
- B. Five or more reported crashes, of types susceptible to correction by a traffic control signal, have occurred within a 12-month period, each***

crash involving personal injury or property damage apparently exceeding the applicable requirements for a reportable crash; and C. For each of any 8 hours of an average day, the vehicles per hour (vph) given in both of the 80 percent columns of Condition A in Table 4C-1 (see Section 4C.02), or the vph in both of the 80 percent columns of Condition B in Table 4C-1 exists on the major-street and the higher-volume minor-street approach, respectively, to the intersection, or the volume of pedestrian traffic is not less than 80 percent of the requirements specified in the Pedestrian Volume warrant. These major-street and minor-street volumes shall be for the same 8 hours. On the minor street, the higher volume shall not be required to be on the same approach during each of the 8 hours (7).

It is logical to assume that if a traffic signal was installed at an intersection because it was unsafe without one, it would once again become unsafe if it were to experience a power failure. For the input value it is anticipated that the user will insert a 'y' for yes if a particular intersection has been identified to meet MUTCD Warrant #7. If the user inserts a 'y' the weighting factor is set to be 15, otherwise it will be zero.

It should be noted that as of now, obtaining this piece of information is nontrivial. Some intersections may have been outfitted with a signal prior to the implementation of this signal warrant. Also, there is no current database that identifies which intersections had traffic signals installed because they met certain warrants. NYSDOT informed the team that this data typically resides at each of the DOT regional offices. Even though this data is difficult to obtain it is important in scoring a signalized intersection for a backup power system.

4.4.1.3 Power outage history

The NYS PSC has provided the team with monthly outage data for the various utility companies that operate across New York. The team has studied this data and has computed the total number of outage hours divided by the total number of customers served for a particular region. This analysis was done for the *Historical Power Outage Analysis* (Task 5) report and it describes in more detail how the data was processed (8).

The data compiled presents a broad picture of the areas across New York with power outage problems. This does not identify specific areas that are prone to outages. If there is a particular area that has known problems it is advisable to change the input of the scoring sheet to reflect the known local conditions as opposed to the broad data. For the input value on the scoring sheet the user shall enter one of the following values depending on the subarea's normalized mean:

- \leq statewide mean **enter '0'**
- Up to 75% higher than the statewide mean **enter '1'**
- 75% or above the statewide mean **enter '2'**

For example, Figure 18 presents a GIS image of the normalized power outage data for the various utility company subareas in NYS between 2003 and 2006. For this time period the mean was 0.40. If an intersection was located in an area, for example in the dark green area of Region 4 the user would enter a '2' in the scoring sheet because it is over 75% above the statewide mean. The weighting factor is set to be 10, therefore the maximum score an intersection could receive for this entry is 20 points.

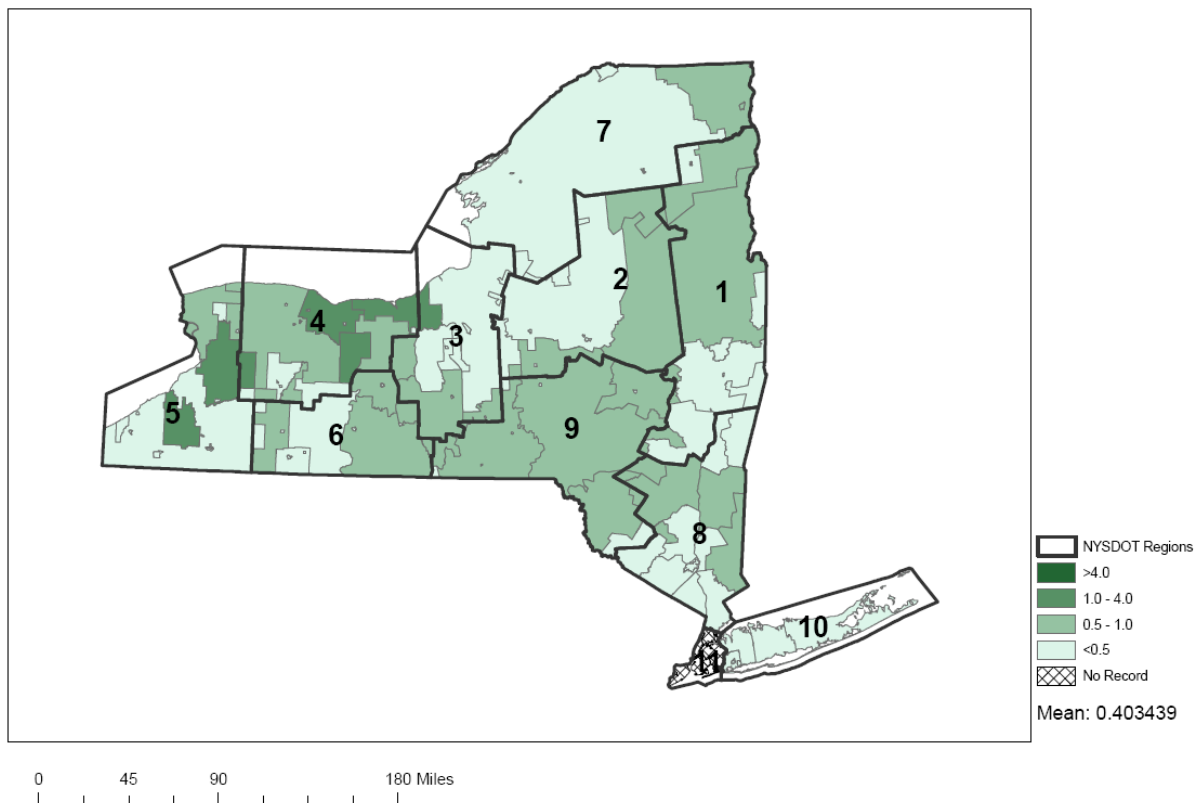

Figure 18 Radial event power outage hours per customer served for utility company subareas averaged between 2003 & 2006

4.4.1.4 Intersection proximity to grade crossings

Railroad grade crossings are considered unsafe, however, when a grade crossing is in close proximity to a signalized intersection the mechanics of the intersection become even more unsafe. The NYSDOT's Office of Modal Safety and Security has stated the following:

The mission of the Department's Grade Crossing Safety and Regulation Section is to reduce the frequency and severity of accidents involving vehicles and pedestrians at highway-railroad grade crossings. Grade crossings, as the intersections of highway and rail modes of transportation, are inherently unsafe. Unlike vehicular intersections, a train cannot safely stop in a timely manner to avoid collisions (9).

During a power outage the railroad grade crossing should be designed to have an automatic backup power system installed. However, the nearby traffic signals are not currently required to have any type of backup system installed. To maintain safety it is critical to ensure the traffic through the intersection is moving efficiently. Therefore, the team has included the proximity of a grade crossing to a signalized intersection as a key factor for installing BBS. The distance the signalized intersection is away from the grade crossing has also been included in the guideline. If there is a grade crossing in close proximity to the signalized intersection the user has to define if it is less than 75' away or falls between 75' and 200' away.

For the input value it is anticipated that the user will insert a '1' if there is a grade crossing less than 75' from the grade crossing or a '2' if there is a grade crossing between 75' and 200' away. Signals less than 75' from the grade crossing will receive a total score of 20, signals between 75' and 200' of a grade crossing will receive a score of 10 and all others will be zero.

4.4.1.5 Speed approaching the intersection

Approach speeds through an intersection are crucial in terms of safety, especially if the intersection is operating during a power failure. As the speeds approaching a signalized intersection increases the likelihood for a severe accident also increases. Therefore, during a power failure intersections with high approach speeds are more likely to yield more severe accidents.

For the input value it is anticipated that the user will insert a 'y' for yes if a particular intersection has anyone approaching lane speed greater than 40 MPH or if any approaching lane is part of a freeway exit ramp. If the user inserts a 'y' the weighting factor is set to be 10, otherwise it will be zero.

4.4.1.6 Vehicular volume through the intersection

The team has found that vehicular traffic volumes through an intersection are less critical than other safety factors when determining which intersections shall be instrumented with backup power systems. This is not to say that considering the vehicular volumes is not important. At intersections with lower volumes, for example rural locations, the intersection may be more difficult to see during dark conditions because there is less traffic at the intersection. This could lead to a vehicle driving through the dark signal and colliding with another vehicle. At higher volume intersections it is more likely that people will be forced to slow down and stop at the

intersection. This is because there are more people competing to get through the intersection creating more confusion amongst the motorists. However at higher volume intersections the efficiency is likely to be very poor when there is a dark traffic signal.

For the input value it is anticipated that the user will insert the total daily traffic volume for all approaches at the intersection. The volume can be rounded to the nearest 5000 vehicles. Depending on the volume the weighting factor will change, the maximum score for this field is 15 points.

4.4.1.7 Designated evacuation route

To facilitate the flow of traffic the team has included a score if an intersection is part of a designated evacuation route. There are sometimes evacuation routes that have been setup by various jurisdictions such as the county or town DOT's. Therefore, it is advised that the user use local knowledge when filling in this field.

For the input value it is anticipated that the user will insert a 'y' for yes if a particular intersection is part of an evacuation route. If the user inserts a 'y' the weighting factor is set to be 5, otherwise it will be zero.

4.4.1.8 Designated truck route

To facilitate the flow of traffic the team has included a score if an intersection is part of a designated truck route. The reason this is important in terms of safety and efficiency. Truck routes may or may not be defined by signage along a route. There are sometimes defined truck routes that will guide trucks around a certain area. In other cases there are routes that are not signed as a truck route but have heavy truck volumes and are accessible by most types of trucks. Therefore, it is advisable that the user use local knowledge of the traffic conditions when filling in this field.

For the input value it is anticipated that the user will insert a 'y' for yes if a particular intersection is part of a designated truck route. If the user inserts a 'y' the weighting factor is set to be 5, otherwise it will be zero.

4.4.1.9 Presence of left turn bays

Intersections that have left turn bays are typically more completed than those without. When the traffic signal is operating correctly these typically operate efficiently. However, when there is a power outage there is often more confusion as to who has the right of way. It is due to this fact that the team has included the presence of left turn bays into the prioritization guidelines. Furthermore, if an intersection has any left turn bay that is multilane the complexity is compounded. This is taken into account with the scoring sheet.

The input for this field is twofold. First the user enters a 'y' for yes or 'n' for no depending on if there are any left turn bays present at the intersection. If the user entered a 'y' they will then insert a 'y' or 'n' on the following line to indicate if any of the left turn bays are multilane. If a user enters a 'y' for left turn bays present but an 'n' for multilane turn bays the score would yield 5 points. If the user entered a 'y' for left turn bays present and a 'y' for multilane turn bays it would yield 10 total points.

4.4.1.10 Proximity of intersection to other intersections

Intersections that are not in close proximity to other intersections are more likely to be unnoticed by motorists in the event of a power failure. The reason for this is that if the motorist is approaching a dark intersection and they have not passed through an intersection in a short time period they are less likely to be anticipating one. This is why there is a scoring criterion for the proximity of a signalized intersection to another signalized intersection.

For the input value it is anticipated that the user will insert an 'n' for no if a particular intersection is more than a certain distance of another signalized intersection. The default distance is set at 2 miles of another signalized intersection. If the user inserts an 'n' the weighting factor is set to be 5, otherwise it will be zero.

4.4.2 Prioritization Summary

Ultimately the score of an intersection is a rating that identifies intersections that would likely be more unsafe than others during power outages. The higher the score the more likely the intersection would be unsafe in the event of a power outage, the maximum score possible is 150 points. Without installing backup systems at each and every intersection there is no way to eliminate all dark signal related accidents. The goal is to substantially reduce the number of dark signal related crashes and reduce the number of injuries. In addition to the methodology it is recommended that engineering judgment by regional DOT officials should be used when choosing intersections to be outfitted with backup power systems. The reason for this is that the engineers within each of the NYSDOT Regions are more likely to be aware of the performance of many of the intersections within the region, especially the ones that rate with a higher score.

Also, this scoring methodology could be used on a few individual intersections or it could be applied to a region or even the entire set of intersections across the state. It is necessary to ensure the proper data is being used for the scoring.

4.5 Conclusions

Improving the safety at intersections across New York State is of utmost importance, particularly at dark intersections. When determining the scoring criteria it was necessary to

consider all of the various regions within NYS. The reason for this is that the state is diverse and there are many rural, suburban and urban areas across the state. Based on the analysis of the accidents at dark intersections most of the motorists noted that they were often confused as to who had the right of way when the power was out. Although the law is to treat unpowered traffic signals as four-way stops, people are often unaware of this and there should be public education to this effect.

The prioritization guidelines identified in Section 4.4 should be used as an aid in determining which intersections should be outfitted with backup power systems. This should be coupled with engineering judgment to choose the intersections that are in the most need of being installed with a BBS. It should be noted that without installing backup systems at each and every intersection there is no way to eliminate all dark signal related accidents. The goal is to substantially reduce the number of dark signal related crashes and to reduce the number of injuries.

Also, as these systems continue to evolve and become more reliable and cost competitive NYSDOT should consider installing BBS at any new construction intersection as well as any signal retrofit. For new traffic signals, it is recommended to develop a system that is fundamentally DC with a single conversion from AC to DC at the input. Under this architecture incorporating energy storage is natural within the DC system, thereby eliminating unnecessary conversions and gaining all of the benefits associated therewith.

4.6 References

- (1) Rogers, M. and Rubens, D. "Commission Report – Senate Bill 84 XX – Battery Backup Program for Light Emitting Diode (LED) Traffic Signals." California Energy Commission. May 2004.
- (2) Nyland, D. "Subject: Uninterruptible Power Supplies (UPS) at Signalized Intersections and at Traffic Control or Warning Devices Interconnected with Railways." Technical Circular – Ministry of Transportation – British Columbia, Canada. Engineering Branch. Circular Number: T-07/06. 1 May 2006.
- (3) Torrey, D., Wallace, W. and Wojtowicz, J. *Task 3: Identify and Evaluate Possible Technologies*. Technical Report 08-03. Center for Infrastructure and Transportation Studies, Department of Civil and Environmental Engineering, Rensselaer Polytechnic Institute, October 2008.
- (4) Minnesota Department of Transportation - Office of Traffic Engineering, "Dark Signals - A Report on Laws Concerning Dark, Malfunctioning or Inoperative Traffic Signals." 1998. <http://www.dot.state.mn.us/trafficing/standards/signals/news/DRKSigREPORT.pdf>.

- (5) Hunt, K. and Magnant, J. "New York State Accident Location Information System Analyzing the Past to Provide a Safer Future." New York State Department of Transportation. 2007. 8 Aug 2008. <http://www.gis-t.org/files/EAPPb.pdf>.
- (6) "Northeast Blackout of 2003," July 2008. http://en.wikipedia.org/wiki/Northeast_Blackout_of_2003#References. Accessed 4 Sep 2008.
- (7) *Manual on Uniform Traffic Controls Devices with Revisions Number 1 and 2 Incorporated*. 2003 ed. 2007. http://mutcd.fhwa.dot.gov/kno_2003r1r2.htm
- (8) Tan, J., Wallace, W. and Wojtowicz, J. *Task 5: Historical Power Outage Analysis*. Technical Report 09-02. Center for Infrastructure and Transportation Studies, Department of Civil and Environmental Engineering, Rensselaer Polytechnic Institute, June 2009.
- (9) New York State Department of Transportation – Office of Modal Safety and Security, "Grade Crossing Safety & Regulation Section." 14 March 2009. <https://www.nysdot.gov/divisions/operating/osss/rail/grade-crossings>.

TASK 5: Historical Power Outage Analysis

5.1 Introduction

Motor vehicle accidents at ‘dark’ traffic signals are much more likely and substantially more severe than compared with a normally operating traffic signal. Power outages which result in signal failure in parts of New York State can occur for a variety of reasons at any given time. For example, during the winter months ice buildup on power lines may cause power outages for an extended period of time, or in the summer months an electrical storm may disrupt the supply of power. Other cases which are not weather related may include a vehicle striking a utility pole or an accidental power disruption due to construction.

As part of this chapter the team has obtained historical power outage data from the New York State Public Service Commission (PSC) as well as published reports. Based on the data analysis this chapter provides a historical perspective on the power outages throughout NYS between 2003 and 2006. Section 5.2 describes the data that has been collected; Section 5.3 presents the data analysis, and Section 5.4 provides notable conclusions. Appendix 5-A is a Microsoft Excel file containing historical power outage data from the NYS PSC; Appendix 5-B through 5-H contain yearly power outage reports from the NYS PSC from 2001 through 2007 respectively; Appendix 5-I through 5-N contains a variety of power outage plots in GIS between 2003 and 2006;

5.2 Historical Power Outage Data

As part of this task many agencies were contacted for historical power outage data. These agencies included the utility companies, the NYS Public Service Commission (PSC), the New York State Energy Research and Development Authority (NYSERDA) and the NYS Department of Transportation (NYSDOT). The only agency that was able to provide historical outage data was the NYS PSC.

The PSC provided outage data across most of NYS from 1989 through 2006. This outage data has been aggregated into a month by month database. Therefore, individual outages are not apparent but trends can be visualized. The data is also broken down by individual utility companies and their subareas. For each subarea there are aggregated monthly totals of outages and total length of time (in customer hours) for

Table 6 Defined event types

Radial Event	Network Event
Storm	Services
Tree	Mains
Overload	Equipment
Error	Accident
Equipment	Prearranged
Accident	Cust. Equip.
Prearranged	Unknown
Cust. Equip.	
Lighting	
Unknown	

a variety of event types. These events are defined in Table 6. A database containing this data can be found in Appendix 5-A. The PSC provides yearly interruption reports on the major utility companies and it is primarily based on the following (1)-(7):

As a means of monitoring the levels of service quality, the Commission's Rules and Regulations require utilities delivering electricity in New York State to collect and submit information to the Commission about electric service interruptions on a monthly basis. Using the data, Staff calculates two primary performance metrics: the System Average Interruption Frequency Index (SAIFI or frequency) and the Customer Average Interruption Duration Index (CAIDI or duration). The information provided is also subdivided into 10 categories that reflect the nature of the cause of interruption (cause code) (7).

These yearly interruption reports are at the utility company level; they are not broken down within the subareas for each utility. The reports are detailed and provide an analysis of the utility company's performance for the given year. These yearly reports can be found in Appendices 5-B through 5-H.

As a point of reference Figure 19 and Figure 20 were derived from the NYS PSC SAIFI and CAIDI data. The SAIFI is essentially the number of customer outages divided by the number of customers served for a particular area, the CAIDI is the total number of customer hours for an outage divided by the total number of customers affected.

Figure 19 indicates that when major storms are excluded from the analysis the frequency of outages across NYS has been remained relatively flat between 2003 and 2007. When the major storm data is included in the analysis there is more variability from year to year.

Figure 20 indicates that the statewide duration of power outages has edged up slightly since 2003. Although 2007 was less than in 2006 the trend is upward. It is also noteworthy to report on the 2 major spikes in duration in Figure 20 with major storms included. In 2003 there was the Northeast Blackout that affected most of the northeast and lasted for several days. In 2006 there was the early lake effect snow storm in the Buffalo, NY area. These two events are the likely causes for the large spikes in.

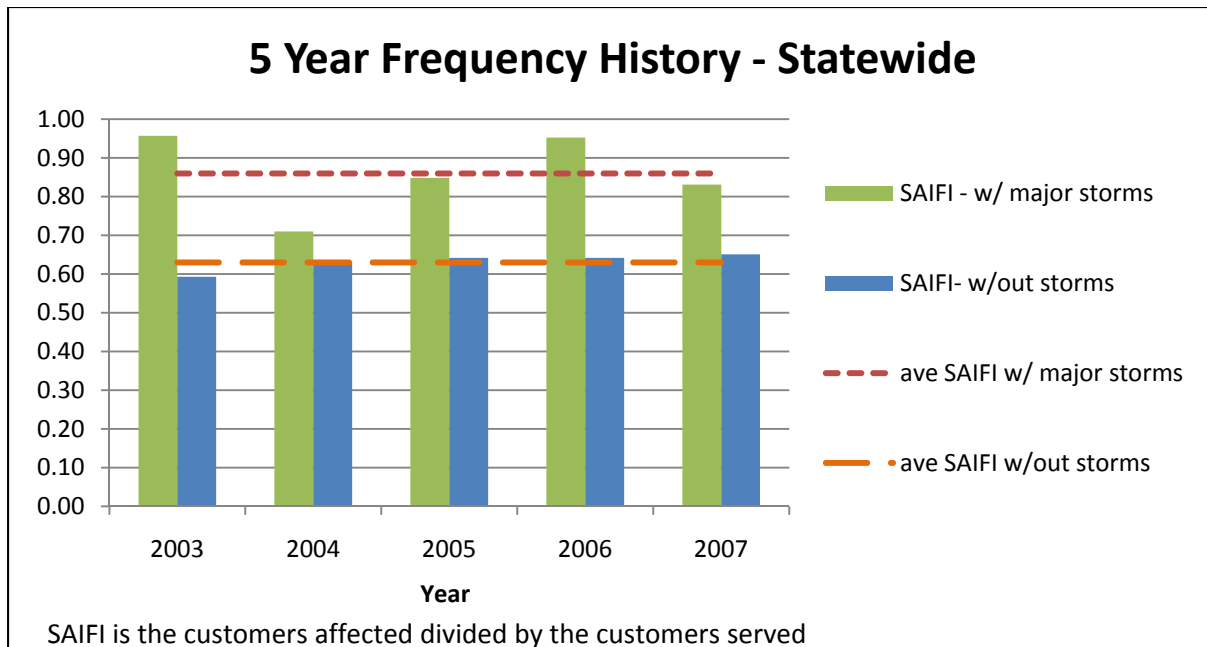

Figure 19 5 year frequency history – statewide source: (7)

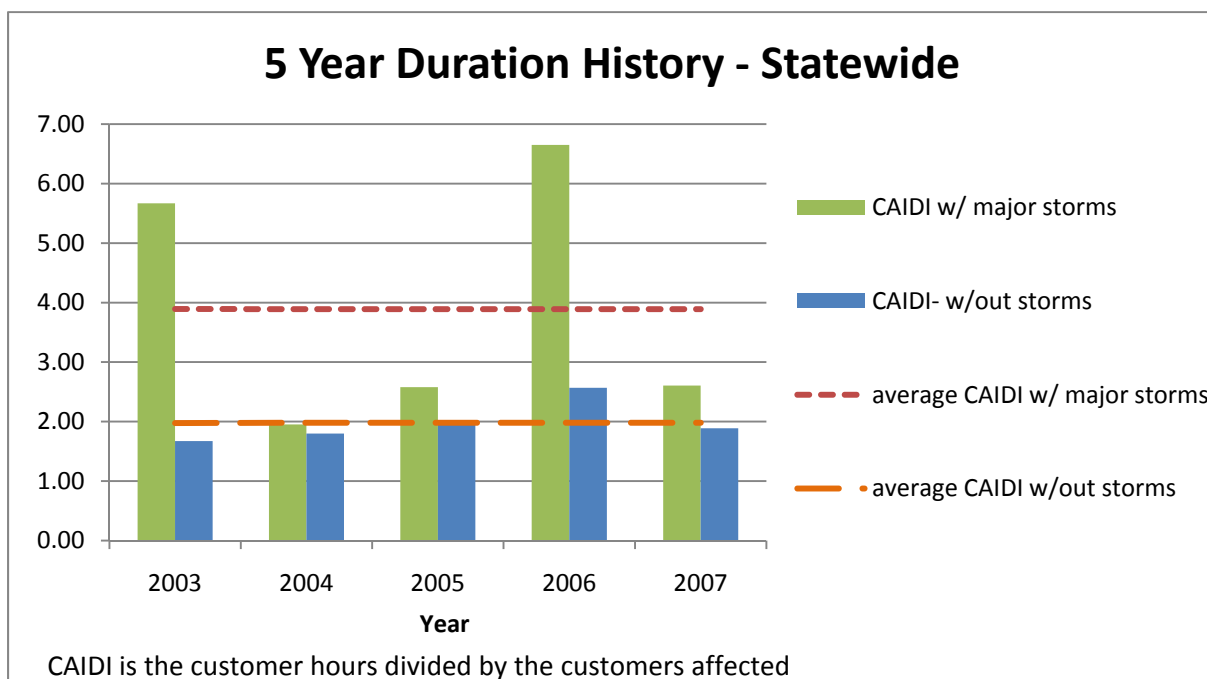

Figure 20 5 year duration history – statewide source: (7)

5.3 Data Analysis

The NYS PSC reports ((1)-(7)) do an excellent job reporting summary information for the major utility companies across NYS. The data however does not present the various subareas operated by the utility companies. For instance, there are seven main utility companies

reporting each year; each of these utilities was various regions that actually comprise 44 individual regions. These boundaries can be seen in Figure 21; the solid colors represent the various utility companies and the lines within the solid colors represent the subarea boundaries for a specific utility. As part of this task report the team used the raw data provided by the NYS PSC to delineate each of the subareas.

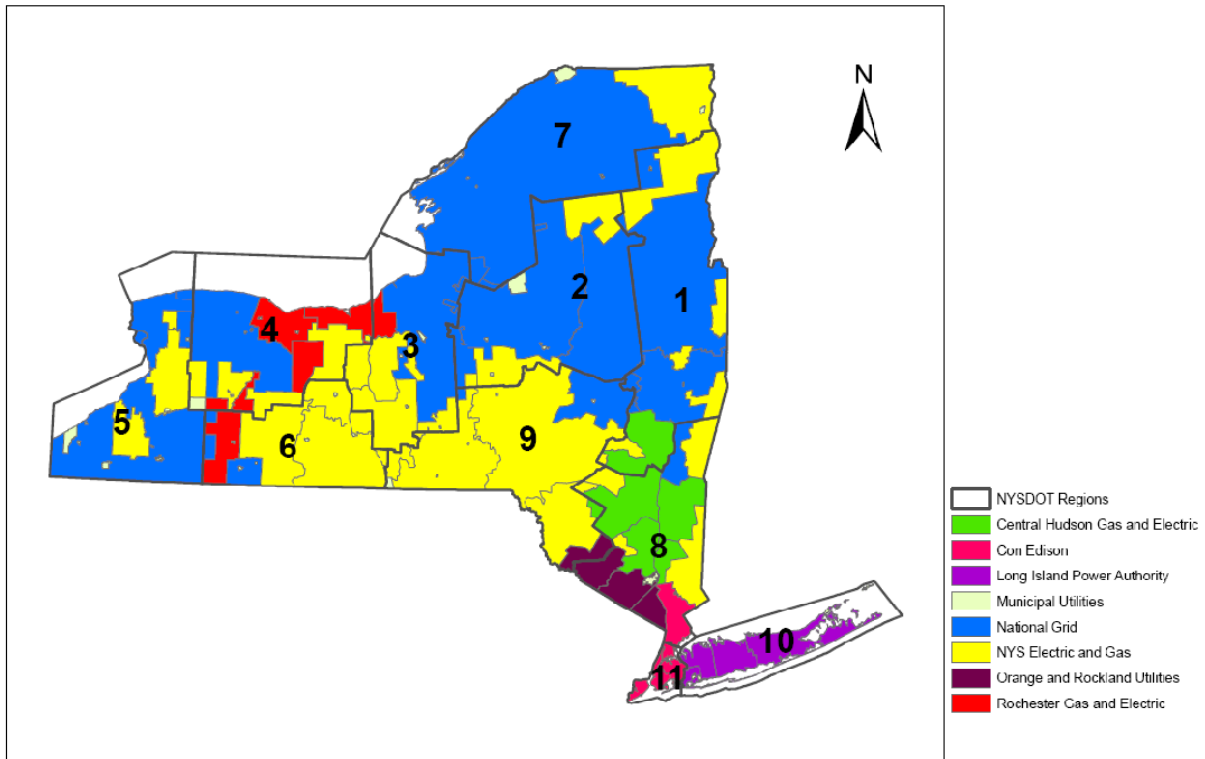

Figure 21 Utility company boundaries within NYS

The power outage data obtained from the NYS PSC identifies the type of event (see Table 6) that caused the outage along with the following three items; 1) total customer hours, 2) number of customers affected and 3) number of interruptions. The team found that “network” events were only reported for the utility company Con Edison which primarily serves NYSDOT’s Region 11. These events were disregarded for any analysis. For this task report the team aggregated all of the “radial” events as one type of event. This is because the team is more interested in all the outages, not just one particular type. The original dataset has been included in Appendix 5-A.

The 2007 PSC Electric Reliability Performance Report found that the performance reliability over a five year period appears to be leveling off with respect to frequency and improving slightly with respect to duration across NYS (7). In general, most of a utility’s interruptions are a result of major storms, trees and branches, equipment failures, and accidents. Table 7 shows

the percentage of the top three causes of power outages by utility company (not including major storms) (7).

From Table 7 it is clear that both ‘Equipment’ and ‘Tree’ failures account for at least of half of each of the utilities companies total failures. Since *Con Edison* serves New York City and

Table 7 Top 3 reasons for utility power outages

Utility Company	Top 3 Reasons for Outage	
	Cause	Percentage of Failures
Con Edison	Equipment	74%
	Tree	12%
	Accident	8%
National Grid	Equipment	26%
	Tree	23%
	Unknown	16%
New York State Electric & Gas	Tree	39%
	Equipment	21%
	Accident	16%
Rochester Gas & Electric	Equipment	29%
	Tree	20%
	Accident	18%
Central Hudson Gas & Electric	Tree	39%
	Accident	23%
	Equipment	17%

Westchester County, 12% of the interruptions caused by *Tree* where significantly lower than other companies; but 74% of the equipment failure shows that the company needs to improve its physical performance, *National Grid* has 16% of the interruptions caused by unknown reasons. Tree related incidents are the highest cause for both *NYSEG* and *Central Hudson*, as a result both should improve their tree trimming programs.

Although the data has been aggregated into monthly summaries the data is still useful in determining patterns across NYS. There are many different ways the data can be interpreted. The PSC interruption reports provide data on the utility company as a whole; they do not focus on the utilities subareas. Therefore it is possible for a particular utility company to have both a poor and a very well performing subarea. When the computations are made the two areas would average out the differences. Since the outage data for the entire state can be looked at in many

different ways, the team focused on presenting the data with a geographic information system (GIS). This makes it possible to quickly look at a map and see how a particular area performed with respect to the entire state. For example the team expanded upon the plots shown in Figure 19 and Figure 20 to show the SAIFI and CAIDI outages on a map across NYS. This analysis was compiled for all of the NYS utility company subareas the team had data for as well as how it related to the NYSDOT Regions. Similar analysis was also done for the total number of interruptions and the total number of outage hours divided by the number of customers served. The following subsections present the findings from these analyses. In most all of the cases the utility company boundaries do not align with the NYSDOT Regional boundaries. The team carefully subdivided the data and manipulated the data to provide summary data for the NYSDOT Regional boundaries. These plots are discussed further in the following subsections.

5.3.1 Frequency & Duration Analysis

As mentioned earlier the NYS PSC has two primary metrics they use for analyzing the utility companies performance. They are the frequency of outages or the SAIFI and the duration or the CAIDI. The SAIFI is essentially the number of customers affected divided by the number of customers served for a particular area. The CAIDI is the total number of customer hours for an outage divided by the total number of customers affected.

The team computed the SAIFI and CAIDI (including major storms) for each of the utility company subareas across NYS. Next a GIS database was created and the data was plotted for NYS. Appendix 5-I contains these plots between the years 2003 and 2006. These plots identify more specifically how the various subareas across the state performed with respect to each other.

Once the team had compiled and analyzed the SAIFI and CAIDI plots it was determined that a metric that would account for all of the customers within a region was desirable. It was determined that computing the customer outage hours divided by the total number of customers served would better represent the power outage trends across NYS. Therefore, the normalized event outage hours per customer for each utility was calculated as a comparative baseline for the years 2003 through 2006. The reason for this is that when looking at dark traffic signals it is important to understand how long the outages last and how many people are within that particular area. Furthermore, the team decided to only focus on the radial events, not network events. The reason for this is that the only data available for network events was from Con Edison. So the calculation that was performed to normalize the data for each subarea across the state was the following:

$$\frac{\text{Total Hours of All Radial Events within Area}}{\text{Total Number of Customers Served within Area}}$$

The normalized statewide average for this time period was found to be 0.403439. Yearly plots for each of the utility company subareas can be found in Appendix 5-J. Figure 18 is a plot that contains the average outage hours within an area divided by the total number of customers served within that area between the years 2003 and 2006. The darker shades of green indicate areas with poorer performance during this time period. The worst performing areas were found to be within Region 4 and 5 and the best in Regions 2 and 7. Most of the rest of the state was found to have similar performance during the four year time period. Similar plots were created for the NYSDOT boundaries; these can be found in Appendix 5-K. To create the NYSDOT boundary plots it was necessary 'trim' the utility company boundaries uniformly based on size. Therefore the plot assumes that the number of customers and the power outages are uniformly distributed within each of their areas.

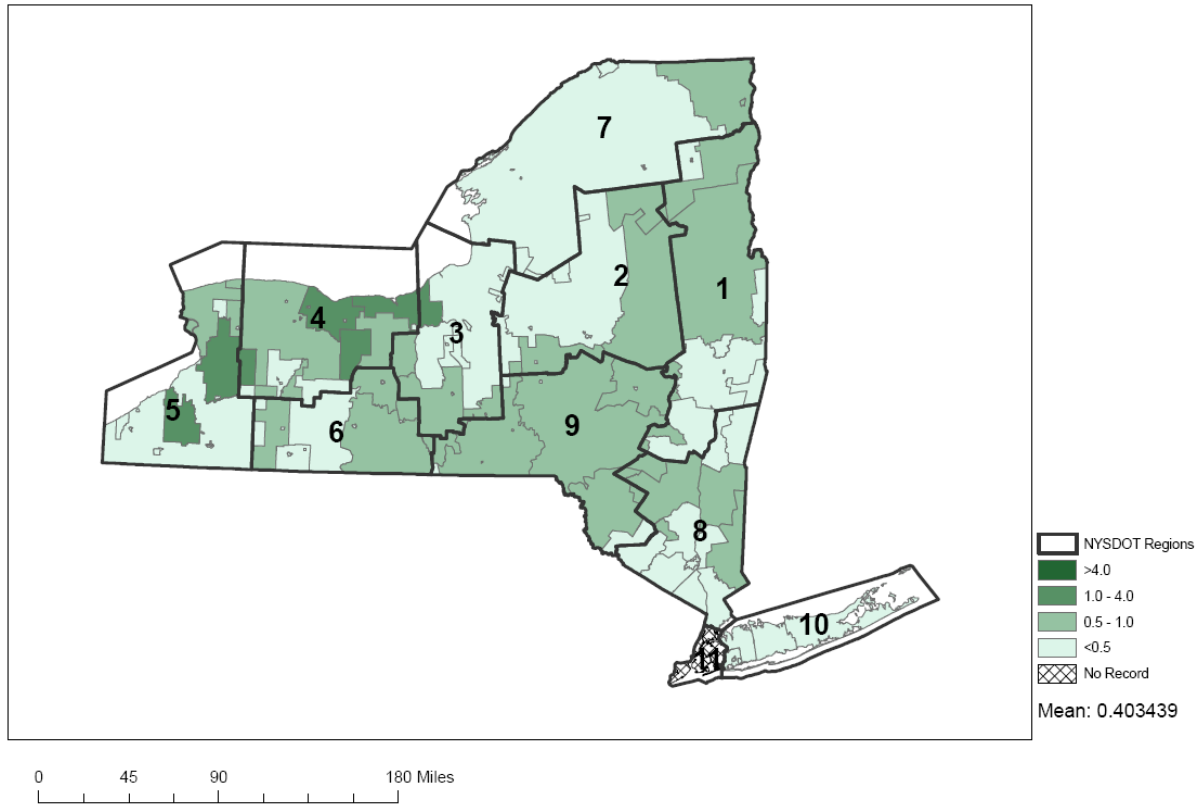

Figure 22 Radial event power outage hours per customer served for utility company subareas averaged between 2003 & 2006

Table 8 identifies the utility companies and their respective subareas that had normalized averages more than double the statewide average, they can also be visually seen in Figure 23. Of the 44 power company regions within NYS that the team had data for only six (6) had four year averages more than double that of the entire state. It should be noted that four of the six only were more than double for one of the four years and two of the regions only had occurrences twice in the four year period. All of these occurrences are likely related to major storms within their respective regions. More specific data for these six subareas can be found in Appendix 5-L. It should also be noted that for the years that did not exceed the statewide average by more than double the mean for the region was typically less than the statewide average.

Table 8 Utility company areas with normalized power outage averages between 2003 & 2006 greater than double the statewide average

UTILITY COMPANY	AREA	% above statewide average	Years Exceeding 0.8 (double 4 year average)			
			2003	2004	2005	2006
Rochester Gas & Electric	LAKESHORE	523%	X			
New York State Gas & Electric	LANCASTER	265%				X
Rochester Gas & Electric	ROCHESTER	182%	X			
Rochester Gas & Electric	CANANDAIGUA	156%	X			
New York State Gas & Electric	BREWSTER	146%			X	X
New York State Gas & Electric	ONEONTA	112%	X		X	

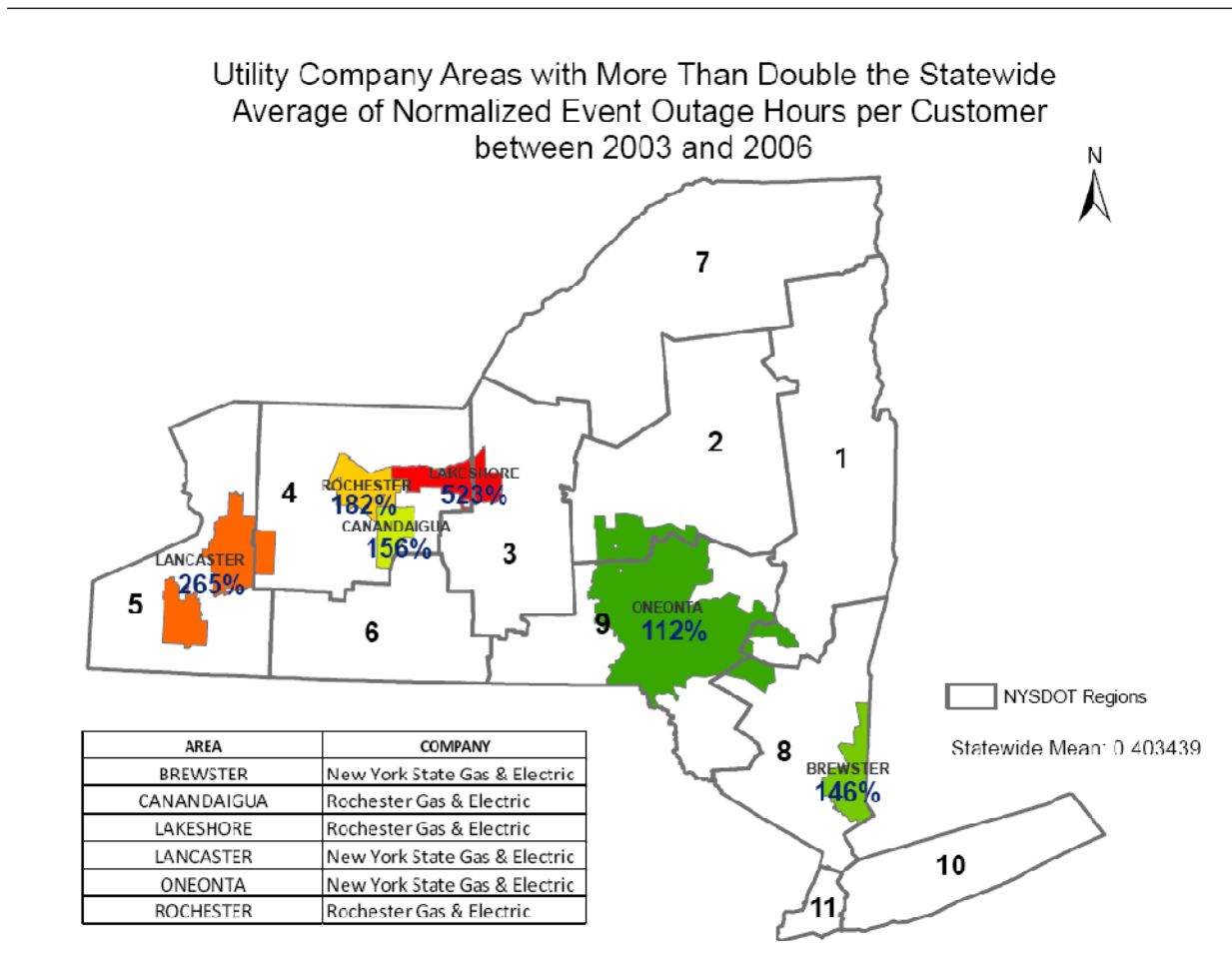

Figure 23 Utility company areas with normalized power outage averages between 2003 & 2006 greater than double the statewide average

5.3.2 Power Interruption Analysis

In addition to the data looked at in Section 5.3.1 the team also studied the number of interruptions for radial events by utility company subarea and NYSDOT Region. The NYS PSC definition of an interruption is the loss of service for five minutes or more. Using this data for purposes of analyzing power performance at intersections is misleading. The reason for this is

that the number of interruptions does not have any correlation to the length of time an intersection might be dark. These plots can be found in Appendix 5-M.

The yearly plots between 2003 and 2006 all appear to be similar. From year to year there are some subareas that change but the overall patterns tend to be the same. Each of the four years National Grid’s Central Region and the Long Island Power Authorities Suffolk Region have the largest number of interruptions caused by radial events in New York State. It is interesting to note that those two subareas did not perform as poorly based on the analysis in Section 5.3.1.

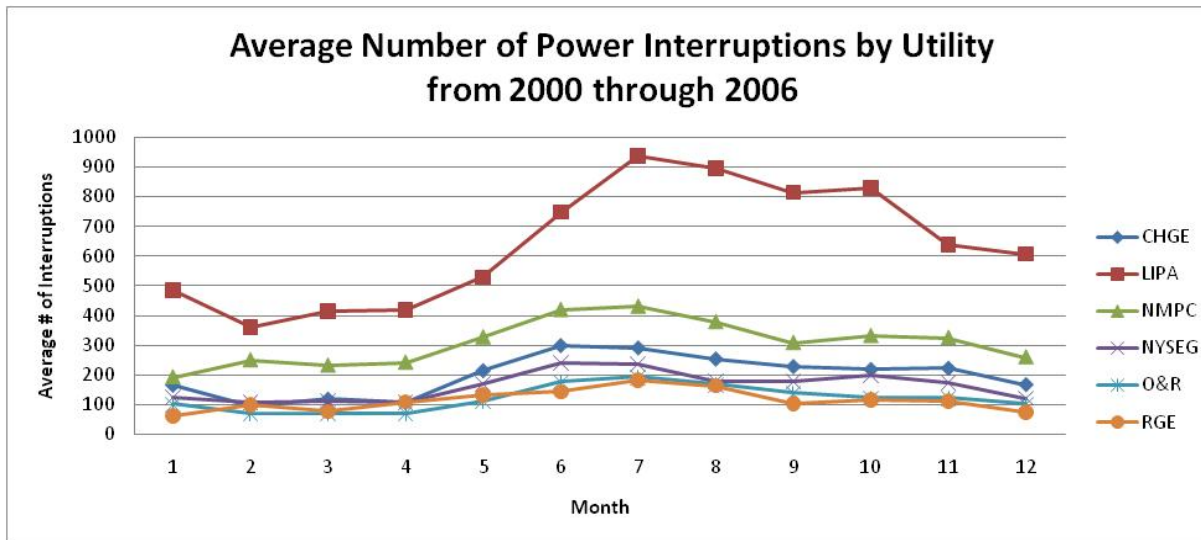

Figure 24 Average number of power interruptions for each utility company between 2000 and 2006

The average number of power interruptions for each utility company was plotted between the years 2000 and 2006, this can be seen in Figure 24. The data indicates that in most cases each utility company experiences more power interruptions in the summer months (June, July and August).

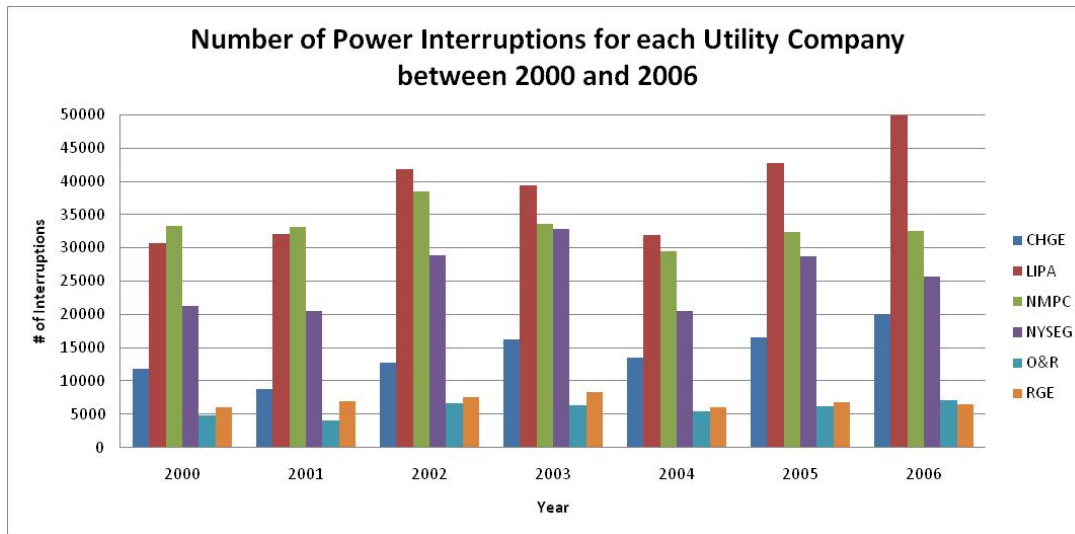

Figure 25 Number of power interruptions for each utility company between 2000 and 2006

Figure 25 shows the total sum of interruptions per year for each of the utility companies (Con Edison excluded). The only two utility companies that showed a stable trend of the number of interruptions in this time period were National Grid (formally Niagara Mohawk) and Rochester Gas & Electric. These two companies showed very little change between 2000 and 2006.

The other four major utility companies showed an upward trend in the number of interruptions between 2000 and 2006.

5.3.3 2007 Recommendations from PCS

In the 2007 Interruption report from PSC they outlined recommendations for the various power companies (7). This section outlines the findings that are noteworthy for NYSDOT.

In 2007, Con Edison's network frequency index increased significantly compared to previous years and failed to meet its reliability performance mechanisms (RPM) target for a second straight year. Con Edison should conduct a self assessment on its deteriorated radial systems.

National Grid's frequency performance continues to be of concern, since the company has failed its reliability performance mechanism for frequency since 2004 by missing a target level of 0.93. National Grid should identify improvements to reduce the effect of tree contact interruptions on system reliability.

2007 was a poor performance year for NYSEG; it recorded its worst performance for both frequency and duration in the past 20 years. NYSEG should conduct a detailed self assessment of its existing crew/field work personnel levels, crew locations, and the effect these levels have on system reliability, particularly interruption duration.

RG&E is one of the better performing utilities within the state, since the company has not failed its RPM targets of 0.90 for SAIFI and 1.90 for CAIDI as established in its rate orders.

Central Hudson's frequency performance of 1.44 in 2007 was better than the previous two years, but still higher than its five-year average. The company should conduct a detailed self assessment of the effectiveness of its modified tree trimming program.

In 2007, Orange and Rockland performed well with regard to frequency as compared with its historic performances. It appears that Orange and Rockland's capital investments and reliability programs are showing success.

5.4 Conclusions

Understanding the power outage history across New York is helpful in determining possible areas where backup power systems for intersections should be considered for deployment. The team was able to obtain power outage data from the NYS PSC for the major utility companies operating across NYS. This data aided the team in understanding how the various regions of the state perform with respect to one another. It was also found the NYS PSC also reports on the performance of the major utility companies each year. Each of the utility companies should continue to improve their system equipment and continue with their tree trimming programs to ensure that power outages across the state are minimized. During the summer months is typically when the largest number of outages occur across NYS, the utility companies should investigate ways to reduce these outages.

5.5 References

- (1) New York State Public Service Commission - Office of Electricity and the Environment, "The 2001 Interruption Report." April 1, 2001.
- (2) New York State Public Service Commission - Office of Electricity and the Environment, "The 2002 Interruption Report." March 14, 2003.
- (3) New York State Public Service Commission - Office of Electricity and the Environment, "The 2003 Interruption Report." April 15, 2004.
- (4) New York State Public Service Commission - Office of Electricity and the Environment, "The 2004 Interruption Report." March 2005.
- (5) New York State Public Service Commission - Office of Electricity and the Environment, "The 2005 Interruption Report." June 2006.

- (6) New York State Public Service Commission - Office of Electricity and the Environment, "The 2006 Interruption Report." July 2007.
- (7) New York State Public Service Commission - Office of Electricity and the Environment, "The 2007 Interruption Report." September 2008.

TASK 6: Alternative Energy Sources

6.1 Introduction

This chapter summarizes an investigation on the methods available to keep signals operating at traffic intersections during utility power interruptions. Technologies that are available for energy storage and power generation are reviewed; technologies that may be applicable in the future are included. This chapter sets the stage for the Task 7 chapter that will have a discussion of short- and long-term implementation plans for outfitting traffic signals with backup power.

The chapter includes an analysis of the power requirements that are necessary to operate the traffic signal lights, associated sensors and electronics of a typical traffic intersection. Alternative methods of power to keep the intersection operating when the utility power is interrupted are examined. Appendix 6-A contains proposed specifications for battery backup systems.

6.2 Analysis of a Typical Traffic Intersection

This section identifies the equipment and power requirements for a typical traffic intersection. The intersection is located at Wade Road and Troy-Schenectady Road (Route 7) in the town of Latham, New York as seen in Figure 26. A trip to this intersection with Advanced Energy Conservation (AEC) and New York State Department of Transportation (NYSDOT) engineers was made to gather data and determine power requirements that are needed to supply a typical system.



Figure 26 Intersection of Wade Road and Route 7 in Latham NY.

The following information was gathered at the site:

- The Route 7/Wade Road intersection is relatively large: there are left turn bays in all directions, and at least two through travel lanes in each direction.
- Signaling is based on inductive loops in the road.
- The red and green signals have been updated with LEDs while the yellow signals are still incandescent bulbs.
- The traffic signal enclosure is fed 120VAC by way of a manual transfer switch. The transfer switch allows use of a backup generator in the event of a power failure. A backup generator is not normally on site at the intersection.
- There is a mixture of AC and DC used within the signal enclosure. AC is fed to the LEDs, which presumably convert the AC into DC before application to the LEDs. There is a DC power supply within the enclosure used for powering the racks that run the loop sensors and signal (solid-state) relays. AC is fed to the traffic controller, where it is subsequently converted to DC internally.
- The main circuit breaker for the enclosure is rated at 40A; there is an auxiliary breaker for ground fault detection that is rated at 15A.
- The signal enclosure communicates with another enclosure at a different intersection through a radio transmitter. The antenna is mounted on one of the traffic signal poles.
- The signal enclosure contains a cable modem so that the controller can be accessed over the internet; the modem is powered by a wall-mounted transformer.

- There were two incandescent bulbs inside the signal enclosure. It was not clear why they were there; they are not used for heating. We suspect they are used to get the current monitor to work with the LEDs by creating a larger current draw.
- NYSDOT uses both 12" and 8" LED signals. The green modules draw about 9W, the red about 12W, and the yellow (12") are rated at 19W. Power consumption goes up with temperature to maintain light output. These power ratings may go up by 50% at elevated temperatures. Yellow LEDs are not being deployed in large numbers because the yellow signal is only active for 4s, so the available energy savings is very small and the life of conventional incandescent bulbs is long.
- The LEDs used by New York draw more power than LEDs used by other states. This is because of the current monitor used as part of redundant checking. The additional power draw is 2-3W per LED module. New York is about to begin the process of phasing out this practice.
- A clip-on ammeter indicated that the signal system (enclosure plus LED signals) draws generally 3.2A rms. There were occasional spikes in the current demand, up to as much as 15A. These spikes did not last long, much less than one second in duration.
- There was no change in the energy meter over a span of more than 30 minutes.
- It is estimated that the signal controller and the equipment in the cabinet draws about 90VA. The overall draw for an intersection is about 400W, which is consistent with our measurement at the Wade Road intersection.
- There were no batteries installed for backup power at the Wade Road intersection.

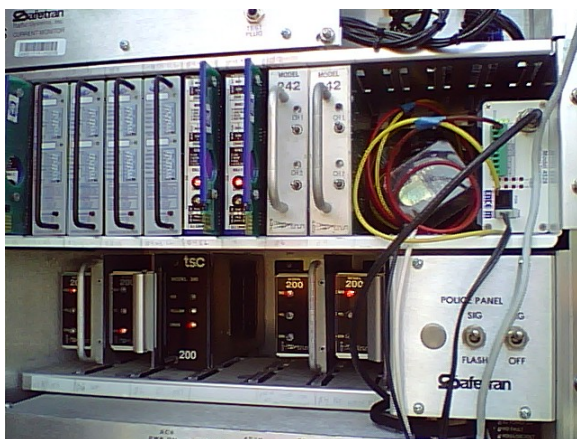



Figure 27 Pictures of the equipment cabinet at the Wade Road and Route 7 intersection

In summary, this traffic intersection uses approximately 400W continuously with short power transients as high as 1800W. There is a mix of sensors, controllers, lamps, radio transmitter, cable modem and power supplies that are all operated from the 120VAC source. None of this equipment has been designed to minimize energy requirements. However, the motivation for moving to LED lamps was to reduce energy use and improve signal lifetime. The power architecture within the traffic signal enclosure suggests an opportunity to reduce energy consumption, reduce the space required for equipment, and substantially simplify the power architecture while integrating energy storage into the system.

6.2.1 Requirements

The NYSDOT would like a backup system that can support 400W for 5 hours for total energy storage of 2kWh.

6.2.2 Plan for Integrating Selected Alternatives with Existing Signal Structure

This study has shown that in existing equipment cabinets there are many operating voltages used by different pieces of equipment. These voltages are derived from power supplies that operate from the 120VAC utility. The most economical method to implement a power back system in existing equipment would be to provide a 120VAC power source such as a UPS (Uninterruptible Power Source). Whichever method is selected the utility power outage must be acknowledged and the backup power source must be operating within two cycles (33ms).

6.2.3 Alternative Power Sources for Backup/Standby Power

The alternative energy sources that have been considered include:

1. Batteries.
2. Fuel Cells.
3. Ultracapacitors.
4. Pseudocapacitors.
5. Gasoline internal combustion engine with generator.
6. Natural gas internal combustion engine with generator.
7. Compressed air motor with generator.
8. Dedicated standby power line.

6.2.3.1 Batteries

Batteries are the most widely used backup power source for the 400W power level range of this application. If batteries are to be used with existing equipment a 120VAC, 60Hz inverter would be required to convert the DC output to AC. Converting the DC to AC would not be a problem since there are many available products on the market. The problem with batteries is that they degrade over time and battery capacity and life changes greatly with the operating and storage temperature. The major battery chemistries are described as follows:

Nickel Cadmium (NiCd) — chemistry is mature and well understood but relatively low in energy density. The NiCd is used where long life, high discharge rate, and economical price are important. Main applications are two-way radios, biomedical equipment, professional video cameras, and power tools. The NiCd contains toxic metals and is not environmentally friendly.

Nickel-Metal Hydride (NiMH) — chemistry has a higher energy density compared to the NiCd at the expense of reduced cycle life. NiMH contains no toxic metals. Applications include mobile phones, laptop computers, and hybrid electric automobiles.

Lead Acid — chemistry is the most economical for larger power applications where weight is of little concern. The lead acid battery is the preferred choice for hospital equipment, wheelchairs, emergency lighting, automotive, and UPS systems.

Lithium Ion (Li-ion) — chemistry is the fastest growing battery system. Li-ion is used where high-energy density and light weight is of prime importance. The Li-ion chemistry is more expensive than other systems and must follow strict guidelines to assure safety. Applications include notebook computers and cellular phones. Future applications are expected to include hybrid electric automobiles.

Lithium Ion Polymer (Li-ion polymer) — chemistry is a potentially lower cost version of the Li-ion chemistry. This chemistry is similar to the Li-ion in terms of energy density. It enables very slim geometry and allows simplified packaging. Its main application is mobile phones.

The following table compares the characteristics of the six most commonly used rechargeable battery systems in terms of energy density, cycle life, exercise requirements and cost. Exotic batteries with above average ratings are not included.

Table 9 A comparison of battery technologies

	NiCd	NiMH	Lead Acid	Li-ion	Li-ion polymer	Reusable Alkaline
Gravimetric Energy Density (Wh/kg)	45-80	60-120	30-50	110-160	100-130	80 (initial)
Internal Resistance (includes peripheral circuits) in mW	100 to 200 ¹ 6V pack	200 to 300 ¹ 6V pack	<100 ¹ 12V pack	150 to 250 ¹ 7.2V pack	200 to 300 ¹ 7.2V pack	200 to 2000 ¹ 6V pack
Cycle Life (to 80% of initial capacity)	1500 ²	300 to 500 ^{2,3}	200 to 300 ²	500 to 1000 ³	300 to 500	50 ³ (to 50%)
Fast Charge Time	1h typical	2-4h	8-16h	2-4h	2-4h	2-3h
Overcharge Tolerance	moderate	low	high	very low	low	moderate
Self-discharge / Month (room temperature)	20% ⁴	30% ⁴	5%	10% ⁵	~10% ⁵	0.3%
Cell Voltage (nominal)	1.25V ⁶	1.25V ⁶	2V	3.6V	3.6V	1.5V
Load Current						
- peak	20C	5C	5C ⁷	>2C	>2C	0.5C
- best result	1C	0.5C or lower	0.2C	1C or lower	1C or lower	0.2C or lower
Operating Temperature (discharge only)	-40 to 60°C	-20 to 60°C	-20 to 60°C	-20 to 60°C	0 to 60°C	0 to 65°C
Maintenance Requirement	30 - 60 days	60 - 90 days	3 - 6 month ⁸	not req.	not req.	not req.
Typical Battery Cost (US\$, reference only)	\$50 (7.2V)	\$60 (7.2V)	\$25 (6V)	\$100 (7.2V)	\$100 (7.2V)	\$5 (9V)
Cost per Cycle (US\$) ⁹	\$0.04	\$0.12	\$0.10	\$0.14	\$0.29	\$0.10-0.50

	NiCd	NiMH	Lead Acid	Li-ion	Li-ion polymer	Reusable Alkaline
--	------	------	-----------	--------	----------------	-------------------

Commercial use since 1950 1990 1970 1991 1999 1992

The Battery Comparison Table was authored by Isidor Buchmann, president CEO of Cadex Electronics Inc.

10. Internal resistance of a battery pack varies with cell rating, type of protection circuit and number of cells. Protection circuit of Li-ion and Li-polymer adds about 100mW.
11. Cycle life is based on battery receiving regular maintenance. Failing to apply periodic full discharge cycles may reduce the cycle life by a factor of three.
12. Cycle life is based on the depth of discharge. Shallow discharges provide more cycles than deep discharges.
13. The discharge is highest immediately after charge, then tapers off. The NiCd capacity decreases 10% in the first 24h, then declines to about 10% every 30 days thereafter. Self-discharge increases with higher temperature.
14. Internal protection circuits typically consume 3% of the stored energy per month.
15. 1.25V is the open cell voltage. 1.2V is the commonly used value. There is no difference between the cells; it is simply a method of rating.
16. Capable of high current pulses.
17. Maintenance may be in the form of 'equalizing' or 'topping' charge.
18. Derived from the battery price divided by cycle life. Does not include the cost of electricity and chargers.

The following information describes the temperature problems associated with batteries:

6.2.3.1.1 *What's Available*

Sealed lead acid (SLA) batteries have been around since the 1850's and are the oldest type of rechargeable battery, but they are still ubiquitous. This is partly because they are so cheap, but also because they function when exposed to extreme environments and a wide operating temperature, ranging from -40°C to 70°C. Unfortunately, SLA batteries have poor energy density and aren't appropriate for handheld applications. Nickel Metal Hydride (NiMH) cells demonstrate a great improvement in energy density, but they operate effectively between -20°C and 60°C, and self-discharge rates are about 30 percent per month. Lithium Ion (Li-ion) technology was introduced commercially in 1991, and with its operating voltage that is 3 times that of NiMH, Li-ion's energy density is the best available today. It is the chemistry of choice for handheld devices. Li-ion cells operate effectively between -20°C and 60°C. Of all the chemistries listed above, Li-ion requires the greatest degree of protection, including a thermal shut down separator and exhaust vents (within each cell) to vent internal pressure, an external safety circuit that prevents over-voltage during charge and under-voltage during discharge and a thermal sensor that prevents thermal runaway. However, with the appropriate level of safety designed into a Li-ion pack, Li-ion offers the most attractive cell chemistry even in extreme temperature environments.

6.2.3.1.2 When Temperatures Soar

Extremely high temperature operation provides equal challenges for cells based on lithium chemistry. As mentioned earlier, the upper range of safe operation for Li-ion cells is 60°C. Cells provide energy through the electrochemical shuttling of lithium ions between the anode and the cathode materials. However, at high discharge rates this chemical reaction generates heat, and so high drain rate applications must be designed with extra caution. The effects of the generated heat is compounded when numerous cells are assembled into a multi-cell pack. High storage temperature can affect the subsequent performance of Li-ion cells, so storage conditions are a concern, as well. Under optimal storage conditions of 20°C, a fully charged Li-ion cell has a natural self-discharge of 1 percent per month. However, with an elevated storage temperature of 60°C for a twelve month period, the capacity naturally discharges down to 40 percent of the original capacity. This drastic self-discharge substantially limits the run time of the cells performance after storage. In addition, prolonged storage at an elevated temperature destroys battery capacity. After storage at an elevated temperature of 60°C for one year, a fully charged cell would only have a recoverable capacity of 70 percent of its original capacity. The recoverable capacity of the battery depends also on the state of charge. A cell stored at 60°C for 12 months at 50 percent state-of-charge would have a recoverable capacity of 90 percent.

6.2.3.1.3 When the Temperature Drops

Performance of rechargeable Li-ion chemistry starts to suffer as the temperature drops below freezing. As the temperature drops below 0°C, the internal impedance of the battery increases. Cell capacity is also reduced during the lower temperatures. The military requires the manufacturers of its equipment to meet Military Standard 810, which requires low temperature operation down to -40°C. The manufacturers of military radios need them to be light for handheld use and to cut down on the soldier's overall pack weight. Some new widely available Li-ion formulations can operate at temperatures close to -40°C, but their performance is severely degraded. For true low temperature operation more obscure cells must be used. One manufacturer has changed the battery active material and electrolyte so that -40°C operation can be achieved, but the cells are large, bulky, and a price premium is certainly paid. Advancements in both the cell's chemistry and the battery pack's construction are allowing rechargeable batteries to be used in a wider variety of environments, from surgical tools to military radios. Surgeons and soldiers are now benefiting from the same new technologies as consumers.¹

¹May/June 2007 issue of Battery Power Products & Technology Magazine, Dr. Robin Sarah Tichy

The telecom industry has been using batteries for standby power for many years and is always looking for alternatives. In a stationary application like this the most cost effective battery has been the lead-acid type. It appears that this will remain the case for some time to come. There are many products available on the market offering different capacity lead-acid type batteries specializing in standby power.

6.2.3.2 Fuel Cells

Fuel cells are a developing technology with many new products under development. The fuel cell functions similar to a battery, which uses electrochemical conversion. The fuel cells take in hydrogen-rich fuel and oxygen and turn them into electricity and heat. The waste product is water. The hydrogen can be derived from gasoline, natural gas, propane or methanol through a process known as reformation. The advantages are high energy density and lack of pollution. The disadvantages are very high cost, and batteries are required for initiation of operation. While fuel cells are being applied for power backup in telecommunications systems, these applications appear to be largely demonstration in nature. Fuel cell systems still have substantially higher maintenance and operating costs than other alternatives.

6.2.3.3 Ultracapacitors

The ultracapacitor is a growing technology and new products are appearing often. The ultracapacitor (UC), sometimes also known as a supercapacitor or electrochemical double layer capacitor, is a cross between a capacitor and a battery. Construction of the UC is similar to a battery but there is no chemical reaction taking place. This allows millions of charge/discharge cycles resulting in a much longer life. The UC voltage decreases to zero like a capacitor as it discharges where a battery will hold its voltage until it is nearly depleted. Another advantage is that the internal resistance of the UC is very low and very high charge and discharge current will not harm it. The UC will work at much larger temperature extremes compared to batteries and at -20C with no degradation of performance. The UC has been commonly used for backup power for memory power in computers. Recently larger devices have been created for energy recovery for vehicles because of the advantages of its high current capabilities. As UC technology improves energy densities in ultracapacitors are expected to reach several kW/kg in comparison to between 0.1 kW/kg and 0.5 kW/kg in lead acid batteries. Ultracapacitors are not being used for long term power requirements because of the cost. For example, a Maxwell Technologies 350F D size cell is \$15, so it will be quite some time before the UC will be challenging the battery for long term standby power. Ultracapacitors may, however, be a useful component within a battery backup system by virtue of their ability to source large amounts of power quickly, in comparison with batteries that are much better at providing continuous power.

6.2.3.4 Pseudocapacitor

The pseudocapacitor is the newest technology showing promise for higher energy density and lower cost than the ultracapacitor. The pseudocapacitor has a structure and characteristics similar to the ultracapacitor. The pseudocapacitor differs from the UC in that it uses a metal oxide rather than an activated carbon for the electrode material. Nesscap has developed a credit card size product with 30W of power. If the pseudocapacitor can compete with the cost of batteries it has a promising future. Pseudocapacitors with small ratings have been demonstrated and are becoming available commercially. It is expected to be some time before pseudocapacitors can be reliably integrated into sufficiently large arrays to support an application such as backup of traffic signals.

6.2.3.5 Gasoline internal combustion engine with generator

A very compact generator set could be built using a small internal combustion engine such as a model airplane engine with a DC generator attached. An inverter would convert the DC generated voltage to 120VAC 60Hz power. Disadvantages of this setup are that there would need to be a method to store the stabilized fuel/oil mixture and a battery would be required for starting. The anticipated low frequency of utility outages raises concerns of maintaining the engine in a state where it can be started reliably. There are also the issues of periodic maintenance and fuel supply.

6.2.3.6 Natural gas internal combustion engine with generator

Commercial generators of 1000W rating are available from Honda, Yamaha, Briggs, etc. These generators could be modified to operate from a natural gas source in the street nearby. Another option is storing propane on site in a tank or cylinder. Disadvantages of this technology include requiring a battery for starting and maintaining the engine in a state where it can be started reliably.

6.2.3.7 Compressed air motor with generator

A very compact generator set could be built using a small air-driven motor with a DC generator attached. An inverter would convert the DC generated voltage to 120VAC 60Hz power. Advantages of this configuration would be no requirement for batteries, no pollutants, no toxic or flammable chemicals would need to be stored, it would require very little maintenance, and it operates over the full operating temperature. Disadvantages of this setup are that there would need to be a compressor to recharge the air tank. In addition, the energy density is relatively low, suggesting a large storage tank would be required.

6.2.3.8 Dedicated Standby Power Line

In locations where there might be many intersections close by, a dedicated backup power line could be installed. A generator could be located at a central location to provide 120VAC power

for multiple intersections. An advantage is that maintenance is reduced to much fewer generator locations. The major disadvantage is the initial installation cost of wiring dedicated circuits.

Table 10 summarizes the advantages and disadvantages of the backup energy sources discussed above

Table 10 A summary of backup energy options

Power Source	Pros	Cons
Batteries		
Lead-Acid	Lowest Cost. Mature Technology.	Loss of power at low temp. Shortened life at high temp. -20 to 60°C operating range. Medium maintenance.
Nickel-Metal-Hydride	Higher Cost than Lead-Acid. Mature Technology. Widely available.	High maintenance Medium maintenance required.
Nickel-Cadmium	Excellent temperature performance -40 to 60°C. Mature Technology. Widely available.	High maintenance. Poor self discharge. Environmentally unfriendly.
Lithium Polymer	No maintenance required. Highest power density.	Highest cost. 0 to 60°C operating range. Special charging required.
Fuel Cells	High energy density. Non polluting.	Very high cost. Moderate maintenance. Batteries required.
Ultracapacitors	Works well at temperature extremes.	Very high cost. Low energy density; large number of cells required.
Pseudocapacitor	Works well at temperature extremes. Cheaper than ultra capacitors.	New technology. Not widely available. Low power density; large number of cells required.

Gasoline internal combustion engine with generator	Generator backup systems are readily available. Works well at temperature extremes. High pollutant levels.	Batteries still needed for starting. Moderate maintenance required. On site fuel storage required.
Natural gas internal combustion engine with generator	Unlimited run time. Works well at temperature extremes. Low pollutant levels.	Batteries still needed for starting. Costly gas line installation, or on site fuel storage required. Medium maintenance required.
Compressed air (or CO ₂) motor with generator	No batteries required. No pollutants. No toxic chemicals. Not affected by temperature. Extremely low maintenance.	Development required, not commercially available. Charging air or (or CO ₂) tank might be a problem.
Dedicated Power Line	Low maintenance.	High cost to run cable. Not applicable for single intersections. Does not eliminate the need for a backup power solution.

6.3 Summary

This chapter has summarized the alternative energy sources that are available for integration into traffic signal systems. Each energy source has its advantages and disadvantages. From the discussion provided, it is possible to conclude that:

The most significant disadvantage of batteries is their performance over the required temperature range, particularly low temperatures.

Alternatives based on local on-site generators have issues of fuel supply, short periodic maintenance issues, and, more significantly, the issue of reliable starting.

Fuel cell systems have both fuel issues, and require batteries for starting the system. While fuel cell technology is finding some application in telecommunications systems, at the power level required for intersections this technology is significantly more expensive than other more reliable alternatives.

Consistent with the findings reported here, it is not surprising that the backup energy systems currently available for traffic signals are based on lead-acid battery technology.

TASK 7: Integration of Energy Storage into Traffic Signals

7.1 Introduction

This chapter builds on the Task 6 Report which discussed alternative energy sources. This chapter addresses practical implementation of energy storage to keep traffic signals operating during power failures of up to four hours in duration.

Two approaches are provided. The first is appropriate for existing traffic signal systems, representing an approach based on adding energy storage while changing as little equipment in the system as possible. The second is appropriate for new traffic signal systems. It represents an opportunity to save energy, space, weight while improving reliability. It accomplishes this by eliminating a number of conversions between AC and DC that are really unnecessary.

7.2 Integration of Energy Storage into Traffic Signals

7.2.1 Approach for Retrofit Into Existing Signal Systems

A near term approach for standby power during power outages would be batteries and a 120VAC 60Hz electronic inverter also know as a UPS (Uninterruptable Power Supply). There are many commercial units available with the option of having a standard unit modified slightly to meet environmental requirements. There are manufacturers that produce standby power units specifically for traffic intersections.

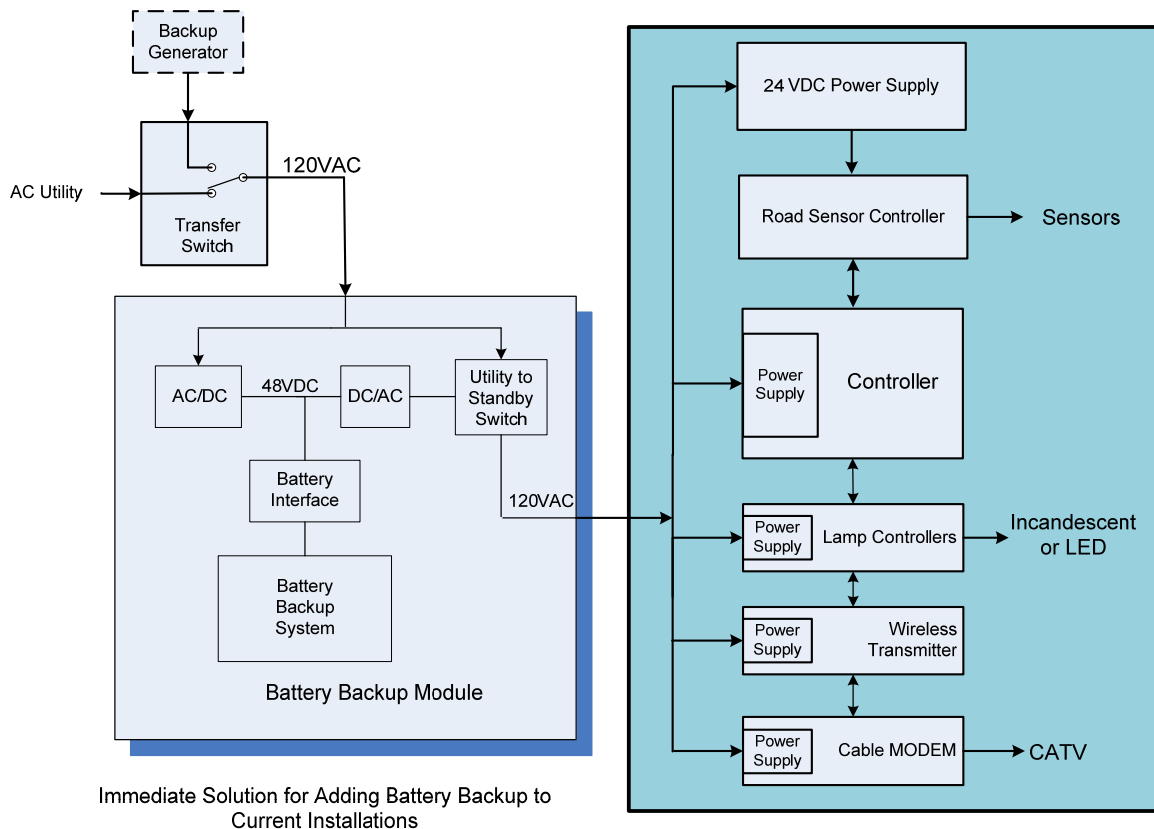

Figure 28 Implementation of a battery backup system for traffic signal control

Figure 28 shows an implementation of a battery backup system for traffic signal control. While this approach is suitable for retrofit into existing traffic signals, it will be appreciated that there is significant energy conversion taking place unnecessarily. This serves to take up space, add cost, reduce reliability, increase weight, and reduce efficiency. For example, within the battery backup module, there is conversion of the incoming utility power into DC for charging the batteries. Elsewhere in the system, equipment is being fed with ac that is subsequently converted to DC before being used. This also holds for the LED signals. For example the large power supply that is presently used for the inductive road sensors are linear with an efficiency of 60% at best.

Power requirements will vary greatly depending on the lamp type used. An intersection with three lanes in each direction with lights will have 12 lamps on at all times. If 100 W incandescent lamps are installed then the power required will be 1200 W continuously just for lamp power. If LEDs are used then the power required is nearly one tenth or 120 to 140 W. Intersections with all incandescent lamps will require nearly 10 times the amount of batteries to operate the same amount of time, greatly increasing costs. Battery backup of traffic signals based on incandescent lamps is not practical. Since LEDs have replaced incandescent lamps at nearly all intersections (at least for the red and green signals), battery backup for traffic signals is practical.

7.2.2 Approach for New Installations

The most efficient approach for the long term is to integrate backup power into all the subsystems of the intersection. This requires that all the controllers, sensors, communications and power supplies operate from a single voltage source that is always connected to a standby power source. Each piece of equipment should be designed to be as efficient as possible to minimize power requirements. Present equipment could be redesigned to reduce power requirements by a factor of 2 or more which would save on the number of batteries required. The energy storage type that is selected should be an intelligent DC source of 12, 24 or 48V. Standby power is an integral part of the system. When the main power source is interrupted the power would seamlessly switch over to the standby energy source. As the standby energy source nears depletion the intelligent power source would communicate to components to shut down specific systems to conserve power.

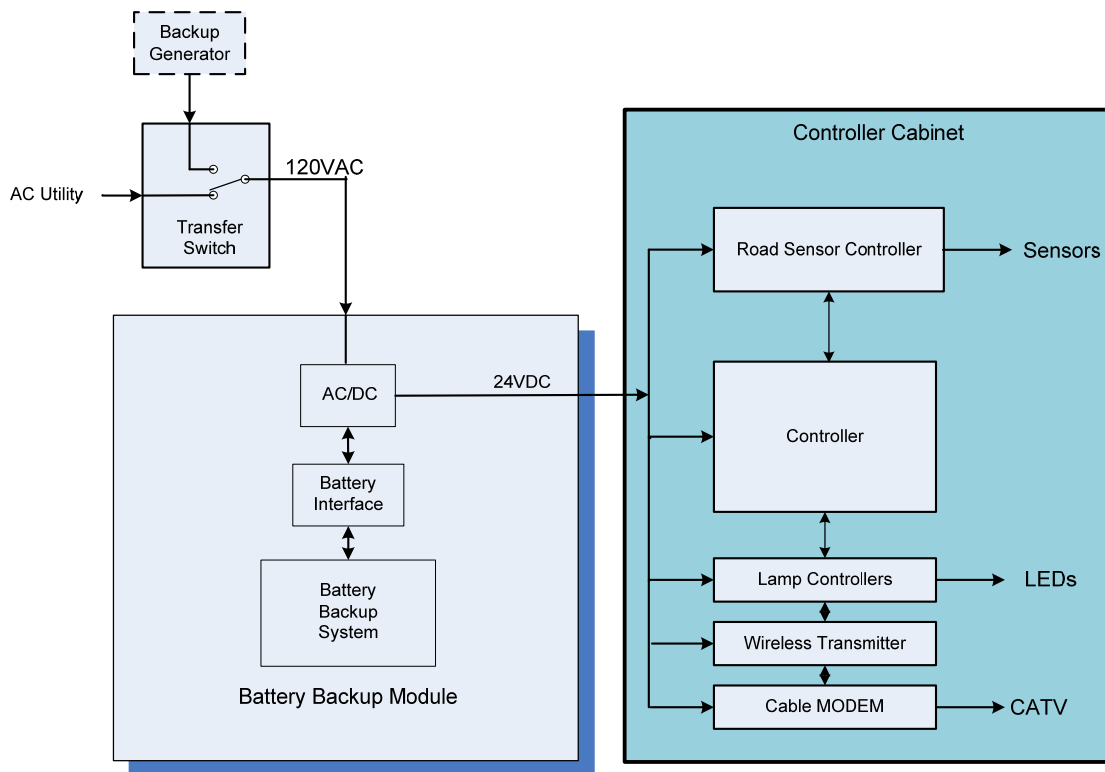

Next Generation Solution for Using Battery Backup

Figure 29 An approach to integrate battery backup within traffic signals

Figure 29 shows an approach to integrating battery backup within traffic signals. The power architecture reflects the use of DC in maintaining battery charge as well as supplying all of the other loads within the system. Figure 29 suggests use of 24V DC for the internal DC voltage. It may also be appropriate to consider 48V. This would open the possibility of leveraging equipment designed for the telecommunications industry. Telecom equipment is designed for similar environments and reliability objectives.

Comparing Figure 29 to Figure 28, it will become apparent that there is a lot less power conversion taking place in the system of Figure 29. The architecture of Figure 29 reflects the ubiquitous use of DC in electronic systems, thereby eliminating unnecessary conversions between AC and DC. Eliminating these unnecessary conversions is expected to save energy, space, and weight while improving efficiency.

7.3 Summary

Battery backup for traffic signals is practical now for intersections that have been converted from incandescent lamps to LEDs. For existing traffic signals, the most expedient way to incorporate energy storage is to use an uninterruptable power supply that is inserted between the AC utility and the input to the traffic signal controls. However, this approach creates redundant conversion between AC and DC within the system, reducing efficiency, increasing weight and volume, and lowering overall reliability.

For new traffic signals, it is recommended to develop a system that is fundamentally DC with a single conversion from AC to DC at the input. Under this architecture incorporating energy storage is natural within the DC system, thereby eliminating unnecessary conversions and gaining all of the benefits associated therewith.

TASK 8: Deployment Plan

8.1 Introduction

This task report presents a plan for the deployment of uninterruptible power systems for traffic signals across New York State. The purpose of this deployment chapter is not to identify specific locations across the state that should be outfitted with a backup system but rather to provide New York State Department of Transportation (NYSDOT) with guidance to help minimize the number of unsafe intersections across the state in the event of traffic signal power outages. This will in turn improve the safety and efficiency of the transportation system. The plan is based on the findings from the previous task reports, mainly the Task 2 (Assessment of Alternative Energy Solutions), Task 4 (Prioritization Guidelines for Installation at Intersections) and the Task 6 (Alternative Energy Sources) reports.

This chapter is organized as follows: Section 8.2 presents a deployment plan; Section 8.3 discusses deployment options; Section 8.4 identifies future steps for this technology; and Section 8.5 provides a summary and conclusions.

8.2 Deployment Plan

Power outages across NYS are typically unscheduled events that can be as short as milliseconds or last as long as several days, even a week or more. This section of the report presents a deployment plan for NYSDOT to use to deploy backup power systems for traffic signals.

8.2.1 Existing Signalized Intersections

Ideally each and every signalized intersection across NYS would be outfitted with a backup system. Due to costs, it is not currently feasible to install systems at all intersections in NYS. Therefore, a more systematic approach is proposed. First the NYSDOT shall use the prioritization guidelines that were presented as part of the Task 4 report. These guidelines provide a weighted score to signalized intersections based on a variety of criteria including the following:

- Historically a problematic location;
- MUTCD warrants;
- Power outage history;
- Proximity to railroad grade crossings;
- Approach speed;
- Intersection volume;
- Evacuation or Truck route;
- Geometry;

- Proximity to other signalized intersections.

NYSDOT could score and rank every intersection they currently operate. Then based on the scores, backup systems could be installed at the intersections ranked the highest. This however would be an intensive effort due to the variety of data sources required for the nearly 6000 NYSDOT operated signals in NYS.

Since these projects would improve safety and efficiency at the intersections it is recommended that the backup systems be installed in a timely manner. Therefore, if NYSDOT is unable to score every intersection they operate in a reasonable amount of time, it would be desirable to request input from each of the regional offices. The regional engineers have a working knowledge of the unsafe and inefficient traffic signals within their regions. For the first round of deployments, the NYSDOT Main Office could request the individual regions identify a set of intersections that should be considered for receiving a backup power system. The regional engineer could then score the selected intersections using the prioritization guidelines outlined in the Task 4 report. The NYSDOT Main Office would compile the results from each of the regions and identify the top ranked intersections. The total number chosen to receive a backup power system would depend on the available budget. Upon completion of the first round of implementation the process could be repeated when more funds were available.

8.2.2 New or Retrofit Signalized Intersections

It would be cost effective to install a backup power system when a new signalized intersection is installed or retrofitted since a large percentage of the cost of a backup system is not the system itself, but rather the cost to integrate it with the existing system. If all of the components were installed together this cost would be minimized. It is recommended that serious consideration be made to install backup power systems at new or retrofitted signalized intersections.

8.3 Deployment Options

To date the most common technological solution for uninterrupted power at a signalized intersection has been the use of battery backup systems in conjunction with LED lights. As documented in the Task 2 report agencies are beginning to experiment with technologies other than battery backup systems. These include auto-start generators, solar panels, and fuel cells. These options have not yet achieved widespread use in the industry but as technological advancements continue they are likely to grow in popularity.

As energy backup technology continues to evolve, it is recommended that NYSDOT choose technologies that work best for a particular intersection. It is anticipated that battery systems will be the most economical in the short term. However, there may be locations, such as along

an evacuation route, that need more power than what a battery system can provide. In this case a system such as an auto-starting natural gas generator may be applicable.

8.4 Future Steps

The previous sections outline what should be done given the existing signalized intersection and backup technologies. As technologies evolve, traffic signal technologies should also advance. The most efficient power approach for the long term is to integrate backup power into all the subsystems of the intersection. This requires that all the controllers, sensors, communications and power supplies operate from a single voltage source that is always connected to a standby power source. Each piece of equipment should be designed to be as efficient as possible to minimize power requirements. Present equipment could be redesigned to reduce power requirements by a factor of 2 or more which would save on the number of batteries required. The energy storage type that is selected should be an intelligent DC source of 12, 24 or 48V, with standby power an integral part of the system. When the main power source is interrupted the power would seamlessly switch over to the standby energy source. As the standby energy source nears depletion, the intelligent power source would communicate to components to shut down specific systems to conserve power.

Figure 30 shows an approach to integrating battery backup within traffic signals. The power architecture reflects the use of DC in maintaining battery charge as well as supplying all of the other loads within the system. Figure 30 suggests use of 24V DC for the internal DC voltage. It may also be appropriate to consider 48V.

Comparing Figure 30 to the architecture within an existing traffic signal system, it is apparent that there is substantially less power conversion taking place in the system of Figure 30. The architecture of Figure 30 reflects the ubiquitous use of DC in electronic systems, thereby eliminating unnecessary conversions between AC and DC. Eliminating these unnecessary conversions is expected to save energy, space, and weight while improving efficiency.

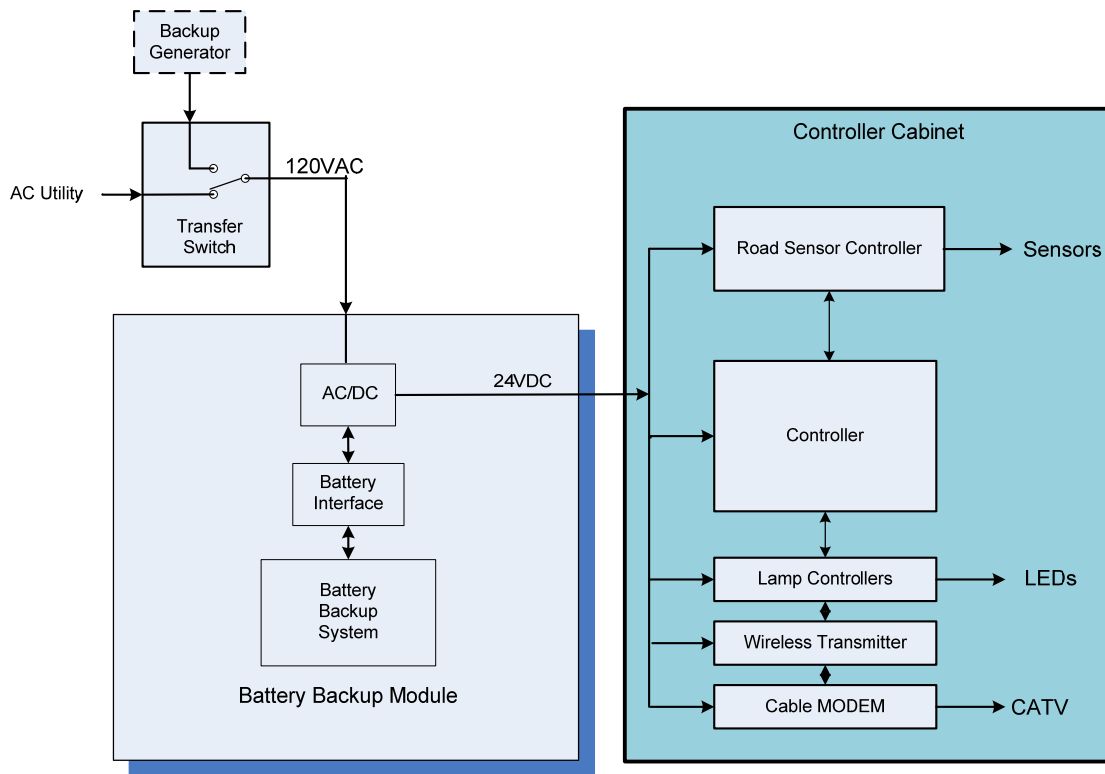

Next Generation Solution for Using Battery Backup

Figure 30

This type of system is not yet in use. It is recommended that NYSDOT build and test a prototype system.

8.5 Conclusions and Summary

NYSDOT has taken a proactive stance on this issue. In order to maintain safe and efficient intersections, they should continue to install backup power systems across NYS as funds permit. In the short term NYSDOT should choose deployment locations based on the input of the regional engineers and a list of priority intersections. However, they should also continue to compile a master dataset containing the data identified in the Task 4 report for the prioritization guidelines. This will allow every intersection to be ranked. It is also recommended that at each new or reconfigured intersection a backup power system be installed. This would increase the construction cost but it would be more cost effective than installing a system at a later date.