

1. Report No. FHWA/TX-09/0-5210-6		2. Government Accession No.		3. Recipient's Catalog No.	
4. Title and Subtitle NCHRP REPORT 350 TEST 3-11 OF THE MODIFIED T8 BRIDGE RAIL				5. Report Date December 2008 Published: April 2009	
				6. Performing Organization Code	
7. Author(s) Roger P. Bligh, William F. Williams, and Wanda L. Menges				8. Performing Organization Report No. Report 0-5210-6	
9. Performing Organization Name and Address Texas Transportation Institute The Texas A&M University System College Station, Texas 77843-3135				10. Work Unit No. (TRAIS)	
				11. Contract or Grant No. Project 0-5210	
12. Sponsoring Agency Name and Address Texas Department of Transportation Research and Technology Implementation Office P.O. Box 5080 Austin, Texas 78763-5080				13. Type of Report and Period Covered Technical Report: September 2004 – August 2008	
				14. Sponsoring Agency Code	
15. Supplementary Notes Project performed in cooperation with the Texas Department of Transportation and the Federal Highway Administration. Project Title: Roadside Crash Testing Program for Design Guidance and Standard Detail Development URL: <a href="http://tti.tamu.edu/documents/0-5210-6.pdf">http://tti.tamu.edu/documents/0-5210-6.pdf</a>					
16. Abstract <p>A new flexible bridge rail system, referred to as the T8 rail, was designed as a replacement for the T6 rail in high-speed applications on culverts and thin deck structures. The T8 rail failed a crash test when the breakaway posts failed the thin deck to which it was attached rather than breakaway as designed. After analysis of the test results, the system was modified in an effort to address the identified failure mechanism. The modifications included increasing the length of the breakaway slot in the tension flange of the steel support posts and incorporating a 1-inch thick offset block between the post and upper portion of the tubular thrie beam rail to raise the point of force application on the post.</p> <p>The impact performance of the modified T8 bridge rail system was evaluated through a full-scale crash test. The crash testing was performed in accordance with the requirements of <i>NCHRP Report 350 Test Level 3 (TL-3)</i>. Despite the modifications to the rail system, the posts once again failed the thin concrete deck prior to breakaway activation.</p> <p>Because the posts did not release from their baseplates as designed, their rotation lowered the rail height and permitted snagging of the wheel of the pickup truck. These behaviors combined to destabilize the pickup truck, causing it to roll as it exited the barrier. Consequently, the modified T8 bridge rail is <u>not</u> suitable for implementation in its present form.</p>					
17. Key Words Bridge Rail, Tubular Thrie Beam, Tubular W-Beam, Flexible Bridge Rail, Roadside Safety, Crash Testing			18. Distribution Statement No restrictions. This document is available to the public through NTIS: National Technical Information Service Springfield, Virginia 22161 <a href="http://www.ntis.gov">http://www.ntis.gov</a>		
19. Security Classif.(of this report) Unclassified		20. Security Classif.(of this page) Unclassified		21. No. of Pages 62	22. Price



**NCHRP REPORT 350 TEST 3-11  
OF THE MODIFIED T8 BRIDGE RAIL**

by

Roger P. Bligh, P.E.  
Research Engineer  
Texas Transportation Institute

William F. Williams  
Assistant Research Engineer  
Texas Transportation Institute

and

Wanda L. Menges  
Associate Research Specialist  
Texas Transportation Institute

Report 0-5210-6  
Project 0-5210  
Project Title: Roadside Crash Testing Program  
for Design Guidance and Standard Detail Development

Performed in cooperation with the  
Texas Department of Transportation  
and the  
Federal Highway Administration

December 2008  
Published: April 2009

TEXAS TRANSPORTATION INSTITUTE  
The Texas A&M University System  
College Station, Texas 77843-3135



## **DISCLAIMER**

This research was performed in cooperation with the Texas Department of Transportation (TxDOT) and the Federal Highway Administration (FHWA). The contents of this report reflect the views of the authors, who are responsible for the facts and the accuracy of the data presented herein. The contents do not necessarily reflect the official view or policies of the FHWA or TxDOT. This report does not constitute a standard, specification, or regulation, and its contents are not intended for construction, bidding, or permit purposes. In addition, the above listed agencies assume no liability for its contents or use thereof. The United States Government and the State of Texas do not endorse products or manufacturers. Trade or manufacturers' names appear herein solely because they are considered essential to the object of this report. The engineer in charge of the project was Roger P. Bligh, P.E. (Texas, #78550).

## **ACKNOWLEDGMENTS**

This research project was conducted under a cooperative program between the Texas Transportation Institute, the Texas Department of Transportation, and the Federal Highway Administration. The TxDOT project director for this research was Rory Meza, P.E. (DES). John Holt (BRG), Jon Ries (BRG), Mark Steves (BRG), and Bobby Dye (DES) served on the project advisory committee and helped guide this research. The authors acknowledge and appreciate their assistance.

# TABLE OF CONTENTS

	<b>Page</b>
List of Figures .....	viii
List of Tables .....	ix
CHAPTER 1. Introduction.....	1
Introduction.....	1
Objectives/Scope of Research.....	6
CHAPTER 2. Crash Test Procedures .....	7
Test Facility .....	7
Test Article.....	7
Crash Test Conditions.....	8
Evaluation Criteria .....	19
CHAPTER 3. Crash Test Results .....	21
Test No. 452108-7 ( <i>NCHRP Report 350</i> Test Designation 3-11) .....	21
Test Vehicle .....	21
Weather Conditions .....	21
Test Description .....	21
Damage to Test Installation .....	24
Vehicle Damage.....	24
Occupant Risk Factors .....	24
CHAPTER 4. Summary and Conclusions .....	31
Assessment of Test Results.....	31
Conclusions.....	33
CHAPTER 5. Implementation Statement .....	35
REFERENCES .....	37
APPENDIX A. Crash Test and Data Analysis Procedures.....	39
Electronic Instrumentation and Data Processing .....	39
Anthropomorphic Dummy Instrumentation .....	40
Photographic Instrumentation and Data Processing .....	40
Test Vehicle Propulsion and Guidance.....	40
APPENDIX B. Test Vehicle Properties and Information.....	41
APPENDIX C. Sequential Photographs .....	45
APPENDIX D. Vehicle Angular Displacements and Accelerations .....	49

## LIST OF FIGURES

Figure	Page
Figure 1.1. T6 Bridge Rail System. ....	1
Figure 1.2. Modified Weld Detail for the T6 Breakaway Post. ....	2
Figure 1.3. Revised Breakaway Connection for the T6 Post. ....	3
Figure 1.4. Slots Details on the Front (Tension) Flange. ....	3
Figure 1.5. New Post Connection Design. ....	4
Figure 2.1. Details of the T8 Bridge Rail Installation – Plan and Elevation. ....	9
Figure 2.2. Details of the T8 Bridge Rail Installation – Terminal Details. ....	10
Figure 2.3. Details of the T8 Bridge Rail Installation – Rebar Detail. ....	11
Figure 2.4. Details of the T8 Bridge Rail Installation – Cross Section. ....	12
Figure 2.5. Details of the T8 Bridge Rail Installation – Rebar Layout. ....	13
Figure 2.6. Details of the T8 Bridge Rail Installation – Post Details. ....	14
Figure 2.7. Details of the T8 Bridge Rail Installation – Slot Details. ....	15
Figure 2.8. Details of the T8 Bridge Rail Installation – Tubular Thrie Beam Details. ....	16
Figure 2.9. Details of the T8 Bridge Rail Installation – Miscellaneous Details. ....	17
Figure 2.10. T8 Bridge Rail Installation before Test 452108-7. ....	18
Figure 3.1. Vehicle/Installation Geometrics for Test 452108-7. ....	22
Figure 3.2. Vehicle before Test 452108-7. ....	23
Figure 3.4. After Impact Trajectory Path for Test 452108-7. ....	25
Figure 3.5. Installation after Test 452108-7. ....	26
Figure 3.6. Vehicle after Test 452108-7. ....	27
Figure 3.7. Interior of Vehicle for Test 452108-7. ....	28
Figure 3.8. Summary of Results for <i>NCHRP Report 350</i> Test 3-11 on the T8 Bridge Rail. ....	29
Figure B1. Vehicle Properties for Test 452108-7. ....	41
Figure C1. Sequential Photographs for Test 452108-7 (Overhead and Frontal Views). ....	45
Figure C2. Sequential Photographs for Test 452108-7 (Rear View). ....	47
Figure D1. Vehicle Angular Displacements for Test 452108-7. ....	49
Figure D2. Vehicle Longitudinal Accelerometer Trace for 452108-7 (Accelerometer Located at Center of Gravity). ....	50
Figure D3. Vehicle Lateral Accelerometer Trace for 452108-7 (Accelerometer Located at Center of Gravity). ....	51
Figure D4. Vehicle Vertical Accelerometer Trace for 452108-7 (Accelerometer Located at Center of Gravity). ....	52



## LIST OF TABLES

<b>Table</b>	<b>Page</b>
Table 3.1. Post Deformation and Deflection. ....	24
Table 4.1. Performance Evaluation Summary for <i>NCHRP Report 350</i> Test 3-11 on the T8 Bridge Rail.....	34
Table B1. Exterior Crush Measurements for Test 452108-7.....	42
Table B2. Occupant Compartment Measurements for Test 452108-7. ....	43



# CHAPTER 1. INTRODUCTION

## INTRODUCTION

Since its original development in 1978, the Texas Type T6 bridge rail system has been widely used as a bridge rail in Texas (1). Figure 1.1 shows a typical T6 bridge rail installation. The system was specifically designed for use on culverts and thin bridge decks. A breakaway mechanism incorporated into the posts is intended to minimize the transfer of forces to the concrete deck, thus reducing the extent of damage to the deck.



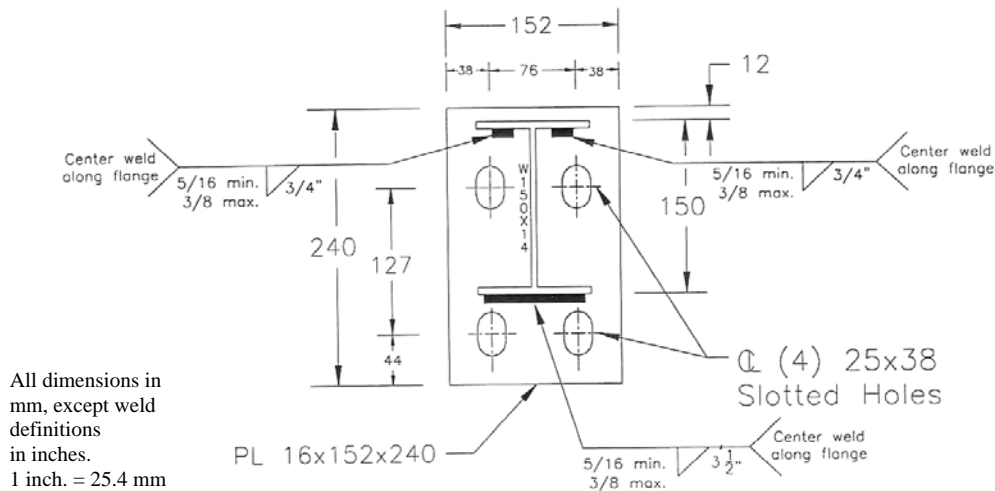
**Figure 1.1. T6 Bridge Rail System.**

Primary components include a tubular W-beam rail element and W6×9 steel posts welded to baseplates, which are bolted to the deck. The tubular rail is fabricated by welding two standard 12-gauge W-beams back to back using a 6-inch long intermittent skip weld. The two beam sections are staggered 1.25 ft in order to accommodate a bolted lap splice connection. The rail is mounted on W6×9 posts spaced 6.25 ft on center using a 5/8-inch diameter button head bolt. A pipe sleeve is used between the tubular rail and post.

The baseplates to which the support posts are attached are anchored into or bolted through the concrete deck. The original breakaway post connection was accomplished by completely welding the tension flange, only slightly welding the inside of the compression flange, and providing no welds on the web. The T6 system was originally tested under *Transportation Research Circular 191* and was later judged to be acceptable under *National Cooperative Highway Research Program (NCHRP) Report 230 (2,3)*. This certification required full-scale crash testing of two scenarios: a 4500-lb passenger vehicle impacting at a speed of 60 mi/h and an angle of 25 degrees, and a 2250-lb passenger vehicle impacting at the same speed at a reduced angle of 15 degrees.

With the adoption of *NCHRP Report 350*, a re-evaluation of the T6 bridge rail was necessary to determine if it could accommodate the new pickup truck design test vehicle. Test Level Three (TL-3) of *NCHRP Report 350* includes a test of a 4409-lb pickup truck impacting the rail at 62 mi/h and 25 degrees (4). In the first full-scale crash test (Test No. 418048-2) of the T6 bridge rail system, which followed the impact conditions of *NCHRP Report 350* test designation 3-11, the T6 system did not perform satisfactorily (5). Although the bridge rail contained and redirected the pickup truck, the pickup truck eventually rolled onto its left side as it exited the installation. Static load tests on posts taken from the prototype rail installation showed that the capacity of the breakaway weld exceeded the plastic moment of the post. Consequently, rupture of the post flange occurred before failure of the baseplate weld. The lack of a reliable breakaway mechanism led to undesired wheel snagging on several posts, which likely contributed to the vehicle instability.

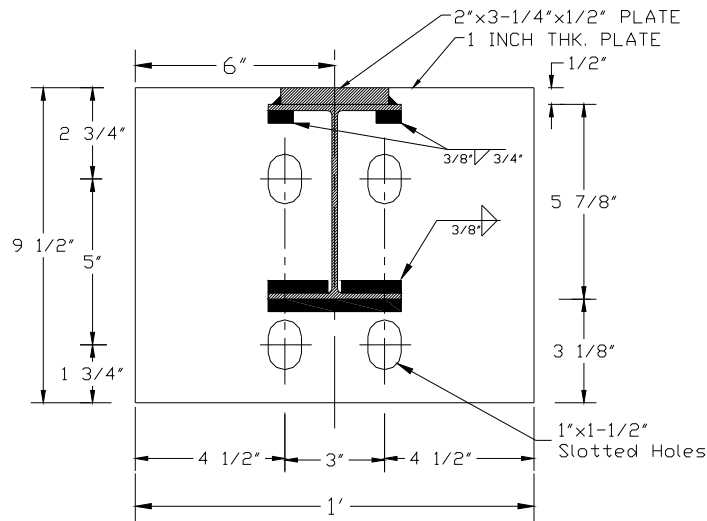
A series of static tests and dynamic pendulum tests was subsequently conducted to assist with evaluation of a revised post-to-baseplate connection. The objective was to reduce the capacity of the connection by inducing controlled failure of the welds rather than requiring rupture of the post flange. Findings of this study resulted in a revised weld detail shown in Figure 1.2 (6). The primary difference was the reduction of the fillet weld on the front flange from a two-sided to a single-sided configuration.



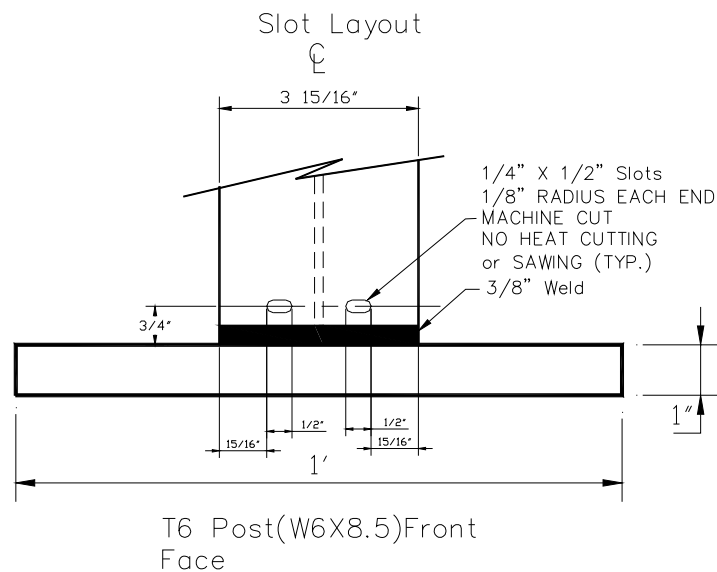
**Figure 1.2. Modified Weld Detail for the T6 Breakaway Post.**

A second full-scale crash test (Test No. 418048-3) was conducted on a T6 rail that incorporated this modification (7). Results of this test were also unsatisfactory. Analysis of the test results revealed that the weak-axis strength of the modified post-to-baseplate connection was inadequate. Consequently, the longitudinal rail forces applied to the posts through the post bolts led to premature breakaway of a large number of posts both upstream and downstream from the impacting vehicle. The associated loss in rail stiffness subsequently led to large rail deflections, which permitted the impacting vehicle to extend completely off of and drop below the bridge deck.

In response to this identified performance issue, a third breakaway post concept was conceived and incorporated into the T6 design. Figure 1.3 and Figure 1.4 shows details of this new post connection. The front flange of the post was fully welded to the baseplate to achieve improved weak axis capacity. The strong-axis capacity was controlled through the introduction of slots in the front flange of the post (see Figure 1.4). A backup plate was welded to the field side of the back flange to facilitate failure of the two welds on the back flange and permit complete release of the post from the baseplate. The size and thickness of the baseplate were increased to help distribute the impact load into the deck and further reduce deck damage. A photograph of the new post connection is shown in Figure 1.5.



**Figure 1.3. Revised Breakaway Connection for the T6 Post.**



**Figure 1.4. Slots Details on the Front (Tension) Flange.**



**Figure 1.5. New Post Connection Design.**

The T6 bridge rail with revised breakaway connection was evaluated in a third full-scale crash test (Test No. 418048-12) (8). The revised post connection performed as designed and eliminated the wheel snagging and excessive deflections observed in the previous tests. However, after being contained and redirected, the pickup truck test vehicle rolled as it exited the barrier. In the absence of wheel snagging, the researchers were able to conclude that there was a basic height incompatibility between the vehicle and rail system. The force imparted to the vehicle from the rail was below the center of gravity (C.G.) of the pickup truck and induced a roll moment that resulted in the instability. It was theorized that increasing the rail height of the system would increase the height of the resultant impact force exerted upon the vehicle and thereby improve the performance of the system in terms of vehicle stability.

Further research was needed to develop a TL-3 bridge rail system suitable for use on thin deck structures. A new, flexible bridge rail system, referred to as the T8 rail, was designed as a replacement for the T6 rail in high-speed applications.

The T8 rail incorporates a tubular thrie beam rail element. As with the tubular W-beam rail, the tubular thrie beam rail consists of welding the free edges of two standard thrie beam sections in a back-to-back fashion to create a tubular section that has significantly increased flexural and torsional strength. The tubular thrie beam provides additional rail height intended to improve stability for light truck vehicles. Compared with the tubular W-beam, the tubular thrie beam rail has a reduced clear opening that minimizes the potential for vehicle underride. Additionally, use of the thrie beam rail, which is an industry standard rail shape, facilitates the transition to the approach guardrail using “off-the-shelf” components.

The typical mounting height of thrie-beam rail is 31 inches compared to 27 inches for a W-beam rail. The thrie-beam rail section is 20 inches deep compared to the 12¼-inch deep W-beam rail section. This places the bottom of the tubular thrie beam 11 inches from the bridge deck compared to approximately 15 inches for the tubular W-beam. The connection of the

tubular thrie-beam rail to the breakaway posts consisted of one 5/8-inch diameter button-head bolt through the upper of the two post bolt slots in the thrie beam section. As with the T6 rail, a pipe sleeve was used to bridge the gap between the valley of the tubular thrie beam and the flange of the support post.

The anchor bolt pattern or “footprint” used for the T8 post is the same as that used for the T6 post. This would facilitate an upgrade of existing T6 installations. As with the T6 system, the posts in the T8 rail are intended to breakaway to prevent vehicle snagging and control deck damage. Structural analyses indicated that the strength of the T6 post may exceed the capacity of a 6.5 inch thick concrete deck. Failure of the deck prior to activation of the post could lead to severe post snagging, vehicle instability, and costly deck repair.

Dynamic pendulum impact testing was conducted on the breakaway support posts to further explore the applicability of the T8 to thin deck structures (9). The testing examined the effect of the length of the weakening slots in the front tension flange of the post on the breakaway strength of the post. The objective was to determine the optimal post configuration for use on decks as thin as 6.5 inches having a concrete compressive strength of 3000 psi.

The post configuration selected for use in the T8 rail incorporated longer 7/8-inch weakening slots to further reduce the lateral capacity of the post for applications on very thin deck structures. This slot length was believed to be the shortest that permitted the post to breakaway prior to inducing catastrophic damage to the thin deck section. The shortest acceptable slot length was chosen in order to maintain as much lateral strength in the post as possible to help keep the number of posts damaged and the dynamic rail deflection during an impact to a minimum.

*NCHRP Report 350* Test 3-11 was performed to evaluate the impact performance of the T8 bridge rail (10). This test involves a 4409-lb pickup truck impacting the rail at a speed of 62 mi/h and an angle of 25 degrees. During the test, the thin deck failed beneath the posts prior to breakaway activation of the post from the baseplate. This behavior led to post snagging and a reduction in rail height, both of which destabilized the vehicle. The vehicle subsequently rolled over as it exited the barrier system.

Analysis of the failure led to the observation that the impact forces were transmitted to the post at a lower height than expected. Once the posts began to rotate, the point of load application shifted down to the lowest corrugation of the tubular thrie beam rail. Given the smaller moment arm, an increased magnitude of force was required to reach the activation moment of the post. However, the increased shear force combined with the applied moment exceeded the capacity of the deck prior to achieving breakaway of the post.

The recommended design modifications included further increasing the length of the breakaway slots in the tension flange of the posts and incorporating a narrow offset block between the posts and the upper two corrugations of the tubular thrie beam rail. The longer breakaway slot would reduce the activation moment of the post. The offset block was intended to provide separation between the post and the lowest corrugation of the tubular thrie beam rail

and, thereby, raise the point of load application on the post to permit the activation moment to be reached at a lower magnitude of impact force.

## **OBJECTIVES/SCOPE OF RESEARCH**

The objective of this research was to evaluate the impact performance of the modified T8 bridge rail. The modified T8 rail system is intended to serve as a replacement for the Texas Type T6 rail for use on culverts and thin deck structures. The crash testing was performed in accordance with the requirements of *NCHRP Report 350* Test Level 3 (TL-3).

This report describes the modified T8 bridge rail, documents the performance of the modified T8 in a full-scale crash test, and presents recommendations regarding implementation and future work.



## **CHAPTER 2. CRASH TEST PROCEDURES**

### **TEST FACILITY**

The Texas Transportation Institute Proving Ground is a 2000-acre complex of research and training facilities located 10 mi northwest of the main campus of Texas A&M University. The site, formerly an Air Force base, has large expanses of concrete runways and parking aprons well suited for experimental research and testing in the areas of vehicle performance and handling, vehicle-roadway interaction, durability and efficacy of highway pavements, and safety evaluation of roadside safety hardware. The site selected for construction and testing of the modified T8 bridge rail evaluated under this project was along the edge of an out-of-service apron. The apron consists of an unreinforced jointed-concrete pavement in 12.5 ft by 15 ft blocks nominally 8 to 12 inches deep. The apron is over 50 years old, and the joints have some displacement, but are otherwise flat and level.

### **TEST ARTICLE**

Details of the modified T8 bridge rail test installation are shown in Figure 2.1 through Figure 2.9. The modified T8 bridge rail installation consisted of a 12 gauge tubular thrie-beam rail supported by W6x8.5 steel posts anchored to a 6-1/2-inch thick concrete cantilevered deck. The length of the modified T8 bridge rail section and cantilevered deck constructed and tested for this project was 97 ft - 9 inches.

The modified T8 bridge rail was anchored on each end using an ET Plus end terminal, making the overall length of the test installation 112 ft - 6 inches. The terminals connected to the tubular thrie beam bridge rail using standard 12 gauge thrie-beam to W-beam transition rail elements.

The W6x8.5 steel posts were welded to 12-inch x 9-1/2-inch x 1-inch thick base plates. Two 1/4-inch wide by 1-inch long slots were machine cut into the traffic side flange of the posts 3/4-inch above the top of the base plate. Each steel post with base plate was anchored to the 6-1/2-inch thick cantilevered deck using four 7/8-inch diameter, ASTM A307 anchor bolts. Please refer to Figure 2.6 and Figure 2.7 for additional details of the W6x8.5 steel post.

The tubular thrie beam rail was mounted to the posts at a height of 31 inches to the top of rail using a 5/8-inch diameter x 3-inch long, ASTM A307 bolt. The connection bolt passed through a 3/4-inch diameter pipe sleeve. A 5-inch wide x 11-1/4-inch long x 1-1/4-inch deep high density polyethylene (HDPE) offset block was placed between the traffic side of the post and the field side of the tubular thrie beam rail. A 1/4-inch deep channel was routed into the field side of the plastic offset block to fit over the flange of the steel support post, thus providing a 1-inch offset distance between the rail and post. The lowest corrugation of the tubular thrie beam rail was left unsupported.

The cantilevered deck was 97 ft - 9 inches in length and 6-1/2 inches thick. The width of the cantilevered deck was 30 inches. Top transverse steel reinforcement in the deck consisted of #5 bars spaced at 6 inches on centers in the top mat. Bottom transverse steel reinforcement in the deck consisted of #5 bars spaced at 18 inches on centers. Longitudinal steel reinforcement in the top mat of steel reinforcement consisted of #4 bars spaced at 9 inches on centers. Longitudinal steel reinforcement in the bottom mat of steel reinforcement consisted of two #5 bars spaced approximately 3-1/4 inches on centers with a third bar located approximately 17 inches from the field side edge of the deck. The specified 28-day compressive strength for the concrete cantilevered deck was 3000 psi. The actual compressive strength of the concrete deck on the day the test was performed was 3536 psi.

Photographs of the completed test installation are shown in Figure 2.10.

## CRASH TEST CONDITIONS

*NCHRP Report 350* recommends two tests for TL-3 evaluation of longitudinal barriers:

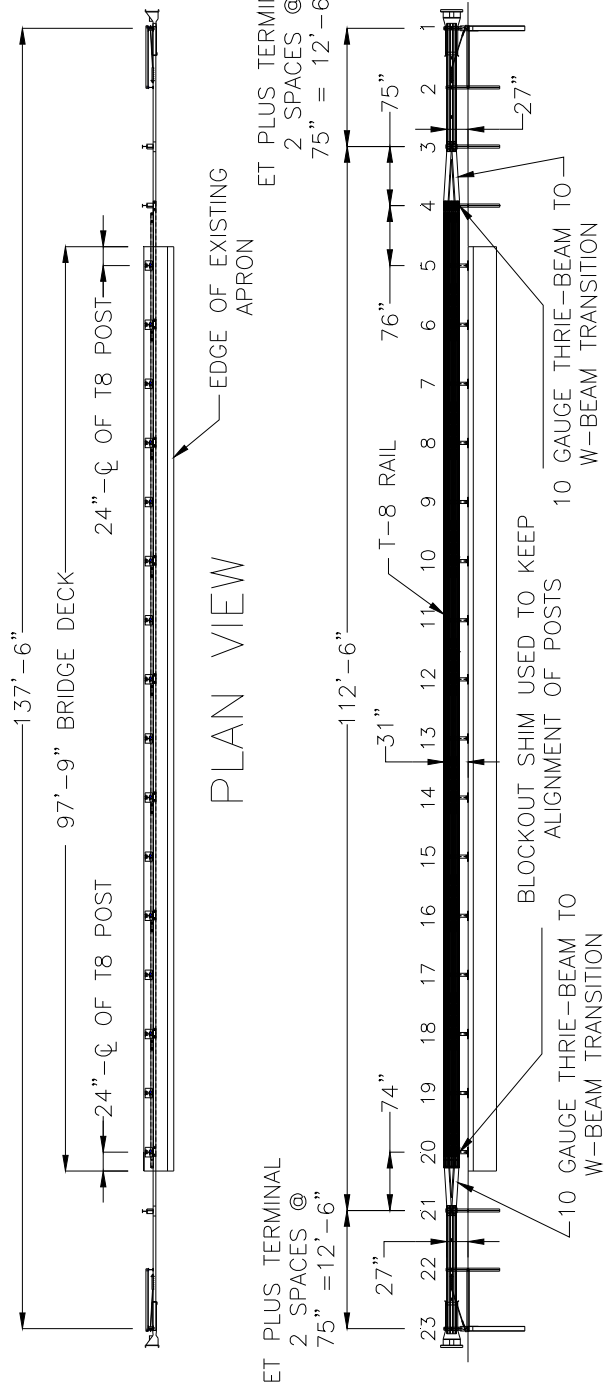
***NCHRP Report 350* test designation 3-10:** This test involves an 1808-lb passenger car impacting the critical impact point (CIP) in the length of need (LON) of the longitudinal barrier at a nominal speed and angle of 62 mi/h and 20 degrees, respectively. The purpose of this test is to evaluate the overall performance of the LON section in general and occupant risk in particular.

***NCHRP Report 350* test designation 3-11:** This test involves a 4409-lb pickup truck impacting the CIP in the LON of the longitudinal barrier at a nominal speed and angle of 62 mi/h and 25 degrees, respectively. The test is intended to evaluate the strength of the rail in terms of its ability to contain and redirect the pickup truck.

Since use of the tubular three beam rail effectively eliminates vehicle underride as an issue, test 3-10 is not considered necessary. Compliance with *NCHRP Report 350* can, therefore, be satisfactorily evaluated with test 3-11. The test performed under this project and reported herein corresponds to *NCHRP Report 350* test designation 3-11. The pickup truck test is considered to be the critical test in the evaluation of the T8 rail in terms of vehicle stability, barrier override, occupant compartment deformation, and deck damage.

The critical impact point for the modified T8 bridge rail for test designation 3-11 was chosen according to guidelines contained in *NCHRP Report 350*. The target impact point was 1.5 ft upstream of post 11 (7th bridge rail post).

All crash test, data analysis, and evaluation and reporting procedures followed under this project were in accordance with guidelines presented in *NCHRP Report 350*. Appendix A presents a brief description of these procedures.



NOTES:

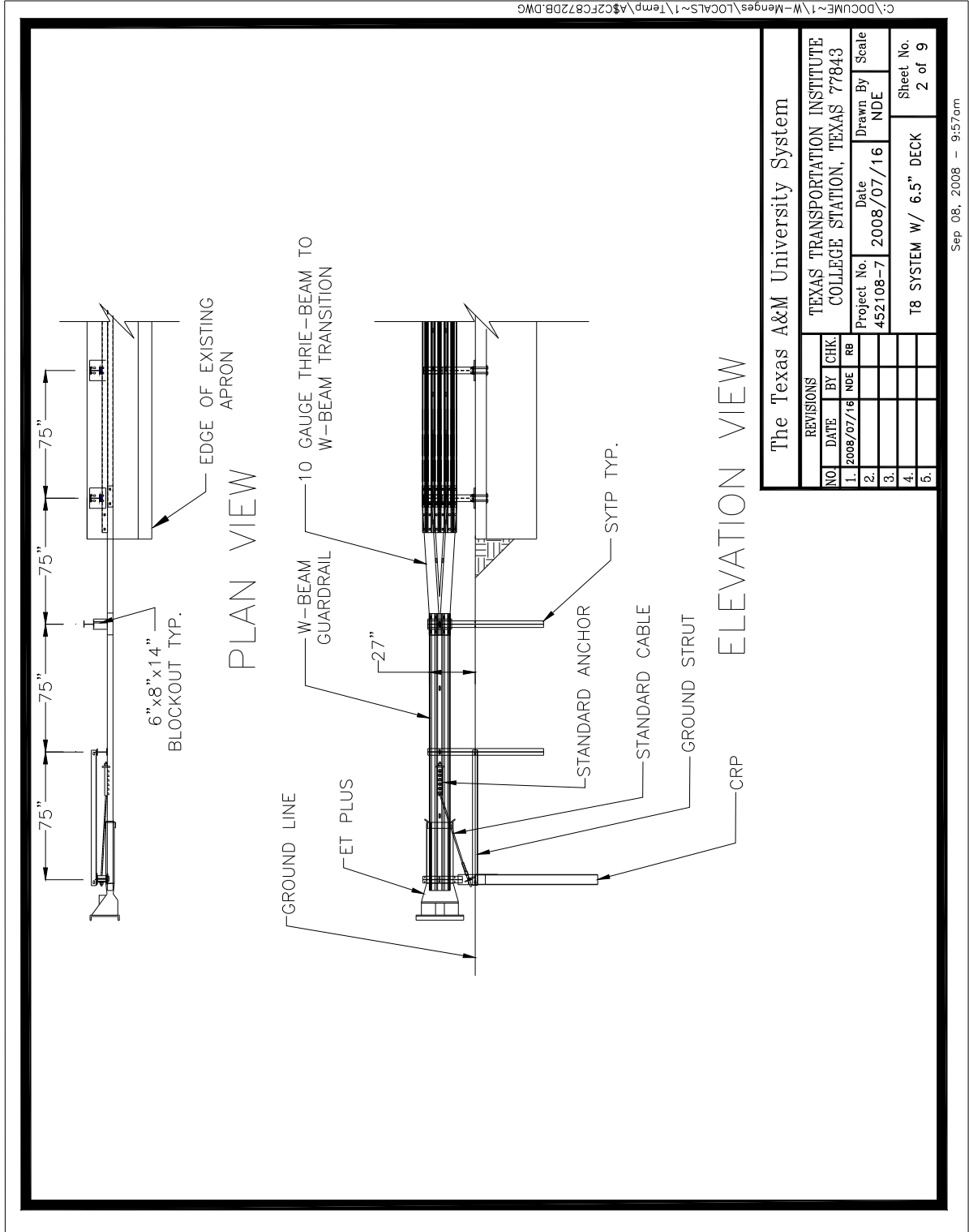
1. DECK CONCRETE SHALL BE CLASS S AND HAVE A MINIMUM COMPRESSIVE STRENGTH (F'c) OF 3000 psi.
2. REINFORCING STEEL SHALL BE GRADE 60 AND HAVE A MINIMUM YIELD STRENGTH (FY) OF 60 Ksi.
3. BLOCKOUT DETAIL G USED FOR POSTS 4-20.

REVISIONS		THE TEXAS A&M UNIVERSITY SYSTEM	
NO.	DATE	BY	CHK
1.	2008/07/16	NDE	RB
2.			
3.			
4.			
5.			
APPROVED:		2008/07/16	
ROGER BLIGH			

TEXAS TRANSPORTATION INSTITUTE	
COLLEGE STATION, TEXAS 77843	
Project No.	Date
452108-7	2008/07/16
Drawn By	Scale
NDE	
T8 SYSTEM W/ 6.5" DECK	
Sheet No.	1 of 9

Figure 2.1. Details of the T8 Bridge Rail Installation – Plan and Elevation.



The Texas A&M University System						
TEXAS TRANSPORTATION INSTITUTE						
COLLEGE STATION, TEXAS 77843						
NO.	DATE	BY	CHK.	Date	Drawn By	Scale
1.	2008/07/16	NDE	RE	2008/07/16	NDE	
2.						
3.						
4.						
5.						
Project No. 452108-7						T8 SYSTEM W/ 6.5" DECK
Sheet No. 2 of 9						

Sep 08, 2008 - 9:57am

Figure 2.2. Details of the T8 Bridge Rail Installation – Terminal Details.

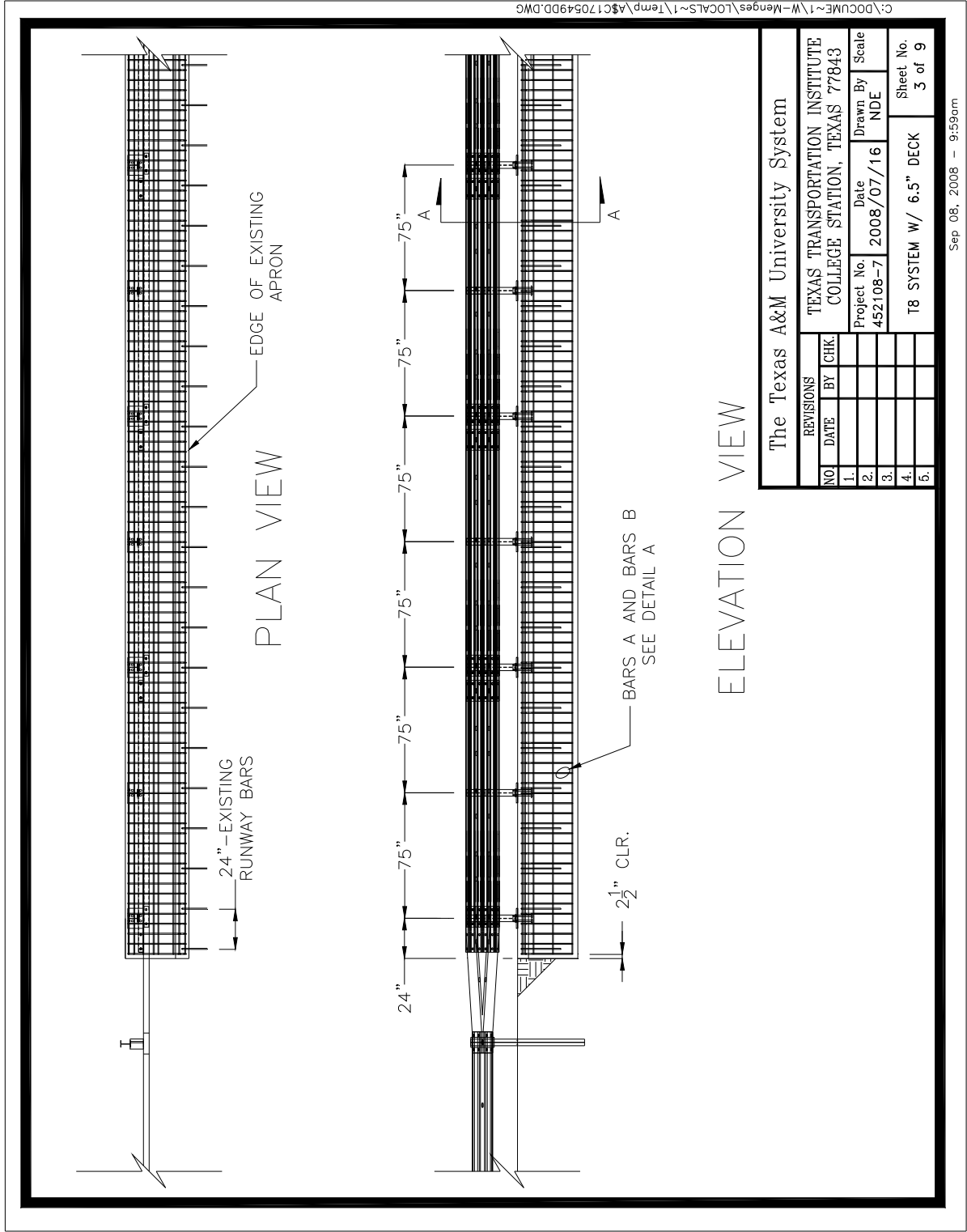
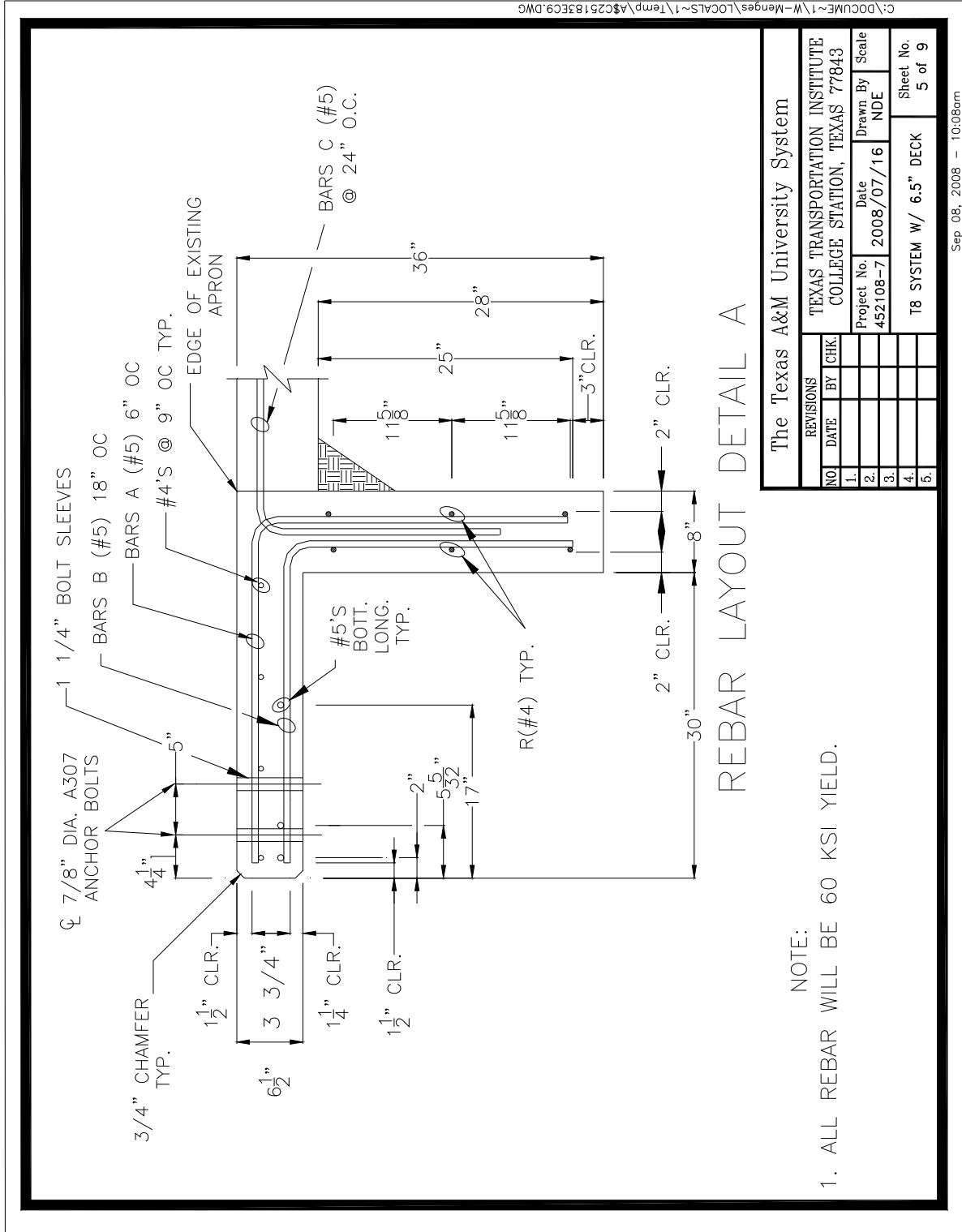


Figure 2.3. Details of the T8 Bridge Rail Installation – Rebar Detail.

C:\DOCUME~1\W-Menges\LOCALS~1\Temp\A5C170549DD.DWG





The Texas A&M University System	
TEXAS TRANSPORTATION INSTITUTE COLLEGE STATION, TEXAS 77843	
Project No.	Date
452108-7	2008/07/16
Drawn By	Scale
NDE	
T8 SYSTEM W/ 6.5" DECK	
Sheet No.	5 of 9

NOTE:  
1. ALL REBAR WILL BE 60 KSI YIELD.

Sep 08, 2008 - 10:08am

**Figure 2.5. Details of the T8 Bridge Rail Installation – Rebar Layout.**

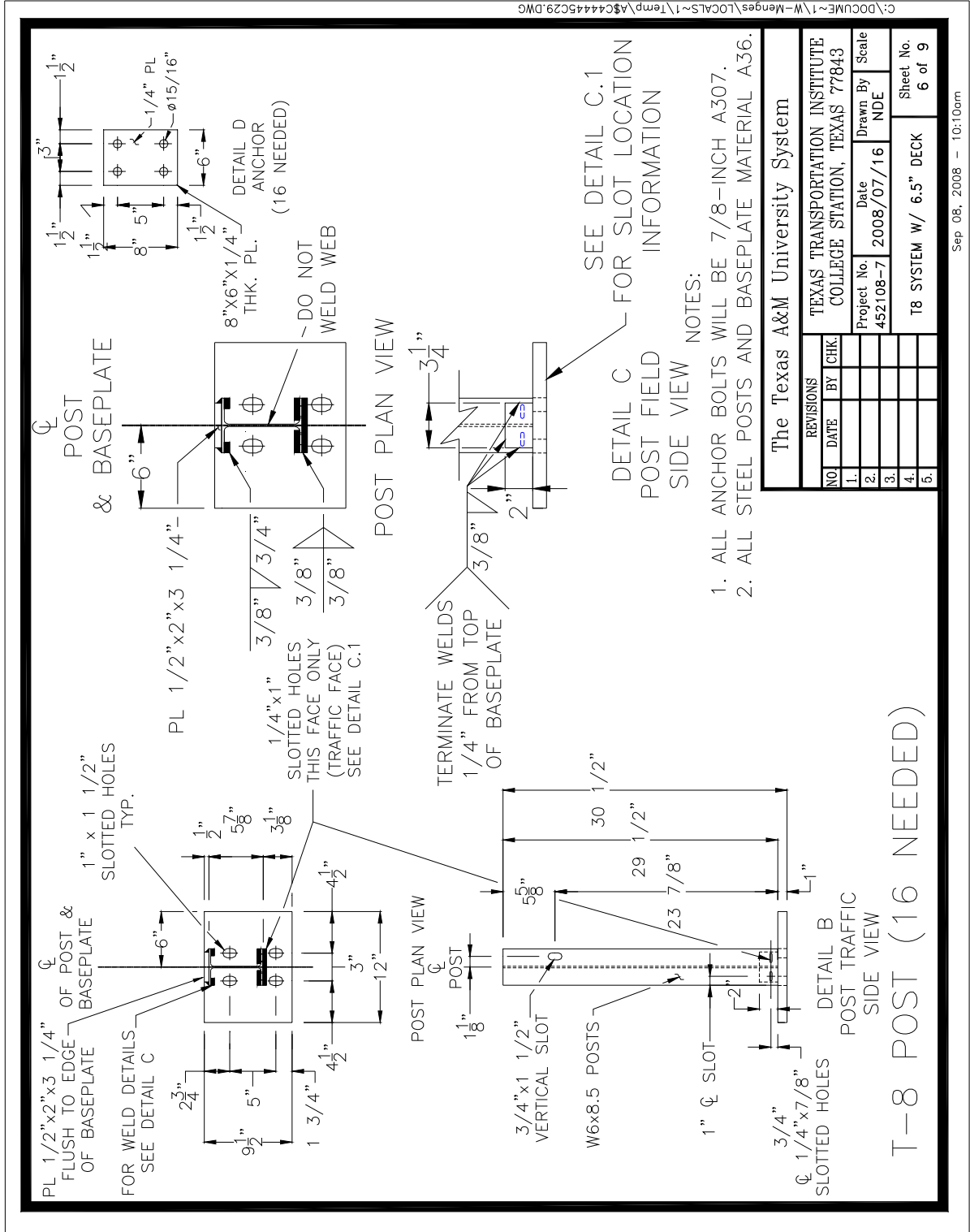


Figure 2.6. Details of the T8 Bridge Rail Installation – Post Details.



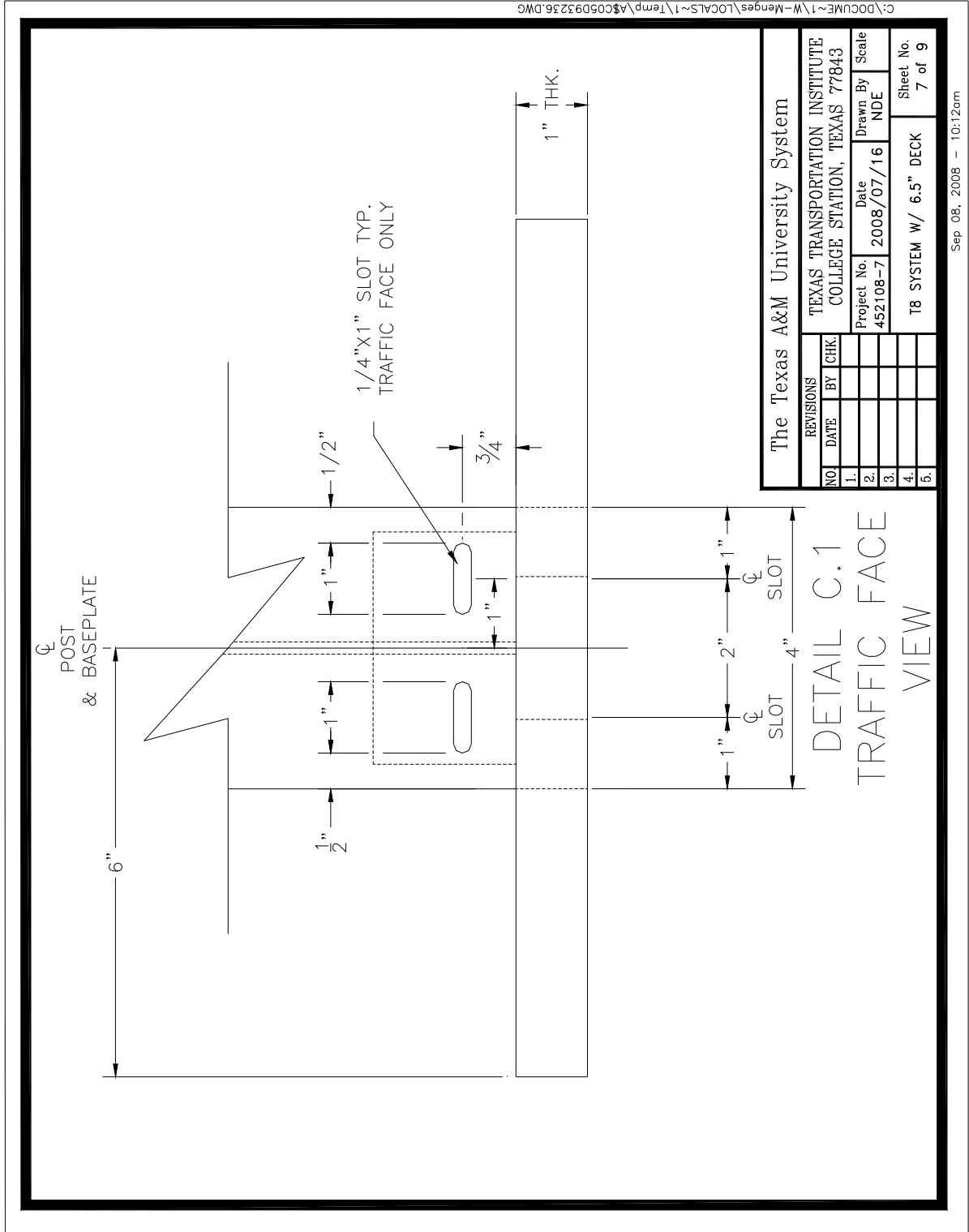
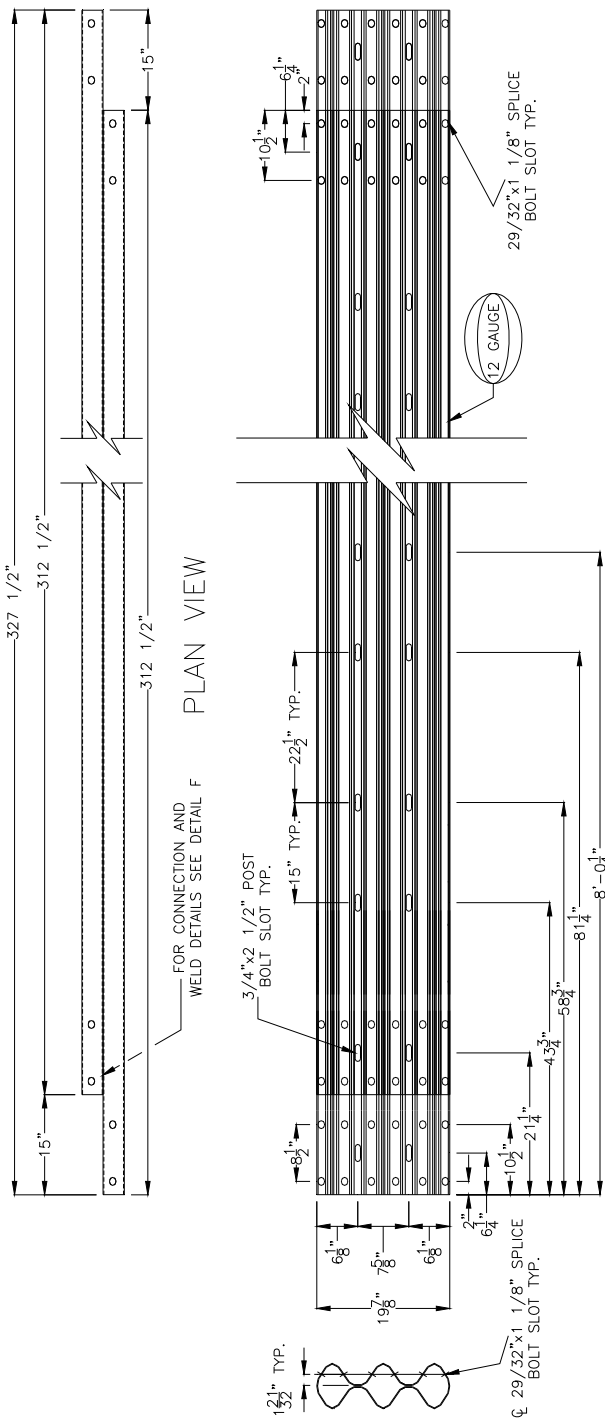


Figure 2.7. Details of the T8 Bridge Rail Installation – Slot Details.



ELEVATION VIEW  
DETAIL E

NOTE: ADDITIONAL POST MOUNTING SLOTS ARE TO BE MADE IN EACH MEMBER 15" FROM THE STANDARD SLOTS AT 75" CENTERS.

NOTES:

1. ALL ANCHOR BOLTS WILL BE 7/8-INCH A307.
2. ALL STEEL POSTS AND BASEPLATE MATERIAL A36.

REVISIONS		The Texas A&M University System	
NO.	DATE	BY	CHK
1.			
2.			
3.			
4.			
5.			
Project No.		Date	Drawn By
452108-7		2008/07/16	NDE
Scale		T8 SYSTEM W/ 6.5" DECK	
Sheet No.		8 of 9	

Sep 08, 2008 - 10:19am

Figure 2.8. Details of the T8 Bridge Rail Installation – Tubular Thrie Beam Details.

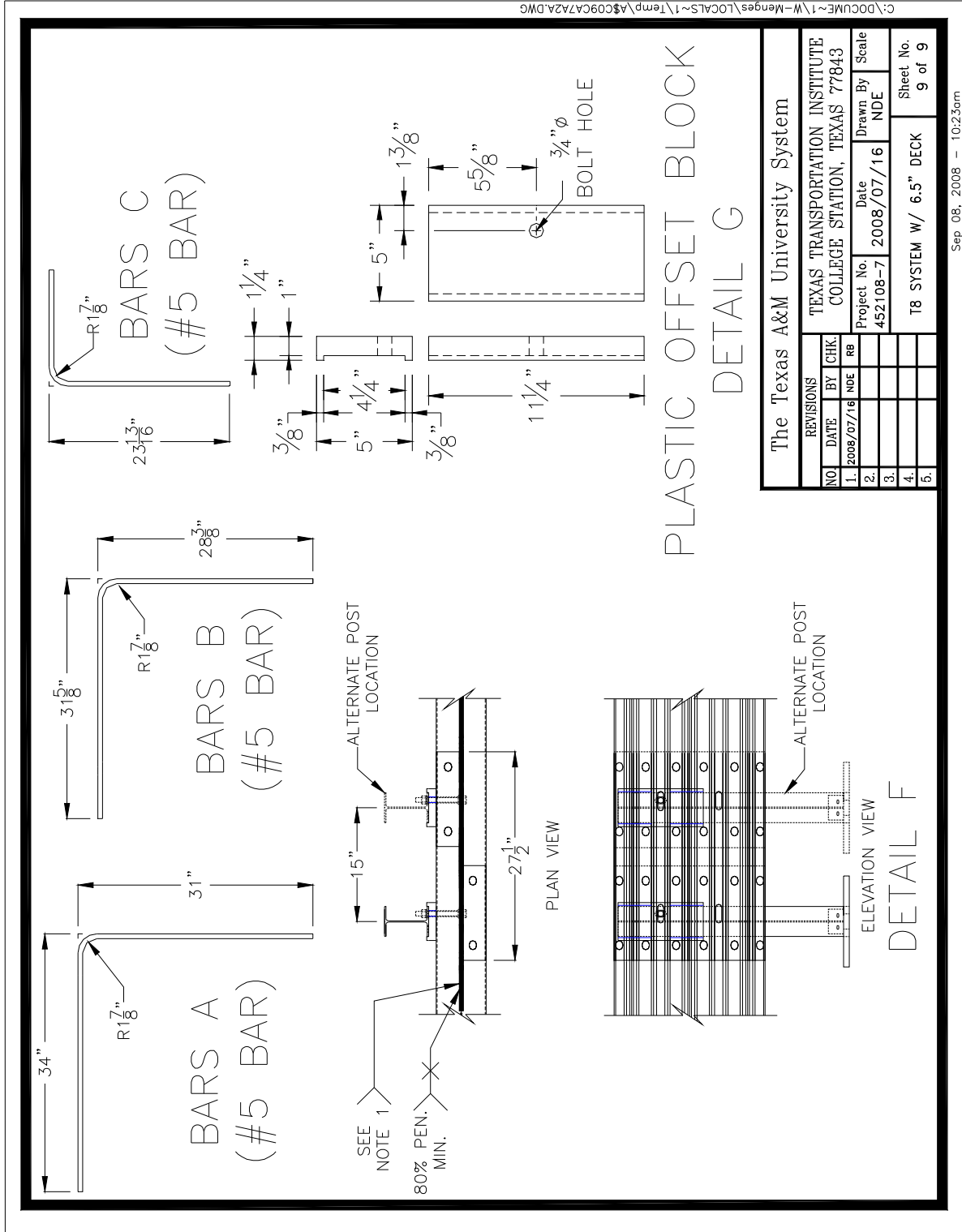


Figure 2.9. Details of the T8 Bridge Rail Installation – Miscellaneous Details.



**Figure 2.10. T8 Bridge Rail Installation before Test 452108-7.**

## **EVALUATION CRITERIA**

The crash test performed under this project and reported herein was evaluated in accordance with *NCHRP Report 350*. As stated in *NCHRP Report 350*, “Safety performance of a highway appurtenance cannot be measured directly but can be judged on the basis of three factors: structural adequacy, occupant risk, and vehicle trajectory after collision.” Accordingly, researchers used the safety evaluation criteria from Table 5.1 of *NCHRP Report 350* to evaluate the impact performance of the modified T8 bridge rail.



## CHAPTER 3. CRASH TEST RESULTS

### TEST NO. 452108-7 (NCHRP REPORT 350 TEST DESIGNATION 3-11)

#### Test Vehicle

A 2000 Chevrolet C2500 pickup truck, shown in Figures 3.1 and 3.2, was used for the crash test. Test inertia weight of the vehicle was 4522 lb, and its gross static weight was 4522 lb. The height to the lower edge of the vehicle bumper was 16.25 inches, and height to the upper edge of the vehicle bumper was 25.0 inches. Figure B1 in Appendix B gives additional dimensions and information on the vehicle. The vehicle was directed into the installation using a cable reverse tow and guidance system, and was released to be free-wheeling and unrestrained just prior to impact.

#### Weather Conditions

The test was performed on the morning of August 28, 2008. Weather conditions at the time of testing were as follows:

- Wind speed: 3 mi/h;
- Wind direction: 340 degrees with respect to the vehicle (vehicle was traveling in a northeasterly direction);
- Temperature: 83°F,
- Relative humidity: 80 percent.

#### Test Description

The 2000P vehicle, traveling at an impact speed of 62.1 mi/h, impacted the T8 bridge rail 20.0 inches upstream of post 11 at an impact angle of 23.8 degrees. At 0.027 s after impact, post 11 began to deflect toward the field side, and at 0.056 s, the 2000P vehicle began to redirect. Posts 12 and 13 began to deflect toward the field side at 0.061 s and 0.068 s, respectively. At 0.259 s, the vehicle began to travel parallel with the bridge rail at a speed of 48.1 mi/h. The 2000P vehicle began to roll at 0.267 s. The vehicle continued to roll as it exited the view of the overhead camera. The 2000P vehicle subsequently came to rest on its right side 163 ft downstream of impact and 48 ft forward of the traffic face of the rail. Figures C1 and C2 in Appendix C show sequential photographs of the test period.





**Figure 3.1. Vehicle/Installation Geometrics for Test 452108-7.**





**Figure 3.2. Vehicle before Test 452108-7.**

## Damage to Test Installation

Damage to the T8 bridge rail is shown in Figures 3.3 and 3.4. Posts 5 through 9 rotated 5 degrees clockwise. Posts 10 through 15 were deformed and deflected toward the field side as listed in Table 3.1.

**Table 3.1. Post Deformation and Deflection.**

Post No.	Lean Toward Field Side	Deflected Toward Field Side
10	10 degrees	1.5 inches
11	35 degrees	5.25 inches
12	58 degrees	8.5 inches
13	210 degrees	14.25 inches
14	17 degrees	3.125 inches
15	5 degrees	0.625 inches

The rail-to-post connection bolt pulled through the tubular thrie beam rail at posts 11 through 13 and was pulled through the first layer of the tubular thrie beam rail element at post 14. The vehicle was in contact with the rail a distance of 24.75 ft. Working width was 2.95 ft. Dynamic deflection of the bridge rail during the test was 1.91 ft, and maximum permanent deformation was 1.69 ft.

## Vehicle Damage

Figure 3.5 shows the damage to the 2000P vehicle. The left upper and lower A-arms, left outer tie rod end, and frame rail were deformed, as well as the A and B pillars. Also damaged were the front bumper, hood, grill, left front fender, left tire and wheel rim, left door, and left rear exterior bed. The windshield and door glass broke when the vehicle rolled onto its side. Maximum exterior crush to the vehicle was 13.0 inches in the front plane at the left front corner at bumper height. The left firewall and floor pan were also deformed. Maximum occupant compartment deformation was 1.2 inches at the left A-pillar. Photographs of the interior of the vehicle are shown in Figure 3.6. Exterior vehicle crush and occupant compartment measurements are shown in Tables B1 and B2 of Appendix B.

## Occupant Risk Factors

Data from the triaxial accelerometer located at the vehicle center of gravity were digitized to compute occupant impact velocity and ridedown accelerations. Only the occupant impact velocity and ridedown accelerations in the longitudinal axis are required from these data for evaluation of criterion L in *NCHRP Report 350*. In the longitudinal direction, occupant impact velocity was 17.4 ft/s at 0.131 s, maximum 0.010-s ridedown acceleration was -6.6 g from 0.148 to 0.158 s, and the maximum 0.050-s average was -5.6 g between 0.057 and 0.107 s. In the lateral direction, the occupant impact velocity was 14.8 ft/s at 0.131 s, the highest 0.010-s occupant ridedown acceleration was -7.4 g from 0.327 to 0.337 s, and the maximum 0.050-s average was -5.3 g between 0.027 and 0.077 s. Figure 3.8 presents these data and other pertinent information from the test. Figures D1 through D4 in Appendix D present vehicle angular displacements and accelerations versus time traces.



**Figure 3.4. After Impact Trajectory Path for Test 452108-7.**





**Figure 3.5. Installation after Test 452108-7.**





Vehicle after being uprighted



**Figure 3.6. Vehicle after Test 452108-7.**



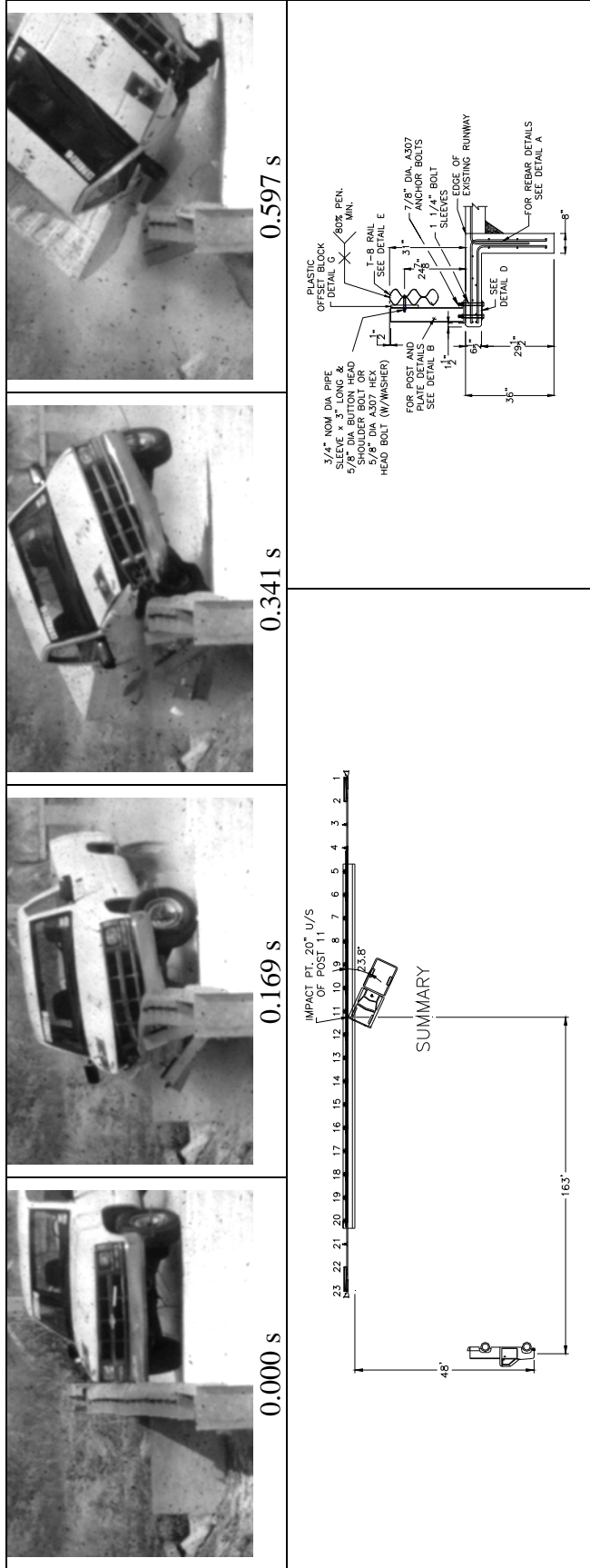
Before Test

After Test



**Figure 3.7. Interior of Vehicle for Test 452108-7.**





<b>General Information</b>	Texas Transportation Institute	<b>Impact Conditions</b>	Speed ..... 62.1 mi/h	<b>Test Article Deflections</b>	Dynamic ..... 1.91 ft
Test Agency .....	452108-7	Angle ..... 23.8 degrees	Permanent ..... 1.69 ft	Permanent .....	11LFQ4
Test No. ....	2008-08-26	<b>Exit Conditions</b>	Speed ..... 50.9 mi/h	Working Width .....	11LDEW3
Date .....		Speed ..... Not obtainable	Occupant Risk Values	Vehicle Damage	13.0 inches
<b>Test Article</b>	Bridge Rail	Angle ..... Not obtainable	Impact Velocity .....	Exterior	LF0000000
Type .....	Modified T8 Bridge Rail	Occupant Risk Values	Longitudinal ..... 17.4 ft/s	CDC	1.2 inches
Name .....	137.5 ft	Longitudinal .....	Lateral ..... 14.8 ft/s	Maximum Exterior	
Installation Length .....	Tubular thrie beam rail element on	Lateral .....	THIV .....	Vehicle Crush .....	
Material or Key Elements .....	breakaway steel posts w/1-inch	Ridedown Accelerations	Longitudinal .....	Interior	
	weakening slots on 6.5 inch bridge deck	Longitudinal .....	Lateral .....	OCDI .....	
	Concrete Bridge Deck, Dry	PHD .....	Max. 0.050-s Average	Maximum Occupant Compartment	
<b>Soil Type and Condition</b> .....		Max. Longitudinal .....	Longitudinal .....	Deformation .....	
<b>Test Vehicle</b>	2000P	Lateral .....	Vertical .....	(during 2.0 sec after impact)	
Type/Designation .....	2000 Chevrolet C2500 Pickup	Max. Lateral .....		Max. Yaw Angle .....	-56
Make/Model .....	4603 lb	Max. Vertical .....		Max. Pitch Angle .....	-17
Mass	4522 lb			Max. Roll Angle .....	125
Curb .....	No Dummy				
Test Inertial .....	4522 lb				
Dummy .....	No Dummy				
Gross Static .....	4522 lb				

**Figure 3.8. Summary of Results for NCHRP Report 350 Test 3-11 on the T8 Bridge Rail.**





## CHAPTER 4. SUMMARY AND CONCLUSIONS

### ASSESSMENT OF TEST RESULTS

An assessment of the test based on the applicable *NCHRP Report 350* safety evaluation criteria is provided below.

#### **Structural Adequacy**

- A. *Test article should contain and redirect the vehicle; the vehicle should not penetrate, underide, or override the installation although controlled lateral deflection of the test article is acceptable.*

**Result:** The T8 Bridge Rail contained and redirected the 2000P vehicle. The vehicle did not penetrate, underide, or override the installation. Maximum dynamic deflection was 1.91 ft. (PASS)

#### **Occupant Risk**

- D. *Detached elements, fragments, or other debris from the test article should not penetrate or show potential for penetrating the occupant compartment, or present an undue hazard to other traffic, pedestrians, or personnel in a work zone. Deformation of, or intrusions into, the occupant compartment that could cause serious injuries should not be permitted.*

**Result:** No detached elements, fragments, or other debris from the test article were present to penetrate or show potential for penetrating the occupant compartment, or to present undue hazard to others in the area. Maximum occupant compartment deformation was 1.2 inches. (PASS)

- F. *The vehicle should remain upright during and after collision although moderate roll, pitching, and yawing are acceptable.*

**Result:** Upon exiting the test installation, the 2000P vehicle rolled onto its right side. (FAIL)

#### **Vehicle Trajectory**

- K. *After collision, it is preferable that the vehicle's trajectory not intrude into adjacent traffic lanes.*

**Result:** The 2000P vehicle came to rest 163 ft downstream of impact and 48 ft forward of the traffic face of the rail and would likely have intruded into adjacent traffic lanes. (FAIL)

- L. *The occupant impact velocity in the longitudinal direction should not exceed 12 m/s [39.4 ft/s] and the occupant ridedown acceleration in the longitudinal direction should not exceed 20 g.*

Result: Longitudinal occupant impact velocity was 17.4 ft/s and longitudinal ridedown acceleration was -6.6 g. (PASS)

M. *The exit angle from the test article preferably should be less than 60 percent of the test impact angle, measured at time of vehicle loss of contact with the test device.*

Result: Exit angle at loss of contact was not attainable. (N/A)

The following supplemental evaluation factors and terminology, as presented in the FHWA memo entitled “ACTION: Identifying Acceptable Highway Safety Features,” were used for visual assessment of test results (2). Factors underlined below pertain to the results of the crash test reported herein.

***Passenger Compartment Intrusion***

1. *Windshield Intrusion*
  - a. No windshield contact
  - b. *Windshield contact, no damage*
  - c. *Windshield contact, no intrusion*
  - d. *Device embedded in windshield, no significant intrusion*
  - e. *Complete intrusion into passenger compartment*
  - f. *Partial intrusion into passenger compartment*
2. *Body Panel Intrusion*                      yes                      or                      no

***Loss of Vehicle Control***

1. Physical loss of control
2. *Loss of windshield visibility*
3. *Perceived threat to other vehicles*
4. *Debris on pavement*

***Physical Threat to Workers or Other Vehicles***

1. *Harmful debris that could injure workers or others in the area*
  2. *Harmful debris that could injure occupants in other vehicles*
- No debris present.

***Vehicle and Device Condition***

1. *Vehicle Damage*
  - a. *None*
  - b. *Minor scrapes, scratches, or dents*
  - c. *Significant cosmetic dents*
  - d. *Major dents to grill and body panels*
  - e. Major structural damage
2. *Windshield Damage*
  - a. *None*
  - b. *Minor chip or crack*
  - c. *Broken, no interference with visibility*
  - d. *Broken or shattered, visibility restricted but remained intact*
  - e. *Shattered, remained intact but partially dislodged*
  - f. *Large portion removed*
  - g. Completely removed (due to rollover)

3. *Device Damage*

a. *None*

b. *Superficial*

c. *Substantial, but can be straightened*

d. *Substantial, replacement parts  
needed for repair*

e. *Cannot be repaired*

## CONCLUSIONS

As summarized in Table 4.1, the modified T8 bridge rail did not perform acceptably for *NCHRP Report 350* test 3-11. Although the pickup truck was contained and redirected, it rolled onto its right side as it exited the test installation.

**Table 4.1. Performance Evaluation Summary for NCHRP Report 350 Test 3-11 on the T8 Bridge Rail.**

Test Agency: Texas Transportation Institute		Test No.: 452108-7	Test Date: 2008-08-26
<b>NCHRP Report 350 Test 3-11 Evaluation Criteria</b>		<b>Test Results</b>	
<b>Structural Adequacy</b>			
<i>A. Test article should contain and redirect the vehicle; the vehicle should not penetrate, underride, or override the installation, although controlled lateral deflection of the test article is acceptable.</i>		The T8 Bridge Rail contained and redirected the 2000P vehicle. The vehicle did not penetrate, underride, or override the installation. Maximum dynamic deflection was 1.91 ft.	Pass
<b>Occupant Risk</b>			
<i>D. Detached elements, fragments, or other debris from the test article should not penetrate or show potential for penetrating the occupant compartment, or present an undue hazard to other traffic, pedestrians, or personnel in a work zone. Deformations of, or intrusions into, the occupant compartment that could cause serious injuries should not be permitted.</i>		No detached elements, fragments, or other debris from the test article were present to penetrate or show potential for penetrating the occupant compartment, or to present undue hazard to others in the area. Maximum occupant compartment deformation was 1.2 inches.	Pass
<i>F. The vehicle should remain upright during and after collision although moderate roll, pitching, and yawing are acceptable.</i>		Upon exiting the test installation, the 2000P vehicle rolled onto its right side.	Fail
<b>Vehicle Trajectory</b>			
<i>K. After collision, it is preferable that the vehicle's trajectory not intrude into adjacent traffic lanes.</i>		The 2000P vehicle came to rest 163 ft downstream of impact and 48 ft forward of the traffic face of the rail and would likely have intruded into adjacent traffic lanes.	Fail*
<i>L. The occupant impact velocity in the longitudinal direction should not exceed 12 m/s [39.4 ft/s] and the occupant ridedown acceleration in the longitudinal direction should not exceed 20 g.</i>		Longitudinal occupant impact velocity was 17.4 ft/s, and longitudinal ridedown acceleration was -6.6 g.	Pass
<i>M. The exit angle from the test article preferably should be less than 60 percent of test impact angle, measured at time of vehicle loss of contact with test device.</i>		Exit angle at loss of contact was not attainable.	N/A*

\* Criteria K and M are preferable, but not required.

## CHAPTER 5. IMPLEMENTATION STATEMENT

A new flexible bridge rail system, referred to as the T8 rail, was designed as a replacement for the T6 rail in high-speed applications on culverts and thin deck structures. The T8 rail failed a crash test when the breakaway posts failed the thin deck rather than breakaway as designed (10). After analysis of the test results, the system was modified in an effort to address the identified failure mechanism. These modifications included increasing the length of the breakaway slot in the tension flange of the steel support posts and incorporating a 1-inch thick offset block between the post and upper portion of the tubular thrie beam rail to raise the point of force application on the post.

Despite these modifications to the rail system, the posts once again failed the thin concrete deck prior to breakaway activation. Localized deformation of the tubular thrie beam rail permitted the lowest rail corrugation to contact the post and reduce the moment arm despite the presence of the 1-inch thick offset block.

Because the posts did not release from their baseplates as designed, their rotation lowered the rail height and permitted snagging of the wheel of the pickup truck. These behaviors combined to destabilize the pickup truck, causing it to roll as it exited the barrier. Consequently, the modified T8 bridge rail is not suitable for implementation in its present form.

Prior to highway implementation, the T8 will need to be further modified and successfully retested. Recommendations for modifying the T8 rail include using a deeper offset block between the posts and upper two corrugations of the tubular thrie beam and possibly further increasing the length of the breakaway slots in the front tension flange of the W6x8.5 steel posts. To prevent the deeper offset block from reducing available deck space for travel lanes, the posts can be fabricated with an offset such that the traffic face of the posts extend beyond the edge of the deck. This would enable the rail to retain its current deck footprint while increasing the depth of the offset block to make certain that the lower corrugation of the tubular thrie beam rail will not contact the post. Preventing this contact will ensure a point of load application consistent with the breakaway design of the post as demonstrated in previous dynamic pendulum tests.

Another potential solution that can be pursued through additional research is replacing the tubular thrie beam rail with one or more tubular structural steel rails. The point of load application on the breakaway posts would be controlled by the mounting height of the tubular rail(s). Two options exist for this type of design. The first concept utilizes two narrow tubular rails inserted into the valleys of a thrie beam rail in a manner similar to the T101 bridge rail. The tubular rails would provide the needed offset between the posts and thrie beam rail, and would control the height of load application to the posts.

In the second concept, wider tubular rails are used to provide more contact surface for vehicle interaction and to eliminate the need for the outer thrie beam rail. The rail would incorporate features of other tubular rail systems but would retain the breakaway post feature for application on thin deck structures.



## REFERENCES

1. T.J. Hirsch, J. Panak, and C.E. Buth. *Tubular W-beam Bridge Rail*. Research Report 230-1. Texas Transportation Institute, Texas A&M University, College Station, Texas, October 1978.
2. *TRC 191: Recommended Procedures for Vehicle Crash Testing of Highway Appurtenances*. Transportation Research Board, National Research Council, Washington, D.C., February 1978.
3. J.D. Michie. *NCHRP Report 230: Recommended Procedures for the Safety Performance Evaluation of Highway Appurtenances*. National Cooperative Highway Research Program Report 350, TRB, National Research Council, Washington, D.C., March 1981.
4. H.E. Ross, D.L. Sickling, R.A. Zimmer, and J.D. Michie. *NCHRP Report 350: Recommended Procedures for the Safety Performance Evaluation of Highway Features*. TRB, National Research Council, Washington, D.C., 1993.
5. C.E. Buth, R.P. Bligh, and W.L. Menges. *NCHRP Report 350 Test 3-11 of the Texas Type 6 Bridge Rail*. Report FHWA/TX-98/1804-4. Texas Transportation Institute, Texas A&M University, College Station, Texas, July 1998.
6. W.F. Williams. *Texas Department of Transportation "T6" Bridge Rail Post to Baseplate Weld Investigation*. TTI Contract No. 418048. Texas Transportation Institute, Texas A&M University, College Station, Texas, July 1998.
7. C.E. Buth, R.P. Bligh, and W.L. Menges. *NCHRP Report 350 Test 3-11 of the Texas Type 6 Bridge Rail on Bridge Deck*. Report FHWA/TX-98/1804-3. Texas Transportation Institute, Texas A&M University, College Station, Texas, October 1998.
8. C.E. Buth, W. F. Williams, R.P. Bligh, and W.L. Menges. *Test 12- NCHRP Report 350 Test 3-11 of the Modified Texas Type 6 Bridge Rail on Bridge Deck*. Report FHWA/TX-00/1804-10. Texas Transportation Institute, Texas A&M University, College Station, Texas, February 2000.
9. R.P. Bligh, A.Y. Abu-Odeh, W.F. Williams, and W.L. Menges. *Analysis of a Flexible Bridge Rail System for High-Speed Roadways*. FHWA/TX-08/0-5210-4. Texas Transportation Institute, Texas A&M University, College Station, Texas, February 2008.
10. W.F. Williams, R.P. Bligh, and W.L. Menges. *Crash Testing and Evaluation of the TXDOT Type T8 Bridge Rail*. Report No. 407049-1. Texas Transportation Institute, Texas A&M University, College Station, Texas, March 2008.





## APPENDIX A. CRASH TEST AND DATA ANALYSIS PROCEDURES

The crash test and data analysis procedures were in accordance with guidelines presented in *NCHRP Report 350*. Brief descriptions of these procedures are presented as follows.

### ELECTRONIC INSTRUMENTATION AND DATA PROCESSING

The test vehicle was instrumented with three solid-state angular rate transducers to measure roll, pitch, and yaw rates; a triaxial accelerometer near the vehicle center of gravity (c.g.) to measure longitudinal, lateral, and vertical acceleration levels; and a backup biaxial accelerometer in the rear of the vehicle to measure longitudinal and lateral acceleration levels. These accelerometers were ENDEVCO® Model 2262CA, piezoresistive accelerometers with a  $\pm 100$  g range.

The accelerometers are strain gage type with a linear millivolt output proportional to acceleration. Angular rate transducers are solid state, gas flow units designed for high-“g” service. Signal conditioners and amplifiers in the test vehicle increase the low-level signals to a  $\pm 2.5$  volt maximum level. The signal conditioners also provide the capability of a resistive calibration (R-cal) or shunt calibration for the accelerometers and a precision voltage calibration for the rate transducers. The electronic signals from the accelerometers and rate transducers are transmitted to a base station by means of a 15-channel, constant bandwidth, Inter-Range Instrumentation Group (I.R.I.G.), FM/FM telemetry link for recording and for display. Calibration signals from the test vehicle are recorded before the test and immediately afterwards. A crystal-controlled time reference signal is simultaneously recorded with the data. Wooden dowels actuate pressure-sensitive switches on the bumper of the impacting vehicle prior to impact by wooden dowels to indicate the elapsed time over a known distance to provide a measurement of impact velocity. The initial contact also produces an “event” mark on the data record to establish the instant of contact with the installation.

The multiplex of data channels, transmitted on one radio frequency, is received and demultiplexed onto a TEAC® instrumentation data recorder. After the test, the data are played back from the TEAC® recorder and digitized. A proprietary software program (WinDigit) converts the analog data from each transducer into engineering units using the R-cal and pre-zero values at 10,000 samples per second per channel. WinDigit also provides Society of Automotive Engineers (SAE) J211 class 180 phaseless digital filtering and vehicle impact velocity.

All accelerometers are calibrated annually according to the SAE J211 4.6.1 by means of an ENDEVCO® 2901, precision primary vibration standard. This device and its support instruments are returned to the factory annually for a National Institute of Standards Technology (NIST) traceable calibration. The subsystems of each data channel are also evaluated annually, using instruments with current NIST traceability, and the results are factored into the accuracy of the total data channel, per SAE J211. Calibrations and evaluations are made any time data are suspect.

The Test Risk Assessment Program (TRAP) uses the data from WinDigit to compute occupant/compartiment impact velocities, time of occupant/compartiment impact after vehicle impact, and the highest 10-millisecond (ms) average ridedown acceleration. WinDigit calculates change in vehicle velocity at the end of a given impulse period. In addition, WinDigit computes maximum average accelerations over 50-ms intervals in each of the three directions. For reporting purposes, the data from the vehicle-mounted accelerometers are filtered with a 60-Hz digital filter, and acceleration versus time curves for the longitudinal, lateral, and vertical directions are plotted using TRAP.

TRAP uses the data from the yaw, pitch, and roll rate transducers to compute angular displacement in degrees at 0.0001-s intervals and then plots yaw, pitch, and roll versus time. These displacements are in reference to the vehicle-fixed coordinate system with the initial position and orientation of the vehicle-fixed coordinate systems being initial impact.

## **ANTHROPOMORPHIC DUMMY INSTRUMENTATION**

Use of a dummy in the 2000P vehicle is optional according to *NCHRP Report 350*, and there was no dummy used in the tests with the 2000P vehicle.

## **PHOTOGRAPHIC INSTRUMENTATION AND DATA PROCESSING**

Photographic coverage of the test included three high-speed cameras: one overhead with a field-of-view perpendicular to the ground and directly over the impact point; one placed behind the installation at an angle; and a third placed to have a field-of-view parallel to and aligned with the installation at the downstream end. A flash bulb activated by pressure-sensitive tape switches was positioned on the impacting vehicle to indicate the instant of contact with the installation and was visible from each camera. The films from these high-speed cameras were analyzed on a computer-linked Motion Analyzer to observe phenomena occurring during the collision and to obtain time-event, displacement, and angular data. A 16-mm movie cine, a BetaCam, a VHS-format video camera and recorder, and still cameras were used to record and document conditions of the test vehicle and installation before and after the test.

## **TEST VEHICLE PROPULSION AND GUIDANCE**

The test vehicle was towed into the test installation using a steel cable guidance and reverse tow system. A steel cable for guiding the test vehicle was tensioned along the path, anchored at each end, and threaded through an attachment to the front wheel of the test vehicle. An additional steel cable was connected to the test vehicle, passed around a pulley near the impact point, through a pulley on the tow vehicle, and then anchored to the ground such that the tow vehicle moved away from the test site. A 2-to-1 speed ratio between the test and tow vehicle existed with this system. Just prior to impact with the installation, the test vehicle was released to be free-wheeling and unrestrained. The vehicle remained free-wheeling, i.e., no steering or braking inputs, until the vehicle cleared the immediate area of the test site, at which time the vehicle's brakes were activated to bring it to a safe and controlled stop.

## APPENDIX B. TEST VEHICLE PROPERTIES AND INFORMATION

Date: 2008-08-28 Test No.: 452108-7 VIN No.: 1GCG24RXYR188656

Year: 2000 Make: Chevrolet Model: C2500

Tire Inflation Pressure: 60 psi Odometer: 281389 Tire Size: 245/75R16

Describe any damage to the vehicle prior to test: \_\_\_\_\_

● Denotes accelerometer location.

NOTES: \_\_\_\_\_  
 \_\_\_\_\_  
 \_\_\_\_\_

Engine Type: V-8

Engine CID: 5.7 liter

Transmission Type:

Auto  
 Manual

Optional Equipment:

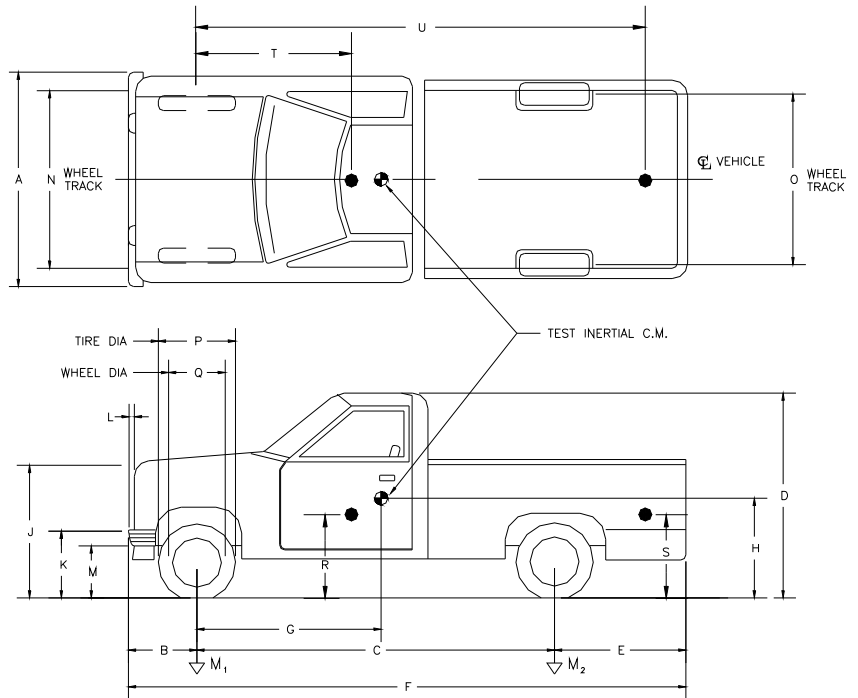
8 lug

Dummy Data:

Type: No dummy

Mass: \_\_\_\_\_

Seat Position: \_\_\_\_\_



**Geometry (inches)**

A	<u>74</u>	E	<u>51.50</u>	J	<u>41</u>	N	<u>62.5</u>	R	<u>29.5</u>
B	<u>32</u>	F	<u>215.35</u>	K	<u>25</u>	O	<u>63.4</u>	S	<u>35.5</u>
C	<u>132</u>	G	<u>57.49</u>	L	<u>2.75</u>	P	<u>28.5</u>	T	<u>57.5</u>
D	<u>71.5</u>	H	_____	M	<u>16.25</u>	Q	<u>17.25</u>	U	<u>132.25</u>

<b>Mass (lb)</b>	<u>Curb</u>	<u>Test Inertial</u>	<u>Gross Static</u>
M <sub>1</sub>	<u>2694</u>	<u>2551</u>	_____
M <sub>2</sub>	<u>1909</u>	<u>1971</u>	_____
M <sub>Total</sub>	<u>4603</u>	<u>4522</u>	_____

Mass Distribution (lb): LF: 1338 RF: 1213 LR: 952 RR: 1019

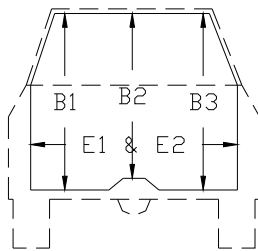
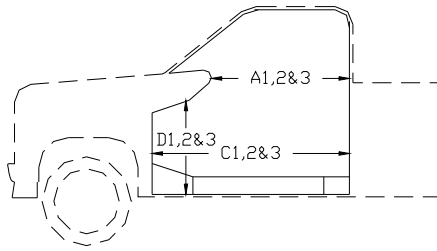
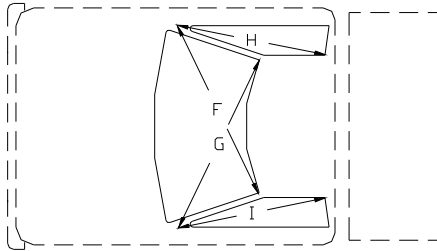
**Figure B1. Vehicle Properties for Test 452108-7.**



**Table B2. Occupant Compartment Measurements for Test 452108-7.**

# TRUCK

## Occupant Compartment Deformation



	BEFORE (inches)	AFTER (inches)
A1	34.1	34.1
A2	37.0	37.0
A3	36.8	36.8
B1	42.1	42.1
B2	37.4	37.4
B3	42.3	41.8
C1	53.9	53.9
C2	NA	NA
C3	54.0	53.9
D1	12.75	12.75
D2	6.1	6.1
D3	12.2	11.7
E1	62.4	61.6
E2	62.6	62.0
F	57.9	57.9
G	57.9	56.7
H	41.75	41.75
I	41.75	42.5
J*	59.8	59.4

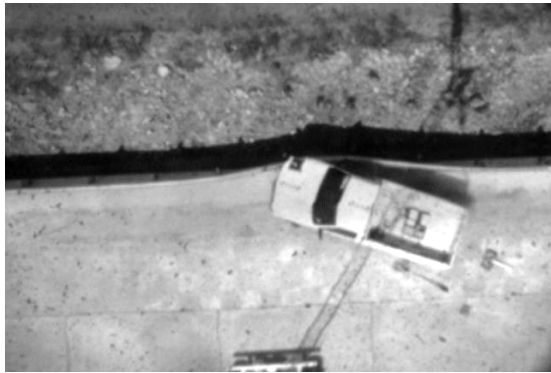
\*Lateral area across the cab from driver's side kickpanel to passenger's side kickpanel.



## APPENDIX C. SEQUENTIAL PHOTOGRAPHS



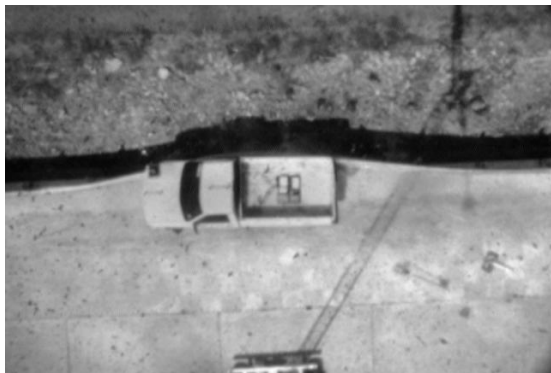
0.000 s



0.086 s



0.169 s



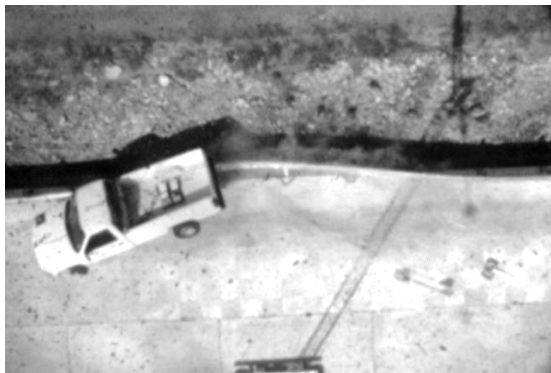
0.255 s



**Figure C1. Sequential Photographs for Test 452108-7  
(Overhead and Frontal Views).**



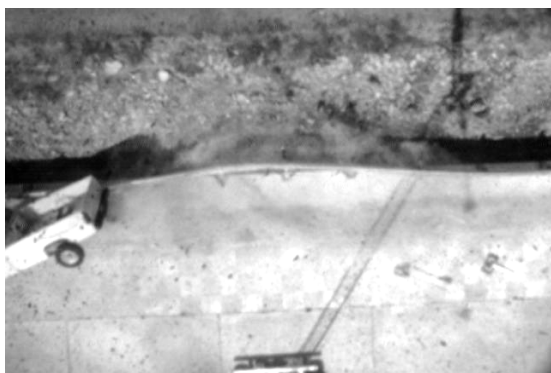
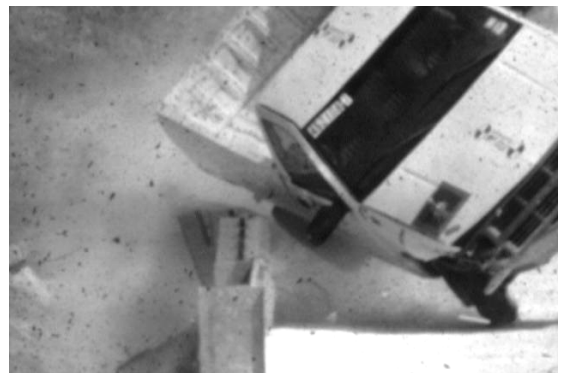
0.341s



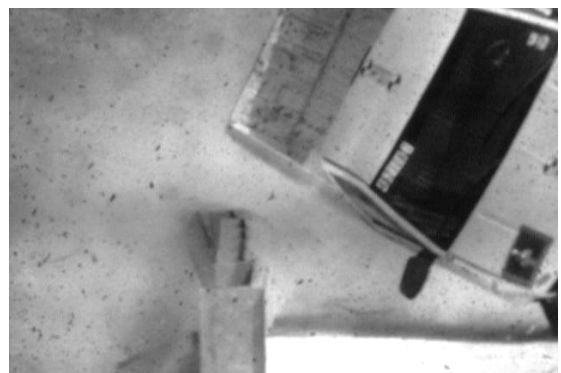
0.427 s



0.511 s



0.597 s

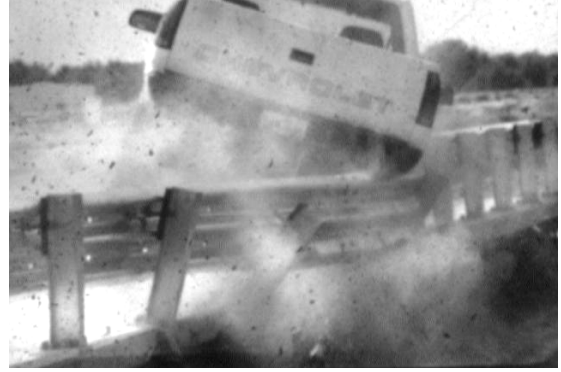


**Figure C1. Sequential Photographs for Test 452108-7  
(Overhead and Frontal Views) (continued).**





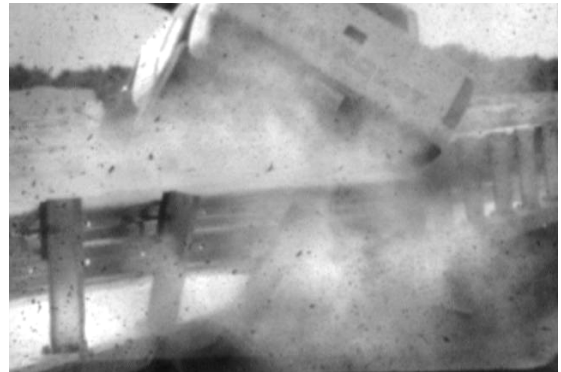
0.000 s



0.341 s



0.086 s



0.427 s



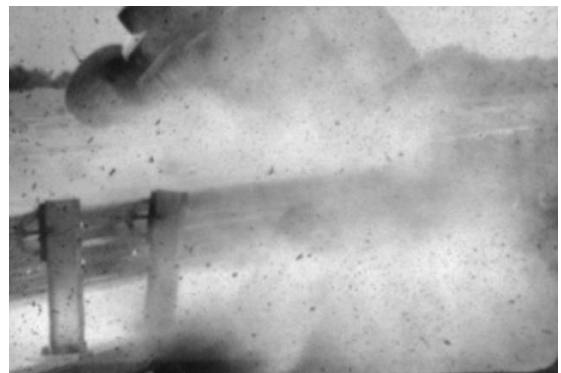
0.169 s



0.511 s



0.255 s

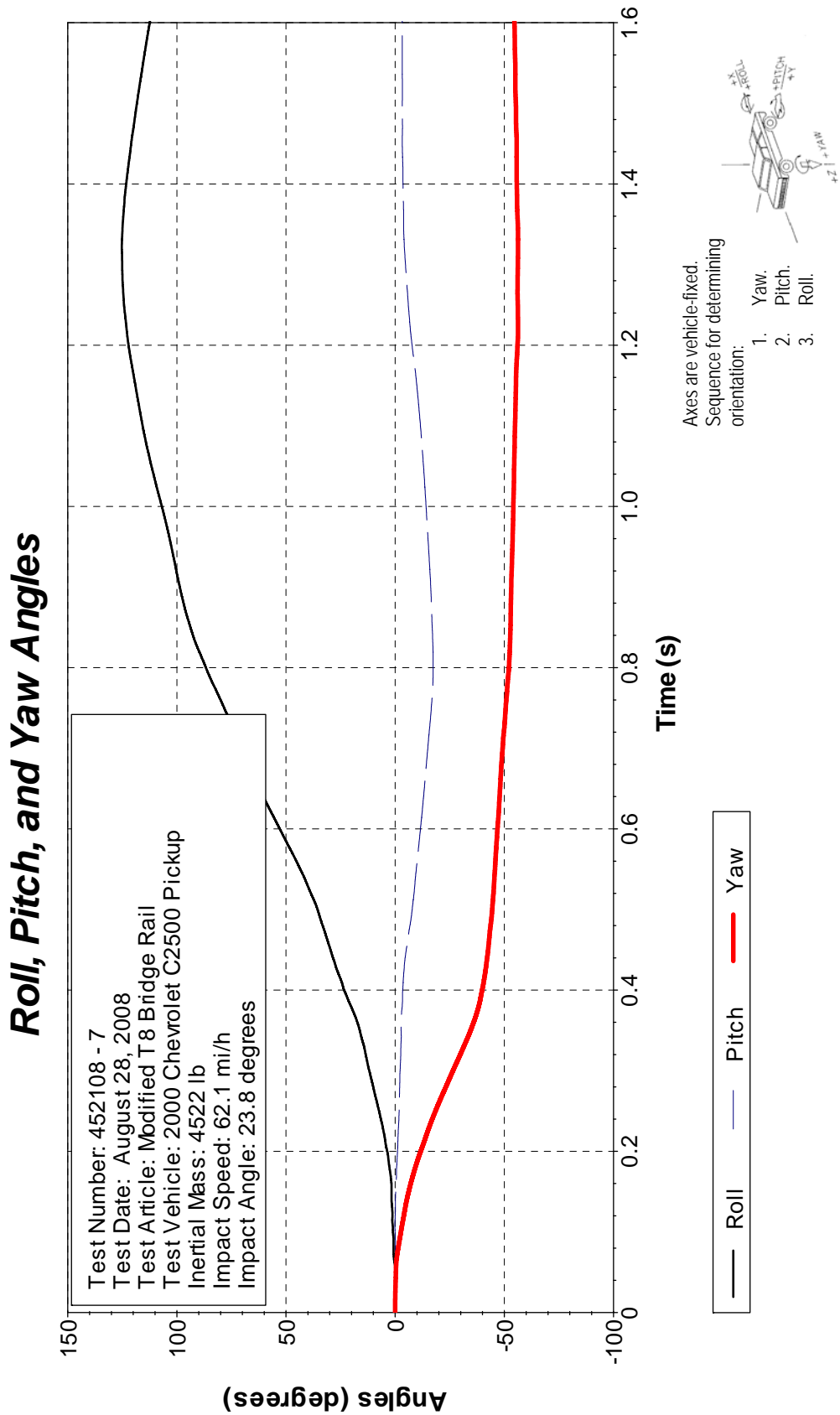


0.597 s

**Figure C2. Sequential Photographs for Test 452108-7  
(Rear View).**

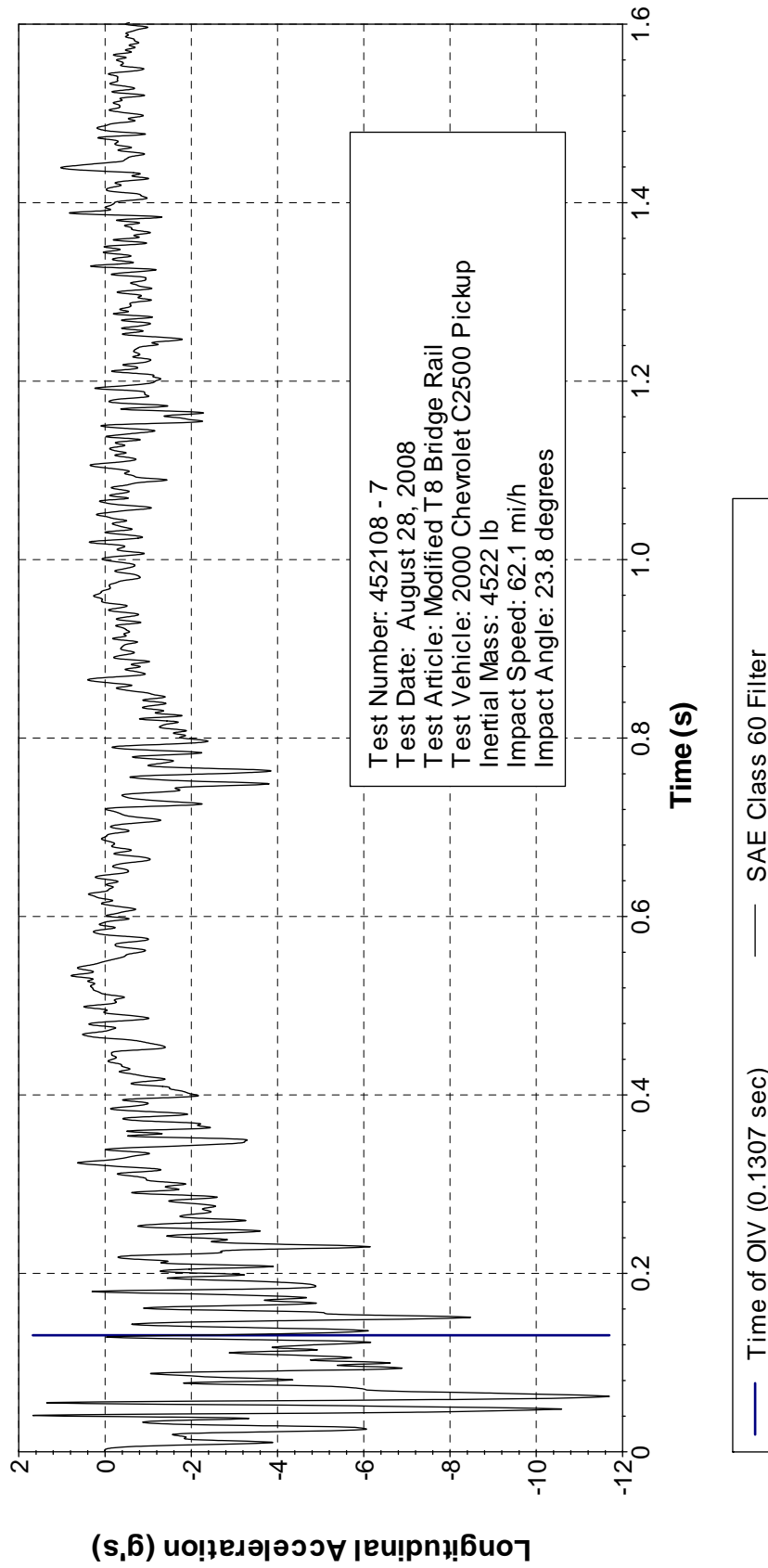


# APPENDIX D. VEHICLE ANGULAR DISPLACEMENTS AND ACCELERATIONS

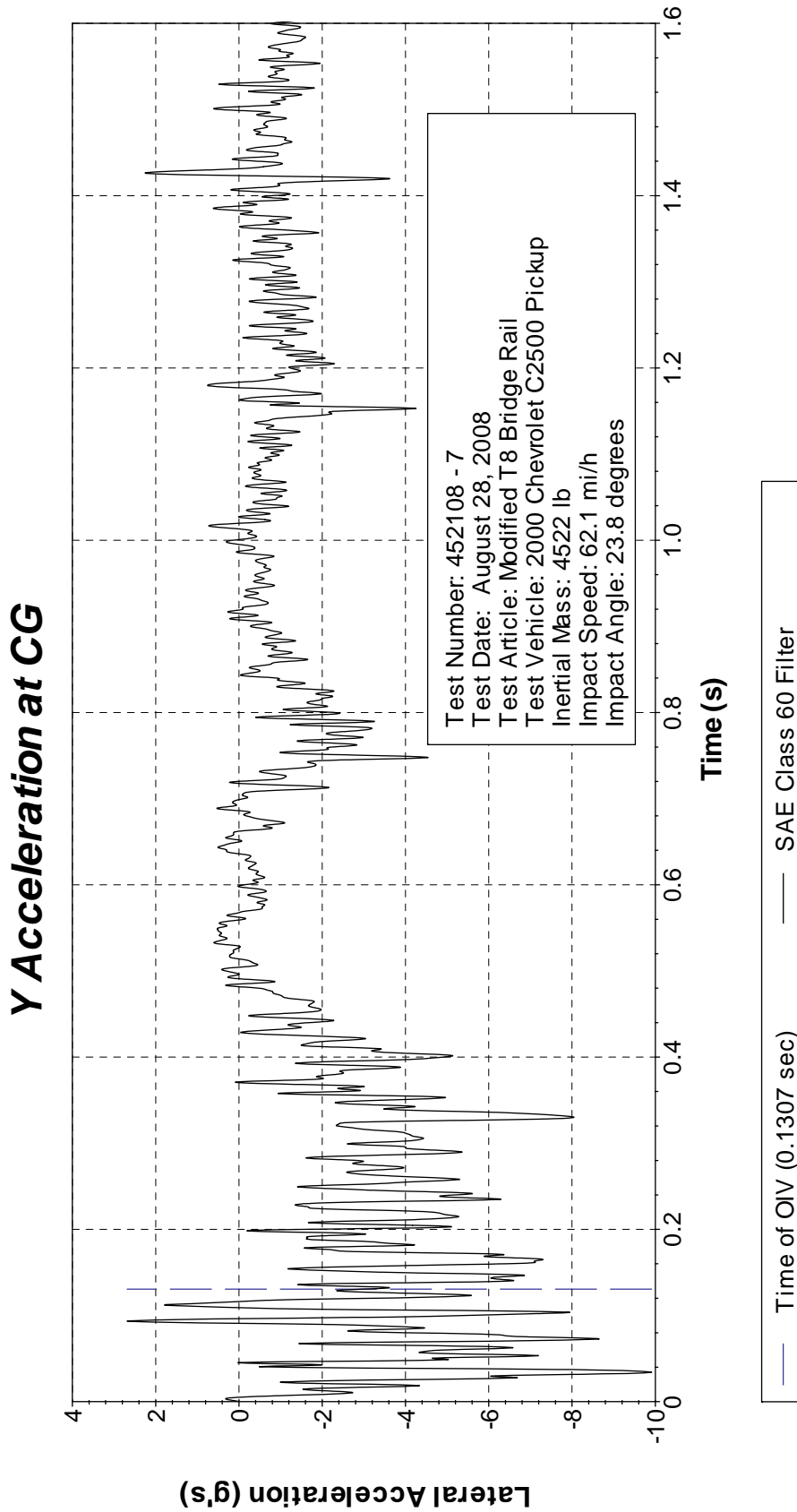


**Figure D1. Vehicle Angular Displacements for Test 452108-7.**

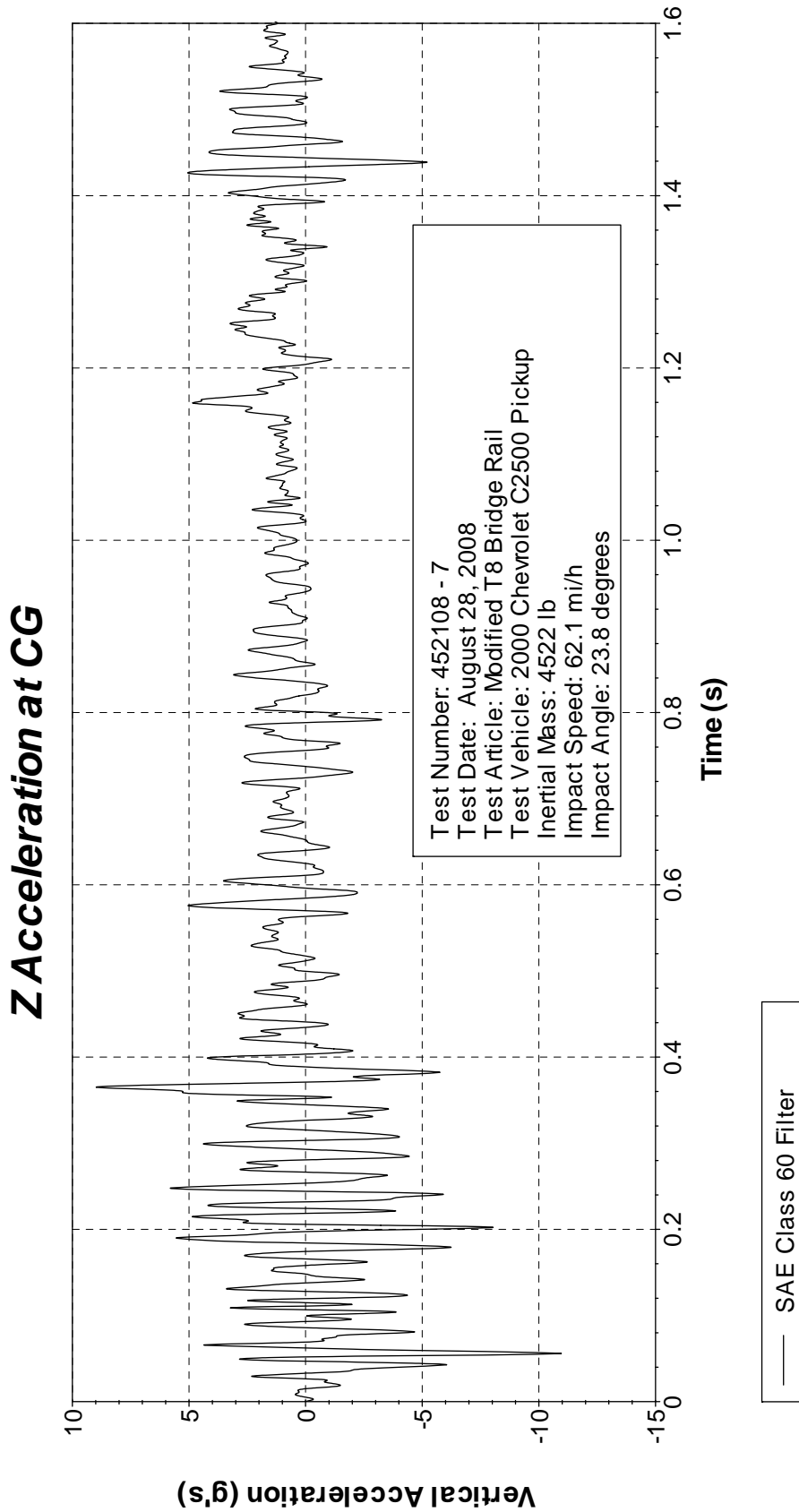
# X Acceleration at CG



**Figure D2. Vehicle Longitudinal Accelerometer Trace for 452108-7  
(Accelerometer Located at Center of Gravity).**



**Figure D3. Vehicle Lateral Accelerometer Trace for 452108-7  
(Accelerometer Located at Center of Gravity).**



**Figure D4. Vehicle Vertical Accelerometer Trace for 452108-7  
 (Accelerometer Located at Center of Gravity).**