

1. Report No. FHWA/TX-09/0-5446-3		2. Government Accession No.		3. Recipient's Catalog No.	
4. Title and Subtitle DRIVER COMPREHENSION OF MANAGED LANE SIGNING				5. Report Date Published: September 2009	
				6. Performing Organization Code	
7. Author(s) Susan T. Chrysler and Alicia A. Nelson				8. Performing Organization Report No. Report 0-5446-3	
9. Performing Organization Name and Address Texas Transportation Institute The Texas A&M University System College Station, Texas 77843-3135				10. Work Unit No. (TRAIS)	
				11. Contract or Grant No. Project 0-5446	
12. Sponsoring Agency Name and Address Texas Department of Transportation Research and Technology Implementation Office P.O. Box 5080 Austin, Texas 78763-5080				13. Type of Report and Period Covered Technical Report: September 2007 – August 2008	
				14. Sponsoring Agency Code	
15. Supplementary Notes Project performed in cooperation with the Texas Department of Transportation and the Federal Highway Administration. Project Title: Guidelines for Signs and Markings for Toll Facilities URL: http://tti.tamu.edu/documents/0-5446-3.pdf					
16. Abstract A statewide survey of driver comprehension of managed lane signing is reported. Computer-based surveys were conducted using video clips of computer animations as well as still images of signs. The surveys were conducted in four Texas cities with a total of 142 participants. Results showed varying levels of comprehension for signs relating to pricing, occupancy requirements, and destinations. A series of guide sign banner designs was tested, as well as various methods to convey form of payment. Some results suggest that participants may have had difficulties seeing all of the details in the computer animations. Future research using this method should carefully consider the stimulus displays, resolution, and play rate of animations.					
17. Key Words Managed Lanes, High Occupancy Toll (HOT) Lanes, Toll Roads, Traffic Sign Comprehension, Computer-based Survey			18. Distribution Statement No restrictions. This document is available to the public through NTIS: National Technical Information Service Springfield, Virginia 22161 http://www.ntis.gov		
19. Security Classif.(of this report) Unclassified		20. Security Classif.(of this page) Unclassified		21. No. of Pages 50	22. Price

DRIVER COMPREHENSION OF MANAGED LANE SIGNING

by

Susan T. Chrysler
Senior Research Scientist
Center for Transportation Safety, Human Factors Group

and

Alicia A. Nelson
Assistant Research Specialist
Center for Transportation Safety, Human Factors Group

Report 0-5446-3
Project 0-5446
Project Title: Guidelines for Signs and Markings for Toll Facilities

Performed in cooperation with the
Texas Department of Transportation
and the
Federal Highway Administration

Published: September 2009

TEXAS TRANSPORTATION INSTITUTE
The Texas A&M University System
College Station, Texas 77843-3135

DISCLAIMER

This research was performed in cooperation with the Texas Department of Transportation (TxDOT) and the Federal Highway Administration (FHWA). The contents of this report reflect the views of the authors, who are responsible for the facts and the accuracy of the data presented herein. The contents do not necessarily reflect the official view or policies of the FHWA or TxDOT. This report does not constitute a standard, specification, or regulation.

This report is not intended for construction, bidding, or permit purposes. The researcher in charge of the project was Susan. T. Chrysler. The United States Government and the State of Texas do not endorse products or manufacturers. Trade or manufacturers' names appear herein solely because they are considered essential to the object of this report.

ACKNOWLEDGMENTS

This project was conducted in cooperation with TxDOT and FHWA. The authors wish to thank Michael Chacon, Flor Tamez, and Dian Naumann of TxDOT Traffic Operations staff for their invaluable assistance throughout this project. The TxDOT Project Advisors also provided useful guidance throughout the project; they were Christine Connor, Carol Rawson; Charlie Wicker, Dexter Hollabaugh, Dale Picha, Hector Canales, Ron Bailey, Rogelio Rubico, Robert Stone, Stuart Corder, and Mark Olson of FHWA. Wade Odell and Sandra Kaderka of the TxDOT Research and Technology Implementation Office also assisted with the progress of the project.

The surveys were completed with the assistance of TTI staff Lisa Patke, Kandis Salazar, Lisa Palmer, and Christie Madsen. Texas A&M University students Kristin Landua and Marco Encina, along with Kaliska Ross, assisted with the data collection and reduction. Kay Fitzpatrick, Beverly Kuhn, and Vichika Iragavarapu helped with earlier portions of the project.

TABLE OF CONTENTS

	Page
List of Figures	viii
List of Tables	ix
Chapter 1: Background	1
Chapter 2: Driver Survey	3
Experimental Design and Procedure	3
Stimulus Preparation	3
Participants.....	9
Procedure	11
Research Questions and Results	13
Lane Entry Decision	13
Lane Use Regulation	16
Information Overload	18
HOV Diamond Symbol Comprehension	19
Lane Designation Banner Comprehension	20
Express Lane Terminology Comprehension	23
TxTAG Payment Plaque Comprehension	26
Price Signing Comprehension	26
Interchange Sequence Signing Comprehension	26
Tolling Gantry Lane Selection	29
ACCESS TO Terminology Comprehension	31
LEFT LANE Plaque Comprehension	33
Form of Payment Comprehension	35
Importance of Travel Time Information	36
Summary and Recommendations	37
Methodological Considerations For Future Research.....	37
References	39

LIST OF FIGURES

	Page
Figure 1. Screen Shot of Video Clip Illustrating Sign A.....	4
Figure 2. Tolling Gantry Area.	4
Figure 3. All Signs Shown in Version 1 on Approach to Managed Lane Entrance.	5
Figure 4. Stimulus Versions 1 - 3.	6
Figure 5. Video Versions 5b, 6, 13.	7
Figure 6. Video Versions 12 & 14.	8
Figure 7. Still Photo Images.	9
Figure 8. Research Participants Taking Survey in San Antonio.....	11
Figure 9. Responses to Lane Entry Question 1.....	15
Figure 10. Responses for Those Who Answered “NO” to Lane Entry Question.	16
Figure 11. Responses to Lane Restriction Question.	17
Figure 12. Responses for Those Who Answered “NO” to Lane Restriction Question.	18
Figure 13. Responses to Information Overload Question.	19
Figure 14. Images Used for Versions 11 a-c Still.	24
Figure 15. Responses to Express Lane Question.	25
Figure 16. Close-up of <i>Interchange Sequence</i> Sign F.....	27
Figure 17. Images Used for Tolling Gantry Version 14 (top) and Version 13 (bottom).	30
Figure 18. ACCESS TO Image Used in Version 10 Still.	32
Figure 19. Images Used for Left Exits in Still Versions 8 and 9.....	33

LIST OF TABLES

	Page
Table 1. Participant Age and Gender by City.....	10
Table 2. Participant Education Level by City.....	10
Table 3. Participant Freeway Driving Frequency by City.....	10
Table 4. Responses to HOV Diamond Symbol Question by City, Collapsed Across Versions 7a, 7b, 7c, 8, 11a, 11b, 11c.	20
Table 5. Responses to HOV Terminology Question.....	20
Table 6. Responses to TOLL LANE Question.	21
Table 7. Responses to HOV/TOLL LANE Banner	21
Table 8. Responses for HOV/TOLL LANE Banner by City	22
Table 9. Responses to TxTAG Logo Meaning Question.	26
Table 10. Percent Responses for Question 5c for Stimuli: Versions 2, 3, 5b, 6.....	28
Table 11. Percent Responses for Question 5d for Stimuli: Versions 2, 3, 5b, 6.	28
Table 12. Responses to Tolling Gantry Lane Question.	31
Table 13. Responses to ACCESS TO Question.	32
Table 14. Responses to LEFT LANE Plaque Question.	34
Table 15. Responses to LEFT LANE Implying EXIT ONLY Condition Question.....	34
Table 16. Responses to Form of Payment Question.	35
Table 17. Percent Responses to Travel Time Importance Question by City.....	36

CHAPTER 1: BACKGROUND

As toll facilities and managed lanes become more common in Texas, the Traffic Operations Division of TxDOT has been working to develop new standards and guidelines for the traffic control devices for these new facilities. This report presents the results of the final year of work on a three year project to investigate driver comprehension of candidate traffic control devices and plans. Previous research reports on this project present a detailed state of the practice and literature review of related work (1, 2).

Since those reports were written there have been several key developments which impact the development of traffic control devices. The first is the creation, by TxDOT, of draft policy guidelines for toll roads and managed lane (3, 4). These documents were developed to provide TxDOT districts with interim guidance for managed lane and toll projects under development. Some of the recommendations in these policies are based on the earlier research by TTI (1, 2). The other recent shift in Texas is the universal use of license-plate video tolling on TxDOT toll facilities. This practice, called “Pay by Mail,” allows drivers who do not possess a Texas toll tag (TxTAG) to use electronic toll collection (ETC) facilities and receive a bill in the mail via the vehicle registration data linked to their license plate. Pay by Mail offers drivers a convenience, but created issues with the existing Texas Manual on Uniform Traffic Control Devices (TMUTCD) guidance for signs in Chapter 2J (5). This 2006 document specified the use of the phrase “TxTAG Only” on signs for ETC roadways. With the advent of Pay by Mail this “tag only” message is no longer valid, and the signing specifications have had to be modified.

Nationally, the major development in 2008 was the release of a Notice of Proposed Amendment (NPA) (6) to the U.S. Department of Transportation (US DOT) Federal Highway Administration (FHWA) Manual on Uniform Traffic Control Devices (MUTCD). Prior to this NPA, the federal MUTCD contained no guidance on toll facilities and only addressed high-occupancy vehicle (HOV) type managed lanes. The 2008 NPA for the first time contained extensive sections on toll and managed lane facilities.

One of the main questions still facing the area of managed lanes is what to call the lanes. For professionals in the transportation field, the term “managed lane” means something, whereas the typical driver could find this term meaningless or confusing. Managed lanes come in many

different varieties, and the wide use of this categorical term may be further confusing. For instance, a High Occupancy Toll (HOT) lane could allow HOVs free at all times, or could charge them during off-peak hours. The term assigned to the lane should attempt to convey the specific operation of the specific facility. In the *Managed Lane Signing Guidelines (4)*, TxDOT defines three different types of managed lanes. The use of the HOV Diamond symbol is limited to those HOV or HOT lanes where HOVs are allowed free of charge at all times. High Occupancy Toll lanes are designated in black on white banners as HOV/TOLL LANE. For those managed lanes facilities that toll all vehicles, even HOVs at a discounted rate, TxDOT recommends using TOLL LANE on the sign banners. Some agencies are using the term EXPRESS LANE (Denver, Miami), and this term was recommended in the FHWA Notice of Proposed Amendment (6). The survey reported here contained several different sign designs and questions aimed at gauging driver understanding of these terms. In addition, the survey examined HOT lane declaration areas, pricing, and travel time signs.

CHAPTER 2: DRIVER SURVEY

EXPERIMENTAL DESIGN AND PROCEDURE

Stimulus Preparation

The survey asked questions about a number of sign features. Participants viewed short video clips and still photographs illustrating sign faces before answering questions. Previous surveys and focus groups had used only still photographs of test signs digitally inserted into photographs of freeway scenes. The researchers felt that it was important in this survey to include dynamic video clips that included managed lane and main lane signing and ambient traffic. This presentation mode better simulates the time pressure and distraction of actual driving. Some sign faces were shown, using still shots from the video clips, to ask particular questions about a sign legend. In some cases the length of time the image was displayed was controlled to simulate a single glance at the sign of 3 seconds (called *computer-controlled picture viewing*), and in other cases participants could view the sign as long as they wanted to and their reading time was recorded (called *participant-controlled picture viewing*).

The video clips were prepared by the HNTB Visualization Group and consisted of a three lane freeway driving scene as shown in Figure 1. Each video clip included other traffic on the road and was rendered at a speed equivalent to 60 mph. Each participant saw the full length of the animation as their first stimulus. This video clip was approximately 2½ minutes in length. The full approach (Version 1) included all advance sequence signs for the managed lane and some typical main lane signs as well as shown in Figure 3. The intent was to re-create the approach to a slip ramp of a two-lane reversible flow managed lane facility that had multiple downstream access points (55th St. and Partner Ln.). The tolling gantry area illustrated includes separate declaration lanes for HOV and toll-paying vehicles for each lane of travel. This design was patterned after the proposed tolling gantry for I-30 West in Dallas (see Figure 2). The video showed the camera vehicle taking the left slip ramp and traveling approximately ½ mile in the managed lane before reaching the tolling gantry area. The camera vehicle then drove in the right lane through the gantry area, and the video stopped shortly downstream from the gantry.



Figure 1. Screen Shot of Video Clip Illustrating Sign A.



Figure 2. Tolling Gantry Area.

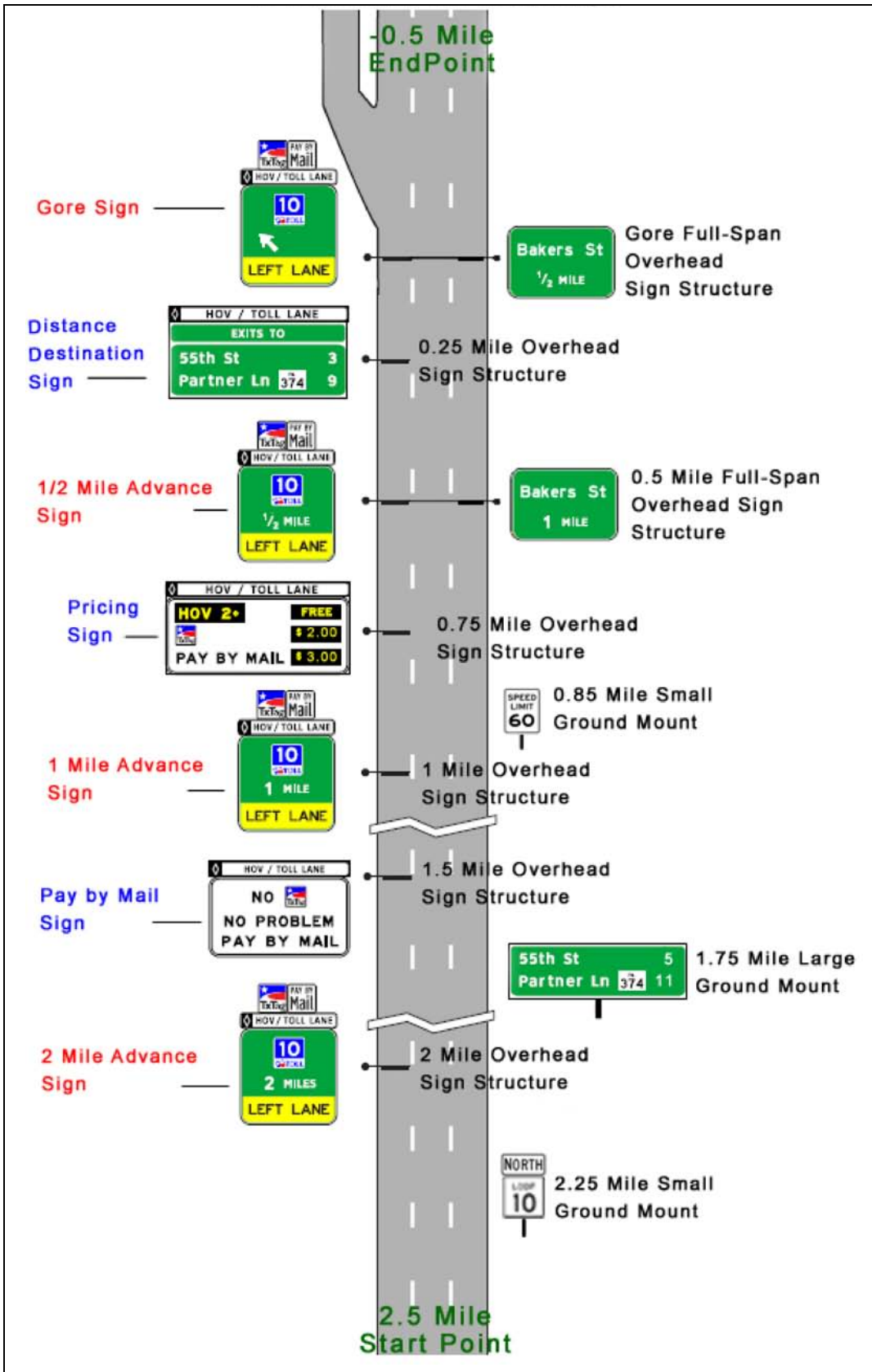

Figure 3. All Signs Shown in Version 1 on Approach to Managed Lane Entrance.

In order to test specific research questions, alternate versions of key signs were created using SignCad™, and the video clips were rendered again with the new signs in place. All versions of the video clips are shown in Figure 4 - Figure 7. The questions asked after each video or image are explained in a later section of the report.















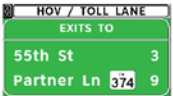

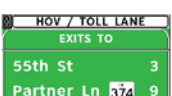
	Version 1-Video	Version 2-Video	Version 3-Video
Sign I (3/4 mile into Managed Lane)			
Sign H (1/2 mile into Managed Lane)	NONE		
Sign G (At gore of Managed Lane Entrance)			
Sign F (1/4 mile from Managed Lane Entrance)			
Sign E (1/2 mile from Managed Lane Entrance)			
Sign D (3/4 mile from Managed Lane Entrance)			
Sign C (1 mile from Managed Lane Entrance)			
Sign B (1.5 mile from Managed Lane Entrance)			
Sign A (2 miles from Managed Lane Entrance)			
Questions Asked	1, 1*, 2, 2*, 3, 4d	4b, 4c, 5a, 5b, 5c, 5d	4b, 4c, 5a, 5b, 5c, 5d

Figure 4. Stimulus Versions 1 - 3.

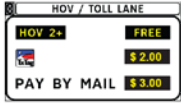
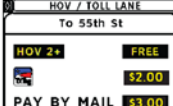
	Version 5b-Video	Version 6-Video	Version 13-Video
Sign I (3/4 mile into Managed Lane)			
Sign H (1/2 mile into Managed Lane)			
Sign G (At gore of Managed Lane Entrance)			
Sign F (1/4 mile from Managed Lane Entrance)			
Sign E (1/2 mile from Managed Lane Entrance)			
Sign D (3/4 mile from Managed Lane Entrance)			
Sign C (1 mile from Managed Lane Entrance)			
Sign B (1.5 mile from Managed Lane Entrance)			
Sign A (2 miles from Managed Lane Entrance)			
Questions Asked	4b, 4c, 5a, 5b, 5c, 5d	1, 1*, 2, 2*, 3, 4b, 4c, 5a, 5b, 5c, 5d	10

Figure 5. Video Versions 5b, 6, 13.

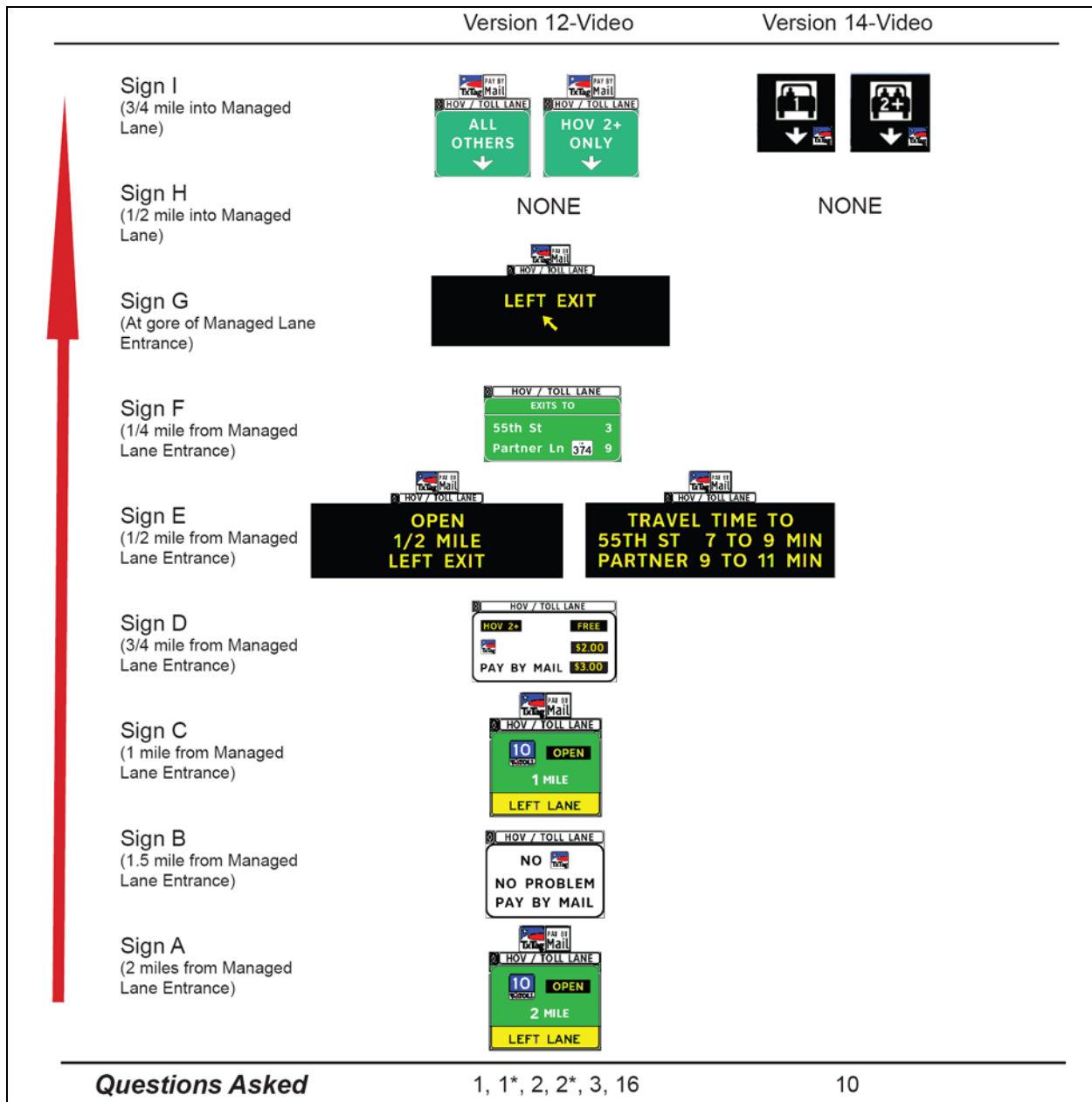

Figure 6. Video Versions 12 & 14.

Note: Sign E was a 2 phase DMS with the two messages alternating.









	Version 7a-Still	Version 7b-Still	Version 7c-Still
			
Questions Asked	4a, 15	4a, 15	4a, 15
	Version 8-Still	Version 9-Still	Version 10-Still
			
Questions Asked	4a, 4b, 13, 14, 15	13, 14	12
	Version 11a-Still	Version 11b-Still	Version 11c-Still
			
Questions Asked	4a, 11, 15	4a, 11, 15	4a, 11, 15

Figure 7. Still Photo Images.

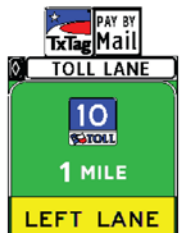
Participants

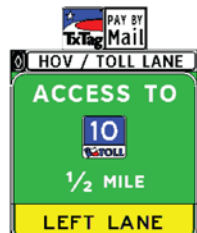
Researchers surveyed 142 participants in 4 cities; 2 cities (College Station and San Antonio) do not have HOV lanes or toll roads, and 2 cities (Dallas and Houston) have both HOV lanes and toll roads in the area. Participants were paid \$30 in College Station and \$40 in the larger cities for their participation. Each session lasted approximately 20-30 minutes.

After reading and signing a consent form, participants began completing the survey by answering questions about themselves. Gender, age, how long have they been driving, their highest level of education, and how often they drive on freeways were the questions asked.

Along with providing valuable information about themselves, this portion of the survey allowed the participants to become more familiar and comfortable with the laptop and the interaction the survey would require. This is important to prevent operator error, especially with older participants who may be unfamiliar and/or uncomfortable using computer equipment.

The distribution of participant age and gender is shown in Table 1 with a total of 88 females and 54 males. Table 2 shows the participant’s education level. Because the survey had to do with managed lane signs that would most likely occur on freeways, participants were asked how often they drive on freeways; these results are shown in Table 3.

Table 1. Participant Age and Gender by City.

City	18-25 yr old		26-54 yr old		55 and older		Total
	Female	Male	Female	Male	Female	Male	
College Station	5	2	5	5	10	7	34
Dallas	3	3	11	11	5	1	34
Houston	1	4	16	4	9		34
San Antonio	3	2	16	12	4	3	40
Total	12	11	48	32	28	11	142

Table 2. Participant Education Level by City

City	Education Level					
	Some High School	High School Grad	Some College	College Graduate	Some Graduate School	Graduate Degree
College Station	0	3	13	13	0	5
Dallas	0	5	10	12	3	4
Houston	2	7	15	8	1	1
San Antonio	3	5	15	13	1	3
Total	5	20	53	46	5	13

Table 3. Participant Freeway Driving Frequency by City.

	College Station	Dallas	Houston	San Antonio	Total
Daily	18	21	25	33	97
Weekly	7	11	6	5	29
Monthly	8	1	1	1	11
Once or twice a year	1	1	1	1	4
Never	0	0	1	0	1
Total	34	34	34	40	142

Procedure

Participants were tested individually in a conference room with four computer workstations present. Each person was greeted in a separate room and completed entry and exit paperwork outside of the actual survey room to maintain a quiet environment. A researcher was present in the survey room to answer any questions and to monitor progress.

Each participant viewed the survey on a 17 in. desktop color monitor attached to a laptop computer running SuperLab™ software. The SuperLab™ software allows measurement of response time (in milliseconds) and keystrokes and controlled presentation of photographs, text, and video. The software can create a unique random order of presentation of test items, or can be programmed to follow a prescribed order. For the current study, each participant saw Version 1 first, and then the order of all subsequent items was individually randomized for each subject to spread out any bias due to the order of questioning.



Figure 8. Research Participants Taking Survey in San Antonio.

Instructions that appeared on the computer screen:

Welcome, and thank you for participating in our study today. We will begin by having you enter in some information about yourself. All information will be kept confidential and will be used for statistical purposes only. Please flag down a researcher at any point if you need assistance. Please hit the spacebar to continue.

Okay, let's get going!

Today you will be viewing various video clips and still pictures of signs along a roadway. Then you will be asked questions about the signs you viewed. Before each video or picture you will receive new instructions pertaining to what you will see. Please read these instructions each time carefully before continuing on. Hit the spacebar to continue to your first task.

Video Task-

Imagine that you are driving with one other passenger. Your destination is Partner Lane. You do not have a Toll Tag on your car. When you are ready, press the space bar and the video will begin. [This instruction screen was repeated before each video clip]

Computer-Controlled Picture Viewing-

In a moment you will be shown a picture of a sign along a roadway for a short amount of time. Then you will answer questions about the sign. Study the sign for as long as it's visible. It may look very similar to other signs you've seen in the study, but there are slight differences. Please hit the spacebar when you are ready to view the sign. (Versions – 7a, 7b, 7c, 8, 11a, 11b, 11c)

Participant - Controlled Picture Viewing-

In a moment you will see a picture of a sign along a roadway. The sign will stay on the screen until you press the space bar. You may study the sign as long as you need to in order to answer questions about it. Hit the spacebar as soon as you feel you understand the sign. Then you will answer questions about the sign. Please hit the spacebar when you are ready to view the sign. (Versions 9, 10)

RESEARCH QUESTIONS AND RESULTS

Different versions of the signs and sign sequence order were created in order to investigate the impact of particular sign features on drivers' comprehension and decision making (see Figure 4 - Figure 7). The number of signs shown in those figures corresponds to the length of the video. So, for instance, the Version 2 video started just before sign C and ended just after sign G while the Version 12 video included all of the signs. The signs included in Version 1 were copied from the TxDOT draft policy memo on managed lanes signs. The main lane signs did not change in the alternate versions tested. Each video or still photo was paired with one to three questions that pertained directly to that stimulus. In many cases the same questions were asked of different sub-groups of participants who had seen alternate versions of a particular sign. This section describes the various research questions and illustrates in detail the changes made to the videos and stills in order to answer these questions.

Lane Entry Decision

The most fundamental question asked was whether or not the participants would actually choose to enter the managed lane themselves. Following the viewing of the Version 1 video, subjects were asked the questions below.

1. The video showed you exiting into a special lane. If you had actually been driving to Partner Lane with your passenger and had seen those signs, would you have exited into that special lane?
 - y) Yes
 - n) No
- 1*. If NO, why not?
 - a) I'm not sure if I'm allowed or not
 - b) I don't want to pay
 - c) I don't like to travel within the walls
 - d) I don't know if it goes to my destination
 - e) I might get stuck in there if a vehicle breaks down
 - f) I am driving alone with no passengers
 - g) I don't have a tag
 - h) I did not mean to pick NO

They were asked these same questions again later in the survey after viewing the Version 12 video with the two-phase dynamic message sign displaying travel time and price (N = 142). They were also asked these questions after Version 6 (N = 36) which showed a simplified toll rate sign (Sign D) and included the roadway segment only between Sign C and Sign G.

Figure 9 shows the pattern of responses to the first question. Recall that all participants saw Version 1 first, and the order of the subsequent items was randomized. The high number of “No” responses following Version 1 may be due to the fact that this was the first question asked, and the participants may have been a bit overwhelmed. The responses to the same question shifted toward more “Yes” responses on subsequent viewings of the video clips in Versions 6 and 12. This indicates that as drivers become more familiar with a facility and accompanying signage after multiple passes, the likelihood of lane use increases.

For those participants who did answer “No”, a follow-up question was asked seeking the reason for their reluctance to enter the lane. The responses to this question are shown in Figure 10. It is interesting to note that the most frequent reason cited was uncertainty about whether the lane went to a desired destination. Recall that in the initial instructions, participants were given the scenario that they had a passenger, did not have a toll tag, and Partner Ln. was their destination. So, despite the presence of advanced Distance/Destination signs in all of these video Versions, participants were not certain if the managed lane went to Partner Ln. Another odd finding here is that for Version 6, many people indicated that they had selected “No” because they were alone in the car, when in fact they had been instructed that they had a passenger. Both of these findings cast doubt as to whether participants really read and retained the scenario provided in the initial instructions.

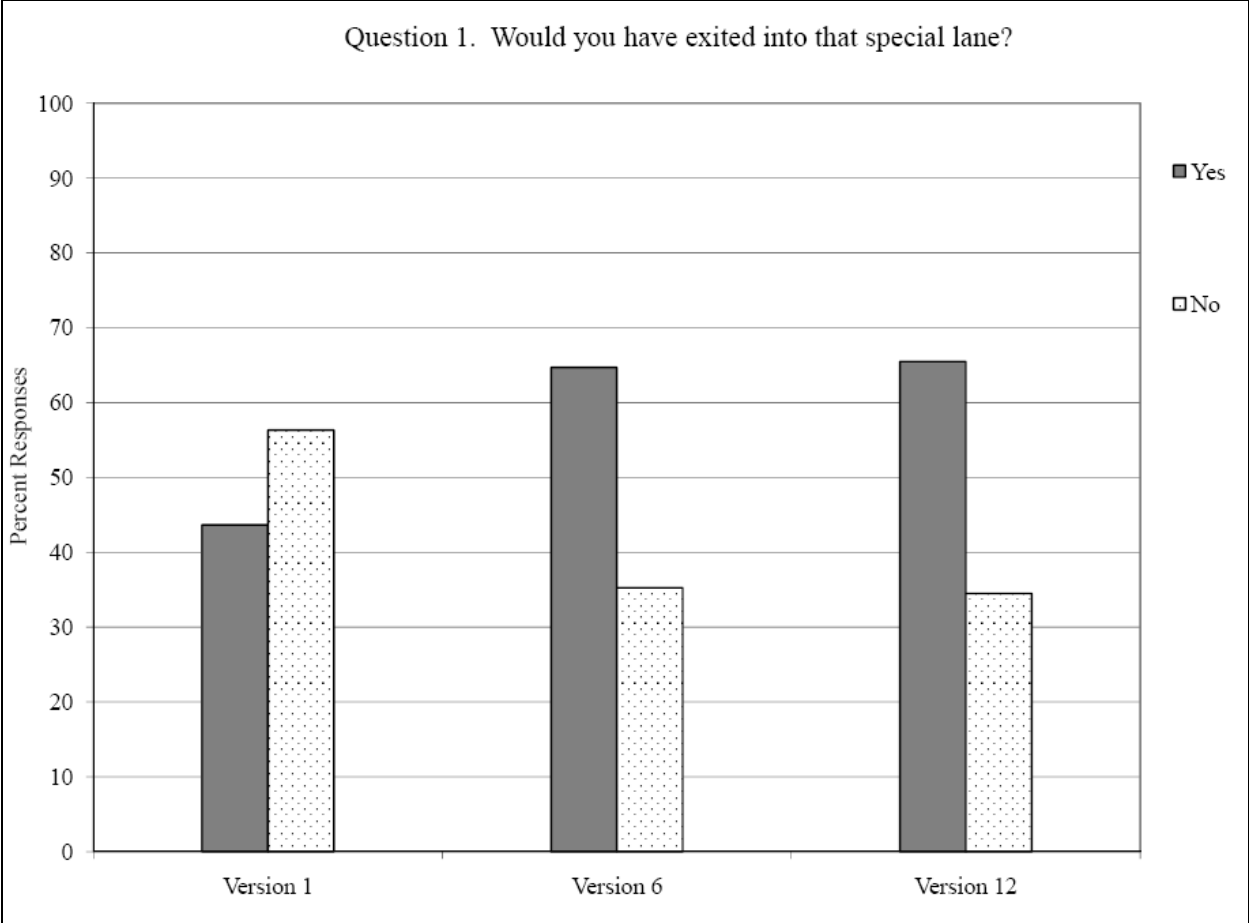

Figure 9. Responses to Lane Entry Question 1.

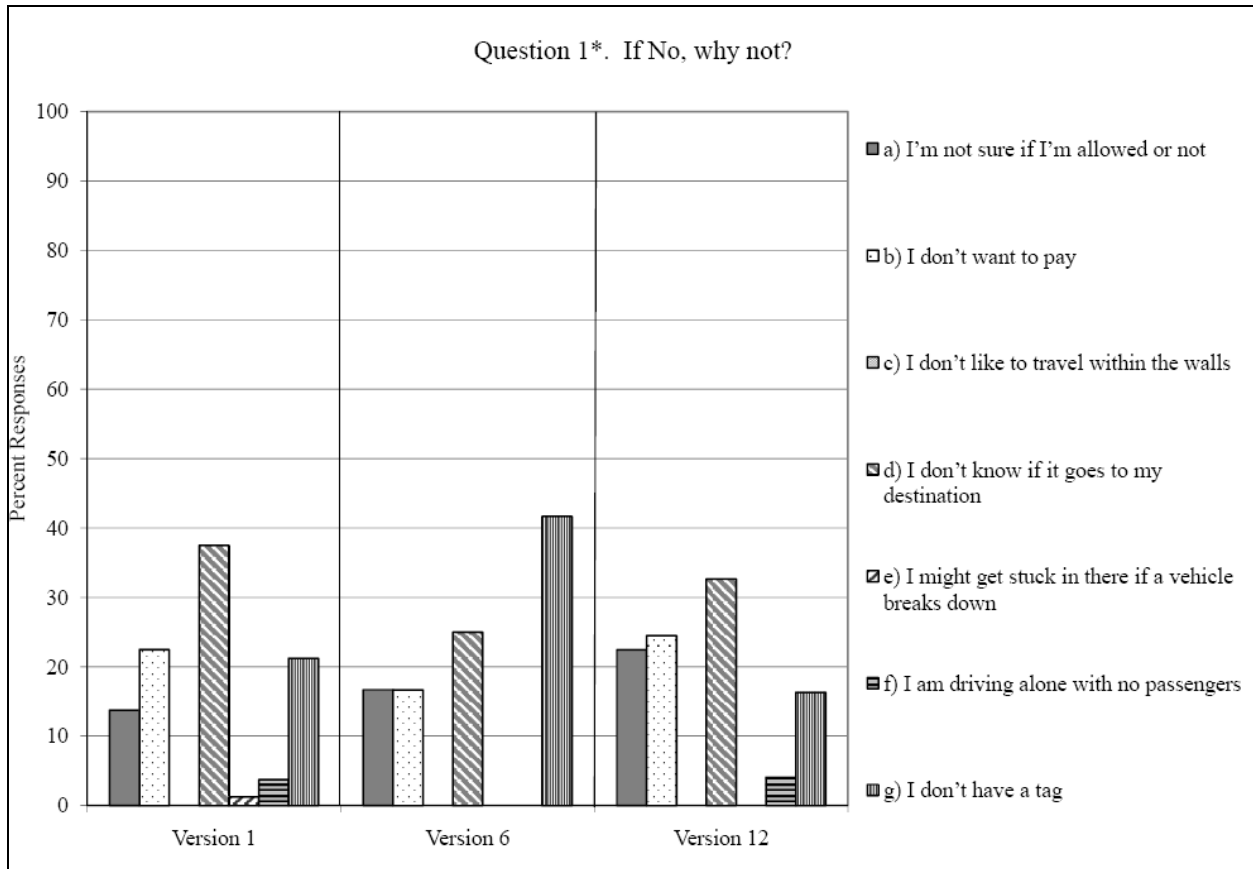

Figure 10. Responses for Those Who Answered “NO” to Lane Entry Question.

Lane Use Regulation

The next questions asked about drivers’ understanding of whether they were legally allowed in the lane. In Versions 1, 6, and 12 after which this question was asked, all of the regulatory banners on the guide and regulatory signs in the sequence said HOV/TOLL LANE and contained the HOV Diamond symbol.

2. Whether or not you would have chosen to drive in the special lane, are you legally allowed in that lane?

- y) Yes
- n) No

2*. If NO, you answered NO because...?

- a) I don't know what HOV/TOLL means
- b) I am driving alone with no passengers
- c) It costs too much
- d) I have no way to pay
- e) I don't know if my vehicle type is allowed
- f) I did not mean to pick NO

The results show good comprehension of the lane restriction with nearly 80 percent or more of respondents correctly answering that they were allowed in the lane (see Figure 11). The number of correct responses increased with multiple viewings as well. For those that answered “No”, the reasons cited are shown in Figure 11. Note that the percentages shown in Figure 12 are based on a small number of participants; the 10-20 percent of people who answered “No” to the previous question. Again, some ignorance of the scenario was demonstrated by those who answered “I am driving alone.” On the other hand, those who indicated that “they had no way to pay” seemed to remember the part of the scenario that stated that they did not have a toll tag. This group must not have understood the “Pay by Mail” plaque (see Question 15 below). One encouraging result here is that very few people cited “I don’t know if my vehicle type is allowed” as a reason.

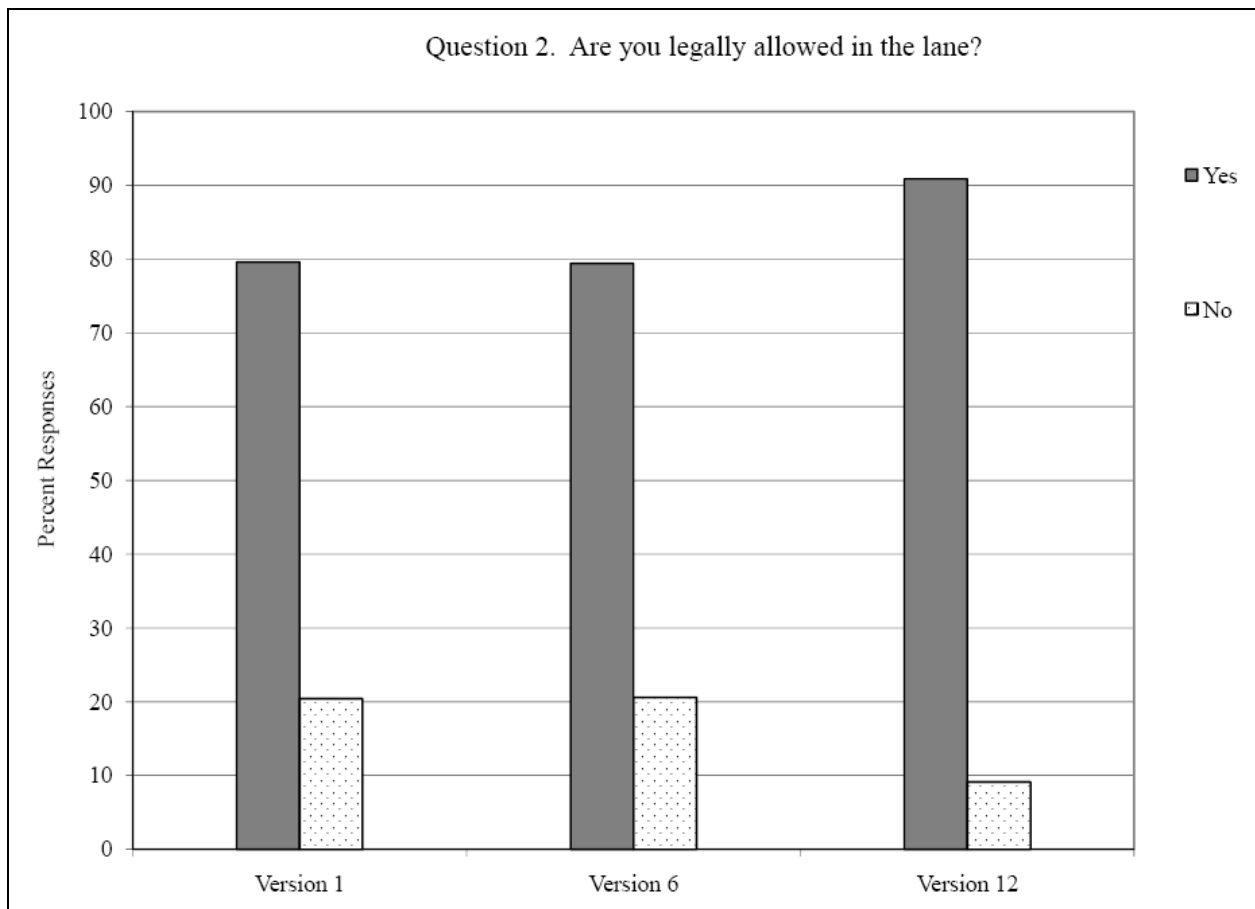

Figure 11. Responses to Lane Restriction Question.

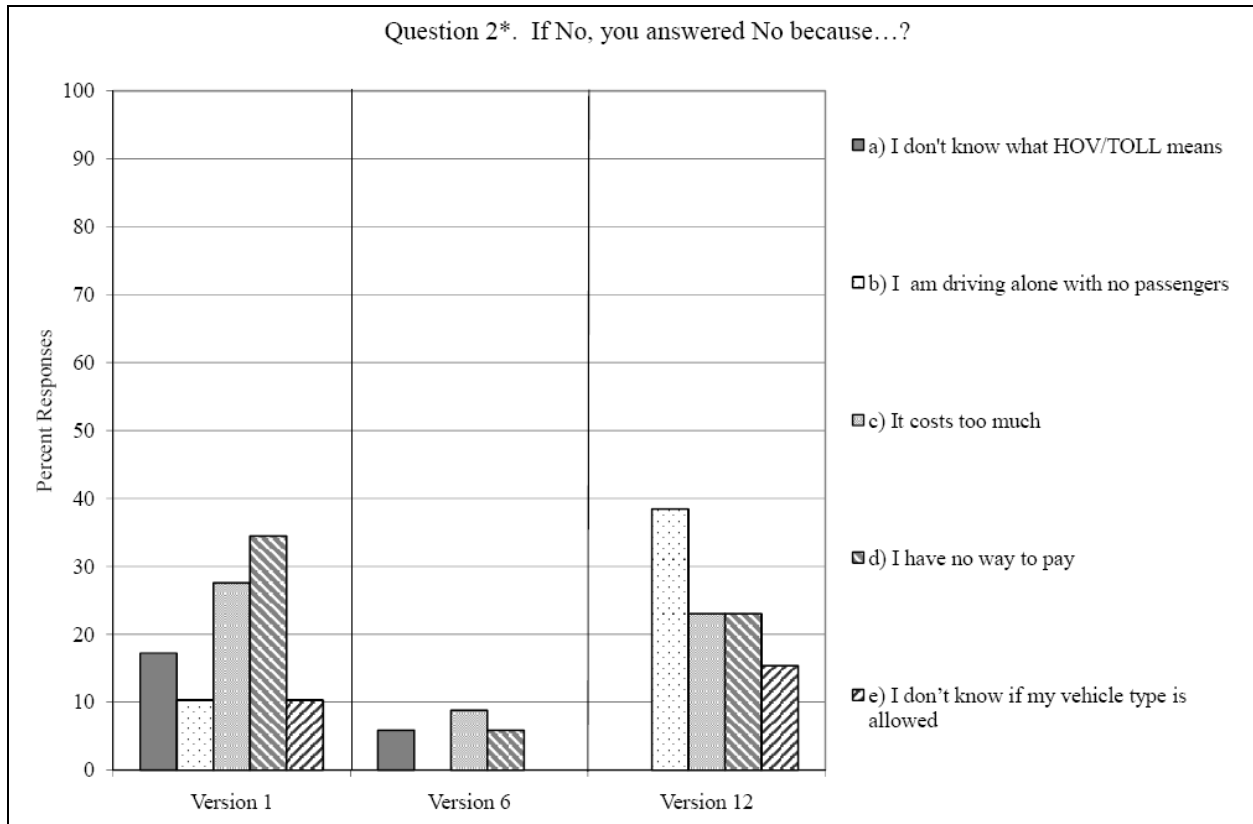

Figure 12. Responses for Those Who Answered “NO” to Lane Restriction Question.

Information Overload

One of the concerns with managed lane signing is driver information overload. The number of signs required to convey vehicle restrictions, occupancy requirements, payment type, and routing information is quite large. In developing the preliminary Managed Lanes Signing Guidelines, TxDOT attempted to use sign spreading to stagger this information across many locations on the approach to the managed lane ramp. Question 3 asked participants how they felt about the amount of information presented. The results are shown in Figure 13.

3. On a scale of 1 to 5 how much information did the signs give you to make a decision?
 - 1 = not enough information
 - 3 = adequate information
 - 5 = more than enough information

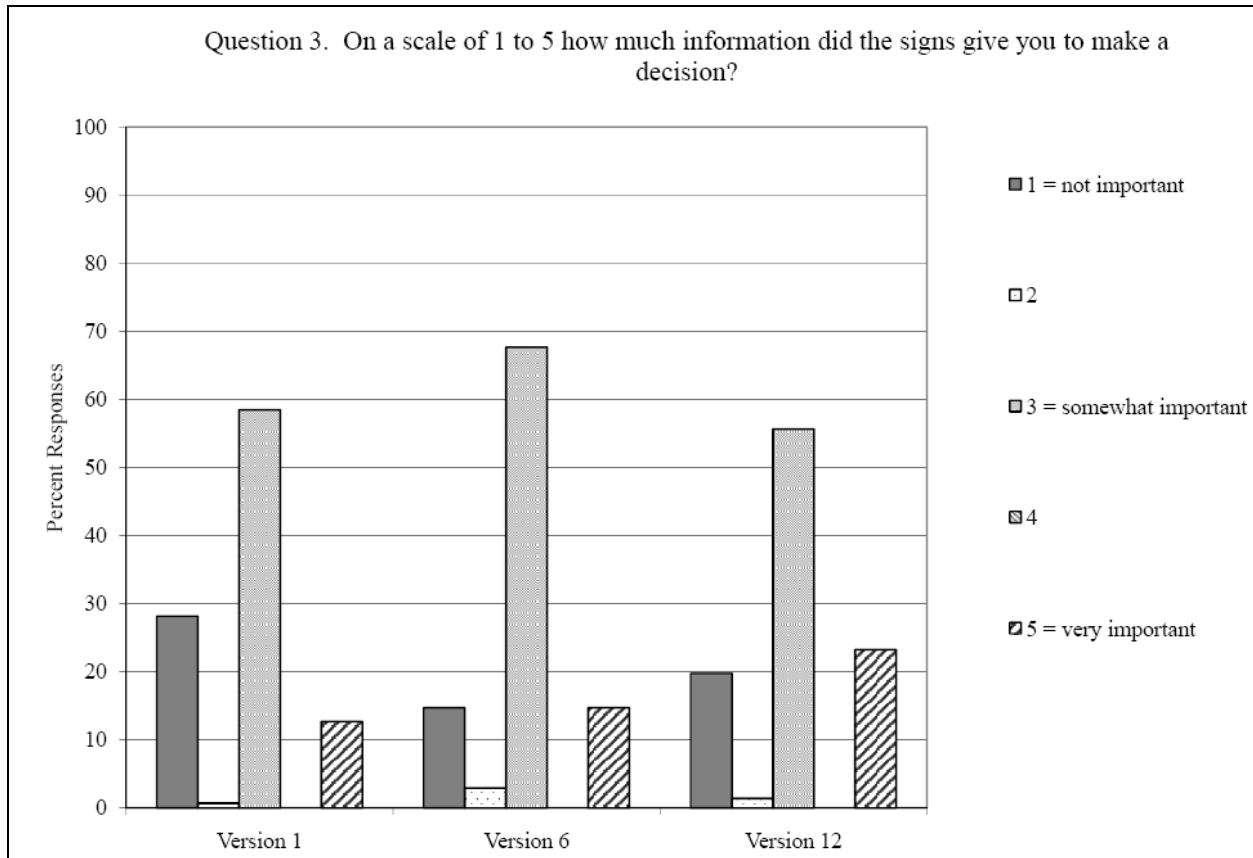

Figure 13. Responses to Information Overload Question.

Verbal text anchors were provided for options 1, 3, and 5 in order to provide a scale for the entire range of numerals. The intent of the question wording was to have participants provide a number 1-5 to rate the information, but it is clear from the pattern of responses that most of them instead treated the question as a multiple choice and only entered 1, 3, or 5. The results showed that most respondents felt that adequate information was given. Roughly an equal number of people felt that there was either too little or too much information given. These results are encouraging and seem to indicate that the sign sequence did not overwhelm drivers.

HOV Diamond Symbol Comprehension

Despite their use in Texas for over 30 years, past studies have shown that some drivers still do not understand the meaning of the black and white HOV diamond symbol used on signs and pavement markings. The next question asked about the survey participants’ understanding of this symbol. This question was asked seven times in total, after viewing the still photographs.

- 4a. Some of the signs had a black and white diamond in the upper left corner. What do you think that means?
- a) Official Vehicles Only
 - b) Bicycles Only
 - c) Carpools and Buses Only

Table 4. Responses to HOV Diamond Symbol Question by City, Collapsed Across Versions 7a, 7b, 7c, 8, 11a, 11b, 11c.

City	College Station	Dallas	Houston	San Antonio
Number of Participants	34	34	34	40
4a. Some of the signs had a black and white diamond in the upper left corner. What do you think that means?				
A	17.23	17.65	21.43	23.57
B	0.84	0.42	1.26	8.21
C	81.93	81.93	77.31	68.21

The results in Table 4 show fair comprehension of the symbol. Recall that Houston and Dallas are the only two urban areas in this sample that have HOV lanes. Therefore, it is surprising that more than 20 percent of Houston area participants did not recognize the symbol despite its wide use in the area. As the following section explains, comprehension for the letters “HOV” was slightly better than for the diamond symbol.

Lane Designation Banner Comprehension

The next set of questions was aimed at assessing comprehension of the terminology and symbols proposed to be used on supplemental regulatory plaques above guide and regulatory signs.

- 4b. Some of the signs said HOV/TOLL LANE across the top. What do you think HOV means?
- a) Highway Official Vehicles (maintenance and emergency)
 - b) High Occupancy Vehicles (carpools, buses)
 - c) High Output Vehicles (hybrids, motorcycles)

Table 5. Responses to HOV Terminology Question.

Version #	2	3	5b	6
Stimulus Type	Video	Video	Video	Video
Number of Participants	36	36	36	34
4b. Some of the signs said HOV/TOLL LANE across the top. What do you think HOV means?				
A	8.33	5.56	2.78	5.88
B	88.89	94.44	97.22	94.12
C	2.78	0.00	0.00	0.00

- 4b. (for Version 8 only) Some of the signs said TOLL LANE across the top. Do you think HOV vehicles are allowed?
- y) Yes
 - n) No
 - e) I don't know

Table 6. Responses to TOLL LANE Question.

Version #	8
Stimulus Type	Still
Number of Participants	142
4b. (for Version 8 only) Some of the signs said TOLL LANE across the top. Do you think HOV vehicles are allowed?	
Y	71.13
N	10.56
E	18.31

- 4c. What do you think HOV/TOLL LANE means?
- a) Only Carpools are allowed and they must pay a toll
 - b) Carpools can drive for free in that lane but non-carpools must pay a toll
 - c) Busses are allowed for free but carpools must pay a toll

Table 7. Responses to HOV/TOLL LANE Banner

Version #	2	3	5b	6
Stimulus Type	Video	Video	Video	Video
Number of Participants	36	36	36	34
4c. What do you think HOV/TOLL LANE means?				
A	52.78	41.67	47.22	47.06
B	41.67	55.56	52.78	50.00
C	5.56	2.78	0.00	2.94

Table 8. Responses for HOV/TOLL LANE Banner by City

4c. What do you think HOV/TOLL LANE means?		Question and Response Choices			
Version #	City	Number of Participants	A	B	C
Version 2	College Station	9	56	44	0
	Dallas	9	44	56	0
	Houston	9	44	44	11
	San Antonio	9	67	22	11
Version 3	College Station	8	25	75	0
	Dallas	9	44	56	0
	Houston	9	44	56	0
	San Antonio	10	50	40	10
Version 5b	College Station	10	60	40	0
	Dallas	8	63	38	0
	Houston	8	25	75	0
	San Antonio	10	40	60	0
Version 6	College Station	7	57	29	14
	Dallas	8	50	50	0
	Houston	8	38	63	0
	San Antonio	11	45	55	0
<i>Note: Response B was correct</i>					

The comprehension scores for the HOV component of the HOV/TOLL LANE banner (Table 5) show even higher comprehension rates for the HOV terms than for the diamond symbol alone (Table 4). Question 4b regarding the TOLL LANE banner (Table 6) showed that nearly 20 percent of respondents were not certain if HOV vehicles were allowed or not. In retrospect, this question could have probed comprehension further by asking whether HOVs would have to pay a toll or not.

This topic was addressed in Question 4c (Table 7) regarding the HOV/TOLL LANE banner. The results here show poor comprehension of the mixed used nature of the lane. Nearly half the respondents incorrectly understood the banner to mean that only carpools are allowed, *and* they must pay a toll. This misunderstanding would prevent toll-paying single occupant vehicle drivers from entering the lane when they were actually allowed. This result points to the need for further public information and education regarding the operation of these lanes and the

terminology applied to them. Table 8 shows the comprehension of the HOV/TOLL LANE banner by city and sign version. Regardless of the guide sign version the banner was paired with, there was no consistent difference in comprehension rates across the four cities.

Express Lane Terminology Comprehension

The FHWA Notice of Proposed Amendment (NPA) recommends using the term *Express Lane* for HOT lanes. The next set of questions in the survey assessed comprehension of this term. Note that the NPA recommends using the term *Express Lane* in a manner similar to a destination name on a guide sign as shown in Figure 14. This type of guide sign was tested with three different versions of type of payment banner as shown in Figure 14. The inset sign images at the bottom were shown in the full roadway scene as a still photo displayed for 3 seconds in the survey.

11. What do you think EXPRESS LANE most likely means?
 - a) The speed limit is higher in that lane
 - b) It is a toll lane
 - c) It is an HOV lane
 - d) It is an HOV and toll lane
 - e) A lane that is shorter distance to the destination
 - f) A lane that has fewer exits to cross-streets along the way to the final destination



Figure 14. Images Used for Versions 11 a-c Still.

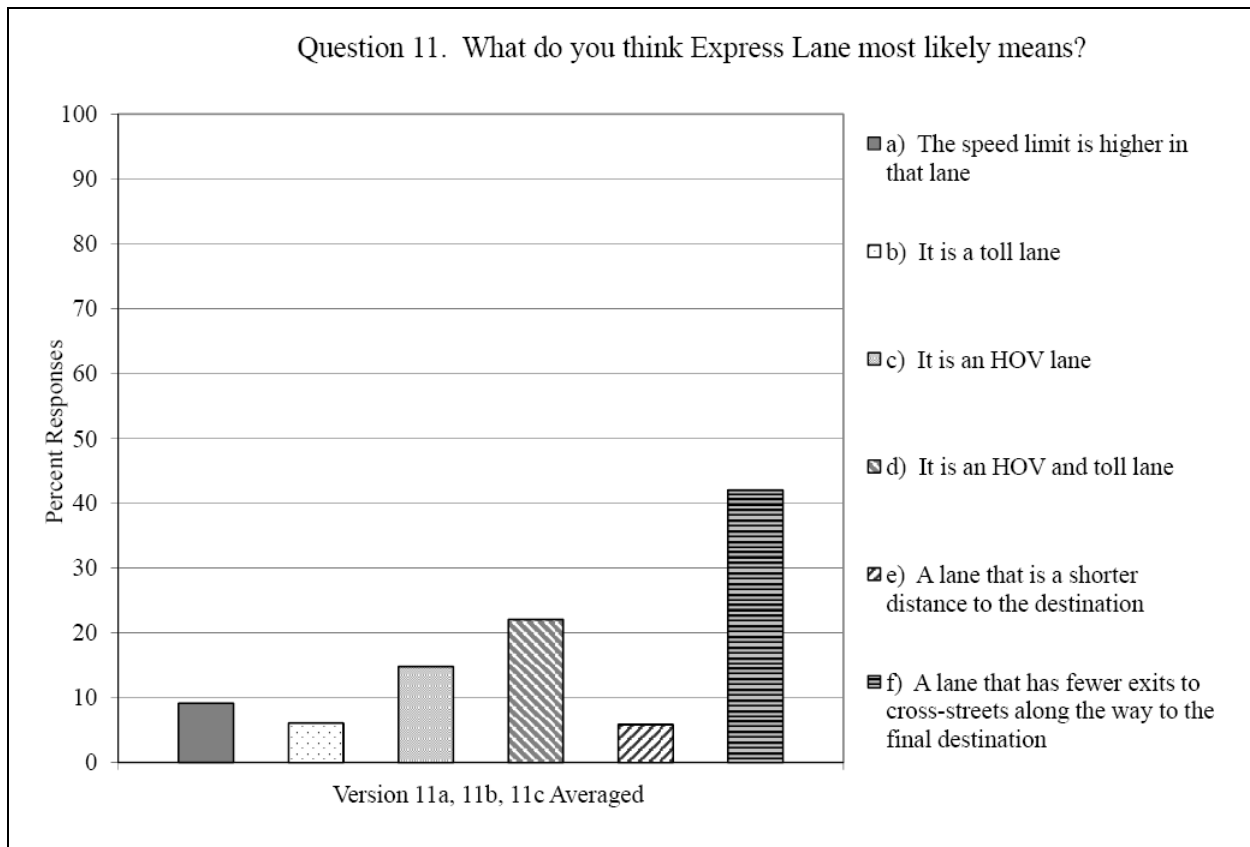

Figure 15. Responses to Express Lane Question.

The results shown in Figure 15 are averaged across all versions of the payment banner. The correct answer per the intent of the NPA is option “d”, chosen by 22 percent of the participants. More than 40 percent of the participants chose option “f” demonstrating their interpretation of *Express Lane* in the conventional usage of the word to mean limited-stop, similar to an express bus or train. In discussions within the National Committee on Uniform Traffic Control Devices Toll Road Task Force, some members have voiced concern that drivers would interpret *Express Lane* to mean higher speed or shorter distance (options “a” and “e” in this survey). This was not the case, with fewer than 10 percent of people selecting these options. Again, these results point to the need for public education concerning terminology and the consistent use of those terms.

TxTAG Payment Plaque Comprehension

In addition to the questions regarding *Express Lane*, the question below was asked after participants viewed the image in Figure 14. This question asked about their comprehension of the TxTAG Electronic Toll Collection pictograph shown in the payment banner.

- 4d. What do you think the blue and red TxTAG logo means?
- a) TxDOT operates this roadway
 - b) That is the route name for this roadway
 - c) TxTAG is an electronic payment that I can use to pay the toll on this roadway
 - d) You must have a TX license plate to drive on this roadway

Table 9. Responses to TxTAG Logo Meaning Question.

Version #	1
Stimulus Type	Video
Number of Participants	142
4d. What do you think the blue and red TxTAG logo means?	
A	12.68
B	4.93
C	78.87
D	3.52

The results in Table 9 show that nearly 80 percent of respondents understand TxTAG. This result can be taken as an indication of the success of TxDOT’s public education campaign surrounding TxTAG since its introduction in 2006.

Price Signing Comprehension

Questions regarding price sign design had been developed for the survey. In analyzing the results, an oversight was noted in the development of these questions. Since all the participants were given the scenario that they had a passenger and no toll tag, a response option of *Free* should have been included. For this reason, the results are not reported here. This error will be corrected in future work regarding price signing under current TxDOT project 0-6173, Driver Understanding of Congestion-Based Pricing Messages.

Interchange Sequence Signing Comprehension

Previous studies have shown that one of the main reasons drivers do not enter HOV lanes is uncertainty about destinations served (1, 2). The animation clips tested here included interchange sequence signs for HOT lane exits in advance of the entrance point. The identical

sign was used in all the video versions, but its position in the sign sequence was changed. In previous focus groups (1, 2) when asked whether they'd like to see the price or the distance information first in a sequence, drivers were evenly split in their response. So, for this survey video Versions 2, 3, and 6 had the distance sign in position F after the price sign, and Version 5b had the distance sign at position D, prior to the price sign (see Figure 4 and Figure 5).

The multiple choice options were intentionally selected to include numbers seen on other signs in the sequence. Figure 3 shows all of the signs, including those for general purpose lane exits. The sign shown at 1.75 miles is an interchange sequence sign for the general purpose lane that lists 11 miles to Partner Ln and 5 miles to 55th St. These numerals were included as multiple choice options "f" and "d". The price signs in the sequences also included numerals, and these were included as options "a" and "b". The purpose in including these numerals as distracter items in the multiple choice questions was to test whether drivers had actually retained the correct distance information or would just select any numeral they had seen on a sign.

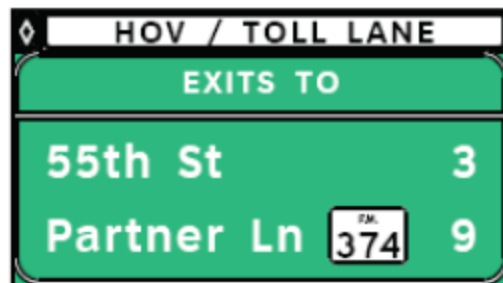

Figure 16. Close-up of *Interchange Sequence* Sign F.

- 5c. How far is it to Partner Ln?
- a) 2 miles
 - b) 3 miles
 - c) 4 miles
 - d) 5 miles
 - e) 9 miles
 - f) 11 miles

Table 10. Percent Responses for Question 5c for Stimuli: Versions 2, 3, 5b, 6.

Version #	2 Pos. F	3 Pos. F	5b Pos. D	6 Pos. F
Stimulus Type	Video	Video	Video	Video
Number of Participants	36	36	36	34
5c. How far is it to Partner Ln?				
A	8.33	19.44	38.89	32.35
B	5.56	2.78	5.56	5.88
C	0.00	8.33	2.78	0.00
D	5.56	2.78	0.00	5.88
E	66.67	50.00	47.22	55.88
F	13.89	16.67	5.56	0.00

5d. How far is it to 55th St?

- a) 2 miles
- b) 3 miles
- c) 4 miles
- d) 5 miles
- e) 9 miles
- f) 11 miles

Table 11. Percent Responses for Question 5d for Stimuli: Versions 2, 3, 5b, 6.

Version #	2 Pos. F	3 Pos. F	5b Pos. D	6 Pos. F
Stimulus Type	Video	Video	Video	Video
Number of Participants	36	36	36	34
5d. How far is it to 55th St.?				
A	13.89	16.67	19.44	17.65
B	27.78	27.78	25.00	26.47
C	5.56	11.11	11.11	5.88
D	25.00	30.56	30.56	14.71
E	5.56	8.33	5.56	0.00
F	22.22	5.56	8.33	35.29

For Question 5c regarding the distance to Partner Ln, Table 10 shows that nearly 25 percent overall selected the incorrect option “a” (2 miles). The numeral 2 appeared on the price signs which is likely the source of the confusion, although the \$2.00 price was not specific to Partner Ln. Interestingly, the same error occurred with lower frequency for Question 5d (Table 11) despite the fact that the \$2.00 price was identified as corresponding to 55th St in the price signs in Versions 2 and 3.

Overall, the comprehension and recall of the distance to Partner Ln was just over 50 percent (Table 10). This is disappointingly low in light of the fact that Partner Ln was provided as the participants' destination repeatedly in the instructions. The distracter item "f" (11 miles) was the distance listed on the general purpose lane sign, and approximately 10 percent of drivers chose that value.

The recall and comprehension for the distance to 55th St was markedly lower (see Table 11). Again, a sizeable number of people incorrectly chose option "a" (2 miles) which was the price given for 55th St. As seen in the previous question, a large number (again nearly 25 percent) chose option "d" (5 miles) which was the distance given on the destination sign for the general purpose lanes. These results indicate that the interchange sequence signs for managed lane exits may need to be made more distinct to avoid confusion with signing for the general purpose lanes.

Tolling Gantry Lane Selection

HOT lane operations depend on the ability to segregate toll-paying single occupant vehicles (SOVs) from free or discounted rate HOVs. There are several different ways to accomplish this, one of which is to have declaration zones at tolling gantry areas where drivers self-declare their vehicle occupancy status. The Dallas I-30 HOT lane is considering such a declaration zone for its two-lane facility. The survey included questions regarding the signing that would accompany such declaration zones (see Figure 17).

Note questions 6-9 were omitted due to survey session length time considerations

10. Ignoring the lane that the video drove in, which lane would you get in to pass under the last set of signs?
 - l) Left
 - r) Right
 - e) Either



Figure 17. Images Used for Tolling Gantry Version 14 (top) and Version 13 (bottom).

Table 12. Responses to Tolling Gantry Lane Question.

Version #	13	14
Stimulus Type	Video	Video
Number of Participants	72	70
10. Ignoring the lane that the video drove in, which lane would you get in to pass under the last set of signs?		
L	20.83	17.14
R	54.17	54.29
E	25.00	28.57

Recall that survey participants had been told that they were in a vehicle with a passenger which would entitle them to use the right lane at the declaration zone. The survey results (Table 12) show that just over half the participants correctly answered “right lane.” The results did not vary for the two sign designs tested indicating that either a static sign (Version 13) or a dynamic sign (Version 14) would perform the same.

Proper lane selection in the declaration zones may be enhanced by providing lane assignment signs prior to the declaration zone. The geometric design of these facilities may be such that there is only a short distance where the lanes widen for the two declaration lanes for each approach lane, such that advance signs would appear at a point where the current number of lanes is half that of the declaration zone. Video version 13 included advance lane assignment signs which were placed ½ mile prior to the tolling gantry. These advance signs did not seem to have any beneficial effect. It should be noted that due to experimental design and time restrictions, the survey was not able to test the advance signs with each version of the gantry signs.

ACCESS TO Terminology Comprehension

The draft TxDOT Managed Lane signing guidelines (4) recommend using a guide sign with the words ACCESS TO at intermediate access points to a managed lane. The animations used for this survey did not include the geometric design for a weave area intermediate access point. The ACCESS TO sign was tested at the initial slip-ramp entrance point instead as shown in Figure 18. This sign was viewed by all survey participants, and their reading time was measured (and reported in the following section).



Figure 18. ACCESS TO Image Used in Version 10 Still.

12. What do you think ACCESS TO most likely means?
- a) An exit ramp is coming up that allows cars to merge into the main lanes of I-10
 - b) The wall separating the special lane ends soon to allow cars to change lanes to and from the main lanes of I-10

Table 13. Responses to ACCESS TO Question.

Version #	10
Stimulus Type	Still
Number of Participants	142
12. What do you think ACCESS TO most likely means?	
A	66.90
B	33.10

The results (Table 13) show poor comprehension of the sign when applied at a slip-ramp entrance. The wording of “b” referring to “the wall” may have been misunderstood in the context of a slip-ramp. This could have contributed to the low accuracy. It is interesting to note that the majority of respondents chose “a” which stated that there was a ramp *to* the main lanes of I-10. It appears that participants understood the drawing to mean that they were already in the managed lane. If this was the case, it bodes well for the use of these signs at intermediate access points where that is the intended meaning. If this sign was indeed over the managed lane, the

route marker would not contain the TOLL plaque, it would contain a standard route marker indicating access to the main lane.

LEFT LANE Plaque Comprehension

Since left-hand exits violate driver expectations, the MUTCD recommends supplemental plaques indicating left exits. The current federal MUTCD calls for a white-on-green plaque indicating a left exit along with the exit number (Figure 2E-3). The recent NPA allows an option of a black-on-yellow plaque to be placed on the left side on top of a guide sign (NPA Figure 2E-7).

Section 2E-49 of the MUTCD provides for supplemental messages such as LEFT LANE to be placed as white text on a green guide sign for advanced entrance signs. TxDOT applied this philosophy in developing the advanced guide sign for managed lanes shown in Figure 19 as detailed in the draft *Managed Lane Signing Guidelines* (4). TxDOT chose to emphasize the LEFT LANE message by placing it on a supplemental yellow plaque the full width of the guide sign similar to an EXIT ONLY plaque.

These two alternatives to signing a left slip-ramp exit (TxDOT and FHWA NPA) were tested and are shown in Figure 19. One concern about the TxDOT approach is that due to the yellow supplemental plaque at the bottom of the sign, some drivers may mistakenly interpret this to mean an EXIT ONLY condition. Question 14 asked about this point.



Figure 19. Images Used for Left Exits in Still Versions 8 and 9.

13. Which direction is the upcoming exit?
l) Left
r) Right

14. Is the lane you're in an EXIT ONLY, meaning you must exit if you're in this lane?
 y) Yes
 n) No

Table 14. Responses to LEFT LANE Plaque Question.

Version #	8	9
Stimulus Type	Still	Still
Number of Participants	142	142
13. Which direction is the upcoming exit?		
L	85.92	95.77
R	14.08	4.23

Table 15. Responses to LEFT LANE Implying EXIT ONLY Condition Question.

Version #	8	9
Stimulus Type	Still	Still
Number of Participants	142	142
14. Is the lane you're in an EXIT ONLY, meaning you must exit if you're in this lane?		
Y	79.58	71.83
N	20.42	28.17

The comprehension question (Table 14) shows overall good comprehension of the direction of the upcoming exit for both signs. Version 9 with the plaque on the top had a slightly higher accuracy. The question regarding EXIT ONLY condition showed surprisingly bad comprehension for both versions of the sign (Table 15). The majority of the participants understood the left exit to also mean EXIT ONLY. This interpretation was slightly higher for the TxDOT LEFT LANE sign (Version 8).

Because TxDOT is proposing to place supplemental plaques at the top of guide signs to indicate payment type, there was concern that placing the LEFT plaque at the top of the sign would cause confusion or that the LEFT plaque would become lost among the payment plaques. For this reason, reading time was recorded for Version 9 (FHWA NPA) and Version 10 (ACCESS TO sign shown in Figure 18). Due to a programming error, Version 8 was presented in the limited-viewing time condition of 3 seconds. The viewing times for the FHWA LEFT plaque at the top of the sign compared to the TxDOT LEFT EXIT plaque at the bottom of the sign were virtually identical at 16 seconds.

Form of Payment Comprehension

With the advance of electronic tags and video tolling, paying a toll has become more complicated than dropping some coins in a hopper. The 2006 TMUTCD showed signs with banners that read TxTAG ONLY because at that time, it was anticipated that facilities would accept tag payments only. Since that time, the use of license-plate capture video systems which send a bill to non-tag toll customers has become the norm in Texas. TxDOT developed the message “Pay by Mail” for this operation. The understanding of these terms was tested (see Figure 7) through a series of still photos, which were viewed by all respondents for 3 seconds each. These images were presented in random order during the survey. It should be noted in Figure 7 that the C versions all contained a banner that stated TxTAG ONLY, so for these the correct answer should have been option “b”.

- 15. How can you pay the toll to use the upcoming lane?
 - a) Cash
 - b) TxTAG Only
 - c) Pay by Mail Only
 - d) TxTAG or Pay by Mail

Table 16. Responses to Form of Payment Question.

Version #	7a	7b	7c	8	11a	11b	11c
Stimulus Type	Still	Still	Still	Still	Still	Still	Still
Number of Participants	142	142	142	142	142	142	142
15. How can you pay the toll to use the upcoming lane?							
A	3	6	6	7	6	3	5
B	7	7	60	8	10	8	40
C	12	4	5	12	8	8	6
D	78	82	29	73	76	82	49

The difference between A and B versions of signs 7 and 11 was in how the “Pay by Mail” message was presented, either as full text in the banner (A) or a distinct plaque (B). Both of these methods generated good comprehension, with 11B doing slightly worse than the others. These results assuage any fears that the text in the Pay by Mail plaque is too small when used in a banner. For the C versions of the signs which stated TxTAG only, accuracy was considerably worse with many respondents still indicating that they could pay by mail. In practice on TxDOT roads this is generally the case that pay by mail is always an option, but on other toll facilities

controlled by local toll authorities, this may not be true. A sign on those facilities that indicates tag-only is true, and those vehicles without a tag may be issued a costly citation.

Importance of Travel Time Information

Previous focus group research had indicated that drivers would like to know the travel time before they decided whether or not to use a managed lane. Video animation Version 12 (see Figure 6) showed an example of travel time information. In this animation Sign position E showed a full matrix DMS with two phases that alternated between travel time and lane status. Participants were asked to rate how important this travel time information was in their lane use decision as shown in Question 16.

- 16. On a scale of 1 to 5, how important is it to know the estimated travel time in order for you to decide whether to use the special lane?
 - 1 = not important
 - 3 = somewhat important
 - 5 = very important

Table 17. Percent Responses to Travel Time Importance Question by City.

City	College Station	Dallas	Houston	San Antonio
Number of Participants	34	34	34	40
16. How important is it to know the estimated travel time in order for you to decide whether to use the special lane? 1 to 5				
1	14.71	8.82	8.82	7.50
2	2.94	2.94	2.94	0.00
3	44.12	38.24	35.29	20.00
4	0.00	0.00	0.00	0.00
5	38.24	50.00	52.94	72.50

The results in Table 17 again show that participants were biased in selecting responses that matched the verbal anchors supplied for the rating scale. It is interesting to note that San Antonio respondents were most likely to rank travel time information highly as a decision factor. The San Antonio area has had travel time DMS throughout their freeway system for many years. The majority of all respondents indicated that travel time was somewhat or very important.

SUMMARY AND RECOMMENDATIONS

The survey revealed several important aspects of drivers' comprehension of signs for toll and managed lanes facilities.

- Advanced destination signing is an important determinant of whether drivers will use a managed lane or not. Distance – Destination signs and Interchange Sequence Signs should be provided in advance of all access points to and from managed lanes.
- Interchange sequence signs for managed lane exits may need to be made more distinct to avoid confusion with signing for the general purpose lanes.
- The HOV Diamond Symbol in the corner of signs is still misunderstood by 15-25 percent of drivers to mean “Official Vehicles Only.”
- The text HOV was well understood by over 90 percent of participants.

Methodological Considerations For Future Research

The survey method used here was slightly different than TTI has used in past studies. The use of computer animation holds promise to simulate the time pressure of actual driving. The researchers did learn from this survey, however, that adjustments in the size of signs and the animation speed may need to be made to provide adequate reading time of signs. Large overhead guide signs can be read up to 1000 feet away in daylight conditions (7). At freeway speeds this provides roughly 10 seconds of visibility time within the range of legibility. On actual roads, drivers make a series of short fixations on signs interspersed with glances to the roadway. So, the total amount of time a driver fixates on a sign summed across these multiple glances may be 5 seconds or less.

The signs used in the computer animations in the current study were legible for approximately 5 seconds. The size of the signs was to roadway scale, and the animation speed was equivalent to 60 mph. Despite this, many participants reported that the signs were too small or went by too quickly to be read and comprehended, particularly for the trials early in the experimental session. Future computer animations may overcome this by slowing down the speed to allow more time with the signs in view, or by re-scaling the signs so that they can be viewed at a greater virtual distance. Providing a practice animation containing non-test signs

also would allow participants to become acquainted with the scenes and animation speed prior to actual testing.

Another methodological consideration is in the wording and administration of the instructions. Prior to each video clip, text appeared on the screen providing instructions to the participants and describing the driving scenario to keep in mind while viewing the video. It was clear from the results that some participants did not read this description carefully (e.g., Figure 9). Although the text told them they had a passenger in the car, some respondents indicated that they did not meet HOV requirements. Future studies should have the experimenter provide critical scenario information verbally to ensure that all participants understand the instructions.

REFERENCES

1. Chrysler, S.T., A. Williams, and K. Fitzpatrick (2007). *Preliminary Guidelines for Signing for Toll Facilities*. Research Report 5446-1, Texas Transportation Institute, College Station, TX.
2. Chrysler, S.T., A. Williams, and K. Fitzpatrick (2008). *Driver Comprehension of Signing and Markings for Toll Facilities*. FHWA/TX-07/0-5446-2, Texas Transportation Institute, College Station, TX.
3. TxDOT Traffic Operations Division, *Toll Road Signing Guidelines*, Draft Policy, Aug. 8, 2008. Available from Michael Chacon, TxDOT.
4. TxDOT Traffic Operations Division, *Managed Lane Signing Guidelines*, Draft Policy, June 22, 2008. Available from Michael Chacon, TxDOT.
5. Texas Department of Transportation Manual on Uniform Traffic Control Devices, 2006 Edition. <http://www.dot.state.tx.us/publications/traffic.htm> Accessed August 15, 2008.
6. US DOT Notice of Proposed Amendment to the Manual on Uniform Traffic Control Devices, January 2, 2008. <http://mutcd.fhwa.dot.gov/> Accessed August 15, 2008.
7. Funkhouser, D.S., S. Chrysler, and A. Nelson (2008). *Traffic Sign Legibility for Different Sign Background Colors: Results of an Open Road Study at Freeway Speeds*, Paper presented at the 52nd Annual Meeting of the Human Factors and Ergonomics Society, New York, September 24, 2008.

